

PB88 - 202700



Maintenance of Aggregate and Earth Roads

WA-RD 144.1
June 1987

REPRODUCED BY
U.S. DEPARTMENT OF COMMERCE
National Technical Information Service
SPRINGFIELD, VA. 22161



Washington State Department of Transportation
Planning, Research and Public Transportation Division

in cooperation with the
United States Department of Transportation
Federal Highway Administration

WASHINGTON STATE DEPARTMENT OF TRANSPORTATION

Duane Berentson, Secretary
A.D. Andreas, Deputy Secretary
James P. Toohey, Assistant Secretary for Planning, Research and Public Transportation

Washington State Transportation Commission Research Committee

William O. Kamps, Chair
Bernice Stern, Commissioner
Leo B. Sweeney, Commissioner

WSDOT Research Executive Committee

A.D. Andreas, Chair, Deputy Secretary for Transportation
E.W. Ferguson, District 4 Administrator
H. W. Parker, Assistant Secretary for Marine Transportation
Robert C. Schuster, Assistant Secretary for Highways
James P. Toohey, Assistant Secretary for Planning Research & Public Transportation

WSDOT Research Technical Committees

Highway Operations and Development
Don Senn, Chair, District 2 Administrator
John Aspaas, District 4 Project Engineer
William P. Carr, Associate Research Director
John Conrad, District 1 District Operations Engineer
Rich Damell, District 3 Maintenance & Operations Engineer
C. Stewart Gloyd, Bridge/Structures Engineer
Wayne Gruen, State Traffic Engineer
Dennis Jackson, Roadway Construction Engineer
Stan Moon, Location/Design Engineer
Dick Shroll, District 6 Maintenance Superintendent
Ken Thomas, Operations Engr., Bellingham Public Works Dept.
George Tsiatis, Structural Engineer, Washington State University

Materials and Product Evaluation

Del Vandehey, Chair, State Construction Engineer
Keith W. Anderson, Federal Program Manager
Jim Buss, District 5 Construction Engineer
Newton Jackson, Pavement/Soils Engineer
Steve Kramer, Assistant Professor, Civil Engineering, U of W
Bob Krier, Bridge Operations Engineer
Bob Spratt, District 2 Maintenance Engineer
John Strada, Materials Engineer

Planning and Multimodal

Don Trantum, Chair, District 6 Administrator
Ron Anderson, Manager, District 6 Management Services
Ken Casavant, Professor, Washington State University
King Cushman, Director, Pierce County Transit Development
Kris Gupta, Manager, Transportation Data Office
Charles Howard, Transportation Planning Office
Jerry Lenzi, Manager, Multi Modal Branch
Jim Slakey, Manager, Public Transportation
Ray Deardorf, Service Planning Manager, Ferry System

WSDOT Research Implementation Committee

Stan Moon, Chair, Location/Design Engineer
Jack E. Hanson, Location Engineer
Dennis Ingham, State Maintenance Engineer
Dennis Jackson, Roadway Construction Engineer
Kern Jacobson, Engineering Superintendent, WSF
Bob Krier, Bridge Operations Engineer
Ed Schlect, Construction Engineer, Paving
Gerald Smith, District 1, Assistant I-90 Construction Engineer
Bob Spratt, District 2 Maintenance Engineer
John Strada, Materials Engineer

WSDOT Research Office

John Doyle, Director
William P. Carr, Associate Director
Keith W. Anderson, Federal Program Manager
Julie Leverson, Database Coordinator
Carl Toney, Research Administrator

WSDOT Research Liaisons

District 1 - John Conrad, Public Transportation & Planning Engr.
District 2 - Dave House, Project Development Engineer
District 3 - Bob George, Assistant Location Engineer
District 4 - Richard N. Coffman, Maintenance Engineer
District 5 - Robert MacNeil, Design Engineer
District 6 - Richard Larson, Design and Planning Engineer
WSDOT Library - Barbara Russo, Librarian

Transportation Research Council

Transportation Commission

Leo B. Sweeney, Chair
William J. Kamps, Vice Chair
Vaughn Hubbard
Bernice Stern
Richard Odabashian
Albert D. Rosellini
Jim Henning

Federal Highway Administration

Paul C. Gregson, Division Administrator

Private Sector

Milton "Bud" Egbers, President, Skagit Valley Trucking
Richard Ford, Managing Partner, Preston, Thorgrimson, Ellis, Holman
Tom Gaetz, Project Manager, David Mowat & Company, Bellevue
Lawrence Houk, Vice President, Lockheed Shipbuilding
Charles H. Knight, President, Concrete Technology
H. Carl Munson, VP for Strategic Planning, Boeing Co., Seattle
Michael Murphy, President, Central Pre-Mix Concrete
Richard Norman, President, Associated Sand & Gravel, Everett
John Ostrowski, Public Works Director, Vancouver, WA
Richard S. Page, President, Washington Roundtable
Sudarshan Sathe, Dir., Technical Services, Polycarb Inc., Cleveland, OH
Gerald E. Weed, Public Works Director, Snohomish County

Universities

Gene L. Woodruff, Vice Provost for Research, UW
Robert V. Smith, Associate Provost for Research, WSU
Neil Hawkins, Associate Dean for Research, College of Engineering, UW
Reid Miller, Dean, College of Engineering, WSU
Colin Brown, Professor and Chair, Civil Engineering, UW
Surinder K. Bhagat, Professor and Chair, Civil Engineering, WSU

Washington State Department of Transportation

Duane Berentson, Secretary
A.D. Andreas, Deputy Secretary
C.W. Beeman, District 5 Administrator
R.E. Bockstruck, District 1 Administrator
J.L. Clemen, Assistant Secretary for Finance & Budget Management
Don Senn, District 2 Administrator
R.L. Daniels, Administrator, Public Affairs Office
E.W. Ferguson, District 4 Administrator
W. H. Hamilton, Assistant Secretary for Aeronautics
W.I. Hordan, State Aid Engineer
H. W. Parker, Assistant Secretary, Marine Transportation
R.C. Schuster, Assistant Secretary for Highways
A.T. Smelser, District 3 Administrator
J.P. Toohey, Assistant Secretary for Plng, Res., and Pub. Trans.
M.D. Trantum, District 6 Administrator
D.J. Vandehey, State Construction Engineer

Representative George Walk, Chair - Legislative Transportation Committee

Federal Highway Administration

M. Eldon Green, Region 10 Administrator
Otis C. Haselton, Region Office Research and T2 Engineer
Ernest J. Valach, Director, Regional Planning and Program Development

Paul C. Gregson, Division Administrator
Barry Brecto, Division Office Programming and T2 Engineer
Charles W. Chappell, Division Transportation Planner
Mike Duman, Assistant Transportation Planner

Washington State Transportation Center (TRAC)

G. Scott Rutherford, Director
Richard Fragaszy, Deputy Director, WSU
Joe P. Mahoney, Deputy Director, UW
Khossrow Babaei, Senior Research Engineer
Don Ernst, Technology Transfer
Mark Hallenbeck, Senior Research Engineer
Alison Kaye, Word Processing Technician
Ed McCormack, Research Engineer
Amy O'Brien, Editor
Bav Odgaard, Program Assistant
Ron Porter, Word Processing Technician
Cy Ulberg, Senior Research Engineer
Duane Wright, Research Aide

**WASHINGTON STATE DEPARTMENT OF TRANSPORTATION
TECHNICAL REPORT STANDARD TITLE PAGE**

1. REPORT NO. WA-RD 144.1	2. GOVERNMENT ACCESSION NO. PB88 - 202700TAS	3. RECIPIENT'S CATALOG NO.
4. TITLE AND SUBTITLE Maintenance of Aggregate and Earth Roads	5. REPORT DATE June 1987	
	6. PERFORMING ORGANIZATION CODE	
7. AUTHOR(S) Robert D. Srombom, P.E.	8. PERFORMING ORGANIZATION REPORT NO.	
9. PERFORMING ORGANIZATION NAME AND ADDRESS Fujiki and Associates, Inc. 22617 76th Ave. West, Suite 107 Edmonds, WA 98020	10. WORK UNIT NO.	
	11. CONTRACT OR GRANT NO. WSDOT Y-3766	
	13. TYPE OF REPORT AND PERIOD COVERED Manual (10/86 - 6/87)	
12. SPONSORING AGENCY NAME AND ADDRESS Washington State Department of Transportation Transportation Building Olympia, WA 98504	14. SPONSORING AGENCY CODE	
	15. SUPPLEMENTARY NOTES This manual is a state-of-the-art document covering road maintenance planning, concepts, scheduling, equipment and materials selection, use of goals and objectives, and field procedures. Emphasis is on travelway, shoulders and roadside ditch maintenance activities.	
18. ABSTRACT Road maintenance is characterized as the continuing care of the roadway and providing for its intended use until such time as needed improvements are identified and undertaken. Within the scope of recurrent and deferred maintenance activities, opportunities are identified to improve cost effectiveness of surfacing and ditch maintenance and reduce future capital improvements. The selection of equipment, materials and procedure is either a commitment to long-term transportation system goals or they create future constraints. The author shows how <ul style="list-style-type: none"> • subgrade and base course damage can be detected and corrected while avoiding actions that add costs or merely hide the problems; • use of geotextiles may benefit road conditions but interfere with future maintenance; • selection of dust palliatives may either increase or decrease future costs; • basic equipment types and limitations affect maintenance prescriptions; • good operating practices improve production and protect equipment; • some historic practices increase the risk of equipment damage; • drainage affects road stability and serviceability; • to reshape or smooth blade surfacing and clean roadside ditches; • an effective maintenance management system helps identify and prioritize needed improvements. Planning, scheduling and performing roadside ditch, travelway and shoulder maintenance requires knowledge and expertise to be successfully and economically accomplished. Basic maintenance approaches and concepts are suggested and new considerations proposed for aggregate, earth and native surfaced roads.		
17. KEY WORDS Aggregate, base, blading, damage, ditch cleaning, drainage, geotextiles, goals, grading, maintenance equipment, maintenance management, objectives, palliatives (dust), planning, scheduling, stabilization, subgrade	18. DISTRIBUTION STATEMENT No restrictions. This document is available to the public through the National Technical Information Service, Springfield, VA 22616	
19. SECURITY CLASSIF. (of this report) None	20. SECURITY CLASSIF. (of this page) None	21. NO. OF PAGES 79
		22. PRICE A05

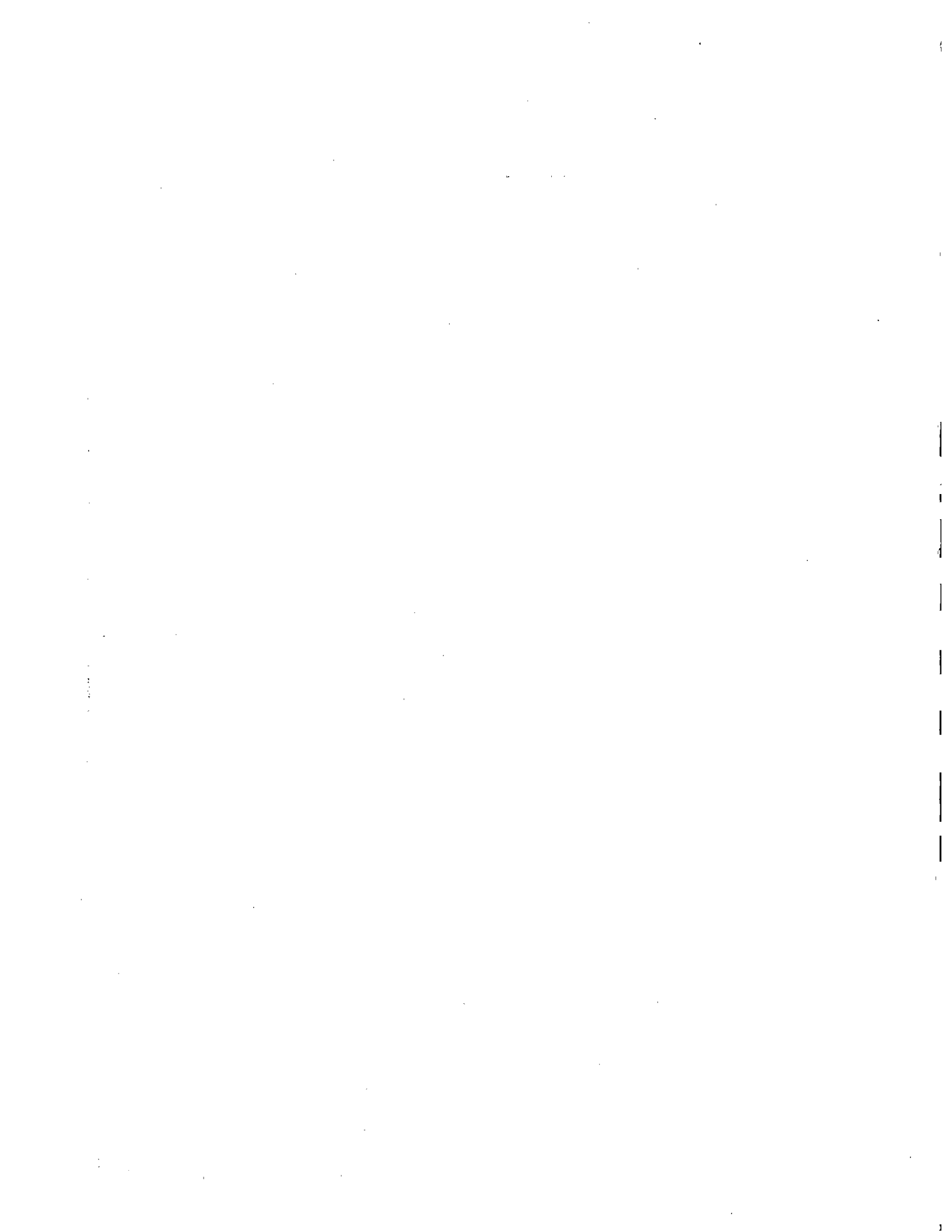

MAINTENANCE OF AGGREGATE AND EARTH ROADS

by
Robert D. Strombom, P.E.
Consulting Engineer
Gresham, Oregon

in association with
Fujiki and Associates
Professional Engineers
Edmonds, Washington

produced by
Washington State Transportation Center
Seattle, Washington

This manual has been prepared to provide maintenance personnel with a review of design, construction and maintenance management practices, focusing on maintenance practices unique to gravel, native and earth surfaced roads.

Some personnel outside of the maintenance organization may want to review the manual to gain added insight into the continuing challenges facing road maintenance departments and personnel.

The length of the manual made it necessary to limit some topics. The author has constrained detailed discussions of activities that are not common to all roads. Treatments of roadside vegetation, cleaning of culverts and other structures, and maintenance of traffic control devices are examples of activities mentioned but not fully examined. The main focus is on the maintenance of road surfacing and roadside ditches. The topic of roadside ditches was included because the maintenance of ditches can more adversely impact aggregate surfacing than light volumes and loadings.

This manual is an introduction to the complex subject of maintenance and is field oriented. A definitive discussion of any portion of the manual would require a separate manual of its own; the entire subject would require a book.

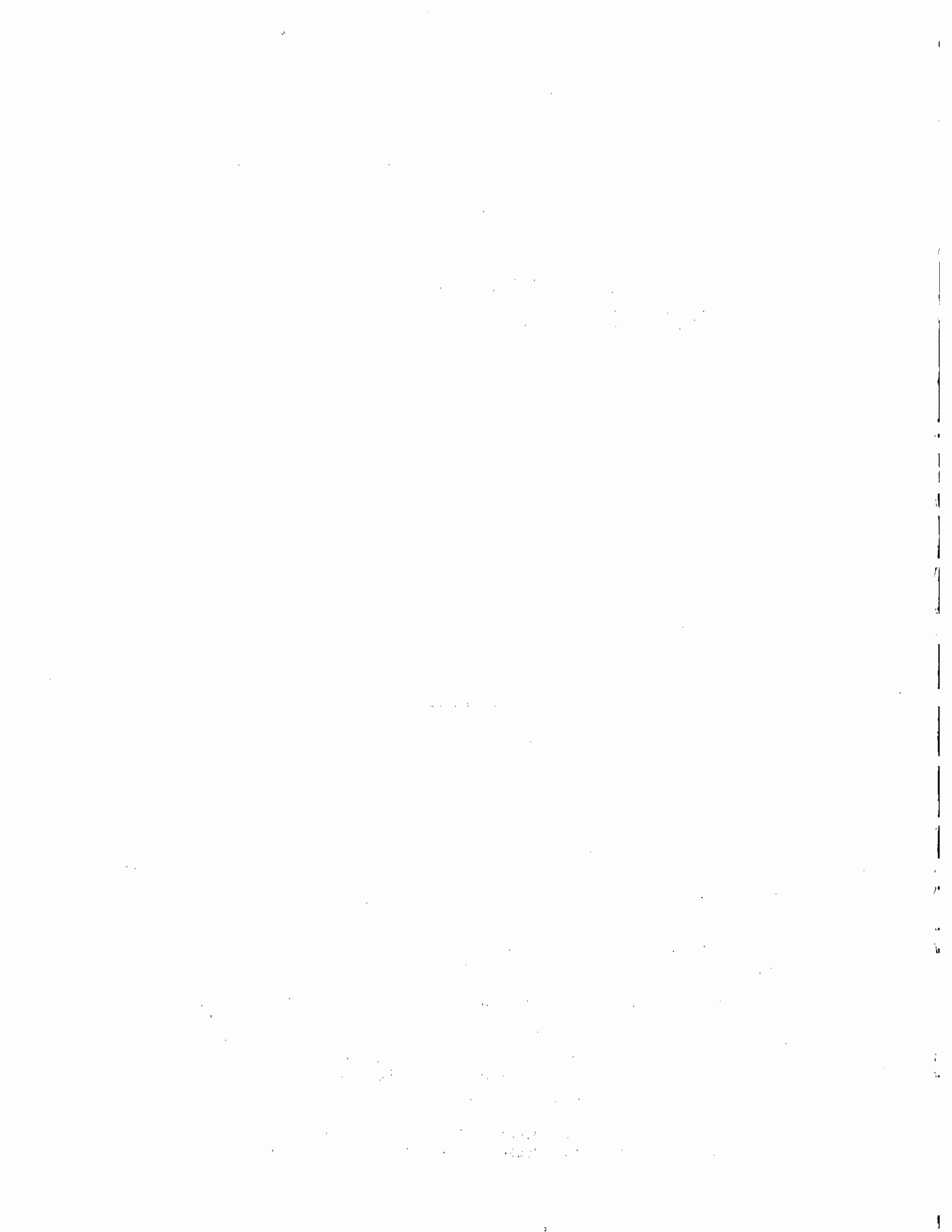

DISCLAIMER

The contents of this report reflect the views of the authors, who are responsible for the facts and the accuracy of the data presented herein. The contents do not necessarily reflect the official views or policies of the Washington State Transportation Commission, Department of Transportation, or the Federal Highway Administration. This report does not constitute a standard, specification, or regulation.



MAINTENANCE OF AGGREGATE AND EARTH ROADS

CONTENTS

SECTION 1 – DEFINITIONS, DRAINAGE AND DAMAGE	1
Definitions	5
What Is Damage?	6
Getting Water Off the Road	7
Crown	8
Superelevation	9
How Far Will Water Go Along the Road?	10
Plan for Safe Maintenance	12
SECTION 2 – ROADSIDE DITCH AND SURFACE ACTIVITIES	13
Roadside Ditches	13
General Discussion	13
Positioning Equipment for Roadside Ditch Work	14
General Guidelines	14
Articulated, Boom Mounted Buckets	15
Self-Loading Ditch Cleaners	16
Front End Loader/Backhoe Combinations	16
Loaders	17
Graders	18
Surface Maintenance Activity	22
Grader Basics	22
Cutting Tilt	23
Smoothing and Scraping Tilt	23
Mixing Tilts	23
Pre-Work Checks	23
Smoothing	24
Before Starting Reshaping	26
Redefine Width	27
Recover Stored Materials from Slope	27
Reshaping	27
1 – Cut and Move Phase	27
2 – Reprocess Phase	29
3 – Spreading Phase	29
4 – Compaction Phase	29
Using Surfacing for Positive Traffic Guidance	30
SECTION 3 – SURFACE STABILIZATION AND WORK SCHEDULING	31
Surface Stabilization	31
Stabilization Goals, Objectives and Constraints	31
Recommended Process	32
Semi-Permanent Stabilization Materials	32
Short-Term and Stage Stabilization	33
Specific Products	34
Using Aggregate to Make Unstable Surfaces Stable	37

Surfacing Replacement	38
Scheduling Maintenance	39
Earth Surfaced Roads	40
Ditch Maintenance	40
Surface Maintenance	40
Crushed and Sized Aggregate	40
Ditch Maintenance	40
Surface Maintenance	40
 SECTION 4 – EQUIPMENT SELECTION	 41
Ditch Cleaning Equipment.....	42
Road Graders	42
Loaders	42
Front End Loader and Backhoe Combinations	42
Boom Mounted Articulated Buckets	42
Self-Loading Ditch Cleaners	43
Self-Propelled Belt Loaders	43
Travelway Maintenance Equipment.....	44
Road Graders	44
General.....	44
Rigid Frame	44
Articulated Frame	44
Single Rear-Axle, Four-Wheel Drive	45
Tandem Rear Drive	45
Tandem Rear, on-Demand Front-Wheel Drive	45
Drags, Rakes, and Underbody Blades	45
Drags	45
Rock Rakes	46
Underbody Truck Blades	46
Specialized Units.....	46
Cross Shaft Rotary Travelling Mixers	46
Travelling Hammermills	47
Portable Pugmills	47
Water Trucks.....	47
Gravity Splash Plates and Spraybars	47
Pressurized Closed-end Spraybars	48
Pressurized Full Circulating Spraybar	48
Pressurized Sprayheads	48
Rollers	49
Selection for Soil Type	49
Towed Rollers	49
Self-Propelled Pneumatic Rollers	49
Self-Propelled Steel Wheel Rollers	49
Self-Propelled, Vibratory, Steel Wheel Roller	50
Small Compactors	50
 SECTION 5 – CONCEPTS OF MAINTENANCE.....	 51
Aggregate Roads Require Maintenance Expertise	51
Maintenance Management Systems (MMS)	52
Uses of a Maintenance Management System	52
Levels of Maintenance Standards	54
Relationship of Designed Features to Maintenance	55
Recurrent and Deferred Maintenance Activities	56

SECTION 6 – FOUNDATIONS OF MAINTENANCE	59
Using Objectives, Goals and Constraints	59
What Is the Difference Between Objectives and Goals?	59
Objectives	59
Goals	59
We Operate Within Constraints	60
Design and Construction Concepts	61
Designing Based on Use and Service Life	61
Other Methods of Increasing Subgrade Strength	62
Base Course Materials	63
Earth Roads	63
Native Roads	63
Crushed and Sized Aggregate Base Courses	64
Surfacing Course Materials	64
Road Width	65
Cross Slope: Crown and Superelevation	65
GLOSSARY OF TERMS	67
BIBLIOGRAPHY	69

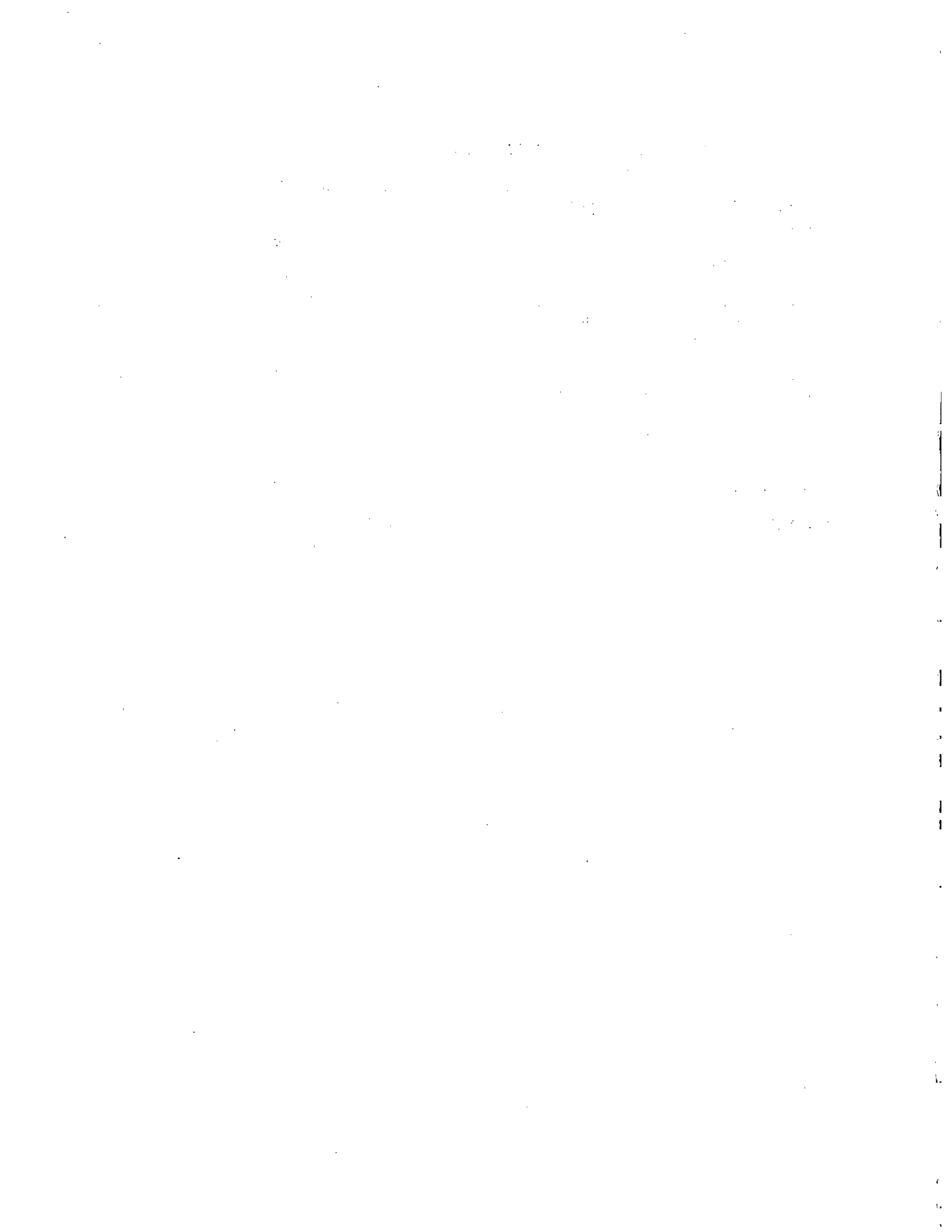

SECTION 1 - DEFINITIONS, DRAINAGE, AND DAMAGE

INTRODUCTION

What is maintenance and what is not? That question has bothered both engineering (administration and maintenance) and accounting people for years.

The definitions have changed over the years and there remain some grey areas where the work may be financed out of maintenance or from development funds for construction and reconstruction. The grey areas are necessary, and it is in these areas that the engineer must make decisions based on professional judgment.

At right is shown a more traditional way of looking at what is or is not road maintenance. The figure also shows the general approach to this manual.

When work is based on previous standards, it is either an activity of road maintenance or it is damage repair usually financed out of maintenance funds and called restoration.

Work based on new or revised standards is usually considered to be reconstruction and is financed out of development or capital investment money set aside for that purpose. Widening a road or making the road stronger are both examples of increasing the road's capacity based on newly adopted standards for that road. Few will disagree with these definitions.

The grey areas are typically those areas where something is being added to the road. Adding a new sign is almost always done by maintenance and operations people but financed out of development funds. Replacement of a culvert is usually accepted as part of maintenance, but adding one or more culverts is usually called reconstruction. Making a culvert larger when it is being replaced is often called maintenance. As long as the character of the surfacing remains the same, changes in aggregate gradations to improve stability and maintenance are considered maintenance. Maintenance does not mean that just because the original surfacing was unstable it must always be unstable.

Some groups work under the rule that if the work is an improvement but will pay for itself in maintenance

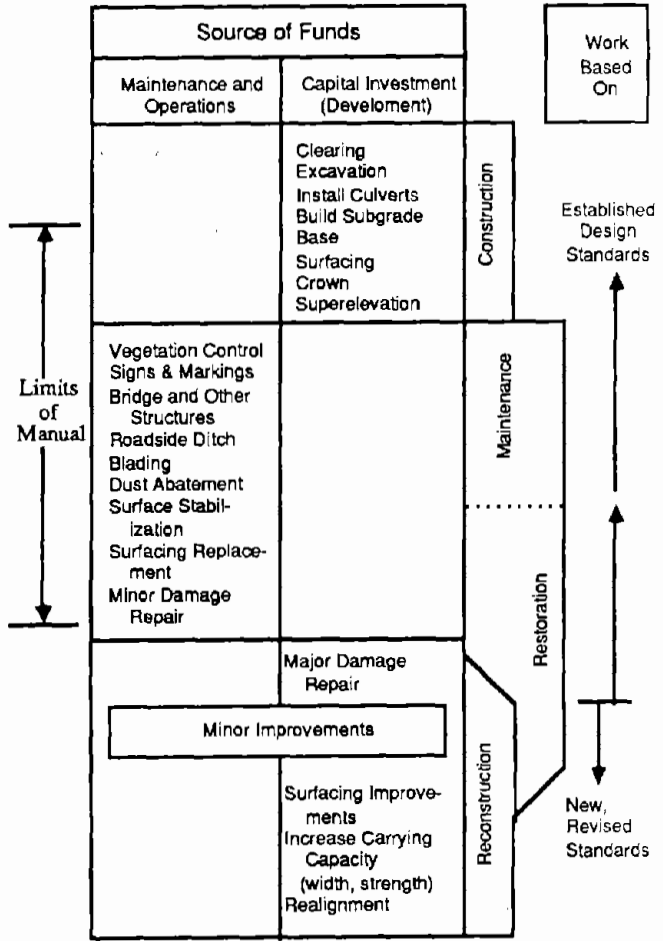

savings in the first year to year-and-a-half, it can be financed out of maintenance.

This manual does not propose to change the local decisions of how work is to be financed. That remains the decision of the local engineer or supervisor.

Road maintenance people need to be aware that similar work may be funded differently. Proper charges need to be made, and the legal constraints for the type of work, defined by the funding, should be followed.

WHAT ROADS ARE DISCUSSED

All roads have some form of surfacing. The surfacing may be concrete, asphalt, crushed aggregate, stabilized surfacings, native or earth surfacing. The last four are discussed in this manual.

The definitions are as follows:

<i>Earth Surfaced</i>	surfaced with soils from within the roadway without the use of imported or manufactured materials.
<i>Crushed Aggregate</i>	surfaced with crushed and sized materials that have been crushed (manufactured) and blended to meet specifications at various screen (sieve) sizes. Particles have fractured faces for better stability.
<i>Native Surfaced</i>	surfaced with naturally occurring imported materials that may or may not be modified by screening or on-the-road actions, such as grid rolling. May be pitrun, cinders, round glacial gravels, natural sands or other type materials.
<i>Stabilized Surfacing</i>	roads whose existing materials are modified by the addition of a stabilizer for purposes such as reducing the amount of dust.

Surfacing Type	Initial Cost	Strength				Repair of Base	Surface Smoothness	Travel Speed	Amount of Dust	Importance of Drainage	Costs to Users	Cost to Maintain	Maint. Cost per Use	Preference by Public
		Predictability	Wet Season	Dry Season	Easy									
Earth	Low	Fair	Poor	Med to Good	Easy	Good	Varies	High	High	Low to Med.	Low	High	Least	
Native	Low to Med.	Fair	Good	Good	Hard	Poor to Good	Low to Med.	Varies	High	Med. to High	Low to High	Low to High	Med.	
Crushed & Sized Aggregate	High	Good	Very Good	Very Good to Gd	Hard	Good to VG	Med. to High	Med. to Low	High	Low to Med.	High	High	High	
Stabilized Surfacing	High	Good	Very Good	Very Good	Hardest	Very Good	High	Low	High	Low	Med.	Med.	Highest	

Road Characteristics

The good and bad features of any type of surfacing will depend on many different factors. Weather, the amount of trucking, and whether the traffic is local are some of the factors that affect opinions. The above figure shows the general good and bad characteristics of roads by their surfacing and base course types, assuming all the roads have good drainage. Poor drainage will reduce strength and increase costs.

The type of surfacing should reflect the amount of use (ADT) in most cases. Factors such as travel speed, surface smoothness, amount of dust, and cost to maintain depend on the amount of effort put into road maintenance.

The "cost to maintain" column assumes that most road systems are surfaced and maintained according to how much they are used and their importance. If that is true, the money actually spent is usually lower on a per mile basis for earth roads than for crushed aggregate. Looking at total costs is a trap unless the quality standards of maintenance and the amount of use are the same. There is a difference between a cheap road and an economical one.

The better measures of the costs of maintenance are: "maintenance cost per user" and the "cost to user."

The best costs are those that reflect the actual costs being experienced on specific roads in a specific area. These come from a maintenance management reporting system as outlined in Section 5.

General Terms

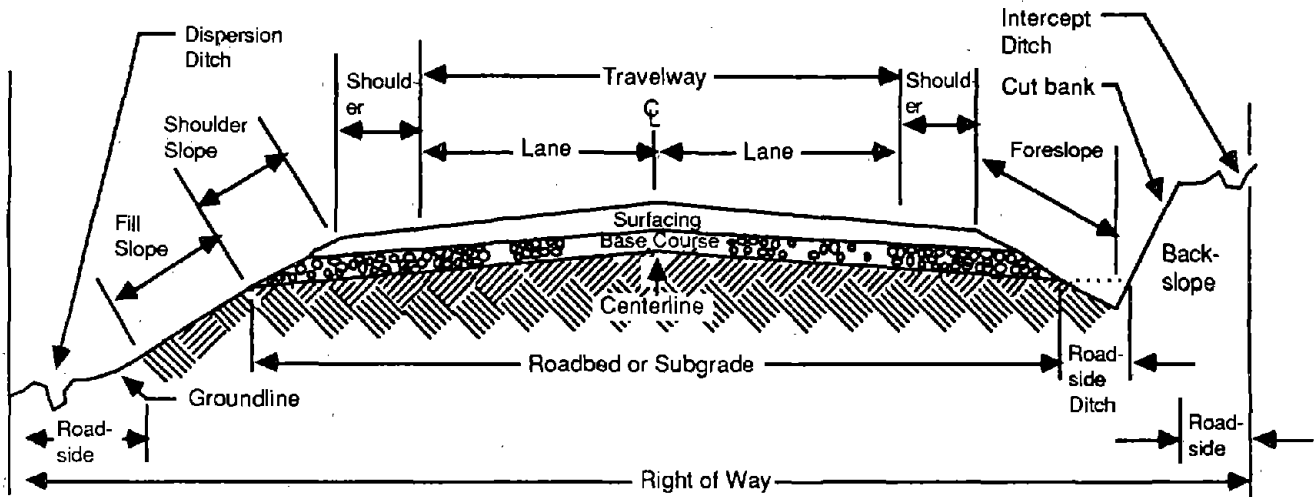

Alternate Surfacing Sections

If open graded: Allows water to reach subgrade

If dense graded: Traps subgrade moisture

Single Graded Layer

Denser surfacing sheds water

Air circulates and moisture drains from base

Multiple Graded Layer

Dense surfacing sheds water but reduces air circulation and drainage from base

Multiple Graded Wraparound

Alternate Ditch Sections

Round Bottom

Vee

Flat Bottom

Original Ground Line

Bottom Drains

DEFINITIONS

Most terms illustrated in the drawing are familiar; however, some bear comment based on their use in this manual:

<i>Travelway</i>	a maximum surfacing width of 12 feet in each of two lanes.
<i>Shoulder</i>	the designated shoulder specified in the design OR any width in excess of 24 feet (two lanes at 12 feet each) available as a usable shoulder.
<i>Base course</i>	the portion of the materials above the subgrade that supports the weight of traffic. On earth surfaced roads there is no base course.
<i>Surfacing</i>	the top layer of the travelway and shoulders; provides materials for maintenance blading and protects the underlying materials from traffic. No strength is assumed for the surfacing, although it has some when it is compacted.
<i>Roadside ditch</i>	the ditch constructed at the bottom of a backslope for the purpose of collecting surface runoff water.
<i>Intercept ditch</i>	a ditch located above the cutbank to collect runoff water and divert it from cutbanks that will erode.
<i>Subdrains</i>	any form of drain placed within the subgrade or under the ditch for the purpose of collecting and removing underground water.

<i>Dispersion ditch</i>	a ditch located below the fill slope to receive collected water from drainage structures (such as culverts and subdrains) for return to soils below the road.
<i>Cross slope</i>	a general term for either the crown or superelevation of the travelway and shoulders.
<i>Ditchdam</i>	a barrier placed within the roadside ditch to prevent ditchwater bypassing a culvert or other drainage structure.

See the Glossary for other terms and definitions.

WHAT IS DAMAGE?

Some types of damage are obvious. A broken guardrail, damaged bridge, crushed culvert inlet and vandalized sign are clearly examples of damage.

Deterioration is also damaging to the road, but it is something that normally happens with use and weather.

Deterioration is not classified as damage.

Between these two extremes are varying degrees of impact. The biggest threat and biggest monetary issue is the type of damage that can be hidden by routine maintenance activity — specifically, damage to the roadbed and surfacing sections.

Deformation affects the surfacing layer only. Shallow rutting and washboarding (corrugations) are limited to the surfacing material.

It is easily observed prior to blading.

It is classified as: **NORMAL DETERIORATION**

It is corrected by routine blading and reshaping.

Earth surfaced roads generally are in this group, provided reshaping does not require more than one to two cutting passes at one location to cut to the full depth of the deformation.

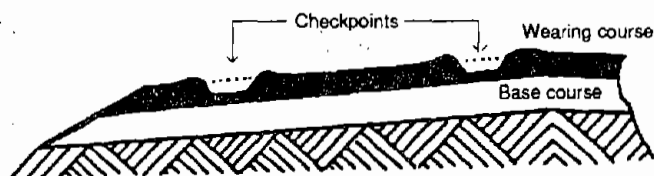

Rutting of Surfacing

In all of the following

when geotextiles (see Section 6) have been placed in the subgrade or base course, correction of the damages is more complicated. The geotextiles will need to be removed and replaced in most cases.

Deformation affects both the base course and surfacing courses.

It is usually detected during the first cutting pass of blade reshaping.

Do not continue reshaping until the deformation is evaluated and documented in accordance with your local procedures.

It is classified as: **SIGNIFICANT DAMAGE**, not correctable by routine maintenance activity.

It is corrected in the following ways:

Potholes: If these are the deepest deformations and few in number, remove loose materials, cut sides vertically, and compact the new base materials into the prepared hole using a mechanical compactor; otherwise see rutting prescription below.

Rutting: Remove and store the surfacing. Reshape (reprocess) the base course to at least the depth of the deepest rut; restore the cross slope and compact it with a roller; reprocess and re-lay the surfacing layer(s) with the proper cross slope; compact with a roller.

Earth surfaced roads requiring more than two cutting passes at the same location may be classified in this grouping. This is the most amount of work that graders should do; beyond this point dozers and scraper or loaders and trucks are probably needed.

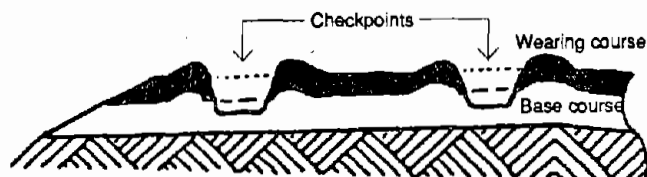

Rutting Extends into Base Course, Significant Damage

Deformation extends through the base and surfacing courses into the subgrade.

Severe cases may be obvious; however detection is usually in two stages.

1. Rutting is severe enough that at least deformation of the base is likely. Reshaping is begun the same as for Significant Damage.
2. During reshaping, subgrade materials are exposed between ruts by the cutting operations.

It is classified as: **MAJOR DAMAGE**

It is corrected by major restoration or reconstruction. Redesign of the subgrade is probably needed.

Typical decisions facing the engineer are the following:

- Are the base and surfacing course materials so contaminated they must be replaced? Are they disposable or usable?
- Thicker material layers may be needed. The engineer will need to consider the depth, type, and sources.
- Geotextiles may already exist or be needed.
- Changes in drainage structure sizing or locations may be needed.

Do not reshape significant, major or severe damage as routine maintenance unless ordered by the engineer after inspection of the conditions.

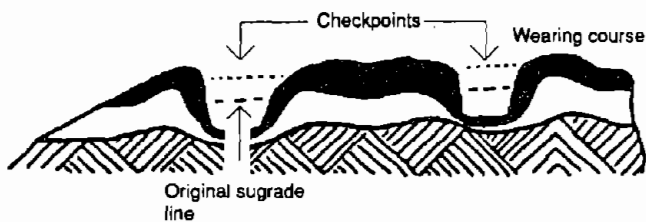

Subgrade Rutted, Major Damage

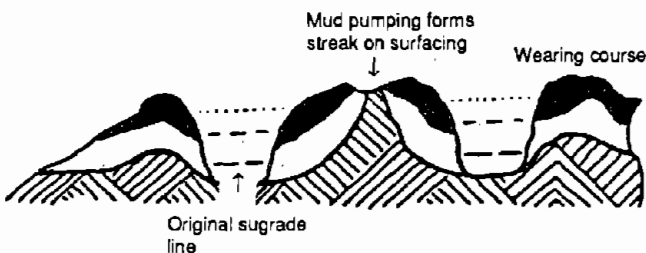

Subgrade Rutted, Severe Damage

GETTING WATER OFF THE ROAD

Poor drainage is a road's worst enemy.

The first three concerns in road design, construction and maintenance have been often stated as drainage, Drainage, and DRAINAGE.

Two sources of moisture affect a road. They are runoff and underground water tables or water-bearing strata.

Underground water-bearing strata may be horizontal or sloped. They are usually the underlying cause of slides and slumps. Moisture sensitive soil layers overlying denser, less sensitive layers become saturated or lubricated by water moving through the soils or along the denser layer. When the sensitive soils are too wet to hold up the weight, a slide or slump occurs.

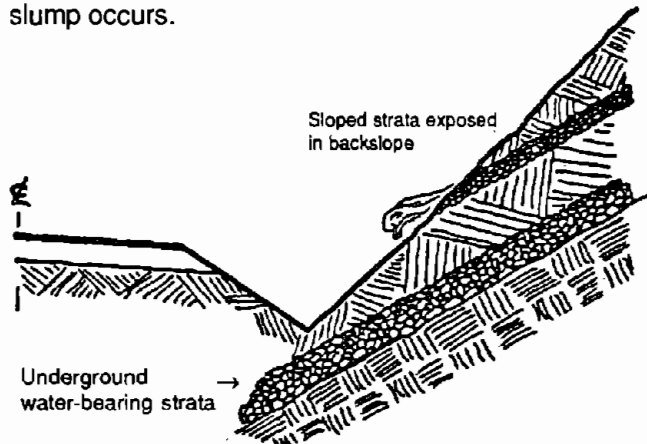

Water tables may be cut by the road or lay just beneath the subgrade. Designers use intercept ditches to collect water above sensitive cutbanks, subsurface drains (such as perforated pipes, french drains, and wicks), and roadside ditches to either intercept the water table or collect surface runoff to prevent it from getting into the strata.

Ditch relief culverts simply drain the ditch so water is not carried too far along the ditch. The best inlet conditions are provided by angling the culvert across the road in the direction of flow and using a ditchdam (illustrated in Section 2). If the ditch is too long or too full, the water flows too fast and causes erosion (scouring) of the ditch, backslope, or foreslope. Ditchdams help force water through the culvert instead of allowing the water to bypass it.

In some cases underground water is detrimental to the road, but it is needed to keep plant life active beyond the road. In these cases, water can be collected, carried across the road and reintroduced to the soil with distribution ditches. The grade of distribution ditch bottoms is nearly flat to allow the water to seep into the soils. The end of distribution ditches do not drain; they are a trench into the ground.

Except for distribution ditches, water should be kept moving and not allowed to stand. Standing water will saturate the soils.

Obviously, not all water comes to the road through or on the ground.

Rainfall and snow melt occur on the travelway and shoulders. They must be removed from the road surface as rapidly as possible or the water will soak through to the subgrade. Subgrades are strongest when kept relatively dry and compacted. If they get too wet they cannot support the loads planned for in the design, and they will fail.

Part of removing water from the road surface is the selection of the surfacing materials so they will act like an umbrella to the base and subgrade. The rest of the story is the cross slope of the road.

Crown

The crown is used on tangents and flatter curves to get water off the road surface. The center of the road is higher than the lane edges by an amount determined by the rate called for.

The acceptable ranges for crowns are from 1/4 to 3/4 inches per foot of road width. Preferred rates are between 1/3 and 1/2 ipf (inches per foot).

A 3/4 ipf rate may be used on lower volume roads in areas with heavy rainfall, provided the surface is not made predominantly of clay. Clay gets slick when wet but is a good waterproofer; lower rates will get the water off and keep the cars on the road.

Some groups express crown rates in a percent of slope. The accompanying table shows a comparison between percent of slope and inches per foot of width.

CROSS SLOPE CONVERSION	
Inches per Foot	Percent(%)
1/4	2.1
1/3	2.8
1/2	4.2
2/3	5.6
3/4	6.3

The "A"-shaped crown looks like an upside-down "V." It is the best shape because it provides a uniform rate of slope from the centerline to the edge of the travelway.

The shoulder cross slope is usually slightly steeper than the rate of cross slope on the lanes. This not only speeds the water off the road but helps define the edge of the travelway.

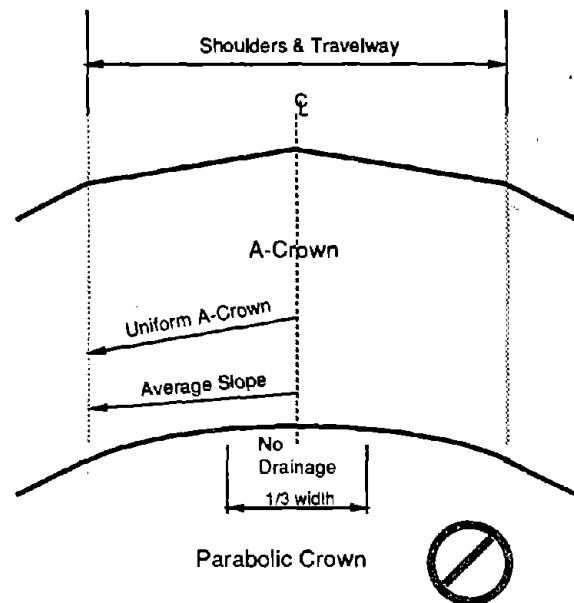

A parabolic crown means bad drainage.

The parabolic crown usually results from the use of drags or other poorly controlled smoothing equipment. The peak is scraped off an "A"-shaped crown. This not only makes the center 1/3 of the road almost flat so that water runs along the road farther, it also reduces the depth of the aggregates at the road's centerline, making it a weaker location.

Parabolic crown is a bad practice.

Superelevation

Superelevation on curves not only provides drainage, it helps keep the vehicles on the road.

From a drainage standpoint, superelevation (super) is cross sloping both travel lanes so water will flow toward the inside of the curve. Superelevation should never be less than the specified rate of crown.

The transition from the crown on the tangents to the super on the curves is important to drainage and driver alike.

The ideal length of the transition from the crown to the super is the one originally designed for the curve. Few people carry a set of the plans with them, but the rate of the super can be measured in the field.

Transitions need to be smooth. The minimum length of a transition for a 5 percent or less rate of super should be

100 feet for 30 mph or 125 feet for 40 mph.

The approximate transition lengths for superelevation rates over 5 percent are

30 mph: 10-foot lane = % x 15 feet
 12-foot lane = % x 17.5 feet

40 mph: 10-foot lane = % x 17.5 feet
 12-foot lane = % x 21 feet

For example, the 12-foot lane transition for an 8 percent rate of superelevation at 40 mph should be

$8 \times 21 = 168$ feet, or 170 feet.

The transition is created in three stages.

1. Bring the outside lane level with the centerline.
2. Raise the outside edge to match the rate of crown.
3. Rotate the entire travelway to the superelevation rate.

If the earlier example was to go from a 4 percent crown to the 8 percent super, Stage 2 would be completed about halfway through the transition, at about 85 feet.

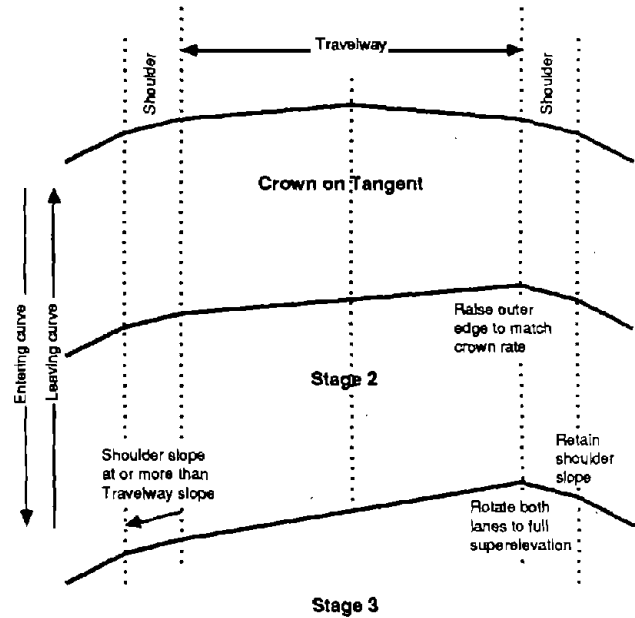

Changing Crown and Superelevation

Roughly 70 percent (range of 60 to 80 percent) of the transition length should be on the tangent. In the previous example,

70 percent of 170 = about 120 feet

The example's full rate of super would be about 50 feet into the curve.

If there is not enough tangent between curves for the transition from the super to the crown and back to the super, the numbers just won't work. The following rules of thumb will help.

For curves in opposite directions, there would be no cross slope halfway between the curves.

For curves in the same direction, reduce the super-elevated cross slope to the rate of the crown halfway between the curves.

Rotation of the surfacing slopes at the inside edge of the lane provides a uniform gradient at that edge.

Ditchlines usually parallel the road grade. The ditchline grade is automatically provided by rotating the super at the inside lane edge.

How Far Will Water Go Along the Road?

Surface runoff water (snow melt or rainfall) will only flow at a right angle to the road centerline if the road is perfectly flat, has no ruts and has a crown or superelevation. This seldom will happen, since road grades of less than 2 percent are usually not designed due to poor drainage and more costly maintenance demands on flat grades.

The Runoff Diagram can be used to determine how far water will travel along the road when it is not rutted. The diagram assumes that a uniform rate of cross slope is available. The distances will therefore be shorter than will normally occur in the field.

At a given rate of cross slope, the flatter the road grade the shorter the distance water will travel along the road before getting onto the foreslope or shoulder slope. The steeper the road grade the farther it will go.

To use the Runoff Diagram, the road grade, rate of cross slope, and road width must be known. The road width for crowned sections is the distance from the centerline to the edge of the shoulder. The road width for superelevated sections will have the added width of the second lane.

Example using the Runoff Diagram:

Road grade = 8% Crown = 1/4 inch per foot.
Width = 25 feet

1. Locate the point where the road grade is 8% and the crown is 1/4 ipf
2. Draw a line from 0 (upper left corner) through that point.
3. Draw a line parallel to the border from a road width of 25 feet (on the left edge) until it hits the line from step 2.
4. Read the distance on the bottom scale: about 92 feet.

If the grade resulting from that grade and cross slope is wanted, measure the distance from 0 to the point (grade 8%, crown 1/4) in step 1. Then measure the same distance along the top margin. Read the answer on the road grade scale: about 8.2 percent in the example.

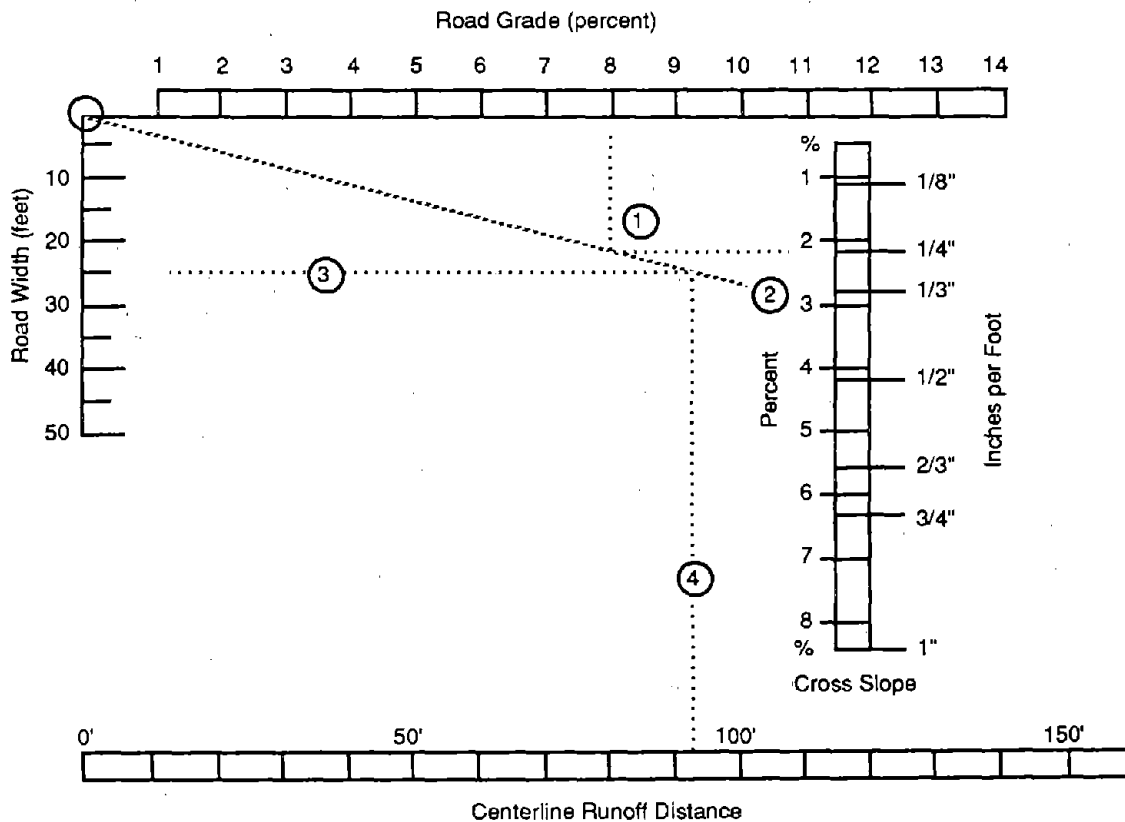

Runoff Diagram

Using the Runoff Diagram to look at parabolic crown gives a better feel for what that type of crown really does. Assuming the center 1/3 of the road has a 1/2 percent cross slope, the remainder has a 1-1/2 percent cross slope and the half-width of the road is 18 feet. We have 6 feet of width at 1/2 percent and 12 feet at 1-1/2 percent. Work out your answer based on the same 8 percent grade.

It works out to about 130 feet before the water gets 6 feet from centerline. It will take another 67 feet for it to get the remaining 12 feet. The "A" crown at 1/4 ipf was 92 feet; the parabolic crown almost 200 feet. Which type crown do you prefer?

Water running on the road surface can saturate the subgrade.

An example of what can happen follows. A fill composed primarily of silty soils began experiencing both fill slope failures and surfacing failures at mid-fill. The road was in mountainous terrain with steep grades and a lot of curves. A vertical curve was centered on the fill to reduce fill height on the steep side-slopes. The type of failures did not fit normal expectations.

Investigation showed a very high moisture content in the middle of the fill. Since few springs bubble up through 20 to 30 foot fills, the source of the water had to be upgrade within the road itself. It was discovered that the grades, cross slopes and road widths all worked together with the curving alignment so that water from a subgrade spring over 1600 feet away did not get off the road until the fill. It seeped into the base and ran back and forth across the road within the base until the grade sag slowed it down and saturated the subgrade and fill slope.

This is a mild case of what can happen.

The previous subsection, "What Is Damage," stated that even "significant damage" (not correctable by maintenance) should not be reshaped unless the base is reshaped. Ruts in the base or subgrade function as ditches. When just the surface of a damaged road is reshaped, those ditches remain under the road surface.

A ditch in the subgrade cannot be cured by reshaping the surfacing.

Water will seep through the most competent surfacing and will be trapped in subgrade deformations.

Similarly, rutting, washboarding and potholes will still catch and hold or channel water if they are not cut to full depth in normal maintenance. Filling them with loose materials will not solve the problem.

Loose materials only act like a filter in a funnel.

The water still goes into the remaining irregularities.

PLAN FOR SAFE MAINTENANCE

Work areas are to be planned to create the least possible traffic disruption or interference with the work. Provide advance notice of delays and detours. Have enough equipment, people and materials to complete the job. Stay within the time limits for stopping traffic set by the engineer.

Work areas should be signed in accordance with the Manual of Uniform Traffic Control Devices (MUTCD), Part IV, and local prescriptions.

Arrange materials and small tool deliveries in a way that will keep work areas uncluttered, but have them there when needed.

Equipment should be checked for oil, fuel, hydraulics, filters and coolants before going to work. Safety devices (e.g. strobe, flashers, headlights) should be fully operable and operating when working.

Workers are to be properly equipped for the specific work activity and location.

Review job hazards with the crew. Use the safety equipment.

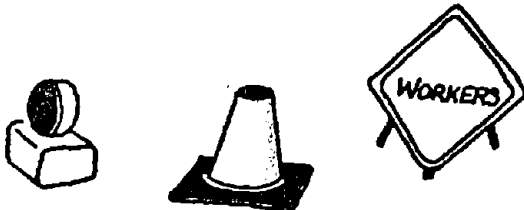
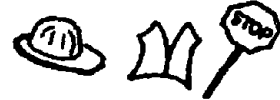
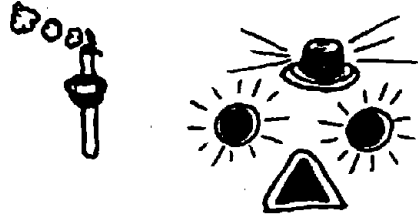

SECTION 2 - ROADSIDE DITCH AND SURFACE ACTIVITIES

This section will cover both a general discussion of roadside ditch and surfacing maintenance activities plus recommended positioning of equipment to perform the needed recurrent work.

ROADSIDE DITCHES

General Discussion

Roadside ditches are a substantial part of the roadway drainage system. Roadside ditch grades usually parallel the grade of the road; however, in some cases the ditch grade will be designed separately to ensure that the water will flow to the point it should. A 2 percent grade is the minimum grade for water to flow well. The bottom of the ditch must be below the subgrade elevation.

The force of water and weakening of soils by saturation are the two biggest concerns to be handled.

The force of water is tied to the volume of the water and its speed. When the forces of the water exceed the stability of the soils, erosion will occur and the soils will end up in the culverts or below the roadway. Severe erosion will undermine the backslope (cut-bank support) and foreslope (shoulder support) unless controlled.

There are several ways to make the soils more stable or to reduce the force of the water:

- compact the ditch bottom and slopes,

- armor the ditch with rock*,
- let grass grow in the ditch bottom,
- use ditchdams on steep grades, and
- make the water more shallow.

*Note: Geotextiles will help if placed under armoring, but they must be protected from maintenance activities.

How do you make water shallow? There are three basic ditch shapes: vee, flat and round bottom. Of these, the vee ditch concentrates water the most yet it is the most common roadside ditch shape. Flat bottom ditches concentrate water least, but they take space and can be hard to maintain. Water can sometimes be slowed too much so that it seeps into the soils. Round bottom ditches are in between: by spreading water over a wider area it makes the water more shallow than a vee ditch. This will slow water.

Compacting the ditch bottom and slopes makes the soils more dense and erosion resistant. Each time they are disturbed by maintenance activity they will need to be compacted again, if this way of improving stability is elected.

How about ditch dams? On sustained grades, over about 4 percent, water can move fast enough that it will bypass ditch relief culvert inlets. Bypassing is especially easy if all the culverts were installed at right angles to the road centerline; water hates to change directions. The first place to look at a ditch dam is at each ditch relief culvert. It will slow the water and force it to go through the culvert.

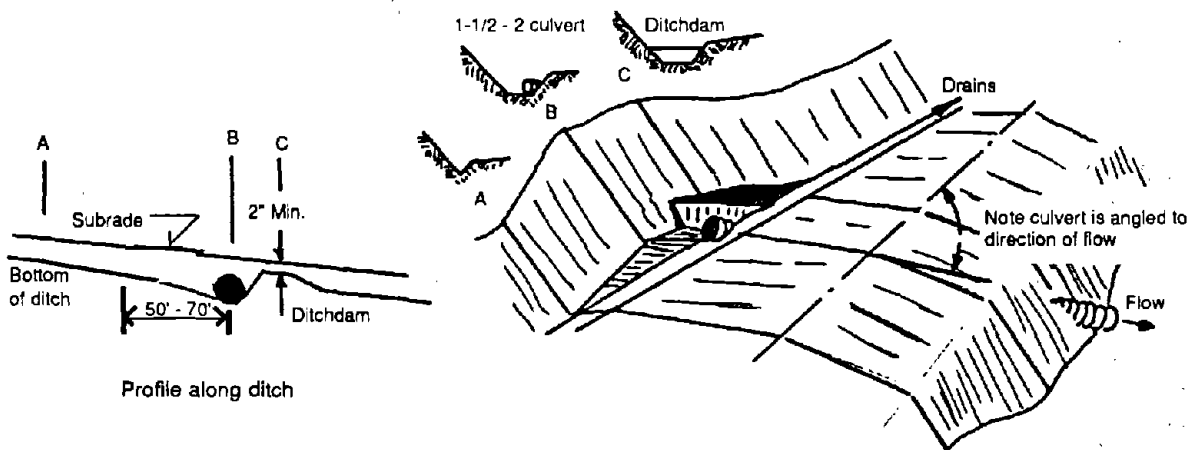

Ditchdam and Catch Basin

Ditch dams can be made from moist materials that would need to be removed from the ditch or catch basin. Here is a real good place for a small compactor. Keep the top of the ditch dam below the culvert inlet at least 2" below the subgrade. If erosion is still a problem, add some 4" - 6" high check dams (small ditch dams) between the culvert locations. Keep the water moving, but more slowly.

If water does not move off the road it will move into it.

Section 1 discussed "Getting Water off the Road," but getting water off the road does not do much good if the water then just stands around. When water stands around it IS doing something. It will saturate the soils.

Saturated soils

- have little strength,
- erode more easily, and
- do not belong in subgrades.

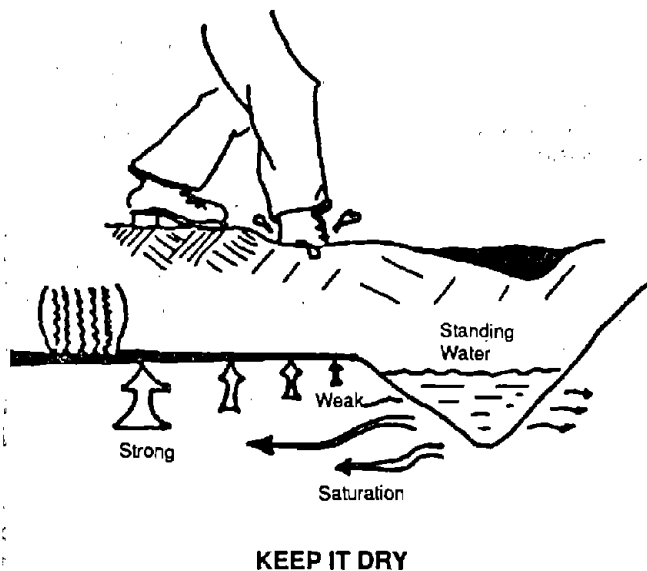

Positioning Equipment for Roadside Ditchwork

The focus on the procedures for cleaning, pulling, heeling and bunching ditch materials with different equipment is described in Section 4. A discussion of how to decide on the type of activity and scheduling tips will be covered under specific surfacing types.

General Guidelines

Whenever possible, roadside ditches should be worked in an upgrade direction. Start at the inlet or ditch relief culvert and go against the flow of water. Several things will be working for you:

- it will be easier to keep proper ditch grade for drainage;
- any remaining wet materials can drain into the downgrade area;
- dirt is moved out of instead of into the catchbasins; and
- gravity helps stop the machine and reduces the possibility of equipment damage.

The last point, stopping the machine, is especially important when the machine is a grader. Moldboards in an extreme side-shift position will put more strain on the circle and control arms. A slipped clutch means that the brake will have to be applied quickly or the end of the moldboard will take all the strain of stopping the grader.

Avoid undercutting backslopes. Cutting out the toe of a stable or near stable backslope removes its support. Long, stable cutbanks have been undercut so severely that the depth of that undercut slid into the ditch clear to the top of the cut. Less severe examples are still not acceptable to any maintenance professional.

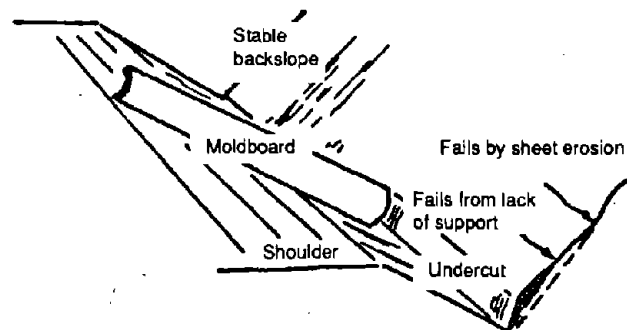

Get rid of ponding before beginning the job.

Water flow should be restored by temporarily repositioning materials with a ditch. Materials that are draining will be easier to handle than mud.

Stay out of wet ditches. Keep your wheels in the dry. Churning a ditch into mud is not good for the ditch. It can also be embarrassing to wait for a tow.

Just because a road needs maintenance doesn't mean it should be punished!

Tracked mud causes some of the worst problems with surfacing.

A small sack of grass seed or even some flower seeds can give disturbed areas some stabilizing roots, and reduce future erosion.

Articulated, Boom Mounted Buckets

The equipment is operated from the road. Its reach allows the machine to be positioned away from potentially soft shoulders for best stability.

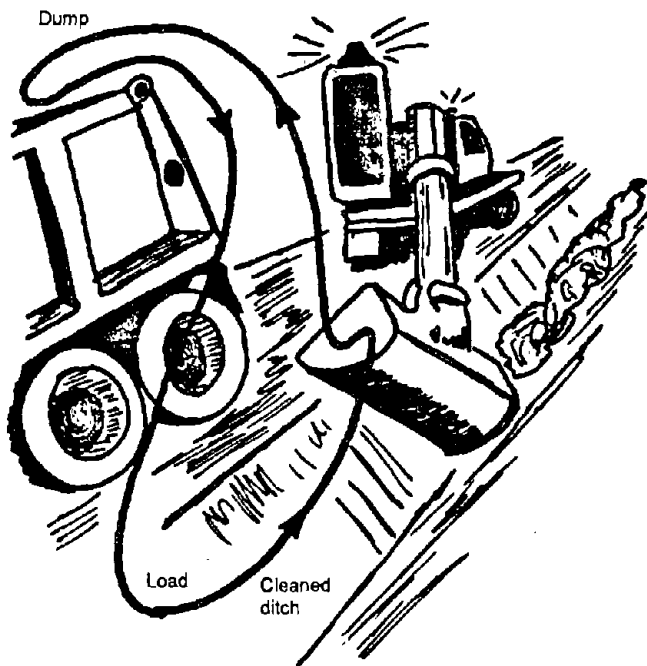

Vee ditches. Operate with the boom angled towards the downgrade culvert. Materials will be loaded as the bucket comes towards the operator.

Position the dump truck down the grade to shorten the loading cycle and to give the operator a better view of the dump box.

Extend the boom and rotate the bucket to conform to the ditch's foreslope.

On flatter backslopes the boom can be shorter so loading is closer to the operator.

For steeper backslopes the boom is extended farther so there is less risk of undercutting the slope.

Tilt the loaded bucket up under the boom and cycle to load the truck over the the tailgate.

After several swings, rotate the bucket to clean any materials from the backslope area.

Narrow, flat bottom ditches. The distance from the road to the ditch is the determining factor for positioning the unit. A specially shaped bucket may be worthwhile.

Ditches close to the road require positioning as for the vee ditch. An initial cleaning pass normally reinstates the backslope to the bottom of the ditch. The second area is the ditch bottom; the bucket may need to be rotated to fit the narrowest ditches and loaded by rotating the boom only. Load from the back to the foreslope.

Ditches farther from the road are cleaned the same as wider, flat bottom ditches, described below.

Wider, flat bottom ditches. The normal loading position is with the boom at a right angle to the ditch but slightly angled to the downgrade culvert.

The dump truck is positioned up grade from the operator for loading over the tailgate. Reduce the boom extension and retracting movements by positioning the truck at a greater distance than for vee ditches.

Start loading the bucket within the ditch near, but not on, the backslope.

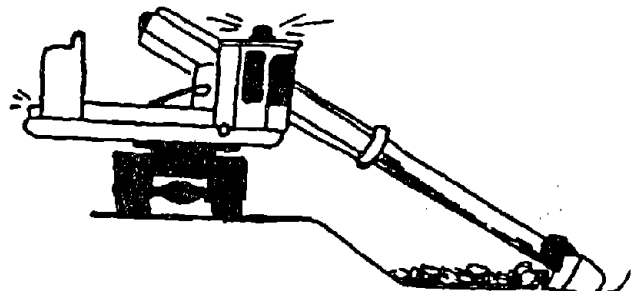

When the materials in front of the backslope have been mostly removed, slide the bucket down the backslope with the boom as close to a right angle as possible. Complete the loading from the ditch bottom toward the foreslope. The foreslope is only roughly cleaned at this point.

The final cleaning of the foreslope is done by swinging back to the section that was cleaned before the machine was moved. The foreslope is then cleaned by retracting the boom.

All swings except for the final cleaning of the foreslope are over materials yet to be removed.

This cycle pattern requires raising the loaded bucket slightly to clear the materials awaiting removal. This is done as the bucket is tucked under the boom. The swing to unload in the truck is in the clear. Extra effort for cleaning up bucket overflow is minimal when this cycle pattern is used. With the bucket tucked under the boom, "backblading," smoothing, and compaction can be provided by extending the boom.

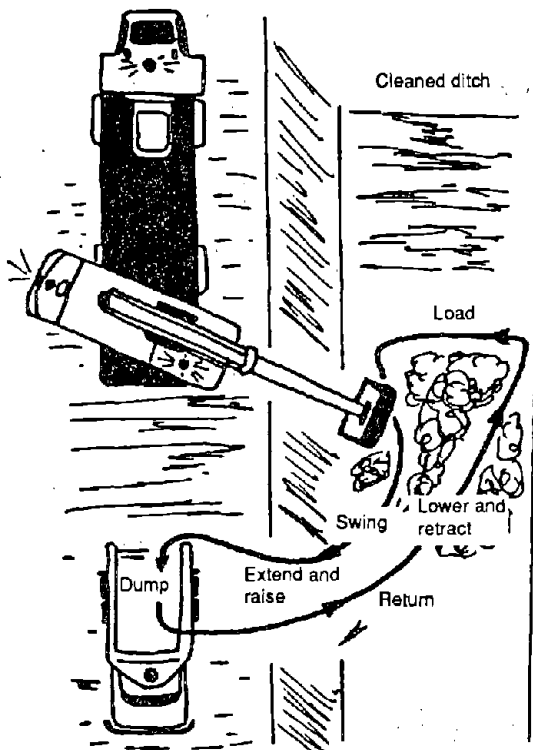

Round bottom ditches. When you use articulated, boom mounted buckets with flat leading edges, the machine is positioned the same as for flat bottomed ditches. Bucket loading is done by rotating the bucket out, lowering the boom, and rotating it back to a tucked position under the boom.

A rounded bucket can be attached and used in the vee ditch positioning; however, the bucket design may slow foreslope and backslope cleaning.

Self Loading Ditch Cleaners

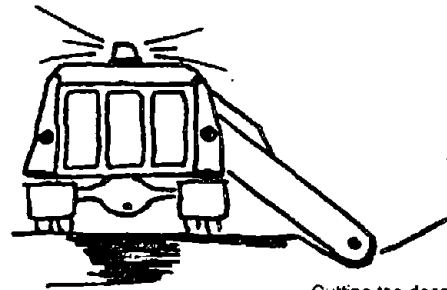

Cutting too deep can undercut the backslope

As noted in the equipment selection section, loading is only available from one side of the machine. Right-sided loading allows you to work with the traffic flow, while left-sided loading gives better driver/operator visibility of the cleaning head but complicates work zone safety.

The location of the truck is the primary control of the ditch cleaning head location. The driver/operator must keep the truck positioned on a safe working platform for lateral stability.

Front End Loader/Backhoe Combinations

Unless they are modified by a special bucket coupling device, backhoe buckets cannot conform to the slopes when worked in the vee ditch cleaning position described for boom mounted, articulated buckets. See loader positioning for loader work.

All ditches are cleaned in the manner described for wide, flat bottom ditches. The machine is normally positioned parallel to the ditch with the loader end up the grade, unless there is adequate road width and traffic control to permit angling. Angling is preferred when trucks are loaded and for final foreslope cleaning.

Set the outriggers and put the downpressure on the loader bucket.

The rear tractor wheels should barely clear the ground.

The backhoe is worked at an almost right angle to the ditch for removing the majority of the materials. Backslope cleaning is done by sliding the bucket along the slope at a right angle to the ditch.

It is often more efficient to use the backhoe to concentrate (bunch) materials into piles for loader removal.

The practice of straddling the ditch places the backhoe in its best operating position but the wheels and outriggers usually tear up the backslope and foreslope too much. Operating from on the foreslope is practical on flatter slopes but on steeper slopes too much dependence is put on the low side outrigger for safety.

Loaders

Loaders are at their best loading slides, piles or windrowed materials.

Under conditions approved by the engineer or established in the Maintenance Performance Standards, loaders may operate on flatter foreslopes parallel to the ditch. Lateral machine stability and the condition of the foreslope are critical factors. Keep the bucket low for the best center of gravity if there is any side-tilt of the loader. In this position the loader must have all wheels on a stable foreslope while loading, unless it is equipped for independent adjustments of its lifting arms.

Loading progresses upgrade, pushing against the materials for best bucket loading action. The loader exits from the ditch by backing across the slope to keep the weight of the bucket towards the low side.

Once on the road, move forward to dump the load into the truck. Always enter the ditch as you left it; back along the road, keeping the bucket near the ground and move forward across the foreslope to keep the weight of the bucket to the low side.

Narrow, steep, or wet foreslopes require the loader to work from the road surface. Four-wheel drive should be engaged to reduce shoulder and foreslope damage. Ditch entry and exit is at right angles to the

shoulder. The loader bucket should slide along the foreslope when you are loading.

There are two loading alternatives.

- A. The truck is positioned downgrade of the loader. As the loader leaves the ditch it backs so that the bucket is about 45 degrees towards the truck. A turn is completed as the loader moves ahead. This works best with an articulated loader and when the truck is across the lane for side loading. In tight spots, loading can be over the tailgate.
- B. The truck is positioned upgrade and parallel to the road. The loader backs across the lane and stops. On signal, the truck backs in front of loader and stops. The loader moves ahead to dump and backs to its pre-dumping position. The truck moves ahead. The loader positions and re-loads the bucket. This works best with a rigid frame or when the truck must stay parallel to the road.

For safety, do NOT park the truck downgrade. The cab should never pass under the loader bucket as the truck moves to its loading position.

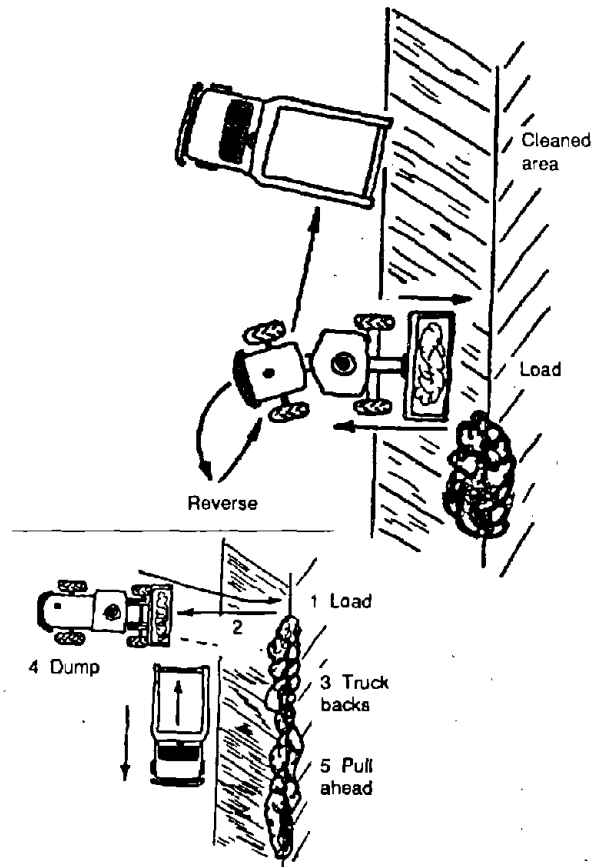

Graders

Graders may be needed to smooth and dress the foreslopes after ditchwork with other equipment. Vee ditches are the only small ditches that can be fully shaped by graders.

For safety,

1. always incline the front wheels away from the ditch; and
2. as in all grader work near edges or where the moldboard is side-shifted, the operator must be ready to stop immediately if the tip gets hung up. The front end can be forced in the direction of the hang-up or many parts of the moldboard and control assembly can be damaged.

The risk is a direct ratio of the length of the moldboard's lever arm.

As the sketch indicates, 4,000 lbs. force yields torques of 40,000 ft. lbs. at 10 feet., only 24,000 ft. lbs. at 6 feet.

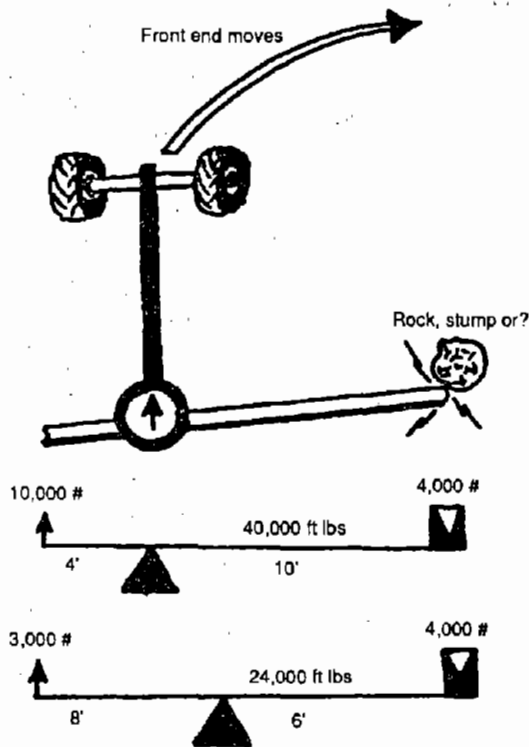

Sidsift Increases Forces on Graders

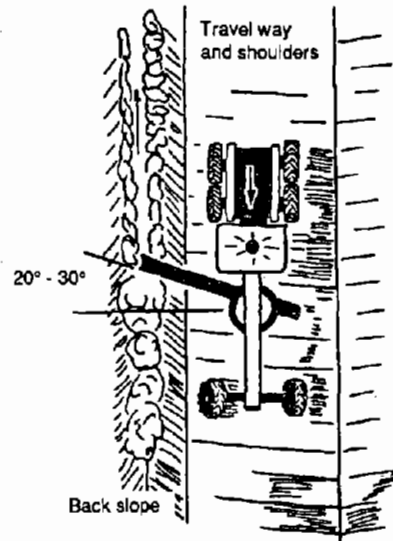

Saturated and ponding ditches. Mud should NEVER be pulled onto the road. The first problem is to get the materials draining. **Stay OUT of the ditch.** If it's plugged too badly, call in for the trucks and a piece of equipment that CAN clean it without getting in the ditch.

THEN:

Heading upgrade, stay on a firm shoulder or lane. Set the moldboard slightly above and roughly parallel to the slope of the foreslope. The heel should be over the center of the ditch.

Start moving and lower the heel just deep enough to start a channel by moving the mud toward the backslope. If materials start up the moldboard toward the road, increase the circle rotation or raise the heel slightly.

All that is needed is to establish some drainage, not clean the ditch. When that is done, document how much is left to do.

Then get out of there so it can drain.

For other ditches, the crew dispatch order should prescribe whether the ditch materials are to be heeled, bunched or pulled. If they are to be pulled, the crew dispatch order should prescribe whether the materials are to remain on the foreslope or can be at the edge of or on the shoulder.

In the remaining portions of this manual, a WET ditch is one in which the material to be moved will NOT support the weight of the equipment's heaviest (normally rear) wheels, but the foreslope will.

Heeling. Heeling is normally prescribed when the original depth is wanted to lower the water table or when the backslope has been undercut by previous maintenance activity or erosion. The small amount of materials within the ditch are to be moved against the backslope and compacted by pressure from the moldboard.

Ditch materials should be damp to dry. Moisture will aid compaction.

Engage all drive wheels.

A rigid frame grader may be positioned entirely on the flatter foreslope or have one side on the shoulder. The low side wheels may be in the ditch bottom or up the foreslope from the materials to be heeled. If the wheels are in the ditch, the bottom materials will be slightly compacted before they are removed.

Articulated graders are positioned so that their front wheels are not on the materials that will be removed.

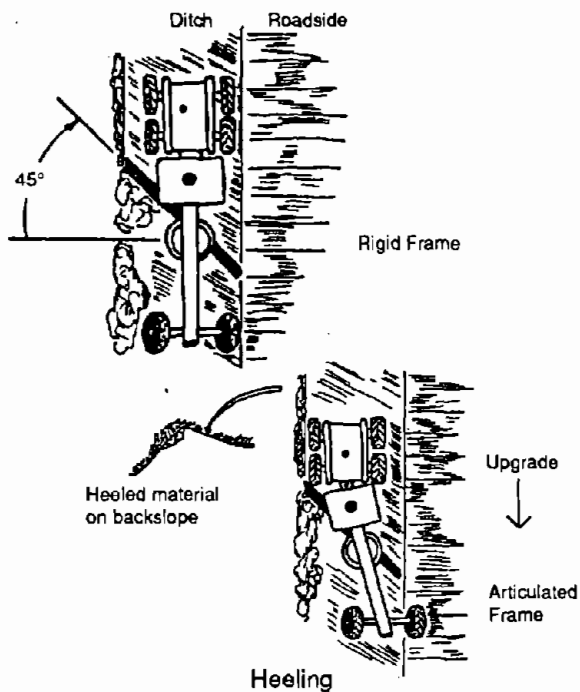

In both positions, the rear wheels compact the bottom of the ditch and the heeled materials.

Set the moldboard parallel to the foreslope. Side-shift to align the heel with the bottom of the ditch. Tilt the moldboard.

Compacted materials may require a tilt back to cut them. Vertical or tilt back positions will not compact heeled materials, however.

Roll forward to scrape and compact the looser materials at the heel.

As the grader moves ahead, lower the heel and toe to skim but not cut the foreslope.

Increase the circle rotation if the materials are being pushed along the ditch instead of flowing along the moldboard toward the backslope.

The top of the heeled materials should slope toward the ditch and be stable. It is usually best to compact and slope by rolling with the front grader tire.

Bunching. Bunching is cleaning the ditch and leaving the materials piled with the ditch and foreslope for loader removal. Schedule removal for the same day. Bunching is prescribed when the materials are distributed along the ditch but are not deep enough for effective loader cleaning.

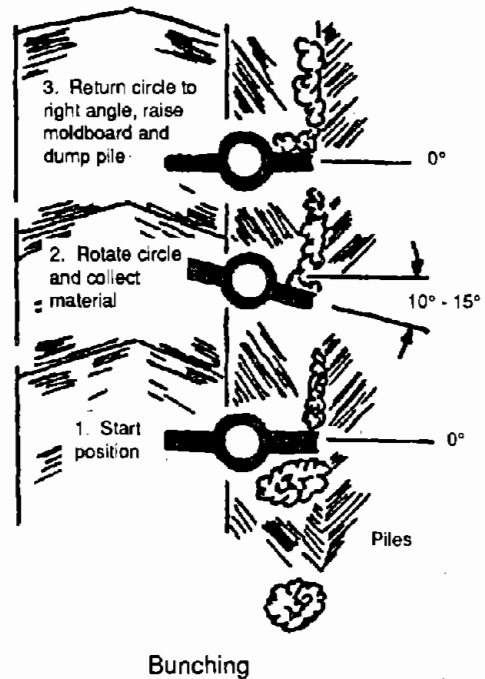

The rigid frame is positioned so that the rear wheels will clear the road edge of the piles.

Articulated graders are usually positioned with their front wheels in the bottom of the ditch and their rear wheels on the foreslope above the piling positions. Some operators prefer to reverse this position, but articulating rear wheels around the piles can tear up the foreslope.

Side-shift the moldboard so it is positioned over the bottom of the ditch when the moldboard is at a right angle to the ditch. The moldboard tilt should be at the middle position. The moldboard is initially set above the foreslope with the heel (ditch end) slightly below parallel.

Rotate the circle so the heel is at 10 to 15 degrees. The moldboard should now parallel the foreslope and be away from the backslope to reduce undercutting risk. Start moving and gradually lower the heel and then the toe to the proper depth.

When the materials being pushed along the ditch are enough for a pile, raise the moldboard (mostly the heel) and return it to a right angle as it clears the ditch bottom. When the moldboard is empty, return it to the moldboard angle and the proper depth to collect the next pile.

Pulling ditches. Under the right circumstances, pulling ditches can benefit both earth and aggregate surfaced roads. More discussion of the "right circumstances" can be found under surfacing type in the scheduling subsection.

Pulling ditches can cause more problems with aggregate surfaces than any other maintenance activity. The soils from the ditch are usually clays or silts. An excess of any kind of fines (especially silts and clay) can upset the stability of an aggregate gradation and increase the potential for damage during wet and freeze-thaw conditions. The following description of the proper process assumes

1. an aggregate surfaced road that cannot tolerate added fines materials,
2. no available alternative way of removing materials directly from the ditch, and
3. that the ditch had to be opened immediately.

Inspect the area to estimate the volume of materials to be "pulled" from the ditchline and where they will be placed.

If the windrow must be placed on the road shoulder, additional work will be needed before the ditch is pulled. The surfacing and base materials are to be removed and stored in separate windrows in the travel lane or on the opposite shoulder.

If the removed materials can be windrowed entirely on the flatter foreslopes, the ditch can be pulled without further pre-work.

The following instructions assume that the materials must be windrowed on the subgrade at the shoulder.

- Rigid frame graders are positioned on the foreslope with their wheels in the bottom of the ditch.
- Articulated graders are positioned with their front wheels at the bottom of the ditch and the rear wheels closer to the centerline.
- The moldboard is rotated to 30 degrees or more as needed for the windrow to be placed outside the wheels at the shoulder or between the rear wheels on narrower foreslopes. When the windrow is placed between the tires, there should be no large rocks that could damage the grader's undercarriage.
- Set the moldboard parallel to the foreslope. Side-shift so that the toe is above and slightly toward the shoulder from the ditch bottom. Tilt the moldboard back behind the middle position so the materials will slide along the face of the moldboard. Compaction or mixing action is not desirable.
- Lower the toe and heel into the materials as the grader moves ahead until the toe is at the ditch grade and the moldboard conforms to the foreslope.

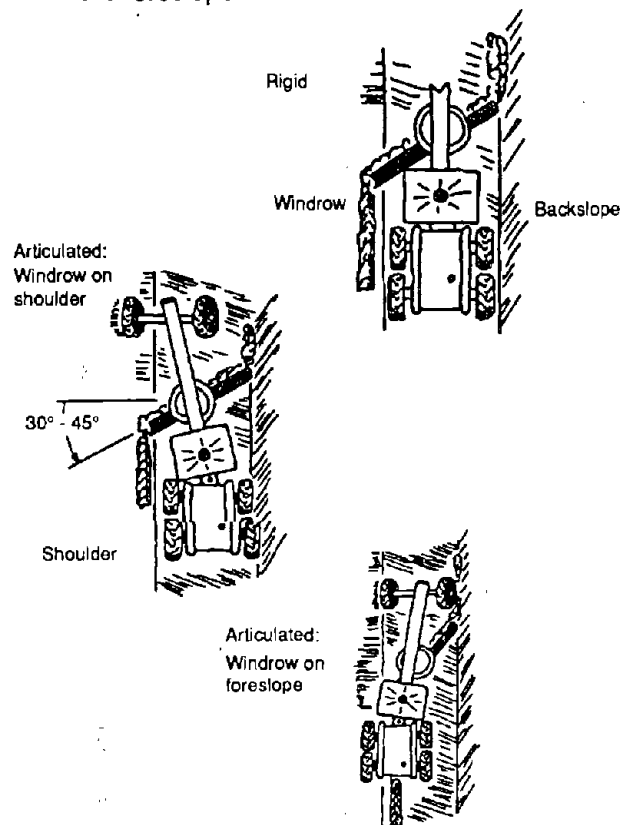

- If a lot of material is to be moved, it may be faster to make a first pass that takes about half the materials by using less side-shift. Then complete the pulling with a second pass to the bottom of the ditch. Keep the moldboard on the foreslope with both passes.

Pulling ditch materials to a foreslope windrow.

On flatter, wide foreslopes the preceding method is preferred with the heel discharge above the grader.

On narrower foreslopes the grader is positioned so that the heel discharges the windrow between the rear tires. Otherwise, positioning is as previously described for ditch pulling. The toe is set close to the front wheel and the heel is set for windrow placement. Other than moldboard angling, the procedure is as previously described.

Pulling ditch materials for belt loader pickup. The basic process for grader work follows that described for shoulder delivery except that an additional grader pass may be needed to position the windrow so that the outside tires of both the belt loader and trucks will be on stable shoulder material.

Work should always progress in an upgrade direction. The self propelled belt loader is centered on the windrow or so the adjustable front wing moldboard will collect the entire windrow in one pass. The cleanest and fastest pickup will normally occur when the windrow is centered on the feeder without being repositioned with the loader's moldboard.

The dump truck is backed under the conveyor for loading over the tailgate.

There are two reasons for progressing upgrade. One reason is that the truck will not roll against the loader if truck power or braking is lost; **keep the truck working against gravity with its engine, not its brakes.** The second reason is that the incline of the conveyor will not be as steep, and the conveyor capability to move rounded rock and other materials will be improved.

When the truck is full, the self-propelled loader is stopped for the truck to leave and an empty to be positioned.

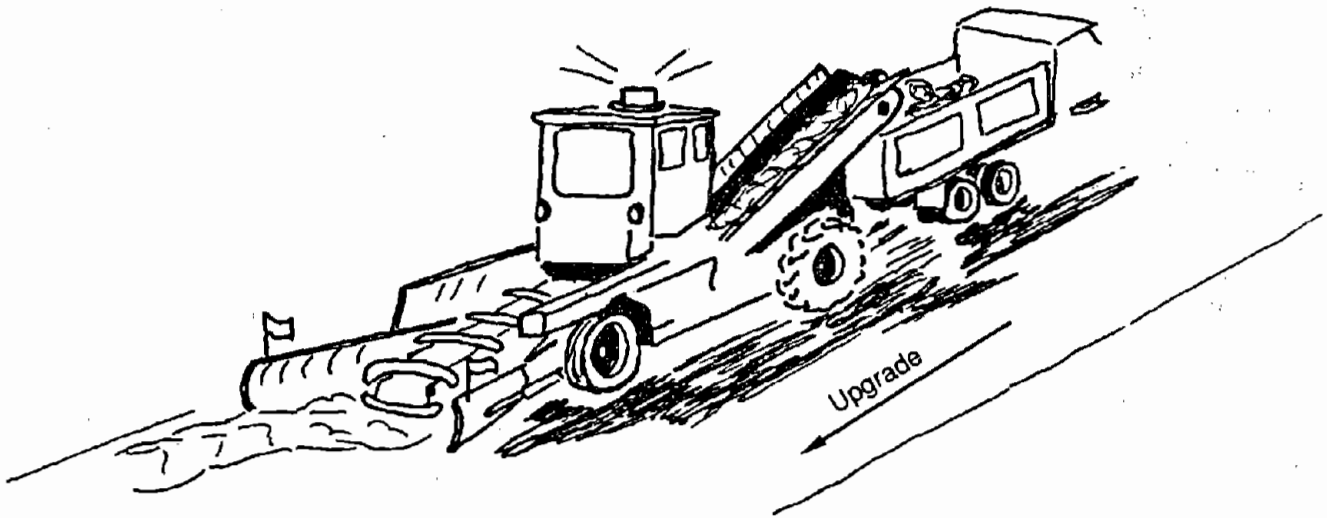

SURFACE MAINTENANCE ACTIVITY

There are two basic recurrent activities on road surfacing materials that are common to earth, native, and crushed and sized aggregates

Smoothing sometimes called smooth blading or dragging.

Reshaping some call it cut and mix, reprocessing or remix.

Reshaping requires a grader, but smoothing can be done by drags, rakes, and underbody blades. Since this is the prime use of graders, the discussion will be focused on their use. The angles and sequencing of passes for smoothing are about the same for all types of smoothing equipment.

Before you get into procedures, some basics and pre-work checks should be reviewed.

Grader Basics

Graders should always be moving forward before downpressure is applied on the moldboard. It can be tough enough getting moving without dragging your anchor. The moldboard is a good brake, but save it for emergencies.

Machines and roads both vary considerably. A good grader operator will have the feel of the machine and focus most attention on the road ahead while keeping the grader laterally positioned on the road surface.

Looking ahead allows smooth adjustment of the moldboard for changing crown, superelevation, and conditions.

Once a grader pass is started, the grader should stay that same distance from the edge; a variance of 6 to 12 inches can affect the final product. Moldboard cross slope depends on keeping the front wheels in the same positioning on the road.

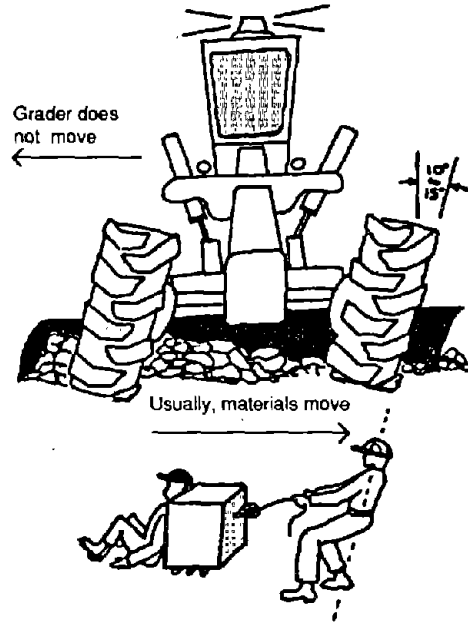

Front wheel tilt helps keep the grader's front end in place and makes steering easier.

While some describe the tilt as being about 15 degrees in the direction the moldboard materials are to move, in heeling we have already seen a case where that is not true; materials moved toward the cutbank but the wheels were tilted toward the centerline.

A better way to describe the proper tilt is to compare it to people digging in their heels. They dig in their heels to apply force and to keep their feet under them. **A grader needs its feet under it, too.** In heeling we do not want the machine to lose its footing and get pulled into the ditch.

Extreme moldboard *side-shift* can damage the grader and the operator if the tip catches on an immovable object. **Do not put undue strain on the grader,** and try to keep the moldboard centered. An articulated grader allows you to keep the moldboard near the machine's center of gravity, putting the power more squarely behind the centered load.

Cutting edges are designed like the iron of a carpenter's plane. The edge is straight and beveled like a chisel. Any sharp tool can be used to cut or to scrape and smooth, depending on how it is tilted.

Cutting Tilt

To cut, the sharp edge must be used like a chisel to cut and lift the cut material. The bevel will be flat against the bottom of the surface materials being removed.

Too much forward tilt makes the edge try to dive deeper. Too little forward tilt makes it climb back out. Either way it will take more effort than if it is flush.

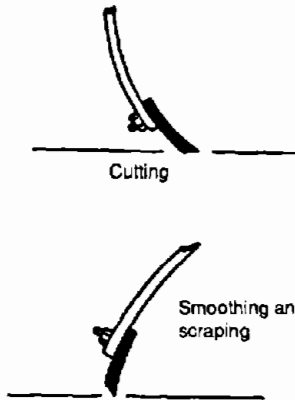

Since machines do differ, try setting a newly installed cutting edge onto a flat plank and tilt it to where it feels right. Get off the grader and see if there is light under the front edge, under the rear edge, or if it is flush. Get back on and make any needed adjustments so that you do feel the right moldboard position when the bevel is flush.

Smoothing and Scraping Tilt

For smoothing or scraping, the sharp edge of a new cutting edge will be tilted so that it drags across the surface.

Removing material depends on putting enough pressure on the edge to scrape off the high points. Grader downpressure and forward movement provide that to the properly positioned cutting edge.

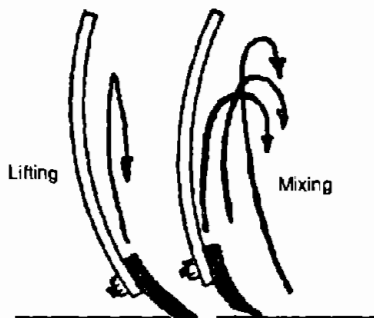

Mixing Tilts

Between the cutting and smoothing positions there are a range of tilts available. The right tilt for mixing depends on the speed of the machine. Generally, mixing is best with the blade slightly back of vertical. Too far back or too much blade angle will make the materials slide up and across the blade. **Watch the windrow**; if coarse materials are away from the grader, the speed is probably too fast and/or the tilt is too far forward so that rocks are being thrown ahead without mixing. If the windrow varies along its length, the speed may be too slow, the tilt too far back, or the angle too steep so that the materials move across the moldboard too fast or do not mix while there. Visualize different weights of clothes tumbling in the dryer - or aggregates in a concrete mixer: that is the action wanted.

Pre-Work Checks

In addition to regular equipment pre-work checks for safety, fuel, air, and other things common to all equipment, there are some special checks for graders.

Check that the cutting edge has enough wear left so that the moldboard will not get damaged before the cutting edge is replaced.

Check the cutting edge straightness. Use a string or straightedge from tip to tip. Wear is usually deepest in the center of the cutting edge. If there is more than 3/8" wear, replace it with straight sections. Before throwing the originals away, check whether they can be recut to save money. If the wear is less than 3/8", the ends can be switched around so that the deepest ends are in the center of the moldboard.

The straightness of the cutting edge will determine how accurately materials can be smoothed or reshaped. Less wear is acceptable for asphalt laying and finish grading work than for smoothing and reshaping aggregates.

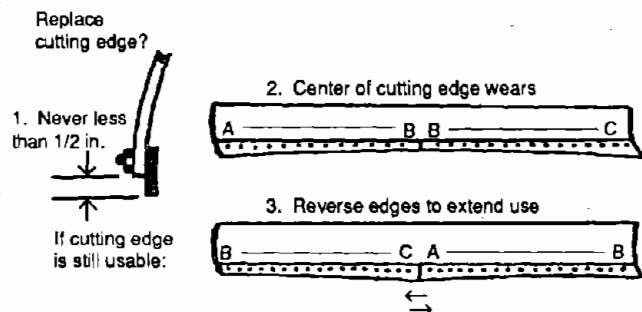

Check Your Cutting Edges

Check the cutting edge sharpness by sighting along the edge from the end. If it is worn from smoothing and will be used for reshaping (cutting and mixing), replace or resharpen it.

Arguments over what moldboard tilt is best always must come back to the cutting edge sharpness. An edge used for cutting will tend to stay sharp from wear. One used for smoothing and spreading will be flattened off. A flattened edge will certainly change the moldboard tilt from that for a sharp cutting edge.

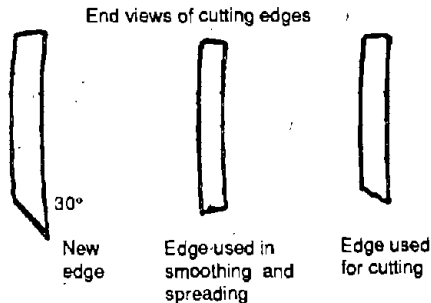

How Has Grader Been Used?

Checking the air pressure, tread depth and sidewall conditions is not enough for grader tires. Grader jump during surface blading activities has often been blamed on the machine or its drive train. Grader tires that receive power from the drive train must have the same circumferences. The size of the tire is not good enough. Measure around the drivers. If the circumferences are off more than 1/2 inch, the grader may jump and, furthermore, the drive train can be damaged.

Smoothing

Smoothing is limited, as its name implies, to smoothing the road surface when it has raveled but still retains a crusted (calloused) layer. The intent is to

keep the stable crust, not to destroy it by cutting into it.

Grader positioning for the initial work can be the same for both rigid or articulated machines. Only small amounts of material will be moved, so the value of articulating would be primarily to keep the drive wheels away from a soft shoulder or steep slope.

Smoothing commonly progresses in the same direction as vehicles travel because of safety considerations. If smoothing is done a number of times a season, materials along the road have a tendency to move. Every third to fourth smoothing should be done in the opposite direction.

Smoothing will start at the edge of the travel lane unless shoulder smoothing is called for in crew dispatching.

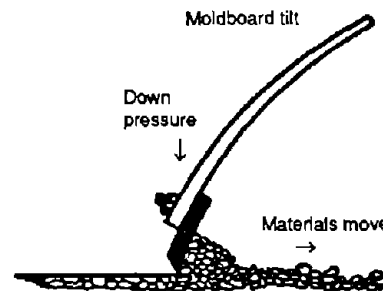

When the moldboard is set to the correct angle for the existing cross slope and smoothing tilt, start moving ahead and apply downpressure on the moldboard. Smoothing will not entirely remove surface irregularities when they are too deep or the surfacing is too dry.

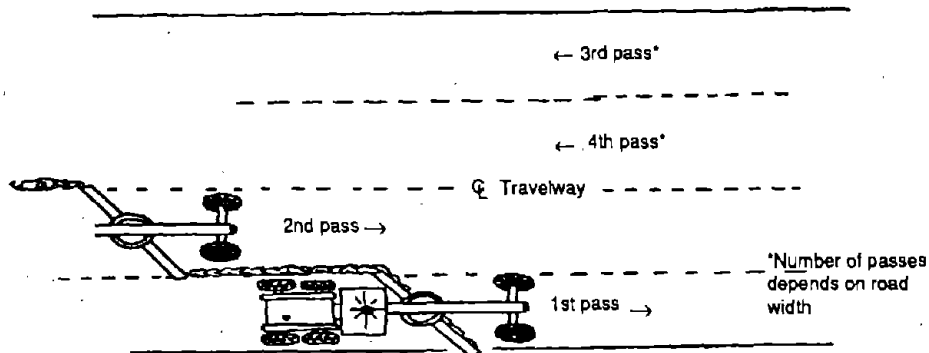

Initial Position and Sequence

If small irregularities are not being smoothed, increase the downpressure to the point where the wheels just start slipping and then ease off a little. Remaining shallow potholes or ripples will fill with loose materials.

If the moldboard empties too fast or overfills, adjust the moldboard angle.

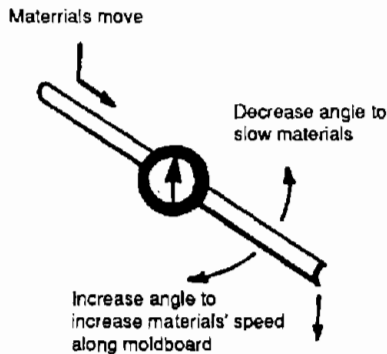

When the initial smoothing passes are completed, the windrow of collected materials will be near the centerline on the same side the work started.

Move the windrow to the centerline and split it equally into windrows for each side of the road.

At this point, articulate so that the front wheels are on the spreading side and the rear wheels straddle the windrow. Rigid frame machines are positioned on the spreading side of the windrow using more side-shift to pick it up. After the windrow is initially moved to provide enough room, the windrow is usually straddled with the front wheels.

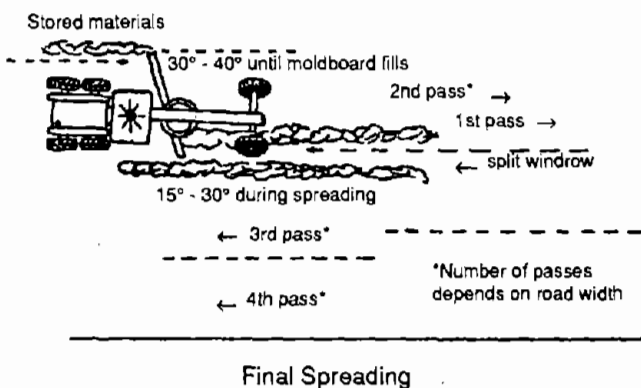

The moldboard is placed near the road surface at a 30-40 degree angle and set for tilt. Note that the tilt is more forward than for the scraping passes to provide some compactive effort on spread materials.

As the grader moves forward and the moldboard fills, decrease the angle and raise the moldboard to spread at a uniform depth. If the materials coming off the heel are not the right amount for spreading the rest of the lane, adjust the angle.

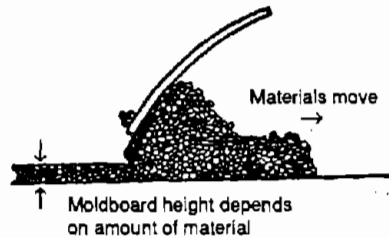

Complete the spreading passes.

The final spreading depth against the undisturbed shoulder should be slightly higher than the shoulder to allow for surfacing settlement.

Never leave the shoulder higher than the travel lane. It will function as a secondary ditch and run water along the edge of the lane. **Trapping water on the road allows more time for erosion or seepage to the subgrade.**

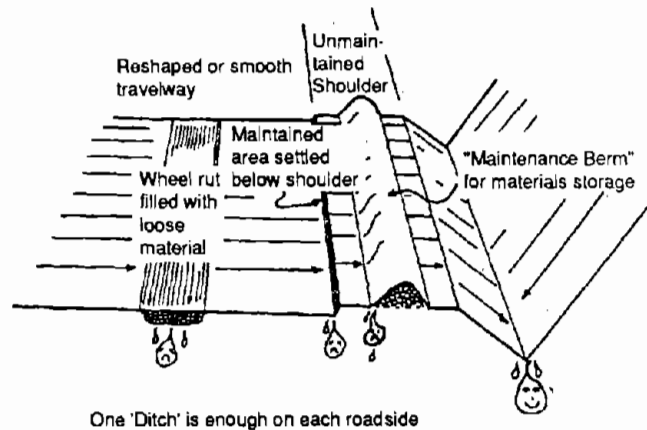

Any remaining materials not spread on the road surface should be stored on the shoulder for recovery when the road is reshaped. **Do NOT store the materials in shoulder windrows (berms) unless the engineer approves.** If shoulder edge windrowing practices are approved by the engineer, drainage breaks should be provided through them even though the materials appear to be just larger aggregate. Windrows should not be placed or left in place immediately before seasonal storms usually start. Storage windrows must be carefully placed to avoid traffic problems.

Even when properly done, smoothing will not completely eliminate existing potholes, wash-boarding, or rutting. Scheduling can catch them when they are small and extend the time it takes for them to become severe.

Smoothing only provides short-term improvements in driving conditions.

Before Starting Reshaping

The purposes of reshaping are to get rid of surface irregularities, restore surface drainage, and reprocess segregated materials to improve surface stability.

Moisture must be available to do the job right. Water trucks may be needed even when moisture is available at the start of work, since the materials will be aerated and will dry as the work progresses.

The initial cutting passes are critical because they control the final shape of the road.

A cutting pass must be started ahead of the area to create a transition to the full depth. Look at the road to see how deep the cutting must go.

Potholes, washboards, and ruts must be cut out or they will come back quickly under traffic.

For smoothing it is acceptable for loose materials to fill any remaining irregularities but not for reshaping.

The depth of the cut may require more than one cutting pass at a location, but cut to full depth.

The surface exposed by the cutting passes is called the anvil. If the anvil is cut at cross slopes different than that for the final surface, the surface will settle and compact unevenly.

Uneven settlement will make the final cross slope about halfway between the cross slope of the anvil and that of the surfacing spread by the grader.

Cut out the irregularities and cut the anvil at the same cross slope needed on the surfacing after compaction.

Reshaping is a good time to add surface replacement rock or materials that will stabilize loose materials.

It is not acceptable to let the road get wider and wider due to stored materials, or surfacing materials that slipped off the heel, being left outside the shoulder.

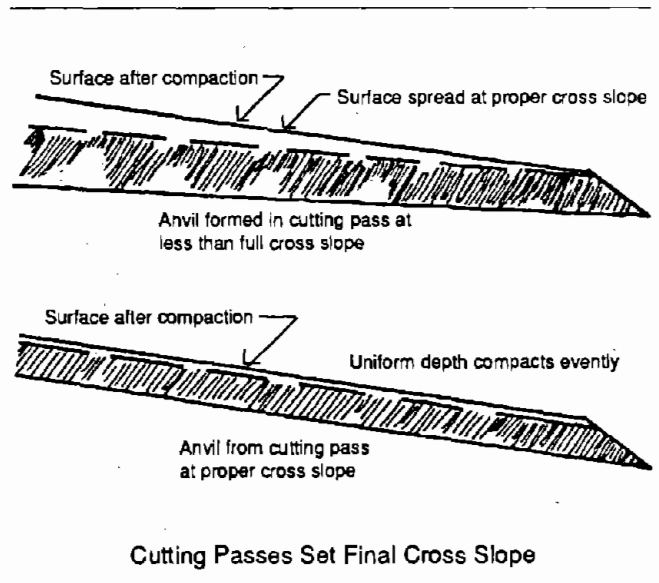
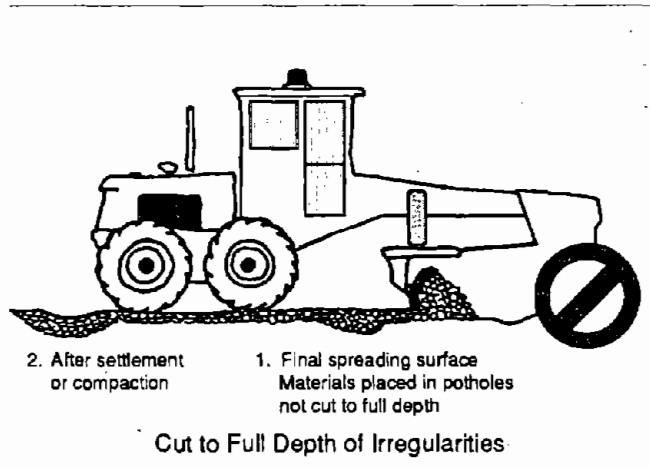
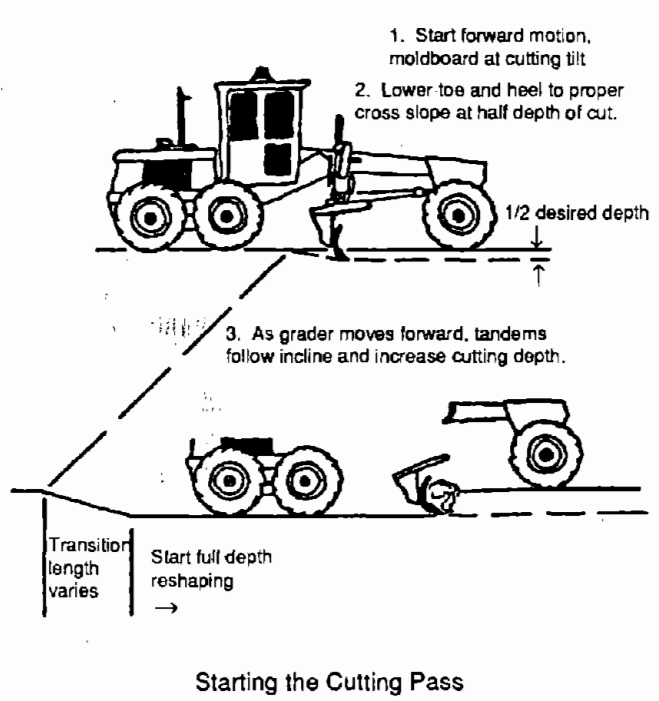

Redefine Width

Reshaping is the time to get the right width restored to the road.

If the road has grown a lot wider than it should be, it is usually safest and fastest to put a short length (3 to 5 feet) of a stepped cutting edge on the toe of the moldboard. Stepped cutting edges are simply a deeper section placed next to regular depth edges. Ice edges will leave a grooved surface if seeding of the exposed area is to be done.

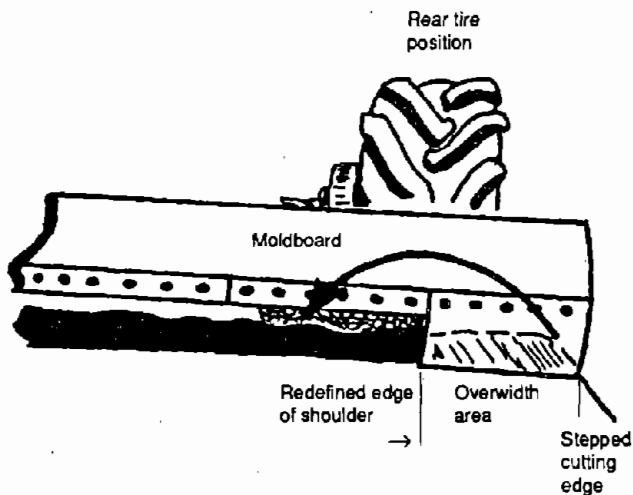

Recover Material from Overwidth Areas

Articulated graders are best. Position the front wheel on the material to be removed and the rear wheels within the redefined road width. Set the toe 45 to 60 degrees forward and the side-shift so the inside of the stepped edge is at the new toe of the shoulder slope. Set the cross slope to ensure drainage and set the tilt to cut. Keep the grader speed slow enough for good control. Lower the toe and heel to pull over-width materials into a windrow on the shoulder.

Recover Stored Materials From Slope

Wraparound surfacing sections are also treated as stored materials.

Articulate the grader so that one front wheel is on the foreslope and the rear wheels are on the road. Rigid frames should straddle the shoulder unless it is unstable.

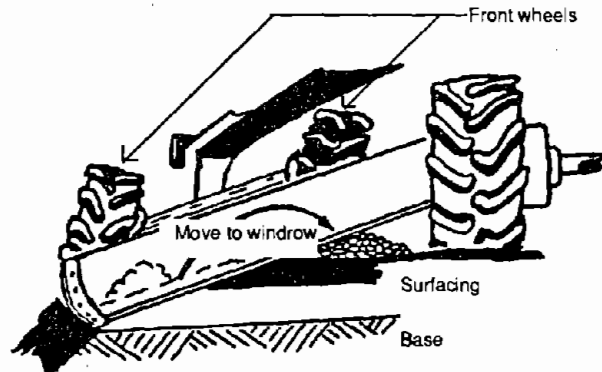

Recover Stored and Wraparound Slope Materials

Angle the moldboard so the toe is over the shoulder slope at about 45 degrees. Side-shift and set the slope at shoulder slope rate. Tilt for cutting.

Set the cutting depth to recover all surfacing materials and place them on the shoulder.

Reshaping is the time to get stored materials rebled into the surfacing.

Reshaping

Reshaping will involve the entire travelway and shoulders. There are four distinct phases in reshaping. Shortcutting only cuts short the time before reshaping is needed again.

1 - Cut and Move Phase

The materials must be moist but not saturated to avoid a loss of fines.

Allow enough length for starting the cutting pass transition. Articulate the grader so that the rear wheels are near the shoulder and the front wheels are offset about 1/2 grader width toward the centerline. A rigid frame grader is set near the shoulder line.

The moldboard angle is fairly sharp to present a narrower moldboard width for more power to cut and move materials across the moldboard rapidly.

Side-shift the toe to just beyond the shoulder, tilt the cutting edge to a cutting position. Set the moldboard at the proper cross slope just above the surfacing. Move ahead and cut the transition to near the full cutting depth. Now the grader is close to the position it will be in for the cutting and moving phase.

Check that the anvil is now at the proper cross slope. Do not trust the existing cross slope.

Back up a short distance to take the load off the moldboard.

Measuring the anvil cross slope can be done with a cab mounted meter that measures the actual moldboard position and angle and corrects the slope normal to the machine or with a carpenter's level and tape.

Bubble-type, cab-mounted crown gauges only tell the angle at which the cab is sloped. This is an indicator of how much change is needed in the cross slope, but it does not tell what slope to cut with the moldboard until the wheels will be on an area that has been cut by it.

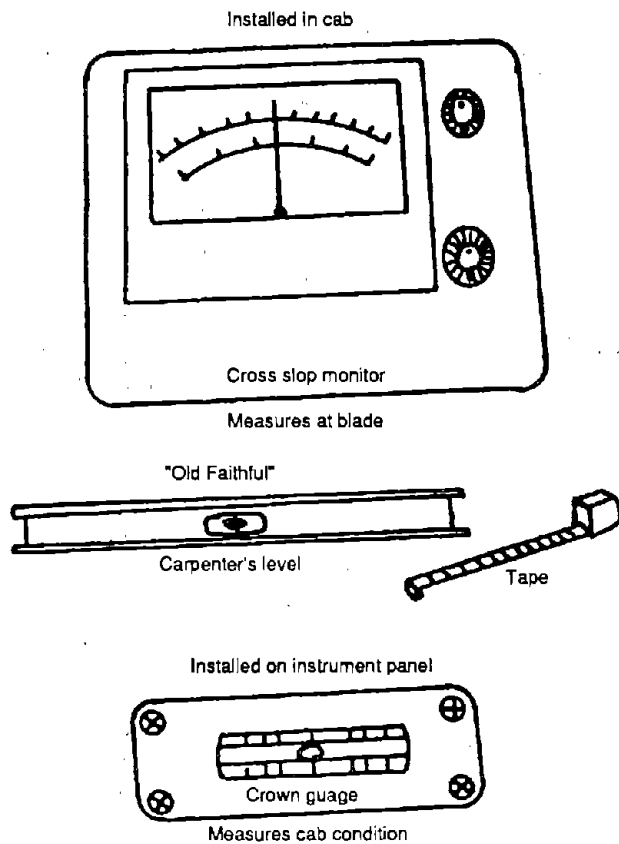

Measure the Cross Slope

Remember that cross slope rates are based on right angles to the road centerline, not along the angle of the moldboard!

Once the proper cross slope is established, all vertical moldboard movement **MUST** be done by changing the toe and heel the same amount.

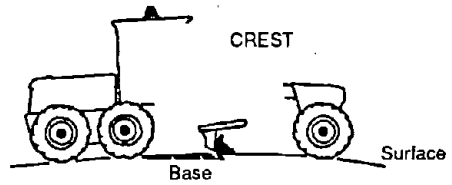

Sharp Vertical Curves Require Adjustments

Raise blade to maintain right depth

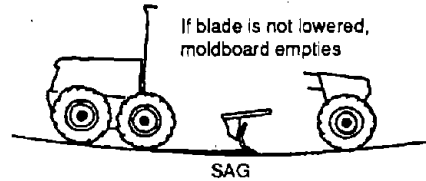

Reshaping

1. Cut and Move

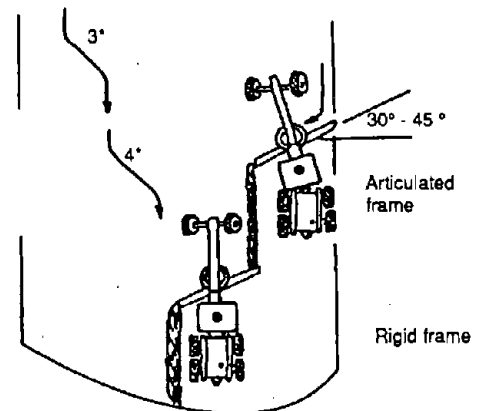

2. Reprocess

Number of passes usually 1-1/2 to 2 times cutting passes

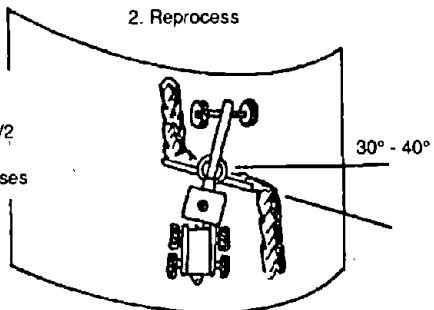

3. Spread

Number of passes same as or less than for cutting

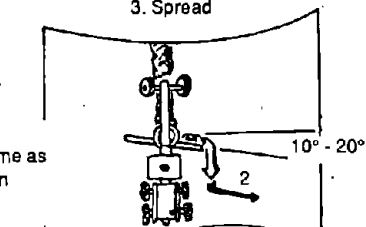

4. Compact

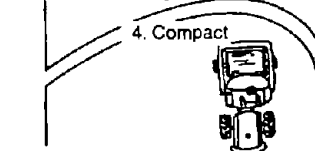

Changing the blade angle or distance from the edge of the road will change the cross slope.

When everything is set, move ahead and pick up the moldboard load. Depths of cut may vary along the road. Make depth changes over at least 50 feet.

Sharp vertical curves will require raising or lowering the moldboard to avoid scalping or filling them.

For shallow irregularities, the minimum cutting depth should be 1-1/2 times the largest surfacing particle size. For 1-1/2" rock, cut 2 -1/4" deep.

If cutting to the full depth of potholes, ruts, and washboards creates a moldboard load that is too heavy, plan on two complete cut-and-move phases over the same location. The first pass will remove looser surfacing and should go more than 1/2 the depth. When materials from the first cutting depth are out of the way, cut and move the remaining, more solid, materials.

Windrows that create too much load on the grader should be moved out of the way so that the power is available for cutting. Windrows should also be moved if they reach a height that cannot be straddled by the grader. Repositioned windrows should be stored out of the traffic's way.

The purpose of the cut-and-move phase is to establish the anvil. No mixing has been intended.

2 - Reprocess Phase

Reprocessing is the mixing of the materials so that coarse and fine particles are uniformly distributed throughout the windrows. It can be done with cross shaft mixers but is usually done with graders.

Mixing is the result of grader speed, moldboard angle, and moldboard tilt. Too big a windrow or the wrong moisture content can prevent thorough mixing.

It may be necessary to reprocess part of the surfacing and spread it, then use the newly spread materials as a mixing platform for the rest.

Water is best applied with a spraybar while the materials are flattened on the road. If stabilizers are being added with the water, the windrows should be flattened. This requires a grader spreading pass and a windrowing pass.

If the windrow is watered to avoid grader spreading and windrowing, care must be taken to avoid flushing

finer and costing at least an equivalent number of mixing passes.

Grader positioning should always be based on keeping the moldboard nearly centered on the grader frame and the power directly behind the moldboard. Articulated graders do this well when their front wheels are offset toward the direction in which the materials will be moved.

Reprocessing continues until the windrows are uniformly mixed and remain moist. The moisture prior to spreading will help determine whether a crust can be developed through roller or traffic compaction.

3 - Spreading Phase

The spreading phase redistributes the reprocessed aggregates across the travel lanes and shoulders.

It is better to spread the materials in two separate operations than to carry too heavy a load on the moldboard. This also allows sizing the windrows so the grader can straddle them without hitting the undercarriage or getting a front wheel on the windrow. It is better to be offset from the windrow and pick it up by side-shifting the toe than to run a front wheel on the windrow.

The basic moldboard position for spreading and moving a windrow is as follows. The full moldboard is angled only 10 to 20 degrees and rolled (tilted) forward from the smoothing position to provide some pressure on the surfacing being relaid.

If several windrows are sized and pre-positioned for straddling and spreading in both directions, the moldboard is not angled.

The cross slope (crown and superelevation) is again critical during spreading. The cross slope should be measured before beginning.

Upon completion of the spreading, the shoulder cross slope should be steeper than the travel lane and the edges should be trimmed as necessary for good definition of the shoulder line.

4 - Compaction Phase

Some spread materials will compact well. When these are compacted by roller instead of traffic, the extended life of the reshaping job will usually more than pay for rolling costs. Cover the entire surface twice or more.

USING SURFACING FOR POSITIVE TRAFFIC GUIDANCE

Positive traffic guidance is more than using signs and markers. It begins with the shape and the condition of the road surfacing.

Carrying one road crown through a junction but eliminating it on the joining road indicates the crowned road is more important.

Flattening the crown on both joining roads says they are equally important.

The crown is like a centerline stripe: it says, "Keep right."

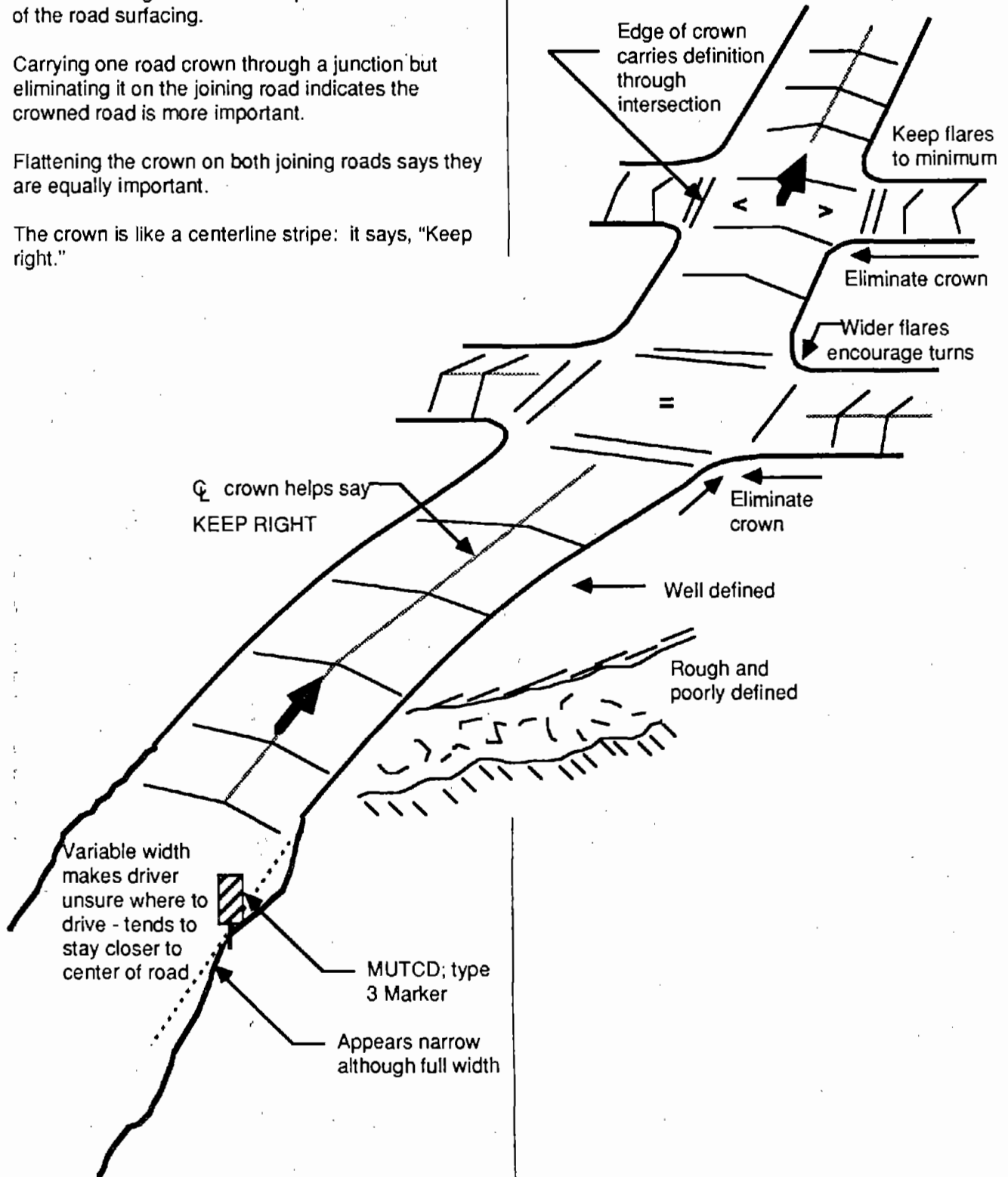

SECTION 3 - SURFACE STABILIZATION AND WORK SCHEDULING

Little has been said about stabilized surfaces before now because they are best discussed on the basis of what benefits and problems are involved. Most people support the principle that the majority of surfacings will be improved by stabilization.

Work scheduling should always be based on what has happened before and what is seen ahead.

SURFACE STABILIZATION

Surface stabilization can take several different forms. Stabilization ranges from temporary dust abatement measures lasting a season or less to full conversion of the surfacing type on a permanent basis. Examples of full conversion are from earth to crushed-and-sized aggregates or from crushed-and-sized aggregates to asphalt surfacing.

Economies can be gained by aiming both recurrent and deferred maintenance activities toward the desired end results. **Money and materials can be wasted when the ongoing maintenance activities are aimed in the wrong, or an unknown, direction.**

Stabilization Goals, Objectives and Constraints

Use of stabilization should be based on accomplishing stated goals and objectives within the established constraints on maintenance and materials. The objectives and goals are the starting point. The constraints determine if it can be done, how it should be scheduled and what funds (construction or maintenance) are appropriate.

Objectives and goals should be stated as completely as possible. An unstated part of a goal is often not attained because interim actions have limited future options.

Various training programs stress how goals and objectives should be formatted; however, it is more important to deal with the issues than it is to follow a prescribed format in the beginning. Formats do help within an organization so everyone knows what is meant and where to look for it.

The first step is to set the long-term goal that will be accomplished for each road or group of roads.

Second, identify the enroute objectives that will help reach that goal. All enroute objectives must be in tune with the long-range goal.

Example: Road is now crushed-and-sized aggregate, 1" minus material.

Long-Term Goal: To convert to asphalt, multiple seal coat (inverse penetration mat) in 3 to 8 years at current width and alignment.

Short-Term Objectives: 1. Reduce dust.
2. Stabilize loose surfacing.
3. Improve strength.

This tells us the road will not be relocated and that all objectives do contribute toward the conversion goal.

The characteristics of appropriate stabilizers and maintenance activities can then be identified.

Stabilizers: (characteristics wanted or criteria)

- A. not moisture sensitive,
- B. do not attract moisture,
- C. allow interim grader smoothing and reshaping,
- D. no bad effects on multiple seal coat,
- E. waterproof existing surface,
- F. add strength.

If these characteristics are accurate and complete, the criteria act as sieves or gates for the process of selecting the right materials and actions.

A) and B) eliminate some materials that collect and/or hold moisture (e.g. salts, clay).

D) eliminates materials that can boil off (evaporate) under the asphalt and force their vapors through the asphalt (e.g. petroleum distillates). Note that A) and B) have already dealt with the water vapor issue.

E) suggests certain materials (e.g. lignin sulfonate, emulsified asphalts).

F) suggests certain products (e.g. same as E) plus cement).

C) eliminates some remaining products (e.g. cement) and controls the application rates of some products (e.g. emulsified asphalts).

The process has narrowed the preferred choices to using lignin sulfonate or controlled application rates for emulsified asphalts. Clearly there are personal factors in the evaluation process to this point. How the objectives are interpreted can also be a factor.

If the reviewer determines that any moisture coming from the air would not be a problem after asphalt surfacing, salts might remain an option. If the moisture is readily available within the subgrade, A) and B) could be critical. Notice that A) did screen out using clay that would not be desirable under an asphalt surface. If clay had been selected as the stabilizer for loose surfacing (objective #2), the top layer would have had to be removed or possibly treated with lime prior to placement of the seal.

The preferred choices can then be ranked for how well they meet the stated objectives and how much they cost to do it. The final decision is based on the economics of the preferred choices. The outlined process allows reducing the extent of the economic analysis by eliminating materials that would be unsatisfactory even if they were the least expensive.

"Cheap" means low initial cost only; "economical" means the least cost over a period of time considering all costs.

When going through any process, be as complete as possible but do not try to make the answer come out according to a predetermined preference.

When decisions will be based on a predetermined answer, do NOT use the decision making process as a justification.

To further illustrate the range of alternatives that can result from dealing with only one objective:

Objective: Retain fines

Alternatives: dust oils
magnesium chloride
salts
lignin sulfonate
add clay
resurface
add cement
pave over it
etc., etc.

Objective: Stabilize loose material

Alternatives: add clay
add fines
add missing gradings
add lime to clays
add cement to granular
add asphalt
cover it up

The list grows very fast and not all alternatives are desirable.

Recommended Process

Use all objectives that fit the long-term goal.

Use constraints and criteria as sieves that sift out preferred choices.

Review the preferred against stated objectives.

Develop maintenance (and reconstruction, if applicable) strategies based on the remaining choices.

Analyze the remaining preferred alternatives for least total cost in the long run.

The decision of what is important is up to the people involved in setting the goals and objectives and making the decisions. The concerns of the public and constraints established on the use of certain materials are part of what is important to them. The observations of field maintenance people and cost indicators from the maintenance management system can help in focusing on the roads that are the highest priority for stabilization work.

Semi-Permanent Stabilization Materials

Portland Cement Its use is normally limited to reconstruction when surfacing is done with asphalt or concrete pavement. Its cracking intervals are similar

to concrete. It works best with granular materials with little if any clay. Its use for maintenance is limited usually to bagged soil cement instead of riprap.

Lime

It is used with clay soils to improve their ability to drain. It may be intermixed with surfacing with a high clay (P.I.) content to reduce slipperiness. Use lab tests to set amounts to be added during reshaping.

Geotextiles

Their use is normally limited to subgrade restoration or reconstruction activities, except for subdrain filtering and separation. Product selection and design should be based on specific application.

Asphalts

The use of paving grade asphalt is predominantly limited to construction or reconstruction activities or waterproofing spray applications for specific design purposes. Emulsified asphalts and cutback asphalts are discussed in the next subsection.

Clay

Crushed and sized aggregate surfaces with no P.I. can be made more stable by adding clay. The amount of clay can be determined by comparing that available in the surfacing with that recommended in current surfacing materials specifications. An excess of clay will make surfacing slippery after rains. Clays hold water and may be detrimental to asphalt overlays.

Crushed aggregate

Crushed aggregates may be used to blanket over wind, traffic, or materials that will erode with water. A full range

of sizes (gap graded) of existing unstable aggregates may not be available; gradation analysis can determine if some fractions are missing and, if so, what amounts should be added during reshaping.

Short-Term and Stage Stabilization

Dust abatement is the more common term for short-term stabilization; some products add strength with a cementing action that contributes to the future goals of conversion to a high type of surfacing. There have been numerous studies and publications regarding dust abatement (palliatives) products and costs. Many of these materials conflict because of location, types of materials existing on the road, previous treatments, or a variety of other reasons.

This is not intended as a reflection on the authors. The statement simply recognizes that many variables affect the performance of dust abatement materials and that what does not work well in one case may be good under other circumstances. Performance factors for off-highway loads can be different than for light local traffic on a rural road. The heavy truck exerts a lot more pressure and will shorten the effective life of the dust abatement job. The local road may experience heavy single- or double-axle use only during the harvest season.

Similarly, annual costs and even costs per application will vary widely. Was the product sprayed on the surface? Was reshaping counted as part of the cost or not? Was the road compacted with rollers afterwards? Unless the process and cost accounting is known, costs from different places can not be compared with any degree of confidence. The best sources of good information are local experience and local costs.

Dust abatement products do their jobs differently:

They make dust particles heavier by attracting and holding water, or by adding oils. . . OR they make particles hold together with cementing action, or by ion attraction.

Some generalization can be made on dust abatement products.

- All products can be washed off the road by severe rains right after application. No rain should be forecast for the next 12 to 24 hours.
- All chlorides and water cause steel to corrode.
- All materials except those with asphaltenes will leach to some degree during seasonal rains.
- Chlorides rely on moisture being available through the ground or from humidity in the air.
- Most products are a waste product from the manufacture of other products:
 - high sulfur content distillates (naphtha and diesel),
 - soft paper manufacturing (lignin sulfonate), or
 - minerals extraction (most salts).
- All dust abatement costs money initially.
- All effective products will return some or most of their cost in other maintenance savings.

Specific Products

Sodium Chlorides

The sodium ion (Na+) has been reported to have severe effects on non-salt resistant plants, animals and aquatic life. They are not recommended for dust abatement.

Calcium Chloride

Adverse environmental effects have been reported from chlorides, especially in stream-side zones. Calcium chloride creates heat when mixed with water, so care in handling is needed. It has enjoyed a reputation as an efficient dust stabilizer. Dry weather periods cause migration and crystallization near the road surface. Subsequent storms wash most of the crystalline calcium chloride from the road surface. It is not recommended within stream-side zones, sensitive plant communities, or where materials can enter under-

ground water courses leading directly to streams or ponds.

Usual rates: 600 pounds in flake form or 1,000 gallons of 25 percent brine solution per lane mile. Apply it to the surface.

Magnesium Chloride

The general effects of magnesium chloride are similar to calcium chloride. No heat is created when it is mixed with water, however. Reports are that about 18 percent more is required than CaCl₂ for comparable quality and length of abatement. Its use restrictions are the same as for calcium chloride.

Usual rate: Delivered in water solution ranging from 28 to 35 percent solids. Approximately 68 to 55 tons of solution per 12 foot lane mile. Apply as spray to the surface.

Lignin Sulfonate

Lignin is highly compatible with the environment. Leaching is minor, provided sufficient fines exist. Permits are issued by the Federal Food and Drug Administration for use in animal feed pellets and in certain food sprays for humans. Arizona has reported 80 percent dust control at five months; some value remains at 14 months. In Washington 8 to 10 months effectiveness can be expected. Adding 0.5 percent lime extends the effectiveness and provides a tighter road surface with less aggregate loss. The pH is usually between 3.5 to 6.5. It is recommended particularly for 3/4" minus materials with 20 to 50 percent silts or clays. It provides water-proofing.

Delivered solution ranges from 45 to 80 percent solids. Use 1 to 2 percent solids by weight for stabilization; mixing in the top 2" to 4", spray additional solution (0.1 gallons per square yard) onto the surface and compact it. Often interim maintenance is done by hand patching with freshly mixed lignin sulfonate and surfacing materials. Surface applications on hard surfaces are not recommended. Surface applications of 0.3 to 0.5 gallons per square yard onto scarified surfacing has limited value. Addition during reshaping is recommended.

Usual rate: Use 1 to 2 percent solids by weight for stabilization during reshaping.

Petroleum distillate products

At one time these products were the most-used commercial dust palliatives in the Northwest. Most products currently are combinations of high sulfur fuels and oils in the lubricant fractions. The products are often mixed from available excess refinery stock. The use of fuel eligible distillates releases hydrocarbons into the atmosphere. Petroleum distillates are not environmentally compatible. They are not recommended for continued use.

Cutback asphalts

These are a combination of petroleum distillates and asphaltenes. They are not recommended for dust abatement.

Products with asphaltenes (resins):

The cementing action of asphalts is created by the

presence of asphaltenes. Any product containing asphaltenes will add strength to surfacing but will gradually build up with added applications until the surface becomes too hard for normal aggregate surface maintenance activities. This limits their use for dust abatement but makes them a candidate for use when the surfacing type will be converted to asphalt in a few years. The main products to be considered are mixing grade emulsified asphalts. CSS and CSS-1 have both been used successfully for this purpose.

Usual rates: Have the aggregates lab-tested and designed as an asphalt stabilized base to determine the amount of residual asphalt needed for the best strength and stability (usually 1-3/4 to 2-3/4 percent). Approximately 1/2 to 3/4 (maximum) of that amount can be added over several years' dust abatement.

Add emulsion to the reprocessing water during the reshaping of the top layer. Have the entire process and annual applications designed before starting.

Water

Water is often used with wetting agents to make it go farther. The cost of dust abating to any standards with water usually makes it the highest cost alternative. Use water only to control short-term, project-generated dust.

The accompanying chart lists factors regarding dust abatement products.

Palliative	Leaching After Cured	Known Leachate Effects	Relative Humidity Required	Attracts Animals (2)	Hazard to Workers	Cementing Action	Solution Lowers Freezing Point	Fuel Eligible	Further Discussion in this Manual
Sodium Chloride (NaCl)	High	Hazards to plants, animals, fish	Yes: 76% at 77°F	Yes (Salts)	Drys skin	No	Yes: -60°F at 25% solution	No	No
Calcium Chloride (CaCl ₂)	High	Damages plants, fish, animals	Yes: 29% at 77°	Yes (Salts)	Gets hot when mixed with water. Can burn.	No	Yes: -60°F at 30% solution	No	Yes
Magnesium Chloride (MgCl ₂)	High to Low	Damages plants, fish	Yes: 32% at 77°	Yes (Salts)	Limited	No	Yes: -27°F at 22% solution	No	Yes
Lignin Sulfonate (Acid Neutralized) Ammonium Based	Low	Livestock feed supplement	No	Yes (Wood Sugar)	Limited	Weak	Yes: Amount not known	Limited (3)	Yes
Asphaltenes (Resins)	Low	Non-applicable	No	No	Limited	Strong	No	Limited (3)	Yes
Petroleum Distillates (1)	Low to High	Damages Plants, Fish, Animals (A)	No	No	Limited	No (5)	No	Yes (5)	Limited

- (1) Mixtures have effect of averaging the following
- (2) Of concern in open range land and wildlife environment
- (3) Lignin sometimes used to fire boilers in wood products industry
- (4) Requires sophisticated methods, does affect purchase price.
- (5) If high sulfur content distillates, some cementing action (weak), fuel eligibility slightly reduced by requiring more refinement
- (A) Also introduces hydrocarbons into atmosphere

The best way to determine how much it costs to dust abate is to look at what it can save you.

Vernon County, Wisconsin, reports dust abatement only costs it \$100 per mile when it considers savings in other maintenance and aggregates.

Onandaga County, New York, estimates that gravel losses have been reduced to 23.5 cubic yards per mile per year from a previous 73+ cubic yards; traffic is at 41 to 216 vehicles per day.

If you can eliminate a reshaping job and a couple smoothing jobs a year plus conserve some of the limited rock supplies, how much will you save?

Only you know what costs you are experiencing and how much maintenance can be saved on your road systems. The value must be determined locally.

Using Aggregate to Make Unstable Surfaces Stable

Some surfacings are unstable because certain rock sizes are missing from the gradation. To provide a stable surface the missing sizes need to be blended into the existing surfacing during reshaping activities.

Two reshaping activities should be scheduled to complete the overall process. The first reshaping allows collecting samples for analysis. The second reshaping is when missing sizes are incorporated.

1. During the first reshaping, reprocessing is completed and materials remain in the windrow.
 - a. Sample the windrow. In the area of unstable surfacing, select a random distance for the interval between sampling points. Take the first sample at that selected distance from where you stopped. This helps obtain representative samples instead of inadvertently picking the best or worst spots by observation.
 - b. Insert plywood or steel plates to extend from the road surface clear across the windrow. Space the two plates about one foot apart. Remove the entire

windrow between the plates to secure the sample. Bag the sample and label it. Mark the location so the sample site can be identified.

- c. Repeat the sampling process at the pre-selected interval until at least three and preferably five or more samples are obtained.
 - d. Complete the current reshaping activity.
2. Take the samples to the laboratory for sieve analysis and determination of missing sizes. They will sieve the samples, compare the gradation of the existing samples with a stable gradation, and determine the missing sizes and how much of those sizes will be needed to provide aggregate stability.
 3. Obtain the proper amounts of the missing sizes to add to the road.
 4. During the next reshaping
 - a. Do the initial cut and move phase to form a uniform windrow in the unstable area.
 - b. Add the proper amount of missing sizes according to the windrow size and thoroughly reprocess to get a complete blending. Complete the reshaping activity.

If the windrow is large, it may be preferable to use a cross shaft rotary traveling mixer to do the major reblending (reprocessing phase) instead of using graders.

In some cases, the missing gradations may simply have settled down into the lower portion of the surfacing. If this has happened, it should be apparent that there is a difference by inspecting the anvil that was uncovered in the first reshaping job. If this is suspected, sample the anvil sufficiently for lab verification. To recover settled materials, use a cross shaft rotary traveling mixer to gain the additional depth and reblending.

SURFACING REPLACEMENT

The purpose of surfacing replacement is to perpetuate the depth of surfacing needed for the surfacing to serve its intended functions.

For crushed and sized aggregates, surfacing losses may be independent of the volume hauled.

This initially appears contrary to most historic guidelines that refer to the number of vehicle miles per year as the standard of comparison. It actually does make some sense. The correlation may be to the number of blade jobs the roads receive.

Surfacing losses are different than surfacing wear. Surfacing losses include all normal losses whether due to wear, the influence of weather, or the local maintenance practices.

In Section 2 the procedures for recovering stored surfacing and for recovering materials from over-wide areas were covered. Both these procedures were aimed at surfacing materials. If a 30-foot wide road becomes 31-foot wide, the surfacing materials going into that widening will be equal to at least 3/8 of an inch in depth over the full 30-foot width. A second foot wider will take away another 1/2 to 5/8 of an inch in depth. The road is now only a couple feet wider than designed but the surfacing is almost an inch shallower. The range is about 200 to 450 cubic yards per mile.

In the last subsection, it was mentioned that one county believed its dust abatement was saving it about 50 cubic yards per mile per year.

The proceedings of the Sixth Annual Meeting of the Highway Research Board included a report from three districts in Indiana. They indicated 0.319, 0.241, and 0.308 for an average of about 0.29 cubic yards per mile per year per average daily traffic (ADT) vehicle. 1000 ADT = 290 cubic yards per mile each year. Incidentally, that meeting was in 1926.

In 1967 there were six roads near Twisp, Washington, studied to determine surfacing losses. Some 39,479 trucks and 110,575 cars traveled the roads; surfacing loss was 1.03 inches per mile or about 0.34 inches per ADT per mile.

These average values could mislead you. Do NOT use them unless you understand what they really mean.

Look more closely at the details of the specific Twisp area study as tabulated in the following. The value of the average figure is demonstrated more clearly.

<u>Road</u>	<u>Trucks</u>	<u>Cars</u>	<u>Inches Lost</u>	<u>Total Vehicles</u>	<u>Inches per 10,000 vehicles per mile</u>
1	8804	3130	1.5	11,934	1.257
2	5164	14762	1.75	19,926	0.878
3	5080	41562	1.5	46,642	0.322
4	5344	16325	0.6	21,669	0.277
5	8680	18310	0.0	26,990	0.0
6	6407	16486	0.8	22,893	0.350
Totals	39,479	110,575	6.15	150,054	0.41

Does it help to know that most of the heavy use on Road #5 occurred in November through January, when the road was frozen and functioned more like a concrete surfaced road? There are other missing pieces in each of these puzzles that prevent getting a good "rule of thumb" number without some guessing. Hardness of rock, traffic mix, quality of maintenance, frequency of maintenance, traffic volume, amount of dusting, and climate are possible pieces to the puzzle. Unless all the pieces are known, averages are dangerous.

The only real answer for estimating surfacing replacement needs is: know what amounts you have used at what intervals on your roads!

Earth Surfaced Roads

Surface replacement on earth surfaced roads is often forgotten. This leaves some roads looking more like trenches or canals.

Surface replacement in some cases can be scheduling ditch pulling after the materials dry out a little bit but before reshaping of the road.

A study of surfacing losses might show that traffic speed, runoff water speeds, and wind speed are the largest causes of surfacing losses. That is no joke: wind and water erosion are excellent movers of fine particles. Use of surface stabilization may be the only answer on some roads.

Check to see if the road surface has gradually widened. It is easier for this to happen on earth surfaces than any other.

Consider using or improving the roadside ditch as the source of surface replacement materials for earth surfaced roads.

Materials salvaged from other roads under reconstruction may allow improvement of the surfaces instead of the materials being intermixed with soils into the subgrade at the reconstruction site.

SCHEDULING MAINTENANCE

Other areas of this manual have mentioned scheduling a number of times. This subsection will not attempt to repeat all of them. Scheduling is an integral part of each day's work.

In the maintenance management system subsection, scheduling was not directly shown. Scheduling includes both the maintenance plan and decisions based on known current deficiencies about when orders are to be sent to crews and contractors.

The real challenge is to identify all the deficiencies that exist and set priorities for getting them done. If only one deficiency exists it is not too difficult to set priorities on correcting it. A systematic way of setting priorities is needed unless you plan to do the maintenance whether it is needed or not.

ADT is commonly used as the factor, but ADT is not all of the answer and it is not always available in the field. Added factors to ADT should be the accident frequency and accident severity experienced. How is a person expected to carry all that information with them? They are not.

A record of established priorities exists in the field.

Normally, priorities for maintenance follow signing priorities.

Starting with the assumption that if the road is more heavily signed for destinations it is a higher priority, the general list of priorities looks as follows:

1. roads with destinations signed on the state highway,
2. roads signed with larger destination signs to interconnect towns and major recreation sites,
3. roads with local destinations signed, and
4. roads signed with road name or number only.

This obviously does not cover all of the elements of risk associated with a deficiency. The relative risk of a deficiency could threaten life, private property, the road, or it could be normal. Referring again to the signing concept; **the greater the number of regulatory and warning signs, the higher the risks associated with that road.**

The precise description of the prioritization process is something that needs to be worked out at the local level. Only in this way can maintenance professionals and engineers fully exercise their judgment as close to the ground as possible. The prioritization system should be a part of the maintenance management system so it remains visible and usable.

Beyond deficiencies there is a whole area of work that is scheduled to prevent the roads from having deficiencies or to take advantage of naturally occurring moisture. Some of this will be recurrent maintenance and most of it, if not all, will be deferred maintenance work.

Scheduling recurrent activities is usually the bigger challenge.

Earth Surfaced Roads

Ditch Maintenance

Ditch cleaning should precede seasonal rains requiring full ditch capacity and should also be before one of the reshaping jobs is scheduled. If materials can be used on the road, schedule ditch pulling after the initial reshaping cutting phase and prior to the reprocessing phase. Moist (not wet or dry) ditch materials may be pulled onto the road since there is no risk of contaminating the surfacing, but the scheduling must call for immediate placement and compaction so the road remains passable. Sort and incorporate suitable materials; temporarily store the remainder on the foreslope for loading and hauling.

Surface Maintenance

Initial spring surface maintenance should be done when natural moisture remains available. Normally, schedule a reshaping job at this time.

Before summer dryout, if the road is to be dust abated, schedule reshaping with the dust abatement and follow that with compaction. If the road is not to be dust abated, evaluate whether an additional reshaping will last long enough to be cost effective over smoothing. If the moisture is right and the road shape is good, a self propelled vibratory roller may be able to do the smoothing plus add compaction for a more lasting dense surface.

Late spring and summer cross slope rates can be less than fall and winter rates. Base your surface maintenance decision more on rutting, potholes, and washboards during drier periods. In wet periods,

base your decisions on drainage first and surface irregularities second.

Before fall rains or snows set in, reshape the cross slopes fully and compact the surface to prevent loose particles from eroding and increasing the surface density that will shed water.

Crushed and Sized Aggregate

Ditch Maintenance

Schedule ditch maintenance when the materials in the ditch are as dry as possible. The moisture under the materials is usually still sufficient for wheel compacting ditch bottom. Preferred equipment will load directly to trucks from the ditch. If the equipment will damage the shoulders, resmoothing should be done by backblading or with travelway smoothing. Any water-transportable soils in the ditch bottom should be compacted after being moistened by the first fall showers. Often fall reshaping scheduling allows compaction with equipment tires.

Surface Maintenance

Surface maintenance follows the same general schedule as for earth roads.

Schedule any surfacing replacement along with dust abatement and reshaping whenever possible.

Schedule dust abatement or other surface stabilization with late spring reshaping. Some dust abatement products can be maintained during the summer by modified patching techniques, releasing graders for other locations.

Whenever moisture is available throughout the summer, the first choice for graders is necessary reshaping of roads to prevent more segregation of the aggregates and more reprocessing time when subsequently reshaped. Surfacing that benefits from rolling should be rolled when the reshaping is done.

Roads with the crusting destroyed should have high priority for the use of water trucks. Roads with crusting intact only require light smooth blading. When natural moisture or trucked water is not available, do not attempt reshaping; smoothing is the only available choice.

Restore the cross slope to the surface and shoulder by reshaping for winter.

SECTION 4 - EQUIPMENT SELECTION

Equipment directly tied to roadside ditch and roadway surface maintenance activity (activities covered in Sections 2 and 3) will be discussed.

This is not a sales pitch, but:

there is such a variety of attachments available for equipment that the choices can be mind boggling. Each attachment is aimed at a certain type of work that may or may not fit well into your program. Some hydraulic systems can be set up to allow the use of hydraulic driven hand tools such as impact wrenches, jacks, chainsaws, and drills. If that is what you are looking for it is best to have the manufacturer adapt the system. Before you say "who would want that," look at how it might eliminate the need for a specially equipped service vehicle or a trip from the shop.

The availability of special attachments may determine which model or make of machine will most benefit your maintenance efficiency.

There is always the question of what horsepower is needed or wanted. Elevation, the type of work the equipment will do, and performance histories provide better recommendations for your equipment decisions than can be provided in a general discussion.

When selecting equipment to purchase, keep in mind that savings may be gained through standardization that reduces shop costs and parts inventories.

Once you have the equipment take care of it.

Often overlooked: it is important that the circumference of all tires using the same sized rims and getting power from the drive train be matched. If they are different circumferences, it not only increases strain on the drive train, it also affects maintenance activity (especially blading) quality. Just because the tires' sidewalls say they are the same size does not mean they are the same distance around. If the machine seems to bounce or jump for no reason, measure those driving tires — all of them. Whether it is two-wheel drive, four-wheel drive, or all-wheel drive determines how many need to be checked.

We are in the business of maintaining roads to prevent damage and deterioration.

That sounds similar to preventive maintenance for equipment. Doesn't it?

DITCH CLEANING EQUIPMENT

Road Graders

Graders are covered under surface maintenance equipment. Graders are often used for ditch cleaning but their best use is surface blading and reshaping.

Loaders

Articulated loaders are preferable to rigid frame loaders for loading from the ditch or windrows and working in narrower areas. Ditching work may be secondary to other reasons for having a loader. Some repair of the foreslope and shoulder is commonly needed where loaders enter the ditchline repeatedly; repairs are usually reduced when an all-wheel drive is used. Use an equipment trailer for longer moves.

Do NOT mount a backhoe attachment on articulated loaders. The joint in the middle of the machine makes it hard to stabilize.

Front End Loader and Backhoe Combinations

There is a smaller bucket capacity for loading, since the loader is most often used to move materials removed by the backhoe. This is a very good tool for shallow trenching. While it is often used for cleaning roadside ditches, it is at its best installing ditch relief culverts, cleaning natural catchbasins at culvert inlets, restoring channels, and removing decks and cleaning materials from cattleguards. The standard rigid mounting of the backhoe bucket limits its use in vee ditches without an accessory bucket. An extendible boom accessory for the backhoe will help reach the deeper culvert inlets and outlets from the road. Some repair of the road surface, shoulders and foreslope is commonly needed; damage is usually less when an all-wheel drive is used. This type of unit has been a reliable maintenance tool. Use an equipment trailer for longer moves.

Boom Mounted Articulated Buckets

The bucket capacity and reach are greater than for loader/backhoe units. The control of the bucket tilt, angle and boom extension make the machine adaptable to various ditch shapes without changing buckets. The reach allows removal of perched rocks and other hazards from backslopes. Removed materials can be delivered directly into standard dump trucks without rehandling. Rotation of the

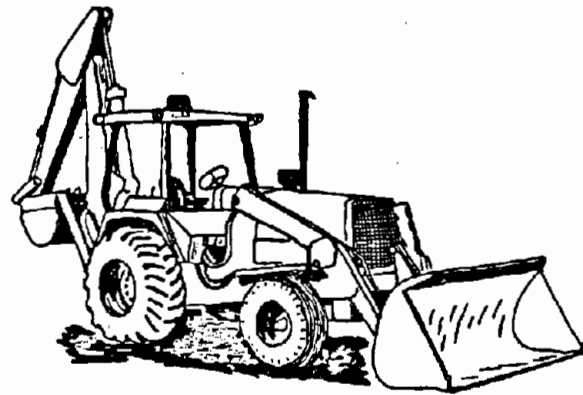

boom is limited on some models. The initial cost is high, but high production capability can keep unit costs down. It operates from the road with post-work cleanup limited to spillage from the bucket. Self-propelled truck mounting eliminates the need for extra equipment hauling units.

Self Loading Ditch Cleaners

Generally these are single-operator, single-purpose machines designed to clean materials from the ditch and continuously load to its own hauling box. Truck mounted, the unit operates from the road shoulder. Its reach is limited. Most units can clean and load from one side only; work may need to progress in opposition to traffic. Steep grades (over 10 percent) may make downhill cleaning and loading difficult. Rocks larger than 6 feet cannot be loaded by some units. The cleaning head leaves a rounded bottom ditch; existing vee and flat bottom ditches will be reshaped with initial machine cleaning. These units can clean ditches and load or haul to disposal areas, but not at the same time. The rounded ditch shape is hydraulically acceptable and preferred by some engineers for rural residential areas.

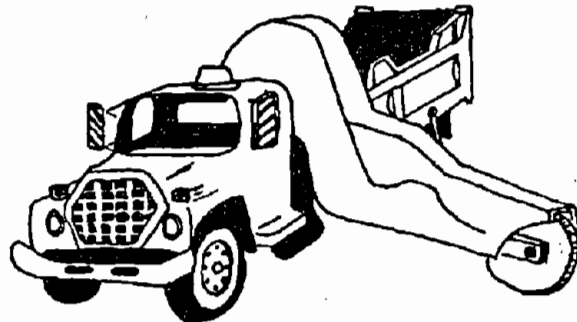

Self-Propelled Belt Loaders

The equipment unit is essentially a self-propelled conveyor belt that is capable of loading trucks from a windrow or limited loading from a stockpile, depending on the type of front wing moldboard selected.

Self-propelled belt loaders are most commonly used for loading windrowed materials from the travelway or stable shoulders into dump trucks. The moldboard allows some shifting of windrows towards the center of the unit. The windrow is then loaded by a force feeder consisting of steel scooping blades that place the materials on the conveyor. The conveyor transports materials towards the rear of the machine for conveyor discharge into trucks. Conveyor lengths from 25 to 31 feet are available.

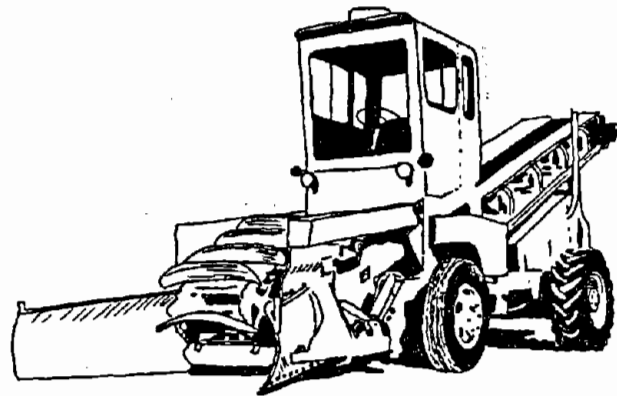

It works best with soils that have little clay. Larger (over 5 inch) rock may cause feed and conveyor difficulties, especially when loading is done down a grade. It is also used for loading sod removed from shoulders.

TRAVELWAY MAINTENANCE EQUIPMENT

Road Graders

General

Many engineers prefer a 14-foot moldboard because of the increased angling capacity that allows more materials to be moved. The only real choices are 12 or 14 feet, since cutting edges can be rotated for more even wear.

A variety of cutting edges are available, including the standard straight, serrated, ice cutting, carbide insert and rubber edges. A special trenching edge is also available. Carbide insert, ice, and hard rubber edges are not recommended for aggregate road blading. They are designed for snow and ice work, as are the ice and rubber edges. Standard and heavy duty straight edges are the workhorses. All straight cutting edges are not the same; keep track of usable life on your cutting edges. Buy the ones that give you the lowest cost per mile, including the labor costs for changing cutting edges.

Scarifiers are attachments. They can be front, middle or rear mounted. The farther back they are mounted on the grader the heavier scarification they can do. Rear mounted units are usually on tool bars, allowing either scarification or ripping work by interchanging of the teeth.

Rigid Frame

It requires space for turning and requires maximum side-shift to clean ditches unless the grader can get into the ditch. It is best kept on a stable work platform. Use caution near road edges. In reshaping work it makes a good #2 or #3 machine in multiple grader operations. It is good for smooth blading.

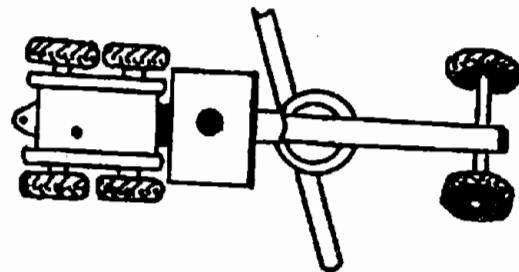

Articulated Frame

It can be turned and maneuvered in tighter spaces. The frame allows offsetting the drive wheels away from edges and ditches. Offsetting puts the most machine power and mass directly behind the load on the moldboard while keeping side-shift to a minimum to reduce strain on the circle. When properly used it is a good choice for the heaviest work and work near edges; use the articulation or it is just a higher priced rigid frame grader.

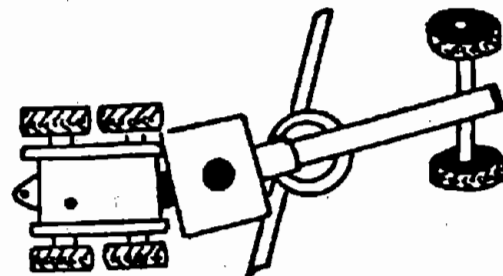

Single Rear-Axle, Four-Wheel Drive

It is used for tighter areas or road alignments. It tends to be too light for heavy mixing work. Its finish grading capabilities are limited to low speeds even with tires matched for circumference. All-wheel drive gives it good control in slick conditions.

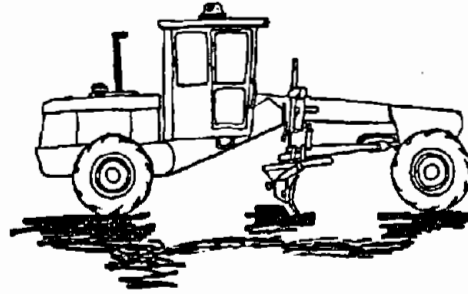

Tandem Rear Drive

This places all the engine weight on the tandem drivers for good traction. Medium to heavy mold-board loadings can be handled in reprocessing. It has good production capability for quality finish grading when all the tires' circumferences are matched; otherwise, it may "jump" and leave chatter marks.

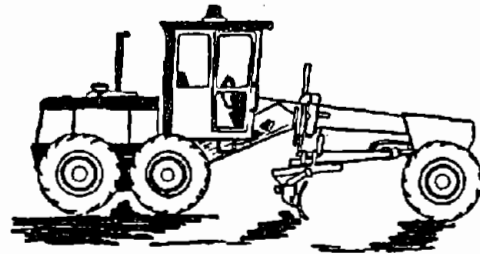

Tandem Rear, on-Demand Front-Wheel Drive

In all-wheel drive it can handle heavier loads than tandems alone. It has good control in slick conditions. Finish quality grading is usually done without front-wheel drive, so the same quality and constraints apply.

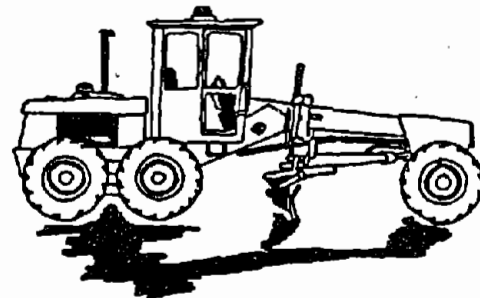

Drags, Rakes, and Underbody Blades

Drags

Few commercially produced drags are available, but at least one three-point hitch mount is being built. Except for the three-point hitch, drags depend on their weight and any materials being carried for their downpressure. They smooth by redistributing loose surface materials but do little cutting on uniform cross slopes. They tend to flatten the peaks of "A" crowns.

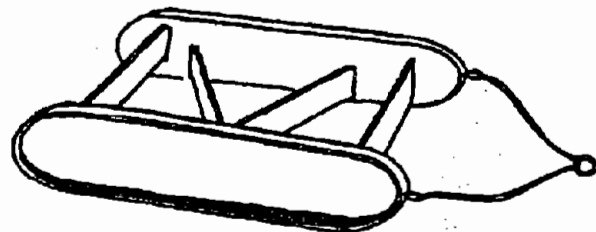

Rock Rakes

Rakes are generally able to smooth by rearranging loose surfacing materials.

Towed rakes, like drags, depend on their own weight for their primary downpressure. Most towed units have manually adjustable angling, although some older, nonadjustable rakes are still in use. Resetting adjustable rakes requires stopping and manually changing them. Cab controlled, driver-adjustable towed rakes may be marketed.

Vehicle mounted rakes have cab controls so the driver can reduce or increase (but not reverse) angles and downpressure while moving. Downpressure is limited by the rake's tine-strengths. Enough pressure can be provided to cut into the lateral ridges of washboards.

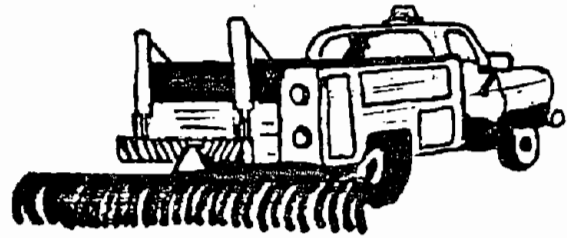
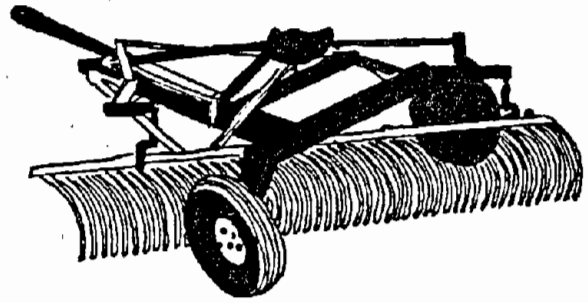

Underbody Truck Blades

Underbody blades are mounted about midway between the cab and the rear wheels of the truck. A short moldboard and ring are controlled by the driver. The moldboard is seen through truck mirrors. Work is limited to areas accessible by a truck. Their primary uses are light snow removal and "sweeping" loose materials off the road. Some maintenance organizations report success with underbody blades for smoothing work. Adding the underbody blade reduces the legal hauling capacity of the dump truck by the weight of the ring and the moldboard assembly.

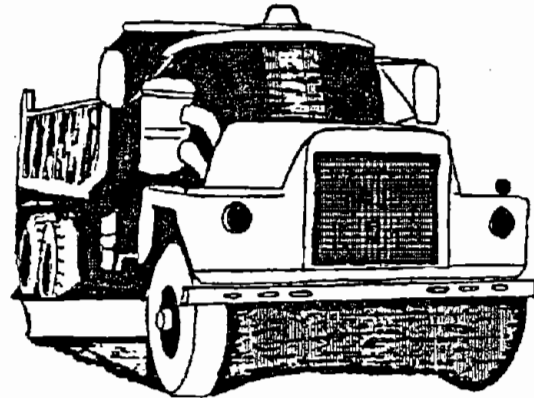

SPECIALIZED UNITS

Cross Shaft Rotary Travelling Mixers

These are used for recovering and reblending settled aggregate fines without windrowing. They are built specifically for in-place stabilization of materials existing on the road.

A few towed units may still exist but most are self-propelled. The hooded mixing unit is either rear or midmounted on a dedicated prime mover. The mixing unit is made up of a powered, transversely (cross shaft) mounted shaft with mixing tines mounted along its length. The shaft normally rotates the mixing tines opposite to the wheel rotation but can be reversed. The mixers function like a big roto-

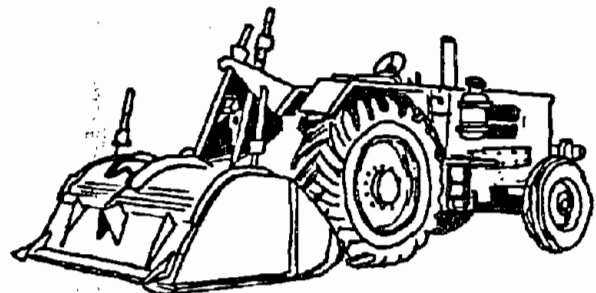

tiller. Compacted surfacing may need to be scarified or ripped before mixing; some units have a limited scarification capability. Most machines will accept one or more tanker hookups for the fluid's (e.g. water, emulsified asphalts, dust palliatives) delivery to the mixer. Dry stabilizers (e.g. portland cement, lime) are spread on the grade ahead of the mixer unless a fines feeder is attached. The road width and surface cross slope should be defined before mixing.

Travelling Hammermills

These are on-the-road rock crushers; built to reduce the rock sizes of windrowed rock by rotating a series of hammers into the materials. Like the cross shaft mixers, rotation is the opposite of the wheel rotation. Hammers swing forward into the windrowed material. Currently available units are towed by large-wheeled tractors or dozers. A hookup for a water truck keeps down dust, aids crushing, and saves newly crushed fines. The general procedure is to rip the road, windrow oversized rock, crush it to size (one or two passes) with the hammermill, reprocess it and relay the entire surface.

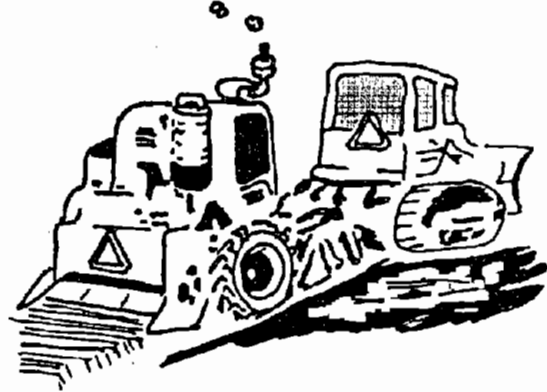

Portable Pugmills

Portable pugmills vary widely. For mobility, a self-erecting, lightweight unit is desirable. The pugmill is plumbed for adding water and/or other fluids into the mixer. A feeder bin and conveyor elevate the aggregates so the mixer discharges directly to the dump trucks. Segregation during aggregate hauling can be reduced or eliminated by processing from the stockpile through a pugmill with the addition of water. Moisture content is controlled by metering of the water. Water-bound aggregates for surface replacement can be spread and compacted with less equipment and traffic interference and without on-road processing, in many cases.

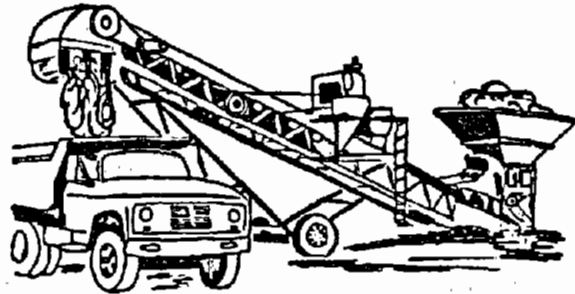

WATER TRUCKS

Gravity Splash Plates and Spraybars

These have the cheapest initial cost but the least control of application rates. Pressure depends on the depth of the water in the tank and whether the truck is going up or downhill. The spraybar is more uniform than for the splash plates. Rear, front or tag-along trailer mounted spraybars are available.

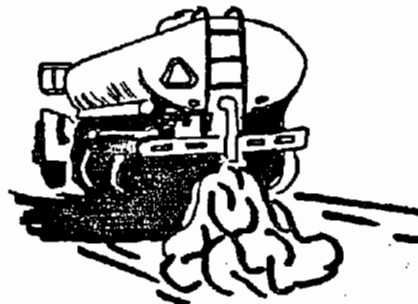

Pressurized Closed-end Spraybars

The spray width and application rates are controlled, but some variance in rates exists between the middle and end of the bar. They are commonly used with spray nozzles, but they are also used without nozzles for watering. Added plumbing allows pressure flushing and firefighting. Pressure sensitive fluids (e.g. emulsified asphalts) are not recommended for spraying because of the pressure surge when they are shut off. Rear, front or trailer mounts are available.

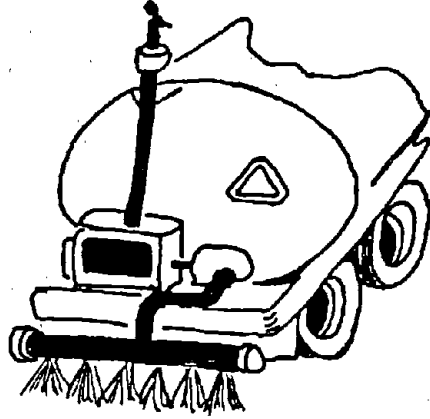

Pressurized Full Circulating Spraybar

This provides the best control of application rates over the full spraybar width. The spray width can be varied. A lack of pressure surges allows use of pressure sensitive fluids. Added plumbing allows pressure flushing and fire-fighting use. Rear or front mounts are available.

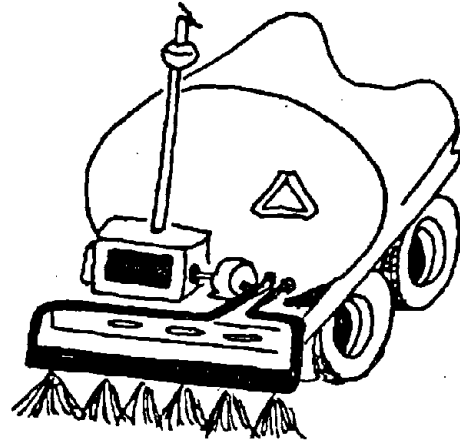

Pressurized Sprayheads

Sprayheads have been front, side, and rear mounted for some applications. Front mounts spray forward within the operator's line of vision for tighter shutoff control. A forward mount adds truck velocity to the nozzle pressure, making flushing of the pavements and decks easier, but the added force may scatter or erode earth and aggregate surfaces. This can be corrected by reducing pump pressures.

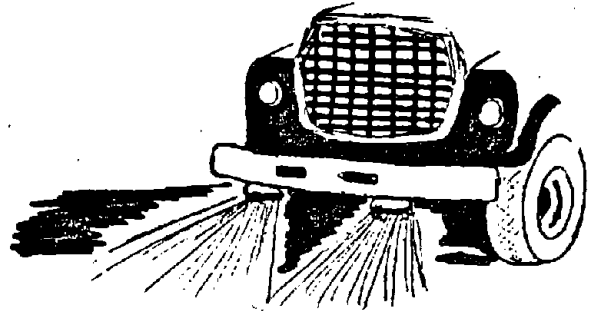

ROLLERS

Selection for Soil Type

<i>Smooth wheel</i>	best for rock, gravel and sands.
<i>Grid</i>	best for rock and sand to 6" deep. Not good for silts and clays. When used for in-place reduction of rock the LAR loss of the rock should be 20 percent or higher.
<i>Sheep's foot</i>	best for clays and silts to 6" deep. Not good for rock or gravels.
<i>Tamping Foot</i>	good for all soils except clean rock and clean sand.

Towed Rollers

These are NOT recommended unless the braking power of the towing vehicle has been determined to be adequate. A grader towed, 10-ton roller will exceed the grader's braking power. Towed rollers are also tough on the final drives of the towing vehicles.

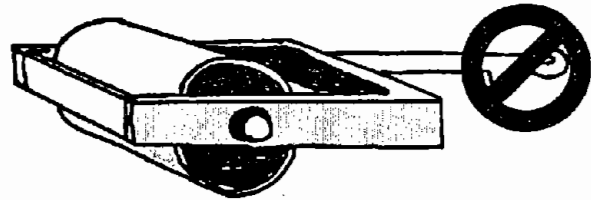

Self-Propelled Pneumatic Rollers

The rubber tire inflation rate can be varied from high pressure (more compaction) to low. Ballast may be added to increase the effective ground pressure for differing conditions. These cause the least aggregate fracture and are good for most aggregate and seal coat work.

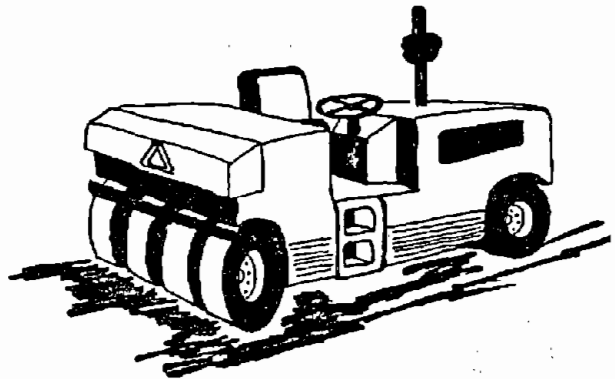

Self-Propelled Steel Wheel Rollers

These can be used on aggregates and earth roads; however their traction and braking are limited. They may cause aggregate fracture. They are not recommended for use on steep grades.

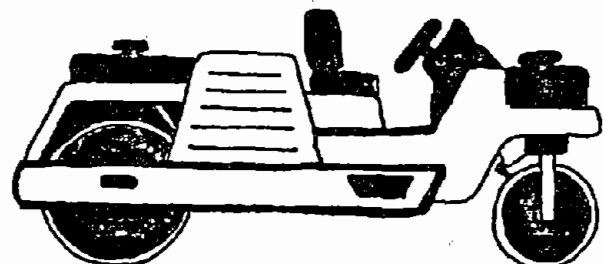

Self-Propelled, Vibratory, Steel Wheel Roller

This can be used as a lightweight steel wheel roller or as a vibratory roller. In vibratory mode, the wrong frequency and amplitude can decrease compaction. Traction is improved over the steel wheel rollers with use of the rubber tired drivewheels.

Some drums can be changed easily or bolt-on accessories can be used to increase the vibratory roller's utility:

- a rubber sleeve, used for special applications and some seal coat materials, reduces fracture while it imbeds chips;
- a special grid pattern can be used for in-place reduction of oversize or pitrun rock for aggregate sizing.

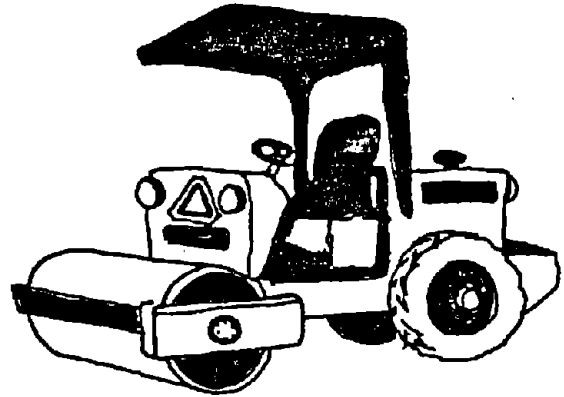

Small Compactors

A variety of plate and hand controlled power compactors are available. Any excavation or repair work will be improved by compaction with the right type of unit.

SECTION 5 - CONCEPTS OF MAINTENANCE

AGGREGATE ROADS REQUIRE MAINTENANCE EXPERTISE

Aggregate roads are not just to be tolerated until they can be asphalt surfaced. As development (construction) funds continue to be limited, the value of having good aggregate roads is being recognized. There will always be a place for aggregate roads in the transportation system.

The challenges of maintaining asphalt and concrete pavements are seen by many people as being more demanding than the maintenance of aggregate and earth roads. This may be partly due to the development of the Interstate Highway System and associated research efforts. Pavement management systems (PMS) have focused primarily on the asphalt and concrete pavements. Aggregate surfaces have been viewed as stopgap or interim surfacing until an asphalt surface can be afforded. This view has hampered quality aggregate road maintenance.

In recent years there has been a strong and increasing international interest in aggregate and earth roads. The challenges are being recognized as complex and demanding.

It is now recognized that aggregate and native surfaced roads will continue to provide a real contribution to the road and highway systems. They can be an asset or a liability, depending on how they are built and maintained.

Research and development funds have historically followed the "higher type pavements" because their design and mixing processes are more controlled. Where tight controls are available, research and refinements have followed because the variables could be reduced and analyzed.

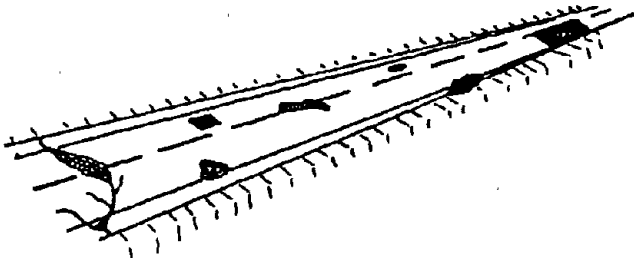

Asphalt Road Failures and Repairs Show!

Research investigation follows work that fails dramatically or where repairs remain visible.

It is hard for most people to see the real problems after an aggregate or earth road has been reshaped. This has led some people to think that maintenance of these roads is "simple," when actually they require better timing and decisions than are needed on asphalt surfaces.

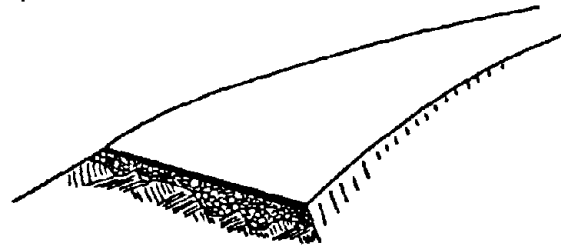

Aggregate Roads Hide Their Damage and Repairs When Reshaped

Aggregate road damage can be hidden by good quality maintenance – out of sight out of mind. That does not take care of the problem, however.

Aggregate, native and earth roads have depended strongly on the skills and expertise of field personnel: crew leaders, operators, and laborers. That is good as long as the knowledge is handed down to younger employees.

As work forces change, documentation of what has been known (carried in field supervisors' heads) is needed for work to continue at the same standards. Workers need to know not only what to do but why it is being done that way; otherwise the only reason becomes: "That is the way we have always done it!"

Documentation of problem areas is more critical than on rigid and semi-rigid pavements. Field crews need to take photos and measurements of the problems they find.

The maintenance of aggregate roads requires more daily expert judgment than is needed for "higher type pavements." Each road differs from its neighbor due to variability of subgrades, types and quality of added materials, traffic, and exposure to the elements. Field people must be constantly aware of problem indicators and their significance.

It takes the sharp, trained eyes of work leaders and equipment operators to recognize signs that damage will occur unless certain things are done.

MAINTENANCE MANAGEMENT SYSTEMS (MMS)

Each maintenance organization may have different requirements for its maintenance management system.

Part of the maintenance management system is an equipment management system (EMS) that determines the true costs of owning, maintaining and operating the equipment. Equipment management systems are established and documented in most organizations. EMS is a vital part of any maintenance management system.

Uses of a Maintenance Management System

A maintenance management system that is NOT used is a waste of time and money for all concerned.

Maintenance management systems allow engineers to

- locate high cost roads and find out what activities cause those costs,
- discover low cost roads and the activities on them,
- improve work by analyzing new or different procedures,
- schedule maintenance at appropriate times and in proper amounts,
- get recognition for needed funds based on actual work needs, and
- defend tort claims.

The results are what counts:

- high cost design features can be eliminated in future designs;
- the effectiveness of the operations is increased;
- realistic maintenance budgets evolve, and people are more willing to listen and act on them because you know what and why it costs;
- better service can be provided to the taxpayers; and
- you gain confidence in where you are going and what you are doing.

It has been said that the mark of an expert is to do complex things and make them look simple. Maintenance management systems scare some people because they appear complicated when fully diagrammed.

They are a sequence of steps that most successful maintenance people have followed over the years. When we have seen maintenance superintendents at work, they have made it look simple because they are competent and experts in their field.

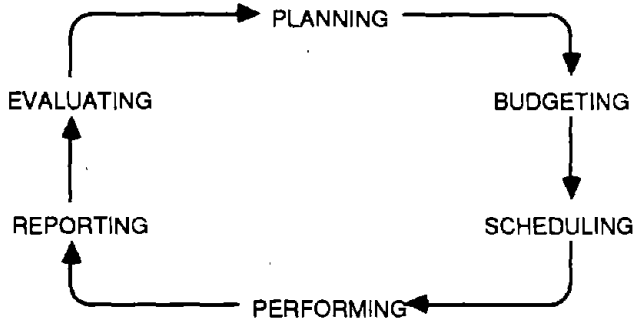

A very simple diagram of a maintenance management system (below, left) shows the general process that is involved.

This is obviously a simplified diagram that has a lot of hidden interactions and activities involved in it.

Compare the simple diagram with the following one that shows more of the relationships and interactions that must take place. It does look more complex, but if you look at it closely you will probably see several things that your supervisory field people do that are not listed.

A detailed discussion of the parts of the maintenance management system can be found in special manuals on that subject. A few comments about the process are important to keep in mind.

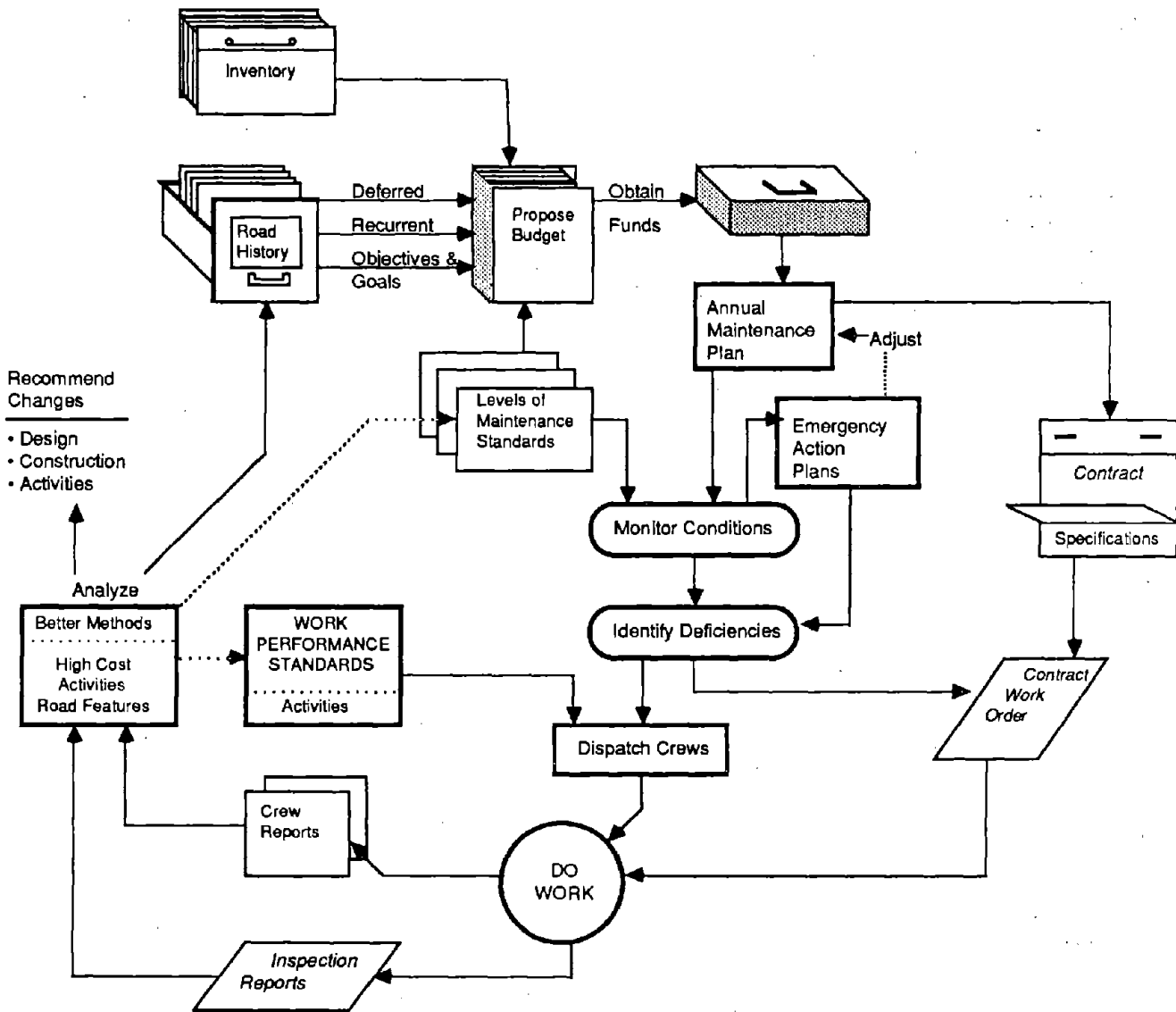

Maintenance Management System

Levels of Maintenance Standards

In the preceding diagram these are positioned near the center of the maintenance management system.

Levels of Maintenance Standards basically identify how much a condition is needed for the road. Surfacing conditions are often expressed as the needed travel speed. 40 mph requires a more stable surfacing than 30 mph, for example.

All roads deteriorate with time and use. Some amount of deterioration is acceptable, but at some point maintenance must be scheduled.

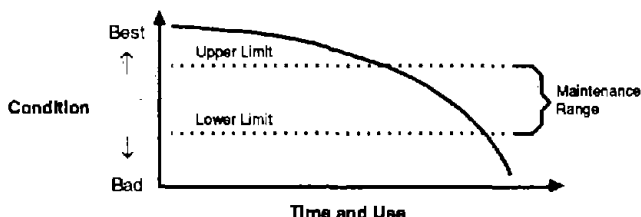

The lower limit is established; it indicates that maintenance should be done before conditions reach that point. The upper limit indicates how much maintenance should be performed. Ideally the road is always kept between these two limits established for that particular group of roads.

If conditions drop below the lower limit, the cost to get the road back into the condition in which it belongs can easily be two to three times the cost of maintenance at the proper time.

If maintenance is done to conditions above the upper limit, the cost can also be at least two to three times the cost of staying within the limits.

Finally, always striving to maintain a condition above the upper limit and then letting things 'coast' longer before reaching the lower limit not only wastes money, it also exposes drivers to a more varied range of conditions and can cause serious safety problems.

Developing a maintenance plan requires the exercise of professional judgment based on experience, knowledge of legal responsibilities and the availability of funding. Setting priorities is one part of the process.

In determining legal matters the maintenance management system can demonstrate that once discretionary planning decisions and priorities have been made, there is an orderly and logical flow of action to do needed work in accordance with established standards and priorities.

The key point is that each step of the maintenance management process can be reconstructed through documentation: when was a deficiency identified, what actions were taken, who did it, and were the decisions made at the appropriate organizational level?

Emergency action plans are needed to deal with various types of emergencies. Once an emergency is over, there may be some financial reimbursement for work already performed in addition to restoration of severely damaged roads and structures. Again, the what, where, when, who and how questions are important factors in determining whether reimbursement is proper.

A factor in determining whether a storm or other severe natural occurrence is a disaster that qualifies for special funds is a record of the "normal" amount of damage experienced on that road system.

The entire process depends on having the best and most accurate information possible.

Information starts in the field and will benefit the field activities with its returns.

RELATIONSHIP OF DESIGNED FEATURES TO MAINTENANCE

Some designed features are established by the design and construction. They are not substantially affected by road maintenance; they are usually changed only by reconstruction action. In the following figure these are shown as design functions.

Other design features are dependent upon ongoing maintenance practices for their continued serviceability. These are shown as maintenance functions in the following figure.

All maintenance items are affected by good, bad, or a lack of maintenance.

<u>DESIGNED FEATURE</u>	<u>FUNCTION</u>
HORIZONTAL ALIGNMENT; location and length of curves and tangents	Design
GRADES AND VERTICAL CURVES	Design
SIGHT DISTANCE	
• Limited by obstructions such as cutbank, road surface and structures	Design
• Limited by vegetation	Maintenance
CROSS SLOPE; crown and superelevation	Maintenance
ROAD WIDTH; total travelway and shoulders	Maintenance
SURFACE SMOOTHNESS	Maintenance
SURFACING STABILITY	Maintenance
TRAFFIC CONTROL DEVICES; signs and markings	Maintenance
DRAINAGE; restrictions in designed capacity	Maintenance

RECURRENT AND DEFERRED MAINTENANCE ACTIVITIES

In developing the maintenance budget and plan there are actually three forms of maintenance that must be considered: restoration, recurrent and deferred activities.

Restoration is actually repair of damage and is usually included only on a project basis or as a contingency fund based on past experience. In most cases a set of drawings or a design is developed for guiding field actions.

The two remaining types of maintenance are usually done without the development of new designs. They fall into the category of routine maintenance; field work is guided by maintenance performance standards and crew dispatch information. The two types are as follows:

Recurrent Maintenance

maintenance done one of more times a year on most of the roads.

Deferred Maintenance

work that is only needed once every few years is called deferred. Some work of this type should be done on the system each year. An individual road may receive deferred maintenance on a cycle of 2-10 years, depending on the activity and locale.

Some maintenance activities and their maintenance types are as follows:

Bridge and other structures

This includes cattleguards and culverts. Cleaning of decks and cleaning to provide drainage are recurrent. Structural elements and painting are deferred.

Disposal sites and materials sources

This is part of the using activity. Use only pre-selected and approved sites. Place materials in accordance with the plan for the site. Roads with the goal of realignment within available rights-of-way are opportunities for obtaining or disposing of suitable materials.

Signs and markings

This includes cleaning, replacement, patching and repair of permanent installations placed in accordance with the Manual of Uniform Traffic Control Devices. These activities are recurrent.

Roadside and other ditches

This includes cleaning and restoring intercept, distribution, lead-off and roadside ditches, and these are recurrent. (See Section 5 for a discussion of roadside ditch maintenance)

Surfacing

Smoothing, reshaping and dust abatement are recurrent (see Sections 2 and 3). Surfacing replacement is deferred.

Roadside vegetation

This includes establishing, fertilizing, mowing or cutting, and chemical control. Slow growth areas are deferred. Fast growth areas are recurrent.

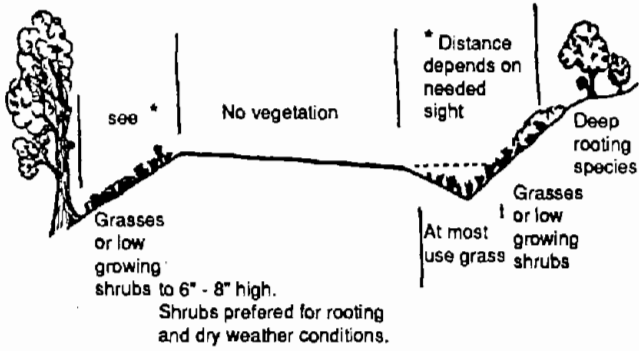

Where and how much vegetation is right?

Bare slopes are sources of erosion. They add to the ditch cleaning work.

Grass in ditches slows water down and reduces erosion and scouring. It interferes when ditches are pulled.

Bushes that grow high and block the driver's sight distance have to be cut.

The choice of plant materials used can decrease or add to the costs of roadside maintenance. In most cases the right kind of vegetation will save maintenance dollars. Where the vegetation is the wrong kind, it is often more economical to get rid of it and plant the right kind.

SECTION 6 - FOUNDATIONS OF MAINTENANCE

Before road maintenance begins there must be a road. Some roads existed before they became part of your road system, but most roads have been built on the basis of a design. Even those that were not based on a documented design must have a purpose for their existence.

USING OBJECTIVES, GOALS AND CONSTRAINTS

"If you do not know where you are going, you will probably end up somewhere else" is as true for the construction and maintenance of a road as for any other action. The availability of documented objectives, goals and constraints can improve the efficiency of road maintenance and improvement activities.

Having them documented, however, is not enough. They need to be followed in the normal day-to-day work. If they are documented but not followed, they can be damaging to any tort claims or lawsuits. Documented objectives, goals, and constraints, if followed, can be of direct benefit in defending against any lawsuits arising from use of the road.

What Is the Difference between Objectives and Goals?

Objectives

Objectives are intended to be currently usable and attainable. They are specific to an individual road.

Objectives should be written down so they are available to everybody as a reference tool. They are also inferred by road surfacing quality and type as well as by signing. For example:

<u>ADI</u>	<u>Surfacing</u>	<u>Common Guide Signing</u>	<u>Maintenance Priority</u>
High	High quality	Major destinations, road name or number	High
Medium	Medium quality	Local destinations, road name or number	Medium
Low	Lowest quality	No destinations, road name or number only	Low

If the objectives have been followed in all activities, the roads within the system will be consistent and drivers will see and accept the apparent differences more easily.

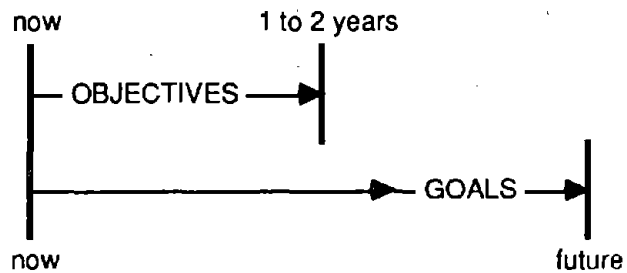

Goals

Goals identify future directions that are desirable but not currently within reach. Goals are the things you are working towards but may never achieve unless things change; for example, more capital investment (development) money is available, or additional rights-of-way become available.

Goals are called long-term objectives by some organizations. If that is the case in yours, continue to use that term.

Goals may be oriented to the entire system or to a specific road.

Preceding page blank

SYSTEM-WIDE GOALS

Long Term Cost Reductions
Add or Improve Service to a Specific Locale
Have all Roads Paved

ROAD-SPECIFIC GOALS

Realignment within Existing Rights-of-Way
Upgrade Surfacing Type
Improve Drainage

Goals are the best basis for identifying opportunities.

Through a series of minor improvements during routine maintenance the goal to "improve drainage" may be accomplished over a period of years. Once the drainage is improved, it may be feasible to shift the "upgrade surfacing type" goal into an objective that is currently feasible. During the interim time the goal of upgrading surfacing may affect the choices of dust palliatives (discussed in Section 6) that will be used on that road.

We Operate Within Constraints

There are always some constraints on the work we do. Some constraints are contained within the existing laws, some within rights-of-way documents, while others that constrain road maintenance activities are built into the road by design and construction actions.

All constraints should be documented and available to all personnel:

In the case of designed constraints, some may be obvious on the road while others will not. The existing alignment and grades are easily seen and therefore serve as their own documentation. The existence of a buried cable or pipeline is best documented by both placing markers in the field and having details contained in the files before doing any new types of work. Both of the cable and pipeline examples are also an example of a constraint contained in law: Washington state's "dig-up law."

Environmental constraints may include

- controlling runoff to specific locations,
- use of chemicals, herbicides, wood preservatives, dust abatement, and reporting of spills,
- acceptable noise levels,
- restricted operations within a stream-side area.

Design features may include

- limited rights-of-way width,
- deck elevations of structures,
- width of structures,
- width of travelway and shoulders,
- subdrains,
- geotextile locations,
- type of surfacing.

The width of the travelway and shoulders may not seem like a true constraint, but the width that was designed was intended to be right for the road and its traffic. While it is not possible to always have the road be exactly the width that was designed, the designed width should be the objective of every maintenance activity. Widening affects sight distances and reduces the available depth of the original base and surfacing materials by making them cover more area.

It is no more acceptable to make a road wider than designed than it is to narrow it.

DESIGN AND CONSTRUCTION CONCEPTS

The objectives and constraints that were used in the original design become constraints on and objectives for road maintenance. Many of the constraints placed on road designers are contained in standards of design and design practices. These standards may have changed over the years or may be the same as at the time of design, but the underlying concepts remain. Discussion will be limited to design decisions on road strength, width, cross slopes and speed, since they are maintenance concerns.

Designing Based on Use and Service Life

The designer is faced with basing the design on the projected use during the designed life (usually 20 years) of the road. These projections affect the selected road width, alignment, grades, depth of the base course and other items.

The intended design speed of the road is identified based on the anticipated need or upon an economic evaluation of construction and maintenance costs, cost of rights-of-way, and costs to the road users.

Projected use is broken down into its various parts:

- number of vehicles by weight class and axle configuration for each critical time period of the year, and
- identification of the "critical vehicle" for each of various design reasons.

The weight on each axle and axle spacing are converted to a measure of their impact, called an 18 kip equivalent axle. This reflects that a car has less impact than a truck and establishes the total needed strength.

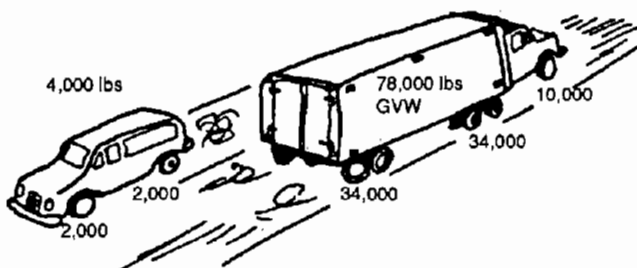

Truck weighs almost 20 times as much but it can have 5,550 times the impact on needed strength

Weight, Axles and Numbers Affect Design

The critical vehicle for designing strength into a road is taken into account by the 18 kip equivalent axle numbers. There are some assumptions built into these numbers. The type of suspensions can make quite a difference; a walking beam axle is harder on roads than a torsion bar carrying the same weight. The pressure of the tires can make a difference, too.

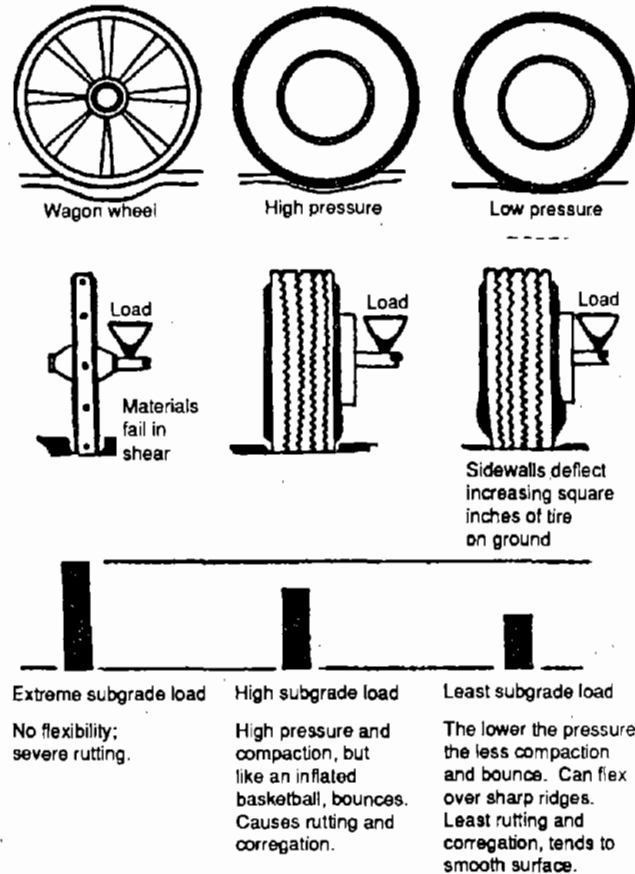

Tires Do Make a Difference

If controls could be placed on the type of axle suspension, tire pressures, and other design factors the design strength could be reduced.

The strength of the proposed subgrade materials can be determined by lab tests. What the subgrade can contribute at the selected rate of compaction is taken away from the total needed strength. This determines how much strength must come from the design of the base course.

At this point the designer may compare the depth of the needed base course with the depth needed to eliminate frost heave. The greater depth is usually chosen.

Frost heave is caused by

1. water,
2. soils that hold water, and
3. freezing temperatures.

It takes all three.

If the moisture or the moisture sensitive soils (silts and clays) can be removed from the depth that will freeze, frost heave can be eliminated.

One of the traditional ways to reduce moisture is to require roadside ditches to intercept the runoff water from cutbanks and from the road surface. Ditches do require maintenance to function. The ability of ditches to intercept underground water is limited.

Subsurface drains (subdrains) within the ditchline and across the subgrade have also been used. Subdrains have a tendency to clog with the migration of soils and lose their effectiveness unless they are well constructed. The use of geotextiles has improved the reliability of subdrains.

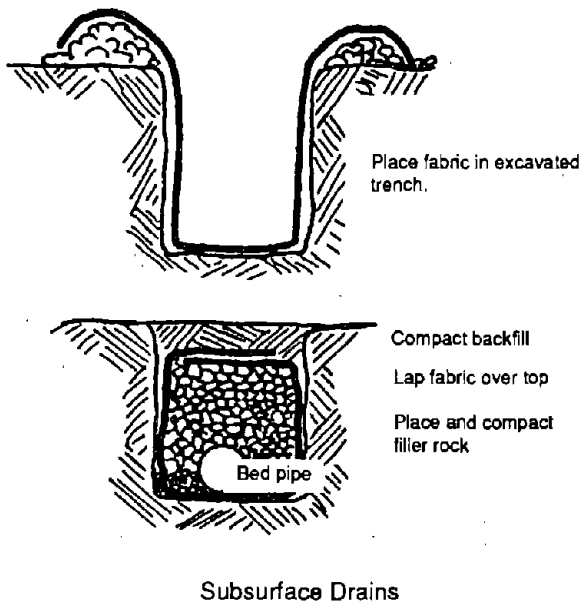

The presence of saturated soils will mean less strength until they are frozen and the occurrence of frost heave during thaws.

Drainage is important to design and is a maintenance priority.

Other Methods of Increasing Subgrade Strength.

Geotextiles are being used increasingly in road design. Geotextiles have been developed for specific purposes. The four main purposes are

- separation of materials,
- reinforcement (distribute loads),
- drainage, and
- filtering.

The selection and design of geotextile installations require care. The designers should be trained in fabric selection and application. The following illustrations show how geotextiles can be used and what locations would be critical to avoid damaging them during maintenance.

The first method involves using rolls of materials laid on the subgrade. Note that the fabric should extend 2 to 3 feet beyond the weak area to gain the best strength.

The second method of using geotextiles is to wrap, or encapsulate, materials into a fabric sausage. Placing dense materials against the sausage will dam water and cause their saturation and the likelihood of freezing. Free draining materials are suggested on the drainage side. No moisture should enter the upper side of super-elevated sections.

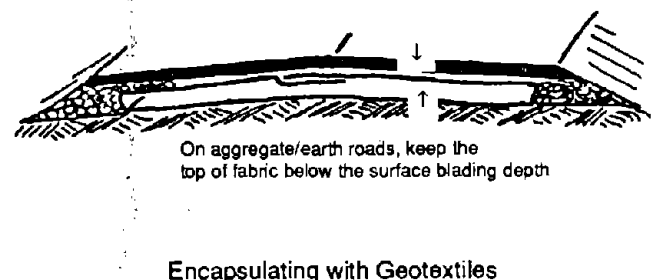
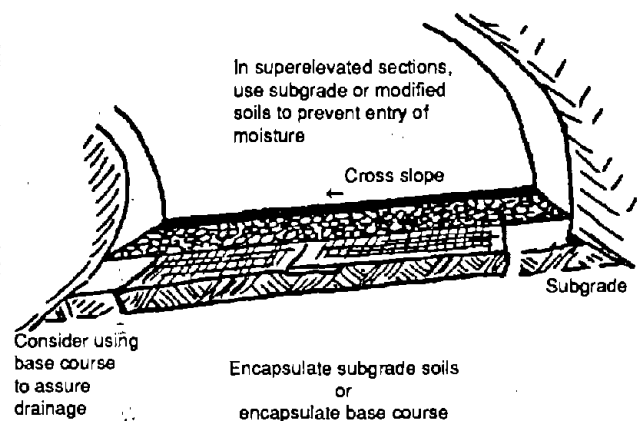

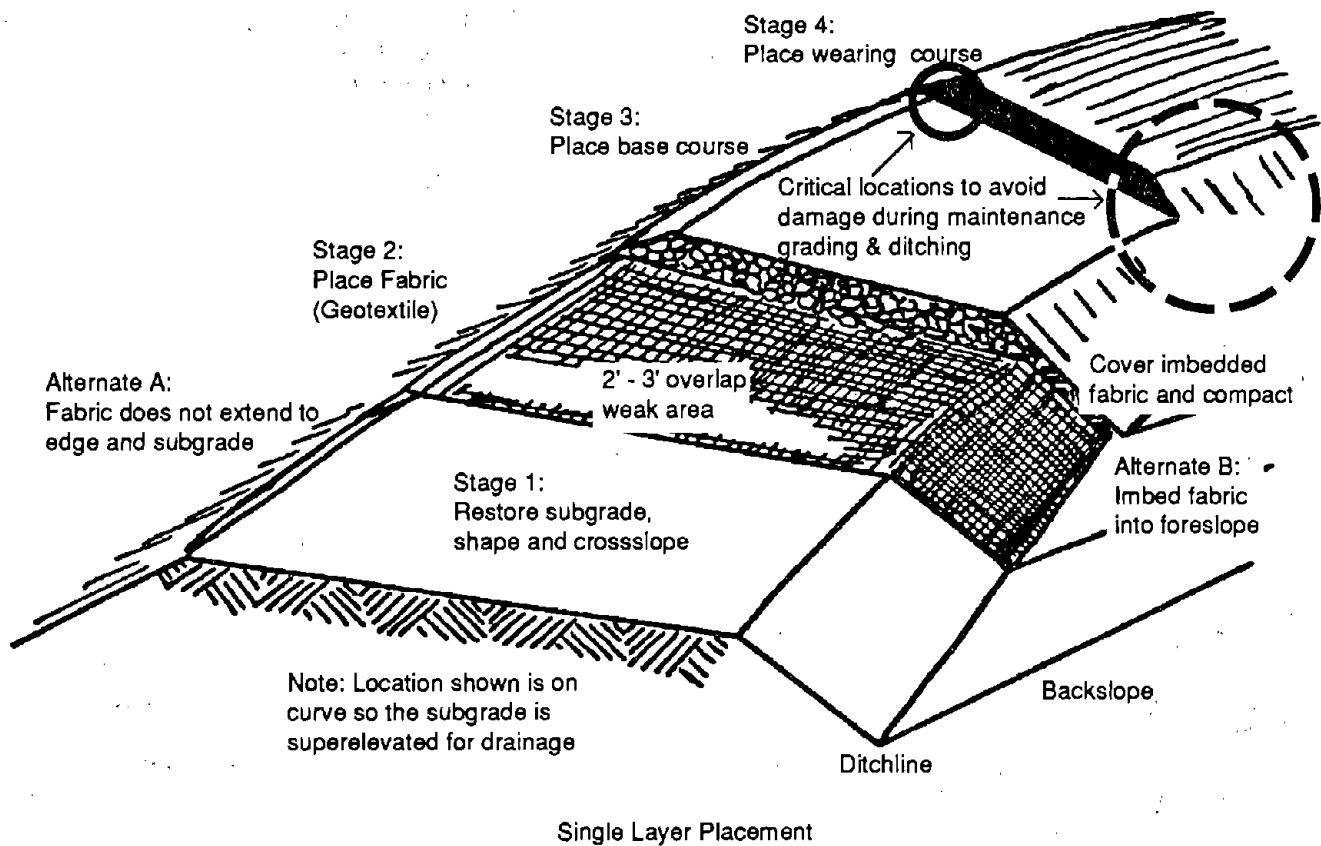

Placement of Geotextile Fabrics

Extension of encapsulated materials into the base course should be restricted to ensure that the geotextiles will not be ruptured or pulled out by blading or scarification activities.

Locations with buried geotextiles should be marked in the field to prevent accidental damage during maintenance.

Stabilization with cement or lime has proven effective in certain cases.

- Lime is particularly effective with clay soils. It improves drainage characteristics of these soils.
- Cement is used with more granular soils. It forms a soil cement that expands and contracts similar to portland cement concrete. Soil cement stabilization is normally used only under asphalt mats or multiple seal coats.

The use of lime or soil cement should be based on site-specific design information.

Base Course Materials

Earth Roads

Since the base course of an earth road is soil, there is little that can be said other than that clay will permanently deform under loads when wet and the silts will flow when wet. The best is a sandy soil.

Native Roads

The base under native roads should have as many of the features of a crushed and sized base course as possible.

Crushed and Sized Aggregate Base Courses

The base course provides all the needed strength above the subgrade. It spreads the pressures from the tires over a larger subgrade area that can support the lower pressures. It also provides for drainage and evaporation of the subgrade surface moisture.

To do its job, the base course must be clean and have a limited amount of fine materials (passing the 200 sieve) for crushed and sized aggregates. The fines should be sandy fines, not either the silt or clay soils that hold moisture.

There are always choices to be made. In designing base courses the best stability and strength comes from having 6 - 8 percent of the grading passing the #200 sieve. Free draining characteristics are best and the base will be non-frost susceptible when materials passing the #200 sieve are limited to a maximum of 5 percent.

Round rocks are not stable under loads; at least one and preferably more faces of the rock should be fractured so it will key together better. Soft materials will crush under the loads the base course must support so the materials should be fairly hard, but they need not be as hard as surfacing materials.

The character of the subgrade can affect base course choices.

Silty subgrade materials can migrate into the base when dry. They are strongest when damp and will flow when wet. A sand blanket or geotextile should be used to provide separation when subgrade fines

exceed 10 percent passing the #200 sieve. The maximum aggregate size may be smaller than for clays to hold some dampness, but materials still need to be free-draining.

Clay subgrades are hardest when dry and may crack if completely dry. They lose strength as the moisture content increases. When wet they will not only permanently deform under load, they will also "pump" up into base course materials. If clay cannot be removed and replaced, geotextiles should be strongly considered. Sand blankets usually hold moisture in the underlying materials and should be avoided. The ideal base will allow air circulation to the subgrade, so it must be very open graded. Two gradations of base may be desirable, with the denser materials near the surfacing. Clay subgrades may justify a surfacing wraparound section to help keep them dry.

Cobbles or pitrun in subgrades depend largely on how much silt or clay is present. If the amount is very small, the cobbles and pitrun act as subgrade reinforcement. Geotextiles are seldom used. If the top is extremely coarse the voids may be filled with sandy materials to conserve crushed and sized base course materials.

Surfacing Course Materials

Surfacing has several functions. It provides attraction surface for tires to start, turn and stop. It sheds water to the roadside instead of letting it all go into the free draining base and onto the subgrade. It allows maintenance blading without disturbing the base course. It protects the structural integrity of the base from being torn up by the weather, traffic or blade maintenance.

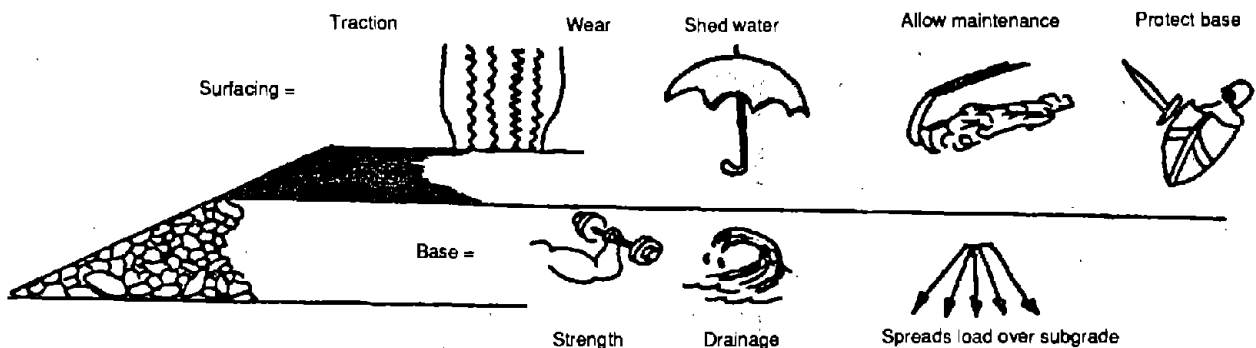

What Do Base and Surfacing Do?

The maximum rock particle size for speeds over 25 mph are preferred to be 1-inch or 3/4-inch materials.

To do its job, surfacing must be able to withstand abrasion from tires and cycling weather conditions. It must therefore be fairly hard and the particles should not have many small fractures for water to get into and freeze. Brittle rock (such as obsidian) should be avoided since it forms sharp cutting edges when it fractures. Similarly, particles should be roughly rectangular; a long thin piece of rock punctures tires like a nail. Soft rock will rapidly break down under traffic and weather, leaving a surface slurry that makes the road more slippery.

If you have a limited number of hardrock crushing sites, save the best for surfacing and asphalt work.

Base courses and riprap can come from lower quality pits.

To shed water, surfacing should have some clay (Liquid Limit less than 35, Plasticity Index or P.I. between 2 and 9) to bind the fine particles together and reduce dusting of the manufactured fines from the crusher. **Too few or too many fines can make the surfacing unstable**; some materials passing the #200 sieve (6 to 10 percent) are required. If frost problems are the controlling factor, a maximum of 4 percent passing the #200 sieve is preferred. The addition of fines during maintenance is a concern discussed previously in the manual under ditching, reshaping and surface stabilization.

Unless the surfacing can shed water, rain will run off by going down through the surfacing and base course materials.

The subgrade must be shaped to shed water at all times!

Surfacing materials on aggregate roads are not credited as part of the strength of the road in the design. This is because strength is tied to consistent depth, compaction and uniformity of the gradation. Since the surfacing is repeatedly disturbed by traffic and maintenance activities there is no way to be sure how much strength can be counted on.

Road Width

Lanes are normally designed at 10, 11 or 12 feet. Ten-foot lanes are appropriate only where low volumes of traffic are involved and the mixture of vehicles is predominantly cars without trailers.

Adding truck traffic adds lane width. It is desirable to have full 12-foot lanes on all roads.

Shoulders have several considerations. They prevent damage to the edge of the surfacing. Shoulders also add width so the travel lanes are fully usable. The impression drivers get when there is any form of width restriction is that the travelway is narrower than it really is. They tend to position their vehicles closer to the centerline and oncoming traffic. For example: restrictions that are 2 feet from the edges will make the travelway appear 2.5 feet to 3 feet narrower than it is; at 4 feet from the edges the road appears about a foot narrower. Based on the average daily traffic (ADT), shoulder widths for each shoulder of paved roads are:

less than 250 ADT = 4 minimum, 6 desirable,

250 to 400 ADT = 4 minimum, 8 desirable.

Curve widening is used on the inside of the curve when the critical vehicle has a long wheelbase so rear tires do not track in the same place as the front wheels. The amount of curve widening depends on the lane widths and the specific vehicle. A general indication of the amount of curve widening is as follows:

- travelway width of 24 feet = curve widening
- less than 10 degree curve (573 or more foot radius) = none
- more than 10 degree curve (572 or less foot radius) = 2 feet

Less travelway width means more curve widening width.

Curve widening is added so that 1/2 to 2/3 of the width is available at the beginning and end of the curve. The length of the transition will depend on the amount of curve widening; 100 to 200 feet is normal.

Cross Slope: Crown and Superelevation

Cross slope is the general term for the sloping of road surfacing, base and subgrade surfaces at right angles to the road centerline. The general purpose of the cross slope is drainage off the road surfaces.

Cross slope is normally expressed as a percentage of slope (%) like a road grade or as the inches per foot (ipf) of road width. A conversion table is included in Section 5. A 2 percent cross slope for 10 feet means one point is 2/10 of a foot (2.4 inches) higher. A 1/2 ipf rate for 10 feet means one point is 5 inches higher than the other.

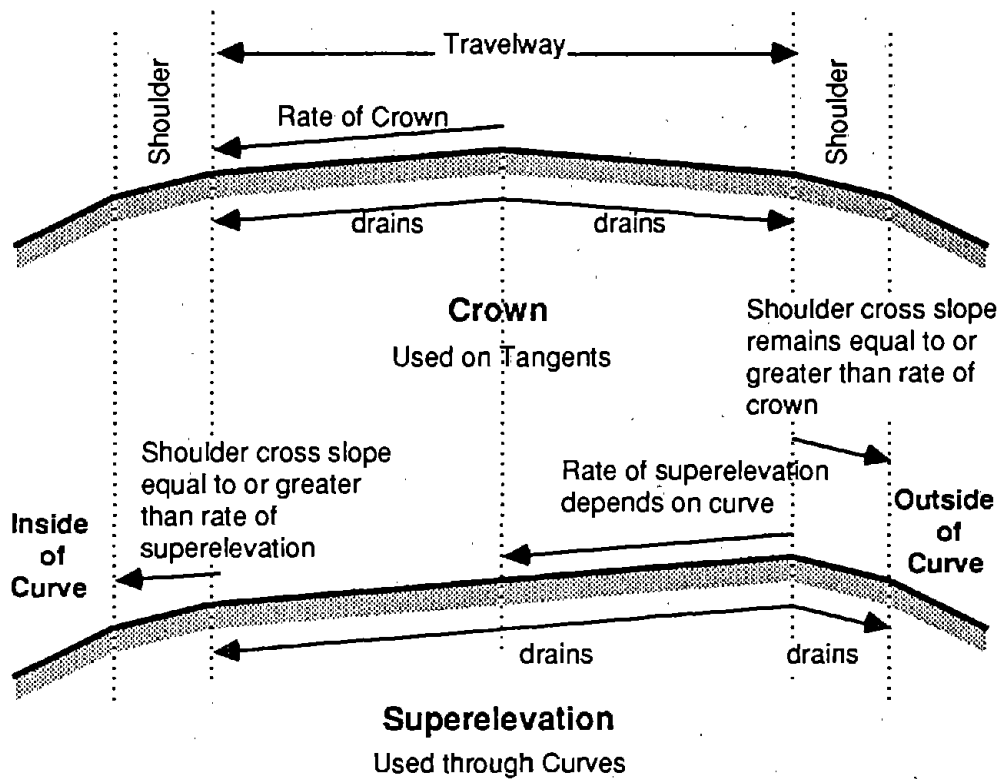

Crown is used to get water off the road along straight (tangent) sections of the road. The center of the road is higher than the edge of the travelway. Rates range from 1/4 to 1/2 ipf; however, 3/4 ipf is sometimes required for specific purposes.

Superelevation (super) is used on curves. In addition to providing drainage, superelevation helps offset the centrifugal forces of the vehicle, making it easier and faster to get through the curve. The rate of super depends on the design speed and the amount of curvature. The maximum percent of superelevation causes more difficulty in snow and ice conditions.

Crown and superelevation must be built into the subgrade to be effective for drainage

Additional discussion of crown, super and cross slopes is found in Section 1, Getting Water Off The Road.

GLOSSARY OF TERMS

<i>ADT:</i>	Average daily traffic	<i>Geotextiles:</i>	<i>Woven or pierced fabrics</i>
<i>Anvil:</i>	The plane or surface exposed by the removal of surfacing material during reshaping.		<i>used in roads for specific purposes.</i>
<i>Articulated:</i>	Able to bend or move like an arm.	<i>Heel:</i>	The end of grader mold-board closest to the rear.
<i>Backblade:</i>	To put the cutting edge on the surface and back up to smooth, to remove materials from a surface.	<i>Heeling:</i>	Using the heel to push ditch materials away from the road.
<i>Base Course:</i>	See Definitions; also called "base."	<i>Intercept Ditch:</i>	See Definitions, pages 4 & 5.
<i>Corrugations:</i>	A series of ridges in the road surface that extend across the road or lane. Also called "wash-boarding."	<i>IPR or ipf:</i>	Inches per foot of crown or superelevation.
<i>Cross Slope:</i>	The slope of the road measured at a right angle to the road centerline. See Definitions.	<i>Plastic Index (P.I.):</i>	A measure of the amount of clay in a soil/aggregate mixture.
<i>Crown:</i>	The center of the road is higher than its edges, a form of cross slope used on straight (tangent) sections of road. See drawing, page 83.	<i>Previous Standards:</i>	The standards in use when the road was built or last reconstructed; may be documented by design drawings or by subsequent survey.
<i>Ditchdam:</i>	See Definitions, page 4 & 5, drawing, page 18.	<i>Ravel:</i>	Loose materials on the surface of the road as opposed to materials rolling from the cutbank into the ditch.
<i>Eighteen (18) Kip Equivalent Axle:</i>	A common measure for the impacts of different weight and size vehicles on supporting strength.	<i>Roadside Ditch:</i>	See Definitions, pages 4 & 5.
<i>Engineer:</i>	The individual established under state law having discretionary decisionmaking authority (e.g. County Engineer)	<i>Sand Blanket:</i>	A layer of sand placed over or between other materials.
<i>French Drain:</i>	A ditch filled part way with rock and sealed over.	<i>Subdrains:</i>	Any form of drainage structure placed to intercept underground water tables or strata.
		<i>Superelevation:</i>	The uniform cross slope of the travelway to offset centrifugal forces on curves. See drawing, page 83.
		<i>Surfacing:</i>	See Definitions, pages 4 & 5.
		<i>Walking Beam Axle:</i>	A suspension system coupling two truck axles.

Washboards: A series of ridges in the road surfacing extending across the road or lane. Also called "corrugations."

Wicks: A specific geotextile placed underground to function as a subdrain.

Windrow: A continuous ridge (or berm) of materials formed by machinery operating parallel to road centerline.

BIBLIOGRAPHY

The following materials were reviewed during the development of this manual.

A Policy on Geometric Design of Rural Highways, 1965, American Association of State Highway officials.

Calcium Chloride Injury to Roadside Trees, Forest C. Strong, Section of Botany and Plant Pathology, Michigan Quarterly Bulletin, Vol. 27, No. 2.

"Can Geotextiles Reduce Road Costs?" Jan. 1987, Better Roads Magazine.

Chemical Aspects of the Rationale in Selecting, Using and Specifying Products for Dust Control, Fritz S. Rosler 1978.

Compaction Data Handbook, Ingersol Rand Company.

"County Maintenance of Unpaved Roads in Indiana," Transportation Research Record 985, 1984.

Transportation Research Board, National Academy of Sciences: John D.N. Riverson, Kumares C. Sinha and Charles F. Scholler.

Definitions of Terms Relating to Maintenance Management, 1971, Highway Research Board, National Research Council.

Design Thickness of Low-Volume Roads, Jacob Greenstein and Moshe Livneh, TRB Research Report #782.

Drainage Structures, Subgrades and Base Courses; Headquarters, Department of the Army; TM 5-335.

Dust and The Forest Service, Robert D. Strombom, 1978.

Dust Control Study, Gallatin National Forest, U.S. Department of Agriculture, U.S. Forest Service, 1981.

Dust Control, Military Operations, Headquarters, Department of the Army, DA PAM 525-5.

Economy of Bituminous Surfacing on Logging Roads, L.P. Renz, Federal Highway Administration, 1968.

Effects of County Highway Management Practices on Unpaved Roads in Indiana, John D.N. Riverson, Kumares C. Sinha and Charles F. Scholler, 1986.

Effects of Deicing Salts on Water Quality and Biota, R.E. Hanes, L.W. Zelazny, and R.E. Blaser, NCHRP Report #91.

"Fabrics Weave Their Way Into Construction," Highway and Heavy Construction Magazine, Feb. 1978.

Geometric Design Standards for Low-Volume Roads, Compendium 1, Transportation Research Board, National Academy of Sciences, 1978.

Geotextiles Engineering Manual, Department of Transportation, Federal Highway Administration.

Guidelines for Use of Fabrics in Construction and Maintenance of Low-Volume Roads, J. Steward, R. Williamson and J. Mohney, Report # FHWA-TS-78-205.

Highway Research Board, *Proceedings of Sixth Annual Meeting*, 1926.

Highway Research Records:

- #294, *Salt Stabilization*.
- #315, *Soil Stabilization: Multiple Aspects*.
- #351, *Soil Stabilization: Asphalt, Lime, Cement*.

Industry Experience With Forest Road Stabilization Methods and Materials, W.G. Paterson, H.W. McFarlane and W.J. Dohaney, W.P. #18, 1970.

Logging Roads and Protection of Water Quality, U.S. Environmental Protection Agency, Region X, Water Division, EPA 910/9-75-007, March 1985.

"Low-Volume Roads: Second International Conference," Transportation Research Board, National Academy of Sciences, Transportation Research Record 702.

Maintaining Gravel Road Surfaces, Vermont Local Roads Program, Fact sheet T-255.

"Maintaining the Maintenance Management System," Transportation Research Board, National Academy of Sciences, Transportation Research Record 781.

Maintenance of Rural Roads, Organization for Economic Cooperation and Development, Paris, 1978.

Maintenance Practices for Local Roads, Prepared by Byrd, Tallamy, MacDonald and Lewis for Pennsylvania Department of Transportation.

Maintenance Procedures, Cooperative Research Program, Texas Highway Department and Texas Transportation Institute.

Maintenance Techniques for Road Surfacing, Organization for Economic Cooperation and Development, Paris, 1978.

Maintenance of Unpaved Roads, Transportation Research Board, National Academy of Sciences, Synthesis 1.

Measuring Dust Levels Emanating from Aggregate and Native Surfaced Forest Roads, Robert D. Stromborn.

Mobile Hammermill for Inplace Processing of Over-size Rock, San Dimas Equipment Development Center, U.S. Department of Agriculture, U.S. Forest Service, ED&T Test Report 7700-13.

National Association of County Engineers:

- *Blading Aggregate Surfaces*, 1986.
- *Action Guide*, Volume III, 1986.

Off-Highway Tire/Road Damage and Healing Mechanisms, San Dimas Equipment Center, U.S. Department of Agriculture, U.S. Forest Service, Project Record 8371 1202.

Road Surfacing Management for Local Governments, Six Case Studies, U.S. Department of Transportation, DOT-1-85-06, Jan. 1985.

Road Builders' Clinic Proceedings; Washington State University:

26th Annual, 1975:

- "How To Live With Existing Systems," Ernest Geissler.
- "Building Roads For Heavy Loads," Robert D. Stromborn.

34th Annual, 1983:

- "Use of Filter Fabrics for Permanent Road Construction," Didrik Voss.
- "Use of Fabric in Forest Road Construction," Michael J. Cook.
- "Applying Data and Judgment to Base and Surfacing Decisions", Robert D. Stromborn.
- "Decision Making - Yakima County Style," Louis J. Haff.

37th Annual, 1986:

- "Controlling Frost Heaving and Thaw Weakening in Washington State Roads," Newton Jackson.
- "Fighting Frost," Ron Hormann.

Road Gravels, Compendium 7, Transportation Research Board, National Academy of Sciences, 1979.

Road Dust Suppressants, Charles E. Dare, P.E., Director, Transportation Technical Assistance Office, University of Missouri-Rolla.

Road Maintenance Problem and International Assistance, The World Bank, 1981.

Road Surfacing Management for Local Governments, Six Case Studies, U.S. Department of Transportation, DOT-1-85-06, 1985.

Soil Cement Construction Handbook, Portland Cement Association.

"Subdrainage and Moisture," Transportation Research Board, National Academy of Sciences, Transportation Research Record 705, 1979.

Surface Replacement Study, Okanogan National Forest, U.S. Department of Agriculture, U.S. Forest Service, 1967.

Techniques for Measuring Vehicle Operating Costs and Road Deterioration Parameters in Developing Countries, Transportation Research Board, National Academy of Sciences, Transportation Research Board Special Report 160.

Underbody Truck Blade, San Dimas Equipment Development Center, U.S. Department of Agriculture, U.S. Forest Service, Project Report 8571 1202.

Users' Manual for Membrane Encapsulated Pavement Sections (MEPS), U.S. Department of Transportation, Federal Highway Administration, Offices of Research and Development, Implementation Division, Implementation Package 74-2, 1974.

"(A) Working system for Programming Maintenance on a Network of Gravel Roads," National Institute for Transport and Road Research, CSIR, RR 389, 1984.

Personal Contact: Content Materials and Discussions:

- Ralph Hunter, John Day, OR. Maintenance Superintendent (Retired).
- Glen Howard, Klamath Falls, OR. Maintenance COR, USDA, U.S. Forest Service.
- Robert G. Nesbitt, P.E., Jefferson County Engineer, Port Townsend, WA.

