

Technical Report Documentation Page

1. Report No. FHWA-RD-77-138	2. Government Accession No.	3. Recipient's Catalog No.
4. Title and Subtitle Seismic Instrumentation of Transportation Tunnels in California	5. Report Date August 1977	6. Performing Organization Code
	8. Performing Organization Report No.	
7. Author(s) Tor L. Brekke and Gregory E. Korbin	10. Work Unit No. (TRAI5)	
9. Performing Organization Name and Address Dr. Tor L. Brekke 1847 Yosemite Road Berkeley, California 94707	11. Contract or Grant No. DOT-FH-PO-7-3-0061	
	13. Type of Report and Period Covered Final Report	
12. Sponsoring Agency Name and Address Office of Research Federal Highway Administration U. S. Department of Transportation Washington D. C. 20590	14. Sponsoring Agency Code	
	15. Supplementary Notes FHWA Contract Manager: James D. Cooper, HRS-11	
16. Abstract The work reported herein was initiated during the spring of 1977, as a limited task in the more comprehensive program on the response of tunnels to earthquakes. The objective has been to provide guidance for an early installment of relatively simple instrumentation in a few selected tunnels in California. The report is composed of three parts. The first part describes suggested instrumentation programs at four different levels of sophistication. For the immediate and initial program at hand, it is foreseen that the first two levels of instrumentation will be employed. The more sophisticated programs have, however, been included to give an appropriate reference frame for the instruments to actually be installed, and also to provide some guidance for possible future installations. The second part lists the criteria that has been used in selecting tunnel sites. The final part contains a description of the tunnels chosen, including a discussion on the geological environment and the tunnel support systems. The candidate tunnels are: 1. Loleta Railroad Tunnel, No. 40 - Humboldt County 2. Caldecott Tunnels - Alameda County 3. San Fernando Railroad Tunnel, No. 25 - Los Angeles County		
17. Key Words Earthquake, Tunnels, Instrumentation, Structural Response	18. Distribution Statement No restrictions. This document is available through the National Technical Information Service, Springfield, Virginia 22161	
19. Security Classif. (of this report) Unclassified	20. Security Classif. (of this page) Unclassified	22. Price A03-A01

PREFACE

This report documents a program for reviewing and selecting candidate transportation tunnels for a seismic instrumentation study. The study is the initial phase of a more comprehensive program for investigating and evaluating the seismic response of tunnels. The work was sponsored by the Office of Research of the Federal Highway Administration.

In establishing the instrumentation program and identifying candidate tunnels, the following persons have been most helpful and co-operative:

J. D. Cooper, Federal Highway Administration
D. Linger

C. A. Hughes, Southern Pacific Transportation Company
R. L. Braustetter
S. Sanders

R. J. Proctor, The Metropolitan Water District of Southern
California

M. Johnson, Los Angeles County Flood Control District

R. C. Cassano, State of California, Department of Transportation
J. Gates
B. H. Nelsen

L. D. Porter, State of California, Division of Mines and Geology
W. M. Wells

R. B. Matthiesen, United States Geological Survey
R. P. Maley

TABLE OF CONTENTS

	<u>Page</u>
TABLE OF FIGURES	iv
INTRODUCTION	1
INSTRUMENTATION PROGRAM	1
Level I. Basic observations and measurements.	2
Level II. Dynamic response of tunnels, simple instrumentation system.	3
Level III. Measurement of relative displacements.	4
Level IV. Dynamic response of tunnels, advanced instrumentation system.	4
Selection of instrumentation level	5
SITE SELECTION CRITERIA	6
CANDIDATE TUNNELS	7
Loleta Railroad Tunnel, No. 40 - Humboldt County	7
Caldecott Tunnels - Alameda County	9
San Fernando Railroad Tunnel, No. 25 - Los Angeles County	10

TABLE OF FIGURES

<u>Figure</u>		<u>Page</u>
1	Principle Layout of Instrumentation, Level II	12
2	Principle Layout of Instrumentation, Level III	13
3	Principle Layout of Instrumentation, Level IV	13
4	Tunnel Location Map	14
5	Loleta Tunnel Site (Fields Landing Quadrangle)	15
6	Profile and Test Stations, Loleta Tunnel	16
7	Typical Test Station Instrumentation Layout, Loleta Tunnel	16
8	Caldecott Tunnel Site (Oakland East Quadrangle)	17
9	Typical Test Station Instrumentation Layout, Caldecott Tunnel	18
10	Geologic Profile and Test Stations, Caldecott Tunnel	19
11	San Fernando Tunnel Site (Oat Mountain Quadrangle)	20
12	Typical Test Station Instrumentation Layout, San Fernando Tunnel	21
13	Geologic Profile and Test Stations, San Fernando Tunnel	22

INTRODUCTION

The work reported herein was initiated during the spring of 1977, as a limited task in the more comprehensive program on the response of tunnels to earthquakes. The objective has been to provide guidance for an early installment of relatively simple instrumentation in a few selected tunnels in California.

The report is composed of three parts. The first part describes suggested instrumentation programs at four different levels of sophistication. For the immediate and initial program at hand, it is foreseen that the first two levels of instrumentation will be employed. The more sophisticated programs have, however, been included to give an appropriate reference frame for the instruments to actually be installed, and also to provide some guidance for possible future installations.

The second part lists the criteria that has been used in selecting tunnel sites. The final part contains a description of the tunnels chosen, including a discussion on the geological environment and the tunnel support systems.

INSTRUMENTATION PROGRAM

Four levels of observation and instrumentation have been identified. Each higher, more detailed level should include all aspects of each previous level. Thus, the higher levels of instrumentation can be implemented at a later date if so desired.

Level I. Basic observations and measurements.

At each station, for a length of approximately 100 feet (30 meters) along the tunnels, the following work should be carried out:

1. All defects in the support/lining system that can be observed at present should be carefully mapped either through sketches and/or through photographs. The orientation, length, and offset of cracks should be noted. Local spalling and/or crushing should be documented. Plaster can be placed occasionally over cracks to serve as an indicator of subsequent displacement.

2. Measuring points for tape extensometer readings should be installed as shown in detail later for each of the three different tunnels. The points can be balls, rings, or pins, depending on the type of tape extensometer that is employed.¹ After installation, careful extensometer readings shall be made, and repeated as part of the maintenance program (i.e., at least once a year) to check for possible deformations that are not earthquake induced.

¹ Suitable tape extensometers and reference points are available, for example, from Slope Indicator, Seattle, Washington, or Terrametrics, Golden, Colorado.

Level II. Dynamic response of tunnels, simple instrumentation system.

The purpose of this instrumentation is to provide qualitative dynamic motion information on the response of a tunnel as compared with the subsurface, free field rock or soil mass response. As indicated in Figure 1, this necessitates not only measurements in the tunnel proper, but also the installation of instruments in the proximity of the tunnel at the same depth below the surface in the surrounding medium as well as at the surface.

The basis for this assessment is as follows: whenever a stress wave passes through a structure or cavity, refraction of the wave occurs and the resulting motions of the structure or cavity are different from those present within the surrounding medium or free field. Therefore, to examine the influence of the cavity and rock/structure interaction, it is important to compare the tunnel response with the subsurface as well as with the surface free field. The introduction of the free boundary at the surface, and the multiple reflections associated with interfaces or variations of rock mass properties with distance from the surface, make the surface free field an inadequate point of measurement for establishing a reference. This is in particular the case when a tunnel is situated in rock overlain by soil. General experience has revealed that the surface free-field is more complex, larger in amplitude, and contains a high frequency component absent at depth.

It is, on the other hand, of importance and interest to measure the tunnel response at the surface, i.e., at the portals. This is the part of the tunnel that is often the most susceptible to damage. It is

therefore proposed that an instrumentation station be included at the portal within this level of instrumentation.

Instrumentation involves three, possibly four triaxial accelerometers¹ with central recording. The recorder can either be an oscillograph, or a direct digital-to-magnetic tape. The system trigger should be placed within the subsurface free field probe to avoid accidental triggering due to traffic vibrations. All horizontal transducers must have one component parallel to the tunnel axis for purpose of comparison.

Level III. Measurement of relative displacements.

By employing one triaxial and two biaxial accelerometers, it is possible to determine the relative displacement and therefore strain between the crown and springlines. The layout is sketched in Figure 2. Any one of the probes can be the triaxial one, installed such that the third component is parallel to the axis of the tunnel. To obtain the resolution that is required, it is necessary in this setup to use a direct, digital recording system.

Data obtained from this instrumentation package would be helpful in assessing the validity of the rather conservative design assumptions that are used for aseismic design of underground openings.

Level IV. Dynamic response of tunnels, advanced instrumentation system.

This system employs an array of seven biaxial accelerometers to

¹ Suitable accelerometers have been developed for the California Strong Motion Instrumentation Program. Their reliability and performance is well documented, and the maintenance is routine.

obtain a total response of the tunnel. It requires a direct digital recording system. The principle layout is shown in Figure 3.

The prime reason for carrying out an instrumentation program of the complexity and cost involved here would be to acquire data for checking the validity of numerical models by comparing predicted and measured response. It would, further, be of interest to establish the "natural" frequencies of the tunnels, although it is recognized that the dynamic response and the use of response spectra is not as well defined for underground structures as it is for surface structures. The tunnels may or may not reveal displacements similar to the mode shapes found for structures.

Selection of instrumentation level.

Basic observations and measurements, Level I, can provide qualitative information on the permanent damage in terms of lining distortion associated with a particular magnitude earthquake and epicentral distance. Level II instrumentation, which is also largely qualitative, records the accelerations responsible for damage, if observed. Further, the influence of the opening and/or support system on the subsurface free field motion is derived by the comparison of the tunnel response with that of the rock or soil mass at depth. A comparison of these results from two or more tunnel sites may differ depending on factors such as ground type (soil versus rock), tunnel support and/or reinforcement system, and depth beneath the surface.

Application of results from the remaining two Levels, III and IV, was described earlier. Given practical constraints, only Level III, the determination of relative displacements, is likely to yield readily useable information commensurate with the cost of implementation. This is not to imply that Level IV is impractical; however, the complexity and expense of this program limits the return for the effort necessary. Further, it is not likely that at present a particular numerical model could be identified as a viable design tool by itself. Rather, the results would provide for a method by which to calibrate these models.

SITE SELECTION CRITERIA

The following criteria were used for the selection of the three tunnels:

1. The tunnels should be located in an area in which there is relatively high frequency of strong motion events (accelerations equal to or greater than .05 g.). Such areas were identified after consultation with Dr. R. B. Matthiesen of the United States Geological Survey, Menlo Park.
2. The tunnels should be situated in reasonably different geological environments in terms of ground conditions.
3. The positioning of stations in the tunnels should be chosen so that the influence of topography and adjacent structures is minimized.
4. The tunnels should, as far as possible, have different support and lining systems. Areas where the support or lining systems

are presently or have recently been distorted or damaged due to squeezing or other nonearthquake induced loads should be avoided. Also, areas where excessive overbreak or disturbance to the ground took place during construction should be avoided.

5. The tunnels chosen should be reasonably easily accessible for installation and maintenance of instruments, and situated such that the subsurface free field accelerometers can be installed from the surface.

CANDIDATE TUNNELS

Two railroad tunnels owned by the Southern Pacific Transportation Company, located in Los Angeles and Humboldt counties, and the Caldecott vehicular tunnels through the Berkeley Hills are proposed for the instrumentation program. Their locations in California are shown in Figure 4. All sites basically conform to the site selection criteria previously discussed. The instrumentation program at each site should, as a minimum effort, consist of a Level I and Level II system. If it is economically possible, it is proposed that one of the instrumentation stations in the Caldecott Tunnels be expanded to Level III.

Loleta Railroad Tunnel, No. 40 - Humboldt County (Figure 5).

The 2030 foot (300 meters) long Loleta Tunnel is about one hundred years old, and was originally timber supported. During a later lining of the tunnel, a continuous concrete footing 3 feet (1 meter) high was installed, and a reinforced concrete lining was placed between redwood posts and caps. Consequently, the opening is not continuously concrete

lined; however, the composite lining is relatively stiff as compared with the surrounding ground.

The ground encountered in the tunnel is largely sand and silt of the Quaternary Hookton Formation. Relatively unconsolidated clays and gravels, also members of this unit, are observed in shallow road cuts. Bedding is nearly horizontal.

There were stability problems relating to footing bearing failure in the vicinity of Section 10, Figure 6. However, several hundred feet east of this section, the opening shows no unusual signs of distress. It is within this region, Sections 13 to 14, along with the east portal, that instrumentation stations are proposed.

The position of the accelerometer and tape extensometer reference points are shown in Figure 7. All transducers and reference points are to be mounted at the center of the concrete lining ribs, not on the wooden posts or caps.

A subsurface transducer should be placed approximately 200 feet (65 meters) off the tunnel axis immediately east of Singley Road. It can be located on either side of the tunnel, (Figure 5), within a 160 foot (50 meters) deep hole. Also, it may be of interest to place a surface free field accelerometer at the top of this hole. All transducers can be linked to one 12-channel recorder, as the distance from the subsurface instrument and east portal is less than 1000 feet (330 meters).

An alternative to the Loleta Tunnel is the Island Mountain Railroad Tunnel, No. 27, located in the southwest corner of Trinity County. One

major disadvantage of this site is its position outside the region where the frequency of strong motion events is reasonably high. Also, excessively steep terrain could introduce complex topographic effects.

Caldecott Tunnels - Alameda County (Figure 8).

Three 3100 foot (1000 meters) long parallel tunnels are utilized to convey vehicular traffic through the Berkeley Hills. The most recently constructed third bore (1961-63), located to the north of the other openings is the most accessible and appropriate for instrumentation. Internal support consists of a concrete lining and steel sets. In addition, an interior roof slab and wall divider forms the ventilation system, Figure 9.

Geology of the Berkeley Hills in the vicinity of the tunnels is a series of steeply dipping sandstones, mudstones, and conglomerates from the Orinda Formation and cherts, shales, and sandstones from the Claremont Formation, Figure 10. All beds dip to the west and strike nearly perpendicular to the axes of the openings. The Hayward Fault passes immediately to the west of the west portal. Additional details of the tunnel geology are presented by Page (1950).¹

Accelerometers and tape extensometer reference points should be installed in three test stations, located halfway through the tunnel, below Tunnel Road, and at the west portal, Figure 10. As shown in

¹Page, B. M. (1950), "Geology of the Broadway Tunnel, Berkeley Hills, California," Economic Geology, Vol. 45, No. 2, March - April, pp. 142-166.

Figure 9, the reference points are placed in both fresh air and exhaust ducts, while the accelerometer is mounted on the north wall, a few feet above the roof slab. All instruments and reference points should be centered between liner construction joints, spaced at roughly 35 feet (12 meters) along the tunnel axis.

A 220 foot (70 meters) hole for the subsurface free field accelerometer can be located off Tunnel Road as shown in Figure 8.

Should a decision be made to install Level III instrumentation in any one of the tunnels, it is proposed that the station below Tunnel Road be chosen.

Data obtained from this site can be correlated with previously installed pressure cells and extensometers surrounding the BART Tunnels at a point where they intersect the Hayward Fault. These tunnels, which also traverse the Berkeley Hills, are roughly 1500 feet (500 meters) north of the Caldecott Tunnel, with nearly the same orientation, Figure 8.

San Fernando Railroad Tunnel, No. 25 - Los Angeles county (Figure 11).

Constructed in 1875, the near 7000 foot (2300 meters) long tunnel was originally timber-supported with the exception of short, concrete-lined sections. Ground conditions can be characterized as "soft" rock, which, as revealed from construction records, was largely excavated by spading. In 1920, the entire opening was lined as shown in Figure 12. Prior to placement of the reinforced concrete liner, timber supports and lagging were removed when possible.

Proposed accelerometer stations are shown in Figure 13, which is

based on a geologic map prepared by the Metropolitan Water District of Southern California. Two stations are within the tunnel and one at the east portal. All accelerometers are placed in the crown, oriented to record axial, radial, and circumferential motion. The position of the accelerometers is shown in Figure 12, along with the tape extensometer reference points. The subsurface free field instrument should be positioned as shown in Figure 11, and as far west of State Highway 14 as possible. One of the two horizontal accelerometers, placed down a hole approximately 140 feet (45 meters) deep, is to be oriented along the tunnel axis, i.e., N 22° W.

A single, 12-channel recorder positioned near the east portal can be used for all transducers. An alternative to linking the subsurface instrument with those within the tunnel is to use two separate recorders and triggers. It may be necessary to locate the second trigger outside and away from the tunnel, as determined by vibration measurements once the transducers are installed. In order to compare accelerograms, both recorders would require a WWVB time code.

The alternatives to the San Fernando Tunnel, located in Los Angeles County, are the Simi Railroad Tunnel, No. 26, owned by the Southern Pacific Transportation Company, and the unlined Santa Anita Dam Tunnel, owned by the Los Angeles County Flood Control District. A negative aspect of the Simi tunnel is that it is prone to extensive vandalism. The Santa Anita Dam Tunnel is a rather small (11 feet) (3.5 meters), unlined tunnel.

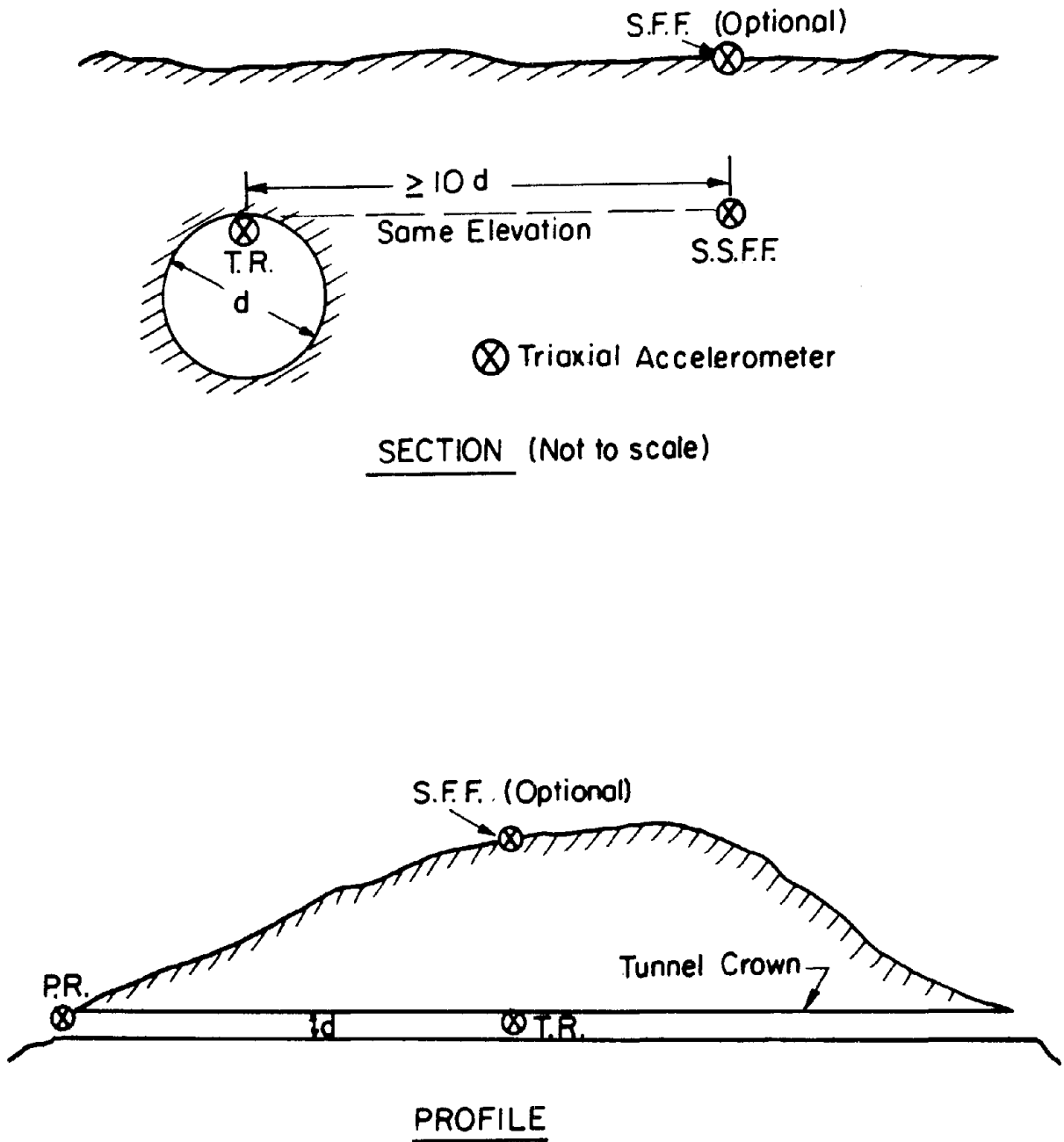
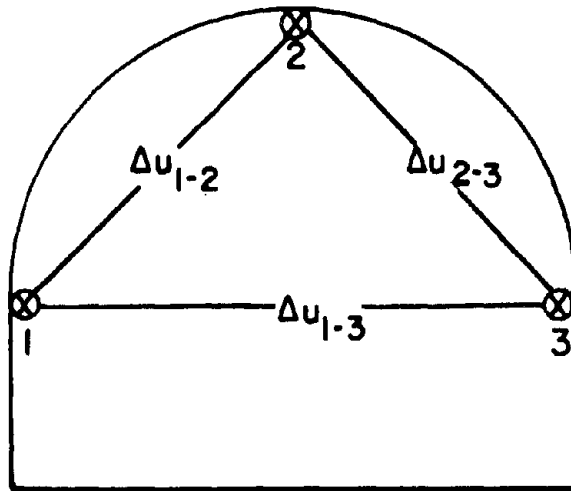

Figure 1. Principal Layout of Instrumentation, Level II

- T.R.: Tunnel Response
- P.R.: Portal Response
- S.F.F.: Surface Free Field
- S.S.F.F.: Subsurface Free Field



⊗_{1,2,3} One Triaxial and Two Biaxial Accelerometers

Figure 2. Principal Layout of Instrumentation, Level III.

Δu : Relative Displacement

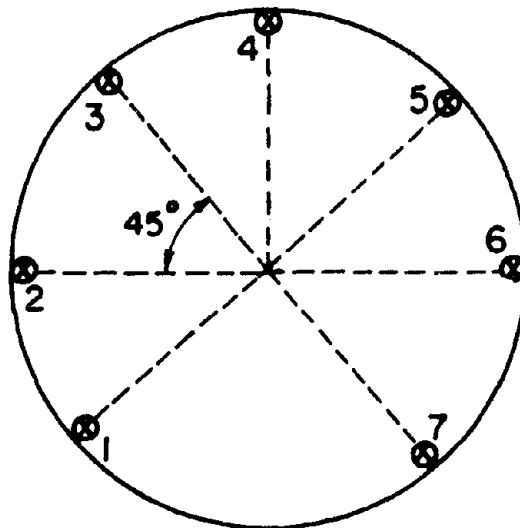

⊗ Biaxial Accelerometer

Figure 3. Principal Layout of Instrumentation, Level IV



Figure 4. Tunnel Location Map

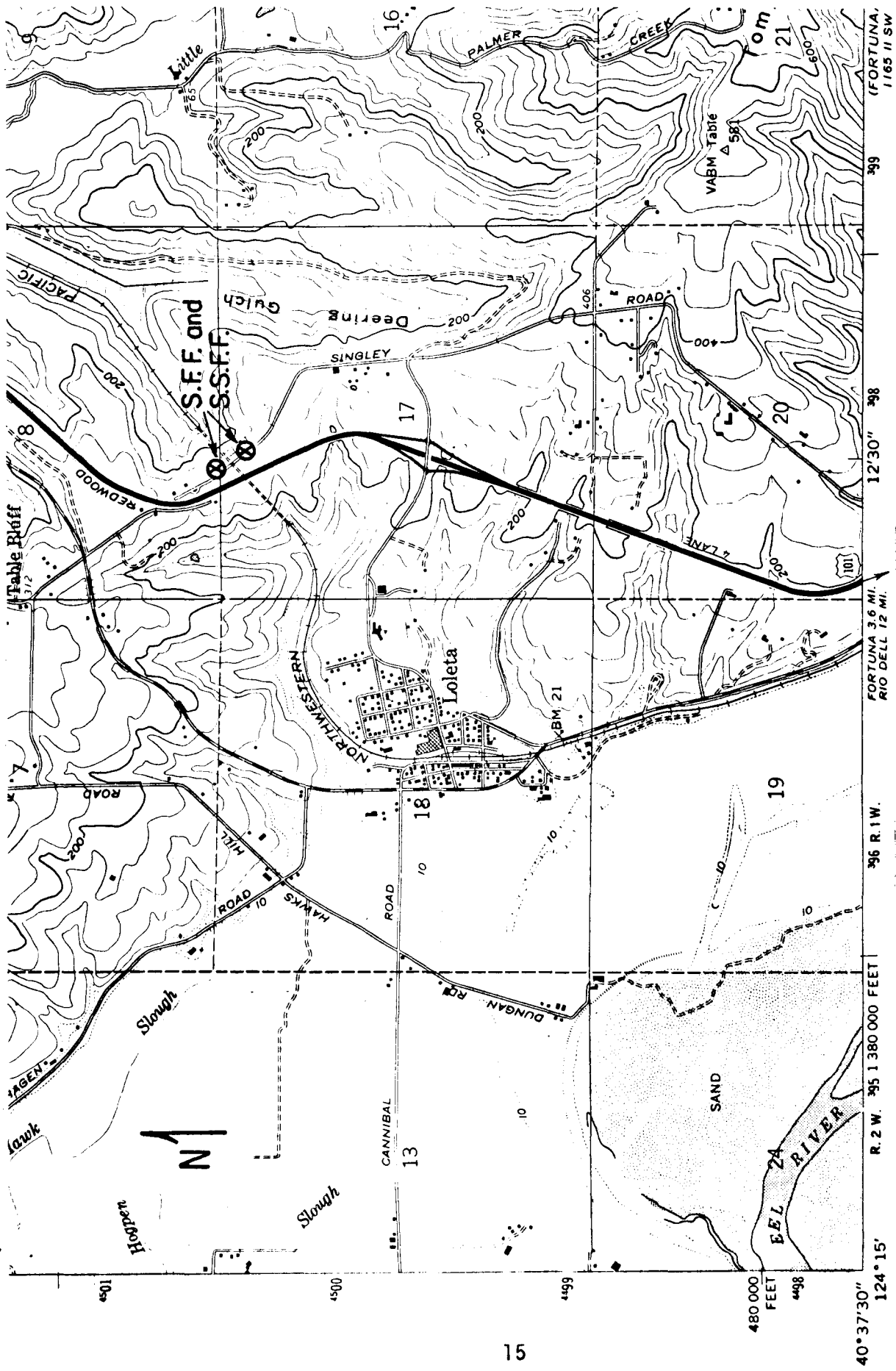

Figure 5. Loleta Tunnel Site (Fields Landing Quadrangle)
 S.F.F. and S.S.F.F.: Alternative Positions for Surface and
 Subsurface Free Field Accelerometers

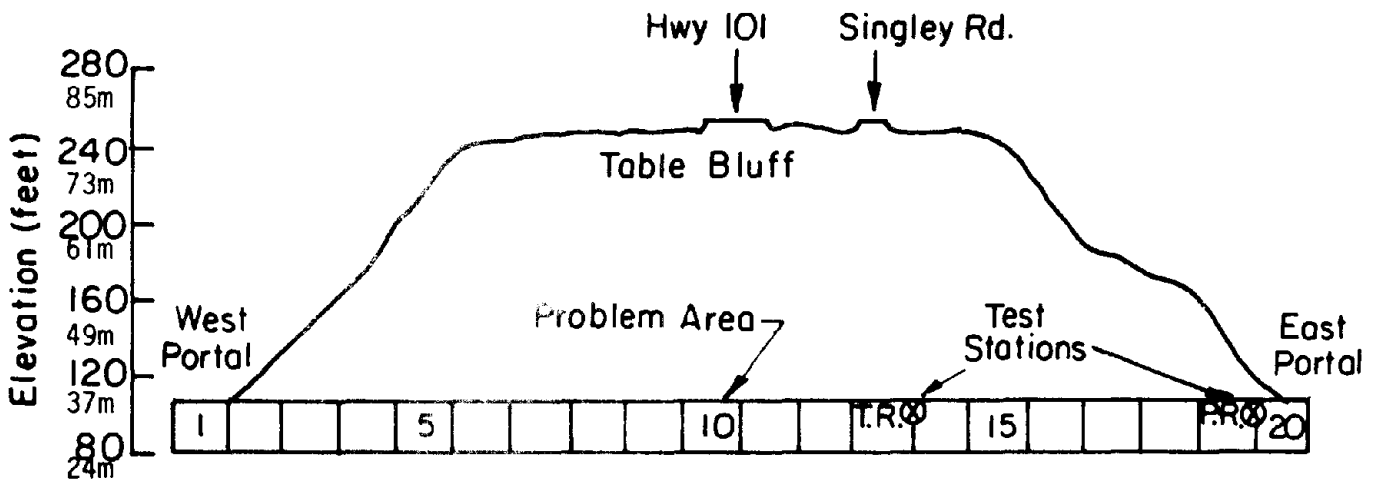
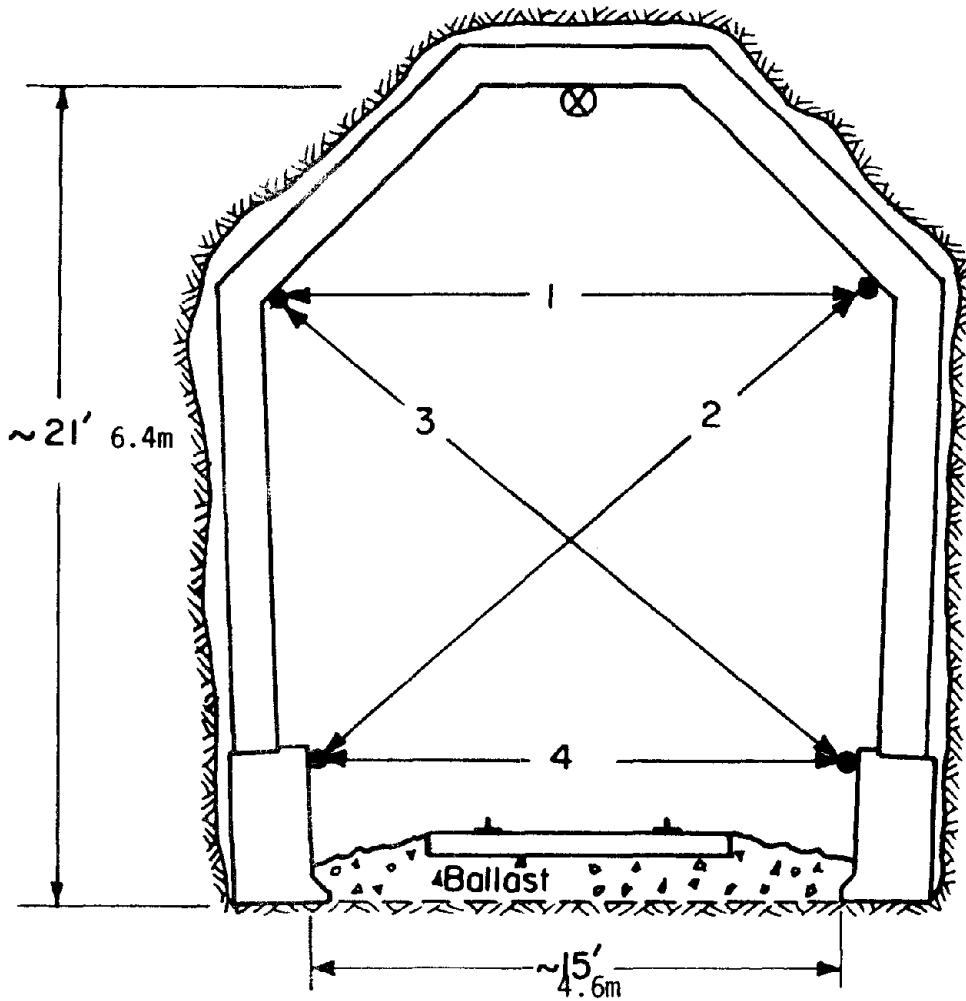

Figure 6. Profile and Test Stations, Loleta Tunnel



⊗ Triaxial Accelerometer

⊙ Tape Extensometer Reference Point

Figure 7. Typical Test Station Instrumentation Layout, Loleta Tunnel

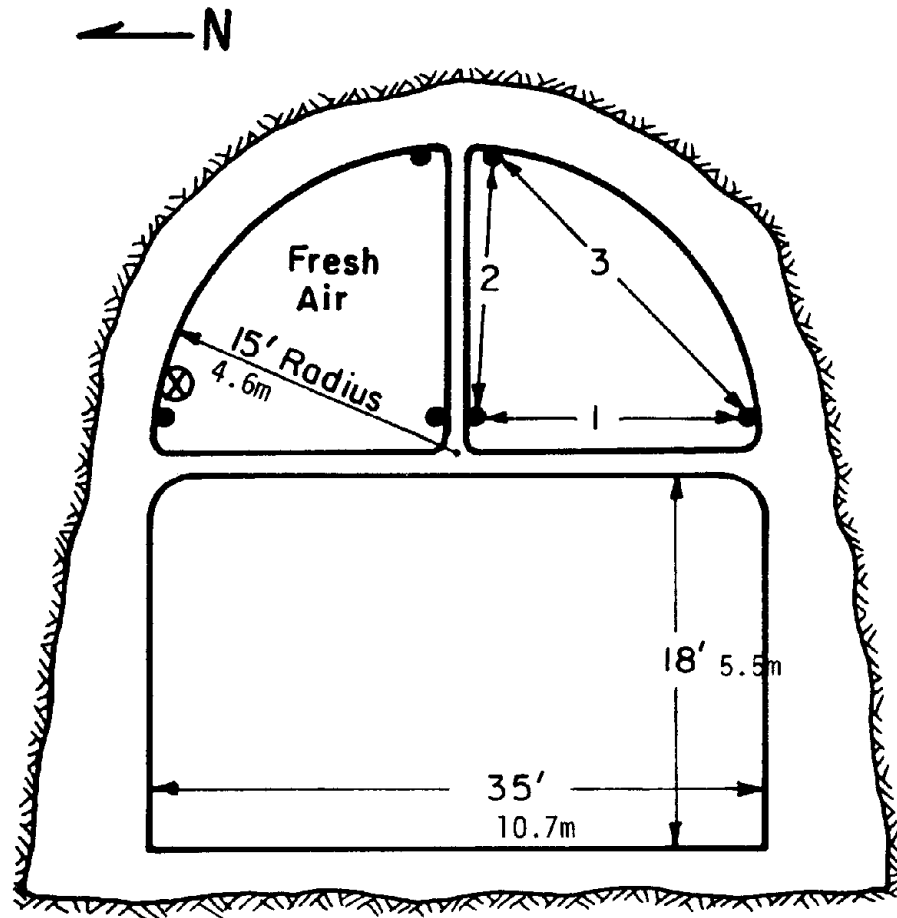

- ⊗ Triaxial Accelerometer
- Tape Extensometer Reference Point

Figure 9. Typical Test Station Instrumentation Layout, Caldecott Tunnel

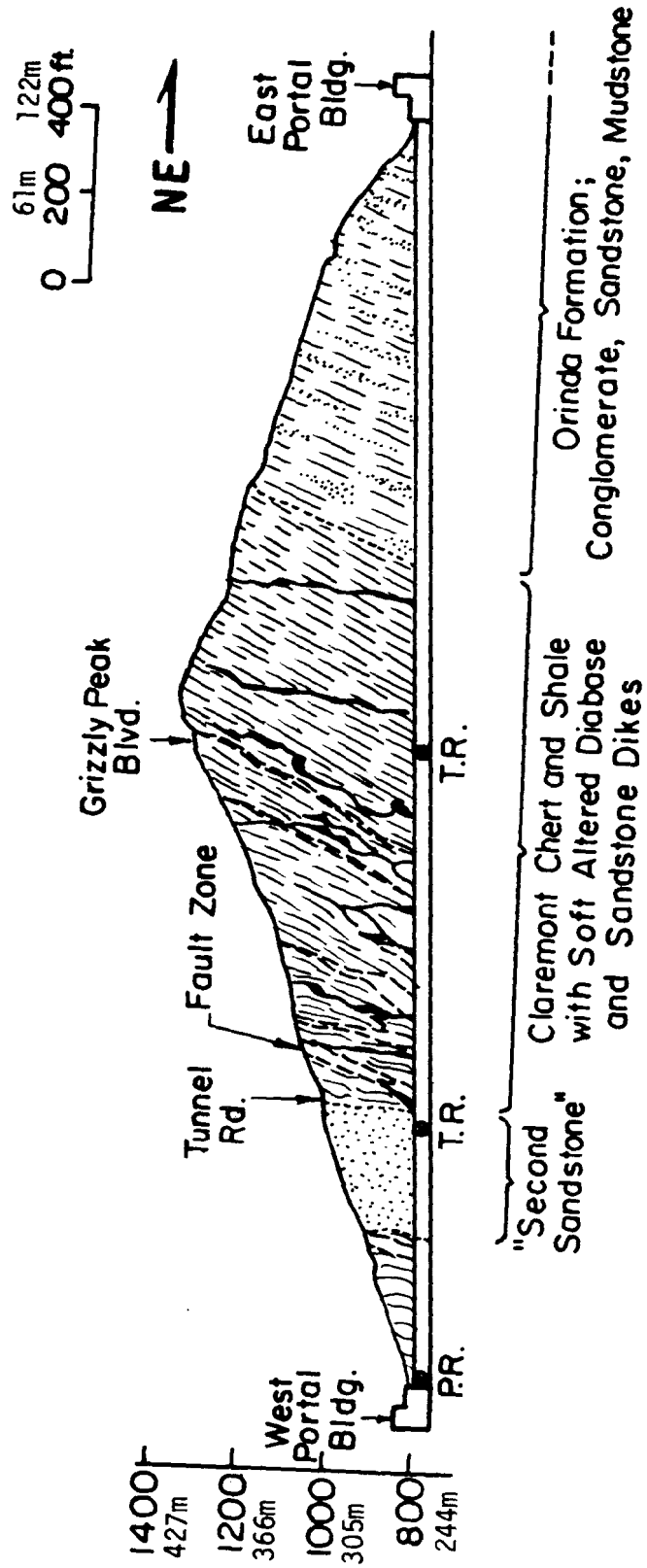

Figure 10. Geologic Profile and Test Stations, Caldecott Tunnel

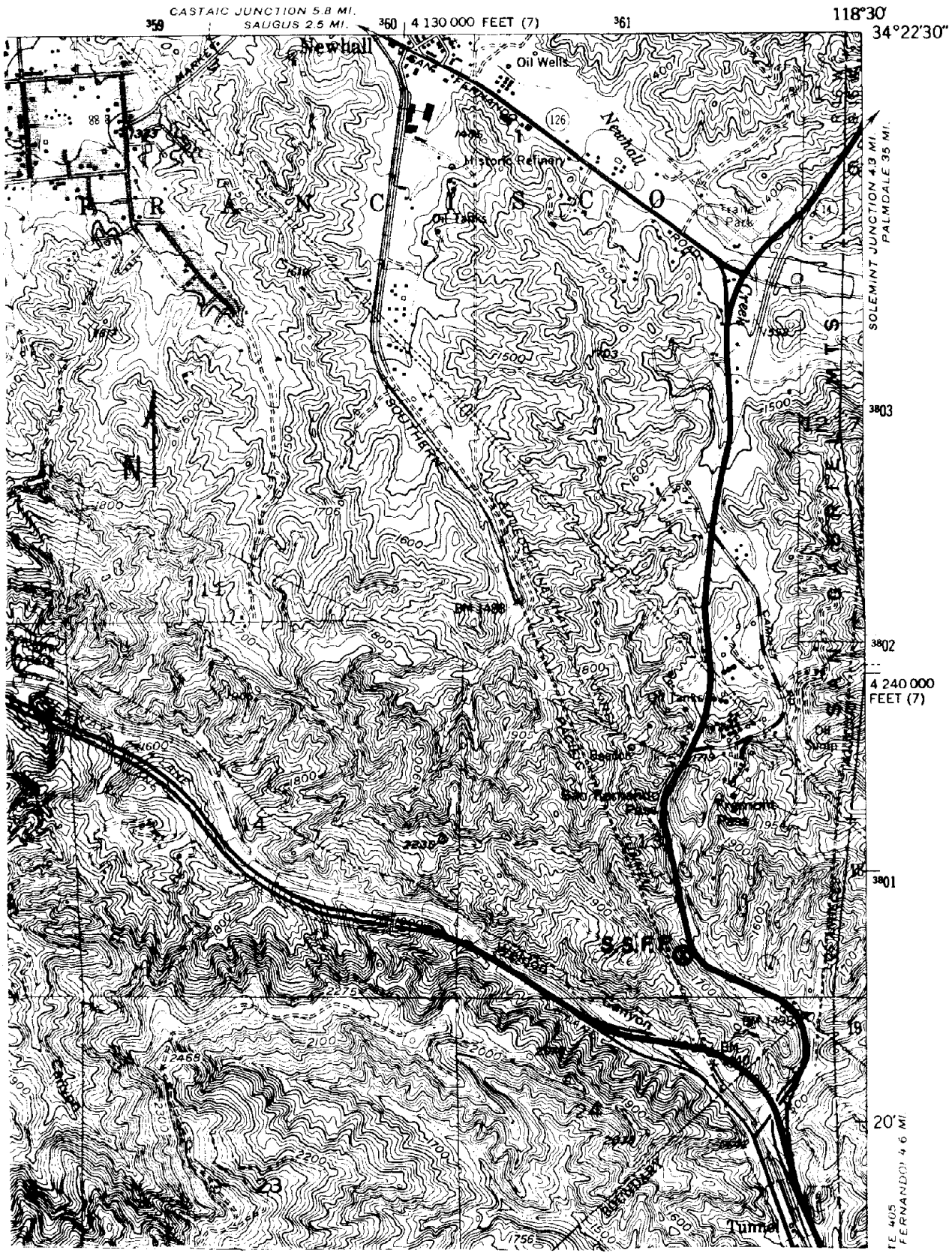
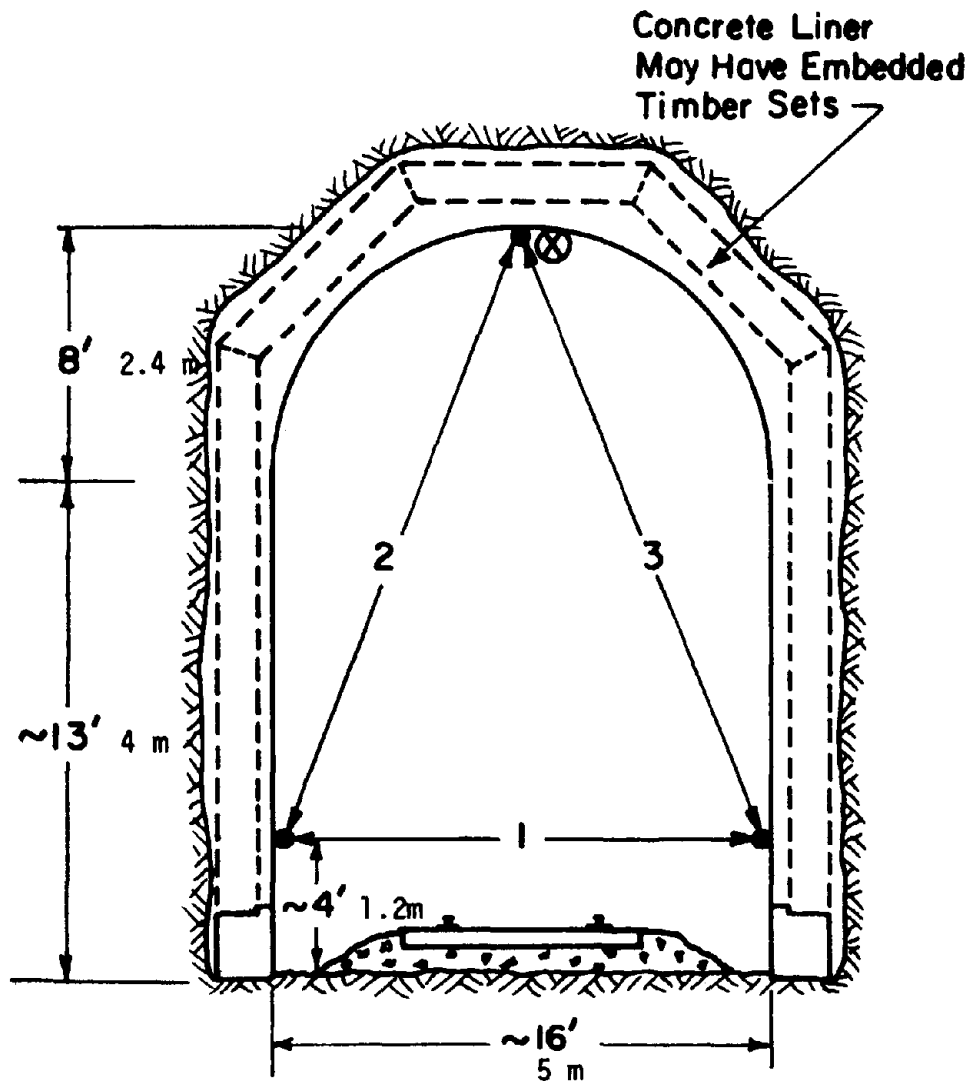

Figure 11. San Fernando Tunnel Site (Oat Mountain Quadrangle)
 S.S.F.F.: Position of Subsurface Free Field Accelerometer



- ⊗ Triaxial Accelerometer
- Tape Extensometer Reference Point

Figure 12- Typical Test Station Instrumentation Layout
San Fernando Tunnel

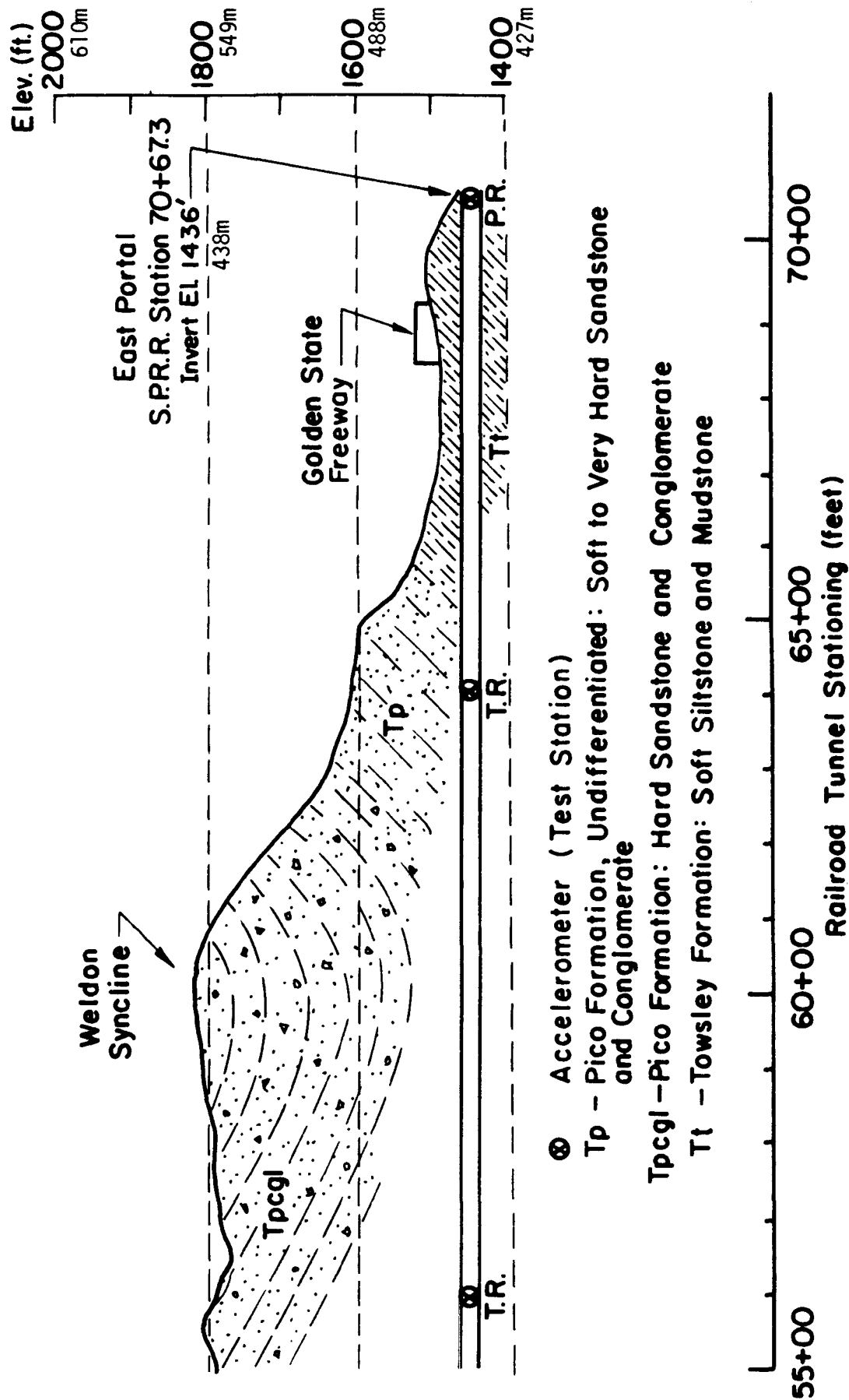

Figure 13. Geologic Profile and Test Stations, San Fernando Tunnel