



**THE UNIVERSITY OF TEXAS AT AUSTIN
CENTER FOR TRANSPORTATION RESEARCH**

5-9053-01 P2

PowerPoint Presentations for the Training Workshop

Research Supervisor:
Chandra Bhat

*TxDOT Project 5-9053-01: Enhancing Road Weather Management during
Wildfires and Flash Floods through New Data
Collection, Sharing, and Public Dissemination
Technologies*

October 2018; Revised January 2019; Published July 2019

Performing Organization: Center for Transportation Research The University of Texas at Austin 3925 W. Braker Lane, 4 th Floor Austin, Texas 78759	Sponsoring Organization: Texas Department of Transportation Research and Technology Implementation Office P.O. Box 5080 Austin, Texas 78763-5080
Performed in cooperation with the Texas Department of Transportation and the Federal Highway Administration.	

This document introduces and summarizes the training workshop material produced during this project and provides guidelines for future instructors to help disseminate project content and findings to interested practitioners. Following this introduction to the three components of the December 2018 training workshop are the three PowerPoint presentation files.

Overview

- **Title:** Weather Savvy Roads: Sensors and Data for Enhancing Road Weather Management
- **Purpose:** To introduce processes and challenges for deploying sensors and using data
- **Objective:** After the workshop, participants should be informed on key concepts needed for a successful sensor deployment.
- **Contents:**
 - Introduction (15 minutes)
 - Part 1: Technologies for Road Sensing (1 hour, 30 minutes)
 - Lunch break and demonstrations (1 hour)
 - Part 2: Data, Decision-Making, and Dissemination (1 hour, 15 minutes)
 - Dismissal and additional one-on-one conversations

Part 1: Technologies for Road Sensing

This first in-depth presentation focuses upon sensors: operation, deployment, and maintenance. Although this section is to be delivered in lecture format, discussion throughout the section is encouraged. The technical level of the audience should be gauged to adjust the depth of technical details that are to be delivered. The presenter should be at least moderately familiar with sensor capabilities and installations. While this presentation does not substitute the knowledge and experience of a vendor or agency personnel who have had significant experience with sensor devices, this presentation is intended to convey the most common challenges and concerns of any sensor deployment. The goal is for participants to achieve a working level of familiarity such that they can ask well-informed questions and have feasible expectations when working with knowledgeable personnel on implementing a sensor deployment.

Part 1 is divided into the following sections:

- **A high-level overview of sensors:** types, topology styles, measureable phenomenon, and total sensor cost
- **Important sensor specifications to select appropriate solutions:** understanding features, sampling rates, and what to look for on a sensor product's datasheet
- **Power considerations:** a primer for understanding power requirements for sensors in the field, with emphasis on operating "off the grid" with solar panels, batteries, and an energy budget
- **Wireless communications considerations:** an overview of the wireless spectrum, communications technologies, expected distances, and international standards
- **Lessons learned:** challenges encountered within this project that may also be relevant to future sensor purchases, integrations, and deployments
- **Five assessment questions** are included at the end of Part 1 to satisfy training material requirements. These may be used in training delivery as group discussion exercises, depending upon the needs of the participants.

Part 2: Data, Decision-Making, and Dissemination

The second primary training component covers several topics on effectively using data that comes from sensors or other sources. Much of this conveys best practices that have been documented in other agencies across the United States, as well as experimental results from efforts conducted through the course of the project. The presenter should be at least moderately familiar with the data topics contained within the materials. Again, while the slide content can be delivered in lecture format, discussion should be encouraged as the wide topic areas of the lecture content may pique thoughts and realizations among the participants.

Part 2 addresses the following:

- **Sensors and IT architecture:** looking at methods for accessing sensor data given IT security policies
- **Low water crossing study:** a review of two low-water crossing studies, including survey results in a 2011 TTI study
- **Case studies:** road weather data: an overview of practices from other DOTs as reported by the FHWA

- **Dissemination to the public:** a look at current and emerging methods for facilitating the dissemination of information to the public, including an introduction to social media, and Pathfinder DMS message guidelines
- **Data analysis:** A look at data fusion experiments that add value to data by combining data sources with novel visualizations
- **Discussion topics** are prompted at the tail end of the section, but may occur throughout as desired and facilitated.



WEATHER-SAVVY ROADS

Sensors and Data for Enhancing Road
Weather Management



Objectives



- We're introducing processes and challenges for deploying sensors and using data
- After the workshop, participants should be informed on key concepts needed for a successful sensor deployment

Agenda



- **Project Background**
- **PART 1**
 - Sensors
- **PART 2**
 - Data, Decision-Making, and Dissemination
- **Sensor and data demonstrations**

Background

- Project 5-9053-01: Enhancing Road Weather Management during Wildfires and Flash Floods through New Data Collection, Sharing, and Public Dissemination Technologies
- **Data collection, analysis and sharing**
 - How can data be acquired and/or combined to enhance today's operational practices?
- **Information dissemination**
 - What are effective ways to share data internally and reach the public today?
- Current practices + Data catalog + Sensors → Workshop

- New proof-of-concepts
 - Sensors
 - Other data sources
- New best practices
- Improve data availability
- Positively impact success and safety of roadway operations in extreme weather

- **TxDOT RTI:**
 - Wade Odell (RS)

- **University of Texas Center for Transportation Research (UT CTR):**
 - Chandra Bhat (PI)
 - Christian Claudel (Co-PI)
 - Natalia Ruiz-Juri (Co-PI)
 - Kenneth Perrine (Researcher)
 - Kamryn Long (Graduate Research Assistant)
 - Abduallah Mohamed (Graduate Research Assistant)
 - Tian Lei (Postdoc Researcher)
 - Kamran Khan (Undergraduate Research Assistant)
 - Jonathan Butler (Undergraduate Research Assistant)

Before Delving In...



- First, introductions.



WEATHER-SAVVY ROADS

Part 1: Technologies for Road Sensing



Objectives

- **Present a high level overview of sensors**
- Give a general overview of what can be sensed
- Important sensor specifications to select appropriate solutions
- Power considerations
- Wireless communications considerations
- Lessons learned

Smart systems

- More and more, systems need to adapt to the **physical world**: environmental conditions, demand, disruptions, etc. Examples: smart roads, smart buildings, smart infrastructure, smart grids (electrical or water)



Iran Startup & Tech Media
<http://techrasa.com/wp-content/uploads/2016/11/Siemens-1074x483.jpg>

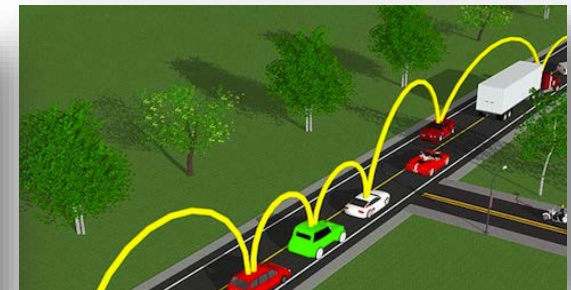

SpaceMart:
http://www.spacemart.com/reports/EU_opens_the_way_for_cars_that_talk_999.html

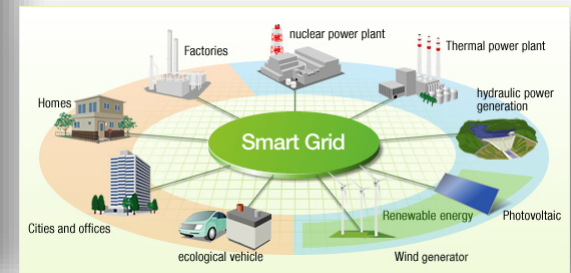

Infinite Information & Technology
<http://infiniteinformationtechnology.com/wp-content/uploads/2016/11/P035.a-Smart-Grid-Concept.jpg>

General systems overview

- These systems require some degree of **monitoring** (or sensing), which allows us to:
 - Track the state of the system, to make sure it is performing as expected (ex: bridge structure monitoring, road ice condition monitoring)
 - Control the system, either by humans or by an automatic system (ex: nuclear power plant, adaptive traffic signal timing, HVAC control in buildings, environmental policy for the water system...)

Structure of a sensor network

- A **sensor network** (network of sensor stations) is a system that allows the measurement of several physical or chemical quantities at **different locations**, and transmit these measurements to a **centralized location**
- Measurements are usually **real-time**

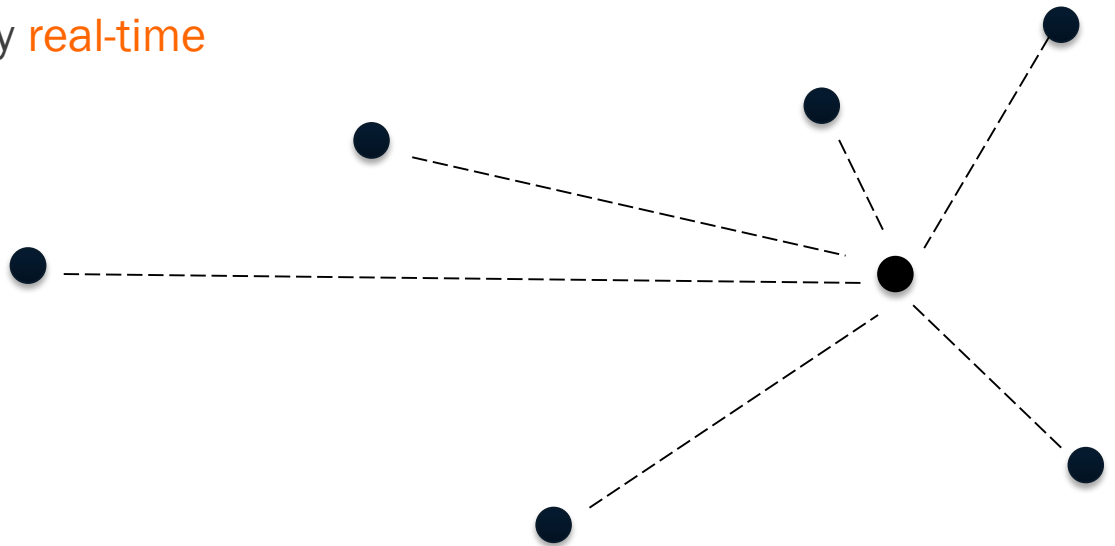

Structure of the sensor nodes

- Each **node** of the sensor network contains the following:
 - One or multiple **sensors**
 - A **microcontroller** or embedded computer
 - A **transmitter** (wired or wireless)
 - An **enclosure**
 - A **power supply**

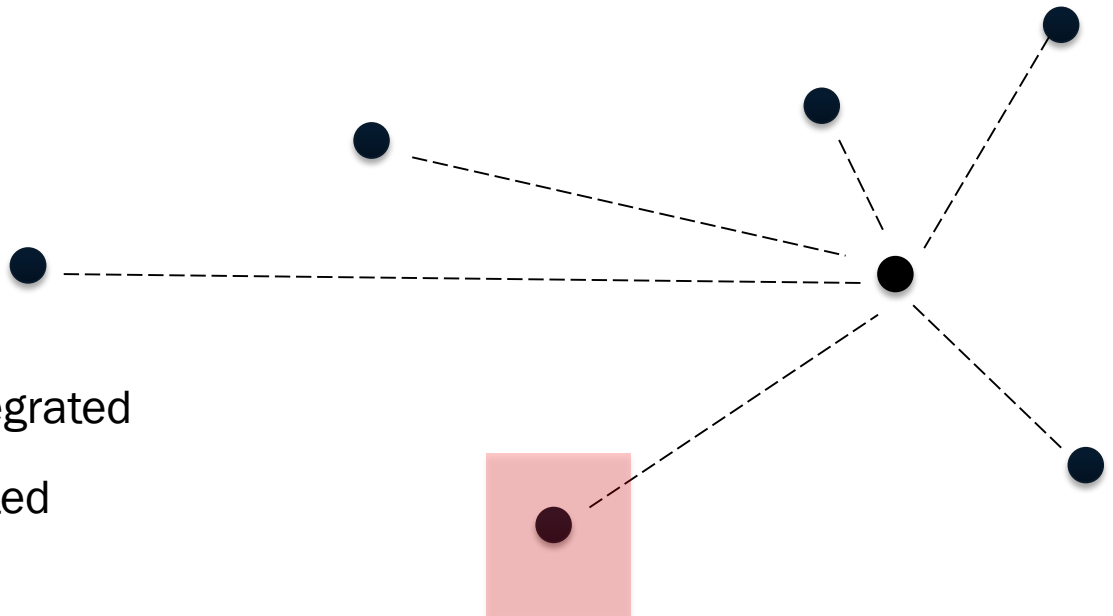

- Some systems are preintegrated
- Others have to be integrated

Sensors

- A sensor is a device, whose purpose is to **detect changes in its environment** and provide an **output**
- There are numerous types of sensors available today, which can sense various **physical or chemical quantities**
- Sensors can have different types of **outputs**, for example:
 - Color/luminosity
 - Mechanical
 - Electrical

Sensors

- Color/luminosity output

Carbon monoxide sensor



<https://www.cfinotebook.net/graphics/aeromedical-and-human-factors/carbon-monoxide-poisoning/carbon-monoxide-detector.png>

Water presence sensor

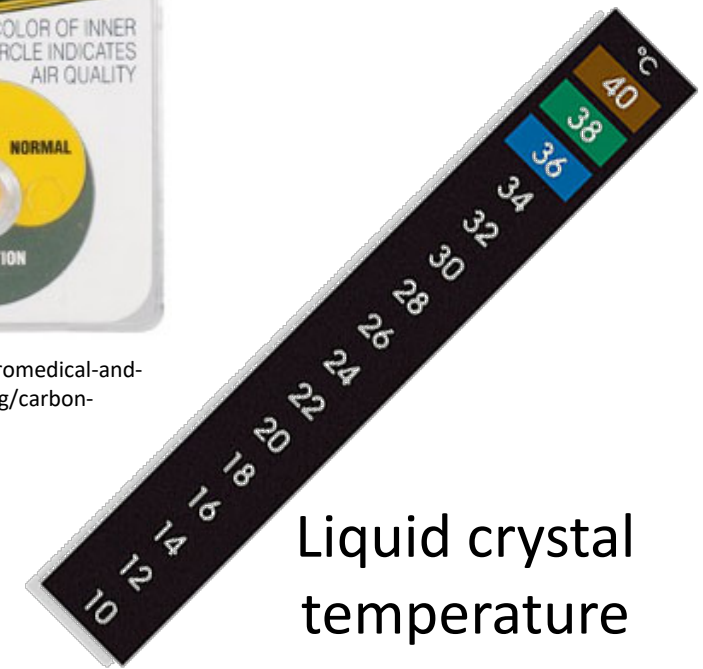

Liquid crystal temperature sensor

https://img1.exportersindia.com/product_images/bc-small/dir_95/2836960/temperature-strip-2626879.jpg

Sensors

- Mechanical output

Mechanical fuel
level sensor



https://www.omega.com/Pressure/images/PGC_m.jpg

Mechanical pressure
sensor



<https://whewellsghost.files.wordpress.com/2016/12/balls.jpg>

Rotation speed sensor
(centrifugal governor)



http://ecx.images-amazon.com/images/I/418SeGMXiwL_AA160_.jpg

Mechanical temperature sensor

Sensors

- Electrical output

Luminosity sensor

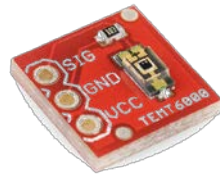

https://botland.com.pl/7992-home_default/temt6000-czujnik-natezenia-swiatla-otoczenia-modul-sparkfun.jpg



<https://cdn.sparkfun.com/r/140-140/assets/parts/2/1/4/2/08875-01a.jpg>

Radioactivity sensor



Temperature sensor

<http://skpang.co.uk/catalog/images/sensors/temperature/11050-04.jpg>

Ultrasound rangefinder



<https://cdn.sparkfun.com/r/140-140/assets/parts/1/0/5/6/MaxSonar-EZ1.jpg>



http://www.icshop.com.tw/images/product_images/info_images/16560_0.jpg

Accelerometer

- Sensors that have an electrical output are the **easiest to interface with computers**, and are thus increasingly used

Sensors

- Sensors do not always have the same capabilities. For example **cameras** can have different pixel resolutions, noise levels, frame rates, color resolution, spectral response,...
- Sensors have different electrical specifications. They also have different types of packaging, power requirements, certifications, dimensions, mass. All this information is summarized in the sensor **datasheet**

Datasheet
example:



<http://pdf.directindustry.com/pdf/dextens/o2-sensor-datasheet/92615-608538.html>

Total Sensor Cost

■ Equipment ■ Installation ■ Maintenance

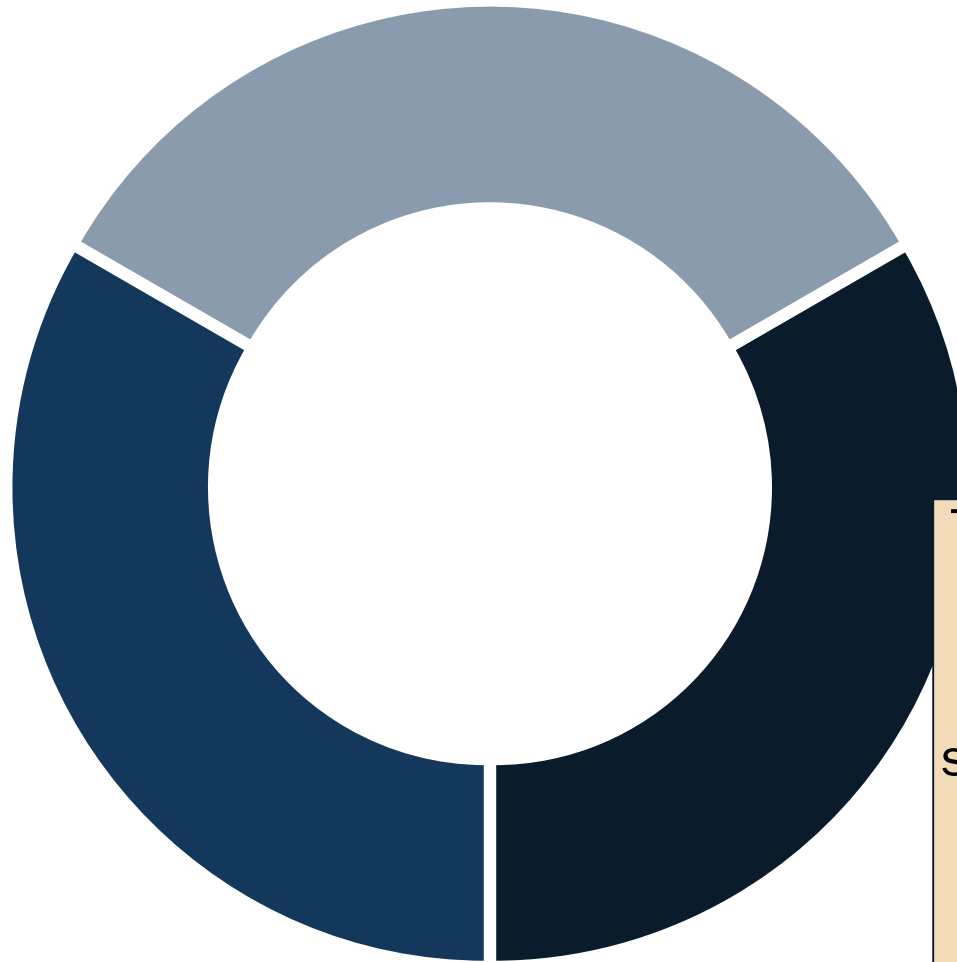

These may even be broken down further. For example, time to spec out equipment is a significant portion of equipment cost!

Probability and Reliability

- **Sensor Station A** has a 10% likelihood of failure, or a rate of 0.1.
- **Sensor Station B** also has a 10% likelihood of failure.

- **Question:** What would our failure rate be if we could run both sensor stations in the same location?
- (Assume the two sensor stations operate independently from each other)

- **Answer:** $0.1 \times 0.1 = 0.01$, or **1%**
- Running multiple sensor stations in the same location and having the ability to validate against each other dramatically improves reliability.
- This may even be further improved by using different sensor types.

Objectives

- Present a high level overview of sensors
- Give a general overview of what can be sensed
- **Important sensor specifications to select appropriate solutions**
- Power considerations
- Wireless communications considerations
- Lessons learned

Selecting sensors for a given task

- The first step is to determine which physical/chemical parameter is to be sensed (check advantages and disadvantages)
- Read sensor datasheets to determine key parameters associated with the **measurement** process:
 - Accuracy (precision/repeatability, noise level, calibration errors, quantization errors)
 - Sampling rate
- Read sensor datasheets to determine key parameters and specifications associated with the **sensor system**:
 - Power characteristics
 - Data output format and transmission method
 - Mechanical parameters (weight, IP rating, dimensions...)

Choosing the type of sensing method

- There are usually (but not always) multiple ways of sensing something
- The right technology has to be chosen by balancing its **advantages and disadvantages** with respect to competing technologies
- Example: water level measurements in rivers. Possible technologies:
 - Contact based (pressure sensors, switches)
 - Non contact (ultrasonic range finders, Lidars, Radars)

Choosing the right type of sensing method

- Example: water level measurements in rivers.
- Contact based sensors:
 - Pressure sensors
 - Advantages: low cost, high precision
 - Disadvantages: high maintenance (biofouling, droughts), measurement errors in fast streams
 - Switches
 - Advantages: high reliability, very low cost
 - Disadvantages: no actual water level measurement (just alert thresholds), maintenance and tests required



<https://www.ott.com/en-us/products/water-level-1/ott-orpheus-mini-water-level-logger-3/>



<https://elteccorp.com/wp-content/uploads/2014/03/MNDOT-MAIN-off-road-sensor-side-view.jpg>

Choosing the right type of sensing method

- [Example: water level measurements in rivers.](#)
- Non-contact sensors:
 - Ultrasonic
 - Advantages: low cost, high precision
 - Disadvantages: measurement errors caused by temperature changes, requires overhead mounting
 - Radars
 - Advantages: high precision
 - Disadvantages: high cost, requires overhead mounting
 - Lidars
 - Advantages: high precision, possibility of measuring multiple channels, side mounting possible
 - Disadvantages: affected by very high rains, do not work well in high ambient luminosity conditions,

Parameters associated with the measurement process

- **Datasheets** are technical documents that summarize the performance and characteristics of a given sensor
- A very important parameter of a sensor is its **accuracy**. An accurate sensor provides a measurement that closely matches the true value of the parameter to be monitored

Precision of our sensors

- Example: precision of the radar sensor
- From a datasheet...

Specifications		
Measuring Range 2.6-115 ft. (0.8-35 m)	Transmitting Frequency 24 GHz Pulse Radar	Dimensions 8.7 in. x 6.0 in. x 7.5 in. (L x W x H)
Accuracy 2.6-6.6 ft.: ±0.03 ft. 6.6-98.5 ft.: ±0.01 ft. 98.5-115 ft.: ±0.03 ft.	Output SDI-12 SDI-12 via RS-485 4-20 mA	Weight 4.6 lbs.
Resolution 0.01 ft. (0.001 m) SDI-12 Interface	Power Requirements 9.6 to 28 Vdc	Ingress Protection Rating IP 67
Units ft, m, cm	Power Consumption Sleep: < 50 µA @ +12 V equal to < 1 mW Active: < 12 mA @ +12 V equal to < 140 mW	
Beam Width 12°	Environmental Conditions Operating Temperature: -40 to 140°F (-40 to 60°C) Storage Temperature: -40 to 185°F (-40 to 85°C) Relative Humidity: 0-100% (non-condensing)	
Beam Angle ±6°		
Sensor Technology Pulse Radar		

Word size and precision

- The precision of the sensor is intrinsically limited by its **word size** (if digital), or the word size of the Analog to Digital Converter (ADC) (if analog)
- **Example: a 12 bit ADC can only encode $2^{12} = 4096$ different possible measurements.**
- Even if the ADC is very accurate (large word size), the sensors always have some level of **intrinsic noise** that affects the precision of the results. The datasheet either specifies these, or the total (worst-case) error taking into account all factors

Sampling rate

- High precision is important, however it is not the only factor. The rate at which the sensor gets measurements (**sampling rate**) is also a critical factor

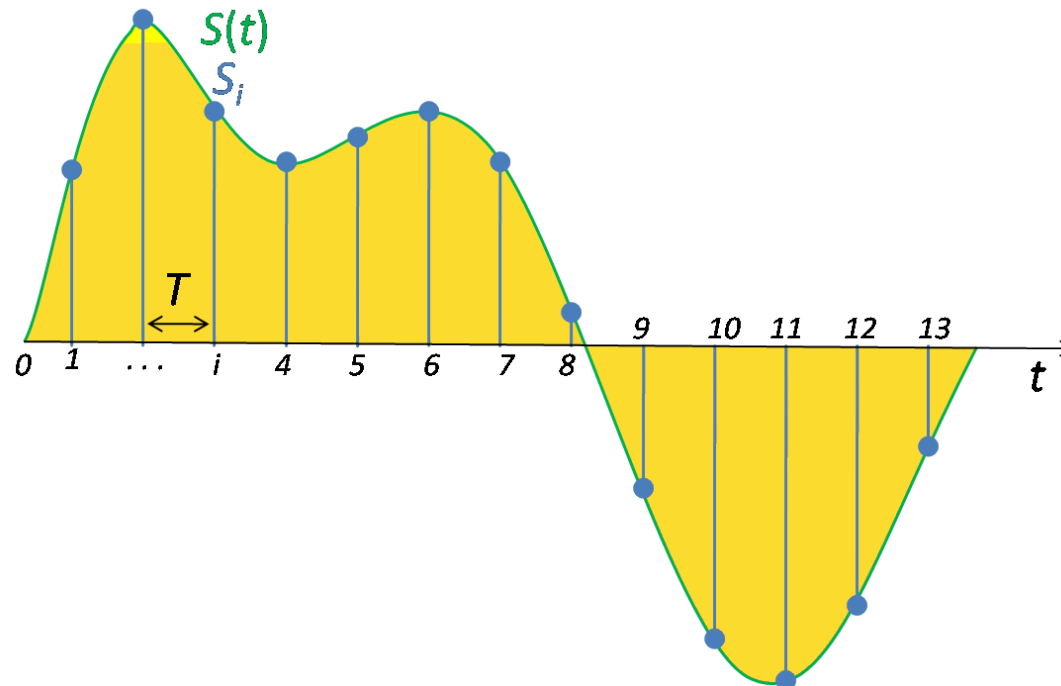

https://images.mentalfloss.com/sites/default/files/800px-Signal_Sampling-565x366_5.png

Sampling rate

- The sampling period T should be chosen according to the time scale of evolution of the phenomenon that we want to monitor (for example **seconds or minutes** for a flood alert, **minutes to hours** for weather or icing)
- Sensors usually have a maximum sampling rate (inverse of the sampling period), which depends on their internal characteristics (data rate), the characteristics of the microprocessor that processes the data (ADC sampling rate), or on physics (ex: ultrasonic sensor)
- Having a high sampling rate is desirable, but can also cause problems:
 - Increasing the sampling rate cause increased **noise levels** (with possibly a decreased precision per measurement)
 - High sampling rates cause **higher power consumption** (sensor, processing, transmitter)

Sampling

- Example of issues associated with an insufficient sampling rate:
 - Temporally: apparition of false frequencies

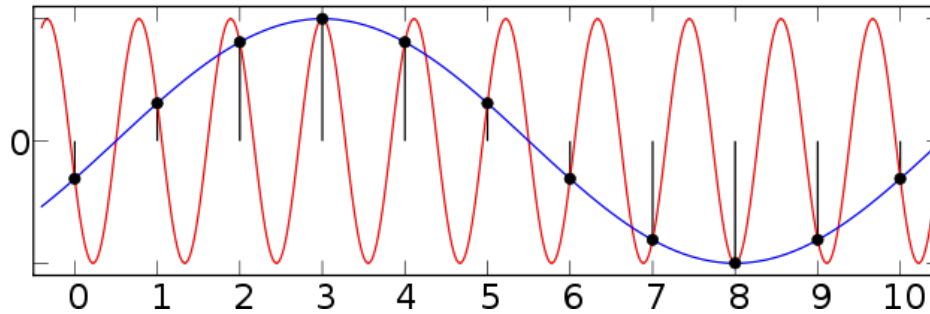

<http://notes.komputerwiz.net:8000/w/images/thumb/2/28/AliasingSines.svg/675px-AliasingSines.svg.png>

- Spatially: aliasing



Other performance factors (mechanical)

- The datasheet also provides information on dimensions, weight and ruggedness of the device
- Dimensions and weight can be a factor in some applications
- The capacity for a sensor node to survive in a hostile environment is described by the **IP rating** of its enclosure

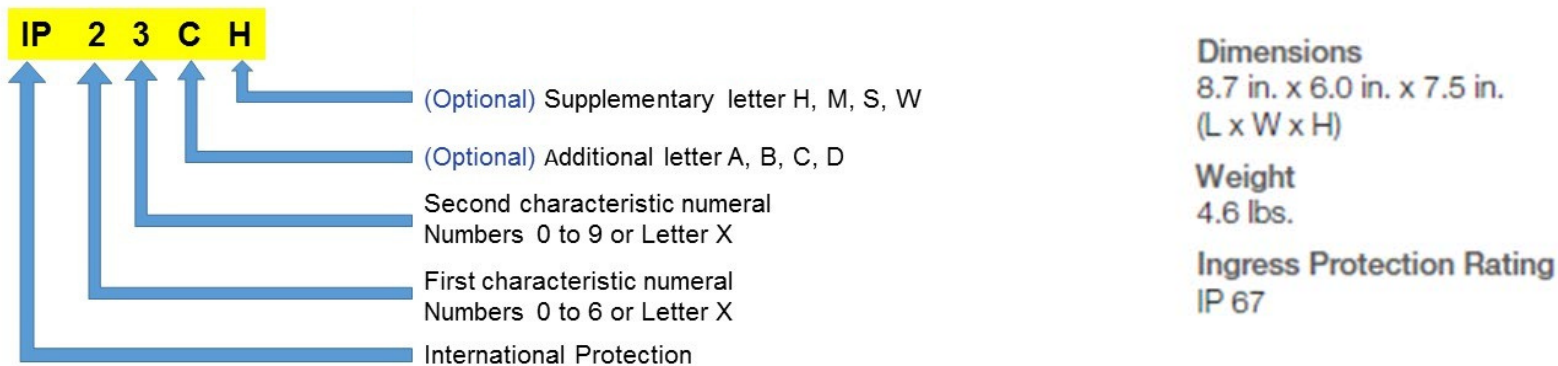

Environmental protection

- IP rating

IP Ratings Table			
The first digit refers to the products Ingress Protection rating against solid particles and the second digit against liquid.			
IP		XX	
Ingress of Solid Objects		Ingress of Liquids	
IP	Protected against	IP	Protected against
0	No protection.	0	No protection.
1	Solid objects over 50mm, e.g. hands, large tools etc.	1	Vertically falling drops of water or condensation. Limited ingress permitted.
2	Solid objects over 12.5mm, e.g. fingers, tools etc.	2	Falling drops of water when product tilted up to 15 degrees from vertical. Limited ingress permitted.
3	Solid objects over 2.5mm, e.g. rod, small tools etc.	3	Sprays of water at up to 60 degrees from the vertical. Limited ingress permitted.
4	Solid objects over 1.0mm, e.g. small wires.	4	Sprays of water from any direction. Limited ingress permitted.
5	Dust, limited ingress with no harmful deposit.	5	Jets of water from any direction. Limited ingress permitted.
6	Dust tight.	6	High pressure jets of water from any direction. Limited ingress permitted.
		7	Temporary immersion in water.
		8	Immersion in water, under pressure for long periods.

<https://www.originalbtc.com/images/faq-ip-rating-table-oz2am2.jpg>

- Surge protection

- Sensors also have a maximum operating and standby **temperatures**. This is usually a limitation of the electronics
- The upper limit is usually **160 degrees F (70 degrees C)**, but can be lower for high power devices or for batteries
- A clear colored (reflective) enclosure reduces the internal temperature

Objectives

- Present a high level overview of sensors
- Give a general overview of what can be sensed
- Important sensor specifications to select appropriate solutions
- **Power considerations**
- Wireless communications considerations
- Lessons learned

Power and energy considerations

- Some sensors can be powered from the grid, however most sensors used in sensor networks are **self-powered**
- This requires an **energy harvesting** device (usually a solar panel or a wind turbine), and a **battery** to store this energy
- The power requirements of a sensor are specified on the datasheet (input voltage, and current usage)
- If unsure, refer to the sensor manufacturer or system integrator



<https://www.homedepot.com>



https://en.wikipedia.org/wiki/NEMA_connector

Power and energy considerations

- Example: radar sensor

Specifications		
Measuring Range 2.6-115 ft. (0.8-35 m)	Transmitting Frequency 24 GHz Pulse Radar	Dimensions 8.7 in. x 6.0 in. x 7.5 in. (L x W x H)
Accuracy 2.6-6.6 ft.: ±0.03 ft. 6.6-98.5 ft.: ±0.01 ft. 98.5-115 ft.: ±0.03 ft.	Output SDI-12 SDI-12 via RS-485 4-20 mA	Weight 4.6 lbs.
Resolution 0.01 ft. (0.001 m) SDI-12 Interface	Power Requirements 9.6 to 28 Vdc	Ingress Protection Rating IP 67
Units ft, m, cm	Power Consumption Sleep: < 50 µA @ +12 V equal to < 1 mW Active: < 12 mA @ +12 V equal to < 140 mW	
Beam Width 12°	Environmental Conditions Operating Temperature: -40 to 140°F (-40 to 60°C) Storage Temperature: -40 to 185°F (-40 to 85°C) Relative Humidity: 0-100% (non-condensing)	
Beam Angle ±6°		
Sensor Technology Pulse Radar		

Power requirements

- The power **dissipated** by a sensor is $P = V \cdot I$, where V is the **voltage** applied to it and I is the **current** drawn by the sensor (units: P (Watt), V (Volt), I (Ampere))
- Most sensors require only a **low** power supply, and can be readily powered using outputs from a microcontroller board (usually 3.3V or 5V, limited to about 50 mA)
- Sensors that require high power (example: IceSight sensor) can be powered by dedicated supplies
- Some sensors require a very **precise** voltage (usually 3.3V), which can require voltage **regulators** if the voltage provided by the board is not well regulated

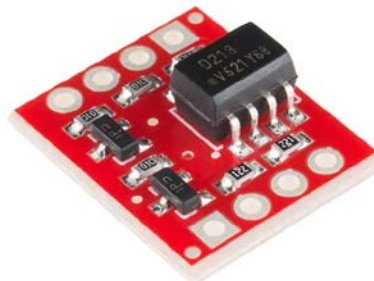

https://www.digikey.com/product-detail/en/sparkfun-electronics/BOB-09118/1568-1279-ND/5762429?WT.srch=1&gclid=CjwKCAjwpKveBRAwEiwAo4Pqm_BipaVelyE3jcxyl1hToqVK_6-rEqjIHYuUfuJXU7yyHHa3aXBdhoCpHIQAvD_BwE#images

Power requirements

- The power dissipated by a sensor has to be known in advance, to ensure that:
 - (If powered from the grid) the supply has to provide the required voltage and currents
 - (If energy harvesting) the supply system (battery and solar panel) has to be dimensioned to ensure permanent sensor operation
 - The **heating** due to the sensor power dissipation has to be taken into account for high power sensors or electronics in insulated enclosures

(Standard electronics is rated to **160 degrees F (70 C)** though batteries are usually rated up to **120 degrees F (50 C)**)

Battery considerations

- Sensors are usually powered by **batteries**. A battery (or **multiple batteries** in some cases (IceSight) is powering the main microcontroller board, and powers the peripherals (including transmitters, controllers, sensors and actuators)
- The microcontroller board usually requires an input voltage in some specified range, usually 2-5V for low power sensors
- The input voltage does not need to be well regulated, provided that it falls in that range

Battery considerations

- These flexible systems can be powered by batteries, since a battery voltage is not **fixed**, and lowers when the battery **discharges** (this is used to determine the percentage of battery left). Ex: single cell Li-Ion 4.2V – 2.7V
- However other factors have to be considered: the **voltage** itself does not fully characterize a battery (ex: 1.5V batteries below)



<http://storage0.dms.mpinteractiv.ro/media/401/321/5109/9227463/1/baterii.jpg?width=640>

Battery considerations

- In addition to its maximum voltage, a battery is characterized by three additional parameters:
 - **Capacity** (usually specified in Ampere hour)
 - **Internal resistance**
 - **Maximum current**

- The battery capacity represents the total charge that can be held by the battery. The discharge current represents the rate at which the battery charge goes down

Battery considerations

- Another important parameter associated with batteries is the **maximal current** that they can supply
- **Ideally**, batteries should be able to maintain their voltage no matter how strong the current is, but in practice the **speed of chemical reactions** is limited, and small batteries are not able to supply high currents (their voltage drops considerably when attempting to do so). Thermal issues (internal resistance) also limit the maximum current of batteries
- The **maximal current** that can be supplied by a battery is given through the **C-rating**

Battery considerations

- Maximal current: $I = Q \cdot C$, where Q is the capacity (in $A \cdot h$) and C is the C rating (in h^{-1}). I is given in A
- Physically, the C rating represents the number of times a battery could be fully discharged per hour (assuming that we recharge it instantly)



https://farm3.staticflickr.com/2839/9453195213_6b76fef1b7.jpg

Battery considerations

- For some applications (very low power sensors), the size of a battery may be limited by **capacity considerations**, while for some applications (high power sensors), the size of a battery can be dictated by **minimal current considerations**
- Some battery technologies are better than others in these two domains, for example:
 - **Lithium** (non rechargeable) or Li-Ion batteries are adapted to systems driven by capacity considerations (with C-ratings of around 1 or less)
 - **Lithium Polymer** (or Lead-Acid) batteries are usually adapted to systems driven by minimal current requirements (C-ratings of 10-50)

Battery considerations

- In other applications, the ability for the battery to sustain extreme **temperatures** or charge profiles (**deep discharges**) over extended periods of time without failing is critical
- The best technology currently available in this case (most reliable) is **LiFePO₄ (Lithium Iron Phosphate)** batteries
- Such batteries have less energy density than Lithium Ion, but more than Lead-Acid batteries, and do not require maintenance

Energy budget

- Solar panels are characterized by a maximum power output. This power output has to be chosen to ensure that the sensor can be reliably powered
- A sensor node requiring 1W of continuous power will need a solar panel with **peak power** on the order of 20-100W (depending on orientation, shadow and prevailing weather conditions)
- The total energy stored in the battery is $E \approx Q \cdot V$. The battery **capacity** has to be sufficient to ensure that the sensor remain powered even if the solar panel does not generate power for a few days
- **Example: a 2 W sensor requires an energy of $2 \cdot 3600 \cdot 24 = 172800 \text{ J}$ per day. Assuming that we want the sensor to stay on with 6 consecutive days of no power supply, we need a battery with a total energy of about 1 M J, for example a 12V battery with a capacity of 23 Ah (83,000 Coulomb)**

Objectives

- Present a high level overview of sensors
- Give a general overview of what can be sensed
- Important sensor specifications to select appropriate solutions
- Power considerations
- **Wireless communications considerations**
- Lessons learned

Radio considerations

- **Electromagnetic waves** are electric and magnetic field perturbations that propagate in space and time

- Visualization:

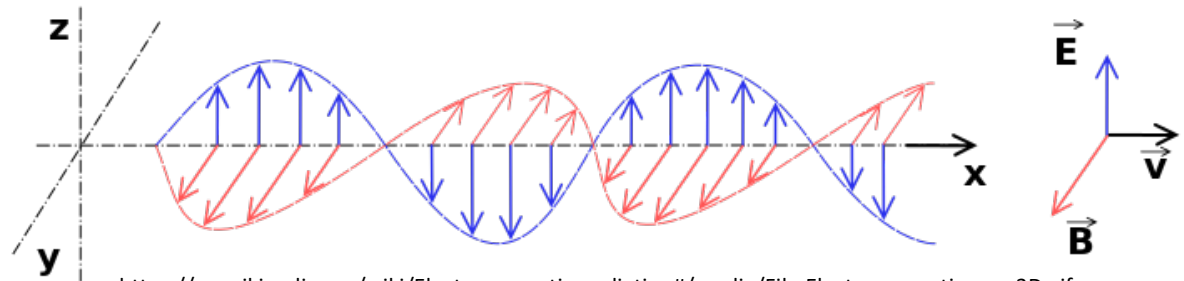

https://en.wikipedia.org/wiki/Electromagnetic_radiation#/media/File:Electromagneticwave3D.gif

Electromagnetic waves

- Electromagnetic waves carry energy in the form of **photons**. The energy of a photon is $E=h\nu$, where h is **Planck's** constant and ν is the **frequency** associated with the photon

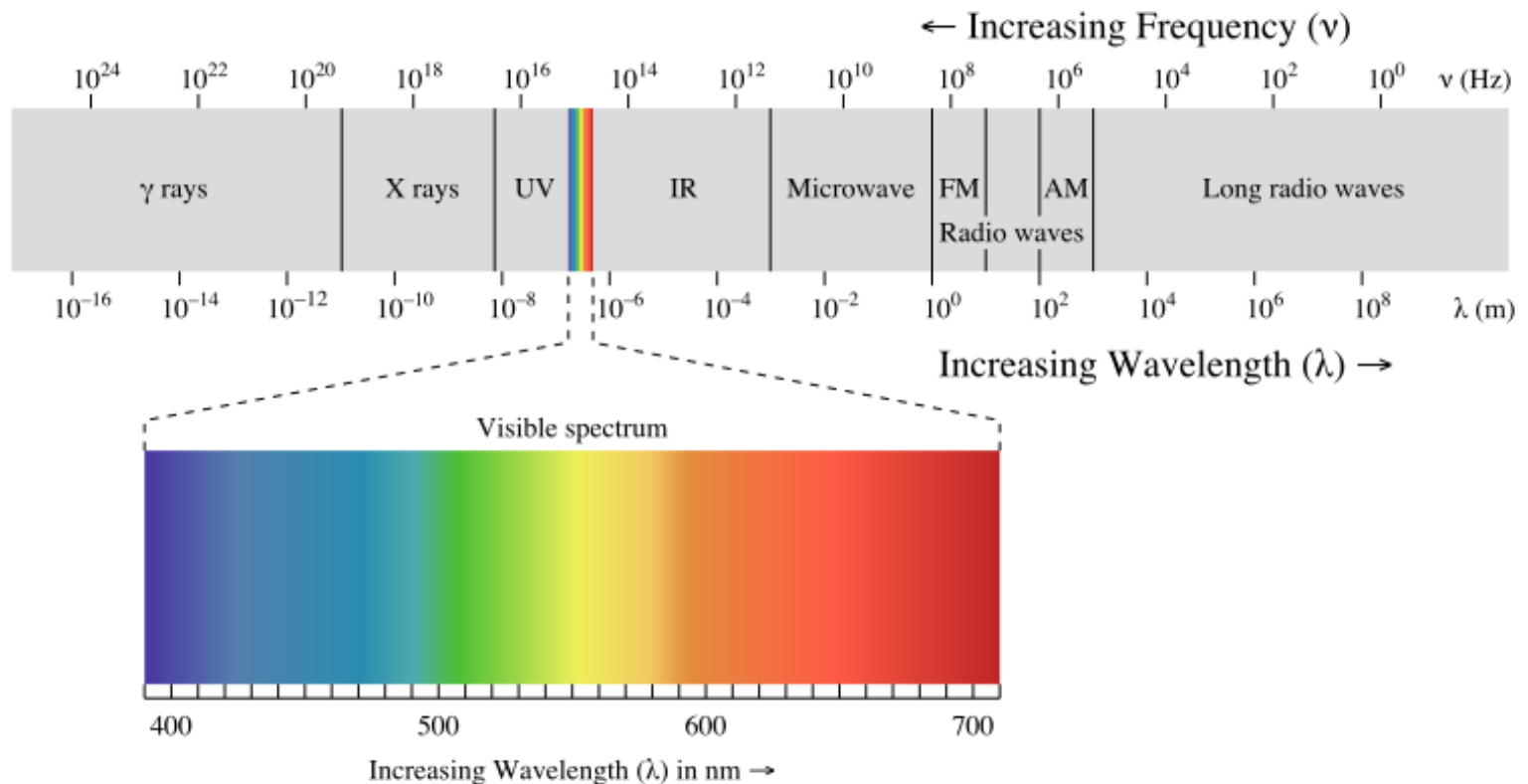

http://www.land-of-kain.de/docs/spaceweather/wikipedia_em_spectrum_small.jpg

Frequency bands

- Transmitters used on sensor nodes rely on radio communications, either in the ISM band, or through Cellular, Bluetooth or WiFi
- Bluetooth and WiFi frequencies are the same everywhere, however the allowed frequencies in the ISM and cellular bands depend on countries (check the frequencies used by the system when dealing with international providers). The maximum radiated power (EIRP) can have country-specific limits in some bands.

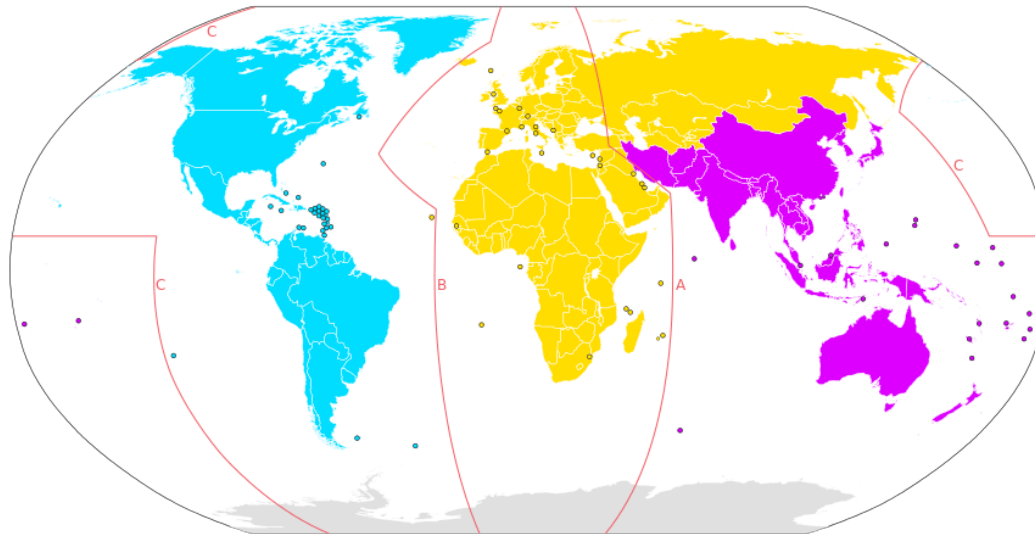

https://upload.wikimedia.org/wikipedia/commons/thumb/9/9b/International_Telecommunication_Union_regions_with_dividing_lines.svg/1200px-International_Telecommunication_Union_regions_with_dividing_lines.svg.png

Fundamentals on wireless communication

- Most networking applications are in the VHF-SHF range (30MHz-30 GHz). Wavelengths are between 1cm and 10m
- In the US, the following frequencies are allowed:
 - 915 MHz (cellular and ISM)
 - 2.4 GHz (Bluetooth and WiFi)
 - 5.8 GHz (rarely used)
- These band have EIRP (power) limits, which limits practical range

CLASS	FREQUENCY	WAVELENGTH	ENERGY
Y	300 EHz	1 pm	1.24 MeV
HX	30 EHz	10 pm	124 keV
SX	3 EHz	100 pm	12.4 keV
EUV	300 PHz	1 nm	1.24 keV
NUV	30 PHz	10 nm	124 eV
	3 PHz	100 nm	12.4 eV
NIR	300 THz	1 μm	1.24 eV
MIR	30 THz	10 μm	124 meV
FIR	3 THz	100 μm	12.4 meV
EHF	300 GHz	1 mm	1.24 meV
SHF	30 GHz	1 cm	124 μeV
UHF	3 GHz	1 dm	12.4 μeV
VHF	300 MHz	1 m	1.24 μeV
HF	30 MHz	10 m	124 neV
MF	3 MHz	100 m	12.4 neV
LF	300 kHz	1 km	1.24 neV
VLF	30 kHz	10 km	124 peV
VF/ULF	3 kHz	100 km	12.4 peV
SLF	300 Hz	1 Mm	1.24 peV
ELF	30 Hz	10 Mm	124 feV
	3 Hz	100 Mm	12.4 feV

http://learnlearn.net/verdensrommet%2Cjorda/res/Default/ESS_PasteBitmap0001197.png

Frequency considerations

- The **frequency** of emission also has a significant impact on radio communications
- In general, lower frequencies are more **resilient** to changes in orientation, or to **obstacles** between the emitter and receiver, due to diffraction. High frequency signals tend to be more directional, and are more affected by smaller obstacles (due to diffraction)

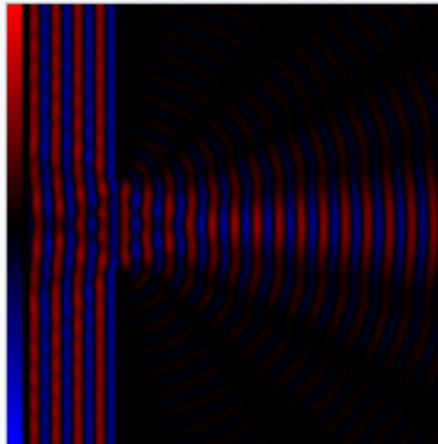

<https://en.wikipedia.org/wiki/Diffraction>

Emission and reception of radio waves

- **Antennas** are devices in which a current oscillates. They are used to emit (as electromagnetic waves) and receive (as a voltage) data

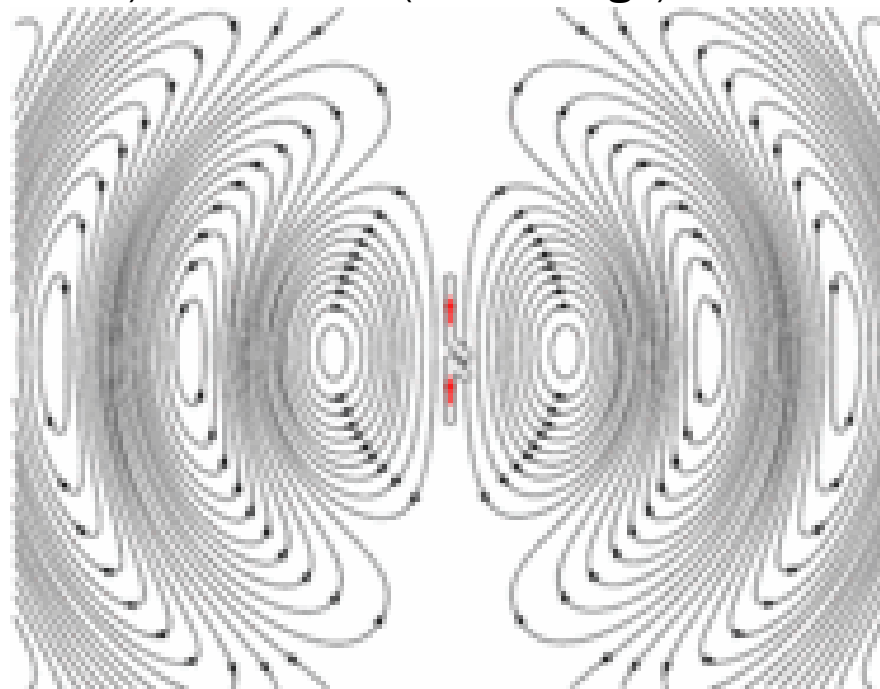

[https://en.wikipedia.org/wiki/Antenna_\(radio\)#/media/File:Dipole_xmting_antenna_animation_4_408x318x150ms.gif](https://en.wikipedia.org/wiki/Antenna_(radio)#/media/File:Dipole_xmting_antenna_animation_4_408x318x150ms.gif)

There are different types of antennas (dipole, whip, spring, patch, array...), with different **efficiencies** (ability to emit a high amount of radiation) and **radiation patterns** (power emitted in different directions)

Antenna gain

- The power emitted by antennas depends on the **direction**. It then decreases as $\frac{1}{r^2}$, where r is the **distance** to the **antenna**
- The **gain** of an antenna denote its ability to send a **high power** signal in some particular direction. Since the same power is spread around following the radiation pattern, a higher gain means that more power is sent in specific directions, though less power will be sent in other directions

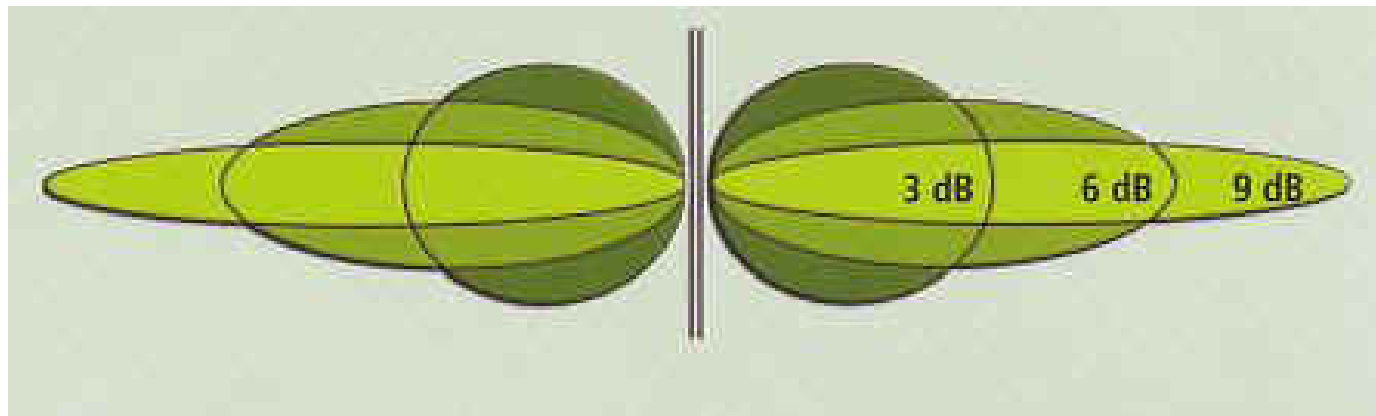

http://www.radiospecialists.com.au/4WD_antenna_gains_2.jpg

Antenna gain

- A high gain antenna is useful to increase the range if the orientation of both the emitter and receivers does **not change over time**
- The higher the gain, the less **robust** the reception will be to small orientation changes (or moving obstacles)
- Laws limit the gain of antennas (for a given transmitter power setting). High gains antennas can only be used on low power settings



0dB



5dB

http://images.libelium.es/content/products/waspmote/overview/interfaces/w_hw_xbee.png

Antenna deployment considerations

- The spatial domain in which obstacles can have a noticeable effect on transmission is known as the **Fresnel zone**

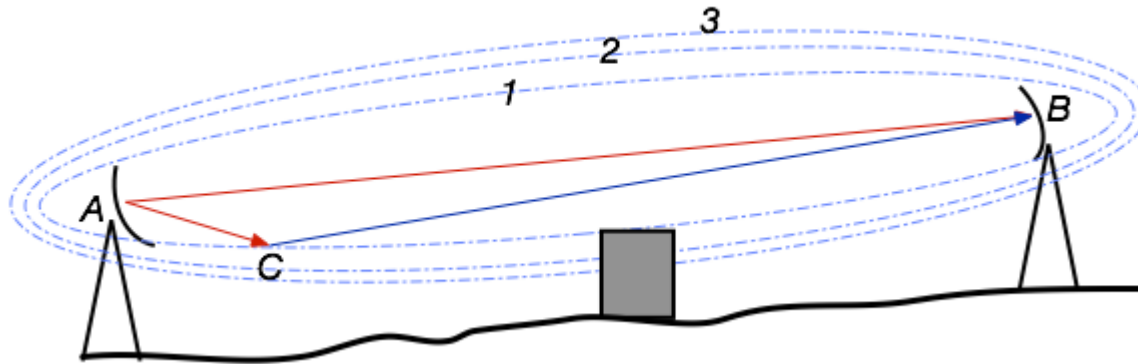

https://upload.wikimedia.org/wikipedia/commons/4/4b/1st_Fresnel_Zone_Avoidance.png

- The Fresnel zone must stay as free of obstacles as possible (typically with no more than 20% obstruction). Obstruction causes **destructive interference** through multi-path effects

Long range communications

- If the **cellular network** is available in the deployment location, cell communications can be used to send data generated by the sensor
- Limitations:
 - Cost (annual or monthly data service plans)
 - Power usage
 - Possibly unavailable (or slow) during emergencies (when the sensors may be most useful)
- Other systems exist for dedicated long range communications, including **LoRa** (over 915 MHz). Range: $\frac{1}{2}$ - 6 mi (depending on obstacles)
- Limitations:
 - Bandwidth (~100 bytes per second with the longest range setting)



https://www.semiconductorstore.com/Pages/asp/Item_MoreImages.asp?ItemNumber=XBC-M5-UT-001



<https://www.seeedstudio.com/RFM95-Ultra-long-Range-Transceiver-Module-LoRa-Module-support-868M-frequency-p-2807.html>

Long range communications

- Some orders of magnitude:

- Locally stored
- Bluetooth (IEEE 802.15.1): 30-100 ft (10-30 meters)
- Wifi (IEEE 802.11): 30-300 ft (10-100 meters)
- IEEE 802.15.4 transceivers (for IoT): 300-1200 ft (100-400 meters)

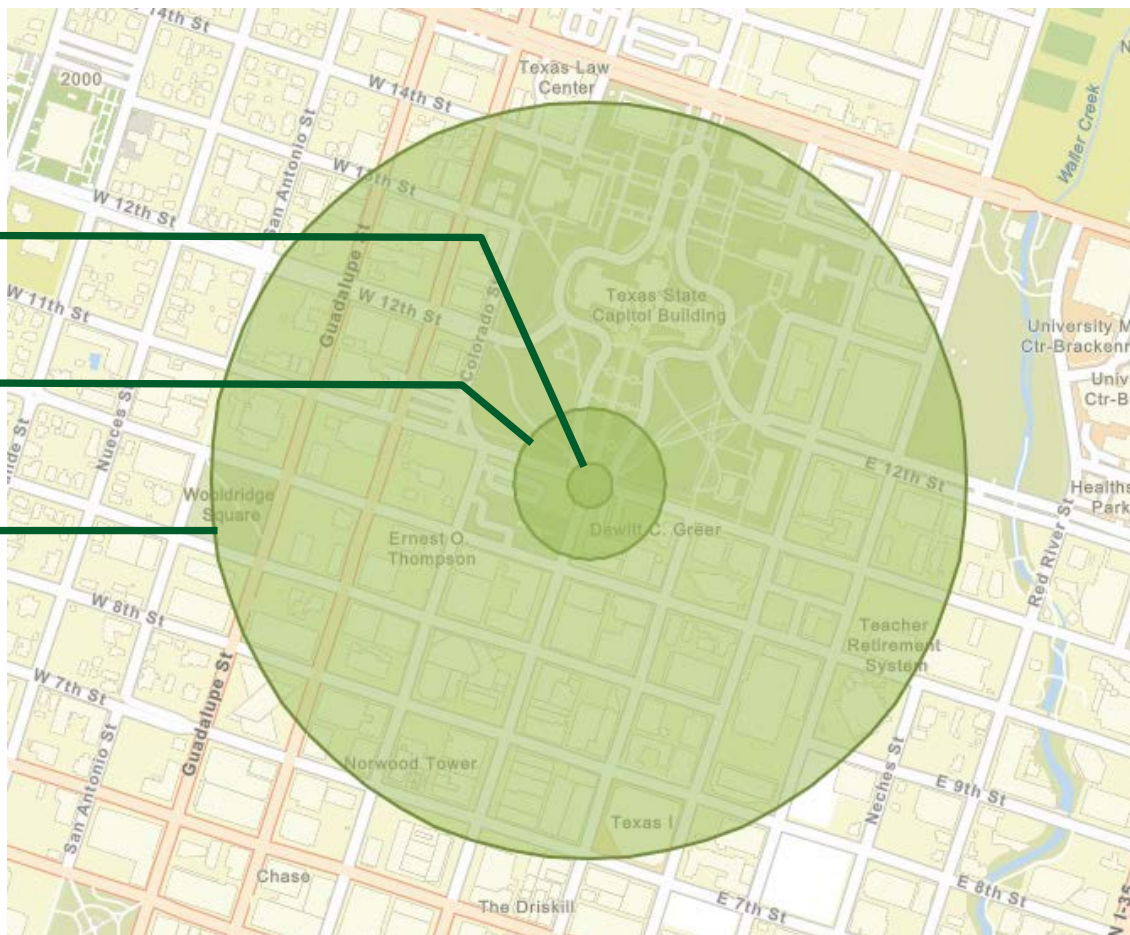

Long range communications

- Some orders of magnitude (continued):

- LORA transceivers: 1/2 - 3 miles (800-5000 meters)

- Cellular transceivers: 1 - 10 miles, depends upon coverage

- Satellite

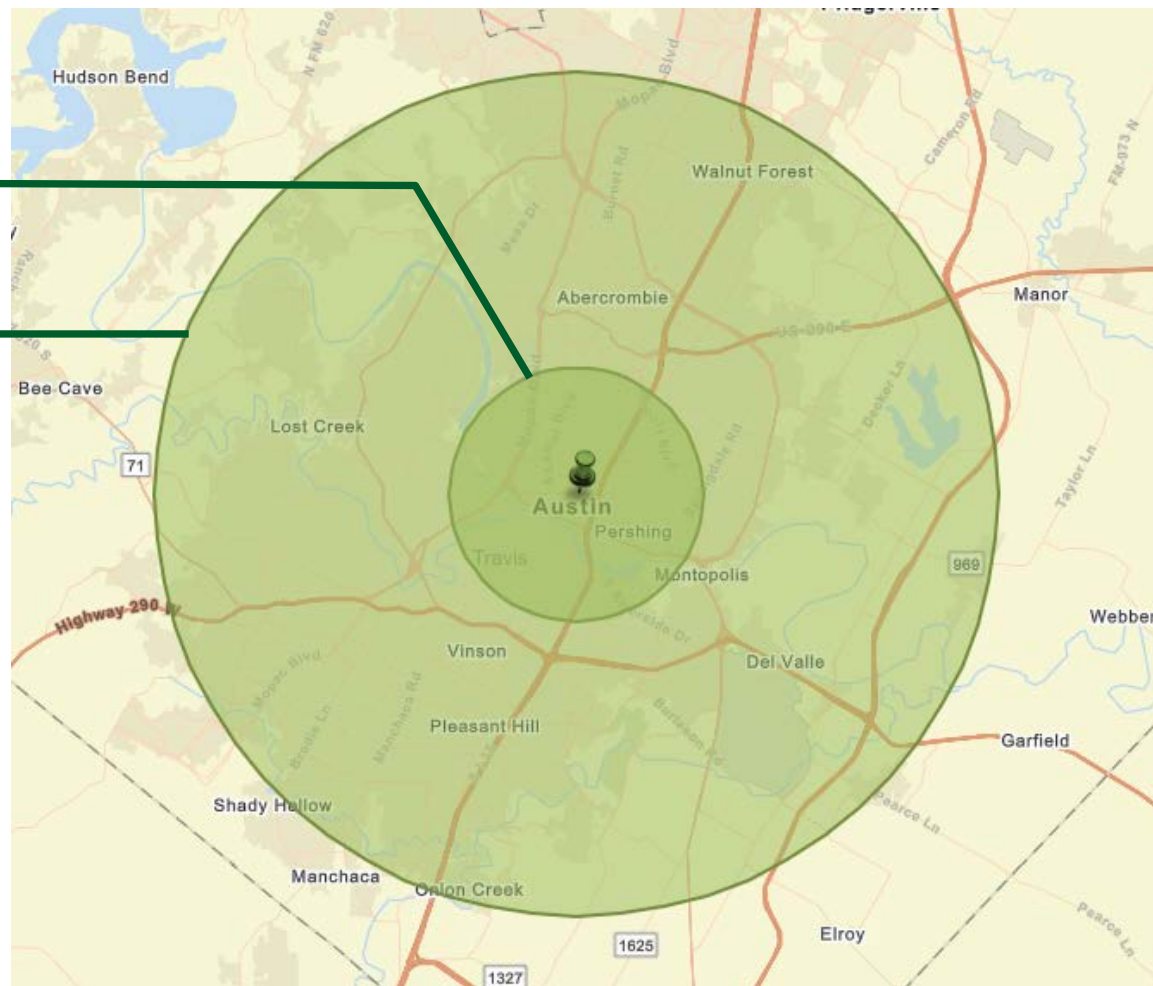

Cellular Data Plan Example

- We have a cluster of sensor stations.
- These sensor stations can communicate via 802.15.4 and each also can be equipped with a cell modem option.
- They are located miles away from the nearest wired network connection.
- What would be an ideal configuration for cellular communications?

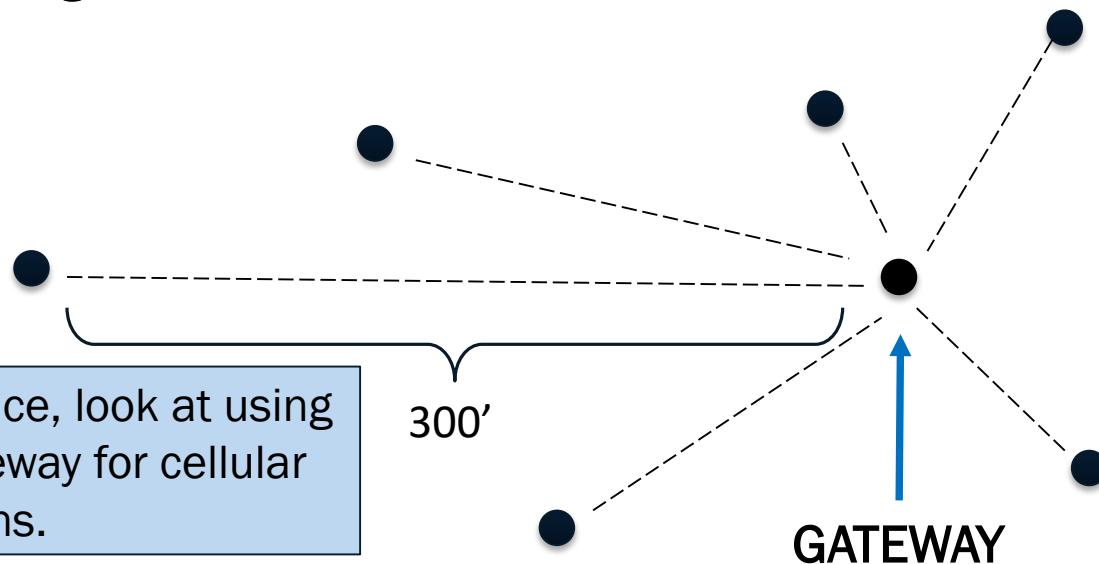

To save costs and maintenance, look at using the central station as a gateway for cellular communications.

Objectives

- Present a high level overview of sensors
- Give a general overview of what can be sensed
- Important sensor specifications to select appropriate solutions
- Power considerations
- Wireless communications considerations
- **Lessons learned**

Lessons learned from deployments/lab tests

- 1) Do a search of the **possible technologies** suitable to some application, in 2 steps:
 - What physical parameter should be sensed?
 - What type of sensor should be used to sense this physical parameter?

Example: for flood detection, we can sense multiple things: rain rate (indirect indication of flooding risk), water presence, water level, water pressure

Once we choose one or multiple physical parameters from the above list, we can use different type of sensors to sense these. For example rain rate can be measured with tipping bucket stations, or with optical sensors (among others)



Lessons learned from deployments/lab tests

- The chosen physical quantity to be sensed is equally important. For example, in the case of **road ice monitoring**, we can do the following:
 - Measure ground temperature (passive infrared)
 - Measure humidity levels and air temperature (from which we can compute the dew point)
 - Detect the presence of ice, slush or water by analyzing the reflection of a light beam over the surface (active measurement)
- Each measurement is valuable, however some are more valuable than others (ex: presence of ice is better than ground temperature). **Combinations** can make measurements more valuable, for example ground temperature + humidity + air temperature

Lessons learned from deployments/lab tests

- 2) Choose the appropriate vendor by comparing their specifications (datasheet)
 - Emphasize on **reliability** over price (taking into account the cost of the deployment itself, and the expected maintenance cost): increased memory, battery capacity, solar panel power can increase reliability but slightly increase the price
 - Check **all items of the specifications** list to look for problems, for example weight, mounting constraints, high power consumption, low radio range, lack of watchdog timer, lack of power monitoring circuitry, incompatibilities, etc.

Lessons learned from deployments/lab tests

- Despite careful checks errors can happen:
 - We ordered a 802.15.4 gateway to extend the range of 802.15.4 compatible sensors (Sadeem water level sensors), but the firmware versions were incompatible (versions are not specified on the datasheet)
 - One manufacturer (IceSight) sent us a sensor cabinet without the keys
 - Some sensors require specific software to query data from the sensors, and cannot be manually configured to push data to a server. These details have to be addressed before the purchase.



Lessons learned from deployments/lab tests

- 3) Emphasize on **reliability**, with the use of simple, rugged equipment, and simple onboard processing
 - Consumer electronics are not reliable enough to be deployed in the field
 - For critical applications, make sensor nodes more **robust to uncertainties** using the following:
 - Oversized power supplies (large solar panels, large, reliable batteries)
 - Reliable communications (possibly using multiple transceivers in the same system)
 - IP 65+ enclosures for water resistance (except when the application prohibits it, for example with air pollution sensors)
 - Lightning resistant embedded systems
 - Watchdog circuitry to enable automatic resets if the system becomes unresponsive after a set period



<https://images.ssstatic.com/raspberrypi-3-modelo-b-27105476n0-18035667.jpg>

Lessons learned from deployments/lab tests

- 4) **Expect the unexpected** during the procurement, test and deployment process
 - Deadlines are sometimes not met
 - Software errors are frequent in embedded systems, and can appear unexpectedly after a period of time (example: memory leaks)
 - Software/hardware versions can change unexpectedly (example: 802.15.4 gateways)
 - Hardware is provided with sometimes minimal specifications and mounting instructions (ex: IceSight sensors) requiring subcontractors to test and deploy the systems
 - Outdoor environments can be punishing (rain, birds, temperature cycles, dust, lightning, etc.). Plan the system accordingly

You have two sensors independently operating at the same location. Each has a failure rate of 5%. What is their approximate combined failure rate?

- A. 25%
- B. 10%
- C. 5%
- D. ¼%
- E. Cannot be determined

- ANSWER: $0.05 \times 0.05 = 0.0025$, which is a quarter of a percent. That's D.

Your sensor system's data sheet says that the ADC operates with 8-bit accuracy. How many different levels of digital output are possible?

- A. 8
- B. 16
- C. 88
- D. 256
- E. 32767

▪ ANSWER: 2^8 , which is 256. That's D.

You'd like to measure the water height of a flood-prone creek and report on whether the flooding is nonexistent, moderate, severe, or critical (based on water height). What kind of sensor device would be most appropriate?

- A. Temperature sensor
- B. Switch-based water level sensor
- C. Pressure, radar, or ultrasound water level sensor
- D. None of the above

- ANSWER: You want a water level sensor, and it must measure more than two levels of water. The best match is **C**.

Your manager asks you to estimate the cost of a sensor. What can be taken into consideration when communicating the total cost?

- A. Equipment
- B. Deployment
- C. Maintenance
- D. All of the above

- ANSWER: All three of these represent significant cost: D.

You'd like to deploy a sensor station that's at a rural low water crossing. The closest networking or ITS devices are about 8 miles away in the nearest town. What will be the best wireless technology to look for in a sensor station solution?

- A. Bluetooth
- B. WiFi
- C. IEEE 802.15.4
- D. Cellular
- E. Satellite

▪ ANSWER: Although it incurs a subscription cost, the best choice is **D**, cellular, assuming service availability. But, watch for devices that allow for the creation of a mesh network via shorter distance signal-hopping.



WEATHER-SAVVY ROADS

Part 2: Data, Decision-Making, and
Dissemination



Objectives

- Sensors and IT architecture
- Low water crossing study
- Case studies: road weather data
- Dissemination to the public
- Data analysis
- Discussion topics

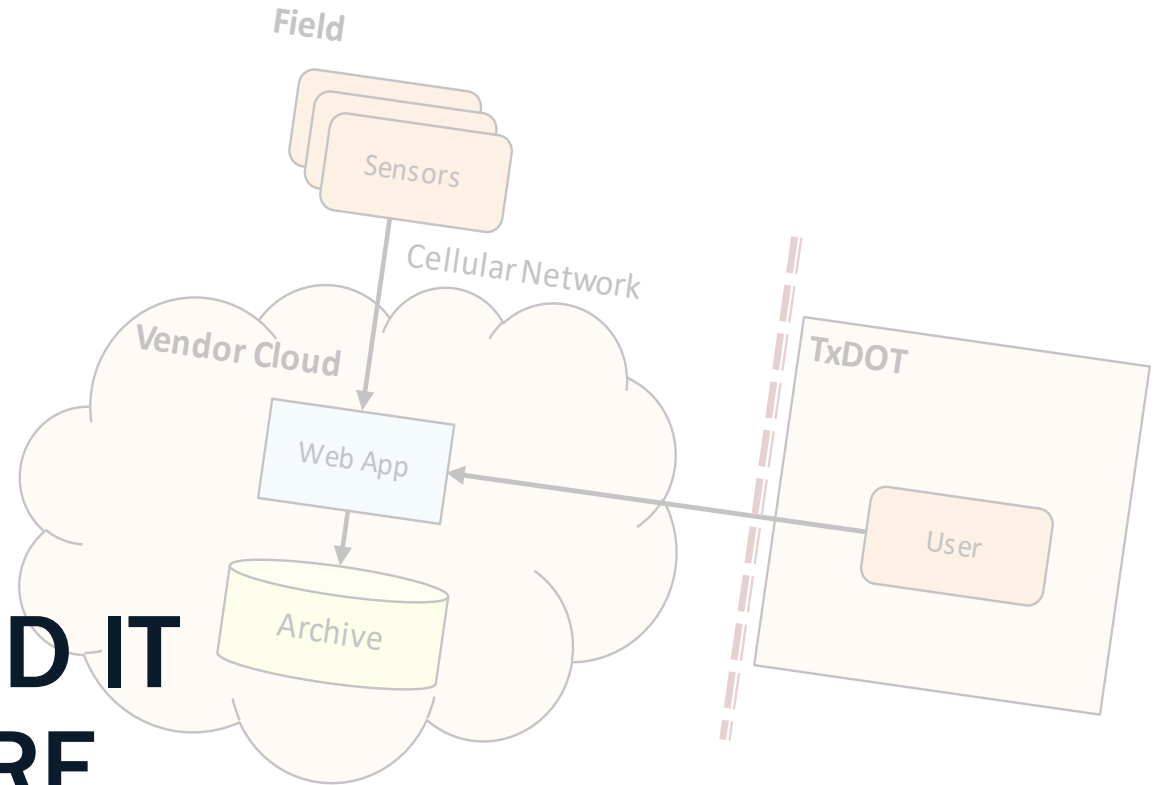

SENSORS AND IT ARCHITECTURE

Looking to the Future

Sensors and TxDOT IT Architecture

- TxDOT IMD creates security guidelines to protect the safety, security, and reputation of IT architecture. This can include sensor equipment that sends data to TxDOT.
- Sensors acquired for this project have not been thoroughly evaluated against these guidelines, but may coincide well if architected properly.
- Further evaluation is an area for future work, as a formal implementation project or as a task tied with future sensor purchases and integrations.

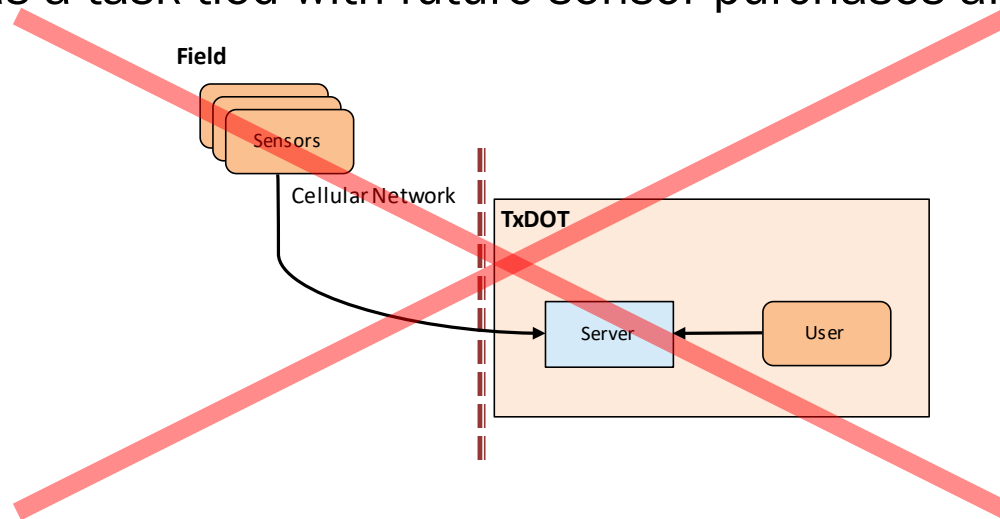

- How to navigate the current scheme with minimal impact?

Sensors and TxDOT IT Architecture

- Use a vendor that provides a cloud service. Access the data from within TxDOT:

Question: How much does the vendor alter the data?

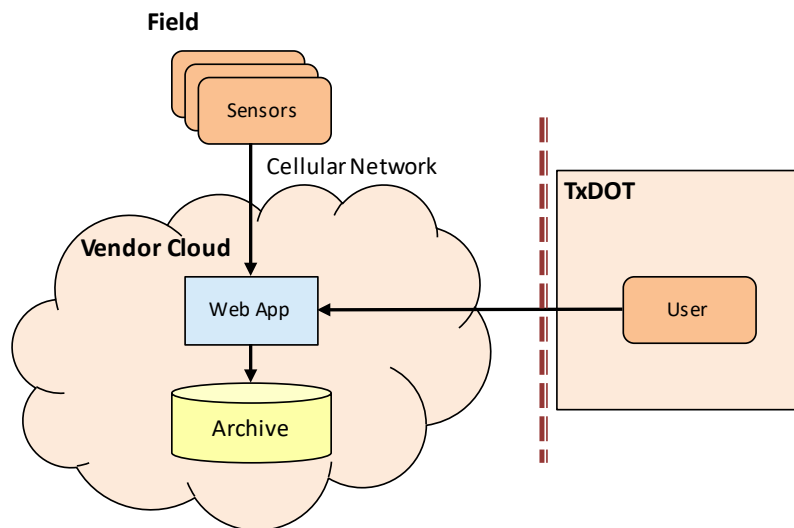

- Use an approved mechanism for bringing data into TxDOT's systems:

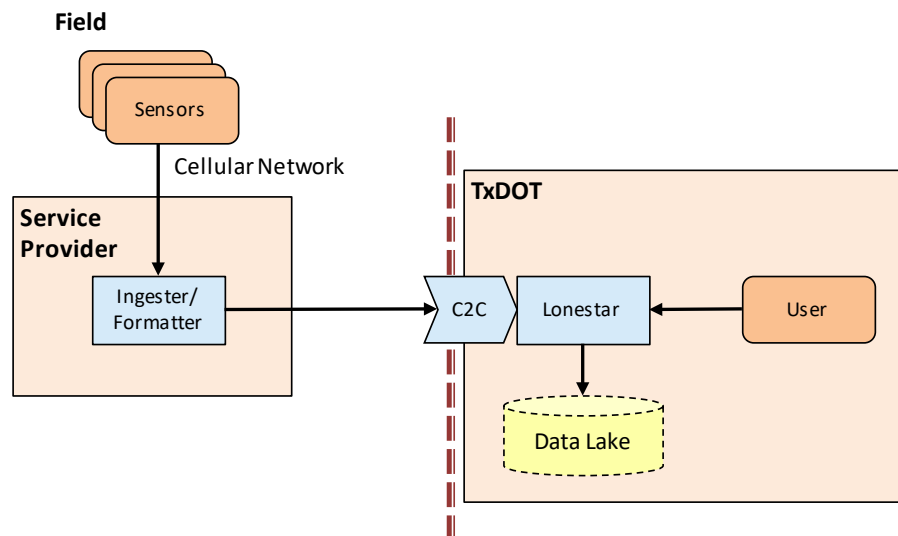

Sensors and TxDOT IT Architecture

- Example: WxDE (the FHWA Weather Data Environment)

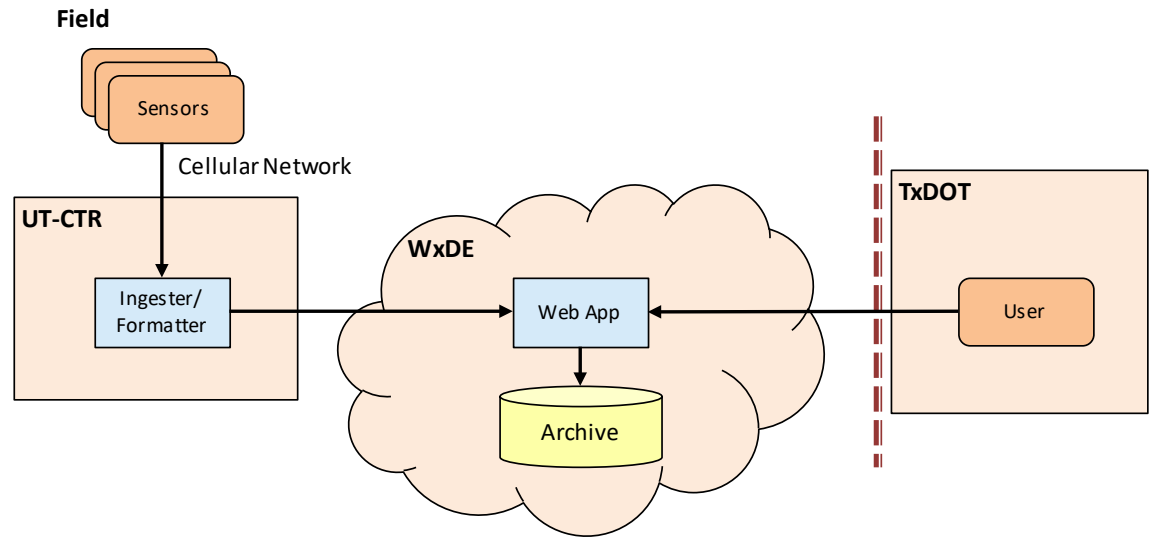

- Example: Smart field devices

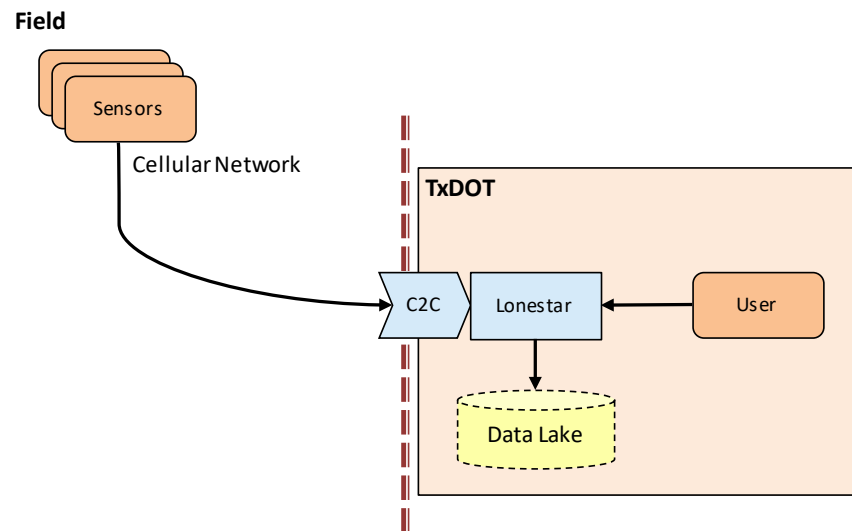



LOW WATER CROSSINGS

Study Results



TxDOT Low Water Crossing Study (2017)

- The study took inventory of LWC in Austin District and prioritized 20 candidate locations for installing High Water Detection Systems
- The study also included the assessment of the HWDS that will detect roadway flooding conditions, notify the assigned District personnel, and warn/inform approaching drivers

Insights Found:

- TxDOT sends maintenance personnel to close flooded roadways and keep up with alerts during the flood events.
 - **There is no available documentation of past road closures and flood events.** The information is limited to the knowledge of the maintenance staff
- TxDOT has determined to not use automatic barriers/gates to close roads within TxDOT Austin District. Therefore, advanced warning, flashing lights, message signs, etc. are very important.

TTI: Messaging Aspect of LWC (2011)

- TTI collected opinions from a total of 74 Texas Drivers to discover what information they find useful/necessary to navigate flood-prone roads, and the most effective ways to present that information.



Sample Pictures for Scenario Questions

TTI: Messaging Aspect of LWC (2011)

- While respondents had varying opinions on what a “flooded” road meant, the information required by users for a **flooded area** included:
 - **Presence** and **depth** of the water
 - Whether the road is closed or dangerous
- How users find this information:
 - Warning signs/gauges
 - Highway Advisory Radio
 - Television/radio
 - Internet sources
 - Telephone hotlines.



TTI: Messaging Aspect of LWC (2011)



- During a **flood event** the devices found most useful included:
 - DMS with specific information
 - Permanent warning signs with automatically activated flashing lights
 - Gates or barricades with flashing lights
- The results also noted that the addition of **stop bar** markings to passive or active warning signs were found **ineffective** by the tested group.

A Possible Future Study

- Solar-powered, black-out signage that activates based upon flood depth:

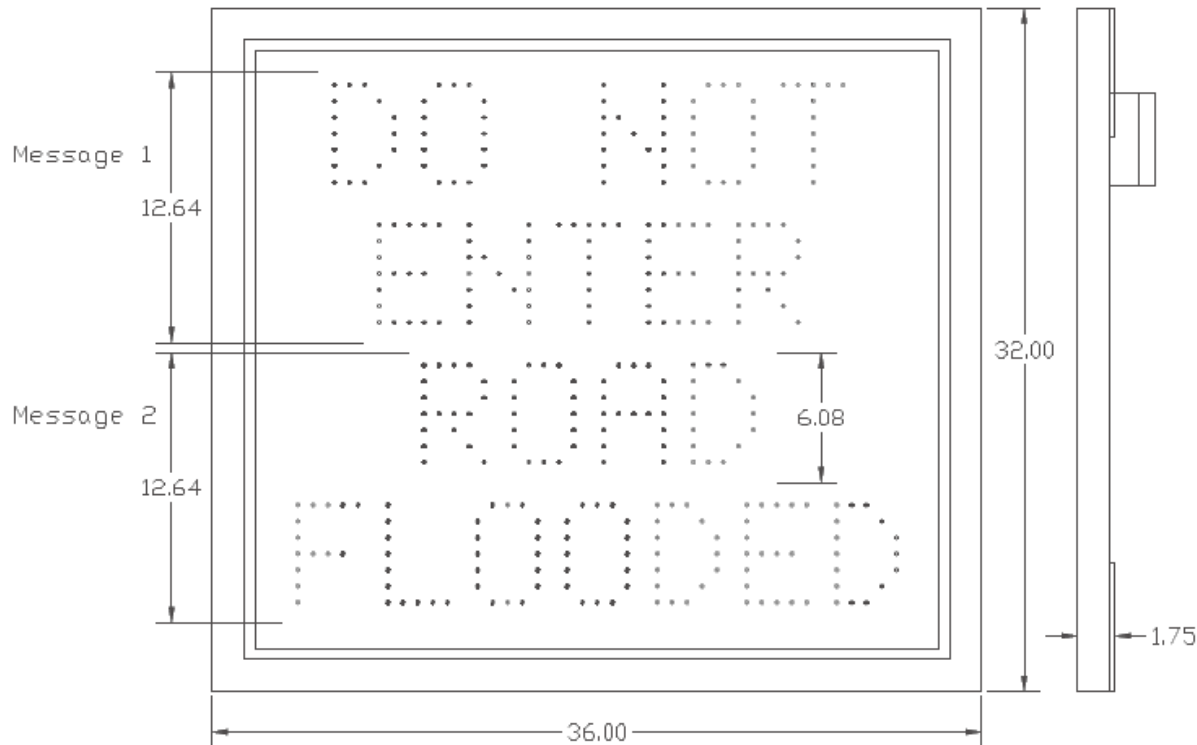

- Powdercoated Black Aluminum Extruded Frame.
- Red LED, HI Brightness.
- 1/4" Polycarbonate Blackout Lens
- 1/4" HDPE Back.
- Junction box with Power Supply on rear.
- T-Slot track w/ 5/16-18 nuts for mounting.
- Alternates between Msq.1 and Msq.2

Source: FLN-MAR



DOT	Technology/Data	Dissemination	Impact
Wyoming	Speed detection, RWIS, CCTV cameras, crash data	DMS, VSL, 511 Travel Alert System	Safety – reduced speed, fewer crashes. Communication – near real-time weather and road condition available to the public.
Florida	Embedded pavement sensors, vehicle detection sensors, crash data	Flashing beacon with VSL	Safety & traffic flow – decreased speed variance and reported crashes
Oregon	Weather sensors, crash data	VSL/DMS	Safety & traffic flow benefits - 21% reduction in crashes, reduction in severity of incidents, improved corridor reliability
Idaho	Weather sensors (primarily visibility data), vehicle detectors, crash data	DMS	Safety – reduced speed due to weather related advisories
Alabama	Weather visibility sensors, CCTV cameras	DMS	Safety – reduced average speed and minimized crash risk

ROAD WEATHER DATA

Case Studies

Wyoming DOT: VSL System

Improving safety and communication

Speed Sensor



Source: WYDOT (2010)

RWIS



VSL Sign



511 System

Traffic Management Center



Source: WYDOT (2012)

- Reduced speed, fewer crashes
- 511 Travel alert system (www.wyoroad.info)

Reducing accidents and improving traffic flow

Florida DOT



Source: FDOT (2010)

- Decreased speed variance
- Reduced crashes

Oregon DOT



Source: KTVB (2016)

- 21% reduction in crashes
- Reduction in crash severity
- Improved corridor reliability

Fog Warning Systems

Reducing speed and increasing safety

Alabama DOT



Source: FHWA (2012)

Idaho DOT: Safety Impacts

Road Weather Condition	Speed without Advisories	Speed with Advisories	Speed Reduction due to Advisories
High Winds (over 20 mph)	54.8 mph	42.3 mph	23%
High Winds and Precipitation	47.0 mph	41.2 mph	12%
High Winds and Snow-Covered Pavement	54.7 mph	35.4 mph	35%

Source: Pisano and Goodwin (2004)

FHWA Road Weather Management Program

- An initiative to improve roadway management and performance during adverse weather through four main categories:
 - 1. Stakeholder Coordination**
 - Bringing a multi-disciplinary approach to road weather challenges
 - 2. Road Weather Research and Development**
 - Improving observing networks, modeling, road weather information dissemination, and integrating road weather technologies
 - 3. Technology Transfer, Training and Education**
 - Raising awareness of road weather capabilities through outreach
 - 4. Performance Management and Evaluation**
 - Defining and tracking performance measures

FHWA RWMP: Weather-Savvy Roads

- The Weather-Savvy Roads initiative hits on FHWA's primary goal categories with two solutions:
 - **Pathfinder Program** - a collaborative effort between the NWS and State DOTs to improve RWM through the dissemination of consistent and effective weather information to the public.
 - Just because you know something is happening doesn't mean people will react the same way or get the same information.
 - **Integrating Mobile Observations (IMO)** - a solution to enhance available real-time weather data to support decision making through the addition of sensors to existing government fleet vehicles.
 - To define and track performance measures for current and future benefits, there is a big push in the IMO solution to integrate and share the data into the **Weather Data Environment (WxDE)** an online road weather observation dashboard.

Data Capture and Management

Defining and tracking performance measures

- Dashboards are one way to monitor this type of information.

Weather Data Environment (WxDE)

- Free online real-time WxDE allows roadway weather observations to be stored in one location and demonstrate the value of sharing the transportation-related weather data.
- Includes NOAA weather data
- Maps, archives, provides quality checks, and pulls data queries.

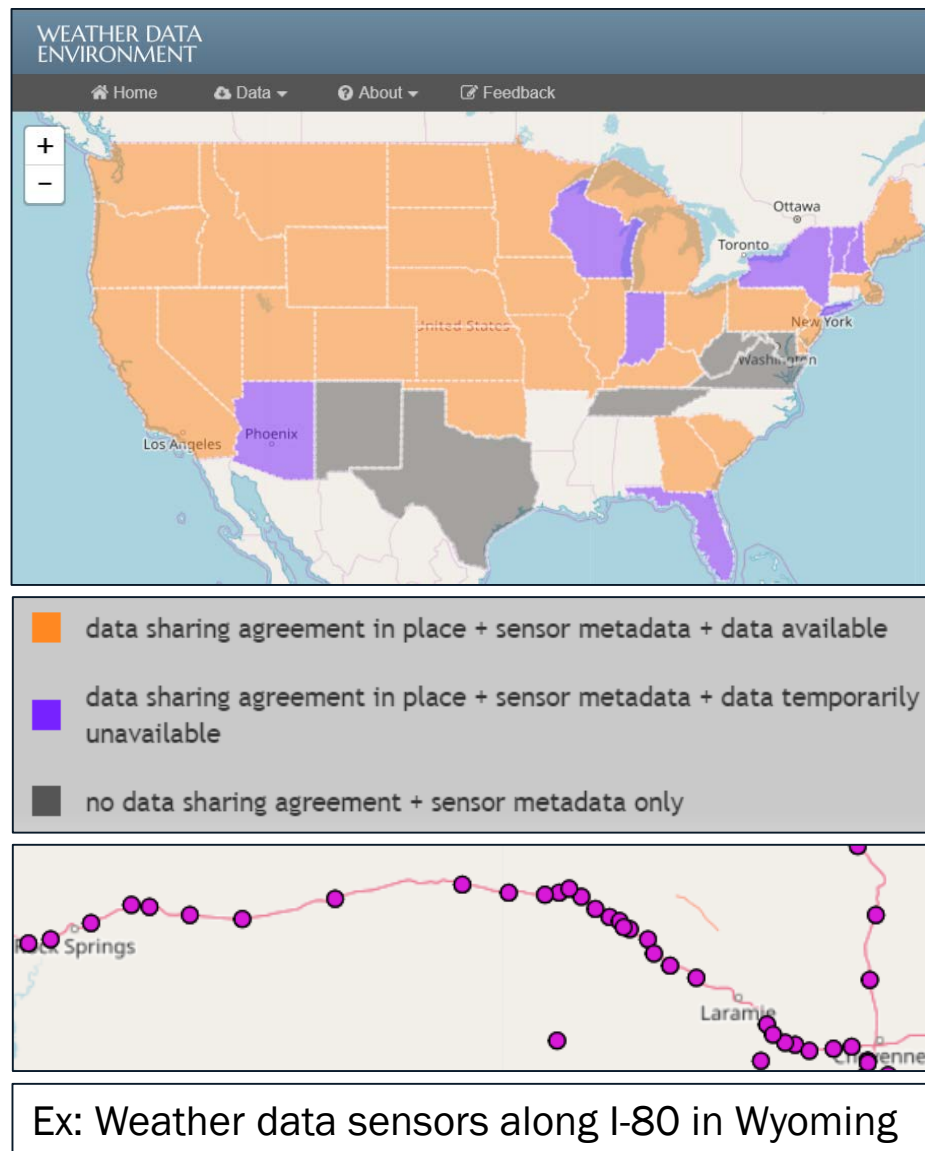



DISSEMINATION

Conveying Information to the Public

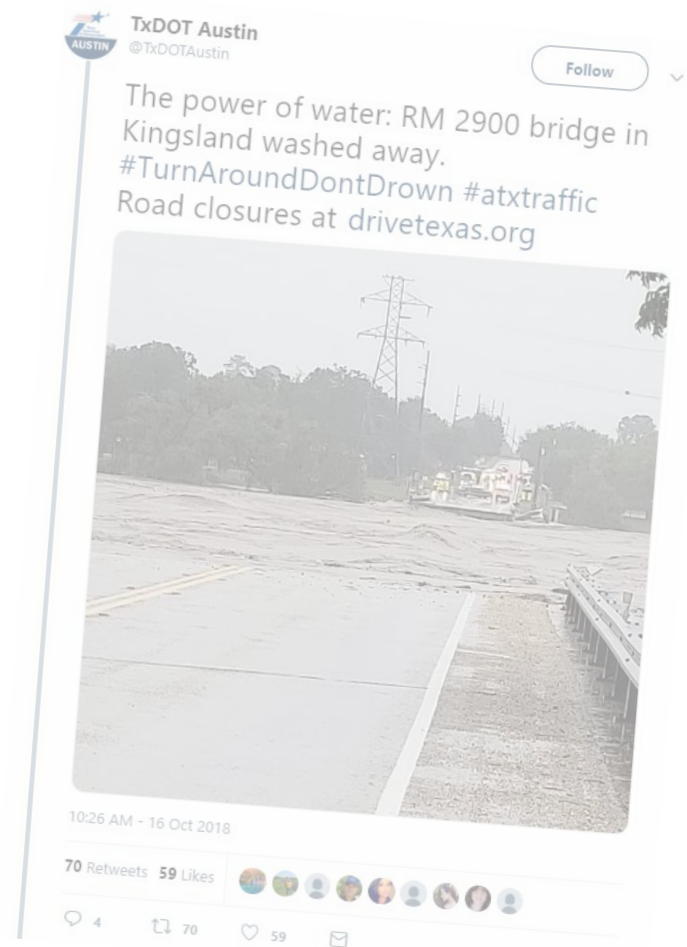

Number of States Disseminating Weather Advisory and Other Road Weather Information to Travelers, by Type

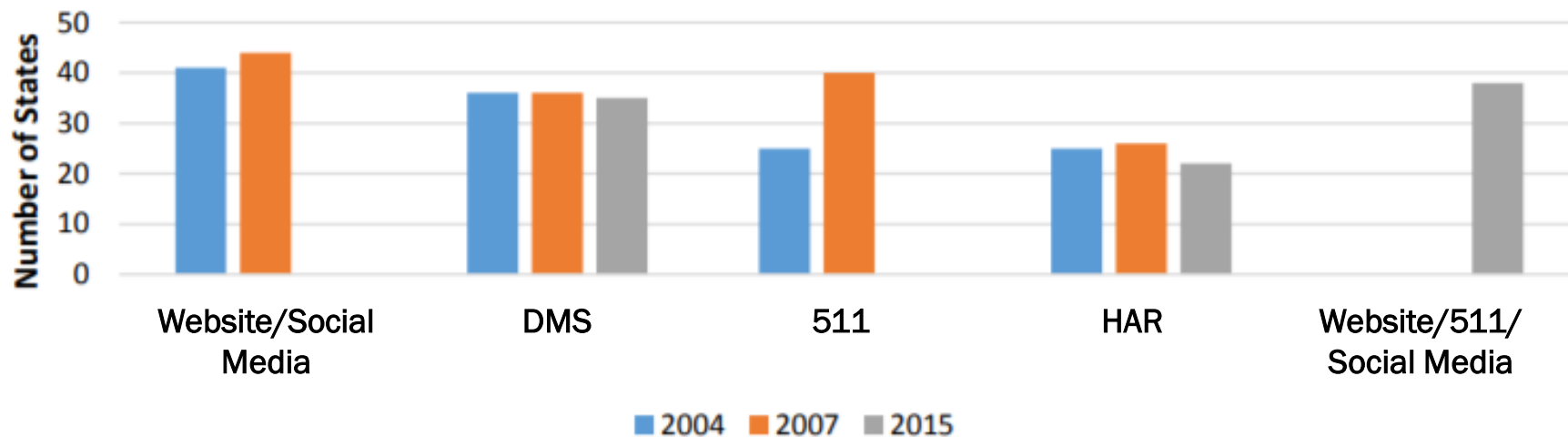

Source: FHWA-HOP-16-001 (2016)

Dissemination to the Public

Percent Change from 2015 Survey

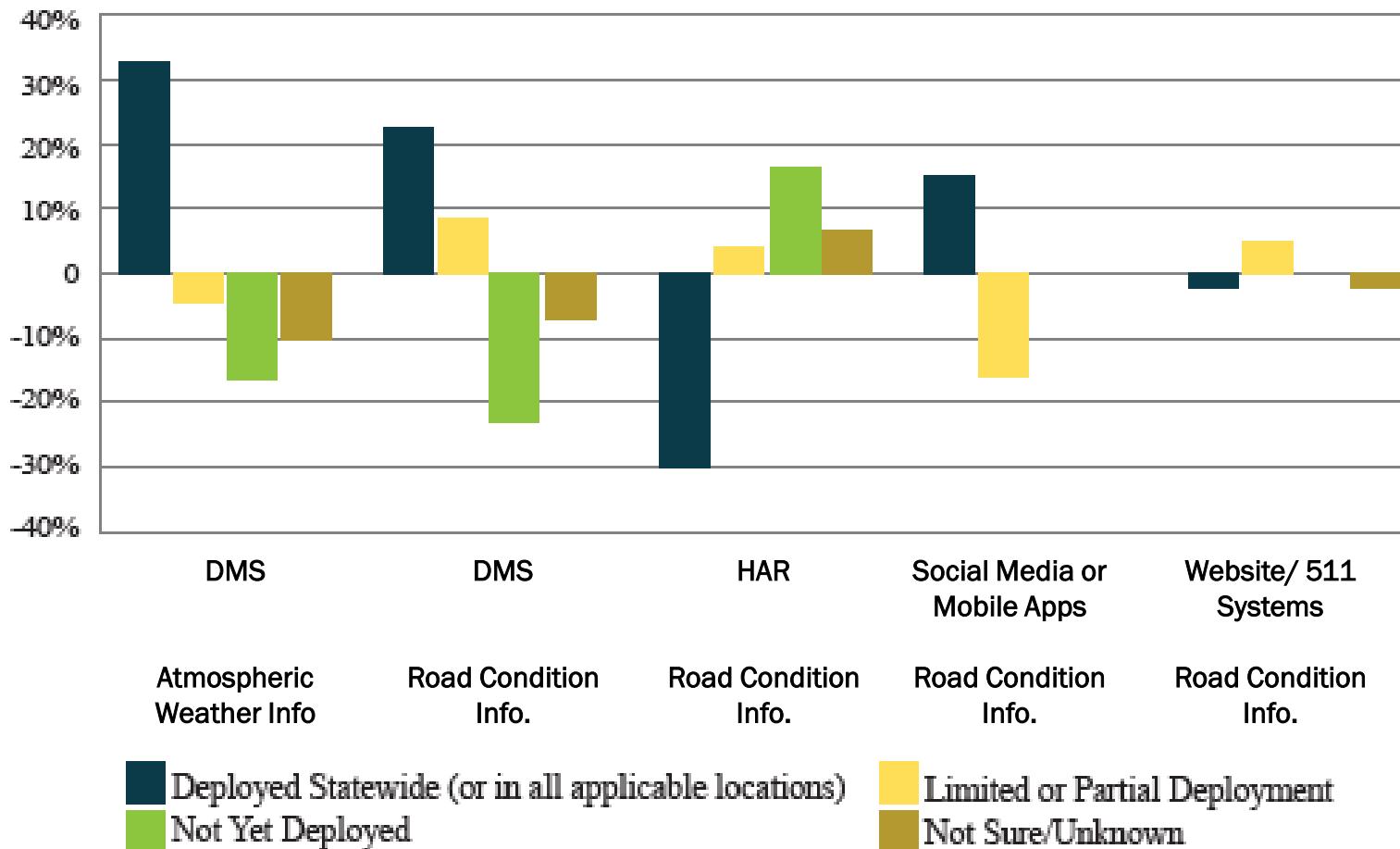

Source: FHWA-HOP- 1-048 (2017)

Websites & Social Media

- DOT personalized websites with varying levels of roadway weather information (ex: DriveTexas, TxDOT's ITS)
- DOT controlled social media (Twitter, Facebook, etc.) to provide related road weather information updates.
 - Hard to track the impact of social media, although most DOTs receive a lot of traffic on social media.
 - Potential social media example provided by Weather-Savvy Roads:



Crash risk is 8x greater during a snowy AM commute!

Social Media

- All 25 TxDOT districts have their own Twitter accounts, as well as a few TxDOT projects
 - Some districts have more active feeds than others (lowest end has <700 followers or <900 tweets)

Twitter Account	Tweets	Followers	Likes
@TxDOT	14,300+	84,200+	5,200+
@TxDOTAustin	9,400+	30,500+	260+
@TxDOTAbilene	3,200+	2,800+	147+
@ImproveMopac	3,500+	4,500+	250+

- Difficult to determine the effectiveness of social media alerts however the redundancy of information only helps to spread the message
 - Account holders do have the ability to check to see how many times the Tweet was seen on Twitter and other Tweet activity

- Advantage of Twitter
 - Travelers can reply to tweets or direct tweets using the “@” sign and twitter name.
 - Hashtags (“#”) can be placed before a word or phrase without spaces in a message to show up more easily in a Twitter Search.
 - Clicking on a hashtag will show all of the other tweets with that hashtag.
 - Can link to other sites for more information. Can also retweet other sources like NWS.

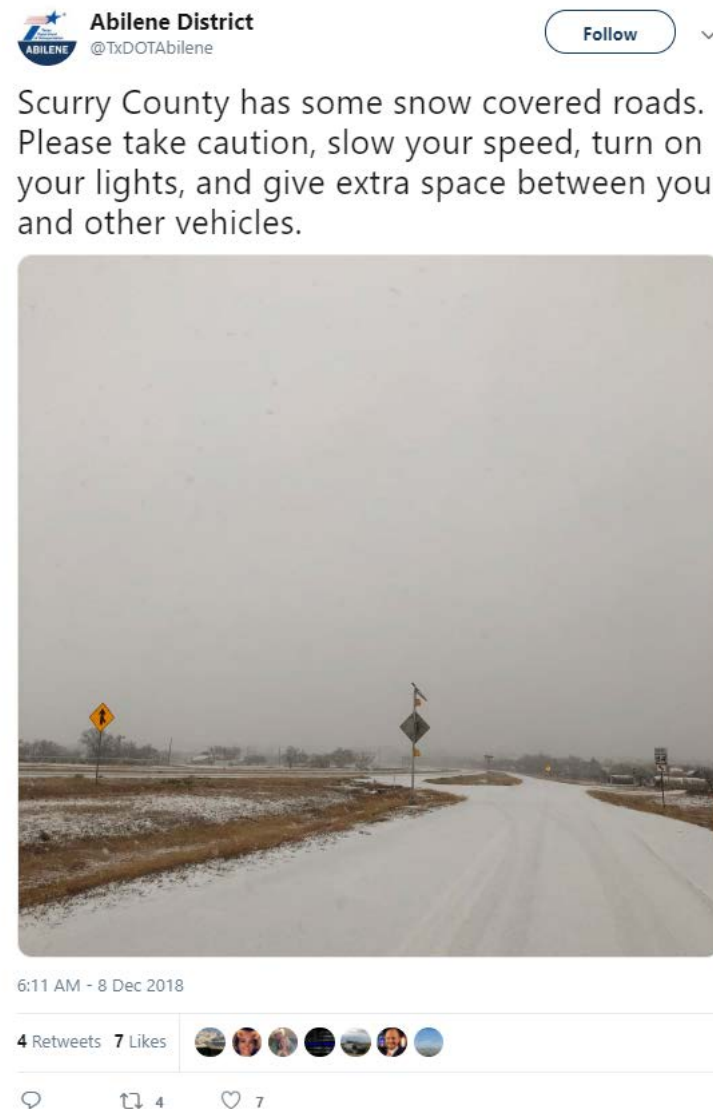

- Allow for more lengthy notifications than DMS, and currently exist in over 30 states. Ex:
 - WYDOT's 511 Notify System
 - 511DFW System and Waze Partnership
 - Real-time data from Lonestar
 - Relatively new system and partnership



- Most prevalent notification method used by states.
- Weather-Savvy Message guidelines:
 - Needs to be simple
 - Needs to capture attention
 - Communicate ahead of impacts
 - Assertive messages are most effective (fines, fatalities)

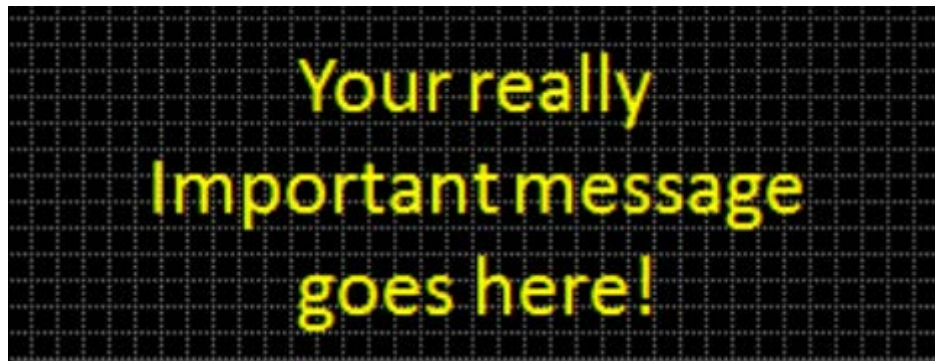

Source: Pisano, Graham, and Williams (2018)

Structuring DMS Message Content

- Guidelines for Disseminating Road Weather Advisory & Control Information FHWA-JPO-12-046 link (<https://rosap.ntl.bts.gov/view/dot/3362>)
- Basic DMS Elements

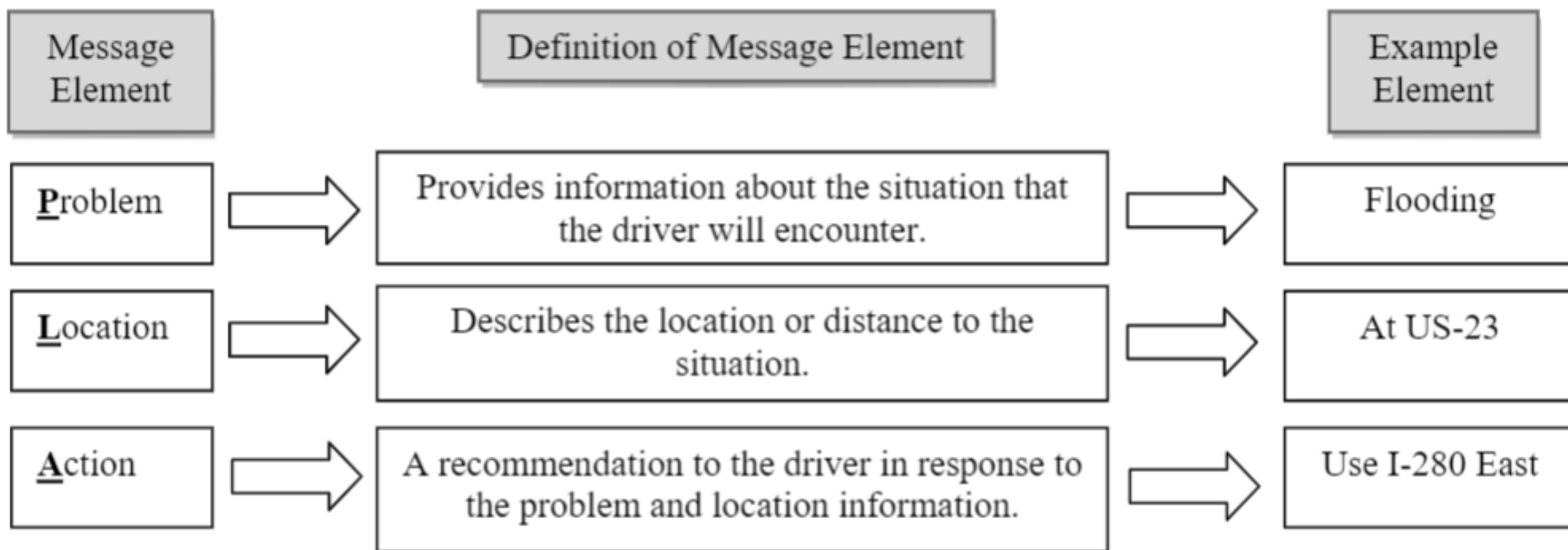

Source: FHWA-JPO-12-046 (2012)

Highway Advisory Radio (HAR)

- Normally sent over AM bands with a limited but portable reach
- Able to communicate more lengthy information
- Useful in emergency (ex: hurricanes, evacuations)
- Provides a redundant and portable information source when other communication may fail



Source: FHWA (2017)

Mass Notification Systems

■ CodeRED

- Previously covered CAPCOG counties



- Used for previous October Floods in Austin by alerting cellphones, landlines, and emails.

■ Everbridge Mass Notification System (EMNS)



- Has been deemed less costly and has enabled more methods of communication for many cities over systems like CodeRED and Blackboard.

- Previous Texas towns and counties to cross over from CodeRED to EMNS include Corsicana, Duncanville, and Denton County.

- As of September 2018, CAPCOG also made the switch and upgraded the regional notification system, WarnCentralTexas.org, to an Everbridge powered system.

- To be notified, residents must be registered through the site





12/16/17 Rain Weekend Near Airport Weather Station

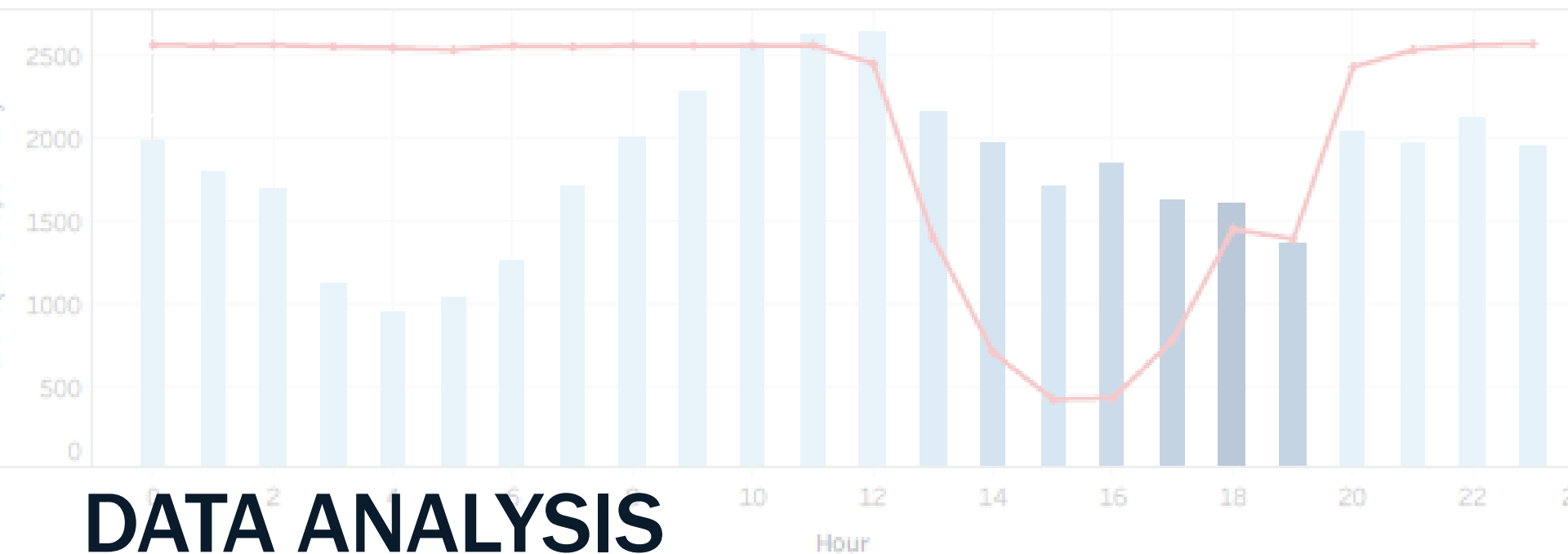

DATA ANALYSIS

An Introduction

Data Source and Storage Types

- Data sources can come in a variety of flavors:
 - Fixed
 - Mobile
 - Live
 - Historic
 - Derived
 - Cleaned
- There are different types of storage and retrieval approaches for data:
 - Data lake
 - Raw or minimally processed data, more for analytics than operations
 - Data warehouse
 - Trusted, clean source of structured data
 - Data mart
 - A well-defined interface or view on a narrow aspect of data
 - Dashboard
 - An application that presents data retrieved from a data mart or warehouse

Tableau Data Analysis

- Tableau was used to conduct a brief analysis using archived data including **weather, traffic, and crash reports,**
- The practical findings from working with large amounts of data and Tableau include:
 - Tableau limitations
 - Difficulties with multi-source sensor data
 - Data visualization for communication

The screenshot shows a Tableau Public profile page for 'TxDOT Weather Project Visualizations' by the University of Texas at Austin. The page features a navigation bar with 'GALLERY', 'AUTHORS', 'BLOG', 'RESOURCES', and 'ACTIVITY'. The profile includes the University of Texas at Austin logo, the name 'TxDOT Weather Project Visualizations', and '7 vizzes'. Below the profile, there are three featured visualizations: 'Demonstration 1: CRIS, Lonestar, INRIX, Wkz, and NOAA data' (10 views), 'Demonstration 2: INRIX and Weather' (6 views), and 'All Data Sources 11_29' (6 views). The first visualization is a line chart showing multiple data series over time. The second is a table with columns for 'Weather Occurrence' and 'Average Speed'. The third is a map showing data points on a road network.

Tableau Limitations

- Limited mapping/GIS capabilities
- Date/coordinates/etc. must be in the primary data source or it will not appear from any secondary source
 - Difficult to compare sensor data collected by timestamp/location
 - Work around: merge data sets before (leaves many null values/requires additional work)
- Sharing results
 - Easy among those connected to Tableau Server or as PDF through email
 - Free online profiles are available to create and look at visuals

Map of I-35 Using Tableau

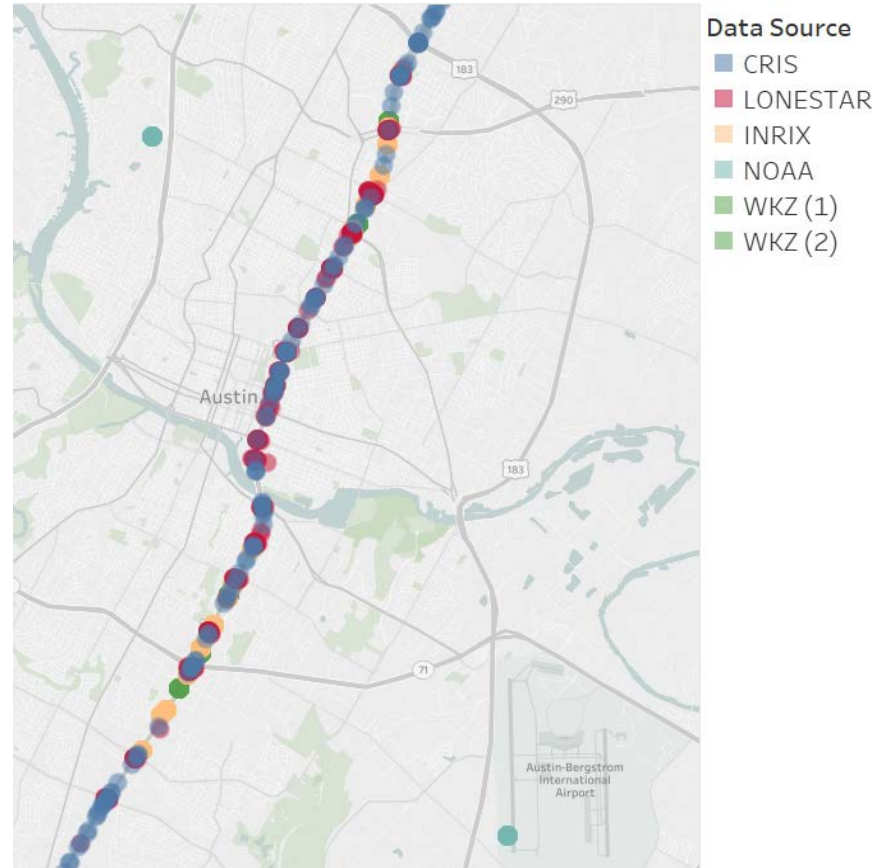

Difficulties with Multi-Source Sensor Data

- More sources mean... more data cleaning and processing
 - Harder to manipulate in terms of time and amount
 - To avoid lag in Tableau, datasets can be extracted rather than viewed “live”
 - Each source has their own data variable classification and reporting system
 - Varying timestamp formats, coordinate value formats, units, naming codes

The screenshot shows a Tableau join configuration for two data sources: '9.26_Wkztrailer Data' and '9.26.NOAA Weather Data'. The join type is set to 'Full Outer'. The 'Date' field from the first source is being compared to the 'Date1' field from the second source. A warning icon (a red 'X' in a circle) is visible above the join configuration, indicating a mismatch. Below the join configuration, a table displays the resulting data rows, showing that the two sources do not have matching data for the specified date.

9.26!Wkztrailer Data	9.26.NOAA Weather Data
Date	Date1
2017:09:26:00:59:59	9/26/2017 12:53:00 AM
2017:09:26:00:59:59	9/26/2017 12:53:00 AM

No Match

Tableau: Rain Effects on Speed and Vehicle Count on I-35

12/09/17 Clear Weekend Near Airport Weather Station

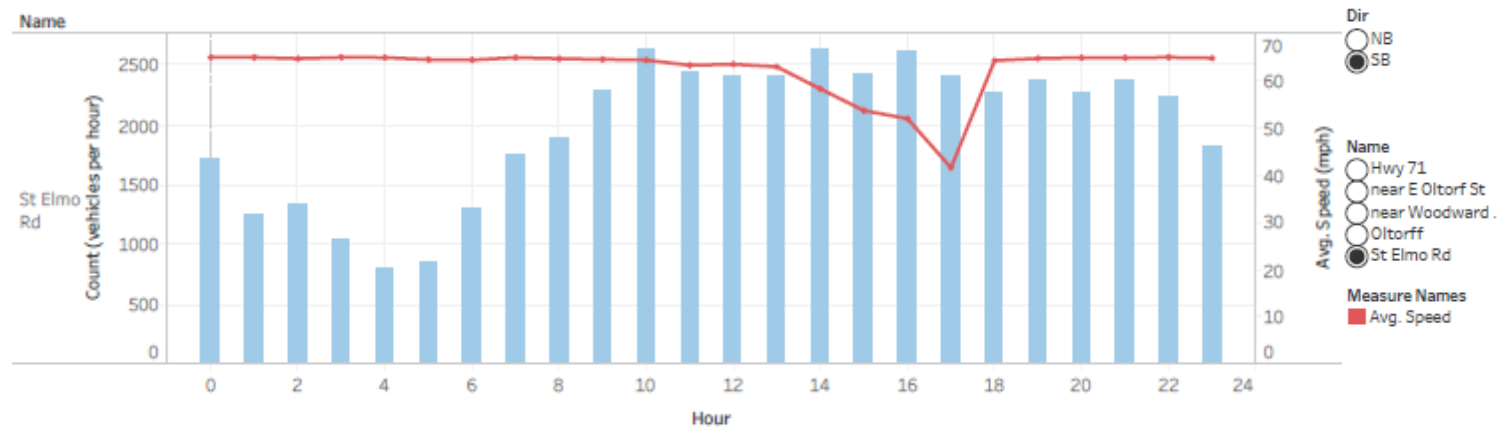

12/16/17 Rain Weekend Near Airport Weather Station



Tableau Visualization

I-35 Merged Dataset Display

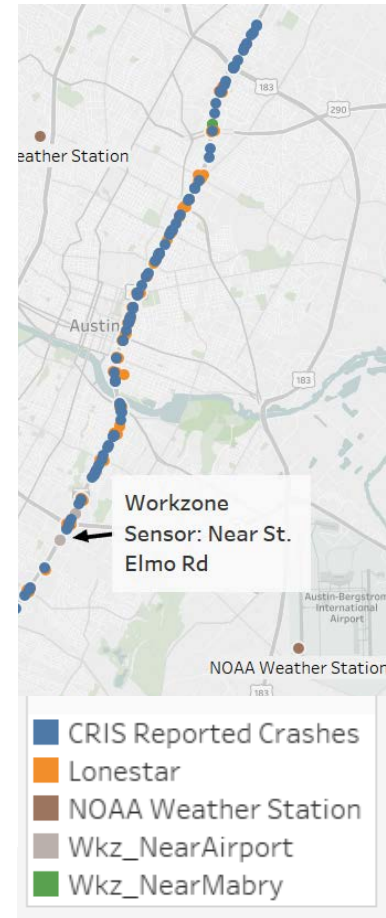
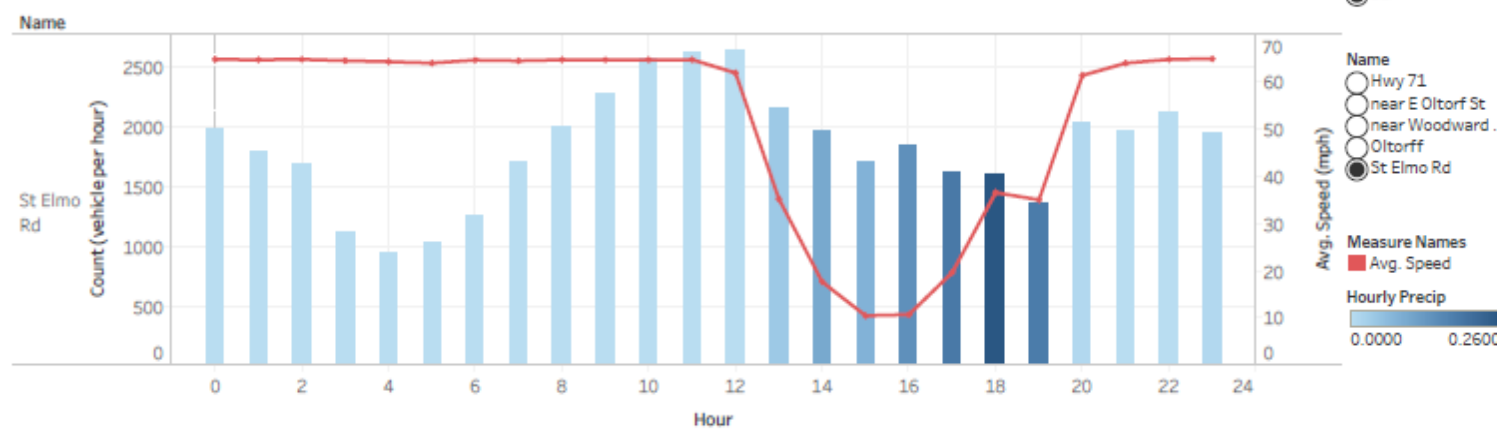
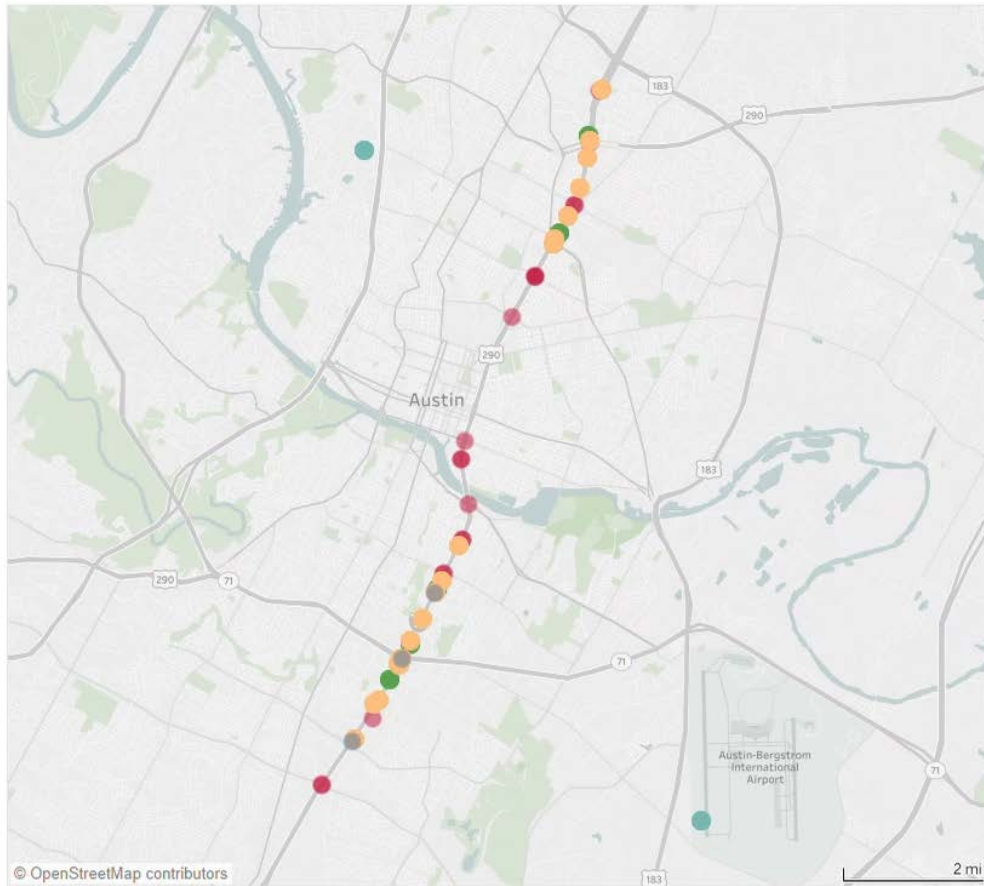

Data Source

- CRIS
- INRIX
- LONESTAR
- NOAA
- WKZ (1)
- WKZ (2)

Highlight Data So..

Highlight Data So... [p](#)

Day

< 8 >

◀ ▶

◀ ▶

Show history



Weather Impact on Average Travel Speeds

Weather Impact	Time Frame	Average Speed Difference (%)				Average Speed Difference (mph)			
		NB		SB		NB		SB	
		Work Zone	INRIX	Work Zone	INRIX	Work Zone	INRIX	Work Zone	INRIX
Snow (Weekday)	AM (6AM-9AM)	-13%	-16%	-19%	-29%	-0.2	-1.7	-3.9	-4.3
	PM (4PM-7PM)	-20%	-31%	-70%	-126%	-5.9	-10.6	-14.9	-15.5
	Off-Peak (9AM-4PM)	1%	-1%	-13%	-10%	1.2	-0.2	-3.6	-0.5
Rain (Weekday)	AM (6AM-9AM)	-18%	-25%	-14%	-34%	-2.6	-6.2	-2.7	-7.2
	PM (4PM-7PM)	4%	4%	-32%	-39%	2.5	2.3	-6.0	-5.3
	Off-Peak (9AM-4PM)	-2%	-4%	-2%	-10%	-0.5	-0.9	-0.2	-2.5
Rain (Weekend)	Peak (12PM-6PM)	-40%	-40%	-49%	-49%	-12	-12	-12	-12

- Performing baseline performance metrics for weather impacts on traffic characteristics are important for tracking effective road weather management.

Texas Motor Vehicle Crash Statistics

2017 Total Crashes by Weather Condition

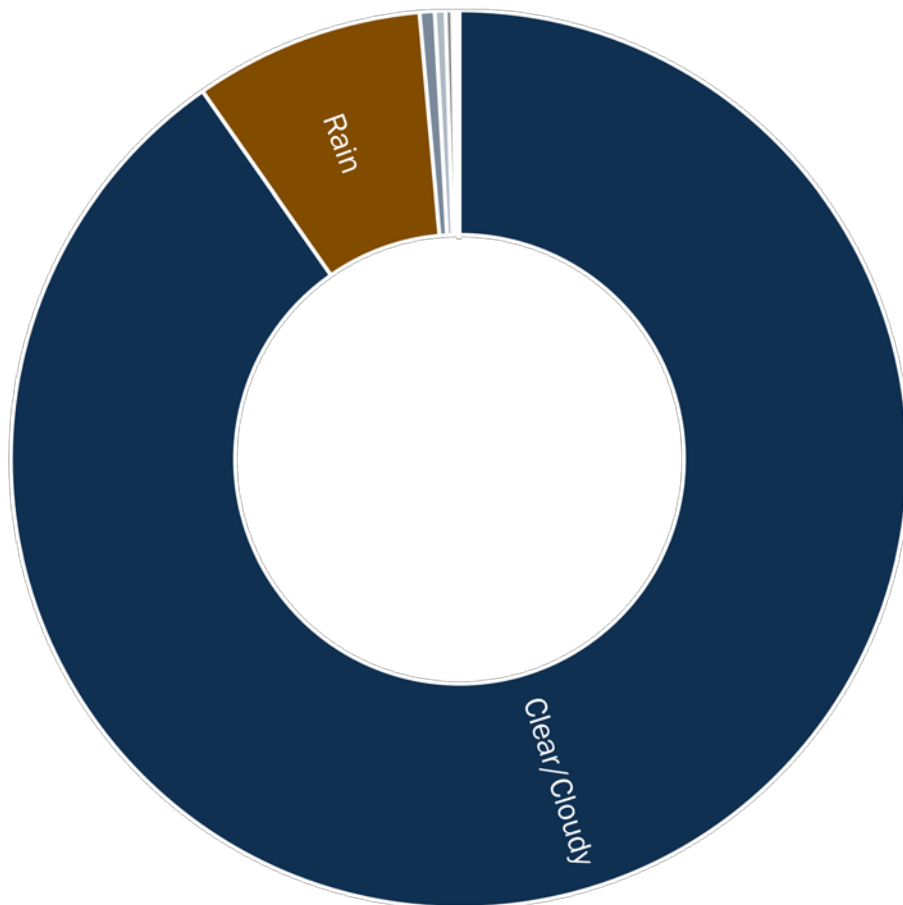

Weather Condition	Number of Crashes Statewide
Blowing Sand/Snow	169
Clear/Cloudy	485,731
Fog	2,915
Rain	44,571
Severe Crosswinds	260
Sleet/Hail	728
Snow	1,293
Other	234
Unknown	2,069
Total	537,970

2017 Total Crashes by Weather Condition

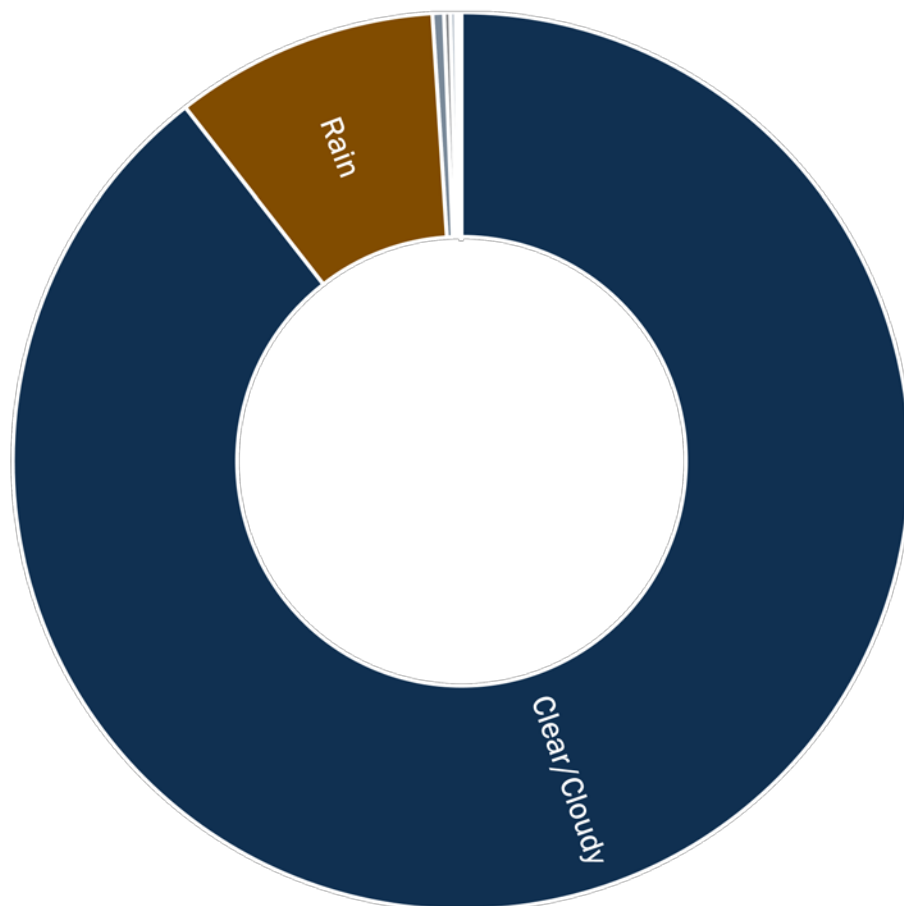

Weather Condition	Number of Crashes on I-35
Blowing Sand/Snow	3
Clear/Cloudy	13,000
Fog	60
Rain	1,383
Severe Crosswinds	5
Sleet/Hail	17
Snow	33
Other	5
Unknown	28
Total	14,534

Texas Motor Vehicle Crash Statistics

2017 Total Crashes by Road Surface Condition

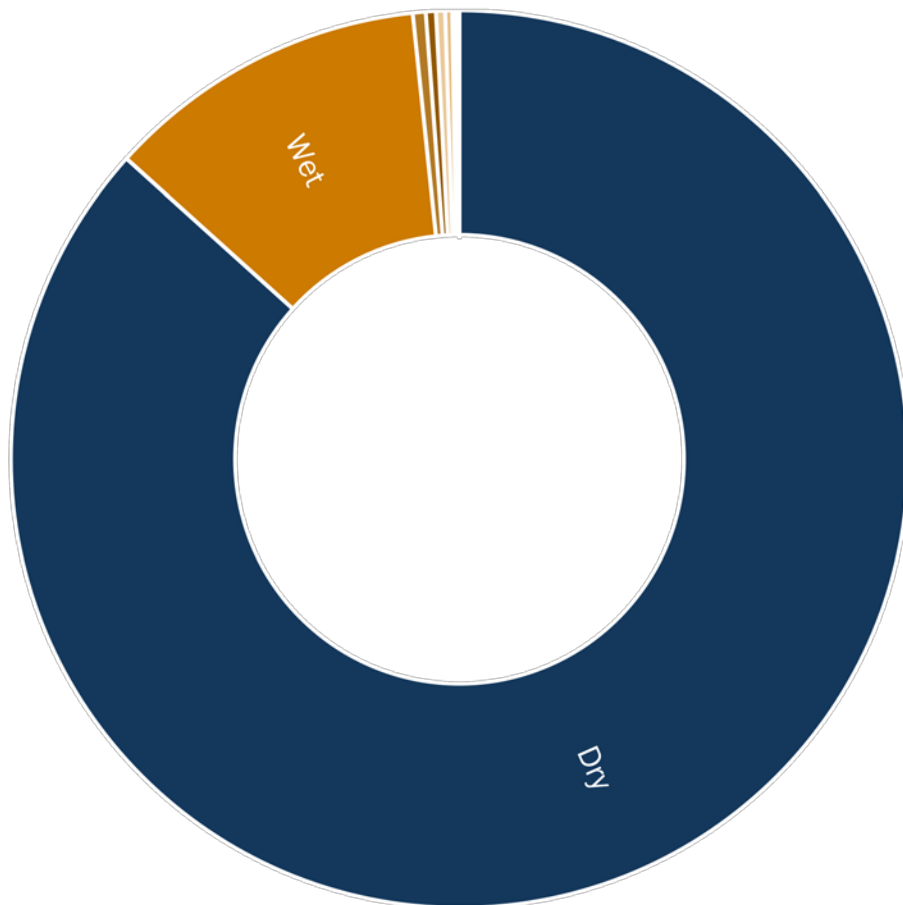

Road Surface Condition	Number of Crashes Statewide
Dry	466,309
Ice	1,951
Sand, Mud, Dirt	1,357
Slush	157
Snow	516
Standing Water	2,497
Wet	62,688
Other	724
Unknown	1,771
Total	537,970

2017 Total Crashes by Road Surface Condition

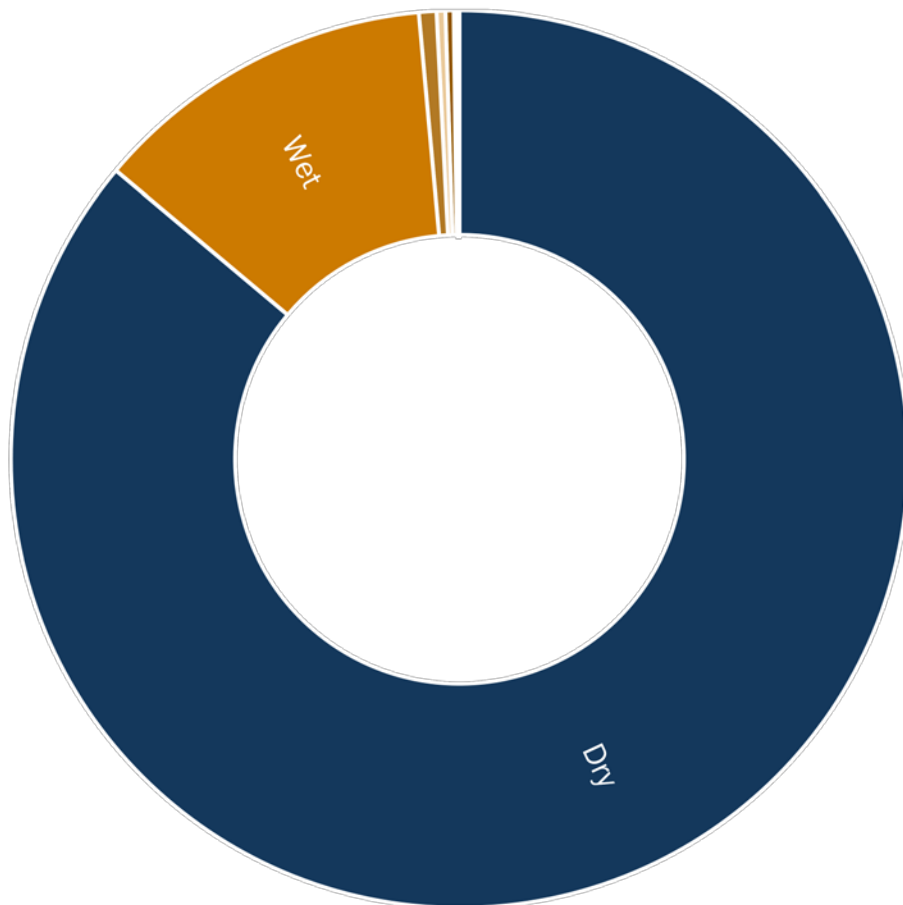

Road Surface Condition	Number of Crashes on I-35
Dry	12,516
Ice	43
Sand, Mud, Dirt	6
Slush	6
Snow	8
Standing Water	92
Wet	1,807
Other	10
Unknown	46
Total	14,534



DISCUSSION TOPIC:

What are your sensor needs?



DISCUSSION TOPIC:

What kinds of information to do want to use for informing the public?



DISCUSSION TOPIC:

What happens if hundreds of sensors can be deployed?