



U.S. Department
of Transportation

Federal Highway
Administration

Drainable Pavement Systems

Participant Notebook

Demonstration Project 87

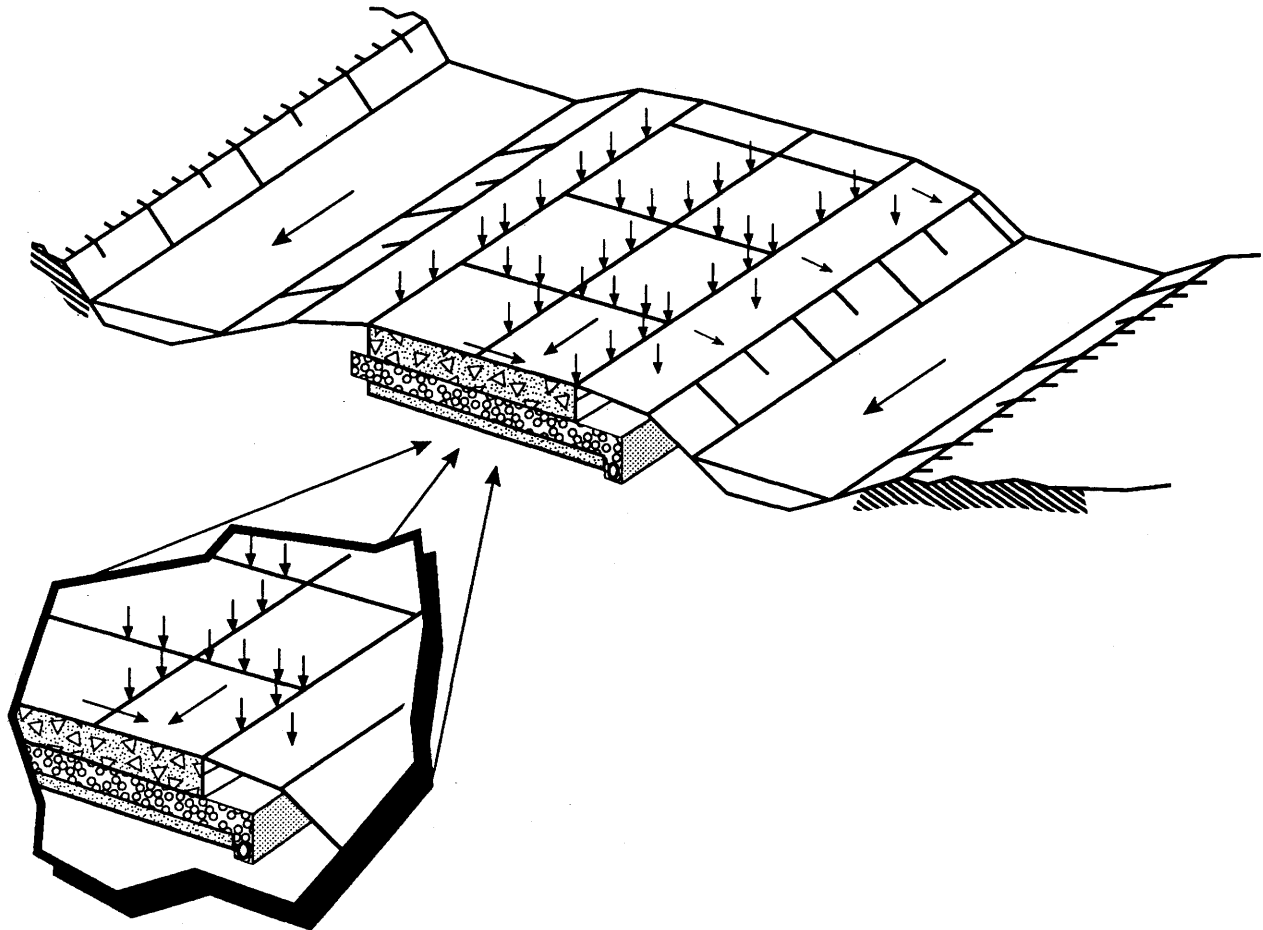

Publication No. FHWA-SA-92-008

March 1992

Office of Technology Applications
and Office of Engineering
400 Seventh Street, S.W.
Washington, D.C. 20590



TABLE OF CONTENTS

1.0	Introduction	1
1.1	Scope	1
1.2	Background	2
1.3	Life-Cycle Costs	4
1.4	Guidelines for Selecting Permeable Bases	4
1.5	Overview of Student Notebook	7
2.0	Sources of Water	11
3.0	Moisture Distress in Pavements	15
4.0	Roadway Geometry	19
5.0	Pavement Infiltration	23
5.1	Infiltration Ratio	24
5.2	Crack Infiltration	25
5.3	Permeable Base Discharge Rate	29
5.4	Edgedrain Pipe Flow Rate	31
6.0	Gradation Analysis	33
6.1	Effective Size (D_{10})	33
6.2	Coefficient of Uniformity (C_U)	33
6.3	Material Identification	35
7.0	Porosity, Effective Porosity, and Percent Saturation	39
7.1	Porosity (N)	39
7.2	Effective Porosity (N_e)	41
7.3	Percent Saturation (S)	43
8.0	Darcy's Law	45
8.1	Darcy's Law	45
8.3	Comparison of Vertical and Horizontal Flow	50
8.4	Discussion of Coefficient of Permeability and Darcy's Law	51
8.5	Non-Steady Flow	52
8.6	Seepage (V_s) and Discharge (V) Velocities	53

TABLE OF CONTENTS (cont.)

9.0	Time To Drain	55
9.1	General	55
9.2	Time to Drain (t) Equation	57
9.3	Design Procedures	61
10.0	Time To Drain Sensitivity	67
10.1	Effective Porosity (N_e)	67
10.2	Coefficient of Permeability (k)	68
10.3	Resultant Slope (S_R)	69
10.4	Resultant Length (L_R)	69
10.5	Thickness (H)	70
10.6	Conclusions	71
11.0	Permeable Bases	73
11.1	General	73
11.2	Pavement Section	75
11.3	Construction Traffic on Completed Base Course	77
11.4	Base Material	78
11.5	Unstabilized Permeable Base	79
11.6	Stabilized Permeable Base	81
11.7	Comparison of Gradations	94
11.8	Base Thickness	97
11.9	Control Strip	97
11.10	Construction Considerations	97
12.0	Separator Layer	101
12.1	Aggregate Separator Layer	101
12.2	Geotextiles	111
13.0	Longitudinal Edgedrains	125
13.1	General	125
13.2	Edgedrain Location	125
13.3	Pipe Edgedrains	126
13.4	Lateral Outlet Pipe	127
13.5	Outlet Spacing	130
13.6	Headwalls	130
13.7	Rodent Screens	132
13.8	Reference Markers	132
13.9	Construction Considerations	132

TABLE OF CONTENTS (cont.)

14.0	Edgedrain Capacity and Outlet Spacing	135
14.1	Design Flows	135
14.2	Circular Pipe Capacity	137
14.3	Outlet Spacing	140
14.4	Edgedrain Trench Design	141
14.5	Practical Considerations	142
15.0	Maintenance	139
16.0	Summary	147
16.1	Permeable Bases	147
16.2	Separator Layer	148
16.3	Construction	149
16.4	Maintenance	149
16.5	Edgedrain System	149
17.0	References	151



LIST OF FIGURES

Figure 1	Drainable Pavement Systems Elements	3
Figure 2	Sources of Water	11
Figure 3	Action of Free Water in Concrete Pavements	16
Figure 4	Faulting of Portland Cement Concrete Pavement	17
Figure 5	Roadway Geometry	19
Figure 6	Horizontal Curve Transition	20
Figure 7	2-year, 1-hour Rainfall Intensity	25
Figure 8	Crack Layout - Plan View	27
Figure 9	Crack Layout - Sectional View	27
Figure 10	Permeable Base Discharge	30
Figure 11	Edgedrain Discharge Based on Permeable Base Discharge	31
Figure 12	Edgedrain Discharge Based on Roadway Geometry	32
Figure 13	Gradation Plot of AASHTO No. 57	34
Figure 14	Aggregate Identification Chart	36
Figure 15	Weight-Volume Relationship of Water in Aggregate	39
Figure 16	Sketch of Permeable Base Capacity	49
Figure 17	Comparison of Vertical and Horizontal Flow	50
Figure 18	Chart for Estimating Maximum Depth of Flow	53

LIST OF FIGURES (cont.)

Figure 19	Time Factors for Drainage of Saturated Layer	58
Figure 20	Time Factor for 50 Percent Drainage	59
Figure 21	Effect of Effective Porosity	67
Figure 22	Effect of Coefficient of Permeability	68
Figure 23	Effect of Slope	69
Figure 24	Effect of Length	70
Figure 25	Effect of Thickness	70
Figure 26	Edgedrain Location for Concrete Pavement with Asphalt Concrete Shoulders	76
Figure 27	Edgedrain Location for Crowned Concrete Pavement with Tied Concrete Shoulders	76
Figure 28	Plot of New Jersey Gradation	82
Figure 29	Plot of AASHTO No. 67 Gradation	86
Figure 30	Comparison of Gradations	96
Figure 31	Comparison of Gradations Used in Drainable Pavement Systems	99
Figure 32	Retention of Spheres Relationship	102
Figure 33	Plot of DGAB Gradation	105
Figure 34	Plot of Subgrade and Permeable Base Gradations	107
Figure 35	Plot of Design Points	109
Figure 36	Plot of Design Envelope and Aggregate Separator Layer	110

LIST OF FIGURES (cont.)

Figure 37	Filter Formation	113
Figure 38	Schematic of Gradient Ratio Test	115
Figure 39	Plot of B Parameter	118
Figure 40	Geotextile Placement Around Edgedrain	128
Figure 41	Outlet Pipe	129
Figure 42	Outlet Pipe Connecting to Storm Drain	130
Figure 43	Edgedrain Design for Maintenance	131
Figure 44	Smooth, Long Radius Bends for Edgedrain Outlet	131
Figure 45	Precast Concrete Headwall with Removable Rodent Screen	133
Figure 46	Capacity of Smooth, Circular Pipe	139
Figure 47	Capacity of Corrugated, Circular Pipe	139
Figure 48	Edgedrain Trench Backfill Design	142



LIST OF TABLES

Table 1	Wisconsin Standard OGBC #1 (AASHTO No. 67)	5
Table 2	Wisconsin Standard OGBC #2	6
Table 3	Water Loss Values - Percentage	42
Table 4	AASHTO Drainage Recommendations for Time to Drain	55
Table 5	Pavement Rehabilitation Manual Guidance for Time to Drain	56
Table 6	Time to Drain Calculation Form	64
Table 7	New Jersey Gradation	80
Table 8	Unstabilized Permeable Base Gradations	83
Table 9	AASHTO No. 57 Gradation	84
Table 10	AASHTO No. 67 Gradation	85
Table 11	Asphalt-Stabilized Permeable Base Gradations	88
Table 12	Cement-Treated Permeable Base Gradations	91
Table 13	Coefficient of Permeabilities for Different Materials	94
Table 14	Comparison of Effective Size and Coefficient of Uniformity of Materials	95
Table 15	Aggregate Separator Layer Gradation	104
Table 16	Sieve Size Openings	114
Table 17	Summary of Design Criteria for Selecting Geotextiles	121

LIST OF TABLES (cont.)

Table 18	Physical Requirements for Drainage Textiles (AASHTO-AGC-ARTBA TASK FORCE 25, JULY, 1986) .	122
Table 19	Physical Property Requirements for Separation Application	124
Table 20	Conveyance of Circular Pipe (K)	137

LIST OF PHOTOGRAPHS

Photo No. 1	Placing Concrete Pavement	78
Photo No. 2	Unstabilized Permeable Base	80
Photo No. 3	Asphalt Stabilized Permeable Base	87
Photo No. 4	Compacting Asphalt Stabilized Base	89
Photo No. 5	Cement-Treated Permeable Base	89
Photo No. 6	Test Cylinder	90
Photo No. 7	Spreading Unstabilized Permeable Base . . .	100
Photo No. 8	Installing Pipe Edgedrain	126



1.0 INTRODUCTION

In 1988, the Federal Highway Administration (FHWA) conducted a field survey (Demonstration Project No. 975, Permeable Base Design and Construction) of ten States (California, Iowa, Kentucky, Michigan, Minnesota, New Jersey, North Carolina, Pennsylvania, West Virginia, and Wisconsin) to determine design criteria and construction problems for building permeable bases. Now there are approximately 20 States using permeable bases.

Design procedures have now stabilized so that a comprehensive design and construction package can be provided to State highway agencies in the form of Demonstration Project No. 87, *Drainable Pavement Systems*. The purpose of this demonstration project is to provide State highway engineers with current state-of-the-art drainage guidance on the design and construction of permeable bases and edgedrains for Portland cement concrete pavements. This notebook is a blend of drainage design, materials design, and construction and maintenance procedures.

A study of retrofit longitudinal edgedrains in ten States was conducted by FHWA to identify successful drainage practices. Experimental Project No. 12, *Concrete Pavement Drainage Rehabilitation*, investigated different edgedrain systems and instrumented field sites to determine the effect of the edgedrain system on drainage of the pavement structure. Basic drainage design philosophy and practices of the participating States were studied and discussed in a state-of-the-practice report [2]¹. Much of the practical guidance on edgedrains contained in this notebook is based on that study.

The FHWA provides guidance to the field through the Technical Paper 90-01 on Pavement Subsurface Pavement Drainage [14]. Most of the technical guidance contained in this notebook is based on material in that technical paper, particularly the information on permeable bases.

1.1 Scope

¹ Numbers shown in brackets [] are reference numbers. References are listed alphabetically by author.

1.0

1.2 Background

Water in the pavement structure has long been recognized as a primary cause of distress. Within the past 5 to 10 years, drainage of pavements has received an increasing amount of consideration. This was evidenced by the American Association of State Highway and Transportation Officials (AASHTO) *Guide for Design of Pavement Structures* (1986) [1] which included drainage considerations. Because the mechanics of moisture distress in Portland Cement Concrete (PCC) pavements is well understood, this discussion will focus primarily on PCC pavements. However, many of the same principles may be applied to drainage of asphalt cement (AC) pavements.

One of the primary distress mechanisms observed on PCC pavements is pumping. Four conditions must exist for pumping to occur:

1. Free water.
2. Heavy wheel loads.
3. Erodible base.
4. Voids beneath the pavement slab.

Unfortunately, all of these conditions are present on the vast majority of PCC pavements designed and constructed to date.

The primary source of free water is infiltration through cracks and joints in the pavement. A major source of infiltrated water is the longitudinal pavement/shoulder joint, particularly when AC shoulders are used. Water also enters the pavement section from shallow ditches and medians.

To reduce water in the pavement section, the following approaches are recommended:

1. Seal all joints and cracks.
2. Provide drainable pavement systems.

Proper joint sealing can reduce the amount of water entering the pavement. The technical advisory on joints, T5040.30, *Concrete Pavement Joints* [13], provides current guidance on joint sealing. The importance of joint sealing is recognized; however, it is beyond the scope of this notebook.

1.0

New or totally reconstructed pavements are excellent opportunities for constructing drainable pavement systems since permeable bases can be provided. Drainable pavement systems remove infiltrated surface water which cannot be prevented from entering the pavement structure. Drainable pavement systems consist of the following elements:

1. Permeable Base.
2. Separator Layer.
3. Edgedrain System.

These elements are shown in Figure 1. This notebook will provide detailed guidance for the design of these elements.

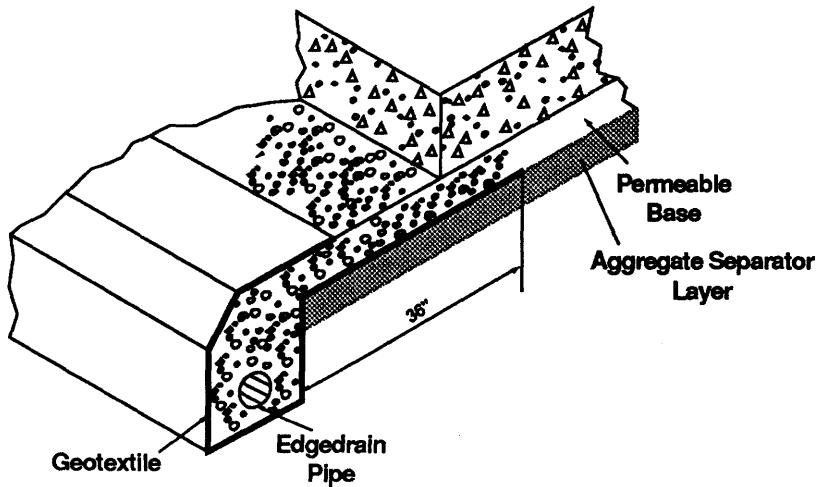

Figure 1. Drainable Pavement System Elements

A number of good texts and papers on pavement subsurface drainage are available [4, 5, 19, and 26].

1.0

1.3 Life-Cycle Costs

Permeable bases must provide an economic benefit to justify their use. A reduction in life-cycle cost is the ultimate measuring stick for permeable bases. This reduction can be accomplished by increasing the service life of the pavement. One economic study [15] suggested that an increase of 33 and 50 percent in the service life of asphalt concrete and PCC pavement, respectively, occurs when permeable bases are provided.

A recent publication, *Asphalt Treated Permeable Material, Its Evolution and Application*, [(16) by the National Asphalt Pavement Association presents an economic comparison of a drained and undrained pavement section [Ref. 16, Table 2, p. 9]. It is interesting to note that the initial cost of the drained section is greater; however, the life-cycle cost is less. A capsulized version of the table is shown below:

Annual ESAL	Initial Cost		Life-Cycle Cost	
	Drained	Undrained	Drained	Undrained
100,000	\$196,938	\$188,323	\$201,809	\$228,496
1,000,000	245,437	255,790	243,164	294,606
2,000,000	263,429	291,382	258,505	329,481

A study of this table shows that the undrained section is 13.2% more costly than the drained section for 100,000 ESAL's. When the ESAL's increase to 2,000,000, the savings increase to 27.5%.

1.4 Guidelines for Selecting Permeable Bases

CALTRANS Guidelines

California's Department of Transportation (CALTRANS) pavement structural drainage policy mandates a treated permeable base under all pavements except where:

1.0

1. The mean annual rainfall is very low (< 5 inches per year).
2. The subgrade soil is free draining ($k \geq 100$ feet per day).

A review of these guidelines reveals that they are very stringent and would result in permeable bases being used in most cases.

The Wisconsin Department of Transportation has developed general guidelines for determining when and which type of permeable bases to be used.

The gradation for Wisconsin Standard No. 1 (OGBC #1) is given in Table 1.

Wisconsin's Department of Transportation Guidelines

**Table 1. Wisconsin Standard OGBC #1
(AASHTO No. 67)**

<i>Steve Size</i>	<i>Percent Passing</i>
1"	100
3/4"	90 - 100
3/8"	20 - 55
No. 4	0 - 10
No. 8	0 - 5

1. Target Permeability is 10,000 ft/day.
2. 90% of particles retained on No. 4 sieve should have one fractured face.
3. Use when subgrade permeability is less than 10 ft/day.
4. Use with a construction platform of 6 inches of dense graded crushed aggregate base course.
5. Minimum thickness of open graded base layer is 4 inches.

1.0

The gradation for Wisconsin standard No. 2 (OGBC #2) is given in Table 2.

Table 2. Wisconsin Standard OGBC #2

<i>Steve Size</i>	<i>Percent Passing</i>
1-1/2	100
1"	75 - 100
3/8"	55 - 75
No. 4	30 - 55
No. 10	10 - 25
No. 40	0 - 10
No. 200	0 - 5

1. Target Permeability is 500 ft/day.
2. 90% of particles retained on No. 4 sieve should have one fractured face.
3. Use when subgrade permeability is 10 ft/day or greater and place directly on subgrade.
4. Filter Layer criteria must be checked for material compatibility with subgrade.
5. Minimum of open graded base layer thickness is 6 inches.

(Note: The Wisconsin DOT's OGBC No. 2 approach is based on vertical flow of water into the subgrade. To accomplish this, there is no aggregate separator layer. The permeable base/subgrade interface must meet the filtration requirement.)

1.0

The following guidance is provided to determine when to use permeable bases:

Concrete Pavements:

1. Interstate Highways use OGBC 100% of the time.
2. Rural Major Arterials and Minor Roadways:
 - a. Daily ESAL's > 500, use OGBC.
 - b. $250 < \text{Daily ESAL's} < 500$, investigate use of OGBC.
 - c. Daily ESAL's < 250, do not use OGBC.
3. Urban Situations – use of OGBC #2 is desirable to maintain local access and provide for ease of construction operations.
4. OGBC typically would not be used on an interchange ramp except on free flow ramps.

Asphalt Concrete Pavements:

Evaluate the use of OGBC on a project by project basis

Other Design Considerations:

Tubular drain should be placed at the bottom of a fabric lined trench, with the trench remaining open at the top. A minimum 6-inch underdrain should be used to protect against the potential for clogging.

Stabilization, if mandated by DOT for maintenance of local access, shall be paid for by the Department. Otherwise, stabilization would be the contractor's option.

The participant notebook is laid out in building block fashion. The sections build upon each other as the participant progresses through the notebook. As previously stated, the three principal elements of a drainable pavement system are the permeable base, separator, and edgedrain. The notebook first provides the necessary technical background to develop the basic parameters. These parameters are then combined into design procedure and equations required to design each element of the pavement drainage system.

1.5 Overview of Participant Notebook

1.0

Sources of Water

Section 2.0, Sources of Water, and Section 3.0, Water Distress in Pavements, provide an introduction to the problems caused by water in the pavement section. Section 4.0, Roadway Geometry, provides design equations for determining the resultant slope (S_R) and length (L_R) that will be used in determining the time to drain (t) (Section 9.0, Time to Drain).

Pavement Infiltration

Drainage design begins with Section 5.0, Pavement Infiltration. This section provides design procedures for estimating water entering the pavement surface. These flows are necessary for determining the flow conditions (Section 8.0, Darcy's Law) in a permeable base and the outlet spacing (Section 14.0, Edgedrain Capacity and Outlet Spacing).

Aggregates

Aggregate material design starts with Section 6.0, Gradation Analysis. The parameters (effective size, coefficient of uniformity, and gradation charts) used in a gradation analysis are defined and discussed in this section. These terms are important in defining the different gradations used for permeable bases; they provide an engineer with the analytical tools necessary for comparing gradations.

Porosity

Porosity (N), effective porosity (N_e), and percent saturation (S) define an aggregate material's ability to store and give up water. These parameters are defined and discussed in Section 7.0, Porosity, Effective Porosity, and Percent Saturation, and are necessary to calculate the time to drain (Section 9.0, Time to Drain).

Darcy's Law

Section 8.0, Darcy's Law, defines Darcy's Law and provides an insight into the coefficient of permeability (k). The coefficient of permeability is the single most important design parameter in the drainage study. It is used to determine flow conditions in the permeable base and the time to drain. This section provides engineers with discussions aimed at understanding and applying the coefficient of permeability. A design chart is provided to determine the maximum depth of flow in a permeable base, based on uniform inflow and a free outfall into an edgedrain system.

1.0

Section 9.0, Time to Drain, combines the drainage parameters to determine the time to drain. The two principal factors (time factor (T) and the "m" factor (m)) are defined. Design charts for determining the time factor based on a specified degree of drainage are provided. Design procedures are provided for calculating the time to drain.

It is extremely important for engineers to understand how the various parameters affect the time to drain. Section 10.0, Time to Drain Sensitivity, provides a graphic picture of how time to drain is affected by varying the effective porosity, coefficient of permeability, slope, length, and thickness of the permeable base. This discussion provides engineers with a good understanding of pavement subsurface drainage.

Section 11.0, Permeable Bases, provides practical design guidance for the design of permeable bases. Both pre- and post-pave installations of the edgedrain system are covered. Design guidance to ensure the quality of the aggregate material is provided. Both unstabilized and stabilized permeable bases are discussed. Aggregate gradations associated with both types of bases are presented. Design guidance for both asphalt and cement stabilized bases is furnished. Practical construction guidelines and compaction guidance for the different types of permeable bases are provided.

The separator layer between the permeable base and subgrade is equally important as the permeable base. An aggregate separator layer or geotextile must be provided so that fines from the subgrade are not pumped up into the permeable base. Section 12.0, Separator Layer, provides design equations and procedures for sizing an aggregate separator layer or geotextile.

Section 13.0, Longitudinal Edgedrains, provides guidance for the edgedrain system. Emphasis is placed on the need to provide a rigid lateral outlet pipe for the outfall. Outlet reference markers or painted arrows on the shoulder and headwalls are recommended so that maintenance forces can locate the outlets. Coordination of the outlet pipe discharge with

Time to Drain

Time to Drain Sensitivity

Permeable Bases

Separator Layer

Longitudinal Edgedrains

1.0

Maintenance

the flow conditions in the roadside ditch is also stressed. A maximum outlet spacing of 250 feet is recommended.

Hydraulic design of the edgedrain system is provided in Section 14.0, Edgedrain Capacity and Outlet Spacing. Design equations, tables, and charts are provided to determine the flow capacity of both smooth and corrugated pipe. Design procedures for determining the outlet spacing are furnished.

Section 15.0, Maintenance, stresses the need to provide periodic inspection and maintenance of edgedrain systems. Use of video equipment on a regular basis for inspection of edgedrain systems is recommended. If a state highway agency (SHA) does not have a commitment to maintenance, permeable bases should not be provided.

Section 16.0, Summary, provides a summary of the main recommendations, while Section 17, References, provides a list of references for permeable bases and edgedrain systems.

2.0 SOURCES OF WATER

The study of pavement drainage must begin by identifying the sources of water entering the pavement section. It is imperative that the engineer has a good understanding of the sources of water that occur in the pavement section. Figure 2 shows the various sources of water [Ref. 10, Figure 4-3.3, p. 222] [Ref. 11, Figure 6, p. 474].

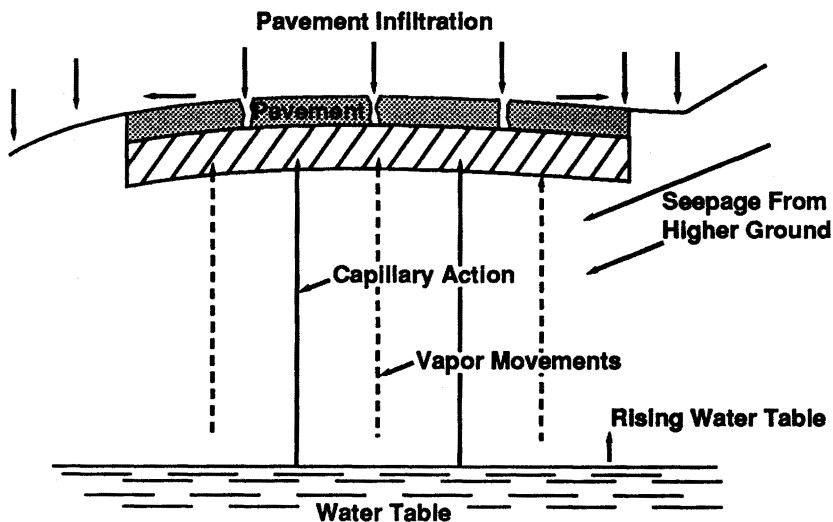

Figure 2. Sources of Water

The sources of water are listed below:

- Surface infiltration.

Water entering the pavement through joints and cracks in the pavement is the single largest source of water-causing PCC performance problems. The purpose of this notebook is to address the handling of this water.

Sources of Water

Surface Infiltration

2.0

Rising Groundwater

- Rising groundwater.

Seasonal fluctuations of the water table can be a significant source of water into the pavement section.

Seepage

- Seepage water.

In cut sections where ditches are shallow, and sections of road have flat longitudinal grades or dead level roads, seepage of water from higher ground may be a significant problem.

Capillary Action

- Capillary action.

Capillary action can transport water well above the water table saturating the subgrade. Typical values for capillary rise are 4 to 8 feet for sandy soils, 10 to 20 feet for silty soils and in excess of 20 feet for clayey soils. This method of water transport is responsible for frost-heave damage. It is also the major source of moisture problems in asphalt concrete pavements.

Vapor Movement

- Vapor movement

Temperature gradients can cause the water vapor, present in the air voids of the subgrade and pavement structure, to migrate and condense. Water vapor does not provide a significant volume of free water in the pavement structure.

Section 13.5.1, Surface Water Coordination, of this notebook stresses the need to provide adequate roadside ditch design for minimizing water entering the pavement section. Ditch design is a difficult balance of safety considerations, hydraulic design, and the drainage of the pavement section. Use of pipe edgedrain systems are stressed in this manual for providing positive drainage of the pavement section. Roadside ditches should be designed with the steepest slopes allowed by safety considerations. Water flow in the ditch must be below the pipe

2.0

outlets of the edgedrain system; if this is not possible, a storm drain pipe collection system should be provided.

Pavement drainage systems are designed to remove water resulting from pavement infiltration. These systems should not be used to alleviate groundwater, artesian flow, etc., conditions.

Again, minimizing water infiltration through the pavement section by sealing joints and cracks is stressed.



3.0 MOISTURE DISTRESS IN PAVEMENTS

Free water in the subgrade and subbase weakens the pavement structure for both AC pavements and PCC pavements. If the pavement section becomes saturated, its ability to support wheel loads is severely limited.

Moisture distress in PCC pavement is a complex and progressive reaction. After the pavement slab has been placed, both thermal and moisture cycles will cause the slab to curl and warp, creating small voids under the pavement slab at the joints. As the pavement joint opens up, water will enter the pavement section and collect in the voids. As heavy wheel loads approach the joint, the approach slab will deflect downwards, sending a pressure wave or water jet towards the leave slab as shown in Figure 3. The approach slab then rebounds, and the leave slab is pushed downwards as the wheel load crosses over the joint.

This churning action results in the erosion of material under the leave slab with some material being deposited under the approach slab, and the remainder of the material being pumped up through the pavement joint. Ejection of free water and this material is called pumping. Material pumped from the pavement section is usually visible as stains on the pavement and shoulder.

The pumping action will be progressive, resulting in a drop in elevation between the slabs which is called faulting. Typical pavement faulting is shown in Figure 4.

Moisture Distress

3.0

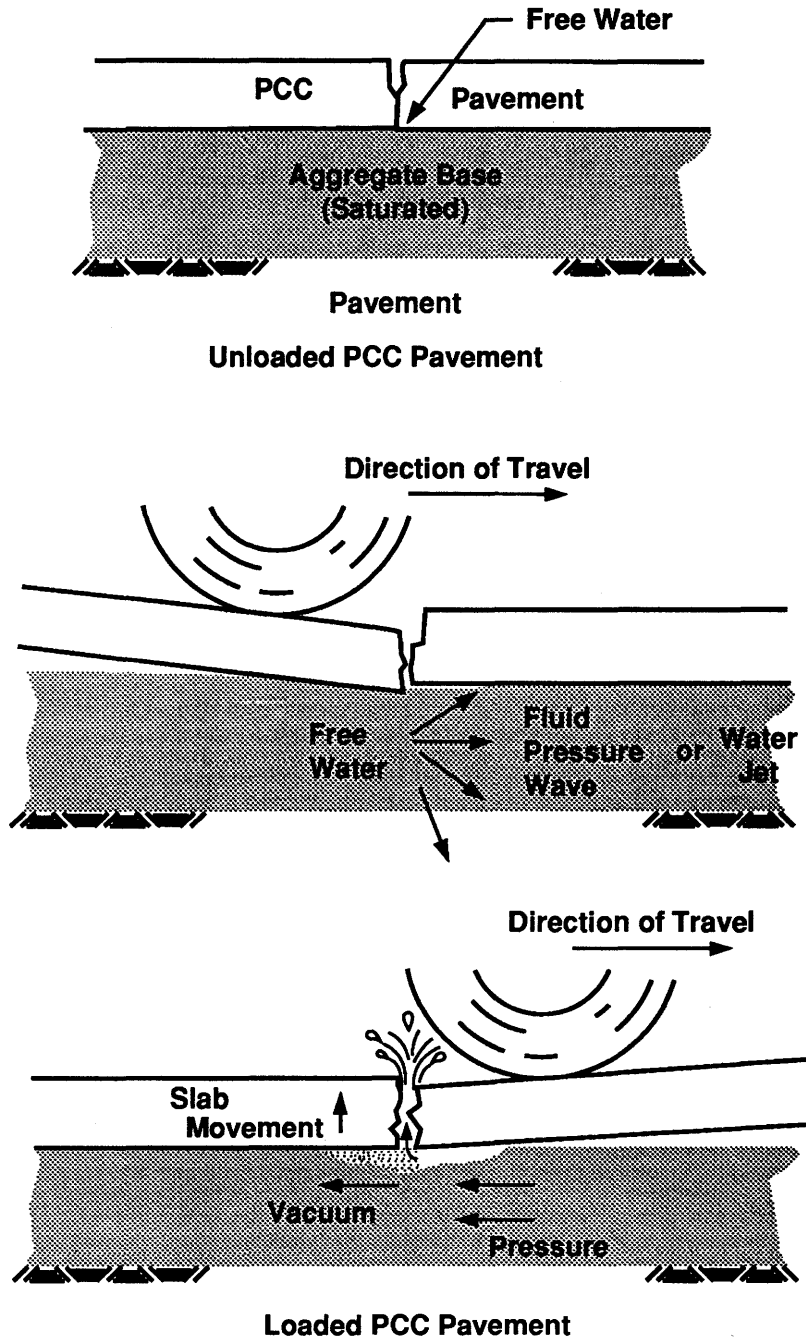

Figure 3. Action of Free Water in Concrete Pavements

3.0

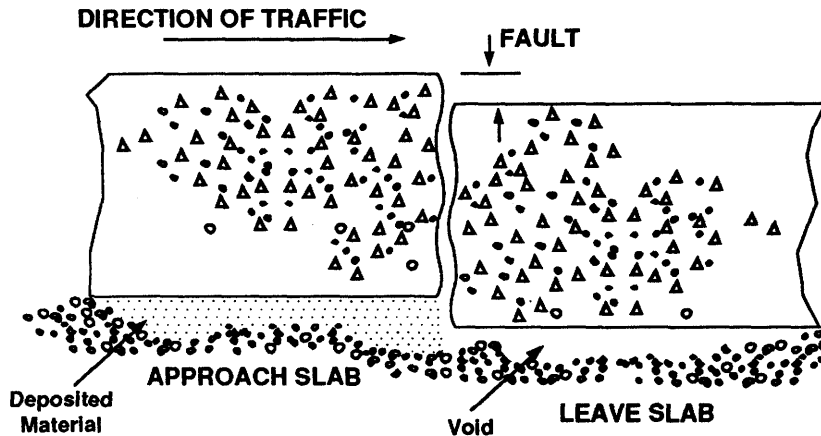

Figure 4. Faulting of Portland Cement Concrete Pavement

The next phase in pavement deterioration is cracking of the pavement slab at mid-panel or third points, with corner breaks, and joint deterioration. This is caused by loss of support under the pavement slab at the joint. The final stage of pavement deterioration is severe cracking and the complete break-up of the pavement slab.

Pumping action also occurs at the pavement/shoulder edge joint. This action can be particularly severe if the shoulder is asphalt concrete or granular materials. Usually asphalt concrete shoulders will experience considerable break-up immediately adjacent to the pavement/shoulder edge joint when water and frost activity is present. FHWA recommends the use of widened lanes with or without tied PCC concrete shoulders to minimize pavement/shoulder joint pumping, and to facilitate joint seal effectiveness between like materials.



4.0 ROADWAY GEOMETRY

In designing the drainage of a permeable base, it is important to use the true slope and length of the permeable layer. The slope relationships are shown in Figure 5. When the longitudinal slope (S) is combined with the pavement cross slope (S_X), the true or resultant slope (S_R) of the flow path is determined by the equation:

$$S_R = (S^2 + S_X^2)^{1/2} \quad (1)$$

where

- S_R = Resultant slope, ft/ft
- S = Longitudinal slope, ft/ft
- S_X = Cross slope, ft/ft

The resultant length of the flow path is:

$$L_R = W \left[1 + \left[\frac{S}{S_X} \right]^2 \right]^{1/2} \quad (2)$$

where

- L_R = Resultant length of flow path through base, ft
- W = Width of permeable base, ft

The orientation of the flow path can be determined by:

$$\tan(A) = \frac{S}{S_X} \quad (3)$$

where

- A = Angle between roadway cross slope and resultant slope

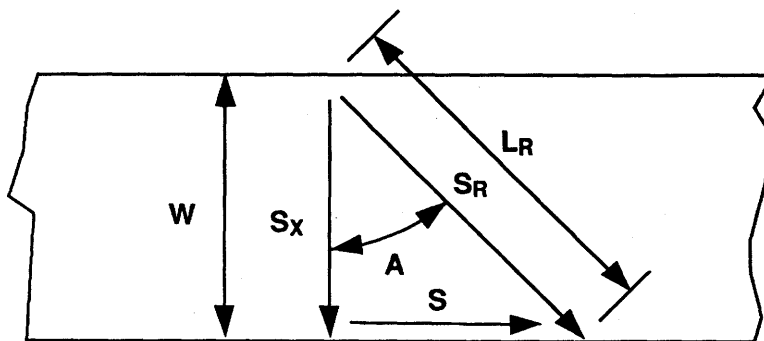

Figure 5. Roadway Geometry

Resultant Slope (S_R)

Resultant Length (L_R)

4.0

 $S_x = 0$

In sag vertical curves, the longitudinal slope (S) will decrease until the low point of the vertical curve is reached. The longitudinal slope will be equal to zero at the bottom of sag vertical curves. For horizontal curves, the cross slope (S_x) will be equal to zero in the transition zone as superelevation is being achieved. This condition is shown in Figure 6. Any time one of the slope components is equal to zero, a potential drainage problem may develop. Therefore on flat roads, both components of the resultant slope will be equal to zero in the transition zone for horizontal curves. Engineers should consider transverse drains to provide drainage at these locations. When transverse drains are used at transitions, the invert of the longitudinal edgedrain may be lowered to ensure a slope on the transverse drain.

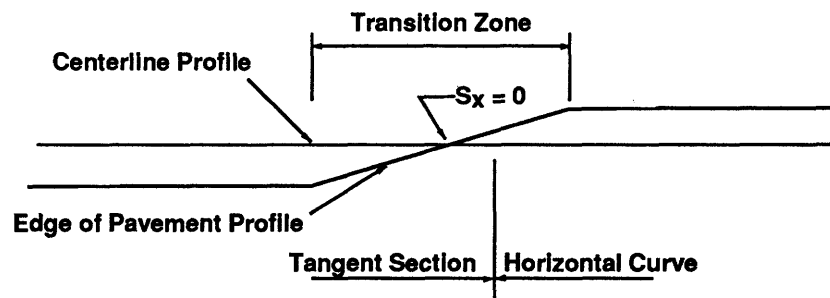

Figure 6. Horizontal Curve Transition

These design procedures can be demonstrated by an example problem.

Given

Longitudinal slope (S)	= 0.02 ft/ft
Cross slope (S_x)	= 0.02 ft/ft
Width of permeable base (W)	= 24 ft

Find

Calculate the resultant slope, length, and flow path orientation.

4.0

Solution

Substituting into Equation 1 for the resultant slope:

$$S_R = (S^2 + S_x^2)^{1/2} = (0.02^2 + 0.02^2)^{1/2} = 0.02828$$

$$S_R = 0.02828 \text{ ft/ft}$$

Substituting into Equation 2 for the resultant length:

$$L_R = W(1 + (\frac{S}{S_x})^2)^{1/2} = 24 \times (1 + (\frac{0.02}{0.02})^2)^{1/2} = 33.94$$

$$L_R = 33.94 \text{ ft}$$

Substituting into Equation 3 for orientation of the flow path:

$$\tan(A) = \frac{S}{S_x} = \frac{0.02}{0.02} = 1$$

$$\text{Angle } A = 45^\circ$$

The flow path will be on a line 45 degrees from a line perpendicular to the centerline of the road.



5.0 PAVEMENT INFILTRATION

The hydraulic design of a permeable base can be a difficult problem. Basically, there are two approaches to the design:

1. Steady-state flow.
2. Time to drain.

In the past FHWA publications [4, 22] have highlighted the steady-state flow approach. In this approach, uniform flow conditions are assumed and the permeable base is sized to carry the design flows that infiltrate the pavement surface. There are two main problems associated with this approach:

1. Estimating the design rainfall rate.
2. Estimating the portion of rainfall that enters the pavement.

There is a continuing controversy among hydraulic engineers over the proper selection of the storm frequency and the time of concentration, or storm duration. Also, there is a paucity of research data on the portion of runoff that enters the pavement section. Selection of these design parameters are so nebulous that many engineers now prefer the time-to-drain approach.

The time-to-drain approach is based on flow entering the pavement until the permeable base is saturated. **Excess runoff will not enter the pavement section after it is saturated; this flow will simply run off on the pavement surface.** After the rainfall event, the base will drain to the edgedrain system. **Engineers must design the permeable base to drain relatively quickly to prevent the pavement from being damaged.** The time-to-drain approach will be discussed in detail in Section 9.0, Time to Drain.

Since some engineers still use the steady-flow state approach, it will be discussed here. Steady-state flow would be useful in determining the required thickness of the permeable base and outlet spacing. **Pavement infiltration (q_i , cu ft/day/sq ft of pavement) is the amount of water entering one square foot of pavement and can be determined by two methods:**

1. Infiltration ratio.
2. Crack Infiltration.

Time to Drain

Steady-State Flow

5.0

5.1 Infiltration Ratio

In the infiltration ratio method, a design rainfall and infiltration ratio are selected. Pavement infiltration is determined by the equation:

$$q_i = C \times R \times 1/12 \text{ (ft/in)} \times 24 \text{ (hr/day)} \times (1 \text{ ft} \times 1 \text{ ft}) \quad (4)$$

which can be simplified to:

$$q_i = 2 C R \quad (5)$$

where

q_i = Pavement infiltration, cu ft/day/sq ft of pavement

C = Infiltration ratio

R = Rainfall rate, in/hr

The flow could be expressed in several different units. Cubic feet per day was selected because it dovetails with the flow rate produced by Darcy's equation.

The infiltration ratio (C) represents the portion of rainfall that enters the pavement through joints and cracks. The following design guidance for selecting the infiltration coefficient is suggested:

Asphalt concrete pavements	0.33 to 0.50
Portland cement concrete pavements	0.50 to 0.67

Since selection of this value is so nebulous, a value of 0.5 is suggested. This should produce an adequate design.

Engineers must select a design storm whose frequency and duration will provide an adequate design. A design storm of 2-year frequency, 1-hour duration is suggested. Hydrologically speaking, the 2-year frequency represents the average worst storm that occurs each year. Figure 7 [9] provides generalized rainfall intensities for a 2-year frequency, 1-hour duration rainfall. More current detailed information for the eastern United States can be found in the NOAA publication NWS-35 [24], while detailed rainfall information for the western States can be found in the appropriate volume of the NOAA Atlas No. 2 [25].

The infiltration ratio method is illustrated by the following example problem:

5.0

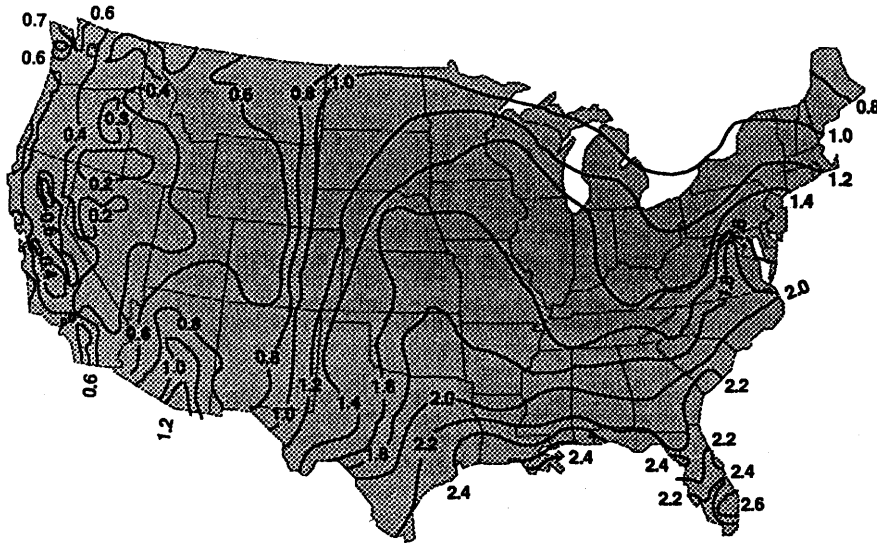

Figure 7. 2-year, 1-hour Rainfall Intensity

Given

Rainfall intensity (Washington, DC) (R) = 1.8 inches/hour
 Infiltration ratio (C) = 0.5

Find

Determine the pavement infiltration (q_i)

Solution

Substituting into the infiltration ratio equation (Equation 6):

$$q_i = 2 C R = 2 \times 0.5 \times 1.8 = 1.8 \text{ cu ft/day/sq ft}$$

$$q_i = 1.8 \text{ cu ft/day/sq ft}$$

The *Highway Subdrainage Design* manual [22] suggests that the crack infiltration method is a preferred method of design. Crack infiltration is determined by the equation:

$$q_i = I_c \left[\frac{N_c}{W} + \frac{W_c}{WC_s} \right] + k_p \quad (6)$$

5.2 Crack Infiltration

5.0

where

- q_i = Pavement infiltration, cu ft/day/sq ft
- I_c = Crack infiltration rate, cu ft/day/ft of crack
- N_c = Number of longitudinal joints or cracks
- W_c = Length of contributing transverse joints or cracks, ft
- C_s = Spacing of contributing transverse joints or cracks, ft
- W = Width of permeable base, ft
- k_p = Pavement permeability, cu ft/day/sq ft

The *Highway Subdrainage Design* manual suggests a crack infiltration rate (I_c) of 2.4 cu ft/day/ft of crack. Using this design value for I_c eliminates the problem of selecting the design storm and infiltration ratio. **Engineers must remember that this value is based on a minimum amount of research data.**

The number of longitudinal cracks (N_c) is determined by the pavement geometry:

1. Number of contributing traffic lanes (N)
2. Uniform cross slope or crowned pavement

The number of longitudinal joints/cracks can be determined by the equation:

$$N_c = N + 1 \quad (7)$$

where

- N_c = Number of longitudinal joints/cracks
- N = Number of contributing traffic lanes

Engineering judgment must be used in calculating the number of longitudinal cracks. For example, if the road consists of two traffic lanes with a uniform cross slope (not crowned), the number of contributing traffic lanes would be two, and the number of longitudinal joints/cracks would be three.

Figure 8 identifies the length of the contributing transverse joints or cracks (W_c), the spacing of transverse joints or cracks (C_s), and width of permeable base (W) in plan view, while Figure 9 shows the length of contributing transverse joints or cracks (W_c) and the width of the permeable base (W) in a sectional view.

5.0

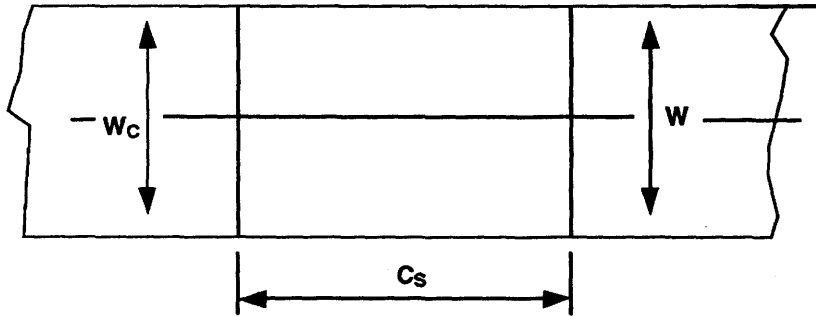

C_s = SPACING OF TRANSVERSE JOINTS OR CRACKS - FT
 W_c = LENGTH OF CONTRIBUTING TRANSVERSE JOINTS OR CRACKS - FT
 W = WIDTH OF PERMEABLE BASE - FT

Figure 8. Crack Layout - Plan View

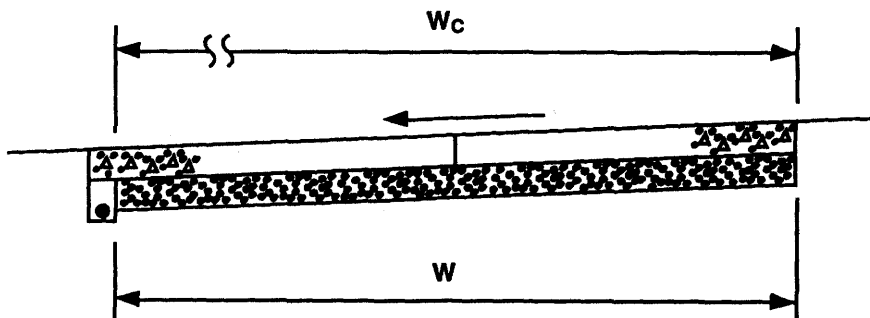

W_c = LENGTH OF CONTRIBUTING TRANSVERSE JOINTS OR CRACKS - FT
 W = WIDTH OF PERMEABLE BASE - FT

Figure 9. Crack Layout - Sectional View

5.0

Preferred Method of Infiltration Design

The *Highway Subdrainage Design* manual [22] suggests that the length of contributing transverse joints or cracks (W_c) be equal to the width of the pavement plus shoulders. Most likely this value will be greater than the width of the permeable base. In effect, this approach is conservative, suggesting that the entire width of the pavement, plus shoulders, can enter the base. It is recommended that the length of contributing transverse joints or cracks (W_c) be set equal to the width of the permeable base (W). This is a more realistic approach.

The subdrainage manual [22] suggests that the transverse crack spacing (C_c) be taken as the regular transverse joint spacing for new portland cement concrete (PCC) pavement and as anticipated average transverse crack spacing for new, continuously reinforced concrete pavement.

The pavement permeability (k_p) represents the flow through uncracked pavements. For purposes of this analysis, the pavement permeability for concrete and densely compacted hot mix asphalt pavements would be zero.

The crack infiltration method provides engineers with a flexible method for modelling pavement infiltration. By changing the transverse joint or crack spacing (C_c) and the number of longitudinal joints cracks (N_c), the engineer can adjust the model to replicate existing pavement conditions or new design cracking patterns.

The crack infiltration method is illustrated by the following example:

Given

The pavement section consists of two 12-foot lanes of PCC pavement with 10-ft AC shoulders on each side with a uniform cross slope (not crowned), and the width of the permeable base is the same as the PCC pavement. The transverse joint spacing is 20 feet.

Crack infiltration rate (I_c)	= 2.4 cu ft/day/ft of crack
Number of contributing lanes (N)	= 2

5.0

Length of transverse contributing joints or cracks (W_c)	= 24 ft
Spacing of transverse joints or cracks (C_s)	= 20 ft
Width of permeable base (W)	= 24 ft
Pavement permeability (k_p)	= 0

Find

Determine the pavement infiltration.

Solution

Determine the number of contributing cracks (Equation 8):

$$N_c = N + 1 = (2 + 1) = 3$$

Substituting into the crack infiltration equation (Equation 7):

$$q_i = I_c \left[\frac{N_c}{W} + \frac{W_c}{WC_s} \right] + k_p$$

$$q_i = 2.4 \left[\frac{3}{24} + \frac{24}{24 \times 20} \right] + 0$$

$$q_i = 2.4 (0.125 + 0.05) = 2.4 \times 0.175 = 0.42$$

$$q_i = 0.42 \text{ cu ft/day/sq ft}$$

Note that the crack infiltration method produces considerably less flow than the infiltration ratio method.

After the infiltration rate has been determined, the permeable base discharge rate can be determined by the equation:

$$q_d = q_i L_R \quad (8)$$

where

q_d = Permeable base discharge rate, cu ft/day/ft of base

q_i = Pavement infiltration, cu ft/day/sq ft

L_R = Resultant length of base, ft

This discharge represents the flow from a resultant foot of permeable base into the edgedrain system. This relationship is shown in Figure 10.

5.3 Permeable Base Discharge Rate

5.0

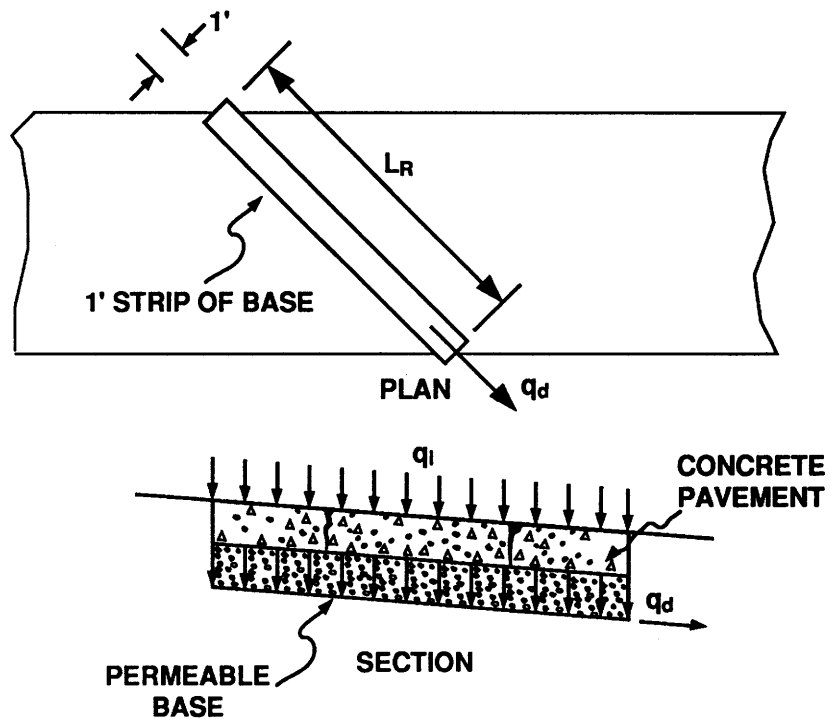

Figure 10. Permeable Base Discharge

The following example problem illustrates permeable base discharge:

Given

Pavement infiltration (q_i)	= 1.8 cu ft/day/sq ft
Resultant length (L_R)	= 33.94 ft

Find

Determine the discharge from the permeable base.

Solution

Substituting into Equation 8:

$$q_d = q_i \times L_R = 1.8 \times 33.94 = 61.1$$

$$q_d = 61.1 \text{ cu ft/day/ft of permeable base}$$

5.0

The edgedrain pipe flow can be determined by the equation:

$$Q = q_d L \cos(A) \quad (9)$$

where

- Q = Pipe flow, cu ft/day
- q_d = Permeable base discharge rate, cu ft/day/ft of base
- L = Longitudinal length of contributing roadway, ft
- A = Angle between a line perpendicular to centerline of the roadway and the flow path

This relationship is shown in Figure 11.

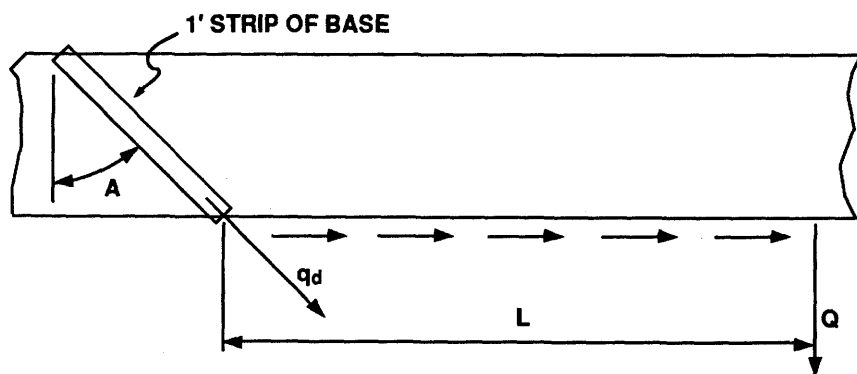

Figure 11. Edgedrain Discharge Based on Permeable Base Discharge

Using substitution of $q_d = q_i L_R$ and $W = L_R \cos(A)$, Equation 9 can be simplified to the following equation:

$$Q = q_i W L \quad (10)$$

where

- q_i = Pavement infiltration, cu ft/day/sq ft of pavement
- W = Width of permeable base, ft
- L = Longitudinal length of contributing roadway, ft

5.4 Edgedrain Pipe Flow Rate

5.0

This relationship is shown in Figure 12.

Edgedrain flow is illustrated in the following problem:

Given

Pavement infiltration (q_f)	= 1.8 cu ft/day/sq ft
Outlet spacing (L)	= 250 ft
Width of permeable base (W)	= 24 ft

Find

Determine the flow at the discharge of the edgedrain system.

Solution

Substituting into Equation 10.

$$Q = q_f \times W \times L = 1.8 \times 24 \times 250 = 10,800$$

$$Q = 10,800 \text{ cu ft/day}$$

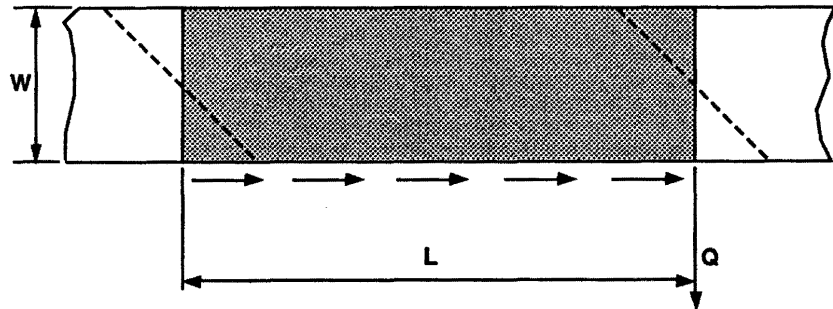

Figure 12. Edgedrain Discharge Based on Roadway Geometry

6.0 GRADATION ANALYSIS

Gradation analysis is an important tool that aids the engineer in evaluating a material. Gradation analysis plays a role in the following design items:

1. Permeability
2. Aggregate separator layer design
3. Geotextile design

As an example, AASHTO No. 57 gradation band is plotted on FHWA 0.45 power graph paper (see Figure 13). The mid-points of the band will be used as the representative gradation. **The AASHTO No. 57 gradation is used as a measuring stick for other gradations because this gradation usually is the most open and permeable used in highway construction.**

The effective size of a gradation is the particle size (in millimeters) in which 10 percent of the material (D_{10}), by weight, is smaller. This point is marked on Figure 13. The effective size is an indicator of a material's permeability. The greater the effective size, the larger the particles of material and the more permeable.

The coefficient of uniformity (C_U) is the ratio of the D_{60} particle size to the D_{10} particle size. This relationship is given by the following equation:

$$C_U = \frac{D_{60}}{D_{10}} \quad (11)$$

where

C_U = Coefficient of uniformity

D_{60} = Particle size in which 60 percent of the material is smaller, mm

D_{10} = Particle size in which 10 percent of the material is smaller, mm

The D_{10} and D_{60} particle sizes of the mid-points of the AASHTO No. 57 gradation are 5.98 mm and 15.18 mm, respectively, and are marked as shown in Figure 13.

6.1 Effective Size (D_{10})

6.2 Coefficient of Uniformity (C_U)

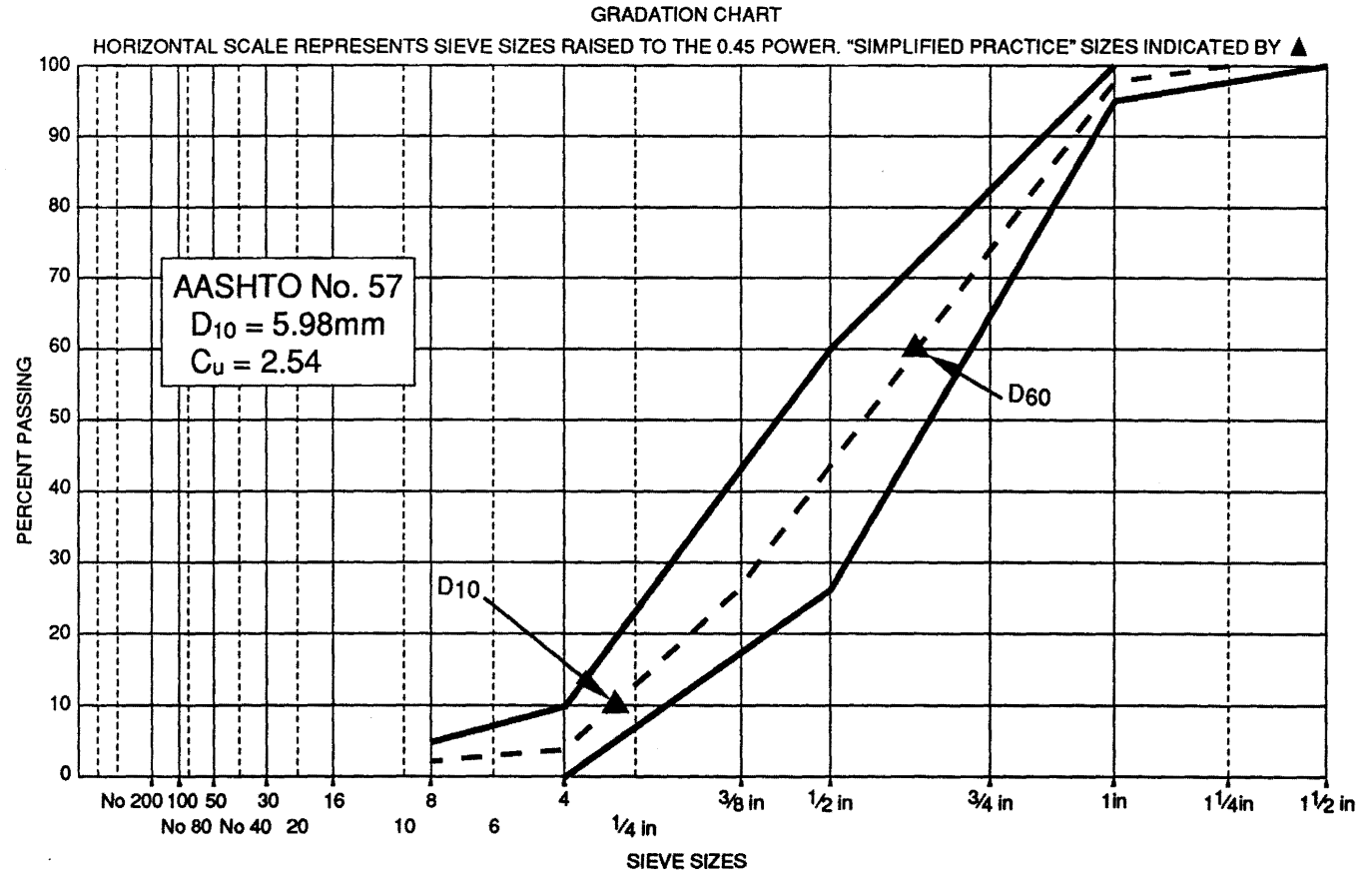

Figure 13. Gradation Plot of AASHTO No. 57

6.0

The coefficient of uniformity is an indication of the spread of particle sizes. It indicates how densely graded the material is. It is also an indirect indicator of the material's permeability. Open-graded material will have a low range of coefficient of uniformity. This range is somewhere between 2 and 6, while densely graded material has a range between 20 and 50. If a material consisted of equal size spheres, the coefficient of uniformity would be one.

It is important for the engineer to have a qualitative feel for the material being used. By superimposing the ASTM soil classification system on the gradation chart, an understanding of the material can be obtained.

The ASTM soil classification system has two basic criteria:

1. If more than 50 percent of the coarse fraction of the material passes the No. 4 sieve, the material is a sand.
2. If more than 50 percent of the material passes the No. 200 sieve, the material is a clay.

These two criteria are not enough to fully identify a material. These criteria are superimposed on the gradation chart along with generalized bands, as shown in Figure 14, to provide the engineer with a feel for the material being used.

For this notebook, general descriptions of permeable base material, sand material, and dense graded aggregate base are provided below:

Permeable base material would have the following characteristics:

1. 100 percent passing the 1-1/2-inch screen.
2. A low percentage of material passing the No. 16 screen.
3. Large range of percent passing for intermediate screens.

Sand material would have the following characteristics:

1. Approximately 100 percent passing the 3/8-inch screen.
2. Greater than 50 percent passing the No. 4 screen.
3. Little or no material passing the No. 50 screen.

6.3 Material Identification

Sand

Clay

Permeable Base Material

Sand Material

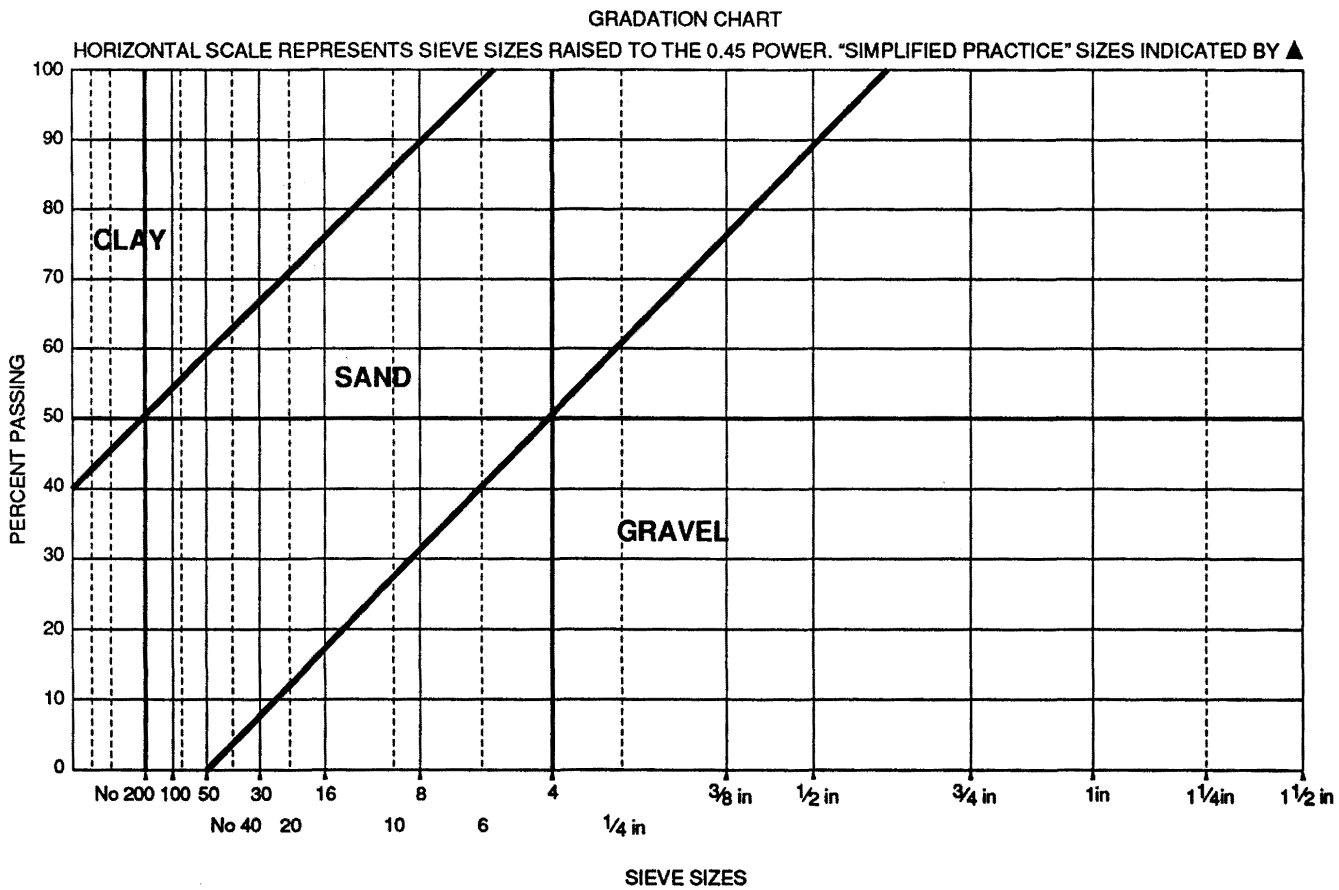

Figure 14. Aggregate Identification Chart

6.0

Dense graded aggregate base material generally has the following characteristics:

1. 100 percent passing the 1-1/2 inch screen.
2. 5 to 12 percent passing the No. 200 screen.
3. Coefficient of uniformity between 20 and 50.

Note that the dense graded aggregate base extends over a wide range of particle sizes.

Dense Graded Aggregate Base



7.0 POROSITY, EFFECTIVE POROSITY, AND PERCENT SATURATION

Porosity (N), effective porosity (N_e), and percent saturation (S) are parameters used to indicate an aggregate material's ability to store and give up water. The porosity of a material is the amount of void space in the material. This, in turn, is an indication of the material's permeability and ability to store water. Effective porosity is an indication of the amount of water that can be drained from the material, while percent saturation defines the amount of water in a material. A sketch [Ref. 11, Figure 9, p. 76] showing the weight-volume relationship of a soil or aggregate is provided in Figure 15. The relationship between porosity and volume of voids (V_v) is confusing. Porosity and volume of voids are two different ways of representing the same parameter—the amount of voids in a soil or aggregate. Porosity is a ratio, while volume of voids is a volume.

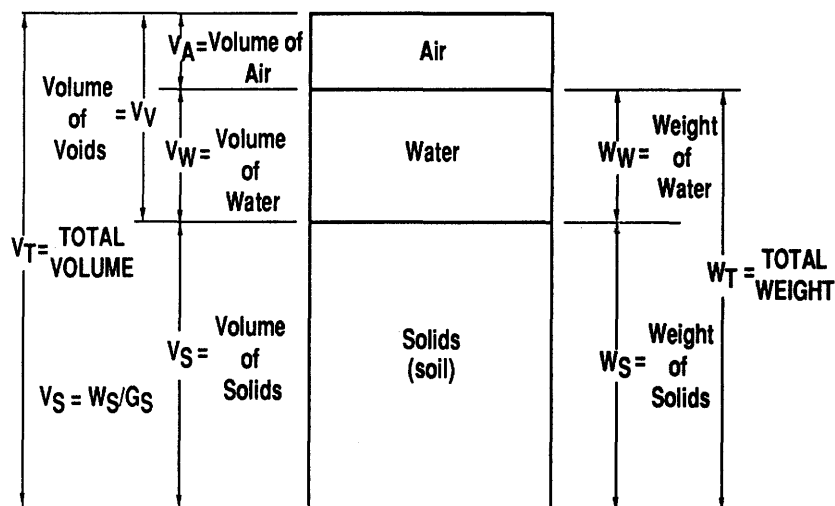

Figure 15. Weight-Volume Relationship of Water in Aggregate

Porosity is the ratio of the volume of voids in an aggregate or soil to the total volume. The porosity of a base material represents the maximum volume of water per unit volume of material that can be stored. The porosity relationship is expressed by the following equation:

$$N = \frac{V_v}{V_T} \quad (12)$$

7.1 Porosity (N)

7.0

where

- N = Porosity of soil sample
 V_V = Volume of voids
 V_T = Total volume

If the total volume (V_T) is a unit volume (1.0), then the porosity becomes numerically equal to the volume of voids, as shown below:

$$N = V_V \quad (13)$$

For computation purposes, the porosity (N) is used for the volume of voids (V_V).

From Figure 15, the following volume relationship can be written:

$$V_T = V_V + V_S \quad (14)$$

where

- V_S = Volume of solids

Rearranging the terms:

$$V_V = V_T - V_S \quad (15)$$

Then dividing by the total volume (V_T):

$$\frac{V_V}{V_T} = \left(1 - \frac{V_S}{V_T} \right) \quad (16)$$

The volume of solids is:

$$V_S = \frac{\gamma_d}{62.4 \times G_{sb}} \quad (17)$$

where

- γ_d = Dry unit weight of material, lbs/cu ft
 G_{sb} = Bulk specific gravity of material

Substituting N for V_V/V_T , and setting $V_T = 1.0$, the porosity of the aggregate material can be calculated by the equation:

$$N = \left(1 - \frac{\gamma_d}{62.4 \times G_{sb}} \right) \quad (18)$$

7.0

Usually, a value of 2.65 to 2.70 is used for the bulk specific gravity for permeable base material.

Unit weight is an important parameter in drainage design since it determines the porosity of the soil or aggregate. A range of unit weights between 121 and 101 pounds per cubic foot is likely in permeable base design. These values produce a range of porosities from .28 to .40, respectively, based on a bulk specific gravity of 2.68.

In the time-to-drain calculation, porosity is used to determine the amount of water associated with 100 percent saturation.

Effective porosity is a measure of how strongly a soil will hold water when a saturated sample is allowed to drain under the influence of gravity [10, 11]. The effective porosity is the ratio of the volume of water that drains under gravity from the soil sample to the total volume of the sample. It is a measure of the amount of water that can be drained from a soil. Now the effective porosity of the material can be obtained by multiplying the porosity of the material by the material's water loss. This is expressed in the following equation:

$$N_e = N \times WL \quad (19)$$

where

N_e = Effective porosity

N = Porosity of the material

WL = Water loss

Guidance for selecting the water loss is provided in Table 3 [Ref. 10, Figure 4-3.23, p. 256] [Ref. 11, Figure 10, p. 78]. A review of this table reveals a wide range in the amount of water loss depending on the percent and type of fines in the material.

Unit Weight

7.2 Effective Porosity (N_e)

7.0

Table 3. Water Loss Values - Percentage

Amount of Fines	<2.5% Fines			5% Fines			10% Fines		
	Filler	Sand	Clay	Filler	Sand	Clay	Filler	Sand	Clay
Gravel	70	60	40	60	40	20	40	30	10
Sand	57	50	35	50	35	15	25	18	8

- Gravel, 0% fines, 75% greater than #4: 80% water loss.
- Sand, 0% fines, well graded: 65% water loss.
- Gap graded material will follow the predominant size.

The effective porosity of an aggregate sample could be determined by placing a saturated sample of the material in a container. By opening a drain on the container, the amount of water draining from the sample could be measured and the effective porosity could be determined as a simple ratio of the volume of drained water to the total volume of the sample.

Effective porosity is used in the time to drain calculations since it represents the maximum amount of water that can be stored or given up, respectively.

The following example illustrates porosity and effective porosity.

Given

$$\begin{aligned} \text{Dry unit weight of base course } (\gamma_d) &= 117 \text{ lbs/cu ft} \\ \text{Bulk specific gravity of material } (G_{sb}) &= 2.68 \\ \text{Water loss } (W_L) &= 83.3 \text{ percent} \end{aligned}$$

Find

Determine the porosity and the effective porosity of the material.

Solution

Calculate the porosity by substituting into Equation 13.

$$N = \left(1 - \frac{\gamma_d}{62.4 \times G_{sb}} \right) = \left(1 - \frac{117}{62.4 \times 2.68} \right) = 0.30$$

$$\text{Porosity} = 0.30$$

7.0

Calculate the effective porosity by substituting into Equation 19.

$$N_e = N \times WL = 0.30 \times 0.833 = 0.25$$

$$\text{Effective porosity} = 0.25$$

Percent saturation represents the total volume of water (V_w) present in the base course. It represents the sum of drainable water and bound water in the base and defines the amount of water present in an aggregate material as a percentage of the available volume.

Time-to-drain design procedures assume that the permeable base is saturated at the time to drain and that there is no additional inflow to the base once the rainfall has ceased. Therefore, saturation is 100 percent and:

$$V_w = V_v \quad (20)$$

where

V_w = Volume of water

V_v = Volume of voids

The amount of water that drains equals the effective porosity times the percent drained.

$$\text{Drained water} = N_e \times U \quad (21)$$

where

N_e = Effective porosity

U = Percent drained

The volume of water present in the base is:

$$V_w = V_v - \text{Drained water}$$

$$V_w = V_v - (N_e \times U) \quad (22)$$

The percent saturation can now be determined:

$$S = \frac{V_w}{V_v} \times 100 \quad (23)$$

It should be noted that the base course can only be completely drained (Percent Saturation = 0) if the effective porosity is equal

7.3 Percent Saturation (S)

7.0

to the porosity. As previously stated, the estimated water loss for permeable bases is approximately 80 percent. This means that once the base is saturated, approximately 20 percent of the water cannot drain.

The previous example can be expanded to calculate the percent saturation.

Given

Porosity (N)	= 0.30
Effective porosity (N_e)	= 0.25
Percent drained (U)	= 50

Find

Determine the percent saturation associated with 50 percent drained.

Solution

Calculate the volume of water in the base.

Remember that V_v is numerically equal to N.

$$V_w = V_v - N_e \times U = 0.30 - (0.25 \times 0.50) = 0.175$$

Calculate percent saturation of the base.

$$S = V_w / V_v \times 100 = (0.175 / 0.30) \times 100 = 0.58$$

Percent Saturation = 58%

8.0 DARCY'S LAW

Darcy's Law has been used since 1856 to define flow conditions in a soil. This law is based on a number of assumptions. The major assumptions are:

1. Steady-state flow.
2. Soil is a porous and homogenous medium.
3. Laminar flow.

These assumptions may not exist in actual practice. Laminar flow is smooth flow (opposite of turbulent) in which the flow streamlines are uniform. Admittedly, some of the more open permeable bases will not meet this requirement. The discharge of a permeable base is calculated using Darcy's Law:

$$Q = k i A \quad (24)$$

where

- Q = Flow capacity of base, cu ft/day
- k = Coefficient of permeability, ft/day
- i = Slope of hydraulic gradient, ft/ft
- A = Cross sectional area of flow, sq ft

Permeability is a generic term used to indicate the capability of a soil to carry water, while coefficient of permeability is an engineering term used to define the flow relationship in a soil. The coefficient of permeability is the flow rate through a unit area (sq ft) with a unit hydraulic gradient. The coefficient of permeability is an indicator of the **quality** of the material to carry water; it provides engineers with a standard to compare the flow capabilities of different materials.

Design Equation

The FHWA's *Highway Subdrainage Design* manual provides a design equation for calculating the coefficient of permeability [Ref. 22, Figure 28, p. 51], [Ref. 10, Figure 4-3.24, p. 258], [Ref. 11, Figure 7, p. 74]. Unfortunately, many engineers have had trouble when calculated results are compared with laboratory results. With materials variability and laboratory constraints, the theoretical assumptions cannot be replicated. When construction variability is also added, the design assumptions become more nebulous. For this reason the equation will not be

8.1 Darcy's Law

Coefficient of Permeability (k)

8.0

presented in this notebook. The subdrainage manual contains good discussions of the factors that affect the coefficient of permeability design equation. The equation contains the following three factors:

1. Effective size (D_{10}).
2. Porosity (N).
3. Percent fines (P_{200}).

As a general statement, base materials will become more permeable, as all three factors increase or decrease correspondingly:

1. The effective size increases.
2. The porosity increases.
3. The percent fines decreases.

The subdrainage manual reports that these three factors account for 91 percent of the variability in permeability.

Hazen's Formula

Some engineers prefer Hazen's approximate formula for determining the coefficient of permeability. This equation is provided in the FHWA publication [7, p. 3-20]. Again, questionable results are obtained depending on the selection of parameters. For this reason, the equation is not provided in this notebook.

The best way to determine the coefficient of permeability (k) is to test representative samples of the material in the laboratory.

Laboratory Determination of Coefficient of Permeability

It is recommended that the coefficient of permeability be determined by conducting a constant head or falling head permeability test on samples of the material in the laboratory. In this test, water flows through a soil sample under standard test conditions. Darcy's equation is applied. Since the hydraulic gradient and area of the sample are known, the coefficient of permeability can be determined.

Conduct Lab Tests

8.0

The permeability tests should be performed in accordance with AASHTO T 215, *Permeability of Granular Soils* (Constant Head), or the U.S. Army Corps of Engineers, *Engineering Manual* (EM 1110-2-1906), *Laboratory Soils Testing*, Appendix VII, Permeability Tests (Falling Head).

Field Determination of Permeability

The field permeability testing device (FPTD) can be used to determine the in-situ permeability of a base material. This device measures the in-situ permeability of a material by measuring the velocity of flow between two points. The FPTD's upper and lower limits are 28,000 feet per day (10 centimeters per second) and 0.28 feet per day (10^{-4} centimeters per second), respectively. Average coefficients of permeability determined in field testing of the FPTD have shown good correlation with average laboratory permeabilities. **The FPTD is a research phototype with only two units available in FHWA. Commercially available devices have not been developed.**

The field percolation test is another method for evaluating the ability of the existing base material to drain. In a percolation test, a hole is cored down to the base and filled with water. By observing the water level in the hole over time, the base's ability to drain can be determined. Caution must be exercised with this method to ensure that percolating water is confined to the layer being tested. If water escapes along an interface, through voids, or through an adjacent material, the percolation test can give false results. In addition, it is important to ensure that the top of the base is not clogged.

The FHWA publication *In Situ Permeability of Base and Subbase Courses* [23] provides guidance for determining in-situ permeability of base courses.

The hydraulic gradient is the slope of the water surface and represents the driving force for water flow. Again, for permeable base design, the slope of the hydraulic gradient is assumed to be the same as the resultant slope (S_R) of the base. The importance of using the resultant slope can not be overstressed.

Field Permeability

Hydraulic Gradient

8.0

Cross-Sectional Area

For the permeable base design, usually a 1-foot wide representative width of base is selected for design. The cross-sectional area is expressed by the following equation:

$$A = H \times 1 \text{ ft} \quad (25)$$

where

A = Cross-sectional area of flow, sq ft per ft of base
H = Base thickness, ft

which simplifies to:

$$A = H \quad (26)$$

8.2 Permeable Base Discharge Equation (q_d)

Recalling Darcy's Law:

$$Q = k i A$$

and substituting:

q_d for Q;
 S_R for i;
and H for A

Darcy's equation can now be rewritten for base flow:

$$q_d = k S_R H \quad (27)$$

where

q_d = Permeable base discharge, cu ft/day/ft of base
k = Coefficient of permeability, ft/day
 S_R = Resultant slope, ft/ft
H = Thickness of permeable base, ft

Figure 16 shows the parameters used in determining flow in a 1-foot width of pavement.

The base discharge (q_d) is then measured in cu ft/day per foot of base.

The following example problem illustrates the use of Darcy's equation:

8.0

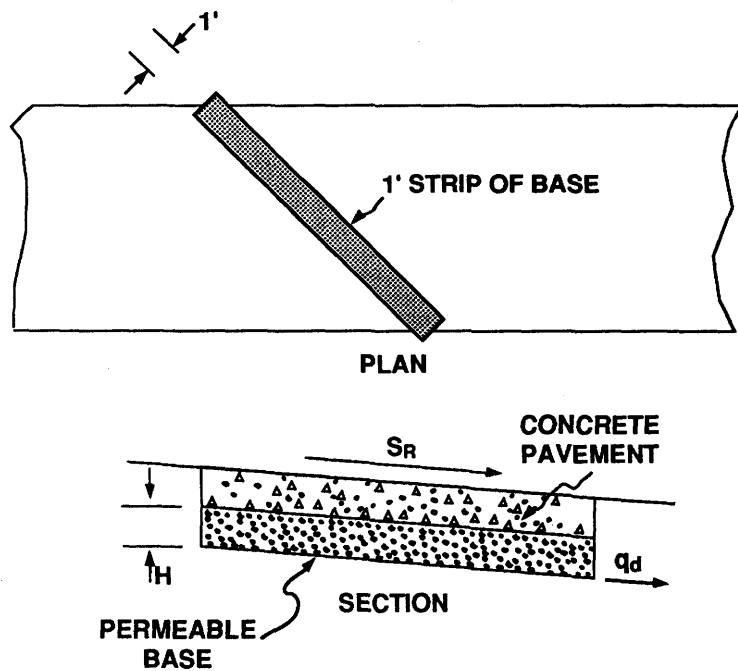

Figure 16. Sketch of Permeable Base Capacity

Given

Pavement Infiltration	= 1.8 cu ft/day/sq ft
Resultant Length	= 33.94 ft
Resultant Slope	= 0.02828
Coefficient of Permeability	= 3,000 ft/day

Find

Determine the required thickness of base.

Solution

Determine the permeable base discharge rate (q_d) (Equation 8).

$$q_d = q_i \times L_R = 1.8 \times 33.94 = 61.1 \text{ cu ft/day/ft of permeable base}$$

Determine base thickness by substituting into Equation 27.

$$q_d = k S_R H;$$

8.0

Rearranging the equation $H = q_d / (k S_R)$

$$H = 61.10 / (3000 \times 0.02828) = .72 \text{ ft}$$

$$H = .72 \text{ ft. or } 8\text{-}5/8 \text{ inches}$$

Note that this approach produces an unrealistically deep base course. This suggests that a non-steady flow approach should be used.

8.3 Comparison of Vertical and Horizontal Flow

To aid in the understanding of Darcy's equation, a comparison of vertical and horizontal flow should be made as shown in Figure 17. The coefficient of permeability is the same in each case.

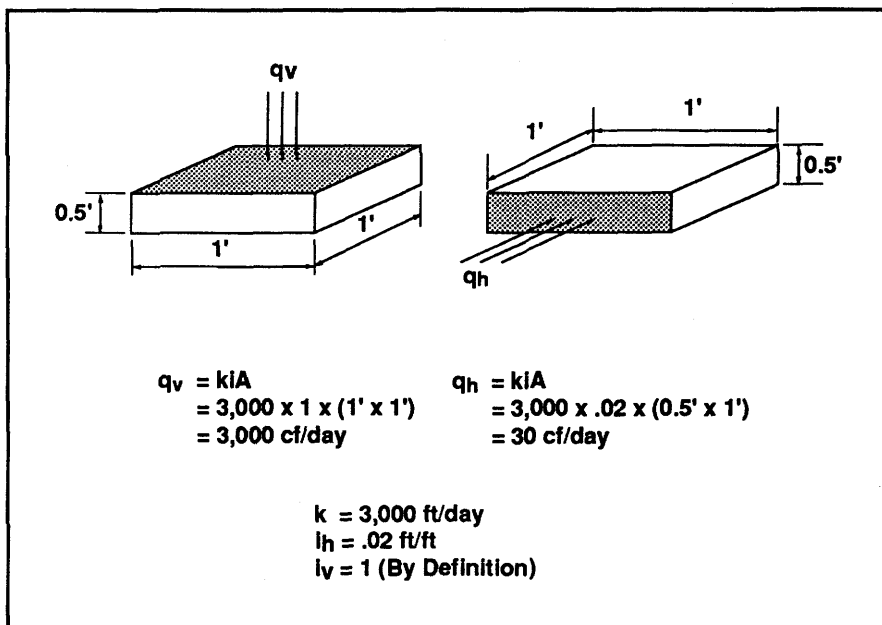

Figure 17. Comparison of Vertical and Horizontal Flow

For vertical flow, the hydraulic gradient is equal to 1, and the cross-sectional area of flow is 1.0 sq ft (1 ft x 1 ft). The vertical flow is:

$$q_v = k i A$$

$$q_v = 3,000 \times 1 \times (1 \text{ ft} \times 1 \text{ ft})$$

$$q_v = 3,000 \text{ cu ft/day}$$

8.0

For horizontal flow, a cross slope of 2 percent (0.02 ft/ft) is assigned along with a base thickness of 6 inches. The horizontal flow is:

$$q_h = k i A$$

$$q_h = 3,000 \times 0.02 \times (0.5 \text{ ft} \times 1 \text{ ft})$$

$$q_h = 30 \text{ cu ft/day}$$

This example illustrates the wide difference between vertical and horizontal flow. It also demonstrates the correct use of the coefficient of permeability, hydraulic gradient, and cross-sectional area.

Engineers often have a problem understanding the workings of the coefficient of permeability. The following comments should be studied in detail to obtain a better understanding of the coefficient of permeability:

- The coefficient of permeability is not a velocity.
- The coefficient of permeability is directionless (vertical vs. horizontal); direction is accounted for by the hydraulic gradient.
- When a coefficient of permeability is given, it must be remembered that it was determined by a permeability test in which a hydraulic gradient of unity (1.0) was used.
- The capacity of a permeable base is determined by Darcy's equation (Equation 24) in which the coefficient of permeability is an element.

To aid in this understanding, an interesting comparison can be made between Darcy's Law and steel beam design. The following comparison can be made:

<i>Darcy's Law</i>	<i>Steel Beam</i>
Coefficient of Permeability (k)	Allowable Steel Stress (f_s)
Cross-Sectional Area (A)	Section Modulus (S)

- **Comparison of size**
If the section modulus (S) of a steel beam is doubled, the carrying capacity of the beam is doubled. If the cross-

8.4 Discussion of Coefficient of Permeability and Darcy's Law

8.0

sectional area (A) of a permeable base is doubled, the flow capacity of the permeable base is doubled.

- **Comparison of quality**

If the allowable steel stress (f_s) is doubled, the carrying capacity of the steel beam is doubled. If the coefficient of permeability (k) is doubled, the flow capacity of the permeable base is doubled.

The coefficient of permeability (k) is similar to an allowable steel stress (f_s). It represents the ability of a flow prism to carry water.

8.5 Non-Steady Flow

In the actual application of Darcy's equation, the flow will increase as the resultant length of the base increases. The depth of flow will increase until the drawdown effect of discharging the water into the edgedrain system is reached. The slope of the hydraulic gradient will change as the flow moves towards the edgedrain.

To model non-steady flow, a design chart [22] from the subdrainage manual is provided as Figure 18. The non-steady flow conditions are shown in the sketch on the figure.

The following example problem compares the depth of base required for non-steady flow with the depth required for steady flow:

Given

Pavement Infiltration	= 1.8 cu ft/day/sq ft
Resultant Length	= 33.94 ft
Resultant Slope	= 0.02828
Coefficient of Permeability	= 3,000 ft/day

Find

Determine required thickness of base.

Solution

Calculate $p = q_r/k = 1.8/3000 = 0.0006$

Entering Figure 26 with $p = 0.0006$, and $SR = 0.02828$ ft/ft

Select $L_R/H = 79$

8.0

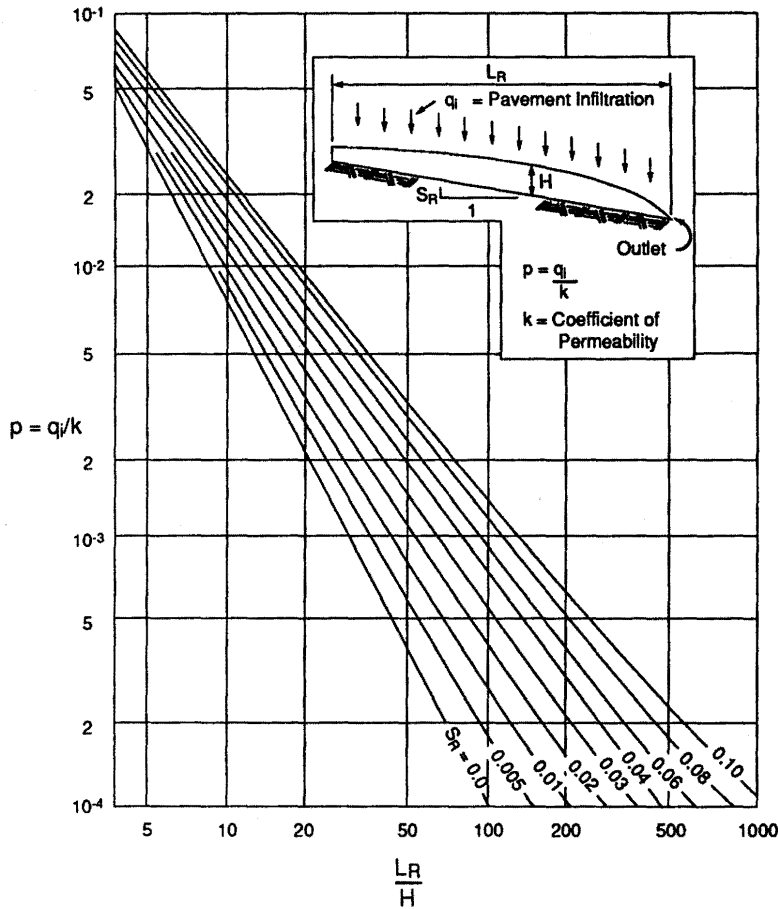

Figure 18. Chart for Estimating Maximum Depth of Flow

$$H = 33.94 / 79 = 0.43 \text{ ft}$$

$$H = 0.43 \text{ ft, or } 5\text{-}1/8 \text{ inches.}$$

where

$$H = \text{Required thickness of base, ft}$$

The required thickness of the base is reduced from 8-5/8 to 5-1/8 inches. This is a reduction of 40 percent.

It is important that engineers understand the difference between the coefficient of permeability and seepage velocity. Seepage velocity is the average velocity of flow through the

8.6 Seepage (V_s) and Discharge (V) Velocities

8.0

pore spaces of the aggregate or soil. It is the actual velocity of the water in the aggregate or soil and would be used to study particle transport in the base. Confusion develops because the units (ft/day) are the same as the coefficient of permeability.

The seepage velocity can be developed as follows:

$$Q = k i A \quad (28)$$

$$V_s N A = k i A \quad (29)$$

$$V_s = \frac{k i}{N} \quad (30)$$

where

V_s = Average velocity through the pore spaces, ft/day

k = Coefficient of permeability, ft/day

i = Hydraulic gradient, ft/ft

N = Porosity of the aggregate or soil

Discharge velocity is the nominal or average velocity through the aggregate or soil. It is the theoretical velocity of the water through the aggregate or soil and would be used to determine the time of flow between two points in the base. The discharge velocity is developed as follows:

$$Q = k i A \quad (31)$$

$$V A = k i A \quad (32)$$

$$V = k i \quad (33)$$

where

V = Discharge of water, ft/day

k = Coefficient of permeability, ft/day

i = Hydraulic gradient, ft/ft

9.0 TIME TO DRAIN

It is imperative that the permeable base drains in a relatively short time to keep moisture damage to a minimum. Time to drain is the best parameter for determining the performance of a permeable base; it is a good standard that meets the needs of pavement drainage. **When rainfall events occur that are greater than the design storm, the permeable base will fill with water and excess water will simply run off on the pavement surface. After the storm event, the permeable base will drain as designed.**

The Corps of Engineers has developed a design approach [8] that considers both the time to drain and the storage capabilities of the permeable base. Highway engineers should be aware of this design procedure.

There are two design approaches for determining the time to drain:

1. AASHTO Percent Drained – 50 percent
2. 85-Percent Saturation

Appendix DD, "Development of Coefficients for Treatment of Drainage" (Vol. 2 *AASHTO Guide for Design of Pavement Structures*), provides the following guidance based on draining 50 percent of the free water. This guidance is provided in Table 4.

Table 4. AASHTO Drainage Recommendations for Time to Drain

<i>Quality of Drainage</i>	<i>Time to Drain</i>
Excellent	2 Hours
Good	1 Day
Fair	7 Days
Poor	1 Month
Very Poor	Does Not Drain

This approach drains 50 percent of the water that can be drained. It does not consider the water retained by the effective porosity quality of the material.

9.1 General

Quality of Drainage

AASHTO Time to Drain

9.0

85-Percent Saturation

Some engineers argue that the 85 percent saturation level is a better threshold for pavement damage due to moisture. Table 5 provides guidance (*Techniques for Pavement Rehabilitation - A Training Course Manual* [11]) based on 85 percent saturation:

Table 5. Pavement Rehabilitation Manual Guidance for Time to Drain

<i>Quality of Drainage</i>	<i>Time to Drain</i>
Excellent	Less than 2 Hours
Good	2 to 5 Hours
Fair	5 to 10 Hours
Poor	Greater Than 10 Hours
Very Poor	Much Greater Than 10 Hours

This method considers both water that can drain and water retained by the effective porosity quality of the material.

The two methods will produce identical results when the water loss of the material is 100 percent; or stated another way when the effective porosity of a material is equal to its porosity.

For permeable bases, this argument is somewhat meaningless since the base material is so open. The water loss will be quite high—in the range of 80 to 90 percent. This means that for practical purposes, the results produced by both methods will be quite close.

Recommendations

A time to drain 50 percent of the drainable water in 1 hour is recommended as a criterion for the highest class roads with the greatest amount of traffic. For most other Interstate highways and freeways, a time to drain 50 percent of the drainable water in 2 hours is recommended. It should be remembered that this is only a target value. The goal of drainage is to remove all drainable water as quickly as possible.

9.0

The time to drain is determined by the following equation:

$$t = T \times m \times 24 \quad (34)$$

where

- t = time to drain, hours
- T = Time Factor
- m = "m" factor

A design chart for determining the time factor (T) is provided by Figure 19 [22, p. 86]. The time factor (T) is based on the geometry of the base course; that is, the resultant slope (S_R) and length (L_R), the thickness of the base (H), and the percent drained (U). First, the slope factor (S_1) must be calculated:

$$S_1 = \frac{L_R S_R}{H} \quad (35)$$

where

- S_1 = Slope factor
- H = Thickness of base, ft
- L_R = Resultant length of base, ft
- S_R = Resultant slope of the base, ft

Figure 19 is then entered with the slope factor (S_1) and the desired percent drained (U). The resulting time factor (T) is then read.

Many times engineers will want to use only one degree of drainage. Figure 19 is difficult to use. By selecting time factors for one degree of drainage over a wide range of slope factors, a simplified chart can be developed. Figure 20 shows such a chart based on 50 percent drained.

9.2 Time to Drain (t) Equation

Time Factor

9.0

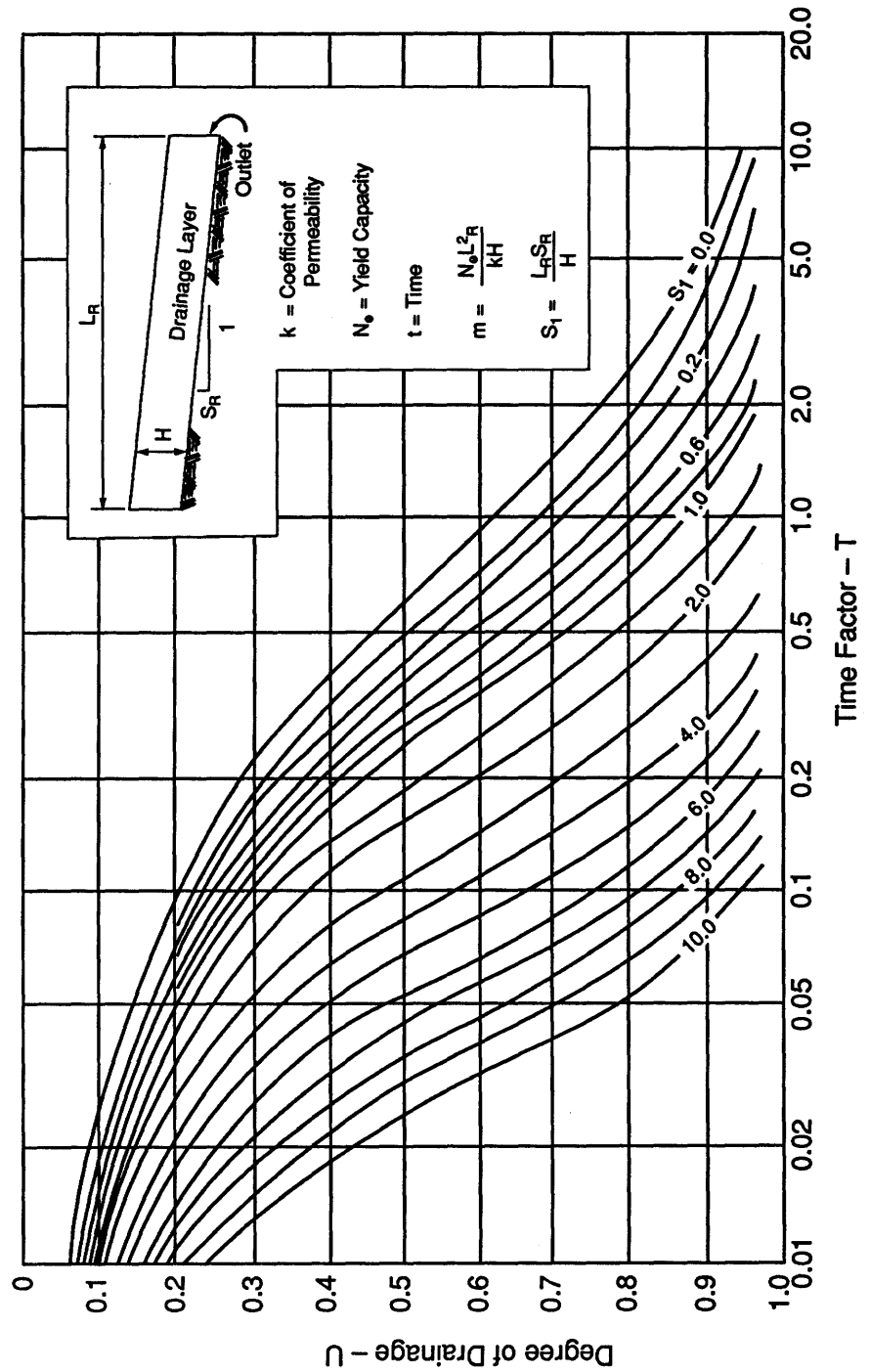

Figure 19. Time Factors for Drainage of Saturated Layer

9.0

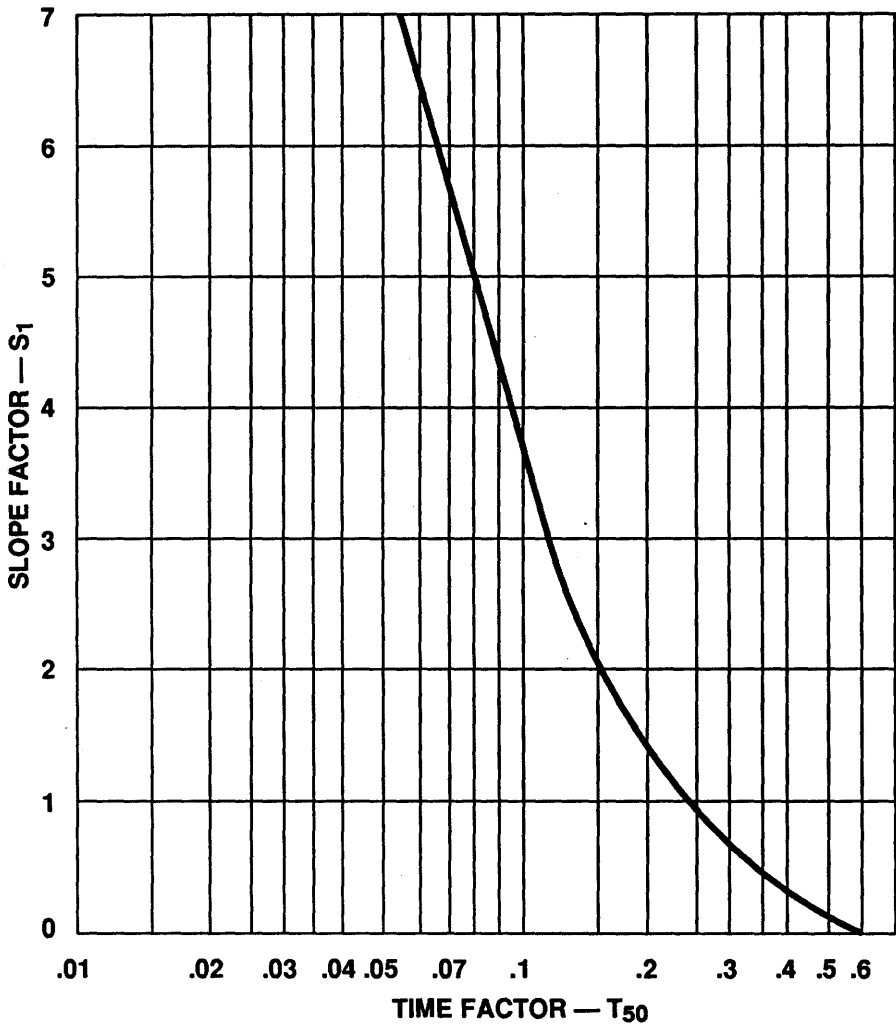

Figure 20. Time Factor for 50 Percent Drainage

9.0

"m" Factor

The "m" factor is determined by the equation:

$$m = \frac{N_e L_R^2}{kH} \quad (36)$$

where

- N_e = Effective porosity
- L_R = Resultant length, ft
- k = Coefficient of permeability, ft/day
- H = Thickness of base, ft

The intrinsic factors that represent the drainage capabilities of the permeable base are represented by the effective porosity (N_e) and the coefficient of permeability (k) of the base. The effect of these terms only occurs in this factor. Guidance for determining the effective porosity and coefficient of permeability has been provided in previous sections. **In actual practice, if the time to drain needs to be reduced to meet a standard, the coefficient of permeability will have to be increased. Therefore, the effective porosity also will increase.** The effect of changing these parameters is discussed in the Section 10.0, Time to Drain Sensitivity.

The "m" factor will be a constant for the given parameters.

After determining the time factor and "m" factor, the time to drain can now be calculated by using Equation 34.

These design procedures are demonstrated in the following example problem:

Given

Roadway Geometry

- Resultant slope (S_R) = 0.02 ft/ft
- Resultant length (L_R) = 24 ft
- Base thickness (H) = 0.5 ft

Permeable Base Material

- Effective porosity (N_e) = 0.25
- Coefficient of permeability (k) = 2000 ft/day

Find

Determine the time to drain (t) for 50 percent drainage of the permeable base.

9.0

Solution

First the slope factor is calculated,

$$S_1 = \frac{L_R S_R}{H} = \frac{24 \times 0.02}{H} = 0.96$$

Entering Figure 20 with the slope factor, select a time factor (T_{50}) of 0.245.

Calculate the "m" factor:

$$m = \frac{N_o L_R^2}{kH} = \frac{0.5 \times (24)^2}{2000 \times 0.5} = \frac{144}{1000} = 0.144$$

Now calculate the time to drain (t):

$$t = T_{50} \times m \times 24 = 0.245 \times 0.144 \times 24 = 0.85$$

$$t = 0.85 \text{ hrs}$$

The required time to drain for 50 percent drainage is 0.85 hours.

Note that the rate of inflow into the pavement does not enter into the design calculations. Again, theoretically, the time to drain does not start until after the design storm has stopped.

Most engineers want to evaluate the drainage over a range of drainage conditions rather than a single standard. The following design procedures allow the engineer to construct a matrix of design information. Time to drain is calculated over a range of 10 to 90 percent drained water. The sensitivity to drainage can then be considered as the design is finalized.

Table 6 is a design form used to calculate the time to drain for the different degrees of drainage. The following discussion provides detailed guidance for completing each column:

First, the necessary design parameters must be calculated.

Determine the base thickness (H) and the coefficient of permeability (k).

Calculate the roadway geometry; resultant length (L_R), and resultant slope (S_R).

9.3 Design Procedures

9.0

Calculate the porosity (N), and the effective porosity (N_e) of the base material.

Calculate the slope factor (S_1) of the permeable base.

$$S_1 = \frac{L_R \times S_R}{H}$$

Calculate the "m" factor.

$$m = \frac{N_e L_R^2}{kH}$$

Now the tabulation can be completed.

Column 1 Percent Drained

Column 1 is assigned with values from 0.1 to 0.9, which represent the percent of water that can be drained from the base.

Column 2 Time Factor (T)

Enter Figure 27 with the slope factor (S_1) and the respective percent drained (U), and select the time factor (T).

Column 3 Time to Drain – hours.

Calculate the time to drain in hours.

$$t = T \times m \times 24$$

$$\text{Column 3} = \text{Column 2} \times m \times 24$$

If the design criteria is based on percent drained, the design can stop here. By plotting a graph of time to drain, Column 3, against the percent drained, Column 1, the drainage relationship can be seen.

If the design criteria is based on percent saturation, the remaining columns must be completed.

Column 4 Drained Water

Calculate the drained water.

$$\text{Drained water} = N_e \times U$$

$$\text{Column 4} = N_e \times \text{Column 1}$$

9.0

Column 5 Volume of water (V_w)

Calculate the volume of water (V_w) in the base. Remembering then, that $V_v = N$.

$$V_w = N - \text{Drained water}$$
$$\text{Column 5} = N - \text{Column 4}$$

Column 6 Percent Saturation (S)

Calculate the percent saturation of the base.

$$S = (V_w / N) \times 100$$
$$\text{Column 6} = (\text{Column 5} / N) \times 100$$

By plotting a graph of time to drain, Column 3, against the percent saturation, Column 6, the drainage relationship can be seen.

The FHWA microcomputer program, *DAMP* [3], will perform the time to drain calculations. Because of the program speed and elimination of computational errors, use of the microcomputer program is suggested.

9.0

Table 6. Time to Drain Calculation Form

Pavement Section

Pavement Section _____

Properties of Base Course

Resultant Slope, S_R _____ ft/ft

Resultant Length, L_R _____ ft

Base Thickness, H _____ ft

Coefficient of Permeability, k _____ ft/day

Slope Factor $S_1 = (L_R \times S_R) / H =$ _____

Porosity (N)

Dry Density, γ_d _____ pcf

Bulk Specific Gravity, G_{sb} _____

Porosity (N) or Volume of Voids (V_v),

$N = (1 - (\gamma_d / (62.4 \times G_{sb}))) =$ _____

Effective Porosity (N_e)

Type of Fines _____

Percent of Fines _____

Effective Size D_{10} _____

Estimated Water Loss, (WL) _____ Percent

Effective Porosity, $N_e = N \times WL =$ _____

Calculate "m" Factor

$m = (N_e \times L_R^2) / (k \times H) =$ _____

9.0

Table 6. Time to Drain Calculation Form (Cont'd.)

(1)	(2)	(3)	(4)	(5)	(6)
U	Time Factor (T)	Time to Drain (hours) (2) x m x 24	Water Drained (1) x N _e	Water Retained (V _w) N - (4)	Percent Saturation (S) ((5) / N) x 100
.1					
.2					
.3					
.4					
.5					
.6					
.7					
.8					
.9					



10.0 TIME TO DRAIN SENSITIVITY

It is important that pavement design engineers understand the effects of various parameters in time to drain calculations. The best way to investigate the problem is to do a sensitivity analysis on the design procedures. In a sensitivity analysis, each parameter is investigated over a range of values while the remaining parameters are held constant.

The time to drain (t) (Equation 34) responds linearly to both of factors; the time factor (T) and the "m" factor (m). This means that any linear effect the various parameters have when used in the calculation of these factors, will have a linear effect on the time to drain.

It should be pointed out that there is a relationship between effective porosity (N_e) and coefficient of permeability (k). If the effective porosity is increased, the permeability of the material will also increase. For simplicity, each factor will be investigated independently in this notebook.

Effective porosity (N_e) and coefficient of permeability (k) are the only factors that represent the drainage capabilities of the base material. The effect of these factors only occurs in the "m" factor.

From Equation 36, it can be seen that the effect of effective porosity (N_e) is linear. This means that if the effective porosity is doubled, the time to drain is doubled. This is logical since twice the amount of water will be released from the base course. A plot of the sensitivity of effective porosity is shown in Figure 21.

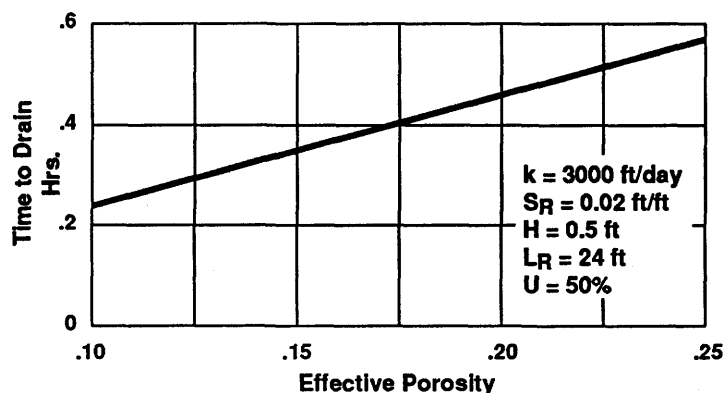

Figure 21. Effect of Effective Porosity

10.1 Effective Porosity (N_e)

10.0

10.2 Coefficient of Permeability (k)

Engineers should not yield to the temptation to reduce the effective porosity so as to reduce the time to drain. It must be remembered that the goal of drainage is to remove as much water as possible from the base course.

From Equation 36, it is seen that the effect of the coefficient of permeability (k) is inversely proportional to the time to drain. Again this is logical. As permeability of the material increases, the faster the base material will drain. This effect is shown in Figure 22. As the permeability increases, the time to drain decreases at a decreasing rate. To meet the target of 50 percent drainage in 1 hour, a coefficient of 1,800 ft/day is required for this particular set of conditions, while the required coefficient of permeability to meet the target of 50 percent drained in 2 hours is 900 ft/day.

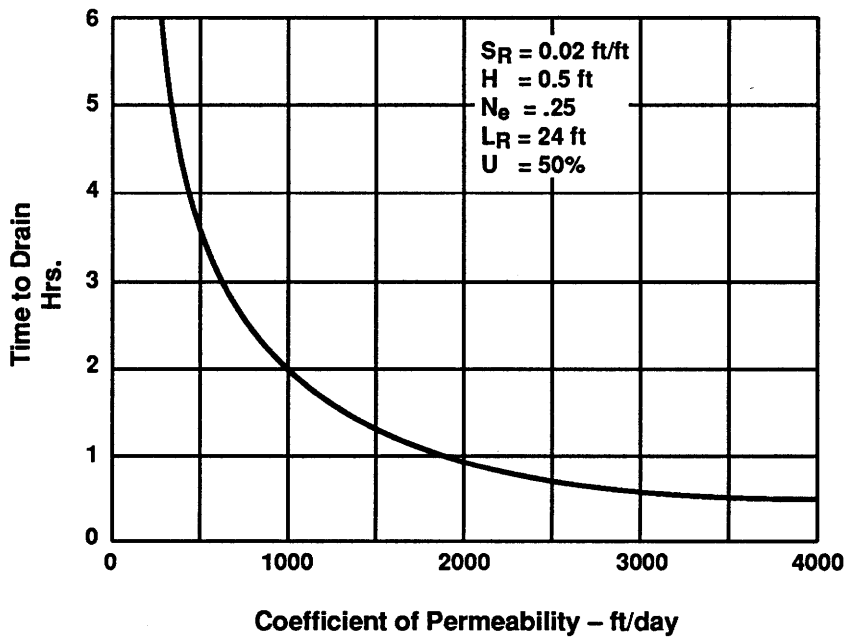

Figure 22. Effect of Coefficient of Permeability

10.0

The effect of resultant slope (S_R) only occurs in the internal calculation of the time factor (T). The only way to identify the effect is to plot a sensitivity analysis for the given conditions as shown in Figure 23. This plot shows the design procedure is sensitive to slope with the time to drain decreasing as the slope increases. This is logical; the steeper the slope, the faster water will drain. The time to drain continues to drop over the entire range of slopes presented. Theoretically, the base will drain even if the slope is flat; however, it is questionable practice to apply the design procedures to flat slopes.

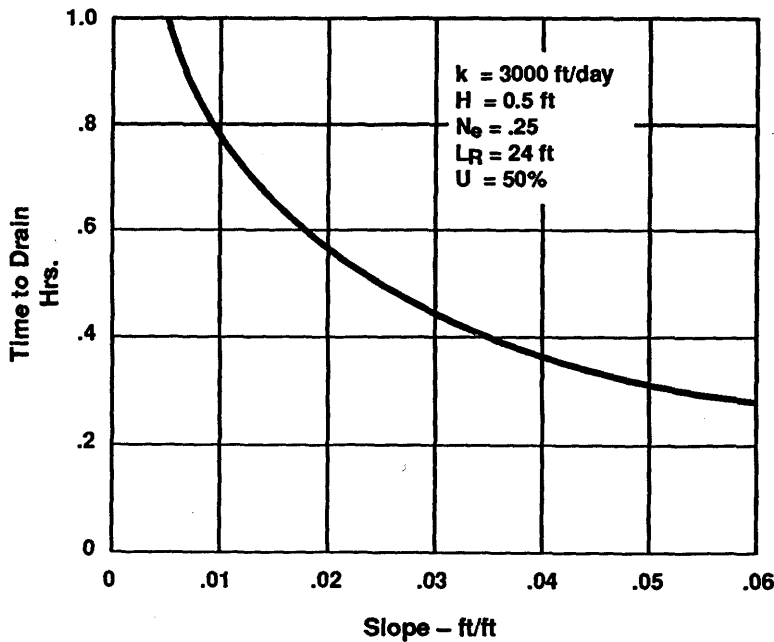

Figure 23. Effect of Slope

Figure 24 shows the effect of resultant length (L_R). This effect occurs in the "m" factor (Equation 26) and the internal calculation of the time factor (T). Surprisingly, the relationship is quite linear. Since the length parameter in the "m" factor is a power function, it is difficult to explain this behavior.

10.3 Resultant Slope (S_R)

10.4 Resultant Length (L_R)

10.0

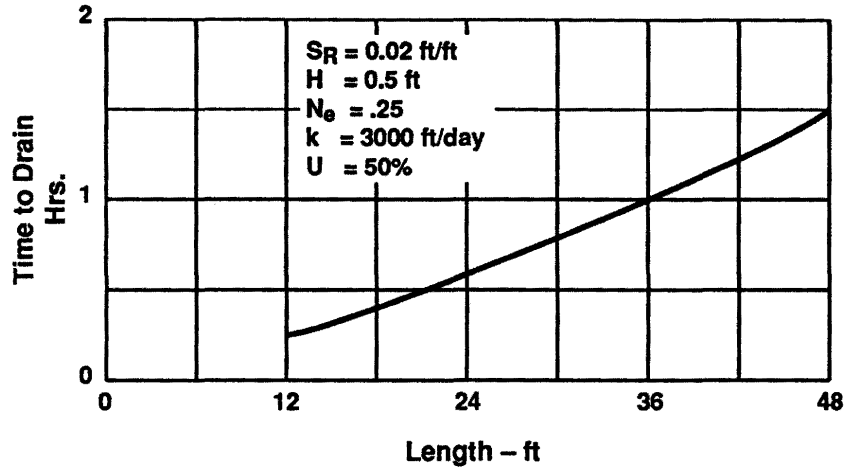

Figure 24. Effect of Length

10.5 Thickness (H)

The effect of thickness (H) occurs in both the "m" factor (Equation 26) and the internal calculation of the time factor (T). Figure 25 plots the sensitivity analysis of base thickness. Based on this figure, the base thickness has little effect on the time to drain.

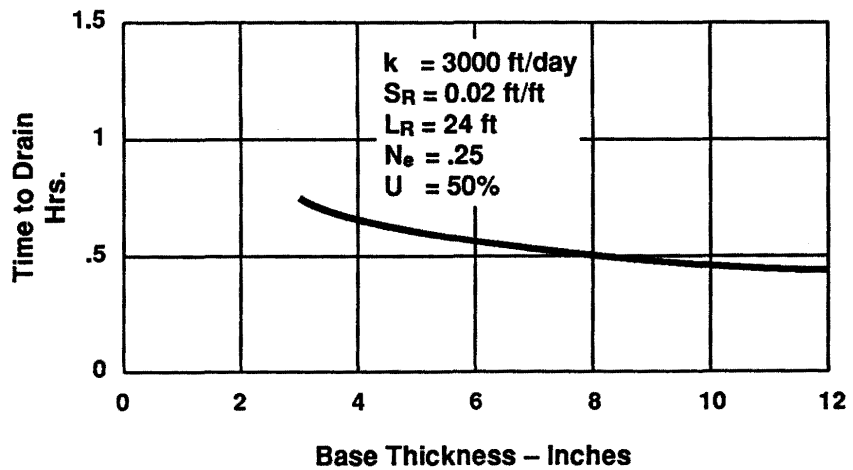

Figure 25. Effect of Thickness

10.0

In summary, the design is most sensitive to permeability and any increase in resultant slope will decrease the time to drain. **Engineers should make a similar analysis for the particular design conditions in their State. A sensitivity analysis is particularly useful in determining the permeability/stability tradeoff.**

Based on the sensitivity discussions, the following general guidance can be provided:

- Provide a base course material with high effective porosity.
- Provide a base course material with a permeability that represents a balanced tradeoff with stability.
- Provide as much slope as possible. A minimum slope of 0.02 ft/ft is suggested.
- If the time to drain is considered to be too long, engineers should consider increasing the coefficient of permeability or providing crowned pavements to reduce the length of the flow path. Crowned pavements are a particularly viable option for multi-lane highways.

10.6 Conclusions

Use High N_e

Balance k with Stability

Maximize Slope

Increase k or Crown Pavement



11.0 PERMEABLE BASES

In the past, the primary function of the base was to provide uniform support for concrete pavements; however, as wheel and traffic loads increased, pumping and erosion of underlying material resulted. This led, in turn, to a new generation of what was thought to be strong, non-erodible bases (i.e., lean concrete, cement treated bases and asphalt treated bases). Time has shown that these materials were not only impermeable but were also erodible in many cases. The combination of infiltrated water, wheel loads, and traffic loads led to pumping, erosion of material, and in many cases premature failure of the pavement section.

To solve this problem, a number of States are going to a more open-graded material to rapidly drain infiltrated water from the pavement structure. This type of base is called a permeable base.

A permeable base must provide three very important functions:

- First, the base material must be permeable enough so that the base course drains within the design time period.
- Second, the base course must have enough stability to support the pavement construction operation.
- Third, the base course must have enough stability to provide the necessary support for the pavement structural design.

The combination of base thickness and permeability must be capable of handling the design flows and keeping the saturation time to a minimum. In Section 9.0, Time to Drain, draining 50 percent of the free water within 1 hour was recommended as a criterion for the highest-class highways, while draining 50 percent in 2 hours was recommended for most Interstates and roads.

From the start, SHA's recognized that permeable base design must be a careful tradeoff of permeability and stability of the base material. Efforts to solve this problem developed into two approaches. First, some SHA's used their existing dense-graded aggregate base gradations removing some of the fines to produce the necessary permeability. Second, other SHA's used the highest permeability that could be obtained with readily

11.1 General

Permeable Base Functions

11.0

available materials. These efforts resulted in two types of permeable bases:

1. Unstabilized.
2. Stabilized.

Unstabilized bases consist of aggregate gradations that contain finer-sized aggregates. These bases develop their stability by good mechanical interlock of the aggregates. Stabilized bases are more open-graded and thus much more permeable. Stability is developed by the cementing action of the stabilizer material at the point of aggregate contact. A number of SHA's that selected the higher permeability path have gradually gravitated to gradations with greater percentages of fine material to achieve more stability.

The permeable base must have enough strength to prevent rutting or displacement during the paving operation. As a general statement, if a permeable base has enough stability to perform adequately during the construction phase, the base should be stable enough to support the pavement structural design.

Daylighting Not Recommended

A longitudinal edgedrain collector system with outlet pipes to roadside ditches should be provided to insure positive drainage [14]. Daylighting the permeable base layer is not recommended since the daylighted layers are subject to clogging from roadway debris and vegetation. In addition, daylighted layers may allow silty material or storm water from ditches to enter the pavement structure.

FHWA's Demonstration Project No. 975, *Permeable Base Design and Construction*, reviewed the design and construction procedures in ten States. A synthesis paper [21] was prepared reporting on the results of the review. Much of the material on permeable bases presented in this section is based on the findings of that review.

It must be pointed out that pavement subsurface drainage is only one element of concrete pavement design. Pavement drainage is not a substitute for pavement thickness, positive load transfer, or a strong, uniform subgrade.

11.0

There are a number of factors that make development of the pavement section difficult. These factors are:

- Material type – (unstabilized or stabilized)
- Separator layer type – (aggregate or geotextile)
- Edgedrain location
- Pre-, or post-installation of edgedrain
- Pavement cross slope – (uniform cross slope or crowned)
- Shoulder type – (similar or dissimilar materials)

The most likely combinations of concrete pavement sections and edgedrain locations are shown in Figures 26 and 27.

Concrete Pavement with Asphalt Concrete Shoulders

Figure 26 shows a widened lane concrete pavement with asphalt concrete shoulders. A uniform cross slope is provided to drain the water over to a roadside ditch. Since it is anticipated that the pavement shoulder joint will open, allowing water to enter the pavement section, the edgedrain is located as close to this joint as is feasible. This will provide a direct path to drain the water to the edgedrain system.

A pre-pave installation is shown in the main sketch. The edgedrain is located far enough away from the edge of the concrete pavement so that the paver tracks will run directly on the permeable base – not over the edgedrain pipe. A geotextile is provided under the edge of the permeable base and wrapped around the edgedrain trench to prevent fines from entering the system. The edgedrain should never be placed under the traffic lanes, as inadequate support may result.

The insert sketch shows a post-pave installation. The edgedrain trench is located far enough away from the pavement slab, so that the slab will not lose support by the permeable base eroding or sloughing during the paving operation. The trench should be backfilled with the same material as the permeable base so there will be no loss of permeability. Again, the edgedrain trench is wrapped with a geotextile to prevent fines from entering.

11.2 Pavement Section

11.0

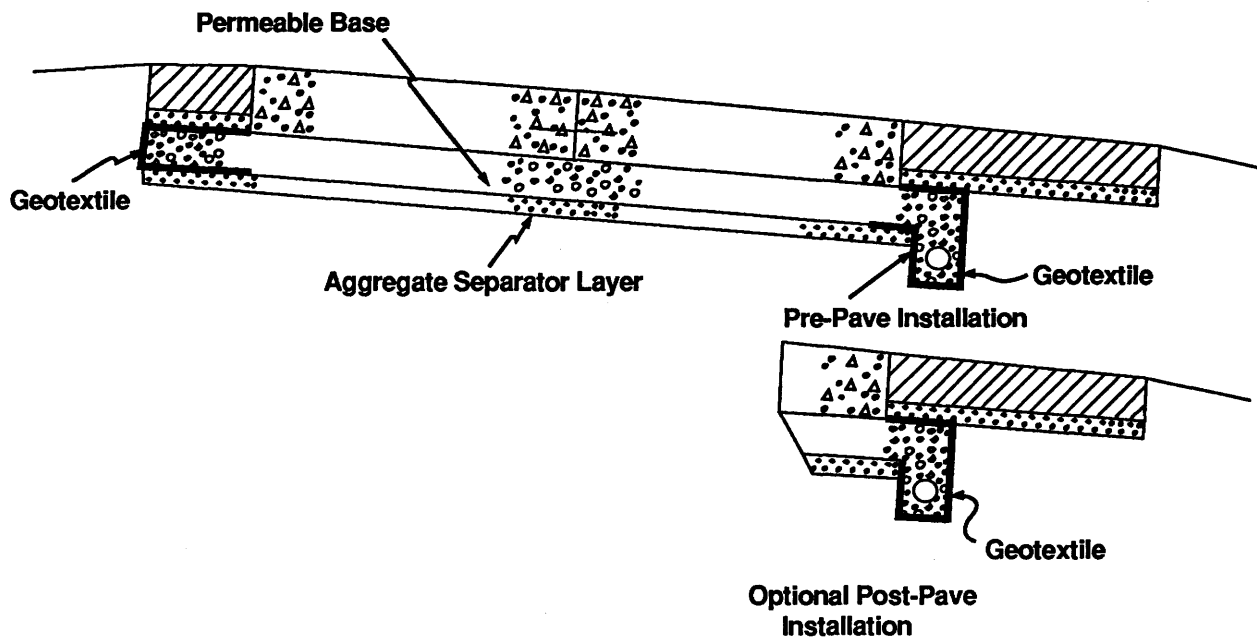

Figure 26. Edgedrain Location for Concrete Pavement with Asphalt Concrete Shoulders

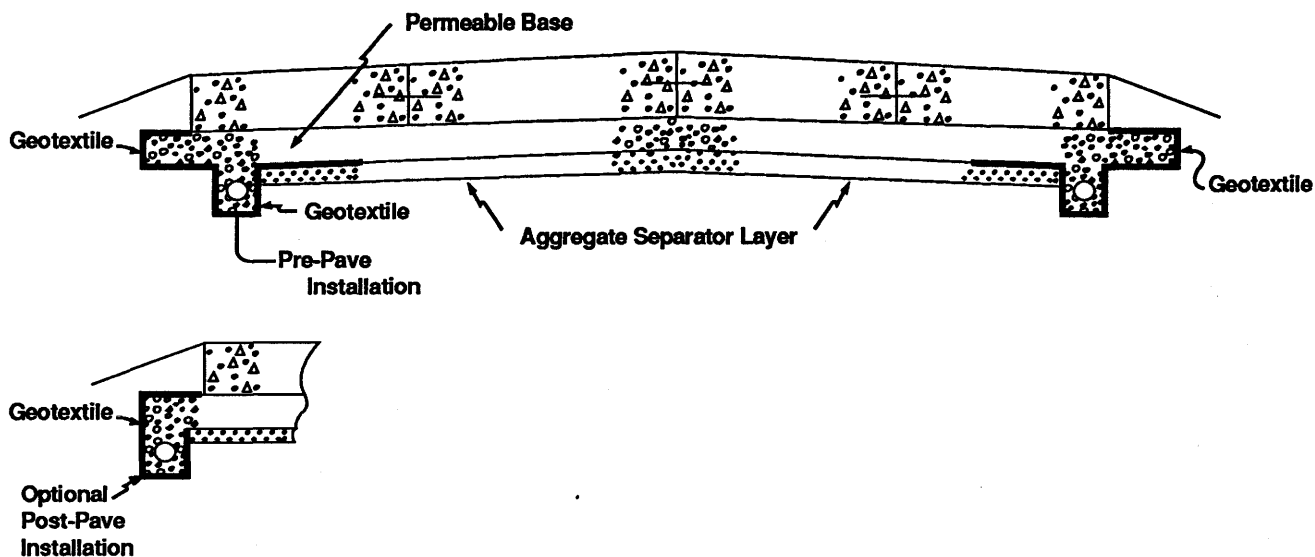

Figure 27. Edgedrain Location for Crowned Concrete Pavement with Tied Concrete Shoulders

11.0

Crowned Concrete Pavement with Tied Concrete Shoulders

A crowned concrete pavement with tied concrete shoulders is shown in Figure 27. Since the pavement is crowned, edgedrains must be provided on both sides of the pavement section. The crowned pavement significantly reduces the length of the drainage path, thus reducing the time to drain, while the tied shoulders provide considerable support to the pavement edge. Durability of the shoulder joint seal is enhanced because of the use of like materials and the reduced movement.

For the pre-pave installation, the edgedrain may be located under the shoulder to avoid the paver tracks during the paving operation; however, the edgedrain should never be placed under a travel lane. If the edgedrain is located outside of the shoulder, it may not have adequate cover over the edgedrain pipe, depending on the ditch side slope. Again, a geotextile is provided under the pavement edge and wrapped around the edge drain trench to prevent fines from entering the drainage system.

The post-pave installation is shown in the sketch insert. Again, the previously stated guidance of locating the trench so that there is no loss of support to the concrete shoulder during the trenching operation still applies. Also, previous guidance about geotextile placement and trench backfill still applies.

Construction traffic on the completed base course is the single most important parameter in the selection of the type of permeable base to be used. The design procedure should contain a decision step on construction traffic.

In the design process, if the answer to allowing construction traffic (concrete delivery trucks only) on the base is yes, then an asphalt or cement-stabilized base is generally needed. If no construction traffic is allowed on the completed base, then a more open, untreated AASHTO No. 67 could be used. Photo No. 1 shows the concrete pavement being placed on a cement stabilized base.

When dowel baskets are used, special attention should be given to anchoring techniques on drainable bases.

11.3 Construction Traffic on Completed Base Course

11.0



Photo No. 1 Placing Concrete Pavement

11.4 Base Material

The aggregate material should have good mechanical interlock; this will require a crushed material. Both **unstabilized and stabilized permeable base material should consist of durable, crushed, angular aggregate with essentially no fines (minus No. 200 sieve material).** The crushed aggregate should have at least two mechanically fractured faces, as determined by the material retained on the No. 4 sieve. Many States require 100-percent crushed stone with a maximum L. A. Abrasion Wear of 40 to 45 percent. A permeable base material should be sufficiently stable for construction equipment to work on without significant displacement; the base must also be stable enough to provide a good-quality ride.

The FHWA recommends that only crushed stone be used in permeable bases. Crushed stone provides needed stability during the construction phase and assures long-term support for the concrete pavement. The aggregate for the permeable base should at least meet the requirements for a Class B Aggregate in accordance with AASHTO M 283-83, *Coarse Aggregate for Highway and Airport Construction*. This means that the L.A. Abrasion Wear should not exceed 45 percent as

11.0

determined by AASHTO T 96-87, *Resistance to Abrasion of Small Size Coarse Aggregate by Use of the Los Angeles Machine*. Since the permeable base is subject to freeze-thaw cycles, the durability of the aggregates should be tested by a soundness test. The FHWA recommends that the soundness percent loss should not exceed the requirement for a Class B Aggregate as specified in AASHTO M 283-83. This specification requires that the soundness percent loss should not exceed 12 or 18 percent as determined by the sodium sulfate or magnesium sulfate tests, respectively. The tests should be conducted in accordance with AASHTO T 104, *Soundness of Aggregate by the Use of Sodium Sulfate or Magnesium Sulfate*.

Recommended gradations of the permeable base material vary depending on whether the material is stabilized or unstabilized. Since the in-place coefficient of permeability can vary significantly from the design coefficient of permeability, a minimum design coefficient of permeability of 1,000 ft/day is recommended.

SHA's that use unstabilized permeable bases have developed a gradation that represents a careful trade-off of constructability/stability and permeability. Unstabilized materials contain more smaller size aggregate to provide stability through increased aggregate interlock; however, this results in lower permeability. To provide good stability for paving equipment, **unstabilized aggregate should be composed of 100 percent crushed stone**. Photo No. 2 shows a finished unstabilized permeable base.

Unstabilized materials generally have a coefficient of permeability on the order of 1,000 to 3,000 feet per day. Below is the New Jersey Department of Transportation gradation, Table 7, for unstabilized material which provides satisfactory permeability (greater than 1,000 feet per day) and good stability during construction.

11.5 Unstabilized Permeable Base

11.0



Table 7. New Jersey Gradation

<i>Sieve Size</i>	<i>Percent Passing</i>
1-1/2"	100
1"	95 - 100
1/2"	60 - 80
No. 4	40 - 55
No. 8	5 - 25
No. 16	0 - 8
No. 50	0 - 5

11.0

This gradation is plotted in Figure 28. An analysis of this gradation reveals that the average effective size (D_{10}) is 1.90 mm, and the coefficient of uniformity (C_u) is 4.68.

The Pennsylvania Department of Transportation recommends that unstabilized permeable base material should have a coefficient of uniformity greater than 4 to insure stability of the base. This recommendation is particularly important if construction traffic (concrete delivering vehicles) is permitted on the base. However, other construction traffic must not be allowed to contaminate the permeable base by pumping fines into the permeable base or tracking material onto the base which might clog it.

Table 8 provides gradation of unstabilized permeable bases being used by SHA's.

Compaction of permeable bases has also been recognized as a concern. The conventional approach of requiring a fixed percent of a standard or target density is not applicable because it is difficult to measure density. The purpose of compacting a permeable base is to seat the aggregate. A level of consolidation should be specified which results in no appreciable displacement of the base following compaction.

For unstabilized permeable bases, most SHA's specify one to three passes of a 5-to-10-ton steel-wheeled roller.

Over-rolling can cause degradation of the material and a subsequent loss of permeability. Vibratory rollers should be used with care to compact unstabilized permeable bases, since they can cause degradation, over-densification, and a subsequent loss of permeability.

Stabilized permeable bases utilize open-graded aggregate that has been stabilized with asphalt cement or Portland cement. Stabilizing the permeable base provides a stable working platform without appreciably affecting the permeability of the material. The primary purpose of the stabilizer is to provide stability of the permeable base during the construction phase.

Unstabilized Permeable Base Gradations

Compaction of Unstabilized Permeable Bases

11.6 Stabilized Permeable Base

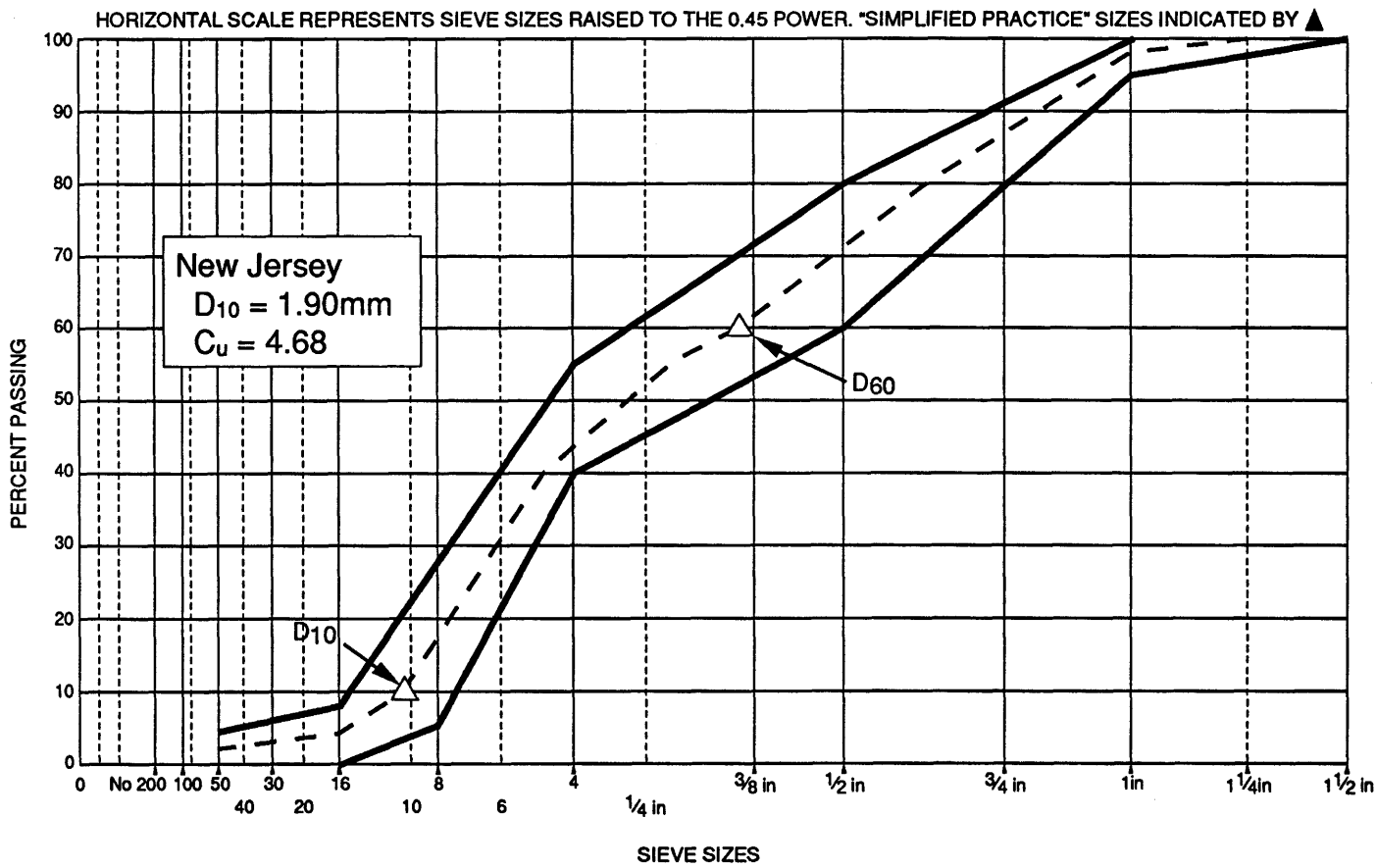

Figure 28. Plot of New Jersey Gradation

11.0

Table 8. Unstabilized Permeable Base Gradations

<i>Sieve Size</i>	<i>Iowa</i>	<i>Minnesota</i>	<i>New Jersey</i>	<i>Pennsylvania*</i>	<i>Wisconsin** OGBC No. 1</i>
2"				100	
1-1/2"			100		
1"	100	100	95 - 100		100
3/4"		65 - 100		52 - 100	90 - 100
1/2"			60 - 80		
3/8"		35 - 70		33 - 65	20 - 55
No. 4		20 - 45	40 - 55	8 - 40	0 - 10
No. 8	10 - 35		5 - 25		0 - 5
No. 10		8 - 25			
No. 16			0 - 8	0 - 12	
No. 40		2 - 10			
No. 50	0 - 15		0 - 5		
No. 200	0 - 6	0 - 3		0 - 5	

*Pennsylvania - a uniformity coefficient of 4 or greater is required.

**Wisconsin - gradation is the same as AASHTO No. 67

Stabilized Permeable Base Gradations

Several SHA's use the AASHTO No. 57 gradation for their stabilized permeable bases. The gradation is provided in Table 9.

11.0

Table 9. AASHTO No. 57 Gradation

Sieve Size	Percent Passing
1-1/2"	100
1"	95 - 100
1/2"	25 - 60
No. 4	0 - 10
No. 8	0 - 5

Some SHA's provide an additional requirement limiting the amount of material passing the No. 200 sieve from 0 to 2 percent. The purpose of this requirement is to limit the amount of fines. This gradation has already been plotted in Figure 13.

By limiting the amount of material passing the No. 8 or 16 screen, the effective diameter (D_{10}) of the material will be large, ensuring high permeability. The coefficient of permeability should be greater than 3,000 feet per day.

An analysis of this gradation reveals that the effective size (D_{10}) is 5.98 mm, and the coefficient of uniformity (C_U) is 2.54. Note that the effective size of this gradation is much larger than the unstabilized base, and that the coefficient of uniformity is less.

The AASHTO No. 67 gradation is now being used by several SHA's for their permeable bases. The gradation is provided in Table 10.

This gradation is plotted in Figure 29.

The effective size (D_{10}) is 5.77 mm, and the coefficient of uniformity (C_U) is 2.14. Note that the effective size of this gradation is slightly less than the AASHTO No. 57 gradation; and the coefficient of uniformity is also less.

11.0

Table 10. AASHTO No. 67 Gradation

Sieve Size	Percent Passing
1"	100
3/4"	90 - 100
3/8"	20 - 55
No. 4	0 - 10
No. 8	0 - 5

The Wisconsin Department of Transportation has reported success using the AASHTO No. 67 gradation in unstabilized bases, asphalt treated bases (Minimum 1-1/2 percent asphalt), and cement treated (200 to 250 pounds of cement per cubic yard). Again, selection of the base type is influenced by the construction traffic consideration.

The FHWA recommends that the contractor be provided with an option to select the type of stabilizing material when stabilization is required.

The stabilization material predominately used is asphalt cement at 2 to 2 1/2 percent (by weight); a harder grade of asphalt cement, AC 40 OR AR 8000, is recommended to improve that the stability of the base during construction. The California Department of Transportation (CALTRANS) recommends that when the stiffer AC-40 asphalt cement is used, the aggregate should be heated to between 275 to 325 degrees Fahrenheit to prepare the aggregate so that the aggregates and asphalt cement are blended into a homogenous mix.

An asphalt-stabilized permeable base is shown in Photo No. 3.

Table 11 provides asphalt-stabilized permeable base gradations being used by SHA's.

Asphalt Stabilized

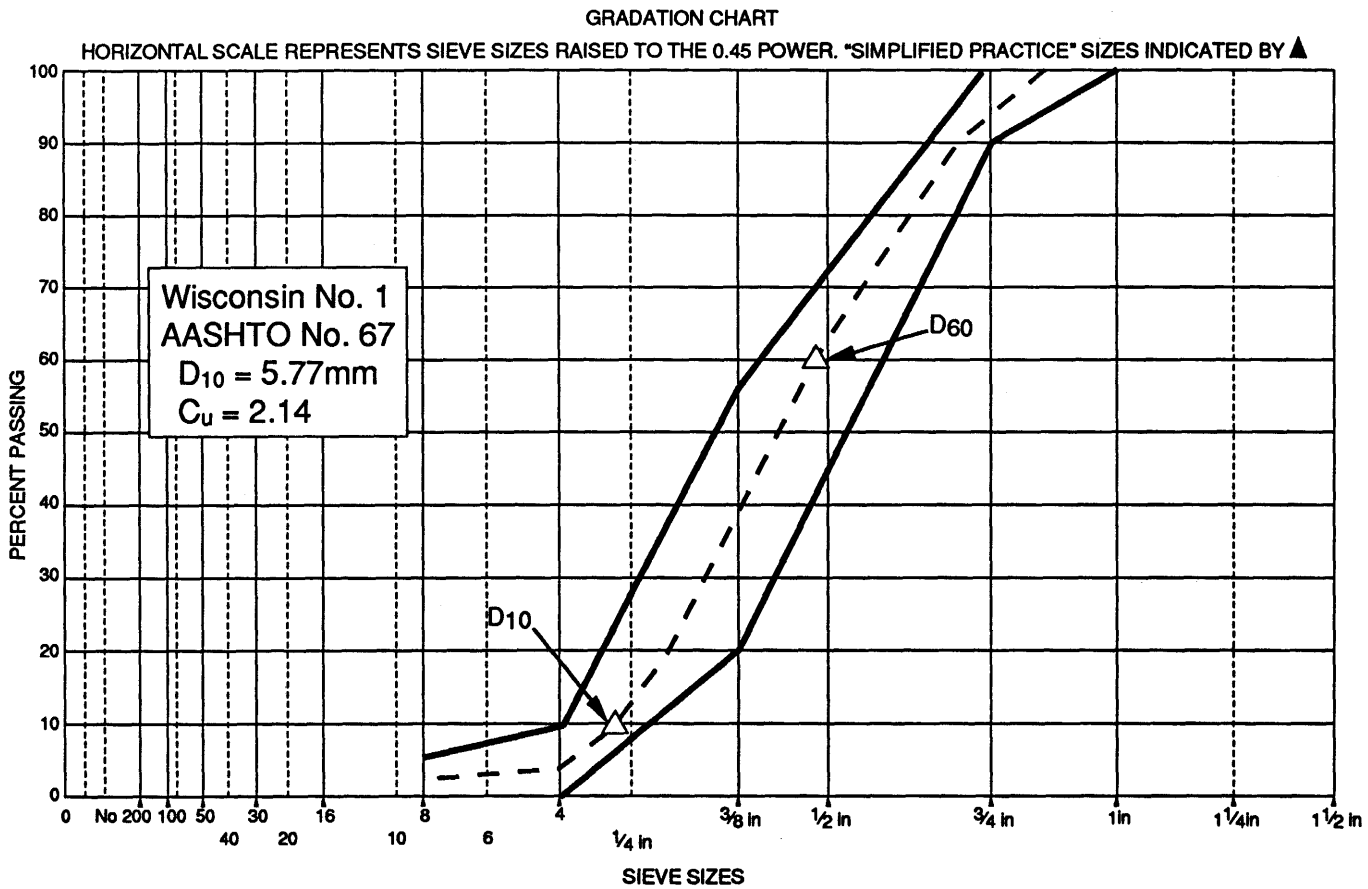

Figure 29. Plot of AASHTO No. 67 Gradation

11.0

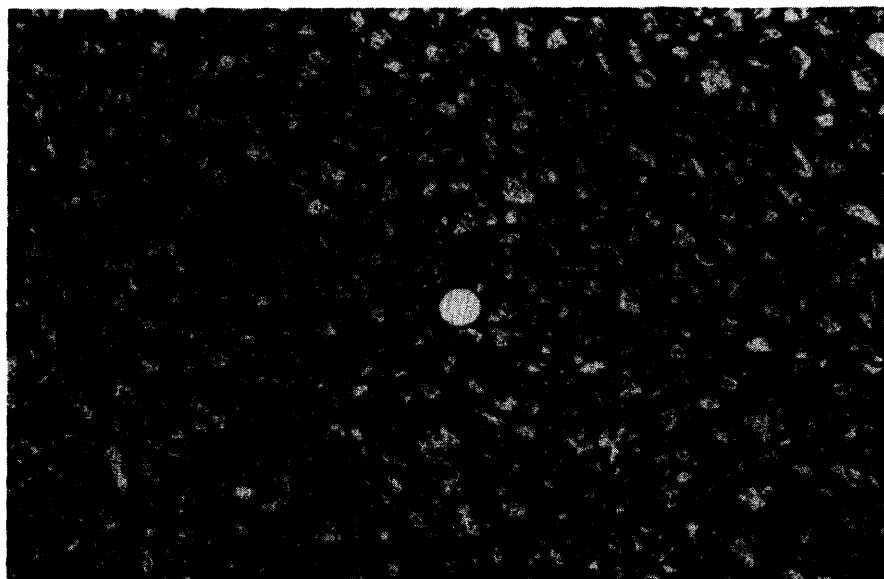

Photo No. 3 Asphalt Stabilized Permeable Base

For asphalt-stabilized permeable bases, most SHA's specify one to three passes of a 5- to 10-ton steel-wheeled roller. Over-rolling can cause degradation of the material and a subsequent loss of permeability. Vibratory rollers should not be used to compact asphalt-stabilized permeable bases, since they can cause degradation, over-densification, and a subsequent loss of permeability.

CALTRANS requires that asphalt-stabilized permeable bases be laid at a temperature between 200 to 250 degrees Fahrenheit as measured in the hopper of the paving machine. One recommended alternate for compaction is one complete coverage of the base course with a steel-wheeled, 2-axle tandem roller weighing between 8 and 12 tons. Compaction should begin when the temperature of the permeable base has cooled to 150 degrees Fahrenheit and should be completed before the temperature falls below 100 degrees Fahrenheit.

Compaction of Asphalt-Stabilized Permeable Bases

11.0

Table 11. Asphalt-Stabilized Permeable Base Gradations

Sieve Size	California	North Carolina	Wisconsin	Wyoming
1-1/2"		100		100
1"	100	95 - 100	100	95 - 100
3/4"	90 - 100		90 - 100	
1/2"	35 - 65	25 - 60		25 - 60
3/8"	20 - 45		20 - 55	
No. 4	0 - 10	0 - 10	0 - 10	0 - 10
No. 8	0 - 5	0 - 5	0 - 5	0 - 5
No. 200	0 - 2	0 - 3		

California - 2-1/2% asphalt content, AR-8000 grade

North Carolina - AASHTO No. 57 gradation plus 0-3% passing No. 200 sieve

Wisconsin - AASHTO No. 67 gradation, > 1-1/2 % asphalt content

Wyoming - AASHTO No. 57 gradation, 2-1/2 % asphalt content, AC 20

Photo No. 4 shows the compaction of an asphalt stabilized permeable base.

Cement Stabilized

Portland cement has also been used as a stabilization material. An application rate of 2-to-3 bags per-cubic yard is recommended. A cement-stabilized permeable base is shown in Photo No. 5. This base material has considerable strength as exhibited by a test cylinder of that material as seen in Photo No. 6.

11.0

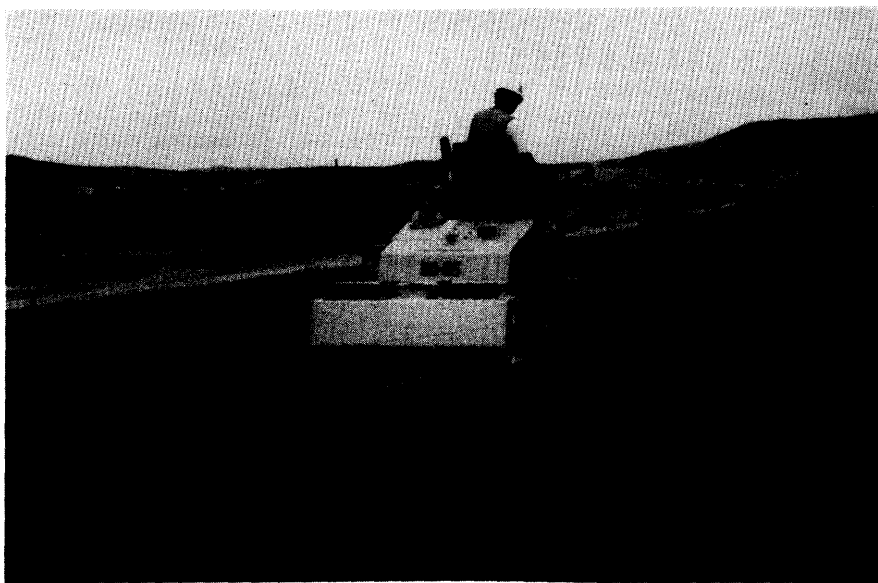

Photo No. 4. Compacting Asphalt Stabilized Base



Photo No. 5. Cement-Treated Permeable Base

11.0

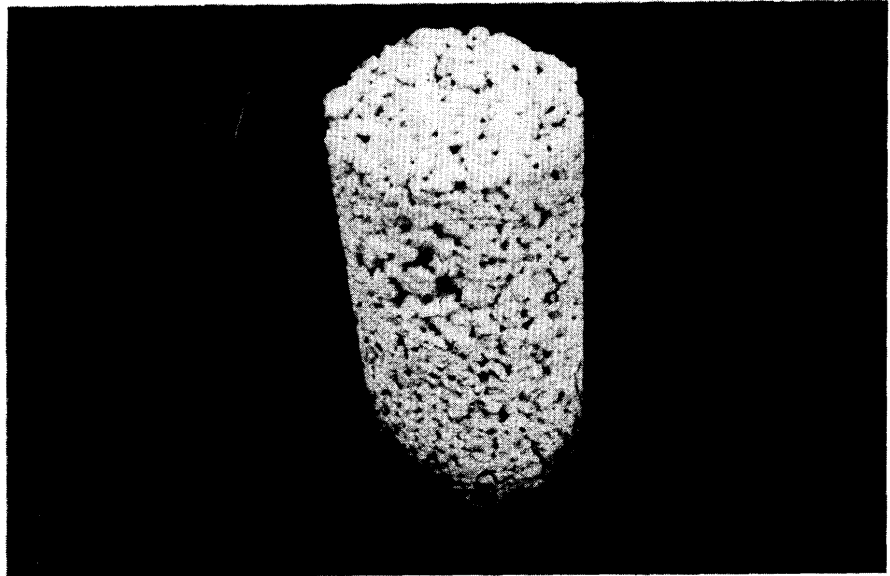

Photo No. 6. Test Cylinder

Cement-Stabilized Permeable Base Gradations

Table 12 provides cement-stabilized permeable base gradations being used by SHA's.

11.0

Table 12. Cement-Stabilized Permeable Base Gradations

Sieve Size	California	Virginia	Wisconsin
1-1/2"	100		
1"	88 - 100	100	100
3/4"	x ± 15		90 - 100
1/2"		25 - 60	
3/8"	x ± 15		20 - 55
No. 4	0 - 16	0 - 10	0 - 10
No. 8	0 - 6	0 - 5	0 - 5

California - 282 lbs, water/cement ratio approximately 0.37
"X" percentage submitted by the Contractor

Virginia - Slightly Modified AASHTO No. 57 Gradation, 225 lbs of cement

Wisconsin - AASHTO No. 67 Gradation, 200 lbs of cement

For compacting cement-stabilized permeable bases, a number of SHA's have had good success in using only vibrating screeds and plates. Again the purpose of the stabilizer material is to set up the permeable base for the concrete paving operation.

The need for curing is one of the least understood aspects of constructing cement stabilized open graded bases. One method is to cover the permeable base with polyethylene sheeting for 3 to 5 days. Another method is to apply a fine water mist cure to the cement-stabilized base several times on the day after the base is placed. Curing compounds and no curing have also been used. A SHA may want to construct a test strip of the base

Compaction of Cement-Stabilized Permeable Bases

Curing of Cement-Stabilized Bases

11.0

Wisconsin Concrete Pavement Association Report

course to determine which curing method to employ as well as which method of compaction should be used.

The Wisconsin Concrete Pavement Association, in cooperation with James Cape & Sons, Wisconsin Department of Transportation, and FHWA conducted a study [17] using cement stabilized open graded base (CSOGB) materials under concrete pavement. Three test sections were laid out on I-90 near Stoughton, Wisconsin. Test sections were constructed with cement contents of 150, 200, and 250 pounds per cubic yard, and the gradation of the aggregate conformed to AASHTO No. 67.

The study had three primary objectives:

- Assess the feasibility of using standard concrete testing methodologies to measure the strength of open-graded materials
- Determine performance under construction loading
- Examine correlation between cement content and the level of performance

Four inches of cement stabilized open-graded base material was placed over four inches of dense graded aggregate base separator layer using a slightly modified finegrader. Compaction was provided by a full-width, heavy steel vibratory plate pulled behind the finegrader. Plastic sheeting was placed over the base material immediately after the cement-stabilized permeable base was placed to prevent evaporation during the curing period.

The report makes the following conclusions and recommendations on the field performance of CSOGB:

Conclusions:

The performance of the CSOGB material under trucking traffic depends on the following:

- Cement content
- Trucking volume
- Stability of underlying layers
- Segregation of the placed material
(The report defines segregation as the separation of the cement paste from the aggregate.)
- Surface Irregularities

11.0

Recommendations:

1. The cement content of the permeable base material should be tailored to the specific level of trucking and sub-base conditions that prevail over individual portions of a project.
 - The use of 150-pound cement content should be restricted to short hauls over stable subbase.
 - Mixes with 200-pound cement content are appropriate for general use.
 - Material with 250-pound cement content should be used in areas where questionable support conditions exist or where heavy trucking will take place.
2. The cement content, rather than the strength, should be used to guide the selection of the material most appropriate for a desired level of performance.
3. The water content of the mix should be adjusted to control segregation of the material.
4. Machinery modifications should be developed to provide for placement of material without segregation.
5. Requirements for moist curing should be investigated to see if they might be eliminated without substantial loss of performance under actual job conditions.

The average flow rate of the test specimens was 3,085 ft/day.

One of the best recommendations of the report is that the cement content should be tailored to meet the trucking levels and subgrade conditions that are encountered. While there is no direct correlation between cement content and strength, there is certainly an implied relationship. The report states that a cement content of 200 pounds should provide enough strength for average trucking and subgrade conditions encountered.

The report does not establish a maximum water/cement ratio. Instead, the contractor determined the water cement ratio based on a subjective assessment of the workability of the mix [17, p. 3]. The report states that a higher water/cement

Recommendations

11.0

11.7 Comparison of Gradations

ratio may encourage the cement paste to flow to points of aggregate contact where its cementing action is needed. FHWA recommends this design approach.

Several different materials were selected for a permeability demonstration model. These materials are listed in Table 13 and represent the spectrum of materials likely to be encountered in highway subdrainage work. A gradation analysis and falling head permeability tests were conducted on these materials.

Table 13. Coefficient of Permeabilities for Different Materials.

Type of Material	Coefficient of Permeability (Feet/day)
AASHTO No. 57 Permeable Base	6,800
AASHTO No. 67 Permeable Base	5,200
3/8" Pea Gravel	2,200
Unstabilized Permeable Base	1,400
Coarse Sand	90
Dense Graded Aggregate Base	4

The unstabilized base gradation and AASHTO No. 57 and 67 gradations are listed in the unstabilized and stabilized base section, respectively, while the dense graded aggregate base gradation is listed in the aggregate separator layer section. Most gradation bands have wide limits which means that the coefficient of permeability can vary significantly within a gradation band, depending on where the actual gradation falls within the band.

Plotting these gradations in Figure 30 shows how the coefficient of permeability increases as the size of the aggregate in the material increases. If the gradation curves are examined at the

11.0

effective size (10 percent passing), the gradations will fall in an increasing order of permeability from left to right.

Test runs of the demonstration model reveal that the AASHTO No. 57 and 67 gradation drained extremely fast, and the 3/8-inch pea gravel and unstabilized permeable base material also drained relatively quickly. However, the coarse sand drained slowly, while the dense graded aggregate base hardly drained. This relationship is consistent with the coefficient of permeabilities of the materials.

It is informative to compare the gradations of the materials most likely used in drainable pavement systems. A comparison of the effective size and coefficient of uniformity for the different materials are provided in Table 14 below:

Table 14. Comparison of Effective Size and Coefficient of Uniformity of Materials

Type of Material	Effective Size (D ₁₀ - mm)	Coefficient of Uniformity
Dense Graded Aggregate Base (DGAB)	0.10	45.97
New Jersey Unstabilized Permeable Base	1.90	4.68
AASHTO No. 67 Gradation	5.77	2.14
AASHTO No. 57 Gradation	5.98	2.54

An analysis of this table reveals that the effective size of the material increases, while the coefficient of uniformity decreases as the material becomes more open. A large effective size combined with a low coefficient of uniformity provides the higher coefficient of permeability.

Figure 30. Comparison of Gradations

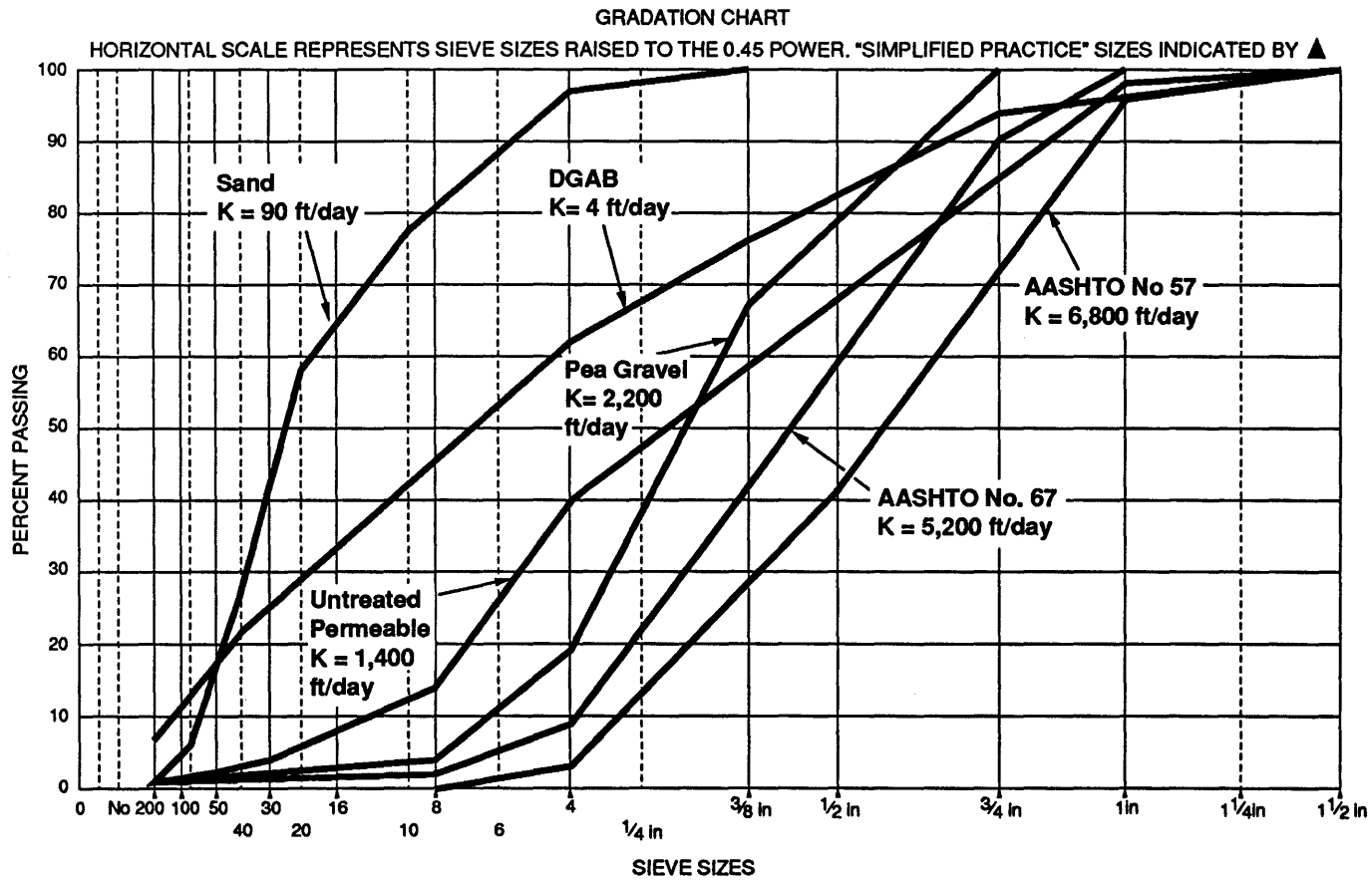

11.0

For simplicity, only the effective size (D_{10}) and the D_{60} points are plotted in Figure 31. These points have connected by a dashed line (again, for simplicity) to represent the average gradation. This figure is important since it shows that the relative positions of the gradations and the sensitivity of the coefficient of permeability increase as the particle size of the gradations increases.

A minimum thickness of 4 inches is recommended for the permeable base. This thickness should be adequate to overcome any construction variances and provide an adequate hydraulic conduit to transmit the water to the edgedrain.

The FHWA recommends that a control strip be constructed at the beginning of construction so the combination of aggregate materials and construction practices be tested, and if necessary, adjusted to produce a stable permeable base with adequate drainage characteristics. The test section should be constructed using the same aggregate materials and compaction practices that will be used on the project. A minimum length of 500 ft is recommended for the test section. The test section should become part of the finished roadway if found acceptable to the SHA.

Quality is the watchword for construction practices. Quality should be provided in both the materials and methods used in each of the construction steps.

The subgrade and aggregate separator layer should be properly constructed so that there is a stable working platform for the placing of the permeable base and concrete pavement. Again, a permeable base is not a substitute for a strong, uniform subgrade.

Quality aggregates should be used in both the aggregate separator layer and the permeable base. Aggregates should meet the required gradations and specifications. Requirements

11.8 Base Thickness

11.9 Control Strip

11.10 Construction Considerations

11.0

covering the number of fractured faces, L.A. abrasion wear and soundness of aggregates are extremely important to ensure stability of their respective layers. **Quality of crushed aggregates is the single most important factor for the stability of a permeable base.** Aggregates that do not meet specifications should not be accepted. Aggregates should be stored, handled, and placed in a manner to keep segregation to a minimum.

If a stabilizer asphalt or cement material is required, the application rate should meet the specifications. The contractor may have the option of providing the type of stabilizer. If asphalt-stabilized materials are used, the contractor may want to establish a test strip to determine the optimum asphalt content, temperature, and compaction effort can be determined.

Construction of unstabilized bases requires care because of the lower stability. In general, these bases are more easily displaced by construction traffic. Unstabilized bases are also subject to segregation of the material during placement. The addition of 2 to 3 percent of water by weight reduces segregation during hauling and placement. Care must be exercised during construction operations to prevent contamination of the permeable base.

Stabilized permeable bases have sufficient stability for paving equipment and construction traffic; however, extra care is needed to prevent contamination of the base since this gradation is usually more open. The grade of the stabilized base is also more difficult to modify once it has been placed and compacted.

Compaction of the permeable base should be in careful compliance with the specifications. Excessive compactive effort can result in degradation of the aggregate and a reduction in permeability.

Construction traffic on the completed bases should be in agreement with design conditions for traffic. Every effort should be made to keep all construction traffic to a minimum by keeping haul lengths short. Truck drivers should be encouraged to keep speeds down and to perform all turning actions on the base as gently as possible. Stopping and starting motions of trucks delivering concrete to the paver should be as

Figure 31. Comparison of Gradations Used in Drainable Pavement Systems

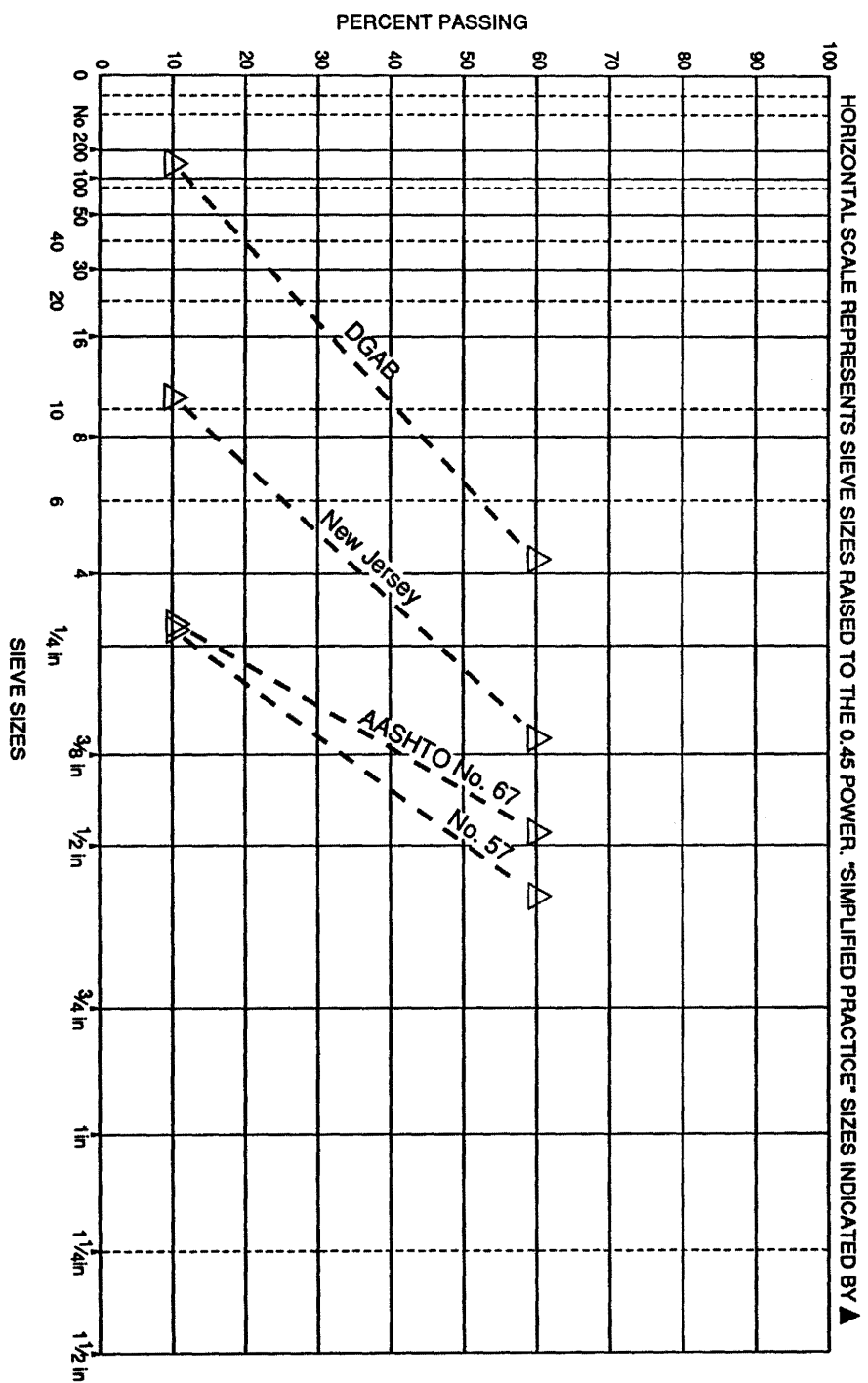

11.0

Maintain Cross Slope

smooth as possible to prevent rutting and shoving of the permeable base. Consideration should be given to specifying stabilized base when allowing construction traffic on the base would facilitate construction operations.

Since concrete pavers are track-driven, there will be minimal effect on the aggregate separator layer in placing a cement-stabilized permeable base; however, if an asphalt-stabilized permeable base is placed, the paver may have tires. Tracked asphalt pavers should be used, since rubber tire pavers may cause rutting of the aggregate separator layer.

The required longitudinal and cross slopes should be maintained so that the permeable base will have enough slope to drain. **A minimum resultant slope of 2 percent is recommended wherever possible.**

Placing of the aggregate separator layer and permeable base contribute to the rideability of the finished pavement. Since many SHA's have incentive/disincentive ride requirements, proper placement of the permeable base takes on added importance.

Photo No. 7 shows the placing of an unstabilized permeable base.

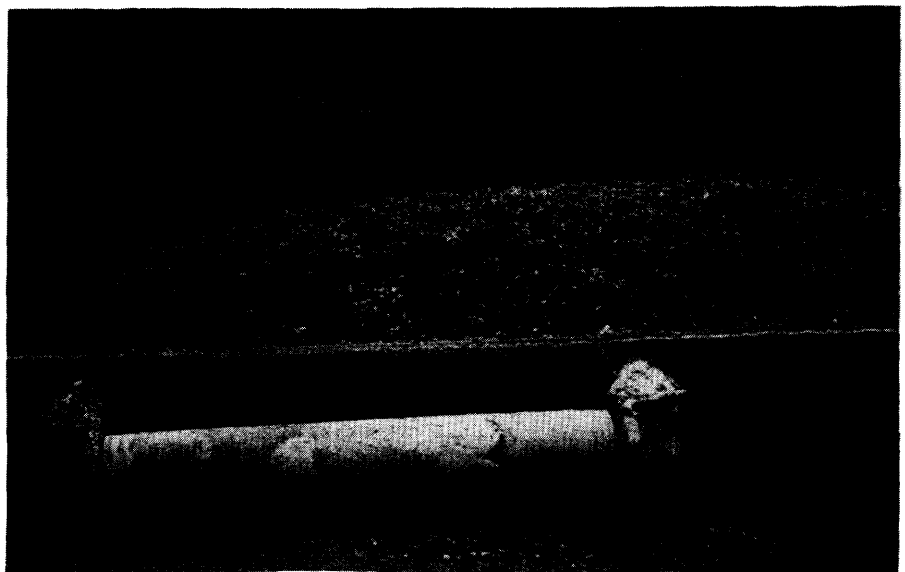

Photo No. 7. Spreading Unstabilized Permeable Base

12.0 SEPARATOR LAYER

A separator layer must be provided between the permeable base and the subbase/subgrade to keep subgrade soil particles from contaminating the permeable base. A separator layer over stabilized subbases/subgrades may not be needed provided the stabilized material is not subject to saturation or high pressures for an extended period of time. An asphalt prime coat placed on the stabilized subbase/subgrade would provide additional protection. A separator layer can be provided by an aggregate separator layer or geotextile.

It is pointed out that a separator layer is not a substitute for a strong subgrade.

The aggregate separator layer must perform several very important functions:

- First, the aggregate separator layer must be strong enough to provide a stable working platform for constructing the permeable base. The aggregate separator layer should not experience any rutting or movement during the paving operation. Since most SHA's use a dense graded aggregate base for the aggregate separator layer, this material should be strong enough to support the paving operation. If the subgrade is weak, stabilization of this layer should be considered to assure good support for the pavement section during construction and expected future truck loadings.
- Second, the gradation of the aggregate separator layer must be carefully selected to prevent fines from pumping up from the subgrade into the permeable base. Basic aggregate filtration equations are used to size the gradation of the aggregate separator to prevent contamination of the permeable base.
- Third, the aggregate separator layer should have a low permeability; the layer should act as a shield to deflect infiltrated water over to the edg drain.

The dynamic effects of wheel loads must also be considered. The following design procedures have been developed with these parameters in mind. Both the aggregate separator

12.1 Aggregate Separator Layer

Adequate Construction Platform

Prevent Fine Migration

Low Permeability

12.0

Design Procedure

layer/subgrade and the permeable base/aggregate separator layer interfaces must be investigated.

The gradation of the aggregate separator layer must meet the requirements for the aggregate separator layer/subgrade interface as listed below:

$$D_{15} \text{ (Separator Layer)} \leq 5 D_{85} \text{ (Subgrade)} \quad (37)$$

$$D_{50} \text{ (Separator Layer)} \leq 25 D_{50} \text{ (Subgrade)} \quad (38)$$

where

D_x is the size at which "X" percent of the particles, by weight, are smaller than that size.

Equation 37 is a filtration requirement. Theoretically, a spherical particle will be retained until the diameter of the retaining spheres is 6.46 times greater than the sphere to be retained. This relationship is shown in Figure 32. By limiting the D_{15} size of the aggregate separator layer to less than five times the D_{85} size of the subgrade, the larger soil particles of the subgrade will be retained, allowing the soil bridging action to start.

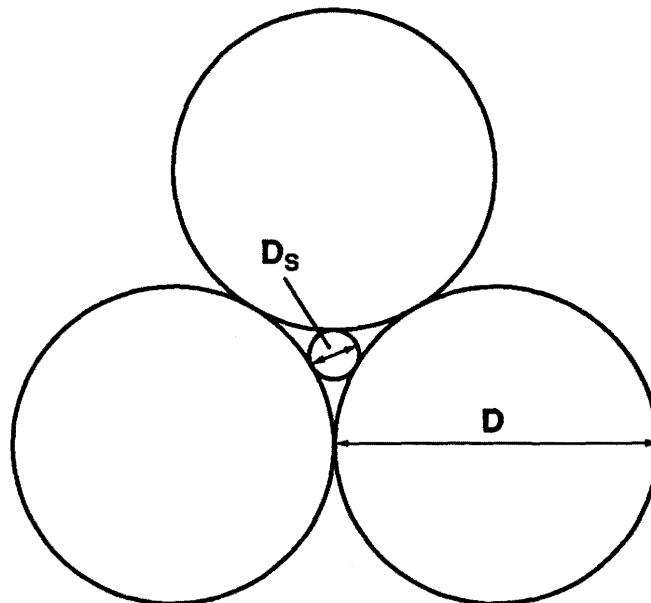

$$D = 6.46 D_s$$

Figure 32. Retention of Spheres Relationship

12.0

Equation 38 is a uniformity requirement. By limiting the D_{50} size of the aggregate separator layer to less than 25 times the D_{50} size of the subgrade, the gradation curves will be kept in balance.

Similarly, these requirements must be applied to the permeable base/aggregate separator layer interface as listed below:

$$D_{15} (\text{Base}) \leq 5 D_{85} (\text{Separator Layer}) \quad (39)$$

$$D_{50} (\text{Base}) \leq 25 D_{50} (\text{Separator Layer}) \quad (40)$$

Many SHA's use a dense graded aggregate base course for an aggregate separator layer to provide the necessary stability as a construction platform for paving operations. Additional requirements are necessary to ensure the dense graded aggregate base does not have too many fines and is well-graded:

<p>Maximum percent of fines passing the No. 200 Sieve should not exceed 12 percent.</p>
<p>Coefficient of Uniformity > 20; preferably 40</p>

The first criterion limits the amount of fines in the aggregate separator layer, while the second criterion provides guidance for developing a well-graded aggregate base.

The results of these equations are then plotted on a gradation chart to develop a design envelope through which the gradation of the aggregate separator layer must pass. These design procedures will narrow the limits of the D_{15} size of the gradation. The engineer must skillfully develop a gradation that will pass through the design envelope.

Table 15 shows a typical dense graded aggregate base gradation that meets the three goals previously established and serves adequately as an aggregate separator layer.

12.0

Table 15. Aggregate Separator Layer Gradation

<i>Steve Size</i>	<i>Percent Passing</i>
1-1/2"	100
3/4"	95 - 100
No. 4	50 - 80
No. 40	20 - 35
No. 200	5 - 12

This gradation is plotted in Figure 33.

The gradation plot in Figure 33 should be studied in detail. Note that there is an extremely wide range of particle sizes and high value of the coefficient of uniformity [45.97]. These features identify the material as a dense graded aggregate base. The coefficient of uniformity is an indicator of the strength of a material. This gradation should ensure a strong platform for the construction operation.

Aggregate Separator Layer Materials

The aggregate separator layer should consist of durable, crushed, angular aggregate material. The aggregate material should have good mechanical interlock. The aggregate for the separator layer should meet the requirements for a Class C Aggregate in accordance with AASHTO M 283-83 Coarse Aggregate for Highway and Airport Construction. This means that the L.A. Abrasion Wear should not exceed 50 percent as determined by AASHTO T 96-87. The FHWA recommends that the soundness percent loss should not exceed the requirements for a Class C Aggregate as specified in AASHTO M 283-83. This specification requires that the soundness percent loss should not exceed 12 or 18 percent as determined by the sodium sulfate or magnesium sulfate tests, respectfully, following AASHTO T 104-86. The material should be compacted until a density of 95 percent of the maximum density as determined by AASHTO T 180-90, Moisture Density Relationship Using a 10-lb (4.54 kg) hammer and an 18-inch (457 mm) drop, Method D, is reached.

Figure 33. Plot of DGAB Gradation

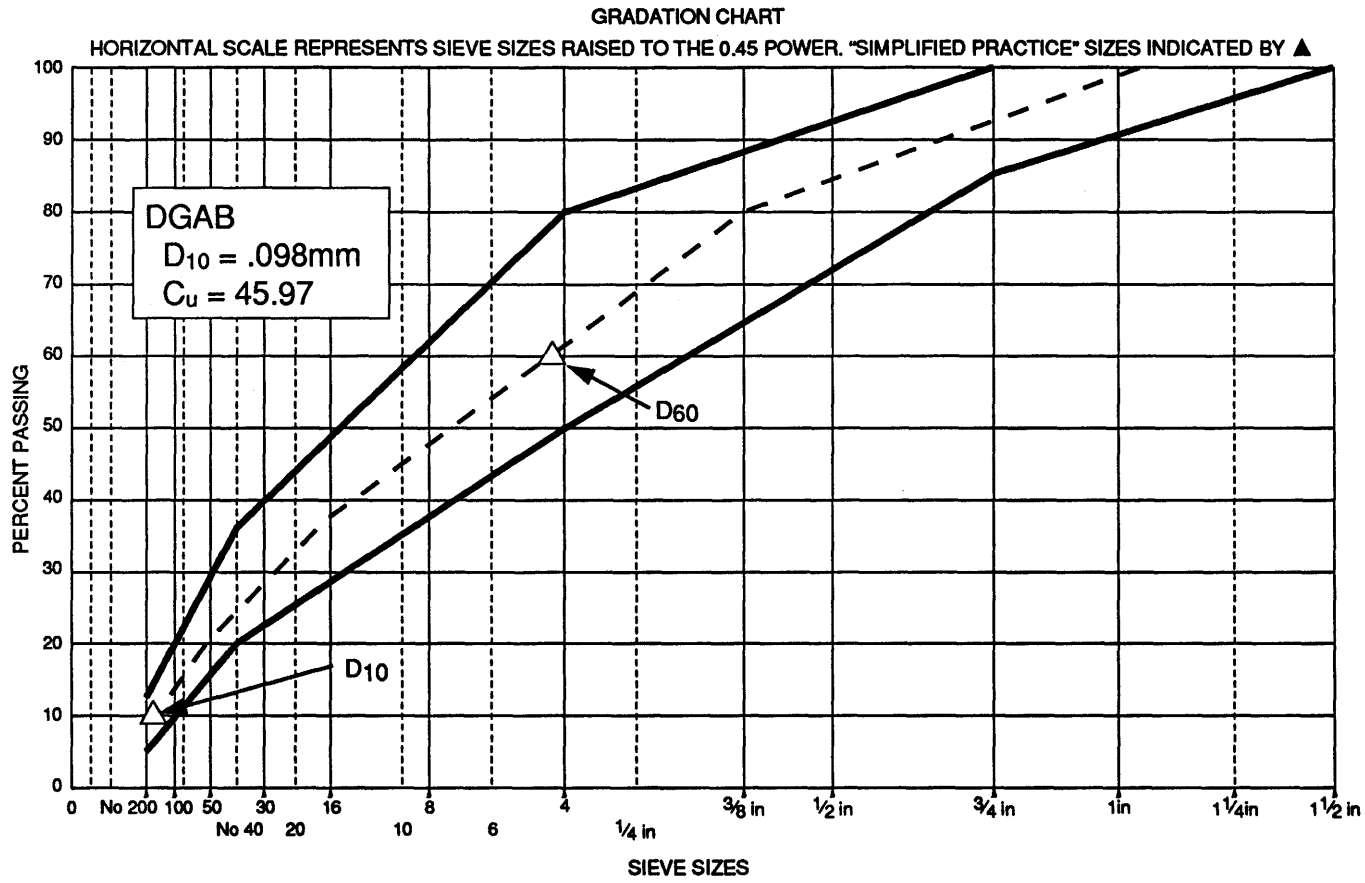

12.0

12.0

Layer Thickness

A minimum thickness of 4 inches is recommended for the aggregate separator layer based on construction considerations.

Example Problem

The following example illustrates aggregate separator layer design.

Given

Gradation of the subgrade and permeable base are given in Figure 34.

Reading Figure 34, the key particle sizes are determined:

Percent Smaller (By Weight)	Particle Size	
	Permeable Base (mm)	Subgrade (mm)
D85	18.0	0.70
D50	6.0	0.13
D15	2.2	0.038

The gradation for the aggregate separator layer is the same as the gradation of the dense graded aggregate base listed in this section (Figure 33).

Find

Determine the design envelope for the aggregate separator layer.

Determine if the proposed gradation meets design requirements to control fines movement and provides desired stability.

Solution

Apply design equations to the aggregate separator layer/subgrade interface.

12.0

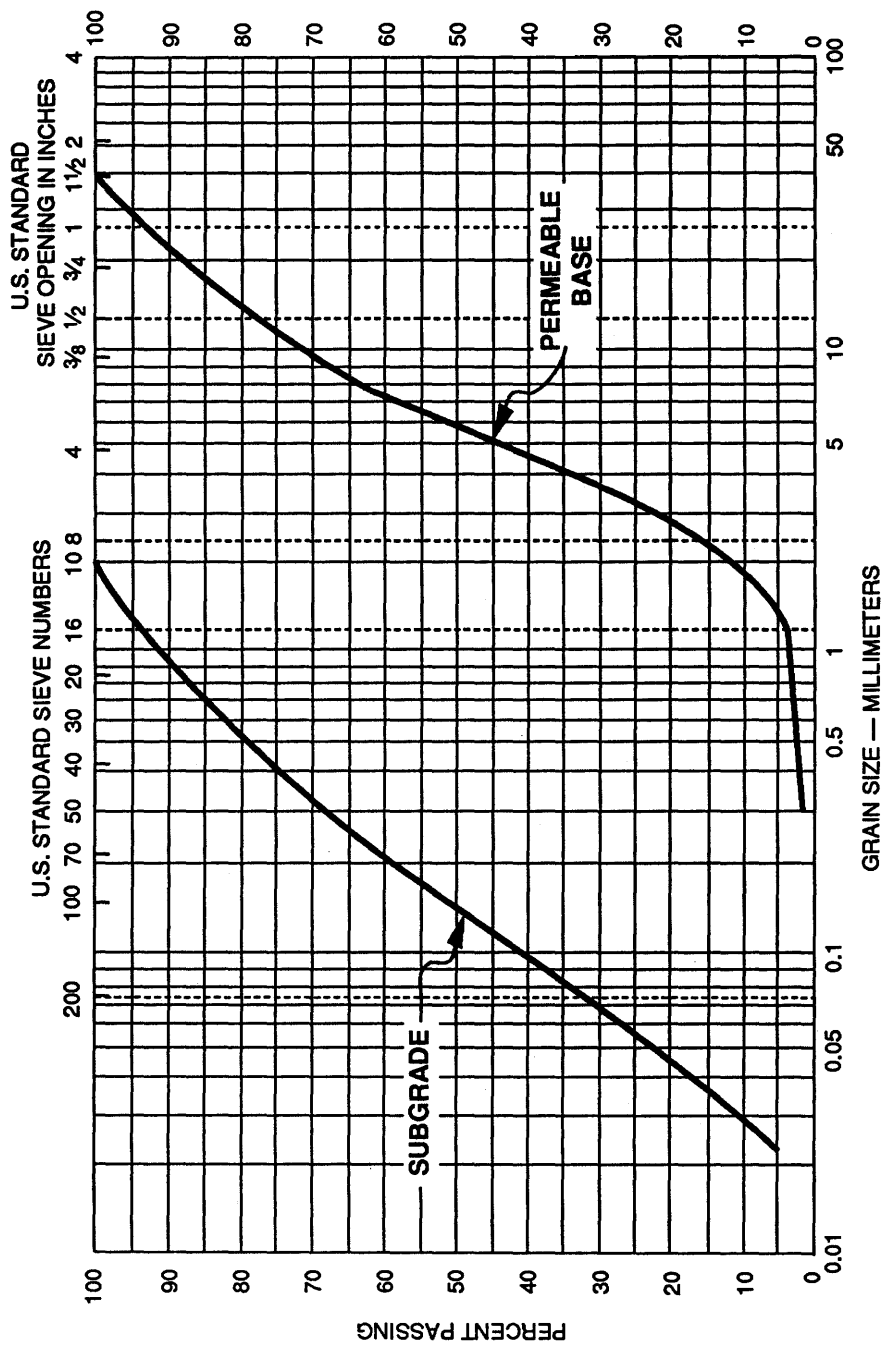

Figure 34. Plot of Subgrade and Permeable Base Gradations

12.0

Filtration Equation (Equation 37):

$$D_{15} \text{ (Separator Layer)} \leq 5 D_{85} \text{ (Subgrade)}$$

$$D_{15} \text{ (Separator Layer)} \leq 5 \times 0.70$$

$$D_{15} \text{ (Separator Layer)} \leq 3.50 \text{ mm}$$

Uniformity Equation (Equation 38):

$$D_{50} \text{ (Separator Layer)} \leq 25 D_{50} \text{ (Subgrade)}$$

$$D_{50} \text{ (Separator Layer)} \leq 25 \times 0.13$$

$$D_{50} \text{ (Separator Layer)} \leq 3.25 \text{ mm}$$

Plot these points as triangles on the gradation chart as shown in Figure 35.

Apply design equations to the permeable base/aggregate separator layer interface.

Filtration Equation (Equation 39):

$$D_{15} \text{ (Permeable Base)} \leq 5 D_{85} \text{ (Separator Layer)}$$

$$2.2 \leq 5 D_{85} \text{ (Separator Layer)}$$

$$D_{85} \text{ (Separator Layer)} \geq 2.2 / 5$$

$$D_{85} \text{ (Separator Layer)} \geq 0.44 \text{ mm}$$

Uniformity Equation (Equation 40):

$$D_{50} \text{ (Permeable Base)} \leq 25 D_{50} \text{ (Separator Layer)}$$

$$6.0 \leq 25 D_{50} \text{ (Separator Layer)}$$

$$D_{50} \text{ (Separator Layer)} \leq 6.0 / 25$$

$$D_{50} \text{ (Separator Layer)} \leq 0.24 \text{ mm}$$

Also plot these points on Figure 35 as hexagons.

The additional requirement of a maximum of 12 percent passing the No. 200 sieve is added. This point is marked as a square.

The aggregate separator layer gradation is superimposed on the grain size analysis as shown in Figure 36.

The resulting coefficient of uniformity is 45.97 (4.50/.098).

The proposed gradation for the aggregate separator layer is adequate.

Construction Considerations

The aggregate separator layer is equally important as the permeable base and subgrade in developing a strong, durable

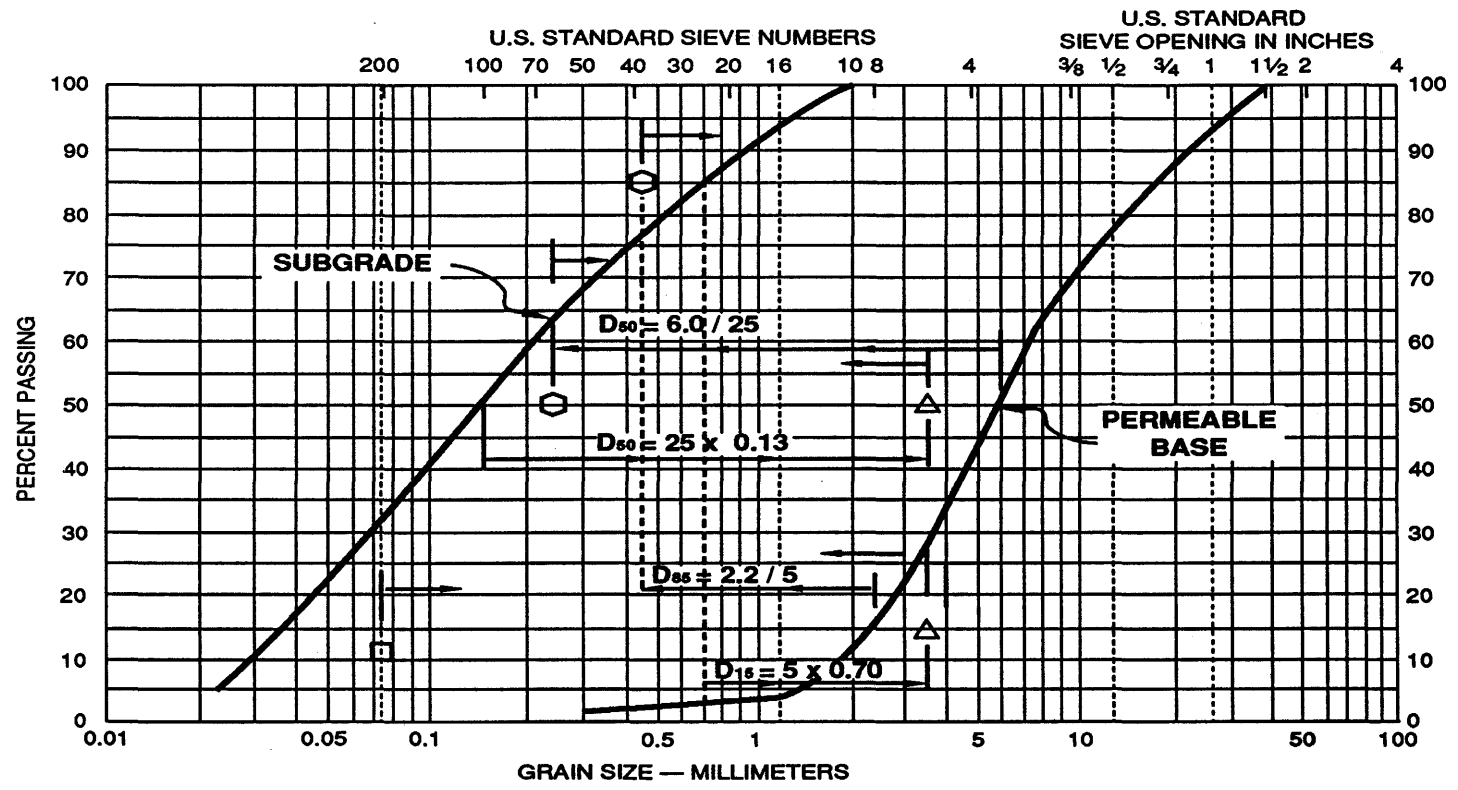

Figure 35. Plot of Design Points

12.0

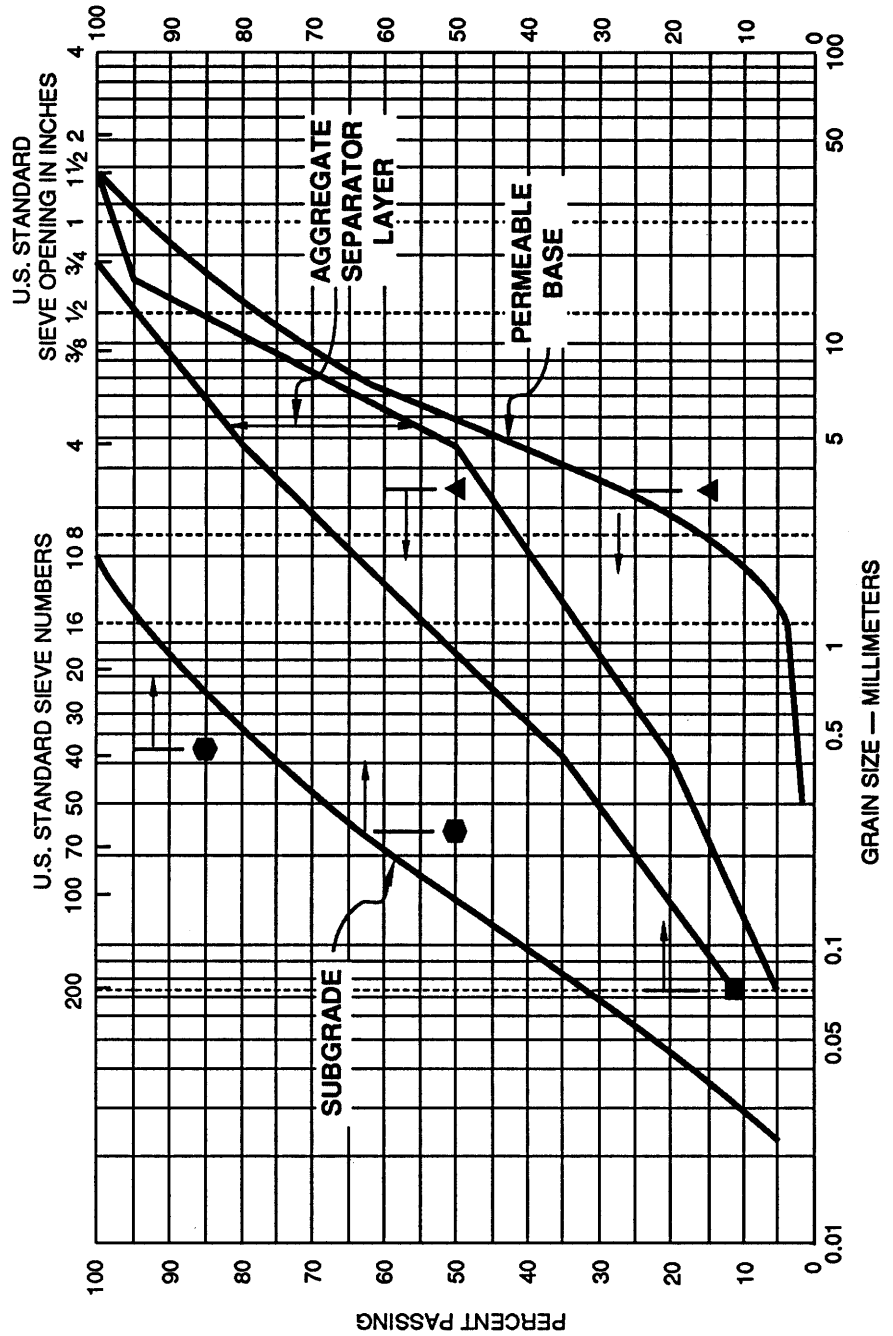

Figure 36. Plot of Design Envelope and Aggregate Separator Layer

12.0

pavement section. Again, quality of aggregates and proper compaction are the keys to a functional separator layer. This layer is necessary to provide a stable platform for placing the permeable base and concrete pavement and to prevent future contamination of the permeable base by fine silts and clay particles which could choke the permeable base and reduce the effective drainage.

Some SHA's use a geotextile instead of a aggregate separator layer. In certain cases, such as subgrades with a high percentage of fines, a geotextile might be a preferred choice rather than an aggregate separator layer. The geotextile should have enough strength to survive the construction phase. Care should be taken in placing the geotextile so that it is not damaged during construction. Base course materials must be placed with care so that the geotextile is not damaged or displaced and to ensure that proper laps and splices are provided. The integrity of the separator layer must be maintained during construction.

The principal advantage of a geotextile is its filtration capability. A geotextile will allow any rising water, due to capillary action or a rising water table, to enter the permeable base and rapidly drain to the edgedrain system. The main disadvantage is if the geotextile clogs or binds, rising water will be trapped under the geotextile, saturating the subgrade and reducing subgrade support.

Actually, permeable bases are not intended to drain the subgrade. The subgrade is in a saturated and weakened condition when water flows from it into a permeable base. Subsurface moisture should be addressed during subgrade construction to prevent subgrade weakening.

Geotextiles perform the following functions:

1. Filtration
2. Drainage
3. Separation
4. Reinforcement

12.2 Geotextiles

12.0

When geotextiles are used to separate the permeable base from the subgrade, they serve all of the noted functions in varying degrees.

The retention concepts of geotextiles are listed below:

- Pore openings should be sized to retain larger soil particles so that soil bridging action can start.
- Pore openings should be sized so that smaller soil particles will pass through the geotextile without clogging the geotextile.
- Large numbers of openings should be provided in case there is some clogging. Additional openings will be available to drain the water.

In most cases, a small amount of fines will pass through the geotextile into the permeable base. This starts the formation of a soil filter zone adjacent to the geotextile. As larger soil particles are retained by the geotextile, a bridging action occurs creating a zone called the "soil bridge network" as shown in Figure 37 [7, page 3-9]. Immediately behind this zone is another zone where the finer soil particles are trapped. This zone is called a "filter cake" and has a lower permeability. In the last zone, the subgrade soil particles will be undisturbed.

Apparent Opening Size

As with other elements of highway design, geotextiles must be engineered. **The apparent opening size (AOS) is the U.S. standard sieve number whose opening size is closest to the geotextile opening size.** The AOS value is an index test that only identifies the largest opening size of the geotextile. This test result becomes less valid for thick, nonwoven geotextiles with smaller sieve size openings. The opening size is determined by sieving single-size glass beads through the geotextile in accordance with ASTM D-4751, **Determining Apparent Opening Size of a Geotextile**. The test is repeated with successive coarser size glass beads until less than 5 percent, by weight, passes through the geotextile. The AOS number is the sieve size number before the 5-percent limit is exceeded. This opening size can also be expressed in millimeters and is referred as the apparent opening size or 95 percent opening size (O_{95}).

12.0

This nomenclature is confusing since both the AOS and O_{95} measure the same geotextile property. Table 16 provides the opening size, in millimeters, for the U.S. standard sieve sizes in the geotextile range. The sieve size nomenclature is sometimes difficult to follow since the opening size decreases as the sieve number increases.

One of the principle design efforts is the proper selection of the AOS opening size. The AOS opening size is a target size; larger particle sizes should be retained by the geotextile.

The AOS opening size of the geotextile should be selected to prevent fines from pumping through the geotextile and plugging the permeable base material. The pore openings must be small enough to retain the larger soil particles to start the soil bridging action.

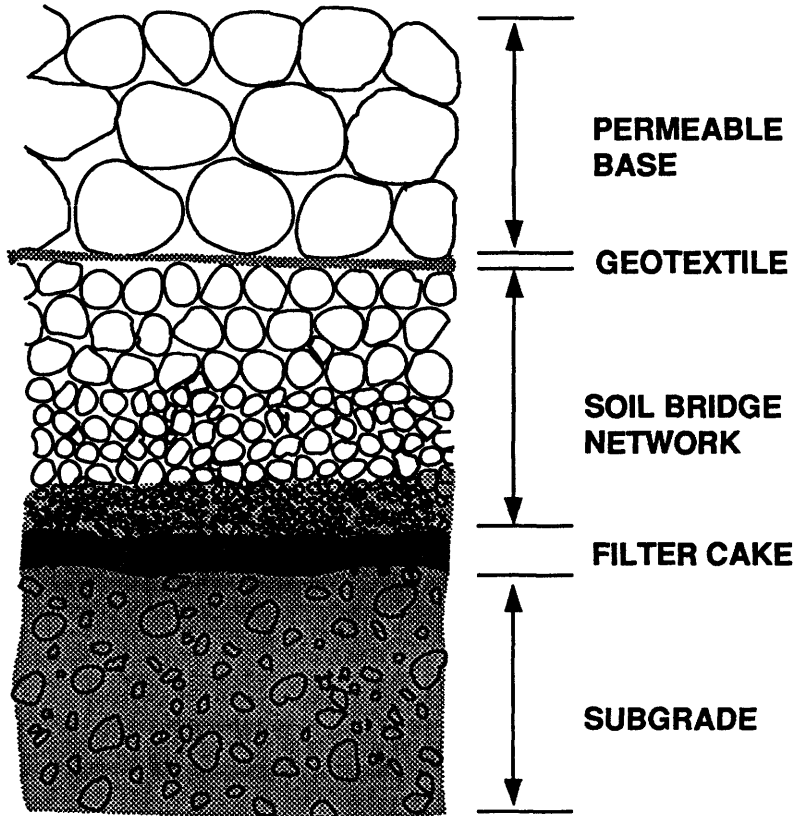

Figure 37. Filter Formation

12.0

The geotextile should have a permeability at least several times greater than the subgrade so that any vertical draining water will not be unduly impeded by the geotextile. The permeability requirement should not be a problem in most applications since most soils have relatively low permeabilities.

Table 16. Sieve Size Openings

<i>Sieve Number</i>	<i>Sieve Opening (mm)</i>
30	0.600
40	0.425
50	0.300
60	0.250
70	0.212
100	0.150
200	0.075

While there is no direct relationship between the AOS number and permeability, both are related to the density (weight) and manufacturing method of the geotextile.

Clogging is definitely a potential problem and any design must take it into consideration. The best approach is to study the interaction of the soil/geotextile interface. The soil and the geotextile combine to form a soil/geotextile system. The gradient ratio test is a performance test that has gained wide acceptance as a performance test to measure the soil/geotextile clogging potential.

Gradient Ratio Test

The gradient ratio test is a direct measurement of the soil/geotextile system's clogging and retention potential. It is the ratio of the hydraulic gradient through the geotextile and 1 inch of soil immediately adjacent to the geotextile (i_g), to the hydraulic gradient over the next 2 inches of soil between

12.0

1 inch and 3 inches from the geotextile (i_g). This relationship is expressed in the following equation:

$$GR = \frac{i_f}{i_g} \quad (41)$$

where

GR = Gradient ratio

i_f = Hydraulic gradient of geotextile and 1 inch of soil

i_g = Hydraulic gradient between 1 inch and 3 inches of soil

This relationship is shown schematically in Figure 38.

If soil particles are trapped in the geotextile, the gradient ratio will rise. Likewise, if soil particles pass through the geotextile, the gradient ratio will drop. The Corp of Engineers suggests the following criteria:

$$GR \leq 3$$

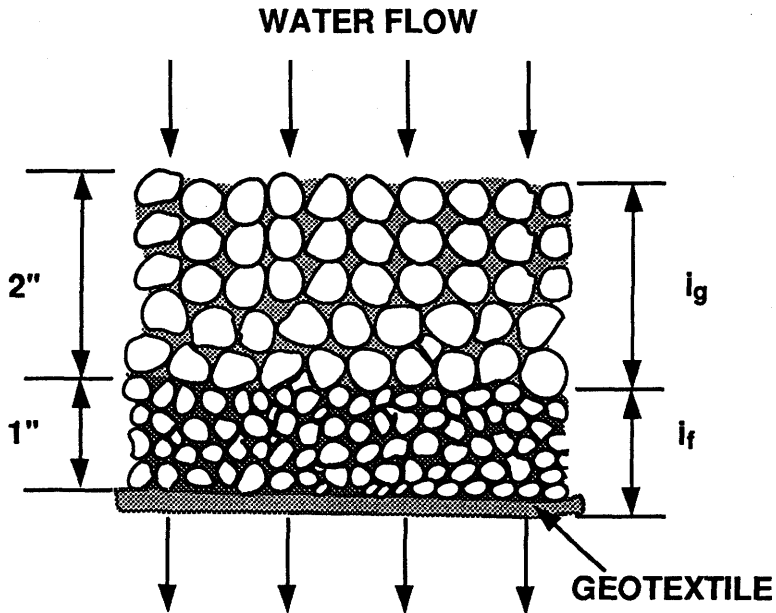

Figure 38. Schematic of Gradient Ratio Test

12.0

Detailed procedures for performing this test are provided in Appendix B, .03.81.09 Test for Geotextile Clogging Potential by the Gradient Ratio Method of the Geotextile Engineering Manual [7, page B-175].

Another approach to study the soil/geotextile system is the use of long-term hydraulic tests in which the interaction of the soil and geotextile are studied over a long period [23].

Selection of the proper geotextile is a difficult tradeoff between filtration, permeability, and clogging requirements.

Geotextiles should be specified based on performance rather than type (woven, nonwoven, or knitted) or bonding process (needle-punched, heat- or chemical-bonding).

Drainage Application

When a geotextile is used in a drainage application such as wrapping an edgedrain trench, design guidance is provided in the FHWA publication [12, Chapter 2, Geotextile Filters in Drainage Systems]. This procedure will be described in this section. The design procedure contains the following three categories:

1. Soil Retention.
2. Permeability Criteria.
3. Clogging Criteria.

Conservative Design

The engineer must first determine the soil retention requirements of the geotextile by completing a rigorous design matrix. To complete the permeability and clogging criteria, the engineer has to determine if the engineering application of the geotextile is Critical/Severe or Less Critical/Less Severe. The FHWA recommends conservative design, when the geotextile is used in edgedrain design; therefore, the Critical/Severe criteria and Class A strengths are recommended.

The design procedure is:

I. SOIL RETENTION

The first step is to determine if the subgrade consists of coarse grain or fine grain soils. If the gradation analysis shows that

12.0

less than 50 percent of the subgrade soil particles pass the No. 200 sieve, the subgrade is classified as coarse grain:

Less than 50% Passing the U.S. No. 200 Sieve — Coarse Grain Soils

The flow condition must be determined next. Since any reversal in the flow pattern would be so gradual, it is suggested that the steady state flow condition be used.

Steady-State Flow

$$O_{95} \leq B D_{85},$$

$$\text{where } B \text{ is determined by: } \begin{array}{l} C_U \leq 2 \text{ or } \geq 8 \quad B = 1 \\ 2 \leq C_U \leq 4 \quad B = 0.5 C_U \\ 4 \leq C_U \leq 8 \quad B = \frac{8}{C_U} \end{array}$$

A plot of the B parameter against the coefficient of uniformity (CU) is provided in Figure 39. This figure shows how the B parameter changes as the coefficient of uniformity changes.

Dynamic, Pulsating and Cyclic Flow

Since the subgrade is so confined by the pavement structure, the selection of the "cannot move case" is suggested:

$$O_{95} \leq D_{15} \text{ — (If soil can move beneath geotextile)}$$

or

$$O_{50} \leq 0.5 D_{85} \text{ — (If soil cannot move beneath geotextile)}$$

If more than 50 percent of the subgrade soil particles pass the No. 200 sieve, then the subgrade is classified as fine grain:

Greater Than 50% Passing U.S. No. 200 Sieve — Fine Grain Soils

Again the flow condition is determined:

Steady-State Flow

$$\text{Woven: } O_{95} \leq D_{85}$$

$$\text{Nonwoven: } O_{95} \leq 1.8 D_{85}$$

$$\text{For both cases: AOS No.}_{(\text{geotextile})} \geq \text{No. 50 Sieve}$$

12.0

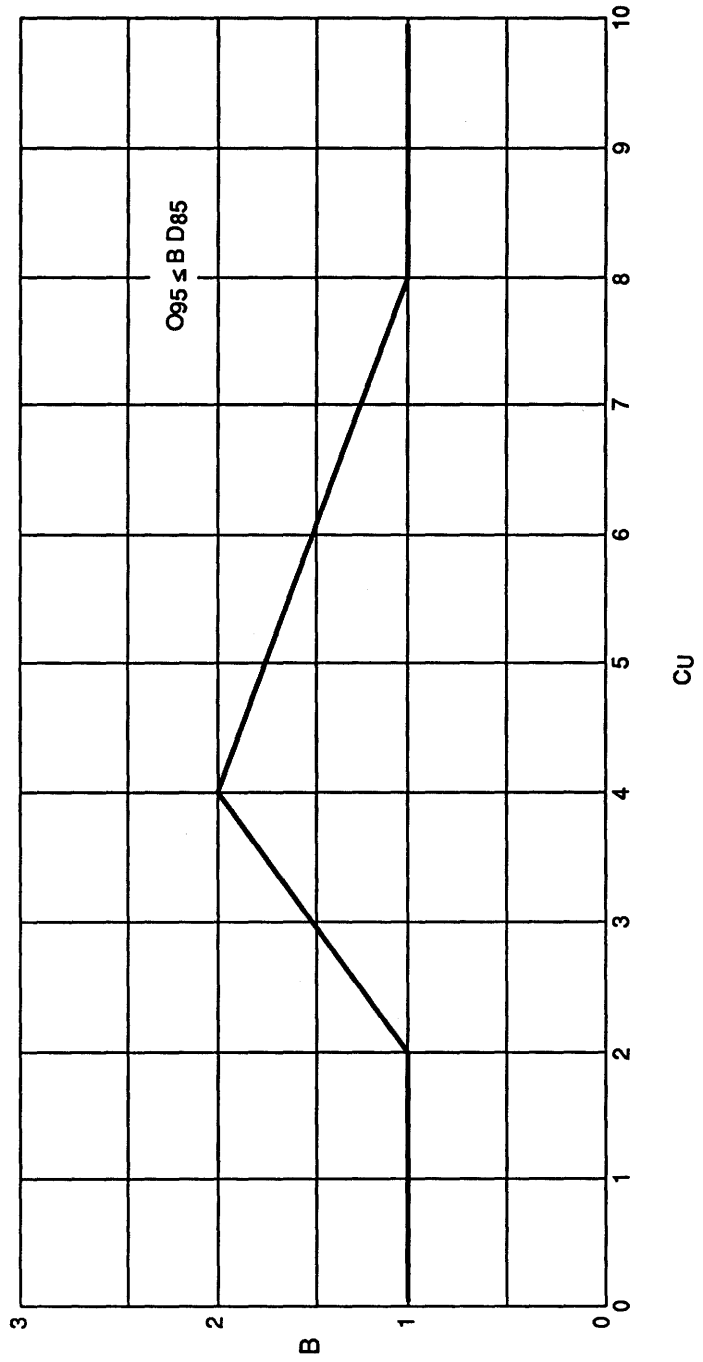

Figure 39. Plot of B Parameter

12.0

Dynamic, Pulsating, and Cyclic Flow

$$O_{50} \leq 0.5 D_{85}$$

II. PERMEABILITY CRITERIA

A decision must be made to determine if the application is **Critical/ Severe or Less Critical/Less Severe**. If the application is separating the permeable base from the subgrade or wrapping the edgedrain trench, a **Critical/Severe application** is recommended.

If the application is Critical/Severe, then:

A. Critical/Severe Applications

$$k_{(\text{geotextile})} \geq 10 k_{(\text{soil})}$$

If the application is Less Critical/Less Severe, then:

B. Less Critical/Severe, and (with Clean Medium to Coarse Sands and Gravels)

$$k_{(\text{geotextile})} \geq k_{(\text{soil})}$$

Permeability of the geotextile should be determined by ASTM D 4491. The permeability criteria for the Less Critical/Less Severe application is somewhat conservative, while the criteria for the Critical/Severe application is far more conservative. This provides a factor of prevention against clogging.

III. CLOGGING CRITERIA

Again, if the application is Critical/Severe, then:

A. Critical/Severe Applications

Select fabrics meeting Criteria I, II, IIIB in this section and perform soil/fabric filtration test before specification, pre-qualifying the fabric, or after selection before bid closing. Alternative: use approved list specification for filtration applications. Suggest performance test method: Gradient Ratio ≤ 3 .

12.0

If the Application is Less Critical/Less Severe, then:

B. Less Critical/Less Severe

1. Whenever possible, the geotextile with maximum opening size possible (lowest AOS No.) from retention criteria should be specified.
2. Effective Open Area Qualifier:
Woven fabrics: Percent Open Area \geq 4%
Nonwoven fabrics: Porosity \geq 30%
3. Additional Qualifier (Optional): $O_{95} \geq 3 D_{15}$
4. Additional Qualifier (Optional): $O_{15} \geq 3 D_{15}$

Porosity and open area requirements are an attempt to control the number of holes in the geotextile. There should be a sufficient number of holes in the geotextile to offset any clogging.

These design guidelines are summarized in Table 17.

12.0

Table 17. Summary of Design Criteria For Selecting Geotextiles

I. SOIL RETENTION CRITERIA

<i>Less than 50% Passing No. 200 Sieve</i>		
Steady-State Flow	Dynamic Flow	
AOS $O_{95} \leq B D_{85}$	Can Move	Cannot Move
$C_u \leq 2$ or ≥ 8 $B = 1$ $2 \leq C_u \leq 4$ $B = 0.5 C_u$ $4 \leq C_u \leq 8$ $B = \frac{8}{C_u}$	$O_{95} \leq D_{15}$	$O_{50} \leq 0.5 D_{85}$

<i>Greater Than 50% Passing No. 200 Sieve</i>		
Steady-State Flow		Dynamic Flow
Woven	Nonwoven	
$O_{95} \leq D_{85}$	$O_{95} \leq 1.8 D_{85}$	$O_{50} \leq 0.5 D_{85}$
AOS No.(fabric) \geq No.50 Sieve		

II. PERMEABILITY CRITERIA

<i>A. Critical / Severe Applications</i>	<i>B. Less Critical / Less Severe Applications (with Clean Medium to Coarse Sands and Gravels)</i>
$k(\text{fabric}) \geq 10 k(\text{soil})$	$k(\text{fabric}) \geq k(\text{soil})$

III. CLOGGING CRITERIA

<i>A. Critical / Severe Applications</i>	<i>B. Less Critical / Less Severe Applications</i>
Select fabrics meeting Criteria I, II, IIIB, and perform soil/fabric filtration tests before specifying. Suggested performance test method: Gradient Ratio ≤ 3 .	<ol style="list-style-type: none"> Select fabric with maximum opening size possible (lowest AOS No.). Effective Open Area Qualifiers: Woven fabrics: Percent Open Area $\geq 4\%$ Nonwoven fabrics: Porosity $\geq 30\%$ Additional Qualifier (Optional): $O_{95} \geq 3 D_{15}$ Additional Qualifier (Optional): $O_{15} \geq 3 D_{15}$

12.0

Based on these selections, the design procedure determines the apparent opening size. In this design method, minimum physical requirements are provided in the AASHTO-AGC-ARTBA Task Force No. 25 General Guideline [12, pg 37]. The minimum required strengths are shown in Table 18:

Table 18. Physical Requirements^{1, 2} for Drainage Textiles (AASHTO-AGC-ARTBA TASK FORCE 25, JULY, 1986)

Test Method	Drainage ³		Test Method
	Class A ⁴	Class B ⁵	
Grab Strength	180 lbs.	80 lbs	ASTM D 4632
Elongation	Not Specified		
Seam Strength ⁶	80 lbs.	25 lbs.	ASTM D 4632
Puncture Strength	80 lbs.	25 lbs.	ASTM D 4833
Burst Strength	290 psi.	130 psi	ASTM D 3787
Trapezoidal Tear	50 lbs.	25 lbs.	ASTM D 4533

1. Acceptance of geotextile material shall be based on ASTM D 4759.
2. Contracting agency may require a letter from the supplier certifying that its geotextile meets specification requirements.
3. Minimum: Use value in weaker principal direction. All numerical values represent minimum average roll values (i.e., test results from any sampled roll in a lot shall meet or exceed the minimum values in the Table). Stated values are for non-critical, non-severe applications. Lot samples according to ASTM D 4354.
4. Class A drainage applications for geotextiles are where installation stresses are more severe than Class B applications, i.e., very coarse, sharp, angular aggregate is used, a heavy degree of compaction (> 95% AASHTO T 99) is specified or depth of trench is greater than 10 feet.
5. Class B drainage applications are those where geotextile is used for smooth graded surfaces having no sharp angular projections, no sharp angular aggregate is used; compaction requirements are light, (< 95% AASHTO T 99), and trenches are less than 10 feet in depth.
6. Values apply to both field and manufactured seams.

12.0

When a geotextile is used in a separation application, such as separating the permeable base from the subgrade design, guidance is provided in an FHWA publication [14, Chapter 5, Using Geotextiles as Separators in Roadways]. In this design procedure, the soil retention, permeability, and clogging criteria presented in the drainage application should be evaluated.

The AASHTO-AGC-ARTBA Task Force No. 25 also provides guidance for the separation function of geotextiles (i.e., separating the permeable base from the subgrade).

Table 19 provides physical property requirements for survivability strengths [12, Table 2, page 126], AOS, and permeability requirements. A high survivability level of stress is recommended when a geotextile is used to separate the permeable base from the subgrade.

Geotextiles are subject to degradation when exposed to sunlight for extended periods of time. To prevent this, geotextiles should be placed and covered as quickly as possible [7, page 2-58].

Extreme care should be used in placing the geotextile to prevent the fabric from being ripped or torn. If a significant amount of wrinkles occur during the placing operation, the geotextile cannot be tensioned and will not function properly.

FHWA publications [12, page 132] provide the following guidance for covering a geotextile:

“The first lift of aggregate should be spread and graded down to 12 inches or to the design thickness if less than 12 inches prior to compaction [Fig. 5.6d]. At no time should equipment be allowed on the road with less than 8 inches [6 inches for $\text{CBR} \geq 2$] of compacted aggregate over the fabric.”

Since many permeable bases will be only 4 inches thick, extreme care must be used in placing the aggregate. A smooth, strong subgrade is the key for placing aggregate lifts this thin. The highest quality of construction must be used in constructing the subgrade and placing the geotextile.

Separation Application

Construction Considerations

12.0

Table 19. Physical Property Requirements¹ for Separation Application

For Geotextiles with less than (<) 50% Geotextile Elongation — Use higher stresses^{2, 3}.

For Geotextiles with greater than (>) 50% Geotextile Elongation — Use lower stresses.

Survivability Level	Grab Strength ASTM D 4632 (lbs)	Puncture Resistance ASTM D 4833 (lbs)	Trapezoidal Tear Strength ASTM D 4533 (lbs)
High	270/180	100/75	100/75
Medium	180/115	70/40	70/40

ADDITIONAL REQUIREMENTS

TEST METHODS

Apparent Opening Size

ASTM D 4751

1. < 50% soil passing a No. 200 US sieve, AOS < 0.6 mm. (No. 30 sieve)
2. > 50% soil passing a No. 200 US sieve, AOS < 0.3 mm. (No. 50 sieve)

Permeability

ASTM D 4491

1. k of the geotextile > k of the soil (permeability times the nominal geotextile thickness).

Ultraviolet Degradation

ASTM D 4355

1. At 150 hours exposure, 70% strength retained for all cases.

Geotextile Acceptance

ASTM D 4759

1. Values shown are minimum roll average values
Strength values are in the weaker principle direction.
2. Elongation as determined by ASTM D 4632.
3. The values of geotextile elongation do not imply the allowable consolidation properties of the subgrade soil. These must be determined by a separate investigation.

13.0 LONGITUDINAL EDGEDRAINS

Longitudinal edgedrains are a key element in conveying the free water in the drainable pavement system. It is imperative that the edgedrain has the necessary hydraulic capacity to handle water being discharged from the permeable base. Each element of the drainage system should increase in capacity as the water moves toward the outlet so that there are no weak links in the system. There are three basic types of edgedrains:

1. Aggregate Trench.
2. Pipe Edgedrain.
3. Geocomposite Fin Drain.

Both the aggregate trench edgedrain and the geocomposite fin drains are not recommended for the following reasons:

1. Low hydraulic capacity.
2. Inability to be cleaned.

Aggregate trench edgedrains and geocomposite fin drains will not be covered in this notebook.

Since a permeable base is used, all runoff that enters the pavement section should drain quickly to the edgedrain. The trench backfill and edgedrain pipe must have the necessary capacity to handle the design flows. Erosion of fines should not be a problem since the base should contain very little erodible fine material. The trench backfill material should be of the same material as the permeable base course to ensure adequate capacity. The geotextile used to wrap the edgedrain trench should not extend up into the permeable base to form a barrier. Geocomposite fin drains are not recommended for use with permeable bases due to their low hydraulic capacity and inability to maintain this type of drain.

Photo No. 8 shows an edgedrain pipe in a geotextile wrapped trench.

For permeable bases (new or reconstructed cases), the edgedrain location was discussed in detail in Section 9.0, Permeable Bases. Edgedrain location and geotextile placement may vary depending on whether the edgedrain is placed prior to, or after, construction of the permeable base.

13.1 General

13.2 Edgedrain Location

13.0

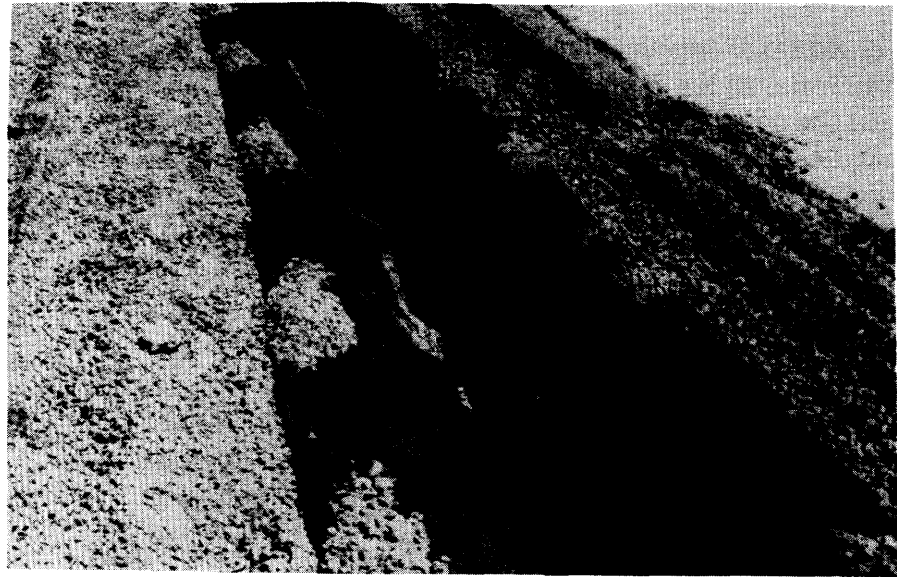

Photo No. 8 Installing Pipe Edgedrain

13.3 Pipe Edgedrains

Pipe Material

Recommend PVC Pipe

Conventional pipe edgedrains are recommended because of their relatively high flow capacity and their ability to be maintained.

Most SHA's use flexible, corrugated polyethylene (CPE) or smooth, rigid polyvinyl chloride (PVC) pipe. Pipe should conform to the appropriate State or AASHTO specification. For CPE pipe, AASHTO Specification M 252, **Corrugated Polyethylene Drainage Tubing**, is suggested, while AASHTO Specification M 278, **Class PC 50 Polyvinyl Chloride (PVC) Pipe**, is recommended for PVC pipe. If the pipe is to be installed in trenches that are to be backfilled with asphalt-stabilized permeable material (ASPM), the pipe must be capable of withstanding the temperature of the ASPM. PVC 90° electric plastic conduit, EPC-40 or EPC-80 conforming to the requirements of the National Electrical Manufacturers Association (NEMA) Specification TC-2, is suggested when ASPM is used as a trench backfill.

13.0

If the edgedrain is installed as the permeable base is being placed, the trench material surrounding the edgedrain pipe will be the same as the permeable base material; however, if the edgedrain is installed after the permeable base has been constructed, placing of the pipe and trench backfill will be a second operation. In the post-installation case, the trench backfill material should be at least as permeable as the permeable base material. Again, if ASPM is used, the pipe must be capable of resisting the temperature.

Depending on pipe size, many SHA's use a trench width of 8 to 10 inches [2]. The trench width must be wide enough to allow proper placement of the pipe and compaction of the backfill material around the pipe.

The trench depth must be deep enough to accomplish the intended drainage function. It is recommended that the trench depth be deep enough to allow the top of the pipe to be located 2 inches below the bottom of the permeable base.

Geotextile placement will vary depending on whether the edgedrain is installed before or after the construction of the permeable base. This has been discussed in Section 11.2, Pavement Section. Since the permeable base should contain no fines, the edgedrain trench should be lined with a geotextile, but the top of the trench adjacent to the permeable base is left open to allow a direct path for the water into the edgedrain pipe (as shown in Figure 1). The primary purpose of the geotextile is filtration; that is, keeping the fines in the subgrade from contaminating the trench backfill material. The geotextile should have a permeability several times greater than the subgrade soils.

A geotextile placement for a pre-installation edgedrain is shown in Figure 40.

Installation of the outlet pipe is critical to the drainage system. A permeable base without a positive outlet is a bathtub section. It is recommended that a metal or rigid (PVC) non-perforated

Trench Design

Trench Backfill

Trench Width and Depth

Geotextile Placement for Pipe Edgedrains

13.4 Lateral Outlet Pipe

13.0

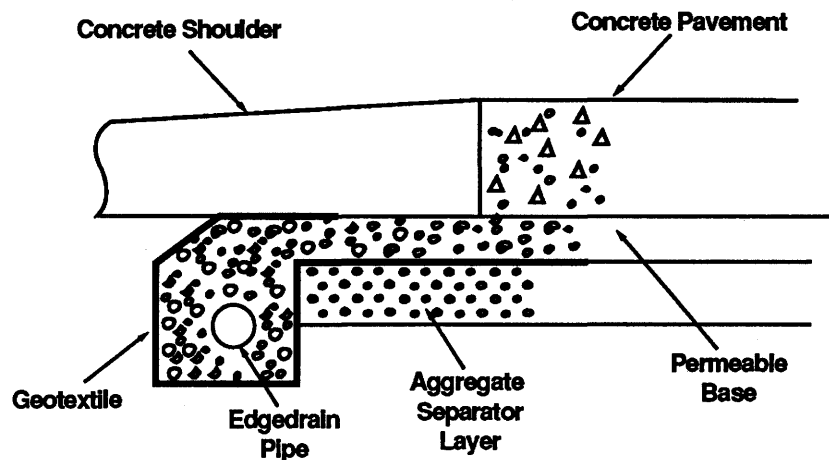

Figure 40. Geotextile Placement Around Edgedrain

pipe [14] be used for the outlet pipe to ensure the proper grade. Rigid pipe provides more strength to protect the outlet pipe from crushing due to mowing operations or errant trucks.

A 3-percent slope [14] of the pipe to the roadside ditch is recommended as shown in Figure 41. This will ensure that the pipe will drain if there is a slight variance of the pipe grade. If ditches or medians are too flat to outlet the edgedrain system, a storm drain system may have to be installed to collect the water. **Subsurface drainage design should be coordinated with surface drainage. The invert of the outlet pipe should be at least 6 inches above the 10-year design flow in the ditch.**

Surface Water Coordination

It is imperative that the subsurface drainage be coordinated with surface drainage. HEC No. 12, *Drainage of Highway Pavements* [18], provides guidance for the design of water flowing on pavement surfaces, while HEC No. 15, *Design of Roadside Channels with Flexible Linings* [6], provides

13.0

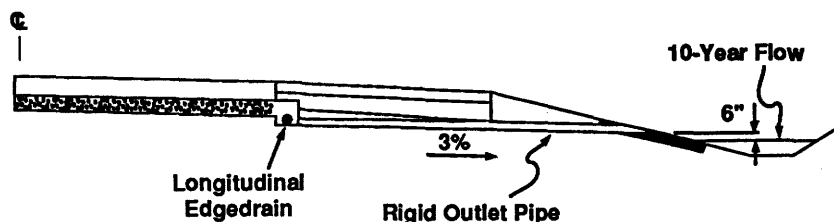

Figure 41. Outlet Pipe

guidance for the design of roadside ditches. Most SHA's design their surface drainage based on a 10-year storm intensity.

Adequate cross slope is the most important item in surface pavement drainage. The pavement cross slope and shoulder slope must be adequate to carry the water away from the traffic lanes. Grass slopes should be as steep as safety considerations allow.

Design of roadside ditches is a careful balance of safety considerations, hydraulic design, and drainage of the pavement section.

When an edg drain pipe system is provided, the invert of the roadside ditch may be lowered providing additional internal drainage of the pavement section. The interface between the outlet pipe and ditch is critical. Again, the guidance of providing 6 inches of freeboard above the 10-year runoff flow depth is suggested as shown in Figure 41. It should be remembered that surface water can flow back up into the pipe from the roadside ditch. If there is not enough vertical drop to accommodate this design, it is recommended that a storm drain pipe system be provided with the outlet pipes discharging into the storm drain system as shown in Figure 42.

A storm drain system should be provided, where necessary, to reduce the amount of water carried in the median ditch. This, in turn, will reduce the chance of water infiltrating into the pavement section from the median ditch.

13.0

Edgedrain Design for Maintenance

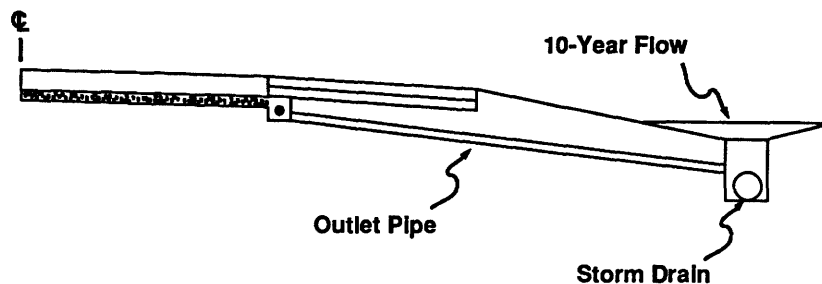

Figure 42. Outlet Pipe Connecting to Storm Drain

The ability to flush or jet rod the system is important in the maintenance scheme. The edgedrain and outlet pipe must have proper bends and vents to facilitate this operation. The edgedrain pipe system should be designed with maintenance in mind. Figure 43 shows a system with outlet pipes located at both ends of an edgedrain system. This allows flushing equipment to enter the edgedrain from both ends. Figure 44 shows the need to provide smooth, long-radius bends in the edgedrain system so rodding equipment can negotiate the bends. Radii of 2 to 3 feet for pipe bends should be used to permit use of jet rodding or cleaning equipment [14].

13.5 Outlet Spacing

The purpose of subsurface drainage is to remove water as quickly as possible; therefore, the FHWA recommends outlet spacing be limited to 250 feet. The edgedrain should be segmented so that each section drains independently.

13.6 Headwalls

Headwalls are recommended because they provide the following functions:

1. Protect outlet pipe from damage.
2. Prevent slope erosion.
3. Locate outlet pipe.

13.0

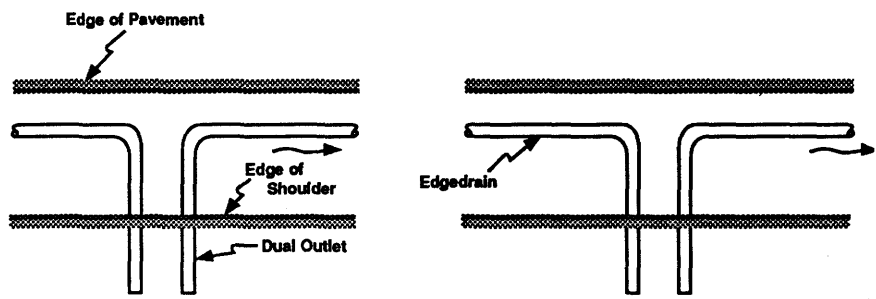

Figure 43. Edgedrain Design for Maintenance

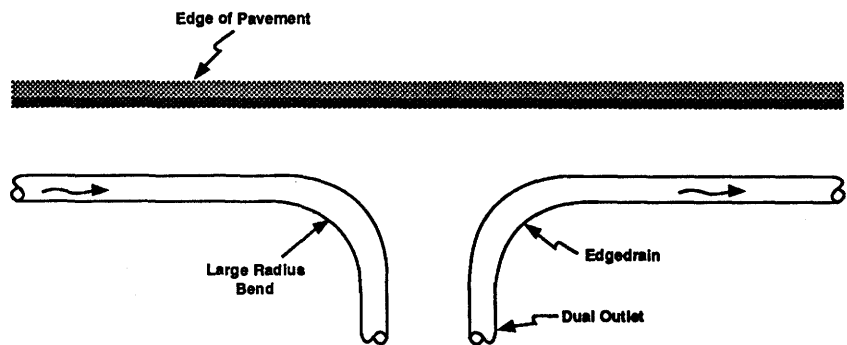

Figure 44. Smooth, Long Radius Bends for Edgedrain Outlet

13.0

Headwalls should be placed flush with the slope so that mowing operations are not impaired and they are not a roadside hazard. Both cast-in-place and precast concrete headwalls can be used. The important consideration is that the outlet pipe drains. Some States have used a metal pipe sleeve around the end of the plastic outlet pipe that extends 4 to 5 feet into the fill to protect the outlet pipe. A recommended headwall design is shown in Figure 45 [14].

13.7 Rodent Screens

Rodent screens are recommended because rodents have been reported to damage geocomposite fin drains and geotextiles, and to build nests in pipe edgedrains [14]. Eroded fines can build up on the screen and plug the outlet. Rodent screens should be easily removable so that the screens and outlet pipes can be cleaned on a routine basis.

13.8 Reference Markers

Reference markers are recommended since they facilitate locating the outlet pipe for maintenance or observation. Some SHA's use a simple flexible delineator post to mark the outlet, while others use a painted arrow [2] or mark on the shoulder.

13.9 Construction Considerations

As with any other drainage facility, correct line and grade are critical to the function of the edgedrain. Placement of the outlet pipe in the trench is important; high or low spots in the trench must be avoided. Proper compaction of the trench backfill material is important to prevent future maintenance problems with early deterioration of the shoulder.

To prevent water entrapment, it is critical that the end of the outlet pipe or concrete headwall be constructed to grade so that the pipe drains. If flexible plastic tubing is used for the outlet pipe, pipe curling may be a problem. Concrete headwalls, which have been constructed or installed to grade, should solve this problem. This is one reason why rigid pipe is recommended for the outlet pipe.

13.0

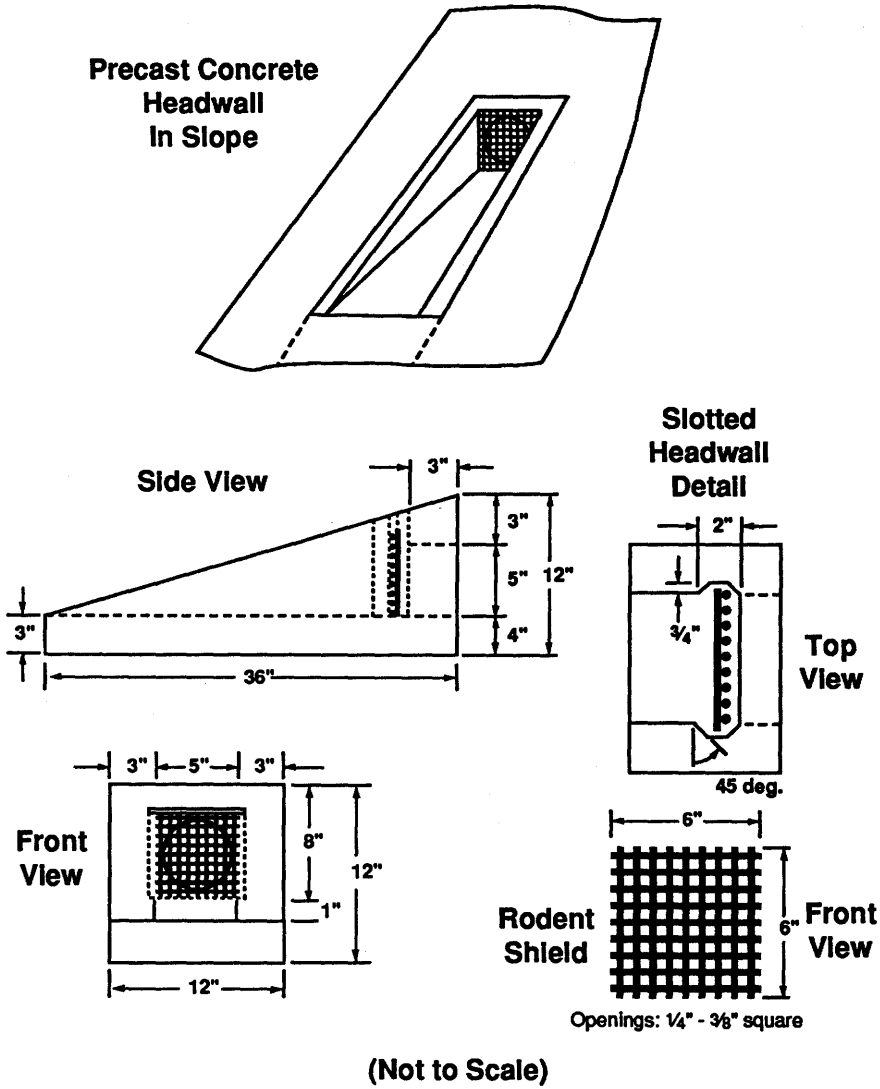

Figure 45. Precast Concrete Headwall with Removable Rodent Screen

13.0

Special care must be taken so guardrail posts, sign posts, lighting bases, and other highway appurtenances do not interfere with the outlets.

Increased emphasis should be placed on better construction control and inspection of edgedrain systems, especially the outlets. Quality construction is essential for the edgedrain system to perform as intended.

Videotaping the completed edgedrain with flexible fiber optic equipment is suggested for final acceptance of the project. A uniform program of videotaping completed projects should improve the quality of construction and minimize problems during future maintenance activities.

14.0 EDGEDRAIN CAPACITY AND OUTLET SPACING

The capacity of the edgedrain and outlet spacing take on an added importance when permeable bases are provided. Since the goal of drainage is to remove water as quickly as possible, **the edgedrain capacity should not be a weak link. The capacity of the edgedrain system should always increase as the water flows through the system.** The combination of edgedrain capacity and outlet spacing must be adequate to handle the design flows.

The design flow for calculating the required pipe capacity and outlet spacing can be determined by one of the following design approaches:

1. Pavement Infiltration (q_i) Discharge Rate.
2. Permeable Base Discharge Rate.
3. Time to Drain Discharge Rate.

The engineer must select the design approach that meets the field conditions.

The design pipe flow for this approach is determined by the following equation (Equation 10):

$$Q_P = q_i W L \quad (43)$$

where

- Q_P = Design flow rate for pipe flow, cu ft/day
- q_i = Pavement infiltration, cu ft/day/sq ft
- W = Width of permeable base, ft
- L = Outlet spacing, ft

Some engineers argue that the edgedrain system should be capable of handling the peak flow that the permeable base can discharge to the edgedrain system. The design discharge rate from the permeable base (Equation 28) is adjusted to determine the required pipe flow. The resulting equation is:

$$Q_P = k S_R H L \cos(A) \quad (44)$$

14.1 Design Flows

**Pavement Infiltration
Discharge Rate Approach
for Pipe Flow**

**Permeable Base Discharge
Rate Approach for Pipe Flow**

14.0

Time to Drain Discharge Rate Approach for Pipe Flow

where

- Q_P = Design flow rate for pipe flow, cu ft/day
- k = Coefficient of permeability, ft/day
- S_R = Resultant slope, ft/ft
- H = Thickness of base, ft
- L = Outlet spacing, ft
- A = Angle between roadway cross slope and resultant slope

In the time to drain discharge rate approach, the edgedrain system should be capable of handling the flow generated by draining of the permeable base. This flow rate is determined by the following equation:

$$Q_P = (W L H N_e U) \left(\frac{1}{t_D}\right) \times 24 \quad (45)$$

where

- Q_P = Design flow rate for pipe flow, cu ft/day
- W = Width of permeable base, ft
- L = Outlet spacing, ft
- H = Thickness of base, ft
- N_e = Effective porosity
- U = Percent drained, expressed as a decimal
- t_D = Drainage time period, hours

The first term of the equation represents the volume of water discharged during the drainage time period (t_D). Dividing this volume by the drainage time period produces a flow rate (cu ft/hour). For example, if 50-percent drainage is required in a 2-hour time period, then:

$$\begin{aligned} U &= 0.50 \\ t_D &= 2 \text{ hrs} \end{aligned}$$

Multiplying this rate by 24 hrs/day produces a flow rate in cu ft/day.

Flow rates produced by these different approaches will vary significantly depending upon the selection of parameters. Engineering judgement should be used in selecting the design flow.

14.0

The capacity of a circular pipe flowing full can be determined by Manning's equation:

$$Q = \frac{53.01}{n} D^{8/3} S^{1/2} \quad (46)$$

where

- Q = Pipe capacity, cu ft/day
- D = Pipe diameter, inches
- S = Slope, ft/ft
- n = Manning's roughness coefficient

Suggested values of Manning's roughness coefficient are:

- Smooth pipe: n = 0.012
- Corrugated pipe: n = 0.024

If the pipe diameter and roughness coefficient are assigned, Equation 47 can be simplified:

$$Q = K S^{1/2} \quad (47)$$

where

- Q = Pipe capacity, cu ft/day
- K = Pipe conveyance (cu ft/day)
- S = Slope, ft/ft

The conveyance for various pipe sizes and roughness are given below:

Table 20. Conveyance of Circular Pipe (K)

Pipe Diameter (inches)	Roughness Coefficient (n)	
	.012	.024
3	82,699	41,349
4	178,102	89,051
6	525,105	262,553

14.2 Circular Pipe Capacity

14.0

The following example problem illustrates use of the conveyance table.

Given

Pipe Diameter	4 inches
Pipe Slope	.01 ft/ft. (1.0 percent)
Corrugated Pipe	$n = 0.024$

Find

Determine the capacity of the pipe using the conveyance table.

Solution

Entering Table 20, select:

$$K = 89,051$$

Substituting into the conveyance equation:

$$Q = K S^{1/2} = 89,051 \times (0.01)^{1/2} = 8,905$$

$$\text{Capacity of pipe} = 8,905 \text{ cu ft/day}$$

Design Charts

Design charts for determining the capacity of circular pipes flowing full are provided in Figures 46 and 47 for smooth and corrugated pipes, respectively. Entering the respective flow chart with the pipe slope and diameter; the flow capacity can be determined.

The following example illustrates the use of these charts:

Given

Pipe Diameter	4 inches
Pipe Slope	.01 ft/ft. (1.0 percent)
Corrugated Pipe	$n = 0.024$

Find

Determine the capacity of the pipe using the design charts.

Solution

Entering Figure 46 with a pipe diameter of 4 inches and a slope of 0.01 ft/ft, read a capacity of 8,900 cf/day.

$$\text{Capacity of pipe} = 8,900 \text{ cu ft/day}$$

14.0

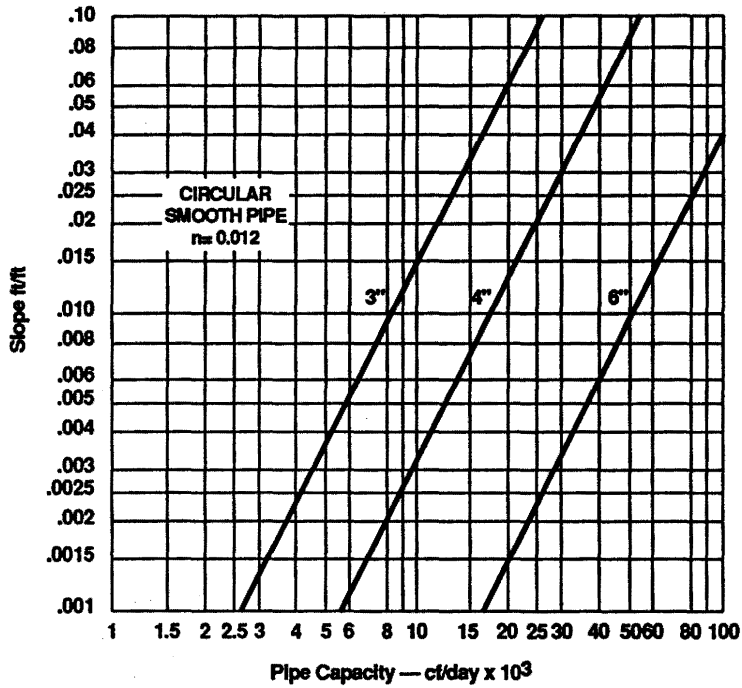

Figure 46. Capacity of Smooth, Circular Pipe

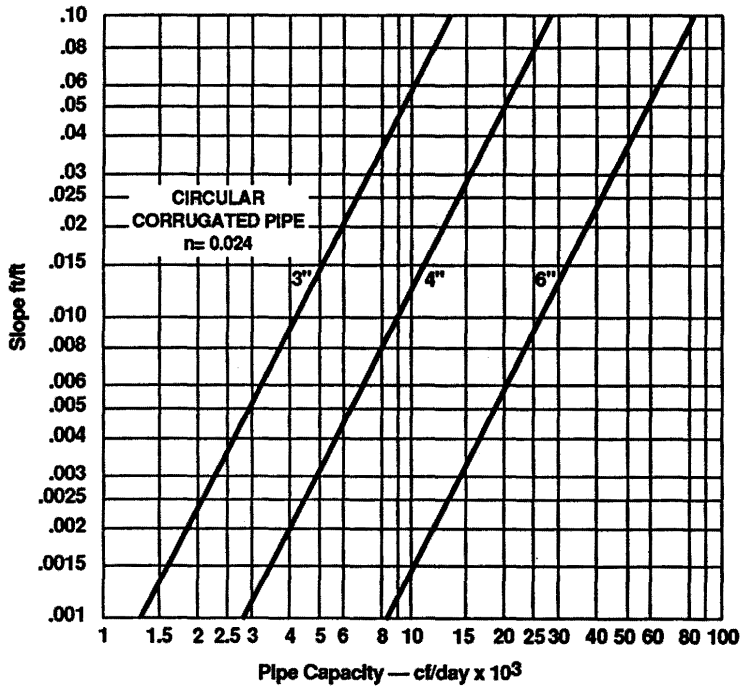

Figure 47. Capacity of Corrugated, Circular Pipe

14.0

14.3 Outlet Spacing

Pavement Infiltration Discharge Rate Approach

By setting the pavement infiltration discharge rate (Equation 43) equal to the pipe capacity equation (Equation 47):

$$q_i W L = K S^{1/2} \quad (48)$$

and rearranging the terms, the outlet spacing can be solved for.

$$L = \frac{K S^{1/2}}{q_i W} \quad (49)$$

where

L = Outlet spacing, ft

An example problem demonstrates the design procedure.

Given

Inflow Conditions

Pavement infiltration (q_i) = 1.8 cu ft/day/sq ft
Width of permeable base (W) = 24 ft

Pipe Data

Pipe diameter (D) = 4 inches
Pipe slope (S) = .01 ft/ft
Manning's coefficient (n) = 0.024

Find

Calculate the outlet spacing.

Solution

Substituting into equation 27:

$$L = \frac{K S^{1/2}}{q_i W} = \frac{89,051 \times (0.01)^{1/2}}{1.8 \times 24} = 206$$

$$L = 206 \text{ ft}$$

Permeable Base Discharge Rate

In this approach, the permeable base discharge rate (Equation 44) is set equal to the pipe capacity (Equation 47):

$$k S_R H L \cos(A) = K S^{1/2} \quad (50)$$

14.0

Rearranging terms, the outlet spacing can be determined by:

$$L = \frac{K S^{1/2}}{k S_R H \cos(A)} \quad (51)$$

where

L = Outlet spacing, ft

The time-to-drain discharge rate (Equation 45) is set equal to the pipe capacity (Equation 47):

$$(W L H N_e U) \left(\frac{1}{t_D} \right) \times 24 = K S^{1/2} \quad (52)$$

Rearranging the terms, the outlet spacing can be determined by the following equation:

$$L = \frac{K S^{1/2} t_D}{24 W H N_e U} \quad (53)$$

where

L = Outlet spacing, ft

The edgedrain trench should transmit the discharging water to the edgedrain pipe. Since the flow is vertical, trench capacity should not be a problem. The required width of the edgedrain trench can be determined by applying Darcy's Law:

$$Q = kiA \quad (54)$$

By definition, the hydraulic gradient (i) will be equal to one (1), and the cross-sectional area will be equal to W (W x 1 ft). This relationship can be seen in Figure 48.

Now setting the design flow (Q) equal to the permeable base discharge (q_d), the equation can be rewritten:

$$q_d = k (1) (W) \quad (55)$$

Solving for W:

$$W = \frac{q_d}{k} \quad (56)$$

Time-to-Drain Discharge Rate Approach

14.4 Edgedrain Trench Design

14.0

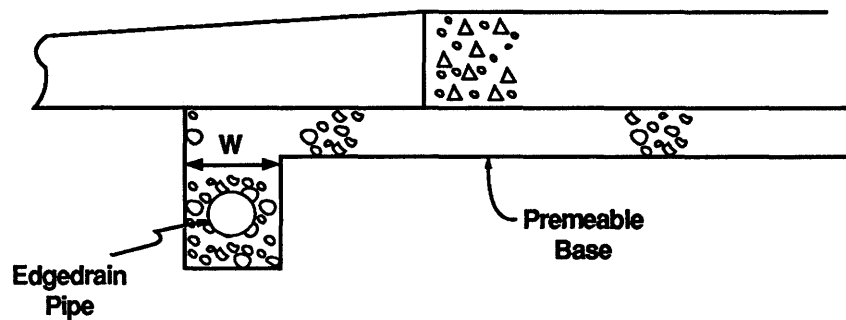

Figure 48. Edgedrain Trench Backfill Design

where

- W = Width of edgedrain trench, ft
 q_d = Permeable base discharge, cu ft/day
 k = Coefficient of permeability, ft/day

The following guidance is provided for the opening in the edgedrain pipe:

Slotted Pipes

$$D_{85} \text{ (Edgedrain backfill)} > 1/2 \text{ Slot width}$$

Circular Holes

$$D_{85} \text{ (Edgedrain backfill)} > 1.0 \text{ Hole diameter}$$

14.5 Practical Considerations

Many SHA's suggest a minimum pipe size of 4 inches based on maintenance considerations, while a maximum outlet spacing of 250 feet is also suggested for maintenance considerations.

A minimum slope of 0.0035 ft/ft for the pipe is recommended. Admittedly, sag vertical curves are very flat, and many times roads are built dead level. For these conditions, the pipe would be driven into the subgrade and could not be daylighted for

14.0

discharge. Engineers must accept the best trade-off of factors available. For the dead level case, Equation 47 does not apply since it is based on steady-state flow and constant slope assumptions. In this case, the water will have to build up in the pipe until enough head is created for the pipe to drain in a non-steady flow.



15.0 MAINTENANCE

Maintenance is critical to the continued success of any longitudinal edgedrain system. Inadequate or nonexistent maintenance is a universal problem. The combination of vegetative growth, debris, and fines discharging from the edgedrains will eventually plug the outlet pipe. Mice's nests, mowing clippings, and sediment collecting on rodent screens at headwall are common maintenance problems. Outlets often cannot be found because they are hidden by vegetative growth. Some outlets have been so plugged that water gushed from the pipes when the obstacles were removed.

It is obvious that if maintenance personnel cannot find the outlets, no maintenance can be performed. SHA's that use concrete headwalls, reference markers, or painted arrows have better success in providing maintenance.

If flexible corrugated plastic pipe has been used as an edgedrain, the pipe will not be perfectly straight since it bends when encountering any large stones during the laying process. These bends provide an opportunity for sediment to build up in the edgedrain. Periodic flushing of the edgedrain is necessary to remove sediment buildup.

Flushing and rodding of the edgedrain system is an important part in the maintenance scheme. These operations should be done on a routine schedule.

Edgedrain outlets and pipe systems should be inspected at least once a year to determine their condition. Use of flexible fiber, optic video equipment for inspecting the edgedrain pipe system is recommended. Flushing of the pipe systems should be performed as necessary.

Maintenance personnel should maintain vegetation (mow or spray) around the outlet pipes at least twice a year. It is important to perform this limited maintenance on a periodic basis to keep vegetative buildup to a minimum. Roadside ditches should also be mowed and kept clean of debris.

If an SHA is unwilling to make a maintenance commitment, permeable bases should not be used since the pavement section will become flooded. This increases the rate of pavement damage.

Reference Outlets

Flush as Necessary

Inspect Annually

Maintain Outlets



16.0 SUMMARY

For new and reconstructed pavements, permeable bases show considerable promise for providing positive drainage of the pavement section and extending the service life. By stabilizing the base course material with asphalt cement or Portland cement, a solid working platform can be provided for the construction phase, while the material will be permeable enough to drain any water that may infiltrate.

Below is guidance for the aggregate material:

- Both unstabilized and stabilized permeable base material should consist of durable, crushed, angular aggregate with essentially no fines (minus No. 200 sieve). The aggregate material should have good interlock.
- The FHWA recommends that only crushed stone be used for permeable bases.
- L.A. Abrasion Wear should not exceed 45 percent. Aggregate material should have adequate soundness.

The following guidance is for the hydraulic design of permeable bases:

- Provide permeable base material with the best possible effective porosity so that the base material will release the maximum amount of water.
- Provide base material with a minimum coefficient of permeability of 1,000 ft/day. A coefficient of permeability of 2,000 to 3,000 ft/day would be preferable.
- Provide as much slope as possible. A minimum slope of 0.02 ft/ft is recommended.
- Keep the length of the drainage path to a minimum.
- A maximum outlet spacing of 250 feet is recommended.
- Select base thickness based primarily on construction considerations. A minimum thickness of 4 inches is recommended.

16.1 Permeable Bases

Use Crushed Stone

Provide 1,000 ft/day

16.0

Pavement drainage is not a substitute for pavement thickness, positive load transfer, or a strong subgrade.

For unstabilized permeable bases, the following guidance is provided:

- **Unstabilized aggregate material should be composed of 100 percent crushed stone.**
- **New Jersey Department of Transportation gradation (Table 7) should provide adequate permeability and good stability during construction.**
- **For compaction, most SHA's specify one to three passes of a 5- to 10-ton steel wheel roller. Vibratory rollers should be used with care since they can cause degradation, over-densification, and a subsequent loss of permeability.**

The following guidance is provided for stabilized bases:

Asphalt-Stabilized

- **Application rate of asphalt cement should be 2 to 1-1/2 percent, by weight.**
- **A harder grade of asphalt, AC 40 or AR 8000 is recommended.**
- **For asphalt-stabilized permeable bases, most SHA's specify one to three passes of a 5- to 10-ton steel wheel roller for compaction. Vibratory rollers are not recommended.**

Cement-Stabilized

- **Application rate of 2 to 3 bags of cement is recommended.**
- **A number of SHA's have good success in using only vibrating screeds and plates for compaction.**

16.2 Separator Layer

A separator layer must be provided between the permeable base and the subbase/subgrade to keep soil particles from contaminating the permeable base. Either an aggregate separator layer or a geotextile can be used.

16.0

A minimum aggregate separator layer thickness of 4 inches is recommended.

A separator layer is not a substitute for proper subgrade preparation.

Contractor construction quality control and the SHA inspection level should ensure design expectations are achieved. Well-designed permeable bases can be contaminated or made nonfunctional by poor construction practices.

A positive drainage system with a separator layer, a permeable base, and longitudinal edgedrains cannot function as designed without requiring routine maintenance. Edgedrains and outfalls should be inspected annually.

It is fully expected that SHA's will experience reduced operating costs and extend service life for pavements with positive drainage.

The following guidance is provided for edgedrain systems:

- **The capacity of the edgedrain system should always increase as the water flows through the system. The edgedrain capacity should be great enough to handle the flows coming to it.**
- **Conventional pipe edgedrains are recommended because of their relatively high flow capacity and their ability to be maintained.**
- **The lateral outlet pipe should be a rigid pipe with a minimum slope of 3 percent.**
- **Maximum outlet spacing of 250 feet is the recommended based on maintenance considerations.**
- **Concrete headwalls and outlet markers should be provided at pipe outlets.**
- **Subsurface drainage design should be coordinated with surface drainage. The invert of the outlet pipe should be**

16.3 Construction

16.4 Maintenance

16.5 Edgedrain System

16.0

located 6 inches above the 10-year design flow in the ditch.

- Edgedrain systems should be designed with maintenance in mind.
- Use of video equipment to inspect completed edgedrain systems is a good approach to ensure quality control. Video equipment should also be used to periodically inspect edgedrain systems for maintenance.
- Periodic inspection and maintenance is an absolute necessity to maintain the performance of a permeable base.

17.0 REFERENCES

1. American Association of State Highway and Transportation Officials, "AASHTO Guide for Design of Pavement Structures," 1986, 444 North Capitol Street, N.W., Suite 225, Washington, DC 20001.
2. Baumgardner, R.H., and Mathis, D.M., Experimental Project No. 12, State of the Practice, "Concrete Pavement Drainage Rehabilitation."
3. Carpenter, S.H., "Highway Subdrainage Design by Microcomputer: (DAMP)," Drainage Analysis & Modeling Programs, FHWA-IP-90-012, August 1990, Federal Highway Administration. Available from: NTIS, 5285 Port Royal Road, Springfield, VA 22161.
4. Cedergren, H.R., O'Brien, K.H., and Arman, J.A., "Guidelines for the Design of Subsurface Drainage System for Highway Structural Systems," FHWA-TS-86-208, July 1986. Available from: NTIS, 5285 Port Royal Road, Springfield, VA 22161.
5. Cedergren, H.R., "Drainage of Highway and Airfield Pavements," 1987 Robert E. Krieger Publishing Co. Inc., Krieger Drive, Malabar, FL 32950.
6. Chen, Y.H., and Cotton, G.K., "Design of Roadside Channels with Flexible Linings," HEC No. 15, April 1988, FHWA-IP-87-7. Available from: NTIS, 5285 Port Royal Road, Springfield, VA 22161.
7. Christopher, B.R., and Holtz, R.D. "Geotextile Engineering Manual," 1985, DTFH 61-83-C00150, Federal Highway Administration, 400 7th St., S.W., Washington, DC 20590.
8. Corps of Engineers, "Technical Guidance for Design of the Subsurface Drainage for Military Pavements," (Draft), Waterways Experiment Station (GP-T), 3909 Halls Ferry Road, Vicksburg, MS 39180-0631.
9. Corps of Engineers, "Interior Drainage of Leveed Urban Areas: Hydrology," EM 1110-2-1410, 3 May 1965, Headquarters Department of the Army, Office of the Chief of Engineers.
10. ERES Consultants, Inc., "Pavement Design for Federal, State and Local Engineers," October 1987, Participant's Notebook, Contract No. DOTFH 61-86-C-0038, P. O. Box 1003, Champaign, IL 61820.
11. ERES Consultants, Inc., "Techniques for Pavement Rehabilitation," Participant's Notebook, October 1987, P.O. Box 1003, Champaign, IL 61820.
12. Federal Highway Administration, "Geotextile Design & Construction Guidelines," October 1989, FHWA-HI-90-001, 400 7th Street, S.W., Washington, DC 20590.
13. Federal Highway Administration, Technical Advisory, T 5140.30 "Concrete Pavement Joints," November 30, 1990, Pavement Division, 400 7th Street, S.W., Washington, DC 20590.

17.0

14. Federal Highway Administration, Technical Guide Paper 90-01, "*Subsurface Pavement Drainage*," October 1990, Pavement Division, 400 7th Street, S.W., Washington, DC 20590.
15. Forsyth, R.A., Wells, G.K., and Woodstrom, J.H., "*Economic Impact of Pavement Subsurface Drainage*," Transportation Research Record 1121, Pages 77-85, January 1987.
16. Forsyth, R.A., "*Asphalt Treated Permeable Material - Its Evolution and Application*," Quality Improvement Series QIP 117, National Asphalt Pavement Association, NAPA Building, 5100 Forbes Boulevard, Lanham, MD 20706-4413.
17. Hall, M., "*Cement Stabilized Open Graded Base*," Strength Testing and Field Performance vs Cement Content, Project 0624-32-65, Interim Report, Wisconsin Concrete Paving Assoc., 5721 Odana Road, Madison, WI 53719.
18. Johnson, F.L., and Chang, F.M., "*Drainage of Highway Pavements*," HEC No. 12, March 1984, FHWA-TS-84-202, Available from: NTIS, 5285 Port Royal Road, Springfield, VA 22161.
19. Koerner, R.M., "*Designing with Geosynthetics*," Second Edition, 1989, Prentice-Hall, Englewood Cliffs, NJ 07632.
20. Koerner, R. M., and Ko, F.K., "*Laboratory Studies on Long Term Drainage Capability of Geotextiles*," Second International Conference on Geotextiles, Las Vegas, NV.
21. Mathis, D.M., "*Permeable Base Design and Construction*," Proceedings, Fourth International Conference on Concrete Pavement Design and Rehabilitation, Purdue University, April 18-20, 1989.
22. Moulton, L.K., "*Highway Subdrainage Design*," Report No. FHWA-TS-80-224, Office of Research and Development, Federal Highway Administration, 400 7th Street S.W., Washington, DC 20590.
23. Moulton, L.K., "*Determination of the In Situ Permeability of Base and Subbase Courses*," Report No. FHWA-RD-79-88, May 1979, Office of Research and Development, Federal Highway Administration, 400 7th Street S.W., Washington, DC 20590.
24. National Oceanic and Atmospheric Administration, "*Five to 60 Minute Precipitation Frequency for Eastern and Central United States*," National Weather Service, NWS HYDRO-35, June 1977, NTIS No. PB 272 112. Available from: NTIS, 5285 Port Royal Road, Springfield, VA 22161.
25. National Oceanic and Atmospheric Administration, "*Precipitation Frequency Atlas of Western United States*," NOAA Atlas No.2, 1973. Available from: U.S. Government Printing Office, Washington DC 20402.
26. Ridgeway, H.H., "*Pavement Subsurface Drainage System*," NCHRP Report No. 96, November 1982, Transportation Research Board, National Research Council, Washington, DC.

DRAINABLE PAVEMENT SYSTEMS**Questions and Answers
OCT 1993****General Design**

Question: The use of AASHTO gradation No. 57 or No. 67 in a cement treated permeable base has been well documented. How much sand can be added and still maintain sufficient drainage?

When sand is added to a AASHTO No. 57 or No. 67 gradation, the gradation is altered considerably. This in turn reduces the permeability. One parameter many investigators use to gauge permeability is the effective size (D_{10}). The effective size of the gradation will be reduced considerably with the addition of sand. The best way to determine the coefficient of permeability is to conduct a permeability test on a sample of the mix. A minimum coefficient of permeability of 1000 ft/day is recommended.

Question: Can recycled Portland cement concrete be used in permeable bases?

Recycled portland cement concrete can be used as a permeable base. The general guidance concerning the quality of the aggregate, stability of the base, and required permeability for permeable bases still apply.

Most likely, a precipitate will be discharged. The long term effects of the precipitate on the capacity of the edgedrain and environment is not known. One State highway agency applies an asphalt emulsion to the recycled concrete to provide stability during the construction phase and to coat the particles to trap the precipitate.

Question: Is there any preference of asphalt or Portland cement as a stabilizer?

We believe that either material can be successfully used as a stabilizer material, if the application rate, quality of the aggregate, and construction procedures follow the guidance we provide. The Contractor should have the option to provide the stabilizer of his choice since he can best bid his equipment and supplies.

Question: Will fines from the pavement surface clog the permeable base over time?

It is difficult to believe that the volume of fines entering a

permeable base from the road surface would be enough to clog the base. We recommend that all joints and cracks be sealed to prevent incompressibles from entering the joints.

Question: Is a thinner concrete section with drainable base better than a thicker section with dense graded base?

Heavily loaded roads need both positive drainage and positive load transfer to provide acceptable long term serviceability for PCCP. Additional thickness is not a cost effective trade-off for either feature. Remember the data from the ASSHO road test was based on only 1 million load repetitions over a relatively short time. Today we are extrapolating the data far beyond the test results! Further the FHWA does not recommend that thickness be reduced on structural thicknesses where a permeable base is used. We recommend that all designs be "engineered" to meet the minimum drainage coefficient (C_d) of 1.0.

Question: Are we spending too much money on keeping water out of the pavement section using both joint seals and drainable bases?

No. Joint seals reduce the surface water infiltration into the pavement section. We believe in sealing the most water out and draining any water that enters the pavement section away as quickly as possible. In this way the chain for pumping and base erosion on PCCP is broken. Additionally, joint sealing prevents collection of incompressibles and thus reduces spalling at the joint and "slab growth" or resultant blow-ups.

Question: Is the drainable base a factor in the wide cracks observed in the joints?

Not necessarily. Many thicker pavements, even those over dense asphalt treated bases have also done this. Minnesota and Australia both have notable experiences in this area. Australia considers cracking criteria by placing a limit on PCC mix shrinkage during the trial mix design. Many States in the United States could take a good look at paving concrete mix designs and could reduce placement problems and early performance concerns.

Question: Costs - what are actual costs of drainable base per mile?

This really varies from State to State and even project to project to project and depends heavily on the sources of acceptable aggregates. Crushed stone is recommended. If either asphalt or cement stabilized base is used, it is unlikely either stabilizer will be permanent, i.e. asphalt may strip in time or the reduced cement may deteriorate due to freeze-thaw action, so high quality aggregates are recommended in all cases.

Question: Is there any problem with freeze-thaw in our 4" drainable base section?

Freeze-thaw has not been noted to be a problem in the northern states. Michigan has used drainable base since 1975. We should note, however, that the use of a drainable base with an edge drain system will increase the exposure to air and increase the number of freeze-thaw cycles to which the pavement section is exposed.

Question: Will pumping and clogging develop due to wide cracks?

It is more likely that faulting may develop, perhaps more due to non-uniform base consolidation than faulting. Unless incompressibles get into the joint, the joint openings should tend to equalize. However, the joints that formed initially, will tend to remain slightly wider than the others. If the concrete shrinks as much as 1/4 to 1/2 inch, there will likely be NO aggregate interlock in any of the joints. In Michigan, 70 to 80% of the slabs showed voids or low corner support on short jointed undowelled PCCP on ASPB after just 12 years of service (barely 1 million ESALs).

Question: What type of performance are we getting with our Neoprene seals and Silicone seals on our concrete pavements? Are they keeping the water out and for how long; 5 years? 10 years? 15 years?

Neoprene seals have been found to be effective for 15 years or longer in original construction if properly placed. Permanent set is the major cause of failure but they still resist incompressibles even when they are no longer water tight. (FHWA-RD-89-136-141). Silicone seals have performed equally well for up to 10 to 12 years. Recently there has been early failures (Iowa, Michigan, and other States). In fact, Germany discontinued the use of silicone three years ago and now is using Phoenix neoprene compression seals as the primary seal.

We should point out that neoprene joint seals should be sized to the crack width. This means on projects with variable cracking patterns, the initial crack widths will vary as will the effective working range of each joint or series of joints. In this case the engineer and contractor should carefully select the proper size compression seal for each situation. This is a common oversight which often contributes to seal failure.

Question: Have any failures of any type been reported with a pavement section with a drainable base?

Yes, we have heard of projects with early performance problems. Michigan, Kentucky, and Mississippi to mention a few. But each of the States and their problems must be looked at independently. Poor performance on I-94 in Michigan on two or three projects was primarily due to:

- Location of the underdrain...in the wheel path
- High annual ESALs...3 million on 10" - 41' JRCP
- Sand subbase...poor filter layer and pumping
- Lack of load support...use of non crushed materials
- Recycled PCCP...lack of adequate load transfer for JRCP

A number of other projects with similar designs are performing satisfactorily. The major problem in these cases probably centered on under design of the JRCP for the actual traffic loadings. In these cases, we believe a 12" JPCP would have been preferable.

Question: How extensive is drainable base used in the northern part of the United States?

The exact number of state practices is unknown at this time but today most States are now considering the need for "positive" drainage. Those states that constitute the majority of the PCCP construction including, Minnesota, Wisconsin, Michigan, Pennsylvania, New Jersey, and Illinois(experimentally).

Question: How much damage does surface moisture cause and will drainable bases eliminate this damage?

Most concrete pavements do not fail in fatigue(mid slab cracking). The most frequent failures are joint related, that is no load transfer and pumping of the base course, both stabilized and unstabilized. See FHWA RD-89-136 to 141 for actual performance information. Pavements, in States with as little as 10" of rainfall, over CTB or LCB have faulted significantly in 10 years or less when the were undowelled and undrained(includes Wyoming, Utah, and Nevada). Remember the three elements necessary for pumping...(1) free water; (2) loads; and (3) voids. With positive drainage we can break the chain by removing the "free water". Permeable bases, when adequately maintained, will reduce moisture related damage.

Question: Which section will give us longer life, dense graded section or drainable base section?

That question is the whole thrust of Demo 87, we know that the dense graded bases are saturated and we are not getting the life out of our PCCP's we could. We know our pavements are pumping and faulting and we see base erosion. We know what we have been doing since the late 50's and early 60's is not working.

For medium to heavy truck loadings, it is expected that permeable bases will increase effective service up to 50%, if combined with positive load transfer. The caveat for proper design, construction quality, and maintenance also goes along. We do not have the long term performance data to fully support what does work. FHWA-RD-89-136 showed good performance up to 12 years (through 1987). A follow up research project is underway to review the original 95 PCCP sections plus a large number of others with field data collected in 1992. This should give us a better indication of the long term performance. We expect an interim report to be made available by mid to late 1993.

Unstabilized Permeable Bases

Question: Can an aggregate gradation used for an unstabilized open graded permeable base be allowed to deviate outside of the New Jersey gradation if it demonstrates satisfactory permeability?

The New Jersey gradation is only one example of an unstabilized permeable base. This gradation has been used successfully by New Jersey DOT for a number of years. Another gradation could be used. Any gradation should be tested in the laboratory to determine its coefficient of permeability. A minimum coefficient of permeability of 1,000 feet per day is recommended. Don't forget the quality of the aggregate; crushed stone with a maximum L.A. abrasion Wear of 45 percent is recommended. A control strip should be placed at the start of construction to determine the stability of the gradation.

Asphalt Stabilized Permeable Bases

Question: Can a structural layer coefficient be identified for a asphalt treated permeable base material?

Mr. Ray Forsyth in the National Asphalt Pavement Association publication "Asphalt Treated Material - Its Evolution and Application" states that "...a structural coefficient corresponding to a stabilized base (AASHTO coefficient (0.20 - 0.25) be used in the design of new pavements." A more conservative approach would be to assign no structural value to the typical 4-inch drainage layer.

Question: What mix design procedure should be used for asphalt stabilized permeable bases?

The role of the stabilizer material is to hold the permeable base together during the construction phase. There is no increase in the structural value of the base due to the stabilizer material; therefore, a mix design is not necessary. An application rate of

2-2 1/2 percent asphalt should be sufficient. We do recommend a laboratory verification to avoid over asphaltting and that stiffer asphalt (AC 40) be used.

Question: Do you need to run a stripping test on the asphalt?

Again, since there has been no structural increase assigned to the asphalt, there is no need for testing. The permeable base is designed for stone to stone contact; therefore, in the confined location, if the thin AC coating strips, there should be no loss of strength.

Question: Is the loss of yield a problem with concrete penetrating into the asphalt treated drainable base?

Yield is always a concern. Every permeable base will be open at the inner face and will, of course, accept some volume of fines and mortar. It is unlikely penetration of a properly designed and mixed concrete should penetrate more than 1/4".

Cement Stabilized Permeable Bases

Question: What is the long term effect of water infiltration on a cement stabilized permeable base?

The long term effects on a cement stabilized base is not known. It is quite possible that the cement may leach out. Since the effect of the stabilizer (asphalt or Portland cement) has not been counted on in the thickness design calculations, the strength of the permeable base should still be adequate.

Question: Can flyash be used in cement treated permeable bases?

Any cementing material including flyash can be used in a cement treated permeable base. The trick is to provide a cost effective mixture that will sustain the construction traffic without degradation and retain the desired drainage characteristics once the pavement is constructed. Remember that strength gain is much slower flyash as compared to a cement. Perhaps a blend is necessary.

One State Highway agency permits a pound for pound substitution of flyash for cement up to a maximum of 10 percent of the cement content.

Question: What is a recommended curing pattern for cement stabilized permeable base?

The Oklahoma Department of Transportation requires that the completed cement stabilized permeable base be cured by sprinkling

the surface of the base with a fine mist spray of water every 2 hours for a period of 8 hours. The sprinkling starts the morning after the base is placed. No traffic or equipment is allowed on the permeable base for at least 7 days after it is placed.

The Wisconsin Department of Transportation requires that the completed cement stabilized permeable base be covered with polyethylene sheeting for at least 3 days. Traffic is allowed on the completed base when the Engineer feels that the base has adequately set up to handle construction traffic.

Groundwater Flow

Question: How does water get into a structural section with low water tables and a dry climate?

Water can enter the pavement section by pavement infiltration that is rainfall that seeps into the pavement through open joints and cracks. Also, depending on the type of soil water can be drawn up considerable distances from the water table by capillary action.

Question: Will a drainable pavement help with a swelling clay?

The combination of a permeable base and an aggregate separator layer should carry any pavement infiltration water over to an edgedrain. Since an aggregate separator layer should have 5-12 percent fines passing the No. 200 sieve it should have a low permeability. Pavement infiltration would be collected on top of the aggregate separator layer, and then drain horizontally through the permeable base over to the edgedrain.

Question: What strategies are there to remove water from groundwater sources?

Groundwater is primarily a geotechnical problem. The best approach would be the use of a drainage layer under the road connecting to deep longitudinal edgedrains along the side of the road. Groundwater strategies are discussed in "Highway Subdrainage Design," Report No. FHWA-TS-80-224.

Question: What strategies are there to prevent water from entering the pavement section from the edges?

Again, this is primarily a geotechnical problem. Deeper longitudinal edgedrains should intercept the water before it enters the pavement section.

Question: Will drainable base remove ground water from the

section of roadway?

Generally, no. The underdrains are designed to only drain "roof leakage" or infiltrated water. Iowa, however, constructs their longitudinal underdrains 42" deep. At this depth they are intercepting some ground water in addition to draining the roof infiltration. The trade off, of course, is added cost of the deep drains.

Question: Will the drainable base section have any effect on the moisture content of the subgrade?

It is expected it will reduce the moisture content of the subbase because it will not be in continuous contact with a saturated base. The separator layer, whether DGAB or geotech fabric, is designed to convey the infiltrated moisture into the longitudinal drains as rapidly as possible. This layer separates the drainable base from the subbase or subgrade. A minimum cross slope of 2% (Europe uses 2 1/2%) and a maximum of 4 1/2% is recommended for the separator layer.

Hydraulics

Question: What is the minimum slope of the longitudinal edgedrain? If the minimum slope can not be obtained, should the depth of the edgedrain be varied so that the slope can be obtained?

This is a good question that points up the problems with edgedrain flow. The minimum slope required to maintain a velocity of 2 feet per second for 4-inch pipe flowing full is 0.0717 and 0.0283 feet per foot for smooth and corrugated pipe, respectfully. When the longitudinal slope of the road is level (0.0 %) or at the bottom of a sag vertical curve the longitudinal slope is 0.0 percent. This means that the water will not flow in uniform, steady state conditions. Most likely any sediment will fall out and plug the pipe. Increasing the slope of the pipe is not recommended since trenching would be difficult. The best solution appears to be to maintain the slope of the pipe the same as the slope of the roadway and to provide periodic maintenance to clean out the pipe.

Question: Clearly define the difference between steady state flow and time to drain.

Perhaps the best discussion can be provided by the following example. The next time you clean the roof gutters on your house you can perform this simple experiment. After cleaning the roof gutter, place the garden house at the high end of the gutter and

turn the water on. Since the flow from the hose is at a uniform rate, the flow in the gutter will quickly stabilize at an uniform depth and velocity. This is uniform steady state flow. Now shut the water flow off. This represents the cessation of rainfall and pavement infiltration. The depth of flow and water velocity will fall off very quickly. Since there is no more input of water, the water in the gutter will drain away. The time required for the water to drain away represents the time to drain.

Maintenance

Question: How important is it to maintain the longitudinal edgedrain system for a permeable base?

IT IS ESSENTIAL THAT THE EDGEDRAIN SYSTEM BE INSPECTED ANNUALLY AND MAINTAINED WHEN NEEDED. If the edgedrain system is not maintained, it will quickly clog flooding the edgedrain system and permeable base. This in turn will saturate the subgrade with an accompanying loss of strength. IF THERE IS NOT A COMMITMENT TO MAINTENANCE, BOTH IN POLICY AND IN MAINTENANCE FUNDS, PERMEABLE BASES SHOULD NOT BE PROVIDED.









