

TOLERABLE MOVEMENT CRITERIA FOR HIGHWAY BRIDGES

Research, Development,
and Technology

Turner-Fairbank Highway
Research Center
6300 Georgetown Pike
McLean, Virginia 22101



U.S. Department
of Transportation

**Federal Highway
Administration**

Report No.
FHWA/RD-85/107

Final Report
October 1985

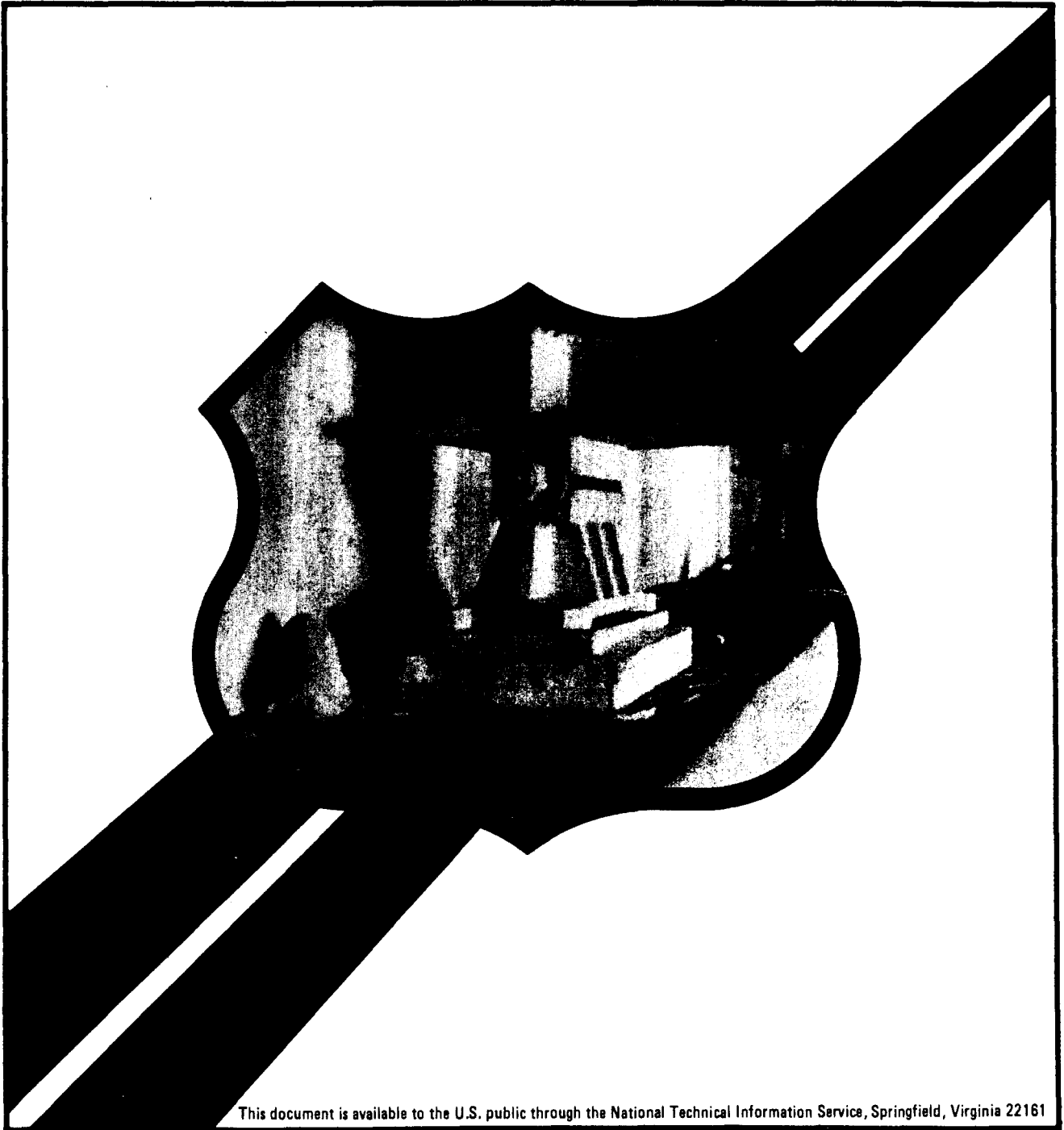

This document is available to the U.S. public through the National Technical Information Service, Springfield, Virginia 22161

FEDERALLY COORDINATED PROGRAM (FCP) OF HIGHWAY RESEARCH, DEVELOPMENT, AND TECHNOLOGY

The Offices of Research, Development, and Technology (RD&T) of the Federal Highway Administration (FHWA) are responsible for a broad research, development, and technology transfer program. This program is accomplished using numerous methods of funding and management. The efforts include work done in-house by RD&T staff, contracts using administrative funds, and a Federal-aid program conducted by or through State highway or transportation agencies, which include the Highway Planning and Research (HP&R) program, the National Cooperative Highway Research Program (NCHRP) managed by the Transportation Research Board, and the one-half of one percent training program conducted by the National Highway Institute.

The FCP is a carefully selected group of projects, separated into broad categories, formulated to use research, development, and technology transfer resources to obtain solutions to urgent national highway problems.

The diagonal double stripe on the cover of this report represents a highway. It is color-coded to identify the FCP category to which the report's subject pertains. A red stripe indicates category 1, dark blue for category 2, light blue for category 3, brown for category 4, gray for category 5, and green for category 9.

FCP Category Descriptions

1. Highway Design and Operation for Safety

Safety RD&T addresses problems associated with the responsibilities of the FHWA under the Highway Safety Act. It includes investigation of appropriate design standards, roadside hardware, traffic control devices, and collection or analysis of physical and scientific data for the formulation of improved safety regulations to better protect all motorists, bicycles, and pedestrians.

2. Traffic Control and Management

Traffic RD&T is concerned with increasing the operational efficiency of existing highways by advancing technology and balancing the demand-capacity relationship through traffic management techniques such as bus and carpool preferential treatment, coordinated signal timing, motorist information, and rerouting of traffic.

3. Highway Operations

This category addresses preserving the Nation's highways, natural resources, and community attributes. It includes activities in physical

maintenance, traffic services for maintenance zoning, management of human resources and equipment, and identification of highway elements that affect the quality of the human environment. The goals of projects within this category are to maximize operational efficiency and safety to the traveling public while conserving resources and reducing adverse highway and traffic impacts through protections and enhancement of environmental features.

4. Pavement Design, Construction, and Management

Pavement RD&T is concerned with pavement design and rehabilitation methods and procedures, construction technology, recycled highway materials, improved pavement binders, and improved pavement management. The goals will emphasize improvements to highway performance over the network's life cycle, thus extending maintenance-free operation and maximizing benefits. Specific areas of effort will include material characterizations, pavement damage predictions, methods to minimize local pavement defects, quality control specifications, long-term pavement monitoring, and life cycle cost analyses.

5. Structural Design and Hydraulics

Structural RD&T is concerned with furthering the latest technological advances in structural and hydraulic designs, fabrication processes, and construction techniques to provide safe, efficient highway structures at reasonable costs. This category deals with bridge superstructures, earth structures, foundations, culverts, river mechanics, and hydraulics. In addition, it includes material aspects of structures (metal and concrete) along with their protection from corrosive or degrading environments.

9. RD&T Management and Coordination

Activities in this category include fundamental work for new concepts and system characterization before the investigation reaches a point where it is incorporated within other categories of the FCP. Concepts on the feasibility of new technology for highway safety are included in this category. RD&T reports not within other FCP projects will be published as Category 9 projects.

FEDERALLY COORDINATED PROGRAM (FCP) OF HIGHWAY RESEARCH, DEVELOPMENT, AND TECHNOLOGY

The Offices of Research, Development, and Technology (RD&T) of the Federal Highway Administration (FHWA) are responsible for a broad research, development, and technology transfer program. This program is accomplished using numerous methods of funding and management. The efforts include work done in-house by RD&T staff, contracts using administrative funds, and a Federal-aid program conducted by or through State highway or transportation agencies, which include the Highway Planning and Research (HP&R) program, the National Cooperative Highway Research Program (NCHRP) managed by the Transportation Research Board, and the one-half of one percent training program conducted by the National Highway Institute.

The FCP is a carefully selected group of projects, separated into broad categories, formulated to use research, development, and technology transfer resources to obtain solutions to urgent national highway problems.

The diagonal double stripe on the cover of this report represents a highway. It is color-coded to identify the FCP category to which the report's subject pertains. A red stripe indicates category 1, dark blue for category 2, light blue for category 3, brown for category 4, gray for category 5, and green for category 9.

FCP Category Descriptions

1. Highway Design and Operation for Safety

Safety RD&T addresses problems associated with the responsibilities of the FHWA under the Highway Safety Act. It includes investigation of appropriate design standards, roadside hardware, traffic control devices, and collection or analysis of physical and scientific data for the formulation of improved safety regulations to better protect all motorists, bicycles, and pedestrians.

2. Traffic Control and Management

Traffic RD&T is concerned with increasing the operational efficiency of existing highways by advancing technology and balancing the demand-capacity relationship through traffic management techniques such as bus and carpool preferential treatment, coordinated signal timing, motorist information, and rerouting of traffic.

3. Highway Operations

This category addresses preserving the Nation's highways, natural resources, and community attributes. It includes activities in physical

maintenance, traffic services for maintenance zoning, management of human resources and equipment, and identification of highway elements that affect the quality of the human environment. The goals of projects within this category are to maximize operational efficiency and safety to the traveling public while conserving resources and reducing adverse highway and traffic impacts through protections and enhancement of environmental features.

4. Pavement Design, Construction, and Management

Pavement RD&T is concerned with pavement design and rehabilitation methods and procedures, construction technology, recycled highway materials, improved pavement binders, and improved pavement management. The goals will emphasize improvements to highway performance over the network's life cycle, thus extending maintenance-free operation and maximizing benefits. Specific areas of effort will include material characterizations, pavement damage predictions, methods to minimize local pavement defects, quality control specifications, long-term pavement monitoring, and life cycle cost analyses.

5. Structural Design and Hydraulics

Structural RD&T is concerned with furthering the latest technological advances in structural and hydraulic designs, fabrication processes, and construction techniques to provide safe, efficient highway structures at reasonable costs. This category deals with bridge superstructures, earth structures, foundations, culverts, river mechanics, and hydraulics. In addition, it includes material aspects of structures (metal and concrete) along with their protection from corrosive or degrading environments.

9. RD&T Management and Coordination

Activities in this category include fundamental work for new concepts and system characterization before the investigation reaches a point where it is incorporated within other categories of the FCP. Concepts on the feasibility of new technology for highway safety are included in this category. RD&T reports not within other FCP projects will be published as Category 9 projects.

1. Report No. FHWA/RD- 85/107		2. Government Accession No.		3. Recipient's Catalog No.	
4. Title and Subtitle Tolerable Movement Criteria for Highway Bridges				5. Report Date October 1985	
				6. Performing Organization Code	
7. Author(s) Lyle K. Moulton, Hota V.S. GangaRao, and Grant T. Halvorsen				8. Performing Organization Report No. CES-8402	
9. Performing Organization Name and Address Department of Civil Engineering West Virginia University Box 6101 Morgantown, West Virginia 26506-6101				10. Work Unit No. (TRAIS) FCP 34H1 022	
				11. Contract or Grant No. DOT-FH-11-9440	
				13. Type of Report and Period Covered Final Report June 28, 1978 - December 31, 1983	
12. Sponsoring Agency Name and Address Federal Highway Administration U. S. Department of Transportation Washington, D.C. 20590				14. Sponsoring Agency Code CME/0181	
15. Supplementary Notes FHWA Contract Officer's Technical Representative - Albert F. DiMillio, HNR-30					
16. Abstract This investigation included (a) a state-of-the-art assessment of tolerable bridge movements based on a literature review, an appraisal of existing design specifications and practice, the collection and analysis of field data on foundation movements, structural damage and the tolerance to movements for a large number of bridges (314) in the United States and Canada, and an appraisal of the reliability of the methods currently used for settlement prediction; (b) a series of analytical studies to evaluate the effect of different magnitudes and rates of differential movement on the potential level of distress produced in a wide variety of steel and concrete bridge structures of different span lengths and stiffnesses; and (c) the development of a methodology for the design of bridges and their foundations that embodies a rational set of criteria for tolerable bridge movements.					
17. Key Words Abutments, Bridges, Deformations, Design, Foundations, Piers, Settlement, Structural Damage, Tolerable Movements			18. Distribution Statement No restrictions. This document is available to the public through the National Technical Information Service, Springfield, VA 22161		
19. Security Classif. (of this report) Unclassified		20. Security Classif. (of this page) Unclassified		21. No. of Pages 118	22. Price

TABLE OF CONTENTS

	Page
LIST OF TABLES	iv
LIST OF FIGURES	vii
1. INTRODUCTION	1
2. STATE-OF-THE-ART ASSESSMENT OF TOLERABLE BRIDGE MOVEMENTS	3
2.1 Literature Review	3
2.2 Existing Design Specifications and Practice	4
2.3 Field Studies	4
2.3.1 Data Collection and Analysis	4
2.3.1.1 Sources of Data	4
2.3.1.2 Limitations of the Data, Assumptions and Definitions	5
2.3.1.3 Methods of Data Analysis	6
2.3.2 Influence of Substructure Variables on Foundation Movement	10
2.3.2.1 Abutment Movements	10
2.3.2.2 Pier Movements	17
2.3.2.3 Causes of Foundation Movements	21
2.3.3 Influence of Foundation Movements on Bridges	23
2.3.4 Tolerance of Bridges to Foundation Movement	35
2.4 Reliability of Settlement Predictions	43
2.4.1 Settlement of Granular Soils	46
2.4.2 Settlement of Cohesive Soils	46
3. ANALYTICAL STUDIES	55
3.1 Steel Bridges	55
3.1.1 Continuous Slab/Stringer Systems	55
3.1.1.1 Static Loading	55
3.1.1.2 Dynamic Loading	61
3.1.1.3 Mathematical Model for the Behavior of Slab/Stringer Systems	61

TABLE OF CONTENTS (continued)

	Page
3.1.2 Continuous Truss Systems	63
3.2 Concrete Bridges	67
3.2.1 AASHTO-PCI Standard I-Girder Bridges	69
3.2.1.1 Continuous I-Girder Bridges	69
3.2.1.2 Precast Girders Made Continuous With a Field Joint	69
3.2.1.3 Girder Composite With Cast-In-Place Deck	71
3.2.1.4 Composite Section With Prestressing	71
3.2.1.5 Summary	77
3.2.2 Box Girder Bridges	77
3.2.2.1 Two-Span Continuous Box Girders	79
3.2.2.2 Four-Span Post Tensioned Box Girder	84
3.2.2.3 Summary	84
4. DEVELOPMENT OF DESIGN METHODOLOGY	
4.1 Basic Design Procedure	87
4.2 Tolerable Movement Criteria	89
4.2.1 Strength Criteria	89
4.2.1.1 Based on Allowable Overstress	90
4.2.1.2 Based Upon Working Stress Design For Service Loads	96
4.2.1.3 Based on Load Factor for Settlement Stresses	97
4.2.2 Serviceability Criteria	97
4.2.2.1 Differential Settlements	99
4.2.2.2 Horizontal Movements of Abutments	100
4.2.2.3 Bridge Vibrations	100
5. SUMMARY AND CONCLUSIONS	101
5.1 Field Studies	101
5.2 Analytical Studies	102
5.3 Design Methodology	103
6. REFERENCES	105

LIST OF TABLES

Table	Page
1. General Summary of Substructure Data	8
2. Summary of the Superstructure Data	9
3. General Summary of Data on Structural Damage	9
4. General Summary of Abutment Movements	11
5. Ranges of Magnitudes of Abutment Movements in General	11
6. Summary of Movements in Terms of Abutment Types	14
7. Ranges of Magnitudes of Abutment Movements in Terms of Abutment Types	15
8. Summary of Movements of Perched Abutments on Spread Footings on Fill in Terms of Construction Sequence	16
9. Summary of Abutment Movements in Terms of Foundation Type	16
10. Summary of Abutment Movements in Terms of Foundation Type and Abutment Type	18
11. Summary of Abutment Movements in Terms of Height of Approach Embankment	19
12. General Summary of Pier Movements	20
13. Ranges of Magnitudes of Pier Movements in General	20
14. Summary of Pier Movements in Terms of Foundation Type	22
15. Summary of Pier Movements in Terms of Pier Location	22
16. Types of Structural Damage Associated with Types of Movements	24
17. Types of Structural Damage Associated with Span Type	27
18. Types of Structural Damage Associated with Material Type	28
19. Types of Structural Damage Associated with Types of Movements for Different Types of Construction materials	29
20. Types of Structural Damage Associated with Types of Abutments	34
21. Tolerance of Bridges to Structural Damage	36
22. Summary of Tolerance to Movements in General	38

LIST OF TABLES (continued)

Table		Page
38.	Comparison Between Measured and Computed Live Load Stresses for Bridge No. 5, a Three-Span Continuous Steel Bridge	95
39.	Recommended Revision of Table 1.2.23 of the AASHTO Specifications (7) to Include Differential Settlement in All Loading Cases	98

LIST OF TABLES (continued)

Table	Page
23. Range of Movement Magnitudes Considered Tolerable or Intolerable	39
24. Range of Movement Magnitudes Considered Tolerable or Intolerable in Terms of Span Type	40
25. Range of Movement Magnitudes Considered Tolerable or Intolerable in Terms of Construction Material	41
26. Ranges of Magnitudes of Longitudinal Angular Distortion Considered Tolerable or Intolerable	42
27. Ranges of Magnitudes of Longitudinal Angular Distortion Considered Tolerable or Intolerable in Terms of Construction Material	44
28. Tolerance of Bridges to Structural Damage in Terms of Construction Material	45
29. Typical Values of Maximum Negative Stresses at the Center Support of Two-Span and Four-Span Continuous Steel Bridges Caused by Differential Settlements	60
30. Time-Dependent Moments and Stresses in Two-Span I-Girder Bridges Caused by 3 Inch Settlement of Center Support	70
31. Time-Dependent Moments and Stresses in Two-Span Bridges Made Continuous with a Field Joint, Caused by 3 Inch Settlement of Center Support	72
32. Long-Term Stresses in Two-Span Continuous Cast-In-Place Composite Bridges Caused by Dead Load and Settlement	73
33. Time-Dependent Stresses for Two-Span Precast Prestressed I-Girders Made Continuous for Live Loads by Cast-In-Place Joint, Acting Composite with Cast-In-Place Deck	78
34. Comparison Between Measured and Computed Live Load Stresses for Bridge No. 1, a Three-Span Continuous Steel Bridge	91
35. Comparison Between Measured and Computed Live Load Stresses for Bridge No. 2, a Three-Span Continuous Steel Bridge	92
36. Comparison Between Measured and Computed Live Load Stresses for Bridge No. 3, a Four-Span Continuous Steel Bridge	93
37. Comparison Between Measured and Computed Live Load Stresses for Bridge No. 4, a Three-Span Continuous Steel Bridge	94

LIST OF FIGURES (continued)

Figure	Page
16. Comparison Between Measured and Calculated Settlements of North Abutment of the Main Street Connector Bridge Over Route 2 in East Hartford, Connecticut	52
17. Comparison Between Measured and Calculated Settlements of North Abutment of U.S. Route 1 Bridge Over Boston and Maine Railroad at Wells, Maine	53
18. Reinforced Earth Supported Embankment That Serves as Foundation for Abutments of Railroad Bridge at Wells, Maine	54
19. Typical Moment Diagram for Two-Span Continuous Bridge Loaded with Dead Load, Live Load and Settlement of Left Abutment	57
20. Typical Displacement Diagrams for Two-Span Continuous Bridge Loaded with Dead Load, Live Load and Settlement of Left Abutment	57
21. Typical Moment Diagram for Two-Span Continuous Bridge, with 100 Foot Spans, Loaded with Dead Load, Live Load and Settlement of Left Abutment	58
22. Theoretical Percent Increase in Positive Stress at Mid-Point of First Span vs. Span Length for Two-Span Continuous Bridge (W36 Composite)	59
23. Theoretical Percent Increase in Negative Stress at Center Support vs. Span Length for Two-Span Continuous Bridge (W36 Composite)	59
24. Theoretical Percent Increase in Positive Stress at Mid-Point of First Span vs. l/ρ for 2-Span Continuous Bridges	62
25. Theoretical Percent Increase in Negative Stress at Center Support vs. l/ρ for 2-Span Continuous Bridges	62
26. Design Aid for Determining the Maximum Positive Stress Increase Caused by Differential Settlement of the Abutment	64
27. Design Aid for Determining the Maximum Negative Stress Increase Caused by Differential Settlement of the Abutment	64
28. Design Aid for Determining the Maximum Positive Stress Increase Caused by Differential Settlement of the First Interior Support	65

LIST OF FIGURES

Figure	Page
1. Illustration of Inward Horizontal Displacement Leading to Abutment Being Jammed Against Beams	12
2. Backwall of Abutment Jammed Against Beam as Result of Inward Horizontal Movement of Abutment	12
3. Tilted Rocker Caused by Backward Horizontal Displacement of Abutment	13
4. Displaced Bearing and Tilted Anchor Bolt Caused by Backward Horizontal Displacement of Abutment	13
5. Minor Cracking in Abutment Caused by Differential Settlement . .	26
6. Opening of Construction Joint in Abutment as Result of Differential Settlement	26
7. Continuous Concrete Box Girder Bridge-Left Abutment Settled Approximately 1.5 Inches (38.1 mm) Relative to the Pier	31
8. Closeup of Bridge Shown in Figure 10 Showing No Signs of Distress in Spite of Differential Settlement of Abutment . . .	31
9. Elevation View of Curved Concrete Box Girder Bridge Showing the Settlements Experienced Following Construction	32
10. View of Side of Curved Concrete Box Girder Bridge Shown in Figure 12 Showing No Signs of Distress in Spite of the Settlements That Took Place	33
11. View of Bottom of Curved Concrete Box Girder Bridge Shown in Figures 12 and 13 Showing No Signs of Distress in Spite of the Settlements That Took Place	33
12. Comparison Between Calculated and Measured Settlements of Sands, After Schultze and Sherif (41)	47
13. Comparison Between Calculated and Measured Settlements Up To 300 mm for Normally Consolidated Clays, after Wahls (44) .	49
14. Comparison Between Calculated and Measured Settlements Up To 1500 mm for Normally Consolidated Clays, after Wahls (44)	50
15. Comparison Between Calculated and Measured Settlements of Overconsolidated Clays, After Butler (50)	51

LIST OF FIGURES (continued)

Figure		Page
29.	Design Aid for Determining the Maximum Negative Stress Increase Caused by Differential Settlement of the First Interior Support	65
30.	Design Aid for Determining the Maximum Positive Stress Increase Caused by Differential Settlement of the Second Interior Support	66
31.	Design Aid for Determining the Maximum Negative Stress Increase Caused by Differential Settlement of the Second Interior Support	66
32.	Time-Dependent Variation of Stresses at Midspan for Two-Span Continuous Concrete Bridge with 100 Foot Spans - Sudden Settlement of Center Support	74
33.	Time-Dependent Variation of Stresses at Midspan for Two-Span Continuous Concrete Bridge with 100 Foot Spans - Gradual Settlement of Center Support	75
34.	Time-Dependent Variation of Stresses at Center Support for Continuous Concrete Bridge with 100 Foot Spans - Gradual Settlement of Center Support	76
35.	Time-Dependent Stresses at Midspan for Two-Span Continuous Concrete Box Girder with 100 Foot Spans - Sudden Settlement of Center Support	80
36.	Time-Dependent Stresses at Center Support for Two-Span Continuous Concrete Box Girder Bridge with 100 Foot Spans - Sudden Settlement of Center Support	81
37.	Time-Dependent Stresses at Center Support for Two-Span Concrete Box Girder Bridge with 200 Foot Spans - Sudden Settlement of Center Support.	82
38.	Time-Dependent Stresses at Midspan for Two-Span Concrete Box Girder Bridge with 200 Foot Spans - Sudden Settlement of Center Support	83
39.	Time-Dependent Stresses at Center Support of Four-Span Continuous Post-Tensioned Concrete Box Girder Bridge with 200 Foot Spans - Sudden Settlement of First Interior Support	85
40.	Schematic Representation of Proposed Methodology for the Design of Highway Bridge Systems	88

1. INTRODUCTION

In current practice, the design of highway bridges commonly begins with the selection of a structure type, based on geometric, functional, architectural, engineering and economic considerations. A preliminary design is prepared and used as the basis for initiating a geotechnical investigation. A program of subsurface explorations, sampling and testing is then undertaken, and, based on the results of these studies and the practice of the highway agency involved, appropriate geotechnical analyses may be conducted. These can include an evaluation of bearing capacity and estimates of immediate and long-term total and differential movements. The resulting estimates can then be used as a basis for deciding how the structure should be founded in order to provide the best combination of safety and economy. Often, one of the major considerations involved in making this decision is whether or not the proposed structure can tolerate the estimated total and differential movements.

If it should be determined that the bridge structure, as originally designed, is unable to tolerate the anticipated foundation movements, then a variety of design alternatives could be considered. These include the use of piles or other deep foundations, the use of precompression or other soil improvement techniques to minimize or eliminate post-construction movements, modification of the structure to a design capable of withstanding the estimated movements, or some combination of these alternatives. Ideally, a cooperative evaluation of the various design alternatives by bridge designer and geotechnical engineer should lead to an optimization of the design of the superstructure and its supporting substructure as a single integrated system offering the best combination of long-term performance and economy. The investigation described herein was initiated as part of a broad research effort designed to establish design methods and criteria that will permit this systems approach to the design of bridges and their foundations to be utilized routinely. It is concerned with the development of rational criteria for determining whether a proposed bridge structure can tolerate the estimated total and differential movements to which it may be subjected.

A great deal of data has been collected and used as the basis for establishing criteria for tolerable movements of buildings and some industrial structures. Among the most significant published accounts of this work are papers by Skempton and MacDonald (1), Polshin and Tokar (2), Feld (3), Grant, Christian and Vanmarcke (4), and Burland and Wroth (5). Unfortunately, the criteria presented in these papers are not applicable to highway bridges. Because of the lack of well founded criteria for tolerable movements of bridges, the designer is commonly forced to rely on seemingly conservative rules of thumb or other guidelines contained in textbooks, building codes or specifications. One such rule of thumb requires that all continuous bridges be founded on rock or piles. Another less restrictive set of guidelines has been suggested by Thornley (6), who recommended that differential and total settlements under working loads be restricted to 1/4 inch (6.4mm) and 3/4 inch (19.1 mm), respectively, and that total settlement under 200 percent of the working load be restricted

to less than 1 1/2 inches (38.1 mm). The current AASHTO "Standard Specifications for Highway Bridges" (7) states, "In general, piling shall be considered when footings cannot, at a reasonable expense, be founded on rock or other solid material." Regardless of the intent of these guidelines, their employment in practice has often led to the decision to use piling or other costly deep foundations, without detailed consideration of other design alternatives, such as those mentioned above, that might have resulted in satisfactory performance at a lower overall cost.

It was recognition of the need for the development of more rational criteria for the tolerable movements of bridges that led the Federal Highway Administration to award Contract No. DOT-FH-11-9440 to West Virginia University to conduct the research described in this report. Although this research was divided into a substantial number of formal tasks and subtasks, basically, the work fell into three general study categories: (a) a state-of-the-art assessment of tolerable bridge movements based on a literature review, an appraisal of existing design specifications and practice, the collection and analysis of field data on movements, structural damage and the tolerance to movements for a large number of bridges in the United States and Canada, and an appraisal of the reliability of the methods currently used for settlement prediction; (b) a series of analytical studies to evaluate the effect of different magnitudes and rates of differential movement on the potential level of distress produced in a wide variety of steel and concrete bridge structures of different span lengths and stiffnesses; and (c) the development of a methodology for the design of bridges and their foundations that would embody a rational set of criteria for tolerable bridge movements.

A substantial amount of this work was completed by September of 1982, and a three-volume Interim Report covering that portion of the research has been published (8,9,10). Although, for completeness, this report deals with all phases of the research, the coverage of some aspects of the work reported earlier is somewhat abbreviated. For greater detail with respect to the earlier phases of the research, the reader is referred to the Interim Report (8,9,10).

2. STATE-OF-THE-ART ASSESSMENT OF TOLERABLE BRIDGE MOVEMENTS

2.1 Literature Review

The initial approach to the literature review was to utilize published indices and abstracts to identify appropriate references relating to bridge movements and their effects. These included the Highway Research Abstracts, the Road Research Laboratory Abstracts, the British Technology Index, the Applied Science and Technology Index, the Engineering Index, the Geodex Structural and Geotechnical Information Service, and the Highway Research Information Service (HRIS). Each of the pertinent references, identified in this manner, was obtained, reproduced and placed in the literature review notebooks. This process was continued until no additional pertinent references or cross-references could be identified.

As an outgrowth of this rather comprehensive process, a substantial number of references were collected dealing with the investigation of approach embankments and bridge foundation movements. These references are cited in Volume I of the Interim Report (8) and are discussed in some detail in Volume III (10) of that report. However, it was found that until recently there was virtually nothing of a specific nature in the literature with respect to the tolerable movement of bridges.

In an effort to gain some insight into the ability of highway bridge structures to withstand foundation movements, Committee SGF-B3 of the Transportation Research Board conducted a survey of bridge movements in 1967, and later Committee A2K03 (Foundations of Bridges and Other Structures) conducted a more comprehensive study, which began in 1975. The results of the 1975 survey were presented in 1978 in papers by Grover (11), Keene (12), Walkinshaw (13) and Bozozuk (14). Based on the results of these studies, Grover (11), Walkinshaw (13) and Bozozuk (14) each suggested criteria for tolerable vertical movements. In addition Walkinshaw (13) and Bozozuk (14) both suggested criteria for tolerable horizontal movements. However, the suggested criteria were very general in nature and did not include consideration of the bridge type, width, span length and type of movement (i.e., total or differential).¹

Thus, in spite of the pioneering efforts of Transportation Research Board Committee A2K03 and the large amount of data that it collected on the influence of movements on the performance of bridge structures, no well-defined set of criteria for tolerable bridge movements was generally agreed upon.

¹The reader is referred to Volume I of the Interim Report (8) for the details of the suggested criteria.

2.2 Existing Design Specifications and Practice

In an effort to establish the extent to which existing design specifications and practice address the issue of tolerable bridge movements, a detailed review was made of the existing AASHTO "Standard Specifications for Highway Bridges" (7), and current design practices were discussed with a number of state highway bridge engineers around the country, both by telephone and through personal interviews.

It was found that the current AASHTO "Standard Specifications for Highway Bridges" (7) does not contain any provisions or criteria for incorporating consideration of tolerance to foundation movements into the design of highway bridges. However, a proposal to modify the existing AASHTO Specifications, to include consideration of differential settlement stresses, when it was determined that they would exceed tolerable limits, was introduced at the four regional meetings of the AASHTO Subcommittee on Bridges and Structures during the Spring of 1982. This proposal met with mixed reaction, with some bridge engineers favoring its adoption but the majority opposing the proposal as presented. Although the proposal was not adopted at the 1982 meetings, it was referred to the Technical Committee for Loads and Load Distribution for review as a possible agenda item for the 1983 meetings.

The discussions with State highway bridge engineers suggested that the design practice of most agencies does not routinely involve the consideration of tolerable bridge movements. Although a relatively small number of highway agencies do design their bridges to accommodate anticipated differential settlements, the majority employ pile foundations as a means of minimizing possible substructure movements. In general, the design practices of those States surveyed do not include the consideration of any tolerable movement criteria in the design of their bridges.

2.3 Field Studies

2.3.1 Data Collection and Analysis

2.3.1.1 Sources of Data. The process of collecting field data on bridge movements and their effects began with the acquisition of the survey data in the files of Transportation Research Board Committee A2K03. As noted earlier, a great deal of information was obtained from the 1975 survey conducted by Committee A2K03 and from the previous survey conducted in 1967 by Committee SGF-B3. Both surveys consisted of sending questionnaires to highway agencies throughout the United States and Canada. In addition to identification information, the questionnaires requested information on the year of completion, the type and number of spans, the type of abutment, soil and foundation conditions, estimated and observed movements, and their effects on the structure. The 1975 questionnaire addressed the question of tolerance to movement, while the 1967 questionnaire did not. In addition to identification information requested by the surveys, some of the highway agencies supplied information such as soil reports and design drawings.

In an effort to supplement the data in the files of Committee A2K03, various highway agencies were asked to supply additional information, including boring logs, settlement data, as-built plans, and tolerance ratings for those bridges that had been included in the 1967 and 1975 surveys. Information was also requested on any bridges that had experienced movement that were not included in the 1967 and 1975 survey responses. In response to this request, supplementary data, including as-built plans, were supplied by 17 States, including Connecticut, Idaho, Indiana, Iowa, Kansas, Michigan, Minnesota, Missouri, New Jersey, New York, North Dakota, Oregon, Virginia, Washington, Wisconsin, West Virginia and Wyoming. In addition, data were also obtained for a substantial number of bridges that were not included in the original surveys, including 28 bridges in the State of Washington that were contained in a Federal Highway Administration staff study reported by DiMillio (15), 89 bridges in Ohio, 9 in Maine, 5 in South Carolina and 3 in Utah. Overall, data are now available on a total of 314 bridges distributed across 39 States, the District of Columbia and 4 Canadian provinces. As-built plans have been obtained for 115 of these structures.

During the data collection process, field trips were made to the States of Connecticut, Ohio, Maine, Michigan, South Carolina, Utah and Washington. During these visits, bridge foundation design and performance were discussed with cognizant State officials, and selected bridges were visited and photographed in Connecticut, Maine, Utah and Washington.

2.3.1.2 Limitations of the Data, Assumptions and Definitions. The data that were available for analysis have certain limitations that must be recognized. Since some of the data was obtained by questionnaires, the quality of the data was dependent on the information requested in the questionnaire and the completeness and accuracy of the information supplied by the respondent. This was also true with respect to the supplementary data supplied by the various highway agencies. In some instances, the data were incomplete or unclear, and there was a general lack of common terminology. Consequently, a number of definitions and simplifying assumptions were adopted in order to generalize the data for classification and analysis. For the sake of brevity, a complete description of all of these definitions and simplifying assumptions has been omitted from this report. However, many of these are self-explanatory or will be obvious from the manner in which the data are organized and presented below. Therefore, this report includes only those definitions that are necessary for an understanding of the various analyses that were performed and their results. The remaining definitions and simplifying assumptions are presented in detail in the three volumes of the Interim Report (8,9,10).

Although most of the terms used to describe structural damage in this report are self-explanatory, some explanation is required for the terms "vertical displacement," "horizontal displacement," "distress in the superstructure" and "damage to bearings." The term "vertical displacement," when applied to structural damage, includes the raising or lowering of the superstructure above or below planned grade or a sag or heave in the deck. Structures requiring shimming or jacking as well as truss structures with increased camber are also included. The term

"horizontal displacement," when applied to structural damage, includes the misalignment of bearings and the superstructure or beams jammed against the abutments. Also included in this category of damage are bridges where the superstructure extended beyond the abutment, where beams required cutting, or where there was a horizontal movement of the floor system. "Distress in the superstructure" consists of cracks or other evidence of excessive stress in beams, girders, struts, and diaphragms as well as cracking and spalling of the deck. Other types of damage included in this category are the shearing of anchor bolts, the opening, closing or damage of deck joints and cases where the cutting of relief joints were required. "Damage to bearings" includes the tilting or jamming of rockers as well as cases where rockers have pulled off bearings, or where movement resulted in an improper fit between bearing shoes and rockers requiring repositioning. Also included under this category are deformed neoprene bearing pads, sheared anchor bolts in the bearing shoes and the cracking of concrete at the bearings.

The subjectivity of the term "tolerable" may be one reason for the lack of generally accepted tolerable movement criteria. Movements that are considered to be tolerable by one engineer may be considered to be intolerable by another. In an attempt to eliminate some of this subjectivity, Transportation Research Board Committee A2K03 defined intolerable movement as follows: "Movement is not tolerable if damage requires costly maintenance and/or repairs and a more expensive construction to avoid this would have been preferable." For the sake of consistency, this definition was also adopted for the study reported herein.

It should be recognized that the data on foundation movements presented herein are biased in the sense that they represent the observed behavior of only those bridge foundations that have experienced some type of movement. No effort has been made in this study to compile data that would permit the comparison of the relative performance of different foundation systems (i.e., piles vs. spread footings). Consequently, no inferences of this type should be drawn from the data presented without proper recognition of their limitations. Furthermore, it should be recognized that, although the total number of bridges that reportedly experienced foundation movements is substantial, only a relatively small number of bridges were reported to have moved in most of the States that contributed data. Thus, the results of this limited study of bridge movements and their effects should not be construed as implying that the occurrence of bridge foundation movements is widespread and that it constitutes a major problem.

2.3.1.3 Methods of Data Analysis. The objective of the analysis of the collected field data was to delineate general trends with regard to the nature of bridge foundation movements, their effects and the ability of the bridges to tolerate these movements. In effect, three separate analyses were conducted, each with a somewhat different methodology.

The first analysis involved the investigation of the influence of substructure variables on bridge abutment and pier movements. For the

abutments, the variables considered were: (a) general soil conditions, (b) type of abutment (full height, perched or spill-through), (c) type of foundation (spread footings or piles) and (d) height of approach embankment. A general summary of the substructure data that were incorporated into this analysis is presented in table 1. In addition to considering the effect of each of these variables on abutment movements, various combinations of variables were considered in an effort to determine combinations that may or may not result in foundation movement. Additional variables considered for the piers were: (a) the span type (simply supported or continuous) and (b) the abutment-embankment-pier geometry. A general summary of the superstructure data, including type of span, that have been incorporated into this and other analyses, is presented in table 2. Again, the influence of each of the selected variables was considered separately and in selected combinations. A valuable by-product of this analysis was the identification of the most common causes of foundation movements for the bridges studied. In addition, it was possible to explore, in a limited way, the influence of construction sequence and precompression (16,17) on abutment movements.

The second analysis involved the investigation of the influence of bridge foundation movements on the bridge structures in an effort to determine what types and magnitudes of movements most frequently result in detrimental structural damage. The variables considered in this analysis were: (a) type of movement (vertical only, horizontal only, or vertical and horizontal in combination), (b) magnitude of movements (maximum differential vertical movements between two successive abutments or piers and maximum horizontal movements), (c) the span type, (d) the type of structural material (steel or concrete), (e) the number of spans and (f) abutment type. A general summary of the types of structural damage and the numbers of bridges that were reported to have experienced these is presented in table 3. It should be noted that many of these structures experienced multiple damaging effects. The implications of this fact will be brought out later in this report.

The third analysis involved the investigation of the tolerance of the various bridge structures to movements. The variables considered in this analysis were: (a) type of structural damage, (b) type of movement, (c) magnitude of movements (maximum differential vertical movements between successive units of the substructure, maximum longitudinal angular distortion and maximum horizontal movement), (d) the span type, (e) the type of structural material, (f) the number of spans and (g) type of abutment.

Initially, the three analyses described above were conducted in great detail, using a manual data reduction and processing system (10). However, these preliminary analyses were begun at a relatively early stage of the data collection process and therefore considered data from only 180 bridges. A later series of analyses employed a computerized data storage and retrieval system (9) and used data from 204 bridges. The results of these analyses were reported in the Interim Report (8). Subsequently, data from 110 additional bridges were added to the data base so that the final analyses reported herein involved a total of 314 bridges. These analyses resulted in the generation of a very large amount of information on the

Table 1. General summary of substructure data.

Substructure Variables	Number of Bridges
General Soil Conditions	
Fine Grained Soil	104
Granular Soils	78
Fine Grained Soils Over Granular Soils	15
Granular Soils Over Fine Grained Soils	30
Interlayered/Intermixed Soils	50
Bedrock	14
Permafrost Soils	3
Soils Conditions not given	20
Foundation Type	
Spread Footings	125
Piles	95
Abutments on Spread Footings/Piers on Piles	21
Abutments on Piles/Piers on Spread Footings	39
Abutments and Piers on Both Spread Footings and Piles	20
Miscellaneous Combinations of Spread Footings, Caissons, etc.	3
Foundation type not given	11
Abutment Type	
Full Height	35
Perched	235
Spill-through	15
Full Height and Perched	2
Perched and Spill-through	3
Abutment type not given or unknown	24
Height of Approach Embankments	
Cut	4
0 feet to 9 feet	13
10 feet to 19 feet	56
20 feet to 29 feet	114
30 feet to 39 feet	77
40 feet to 49 feet	16
50 feet to over 100 feet	19
Approach height not given	15

Note: 1 foot = 0.3048 meters.

Table 2. Summary of the superstructure data.

Superstructure Variables	Number of Bridges
Type of Span	
Simple	97
Continuous	158
Simple and Continuous	14
Rigid Frame	7
Cantilever	10
Miscellaneous or not given	28
Type of Structural Material	
Steel	197
Concrete	78
Steel and Concrete	4
Material not given	35
Number of Spans	
One	25
Two	24
Three	120
Four	67
Five	25
More than five	50
Number of spans not given	3

Table 3. General summary of data on structural damage.

Type of Structural Damage	Number of Bridges
Damage to Abutments	69
Damage to Piers	18
Vertical Displacement	45
Horizontal Displacement	68
Distress in the Superstructure	117
Damage to Rails, Curbs, Sidewalks, Parapets	30
Damage to Bearings	34
Poor Riding Quality	12
Not Given/Corrected During Construction	10
None	81

influence of substructure variables on bridge foundation movements, the influence of these movements on bridge structures and the tolerance of bridges to these movements. For the sake of brevity, only a limited portion of the results can be presented here. The details of the data storage and retrieval system and the preliminary analysis are presented in Volume II (9) and Volume III (10) of the Interim Report, respectively.

2.3.2 Influence of Substructure Variables on Foundation Movement

2.3.2.1 Abutment Movements. There were a total of 580 abutments which had sufficient data to be included in the analysis. Over three-quarters of these experienced some type of movement. A general summary of the movement data for these 439 abutments is presented in table 4. These data show that a great majority of the abutments that moved experienced vertical movement, less than one-third of them moved horizontally, and a substantial number moved both vertically and horizontally. This is further illustrated in table 5, which shows the frequency of occurrence of the various ranges of vertical and horizontal movements. The magnitudes of the vertical movements tended to be substantially greater than the horizontal movements. This can be explained, in part, by the fact that in many instances the abutments moved inward until they became jammed against the beams or girders (see figures 1 and 2), which acted as struts, thus preventing further horizontal movements. For those "sill" type abutments that had no back walls, the horizontal movements were often substantially larger, with the abutments moving inward until the beams or girders were, in effect, extruded out behind the abutments. However, a significant number of abutments (a total of 39) did move outward away from the bridge superstructure and toward their approach embankments (see figures 3 and 4). These were almost invariably perched abutments founded on piles driven through approach fills placed over deep compressible soils. This type of movement has been described by Stermac, Devata and Selby (18). Table 4 also shows that the vertical abutment movements tended to be larger for those abutments that experienced both vertical and horizontal movements.

Of those abutments with sufficient data to be included in the analysis, substantially more perched abutments were reported than either full height or spill-through abutments. Both the full height and perched abutments tended to move more frequently than the spill-through abutments. However, the summary of abutment movements in terms of abutment type, given in tables 6 and 7, shows that perched and spill-through abutments tended to undergo a wider range of movements than did the full height abutments. This was true with respect to both vertical and horizontal movements. The large number of perched abutments that did move suggests that in the future greater attention needs to be directed to the design and construction of the foundation systems for this type of abutment.

In this connection, it was also found that the construction sequence and/or the use of precompression (16,17) exerted a significant influence on the movements of perched abutments founded on spread footings on fill. This is illustrated in table 8, which shows that the range and average magnitude of abutment movements were substantially lower when a preload

Table 4. General summary of abutment movements.

Movement Type	Frequency		Magnitude	
	Number of Abutments	Percent Moved	Range in Inches	Average in Inches
All Types	439	100.0		
Vertical	379	86.3	0.03 - 50.4	3.7
Horizontal	138	31.4	0.1 - 14.4	2.6
Vertical & Horizontal	77	17.5	0.1 - 50.4	6.9
			0.1 - 14.4	2.2

^aTwo abutments, which raised vertically, are not included in total, range or average. Note: 1 inch = 25.4 mm.

Table 5. Ranges of magnitudes of abutment movements in general.

Movement Interval in Inches	Type of Movement			
	Vertical		Horizontal	
	Number of Abutments	Percent of Total	Number of Abutments	Percent of Total
0 - 1.9	184	48.5	56	40.6
2.0- 3.9	98	25.9	58	42.0
4.0- 5.9	31	8.2	15	10.9
6.0- 7.9	20	5.3	2	1.5
8.0- 9.9	11	2.9	6	4.3
10.0-14.9	18	4.7	1	0.7
15.0-19.9	9	2.4	0	0.0
20.0-60.0	8	2.1	0	0.0
Total	379 ^a	100.0	138	100.0

^aTwo abutments, which raised vertically, are not included.
Note: 1 inch = 25.4 mm.

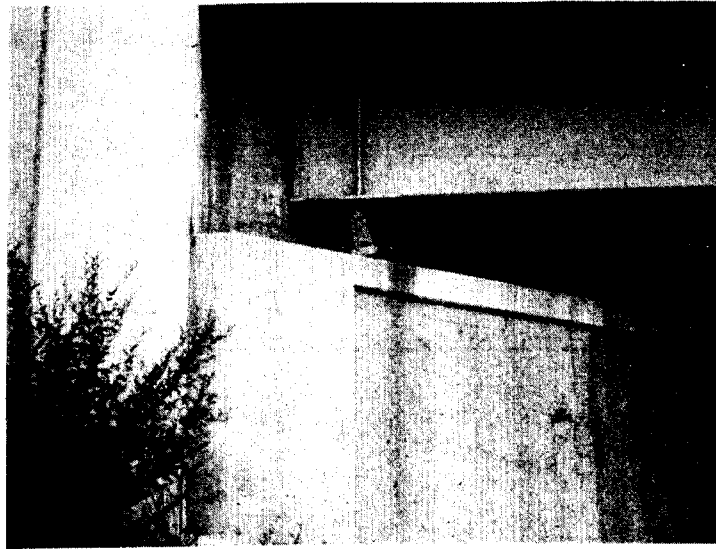

Figure 1. Illustration of inward horizontal displacement leading to abutment being jammed against beams.



Figure 2. Backwall of abutment jammed against beam as result of inward horizontal movement of abutment.



Figure 3. Tilted rocker caused by backward horizontal displacement of abutment.

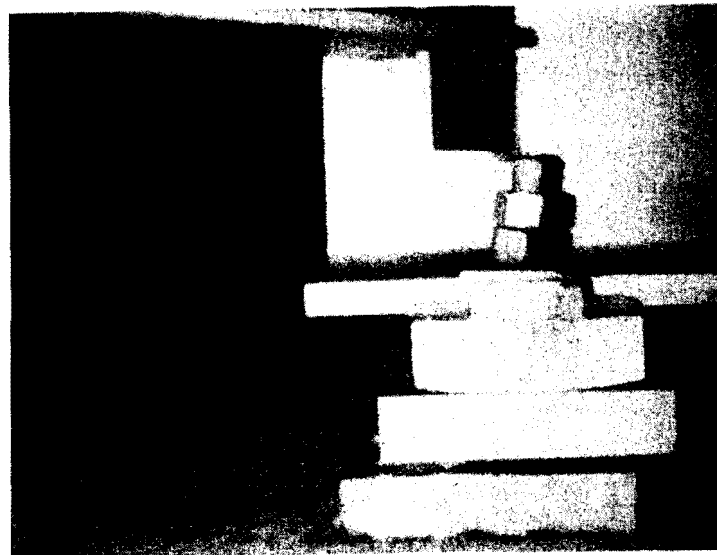

Figure 4. Displaced bearing and tilted anchor bolt caused by backward horizontal displacement of abutment.

Table 6. Summary of movements in terms of abutment types.

Abutment Type	Movement Type	Frequency		Magnitude	
		Number of Abutments	Percent Moved	Range in Inches	Average in Inches
Full Height	All Types	64	100.0		
	Vertical ^a	56	87.5	0.3-17.0	3.8
	Horizontal	32	50.0	0.1-8.0	2.1
	Vertical & Horizontal	24	37.5	0.3-17.0 0.1-8.0	4.8 2.1
Perched	All Types	357	100.0		
	Vertical	307	86.0	0.03-50.4	3.5
	Horizontal	93	26.0	0.3-14.4	2.9
	Vertical & Horizontal	43	12.0	0.1-50.4 0.3-14.4	7.9 2.5
Spill-Through	All Types	21	100.0		
	Vertical	16	76.2	1.2-24.0	8.2
	Horizontal	13	61.9	0.5-8.8	2.4
	Vertical & Horizontal	8	38.1	1.2-24.0 0.5-3.0	7.8 1.4

^aTwo full height abutments, which raised 3 inches, are not included.

Note: 1 inch = 25.4 mm.

Table 7. Ranges of magnitudes of abutment movements in terms of abutment types.

Type of Abutment	Movement Interval in Inches	Type of Movement			
		Vertical		Horizontal	
		Number of Abutments	Percent of Total	Number of Abutments	Percent of Total
Full Height	0 - 1.9	19	33.9	19	59.3
	2.0 - 3.9	18	32.2	10	31.4
	4.0 - 5.9	7	12.5	1	3.1
	6.0 - 7.9	6	10.7	1	3.1
	8.0 - 9.9	1	1.8	1	3.1
	10.0 -14.9	4	7.1	0	0.0
	15.0 -19.9	1	1.8	0	0.0
	20.0 -60.0	0	0.0	0	0.0
Total	56 ^a	100.0	32	100.0	
Perched	0 - 1.9	164	53.4	31	33.3
	2.0 - 3.9	73	23.8	42	45.1
	4.0 - 5.9	24	7.8	14	15.1
	6.0 - 7.9	12	3.8	1	1.1
	8.0 - 9.9	8	2.6	4	4.3
	10.0 -14.9	14	4.6	1	1.1
	15.0 -19.9	6	2.0	0	0.0
	20.0 -60.0	6	2.0	0	0.0
Total	307	100.0	93	100.0	
Spill-Through	0 - 1.9	1	6.2	6	46.2
	2.0 - 3.9	7	43.8	6	46.2
	4.0 - 5.9	0	0.0	0	0.0
	6.0 - 7.9	2	12.5	0	0.0
	8.0 - 9.9	2	12.5	1	7.6
	10.0 -14.9	0	0.0	0	0.0
	15.0 -19.9	2	12.5	0	0.0
	20.0 -60.0	2	12.5	0	0.0
Total	16	100.0	13	100.0	

^aTwo full height abutments, which raised vertically, are not included.
 Note: 1 inch = 25.4 mm

Table 8. Summary of movements of perched abutments on spread footings on fill in terms of construction sequence.

Construction Sequence	Movement Type	Frequency		Magnitude	
		Number of Abutments	Percent Moved	Range in Inches	Average in Inches
Preload and/or Waiting Period	All Types	81	100.0		
	Vertical	81	100.0	0.2-5.2	1.8
	Horizontal	2	2.5	0.3-0.3	0.3
	Vertical & Horizontal	2	2.5	4.0-5.0	4.5
				0.3-0.3	0.3
No Preload or Waiting Period	All Types	63	100.0		
	Vertical	60	95.2	0.1-35.0	7.3
	Horizontal	13	20.6	0.3- 5.0	3.5
	Vertical & Horizontal	10	15.0	0.1-35.0	18.2
				0.3- 5.0	3.7

Note: 1 inch = 25.4 mm.

Table 9. Summary of abutment movements in terms of foundation type.

Foundation Type	Movement Type	Frequency		Magnitude	
		Number of Abutments	Percent Moved	Range in Inches	Average in Inches
Spread Footings	All Types	266	100.0		
	Vertical	254	95.5	0.1-35.0	3.7
	Horizontal	40	15.0	0.1-8.8	2.4
	Vertical & Horizontal	28	10.5	0.1-35.0	6.1
				0.1-8.0	2.2
Piles	All Types	173	100.0		
	Vertical	122	70.5	0.03-50.4	3.9
	Horizontal	99	57.2	0.3-14.4	2.7
	Vertical & Horizontal	48	27.7	0.3-50.4	5.6
				0.3-14.4	2.3

Note: 1 inch = 25.4 mm.

and/or waiting period was employed prior to construction of the abutments than when the abutments were constructed immediately following completion of the embankments. For the 81 perched abutments where a preload and/or waiting period was used, the abutment construction was delayed for one month to six months following completion of the approach embankments. Usually these delays permitted most of the embankment and foundation movement to take place before the beginning of abutment construction.

In terms of foundation type, abutments founded on spread footings had a slightly higher incidence of movement than abutments founded on piles, with 88.7 percent of 300 abutments on spread footings moving as compared to 65.5 percent of 264 abutments founded on piles. However, the summary of abutment movements in terms of foundation types, presented in table 9, shows that abutments founded on piles actually experienced a larger range and a slightly larger average vertical movement than did those founded on spread footings. This situation also existed with respect to horizontal movements. These same general trends were observed in most cases when the data were further broken down in terms of abutment type, as shown in Table 10. These findings, coupled with the relatively large number of pile supported abutments that did move, tends to suggest that the mere use of pile foundations does not necessarily guarantee that abutment movements will be within acceptable limits, particularly for the case of perched abutments on fills. In fact, there is an existing body of evidence that, under some circumstances, bridges founded on piles or other deep foundations can move, sometimes substantially (18-24). In light of this information, it is suggested that in the future the design and construction of pile supported abutments should be pursued with great care and attention to detail, in order to assure that the performance of these substructure units meets expectations.

With respect to foundation soil type, there was a high incidence of vertical movement for abutments founded on spread footings on soil profiles with substantial quantities of fine grained soils. Horizontal movements occurred most often for pile foundations in fine grained soils overlying granular soils. The largest vertical movements tended to occur for abutments on spread footings in fine grained soils and on pile foundations in granular soils overlying fine grained soils. The largest horizontal movements occurred for pile foundations and spread footings in fine grained soil.

Although some general trends were evident, approach embankment heights did not correlate particularly well with the frequency and magnitude of abutment movements. This tends to agree with the findings reported by Grover (11) for Ohio bridges. As might be expected, there was a general trend toward increasing magnitude of vertical movements with increase in height of approach embankments, as shown in table 11. However, additional analyses with regard to embankment height, in terms of abutment type, did not show a great deal of evidence of meaningful trends.

2.3.2.2 Pier Movements. The results of the analysis of pier movements showed that, in general, piers moved less often than abutments. Only 25.2 percent of the 1,068 piers considered in the analysis showed any movement. The general summaries of pier movements given in table 12 and 13

Table 10. Summary of abutment movements in terms of foundation type and abutment type.

Abutment Type	Movement Type	Spread Footing Foundations				Pile Foundations			
		Frequency		Magnitude		Frequency		Magnitude	
		No. of Abuts.	Percent Moved	Range in Inches	Avg. in Inches	No. of Abuts.	Percent Moved	Range in Inches	Avg. in Inches
Full Height	All Types	45	100.0			19	100.0		
	Vertical	39	86.7	0.4 - 11.4	3.4	17	89.5	0.2 - 17.0	4.8
	Horizontal	18	40.0	0.1 - 8.0	1.8	14	73.7	1.1 - 5.5	2.5
	Vertical & Horizontal	12	26.7	0.5 - 11.4 0.1 - 8.0	3.8 1.6	12	63.2	0.3 - 17.0 1.1 - 5.5	5.7 2.7
Perched	All Types	215	100.0			142	100.0		
	Vertical	211	98.1	0.1 - 35.0	3.8	96	67.6	0.03- 50.4	3.1
	Horizontal	19	8.8	0.3 - 5.0	2.6	74	52.1	0.3 - 14.4	2.9
	Vertical & Horizontal	15	7.0	0.1 - 35.0 0.3 - 5.0	13.3 2.7	28	19.7	0.6 - 50.4 0.3 - 14.4	5.0 2.5
Spill-Through	All Types	6	100.0			15	100.0		
	Vertical	4	66.7	3.6 - 8.0	6.4	12	80.0	1.2 - 24.0	8.8
	Horizontal	2	33.3	3.0 - 8.8	5.9	11	73.3	0.5 - 3.0	1.7
	Vertical & Horizontal	0	0.0			8	53.3	1.2 - 24.0 0.5 - 3.0	7.8 1.4

Note: 1 inch = 25.4 mm.

Table 11. Summary of abutment movements in terms of height of approach embankment.

Embankment Height Interval in Feet	Movement Type	Frequency		Magnitude	
		Number of Abutments	Percent Moved	Range in Inches	Average in Inches
0 - 9.9	All Types	16	100.0		
	Vertical	15	93.8	0.2 - 11.0	2.4
	Horizontal	2	12.5	1.8 - 3.6	2.7
	Vertical & Horizontal	1	6.3	2.4 1.8	2.4 1.8
10 - 19.9	All Types	75	100.0		
	Vertical	56	74.7	0.3 - 18.0	4.4
	Horizontal	41	54.7	0.3 - 9.1	2.9
	Vertical & Horizontal	22	29.3	0.3 - 18.0 0.3 - 9.0	5.8 2.8
20 - 29.9	All Types	187	100.0		
	Vertical	161	86.1	0.03 - 50.4	3.3
	Horizontal	51	27.3	0.1 - 14.4	2.6
	Vertical & Horizontal	25	13.4	0.5 - 50.4 0.1 - 14.4	6.7 2.7
30 - 39.9	All Types	113	100.0		
	Vertical	102	90.3	0.1 - 24.0	3.7
	Horizontal	25	22.1	0.3 - 4.0	1.8
	Vertical & Horizontal	14	12.4	0.1 - 24.0 0.3 - 4.0	6.9 1.4
40 - 49.9	All Types	24	100.0		
	Vertical	21	87.5	0.7 - 18.0	4.0
	Horizontal	9	37.5	0.3 - 8.8	3.3
	Vertical & Horizontal	6	25.0	1.0 - 18.0 0.3 - 5.5	8.3 2.3
50 - 100+	All Types	24	100.0		
	Vertical	24	100.0	0.3 - 35.0	9.2
	Horizontal	8	33.3	3.5 - 5.0	4.1
	Vertical & Horizontal	8	33.3	2.1 - 35.0 3.5 - 5.0	14.7 4.1

Note: 1 foot = 304.8 mm, and 1 inch = 25.4 mm.

Table 12. General summary of pier movements.

Movement Type	Frequency		Magnitude	
	Number of Piers	Percent Moved	Range in Inches	Average in Inches
All Types	269	100.0		
Vertical	234 ^a	87.0	0.03-42.0	2.5
Horizontal	52	19.3	0.1 -20.0	3.3
Vertical & Horizontal	17	6.3	0.3- 13.7 0.6- 20.0	5.1 2.7

^aThe number of piers with movement included 7 piers which raised vertically. These piers are not included in the total with vertical movement. Note: 1 inch = 25.4 mm.

Table 13. Ranges of magnitudes of pier movements in general.

Movement Interval in Inches	Type of Movement			
	Vertical		Horizontal	
	Number of Piers	Percent of Total	Number of Piers	Percent of Total
0 - 1.9	152	68.8	32	64.0
2.0- 3.9	22	10.0	6	12.0
4.0- 5.9	15	6.8	4	8.0
6.0- 7.9	23	10.4	2	4.0
8.0- 9.9	1	0.4	2	4.0
10.0-14.9	3	1.4	2	4.0
15.0-19.9	4	1.8	1	2.0
20.0-60.0	1	0.4	1	2.0
Total	221 ^a	100.0	50	100.0

^aSeven piers, which raised vertically, are not included. Note: 1 inch = 25.4 mm.

shows that vertical movements tended to be substantially less than for abutments. Unlike the abutment movements, average horizontal pier movements tended to be larger than the vertical movements.

Although many more piers were founded on piles than on spread footings, 55.8 percent of the piers that moved were founded on spread footings. When compared with corresponding data for abutments, these data suggest that the rate of success in founding piers on piles is substantially greater than that of founding abutments on piles, particularly for perched and spill-through abutments. Table 14, which summarizes the pier movements in terms of foundation type, shows that the average magnitude of vertical movement was substantially greater for pile foundations than for spreading footings. However, the vertical movements for the piers on spread footings had a wider range than for those founded on piles.

Very few trends were evident with regard to pier movements in terms of soils and foundation conditions. As would be expected, the most frequent movements for both spread footings and pile foundations were associated with fine grained soils.

Piers located in or near the toe of approach embankments experienced movement more than twice as frequently as piers that were located away from the embankment, as shown in table 15. These data show that, contrary to what might be expected, the magnitudes of vertical movements tended to be larger for piers located away from the embankments, with an average movement of 3.3 inches (83.8 mm), as compared to 1.9 inches (48.3 mm) for piers located in or near the embankment. The magnitudes of horizontal movements, however, were significantly larger for piers located in or near the embankment with an average of 3.2 inches (81.3 mm) as compared to only 1.5 inches (38.1 mm) for the piers located away from the embankment. This would suggest that, in designing bridge piers in or near the toe of embankments, more consideration needs to be given to the increased level of horizontal stresses that exist in these areas.

2.3.2.3 Causes of Foundation Movements. The investigation of the influence of substructure variables on bridge abutment and pier movements also resulted in the identification of the cause or causes of these movements for the majority of the bridges studied. The primary causes of substructure movements usually fell into three general categories: (a) movements of approach embankments and/or their foundations; (b) unsatisfactory performance of pile foundations; and (c) inadequate resistance to lateral earth pressures, causing horizontal movements of abutments.

The movements of approach embankments were commonly caused by (a) consolidation settlements of compressible foundation soils underlying the embankments, (b) post-construction settlements of the embankments themselves, or (c) sliding caused by slope or foundation instability. Among the most commonly identified conditions that led to slope or foundation instability were excessively steep slopes, low shear strength of embankment or underlying foundation soils and scour at the toe of the slope. The movements of perched and spill-through abutments, which were

Table 14. Summary of pier movements in terms of foundation Type.

Foundation Type	Movement Type	Frequency		Magnitude	
		Number of Piers	Percent Moved	Range in Inches	Average in Inches
Spread Footings	All Types	145	100.0		
	Vertical	134	92.4	0.1-42.0	1.8
	Horizontal	19	13.1	0.5-20.0	3.1
	Vertical & Horizontal	7	4.8	0.8-9.00	3.8
				0.6-20.0	4.9
Piles	All Types	115	100.0		
	Vertical	92	80.0	0.03-18.0	3.6
	Horizontal	33	28.7	0.1-16.0	3.2
	Vertical & Horizontal	10	8.7	0.3-18.0	6.0
				0.6-4.04	1.3

^aNumber of Piers with movement includes 7 piers which raised vertically. These are not included for vertical movements. Note: 1 inch = 25.4mm.

Table 15. Summary of pier movements in terms of pier location.

Pier Location	Movement Type	Frequency		Magnitude	
		Number of Abutments	Percent Moved	Range in Inches	Average in Inches
In or Near Embankment	All Types	198	100.0		
	Vertical	175	88.4	0.06- 42.0	1.9
	Horizontal	41	20.7	0.1 - 20.0	3.2
	Vertical & Horizontal	18	9.9	0.3 - 18.0	3.9
				0.4 - 20.0	2.9
Away From Embankment	All Types	86	100.0		
	Vertical	79	91.9	0.03- 18.0	3.3
	Horizontal	8	9.3	0.1 - 4.0	1.5
	Vertical & Horizontal	1	1.2	18.0	18.0
				2.0	2.0

Note: 1 inch = 25.4 mm

caused by movements of approach embankments, were not limited to those abutments founded on spread footings. In fact, a substantial number of these types of abutments that moved along with their underlying embankments were founded on piling, as shown in table 10.

Although, as noted earlier, a substantial number of pile supported foundations were reported to have experienced movements, thus suggesting unsatisfactory performance of the piles in resisting applied loads, in many instances it was difficult to pinpoint the reasons for this poor performance. This is because many of the case histories studied lacked sufficient detail with respect to the design and construction of the pile foundations to permit a reliable evaluation to be made. Of course, in those cases where pile supported perched or spill-through abutments moved as a result of embankment sliding, it is obvious that the pile foundations were not designed to resist the loads imposed by the embankment movements. In fact, it would be unreasonable to expect a pile foundation to resist the loads imposed by an unstable embankment unless it was specifically designed to do so.

In those instances of forward horizontal abutment movement, either by sliding or rotation or both, where slope stability was not a factor, it was apparent that the abutment foundation could not adequately resist the applied lateral earth pressures. However, in most of these cases it was not readily apparent whether the lateral earth pressures had been underestimated or the foundation design did not provide adequate resistance against sliding and overturning.

2.3.3 Influence of Foundation Movements on Bridges

As indicated in table 3, the most frequently occurring types of structural damage were distress in the superstructure, damage to abutments, horizontal displacement, vertical displacement and damage to bearings. Those structures with only abutment movements had a high frequency of distress in the superstructure and a somewhat lower incidence of horizontal displacement and abutment damage. Distress in the superstructure also occurred very frequently for bridges with only pier movements and for bridges with both abutment and pier movements. Table 16, which relates structural damage to type of foundation movement, shows that the most types of structural damage appear to occur for those bridges with both vertical and horizontal movements occurring simultaneously. Horizontal displacement, abutment damage and distress in the superstructure occurred relatively frequently for bridges with both vertical and horizontal movements. In contrast, structures for which only vertical movement was reported had the lowest frequency of damaging structural effects, with 77 structures having no damage at all.

This same general trend was evident in terms of magnitudes of movements, in that even moderate differential vertical movements tended to produce a relatively low incidence of structural damage. Of the 155 bridges with maximum differential vertical settlements of less than 4 inches (101.5 mm), 79 experienced no damage whatsoever. The majority of the remaining 76 structures experienced primarily abutment damage, in the

Table 16. Types of structural damage associated with types of movements.

Structural Damage	Type of Movement					
	Vertical		Horizontal		Vertical and Horizontal	
	Number of Bridges	Percent of Category ^a	Number of Bridges	Percent of Category	Number of Bridges	Percent of Category
Damage to Abutments	30	16.0	7	16.2	25	37.3
Damage to Piers	3	1.6	5	11.6	8	11.9
Vertical Displacement	30	16.0	0	0.0	11	16.4
Horizontal Displacement	11	5.9	20	46.5	31	46.3
Distress in Superstructure	53	28.2	27	62.8	32	47.8
Damage to Rails, Curbs, Sidewalks, Parapets	16	8.5	3	6.9	10	14.9
Damage to Bearings	1	0.5	18	41.9	13	19.4
Poor Riding Quality	8	4.3	0	0.0	4	6.0
Not Given or Corrected						
During Construction	6	3.2	1	2.3	1	1.5
None	77	41.0	0	0.0	3	4.5
Total Bridges in Category	188		43		67	

^aPercent of bridges in this category with indicated structural damage.

form of minor cracking, opening or closing of construction joints, etc., and relatively minor distress in the superstructure (see figures 5 and 6). For differential vertical movements in excess of 4 inches (101.5 mm), distress in the superstructure tended to be the predominate structural effect. There was an increased incidence of vertical displacement and poor riding quality for differential vertical movements of 8 inches (203.2 mm) and greater. However, it should be pointed out that there were only 12 bridges, out of the 314 considered, for which poor riding quality was reported. This matter will be given further consideration later in this report.

Bridges that experienced either horizontal movement alone, or horizontal movement in conjunction with differential vertical movement, had a high frequency of damaging structural effects, even for relatively small horizontal movements, suggesting that horizontal movements are much more critical than vertical movements in causing structural damage. For those structures with horizontal movements alone, movements of from 1.0 to 2.0 inches (25.4 to 50.8 mm) caused distress in the superstructure very commonly, occurring in more than two-thirds of the cases. The bearings were also affected in more than a third of these structures. Abutment damage and horizontal displacement appeared to begin occurring with greater frequency for horizontal movements of 2 inches (50.8 mm) and greater.

It was more difficult to correlate structural damage with magnitudes of substructure movements for those cases where vertical and horizontal movements occurred simultaneously, because of the possible interaction of the two types of movements. However, a detailed review of the actual causes of the various types of distress in the bridges revealed that it was most commonly the horizontal component of the movement that was responsible for the reported damage. Thus, as suggested earlier, horizontal movements appear to be much more critical than differential vertical settlement in causing most types of structural distress. This tends to confirm the findings of Walkinshaw (13) and Bozozuk (14).

In terms of span type (simply supported or continuous), the data presented in table 17 show that distress in the superstructure was the most common structural effect reported for both continuous and simply supported bridges, although this type of distress was reported for 43.5 percent of the simply supported bridges and only 31.2 percent of the continuous bridges. The data in table 17 also show that abutment damage and horizontal displacement were the second most common effects for the simply supported bridges, occurring in 30.4 and 27.2 percent of the cases, respectively, while these types of damages were reported for only 14.2 and 18.8 percent, respectively, of the continuous bridges. Moreover, 37.0 percent of the continuous bridges experienced no damage while only 15.2 percent of the simply supported bridges were reported to be undamaged. Thus, contrary to what might have been expected, it appears that the continuous bridges were less susceptible to many types of structural damage as a result of substructure movements than were the simply supported bridges. For both types of spans, however, the most frequent and most serious type of structural distress seemed to be related to horizontal movements.



Figure 5. Minor cracking in abutment caused by differential settlement.

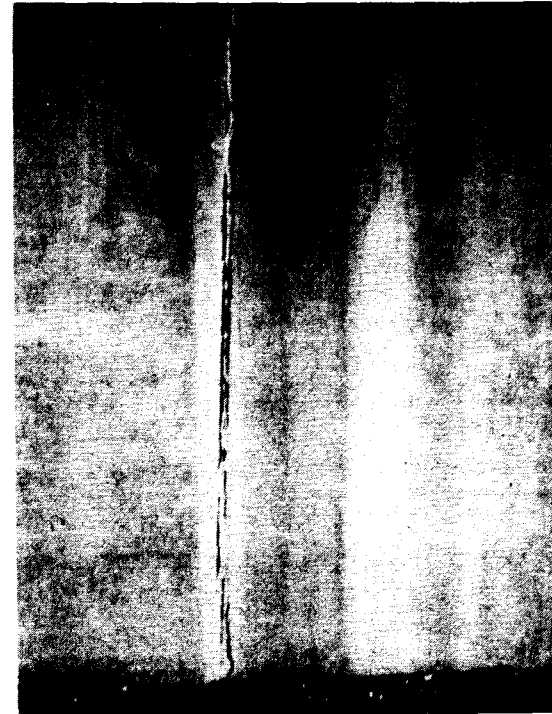

Figure 6. Opening of construction joint in abutment as result of differential settlement.

Table 17. Types of structural damage associated with span type.

Structural Damage	Type of Span			
	Simple		Continuous	
	Number of Bridges	Percent of Category ^a	Number of Bridges	Percent of Category
Damage to Abutments	28	30.4	22	14.2
Damage to Piers	6	6.5	9	5.8
Vertical Displacement	8	8.7	26	16.8
Horizontal Displacement	25	27.2	29	18.8
Distress in Superstructure	40	43.5	48	31.2
Damage to Rails, Curbs, Sidewalks, Parapets	8	8.7	16	10.4
Damage to Bearings	9	9.8	17	11.0
Poor Riding Quality	5	5.4	5	3.2
Not Given or Corrected During Construction	2	2.2	5	3.2
None	14	15.2	57	37.0
Total Bridges in Category	92		154	

^aPercent of bridges in this category with indicated structural damage.

Table 18. Types of structural damage associated with material type.

Structural Damage	Type of Material			
	Steel		Concrete	
	Number of Bridges	Percent of Category ^a	Number of Bridges	Percent of Category
Damage to Abutments	49	25.9	11	14.1
Damage to Piers	7	3.7	6	7.6
Vertical Displacement	30	15.9	8	10.3
Horizontal Displacement	44	23.3	9	11.5
Distress in Superstructure	56	29.6	42	53.8
Damage to Rails, Curbs, Sidewalks, Parapets	10	5.3	17	21.8
Damage to Bearings	22	11.6	5	6.4
Poor Riding Quality	4	2.1	4	5.1
Not Given or Corrected During Construction	5	2.6	3	3.8
None	60	31.7	15	19.2
Total Bridges in Category	189		78	

^aPercent of bridges in this category with indicated structural damage.

Table 19. Types of structural damage associated with types of movements for different types of construction materials.

Construction Material	Structural Damage	Type of Movement					
		Vertical		Horizontal		Vertical and Horizontal	
		Number of Bridges	Percent of Category ^a	Number of Bridges	Percent of Category	Number of Bridges	Percent of Category
Steel	Damage to Abutments	21	17.9	6	27.3	20	45.5
	Damage to Piers	0	0.0	4	18.2	4	9.1
	Vertical Displacement	25	21.4	0	0.0	4	9.1
	Horizontal Displacement	11	9.4	12	54.5	21	47.7
	Distress in Superstructure	19	16.2	16	72.7	21	47.7
	Damage to Rails, Curbs, Sidewalks, Parapets	5	4.3	0	0.0	5	11.4
	Damage to Bearings	1	0.9	11	50.0	11	25.0
	Poor Riding Quality	2	1.7	0	0.0	2	4.5
	Not Given or Corrected						
	During Construction	2	1.7	0	0.0	2	4.5
	None	57	48.7	0	0.0	2	4.5
Total Bridges in Category	117		22		44		
Concrete	Damage to Abutments	7	12.3	1	8.3	3	37.5
	Damage to Piers	3	5.3	1	8.3	2	25.0
	Vertical Displacement	5	8.8	0	0.0	3	37.5
	Horizontal Displacement	0	0.0	6	50.0	4	50.0
	Distress in Superstructure	29	50.9	7	58.3	5	62.5
	Damage to Rails, Curbs, Sidewalks, Parapets	10	17.5	3	25.0	4	50.0
	Damage to Bearings	0	0.0	5	41.7	0	0.0
	Poor Riding Quality	4	7.0	0	0.0	0	0.0
	Not Given or Corrected						
	During Construction	2	3.5	1	8.3	0	0.0
	None	15	26.3	0	0.0	0	0.0
Total Bridges in Category	57		12		8		

^aPercent of bridges in this category with indicated structural damage.

The data on the frequency of occurrence of the various types of bridge damage in terms of structural material, presented in table 18, show that distress in the superstructure was reported much more frequently for concrete structures than for steel structures. However, the steel structures had a higher frequency of abutment damage, vertical and horizontal displacement and damage to bearings. In terms of vertical and horizontal movements, table 19 shows that the steel bridges, with differential vertical movement alone, had a lower incidence and severity of structural damage than did the concrete bridges. Of the 117 steel bridges which experienced only vertical movements, only 16.2 percent experienced distress in the superstructure, while this type of damage was reported in 50.9 percent of the 57 concrete bridges with the same type of movement. In addition, there were substantially more steel bridges that were undamaged by vertical differential settlements. Nevertheless, there were a substantial number of concrete bridges that were subjected to moderate differential settlements without experiencing any structural damage at all. Two such bridges are shown in figures 7 through 11. However, both steel and concrete bridges experienced a high incidence of structural damage from horizontal movements or horizontal movements in combination with vertical movements. Again, it was found that even relatively small horizontal movements, on the order of 2 inches (50.8 mm), produced more frequent and more severe structural damage than did much larger differential vertical movements, regardless of type of structural material.

Relatively few positive conclusions can be drawn with respect to the influence of number of bridge spans on the effects produced by foundation movements, because of sample sizes. However, the data do tend to indicate that multispan structures had a higher frequency of more severe structural effects than did single span bridges.

The data on the frequency of occurrence of each of the various types of structural distress in terms of abutment type, presented in table 20, show that structures on full height abutments tended to have the highest occurrence of abutment damage, but a relatively low occurrence of distress in the superstructure, damage to bearings and vertical and horizontal displacement. Although those bridges on perched abutments, in general, had the highest occurrence of the more serious types of structural damage, they also had, by far, the largest number that experienced no structural damage. This is somewhat of a paradox since, as reported earlier, perched abutments tended to undergo a larger and a wider range of movements than did the full height abutments. However, a detailed examination of the data revealed that it was primarily differential vertical abutment movements in excess of 4 inches (101.6 mm) that caused damage to those bridges with perched abutments. The most damaging effects were produced primarily by horizontal movements between one inch (25.4 mm) and 4 inches (101.6 mm) in magnitude, and these effects were particularly serious when these horizontal movements were accompanied by larger differential vertical movements, i.e. differential settlements in excess of 4 inches (101.6 mm). The relatively high vertical movements experienced by the spill-through abutments (table 6) were found to be largely responsible for the high incidence of superstructure distress reported for bridges with this type of abutment.

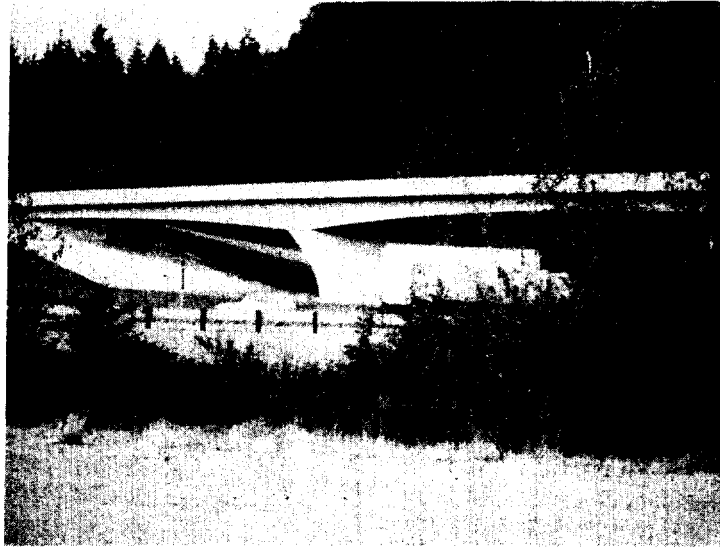
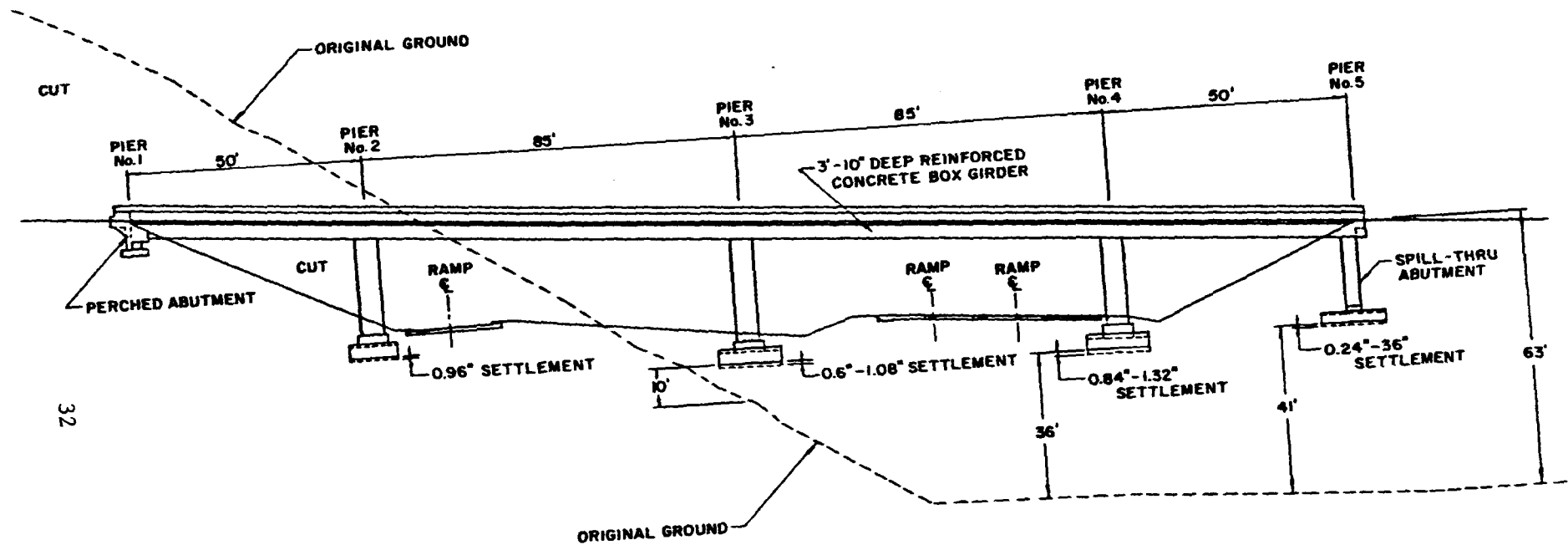

Figure 7. Continuous concrete box girder bridge-
left abutment settled approximately
1.5 inches (38.1 mm) relative to the
pier.



Figure 8. Closeup of bridge shown in figure 10
showing no signs of distress in spite
of differential settlement of abutment.



NOTES: PIERS No. 1 & 2 FOUNDED ON SPREAD FOOTINGS ON NATURAL GROUND WITH MAXIMUM ALLOWABLE BEARING PRESSURE OF 5 TONS/SQ. FT. PIERS No. 3, 4, AND 5 FOUNDED ON SPREAD FOOTINGS ON FILL WITH MAXIMUM ALLOWABLE BEARING PRESSURE OF 3 TONS/SQ. FT. 1 INCH = 25.4 mm., 1 FOOT = 0.305 METERS

Figure 9. Elevation view of curved concrete box girder bridge showing the settlements experienced following construction.

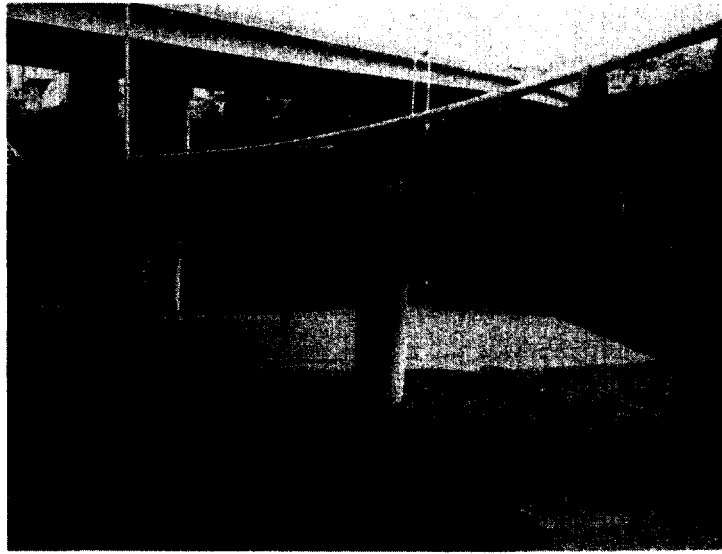

Figure 10. View of side of curved concrete box girder bridge shown in figure 12 showing no signs of distress in spite of the settlements that took place.



Figure 11. View of bottom of curved concrete box girder bridge shown in figures 12 and 13 showing no signs of distress in spite of the settlements that took place.

Table 20. Types of structural damage associated with types of abutments.

Structural Damage	Type of Abutment					
	Full Height		Perched		Spill-Through	
	Number of Bridges	Percent of Category ^a	Number of Bridges	Percent of Category	Number of Bridges	Percent of Category
Damage to Abutments	23	63.9	35	15.4	3	21.4
Damage to Piers	3	8.3	9	3.9	2	14.3
Vertical Displacement	3	8.3	34	14.9	1	7.1
Horizontal Displacement	7	19.4	45	19.7	4	28.6
Distress in Superstructure	7	19.4	85	37.3	11	78.6
Damage to Rails, Curbs, Sidewalks, Parapets	1	2.8	22	9.6	1	7.1
Damage to Bearings	4	11.1	23	10.0	1	7.1
Poor Riding Quality	1	2.8	9	3.9	1	7.1
Not Given or Corrected						
During Construction	1	2.8	6	2.6	0	0.0
None	2	5.6	75	32.9	0	0.0
Total Bridges in Category	36		228		14	

^aPercent of bridges in this category with indicated structural damage.

2.3.4 Tolerance of Bridges to Foundation Movement

Overall, of the 280 structures where data on tolerance to foundation movements were available or could reasonably be assumed, the movements were considered tolerable for 180 bridges and intolerable for 100. The data in table 21 show that, of all the structural effects associated with foundation movements that were considered tolerable, damage to abutments and distress in the superstructure appear most frequently. In most instances, the reported damage involved relatively minor cracking and/or the opening or closing of construction joints in the abutments, as shown in figures 5 and 6, and cracking and spalling of concrete decks. Of course, as would be expected, the foundation movements associated with all of the 81 bridges which experienced no structural damage were considered as being tolerable.

For those 100 bridges with intolerable movements, table 21 shows that almost half were reported to have distress in the superstructure. Horizontal displacement, vertical displacement and damage to bearings were also reported quite frequently. In addition, almost one-quarter of those bridges with intolerable movements had abutment damage. As might have been expected, a larger number of bridges having intolerable movements exhibited multiple damaging effects than did the bridges having tolerable movements. The most frequently occurring combinations of intolerable structural effects were distress in the superstructure, horizontal displacement, vertical displacement, damage to abutments and damage to bearings. A detailed study of the bridge damage data revealed that, in the majority of the cases, there was a direct interrelationship between these most frequently occurring categories of structural damage, and that most were related to horizontal movements or horizontal movements in combination with vertical movements. Although there were a variety of damaging incidents reported, by far the most frequently occurring sequence of events involved the inward horizontal movement of abutments, jamming the beams or girders against the back wall of the abutments, closing the expansion joints in the deck and causing serious damage to the bearings.

Because of the rather common problem of poor riding quality associated with the approaches to bridges (11,25-27), riding quality was initially identified as one of the major areas of emphasis with respect to the evaluation of tolerable bridge movements. However, as shown in table 21, with respect to the bridge structure itself, poor riding quality was only reported for 12 bridges, and it was reported as being intolerable in 11 of these. However, for these 11 structures, the maximum differential vertical settlement ranged from 2.4 inches (61.0 mm) to 35 inches (889 mm), with an average of 14.0 inches (355.6 mm). More important, however, is the fact that the maximum longitudinal angular distortion (differential vertical settlement divided by the span length) ranged from 0.0077 to 0.063, with an average of 0.021. As illustrated by data presented below, even the smallest of these values is larger than what might reasonably be expected to be tolerable either from a stress or serviceability standpoint. In other words, the data appear to indicate that the foundation movements would become intolerable for some other reason before reaching a magnitude that would create intolerable rider discomfort. Consequently, it appears

Table 21. Tolerance of bridges to structural damage.

Structural Damage	Movement Category					
	Tolerable			Intolerable		
	Number of Bridges	Percent of Category ^a	Multiple Damage ^b	Number of Bridges	Percent of Category	Multiple Damage
Damage to Abutments	37	20.6	17	24	24.0	23
Damage to Piers	8	4.4	7	8	8.0	8
Vertical Displacement	3	1.7	2	42	42.0	21
Horizontal Displacement	22	12.2	17	37	37.0	31
Distress in Superstructure	49	27.2	28	46	46.0	39
Damage to Rails, Curbs Sidewalks, Parapets	17	9.4	16	8	8.0	8
Damage to Bearings	8	4.4	6	17	17.0	17
Poor Riding Quality	1	0.1	1	11	11.0	4
Not Given or Corrected During Construction	6	3.3	0	2	2.0	0
None	81	31.1	0	0	0.0	0
Total Bridges in Category	180			100		

^aPercent of bridges in this category with indicated structural damage.

^bMultiple damage refers to the number of bridges in this category that had structural damage in addition to the indicated effects.

that, in terms of static displacement, riding quality will probably not have to be given serious consideration in the establishment of tolerable movement criteria for highway bridges.

The results of the analysis of tolerance to bridge foundation movements in terms of type and magnitude of movement are presented in tables 22 and 23. Table 22 gives a summary of movement characteristics, including type of movement, range of movements and average movements, while table 23 gives the frequency of occurrence of the various ranges of magnitudes of both tolerable and intolerable movements. With regard to movements in general, it is evident from table 22, as might have been expected, that the intolerable movements generally tended to be substantially larger than the tolerable movements. Table 23 shows that moderate magnitudes of differential vertical movements occurring by themselves were most often considered tolerable, while horizontal movements were most commonly considered to be tolerable. Almost 98 percent of the differential vertical settlements less than 2.0 inches (50.8 mm) and 91.2 percent of those less than 4.0 inches (101.6 mm) were considered to be tolerable. However, although there were some larger differential vertical settlements that were considered tolerable, generally the tolerance to differential vertical movements decreased significantly for values over 4.0 inches (101.6 mm). Only 23.5 percent of the differential vertical settlements between 4.0 inches (101.6 mm) and 8 inches (203.2 mm) and 17.6 percent of those over 8 inches (203.2 mm) were reported as being tolerable. In terms of horizontal movements alone, of those bridges with maximum movement less than 2.0 inches (50.8 mm), the movements were considered tolerable in 88.8 percent of the cases. However, a large majority (81.8 percent) of the maximum horizontal movements of 2.0 inches (50.8 mm) and greater were found to be intolerable. Furthermore, table 23 shows that even horizontal movements less than 2.0 inches (50.8 mm) were only reported as being tolerable in 60.0 percent of the cases, when accompanied by differential vertical movements. In fact, a more detailed analysis of the data revealed that for the simultaneous horizontal and vertical movements of this type, the horizontal movements were only reported as being tolerable, in the great majority of cases, when their magnitudes approached one inch (25.4 mm) and less.

Although the sample sizes were smaller, the same general trends with respect to the magnitudes of tolerable and intolerable foundation movements, shown in table 23 and described above, were observed to hold, regardless of span type (simply supported or continuous) and structural materials (steel or concrete). This is illustrated in tables 24 and 25. However, there was a tendency for the simply supported structures and concrete bridges to be more tolerant of vertical differential movements.

The influence of span length on the tolerance of bridges to foundation movements was studied in terms of maximum longitudinal angular distortion (differential vertical settlement divided by span length). There were 204 of the 280 bridges with tolerance data, where the data were sufficiently complete to permit this type of analysis. Of these 204 bridges, the movements were reported to be tolerable for 144 and intolerable for 60. Table 26 presents a summary of the frequency of occurrence of the various

Table 22. Summary of tolerance to movements in general.

Tolerance to Movements	Movement Type	Frequency		Magnitude	
		Number of Bridges	Percent Moved	Range in Inches	Average in Inches
Tolerable	All Types	173	100.0		
	Vertical	135	78.0	0.03- 24.2	1.6
	Horizontal	11	6.4	0.1 - 7.0	1.5
	Vertical & Horizontal	28	16.2	0.1 - 11.4 0.1 - 20.0	2.1 1.6
Intolerable	All Types	89	100.0		
	Vertical	39	43.8	0.2 - 21.6	4.9
	Horizontal	19	21.3	0.5 - 12.0	3.8
	Vertical & Horizontal	31	34.8	0.6 - 50.4 1.0 - 14.4	10.2 3.5

Note: 1 inch = 25.4 mm

Table 23. Range of movement magnitudes considered tolerable or intolerable.

Interval ^a in Inches	Number of Bridges with the Given Type of Movement							
	Vertical Only		Horizontal Only		Vertical and Horizontal Component			
					Vertical Component		Horizontal Component	
	Tol.	Intol.	Tol.	Intol.	Tol.	Intol.	Tol.	Intol.
0.0 - 0.9	52	0	3	0	9	1	8	0
1.0 - 1.9	40	2	5	1	9	3	7	10
2.0 - 3.9	33	10	1	10	6	4	8	10
4.0 - 5.9	1	8	2	0	2	5	0	8
6.0 - 7.9	3	5	1	3	0	2	0	1
8.0 - 9.9	0	5	0	3	0	2	0	2
10.0 - 14.9	2	5	0	2	0	6	0	2
15.0 - 19.9	1	4	0	0	0	3	0	1
20.0 - 60.0	0	0	0	0	0	4	1	0
Total	132	39	12	19	26	30	24	34

^aFor vertical moments, magnitudes refer to maximum differential vertical movement. For horizontal movements, magnitudes refer to maximum horizontal movement of a single foundation element. Note: 1 inch = 25.4 mm.

Table 24. Range of movement magnitudes considered tolerable or intolerable in terms of span type.

		Number of Bridges With the Given Type of Movement							
Type of Span	Interval ^a in Inches	Vertical and Horizontal							
		Vertical Only		Horiz. Only		Vertical Component		Horiz. Component	
		Tolerable	Intol.	Tolerable	Intol.	Tolerable	Intol.	Tolerable	Intol.
Simply Supported	0.0 - 0.9	18	0	3	0	3	0	2	0
	1.0 - 1.9	7	0	2	0	4	1	5	7
	2.0 - 3.9	2	0	1	5	3	1	4	4
	4.0 - 5.9	0	0	0	0	1	4	0	2
	6.0 - 7.9	1	0	0	0	0	0	0	1
	8.0 - 9.9	0	2	0	0	0	2	0	1
	10.0 -14.9	2	1	0	0	0	2	0	0
	15.0 -19.9	0	2	0	0	0	2	0	0
	20.0 -60.0	0	0	0	0	0	1	0	0
	Total	30	5	6	5	11	13	11	15
Continuous	0.0 - 0.9	33	0	0	0	4	1	2	1
	1.0 - 1.9	25	2	2	1	3	1	0	1
	2.0 - 3.9	24	9	0	4	0	3	0	3
	4.0 - 5.9	0	6	2	0	1	1	0	5
	6.0 - 7.9	2	3	1	1	0	0	0	0
	8.0 - 9.9	0	2	0	2	0	0	0	1
	10.0 -14.9	0	4	0	1	0	2	0	1
	15.0 -19.9	0	1	0	0	0	1	0	0
	20.0 -60.0	0	0	0	0	0	3	1	0
	Total	84	27	5	9	8	12	3	12

^aFor vertical movements, magnitudes refer to maximum differential vertical movement. For horizontal movements, magnitudes refers to maximum horizontal movement of a single foundation element.

Note: 1 inch = 25.4 mm.

Table 25. Range of movement magnitudes considered tolerable or intolerable in terms of construction material.

		Number of Bridges With the Given Type of Movement							
		Vertical Only				Horizontal Only			
Construction Material	Interval ^a in Inches	Vertical Only		Horizontal Only		Vertical Component		Horiz. Component	
		Tolerable	Intol.	Tolerable	Intol.	Tolerable	Intol.	Tolerable	Intol.
Steel	0.0 - 0.9	32	0	2	0	7	1	5	0
	1.0 - 1.9	24	2	2	1	8	2	6	3
	2.0 - 3.9	23	6	0	8	3	2	8	4
	4.0 - 5.9	0	7	2	0	1	3	0	8
	6.0 - 7.9	1	4	0	1	0	2	0	0
	8.0 - 9.9	0	2	0	2	0	1	0	2
	10.0 -14.9	2	4	0	1	0	3	0	0
	15.0 -19.9	1	4	0	0	0	1	0	1
	20.0 -60.0	0	0	0	0	0	3	0	0
	Total	83	29	6	13	19	18	19	18
Concrete	0.0 - 0.9	18	0	0	0	1	0	1	0
	1.0 - 1.9	13	0	0	0	0	1	2	2
	2.0 - 3.9	9	2	0	2	2	0	1	1
	4.0 - 5.9	1	1	0	0	1	0	0	0
	6.0 - 7.9	2	1	1	1	0	0	0	0
	8.0 - 9.9	0	2	0	1	0	0	0	0
	10.0 -14.9	0	1	0	2	0	2	0	0
	15.0 -19.9	0	0	0	0	0	0	0	0
	20.0 -60.0	0	0	0	0	0	0	1	0
	Total	43	7	1	6	4	3	5	3

^a For vertical movements, magnitudes refer to maximum differential vertical movement. For horizontal movements, magnitudes refers to maximum horizontal movement of a single foundation element.

Note: 1 inch = 25.4 mm.

Table 26. Ranges of magnitudes of longitudinal angular distortion considered tolerable or intolerable.

Angular Distortion Interval (x 10 ⁻³)	Number of Bridges of the Given Type and Tolerance					
	All Bridges		Span Type			
			Simple		Continuous	
	Tolerable	Intolerable	Tolerable	Intolerable	Tolerable	Intolerable
0 - 0.99	43	1	17	1	23	0
1.0 - 1.99	36	5	7	0	25	4
2.0 - 2.99	32	0	4	0	19	0
3.0 - 3.99	14	1	5	0	7	1
4.0 - 4.99	10	4	2	0	5	4
5.0 - 5.99	2	6	0	1	2	5
6.0 - 7.99	2	7	1	2	1	4
8.0 - 9.99	1	3	0	1	1	1
10.0 - 19.99	3	20	2	4	1	12
20.0 - 39.9	1	8	1	5	0	2
40.0 - 59.9	0	3	0	2	0	1
60.0 - 79.9	0	2	0	1	0	1
Total	144	60	39	17	84	35

ranges of magnitudes of angular distortion considered tolerable and intolerable for all types of bridges included in this portion of the study and for a subdivision by span type. When all of the bridges in the analysis are considered, table 26 shows that 97.7 percent of the 44 angular distortions less than 0.001 and 94.6 percent of the 132 angular distortions less than 0.004 were considered to be tolerable. However, only 42.9 percent of the values of angular distortion between 0.004 and 0.01, 7.1 percent of those over 0.01, were considered to be tolerable. This would suggest that, on the basis of all the available field data, an upper limit on angular distortion of 0.004 would be reasonable. However, when the data are subdivided by span type, table 26 shows that the simply supported bridges tended to be less sensitive to angular distortion than the continuous bridges. While this result was expected, it was anticipated that there would be a more dramatic difference than that shown in table 26. For the continuous bridges, 93.7 percent of the 79 angular distortions less than 0.004 were considered to be tolerable, while only 25.0 percent of those over 0.004 were considered to be tolerable. Translated in terms of differential settlement, these data suggest that, for simply supported bridges, differential settlements of 3.0 inches (76.2 mm) and 6.0 inches (152.4 mm) would most probably be tolerable for spans of 50 feet (15.2 meters) and 100 feet (30.5 meters), respectively. However, for continuous bridges, it would appear that differential settlements of 2.4 inches (61.0 mm) and 4.8 inches (121.9 mm) would be more reasonable tolerable limits for spans of 50 and 100 feet (15.2 and 30.5 meters), respectively.

When the data in table 26 were broken down in terms of material type, as shown in table 27, they suggested that the concrete bridges might be slightly more tolerant to angular distortion than the steel bridges. For the concrete bridges, 97.4 percent of the 38 angular distortions less than 0.005 were considered to be tolerable, while for the steel bridges, only 91.3 percent of the 103 angular distortions less than 0.005 were reported to be tolerable. Thus, the reported trend for the concrete bridges to experience more frequent and more severe superstructure damage than the steel bridges as a result of foundation movements did not show up in terms of the tolerance data. This implies that the frequently reported distress in the superstructure of concrete bridges was quite often considered to be tolerable. A detailed breakdown of the data in table 21, in terms of material type, as shown in table 28, provided verification for this observation.

2.4 Reliability of Settlement Predictions

One of the most common issues raised by the various bridge engineers, who were contacted throughout the course of this study, pertained to the reliability of the current methods used for predicting settlements. In an effort to address this issue, a detailed review of the literature was made to determine the state-of-the-art of settlement prediction for both granular and cohesive soils. A search was then made of the settlement records and soil properties data collected during the field studies, in an effort to select some case histories of bridge foundation movements that would permit a comparison to be made between measured and predicted settlements.

Table 27. Ranges of magnitudes of longitudinal angular distortion considered tolerable or intolerable in terms of construction material.

Angular Distortion Interval ($\times 10^{-3}$)	Number of Bridges of Given Material and Tolerance			
	Concrete		Steel	
	Tolerable	Intolerable	Tolerable	Intolerable
0.0 - 0.99	13	0	29	1
1.0 - 1.99	12	0	22	5
2.0 - 2.99	7	0	25	0
3.0 - 3.99	3	0	11	1
4.0 - 4.99	2	1	7	3
5.0 - 5.99	1	1	1	5
6.0 - 7.99	1	0	1	4
8.0 - 9.99	1	1	0	2
10.0 -19.99	1	2	2	15
20.0 -39.9	0	2	1	5
40.0 -59.9	0	2	0	1
60.0 -79.9	0	0	0	1
Total	41	9	99	43

Table 28. Tolerance of bridges to structural damage in terms of construction material.

Construction Material	Structural Damage	Movement Category					
		Tolerable			Intolerable		
		Number of Bridges	Percent of Category ^a	Multiple Damage ^b	Number of Bridges	Percent of Category	Multiple Damage
Steel	Damage to Abutments	29	25.4	10	19	29.7	18
	Damage to Piers	4	3.5	4	4	6.3	4
	Vertical Displacement	1	0.9	1	31	48.4	15
	Horizontal Displacement	17	14.9	14	25	39.1	22
	Distress in Superstructure	17	14.9	14	31	48.4	28
	Damage to Rails, Curbs, Sidewalks, Parapets	6	5.2	5	3	4.7	3
	Damage to Bearings	7	6.1	5	13	20.3	13
	Poor Riding Quality	0	0.0	0	4	6.3	3
	Not Given or Corrected						
	During Construction	13	11.4	0	0	0.0	0
	None	50	43.9	0	1	1.6	0
	Total Bridges in Category	114			64		
Concrete	Damage to Abutments	8	15.7	7	2	13.3	2
	Damage to Piers	4	7.8	3	1	6.7	1
	Vertical Displacement	2	3.9	1	7	46.7	4
	Horizontal Displacement	2	3.9	2	5	33.3	4
	Distress in Superstructure	27	52.9	14	7	46.7	5
	Damage to Rails, Curbs Sidewalks, Parapets	11	21.5	11	2	13.3	2
	Damage to Bearings	0	0.0	0	2	13.3	2
	Poor Riding Quality	1	2.0	1	3	20.0	1
	Not Given or Corrected						
	During Construction	7	13.7	0	0	0.0	0
	None	10	19.6	0	0	0.0	0
	Total Bridges in Category	51			15		

^aPercent of bridges in this category with indicated structural damage.

^bMultiple damage refers to the number of bridges in this category that had structural damage in addition to the indicated effects.

2.4.1 Settlement of Granular Soils

For granular soils, it was found that there are a wide variety of methods currently in use for settlement prediction. For the most part, these methods are either entirely empirical or they contain some elements of empiricism. It appears that the most popular of these methods fall in two general categories: (a) empirical methods based on the Terzaghi and Peck approach (28), with modifications by Teng (29), Meyerhof (30,31), Bazaraa (32), Peck and Bazaraa (33), Peck et al. (34), Alpan (34), and other authors; and (b) semi-empirical methods, which are based on the theory of elasticity and use standard penetration test results, or the results of cone penetrometer tests, to estimate the elastic constants for the foundation soils. Falling in this latter category are the methods discussed by DeBeer and Martens (36), DeBeer (37), D'Appolonia et al. (38), Webb (39), Schmertmann (40), Schultze and Sherif (41) and Oweis (42). An excellent summary of many of the insitu measurement techniques required to produce the data needed to utilize these methods has been presented by Mitchell and Gardner (43). Although some very good agreement is reported in the literature between predicted and measured settlements of granular soils, efforts to compare the various settlement prediction methods for the same case history appearing in the literature were not particularly productive, either because of a lack of soil property data, loading data or both. However, overall, the data extracted from the literature did indicate that the settlement of sands could usually be predicted within 50 percent of the measured value (44). An excellent comparison of this type has been presented by Schultze and Sherif (41) and is reproduced here as figure 12. The dashed lines in figure 12 represent a 50 percent departure from perfect agreement between calculated and measured settlements.

A review of the data collected for all 314 of the bridges included in the field studies revealed that there were no bridge foundations on granular soils where the data was sufficiently complete to permit a comparison between measured and predicted settlement. While this finding was disappointing, it should be pointed out that, from a practical standpoint, the reliability of prediction of the settlements of granular soils is substantially less important than that of cohesive soils as far as bridge foundations are concerned. This is because the settlements of granular soils are usually relatively small (see figure 12) and occur very rapidly, so that at each stage of loading during the process of bridge construction, the settlement is essentially completed before the next stage of loading is applied. Thus, adjustments in grade can be made during construction, and there are no post-construction settlements of significance to contend with.

2.4.2 Settlement of Cohesive Soils

For cohesive soils, it was found that, although there are some fairly sophisticated methods of settlement prediction available, including computer methods, (e.g. see the discussion and references in TRB Special Report 163 (45)), most commonly these predictions are made with the Terzaghi theory of one-dimensional consolidation (46), using the Taylor modification for gradual rate of loading (47). The Casagrande method of predicting maximum past (preconsolidation) pressure (48) is widely used along with Schmertmann's procedure (49) for correcting for sample disturbance. In

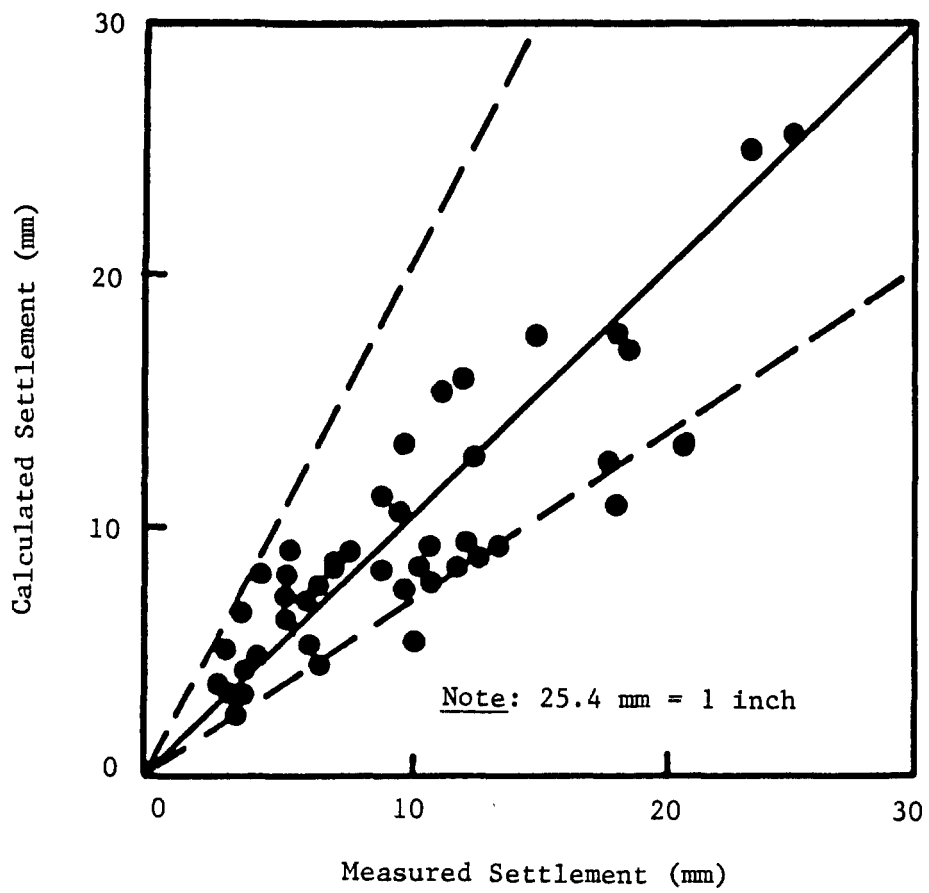

Figure 12. Comparison between calculated and measured settlements of sands, after Schultze and Sherif (41).

implementing these methods, the stress increases in the foundation soils, caused by the loads applied at the foundation level, are commonly estimated using the theory of elasticity (45). The data extracted from the literature and that collected during the field studies for bridges founded on cohesive soils were sufficiently complete in a number of cases to permit the comparison of measured and predicted settlements. Comparisons between calculated and measured settlements, extracted from the literature, for normally loaded clays are presented in figures 13 and 14 (44) and similar data for overconsolidated clays are presented in figure 15 (40). Figure 13 shows the comparison between calculated and measured settlements up to 300 millimeters (11.8 inches) for normally consolidated clays, while figure 14 presents a similar comparison for settlements up to 1150 millimeters (45.3 inches). The dashed lines in figures 13, 14 and 15 represent a 25 percent departure from perfect agreement between the calculated and measured settlements.

The results of two typical comparisons between calculated and measured settlements collected during the field studies are presented in figures 16 and 17. Figure 16 shows the comparison between measured and calculated settlements beneath the center of the north abutment of the Main Street Connector bridge over Route 2 in East Hartford, Connecticut, for the first seven months following the start of construction. This bridge is a two-span simply supported structure founded on 13 feet (4.0 meters) of fine to medium sand underlain by 86 feet (26.2 meters) of varved clay. The final calculated north abutment settlement of 3.1 inches (7.9 cm) compared quite favorably with the final observed abutment settlement, which varied from 3.0 to 3.5 inches (7.6 to 8.9 cm).

Figure 17 shows the comparison between measured and calculated settlements beneath the center of the north abutment of the U.S. Route 1 bridge over the Boston and Maine Railroad at Wells, Maine, for the first 23 months following the start of construction. This bridge is a single span structure whose abutments are founded on approach embankments supported by reinforced earth, as shown in figure 18. The foundation soil consists of 30 feet (9.1 meters) of loose to medium dense sand overlying 50 feet (15.2 meters) of sensitive silty clay. The reinforced earth supported embankment was constructed first as a preload and was allowed to settle for about a year, as shown in figure 17, before the bridge was constructed. The final calculated settlement at the north abutment is 31.0 inches (78.8 cm). However, a comparison with the final measured settlement is not possible at this time because the settlement is incomplete.

Overall, the results of the comparisons between predicted and measured settlements for cohesive soils showed that reasonably reliable predictions of the ultimate foundation settlement can be made, usually within 25 percent of the measured value, as shown in figures 13, 14 and 15, as long as good subsurface information and consolidation test data are available. However, in general, predictions of the time rate of settlement were less satisfactory than predictions of final settlement, as illustrated in figures 16 and 17.

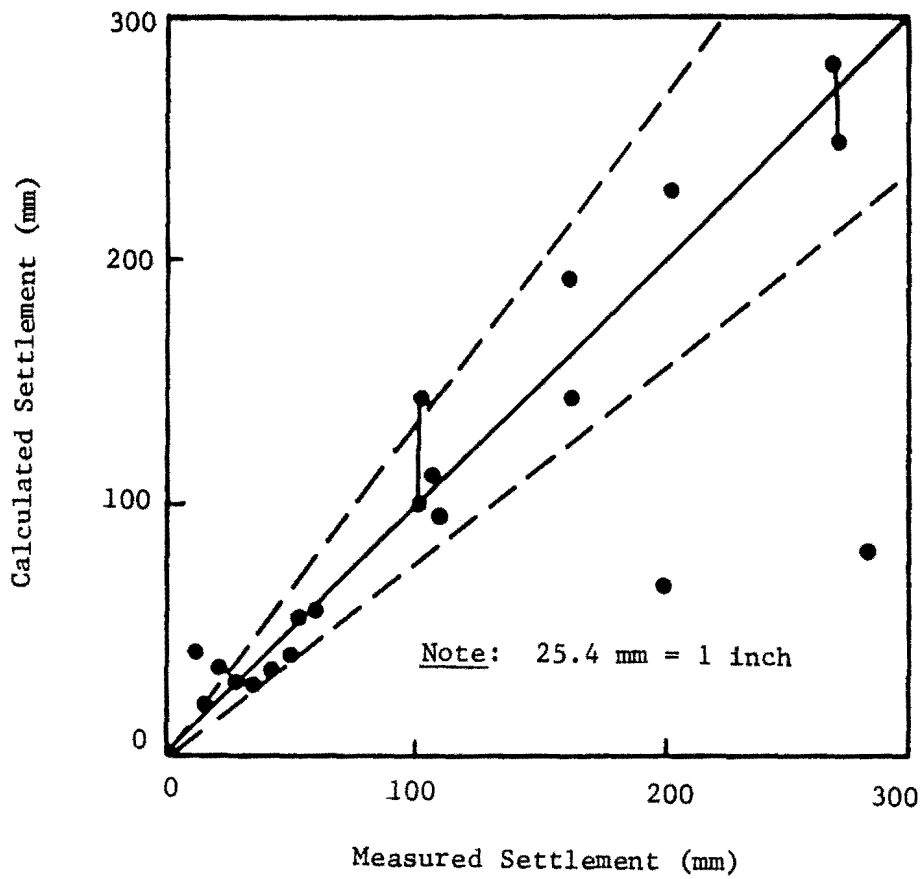

Figure 13. Comparison between calculated and measured settlements up to 300 mm for normally consolidated clays, after Wahls (44).

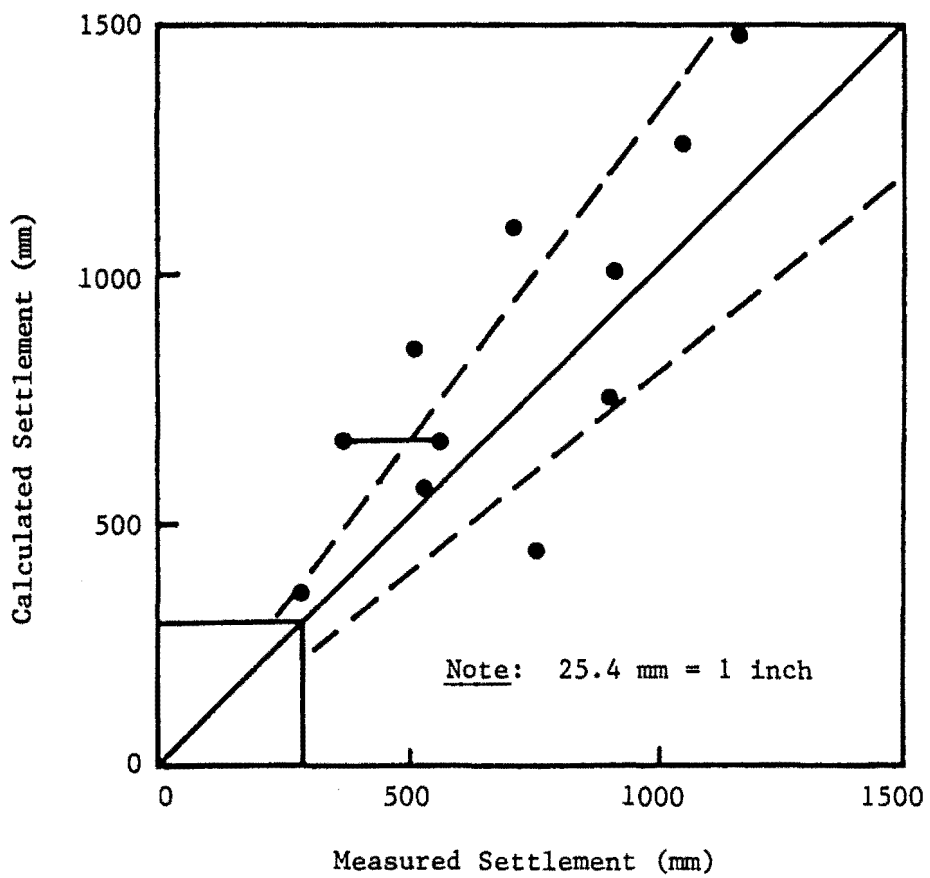

Figure 14. Comparison between calculated and measured settlements up to 1500 mm for normally consolidated clays, after Wahls (44).

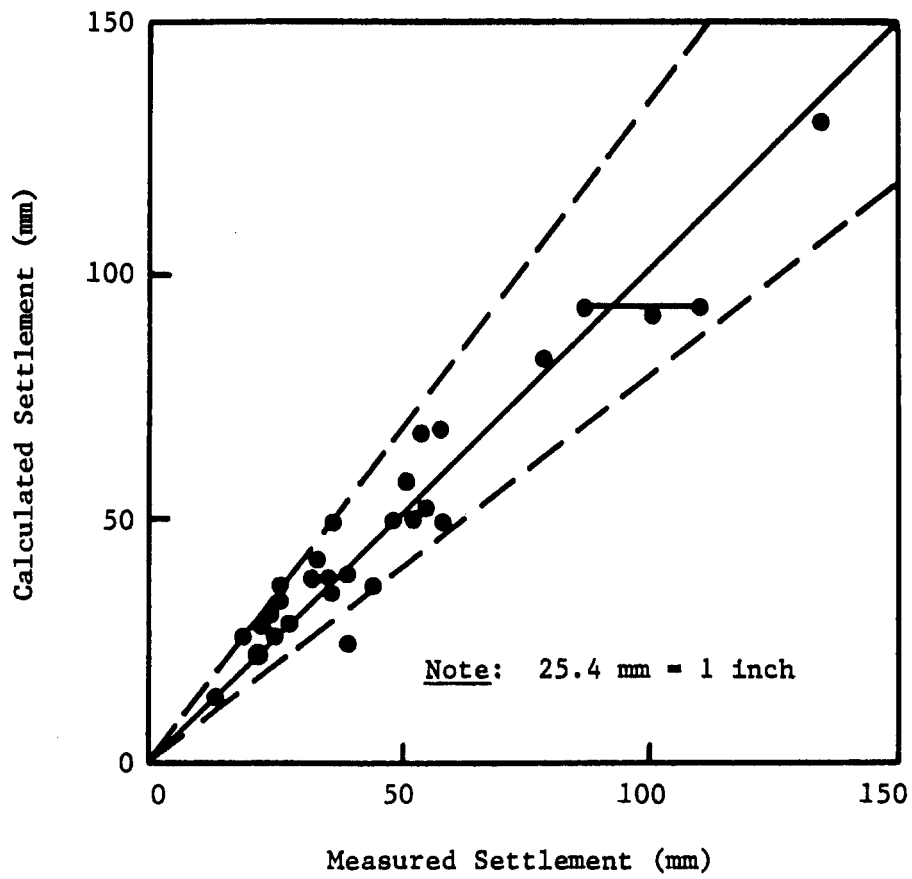

Figure 15. Comparison between calculated and measured settlements of overconsolidated clays, after Butler (50).

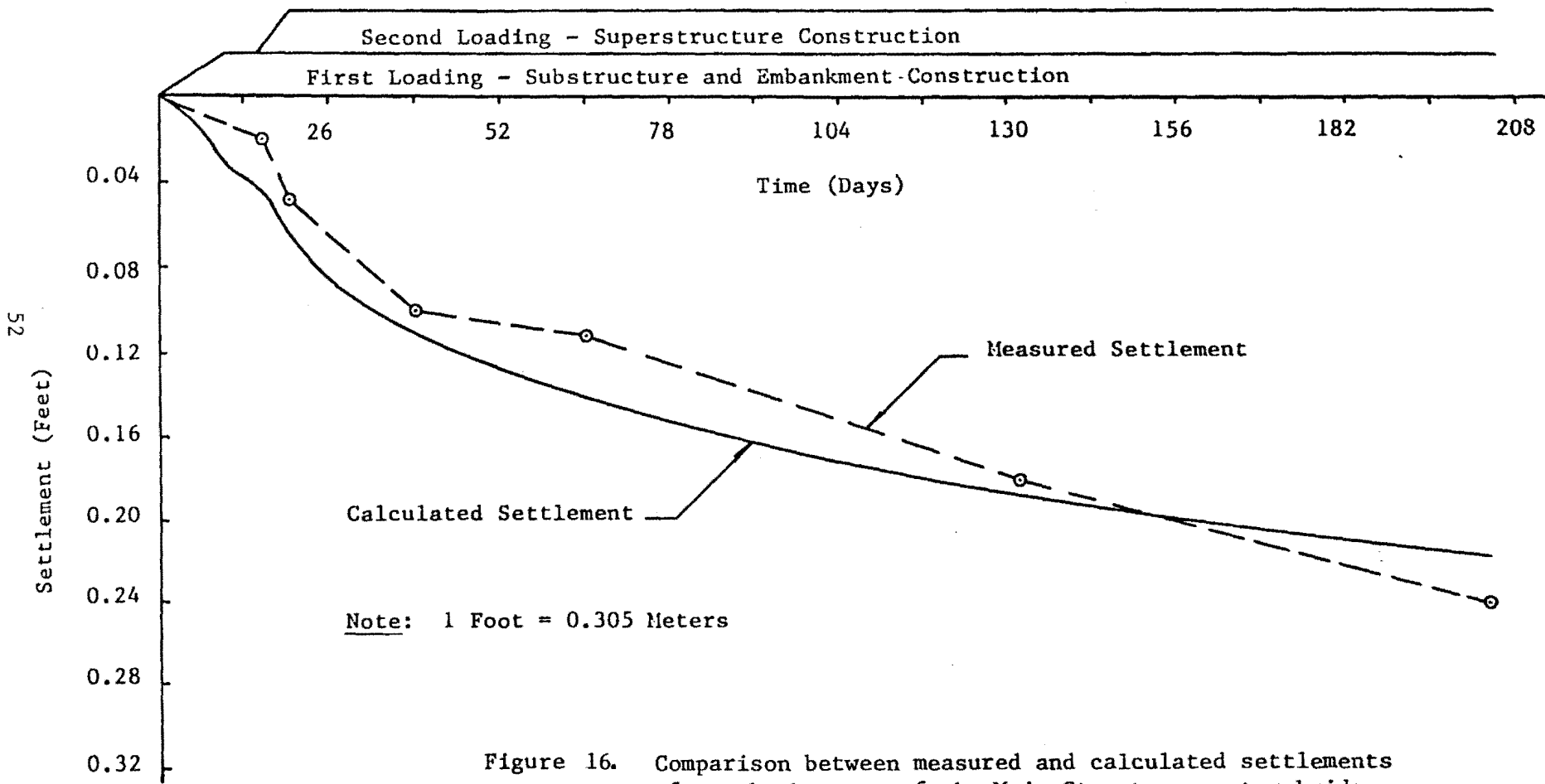

Figure 16. Comparison between measured and calculated settlements of north abutment of the Main Street connector bridge over Route 2 in East Hartford, Connecticut.

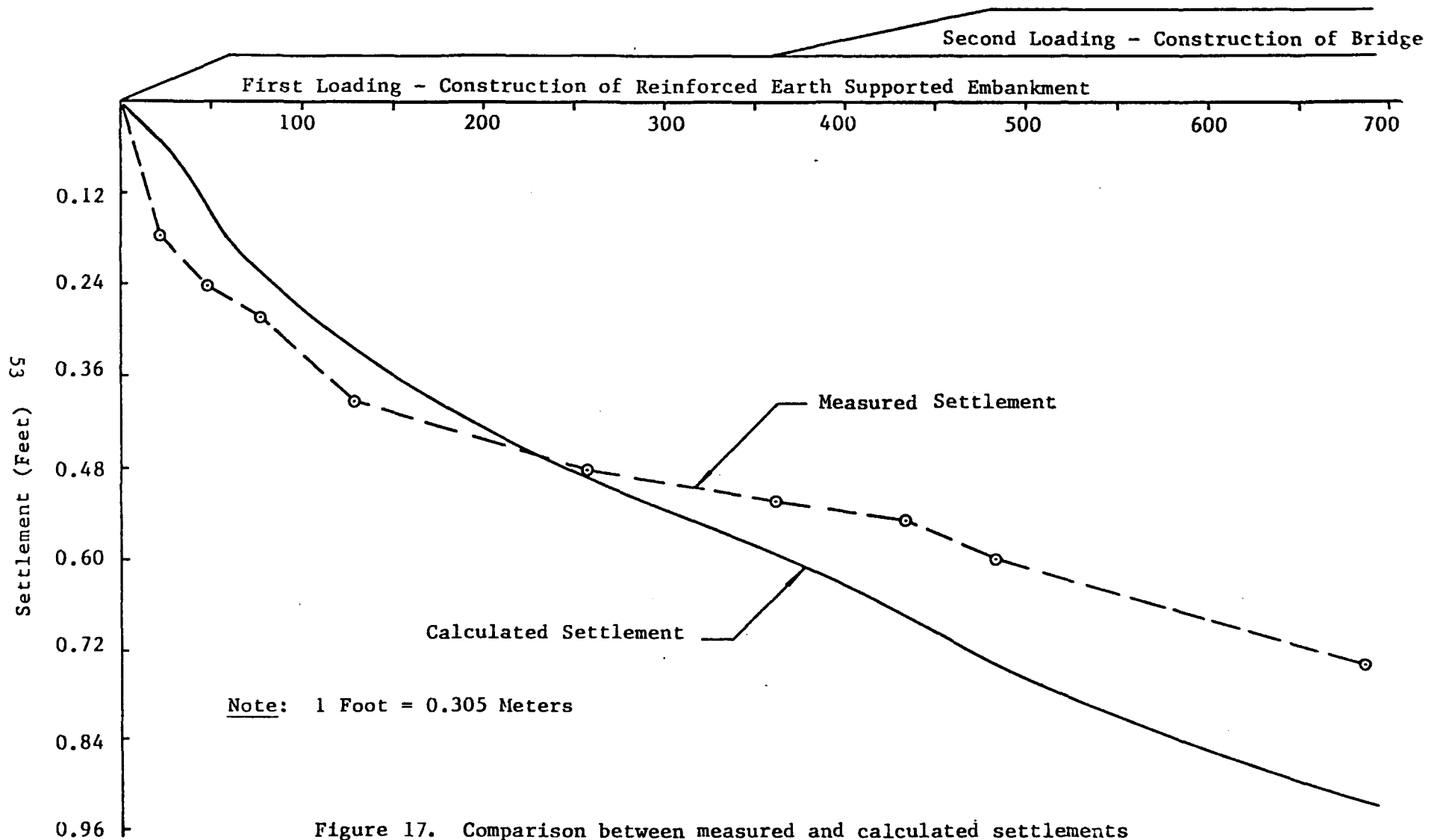

Figure 17. Comparison between measured and calculated settlements of north abutment of U.S. Route 1 Bridge over Boston and Maine Railroad at Wells, Maine.

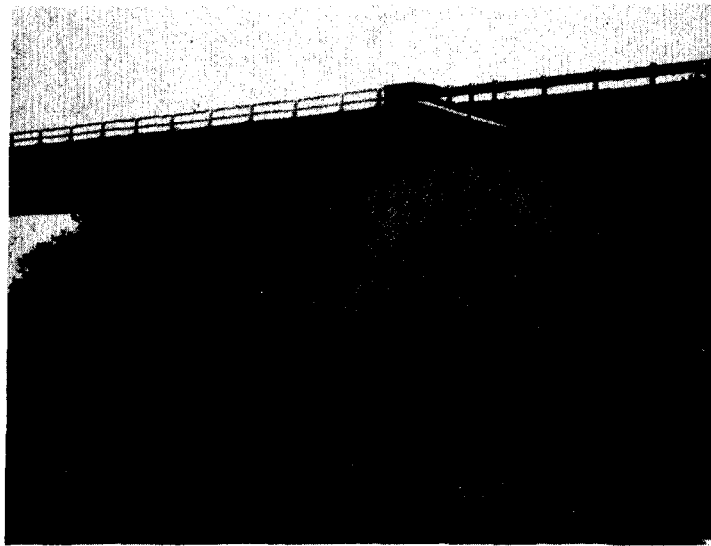

Figure 18. Reinforced earth supported embankment that serves as foundation for abutments of railroad bridge at Wells, Maine.

3. ANALYTICAL STUDIES

The primary objective of the analytical studies was to evaluate the effects of differential vertical movements of various magnitudes on two-span and four-span continuous bridges of steel and concrete for a wide variety of span lengths. The tolerance of the bridge superstructures to the settlement of their foundations was investigated as a function of span length, stiffness and other problem parameters. For the most part, static loading conditions were used in the analysis, although for the steel bridges a limited investigation of the effect of dynamic loading was conducted. The results of the analyses were presented in graphical and/or tabular form showing the increases in stresses caused by differential settlements. In addition, a mathematical model for the behavior of multispan continuous steel slab/stringer systems was developed and used to prepare a series of design aids that could be used to estimate the stress increases resulting from the differential settlement of abutments or piers. Only a limited discussion of these analyses, their results and observations are presented here, and the reader is referred to the Interim Report (8) for the details of the analyses and their results.

3.1 Steel Bridges

3.1.1 Continuous Slab/Stringer Systems

3.1.1.1 Static Loading. The analysis of the effect of support settlement for static loading was accomplished with the aid of the ICES-STRUDL-II computer package (51). The bridge superstructures were designed according to the "Standard Specifications for Highway Bridges" (7) of the American Association of State Highway and Transportation Officials (AASHTO) for both dead and live loads. The live loading consisted of the AASHTO HS-20-44 wheel loading or its equivalent lane loading (7), depending on span length. Generally, three loading conditions were investigated: (a) dead load; (b) live load and dead load, with live load positioned to produce maximum negative moment; and (c) live load and dead load, with the live load positioned to produce maximum positive moment.

The settlements of the bridge supports were varied from zero up to three inches (76.2 mm) in increments of one-half inch (12.7 mm) or one inch (25.4 mm), depending on bridge type and span length. For the two-span bridges, two settlement cases were studied: (a) settlement of the exterior support (abutment) and (b) settlement of the center support (pier). For the four-span bridges, three settlement cases were studied: (a) settlement of the exterior support; (b) settlement of the interior support immediately adjacent to the exterior support; and (c) settlement of the center support.

The bridges investigated included continuous two-span and four-span slab/stringer systems consisting of rolled beam spans up to 60 feet (18.3 meters) in length, rolled beams with cover plates up to 150 feet (45.7 meters) in length, and plate girder spans up to 250 feet (76.2 meters) in

length. A variety of stringer sizes and spacings were investigated. All slab/stringer systems utilized an 8 inch (203.2 mm) concrete deck, and composite action was assumed between the slab and the stringers. In each individual bridge, equal span lengths were used in order to reduce the number of variables considered.

The computer aided analyses resulted in graphical representations of the effects of support settlements on the moment and displacement diagrams for each structure, as illustrated for typical bridges in figures 19, 20, and 21. From moment diagrams, such as those shown in figures 19 and 21, the effect of differential settlement on the member stresses was determined. The results of these analyses showed that two settlement conditions were critical. For the two-span bridges, the maximum negative stress occurred at the center support, with settlement of the exterior support, under conditions of loading that would produce maximum negative stress. The maximum positive stress occurred near the mid-point of the first span of the structure, with settlement of the center support, under conditions of loading that produces maximum positive moment. For the four-span bridges, the maximum negative stress occurred at the center support, with settlement of the first interior support, under conditions of loading to produce maximum negative moment. The maximum positive stress occurred at approximately the mid-point of the second span, with settlement of the center support, under conditions of loading to produce maximum positive moment in that span.

A study of the data resulting from the analyses of the two-span and four-span bridges showed that the effect of altering the stringer spacing was negligible. Although reducing the stringer spacing reduced the load on each stringer and thus reduced the moments, the effect of the differential settlement of the supports on the moments was very nearly the same for the stringer spacings investigated. However, the data show that support settlements of up to three inches (76.2 mm) can have a very important effect upon the stresses, depending upon the span length and rigidity (EI) of the slab/stringer system. This effect is particularly significant for short span bridges, up to 60 feet (18.3 meters) in length, as illustrated in figures 22 and 23, which show the effects of changing span length on the percentage increase in stresses in two-span continuous bridges for the two critical settlement conditions described above. It should be recognized that these are theoretical stress increases, calculated on the basis of assumed elastic behavior, and that yielding would occur before the higher theoretical stress levels (shown dashed in figures 22 and 23) are reached. Similar data for four-span bridges showed that, for a given span length, the theoretical percentage increase in stress caused by differential settlement was substantially greater than for the two-span bridges. This is because the continuity of these structures increases their effective stiffness. However, as the span lengths increase, the stresses caused by differential settlements decrease substantially, as illustrated in figures 22 and 23 and by a comparison of the typical moment diagrams given in figures 19 and 21. This is further illustrated by the typical results of the analyses given in table 29, where the calculated maximum levels of the stresses produced by differential settlements up to three inches (76.2 mm) are compared to the design stresses for the zero settlement case. The low

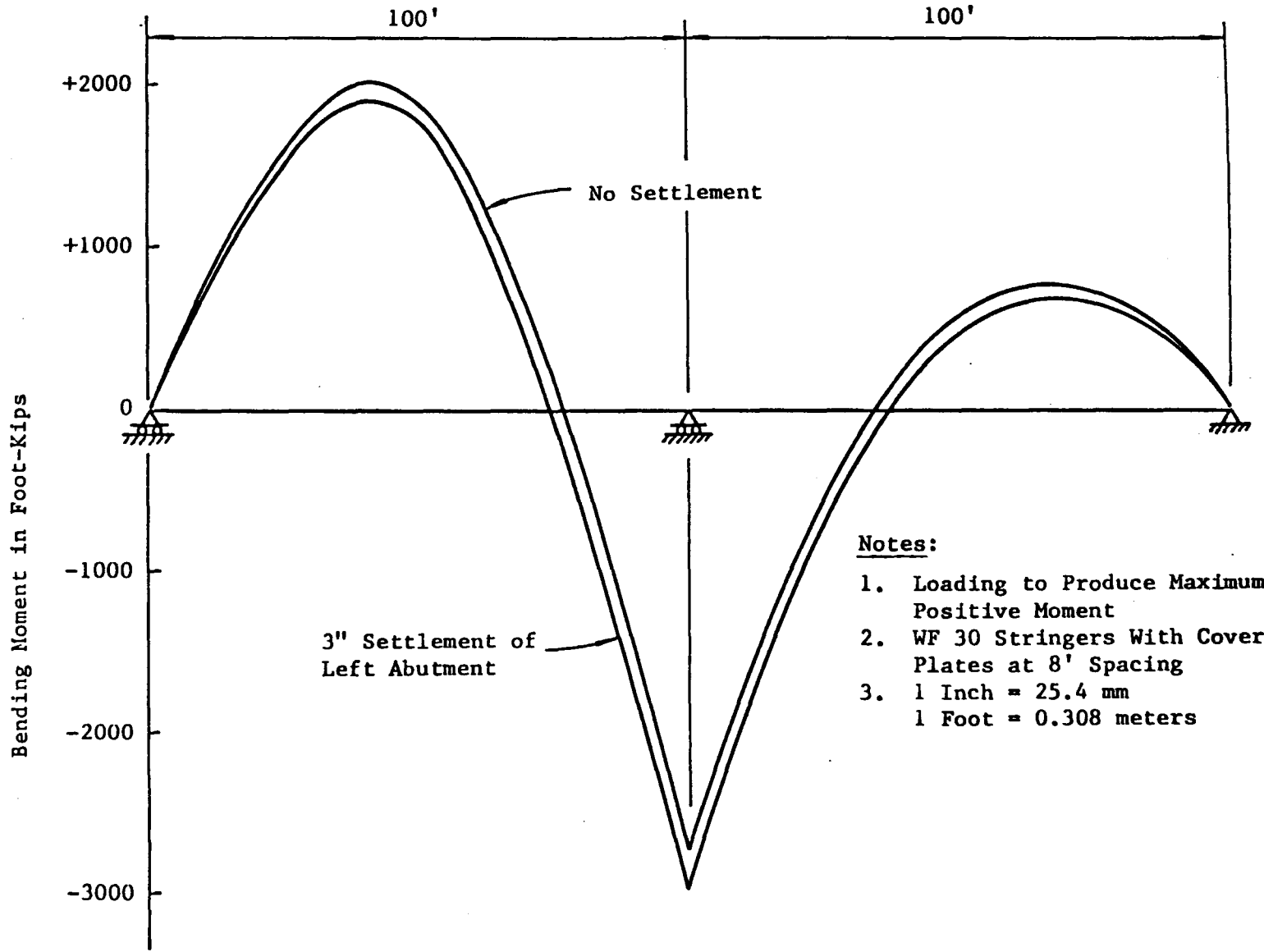

Figure 21. Typical moment diagram for two-span continuous bridge, with 100 foot spans, loaded with dead load, live load and settlement of left abutment.

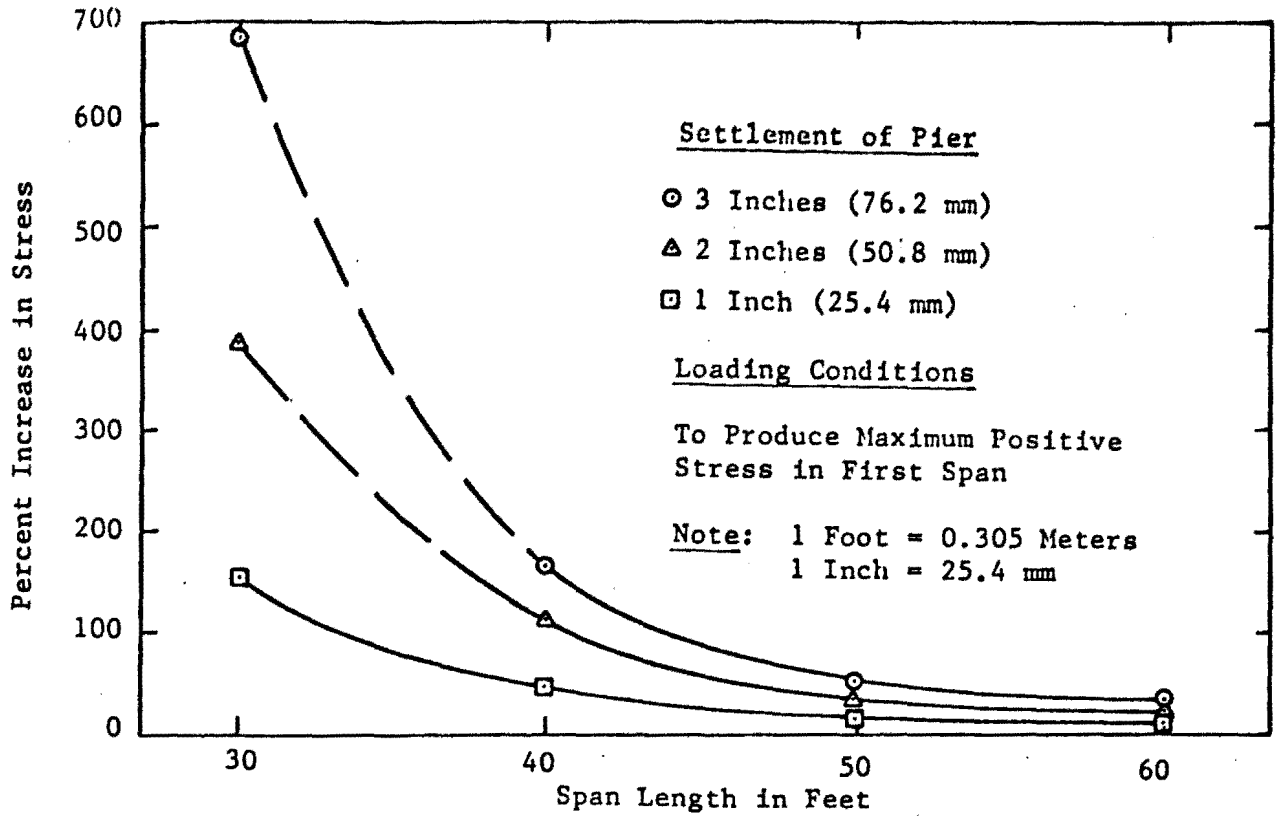

Figure 22. Theoretical percent increase in positive stress at mid-point of first span vs. span length for two-span continuous bridge (W36 composite).

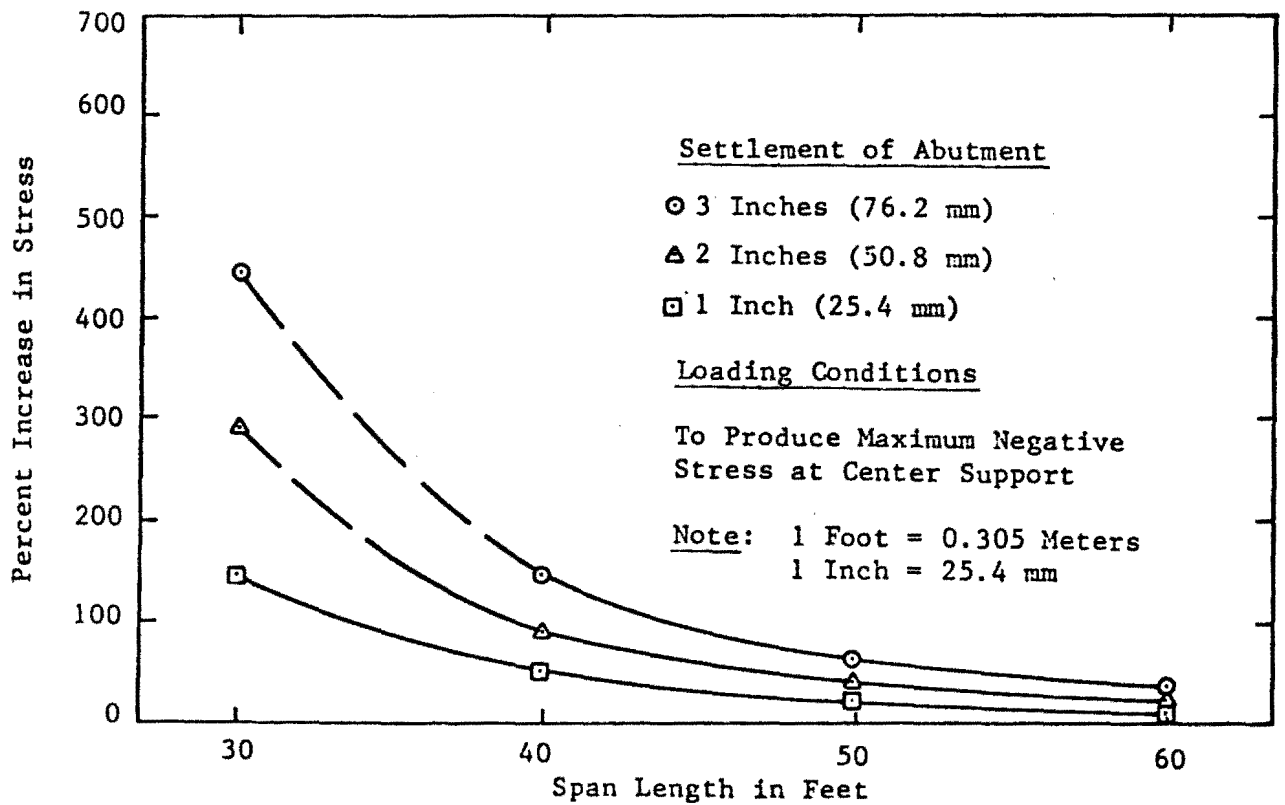

Figure 23. Theoretical percent increase in negative stress at center support vs. span length for two-span continuous bridge (W36 composite).

Table 29. Typical Values of Maximum Negative Stresses at the Center Support of Two-Span and Four-Span Continuous Steel Bridges Caused by Differential Settlements

Span Length in Feet ^a	Settlement in Inches	Maximum Calculated Stresses(ksi)	
		Two-Span Bridges With Settlement of Exterior Support	Four-Span Bridges With Settlement of First Interior Support
30	0	14.6	11.0
	1	18.8	21.0
	2	28.2	36.5
	3	38.4	50.5
50	0	18.0	17.0
	1	22.5	23.2
	2	26.5	29.0
	3	30.0	35.0
100	0	18.8	18.4
	3	21.2	23.0
150	0	18.9	19.8
	3	21.8	21.5
200	0	20.0	19.0
	3	21.0	21.5
250	0	19.8	20.0
	3	21.2	21.3

^aThe 30 and 50 foot spans were designed with W36 stringers, the 100 foot span was designed with W36 sections and cover plates, and the 150 to 250 foot spans consist of plate girders.

Note: 1 inch = 25.4 mm, 1 foot = 0.305 meters and 1 ksi = 6.9 MPa.

stresses for the zero settlement case for the 30 foot (9.1 meters) are, in part, the result of the overdesign produced by using W36 stringers for this short span. The data in table 29 show that for longer spans, i.e. spans in excess of 100 feet, the calculated increases in stress caused by differential settlements up to three inches (76.2 mm) were virtually negligible.

The influence of the rigidity of the slab/stringer systems on their response to differential settlements was quite apparent when the data contained in figures 22 and 23 for the W36 - composite design were compared with similar data developed for designs using W33 and W30 stringers. These data showed that the lower rigidity of the W33 and W30 stringers led to a significantly lower level of stress increase as a result of differential settlement. However, the combined influence of span length and rigidity (stiffness) is best illustrated by comparing the theoretical stress increase, caused by differential settlement, with the ratio of the moment of inertia, I , to the span length, ℓ , as shown in figures 24 and 25 for the two-span bridges. These data show that, for stiff structures with short spans, the stress increase caused by differential settlement is much greater than for more flexible structures with long spans. Again, similar data for the four-span bridges showed greater percentage increases in stress levels than for the two-span structures. Overall, however, the results of the analysis showed that, for differential settlements up to three inches (76.2 mm), the stress increases would most likely be quite modest, as long as the ratio of moment of inertia to span length (I/ℓ) was 20 in^3 . ($327,741 \text{ mm}^3$) or less for both two-span and four-span bridges.

3.1.1.2 Dynamic Loading. The vibrations induced by traffic are generated by fluctuations of wheel contact loads as vehicles travel over bridge deck irregularities. These irregularities can be the result of (a) bridge deck deterioration and/or general roughness caused by poor construction control, or (b) a "bump" or "ramp" caused by the differential vertical movement of abutments or piers. The dynamic effects of both types of irregularities on two-span continuous steel bridges, with spans of from 30 to 250 feet (9.1 to 76.2 meters) were investigated in an effort to establish tolerable limits on frequencies, amplitudes, and human response levels. The analysis of each structure considered the effect of the weight of the load, the stiffness of the structures, the velocity of the moving load, and the truck axle spacing, as described in the Interim Report (8). Computer methods were utilized to perform these analyses.

The results of the analysis of slab/stringer systems under dynamic loading indicated that excessive dynamic deflection and frequency increases might occur as the "resonance factor", i.e. the ratio of forced (ω_f) to the natural (ω_n) frequencies, approaches one. This information was used to establish a criterion that can be used by the designer to determine if a proposed bridge structure has sufficient mass and stiffness to prevent excessive dynamic deflection. The reader is referred to the Interim Report (8) for further details.

3.1.1.3 Mathematical Model for the Behavior of Slab/Stringer Systems. Although the results produced by the analysis of the various steel bridge

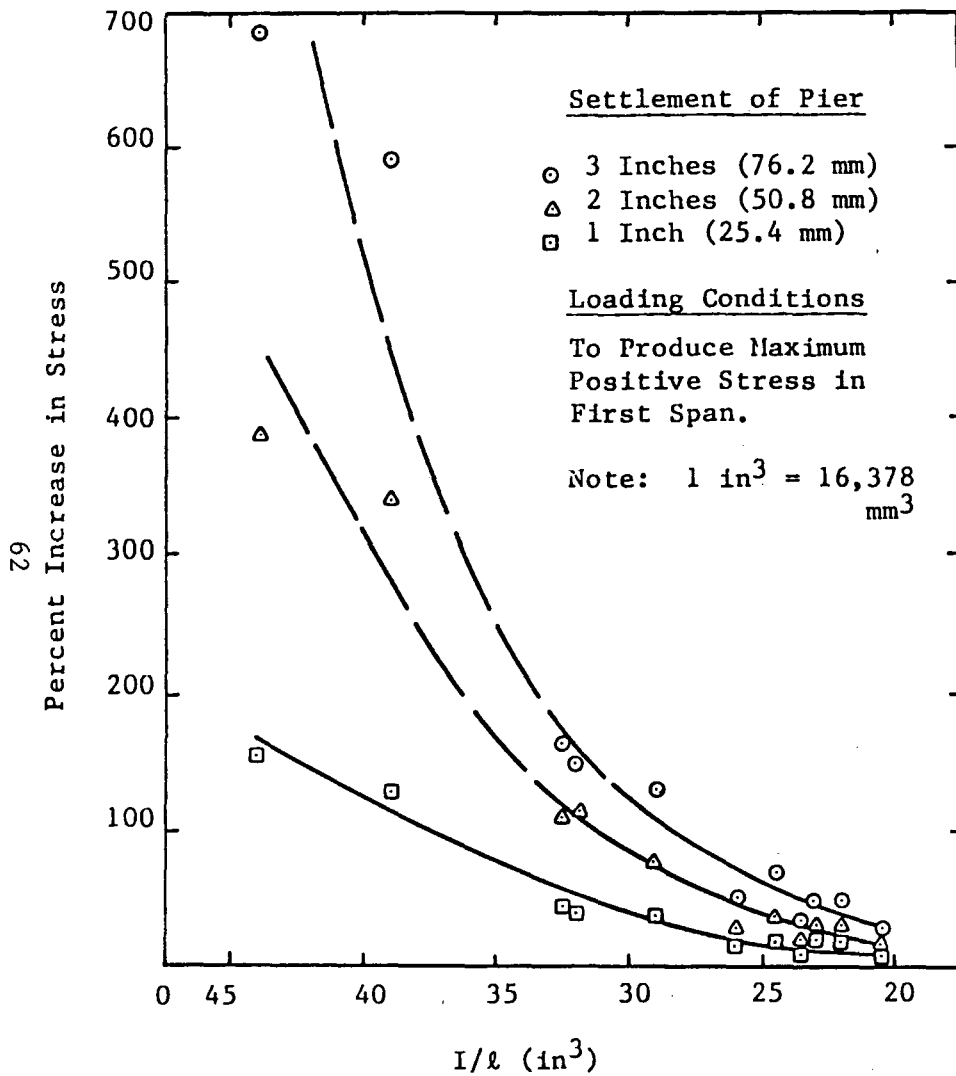

Figure 24. Theoretical percent increase in positive stress at mid-point of first span vs. I/l for 2-span continuous bridges.

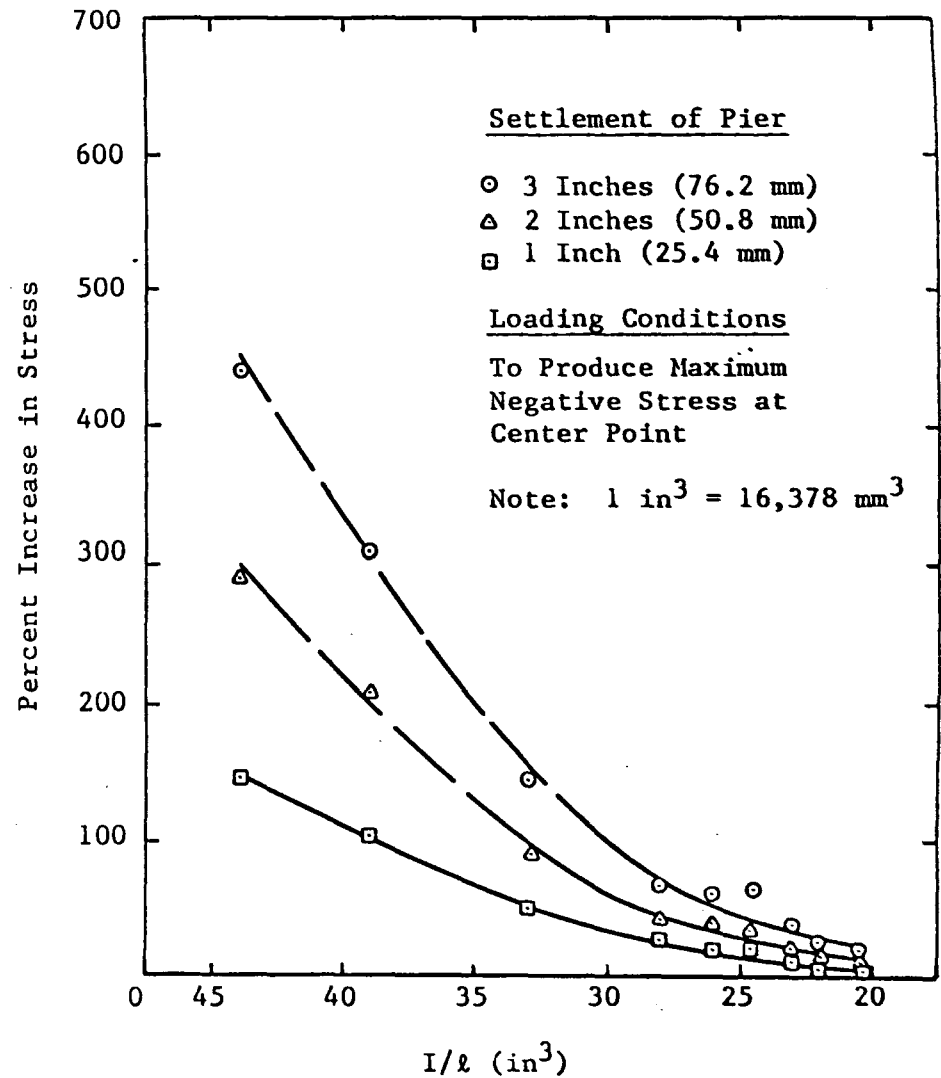

Figure 25. Theoretical percent increase in negative stress at center support vs. I/l for 2-span continuous bridges.

systems, as illustrated in figures 22 through 25, were very informative with respect to the influence of support settlements on stress increases, they are not particularly useful from a design standpoint. In an effort to remedy this situation, a mathematical model for the behavior of multispan continuous steel bridges was developed, using the macro flexibility approach (52), as described in the Interim Report (8). The expressions that were produced were simplified for computational ease and put in a form that would permit relatively simple checks to be made on the maximum stress increase produced by the settlement of any bridge support (either abutment or piers). The resulting equations were then used to develop a series of six design aids that would permit the estimation of the maximum positive and negative stresses in steel bridges resulting from differential settlement of abutments or piers. These design aids, which are presented in figures 26 through 31, provide solutions for continuous steel bridges with up to five spans and with span lengths up to 250 feet (76.2 meters).

In practice, the designer would enter the appropriate design aid with the span length, ℓ , and the number of spans, n , and pick off the values of $\Delta_o c/f_o(+)$ and $\Delta_o \bar{c}/f_o(-)$, for the case of abutment settlements, or values of $\Delta_\alpha c/f_\alpha(+)$ and $\Delta_\alpha \bar{c}/f_\alpha(-)$, for the case of pier settlement. These values could then be used with the anticipated abutment settlement, Δ_o , or pier settlement, Δ_α , and the estimated distances from the neutral axis to the outer fiber, c or \bar{c} , to calculate the maximum positive settlement stresses, $f_o(+)$ or $f_\alpha(+)$, or the maximum negative settlement stresses, $f_o(-)$ or $f_\alpha(-)$.

For example, consider a two span continuous bridge with 70 foot (21.3 meter) spans, a seven inch (177.8 mm) deck slab, assuming composite action for both positive and negative moments, and a 2 inch (50.8 mm) differential settlement of one abutment. In the positive movement region, where it is assumed that the live load moment is resisted by the composite action of steel and concrete with a modular ratio of 8, a W36 x 160 beam with a 10 inch x 1 inch (254 mm x 25.4 mm) bottom cover plate was chosen to resist the positive moment. In this region, the effect of the differential settlement of the abutment is a net reduction (decrease) in the positive bending moment and, thus, in the maximum positive stress. However, in the negative moment region, where the design resulted in the use of 10 inch x 1 inch (254 mm x 25.4 mm) cover plates both top and bottom, the differential settlement of the abutment would produce an increase in the maximum negative stress. This can be evaluated by entering figure 27 with $\ell = 70$ and $n = 2$, giving $\Delta_o \bar{c}/f_o(-) = 17.0$. Thus, for an abutment settlement of 2 inches (50.8 mm) and a value of $\bar{c} = 17.55$ inches (445.8 mm), it is found that the maximum negative settlement stress is $f_o(-) = 2(17.55)/17.0 = 2.06$ ksi (14.19 MPa).

3.1.2 Continuous Truss Systems

In addition to the investigation of the effect of differential abutment and pier settlements on continuous two and four-span slab/stringer systems, two-span continuous parallel chord truss systems, with spans up to 680 feet (207.3 meters), and two-span continuous non-parallel chord truss systems, with spans up to 880 feet (268.2 inches), were also investigated.

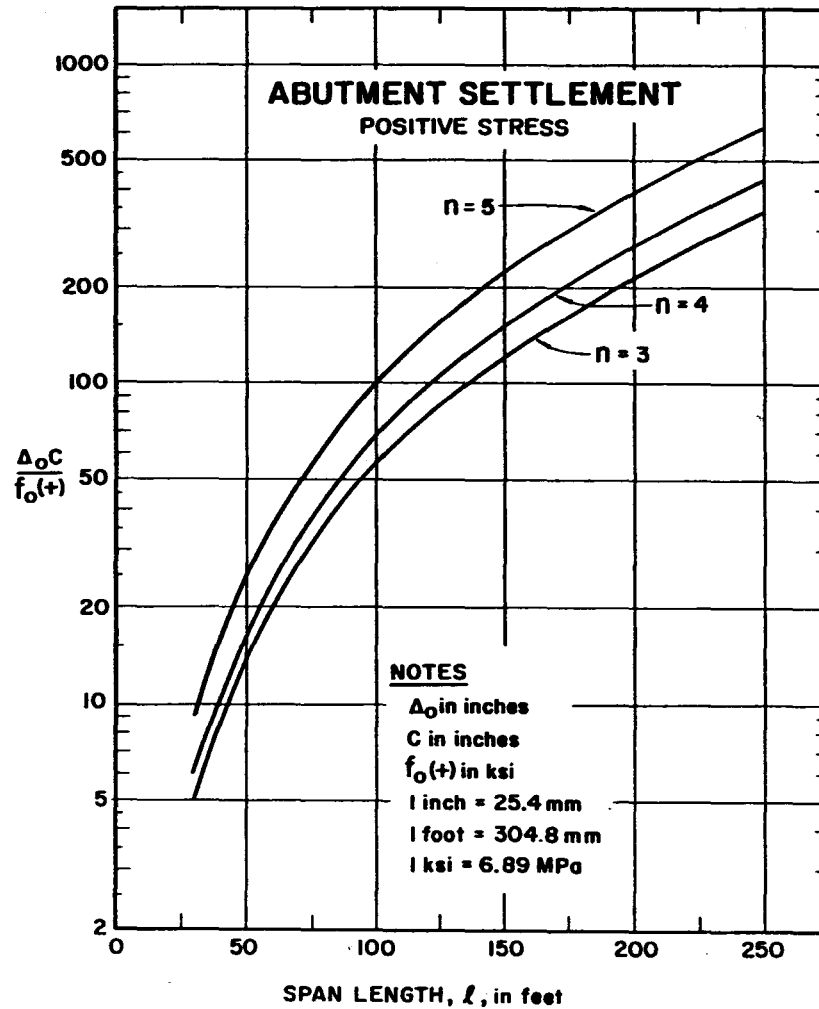

Figure 26. Design aid for determining the maximum positive stress increase caused by differential settlement of the abutment.

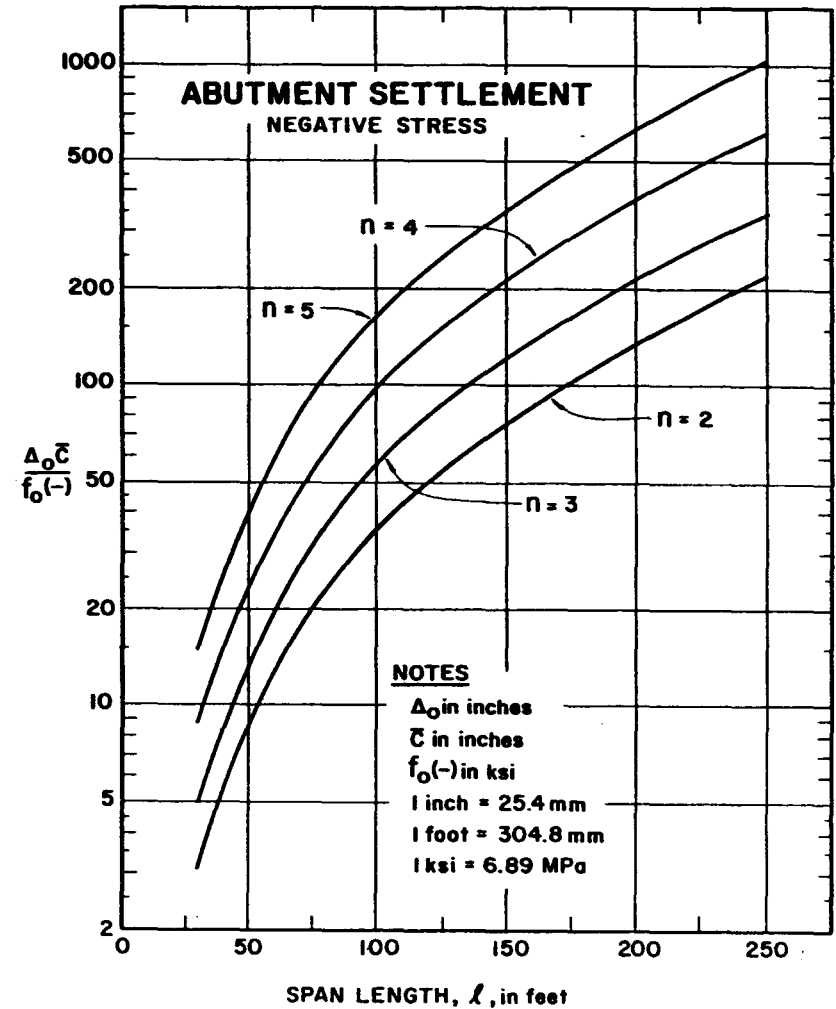

Figure 27. Design aid for determining the maximum negative stress increase caused by differential settlement of the abutment.

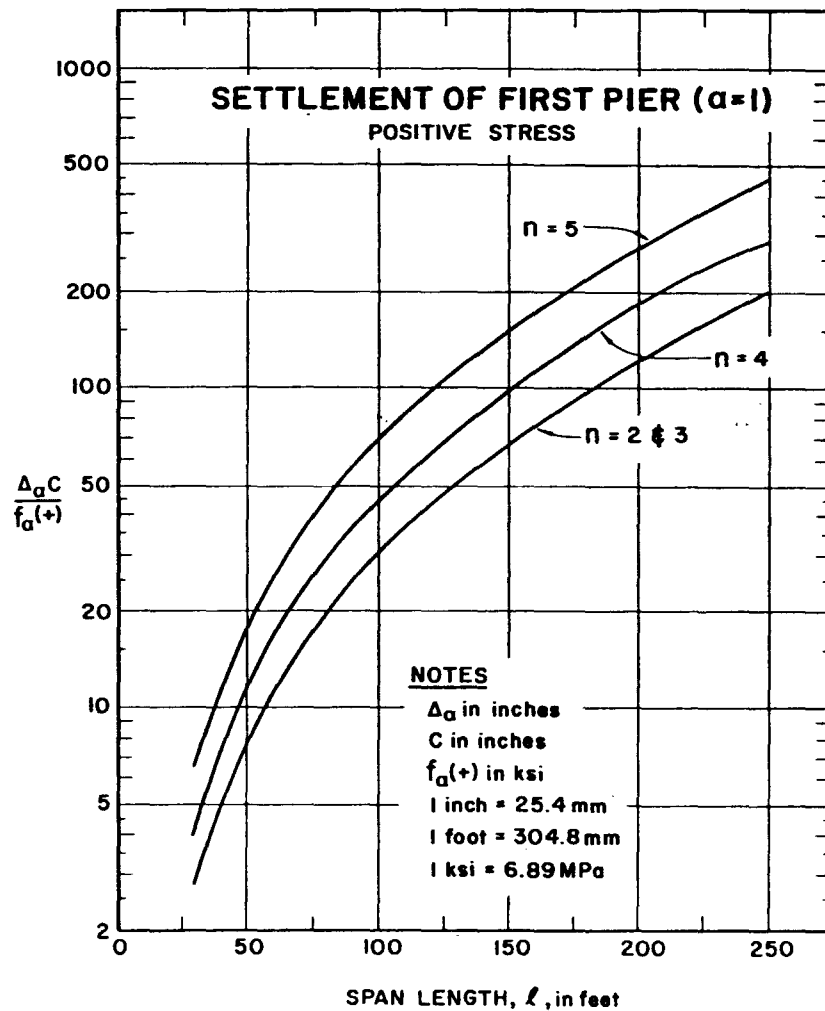

Figure 28. Design aid for determining the maximum positive stress increase caused by differential settlement of the first interior support.

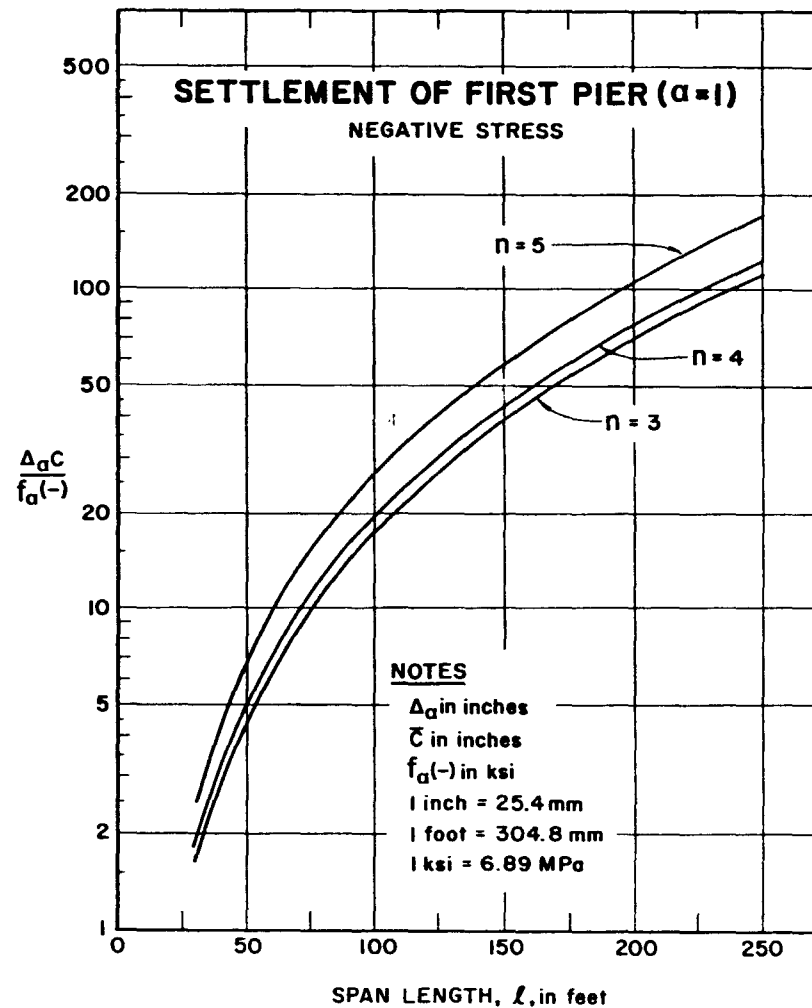

Figure 29. Design aid for determining the maximum negative stress increase caused by differential settlement of the first interior support.

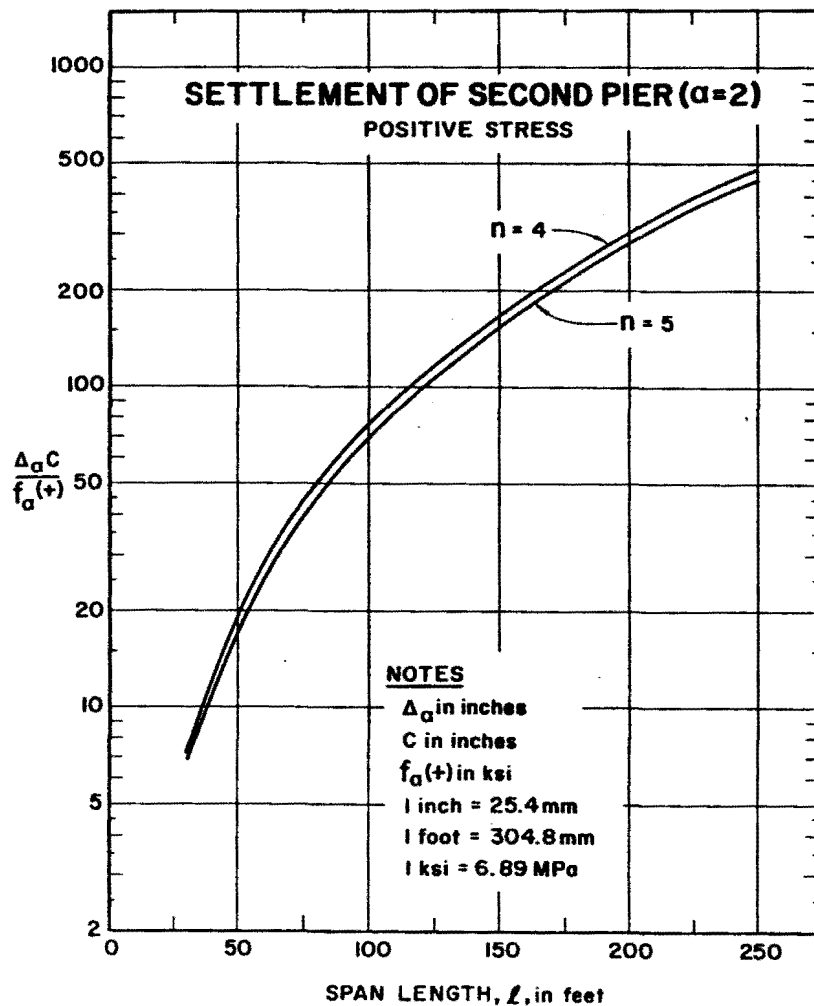

Figure 30. Design aid for determining the maximum positive stress increase caused by differential settlement of the second interior support.

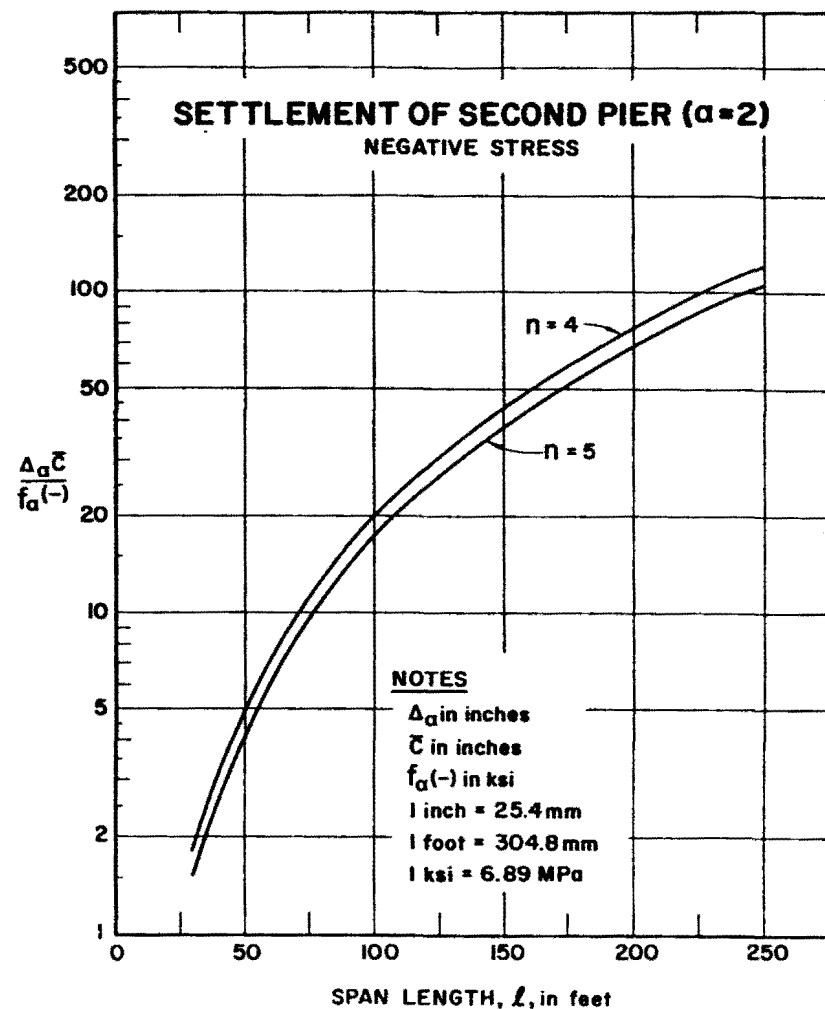

Figure 31. Design aid for determining the maximum negative stress increase caused by differential settlement of the second interior support.

For the two-span parallel chord trusses, span lengths of 480, 600 and 680 feet (146.3, 182.9 and 207.3 meters), with panel depths of 50, 60 and 70 feet (15.2, 18.3 and 21.3 meters), respectively, were investigated. A constant panel width of 40 feet (12.2 meters) was used in all cases, and the chord dimensions were kept constant for all spans in order to reduce the number of variables considered. For the nonparallel chord trusses, span lengths of 720, 800 and 880 feet (219.5, 243.8 and 268.2 meters) were analyzed. Again, the panel width was held constant at 40 feet (12.2 meters), but the depth of each truss varied from a maximum of 80 feet (24.4 meters), at the center support to a minimum of 40 feet (12.2 meters) at each quarter point. As the span length increased, the size of the chords was increased to increase the capacity of the structure. For both types of truss systems, the loads were applied at the panel points on the assumption that the floor beams would transfer the lane loadings to the trusses at these points. All trusses were analyzed as frames in order to account for any "secondary" stresses that might develop.

The results of the analysis of the two-span continuous truss systems showed that differential settlements up to three inches (76.2 mm) of either pier or abutment do not significantly affect the internal member stresses for long span trusses. For the parallel chord trusses, a maximum stress increase of about 9 percent was produced by a three inch (76.2 mm) settlement of the pier of the 70 foot (21.3 meter) deep truss with spans of 480 feet (146.3 meters), and the stress increases for the longer spans and smaller panel depths were substantially lower. The stress increases caused by a three inch (76.2 mm) differential settlement of the abutment were also very low. For the nonparallel chord trusses, a maximum stress increase of a little over three percent was produced by a three inch (76.2 mm) settlement of the abutment of the stiffest truss with spans of 720 feet, and again, the stress increases for the longer spans and lower stiffnesses were substantially less. The stress increases caused by a three inch (76.2 mm) differential settlement of the pier were virtually negligible.

3.2 Concrete Bridges

The analysis of concrete highway bridges for the effects of support movement is an extremely complex problem. During the course of the investigation reported herein, the nature of these complexities was more fully appreciated, and, as the work progressed, it became apparent that the research originally proposed in this study could provide only a partial and fragmented answer to the question of what support movements may be tolerable for concrete highway bridges. The complexities of the problem lie in several primary areas: material properties, especially the creep behavior of concrete; structural configuration; sequence of construction; and analytical methods and simplifications. Each of these considerations leads to problems not encountered in the analysis of steel bridges.

The creep behavior of concrete materials is influenced by properties and proportions of the concrete mix constituents, as well as environmental factors associated with curing conditions.

Considerations of structural configuration are, in part, similar to those of steel bridges with comparable span lengths. However, some significant differences occur in the case of bridges constructed with precast, prestressed concrete I-type girders. For steel beams, the designer may make a refined choice of cross section by incrementing the overall height of the section and increasing the size of the flanges. In concrete, the choice may be reduced to selecting one of two standard sections, and providing an appropriate prestressing force. For example, in the case of a composite bridge with two equal spans of 100 feet (30.5 meters), made continuous for live loads, the designer might choose either an AASHTO-PCI standard Type IV or a Type V I-girder. The moment of inertia of the Type V section is about twice that of the Type IV, yet the section is only 17 percent deeper. Accordingly, the required prestressing force will be less for the Type V section, and the influence of creep due to a combination of dead load and prestressing force will be smaller. However, the settlement-induced stresses will be larger for the deeper Type V section. Thus, the overall comparison of the two sections shows that the Type V section would be subjected to greater stresses due to settlement, but the effects of creep (and possibly creep relief of settlement-related stresses) will be less. This is but one example of the interactions of structural design parameters which complicate the analysis for conditions of support settlement. These parameters include number of spans, span length, girder type, prestress level, and profile of the prestressing strand.

The sequence of construction is particularly important in the analysis of bridges constructed of precast elements, made continuous to resist live loads, and acting composite with a cast-in-place deck. The creep behavior of precast elements, subsequently made continuous, is significantly different than that of a beam initially made continuous. Three events can be identified as significant with respect to the construction sequence: (a) the first loading of the concrete, (b) the time at which continuity is imposed, and (c) the time when settlement occurs. The order in which these last two events occur is also important, particularly where a gradual settlement is considered. Each of these aspects of construction is important in determining the significance of creep effects, and also the possibility of creep relief of settlement-induced stresses.

Each of these considerations, i.e. creep properties of the concrete, structural configuration and the sequence of construction, can be accounted for by using a sophisticated time-incremental solution employing computer methods (53,54). This procedure is very expensive to implement, because of the large amount of computer time required to analyze any particular case. It rapidly becomes infeasible when the number of cases for a meaningful parametric study is large. However, other, less sophisticated, methods are available for analysis either manually or on the computer, but they are, of course, more approximate in nature. Both types of solutions were employed for the studies reported herein, and a detailed description of these methods is included in the Interim Report (8).

The bridges investigated included composite and non-composite two-span continuous AASHTO-PCI standard I-girders, Types III, IV and VI, for spans of 75, 100 and 125 feet (22.9, 30.5 and 38.1 meters), respectively. These

same girders and spans were also investigated for the non-composite case, where the beams were made continuous by means of a cast-in-place joint over the center support. In addition, two-span continuous cast-in-place box girder bridges with spans of 100 and 200 feet (30.5 and 61.0 meters), and a four-span continuous post tensioned box girder bridge with spans of 200 feet (61.0 meters) were also studied. For the two-span bridges, the effect of sudden and gradual settlements of the center support were considered, while for the four-span bridge, sudden and gradual settlements of the first interior support were considered. The differential settlements of the supports were varied between one inch (25.4 mm) and three inches (76.2 mm).

3.2.1 AASHTO-PCI Standard I-Girder Bridges

3.2.1.1 Continuous I-Girder Bridges. The analysis of a two-span continuous I-type girder provided a useful starting point for the discussion of bridges with spans of 75 to 125 feet (22.9 to 38.1 meters). Although this is not a practical type of construction, it is a convenient way to isolate effects of settlement. Using material properties corresponding to 5000 psi (34.5 MPa) concrete, the effect of a 3 inch (76.2 mm) settlement at the central support was considered. Girder types II, IV and VI were used for spans of 75, 100, and 125 feet (22.9, 30.5 and 38.1 meters), respectively. Comparing these I-sections, the approximate relative moments of inertia for the 75, 100 and 125 foot (22.9, 30.5 and 38.1 meter) spans increase as 1:2:6 and the relative section depths as 1:1.2:1.6.

Table 30 presents time-dependent moments and stresses in these continuous I-girder bridges for both sudden and gradual settlement. For the shortest span, a sudden 3 inch (76.2 mm) settlement produces bending moments significantly larger than dead load only. Even a settlement of only 1 inch (25.4 mm) would produce an effect on the order of 44 percent of the dead load moments.

In studying these results, it is important to remember that the cross section and span length are varying at the same time. An increase in span length, when other parameters are held constant, results in a more flexible structure and lower effects of settlement, since settlement moments are proportional to $3EI/\ell^2$, where E is the modulus of elasticity, I is the moment of inertia of the cross-section, and ℓ is the span length. However, longer spans also have greater effects of dead and live load, so a larger cross section is required.

For the 75, 100 and 125 foot (22.9, 30.5 and 38.1 meter) I-girders considered, the factor I/ℓ^2 and, hence, the settlement moments, increase with increasing span, as 1:1.2:2.1. However, the ratio of settlement stresses to dead load stresses varies as I/ℓ^4 , since dead load moments increase as the square of the span length. For these I-girders and spans, the term I/ℓ^4 varies as 1:0.66:0.75. Thus, the relatively effect of settlement drops off and then increases again as span lengths increase, a result of the particular choice of girder section.

3.2.1.2 Precast Girders Made Continuous With a Field Joint. A similar analysis to that of the previous section was performed for two-span

Table 30. Time-dependent moments and stresses in two-span I-Girder bridges caused by 3 inch settlement of center support.

Span Length in Feet (Girder Type)	Location of Moments and Stresses	Settlement Rate	Bending Moments in Foot-kips at Given Elapsed Time			Stresses in ksi at Given Elapsed Time at Given Location (Top or Bottom of Girder)					
			Zero Days	180 Days	1800 Days	Zero Days		180 Days		1800 Days	
						Top	Bottom	Top	Bottom	Top	Bottom
75 (III)	At Midspan	Sudden	+459	+281	+262	-1.00	+0.89	-0.66	+0.54	-0.62	+0.50
		Gradual	+198	+271	+282	-0.46	+0.38	-0.64	+0.52	-0.66	+0.54
	At Pier	Sudden	-125	-229	-268	-0.30	+0.24	+0.54	-0.44	+0.63	-0.52
		Gradual	-396	-249	-227	+0.93	-0.76	+0.59	-0.48	+0.53	-0.44
100 (IV)	At Midspan	Sudden	+805	+597	+574	-1.08	+0.90	-0.80	+0.68	-0.70	+0.60
		Gradual	+500	+585	+598	-0.67	+0.57	-0.78	+0.66	-0.80	+0.50
	At Pier	Sudden	-389	-806	-851	+0.52	-0.44	+1.08	-0.90	+1.10	-0.96
		Gradual	-1000	-839	-803	+1.30	-1.10	+1.10	-0.94	+1.08	-0.90
125 (VI)	At Midspan	Sudden	+1624	+1249	+1208	-0.94	+0.96	-0.72	+0.74	-0.70	+0.71
		Gradual	+1074	+1228	+1251	-0.62	+0.64	-0.71	+0.73	-0.72	+0.74
	At Pier	Sudden	-1048	-1798	-1879	+0.61	-0.62	+1.04	-1.07	+1.09	-1.10
		Gradual	-2148	-1840	-1794	+1.20	-1.27	+1.07	-1.09	+1.04	-1.06

Positive moment causes positive stress (tension) in bottom fibers.

Note: 1 ksi = 6.9 MPa, 1 kip-foot = 1.37 kN - m, 1 inch = 25.4 mm, 1 foot = 0.305 meters

continuous structures made from two precast beams with a cast-in-place field joint. Spans and girder sizes are the same as before, and the results are shown in table 31. For this type of structure, stresses follow the I/l^2 relationship described previously. In all cases, cracking may result at the central support due to the effects of sudden settlement. The effects of sudden settlement are reduced with time due to creep relief of the settlement moment in conjunction with the creep redistribution of dead load moments. In the case of gradual settlement, moments induced by settlement, and those resulting from moment redistribution, offset one another.

Because of redistribution of dead load movements due to creep, the stresses resulting from settlement in a continuous structure made continuous by a cast-in-place joint are considerably lower than for a cast-in-place continuous bridge.

3.2.1.3 Girder Composite With Cast-in-Place Deck. In the analyses reported in this section, composite action was introduced by casting a concrete deck over cast-in-place I-type girders. The material properties assumed in analysis are typical of 5000 psi (34.5 MPa) concrete in the girder, and 4000 psi (27.6 MPa) concrete in the deck. A maximum sudden settlement of 3 inches (76.2 mm) at the central support of the resulting two-span continuous composite beam was assumed. Girder sections and spans were the same as in previous examples. Settlement was assumed to occur when the girder age was 28 days and the slab was one day old.

Results for the three span lengths are shown in table 32. A comparison is provided for composite action, both accounting for and ignoring the effects of shrinkage and creep. Deck stresses change only slightly due to settlement, since the settlement occurs when the deck concrete is very weak and has low stiffness. Consequently, girder stresses are comparable to those of cast-in-place bridges. Creep and shrinkage tend to reduce the effects of settlement, as illustrated in figure 32, which shows the time-dependent variation of stresses at midspan of the 100 foot (30.5 meter) span bridge resulting from a 3 inch (76.2 mm) sudden settlement of the center support.

To contrast the effects of sudden and gradual settlements, the same 100 foot (30.5 meter) span bridge was analyzed for a total settlement of 3 inches (76.2 mm), assuming a time-dependent variation of the settlement. Equal increments of 1 inch (25.4 mm) settlement were applied at 93 days, 453 days and 1553 days. Time-dependent stresses for the gradual settlement are shown in figures 33 and 34 for midspan and the central support, respectively. In this case, a gradual settlement results in eventual higher stresses at the central support than does sudden settlement. Maximum stresses occur during the application of the second increment of deflection at 453 days. Thus, a slow gradual application of settlement does not create high initial stresses, but the lack of creep relief causes the stresses to ultimately be higher than those caused by sudden settlement.

3.2.1.4 Composite Section With Prestressing. To supplement the studies described above, a series of analyses were conducted for two-span

Table 31. Time-dependent moments and stresses in two-span bridges made continuous with a field joint, caused by 3 inch settlement of center support.

Span Length in Feet (Girder Type)	Location of Moments and Stresses	Settlement Rate	Bending Moments in Foot-kips at Given Elapsed Time			Stresses in ksi at Given Elapsed Time at Given Location (Top or Bottom of Girder)					
			Zero Days	180 Days	1800 Days	Zero Days		180 Days		1800 Days	
						Top	Bottom	Top	Bottom	Top	Bottom
75 (III)	At Midspan	Sudden	+657	+344	+310	-1.55	+1.27	-0.81	+0.66	-0.73	+0.60
		Gradual	+396	+334	+330	-0.93	+0.76	-0.79	+0.64	-0.78	+0.64
	At Pier	Sudden	+522	-103	-171	-1.23	+1.01	+0.24	-0.20	+0.40	-0.33
		Gradual	0	-124	-131	0	0	+0.29	-0.24	+0.31	-0.25
100 (IV)	At Midspan	Sudden	+1305	+756	+696	-1.75	+1.48	-1.01	+0.86	-0.93	+0.79
		Gradual	+1000	+744	+720	-1.34	+1.13	-1.00	+0.84	-0.87	+0.82
	At Pier	Sudden	+611	-488	-607	-0.82	+0.69	+0.65	+0.68	+0.81	-0.69
		Gradual	0	-511	-599	0	0	-0.55	-0.58	+0.80	-0.68
125 (VI)	At Midspan	Sudden	+2684	+1760	+1710	-1.56	+1.59	-1.02	+1.04	-0.99	+1.01
		Gradual	+2134	+1637	+1524	-1.24	+1.27	-0.95	+0.97	-0.88	+0.90
	At Pier	Sudden	+1100	-748	-847	-0.64	+0.65	+0.43	-0.44	+0.49	-0.50
		Gradual	0	-992	-1218	0	0	+0.57	-0.59	+0.70	-0.72

Positive moment causes positive stress (tension) in bottom fibers.

Note: 1 ksi = 6.9 MPa, 1 kip-foot = 1.37 kN - m, 1 inch = 25.4 mm, 1 foot = 0.305 meters

Table 32. Long-term stresses in two-span continuous cast-in-place composite bridges caused by dead load and settlement.

Span Length in Feet (Girder Type)	Assumed Settlement of Central Support	Assumed Behavior with Respect to Creep and Shrinkage	Stresses in ksi in Given Member at Given Location							
			At Central Support				At Mid Span			
			Slab		Girder		Slab		Girder	
			Top	Bottom	Top	Bottom	Top	Bottom	Top	Bottom
75 (III)	3 Inch Sudden	Included	+0.43	+0.27	-0.01	-0.84	-0.12	-0.05	-0.79	+0.83
		None	-0.38	-0.25	-0.65	+1.30	-0.39	-0.26	-1.60	+2.10
	None	Included	+0.43	+0.28	+0.22	-1.00	-0.11	-0.04	-0.67	+0.75
		None	0.00	0.00	0.00	0.00	-0.20	-0.13	-1.30	+1.50
100 (IV)	3 Inch Sudden	Included	+0.60	+0.43	+0.24	-1.20	-0.16	-0.09	-1.00	+1.10
		None	-0.15	-0.11	-0.29	+0.48	-0.41	-0.29	-2.10	+2.40
	None	Included	+0.60	+0.44	+0.45	-1.30	-0.16	-0.08	-1.00	+1.10
		None	0.00	0.00	0.00	0.00	-0.26	-0.18	-1.80	+1.90
125 (VI)	3 Inch Sudden	Included	+0.64	+0.50	+0.32	-1.20	-0.16	-0.09	-1.00	+1.20
		None	-0.16	-0.12	-0.32	+0.54	-0.39	-0.30	-2.00	+2.50
	None	Included	+0.64	+0.50	+0.55	-1.30	-0.16	-0.09	-0.96	+1.10
		None	0.00	0.00	0.00	0.00	-0.23	-0.17	-1.70	+2.00

Note: 1 ksi = 6.9 MPa, 1 inch = 25.4 mm, 1 foot = 0.305 meters.

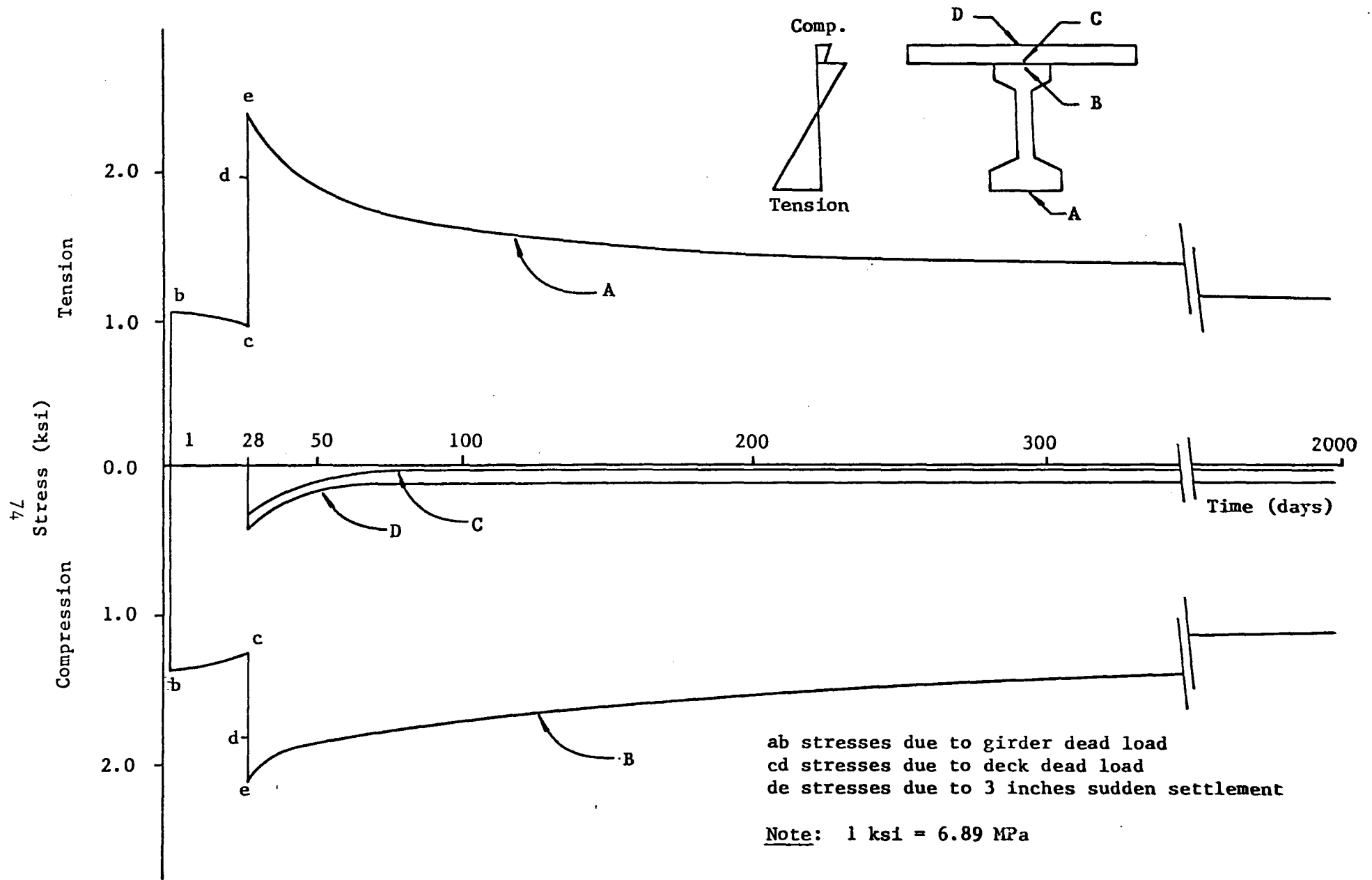

Figure 32. Time-dependent variation of stresses at midspan for two-span continuous concrete bridge with 100 foot spans - sudden settlement of center support.

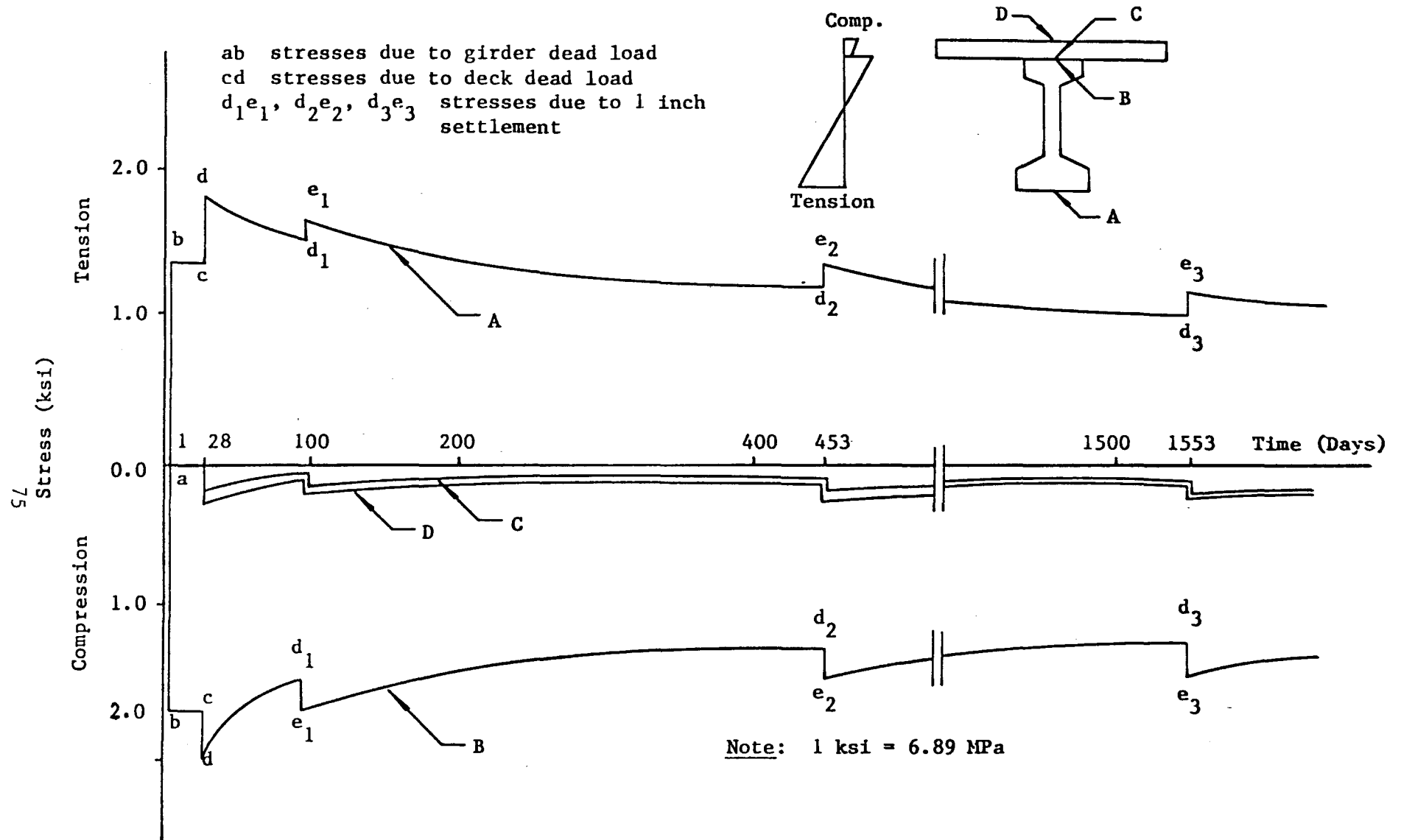
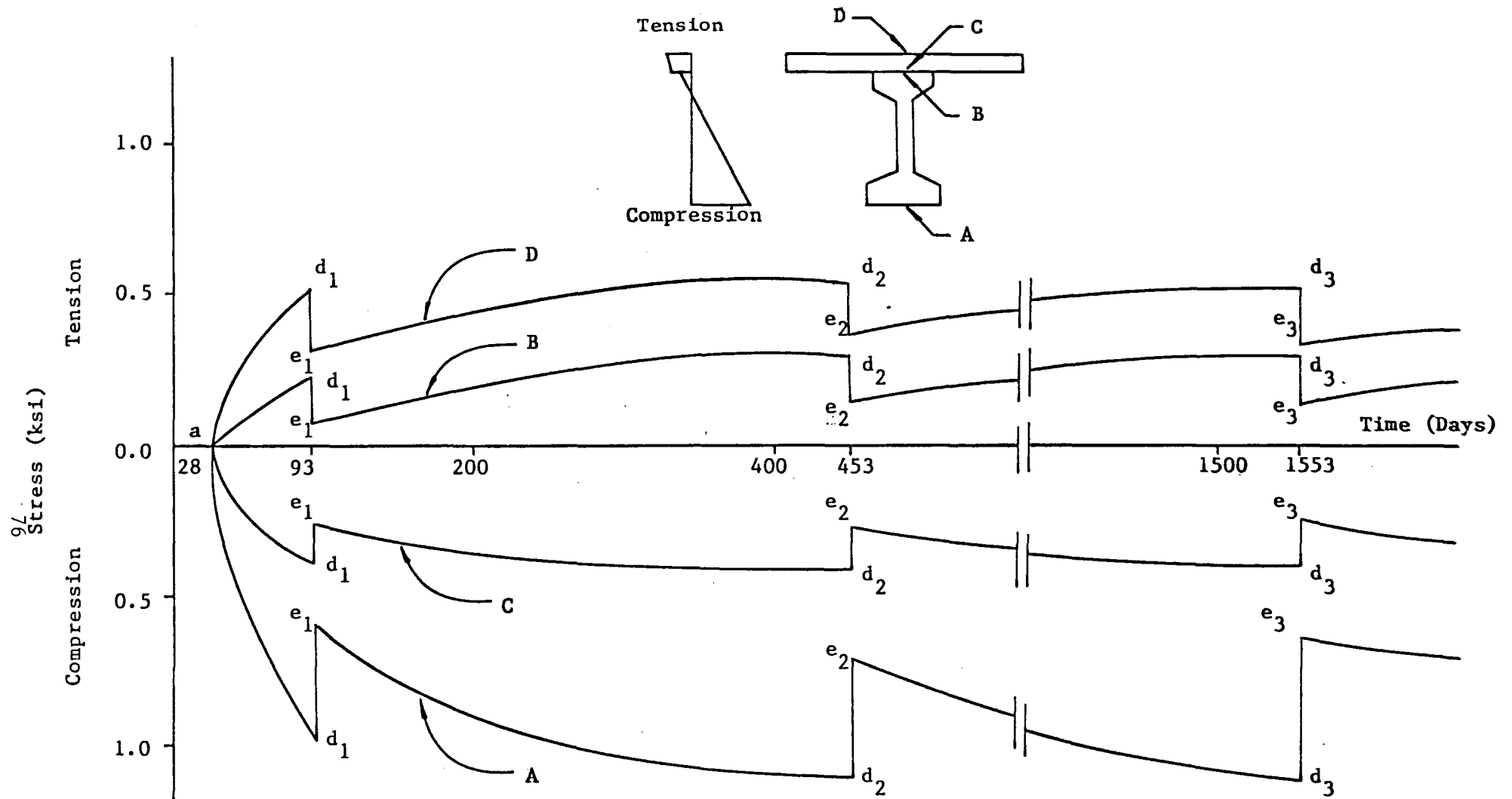

Figure 33. Time-dependent variation of stresses at midspan for two-span continuous concrete bridge with 100 foot spans - gradual settlement of center support.



ad stresses due to dead loads
 d_1e_1, d_2e_2, d_3e_3 stresses due to 1 inch settlement

Note: 1 ksi = 6.89 MPa

Figure 34. Time-dependent variation of stresses at center support for continuous concrete bridge with 100 foot spans - gradual settlement of center support.

precast prestressed I-girders, made continuous for live loads by a cast-in-place joint, acting composite with cast-in-place deck. The prestressing force was chosen to exactly balance the tensile stress at midspan for the loading condition which produces maximum positive moments. A parabolic strand profile was assumed, so the effects of prestressing can be accounted for by means of an equivalent distributed load. In the analysis, it was assumed that girder and deck had identical properties and that the settlement occurred just after continuity was imposed.

The results of these analyses for spans of 75 and 125 feet (22.9 and 38.1 meters), with Type III and Type VI girders, respectively, are shown in table 33. These results show the same general trends as for composite sections where prestressing was neglected, with the stresses merely shifted by the effect of prestress. As before, the total effects of settlement are reduced to about one-third of the instantaneous value due to the effects of creep. Analysis shows the stresses to remain within the allowable range for dead, load settlement and prestress, but live load will cause the allowable compressive stress to be exceeded.

3.2.1.5 Summary. The analyses described above have considered the combined effects of settlement and creep for various structural configurations with AASHTO-PCI standard I-girders. It was found that stresses resulting from sudden settlement are proportional to the settlement itself, the modulus of elasticity of the concrete when loaded, and the depth of the cross section, and inversely proportional to the span length. The overall ratio of settlement stresses to those caused by dead loads varies as the term I/l^4 . Therefore, a designer faced with a choice of possible cross sections should choose the section with a lower ratio of I/l^4 to minimize the relative effects of settlement.

The effects of settlement and creep are in opposing senses in the case of precast elements made continuous for live loads. This does not, however, eliminate the need to investigate settlement-related stresses in these structures. Generally, for these structures, the effects of a 3 inch (76.2 mm) sudden settlement are unacceptably high when span lengths are on the order of 100 feet (30.5 meters) or less. The effects do drop off with increasing span length, and with 125 feet (38.1 meters) spans, stresses may be controlled by additional reinforcement.

Limited investigation of the effects of prestressing shows a need to study additional effects of span profile, age at loading, and gradual loading.

3.2.2 Box Girder Bridges

The research originally planned involved the study of the effects of sudden and gradual settlements of up to 3 inches (76.2 mm) for bridges constructed of precast box sections for spans of 100, 125 and 150 feet (30.5, 38.1 and 45.8 meters), and cast-in-place box girders for span lengths from 100 to 300 feet (30.5 to 91.5 meters) in increments of 25 feet (7.6 meters). However, upon evaluating the pilot study accomplished as a part of this investigation (55), it was felt that the additional studies of precast box sections in the span range of 100 to 150 feet (30.5 to 45.8

Table 33. Time-dependent stresses for two-span precast prestressed I-Girders made continuous for live loads by cast-in-place joint, acting composite with cast-in-place deck.

Span Length in Feet (Girder Type)	Location of Stresses	Settlement of Central Support in Inches	Stresses ^a in ksi at the Given Location for the Given Loading Condition and Elapsed Time					
			Dead Load+Prestress Zero Days		Dead Load + Prestress +Settlement, Zero Days		Dead Load + Prestress +Settlement, 10,000 Days	
			Top	Bottom	Top	Bottom	Top	Bottom
78 75 (III)	At Midspan	0	-1.53	-1.76	-1.53	-1.76	-1.61	-1.45
		3	-1.53	-1.76	-1.74	-0.96	-1.61	-1.48
	At Pier	0	-1.58	-1.58	-1.58	-1.58	-1.55	-1.69
		3	-1.58	-1.58	-2.00	0.00	-1.73	-1.02
100 (IV)	At Midspan	0	-1.40	-1.37	-1.40	-1.37	-1.39	-1.38
		3	-1.40	-1.37	-1.57	-0.97	-1.44	-1.27
	At Pier	0	-1.39	-1.39	-1.39	-1.39	-1.39	-1.40
		3	-1.39	-1.39	-1.73	-0.58	-1.47	-1.18

^aNegative stresses are compression.

Note: 1 ksi = 6.9 MPa, 1 foot = 0.305 meters, 1 inch = 25.4 mm.

meters) would be redundant in the light of the results of the analysis of the AASHTO-PCI standard I-girders, so additional analyses were not conducted.

The original intent for the many span length combinations to be analyzed for the cast-in-place box girders was to consider the possibility of tuning the superstructure; that is, adjusting the post-tensioning force over a period of time to keep total stresses within some acceptable range. After some preliminary analysis of two- and four-span continuous box girders, additional efforts did not seem prudent. The analyses were quite expensive, and additional parameters other than span length should have been considered for completeness. The balance of this section will report the preliminary analysis made for two- and four-span box girders with span lengths of 100 and 200 (30.5 and 61.0 meters).

3.2.2.1 Two-Span Continuous Box Girders. The effects of sudden settlement were investigated for symmetrical two-span, continuous, cast-in-place box girder bridges with span lengths of 100 and 200 feet (30.5 and 61.0 meters). These structures were analyzed, as described in the Interim Report (8), using an in-house computer program. The box girders had an overall deck width of 27 feet, 4 inches (8.3 meters), and a cell width of 13 feet (4.0 meters) at the bottom. Deck thickness was 7 inches (177.8 mm), the webs were 12 inches (305.2 mm) thick, and the bottom of the cell was 8 inches (203.2 mm) thick. Overall depth of the box section was 90 inches (2.4 meters). Concrete material properties assumed for purposes of analysis included a compressive strength of 5000 psi (35 MPa), a modulus of elasticity of 4500 ksi (31.5 GPa), a normal creep coefficient, ν , of 1.9 and an ultimate shrinkage of 210 micro strains.

For simplicity, several assumptions are necessary regarding the sequences of construction and loading. First, all concrete in the box girder was assumed to be placed at the same time, so elastic and time-dependent material properties would be the same throughout. Second, the girder was assumed to be shored until the concrete had reached an age of 28 days, when shoring was removed. At that time, the girder must support its own weight, and the concrete begins to creep. Finally, a sudden settlement of 3 inches (76.2 mm) at the central support was assumed to occur just after the shoring was removed.

Results of the analyses are shown in figures 35 and 36 for the bridge with 100 foot (30.5 meter) spans, and figures 37 and 38 for the bridge with the 200 foot (61 meters) spans. In each of these Figures, the combined effects of dead load, settlement, shrinkage and creep are shown by a solid line, while the combined effects of dead load and settlement acting without creep relief are shown by a dashed line.

At the mid-span section, stresses due to settlement have the same sense as stresses due to dead loads. In doubling the span length it can be seen that dead load stresses increase by a factor of four, while the settlement stresses are decreased by a factor of four. Thus, the ratio of settlement to dead load stresses is inversely proportional to the fourth power of span length. For both span lengths, the effect of creep is to

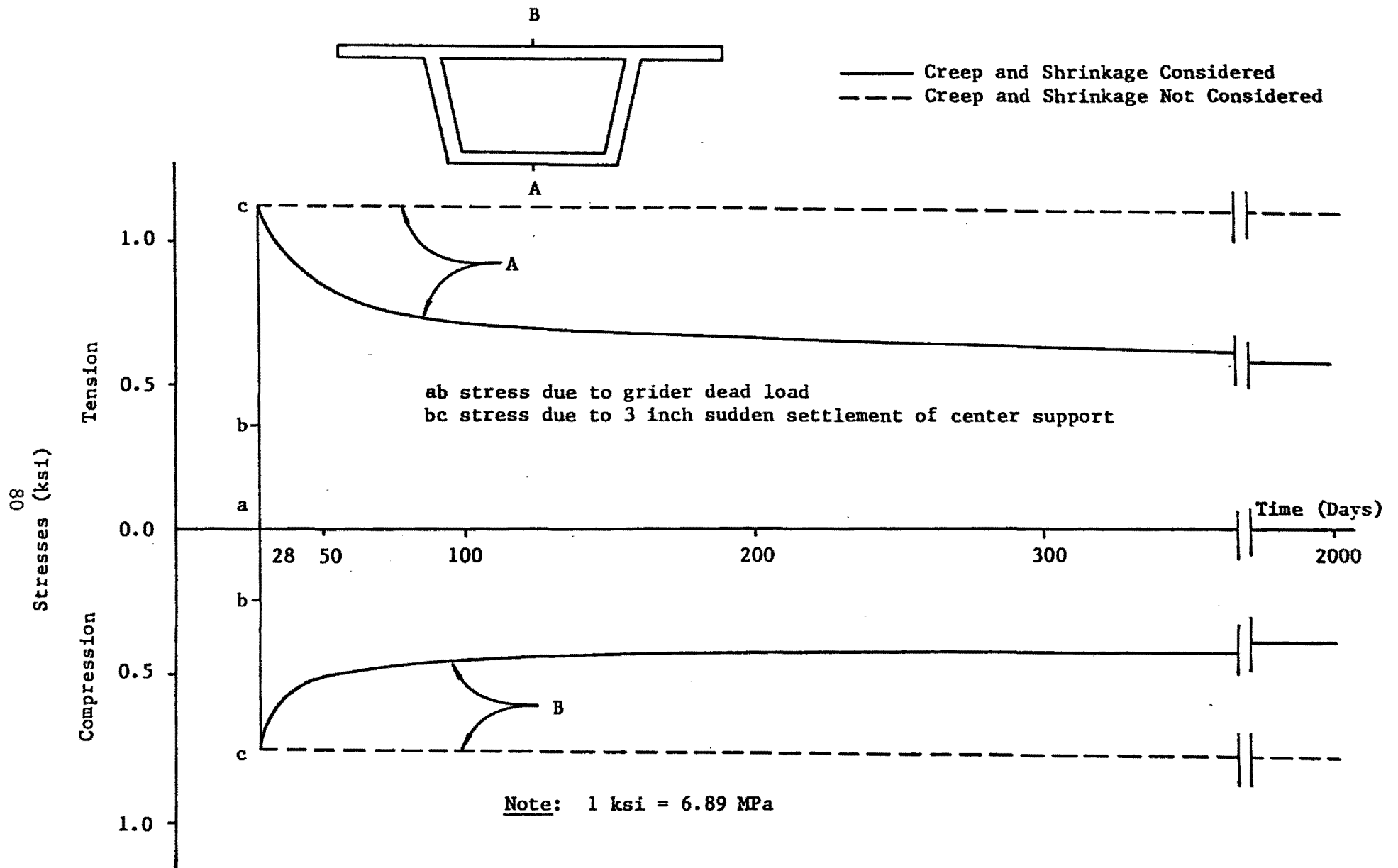

Figure 35. Time-dependent stresses at midspan for two-span continuous concrete box girder with 100 foot spans - sudden settlement of center support.

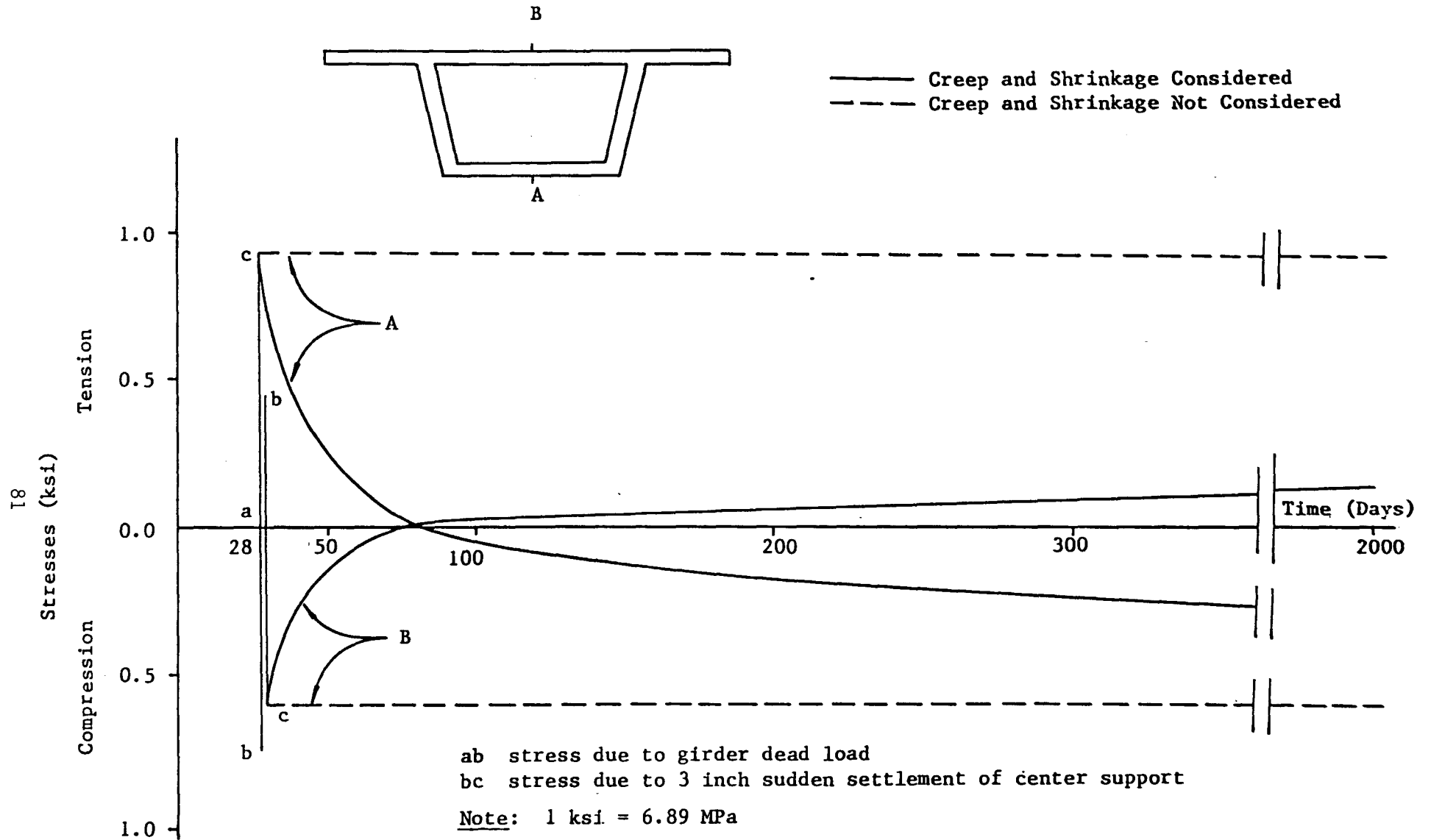

Figure 36. Time-dependent stresses at center support for two-span continuous concrete box girder bridge with 100 foot spans - sudden settlement of center support.

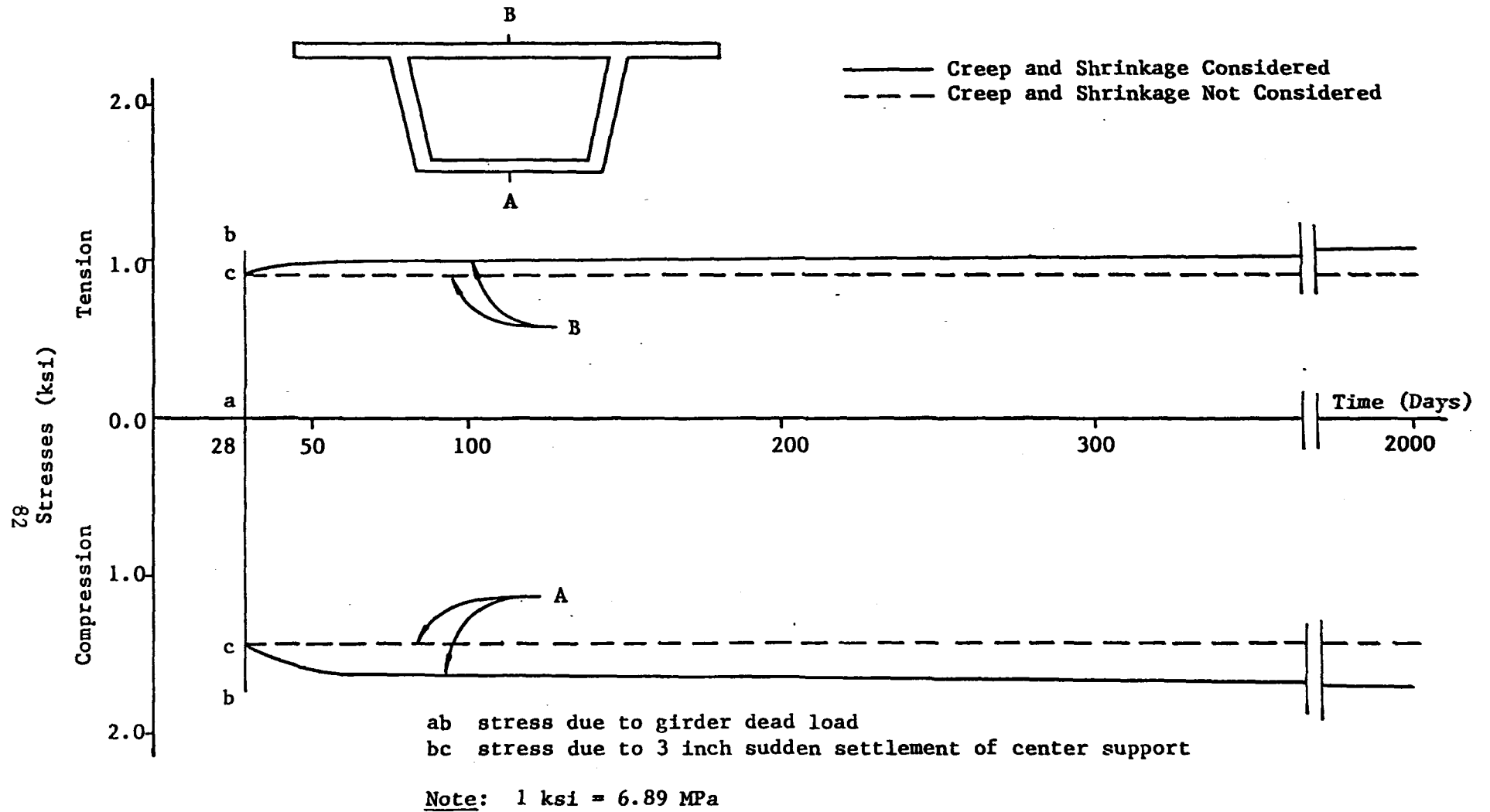

Figure 37. Time-dependent stresses at center support for two-span concrete box girder bridge with 200 foot spans - sudden settlement of center support.

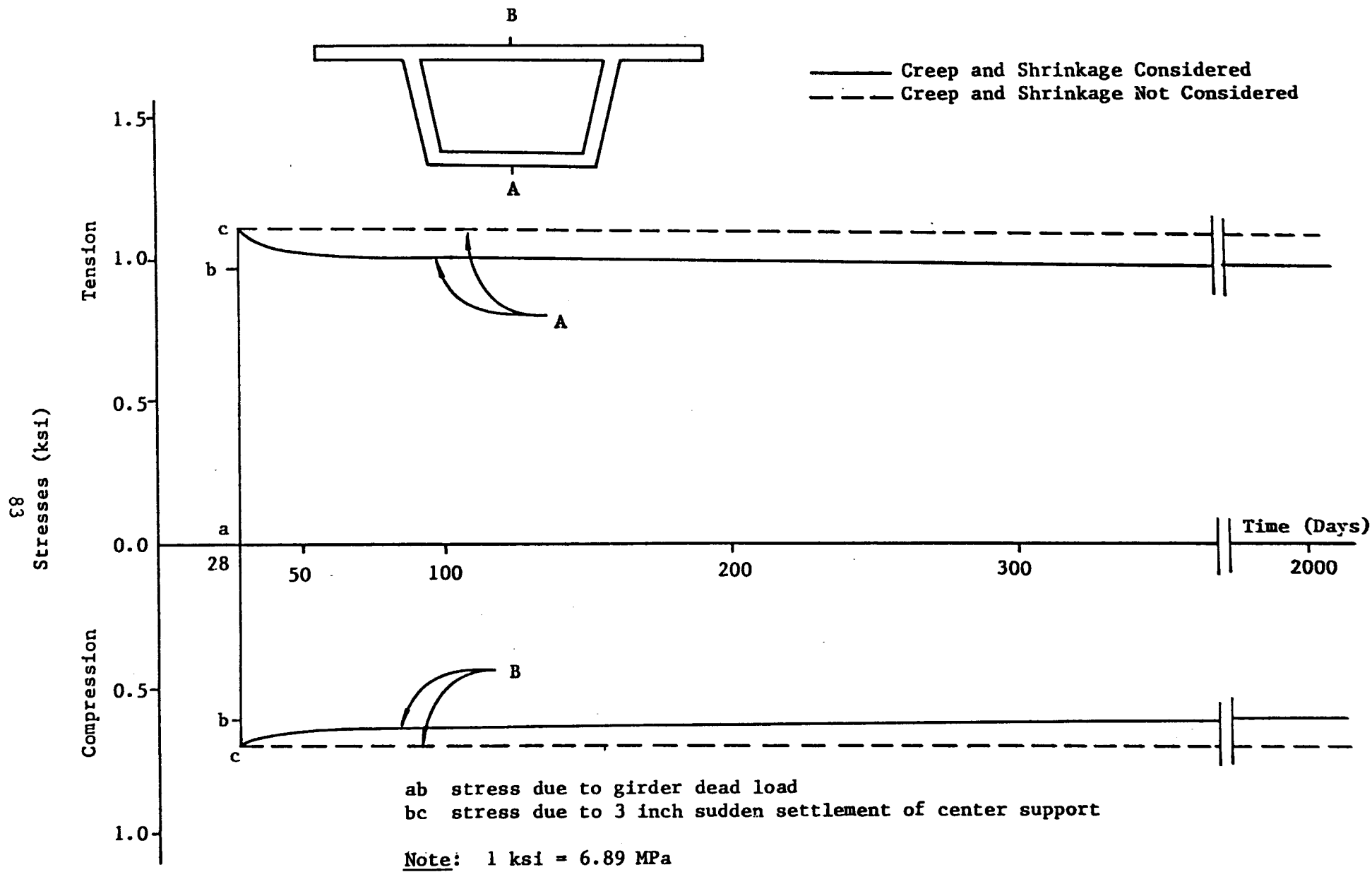

Figure 38. Time-dependent stresses at midspan for two-span concrete box girder bridge with 200 foot spans - sudden settlement of center support.

reduce the settlement-related stresses to about one-third of the instantaneous value.

For stresses at the center support, the conclusions are similar, with one important difference. At this section, the sense of stresses induced by the effects of dead load and settlement are opposite. For example at the bottom flange, compressive stresses result from the effects of dead load, while tension effects are induced by settlement. This is shown to be quite significant for the shorter span, as shown in figure 36. In this case, a stress reversal occurs at the central support, leaving a significant net tension in the bottom flange. Since all of the analysis has assumed an uncracked elastic section, this figure likely overestimates the actual value of the tensile stress. However, a significant amount of cracking is certain to occur in the vicinity of the support. This stress is mitigated by the effects of creep and shrinkage, and a compressive stress is eventually restored.

In the case of the center support stress in the longer span case, the effects of settlement are less dramatic. Immediately after the settlement occurs, the immediate effect is a stress relief. With time, the effects of creep restore the stresses to approximately those due to dead load alone.

3.2.2.2 Four-Span Post Tensioned Box Girder. As an example of the effects of span length on settlement-induced stresses, a post-tensioned box girder bridge was analyzed for the effects of sudden settlement. This structure assumed the same box section as used in the previous example, with four continuous spans of 200 feet (61.0 meters). For this analysis, dead load, prestressing force and settlement were assumed to act on the structure when the concrete reached an age of 28 days. Draped strands provided a prestressing force to balance approximately 75 percent of the dead load effect.

For this structure, the maximum effects of settlement are produced by settlement at the first interior support. By considering various loading patterns for live loads, it was determined that the maximum overall stresses occur at the second interior support. In figure 39, stresses at the second interior support are shown for a 3 inch (76.2 mm) sudden settlement at the first interior support. A "spike" on the curves shows the maximum live load effect at this section.

The four-span structure is inherently stiffer than the two-span structure, so the resulting settlement stresses are somewhat higher for bridges with the same span length. However, for this 200 foot (61.0 meters) span, the overall magnitude of settlement stresses is still relatively small.

3.2.2.3 Summary. For two- and four-span continuous box girders with 200 feet (61.0 meters) spans, the effects of a sudden support settlement of up to 3 inches (76.2 mm) are very small, and may be ignored for practical purposes. For spans of 100 feet (61.0 meters), the ratio of settlement to dead load stresses is significantly higher. In this case, midspan stresses are more than doubled just after the settlement occurs, and a stress increase of almost 70 percent remains after stresses are relieved by creep.

A significant amount of tension cracking may be expected at midspan. At the center support, a 3 inch (76.2 mm) suddenly applied settlement results in a stress reversal, producing a high tension stress and tension cracking in the bottom flange of the box section. Since the ratio of settlement to dead load stresses varies inversely as the fourth power of span length, this stress reversal might be expected in similar two-span continuous box girders with spans less than about 125 feet (38.1 meters).

4. DEVELOPMENT OF DESIGN METHODOLOGY

The results of the field studies and analytical studies described above were used in the consideration of a number of possible methodologies for the design of highway bridges and their foundations that would embody a rational set of criteria for tolerable bridge movements. This resulted in the selection of a methodology that entails a systems approach to the design of highway bridges, whereby the bridge superstructure and its resulting substructure are not designed separately, but as a single integrated system offering the best combination of economy and long-term low-maintenance performance. This design methodology and some of the tolerable movement criteria that have been developed for use with this procedure are presented below.

4.1 Basic Design Procedure

The methodology for the design of bridge systems that evolved from this research is presented schematically in figure 40. It is envisioned that in practice a trial structure type or types would be selected and a preliminary design or designs of the superstructure would be prepared, based upon geometric constraints and a preliminary assessment of subsurface conditions, as illustrated in figure 40. A detailed program of subsurface exploration, sampling and testing would then be undertaken, and, based upon the results of these studies, a trial foundation system or systems would be selected. At this stage, it appears reasonable that spread footing foundations should be considered as one viable alternative, pending further analysis, unless there is some compelling reason for the exclusive use of deep foundations, such as, for example, the possibility of streambed scour or the presence of compressible foundation soils that could lead to very large differential settlements.

Appropriate geotechnical analyses would then be conducted, as indicated in figure 40. In the case of spread footings, these analyses should include an evaluation of bearing capacity, estimates of long term total and differential settlements and some appraisal of the potential for horizontal movements, including an evaluation of lateral earth pressures and the stability of approach embankments. Similar analyses should be conducted in the case of deep foundations. At this point in the design procedure, it is envisioned that the tolerance of the bridge superstructure(s) to the estimated foundation movements would be evaluated using tolerable bridge movement criteria such as those described below.

If it is determined that the original superstructure design(s) could tolerate the anticipated foundation movements, then the designer would proceed to perform appropriate cost comparisons and select the most economical bridge system (superstructure and supporting foundation). On the other hand, if it is found that the original superstructure design(s) could not tolerate the anticipated foundation movements, then the designer could consider a variety of design alternatives, as shown in figure 40. In the case of spread footing foundations, these could include (a) the use of piles or other deep foundations; (b) the use of a number of available soil and site improvement techniques (16,17,56-59), in an effort to minimize

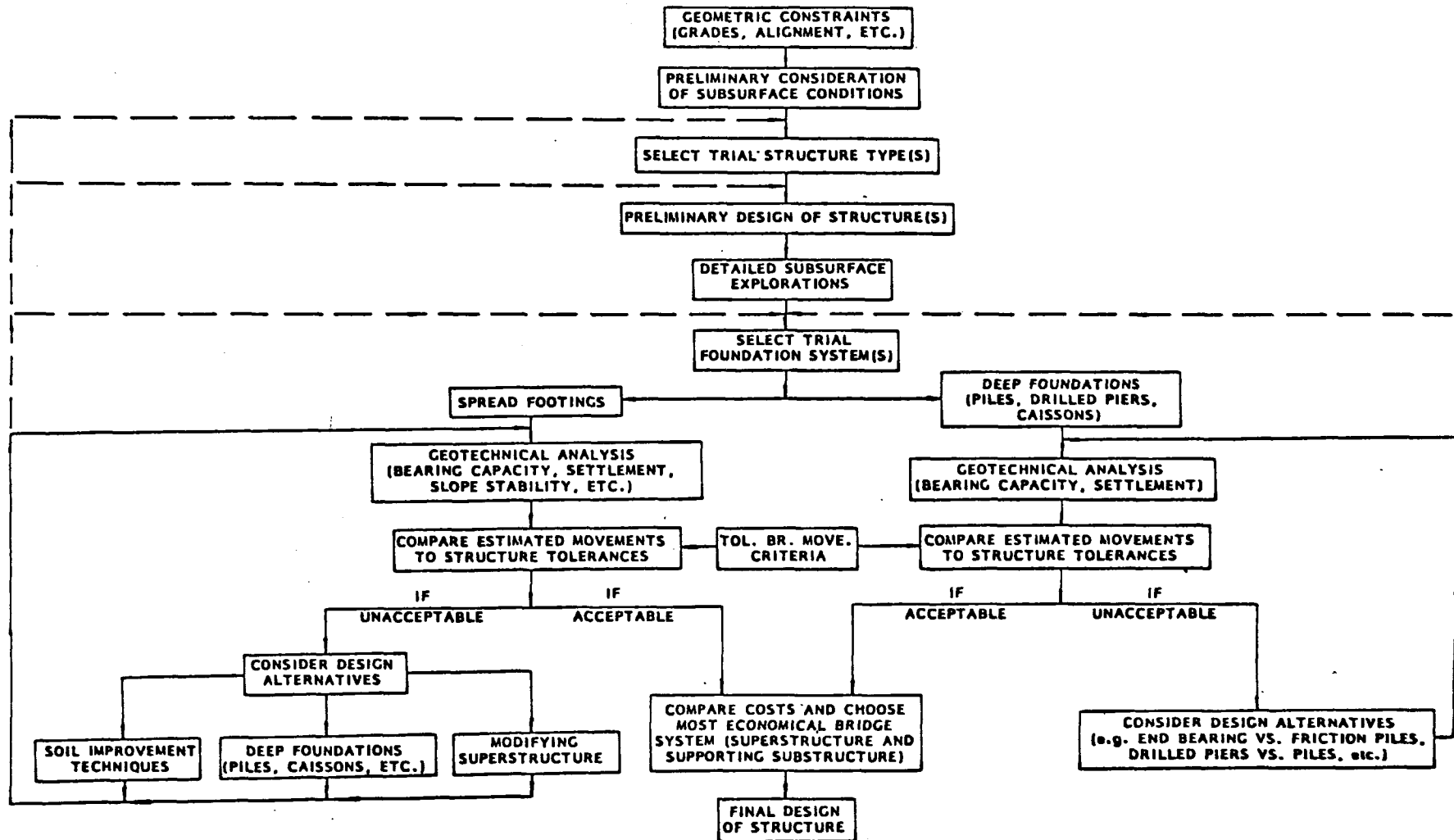

Figure 40. Schematic representation of proposed methodology for the design of highway bridge systems.

post construction movements; (c) the modification of the superstructure design to one that could better tolerate the anticipated foundation movements; or (d) some combination of these methods. This procedure will often lead to one or more new or revised designs, or an alteration of the subsurface conditions, requiring a return to an intermediate step in the design and analysis process, as indicated in figure 37. In the case of deep foundations, the consideration of design alternatives is somewhat limited. Nevertheless, the designer could consider alternate types of pile foundations, e.g. steel H-piles rather than cast-in-place concrete piles, or alternate types of deep foundations, such as drilled piers or caissons rather than some type of driven pile foundation. This procedure could also lead to a new or revised design requiring a return to an intermediate step in the design and analysis process. Ultimately, it is anticipated that this process will lead to two or more designs that can be expected to provide satisfactory long-term performance, thus permitting a selection of the final design based on cost effectiveness.

4.2 Tolerable Movement Criteria

As a result of both field and analytical studies, it became clear that the criteria for tolerable bridge movements should include consideration of both strength and serviceability. The strength criteria must insure that any stress increases in a bridge system caused by the predicted foundation movements do not adversely affect the long term load carrying capacity of the structure. The serviceability criteria, on the other hand, must insure rider comfort and the control of functional distress. The fact that the predicted foundation movements do not immediately jeopardize the load carrying capacity of the bridge does not necessarily insure the long term usefulness and safety of the structure. If the foundation movements significantly reduce the ability of a bridge to serve its intended function, then these movements may be intolerable, even though the load carrying capacity of the bridge is not seriously impaired. For example, movements that could lead to poor riding quality, reduced clearance at overpasses, deck cracking, bearing damage, and other kinds of functional distress that require costly maintenance must be controlled properly for satisfactory long term bridge performance. This control can be provided by adopting appropriate tolerable movement criteria based on serviceability.

In the following discussion of tolerable movement criteria, the emphasis has been placed, for the time being, on steel bridges, and only limited consideration of tolerable movement criteria for concrete bridges has been included until some of the complexities associated with the time-dependent behavior of these structures can be resolved.

4.2.1 Strength Criteria

From a strength standpoint, consideration of differential settlements will not require any change in the current design procedure for simply supported steel bridges with rectangular deck shapes. This is because of the fact that no significant internal stresses will develop in simply supported bridge members as a result of differential settlements. However, for continuous bridges, the superstructure design must embody some

consideration of the possible increase in stress that could result from differential movement of the foundation elements.

4.2.1.1 Based on Allowable Overstress. Both field and analytical studies have shown that, depending upon span length and stiffness, many continuous bridges may experience relatively modest increases in stress because of foundation movements. These findings suggested that one basis for the establishment of strength criteria might be to define limits of overstress that would be acceptable for various bridge systems without risking serious damage. There are ample precedents for such criteria in existing American Association of State Highway and Transportation Officials (AASHTO) standards for design and maintenance (7,60) and in other building codes and design specifications. However, these criteria generally involve temporary or transient overloads. For continuous bridges that experience differential settlements, the induced stresses might be permanent, unless remedial jacking operations are undertaken to relieve the overstress. Moreover, the increased stress levels could conceivably reduce the overall safety of the structure with respect to its ultimate load carrying capacity, and the risk of damage from fatigue could increase. Nevertheless, the design on the basis of a relatively small overstress might constitute an attractive alternative to the use of costly deep foundations to prevent differential movements.

In order to explore this alternative, an extensive literature search was conducted in an effort to find published accounts of research dealing with the measured behavior of bridges under load. It was found that there was a substantial body of literature describing measurements of the strains in a wide variety of highway bridges in the United States and Canada under actual highway loading or simulated highway loading using test trucks¹. In fact, measurements were available on over seventy such bridges. In general, the interpretation of these measured strains in terms of stress history showed that, under typical highway loading conditions, the peak live load stresses occurred relatively infrequently, and their magnitude was usually below the level that would have been expected based on current design criteria.

However, in order to investigate this general finding in greater detail, six of these case histories that were particularly well documented (61) were selected for further study. These included five three-span continuous steel bridges and one four-span continuous steel structure. A specially prepared computer program was then used to compute the live load stresses in the test bridges under AASHTO HS20-44 truck loading at the same locations at which the strain measurements had been recorded in the field. The results of these computations permitted detailed comparisons to be made between live load stresses based on field measurements and computed stresses based on AASHTO HS20-44 truck loading. Five of these comparisons are presented in tables 34 through 38. For the sixth bridge, a three-span continuous structure with end spans of 60 feet (18.5 meters) and a center

¹For the sake of brevity, the bibliographic references to this literature have been omitted from this report. However, this list of references can be supplied upon request.

Table 34. Comparison between measured and computed live load stresses for Bridge No. 1, a three-span^a continuous steel bridge.

Location of Point at Which Measurement was Made	Live Load Stresses in ksi		
	Measured		Computed Using HS20-44 Loading
	Stress Range	Frequency in Percent	
Span No. 1	0 - 2.0	73.0	8.00
	2 - 2.5	9.0	
	2.5 - 3.0	10.5	
	3.0 - 3.5	5.2	
	3.5 - 4.0	1.8	
	> 4.0	<<1.0	
Span No. 2	0 - 2.0	67.0	9.63
	2 - 2.5	12.0	
	2.5 - 3.0	10.0	
	3.0 - 3.5	7.0	
	3.5 - 4.0	3.2	
	> 4.0 ^b	<<1.0	
Edge of Cover Plate	0 - 2.0	93.5	6.24
	2.0 - 2.5	5.7	
	> 2.5	<<1.0	
At Piers No. 1 and No. 2	0 - 2.0	98.5	6.6
	2.0 - 2.5	1.0	
	> 2.5	<<1.0	

^aSpans lengths are 44, 63 and 44 feet (13.4, 19.2 and 13.4 meters).

^bMaximum measured stress level in Span No. 2 was 4.5 to 5.0 ksi at a 0.2 percent frequency of occurrence.

Note: 1 ksi = 6.9 MPa.

Table 35. Comparison between measured and computed live load stresses for Bridge No. 2, a three-span^a continuous steel bridge.

Location of Point at Which Measurement was Made	Live Load Stresses in ksi		
	Measured		Computed Using HS20-44 Loading
	Stress Range	Frequency in Percent	
Span No. 1	0 - 2.0	66.0	8.05
	2 - 2.5	11.0	
	2.5 - 3.0	7.0	
	3.0 - 3.5	2.0	
	3.5 - 4.0	1.2	
	4.0 - 4.5	1.6	
	> 4.0	<<1.0	
Span No. 2	0 - 2.0	80.0	8.40
	2 - 2.5	12.0	
	2.5 - 3.5	6.0	
	3.5 - 4.0	1.0	
	> 4.0 ^b	<<1.0	
Edge of Cover Plate	0 - 2.0	98.0	5.40
	2.0 - 2.5	1.8	
	> 2.5	<<1.0	

^aSpans lengths are 37'-3", 46'-6" and 37'-3" feet (11.5, 14.3 and 11.5 meters).

^bMaximum measured stress level in Span No. 2 was 5.5 to 6.0 ksi at a 0.2 percent frequency of occurrence.

Note: 1 ksi = 6.9 MPa.

Table 36. Comparison between measured and computed live load stresses for Bridge No. 3, a four-span^a continuous steel bridge.

Location of Point at Which Measurement was Made	Live Load Stresses in ksi		
	Measured		Computed Using HS20-44 Loading
	Stress Range	Frequency in Percent	
Span No. 1	0 - 2.0	81.2	8.27
	2 - 2.5	12.4	
	2.5 - 3.0	4.8	
	3.0 - 3.5	1.0	
	> 3.5	<<1.0	
Span No. 2	0 - 2.0	77.5	8.55
	2 - 2.5	18.0	
	2.5 - 3.0	3.2	
	3.0 - 3.5	1.0	
	> 3.5 ^b	<<1.0	
At Piers No. 1 and No. 3	0 - 2.0	99.4	5.68
	> 2.0	<<1.0	
At Pier No. 2	0 - 2.0		5.43
	> 2.0	<<1.0	

^aSpans lengths 48,60,60 are 48 feet (14.8,18.5,18.5 and 14.8 meters).

^bMaximum measured stress level in Span No. 2 was 4.0 to 4.5 ksi at a 0.06 percent frequency of occurrence.

Note: 1 ksi = 6.9 MPa.

Table 37. Comparison between measured and computed live load stresses for Bridge No. 4, a three-span^a continuous steel bridge.

Location of Point at Which Measurement was Made	Live Load Stresses in ksi		
	Measured		Computed Using HS20-44 Loading
	Stress Range	Frequency in Percent	
Span No. 1	0 - 2.0	91.2	5.80
	2 - 2.5	6.8	
	2.5 - 3.0	1.5	
	> 3.0 ^b	<<1.0	
Span No. 2	0 - 2.0	93.8	7.32
	2 - 2.5	5.4	
	2.5 - 3.0	<1.0	
	> 3.0	<<1.0	
Edge of Cover Plate	0 - 2.0	99.0	5.33
	> 2.0	<<1.0	
At Piers No. 1 and No. 2	0 - 2.0	100.0	4.76

^aSpans lengths 41,66 and 41 feet (12.6, 20.3 and 12.6 meters).

^bMaximum measured stress level in Span No. 1 was 5.5 to 6.0 ksi at a 0.03 percent frequency of occurrence.

Note: 1 ksi = 6.9 MPa.

Table 38. Comparison between measured and computed live load stresses for Bridge No. 5, a three-span^a continuous steel bridge.

Location of Point at Which Measurement was Made	Live Load Stresses in ksi		
	Measured		Computed Using HS20-44 Loading
	Stress Range ^b	Frequency in Percent	
Span No. 1	0 - 2.0	98.0	7.54
	2 - 2.5	1.5	
	2.5 - 3.0	0.5	
Span No. 2	0 - 2.0	97.0	7.85
	2 - 2.5	2.0	
	2.5 - 3.0	1.0	

^aSpans lengths are 64, 80 and 46 feet (19.7, 24.6 and 19.7 meters).

^bMaximum measured stress level was 3.0 to 3.5 ksi at <<1 percent frequency of occurrence.

Note: 1 ksi = 6.9 MPa.

span of 80 feet (24.6 meters), the maximum measured live load stress caused by a test truck was 4.0 ksi, while the corresponding computed stress with HS20-44 loading was 11.5 ksi. It is clear from these data that the maximum computed live load stresses, based on current design criteria (7), are substantially higher than the stresses based on field measurements.

For the bridges included in this study, it appears that a modest increase in stress level, as a result of differential settlement, could be tolerated without resulting in the structure being seriously overstressed. Although, in terms of the existing design specifications, these additional differential settlement stresses would theoretically constitute an overstress, the data suggest that the actual stresses could be kept at tolerable levels by setting appropriate limits on this theoretical overstress. The establishment of such limits, of course, will require further study.

4.2.1.2 Based Upon Working Stress Design For Service Loads. A more conservative approach to the establishment of a tolerable movement criterion based upon strength would be to adopt a design procedure that insures that the structure can accommodate the anticipated foundation movements without exceeding the allowable stresses provided by existing AASHTO specifications (7). Although, in the context of the research described herein, this approach establishes one type of tolerable movement criteria based upon strength, it also constitutes one of the design alternatives (modifying superstructure) in the design procedure illustrated in figure 40. As such, it should probably be considered in competition with other possible design alternatives in terms of effectiveness and economy.

One method of implementing this approach for both steel and concrete bridges would be simply to design the bridge to accommodate the anticipated settlements. For concrete bridges, these designs should include consideration of creep and shrinkage, and, in the case of spans in excess of 200 feet (61.0 meters), differential settlements up to three inches (76.2 mm) can be safely ignored.

Another method of implementing this approach for steel bridges would be to adopt a design procedure based on working stress design for service loads, reducing the allowable stress by a value equivalent to the stress increase caused by the predicted differential settlements. This design procedure would involve three basic steps: (a) the design of the bridge under the assumption that no movement will take place using the AASHTO working stress design procedures, but using reduced allowable stresses in the top and bottom fibers to adjust for anticipated settlement; (b) the comparison of the predicted movements with tolerable movements established on the basis of serviceability criteria; and (c) the modification of the original design in order to satisfy minimum strength and serviceability criteria. Of course, the third step might not be necessary if the comparisons embodied in step (b) show that the original design can safely tolerate the anticipated movements. It should be noted that the use of the procedure contained in step (a) will produce the same results as if the bridge were designed from the beginning to accommodate the anticipated settlements, although the availability of design aids such as those given in figures 26 through 31 make the former method somewhat easier. In

practice, the designer could use the appropriate design aids, along with predicted values of foundation settlements, to solve for maximum positive and negative settlement stresses. The resulting values could then be subtracted from the AASHTO limit of $0.55 f_y$ in order to obtain allowable stresses for use in design. The primary advantage that this method has over alternate procedures is that it provides a uniform method of design that is applicable regardless of whether or not any foundation movement is anticipated. However, this procedure will lead to somewhat heavier sections than the design based on an allowable overstress as discussed above.

4.2.1.3 Based on Load Factor for Settlement Stresses. In an effort to overcome some of the limitations of the approaches to establishment of tolerable movement criteria based upon strength, discussed above, the possible application of a design procedure based upon the load factor concept was studied in some detail. Such procedures have become widely accepted and are recognized as being more realistic than working stress design. The research efforts that were undertaken in this connection concentrated on the development of a load factor for settlement stresses. However, it was recognized that the establishment of a load factor for settlement stresses on a strictly theoretical basis required a knowledge of the statistical reliability of the settlement prediction. Although, as noted earlier in this report, reasonably reliable settlement predictions can be made as long as good subsurface information and laboratory test results are available, after some study it was concluded that there were insufficient field data available upon which to determine the statistical reliability of settlement predictions for bridge foundations. Consequently, it was not possible to develop a load factor for settlement stresses on a rational basis. However, it does appear that in the light of the load factors and coefficients used in the existing AASHTO Specifications (7), it may be possible to establish a reasonable empirical load factor for settlement stresses. In fact, after some study, it was concluded that the proposal considered at the four regional meetings of the AASHTO Subcommittee on Bridges and Structures during the Spring of 1982 (see Section 2.2) was quite reasonable. This proposal included the addition of a new article to the AASHTO Specifications at the end of Article 1.2.21 as follows:

"1.2.22 - Differential Settlement Stresses

Differential settlement shall be considered in design of rigid frame or continuous structures where it is anticipated from loading tests or soil analysis that it exceeds on allowable settlement tolerance."

In addition, it was proposed to add a new column, 3B, to table 1.2.23 of the AASHTO Specifications, as illustrated in table 39. Thus, as shown in table 39, it was proposed that differential settlement be considered in all loading combination groups for continuous bridges, when load factor design was used.

4.2.2 Serviceability Criteria

Serviceability criteria deal with the maintenance of rider comfort and the control of functional distress. The types of movements that were

Table 39. Recommended revision of Table 1.2.23 of the AASHTO Specifications (7) to include differential settlement in all loading cases.

TABLE OF COEFFICIENTS δ AND β

COL. NO.	1	2	3	3A	3B	4	5	6	7	8	9	10	11	12	13	14	
GROUP	δ	β FACTORS														%	
		D	$(L \cdot I)_n$	$(L \cdot I)_p$	DS	CF	E	B	SF	W	WL	LF	R·S·T	EQ	ICE		
SERVICE LOAD	I	1.0	1	1	0	1	1	βE	1	1	0	0	0	0	0	0	100
	IA	1.0	1	2	0	1	0	0	0	0	0	0	0	0	0	0	150
	IB	1.0	1	0	1	1	1	βE	1	1	0	0	0	0	0	0	**
	II	1.0	1	0	0	1	0	1	1	1	1	0	0	0	0	0	125
	III	1.0	1	1	0	1	1	βE	1	1	0.3	1	1	0	0	0	125
	IV	1.0	1	1	0	1	1	βE	1	1	0	0	0	1	0	0	125
	V	1.0	1	0	0	1	0	1	1	1	1	0	0	1	0	0	140
	VI	1.0	1	1	0	1	1	βE	1	1	0.3	1	1	1	0	0	140
	VII	1.0	1	0	0	1	0	1	1	1	0	0	0	0	1	0	133
	VIII	1.0	1	1	0	1	1	1	1	1	0	0	0	0	0	1	140
	IX	1.0	1	0	0	1	0	1	1	1	1	0	0	0	0	1	150
X	1.0	1	1	0	1	0	βE	0	0	0	0	0	0	0	0	0	100
LOAD FACTOR DESIGN	I	1.3	βD	1.67*	0	1	1.0	βE	1	1	0	0	0	0	0	0	
	IA	1.3		2.20	0	1	0	0	0	0	0	0	0	0	0	0	
	IB	1.3		0	1	1	1.0	βE	1	1	0	0	0	0	0	0	
	II	1.3		0	0	1	0	βE	1	1	1	0	0	0	0	0	
	III	1.3		1	0	1	1		1	1	0.3	1	1	0	0	0	
	IV	1.3		1	0	1	1		1	1	0	0	0	1	0	0	
	V	1.25		0	0	1	0		1	1	1	0	0	1	0	0	
	VI	1.25		1	0	1	1		1	1	0.3	1	1	1	0	0	
	VII	1.3		0	0	1	0		1	1	0	0	0	0	1	0	
	VIII	1.3		1	0	1	1		1	1	0	0	0	0	0	1	
	IX	1.20	βD	0	0	1	0	βE	1	1	1	0	0	0	0	1	
X	1.30	1	1.67	0	1	0	βE	0	0	0	0	0	0	0	0		

Culvert

Not Applicable

Culvert

identified as being sufficiently important for consideration with respect to serviceability are: (a) vertical displacements, including total settlement, differential settlements, longitudinal angular distortion, and transverse angular distortion; (b) horizontal displacements, including translation, differential translation, and tilting; and (c) dynamic displacements.

The establishment of realistic limits on these movements can only be accomplished if sufficient and relevant field data are available. Based upon the data accumulated during this study, limits could only be established on some of these movements. The establishment and implementation of criteria for limiting the remaining types of movements will have to await the accumulation of additional relevant field data on these movements and their effects. For example, based on the existing field data presented above, it is clear that horizontal movements of abutments and piers, either by translation or tilting, must be very carefully controlled in order to avoid structural damage. Although setting tolerable limits on these horizontal movements has not been difficult, at present we do not have well established procedures for predicting these horizontal movements with reasonable reliability.

On the basis of the data that were assembled during the course of this research, tolerable limits were established on (a) differential settlements, both in terms of angular distortion and deck cracking; (b) horizontal movement of abutments; and (c) bridge vibrations.

4.2.2.1 Differential Settlements. The field data assembled during the course of this project indicated that structural damage requiring costly maintenance tended to occur more frequently as the longitudinal angular distortion (differential settlement/span length) increased. In order to evaluate this phenomenon, the frequency of occurrence of the various ranges of tolerable and intolerable angular distortions was studied for both simply supported and continuous steel bridges. The results of this study, presented earlier in this report, showed that, for continuous steel bridges, 93.7 percent of the angular distortions less than 0.004 were considered to be tolerable. In contrast, for simply supported steel bridges, 97.2 percent of the angular distortions less than 0.005 were reported as being tolerable. Similar results were reported for the concrete bridges. It was found that the tolerance of both types of bridges to angular distortions dropped very rapidly for values greater than these. A statistical analysis of these field data showed that there was a very high probability that angular distortions less than 0.004 and 0.005 would be tolerable for continuous and simply supported bridges, respectively, of both steel and concrete. Tolerable limits on angular distortion were thus established at these values.

The potential for deck cracking as a result of differential settlement is normally restricted to continuous bridges. This is a function of the tensile stress developed over the supports (i.e., in the negative moment region), the allowable tensile stress in the deck concrete, and the spacing and size of negative reinforcement. The maximum negative stress (tension at the top of the bridge deck) due to anticipated vertical differential settlement of abutments or piers can be determined analytically, or by the use of appropriate design aids, such as figures 26-31. The total maximum

negative stress is then obtained by adding this value to the negative stress produced at the same point by the design live and dead loads. This total maximum negative stress is limited to the allowable value given by Equation 6-30 in Section 1.5.39 of the AASHTO Specifications. In essence, this comparison, between the total maximum negative stress and the limiting stress provided for in the AASHTO Specifications, constitutes a check on the tolerance of the bridge to the anticipated differential settlements in terms of deck cracking. If it is found that the computed total maximum negative stress exceeds the AASHTO requirement, then some adjustment may be required in the size and/or spacing of the deck reinforcement.

4.2.2.2 Horizontal Movements of Abutments. As noted earlier in this report, bridges that experienced either horizontal movement alone or horizontal movement in conjunction with differential vertical movement, had a high frequency of damaging structural effects, suggesting that horizontal movements are much more critical than vertical movements in causing structural damage. In terms of horizontal movements alone, movements less than 2.0 inches (50.8 mm) were considered to be tolerable in 88.8 percent of the cases. When accompanied by vertical movements, horizontal movements less than 2.0 inches (50.8 mm) were considered to be tolerable in only 60.0 percent of the cases. However, horizontal movements of 1.0 inch (25.4 mm) and less were almost always reported as being tolerable. On the basis of these data, it appeared that a logical tolerable limit on horizontal movements could be established at a value somewhere between 1.0 and 2.0 inches (25.4 and 50.8 mm). Consequently, it is recommended that horizontal movements of abutments be limited to 1.5 inches. However, it is evident that more consideration needs to be directed to the possibility of horizontal movements and their potential effects during the design stage. A study of the factors contributing to horizontal movements of abutments and methods for limiting these movements would also be desirable.

4.2.2.3 Bridge Vibrations. As noted earlier in this report, it was found that a substantial increase in dynamic deflections leading to uncomfortable levels of human response were likely to occur if the "reasonance factor", i.e. the ratio of the forced (ω_f) to natural (ω_n) frequencies, approached one. This relationship can be used to determine if a proposed bridge has sufficient mass and stiffness to prevent excessive dynamic deflections. The details of this procedure were presented in the Interim Report.

5. SUMMARY AND CONCLUSIONS

5.1 Field Studies

The data resulting from the field studies showed that a rather wide range of both vertical and horizontal movements of substructure elements has been experienced by a substantial number of highway bridges throughout the United States and Canada. Generally, abutment movements occurred much more frequently than pier movements. Although both the frequency and magnitude of vertical movements were often substantially greater than horizontal movements, the horizontal movements generally tended to be more damaging to bridge superstructures. The data suggest that more consideration needs to be directed to the potential effects of horizontal movements during the design stage, particularly for perched and spill-through abutments on fills and piers located near the toe of approach embankments. Furthermore, care should be exercised in the design and construction of approach embankments in order to eliminate this important potential source of damaging post-construction movements. The data show that precompression and/or the use of a waiting period, following embankment construction and prior to abutment construction, can be helpful in this regard.

The field studies also showed that, for both abutments and piers that experienced foundation movements, substantially more were founded on spread footings than on piles. However, the average magnitude of the movements of pile foundations were slightly longer than those of the spread footing foundations. Since the data included in these field studies represent the observed behavior of only those bridge foundations that experienced foundation movements, no inferences can be drawn with respect to the relative performance of the different foundation systems (i.e. piles vs. spread footings). However, these findings do suggest the need for a more detailed examination of those cases of pile foundation movement, in order to determine the reasons for the failure of the pile foundations to serve their intended function of eliminating or minimizing substructure movements.

The results of this study have shown that, depending on type of spans, length and stiffness of spans, and the type of construction material, many highway bridges can tolerate significant magnitudes of total and differential vertical settlement without becoming seriously overstressed, sustaining serious structural damage, or suffering impaired riding quality. In particular, it was found that a longitudinal angular distortion (differential settlement/span length) of 0.004 would most likely be tolerable for continuous bridges of both steel and concrete, while a value of angular distortion of 0.005 would be a more suitable limit for simply supported bridges.

It was found that the field settlement data for bridges founded on sands was insufficient to permit a valid assessment of the reliability of settlement prediction techniques for sands. However, data obtained from the literature showed that the settlement of sands could be predicted within 50 percent of the measured value. Moreover, it was shown that reasonably reliable predictions of the settlement of bridges founded on

clays could be obtained, usually within 25 percent of the measured values, as long as adequate subsurface information and laboratory test data were available.

5.2 Analytical Studies

The data resulting from the analytical evaluation of the effects of support settlements and dynamic vibrations on continuous steel bridges show that the tolerance of any given bridge to movements of these types is dependent upon a number of structural and geometric parameters of the system, such as flexural rigidity (EI), stiffness (I/ℓ), magnitude of differential settlement, number of spans, span length, vehicle velocity, axle spacing and structural mass.

For the continuous two- and four-span steel bridges included in this study, it was found that differential settlements of one inch (25.4 mm) or more would be intolerable for span lengths up to 50 feet (18.3 meters) because of the rather significant increase in stresses caused by these settlements (see table 29). However, for span lengths between 100 and 200 feet (30.5 and 61.0 meters), the stress increases caused by differential settlements up to 3 inches (76.2 mm) were found to be quite modest, and for span lengths in excess of 200 feet (61.0 meters), the stress increases caused by 3 inch (76.2 mm) differential settlements were negligible. For span lengths ranging from 50 feet (18.3 meters) to 200 feet (61.0 meters), it was found that a 3 inch (76.2 mm) differential settlement would most likely be tolerable if the stiffness (I/ℓ) were 20 in^3 ($327,742 \text{ mm}^3$) or less. However, care should be exercised in implementing these findings, since the stress increases in continuous steel bridges caused by differential settlement are very sensitive to the stiffness (I/ℓ), and it is not uncommon for a design to result in a stiffness that is in excess of 20 in^3 ($327,742 \text{ mm}^3$).

The stress increases produced in the two-span continuous parallel and non-parallel chord steel trusses by differential support settlements up to 3 inches (76.2 mm) in magnitude were less than 10 percent and, in most instances, were negligible.

A limited analytical study of the effects of instantaneous and time-dependent support settlements on continuous concrete bridges was performed considering the influence of dead loads, live loads, prestressing loads and the effects of shrinkage and creep. It was found that consideration of time-dependent material properties is absolutely necessary to accurately assess the effects of support settlements on concrete bridge superstructures.

"Real world" settlements are most likely to be gradual in nature. However, sudden settlements are much easier to analyze, and the stresses calculated on the basis of assumed sudden settlement do provide a guide to the overall significance of settlement effects on concrete bridges. Creep may reduce the effect of settlement to about one-third of its initial value, if the settlement occurs early in the life of the structure. Settlements occurring after a few months cannot be reduced as significantly.

The analyses reported herein tend to confirm intuitive estimates of the effects of support settlements on continuous concrete bridges. For example, as expected, it was found that settlement effects increase with overall stiffness of the structure. Thus, a two-span continuous structure has settlement stresses about 43 percent less than a four-span structure with the same cross section. In terms of structural configuration, settlement-induced stresses increase approximately as the ratio of d/ℓ^2 , where d is the overall depth of the cross section and ℓ is the span length. However, the ratio of settlement stresses to dead load stresses increases as the ratio I/ℓ^4 , where I is the moment of inertia for the cross section. Overall, the span length was found to be the most significant term governing settlement stresses. Continuous concrete bridges with span lengths less than 100 feet (30.5 meters) are very sensitive to differential foundation movements, while those with span lengths of 200 feet (61.0 meters) or more can tolerate differential settlements as large as three inches (76.2 mm) with only a relatively small change in total stresses.

5.3 Design Methodology

A basic design procedure has been suggested which will permit a systems approach to be used for the design of highway bridges. In this procedure, an initial design is prepared on the assumption that no foundation movement will take place. The potential foundation movements are then estimated and the tolerance of the structure to these movements is evaluated using tolerable movement criteria based upon both strength and serviceability. If the original design will not tolerate the estimated movements, then a variety of design alternatives can be considered in order to reduce the potential movements or increase the tolerance of the structure to these movements. It is anticipated that this procedure will result in the optimization of the design of the superstructure and its supporting substructure as a single integrated system offering the best combination of long-term performance and economy.

The results of both field and analytical studies were utilized in an investigation aimed at developing tolerable movement criteria based upon both strength and serviceability. Because of the complexities associated with the time dependent behavior of concrete bridges, this investigation concentrated on steel bridges, and only limited consideration was given to tolerable movement criteria for concrete bridges. It was found that a basis does exist for the establishment of strength criteria for steel bridges based on defining limits of "overstress", caused by differential foundation movements, that would be acceptable for various bridge systems without risking serious damage. An alternate, more conservative, procedure that was investigated involves the design of bridges under the assumption that no settlement will take place, using the AASHTO working stress design procedure, with the allowable stress being reduced to compensate for anticipated settlements. The resulting design is then checked for compliance with serviceability criteria based on limiting longitudinal angular distortion, horizontal movement of abutments, deck cracking and bridge vibrations. Convenient equations and graphical design aids were developed to facilitate these operations. This procedure may lead to the modification of the original design in order to satisfy minimum strength and serviceability criteria. Another approach that was studied was the use

of load factor design, which has been increasing in popularity in recent years. Although it was found that there was insufficient data presently available on the statistical reliability of settlement predictions to permit the development of a load factor for settlement stresses on a strictly theoretical basis, it was concluded that the selection of a reasonable empirical load factor for settlement stresses may be possible within the existing framework of the current AASHTO design procedure. Serviceability criteria were developed based on limiting longitudinal angular distortion, horizontal movement of abutments, deck cracking and bridge vibrations.

6. REFERENCES

1. Skempton, A.W. and MacDonald, D.H., "Allowable Settlements of Buildings", Proceedings, Institute of Civil Engineers, Part III, Vol. 5, London, England, December 1956, pp. 727-768.
2. Polshin, D.E., and Tokar, R.A., "Allowable Non-Uniform Settlement of Structures", Proceedings of the Fourth International Conference on Soil Mechanics, Vol. 1, London, August, 1957, pp. 402-405.
3. Feld, J., "Tolerance of Structures to Settlement", Journal of the Soil Mechanics and Foundations Division, ASCE, Vol. 91, No. SM3, May, 1965, pp. 63-77.
4. Grant, R., Christian, J.T., and Vanmarcke, E.H., "Differential Settlement of Buildings", Journal of the Geotechnical Engineering Division, ASCE, Vol. 100, No. GT9, September 1974, pp. 973-991.
5. Burland, J.B. and Wroth, C.P., "Settlement of Buildings and Associated Damage. State-of-the-Art Review", Proceedings, Conference on Settlement of Structures, Cambridge, Pentech Press, London, 1974, pp. 611-654.
6. Thornley, J.H., Foundation Design and Practice, Columbia University Press, Morningside Heights, New York, 1959, p. 31.
7. American Association of State Highway and Transportation Officials, Standard Specifications for Highway Bridges, Twelfth Edition, 1977.
8. Moulton, L.K., GangaRao, H.V.S., and Halvorsen, G.T., Tolerable Movement Criteria For Highway Bridges, Volume I - Interim Report, Report No. FHWA/RD-81/162, Federal Highway Administration, Washington, D.C., December, 1981, 127 pp.
9. Moulton, L.K., and Chen, Ran-Jay, Tolerable Movement Criteria For Highway Bridges, Volume II - Appendix A - Bridge Data Storage and Retrieval System, Report No. FHWA/RD-81/163, Federal Highway Administration, Washington, D.C., December, 1981, 352 pp.
10. Moulton, L.K., and Kula, J.R., Tolerable Movement Criteria For Highway Bridges, Volume III - Appendix B - Analysis of Bridge Movements and Their Effects, Report No. FHWA/RD-81/164, Federal Highway Administration, Washington, D.C., December, 1981.
11. Grover, R.A., "Movements of Bridge Abutments and Settlements of Approach Pavements in Ohio", Transportation Research Record No. 678, Transportation Research Board, Washington, D.C., 1978, pp. 12-17.
12. Keene, P., "Tolerable Movements of Bridge Foundations", Transportation Research Record No. 678, Transportation Research Board, Washington, D.C., 1978, pp. 1-6.

13. Walkinshaw, J.L., "Survey of Bridge Movements in the Western United States", Transportation Research Record No. 678, Transportation Research Board, Washington, D.C., 1978, pp. 6-10.
14. Bozozuk, M. "Bridge Foundation Move", Transportation Research Record No. 678, Transportation Research Board, Washington, D.C., 1978, pp. 17-21.
15. DiMillio, A.F., Performance of Highway Bridge Abutments Supported by Spread Footings on Compacted Fill, Report No. FHWA/RD-81/184, Federal Highway Administration, Washington, D.C., October, 1982, 54 pp.
16. Aldrich, H.P., "Precompression for Support of Shallow Foundations", Journal of the Soil Mechanics and Foundations Division, ASCE, Vol. 91, 1965, SM2, pp. 5-20.
17. Johnson, S.J., "Precompression for Improving Foundation Soils", Journal of the Soil Mechanics and Foundations Division, ASCE, Vol. 96, SM1, 1970, pp. 73-110.
18. Stermac, A.G., Devata, M., and Selby, K.G., "Unusual Movements of Abutments Supported on End-Bearing Piles", Canadian Geotechnical Journal, Vol. V, No. 2, May, 1969.
19. Barber, E.S., "Observed Settlements of Highway Structures Due to Consolidation of Alluvial Clay", Public Roads, Vol. 26, No. 11, December, 1951, pp. 217-224.
20. Bjerrum L., Jonson, W. and Ostenfeld, C., "The Settlement of a Bridge Abutment on Friction Piles", Proceedings of the 4th International Conference on Soil Mechanics and Foundation Engineering, Vol. 2, 1957, pp. 14-18.
21. George, A.B., Sherrell, F.W., and Tomlinson, M.J., "The Behavior of Steel H-Piles in Slaty Mudstone", Geotechnique, Vol. 26, May, 1976, pp. 95-104.
22. Kimball, W.P., "Settlement Studies of Huey P. Long Bridge", Civil Engineering, Vol. 10, No. 3, March, 1940, pp. 15-148.
23. Marche, R. and Lacroix, Y., "Stabilite des culees de ponts establies sur des pieux traversant une couche molle", Canadian Geotechnical Journal, Vol. 9, No. 1, February, 1972, pp. 1-24.
24. Nicu, N.D., Antes, D.R. and Kessler, R.S., "Field Measurements on Instrumented Piles Under an Overpass Abutment", Highway Research Record No. 354, Highway Research Board, Washington, D.C., 1971, pp. 90-102.
25. Hopkins, T.C., "Settlement of Highway Bridges Approaches and Embankment Foundations, Blue Grass Parkway Bridges Over Chaplin River", Interim Report KYHPR-64-17; HRP-1(8), Part 2, Kentucky Department of Highways Division of Research, Lexington, February 1973, 39 p.
26. Hopkins, T.C. and Deen, R.C., "The Bump at the End of the Bridge", Highway Research Record No. 302, Highway Research Board, 1970, pp. 72-75.

27. Hopkins, T.C. and Scott, G.D., "Estimated and Observed Settlements of Bridge Approaches", Highway Research Record No. 302, Highway Research Board, Washington, D.C., 1970, pp. 76-86.
28. Terzaghi, K. and Peck, R.B., Soil Mechanics in Engineering Practice, John Wiley and Sons, Inc., 1967.
29. Teng, W.C., Foundation Design, Prentice Hall, Inc., 1962, p. 118-119.
30. Meyerhof, G.G., "Penetration Tests and Bearing Capacity of Cohesionless Soils", Journal of the Soil Mechanics and Foundation Division, ASCE, Vol. 82, SM1, January 1956, pp. 1-19.
31. Meyerhof, G.G., "Shallow Foundations", Journal of the Soil Mechanics and Foundation Division, ASCE, Vol. 91, SM2, March, 1965, p.25.
32. Bazaraa, A.R.S., "Use of the Standard Penetration Test for Estimating Settlements of Shallow Foundations on Sand", Ph.D. Thesis, Presented to the University of Illinois at Urbana, Illinois, in partial fulfillment of the requirements for the degree of Doctor of Philosophy, 1967.
33. Peck, R.B., and Bazaraa, A.R.S., discussion of "Settlement of Spread Footings on Sand", Journal of the Soil Mechanics and Foundation Division, ASCE, SM3, May, 1969, pp. 905-909.
34. Peck, R.B., Hanson, W.E., and Thornburn, T.H., Foundation Engineering, John Wiley and Sons, Inc., 1974.
35. Alpan, I., "Estimating the Settlements of Foundations on Sand", Civil Engineering and Public Works Review, London, November, 1964, p. 1415.
36. DeBeer, E.E. and Martens, A., "Methods of Computation of an Upper Limit for the Influence of Heterogeneity of Sand Layers on the Settlement of Bridges", Proceedings, 4th International Conference on Soil Mechanics and Foundation Engineering, London, Vol. 1, 1957, p. 275.
37. DeBeer, E.E., "Bearing Capacity and Settlement of Shallow Foundations on Sand", Proceedings, Symposium on Bearing Capacity and Settlement of Foundations, Duke University, Durham, N.C., April, 1965.
38. D'Appolonia, D.J., D'Appolonia, E.D., and Brissette, R.F., "Settlement of Spread Footings on Sand", Journal of the Soil Mechanics and Foundations Division, ASCE, SM3, May, 1968, pp. 735-760.
39. Webb, D.L., "Settlement of Structures on Deep Alluvial Sand Sediments in Durham, South Africa", British Geotechnical Society Conference on In-Situ Investigations in Soil and Rock, Session III, Paper 16, London, England, 13-15 May, 1969, pp. 133-140.
40. Schmertmann, J.H., "Static Cone to Compute Static Settlement over Sand", Journal of the Soil Mechanics and Foundations Division, ASCE, SM3, May, 1970, pp. 1011-1043.

41. Schultze, E. and Sherif, G., "Predictions of Settlements From Evaluated Settlement Observation for Sand", Proceedings, Eighth International Conference on Soil Mechanics and Foundations Engineering, Vol. II, 1973.
42. Oweis, I.S., "Equivalent Linear Model For Predicting Settlements of Sand Bases", Journal of the Geotechnical Engineering Division, ASCE, GT12, December, 1979, pp. 1525-1544.
43. Mitchell, J.K. and Gardner, W.S., "In-Situ Measurement of Volume Change Characteristics", Proceedings, Conference on the In-Situ Measurement of Soil Properties, Volume II, ASCE, Raleigh, North Carolina, June 1-4, 1975, pp. 279-345.
44. Wahls, H.E., "Reliability of Settlement Predictions", Presented at the Symposium on Increasing Communication Between Bridge and Geotechnical Engineers, Annual Meeting of the Transportation Research Board, Washington, D.C., January, 1984.
45. Estimation of Consolidation Settlement, Special Report No. 163, Transportation Research Board, Washington, D.C., 1976, 26 p.
46. Terzaghi, K., Theoretical Soil Mechanics, John Wiley and Sons, New York, 1943.
47. Taylor, D.W., Fundamentals of Soil Mechanics, John Wiley and Sons, New York, 1948.
48. Casagrande, A., "The Determination of the Pre-Consolidation Load and its Practical Significance", Proceedings, International Conference on Soil Mechanics and Foundation Engineering, Vol. 3, 1936, pp. 60-64.
49. Schmertmann, J.M., "The Undisturbed Consolidation of Clay", Transactions, ASCE, Vol. 120, 1955, p. 1201.
50. Butler, F.G., "Heavily Over-Consolidated Clays", Settlement of Structures, Proceedings of the Conference Organized by the British Geotechnical Society, Cambridge, England, April, 1974, p. 531-578.
51. Logcher, R.D., Connor, J.J. and Nelson, M.R., ICES STRUDLE-II, The Structural Design Language Engineering Users Manual, Second Edition, Volumes 1 and 2, Research Report No. R70-71, Structural Division and Civil Engineering Systems Laboratory, Department of Civil Engineering, Massachusetts Institute of Technology, Cambridge, Massachusetts, 1971.
52. Dean, D.L. and GangaRao, H.V.S., "A Macro Approach to Discrete Field Analysis", Journal of the Engineering Mechanics Division, ASCE, Volume 96, No. EM4, August, 1970, pp. 277-294.
53. Tadros, M.K., "Time Dependent Deformations and Stresses in Prestressed Concrete Structures", Ph.D. Dissertation, Department of Civil Engineering, University of Calgary, Calgary, Alberta, Canada, 1975, 165 p.

54. Tadros, M.K., Ghali, A. and Dilger, W.H., "Time Dependent Analysis of Composite Forms", Journal of the Structural Division, ASCE, April 1977, p. 871.
55. Nikjeh, F.M., "Time-Dependent Effects of Support Settlements in Concrete Bridges", M.S. Problem Report, Civil Engineering, West Virginia University, Morgantown, West Virginia, 1979.
56. American Society of Civil Engineers, Soil Improvement; History, Capabilities and Outlook, Report by the Committee on Placement and Improvement of Soils and the Geotechnical Engineering Division, 1978.
57. Barksdale, R.D. and Bachus, R.C., "Methodology for the Design and Construction of Stone Columns", Paper presented at the FHWA Research Review Conference, Springfield, VA, 1980.
58. Holz, R.D., "Preloading by Vacuum: Current Prospects", Transportation Research Record No. 548, Transportation Research Board, Washington, D.C., 1975, pp. 26-29.
59. Mitchell, J.K., "Soil and Site Improvement Techniques to Enhance the Use of Shallow Foundations", paper prepared for FHWA FCP Research Review Conference, Atlanta, Georgia, 1977.
60. American Association of State Highway and Transportation Officials, Manual for Maintenance Inspection of Bridges, 1974, 85 p.
61. Goble, G.G., Moses, F. and Pavia, Field Measurements and Laboratory Testing of Bridge Components, Report No. Ohio-DOT-08-74, Case Western Reserve University, Cleveland, Ohio, 1974, 126 p.

