

Report No. UT-20.24

ASSESSING CORROSION OF EXTRACTED MSE WALL REINFORCEMENT COUPONS, UTAH PHASE II STUDY

Prepared For:

Utah Department of Transportation
Research and Innovation Division

Final Report

September 2020

DISCLAIMER

The authors alone are responsible for the preparation and accuracy of the information, data, analysis, discussions, recommendations, and conclusions presented herein. The contents do not necessarily reflect the views, opinions, endorsements, or policies of the Utah Department of Transportation or the U.S. Department of Transportation. The Utah Department of Transportation makes no representation or warranty of any kind, and assumes no liability therefore.

ACKNOWLEDGMENTS

The authors acknowledge the Utah Department of Transportation (UDOT) for funding this research, and the following individuals from UDOT for helping to guide the research:

- Darin Sjoblom, P.E., Geotechnical Engineer, Utah DOT
- Jon Ogden, P.E., Resident Engineer, Utah DOT Region 2
- David Stevens, P.E., Project Manager, Utah DOT Research & Innovation

The contributions of Trenton Parks, Matthew Martino, Adam Foulk and Marco Rosas Rodrigues, undergraduate students at BYU, during extraction of the coupons from the MSE walls are gratefully acknowledged. The contributions of Shane Oh, also an undergraduate student at BYU, during laboratory testing of the coupons is also gratefully acknowledged.

The support from David Anderson, BYU Structures Laboratory Supervisor, Rodney Mayo, BYU Structures Laboratory Technician, and Andrew Cheney, BYU Structures Laboratory Assistant were essential for the success of the project.

TECHNICAL REPORT ABSTRACT

1. Report No. UT-20.24		2. Government Accession No. N/A		3. Recipient's Catalog No. N/A	
4. Title and Subtitle ASSESSING CORROSION OF EXTRACTED MSE WALL REINFORCEMENT COUPONS, UTAH PHASE II STUDY				5. Report Date September 2020	
				6. Performing Organization Code N/A	
7. Author(s) Fernando S. Fonseca ¹ , Robert A. Thompson ¹ , and Travis M. Gerber ²				8. Performing Organization Report No. N/A	
9. Performing Organization Name and Address ¹ Brigham Young University, Dept. of Civil and Environmental Engineering, 403 EB, Provo, UT 84602 ² Gerhart Cole Inc., PO Box 880, 7657 S. Holden Street, Midvale, UT 84047				10. Work Unit No. 5H08470H	
				11. Contract or Grant No. 18-9055	
12. Sponsoring Agency Name and Address Utah Department of Transportation 4501 South 2700 West P.O. Box 148410 Salt Lake City, UT 84114-8410				13. Type of Report & Period Covered Final Report May 2018 to Jan 2020	
				14. Sponsoring Agency Code PIC No. AM18.01	
15. Supplementary Notes Prepared in cooperation with the Utah Department of Transportation and the U.S. Department of Transportation, Federal Highway Administration					
16. Abstract The purpose of this study was to extract galvanized steel wire reinforcement coupons from mechanically stabilized earth (MSE) walls along I-15 in Salt Lake Valley and determine the rate of corrosion that has taken place since Phase I, which was conducted by Gerber and Billings (2010). The galvanized steel reinforcement analyzed in this study has been in place for 19 to 20 years at the time of extraction. A total of 85 coupons were extracted and laboratory analysis was performed to determine the thickness of remaining zinc galvanization on each coupon. Soil samples were obtained from each one-stage wall extraction location to determine moisture content for correlation with corrosion. After laboratory testing was performed, the measured zinc coating thickness was compared to that determined in Phase I. An average corrosion rate of approximately 0.024 oz/ft ² /year has occurred since Phase I. According to the AASHTO (2017) design corrosion rate of 0.35 oz/ft ² /year for the first two years and 0.09 oz/ft ² /year until the depletion of the zinc, the zinc coating would have been completely depleted after 16 years. Based on the results of laboratory testing, the initial galvanization coating was likely greater than the specified thickness of 2.0 oz/ft ² (86 μm). The zinc galvanization is corroding at a slower rate than the AASHTO design rate. The AASHTO design rate for depletion of zinc coating and subsequent corrosion of the steel reinforcement is conservative for the corrosion conditions present in the MSE wall reinforcement coupons tested. The integrity of the steel reinforcement that is currently in place is not likely to be compromised by corrosion.					
A17. Key Words Mechanically stabilized earth walls, MSE walls, reinforcement corrosion, corrosion rate		18. Distribution Statement Not restricted. Available through: UDOT Research & Innov. Division 4501 South 2700 West P.O. Box 148410 Salt Lake City, UT 84114-8410 www.udot.utah.gov/go/research		23. Registrant's Seal N/A	
19. Security Classification (of this report) Unclassified	20. Security Classification (of this page) Unclassified	21. No. of Pages 137	22. Price N/A		

TABLE OF CONTENTS

ACKNOWLEDGMENTS i

TECHNICAL REPORT ABSTRACT ii

TABLE OF CONTENTS iii

LIST OF TABLES vi

LIST OF FIGURES vii

UNIT CONVERSION FACTORS ix

LIST OF ACRONYMS x

EXECUTIVE SUMMARY 1

1.0 INTRODUCTION 2

 1.1 Problem Statement 2

 1.2 Objectives 3

 1.3 Scope 4

2.0 BACKGROUND 10

 2.1 MSE Walls 10

 2.1.1 One-Stage Walls 10

 2.1.2 Two-Stage Walls 12

 2.2 Corrosion Factors 14

 2.2.1 Gradation of Structural Fill 15

 2.2.2 Resistivity 15

 2.2.3 pH 16

 2.2.4 Soluble Salts 16

 2.2.5 Organic Content 16

 2.2.6 Moisture Content 17

 2.2.7 Electrochemical Limits 17

 2.3 Galvanization 17

 2.3.1 Design Life 18

 2.3.2 Corrosion Design Rates 18

 2.4 UDOT MSE Wall Design Specifications for the I-15 Project 19

3.0 PROCEDURES 20

 3.1 Overview 20

3.1.1 Extractable Coupons	20
3.1.2 Coupon Locations	22
3.2 Extraction Procedures	26
3.2.1 Steel Saddle Safety System.....	26
3.2.2 Extraction Device.....	27
3.2.3 Extraction.....	28
3.3 Corrosion Lab Test Methods	31
3.3.1 By Weight	32
3.3.2 Diameter Difference.....	37
3.3.3 Digital Measurement.....	37
3.4 Tensile Testing Procedures	38
3.4.1 Tension Testing Phase I Samples	39
3.4.2 Tension Testing Phase II Samples	40
3.5 Moisture Content Determination	41
4.0 TESTING RESULTS.....	43
4.1 Overview.....	43
4.2 Pullout Force.....	43
4.3 Corrosion Results.....	47
4.3.1 Weight Method	48
4.3.2 Diameter Difference and Magnetic Measurement	52
4.4 Tension Testing.....	58
4.4.1 Tension Results from Phase I Samples	58
4.4.2 Tension Results from Phase II Samples.....	60
4.5 Moisture Content	64
5.0 ANALYSIS.....	68
5.1 Overview.....	68
5.2 Pullout Force Analysis.....	68
5.3 Zinc Loss Over 8 Years	70
5.4 Corrosion Correlations.....	76
5.4.1 Corrosion and Moisture Content.....	76
5.4.2 Corrosion and Height of Overburden Soil	77

5.4.3 Corrosion and Pullout Force	78
5.5 Tensile Strength	78
6.0 CONCLUSIONS.....	81
6.1 Findings	81
6.1.1 Rate of Corrosion.....	81
6.1.2 Tensile Capacity.....	82
6.1.3 Moisture Content	82
6.2 Limitations and Challenges	82
7.0 RECOMMENDATIONS AND IMPLEMENTATION	83
7.1 Recommendations.....	83
REFERENCES	84
APPENDIX A: COUPON LOCATION MAPS	86
APPENDIX B: MANUFACTURER SPECIFICATIONS	98
APPENDIX C: PICTURES AND RAW DATA.....	126

LIST OF TABLES

Table 1-1: Coupons Extracted During Phase I (x) and During Phase II: Task 3-I, 3-II (●)	6
Table 1-2: Addition Locations of Coupons Extracted During Task 3-II, 3-III (●).....	8
Table 1-3: Additional Locations of Coupons Extracted During Task 3-IV (●)	8
Table 1-4: Additional Locations of Coupons Extracted During Task 3-V (●).....	9
Table 2-1: Electrochemical Limits of Metallic Reinforcement	17
Table 2-2: AASHTO Design Corrosion Rates.....	19
Table 3-1: Locations of Extracted Test Coupons	23
Table 4-1: Summary of Coupon Extraction Data	44
Table 4-2: Zinc Coating by Weight	48
Table 4-3: Zinc Coating All Methods.....	54
Table 4-4: Yield Stress and Ultimate Stress for Phase I Samples Group A	59
Table 4-5: Yield Stress and Ultimate Stress for Phase I Samples Group B	60
Table 4-6: Yield and Ultimate Stress of Tension Tests Groups A and B	60
Table 4-7: Moisture Content Results	64
Table 4-8: Summary of Moisture Content Results	67
Table 5-1: UDOT Wall Number and Corresponding Coupons	70
Table 5-2: Zinc Coating Thickness Difference from Phase I to Phase II	73
Table 5-3: AASHTO Design Loss Rate and Projected Loss Rate.....	74

LIST OF FIGURES

Figure 1-1: Aerial View Illustrating Basis of Coupon Nomenclature	5
Figure 1-2: MSE Wall Panel with Coupons	6
Figure 2-1: Typical One-Stage Wall Detail	11
Figure 2-2: Typical Two-Stage Wall Detail	13
Figure 2-3: Chemical Process of Corrosion.....	14
Figure 3-1: Typical MSE Wall Panels with Test Coupons.....	21
Figure 3-2: Outer End of Test Coupon with Protective Sleeve	22
Figure 3-3: Steel Saddle Safety System.....	27
Figure 3-4: Steel Saddle Drawings	27
Figure 3-5: Center-Hole Hydraulic Cylinder Jack.....	28
Figure 3-6: Extraction Procedure.....	29
Figure 3-7: Pullout Force vs. Time for Trial Extraction.....	30
Figure 3-8: Typical Sample Conditions – Top (a), Middle (b), Bottom (c)	33
Figure 3-9: Coupon Segmentation.....	34
Figure 3-10: Zinc Coating Surface Abnormality	35
Figure 3-11: Hydrochloric Acid Bath in Ventilated Fume Hood	36
Figure 3-12: DeFelsko Positector 6000 device.....	38
Figure 3-13: Instron Testing Machine	41
Figure 3-14: Soil Weight Determination	42
Figure 4-1: Pullout Force vs. Time for Trial Extraction.....	43
Figure 4-2: Average Zinc Coating Thickness for All Measurement Methods	53
Figure 4-3: Stress-Strain Curve for Phase I Samples Group A	58
Figure 4-4: Stress-Strain Curve for Phase I Samples Group B.....	59
Figure 5-1: Peak Pullout Force vs. Embedded Length	69
Figure 5-2: Pullout Force / Embedded Length vs. Overburden Soil Height	70
Figure 5-3: AASHTO Design Loss Rate and Projected Loss Rate	75
Figure 5-4: Zinc Coating Thickness vs. Moisture Content.....	76
Figure 5-5: Zinc Coating Thickness vs. Overburden Soil Height	77
Figure 5-6: Pullout Force / Embedment Length vs. Zinc Coating Thickness	78
Figure A-1: 300 N Argyle Ct, Coupon – 61	86

Figure A-2: N Temple, Coupon – 58	87
Figure A-3: 400 S, Coupons – 54-57	88
Figure A-4: 800 S, Coupons – 84-85	89
Figure A-5: 1700 S, Coupons – 80-83	90
Figure A-6: 3300 S & 3650 S, Coupons – 6-8, 22-26, 59-60	91
Figure A-7: 4500 S, Coupons – 9-11, 12, 41-44, 47-49	92
Figure A-8: 4800 S, Coupons – 62-73, 76-79	93
Figure A-9: 5300 S, Coupons – 13, 50-53	94
Figure A-10: 5900 S, Coupons – 1-5, 45-46	95
Figure A-11: I-15 & I-215, Coupon – 14	96
Figure A-12: 7200 S, Coupons – 15-21, 27-40, 74-75	97

UNIT CONVERSION FACTORS

Units used in this report and not conforming to the U.S. Customary system are given below with their U.S. Customary equivalents:

- 1 meter (m) = 3.28 feet (ft)
- 1 kilometer (km) = 0.62 mile (mi)
- 1 centimeter (cm) = 0.394 inch (in)
- 1 micrometer (μm) = 0.0394 thousandths of an inch (mils)
- 1 gram (g) = 0.035 ounce (oz)
- $^{\circ}\text{C} = 5(^{\circ}\text{F}-32)/9$
- For zinc thickness specifically: 1 mil = 0.588 oz/ft²

LIST OF ACRONYMS

AASHTO	American Association of State Highway and Transportation Officials
CV (%)	Coefficient of variation
FHWA	Federal Highway Administration
I-15	Interstate 15
MSE	Mechanically stabilized earth
OSHA	Occupational Safety and Health Administration
Phase I	2010 study conducted by Gerber and Billings
Phase II	Current study presented herein
PPM	Parts per million
UDOT	Utah Department of Transportation

EXECUTIVE SUMMARY

Mechanically stabilized earth (MSE) walls were constructed during the Interstate-15 (I-15) expansion project from 1997 to 2001 in the Salt Lake Valley. During construction, galvanized steel wire reinforcement coupons were installed in select MSE walls for the purpose of being extracted and analyzed. The purpose of this research was to extract galvanized steel coupons and conduct analysis to determine the extent of corrosion that has taken place since the study performed by Gerber and Billings (2010). Due to another widening of I-15 taking place in 2018-2020 that would bury access to many of the coupons, extraction began in early summer 2018.

Eighty-five galvanized steel coupons have been extracted from MSE walls along I-15. These coupons have been embedded in the soil backfill for approximately 20 years. The initial coating thickness of the steel coupons at time of installation is not known. Gerber and Billings (2010) conducted a similar study about 12 years after installation and determined the average coating thickness of the zinc galvanization. A corrosion rate could not be accurately determined at that time because the initial coating thickness was not known.

Extraction and lab analyses have been performed and an average zinc galvanization coating thickness remaining after the 20 years in service determined. This value has been compared to the average zinc thickness determined after 12 years, and a corrosion rate for the eight-year period developed. The average rate of corrosion over the nominal eight-year period is approximately 0.024 oz/ft²/year (0.041 mils/year).

The AASHTO design corrosion rate is 0.35 oz/ft²/year (0.59 mils/year) for the first two years and 0.09 oz/ft²/year (0.16 mils/year) until the depletion of the zinc (AASHTO 2017). The AASHTO design rate for depletion of zinc coating and subsequent corrosion of the steel reinforcement seems conservative for the corrosion conditions present for the MSE wall reinforcement coupons tested. Based on the corrosion coupons tested, the reinforcement of the MSE walls seems to have sufficient zinc galvanization remaining and total steel remaining to function as designed for more than the remaining design life.

1.0 INTRODUCTION

1.1 Problem Statement

Mechanically stabilized earth (MSE) walls are earth retaining systems frequently used for bridge abutments and retaining walls. They are used by the Utah Department of Transportation (UDOT) to support approach ramps to bridges along Interstate-15 (I-15) in the Salt Lake Valley (as well as at many other locations) and as retaining walls where there is a grade difference from the freeway to adjacent roads or properties.

MSE walls are cost-effective forms of structural support that can tolerate larger settlements than many other types of retaining walls. MSE walls have three main components: a structural facing, the soil backfill, and the soil reinforcement. The structural facing is often pre-cast concrete panels, used to prevent soil raveling and to anchor the soil reinforcement. The soil backfill material should typically be granular and to allow proper drainage. The soil reinforcement is metallic (strip or grid type) or geosynthetic (geotextile, strip, or geogrid) and is attached to the wall structural facing and placed in layers along the height of the soil backfill (AASHTO 2017).

The MSE walls from which reinforcement coupons were extracted in this study were of two different types: one-stage walls made of concrete panel facing with welded wire reinforcement, and two-stage walls made with a metallic retention facing grid (mesh) with geosynthetic backing connected to a non-structural concrete panel wall. UDOT uses both types of MSE walls in bridge abutments and retaining wall systems, where the latter is typically used to accommodate larger settlements in subgrade soils.

When the I-15 reconstruction project was underway in 1997 to 2001, UDOT required contractors to install steel wire coupons in selected MSE walls. These steel wire coupons were installed with the intent of later extraction to determine the levels of corrosion present. In 2010, Dr. Travis Gerber and Mr. Daniel Billings performed Phase I of the MSE wall reinforcement extraction project for UDOT; their extraction, laboratory work, and analysis will be referred to as “Phase I” for the remainder of this document (Gerber and Billings 2010). The work recently performed and presented herein will be referred to as “Phase II”. During Phase I, one coupon

was extracted from each of several MSE walls along I-15 between approximately 12300 South and 600 North, in Salt Lake County, Utah. The results from Phase I are used herein as a baseline to determine the corrosion rate of the reinforcement in the same MSE walls. The extraction and testing procedures used in this study are generally similar to those used by Gerber and Billings.

The strength of an MSE wall is based upon the compound stability of the three wall elements, namely, the structural facing, the soil backfill, and the soil reinforcement. If any of these components fail, the integrity of the MSE wall could be compromised. This study determines the rate of corrosion of the galvanized steel coupons between Phase I and Phase II. The corrosion rate determined herein can be used to determine if the walls can be expected to perform as intended for the duration of their design life. The corrosion rate might also be used to inform future design decisions regarding the use/amount of zinc galvanization or sacrificial steel used for MSE wall reinforcement.

The type of reinforcement used in the MSE walls in this study is welded wire (mesh) steel reinforcement. The steel reinforcement was galvanized with zinc for corrosion protection. The reinforcement is embedded into the soil backfill to develop frictional and mechanical resistance against pullout. The friction between the steel reinforcement and soil as well as the tensile capacity of the steel itself resists lateral movements of the MSE wall. If the steel reinforcement corrodes, the efficacy of the steel reinforcement diminishes. If the steel reinforcement corrodes excessively, the internal stability of the MSE wall would decrease allowing for potential pull-out or rupture of the reinforcement, which would cause displacement of the concrete panels.

1.2 Objectives

The purpose of the research presented herein was to determine the corrosion rate of the steel reinforcement in the MSE walls along I-15 between approximately 12300 South and 600 North, in Salt Lake County, Utah. Knowing the corrosion rate of the reinforcement will allow UDOT engineers to take measures, if necessary, to prevent failure of the MSE walls. The design of future MSE walls could also be optimized using the corrosion rate determined herein, requiring less galvanization and/or sacrificial steel.

1.3 Scope

The research conducted and presented herein had six tasks:

1. Conduct a literature review. Previous research detailing MSE wall construction, corrosion of steel reinforcement in MSE walls, and effects of soil properties on reinforcement corrosion were studied. The findings of this study are summarized in the Background section of this document.
2. Conduct tensile strength tests on selected reinforcement coupons that were extracted during Phase I to obtain a baseline value of the strength of the reinforcement used in the MSE walls.
3. Extract reinforcement coupons from several MSE walls along I-15 between approximately 12300 S and 600 N, in Salt Lake County, Utah. The locations of the coupons to be extracted are listed in Table 1-1 to Table 1-4. Aerial imagery maps indicating each coupon location are in Appendix A. The extraction was performed in 5 steps:
 - I. Extract coupons in the walls listed in Table 1-1 that were going to be buried during the 2018-2020 I-15 widening/expansion project. The walls to be buried were located on the west side of the freeway (walls underlined in Table 1-1).
 - II. Extract the remaining coupons listed in Table 1-1 and the coupons listed in the first two rows of Table 1-2.
 - III. Extract coupons listed in the last two rows of Table 1-2. These coupons were located approximately 20 ft from the ground level and their extraction was aided by a steel saddle anchored at the top of the wall.
 - IV. Extract coupons listed in Table 1-3. These additional coupons were identified after the start of the project through an inspection of the MSE walls at 7200 S and 4500 S.

- V. Extract coupons listed in Table 1-4. These additional coupons were also identified after the start of the project by conducting a site visit to MSE walls along the I-15 corridor between approximately 7200 South and 800 South.
4. Perform laboratory analysis to determine the corrosion on the galvanized steel coupons.
5. Conduct soil moisture content analysis on extracted soil samples.
6. Conduct tensile strength tests on the steel reinforcement coupons that were extracted during this study.

In Figure 1-1, the nomenclature used to identify coupons in Table 1-1 through Table 1-4 and Table 3-1 is illustrated. In these tables, the column labeled “Intersection, Quadrant, and Distance from End of Wall (ft)” describes the location of coupon extraction. The intersection is the street address of the intersection closest to the wall, and in some cases is the exact location of the wall. The quadrant (typically NW, NE, SW, or SE) is an imaginary grid if the intersection was to be split in four sections. The quadrant gives a description of direction from the intersection. The distance from the end of the wall is an approximate distance, in feet, from the MSE wall panel where the coupons are extracted, to the end of the MSE wall closest to the intersection. Each wall panel is typically 10 feet long, so distances are in increments of 10. For example, Coupon 80 would be labeled “1700S and I-15, NW, (260)”.



Figure 1-1: Aerial View Illustrating Basis of Coupon Nomenclature

Columns labeled “Position of Coupon” are a spatial representation of where the coupons to be extracted are on the wall as shown in Figure 1-2. Wall numbers underlined in Table 1-1 identify walls that are now buried and inaccessible due to the 2018-2020 I-15 expansion project.



Figure 1-2: MSE Wall Panel with Coupons

Table 1-1: Coupons Extracted During Phase I (x) and During Phase II: Task 3-I, 3-II (●)

Wall #	Intersection, Quadrant, and Distance from End of Wall (ft)	Position of Coupon *	No. of Coupons To be Extracted
<u>R-343-7</u>	7200S and I-15, SW, (60)	N ● ○ ○ ○ ○ ● S – TR N x ○ ○ ○ ○ ● S – BR	3
R-343-13	7200S and I-215 Ramp, NW, (100)	N ● ○ ○ ○ ○ ● S – TR N ● ○ ○ ○ ○ x S – BR	3
R-343-37	7200S and I-215 Ramp, SE, (100)	S ● ○ ○ ○ ○ ● N – TR S ● ○ ○ ○ ○ x N – BR	3
R-343-42	I-215 WB to I-15 SB Ramp, NW, (45)	N x ○ ○ ○ ○ ● S	1
<u>R-344-1-A</u>	5900S and I-15, SW, (250)	N x ○ ○ ○ ○ ● S	1

* BR = Bottom Row; MR = Middle Row; TR = Top Row.

Table 1-1: Continued

Wall #	Intersection, Quadrant, and Distance from End of Wall (ft)	Position of Coupon *	No. of Coupon To be Extracted
R-344-1-B	5900S and I-15, SW, (565)	N x o o o o ● S	1
R-344-2-A	5900S and I-15, SE, (240)	S ● o o o o x N	1
R-344-2-B	5900S and I-15, SE, (490)	S x o o o o ● N	1
<u>R-344-4</u>	5900S and I-15, NW, (260)	N ● o o o o ● S – TR N ● o o o o x S – BR	3
<u>R-344-7</u>	5300S and I-15, SW, (550)	N ● o o o o x S	1
R-344-11	5300S and I-15, NE, (200)	S ● o o x o o N	1
<u>R-345-3</u>	4500S and I-15, SW, (45)	N ● o o o o x S	1
<u>R-345-4</u>	4500S and I-15, NW, (75)	S ● o o o o ● N – TR S x o o o o ● N – BR	3
R-345-10	4500S and I-15, NE, (45)	N ● o o o o ● S – TR N x o o o o ● S – BR	3
<u>R-346-1C</u>	3650S and I-15, W, (175)	N ● o o o o ● S – TR N ● o o o o ● S – MR N o x o o o ● S – BR	5
<u>R-346-8</u>	3300S and I-15, NW, (95)	N ● o o o o ● S – TR N x o o o o ● S – BR	3
R-351-9	I-15 and 400S (@765W), SE, (150)	S ● o o o o x N – TR S ● o o o o x N – BR	2
R-351-34	400S and UPRR, S side, (130)	W ● o o o o x E	1
R-351-50	400S and UPRR, N side, (26)	E x o o o o ● W	1
R-351-26	N Temple and I-15, SE, (190)	S x o o o o ● N	1
R-351-30	Argyle Ct (300N) and I-15, NE, (60)	S ● o o o o x N	1

* BR = Bottom Row; MR = Middle Row; TR = Top Row.

Table 1-2: Addition Locations of Coupons Extracted During Task 3-II, 3-III (●)

Wall #	Intersection, Quadrant, and Distance from End of Wall (ft)	Position of Coupon *	No. of Coupons To be Extracted
R-343-13	7200S and I-215 Ramp, NW, (200)	N ● ○ ○ ○ ○ ● S – TR N ● ○ ○ ○ ○ ● S – BR	4
R-344-18	South Vine Street (5280 Commerce Dr)	N ● ○ ○ ○ ○ ● S	2
R-345-09	4500S and I-15, SE, (45)	N ● ○ ○ ○ ○ ● S	2
R-346-05	3300S and I-15, SE, (45)	N ● ○ ○ ○ ○ ● S	2

* BR = Bottom Row; TR = Top Row.

Table 1-3: Additional Locations of Coupons Extracted During Task 3-IV (●)

Wall #	Intersection, Quadrant, and Distance from End of Wall (ft)	Position of Coupon *	No. of Coupons To be Extracted
R-343-7	7200S and I-15, SW, (400)	N ● ○ ○ ○ ○ ● S – TR N ● ○ ○ ○ ○ ● S – BR	4
R-343-7	7200S and I-15, Southbound on Ramp, (450)	N ● ○ ○ ○ ○ ● S – TR N ● ○ ○ ○ ○ ● S – BR	4
R-345-09	4500S and I-15, SE, (South end of Wall)	N ● ○ ○ ○ ○ ● S	2

* BR = Bottom Row; TR = Top Row.

Table 1-4: Additional Locations of Coupons Extracted During Task 3-V (●)

Wall #	Intersection, Quadrant, and Distance from End of Wall (ft)	Position of Coupons *	No. of Coupons To be Extracted
R-343-8	7200S and I-15, NE on Ramp NB, (750)	N ● ○ ○ ○ ○ ● S	2
R-344-11	5300S and I-15, NE, (100)	N ● ○ ○ ○ ○ ● S	2
R-345-2	4800S and I-15, NW, (150)	N ● ○ ○ ○ ○ ● S – TR N ● ○ ○ ○ ○ ● S – BR	4
R-345-2	4800S and I-15, NW, (500)	N ○ ○ ● ○ ● ○ S – TR N ● ○ ○ ○ ○ ● S – BR	4
R-345-2	4800S and I-15, NW, (1000, 1010)	N ● ○ ○ ○ ○ ● S – TR N ● ○ ○ ○ ○ ● S – BR	4
R-345-6	4800S and I-15, SE, (600)	N ● ○ ○ ○ ○ ● S – TR N ● ○ ○ ○ ○ ● S – MR N ● ○ ○ ○ ○ ● S – BR	6
R-350-1	1700S and I-15, SE, (150)	N ● ○ ○ ○ ○ ● S	2
R-350-11	1700S and I-15, NW, (260)	N ● ○ ○ ○ ○ ● S	2
R-351-4	800S and I-15, NE, (150)	N ● ○ ○ ○ ○ ● S	2

* BR = Bottom Row; MR = Middle Row; TR = Top Row.

2.0 BACKGROUND

2.1 MSE Walls

MSE walls are retaining structures that include reinforced soil. Applications for MSE walls are bridge abutments, wing walls, and embankments. They are cost-effective alternatives to reinforced concrete or gravity type walls and can tolerate larger settlements. In Utah, there are two common types of MSE walls: one-stage and two-stage walls.

2.1.1 One-Stage Walls

MSE walls are built layer by layer. At the beginning of a one-stage MSE wall, a concrete leveling pad is cast in place on the existing ground. This leveling pad acts as a placement guide for the MSE wall structural face panels. The first row of panels is set on the leveling pad to retain the first lift of soil. In Utah, concrete face panels are commonly 5 ft high by 5 ft long, or 5 ft high by 10 ft long.

The first lift of structural backfill is placed on the native soil and compacted. Once compaction of the first layer is complete, the soil reinforcement is attached to the face panels and laid on the top of the layer of structural backfill, after which the next lift of structural backfill is placed and compacted. Each successive layer of the wall is constructed by adding additional rows of face panels on top of the previous row, filling the enclosed area with structural backfill, compacting the backfill, and laying subsequent layers of reinforcement.

Once the specified number of layers has been placed, a concrete coping caps the wall face panels and provides an aesthetic finish to the top of the wall. Through this process of placing structural face panels, structural soil backfill and compaction, and reinforcement layering, the MSE wall becomes a composite system that can withstand lateral earth pressures, surcharge loads, seismic activity, and water infiltration. Figure 2-1 shows a typical cross-section of a one-stage MSE wall.

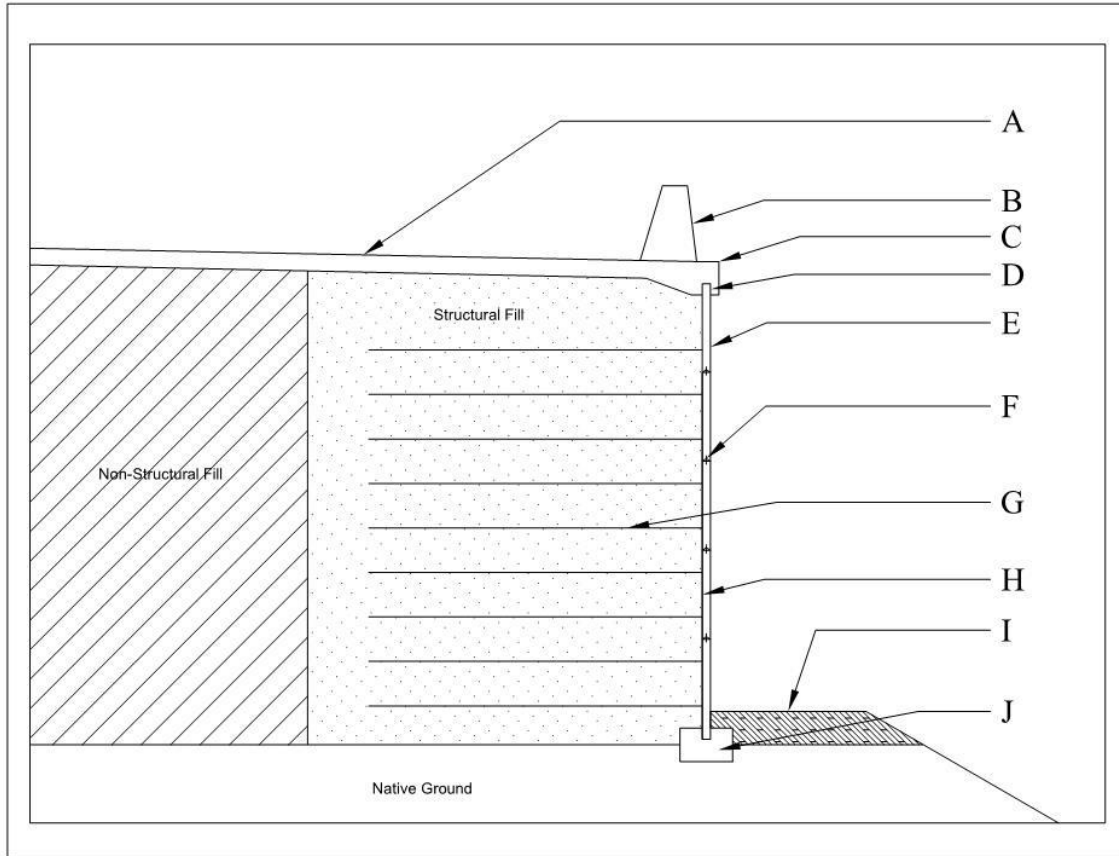

- | | |
|---|--|
| A. Road Surface | F. Tongue & Groove Joint Reinforced with Steel Dowels |
| B. Traffic Barrier | G. Soil Reinforcement, Welded Wire Mesh or Straps |
| C. Coping | H. Geo-textile for Soil Retention |
| D. Bond Breaker (typ. extruded polystyrene) | I. Protective Clay Layer to Reduce Erosion at the Foundation |
| E. Concrete Wall Panels | J. Leveling Pad |

Figure 2-1: Typical One-Stage MSE Wall Detail

2.1.2 Two-Stage Walls

Two-stage MSE walls are used when large post-construction differential settlements are expected. Two-stage MSE walls differ in construction from one-stage MSE walls by the primary method of structural soil retention. While one-stage MSE walls retain the structural soil backfill with concrete face panels, two-stage MSE walls retain the structural soil backfill with a metallic welded wire facing grid backed with a geosynthetic fabric, which is anchored by reinforcement in the structural backfill.

Although the structural soil-retention system is somewhat different, the initial construction sequence of the two types of MSE walls is similar. Once all layers of structural backfill, reinforcement, and fabric have been installed, an outer concrete paneling wall is installed as a second stage, leaving a space (gap or air void) between the first and second stages of the wall.

The concrete panels for two-stage walls are basically the same as that used in one-stage walls. The panels are placed row by row and tied to the vertical, fabric-backed wire facing grid using metallic turnbuckle-type connectors; a gap is left between the face of the wire and fabric and the concrete panels. The two-stage MSE walls in this study have a gap of approximately two feet between the interior face of the concrete panels and the geosynthetic fabric. Figure 2-2 shows a typical cross-section of a two-stage MSE wall.

The two-stage MSE wall system is beneficial when large settlements occur. Because the concrete panels are not the system retaining the soil, when large soil settlement occurs, the concrete panels are not damaged like the panels in a one-stage wall if they were subjected to such settlement.

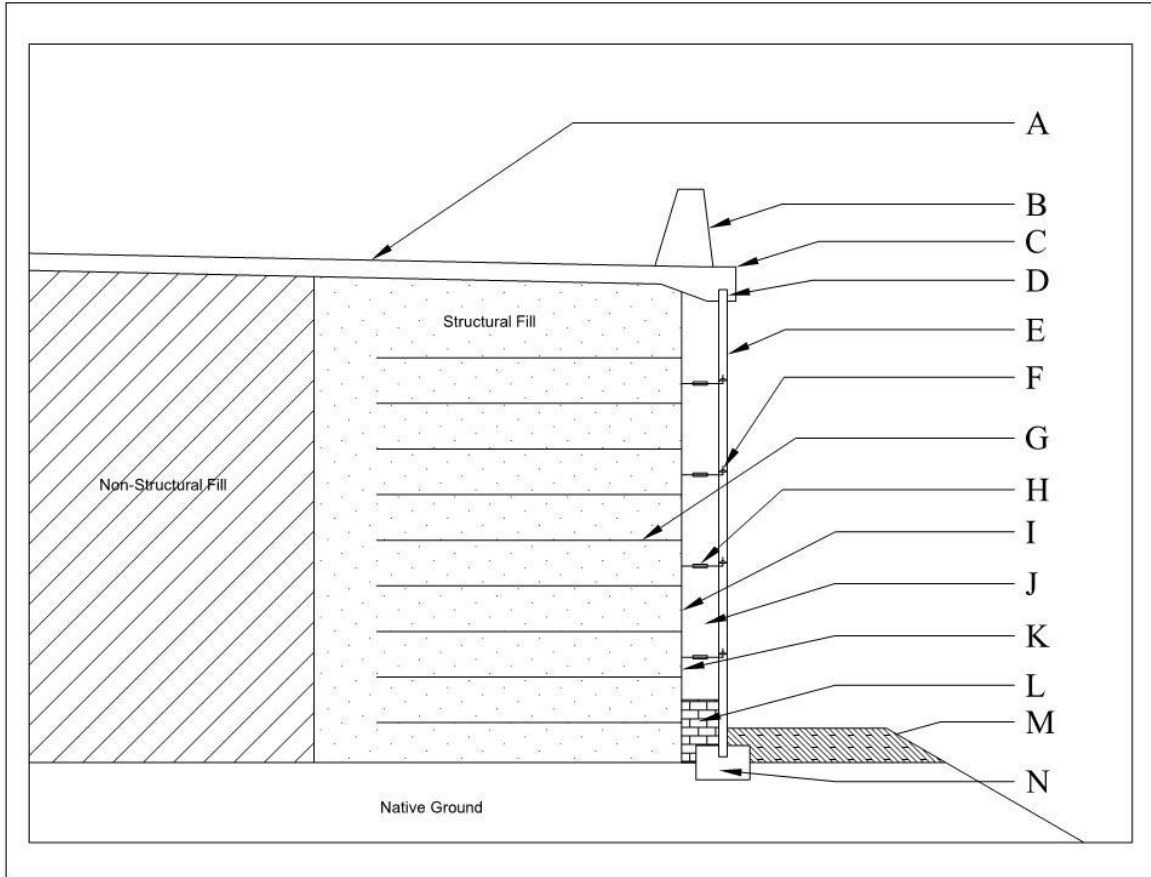

- | | |
|---|--|
| A. Road Surface | I. Geo-textile for Soil Retention |
| B. Traffic Barrier | J. Air Void |
| C. Coping | K. Structural Facing, Welded Wire Mesh |
| D. Bond Breaker (typ. extruded polystyrene) | L. Optional Fill to Reinforce Base of Wall |
| E. Concrete Wall Panels | M. Protective Clay Layer to Reduce Erosion at the Foundation |
| F. Tongue & Groove Joint Reinforced with Steel Dowels | N. Leveling Pad |
| G. Soil Reinforcement, Welded Wire Mesh or Straps | |
| H. Panel-to-Wall Connectors | |

Figure 2-2: Typical Two-Stage MSE Wall Detail

2.2 Corrosion Factors

Corrosion is an electro-chemical process involving water, oxygen, and a metallic element; an electrical current is required for the reaction to occur. On a bare steel reinforcing element, iron is oxidized in an anodic reaction as depicted in Figure 2-3. The buried reinforcement in an MSE wall becomes oxidized because electrons are transferred to the oxygen or the water in the surrounding soil. The soil and its components are reduced in a cathodic reaction, acquiring the electrons that are lost by the anodic reaction. The electrical current goes from anode to cathode in the soil and from cathode to anode in the reinforcing steel. At locations where the iron becomes oxidized, iron oxides and a corrosion product (rust) are produced (Mindess, Young, and Darwin 2003).

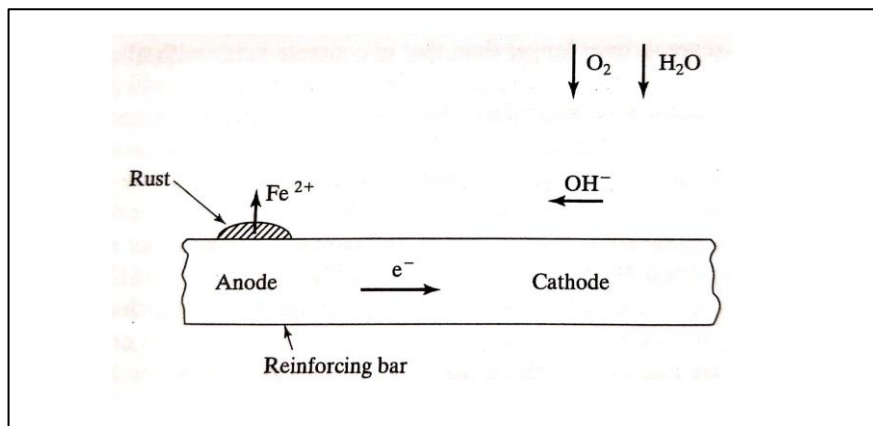

Figure 2-3: Chemical Process of Corrosion

When the iron ions leave the steel element to form rust, voids appear in the steel element causing a reduction in the cross-sectional area. This reduction in steel material leads to a loss of load capacity (i.e., strength of the reinforcement). The reduction in reinforcement strength weakens the MSE wall. If the reduction in strength is significant, the reinforcement in the MSE wall might fail, and failure of the MSE wall system can occur. To reduce the corrosion potential of bare steel, the steel can be galvanized. The process and benefits of galvanization are discussed in the next section of this chapter.

2.2.1 Gradation of Structural Fill

During the construction process of MSE walls, structural fill (soil) material is placed in layers with reinforcement placed in between structural fill layers. This layering gives MSE walls their composite strength. To achieve such composite strength, the gradation of the structural fill soil material must meet certain standards. The MSE walls in this study were designed with a structural fill that conformed to the UDOT specification shown in Appendix B. Structural fill should also be such as to allow proper drainage of water. Without proper drainage, the fill will stay moist and significant amounts of water may exist near the metal reinforcement, enhancing the corrosion process. Other structural fill properties affecting corrosion potential include resistivity, pH, chlorides, salt content, and moisture content. These properties are discussed below.

2.2.2 Resistivity

Soil resistivity is a measure of how well the soil resists the flow of electrons. Corrosion occurs when the metallic reinforcing loses electrons. Water is typically very conductive, attracting electrons. When there is water present in soil and the soil is less resistive, the electrons can flow more freely from the metal reinforcement. In contrast, if the soil has high resistivity, the migration of electrons will be more difficult. The current AASHTO minimum requirement for soil resistivity is 3000 ohm-cm. Structural fill with a resistivity of 3000 ohm-cm or greater is generally considered to be nonaggressive (AASHTO 2017). (It should be noted that other entities may use a lower threshold).

Soil resistivity is commonly determined following the testing procedures outlined in AASHTO T-288 (AASHTO 2012) or ones similar. Current testing procedures, however, may not provide an accurate representation of the resistivity of coarser grained materials used as backfill. To find an alternative method for determining resistivity of coarse backfills, Arciniega et al. (2018) conducted a study to determine a correlation between particle size distribution of the soil fill and its resistivity. The authors were able to develop a model to design the gradation of a structural fill to achieve acceptable resistivity. The correlation between resistivity and particle size distribution developed from their research indicates (and confirms the rather widely held

understanding) that gradations with a greater weight fraction of fine sand and fines present lower resistivity.

2.2.3 pH

The level of pH of the soil represents the activity of hydrogen in the soil mixture. The pH can be used to help assess the effect that the soil will have on the corrosion of metal reinforcement embedded in the soil. Soils that are extremely acidic (having a pH less than 4) or that are strongly alkaline (having a pH greater than about 10), are associated with elevated corrosion rates. One of the major factors that contributes to the pH level in soil is the dissolved salts content. With high salt contents, pH levels in the soil will increase (Elias et al. 2009).

2.2.4 Soluble Salts

Salts, including chlorides and sulfates, increase the electrolytic conductivity of a soil solution. Due to the electrochemical process of corrosion, an increased amount of salts in the soil will cause more electrons to be lost from metallic reinforcement. The maximum acceptable level of salt content per AASHTO design guidelines for MSE walls is typically 100 PPM for chlorides and 200 PPM for sulfates (Elias et al. 2009).

2.2.5 Organic Content

Soils containing organic material are susceptible to the production of organic acids, which tend to produce pitting corrosion in metallic reinforcement. Organic material in soil can be reduced to organic acids when microbial growth in the soil is present. Organic material can infiltrate the soil during the service life of the structural fill. One of the ways that organic material can be introduced is through fertilizers for vegetation adjacent to the MSE walls. This fertilizer could leech into the soil from rain water or storm runoff. If vegetation or other microbial organisms are present or infiltrate the structural fill, the organic material that has infiltrated the fill could be reduced into organic acids. The pitting corrosion could reduce the strength of the MSE wall and cause early failures (Elias et al. 2009).

2.2.6 Moisture Content

Gravimetric soil moisture content is the ratio of the mass of water present in a soil sample to the dry mass of the soil sample. High moisture content in the structural backfill of MSE walls can lead to accelerated corrosion rates. Well-drained, granular soils with moisture content of less than 5 percent are typically considered to be non-aggressive (Berg et al. 2009). The rate of general corrosion is increased in soils with a moisture content greater than 25 to 40 percent, or with a degree of saturation greater than 50 percent (Elias et al. 2009).

2.2.7 Electrochemical Limits

Table 2-1 summarizes the electrochemical limits for protection of metallic reinforcements as discussed above. Soils shall typically be considered nonaggressive if they meet this criteria (AASHTO 2017). It should be noted that nonaggressive does not mean non-corrosive.

Table 2-1: Electrochemical Limits of Metallic Reinforcement

Property	Standard	Test Procedures
Resistivity	$\geq 3000 \Omega\text{-cm}$	AASHTO T-288
pH	5 to 10	AASHTO T-289
Organic Content	1% Max.	AASHTO T-267
Chlorides	$\leq 100 \text{ PPM}$	ASTM D4327
Sulfates	$\leq 200 \text{ PPM}$	ASTM D4327

2.3 Galvanization

Galvanization is the process of applying a protective coating of zinc or zinc alloy to steel. Typically, zinc is applied to steel members by a method called hot-dip galvanization, where the steel is immersed in a bath of molten zinc at a temperature of around 840°F (449°C). The zinc layer creates a protective coating around the steel that acts as a sacrificial surface for corrosion. Zinc has a lower rate of oxidation relative to steel, providing a slowly corroding surface which decreases the overall rate of corrosion of the composite metal sample. Also, the zinc oxide that is formed during the corrosion of the zinc adheres to the reinforcement and binds with the soil near

the metal surface, thereby creating a supplemental, protective barrier (Gladstone et al. 2006). Galvanization can be specified in terms of coating thickness (such as in mils) or the amount of material per surface area (such as in oz/ft²).

Other coatings that have been used to protect steel samples are epoxy and other non-metallic coatings. These other coatings protect the reinforcement against corrosion only by completely covering the steel sample. If there is any damage on the protective coating, localized corrosion and pitting can occur and decrease the structural integrity of the steel. Epoxy coated bars are not typically used in MSE wall reinforcement as zinc provides equivalent corrosion protection and increased frictional pullout resistance in comparison to smooth epoxy coatings.

The reinforcement in the MSE walls studied was zinc galvanized welded wire reinforcement. The design specifications for the walls in this study are discussed in Section 2.4.

2.3.1 Design Life

MSE walls for transportation projects in the United States typically have a minimum design life of 75 years. MSE walls should be designed for a service life based on potential long term effects of material deterioration, seepage, corrosion of reinforcement, and other environmental factors that compromise the structural components of the wall (Berg et al. 2009). The MSE walls in this study have a design life of 75 years.

2.3.2 Corrosion Design Rates

Romanoff (1957) developed a predictive equation for general corrosion, and the formula proposed is presented in Equation (2-1):

$$X = kt^n \quad (2-1)$$

where X is the amount of material (weight or thickness) lost, k and n are constants related to soil condition and metal type, and t is time (usually in years, depending upon the constants used).

AASHTO's design corrosion rates (AASHTO 2017), presented in Table 2-2, were developed based on Romanoff's work with buried metallic samples (Romanoff 1957). The zinc is assumed to corrode first and have been consumed before the corrosion of the steel begins.

AASHTO’s corrosion rates reflect the soil parameters and limits previously discussed in Section 2.2.

The results of the tests conducted on the reinforcement extracted from MSE walls in this study are compared in Section 5.3 to the corrosion rates presented in Table 2-2.

Table 2-2: AASHTO Design Corrosion Rates

Component Type (age)	Loss		
	µm/year	mil/year	oz/ft²/year
Zinc (<2 years)	15	0.59	0.35
Zinc (>2 years)	4	0.16	0.09
Steel (after zinc)	12	0.47	0.31

2.4 UDOT MSE Wall Design Specifications for the I-15 Project

The MSE wall manufacturer for the MSE walls used in the I-15 corridor reconstruction project was VSL Corporation. The UDOT and VSL Corporation specifications and wall shop drawings presented in Appendix B reflect a galvanization coating of at least 86 µm (3.4 mils, 2.0 oz/ft²), conforming to ASTM A123 (ASTM 1997). The minimum thickness specified is consistent with the FHWA MSE Wall design manual (Berg et al. 2009). ASTM A123 specifies a minimum coating thickness for W11 wire of 85 µm. The VSL Corporation drawings detail that the steel wire material shall conform to ASTM A82 (ASTM 1997b) and ASTM A185 (ASTM 1997c) with a specified yield stress of 448 MPa (65 ksi). The MSE walls in this study have W-11 galvanized steel welded wire mesh reinforcement.

The other reinforcement, backfill, and construction specifications for the MSE walls are listed in the specification documents presented in Appendix B.

3.0 PROCEDURES

3.1 Overview

The MSE walls discussed in this study were constructed from 1997 to 2001 as part of UDOT's I-15 corridor expansion project. As part of the construction of the MSE walls, extractable reinforcement coupons were installed with exterior access. Due to another I-15 expansion taking place in 2018-2020 that would bury access to the coupons, it was decided that coupons would be extracted beginning in early summer 2018.

The UDOT Report No. [UT-10.20](#) (Gerber and Billings 2010) and the Graduate Project report of Mr. Daniel A. Billings (Billings 2011) were reviewed to determine the procedure used in Phase I to extract the reinforcement coupons. Based on the review conducted, a procedure was designed for this phase of study, including a new extracting apparatus. The locations or sites along I-15 where reinforcement coupons were extracted in Phase I are listed in Gerber and Billings (2010).

The sites of MSE walls with coupons were visited to verify correct site location and then to assess site access, needed safety precautions, and required placement location of the coupon extraction apparatus. During the site visits, several MSE walls containing reinforcement coupons that had not previously been assessed were found. Due to the additional locations of reinforcement coupons, the scope was expanded to include all known locations. Locations of reinforcement coupons are shown in Table 3-1.

3.1.1 Extractable Coupons

Concrete panels where the reinforcement coupons were installed had six access holes, as shown in Figure 3-1, to allow the extraction of the coupons. Depending on the number of coupons that were originally installed, MSE walls had either one, two, or three concrete panels, located one above the other, each with six access holes.



Figure 3-1: Typical MSE Wall Panels with Test Coupons

The reinforcement coupons were accessed through a 2-inch PVC pipe that was cast into the concrete panel. Typically, each access hole was plugged with two rubber stoppers; one that was flush with the exterior of the panel face (outer plug), and one that was approximately six inches back from the panel face (inner plug). Reinforcement coupons were threaded at the outer end and were installed through the inner plug so that the coupon was aligned with the center of the 2-inch diameter PVC pipe. The inner plug was also used to prevent the structural backfill of one-stage walls from raveling out through the PVC pipe. Most sites also had a hard-plastic disk between the two plugs to hold the end of the coupon in place. The coupons were often installed such that the tip of the coupon touched the interior face of the outer plug. Access holes in two-stage MSE walls only had the outer plug.

Two inches at the near end of each coupon was threaded to allow a coupler to be attached so that the coupon could be extracted. Due to the location of the threaded end of the coupon, the end was subject to a greater potential for corrosion since it was almost flush with the face of the

concrete panel. Water runoff, exposure to air, and potential for dislocation of the rubber outer plug increased the probability of corrosion to the end of the coupon. In order to protect the threaded end of the coupon against corrosion, most of the coupons had a silicone sleeve over the threaded portion as shown in Figure 3-2.



Figure 3-2: Outer End of Test Coupon with Protective Sleeve

Some of the ends were greased, some had both the silicone sleeve and grease, while others had no protection at all. The type of protection on the end of the coupon varied for each location. No particular pattern was detected, and no reason is known for the use of one method over the other, other than different installation crews were likely involved in different areas of the project.

3.1.2 Coupon Locations

A total of 85 coupons were extracted from MSE walls along I-15 in 2018 for Phase II. Due to the expansion of I-15 to begin in 2018, extra coupons were extracted from walls that would be buried behind new MSE walls. Being able to extract and analyze more coupons at each location is believed to result in the determination of a more representative rate of corrosion.

Table 3-1 shows the coupon locations along I-15, the position of the coupon on the wall, and the wall height above each coupon. The wall height above the coupon was measured from the center of the 2-inch rubber plug to the bottom of the concrete coping at the top of the wall. This distance of wall height above the coupon will be used to determine the effect of proximity of the coupon to the soil surface on the amount of corrosion. It can also be considered in the evaluation of pullout efforts.

Aerial imagery maps indicating the extraction location of each coupon are presented in Appendix A. The nomenclature used in the tables was described previously in Section 1.3.

Table 3-1: Locations of Extracted Test Coupons *

Wall #	ID#	Intersection, Quadrant, and Distance from End of Wall (ft)	Wall Stage	Position of Extracted Coupon	Height Above (ft)
R-344-4-A	1	5900S and I-15, NW, (260)	1	N ● ○ ○ ○ ○ x S	15.2
R-344-4-A	2	5900S and I-15, NW, (260)	1	N ● ○ ○ ○ ○ ● S	10.2
R-344-4-A	3	5900S and I-15, NW, (260)	1	N ● ○ ○ ○ ○ ● S	10.2
R-344-1-A	4	5900S and I-15, SW, (250)	1	N x ○ ○ ○ ● ○ S	7.3
R-344-1-B	5	5900S and I-15, SW, (565)	1	N x ○ ○ ○ ○ ● S	6.7
R-346-8-A	6	3300S and I-15, NW, (95)	1	N x ○ ○ ○ ○ ● S	11.0
R-346-8-A	7	3300S and I-15, NW, (95)	1	N ● ○ ○ ○ ○ ● S	6.0
R-346-8-A	8	3300S and I-15, NW, (95)	1	N ● ○ ○ ○ ○ ● S	6.0
R-345-4-A	9	4500S and I-15, NW, (75)	1	S x ○ ○ ○ ○ ● N	11.9
R-345-4-A	10	4500S and I-15, NW, (75)	1	S ● ○ ○ ○ ○ ● N	6.9
R-345-4-A	11	4500S and I-15, NW, (75)	1	S ● ○ ○ ○ ○ ● N	6.9
R-345-3-A	12	4500S and I-15, SW, (45)	1	N ● ○ ○ ○ ○ x S	7.5
R-344-7-A	13	5300S and I-15, SW, (550)	1	N ● ○ ○ ○ ○ x S	6.7
R-343-42-A	14	I-215 WB to I-15 SB Ramp, NW, (45)	1	N x ○ ○ ○ ○ ● S	9.5
R-343-7-A	15	7200S and I-15, SW, (400)	1	N ● ○ ○ ○ ○ ● S	35.0
R-343-7-A	16	7200S and I-15, SW, (400)	1	N ● ○ ○ ○ ○ ● S	35.0
R-343-7-A	17	7200S and I-15, SW, (400)	1	N ● ○ ○ ○ ○ ● S	30.0
R-343-7-A	18	7200S and I-15, SW, (400)	1	N ● ○ ○ ○ ○ ● S	30.0
R-343-7-A	19	7200S and I-15, SW, (60)	1	N x ○ ○ ○ ○ ● S	35.0
R-343-7-A	20	7200S and I-15, SW, (60)	1	N ● ○ ○ ● ○ ○ S	35.0
R-343-7-A	21	7200S and I-15, SW, (60)	1	N ● ○ ○ ● ○ ○ S	35.0
R-346-1C-A	22	I-15 Near 500W 3650S**	2	N ○ x ○ ○ ● ○ S	19.5
R-346-1C-A	23	I-15 Near 500W 3650S**	2	N ○ ○ ● ○ ○ ● S	14.5
R-346-1C-A	24	I-15 Near 500W 3650S**	2	N ○ ○ ● ○ ○ ● S	14.5
R-346-1C-A	25	I-15 Near 500W 3650S**	2	N ○ ● ○ ○ ○ ● S	9.5
R-346-1C-A	26	I-15 Near 500W 3650S**	2	N ○ ● ○ ○ ○ ● S	9.5

*● = Extracted Coupon, ● = Extracted Coupon (corresponding to different ID # in this table), x = Extracted in Phase-I, ○ = Coupon still in-place in MSE wall

**The distance from the nearest intersection is 1,700ft to the South at 3900 S and I-15 or 3,000ft to the North at 3300 S and I-15.

Table 3-1: Continued*

Wall #	ID#	Intersection, Quadrant, and Distance from End of Wall (ft)	Wall Stage	Position of Extracted Coupon	Height Above (ft)
R-343-13-A	27	7200 and I-215 Ramp, NW, (100)	1	N ● ○ ○ ○ ○ x S	11.6
R-343-13-A	28	7200 and I-215 Ramp, NW, (100)	1	N ● ○ ○ ○ ○ ● S	6.6
R-343-13-A	29	7200 and I-215 Ramp, NW, (100)	1	N ● ○ ○ ○ ○ ● S	6.6
R-343-13-A	30	7200 and I-215 Ramp, NW, (280)	1	N ● ○ ○ ○ ○ ● S	11.6
R-343-13-A	31	7200 and I-215 Ramp, NW, (280)	1	N ● ○ ○ ○ ○ ● S	11.6
R-343-13-A	32	7200 and I-215 Ramp, NW, (280)	1	N ● ○ ○ ○ ○ ● S	6.6
R-343-13-A	33	7200 and I-215 Ramp, NW, (280)	1	N ● ○ ○ ○ ○ ● S	6.6
R-343-37-A	34	7200S NB I-15 Exit, (100)	1	S ● ○ ○ ○ ○ x N	12.4
R-343-37-A	35	7200S NB I-15 Exit, (100)	1	S ● ○ ○ ○ ○ ● N	7.4
R-343-37-A	36	7200S NB I-15 Exit, (100)	1	S ● ○ ○ ○ ○ ● N	7.4
R-343-33-A	37	7200S and I-15 SB on Ramp, (450)	1	N ● ○ ○ ○ ○ ● S	5.0
R-343-33-A	38	7200S and I-15 SB on Ramp, (450)	1	N ● ○ ○ ○ ○ ● S	5.0
R-343-33-A	39	7200S and I-15 SB on Ramp, (450)	1	N ● ○ ○ ○ ○ ● S	10.0
R-345-9-B	41	4500S and I-15, SE, (110)	1	S ○ ● ○ ○ ○ ● N	4.5
R-345-9-B	42	4500S and I-15, SE, (110)	1	S ○ ● ○ ○ ○ ● N	4.5
R-345-9-A	43	4500S and I-15, SE, (40)	1	S ○ ○ ● ○ ○ ● N	7.0
R-345-9-A	44	4500S and I-15, SE, (40)	1	S ○ ○ ● ○ ○ ● N	7.0
R-344-2-A	45	5900S and I-15, SE, (240)	1	S ● ○ ○ ○ ○ x N	9.4
R-344-2-B	46	5900S and I-15, SE, (490)	1	S x ○ ● ○ ○ ○ N	13.2
R-345-10-A	47	4500S and I-15, NE, (45)	1	S x ○ ○ ○ ○ ● N	17.3
R-345-10-A	48	4500S and I-15, NE, (45)	1	S ● ○ ○ ○ ○ ● N	12.3
R-345-10-A	49	4500S and I-15, NE, (45)	1	S ● ○ ○ ○ ○ ● N	12.3
R-344-11-A	50	South Vine Street (5280 Commerce Dr)	1	S ● ○ ○ ○ ○ ● N	8.5
R-344-11-A	51	South Vine Street (5280 Commerce Dr)	1	S ● ○ ○ ○ ○ ● N	8.5
R-344-11	52	5300S and I-15, NE, (100)	1	S ● ○ ○ ○ ○ ● N	7.9
R-344-11	53	5300S and I-15, NE, (100)	1	S ● ○ ○ ○ ○ ● N	7.9

*● = Extracted Coupon, ● = Extracted Coupon (corresponding to different ID # in this table), x = Extracted in Phase-I, ○ = Coupon still in-place in MSE wall

Table 3-1: Continued*

Wall #	ID#	Intersection, Quadrant, and Distance from End of Wall (ft)	Wall Stage	Position of Extracted Coupon	Height Above (ft)
R-351-9-A	54	I-15 and 400S (@765W), SE, (150)	2	S ● ○ ○ ○ ○ x N	13.5
R-351-9-B	55	I-15 and 400S (@765W), SE, (150)	2	S ● ○ ○ ○ ○ x N	8.5
R-351-34-A	56	400S West Abutment, South Side	2	W ● ○ ○ ○ ○ x E	8.7
R-351-50-A	57	400S West Abutment, North Side	2	E x ○ ○ ○ ○ ● W	13.3
R-351-26-A	58	N Temple and I-15, SE, (190)	2	S x ○ ○ ○ ○ ● N	18.0
R-346-5B	59	3300S and I-15, SE, (100)	1	S ○ ○ ● ○ ○ ● N	4.5
R-346-5B	60	3300S and I-15, SE, (100)	1	S ○ ○ ● ○ ○ ● N	4.5
R-351-30-A	61	Argyle Ct (300N) and I-15, NE, (60)	2	S ● ○ ○ ○ ○ x N	13.1
R-345-2	62	4800S and I-15, NW, (500)	1	N ○ ○ ○ ○ ● ○ S	8.6
R-345-2	63	4800S and I-15, NW, (500)	1	N ○ ○ ○ ○ ● S	13.6
R-345-2	64	4800S and I-15, NW, (500)	1	N ○ ○ ● ○ ● ○ S	8.6
R-345-2	65	4800S and I-15, NW, (500)	1	N ● ○ ○ ○ ○ ● S	13.6
R-345-2	66	4800S and I-15, NW, (150)	1	N ● ○ ○ ○ ○ ● S	14.2
R-345-2	67	4800S and I-15, NW, (150)	1	N ● ○ ○ ○ ○ ● S	14.2
R-345-2	68	4800S and I-15, NW, (150)	1	N ● ○ ○ ○ ○ ● S	9.2
R-345-2	69	4800S and I-15, NW, (150)	1	N ● ○ ○ ○ ○ ● S	9.2
R-345-6	70	4800S and I-15, SE, (600)	1	S ○ ● ○ ○ ○ ● N	8.8
R-345-6	71	4800S and I-15, SE, (600)	1	S ○ ● ○ ○ ○ ● N	8.8
R-345-6	72	4800S and I-15, SE, (600)	1	S ● ○ ○ ○ ○ ● N	13.8
R-345-6	73	4800S and I-15, SE, (600)	1	S ● ○ ○ ○ ○ ● N	13.8
R-343-8	74	7200S and I-15, NE on Ramp NB, (750)	1	S ● ○ ○ ○ ○ ● N	7.4
R-343-8	75	7200S and I-15, NE on Ramp NB, (750)	1	S ● ○ ○ ○ ○ ● N	7.4
R-345-2	76	4800S and I-15, NW, (1000)	1	N ● ○ ○ ○ ○ ● S	9.7
R-345-2	77	4800S and I-15, NW, (1000)	1	N ● ○ ○ ○ ○ ● S	9.7
R-345-2	78	4800S and I-15, NW, (1010)	1	N ● ○ ○ ○ ○ ● S	7.1
R-350-11	80	1700S and I-15, NW, (260)	2	N ● ○ ○ ○ ○ ● S	20.0

*● = Extracted Coupon, ● = Extracted Coupon (corresponding to different ID # in this table), x = Extracted in Phase-I, ○ = Coupon still in-place in MSE wall

Table 3-1: Continued*

Wall #	ID#	Intersection, Quadrant, and Distance from End of Wall (ft)	Wall Stage	Position of Extracted Coupon	Height Above (ft)
R-350-11	81	1700S and I-15, NW, (260)	2	N ● ○ ○ ○ ○ ● S	20.0
R-350-1	82	1700S and I-15, SE, (150)	2	S ● ○ ○ ○ ○ ● N	6.7
R-350-1	83	1700S and I-15, SE, (150)	2	S ● ○ ○ ○ ○ ● N	6.7
R-351-4	84	800S and I-15, NE, (150)	2	S ● ○ ○ ○ ○ ● N	12.9
R-351-4	85	800S and I-15, NE, (150)	2	S ● ○ ○ ○ ○ ● N	12.9

*● = Extracted Coupon, ● = Extracted Coupon (corresponding to different ID # in this table), x = Extracted in Phase-I, ○ = Coupon still in-place in MSE wall

3.2 Extraction Procedures

The galvanized reinforcement coupons embedded in MSE walls required extraction to perform laboratory analysis to evaluate the extent of corrosion that had occurred. The main equipment used to extract the coupons were a steel saddle, a center-hole hydraulic cylinder jack, couplers and extension rods, and a slide hammer. The procedure and use of each of these items are explained in this section.

3.2.1 Steel Saddle Safety System

Due to the height of some of the coupons above the ground, ladders were required to access the extraction holes. In order to comply with UDOT safety regulations and to reduce job site hazards, a safety device was designed and manufactured to assist with the extraction of the coupons. Figure 3-3 and Figure 3-4 show the Steel Saddle Safety System that was used to anchor safety harnesses and a pulley system for the hydraulic jack to the traffic barrier located at the top of the MSE wall.

The saddle was transported to the freeway above the MSE wall and installed on the concrete barrier directly over the extraction location. The saddle was set on the barrier and bolted in place with set bolts underlain by neoprene pads to protect the concrete barrier surface. The safety harness and pulley for the jack were lowered to the extraction site below. The harness was then attached to a worker, and the jack was attached to the pulley system.



Figure 3-3: Steel Saddle Safety System

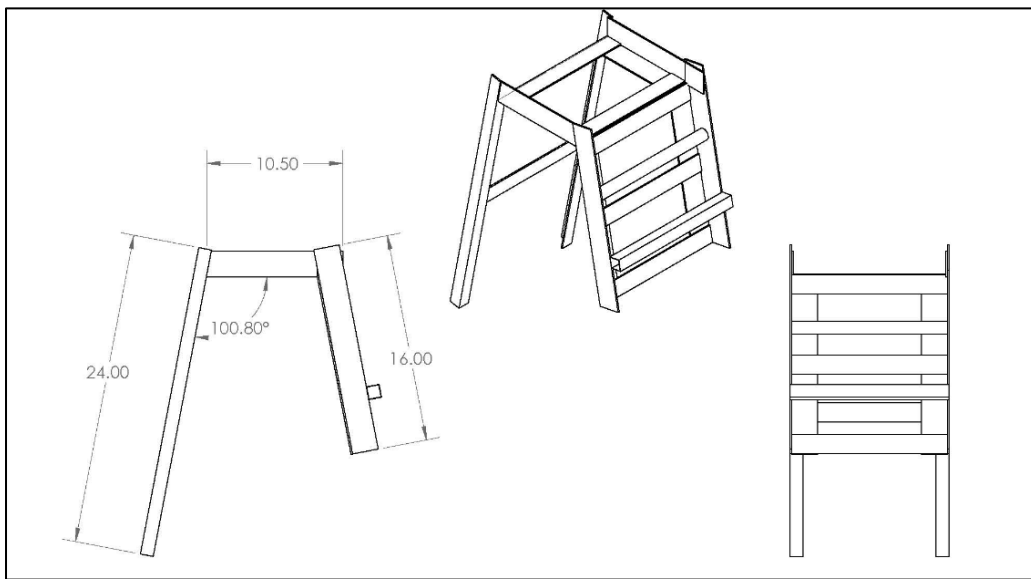

Figure 3-4: Steel Saddle Drawings

3.2.2 Extraction Device

The device used to extract the steel coupons was a center-hole hydraulic cylinder jack, shown in Figure 3-5. The jack was welded to a 16 in. by 16 in. baseplate supported by a neoprene pad and stiffeners to distribute the force as uniformly as possible to the concrete panel face. Due to its appreciative weight and bulkiness, the extraction device was attached to a pulley

system to lift and center the jack over the extraction hole, rather than manually doing so via a ladder.



Figure 3-5: Center-Hole Hydraulic Cylinder Jack

3.2.3 Extraction

Due to the varying degree of corrosion that had occurred at the end of many of the coupons as shown in Figure 3-6a, the end of the coupons were frequently re-threaded as shown in Figure 3-6b in order to facilitate attaching a coupler to the end of the coupon. The coupler was connected to the end of the coupon, as shown in Figure 3-6c, and an 18-inch, 3/8-inch diameter steel rod was attached to the coupler, as shown in Figure 3-6d.

The center-hole jack was then mounted on the wall with the rod being positioned through the center of the jack, as shown in Figure 3-6e. Washers and a nut were then fitted on the end of the rod. A hydraulic pump, fitted with a calibrated pressure transducer, was attached to the center-hole jack, and the pressure transducer was connected to a computer. The jack was pumped, and the load was monitored and recorded throughout the procedure. The jack was continually pumped until the reinforcement coupon was extracted approximately 7 inches, as shown in Figure 3-6f; the pressure was then released, and the jack cylinder retracted.

When the jack was fully retracted, the nut and washers were pushed flush with the edge of the jack and the pumping process repeated. Once the coupon was extracted approximately another 7 inches, the jack was completely removed from the wall, as shown in Figure 3-6g. After the jack was removed from the wall, a lightweight slide hammer was used to continue the coupon extraction, as shown in Figure 3-6h, i, j. Once the coupon was completely extracted, a soil sample was obtained (where possible for the one-stage walls), as shown in Figure 3-6k, l.



Figure 3-6: Extraction Procedure

Figure 3-7 shows a typical pullout force vs time plot for a coupon. In this case, the load required to pull out the coupon was approximately 3500 lbs. The very small decreases in load observed between 0 and 3500 lbs are due to the pumping of the center-hole jack. In the plot shown, and as typical, the load dropped suddenly as the initial pull out of the coupon was observed. As extraction continued, however, the coupler sometimes was caught at the edge of the steel plate supporting the center-hole jack and, when that happened, the load would increase. In the plot shown, the load increased to approximately 3600 lbs. The coupler would eventually be freed as extraction continued and the load dropped suddenly. For the case shown, the extraction continued but the coupler was caught again at the edge of the center-hole jack, which happened sometimes, and the load would increase again. In the plot shown, the load increased to approximately 2200 lbs. As extraction continued, the coupler would slowly slide inside the cylinder of the center-hole jack and would eventually be freed again; causing the load to drop completely.

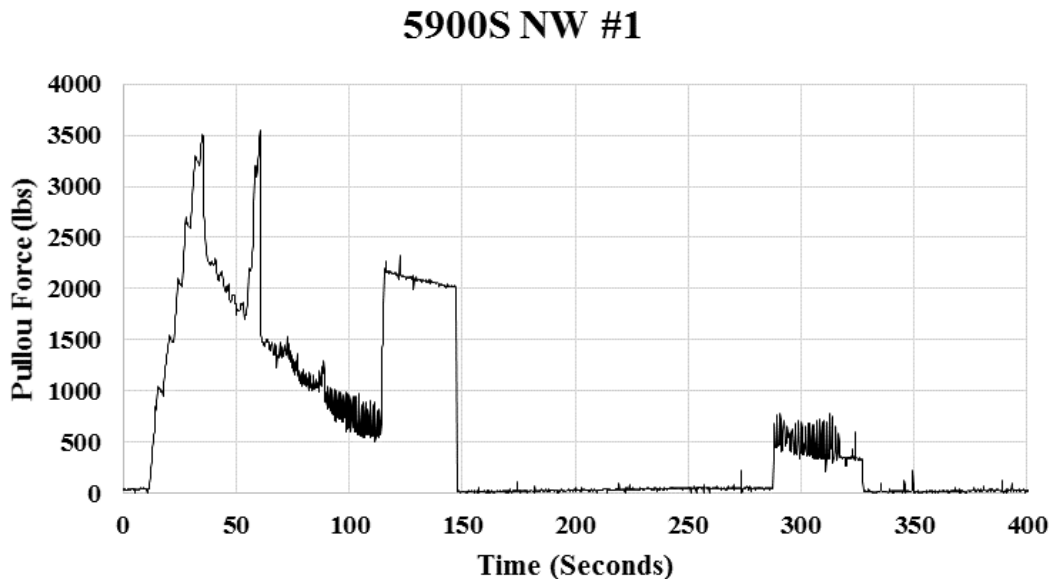

Figure 3-7: Pullout Force vs. Time for Trial Extraction

In a more typical extraction, the coupon was extracted approximately 7 inches during the procedure just described. The pressure in the center-hole jack was then released and the center-

hole cylinder retracted to its resting position. The nut and washers were then pushed flush with the edge of the cylinder and the extraction resumed. The coupon was then extracted approximately an additional 7 inches. In the plot shown, a residual load of approximately 400 lbs remained before the pressure in the center-hole jack was released again. The coupon was then completely extracted using a slide hammer.

The issues of the coupler frequently snagging on the edge of the steel plate and the center hole jack were resolved by grinding the long coupler nuts down on one end. This grinding created a tapered long nut that would slide more seamlessly past the different components of the extraction system.

Once the coupon was completely extracted, a soil sample was obtained. The inner plug was located approximately 5 inches inside the hole and in order to retrieve a sample, the inner plug was removed by inserting a bent rod through the hole in the plug that was left by the steel coupon and pulling the plug out. Approximately 250 grams of soil was then obtained and the container and soil were immediately weighed. The outer plug was then replaced to cover the hole.

3.3 Corrosion Lab Test Methods

The purpose of this study is to determine the extent of the zinc coating loss (i.e., reinforcement corrosion) that has occurred since Phase I. By comparing both sets of data, the rate of corrosion was determined. The methods used to evaluate metal loss as in Phase I are used again in this Phase II.

The zinc coating was measured using three methods. The primary method used to measure the zinc coating was by weight in general accordance with ASTM A90/A90M (ASTM 2018a). The weight method of measurement is considered to be more accurate and precise than the other methods and is therefore used in analysis and predictions for future corrosion behavior on the reinforcement in the walls in this study. The results of this method are used to calculate a rate of corrosion over the past 8 years.

The second method of measurement used the difference in diameter before and after acid stripping, i.e., the method specified in ASTM A90/A90M. This difference in diameter method is believed to not be as precise as the weight measurement method due to the bulking effect of zinc oxide. Oxidation of the galvanization expands the zinc layer, creating air voids between the zinc layer and the steel surface. The air voids would cause an inflated diameter reading and variation in the determination of the actual zinc present on the coupon. The difference in diameter method was used for comparison purposes only, and not for analysis and prediction of future corrosion rates. The thickness of zinc coating was also determined by a Magnetic Thickness Gauge. These three methods are described in more detail below.

3.3.1 By Weight

The method of determining the zinc coating thickness by weight was performed in general accordance with ASTM A90/A90M. Upon extraction of the steel coupons from the MSE walls, each sample was tagged with an identification number and transported back to the lab. The average conditions of the samples are represented by the samples shown in Figure 3-8. The majority of the coupons exhibited what was judged to be moderate to heavy zinc oxidation, but with minimal signs of steel corrosion or damage as shown in Figure 3-8a. A few samples showed light oxidation as shown in Figure 3-8b, whereas a few coupons had heavy mechanical damage as shown in Figure 3-8c.

Coupons that had heavy mechanical damage were likely damaged upon installation and not caused by movement in the soil backfill. These visual observations relate to the samples tested by Gerber and Billings (2010), which showed light oxidation present on the samples. The visual difference in the eight years since the first phase of this study is a change from light oxidation to moderate oxidation. This condition of the coupons is expected, as zinc oxidation will gradually increase with time until full depletion of the zinc coating.

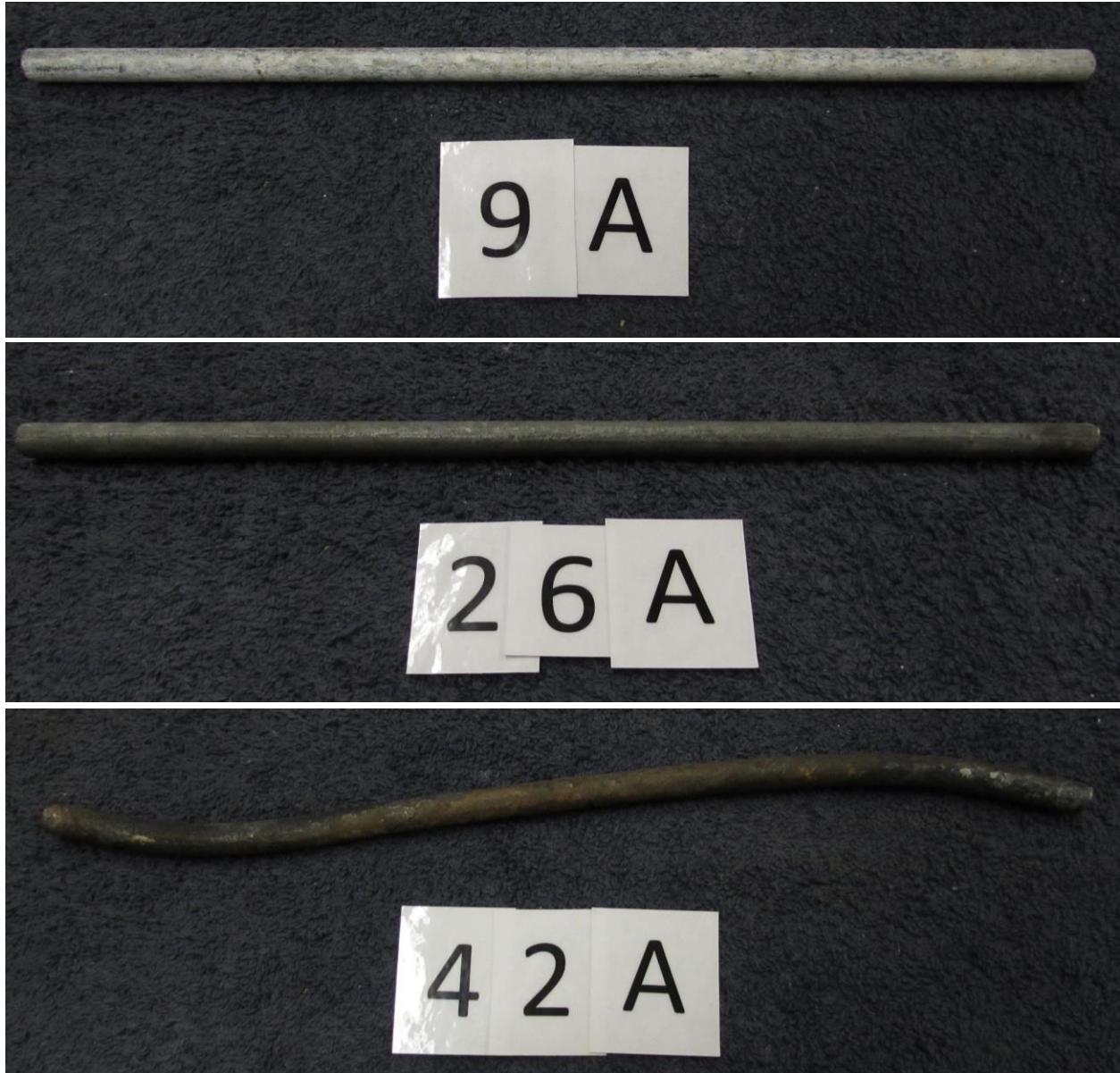

Figure 3-8: Typical Sample Conditions – Top (a), Middle (b), Bottom (c)

3.3.1.1 Sample Preparation

The steel coupons were cut into segments to facilitate lab testing and the qualitative measurement of corrosion due to distance of embedment from the concrete panel facing. Each coupon was punched (i.e., stamped) with a letter representing position along the coupon and a number denoting the coupon identification number. Figure 3-9 shows how each coupon was segmented. The first 12 inches of the coupon near the wall face and yet embedded in soil was

labeled sample “A”, the second 12 inches was labeled “B”. The third sample taken from each coupon was cut 24 inches from the end furthest from the concrete panel facing. This last sample was labeled “C”. The threaded portion of the coupon that was used for extraction purposes was cut off along with any coupon length that was not embedded in soil. For one-stage walls, the portion not embedded in soil was typically five inches. For two-stage walls, the portion not embedded in soil was typically about two feet. ASTM A90/A90M (ASTM 2018a) requires a minimum sample length of 12 inches for testing.

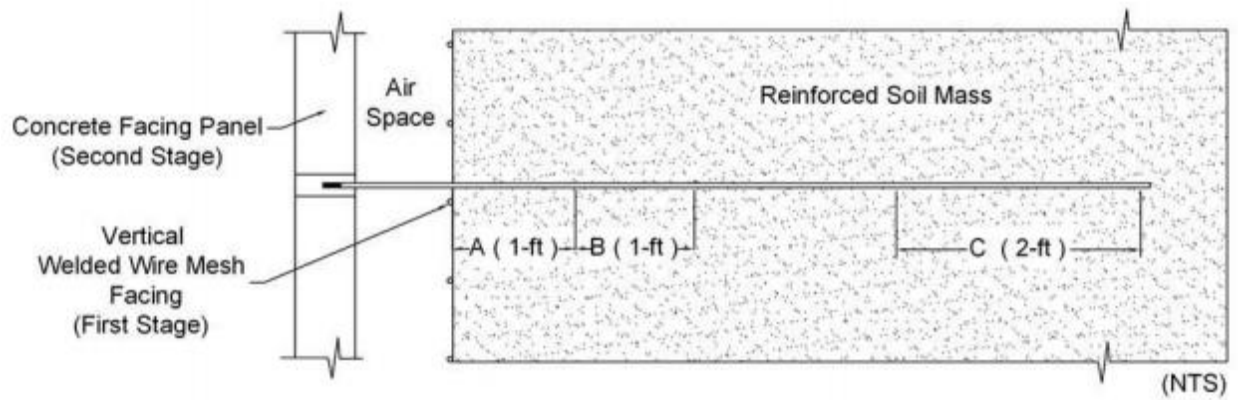

Figure 3-9: Coupon Segmentation

The physical side (end) of the sample with the stamped letter corresponds to the side of the sample that was closest to the concrete panel face. The side with the coupon identification number represents the side of the sample that was embedded deepest into the soil mass. After segmentation, a picture was taken of each sample; these pictures are presented in Appendix C. The samples were then washed in a xylol bath. Xylol is a volatile organic solvent used to remove any attached soil and very light oxidation prior to the acid stripping procedure. After the xylol bath, the samples were rinsed with denatured alcohol to remove the xylol.

3.3.1.2 Initial Measurements

Each sample was weighed to a precision of 0.01g using a small digital scale. The sample length was recorded using a tape measure to the nearest 1/16 of an inch. The diameter of each sample was measured five times at three different locations for a total of 15 measurements per

sample. The measurements were taken at each end and at the center of the sample. At each of the three locations along the length of the sample, the sample was rotated approximately 72° between each measurement. The average of all 15 measurements was used in analysis of the results. This was done to average out any abnormalities or bumps in the coating surface.

Some samples had extreme unevenness (i.e., extrusions or dripping) of the zinc galvanization. This is likely due to the hot dipping process for galvanization, which requires the sample to be dipped and then left to dry. The time it takes for the zinc to solidify could allow for some flow or dripping of the zinc coating, thus causing bumps in the coating as shown in Figure 3-10.

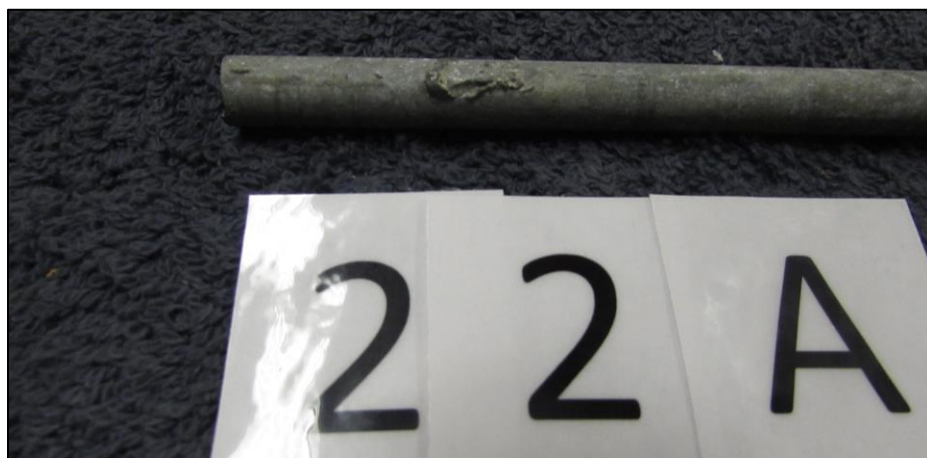

Figure 3-10: Zinc Coating Surface Abnormality

3.3.1.3 Acid Stripping

The zinc galvanization was stripped away in general accordance with ASTM A90/A90M. Due to the dangerous nature of hydrochloric acid, safety measures following the MSDS for the safe use of the chemical were followed. The acid stripping procedure was done in a ventilated fume hood, meeting OSHA safety requirements for volume of air flow. Respirator masks and gloves were worn during the procedure. Samples were placed and removed from the acid by tongs to avoid any contact with the acid. Once stripping was complete, the acid and other chemicals used in the procedure were properly and safely disposed.



Figure 3-11: Hydrochloric Acid Bath in Ventilated Fume Hood

Each sample was submerged in a 50% solution of hydrochloric acid and water for five minutes or until the stripping process was complete as indicated by the ceasing of bubbling from the chemical reaction as shown in Figure 3-11. The samples were placed in the acid solution with about one inch of space between each sample to allow the acid to contact each surface. Periodically during the five-minute bath, the samples were rotated using tongs to allow all surfaces to be stripped.

The chemical reaction of the hydrochloric acid with the zinc would slow down after using the same bath of acid for multiple batches of samples. If the chemical reaction was slowed such that the zinc coating was not being fully removed in the five-minute period, the acid was disposed of, and a bath of new acid was made. Once bubbling ceased the samples were removed from the acid bath and placed in a bath of distilled water. After soaking in the distilled water for five minutes, the samples were rinsed again with water and dried using microfiber towels.

After the acid stripping procedure was completed and the samples had dried, the samples were measured again for weight and diameter as described above in Section 3.3.1.2.

3.3.2 Diameter Difference

The diameter difference method of determining zinc coating thickness is susceptible to relatively high error and variation in measurements. This error and variation are due to physical limitations of the digital calipers in precisely engaging the surface of the zinc coating. Due to the micro-peaks and abnormalities of the surface, an accurate diameter that qualitatively represents the diameter along the entire length of the sample is difficult to obtain. The diameter of each sample was measured 15 times and averaged to normalize the surface abnormalities of the zinc coating. The diameter was measured again 15 times and averaged after the zinc coating was stripped.

The difference in the initial and final diameters was used as a measurement of zinc coating thickness only to compare results obtained from the other test methods. The results from the diameter difference method are not used to analyze the data and determine corrosion rates. This final diameter is considered to be a more accurate measurement because the stripped steel samples had smooth surfaces that rendered more consistent diameter readings. This value of final diameter is used in the weight method to determine zinc coating thickness.

3.3.3 Digital Measurement

The thickness of the zinc coating was also measured using a digital magnetic thickness gauge. The DeFelsko Positector 6000 device shown in Figure 3-12 was used as another method to verify that the results of zinc coating thickness determined using the weight method are in a reasonable range of accuracy. The results obtained from the digital measurements are not used to analyze the corrosion data; they are presented as a comparison to the weight method results.

The magnetic thickness gauge measures the change in magnetic flux density at the surface of a magnetic probe as it nears a steel surface. The magnitude of the flux density at the head of the probe is directly related to the distance to the surface of the steel. This distance between the probe and the surface of the steel is taken as the zinc coating thickness.

This test method does have similar limitations to that of the digital calipers. Because there are surface bumps and abnormalities, the digital readings of coating thicknesses can be variable along the length of each sample. In order to gather data that would represent the sample,

the digital measurements were taken at six locations along the sample. Two measurement locations were near one end (spaced about an inch apart), two in the middle, and two at the other end. At each of these six locations, measurements were taken at third points along the circumference of the sample for a total of 18 measurements. The 18 measurements were averaged for each sample to obtain a more accurate representation of the overall zinc coating thickness.



Figure 3-12: DeFelsko Positector 6000 device

3.4 Tensile Testing Procedures

The strength of the steel coupons was determined and used to evaluate if there was a reduction in the tensile strength from samples of Phase I to the samples of Phase II. A reduction in strength could indicate that there may be some pitting in the steel.

Tensile tests were not performed in the study by Gerber and Billings (2010). The samples that were extracted as part of their Phase I study were stored in a cool, dry location after

extraction and laboratory analysis, so corrosion was not present on stored samples. The Phase II samples were tested and compared to the samples tested from the extraction in Phase I.

3.4.1 Tension Testing Phase I Samples

Sixteen specimens from reinforcement coupons that were extracted in Phase I were tested to determine their yield and ultimate strengths. Eight specimens with the least amount of corrosion (Group X) and eight specimens with the most amount of corrosion (Group Y) were visually selected for testing.

The specimens in Group X were chosen based on their apparent lack of corrosion. Eight specimens were selected: four specimens had their galvanization stripped while four specimens were still galvanized. Each sample was 10 inches long. To ensure fracture of the specimens within a specific location along their lengths, approximately two inches of gage length in the middle of the specimens was ground down to reduce the diameter of the specimens; the reduced diameters were measured and used to calculate the cross-sectional area, which was then used to calculate stresses. The four specimens that were still galvanized during selection of the coupons to be tested had their galvanization removed along the gage length when the specimens were ground down to reduce their diameters. Fracture of all specimens in Group X occurred within the gage length where no galvanization was present.

The first four and second four of the Group X coupons proved to be identical (as would be expected) in the properties at their failure point. The fact that four were still galvanized and four were not had no effect on the results of the tension test because all failure locations did not have galvanization after the gauge length was ground down.

The specimens in Group Y were chosen based on their apparent relatively high degree of corrosion. Group Y consisted also of eight coupons: four with and four without galvanization. Unlike specimens in Group X, specimens in Group Y were not ground down to reduce their diameter along the gage length. Thus, specimens could fracture anywhere along their lengths. In fact, all but two specimens began necking and eventually fractured outside of the 2-inch gage length being monitored during the test. The strain in these six specimens was not measured after

their ultimate stress was reached. Diameters measured using digital calipers were used for stress calculations.

3.4.2 Tension Testing Phase II Samples

The 12-inch samples in segmented groups A and B (corresponding to the location in the wall as shown in Fig 3-9) were tested in tension after the acid stripping procedure. The diameter after stripping was used for calculations of yield and ultimate strengths. The samples were tested using an Instron Machine, shown in Figure 3-13, and loaded with a strain rate of 0.1 in/min to failure. Yield and ultimate stress values were determined using equation (3-1):

$$\sigma = F/A \quad (3-1)$$

where σ is the tensile stress in ksi, F is the measured force in kips, and A is the cross-sectional area of the sample in square inches.

Each sample was placed vertically in the testing machine shown in Figure 3-13. The head grips at the top and bottom of the sample gripped about two inches each leaving an eight-inch potential failure area. An extensometer was attached in the middle of the eight-inch failure length. The gauge length of the extensometer was two inches. The failure did not always occur in the region recorded by the extensometer. Therefore, when necking in the sample began to occur outside the gauge length, the recorded value of strain dropped to zero. The value of stress recorded and used for comparisons was not affected by lack of strain recorded by the extensometer.



Figure 3-13: Instron Testing Machine

3.5 Moisture Content Determination

The moisture content of soil samples taken from extraction holes was determined in general accordance with ASTM D2216-10 (ASTM 2019). The soil sample was weighed in the field on a portable digital scale. An aluminum foil lid was placed over the soil sample and the container was placed in a zip-lock bag and sealed. The sealed sample was then placed in a cooler to reduce moisture loss due to evaporation. The soil samples were transported to the laboratory and the weight of the soil and container were determined, as shown in Figure 3-14, before being put in the oven at $110^{\circ}\text{C} \pm 5^{\circ}\text{C}$.



Figure 3-14: Soil Weight Determination

The moisture content of the soil samples was determined using equation (3-2):

$$w = \left[\frac{W_w - W_d}{W_d} \right] * 100 \quad (3-2)$$

where w is the moisture content, W_w is the weight of the moist sample, and W_d is the weight of the dry sample.

4.0 TESTING RESULTS

4.1 Overview

The results obtained from the testing procedures described in the last chapter are presented in this chapter. The results are analyzed, interpreted, and discussed in the following chapter.

4.2 Pullout Force

As each coupon was extracted, the load was recorded during the entire extraction. In Figure 3-7, the response of the first and most complicated extraction accomplished was presented. In Figure 4-1, a more typical load vs. time response is presented.

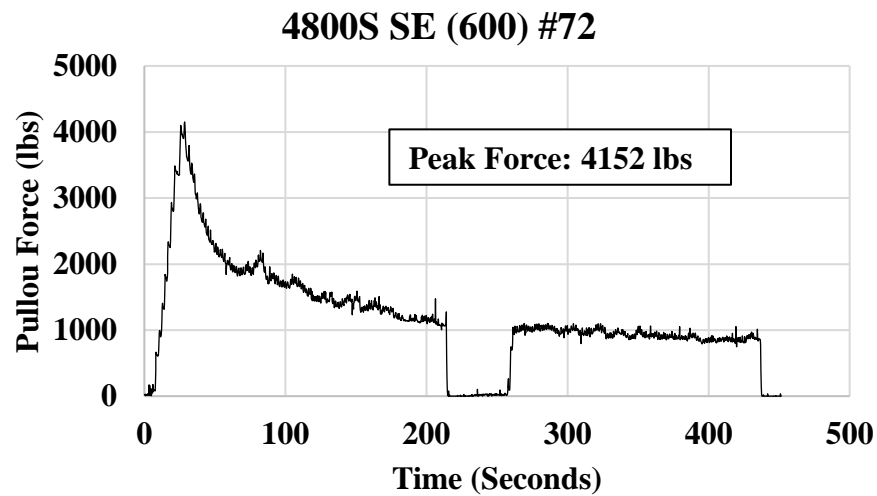

Figure 4-1: Pullout Force vs. Time for Trial Extraction

The peak force was used in comparisons to the following parameters: wall height above coupon, wall type, and coupon length. These parameters are listed in Table 4-1.

Table 4-1: Summary of Coupon Extraction Data

Coupon ID #	Wall Stage (1 or 2)	Overall Coupon Length (ft)	Embedded Length (ft)	Wall Height Above Coupon (ft)	Peak Pullout Force (kips)
1	1	6.5	6.0	15.2	3.56
2	1	6.5	6.0	10.2	4.17
3	1	6.5	6.0	10.2	4.60
4	1	10.0	9.5	7.3	5.41
5	1	10.3	9.8	6.7	5.99
6	1	8.0	7.7	11.0	6.43
7	1	8.0	7.6	6.0	6.14
8	1	8.0	7.6	6.0	7.18
9	1	6.5	6.1	11.9	4.28
10	1	6.5	6.2	6.9	2.10
11	1	6.5	6.3	6.9	3.24
12	1	7.9	7.6	7.5	0.50
13	1	10.0	9.6	6.7	1.44
14	1	10.3	10.3	9.5	5.31
15	1	10.3	9.9	35.0	4.60
16	1	10.0	9.6	35.0	5.47
17	1	6.5	6.1	30.0	2.28
18	1	6.5	6.1	30.0	2.14
19	1	6.5	6.1	35.0	3.33
20	1	10.0	9.6	35.0	6.86
21	1	10.3	9.9	35.0	5.44

Table 4-1: Continued

Coupon ID #	Wall Stage (1 or 2)	Overall Coupon Length (ft)	Embedded Length (ft)	Wall Height Above Coupon (ft)	Peak Pullout Force (kips)
22	2	8.0	6.0	19.5	0.50
23	2	8.0	6.0	14.5	0.98
24	2	8.0	6.0	14.5	1.76
25	2	8.0	6.0	9.5	1.08
26	2	8.0	6.0	9.5	1.02
27	1	6.5	6.1	11.6	5.32
28	1	6.5	6.1	6.6	4.69
29	1	6.5	6.1	6.6	4.25
30	1	6.5	6.1	11.6	4.53
31	1	6.5	6.1	11.6	3.78
32	1	6.5	6.1	6.6	4.94
33	1	6.5	6.1	6.6	4.06
34	1	6.5	6.2	12.4	7.20
35	1	6.5	6.3	7.4	6.20
36	1	6.5	6.3	7.4	3.67
37	1	6.5	6.0	5.0	6.14
38	1	6.5	6.1	5.0	7.35
39	1	6.5	6.1	10.0	2.56
40	1	6.5	6.0	10.0	5.43
41	1	8.3	8.0	4.5	2.26
42	1	7.6	7.3	4.5	1.85
43	1	8.0	7.6	7.0	2.29
44	1	8.0	7.6	7.0	3.27
45	1	6.5	6.2	9.4	1.29
46	1	10.0	9.5	13.2	6.89

Table 4-1: Continued

Coupon ID #	Wall Stage (1 or 2)	Overall Coupon Length (ft)	Embedded Length (ft)	Wall Height Above Coupon (ft)	Peak Pullout Force (kips)
47	1	8.0	7.7	17.3	5.53
48	1	8.0	7.8	12.3	5.29
49	1	8.0	7.6	12.3	5.49
50	1	10.0	9.7	8.5	7.17
51	1	10.1	9.7	8.5	5.65
52	1	6.5	6.2	7.9	1.47
53	1	6.5	6.1	7.9	2.87
54	2	8.0	6.1	13.5	1.10
55	2	8.0	6.1	8.5	0.92
56	2	10.0	8.5	8.7	1.92
57	2	10.0	8.3	13.3	1.01
58	2	10.3	8.6	18.0	1.96
59	1	6.5	6.3	4.5	1.24*
60	1	6.5	6.3	4.5	1.24
61	2	10.0	8.0	13.1	1.02
62	1	6.5	6.2	8.6	1.79
63	1	6.5	6.4	13.6	2.11
64	1	6.5	6.1	8.6	2.99
65	1	6.5	6.3	13.6	2.47
66	1	6.5	6.2	14.2	2.10
67	1	6.5	6.2	14.2	2.64
68	1	6.5	6.1	9.2	5.90
69	1	6.5	6.2	9.2	3.56
70	1	8.0	7.7	8.8	3.85
71	1	8.0	7.7	8.8	2.92

*Load for coupon #59 was estimated to be the same as the adjacent coupon #60

Table 4-1: Continued

Coupon ID #	Wall Stage (1 or 2)	Overall Coupon Length (ft)	Embedded Length (ft)	Wall Height Above Coupon (ft)	Peak Pullout Force (kips)
72	1	10.0	9.7	13.8	4.15
73	1	10.0	9.6	13.8	5.04
74	1	10.3	9.8	7.4	5.54
75	1	10.3	9.9	7.4	3.76
76	1	6.5	6.2	9.7	4.53
77	1	6.5	6.3	9.7	5.20
78	1	6.5	6.2	7.1	3.66
79	1	6.5	6.1	7.1	2.19
80	2	10.0	7.9	20.0	1.24
81	2	10.0	7.8	20.0	1.66
82	2	10.3	8.3	6.7	0.96
83	2	10.0	8.0	6.7	1.40
84	2	10.0	8.5	12.9	1.81
85	2	10.3	8.8	12.9	2.00

4.3 Corrosion Results

The thickness of zinc coating on each sample was determined in order to compare the current zinc coating thickness to the zinc coating thickness obtained by Gerber and Billings (2010). By comparing these data points, a corrosion rate (loss of zinc coating) over the past eight years was developed. The obtained corrosion rate is later compared in Chapter 5 to the AASHTO design rate for zinc depletion to determine if the MSE wall reinforcement is being depleted at a rate that might require mitigation or reconstruction.

As discussed in Section 3.3, the method used in analyzing the data and making comparisons to past data as well as projecting corrosion rates is the weight method as described

in ASTM A90/A90M. The results of all three methods of zinc coating thickness determination that were performed are presented. However, the digital measurement method and the diameter difference method are not used in subsequent analyses.

4.3.1 Weight Method

After following the procedures stated in Section 3.3, the zinc coating remaining on the steel samples after being embedded in MSE walls for 20 years was determined using equation (4-1):

$$C = \left[\frac{W_i - W_f}{W_f} \right] * D * M \quad (4-1)$$

where C is the coating thickness in oz/ft², W_i is the initial weight in grams, W_f is the final weight in grams, D is the diameter of the stripped samples in inches, and M is a constant equal to 163 (ASTM 2018a). The results of the coating thickness measurements are shown in Table 4-2.

Table 4-2: Zinc Coating by Weight

Zinc Coating by Weight [oz/ft² (mil)]				
Coupon ID	Sections Along Coupon Length			Average
	A	B	C	
1	2.78 (4.7)	2.54 (4.3)	2.23 (3.8)	2.45 (4.2)
2	2.89 (4.9)	2.85 (4.8)	1.97 (3.3)	2.42 (4.1)
3	2.89 (4.9)	3.09 (5.2)	2.14 (3.6)	2.56 (4.4)
4	2.73 (4.6)	2.95 (5.0)	2.20 (3.7)	2.52 (4.3)
5	2.59 (4.4)	2.78 (4.7)	2.25 (3.8)	2.47 (4.2)

Table 4-2: Continued

Zinc Coating by Weight [oz/ft² (mil)]				
Coupon ID	Sections Along Coupon Length			Average
	A	B	C	
6	3.02 (5.1)	3.24 (5.5)	3.31 (5.6)	3.22 (5.5)
7	3.89 (6.6)	3.51 (6.0)	2.84 (4.8)	3.27 (5.6)
8	3.39 (5.8)	3.42 (5.8)	3.45 (5.9)	3.43 (5.8)
9	2.31 (3.9)	2.19 (3.7)	2.61 (4.4)	2.43 (4.1)
10	3.00 (5.1)	2.72 (4.6)	2.88 (4.9)	2.87 (4.9)
11	2.74 (4.7)	2.67 (4.5)	3.40 (5.8)	3.05 (5.2)
12	3.86 (6.6)	3.62 (6.2)	3.24 (5.5)	3.49 (5.9)
13	2.50 (4.3)	2.50 (4.3)	2.46 (4.2)	2.48 (4.2)
14	2.59 (4.4)	2.44 (4.2)	2.24 (3.8)	2.38 (4.0)
15	2.89 (4.9)	2.94 (5.0)	2.54 (4.3)	2.72 (4.6)
16	3.04 (5.2)	3.32 (5.7)	2.68 (4.5)	2.93 (5.0)
17	2.90 (4.9)	2.92 (5.0)	3.11 (5.3)	3.01 (5.1)
18	2.41 (4.1)	2.55 (4.3)	2.59 (4.4)	2.53 (4.3)
19	2.79 (4.7)	2.93 (5.0)	3.03 (5.2)	2.95 (5.0)
20	2.30 (3.9)	2.31 (3.9)	1.83 (3.1)	2.07 (3.5)
21	2.96 (5.0)	2.78 (4.7)	2.55 (4.3)	2.71 (4.6)
22	3.69 (6.3)	3.72 (6.3)	3.41 (5.8)	3.56 (6.0)
23	3.94 (6.7)	3.81 (6.5)	3.63 (6.2)	3.75 (6.4)
24	3.57 (6.1)	3.68 (6.2)	3.75 (6.4)	3.68 (6.3)
25	3.49 (5.9)	3.88 (6.6)	3.73 (6.3)	3.71 (6.3)
26	4.15 (7.1)	4.07 (6.9)	3.36 (5.7)	3.74 (6.4)
27	2.26 (3.8)	2.09 (3.6)	2.20 (3.7)	2.19 (3.7)
28	2.26 (3.8)	2.03 (3.4)	2.15 (3.7)	2.15 (3.6)
29	2.18 (3.7)	2.10 (3.6)	2.34 (4.0)	2.24 (3.8)
30	2.81 (4.8)	2.14 (3.6)	2.35 (4.0)	2.41 (4.1)

Table 4-2: Continued

Zinc Coating by Weight [oz/ft² (mil)]				
Coupon ID	Sections Along Coupon Length			Average
	A	B	C	
31	2.33 (4.0)	2.46 (4.2)	2.12 (3.6)	2.26 (3.8)
32	2.32 (3.9)	2.19 (3.7)	2.35 (4.0)	2.30 (3.9)
33	2.03 (3.5)	2.10 (3.6)	2.30 (3.9)	2.18 (3.7)
34	2.70 (4.6)	2.28 (3.9)	2.63 (4.5)	2.56 (4.4)
35	2.31 (3.9)	1.97 (3.3)	1.85 (3.1)	1.99 (3.4)
36	2.45 (4.2)	2.30 (3.9)	2.40 (4.1)	2.39 (4.1)
37	0.34 (0.6)	1.23 (2.1)	2.19 (3.7)	1.49 (2.5)
38	1.36 (2.3)	1.09 (1.8)	1.77 (3.0)	1.50 (2.5)
39	2.50 (4.2)	2.20 (3.7)	2.01 (3.4)	2.18 (3.7)
40	2.60 (4.4)	2.19 (3.7)	1.91 (3.2)	2.15 (3.7)
41	2.76 (4.7)	3.79 (6.4)	3.11 (5.3)	3.19 (5.4)
42	0.50 (0.9)	0.83 (1.4)	1.84 (3.1)	1.25 (2.1)
43	3.53 (6.0)	3.96 (6.7)	3.87 (6.6)	3.81 (6.5)
44	3.45 (5.9)	3.90 (6.6)	3.14 (5.3)	3.41 (5.8)
45	2.67 (4.5)	2.92 (5.0)	2.86 (4.9)	2.83 (4.8)
46	2.80 (4.8)	3.13 (5.3)	2.51 (4.3)	2.74 (4.7)
47	3.39 (5.8)	3.40 (5.8)	3.48 (5.9)	3.44 (5.8)
48	3.58 (6.1)	3.21 (5.5)	3.36 (5.7)	3.38 (5.7)
49	3.36 (5.7)	3.30 (5.6)	3.42 (5.8)	3.37 (5.7)
50	2.76 (4.7)	2.61 (4.4)	2.18 (3.7)	2.43 (4.1)
51	2.95 (5.0)	2.85 (4.8)	2.34 (4.0)	2.62 (4.5)
52	2.66 (4.5)	2.31 (3.9)	2.76 (4.7)	2.62 (4.5)
53	2.93 (5.0)	2.44 (4.2)	2.56 (4.3)	2.62 (4.5)
54	3.77 (6.4)	3.99 (6.8)	3.53 (6.0)	3.70 (6.3)
55	3.46 (5.9)	3.65 (6.2)	3.78 (6.4)	3.66 (6.2)

Table 4-2: Continued

Zinc Coating by Weight [oz/ft² (mil)]				
Coupon ID	Sections Along Coupon Length			Average
	A	B	C	
56	2.63 (4.5)	2.59 (4.4)	2.27 (3.9)	2.44 (4.2)
57	2.60 (4.4)	2.64 (4.5)	2.54 (4.3)	2.58 (4.4)
58	2.65 (4.5)	2.96 (5.0)	2.86 (4.9)	2.84 (4.8)
59	3.06 (5.2)	2.69 (4.6)	2.36 (4.0)	2.62 (4.5)
60	2.49 (4.2)	2.51 (4.3)	2.80 (4.8)	2.65 (4.5)
61	2.61 (4.4)	2.41 (4.1)	2.48 (4.2)	2.49 (4.2)
62	3.02 (5.1)	2.68 (4.6)	2.74 (4.7)	2.80 (4.8)
63	3.30 (5.6)	3.53 (6.0)	2.98 (5.1)	3.20 (5.4)
64	3.03 (5.2)	2.87 (4.9)	2.90 (4.9)	2.93 (5.0)
65	2.60 (4.4)	2.54 (4.3)	3.05 (5.2)	2.81 (4.8)
66	2.56 (4.4)	2.71 (4.6)	2.87 (4.9)	2.75 (4.7)
67	2.78 (4.7)	2.54 (4.3)	2.40 (4.1)	2.53 (4.3)
68	2.78 (4.7)	2.76 (4.7)	2.79 (4.7)	2.78 (4.7)
69	2.84 (4.8)	2.80 (4.8)	2.71 (4.6)	2.76 (4.7)
70	3.67 (6.2)	4.00 (6.8)	3.54 (6.0)	3.69 (6.3)
71	3.89 (6.6)	4.05 (6.9)	3.76 (6.4)	3.87 (6.6)
72	2.44 (4.2)	2.46 (4.2)	2.12 (3.6)	2.29 (3.9)
73	2.82 (4.8)	2.71 (4.6)	2.50 (4.3)	2.63 (4.5)
74	2.70 (4.6)	2.57 (4.4)	2.35 (4.0)	2.49 (4.2)
75	2.93 (5.0)	2.97 (5.1)	2.43 (4.1)	2.69 (4.6)
76	1.39 (2.4)	1.61 (2.7)	0.89 (1.5)	1.20 (2.0)
77	0.35 (0.6)	1.16 (2.0)	0.62 (1.1)	0.69 (1.2)
78	2.92 (5.0)	2.72 (4.6)	2.16 (3.7)	2.49 (4.2)
79	2.65 (4.5)	2.11 (3.6)	2.22 (3.8)	2.30 (3.9)
80	2.71 (4.6)	2.67 (4.5)	2.75 (4.7)	2.72 (4.6)

Table 4-2: Continued

Zinc Coating by Weight [oz/ft² (mil)]				
Coupon ID	Sections Along Coupon Length			Average
	A	B	C	
81	2.81 (4.8)	2.79 (4.7)	2.50 (4.3)	2.65 (4.5)
82	2.69 (4.6)	2.56 (4.4)	2.37 (4.0)	2.50 (4.2)
83	2.80 (4.8)	2.25 (3.8)	2.21 (3.8)	2.36 (4.0)
84	3.19 (5.4)	3.50 (5.9)	2.96 (5.0)	3.15 (5.4)
85	3.02 (5.1)	2.83 (4.8)	2.33 (4.0)	2.63 (4.5)
Average	2.78 (4.7)	2.77 (4.7)	2.64 (4.5)	2.71 (4.6)
CV (%)	24.5	24.6	22.9	23.7
Median	2.78 (4.7)	2.71 (4.6)	2.54 (4.3)	2.64 (4.5)

The average zinc coating determined by the weight method for all samples is 2.71 oz/ft² (4.6 mils). A comparison of these samples and calculation of a corrosion rate (or loss of zinc) is obtained and discussed in Section 5.3. Segments C are two-foot-long while segments A and B are one-foot-long samples; thus, the group C samples are double weighted.

4.3.2 Diameter Difference and Magnetic Measurement

The results from both the diameter difference and the magnetic measurement methods are shown in Table 4-3 and Figure 4-2. The weight method is shown for comparison purposes. For determination of zinc coating thickness using the diameter difference method, equation (4-2) was used:

$$C = \left[\frac{D_i - D_f}{2} \right] * 1000 * X \quad (4-2)$$

where C is the coating thickness in oz/ft², D_i is the initial diameter in inches, D_f is the final stripped diameter in inches, 1000 is used to convert inches to mils, and X is a conversion factor from mils to oz/ft² equal to 0.588.

The results from the magnetic measurement method are obtained in mils from the DeFelsko Positector 6000 and converted to oz/ft² for comparison.

Figure 4-2 is a visual representation of the thickness measurements using all three methods. As mentioned in Section 3.3.2, the diameter difference method has the most variability. The coefficients of variation for the zinc coating thicknesses from weight, magnetic, and diameter methods are 23.7, 20.6, and 54.1% respectively.

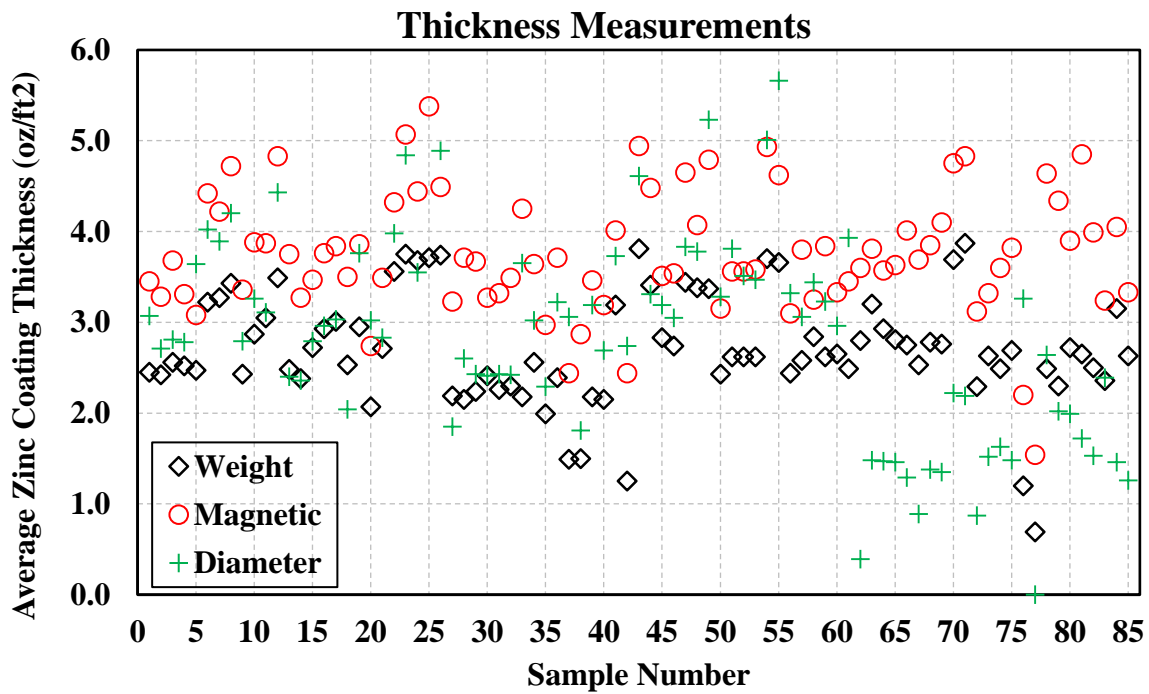

Figure 4-2: Average Zinc Coating Thickness for All Measurement Methods

In addition to the potential error that occurs when measuring a rough surface with digital calipers, the significant decrease in coating thickness for the diameter method observable for samples 62 and higher is likely attributed to different personnel making the measurements. As neither the weight nor the magnetic methods use the initial diameter in their calculation of zinc coating thicknesses, the variability shown in the diameter method is not observed in the other methods. As discussed in Section 3.3, only the weight method is used in the analysis of corrosion rates. This variance in the data does, however, suggest the benefits of having all testing performed by the same individual (tester).

Table 4-3: Zinc Coating All Methods

Average Coating Thickness Measurements [oz/ft² (mil)]			
Coupon ID	By Weight	Magnetic Measurement	Diameter Difference
1	2.45 (4.2)	3.45 (5.9)	3.07 (5.2)
2	2.42 (4.1)	3.28 (5.6)	2.71 (4.6)
3	2.56 (4.4)	3.68 (6.3)	2.81 (4.8)
4	2.52 (4.3)	3.31 (5.6)	2.78 (4.7)
5	2.47 (4.2)	3.08 (5.2)	3.64 (6.2)
6	3.22 (5.5)	4.42 (7.5)	4.02 (6.8)
7	3.27 (5.6)	4.22 (7.2)	3.89 (6.6)
8	3.43 (5.8)	4.72 (8.0)	4.20 (7.1)
9	2.43 (4.1)	3.36 (5.7)	2.79 (4.7)
10	2.87 (4.9)	3.88 (6.6)	3.26 (5.5)
11	3.05 (5.2)	3.87 (6.6)	3.11 (5.3)
12	3.49 (5.9)	4.83 (8.2)	4.43 (7.5)
13	2.48 (4.2)	3.75 (6.4)	2.40 (4.1)
14	2.38 (4.0)	3.27 (5.6)	2.36 (4.0)
15	2.72 (4.6)	3.47 (5.9)	2.79 (4.7)

Table 4-3: Continued

Average Coating Thickness Measurements [oz/ft² (mil)]			
Coupon ID	By Weight	Magnetic Measurement	Diameter Difference
16	2.93 (5.0)	3.76 (6.4)	2.96 (5.0)
17	3.01 (5.1)	3.84 (6.5)	3.03 (5.2)
18	2.53 (4.3)	3.50 (5.9)	2.04 (3.5)
19	2.95 (5.0)	3.86 (6.6)	3.76 (6.4)
20	2.07 (3.5)	2.74 (4.7)	3.02 (5.1)
21	2.71 (4.6)	3.49 (5.9)	2.83 (4.8)
22	3.56 (6.0)	4.32 (7.4)	3.98 (6.8)
23	3.75 (6.4)	5.07 (8.6)	4.84 (8.2)
24	3.68 (6.3)	4.44 (7.6)	3.55 (6.0)
25	3.71 (6.3)	5.38 (9.2)	6.12 (10.4)
26	3.74 (6.4)	4.49 (7.6)	4.89 (8.3)
27	2.19 (3.7)	3.23 (5.5)	1.85 (3.2)
28	2.15 (3.6)	3.71 (6.3)	2.60 (4.4)
29	2.24 (3.8)	3.67 (6.2)	2.43 (4.1)
30	2.41 (4.1)	3.27 (5.6)	2.41 (4.1)
31	2.26 (3.8)	3.32 (5.6)	2.43 (4.1)
32	2.30 (3.9)	3.49 (5.9)	2.42 (4.1)
33	2.18 (3.7)	4.25 (7.2)	3.65 (6.2)
34	2.56 (4.4)	3.64 (6.2)	3.02 (5.1)
35	1.99 (3.4)	2.97 (5.0)	2.29 (3.9)
36	2.39 (4.1)	3.71 (6.3)	3.22 (5.5)
37	1.49 (2.5)	2.44 (4.2)	3.06 (5.2)
38	1.50 (2.5)	2.87 (4.9)	1.81 (3.1)
39	2.18 (3.7)	3.46 (5.9)	3.19 (5.4)
40	2.15 (3.7)	3.19 (5.4)	2.69 (4.6)

Table 4-3: Continued

Average Coating Thickness Measurements [oz/ft² (mil)]			
Coupon ID	By Weight	Magnetic Measurement	Diameter Difference
41	3.19 (5.4)	4.01 (6.8)	3.73 (6.3)
42	1.25 (2.1)	2.44 (4.1)	2.74 (4.7)
43	3.81 (6.5)	4.94 (8.4)	4.61 (7.8)
44	3.41 (5.8)	4.48 (7.6)	3.31 (5.6)
45	2.83 (4.8)	3.51 (6.0)	3.19 (5.4)
46	2.74 (4.7)	3.54 (6.0)	3.05 (5.2)
47	3.44 (5.8)	4.65 (7.9)	3.83 (6.5)
48	3.38 (5.7)	4.07 (6.9)	3.78 (6.4)
49	3.37 (5.7)	4.79 (8.1)	5.23 (8.9)
50	2.43 (4.1)	3.15 (5.4)	3.28 (5.6)
51	2.62 (4.5)	3.56 (6.1)	3.81 (6.5)
52	2.62 (4.5)	3.56 (6.1)	3.51 (6.0)
53	2.62 (4.5)	3.58 (6.1)	3.47 (5.9)
54	3.70 (6.3)	4.93 (8.4)	5.01 (8.5)
55	3.66 (6.2)	4.62 (7.8)	5.66 (9.6)
56	2.44 (4.2)	3.10 (5.3)	3.32 (5.6)
57	2.58 (4.4)	3.80 (6.5)	3.06 (5.2)
58	2.84 (4.8)	3.25 (5.5)	3.44 (5.8)
59	2.62 (4.5)	3.84 (6.5)	3.23 (5.5)
60	2.65 (4.5)	3.33 (5.7)	2.96 (5.0)
61	2.49 (4.2)	3.45 (5.9)	3.93 (6.7)
62	2.80 (4.8)	3.60 (6.1)	0.39 (0.7)
63	3.20 (5.4)	3.81 (6.5)	1.48 (2.5)
64	2.93 (5.0)	3.57 (6.1)	1.47 (2.5)
65	2.81 (4.8)	3.63 (6.2)	1.46 (2.5)

Table 4-3: Continued

Average Coating Thickness Measurements [oz/ft² (mil)]			
Coupon ID	By Weight	Magnetic Measurement	Diameter Difference
66	2.75 (4.7)	4.01 (6.8)	1.29 (2.2)
67	2.53 (4.3)	3.69 (6.3)	0.89 (1.5)
68	2.78 (4.7)	3.85 (6.5)	1.38 (2.3)
69	2.76 (4.7)	4.1 (7.0)	1.35 (2.3)
70	3.69 (6.3)	4.75 (8.1)	2.22 (3.8)
71	3.87 (6.6)	4.83 (8.2)	2.19 (3.7)
72	2.29 (3.9)	3.12 (5.3)	0.87 (1.5)
73	2.63 (4.5)	3.32 (5.7)	1.52 (2.6)
74	2.49 (4.2)	3.60 (6.1)	1.63 (2.8)
75	2.69 (4.6)	3.82 (6.5)	1.48 (2.5)
76	1.20 (2.0)	2.20 (3.7)	3.26 (5.5)
77	0.69 (1.2)	1.54 (2.6)	0.00 (0.0)*
78	2.49 (4.2)	4.64 (7.9)	2.64 (4.5)
79	2.30 (3.9)	4.34 (7.4)	2.02 (3.4)
80	2.72 (4.6)	3.90 (6.6)	1.99 (3.4)
81	2.65 (4.5)	4.85 (8.2)	1.72 (2.9)
82	2.50 (4.2)	3.99 (6.8)	1.53 (2.6)
83	2.36 (4.0)	3.24 (5.5)	2.39 (4.1)
84	3.15 (5.4)	4.05 (6.9)	1.46 (2.5)
85	2.63 (4.5)	3.33 (5.7)	1.26 (2.1)
Average	2.71 (4.6)	3.75 (6.4)	2.85 (4.8)
CV (%)	23.7	20.6	54.1
Median	2.64 (4.5)	3.68 (6.3)	2.88 (4.9)

* This coupon experienced significant corrosion, so there was not much zinc present on the coupon when extracted. The coupon surface had large variations in roughness, peaks, and crests. For all 3 sections of the sample (Group A, B, and C) the diameter measured by the calipers was either negative (not actually possible) or zero. This is due to the fact that there was so much variation in the surface thickness along the length of the sample, and the average before and after stripping the zinc could not be taken at the exact same location along the length of the sample by the calipers, the value was taken as zero rather than a negative number.

4.4 Tension Testing

Samples were tested from both the Phase I extraction and Phase II extraction.

4.4.1 Tension Results from Phase I Samples

The results for Group X of the Phase I samples are shown in Figure 4-3 and summarized in Table 4-4. The results for Group Y of the Phase I samples are shown in Figure 4-4 and summarized in Table 4-5. The results from Group X and Group Y of the Phase I samples are used as a baseline comparison for the tension results of the Phase II samples.

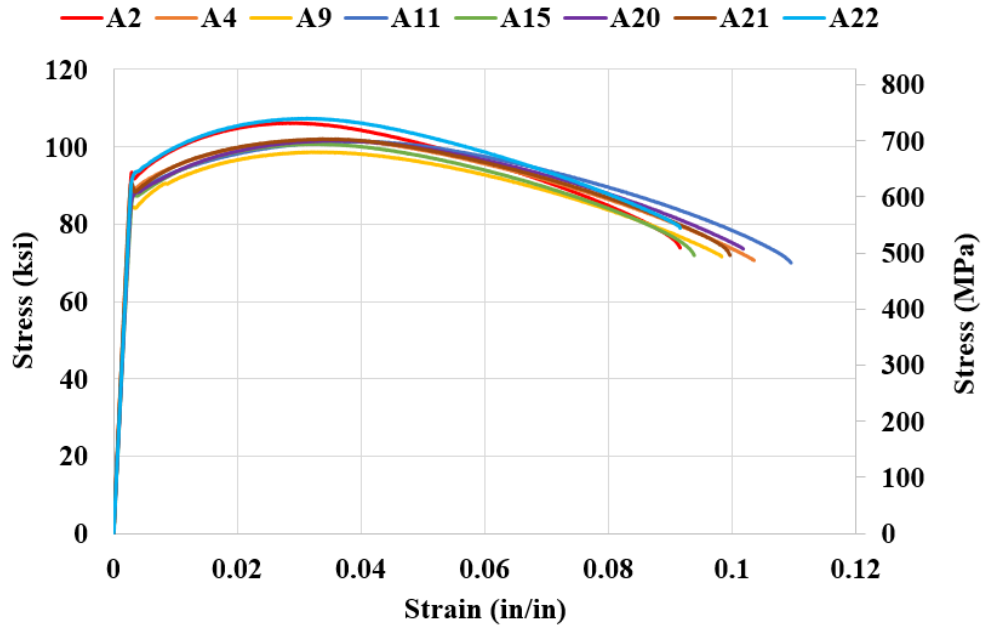

Figure 4-3: Stress-Strain Curve for Phase I Samples Group X

Table 4-4: Yield Stress and Ultimate Stress for Phase I Samples Group X

Specimen ID	F _y		F _u		Original Galvanization Present	Galvanized Gage Length
	ksi	MPa	ksi	MPa		
A2	93.4	644.0	106.2	732.1	No	No
A4	87.0	599.8	101.8	702.2		
A15	87.4	602.4	100.7	694.4		
A20	87.6	603.8	101.6	700.8		
Average	88.8	612.5	102.6	707.4		
A9	84.3	581.3	98.6	680.1	Yes	No
A11	88.4	609.4	101.4	699.4		
A21	90.7	625.5	102.0	703.5		
A22	93.6	645.7	107.4	740.3		
Average	89.3	615.5	102.4	705.8		
Overall Average	89.1	614.0	102.5	706.6		

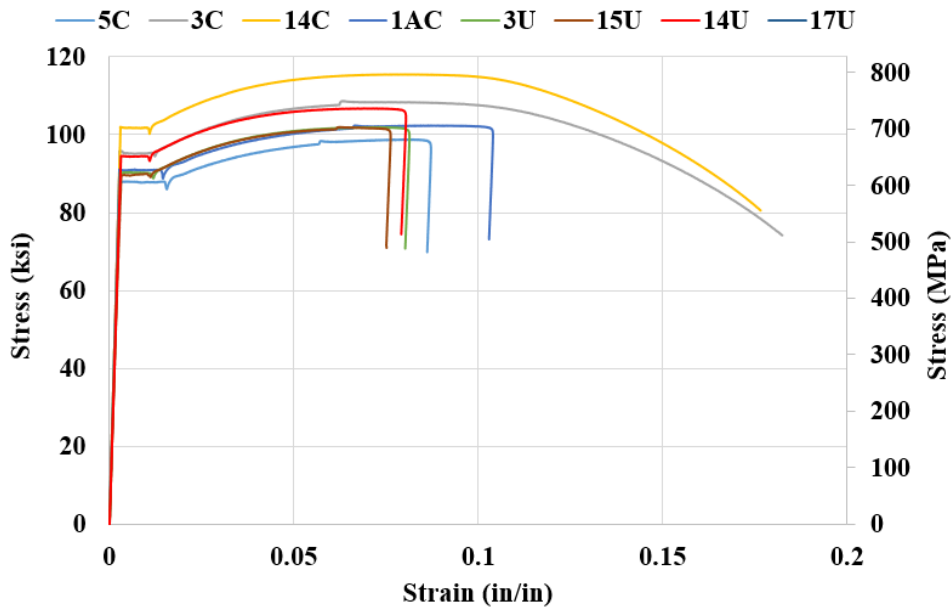

Figure 4-4: Stress-Strain Curve for Phase I Samples Group Y

Table 4-5: Yield Stress and Ultimate Stress for Phase I Samples Group Y

Specimen ID	F _y		F _u		Original Galvanization Present	Galvanized Gage Length
	ksi	MPa	ksi	MPa		
5C	87.9	606.1	97.6	672.7		
3C	95.2	656.6	108.7	749.2		
14C	101.7	701.4	115.5	796.2	No	No
1AC	90.9	626.6	101.7	701.1		
Average	93.9	647.7	105.8	729.8		
3U	90.2	621.6	101.9	702.9		
15U	89.5	616.8	102.0	703.0		
14U	94.0	648.4	106.8	736.1	Yes	Yes
17U	88.9	613.0	100.1	690.0		
Average	90.6	625.0	102.7	708.0		
Overall Average	92.3	636.3	104.3	718.9		

4.4.2 Tension Results from Phase II Samples

The results of tensile stress from the Phase II samples are shown in Table 4-6.

Table 4-6: Yield and Ultimate Stress of Tension Tests Groups A and B

Coupon ID	Group A		Group B	
	Yield (ksi)	Ultimate (ksi)	Yield (ksi)	Ultimate (ksi)
1	69.84	95.34	85.58	95.49
2	85.00	96.11	85.45	95.60
3	83.56	94.21	84.22	94.82
4	93.95	105.41	92.90	105.87
5	90.17	101.29	89.85	101.16

Table 4-6: Continued

Coupon ID	Group A		Group B	
	Yield (ksi)	Ultimate (ksi)	Yield (ksi)	Ultimate (ksi)
6	90.71	102.49	89.74	101.73
7	90.02	102.05	89.97	102.01
8	91.24	103.11	89.46	101.07
9	85.67	95.84	84.61	94.69
10	86.02	96.63	85.00	95.53
11	85.27	95.65	85.35	94.98
12	89.67	102.02	90.20	102.53
13	94.33	106.46	92.66	105.46
14	88.65	100.45	88.27	100.14
15	89.02	100.86	89.83	101.32
16	97.30	109.28	97.05	109.45
17	72.09	96.75	85.93	95.61
18	86.50	96.59	84.90	95.07
19	85.01	95.16	85.49	95.91
20	92.59	106.78	93.76	106.31
21	89.39	101.18	89.64	101.48
22	90.01	102.03	89.23	101.58
23	89.45	101.71	90.11	102.12
24	89.54	101.56	89.64	101.96
25	90.27	102.00	90.14	101.86
26	90.13	102.09	89.10	101.08
27	85.20	95.40	85.73	95.54
28	84.12	94.26	84.85	95.12
29	85.26	95.70	85.25	95.66
30	85.33	95.81	84.44	95.13
31	85.19	95.63	84.83	94.55
32	85.71	95.84	84.84	94.60

Table 4-6: Continued

Coupon ID	Group A		Group B	
	Yield (ksi)	Ultimate (ksi)	Yield (ksi)	Ultimate (ksi)
33	83.90	93.86	84.26	94.25
34	86.54	97.05	85.65	95.46
35	84.36	94.15	84.40	95.14
36	86.39	96.41	85.54	95.91
37	84.82	92.78	81.75	88.22
38	86.37	96.00	81.11	91.86
39	84.78	94.57	84.46	94.68
40	84.91	95.16	84.68	94.85
41	89.45	102.44	90.40	102.59
42	84.11	99.71	89.93	100.67
43	91.64	103.64	90.04	102.06
44	90.65	102.62	90.89	102.75
45	86.41	96.93	86.42	96.52
46	95.07	107.63	93.80	106.34
47	90.45	102.51	90.31	102.45
48	90.70	102.46	90.60	102.94
49	90.13	101.93	90.09	102.03
50	95.41	108.13	95.70	108.32
51	95.52	107.81	95.37	107.70
52	85.30	95.65	85.20	95.61
53	83.05	94.90	84.96	95.63
54	90.34	102.58	89.83	101.90
55	90.39	102.23	90.62	102.57
56	94.60	107.95	95.82	108.03
57	89.34	101.69	88.51	100.50
58	86.78	100.57	89.16	101.10
59	85.53	95.93	84.12	95.58

Table 4-6: Continued

Coupon ID	Group A		Group B	
	Yield (ksi)	Ultimate (ksi)	Yield (ksi)	Ultimate (ksi)
60	85.48	96.17	84.69	94.53
61	96.13	108.71	95.16	107.25
62	79.82	89.51	80.58	90.67
63	81.77	91.42	80.81	90.85
64	80.84	91.07	80.90	91.36
65	81.72	91.86	82.09	92.08
66	82.14	92.11	80.98	90.75
67	82.50	92.51	82.09	91.88
68	81.03	92.15	75.00	92.39
69	81.73	92.31	81.93	92.15
70	86.33	97.71	86.65	98.00
71	86.48	97.85	86.98	98.22
72	91.04	102.88	90.92	103.14
73	90.06	102.17	90.53	102.52
74	85.50	97.06	82.73	97.64
75	86.52	97.75	86.31	97.14
76	81.47	92.55	67.09	74.37
77	77.48	84.24	68.58	75.06
78	82.23	92.04	82.11	92.26
79	82.40	92.91	82.21	91.79
80	85.42	97.18	86.34	97.96
81	89.79	102.04	90.46	102.77

Table 4-6: Continued

Coupon ID	Group A		Group B	
	Yield (ksi)	Ultimate (ksi)	Yield (ksi)	Ultimate (ksi)
82	86.81	98.00	87.01	97.73
83	90.83	102.71	91.26	103.07
84	89.97	102.60	90.67	102.94
85	86.69	97.90	86.89	97.94
Average	87.00	98.57	86.85	97.97
CV (%)	5.5	5.1	5.8	6.1
Median	86.48	97.71	86.42	97.73

4.5 Moisture Content

The results of the laboratory determination of moisture content are shown in Table 4-7. Researchers were not able to obtain soil samples from two-stage walls; therefore, no value for moisture content is shown for coupon ID's related to two-stage walls. The average, maximum, minimum, and coefficient of variation for the moisture content results are shown in Table 4-8.

Table 4-7: Moisture Content Results

Coupon ID #	Moisture Content (%)
1	4.7
2	4.1
3	4.5
4	3.8
5	4.8
6	5.4

Table 4-7: Continued

Coupon ID #	Moisture Content (%)
7	3.8
8	4.2
9	5.5
10	4.5
11	5.0
12	6.9
13	5.0
14	5.5
15	5.0
16	5.4
17	5.9
18	5.4
19	4.6
20	4.8
21	4.3
27	3.8
28	3.6
29	4.0
30	3.9
31	4.4
32	3.4
33	4.0
34	4.3
35	3.1
36	3.3

Table 4-7: Continued

Coupon ID #	Moisture Content (%)
37	5.6
38	5.1
39	5.6
40	5.8
41	4.2
42	5.5
43	3.5
44	5.6
45	6.2
46	4.4
47	3.6
48	3.4
49	3.9
50	3.0
51	3.6
52	3.7
53	3.9
59	2.3
60	2.1
62	4.1
63	5.1
64	3.8
65	5.4
66	5.8
67	5.1

Table 4-7: Continued

Coupon ID #	Moisture Content (%)
68	4.9
69	4.9
70	1.3
71	1.4
73	1.7
74	4.9
75	5.6
76	5.5
77	5.6
78	2.9
79	4.9

Table 4-8: Summary of Moisture Content Results

Moisture Content Summary (%)			
Average	Minimum	Maximum	CV (%)
4.4	1.3	6.9	25.8

5.0 ANALYSIS

5.1 Overview

The zinc coating thicknesses measured as part of this study were compared to the results obtained by Gerber and Billings (2010) in the Phase I study of these same MSE walls. By comparing the zinc coating thickness results determined in Phase I to Phase II, a total zinc loss over a nominal eight-year period can be determined. The previously presented results regarding pullout resistance, tensile strength, and moisture content are also assessed in the chapter and compared to the remaining zinc coating thickness to determine if there are any correlations between the parameters measured during testing and the susceptibility the coupons have to corrosion. It should be noted that the coefficients of correlation (R^2 values) displayed on charts in this chapter are for the one-stage MSE walls' data points only.

Information is not available which indicates the initial galvanization thickness at time of installation of the coupons. Only a minimum of 2.0 oz/ft² was specified as part of the project requirements (shown in Appendix B); however, measurements show that the present average galvanization thickness even after 20 years still exceeds the initial minimum coating thickness requirement. Since there is not information regarding the initial coating that was applied to the specimens before installation in 1998 and 1999, the results of coating thickness from the Phase I and Phase II studies will be compared to evaluate a rate of corrosion.

5.2 Pullout Force Analysis

The first evaluation made as part of this research effort is the relationship between the peak pullout force and the embedded length of the coupon (i.e., portion of the coupon that was in contact with soil). Figure 5-1 shows that there is a very slightly positive relationship between the embedded length and the force required to extract the coupon.

In order to normalize the pullout force required for each extraction, the pullout force was divided by the embedded length. This gives a value of kip/ft that can be compared to the amount of overburden soil on the coupon. The wall height above the coupon was measured and is

assumed to be equal to the height of soil that is applying overburden pressure on the steel coupon. It was initially assumed that the weight of the soil bearing on the embedded coupons would generate a greater frictional resistance, thus increasing the required pullout force for extraction. Figure 5-2 shows the pullout force per length of embedded coupon vs. the overburden soil height. Force per embedment length does not have a strong correlation to the height of overburden soil above the coupon. One potential explanation for this is the effect of arching of backfill above the single element of wire reinforcement together with the absence of any orthogonally welded wires. What can more readily be determined from the comparison in Figure 5-1 and Figure 5-2 is that two-stage wall coupons typically require less pullout force than coupons from one-stage walls. We suspect this is likely due to a lower relative soil density and less effective compaction effort as a result of the flexible facing behind the wall facing panel.

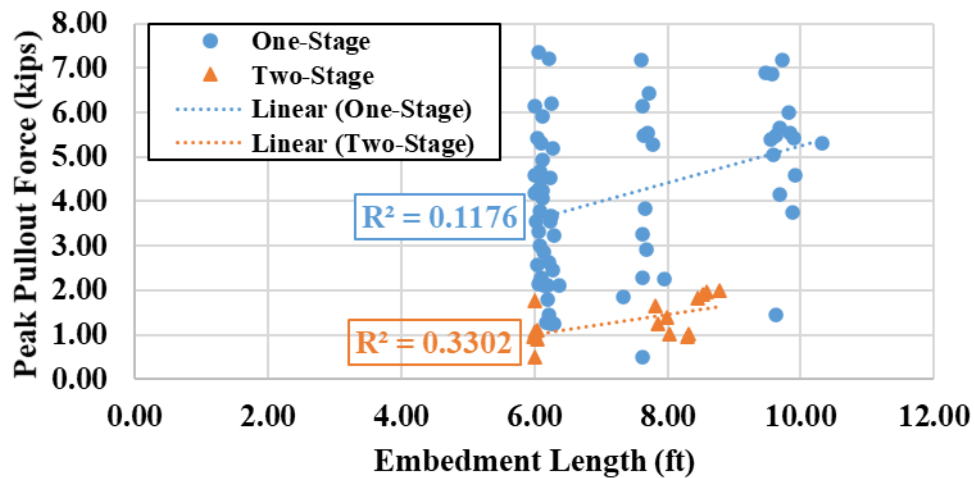

Figure 5-1: Peak Pullout Force vs. Embedded Length

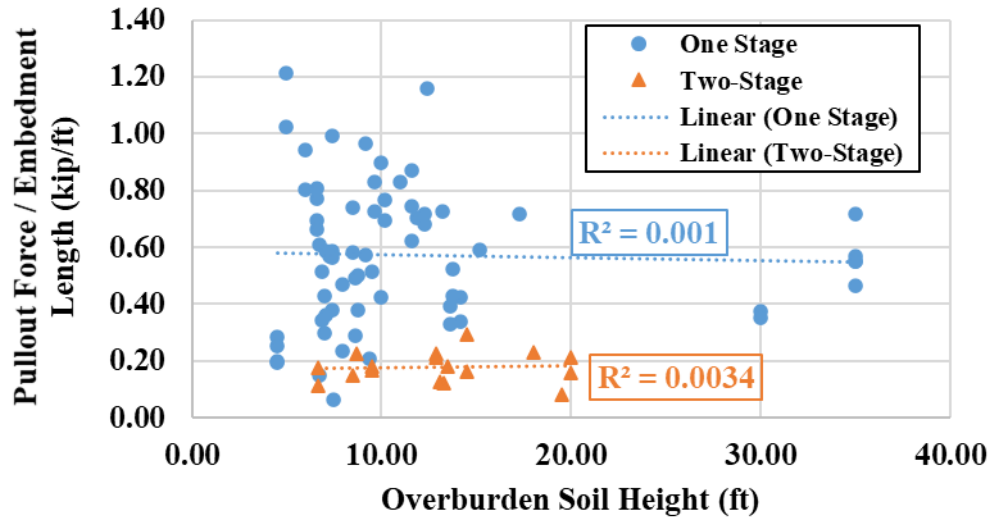

Figure 5-2: Pullout Force / Embedded Length vs. Overburden Soil Height

5.3 Zinc Loss Over 8 Years

Table 5-1 shows the correlation between coupon ID numbers from this study and the earlier study conducted by Gerber and Billings (2010), as well as the walls from where they were extracted. In some cases, multiple coupons were extracted from the same wall during Phase II, but are compared to just a single coupon extracted from that wall during Phase I. In this case, the zinc coating thickness values for all coupons extracted from the same wall are averaged and compared to the single value determined in Phase I.

Table 5-1: UDOT Wall Number and Corresponding Coupons

UDOT Wall #	Gerber & Billings (Phase I) Coupon ID	Fonseca, Thompson, & Gerber (Phase II) Coupon ID
R-343-7-A	6	15, 16, 17, 18, 19, 20, 21
R-343-13-A	8	27, 28, 29, 30, 31, 32, 33
R-343-37-A	7	34, 35, 36
R-343-42-A	22	14
R-344-1-A	3	4
R-344-1-B	4	5

R-344-2-A	1	45
R-344-2-B	2	46
R-344-4-A	5	1, 2, 3
R-344-7-A	15	13
R-344-11-A	14	50, 51
R-345-3-A	16	12
R-345-4-A	17	9, 10, 11
R-345-10-A	18	47, 48, 49
R-346-8-A	19	6, 7, 8
R-346-1C-A	20	22, 23, 24, 25, 26
R-351-9-A	9	54
R-351-9-B	10	55
R-351-26-A	13	58
R-351-30-A	12	61
R-351-34-A	11	56
R-351-5-A	21	57

The amount of zinc coating by weight for both Phase I and Phase II are compared in Table 5-2. In some cases, the zinc coating thickness measured in Phase II was greater than those determined in Phase I. This could be attributed to the fact that even coupons installed in the same wall may have initially had such varying zinc coating thicknesses. Even though the coupons adhere to the minimum thickness of zinc coating requirements, they likely were over-coated, leading to slight variation in comparisons even in coupons installed in the same wall. This matter becomes more conspicuous in the data as loss rates appear to be quite low.

When calculating the difference between the zinc coating thickness values determined in Phase I and Phase II, it is more conservative to take any negative difference as a value of zero. This yields a higher value for the calculated rate of zinc loss. In Table 5-2 the “Practical Difference” column values were calculated by setting any negative difference equal to zero. The “Mathematical Difference” column shows the calculated difference without setting negative values equal to zero. The conservative, non-negative values are used to develop a corrosion rate. By setting negative coating differences equal to zero, it is equivalent to state that there was neither gain nor loss in zinc coating at that location.

The average zinc loss using only the common walls of Phase I and Phase II over the eight-year period was 0.191 oz/ft² (0.325 mils). This gives a rate of 0.024 oz/ft²/year (0.041 mils/year) of zinc loss. If the average zinc coating thickness is calculated using all 85 coupons from this study and compared to the zinc coating thickness determined in Phase I, a total zinc loss of 0.255 oz/ft² (0.434 mils) and a corrosion rate of 0.032 oz/ft²/year (0.054 mils/year) are calculated. The largest apparent loss of zinc coating occurred at wall R-345-4-A, with a loss of 0.586 oz/ft² (0.996 mils). Using this value to develop a conservative “worst-case” corrosion rate gives 0.073 oz/ft²/year (0.125 mils/year).

Table 5-2: Zinc Coating Thickness Difference from Phase I to Phase II

Zinc Coating by Weight (oz/ft²)											
UDOT Wall #	Gerber & Billings (Phase I)				Fonseca, Thompson & Gerber (Phase II)				Practical Difference	Math Difference	
	A	B	C	Avg	A	B	C	Avg			
R-343-7-A	2.57	2.67	3.13	2.87	2.75	2.82	2.62	2.70	0.17	0.17	
R-343-13-A	2.82	2.22	2.66	2.59	2.31	2.16	2.26	2.25	0.34	0.34	
R-343-37-A	2.68	2.41	2.64	2.59	2.49	2.18	2.29	2.31	0.28	0.28	
R-343-42-A	2.88	3.13	2.66	2.83	2.59	2.44	2.24	2.38	0.45	0.45	
R-344-1-A	2.76	2.77	2.07	2.42	2.73	2.95	2.20	2.52	0.00	-0.10	
R-344-1-B	2.83	2.76	2.44	2.62	2.59	2.78	2.25	2.47	0.15	0.15	
R-344-2-A	3.01	3.02	3.20	3.11	2.67	2.92	2.86	2.83	0.28	0.28	
R-344-2-B	2.93	2.93	2.36	2.64	2.80	3.13	2.51	2.74	0.00	-0.10	
R-344-4-A	2.33	2.40	2.49	2.43	2.85	2.83	2.11	2.48	0.00	-0.05	
R-344-7-A	2.53	2.55	2.37	2.46	2.50	2.50	2.46	2.48	0.00	-0.02	
R-344-11-A	2.81	2.69	2.40	2.57	2.86	2.73	2.26	2.53	0.04	0.04	
R-345-3-A	2.72	2.83	2.88	2.83	3.86	3.62	3.24	3.49	0.00	-0.66	
R-345-4-A	3.11	3.42	3.49	3.37	2.68	2.52	2.96	2.78	0.59	0.59	
R-345-10-A	3.00	3.17	3.40	3.24	3.44	3.30	3.42	3.40	0.00	-0.16	
R-346-8-A	3.61	3.65	3.70	3.67	3.43	3.39	3.20	3.31	0.36	0.36	
R-346-1C-A	4.00	4.20	3.56	3.83	3.77	3.83	3.58	3.69	0.14	0.14	
R-351-9-A	4.06	4.01	3.53	3.78	3.77	3.99	3.53	3.70	0.08	0.08	
R-351-9-B	3.91	3.72	3.42	3.62	3.46	3.65	3.78	3.66	0.00	-0.04	
R-351-26-A	3.35	3.18	3.49	3.38	2.65	2.96	2.86	2.84	0.54	0.54	
R-351-30-A	2.63	2.34	2.84	2.66	2.61	2.41	2.48	2.49	0.17	0.17	
R-351-34-A	2.75	2.61	2.43	2.55	2.63	2.59	2.27	2.44	0.11	0.11	
R-351-5-A	3.06	3.05	3.12	3.08	2.60	2.64	2.54	2.58	0.50	0.50	
Average				2.96				2.82	0.19	0.14	
CV (%)				15.4				16.7			
Median				2.83				2.64			

Comparing the conservative worst case corrosion rate and the average corrosion rate from all samples to the AASHTO design rate (AASHTO 2017), the reinforcement in the MSE walls in this study are corroding at a slower rate than the AASHTO design rate. It is likely that the AASHTO design rate is conservatively established; hence, actual corrosion rates would typically appear to be slower than the design rate. The difference in the projected corrosion rates and the AASHTO design rate could also be attributed to more favorable soil conditions and soil properties that are present in these MSE walls. A summary of the comparisons is presented in Table 5-3.

Table 5-3: AASHTO Design Loss Rate and Projected Loss Rate

Component Type (age)	Loss (oz/ft ² /year)		
	AASHTO	Projected Worst Case	Projected Average
Zinc (<2 years)	0.35	-	-
Zinc (2-12 years)	0.09	-	-
Zinc (>12 years)	0.09	0.073	0.032
Steel (after zinc)	0.31	-	-

Figure 5-3 represents the material loss that would occur in MSE wall reinforcement by following the loss from the AASHTO design rate and the projected corrosion rate developed in this study over the course of a 75-year design life. The AASHTO design zinc coating thickness is 2.0 oz/ft². If the design coating thickness was applied, and the wall reinforcement corroded at the AASHTO design rate, the zinc would be completely depleted after 16 years in service and then the steel would continue to deplete until the end of the design life (and beyond that point, ultimately to failure). The corrosion rate developed from the data in this study assumes that there is a zinc coating thickness of 2.71 oz/ft² remaining in 2018. By assuming that the wall reinforcement initially corrodes at the AASHTO design rate until the time of Phase I of this study (12 years), the amount of metal loss would follow the line of “projected” metal loss shown in Figure 5-3. This projected metal loss was developed assuming that the worst-case corrosion

rate of 0.073 oz/ft²/year developed in this study would be constant from 12 years until the depletion of the existing 2.71 oz/ft² of zinc coating. Applying this projected corrosion rate to the MSE walls in this study, the zinc coating is expected to be completely depleted by 2055, after 57 years in service, after which point corrosion of the steel would commence.

Although it is unknown exactly what the initial coating thickness was, the corrosion rate of 0.073 oz/ft²/year was used to back-calculate a theoretical initial coating thickness of 4.89 oz/ft². Figure 5-3 shows the AASHTO design corrosion rate applied to this estimated initial coating thickness of 4.89 oz/ft², which would result in depletion of the zinc coating after 49 years in service.

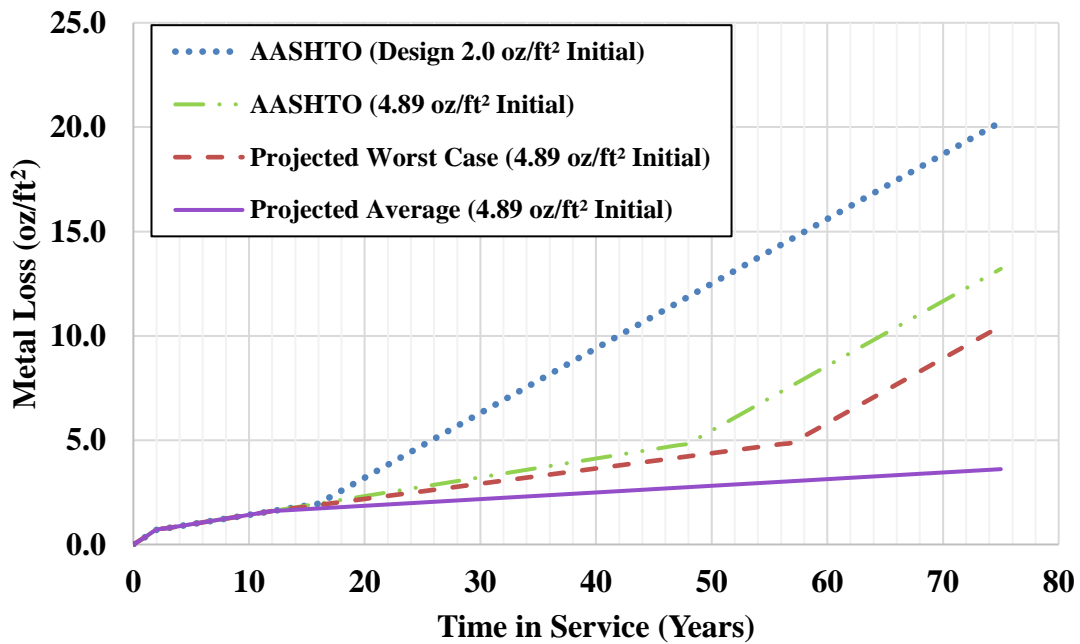

Figure 5-3: AASHTO Design Loss Rate and Projected Loss Rate

Figure 5-3 is shown to provide a comparison and a potential projection of metal loss. This corrosion rate and projected loss could be used to determine when maintenance or rehabilitation of the MSE walls in this study may be required. The portion of the graph corresponding to rate of steel loss is calculated assuming that the rate of steel loss in the MSE walls in this study will corrode at a rate equal to the AASHTO design rate for steel. The decreased rate of corrosion of

the zinc in these walls indicates that the soil environment is favorable and may lead to a decreased corrosion rate for steel as well.

5.4 Corrosion Correlations

The following comparisons are to determine if any conclusions can be drawn about the effect that moisture content and overburden soil height have on the zinc coating thickness; as well as the effect that the remaining zinc coating thickness may have on the required pullout strength.

5.4.1 Corrosion and Moisture Content

As discussed in Section 2.2.6, corrosion increases in soils with a moisture content above 25 to 40 percent. The maximum moisture content calculated for the backfill sampled in this study was 6.9%. The maximum moisture content determined herein is well below the range for a corrosive environment. The moisture contents encountered in this study are compared to the thickness of zinc coating determined at the same locations. Figure 5-4 shows the correlation of moisture content to zinc coating thickness.

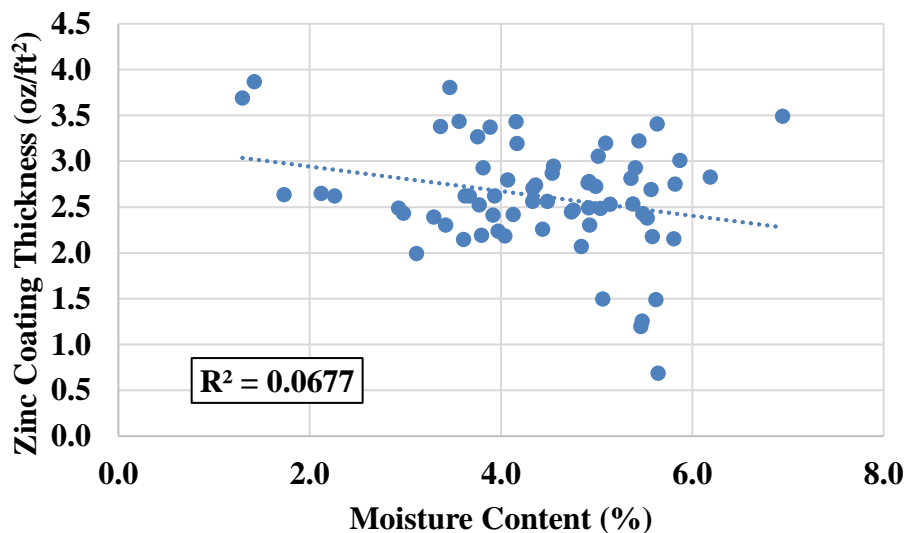

Figure 5-4: Zinc Coating Thickness vs. Moisture Content

The trend line on Figure 5-4 shows a slightly negative correlation between the moisture content of the backfill and the zinc coating thickness present on the steel coupon. This correlation indicates there is not a significant relationship between moisture content (within the low range of moisture content present) and corrosion of the zinc coating. The soils in this study appear to present good drainage and low moisture contents. Variations of moisture conditions within the MSE walls over time are unknown. Utah, however, presents a relatively arid climate and all coupons were sampled during the summer months and from locations at least several feet above the ground. If the soil backfill continues to effectively drain runoff water, the effect of moisture content of the backfills in this study are likely not a concern for causing corrosion in the future.

5.4.2 Corrosion and Height of Overburden Soil

Figure 5-5 shows the zinc coating as a function of the overburden soil height for one-stage and two-stage walls. There is not a strong correlation between overburden height and the amount of zinc coating remaining on the steel coupons. From the data gathered in this study, there is not a significant effect that overburden height has on the zinc coating thickness.

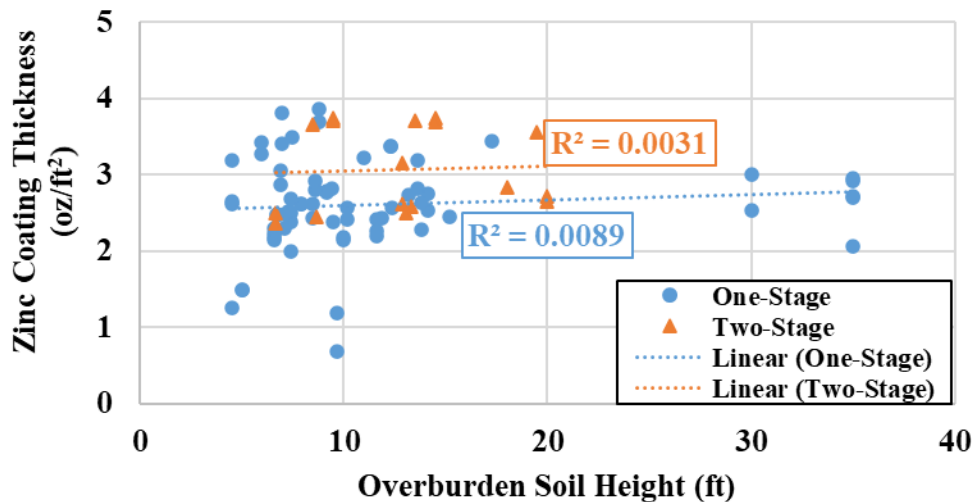

Figure 5-5: Zinc Coating Thickness vs. Overburden Soil Height

5.4.3 Corrosion and Pullout Force

Figure 5-6 compares the pullout force / embedment length to the zinc coating thickness for both one-stage and two-stage walls. In this comparison, the pullout force / embedment length is taken as the dependent variable to determine if zinc coating thickness increases or decreases required force per length. For one-stage walls, there is a slightly negative correlation, but not strong enough to determine if the extent to which the zinc has corroded has an effect on the required pullout force. Similar results were determined by Gerber and Billings in Phase I (2010). If the zinc does not corrode uniformly, this non-uniform surface on the reinforcement might theoretically increase frictional resistance to pullout, but only if the backfill were to also deform as to be compliant with the interface surface.

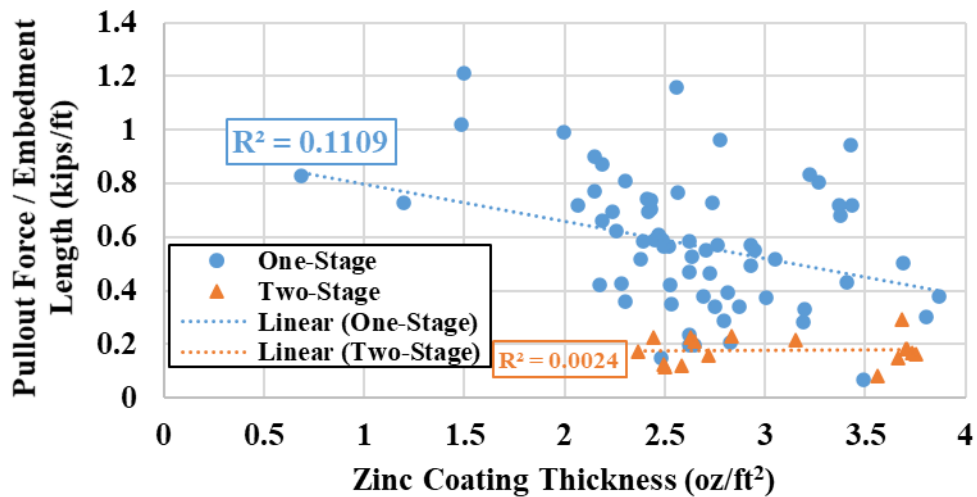

Figure 5-6: Pullout Force / Embedment Length vs. Zinc Coating Thickness

5.5 Tensile Strength

The results of the two groups of samples from the Phase I extraction differ by an average of 3.2 ksi. This difference is larger than anticipated. In Phase I Group Y, samples 3C, 14C, and 14U have significantly higher stresses than others in Group Y. These samples could be anomalies, or errors in the calculation of the samples' areas could have caused higher values. If

these outliers were removed, the average yield stress from group Y would be 89.5 ksi. This would be a difference of only 0.4 ksi between Groups X and Y of Phase I.

Another factor that may have contributed to the difference of measured tensile stresses is the preparation of the Group X samples. The Group X samples were ground down along a two-inch gauge length in order to control the failure location. Because the reduced section was achieved using a grinding belt, the surface was not as smooth as the original welded wire surface. This non-cylindrical gauge length could have led to error in determination of the diameter of the reduced section. The measured diameter of the group X samples may have been slightly larger than the actual diameter, leading to a smaller measured tensile stress of the Group X samples.

In order to validate the accuracy of the tensile testing results, the Instron machine was calibrated before the testing of the Phase II tension samples. This calibration verified that the data output from the Instron machine was accurate; but the difference in stresses could still be linked to the potential errors discussed above.

The average yield stress of the Phase II samples for Groups A and B are 87.0 ksi and 86.9 ksi, respectively. As noted in the VSL Corporation drawings shown in Appendix B, W11 steel wire material shall conform to ASTM A82 (ASTM 2007a) and ASTM A185 (ASTM 2007b), where $F_y = 448 \text{ MPa}$ (65 ksi). Both ASTM A82 and ASTM A185 have since been replaced by ASTM A1064 (ASTM 2018b). The yield stress calculated herein is significantly larger than the specification. This is a minimum specification, however, and it is probable that the steel provided was a higher-grade material than the minimum specified. As specified in ASTM A1064 (ASTM 2018b), Grade 80 steel may be used for wire with sizes larger than W1.2. Grade 80 steel has a minimum yield strength of 80 ksi. The results indicate that Grade 80 steel meeting the minimum yield strength was likely provided for the coupons tested in this study.

The difference in average yield stresses from Phase I to Phase II is a reduction from 90.7 ksi to 86.7 ksi, respectively. This reduction in yield strength could be attributable to the variability in diameter measurement from digital calipers. Although a reduction in strength could also indicate pitting corrosion, the difference between strengths is not significant. The difference can likely be attributed to error. Error in diameter measurements could lead to a reduced cross-sectional area which would cause calculation of a smaller value for yield strength. We are of the

opinion that based on the remaining amount of zinc, observable conditions of the corrosion, and the results of the tensile testing, pitting corrosion of the MSE wall reinforcement is negligible.

6.0 CONCLUSIONS

6.1 Findings

The purpose of this study was to determine the rate at which MSE wall reinforcement is corroding by observing conditions on the embedded, galvanized steel coupons. This task was accomplished, and the implications are summarized below.

6.1.1 Rate of Corrosion

The average rate of corrosion for coupons extracted from walls common to both Phase I and Phase II over a nominal eight-year period was determined to be approximately 0.024 oz/ft²/year (0.041 mils/year). Using an average value from all Phase II coupons rather than just those from walls common to both studies, the average rate of corrosion was determined to be 0.032 oz/ft²/year (0.054 mils/year). The worst-case corrosion rate for a single wall was 0.073 oz/ft²/year (0.125 mils/year). These rates of corrosion are far below the AASHTO design rate. The MSE wall reinforcement, which the coupons tested represent, have sufficient zinc galvanization remaining and total steel remaining to function as designed for the entirety of the design life and beyond.

The AASHTO design rate for depletion of zinc coating and subsequent corrosion of the steel reinforcement appears to be conservative for the corrosion conditions present for the MSE wall reinforcement coupons tested. The thickness of the zinc coating initially present on the reinforcement coupons at the time of installation may have been well over the specified design thickness. This would also contribute to a longer service life.

Some of the MSE walls in this study have been expanded due to the addition of a new lane on I-15. Some of the reinforcement analyzed herein represents reinforcement that has been covered (buried) and hence become inaccessible.

6.1.2 Tensile Capacity

The average yield stress of the samples tested meet or exceeded expected values. The average yield stress of the samples tested decreased from Phase I samples to Phase II samples by a value of 4.0 ksi, which could be due to variability in diameter measurements from the zinc bulking effect. Due to the initial over coating and remaining zinc coating, and the absence of any apparent loss of tensile strength, pitting corrosion has likely not occurred over the course of the eight years between Phase I and Phase II.

6.1.3 Moisture Content

The in-situ moisture contents for the MSE walls studied have an average moisture content of 4.4%. This is well below the moisture content which the soil is often assumed to enhance corrosivity, being on the order of at least 25%. The low moisture content of the soil indicates that proper drainage is likely present. Variations in moisture conditions over time, however, are unknown. All coupons were extracted during the summer months and from locations at least several feet above the ground, so in-situ moisture contents may be slightly higher than those observed in laboratory analysis.

6.2 Limitations and Challenges

A few limitations were encountered during this study that led to less data being gathered and analyzed than initially intended. One of the limitations encountered was the inability to obtain soil samples from the two-stage walls. This led to fewer moisture content assessments and data being limited to only one-stage MSE walls. Another limitation was the difficulty of obtaining a large soil sample from the one-stage walls. Because of the volume limitation of the soil samples, limited soil property tests were able to be conducted.

7.0 RECOMMENDATIONS AND IMPLEMENTATION

7.1 Recommendations

According to the analysis of the results herein, no additional action on behalf of UDOT besides proper maintaining of the existing MSE walls is recommended. However, UDOT may wish to consider reducing thickness requirements for galvanization or sacrificial steel for MSE wall reinforcement.

With respect to future research, recommendations regarding the extracting and testing of samples at the next phase of work are provided:

1. All testing done herein should be repeated on new samples at the next phase of the project to compare results and verify analysis and conclusions.
2. If possible, larger soil samples should be obtained in order to run more analysis on the properties of the soil that may contribute to corrosion including: gradation, resistivity, pH, and salt content.
3. When measuring pullout resistance of the coupons, measure the displacement in order to develop a pullout vs. displacement curve.
4. Due to the favorable conditions of the coupons tested. It may be beneficial to wait more than 10 years to do the next phase of this study. Doing this would allow more coupons to be tested in the latter half of the design life where corrosion would be more prevalent, and knowledge of potential reduction in capacity of the steel reinforcement would be more critical near the end of the design life.

REFERENCES

- American Association of State Highway and Transportation Officials [AASHTO]. 2017. *AASHTO LRFD bridge design specifications*.
- American Association of State Highway and Transportation Officials [AASHTO]. 2012. AASHTO Standard T 288-12. . *Standard method of test for determining minimum laboratory soil resistivity*. Washington, DC.
- Anderson, Peter L., Robert A. Gladstone, and John E. Sankey. 2012. "State of the Practice of MSE Wall Design for Highway Structures." In *Geotechnical Engineering State of the Art and Practice*, 443-463.
- Arciniega, Jose Luis, W. Shane Walker, Soheil Nazarian, and Kenneth L. Fishman. 2018. "A Process for Optimizing Gradation of Marginal Backfill of Mechanically Stabilized Earth Walls to Achieve Acceptable Resistivity." *Transportation Research Record* no. 2672 (52):251-257. doi: 10.1177/0361198118770166.
- ASTM International. 1997a. ASTM A123, Standard Specification for Zinc (Hot-Dip Galvanized) Coatings on Iron and Steel Products. West Conshohocken, PA.
- ASTM International. 1997b. ASTM A82, Standard Specification for Steel Wire, Plain, for Concrete Reinforcement. West Conshohocken, PA.
- ASTM International. 1997c. ASTM A185, Standard Specification for Steel Welded Wire Reinforcement, Plain, for Concrete. West Conshohocken, PA.
- ASTM International. 2018a. ASTM A90/A90M-13(2018), Standard Test Method for Weight [Mass] of Coating on Iron and Steel Articles with Zinc or Zinc-Alloy Coatings. West Conshohocken, PA.
- ASTM International. 2018b. ASTM A1064/A1064M-18a, Standard Specification for Carbon-Steel Wire and Welded Wire Reinforcement, Plain and Deformed, for Concrete. West Conshohocken, PA.
- ASTM International. 2019. ASTM D2216-19, Standard Test Methods for Laboratory Determination of Water (Moisture) Content of Soil and Rock by Mass. West Conshohocken, PA.
- Berg, Ryan R., Barry R. Christopher, and N. C. Samtani. 2009. "Design of Mechanically Stabilized Earth Walls and Reinforced Soil Slopes." Volume I. Washington, D.C.: National Highway Institute: Federal Highway Administration: U.S. Department of Transportation.

- Billings, Daniel A. 2011. "Assessing Corrosion of MSE Wall Reinforcement for I-15, Salt Lake County, UT." *Brigham Young University, Department of Civil and Environmental Engineering, Master of Science Project.*
- Elias, V., Kenneth Fishman, Barry R. Christopher, and Ryan R. Berg. 2009. *Corrosion/Degradation of Soil Reinforcements for Mechanically Stabilized Earth Walls and Reinforced Soil Slopes.* Washington, D.C.: National Highway Institute: Federal Highway Administration: U.S. Department of Transportation.
- Gerber, Travis M., and Daniel A. Billings. 2010. *Assessing Corrosion of MSE Wall Reinforcement.* Report No. [UT-10.20](#), Utah Department of Transportation, Salt Lake City.
- Gladstone, Robert A., Peter L. Anderson, Kenneth L. Fishman, and James L. Withiam. 2006. "Durability of Galvanized Soil Reinforcement: More than 30 Years of Experience with Mechanically Stabilized Earth." *Transportation Research Record* no. 1975 (1):49-59. doi: 10.1177/0361198106197500106.
- Mindess, Sidney, FJ Young, and David Darwin. 2003. *Concrete 2nd Edition.* 2 ed. Upper Saddle River, NJ 07458: Pearson Education, Inc.
- Romanoff, Melvin. 1957. "Underground Corrosion, National Bureau of Standards Circular 579." *US Government Printing Office, Washington* no. 25.

APPENDIX A: COUPON LOCATION MAPS



Figure A-1: 300 N Argyle Ct, Coupon – 61

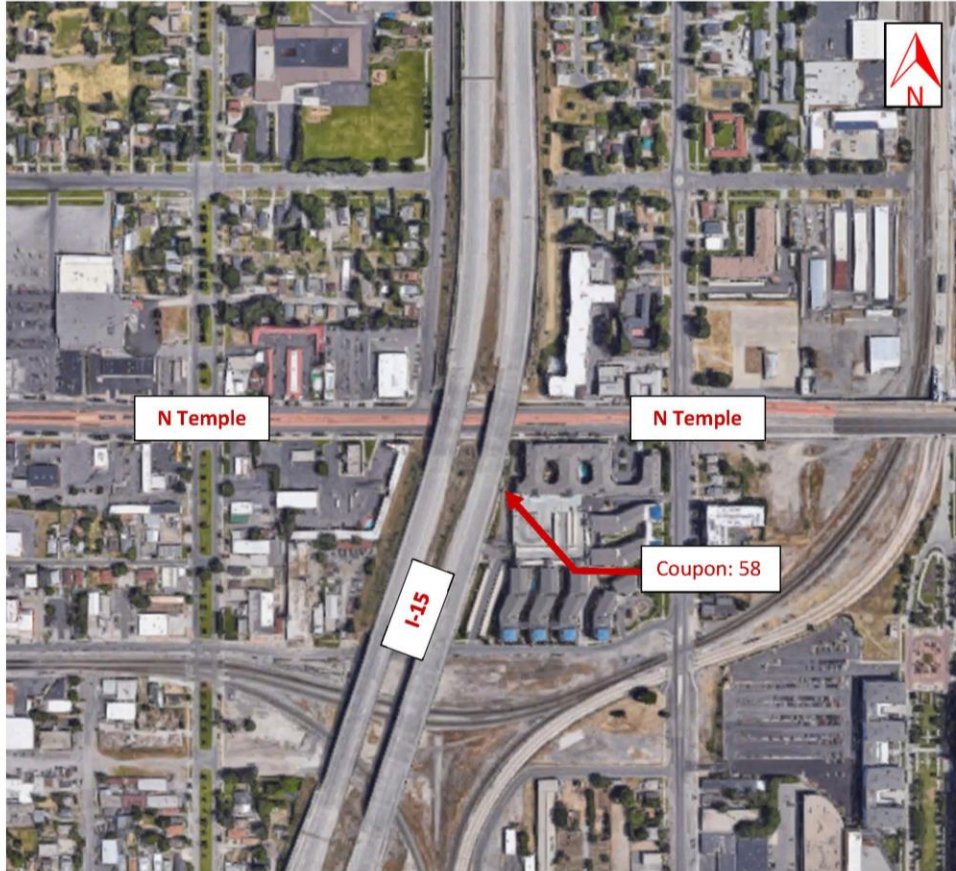

Figure A-2: N Temple, Coupon – 58



Figure A-3: 400 S, Coupons – 54-57



Figure A-4: 800 S, Coupons – 84-85



Figure A-5: 1700 S, Coupons – 80-83



Figure A-6: 3300 S & 3650 S, Coupons – 6-8, 22-26, 59-60



Figure A-7: 4500 S, Coupons – 9-11, 12, 41-44, 47-49



Figure A-8: 4800 S, Coupons – 62-73, 76-79



Figure A-9: 5300 S, Coupons – 13, 50-53



Figure A-10: 5900 S, Coupons – 1-5, 45-46



Figure A-11: I-15 & I-215, Coupon – 14

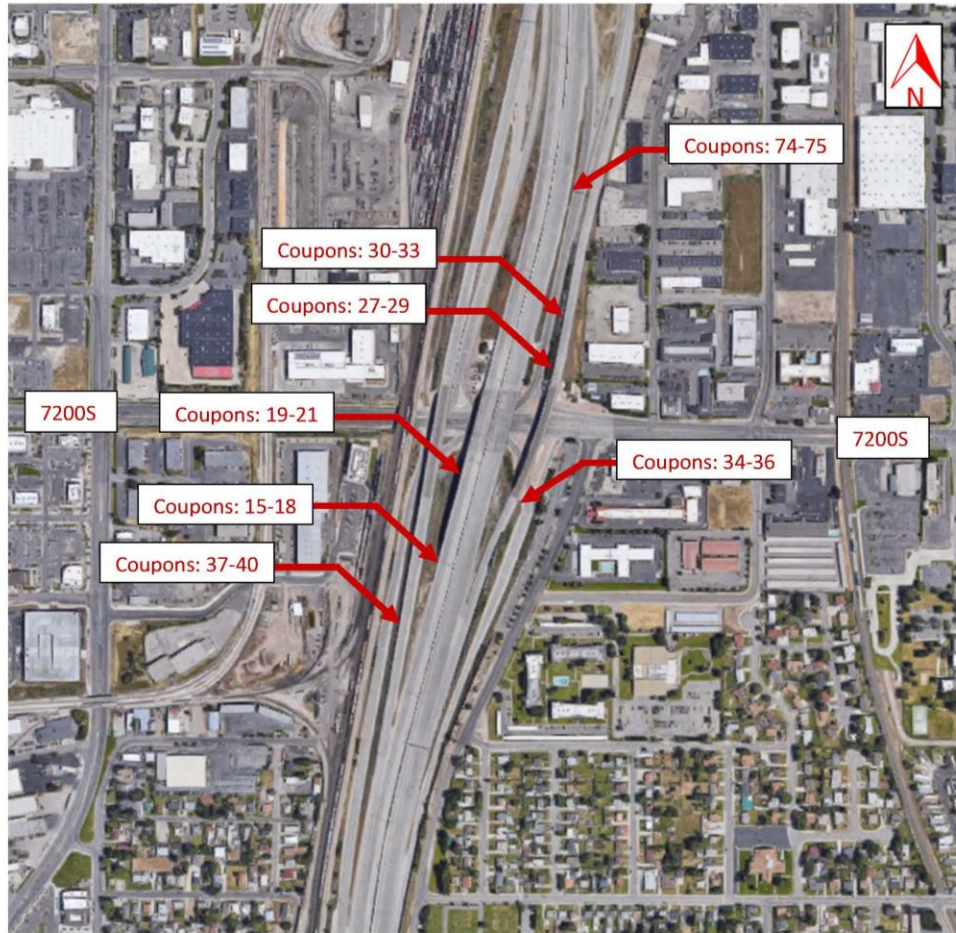

Figure A-12: 7200 S, Coupons – 15-21, 27-40, 74-75

APPENDIX B: MANUFACTURER SPECIFICATIONS

This appendix contains project specifications and the construction drawings for the MSE walls associated with this study.

SELECT MATERIAL (525)

This Specification has been released per Technical Agreement Number 054.

525.1 DESCRIPTION

525.1.1 Select Material shall be processed for constructing the embankment for MSE Walls.

525.1.2 **Related Work** Not Used

525.2 MATERIALS

525.2.1 The select material used in the MSE Wall structures shall be reasonably free from organic and otherwise deleterious materials and shall conform to the following gradation limits as determined by AASHTO T-27:

Sieve Size	Percent Passing
6 inches	100
3 inches	75-100
No. 200	0-15

<u>Sieve Size</u>	<u>Percent Passing</u>
<u>100mm(4 inch)</u>	<u>100</u>
<u>37.5mm (1 ½ inch)</u>	<u>80-90</u>
<u>9.5mm (inch)</u>	<u>55-90</u>
<u>4.75mm (#4)</u>	<u>40-80</u>
<u>2.06mm (#10)</u>	<u>25-70</u>
<u>450µm (#40)</u>	<u>0-50</u>
<u>75µm (#200)</u>	<u>0-15</u>

Backfill materials which do not meet the above gradation limits will be evaluated on a case-by-case basis. In order to carry out such evaluations, representative grain size curves, soil classifications, laboratory compaction test data and maximum and minimum index density test results must be submitted to VSL for approval.

525.2.2 In addition, the select material shall conform to all the following requirements:

525.2.2.1 Plasticity Index - The Plasticity Index (P.I.), as determined by AASHTO T-90, shall not exceed 6.

525.2.2.2 Internal Friction Angle - The material shall exhibit an internal friction angle of not less than 34 degrees as determined by the standard direct shear test, AASHTO T-236, utilizing a sample of the material compacted to 95 percent of AASHTO T-99, Methods C or D (with oversize correction, as outlined in note 7), at optimum moisture content. Internal friction angle testing is not required for backfill materials that have at least 80 percent of the material greater than or equal to the ~~3/4 inch~~ 19 mm size.

525.2.2.3 Soundness - The material shall be substantially free of shale or other soft, poor durability particles. The material shall have a sodium sulfate soundness loss of less than 16 percent after five (5) cycles, as determined by AASHTO T-104.

525.2.2.4 Electrochemical Requirements - The material shall conform to the following electrochemical requirements:

<u>Property</u>	<u>Requirements</u>	<u>Test Method</u>
Resistivity	Minimum 3000 Ohm-cm, at 100% saturation	UDOT 8-939
pH	Acceptable Range 5-10	UDOT 8-934
Chlorides	Maximum 100 ppm	UDOT Method
Sulfates	Maximum 200 ppm	UDOT Method

525.2.3 Furnish a Certificate of Compliance certifying that the select material complies with this section of the specifications. This Certificate must be

(525)

made by a certified testing lab.

525.2.4 A copy of all test results performed by the Contractor, which are necessary to ensure compliance shall be furnished to the ~~Department~~ Engineer.

525.3 CONSTRUCTION REQUIREMENTS

525.3.1 Backfill placement shall closely follow erection of each course of panels or wire facing.

525.3.2 Backfill shall be placed in such a manner as to avoid any damage or disturbance to the wall materials or misalignment of the facing panels.

525.3.3 Wall materials which become damaged or disturbed during backfill placement shall be either removed and replaced at the Contractor's expense.

525.3.4 Backfill material placed which does not meet the requirements of this specification shall be corrected or removed and replaced at the Contractor's expense.

525.3.5 Backfill shall be compacted to 95 percent of the maximum density as determined by AASHTO T-99, Method C or D (with oversized correction, outlined in Note 7).

525.3.5.1 Walls within the embankment for bridge zone Section 222, shall meet compaction requirements of Section 225.3.5.1.

525.3.6 The moisture content of the backfill material prior to and during compaction shall be uniform throughout each layer.

525.3.7 Backfill material shall have a placement moisture content less than or equal to the optimum moisture content.

525.3.8 Backfill with a placement moisture content in excess of the optimum moisture content will be removed and reworked until the moisture content is uniform and acceptable throughout the entire lift.

525.3.9 The optimum moisture content will be determined in accordance with AASHTO T-99, Method C or D (with oversize correction, as outlined in Note 7).

525.3.10 If 30 percent or more of the select material is greater than ~~3/4 inch~~ 19 mm in size, AASHTO T-99 is not applicable.

(525)

For such a material, the acceptance criterion for control of compaction shall be either a minimum of 70 percent of the relative density of the material as determined by a method specification, based on a test compaction section, which defines the type of equipment, lift thickness, number of passes of the specified equipment and placement moisture content.

525.3.11 The maximum lift thickness after compaction shall not exceed ~~40 inches~~ 300 mm. The Contractor shall decrease this lift thickness, if necessary, to obtain the specified density.

525.3.12 Prior to placement of the reinforcement, the backfill elevation, after compaction, shall be ~~2 inches~~ 50 mm above the reinforcement elevation from a point approximately ~~42 inches~~ 300 mm behind the back face of the panels or wire facing to the end of the reinforcing, unless otherwise shown on the plans.

525.3.13 Compaction within ~~3 feet~~ 1 meter of the back face of the panels or wire facing shall be achieved by at least three (3) passes of a lightweight mechanical tamper, roller or vibratory system.

525.3.14 The specified lift thickness shall be adjusted as warranted by the type of compaction equipment actually used, but no soil density tests need to be taken within this area.

525.3.15 Care shall be exercised in the compaction process to avoid misalignment of the panels.

525.3.16 At the end of each day's operation, the Contractor shall slope the backfill away from the wall to direct runoff of rainwater away from the wall face. In addition, the Contractor shall not allow surface runoff from adjacent areas to enter the wall construction site.

**MECHANICALLY STABILIZED EARTH (MSE) WALLS CONVENTIONAL
SINGLE STAGE AND TWO STAGE (526)**

This Specification has been released per Technical Agreement Number 015.

526.1 DESCRIPTION

526.1.1 Furnish and construct reinforced walls noted on the plans, including leveling pad, select material, and concrete coping.

526.1.2 The Contractor shall make arrangements to purchase the reinforced concrete face panels, welded wire facing, filter fabric, soil reinforcing, and all necessary attachments and accessories from:

VSL Corporation
1671 Dell Avenue
Campbell, California 95008
Telephone: (408)866-5000

526.1.3 Arrange for a qualified representative from the wall supplier to be at the job site during all phases of wall construction until erection crews have demonstrated competency as determined by VSL. After that time, VSL shall provide a qualified representative at the job in a timely manner when so requested by the Contractor and or the Engineer. VSL shall monitor field data to ensure wall construction meets requirements.

526.1.4 VSL Corporation shall use information from the appropriate geotechnical design memorandum in the design of the MSE wall. Appropriate factors of safety shall be used by the VSL Corporation in the design of the internal stability of the wall.

526.2 MATERIALS

526.2.1 Concrete

526.2.1.1 Class AA(AE) per Sections 505 and 506 of the I-15 Corridor Specifications for precast panels and concrete coping except as modified below.

526.2.1.2 Precast panels and concrete coping shall use concrete with minimum $f'c$ (at 28 days) of 27,500 kPa (4000 psi) or as specified in the Fabrication / Erection Design Drawings.

526.2.2 Reinforcing Steel

(526)

526.2.2.1 Panel reinforcing steel shall be epoxy coated or galvanized and conform to Subsection 508.2.1 and Subsection 508.2.2 or 508.2.3 of the I-15 Corridor Specifications.

526.2.3 Soil Reinforcing and Attachment Devices

526.2.3.1 Soil Reinforcing and Welded Wire Facing

The soil reinforcing and welded wire facing shall be shop fabricated of cold drawn steel wire conforming to the minimum requirements of ASTM A82 and shall be welded into the finished mesh fabric in accordance with ASTM A185. In addition to the structural thickness required 28 microns per year of sacrificial steel (based on 75 year life) shall be added. Galvanization (86 microns minimum) shall be applied after the soil reinforcing or welded wire facing is fabricated and conform to the requirements of ASTM A123. Any damage done to the soil reinforcing or welded wire facing galvanization prior to installation shall be repaired in an acceptable manner per Section 508.2.4 of the I-15 Corridor Standard Specifications.

526.2.3.2 Attachments and Accessories

All steel attachments and accessories such as loop embeds, connection pins, two stage alignment pins, and two stage wall connectors will meet the specifications shown on the Fabrication and Erection Drawings, have 28 microns per year of sacrificial steel (based on a 75 year life) and will be epoxied or galvanized in accordance with ASTM A123.

Two stage wall alignment pins shall be grouted or epoxied during erection using a premixed, non shrink cementitious grout or epoxy with minimum compressive strength of 4000 psi. (27500 kPa)

526.2.4 Geotextile Fabric

Filter Fabric used to retain backfill soil behind welded wire facing shall be Mirafi Filterweave 700 or equivalent as supplied by VSL Corporation.

526.2.5 Adhesive

Sonolastic Adhesive made by Chemrex Incorporated or equivalent as supplied by VSL Corporation.

526.2.6 Lifting Devices

526.2.8.1 VSL Corporation shall provide adequate lifting devices for moving panels

(526)

during handling and construction.

526.2.7 Joint Filler--Filter Fabric

Filter Fabric used to cover joints in the single stage MSE wall concrete panels prior to backfilling shall be Bonded Fibre Products WQ275 Geotextile or equivalent as supplied by VSL Corporation.

526.2.8 Select Backfill Material for Retained Earth Backfill

526.2.8.1 Comply with Section 525 of the I-15 Corridor Standard Specifications.

526.2.9 Bearing Pads

HDPE Bearing pads shall be placed by the contractor between horizontal panel joints to prevent damage to the panel edges during construction. Bearing pads shall be provided by VSL Corporation.

526.2.10 Low Permeability Clay

Construct a low permeability clay cap at finish grade at the face of MSE walls, as shown in the plans, to protect the underlying structural fill. Clay cap shall be constructed from a clay conforming to AASHTO Classification A-6.

526.3 CONSTRUCTION REQUIREMENTS

526.3.1 Precast Panels

526.3.1.1 Comply with subsection 506.3 of the I-15 Corridor Specifications.

Reinforcing Steel - minimum cover on the side exposed to soil shall not be less than 50 mm - 2 inches.

526.3.1.2 Casting

Cast the panels on a flat surface with the front face down. Place the concrete in each panel without interruption.

Standard Specifications (Revision 2) March 26, 1998 I-15 Reconstruction Page 3 of 8

(526)

Vibrate the concrete in each form such that the concrete is forced into the corners of the forms to prevent stone pockets or cleavage planes.

Use clear, non-staining form oil.

526.3.1.3 Curing

Cure all panels with steam or water.

Cure the panels for a minimum of 7 days or until concrete has reached 75% of sufficient length of time so that the concrete will develop the specified 28-day compressive strength. ~~within 28 days.~~

526.3.1.4 Removal of Forms

The forms shall remain in place until they can be removed without damage to the panel.

526.3.1.5 Concrete Finish

Provide uniform texture Type C as shown in the approved aesthetic layout to the front face of the panels ~~using the approved form liner Type 3~~. The thickness of the architectural treatment shall be in addition to the required design thickness of the panel.

Provide a uniform surface finish to the back face of the panels as specified in Section 506 of the I-15 Corridor Standard Specifications. Scream the surface to eliminate open pockets of aggregate and surface distortion in excess of 6 mm.

Do not add color to any wall prior to installation.

526.3.1.6 Tolerances:

All panel units shall be manufactured such that all dimensions are within ± 5 mm.

The back face of panel shall have an angular distortion of not greater than 6 mm in 1525 mm.

526.3.1.7 All reinforcing and attachments shall be free of defects.

526.3.1.8 Marking

Scribe the date of manufacture on the rear of each panel.

(526)

526.3.1.9 Hauling, Storage, and Shipping

Hauling, storage and shipping shall be done in such a manner as to eliminate the danger of producing any type of defects. Store panels such that the connectors do not bend.

526.3.1.10 Acceptance of precast panels is based upon the following:

Compression test results indicate that the concrete strength will meet the 28-day compression test.

Panels may be placed in the wall when ~~seven-day~~ strengths exceed 75 percent of 28-day strength.

Submit a certificate of compliance.

526.3.1.11 Panels will be subject to rejection for any of the following reasons:

The panel does not achieve the specified compressive strength within 28 days.

The panel does not meet the requirements of the I-15 Corridor Specifications or the plans.

The panel contains defects due to imperfect molding.

The panel contains defects due to honeycombed or open texture concrete on the front face.

526.3.1.12 Precast Corner Elements

Provide precast corner elements at inside and outside corners where deflection exceeds the tolerance of the panels' standard connection. Corner elements shall also comply with the applicable portions of Subsection 526.3.1 of this specification.

The exterior faces of the corner elements shall have an ordinary finish as specified in Section 506 of the I-15 Corridor Specifications.

526.3.2 Excavation and Foundation Preparation

526.3.2.1 Excavate and grade level the foundation area for the reinforced earth wall equal to or exceeding the length of the soil reinforcing or as shown on the plans.

(526)

526.3.2.2 Prior to placing the leveling pad, compact the area beneath the leveling pad with a minimum of three passes of a lightweight, steel, smooth-wheel vibratory roller unless otherwise specified in the plans.

526.3.2.3 Remove and replace all foundation soils found to be unsuitable by the Engineer or as shown in the plans.

526.3.2.4 Leveling pad shall meet the requirements of Sections 505 and 506 of the I-15 Corridor Specifications Class C A ~~except as modified to meet a minimum 28-day compressive strength of 17,500 kPa (2500 psi)~~. Do not start placing wall panels until the leveling pad has cured 12 hours.

526.3.3 Wall Construction

526.3.3.1 Handle the panels by means of a lifting device set vertically into the upper edge of the panels.

526.3.3.2 Place the panels or wire facing on successive horizontal lifts in the sequence shown on the plans as select backfill material placement proceeds. A panel or wire facing may be placed on top of the lower panel which has not been completely backfilled in order to facilitate the construction. At no time will the upper panel or wire facing hinder or compromise the compaction process of the lower panel or wire facing. All compaction requirements of Section 525 of the Corridor Specifications shall be maintained.

~~**526.3.3.3** The contractor shall batter the wall utilizing the wall rotation information shown in the plans. Adjustments in batter will be made during construction as necessary to achieve the appropriate visual alignment of the wall and to meet requirements shown in the plans.~~

526.3.3.3 For two stage walls MSE walls comprising permanent welded wire mesh (WWM) facing, the maximum lateral displacement of the facing mid-way between the adjacent primary soil reinforcing layers shall not exceed 127mm (5 inches) at the end of wall construction.

Where lateral displacements during construction exceed the value stated above a separate analysis shall be undertaken by VSL to determine wall soundness. If required, remedial measures will be developed by VSL and constructed by the contractor.

526.3.3.4 Walls shall be constructed level and plumb and at time of final acceptance shall be within 30 mm in 3 m for level and plumb.

(526)

526.3.3.5 All joints shall be uniform. Joint width shall be 30 mm maximum and 12 mm minimum.

526.3.3.6 The contractor shall construct concrete coping along the top of the wall as shown in the plans.

526.3.3.7 Pile Driving near MSE walls must conform to Section 502 of the I-15 Corridor Specifications.

526.3.4 Materials Sampling and Testing

526.3.4.1 Certificates of Compliance

Furnish to the ~~Engineer~~ QA Manager a copy of the certificate of compliance for materials and the results of any material tests run by VSL Corporation. The QA Manager will furnish a copy of this certificate to the Department.

526.3.4.2 Concrete Testing shall conform to Section 505.

526.3.5 Retrievable Samples (Inspection Wires)

Contractor shall install retrievable samples furnished by VSL Corporation in each wall at the locations shown on the plans.

Retrievable sample panels for single stage walls shall have holes and plugs as shown in the plans. Retrievable sample panels shall be installed per the Fabrication and Erection Drawings. For two stage walls the retrievable samples shall be placed in the wire wall as shown in the plans. When the final wall panel is placed the Contractor shall core holes in the panel at the location of the retrievable sample. Size of hole and plug shall be as shown in the plans.

Samples shall be embedded into the reinforced soil mass a minimum of 2 meters. Sample shall be threaded on one end and extend out from the soil reinforcing as shown in the plans.

Details of access hole and plug shall be shown in Fabrication and Erection Drawings by VSL Corporation.

Panels with holes in place and plugs will be furnished by VSL Corporation for all single stage walls. Plugs for two stage walls will be furnished by VSL Corporation.

(526)

Each sample shall be W11 wire galvanized (86 microns minimum) according to ASTM A123.

526.3.6 Select Material (MSE Backfill) Sampling and Testing

One density determination shall be made per each lift for each 30 meters of retaining wall. The test shall be made at random locations, but the test location shall be at least one meter behind the panel face for one stage walls or wire face for two stage walls.

H:\RE_EARTH\PROJECT\339-0007\REBAR\TYPE-3\BAR-SK10
 FINAL PLOT 12-19-97
 VICE (K-UNIFORM)

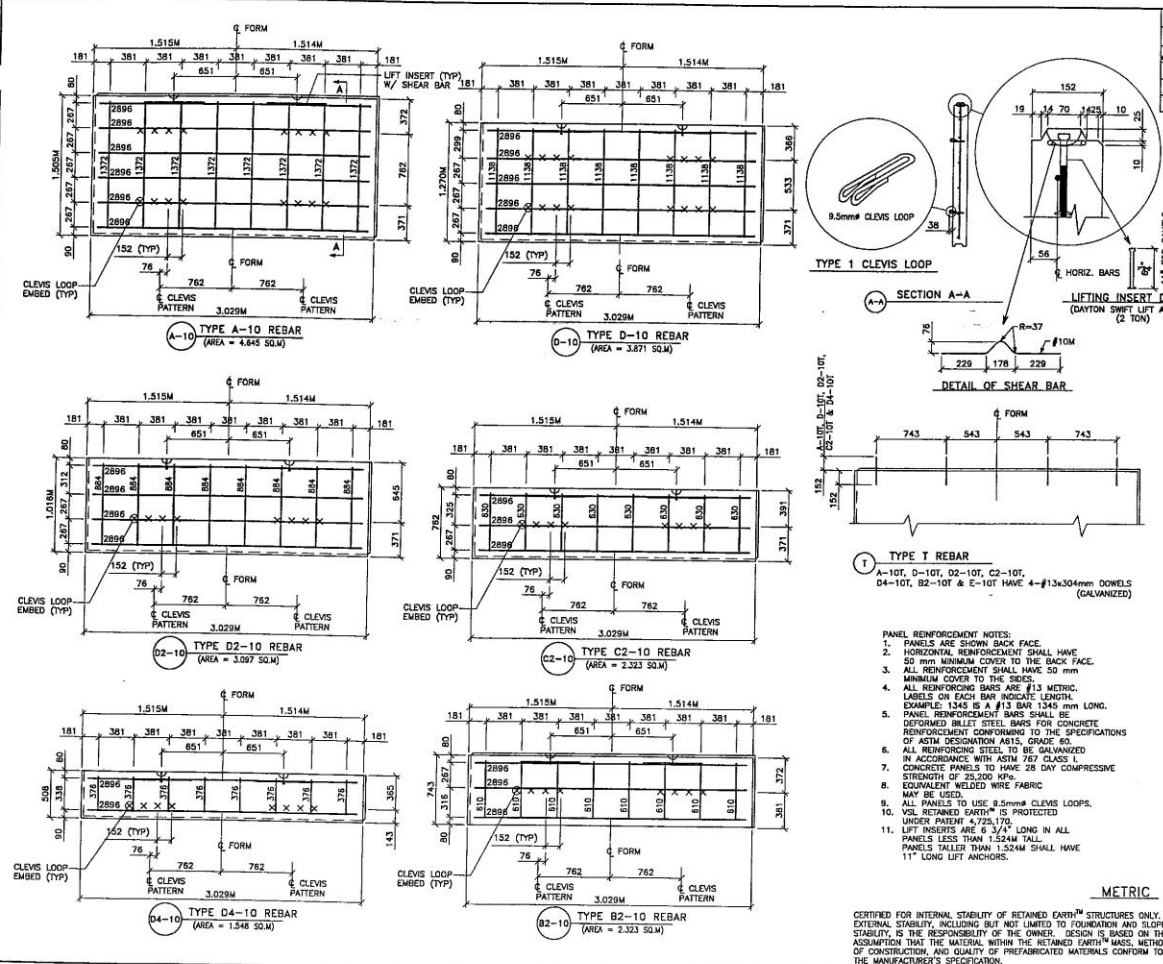

APPROVED FOR CONSTRUCTION		
NO.	DATE	DESCRIPTION
1	8-30-98	RELEASE FOR CONSTRUCTION
2	5-2-99	ISSUED AS CSP

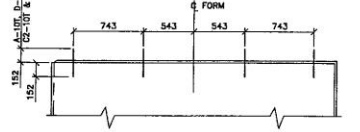
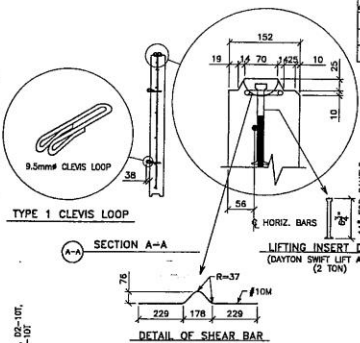

TYPE T REBAR
 A-10T, D-10T, D2-10T, C2-10T,
 D4-10T, B2-10T & E-10T HAVE 4-#13x304mm DOWELS
 (GALVANIZED)

- PANEL REINFORCEMENT NOTES:
- PANELS ARE SHOWN BACK FACE.
 - HORIZONTAL REINFORCEMENT SHALL HAVE 50 mm MINIMUM COVER TO THE BACK FACE.
 - ALL REINFORCEMENT SHALL HAVE 50 mm MINIMUM COVER TO THE SEES.
 - ALL REINFORCING BARS ARE #13 METRIC. LABELS ON EACH BAR INDICATE LENGTH. EXAMPLE: 1345 IS A #13 BAR 1345 mm LONG.
 - PANEL REINFORCEMENT BARS SHALL BE DEFORMED BULLET STEEL BARS FOR CONCRETE REINFORCEMENT CONFORMING TO THE SPECIFICATIONS OF ASTM DESIGNATION A615, GRADE 60.
 - ALL REINFORCING STEEL TO BE GALVANIZED IN ACCORDANCE WITH ASTM 767 CLASS 1.
 - CONCRETE PANELS TO HAVE 28 DAY COMPRESSIVE STRENGTH OF 25,000 KPa.
 - EQUIVALENT WELDED WIRE FABRIC MAY BE USED.
 - ALL PANELS TO USE 9.5mm#8 CLEVIS LOOPS.
 - VSL RETAINED EARTH™ IS PROTECTED UNDER PATENT # 725,173.
 - LIFT INSERTS ARE 6 3/4\"

CERTIFIED FOR INTERNAL STABILITY OF RETAINED EARTH™ STRUCTURES ONLY.
 EXTERNAL STABILITY, INCLUDING BUT NOT LIMITED TO FOUNDATION AND SLOPE STABILITY, IS THE RESPONSIBILITY OF THE OWNER. DESIGN IS BASED ON THE ASSUMPTION THAT THE MATERIAL WITHIN THE RETAINED EARTH™ MASS, METHODS OF CONSTRUCTION, AND QUALITY OF PREFABRICATED MATERIALS CONFORM TO THE MANUFACTURER'S SPECIFICATION.

WASATCH CONSTRUCTORS
 JUN 17 1999
 RELEASED FOR CONSTRUCTION

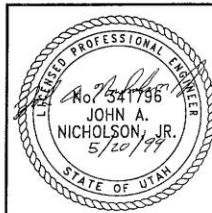

NO.	DATE	DESCRIPTION	BY	CHK
1	12-19-97	ISSUED AS CSP	BM	
2	12-19-97	ISSUED AS CSP	BM	
3	12-19-97	ISSUED AS CSP	BM	

NO.	DATE	DESCRIPTION	BY	CHK
1	12-19-97	ISSUED AS CSP	BM	
2	12-19-97	ISSUED AS CSP	BM	
3	12-19-97	ISSUED AS CSP	BM	

NO.	DATE	DESCRIPTION	BY	CHK
1	12-19-97	ISSUED AS CSP	BM	
2	12-19-97	ISSUED AS CSP	BM	
3	12-19-97	ISSUED AS CSP	BM	

FINAL PLOT 12-19-97

RETAINED EARTH PROJECT 233-0007 REBAR TYPE-Y BAR-S10

ENCL (C-LINKING)

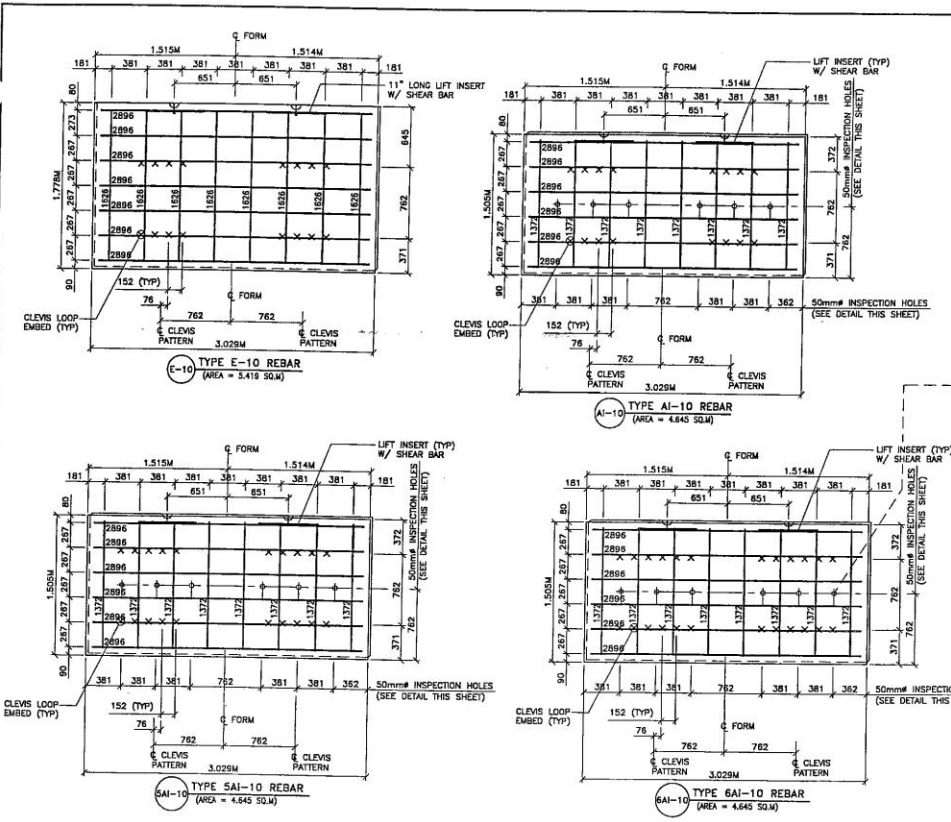

- PANEL REINFORCEMENT NOTES:**
1. PANELS ARE SHOWN BACK FACE.
 2. HORIZONTAL REINFORCEMENT SHALL HAVE 50 mm MINIMUM COVER TO THE BACK FACE.
 3. ALL REINFORCING BARS SHALL HAVE 50 mm MINIMUM COVER TO THE SIDES.
 4. ALL REINFORCING BARS ARE #13 METRIC. LABELS ON EACH BAR INDICATE LENGTH. EXAMPLE: 1345 IS A #13 BAR 1345 mm LONG.
 5. PANEL REINFORCEMENT BARS SHALL BE DEFORMED BILLET STEEL BARS FOR CONCRETE REINFORCEMENT CONFORMING TO THE SPECIFICATIONS OF ASTM DESIGNATION A615, GRADE 60.
 6. ALL REINFORCING STEEL TO BE GALVANIZED IN ACCORDANCE WITH ASTM 767 CLASS 1.
 7. CONCRETE PANELS TO HAVE 28 DAY COMPRESSIVE STRENGTH OF 25,200 KPS.
 8. EQUIVALENT WELDED WIRE FABRIC MAY BE USED.
 9. ALL PANELS TO USE 9.5mm# CLEVIS LOOPS.
 10. VSL RETAINED EARTH IS PROTECTED UNDER PATENT 4,725,170.
 11. SEE SH1 NO. 310-1 FOR CLEVIS LOOP AND LIFT INSERT DETAILS.
 12. LIFT INSERTS ARE 8 1/4" LONG IN ALL PANELS LESS THAN 1.524M TALL. PANELS TALLER THAN 1.524M SHALL HAVE 11" LONG LIFT ANCHORS.

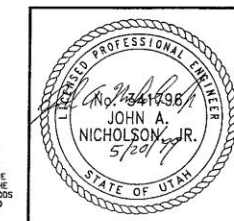
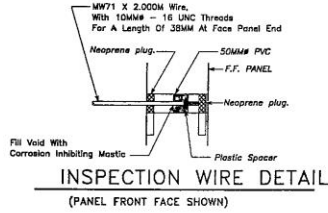
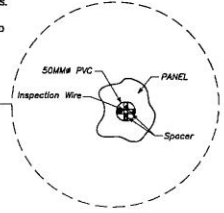

WASATCH CONSTRUCTORS
JUN 17 1999
RELEASED FOR CONSTRUCTION
METRIC

CERTIFIED FOR INTERNAL STABILITY OF RETAINED EARTH STRUCTURES ONLY. EXTERNAL STABILITY, INCLUDING BUT NOT LIMITED TO FOUNDATION AND SLOPE STABILITY, IS THE RESPONSIBILITY OF THE OWNER. DESIGN IS BASED ON THE ASSUMPTION THAT THE MATERIAL HAS THE RETAINED EARTH MASS, METHODS OF CONSTRUCTION, AND QUALITY OF PREFABRICATED MATERIALS CONFORM TO THE MANUFACTURER'S SPECIFICATION.

APPROVED FOR CONSTRUCTION		
NO.	DATE	DESCRIPTION
9-30-98		RELEASE FOR CONSTRUCTION
5-21-99		ISSUED AS CSP

NO. DATE	DESCRIPTION	BY
9-30-98	RELEASE FOR CONSTRUCTION	
5-21-99	ISSUED AS CSP	

MM	12-19-97	MM	12-19-97	MM	12-19-97
DD	12-19-97	DD	12-19-97	DD	12-19-97
MM	12-19-97	MM	12-19-97	MM	12-19-97

VSL
VIBRATED SLAB SYSTEM
MADE IN THE U.S.A.
VIBRATED SLAB SYSTEM
MADE IN THE U.S.A.

RETAINED EARTH WALLS
CORROSION STANDARD PLAN
"E" & "T" PANEL REINFORCEMENT 1.524Mx5.08M
SALT LAKE COUNTY, UTAH
UTAH DEPARTMENT OF TRANSP.

DWG. NO. CS-302
JOB NO. 233-0007
SHEET NO. STD-2

FINAL PLOT 12-19-97
 H:\EARTH\PROJECT\239-0007\REBAR\TYPE-3\BAR-3X10
 W/FORME (C-LOADING)

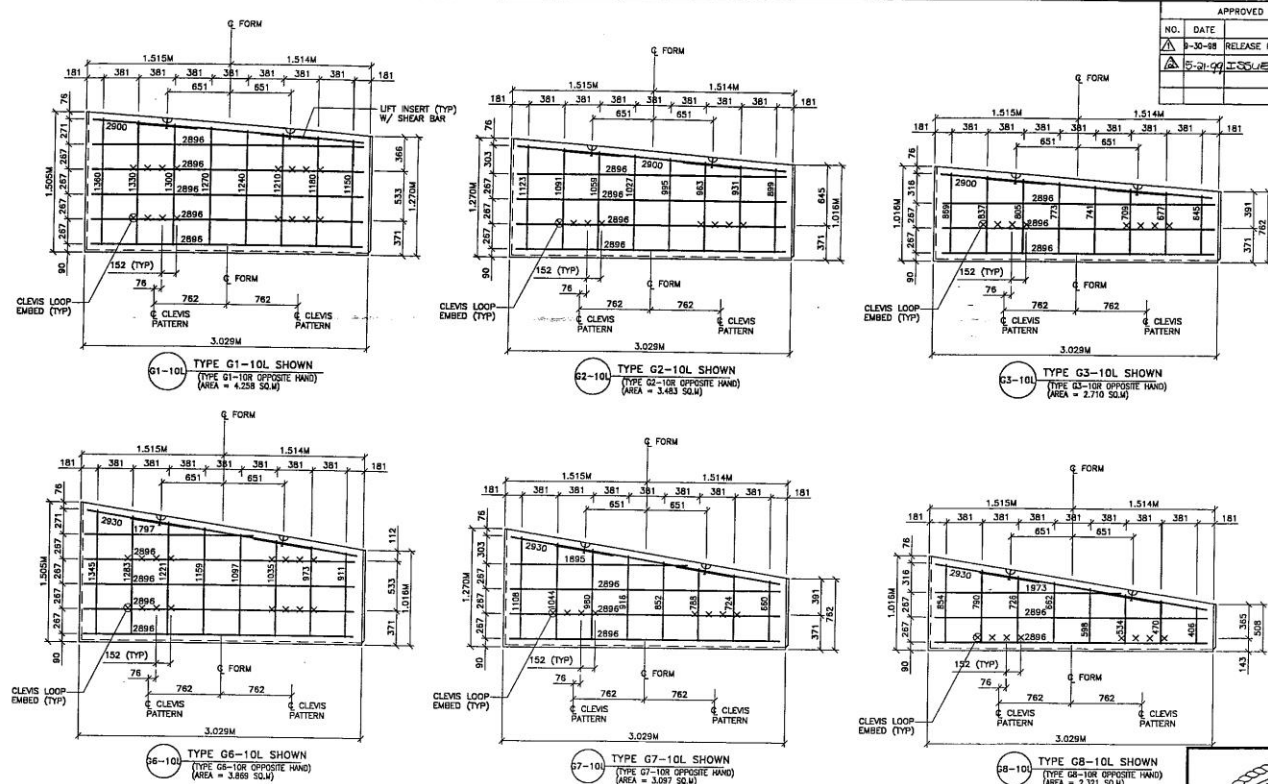

- PANEL REINFORCEMENT NOTES:**
- PANELS ARE SHOWN BACK FACE.
 - HORIZONTAL REINFORCEMENT SHALL HAVE 50 mm MINIMUM COVER TO THE BACK FACE.
 - ALL REINFORCEMENT SHALL HAVE 50 mm MINIMUM COVER TO THE SIDES.
 - ALL REINFORCING BARS ARE #13 METRIC. LABELS ON EACH BAR INDICATE LENGTH, EXAMPLE: 1345 IS A #13 BAR 1345 mm LONG.
 - PANEL REINFORCEMENT BARS SHALL BE DEFORMED BILLET STEEL BARS FOR CONCRETE REINFORCEMENT CONFORMING TO THE SPECIFICATIONS OF ASTM DESIGNATION A615, GRADE 60.
 - ALL REINFORCING STEEL TO BE GALVANIZED IN ACCORDANCE WITH ASTM 797 CLASS 1.
 - CONCRETE PANELS TO HAVE 28 DAY COMPRESSIVE STRENGTH OF 25,000 KPa.
 - EQUIVALENT WELDED WIRE FABRIC MAY BE USED.
 - ALL PANELS TO USE 9.5mm CLEVIS LOOPS.
 - VSL RETAINED EARTH™ IS PROTECTED UNDER PATENT 4,725,170.
 - SEE SHT NO. STD-1 FOR CLEVIS LOOP AND LIFT INSERT DETAILS.
 - LIFT INSERTS ARE 8 3/4" LONG IN ALL PANELS LESS THAN 1.524M TALL. PANELS TALLER THAN 1.524M SHALL HAVE 11" LONG LIFT ANCHORS.

APPROVED FOR CONSTRUCTION		
NO.	DATE	DESCRIPTION
1	9-30-98	RELEASE FOR CONSTRUCTION
2	5-21-99	ISSUED AS CSP



VSL
 VIBRATED SLAB LIFTING

RETAINED EARTH™ WALLS
 75° CONCRETE STANDARD PLAN
 1.524M x 3.048M
 UTAH I-15 INTERCHANGE
 SALT LAKE COUNTY, UTAH
 UTAH DEPARTMENT OF TRANSP.

DATE: 5/20/99
 JOB NO: 239-0007
 SHEET: STD-3

CERTIFIED FOR INTERNAL STABILITY OF RETAINED EARTH™ STRUCTURES ONLY. EXTERNAL STABILITY, INCLUDING BUT NOT LIMITED TO FOUNDATION AND SLOPE STABILITY, IS THE RESPONSIBILITY OF THE OWNER. DESIGN IS BASED ON THE ASSUMPTION THAT THE MATERIAL WITHIN THE RETAINED EARTH™ MASS, METHODS OF CONSTRUCTION, AND QUALITY OF PREFABRICATED MATERIALS CONFORM TO THE MANUFACTURER'S SPECIFICATION.

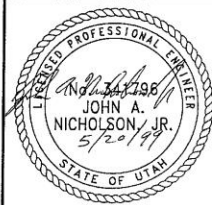

WASATCH CONSTRUCTORS
 JUN 17 1999
 RELEASED FOR CONSTRUCTION
 METRIC

REFERENCE (S-106) (M)

H:\VE\EMTH\PROJECT\239-0007\REBAR\TYPE-3\BAR-5X10

FINAL PLOT 12-19-97

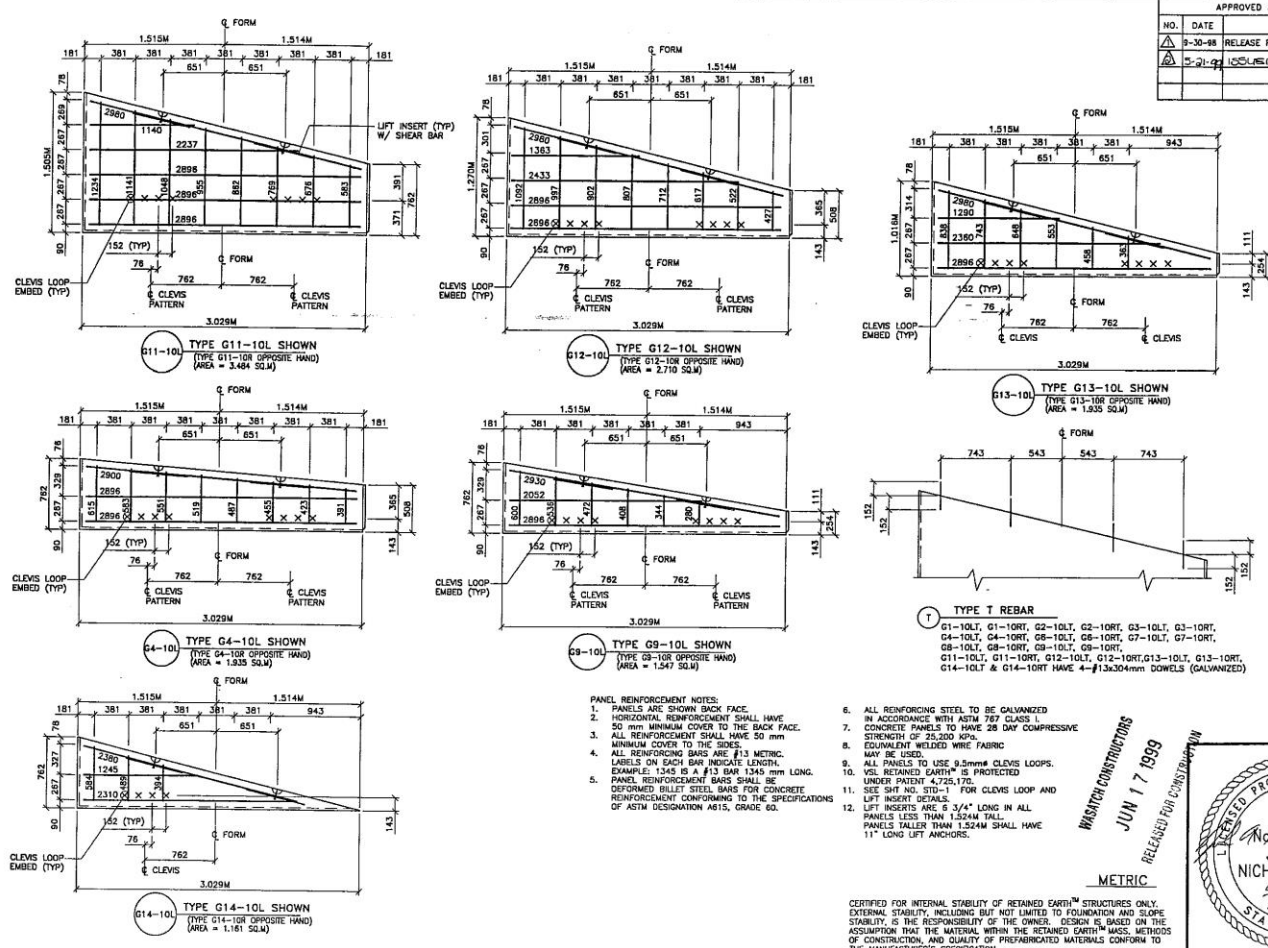

APPROVED FOR CONSTRUCTION		
NO.	DATE	DESCRIPTION
3-30-88		RELEASE FOR CONSTRUCTION
5-24-90		ISSUED AS CSP

PANEL REINFORCEMENT NOTES:

1. PANELS ARE SHOWN BACK FACE.
2. HORIZONTAL REINFORCEMENT SHALL HAVE 50 mm MINIMUM COVER TO THE BACK FACE.
3. ALL REINFORCEMENT SHALL HAVE 50 mm MINIMUM COVER TO THE SIDES.
4. ALL REINFORCING BARS ARE #13 METRIC. LABELS ON EACH BAR INDICATE LENGTH. EXAMPLE: 1345 IS A #13 BAR 1345 mm LONG.
5. PANEL REINFORCEMENT BARS SHALL BE DEFORMED BILLET STEEL BARS FOR CONCRETE REINFORCEMENT CONFORMING TO THE SPECIFICATIONS OF ASTM DESIGNATION A615, GRADE 60.

6. ALL REINFORCING STEEL TO BE GALVANIZED IN ACCORDANCE WITH ASTM A757 CLASS 1.
7. CONCRETE PANELS TO HAVE 28 DAY COMPRESSIVE STRENGTH OF 20,000 KPa.
8. EQUIVALENT WELDED WIRE FABRIC MAY BE USED.
9. ALL PANELS TO USE 8.5mm#8 CLEVIS LOOPS.
10. REINFORCING BARS TO BE PROTECTED UNDER PATENT 4,726,172.
11. SEE SH1 NO. STD-1 FOR CLEVIS LOOP AND LIFT INSERT DETAILS.
12. LIFT INSERTS ARE 6 3/4" LONG IN ALL PANELS LESS THAN 1.524M TALL. PANELS TALLER THAN 1.524M SHALL HAVE 11" LONG LIFT ANCHORS.

RETAINED EARTH™ STRUCTURES ONLY. EXTERNAL STABILITY INCLUDING BUT NOT LIMITED TO FOUNDATION AND SLOPE STABILITY IS THE RESPONSIBILITY OF THE OWNER. DESIGN IS BASED ON THE ASSUMPTION THAT THE MATERIAL WITHIN THE RETAINED EARTH™ MASS METHODS OF CONSTRUCTION, AND QUALITY OF PREFABRICATED MATERIALS CONFORM TO THE MANUFACTURER'S SPECIFICATION.

WASHCRO CONSTRUCTORS
JUN 17 1999
RELEASED FOR CONSTRUCTION

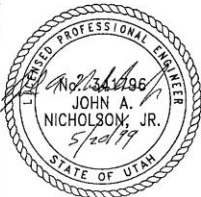

VSL CORPORATION 2800 North Park Ave. 2nd Fl. Salt Lake City, UT 84143 Phone: (801) 388-4822 Fax: (801) 388-4823		REV. NO.	DATE	DESCRIPTION
001	12-19-97	MM		
002	12-19-97	DD		
003	12-19-97	MM		
004	12-19-97	DD		
		REV. NO.	DATE	DESCRIPTION
RETAINED EARTH™ WALLS CHANNEL STANDARD PLAN "G" PANEL REINFORCEMENT 1.524M x 3.048M UTAH I-TIS INTERCHANGE SALT LAKE COUNTY, UTAH UTAH DEPARTMENT OF TRANSP.		001	12-19-97	MM
DWG. NO. CS-204		002	239-0007	
STD. NO. STD-4				

FINAL PLOT 12-19-97
E:\PROJECT\239-000\REBAR\M-PANEL
DICE (C-LINING)

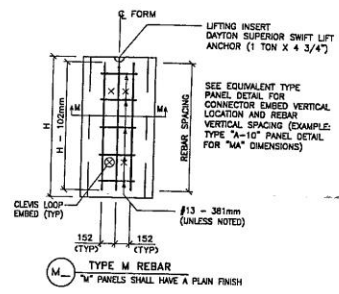

PANEL NAME	SO. M.
MA	1.277
MD	1.065
MD2	0.852
MC2	0.639
MD4	0.426
MB2	0.639

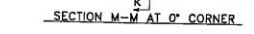
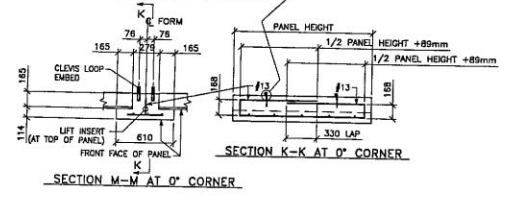
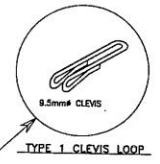
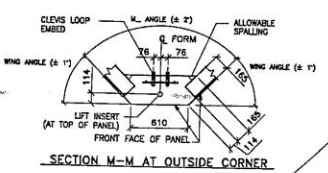
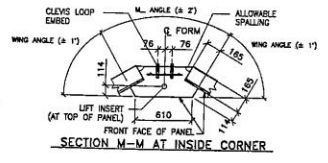
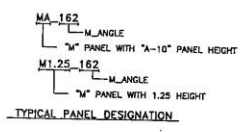

APPROVED FOR CONSTRUCTION		
NO.	DATE	DESCRIPTION
1	9-30-98	RELEASE FOR CONSTRUCTION
2	5-21-99	ISSUED AS CSP

- PANEL REINFORCEMENT NOTES:
- PANELS ARE SHOWN BACK FACE.
 - HORIZONTAL REINFORCEMENT SHALL HAVE 50 mm MINIMUM COVER TO THE BACK FACE.
 - ALL REINFORCEMENT SHALL HAVE 50 mm MINIMUM COVER TO THE SIDES.
 - ALL REINFORCING BARS ARE #13 METRIC. LABELS ON EACH BAR INDICATE LENGTH. EXAMPLE: 1345 IS A #13 BAR 1345 mm LONG.
 - PANEL REINFORCEMENT BARS SHALL BE DEFORMED BULLET STEEL BARS FOR CONCRETE REINFORCEMENT CONFORMING TO THE SPECIFICATIONS OF ASTM DESIGNATION A615, GRADE 60.
 - ALL REINFORCING STEEL TO BE GALVANIZED IN ACCORDANCE WITH ASTM 767 CLASS 1.
 - CONCRETE PANELS TO HAVE 28 DAY COMPRESSIVE STRENGTH OF 28,500 KPa.
 - EQUIVALENT WELDED WIRE FABRIC MAY BE USED.
 - ALL PANELS TO USE 9.5mm# CLEVIS LOOPS.
 - VSL RETAINED EARTH™ IS PROTECTED UNDER PATENT 4,725,170.

WINSBATH CONSTRUCTORS
JUN 17 1999
RELEASED FOR CONSTRUCTION

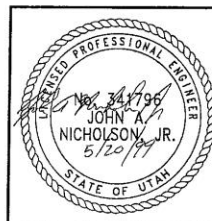

METRIC

CERTIFIED FOR INTERNAL STABILITY OF RETAINED EARTH™ STRUCTURES ONLY. EXTERNAL STABILITY, INCLUDING BUT NOT LIMITED TO FOUNDATION AND SLOPE STABILITY, IS THE RESPONSIBILITY OF THE OWNER. DESIGN IS BASED ON THE ASSUMPTION THAT THE MATERIAL WITHIN THE RETAINED EARTH™ MASS, METHODS OF CONSTRUCTION, AND QUALITY OF PREFABRICATED MATERIALS CONFORM TO THE MANUFACTURER'S SPECIFICATION.

NO.	DATE	DESCRIPTION	BY	CHK
1	9-30-98	RELEASE FOR CONSTRUCTION		
2	5-21-99	ISSUED AS CSP		

REV.	DATE	DESCRIPTION	BY	CHK
1	12-18-97	MM		
2	12-18-97	DDD		
3	12-18-97	MM		
4	12-18-97	MM		

VSL CORPORATION
P.O. Box 100
Munich, Germany 80900
Tel: +49 89 30924-0
Fax: +49 89 30924-200

VSL RETAINED EARTH™ IS A REGISTERED TRADEMARK OF VSL INDUSTRIES INC. 17000 W. PARKWAY, SUITE 100, PLYMOUTH, WISCONSIN 53154

UTAH 1-15 INTERCHANGE
SALT LAKE COUNTY, UTAH
UTAH DEPARTMENT OF TRANSP.

ONE NO.
CS-305

JOB NO:
239-0007

DWG NO.
STD-5

FINAL PLOT 12-19-97
 H:\VE_EARTH\PROJECT\239-000\STDS\STD-8
 (X-LINING)

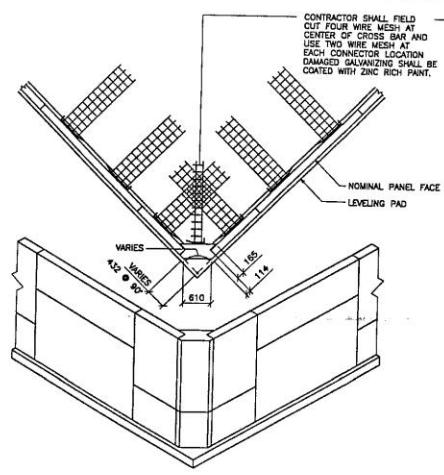

80 OUTSIDE CORNER ELEMENT
PLAN VIEW / ISOMETRIC

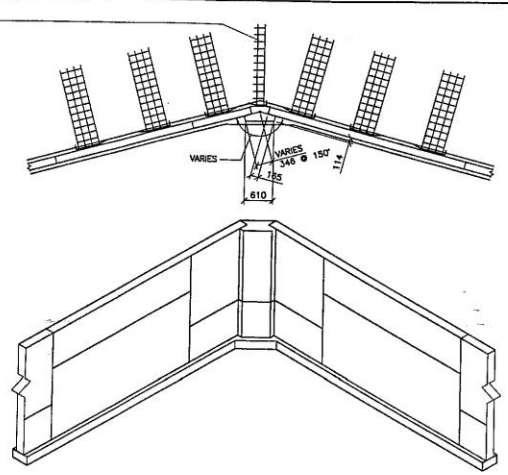

80 INSIDE CORNER ELEMENT
PLAN VIEW / ISOMETRIC

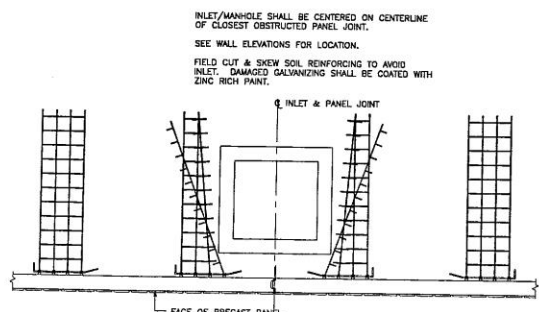

100 INLET OBSTRUCTION DETAIL
FACE OF PRECAST PANEL

CERTIFIED FOR INTERNAL STABILITY OF RETAINED EARTH™ STRUCTURES ONLY.
 EXTERNAL STABILITY, INCLUDING BUT NOT LIMITED TO FOUNDATION AND SLOPE
 STABILITY, IS THE RESPONSIBILITY OF THE OWNER. DESIGN IS BASED ON THE
 ASSUMPTION THAT THE MATERIAL WITHIN THE RETAINED EARTH™ MASS, METHODS
 OF CONSTRUCTION, AND QUALITY OF PREFABRICATED MATERIALS CONFORM TO
 THE MANUFACTURER'S SPECIFICATION.

WASATCH CONSTRUCTORS
 JUN 17 1999
 RELEASED FOR CONSTRUCTION

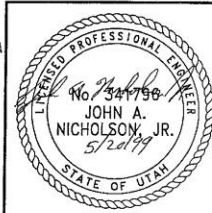

APPROVED FOR CONSTRUCTION		
NO.	DATE	DESCRIPTION
9-30-88		RELEASE FOR CONSTRUCTION
5-21-99		ISSUED AS CSP

VSL CORPORATION
 2400 North Park, Salt Lake City, UT 84143
 Phone: (801) 224-8272
 Fax: (801) 224-8888

VSL
 A Division of Retained Earth, Inc. (Corporate Office)
 1000 S. 1200 E., Suite 100, Provo, UT 84601

RETAINED EARTH™ WALLS
 CORRIDOR STANDARD PLAN
 SPECIAL DETAILS
 UTAH I-15 INTERCHANGE
 SALT LAKE COUNTY, UTAH
 UTAH DEPARTMENT OF TRANSP.

DWG. NO. CS-308
 JOB NO. 239-0007
 STD-8

FINAL PLOT 12-19-97 HARE PART (PARTS) 239-0007, STD-12

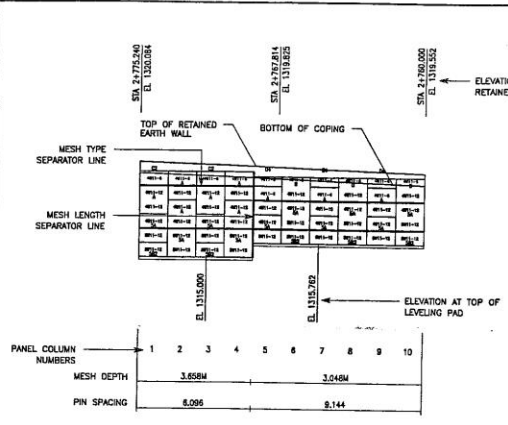

1 WALL ELEVATION KEY
(FRONT FACE SHOWN)

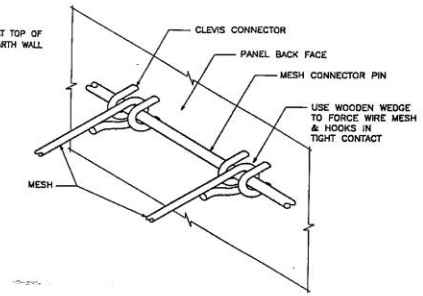

2 MESH CLEVIS CONNECTOR
VSL RETAINED EARTH IS PROTECTED UNDER U.S. PATENT 4,725,170.

APPROVED FOR CONSTRUCTION

NO.	DATE	DESCRIPTION
9-30-98		RELEASE FOR CONSTRUCTION
5-21-99		ISSUED AS CSP

MESH TYPE AT LAYER*	NUMBER OF CONNECTOR BRIDGES PER LAYER*	PANEL TYPE
5W11-6		
6XA-10(L)		
90.0		
6W11-12		

* NO LABEL INDICATES STANDARD TYPE

3 PANEL LABELS

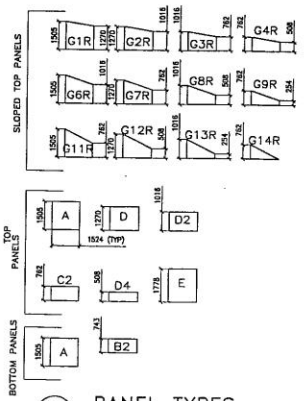

4 PANEL TYPES
ALL DIMENSIONS ARE IN MILLIMETERS

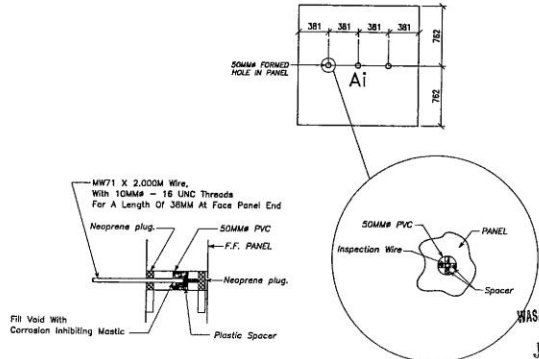

5 INSPECTION WIRE DETAIL
(PANEL FRONT FACE SHOWN)

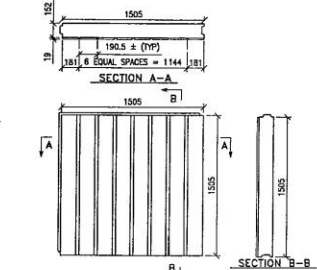

6 ARCHITECTURAL PANEL FINISH
(PANEL FRONT FACE SHOWN)

WASATCH CONSTRUCTORS
JUN 17 1999
RELEASED FOR CONSTRUCTION

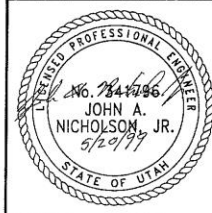

CERTIFIED FOR INTERNAL STABILITY OF RETAINED EARTH STRUCTURES ONLY. EXTERNAL STABILITY, INCLUDING BUT NOT LIMITED TO FOUNDATION AND SLOPE STABILITY, IS THE RESPONSIBILITY OF THE OWNER. DESIGN IS BASED ON THE ASSUMPTION THAT THE MATERIAL WITHIN THE RETAINED EARTH MASS, METHODS OF CONSTRUCTION, AND QUALITY OF PREFABRICATED MATERIALS CONFORM TO THE MANUFACTURER'S SPECIFICATION.

VSL CORPORATION
2800 PARKWAY, SUITE 200
ANN ARBOR, MI 48106
TEL: (313) 963-4000
FAX: (313) 963-4001

VSL
VSL RETAINED EARTH WALLS
CONFORM TO STANDARD PLAN
SINGLE STAGE - TYPICAL DETAILS
UTAH I-TIS INTERCHANGE
SALT LAKE COUNTY, UTAH
UTAH DEPARTMENT OF TRANSP.

NO.	DATE	DESCRIPTION
9-30-98		RELEASE FOR CONSTRUCTION
5-21-99		ISSUED AS CSP

REV.	DATE	DESCRIPTION

DATE: 05-31-99
JOB NO: 239-0007
SHEET NO: 239-0007
SCALE: STD-12

FINAL PLOT 12-19-97
 H:\RE_EARTH\PROJECT\239-0007\STDS\SP-13
 VICE (6-UTD/SLG)

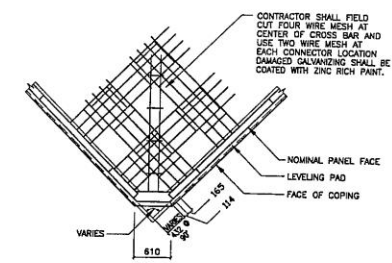

81 OUTSIDE CORNER ELEMENT
 PLAN VIEW / ISOMETRIC

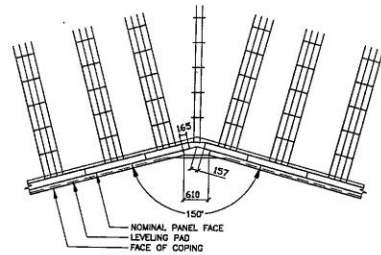

81 INSIDE CORNER ELEMENT
 PLAN VIEW / ISOMETRIC

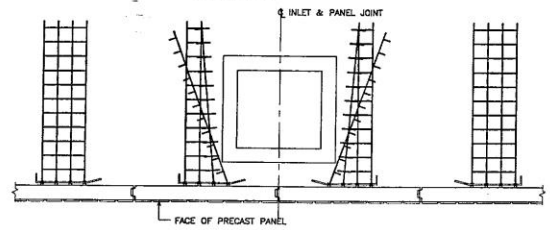
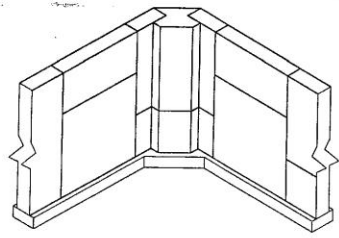
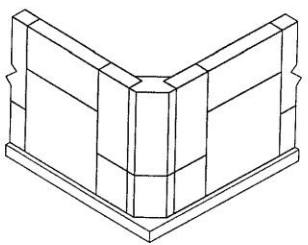

101 INLET OBSTRUCTION DETAIL

APPROVED FOR CONSTRUCTION		
NO.	DATE	DESCRIPTION
9-30-88		RELEASE FOR CONSTRUCTION
5-2-99		ISSUED AS CBP

INLET/MANHOLE SHALL BE CENTERED ON CENTERLINE OF CLOSEST OBSTRUCTED PANEL JOINT.
 SEE WALL ELEVATIONS FOR LOCATION.
 FIELD CUT & SKEW SOL REINFORCING TO AVOID INLET. DAMAGED GALVANIZING SHALL BE COATED WITH ZINC RICH PAINT.

DES.	12-19-97	UM			
CHK.	12-19-97	MD			
CHK.	12-19-97	UM			
CHK.	12-19-97	UM			

VSL CORPORATION
 10000 W. 12TH AVE. SUITE 200
 DENVER, CO 80202
 TEL: (303) 751-9888
 FAX: (303) 751-9889

PLANS, ELEVATIONS, & FOUNDATION DRAWINGS
 DRAWN BY: JIM ANDERSON, P.E.

VSL

RETAINED EARTH WALLS
 CORRIDOR & DIVIDED PLAN
 SPECIAL DETAILS
 UTAH I-15 INTERCHANGE
 SALT LAKE COUNTY, UTAH
 UTAH DEPARTMENT OF TRANSP.

DATE NO. CS-313
 JOB NO. 239-0007
 SHEET NO. STD-13

WASATCH CONSTRUCTORS
 JUN 17 1999
 RELEASED FOR CONSTRUCTION

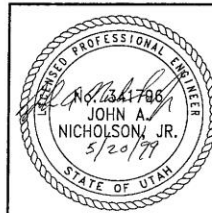

METRIC
 CERTIFIED FOR INTERNAL STABILITY OF RETAINED EARTH™ STRUCTURES ONLY.
 EXTERNAL STABILITY, INCLUDING BUT NOT LIMITED TO FOUNDATION AND SLOPE STABILITY, IS THE RESPONSIBILITY OF THE OWNER. DESIGN IS BASED ON THE ASSUMPTION THAT THE MATERIAL WITHIN THE RETAINED EARTH™ MASS, METHODS OF CONSTRUCTION, AND QUALITY OF PREFABRICATED MATERIALS CONFORM TO THE MANUFACTURER'S SPECIFICATION.

FINAL PLOT 10-1-99
 H:\VCL\EMPH\PROJECT\335-0007\VTRM\STD-14
 INDEX (L-TO-R)

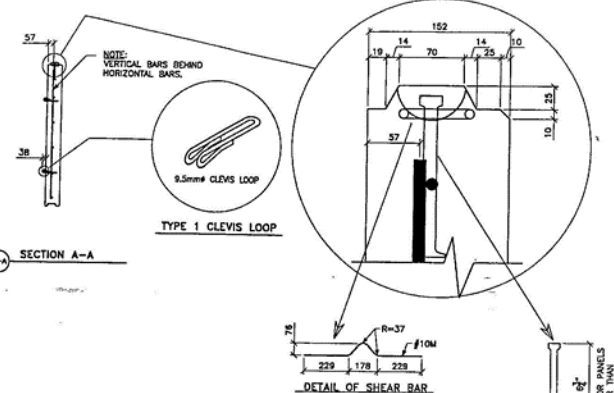
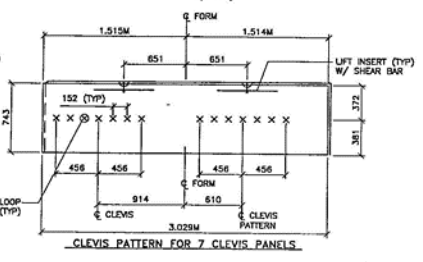
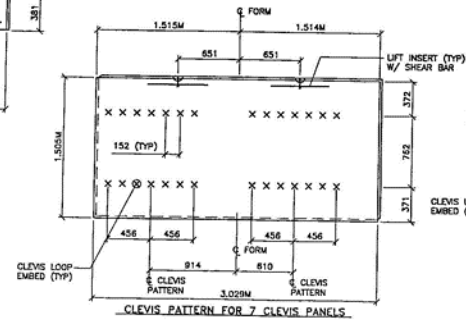
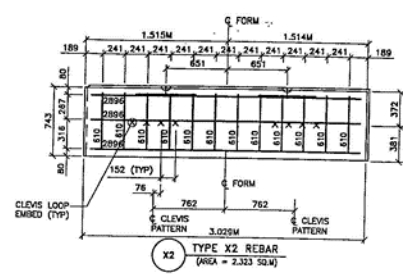
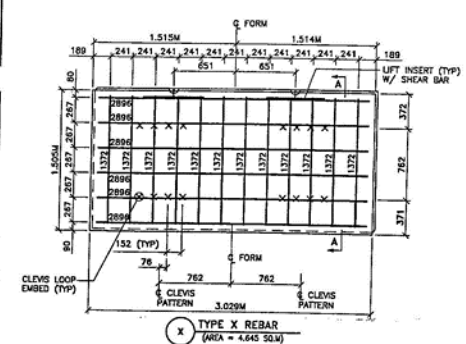

APPROVED FOR CONSTRUCTION		
NO.	DATE	DESCRIPTION
1	9-30-98	RELEASE FOR CONSTRUCTION
2	5-11-99	ISSUED AS CSP

- PANEL REINFORCEMENT NOTES:
- PANELS ARE SHOWN BACK FACE.
 - HORIZONTAL REINFORCEMENT SHALL HAVE 50 mm MINIMUM COVER TO THE BACK FACE.
 - ALL REINFORCEMENT SHALL HAVE 50 mm MINIMUM COVER TO THE SIDES.
 - ALL REINFORCING BARS ARE #13 METRIC. LABELS ON EACH BAR INDICATE LENGTH. EXAMPLE: 2852 IS A #13 BAR 2852 mm LONG.
 - PANEL REINFORCEMENT BARS SHALL BE DEFORMED BILLET STEEL BARS FOR CONCRETE REINFORCEMENT CONFORMING TO THE SPECIFICATIONS OF ASTM DESIGNATION A615, GRADE 60.
 - ALL REINFORCING STEEL TO BE GALVANIZED IN ACCORDANCE WITH ASTM A767 CLASS 1.
 - CONCRETE PANELS TO HAVE 28 DAY COMPRESSIVE STRENGTH OF 28,000 KPA.
 - EQUIVALENT WELDED WIRE FABRIC MAY BE USED.
 - ALL PANELS TO USE 9.5mm CLEVIS LOOPS.
 - VSL RETAINED EARTHTM IS PROTECTED UNDER PATENT 4,725,170.
 - LIFT INSERTS ARE 6.34" LONG IN ALL PANELS LESS THAN 1.524M TALL. PANELS TALLER THAN 1.524M SHALL HAVE 11" LONG LIFT ANCHORS.

WASATCH CONSTRUCTORS
 JUN 17 1999
 RELEASED FOR CONSTRUCTION

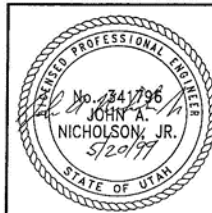

METRIC
 DESIGNED FOR INTERNAL STABILITY OF RETAINED EARTHTM STRUCTURES ONLY. EXTERNAL STABILITY, INCLUDING BUT NOT LIMITED TO FOUNDATION AND SLOPE STABILITY, IS THE RESPONSIBILITY OF THE OWNER. DESIGN IS BASED ON THE ASSUMPTION THAT THE MATERIAL WITHIN THE RETAINED EARTHTM MASS, METHODS OF CONSTRUCTION, AND QUALITY OF PREFABRICATED MATERIALS CONFORM TO THE MANUFACTURER'S SPECIFICATION.

VSL CORPORATION 2000 Park Lane SW Wallingford, UT 84086 Tel: (435) 338-4527 Fax: (435) 338-4588	VSL (CANADA) LTD. 2000 Park Lane SW Wallingford, UT 84086 Tel: (435) 338-4527 Fax: (435) 338-4588
VSL (INDIA) PVT. LTD. 2000 Park Lane SW Wallingford, UT 84086 Tel: (435) 338-4527 Fax: (435) 338-4588	VSL (AUSTRALIA) PTY. LTD. 2000 Park Lane SW Wallingford, UT 84086 Tel: (435) 338-4527 Fax: (435) 338-4588
RETAINED EARTH TM WALLS CORROSION STAINLESS PLAN HEAVY PANEL REINFORCEMENT 1.524M x 3.048M UTAH I-15 INTERCHANGE SALT LAKE COUNTY, UTAH UTAH DEPARTMENT OF TRANSP.	SHEET NO. STD-14
DWG. NO. CS-314	JOB NO. 239-0007

APPENDIX C: PICTURES AND RAW DATA

Pictures of coupons, extraction procedures, and lab testing were given to UDOT on a flash drive along with raw data used to create the figures and tables used herein. These items are available by contacting the UDOT Research and Innovation Division or by going online to the following Google Drive folder link managed by this division (as of the time of report publishing):

https://drive.google.com/drive/folders/1bLeX1PTPdL4R_oIxMLrHQPj9_ADxzHjg