

Improving the Quality of Bridge Inspections Using Unmanned Aircraft Systems (UAS)

Barritt Lovelace, Principal Investigator
Collins Engineers, Inc.

July 2018

Research Project
Final Report 2018-26

To request this document in an alternative format, such as braille or large print, call [651-366-4718](tel:651-366-4718) or [1-800-657-3774](tel:1-800-657-3774) (Greater Minnesota) or email your request to ADArequest.dot@state.mn.us. Please request at least one week in advance.

Technical Report Documentation Page

1. Report No. MN/RC 2018-26	2.	3. Recipients Accession No.	
4. Title and Subtitle Improving the Quality of Bridge Inspections Using Unmanned Aircraft Systems (UAS)		5. Report Date July 2018	
		6.	
7. Author(s) Jennifer Wells, PE Barritt Lovelace, PE		8. Performing Organization Report No.	
9. Performing Organization Name and Address Collins Engineers, Inc. 1599 Selby Avenue, Suite 206 St. Paul, MN 55104		10. Project/Task/Work Unit No.	
		11. Contract (C) or Grant (G) No. 1027210	
12. Sponsoring Organization Name and Address Minnesota Department of Transportation Research Services & Library 395 John Ireland Boulevard, MS 330 St. Paul, Minnesota 55155-1899		13. Type of Report and Period Covered Final Report	
		14. Sponsoring Agency Code	
15. Supplementary Notes http://mndot.gov/research/reports/2018/201826.pdf			
16. Abstract (Limit: 250 words) Bridges are a key part of our transportation system and maintaining this infrastructure is important to ensure the safety of the traveling public and to effectively manage these valuable assets. Safety inspections not only ensure the structural integrity of a bridge but provide valuable data to decision makers. The Minnesota Department of Transportation and Collins Engineers, Inc. has completed this third phase of research focused on utilizing drones as a tool for improving the quality of bridge inspections. The previous phases focused on the rules and regulations, drone hardware and the ability of drones to collect quality inspection data. This phase of research has identified new drone technology and methods to address limitations identified in Phase II. More importantly, this research phase has focused on the value of data collected during the inspection and finding ways to process the data into actionable inspection deliverables that greatly improve the quality of the inspections. These inspection deliverables better communicate the inspection results to bridge owners and engineers. Our world is being transformed by technology including drones that can collect, process, store, and analyze large amounts of data and this research is applying the same transformative concepts and technology to improve bridge inspection outcomes.			
17. Document Analysis/Descriptors Inspection, Drones, Unmanned aircraft systems, Information processing, Structural health monitoring		18. Availability Statement No restrictions. Document available from: National Technical Information Services, Alexandria, Virginia 22312	
19. Security Class (this report) Unclassified	20. Security Class (this page) Unclassified	21. No. of Pages 345	22. Price

Improving the Quality of Bridge Inspections Using Unmanned Aircraft Systems (UAS)

FINAL REPORT

Prepared by:

Jennifer L. Wells, P.E.
MnDOT Bridge Office

Barritt Lovelace
Collins Engineers, Inc.

July 2018

Published by:

Minnesota Department of Transportation
Research Services & Library
395 John Ireland Boulevard, MS 330
St. Paul, Minnesota 55155-1899

This report represents the results of research conducted by the authors and does not necessarily represent the views or policies of the Minnesota Department of Transportation or Collins Engineers Inc. This report does not contain a standard or specified technique.

The authors, the Minnesota Department of Transportation, and Collins Engineers Inc. do not endorse products or manufacturers. Trade or manufacturers' names appear herein solely because they are considered essential to this report.

ACKNOWLEDGMENTS

This report would not be possible without the support of the professionals at the Minnesota Department of Transportation and our industry partners. This research was both a local and international effort. Local bridge owners volunteered their structures as case studies and industry partners contributed by volunteering their time to demonstrate and assist with technology and software solutions. Their input, hard work, ideas and enthusiasm for this study were critical to the success of the project. The following team members contributed in a significant way to this project:

Kevin Western, MnDOT State Bridge Engineer
Edward Lutgen, MnDOT Bridge Office of Bridges and Structures
Bruce Holdhusen, MnDOT Research Services
Nancy Daubenger, MnDOT Engineering Services Division Director
Amber Blanchard, MnDOT Office of Bridges and Structures
Paul Pilarski, MnDOT Office of Bridges and Structures
Sarah Sondag, MnDOT Office of Bridges and Structures
Mike Arsenau, MnDOT Metro District
Joe Triplett, Chisago County
Zachory Johnson, City of Lakeville
Bruce Hasbargen, Beltrami County
Brent Christiansen, City of St. Paul
Allan Brandt, Washington County
Tekeste Amare, Maryland Transportation Authority
Tony Winiecki, Scott County
Cory Stuber, Collins Engineers, Inc.
Marc Parker, Collins Engineers, Inc.
Thomas J. Collins, Collins Engineers, Inc.
Lisa Chen, Pix4D
Benjamin Pinquet, senseFly
Adam Zylka, senseFly
Briton Voorhees, senseFly
Roberto Passini, Flyability
Marc Gandillion, Flyability
Dan Stong, RDO Integrated Solutions
Adam Gilbertson, RDO Integrated Solutions
Baptiste Tripard, Intel
Joseph Bahous, Intel
John Frost, Propeller

TABLE OF CONTENTS

CHAPTER 1: Introduction	1
1.1 Project Background and Objectives.....	1
1.2 Previous Research.....	2
1.2.1 Phase I – Unmanned Aerial Vehicle Bridge Inspection Demonstration Project.....	2
1.2.2 Phase II – Unmanned Aircraft System Bridge Inspection Demonstration Project	4
1.3 UAS Bridge Inspection Research Statistics	7
CHAPTER 2: Government Rules and Regulations	9
2.1.1 FAA Current Operating Rules and Regulations	9
2.1.2 Federal Highway Administration and National Bridge Inspection Standards	10
2.1.3 MnDOT Regulations	10
CHAPTER 3: UAS Hardware	11
3.1 Inspection-Specific Commercial UAS.....	11
3.2 Opportunities for Hardware Advancement.....	21
CHAPTER 4: Data Processing and Deliverables	22
4.1 Data Processing	22
4.1.1 Processing Inputs	22
4.1.2 UAS Reality Modeling Platforms	23
4.1.3 Deliverables.....	24
4.2 Reality Capture Inspection Workflows	32
4.2.1 Field Inspection – Data Capture and Processing	32
4.2.2 Data Capture and Processing – Field Inspection	33
CHAPTER 5: Cost and Time Analysis	34
CHAPTER 6: Safety Improvements	37
CHAPTER 7: Conclusions and Recommendations	38

7.1 Conclusions..... 38

 7.1.1 Cost..... 38

 7.1.2 Improved Deliverables/Reality Modeling 38

 7.1.3 Collision Tolerant/Confined Spaces 38

 7.1.4 Safety..... 39

7.2 Recommendations..... 39

REFERENCES40

APPENDIX A Bridge UAS Inspection Reports

APPENDIX B MnDOT Safety Plan

APPENDIX C Equipment Specifications and Data Sheets

APPENDIX D FAA Waivers and Exemptions

LIST OF FIGURES

Figure 1.1 Overall Photographs of Four Bridges Selected for Phase I UAS Inspection.....	3
Figure 1.2 Overall Photographs of Four Bridges Selected for Phase II UAS Inspection.....	5
Figure 1.3 Breakdown of Number of Structures Inspected Using a UAS by Structure Size.....	7
Figure 1.4 Breakdown of Number of Structures Inspected Using a UAS by Structure Type.....	7
Figure 1.5 Breakdown of Number of Structures Inspected Using a UAS by Material Type.....	8
Figure 1.6 Breakdown of Number of Structures Inspected Using a UAS by Location.....	8
Figure 3.1 senseFly Emotion Software Flight Controls.....	12
Figure 3.2 Image of the senseFly albris UAS.....	13
Figure 3.3 Image of the Sensor Payload On-Board senseFly albris UAS.....	13
Figure 3.4 Example of albris High-Resolution Image Capability.....	14
Figure 3.5 Example of albris IR Image Capability.....	15
Figure 3.6 Image of the Flyability Elios UAS.....	18
Figure 3.7 Photograph of the Elios UAS Rolling on Top of an Abutment Bearing Seat.....	19
Figure 3.8 Photograph of the Elios UAS Rolling along a Concrete Deck Soffit.....	19
Figure 3.9 Photograph of the Elios UAS Rolling Inside a Steel Box Beam.....	20
Figure 4.1 High Resolution UAS Image.....	23
Figure 4.2 Traditional Photolog.....	25
Figure 4.3 Pix4D 3D Reality Model Photo Log.....	25
Figure 4.4 Pix4D 3D Point Cloud.....	26
Figure 4.5 Pix4D 3D Triangular Mesh.....	26
Figure 4.6 Orthomosaic of Bridge Site.....	27
Figure 4.7 Pix4D Bridge Facade Orthoplane.....	27
Figure 4.8 Cloud Virtual Inspector.....	28
Figure 4.9 3D Model of Bridge Pier Created from Terrestrial Photos.....	30

Figure 4.10 Scale Used During Image Collection	30
Figure 4.11 AeroPoint Automated Ground Control Point Figure	31
Figure 4.12 Pier Inspection	32
Figure 5.1 Traditional Inspection vs. UAS Assisted Inspection Savings	36
Figure 6.1 Pier Typical Bridge Inspection Work Zone with Traffic Control	37

LIST OF TABLES

Table 1: Cost Assumptions by Unit/Cost.....	34
Table 2: Cost Analysis by Individual Bridge.....	35

LIST OF ABBREVIATIONS

3D	Three-Dimensional
UAS	Unmanned Aircraft System
AASHTO	American Association of State Highway and Transportation Officials
ADT	Average Daily Traffic
BSIPM	Bridge and Structure Inspection Program Manual
CFR	Code of Federal Regulations
CoRE	Commonly Recognized Structural Elements
FAA	Federal Aviation Administration
FC	Fracture Critical
FCM	Fracture Critical Member
FHWA	Federal Highway Administration
GPS	Global Positioning System
IRT	Infrared Thermography
LRFD	Load Resistance Factor Design
MBE	AASHTO Manual for Bridge Evaluation
MNDOT	Minnesota Department of Transportation
MT	Magnetic Particle Testing
MUTCD	Manual of Uniform Traffic Control Devices
NBI	National Bridge Inventory
NBIS	National Bridge Inspection Standards
NCHRP	National Cooperative Highway Research Program
NDE	Non-destructive Evaluation
NDT	Non-destructive Testing
NHI	National Highway Institute

NRHP	National Register of Historic Places
PPE	Personal Protection Equipment
PT	Liquid Penetrant Testing
SI&A	Structure Inventory and Appraisal
SIMS	Structure Information Management System
TH	Trunk Highway
TL	Team Leader
UBIV	Under Bridge Inspection Vehicle
UT	Ultrasonic Testing
UTG	Ultrasonic Thickness Gage
UW	Underwater

EXECUTIVE SUMMARY

The ability to collect and utilize large amounts of data is transforming our world. Many industries including healthcare, finance, energy, communication and transportation are finding ways to utilize data to improve people's lives. The Minnesota Department of Transportation (MnDOT) and Collins Engineers, Inc. are utilizing drones to collect and process large amounts of data during bridge inspections with the goal of improving the quality of bridge inspections and improving safety for both inspectors and the traveling public. Processing software and inspection specific asset management platforms are giving bridge engineers the ability to utilize this data to improve the quality of bridge inspections and accelerating their ability to effectively manage these important assets. MnDOT and Collins Engineers have utilized drones on over 60 bridges in Minnesota with plans to leverage what has been learned by continuing the implementation and taking advantage of this transformative technology.

Bridges are a key part of our transportation system. Maintaining this infrastructure is important to ensure the safety of the traveling public, as well as to maximize the useful life of these valuable assets. The most important objective of a safety inspection is to verify the structural integrity of the bridge. Information gathered during bridge inspections is used to give bridge owners and engineers the necessary data to plan for the maintenance, rehabilitation, and replacement of bridges. The National Bridge Inspection Standards (NBIS) set minimum requirements for bridge inspections including inspector qualifications, inspection intervals, and inspection procedures. The NBIS was implemented into Federal law in 1968 and bridge inspections have been performed in a similar manner until recently. Recent technological advancements in Unmanned Aerial Systems (UAS) hardware and software have demonstrated that this transformative technology can improve the quality of bridge inspections. Inspection specific drones have proven to be a tool that can collect high-quality inspection data. Software is now available to process the data collected by drones into deliverables that assist bridge owners in making better risk-based data-driven decisions.

The aviation industry has a safety culture that is more conservative than the transportation industry. This is reflected in the low number of fatalities in commercial aviation compared to the high number of roadway fatalities. As a result, The Federal Aviation Administration (FAA) rules and regulations are conservative regarding the use of drones and have changed slowly as opportunities such as bridge inspection have been identified. The FAA is allowing the adoption of this technology and, as a result, barriers to UAS implementation have been greatly reduced since Phase I of this research began in 2015. One major barrier is the time required for approval to fly in restricted airspace. Recent testing and implementation of near real-time airspace authorizations will dramatically improve the ability of engineers to utilize UAS for bridge inspections. Another barrier includes the ability to fly over traffic and people especially where risks to the inspectors and public can be reduced with the use of drones.

The Federal Highway Administration (FHWA) has identified this technology as a tool that can provide benefits for bridge inspections and the transportation industry. In the hands of qualified and experienced bridge inspectors, drones have the ability to improve the safety and quality of inspections. One of the key contributing factors to the success of the National Bridge Inspection Program is the ability to collect quality data on the nation's bridges, which can be analyzed to ensure quality inspection

results. Drones are a platform for collecting quality data, and the use of this technology satisfies one of the primary goals of the NBIS. As the FHWA moves towards risk-based inspections, drones are playing an important role as a tool for an experienced and qualified bridge inspector.

Inspection specific drone technology is maturing and several drone models now exist that serve the inspection and asset management industry. These drones include features important to bridge inspection such as sense and avoid, infrared imaging, autonomous flights, and collision-tolerant features. Inspection specific drone models have their own strengths and weaknesses, but all can accomplish the task of obtaining high-quality data. As technology has improved, the focus has shifted from the ability to collect data to making effective use of the data.

An opportunity identified during previous MnDOT research was the ability to inspect very tight areas and confined spaces. An important focus of this phase of research was identification of a drone that can accomplish this challenging task. The Flyability Elios drone was identified and tested extensively on a wide variety of bridges. This collision-tolerant drone solves the issue of accessing those difficult to reach areas by employing a cage around the drone that enables the drone to come in contact with the structure and to use the structure itself to fly and navigate. One case that emerged as valuable to bridge inspection was the ability to fly between beams and through diaphragms. The majority of bridge superstructures are comprised of multiple beam lines. These bridges have redundant load paths, making them lower risk compared to other bridge types. Since Under Bridge Inspection Vehicles (UBIV's) and traffic control are expensive and tend to be highly restrictive in metropolitan areas, many of these bridges do not get a regular close-up inspection. The collision-tolerant drone provides an effective, safe, and cost-effective way to inspect these bridges. The use of these types of drones may also reduce the need for expensive access methods and traffic control. Combined with typical inspection specific drones, such as the senseFly Albris drone, we can now achieve nearly 100 percent inspection coverage of the bridge.

Effective bridge inspections are comprised of three key components. The first component is the ability to detect deficiencies. To be successful in this endeavor, the bridge inspector's experience and knowledge play a key role. Access to bridge components is vitally important, typically consisting of under bridge inspection vehicles (UBIV), lifts, rope access, scaffolding, and ladders. These methods are effective but can be costly and pose safety challenges not only to inspectors but to the traveling public. In metropolitan areas, lane closures to inspect bridges are also very prohibitive. Phase I and II of MnDOT's research into the use of UAS for bridge inspections have proven that UAS is another effective access tool and this phase of the research has shown that it can be implemented safely and effectively on a large number of bridge types and sizes.

The second component is the ability to document deficiencies. Traditionally this has been accomplished by documenting the inspection with detailed notes and photos in the field by paper and pen. While this method has been effective, the results of this study have identified methods to improve the documentation of defects with the use of drone imagery in addition to the expanded use of terrestrial photos.

The third component of a successful inspection is the ability to clearly communicate inspection results to bridge owners, engineers, and decision makers. Traditional methods have included paper and electronic reporting. This research effort has demonstrated much more effective ways to communicate inspection data by employing recent advancements in the modeling of bridges and inspection data. These new methods are improving the ability for bridge inspectors to clearly communicate inspection results and to make actionable decisions. This helps avoid oversights and save money.

Safety of bridge inspectors and the traveling public during bridge inspections is critical. A risk often associated with bridge inspection is the failure of access equipment including UBIV's. Perhaps the highest risk factor associated with bridge inspection is the closure of traffic lanes. The risk of injury or death is for both the traveling public and bridge inspectors. While statistics on injuries and fatalities are difficult to find, news article searches show fatalities happen every year. For many bridge inspections, the use of UAS can eliminate or reduce the need for access vehicles and/or lane closures thereby reducing risk.

This research phase implemented UAS technology on 39 bridges including a wide range of bridge sizes, types, and locations. The results of this research effort demonstrated that drone technology and processing software are effective tools to improve the quality of bridge inspections in addition to improving safety and reducing costs. Traditional access and reporting methods will continue to be utilized even as UAS technology improves, but UAS has proven to be another effective tool. This report will help bridge owners identify opportunities to improve the quality of their inspections, improve safety, and reduce costs.

CHAPTER 1: INTRODUCTION

1.1 PROJECT BACKGROUND AND OBJECTIVES

Bridges are a key part of our transportation system, and maintaining this infrastructure is important to ensure the safety of the traveling public and to protect these valuable assets. The most important objective during a bridge safety inspection is to verify the structural integrity of the bridge. Information gathered during bridge inspections is also used to give bridge owners and engineers data to plan for the maintenance, rehabilitation and replacement of bridges. The National Bridge Inspection Standards (NBIS) set minimum requirements for bridge inspections including inspector qualifications, inspection intervals and inspection procedures. The NBIS was implemented into Federal law in 1968, and bridge inspections have been documented in a similar manner until recently. Recent technological advancements in Unmanned Aerial Systems (UAS) hardware and software have demonstrated that this transformative technology can also improve on the quality of bridge inspection. Inspection specific drones have proven effective in providing high-quality data that can be processed by software into multiple formats that can easily be shared via the Cloud.

In the summer of [2015](#) and [2016](#), two research phases were carried out to evaluate the use of UASs for bridge inspections by the MnDOT Bridge Office. The resulting studies were published by MnDOT's Research Services. As this research has progressed, the focus has shifted from data collection to data analysis and presentation.

An Unmanned Aircraft System (UAS) is defined by the Federal Aviation Administration (FAA) as an aircraft operated without the possibility of direct human intervention from within the aircraft. UASs are commonly referred to as drones, and the names can be used interchangeably. Inspection specific UAS technology is maturing, and several models now exist that serve the inspection and asset management industry. These drones include features important to bridge inspection such as sense and avoid, infrared imaging, autonomous flights, and collision-tolerant features. Each have their own strengths and weaknesses, but can all accomplish the task of obtaining high-quality data. As the technology improved, the focus shifted from UAS hardware to data.

An opportunity identified during previous MnDOT research, was the ability to inspect very tight areas and confined spaces. One focus of this research phase was identifying a drone that could accomplish this challenging task. Another research objective was to scale the UAS inspection effort to demonstrate that full implementation is achievable. This research phase implemented UAS technology on 39 bridges including a wide range of bridge sizes, types, and locations to demonstrate the benefits and challenges of employing UAS on a large scale. When processed with modeling software high-quality images can be collected and processed into useful inspection data such as point clouds, 3D photologs, and orthoplane images.

The ability to efficiently utilize large amounts of data is transforming our world. Drones have the ability to collect large amounts of data during bridge inspections. Software is available to process and share

that data in meaningful ways. While not an original goal of the project, the ability to process the drone data into bridge inspection deliverables was a key focus of this effort is perhaps the most impactful result.

Phase III included the utilization of drones on 39 bridges of various sizes, types and locations. Case study inspection reports were compiled for a select number of bridges representative of various use cases. Those case studies can be found in Appendix A. A video summary of Phase III efforts can be found [here](#).

1.2 PREVIOUS RESEARCH

1.2.1 Phase I – Unmanned Aerial Vehicle Bridge Inspection Demonstration Project

1.2.1.1 Scope

This project phase, completed in 2015, demonstrated the use of UAS for bridge inspection, evaluated the technology's effectiveness, and addressed the safety implications for routine bridge inspections.

1.2.1.2 Execution

Investigators identified four bridges in Minnesota that represented a variety of bridge types and sizes: an 80-foot local bridge in Chisago County, a medium-sized concrete arch bridge in Oronoco, a large steel truss bridge in Morrison County, and a 2,682-foot long railroad bridge near Stillwater that rises 185 feet above the St. Croix River.

Researchers then reviewed current and proposed FAA rules and regulations pertaining to UAS use for bridge inspection and worked with the MnDOT Office of Aeronautics to acquire necessary authorization for inspections. After reviewing UAS options, investigators selected the Aeyron Skyraanger UAS and contracted a drone pilot to help conduct inspections of each selected bridge. Researchers compared UAS results to recent bridge inspection records.



Figure 1.1 Overall Photographs of Four Bridges Selected for Phase I UAS Inspection.

1.2.1.3 Findings

The UAS provided high-quality detail on the two large bridges, and its zoom lens was effective with the medium-sized concrete arch bridge, allowing viewing and assessment of many bridge element conditions. Smaller bridges with limited clearance underneath proved challenging for the UAS due to loss of GPS signal under concrete decks. As the UAS lost GPS signal, it would then return automatically to its take-off point, or home base. Another barrier of this specific UAS was that the camera mounted underneath the drone could not look up.

Before UAS field work began on any of the selected bridges, detailed investigation and safety plans were prepared for each structure. Site-specific plans addressed safety, potential hazards and how to mitigate them, current FAA rules, and inspection methods.

Based on analysis of field work, inspection results, regulations for UAS use, and emerging inspection-specific UAS technology, researchers concluded the following:

- UASs can be used for bridge inspection with little risk to inspectors and the public and can reduce safety risks that inspectors currently face. They should be considered a tool in routine inspection and for situations not requiring hands-on inspection, testing, sounding, or cleaning. They also suit

pre-inspection surveys, and can identify rope anchor points and other safety needs before hands-on inspection begins.

- UASs provide inspection detail that effectively replicates detail learned through use of snoopers without traffic control at significantly lower cost in equipment and traffic control needs.
- UASs provide both infrared and 3D modeling detail of bridges, effectively identify concrete delamination, gather topographic mapping detail, and efficiently map riverbank conditions upstream and downstream from the bridge sites.
- Inspectors should select UASs capable of pointing cameras upward and operating without GPS.

1.2.2 Phase II – Unmanned Aircraft System Bridge Inspection Demonstration Project

1.2.2.1 Scope

This project phase aimed to expand the demonstration to different structure types and size utilizing an inspection-specific UAS to further assess the ability of a UAS to be a widespread and accepted inspection tool. Technology and federal regulation were further evaluated to refine the inspection method. The development of a best practices manual was drafted.

1.2.2.2 Execution

This Phase II study built on Phase I findings and looked at additional Minnesota bridges including a large steel through arch, a steel high truss, a large corrugated steel culvert, and a movable steel truss. Now having acquired a new inspection-specific UAS prototype, the performance was compared to the industry standards of hands-on inspections. Each method was evaluated by focusing on the differences in access methods, data collection, and the ability of the drone to be used as a tool for interim and special inspections. FAA rules were explored to determine how practical they were regarding UAS bridge inspection applications.

Before UAS field work began on any of the selected bridges, detailed investigation and safety plans were prepared for each structure. Site-specific plans addressed safety, potential hazards and how to mitigate them, current FAA rules, and inspection methods.

Several imaging devices were tested including still image, video and infrared cameras. After the data collection was completed, data was processed through the computer software [Pix4D](#).



Figure 1.2 Overall Photographs of Four Bridges Selected for Phase II UAS Inspection.

1.2.2.3 Findings

Based on our observations in the field from the Phase I and Phase II studies, the following conclusions were made:

- UASs can be used safely and effectively on bridges in challenging conditions.
- UASs can be used in GPS-deprived environments, but piloting skills become more important.
- UASs are more suitable as a tool for inspection of bridges with elements that are difficult to access.
- UASs themselves cannot perform inspections independently and should be used as a tool for qualified and experienced bridge inspectors to view and assess bridge element conditions in accordance with the National Bridge Inspection Standards (NBIS).
- UASs used in conjunction with thermal sensors can be an effective way to detect concrete delaminations and can be done without closing the bridge to traffic.
- The ability to direct cameras 90 degrees upward and the ability to fly without a GPS signal are important features when using this technology as an inspection tool.
- In some types of inspections, a UAS has the capabilities to be used in lieu of an under-bridge inspection vehicle and would provide significant savings. These savings would come in the form of reduced or eliminated traffic control and reduced use of under bridge inspection vehicles and lifts.
- Safety risks associated with traffic control, working at heights and/or confined spaces, and near traffic could be reduced with the use of UASs.

- UASs can provide important pre-inspection information for planning large-scale inspections. Information such as clearances, rope access anchor points, and general conditions can easily be secured with a UAS and would aid in the planning of an inspection.
- Utilizing UAS in conjunction with photogrammetry software such as Pix4D can provide a 3D model and point cloud of a bridge and bridge site that is valuable in determining unknown dimensions and provides a high-quality inspection report deliverable.

1.3 UAS BRIDGE INSPECTION RESEARCH STATISTICS

The following is a summary of structure size, types, materials, and locations inspected with UAS in Phase I through Phase III:

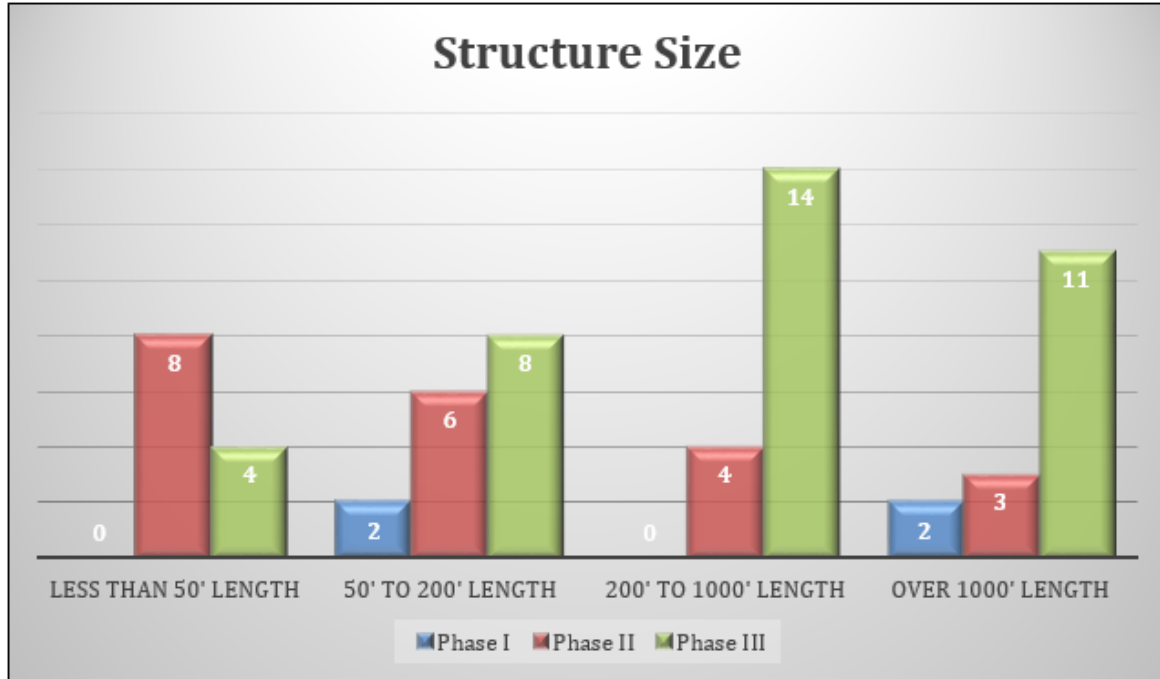

Figure 1.3 Breakdown of Number of Structures Inspected Using a UAS by Structure Size

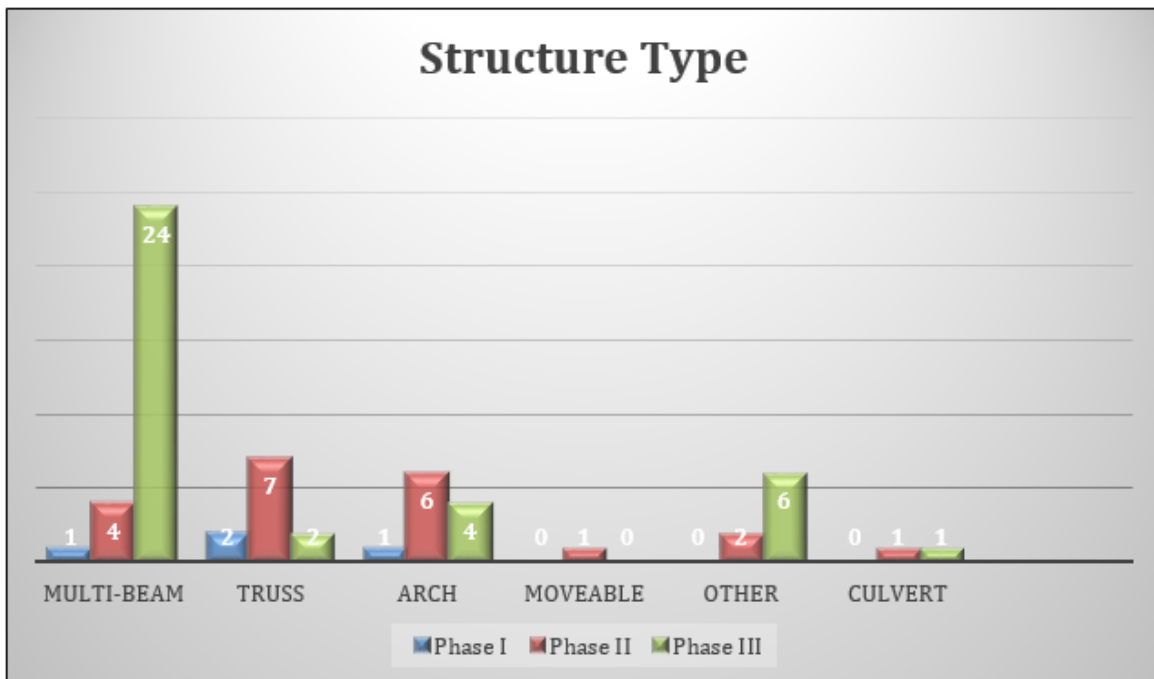

Figure 1.4 Breakdown of Number of Structures Inspected Using a UAS by Structure Type

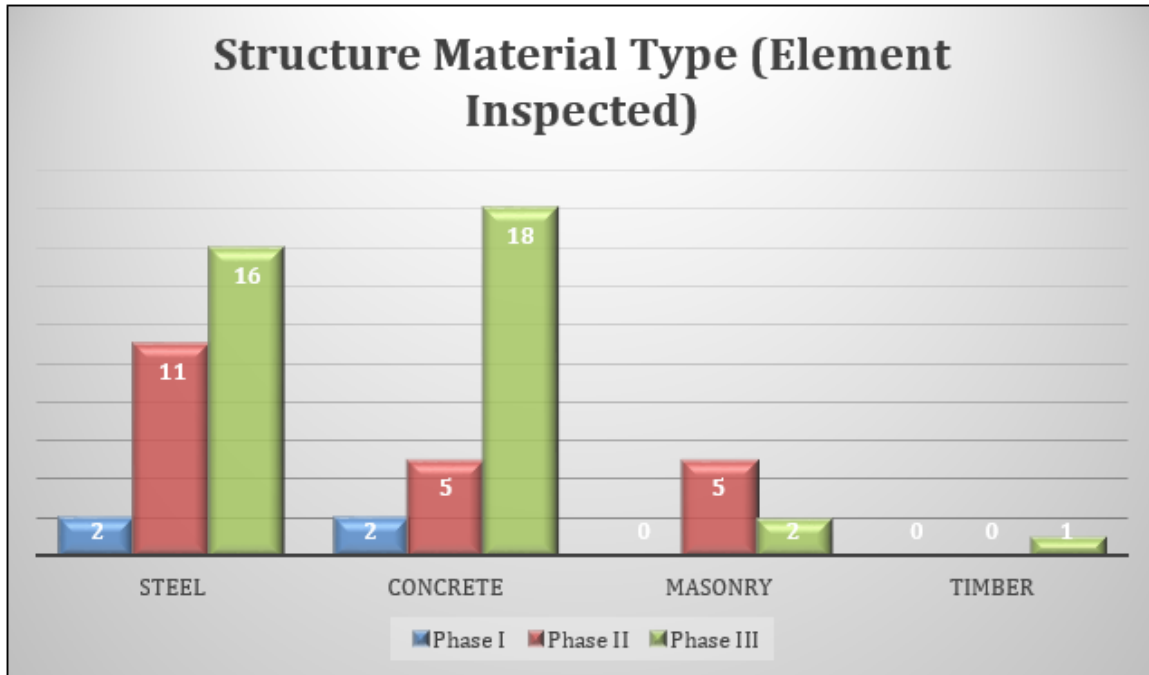

Figure 1.5 Breakdown of Number of Structures Inspected Using a UAS by Material Type

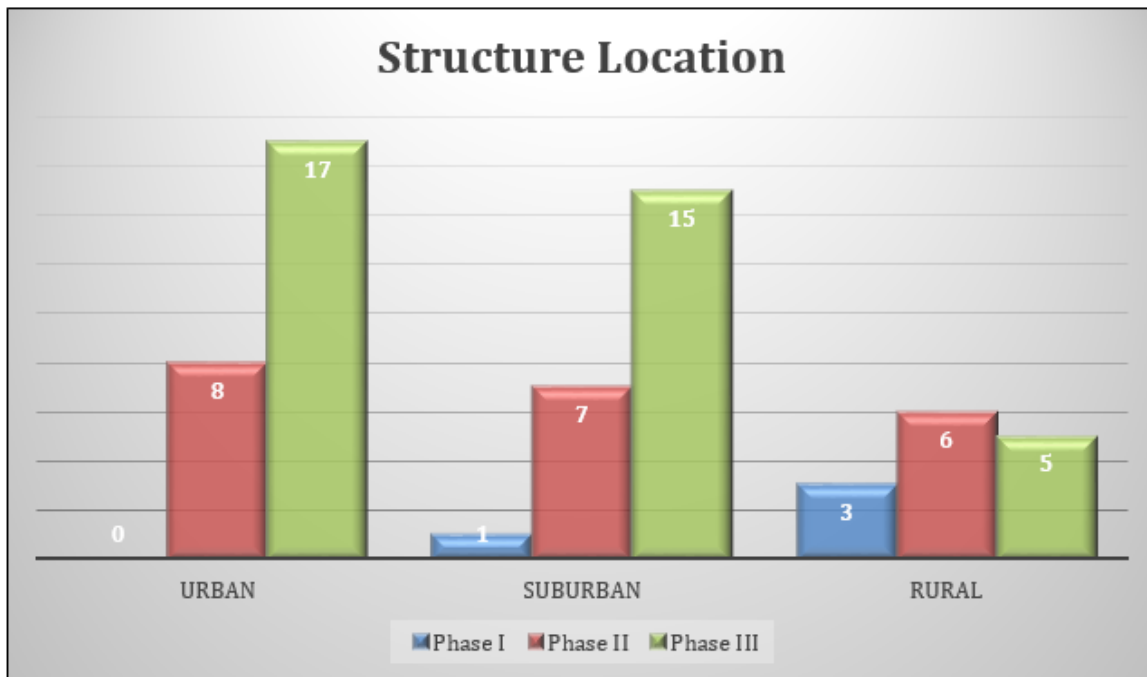

Figure 1.6 Breakdown of Number of Structures Inspected Using a UAS by Location

CHAPTER 2: GOVERNMENT RULES AND REGULATIONS

2.1.1 FAA Current Operating Rules and Regulations

The aviation industry has a safety culture that is more conservative than the transportation industry in general. This is reflected in the low number of fatalities in commercial aviation compared to the high number of roadway fatalities. As a result, The Federal Aviation Administration (FAA) rules and regulations have changed slowly as opportunities such as bridge inspection have been identified. It should be the goal of both the aviation industry and the transportation industry to focus on reducing the risks associated with the entire inspection process. Too much focus is placed on the risk associated with a collision with an aircraft which is extremely low when operating at the low altitudes required for bridge inspections.

The FAA has been gradually allowing the adoption of this technology, and thus barriers to implementation have been reduced since Phase I of this research began in 2015. The last major barrier is the time required for approval to fly in restricted airspace along with the ability to fly over traffic. Recent testing and implementation of near real-time airspace authorizations will dramatically improve the ability of engineers to utilize UAS for bridge inspections.

On August 29th, 2016, the FAA issued new regulations regarding the commercial use of UASs. The new policies are referred to as Small Unmanned Aircraft Regulations (Part 107). These new regulations are intended to establish more flexible requirements for commercial operations. Part 107 significantly reduces the steps in the approval process, creating a more straightforward path to employing UASs in commercial applications. The new rules apply to drones weighing less than 55 pounds, operated within the visual line of sight of the remote pilot in command, and flown during daylight hours. The remote pilot in command must have a Remote Pilot Certification from the FAA, which can be obtained by passing an aeronautical knowledge test. This is a significant improvement as previously a UAS pilot had to have an FAA pilot's license. With direct supervision from a licensed remote pilot, anyone at least 16 years old can legally operate a drone for commercial purposes. Each UAS must be registered with the FAA. Operations in Class G airspace are allowed without air traffic control permission; however, operations in Class B, C, D and E airspace need air traffic control (ATC) approval.

Part 107 was widely regarded as a big improvement in the path toward utilizing UAS technology for commercial operations. The majority of bridges and airports are near populated areas, so most bridges fall outside of "G" airspace and require specific airspace authorizations. Receiving airspace authorizations in Class B, C, D and E airspace have been inconsistent, but generally take from 2 weeks to 3 months for approval. Part 107 airspace waivers are taking up to 120 days. These timelines fall outside of the typical planning window for bridge inspections, especially for emergency inspection cases. Other waivers can be applied for [here](#) for the following use cases:

- Flying at night
- Flying directly over a person or people
- Flying from a moving vehicle or aircraft, not in a sparsely populated area

- Flying multiple aircraft with only one pilot
- Flying beyond the pilot's visual line-of-sight
- Flying above 400 feet
- Flying near airports / in controlled airspace

For this study, a Certificate of Authorization was obtained from the FAA for Minneapolis Saint Paul Airport and Homan Field. The authorizations allowed flights based on an [airspace map](#) that gives operating ceilings based on proximity to the airports. These authorizations allowed our team's UAS pilots to operate without acquiring specific authorizations for each individual bridge site. The time savings was significant and allowed the team to inspect a large number of bridges efficiently and cost effectively. The authorizations can be found in Appendix D.

Details on the FAA Part 107 Rules can be found here:

https://www.faa.gov/uas/getting_started/part_107/

The FAA has developed an application that gives instantaneous airspace authorizations based on airspace maps called the [Low Altitude Authorization and Notification Capability \(LAANC\)](#). This technology is being rolled out at different times throughout 2018 depending on location. This system will allow bridge inspections to receive near immediate authorizations which are critical to widespread deployment of drones and will allow for emergency inspections. The system is expected to roll out in Minnesota in September of 2018.

2.1.2 Federal Highway Administration and National Bridge Inspection Standards

The Federal Highway Administration (FHWA) has identified this technology as a tool that can provide benefits for bridge inspections and the transportation industry. In the hands of qualified and experienced bridge inspectors, drones can improve the safety and quality of inspections. One of the key contributing factors to the success of the National Bridge Inspection Program is the ability to collect quality data on the nation's bridges which can be analyzed to ensure proper management of the nation's bridges. Drones are a platform for collecting quality data, and the use of this technology satisfies one of the primary goals of the NBIS. As FHWA moves towards risk-based inspections, drones will play an important role in bridge inspection. FHWA has taken an active role in promoting the safe use of UAS in Transportation and is currently studying their use. Our project team has assisted FHWA by conducting a webinar and field demonstration.

2.1.3 MnDOT Regulations

The research team worked in close coordination with the MnDOT Office of Aeronautics to plan the project and attain the necessary approvals. The Aeronautics Office has an official policy for the use of UAS on MnDOT projects. UAS registration and proof of insurance are required, as well as a site-specific safety plan. Before embarking on any commercial UAS use in Minnesota, pilots should first contact MnDOT's Office of Aeronautics. The policy is detailed at the following website:

<http://www.dot.state.mn.us/policy/operations/op006.html>

CHAPTER 3: UAS HARDWARE

3.1 INSPECTION-SPECIFIC COMMERCIAL UAS

Inspection specific drone technology is maturing, and several models now exist that serve the inspection and asset management industry. These drones include features important to bridge inspection such as sense and avoid, infrared imaging, autonomous flights, and collision-tolerant features. Each has their own strengths and weaknesses, but all can accomplish the task of obtaining high-quality data. As technology has improved, the focus has shifted from the hardware to the data. Hardware is still important, and opportunities exist for improvement, especially in regard to different payload items such as non-destructive testing equipment.

The primary data collection methods were from an imaging payload integrated into the UAS platform. Two UASs were selected based on observations from the Phase II study which identified two key features critical to UASs used in bridge inspection. The first was the imaging field of view needed to face vertically directly up and down. This allows for inspection of members above the UAS such as deck soffit and interior beams. The second feature was the ability to fly without the need for a GPS signal. This is important when operating under a structure or in confined spaces.

Both UASs used are considered professional inspection-specific which set them apart from other off the shelf UASs. The quality of build, imaging payload, and flight software are industry-leading and crucial for proper safe inspection of bridge elements.

3.1.1.1 Mapping and Photogrammetry UAS

The team utilized the [senseFly albris](#) drone, which was designed for commercial inspection and mapping purposes. This model can fly under bridge decks, and the camera can view straight up. The albris UAS can be controlled interactively with a controller or autonomously with a pre-programmed flight. Both flight modes utilize a laptop computer to control the UAS. The flight control software contains the UASs settings, which include a real-time map that displays the drone's location, live image views, and flight data. The software can also be used to plan and monitor autonomous flights.

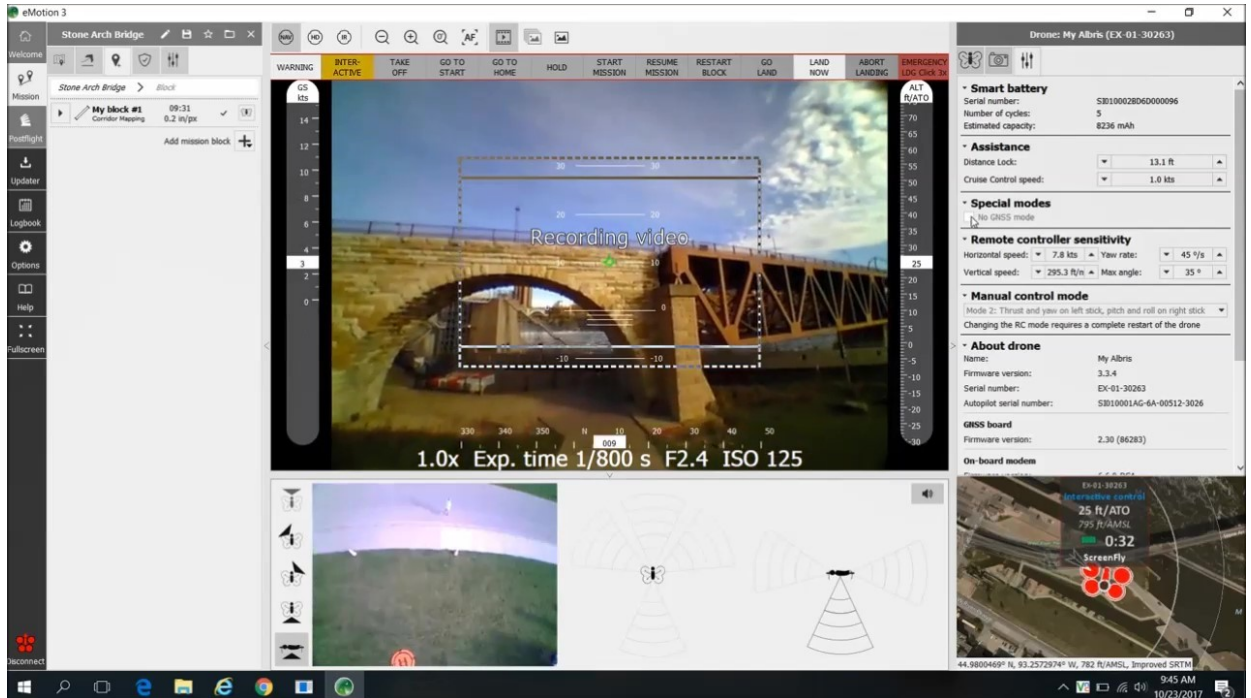

Figure 3.1 senseFly Emotion Software Flight Controls

This UAS was used in Phase II and selected again for Phase III given the overwhelming positive results. There have been a few changes to the albris hardware or software since the Phase II study, although the cost has decreased significantly since then. The UAS is approximately 22in by 32in by 7in and weighs 3.96lbs. This allows for easy handling and transportation. The batteries typically provide up to 20 minutes of flight time when operating under safe manufacturer guidelines. Flight hardware restrictions include wind speeds greater than 22 mph, range over 2.8mi away, or speeds in excess of 26mph.



Figure 3.2 Image of the senseFly albris UAS.



Figure 3.3 Image of the Sensor Payload On-Board senseFly albris UAS.

The albris imaging payload consists of a TripleView head containing a high-definition video camera, a 38 Mega-Pixel (MP) still camera, and an infrared camera. The 38MP camera is the primary data acquisition tool. With pre-programmed or interactive flights, the albris can take still images at regular intervals which can then be processed by software to produce high-resolution images and models. The absolute horizontal/vertical accuracy of the UAS is reported at 3ft to 16ft without using ground control points and down to 0.04 in when using ground control points.



Figure 3.4 Example of albris High-Resolution Image Capability.

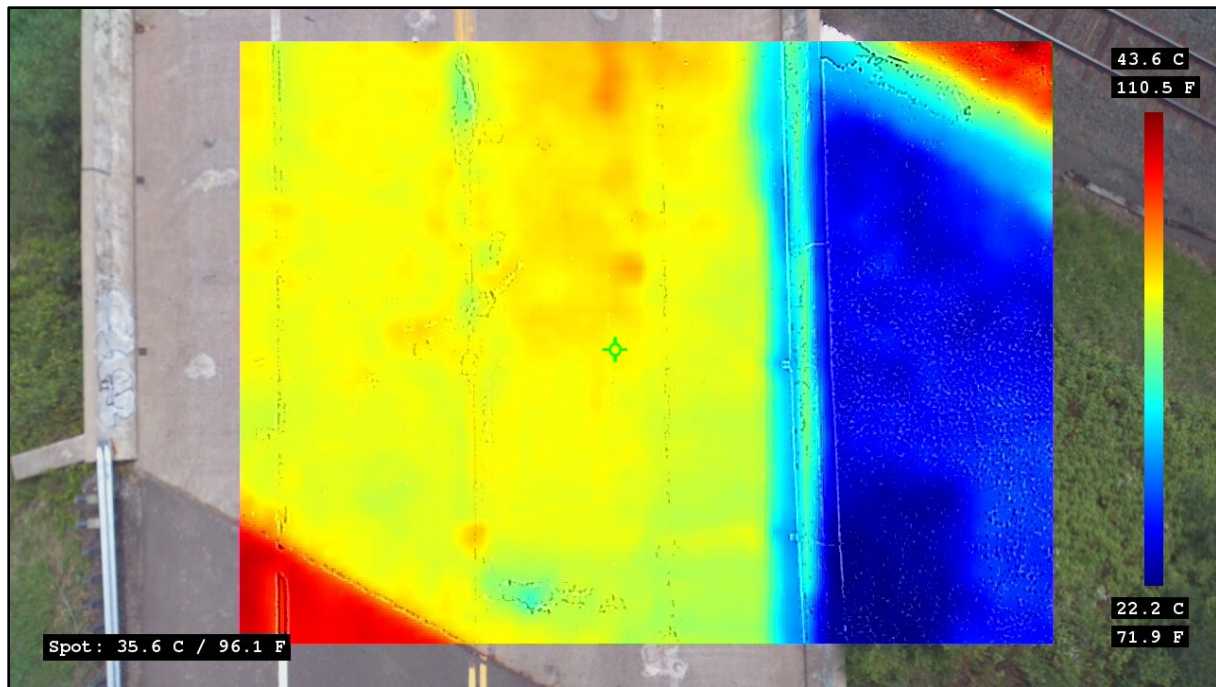

Figure 3.5 Example of albris IR Image Capability

Recognized benefits of using an inspection specific mapping and photogrammetry UAS:

- Ability to view vertically up and down: The TripleView head containing the imaging payload is mounted to the front of the body rather than the typical under-body mounting location. This allows the UAS to look directly up and down.
- Option of pre-programmed flight or interactive flight: Using the UAS software and available mapping information, a user can pre-program the flight prior to leaving for the site. This can save time on site and better prepare the pilot for site conditions. Alternatively, the UAS can be switched in and out of interactive flight at any time, allowing the pilot to deviate from pre-program flights or carry out a real-time pilot navigated mission.
- High-Resolution Photogrammetry: The 38MP still camera takes excellent photographs which are geo-tagged and vibration/motion isolated, making them high-quality images for inspection.
- Ability to fly without GPS signal: The albris has redundant stabilization systems consisting of GPS Navigation, intergrated 3D accelerometers and 3D gyroscopes providing Six-Axis Gyro Stabilization, and on-board photo-recognition software which uses a continuously down facing camera to analyze movement of the UAS relative to the ground points for stabilization. The benefit of redundant stabilization is that any of the three stabilization systems can be lost or not relied on and the flight remains highly controllable.
- Relatively long battery life: Up to 20 minutes of usable flight time means that missions requiring long ranges or large area coverage can be achieved without losing quality or increases time for multiple missions and set-up.
- Distance Lock and Cruise Control: The albris has onboard acoustic and visual sensors that provide it with complete situational awareness, allowing it to sense objects and the distance to an object. The

albris also has a distance lock function that can be used with cruise control to run a vertical surface mapping mission resulting in high-resolution images with proper overlap for generation of orthomosaic images. This proved to be a very useful feature and was used extensively during Phase III.

- Onboard LED lighting and camera flash.

Recognized limitations of using an inspection-specific mapping and photogrammetry UAS:

- Confined Space: The size and lack of complete body protection (there are only shrouds to protect the propellers) limit the operation of the larger mapping UASs to open areas with at least 5 feet of open air on all sides.
- Set-up: Mapping and photogrammetry UASs typically require a more involved set-up and site assessment due to the additional settings required for the back up systems such as working areas and backup controllers. Setup takes approximately 15 minutes depending upon bridge site, type, and location. Additionally, this usually includes mission preparation prior to mobilization which can take from 15 minutes to several hours.

3.1.1.2 Commercial Inspection Specific Drones

As the market matures, other inspection specific UASs have become available. While this study did not compare all drones, it is important to understand what is available. The following is a list of known inspection specific drones available at the time this paper was published.

- [senseFly albris](#)
- [Intel Falcon 8+](#)
- [DJI M200 Series](#)

3.1.1.3 Consumer Grade Drones

Consumer grade drones are very popular and low cost. While their photo and video quality can be very good, they typically don't have the inspection specific features such as the ability to operate without GPS, object avoidance, cruise control and navigational cameras. They also may not have robust failsafe hardware or software such as an independent backup remote. There are situations where a consumer grade drone can provide useful inspection data, but commercial UAS should be employed when possible to take advantage of the advanced features.

3.1.1.4 Collision-Tolerant UAS

As part of the Phase II study, it was identified that there are many areas within bridge inspection that are prohibitive for imaging using a larger mapping UAS. Additionally, these are often the same areas that are very difficult, or even impossible, for inspectors to gain visual or tactile access due to environmental hazards and entry restrictions. Examples of these types of restricted access locations are:

- Interior of tub girders, steel pier caps, and hollow abutments

- Culverts, pipes, or tunnels with or without water present
- Bridge deck soffit of large span bridges over water or heavily trafficked routes
- Web faces and top flanges of large span bridges over water or heavily trafficked routes
- High wall abutments
- Top of pier caps
- Bearings
- Vaulted spans

Many of these areas have safety concerns as well as access restriction. Some tub girder interiors, pier caps, and vaulted areas can be defined as confined spaces per Occupational Safety and Health Administration (OSHA), which require additional inspector training, equipment, and permits for confined space entry. Some of these locations can be imaged and post-inspected using a larger mapping and photogrammetry UAS from far away with a high-resolution camera; however, most of these are located where a camera would need to be within a few feet of the element being inspected. For these identified areas, the concept of a collision-tolerant UAS was explored as part of this project. Other options were considered to access these hard to reach areas with a smaller micro-UAS, larger propeller shrouds, or additional acoustic anti-impact sensors. The collision-tolerant was the most cost-effective option to move forward with.

The philosophy behind a collision-tolerant UAS is very different from that of the mapping and photogrammetry UAS. The operation is focused on using interaction with objects to help navigate, stabilize, and guide UAS through tight areas with or without line of sight. Designers at Flyability, a manufacturer specializing in collision-tolerant UAS's, identified this philosophy and created the [Elios UAS](#) based on this recognized need. Using a gimbal system and protective frame, the Elios can maintain flight during and after collisions with objects at speeds of up to 13 feet per second. The protective frame is carbon fiber rods and nodes in a geodesic polyhedron shape. The shape of the frame allows for impact absorption through deformation. The gimbal, which is the second key design feature, allows the frame to rotate 365 degrees in any direction. Along with the frame dissipating impact energy with deformation, the freely rotating frame allows energy to be dissipated with deflection. The video payload on the Elios consists of an infrared and high definition video camera. Sample videos of a bridge inspection performed as part of this project can be found here:

[Lakeville Bridge Inspection](#)

[St. Croix Crossing Pier Tower Inspection](#)

[Shakopee Pedestrian Bridge Beam Inspection](#)

[St. Paul High Bridge Confined Space Inspection](#)

[TH 55 Over Lake Street Bridge Confined Space Inspection](#)



Figure 3.6 Image of the Flyability Elios UAS.

The collision-tolerant UAS was selected for use in the inspection of 17 bridges. At several of these bridges, the collision-tolerant UAS was used in conjunction with the larger mapping and photogrammetry UAS. The operation of the Elios was performed by a FAA licensed remote pilot and followed FAA regulations. Set up and operation of the Elios was very simple, taking about 5 minutes. All flights were done interactively, meaning the pilot was under control of the UAS throughout the mission because the Elios is not capable of preprogrammed flight paths. The pilot navigated the UAS using a live video stream through a proprietary application on a tablet mounted on the remote control.

Recognized benefits of an inspection specific collision-tolerant UAS are the following:

- Easily piloted: UAS was easily operated by a pilot due to the ability to hit objects without fear of damage
- Ability to roll: The protective frame can serve as a rolling device to better control the UAS, save battery life, and maintain a fixed distance from the face of an object. It was ideal for inspecting wide flange beams and concrete deck soffits by rolling the UAS along the top side of the bottom flanges.
- Set-Up: Due to the simplicity of the equipment and interactive flight type, set up and site assessment are quick processes (typically 5 minutes).
- Lighting: The UAS is equipped with on-board lighting which is required due to fluctuating light/dark environments and proximity to elements.
- Safety for the inspector can be greatly improved by eliminating the need for confined space entries and risks associated with access equipment and working from heights.
- Safety for the traveling public can be improved by eliminated traffic control and lane closures.



Figure 3.7 Photograph of the Elios UAS Rolling on Top of an Abutment Bearing Seat.



Figure 3.8 Photograph of the Elios UAS Rolling along a Concrete Deck Soffit.



Figure 3.9 Photograph of the Elios UAS Rolling Inside a Steel Box Beam

Recognized limitations of an inspection specific collision-tolerant UAS:

- Short battery life: The added weight of the protective frame and equipment reduces the allowable battery size, and thus reduces the battery life. A single battery operating under proper piloting conditions and operation yielded an average of 10 minutes of flight time, which limits its range and coverage. Swapping batteries is a quick process which mitigates this limitation.
- Video Interference: The protective frame is outside the video payload, meaning the frame will always be in the video partially obstructing the view.
- Air Flow and Debris: While operating in confined areas or near object surfaces, the UAS can create air flow eddies which affect the UASs flight. Additionally, operating in close proximities to surfaces kicks up dirt and debris which can damage the propellers and interfere with video quality.

The results of exploring the use of collision-tolerant UASs in bridge inspection were overwhelming positive. The relative ease of use and minimal set up make the collision-tolerant UAS a great addition to an inspector's tool box. Where limitations exist, time and experience can address with this specific drone. Compared to traditional methods of access, a collision-tolerant UAS can, at a minimum be 25% more cost efficient, safer for the inspector and the structure, and give access to areas previously deemed inaccessible to an inspector.

3.2 OPPORTUNITIES FOR HARDWARE ADVANCEMENT

UAS hardware for bridge inspections have matured, and the ability to collect useful data is available and deployable. There still exists opportunities for improvement. The following improvements could reduce risk and increase the level of adoption by reducing the training and skill required to operate.

- Improved sense and avoid technology.
- More automated flight capabilities, especially in GPS denied environments.
- Improved battery life and reliability.
- Improved lighting or low light imaging capabilities.

CHAPTER 4: DATA PROCESSING AND DELIVERABLES

Effective bridge inspections are comprised of three key components. The first component is the ability to detect deficiencies. To be successful in this endeavor, the bridge inspector's experience and knowledge play a key role. This research has demonstrated that a qualified inspector utilizing UAS can improve the ability to detect deficiencies by alternative access and utilizing high-quality images and infrared imaging.

The second component is the ability to document deficiencies. Traditionally this has been accomplished by documenting the inspection with detailed notes and photos. While this method has been effective, the results of this study have identified methods to improve the documentation of defects with the use of drone imagery in addition to the expanded use of terrestrial photos. 3D models and photo logs can be created with this imagery which greatly improves the ability to completely document inspections.

The third component of a successful inspection is the ability to clearly communicate inspection results to bridge owners, engineers, and decision makers. Traditional methods have included paper and electronic reporting. This research effort has demonstrated much more effective ways to communicate inspection data by employing recent advancements in the reality modeling of bridges and inspection data. These new methods are improving the ability for bridge inspectors to clearly communicate inspection results and ensure improved communication of results resulting in better decisions, which can help avoid oversights and save money. Recent advancements have also improved the ability to share the information using cloud-based inspection platforms that host the data for easy viewing.

The ability to gather and utilize large amounts of data is transforming our world. Drones can easily collect large amounts of data during bridge inspections. Processing software and inspection specific asset management platforms are giving engineers the ability to efficiently use this data to improve bridge inspections and are accelerating the ability to effectively manage these important assets.

4.1 DATA PROCESSING

4.1.1 Processing Inputs

4.1.1.1 UAS Images

All bridge inspections include some form of photo documentation, and digital cameras have improved the ability to document the inspection. However, the number of photos is usually limited to general overall photos and photos of specific deficiencies. If a large number of photos are taken during an inspection it becomes difficult to organize because each photo needs to be labeled with a description, location, and direction. Images from inspection specific drones are high-quality, and drones can collect a large number of images in a short amount of time. A typical UAS inspection can collect anywhere from 5 to 50 Gigabytes of data. Therefore, efficient processing and utilization of this data is critical.

There is much focus on the image quality and the ability to detect deficiencies by viewing images taken with a drone. It is very difficult to quantify a minimum resolution or minimum camera parameters because the conditions encountered during an inspection differ widely. Image sensors and processing software have become sophisticated and it is difficult to rely on camera specifications alone. Our research has shown that the focus should be on the inspector's qualifications and their ability to determine on a case by case basis if the image quality is enough to determine with certainty the structural condition of the bridge element that is being inspected. In many cases, suspect deficiencies or areas should be followed up with a hands-on inspection. This is especially true when an inspector feels the need to use tools such as a hammer for sounding. For routine bridge inspections, there is no examination of an inspector's visual acuity, and this is not used as a metric for measuring the quality of bridge inspections. The exception is for NDT Certified inspectors to typically have their eyesight examined annually.

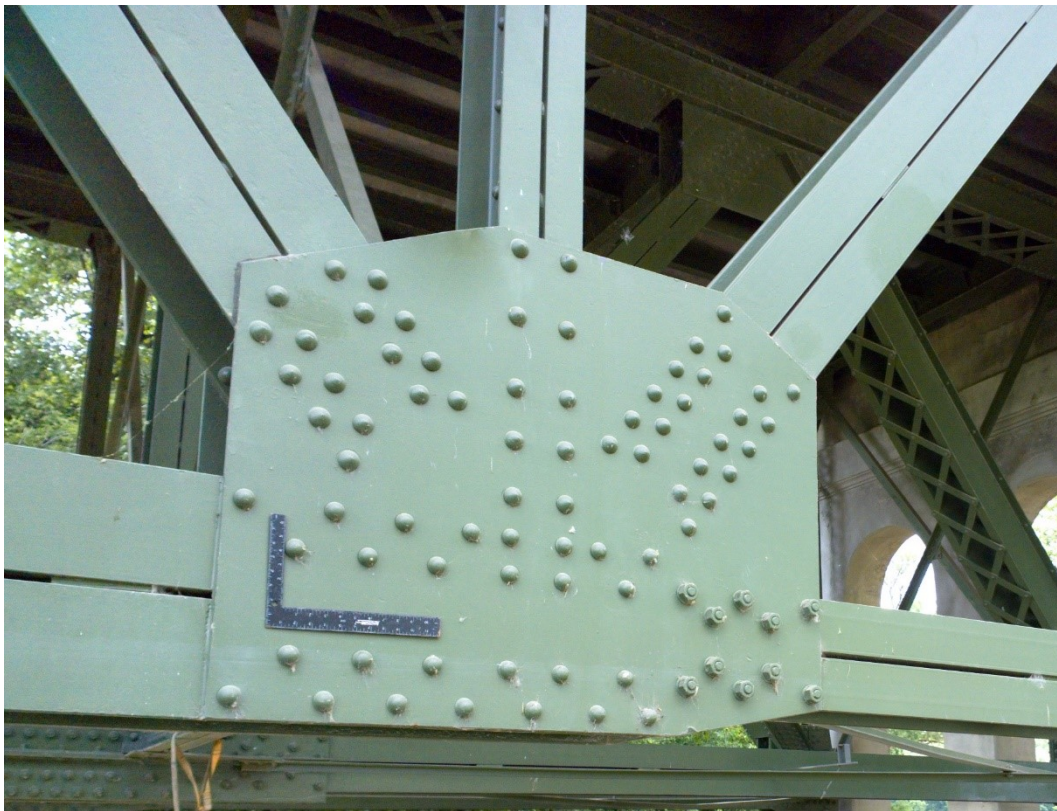

Figure 4.1 High Resolution UAS Image

4.1.2 UAS Reality Modeling Platforms

There currently exist many photogrammetry software packages available to process both drone and terrestrial images into useful and actionable data to document and communicate inspection results. For this study, we used the Pix4D software which includes both a desktop and cloud version. The desktop and cloud version are integrated so that models created on the desktop version can be uploaded, processed and shared on the cloud version. Our team also used the Intel Insight and Propeller cloud

platforms to process and analyze data. These platforms process and create numerous outputs including the following:

- Orthomosaic Map
- GeoTIFF
- 3D Point Cloud
- 3D Textured Mesh
- 3D Photologs
- Orthoplane
- Digital Surface Model (DSM)
- Digital Terrain Model (DTM)

Several platforms are available to process drone data including the following:

- [Pix4D](#)
- [ContextCapture](#)
- [Recap](#)
- [Intel Insight](#)
- [Propeller](#)

The general workflow for a UAS inspection is as follows:



4.1.3 Deliverables

4.1.3.1 3D Models and Photo Logs

Reality modeling is the process of creating 3D photorealistic models from both drone and terrestrial images. The models generated are comprised of highly precise georeferenced point clouds and triangular meshes. The models can be used to measure deficiencies and can be annotated with inspection notes. Once a model is generated, the photos are located and referenced to the model. When the user clicks anywhere on the bridge model, the corresponding images of that area or bridge element are displayed. Therefore, the inspector no longer needs to create a photo log of the inspection, which can save a great deal of time during report generation. Traditional inspection photo logs are cumbersome, and time consuming to create and navigate. The reality model 3D photo log is easier to navigate and reference. It also creates a record of the bridge condition at a point in time so that as the bridge ages, deterioration rates can be observed.



P1300083 – Pier 37WB, looking east



P1300096 – Pier 37EB, looking east



P1300097 – Pier 37EB, looking west



P1300082 – Pier 37WB, looking west

3/25/2018

MnDOT Dunwoody Bridges Photo Log - Bridge 27831

19

Figure 4.2 Traditional Photolog

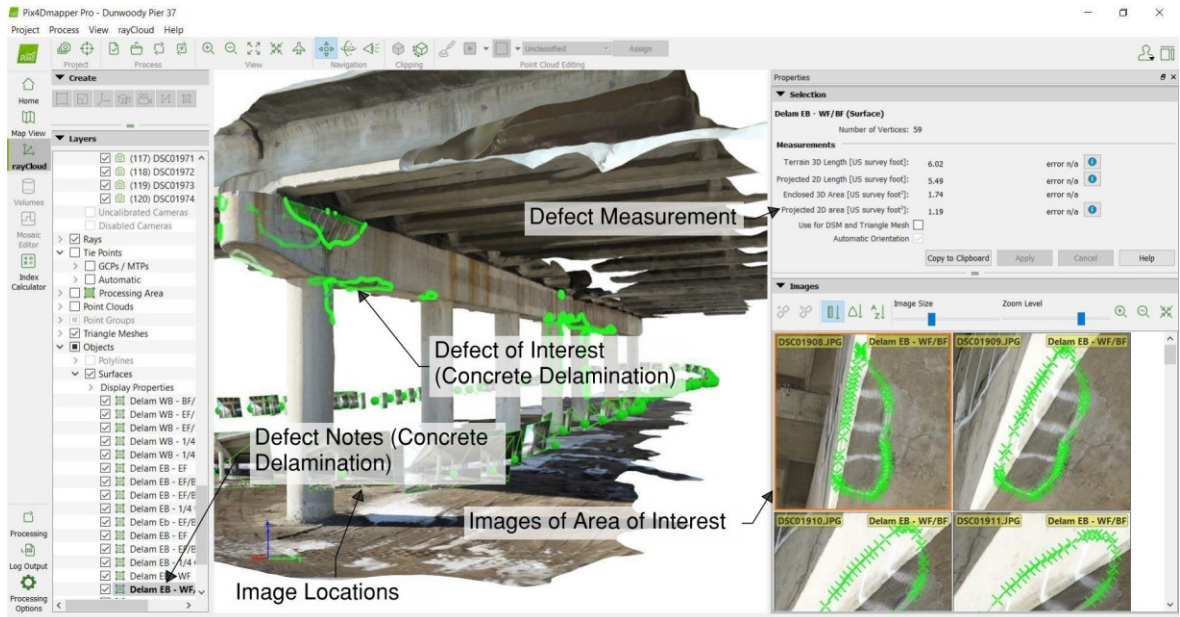

Figure 4.3 Pix4D 3D Reality Model Photo Log



Figure 4.4 Pix4D 3D Point Cloud



Figure 4.5 Pix4D 3D Triangular Mesh

4.1.3.2 Orthomosaics and Orthoplanes

Other useful deliverables can be created in 2D formats including orthomosaics and orthoplanes. Both of these formats are simply large images that are created by combining individual images. An orthomosaic is a top down image that represents a map of an area and an orthoplane can be any planar surface such as a bridge facade or pier face.

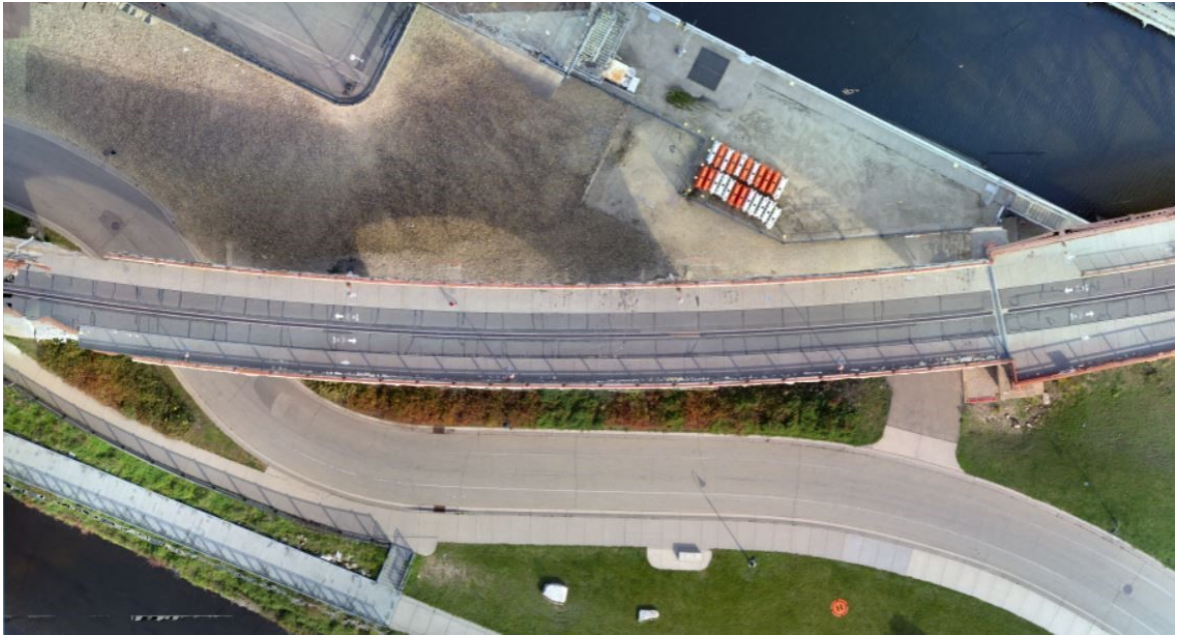

Figure 4.6 Orthomosaic of Bridge Site



Figure 4.7 Pix4D Bridge Facade Orthoplane

4.1.3.3 Cloud Sharing

The last component of a successful inspection is the ability to clearly communicate the inspection results. Performing bridge inspections with drones typically generates large amounts of data which can

be difficult to share with bridge owners and decision makers, especially via email and ftp sites where firewalls may exist. The solution lies in the ability to share inspection results on cloud based platforms. Using the cloud interface, a bridge engineer or owner can view the inspection data in 3D models without having to download and store large amounts of data.



Figure 4.8 Cloud Virtual Inspector

Below are hyperlinks to sample bridge models from this project that are shared on the web platform:

Stone Arch Bridge

<https://cloud.pix4d.com/pro/project/262981/3d?shareToken=db3d5be0e4fc4b8687aba5bd2bb48ba1>

Dunwoody Bridge Pier 37

<https://cloud.pix4d.com/pro/project/265642/3d?shareToken=3aec98c6fc1b4fa88537eb4f2292015f>

Lakeville Bridge

<https://cloud.pix4d.com/pro/project/164949/3d?shareToken=e48e6ce380a047f5a3e92d083299d23b>

Dunwoody Pier Model

<https://cloud.pix4d.com/pro/project/263323/3d?shareToken=6fba4bbc2e4a443f9029a71b72666f65>

Washington County Bridge Deck Delamination Survey

<https://cloud.pix4d.com/pro/project/153881/mesh?shareToken=cacccbbaa7032478d9bd4ce102b4860dc>

St. Croix Crossing Box

<https://sketchfab.com/models/23418bbd1efe4069aa7b6668e5ddb161> <https://youtu.be/Gxf1NLQqDHc>

South St. Paul Retaining Wall Inspection

<https://cloud.pix4d.com/pro/project/202326/map?shareToken=aa9bc85840f2402f902aa9ca622932e6>

3rd Avenue Bridge Pier

<https://skfb.ly/6t86G>

Freeway Corridor and Bridge Deck Survey

<https://cloud.pix4d.com/pro/project/187948/mesh?shareToken=c0a7484219044a908fe65250bf47c74c>

4.1.3.4 Terrestrial Photography

The task of capturing photographs from the ground has been routine for bridge inspection and will continue to be necessary. When considering the use of UASs in bridge inspection, it is important that the inspector be aware of the process and potential of using terrestrial photographs (photographs taken from the ground) in conjunction with aerial photographs to create high-resolution images and models. For several structures, imagery was taken from a point-and-shoot digital camera or action type camera. The method of taking photographs from these types of platforms is similar to aerial photography, in that the user needs to assure there is plenty of overlap as a series of photographs are taken. Additionally, it was found that the processing software worked better when images were taken in a smooth continuous path with approximately 75% overlap. The photographs taken can be used in the same programs as the high-resolution photographs from mapping missions. In conjunction with aerial photographs, they can provide a more comprehensive model as the final deliverable.

In several cases, terrestrial photographs alone were used to obtain high-resolution photographs and 3D models for post-inspection reviewing. The final results were positive and illustrated that the concept of photogrammetry in bridge inspection is a method which includes but is not limited to UASs. An example of the 3rd Avenue Bridge Pier Inspection can be found [here](#).



Figure 4.9 3D Model of Bridge Pier Created from Terrestrial Photos

4.1.3.5 Ground Control and Scaling

Another important input when creating bridge inspection deliverables are scales and/or ground control points (GCPs). The ability to accurately measure defects in the models is important. Generally, models created without these inputs can have an accurate scale within about an inch. However, to ensure accuracy, a scale can be placed before images are collected and can be used to check the accuracy or to manually scale the model.



Figure 4.10 Scale Used During Image Collection

Using GPS, a drone will place the model into the correct global position within several feet which is generally good enough for inspection purposes. The use of ground control points can add absolute accuracy and place the inspection model in the exact global position. Typically, these would be set by a land surveyor as aerial targets and their exact position would be recorded. These coordinates can be included in the model so when processed, the absolute accuracy can be set to as low as a few millimeters. The accuracy depends not only on the precision of the actual GCP's, but also on the height at which the drone is flown. The lower the drone flies, the higher image resolution is which improves the accuracy.

Recently introduced to the market, are drone specific aerial targets that record their own position using GPS, which is processed and corrected to ensure survey grade accuracy. Our team used the [Propeller Aeropoints](#) with very good success. These targets allows the documentation each defect, deficiency and condition in their exact global coordinates. The ability to locate defects accurately enables engineers to track things such as crack locations and lengths.



Figure 4.11 AeroPoint Automated Ground Control Point Figure

4.2 REALITY CAPTURE INSPECTION WORKFLOWS

Based on the results of this research, there are two workflows that can be used when incorporating UAS and terrestrial data. Both workflows offer time savings and generally result in inspection deliverables that are more detailed than traditional inspection reports.

4.2.1 Field Inspection – Data Capture and Processing

The first workflow includes performing the inspection first before collecting imagery data. Typically, the inspection results are annotated directly on the structure itself and the resulting 3D model can then be used to measure and quantify defects such as concrete delaminations. The most common application of this workflow would be a deck condition survey where the deck is chain dragged and concrete delaminations and cracking are marked or outlined. The deck is then flown by drone to obtain the imagery used to create a photo-realistic orthomosaic map and 3D model of the entire deck. Cost savings and safety improvements are introduced in the reduction of time spent measuring deficiencies in the field as they can be measured in the office. Performing the measurements in the office has also proven to be more accurate as it can be difficult to measure deficiencies in the field that are comprised of complex geometry. With more accurate measurements, owners can better compare inspection results over different inspection cycles and improve the ability to determine deterioration rates.



Figure 4.12 Pier Inspection

4.2.2 Data Capture and Processing – Field Inspection

The second workflow involves collecting data on the bridge prior to performing the field inspection. Once the data has been collected and processed, the 3D model and other deliverables can be used to document the inspection in the field. The benefit of this workflow is that the inspectors in the field have a dimensionally accurate photorealistic model of the bridge to document the inspection. The deficiencies can be annotated in the exact location on the structure which improves the accuracy of inspection data and reduces the time spent in the field. The final deliverables are greatly improved, and the bridge owner can view the inspection results in three dimensions.



CHAPTER 5: COST AND TIME ANALYSIS

Traditional access methods for bridge inspection include Under Bridge Inspection Vehicles (UBIV), man lifts and rope access. UBIV's can cost from \$500,000 to \$1,000,000 to purchase and per day costs range from \$2,000 to \$3,500 per day. With the use of this inspection equipment traffic control is also often required in the form of lane or shoulder closures. Traffic control can cost from \$500 - \$2500 per day. These costs can make up a significant portion of the total inspection costs for larger bridges. The use of drones for bridge inspection can offset some or all of these costs depending on the bridge configuration and location.

For smaller local bridge routine inspections where access equipment and traffic control is not needed utilizing drones may increase the overall cost of the inspection slightly but the inspection deliverables are greatly improved.

Bridge inspection reports in Appendix A include detailed cost comparisons between tradition inspection and access methods with UAS assisted inspection. For bridges where access methods such as UBIV's, lifts, rope access are required the cost savings can be significant. The following assumptions were used in determining the cost savings:

Table 1: Cost Assumptions by Unit/Cost

Cost Assumptions	Unit	Cost
Bridge Inspection Team Leader	Hour	\$150
Assistant Bridge Inspector	Hour	\$120
Under Bridge Inspection Vehicle with Operator	Day	\$3,000
Drone Equipment	Day	\$300
Post Processing Engineer	Hour	\$120
Low Speed Lane/Shoulder Closure	Each	\$2,000
Mobile Lane/Shoulder Closure	Each	\$1,500
High Speed Lane/Shoulder Closure	Each	\$2,500

For the selected case studies presented in the Appendix the average cost savings was 40% which is significant decrease. Most of the cost savings comes in the form of reduced traffic control and access equipment costs. The inspection hours show a slight increase when using UAS which can be accounted for in the time to post process the data. As automation improves these costs will go down. A summary of the cost and inspection hours analysis for each individual bridge is summarized below:

Table 2: Cost and Inspection Hours Analysis by Individual Bridge

Structure	Traditional Inspection Cost	UAS Assisted Inspection Cost	Savings +/-	Savings Percentage	Traditional Inspection Hours	UAS Assisted Inspection Hours	Savings +/-
19538	\$1,080	\$1,860	-\$780	-72%	8	12	-4
4175	\$15,980	\$13,160	\$2,820	18%	48	48	0
27004	\$6,080	\$4,340	\$1,740	29%	8	16	-8
27201	\$2,160	\$1,620	\$540	25%	16	10	6
MDTA Bridges	\$40,800	\$19,800	\$21,000	51%	80	120	-40
2440	\$2,160	\$1,320	\$840	39%	16	10	6
27831	\$2,580	\$540	\$2,040	79%	8	3	5
82045	\$2,660	\$1,920	\$740	28%	16	12	4
62080	\$2,580	\$1,350	\$1,230	48%	8	8	0
62090	\$2,410	\$1,570	\$840	35%	16	10	6
62504	\$3,660	\$1,020	\$2,640	72%	16	8	8
82502	\$3,240	\$2,400	\$840	26%	24	16	8

Average Cost Savings

40%

Average Hours Increase

2%

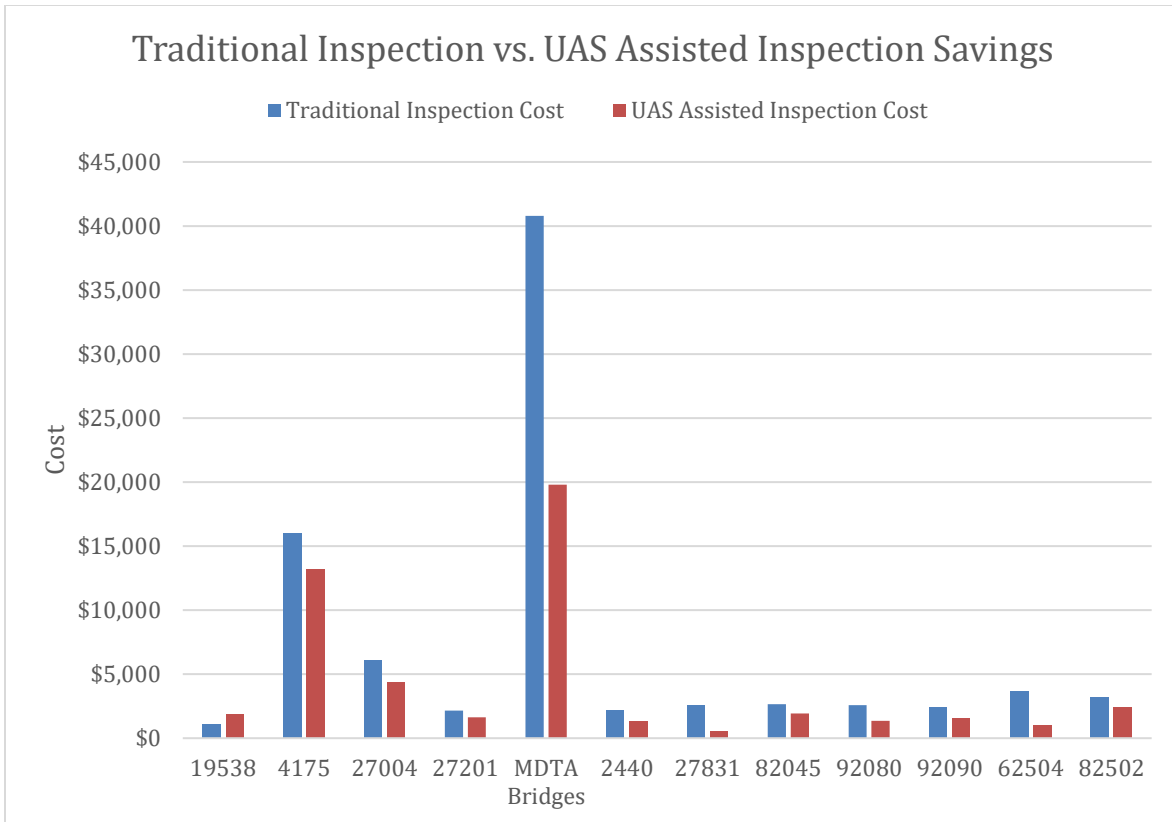

Figure 5.1 Traditional Inspection vs. UAS Assisted Inspection Savings

The quality of a hands on versus a drone inspection is difficult to generalize and must be determined by a qualified inspector on a case by case basis. Typically, a hands-on inspection will provide more confidence in the inspection results but in many cases the quality of a drone inspection is enough to determine with confidence the condition of the bridge and defect detection is comparable. The quality of the deliverables in most cases is improved with the use of drones and the communication of the inspection results is also improved. The quality of the deliverables should also be considered when determining what access method is appropriate for each individual bridge.

It is relatively easy to determine the cost savings associated with actual inspection costs. It is much more difficult to determine the cost savings associated with improved deliverables. The improvement of deliverables may have an even larger impact on cost savings. Bridge owners and engineers must make risk-based decisions on repair, replacement and maintenance needs for a bridge. With improved inspection information bridge owners can make better decisions which leads to better investments in their bridges.

CHAPTER 6: SAFETY IMPROVEMENTS

While using a drone during a bridge inspection creates minor risks associated with the risk of crashing the drone into a person, vehicle or airplane. Because of the very low altitude of flights needed for bridge inspections the risk of a collision with an airplane is almost non-existent when using commercial quality drones that control the risks of an uncontrolled flight. These risks are offset by a dramatic reduction in risks for the public and inspection personnel. Roadway work zones pose significant safety hazards for the public and transportation workers. The Federal Highway Administration has a [Work Zone Management Program](#) that deals with work zone safety. A work zone crash occurs every 5.4 minutes in the United States. In 2014 669 fatalities occurred in work zones and unfortunately the trend is an increase in crashes as distracted driving is becoming more prevalent.

There are no statistics specifically associated with bridge inspections but accidents and fatalities resulting from bridges inspections are not uncommon. There is some risk associated with the use of bridge inspection equipment and working at heights, but the largest risk factor is associated with working near traffic and in shoulder and lane closures. Drones can be utilized during bridge inspections to reduce or eliminate the need for traffic control and the need for inspection personnel to work near traffic. Bridge owners should consider the use of drones when the risks to the public and inspectors can be reduced while considering the inspection quality and condition of the bridge. For low risk bridges the use of drones should be considered even when reduced inspection quality is expected if there is a significant improvement in overall safety. While traditional access methods will continue to be needed the use of drones for bridge inspections are underutilized by bridge owners.

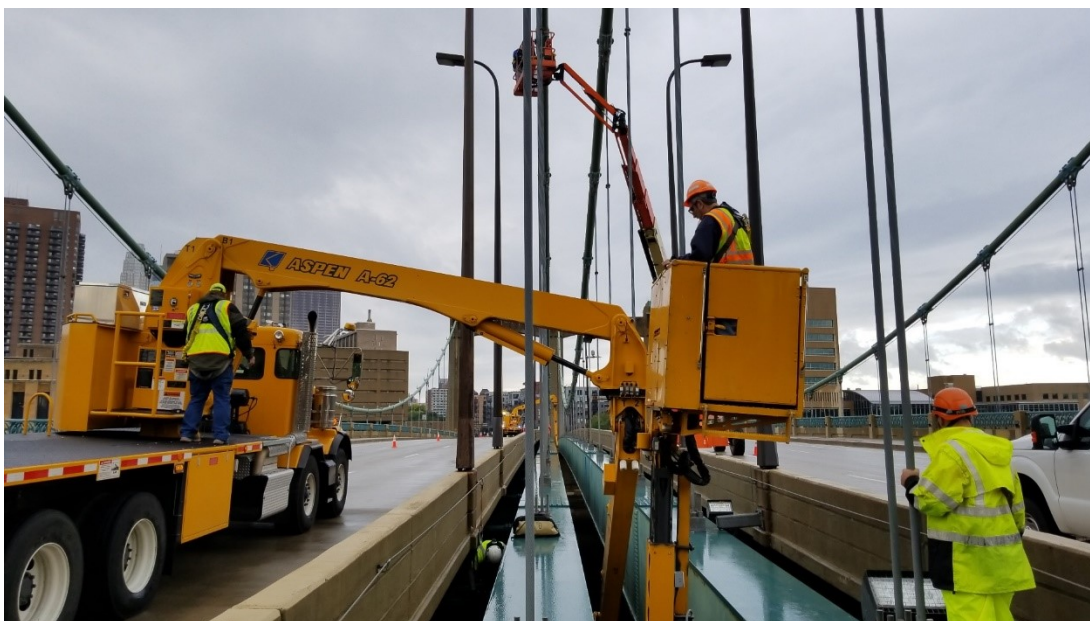

Figure 6.1 Pier Typical Bridge Inspection Work Zone with Traffic Control

CHAPTER 7: CONCLUSIONS AND RECOMMENDATIONS

7.1 CONCLUSIONS

7.1.1 Cost

Bridge inspection costs can be reduced with the use of drones. UBIVs cost anywhere from \$500,000 to \$1,000,000 to purchase, and rental costs per day range from \$2,000 to \$3,500 with an operator. Inspection-specific drones equipped with state of the art imaging devices cost anywhere from \$15,000 to \$40,000. Bridge owners should consider the use of drones where costs can be reduced without a reduction in inspection quality. Traffic control is also expensive and can range from \$500 to \$2,500 per day, which can be reduced or eliminated with drone integration. Appendix A includes a cost analysis for representative bridges considered in this research effort. The overall average cost savings was 40%. Where there were no cost savings exhibited, the quality of the deliverables was greatly improved. More difficult to quantify is the cost savings realized where improved data leads to more informed decisions on investments in bridge maintenance, repair, and rehabilitation. While difficult to compute, these cost savings are likely greater than realized with the reduction of expensive access methods and traffic control.

7.1.2 Improved Deliverables/Reality Modeling

Traditional bridge inspection results are typically compiled in a tabular format supplemented with images by low resolution hand-held cameras. Drones and related processing software give engineers the ability to collect large amounts of data and process it into actionable information. The tabular data consist of bridge inventory items, bridge elements and their quantities, and defects. Utilizing drone technology allows inspectors to communicate bridge inspection results in a more graphical manner, which can be easily reviewed and understood by bridge owners and engineers. The tabular data is important and will remain an important part of the inspection deliverables. Communicating the results in a 3D manner allows inspectors to generate better data and gives the inspector the ability to generate more accurate quantities. For instance, a concrete spall can be drawn directly on a model to get a very accurate measurement. This ability to better communicate results through reality modeling allows for improvement in asset management and provides better information that was previously not available.

7.1.3 Collision Tolerant/Confined Spaces

One of the main objectives of this phase of research was to identify and test a drone technology that would allow for the inspection of very tight and confined spaces. The team identified and extensively tested the [Flyability Elios](#) collision-tolerant drone. Multiple applications included several confined space inspections in steel and concrete box beams and pier towers. Another application that proved very effective was the ability to inspect between beams for multi-beam bridges. Beam bridges are low risk due to their load path redundancy, so many do not receive a hands-on inspection. In addition, lane closures are undesirable and may be difficult to obtain permission for, especially in busy urban areas.

The collision-tolerant drone may not quite attain the quality of a hands-on inspection since the inspection is by viewing video, but the overall effect is a much-improved inspection for a low cost when compared to an inspection that is performed from the ground.

7.1.4 Safety

With over 60 bridges inspected to date and hundreds of flights, this project has demonstrated that the use of drones for bridge inspection can reduce safety risks and this is accomplished in two ways. The first is the ability to reduce risk by removing or reducing the need for traditional access methods such as UBIV's, rope access, ladders and scaffolding. Those traditional access methods will still be necessary, but the use of drones can reduce their use to the short term, which reduces risk to bridge inspectors. The second opportunity to reduce safety risks is the elimination or reduction in traffic control. There is a significant risk to both the public and bridge inspectors when lane and shoulder closures are needed to complete a bridge inspection with traditional access methods such as UBIV's. Compounding this issue is the rise of distracted driving, which is increasing this risk.

7.2 RECOMMENDATIONS

Based on the research work of this phase, the following recommendations are presented:

- Drone use should be considered as part of a risk-based approach to bridge inspection where safety, cost and quality improvements can be realized.
- Safety risks can be reduced for both inspectors and the public. Much of the focus has been on the safety of flying a drone, but the emphasis should be on reducing the risk of the overall inspection.
- Collision-tolerant drones should be considered for confined space inspections where access and safety can be improved without a reduction in inspection quality.
- Collision-tolerant drones should be considered for the inspection of multi-beam bridges, especially when a hands-on inspection is cost prohibitive and may be prohibited entirely due to access restrictions.
- Field conditions, weather, bridge types, bridge locations and bridge configurations vary widely. While image quality is important the focus should be on the inspector's qualifications and experience and ability to determine if the quality of the data is enough to determine with certainty the structural condition of a bridge.
- Bridge reality models can also be generated with terrestrial digital cameras. Models of specific bridge components such as piers can be generated in combination with a drone or with terrestrial images only.
- Drone technology has advanced rapidly but their benefits are not being realized due to underutilization. Bridge owners should consider their use when considering inspection quality, cost savings and safety.
- Reality modeling of bridges is revolutionizing the ways we document and communicate inspection results. Bridge owners should take advantage of this technology to improve their bridge inspection programs.

REFERENCES

- F. Khan, A. Ellenberg, S. Ye, A.E. Aktan, F. Moon, A. Kontsos, A. Pradhan, I. Bartoli, (2014) "Multispectral Aerial Imaging for Infrastructure Evaluation," ASNT Structural Materials Conference 2014, Charleston, SC, October 2014
- Federal Highway Administration, (2004) *National Bridge Inspection Standards*, 23 CFR 650, FHWA, Washington, DC.
- Federal Aviation Administration (2016). Internet. Unmanned Aircraft Systems, Retrieved from <https://www.faa.gov/uas/>.
- Federal Highway Administration (2018). Internet. Work Zone Management Program, Retrieved from <https://ops.fhwa.dot.gov/wz/index.asp>
- Minnesota Department of Transportation (2017), *Bridge and Structure Inspection Program Manual*, MnDOT Office of Bridges and Structures, Oakdale, MN
- U.S. Department of Transportation (2012), *Bridge Inspector's Reference Manual*, Federal Highway Administration, Washington, DC.

APPENDIX A
BRIDGE UAS INSPECTION REPORTS



UAS INSPECTION REPORT

BRIDGE NUMBER: 27004

STONE ARCH BRIDGE

OVER THE MISSISSIPPI RIVER

MINNEAPOLIS, MINNESOTA

November 28, 2017

Prepared for:



*As part of MnDOT Research Project
A-1 Improving Quality of Bridge Inspections Using Unmanned Aircraft Systems
(UAS) Phase III*

Prepared by:

**COLLINS
ENGINEERS** INC.

1599 Selby Avenue
St. Paul, MN 55104

651.646.8502 • www.collinsengr.com



Table of Contents

1.0	INTRODUCTION	
1.1	Purpose and Scope	2
1.2	General Description of the Structure	3
2.0	UAS OPERATION	
2.1	UAS Equipment and Operating Conditions	4
2.2	Mission Scope	5
2.3	Deliverables.....	8
3.0	SUMMARY OF FINDINGS	
3.1	Opportunities	11
3.2	Limitations.....	12
3.3	Evaluation of Potential Cost Savings	12

Table of Images

Image 1: Location Map	2
Image 2: Overall View of Bridge Looking East.	3
Image 3: Overall View of Bridge Looking West.	3
Image 4: View of SenseFly Albris.	4
Image 5: View of Flyability Elios.	4
Image 6: View of Mission Flight Map (Preplanned and Interactive).	5
Image 7: View of Camera Position (Green Dot) at Locations of Photographing.	6
Image 8: View Flight Camera During Inspection.	6
Image 9: Image Clipped from Elios Inspection Video	7
Image 10: View of the Level of Detail in a Single High-Resolution Image.	8
Image 11: View of the Inspector Tool providing a Photograph Log from a selected area of the 3D model.	9
Image 12: View of the 3D model in SketchFab.	10
Image 13: View of the 3D model of Pier 4 in Pix4D.	10
Image 14: View of the 3D model of Pier 9 in Pix4D.	11



EXECUTIVE SUMMARY

- Project:** Stone Masonry Arch Inspection Using UAS's for Bridge Number 27004.
- Purpose of Project:** To perform a partial inspection of select superstructure and substructure elements using unmanned aircraft system (UAS) techniques to determine the structural and physical condition of difficult to access bridge elements. The inspection is supplemental to a routine visual, tactile, and non-destructive testing inspection.
- Inspection Team:** Team Leader – Barritt Lovelace, P.E. (Pilot)
Team Member – Cory Stuber, P.E. (Crew Hand)
- Inspection Date(s):** April 22, 2017; September 27 & 28, 2017; November 28, 2017

Data Collection Tools:

- SenseFly Albris Flyability Elios Other: Digital Camera

Summary of Mission Scope(s) and Deliverable(s):

- Aerial Mapping & Photogrammetry 3D Model & High Resolution Photograph Log High Definition Video for Limited Access Areas
- Orthomosaic Image Creation for Inspection Defect Measurement Construction/Repair Plan Documentation
- Thermal Imaging Other: _____

Summary of Findings, Opportunities, and Limitations:

The inspection of two masonry arch spans of the Stone Arch Bridge generated very good results. The 3D model and orthomosaic generated significantly improve the quality of the inspection deliverables. During a traditional inspection detailing the results of the inspection can be difficult and time consuming. The inspection workflow with the integration of drones includes flying the bridge first to create the bridge models which can then be used during the hands-on inspection. This method significantly improves the quality of the deliverables and reduces the amount of field time required since deficiencies can be identified in the field and quantified in the office using the models of the bridge. The cost savings are significant while at the same time improving the quality of the deliverables.

UAS INSPECTION REPORT

Bridge Number 27004 • Stone Arch Bridge over the Mississippi River
Minneapolis, MN • September 2017



1.0 INTRODUCTION

1.1 Purpose and Scope

This report consists of the results of an unmanned aircraft (UAS) inspection of Bridge Number 27004, the Stone Arch Bridge over the Mississippi River in Minneapolis, Minnesota. Refer to Image 1 for a location map. Collins Engineers, Inc. (Collins) conducted the UAS Inspection for the Minnesota Department of Transportation (MnDOT) on September 27 & 28, 2017 and November 28, 2017 as part of a research project titled “Improving Quality of Bridge Inspections Using Unmanned Aircraft Systems (UAS) Project Phase III”. Additionally, images were used from an inspection on April 22, 2017. The primary purpose of the UAS usage during the inspection was to identify possible opportunities and limitations of UAS involvement in various capacity of bridge inspection. The following report includes a brief description of the structure, description of UAS equipment and operating conditions, the mission scope and deliverables, a summary of findings, opportunities, and limitations, and an evaluation of potential cost savings.



Image 1: Location Map

UAS INSPECTION REPORT

Bridge Number 27004 • Stone Arch Bridge over the Mississippi River
Minneapolis, MN • September 2017



1.2 General Description of the Structure

Bridge Number 27004 is historically significant and spans approximately 2100 feet over the Mississippi River and carries a Pedestrian Walkway. The bridge deck is approximately 28 feet wide and consists of a bituminous wearing surface over concrete and steel plate. The bridge superstructure consists of 1 steel deck truss span with steel floor beams and stringers and 21 stone masonry arch spans. The substructure consists of stone masonry spread footings founded on rock. The longitudinal axis of the bridge is orientated approximately east to west. Refer to Images 2 and 3 for overall views of the bridge.

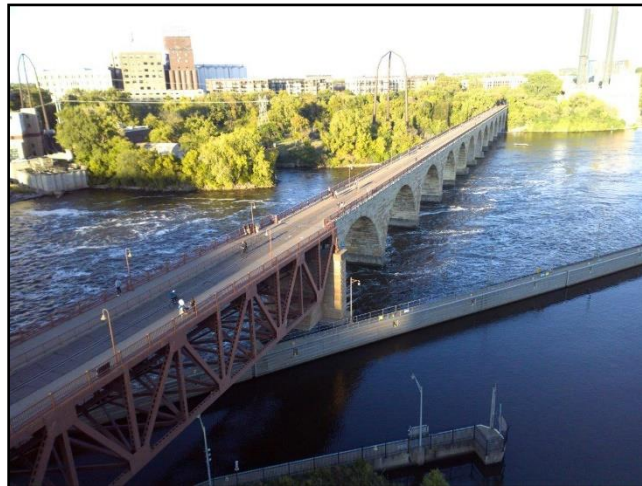

Image 2: Overall View of Bridge Looking East.

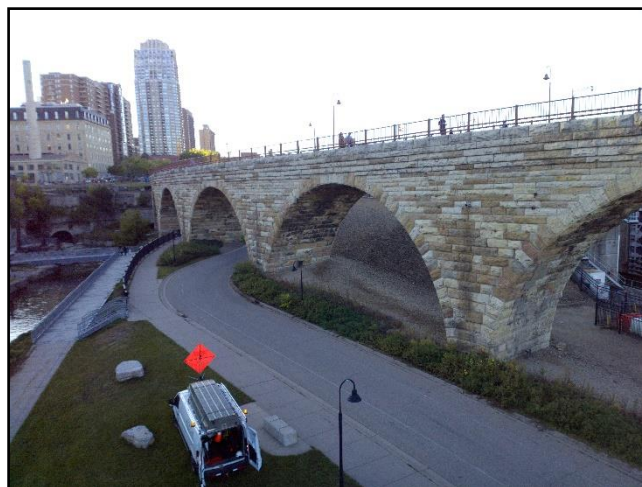

Image 3: Overall View of Bridge Looking West.

2.0 UAS OPERATION

2.1 UAS Equipment and Operating Conditions

A two-person crew, consisting of a professional engineer-pilot and a field engineer, conducted the UAS inspection. The pilot was certified as a FAA Remote Pilot. The inspection was conducted using two different registered UAS's; an Inspection and Mapping UAS and an Collision-Tolerant UAS. The aerial mapping UAS was a SenseFly Albris quadcopter equipped with a TripleView head consisting of a HD video camera, a 38MP still camera, and an infrared camera. Additionally, the Albris contains five acoustic sensors, GPS location, and navigation camera technology which aid both 3D preplanned and interactive flight missions. The Collision-Tolerant UAS was a Flyability Elios quadcopter equipped with a full HD camera, Infrared camera, and on-board lighting system. Additionally, the Elios has a protective frame surrounding the UAS body allowing for access to tight locations and up-close imaging. Refer to Image 4 for a view of the SenseFly Albris and Image 5 for a view of the Flyability Elios.



Image 4: View of SenseFly Albris.



Image 5: View of Flyability Elios.

UAS INSPECTION REPORT

Bridge Number 27004 • Stone Arch Bridge over the Mississippi River

Minneapolis, MN • September 2017



During the inspection, the pilot worked with a mobile work station suspended from his body and the other crew member maintained line-of-sight with the UAS. Aerial targets and a scale were placed prior to the aerial mapping mission to provide a higher level of accuracy. At the time of flight, the weather was clear with low wind. The bridge was located in Class G Airspace; thus, no FAA waiver or additional authorization was necessary.

2.2 Mission Scope

A Mapping & Photogrammetry mission using the Albris was identified for this bridge to explore the potential of UAS photography to map bituminous deck surface defects. The target goal of the mission was to gather information in the form of photographs in a quick, efficient process which could later be used to map the deck and have a post-inspection tool to aid in report writing and historical documentation. Additionally, the ease of use in an urban environment was displayed. The mission consisted of a pre-planned flight path that imaged the top of deck. The north and south fascias were mapped using the distance lock and cruise control features to ensure adequate image overlap. The underside of the arches were flown manually. The UAS collected over 720 high-resolution still images of the bridge fascia and top side. All images were geo-tagged with GPS coordinates. Refer to Images 6 and 7 for views of the Flight and Mapping Mission.



Image 6: View of Mission Flight Map (Preplanned and Interactive).

UAS INSPECTION REPORT

Bridge Number 27004 • Stone Arch Bridge over the Mississippi River
Minneapolis, MN • September 2017

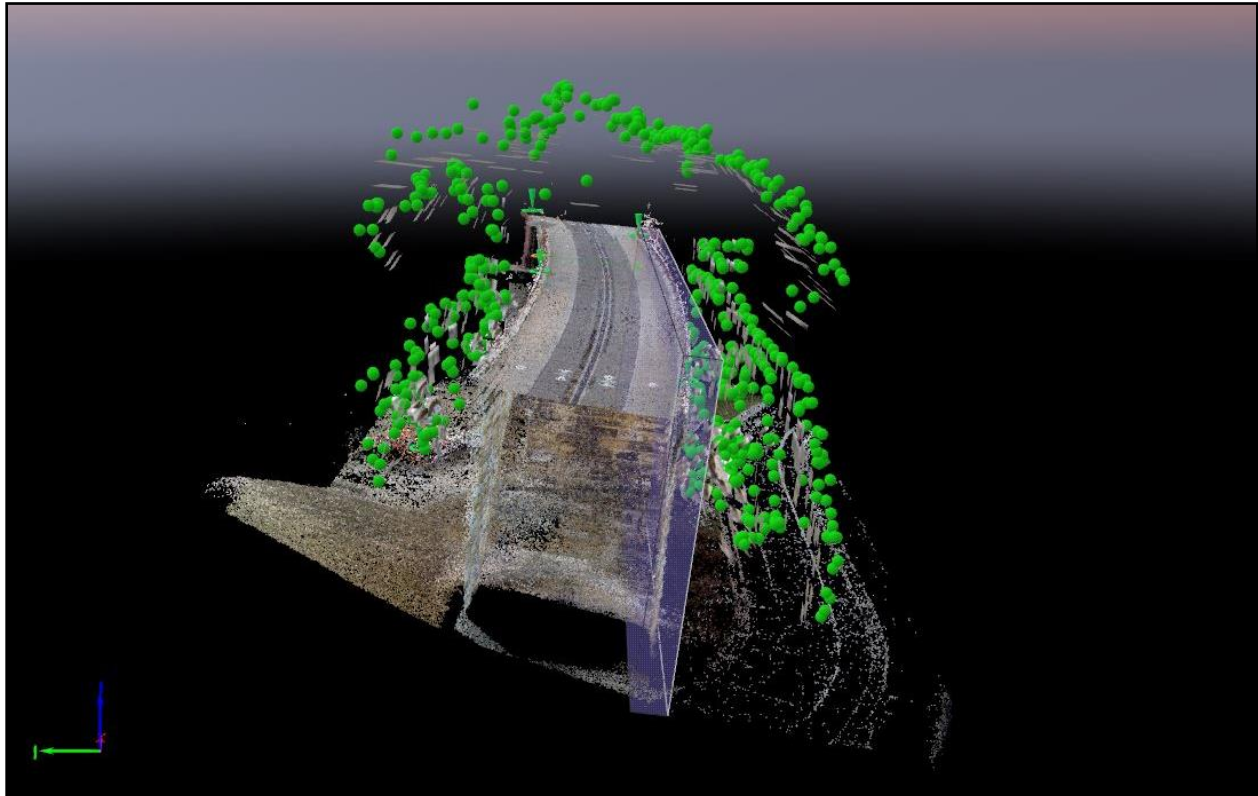

Image 7: View of Camera Position (Green Dot) at Locations of Photographing.



Image 8: View Flight Camera During Inspection. [\(Click Image to play video\)](#).

UAS INSPECTION REPORT

Bridge Number 27004 • Stone Arch Bridge over the Mississippi River
Minneapolis, MN • September 2017



A High Definition Video Mission was conducted of limited access areas using the Elios UAS. The target goal of this mission was to determine the quality and applicability of using a Collision-Tolerant UAS to capture images and assess the condition of bridge elements which are typically not tactically accessible or easily viewed during the scope of a routine inspection. The site also tested the UASs quality of flight in open-air environments. The mission consisted of an interactive flight using only pilot controls. During a typical routine inspection, the masonry of the fascia at an elevation high above the ground level would have been difficult to access. The use of the Elios UAS focuses on these hard to access locations. An inspector can then review the video footage to look for defects or findings. Refer to Image 9 for a view of the Elios UAS in a difficult to access location.

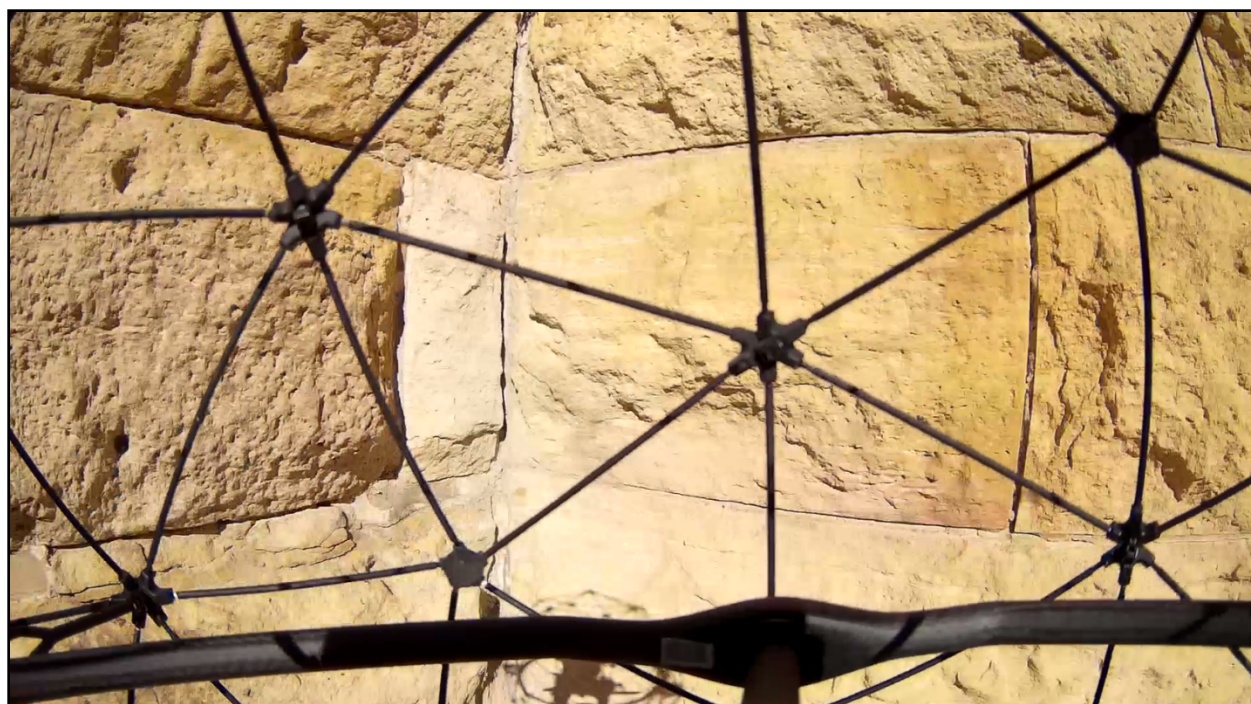

Image 9: Image Clipped from Elios Inspection Video ([Click Image to play video](#)).

At all piers Imaging using a terrestrial point-and-shoot type digital camera was used to photograph the lower portion of the stone masonry arch. The goal of this Mission was to determine the level of effort necessary to obtain quality images necessary for producing a usable 3D model. Photographs were taken in an orderly fashion circling the pier and allowing enough overlap for post-processing software to be able to mesh together the photographs. The results of these images would then be compared to those from the UAS mission for expanded knowledge of the imaging process and applicability.

2.3 Deliverables

An Orthomosaic image of the bridge fascia was created in the Pix4D software to use as an inspection tool. The target goal for this process was to produce an easily viewable, high resolution image of a large area that could be used by an inspector to carry out a detailed inspection, area measurements, condition assessment, or historical documentation. An Orthomosaic image is a single image file which is created from many individual images captured during the Mapping and Photogrammetry Mission. The final product of an Orthomosaic image is an image file that can be used to measure true distances. For this bridge, an Orthomosaic image was made of the vertical fascia of Spans 14 and 15 of the stone masonry arch. An inspector then reviewed a single file and can measure true distances and areas for a final product. Refer to Image 10 and 11 for a view of Orthomosaic Detail.



Image 10: View of the Level of Detail in a Single High-Resolution Image. [\(Click Image to Access Video\)](#)

A 3D Model with a High-Resolution Photograph Log was processed for bridge. The target goal for this process was to determine the ease of use and applicability of having a 3D photolog to assist an inspector during post-processing, report writing, and future inspection. Additionally, the applicability of an easily manipulated 3D model which could be shared with others was explored. All photographs taken during the Mapping and Photogrammetry Mission were processed in Pix4D. The software processes all photographs to form a 3D point cloud for digital viewing. The point cloud was then processed by the same software to generate a 3D mesh of the bridge.

An inspector was able to use the Pix4D program to navigate the 3D model and select areas of interest. The software provides the inspector with all still images containing the selected area of interest which can then be viewed in high resolution. Additionally, the inspector can place annotations within the file for future reference or for clarification when sharing the file. Refer to Image 11 for a view of the Inspector Tool providing a Photograph Log from a selected area of the 3D model.

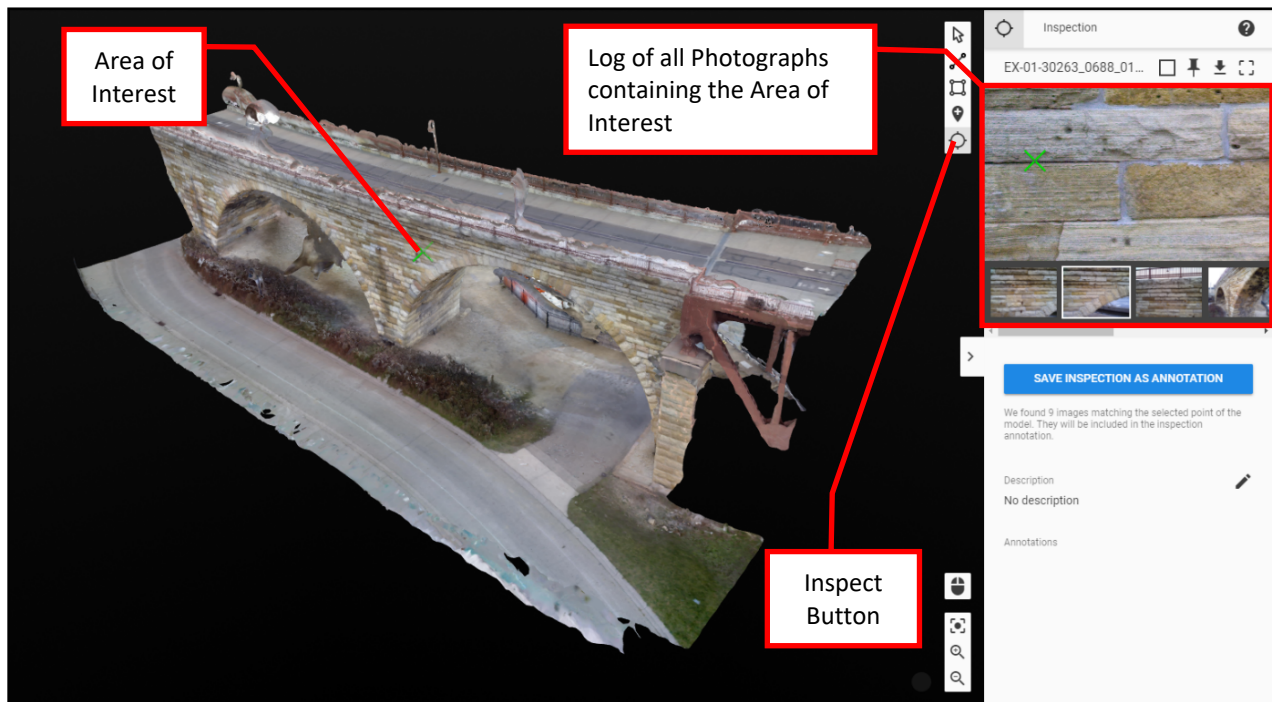

Image 11: View of the Inspector Tool providing a Photograph Log from a selected area of the 3D model.
(Click Image to access 3D Model and Inspection Photolog – Click on the Inspect Button)

The model was also uploaded to the SketchFab website to evaluate another method of sharing results. Refer to Image 13 for a view of the SketchFab 3D model.

UAS INSPECTION REPORT

Bridge Number 27004 • Stone Arch Bridge over the Mississippi River
Minneapolis, MN • September 2017



Image 12: View of the 3D model in SketchFab. [\(Click Image to access 3D Model\)](#)

The example results of the Pier 4 and Pier 9 terrestrial Imaging yielded a total of 58 and 80 usable images, respectively, for each pier. These images were processed with the Pix4D software to provide the inspector with a 3D model and high-resolution photograph log. Refer to Images 13 and 14 below for views of Pier 4 and 9, respectively.



Image 13: View of the 3D model of Pier 4 in Pix4D.
[\(Click Image to access 3D Model\)](#)

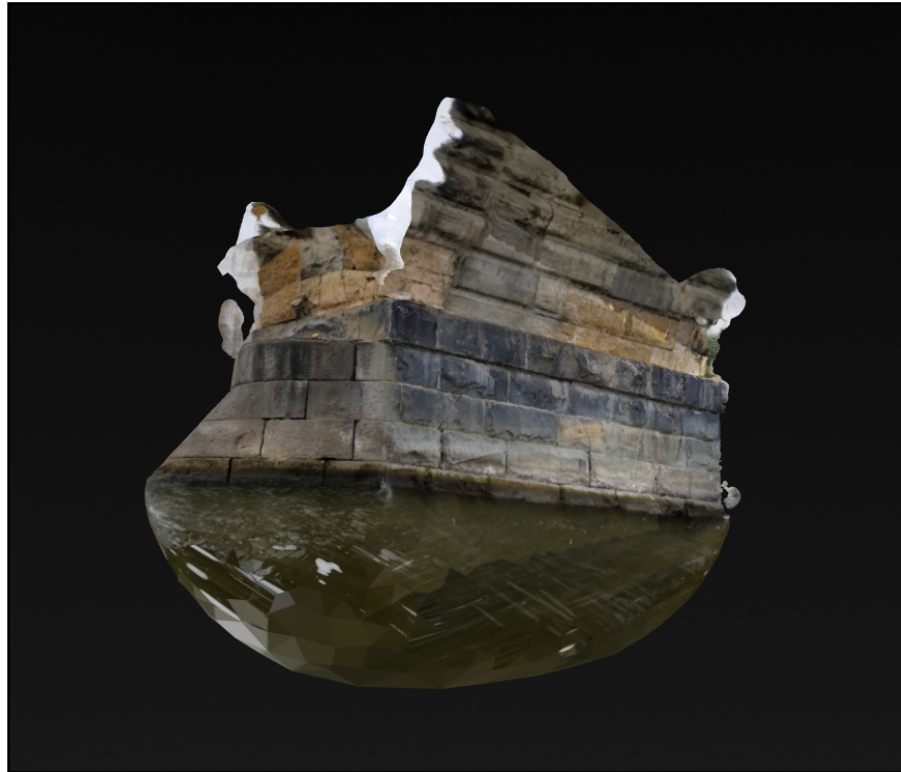

Image 14: View of the 3D model of Pier 9 in Pix4D. [\(Click Image to access 3D Model\)](#)

Video from the High Definition Video Mission using the Elios was viewed by an inspector after returning from the flight mission. The video could be observed in any software capable of playing .MP4 files. Additionally, the manufacturer of Elios, Flyability, has created an inspection software where the UASs flight log can be opened with the video file to show inspector UAS attributes such as heading, altitude, and temperature. The inspector can then maneuver their way through the video to obtain still images of defects or notable findings.

3.0 SUMMARY OF FINDINGS

3.1 Opportunities

The execution of the Mapping and Photogrammetry Mission was a success and provided great insight into the potential for UAS as a tool during routine inspections. The set-up, flight, and data generation went as planned and was substantial enough to create the planned deliverables. The Stone Arch Bridge is an ideal bridge to take advantage of UAS Technology.

UAS INSPECTION REPORT

Bridge Number 27004 • Stone Arch Bridge over the Mississippi River
 Minneapolis, MN • September 2017



3.2 Limitations

While the mapping mission was a success and a quality 3D model was generated some additional effort was needed to generate the model including the addition of manual tie points and the manual removal of noise from the model. Future missions should include a more consistent pattern of photos especially of the areas underneath the arches to avoid the additional processing effort.

3.3 Evaluation of Potential Cost Savings

The following cost evaluation is based on two masonry arch spans for field work only. Reporting costs are not included but would be similar for either case. Cost savings can be obtained with the use of UAS due to the reduction in UBIV costs which are significant. The UAS costs include follow up with the UBIV to verify deficiencies and employ tactile inspection on suspect areas where needed. The use of UAS significantly improves the deliverables even with a reduced cost vs. traditional inspection.

Bridge 27004 - Based on Two Spans Only								
Expense Description	Traditional Inspection Cost				UAS Assisted Inspection Cost			
	Quantity	Unit	Unit Price	Cost	Quantity	Unit	Unit Price	Cost
Bridge Inspection Team Leader	4	Hour	150	\$600	4	Hour	\$150	\$600
Assistant Bridge Inspector	4	Hour	120	\$480	4	Hour	\$120	\$480
Under Bridge Inspection Vehicle with Operator	1	Day	3,000	\$3,000	0.5	Day	\$3,000	\$1,500
Drone Rental	0	Day	300	\$0	1	Day	\$300	\$300
UAS Post Processing Engineer	0	Hour	120	\$0	8	Hour	\$120	\$960
Misc Traffic Control (Ped Only Etc)	1	Each	500	\$500	1	Each	\$500	\$500
Mobile Lane/Shoulder Closure	1	Each	1,500	\$1,500	0	Each	\$1,500	\$0
High Speed Lane/Shoulder Closure	0	Each	2,500	\$0	0	Each	\$2,500	\$0
			Traditional Inspection Cost	\$6,080			UAS Assisted Inspection Cost	\$4,340

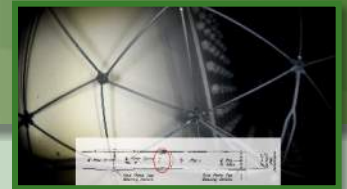

UAS INSPECTION REPORT

BRIDGE NUMBER: 27201

TRUNK HIGHWAY 55

OVER THE LAKE STREET

MINNEAPOLIS, MINNESOTA

June 15, 2017

Prepared for:



*As part of MnDOT Research Project
A-15 Improving Quality of Bridge Inspections Using Unmanned Aircraft Systems
(UAS) Phase III*

Prepared by:

**COLLINS
ENGINEERS** INC.

1599 Selby Avenue
St. Paul, MN 55104

651.646.8502 • www.collinsengr.com



Table of Contents

1.0	INTRODUCTION	
1.1	Purpose and Scope	1
1.2	General Description of the Structure	2
2.0	UAS OPERATION	
2.1	UAS Equipment and Operating Conditions	3
2.2	Mission Scope	3
2.3	Deliverables.....	5
3.0	SUMMARY OF FINDINGS	
3.1	Opportunities	7
3.2	Limitations.....	7
3.3	Evaluation of Potential Cost Savings	7

Table of Images

Image 1: Location Map	1
Image 2: Overall View of Bridge.	2
Image 3: Overall View of Bridge Underside.	2
Image 4: View of Flyability Elios.	3
Image 5: View of Box Girder Dimensions.	4
Image 6: View of Box Girder Entrance Hatch.	4
Image 7: Image Clipped from Elios Inspection Video.	5
Image 8: Image Clipped from Elios Inspection Video (Splice Assembly).	6
Image 9: Image Clipped from Elios Inspection Video (Defects of Deck Soffit).	6



EXECUTIVE SUMMARY

Project: Steel Box Girder Inspection Using UAS for Bridge Number 27201.

Purpose of Project: To perform a partial inspection of select superstructure elements using unmanned aircraft system (UAS) techniques to determine the structural and physical condition of difficult to access bridge elements. The inspection is supplemental to a routine visual, tactile, and non-destructive testing inspection.

Inspection Team: Team Leader – Barritt Lovelace, P.E. (Pilot)
Team Member – Cory Stuber, P.E. (Crew Hand)

Inspection Date(s): June 15, 2017

Data Collection Tools:

- SenseFly Albris, Flyability Elios, Other:

Summary of Mission Scope(s) and Deliverable(s):

- Aerial Mapping & Photogrammetry, 3D Model & High Resolution Photograph Log, High Definition Video for Limited Access Areas, Orthomosaic Image Creation for Inspection, Defect Measurement, Construction/Repair Plan Documentation, Thermal Imaging, Other:

Summary of Findings, Opportunities, and Limitations:

The execution of the inspection went without problems. The collision tolerant drone was able to fly from the ground into the steel box girders, perform the inspection and return safety to the ground. Utilizing UAS in this way eliminates the need for an inspector to enter the confined space. This improves safety in two ways. The first is that the box girders are typically entered with tall ladders or a man lift. Both of which pose safety risks. The other safety improvement is the elimination of a confined space entry for inspection staff. The video provided good quality to view deficiencies. This example of UAS use is one of the more practical applications for the Phase III research effort. The application reduces safety risks and costs while providing a quality product.

UAS INSPECTION REPORT

Bridge Number 27201 • Trunk Highway 55 over Lake St.
Minneapolis, MN • June 2017



1.0 INTRODUCTION

1.1 Purpose and Scope

This report consists of the results of an unmanned aircraft (UAS) inspection of Bridge Number 27201, Trunk Highway 55 over Lake St. in Minneapolis, Minnesota. Refer to Image 1 for a location map. Collins Engineers, Inc. (Collins) conducted the UAS Inspection for the Minnesota Department of Transportation (MnDOT) on June 15, 2017 as part of a research project titled “Improving Quality of Bridge Inspections Using Unmanned Aircraft Systems (UAS) Project Phase III”. The primary purpose of the UAS usage during the inspection was to identify possible opportunities and limitations of UAS involvement in support of bridge inspection. The following report includes a brief description of the structure, description of UAS equipment and operating conditions, the mission scope and deliverables, a summary of findings, opportunities, and limitations, and an evaluation of potential cost savings.

UAS INSPECTION REPORT

Bridge Number 27201 • Trunk Highway 55 over Lake St.
Minneapolis, MN • June 2017

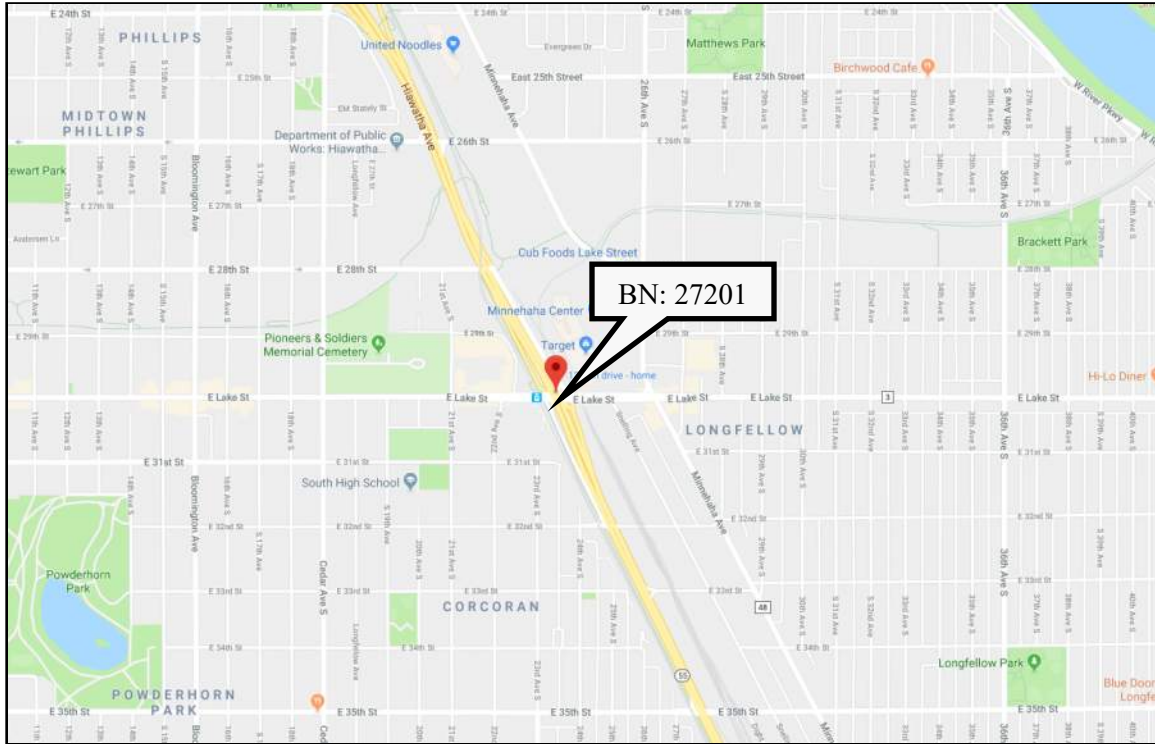

Image 1: Location Map

1.2 General Description of the Structure

Bridge Number 27201 spans approximately 505 feet over Lake St. and carries two northbound and two southbound lanes of Trunk Highway 55 (Hiawatha Ave.). The bridge deck is approximately 110 feet wide and consists of cast in place concrete with a concrete overlay wearing surface. The bridge superstructure consists of three spans of four continuous closed steel box girders. The substructure consists of reinforced concrete abutments and pier walls all founded on piles. The longitudinal axis of the bridge is orientated approximately north to south. Refer to Images 2 and 3 for overall views of the bridge.



Image 2: Overall View of Bridge.



Image 3: Overall View of Bridge Underside.

2.0 UAS OPERATION

2.1 UAS Equipment and Operating Conditions

A three-person crew, consisting of a professional engineer-pilot and two field engineers, conducted the UAS inspection. The pilot was certified as a FAA Remote Pilot. The inspection was conducted using a Collision-Tolerant UAS. The Collision-Tolerant UAS was a Flyability Elios quadcopter equipped with a full HD camera, Infrared camera, and on-board lighting system. Additionally, the Elios has a protective frame surrounding the UAS body allowing for access to tight locations and up-close imaging. Refer to Image 4 for a view of the Flyability Elios.



Image 4: View of Flyability Elios.

During the inspection, the pilot worked mobile remote control. The flight mission was conducted entirely within the confines of the bridge structure; thus, no authorization was necessary from FAA.

2.2 Mission Scope

A High Definition Video Mission was conducted of limited access areas using the Elios UAS. The target goal of this mission was to determine the quality and applicability of using a Collision-Tolerant UAS to capture images and assess the condition of enclosed steel box girders. These bridge elements are typically not able to be inspected efficiently by inspectors given the confined space and physical size limitations. For this Mission, the pilot accessed the box girders from hatches located in the bottom of the steel girders. Refer to Image 5 and 6 for views of the girders.

UAS INSPECTION REPORT

Bridge Number 27201 • Trunk Highway 55 over Lake St.
Minneapolis, MN • June 2017

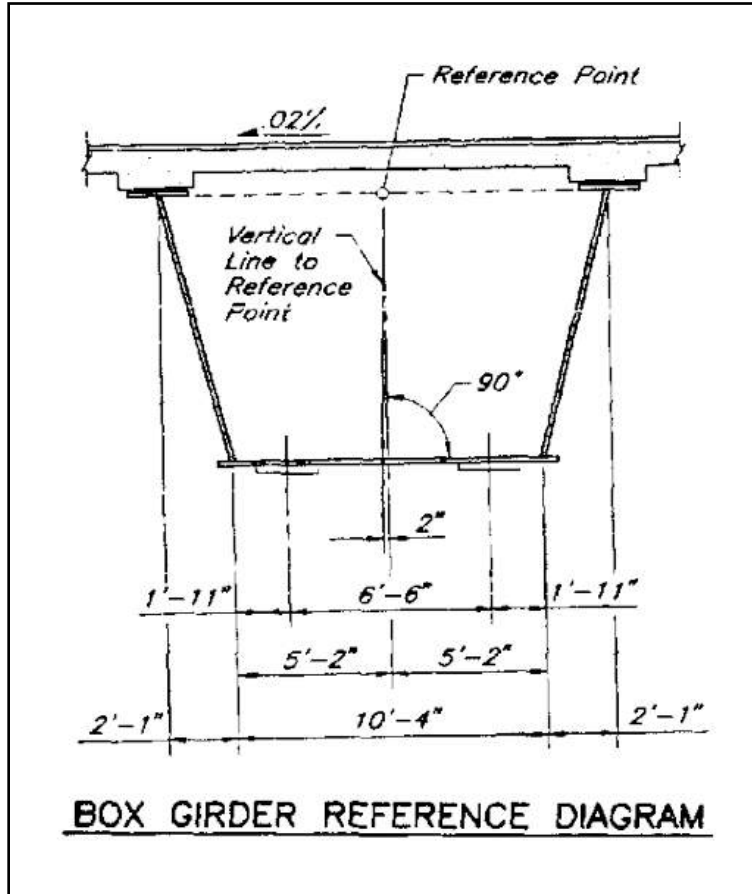

Image 5: View of Box Girder Dimensions.



Image 6: View of Box Girder Entrance Hatch.

UAS INSPECTION REPORT

Bridge Number 27201 • Trunk Highway 55 over Lake St.
Minneapolis, MN • June 2017



The lead pilot/inspector flew the mission in interactive mode. The live video stream was viewed throughout the inspection to provide both navigational awareness and view areas of inspection interest. A total of seven flights were conducted through one girder line at Span 1. Each flight was progressively more thorough and inspected a longer stretch of girder. The UAS was flown from grade, up through the box hatches and longitudinally down the boxes. The UAS was navigated using a combination of rolling the protective frame along box walls, floor and ceiling and free flying through the girders. The UAS used an on-board LED light for navigation light, however often had to refer to a light shining through the hatch for global orientation. The UAS was also flown outside the box girders also to inspect the concrete deck soffit within Span 1.



Image 7: Image Clipped from Elios Inspection Video ([Click Image to play video](#)).

2.3 Deliverables

Video from the High Definition Video Mission using the Elios was viewed by an inspector after returning from the flight mission. The video could be observed in any software capable of playing .MP4 files. Additionally, the manufacturer of Elios, Flyability, has created an inspection software where the UASs flight log can be opened with the video file to show inspector UAS attributes such as heading, altitude, and temperature. The inspector can then maneuver their way through the video to obtain still images of defects or notable findings.

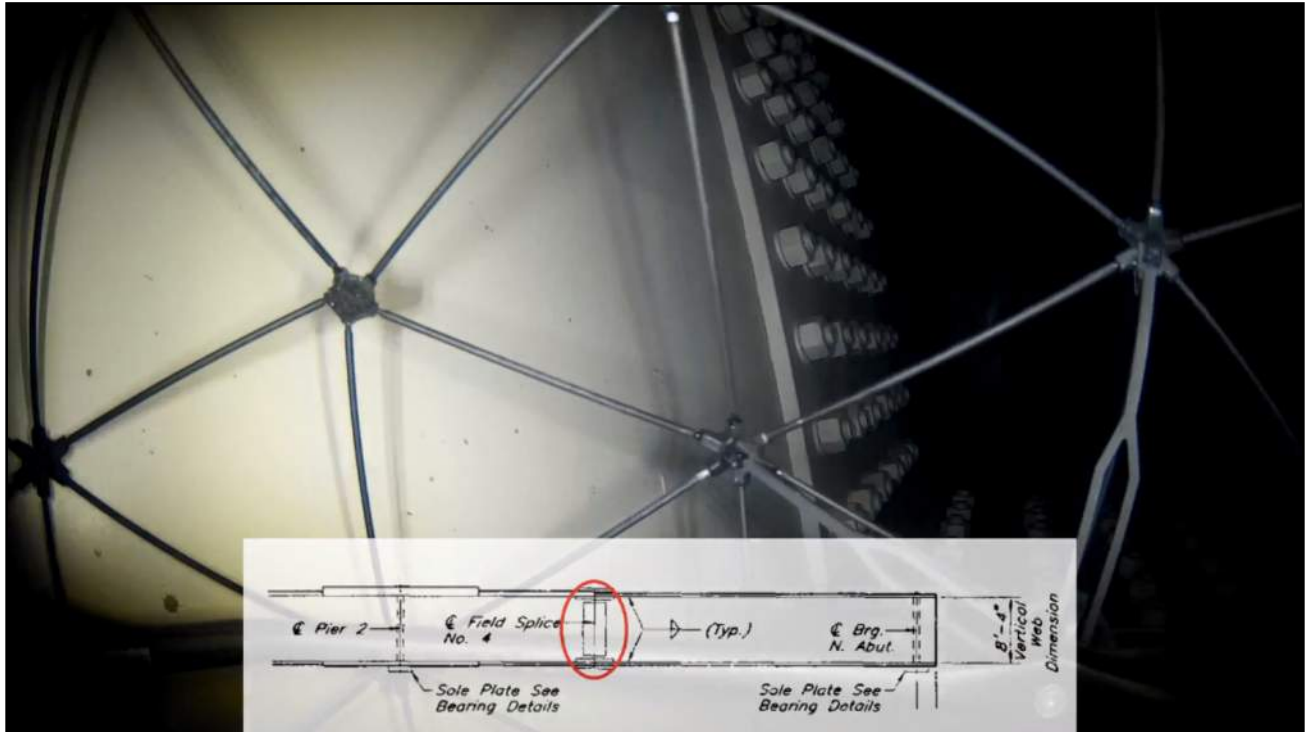

Image 8: Image Clipped from Elios Inspection Video. Inspection of Splice Assembly.



Image 9: Image Clipped from Elios Inspection Video. Inspection of Deck Soffit, note efflorescence and cracking.

UAS INSPECTION REPORT

Bridge Number 27201 • Trunk Highway 55 over Lake St.

Minneapolis, MN • June 2017



3.0 SUMMARY OF FINDINGS

3.1 Opportunities

The execution of the inspection went without problems. The collision tolerant drone was able to be flown from the ground into the steel box girders and back to the ground. Utilizing UAS in this way eliminates the need for an inspector to enter the confined space. This improves safety in two ways. The first is that the box girders are typically entered with tall ladders or a man lift. Both of which pose safety risks. The other safety improvement is the elimination of a confined space entry for inspection staff. The video provided good quality to view deficiencies.

3.2 Limitations

While the video quality was good it is not as good as a hands-on inspection. Since this bridge is not fracture critical a hands-on inspection is not required. However, the use of UAS for this bridge should be considered from a risk perspective and a hands on inspection should be performed for areas of concern or at an interval possibly alternating with a UAS inspection.

3.3 Evaluation of Potential Cost Savings

Bridge 27201 - Based on One Box Girder and One Span								
Expense Description	Traditional Inspection Cost				UAS Assisted Inspection Cost			
	Quantity	Unit	Unit Price	Cost	Quantity	Unit	Unit Price	Cost
Bridge Inspection Team Leader	8	Hour	150	\$1,200	4	Hour	\$150	\$600
Assistant Bridge Inspector	8	Hour	120	\$960	4	Hour	\$120	\$480
Under Bridge Inspection Vehicle with Operator	0	Day	3,000	\$0	0	Day	\$3,000	\$0
Drone Rental	0	Day	300	\$0	1	Day	\$300	\$300
UAS Post Processing Engineer	0	Hour	120	\$0	2	Hour	\$120	\$240
Misc Traffic Control (Ped Only Etc)	0	Each	500	\$0	0	Each	\$500	\$0
Mobile Lane/Shoulder Closure	0	Each	1,500	\$0	0	Each	\$1,500	\$0
High Speed Lane/Shoulder Closure	0	Each	2,500	\$0	0	Each	\$2,500	\$0
			Traditional Inspection Cost	\$2,160			UAS Assisted Inspection Cost	\$1,620



UAS INSPECTION REPORT

BRIDGE NUMBER: 27831

INTERSTATE 394

OVER DUNWOODY BOULEVARD

MINNEAPOLIS, MINNESOTA

November 2017 & January 2018

Prepared for:



*As part of MnDOT Research Project
A-26 Improving Quality of Bridge Inspections Using Unmanned Aircraft Systems
(UAS) Phase III*

Prepared by:

**COLLINS
ENGINEERS** INC.

1599 Selby Avenue
St. Paul, MN 55104

651.646.8502 • www.collinsengr.com

UAS INSPECTION REPORT

Bridge Number 27831 • I 394 over Dunwoody Blvd.
Minneapolis, MN • November 2017



Table of Contents

1.0	INTRODUCTION	
1.1	Purpose and Scope	1
1.2	General Description of the Structure	2
2.0	UAS OPERATION	
2.1	UAS Equipment and Operating Conditions	3
2.2	Mission Scope	5
2.3	Deliverables.....	6
3.0	SUMMARY OF FINDINGS	
3.1	Opportunities	14
3.2	Limitations.....	14
3.3	Evaluation of Potential Cost Savings	14

Table of Images

Image 1: Location Map	1
Image 2: Overall View of Bridge North Elevation.	2
Image 3: Overall Elevation View of Typical Concrete Pile Bent.	2
Image 4: View of SenseFly Albris.	3
Image 5: View of Flyability Elios.	3
Image 6: View of Sony Alpha A75 II.	4
Image 7: View of GoPro Hero 5.	4
Image 8: View of the Image from the Albris UAS.	7
Image 9: View of the Image Quality from the Albris UAS.	7
Image 10: View of the Image from the Sony Alpha A75 II.	8
Image 11: View of the Image Quality from the Alpha A75 II.	8
Image 12: View of the Image from the GoPro Hero 5.	9
Image 13: View of the Image Quality from the GoPro Hero 5.	9
Image 14: View of the Image from the Samsung Galaxy S8.	10
Image 15: View of the Image Quality from the Samsung galaxy S8.	10
Image 16: View of the Sony Alpha A75 II 3D Model with Annotations.	11
Image 17: View of a Crack Using the Inspector Tool from the Sony 3D Model.	12
Image 18: View of Spall Measurements and Annotations from the Sony 3D Model.	12
Image 19: View of the 3D Model Created from the GoPro Images.	13
Image 20: View of Screenshot from the Flyability Inspector Program.	14

UAS INSPECTION REPORT

Bridge Number 27831 • I 394 over Dunwoody Blvd.
Minneapolis, MN • November 2017



EXECUTIVE SUMMARY

- Project:** Pier Condition Survey and Defect Mapping Using UAS for Bridge Number 27831.
- Purpose of Project:** To perform a detailed concrete pier element condition assessment and defect mapping using unmanned aircraft system (UAS) techniques to determine the structural and physical condition as well a platform for documenting detailed defect measurements.
- Inspection Team:** Team Leader – Barritt Lovelace, P.E. (Team Leader/Pilot)
Team Member – Cory Stuber, P.E. (Team Leader)
- Inspection Date(s):** Various

Data Collection Tools:

- SenseFly Albris Flyability Elios Other: Digital Cameras

Summary of Mission Scope(s) and Deliverable(s):

- | | | |
|---|---|--|
| <input checked="" type="checkbox"/> Aerial Mapping & Photogrammetry | <input checked="" type="checkbox"/> 3D Model & High Resolution Photograph Log | <input checked="" type="checkbox"/> High Definition Video for Limited Access Areas |
| <input checked="" type="checkbox"/> Orthomosaic Image Creation for Inspection | <input checked="" type="checkbox"/> Defect Measurement | <input checked="" type="checkbox"/> Construction/Repair Plan Documentation |
| <input type="checkbox"/> Thermal Imaging | <input type="checkbox"/> Other: _____ | |

Summary of Findings, Opportunities, and Limitations:

- [UPDATE UPON FINISHING SUMMARY OF FINDINGS]

UAS INSPECTION REPORT

Bridge Number 27831 • I 394 over Dunwoody Blvd.
Minneapolis, MN • November 2017



1.0 INTRODUCTION

1.1 Purpose and Scope

This report consists of the results of an unmanned aircraft system (UAS) concrete pier element condition assessment and defect mapping of several piers at bridge Number 27831, I 394 over Dunwoody Blvd. in Minneapolis, Minnesota. Refer to Image 1 for a location map. Collins Engineers, Inc. (Collins) conducted the UAS Inspection for the Minnesota Department of Transportation (MnDOT) in November 2017 and January 2018 as part of a research project titled “Improving Quality of Bridge Inspections Using Unmanned Aircraft Systems (UAS) Project Phase III”. The primary purpose of the UAS usage during the inspection was to identify possible opportunities and limitations of UAS involvement in support of bridge element condition assessment and defect mapping. The following report includes a brief description of the structure, description of UAS equipment and operating conditions, the mission scope and deliverables, a summary of findings, opportunities, and limitations, and an evaluation of potential cost savings.

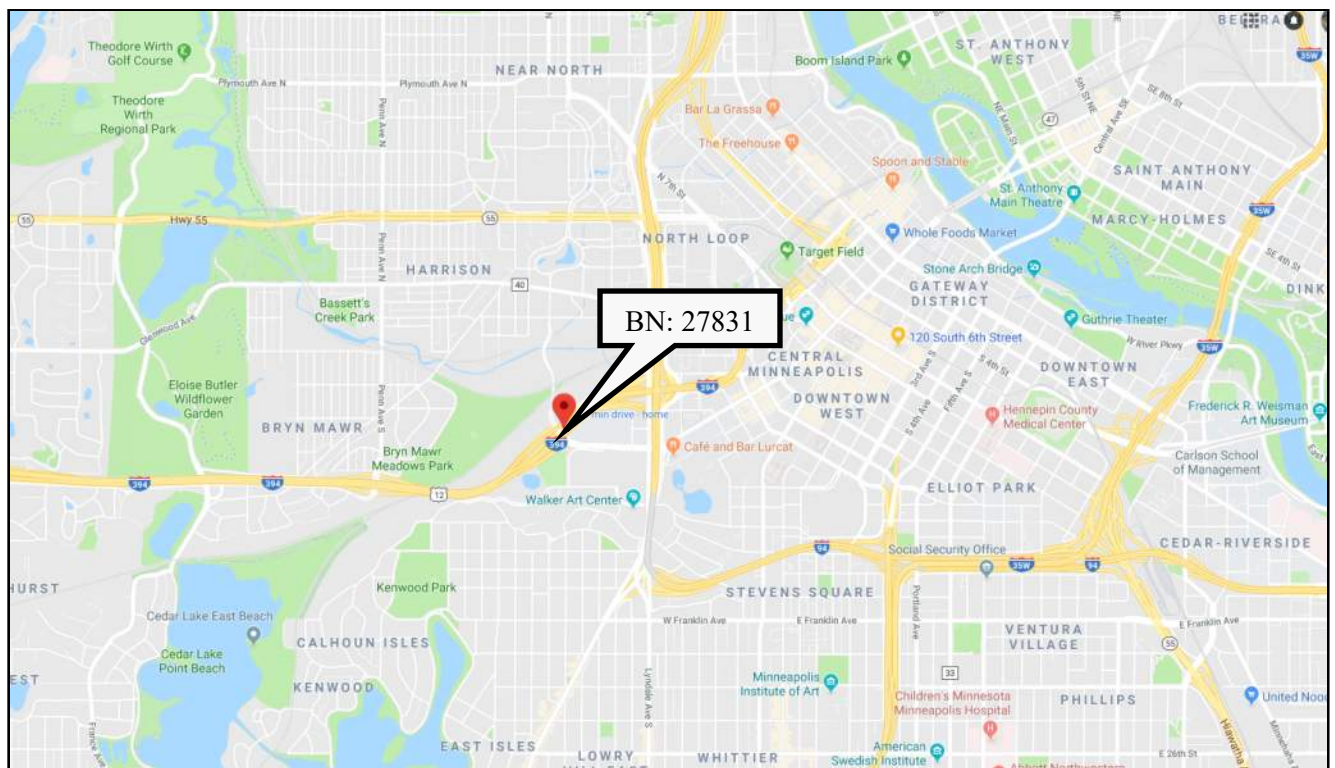

Image 1: Location Map

UAS INSPECTION REPORT

Bridge Number 27831 • I 394 over Dunwoody Blvd.
Minneapolis, MN • November 2017



1.2 General Description of the Structure

Bridge Number 27831 spans approximately 2740 feet over Dunwoody Boulevard and carries three eastbound and three westbound lane of I 394. The bridge deck varies in width but is approximately 100 feet wide and consists of a cast-in-place concrete with a concrete wearing surface. The bridge superstructure consists of 50 prestress concrete beam spans. The substructure consists of 2 reinforced concrete abutments, 29 driven steel pile bents and 20 concrete pile bents founded on concrete footings on piles. The longitudinal axis of the bridge is orientated approximately northeast to southwest. Refer to Images 2 and 3 for overall views of the bridge.



Image 2: Overall View of Bridge North Elevation.



Image 3: Overall Elevation View of Typical Concrete Pile Bent.

2.0 UAS OPERATION

2.1 UAS Equipment and Operating Conditions

A two-person crew, consisting of a professional engineer-pilot and a field engineer, conducted the UAS inspection. The pilot was certified as a FAA Remote Pilot. The inspection was conducted using two different registered UAS's; an Inspection and Mapping UAS and an Collision-Tolerant UAS. The aerial mapping UAS was a SenseFly Albris quadcopter equipped with a TripleView head consisting of a HD video camera, a 38MP still camera, and an infrared camera. Additionally, the Albris contains five acoustic sensors, GPS location, and photo-identification stabilization technology which aid both 3D preplanned and interactive flight missions. The Collision-Tolerant UAS was a Flyability Elios quadcopter equipped with a full HD camera, Infrared camera, and on-board lighting system. Additionally, the Elios has a protective frame surrounding the UAS body allowing for access to tight locations and up-close imaging. Refer to Image 4 for a view of the SenseFly Albris and Image 5 for a view of the Flyability Elios.



Image 4: View of SenseFly Albris.



Image 5: View of Flyability Elios.

UAS INSPECTION REPORT

Bridge Number 27831 • I 394 over Dunwoody Blvd.
Minneapolis, MN • November 2017



During the inspection, the pilot worked with a mobile work station and the other crew member maintained line-of-sight with the UAS. The entirety of flight was conducted under the bridge deck which hindered the GPS connection meaning the flight was conducted in interactive mode. The bridge was located in Class G Airspace; thus, no FAA waiver or additional authorization was necessary.

In addition to the UASs, a high-resolution low-light mirrorless digital camera, a high-resolution action camera, and a phone camera were used to capture photographs from the ground. The low-light camera was a Sony Model Alpha A7R II. The Sony camera specializes in low light conditions. It has a 42MP resolution, 5 axis stabilization, and high ISO setting (409,600). The action camera was a GoPro Hero 5 High-Resolution Camera. The camera was equipped with a 12 Megapixel still camera and a fisheye lens. The phone camera was a Samsung Galaxy S8 with a 12MP camera and a f/1.7 lens. Refer to Image 6 for a view of the Sony Alpha A7R II and Image 7 for a view of the GoPro Hero 5.



Image 6: View of Sony Alpha A7R II.



Image 7: View of GoPro Hero 5.



2.2 Mission Scope

A mapping mission using the Albris was identified for this bridge to explore the potential of UAS photography to map concrete substructure defects. The target goal of the mission was to gather information in the form of photographs in a quick, efficient process which could later be used to map the substructure and have a post-inspection tool to aid in repair plans, quantity estimation and historical documentation. Additionally, the mission was carried out to explore the effect of operating in a GPS deprived environment which was low light and had a deck overhead. The Imaging of a single reinforced concrete pile bent (Pier 40) was selected for imaging. The Albris was flown using interactive flight encircling the pier at an elevation of approximately 10 feet above ground level. A total of 142 images were taken.

A total of 4 additional mapping missions using terrestrial cameras was identified for this bridge to explore the potential of terrestrial photography to map concrete substructure defects. The target goal of the mission was to explore the difference in quality between UASs and terrestrial photography and determine the difference between quality of different grade of terrestrial cameras. The imaging of two reinforced concrete pile bent (Pier 37 and 40) was selected for imaging. The low-light Sony Alpha A7R II was used on both piers. A total of 120 and 91 images were taken encircling Piers 37 and 40, respectively. The GoPro was used to image Pier 40 only. The GoPro camera was used to video the pier in a circular motion. Images were then pulled from the video at a constant interval. A total of 459 images were taken from the video. The phone camera was used to photograph Pier 40 in a circular at constant intervals. The phone camera captured 210 images.

A high definition video mission was conducted of limited access areas using the Elios UAS. The target goal of this mission was to determine the quality and applicability of using a Collision-Tolerant UAS to capture images and assess the condition of bridge pier cap topside, end diaphragms and bearing elements which are typically difficult and costly to access and not easily viewed during the scope of a routine inspection. The site also tested the UASs quality of flight in open-air environments. The mission consisted of two interactive flights using only pilot controls. The use of the Elios UAS focuses on these hard to access locations. An inspector can then review the video footage to look for defects or findings. Refer to Image 13 and 14 for a view of different hard to access location.

UAS INSPECTION REPORT

Bridge Number 27831 • I 394 over Dunwoody Blvd.
Minneapolis, MN • November 2017



A substructure condition survey and defect mapping using NDT methods was carried out using hammer sounding and visual techniques prior to the mapping missions. The condition survey was part of a project with MnDOT to inspect and provide repair plans for bridge rehabilitation.

2.3 Deliverables

A 3D Model with a High-Resolution Photograph Log was processed for each of the 5 missions (1 using UAS and 4 using terrestrial photography). The target goal for this process was to determine the ease of use and applicability of having a 3D photolog to assist a designer during repair plan development and construction modeling. Additionally, the difference in quality, ease of processing, and data management was explored for the different types of data acquisition. All photographs taken during the Mapping Missions were processed in the Pix4D software. The software processes all photographs to form a 3D point cloud for digital viewing. The point cloud was then processed by the same software to generate a 3D mesh of the bridge. Refer to Images 8 through 15 for images and image detail from the 4 different data collection tools.

UAS INSPECTION REPORT

Bridge Number 27831 • I 394 over Dunwoody Blvd.
Minneapolis, MN • November 2017



Image 8: View of the Image from the Albris UAS.



Image 9: View of the Image Quality from the Albris UAS.

UAS INSPECTION REPORT

Bridge Number 27831 • I 394 over Dunwoody Blvd.
Minneapolis, MN • November 2017



Image 10: View of the Image from the Sony Alpha A7R II.



Image 11: View of the Image Quality from the Sony Alpha A7R II.

UAS INSPECTION REPORT

Bridge Number 27831 • I 394 over Dunwoody Blvd.
Minneapolis, MN • November 2017



Image 12: View of the Image of the GoPro Hero 5 Video.



Image 13: View of the Image Quality of the GoPro Hero 5 Video.

UAS INSPECTION REPORT

Bridge Number 27831 • I 394 over Dunwoody Blvd.
Minneapolis, MN • November 2017



Image 14: View of the Image from the Samsung Galaxy S8 Phone Camera.



Image 15: View of the Image Quality of the Samsung Galaxy S8 Phone Camera.

UAS INSPECTION REPORT

Bridge Number 27831 • I 394 over Dunwoody Blvd.
Minneapolis, MN • November 2017



An inspector was able to use the Pix4D program to navigate the 3D model and select areas of interest. The software provides the inspector with all still images containing the selected area of interest which can then be viewed in high resolution. Additionally, the inspector can place annotations or measurements areas in the model for design plans, further detailed inspection or construction documents. Refer to Image 17 for a view of the Inspector Tool providing a Photograph Log from a selected area of the 3D model.



Image 16: View of the Sony Alpha A7R II 3D Model with Annotations. [\(Click Image to Access 3D Model\)](#)

UAS INSPECTION REPORT

Bridge Number 27831 • I 394 over Dunwoody Blvd.
Minneapolis, MN • November 2017

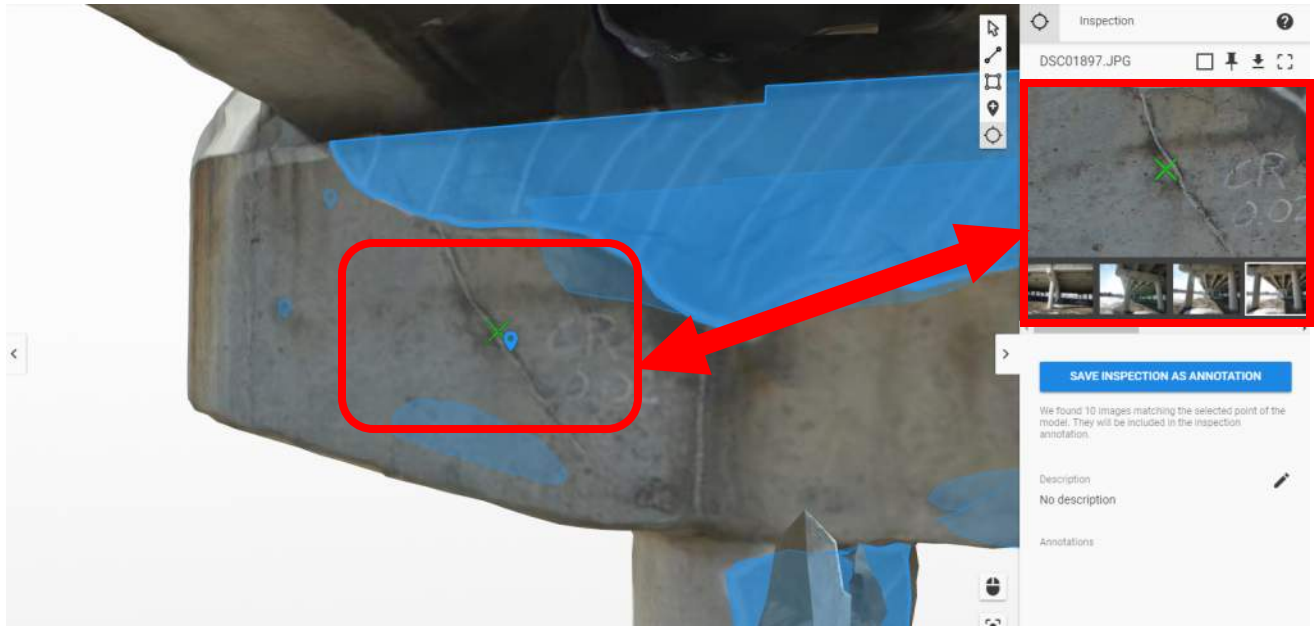

Image 17: View of a Crack Viewed from the Inspector Tool from the Sony Alpha A7R II 3D Model.

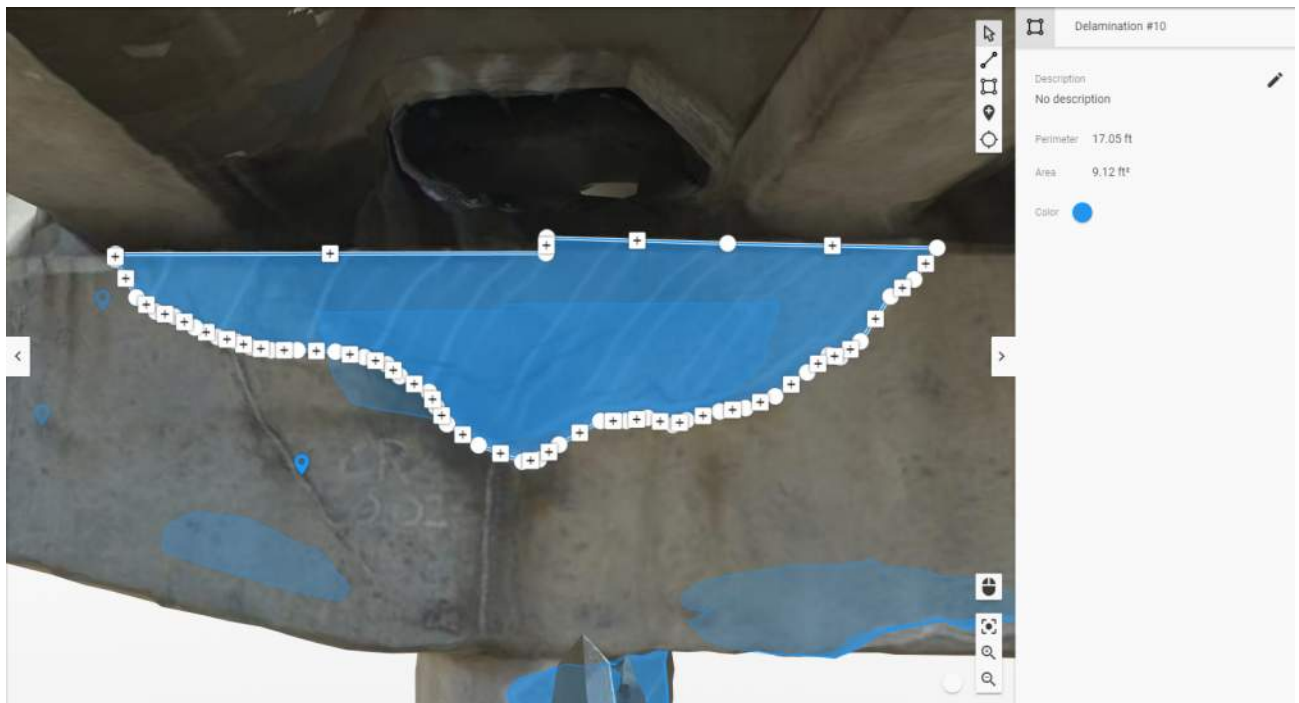

Image 18: View of a Spall Measurement and Annotation from the Sony Alpha A7R II 3D Model. Note Spall Area and Perimeter are Provided.

UAS INSPECTION REPORT

Bridge Number 27831 • I 394 over Dunwoody Blvd.
Minneapolis, MN • November 2017



Image 19: View of the 3D Model Created from the GoPro Images. [\(Click Image to access Model\)](#)

Video from the High Definition Video Mission using the Elios was viewed by an inspector after returning from the flight mission. The video could be observed in any software capable of playing .MP4 files. Additionally, the manufacturer of Elios, Flyability, has created an inspection software where the UASs flight log can be opened with the video file to show inspector UAS attributes such as heading, altitude, and temperature. The inspector can then maneuver their way through the video to obtain still images of defects or notable findings. General areas of deterioration, specific types of deterioration, and extent could all be observed through the video. These results could be used in conjunction with the topside survey to determine overall deck condition.

UAS INSPECTION REPORT

Bridge Number 27831 • I 394 over Dunwoody Blvd.

Minneapolis, MN • November 2017

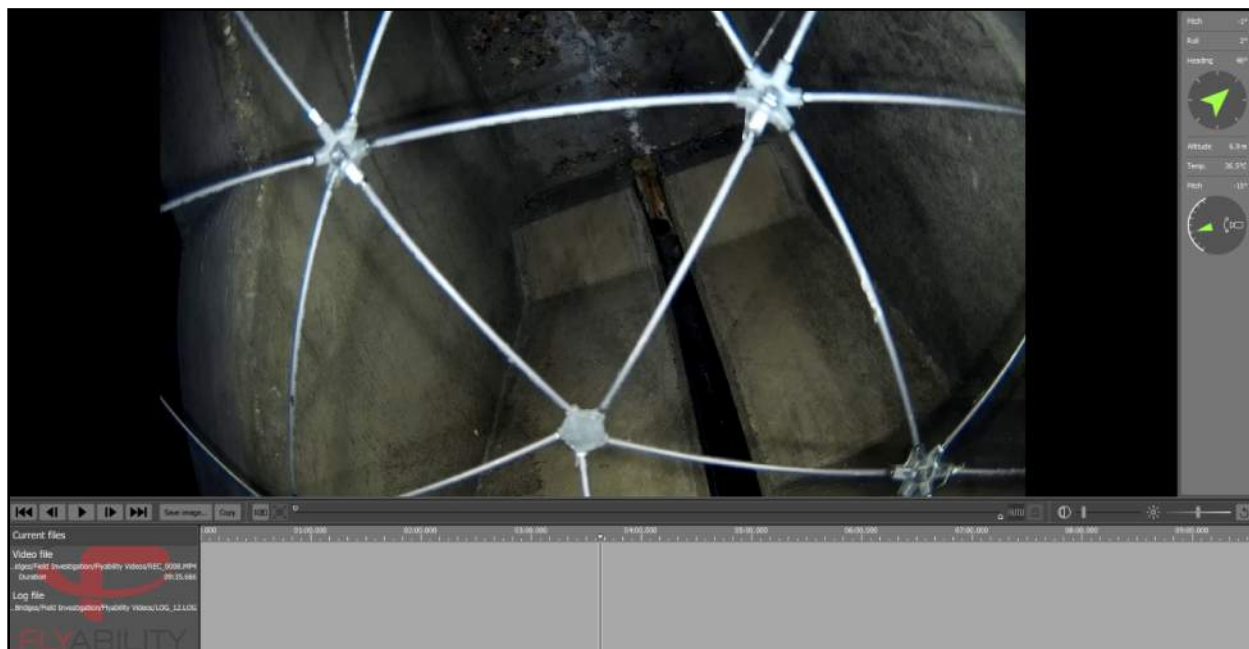

Image 20: View of a Screenshot from the Flyability Inspector Program. [\(Click Image to access Video\)](#)

3.0 SUMMARY OF FINDINGS

3.1 Opportunities

The execution of the Mapping and Photogrammetry Mission was a success and provided great insight into the potential for UAS as a tool during routine inspections. The set-up, flight, and data generation went as planned and was substantial enough to create the planned deliverables. The deliverables demonstrate that significant improvements can be made in inspection documentation utilizing photogrammetry techniques. Defect measurement is more accurate and easier to share with the bridge owner.

The Elios collision tolerant drone performed well and demonstrated a cost effective and efficient way to inspect bearings and top of pier cap which are inaccessible during a routine inspection because of the high cost of access equipment.

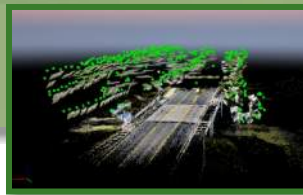

UAS INSPECTION REPORT

BRIDGE NUMBER: 19538

HERITAGE DR.

OVER THE N. BR. SOUTH CREEK

LAKEVILLE, MINNESOTA

August 24, 2017

Prepared for:



Prepared by:

**COLLINS
ENGINEERS** INC.

1599 Selby Avenue
St. Paul, MN 55104

651.646.8502 • www.collinsengr.com

UAS INSPECTION REPORT

Bridge Number 19538 • Heritage Dr. over the N. Br. South Creek
Lakeville, MN • August 2017



Table of Contents

1.0	INTRODUCTION	
1.1	Purpose and Scope	1
1.2	General Description of the Structure.....	Error! Bookmark not defined.
2.0	UAS OPERATION	
2.1	UAS Equipment and Operating Conditions	3
2.2	Mission Scope	4
2.3	Deliverables.....	7
3.0	SUMMARY OF FINDINGS	
3.1	Opportunities	10
3.2	Limitations.....	10
3.3	Evaluation of Potential Cost Savings	11

Table of Images

Image 1: Location Map	1
Image 2: Overall View of Bridge Topside.	2
Image 3: Overall View of Bridge Underside.	2
Image 4: View of SenseFly Albris.	3
Image 5: View of Flyability Elios.	3
Image 6: View of Mission Flight Map (Preplanned and Interactive).	4
Image 7: View of Camera Position at Locations of Photographing.	5
Image 8: View of Elios Inspecting a Hard to Reach Bearing.	6
Image 9: View of Elios Inspecting a Hard to Reach Face of a Concrete Beam.	6
Image 10: Image Clipped from Elios Inspection Video.	6
Image 11: View of Inspector Tool Within Pix4d.	7
Image 12: View of the Level of Detail in a Single High-Resolution Photograph.	8
Image 13: View of the Overall Orthomosaic Image.	9
Image 14: View of Level of Detail of the Orthomosaic Image.	10

UAS INSPECTION REPORT

Bridge Number 19538 • Heritage Dr. over the N. Br. South Creek
Lakeville, MN • August 2017



EXECUTIVE SUMMARY

- Project:** Routine Inspection of Bridge Number 19538.
- Purpose of Project:** To perform a routine inspection utilizing unmanned aircraft system (UAS) techniques to determine the structural and physical condition of difficult to access bridge elements. The inspection was integrated with the routine visual, tactile, and non-destructive testing inspection.
- Inspection Team:** Team Leader – Barritt Lovelace, P.E. (Pilot)
Team Member – Cory Stuber, P.E. (Crew Hand)
- Inspection Date(s):** August 24, 2017

Data Collection Tools:

- SenseFly Albris Flyability Elios Other: Digital Camera

Summary of Mission Scope(s) and Deliverable(s):

- Aerial Mapping & Photogrammetry 3D Model & High Resolution Photograph Log High Definition Video for Limited Access Areas
- Orthomosaic Image Creation for Inspection Defect Measurement Construction/Repair Plan Documentation
- Thermal Imaging Other: _____

Summary of Findings, Opportunities, and Limitations:

This routine inspection is typical of many bridge inspections. The bridge is in good condition, relatively small but has areas of the bridge that are difficult to access without expensive access techniques. The bearings and areas between the beams are difficult to view but the cost of access equipment is prohibitive for a low risk bridge such as this. Utilizing drones allows close up views of bearings, bridge seats and bottom of deck areas. Drone use also allowed the inspectors to create a 3D model of the bridge and orthomosaic image of the entire bridge deck and an orthomosaic map of the bridge area.

UAS INSPECTION REPORT

Bridge Number 19538 • Heritage Dr. over the N. Br. South Creek
Lakeville, MN • August 2017



1.0 INTRODUCTION

1.1 Purpose and Scope

This report consists of the results of an Unmanned Aircraft System (UAS) inspection of Bridge Number 19538, Heritage Dr. over the North Branch of the South Creek located in Lakeville, Minnesota. Refer to Image 1 for a location map. Collins Engineers, Inc. (Collins) conducted the UAS Inspection for the Minnesota Department of Transportation (MnDOT) on August 24th, 2017 as part of a research project titled “Improving Quality of Bridge Inspections Using Unmanned Aircraft Systems (UAS) Project Phase III”. The inspection was also part of the routine inspection for the City of Lakeville. The primary purpose of the UAS usage during the inspection was to identify possible opportunities and limitations of UAS involvement in various capacity of bridge inspection. The following report includes a brief description of the structure, description of UAS equipment and operating conditions, the mission scope and deliverables, a summary of findings, opportunities, limitations, and an evaluation of costs.

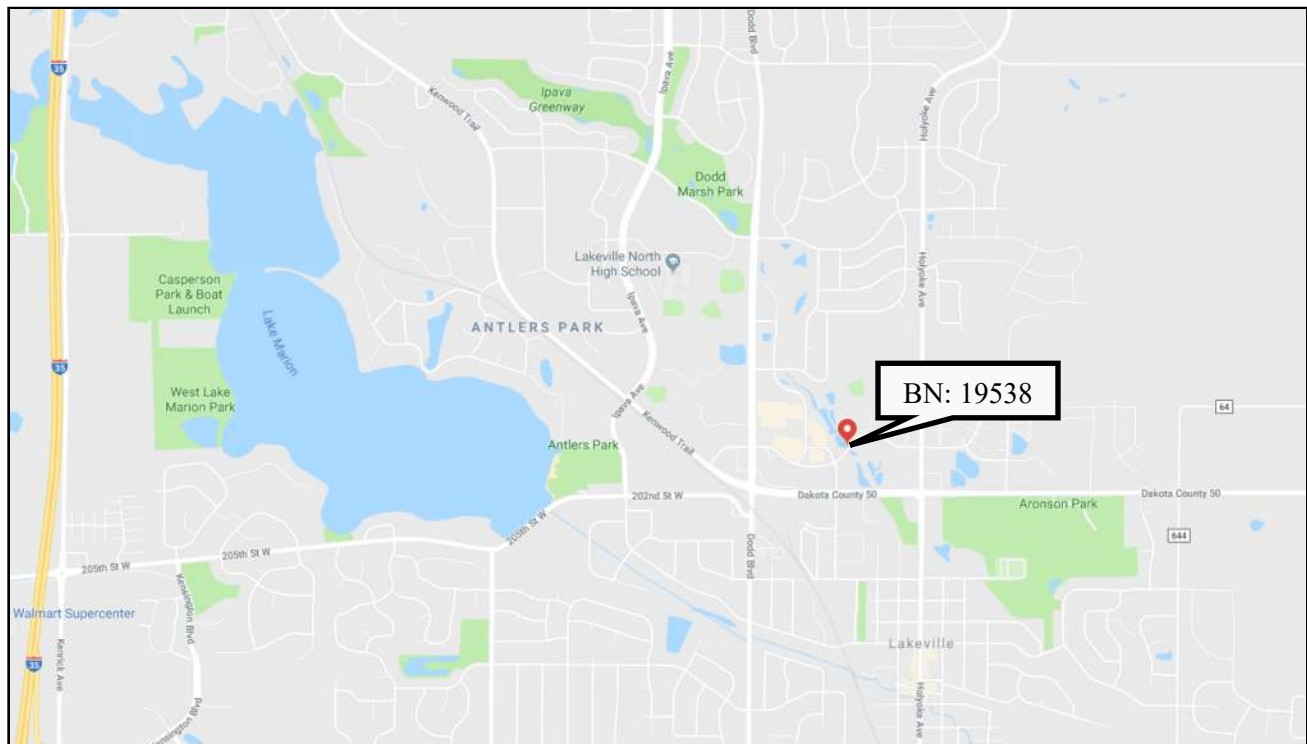

Image 1: Location Map

UAS INSPECTION REPORT

Bridge Number 19538 • Heritage Dr. over the N. Br. South Creek
Lakeville, MN • August 2017



1.2 General Description of the Structure

Bridge Number 19538 spans approximately 45.0 feet over the North Branch of the South Creek and carries one east bound and one west bound lane of Heritage Drive. The bridge deck is approximately 62.5 feet wide and consists of cast in place concrete with epoxy coated reinforcing steel. The bridge superstructure consists of six precast prestressed concrete beams bearing on steel and elastomeric bearings. The bridge substructure consists of a concrete abutment and footing bearing on piles. The longitudinal axis of the bridge is orientated approximately northeast to southwest. Refer to Images 2 and 3 for overall views of the bridge.



Image 2: Overall View of Bridge Topside.



Image 3: Overall View of Bridge Underside.

2.0 UAS OPERATION

2.1 UAS Equipment and Operating Conditions

A two-person crew, consisting of a professional engineer-pilot and a field engineer, conducted the UAS inspection. The pilot was certified as a FAA Remote Pilot. The inspection was conducted using two different registered UAS's; an Inspection and Mapping UAS and an Collision-Tolerant UAS. The aerial mapping UAS was a SenseFly Albris quadcopter equipped with a TripleView head consisting of a HD video camera, a 38MP still camera, and an infrared camera. Additionally, the Albris contains five acoustic sensors, GPS location, and navigation camera technology which aid both 3D preplanned and interactive flight missions. The Collision-Tolerant UAS was a Flyability Elios quadcopter equipped with a full HD camera, Infrared camera, and on-board lighting system. Additionally, the Elios has a protective frame surrounding the UAS body allowing for access to tight locations and up-close imaging. Refer to Image 4 for a view of the SenseFly Albris and Image 5 for a view of the Flyability Elios.



Image 4: View of SenseFly Albris.



Image 5: View of Flyability Elios.

During the inspection, the pilot worked using a mobile work station suspended from their body and the other crew member maintained line-of-sight with the UAS. Aerial targets and a scale were placed prior to the aerial mapping mission to provide a higher level of accuracy. At the time of flight, the weather was clear with low wind.

UAS INSPECTION REPORT

Bridge Number 19538 • Heritage Dr. over the N. Br. South Creek
Lakeville, MN • August 2017



2.2 Mission Scope

A Mapping & Photogrammetry mission using the Albris was identified for this bridge to explore the potential of UAS inspection of simple, relatively small, routine inspections. The target goal of the mission was to gather information in the form of photographs in a quick, efficient process which could be streamlined to aid inspectors in routine inspections. The mission consisted of a pre-planned flight path at an elevation of approximately 180 feet above ground level (AGL). The UAS collected over 450 high-resolution still images of the bridge facia and top side. Images of the underside of the bridge was also acquired with a handheld digital camera. All images were geo-tagged with GPS coordinates. Refer to Images 6 and 7 for views of the Flight and Mapping Mission.

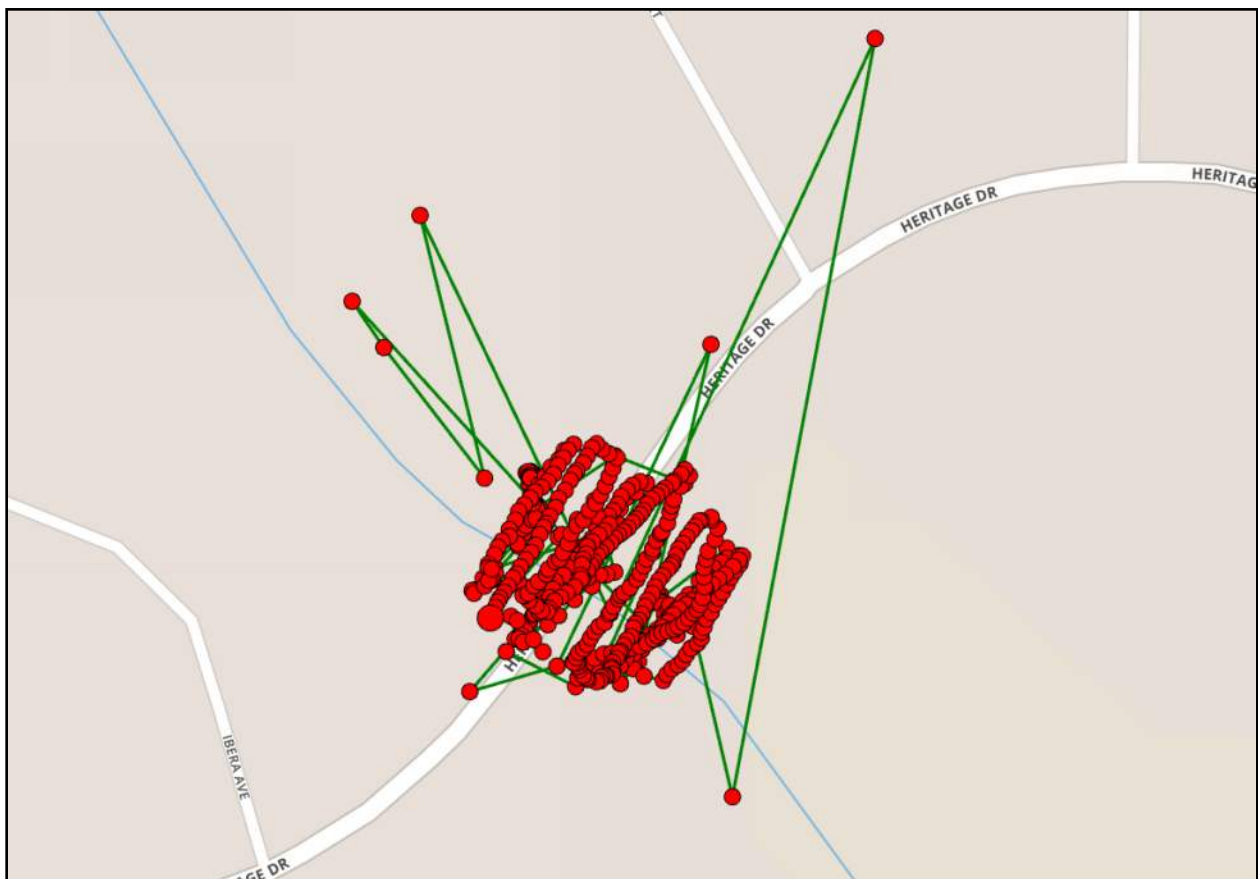

Image 6: View of Mission Flight Map (Preplanned and Interactive).

UAS INSPECTION REPORT

Bridge Number 19538 • Heritage Dr. over the N. Br. South Creek
Lakeville, MN • August 2017

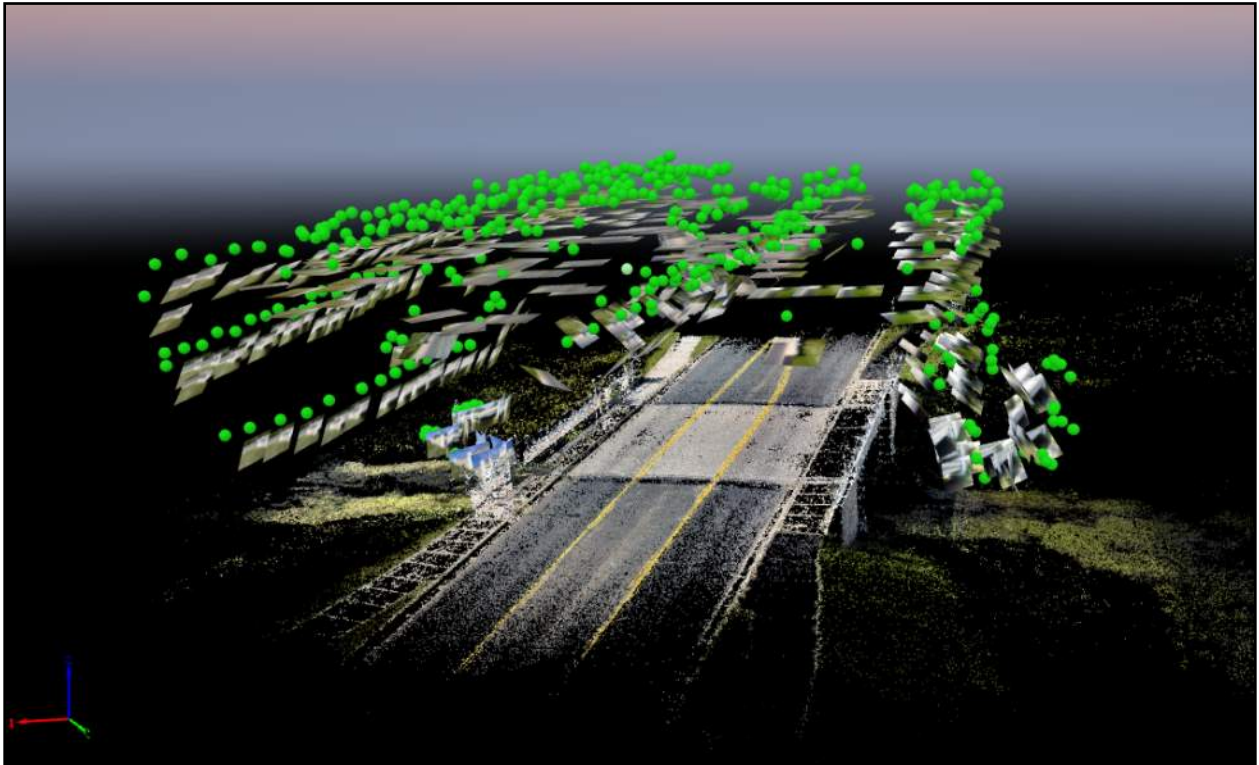

Image 7: View of Camera Position (Green Dot) at Locations of Photographing.

A High Definition Video Mission was conducted of limited access areas using the Elios UAS. The target goal of this mission was to determine the quality and applicability of using a Collision-Tolerant UAS to capture images and assess the condition of bridge elements which are typically not easily visually or tactically accessible during the scope of a routine inspection. The mission consisted of an interactive flight using only manual pilot controls. During a typical routine inspection, the deck soffit, beam faces, and bearings would have been difficult to access. The use of the Elios UAS focuses on these hard or impossible to access locations. An inspector can then review the video footage to look for defects or findings. Refer to Images 8 and 9 for views of the Elios UAS in a difficult to access locations.

UAS INSPECTION REPORT

Bridge Number 19538 • Heritage Dr. over the N. Br. South Creek
Lakeville, MN • August 2017



Image 8: View of Elios Inspecting a Hard to Reach Bearing.



Image 9: View of Elios Inspecting a Hard to Reach Face of a Concrete Beam.



Image 10: Image Clipped from Elios Inspection Video ([Click Image to play video](#)).

A routine inspection of the bridge by the Inspection crew was also carried out. The target goal of this activity was to ascertain the quality and efficiency improvements versus traditional methods with the addition of a UAS. The inspectors documented defects or notable findings which could then be reviewed in detail using the data that the UAS's captured. Additionally, the inspectors took photographs of areas of the bridge that the Mapping and Photogrammetry Mission may have not been able to access. The goal of this was to combine terrestrial photographs with aerial photographs to create a more comprehensive data set.

2.3 Deliverables

A 3D Model with a High-Resolution Photograph Log was processed for bridge. The target goal for this process was to determine the ease of use and applicability of having a 3D photolog to assist an inspector during post-processing, report writing, and future inspection. All photographs taken during the Mapping and Photogrammetry Mission were processed in the Pix4D software. The software processes all photographs to form a 3D point cloud for digital viewing. The point cloud was then processed by the same software to generate a 3D mesh of the bridge. An inspector was then able to navigate the 3D model and select areas of interest. The software provides the inspector with all still images containing the selected area of interest which can then be viewed in high resolution. Additionally, the inspector can place annotations within the file for future reference or for clarification when communicating inspection results. Refer to Image 11 for a view of the Inspector Tool providing a Photograph Log from a selected area of the 3D model.

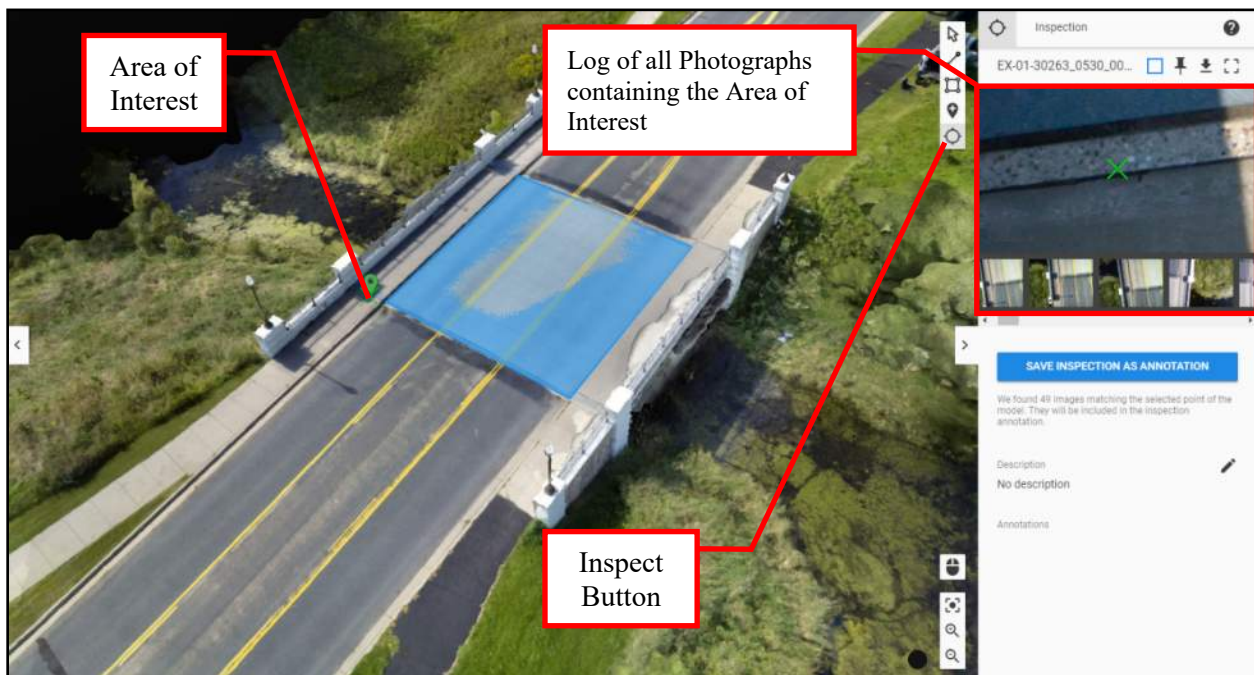

Image 11: View of the Inspector Tool providing a Photograph Log from a selected area of the 3D model. Note the annotated areas for future reference or ease of sharing.

(Click Image to access 3D Model and Inspection Photolog – Click on the Inspect Button)

UAS INSPECTION REPORT

Bridge Number 19538 • Heritage Dr. over the N. Br. South Creek
Lakeville, MN • August 2017



Image 12: View of the Level of Detail in a Single High-Resolution Image.

A Orthomosaic image was created to use as an inspection tool and to document the condition of the bridge deck at the time of inspection. The target goal for this process was to produce an easily viewable, high resolution image of a large area that could be used by an inspector to carry out a detailed inspection, area measurements, condition assessment, or historical documentation. An Orthomosaic image is a single image file which is created from many individual images captured during the Mapping and Photogrammetry Mission. The final product is an image file that can be used to measure true distances. For this bridge, an Orthomosaic image was made of the concrete deck topside. An inspector then reviews a single file and can measure true distances and areas for a final product. Refer to Image 11 for a view of Orthomosaic Detail.

UAS INSPECTION REPORT

Bridge Number 19538 • Heritage Dr. over the N. Br. South Creek
Lakeville, MN • August 2017

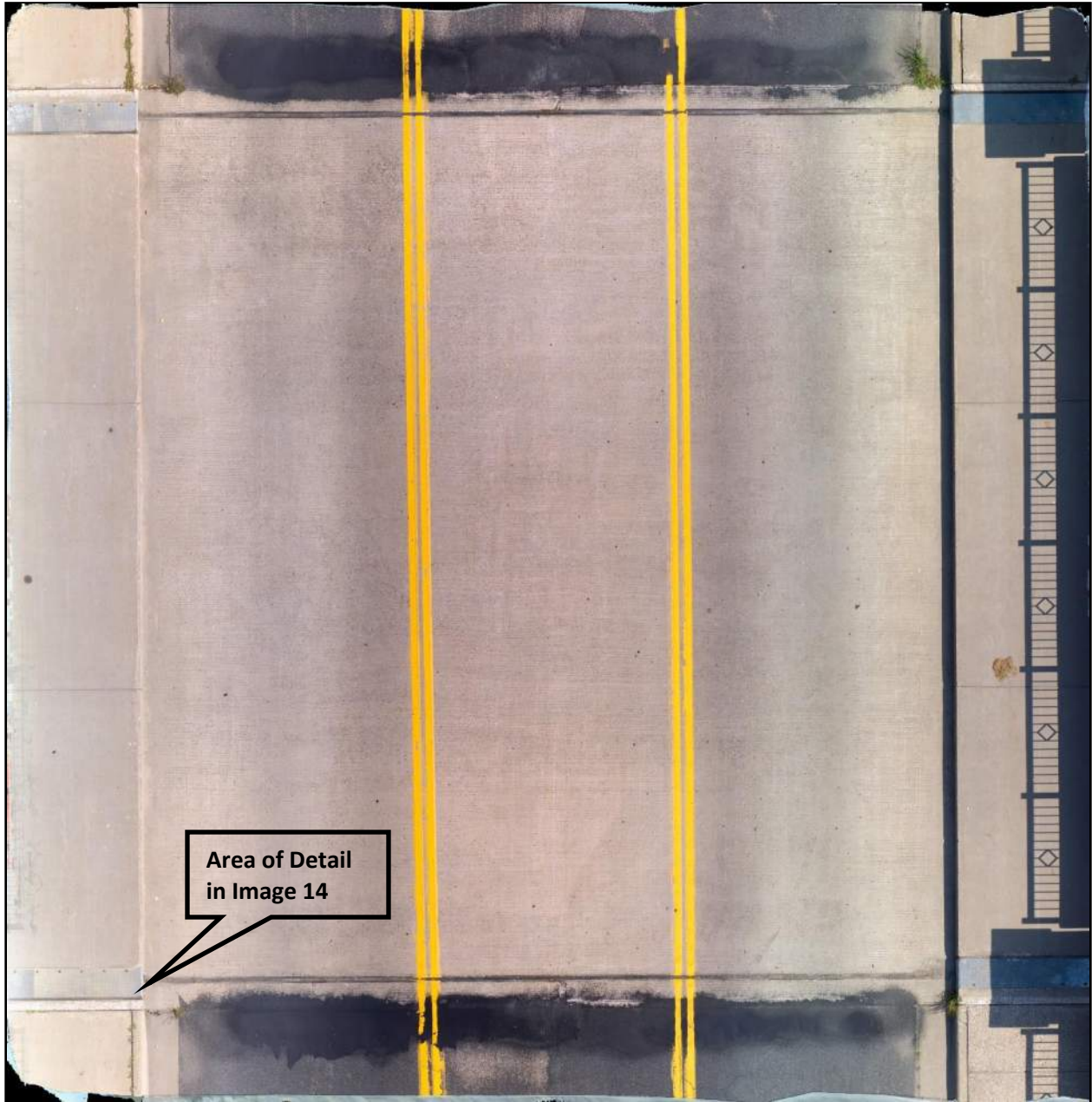

Image 13: View of the Overall Orthomosaic Image Created from Many High-Resolution Images.
[\(Click Image to access Orthomosaic Image to Explore Image Quality\)](#)



Image 14: View of level of Detail of the Orthomosaic Image.

3.0 SUMMARY OF FINDINGS

3.1 Opportunities

The execution of the Mapping and Photogrammetry Mission was a success and provided great insight into the potential for UAS as a tool during routine inspections. The set-up, flight, and data generation went as planned and was substantial enough to create the planned deliverables.

3.2 Limitations

The terrestrial images taken below deck were not adequate to completely model the bottom of deck. Future inspections will include an increased number and a more orderly pattern of images so the processing software can create a complete 3D model of the bridge.

UAS INSPECTION REPORT

Bridge Number 19538 • Heritage Dr. over the N. Br. South Creek
Lakeville, MN • August 2017



3.3 Evaluation of Potential Cost Savings

A cost analysis was performed that shows there was an increase in cost to utilize a drone during the inspection. This bridge is a very routine typical bridge inspection that typically would not employ any specialized access equipment. For bridge 19538 the utilization of drones allows for a more thorough inspection by getting close up views of the bearings and areas between beams that is normally accomplished by viewing from the ground. An approximate \$800 increase in inspection cost also provides much better inspection deliverables including a 3D model of the bridge, orthomosaic deck survey, orthomosaic site map and close up digital imagery of the bridge bearings.

Bridge 19538								
Expense Description	Traditional Inspection Cost				UAS Assisted Inspection Cost			
	Quantity	Unit	Unit Price	Cost	Quantity	Unit	Unit Price	Cost
Bridge Inspection Team Leader	4	Hour	\$150.00	\$600	4	Hour	\$150.00	\$600
Assistant Bridge Inspector	4	Hour	\$120.00	\$480	4	Hour	\$120.00	\$480
Under Bridge Inspection Vehicle with Operator	0	Day	\$3,000.00	\$0	0	Day	\$3,000.00	\$0
Drone Rental	0	Day	\$300.00	\$0	1	Day	\$300.00	\$300
UAS Post Processing Engineer	0	Hour	\$120.00	\$0	4	Hour	\$120.00	\$480
Low Speed Lane Closure	0	Each	\$2,000.00	\$0	0	Each	\$2,000.00	\$0
Mobile Lane Closure	0	Each	\$1,500.00	\$0	0	Each	\$1,500.00	\$0
High Speed Lane Closure	0	Each	\$2,500.00	\$0	0	Each	\$2,500.00	\$0
Misc Traffic Control (Ped Only Etc)	0	Each	\$500.00	\$0	0	Each	\$500.00	\$0
				Traditional Inspection Cost				\$1,080
								UAS Assisted Inspection Cost
								\$1,860



UAS INSPECTION REPORT

BRIDGE NUMBER: 2440

Trunk Highway 65 (3RD AVE S)

OVER MISSISSIPPI RIVER, CITY ST.

MINNEAPOLIS, MINNESOTA

August 9, 2017

Prepared for:



*As part of MnDOT Research Project
A-58 Improving Quality of Bridge Inspections Using Unmanned Aircraft Systems
(UAS) Phase III*

Prepared by:

**COLLINS
ENGINEERS** INC.

1599 Selby Avenue
St. Paul, MN 55104

651.646.8502 • www.collinsengr.com

UAS INSPECTION REPORT

Bridge Number 2440 • Trunk Highway 65 over Mississippi River, City St.
Minneapolis, MN August 2017



Table of Contents

1.0	INTRODUCTION	
1.1	Purpose and Scope	1
1.2	General Description of the Structure	2
2.0	UAS OPERATION	
2.1	UAS Equipment and Operating Conditions	3
2.2	Mission Scope	3
2.3	Deliverables.....	4
3.0	SUMMARY OF FINDINGS	
3.1	Opportunities	6
3.2	Limitations.....	6
3.3	Evaluation of Potential Cost Savings	6

Table of Images

Image 1: Location Map	1
Image 2: Overall View of Bridge Topside.	2
Image 3: Overall View of Bridge Pier.	2
Image 4: View of GoPro Hero 5	3
Image 5: View of 3D Model	4
Image 6: View of Pier 7	5
Image 7: View of Inspector Tool Within Pix4d	5

UAS INSPECTION REPORT

Bridge Number 2440 • Trunk Highway 65 over Mississippi River, City St.
Minneapolis, MN August 2017



EXECUTIVE SUMMARY

- Project:** Routine Inspection of Bridge Piers Using UAS for Bridge Number 2440.
- Purpose of Project:** To perform a partial routine inspection using photogrammetry techniques to determine the structural and physical condition of select, difficult to access bridge elements. The inspection is supplemental to a routine visual, tactile, and non-destructive testing inspection.
- Inspection Team:** Team Leader – Barritt Lovelace, P.E. (Pilot)
Team Member – Cory Stuber, P.E. (Crew Hand)
- Inspection Date(s):** August 9, 2017

Data Collection Tools:

- SenseFly Albris Flyability Elios Other: GoPro

Summary of Mission Scope(s) and Deliverable(s):

- Aerial Mapping & Photogrammetry 3D Model & High Resolution Photograph Log High-Definition Video for Limited Access Areas
- Orthomosaic Image Creation for Inspection Defect Measurement Construction/Repair Plan Documentation
- Thermal Imaging Other: _____

Summary of Findings, Opportunities, and Limitations:

Inspecting a bridge component with severe deterioration is a challenging task. The challenge arises while trying to document deficiencies that are widespread and are of varying form and dimension. Our scope of work was to inspect the bridge piers from the spring line of the arch to the waterline. Each pier was documented with high resolution photographs and those were processed into models. These models improved both the quality of the inspection deliverable but also reduced cost by saving inspection time in the field. While the result was not directly from the use of UAS we used the same principles showing that similar benefits can be achieved with terrestrial cameras. A rendering of Pier 6 can be found here: [Video](#)

UAS INSPECTION REPORT

Bridge Number 2440 • Trunk Highway 65 over Mississippi River, City St.
Minneapolis, MN August 2017



1.0 INTRODUCTION

1.1 Purpose and Scope

This report consists of the results of a photogrammetry mission of Bridge Number 2440, Trunk Highway 65 over the Mississippi River located in Minneapolis, Minnesota. Refer to Image 1 for a location map. Collins Engineers, Inc. (Collins) conducted the Inspection for the Minnesota Department of Transportation (MnDOT) on August 9, 2017 as part of a research project titled “Improving Quality of Bridge Inspections Using Unmanned Aircraft Systems (UAS) Project Phase III”. The primary purpose of the inspection was to identify possible opportunities and limitations of photogrammetry in support of bridge inspection. The following report includes a brief description of the structure, description of equipment and operating conditions, the mission scope and deliverables, a summary of findings, opportunities, and limitations, and an evaluation of potential cost savings.



Image 1: Location Map

UAS INSPECTION REPORT

Bridge Number 2440 • Trunk Highway 65 over Mississippi River, City St.
Minneapolis, MN August 2017



1.2 General Description of the Structure

Bridge Number 2440 spans approximately 1,887 feet over the Mississippi River and carries two north bound and two south bound lanes of Trunk Highway 65 (3rd Ave). The bridge deck is approximately 81.6 feet wide and consists of cast in place concrete with a low slump concrete wearing surface. The bridge superstructure consists of 11 concrete open spandrel arch spans. The bridge substructure consists of concrete abutment walls on steel piles and concrete piers founded on bedrock. The longitudinal axis of the bridge is orientated approximately northeast to southwest. Refer to Images 2 and 3 for overall views of the bridge.



Image 2: Overall View of Bridge Topside.



Image 3: Overall View of Bridge Pier.

2.0 UAS OPERATION

2.1 UAS Equipment and Operating Conditions

A two-person crew, consisting of a professional engineer and a field engineer, conducted the inspection. The inspection was conducted using GoPro Hero 5 High-Resolution Camera. The camera was equipped with a 12 Megapixel still camera and a fisheye lens. Refer to Image 4 for a view of the GoPro Hero 5.



Image 4: View of GoPro Hero 5.

During the inspection, the crew used the High-Resolution camera to methodically image the bridge piers by means of underwater dives, and snoopers inspection. At the time of inspection, the weather was clear with low wind.

2.2 Mission Scope

A Photogrammetry mission using the terrestrial camera was identified for this bridge to explore the potential of photogrammetry for a bridge inspections. The target goal of the mission was to gather information in the form of photographs in a quick, efficient process which could be streamlined to aid inspectors in inspection for rehabilitation. The mission consisted of a pre-planned path of photographs taken by the inspector a boat and while utilizing rope access using a point and shoot camera. The inspector collected high-resolution still images of the bridge piers. All images were geo-tagged with GPS coordinates.

2.3 Deliverables

A 3D Model with a high-resolution photo log was processed for bridge which can be seen in Image 5 below. The target goal for this process was to determine the ease of use and applicability of having a 3D photolog to assist an inspector during post-processing, report writing, and future inspection. All photographs taken during the Photogrammetry Mission were processed in the Pix4D software. The software processes all photographs to form a 3D point cloud for digital viewing. The point cloud was then processed by the same software to generate a 3D mesh of the bridge. Refer to Images 6 and 7 for a comparison between the real-life picture and the 3D model in Pix4D. An inspector was then able to navigate the 3D model and select areas of interest. The software provides the inspector with all still images containing the selected area of interest which can then be viewed in high-resolution. Additionally, the inspector can place annotations within the file for future reference or for clarification when sharing the file. Refer to Image 7 for a view of the Inspector Tool providing a Photograph Log from a selected area of the 3D model.



Image 5: View of the 3D Model of Pier 7 in Pix4D ([Click Image to access 3D Model and Inspection Photolog](#))

UAS INSPECTION REPORT

Bridge Number 2440 • Trunk Highway 65 over Mississippi River, City St.
Minneapolis, MN August 2017

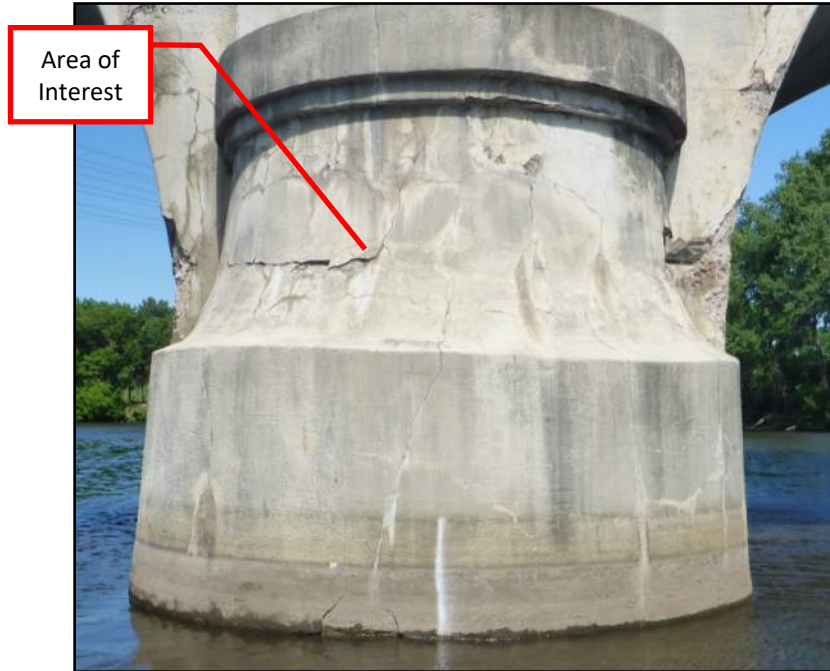

Image 6: View of Pier 7.

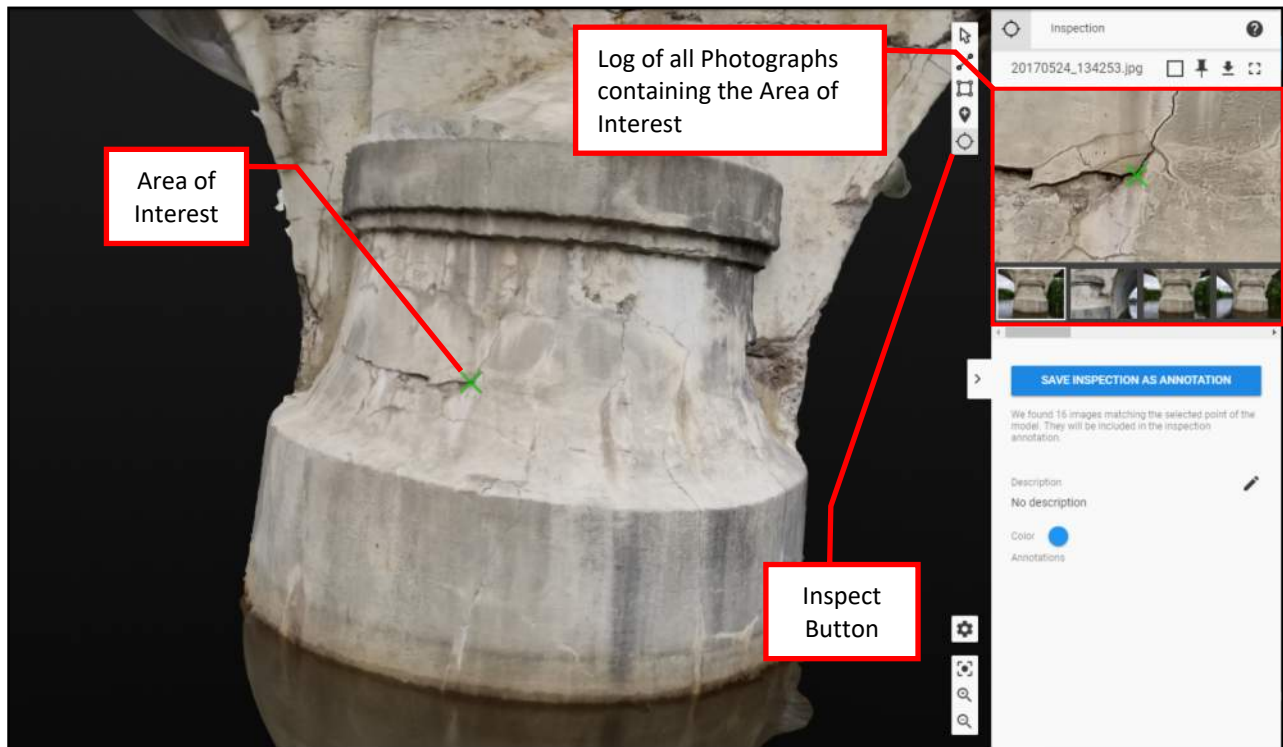

Image 7: View of the Inspector Tool providing a Photograph Log from a selected area of the 3D model.

[\(Click Image to access 3D Model and Inspection Photolog – Click on the Inspect Button\)](#)

UAS INSPECTION REPORT

Bridge Number 2440 • Trunk Highway 65 over Mississippi River, City St.
Minneapolis, MN August 2017



3.0 SUMMARY OF FINDINGS

3.1 Opportunities

Inspecting a bridge component with severe deterioration is a challenging task. The challenge arises while trying to document deficiencies that are widespread and are of varying form and dimension. Our scope of work was to inspect the bridge piers from the spring line of the arch to the waterline. Each pier was documented with high resolution photographs and those were processed into models. These models improved both the quality of the inspection deliverable but also reduced cost by saving inspection time in the field. While the result was not directly from the use of UAS we used the same principles showing that similar benefits can be achieved with terrestrial cameras.

3.2 Limitations

The bridge is near St. Anthony Falls which is a difficult area to access. Most piers could be access with a bot but piers 3 and 4 utilized rope access. It can be difficult to get enough photos to build a good model with rope access alone on these piers.

3.3 Evaluation of Potential Cost Savings

These models improved both the quality of the inspection deliverable but also reduced cost by saving inspection time in the field. The following evaluation is for one pier but can be extrapolate to all the piers.

Bridge 2440 - Based on Two Spans Only								
Expense Description	Traditional Inspection Cost				Photogrammetry Inspection Cost			
	Quantity	Unit	Unit Price	Cost	Quantity	Unit	Unit Price	Cost
Bridge Inspection Team Leader	8	Hour	150	\$1,200	4	Hour	\$150	\$600
Assistant Bridge Inspector	8	Hour	120	\$960	4	Hour	\$120	\$480
Under Bridge Inspection Vehicle with Operator	0	Day	3,000	\$0	0	Day	\$3,000	\$0
Drone Rental	0	Day	300	\$0	0	Day	\$300	\$0
UAS Post Processing Engineer	0	Hour	120	\$0	2	Hour	\$120	\$240
Misc Traffic Control (Ped Only Etc)	0	Each	500	\$0	0	Each	\$500	\$0
Mobile Lane/Shoulder Closure	0	Each	1,500	\$0	0	Each	\$1,500	\$0
High Speed Lane/Shoulder Closure	0	Each	2,500	\$0	0	Each	\$2,500	\$0
			Traditional Inspection Cost	\$2,160			UAS Assisted Inspection Cost	\$1,320



UAS INSPECTION REPORT

BRIDGE NUMBER: 4175

PEDESTRIAN BRIDGE

OVER THE MINNESOTA RIVER

SHAKOPEE, MINNESOTA

August 2, 2017

Prepared for:



*As part of MnDOT Research Project
A:67 Improving Quality of Bridge Inspections Using Unmanned Aircraft Systems
(UAS) Phase III*

Prepared by:

COLLINS
ENGINEERS INC.

1599 Selby Avenue
St. Paul, MN 55104

651.646.8502 • www.collinsengr.com



Table of Contents

1.0	INTRODUCTION	
1.1	Purpose and Scope	1
1.2	General Description of the Structure	2
2.0	UAS OPERATION	
2.1	UAS Equipment and Operating Conditions	3
2.2	Mission Scope	4
2.3	Deliverables.....	6
3.0	SUMMARY OF FINDINGS	
3.1	Opportunities	11
3.2	Limitations.....	12
3.3	Evaluation of Potential Cost Savings	12

Table of Images

Image 1: Location Map	1
Image 2: Overall View of the Bridge fascia.	2
Image 3: Overall View of Bridge Topside.	2
Image 4: View of SenseFly Albris.	3
Image 5: View of Flyability Elios.	3
Image 6: View of Mission Flight Map	5
Image 7: View of Mission Control Desktop View.	5
Image 8: Image Clipped from Elion Inspection Video.	6
Image 9: View of the Inspector Tool providing a Photograph Log from a selected area of the 3D model.	7
Image 10: View of the Orthomosaic Deck Image.	8
Image 11: View of the Orthomosaic Detail and Measuring Ability in the Pix4D software.	8
Image 12: View of the 3D Model of Gusset Plate.	9
Image 13: View of the Detail of the 3D Model of the Gusset Plate located at Point 1 in Image 9.	10
Image 14: View of snapshot of Albris Video of the Gusset Plate.	10
Image 15: View of a Still Image Taken from the Video Playback Showing a Crack in the Concrete.	11

UAS INSPECTION REPORT

Bridge Number 4175 • Pedestrian Bridge over the Minnesota River
Shakopee, MN • August 2017



EXECUTIVE SUMMARY

- Project:** Steel Truss, Concrete Soffit, Bearing and Gusset Plate Inspection Using UAS's of Bridge Number 4175.
- Purpose of Project:** To perform a partial inspection of select superstructure elements using unmanned aircraft system (UAS) techniques to determine the structural and physical condition of difficult to access bridge elements. The inspection is supplemental to a routine visual, tactile, and non-destructive testing inspection.
- Inspection Team:** Team Leader – Barritt Lovelace, P.E. (Pilot)
Team Member – Cory Stuber, P.E. (Crew Hand)
- Inspection Date(s):** August 2, 2017

Data Collection Tools:

- SenseFly Albris Flyability Elios Other: _____

Summary of Mission Scope(s) and Deliverable(s):

- Aerial Mapping & Photogrammetry 3D Model & High Resolution Photograph Log High Definition Video for Limited Access Areas
- Orthomosaic Image Creation for Inspection Defect Measurement Construction/Repair Plan Documentation
- Thermal Imaging Other: _____

Summary of Findings, Opportunities, and Limitations:

Bridge 4175 is a fracture critical bridge which requires a hand on inspection to meet NBIS guidelines. However, our team tested the confined space drone on the multibeam spans and used the Albris drone to map the deck and model a gusset plate. While drones will not replace a hands-on inspection this effort showed that drones can supplement the inspection effort and also provide better documentation of the inspection supplementing the hands on effort.

UAS INSPECTION REPORT

Bridge Number 4175 • Pedestrian Bridge over the Minnesota River
Shakopee, MN • August 2017



1.0 INTRODUCTION

1.1 Purpose and Scope

This report consists of the results of an unmanned aircraft (UAS) inspection of Bridge Number 4175, Pedestrian bridge over Minnesota River and Levee Drive located in Shakopee, Minnesota. Refer to Image 1 for a location map. Collins Engineers, Inc. (Collins) conducted the UAS Inspection for the Minnesota Department of Transportation (MnDOT) on May 25, 2017 as part of a research project titled “Improving Quality of Bridge Inspections Using Unmanned Aircraft Systems (UAS) Phase III”. The primary purpose of the UAS usage during the inspection was to identify possible opportunities and limitations of UAS involvement in various capacity of bridge inspection. The following report includes a brief description of the structure, description of UAS equipment and operating conditions, the mission scope and deliverables, a summary of findings, opportunities, and limitations, and an evaluation of potential cost savings.

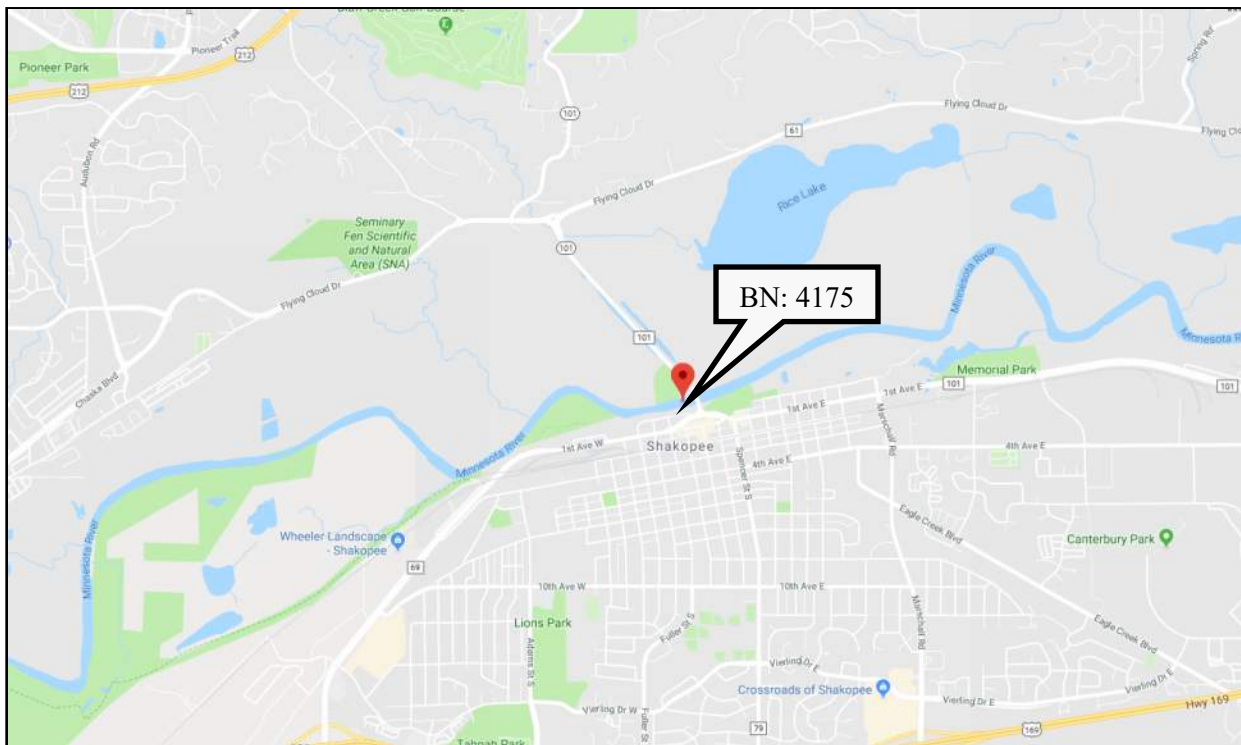

Image 1: Location Map

1.2 General Description of the Structure

Bridge Number 4175 spans approximately 635 feet over the Minnesota River and carries a Pedestrian Walkway. The bridge deck is approximately 42 feet wide and consists of cast in place concrete with no wearing surface. The bridge superstructure consists of 4 steel deck truss spans with steel floor beams and stringers and 4 cast-in-place concrete deck grid spans. The substructure consists of reinforced concrete abutments, pier walls and column bents all founded on piles. The longitudinal axis of the bridge is orientated approximately north to south. Refer to Images 2 and 3 for overall views of the bridge.



Image 2: Overall View of the Bridge fascia.



Image 3: Overall View of Bridge Topside.

2.0 UAS OPERATION

2.1 UAS Equipment and Operating Conditions

A two-person crew, consisting of a professional engineer-pilot and a field engineer, conducted the UAS inspection. The pilot was certified as a FAA Remote Pilot. The inspection was conducted using two different registered UAS's; an Inspection and Mapping UAS and an Collision-Tolerant UAS. The aerial mapping UAS was a SenseFly Albris quadcopter equipped with a TripleView head consisting of a HD video camera, a 38MP still camera, and an infrared camera. Additionally, the Albris contains five acoustic sensors, GPS location, and navigation camera technology which aids both 3D preplanned and interactive flight missions. The Collision-Tolerant UAS was a Flyability Elios quadcopter equipped with a full HD camera, Infrared camera, and on-board lighting system. Additionally, the Elios has a protective frame surrounding the UAS body allowing for access to tight locations and up-close imaging. Refer to Image 4 for a view of the SenseFly Albris and Image 5 for a view of the Flyability Elios.



Image 4: View of SenseFly Albris.



Image 5: View of Flyability Elios.

UAS INSPECTION REPORT

Bridge Number 4175 • Pedestrian Bridge over the Minnesota River
Shakopee, MN • August 2017



During the inspection, the pilot flew the drone and the other crew member maintained line-of-sight with the UAS. Aerial targets and a scale were placed prior to the aerial mapping mission to provide a higher level of accuracy. At the time of flight, the weather was clear with low wind. Prior to carrying out the inspection, it was determined that the bridge was located in Class D Airspace. The pilot/inspector submitted a request for FAA authorization through the FAA portal. Authorization was granted by the FAA and Scott County.

2.2 Mission Scope

A Mapping & Photogrammetry mission using the Albris was identified for this bridge to explore the potential of UAS photography to map concrete deck surface defects. The target goal of the mission was to gather information in the form of photographs in a quick, efficient process which could later be used to map the concrete deck and have a post-inspection tool to aid in report writing and historical documentation. The mission consisted of a pre-planned flight path. The UAS collected over 110 high-resolution still images of the bridge top side. All images were geo-tagged with GPS coordinates. Refer to Image 6 for a view of the Flight and Mapping Mission.

A separate Photogrammetry Mission was carried out using the Albris during the same flight time. The Mission was identified for this bridge to explore the ability to gather detailed photographs of a specific element located on the superstructure. A gusset plate at the bottom chord of the truss was selected as the element to be photographed. The intent of the mission was to gather photographs with enough detail and overlap to post process the images in the software into a 3D model which could be inspected, documented or repair plans created from the model. The mission was flown in interactive mode, meaning the pilot operated the UAS in real time with a remote control.

UAS INSPECTION REPORT

Bridge Number 4175 • Pedestrian Bridge over the Minnesota River
Shakopee, MN • August 2017



Image 6: View of Mission Flight Map (Both Mapping & Photogrammetry Mission and Gusset Plate Model Mission).

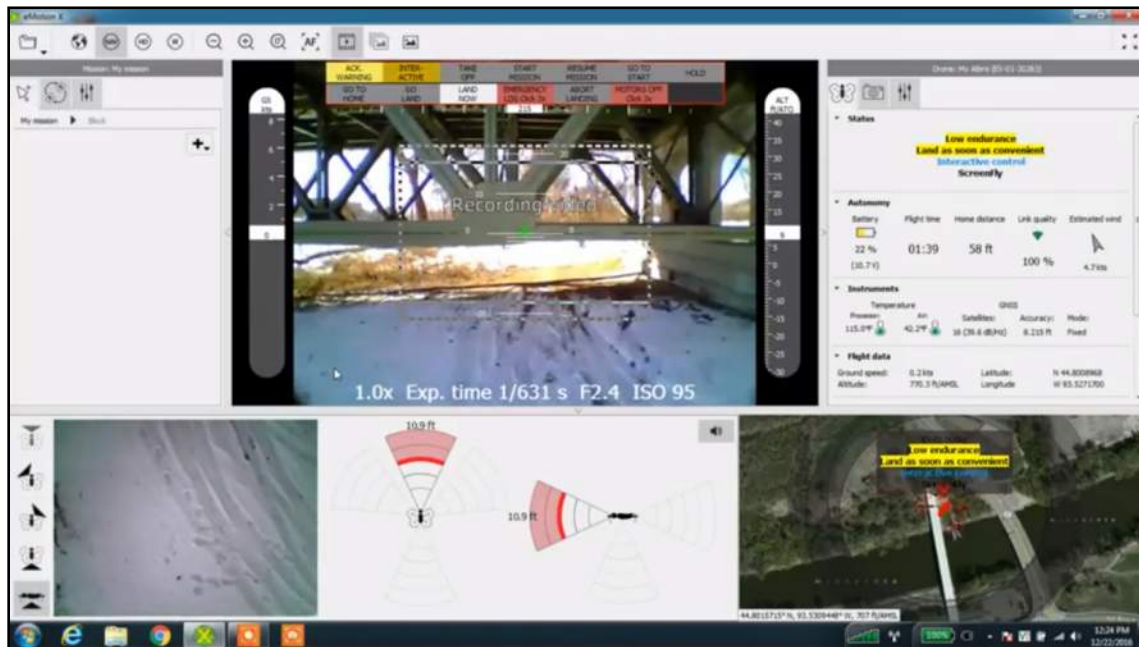

Image 7: View of Mission Control Desktop View. [\(Click Image to play video\).](#)

UAS INSPECTION REPORT

Bridge Number 4175 • Pedestrian Bridge over the Minnesota River
Shakopee, MN • August 2017



A High Definition Video Mission was conducted of limited access areas using the Elios UAS. The target goal of this mission was to determine the quality and applicability of using a Collision-Tolerant UAS to capture images and assess the condition of bridge elements which are typically difficult to access in a close-up view during the scope of a routine inspection. The mission consisted of an interactive flight using only pilot controls. During a typical routine inspection, the deck soffit, beam faces, and bearings would have been difficult to access. The use of the Elios UAS focuses on these hard to view locations. An inspector can then review the video footage to look for defects or findings. Refer to Images 8 for a view of the Elios UAS in a difficult to access locations.



Image 8: Image Clipped from Elion Inspection Video. [\(Click Image to play video\).](#)

2.3 Deliverables

A 3D Model with a High-Resolution Photograph Log was processed for bridge. The target goal for this process was to determine the ease of use and applicability of having a 3D photolog to assist an inspector during post-processing, report writing, and future inspections. All photographs taken during the Mapping and Photogrammetry Mission were processed in the Pix4D software. The software processes all photographs to form a 3D point cloud for digital viewing. The point cloud was then processed by the same software to

generate a 3D mesh of the bridge. An inspector was then able to navigate the 3D model and select areas of interest. The software provides the inspector with all still images containing the selected area of interest which can then be viewed in high resolution. Additionally, the inspector can place annotations within the file for future reference or for clarification when sharing the file. Refer to Image 9 for a view of the Inspector Tool providing a Photograph Log from a selected area of the 3D model.

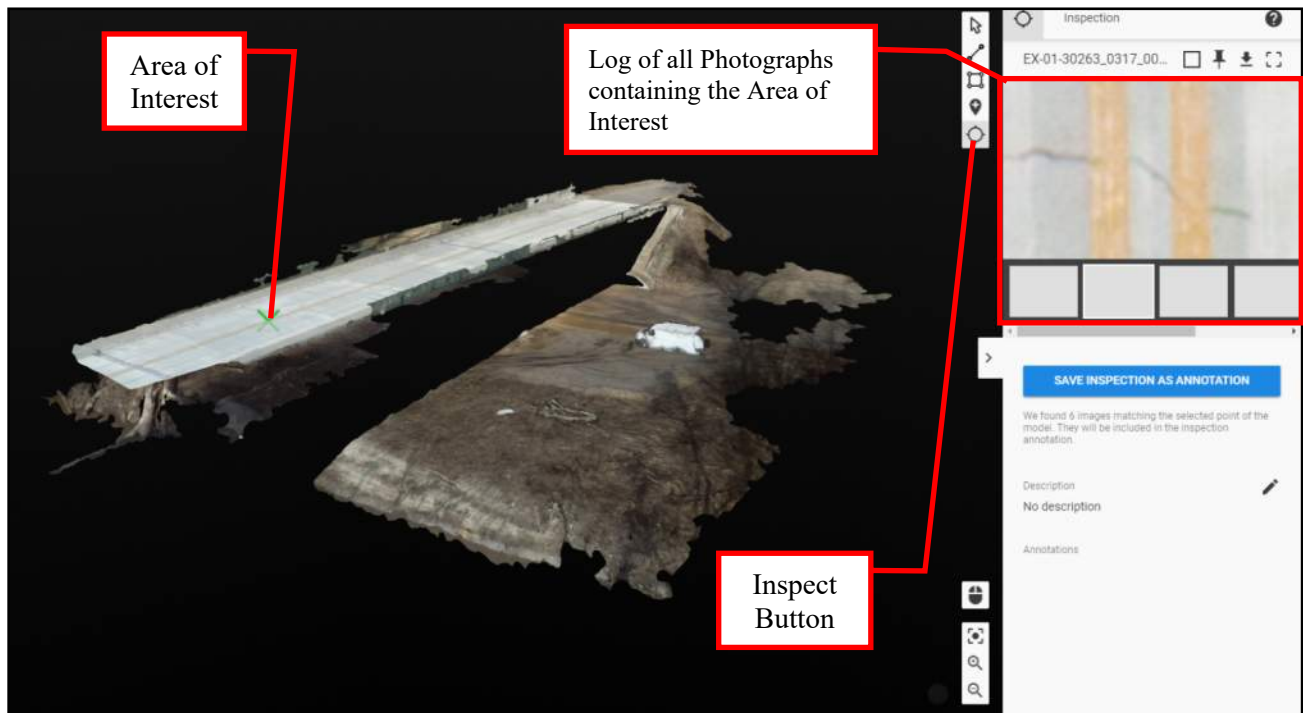

Image 9: View of the Inspector Tool providing a Photograph Log from a selected area of the 3D model.
(Click Image to access 3D Model and Inspection Photolog – Click on the Inspect Button)

A Orthomosaic image was created to use as an inspection tool. The target goal for this process was to produce an easily viewable, high resolution image of a large area that could be used by an inspector to carry out a detailed inspection, area measurements, condition assessment, or historical documentation. An Orthomosaic image is a single image file which is created from many individual images captured during the Mapping and Photogrammetry Mission. The final product of an Orthomosaic image is an image file that can be used to measure true distances. For this bridge, an Orthomosaic image was made of a portion of the concrete deck topside. Refer to Images 10 and 11 for a view of Orthomosaic Detail.

UAS INSPECTION REPORT

Bridge Number 4175 • Pedestrian Bridge over the Minnesota River
Shakopee, MN • August 2017

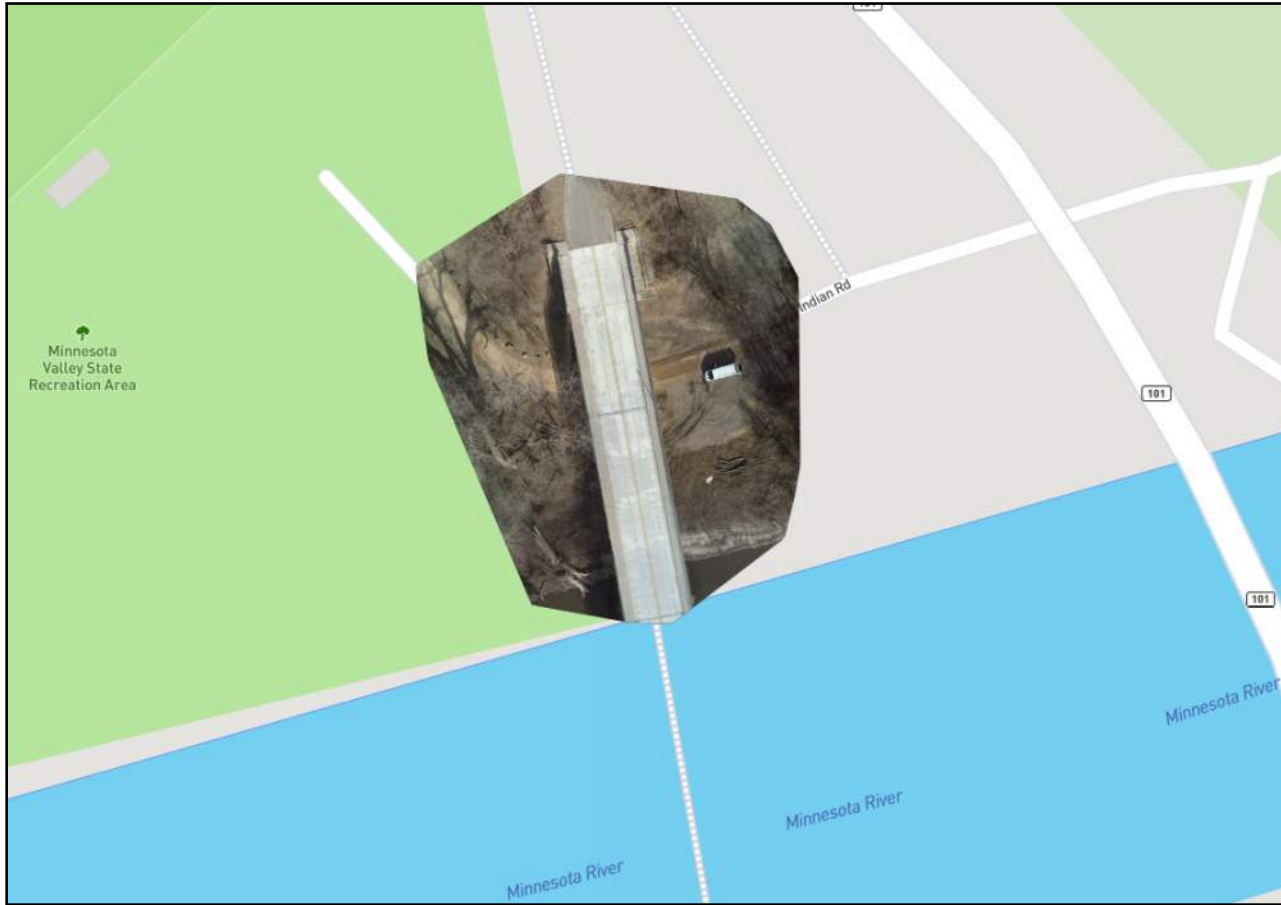

Image 10: View of the Orthomosaic Deck Image. [\(Click Image to Access Orthomosaic\)](#)



Image 11: View of the Orthomosaic Detail and Measuring Ability in the Pix4D software.

UAS INSPECTION REPORT

Bridge Number 4175 • Pedestrian Bridge over the Minnesota River
Shakopee, MN • August 2017



Images collected by the Albris and Terrestrial Photography of a specific bridge element were also post processed to produce a 3D Model. The primary purpose of this deliverable is to identify the quality of photographs for use in inspecting steel members and ease of collaboration when using the model to share findings. Additionally, the use of a different post-processing software system was explored. The element selected to image was the bottom chord outside gusset plate of a steel truss span. Approximately 44 images were collected using the Albris UAS and 22 images were collected using a point-and-shoot camera. The images were processed using Pix4D software to create a 3D model meshed from images. Refer to Images 12 and 13 for views of the gusset plate model.

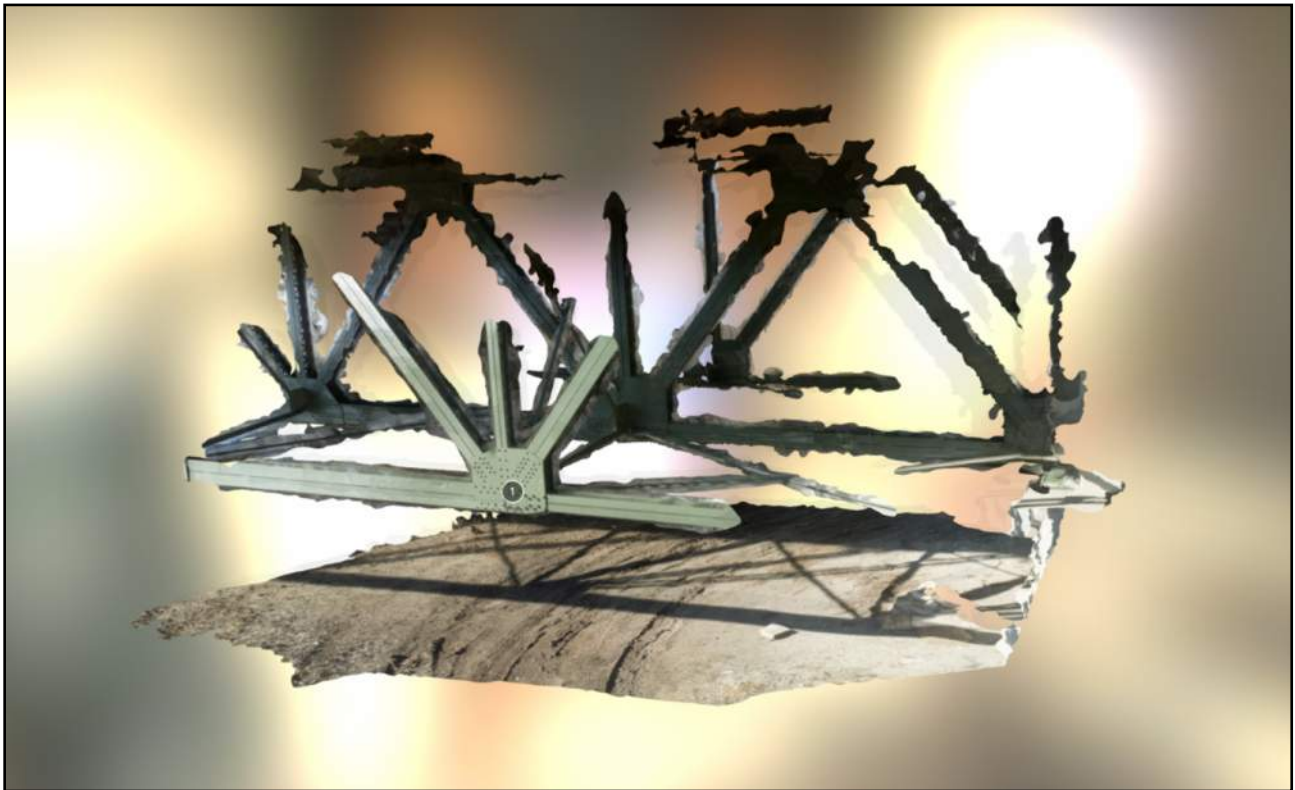

Image 12: View of the 3D Model of Gusset Plate. [\(Click Image to Access Model\)](#)

UAS INSPECTION REPORT

Bridge Number 4175 • Pedestrian Bridge over the Minnesota River
Shakopee, MN • August 2017

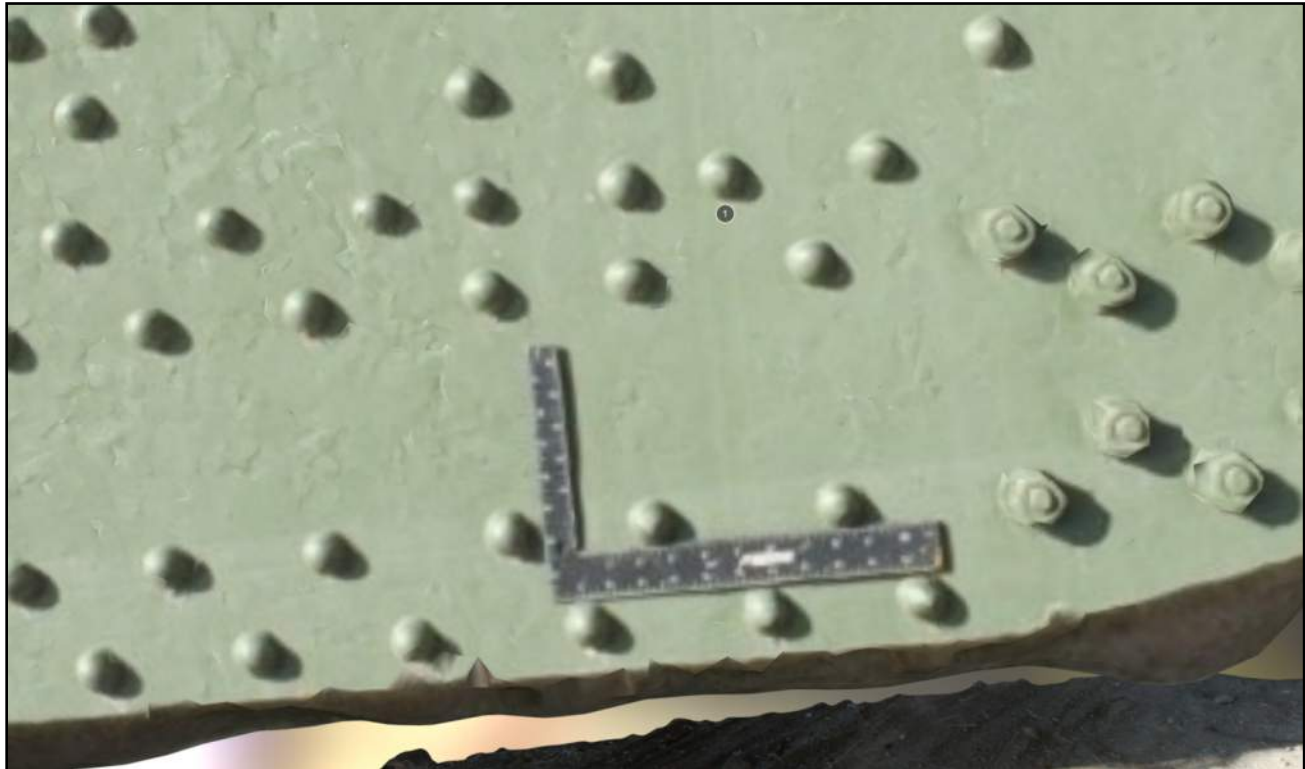

Image 13: View of the Detail of the 3D Model of the Gusset Plate located at Point 1 in Image 9.

During the Albris UASs flight Mission, a video of the gusset plate was also taken to explore the potential for video inspection using the albris. Refer to Image 14 for the Albris UAS video of the gusset plate.



Image 14: View of snapshot of Albris Video of the Gusset Plate. [\(Click Image to Access Video\)](#)

UAS INSPECTION REPORT

Bridge Number 4175 • Pedestrian Bridge over the Minnesota River
Shakopee, MN • August 2017



Video from the High Definition Video Mission using the Elios was viewed by an inspector after returning from the flight mission. The video could be observed in any software capable of playing .MP4 files. Additionally, the manufacturer of the Elios, Flyability, have created an inspection software where the UAS flight log can be opened with the video file to show inspector UAS attributes such as heading, altitude, and temperature. The inspector can then maneuver their way through the video to obtain still images of defects or notable findings. Refer to Image 15 below for a view of the Elios inspecting cracking defects on the bridge.



Image 15: View of a Still Image Taken from the Video Playback Showing a Crack in the Concrete. [\(Click Image to Access Video\)](#)

3.0 SUMMARY OF FINDINGS

3.1 Opportunities

The execution of the Mapping and Photogrammetry Mission was a success and provided great insight into the potential for UAS as a tool during routine inspections. The set-up, flight, and data generation went as planned and was substantial enough to create the planned deliverables. The Flyability Elios was able to inspect portions of the bridge which are not fracture critical including the beam spans. This proved to be an efficient and cost-effective way to inspect these low risk portions of the bridge.

UAS INSPECTION REPORT

Bridge Number 4175 • Pedestrian Bridge over the Minnesota River
 Shakopee, MN • August 2017



3.2 Limitations

Since this bridge is fracture critical the main superstructure components require a hands-on arm’s length inspection. The drone will not meet this requirement but many non-fracture components of the bridge can benefit. In addition, the drone can be used for a pre-inspection survey to assist in the planning of a hands-on inspection.

3.3 Evaluation of Potential Cost Savings

The hands-on inspection cannot be replaced with drone use for this bridge but the non-fracture components can be which results is a modest costs savings. However, the deliverables will be improved resulting in an overall higher quality inspection for less cost.

Bridge 4175						
Expense Description	Traditional Inspection Cost				UAS Inspection Cost	
	Quantity	Unit	Unit Price	Cost	Quantity	Unit Price
Bridge Inspection Team Leader	24	Hour	150	\$3,600	20	Hour
Assistant Bridge Inspector	24	Hour	120	\$2,880	20	Hour
Under Bridge Inspection Vehicle with Operator	3	Day	3,000	\$9,000	2	Day
Drone Rental	0	Day	300	\$0	1	Day
UAS Post Processing Engineer	0	Hour	120	\$0	8	Hour
Low Speed Lane/Shoulder Closure	0	Each	2,000	\$0	0	Each
Mobile Lane/Shoulder Closure	0	Each	1,500	\$0	0	Each
Misc Traffic Control (Ped Only Etc)	1	Each	500	\$500	1	Each
High Speed Lane/Shoulder Closure	0	Each	2,500	\$0	0	Each

**Traditional Inspection
 Cost \$15,980**

UAS INSPECTION REPORT

Bridge Number 4175 • Pedestrian Bridge over the Minnesota River
Shakopee, MN • August 2017



Bridge 4175								
Expense Description	Traditional Inspection Cost				UAS Assisted Inspection Cost			
	Quantity	Unit	Unit Price	Cost	Quantity	Unit	Unit Price	Cost
Bridge Inspection Team Leader	24	Hour	\$150.00	\$3,600	20	Hour	\$150.00	\$3,000
Assistant Bridge Inspector	24	Hour	\$120.00	\$2,880	20	Hour	\$120.00	\$2,400
Under Bridge Inspection Vehicle with Operator	3	Day	\$3,000.00	\$9,000	2	Day	\$3,000.00	\$6,000
Drone Rental	0	Day	\$300.00	\$0	1	Day	\$300.00	\$300
UAS Post Processing Engineer	0	Hour	\$120.00	\$0	8	Hour	\$120.00	\$960
Low Speed Lane Closure	0	Each	\$2,000.00	\$0	0	Each	\$2,000.00	\$0
Mobile Lane Closure	0	Each	\$1,500.00	\$0	0	Each	\$1,500.00	\$0
Misc Traffic Control (Ped Only Etc)	1	Each	\$500.00	\$500	1	Each	\$500.00	\$500
High Speed Lane Closure	0	Each	\$2,500.00	\$0	0	Each	\$2,500.00	\$0
			Traditional Inspection Cost	\$15,980			UAS Assisted Inspection Cost	\$13,160

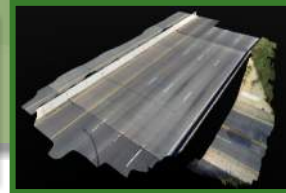

UAS INSPECTION REPORT

BRIDGE NUMBER: 9731

I 35W

OVER E 31ST ST

MINNEAPOLIS, MINNESOTA

September 30, 2017

Prepared for:



*As part of MnDOT Research Project
A-83 Improving Quality of Bridge Inspections Using Unmanned Aircraft Systems
(UAS) Phase III*

Prepared by:

COLLINS
ENGINEERS INC.

1599 Selby Avenue
St. Paul, MN 55104

651.646.8502 • www.collinsengr.com



Table of Contents

1.0	INTRODUCTION	
1.1	Purpose and Scope	1
1.2	General Description of the Structure	2
2.0	UAS OPERATION	
2.1	UAS Equipment and Operating Conditions	3
2.2	Mission Scope	4
2.3	Deliverables.....	5
3.0	SUMMARY OF FINDINGS	
3.1	Opportunities	7
3.2	Limitations.....	7

Table of Images

Image 1: Location Map.	1
Image 2: Overall View of Bridge.	2
Image 3: Overall View of Bridge Deck.	2
Image 4: View of SenseFly Albris.	3
Image 5: View of Mission Flight Map.	4
Image 6: View of Camera Position at Location of Photographing.	5
Image 7: View of the Level of Detail Included in a Single High-Resolution Photograph.	6
Image 8: View of the 3D Model.	6
Image 9: View of the Inspector Tool in Pix4d.	7

UAS INSPECTION REPORT

Bridge Number 9731 • I 35W Over East 31st St.
Minneapolis, MN • September 2017



EXECUTIVE SUMMARY

Project: Routine Inspection of Bridge Deck Using UAS's of Bridge Number 9731.

Purpose of Project: To perform a partial routine inspection using unmanned aircraft system (UAS) techniques to determine the structural and physical condition of the bridge deck. The inspection is supplemental to a routine visual, tactile, and non-destructive testing inspection.

Inspection Team: Team Leader – Barritt Lovelace, P.E. (Pilot)
Team Member – Cory Stuber, P.E. (Crew Hand)

Inspection Date(s): September 30, 2017

Data Collection Tools:

- SenseFly Albris Flyability Elios Other: _____

Summary of Mission Scope(s) and Deliverable(s):

- | | | |
|---|---|---|
| <input checked="" type="checkbox"/> Aerial Mapping & Photogrammetry | <input checked="" type="checkbox"/> 3D Model & High Resolution Photograph Log | <input type="checkbox"/> High Definition Video for Limited Access Areas |
| <input checked="" type="checkbox"/> Orthomosaic Image Creation for Inspection | <input type="checkbox"/> Defect Measurement | <input type="checkbox"/> Construction/Repair Plan Documentation |
| <input type="checkbox"/> Thermal Imaging | <input type="checkbox"/> Other: _____ | |

Summary of Findings, Opportunities, and Limitations:

- [UPDATE UPON FINISHING SUMMARY OF FINDINGS]

Summary of Cost Savings:

- [UPDATE UPON FINISHING SUMMARY OF FINDINGS]

UAS INSPECTION REPORT

Bridge Number 9731 • I 35W Over East 31st St.
Minneapolis, MN • September 2017



1.0 INTRODUCTION

1.1 Purpose and Scope

This report consists of the results of an unmanned aircraft (UAS) inspection of Bridge Number 9731, I 35W over E 31st St. located in Minneapolis, Minnesota. Refer to Image 1 for a location map. Collins Engineers, Inc. (Collins) conducted the UAS Inspection for the Minnesota Department of Transportation (MnDOT) on September 30, 2017 as part of a research project titled “Improving Quality of Bridge Inspections Using Unmanned Aircraft Systems (UAS) Project Phase III”. The primary purpose of the UAS usage during the inspection was to identify possible opportunities and limitations of UAS involvement in various capacity of bridge inspection. The following report includes a brief description of the structure, description of UAS equipment and operating conditions, the mission scope and deliverables, a summary of findings, opportunities, and limitations, and an evaluation of potential cost savings.

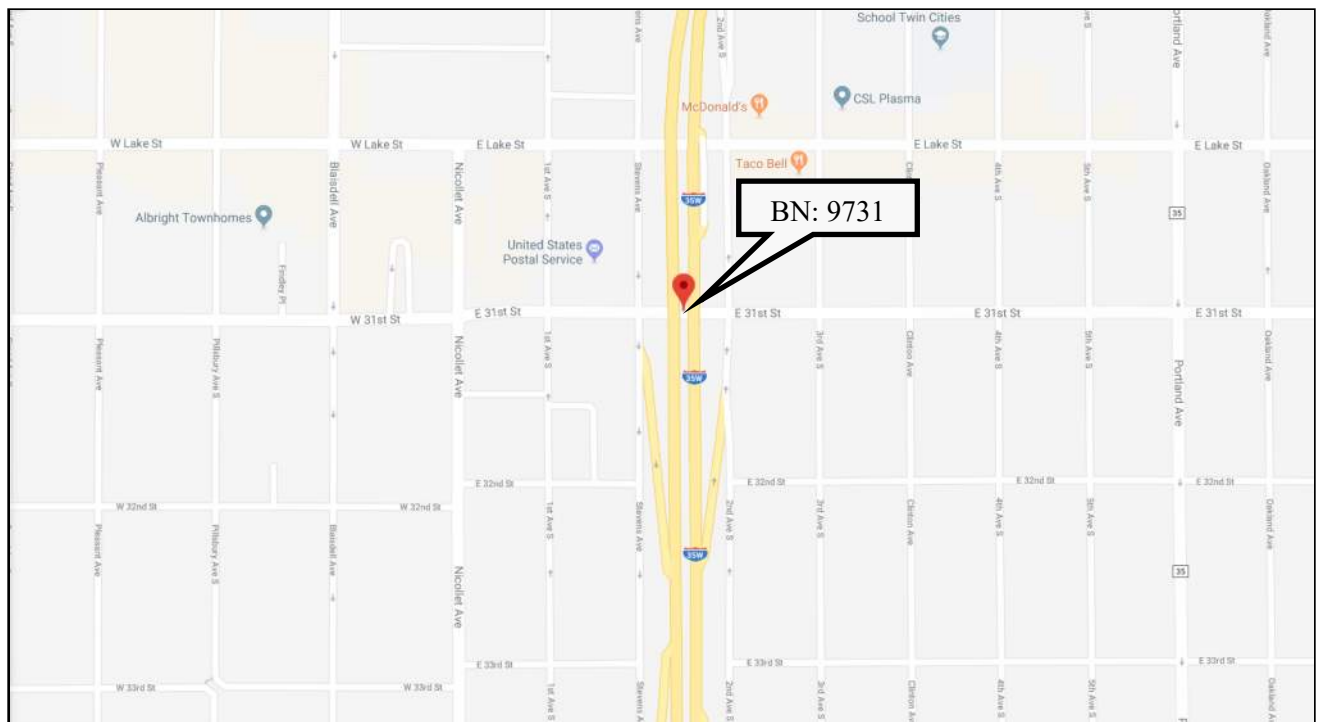

Image 1: Location Map

UAS INSPECTION REPORT

Bridge Number 9731 • I 35W Over East 31st St.
Minneapolis, MN • September 2017



1.2 General Description of the Structure

Bridge Number 62504 spans approximately 128.6 feet over E 31st St. and carries four north bound and four south bound lanes of I 35W. The bridge deck is approximately 141.3 feet wide and consists of cast in place concrete with a low slump concrete wearing surface. The bridge superstructure consists of sixteen precast concrete beams and the bridge substructure consists of concrete abutments bearing on piles. The longitudinal axis of the bridge is orientated approximately north to south. Refer to Images 2 and 3 for overall views of the bridge.



Image 2: Overall View of Bridge.

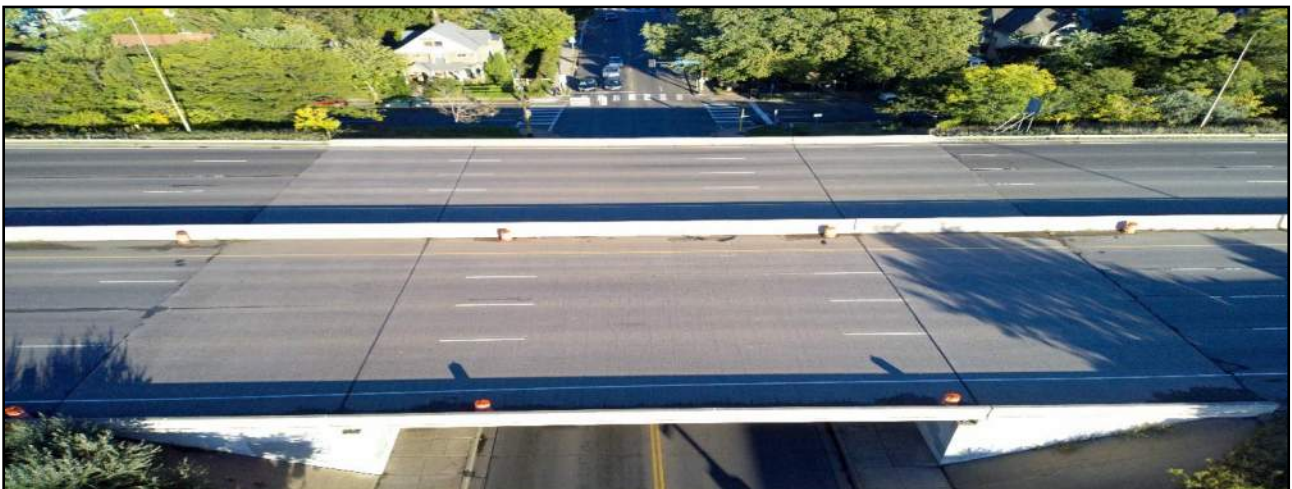

Image 3: Overall View of Bridge Deck.

2.0 UAS OPERATION

2.1 UAS Equipment and Operating Conditions

A one-person crew, consisting of a professional engineer-pilot, conducted the UAS inspection. The pilot was certified as a FAA Remote Pilot, and conducted the inspection using an Inspection and Mapping UAS. The aerial mapping UAS was a SenseFly Albris quadcopter equipped with a TripleView head consisting of a HD video camera, a 38MP still camera, and an infrared camera. Additionally, the Albris contains five acoustic sensors, GPS location, and photo-identification stabilization technology which aid both 3D preplanned and interactive flight missions. Refer to Image 4 for a view of the SenseFly Albris.



Image 4: View of SenseFly Albris.

During the inspection, the pilot worked mobile work station suspended from his body and maintained line-of-sight with the UAS. Aerial targets and a scale were placed prior to the aerial mapping mission to provide a higher level of accuracy. At the time of flight, the weather was clear with low wind and the bridge and corridor was closed for construction. The bridge was located in Class B Airspace; thus, an FAA waiver or additional authorization was necessary for this mission to commence. The FAA waiver was submitted prior to mission start and was approved on July 10, 2017.

2.2 Mission Scope

A Mapping & Photogrammetry mission using the Albris was identified for this bridge to explore the potential of UAS photography to map deck surface defects. The target goal of the mission was to gather information in the form of photographs in a quick, efficient process which could later be used to map the deck and have a post-inspection tool to aid in report writing and historical documentation. Additionally, the ease of use in an urban environment was displayed. The mission consisted of a pre-planned flight path that imaged the top of deck and both north and south fascia. The UAS collected over 156 high-resolution still images of the bridge fascia and top side. All images were geo-tagged with GPS coordinates. Refer to Images 5 and 6 for views of the corridor Flight and Mapping Mission. Additional missions were flown to determine the ability of the drone to map deck defects from different altitudes or different ground sampling distances.

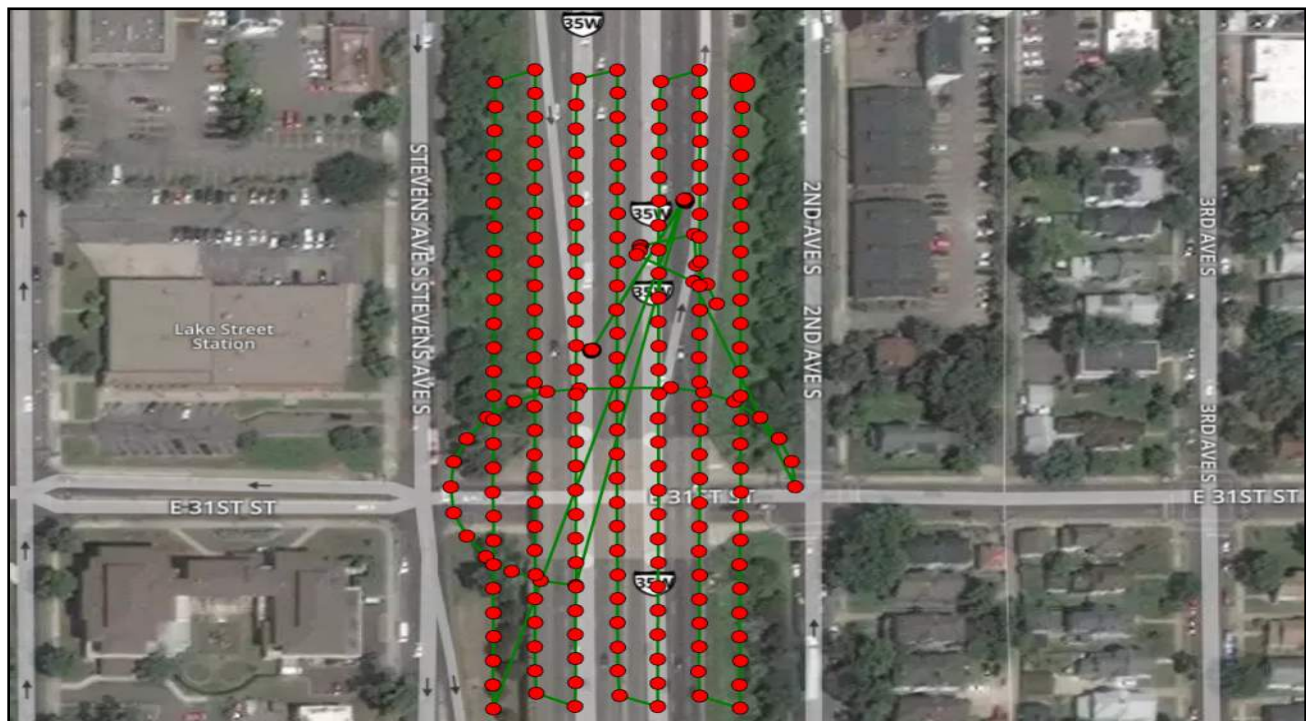

Image 5: View of Mission Flight Map (Preplanned and Interactive).

UAS INSPECTION REPORT

Bridge Number 9731 • I 35W Over East 31st St.
Minneapolis, MN • September 2017

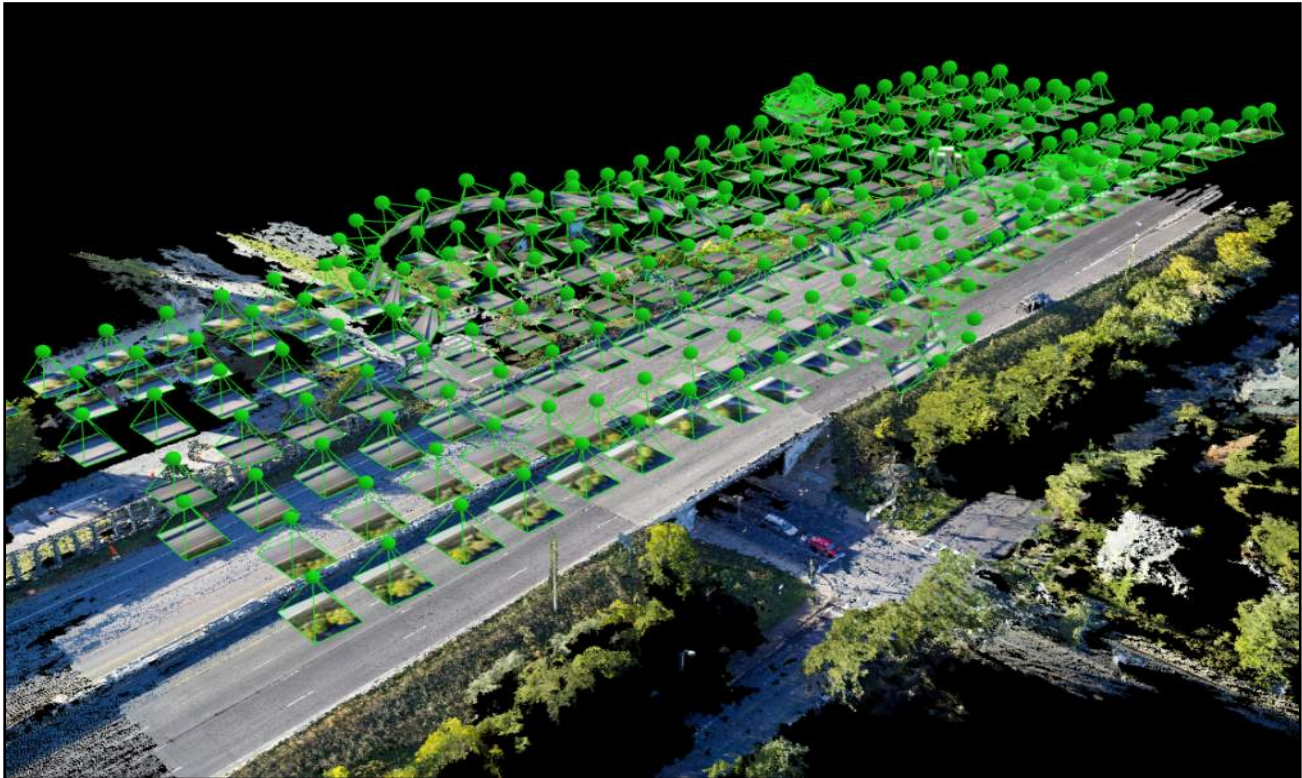

Image 6: View of Camera Position (Green Dot) at Locations of Photographing. [\(Click Image to access 3D Model of the Corridor\)](#)

2.3 Deliverables

An Orthomosaic image was created in the Pix4D software to use as an inspection tool. The target goal for this process was to produce an easily viewable, high resolution image of a large area that could be used by an inspector to carry out a detailed inspection, area measurements, condition assessment, or historical documentation. An Orthomosaic image is a single image file which is created from many individual images captured during the Mapping and Photogrammetry Mission. The final product of an Orthomosaic image is an image file that can be used to measure true distances. For this bridge, an Orthomosaic image was made of the entire bridge deck. An inspector then reviewed a single file and can measure true distances and areas for a final product. Refer to Image 7 for a view of Orthomosaic Detail.

UAS INSPECTION REPORT

Bridge Number 9731 • I 35W Over East 31st St.
Minneapolis, MN • September 2017



Image 7: View of the Level of Detail in a Single High-Resolution Image.

A 3D Model with a High-Resolution Photograph Log was processed for bridge. The target goal for this process was to determine the ease of use and applicability of having a 3D photolog to assist an inspector during post-processing, report writing, and future inspection. Additionally, the applicability of an easily manipulated 3D model which could be shared with others was explored. All photographs taken during the Mapping and Photogrammetry Mission were processed in Pix4. The software processes all photographs to form a 3D point cloud for digital viewing. The point cloud was then processed by the same software to generate a 3D mesh of the bridge. Refer to image 8 for a view of the 3D model.

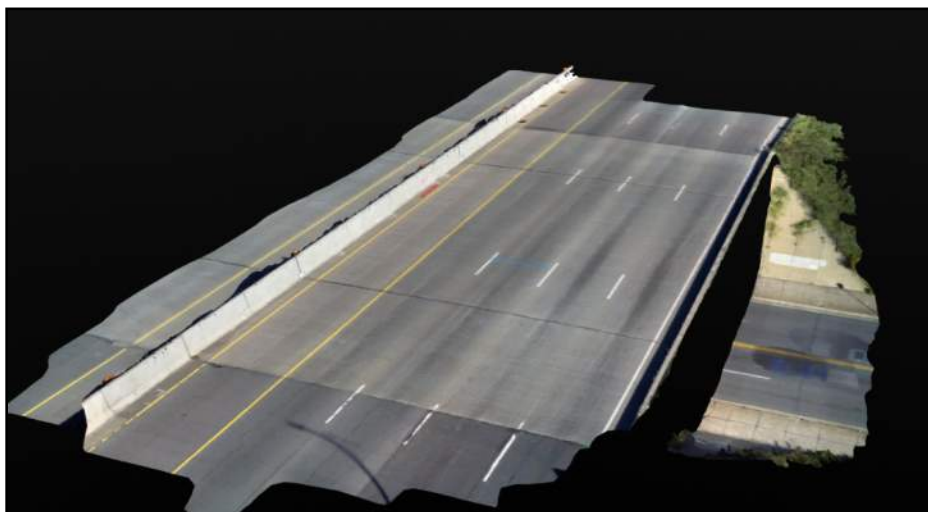

Image 8: View of the 3D model. [\(Click Image to access 3D Model\)](#)

UAS INSPECTION REPORT

Bridge Number 9731 • I 35W Over East 31st St.

Minneapolis, MN • September 2017



An inspector was able to use the Pix4D program to navigate the 3D model and select areas of interest. The software provides the inspector with all still images containing the selected area of interest which can then be viewed in high resolution. Additionally, the inspector can place annotations within the file for future reference or for clarification when sharing the file. Refer to Image 9 for a view of the Inspector Tool providing a Photograph Log from a selected area of the 3D model.



Image 9: View of the Inspector Tool providing a Photograph Log from a selected area of the 3D model.

(Click Image to access 3D Model and Inspection Photolog – Click on the Inspect Button)

3.0 SUMMARY OF FINDINGS

3.1 Opportunities

The execution of the Mapping and Photogrammetry Mission was a success and provided great insight into the potential for UAS as a tool during routine inspections. The set-up, flight, and data generation went as planned and was substantial enough to create the planned deliverables.

3.2 Limitations

This inspection was only possible during the road closure and would be difficult to perform with traffic.

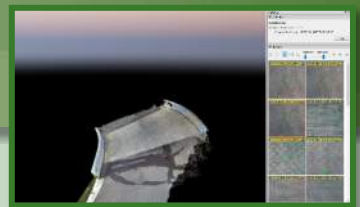
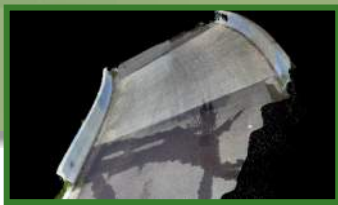

UAS INSPECTION REPORT

BRIDGE NUMBER: 19565

168th STREET WEST

OVER NORTH CREEK

LAKEVILLE, MINNESOTA

August 25, 2017

Prepared for:



*As part of MnDOT Research Project
A-93 Improving Quality of Bridge Inspections Using Unmanned Aircraft Systems
(UAS) Phase III*

Prepared by:

**COLLINS
ENGINEERS** INC.

1599 Selby Avenue
St. Paul, MN 55104

651.646.8502 • www.collinsengr.com



Table of Contents

1.0	INTRODUCTION	
1.1	Purpose and Scope	1
1.2	General Description of the Structure	2
2.0	UAS OPERATION	
2.1	UAS Equipment and Operating Conditions	3
2.2	Mission Scope	4
2.3	Deliverables.....	5
3.0	SUMMARY OF FINDINGS	
3.1	Opportunities	7
3.2	Limitations.....	7
3.3	Evaluation of Potential Cost Savings	7

Table of Images

Image 1:	Location Map	1
Image 2:	Overall View of Bridge.	2
Image 3:	Overall View of Bridge Deck.	2
Image 4:	View of SenseFly Albris.	3
Image 5:	View of Mission Flight Map.	4
Image 6:	View of Camera Position at Locations of Photographing..	4
Image 7:	View of the Inspector Tool Within Pix4d.	5
Image 8:	View of the Level of Detail in a Orthomosaic Image.	6

UAS INSPECTION REPORT

Bridge Number 19565 • 168th St. West. over North Creek

Lakeville, MN • August 2017



EXECUTIVE SUMMARY

- Project:** Routine Inspection of Bridge Deck Using UAS for Bridge Number 19565.
- Purpose of Project:** To perform a partial inspection of select superstructure elements using unmanned aircraft system (UAS) techniques to map and measure the bridge deck cracking. The inspection is supplemental to a routine visual, tactile, and non-destructive testing inspection.
- Inspection Team:** Team Leader – Barritt Lovelace, P.E. (Pilot)
- Inspection Date(s):** August 25, 2017

Data Collection Tools:

- SenseFly Albris Flyability Elios Other: _____

Summary of Mission Scope(s) and Deliverable(s):

- Aerial Mapping & Photogrammetry 3D Model & High Resolution Photograph Log High Definition Video for Limited Access Areas
- Orthomosaic Image Creation for Inspection Defect Measurement Construction/Repair Plan Documentation
- Thermal Imaging Other: _____

Summary of Findings, Opportunities, and Limitations:

The execution of the Mapping and Photogrammetry Mission was a success and provided great insight into the potential for UAS as a tool during routine inspections. The set-up, flight, and data generation went as planned and was substantial enough to create the planned deliverables. Bridge 19565 requires only a simple routine inspection. It does have deck cracking and the drone documentation proved to be an efficient way to accurately map and measure the cracking. The documented cracks can now be compared with future bridge inspections to determine if the cracks are growing.

UAS INSPECTION REPORT

Bridge Number 19565 • 168th St. West. over North Creek
Lakeville, MN • August 2017



1.0 INTRODUCTION

1.1 Purpose and Scope

This report consists of the results of an unmanned aircraft system (UAS) inspection of Bridge Number 19565, 168th St. West over the North Creek located in Lakeville, Minnesota. Refer to Image 1 for a location map. Collins Engineers, Inc. (Collins) conducted the UAS Inspection for the Minnesota Department of Transportation (MnDOT) on August 25, 2017 as part of a research project titled “Improving Quality of Bridge Inspections Using Unmanned Aircraft Systems (UAS) Project Phase III”. The primary purpose of the UAS usage during the inspection was to identify possible opportunities and limitations of UAS involvement in support of the bridge inspection. The following report includes a brief description of the structure, description of UAS equipment and operating conditions, the mission scope and deliverables, a summary of findings, opportunities, and limitations, and an evaluation of potential cost savings.

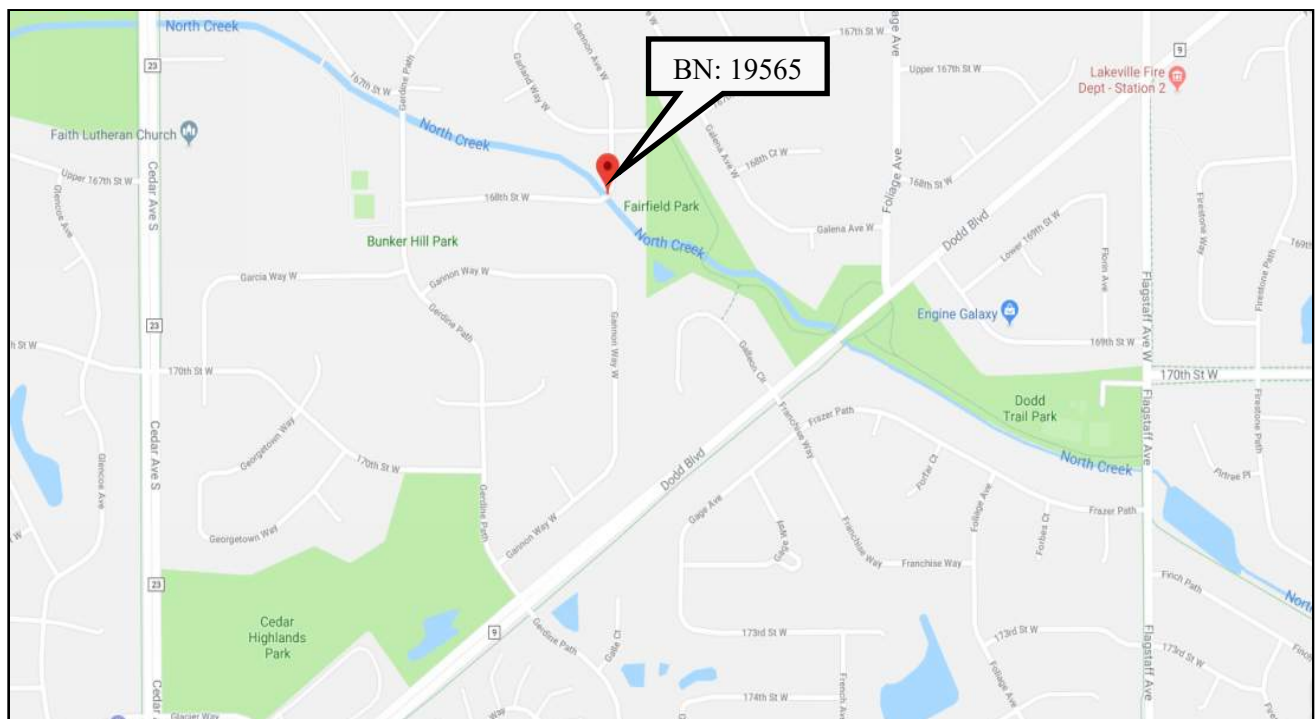

Image 1: Location Map

UAS INSPECTION REPORT

Bridge Number 19565 • 168th St. West. over North Creek
Lakeville, MN • August 2017



1.2 General Description of the Structure

Bridge Number 19565 spans approximately 30 feet over North Creek and carries one east bound and one west bound lane of 168th St. West. The bridge deck is approximately 35.2 feet wide and consists of cast in place concrete with no wearing surface. The bridge superstructure consists of a curved reinforced concrete slab span. The longitudinal axis of the bridge is orientated approximately southwest to northeast. Refer to Images 2 for an overall view of the bridge.



Image 2: Overall View of Bridge.

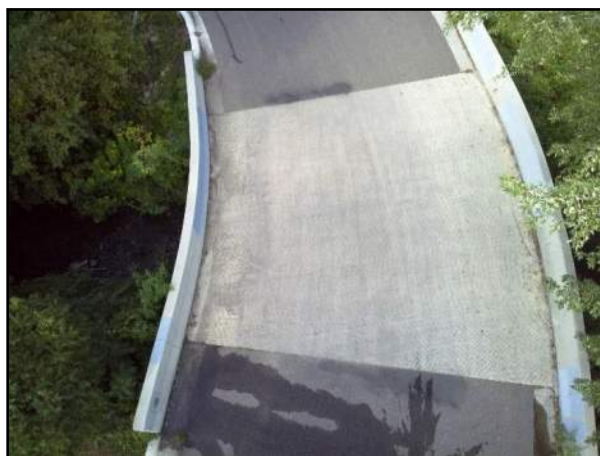

Image 3: Overall View of Bridge Deck.

2.0 UAS OPERATION

2.1 UAS Equipment and Operating Conditions

A one-person crew, consisting of a professional engineer-pilot, conducted the UAS inspection. The pilot was certified as a FAA Remote Pilot, and conducted the inspection using an Inspection and Mapping UAS. The aerial mapping UAS was a SenseFly Albris quadcopter equipped with a TripleView head consisting of a HD video camera, a 38MP still camera, and an infrared camera. Additionally, the Albris contains five acoustic sensors, GPS location, and image flow stabilization technology which aid both 3D preplanned and interactive flight missions. Refer to Image 4 for a view of the SenseFly Albris.



Image 4: View of SenseFly Albris

During the inspection, the pilot worked with mobile work station body while maintaining line-of-sight with the UAS. At the time of flight, the weather was clear with low wind.

2.2 Mission Scope

A Mapping & Photogrammetry mission using the Albris was identified for this bridge to explore the potential of UAS photography to map concrete deck surface defects. The target goal of the mission was to gather information in the form of photographs in a quick, efficient process which could later be used to map the concrete deck and have a post-inspection tool to aid in report writing and historical documentation. The mission consisted of a pre-planned flight path at an elevation 25 feet above feck level. The UAS collected high-resolution still images of the top side of the bridge deck. All images were geo-tagged with GPS coordinates. Refer to Images 5 and 6 for views of the Flight and Mapping Mission.

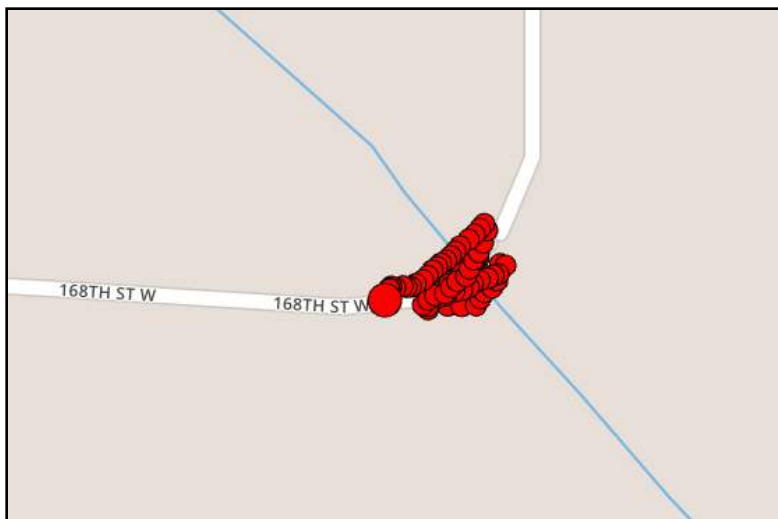

Image 5: View of Mission Flight Map (Preplanned and Interactive).

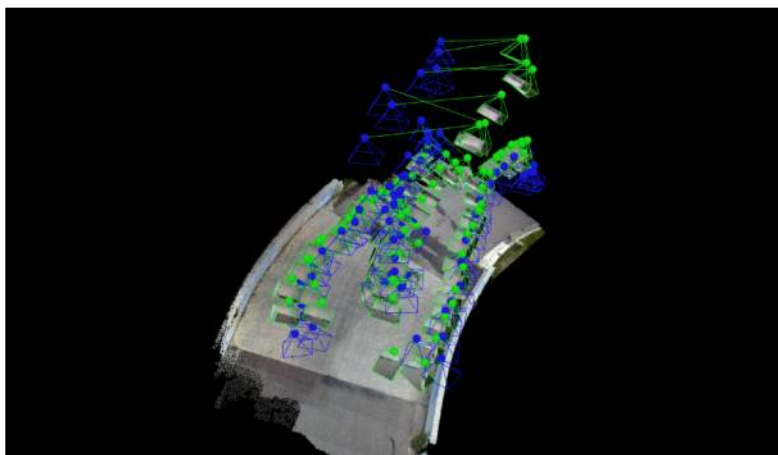

Image 6: View of Camera Position (Green Dot) at Locations of Images

2.3 Deliverables

A 3D Model with a high-resolution photog log was processed for bridge. The target goal for this process was to determine the ease of use and applicability of having a 3D photolog to assist an inspector during post-processing, report writing, and future inspection. All photographs taken during the Mapping and Photogrammetry Mission were processed in the Pix4D software. The software processes all photographs to form a 3D point cloud for digital viewing. The point cloud was then processed by the same software to generate a 3D mesh of the bridge. An inspector was then able to navigate the 3D model and select areas of interest. The software provides the inspector with all still images containing the selected area of interest which can then be viewed in high resolution. Additionally, the inspector can place annotations within the file for future reference or for clarification when sharing the file. Refer to Image 7 for a view of the Inspector Tool providing a Photograph Log from a selected area of the 3D model. Bridge 19565 has some deck cracking that was measured using the 3D model. These measurements are more accurate than field measurements and the model will allow for comparison during future inspection cycles to determine if the cracks are growing or if they are stable.



Image 7: View of the Inspector Tool providing a Photo Log from a selected area of the 3D model. Note the annotated areas for future reference or ease of sharing.

UAS INSPECTION REPORT

Bridge Number 19565 • 168th St. West. over North Creek
Lakeville, MN • August 2017



A Orthomosaic image was created to use as an inspection tool. The target goal for this process was to produce an easily viewable, high resolution image of a large area that could be used by an inspector to carry out a detailed inspection, area measurements, condition assessment, or historical documentation. An Orthomosaic is a single image file which is created from many individual images captured during the Mapping and Photogrammetry Mission. The final product is an image file that can be used to document and measure defects. For this bridge, an Orthomosaic was made of the concrete deck topside. An inspector then reviews a single file and can measure true distances and areas for a final product. Refer to Image 7 for a view of the Orthomosaic Detail.



Image 8: View of the Level of Detail in an Orthomosaic Image.

UAS INSPECTION REPORT

Bridge Number 19565 • 168th St. West. over North Creek
Lakeville, MN • August 2017



3.0 SUMMARY OF FINDINGS

3.1 Opportunities

The execution of the Mapping and Photogrammetry Mission was a success and provided great insight into the potential for UAS as a tool during routine inspections. The set-up, flight, and data generation went as planned and was substantial enough to create the planned deliverables. Bridge 19565 requires only a simple routine inspection. It does have deck cracking and the drone documentation proved to be an efficient way to accurately map and measure the cracking. The documented cracks can now be compared with future bridge inspections to determine if the cracks are growing.

3.2 Limitations

None identified.

3.3 Evaluation of Potential Cost Savings

No cost savings were identified as the tradeoff between the time to use the drone was similar to measuring the cracks by hand. The deliverables were of higher quality for the same cost.



UAS INSPECTION REPORT

BRIDGE NUMBER: 62080

KELLOGG BLVD

OVER I-94; RR; COMMERCIAL ST.

ST. PAUL, MINNESOTA

August 30, 2017

Prepared for:



*As part of MnDOT Research Project
A-103 Improving Quality of Bridge Inspections Using Unmanned Aircraft Systems
(UAS) Phase III*

Prepared by:

**COLLINS
ENGINEERS** INC.

1599 Selby Avenue
St. Paul, MN 55104

651.646.8502 • www.collinsengr.com

UAS INSPECTION REPORT

Bridge Number 62080 • Kellogg Blvd. over I-94; RR; Commercial St.
St. Paul, MN • August 2017



Table of Contents

1.0	INTRODUCTION	
1.1	Purpose and Scope	1
1.2	General Description of the Structure	2
2.0	UAS OPERATION	
2.1	UAS Equipment and Operating Conditions	3
2.2	Mission Scope	4
2.3	Deliverables.....	5
3.0	SUMMARY OF FINDINGS	
3.1	Opportunities	7
3.2	Limitations.....	7
3.3	Evaluation of Potential Cost Savings	7

Table of Images

Image 1: Location Map	1
Image 2: Overall View of Bridge Topside.	2
Image 3: Overall View of Bridge Underside.	2
Image 4: View of SenseFly Albris.	3
Image 5: View of Mission Flight Map (Preplanned and Interactive).	4
Image 6: View of Camera Position (Green Dot) at Locations of Photographing.	5
Image 8: View of the Level of Detail in a Single High-Resolution Image.	6
Image 9: Orthomoplane of Pier Cap	7

UAS INSPECTION REPORT

Bridge Number 62080 • Kellogg Blvd. over I-94; RR; Commercial St.
St. Paul, MN • August 2017



EXECUTIVE SUMMARY

- Project:** Reinforced Concrete Pier Inspection Using UAS's of Bridge Number 62080.
- Purpose of Project:** To perform a partial inspection of select superstructure elements using unmanned aircraft system (UAS) techniques to determine the structural and physical condition of difficult to access bridge elements. The inspection is supplemental to a routine visual, tactile, and non-destructive testing inspection.
- Inspection Team:** Team Leader – Barritt Lovelace, P.E. (Pilot)
Team Member – Cory Stuber, P.E. (Crew Hand)
- Inspection Date(s):** August 30, 2017

Data Collection Tools:

- SenseFly Albris Flyability Elios Other: _____

Summary of Mission Scope(s) and Deliverable(s):

- Aerial Mapping & Photogrammetry 3D Model & High Resolution Photograph Log High Definition Video for Limited Access Areas
- Orthomosaic Image Creation for Inspection Defect Measurement Construction/Repair Plan Documentation
- Thermal Imaging Other: _____

Summary of Findings, Opportunities, and Limitations:

The execution of the Mapping and Photogrammetry Mission was a success and provided great insight into the potential for UAS as a tool during routine inspections. The set-up, flight, and data generation went as planned and was substantial enough to create the planned deliverables. Utilizing UAS to inspect these piers with known shear cracking proved to be an effective way to monitor, measure and document the cracks and deterioration. Utilizing UAS eliminates the need for expensive access equipment and creates deliverables that improve the quality of the inspection. There are railroad tracks and property nearby and if the piers near the tracks were inspected permissions from the railroad may be required.

UAS INSPECTION REPORT

Bridge Number 62080 • Kellogg Blvd. over I-94; RR; Commercial St.
St. Paul, MN • August 2017



1.0 INTRODUCTION

1.1 Purpose and Scope

This report consists of the results of an unmanned aircraft (UAS) inspection of Bridge Number 62080, Kellogg Blvd. over I-94 and Commercial St. located in St. Paul, Minnesota. Refer to Image 1 for a location map. Collins Engineers, Inc. (Collins) conducted the UAS Inspection for the Minnesota Department of Transportation (MnDOT) on August 30, 2017 as part of a research project titled “Improving Quality of Bridge Inspections Using Unmanned Aircraft Systems (UAS) Project Phase III”. The primary purpose of the UAS usage during the inspection was to identify possible opportunities and limitations of UAS involvement in various capacity of bridge inspection. The following report includes a brief description of the structure, description of UAS equipment and operating conditions, the mission scope and deliverables, a summary of findings, opportunities, and limitations, and an evaluation of potential cost savings.



Image 1: Location Map

UAS INSPECTION REPORT

Bridge Number 62080 • Kellogg Blvd. over I-94; RR; Commercial St.
St. Paul, MN • August 2017



1.2 General Description of the Structure

Bridge Number 62080 spans approximately 1,914 feet over I-94; RR; Commercial St. and carries two westbound and two eastbound lanes of Kellogg Blvd. The bridge deck is approximately 69.3 feet wide and consists of cast in place concrete with a low slump concrete wearing surface. The bridge superstructure consists of 7 prestressed concrete girders and a cast in place concrete deck. The substructure consists of cast in place concrete abutments and pier caps on 2 rectangular columns all bearing on steel piles. The longitudinal axis of the bridge is orientated approximately northeast to southwest. Refer to Images 2 and 3 for overall views of the bridge.



Image 2: Overall View of Bridge Topside.



Image 3: Overall View of Bridge Underside.

UAS INSPECTION REPORT

Bridge Number 62080 • Kellogg Blvd. over I-94; RR; Commercial St.
St. Paul, MN • August 2017



2.0 UAS OPERATION

2.1 UAS Equipment and Operating Conditions

A two-person crew, consisting of a professional engineer-pilot and inspection team leader, conducted the UAS inspection. The pilot was certified as a FAA Remote Pilot, and conducted the inspection using an Inspection and Mapping UAS. The aerial mapping UAS was a SenseFly Albris quadcopter equipped with a TripleView head consisting of a HD video camera, a 38MP still camera, and an infrared camera. Additionally, the Albris contains five acoustic sensors, GPS location, and image flow stabilization technology which aid both 3D preplanned and interactive flight missions. Refer to Image 4 for a view of the SenseFly Albris.



Image 4: View of SenseFly Albris.

During the inspection, the pilot worked with a mobile work station suspended from their body and maintained line-of-sight with the UAS. Aerial targets and a scale were placed prior to the aerial mapping mission to provide a higher level of accuracy. At the time of flight, the weather was clear with low wind. The bridge was located in Class B Airspace; thus, an FAA waiver or additional authorization was necessary for this mission to commence. The FAA waiver was submitted prior to mission start and was approved on July 5, 2017.

UAS INSPECTION REPORT

Bridge Number 62080 • Kellogg Blvd. over I-94; RR; Commercial St.
St. Paul, MN • August 2017



2.2 Mission Scope

A Mapping & Photogrammetry mission using the Albris was identified for this bridge to explore the potential of UAS photography to map defects on concrete reinforced piers. The target goal of the mission was to gather information in the form of photographs in a quick, efficient process which could later be used to map the concrete deck and have a post-inspection tool to aid in report writing and historical documentation. The mission consisted of a pre-planned flight path at an elevation of approximately 50 feet or less above ground level (AGL). The UAS collected high-resolution still images of the bridge piers. All images were geo-tagged with GPS coordinates. Refer to Images 5 and 6 for views of the Flight and Mapping Mission.



Image 5: View of Mission Flight Map (Preplanned and Interactive).

UAS INSPECTION REPORT

Bridge Number 62080 • Kellogg Blvd. over I-94; RR; Commercial St.
St. Paul, MN • August 2017

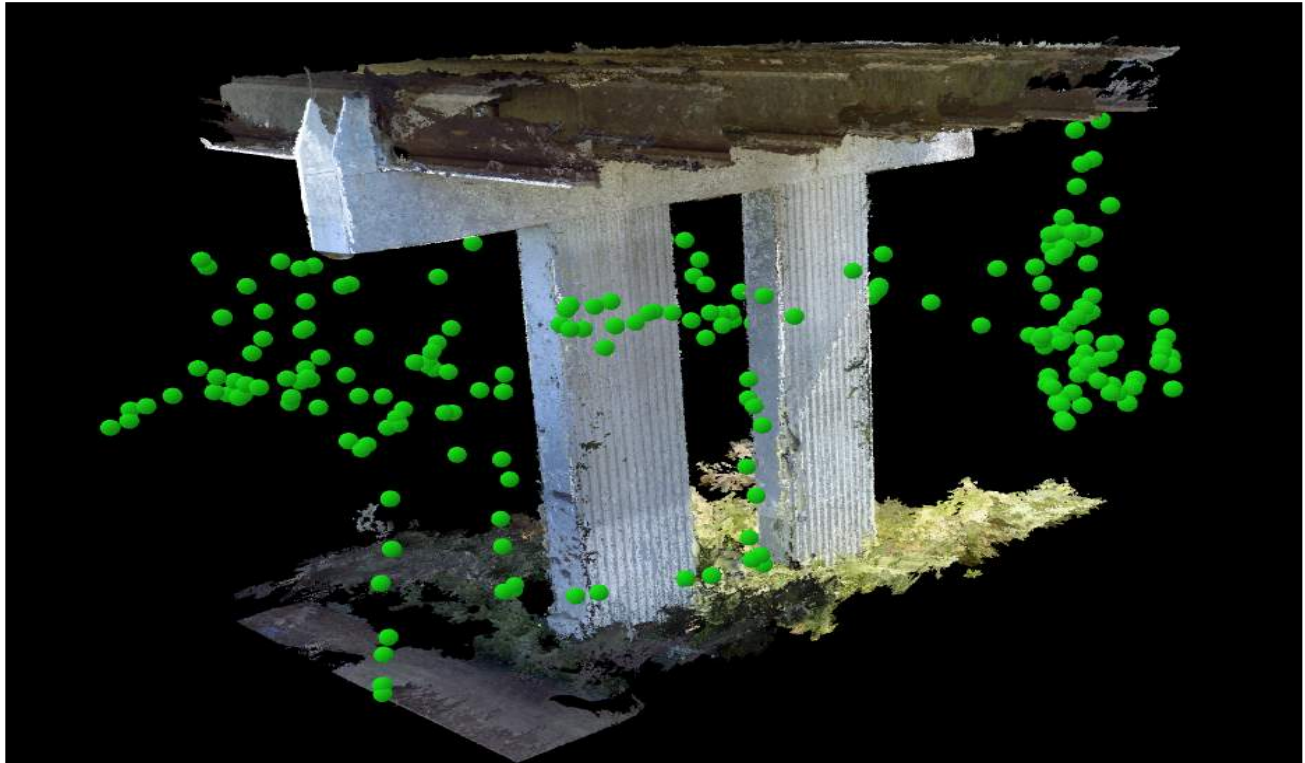

Image 6: View of Camera Position (Green Dot) at Locations of Photographing.

2.3 Deliverables

A 3D Model with a High-Resolution Photograph Log was processed for bridge. The target goal for this process was to determine the ease of use and applicability of having a 3D photolog to assist an inspector during post-processing, report writing, and future inspection. All photographs taken during the Mapping and Photogrammetry Mission were processed in the Pix4D software. The software processes all photographs to form a 3D point cloud for digital viewing. The point cloud was then processed by the same software to generate a 3D mesh of the bridge. An inspector was then able to navigate the 3D model and select areas or interest. The software provides the inspector with all still images containing the selected area of interest which can then be viewed in high resolution. Additionally, the inspector can place annotations within the file for future reference or for clarification when sharing the file. Refer to Image 7 for a view of the Inspector Tool providing a Photograph Log from a selected area of the 3D model, and Image 8 for a view of the detail included in the photo logs.

UAS INSPECTION REPORT

Bridge Number 62080 • Kellogg Blvd. over I-94; RR; Commercial St.
St. Paul, MN • August 2017



Image 7: View of the Inspector Tool providing a Photograph Log from a selected area of the 3D model. Note the annotated areas for future reference or ease of sharing.



Image 8: View of the Level of Detail in a Single High-Resolution Image.

UAS INSPECTION REPORT

Bridge Number 62080 • Kellogg Blvd. over I-94; RR; Commercial St.
St. Paul, MN • August 2017



Image 9: Orthomoplane of Pier Cap

3.0 SUMMARY OF FINDINGS

3.1 Opportunities

The execution of the Mapping and Photogrammetry Mission was a success and provided great insight into the potential for UAS as a tool during routine inspections. The set-up, flight, and data generation went as planned and was substantial enough to create the planned deliverables. Utilizing UAS to inspect these piers with known shear cracking proved to be an effective way to monitor, measure and document the cracks and deterioration. Utilizing UAS eliminates the need for expensive access equipment and creates deliverables that improve the quality of the inspection.

3.2 Limitations

There are railroad tracks and property nearby and if the piers near the tracks were inspected permissions from the railroad may be required.

3.3 Evaluation of Potential Cost Savings

Bridge 92080 - Based on Tone Pier Inspection Only								
Expense Description	Traditional Inspection Cost				UAS Assisted Inspection Cost			
	Quantity	Unit	Unit Price	Cost	Quantity	Unit	Unit Price	Cost
Bridge Inspection Team Leader	4	Hour	150	\$600	3	Hour	\$150	\$450
Assistant Bridge Inspector	4	Hour	120	\$480	3	Hour	\$120	\$360
Access Lift	0.5	Day	3,000	\$1,500	0	Day	\$3,000	\$0
Drone Rental	0	Day	300	\$0	1	Day	\$300	\$300
UAS Post Processing Engineer	0	Hour	120	\$0	2	Hour	\$120	\$240
Misc Traffic Control (Ped Only Etc)	0	Each	500	\$0	0	Each	\$500	\$0
Mobile Lane/Shoulder Closure	0	Each	1,500	\$0	0	Each	\$1,500	\$0
High Speed Lane/Shoulder Closure	0	Each	2,500	\$0	0	Each	\$2,500	\$0
			Traditional Inspection Cost	\$2,580			UAS Assisted Inspection Cost	\$1,350



UAS INSPECTION REPORT

BRIDGE NUMBER: 62090

TRUNK HIGHWAY 149 (SMITH AVE)

OVER MISSISSIPPI RIVER

ST. PAUL, MINNESOTA

June 12, 2017

Prepared for:



*As part of MnDOT Research Project
A-113 Improving Quality of Bridge Inspections Using Unmanned Aircraft Systems
(UAS) Phase III*

Prepared by:

COLLINS
ENGINEERS INC.

1599 Selby Avenue
St. Paul, MN 55104

651.646.8502 • www.collinsengr.com

UAS INSPECTION REPORT

Bridge Number 62090 • Trunk Highway 149 (Smith Ave) over Mississippi River
St. Paul, MN • June 2017



Table of Contents

1.0	INTRODUCTION	
1.1	Purpose and Scope	2
1.2	General Description of the Structure	2
2.0	UAS OPERATION	
2.1	UAS Equipment and Operating Conditions	3
2.2	Mission Scope	4
2.3	Deliverables.....	5
3.0	SUMMARY OF FINDINGS	
3.1	Opportunities	6
3.2	Limitations.....	6
3.3	Evaluation of Potential Cost Savings	7

Table of Images

Image 1: Location Map	1
Image 2: Overall View of Bridge.	2
Image 3: Overall View of Bridge Underside & Inspection Limits for Steel Arch.	2
Image 5: View of Steel Arch Entrance Hatch.	4
Image 6: View of Elios Inspecting a Splice in the Arch.	4
Image 7: View of Splice Cross Section.	4
Image 8: Image Clipped from Elios Inspection Video (Click Image to play video).	5
Image 10: View of Elios Inspecting an Arch Rib Section.	6
Image 11: View of Arch Rib Section	6

UAS INSPECTION REPORT

Bridge Number 62090 • Trunk Highway 149 (Smith Ave) over Mississippi River
St. Paul, MN • June 2017



EXECUTIVE SUMMARY

- Project:** Interior of Steel Arches Inspection Using UAS's of Bridge Number 62090.
- Purpose of Project:** To perform a partial inspection of select superstructure elements using unmanned aircraft system (UAS) techniques to determine the structural and physical condition of difficult to access bridge elements. The inspection is supplemental to a routine visual, tactile, and non-destructive testing inspection.
- Inspection Team:** Team Leader – Barritt Lovelace, P.E. (Pilot)
Team Member – Cory Stuber, P.E. (Crew Hand)
- Inspection Date(s):** June 12, 2017

Data Collection Tools:

- SenseFly Albris Flyability Elios Other: GoPro

Summary of Mission Scope(s) and Deliverable(s):

- Aerial Mapping & Photogrammetry 3D Model & High Resolution Photograph Log High Definition Video for Limited Access Areas
- Orthomosaic Image Creation for Inspection Defect Measurement Construction/Repair Plan Documentation
- Thermal Imaging Other: _____

Summary of Findings, Opportunities, and Limitations:

The execution of the confined space inspection was a success and provided great insight into the potential for UAS as a tool during complex bridge inspections. The set-up, flight, and data generation went as planned and was substantial enough to create the planned deliverables. The Flyability Elios Drone performed well and the ability to inspect a confined space bridge with the use of UAS improved safety and reduced costs. The use of UAS should be considered for an inspection as part of a risk based approach even if it is to supplement a hands-on inspection. The safety benefits alone can justify consideration as the arch is difficult to access and even a minor injury during an inspection could lead to a very difficult rescue or extraction. The quality of the video does not equal the quality of a hands-on arm's length inspection to this approach should be considered as part of a well thought out risk based inspection plan.

UAS INSPECTION REPORT

Bridge Number 62090 • Trunk Highway 149 (Smith Ave) over Mississippi River
St. Paul, MN • June 2017



1.0 INTRODUCTION

1.1 Purpose and Scope

This report consists of the results of an unmanned aircraft (UAS) inspection of Bridge Number 62090, Trunk Highway 149 (Smith Ave) over Mississippi River in St. Paul, Minnesota. Refer to Image 1 for a location map. Collins Engineers, Inc. (Collins) conducted the UAS Inspection for the Minnesota Department of Transportation (MnDOT) on June 12, 2017 as part of a research project titled “Improving Quality of Bridge Inspections Using Unmanned Aircraft Systems (UAS) Project Phase III”. The primary purpose of the UAS usage during the inspection was to identify possible opportunities and limitations of UAS involvement in various capacity of bridge inspection. The following report includes a brief description of the structure, description of UAS equipment and operating conditions, the mission scope and deliverables, a summary of findings, opportunities, and limitations, and an evaluation of potential cost savings.



Image 1: Location Map

UAS INSPECTION REPORT

Bridge Number 62090 • Trunk Highway 149 (Smith Ave) over Mississippi River
St. Paul, MN • June 2017



1.2 General Description of the Structure

Bridge Number 62090 spans approximately 2,769 feet over the Mississippi River and carries 1 northbound and 1 southbound lane of Trunk Highway 149 (Smith Ave). The bridge deck is approximately 54 feet wide and consists of cast in place concrete with a low slump concrete wearing surface. The bridge is an 11-span continuous steel and post-tensioned, tied steel arch bridge. The substructure consists of reinforced concrete abutments and pier walls all founded on piles. The longitudinal axis of the bridge is orientated approximately northwest to southeast. Refer to Images 2 and 3 for overall views of the bridge.



Image 2: Overall View of Bridge.



Image 3: Overall View of Bridge Underside & Inspection Limits for Steel Arch.

UAS INSPECTION REPORT

Bridge Number 62090 • Trunk Highway 149 (Smith Ave) over Mississippi River
St. Paul, MN • June 2017



2.0 UAS OPERATION

2.1 UAS Equipment and Operating Conditions

A three-person crew, consisting of a professional engineer-pilot and two field engineers, conducted the UAS inspection. The pilot was certified as a FAA Remote Pilot. The inspection was conducted using a Collision-Tolerant UAS. The Collision-Tolerant UAS was a Flyability Elios quadcopter equipped with a full HD camera, Infrared camera, and on-board lighting system. Additionally, the Elios has a protective frame surrounding the UAS body allowing for access to tight locations and up-close imaging. The action camera was a GoPro Hero 5 High-Resolution Camera. The camera was equipped with a 12 Megapixel still camera and a fisheye lens. Refer to Image 4 for a view of the Flyability Elios and Image 5 for a view of the GoPro Hero 5.



Image 4: View of Flyability Elios.

During the inspection, the pilot worked mobile work station suspended from his body. The flight mission was conducted entirely within the confines of the bridge structure; thus, no authorization was necessary from FAA. Access to the inside of the bridge's steel arch was necessary via MnDOT personnel.

UAS INSPECTION REPORT

Bridge Number 62090 • Trunk Highway 149 (Smith Ave) over Mississippi River
St. Paul, MN • June 2017



2.2 Mission Scope

A High Definition Video Mission was conducted of limited access areas using the Elios UAS. The target goal of this mission was to determine the quality and applicability of using a Collision-Tolerant UAS to capture images and assess the condition of enclosed steel arches. These bridge elements are typically not able to be inspected efficiently by inspectors given the confined space and physical size limitations. For this Mission, the pilot accessed the inside of the arch from a hatch located near the bottom of the arch where it ties into pier number 4. Refer to Image 5 and 6 for views of the arch inspected.

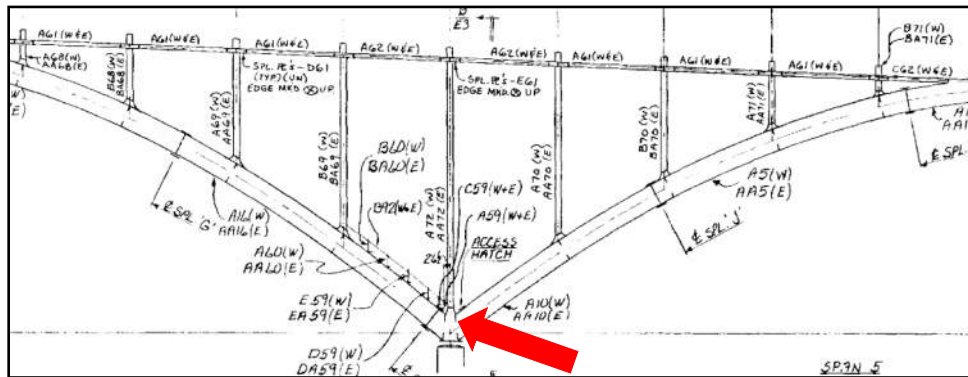

Image 5: View of Steel Arch Entrance Hatch.



Image 6: View of Elios Inspecting a Splice in the Arch.

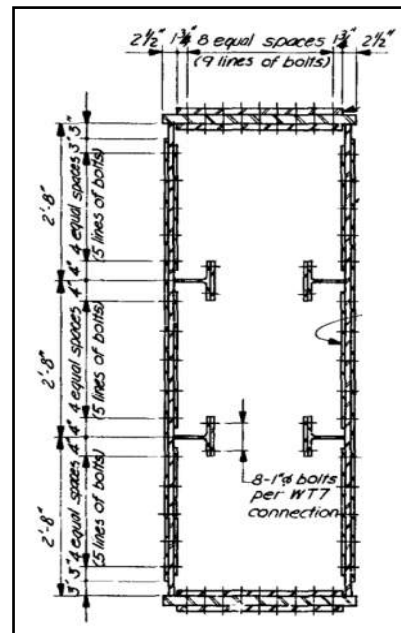

Image 7: View of Splice Cross Section.

UAS INSPECTION REPORT

Bridge Number 62090 • Trunk Highway 149 (Smith Ave) over Mississippi River
St. Paul, MN • June 2017



The lead pilot/inspector flew the mission in interactive live-time controlling. The live video stream was viewed throughout the inspection to provide both navigational awareness and look for areas of inspection interest. A total of seven flights were conducted through one girder line at Span 1. Each flight was progressively more thorough and inspected a longer stretch of the arch. The UAS was flown the inside at the bottom of the arches, up through the steel arch. The UAS was navigated using a combination of rolling the protective frame inside the arch walls along the floor and ceiling and free flying through the arch. The UAS used an on-board LED light for navigation to traverse its way through the arch.



Image 8: Image Clipped from Elios Inspection Video ([Click Image to play video](#)).

2.3 Deliverables

Video from the High Definition Video Mission using the Elios was viewed by an inspector after returning from the flight mission. The video could be observed in any software capable of playing .MP4 files. Additionally, the manufacturer of Elios, Flyability, has created an inspection software where the UASs flight log can be opened with the video file to show inspector UAS attributes such as heading, altitude, and temperature. The inspector can then maneuver their way through the video to obtain still images of defects or notable findings.

UAS INSPECTION REPORT

Bridge Number 62090 • Trunk Highway 149 (Smith Ave) over Mississippi River
St. Paul, MN • June 2017



Image 9: View of Elios Inspecting an Arch Rib Section.

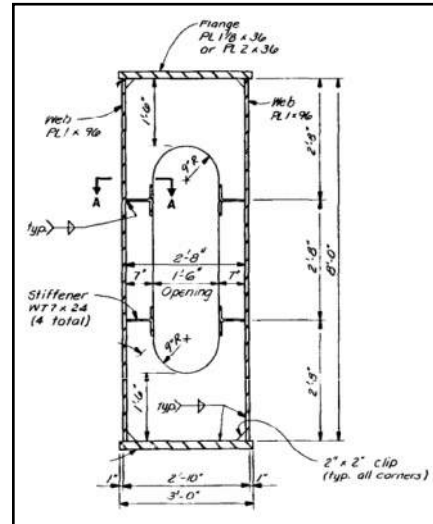

Image 10: View of Arch Rib Section.

3.0 SUMMARY OF FINDINGS

3.1 Opportunities

The execution of the confined space inspection was a success and provided great insight into the potential for UAS as a tool during complex bridge inspections. The set-up, flight, and data generation went as planned and was substantial enough to create the planned deliverables. The Flyability Elios Drone performed well and the ability to inspect a confined space bridge with the use of UAS improved safety and reduced costs. The use of UAS should be considered for an inspection as part of a risk based approach even if it is to supplement a hands-on inspection. The safety benefits alone can justify consideration as the arch is difficult to access and even a minor injury during an inspection could lead to a very difficult rescue or extraction.

3.2 Limitations

The quality of the video does not equal the quality of a hands-on arm's length inspection to this approach should be considered as part of a well thought out risk based inspection plan.

UAS INSPECTION REPORT

Bridge Number 62090 • Trunk Highway 149 (Smith Ave) over Mississippi River
 St. Paul, MN • June 2017



3.3 Evaluation of Potential Cost Savings

Bridge 92090 - Based on One Arch Span								
Expense Description	Traditional Inspection Cost				UAS Assisted Inspection Cost			
	Quantity	Unit	Unit Price	Cost	Quantity	Unit	Unit Price	Cost
Bridge Inspection Team Leader	8	Hour	150	\$1,200	4	Hour	\$150	\$600
Assistant Bridge Inspector	8	Hour	120	\$960	4	Hour	\$120	\$480
Under Bridge Inspection Vehicle with Operator	0	Day	3,000	\$0	0	Day	\$3,000	\$0
Drone Rental	0	Day	300	\$0	0	Day	\$300	\$0
UAS Post Processing Engineer	0	Hour	120	\$0	2	Hour	\$120	\$240
Boat Rental	1	Each	250	\$250	1	Each	\$250	\$250
Mobile Lane/Shoulder Closure	0	Each	1,500	\$0	0	Each	\$1,500	\$0
High Speed Lane/Shoulder Closure	0	Each	2,500	\$0	0	Each	\$2,500	\$0
			Traditional Inspection Cost	\$2,410			UAS Assisted Inspection Cost	\$1,570



UAS INSPECTION REPORT

BRIDGE NUMBER: 62504

SUMMIT AVE (MSAS 203)

OVER AYD MILL RD; CP RAIL

ST. PAUL, MINNESOTA

September 24, 2017

Prepared for:



*As part of MnDOT Research Project
A-123 Improving Quality of Bridge Inspections Using Unmanned Aircraft Systems
(UAS) Phase III*

Prepared by:

**COLLINS
ENGINEERS** INC.

1599 Selby Avenue
St. Paul, MN 55104

651.646.8502 • www.collinsengr.com

UAS INSPECTION REPORT

Bridge Number 62504 • Summit Ave (MSAS 203) Over AYD Mill Road; CP Rail
St. Paul, MN •September 2017



Table of Contents

1.0	INTRODUCTION	
1.1	Purpose and Scope	1
1.2	General Description of the Structure	2
2.0	UAS OPERATION	
2.1	UAS Equipment and Operating Conditions	3
2.2	Mission Scope	4
2.3	Deliverables.....	6
3.0	SUMMARY OF FINDINGS	
3.1	Opportunities	7
3.2	Limitations.....	7
3.3	Evaluation of Potential Cost Savings	8

Table of Images

Image 1: Location Map	1
Image 2: Overall View of Bridge.	2
Image 3: Overall View of Bridge Deck.	2
Image 4: View of SenseFly Albris.	3
Image 5: View of Mission Flight Map.	4
Image 6: View of Camera Positions at Time of Photographing.	5
Image 7: View of Flight Camera During Inspection.	5
Image 8: View of the Level of Detail in a Single High-Resolution Image.	6
Image 9: View of the Inspector Tool Within Pix4d.	7

UAS INSPECTION REPORT

Bridge Number 62504 • Summit Ave (MSAS 203) Over AYD Mill Road; CP Rail
St. Paul, MN • September 2017



EXECUTIVE SUMMARY

Project: Routine Inspection of Bridge Deck Using UAS's of Bridge Number 62504.

Purpose of Project: To perform a partial routine inspection using unmanned aircraft system (UAS) techniques to determine the structural and physical condition of the bridge deck. The inspection is supplemental to a routine visual, tactile, and non-destructive testing inspection.

Inspection Team: Team Leader – Barritt Lovelace, P.E. (Pilot)
Team Member – Cory Stuber, P.E. (Crew Hand)

Inspection Date(s): September 24, 2017

Data Collection Tools:

- SenseFly Albris Flyability Elios Other: _____

Summary of Mission Scope(s) and Deliverable(s):

- Aerial Mapping & Photogrammetry 3D Model & High Resolution Photograph Log High Definition Video for Limited Access Areas
- Orthomosaic Image Creation for Inspection Defect Measurement Construction/Repair Plan Documentation
- Thermal Imaging Other: _____

Summary of Findings, Opportunities, and Limitations:

The execution of the Mapping and Photogrammetry Mission was a success and provided great insight into the potential for UAS as a tool during routine inspections. The set-up, flight, and data generation went as planned and was substantial enough to create the planned deliverables. The utilization of UAS proved to be a very efficient way to map the bridge deck for inspection purposes. The entire time in the field was less than two hours and processing time was less than four hours. The area is typically busy with pedestrians and vehicular traffic so the inspection was completed on a Sunday morning when it was the least busy. The flight was continually monitored and paused several times to ensure the drone did not pose any safety issues by flying overhead.

UAS INSPECTION REPORT

Bridge Number 62504 • Summit Ave (MSAS 203) Over AYD Mill Road; CP Rail
St. Paul, MN • September 2017



1.0 INTRODUCTION

1.1 Purpose and Scope

This report consists of the results of an unmanned aircraft (UAS) inspection of Bridge Number 62504, Summit Ave (MSAS 203) over AYD Mill Road and Canadian Pacific Rail located in St. Paul, Minnesota. Refer to Image 1 for a location map. Collins Engineers, Inc. (Collins) conducted the UAS Inspection for the Minnesota Department of Transportation (MnDOT) on September 24, 2017 as part of a research project titled “Improving Quality of Bridge Inspections Using Unmanned Aircraft Systems (UAS) Project Phase III”. The primary purpose of the UAS usage during the inspection was to identify possible opportunities and limitations of UAS involvement in various capacity of bridge inspection. The following report includes a brief description of the structure, description of UAS equipment and operating conditions, the mission scope and deliverables, a summary of findings, opportunities, and limitations, and an evaluation of potential cost savings.

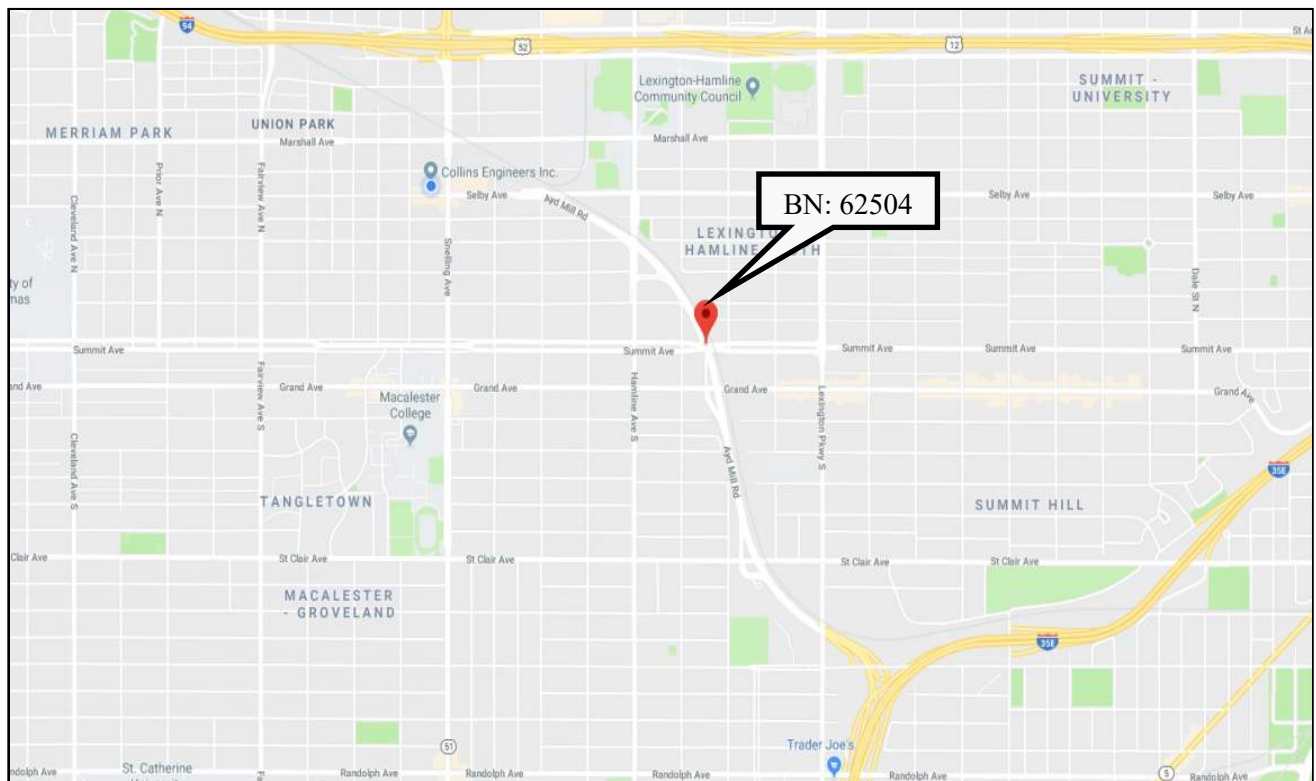

Image 1: Location Map

UAS INSPECTION REPORT

Bridge Number 62504 • Summit Ave (MSAS 203) Over AYD Mill Road; CP Rail
St. Paul, MN • September 2017



1.2 General Description of the Structure

Bridge Number 62504 spans approximately 214 feet over AYD Mill Road and carries two east bound and two west bound lanes of Summit Ave. The bridge deck is approximately 101.6 feet wide and consists of cast in place concrete with a low slump concrete wearing surface. The bridge superstructure consists of sixteen continuous steel beams and the bridge substructure consists of concrete abutments and piers bearing on piles. The longitudinal axis of the bridge is orientated approximately east to west. Refer to Images 2 and 3 for overall views of the bridge.



Image 2: Overall View of Bridge.



Image 3: Overall View of Bridge Deck.

UAS INSPECTION REPORT

Bridge Number 62504 • Summit Ave (MSAS 203) Over AYD Mill Road; CP Rail
St. Paul, MN • September 2017



2.0 UAS OPERATION

2.1 UAS Equipment and Operating Conditions

A one-person crew, consisting of a professional engineer-pilot, conducted the UAS inspection. The pilot was certified as a FAA Remote Pilot, and conducted the inspection using an Inspection and Mapping UAS. The aerial mapping UAS was a SenseFly Albris quadcopter equipped with a TripleView head consisting of a HD video camera, a 38MP still camera, and an infrared camera. Additionally, the Albris contains five acoustic sensors, GPS location, and image flow stabilization technology which aid both 3D preplanned and interactive flight missions. Refer to Image 4 for a view of the SenseFly Albris.



Image 4: View of SenseFly Albris.

During the inspection, the pilot worked mobile work station suspended from his body and maintained line-of-sight with the UAS. Aerial targets and a scale were placed prior to the aerial mapping mission to provide a higher level of accuracy. At the time of flight, the weather was clear with low wind. The bridge was located in Class B Airspace; thus, an FAA waiver or additional authorization was necessary for this mission to commence. The FAA waiver was submitted prior to mission start and was approved on July 10, 2017.

UAS INSPECTION REPORT

Bridge Number 62504 • Summit Ave (MSAS 203) Over AYD Mill Road; CP Rail
St. Paul, MN • September 2017



2.2 Mission Scope

A Mapping & Photogrammetry mission using the Albris was identified for this bridge to explore the potential of UAS photography to map bituminous deck surface defects. The target goal of the mission was to gather information in the form of photographs in a quick, efficient process which could later be used to map the deck and have a post-inspection tool to aid in report writing and historical documentation. Additionally, the ease of use in an urban environment was displayed. The mission consisted of a pre-planned flight path that imaged the top of deck and both north and south fascia. The UAS collected over 192 high-resolution still images of the bridge fascia and top side. All images were geo-tagged with GPS coordinates. Refer to Images 5-7 for views of the Flight and Mapping Mission.



Image 5: View of Mission Flight Map (Preplanned and Interactive).

UAS INSPECTION REPORT

Bridge Number 62504 • Summit Ave (MSAS 203) Over AYD Mill Road; CP Rail
St. Paul, MN • September 2017

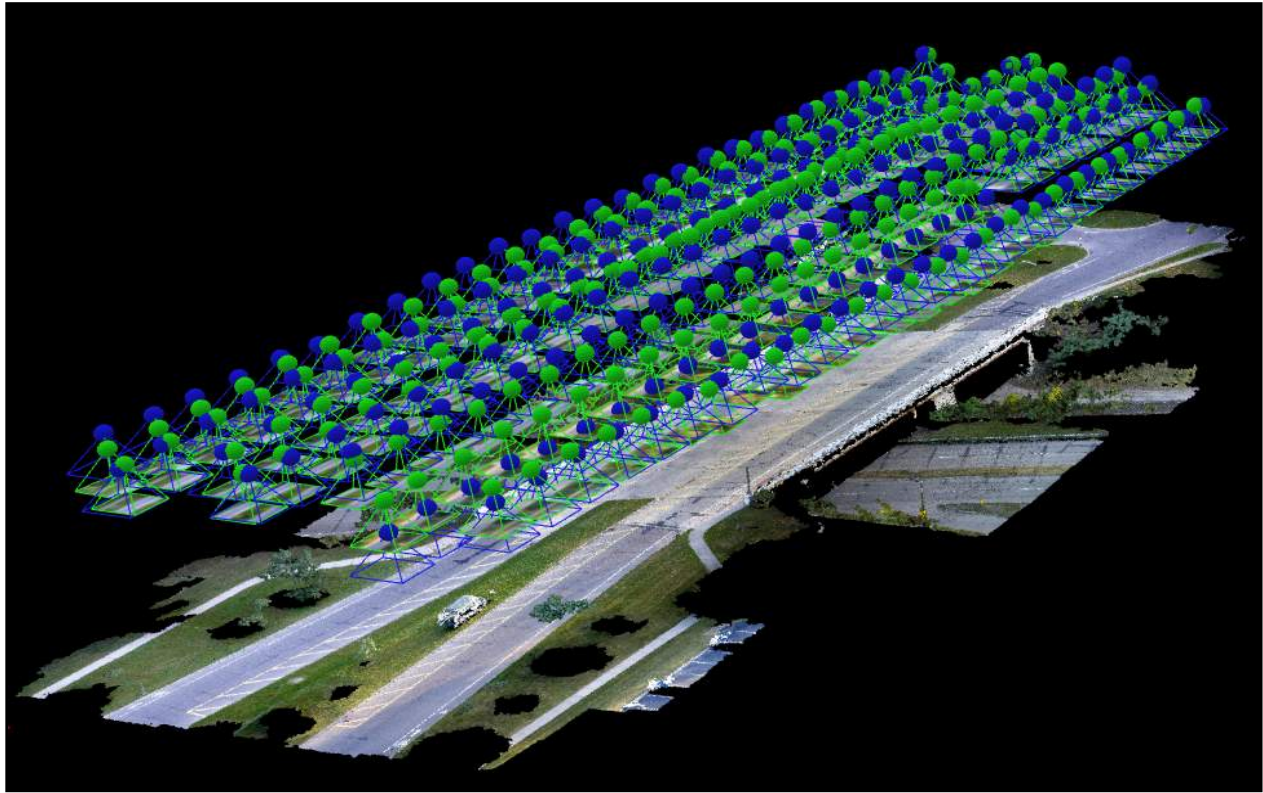

Image 6: View of Camera Position (Green Dot) at Locations of Photographing.

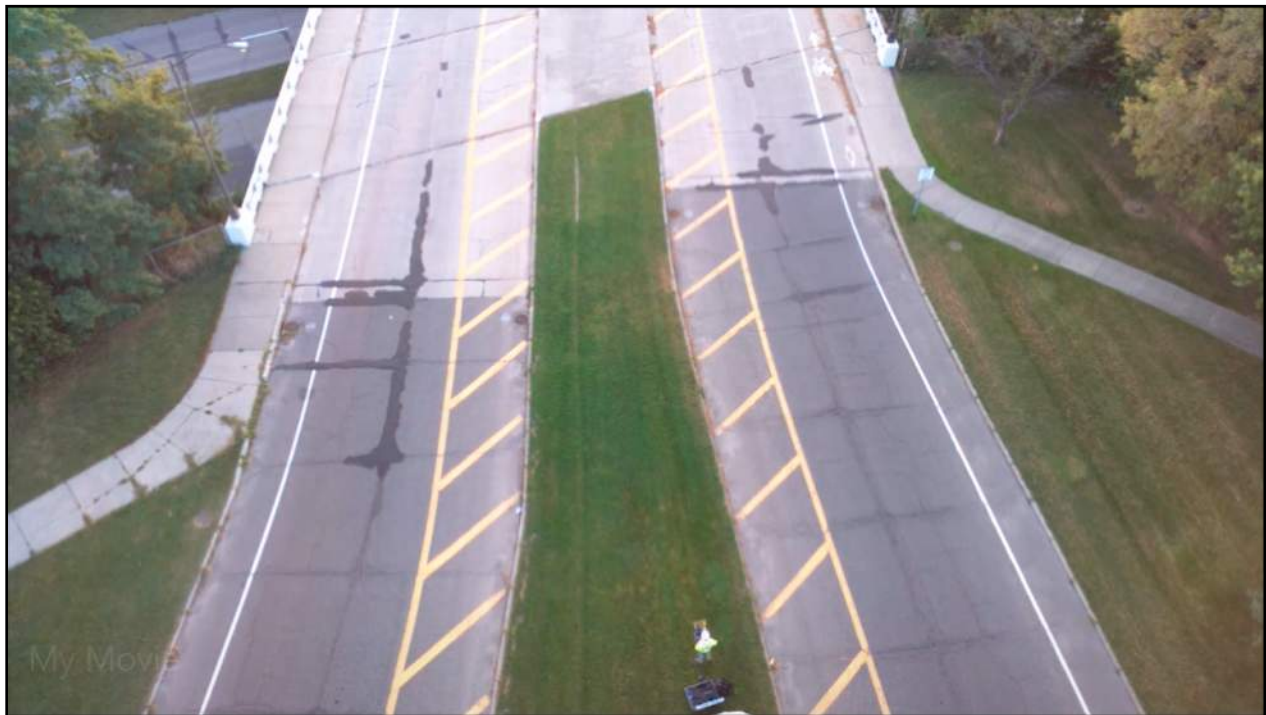

Image 7: View Flight Camera During Inspection. [\(Click Image to play video\)](#).

2.3 Deliverables

An Orthomosaic image was created in the Pix4D software to use as an inspection tool. The target goal for this process was to produce an easily viewable, high resolution image of a large area that could be used by an inspector to carry out a detailed inspection, area measurements, condition assessment, or historical documentation. An Orthomosaic image is a single image file which is created from many individual images captured during the Mapping and Photogrammetry Mission. The final product of an Orthomosaic image is an image file that can be used to measure true distances. For this bridge, an Orthomosaic image was made of the entire bridge deck. An inspector then reviewed a single file and can measure true distances and areas for a final product. Refer to Image 8 for a view of Orthomosaic Detail.

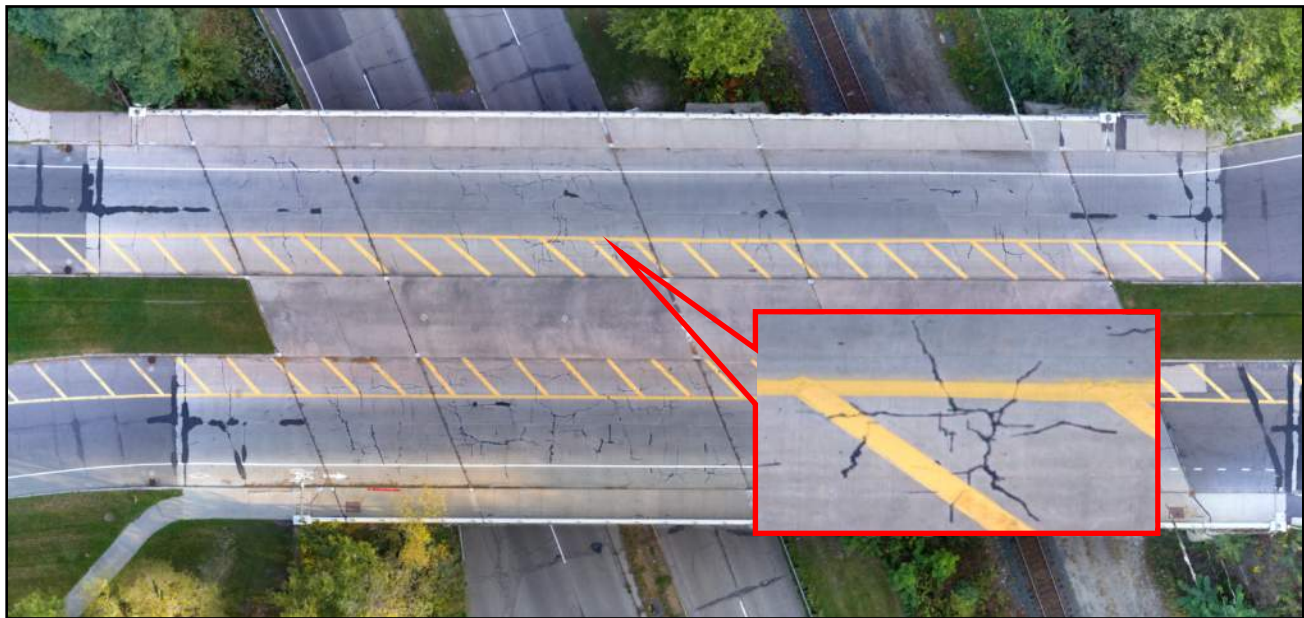

Image 8: View of the Level of Detail in a Single High-Resolution Image. [\(Click Image to Access Video\)](#)

A 3D Model with a High-Resolution Photograph Log was processed for bridge. The target goal for this process was to determine the ease of use and applicability of having a 3D photolog to assist an inspector during post-processing, report writing, and future inspection. Additionally, the applicability of an easily manipulated 3D model which could be shared with others was explored. All photographs taken during the Mapping and Photogrammetry Mission were processed in the Pix4D and SketchFab software. The software processes all photographs to form a 3D point cloud for digital viewing. The point cloud was then processed by the same software to generate a 3D mesh of the bridge.

UAS INSPECTION REPORT

Bridge Number 62504 • Summit Ave (MSAS 203) Over AYD Mill Road; CP Rail
St. Paul, MN • September 2017



An inspector was able to use the Pix4D program to navigate the 3D model and select areas of interest. The software provides the inspector with all still images containing the selected area of interest which can then be viewed in high resolution. Additionally, the inspector can place annotations within the file for future reference or for clarification when sharing the file. Refer to Image 12 for a view of the Inspector Tool providing a Photograph Log from a selected area of the 3D model.

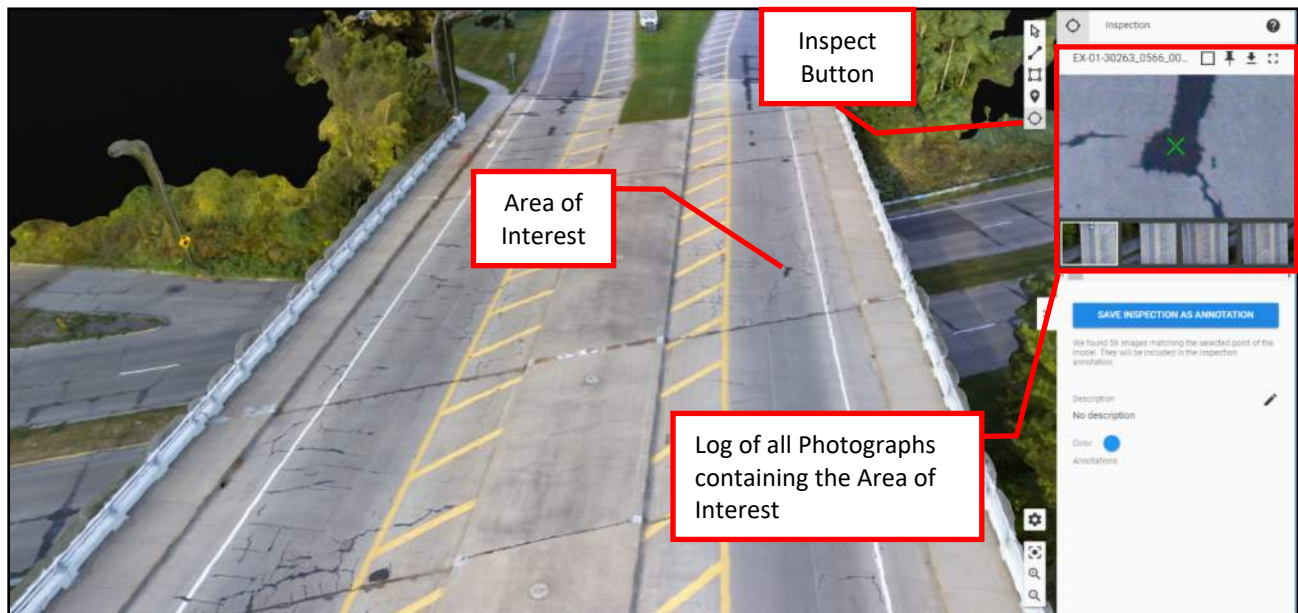

Image 9: View of the Inspector Tool providing a Photograph Log from a selected area of the 3D model.

(Click Image to access 3D Model and Inspection Photolog – Click on the Inspect Button)

3.0 SUMMARY OF FINDINGS

3.1 Opportunities

The execution of the Mapping and Photogrammetry Mission was a success and provided great insight into the potential for UAS as a tool during routine inspections. The set-up, flight, and data generation went as planned and was substantial enough to create the planned deliverables. The utilization of UAS proved to be a very efficient way to map the bridge deck for inspection purposes. The entire time in the field was less than two hours and processing time was less than four hours.

3.2 Limitations

The area is busy with pedestrians and vehicular traffic so the inspection was completed on a Sunday morning when it was the least busy. The flight was continually monitored and paused several times to ensure the drone did not pose any safety issues by flying overhead.

UAS INSPECTION REPORT

Bridge Number 62504 • Summit Ave (MSAS 203) Over AYD Mill Road; CP Rail
 St. Paul, MN • September 2017



3.3 Evaluation of Potential Cost Savings

Bridge 62504- Based on Deck Mapping Only								
Expense Description	Traditional Inspection Cost				UAS Assisted Inspection Cost			
	Quantity	Unit	Unit Price	Cost	Quantity	Unit	Unit Price	Cost
Bridge Inspection Team Leader	8	Hour	150	\$1,200	2	Hour	\$150	\$300
Assistant Bridge Inspector	8	Hour	120	\$960	2	Hour	\$120	\$240
Under Bridge Inspection Vehicle with Operator	0	Day	3,000	\$0	0	Day	\$3,000	\$0
Drone Rental	0	Day	300	\$0	0	Day	\$300	\$0
UAS Post Processing Engineer	0	Hour	120	\$0	4	Hour	\$120	\$480
Misc Traffic Control (Ped Only Etc)	0	Each	500	\$0	0	Each	\$500	\$0
Mobile Lane/Shoulder Closure	1	Each	1,500	\$1,500	0	Each	\$1,500	\$0
High Speed Lane/Shoulder Closure	0	Each	2,500	\$0	0	Each	\$2,500	\$0
			Traditional Inspection Cost	\$3,660			UAS Assisted Inspection Cost	\$1,020



UAS INSPECTION REPORT

BRIDGE NUMBER: 82045

TRUNK HIGHWAY 36

OVER THE ST. CROIX RIVER

OAK PARK HEIGHTS, MINNESOTA

September 15, 2017

Prepared for:



*As part of MnDOT Research Project
A-134 Improving Quality of Bridge Inspections Using Unmanned Aircraft Systems
(UAS) Phase III*

Prepared by:

**COLLINS
ENGINEERS** INC.

1599 Selby Avenue
St. Paul, MN 55104

651.646.8502 • www.collinsengr.com

UAS INSPECTION REPORT

Bridge Number 82045 • Trunk Highway 36 over the St. Croix River
Oak Park Heights, MN • September 2017



Table of Contents

1.0	INTRODUCTION	
1.1	Purpose and Scope	1
1.2	General Description of the Structure	2
2.0	UAS OPERATION	
2.1	UAS Equipment and Operating Conditions	3
2.2	Mission Scope	4
2.3	Deliverables.....	8
3.0	SUMMARY OF FINDINGS	
3.1	Opportunities	9
3.2	Limitations.....	9
3.3	Evaluation of Potential Cost Savings	9

Table of Images

Image 1: Location Map	1
Image 2: Overall View of Bridge.	2
Image 3: Overall View of Inside of Box Girder.	2
Image 4: View of SenseFly Albris.	3
Image 5: View of Flyability Elios.	3
Image 6: View of Sony Alpha A75 II.	4
Image 7: View of GoPro Hero 5.	4
Image 8: View of Mission Flight Map (Interactive).	5
Image 9: View of Albris Gathering Detailed Photographs of Box Girder.	6
Image 10: View of Elios Inspecting a Hard to Reach Area.	7
Image 11: View of Elios Inspecting a Hard to Reach Face of Girder.	7
Image 12: Image Clipped from Elios Inspection Video.	7
Image 13: 3D Model of Inside of Box Girder.	8
Image 14: Actual View of Inside of Box Girder.	8

UAS INSPECTION REPORT

Bridge Number 82045 • Trunk Highway 36 over the St. Croix River
Oak Park Heights, MN • September 2017



EXECUTIVE SUMMARY

Project: Post-Tensioned Concrete Box Girder Inspection Using UAS's of Bridge Number 82045.

Purpose of Project: To perform a partial inspection of select superstructure elements using unmanned aircraft system (UAS) techniques to determine the structural and physical condition of difficult to access bridge elements. The inspection is supplemental to a routine visual, tactile, and non-destructive testing inspection.

Inspection Team: Team Leader – Barritt Lovelace, P.E. (Pilot)
Team Member – Cory Stuber, P.E. (Crew Hand)

Inspection Date(s): September 15, 2017

Data Collection Tools:

- SenseFly Albris Flyability Elios Other: GoPro Hero 5
- Other: Digital Cameras

Summary of Mission Scope(s) and Deliverable(s):

- | | | |
|---|---|--|
| <input checked="" type="checkbox"/> Aerial Mapping & Photogrammetry | <input checked="" type="checkbox"/> 3D Model & High Resolution Photograph Log | <input checked="" type="checkbox"/> High Definition Video for Limited Access Areas |
| <input type="checkbox"/> Orthomosaic Image Creation for Inspection | <input type="checkbox"/> Defect Measurement | <input type="checkbox"/> Construction/Repair Plan Documentation |
| <input type="checkbox"/> Thermal Imaging | <input type="checkbox"/> Other: _____ | |

Summary of Findings, Opportunities, and Limitations:

The execution of the Mapping and Photogrammetry Mission was a success and provided great insight into the potential for UAS as a tool during routine inspections. The set-up, flight, and data generation went as planned and was substantial enough to create the planned deliverables. Flying a drone inside of the box was very low risk and improved the ability of the inspector to view hard to access areas. Both the Sensefly Albris and the Flyability Elios worked well for their intended missions. The ultrasonic distance lock and cruise control features of the Albris worked very well to map the interior and get consistent image overlap. The Elios worked well to view limited access areas especially the towers.

UAS INSPECTION REPORT

Bridge Number 82045 • Trunk Highway 36 over the St. Croix River
Oak Park Heights, MN • September 2017



1.0 INTRODUCTION

1.1 Purpose and Scope

This report consists of the results of an unmanned aircraft (UAS) inspection of the inside of the box girder for Bridge Number 82045, Trunk Highway 36 over the St. Croix River located in Oak Park Heights, Minnesota. Refer to Image 1 for a location map. Collins Engineers, Inc. (Collins) conducted the UAS Inspection for the Minnesota Department of Transportation (MnDOT) on September 15, 2017 as part of a research project titled “Improving Quality of Bridge Inspections Using Unmanned Aircraft Systems (UAS) Project Phase III”. The primary purpose of the UAS usage during the inspection was to identify possible opportunities and limitations of UAS involvement in various capacity of bridge inspection. The following report includes a brief description of the structure, description of UAS equipment and operating conditions, the mission scope and deliverables, a summary of findings, opportunities, and limitations, and an evaluation of potential cost savings.



Image 1: Location Map

UAS INSPECTION REPORT

Bridge Number 82045 • Trunk Highway 36 over the St. Croix River
Oak Park Heights, MN • September 2017



1.2 General Description of the Structure

Bridge Number 82045 spans approximately 3,360 feet over the St. Croix River and carries two eastbound and two westbound lanes of Trunk Highway 36. The bridge deck is approximately 99 feet wide and is a concrete extradosed bridge. The substructure consists of reinforced concrete abutments and piers all founded on piles. The longitudinal axis of the bridge is orientated approximately northeast to southwest. Refer to Images 2 and 3 for overall views of the bridge.



Image 2: Overall View of Bridge.



Image 3: Overall View of Inside of a Box Girder.

2.0 UAS OPERATION

UAS INSPECTION REPORT

Bridge Number 82045 • Trunk Highway 36 over the St. Croix River
Oak Park Heights, MN • September 2017



2.1 UAS Equipment and Operating Conditions

A two-person crew, consisting of a professional engineer-pilot and a field engineer, conducted the UAS inspection. The pilot was certified as a FAA Remote Pilot. The inspection was conducted using two different registered UAS's; an Inspection and Mapping UAS and an Collision-Tolerant UAS. The aerial mapping UAS was a SenseFly Albris quadcopter equipped with a TripleView head consisting of a HD video camera, a 38MP still camera, and an infrared camera. Additionally, the Albris contains five acoustic sensors, GPS location, and image flow stabilization technology which aid both 3D preplanned and interactive flight missions. The Collision-Tolerant UAS was a Flyability Elios quadcopter equipped with a full HD camera, Infrared camera, and on-board lighting system. Additionally, the Elios has a protective frame surrounding the UAS body allowing for access to tight locations and up-close imaging. Refer to Image 4 for a view of the SenseFly Albris and Image 5 for a view of the Flyability Elios.



Image 4: View of SenseFly Albris.



Image 5: View of Flyability Elios.

During the inspection, the pilot worked mobile work station suspended from his body and the other crew member maintained line-of-sight with the UAS. A scale was placed prior to the mapping mission to provide a higher level of accuracy. The entirety of flight was conducted inside the bridge's box girder which hindered the GPS connection meaning the flight was conducted in interactive mode. The bridge was located in Class G Airspace and all work was inside of the bridge; thus, no FAA waiver or additional authorization was necessary.

UAS INSPECTION REPORT

Bridge Number 82045 • Trunk Highway 36 over the St. Croix River
Oak Park Heights, MN • September 2017



In addition to the UASs a high-resolution action camera, and a phone camera were used to capture photographs from the ground. The action camera was a GoPro Hero 5 High-Resolution Camera. The camera was equipped with a 12 Megapixel still camera and a fisheye lens. The phone camera was a Samsung Galaxy S8 with a 12MP camera and a f/1.7 lens. Refer to Image 6 for a view of the GoPro Hero 5.



Image 6: View of GoPro Hero 5.

2.2 Mission Scope

An interior inspection mission using the Albris and Elios was identified for this bridge to explore the potential of UAS photography to perform inspection of confined spaces with limited access areas. The target goal of the mission was to gather information in the form of photographs in a quick, efficient process which could later be used to create a 3D model and high-resolution photo log of the post-tensioned box girder, and have a post-inspection tool to aid in report writing and historical documentation. As well as a 3D model and photo log, the Elios was also utilized to demonstrate the capabilities to obtain high definition video of limited access areas which would otherwise be challenging and time consuming to do by regular inspection. These areas included the inside of the box girders and the pier towers. The UAS collected 113 high-resolution still images of the inside of the box girder. Refer to Images 7 and 8 for views of the Flight and Mapping Mission.

UAS INSPECTION REPORT

Bridge Number 82045 • Trunk Highway 36 over the St. Croix River
Oak Park Heights, MN • September 2017

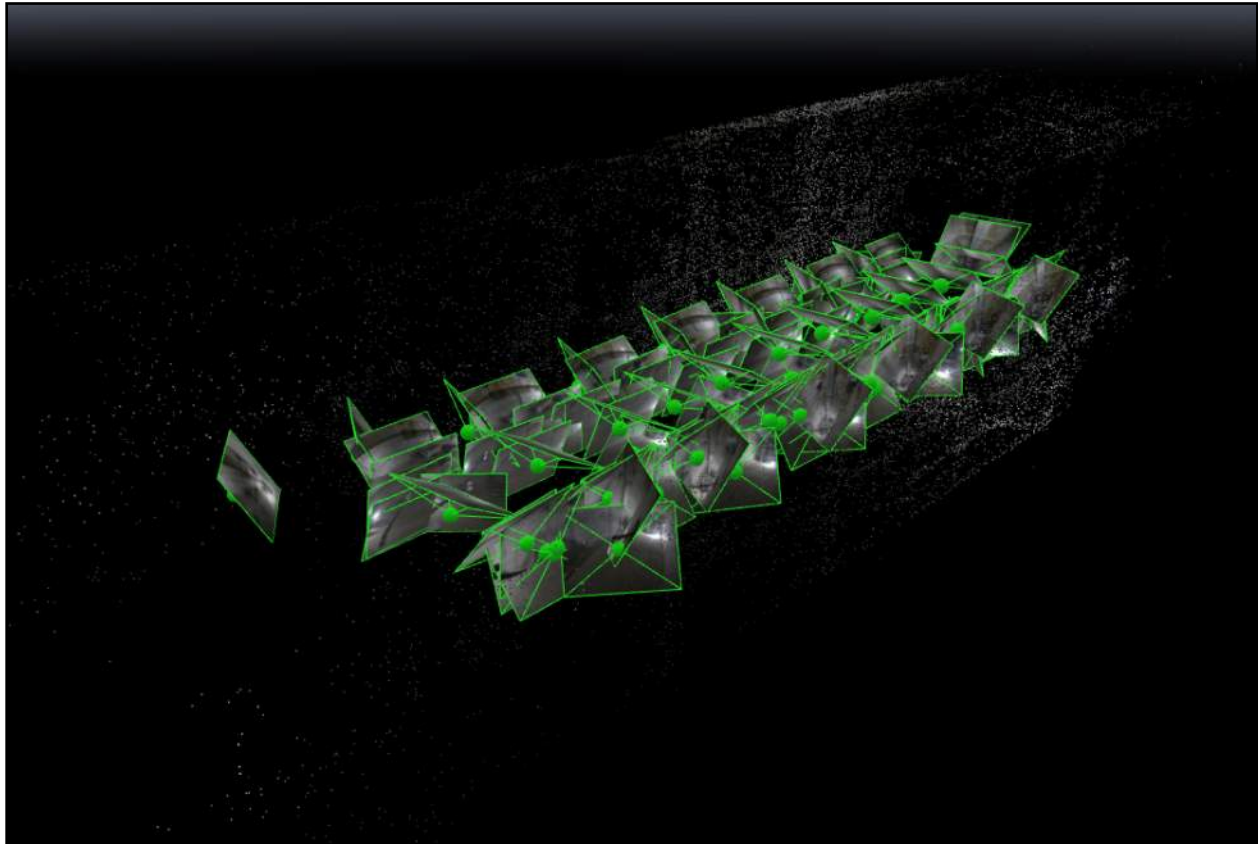

Image 7: View of Mission Flight Map (Interactive).



Image 8: View of Albris Gathering Detailed Photographs of Girder.

UAS INSPECTION REPORT

Bridge Number 82045 • Trunk Highway 36 over the St. Croix River
Oak Park Heights, MN • September 2017



A High Definition Video Mission was conducted of limited access areas using the Elios UAS. The target goal of this mission was to determine the quality and applicability of using a Collision-Tolerant UAS to capture images and assess the condition of bridge elements which are typically not visually or tactically accessible during the scope of a routine inspection. The mission consisted of an interactive flight using only pilot controls. During a typical routine inspection, the interior of the concrete box girder and pier towers were flown. The use of the Elios UAS focuses on these difficult to access locations. An inspector can then review the video footage to look for defects or inspection findings. Refer to Images 9 and 10 for views of the Elios UAS in a difficult to access locations, and image 11 and 12 to see the full video of the Elios in action.



Image 9: View of Elios Inspecting a Hard to Reach Area.



Image 10: View of Elios Inspecting a Hard to Reach Face of Girder.

UAS INSPECTION REPORT

Bridge Number 82045 • Trunk Highway 36 over the St. Croix River
Oak Park Heights, MN • September 2017



Image 11: Image Clipped from Elios Box Girder Inspection Video ([Click Image to play video](#)).

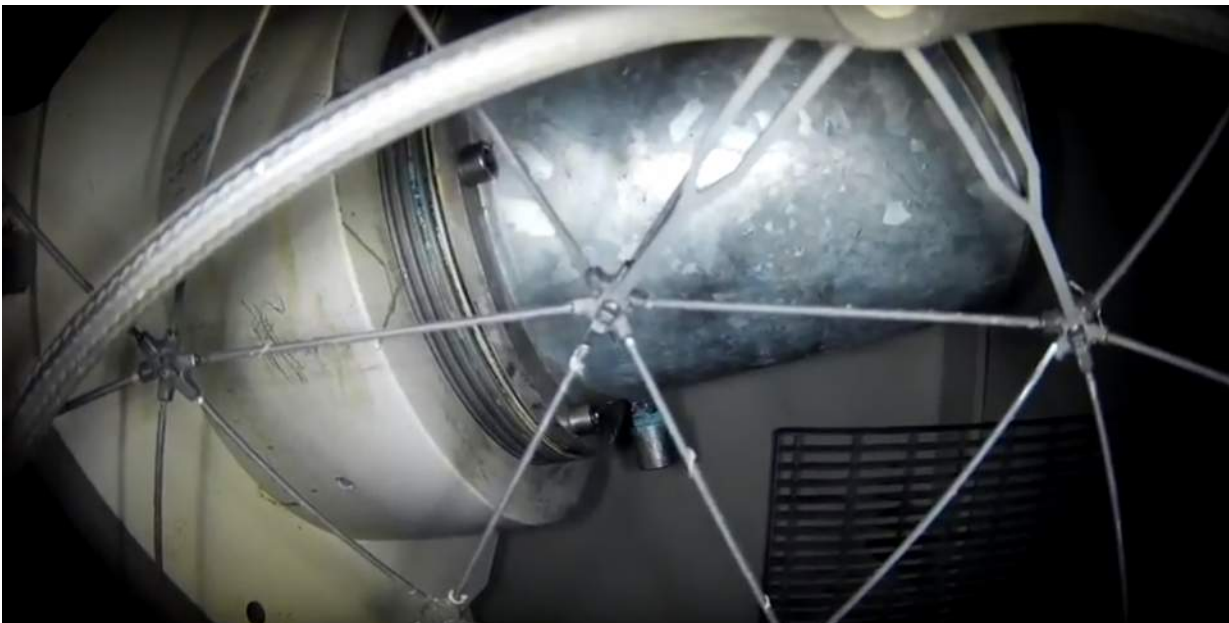

Image 12: Image Clipped from Elios Pier Tower Inspection Video ([Click Image to play video](#)).

2.3 Deliverables

A 3D Model with a High-Resolution Photograph Log was processed for the bridge interior. The target goal for this process was to determine the ease of use and applicability of having a 3D photolog to assist an inspector during post-processing, report writing, and future inspection. All photographs taken during the Mapping and Photogrammetry Mission were processed in the Pix4D software. The software processes all photographs to form a 3D point cloud for digital viewing. The point cloud was then processed by the same software to generate a 3D mesh of the bridge. An inspector was then able to navigate the 3D model and select areas or interest. The software provides the inspector with all still images containing the selected area of interest which can then be viewed in high resolution. Additionally, the inspector can place annotations within the file for future reference or for clarification when sharing the file. Refer to Image 13 for a view of the 3D model and image 14 for an photo from the same angle.



Image 13: 3D model of the Inside of the Box Girder.
(Click Image to access 3D Model)



Image 14: Actual view of the Inside of the Box Girder.

UAS INSPECTION REPORT

Bridge Number 82045 • Trunk Highway 36 over the St. Croix River

Oak Park Heights, MN • September 2017



3.0 SUMMARY OF FINDINGS

3.1 Opportunities

The execution of the Mapping and Photogrammetry Mission was a success and provided great insight into the potential for UAS as a tool during routine inspections. The set-up, flight, and data generation went as planned and was substantial enough to create the planned deliverables. Flying a drone inside of the box was very low risk and improved the ability of the inspector to view hard to reach areas. Both the Sensefly Albris and the Flyability Elios worked well for their intended missions. The ultrasonic distance lock and cruise control features of the Albris worked very well to map the interior and get consistent image overlap. The Elios worked well to view limited access areas especially the towers.

3.2 Limitations

The inside of the bridge was very dusty and the UAS disturbed the dust enough to degrade the image quality. This was solved

3.3 Evaluation of Potential Cost Savings

For the St. Croix Crossing Bridge cost savings can be found in efficiencies from not needing ladders, lifts or scaffolding to reach the higher interior areas of the box girder.

Bridge 82045 - Based on One Box Girder Span Only								
Expense Description	Traditional Inspection Cost				UAS Assisted Inspection Cost			
	Quantity	Unit	Unit Price	Cost	Quantity	Unit	Unit Price	Cost
Bridge Inspection Team Leader	8	Hour	150	\$1,200	6	Hour	\$150	\$900
Assistant Bridge Inspector	8	Hour	120	\$960	6	Hour	\$120	\$720
Access Equipment	1	Day	500	\$500	0	Day	\$3,000	\$0
Drone Rental	0	Day	300	\$0	1	Day	\$300	\$300
UAS Post Processing Engineer	0	Hour	120	\$0	0	Hour	\$120	\$0
Misc Traffic Control (Ped Only Etc)	0	Each	500	\$0	0	Each	\$500	\$0
Mobile Lane/Shoulder Closure	0	Each	1,500	\$0	0	Each	\$1,500	\$0
High Speed Lane/Shoulder Closure	0	Each	2,500	\$0	0	Each	\$2,500	\$0
			Traditional Inspection Cost	\$2,660			UAS Assisted Inspection Cost	\$1,920

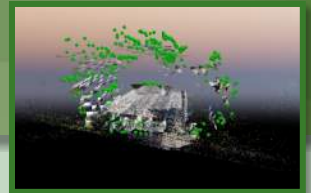
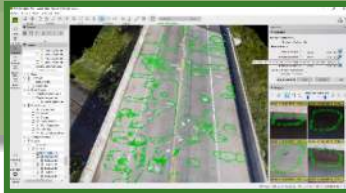

UAS INSPECTION REPORT

BRIDGE NUMBER: 82502

COUNTY ROAD 51

OVER THE WS LIMITED RR

STILLWATER, MINNESOTA

July & August, 2017

Prepared for:



*As part of MnDOT Research Project
A-146 Improving Quality of Bridge Inspections Using Unmanned Aircraft Systems
(UAS) Phase III*

Prepared by:

**COLLINS
ENGINEERS** INC.

1599 Selby Avenue
St. Paul, MN 55104
651.646.8502 • www.collinsengr.com

UAS INSPECTION REPORT

Bridge Number 82502 • County Road 51 over the WS Limited RR
Stillwater, MN • July – August 2017



Table of Contents

1.0	INTRODUCTION	
1.1	Purpose and Scope	1
1.2	General Description of the Structure	3
2.0	UAS OPERATION	
2.1	UAS Equipment and Operating Conditions	4
2.2	Mission Scope	6
2.3	Deliverables.....	11
3.0	SUMMARY OF FINDINGS	
3.1	Opportunities	16
3.2	Limitations.....	16
3.3	Evaluation of Potential Cost Savings	16

Table of Images

Image 1: Location Map	1
Image 2: Overall View of Bridge Topside.	2
Image 3: Overall Elevation View of Bridge.	2
Image 4: View of SenseFly Albris.	3
Image 5: View of Flyability Elios.	3
Image 6: View of Pilot and Mobile Work Station.	4
Image 7: View of Sub-Mission 1 Flight Map.	6
Image 8: View of Sub-Mission 1 Camera Position (Green Dot) at Locations of Photographing.	6
Image 9: View of Sub-Mission 2 Flight Map.	7
Image 10: View of Sub-Mission 2 Camera Position (Green Dot) at Locations of Photographing.	7
Image 11: View of Sub-Mission 3 Flight Map.	8
Image 12: View of Sub-Mission 3 Camera Position (Green Dot) at Locations of Photographing.	8
Image 13: Image of Hard to Access Locations.	9
Image 14: Image of Hard to Access Locations.	10
Image 15: View of the Sub-Mission 3 Orthomosaic and Area measurement.	11
Image 16: View of the Sub-Mission 1 Orthomosaic detail.	12
Image 17: View of the Sub-Mission 2 Orthomosaic detail.	12
Image 18: View of the Sub-Mission 3 Orthomosaic detail.	12
Image 19: View of the Model a Photograph Log from a selected area of the 3D model.	13
Image 20: View of a Screenshot from the Elios Inspection Video	14

UAS INSPECTION REPORT

Bridge Number 82502 • County Road 51 over the WS Limited RR
Stillwater, MN • July – August 2017



EXECUTIVE SUMMARY

- Project:** Deck Condition Survey Using UAS's of Bridge Number 82502.
- Purpose of Project:** To perform a detailed concrete deck element condition assessment using unmanned aircraft system (UAS) techniques to determine the structural and physical condition as well a platform for documenting detailed defect measures.
- Inspection Team:** Team Leader – Barritt Lovelace, P.E. (Pilot)
Team Member – Cory Stuber, P.E. (Crew Hand)
- Inspection Date(s):** July and August 2017

Data Collection Tools:

- SenseFly Albris Flyability Elios Other: Digital Camera

Summary of Mission Scope(s) and Deliverable(s):

- Aerial Mapping & Photogrammetry 3D Model & High Resolution Photograph Log High Definition Video for Limited Access Areas
- Orthomosaic Image Creation for Inspection Defect Measurement Construction/Repair Plan Documentation
- Thermal Imaging Other: _____

Summary of Findings, Opportunities, and Limitations:

The execution of the Mapping and Photogrammetry Mission was a success and provided great insight into the potential for UAS as a tool during routine inspections. The set-up, flight, and data generation went as planned and was substantial enough to create the planned deliverables. The data collected was very useful in determining the total deck delaminations by using the model to measure the delaminations that were discovered and marked in the field. This reduced the inspectors time on the deck by 50% which reduced costs and improved safety since the deck survey was completed without lane closures. The information gathered proved very useful in the subsequent bridge rehabilitation project. There is a minor amount of traffic on the bridge so the flights needed to be paused several times to avoid flying over vehicles.

UAS INSPECTION REPORT

Bridge Number 82502 • County Road 51 over the WS Limited RR
Stillwater, MN • July – August 2017



1.0 INTRODUCTION

1.1 Purpose and Scope

This report consists of the results of an unmanned aircraft (UAS) Concrete Deck Element Condition Assessment of Bridge Number 82502, County Road 51 over the WS Limited Railroad in Stillwater, Minnesota. Refer to Image 1 for a location map. Collins Engineers, Inc. (Collins) conducted the UAS Inspection for the Minnesota Department of Transportation (MnDOT) in July and August 2017 as part of a research project titled “Improving Quality of Bridge Inspections Using Unmanned Aircraft Systems (UAS) Project Phase III”. The primary purpose of the UAS usage during the inspection was to identify possible opportunities and limitations of UAS involvement in various capacity of bridge deck condition assessment. Bridge 82502 was being considered for rehabilitation and the data collected was intended to assist in making planning decisions. The following report includes a brief description of the structure, description of UAS equipment and operating conditions, the mission scope and deliverables, a summary of findings, opportunities, and limitations, and an evaluation of potential cost savings.



Image 1: Location Map

UAS INSPECTION REPORT

Bridge Number 82502 • County Road 51 over the WS Limited RR
Stillwater, MN • July – August 2017



1.2 General Description of the Structure

Bridge Number 82502 spans approximately 160 feet over the WS Limited Railroad and carries one northbound and one southbound lane of County Road 51. The bridge deck is approximately 44 feet wide and consists of a bare cast-in-place concrete deck. The concrete deck area is approximately 6700 square feet. The bridge superstructure consists of 3 prestress concrete beam spans. The substructure consists of reinforced concrete abutments and pile bents founded on concrete footing on piles. The longitudinal axis of the bridge is orientated approximately north to south. Refer to Images 2 and 3 for overall views of the bridge.

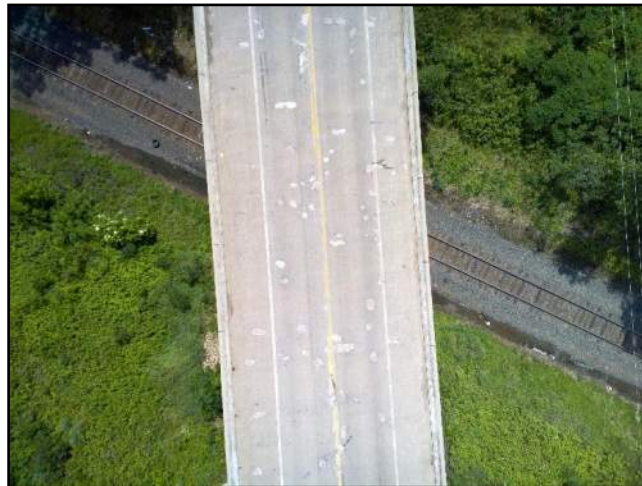

Image 2: Overall View of Bridge Topside.



Image 3: Overall Elevation View of Bridge.

UAS INSPECTION REPORT

Bridge Number 82502 • County Road 51 over the WS Limited RR
Stillwater, MN • July – August 2017



2.0 UAS OPERATION

2.1 UAS Equipment and Operating Conditions

A two-person crew, consisting of a professional engineer-pilot and a field engineer, conducted the UAS inspection. The pilot was certified as a FAA Remote Pilot. The inspection was conducted using two different registered UAS's; an Inspection and Mapping UAS and an Collision-Tolerant UAS. The aerial mapping UAS was a SenseFly Albris quadcopter equipped with a TripleView head consisting of a HD video camera, a 38MP still camera, and an infrared camera. Additionally, the Albris contains five acoustic sensors, GPS location, and photo-identification stabilization technology which aid both 3D preplanned and interactive flight missions. The Collision-Tolerant UAS was a Flyability Elios quadcopter equipped with a full HD camera, Infrared camera, and on-board lighting system. Additionally, the Elios has a protective frame surrounding the UAS body allowing for access to tight locations and up-close imaging. Refer to Image 4 for a view of the SenseFly Albris and Image 5 for a view of the Flyability Elios.



Image 4: View of SenseFly Albris.



Image 5: View of Flyability Elios.

UAS INSPECTION REPORT

Bridge Number 82502 • County Road 51 over the WS Limited RR
Stillwater, MN • July – August 2017



During the inspection, the pilot worked mobile work station suspended from his body and the other crew member maintained line-of-sight with the UAS. Aerial targets and a scale were placed prior to the aerial mapping mission to provide a higher level of accuracy. At the times of flight, the weather was clear with low wind. The bridge was located in Class G Airspace; thus, no FAA waiver or additional authorization was necessary. Refer to Image 6 for a view of Pilot and mobile work station.



Image 6: View of Pilot and Mobile Work Station.

UAS INSPECTION REPORT

Bridge Number 82502 • County Road 51 over the WS Limited RR
Stillwater, MN • July – August 2017



2.2 Mission Scope

A Mapping & Photogrammetry mission using the Albris was identified for this bridge to explore the potential of UAS photography to map concrete deck surface defects. The target goal of the mission was to gather information in the form of photographs in a quick, efficient process which could later be used to map the deck and have a post-inspection tool to aid in repair plans, quantity estimation and historical documentation. Additionally, the mission was carried out in three separate sub-missions to explore the effect of quality on photograph elevation, photograph overlap, and number of photographs. The three sub-missions consisted of pre-planned flight path that imaged the top of deck from several elevations to allow for a high-resolution final product. The first sub-mission consisted of 53 high-resolution still images of the bridge topside taken from the UAS at an elevation of 105 feet above the deck surface. The second sub-mission consisted of 118 high-resolution still images of the bridge topside taken from the UAS at an elevation of approximately 50 feet above the deck surface. The third sub-mission consisted of 402 high-resolution still images of the bridge topside taken from the UAS at varying elevations ranging from 10 feet to 50 feet above the deck surface. All images were geo-tagged with GPS coordinates. Refer to Images 7 through 12 for views of the Flight and Mapping Missions.

UAS INSPECTION REPORT

Bridge Number 82502 • County Road 51 over the WS Limited RR
Stillwater, MN • July – August 2017



Image 7: View of Sub-Mission 1 Flight Map.

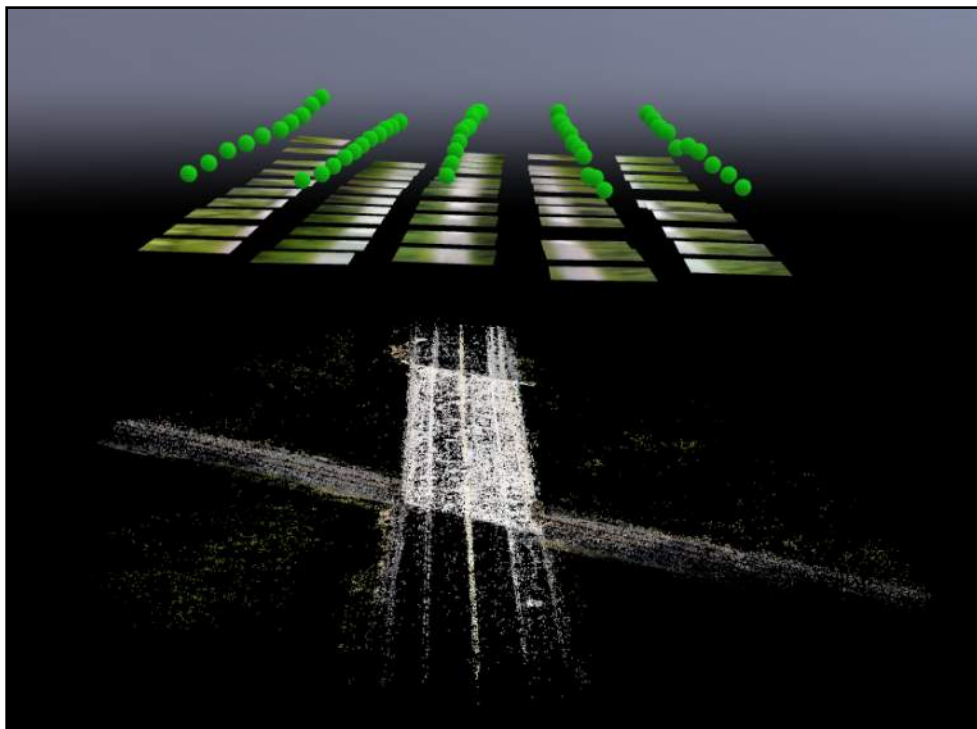

Image 8: View of Sub-Mission 1 Camera Position (Green Dot) at Locations of Photographing.

UAS INSPECTION REPORT

Bridge Number 82502 • County Road 51 over the WS Limited RR
Stillwater, MN • July – August 2017



Image 9: View of Sub-Mission 2 Flight Map.

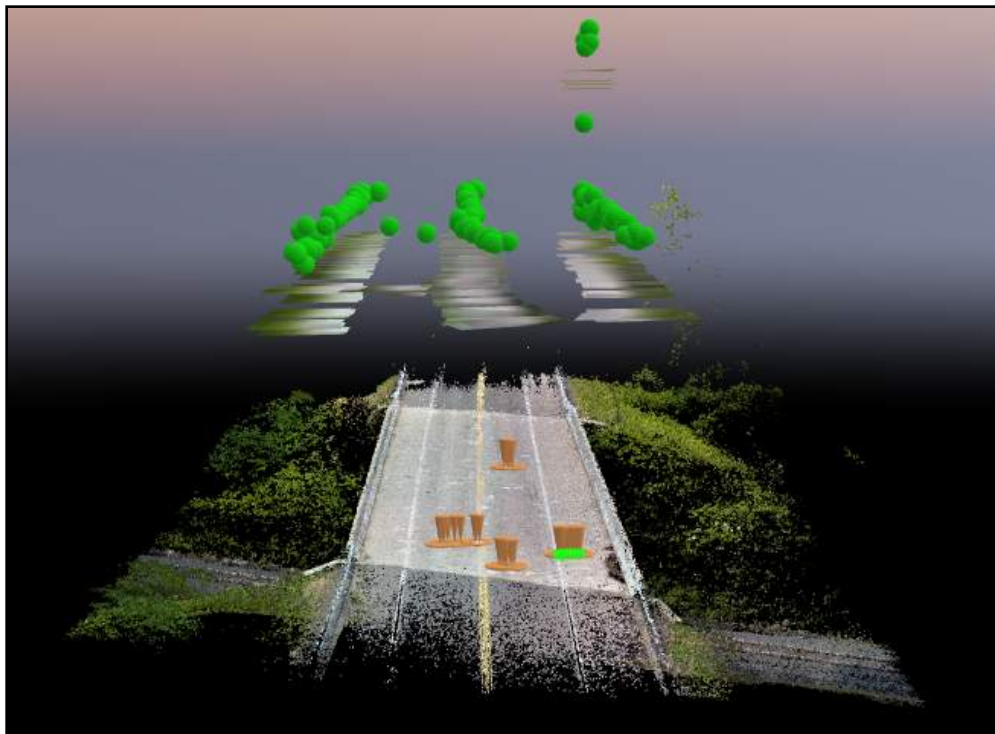

Image 10: View of Sub-Mission 2 Camera Position (Green Dot) at Locations of Photographing.

UAS INSPECTION REPORT

Bridge Number 82502 • County Road 51 over the WS Limited RR
Stillwater, MN • July – August 2017



Image 11: View of Sub-Mission 3 Flight Map.

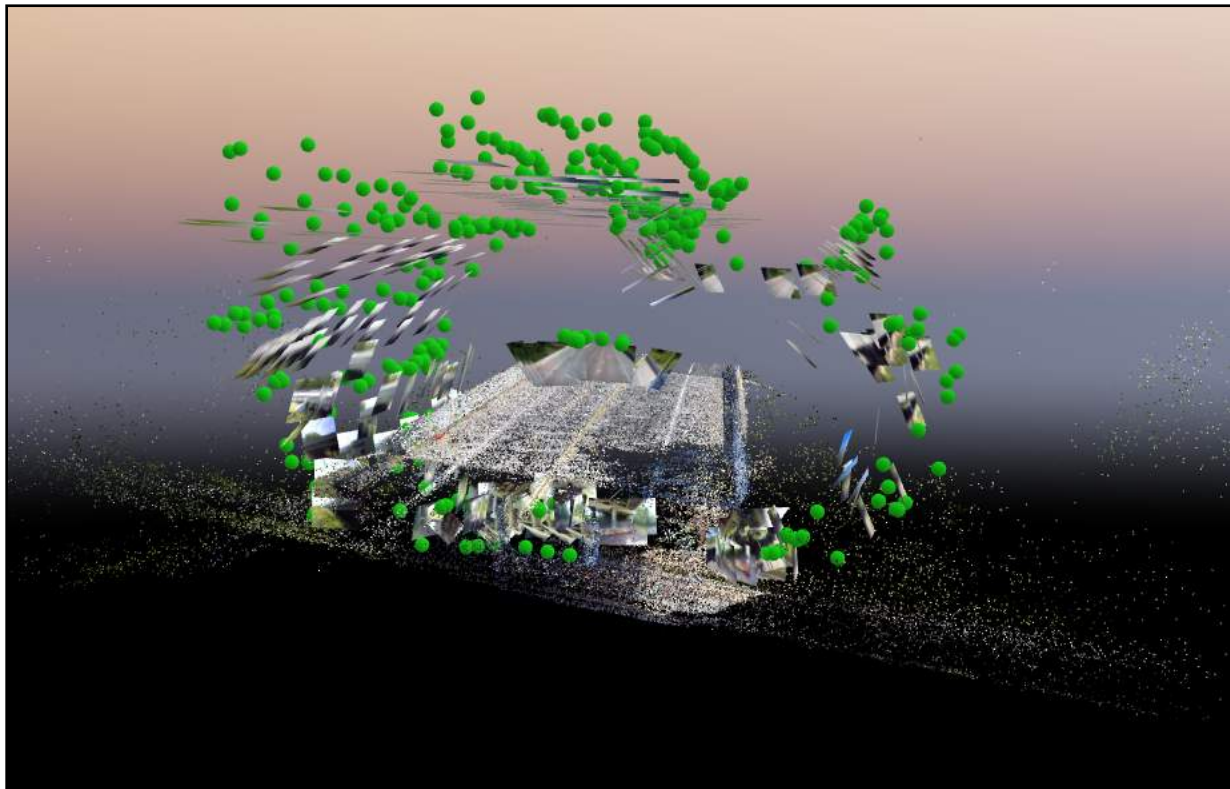

Image 12: View of Sub-Mission 3 Camera Position (Green Dot) at Locations of Photographing.

UAS INSPECTION REPORT

Bridge Number 82502 • County Road 51 over the WS Limited RR
Stillwater, MN • July – August 2017



A High Definition Video Mission was conducted of limited access areas using the Elios UAS. The target goal of this mission was to determine the quality and applicability of using a Collision-Tolerant UAS to capture images and assess the condition of bridge deck underside element which is typically difficult and costly to access and not easily viewed during the scope of a special inspection. The site also tested the UASs quality of flight in open-air environments. The mission consisted of an interactive flight using only pilot controls. During a typical special inspection, the concrete deck soffit would have been difficult to access and typically require coordination of an aerial work platform. The use of the Elios UAS focuses on these hard to access locations. An inspector can then review the video footage to look for defects or findings. Refer to Image 13 and 14 for a view of different hard to access location.



Image 13: Image of Hard to Access Locations.

UAS INSPECTION REPORT

Bridge Number 82502 • County Road 51 over the WS Limited RR
Stillwater, MN • July – August 2017



Image 14: Image of Hard to Access Locations.

A deck condition survey was carried out using chain dragging techniques after sub-mission 2 and before sub-mission 3 of the aerial mapping and photogrammetry missions. The purpose of the deck assessment was to determine the accuracy of aerial photography to capture spalling and delaminations. The areas identified as spalled, delaminated or impending delamination was marked in white paint.

2.3 Deliverables

Orthomosaic images were created in the Pix4D software to use as an inspection tool. The target goal for this process was to produce an easily viewable, high resolution image of a large area that could be used by an engineer to carry out a detailed defect mapping, area measurements, condition assessment, or help prepare repair plans. An Orthomosaic image is a single image file which is created from many individual images captured during the Mapping and Photogrammetry Mission. The final product of an Orthomosaic image is an image file that can be used to measure true distances. For this bridge, Orthomosaic images were made of the

UAS INSPECTION REPORT

Bridge Number 82502 • County Road 51 over the WS Limited RR
Stillwater, MN • July – August 2017



topside of the concrete deck. An inspector then reviewed the orthomosaic images and measured true distances and areas for a final product. The quality of the orthomosaic image was also compared between the three sub-missions to gain knowledge of photogrammetry techniques. Refer to Image 15 through 18 for views of Orthomosaic Detail and comparison.



Image 15: View of the Sub-Mission 3 Orthomosaic and Area measurement. [\(Click Image to Access Orthomosaic\)](#)

UAS INSPECTION REPORT

Bridge Number 82502 • County Road 51 over the WS Limited RR
Stillwater, MN • July – August 2017



Image 16: View of the Sub-Mission 1 Orthomosaic detail.



Image 17: View of the Sub-Mission 2 Orthomosaic detail.



Image 18: View of the Sub-Mission 3 Orthomosaic detail.

UAS INSPECTION REPORT

Bridge Number 82502 • County Road 51 over the WS Limited RR
Stillwater, MN • July – August 2017



A 3D Model with a High-Resolution Photograph Log was processed for bridge. The target goal for this process was to determine the ease of use and applicability of having a 3D photolog to assist an designer during repair plan development and construction modeling. Additionally, the applicability of an easily manipulated 3D model which could be shared with others was explored. All photographs taken during the Mapping and Photogrammetry Mission were processed in the Pix4D software. The software processes all photographs to form a 3D point cloud for digital viewing. The point cloud was then processed by the same software to generate a 3D mesh of the bridge.

An inspector was able to use the Pix4D program to navigate the 3D model and select areas of interest. The software provides the inspector with all still images containing the selected area of interest which can then be viewed in high resolution. Additionally, the inspector can place annotations or measurements areas in the model for design plans, further detailed inspection or construction documents. Refer to Image 19 for a view of the Inspector Tool providing a Photograph Log from a selected area of the 3D model.



Image 19: View of the Model a Photograph Log from a selected area of the 3D model. [\(Click Image to access Video\)](#)

UAS INSPECTION REPORT

Bridge Number 82502 • County Road 51 over the WS Limited RR
Stillwater, MN • July – August 2017



Video from the High Definition Video Mission using the Elios was viewed by an inspector after returning from the flight mission. The video could be observed in any software capable of playing .MP4 files. Additionally, the manufacturer of Elios, Flyability, has created an inspection software where the UASs flight log can be opened with the video file to show inspector UAS attributes such as heading, altitude, and temperature. The inspector can then maneuver their way through the video to obtain still images of defects or notable findings. General areas of deterioration, specific types of deterioration, and extent could all be observed through the video. These results could be used in conjunction with the topside survey to determine overall deck condition. Refer to Image 20 below to watch the Elios in action.



Image 20: View of a Screenshot from the Elios Interactive Flight Mission. [\(Click Image to access Video\)](#)



UAS INSPECTION REPORT

BRIDGE NUMBER: 97649

TWP 398

OVER MEADOW CREEK

CORMANT, MINNESOTA

NOVEMBER 20, 2017

Prepared for:



*As part of MnDOT Research Project
Unmanned Aircraft System Bridge Inspection Demonstration Phase III*

Prepared by:

**COLLINS
ENGINEERS** INC.

1599 Selby Avenue
St. Paul, MN 55104

651.646.8502 • www.collinsengr.com

UAS INSPECTION REPORT

Bridge Number 97649 • TWP 398 over Meadow Creek
Cormant, MN • November 2017



Table of Contents

1.0	INTRODUCTION	
1.1	Purpose and Scope	1
1.2	General Description of the Structure	2
2.0	UAS OPERATION	
2.1	UAS Equipment and Operating Conditions	3
2.2	Mission Scope	4
2.3	Deliverables.....	5
3.0	SUMMARY OF FINDINGS	
3.1	Opportunities	8
3.2	Limitations.....	8
3.3	Evaluation of Potential Cost Savings	8

Table of Images

Image 1: Location Map	1
Image 2: Overall View of Culvert Topside.	2
Image 3: View of Culverts East Entrance.	2
Image 4: View of SenseFly Albris.	3
Image 5: View of GoPro Hero 5.	3
Image 6: View of Mission Flight Map (Preplanned and Interactive).	4
Image 7: View of Camera Position at Locations of Photographing.	5
Image 8: View of Inspector Tool Within Pix4d.	6
Image 9: View of the 3D Model Generated Using Pix4d.	6
Image 10: View of the Level of Detail Included in an Orthomosaic Image.	7

UAS INSPECTION REPORT

Bridge Number 97649 • TWP 398 over Meadow Creek
Cormant, MN • November 2017



EXECUTIVE SUMMARY

Project: Routine Culvert Inspection Using UAS's of Bridge Number 97649.

Purpose of Project: To perform a partial inspection of select superstructure elements using unmanned aircraft system (UAS) techniques to determine the structural and physical condition of difficult to access bridge elements. The inspection is supplemental to a routine visual, tactile, and non-destructive testing inspection.

Inspection Team: Team Leader – Barritt Lovelace, P.E. (Pilot)

Inspection Date(s): November 20, 2017

Data Collection Tools:

- SenseFly Albris Flyability Elios Other: GoPro Hero 5

Summary of Mission Scope(s) and Deliverable(s):

- Aerial Mapping & Photogrammetry 3D Model & High Resolution Photograph Log High Definition Video for Limited Access Areas
- Orthomosaic Image Creation for Inspection Defect Measurement Construction/Repair Plan Documentation
- Thermal Imaging Other: _____

Summary of Findings, Opportunities, and Limitations:

- [UPDATE UP FINISHING SUMMARY OF FINDINGS]

Summary of Cost Savings:

- [UPDATE UP FINISHING SUMMARY OF FINDINGS]

UAS INSPECTION REPORT

Bridge Number 97649 • TWP 398 over Meadow Creek
Cormant, MN • November 2017



1.0 INTRODUCTION

1.1 Purpose and Scope

This report consists of the results of an unmanned aircraft (UAS) inspection of Bridge Number 97649, TWP 398 over Meadow Creek located in Cormant, Minnesota. Refer to Image 1 for a location map. Collins Engineers, Inc. (Collins) conducted the UAS Inspection for the Minnesota Department of Transportation (MnDOT) on November 20, 2017 as part of a research project titled “Improving Quality of Bridge Inspections Using Unmanned Aircraft Systems (UAS) Project Phase III”. The primary purpose of the UAS usage during the inspection was to identify possible opportunities and limitations of UAS involvement in various capacity of bridge inspection. The following report includes a brief description of the structure, description of UAS equipment and operating conditions, the mission scope and deliverables, a summary of findings, opportunities, and limitations, and an evaluation of potential cost savings.



Image 1: Location Map

UAS INSPECTION REPORT

Bridge Number 97649 • TWP 398 over Meadow Creek
Cormant, MN • November 2017



1.2 General Description of the Structure

Bridge Number 97649 is a precast pipe arch that carries Meadow Creek under TWP 398 and spans 10 feet along the roadway. The 122" x 77" culvert lies 4 feet below the roadway covered by a gravel wearing surface. The longitudinal axis of the bridge is orientated approximately north to south. Refer to Images 2 and 3 for overall views of the bridge.



Image 2: Overall View of Culverts Topside.



Image 3: View of Culverts East Entrance.

2.0 UAS OPERATION

2.1 UAS Equipment and Operating Conditions

A one-person crew, consisting of a professional engineer-pilot, conducted the UAS inspection. The pilot was certified as a FAA Remote Pilot. The inspection was conducted using an aerial mapping UAS called the SenseFly Albris quadcopter which is equipped with a TripleView head consisting of a HD video camera, a 38MP still camera, and an infrared camera. Additionally, the Albris contains five acoustic sensors, GPS location, and photo-identification stabilization technology which aid both 3D preplanned and interactive flight missions. The action camera was a GoPro Hero 5 High-Resolution Camera. The camera was equipped with a 12 Megapixel still camera and a fisheye lens. Refer to Image 4 for a view of the SenseFly Albris and Image 5 for a view of the GoPro Hero 5.



Image 4: View of SenseFly Albris.



Image 5: View of GoPro Hero 5.

During the inspection, the pilot worked from a mobile work station suspended from his body while maintaining line-of-sight with the UAS. Aerial targets and a scale were placed prior to the aerial mapping mission to provide a higher level of accuracy. At the time of flight, the weather was clear with low wind. The bridge was located in military operations area (MOA) airspace which required that the drone be operated below 300 feet above ground level.

UAS INSPECTION REPORT

Bridge Number 97649 • TWP 398 over Meadow Creek
Cormant, MN • November 2017



2.2 Mission Scope

A Mapping & Photogrammetry mission using the Albris was identified for this bridge to explore the potential of UAS photography to map the culvert structure along with the surrounding water channel. The target goal of the mission was to gather information in the form of photographs in a quick, efficient process which could later be used to map the structure/channel and have a post-inspection tool to aid in report writing and historical documentation. The mission consisted of a pre-planned flight path at an elevation of approximately 180 feet above ground level (AGL). The UAS collected over 72 high-resolution still images of the bridge fascia and top side. All images were geo-tagged with GPS coordinates. Refer to Images 6 and 7 for views of the Flight and Mapping Mission.



Image 6: View of Mission Flight Map (Preplanned and Interactive).

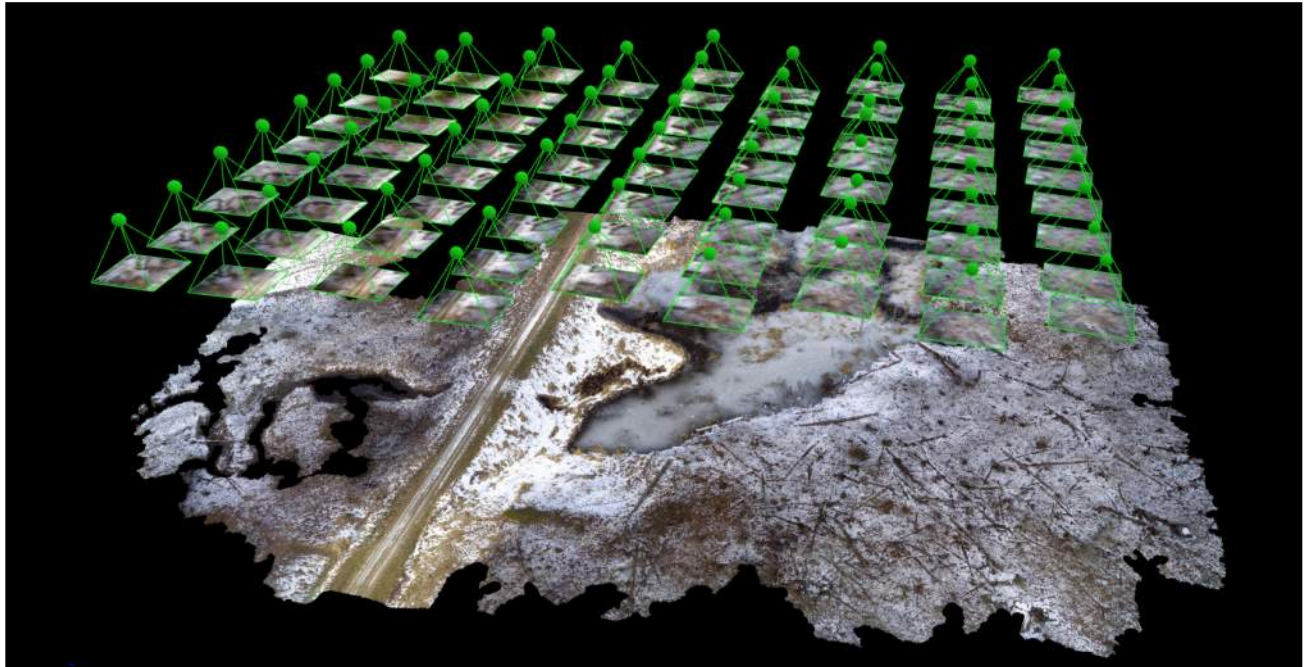

Image 7: View of Camera Position (Green Dot) at Locations of Photographing

2.3 Deliverables

A 3D Model with a High-Resolution Photograph Log was processed for bridge. The target goal for this process was to determine the ease of use and applicability of having a 3D photolog to assist an inspector during post-processing, report writing, and future inspection. All photographs taken during the Mapping and Photogrammetry Mission were processed in the Pix4D software. The software processes all photographs to form a 3D point cloud for digital viewing. The point cloud was then processed by the same software to generate a 3D mesh of the bridge. An inspector was then able to navigate the 3D model and select areas or interest. The software provides the inspector with all still images containing the selected area of interest which can then be viewed in high resolution. Additionally, the inspector can place annotations within the file for future reference or for clarification when sharing the file. Refer to Image 8 for a view of the Inspector Tool providing a Photograph Log from a selected area of the 3D model, and Image 9 for an overall view of the 3D model.

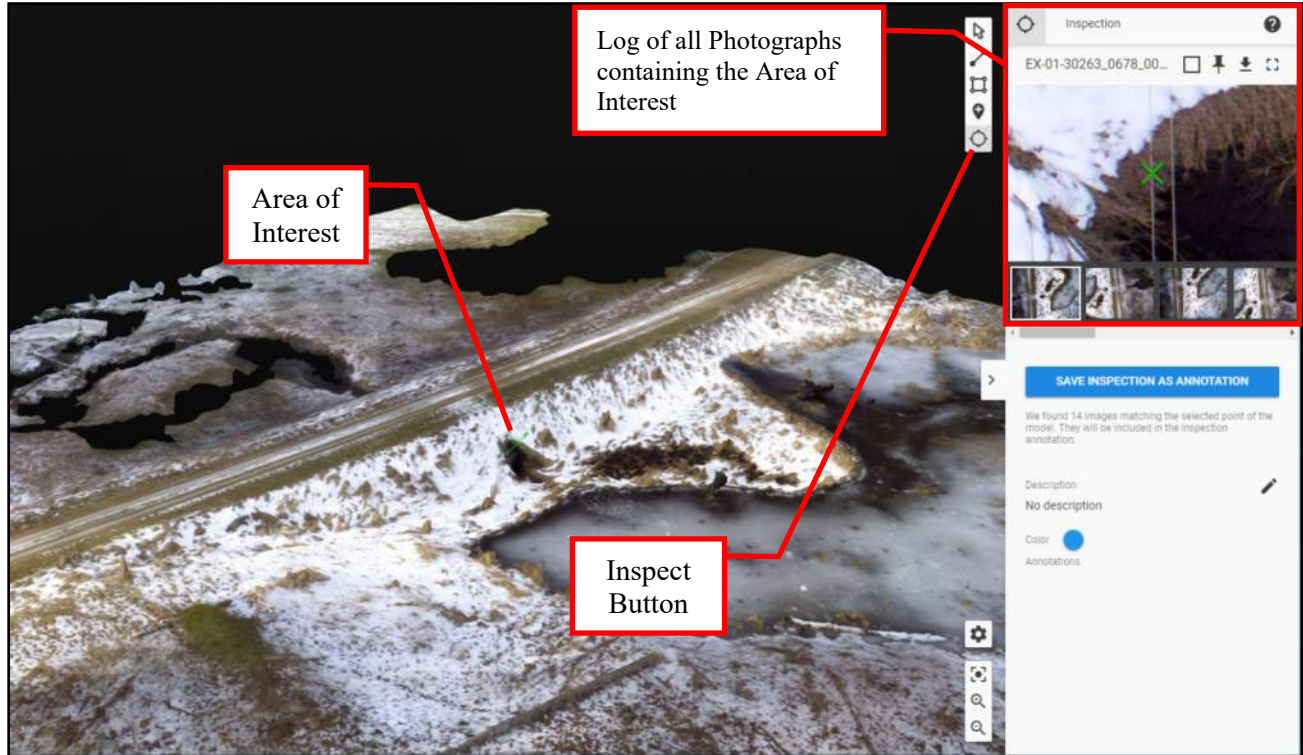

Image 8: View of the Inspector Tool providing a Photograph Log from a selected area of the 3D model. Note the annotated areas for future reference or ease of sharing. **(Click Image to access 3D Model and Inspection Photolog – Click on the Inspect Button)**

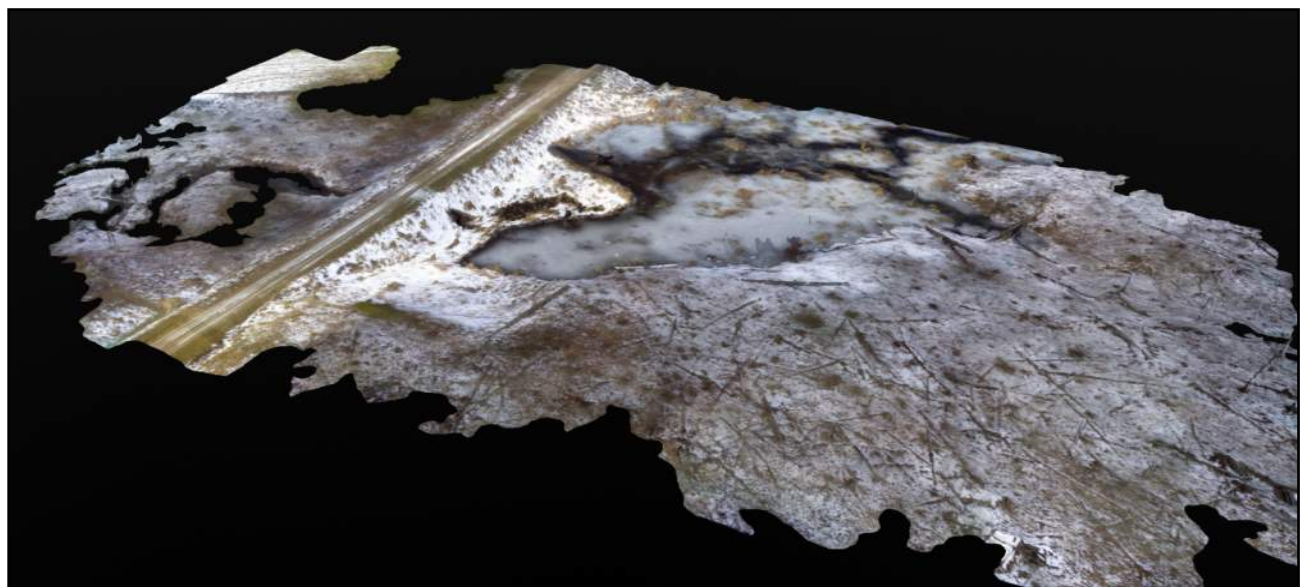

Image 9: View of the 3D Model Generated Using Pix4d Software. **(Click Image to access 3D Model)**

UAS INSPECTION REPORT

Bridge Number 97649 • TWP 398 over Meadow Creek
Cormant, MN • November 2017



A Orthomosaic image was created to use as an inspection tool. The target goal for this process was to produce an easily viewable, high resolution image of a large area that could be used by an inspector to carry out a detailed inspection, area measurements, condition assessment, or historical documentation. An Orthomosaic image is a single image file which is created from many individual images captured during the Mapping and Photogrammetry Mission. The final product of an Orthomosaic image is an image file that can be used to measure true distances. For this bridge, an Orthomosaic image was made of the culvert and the surrounding water channel. An inspector then reviews a single file and can measure true distances and areas for a final product. Refer to Image 10 for a view of the Orthomosaic and level of detail included.

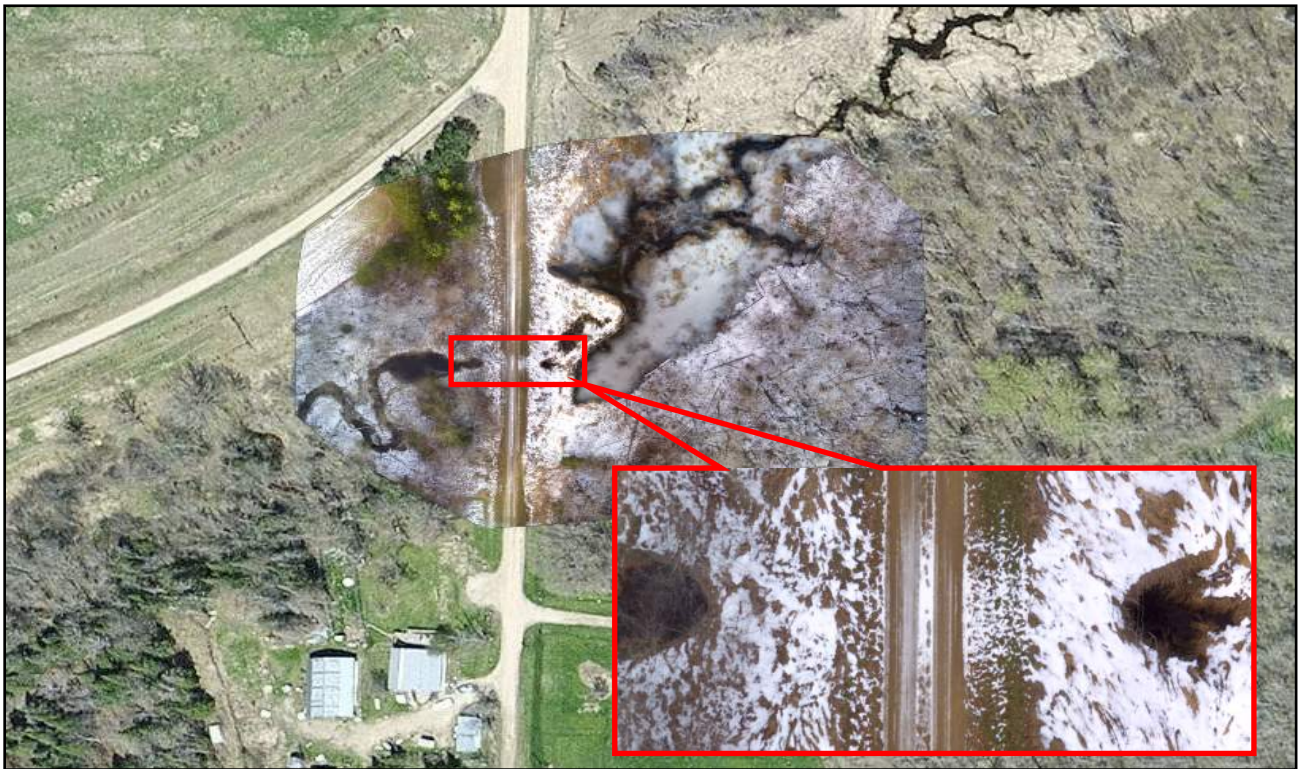

Image 10: View of the Orthomosaic Image Generated Using Pix4d Software. [\(Click Image to access Model\)](#)

UAS INSPECTION REPORT

Bridge Number 97649 • TWP 398 over Meadow Creek
Cormant, MN • November 2017



3.0 SUMMARY OF FINDINGS

3.1 Opportunities

The execution of the Mapping and Photogrammetry Mission was a success and provided great insight into the potential for UAS as a tool during routine inspections. The set-up, flight, and data generation went as planned and was substantial enough to create the planned deliverables.

3.2 Limitations

None Identified



UAS INSPECTION REPORT

OVERHEAD SIGN

OVER I-35W

MINNEAPOLIS, MINNESOTA

September 30, 2017

Prepared for:



As part of MnDOT Research Project
A-175 Improving Quality of Bridge Inspections Using Unmanned Aircraft Systems
(UAS) Phase III

Prepared by:

COLLINS
ENGINEERS INC.

1599 Selby Avenue
St. Paul, MN 55104

651.646.8502 • www.collinsengr.com

Table of Contents

1.0	INTRODUCTION	
1.1	Purpose and Scope	1
1.2	General Description of the Structure	2
2.0	UAS OPERATION	
2.1	UAS Equipment and Operating Conditions	3
2.2	Mission Scope	4
2.3	Deliverables.....	5
3.0	SUMMARY OF FINDINGS	
3.1	Opportunities	8
3.2	Limitations.....	8
3.3	Evaluation of Potential Cost Savings	8

Table of Images

Image 1: Location Map	1
Image 2: Overall View of Gantry Topside.	2
Image 3: Overall View of Gantry Underside.	2
Image 4: View of SenseFly Albris.	3
Image 5: View of Flyability GoPro Hero 5.	3
Image 6: View of Mission Flight Map (Preplanned and Interactive).	4
Image 7: View of Camera Position at Locations of Photographing.	5
Image 8: View of the Inspector Tool Within Pix4d.	6
Image 9: View of the Level of Detail Included in an Image Captured by GoPro.	6
Image 10: View of Orthomosaic and Level of Detail Included in a Single High-Resolution Image.	7



EXECUTIVE SUMMARY

- Project:** Routine Inspection Using UAS's of Highway Gantry Over I-35W.
- Purpose of Project:** To perform a partial inspection of select superstructure elements using unmanned aircraft system (UAS) techniques to determine the structural and physical condition of difficult to access Gantry elements. The inspection is supplemental to a routine visual, tactile, and non-destructive testing inspection.
- Inspection Team:** Team Leader – Barritt Lovelace, P.E. (Pilot)
- Inspection Date(s):** September 30, 2017

Data Collection Tools:

- SenseFly Albris Flyability Elios Other: GoPro Hero 5

Summary of Mission Scope(s) and Deliverable(s):

- Aerial Mapping & Photogrammetry 3D Model & High Resolution Photograph Log High Definition Video for Limited Access Areas
- Orthomosaic Image Creation for Inspection Defect Measurement Construction/Repair Plan Documentation
- Thermal Imaging Other: _____

Summary of Findings, Opportunities, and Limitations:

The execution of the Mapping and Photogrammetry Mission was a success and provided great insight into the potential for UAS as a tool during routine inspections. The set-up, flight, and data generation went as planned and was substantial enough to create the planned deliverables. The ability to quickly collect, process and share large amounts of data on the structures physical characteristics and conditions was very beneficial.

1.0 INTRODUCTION

1.1 Purpose and Scope

This report consists of the results of an unmanned aircraft (UAS) inspection of a highway gantry over I-35W located in Minneapolis, Minnesota. Refer to Image 1 for a location map. Collins Engineers, Inc. (Collins) conducted the UAS Inspection for the Minnesota Department of Transportation (MnDOT) on September 30, 2017 as part of a research project titled “Improving Quality of Bridge Inspections Using Unmanned Aircraft Systems (UAS) Project Phase III”. The primary purpose of the UAS usage during the inspection was to identify possible opportunities and limitations of UAS involvement in various capacity of structure inspections. The following report includes a brief description of the structure, description of UAS equipment and operating conditions, the mission scope and deliverables, a summary of findings, opportunities, and limitations.

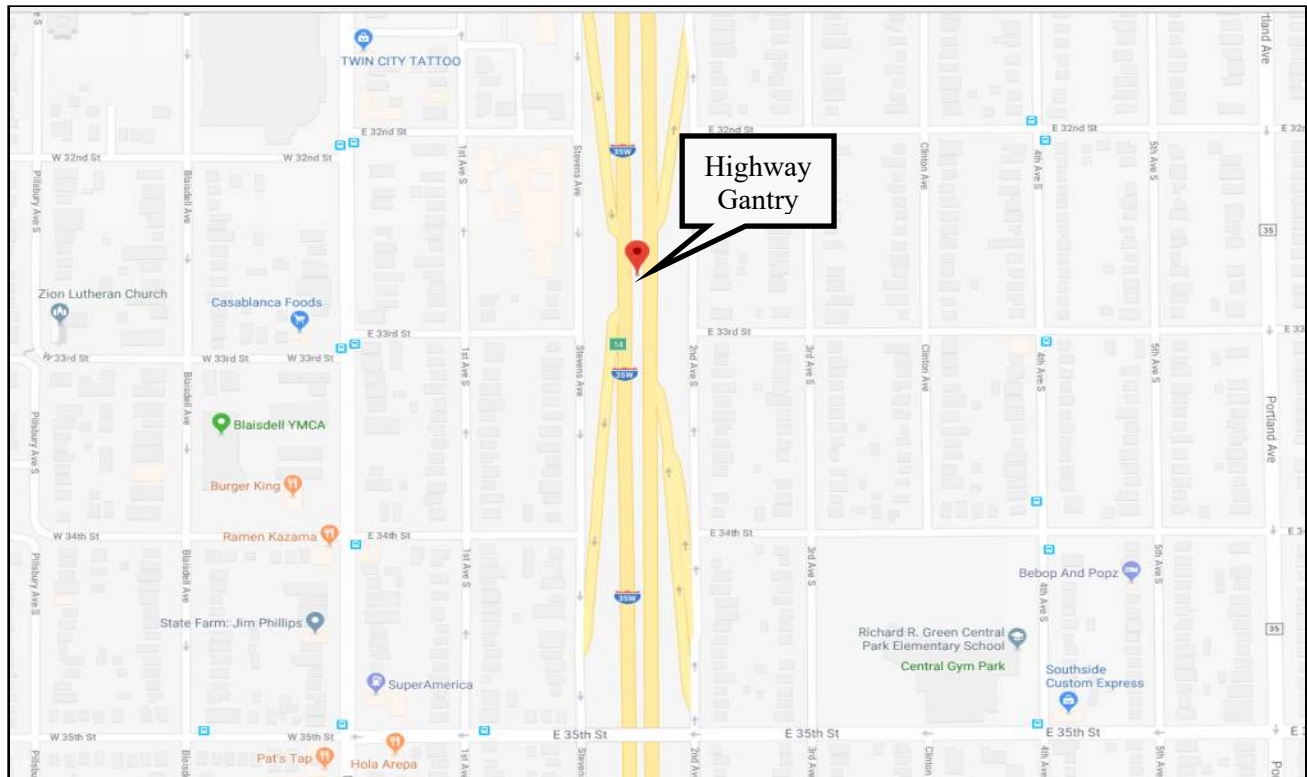

Image 1: Location Map

1.2 General Description of the Structure

The overhead sign spans approximately 169 feet over highway I-35W. The structure is a 6 feet wide steel truss supported on two steel columns bearing on concrete foundations. The longitudinal axis of the structure is orientated approximately east to west. Refer to Images 2 and 3 for overall views of the bridge.

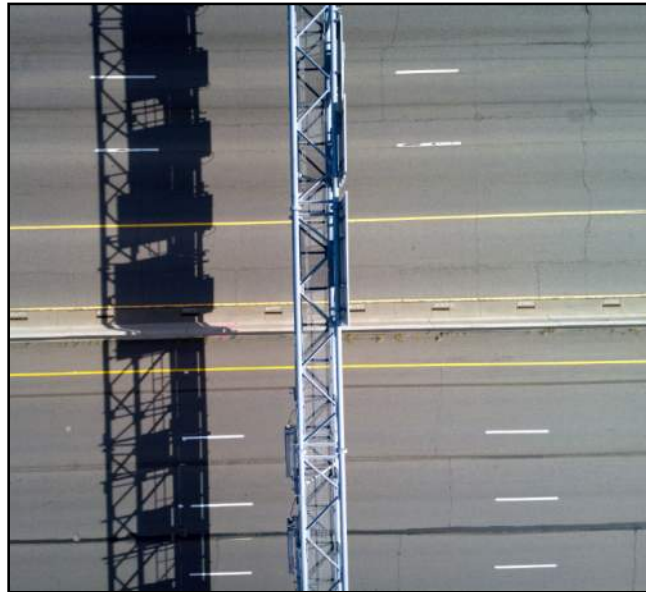

Image 2: Overall View of Gantry Topside.



Image 3: Overall View of Gantry Underside.

2.0 UAS OPERATION

2.1 UAS Equipment and Operating Conditions

A one-person crew, consisting of a professional engineer-pilot, conducted the UAS inspection. The pilot was certified as a FAA Remote Pilot, and conducted the inspection using an Inspection and Mapping UAS. The aerial mapping UAS was a SenseFly Albris quadcopter equipped with a TripleView head consisting of a HD video camera, a 38MP still camera, and an infrared camera. Additionally, the Albris contains five acoustic sensors, GPS location, and photo-identification stabilization technology which aid both 3D preplanned and interactive flight missions. The action camera was a GoPro Hero 5 High-Resolution Camera. The camera was equipped with a 12 Megapixel still camera and a fisheye lens. Refer to Image 4 for a view of the SenseFly Albris and Image 5 for a view of the GoPro Hero 5.



Image 4: View of SenseFly Albris.



Image 5: View of GoPro Hero 5.

During the inspection, the pilot worked mobile work station suspended from his body and the other crew member maintained line-of-sight with the UAS. Aerial targets and a scale were placed prior to the aerial mapping mission to provide a higher level of accuracy. At the time of flight, the weather was clear with low wind. The sign was located in class B airspace which is covered under the universal waiver Collins received prior to mission start.

2.2 Mission Scope

A Mapping & Photogrammetry mission using the Albris was identified for this structure to explore the potential of UAS photography to map overhead roadway sign defects. The target goal of the mission was to gather information in the form of photographs in a quick, efficient process which could later be used to map the structure and have a post-inspection tool to aid in report writing and historical documentation. The mission consisted of a pre-planned flight path at an elevation of approximately 50 feet above ground level (AGL). The UAS collected over 159 high-resolution still images of the gantry trusses and top side. All images were geo-tagged with GPS coordinates. Refer to Images 6 and 7 for views of the Flight and Mapping Mission.

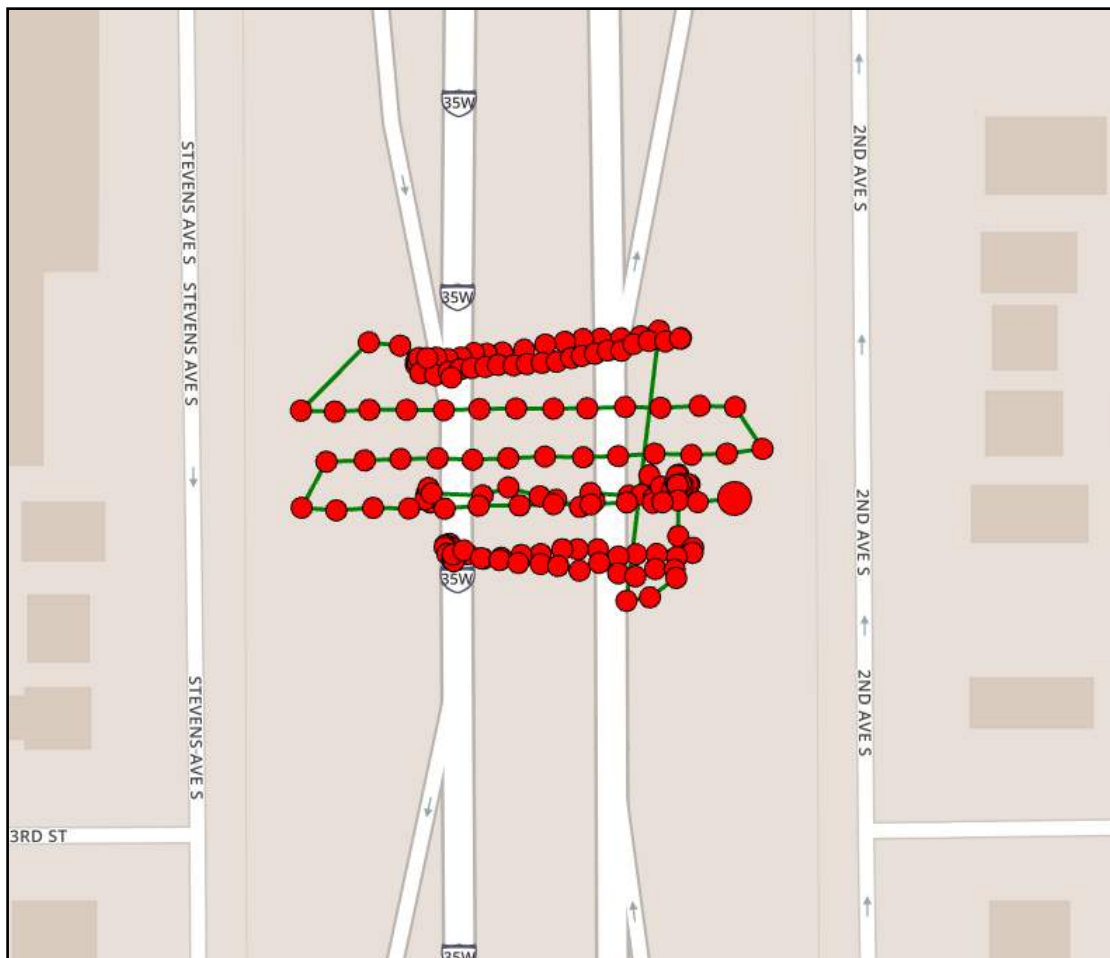

Image 6: View of Mission Flight Map (Preplanned and Interactive).

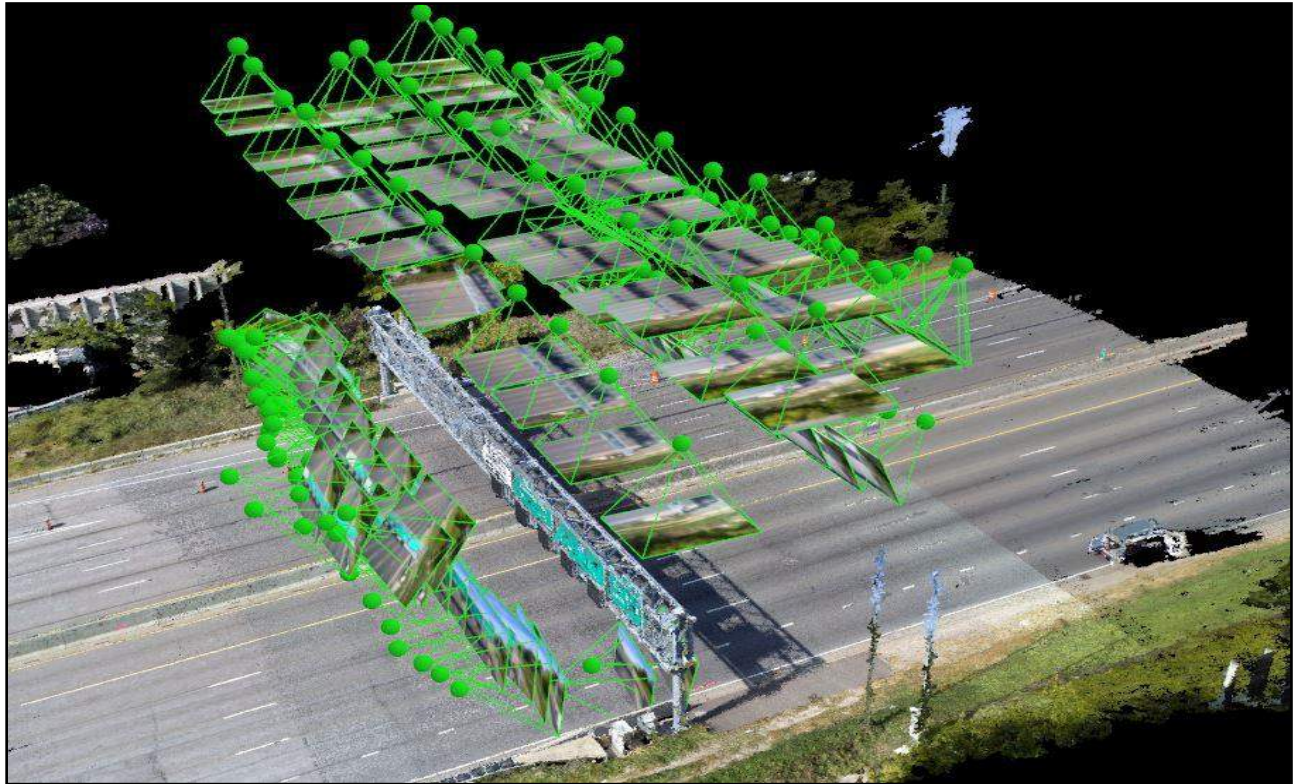

Image 7: View of Camera Position (Green Dot) at Locations of Photographing

2.3 Deliverables

A 3D Model with a High-Resolution Photograph Log was processed for the sign structure. The target goal for this process was to determine the ease of use and applicability of having a 3D photolog to assist an inspector during post-processing, report writing, and future inspection. All photographs taken during the Mapping and Photogrammetry Mission were processed in the Pix4D software. The software processes all photographs to form a 3D point cloud for digital viewing. The point cloud was then processed by the same software to generate a 3D mesh of the structure. An inspector was then able to navigate the 3D model and select areas of interest. The software provides the inspector with all still images containing the selected area of interest which can then be viewed in high resolution. Additionally, the inspector can place annotations within the file for future reference or for clarification when sharing the file. Refer to Image 8 for a view of the Inspector Tool providing a Photograph Log from a selected area of the 3D model, and Image 9 for a view of the detail included in the photo logs.



Image 8: View of the Inspector Tool providing a Photograph Log from a selected area of the 3D model. Note the annotated areas for future reference or ease of sharing.

(Click Image to access 3D Model and Inspection Photolog – Click on the Inspect Button)



Image 9: View of the Level of Detail Taken from GoPro Hero 5.

A Orthomosaic image was created to use as an inspection tool. The target goal for this process was to produce an easily viewable, high resolution image of a large area that could be used by an inspector to carry out a detailed inspection, area measurements, condition assessment, or historical documentation. An Orthomosaic image is a single image file which is created from many individual images captured during the Mapping and Photogrammetry Mission. The final product of an Orthomosaic image is an image file that can be used to measure true distances. For this structure, an Orthomosaic image was made of the top of the gantry and surrounding area. An inspector then reviews a single file and can measure true distances and areas for a final product. Refer to Image 10 for a view of Orthomosaic Detail.



Image 10: View of Orthomosaic Image



3.0 SUMMARY OF FINDINGS

3.1 Opportunities

The execution of the Mapping and Photogrammetry Mission was a success and provided great insight into the potential for UAS as a tool during routine inspections. The set-up, flight, and data generation went as planned and was substantial enough to create the planned deliverables. The ability to quickly collect, process and share large amounts of data on the structures physical characteristics and conditions was very beneficial.

3.2 Limitations

None noted. The data was collected while the roadway was closed. This mission would not be possible over live traffic without a special FAA authorization.



UAS INSPECTION REPORT

RETAINING WALL INSPECTIONS

KENWOOD TRAIL RETAINING WALL, LAKEVILLE, MN

CONCORD STREET RETAINING WALL, SOUTH ST. PAUL, MN

August 24 & November 4, 2017

Prepared for:



*As part of MnDOT Research Project
A-186 Improving Quality of Bridge Inspections Using Unmanned Aircraft Systems
(UAS) Phase III*

Prepared by:

COLLINS
ENGINEERS INC.

1599 Selby Avenue
St. Paul, MN 55104

651.646.8502 • www.collinsengr.com

UAS INSPECTION REPORT

Retaining Wall Inspections • Kenwood Trail, Lakeville, MN
Concord St. St. Paul, MN • November 2017



Table of Contents

1.0	INTRODUCTION	
1.1	Purpose and Scope	1
1.2	General Description of the Structure	2
2.0	UAS OPERATION	
2.1	UAS Equipment and Operating Conditions	4
2.2	Mission Scope	5
2.3	Deliverables.....	6
3.0	SUMMARY OF FINDINGS	
3.1	Opportunities	8
3.2	Limitations.....	8
3.3	Evaluation of Potential Cost Savings	8

Table of Images

Image 1: Location Map (Lakeville)	1
Image 2: Location Map (South St. Paul).	2
Image 3: Overall View of Lakeville Retaining wall.	2
Image 4: Overall View of South St. Paul Retaining wall.	3
Image 5: View of SenseFly Albris.	4
Image 6: View of Mission Flight Map (Preplanned and Interactive) for the Lakeville Wall.	5
Image 7: View of Camera Position (Green Dot) at Locations of Photographing (Lakeville).	6
Image 8: View of the Level of Detail in a Single High-Resolution Image.	6
Image 9: View of the Lakeville 3D Model in Pix4D.	7
Image 10: View of the South St. Paul 3D Model in Pix4D.	7
Image 11: View of the Inspector Tool Within Pix4D.	8

UAS INSPECTION REPORT

Retaining Wall Inspections • Kenwood Trail, Lakeville, MN
Concord St. St. Paul, MN • November 2017



EXECUTIVE SUMMARY

Project: Retaining Wall Inspection Using UAS.

Purpose of Project: To perform an inspection of select Retaining Wall elements using unmanned aircraft system (UAS) techniques to determine the structural and physical condition of the walls. The inspection is supplemental to a routine visual, tactile, and non-destructive testing inspection.

Inspection Team: Team Leader – Barritt Lovelace, P.E. (Pilot)

Inspection Date(s): August 24, 2017; November 4, 2017

Data Collection Tools:

- SenseFly Albris Flyability Elios Other: _____

Summary of Mission Scope(s) and Deliverable(s):

- | | | |
|---|---|---|
| <input checked="" type="checkbox"/> Aerial Mapping & Photogrammetry | <input checked="" type="checkbox"/> 3D Model & High Resolution Photograph Log | <input type="checkbox"/> High Definition Video for Limited Access Areas |
| <input checked="" type="checkbox"/> Orthomosaic Image Creation for Inspection | <input checked="" type="checkbox"/> Defect Measurement | <input type="checkbox"/> Construction/Repair Plan Documentation |
| <input type="checkbox"/> Thermal Imaging | <input type="checkbox"/> Other: _____ | |

Summary of Findings, Opportunities, and Limitations:

Utilizing UAS on retaining wall inspections proved to be an efficient way to collect data and document the inspection of each of the walls. The use of both autonomous missions and manual missions proved successful. The ability to use distance lock and cruise control allowed the ability to fly close to the wall and gain very good detail in the output.

UAS INSPECTION REPORT

Retaining Wall Inspections • Kenwood Trail, Lakeville, MN
Concord St. St. Paul, MN • November 2017



1.0 INTRODUCTION

1.1 Purpose and Scope

This report consists of the results of an unmanned aircraft (UAS) inspection of two retaining walls, located in the Twin Cities Metro area. One retaining wall was located in Lakeville, MN along the west side of Kenwood Trail between the north and south entrances of Kenwood Way. Refer to Image 1 for a location map. The other retaining wall was located in South St. Paul, MN along the east edge of Concord St. near Page St. E. Refer to Image 2 for a location map. Collins Engineers, Inc. (Collins) conducted the UAS Inspection for the Minnesota Department of Transportation (MnDOT) on August 24, 2017 and November 4, 2017 as part of a research project titled “Improving Quality of Bridge Inspections Using Unmanned Aircraft Systems (UAS) Project Phase III”. The primary purpose of the UAS usage during the inspection was to identify possible opportunities and limitations of UAS involvement in various capacity of retaining wall and vertical structure inspection. The following report includes a brief description of the structure, description of UAS equipment and operating conditions, the mission scope and deliverables, a summary of findings, opportunities, and limitations, and an evaluation of potential cost savings.



Image 1: Location Map

UAS INSPECTION REPORT

Retaining Wall Inspections • Kenwood Trail, Lakeville, MN
Concord St. St. Paul, MN • November 2017



Image 2: Location Map

1.2 General Description of the Structure

The Lakeville Retaining Wall is located directly to the west of Kenwood Trail between the north and south entrances of Kenwood Way. The retaining wall is approximately 212 feet long and tapers from 11 feet at the north quarter point to grade at each end. The wall consists of a cast in place concrete wall with a concrete cap. A chain link fence was affixed to the top of the concrete cap along the wall length. Refer to Image 3 for an overall view of the Lakeville Retaining Wall.

UAS INSPECTION REPORT

Retaining Wall Inspections • Kenwood Trail, Lakeville, MN
Concord St. St. Paul, MN • November 2017



Image 3: Overall View of Lakeville Retaining Wall.

The South St. Paul Retaining Wall is located directly to the east of Concord St. and adjacent to two rail tracks approximately between Arthur Ave. and Concord St. (west frontage road). The portion of wall imaged was approximately 243 feet long and generally tapers from approximately 15 feet at the south end to 6 feet at the north end. The wall imaged was a segment of a longer retaining wall. The wall consisted of cast in place concrete wall with a concrete cap and concrete-steel wire parapet. Refer to Image 4 below for a view of the South St. Paul Retaining Wall.



Image 4: Overall View of South St. Paul Retaining Wall.

UAS INSPECTION REPORT

Retaining Wall Inspections • Kenwood Trail, Lakeville, MN
Concord St. St. Paul, MN • November 2017



2.0 UAS OPERATION

2.1 UAS Equipment and Operating Conditions

A one person crew, consisting of a professional engineer-pilot conducted the UAS inspection. The pilot was certified as a FAA Remote Pilot. The inspection was conducted using an Inspection and Mapping UAS called the SenseFly Albris quadcopter which comes equipped with a TripleView head consisting of a HD video camera, a 38MP still camera, and an infrared camera. Additionally, the Albris contains five acoustic sensors, GPS location, and image flow stabilization technology which aid both 3D preplanned and interactive flight missions. Refer to Image 5 for a view of the SenseFly Albris.



Image 5: View of SenseFly Albris.

During the inspection, the pilot worked using a mobile work station and maintained line-of-sight with the UAS. At the time of flight, the weather was clear with low wind. The bridge was located in Class G Airspace; thus, no FAA waiver or additional authorization was necessary.

2.2 Mission Scope

A Mapping & Photogrammetry mission using the Albris was identified for this bridge to explore the potential of UAS photography to map defects on retaining walls. The target goal of the mission was to gather information in the form of photographs in a quick, efficient process which could later be used to map the wall and have a post-inspection tool to aid in report writing and historical documentation. Additionally, the ease of use in an urban environment was displayed. The mission consisted of a pre-planned flight path that imaged the entire faces of the walls and the area immediately adjacent to the walls. All images were geo-tagged with GPS coordinates. Refer to Images 6 and 7 for views of the Flight and Mapping Mission.

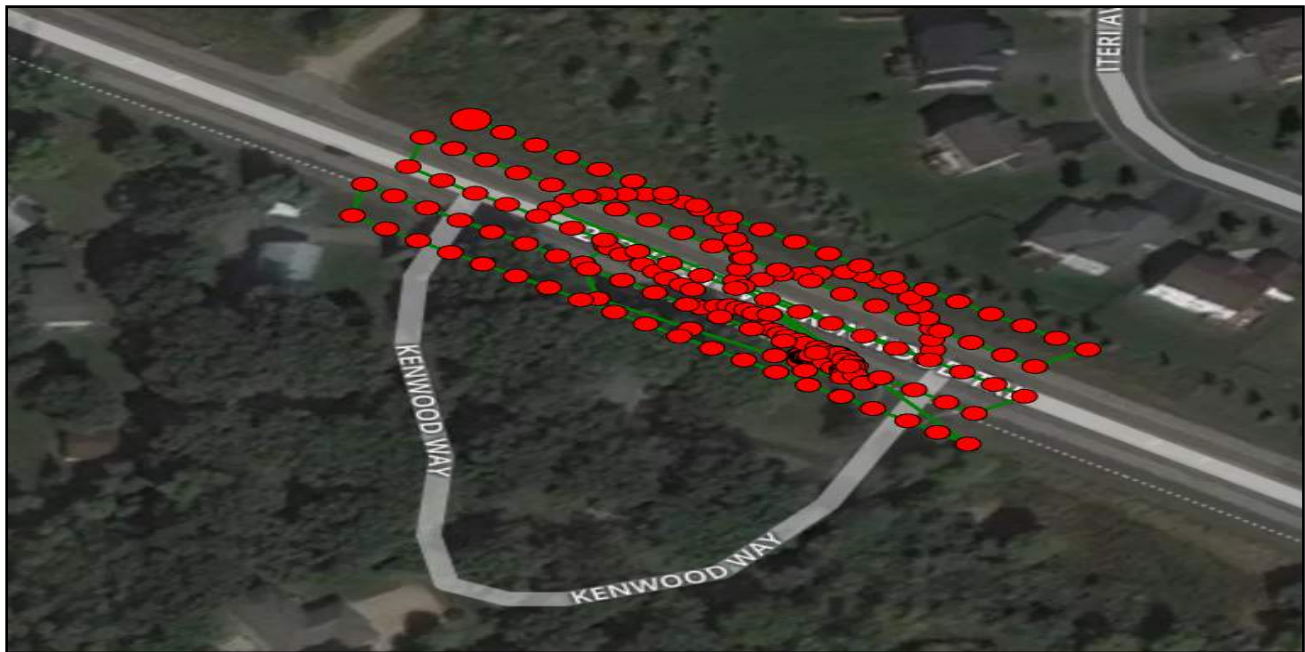

Image 6: View of Mission Flight Map (Preplanned and Interactive) for the Lakeville Retaining Wall.

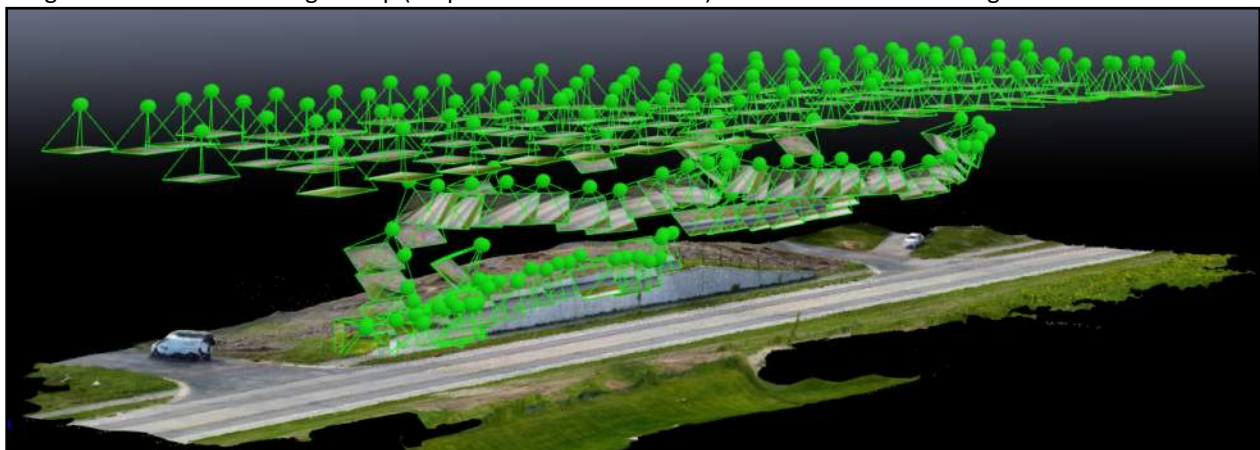

Image 7: View of Camera Position (Green Dot) at Locations of Photographing for the Lakeville Retaining Wall.

2.3 Deliverables

An Orthomosaic image was created in the Pix4D software to use as an inspection tool and deliverable. The target goal for this process was to produce an easily viewable, high resolution image of a large area that could be used by an inspector to carry out a detailed inspection, area measurements, condition assessment, or historical documentation. An Orthomosaic image is a single image file which is created from many individual images captured during the Mapping and Photogrammetry Mission. The final product of an Orthomosaic image is an image file that can be used to measure distances and areas. For this wall, an Orthomosaic image was made of the entire length of the retaining wall and rail in close proximity to the wall. An inspector then reviewed a single file and can measure true distances and areas for a final product. Refer to Image 8 for a view of Orthomosaic Detail.

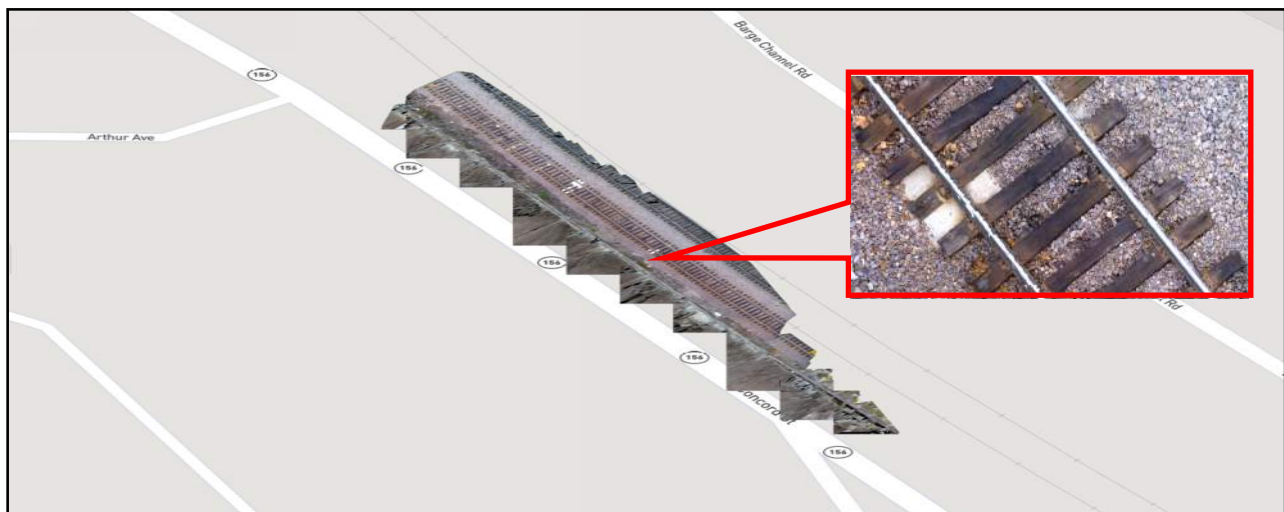

Image 8: View of the Level of Detail in a Single High-Resolution Image. [\(Click Image to View the Model\)](#)

A 3D Model with a High-Resolution Photograph Log was processed for bridge. The target goal for this process was to determine the ease of use and applicability of having a 3D photolog to assist an inspector during post-processing, report writing, and for future inspection reference. Additionally, the applicability of an easily manipulated 3D model which could be shared with others was explored. All photographs taken during the Mapping and Photogrammetry Mission were processed in the Pix4D software. The software processes all photographs to form a 3D point cloud for digital viewing. The point cloud was then processed by the same software to generate a 3D mesh of the bridge.

UAS INSPECTION REPORT

Retaining Wall Inspections • Kenwood Trail, Lakeville, MN
Concord St. St. Paul, MN • November 2017



The results of the retaining wall terrestrial Imaging yielded a total of 217 and 179 usable images for the Lakeville and South St. Paul retaining walls respectively. These images were processed with the Pix4D software to provide the inspector with a 3D model and high-resolution photograph log. Refer to Images 9 and 10 below for views of Lakeville and South St. Paul retaining walls.



Image 9: View of the Lakeville 3D model in Pix4D. [\(Click Image to access 3D Model\)](#)



Image 10: View of the South St. Paul 3D model in Pix4D. [\(Click Image to access 3D Model\)](#)

An inspector was able to use the Pix4D program to navigate the 3D model and select areas or interest. The software provides the inspector with all still images containing the selected area of interest which can then be viewed in high resolution. Additionally, the inspector can place annotations within the file for future reference or for clarification when sharing the file. Refer to Image 11 for a view of the Inspector Tool providing a Photograph Log from a selected area of the 3D model.

UAS INSPECTION REPORT

Retaining Wall Inspections • Kenwood Trail, Lakeville, MN
Concord St. St. Paul, MN • November 2017

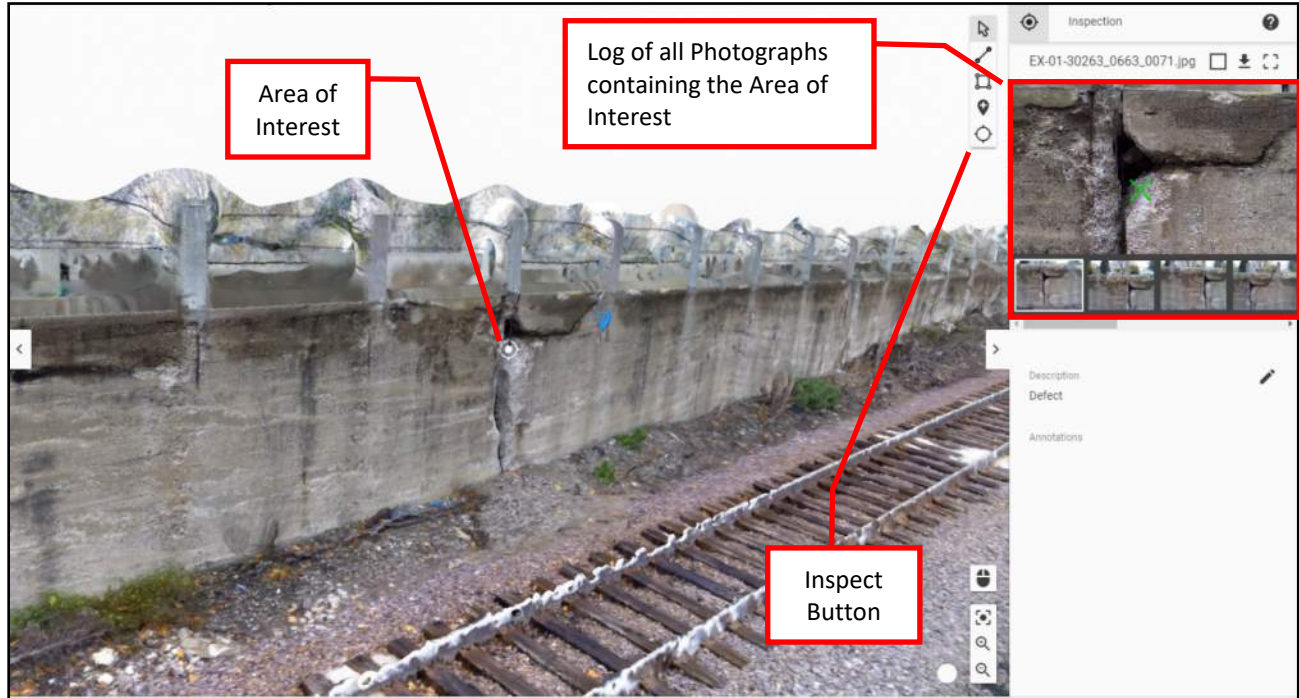

Image 11: View of the Inspector Tool providing a Photograph Log from a selected area of the 3D model.
(Click Image to access 3D Model and Inspection Photolog – Click on the Inspect Button)

3.0 SUMMARY OF FINDINGS

3.1 Opportunities

The execution of the Mapping and Photogrammetry Mission was a success and provided great insight into the potential for UAS as a tool during routine inspections. The set-up, flight, and data generation went as planned and was substantial enough to create the planned deliverables. Utilizing UAS on a retaining wall proved to be an efficient way to collect data and document the inspection of each of the walls. The use of both autonomous missions and manual missions proved successful. The ability to use distance lock and cruise control allowed the ability to fly close to the wall and gain very good detail in the output.

3.2 Limitations

None.



UAS INSPECTION REPORT

UP BRIDGE PIER

UNION PACIFIC RAIL

OVER THE MISSISSIPPI RIVER

ST. PAUL, MINNESOTA

November 1, 2017

Prepared for:



*As part of MnDOT Research Project
A-198 Improving Quality of Bridge Inspections Using Unmanned Aircraft Systems
(UAS) Phase III*

Prepared by:

COLLINS
ENGINEERS INC.

1599 Selby Avenue
St. Paul, MN 55104
651.646.8502 • www.collinsengr.com

UAS INSPECTION REPORT

UP Bridge Pier • Union Pacific Rail over the Mississippi River
St. Paul, MN • November 2017



Table of Contents

1.0	INTRODUCTION	
1.1	Purpose and Scope	1
1.2	General Description of the Structure	2
2.0	UAS OPERATION	
2.1	UAS Equipment and Operating Conditions	3
2.2	Mission Scope	4
2.3	Deliverables.....	5
3.0	SUMMARY OF FINDINGS	
3.1	Opportunities	8
3.2	Limitations.....	8
3.3	Evaluation of Potential Cost Savings	8

Table of Images

Image 1: Location Map	1
Image 2: Overall View of Bridge Topside.	2
Image 3: Overall View of Bridge Underside.	2
Image 4: View of SenseFly Albris.	3
Image 5: View of GoPro Hero 5.	3
Image 6: View of Mission Flight Map (Preplanned and Interactive).	4
Image 7: View of Camera Position at Locations of Photographing.	5
Image 8: View of the Inspector Tool Within Pix4d.	6
Image 9: View of the Level of Detail Captured in a GoPro Image.	6
Image 10: View of the Level of Detail Included in a Single High-Resolution Image.	7

UAS INSPECTION REPORT

UP Bridge Pier • Union Pacific Rail over the Mississippi River
St. Paul, MN • November 2017



EXECUTIVE SUMMARY

- Project:** Reinforced Concrete Pier Inspection Using UAS's of Union Pacific Railroad Bridge.
- Purpose of Project:** To perform a partial inspection of select superstructure elements using unmanned aircraft system (UAS) techniques to determine the structural and physical condition of difficult to access bridge elements. The inspection is supplemental to a routine visual, tactile, and non-destructive testing inspection.
- Inspection Team:** Team Leader – Barritt Lovelace, P.E. (Pilot)
Team Member – Cory Stuber, P.E. (Crew Hand)
- Inspection Date(s):** November 1, 2017

Data Collection Tools:

- SenseFly Albris Flyability Elios Other: GoPro Hero 5

Summary of Mission Scope(s) and Deliverable(s):

- Aerial Mapping & Photogrammetry 3D Model & High Resolution Photograph Log High Definition Video for Limited Access Areas
- Orthomosaic Image Creation for Inspection Defect Measurement Construction/Repair Plan Documentation
- Thermal Imaging Other: _____

Summary of Findings, Opportunities, and Limitations:

The execution of the Mapping and Photogrammetry Mission was a success and provided great insight into the potential for UAS as a tool during routine inspections. The set-up, flight, and data generation went as planned and was substantial enough to create the planned deliverables. The ability to scan the bridge quickly and get post damage information was very positive. The collection of data was efficient and cost effective. Combining the underwater and above water scans of the pier was particularly useful in determining and communicating the extent of the concrete fracture that had occurred.

UAS INSPECTION REPORT

UP Bridge Pier • Union Pacific Rail over the Mississippi River
St. Paul, MN • November 2017



1.0 INTRODUCTION

1.1 Purpose and Scope

This report consists of the results of an unmanned aircraft (UAS) inspection of a Union Pacific railroad bridge over the Mississippi River located in St. Paul, Minnesota. Refer to Image 1 for a location map. Collins Engineers, Inc. (Collins) conducted the UAS Inspection on November 1, 2017 as part of a research project titled “Improving Quality of Bridge Inspections Using Unmanned Aircraft Systems (UAS) Project Phase III”. The primary purpose of the UAS usage during the inspection was to identify possible opportunities and limitations of UAS involvement in various capacity of bridge inspection. The following report includes a brief description of the structure, description of UAS equipment and operating conditions, the mission scope and deliverables, a summary of findings, opportunities, and limitations, and an evaluation of potential cost savings.

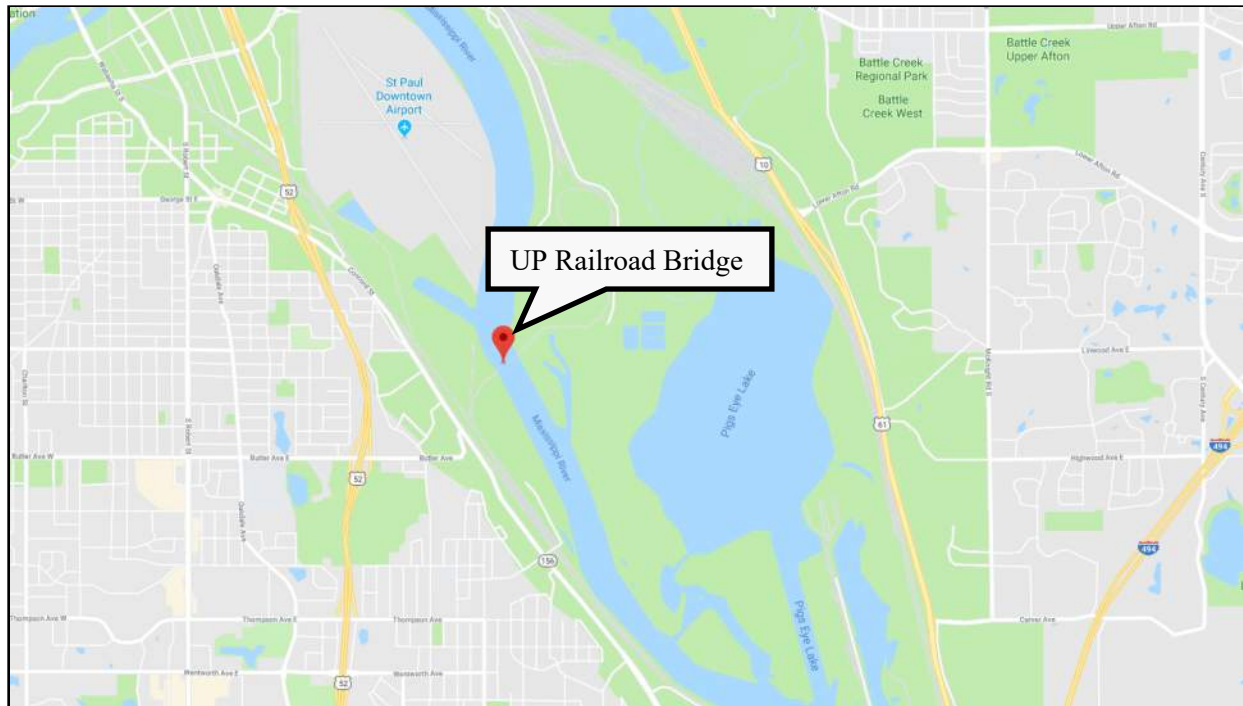

Image 1: Location Map

UAS INSPECTION REPORT

UP Bridge Pier • Union Pacific Rail over the Mississippi River
St. Paul, MN • November 2017



1.2 General Description of the Structure

Union Pacific railroad bridge is a swing bridge that spans approximately 1275 feet over the Minnesota River and carries one track of Union Pacific railroad. The bridge deck is approximately 18 feet wide and consists of steel tracks on timber beams. The bridge superstructure consists of a steel truss span with steel floor beams and stringers. The substructure consists of reinforced concrete abutments and piers founded on piles. The longitudinal axis of the bridge is orientated approximately northeast to southwest. Refer to Images 2 and 3 for overall views of the bridge.



Image 2: Overall View of Bridge Topside.



Image 3: Overall View of Bridge Underside.

2.0 UAS OPERATION

2.1 UAS Equipment and Operating Conditions

A one-person crew, consisting of a professional engineer-pilot, conducted the UAS inspection. The pilot was certified as a FAA Remote Pilot. The inspection was conducted using an aerial mapping UAS called the SenseFly Albris quadcopter which is equipped with a triple View head consisting of a HD video camera, a 38MP still camera, and an infrared camera. Additionally, the Albris contains five acoustic sensors, GPS location, and photo-identification stabilization technology which aid both 3D preplanned and interactive flight missions. The action camera was a GoPro Hero 5 High-Resolution Camera. The camera was equipped with a 12 Megapixel still camera and a fisheye lens. Refer to Image 4 for a view of the SenseFly Albris and Image 5 for a view of the GoPro Hero 5.



Image 4: View of SenseFly Albris.



Image 5: View of GoPro Hero 5.

During the inspection, the pilot worked from a mobile work station suspended from his body while maintaining line-of-sight with the UAS. At the time of flight, the weather was overcast with low wind. The bridge was located in class D airspace which is covered under the blanket waiver obtained by Collins.

2.2 Mission Scope

UAS INSPECTION REPORT

UP Bridge Pier • Union Pacific Rail over the Mississippi River
St. Paul, MN • November 2017



A Mapping & Photogrammetry mission using the Albris was identified for this bridge to explore the potential of UAS photography to map the railway structure and substructure elements. The target goal of the mission was to gather information in the form of photographs in a quick, efficient process which could later be used to map the steel truss railroad bridge and have a post-inspection tool to aid in report writing and historical documentation. The mission consisted of a pre-planned flight path at an elevation of approximately 180 feet above ground level (AGL). The UAS collected over 141 high-resolution still images of the bridge pier and top side. All images were geo-tagged with GPS coordinates. Refer to Images 6 and 7 for views of the Flight and Mapping Mission.

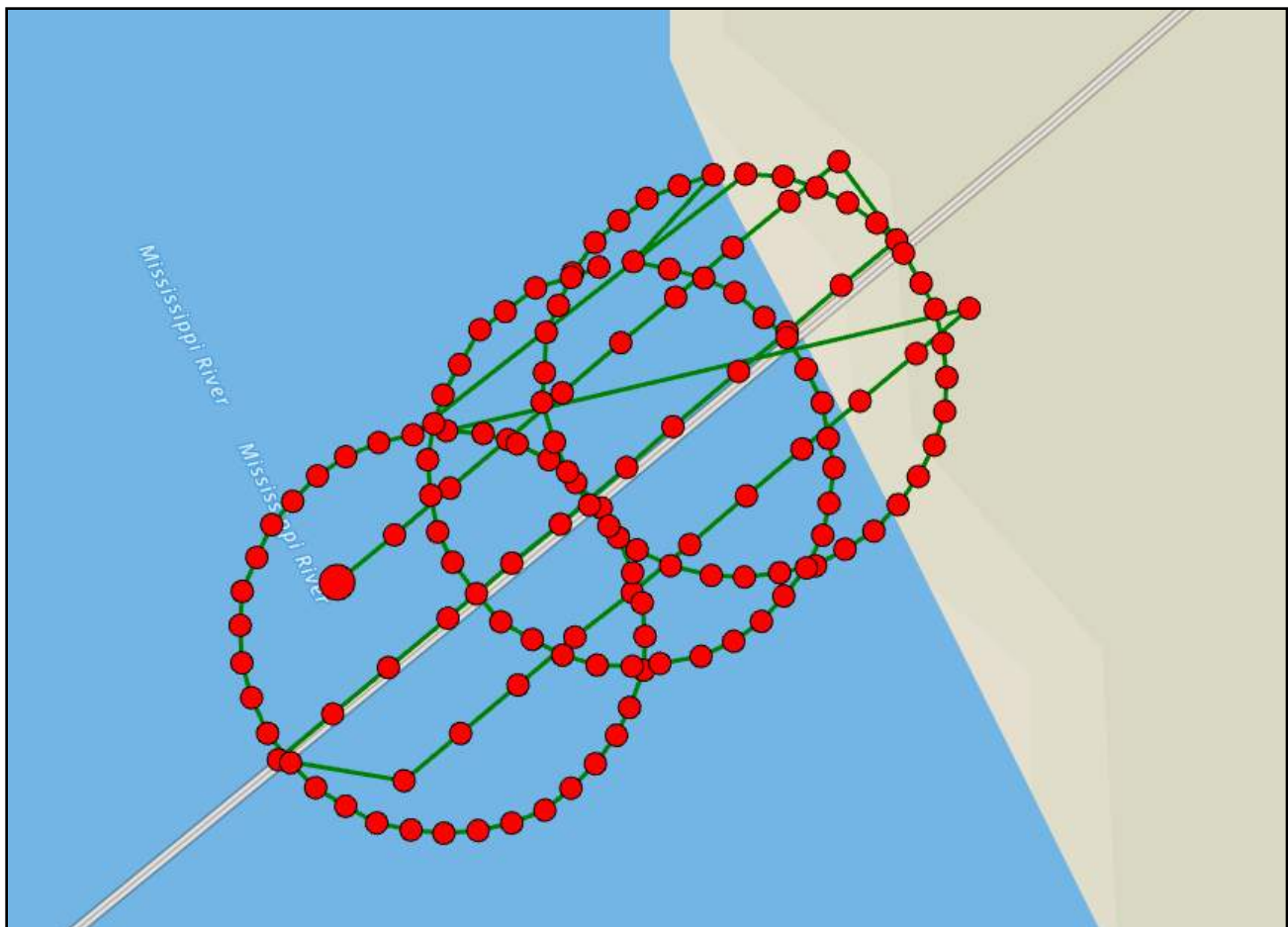

Image 6: View of Mission Flight Map (Preplanned and Interactive).

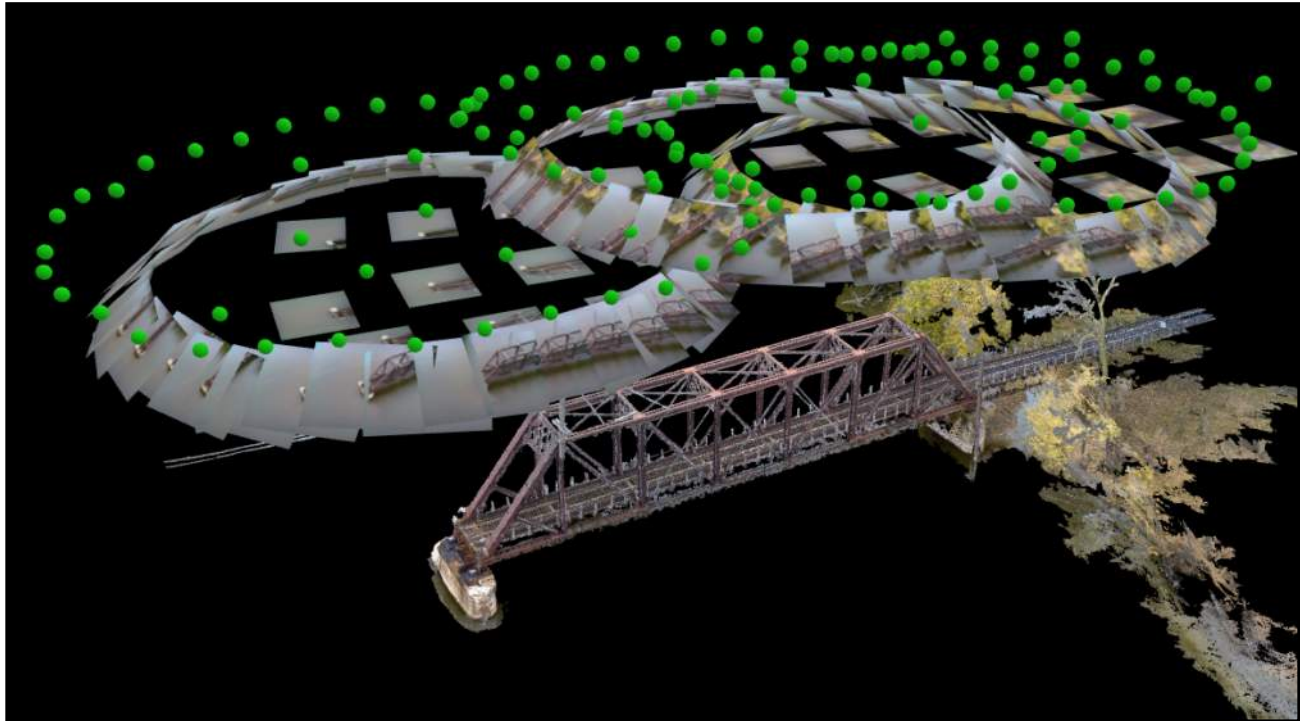

Image 7: View of Camera Position (Green Dot) at Locations of Photographing

2.3 Deliverables

A 3D Model with a High-Resolution Photograph Log was processed for bridge. The target goal for this process was to determine the ease of use and applicability of having a 3D photolog to assist an inspector during post-processing, report writing, and future inspection. All photographs taken during the Mapping and Photogrammetry Mission were processed in the Pix4D software. The software processes all photographs to form a 3D point cloud for digital viewing. The point cloud was then processed by the same software to generate a 3D mesh of the bridge. An inspector was then able to navigate the 3D model and select areas or interest. The software provides the inspector with all still images containing the selected area of interest which can then be viewed in high resolution. Additionally, the inspector can place annotations within the file for future reference or for clarification when sharing the file. Refer to Image 8 for a view of the Inspector Tool providing a Photograph Log from a selected area of the 3D model, and Image 9 for a view of the level of detail included in the photograph log.

UAS INSPECTION REPORT

UP Bridge Pier • Union Pacific Rail over the Mississippi River
St. Paul, MN • November 2017

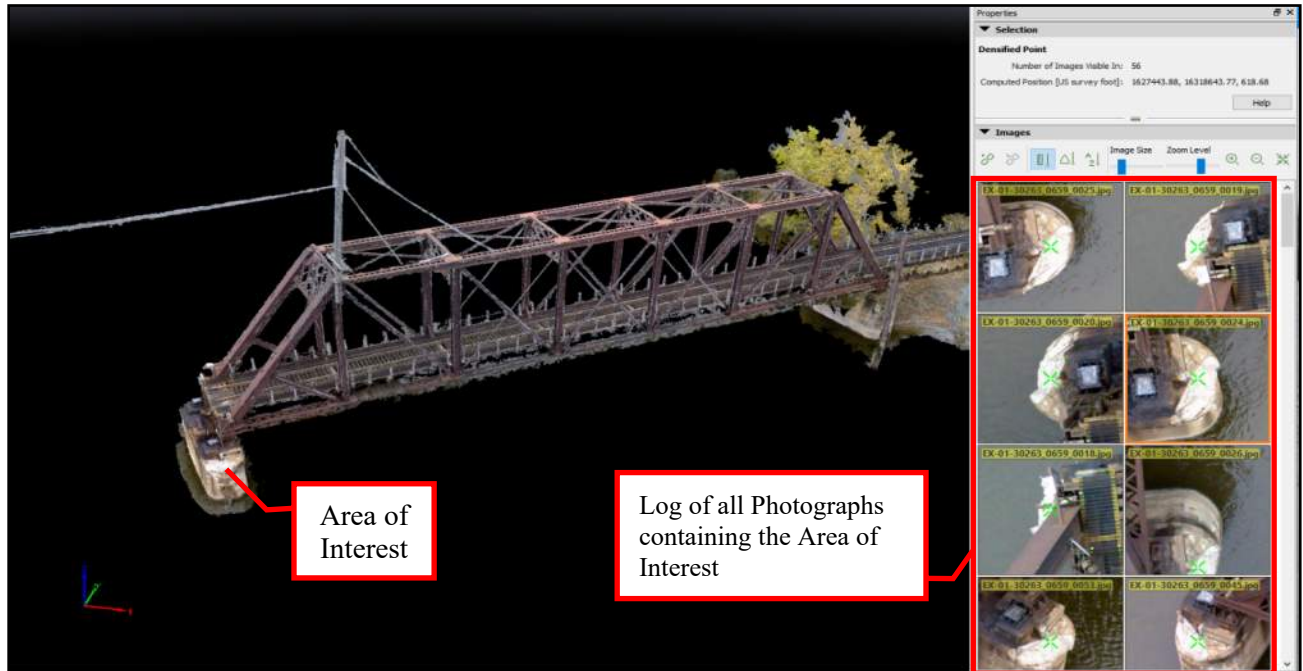

Image 8: View of the Inspector Tool providing a Photograph Log from a selected area of the 3D model. Note the annotated areas for future reference or ease of sharing. **(Click Image to access 3D Model and Inspection Photolog Click on the Inspect Button)**



Image 9: View of the Level of Detail in a Single High-Resolution Image.

UAS INSPECTION REPORT

UP Bridge Pier • Union Pacific Rail over the Mississippi River
St. Paul, MN • November 2017



A Orthomosaic image was created to use as an inspection tool. The target goal for this process was to produce an easily viewable, high resolution image of a large area that could be used by an inspector to carry out a detailed inspection, area measurements, condition assessment, or historical documentation. An Orthomosaic image is a single image file which is created from many individual images captured during the Mapping and Photogrammetry Mission. The final product of an Orthomosaic image is an image file that can be used to measure true distances. For this bridge, an Orthomosaic image was made of the railroad bridge topside. An inspector then reviews a single file and can measure true distances and areas for a final product. Refer to Image 10 for a view of Orthomosaic Detail.



Image 10: View of the Level of Detail in a Single High-Resolution Image.

Shotcrete pureness bridge was struck by a barge and as part of another project the concrete pier was mapped above water with a handheld GoPro camera and the underwater portions of the pier were scanned with Multi-Beam sonar underwater imaging. The above water and below water scans were then combined in software

UAS INSPECTION REPORT

UP Bridge Pier • Union Pacific Rail over the Mississippi River
St. Paul, MN • November 2017



called CloudCompare to create one entire model of the structure. The resulting model demonstrates the ability to create three D model of both the above water and below water portions of the structure. But



Image 11: View of the Level of Detail in a Single High-Resolution Image. [\[Click Image for Video of 3D Model\]](#)

3.0 SUMMARY OF FINDINGS

3.1 Opportunities

The execution of the Mapping and Photogrammetry Mission was a success and provided great insight into the potential for UAS as a tool during routine inspections. The set-up, flight, and data generation went as planned and was substantial enough to create the planned deliverables. The ability to scan the bridge quickly and get post damage information was very positive. The collection of data was efficient and cost effective. Combining the underwater and above water scans of the piers was particularly useful in determining and communicating the extent of the concrete fracture that had occurred.

3.2 Limitations

None.

APPENDIX B
MNDOT SAFETY PLAN



Improving the Quality of Bridge Inspections Using Unmanned Aircraft Systems (UAS) Investigation and Safety Plan (Revision 1) 2017

Prepared for:



Prepared by:

COLLINS
ENGINEERS INC.

1599 Selby Avenue
St. Paul, MN 55104

651.646.8502 • www.collinsengr.com



PROJECT SUMMARY

Project: Improving the Quality of Bridge Inspections Using Unmanned Aircraft Systems (UAS)

Purpose of Project: The overall goal of the Improving the Quality of Bridge Inspections Using Unmanned Aircraft Systems (UAS) Project is to study the effectiveness of UAV technology when applied to bridge safety inspections.

Field Team: Jennifer Wells - MnDOT Project Manager
Barritt Lovelace – Collins Engineers - Project Manager, Quality Mangement, Remote Pilot
Garrett Owens – Collins Engineers – Remote Pilot
Cory Stuber– Collins Engineers – Inspector
Rebecca Keller– Collins Engineers – Assistant Inspector

Field Date(s): June – December 2017, Specific Dates Pending Weather

Airspace: Airspace classification is listed by bridge in Appendix B. Airspace authorizations will follow the FAA’s Part 107 rules.

Bridge List: Bridge 2440, Third Avenue Bridge
Bridge 4175, Shakopee Pedestrian Bridge
Bridge 10509, Chanhassen Bridge
Bridge 13501, Chisago County Bridge
Bridge 13510, Chisago County Bridge
Bridge 19583, Lakeville Bridge
Bridge 27004, Stone Arch Bridge
Bridge 27201, Lake Street Bridge
Bridge 27831, Dunwoody Bridges
Bridge 62080, St. Paul Kellogg Bridge
Bridge 62090, St. Paul High Bridge
Bridge 62504, St. Paul CP Rail Over Ayd Mill

BRIDGE INVESTIGATION AND SAFETY PLAN

Improving the Quality of Bridge Inspections Using Unmanned Aircraft Systems (UAS)
MnDOT • September 2017



Bridge 62513, St. Paul Culvert
Bridge 62515, St. Paul CP Rail Over BNSF
Bridge 62531, Warner Road Bridge
Bridge 82045, St. Croix Crossing
Bridge 89182, Mayowood Bridge
Bridge L5981, Chisago County Bridge
Bridge 82502, Washington County Bridge
Bridge 9805 and 9805A, I-94 Concrete Box
Bridge 27636, Hennepin Avenue over Mississippi
Bridge 9731, 35W over 31st Street
Bridge 27871, 35W over TH 65
Bridge 2519, Viking Blvd over the Rum River
Bridge 2521, Coon Rapids Blvd over RR
Bridge 2522 Coon Rapids Blvd over East River Road

Maps:

Google Map of Bridge Sites:

https://drive.google.com/open?id=1aUWVRXfo_z4ysyHGq1gdOQ2oJOI&usp=sharing

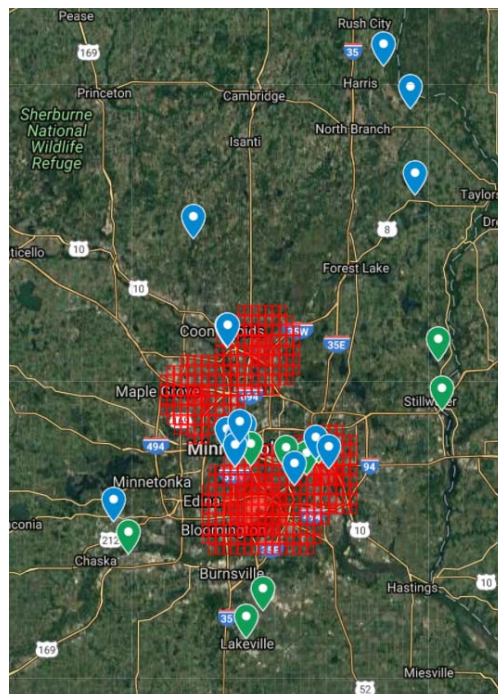

Figure 1. Overall Phase III Map.

BRIDGE INVESTIGATION AND SAFETY PLAN

Improving the Quality of Bridge Inspections Using Unmanned Aircraft Systems (UAS)
MnDOT • September 2017

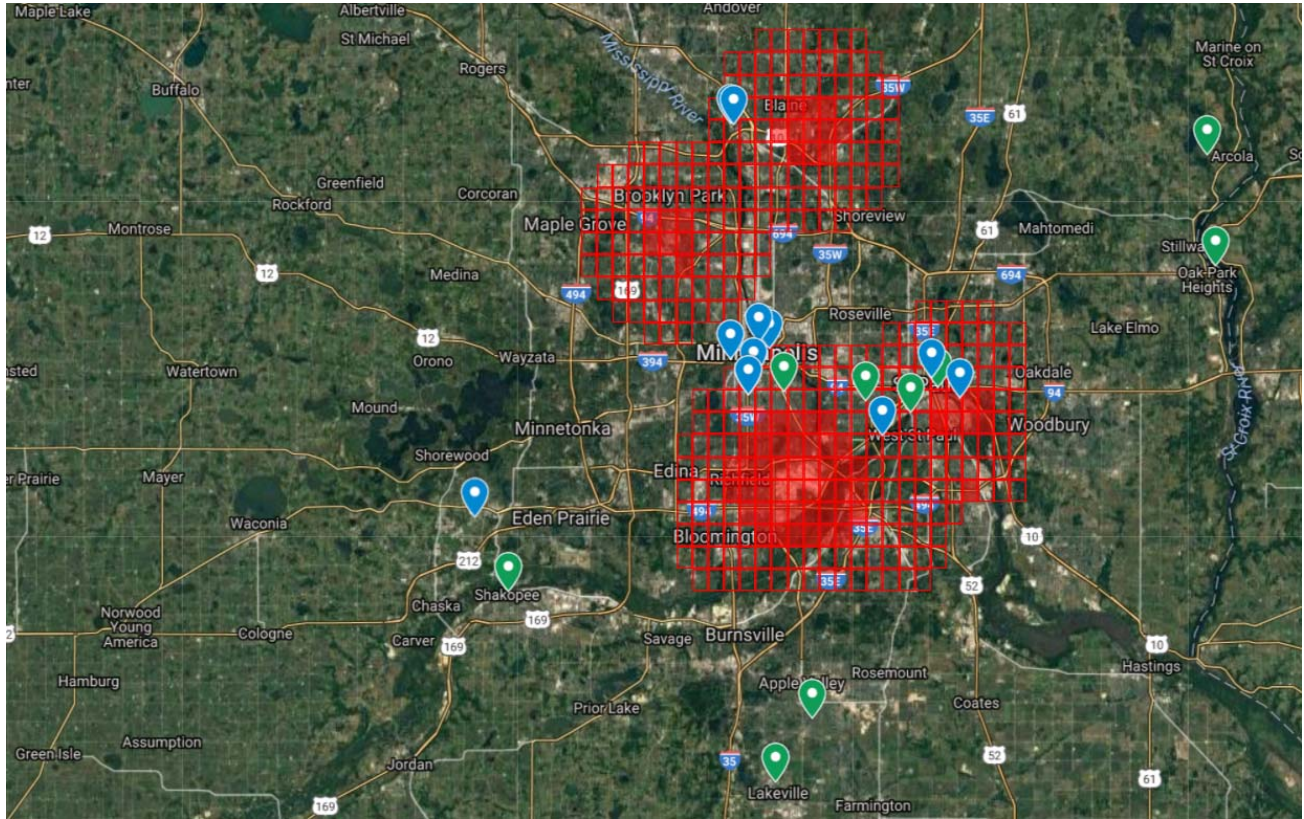

Figure 2. Minneapolis - St. Paul Metro Map.



1.0 INTRODUCTION

Increasing bridge maintenance and inspection costs are a concern for existing bridges in Minnesota. These additional costs can be minimized and the quality of inspections can be improved by utilizing Unmanned Aerial Systems (UAS). In 2015 and 2016 MnDOT performed Phase I and Phase II studies to evaluate the usage of UASs for bridge inspections. The resulting studies were published by the MnDOT Research Office. A Best Practices document was created as part of Phase II. Based on the conclusions and recommendations of these initial studies the overall goal of the Phase III contract is to further evaluate the effectiveness of UAS as they apply to Bridge Safety Inspections, particularly in confined spaces. The Sensefly Albris and the Flyability Elios, a collision-tolerant UAS designed for industrial inspection, will be utilized to conduct fieldwork. The study will culminate in a report detailing advantages and disadvantages of using the UAS during an inspection and provide a contrast comparison between the UAS used in all phases.

2.0 INVESTIGATION PLAN

The following describes the inspection plan for all bridges in Phase III. The rules outlined in the FAA's Small Unmanned Aircraft Regulations (Part 107) will be adhered to at all times. The bridges outside of G airspace will have Airspace Authorizations, which will be adhered to at all times. The location and structure description are presented in detail in Appendix B. A general discussion of access methods, investigation methods, and site safety and privacy is detailed below.

2.1 Access Methods

The bridges will be accessed from MnDOT/owner right of way. The UAS will be launched and flown from locations that are within the limits of the normal bridge inspections. The UAS will not be flown from private property at any time.

2.2 Investigation Methods

The bridge will be inspected with the use of UAS technology to determine its effectiveness as a tool for bridge safety inspection. Using the previous reports as a reference, previously identified deficiencies will be investigated to determine if those deficiencies could reasonably be identified with the use of a UAS. Any additional deficiencies discovered will be noted as well.



2.3 Site Safety and Privacy

A job hazard analysis has been prepared and will be utilized to facilitate daily site safety briefings. This document can be found in Appendix A. Privacy is not expected to be an issue but efforts will be made to not include the public in any photos or video taken during the fieldwork.

Respectfully Submitted,
COLLINS ENGINEERS, INC.

A handwritten signature in blue ink that reads "Barritt Lovelace".

Barritt Lovelace, P.E., Regional Manager



Appendix A

Job Hazard Analysis

COLLINS ENGINEERS JOB SAFETY ANALYSIS BRIDGE INSPECTION

Submit to Project Manager / Supervisor for approval prior to commencing work if necessary.

PROJECT INFORMATION:

Collins Project Number:	<u>10456</u>	Date:	<u>6/23/2017</u>
Client:	<u>MnDOT</u>	Prepared By:	<u>Barritt Lovelace</u>
Inspection Team Leader:	<u>Barritt Lovelace</u>	For Date(s):	<u>June - December 2017</u>
General Work Location:	<u>MnDOT Metro District</u>	Expected Work Duration:	<u>15-20 Days</u>

REQUIRED SAFETY EQUIPMENT FOR INSPECTION CHECK LIST:

(Check if in Possession; obtain all applicable and required equipment prior to commencing work)

Personal Protective Equipment (PPE)		General Equipment		First Aid / Other:	
Hard Hat:	<input checked="" type="checkbox"/>	Project Work Plan:	<input checked="" type="checkbox"/>	First Aid Kit:	<input checked="" type="checkbox"/>
Safety Glasses:	<input checked="" type="checkbox"/>	GPS/Atlas/Maps:	<input checked="" type="checkbox"/>	Sunscreen:	<input checked="" type="checkbox"/>
Steel Toe Boots:	<input checked="" type="checkbox"/>	Harness:	<input checked="" type="checkbox"/>	Insect Repellent:	
Gloves:	<input checked="" type="checkbox"/>	Stress Release Straps for Harness:	<input checked="" type="checkbox"/>	Drinking Water:	<input checked="" type="checkbox"/>
Hearing Protection:		Lanyards:	<input checked="" type="checkbox"/>	Strobe Lights:	
Reflective Vests:	<input checked="" type="checkbox"/>	Tethers for Climbing Tools:		Two-Way Radios:	<input checked="" type="checkbox"/>
Reflective Pants (night work):		Personal Floatation Device:		Mobile Phone:	<input checked="" type="checkbox"/>
Rope Access Equipment:					
:					

WORK LOCATIONS / EMERGENCY CONTACT INFORMATION:

If information is located in field books, work plan, or elsewhere, ensure inspection team is aware and can readily locate.

Mobile phone or other means of contacting emergency personnel must be on site prior to starting inspection.

List complete location information for work in case of need for emergency response. List multiple if required.

Work Location MnDOT Metro District	Nearest Municipality (Name of City, Village, etc.) Minneapolis, MN
---------------------------------------	---

Nearest Hospital Location: Hennepin County Medical Center, 730 S 8th St, Minneapolis, MN 55404

Nearest Police / Fire Phone Numbers: 911

COLLINS ENGINEERS JOB SAFETY ANALYSIS

BRIDGE INSPECTION (Continued)

SAFETY ANALYSIS			Responsible
Job Step	Specific Hazards	Corrective Action & Safe Work Practices	Party / Team Lead
Assess Site Conditions	Weather Conditions: Rain, lightening, extreme temp. or wind, ice, other	Check forecast to be aware of possible inclement weather. Wait for improved conditions (at least 30 minutes after last lightening strike) or limit access to structure. Ensure inspection team is properly clothed and equipped (cold weather clothes, rain gear, etc.)	
	Traffic Conditions: Vehicular traffic	Avoid high volume, high speed areas under construction or otherwise temporarily impeded (accidents, etc.) Wear proper reflective clothing and stay alert and vigilant. Coordinate with local authorities and inform them of our presence. Coordinate with Safety Signs for flagging and lane closure.	
	Rail traffic	Coordinate with proper jurisdiction if necessary, and arrange for flagman if required.	
	Boat traffic	Coordinate with proper jurisdiction if necessary, and stay alert for boat traffic and floating debris.	
Access Site	Vehicular Traffic: Traffic at site	Park vehicle in safe location 10 foot from roadway edge, or off of roadway when possible.	
	Obstructions: Obstructions (fences, retaining walls, vegetation, water, etc.)	Review previous inspection report, bridge file, and plans prior to inspection. Survey area for safest point of entry.	
	Traffic Control: Traffic control setup	Traffic control should be setup in accordance with jurisdiction standard specifications (State/City/County etc.) or MUTCD. If roadway constraints do not allow for standard setup, competent person(s) should design proper traffic control.	
	Work zone check (traffic control)	Drive through work zone to ensure compliance with work zone standards (proper signage, configuration, etc.). Ensure traffic is flowing through work zone, and not encroaching on work zone.	
	General Inspection: Insects, rodents, reptiles, other animals, poison ivy/oak, sunburn	Perform visual inspection of site prior to beginning work. Contact animal control or client if needed. Use wasp/hornet killer as needed. Wear proper PPE. Wear insect repellent clothing and sunscreen.	
Sharp objects (rust, galvanizing drips, bolts, edges of plates, angles, etc.)	Visually inspect site for dangers. Wear proper PPE.		
Slips, trips, and falls	Identify and avoid hazards if possible, guardrails, barriers, steep embankments, grade changes, etc. Wear proper PPE.		
Inspection	Vehicular Traffic: Crossing lanes of traffic	Do not attempt to cross lanes of traffic in high volume conditions, low visibility condition, or high speed conditions. Do not cross traffic if traffic can not see you.	
	Traffic encroaching on work zone	Observe erratic drivers and avoid. Position yourself in safe place out of way of traffic when possible (behind guardrail or barrier, well off the road, etc.)	
	Aerial Lifts: * Ensure all team members are properly trained and qualified to operate lift.		
	Fall from height greater than 6 feet	Wear fall protection. Follow Collins fall protection and rescue plan. Report any incidents to team leader immediately.	
	Overhead hazards (electrical lines, bridge beams, etc.). Aerial lifts over water: Proper PPE including PFD, Marine Radio	Visually inspect site for dangers prior to entering lift. Wear proper PPE. Stay a least 10 feet from power lines at all times.	
	Over/Near Water	Wear proper PPE including PFD. Marine Radio to be at site. Throwable life ring to be on site.	

**COLLINS ENGINEERS JOB SAFETY ANALYSIS
BRIDGE INSPECTION (Continued)**

SAFETY ANALYSIS (Continued)

Job Step	Specific Hazards	Corrective Action & Safe Work Practices	Responsible
			Party / Team Lead
Inspection (continued)	Wading		
	Enter water (slips /falls)	Visually inspect site prior to entering water. Survey area around bridge for best point of entry. Probe ahead of path with rod as entering. All team members aware of inspection POA. When working adjacent to water, you must wear a Personal Flotation Device.	
	Wade inspection / boat traffic / fast current	Stay alert for boat traffic, floating debris and swift currents. Probe ahead of path with rod when moving.	
	Exit water (slips/falls)	All team members assist each other when exiting the water.	
	UAV Concerns	Review and follow operations manual and use radios to communicate with operators to ensure public safety	
	Environmental Concerns	Stay alert for environmental factors.	
Post Inspection	General		
	Health and safety of inspector after inspection	Check inspectors health/condition after inspection. Inform the Team Leader of any inspection related injuries.	
	Work zone break down / vehicular traffic	Follow standards for work zone breakdown. Use proper MOT devices, vehicle with warning lights as needed to breakdown closure in reverse order.	

By signing this JSA, you confirm that each listed hazard has been reviewed during the safety briefing and you fully understand the work and safety procedures that can be utilized to mitigate these potential hazards. Inspectors are to report any physical problems before, during, or after the inspection. All incidents are to be reported to team leader as soon as possible.

Team leader shall complete an incident report and submit to Structural Inspection Program Manager and their respective Regional Manager.

Name / Signature / Date

Team Leader: _____

Inspector: _____

Inspector: _____

Inspector: _____

Inspector: _____

Inspector: _____



Appendix B

Bridge List

Bridge Number	Bridge Name	Latitude	Longitude	Airspace Class	FAA Authorization	Owner	Scope	Notes
2440	3rd Avenue Bridge	44.98341666	-93.25885833	Class G	Not Required	MnDOT	Concrete Condition Mapping and IR Mapping	
4175	Shakopee Pedestrian Bridge	44.800141	-93.52708056	Class D	Submitted	Scott County	Gussett Plate Model - Deck Model	FAA Authorization ends Aug. 31st
10509	Chanhasen Bridge	44.85511667	-93.56175278	Class G	Not Required	City of Chanhasen	Overall Inspection - Deck Map	
13501	Chisago County Bridge	45.399977	-92.847375	Class G	Not Required	Chisago County	Bottom of Deck Mapping	
13510	Chisago County Bridge	45.544375	-92.8588777	Class G	Not Required	Chisago County	Between Beams - Tight Space	
19538	Lakeville Bridge	44.6575	-93.248333	Class G	Not Required	City of Lakeville	Overall Inspection - Deck Map	
19565	Lakeville Bridge	44.7053863	-93.2083055	Class G	Not Required	City of Lakeville	Overall Inspection - Deck Map	
27004	Stone Arch Bridge	44.9807444	-93.25330278	Class G	Not Required	MnDOT	Masonry Condition Mapping	
27201	Lake Street Bridge	44.948422	-93.2381888	Class B, Area A	N/A (Interior Only)	MnDOT	Interior of Steel Boxes	
27831	Dunwoody Bridges	44.972644	-93.29450277	Class G	Not Required	MnDOT		
62080	St. Paul Kellogg Bridge	44.95197222	-93.07663611	Class D	Submitted	City of St. Paul	Pier Cracking	Approved 7/10/17
62090	St. Paul High Bridge	44.93300278	-93.10453056	Class B	N/A (Interior Only)	MnDOT	Interior of Arches	
62504	St. Paul CP Rail over Ayd Mill	44.94142777	-93.15278611	Class B	Submitted	City of St. Paul		Approved
62513	St. Paul Culvert	44.91565833	-93.13434722	Class B	N/A (Interior Only)	City of St. Paul	Culvert Interior Inspection	
62515	St. Paul CP Rail over BNSF	44.95904167	-93.0834666	Class D	Submitted	City of St. Paul		Submitted FAA Request 6/9/2017
62531	Warner Road Bridge	44.94386944	-93.05316944	Class D		City of St. Paul		Not Approved
82045	St. Croix Crossing	45.04201944	-92.78508055	Class G	Not Required	MnDOT	TBD	
89182	Mayowood Bridge	43.99417	-92.52056	Class G	Not Required	Olmsted County	Overall Inspection - Deck Map	
L5981	Chisago County Bridge	45.61516944	-92.92292778	Class G	Not Required	Chisago County	Steel Culvert with Deformations	
2519	Anoka County Bridge - Oak Grove	45.32754	-93.37285	Class G		Anoka County		
2521	Anoka County Bridge - Coon Rapids	45.14644	-93.29104	Class G		Anoka County		
2522	Anoka County Bridge - Coon Rapids	45.14753	-93.29353	Class G		Anoka County		
9805	MnDOT Metro Concrete Box	44.950611	-93.101833	Class D	Yes (interior Only)	MnDOT Metro	Box Girder Interior for Scoping	
9805A	MnDOT Metro Concrete Box	44.950611	93.101833	Class D	Yes (interior Only)	MnDOT Metro	Box Girder Interior for Scoping	
82502	Washington County Bridge	44.950611	93.101833	Class G	Not Required	Washington County	Bridge Deck Survey and Bearing Inspection	
27871	35W over 31st Street	44.9591765	93.2696128	Class B	Submitted	MnDOT Metro	Bridge Deck Survey	Approved
9731	Washington County Bridge	44.9466751	93.2747573	Class B	Submitted	MnDOT Merto	Bridge Deck Survey	Approved

APPENDIX C
EQUIPMENT SPECIFICATIONS AND DATA SHEETS



The intelligent **mapping**
& **inspection** drone



C-2

3 reasons to choose albris

- **1 flight, 3 types of imagery**

With the senseFly albris you can switch between capturing high-res still, thermal and video imagery during the same flight, without landing to change cameras. Thanks to the drone's unobstructed field of view and its head's 180° vertical range of motion, you can capture clear, stabilised imagery ahead of, above and below the albris.

- **Advanced situational awareness**

The senseFly albris features five dual-sensor modules, positioned around the drone. These provide the situational awareness required to operate albris close to structures and surfaces, even in confined environments, in order to achieve sub-millimetre image resolutions (without the movement issues caused by zooming in from afar).

- **Choose your flight mode**

The albris offers full flight mode flexibility. Choose the mode that best fits your project: an Autonomous, GPS-guided mapping mission or a live-streaming Interactive ScreenFly flight. Or start in mapping mode and 'go live' on demand.



Main camera
(HD video & high-res still camera)

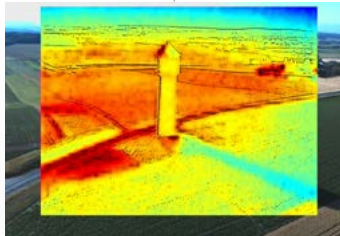

Thermal camera + edge overlay
(video & images)



Head navcam
(wide-angle video camera)

1 flight, 3 types of imagery

The senseFly albris is a sensor-rich platform with the widest camera breadth of any civilian drone. Its fully stabilised TripleView camera head allows you to switch between HD and thermal video imagery, live during

your flight, plus you can capture high-resolution still images on demand. All of this data can be saved for further analysis post-flight, and all without landing to change payloads.

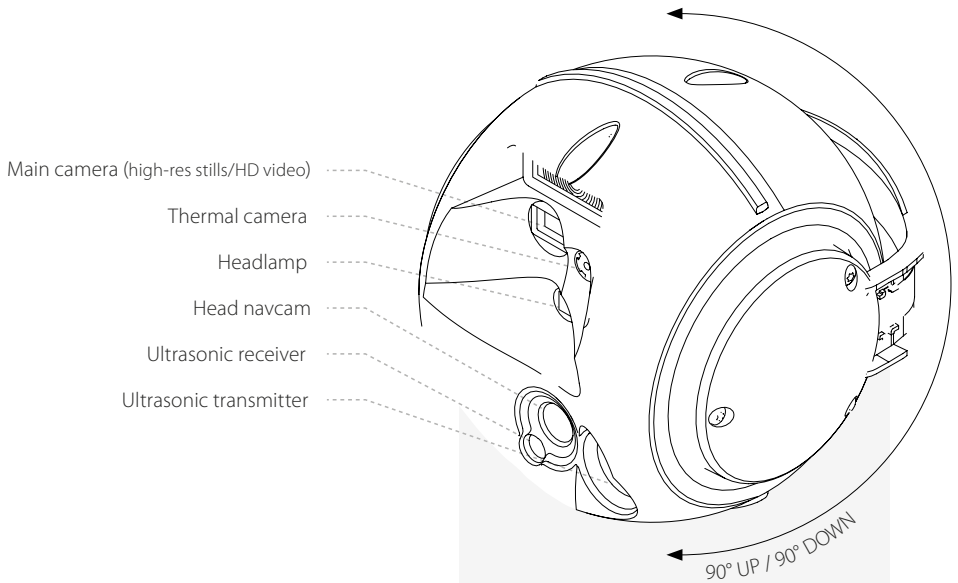

TripleView head

- * 180° vertical range of motion
- * 6x digital zoom
- * Approx. 1 mm still image resolution at 5 m (16.4 ft) distance
- * Active gimbal stabilisation
- * Unobstructed field of view



Advanced situational awareness

The senseFly albris is designed from the ground up to perform live inspections of buildings and other structures. Its onboard navcams and ultrasonic sensors provide the

visual and proximity feedback you require to take the right decisions and maximise every mission's chances of success.

Navcams



Ultrasonic sensors



Head position

Navigate, check for obstacles, keep constant distance from vertical surfaces

Left/Right

Navigate, check for obstacles, see side views

Bottom

Navigate, check for obstacles, land autonomously

Rear

Navigate, check for obstacles, reverse safely

Choose the flight mode that suits your project

Fully autonomous

Are you looking to map a small site, such as a plant or construction site, directly from above? Or maybe a specific point of interest such as a building or tower? If so, choose an autonomous albris mission.

- Specify your area/point of interest in the drone's supplied eMotion 3 software
- eMotion 3 generates a GPS waypoint-based flight plan
- The albris takes off, flies, acquires imagery & lands itself
- View albris' live video stream during flight
- Record imagery on albris' SD card as required for post-flight analysis
- Use image processing software to generate 2D maps & 3D models

Suits: High-res 2D mapping, 3D building mapping, construction monitoring, agricultural & archaeological mapping.

Interactive ScreenFly mode

Need to perform a live inspection? Use the drone's supplied ScreenFly controller to fly an assisted interactive mission.

- Take-off in interactive mode (or switch into this during an autonomous flight)
- 'See what albris sees' on-screen via its multiple live video feeds
- Anti-Drift, Cruise Control & Distance Lock
- Centre albris' cameras on a target
- Capture high-res still images on demand
- GNSS Off option to fly in GNSS-deprived environments

Suits: Structural inspection & documentation, crack/defect detection, solar panel analysis, tower inspection etc.

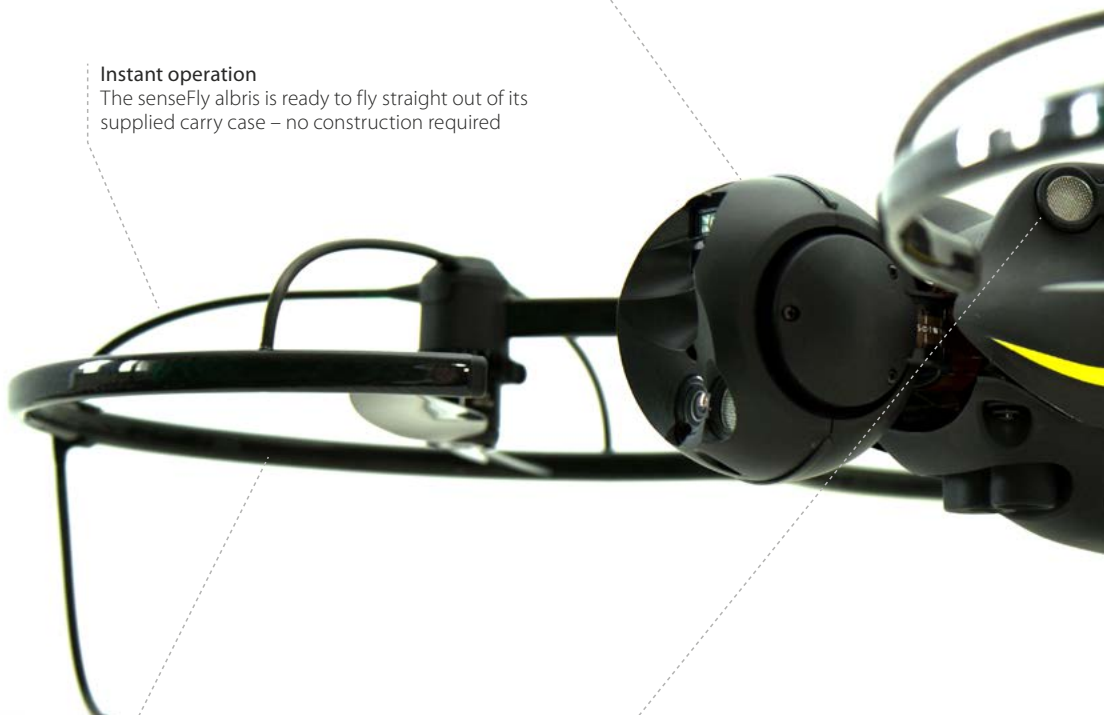

Instant operation

The senseFly albris is ready to fly straight out of its supplied carry case – no construction required

Live feedback

See what albris sees via its wide-angle navcams

Safety smart

Numerous self-monitoring & automated failsafe procedures reduce the risk of inflight issues, minimising potential danger to structures, people & the albris airframe

Close-object operation

Advanced situational awareness and flight stabilisation are enabled by the drone's:

- 5 ultrasonic sensors
- 5 navcams (visual sensors)

Onboard albris

The senseFly albris is lightweight, shock-absorbent and durable, designed to operate in tight working environments. With its forward-positioned TripleView camera

head and open-fronted airframe it offers an unrivalled field of view, while its propellers are fully protected by its advanced carbon fibre shrouding.



Electric powered
Low noise, no pollution,
and easy battery swapping
for prolonged use

Leading autopilot technology
The artificial intelligence built into
the senseFly autopilot analyses
a raft of data to optimise every
aspect of your flight

Bump-safe construction
The senseFly albris' shock-absorbent
carbon fibre shrouding protects the drone
in case of low-speed surface contact

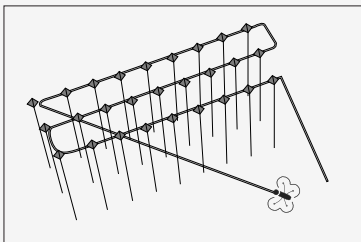

Horizontal Mapping

Use this mission block to fly a 'bird's eye', top-down mapping mission (senseFly eBee style). Just set a few key mission parameters, such as your preferred ground resolution, and eMotion 3 does the rest — creating flight lines and setting GPS waypoints, which are adapted to the terrain, automatically.

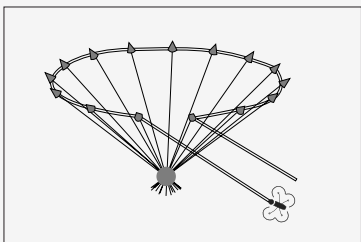

Around Point of Interest

This mission block automatically centres the drone's flight path around a specific point of interest. Once you've set the resolution/distance required, eMotion 3 automatically programs the image capture points. Use this mission block to create a 3D model of an object.

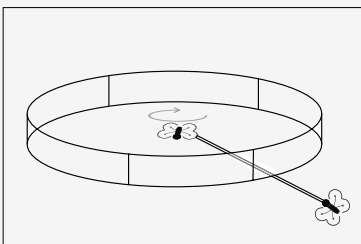

Panorama

This mission block suits a wide range of applications. You could fly a panoramic mission to gain an initial overview of a concave location, such as the curved cliff face of an open pit mine, to give that wow effect to reporting and documentation, to enhance the quality of 3D models... the choice is yours!

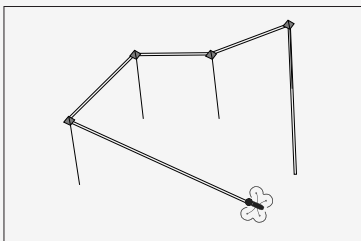

Custom Route

This mission block is perfect for guiding the drone through complex environments. Or if you want to use different types of mission block during a single flight, you can link these together using custom routes.

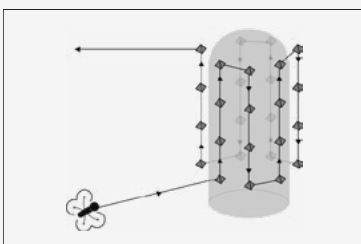

Cylinder

Inspect & digitally model structures such as wind turbines and towers using a senseFly albris. Just set the cylinder's height, its height above ground, plus the image resolution & overlap required. eMotion 3 sets the drone parameters and waypoints required to capture exactly the photos required—in overlapping layers—around the structure.

Intuitive flight planning & feedback



Every senseFly albris is supplied with eMotion 3 software, senseFly's proprietary flight planning, control and feedback program. Developed specifically for albris, eMotion 3 is your flight control centre — featuring live streaming video feedback, full control of what imagery albris captures, access to sensor and flight data, plus full flight planning functionality.

Choose your mission block

Flight planning in eMotion 3 is simple: just select the pre-programmed mission block that best suits your project. Further advanced mission blocks and software updates will be available for free.

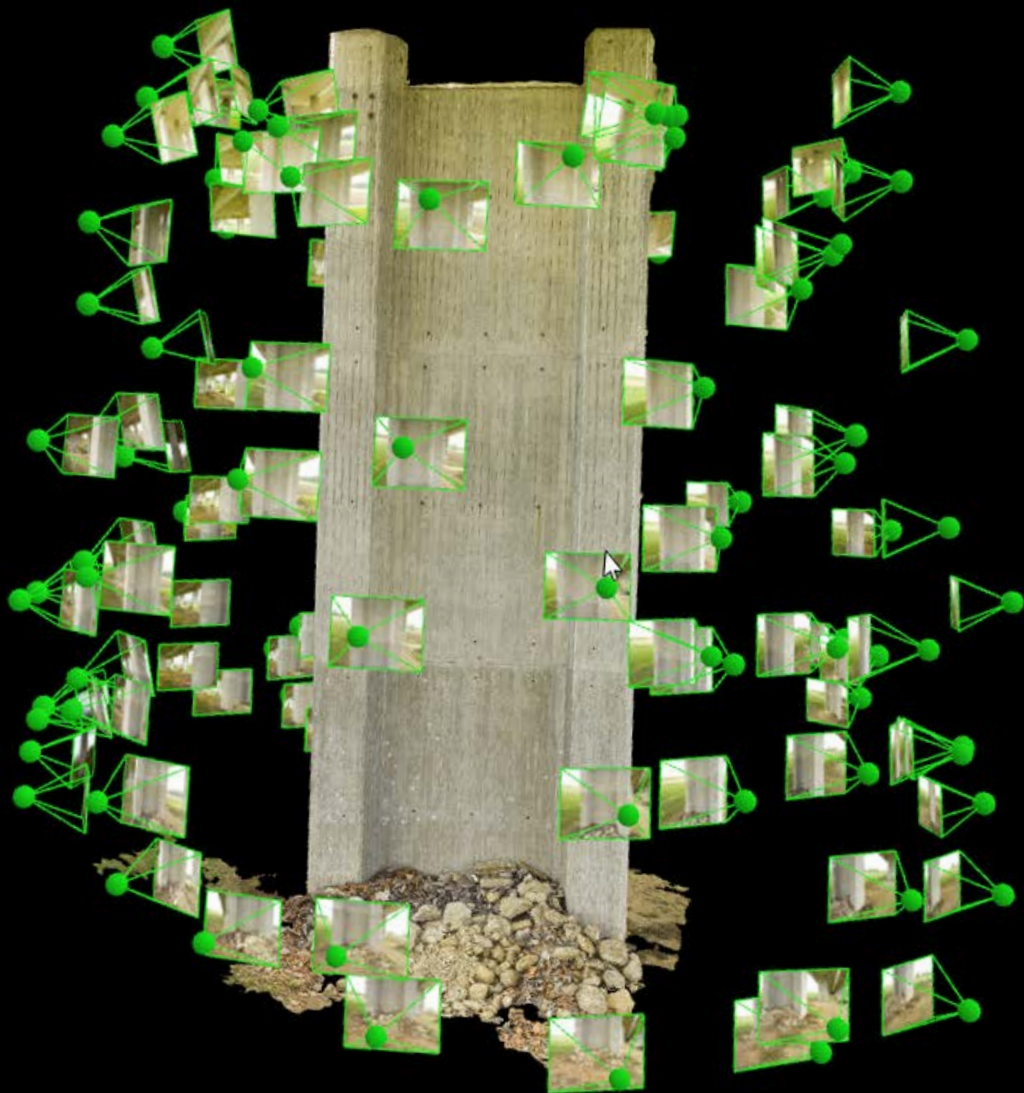

Road bridge pillar inspection, Switzerland

Create geo-referenced maps & models



After albris lands, simply use eMotion 3's built-in Flight Data Manager to pre-process, geotag and organise its images, before starting image processing.

Then use professional image processing software to transform the drone's images into geo-referenced 2D orthomosaics, 3D building models, 3D point clouds, triangle models, digital surface models and more.



C-16

High-resolution mapping

Create high-resolution 2D and 3D maps, or complement fixed-wing drone data by mapping a site's highly inclined and vertical surfaces

3D modelling

Capture high-resolution aerial imagery and transform this into full 3D models of buildings and small/medium-sized infrastructure

Inspection

Examine and document surfaces and objects—such as bridges, towers, rooftops and cliff faces—in high-resolution

Plus...

- Crack detection
- Bridge, pipe & tower inspection
- Plant inspection & documentation
- Stockpile assessment
- Construction monitoring
- Close agricultural & archaeological mapping
- Solar panel hotspot detection
- Conservation & environmental monitoring

... and much more

Flight modes

Types	Automatic Interactive ScreenFly Manual (RC)
Availability	Switch between modes at any time

Automatic

Control interface	Mouse, keyboard or touchscreen
Mission planning	Drag-and-drop mission blocks
Types of mission blocks	Horizontal mapping Around point of interest Panorama Custom route
In-flight mission changes	Yes: manual waypoint changes and updates possible at any time

Interactive ScreenFly

Primary control interface	Screen-based actions & USB controller
Flight assistance (depending on the flight phase)	Cruise control Distance lock Range sensing

Manual (RC)

Primary control interface	RC (remote control)
---------------------------	---------------------

On-board computing

Type	4 on-board CPUs
Quad-core processor	Principal autopilot & artificial intelligence
Dual-core processor	Video co-processing
Single-core processor	Low-level autopilot (safety fallback) and motor control
Single-core processor	Communication link management

Flight system

Type	V-shaped quadcopter
Dimensions (incl. shrouding)	56 x 80 x 17 cm (22 x 32 x 7 in)
Engines	4 electric brushless motors
Propellers	4
Take-off weight	1.8 kg (3.9 lb) incl. battery, payload & shrouding
Flight time (full system)	Up to 22 min
Max. climb rate	7 m/s (15 mph)
Max. airspeed	Automatic flight: 8 m/s (18 mph) Manual flight: 12 m/s (27 mph)
Wind resistance	Automatic: up to 8 m/s (18 mph) Manual: up to 10 m/s (22 mph)
Autopilot & control	IMU, magnetometer, barometer & GPS/GNSS
Materials	Composite body, moulded carbon fibre arms and legs, precision-molded magnesium frame, precision-molded injected plastic
Operating temperature	-10 to 40° C (14°-104° F)

Wireless communication

Main communication link

Type	Digital, dual omnidirectional antennas, dual band, encrypted
Frequency	2.4 GHz & 5 GHz ISM bands (country dependent)
Data transmitted	Commands, main camera stream, navcam stream, sensor data, etc.
Range	Up to 2 km (1.2 mi)

RC (Remote control)

Type	Digital
Frequency	2.4 GHz
Range	Up to 800 m (0.5 mi)

System power

Technology	Smart battery
Type	LiPo, 3 cell, 8500 mAh
Power level display	LED display on battery, on-screen information
Charging time	1 - 1.5 h

Integrated payloads

TripleView head

Main camera

Still images	38 MP, mechanical shutter DNG (RAW image with correction metadata) Ground sampling distance (GSD): <ul style="list-style-type: none">- 1 mm/pixel at 6 m- 1 cm/pixel at 60 m Recorded on board Geo-referenced (position & orientation)
Video	HD (1280 x 720 pixels) Recorded on board or streamed
Horizontal field of view	63 degrees
Digital zoom	6x

Thermal camera

Still images/video	Thermal (80 x 60 pixels) overlaid on main camera stream
Horizontal field of view	50 degrees
Edge enhancement	Yes

Head navcam (visual sensor)

Video	VGA (640 x 480 pixels)
Video live streaming range	Up to 2 km (1.24 miles)
Horizontal field of view	100 degrees

Lights

Headlamp	Yes, used for video
Flash	Yes

Additional navcams (visual sensors)

Number	4 navcams
Positions	Left, right, rear, bottom
Video	VGA (640 x 480 pixels)
Horizontal field of view	100 degrees
Availability	One navcam at a time
Operational use	Side views (w/o turning main camera) & parallel flight along objects Back-up safely & control in tight environments Landing & ground proximity

Situational awareness & assistance

Multidirectional video feed

Source	Navcams (visual sensor)
Number	5
Video	VGA (640 x 480 pixels)
Horizontal field of view	100 degrees
Availability	One navcam at a time

Object & range detection

Sensor	Ultrasonic
Number	5
Range	Up to 6 m (20 ft)
Feedback	Audio and visual object warning

Operational safety

Shrouding

Material	Carbon fibre
Function	Defines propeller rotation area Protects from damage at low speed

Signalisation lights

Navigation lights	2 green on the right, 2 red on the left
Anti-collision lights	1 top strobe, 1 bottom strobe

Ground proximity detection

Avoidance procedure	Automatic stop (can be deactivated)
Warning signals	Audio & visual

Flight assistance features (Interactive mode)

Cruise control	Maintains (low) constant speed in a given direction
Distance lock	Keeps distance to frontal objects 3 - 5 m (9.8 - 16 ft)
Obstacle avoidance	Depending on flight phase

Safety procedures

Automated failsafe behaviours	Geofencing, return home, emergency stop, emergency landing
Operator triggered	Hold position, return home, go land, land now, emergency motor cut-off

Autopilot fallback

Type	Independent low-level autopilot (backup for main autopilot)
Manual RC control	Independent RC controller (take manual control at any time)

Ground station software

Software application	senseFly eMotion 3 (supplied)
Mission planning	Intuitive 3D user interface Click and drag to set mission blocks Automatic 3D flight planning Edit mission plans during flight
Flying	Automated system checks Automated take-off & landing Real-time flight status Main camera video feed integration Thermal video feed integration Navcam video feed integration Fully automatic flight Interactive ScreenFly Manual flight (with assistance functions) In-flight switch between flight modes Black-box recording of all flight & mission parameters
After your flight	Project & data management DNG to JPEG conversion

Package contents

- 1 senseFly albris drone
- 1 Interactive ScreenFly controller
- 2.4 GHz remote control (for safety pilots)
- 2.4 GHz/5GHz dual band USB radio modem
- 2 SD memory cards (32 GB)
- 2 batteries
- 2 single battery chargers w/power supplies
- 1 wheeled carry case
- 1 user manual
- 1 USB cable set
- 1 spare leg set
- 1 spare propeller set
- eMotion 3 flight planning & control software





About senseFly: At senseFly, we believe in using technology to make work safer and more efficient. Our proven drone solutions simplify the collection and analysis of geospatial data, allowing professionals in surveying, agriculture, engineering and humanitarian aid to make better decisions, faster.

senseFly was founded in 2009 and quickly became the leader in mapping drones. The company is a commercial drone subsidiary of Parrot Group. For more information, go to www.sensefly.com.

How to order your albris? Visit www.sensefly.com/about/where-to-buy to locate your nearest distributor.

senseFly Ltd
Route de Genève 38
1033 Cheseaux-Lausanne
Switzerland

Content and images non contractual © 2017 senseFly Ltd



www.sensefly.com/albris
Swiss made 



senseFly
Parrot Group

For albris updates
subscribe to our newsletter at
www.sensefly.com





ELIOS

INSPECT & EXPLORE INDOOR AND CONFINED SPACES

Discover the first collision-tolerant drone, designed for the inspection and exploration of the most inaccessible places. Allowing for the first time to fly in complex, cluttered or indoor spaces, Elios unleashes the potential of UAVs in numerous applications where their use was previously too dangerous or simply impossible.

COLLISION-TOLERANCE.

400'000'000 YEARS OF EVOLUTION SOLVING INDOOR FLIGHT CHALLENGES

Inspired by the ability of insects to keep their stability after an in-flight collision, the flight concept of Elios is the result of hundreds of millions of years of natural evolution. Using a unique and pragmatic approach, Elios solves the biggest challenges of flying drones indoor in complex and confined spaces or in contact with humans: the risk of collisions and injuries. Privileging tolerance to collisions over the attempt to sense and avoid obstacles, Elios provides the level of reliability that is expected by professionals operating in environments where failure to operate is not an option.

BENEFITS.

CHANGING THE RULES OF THE GAME



IMPROVE SAFETY

By enabling remote visual inspection in any indoor environments, Elios prevents the need for workers to enter hazardous places or face dangerous situations.

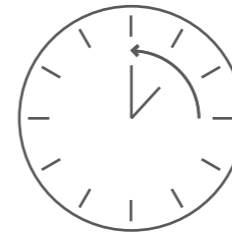

REDUCE DOWNTIME

Elios is deployed and ready to gather visuals within a minute. Performing an entire inspection is no longer a matter of days but hours.

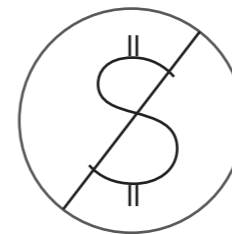

LOWER COST

Scaffolding, rope access, or crane are no longer needed to perform visual inspections. Elios gathers visuals of the most complex and cluttered spaces for you.

FEATURES

INTEGRATED PAYLOAD

Simultaneous full HD and thermal imagery recording, and adjustable tilt angle.

ON BOARD LIGHTING

Powerful LEDs for navigation and inspection in dark places.

CONTINUOUS OPERATION

Batteries can be changed in seconds.



LIVE 2.4 GHZ VIDEO FEEDBACK

Robust digital video downlink for beyond line of sight operation, even in metallic environments.

PROTECTIVE FRAME

Carbon fiber structure, collision-tolerant up to 15 km/h. Modular design for easy maintenance.

POST-MISSION REVIEW

After finishing the inspection flight, our software presents mission data for future reference.

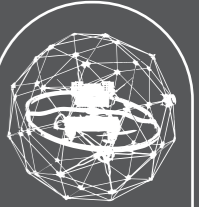

Patented
Technology

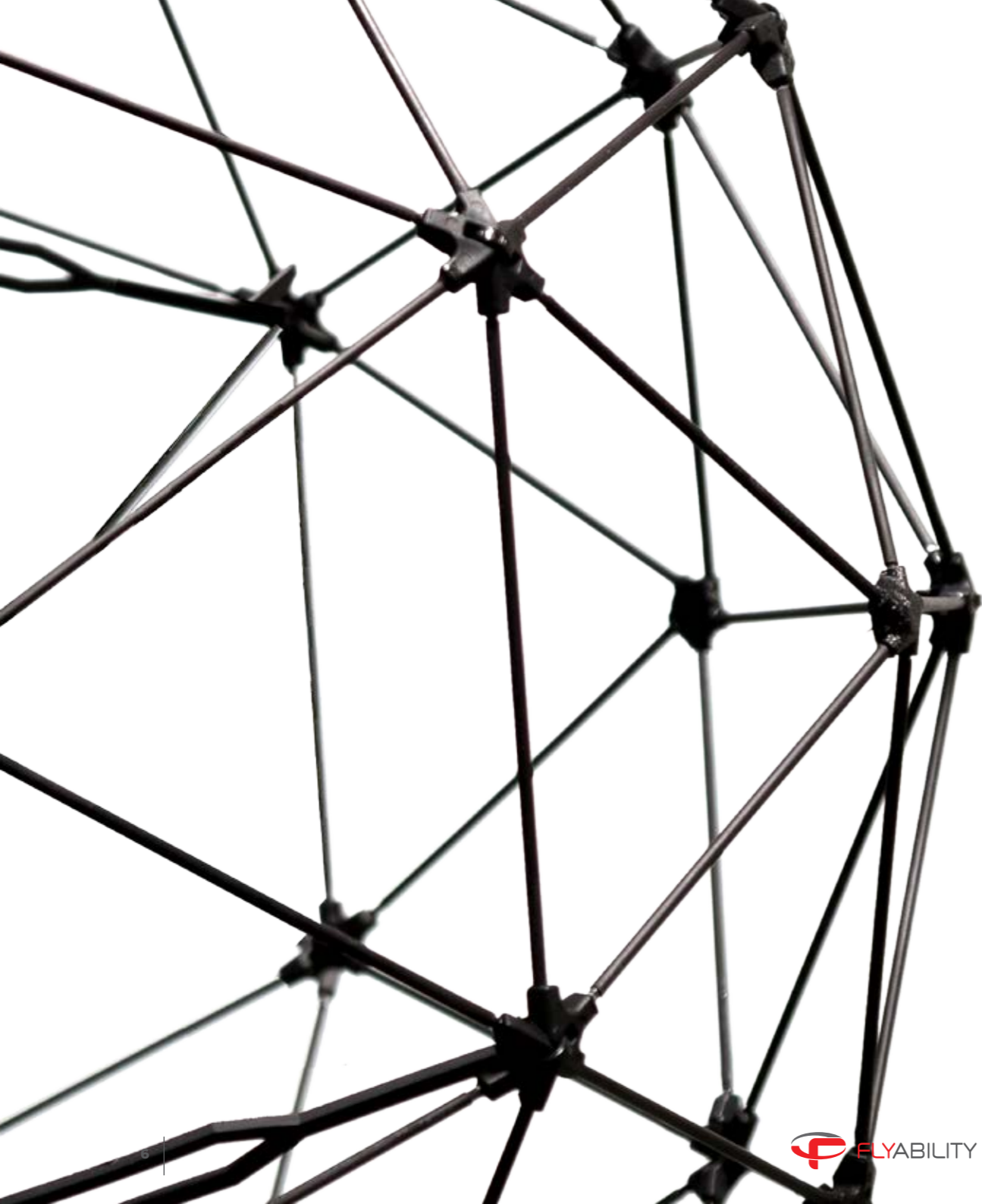

PROTECTIVE FRAME COLLISION-TOLERANCE. A REVOLUTIONARY WAY TO FLY.

Carrying its own protective frame, Elios is collision-tolerant. This means you can access the tightest spaces without any risk of crashing. No need to focus on avoiding obstacles, Elios bounces off and roll on them to find its way. You can fly close or even in direct contact with humans without any risks of injuries.

DECOUPLING IS KEY.



The protective frame of Elios is no ordinary one. It is decoupled on three axes from the inner frame – the drone – using a gimbal mechanism. This ingenious decoupling mechanism is what allows Elios to remain stable in the event of a collision.

UNIQUE.



Patented by Flyability, the protective frame is a unique and pragmatic approach to flying indoors, in complex and confined spaces and in contact with people. Discarding the need to sense and avoid obstacles, you can start inspecting and exploring – without waiting – the hardest places to reach.

LIGHT AND ROBUST. RIGHT SIZED.

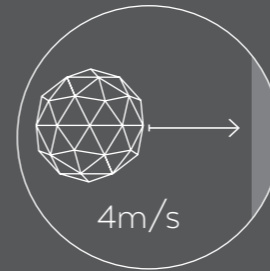

Elios' protective frame is made up of carbon fiber covered with a soft coating. It can sustain collisions, evenly, all around the drone at a speed reaching up to 4 m/s.

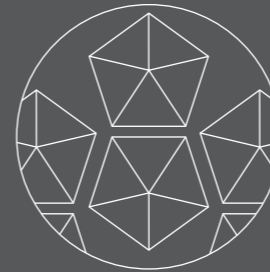

Built with modular subcomponents it eases the maintenance process and offers openings large enough to fit one's hand and access the battery container or SD card compartments.

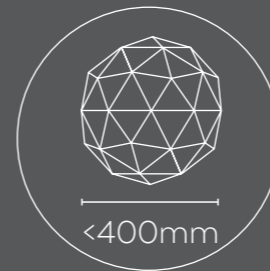

Spherical, the protective frame comes in one size only. With a diameter just below 400 mm, it is slightly smaller than the smallest standard manhole.

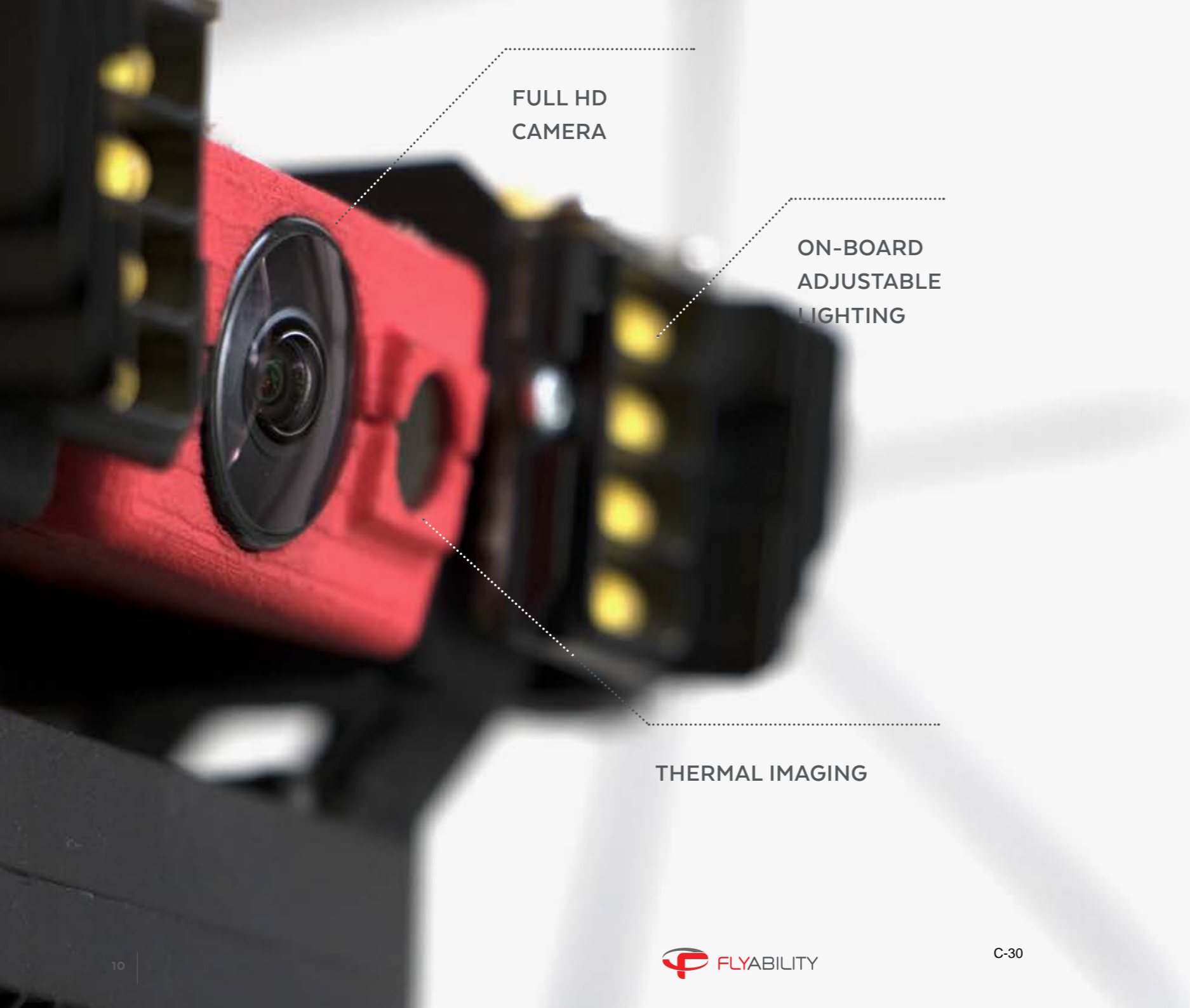

FULL HD
CAMERA

ON-BOARD
ADJUSTABLE
LIGHTING

THERMAL IMAGING

PAYLOAD DESIGNED FOR THE PROFESSIONALS.

Elios embeds a full HD camera, a thermal camera, and an on-board LED lighting system with a remotely adjustable intensity. Once you have reached the most inaccessible places, you have all the tools on board to take the best possible shot in nearly any lighting conditions.

FULL HD CAMERA



When flying in contact with a surface, Elios can gather close-up images with a sub-millimeter resolution of 0.2 mm/px.

The camera video stream is recorded on board, on an SD card housed in the payload head. It is also streamed to the pilot at a lower resolution.

The Full HD camera offers a resolution of 1920 x 1080 at 30 frames per second and performs well in low light. Automatically corrected by default, the Exposure Value (EV) of the captured images can also be remotely adjusted, from the ground station.

THERMAL CAMERA

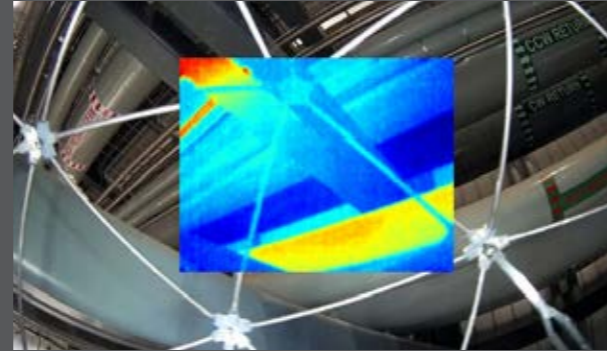

Seeing beyond what a human can see may be crucial in many cases. Detecting a crack that is invisible can help to anticipate potential major degradations. Detecting a body in very poor lighting conditions can simply save lives.

Elios embeds an uncooled FLIR camera core with a resolution of 160 x 120 pixels at 9 frames per second.

A FLEXIBLE VISION. SEE ABOVE AND BELOW.



Mounted on a rotatable head the cameras can capture images looking above and below the drone. The full HD camera offers a total field of view of 215° and a horizontal field of view of 130° while the thermal camera offers a total vertical field of view of 42° and a horizontal field of view of 56°.

ON-BOARD LIGHTING. LET THERE BE LIGHT.



When inspecting and exploring pitch dark environments the onboard LED lighting system becomes very useful. Preventing the need for any additional external lighting, it lights up the scene in all the directions you may be looking.

The intensity of the 5 arrays of high-efficiency LEDs providing even lighting in front, top, and bottom of the robot, can be adjusted remotely using the ground station.

When changing the pitch angle of the camera head, the light beam is adapted, always providing the right lighting.



WIRELESS COMMUNICATION ROBUSTNESS AND PERFORMANCE.

Elios is equipped with a cutting-edge wireless communication system that provides a live video feedback allowing the pilot to bring the drone to the most inaccessible places up to multiple hundreds of meters beyond line of sight.

WIRELESS COMMUNICATION. STANDING THE NEEDS OF INDOOR INSPECTION AND EXPLORATION

The wireless communication system offers a robust digital, bidirectional, long range signal transmission which includes a video and data downlink - from the UAV to the Ground Station - and command uplink - from the Ground Station to the UAV. Using the 2.4 GHz frequency band, the wireless communication system does not require any special authorization to operate and preserve its high-quality even in the most complex and confined spaces. For example, it is possible to fly Elios over 100 meters above the ground in a closed boiler with the pilot safely standing outside next the entrance manhole. Since every use case has its own specificities, we have put together a table representing standard use cases and the signal coverage to expect.

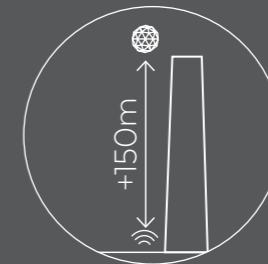

Over 150 m in a chimney while staying at the base.

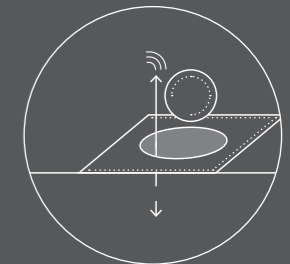

Tens of meters away in a metallic ballast tank multiple compartments away.

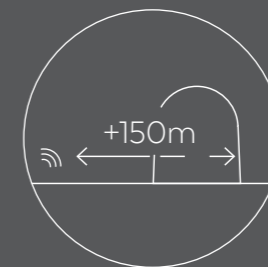

Over 150 m in tunnels comprising small curves.

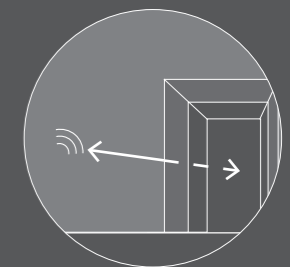

Multiple rooms away in a standard building, up a flight of stairs.

GROUND STATION EFFICIENTLY PILOT FROM A SAFE PLACE.

Elios Ground Station is composed of a remote controller, a tablet and a purpose designed ground control application providing the pilot with live telemetry data, an SD live video stream captured by Elios, and the information and controls that you need to operate it efficiently and safely. In addition to giving you full control over the navigation of the drone, the different buttons of the remote controller let you adjust, in real-time, all the settings of the camera head such as exposure, lighting and pitch angle.



ELIOS COCKPIT. EVERYTHING UNDER CONTROL.

In addition to displaying the live SD stream received from the drone, Elios Cockpit displays live telemetry data, gives you access to a detailed status of your drone and let you adjust settings right from the application.

LIVE TELEMETRY DATA:

STATUS & SETTINGS:

USABILITY.

BUILT FOR THE REAL WORLD.
ADAPTED TO YOUR BUSINESS.

As it applies to all new technologies, integrating drones into your workflow requires driving changes. However, it is important that these changes have a minimal impact on your own schedule and comply with the singular aspects of your profession.

We made Elios dust and splash resistant, operational in environments between 0° and 50°C, and mistake tolerant so that it can be easily piloted by everyone. Operational after a few hours of training, your personnel will quickly get up to speed with their piloting skills. Designed to fly indoors where few or no drone regulations apply, Elios will be smoothly integrated into your workflow.



PHOTO © RIMS

FLIGHT #1

Reconnaissance flight



FLIGHT #2

Beams and roof integrity

FLIGHT #3

Corrosion on the walls

BATTERY LIFE. MULTIPLE 10 MINUTES SLOTS TO CAPTURE ALL THE DETAILS.

A typical drone-based inspection usually starts with a reconnaissance flight which allows finding all the areas of interest deserving a closer look. The experience gathered through missions in boilers, storage tanks, ballast tanks, buildings, chimneys and so on, shows that 10 minutes is sufficient for most infrastructures to perform this reconnaissance flight. Based on the information gathered during the reconnaissance flight, further flights are planned to more deeply

inspect defined points of interest through the capture of close up images. Bringing the drone back to the operators after each segment of the inspection allows for reviewing the images in details and refine/update the inspection plan on-the-go based on actual data.

After each flight, batteries are swapped in seconds. Just remove the used one, insert a new one and you are back to flying again.

DATA. MAKING THE BEST OUT OF YOUR FLIGHT TIME.

Once you're done flying, you can exploit the data recorded on the SD card, embedded on Elios, right away. No post processing or specific software is required. To avoid hurdles, we are using simple video files that can be read i.e. on the tablet of the Ground Station. Flight data, thermal video and selected Points Of Interest (POI) are recorded on a dedicated SD card. By using Flyability Inspector, you can correlate flight data and POIs with both video streams.

FLYABILITY INSPECTOR. POST-FLIGHT VIDEO, THERMAL AND LOG ANALYSIS.

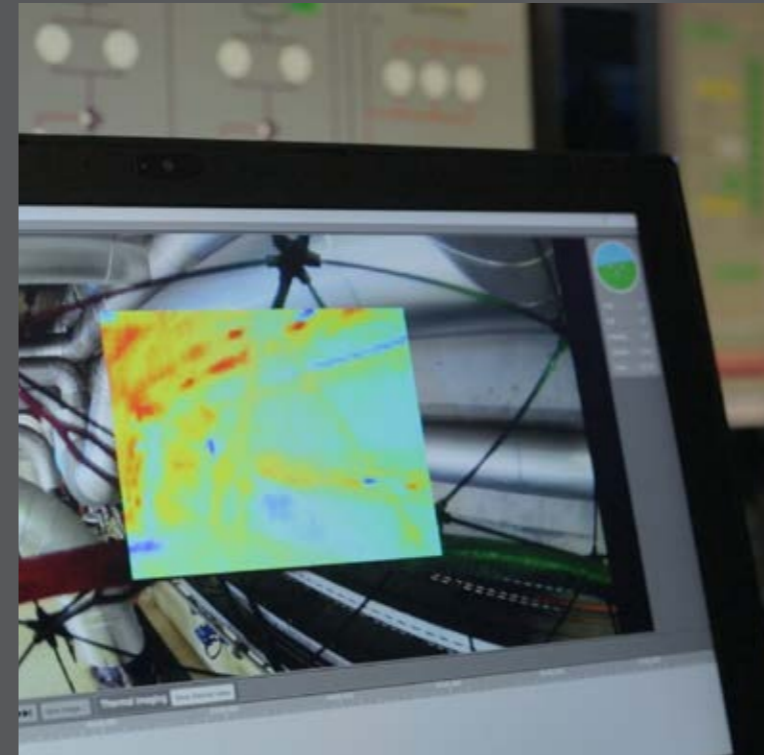

Using Flyability Inspector, you can review your flights, frame by frame, and benefit, on top of the image, from the precious flight information recorded on the log SD card.

You can recover the Points Of Interest (POI) marked during a flight, and only extract the still images of interest for your mission.

Recorded as well on the log SD card, the video stream recorded with the thermal sensor is displayed as an overlay of the Full HD video stream, providing you with additional information.

TECHNICAL SPECIFICATION

FLIGHT MODES

TYPES:	Manual thrust, altitude hold, pro mode (high speed)
AVAILABILITY:	Switch between modes at any time
FAIL SAFES:	Auto-landing on low-battery or signal lost

ON-BOARD ELECTRONICS

AVIONIC-BOARD:	Autopilot, thermal video and system management
POWER-BOARD:	Motors control

FLIGHT SYSTEM

TYPE:	Quadcopter configuration
DIMENSIONS:	Fits in <400mm sphere
MOTORS:	4 electric brushless motors
PROPELLERS:	4 propellers, 5 inches
TAKE-OFF WEIGHT:	700 g including battery, payload & protection
FLIGHT TIME:	Up to 10min
MAX.CLIMB RATE:	1.5 m/s (in normal mode) 2.5m/s (in pro mode)
MAX.AIRSPEED:	6.5 m/s (in normal mode) 9 m/s (in pro mode)
WIND RESISTANCE:	Max 5m/s (in pro mode)
FLIGHT SENSORS:	IMU, magnetometer, barometer
MATERIALS:	Carbon fiber composites, magnesium alloy, aeronautical grade aluminium, high quality thermoplastics
OPERATING TEMP:	0 to 50°C

WIRELESS COMMUNICATION

TYPE:	Digital, bidirectional, long range Video and data downlink to RC Command uplink to UAV
FREQUENCY:	2.4GHz
RANGE:	Up to 500m in direct line of sight

REMOTE CONTROLLER

TYPE:	Ergonomic Joysticks and Payload controls Integrated video outputs
WEIGHT:	810g
OPERATING TEMP:	0°C to 40°C
OUTPUT PORT:	HDMI, SDI, USB
BATTERY:	6000 mAh 2S
CONTROLS:	Payload settings and aircraft control
	Optional Remote Controller (Camera operator) with video stream reception on secondary screen, and dual control of camera settings.

SYSTEM POWER

TYPE:	Lithium polymer battery, 3 cells, 2800mAh, 33.08Wh
CHARGING TIME:	1h
BATTERY CHANGE:	< 1 minute

INTEGRATED PAYLOADS

PAYLOAD HEAD:	Damped from vibrations
UPWARDS TILT:	+65 degrees
DOWNWARDS TILT:	-60 degrees

MAIN CAMERA

VIDEO:	FHD (1920 x 1080) at 30fps, good low light performance, recorded on board and streamed to pilot and camera operator
HORIZONTAL FOV:	130 degrees
VERTICAL FOV:	75 degrees
TOTAL VERTICAL FOV:	215 degrees (considering payload up/down rotation)
CONTROL MODES:	Auto with EV correction, full manual mode

THERMAL CAMERA

TYPE: Uncooled FLIR camera core
VIDEO: 160 x 120 pixels at 9fps, recorded on board
HORIZONTAL FOV: 56 degree
VERTICAL FOV: 42 degree

LIGHTING SYSTEM

TYPE: 5 arrays of high efficiency LEDs for even lighting in front, top and bottom of the robot
CONTROL: From remote controller, adaptive light beam controlled by camera pitch
POWER: 11.4W nominal power for front lighting, 28W total installed max.

OPERATIONAL SAFETY & CRASHWORTHINESS

NAVIGATION LIGHTS: Green (starboard) and red (port) lights.
PROTECTION CAGE: Carbon fiber cage with soft coating, modular subcomponents for maintenance ease. Thermoplastic elastomer suspensions. Size of openings: triangles of about 11cm sides. Allows for hand to access inside to swap batteries.
COLLISION TOLERANCE: Uniform all around the drone. Up to 3m/s on sharp objects, up to 4m/s on flat objects.
DECOUPLING: 3-axes gimbal system. Carbon fiber composite ring and transverse beam.

ACCESSORIES

TRANSPORT CASE: IATA compliant transport case for checked-in luggage. Dimensions (approximate): 60 cm x 50 cm x 50 cm
CHARGERS: 3 A / 35 W Lithium Polymer battery balance charger, with charging status indicator. RC charger: 17.4 V, 57 W, tablet USB charger: 5V

GROUND STATION SOFTWARE

MOBILE APPLICATION USED DURING FLIGHT

FEATURES: Real time video and UAV telemetry, status visualization (remaining battery, payload settings, warnings, etc.), control payload settings and various configurations.
OPERATING SYSTEM: Android, optimized for Tablet provided with UAV system

POST FLIGHT VIDEO, THERMAL AND LOG ANALYSIS (FLYABILITY INSPECTOR)

FEATURES: Video and thermal video viewer (frame by frame), flight log analysis including point of interests recorded during flight, screenshots and flight data export.
OPERATING SYSTEM: Windows 7, 8 and 10 (64 bits only).

Flyability is a Swiss company building safe drones for inaccessible places. By allowing drones to be used safely inside cities, buildings, and in contact with people, it enables new interactions and services with UAVs and solves the two most critical issues of one of the fastest growing industries: collision and injury risks. The company's main market is in industrial inspection where it avoids sending people in dangerous and confined spaces for the inspection of Power Generation, Oil & Gas or Maritime infrastructures. It is also active in Search & Rescue and Security to assess emergency situations without putting humans at risk.

Flyability SA

EPFL Innovation Park – Building C

1015 Lausanne, Switzerland

+41 21 311 55 00

sales@flyability.com





propeller aeropoints

USER MANUAL

An up-to-date version of this manual is available at:
propelleraero.com/aeropoints-help

AeroP i 1.2

Contains FCC ID: 2AHM -ESP12S

IC ID: 2243 -APV102

Battery: 5000 mAh 3.2 V (16 Wh) LiFePO₄



IC RSS-102 Compliance

This system has been evaluated for RF Exposure per RSS-102 and is in compliance with the limits specified by Health Canada Safety Code 6. The system must be installed at a minimum separation distance from the antenna to a general bystander of 8 inches (20 cm) to maintain compliance with the General Population limits.

L'exposition aux radiofréquences de ce système a été évaluée selon la norme RSS-102 et est jugée conforme aux limites établies par le Code de sécurité 6 de Santé Canada. Le système doit être installé à une distance minimale de 8 pouces (20 cm) séparant l'antenne d'une personne présente en conformité avec les limites permises d'exposition du grand public.

IC RSS-Gen 8.4 Compliance

This device complies with Industry Canada license-exempt RSS standard(s). Operation is subject to the following two conditions: (1) this device may not cause interference, and (2) this device must accept any interference, including interference that may cause undesired operation of the device.

Le présent appareil est conforme aux CNR d'Industrie Canada applicables aux appareils radio exempts de licence. L'exploitation est autorisée aux deux conditions suivantes: (1) l'appareil ne doit pas produire de brouillage, et (2) l'utilisateur de l'appareil doit accepter tout brouillage radioélectrique subi, même si le brouillage est susceptible d'en compromettre le fonctionnement.

This Class B digital apparatus complies with Canadian ICES-003.

Cet appareil numérique de la classe B est conforme à la norme NMB-003 du Canada.

Contents

Introducing AeroPoints	1
Specifications	1
Care instructions	2
Activate online	3
Conduct a flight	3
Before your flight	3
During your flight	4
After your flight	4
Upload your AeroPoints Data	5
Establishing a WiFi network	5
Connecting AeroPoints	5
Apply corrections and share your AeroPoints data	6
Open the AeroPoints interface	6
Check all uploads are complete	6
Apply corrections	6
Share AeroPoints data	6
Upload your drone images	7
AeroStencils: For frequent flyers	8
FAQ	9
Troubleshooting	10
Appendix I:	
AeroPoints correction methods	11
Appendix II:	
Configure your smartphone hotspot to act as Propeller WiFi network	14
Support	14



Introducing AeroPoints

AeroPoints are the world's first **smart Ground Control Points**.

Purpose-built for **drone surveying**, each AeroPoint includes a solar panel, battery, GPS and WiFi inside a fully-sealed, rugged, lightweight shell.

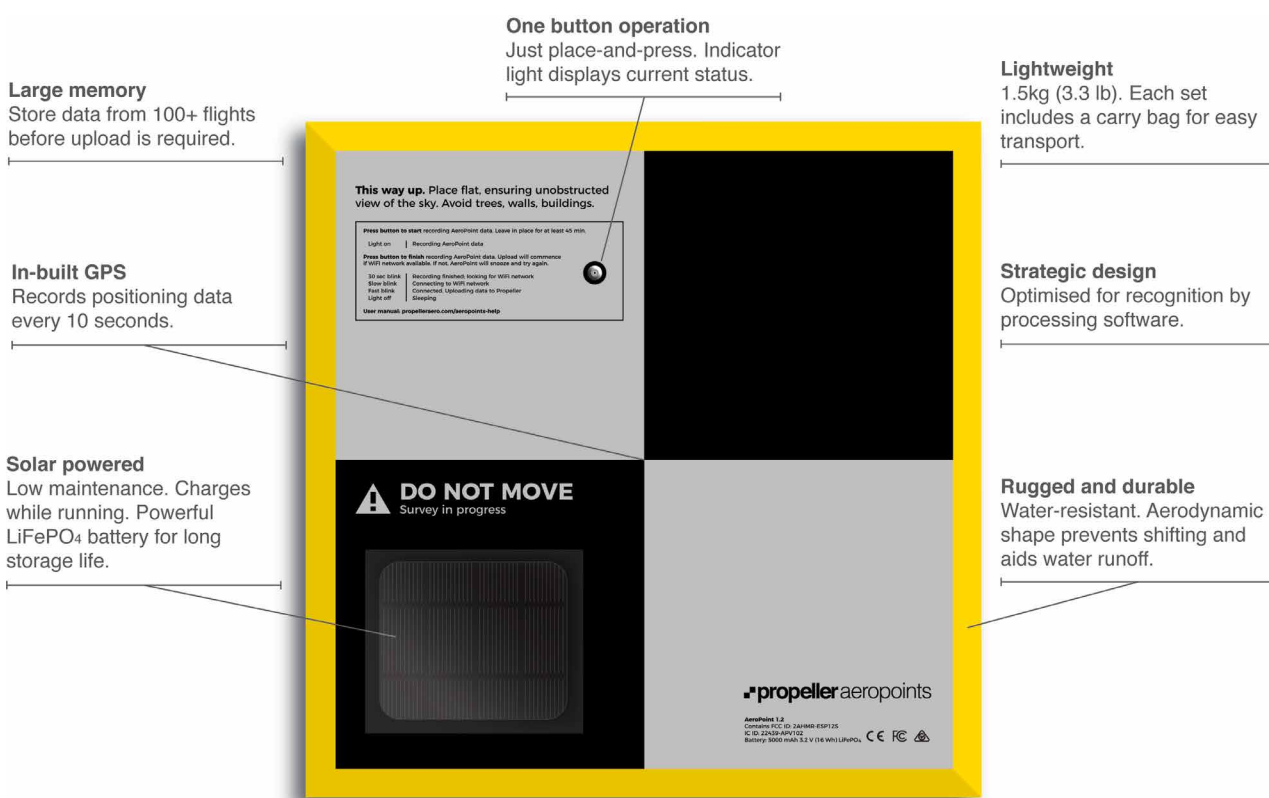

Specifications

Dimensions	544mm (W) x 544mm (L) x 32mm (H)
Weight	1.55kg
Power supply:	5000 mAh 3.2 V (16 Wh) LiFePO ₄ battery with solar charging (Newly purchased AeroPoints come fully charged)
Storage:	4GB Flash
Wireless connectivity:	2.4GHz WiFi (802.11 b/g/n)
Operating temperature:	0°C/32°F (min); 40°C/104°F (max)

Care instructions

AeroPoints are built tough, but you can extend their life by keeping them clean and dry when not in use. Simply remove dirt and dust with a damp cloth as soon as practicable once your job is complete.



Above: Stack and store Aeropoints with their undersides together.

Like a phone or a watch, AeroPoints are water-resistant (they can handle some mud, splashes, or light rain) but not waterproof (they shouldn't be submerged or left out in heavy rain).

Reduce the risk of sand or gravel scratching the solar panels by stacking and storing AeroPoints with the undersides together (as illustrated at left).

WARRANTY

AeroPoints are covered by a standard international warranty for one year from the date of dispatch.

Integrated cloud-based processing

We recommend using AeroPoints together with Propeller's industry-leading **cloud-based processing and visualization platform**.

Simply upload your geotagged images, and within 24 hours you'll be able to see the results of your flight as precise 2D and 3D data.

Powerful analysis tools let you measure and monitor your site from within the browser, and it's easy to share datasets with your team or client/s.

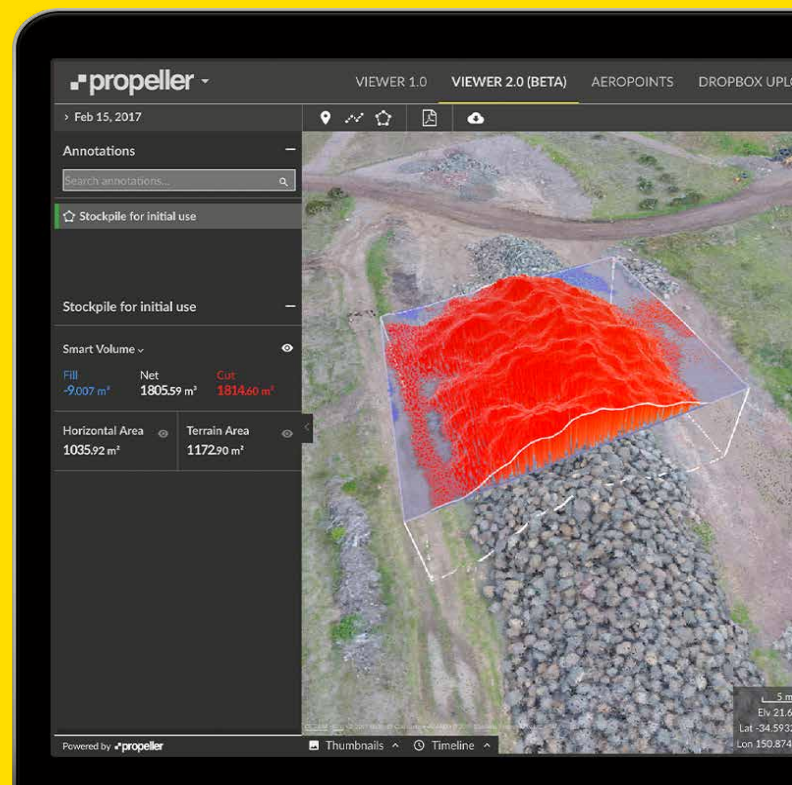

Activate online

Each set of AeroPoints **must be activated** before first use. To do this, go to propelleraero.com/activate-aeropoints and enter the unique 8-character code included with your AeroPoints set.

Under 'Portal Name', enter the business/entity you wish your AeroPoints to be assigned to.

YOUR PROPELLER ACCOUNT:

You may be prompted to log into your Propeller account before activating your AeroPoints. If you don't have an account, you can register for one at app.prpeller.com/accounts/register.

Conduct a flight

Before your flight

Got to propelleraero.com/aeropoints-coverage-map to see whether your site is covered by the Propeller Correction Network.

If you're flying inside the network, proceed as normal. If not, turn to *Appendix I* (on page 11 of this guide) to learn about alternative correction methods.

Distribute **the full set** of AeroPoints (10 x units) around your site, paying special attention to the perimeter.

For best results, place an AeroPoint near each corner and distribute the remainder around the centre, aiming to cover both high and low elevations.

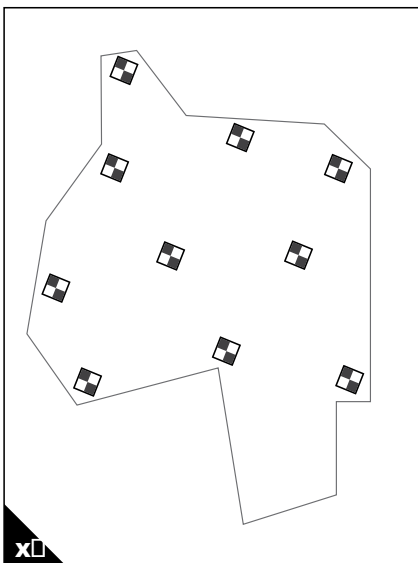

Fail: AeroPoints are missing from one part of the site (protruding area at bottom).

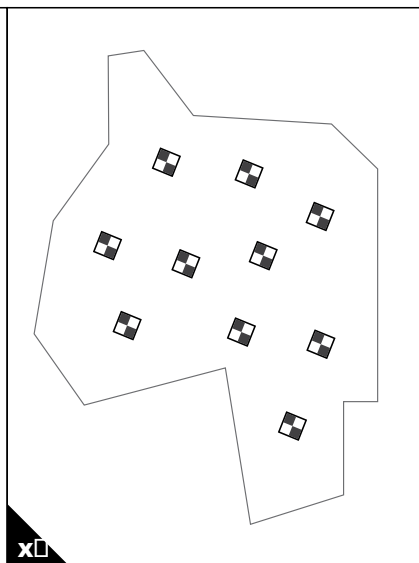

Fail: AeroPoints are too far away from the site perimeter.

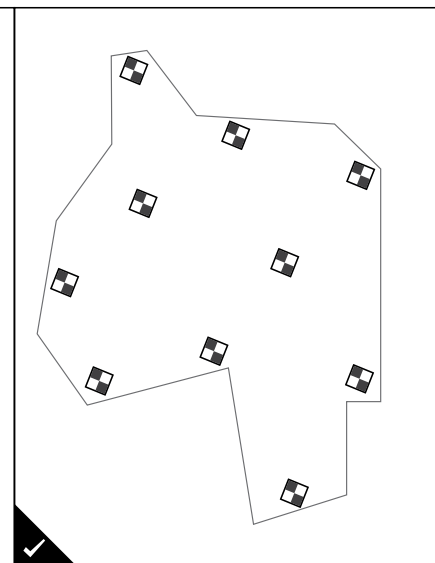

Success: AeroPoints are distributed evenly around the site perimeter, with remainder near the center.

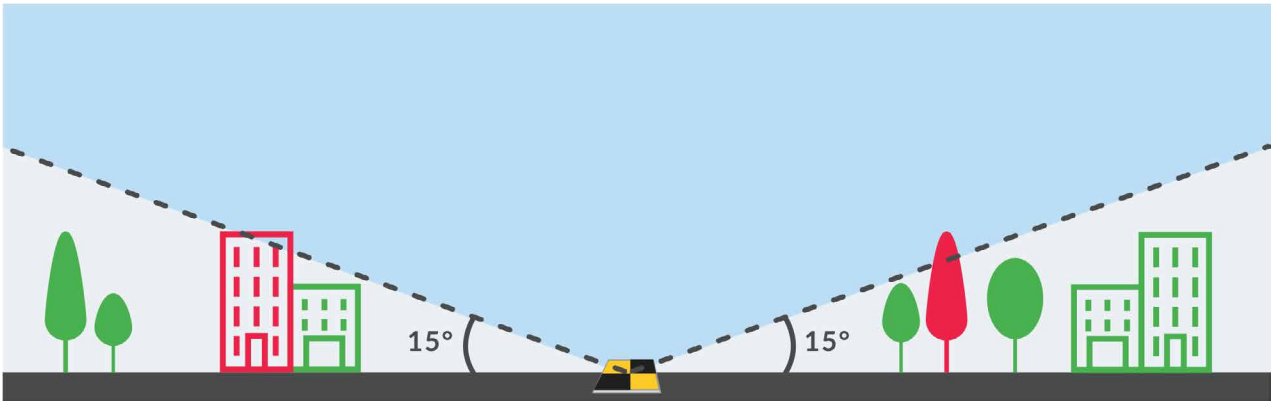

Important: AeroPoints (and/or AeroStencil marks) should have an unobstructed view of the sky in every direction above a 15° angle.

After you place each AeroPoint, press the button to start recording.

The light will turn on, indicating AeroPoints are in 'recording mode'.

Avoid placing AeroPoints beneath trees, walls, buildings or power lines. For the best results, they should have an **unobstructed view of the sky** in every direction above a 15 degree angle (as illustrated).

Avoid placing AeroPoints where they will be disturbed by people, animals or vehicles. (You should notify site manager/ personnel that AeroPoints are in use.)

AeroPoints will begin recording data 60 seconds after you press the button to start. Avoid adjusting the position of an AeroPoint after this time.

MADE A MISTAKE?

If you change your mind about the position of a AeroPoint and want to start over, that's fine.

Just push the button once to stop recording, move your AeroPoint, then push button again to start recording.

During your flight

Each AeroPoint should be left in place to record **at least 45 minutes** of data.

To maximise recording time, we recommend carrying out pre-flight drone checks and safety routines after you

lay out AeroPoints, and packing up your drone before collecting AeroPoints.

Be aware that AeroPoints will automatically turn themselves off (sleep mode) after five hours.

After your flight

Collect AeroPoints **in reverse order** to how you laid them out (ie. pick up the last-placed AeroPoint first; finish with the first-placed AeroPoint).

Press the button on each AeroPoint to finish recording **before** you pick them up.

AeroPoints can store GPS data from at least 100 surveys before requiring upload (useful when doing multiple surveys in remote areas).

Data from separate locations will be automatically grouped within Propeller.

Upload your AeroPoints data

Establishing a WiFi network

When you press the button on AeroPoints to finish recording, they'll enter 'WiFi search mode', indicated by the light blinking once every 30 seconds.

In this mode AeroPoints will search intermittently for a WiFi network called 'propeller' with the password 'propeller'.

Turn to *Appendix II* (on page 14 of this guide) for instructions on how to set up this WiFi network using the hotspot functionality on your smartphone or device. Alternatively, you can use a wireless router.

If AeroPoints find the propeller WiFi network within 24 hours, they'll enter 'upload mode' whereby they automatically connect to the network and upload recorded data. This mode is indicated by a slow blink (connecting) followed by a fast blink (uploading).

If more than 24 hours have passed since AeroPoints finished recording, you'll need to wake them up from 'sleep mode' (light off) in order to upload data. To do this, simply press the button twice (once to switch to 'recording mode'; again to switch to 'WiFi search mode').

Connecting AeroPoints

In 'upload mode', the light on an AeroPoint will blink fast, indicating that it is connected and uploading data to Propeller. At the same time, you'll see a blue bar at the top of your device screen, indicating that your hotspot connection is active.

If you're logged into the Propeller platform, you can also monitor upload progress from the 'AeroPoints' tab.

It takes approximately one minute to upload each hour of recorded AeroPoint data (but can take longer if you have a slow connection). When upload is complete, AeroPoint light will turn off (sleep mode).

UPLOADING USING IOS:

iOS devices allow only five concurrent connections to your Personal Hotspot.

If you're using an iOS device, we recommend uploading your data five AeroPoints at a time.



Above: A blue bar will indicate that your Personal Hotspot is active as AeroPoint data uploads.

Apply corrections and share your AeroPoints data

After uploading AeroPoints data, you need to choose the corrections method appropriate for your flight.

Open the AeroPoints interface

Log in to your Propeller portal, and click 'AeroPoints' in the top navigation bar to open the interface.

Select your AeroPoints set from the left-hand menu.

Click on the 'AeroPoints' tab to see the unique ID code associated with each AeroPoint unit, along with the time of the most recent upload, and the battery level at that time (Note: battery level is *not* a live indicator)

Check all uploads are complete

In the 'Surveys' tab, you'll see a list of completed surveys performed using your selected AeroPoints set.

Make sure that data from each of your 10 AeroPoints units is visible for each survey.

If you're missing data from any of your AeroPoints, it's possible that your upload may have failed.

In this instance, refer to *Troubleshooting* (on page 10 of this guide) for further instruction.

Apply corrections

Click to 'Apply corrections' to your selected flight and indicate the appropriate corrections method for your site. Refer to *Appendix I* (on page 11 of this guide) to understand the correction options available.

Expect a short delay (a few minutes) while corrections are retrieved and applied.

'WAITING FOR CORRECTION DATA'

For some locations, retrieving Propeller Corrections Network data can take a little longer (several hours). In this case, your interface will display the above message.

Share AeroPoints data

Information is most useful when it's shared, and sharing your AeroPoints data with a colleague or client is easy.

To grant another user access, click on 'User Permissions' next to the AeroPoints set

name, and enter a valid email address. An email will be sent to that address, inviting the recipient to view your AeroPoints data.

To download corrected AeroPoints data, just click 'Download'.

Upload your drone images

Propeller's cloud-based processing and visualization platform is the perfect companion for AeroPoints.

We can process your drone images **within 24 hours***, and integrate your corrected AeroPoints data to deliver the highest quality accuracy.

To upload your drone images for processing, you'll need a valid Propeller platform licence.

Contact your account manager or email us at sales@propelleraero.com for information about a licence type to suit your business.

Detailed instructions regarding the drone image upload process are available at help.propelleraero.com.

** For a standard site.*

IT'S YOUR CHOICE:

Don't want to process your drone images using the Propeller platform? That's okay. You can always download your corrected AeroPoints data for use in other applications.





AeroStencils: For frequent flyers

Do you fly the same site every day? If so, you can avoid placing out and picking up your AeroPoints each time by using **AeroStencils** to mark your AeroPoint positions semi-permanently.

AeroStencil marks work best on hard, flat surfaces that will not move or be disturbed (carparks and peacock blocks are good choices).

Use heavy-duty aerosol paint (like that used for line-marking) in a high-contrast colour like pink or yellow.

FIRST FLIGHT:

Distribute the full set of AeroPoints around your site as usual. But before placing each unit, spray an AeroStencil mark (including outside corners) then place your AeroPoint on top (using the corner marks to align).

Press the button on each AeroPoint to start recording, and complete your survey as normal.

SUBSEQUENT FLIGHTS:

Carry out your drone flight *without* distributing AeroPoints, and Propeller will use your existing AeroStencil marks to calibrate your data set instead.

Alternatively, you can use a combination of AeroStencil marks (in stable areas) and AeroPoints (in unstable areas, like a pit floor) for subsequent flights.

You can rely on AeroStencil marks for **up to three months**.

After this time, we recommend you complete another survey using AeroPoints to maintain the highest accuracy.

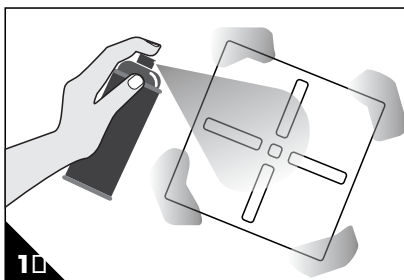

Before you place each AeroPoint, spray an AeroStencil mark (paying special attention to the outside corners).

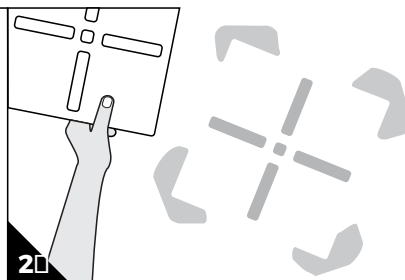

Remove AeroStencil and allow paint to dry.

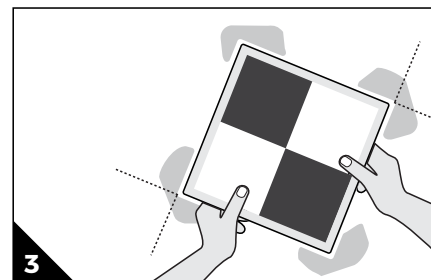

Place AeroPoint on top of AeroStencil mark, using painted corners to align exactly. Activate each AeroPoint and complete flight as usual.

FAQ

For more AeroPoints FAQs, visit propelleraero.com/aeropoints-faq. Can't find an answer to your question? Talk to us: support@propelleraero.com.

DO I NEED A PROPELLER PLATFORM LICENSE TO USE AEROPOINTS?

No. But you'll need access to the Propeller Correction Network if this is your preferred corrections method. 12 months access is included in your first AeroPoints purchase. After that, we charge an annual fee of \$600 USD.

Access to the Propeller Correction Network comes free with any Propeller platform licence.

CAN I USE AEROPOINTS WITH OTHER CLOUD OR DESKTOP-BASED PROCESSING SOLUTIONS?

Yes. You can export AeroPoints data in CSV, KML & PDF formats.

HOW BIG AN AREA CAN I COVER WITH ONE SET OF AEROPOINTS?

A set of 10 AeroPoints can achieve accurate results for an area up to 150ha/370 acres. For larger areas (up to 350ha/865 acres) we recommend using two sets.

SOMETHING WENT WRONG WHEN I WAS UPLOADING MY AEROPOINTS DATA. HAVE I LOST MY DATA?

It's pretty much impossible to 'lose' data from an AeroPoint. AeroPoints will retain all recorded data until it is completely and successfully uploaded to Propeller.

Data is automatically removed from AeroPoints once uploaded.

WHERE DOES AN AEROPOINT MEASURE FROM?

AeroPoints' measurements are taken from top of the unit, at the place where the checkerboard intersects.

THE SITE IS WINDY—WILL MY AEROPOINTS GET BLOWN OUT OF POSITION?

Their aerodynamic design means AeroPoints should be unaffected by anything other than extreme winds. It isn't safe to fly a drone in such conditions and we recommend delaying your flight.

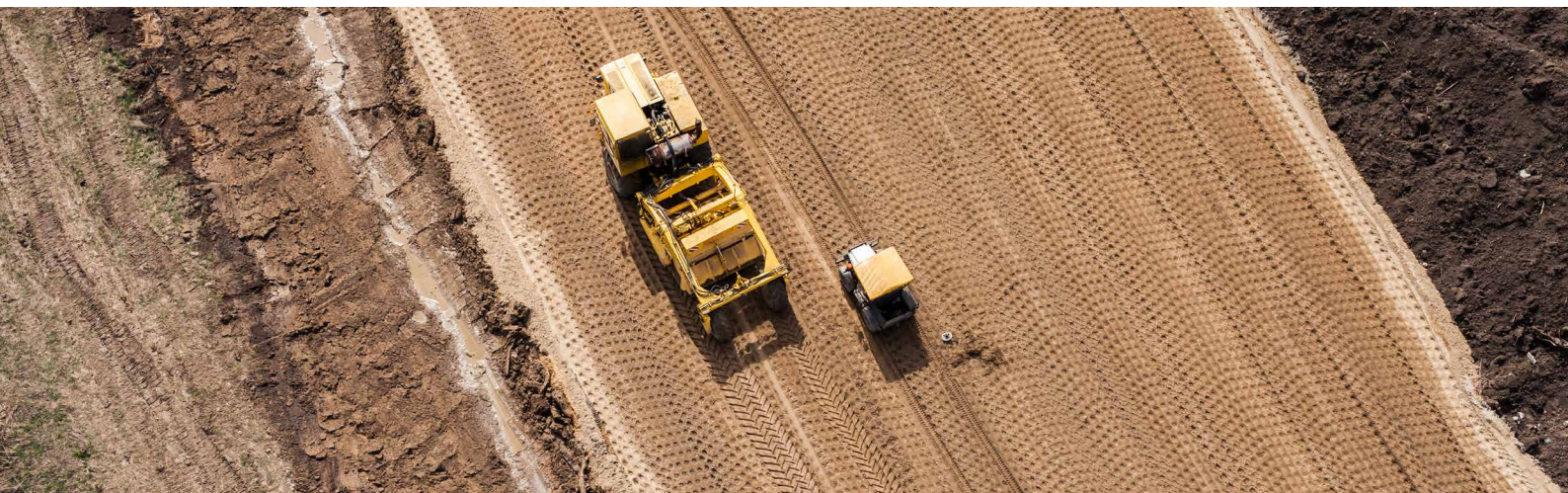

Troubleshooting

ONE OF MY AEROPOINTS ISN'T TURNING ON.

Your AeroPoint may have a flat battery. Place the AeroPoint in the sun to charge for 1-2 hours. (Only a long, continuous period of use without sun exposure will cause an AeroPoint battery to deplete faster than it recharges).

PROPELLER IS MISSING DATA FROM ONE OF MY AEROPOINTS.

Your data upload may have failed. To try again, first restart your device, then activate your WiFi hotspot (according to instructions on page 5). Press the AeroPoint button twice (once to turn it on; a second time to commence upload).

A small number of users have reported difficulty uploading data using an

iOS device. If this is you, please try again using an Android device.

I CAN'T SEE ANY OF THE AEROPOINTS IN MY IMAGES.

It may be that your image resolution isn't high enough, your images are blurry, or your GSD (Ground Sample Distance) is too high.

Make sure your drone is setup to capture images at a sufficient resolution and flight height (AeroPoints are designed for GSD of <5cm pixel).

Alternatively, your AeroPoints may have been obscured by trees, walls, or other objects.

Make sure that AeroPoints are placed with an unobstructed view of the sky in every direction (refer to page 4).



Appendix I:

AeroPoints correction methods

For accurate positions, corrections must be applied to AeroPoints data using one of the methods below. (Note that some methods have specific logging and/or placement requirements that should be adhered to).

a | The Propeller Correction Network

If you're flying within the Propeller Correction Network, then take advantage of our fully automated AeroPoints correction. This is the simplest way to use AeroPoints.

In countries like Australia, where a national survey system is in use on most worksites, this data will be accurate and aligned with other site data and information.

In countries like the USA, the Propeller Correction Network is ideal for accurate general mapping, but most worksites use a local calibrated system, and should therefore use the 'known mark' correction method if possible.

Go to propelleraero.com/aeropoints-coverage-map to see whether your site is covered by the Propeller Correction Network.

Not on the map yet? Let us know—we're expanding our network coverage daily.

Global accuracy:

20mm/20mm/50mm (the best available)

Consistency:

20mm/20mm/50mm (the best available)

Internal accuracy:

10mm or less (precise internal reconstruction)

b | Using a known mark

You can place one AeroPoint at a known survey mark or benchmark location.

If you've got access to GPS rover equipment, you can use it to create a new known mark. This is the best approach for worksites using their own site calibration.

Be sure to place an AeroPoint on the known mark first, and pick it up last—it must be recording data for the duration of your flight.

We can use data from this AeroPoint, combined with the coordinates of the known mark, as the reference point for the other AeroPoints used in the survey.

Global accuracy:

20mm/20mm/50mm (the best available—dependant on accurate placement of AeroPoint and accuracy of known mark itself)

Consistency:

20mm/20mm/50mm (the best available—dependant on using the same known mark each time)

Internal accuracy:

10mm or less (precise internal reconstruction)



LOCAL SITE CALIBRATION:

If your site has its own local calibration, we can correct your AeroPoints to positions in your local site coordinates.

You'll just need to upload a local site calibration file (eg a Trimble .CAL) or send us or a point pair file (ie a list of points in both global and local co-ordinates).

If you're interested in using this correction method, please talk to us first: support@propelleraero.com.

c | Using an AeroPoint to create a known mark

If there are no known marks available, the global accuracy of your data will be reduced. However, you can still use AeroPoints to get results that are internally accurate and consistent over time.

Find a hard, flat surface that will not move or be disturbed, and establish your own 'mark' (we recommend using heavy-duty aerosol paint like that used for line-marking). Place one AeroPoint at this mark and ensure it is left in place to record at least two hours of data.

For your first flight, we'll use the data from this AeroPoint to calculate an

estimated point (accurate within 50cm). For subsequent flights, we'll treat that coordinate as a 'known mark'.

Global accuracy:

500mm/500mm/500mm

Consistency:

20mm/20mm/50mm (the best available—dependant on using same known mark each time)

Internal accuracy:

10mm or less (precise internal reconstruction)

d | Using your own RINEX corrections

You might have access to a dual frequency L1/L2 RTK rover, or your site may have an RTK base station receiver. Provide us with RINEX formatted GNSS observations for the period of your survey and we can use these as the reference point.

Note: The RINEX file must have an accurate location for the base in the header, as this is the location that the AeroPoints will be measured against.

Global accuracy:

20mm/20mm/50mm (the best available)

Consistency:

20mm/20mm/50mm (the best available)

Internal accuracy:

10mm or less (precise internal reconstruction)

e | 'Just lay them out' - PPP processing

If none of the methods above are an option, the global accuracy of your data, and consistency over time, will be reduced.

However, you can still use AeroPoints to get an internally accurate reconstruction—measurements and distances will be precise.

If you're only capturing a site once (like a damage assessment or a traffic accident capture) and don't need to measure changes over time, this method may fulfil your requirements.

Global accuracy:

500mm/500mm/500mm

Consistency:

500mm/500mm/500mm

Internal accuracy:

10mm or less (precise internal reconstruction)

Appendix II: Configure your smartphone hotspot to act as Propeller WiFi network

Using an Android device

The procedure for setting up a WiFi hotspot is different for each Android device.

Refer to instructions from your specific device manufacturer (or Google it!)

Using an iOS device

Change your device name

From Settings, navigate to General> About> Name. Change the name of your device to 'propeller'.

Change your Personal Hotspot password

From Settings, navigate to Personal Hotspot. Change WiFi password to 'propeller' and toggle Personal Hotspot to 'on' (green).

Important: Keep your iOS device open on the Personal Hotspot screen to maintain connection and monitor data upload.

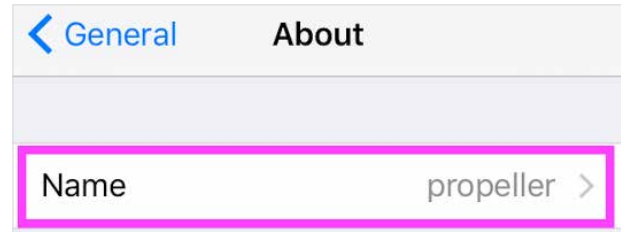

Above: Changing your device name on iOS.



Above: Opening your hotspot settings on iOS.

Support

Need help? Visit help.propelleraero.com for how-to articles, tutorial videos and more. Email support@propelleraero.com at any time to get in touch with our support team.



Propeller Aero

Sydney, AU | Denver, USA

Talk to us:

hello@propelleraero.com

propelleraero.com

APPENDIX D
FAA WAIVERS AND EXEMPTIONS

DEPARTMENT OF TRANSPORTATION
FEDERAL AVIATION ADMINISTRATION

CERTIFICATE OF WAIVER OR AUTHORIZATION

ISSUE TO Collin Engineer	POC PHONE NUMBER 651-341-4039
1599 Selby Ave. St. Paul, MN. 55105	

This certificate is issued for the operations specifically described hereinafter. No person shall conduct any operation pursuant to the authority of this certificate except in accordance with the standard and special provisions contained in this certificate, and such other requirements of the Federal Aviation Regulations not specifically waived by this certificate.

OPERATIONS AUTHORIZED
Operation under this certificate of authorization are limited to the maximum altitude limited below
This altitude is an absolute value and it shall not be added to the height of any structures.
Class of Airspace: D
At or Below: **200 feet Above Ground Level (AGL)(100 AGL Minimum, 50 AGL Maximum)**
With a radius of: **4.0 NM (Excludes ALL Red Noise Abatement Procedures)**
Under the Jurisdiction of: **St. Paul Downtown Airport/Holman Field (STP)**

LIST OF WAIVED REGULATIONS BY SECTION AND TITLE
N/A

STANDARD CONDITIONS

1. A copy of the application made for this certificate shall be attached and become a part hereof.
2. This certificate shall be presented for inspection upon the request of any authorized representative of the Federal Aviation Administration, or of any State or municipal official charged with the duty of enforcing local laws or regulations.
3. The holder of this certificate shall be responsible for the strict observance of the terms and provisions contained herein.
4. This certificate is nontransferable.

Note-This certificate constitutes a waiver of those Federal rules or regulations specifically referred to above. It does not constitute a waiver of any State law or local ordinance.

SPECIAL CONDITIONS

Special provisions 1 thru 3, inclusive, are set forth in this authorization.

This certificate 2017- 107-C A-9655 is effective from August 10, 2017 to June 30, 2018, and is subject to cancellation at any time upon notice by the Administrator or his/her authorized representative.

BY DIRECTION OF THE ADMINISTRATOR

Shanora N. Davis

FAA Headquarters, AJV-115
(Region)

Scott J. Gardner
(Signature)

August 9, 2017
(Date)

Acting Manager, UA Tactical Operations Section
(Title)

SPECIAL PROVISIONS

INFORMATION :

Barritt Lovelace is the person designated as responsible for the overall safety of UA operations under this Certificate of Waiver or Authorization. During UA operations for on-site communication/recall, the Responsible person shall be continuously available for direct contact at 651-341-4039 by Text or designated representative

FLIGHT OPERATION :

- a. This Certificate of Waiver or Authorization and the special provisions shall be in effect between civil sunrise and civil sunset local time.
- b. This airspace authorization does not relieve the remote pilots from the responsibility to check the airspace they are operating in and comply with all restrictions that may be present in accordance with see 14 CFR 107.45 and 107.49 (a)(2), such as restricted and prohibited Airspace, Temporary Flight Restrictions, etc.
- c. The facility may disapprove, terminate, restrict, or delay UA flight operations covered by this authorization at any time.
- d. Before each operation, the proponent must verify the accuracy of the UA Facility Map for the most current approved published altitude at <http://uas-faa.opendata.arcgis.com/>. If the proponent's authorized altitude is higher than the published altitude depicted on <http://uas-faa.opendata.arcgis.com/>, the authorization is void. A new authorization must be submitted.

EMERGENCY /CONTINGENCY PROCEDURE - Lost Link/Lost

Communications procedures:

- a. If the UA loses communications or loses its GPS signal, the UA must return to a pre-determined location within the operating area and land.
- b. The PIC must abort the flight in the event of unpredicted obstacles or emergencies.

ATTACHMENT 1

Opera i

Class D Airspace

At or below **200** feet AGL

At or below **100** feet AGL (In Yellow Areas)

At or below **50** feet AGL (In Lime Area)

44° 56' 04.6410" N, 93° 03' 37.2328" W

4.0 NM Radius (**Excludes ALL Red N -**

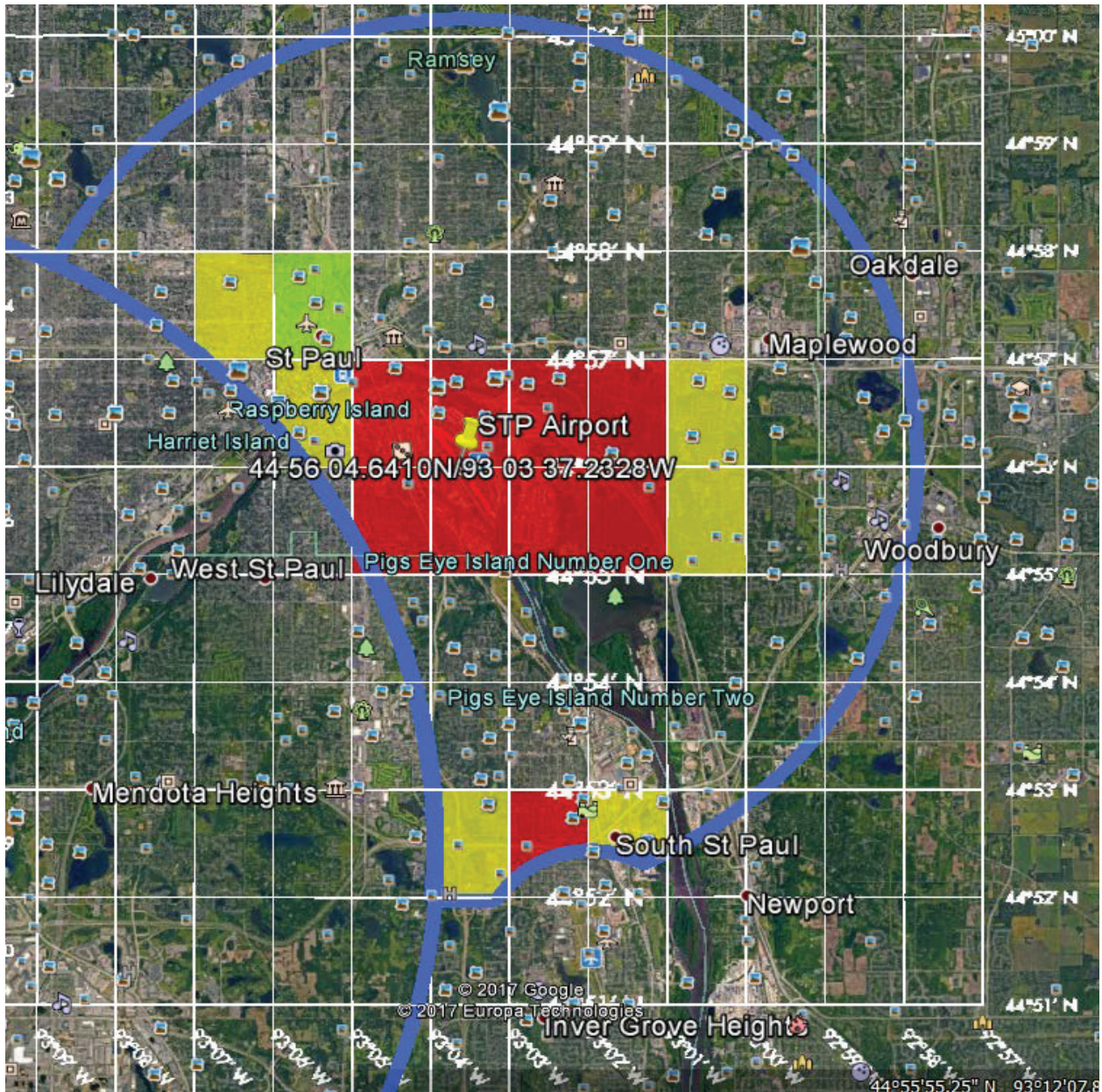

CIVIL PART 107 AUTHORIZATION, JUNE 26, 2017

DEPARTMENT OF TRANSPORTATION
FEDERAL AVIATION ADMINISTRATION

CERTIFICATE OF WAIVER OR AUTHORIZATION

ISSUED TO Collins Engineers	POC PHONE NUMBER 651-341-4039
1599 Selby Ave. St. Paul, MN. 55105	

This certificate is issued for the operations specifically described hereinafter. No person shall conduct any operation pursuant to the authority of this certificate except in accordance with the standard and special provisions contained in this certificate, and such other requirements of the Federal Aviation Regulations not specifically waived by this certificate.

OPERATIONS AUTHORIZED
Unmanned Aircraft systems operations in accordance with Title 14 CFR part 107.41, except "Operations for small unmanned aircraft" part 107.51 b(2) are limited to the altitude listed below.
Class of Airspace: B
At or Below: **200 feet Above Ground Level (AGL)(100 AGL Minimum, 50 AGL Maximum)**
With a radius of: 6.5 NM (**Excludes ALL Red Noise Abatement**)
Under the Jurisdiction of: Minneapolis-St. Paul International/World-Chamberlain Airport (MSP)

LIST OF WAIVED REGULATIONS BY SECTION AND TITLE
N/A

STANDARD PROVISIONS

1. A copy of the application made for this certificate shall be attached and become a part hereof.
2. This certificate shall be presented for inspection upon the request of any authorized representative of the Federal Aviation Administration, or of any State or municipal official charged with the duty of enforcing local laws or regulations.
3. The holder of this certificate shall be responsible for the strict observance of the terms and provisions contained herein.
4. This certificate is nontransferable.

Note-This certificate constitutes a waiver of those Federal rules or regulations specifically referred to above. It does not constitute a waiver of any State law or local ordinance.

SPECIAL PROVISIONS

Special provisions 1 thru 3, inclusive, are set forth in this authorization.

This certificate 2017- 107-C A-9657 is effective from August 11, 2017 to June 30, 2018, and is subject to cancellation at any time upon notice by the Administrator or his/her authorized representative.

BY DIRECTION OF THE ADMINISTRATOR

FAA Headquarters, AJV-115
(Region)

SCOTT JAMES GARDNER
Digitally signed by SCOTT JAMES GARDNER
Date: 2017.08.10 09:16:55 -0400
Scott J. Gardner
(Signature)

August 10, 2017
(Date)

Acting Manager, UA Tactical Operations Section
(Title)

SPECIAL PROVISIONS

INFORMATION :

Barritt Lovelace is the person designated as responsible for the overall safety of UA operations under this Certificate of Waiver or Authorization. During UA operations for on-site communication/recall, the Responsible person shall be continuously available for direct contact at 651-341-4039 by Mobile or designated representative

FLIGHT OPERATION :

- a. This Certificate of Waiver or Authorization and the special provisions shall be in effect between civil sunrise and civil sunset local time.
- b. This airspace authorization does not relieve the remote pilots from the responsibility to check the airspace they are operating in and comply with all restrictions that may be present in accordance with see 14 CFR 107.45 and 107.49 (a)(2), such as restricted and prohibited Airspace, Temporary Flight Restrictions, etc.
- c. The facility may disapprove, terminate, restrict, or delay UA flight operations covered by this authorization at any time.
- d. Before each operation, the proponent must verify the accuracy of the UA Facility Map for the most current approved published altitude at <http://uas-faa.opendata.arcgis.com/>. If the proponent's authorized altitude is higher than the published altitude depicted on <http://uas-faa.opendata.arcgis.com/>, the authorization is void. A new authorization must be submitted.

EMERGENCY /CONTINGENCY PROCEDURE - Lost Link/Lost

Communications procedures:

- a. If the UA loses communications or loses its GPS signal, the UA must return to a pre-determined location within the operating area and land.
- b. The PIC must abort the flight in the event of unpredicted obstacles or emergencies.

ATTACHMENT 1

Operations Area

Class B Airspace

At or below **200** feet AGL

At or below **100** feet AGL (In Yellow Areas)

At or below **50** feet AGL (In Lime Area)

44° 52' 55.10" N, 93° 13' 18.40" W

6.5 NM Radius (**Excludes ALL Red NO-FLY Areas**)

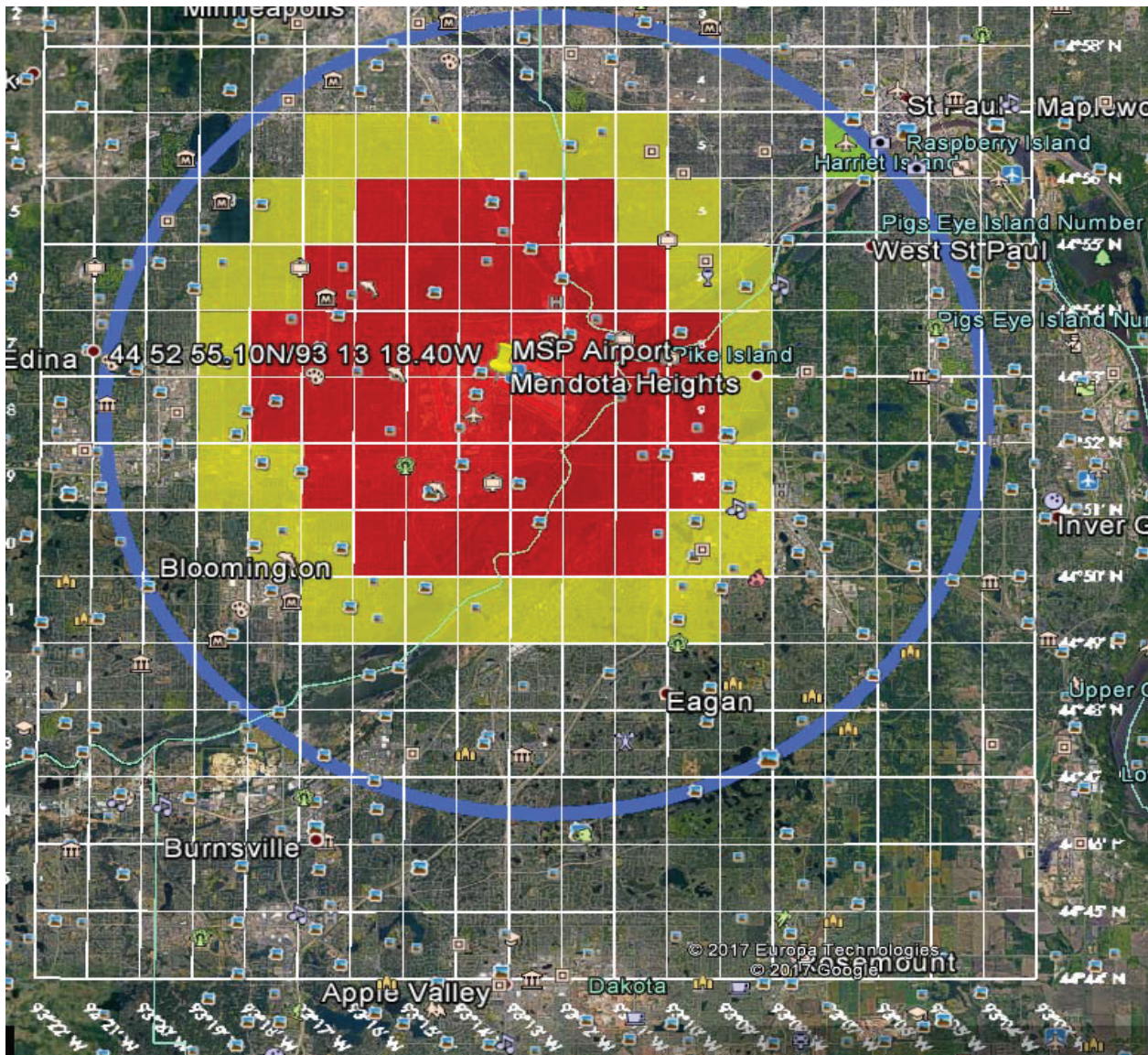

CIVIL PART 107 AUTHORIZATION, JUNE 26, 2017

DEPARTMENT OF TRANSPORTATION
FEDERAL AVIATION ADMINISTRATION

CERTIFICATE OF WAIVER OR AUTHORIZATION

ISSUED TO

Collins Engineers, Inc.

POC PHONE NUMBER

(651) 212-4075

ATTN: Barritt Lovelace

This certificate is issued for the operations specifically described hereinafter. No person shall conduct any operation pursuant to the authority of this certificate except in accordance with the standard and special provisions contained in this certificate, and such other requirements of the Federal Aviation Regulations not specifically waived by this certificate.

OPERATIONS AUTHORIZED

Operations under this certificate of authorization are limited to the maximum altitude listed below. This altitude is an absolute value and it shall not be added to the height of any structures.

Class of Airspace: B

At or Below: Altitudes in accordance with published UAS facility map

Under the Jurisdiction of: Minneapolis-St Paul International/Wold-Chamberlain Airport (MSP) Air Traffic Control Tower (ATCT)

Airport Identifier: MSP

LIST OF WAIVED REGULATIONS BY SECTION AND TITLE

N/A

STANDARD PROVISIONS

1. A copy of the application made for this certificate shall be attached and become a part hereof.
2. This certificate shall be presented for inspection upon the request of any authorized representative of the Federal Aviation Administration, or of any State or municipal official charged with the duty of enforcing local laws or regulations.
3. The holder of this certificate shall be responsible for the strict observance of the terms and provisions contained herein.
4. This certificate is nontransferable.

Note-This certificate constitutes a waiver of those Federal rules or regulations specifically referred to above. It does not constitute a waiver of any State law or local ordinance.

SPECIAL PROVISIONS

Special Provisions 1 thru 3, inclusive, are set forth in this authorization.

This certificate 2016-ATO-P107-00373 is effective from December 8, 2017 to June 30, 2018, and is subject to cancellation at any time upon notice by the Administrator or his/her authorized representative.

BY DIRECTION OF THE ADMINISTRATOR

Shanora N. Davis

For

Scott J. Gardner

(Signature)

FAA Headquarters, AJV-115

(Region)

December 7, 2017

(Date)

Acting Manager, UAS Tactical Operations Section

(Title)

SPECIAL PROVISIONS

1. CONTACT INFORMATION:

- a. Barritt Lovelace is the person designated as responsible for the overall safety of UAS operations under this Certificate of Waiver or Authorization. During UAS operations for on-site communication/recall, the Responsible Person shall be continuously available for direct contact at (651) 212-4075 by MSP ATCT or designated representative.
- b. The Responsible Person listed on this Authorization must maintain a current list of pilots by name and the remote pilot certificate number(s) associated with the Authorization holder's operation. This list must be presented for inspection upon request from the Administrator or an authorized representative.

2. SCHEDULE OF FLIGHT OPERATIONS:

- a. This Certificate of Waiver or Authorization and the Special Provisions shall be in effect between civil sunrise and civil sunset local time.
- b. This airspace authorization does not relieve the remote pilots from the responsibility to check the airspace they are operating in and comply with all restrictions that may be present in accordance with see 14 CFR 107.45 and 107.49 (a)(2), such as restricted and Prohibited Airspace, Temporary Flight Restrictions, etc.
- c. The facility may disapprove, terminate, restrict, or delay UAS flight operations covered by this authorization at any time.
- d. The operator is responsible for reviewing the published UASFM at <http://uas-faa.opendata.arcgis.com/> prior to each flight to ensure that no changes have been made to the map, i.e., altitude changes, airspace modifications, etc. **If you need to operate at an altitude that is not in accordance with the published UASFM, you must apply for a new authorization requesting that altitude.**

3. EMERGENCY/CONTINGENCY PROCEDURES - Lost Link/Lost Communications Procedures:

- a. If the UAS loses communications or loses its GPS signal, the UA must return to a pre-determined location within the operating area and land.
- b. The PIC must abort the flight in the event of unpredicted obstacles or emergencies.