

# ***Wyoming Cooperative Fish and Wildlife Research Unit***

Biological Science Building, Rm. 419, University of Wyoming, Laramie, WY 82071-3166

Phone: (307) 766-5415 Fax: (307) 766-5400

---



## **HIGH TENSILE ELECTRIC FENCE: PHASE 2 – LIABILITY ISSUES, MAINTENANCE COSTS, AND CONTAINMENT OF BISON**

### **Final Report**

#### **Principal Investigators**

Casey J. Quitmeyer<sup>a</sup>, Jesse A. Bopp<sup>b</sup>, Robert M. Stephens<sup>c</sup>, Rory Karhu<sup>d</sup>, and Dr. Stanley Anderson<sup>a</sup>

<sup>a</sup>Wyoming Cooperative Fish and Wildlife Research Unit

Dept. 3166, 1000 E. University Ave, Laramie, WY 82071

Phone: (307)766-2091 Fax: (307)766-5400

<sup>b</sup>University of Wyoming College of Law

Dept. 3035, 1000 E. University Ave, Laramie WY, 82071

<sup>c</sup>Wyoming Game and Fish Department

528 S. Adams, Laramie, WY 82070

Phone: (307)745-4046

<sup>d</sup>Wyoming Game and Fish Department

408 Greybull Ave., Greybull, WY 82426

Phone: (307)765-2483 Fax: (307)765-9243

#### **Submitted to**

Wyoming Department of Transportation

Programming Research Unit

5300 Bishop Blvd.

Cheyenne, WY 82009

**December 2004**

## **ACKNOWLEDGEMENTS**

The Wyoming Department of Transportation, Bureau of Land Management, Wyoming Game and Fish Department, and Rocky Mountain Elk Foundation provided funding for this project. Doug Moench of the Wyoming Attorney General's Office reviewed the liability analysis for WYDOT. M. Renner with Gallagher Group provided valuable advice as well as many hours of help constructing fences. We thank B. Strauch for help in constructing fences. We are also grateful to the numerous Wyoming landowners, a Colorado landowner, a Nebraska landowner, and the staff on each of the ranches for allowing us access to their land and animals and allowing us to manipulate them for our tests.

## **DISCLAIMER**

This Final Report serves as general guidance on matters that relate to issues of 3-Wire HTEF liability, maintenance, livestock containment, and big game passage. Although the authors have made every attempt to ensure that the information contained herein is accurate, complete, and culled from reliable sources, we explicitly note that scientific principles, fencing technology, laws, statutes, and regulations are not static and may change upon completion of this report. As a consequence, the authors and the Wyoming Cooperative Fish and Wildlife Research Unit have engaged in providing scientific and legal information with the understanding that this report does not constitute, and will not serve as, binding scientific or legal advice. Accordingly, neither the authors nor the Wyoming Cooperative Fish and Wildlife Research Unit shall bear any responsibility or liability for errors, omissions, or results arising out of the use of the information contained herein. Prior to commencing any action from information contained within this report, or to seek seminal scientific or legal advice, the interested agency should consult with professional biologists and legal representatives within their respective agency, attorney general's office, or federal solicitor's office.

## EXECUTIVE SUMMARY

Fences are typically built to restrict the movement of livestock and consequently become barriers to wildlife. Research done by Karhu and Anderson (2003) has shown that High Tensile Electric Fence (HTEF) can contain livestock while allowing wildlife to freely move across the fence. Before widespread implementation of HTEF can occur, issues involving the liability and maintenance of HTEF need to be addressed.

We investigated liability issues and maintenance costs of 3-Wire HTEF. We also tested the effectiveness of 3-Wire HTEF at containing bison. The 3-Wire HTEF was designed according to recommendations made by Karhu and Anderson (2003). The design stipulated wire spacing of 22, 32, and 42-inches above the ground, 12.5 gauge 170,000-psi tensile strength wire, and  $\frac{3}{4}$ "- 1" diameter solid fiberglass posts 60-inches long spaced 50-ft apart.

The liability associated with the use of 3-Wire HTEF appears to be no greater than the liability incurred with the use of more traditional fence designs. Selection of an Underwriters Laboratory (UL) certified energizer as well as proper fence maintenance and monitoring limits fence owner liability.

Maintenance of the 3-Wire HTEF was minimal. Most of the maintenance issues that occurred were due to improper construction and/or problems with the satellite monitoring system. Once these problems were corrected the fence and monitoring systems functioned effectively, at containing livestock and allowing pronghorn to cross with relative ease. Almost 96% of the pronghorn observed interacting with the HTEF were successful in crossing it.

Bison appear to be effectively contained by the 3-Wire HTEF. In 4 out of 5 tests there was 100% containment of bison. We feel that there is potential to use this fence design for the containment of bison.

We provide a record of our maintenance on the 3-Wire HTEF and associated costs. We also provide specific information on the design and construction of 3-Wire HTEF. Overall we feel

that 3-Wire HTEF has the potential to be an effective means of controlling livestock while allowing wildlife to move across the fence wildlife.

## TABLE OF CONTENTS

Chapter	Page Number
1 INTRODUCTION.....	1
Background.....	1
Problem Statement.....	1
Study Area.....	2
2 OBJECTIVES.....	5
Objective 1: Risk, Liability, and Applications.....	5
Objective 2: Maintenance Costs.....	5
Objective 3: Bison Containment.....	6
3 METHODS.....	7
Risk, Liability, and Applications.....	7
Maintenance Costs.....	7
Bison Containment.....	9
4 LIABILITY RESULTS AND DISCUSSION.....	11
Scope of Review.....	11
Wyoming Statutory Law on Fencing.....	12
<i>Lawful Fences</i> .....	12
<i>Fence Construction, Repair, and Maintenance</i> .....	12
<i>Summary</i> .....	12
States with Statutory Law on Electric Fence.....	13
<i>Standards and Specifications for Compliance</i> .....	13
<i>Liability for Accident, Injury, or Death</i> .....	14
<i>Penalties for Non-Compliance</i> .....	14
<i>Summary</i> .....	15
BLM Electric Fence Policy, Design, and Safety Requirements.....	15

<i>Background</i> .....	15
<i>Fence Policy</i> .....	15
<i>Fence Design</i> .....	16
<i>Safety Requirements</i> .....	16
<i>Summary</i> .....	16
Wyoming Governmental Claims Act (GCA).....	17
<i>Purpose and Exceptions</i> .....	17
<i>Liability Proceedings Under the GCA</i> .....	18
<i>Summary</i> .....	19
Federal Tort Claims Act (FTCA).....	20
<i>Purpose and Exceptions</i> .....	20
<i>Liability Proceedings under the FTCA</i> .....	23
<i>Administrative Tort Claims Requirement</i> .....	23
<i>Suits in Federal District Court</i> .....	25
<i>Indemnification of BLM and DOI Employees</i> .....	27
<i>Summary</i> .....	28
Wyoming Negligence and Comparative Fault.....	28
<i>Liability Proceedings for Common Law and Statutory Negligence</i> .....	29
<i>Comparative Fault</i> .....	31
<i>Summary</i> .....	32
Federal Administrative Proceedings on Electric Fence Use.....	32
<i>Department of Interior</i> .....	33
<i>Idaho</i> .....	33
<i>Nevada</i> .....	33
<i>Alaska</i> .....	34
<i>California</i> .....	35
<i>Department of Agriculture</i> .....	35
<i>Missouri</i> .....	35
<i>Summary</i> .....	36
Caselaw on Electric Fence Injury.....	37

<i>Missouri</i> .....	37
<i>Oklahoma</i> .....	38
<i>Indiana</i> .....	39
<i>California</i> .....	40
<i>Summary</i> .....	41
Caselaw on Vehicle-Livestock Collisions.....	42
<i>Wyoming</i> .....	43
<i>Montana</i> .....	44
<i>Colorado</i> .....	45
<i>Kansas</i> .....	47
<i>New Mexico</i> .....	49
<i>Summary</i> .....	51
Caselaw on Livestock Breach and Injury.....	52
<i>Injury to Livestock from Direct Contact with HTEF</i> .....	52
<i>Remedy for Trespass by Livestock</i> .....	53
<i>Summary</i> .....	53
5 MAINTENANCE AND BISON CONTAINMENT RESULTS AND DISCUSSION.....	55
Maintenance Costs.....	55
Wildlife Use.....	57
<i>Pronghorn</i> .....	57
<i>Elk</i> .....	58
Bison Containment.....	58
6 RECOMMENDATIONS AND CONCLUSIONS.....	61
Risk, Liability, and Applications.....	61



<i>Short Answer</i> .....	61
<i>Conclusion</i> .....	61
Agency Use.....	62
Car Accidents.....	62
Animal Tangling.....	63
Maintenance Costs.....	63
Wildlife Use.....	64
Power Failure and Livestock Escaping.....	64
Fire Hazard.....	65
Visibility.....	65
Bison Containment.....	66
 APPENDICES.....	 67
A. Maintenance Data for 3-Wire HTEF and Cost Comparison Between 3- Wire HTEF and WYDOT Right-of-Way Fencing.....	67
B. Log of issues involving the 3-Wire HTEF.....	71
C. Materials and Design Diagrams for 3-Wire HTEF.....	73
D. Explanation of Legal Citation and Format.....	81
 REFERENCES.....	 83
 TABLE OF AUTHORITIES.....	 84
Administrative Hearings.....	84
Caselaw.....	84
Statutory Law.....	86

## LIST OF TABLES

<b>Table</b>	<b>Page Number</b>
1 Wildlife results from Karhu and Anderson (2003) for 3-Wire HTEF.....	58
2 Results for bison containment tests.....	59

## LIST OF FIGURES

<b>Figure</b>	<b>Page Number</b>
1 Highway and bison test fence locations.....	3
2 Electric fence design detail for 3-Wire Type A HTEF.....	8
3 Shock energy released by the energizer indicated by volume of the electrical pulse.....	9
4 Example of data reported by the satellite-modem-monitors via the Internet.....	55
5 Two wires twisted around a wire tightener causing a short.....	56



# CHAPTER 1

## INTRODUCTION

### **Background**

Electric fences of various designs have been used to control numerous animal species ranging from elephants (*Elephas maximus*) to rats (*Rattus rattus mindanensis*) (McKillop and Sibly 1988). In the majority of cases, electric fences are used to exclude or contain specific animals. Karhu and Anderson (2003) determined that a specific design of High-Tensile Electric Fence (HTEF) effectively contained cattle (*Bos taurus*) and bison (*Bison bison*), but still allowed elk (*Cervus elaphus*), mule deer (*Odocoileus hemionus*), and pronghorn (*Antilocapra americana*) to cross with relative ease. This is especially important in areas where big game migrations occur and corridors are needed to facilitate wildlife movement.

Karhu and Anderson (2003) investigated the effectiveness of HTEF designs on big game movements and livestock containment. This research was conducted due to the increasing popularity of HTEF and the need to examine its effectiveness at containing livestock, while still allowing wildlife to traverse the fence. They concluded that 3-Wire Type A HTEF (hereon referred to as 3-Wire HTEF) was the best design to meet the goals of both livestock producers and wildlife managers. This design made it relatively easy for big game animals (elk, mule deer, and pronghorn) to cross, while effectively containing cattle. They also collected data that suggested 3-Wire HTEF was effective for containment of bison.

### **Problem Statement**

Before more widespread use of HTEF by the Wyoming Department of Transportation (WYDOT), Bureau of Land Management (BLM), Wyoming Game and Fish Department (WGFD), and other agencies is likely to occur, more information was needed on the risk and liability associated with the use of HTEF, specifically in areas accessible to the public. The available literature indicates that human injury due to direct contact with HTEF is extremely rare since the advent of low-impedance, high voltage energizers in the 1960's, as well as the adoption

of national standards for energizers by several countries as early as the 1940's (McCutchan 1980). Even though evidence suggests HTEF is safe, a risk assessment concerning the 3-Wire design was needed to address liability issues. Additionally, agencies needed information on the maintenance costs and applications of 3-Wire HTEF. Karhu and Anderson (2003) showed that HTEF was cheaper to construct than WYDOT Type F, 4-Wire barbed fence, and it was thought that HTEF would also have less maintenance costs. Yet, assessment was lacking concerning the cost and effort required to maintain HTEF in actual applications over time.

While, Karhu and Anderson (2003) sufficiently studied the effectiveness of 3-Wire HTEF for containing cattle, bison containment needed to be addressed more thoroughly. Disagreements have occurred in the past between WYDOT, WGFD, BLM, and private landowners when deciding how to best fence bison ranching operations where HTEF was proposed (Tim Stephens, BLM, personal communication). Information on the effectiveness of 3-Wire HTEF for containing bison will benefit all involved agencies when such dilemmas arise in the future. Preliminary research indicated that 3-Wire electric fence designs were equally successful at containing bison as 4-Wire electric fence designs (Karhu and Anderson 2003). However, the sample size of bison contacts with 3-Wire designs was limited and the study did not address bison operator concerns related to yearling separation or bull-cow separation during breeding season. Successful containment of bison under these conditions could help convince bison producers to build 3-Wire HTEF instead of 4, 5, or even 6-Wire designs, which can be detrimental to wildlife movements.

## **Study Area**

Three test fences were constructed along highways throughout the state. One-mile sections of fence were constructed along each side of U.S. Highway 16/20 near Cody, WYO 72 between Elk Mountain and Hanna, and WYO 34 near the west entrance of Sybille Canyon (Figure 1). Fences were also constructed on four private ranches during the spring-summer of 2004 for testing bison containment. These ranches were located in southeastern Wyoming (Iron Mountain Bison Ranch, Prairie Monarch Bison Ranch), northern Colorado (Diamond Tail Ranch) and western Nebraska (High Point Bison Ranch) (Figure 1)

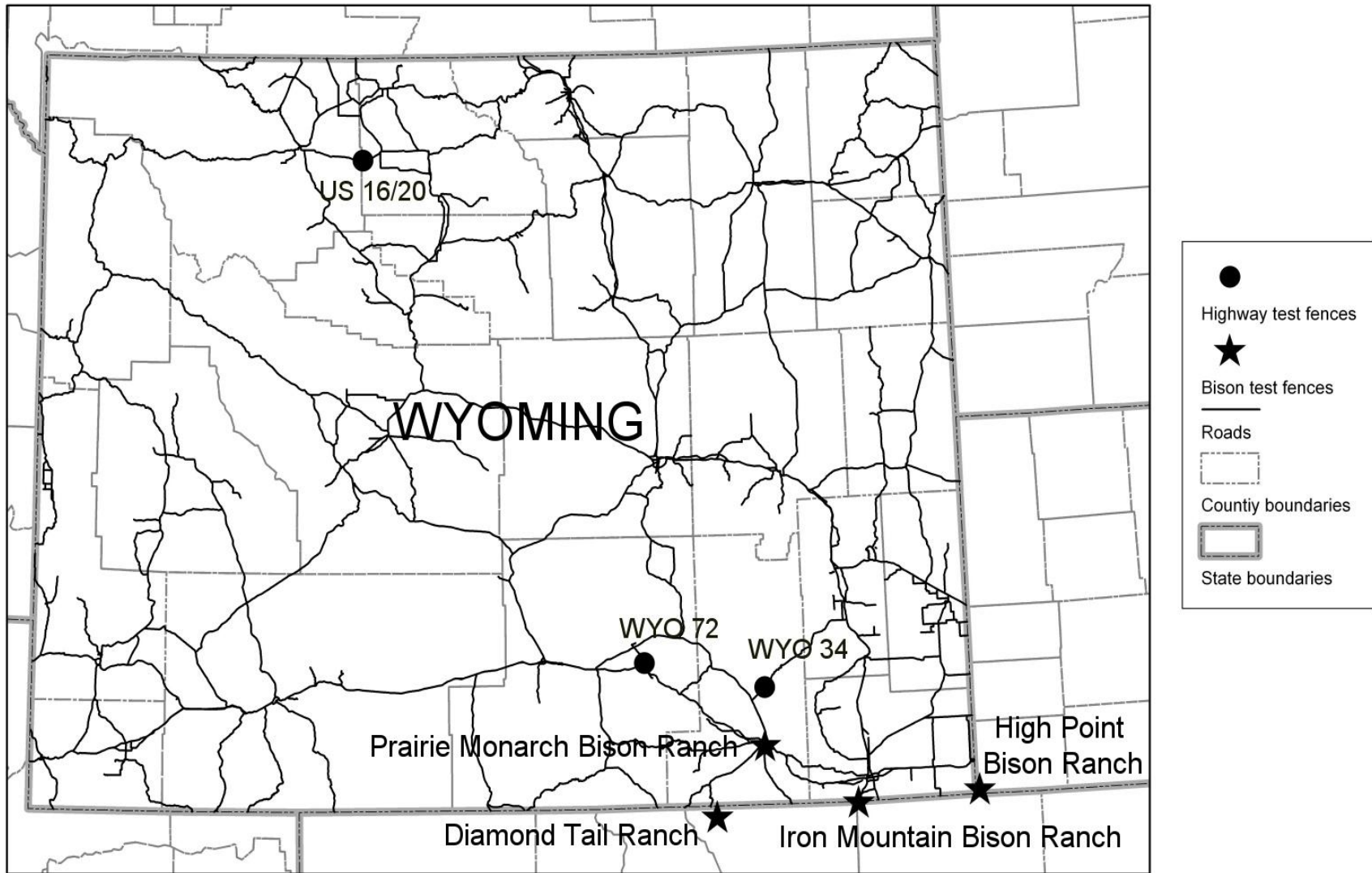

**Figure 1.** Highway and bison test fence locations.





## **CHAPTER 2**

### **OBJECTIVES**

Given the questions that arose from Karhu and Anderson's study, we examined three objectives to further determine the potential for HTEF applications.

#### **Objective 1: Risk, Liability, and Applications**

Our goal was to determine if 3-Wire HTEF designs are safe and do not result in increased liability. We investigated the risk and legal liability of HTEF by performing a thorough review of the literature, statutes, and legal cases. Issues investigated included: 1) What is the likelihood and liability associated with power failure and livestock escaping through the fence? 2) What is the likelihood and associated liability of human injury due to contact with HTEF? 3) Are other agencies in Wyoming and the western United States using HTEF? 4) How should car accidents that involve contact with HTEF be handled? 5) What is the likelihood of animals getting tangled in 3-Wire HTEF? 6) What is a legal fence according to Wyoming statutes and how does the classification of 3-Wire HTEF by the State affect the use of this fence type? Additionally, we included information on how to properly design 3-Wire HTEF.

#### **Objective 2: Maintenance Costs of 3-Wire HTEF**

Our goal was to provide all interested parties with information on the maintenance costs and effort associated with maintaining 3-Wire HTEF over time. We also identified causes of HTEF failure. To accomplish this objective, we constructed 1-mile sections of 3-Wire HTEF along both sides of a highway at three sites. Locations were selected so that the fences were in areas where cattle grazing and big game movements occur. Fences were field checked at 7-14 day intervals to ensure proper functioning and to repair fences when necessary, as well as being monitored by satellite-modem-monitors that were accessed via the Internet. These monitors informed us of the output of the energizer, the voltage of the battery, and the status of the fence as it pertains to voltage. We also recommend an appropriate monitoring schedule and give cost comparisons for the maintenance of 3-Wire HTEF compared to traditional right-of-way fencing.

### **Objective 3: Bison Containment**

Our goal was to determine if 3-Wire HTEF was effective at containing bison. We investigated this by monitoring the effectiveness of 3-Wire HTEF when subjected to three types of pressure by bison: 1) yearling separation, 2) bulls and cows were separated during the breeding season, and 3) exclusion of bison from a winter wheat field.

## CHAPTER 3

### METHODS

#### **Risk, Liability, and Applications**

We examined liability issues using the Westlaw legal database. Particular databases searched within the Westlaw service were: ‘*Wyoming Statutes Annotated*’ for Wyoming law on fencing, negligence, comparative fault, and the Government Claims Act; ‘*State Statutes*’ for all states that codified electric fence use; ‘*U.S. Code Annotated*’ for law addressing the Federal Tort Claims Act (FTCA); ‘*Code of Federal Regulations – Current Version*’ for BLM rules and regulations addressing the FTCA; ‘*United States Department of Interior Materials*’ and ‘*United States Department of Agriculture Materials*’ for administrative hearings addressing electric fence use; ‘*All State and Federal Cases*’ for caselaw addressing electric fence injury; ‘*All Federal & State Cases - Tenth Circuit*’ for caselaw addressing vehicle-livestock collisions; “*Wyoming State Cases*” for caselaw addressing allotment breach by livestock; and “*All State & Federal Cases*” for injury to the animal itself through contact with HTEF. To address BLM electric fence policy, design specification, and safety requirements, we used the Bureau’s Fencing Handbook 1741-1 (USDI BLM 1989), and the Supplement to the Bureau’s Fencing Handbook 1741-1: Installation of Electric Fences (USDI BLM 2003).

#### **Maintenance Costs of 3-Wire HTEF**

Three test fences were constructed during the summer of 2003 following the design recommendations of Karhu and Anderson (2003) (Figure 2). Each fence replaced the existing highway right-of-way fence. Satellite-modem monitoring systems (ARCSIS, San Diego, CA) were installed on each of the fences at the energizer, to determine their ability to accurately monitor voltage output of the energizers, charge of the 12-volt source battery, and fence status (i.e., shorting out of the fence). The cost of the monitors was \$1,000 each and \$35 per month was charged for the monitoring service provided by each unit. The monitors reported the status of the fences approximately every hour. This information was accessed via the Internet

(<http://satguard.com/Fence>, User Name: fence, Password: fence). Field checks of the study fences were conducted every 7-14 days, or when the monitors reported a fence failure.

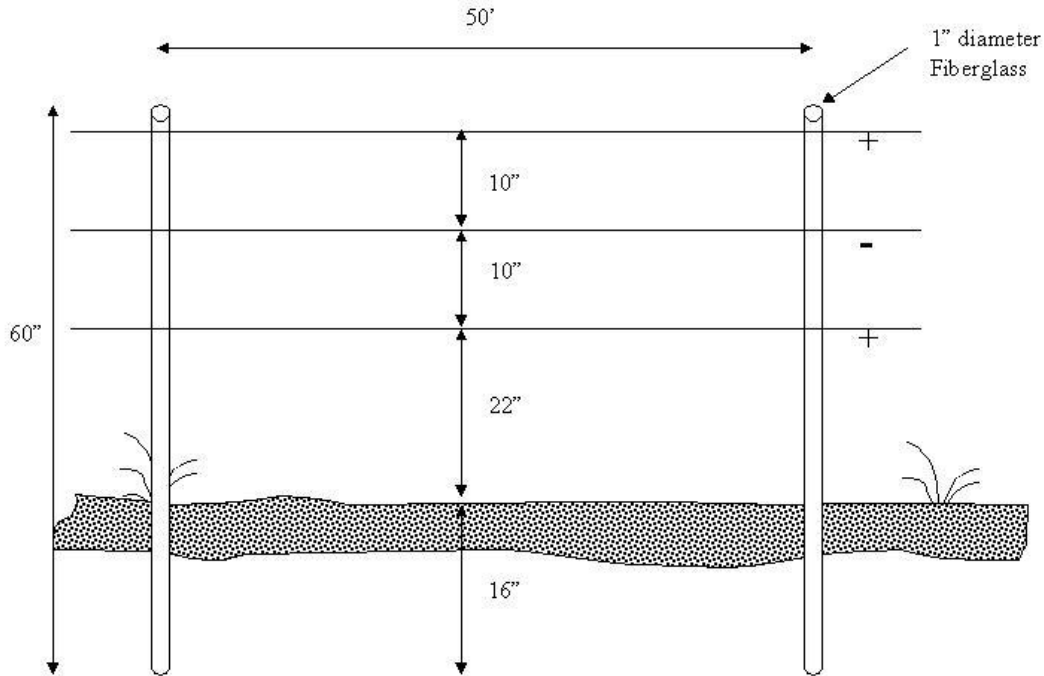
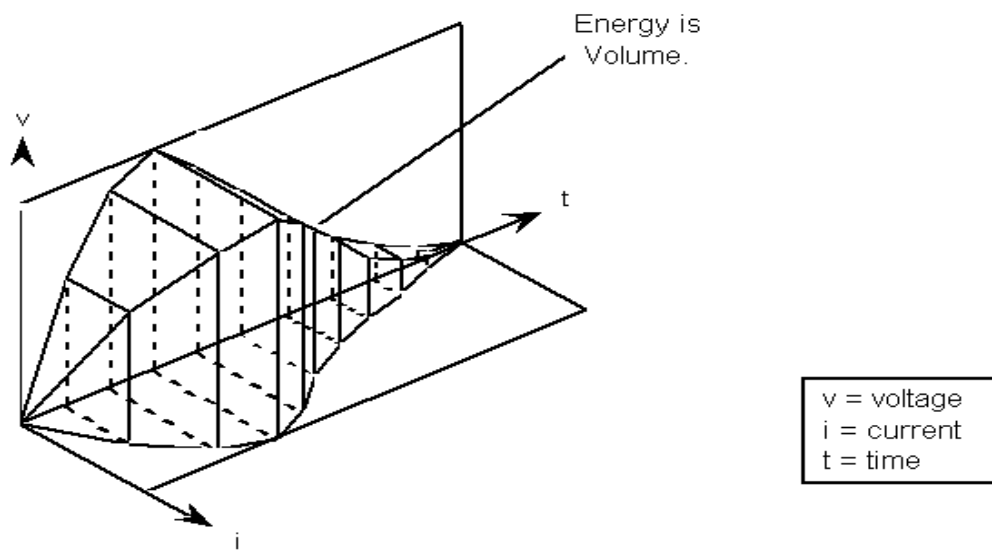

**Figure 2.** Electric fence design detail for 3-Wire Type A HTEF. All fences use 3/4" - 1" diameter, 60" tall solid fiberglass line posts. Wire is 12.5 gauge, Class III galvanized with a maximum tensile strength of 170,000-psi and maximum breaking strength of 1,308-lbs. Wires are connected to line posts using metal clips (Karhu and Anderson 2003).

Additionally, using methods from Karhu and Anderson (2003), video cameras and infrared monitors were set up to monitor wildlife and livestock interactions with the HTEF. Animals were recorded as either successful or unsuccessful in their attempt(s) to cross the fence.

A Gallagher B260 energizer rated at 2.5-joules stored energy powered each of the highway right-of-way test fences. Joules are the shock energy available at any point on a particular fence; you need to know not only voltage, but also current, pulse shape, and pulse length (Figure 3) to measure joules (Hancock 1995). Initially a 22-watt solar panel connected to a marine deep cycle battery was used for a power source. It was later determined that because of the addition of the

satellite-monitors this was not a large enough panel to keep the battery charged. Thus, an additional 22-watt panel was added to ensure an adequate power supply. A SunSaver regulator (Morningstar Corporation, Washington Crossing, PA) was also installed on each unit after it was discovered that the solar panels did not contain a voltage regulator. These regulators controlled the amount of charge going into the 12V battery in order to prevent overcharging.



**Figure 3.** Shock energy released by the energizer is indicated by the volume of the electrical pulse (Hancock 1995).

The fences built for bison containment tests were also monitored for maintenance by periodically checking the fences, as well as contacting the ranchers to see if they had performed any maintenance on the fences.

### **Bison Containment**

Fences used for the bison containment tests were constructed during the spring and summer of 2004. The same 3-Wire HTEF design was used for these fences as well (Figure 2). Three types

of tests were performed to determine the fence's ability to contain bison: yearling separation, bull-cow separation, and winter wheat exclusion. Fence lengths varied for each test from a few hundred feet up to 2-miles depending on the site where each test was conducted.

Two replicates of the yearling test were performed by separating two individuals from a herd and placing them across the test fence from other bison.

Two replicates of the bull-cow separation test were conducted by constructing a test fence across a pasture and positioning bulls across from cows prior to each ranches' breeding season. During one test, the bison broke through a gate and were all on the same side of the fence. Since the bison broke through a gate rather than the fence, the gates were strengthened with portable livestock panels and this test was conducted again.

The winter wheat test was conducted by constructing a 3-Wire HTEF around a wheat field that had been previously accessible to bison. In order to entice the bison to pressure the fence, this test was conducted in early spring when the wheat inside the fence was green, but before the grass outside had begun to grow.

Each of the fences used during the tests were new (i.e. not replacing an existing fence). At the start of each test the animals were made aware of the existence of the fence either by someone standing near the fence as the animals approached so that they perceived the fence or by making sure that the animals approached in a manner so that they were aware of the fence before they made contact (i.e. not running full speed toward the fence). This was done so that the bison did not blindly run through the fence without knowing of its presence. Data were collected by either direct observations of field personnel or video cameras with infrared monitors. All tests were conducted for a maximum of 7-days, if possible (the bull-cow tests were only conducted for four days), or until all of the test subjects were on the same side of the fence (i.e. test failure). All of the bison tests were conducted using the same Gallagher B160 energizer rated at 1.5 Joules stored energy. This energizer was selected based on the lengths of fence we were using, and to maintain consistency between our tests and the tests done by Karhu and Anderson (2003).

## **CHAPTER 4**

### **LIABILITY RESULTS AND DISCUSSION**

#### **Scope of Review**

The material that follows presents a discussion of 1) Wyoming statutory law on fencing, 2) the BLM's Handbook on fencing, 3) the Wyoming Government Claims Act, 4) the Federal Tort Claims Act, 5) Wyoming law on the tort of negligence and the doctrine of comparative fault, and 6) four likely scenarios from which liability may flow (i.e. injury to person due to direct contact with High Tensile Electric Fence (HTEF), injury to person due to breaching livestock and a resulting vehicle-livestock collision, injury to property owners from breaching livestock, and injury to the animal itself from contact with HTEF).

Two agencies, Wyoming Department of Transportation (WYDOT) and the Bureau of Land Management (BLM), serve as the focus for discussion and application. However, because a Wyoming agency, the Wyoming Game and Fish Department (WGFD), has also expressed an interest in implementing HTEF, WGFD can view most, if not all, of the discussion and analysis pertaining to Wyoming law and WYDOT as a guiding source to limit its own liability. In fact, all agencies concerned may view the recommendations arising out of the discussion of general negligence principles as a guiding source to limit their liability.

When available, we present law specific to Wyoming. We did, however, expand the scope of discussion beyond Wyoming when we could not fully address an issue through Wyoming's existing statutory or caselaw. To address federal issues, we present relevant sections of the U.S. Code and Code of Federal Regulations as well as federal administrative/agency decisions and caselaw.

## Wyoming Statutory Law on Fencing

### *Lawful Fences*

Wyo. Stat. § 11-28-102(a)(i) (2003) prescribes a lawful fence as a “fence made of steel, concrete, or sound wooden posts and three (3) spans of barbed wire not more than fifteen (15) inches or not less than ten (10) inches apart. Wooden posts shall be at least four (4) inches in diameter. Posts shall be set firmly in the ground at least (20) inches deep, at no greater distance apart than twenty-two (22) feet between the posts or thirty-three (33) feet with at least two (2) iron or wooden stays between the posts. Stays shall be placed equal distance apart from themselves and the post on either side.”

Wyo. Stat. § 11-28-102(b) (2003) prescribes that “all other fences made and constructed...which upon evidence [are] declared to be as strong and well calculated to protect enclosures, and [are] as effective for resisting breaching livestock as those described in subsection (a)...shall be considered a lawful fence.”

### *Fence Construction, Repair, and Maintenance*

Wyo. Stat. § 24-1-112(a) and (b) (2003) gives WYDOT the duty to repair, reconstruct, and maintain “fences paralleling state highways, or built on the highway right-of-way” so as to meet legal fence requirements set forth in Wyo. Stat. § 11-28-102(a), (b) (2003).

### *Summary*

Wyo. Stat. § 11-28-102 (2003) defines “lawful fences.” The legislative intent of § 11-28-102 was merely to prescribe such a fence as would enable landowners to enforce certain remedies against the owners of trespassing animals (*Stilwell v. Nation*, 363 P. 2d 916, 917, Wyo. 1961) (for explanation of legal citation see Appendix C). Thus, although specific statutory law addressing HTEF is absent in Wyoming, the current statutory law on fencing does not prohibit its construction or use; rather, subsection (b) of § 11-28-102 deems HTEF lawful if it “is as effective for resisting breaching stock as those described in subsection (a).”



Under Wyo. Stat. § 24-1-112 (2003), WYDOT has a duty to maintain HTEF in accordance with Wyo. Stat. § 11-28-102. Of particular relevance to the current analysis is the definition in Wyo. Stat. § 11-28-102(b). This makes a fence “lawful” where evidence demonstrates that the particular HTEF design is as effective for resisting breaching livestock as the lawful construction prescribed under § 11-28-102(a).

### **States with Statutory Law on Electric Fencing**

Eleven states (Alabama, Arkansas, California, Hawaii, Kansas, Maine, Minnesota, New Hampshire, North Dakota, Pennsylvania, and Virginia) have statutory law regarding electric fences. Although the intent of such legislation varies widely (e.g. Ark. Stat. § 20-19-404 addresses proper use of electric fences for the confinement of wolves and wolf-dog hybrids) a reading of the statutory language reveals the following recurring themes: 1) standards and specifications for compliance; 2) liability for accident, injury, or death; and 3) penalties for non-compliance.

#### *Standards and Specifications for Compliance*

The most frequent specification addresses the energizer whose function is to produce and regulate the electrical current. The statutory language requires that energizers meet or exceed standards promulgated by one of several institutions. The Underwriters Laboratories (UL) was the most frequently referenced institution (Cal. Food and Agriculture Code § 17152; Haw. Stat. § 142-61; Me. Stat. § 3956; N.H. Stat. § 158:26; Va. Stat. § 55-298.1). However, every statute that made reference to the UL also made reference to some separate, yet approved institution. For example, Cal. Food and Agriculture Code § 17152 lists the National Electrical Code of the National Fire Protection Association, the New Zealand Standards Institute, or the Standards Association of Australia as approved institutions; Haw. Stat. § 142-61 lists the National Bureau of Standards or any other similar institution of recognized standing as an approved institution; Me. Stat. § 3956 lists the Department of Industrial Cooperation at the University of Maine System as an approved institution; N.H. Stat. § 158:26 lists the State Fire Marshal's Office as an

approved institution; and Va. Stat. § 55-298.1 lists the International Commission for Conformity Certification of Electrical Equipment as an approved institution. Despite the particular institution referenced, these listings demonstrate a legislative intent to establish a standard for approving the use of energizers.

A less common specification prescribes methods for the labeling of energizers. For example, Haw. Stat. § 142-61 prescribes that an energizer “shall be labeled...as conforming to the standards of...[the aforementioned institutions]...and shall bear a recognized commercial trade name and the name of the selling agency of same;” Me. Stat. § 3956 prescribes that an energizer “shall...carry...[the aforementioned institution’s]...label thereon;” and Va. Stat. § 55-298.1 prescribes that the energizer “shall display the approved label of...” [The aforementioned institutions]. Presumably, the legislative intent was to create an easily visible means for statutory compliance.

#### *Liability for Accident, Injury or Death*

Two states have statutory language that limits the liability of a provider of parts, electricity, or both. Kansas § 29-109 states, “no utility which furnishes electricity shall have or incur any liability to any person in the event of electric power failure to or for any electric fence.”

Alabama Stat. § 14-3-73 states that “a provider of electricity for the electric fence system authorized by this article or the providers of parts for construction of the system shall not be liable for any accident, injury, or death which may occur as a result of the construction or operation of the system.” Although these statutes differ in their scope, their intent was to limit liability that may flow from plaintiff’s alleged damages.

#### *Penalties for Non-Compliance*

Two states have statutory language that prescribes penalties for non-compliance. Haw. Stat. § 142-61 states that “any person who constructs or maintains an electrically charged fence or fence with electrically charged attachments not conforming to the requirements of this section shall be fined not more than \$500, or imprisoned not more than one year, or both.” Me. Stat. § 3956 states that “any violation of this section shall be punishable by a fine of not more than \$100, or

by imprisonment for not more than 90-days, or by both.” The legislative intent for such language was to provide a form of recourse for statutory non-compliance.

### *Summary*

The overlying policy rationale for tort law is to safeguard individuals through the exercise of reasonable care. The preceding material delineates some recurring themes for states with electric fence legislation. Although Wyoming does not have specific legislation addressing electric fence use, these statutes outline how WYDOT could exercise reasonable care in its operation of an electric fence. Accordingly, the use of a UL approved and labeled energizer may help WYDOT demonstrate their exercise of reasonable care.

## **BLM Electric Fence Policy, Design, and Safety Requirements**

### *Background*

Following the final report of Karhu and Anderson (2003), the BLM published a supplement to its Fencing Handbook 1741-1 (USDI BLM 2003). The supplement discussed the use of HTEF for permanent allotment boundaries and/or interior pastures; as a corollary, the supplement addressed measures to alleviate the effects that HTEF may have on public lands access, human safety, and wildlife.

### *Fence Policy*

Prior to approving the use of HTEF on BLM administered lands, a request or application is subject to assessment under existing National Environmental Policy Act (NEPA) guidelines and policy. The BLM will consider the request or application in a multiple-use context consistent with the Resource Management Plan for the public lands affected. Emphasis will be given to measures that provide safe human access to public lands and that improve wildlife migration and/or movement. The BLM will determine the extent of public involvement from the scale of the particular request or application; however, some level of public involvement is required.

### *Fence Design*

Based upon the findings of Karhu and Anderson (2003), the BLM advocates 3-Wire HTEF as optimal to achieve livestock control (i.e. cattle) and wildlife passage (i.e. elk, deer, and antelope). In this context, the BLM recommends: 1) smooth, high tensile, 12.5 gauge wire, of 170,000 to 200,000 PSI, tightened to 150 lbs. tension; and, 2) 3/4” to 1” fiberglass posts spaced every 50’ without stays. In addition, the BLM requires an energizer approved by the UL, in accordance with UL 69; and, regardless of the number of wires or miles of fence to be energized, the BLM limits output to a range of 5 to 8-joules with a peak current equal to or less than 10-amperes. For further detail and information regarding permissible and impermissible variations, as well as for details concerning sheep (*Ovis aires*), other big game, and avian concerns, please refer to the 1741-1 Installation of Electric Fence Supplement (USDI BLM 2003), along with the core 1741-1 Fencing Manual (USDI BLM 1989).

### *Safety Requirements*

Aside from a UL certified energizer with joule and ampere limits, the BLM requires the following measures for operators of HTEF on public lands: 1) the shutting-down of power when livestock are absent from the pasture; 2) the non-electrification of gates; 3) the installation of stiles or pedestrian crossings at reasonable intervals (to be determined by ‘special condition’ in Sec. 14 of Form 4120-6, Cooperative Range Improvement Agreement); and, 4) the placing and securing of signs that warn of electric current at known crossings and/or reasonable intervals. To further reduce safety concerns of allottees and the public at-large, the BLM has committed to completing a brochure that details electric fencing, including methods for safe passage.

### *Summary*

BLM’s 1989 fencing handbook inadequately addresses policy, design, and safety concerns surrounding the use of HTEF as a permanent allotment boundary and/or interior pasture fence. In response to the findings of Karhu and Anderson (2003), the BLM published a 2003 supplement to its 1989 fencing handbook. The supplement addresses 3-wire HTEF policy, design, and safety. To meet the dual objective of livestock control and wildlife passage, the

agency advocates a 3-Wire design with fiberglass posts and no stays. The energizer must be UL certified and meet specific joule and ampere limits. To help alleviate concerns over public safety, allottees must follow specific maintenance and operation standards, detailed within their Cooperative Range Improvement Agreement, and the BLM will provide a safety brochure for the public at-large.

## **Wyoming Governmental Claims Act (GCA)**

### *Purpose and Exceptions*

Wyo. Stat. § 1-39-102(a) (2003) in relevant part states that the purpose of the Wyoming Governmental Claims Act (GCA) is to recognize “the inherently unfair and inequitable results which occur in the strict application of the doctrine of governmental immunity.” Thus the GCA serves “to balance the respective equities between persons injured by governmental actions and the taxpayers of the state of Wyoming whose revenues” the government utilizes in defense of litigation (Wyo. Stat. § 1-39-102(a), 2003). In balancing respective equities, the Wyoming legislature has created several exceptions where parties may hold governmental entities liable. See Wyo. Stat. § 1-39-105 through § 1-39-112 (2003) and § 1-39-121 (2003). Examples include the government’s duty to maintain buildings, recreation areas, and public parks (§ 1-39-106), the duty of health care providers to act with non-negligent conduct (§ 1-39-110), and the duty of peace officers to act with non-tortuous conduct (§ 1-39-112).

Although none of the exceptions create explicit liability for fencing or prescribe governmental liability for any scenario listed under the Scope of Review, Wyo. Stat. § 24-1-112(a) and (b) (2003) prescribes a duty upon WYDOT to repair or reconstruct fences paralleling state highways in order to meet legal fence requirements set forth in Wyo. Stat. § 11-28-102 (2003). Aside from a statutory duty, Wyoming’s common law of negligence creates the general duty “to exercise the degree of care required of a reasonable person in light of all the circumstances” (*McClellan v. Tottenhoff*, 666 P. 2d 408, 411, Wyo. 1983). Presuming that a claim arises from either a breach of statutory duty or a breach of statutory and common law duty, the material that follows will describe a GCA proceeding in brief.

### *Liability Proceedings under the GCA*

Under Wyo. Stat. § 1-39-103(a)(vi) (2003), WYDOT is a “governmental entity.” As a governmental entity, WYDOT may be exposed to liability for an “act, error or omission” (Wyo. Stat. § 1-39-113(a), 2003) that it “requests, requires, or authorizes” to be performed by a public employee (Wyo. Stat. 1-39-103(a)(v), 2003). Such liability may arise “regardless of the time and place of performance” by the employee (*Id.*).

A claiming party must present WYDOT with a written itemized statement within two years of the alleged “act, error or omission” unless the claimant can establish that the “act, error or omission” was “not reasonably discoverable within a two year period,” or “the claimant failed to discover the alleged act, error, or omission within the two year period despite the exercise of due diligence” (Wyo. Stat. § 1-39-113(a)(i)-(ii), 2003). The claiming party must then commence action within one year after presenting the itemized statement to WYDOT, or forever be barred (Wyo. Stat. § 1-39-114, 2003). Exception exists in the case of a minor seven years of age or younger. Here, the claiming party must commence action within two years after presenting the itemized statement to WYDOT, or before the claimants eighth birthday, whichever period is greater (Wyo. Stat. § 1-39-114, 2003).

In response to a claiming party, WYDOT “retains any common law defenses from this or other jurisdictions,” (Wyo. Stat. § 1-39-102(a), 2003), for which the office of the attorney general has the duty to advise and defend (Wyo. Stat. § 24-2-101(e), 2003). Affirmative defenses may include a demonstration that the claimant: 1) assumed the risk; 2) was contributorily negligent; 3) is barred due to a statute of limitation; or 4) is barred due to state immunity under the GCA (W.R.C.P. 8(c), 2003). In addition to arguing an affirmative defense, WYDOT will rebut the elements of a negligence claim. Here, the office of the attorney general would argue that the claiming party failed to prove: 1) the existence of a duty; 2) the breach of an existing duty; or 3) proximate cause for the harm (*Hill v. Park County By and Through Bd. of County Com'rs*, 856 P. 2d 456, 458, Wyo. 1993).

In view of the facts and circumstances, WYDOT may choose to reject the claim, settle out of court, or defend in court against the claiming party. For example, if the office of the attorney general determines that the claimed damages were “caused by such negligence on the part of the state or its public employees as might entitle the claimant to a judgment,” the claim may be settled out of court (Wyo. Stat. § 1-39-115(b), 2003). If the claim is rejected or if the party is unsatisfied with the settlement offer, the claimant may opt to commence an action in the appropriate court (Wyo. Stat. § 1-39-115(b), 2003).

A damages award, whether granted through settlement or judgment, will not exceed “the sum of two-hundred-fifty-thousand dollars (\$250,000.00) to any claimant for any number of claims arising out of a single transaction or occurrence,” or “the sum of five-hundred-thousand dollars (\$500,000.00) for all claims of all claimants arising out of a single transaction or occurrence” (Wyo. Stat. § 1-39-118(a)(i)-(ii), 2003). Exception exists, however, if WYDOT has “liability insurance...covering any acts or risks including all or any portion of the risks provided under this act” (Wyo. Stat. § 1-39-118(b), 2003). If such insurance coverage exceeds the limits of liability in Wyo. Stat. § 1-39-118(a)(i)-(ii) or covers liability not authorized by this act [as defined by Wyo. Stat. § 1-39-103(a)(viii)], then “the governmental entity’s liability is extended to the coverage” (Wyo. Stat. § 1-39-118(b)(i), 2003). Yet an exception within this exception states that if the purpose of the insurance coverage was for WYDOT to protect “itself against potential loss under a federal law” and if such purpose “is stated as a part of or by an amendment to the insurance policy, the increased limits shall be applicable only to claims brought under the federal law” (Wyo. Stat. § 1-39-118(b)(ii), 2003).

### *Summary*

The legislative intent of the GCA was to provide remedy to individuals harmed through the negligent conduct of governmental entities. Under the GCA, WYDOT is a governmental entity and a claiming party may be able to bring suit. Aside from the two noted exceptions addressing the discovery of negligent conduct, a claiming party has two years from the date of the alleged “act, error, or omission” to present WYDOT with a written itemized calculation of damages.

Aside from the noted exception for minors, a claiming party has one year to commence action after presentation of the itemized calculation.

In light of any common law or statutory defenses, WYDOT may elect to reject the claim, settle the claim out of court, or defend in court against the claiming party. If the claim is not rejected and damages are awarded through a settlement or judgment, each award that arises out of a single transaction or occurrence is limited to \$250,000 to any one claimant or \$500,000 to all claimants. Exception exists if WYDOT procures separate liability insurance. Here, the damage award may be increased to the limits of the coverage unless such coverage was explicitly procured to protect against potential loss under federal law.

### **Federal Tort Claims Act (FTCA)**

#### *Purpose and Exceptions*

The overarching purpose of the Federal Tort Claims Act (FTCA) was to limit and condition the federal government's immunity from suit (28 U.S.C. §§ 1346(b), 2680). To achieve the legislative intent of placing private parties on more equal footing with the federal government (*Lozada For and on Behalf of Lozada v. U.S.*, 974 F. 2d 986, 988, C.A. 8 1992), the FTCA established procedural rules for those who allege injury through a negligent or wrongful act or omission of a federal employee acting within the scope of employment (28 U.S.C.A. §§1346(b)(1), 2671 through 2680). Despite its breadth of coverage, the FTCA does not establish substantive tort law for parties to demonstrate; instead, private parties must demonstrate the substantive law of the state where the tortious act or omission occurred (28 U.S.C. § 1346(b)(1); *Ochran v. U.S.*, 273 F. 3d 1315, 1317, 11th Cir. 2001). Accordingly, the FTCA renders the federal government liable in tort in the same manner as a private party in like circumstance, while limiting those actions against the federal government to state tort laws applicable to private parties (28 U.S.C. § 2674; *Federal Exp. Corp. v. U.S. Postal Service*, 151 F. 3d 536, 540, C.A. 6 Tenn.1998).



As a limited waiver to immunity, the FTCA expressly excludes certain listed acts of tortious conduct from being claimed against the federal government. See 28 U.S.C. § 2680(a) through (n). Examples include claims for damages caused by the fiscal operations of the Treasury or by the regulation of the monetary system, claims arising out of the combatant activities of the military, naval forces, or Coast Guard during a time of war, and claims arising in a foreign country (28 U.S.C. § 2680(i), (j), (k), respectively). Of particular relevance to the current analysis is sub-section (a) of 28 U.S.C. § 2680, which excludes liability for tortious acts or omissions arising out of the execution of a statute or regulation, or the exercise of a discretionary function or duty.

In executing a statute or regulation, courts will evaluate whether the statute or regulation prescribed specific conduct for an employee to follow (e.g. a BLM regulation that prescribes when, where, or how to construct or maintain an electric fence). If a statute or regulation does prescribe specific conduct, the exception will apply if the employee exercised due care in following the prescribed course of action (*Crumpton v. Stone*, 59 F. 3d 1400, U.S. APP. D.C. 1995). If the statute or regulation does not prescribe specific conduct, the exception will apply if the employee exercised due care absent a prescribed course of action: *Sumner v. U.S.*, 794 F.Supp. 1358 (M.D. Tenn. 1992), holding that failure of an official to execute a statute or regulation with due care is grounds for liability; and, *Jackson v. U.S.*, 24 F. Supp. 2d 823 (W.D. Tenn. W. Div. 1998), holding that an act or omission in the execution of a statute or regulation must be exercised with due care. A BLM employee may satisfy due care if the act or omission demonstrated some minimal concern for the rights of another (*Hatahley v. United States*, 76 S.Ct. 745, 1956).

In exercising a discretionary function or duty, the agency or employee should exercise due care, yet courts have applied the exception absent due care: *Dalehite v. United States*, 73 S. Ct. 956, 966 (1953), holding that the exception excludes liability whether or not the discretion was abused; *General Public Utilities Corp. v. U.S.*, 551 F. Supp. 521, 524 (D.C. Pa. 1982), holding that the exception applies even where there is an abuse of discretion; and, *Buchanan v. U.S.*, 915 F. 2d 969, 971 (C.A. 5 La.1990), holding that due care is not required to apply the exception. By applying this exception broadly, courts are following the legislative intent of the FTCA to

“prevent judicial ‘second-guessing’ of...administrative decisions grounded in social, economic, and political policy through...actions in tort” (*U.S. v. S.A. Empresa de Viacao Aerea Rio Grandense (Varig Airlines)*, 104 S. Ct. 2755, 2765, 1984). To help analyze this exception, the U.S. Supreme Court has developed a two-prong test. The first prong asks whether the employee had discretion to act; for example, the employee may not have discretion to act if a regulation or statute prescribes some specific, mandatory conduct to follow. Second, if the employee had discretion to act, was the act susceptible of being based in social, economic, or political policy. If both prongs are satisfied, the exception becomes applicable, sovereign immunity has not been waived, and the court is divested of jurisdiction to review the allegations of negligence. See *Laurence v. U.S.*, 851 F. Supp. 1445, 1450 (N.D. Cal. 1994) discussing the Supreme Court’s development of this two-prong test under *Varig Airlines*, 104 S. Ct. 2755 (1984); *Berkovitz by Berkovitz v. United States*, 108 S. Ct. 1954 (1988); and, *U.S. v. Gaubert*, 111 S. Ct. 1267 (1991).

For decisions based upon considerations of social, economic, or political policy, Courts have applied the discretionary function or duty exception to decisions made at the level of planning or operation (*Industria Panificadora, S.A. v. U.S.*, 957 F. 2d 886, 887, D.C. Cir. 1992; *Deel v. U.S. By and Through Dept. of Labor*, 923 F. Supp. 98, 102-103, W.D. Va. 1996; and, *Ochran v. U.S.*, 117 F. 3d 495, 501, 11th Cir. 1997). For example, the exception can apply to decisions made in the broad development of a program or activity; in addition, the exception can apply to decisions made in establishing a plan, specification, or schedule of operation for a program or activity (*Dalehite*, 73 S. Ct. at 968, 1953; *Gaubert*, 111 S. Ct. at 1275, 1991; and, *Laurence*, 851 F.Supp. at 1451, N.D. Cal., 1994). The exception may even apply to an agency or employee decision that concerns the day-to-day operation of a program or activity (*Wilson v. U.S.*, 940 F. Supp. 286, 290, D. Or. 1996; *Gaubert*, 111 S. Ct. at 1275, 1991).

Although courts apply the discretionary function or duty exception more broadly than the statute or regulation exception, numerous courts have denied the federal government’s argument to apply either exception in defense to a claim of injury or death: *Aslakson v. U.S.*, 790 F. 2d 688 (C.A. 8 N.D. 1986), holding the Western Area Power Administration liable for non-compliance with its own safety policy regarding the height of its electric transmission lines; *Greene v. U.S.*, 207 F. Supp. 2d. 1113 (E.D. Cal. 2002), holding that a decision concerning where to place

sculptures in a federal courthouse was not discretionary when in violation of the applicable Model Building Code; and, *Schalliol v. Fare*, 205 F. Supp. 2d. 432 (E.D. Pa. 2002), holding that no rational connection existed between the Federal Aviation Administration publishing an approach chart to an out-of-service runway and policy concerns underlying the discretionary function exception. In fact, the federal government may be held liable for personal injuries arising out of the negligence of a federal agency in carrying out programs to control and preserve wildlife: *Worley v. U.S.*, 119 F. Supp. 719 (D.C. Or. 1952), holding the U.S. Fish & Wildlife Service liable for personal injuries caused by the poison of a ‘coyote control’ device operating illegally under Oregon law and with inadequate signs to warn the public. In contrast, the discretionary function exception has barred an action for property damages arising out of a federal program to control and preserve wildlife: *Sickman v. U.S.*, 184 F. 2d 616 (C.A. 7 1950), holding that in executing the Migratory Bird Treaty Act, federal employees exercised due care and the owner of property may not recover for crop damage from migratory waterfowl.

#### *Liability Proceedings under the FTCA*

The BLM is a “federal agency within the executive department” (28 U.S.C. § 2671). As such, the agency is liable in the same manner and to the same extent as a private individual under like circumstances (28 U.S.C. § 2674). Exposure to liability may occur through personal injuries caused by the negligent or wrongful act or omission of any BLM employee acting within the scope of his or her office or employment (28 U.S.C. § 2675(a)). Yet, prior to filing a suit in tort against the federal government, the FTCA requires that the claimant first proceed administratively through the BLM (28 U.S.C. § 2675(a), 43 C.F.R. § 22.2(b)).

#### *Administrative Tort Claims Requirement*

To proceed administratively against the BLM, a claimant – acting personally or through an authorized agent, legal representative, executor, administrator, or insurer – must execute written notification of the incident detailing damages with monetary certainty (43 C.F.R. § 22.3(a); 28 C.F.R. §§ 14.2(a), 14.3(a) through (d), 14.4 (a) through (c)). The claimant must file notification with the BLM or Department of Interior (DOI) field office whose activities gave rise to the

incident (43 C.F.R. § 22.3(b)). Federal Standard Form 95 is the preferred notification instrument. Notification must be received within two-years of the incident or the claim is barred (43 C.F.R. § 22.2(e); 28 U.S.C. § 2401(b); See *Crawford v. United States*, 796 F. 2d 924 (7th Cir. 1986), and *Thompson v. U.S.*, 642 F. Supp. 762 (N.D. Ill. 1986), for a discussion of tolling and the discovery rule). The BLM measures receipt by the date its field office received notification, not by the date the claimant mailed notification (43 C.F.R. § 22.3(a); 28 U.S.C. § 2401(b); 28 C.F.R. §§ 14.2(a), (b)(1)).

Upon receiving notification, the BLM or DOI field office must record the time and date, and immediately forward the file to an appropriate federal solicitor (43 C.F.R. § 22.3(c)). The agency has six months from the date of notification to issue a final action (43 C.F.R. § 22.2(b); 28 U.S.C. § 2675(a)). During this period, the head of the BLM and a federal solicitor “may consider, ascertain, adjust, determine, compromise, and settle any claim for injury or death caused by the negligent or wrongful act or omission of any employee... while acting within the scope of his office or employment, under circumstances where the [BLM], if a private person, would be liable to the claimant in accordance with the law of the place where the act or omission occurred” (43 C.F.R. § 22.2(a); 28 U.S.C. § 2672). To assist in determining responsibility for either the injury or the damages claimed, the BLM may request supplemental information from the claimant (28 C.F.R. §§ 14.4(a) through (c)). The claimant is provided a similar opportunity to amend the claim at any time prior to the agency taking final action (28 C.F.R. § 14.2(c)). The amendment, like the original claim, must be submitted in writing and signed by the claimant or the claimant's attorney or representative (*Id.*). Once the amendment is properly filed, the BLM has six months to take final action on the claim as amended (*Id.*).

The BLM must notify the claimant, the claimant's attorney, or representative of its final action through certified or registered mail (28 C.F.R. § 14.9(a)). If its final action is to deny the claim, the BLM is not required to state the reasons for denial; yet, the agency is required to inform the claimant of their right to file suit in federal district court within six months of the date BLM mailed notification (28 C.F.R. § 14.9(a)). If the BLM's final action is to issue an award, compromise, or settlement equal to or less than \$2,500, then the agency head or designee shall issue the payment through appropriations made available to that field office. If the BLM's final

action is to issue an award, compromise, or settlement exceeding \$2,500, then the agency head or designee must seek review by a federal solicitor (28 C.F.R. § 14.5; 28 U.S.C. § 2672). If the BLM's final action is to issue an award, compromise, or settlement exceeding \$25,000, then the agency head or designee must obtain the prior written approval of the Attorney General or designee (43 C.F.R. § 22.2(a); 28 U.S.C. § 2672).

Upon accepting any award, compromise, or settlement, the claimant completely releases all claims, arising out of the same subject matter, against the BLM or its employees (43 C.F.R. § 22.2(b); 28 U.S.C. § 2675(a)). A claim is not released, however, if the claimant can demonstrate that the BLM exercised fraud when issuing the award, compromise, or settlement (*Id.*). Finally, the claimant's attorney may not charge, demand, receive, or collect a fee in excess of 20 percent of any award, compromise, or settlement (28 U.S.C. § 2678).

The claimant may conclude his or her claim upon the BLM's denial of the claim or upon an offer of award, compromise, or settlement. If a claimant deems the final action unacceptable, the claimant may execute a written request for reconsideration (28 C.F.R. § 14.9(b)). The BLM must receive such request within six months of the date the agency mailed its final action (*Id.*). Upon proper receipt of a request for reconsideration, the BLM has an additional six months to issue a final action (*Id.*).

If the BLM denies the claim or fails to issue a final action within six months of receiving the claim, any amendment thereto, or a request for reconsideration, the claimant may proceed in federal district court (43 C.F.R. § 22.2(b); 28 U.S.C. § 2675(a)). If the claimant does choose to proceed, he or she may amend the claim prior to filing suit (28 C.F.R. § 14.2(c)).

### *Suits in Federal District Court*

Assuming that the claimant does comply with the requirements of an administrative claim, he or she must file suit within six months of the date the BLM mailed its final action (28 U.S.C. § 2401(b)). For suits against BLM employees arising under the FTCA, the claimant must bring the action in the federal judicial district of the claimant's residence, or the district where the act or

omission occurred (28 U.S.C. § 1346(b)(1)). The claimant must once again demonstrate: 1) that the incident arose out of the conduct of a BLM employee acting within the scope of employment (28 U.S.C. § 2672), 2) that the conduct was a negligent or wrongful act or omission (*Id.*), and, 3) the conduct caused the personal or property damage stated within the claim. (*Id.*). If the Attorney General certifies that the employee acted within the scope of his or her office or employment, the Attorney General will substitute the “United States” as the named defendant (28 U.S.C. § 2679(a), (d)(1)), and will provide for a defense through the Justice Department (28 U.S.C. § 2679(c)).

The United States may assert any defense of judicial or legislative immunity already available to the employee whose act or omission gave rise to the claim, plus any additional defense available to the United States (28 U.S.C. § 2674). For example, the United States may first raise the affirmative defense of immunity under 28 U.S.C. § 2680(a) (i.e. execution of a statute and regulation or the exercise of a discretionary function and duty, discussed *supra*). Here, it is the claimant’s burden to demonstrate that some unequivocal and express waiver to immunity applies (*United States v. King*, 89 S. Ct. 1501, 1502, 1969; *Cole v. United States*, 657 F. 2d 107, 109, 7th Cir. 1981). Immunity serves as a threshold question for suits under the FTCA (*Hughes v. Sullivan*, 514 F. Supp. 667, E.D. Va. 1980), and, if the court, as a matter of law, holds the exception to apply, sovereign immunity has not been waived, and the court lacks jurisdiction to hear the case (*Mundy v. U.S.*, 983 F. 2d 950, 952, C.A. 9 Cal. 1993).

In addition to rebutting the elements of a claim or to arguing an affirmative defense, the Attorney General or designee may arbitrate, compromise, or settle the suit at any time (28 U.S.C. § 2677). In fact, once suit is filed, the BLM has no authority to compromise or settle the claim, and if the claimant or government should want to settle, the Justice Department will handle the settlement (28 U.S.C. § 2677). In the event of settlement, the BLM’s final action will not serve as competent evidence of either the government’s liability or the amount claimed (28 U.S.C. § 2675(c)). If, however, the suit does proceed through to judgment, the court will render a ruling absent a jury (28 U.S.C. § 2402).

If the judgment is to award the claimant, such award cannot exceed the amount requested in the administrative claim (28 U.S.C. § 2675(b)). Exception does exist if the claimant can demonstrate newly discovered evidence not reasonably known at the time or some other intervening fact relating to the amount of the claim (*Id.*). Even with exception, the United States will not be ordered to pay any interest accrued prior to judgment or punitive damages (28 U.S.C. § 2674). The FTCA additionally limits recovery by the claimant's attorney to the equal or lesser of 25-percent of any award by judgment, arbitration, compromise, or settlement (28 U.S.C. § 2678). Short of an appeal, a judgment will serve as a complete bar to any action by the claimant, arising from the same subject matter, against the United States or the BLM employee whose act or omission gave rise to the claim (28 U.S.C. § 2676).

#### *Indemnification of BLM and DOI Employees*

The Department of Interior (DOI) may indemnify a BLM employee personally named as a defendant in a proceeding of arbitration, state court, federal court, or other civil matter that seeks to recover monetary damages against the employee (43 C.F.R. § 22.6(a)). The conduct-giving rise to the claim must occur within the scope of employment and indemnification must serve the DOI's interest as determined by the Secretary or designee (*Id.*). Payment to the claimant is contingent upon the availability of DOI appropriated funds, and payments may be distributed only after the entry of an adverse verdict, judgment, or award for personal damages (43 C.F.R. § 22.6(b), (c), (e)).

A BLM employee may also request indemnification to satisfy an adverse entry (43 C.F.R. § 22.6(d)). To receive indemnity, the employee must submit a timely, written request to the Solicitor (*Id.*). The request must contain all appropriate documentation, including a copy of the verdict, judgment, award, or settlement (*Id.*). The Solicitor will then provide an opinion and forward all the materials to the Secretary or a designee for final action; the DOI may be required to seek review by the Justice Department (*Id.*).

## *Summary*

The Federal Tort Claims Act (FTCA) serves to limit and condition federal government immunity by establishing procedural rules for persons who allege injury through a negligent or wrongful act or omission of a federal employee acting within the scope of employment. Accordingly, the FTCA renders the federal government liable in tort in the same manner as a private party in like circumstances under the law of the state where the tortious incident occurred.

Prior to filing suit against the United States in federal district court, the claimant must proceed administratively against the BLM. Upon notifying the agency of the elements of the claim and the damages sought, the BLM may deny the claim, or issue an award, compromise, or settlement. The claimant may accept the final agency decision or execute a request for reconsideration. If the claimant accepts, his or her action constitutes a release of all subsequent claims arising out of the same subject matter; if the claimant requests reconsideration, the BLM has a limited period to reconsider its former action.

If the claimant exhausts the administrative process and does not accept the agency's final disposition, he or she may file suit in federal district court. The elements of the suit will mirror those within the administrative tort claim. If the court holds an express waiver of immunity to apply, and the case is heard to judgment absent arbitration, compromise, or settlement, any award is limited to the sum requested in the administrative claim. A judgment will bar all further action against the United States and BLM employee whose actions gave rise to the incident.

## **Wyoming Negligence and Comparative Fault**

The following provides an outline of Wyoming's 1) common law on the tort of negligence, 2) relevant statutory law on the tort of negligence, and 3) statutory law on the doctrine of comparative fault. Given that an action brought under the FTCA will follow the substantive law of the state where the act or omission occurred (28 U.S.C. § 1346(b)(1)), discussion of Wyoming's common and statutory law on negligence and comparative will apply to both a GCA and FTCA proceeding; when appropriate, we cite federal caselaw where the court did apply the state substantive law at issue.



For any action in negligence, the claimant will have the initial burden of demonstrating the Prima Facie Case (PFC). Here, the claimant must demonstrate, by a preponderance of the evidence, the elements of each tort claimed. In Wyoming, the elements of negligence are: 1) a duty owed; 2) breach of that duty; 3) proximate cause; and, 4) injury to the claimant (*Hill*, 856 P. 2d at 458, Wyo. 1993).

The burden then shifts to WYDOT or the BLM to discredit the elements presented by the claimant and to present affirmative defenses. At the conclusion of party arguments, a trier of fact will determine the total sum of damages to the claimant and apportion fault among all parties. The court will enter judgment against WYDOT or the BLM only to the extent of that party's percentage of the total fault.

#### *Liability Proceedings for Common law and Statutory Negligence*

The claimant must first establish that WYDOT or the BLM owed the specific duty stated in the complaint. Whether the duty exists is a question of law for the court. In Wyoming, a duty can arise by statute or common law (*Dellapenta v. Dellapenta*, 838 P. 2d 1153, 1160, Wyo. 1992). For example, Wyo. Stat. § 24-1-112(a) (2003) prescribes upon WYDOT the specific duty to repair and reconstruct right-of-way fencing so as to meet legal fence requirements under § 11-28-102(b) (2003); Wyo. Stat. § 11-24-108(g) (2003) prescribes upon WYDOT the specific duty to dispose of carcasses from state highways; and Wyoming common law prescribes upon every person the general duty to exercise the degree of care required of a reasonable person in light of all the circumstances (*McClellan*, 666 P. 2d at 411, Wyo. 1983). Under a GCA proceeding, the court may solely apply the common law duty upon WYDOT. If a statutory duty is found to exist, then the court may apply the common law duty in conjunction with the statutory duty to better determine whether WYDOT breached the duty owed to the claimant. Here, the court would permit the trier of fact (i.e. a jury in a GCA proceeding) to ask whether WYDOT acted with the degree of care required under the circumstances to fulfill the statutory duty. Under an FTCA proceeding, the court - acting as the trier of fact - would also likely ask whether the BLM acted with the degree of care required under the circumstances to fulfill the statutory duty; yet, as previously discussed, critical evaluation will turn on whether a statute or regulation prescribed

some specific, mandatory conduct to be followed. If yes, the BLM must exercise due care in following the prescribed course of action (*Crumpton*, 59 F. 3d at 1415, C.A.D.C., 1995; *Sumner*, 794 F. Supp. at 1364, M.D. Tenn., 1992; and, *Jackson*, 24 F. Supp. 2d at 830, W.D. Tenn. W.Div. 1998). If no, the BLM must exercise due care through acts or omissions that demonstrate some minimal concern for the rights of another (*Hatahley*, 76 S. Ct. at 752, 1956); yet, state law will likely serve as the definitive determination for the extent of due care required of the BLM (*Hines v. U.S.*, 60 F. 3d 1442, 9th Cir. 1995). Regardless of whether the action is brought under the GCA or FTCA, if the claimant cannot establish the specific duty stated in the complaint, the claimant cannot sustain an action in negligence (*Thomas by Thomas v. South Cheyenne Water and Sewer District*, 702 P. 2d 1303, 1307, Wyo. 1985; *Dorking Genetics v. U.S.*, 76 F. 3d 1261, 2d Cir. 1996).

The second element of the PFC is to establish that WYDOT or the BLM breached its duty to the claimant. Whether a duty was breached is a question of fact answered by a trier of fact. The claimant could establish a breach of duty through 1) statute, 2) risk-utility analysis, or 3) industry-wide custom and practice. If the claimant contends a breach of duty through statute, the breach will demonstrate evidence of negligence rather than per se negligence: *Nylen v. Dayton*, 770 P. 2d 1112, 1117 (Wyo. 1989), holding that the mere presence of a horse on the highway, absent some showing of negligent conduct on the part of the livestock owner, failed to establish a per se violation of Wyo. Stat. § 11-24-108(a) by the livestock owner; and, *Cecile Industries, Inc. v. U.S.*, 793 F. 2d 97 (3d. Cir. 1986), suggesting that a federal district court is likely to follow a state court in determining that a violation of a federal statute does not constitute negligence per se. If the claimant performs a risk-utility analysis, the claimant would analyze 1) the frequency and severity of harm resulting from HTEF use, 2) the social utility of HTEF use or of the agency's conduct; and 3) the alternatives to HTEF use and the agency's conduct. If the claimant scrutinizes custom and practice, the claimant would compare the conduct similar agency custom and practice in regards to HTEF use or non-use.

The third element of the PFC is to establish causation. Whether causation exists is a question of fact. To establish causation, the claimant must demonstrate proximate cause (*Hill*, 856 P. 2d at 458, Wyo. 1993). The claimant will contend that the acts, errors, or omissions of WYDOT or

the BLM were a substantial factor in causing the harm; but for the acts, errors, or omissions of the respective agency or its employee, the claimant would not have received the electric-related injury, collided with the livestock, or received property damage from breaching livestock.

The final element is injury. Whether the claimant suffered injury is a question of fact. The claimant may demonstrate this final element through injury to person or property (28 U.S.C. § 1346(b)(1)).

WYDOT or the BLM would answer the complaint by discrediting the elements of the PFC. The agency could: refute the existence of the specific duty complained of; contend that its acts, errors, or omissions did not breach any duty established by the claimant; contend that its acts, errors, or omissions were not the proximate cause of the claimant's injury; or discredit the injury itself. Either agency would also present affirmative defenses. Likely affirmative defenses include governmental immunity, an expired statute of limitation, a claimant's assumption of risk, or a claimant's contributory negligence (W.R.C.P Rule 8(c), 2003; *Curry v. U.S.*, 129, F. Supp. 38, W.D. S.C. 1958; and, *Jones v. U.S.*, 241 F. 2d 26, 4th Cir. 1957). A successful demonstration of governmental immunity, expired statute of limitation, or assumption of risk will serve as a complete defense and the agency will be absolved of liability. A successful demonstration of contributory negligence will serve as an incomplete defense and the agency would be held liable, unless, as discussed next, the claimant is apportioned greater than 50-percent of the total fault of all actors.

### *Comparative Fault*

Subsequent to either agency answering the claimant's PFC and presenting affirmative defenses, a trier of fact will apportion fault among all actors in the suit (Wyo. Stat. § 1-1-109(c)(i)(A), 2003; *Murff v. U.S.*, 785 F. 3d 552, 5th Cir. 1986). In essence, the trier of fact will assign percentages of responsibility to each actor. Negligent actors may include the claimant(s), the respective agency, or a third party.

Under Wyo. Stat. § 1-1-109(b) (2003), a claimant can recover only “if the contributory fault of the claimant is not more than fifty-percent (50%) of the total fault of all actors.” If the claimant does recover damages, the recovery shall be diminished in proportion to the percentage of fault attributed to the claimant. Therefore, a trier of fact will determine the total amount of damages sustained by the claimant, and the court will reduce the claimant’s recovery of damages in proportion to the percentage of fault attributed to the claimant (Wyo. Stat. § 1-1-109 (c)(i)(A), (d), 2003). Finally, the court will enter judgment against WYDOT or the BLM only to the extent of the respective agency’s percentage of the total fault (Wyo. Stat. § 1-1-109(e), 2003).

### *Summary*

The claimant will prevail if, as a question of law, the court affirms the existence of a duty originating from statute or common law, and a trier of fact affirms that the breach of duty, proximate cause, and harm were established by a preponderance of the evidence. WYDOT or the BLM will likely prevail if they successfully attack the elements of the PFC or establish an affirmative defense. Concerning a claimant’s compensation for injury, a trier of fact will apportion percentages of fault to all parties in the suit; and, the claimant will recover only if the claimant’s fault amounts to less than fifty-percent of the total fault of all actors from which the claimant seeks recovery.

### **Federal Administrative Proceedings on Electric Fence Use**

The following provides a review of five administrative law proceedings where electric fence use was at issue. Four of the proceedings involve the DOI, and the BLM in particular: in two proceedings, the BLM used, or permitted an allottee to use, electric fencing to achieve riparian management objectives; in a third proceeding, the BLM recommended a mining claimant use electric fencing to control predators; and in the fourth proceeding, the BLM repossessed a horse from a permittee who impermissibly contained the horse within electric fencing. The fifth proceeding involves the Department of Agriculture’s Animal Plant and Health Inspection Service (APHIS); here, the agency brought an unsuccessful challenge to a permittee’s use of electric fencing for primary animal containment and enclosure. These administrative law

proceedings represent every document containing the term “electric fence” within the U.S. Department of Interior or Agriculture databases.

### *Department of Interior*

#### *Idaho*

In *Idaho Watersheds Project*, the Court upheld the decision of the Idaho State Office of the BLM to construct a temporary 3-Wire electric fence within a Wilderness Study Area (WSA) (*Idaho Watersheds Project*, 147 IBLA 186, 1999). Appellants, Idaho Watersheds Project (IWP), alleged the agency violated the non-impairment mandate of section 603(c) of the Federal Land Policy and Management Act of 1976, 43 U.S.C. § 1782(c), 1994 (*Id.*, at 186). In particular, IWP argued that the fence would adversely impact the naturalness of the WSA (*Id.*, at 194).

The BLM countered by stating that the protective listing of Snake River Chinook salmon (*Oncorhynchus tshawytscha*) and the pending listing of bull trout (*Salvelinus confluentus*) under the Endangered Species Act required the use of 3-Wire electric fencing to protect riparian vegetation within the critical habitat area, thereby reducing sediment inputs from livestock grazing impacts along riparian habitat (*Id.*, at 187). In upholding the agency’s decision, the Court reasoned that the IWP failed to demonstrate, by a preponderance of the evidence, that the BLM erred in finding that the fence would protect and enhance wilderness values (*Id.*, at 194). IWP also failed to demonstrate that the fence would be substantially noticeable within the WSA as a whole or any significant portion thereof (*Id.*).

In fact, the Court held sufficient record existed to demonstrate that the BLM properly determined the fencing would protect and enhance wilderness values within the WSA (*Id.*, at 192).

#### *Nevada*

In *John. L. Falen*, Falen appealed an Order for willful trespass by the Nevada State Office of the BLM (*Falen*, 143 IBLA 1, 1998). The Order provided for payment of \$349 total damages for two days willful trespass within a non-permitted area (*Id.*, at 2).

Preceding the Order, Falen had agreed to complete a permanent fence around particular riparian habitat within a noted pasture (*Id.*). Falen was to complete before the onset of the 1991 summer grazing season (*Id.*). In the event the deadline was not met, the BLM had permitted Falen to erect a temporary electric fence to restrict livestock access to a majority of the noted stream and pasture (*Id.*, at 5). The record is absent specifications for construction of the temporary fence. The BLM also conditioned Falen's rights to graze in the noted pasture upon completion of either fence (*Id.*). Falen failed to complete the condition prior to grazing, and the Court upheld the BLM's Order for willful trespass (*Id.*, at 6).

### *Alaska*

In *Dan Solecki, MaryLou Teel, and Alfred Cook*, the Northern Field Office of the BLM issued an 'Occupancy Non-Concurrence and Cessation Order' to respondents, collectively Gold Rim Associates (GRA) (*Solecki, Teel, and Cook*, 162 IBLA 178, 2004). The Order informed GRA that they were in violation of regulations governing the use and occupancy of mining claims (*Id.*, at 179). In particular, the BLM ordered GRA to provide a schedule for the removal of two portable ATCO trailers and other personal property that violated the presently accepted occupancy standard for casual use, exploration, and testing programs (*Id.*, at 185).

Focusing on the material relevant to the present analysis, GRA asserted that the trailers served as shelter to protect from bears, and as such were necessary protection absent emergency air transportation (*Id.*, at 184). The BLM countered that GRA could effectively deter bears through "proper food storage techniques and solar panel powered electric fences" used in concurrence with "tent structures, 'Weatherport' structures, and tarp-type lean-tos" (*Id.*, at 185).

Considering these arguments, the Court set aside BLM's Cessation Order to the extent it proposed a remedy, and remanded the matter to the BLM for further consideration and explanation consistent with 43 C.F.R. Subpart 3715 (*Id.*, at 197). The Court noted the inconsistency in BLM's suggestion that "solar panel powered electric fences...[were]...effective bear deterrents" when such fences constituted occupancies under 43 C.F.R. § 3715.0-5 (*Id.*, at footnote 3). Thus, the BLM prematurely concluded that an electric fence would be deemed a

temporary-structure, like a tent, and not a permanent structure in violation of presently accepted occupancy standards for casual use (*Id.*).

### *California*

In *Stefanie Lee*, the Bakersfield District Office of the BLM repossessed a horse and canceled a Private Maintenance and Care Agreement (PMACA) when Lee failed to comply with the terms and conditions of the PMACA (*Lee*, 151 IBLA 1, 2000). In issuing its decision, the BLM alleged unauthorized transfer and enclosure violations (*Id.*, at 2).

The agency had discovered the horse at a facility not owned by Lee. Lee had transferred the horse to a “separate location and care of another for greater than thirty days without the prior approval of an authorized officer.” In addition, the horse was enclosed by an electric fence. Although the record states that the fence was “an improper electrified fence enclosure,” it fails to provide further description. The Court held Lee in violation of the PMACA, and rendered the agreement subject to cancellation and the animal subject to repossession by the BLM.

### *Department of Agriculture*

#### *Missouri*

In *re Marilyn Shepherd*, Shepherd was convicted of willful violation of several regulations and standards of the Animal Welfare Act (AWA) (*Shepherd*, 57 Agric. Dec. 242, 1998 WL 385884 U.S.D.A.). In particular, the court held Shepherd, a dog breeder, to be in reckless disregard of AWA procedures for marking animals and AWA regulations and standards relating to animal care and housing (*Id.*, at 2).

Concerning animal care and housing, Shepherd used a two-wire electric fence as the primary enclosure for her kennels. The bottom and top wires were six (6) and forty-eight (48) inches off the ground, respectively (*Id.*, at 10). Yet, the Department of Agriculture’s Animal and Plant Health Inspection Service (APHIS) cited Shepherd for not meeting the requirements of a primary enclosure fence; APHIS did not believe the fence would keep “large dogs in and predators out”

(*Id.*, at 13). Upon the advice of an APHIS officer, Shepherd requested a variance (i.e. permission to retain the fence despite the violation). APHIS denied the request.

In denying the request, APHIS stated that electric fencing does not meet AWA standards for primary enclosures; furthermore, APHIS alleged animal escape and electrocution from facilities utilizing electric fencing as their primary enclosure (*Id.*). The agency did state, however, that electric fencing might be permitted as a secondary fence if used in concurrence with a proper primary enclosure (e.g. such as at the top or bottom of an independent chain-wire fence) (*Id.*).

In her defense, Shepherd challenged APHIS' determination with a letter from the fence manufacturer, which stated that millions of its UL approved energizers and fences had been sold for 50 years “without [a] single instance of injury to anyone” (*Id.*, at 14). The letter also stated that the manufacturer’s fences had been used “worldwide for every conceivable application, from controlling livestock on farms, [to] controlling wild animals in city zoos, and protecting gardens and flower beds from small animals such as dogs, rabbits, and raccoons” (*Id.*). Finally, Shepherd provided an expert witness who testified that electric fences, similar to the one at issue, have protected sheep from coyotes; indicating that “if [a fence] keeps predators out, it’ll keep dogs in.” The expert also testified that UL certified fences do not harm animals and that the U.S. Dept. of Agriculture’s Extension Service recommends electric fencing for the protection of animals against predators (*Id.*).

Despite the fact that Shepherd was held in violation of several AWA provisions, the court did not view the electric fence to violate AWA standards at 9 C.F.R. § 3.6(a)(1) (*Id.*, at 19). The court stated that section 3.6(a)(1) merely provides for the structural soundness and good repair of primary enclosures. Here, APHIS had failed to prove, by a preponderance of the evidence, that Shepherd’s electric fence was structurally unsound or in poor repair (*Id.*).

### *Summary*

Of the preceding administrative law holdings, *Shepherd* best reiterates the nearly ubiquitous notion that electric fence energizers should be UL certified, with the fence structurally sound for



the intended purpose and maintained in good repair. *IWP* and *Falen* demonstrate the BLM's willingness to use HTEF to achieve habitat management objectives. *Solecki, Teel, and Cook* indicates the BLM's reliance on electric fencing to ease safety concerns over predators. And, *Lee* demonstrates that particular BLM permits and situations may prohibit the use of electric fencing altogether. Viewed collectively, the paucity of electric fence proceedings within the Department of Interior and Agriculture databases suggests that proper HTEF use poses minimal risk of liability.

### **Caselaw on Electric Fence Injury**

The following provides a review of three state court holdings and one journal article where electric fence use was at issue. The *Ponder* Court addressed whether an electric fence served as the proximate cause for fatal injuries received by a young child; the *Akers* Court addressed whether an injured employee was properly denied temporary total workers compensation; and, the *Jones* Court addressed whether a jury was entitled to award punitive damages when a farm laborer sustained injury from electric fence contact. The journal article addressed an investigation of a young boy's death from electrocution by an electric fence.

Despite extensive research into all state and federal caselaw, these cases represent the only relevant, discovered holdings addressing injury from electric fence contact. In particular, we found no caselaw where a governmental entity was named as a party, or where right-of-way or boundary allotment electric fencing was at issue.

#### *Missouri*

In *State v. Ponder*, Ponder was convicted of involuntary manslaughter for fatal injuries he caused to a two-and-one-half-year-old victim (Shelton) (*Ponder*, 950 S.W. 2d 900, Mo. App. S.D. 1997). Ponder testified that Shelton became entangled within an "electrified cattle-containment fence and had to be knocked off" (*Id.* at 903). Evidence indicated that Shelton's death did not result from entanglement with the electric fence, but rather from violent shaking and head trauma (*Id.* at 904).

Focusing on the relevant material in *Ponder*, the fence consisted of a single electrified wire connected to insulated posts. The wire was electrified by a "fencer" energizer plugged into 110-volt outlet (*Id.* at 903). The current pulsed at intervals averaging one and one-third seconds; the current remained off for a longer period than it remained on (*Id.*).

The cattle-owner who installed and maintained the fence testified that he never suffered injury or muscular tetanus (i.e. involuntary and sustained muscular contraction) from repeated accidental contact with the charged wire (*Id.*). Shelton's grandfather testified that he did receive a "tingle" from intentional contact (i.e. grasping) with the charged wire, yet there was no difficulty releasing his grasp from the pulsating current (*Id.*). Lastly, the treating physicians found no indication of electric shock or burn when examining fifty-eight pound Shelton (*Id.* at 906).

From this testimony and other evidence, the Missouri court of appeals affirmed the holding of the lower court. The Court held that sufficient evidence supported a finding, beyond a reasonable doubt, that the fatal injuries were inflicted by Ponder, through acts of intention not accident, during his attempt to extricate Shelton from the electric fence (*Id.*). The electric fence was not the cause of Shelton's injuries or death.

### *Oklahoma*

In *Akers v. Seaboard Farms*, Akers brought suit against his employer (Seaboard Farms) for injuries sustained during the course of his employment (*Akers*, 972 P. 2d 885, Okla.Civ.App. Div. 3 1998). Akers alleged he sustained an electric shock when he fell onto an electric fence at his employer's farm (*Id.* at 885). He testified that the electric current entered his shoulder and exited his right ankle (*Id.*). Upon immediate medical examination, physicians treated the ankle with ice and crutches (*Id.*). The subsequent morning, Akers' toes were swollen together (*Id.*, at 886). Upon a second medical examination, physicians treated the ankle with a walking cast and released Akers to light work with no allowance for prolonged walking or standing (i.e. Akers should sit 100% of the work period) (*Id.*). The court record is absent any detail regarding the construction of the electric fence or the energizer.

The trial court and the Workers Compensation Court denied Akers' request for temporary total disability compensation (*Id.* at 885). The court of appeals affirmed. In affirming the lower court holdings, the Court concluded that Akers' loss of earning power did not result from his temporary impairment, which would qualify him for worker's compensation, but rather from his refusal to continue accepting the light duty work provided by his employer (*Id.* at 888).

### *Indiana*

In *Jones v. Hernandez*, a migrant farm worker (Hernandez) brought suit against the owners of an electric fence (Jones) for injuries resulting from accidental and direct contact with the fence (*Jones*, 263 N.E. 2d 759, Ind. App. 1970). Immediately preceding the injury, Hernandez was loading tomatoes onto a truck in a field adjacent to the Jones' property when the truck floundered in soft dirt and spilled half the load (*Id.* at 761). Some of the spilled tomatoes fell in the vicinity of the Jones' electric fence. The fence actually comprised two or three older fences woven together and intermingled among the dirt, weeds, grass and trees (*Id.*). While retrieving the tomatoes, Hernandez contacted the fence. The ground was humid and moist. Hernandez's hands involuntarily clasped the charged wire and he could not release (*Id.*). In an attempt to remove Hernandez, a co-worker subsequently suffered muscular tetanus when contacting the charged wire (*Id.*). After a few minutes, a third co-worker handed a box to the electrified men and within ten minutes they detached themselves from the fence. Hernandez's hands were cut and bleeding and he was screaming, "Oh, my God, my God I'm dying" and "Oh, My God, my God I'm dead" (*Id.*). Hernandez was immediately taken to a physician who treated the extensive burns and cuts and restricted Hernandez from work for 40–60 days (*Id.*).

The wire in question was connected directly to a 110-volt outlet (*Id.* at 762). The wire exited a shed on the Jones' land to connect with the Jones' conglomerate fence-line. On route from the shed to the fence, the wire passed through the housing of a 15-watt light bulb (*Id.*). Expert testimony stated that sending the current through 15-watt housing would not reduce the dangerous propensity of 110-volts. Expert testimony also stated that under particular conditions creating a solid ground connection, 110-volts could extensively or fatally injure a person (*Id.*).

Hernandez alleged the following points of negligence against Jones: 1) failure to follow prescribed standards of use for an electric fence wire on farm land (i.e. the Jones improperly installed a fence wire by designing the wire to carry a non-pulsating current from a 110-volt outlet); 2) failure to warn all persons in the area of the highly dangerous condition; 3) failure to inspect and repair the fence line; 4) permitting a continued state of “disrepair” such that safe use of the fence would be impossible; and 5) willful and wanton conduct because the Jones knew that 110 volts of electricity would cause personal injury or death (*Id.*, at 760-761).

Hernandez prevailed at the trial court level. The jury awarded \$7,500 compensatory damages and \$500 punitive damages [in 1969] (*Id.*, at 761). Jones’ motion for a new trial was overruled, and the party took appeal. The scope of discussion in this appeal did not address all of the above allegations, but the Court did find punitive damages appropriate. Substantial evidence demonstrated the existence of considerable animosity between the Jones and the migrant laborers, and thus the jury was entitled to answer the issue of punitive damages (*Id.*, at 763). The Court concluded that the Jones knew that Hernandez and other laborers were working in close proximity to the fence, and that Jones’ act of connecting the fence to a 110-volt outlet manifested a heedless disregard for the probable consequences to persons contacting the fence (*Id.*, at 764).

### *California*

An article in *Agricultural Engineering* discusses the electrocution of a seven-year-old boy, George Boles (Boles) (Dalziel 1944). Immediately preceding the electrocution, Boles and friends entered a neighbor’s ranch to swim in a newly filled irrigation reservoir. While wet, and apparently to re-enter the reservoir by jumping, Boles stood on an eight (8) inch steel discharge pipe and grasped a barbed electric wire for balance. Upon grasping the wire, Boles received an electric shock. The shock caused him to slip off the pipe and into the reservoir. The wire, however, lodged between his left arm and chest, leaving his feet submerged in water. The fence wire continued to pulse with current, and Boles suffered muscular tetanus causing his left arm to clamp against his torso. He could not release and remained suspended for a matter of minutes. Upon notification, the ranch owner immediately removed Boles from the fence and water, drove

him one-half mile, and called for the aid of physicians. Although the boy was gasping during the drive, he was pronounced dead upon the arrival of physicians.

In investigating the scene, the pipe and fence formed a 90° angle; the pipe emerged from the earthen bank of the reservoir, a few inches above water line, and the electric fence ran along the earthen bank about 12” away from water line. Officials from the electric utility conducted extensive tests of the fence and energizer, yet found no reason to question the installation with regard to defective wiring or equipment. The energizer was UL approved and sealed, of the alternating current intermittent type, had an electric current limited to 25-rms milliamperes, an ‘on-period’ of less than one-half second (i.e. 0.065-seconds), and an ‘off period’ greater than one second (i.e. 1.20-seconds). The energizer showed no evidence of moisture, repairs, or tampering.

The investigators concluded that although the milliamperes were well below the value believed to be dangerous, Boles’ electrocution resulted from muscular tetanus and repeated shock over the course of several minutes. The investigators note that all other fatalities attributed to electric fence contact have arisen out of wires charged without the use of an energizer or through the use of a non-approved (e.g. non-UL) energizer; for example, wires energized directly from 110-volt lighting circuits or homemade devices. Because the milliamperes were low and presumably safe, the author suggests special significance may lie in the fact that the energizer was of the a-c intermittent type.

### *Summary*

*Ponder* and the Boles’ article represent uses of an electric fence most analogous to that proposed by WYDOT and the BLM. The electric fence at issue in *Ponder* and Boles had an energizer that regulated a current by pulsation. The evidence presented in *Ponder* suggests that if either agency were to use a similar fence design, each agency could virtually eliminate the possibility of electric shock, muscular tetanus, burn, or other associated injury from accidental or intentional contact with the charged wire. Likewise, presuming the fence in *Akers* was energizer regulated, the injury sustained therein did not cause a burn and was treatable with ice, crutches, and a cast;

indicating that the injury may have not resulted from the electric current per se, but rather from an incorrect fall onto one's ankle.

In contrast, the Boles' article does indicate that a UL certified energizer, of low milliamperes, might nevertheless cause electrocution where the energizer is of the a-c intermittent type and situated near a water source that allows concurrent contact with the fence and partial submersion in water. Similarly, *Jones* represents a form of injury that results from direct contact with a non-regulated charged wire. Although the electric current in *Jones* was 110-volts of non-pulsating and ineffectively diminished flow (i.e. 15-watt housing), the range of injury evidenced (i.e. muscular tetanus and burns) likely represents the danger of having an improperly functioning energizer on an agency operated HTEF. Thus, to virtually eliminate liability resulting from electric-related injury, both agencies should 1) exercise care in selecting a reliable, UL certified energizer model of the non a-c intermittent type, 2) exercise due diligence in their monitoring to ensure that all energizers function properly, and 3) construct all sections of HTEF at a distance that will not permit individuals to simultaneously contact the fence and a substantial body of standing water.

### **Caselaw on Vehicle-Livestock Collisions**

The following provides a review of five state court holdings that address litigation brought against the respective State and its Sheriff or Highway Department. In each case, litigation arose from personal injuries sustained through allegations of 1) negligent conduct of a state employee upon the observance of livestock on a roadway or 2) negligent upkeep of state maintained right-of-way fencing. Of the following caselaw, Kansas was held negligent in its conduct, Wyoming and Montana were held non-negligent in their conduct, and Colorado and New Mexico were held potentially negligent in their conduct, with those hearings remanded to the lower court for further proceedings consistent with the opinion of the reviewing court.

Wyo. Stat. § 1-39-117(a) (2003) prescribes that "original and exclusive jurisdiction for any claim under the GCA shall be in the district courts of Wyoming." A claim against the state of Wyoming must be brought in a state district court; consequently, federal district courts lack jurisdiction to hear claims against the State of Wyoming. Despite this fact, we have broadened

the scope of the following material to include all relevant state and federal holdings within the Tenth Circuit Court of Appeals, which includes Wyoming. We have done this because the Tenth Federal Circuit would be the next logical expansion for binding, or at the least, persuasive, authority. Wyoming, Utah, Colorado, New Mexico, Kansas, and Oklahoma comprise the Tenth Federal Circuit. Caselaw for Utah and Oklahoma is absent because there were no relevant proceedings with those states named as a defendant. We have incorporated Montana, although it is within the Ninth Federal Circuit, because Wyoming's *Hill* opinion cites Montana's *Whitfield* opinion.

### *Wyoming*

In *Hill v. Park County By and Through Bd. of County Com'rs.*, Carol Hill (Hill) brought suit against the Park County Sheriff's office and the Board of County Commissioners of Park County for injuries resulting from a collision with a horse on Southfork Road south of Cody, Wyoming (*Hill*, 856 P. 2d 456, Wyo. 1993). Shortly preceding the collision, an off-duty deputy sheriff (Thompson) observed the horse grazing in the right-of-way of Southfork Road. Thompson radioed the Sheriff's dispatcher to report the horse and the location. He remained at the scene until receiving information that the horse's owner had been located and was in route to retrieve the horse. Upon receiving this information, Thompson continued home. The collision occurred shortly after Thompson's departure. Hill and her passenger received injuries that required both emergency and extended medical treatment (*Id.*, at 457).

In her claim, Hill alleged that Thompson was negligent in failing to either corral the horse or warn oncoming motorists of the stray animal and that his negligence was the proximate cause of the injuries (*Id.*). The Wyoming Supreme Court held that: 1) Thompson, acting as an off-duty peace officer, had neither a statutory nor common law duty to corral the stray horse or to warn oncoming motorists of its presence; and 2) that Thompson's actions upon observing the horse were reasonable (*Id.*, at 459).

In issuing summary judgment for Park County, the Court reasoned that under the GCA, a governmental entity is entitled to immunity unless one of the statutory exceptions applies. See

Wyo. Stat. § 1-39-105 through 112 and § 1-39-121 (2003), discussed supra. Here, the exception prescribing that a peace officer act with non-tortuous conduct was inapplicable because Thompson was an off-duty officer not “acting within the scope” of any duty for Park County (*Id.*, at 458, citing Wyo. Stat. § 1-39-112 Rev. 1998). Thus, the portion of Hill’s claim addressing the exception to governmental immunity under the GCA failed because it did not establish a statutory duty (*Id.*, at 458). A duty, however, can arise through statute or common law (*Id.*, at 459, citing *Dellapenta*, 838 P. 2d at 1160). Consequently, the Court proceeded with a discussion of Wyoming’s common law of negligence. Here, however, the court addressed the actions of Thompson as separate from that of his employment with Park County.

In Wyoming, the common law of negligence creates a general duty "to exercise the degree of care required of a reasonable person in light of all the circumstances" (*Id.*, at 459, citing *McClellan*, 666 P. 2d at 411, Wyo. 1983). Accordingly, Hill’s claim did establish a common law duty, but the Court reasoned that Thompson demonstrated the requisite care when he 1) stopped upon observing the horse, 2) alerted the Sheriff’s department, and 3) verified that the owner was on his way to retrieve the horse prior to leaving the area (*Id.*, at 459). Reasonable care in light of these circumstances did not require Thompson to corral the horse or to warn oncoming traffic of its presence near the highway (*Id.*).

### *Montana*

In *Whitfield v. Therriault Corp.*, the surviving family members of a father-decedent (Whitfield) brought suit against the owners of a horse (Therriault) and the State Highway Department of Montana (State) for fatal injuries resulting from a collision with a horse on U.S. Highway 93 (U.S. 93) south of Eureka, Montana (*Whitfield*, 745 P. 2d 1126, Mont. 1987). Approximately two-hours preceding the collision, a highway department employee observed several horses along U.S. 93 and proceeded to follow them for one-half mile until the horses exited the highway and entered an approach road. The employee did not radio a report of the horses, but noted the observation in his logbook. During the employee’s return travel, approximately an hour and a half later, the horses were not seen along U.S. 93. The collision occurred approximately one-half hour after the employee’s return travel. Whitfield received fatal injuries (*Id.* at 1126).



Although Therriault settled with Whitfield, the State defended in court against the Whitfield allegation that the highway department employee failed to exercise reasonable care after discovering the horses on U.S. 93. Similar to the claim in Hill, Whitfield argued that the employee breached a duty owed by failing to clear the horses from the roadway or to warn oncoming motorists (*Id.* at 1127). The Montana Supreme Court held that: 1) the highway maintenance employee had no duty to remove live animals from the roadway; and 2) the maintenance employee, upon observing the horses exit the roadway, had no duty to ensure that they did not return onto U.S. 93 (*Id.* at 1126).

In affirming summary judgment for the State, the Court reasoned that neither a statutory nor common law duty prescribed that a highway employee shall remove *live* animals from a roadway or ensure *live* animals do not return to a roadway [emphasis added] (*Id.* at 1127). Thus, despite a statutorily prescribed duty for the State to maintain highways in a safe condition, Whitfield failed to prove that the employee owed a duty greater than the employee performed (*Id.* at 1127-28 citing Mont. Stat. § 60-1-101 and –102). The statutory language prescribed a general duty owed, yet the statute failed to prescribe the specific duties complained of; consequently the complaint did not support an action in negligence.

### *Colorado*

In *State v. Moldovan*, an injured motorcyclist (Moldovan) brought suit against the Colorado Highway Department (State) for injuries resulting from a collision with a cow on State Highway 96 (S.H. 96) (*Moldovan*, 842 P. 2d 220. Colo. 1992). The cow had entered S.H. 96 through a state maintained right-of-way fence in disrepair. Moldovan collided with the cow and sustained personal injuries (*Id.*, at 221).

Moldovan alleged that the State had failed to properly maintain the right-of-way fence, that such failure was a violation of Colo. Stat. § 35-46-111 – thereby constituting negligence and negligence per se – and that this negligence was the proximate cause of the cow's presence, the ensuing collision, and Moldovan's injuries (*Id.*, at 222). The State moved for summary judgment on the grounds that Moldovan's complaint was barred by the Colorado Governmental Immunity

Act (CGIA) (Colo. Stat. § 24-10-101 to –120, 1988), and that, even if not barred, Moldovan's complaint failed to state a claim for relief because the State's Fence Law did not create a private cause of action against the State for injuries sustained by a highway user (*Id.*). The district court granted the motion for summary judgment. The district court reasoned that, although the CGIA did not bar Moldovan's claim, and although the condition of the fence could have constituted a dangerous condition for the traveling public, the statute did not create a private action remedy for personal injuries caused to a highway user (*Id.*). The appellate court reversed the judgment of the district court. The Colorado Court of Appeals did agree with the district court that the CGIA did not bar Moldovan's claim, yet the Court reasoned that Colo. Stat. 35-46-111 did create a cognizable private action tort claim against the State (*Id.*). The Supreme Court of Colorado affirmed the ruling of the court of appeals.

In affirming the ruling of the court of appeals, the Supreme Court rejected the State's first argument that the intent of the CGIA is to hold governmental entities responsible only for injuries caused by a failure to maintain safe conditions on a paved highway surface and not for injuries caused by conditions which are not an integral part of the highway itself, such as the failure to maintain right-of-way fencing. The Court reasoned that the legislative intent of the CGIA coupled with prior caselaw precedent did allow private action claims for injuries resulting from dangerous conditions off the paved surface, which physically interfere with motoring traffic on the paved surface (*Id.*, at 225). Here, the Court extended its rationale from *Stephen v. City and County of Denver* to state that the functionally integrated character of a highway system involves not only the road surface, but also other safety devices separated from the road surface (*Id.*, at 223), citing *Stephen*, 659 P. 2d 666 (Colo. 1983) holding that an improperly placed stop sign at the intersection of a city street constituted a dangerous condition on a public street and, thus could serve the basis of a tort claim against a governmental entity responsible for maintaining the device.

In denying the State's claim for immunity, the Court then proceeded to determine if the State was liable by the same method as it would be for a private party. In analyzing the nature and extent of the State's statutory duty under the Fence Law (Colo. Stat. § 35-46-101 to 114, 1984),

the Court reasoned that the State was under a duty to protect the safety of highway users, and thus it could be liable for the negligent care of right-of-way fencing, but that Moldovan was not entitled to a claim of negligence per se, and rather he must demonstrate all the elements of general negligence, including the showing of a breach of a duty owed (*Id.*, at 228). The Court, however, did not proceed to evaluate the elements of Moldovan's claim of negligence. Rather the Court remanded the case to the appellate court with directions to return the case to the district court for further proceedings consistent with these views (*Id.*).

### *Kansas*

In *Reynolds v. Kansas Dept. of Transportation*, the family members of an injured daughter-passenger and the estate of the mother-decedent (Reynolds) brought suit against the owners of a cow (Jones), the owners of a pasture (Van Kirk), and the State Highway Department of Kansas (State) for injuries resulting from a collision with a cow on U.S. Highway 69 (U.S. 69) north of Louisburg, Kansas (*Reynolds*, 43 P. 3d 799, Kan. 2002). The evening of the collision, highway patrol troopers and Miami County sheriff deputies located 10 to 20 cattle in the right-of-way of U.S. 69. In the process of herding the cattle into a temporary and neighboring pasture, one cow left the herd, jumped a guard-rail, cleared a pasture fence, and ran approximately 50 to 100 yards in a southeast direction. The officers, believing the separated cow was safely fenced, continued to herd the remaining cattle into the temporary pasture. Before the officers had returned to their vehicles, the Reynolds' vehicle collided with the cow in a southbound lane of U.S. 69 (*Id.* at 802).

In the vicinity of the collision, a state fence paralleled U.S. 69. The fence was heavy gauge woven wire with 4 to 5 inch openings, metal posts, and a strand of barbed wire along the top. An adjacent pasture and cattle owner (Phillips) described the fence as "cattle type" (*Id.* at 801). Phillips testified that a post of the State fence in the vicinity of the collision had been knocked down completely for at least a year-and-a-half before the evening of the collision. He further testified that he had often witnessed deer pass through the gap in the fence (*Id.*). Phillips did not report the downed post because he had observed state highway department employees mow twice in the year preceding the collision and believed that they themselves would observe the need for repair (*Id.*).

A state highway maintenance supervisor for the Louisburg area testified that, although the fences were inspected weekly from the road, it would be a waste of state resources to physically inspect fences once per year (*Id.*). The supervisor further testified that fence maintenance was very low on the Department's priority list, and that although cattle restraint was not an express purpose of the fence along U.S. 69, he recognized that farmers do not install a second fence to supplement the state fence. In such circumstances, state fence repair became a priority (*Id.*). Finally, the supervisor testified that the particular land from which the separated cow entered and eventually exited did not contain livestock, and, for that reason, repair of the fence was not an immediate priority (*Id.* at 802).

Reynolds alleged that the State was negligent in failing to maintain the fence in sufficient repair to prevent livestock from entering the highway and/or in breach of a duty to maintain the highway in a reasonably safe condition (*Id.*). Despite some factual uncertainty of whether the escaped cow exited the pasture and re-entered the highway through the portion of the state fence in disrepair, a jury verdict and judgment found the State 35% at fault, Jones 45% at fault, and Reynolds 20% at fault. The State appealed the trial court's judgment as well as the trial court's denial of a motion for summary judgment and directed verdict. The appeals court reversed the holding of the trial court by reasoning that, absent clear evidence that the cow re-entered the highway through the portion of State fence in disrepair, the State was not the proximate cause of Reynolds' injury (*Id.* at 803). In granting the Reynolds' petition for review, the Kansas Supreme Court reversed the court of appeals and re-affirmed the holding of the trial court. The Court held that: 1) since the State undertook the job of installing fences along U.S. 69, the State had a duty to promptly repair downed fencing, regardless of whether the adjoining land contained cattle; and 2) in an action of negligence, whether the untimely repair of the fence proximately caused or contributed to the injury was a question for the jury, not the court of appeals (*Id.* at 807).

In finding against the State, the Court cited caselaw precedent evidencing that the State had a non-delegable common law duty to protect the motoring public, (*Id.* at 802, citing *Trout v. Koss Constr. Co.*, 727 P. 2d 450, Kan. 1986), and that, by having undertaken to act so that another may reasonably rely, the State became subject to the duty to perform the undertaking with reasonable care (*Id.* at 803, citing *Circle Land & Cattle Corp. v. Amoco Oil Co.*, 657 P. 2d 532,

Kan. 1983). Furthermore, the Highway Department's maintenance manual commits the Department to immediate repair of state fencing where the disrepair severely reduces its effectiveness in providing safety to the traveling public (*Reynolds*, 43 P.3d at 803). Having determined both the existence and breach of a duty, the Court proceeded to determine whether the State's breach proximately caused the injuries (*Id.*).

The State presented several arguments for why its breach did not proximately cause the injuries. First, the State argued that the initial escape of 10 to 20 cattle was the proximate cause; and, that, within the initial area of escape, the State owed no duty to maintain the fence (*Id.* at 804). Second, the State argued insufficient evidence existed to demonstrate that the separated cow re-entered the U.S. 69 right-of-way through the portion of state fence in disrepair; that it was as probable the separated cow re-entered U.S. 69 by jumping a well-maintained portion of state fence (*Id.* at 806). In response, the Court acknowledged that the State owed no duty in the area of initial escape, but that circumstantial evidence addressing the second argument demonstrated a jury could reasonably infer the separated cow re-entered the U.S. 69 right-of-way through the portion of fence in disrepair (*Id.* at 805).

As in Wyoming, Kansas' adoption of comparative fault allowed the jury to compare the percentages of fault of all alleged wrongdoers. Accordingly, the jury received instruction that "a party is at fault when he or she is negligent and that negligence caused or contributed to the event which brought about the injury or damages for which the claim is made" (*Id.*). The jury must weigh the respective contributions of the parties in determining causation and apportioning a percentage of fault (*Id.* at 804-05). The Court affirmed the trial court's judgment of 35% apportionment of fault to the State by concluding that the jury could have properly found that the State was negligent, and that the negligence contributed to the Reynolds' injuries and damages (*Id.* at 806).

### *New Mexico*

In *Madrid v. New Mexico State Highway Dept.*, the surviving family members of an injured motorcyclist and decedent passenger (Madrid) brought suit against the owners of a cow (Blair)

and the State Highway Department of New Mexico (State) for injuries resulting from a collision on State Highway 90 (S.H. 90) (*Madrid*, 870 P. 2d 133, N.M. 1994). Shortly preceding the collision, a separate motorist had hit and killed the cow (that motorist was named as a defendant but was not party to the current appeal) (*Id.* at 135). In the area of the collision, pastureland bordered roadside businesses and state fencing lined the highway. Also in the area of the collision, a large gap in the state's fence existed. The gap permitted access to businesses. A second fence, erected by Blair, filled the gap left by the state's fence. Sections of both State and Blair fencing were in disrepair (*Id.*).

Madrid alleged negligence as a proximate cause for the cow's presence on the highway. The district court granted summary judgment in favor of both the State and Blair (*Id.*). The district court granted the State summary judgment by reasoning that the failure to completely fence the highway was a matter of design and, consequently, the State was immune from suit under N.M. Stat. § 41-4-11(b)(1) (1989) (*Id.*). The district court granted Blair summary judgment by reasoning that the highway was classified as "unfenced" and thus, as required under N.M. Stat. § 66-7-363 (1987), Madrid could not demonstrate negligence as a proximate cause for the cow's presence on the highway (*Id.*). The Court of Appeals reversed both motions for summary judgment granted by the district court.

In reversing the district court's grant of summary judgment for the State, the Court reasoned that the section of S.H. 90 in question was indeed a "fenced" highway. In re-classifying this portion of S.H. 90 from "unfenced" to "fenced," the Court concluded that N.M. Stat. § 30-8-13 and 14 governed the issue, not § 66-7-363 (1987) (*Id.* at 138). Under N.M. Stat. § 30-8-13 and 14, the State had a duty to either construct fences along all public highways or otherwise afford protection to the traveling public by having: 1) made a factual determination that no livestock could enter the highway through gaps in the fence; 2) placed warning signs on portions left unfenced; or 3) made an agreement with the adjacent owner or lessee to assume complete responsibility for constructing and maintaining fencing that prevents livestock from entering the highway (*Id.* at 136). The record from the lower court failed to show that the State had exercised any of these duties, thus summary judgment was inappropriate because questions of material fact remained.

In reversing the district court's grant of summary judgment for Blair, the court reasoned that the record failed to resolve several issues of fact concerning Blair's liability. Specifically, the record failed to show: 1) whether an agreement existed between Blair and the State, and if an agreement did exist, whether Blair had complied with that agreement; and, 2) whether the cow had entered S.H. 90 through an area of fence maintained by Blair or through an area maintained by the State (*Id.*, at 137). Summary judgment in favor of Blair, therefore, was also inappropriate because questions of material fact remained.

### *Summary*

In *Hill*, the Wyoming Supreme Court stated that under the GCA, a governmental entity is entitled to immunity unless a statutory exception applies (*Hill*, 856 P. 2d at 458). Accordingly, none of the statutory exceptions listed under Wyo. Stat. § 1-39-105 through -112 and § 1-39-121 (2003) appear applicable to the specific legal issue of vehicle-livestock collisions or the broader legal issue of maintaining safe roadways. Thus, WYDOT may be immune to an action in negligence resulting from injuries sustained because right-of-way fencing was in disrepair or because WYDOT negligently reacted to the observance of livestock on a roadway.

Presuming, however, that a Wyoming district court is presented with a fact pattern where they determine WYDOT is not immune from suit under the GCA, the preceding caselaw reveals information that may assist WYDOT in defeating a claim of negligence. First, the claimant must establish the specific duty complained of through statute or common law (i.e. WYDOT is under a statutory duty to repair and reconstruct right-of-way fencing so as to meet legal fence requirements and to dispose of carcasses from state highways; and WYDOT is under the common law duty to exercise a degree of care that is reasonable in light of all the circumstances) (Wyo. Stat. § 24-1-112(a) and § 11-24-108(g), 2003; *McClellan*, 666 P. 2d at 411). Second, if the claimant fails to establish the specific duty complained of, the claimant will not prevail (*Whitfield*, 745 P.2d at 1126). Third, if the claimant fails to demonstrate that WYDOT's actions amounted to less than the prescribed statutory or common-law duty, the claimant will not prevail (*Hill*, at 459). Fourth, if the claimant could establish the duty to maintain "roadways" in a safe condition for the traveling public, this duty will likely extend beyond the road's surface to

involve other devices physically separate from the road's surface, such as right-of-way fencing (*Moldovan*, 842 P. 2d at 225). Fifth, if the claimant could establish that WYDOT undertook the job of installing HTEF, WYDOT is under a continuing duty to perform the task with reasonable care (e.g. to diligently ensure the flow of pulsating current, monitor the occurrence of breaching livestock, and promptly correct any fence portions in "disrepair") (*Reynolds*, 43 P. 3d at 807). Finally, if the claimant could establish that livestock may – or were known to – breach HTEF, WYDOT should assume a duty to post warning signs indicating the presence of livestock on those portions of roadway (*Madrid*, 870 P. 2d at 136).

The preceding caselaw occurring in states other than Wyoming is not binding authority on the district courts of Wyoming. Fact patterns and holdings, however, within these states may serve as persuasive authority for all courts in Wyoming. The willingness of Wyoming courts to cite persuasive authority was evidenced by the *Hill* opinion. Thus, the information gleaned from these cases could assist WYDOT in defeating a claim of negligence.

### **Caselaw on Livestock Breach and Injury**

#### *Injury to Livestock from Direct Contact with HTEF*

We found no caselaw addressing livestock injury or entanglement arising out of the use of HTEF. Indeed, the opportunity for entanglement would appear minimal as, in comparison to traditional fencing, HTEF is constructed from fewer wires, of smooth surface, and increased flexibility. Even in reference to traditional fencing, we discovered no caselaw where a fence was the direct cause of injury to livestock; perhaps, as with other scenarios in this report where caselaw is lacking, recovery was never sought, recovery was received prior to suit, or settlement was reached prior to judgment.

We should note, however, that a Montana statute does address one scenario whereby owners of barbed wire fencing in disrepair are liable for damages equal to the value of the livestock injured from contact with the fence (Mont. Stat. § 81-4-104, 2003). Yet, no Montana caselaw addresses the statute in that context.



### *Remedy for Trespass by Livestock*

A Wyoming statute and limited caselaw does address injury to third party property owners where livestock breach third party lawful enclosures (i.e. fences) (Wyo. Stat. § 11-28-108(a) through (e) 2003; and, *Garretson v. Avery*, 176 P. 433 Wyo. 1918, holding that, absent contract, statute, or prescription, a landowner has no absolute duty to fence-out and, where the option to fence-out is not exercised, the landowner is not liable for the death of straying livestock). If a third party does choose to fence-out pursuant to the lawful standards of Wyo. Stat. § 11-28-102, then subsection (a) of § 11-28-108 prescribes that “any person owning or having in his possession or charge any livestock or domesticated buffalo which breaches into any lawful enclosure belonging to [a third party] is liable...for all damages...[caused by] such [breach].” Upon discovery, the third party claimant has a duty to notify the owner – or person having charge – of the probable monetary damages (*Id.* at (b)). Damages may be recovered by civil action or by arbitration as set forth in subsection (a) (*Id.* at (a)). Prior to judgment or arbitration, the claimant may keep in custody as many of the offending animals as are equal to the value of probable damages; yet, if the claimant receives the requested compensation – which may include actual damages plus expenses incurred from keeping the livestock – prior to initiating civil action or arbitration, the offending animal(s) must be returned to the owner or person having charge (*Id.* at (c) and (d)). Finally, if it appears upon trial or arbitration that the claimant did not maintain a lawful fence or sustain damages, the claimant will be ordered to pay the cost of the suit or arbitration plus damages sustained by the defendant (*Id.* at (d)).

### *Summary*

Although Mont. Stat. § 81-4-104 does address injury to livestock by prescribing liability to owners of barbed wire fencing in disrepair, we found no Montana caselaw addressing the statute in that context, nor did we find any caselaw where direct contact with HTEF caused injury to livestock.

Wyo. Stat. § 11-28-102 does address remedy by third party property owners who are injured from trespass by livestock. The statute prescribes procedure through civil action or arbitration,

compensation through actual monetary damages or expenses incurred from caring for the trespassing livestock, and the requirement that a claimant have maintained a lawful enclosure prior to bringing the action.

## CHAPTER 5

### MAINTENANCE AND BISON CONTAINMENT RESULTS AND DISCUSSION

#### Maintenance Costs

Maintenance of the three test fences as well as those used for bison containment was minimal. Appendix A describes maintenance issues, the actions necessary to correct them, and the cost of materials. Most of the maintenance done was a result of improper construction (i.e. not tightening clamps or placing wire tighteners too far away from a post) and false readings by the satellite-monitors.

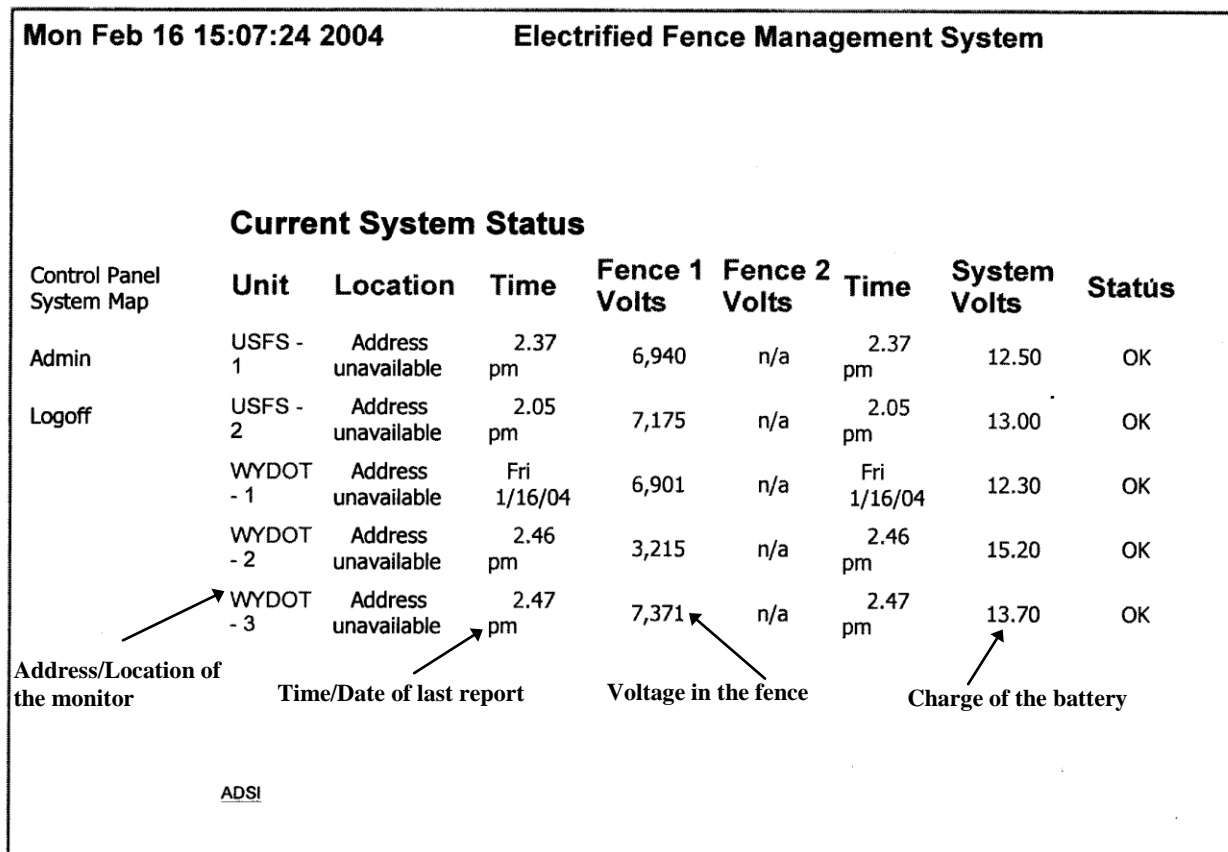

**Figure 4.** Example of data reported by the satellite-modem-monitors via the Internet.

Satellite-modem monitoring systems reported fence voltage and battery charge (Figure 4). They also indicated when the fence was shorted-out by giving low readings of both the fence and battery voltages. During cold weather particularly, but also at other times, the monitors would give false readings of the system or battery voltage indicating that there was something wrong with the fence. If a “failure” reading was observed, the fence was checked by field personnel. In all but two instances the fence system was functioning properly. The two instances involved: 1) an actual short in the fence caused by a tightener on the top “hot” wire catching the middle ground wire (Figure 5) and 2) the 12-volt battery losing charge and freezing. The short appeared to be caused by a deer (presence of tracks) jumping over the fence and causing the wires to twist and catch on the tightener. In the other case, the 12-volt battery being frozen caused the fence to quit functioning. Fence failure could have been prevented in each of these cases. The first case could have been prevented if the tightener was installed closer to a post so that it would be more difficult to catch on another wire. The second case was preventable if a larger solar panel had been used to keep up with the power needs of both the monitor and the energizer.



**Figure 5.** Two wires caught around a wire tightener causing a short.

Since the majority of the “failure” readings reported by the satellite-monitors were unfounded and the fences were functioning properly, we sent the monitors back to the manufacturer (AIRSIS) for testing. It was found that the computer chip that reads the voltages was not functioning properly and needed to be replaced with one that had a broader operating temperature range (Jim Drewett, ARCSIS, personal communication). Once this chip was replaced, the monitors were more reliable in their reporting of the fence status and voltage.

Since the monitors were repaired, we have had one case of fence failure. This failure was caused by hooking up the two 22-watt solar panels on the Cody and Sybille fences incorrectly so that they were not charging the battery. This caused the batteries to go dead and the fence system failed. This failure was correctly reported by the monitors. We did not see any false reporting by the monitors since the repairs were made (e.g. 3 months with out a false report).

## **Wildlife Use**

### *Pronghorn*

A total of 1,773 pronghorn were observed interacting with the fences built during this study. Pronghorn seem to have little difficulty crossing under the 3-Wire HTEF. It appears that they are not shocked unless they touch the fence with an exposed portion of the body (i.e., their nose). The majority of the data came from the WYO 34 fence, and in particular, where the 3-Wire HTEF meets a 7-Wire barbed fence that is not associated with the highway. The movement through this area indicates that the 3-Wire HTEF allows them to cross, while the 7-Wire fence prevents them from crossing, due to an extremely low bottom wire (1-2” above the ground). The vast majority of pronghorn (97.01%; N = 1,720) successfully passed under the HTEF, while 2.99% (N = 53) were unsuccessful in crossing the fence while in view of the camera. An animal was counted as unsuccessful if it approached a fence, but was not observed to cross while in view of the camera. These results are significantly different from a random distribution using a binomial test,  $Z = -39.5896$ ,  $p < 0.0001$  (Ott 1993). These results are also similar to the results that Karhu and Anderson (2003) found for the same fence design (Table 1).

**Table 1.** Wildlife results from Karhu and Anderson (2003) for 3-Wire HTEF.

Species	Design <sup>a</sup>	N	n <sup>b</sup>	Outcome <sup>c</sup>	
				%Succeed	%Fail
Elk	3-wire	51	3	90.2	9.8
Deer	3-wire	54	2	96.3	3.7
Pronghorn	3-wire	23	3	95.7	4.3

<sup>a</sup> Data from all three 3-wire configurations were combined for this analysis.

<sup>b</sup> n equals the number of data collection sites monitored that contributed to the total sample N and were considered significantly independent.

<sup>c</sup> Outcome refers to the eventual success or failure of an animal to get to the other side of a fence while being videotaped, regardless of how many attempts were made.

### *Elk*

Only one elk was observed interacting with the 3-Wire HTEF. The elk was unsuccessful in its attempt to cross, however, since we have only one sample we cannot make any conclusions beyond what Karhu and Anderson (2003) found for elk and 3-Wire HTEF (Table 1).

### **Bison Containment**

Bison containment tests were performed during the 2004 field season. Table 2 gives the results for each group of tests.

Two replicates of the yearling separation test were conducted (1 each on the High Point Bison and Prairie Monarch Bison Ranches). In each case there was 100% containment of the bison. The test at High Point Bison ranch was conducted in a corral, while the other test was conducted in a pasture setting.

**Table 2.** Results for bison containment tests.

Test	Location	N	%Contain	%Escape
Yearling Separation	High Point Bison	8	100	0
	Prairie Monarch	31	100	0
Bull-Cow Separation	Diamond Tail	935	100 <sup>a</sup>	0
	Iron Mtn.	101	0	100
	Iron Mtn. retest	101	95	5
Winter Wheat exclusion	High Point Bison	102 <sup>b</sup>	100	0

<sup>a</sup> 6 calves escaped under a water gap.

<sup>b</sup> Test consisted of cows, bulls, yearlings, and young calves.

Two replicates of the bull-cow separation test were conducted (1 each on the Diamond Tail and Iron Mountain Ranches). At the Diamond Tail Ranch we observed 100% containment of adults (N = 935), but six calves crossed through a water gap in the fence. The calves were young (1-4 weeks old) and most were in the process of crossing under the water gap when they received a shock. Floyd (1960, in McKillop and Sibly 1988) and McCutchan (1980) note that if an animal is in the process of crossing before the pulse of current is generated, it usually completes the crossing. The water gaps in HTEF are a potential weak point since they are constructed of hanging electrified wires with little physical resistance when pushed against. Thus, the only real barrier to the animals is the potential shock they may receive. Although control of livestock using electric fencing is based on a mental and not physical barrier (McAtee 1939, McCutchan 1980), very young animals have had little or no experience with electric fence and it is reasonable to assume they would not yet have a respect for the HTEF. As time passes and they come into contact or observe others coming into contact with an electrified wire, they should learn to avoid HTEF and be less likely to cross under the fence at water gaps or other places along the fence line (McKillop and Sibly 1988).

While constructing the fence on the Diamond Tail Ranch, several bulls escaped through a broken portion of the test fence before the bull-cow test was run. It was unclear whether the bison broke through the fence or if wildlife, specifically elk, broke the wires and the bison later passed through the downed portion of the fence. The animals were aware of the presence of the fence, as they had been in the pasture for several days during and after its construction. Bison rarely break through the other fences on the ranch, which are 52" tall 4-Wire HTEF (Scott Butcher, Diamond Tail Ranch manager, personal communication).

During the bull-cow test on the Iron Mountain Ranch some of the test animals crossed through one of the electric gates in the fence during the first evening of the test. It is unclear whether the bulls or cows broke through. Since the animals only went through the gate and not the fence, the test was run again after the gates were strengthened by placing portable livestock panels across each one. Again, bulls were separated from the cows. Three of the eight bulls as well as two cows escaped during the second test. The bulls escaped during the second day of the test, however, they did no damage to the fence. The two cows were pushed through the fence when the herd was crowded into a corner.

One replicate of a winter wheat test was performed on the High Point Bison Ranch. The test animals consisted of a herd of bison ranging in size from mature herd bulls to calves less than a week old. The animals were contained 100% regardless of age.



## CHAPTER 6

### RECOMMENDATIONS AND CONCLUSIONS

Overall, we continue to recommend 3-Wire HTEF for use in controlling cattle and allowing wildlife to cross. There should not be an increase in liability if proper precautions are taken. We also conclude that this fence can be used for bison containment, while noting that some bison escape is possible. Within the fence design, we continue to recommend the same specifications as Karhu and Anderson (2003), however, we disagree with the BLM specifications for use of 200,000-psi wire. This is due to the fact that 200,000-psi wire is much harder to work with and repair compared to 170,000-psi wire.

#### **Risk, Liability, and Applications**

##### *Short Answer*

Pursuant to the recommendations contained herein, implementation of 3-Wire HTEF by WYDOT is unlikely to increase the State of Wyoming's potential for legal liability.

Pursuant to the recommendations contained herein, implementation of 3-Wire HTEF by the BLM is unlikely to increase the federal government's potential for legal liability.

##### *Conclusion*

Wyoming's current statutory law on fencing does not prohibit the use of HTEF. Thus, pursuant to several readily obtainable measures, WYDOT can implement HTEF while likely not incurring increased exposure to liability. Obtainable measures include: 1) selection of a HTEF design that is as resistant to breaching livestock as are current lawful fences in Wyoming (e.g. a 3-wire design w/ an 18" bottom gap); 2) selection of a high quality, dependable, UL certified and labeled energizer; 3) diligent monitoring and reasonably responsive repair of any energizer or fence-line in disrepair; 4) diligent monitoring of the occurrence of livestock breach; 5) posting signs warning of the use of electric current and of the presence of livestock and wildlife on

roadways. Assuming WYDOT applies such cautionary measures, and/or given favorable facts and circumstances, a court will likely hold WYDOT immune from, absolved from, or of diminished liability for an action in negligence resulting from injuries sustained in association with the use of HTEF.

The BLM's current supplement on electric fence installation details several measures likely to safeguard against an increase in liability arising out of HTEF use. Measures within the agency's supplement include: 1) compliance with NEPA guidelines; 2) adequate notice to the public with an opportunity to be heard; 3) a 3-Wire design with noted energizer specifications; 4) reasonable public access through pedestrian stiles and non-electrified gates; 5) mandatory, ample, and securely fastened signs that warn of electric current; 6) diligent monitoring and maintenance of structurally sound fencing; and, 7) and a brochure for the public at-large that explains electric fence use and safe methods for passage. Assuming the BLM applies such measures, and/or given favorable facts and circumstances, the agency will likely be held immune from, absolved from, or of diminished liability for an action in negligence arising out of injuries sustained in association with the use of HTEF.

### **Agency Use**

HTEF is seeing increased use throughout the western United States. As well as becoming popular among ranchers, several agencies are using HTEF to meet management objectives. The United States Forest Service (USFS) and the BLM are both implementing HTEF to meet certain management objectives. While the fence designs may vary depending on the objective (e.g. using 6-ft tall HTEF to exclude Moose (*Alces alces*) from aspen (*Populus tremuloides*) and willows (*Salix spp.*) (Gary Kees, USFS Montana, personal communication)) the issues involving liability remain the same.

### **Car Accidents**

We have not observed any accidents involving HTEF and thus, we cannot make any comments on how to specifically handle accidents involving HTEF. However, with our assessment of

HTEF, we feel that there is no imminent risk from HTEF to either emergency personnel or victims involved in an accident.

### **Animal Tangling**

We have not observed any wild or domestic animals entangled in HTEF. We have also not discovered any documented accounts of animals becoming entangled in HTEF. It appears that there would be a reduced risk of becoming entangled in HTEF, due to the use of smooth wire and the increased flexibility of the fence. However, we cannot state that animals will not become entangled in HTEF.

### **Maintenance Costs**

Maintenance costs on test sections of 3-Wire HTEF were relatively minor and most maintenance was preventative. From our observations, HTEF appears to hold up better than traditional fences under snow loads and requires considerably less spring maintenance after snowmelt. This is due to the increased flexibility of the HTEF as compared to traditional barbed or woven wire fences. The satellite-modem-monitors initially provided inconsistent and unreliable fence status information. However, once the problems were corrected, the satellite-monitors were reliable and did slightly reduce the amount of physical monitoring needed to maintain HTEF.

While the satellite-modem-monitors are an effective tool for indicating the status of the fence and its primary components, especially in remote areas where physical monitoring maybe difficult. However, information gathered thus far indicates field monitoring of the fences is still needed and is superior to the remote monitoring systems. The effort and cost of this type of monitoring is dependant upon many factors including location, miles of fence, monitoring frequency, and natural grounding hazards such as snow loading and vegetation, as well as the amount of wildlife and livestock pressure.

Regardless of whether a satellite-monitor or other monitoring devices is used, we recommend that fences are physically checked a minimum of once a month when livestock are present in the pasture. This will ensure everything continues working properly, including monitoring devices.

We also recommend that fences remain energized even when livestock are not present. This ensures that animals will not be against a fence that is off, and will help to limit liability if livestock are present without the agencies knowledge (i.e. *Reynolds v. Kansas Dept. of Transportation*). Keeping the fence electrified will also help to reduce damage when wildlife, such as bull elk (Karhu and Anderson 2003), push against and through non-electrified wires.

### **Wildlife Use**

Pronghorn appear to prefer crossing HTEF to fence designs with low bottom wires, as indicated by the amount of use along the WYO 34 test fence. Pronghorn data collected on the test fences supports the findings of Karhu and Anderson (2003) on existing 3-Wire HTEF. While only one observation of other big game species was made during this study, Karhu and Anderson (2003) have shown that 3-Wire HTEF would also allow mule deer and elk to cross with apparent ease.

### **Power Failure and Livestock Escaping**

While the likelihood of power failure is low with proper maintenance and monitoring, it is still a concern. McCutchan (1980) studied the possibility of cattle escaping across electrified fences that had been switched off. Eighteen Angus heifers were enclosed for several days on a 10-ha enclosure with one side consisting of a single wire electric fence 0.75-m above the ground. Once the fence was switched off, it took 52-hours for the animals to cross the unelectrified fence. Twenty-four Angus heifers were also placed in the same enclosure for 24-hours and then the fence was turned off. It took nearly 150-hours before any of the heifers crossed the unelectrified fence (McCutchan, 1980; McDonald et al., 1981). The results of these studies must be interpreted carefully in regards to pasture size, stocking rates, fence design, and the urge for the animals to escape. Given the stocking rates likely to be found on rangeland in the western United States, it is likely that a power failure will not result in immediate escape of cattle.

However, the amount of time required for animals to escape could vary and power should be restored as soon as possible in order to minimize the potential for such escapes.

While 3-Wire HTEF contains cattle and bison as well as 4-Wire HTEF (Karhu and Anderson 2003), it should not be used to contain sheep, goats, or in places where the ability of young calves to freely move across the fence would pose a potential problem. This is only a concern for very young calves and 3-Wire HTEF appears to contain calves once they reach a size where they are unable to easily pass under the fence without contacting the bottom wire.

### **Fire Hazard**

There is very little information or documentation on the fire hazard of electric fences. McCutchan (1980) describes a fire that was reportedly started by an electric fence near Winchelsea, Australia in 1971. McCutchan (1980) also notes that an extensive survey did not reveal any other fires that could be attributed to an electric fence. McCutchan (1980) studied the fire hazard in the laboratory and concluded that starting of fires by electric fences was statistically improbable, but still possible. With the development of new technology, this slight potential for fire has been further reduced. With the energizers used in this study the electric pulse generated only lasts for approximately 0.003-seconds, and thus does not generate enough heat to ignite most materials. For example, arcing between wires will not even ignite tissue paper (Morgan Renner, Gallagher, Inc., personnel communication).

### **Visibility**

A potential issue with the use of HTEF is its low visibility. Under low light conditions, or when viewed from an angle, the fence can almost become invisible. This can be an advantage or disadvantage. If the user does not want the fence to detract from the surrounding scenery, HTEF can be ideal. However, if livestock or people are not aware of the presence of the fence, it may be difficult to see it until it is too late to avoid running into the fence. The posting of signs at key locations, such as gates, energizers, and any crossings, as well as the possible addition of flagging or danglers will increase the visibility and lessen the chance that an animal or person will come into contact with the fence accidentally.

## **Bison Containment**

While bison have been shown to be effectively contained by 3-Wire HTEF in this study, we recommend that in cases where bison, or any livestock for that matter, are being contained, that it not be taken for granted that the fence will be 100% effective. Bison can be temperamental and no fence regardless of height or strength can be considered to effectively contain bison at all times.

**Appendix A.** Maintenance Data for 3-Wire HTEF and Cost Comparison Between 3-Wire HTEF and WYDOT Right-of-Way Fences.

Locations: Cody (U.S. 16/20), Hanna (WYO 72), Sybille (WYO 34) (See figure 1).

Date	Location	Maintenance Problem	Repair	Materials Cost
9/5/03	Cody	A clamp attaching the main power feed from the energizer to the "hot" fence wire became disconnected, due to improper installation (not being tightened), and caused a 1/4-mile section of the fence to fail.	Proper installation of a clamp.	No cost
11/13/03	Hanna	Post clip was missing on the fence.	Replaced clip.	Post clip= \$0.09/clip or = \$9.49/100 clips
12/4/03	Hanna	Four post clips were incorrectly installed.	Proper installation of clips.	No cost
12/11/03	Hanna	Snow drifted into battery box.	Removal of the snow to prevent any problem with shorts. Also covered the vent slots on the battery box to hopefully prevent this from occurring again.	No cost
1/9/04	Hanna	Snow drifted into battery box.	Same as 12/11/03 repair.	No cost
1/21/04	Cody	Battery froze, fence system not functioning.	Replaced 12V battery (under warranty) and disconnected monitor, and replaced B260 energizer module (under warranty).	No cost
4/1/04	Hanna	Walked fence and checked for maintenance. Found 1 post clip incorrectly installed.	Proper installation of clip. No other problems were discovered.	No cost

6/22/04	Hanna	Wires twisted and caught on tightener (not installed in the proper place) causing a short of entire fence.	Untwisted wires and moved tightener closer to post.	No cost
7/19/04	Sybille	Wires on short E-W section, loose from field personnel crossing.	Tightened wires, short stretches of HTEF tend to become loose and need to be retightened.	No cost
8/5/04	Hanna	Clamp loose on hot wire, east side of fence dead.	Tightened clamp.	No cost
10/5/04	Cody	Theft of solar panel fence. Had been missing for some time.	Installed new solar panel, added a voltage regulator, and reinstalled monitor with new computer components.	Solar panel and mounting bracket = \$400
11/1/04	Sybille	Monitor reporting fence not working.	Determined that solar panels were hooked up incorrectly and not charging battery. Batteries dead. Rewired panels and charged battery. Voltage regulator not functioning.	Regulator = \$47.60
11/1/04	Cody	Monitor reporting fence not working.	Determined that solar panels were hooked up incorrectly and not charging battery. Batteries dead. Rewired panels and charged battery.	No cost



This section only compares material costs for HTEF and other WYDOT right-of-way fences. We are assuming that other costs, such as travel and labor, will be the same regardless of fence type.

**Total Maintenance Cost = \$447.69** = 1 post clip (\$0.09), 22-watt solar panel and mounting bracket (\$400), voltage regulator (\$47.60)

Duration of study approximately 1.5 yrs

Maintenance cost per year = \$298.46/yr

Approximately 5.7-miles of HTEF = 30,096 linear ft of fence

\$298.46/30,096 linear ft per yr = **\$9.92/1,000 linear ft per yr**

This cost estimate is inflated by the fact that a solar panel was stolen and had to be replaced. This can be prevented in the future by placing the panels on a taller mast that is less accessible to the public. Taking into account only maintenance on the fence due to broken or missing components the cost of materials per 1,000 linear ft per year is \$1.06.

WYDOT estimate of materials cost for general fence repair and maintenance for right-of-way fences (includes stretching wires, splicing, replacing staples, replacing posts, etc.) = **\$0.20/1,000 linear ft per year** (2004 fiscal year estimate).

While our cost estimate for the materials cost of HTEF is larger than WYDOT's estimate (\$1.06 vs \$0.20/1000 linear ft per yr), it may be further be reduce when more miles of HTEF are construct



**Appendix B.** Log of issues involving the 3-Wire HTEF.

The issues listed in the log below involved costs that were incurred in order to have the fence system function properly. These costs should not be incurred by future users, and thus are not included in the maintenance.

Locations: Cody (U.S. 16/20), Hanna (WYO 72), Sybille (WYO 34), Diamond Tail Ranch (DT), and Iron Mtn. Bison Ranch (IMB) (See figure 1).

Date	Location	Maintenance Problem	Repair	Materials Cost
6/03	Cody	Monitor not functioning properly.	Added a microchip.	No cost
8/03	Hanna	Monitor not functioning properly.	Not sure what the problem was.	No cost
11/20/03	Hanna & Sybille		Jim Drewett (AIRSIS) looked at monitors, nothing conclusive found.	No cost
1/30/04	Hanna	Satellite-monitor in alarm mode, energizer pulsing about 1/3 normal speed.	Unhooked monitor to reduce drain on battery.	No cost
2/4/04	Hanna	Battery not holding an adequate charge to run the system.	Installed larger solar panel and voltage regulator on Hanna unit (WYDOT assistance).	Solar panel and voltage regulator from WYDOT = \$400 solar panel = \$47.60 voltage regulator
3/25/04	Sybille	Removed monitor for testing.	Sent to AIRSIS to see if they could determine why monitor was not functioning properly.	Avg. round trip shipping = \$66
5/26/04	Hanna	Monitor sounding alarm.	Reset monitor, everything is working properly.	No cost

6/2/04 *	DT	An ungulate (bison/elk) went through the fence, broke top two wires at H-brace insulators.	Retied knots at strainer post and replaced 2 bull nose insulators.	Bull-nose insulator = \$0.95/insulator or = \$9.49/10 insulators/pkg
6/29/04	Hanna	Monitor sounding alarm.	Reset monitor, everything working properly.	No cost
7/27/04	Hanna		Moved a wire tightener closer to line post (preventative maintenance).	No cost
9/14/04	Hanna	Monitor sounding alarm.	Reset monitor. Removed monitor and sent Cody and Hanna monitors to AIRSIS for repair.	Shipping = \$66/monitor
9/22/04	Hanna		Reinstalled monitor with new computer components.	No cost
9/22/04 *	IMB	Bison broke through gate.	Placed portable livestock panels across gate.	No cost, did not replace gate
9/24/04 *	IMB	Observed a bison calf run through fence.	No damage.	No cost
10/14/04	Sybille		Reinstalled monitor with new computer components and added another solar panel. Also installed a voltage regulator.	Solar panel and mounting bracket = \$400 Voltage Regulator = \$47.60
10/28/04	Cody		Added another solar panel.	Solar panel and mounting bracket = \$400

\* Maintenance from bison test fences. Not included in total maintenance cost estimate.

## **Appendix C. Materials and Design Diagrams for 3-Wire HTEF.**

Below is a description of the materials needed to construct a 3-Wire HTEF, as well as detailed diagrams depicting the proper building and design of the fence. Recommendations are from R. Karhu and CAD drawings are from T. Rehack (BLM Worland Field Office, Worland, WY).

### *Wire*

1. High tensile wire, 12.5 gauge, class III, galvanized steel wire. Tensile strength of 170,000-psi (1,308 lbs breaking strength). We do not recommend the use of 200,000-psi wire due to the fact that it is much stiffer and the specific knots, splices, and wire tightheners involved with 3-Wire HTEF cannot be used with this wire.
2. Insulated wire, 12.5 gauge, insulated wire supplied by the manufacturer of the electric fence materials. Insulated wire is used for passing under gates as well as “jumping” across wood posts or other gaps.

### *Insulators*

1. Porcelain bullnose insulators that are fire resistant and with a high quality glaze finish. They are used on the terminal ends, corners, and strainer posts supporting a horizontal change of direction.
2. Porcelain donut insulators that are fire resistant and with a high quality glaze finish. They are used for vertical direction change where a wood strainer post is need (i.e. for stream crossings or at the toe of slopes).
3. Plastic post insulators, for wood strainer posts. Use the pinlock type.

### *Other Electrical Fence Parts*

1. Cut-out switches, rated for the voltage and amperage level of the energizer.
2. Ground rods, galvanized, single-length steel rods not less than ½-inch in diameter and not less than 6-ft in length, complete with ground rod clamps designed for this type of application.

3. Lightning diverter system designed for fencing applications and compatible with the energizer. Install a diverter at the energizer, and if needed, along the fence line as shown below.
4. Warning signs, durable signs with fade resistant lettering, do not use metal signs, use fasteners compatible with 12.5 gauge wire.
5. Wood posts and bed logs, use sizes shown in diagrams. Install bed logs as shown so that they are just below the ground surface and fit very tightly against the post.
6. Line posts, solid round fiberglass with a minimum diameter of ¾-inch. Holes are drilled in the posts and spaced to accommodate the wire spacing shown in diagram. Post length of 60-inches.
7. Post clips, used to attach wires to the line posts. Use stainless or galvanized clips provided by the manufacturer and designed for this application.
8. Joint clamps, used to attach wires together. Use stainless or galvanized clamps made for this application.
9. In-line wire tighteners, durable, galvanized steel in-line wheel tighteners compatible with the specified wire. Place tighteners no more than 6 feet from a line post and alternate on either side of the post between wires (see diagram).
10. Energizer, choose an energizer that is correctly sized to work with the specific fence system (take into account fence length and grounding hazards). The energizer should supply a minimum of 2,000 Volts at the end of the fence line farthest from the energizer. It should be a solid state, capacitor discharge type, rated for operation on a rechargeable battery. The energizer should meet the requirements of UL 69 or other approved testing agency as follows: maximum output current transient peak measured at the 300 MA level shall not exceed 300 microseconds, intermittent peak discharge output shall consist of regularly timed pulses of not more than 0.2-sec “on” and not less than 0.75-sec “off” per cycle.
11. Battery, use a 12-volt deep cycle marine battery with the maximum amp hours available (at least 100 amp hrs). Battery may be either sealed-gel electrolyte or wet cell type.
12. Solar panel, solar panel should be chosen so that it has adequate power to keep the battery charged even in short daylight conditions. For our project, we used a 44-watt solar panel to run a 2.6-Joule energizer as well as a satellite-monitor.

13. Voltage Regulator, use a regulator that is designed to charge the battery without overcharging or discharging back through the solar panel.

### *Tension*

Tighten wires to approximately 150-lbs, so that there is no visible sag between posts. Over tightening can result in pulling line posts out of the ground at low spots and over stressing braces.

### *Knots and Splices*

Use knots for connecting line wires to insulators and terminal posts. Use a figure-8 knot or wire “joiner” for splicing wires together, as shown below.

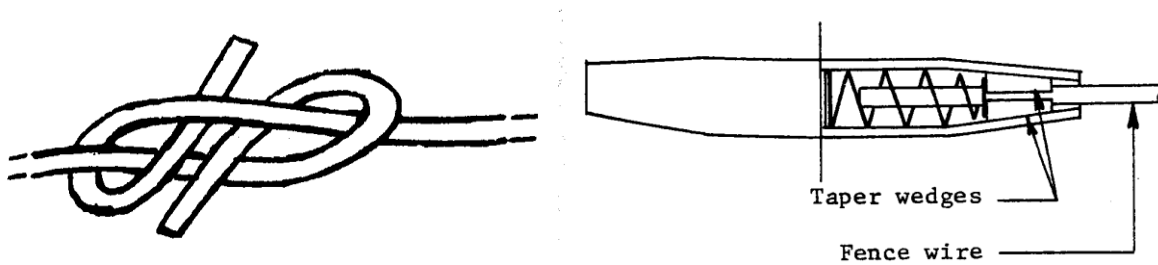
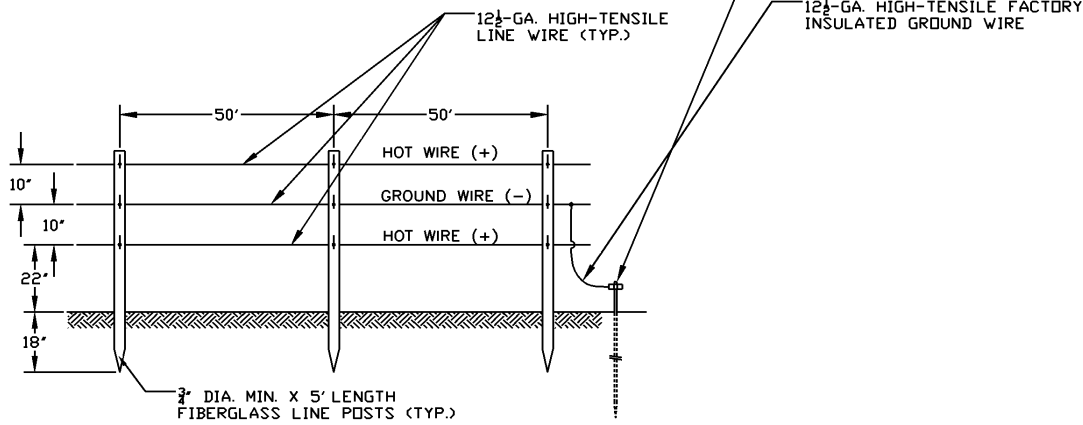

Figure-8 knot and wire “joiner” (McCutchan 1980).

### *Maintenance*

1. Voltmeter, for testing the charge in the fence. A meter that measures amperage can also aid in finding shorts.
2. Battery voltmeter, use for testing charge in battery as well as amount of charge coming from the solar panel.
3. Tightener handle, use to adjust tension of wires for fixing breaks.
4. Spare wire and splices, use to fix broken wires.

FENCE LINE GROUND ROD. SINGLE 6' LENGTH  
GROUND ROD W/TOP 6" EXPOSED. GROUND AT  
1,600' INTERVALS FULL FENCE LENGTH/PERIMETER  
AND AT TERMINAL STRAINER POST ASSEMBLIES



ELECTRIFIED WIRE FENCE

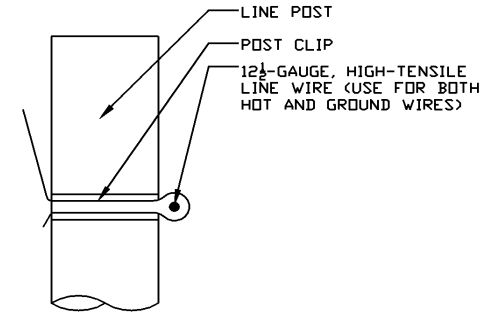

LINE WIRE TO LINE POST CONNECTION DETAIL

ATTACH SIGN TO LINE WIRE  
W/ LIGHTWEIGHT WIRE

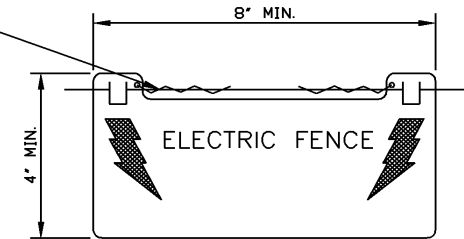

SIGN DETAIL

NOTE: ALTERNATE STRAINERS ON EITHER SIDE  
OF THE LINE POST. DO NOT LINE UP STRAINERS  
OVER EACH OTHER ON ADJACENT WIRES.

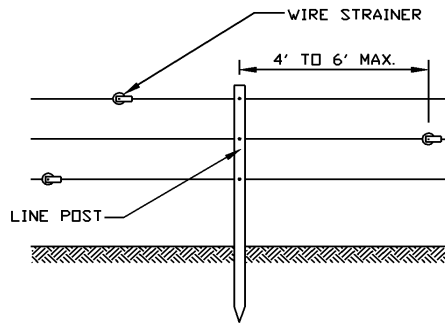

WIRE STRAINER INSTALLATION

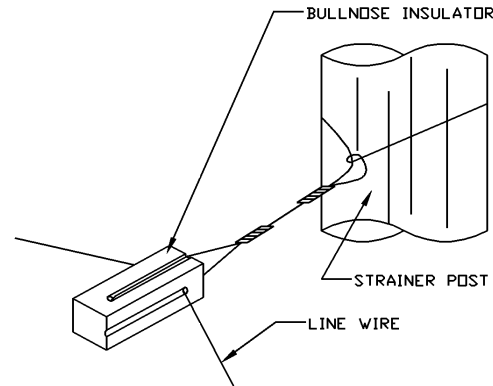

CONNECTION DETAIL

T. REHACK  
BLM WORLAND FIELD OFFICE  
WORLAND, WY

UNITED STATES DEPARTMENT OF THE INTERIOR  
BUREAU OF LAND MANAGEMENT  
Worland Field Office Wyoming

MISCELLANEOUS ELECTRIC  
FENCE DETAILS

DESIGNED KARHU/OTHERS  
REVIEWED \_\_\_\_\_  
APPROVED \_\_\_\_\_

DRAWN REHAK/OTHERS	SCALE NONE
DATE DESIGNED	SHEET 1 OF
DRAWING NO.	

ALWAYS THINK SAFETY



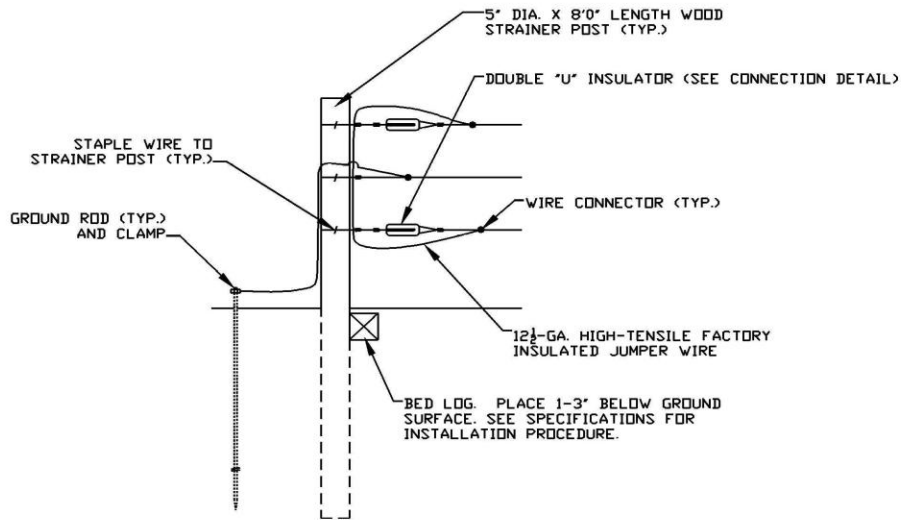

TERMINAL STRAINER POST ASSEMBLY

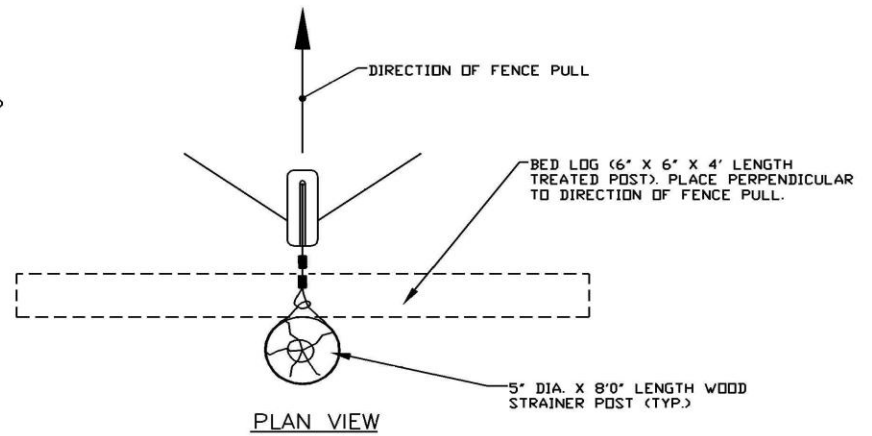

CORNER STRAINER POST ASSEMBLY

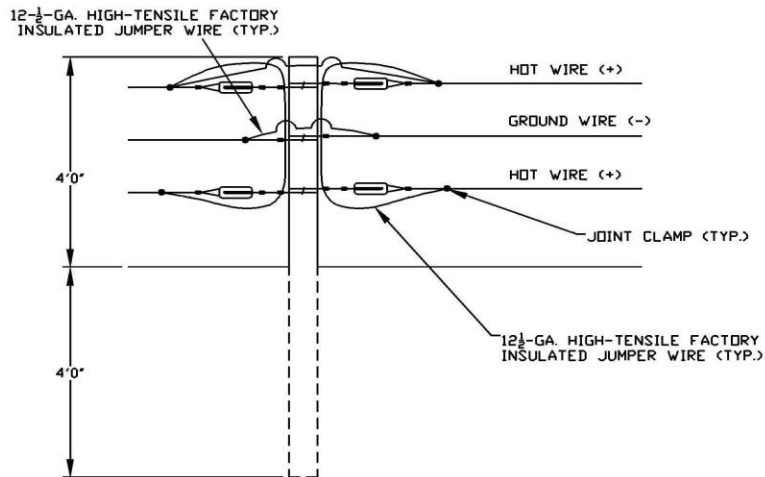

TWO-WAY STRAINER POST ASSEMBLY

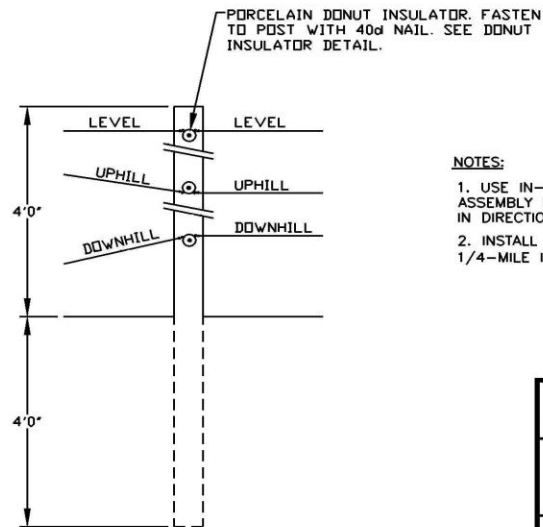

IN-LINE STRAINER POST ASSEMBLY

**NOTES:**

1. USE IN-LINE STRAINER POST ASSEMBLY FOR VERTICAL CHANGES IN DIRECTION.
2. INSTALL A STRAINER POST AT MIN. 1/4-MILE INTERVALS ON LEVEL GROUND.

T. REHACK  
BLM WORLAND FIELD OFFICE  
WORLAND, WY

UNITED STATES DEPARTMENT OF THE INTERIOR BUREAU OF LAND MANAGEMENT Worland Field Office		Wyoming
<b>STRAINER POST ASSEMBLIES</b>		
DESIGNED <u>KARHU/OTHERS</u>		
REVIEWED _____		
APPROVED _____		
DRAWN <u>REHAK/OTHERS</u>	SCALE	NONE
DATE <u>01/04</u>	SHEET 2 OF _____	
DRAWING NO. _____		

ALWAYS THINK SAFETY



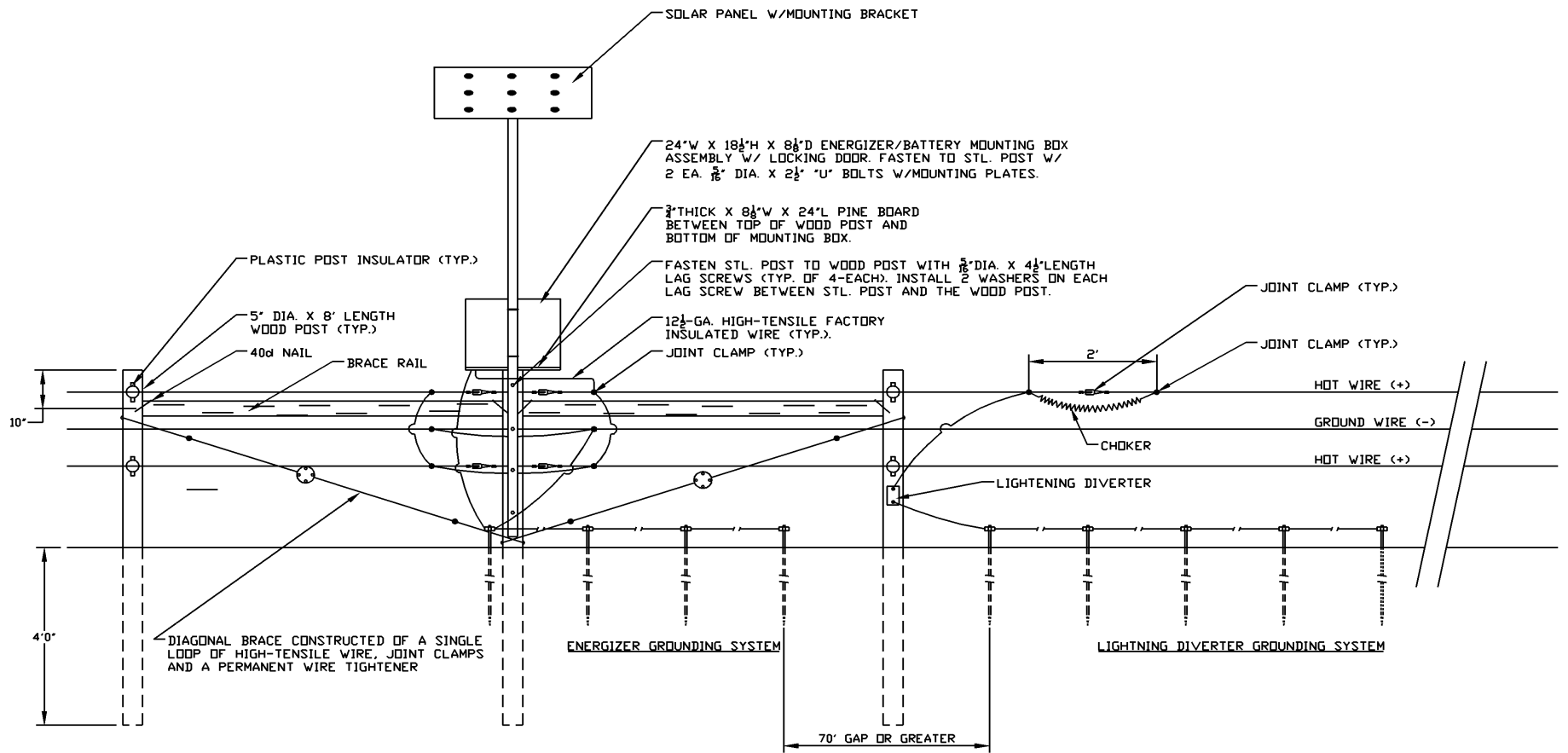

T. REHACK  
 BLM WORLAND FIELD OFFICE  
 WORLAND, WY

**NOTES:**

1. GROUND RODS SHOULD BE LOCATED A MINIMUM OF 24 FT. FROM THE FOLLOWING:
  - A. GROUND RODS CONNECTED TO ANOTHER ELECTRICAL SYSTEM.
  - B. TELEPHONE GROUND RODS.
  - C. UNDERGROUND METAL PIPING SYSTEMS.
  - D. METAL SUPPORTS OR OTHER ELEMENTS OF A STRUCTURE WHICH RESTS UPON OR HAS BEEN DRIVEN INTO THE SOIL.

ALWAYS THINK SAFETY

UNITED STATES DEPARTMENT OF THE INTERIOR BUREAU OF LAND MANAGEMENT Worland Field Office Wyoming	
<b>ENERGIZER ASSEMBLY &amp; LIGHTNING DIVERTER</b>	
DESIGNED <u>KARHU/OTHERS</u>	REVIEWED _____
APPROVED _____	
DRAWN <u>REHAK/OTHERS</u>	SCALE NONE
DATE <u>01/04</u>	SHEET 3 OF _____
DRAWING NO. _____	





## **Appendix D.** Explanation of Legal Citation and Format.

We modified the standard Blue Book format for all legal citations. Our modification was to place parentheses around an entire legal citation; we did this to unify the format of all citations throughout the report (i.e. to have all legal citations reflect a format similar to that of scientific literature). However, because the Blue Book format is unique to legal applications, we provide explanation to assist the reader. The first time a case, statute, or regulation is cited, it is custom to provide the full citation. Once a full citation is provided, three separate and distinct practices are appropriate to abbreviate a recurring citation to the same case, statute, or regulation.

### *Standard Full Legal Citation for Caselaw*

*Akers v. Seaboard Farms*, 972 P.2d 885 (Okla.Civ.App. Div.3, 1998). A standard citation format provides the party names, starting page number of the document (i.e. 885), and volume number (i.e. 972) of the Reporter (i.e. P.2d for Pacific Reporter 2<sup>nd</sup> edition) where the case may be located.

### *Our Modified Full Legal Citation for Caselaw*

(*Akers v. Seaboard Farms*, 972 P.2d 885, Okla.Civ.App. Div. 3 1998). Note the use of parentheses around the entire citation so as to reflect the scientific format.

### *Three Methods Used to Abbreviate Caselaw Citation*

(*Akers*, 972 P.2d at 886, Okla.Civ.App. Div. 3 1998). This method abbreviates the case name and pinpoints the page number where the reader can find the cited law within the document. Appropriate use of this method occurs when a case, statute, or regulation is being revisited from a previous page in the report, yet some distinct and separate case, statute, or regulation has been cited in between.

*(Id.)* This method abbreviates a citation to indicate that the law being cited may be found within the same document and page number immediately previous to the use of *(Id.)*. Appropriate use of this method occurs when a case, statute, or regulation is being cited from an immediately preceding sentence or paragraph, and no distinct and separate case, statute, or regulation has been cited in between.

*(Id. at 887)*. This method pinpoints a separate page number where the reader can find the cited law within the same document. Appropriate use of this method occurs when a case, statute, or regulation is being cited from an immediately preceding sentence or paragraph, and no distinct and separate case, statute, or regulation has been cited in between.

## REFERENCES

- Dalziel, C.F. 1944. Electrocutation by electric fence controller. *Agricultural Engineering* 25(8): 308.
- Floyd, J. 1960. Crop damage by deer and bear. *Florida Wildlife*. November: 18-21.
- Hancock, T. 1995. Energizers and energy: an explanation of electric fence concepts. Gallagher Group Limited Research and Development Laboratory. Hamilton, New Zealand.
- Karhu, R. and S. H. Anderson. 2003. Evaluation of high tensile electric fence designs on big game movements and livestock containment. Final Report. Wyoming Cooperative Fish and Wildlife Research Unit, Laramie, WY.
- McAtee, W. L. 1939. The electric fence in wildlife management. *Journal of Wildlife Management* 3:1-13.
- McCutchan, J. C. 1980. Electric fence design and principles. University of Melbourne, Australia. 460pp.
- McDonald, C. L., R. G. BeilHarz, and J. McCutchan. 1981. How cattle respond to electric fences. *Journal of Agriculture, Western Australia* 22:99-101.
- McKillop, I. G., and R. M., Sibly. 1988. Animal behavior at electric fences and the implications for management *Mammal Review* 18:91-103.
- Ott, R. L., 1993. *An Introduction to Statistical Methods: Data Analysis*, 4<sup>th</sup> edition. Wadsworth Publishing Company, Belmont, CA.
- United States Department of Interior. Bureau of Land Management. 1989. Fencing: BLM Manual Handbook H-1741-1. Copies available through the Wyoming State Office of the BLM, Chief Records Clerk. 307-775-6008.
- United States Department of Interior. Bureau of Land Management. 2003. Supplement to the BLM Fencing Handbook H-1741-1: Installation of Electric Fences. [On-line] available from <http://www.blm.gov/nhp/efoia/wy/2003im/Wy2003-030atch1.pdf>; accessed Nov. 16, 2004.



## TABLE OF AUTHORITIES

### Administrative Hearings

*John. L. Falen*, 143 IBLA 1 (1998)

*Idaho Watersheds Project*, 147 IBLA 186 (1999)

*In re Marilyn Shepherd*, 57 Agric. Dec. 242, 1998 WL 385884 (U.S.D.A.)

*Dan Solecki, MaryLou Teel, and Alfred Cook*, 162 IBLA 178 (2004)

*Stefanie Lee*, 151 IBLA 1 (2000)

### Caselaw

*Akers v. Seaboard Farms*, 972 P. 2d 885 (Okla. Civ. App. Div. 3 1998)

*Aslakson v. U.S.*, 790 F. 2d 688 (C.A. 8 N.D. 1986)

*Berkovitz v. United States*, 108 S. Ct. 1954 (1988)

*Buchanan v. U.S.*, 915 F. 2d 969 (C.A. 5 La. 1990)

*Cecile Industries, Inc. v. U.S.*, 793 F. 2d 97 (3d Cir. 1986)

*Circle Land & Cattle Corp. v. Amoco Oil Co.*, 657 P. 2d 532 (Kan. 1983)

*Cole v. United States*, 657 F. 2d 107 (7th Cir.1981).

*Crawford v. United States*, 796 F. 2d 924 (7th Cir. 1986)

*Crumpton v. Stone*, 59 F. 3d 1400 (C.A.D.C. 1995)

*Curry v. U.S.*, 129, F. Supp. 38 (W.D.S.C. 1958)

*Dalehite v. United States*, 73 S. Ct. 956 (1955)

*Deel v. U.S. By and Through Dept. of Labor*, 923 F. Supp. 98 (W.D. Va. 1996)

*Dellapenta v. Dellapenta*, 838 P. 2d 1153 (Wyo. 1992)

*Dorking Genetics v. U.S.*, 76 F. 3d 1261 (2d Cir. 1996)

*Federal Exp. Corp. v. U.S. Postal Service*, 151 F. 3d 536 (C.A. 6 Tenn. 1998)

*Garretson v. Avery*, 176 P. 433 (Wyo. 1918)

*General Public Utilities Corp. v. U.S.*, 551 F.Supp. 521 (D.C. Pa. 1982)

*Greene v. U.S.*, 207 F. Supp. 2d 1113 (E.D. Cal. 2002)

*Hatahley v. United States*, 76 S. Ct. 745 (1956)

*Hill v. Park County By and Through Bd. of County Com'rs.*, 856 P. 2d 456 (Wyo. 1993)  
*Hines v. U.S.*, 60 F. 3d 1442 (9<sup>th</sup> Cir. 1995)  
*Hughes v. Sullivan*, 514 F. Supp. 667 (E.D. Va. 1980)  
*Industria Panificadora, S.A. v. U.S.*, 957 F. 2d 886 (D.C. Cir. 1992)  
*Jackson v. U.S.*, 24 F. Supp. 2d 823 (W.D. Tenn. 1998)  
*Jones v. U.S.*, 241 F. 2d 26 (4<sup>th</sup> Cir. 1957)  
*Jones v. Hernandez*, 263 N.E. 2d 759 (Ind. App. 1970)  
*Laurence v. U.S.* 851 F. Supp. 1445 (N.D. Cal. 1994)  
*Lozada For and on Behalf of Lozada v. U.S.*, 974 F. 2d 986 (C.A. 8 1992)  
*Madrid v. New Mexico State Highway Dept.*, 870 P. 2d 133 (N.M. 1994)  
*McClellan v. Tottenhoff*, 666 P. 2d 408 (Wyo. 1983)  
*Mundy v. U.S.*, 983 F. 2d 950 (C.A. 9 1993)  
*Murff v. U.S.*, 785 F. 3d 552 (5<sup>th</sup> Cir. 1986)  
*Nylen v. Dayton* 770 P. 2d 1112 (Wyo. 1989)  
*Ochran v. U.S.*, 117 F. 3d 495 (11th Cir. 1997); and, 273 F. 3d 1315 (11th Cir. 2001)  
*Reynolds v. Kansas Dept. of Transportation*, 43 P. 3d 799 (Kan. 2002).  
*Schallioli v. Fare*, 205 F. Supp. 2d 432 (E.D. Pa. 2002)  
*Sickman v. U.S.*, 184 F. 2d 616 (C.A. 7 1950)  
*State v. Moldovan*, 842 P. 2d 220 (Colo. 1992)  
*State v. Ponder*, 950 S.W. 2d 900 (Mo. App. S.D. 1997).  
*Stephen v. City and County of Denver*, 659 P. 2d 666 (Colo. 1983)  
*Stilwell v. Nation*, 363 P. 2d 916 (Wyo. 1961)  
*Sumner v. U.S.*, 794 F.Supp. 1358 (M.D. Tenn. 1992)  
*Thomas by Thomas v. South Cheyenne Water and Sewer District*, 702 P. 2d 1303 (Wyo. 1985)  
*Thompson v. U.S.* 642 F. Supp. 762 (N.D. Ill. 1986)  
*Trout v. Koss Constr. Co.*, 727 P. 2d 450 (Kan. 1986)  
*U.S. v. Gaubert*, 111 S. Ct. 1267 (1991)  
*United States v. King*, 89 S. Ct. 1501 (1969)  
*U.S. v. S.A. Empresa de Viacao Aerea Rio Grandense (Varig Airlines)*, 104 S. Ct. 2755 (1984)  
*Whitfield v. Therriault Corp.*, 745 P. 2d 1126 (Mont. 1987)  
*Wilson v. U.S.*, 940 F. Supp. 286 (D. Or. 1996)

*Worley v. U.S.*, 119 F.Supp. 719 (D.C. Or. 1952)

## **Statutory Law**

### *Alabama*

Ala. Stat. § 14-3-73

### *Arkansas*

Ark. Stat. § 20-19-404

### *California*

Cal. Stat. § 17152

### *Colorado*

Colo. Stat. § 24-10-101 through -120

Colo. Stat. § 35-46-101 through -114

### *Hawaii*

Haw. Stat. § 142-61

### *Maine*

Me. Stat. § 3956

### *Montana*

Mont. Stat. § 60-1-101 through -102

### *New Hampshire*

N.H. Stat. § 158:26

### *New Mexico*

N.M. Stat. § 30-8-13 through -14

N.M. Stat. § 41-4-11(b)(1)

N.M. Stat. § 66-7-363

*Wyoming*

W.R.C.P 8(c)

Wyo. Stat. § 11-24-108(a), (g)

Wyo. Stat. § 11-28-102(a)(i), (b)

Wyo. Stat. § 11-28-108(a), (b), (c), (d), (e)

Wyo. Stat. § 24-1-112(a), (b)

Wyo. Stat. § 24-2-101(e)

Wyo. Stat. § 1-1-109(b), (c)(i)(A), (d), (e)

Wyo. Stat. § 1-39-102(a)

Wyo. Stat. § 1-39-103(a)(v), (a)(vi), (a)(viii)

Wyo. Stat. § 1-39-105 through -112

Wyo. Stat. § 1-39-112

Wyo. Stat. § 1-39-113(a), (a)(i), (a)(ii)

Wyo. Stat. § 1-39-114

Wyo. Stat. § 1-39-115(b)

Wyo. Stat. § 1-39-117(a)

Wyo. Stat. § 1-39-118(a)(i)-(ii), (b), (b)(i), (b)(ii)

Wyo. Stat. § 1-39-121

*Virginia*

Va. Stat. § 55-298.1

*United States Code*

28 U.S.C. § 1346(b), (b)(1)

28 U.S.C. § 2401(b)

28 U.S.C. § 2402

28 U.S.C. § 2671

28 U.S.C. § 2672

28 U.S.C. § 2674

28 U.S.C. § 2675(a), (b), (c)

28 U.S.C. § 2676

28 U.S.C. § 2677

28 U.S.C. § 2678

28 U.S.C. § 2679(a), (c), (d)(1)

28 U.S.C. § 2680(a), (i), (j), (k)

*Code of Federal Regulations*

28 C.F.R. § 14.2(a), (b)(1), (c)

28 C.F.R. § 14.3(a), (b), (c), (d)

28 C.F.R. § 14.4(a), (b), (c)

28 C.F.R. § 14.5

28 C.F.R. § 14.9(a), (b)

43 C.F.R. § 22.2(a), (b), (e)

43 C.F.R. § 22.3(a), (b), (c)

43 C.F.R. § 22.6(a), (b), (c), (d), (e)