



DEPARTMENT OF TRANSPORTATION
UNITED STATES COAST GUARD

MAILING ADDRESS:
U.S. COAST GUARD (G-MMT-5/82)
WASHINGTON, D.C. 20390
PHONE: (202) 426-2187

*NVC 3-75

20 AUG 1975

NAVIGATION AND VESSEL INSPECTION CIRCULAR NO. 3-75

*Subj: Bulk Grain Cargoes

1. Purpose. Enclosure (1), new Chapter VI of the International Convention for the Safety of Life at Sea (SOLAS), 1960, is published as information to naval architects, ship operators, marine surveyors, and others involved in the design or operation of vessels carrying bulk grain cargoes.
2. Cancellation. Navigation and Vessel Inspection Circular No. 10-69 is hereby cancelled.
3. Background. As the result of studies and tests to determine the behavior of grain, the Inter-Governmental Maritime Consultative Organization (IMCO) in 1969 promulgated Resolution A.184(VI), which recommended that the Grain Regulations set out in the Appendix to that Resolution be accepted as an equivalent to and a total alternative to the provisions of Chapter VI of SOLAS, 1960, by member governments. 46 CFR Subchapter M was amended on 4 December 1969 to permit vessels carrying bulk grain to use the 1969 Equivalent Grain Regulations. After a three-year period, IMCO Resolution A.264(VIII) adopted these regulations, with improvements as a proposed amendment to Chapter VI of SOLAS, 1960.
4. Discussion. In accordance with a recommendation contained in IMCO Resolution A.264(VIII), the Coast Guard has promulgated regulations given in the Federal Register dated 20 Aug. 1975 revoking 46 CFR 144 and amending 46 CFR Parts 31, 74 and 93 to require all vessels carrying bulk grain to meet the requirements of enclosure (1).

W. M. Benkert
W. M. BENKERT

Chief, Office of Merchant Marine Safety

Encl: (1) IMCO Resolution A.264(VIII),
Amendment to Chapter VI of the
International Convention for the
Safety of Life at Sea, 1960

DIST: (SDL No. 101)

A: None
B: n(45); c(10); eg(3); bjp(1); q(6)
C: em(4); o(2)
D: ij(2); k(1)
E: mn(1); o(2)
F: None
LIST CG-12

INTER-GOVERNMENTAL MARITIME
CONSULTATIVE ORGANIZATION



20 AUG 1975

Distr. 20 AUG 1975
GENERAL

A VIII/Res. 264
10 December 1973

Original: ENGLISH

ASSEMBLY - 8th session
Agenda item 9

IMCO

RESOLUTION A.264(VIII)

adopted on 20 November 1973

AMENDMENT TO CHAPTER VI OF THE INTERNATIONAL CONVENTION FOR THE SAFETY OF LIFE AT SEA, 1960

THE ASSEMBLY,

RECOGNIZING the need to improve safety of life at sea,

NOTING Article 16(i) of the Convention on the Inter-Governmental Maritime Consultative Organization, concerning the functions of the Assembly with regard to regulations relating to maritime safety,

NOTING FURTHER that Article IX of the International Convention for the Safety of Life at Sea, 1960 provides for procedures of amendment involving participation of the Organization,

RECALLING its Resolution A.184(VI) which recommended that the governments concerned accept the total application of the Grain Regulations set out in the Appendix to that Resolution as being equivalent to and a total alternative to the provisions of Chapter VI of the International Convention for the Safety of Life at Sea, 1960,

RECALLING FURTHER that by the same Resolution it requested the Maritime Safety Committee to study data compiled as the result of use of these Regulations with a view to practical evaluation of the Regulations and determining their suitability as an Amendment to Chapter VI of the International Convention for the Safety of Life at Sea, 1960,

HAVING NOTED the successful completion of the study referred to above and the subsequent conclusion and recommendation of the Maritime Safety Committee, which does not relate to or affect the permanent structure of a ship within the meaning of Article IX(f) of that Convention,

HAVING CONSIDERED the amendment to the International Convention for the Safety of Life at Sea, 1960, forming the subject of the recommendation adopted by the Maritime Safety Committee at its twenty-seventh session in accordance with Article IX of that Convention, directed towards the improvement of requirements for the carriage of grain in bulk,

RESOLVES:

- (a) to adopt the amendment which replaces and supersedes the present Chapter VI in its entirety and all reference to it with a new Chapter VI, the text of which is at Annex to this Resolution;
- (b) to request the Secretary-General of the Organization to communicate in conformity with Article IX(b)(i), for purposes of acceptance, certified copies of this Resolution and its Annex to all Contracting Governments to the International Convention for the Safety of Life at Sea, 1960, together with copies to all Members of the Organization;
- (c) to recommend that all governments put into effect as soon as possible the provisions of the amendment as a total replacement for the present Chapter VI;
- (d) to invite all governments concerned to accept this amendment at the earliest possible date;
- (e) to further recommend that the validity of approvals which have been issued under the existing Chapter VI prior to entry into force of the new Chapter VI should be left to the decision of each Administration of the country in which the ship is registered and such decision accepted by other Contracting Governments;
- (f) to revoke Resolution A.184(VI) whilst recognizing that approvals issued under its provisions shall be considered as generally complying with the amended Chapter VI;

A VIII/Res.264

- (g) to revoke Resolution A.185(VI); and
- (h) to recommend that governments apply the principles of the proposed amended Chapter VI to cargo ships of less than 500 tons gross tonnage as far as reasonable and practicable.

ANNEX

NEW CHAPTER VI OF THE INTERNATIONAL CONVENTION FOR THE SAFETY OF LIFE AT SEA, 1960

The existing Chapter VI is replaced by the following:

CHAPTER VI - CARRIAGE OF GRAIN

PART A - GENERAL PROVISIONS

Regulation 1

Application

Unless expressly provided otherwise, this Chapter, including Parts A, B and C, applies to the carriage of grain in all ships to which the present Regulations apply.

Regulation 2

Definitions

- (a) The term "grain" includes wheat, maize (corn), oats, rye, barley, rice, pulses, seeds and processed forms thereof, whose behaviour is similar to that of grain in its natural state.
- (b) The term "filled compartment" refers to any compartment in which, after loading and trimming as required under Regulation 3, the bulk grain is at its highest possible level.
- (c) The term "partly filled compartment" refers to any compartment wherein bulk grain is not loaded in the manner prescribed in paragraph (b) of this Regulation.
- (d) The term "angle of flooding" (θ_f) means an angle of heel at which openings in the hull, superstructures or deckhouses, which cannot be closed weathertight, immerse. In applying this definition, small openings through which progressive flooding cannot take place need not be considered as open.

Regulation 3

Trimming of Grain

All necessary and reasonable trimming shall be performed to level all free grain surfaces and to minimize the effect of grain shifting.

- (a) In any "filled compartment" the bulk grain shall be trimmed so as to fill all the spaces under the decks and hatch covers to the maximum extent possible.
- (b) After loading, all free grain surfaces in "partly filled compartments" shall be level.
- (c) The Administration issuing the document of authorization, may, under Regulation 9, grant dispensation from trimming in those cases where the underdeck void geometry resulting from free flowing grain into a compartment, which may be provided with feeding ducts, perforated decks or other similar means, is taken into account to its satisfaction when calculating the void depths.

20 AUG 1975

A VIII/Res.264

Regulation 4*Intact Stability Requirements*

- (a) The calculations required by this Regulation shall be based upon the stability information provided in accordance with Regulation 19 of Chapter II, or with the requirements of the Administration issuing the document of authorization under Regulation 10 of this Chapter.
- (b) The intact stability characteristics of any ship carrying bulk grain shall be shown to meet, throughout the voyage, at least the following criteria after taking into account in the manner described in Part B, the heeling moments due to grain shift:
- (i) the angle of heel due to the shift of grain shall be not greater than 12 degrees except that an Administration giving authorization in accordance with Regulation 10 may require a lesser angle of heel if it considers that experience shows this to be necessary;¹
 - (ii) in the statical stability diagram, the net or residual area between the heeling arm curve and the righting arm curve up to the angle of heel of maximum difference between the ordinates of the two curves, or 40 degrees or the "angle of flooding (θ_f)", whichever is the least, shall in all conditions of loading be not less than 0.075 metre-radians; and
 - (iii) the initial metacentric height, after correction for the free surface effects of liquids in tanks, shall be not less than 0.30 metre.
- (c) Before loading bulk grain the master shall, if so required by the Contracting Government of the country of the port of loading, demonstrate the ability of the ship at all stages of any voyage to comply with the stability criteria required by paragraph (b) of this Regulation using the information approved and issued under Regulations 10 and 11.
- (d) After loading, the master shall ensure that the ship shall be upright before proceeding to sea.

Regulation 5*Longitudinal Divisions and Saucers*

- (a) In both "filled compartments" and "partly filled compartments", longitudinal divisions may be provided as a device either to reduce the adverse heeling effect of grain shift or to limit the depth of cargo used for securing the grain surface. Such divisions shall be fitted grain-tight and constructed in accordance with the provisions of Section I of Part C.
- (b) In a "filled compartment", a division, if fitted to reduce the adverse effects of grain shift, shall:
- (i) in a 'tween-deck compartment extend from deck to deck; and
 - (ii) in a hold extend downwards from the underside of the deck or hatch covers as described in Section II of Part B.

Except in the case of linseed and other seeds having similar properties, a longitudinal division beneath a hatchway may be replaced by a saucer formed in the manner described in Section I of Part C.

- (c) In a "partly filled compartment", a division, if fitted, shall extend from one-eighth of the maximum breadth of the compartment above the level of the grain surface and to the same distance below the grain surface. When used to limit the depth of overstowing, the height of the centreline division shall be at least 0.6 metre above the level grain surface.
- (d) Furthermore, the adverse heeling effects of grain shift may be reduced by tightly stowing the wings and ends of a compartment with bagged grain or other suitable cargo adequately restrained from shifting.

¹ For example, the permissible angle of heel might be limited to the angle of heel at which the edge of the weather deck would be immersed in still water.

20 AUG 1975

A VIII/Res.264

Regulation 6

Securing

(a) Unless account is taken of the adverse heeling effect due to grain shift in accordance with these Regulations, the surface of the bulk grain in any "partly filled compartment" shall be level and topped off with bagged grain tightly stowed and extending to a height of not less than one-sixteenth of the maximum breadth of the free grain surface or 1.2 metres, whichever is the greater. Instead of bagged grain, other suitable cargo exerting at least the same pressure may be used.

(b) The bagged grain or such other suitable cargo shall be supported in the manner described in Section II of Part C. Alternatively, the bulk grain surface may be secured by strapping or lashing as described in Section II of Part C.

Regulation 7

Feeders and Trunks

If feeders or trunks are fitted, proper account shall be taken of the effects thereof when calculating the heeling moments as described in Section III of Part B. The strength of the divisions forming the boundaries of such feeders shall conform with the provisions of Section I of Part C.

Regulation 8

Combination Arrangements

Lower holds and 'tween deck spaces in way thereof may be loaded as one compartment provided that, in calculating transverse heeling moments, proper account is taken of the flow of grain into the lower spaces.

Regulation 9

Application of Parts B and C

An Administration or a Contracting Government on behalf of an Administration may authorize departure from the assumptions contained in Parts B and C in those cases where it considers this to be justified having regard to the provisions for loading or the structural arrangements, provided the stability criteria in Regulation 4(b) are met. Where such authorization is granted under this Regulation, particulars shall be included in the document of authorization or grain loading data.

Regulation 10

Authorization

(a) A document of authorization shall be issued for every ship loaded in accordance with these Regulations either by the Administration or an organization recognized by it or by a Contracting Government on behalf of the Administration. It shall be accepted as evidence that the ship is capable of complying with the requirements of these Regulations.

(b) The document shall accompany and refer to the grain loading stability booklet provided to enable the master to meet the requirements of Regulation 4(c). This booklet shall meet the requirements of Regulation 11.

(c) Such a document, grain loading stability data and associated plans may be drawn up in the official language or languages of the issuing country. If the language used is neither English nor French, the text shall include a translation into one of these languages.

(d) A copy of such a document, grain loading stability data and associated plans shall be placed on board in order that the master, if so required, shall produce them for the inspection of the Contracting Government of the country of the port of loading.

(e) A ship without such a document of authorization shall not load grain until the master demonstrates to the satisfaction of the Administration or the Contracting Government of the port of loading on behalf of the Administration that the ship in its proposed loaded condition will comply with the requirements of these Regulations.

Regulation 11

Grain Loading Information

This information shall be sufficient to allow the master to determine in all reasonable loading conditions the heeling moments due to grain shift calculated in accordance with Part B. It shall include the following:

- (a) Information which shall be approved by the Administration or by a Contracting Government on behalf of the Administration:
 - (i) curves or tables of grain heeling moments for every compartment, filled or partly filled, or combination thereof, including the effects of temporary fittings;
 - (ii) tables of maximum permissible heeling moments or other information sufficient to allow the master to demonstrate compliance with the requirements of Regulation 4(c);
 - (iii) details of the scantlings of any temporary fittings and where applicable the provisions necessary to meet the requirements of Section I(E) of Part C;
 - (iv) typical loaded service departure and arrival conditions and where necessary, intermediate worst service conditions;
 - (v) a worked example for the guidance of the master;
 - (vi) loading instructions in the form of notes summarizing the requirements of this Chapter.
- (b) Information which shall be acceptable to the Administration or to a Contracting Government on behalf of the Administration:
 - (i) ship's particulars;
 - (ii) lightship displacement and the vertical distance from the intersection of the moulded base line and midship section to the centre of gravity (KG);
 - (iii) table of free surface corrections;
 - (iv) capacities and centres of gravity.

Regulation 12

Equivalent

Where an equivalent accepted by the Administration in accordance with Regulation 5 of Chapter I is applied, particulars shall be included in the document of authorization or grain loading data.

Regulation 13

Exemptions for Certain Voyages

The Administration, or a Contracting Government on behalf of the Administration, may, if it considers that the sheltered nature and conditions of the voyage are such as to render the application of any of the requirements of Regulations 3 to 12 of this Chapter unreasonable or unnecessary, exempt from those particular requirements individual ships or classes of ships.

Encl. (1) to NVC 3-75
20 AUG 1975

A VIII/Rés.264

PART B - CALCULATION OF ASSUMED HEELING MOMENTS

- SECTION I - DESCRIPTION OF THE ASSUMED VOIDS AND METHOD OF CALCULATING INTACT STABILITY
- SECTION II - ASSUMED VOLUMENTRIC HEELING MOMENT OF A FILLED COMPARTMENT
- SECTION III - ASSUMED VOLUMETRIC HEELING MOMENT OF FEEDERS AND TRUNKS
- SECTION IV - ASSUMED VOLUMETRIC HEELING MOMENT OF PARTLY FILLED COMPARTMENTS
- SECTION V - ALTERNATIVE LOADING ARRANGEMENTS FOR EXISTING SHIPS

SECTION I - DESCRIPTION OF THE ASSUMED VOIDS AND METHOD OF CALCULATING INTACT STABILITY

(A) GENERAL

(a) For the purpose of calculating the adverse heeling moment due to a shift of cargo surface in ships carrying bulk grain it shall be assumed that:

- (i) In "filled compartments" which have been trimmed in accordance with Regulation 3 a void exists under all boundary surfaces having an inclination to the horizontal less than 30 degrees and that the void is parallel to the boundary surface having an average depth calculated according to the formula:

$$Vd = Vd_1 + 0.75(d - 600) \text{ mm}$$

Where:

Vd = Average void depth in mm;

Vd_1 = Standard void depth from Table I below;

d = Actual girder depth in mm.

In no case shall Vd be assumed to be less than 100 mm.

TABLE I

Distance from hatchend or hatchside to boundary of compartment	Standard void depth Vd_1
<i>metres</i>	<i>mm</i>
0.5	570
1.0	530
1.5	500
2.0	480
2.5	450
3.0	440
3.5	430
4.0	430
4.5	430
5.0	430
5.5	450
6.0	470
6.5	490
7.0	520
7.5	550
8.0	590

20 AUG 1975

A VIII/Res.264

NOTES ON TABLE I:

For distances greater than 8.0 metres the standard void depth Vd_1 shall be linearly extrapolated at 80 mm increase for each 1.0 metre increase in distance. Where there is a difference in depth between the hatchside girder or its continuation and the hatchend beam the greater depth shall be used except that:

- (1) when the hatchside girder or its continuation is shallower than the hatchend beam the voids abreast the hatchway may be calculated using the lesser depth; and
- (2) when the hatchend beam is shallower than the hatchside girder or its continuation the voids fore and aft of the hatchway inboard of the continuation of the hatchside girder may be calculated using the lesser depth;
- (3) where there is a raised deck clear of a hatchway the average void depth measured from the underside of the raised deck shall be calculated using the standard void depth in association with a girder depth of the hatchend beam plus the height of the raised deck.

(ii) In "filled compartments" which are not trimmed in accordance with Regulation 3 and where the boundary surface has an inclination to the horizontal which is less than 30 degrees, the cargo surface has an inclination of 30 degrees to the horizontal after loading.

(iii) Within filled hatchways and in addition to any open void within the hatch cover there is a void of average depth of 150 mm measured down to the grain surface from the lowest part of the hatch cover or the top of the hatchside coaming, whichever is the lower.

(b) The description of the pattern of grain surface behaviour to be assumed in "partly filled compartments" is shown in Section IV of this Part.

(c) For the purpose of demonstrating compliance with the stability criteria in Regulation 4(b) (see Figure 1), the ship's stability calculations shall be normally based upon the assumption that the centre of gravity of cargo in a "filled compartment" is at the volumetric centre of the whole cargo space. In those cases where the Administration authorizes account to be taken of the effect of assumed underdeck voids on the vertical position of the centre of gravity of the cargo in "filled compartments" it will be necessary to compensate for the adverse effect of the vertical shift of grain surfaces by increasing the assumed heeling moment due to the transverse shift of grain as follows:

$$\text{total heeling moment} = 1.06 \times \text{calculated transverse heeling moment.}$$

In all cases the weight of cargo in a "filled compartment" shall be the volume of the whole cargo space divided by the stowage factor.

(d) In "partly filled compartments" the adverse effect of the vertical shift of grain surfaces shall be taken into account as follows:

$$\text{total heeling moment} = 1.12 \times \text{calculated transverse heeling moment.}$$

(e) Any other equally effective method may be adopted to make the compensation required in paragraphs (c) and (d) above.

A VIII/Res.264

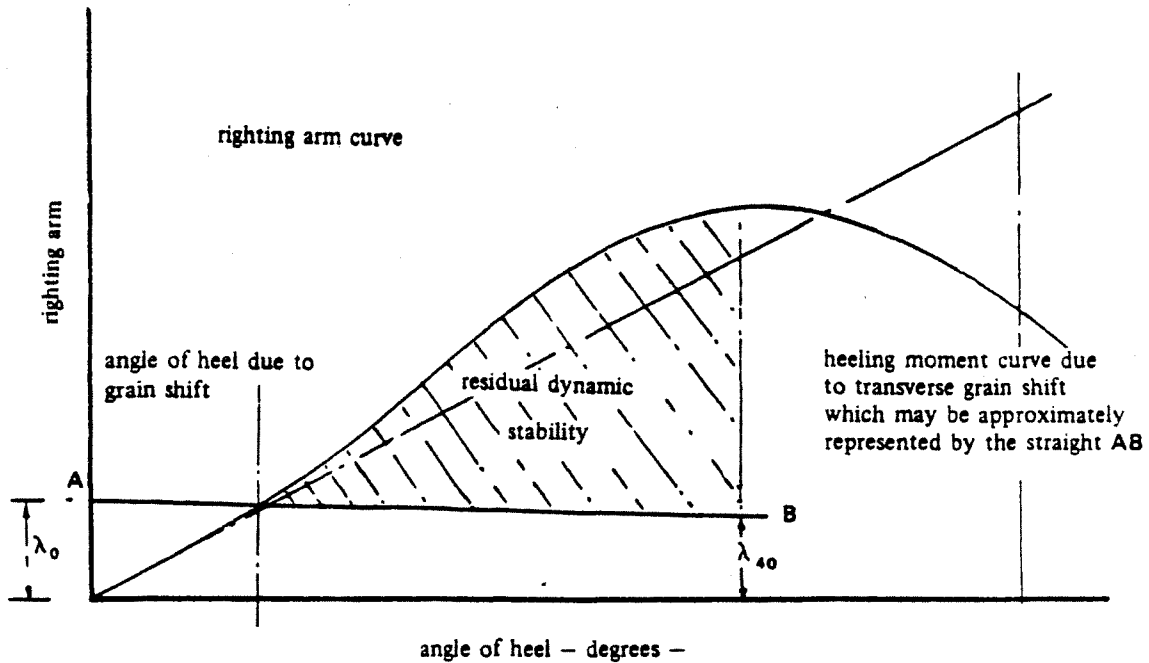

Figure 1

NOTES ON FIGURE 1:

(a) Where:

$$\lambda_0 = \frac{\text{Assumed Volumetric Heeling Moment due to Transverse Shift}}{\text{Stowage Factor} \times \text{Displacement}}$$

$$\lambda_{40} = 0.8 \times \lambda_0;$$

Stowage factor = Volume per unit weight of grain cargo;

Displacement = Weight of ship, fuel, fresh water, stores etc. and cargo.

(b) The righting arm curve shall be derived from cross-curves which are sufficient in number to accurately define the curve for the purpose of these requirements and shall include cross-curves at 12 degrees and 40 degrees.

SECTION II - ASSUMED VOLUMETRIC HEELING MOMENT OF A FILLED COMPARTMENT

(A) GENERAL

(a) The pattern of grain surface movement relates to a transverse section across the portion of the compartment being considered and the resultant heeling moment should be multiplied by the length to obtain the total moment for that portion.

(b) The assumed transverse heeling moment due to grain shifting is a consequence of final changes of shape and position of voids after grain has moved from the high side to the low side.

(c) The resulting grain surface after shifting shall be assumed to be at 15 degrees to the horizontal.

(d) In calculating the maximum void area that can be formed against a longitudinal structural member, the effects of any horizontal surfaces, e.g. flanges or face bars, shall be ignored.

(e) The total areas of the initial and final voids shall be equal.

20 AUG 1975

A VIII/Res.264

(f) A discontinuous longitudinal division shall be considered effective over its full length.

(B) ASSUMPTIONS

In the following paragraphs it is assumed that the total heeling moment for a compartment is obtained by adding the results of separate considerations of the following portions:

(a) Before and abaft hatchways:

- (i) If a compartment has two or more main hatchways through which loading may take place the depth of the underdeck void for the portion(s) between such hatchways shall be determined using the fore and aft distance to the midpoint between the hatchways.
- (ii) After the assumed shift of grain the final void pattern shall be as shown in Figure 2 below:

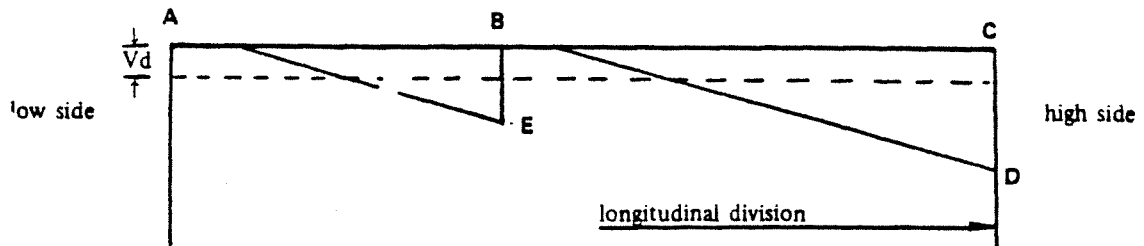

Figure 2

NOTES ON FIGURE 2:

If the maximum void area which can be formed against the girder at B is less than the initial area of the void under AB, i.e. $AB \times Vd$, the excess area shall be assumed to transfer to the final void on the high side.

If the longitudinal division at C is one which has been provided in accordance with Regulation 5(b)(ii) it shall extend to at least 0.6 m below D or E whichever gives the greater depth.

(b) In and abreast hatchways:

After the assumed shift of grain the final void pattern shall be as shown in the following Figure 3 or Figure 4.

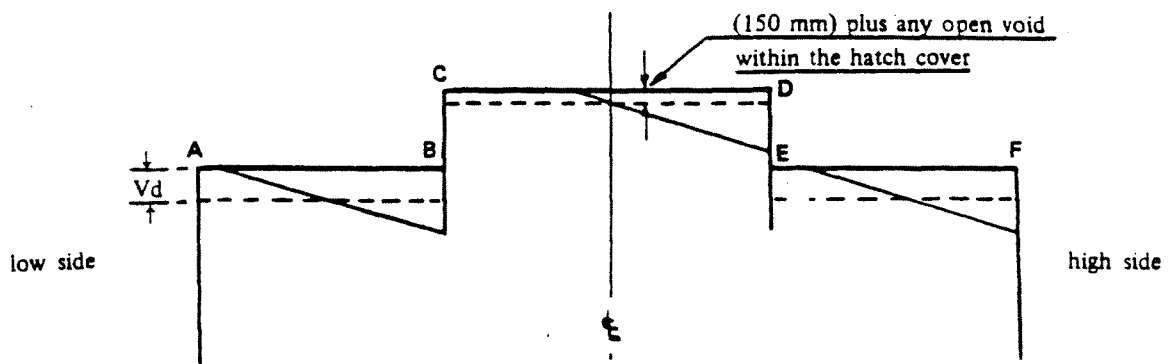

Figure 3

NOTES ON FIGURE 3:

- (1) **AB** Any area in excess of that which can be formed against the girder at B shall transfer to the final void area in the hatchway.
- (2) **CD** Any area in excess of that which can be formed against the girder at E shall transfer to the final void area on the high side.

20 AUG 1975

A VIII/Res.264

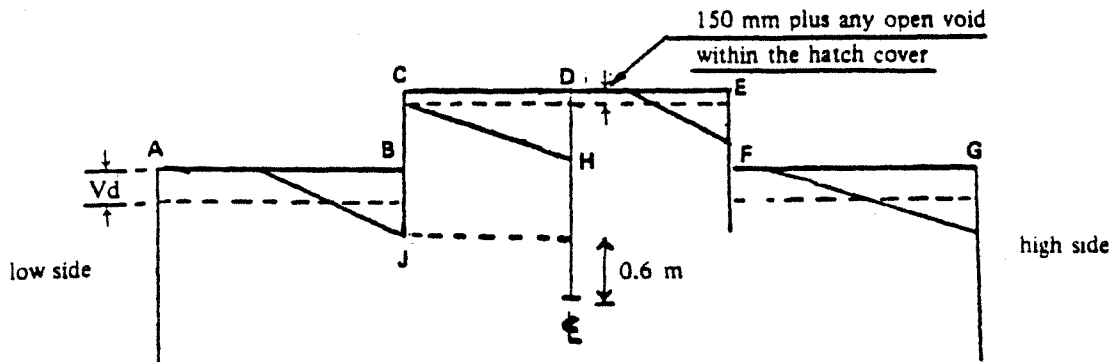

Figure 4

NOTES ON FIGURE 4:

- (1) If the centreline division is one which has been provided in accordance with Regulation 5(b)(ii) it shall extend to at least 0.6 m below H or J whichever gives the greater depth.
- (2) The excess void area from AB shall transfer to the low side half of the hatchway in which two separate final void areas will be formed viz. one against the centreline division and the other against the hatchside coaming and girder on the high side.
- (3) If a bagged saucer or bulk bundle is formed in a hatchway it shall be assumed, for the purpose of calculating transverse heeling moment, that such a device is at least equivalent to the centreline division.

(C) COMPARTMENTS LOADED IN COMBINATION

The following paragraphs describe the pattern of void behaviour which shall be assumed when compartments are loaded in combination:

- (a) Without effective centreline divisions:
 - (i) Under the upper deck – as for the single deck arrangement described in Section II(B) of this Part.
 - (ii) Under the second deck – the area of void available for transfer from the low side, i.e. original void area less area against the hatchside girder, shall be assumed to transfer as follows:
one half to the upper deck hatchway and one quarter each to the high side under the upper and second deck.
 - (iii) Under the third and lower decks – the void areas available for transfer from the low side of each of these decks shall be assumed to transfer in equal quantities to all the voids under the decks on the high side and the void in the upper deck hatchway.
- (b) With effective centreline divisions which extend into the upper deck hatchway:
 - (i) At all deck levels abreast the division the void areas available for transfer from the low side shall be assumed to transfer to the void under the low side half of the upper deck hatchway.
 - (ii) At the deck level immediately below the bottom of the division the void area available for transfer from the low side shall be assumed to transfer as follows:
one half to the void under the low side half of the upper deck hatchway and the remainder in equal quantities to the voids under the decks on the high side.
 - (iii) At deck levels lower than those described in sub-paragraphs (i) and (ii) above the void area available for transfer from the low side of each of those decks shall be assumed to transfer in equal quantities to the voids in each of the two halves of the upper deck hatchway on each side of the division and the voids under the decks on the high side.
- (c) With effective centreline divisions which do not extend into the upper deck hatchway:

Since no horizontal transfer of voids may be assumed to take place at the same deck level as the division the void area available for transfer from the low side at this level shall be assumed to transfer above the division to voids on the high sides in accordance with the principles of paragraphs (a) and (b) above.

20 AUG 1975

A VIII/Res.264

SECTION III - ASSUMED VOLUMETRIC HEELING MOMENT OF FEEDERS AND TRUNKS

(A) SUITABLY PLACED WING FEEDERS (See Figure 5)

It may be assumed that under the influence of ship motion underdeck voids will be substantially filled by the flow of grain from a pair of longitudinal feeders provided that:

- (a) the feeders extend for the full length of the deck and that the perforations therein are adequately spaced;
- (b) the volume of each feeder is equal to the volume of the underdeck void outboard of the hatchside girder and its continuation.

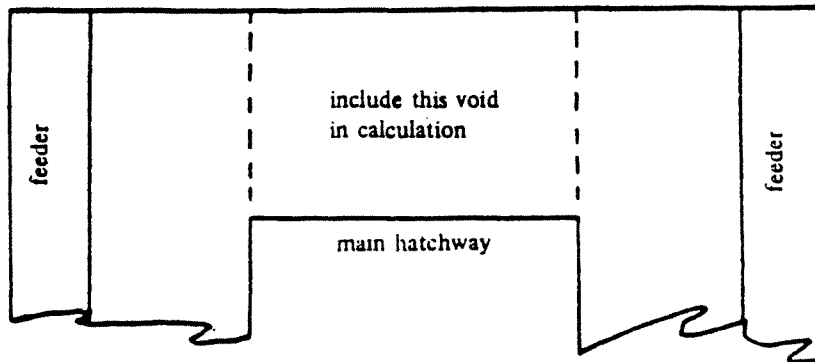

Figure 5

(B) TRUNKS SITUATED OVER MAIN HATCHWAYS

After the assumed shift of grain the final void pattern shall be as shown in Figure 6.

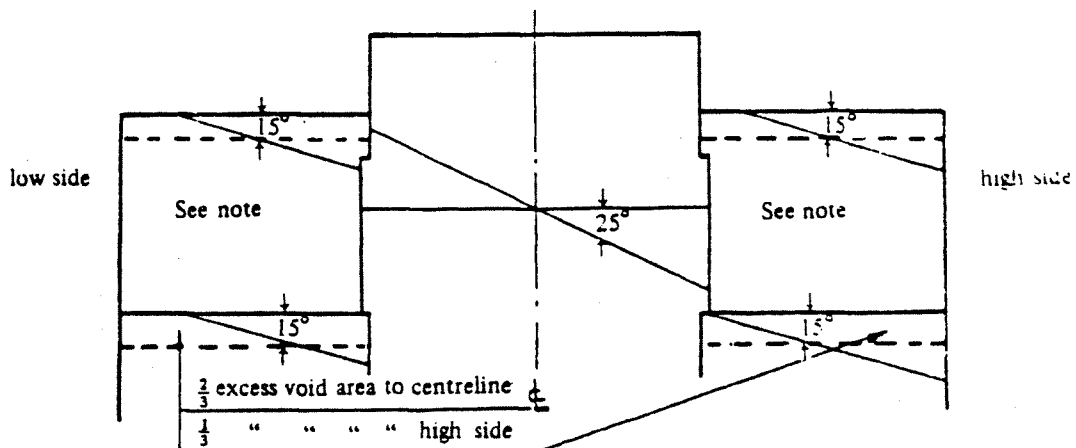

Figure 6

NOTE ON FIGURE 6:

If the wing spaces in way of the trunk cannot be properly trimmed in accordance with Regulation 3 it shall be assumed that a 25 degree surface shift takes place.

20 AUG 1975

A VIII/Res.264

SECTION IV - ASSUMED VOLUMETRIC HEELING MOMENT OF PARTLY FILLED COMPARTMENTS

(A) GENERAL

When the free surface of the bulk grain has not been secured in accordance with Regulation 6 it shall be assumed that the grain surface after shifting shall be at 25° to the horizontal.

(B) DISCONTINUOUS LONGITUDINAL DIVISIONS

In a compartment in which the longitudinal divisions are not continuous between the transverse boundaries, the length over which any such divisions are effective as devices to prevent full width shifts of grain surfaces shall be taken to be the actual length of the portion of the division under consideration less two-sevenths of the greater of the transverse distances between the division and its adjacent division or ship's side.

This correction does not apply in the lower compartments of any combination loading in which the upper compartment is either a "filled compartment" or a "partly filled compartment".

SECTION V - ALTERNATIVE LOADING ARRANGEMENTS FOR EXISTING SHIPS

(A) GENERAL

A ship loaded in accordance with either Sub-Section (B) or Sub-Section (C) below shall be considered to have intact stability characteristics at least equivalent to the requirements of Regulation 4(b). Documents of authorization permitting such loadings shall be accepted under the provisions of Regulation 10(e).

For the purpose of this Part, the term "Existing Ship" means a ship, the keel of which is laid before the date of coming into force of this Chapter.

(B) STOWAGE OF SPECIALLY SUITABLE SHIPS

(a) Notwithstanding anything contained in Part B of this Chapter, bulk grain may be carried without regard to the requirements specified therein in ships which are constructed with two or more vertical or sloping grain-tight longitudinal divisions suitably disposed to limit the effect of any transverse shift of grain under the following conditions:

- (i) as many holds and compartments as possible shall be full and trimmed full;
- (ii) for any specified arrangement of stowage the ship will not list to an angle greater than 5 degrees at any stage of the voyage where:
 - (1) in holds or compartments which have been trimmed full the grain surface settled 2 per cent by volume from the original surface and shifts to an angle of 12 degrees with that surface under all boundaries of these holds and compartments which have an inclination of less than 30 degrees to the horizontal;
 - (2) in "partly filled compartments or holds" free grain surfaces settle and shift as in sub-paragraph (ii)(1) of this paragraph or to such larger angle as may be deemed necessary by the Administration, or by a Contracting Government on behalf of the Administration, and grain surfaces if overstowed in accordance with Regulation 5 of this Chapter shift to an angle of 8 degrees with the original levelled surfaces. For the purpose of sub-paragraph (ii) of this paragraph shifting boards, if fitted, will be considered to limit the transverse shift of the surface of the grain;
- (iii) the master is provided with a grain loading plan covering the stowage arrangements to be adopted and a stability booklet, both approved by the Administration, or by a Contracting Government on behalf of the Administration, showing the stability conditions upon which the calculations given in sub-paragraph (ii) of this paragraph are based.

(b) The Administration, or a Contracting Government on behalf of the Administration, shall prescribe the precautions to be taken against shifting in all other conditions of loading of ships designed in accordance with paragraph (B)(a) of this Section which meet the requirements of sub-paragraphs (ii) and (iii) of that paragraph.

20 AUG 1975

A VIII/Res.264

(C) SHIPS WITHOUT DOCUMENTS OF AUTHORIZATION

A ship not having on board documents of authorization issued in accordance with Regulations 4 and 10 may be permitted to load bulk grain under the requirements of Sub-Section (B) above or provided that:

- (a) All "filled compartments" shall be fitted with centreline divisions extending for the full length of such compartments which extend downwards from the underside of the deck or hatch covers to a distance below the deck line of at least one-eighth of the maximum breadth of the compartment or 2.4 metres, whichever is the greater except that saucers constructed in accordance with Section II of Part C may be accepted in lieu of a centreline division in and beneath a hatchway.
- (b) All hatches to "filled compartments" shall be closed and covers secured in place.
- (c) All free grain surfaces in "partly filled compartments" shall be trimmed level and secured in accordance with Section II of Part C.
- (d) Throughout the voyage the metacentric height after correction for the free surface effects of liquids in tanks shall be 0.3 metre or that given by the following formula, whichever is the greater:

$$GM_R = \frac{L B V d (0.25 B - 0.645 \sqrt{V d B})}{SF \times \Delta \times 0.0875}$$

Where:

- L = total combined length of all full compartments;
- B = moulded breadth of vessel;
- SF = stowage factor;
- V = calculated average void depth as per paragraph (a)(i) of Section I(A) of this Part;
- Δ = displacement

PART C - GRAIN FITTINGS AND SECURING**SECTION I - STRENGTH OF GRAIN FITTINGS**

- (A) GENERAL (INCLUDING WORKING STRESSES)
- (B) DIVISIONS LOADED ON BOTH SIDES
- (C) DIVISIONS LOADED ON ONE SIDE ONLY
- (D) SAUCERS
- (E) BUNDLING OF BULK
- (F) SECURING HATCH COVERS IN FILLED COMPARTMENTS

SECTION II - SECURING OF PARTLY FILLED COMPARTMENTS

- (A) STRAPPING OR LASHING
- (B) OVERSTOWING ARRANGEMENTS
- (C) BAGGED GRAIN

SECTION I - STRENGTH OF GRAIN FITTINGS**(A) GENERAL**

(a) *Timber.* All timber used for grain fittings shall be of good sound quality and of a type and grade which has been proved to be satisfactory for this purpose. The actual finished dimensions of the timber shall be in accordance with the dimensions hereinafter specified in this Part. Plywood of an exterior type bonded with waterproof glue and fitted so that the direction of the grain in the face plies is perpendicular to the supporting uprights or binder may be used provided that its strength is equivalent to that of solid timber of the appropriate scantlings.

20 AUG 1975

A VIII/Res.264

(b) *Working Stresses.* When calculating the dimensions of divisions loaded on one side, using the Tables in paragraphs (C)(a) and (b) of this Part, the following working stresses should be adopted:

For divisions of steel2000 kg per square cm

For divisions of wood 160 kg per square cm

(c) *Other Materials.* Materials other than wood or steel may be approved for such divisions provided that proper regard has been paid to their mechanical properties.

(d) *Uprights*

(i) Unless means are provided to prevent the ends of uprights being dislodged from their sockets, the depth of housing at each end of each upright shall be not less than 75 mm. If an upright is not secured at the top, the uppermost shore or stay shall be fitted as near thereto as is practicable.

(ii) The arrangements provided for inserting shifting boards by removing a part of the cross-section of an upright shall be such that the local level of stresses is not unduly high.

(iii) The maximum bending moment imposed upon an upright supporting a division loaded on one side shall normally be calculated assuming that the ends of the uprights are freely supported. However, if an Administration is satisfied that any degree of fixity assumed will be achieved in practice, account may be taken of any reduction in the maximum bending moment arising from any degree of fixity provided at the ends of the upright.

(e) *Composite Section.* Where uprights, binders or any other strength members are formed by two separate sections, one fitted on each side of a division and inter-connected by through bolts at adequate spacing, the effective section modules shall be taken as the sum of the two moduli of the separate sections.

(f) *Partial Division.* Where divisions do not extend to the full depth of the hold such divisions and their uprights shall be supported or stayed so as to be as efficient as those which do extend to the full depth of the hold.

(B) DIVISIONS LOADED ON BOTH SIDES

(a) *Shifting Boards*

(i) Shifting boards shall have a thickness of not less than 50 mm and shall be fitted grain-tight and where necessary supported by uprights.

(ii) The maximum unsupported span for shifting boards of various thicknesses shall be as follows:

<i>Thickness</i>	<i>Maximum Unsupported Span</i>
50 mm	2.5 metres
60 mm	3.0 metres
70 mm	3.5 metres
80 mm	4.0 metres

If thicknesses greater than these are provided the maximum unsupported span will vary directly with the increase in thickness.

(iii) The ends of all shifting boards shall be securely housed with 75 mm minimum bearing length.

(b) *Other Materials.* Divisions formed by using materials other than wood shall have a strength equivalent to the shifting boards required in paragraph (B)(a) above.

(c) *Uprights*

(i) Steel uprights used to support divisions loaded on both sides shall have a section modulus given by

$$W = a \times W_1$$

Where:

W = section modulus in cm³;

a = horizontal span between uprights in metres.

The section modulus per metre span W_1 shall be not less than that given by the formula:

$$W_1 = 14.8 (h_1 - 1.2) \text{ cm}^3 \text{ per metre};$$

Where:

h_1 is the vertical unsupported span in metres and shall be taken as the maximum value of the distance between any two adjacent stays or between the stay or either end of the upright. Where this distance is less than 2.4 metres the respective modulus shall be calculated as if the actual value was 2.4 metres.

- (ii) The moduli of wood uprights shall be determined by multiplying by 12.5 the corresponding moduli for steel uprights. If other materials are used their moduli shall be at least that required for steel increased in proportion to the ratio of the permissible stresses for steel to that of the material used. In such cases attention shall be paid also to the relative rigidity of each upright to ensure that the deflection is not excessive.
 - (iii) The horizontal distance between uprights shall be such that the unsupported spans of the shifting boards do not exceed the maximum span specified in paragraph (B)(a)(ii) of this Section.
- (d) *Shores*
- (i) Wood shores, when used, shall be in a single piece and shall be securely fixed at each end and heeled against the permanent structure of the ship except that they shall not bear directly against the side plating of the ship.
 - (ii) Subject to the provisions of sub-paragraphs (iii) and (iv) below, the minimum size of wood shores shall be as follows:

<i>Length of Shore in metres</i>	<i>Rectangular Section</i>	<i>Diameter of Circular Section</i>
	mm	mm
Not exceeding 3 m	150 x 100	140
Over 3 m but not exceeding 5 m	150 x 150	165
Over 5 m but not exceeding 6 m	150 x 150	180
Over 6 m but not exceeding 7 m	200 x 150	190
Over 7 m but not exceeding 8 m	200 x 150	200
Exceeding 8 m	200 x 150	215

Shores of 7 metres or more in length shall be securely bridged at approximately mid-length.

- (iii) When the horizontal distance between the uprights differs significantly from 4 metres, the moments of inertia of the shores may be changed in direct proportion.
 - (iv) Where the angle of the shore to the horizontal exceeds 10 degrees the next larger shore to that required by sub-paragraph (ii) of this paragraph shall be fitted provided that in no case shall the angle between any shore and the horizontal exceed 45 degrees.
- (e) *Stays* Where stays are used to support divisions loaded on both sides, they shall be fitted horizontally or as near thereto as practicable, well secured at each end and formed of steel wire rope. The sizes of the wire rope shall be determined assuming that the divisions and upright which the stay supports are uniformly loaded at 500 kg/m². The working load so assumed in the stay shall not exceed one-third of its breaking load.

20 AUG 1975

A VIII/Rsa.264

(C) DIVISIONS LOADED ON ONE SIDE ONLY

(a) *Longitudinal Divisions.* The load in kg per metre length of the division shall be taken to be as follows:TABLE I¹

B (m)

h (m)	2	3	4	5	6	7	8	10
1.5	850	900	1010	1225	1500	1770	2060	2645
2.0	1390	1505	1710	1985	2295	2605	2930	3590
2.5	1985	2160	2430	2740	3090	3435	3800	4535
3.0	2615	2845	3150	3500	3885	4270	4670	5480
3.5	3245	3525	3870	4255	4680	5100	5540	6425
4.0	3890	4210	4590	5015	5475	5935	6410	7370
4.5	4535	4890	5310	5770	6270	6765	7280	8315
5.0	5185	5570	6030	6530	7065	7600	8150	9260
6.0	6475	6935	7470	8045	8655	9265	9890	11150
7.0	7765	8300	8910	9560	10245	10930	11630	13040
8.0	9055	9665	10350	11075	11835	12595	13370	14930
9.0	10345	11030	11790	12590	13425	14260	15110	16820
10.0	11635	12395	13230	14105	15015	15925	16850	18710

h = height of grain in metres from the bottom of the division²

B = transverse extent of the bulk grain in metres

For other values of h or B the loads shall be determined by linear interpolation or extrapolation as necessary.

(b) *Transverse Divisions.* The load in kg per metre length of the divisions shall be taken to be as follows:TABLE II¹

L (m)

h (m)	2	3	4	5	6	7	8	10	12	14	16
1.5	670	690	730	780	835	890	935	1000	1040	1050	1050
2.0	1040	1100	1170	1245	1325	1400	1470	1575	1640	1660	1660
2.5	1460	1565	1675	1780	1880	1980	2075	2210	2285	2305	2305
3.0	1925	2065	2205	2340	2470	2590	2695	2845	2925	2950	2950
3.5	2425	2605	2770	2930	3075	3205	3320	3480	3570	3595	3595
4.0	2950	3160	3355	3535	3690	3830	3950	4120	4210	4235	4240
4.5	3495	3725	3940	4130	4295	4440	4565	4750	4850	4880	4885
5.0	4050	4305	4535	4735	4910	5060	5190	5385	5490	5525	5530
6.0	5175	5465	5720	5945	6135	6300	6445	6655	6775	6815	6825
7.0	6300	6620	6905	7150	7365	7445	7700	7930	8055	8105	8115
8.0	7425	7780	8090	8360	8590	8685	8950	9200	9340	9395	9410
9.0	8550	8935	9275	9565	9820	9930	10205	10475	10620	10685	10705
10.0	9680	10095	10460	10770	11045	11270	11460	11745	11905	11975	11997

h = height of grain in metres from the bottom of the division²

L = longitudinal extent of the bulk grain in metres

For other values of h or L the loads shall be determined by linear interpolation or extrapolation as necessary.

¹ For the purpose of converting the above loads into British units (ton/ft) 1 kg per metre length shall be taken to be equivalent to 0.0003 ton per foot length.

² Where the distance from a division to a feeder or hatchway is 1 metre or less, the height - h - shall be taken to the level of the grain within that hatchway or feeder. In all cases the height shall be taken to the overhead deck in way of the division.

20 AUG 1975

A VIII/Res.264

(c) *Vertical Distribution of the Loads.* The total load per unit length of divisions shown in the Tables I and II above may, if considered necessary, be assumed to have a trapezoidal distribution with height. In such cases, the reaction loads at the upper and lower ends of a vertical member or upright are not equal. The reaction loads at the upper end expressed as percentages of the total load supported by the vertical member or upright shall be taken to be those shown in Tables III and IV below.

TABLE III

LONGITUDINAL DIVISIONS LOADED ON ONE SIDE ONLY

Bearing Reaction at the Upper End of Upright as Percentage of Load (Table I)

h (m)	B (m)							
	2	3	4	5	6	7	8	10
1.5	43.3	45.1	45.9	46.2	46.2	46.2	46.2	46.2
2	44.5	46.7	47.6	47.8	47.8	47.8	47.8	47.8
2.5	45.4	47.6	48.6	48.8	48.8	48.8	48.8	48.8
3	46.0	48.3	49.2	49.4	49.4	49.4	49.4	49.4
3.5	46.5	48.8	49.7	49.8	49.8	49.8	49.8	49.8
4	47.0	49.1	49.9	50.1	50.1	50.1	50.1	50.1
4.5	47.4	49.4	50.1	50.2	50.2	50.2	50.2	50.2
5	47.7	49.4	50.1	50.2	50.2	50.2	50.2	50.2
6	47.9	49.5	50.1	50.2	50.2	50.2	50.2	50.2
7	47.9	49.5	50.1	50.2	50.2	50.2	50.2	50.2
8	47.9	49.5	50.1	50.2	50.2	50.2	50.2	50.2
9	47.9	49.5	50.1	50.2	50.2	50.2	50.2	50.2
10	47.9	49.5	50.1	50.2	50.2	50.2	50.2	50.2

B = transverse extent of the bulk grain in metres

For other values of h or B the reaction loads shall be determined by linear interpolation or extrapolation as necessary.

TABLE IV

TRANSVERSE DIVISIONS LOADED ON ONE SIDE ONLY

Bearing Reaction at the Upper End of Upright as Percentage of Load (Table II)

h (m)	L (m)										
	2	3	4	5	6	7	8	10	12	14	16
1.5	37.3	38.7	39.7	40.6	41.4	42.1	42.6	43.6	44.3	44.8	45.0
2	39.6	40.6	41.4	42.1	42.7	43.1	43.6	44.3	44.7	45.0	45.2
2.5	41.0	41.8	42.5	43.0	43.5	43.8	44.2	44.7	45.0	45.2	45.2
3	42.1	42.8	43.3	43.8	44.2	44.5	44.7	45.0	45.2	45.3	45.3
3.5	42.9	43.5	43.9	44.3	44.6	44.8	45.0	45.2	45.3	45.3	45.3
4	43.5	44.0	44.4	44.7	44.9	45.0	45.2	45.4	45.4	45.4	45.4
5	43.9	44.3	44.6	44.8	45.0	45.2	45.3	45.5	45.5	45.5	45.5
6	44.2	44.5	44.8	45.0	45.2	45.3	45.4	45.6	45.6	45.6	45.6
7	44.3	44.6	44.9	45.1	45.3	45.4	45.5	45.6	45.6	45.6	45.6
8	44.3	44.6	44.9	45.1	45.3	45.4	45.5	45.6	45.6	45.6	45.6
9	44.3	44.6	44.9	45.1	45.3	45.4	45.5	45.6	45.6	45.6	45.6
10	44.3	44.6	44.9	45.1	45.3	45.4	45.5	45.6	45.6	45.6	45.6

L = longitudinal extent of the bulk grain in metres

For other values of h or L the reaction loads shall be determined by linear interpolation or extrapolation as necessary.

20 AUG 1975

A VIII/Res.264

The strength of the end connections of such vertical members or uprights may be calculated on the basis of the maximum load likely to be imposed at either end. These loads are as follows:

Maximum load at the top	50% of the appropriate total load from Table I
Longitudinal Divisions	
Maximum load at the bottom	55% of the appropriate total load from Table I
Maximum load at the top	45% of the appropriate total load from Table II
Transverse Divisions	
Maximum load at the bottom	60% of the appropriate total load from Table II

The thickness of horizontal wooden boards may also be determined having regard to the vertical distribution of the loading represented by Tables III and IV above and in such cases

$$t = 10 a \sqrt{\frac{p \times k}{h \times 213.3}}$$

Where:

- t = thickness of board in mm;
- a = horizontal span of the board i.e. distance between uprights in metres;
- h = head of grain to the bottom of the division in metres;
- p = total load per unit length derived from Table I or II in kg;
- k = factor dependent upon vertical distribution of the loading.

When the vertical distribution of the loading is assumed to be uniform, i.e. rectangular, k shall be taken as equal to 1.0. For a trapezoidal distribution

$$k = 1.0 + 0.06 (50-R)$$

Where:

R is the upper end bearing reaction taken from Table III or IV.

(d) *Stays or Shores*. The sizes of stays and shores shall be so determined that the loads derived from Tables I and II in the preceding paragraphs (a) and (b) shall not exceed one-third of the breaking loads.

(D) SAUCERS

When a saucer is used to reduce the heeling moments in a "filled compartment", its depth, measured from the bottom of the saucer to the deck line, shall be as follows:

- For ships with a moulded breadth of up to 9.1 metres, not less than 1.2 metres.
- For ships with a moulded breadth of 18.3 metres or more, not less than 1.8 metres.
- For ships with a moulded breadth between 9.1 metres and 18.3 metres, the minimum depth of the saucer shall be calculated by interpolation.

The top (mouth) of the saucer shall be formed by the underdeck structure in the way of the hatchway, i.e. hatchside girders or coamings and hatchend beams. The saucer and hatchway above shall be completely filled with bagged grain or other suitable cargo laid down on a separation cloth or its equivalent and stowed tightly against adjacent structures and the portable hatchway beams if the latter are in place.

(E) BUNDLING OF BULK

As an alternative to filling the saucer with bagged grain or other suitable cargo a bundle of bulk grain may be used provided that:

- (a) The saucer is lined with a material acceptable to the Administration having a tensile strength of not less than 274 kg per 5 cm strip and which is provided with suitable means for securing at the top.

- (b) As an alternative to paragraph (a) above a material acceptable to the Administration having a tensile strength of not less than 137 kg per 5 cm strip may be used if the saucer is constructed as follows:

Athwartship lashings acceptable to the Administration shall be placed inside the saucer formed in the bulk grain at intervals of not more than 2.4 metres. These lashings shall be of sufficient length to permit being drawn up tight and secured at the top of the saucer.

Dunnage not less than 25 mm in thickness or other suitable material of equal strength and between 150 to 300 mm in width shall be placed fore and aft over these lashings to prevent the cutting or chafing of the material which shall be placed thereon to line the saucer.

- (c) The saucer shall be filled with bulk grain and secured at the top except that when using material approved under paragraph (b) above further dunnage shall be laid on top after lapping the material before the saucer is secured by setting up the lashings.
- (d) If more than one sheet of material is used to line the saucer they shall be joined at the bottom either by sewing or a double lap.
- (e) The top of the saucer shall be coincidental with the bottom of the beams when these are in place and suitable general cargo or bulk grain may be placed between the beams on top of the saucer.

(F) SECURING HATCH COVERS OF FILLED COMPARTMENTS

If there is no bulk grain or other cargo above a "filled compartment" the hatch covers shall be secured in an approved manner having regard to the weight and permanent arrangements provided for securing such covers.

The documents of authorization issued under Regulation 10 shall include reference to the manner of securing considered necessary by the Administration issuing such documents.

SECTION II - SECURING OF PARTLY FILLED COMPARTMENT

(A) STRAPPING OR LASHING

- (a) When, in order to eliminate heeling moments in "partly filled compartments", strapping or lashing is utilized, the securing shall be accomplished as follows:
- (i) The grain shall be trimmed and levelled to the extent that it is very slightly crowned and covered with burlap separation cloths, tarpaulins or the equivalent.
 - (ii) The separation cloths and/or tarpaulins shall overlap at least 1.8 metres.
 - (iii) Two solid floors of rough 25 mm by 150 mm to 300 mm lumber shall be laid with the top floor running longitudinally and nailed to an athwartships bottom floor. Alternatively, one solid floor of 50 mm lumber, running longitudinally and nailed over the top of a 50 mm bottom bearer not less than 150 mm wide, may be used. The bottom bearers shall extend the full breadth of the compartment and shall be spaced not more than 2.4 metres apart. Arrangements utilizing other materials and deemed by an Administration to be equivalent to the foregoing may be accepted.
 - (iv) Steel wire rope (19 mm diameter or equivalent), doubled steel strapping (50 mm x 1.3 mm and having a breaking load of at least 5000 kg), or chain of equivalent strength, each of which shall be set tight by means of a 32 mm turnbuckle, may be used for lashings. A winch tightener, used in conjunction with a locking arm, may be substituted for the 32 mm turnbuckle when steel strapping is used, provided suitable wrenches are available for setting up as necessary. When steel strapping is used, not less than three crimp seals shall be used for securing the ends. When wire is used, not less than four clips shall be used for forming eyes in the lashings.
 - (v) Prior to the completion of loading the lashing shall be positively attached to the framing at a point approximately 450 mm below the anticipated final grain surface by means of either a 25 mm shackle or beam clamp of equivalent strength.
 - (vi) The lashings shall be spaced not more than 2.4 metres apart and each shall be supported by a bearer nailed over the top of the fore and aft floor. This bearer shall consist of not less than 25 mm by 150 mm lumber or its equivalent and shall extend the full breadth of the compartment.
 - (vii) During the voyage the strapping shall be regularly inspected and set up where necessary.

Encl. (1) to NVC 3-75
20 AUG 1975

A VIII/Res.264

(B) OVERSTOWING ARRANGEMENTS

Where bagged grain or other suitable cargo is utilized for the purpose of securing "partly filled compartments", the free grain surface shall be covered with a separation cloth or equivalent or by a suitable platform. Such platforms shall consist of bearers spaced not more than 1.2 metres apart and 25 mm boards laid thereon spaced not more than 100 mm apart. Platforms may be constructed of other materials provided they are deemed by an Administration to be equivalent.

(C) BAGGED GRAIN

Bagged grain shall be carried in sound bags which shall be well filled and securely closed.

20 AUG 1975

Resolution A.264(VIII)

Corrections

Page 8 – Notes on Figure 1

Replace "(a)" and "(b)" by "(1)" and "(2)".

Page 9 – Notes on Figure 2

Number paragraphs (1) and (2).

Page 9 – Figure 3

Delete () around 150 mm.

Page 13 – Section (C) paragraph (d)

Penultimate line should read:

"Vd = calculated average void depth as per paragraph (a)(i) of Section I(A) of this Part;"

Page 18

First paragraph should read as follows:

"The strength of the end connections of such vertical members or uprights may be calculated on the basis of the maximum load likely to be imposed at either end. These loads are as follows:

Longitudinal Divisions

Maximum load at the top	50% of the appropriate total load from Table I
Maximum load at the bottom	55% of the appropriate total load from Table I

Transverse Divisions

Maximum load at the top	45% of the appropriate total load from Table II
Maximum load at the bottom	60% of the appropriate total load from Table II"