



---

at the CENTER FOR URBAN TRANSPORTATION RESEARCH  
University of South Florida  
Florida State University  
Florida A&M University  
Florida International University

---



PB99-140154

## At-Grade Busway Planning Guide

L. David Shen, Hesham Elbadrawi, Fang Zhao and Diana Ospina  
Principal Investigators  
Florida International University

December 1998



Lehman Center for Transportation Research  
College of Engineering and Design  
Florida International University  
The State University of Florida at Miami  
Miami, FL 33199  
TEL: (305) 348-3055  
FAX: (305) 348-4057





1. Report No. <b>NUTI95FIU1.2</b>	2. Government Accession No.	3.  PB99-140154
4. Title and Subtitle <b>At-Grade Busway Planning Guide</b>	5. Report Date <b>December 1998</b>	6. Performing Organization Code
	8. Performing Organization Report No.	
7. Author(s) <b>L. David Shen, Hesham Elbadrawi, Fang Zhao and Diana Ospina</b>	10. Work Unit No.	11. Contract or Grant No.
9. Performing Organization Name and Address <b>National Urban Transit Institute          Lehman Center for Transportation Research, Florida International University          University Park, Miami, FL 33199</b>	13. Type of Report and Period Covered <b>Sept. 1997 through December 1998</b>	14. Sponsoring Agency Code
	12. Sponsoring Agency Name and Address <b>Office of Research and Special Programs          U.S. Department of Transportation, Washington, D.C. 20690</b>	
15. Supplementary Notes <b>Supported by a grant from the U.S. Department of Transportation, University Research Institute Program</b>		
16. Abstract <p>At-grade busways can be a major component of strategies designed to make better use of existing transit facilities with relatively low capital expenditures. The objective of at-grade busways is to attract auto drivers or other transit users from major traffic corridors by improving comfort, economy, travel time, and quality of transit services and providing express services that collect transit riders from residential neighborhoods and parking facilities. The main advantages of at-grade busway transit system include flexibility, self-enforcement, incremental development, low construction costs, and implementation speed. While it is important that the general public understands the technical aspects of at-grade busways, it is even more important that the potential users become aware of the enhanced quality of services provided by a busway system and its attractiveness in terms of shorter commuting time and minimal environmental impact. This report presents to transportation official a guideline for planning and design consideration for at-grade busway systems. The report reviews planning procedure for selected busway systems in North and South America, Europe, and other developing countries. Design issues to assure a safer operation of at-grade busway systems are also presented in this report. The information presented in this report in general and it can be modified according to the needs of each transit agency.</p>		
17. Key Words <b>busways, at-grade busways, public transit, planning, implementation</b>	18. Distribution Statement <b>Available to the public through the National Technical Information Service (NTIS), 5285 Port Royal Road, Springfield, VA 22181, ph</b>	
19. Security Classif. (of this report) <b>Unclassified</b>	20. Security Classif. (of this page) <b>Unclassified</b>	21. No. of pages
22. Price		

## **ACKNOWLEDGMENT**

This project is made possible through a grant from the National Urban Transit Institute (NUTI). Their support is gratefully acknowledged.

We would like to express our sincere thanks to the following individuals:

Sataya Pinapaka, a graduate assistant, for his effort in research in the literature and collecting and compiling information on busway transit systems. For Ms. Vivian Donis for her grammatical review of the report and for her administrative efforts made this project possible.

We would like to our Florida Department of Transportation District VI, Miami-Dade Transit Agency and Miami-Dade Metropolitan Planning Organization for the encouragement and their technical support.

The views expressed here are those of the authors' and do not reflect the opinions or policies of the National Urban Transit Institute.

## Table of Contents

1.0	INTRODUCTION .....	1
2.0	LITERATURE REVIEW .....	3
2.1	Ottawa, Canada .....	3
2.2	Pittsburgh, PA .....	7
2.3	Runcorn, UK .....	10
2.4	Brisbane City, Queensland .....	12
2.5	Abidjan, Cote D'Ivoire .....	17
2.6	Ankara, Turkey .....	17
2.7	Belo Horizonte, Brazil .....	18
2.8	Istanbul, Turkey .....	18
2.9	Porto Alegre, Brazil .....	19
2.10	Sao Paulo, Brazil .....	20
3.0	AT-GRADE BUSWAY SAFETY .....	24
3.1	Overview of Accident Types and Possible Solutions .....	24
3.1.1	Side-Aligned At-Grade Busways .....	24
3.1.2	Medina At-Grade Busways .....	25
3.2	Alignment Consideration .....	26
3.3	Intersection Design and Control .....	26
3.4	Safety Analysis of the South Miami-Dade Busway .....	26
4.0	BUSWAY PLANNING .....	29
4.1	Introduction .....	29
4.2	Busway Performance .....	31
4.2.1	Effect of Special Operational Measures .....	31
4.3	Capacity of At-Grade Busways .....	34
4.3.1	Development of Revised Capacity Estimate .....	36
4.3.2	Capacity Adjustment for the Availability of Overtaking Facilities .....	38
4.4	Bus Stop Capacity .....	39
5.0	DESIGN GUIDELINES FOR AT-GRADE BUSWAYS .....	41
5.1	Introduction .....	41
5.2	Right-of-Way Characteristics .....	41
5.2.1	Median At-grade Busway Cross-section .....	42
5.2.2	Side-Aligned At-grade Busway Cross-section .....	45
5.3	Bus Stop Characteristics .....	47
5.3.1	Bus Stop Location .....	47
5.3.2	Station Amenities .....	49

5.4	Customer Information at Bus Stops .....	54
5.5	Elderly and Disabled Requirements .....	56
5.6	Bike Lanes .....	57
5.7	Horizontal and Vertical Clearance for Buses .....	59
6.0	PAVEMENT DESIGN .....	61
6.1	Types of Pavements .....	61
6.2	Design Factors .....	62
7.0	TRAFFIC CONTROL DEVICES .....	65
7.1	Busway Signing and Pavement Marking .....	65
7.1.1	Signing .....	65
7.1.2	Pavement Marking .....	68
7.2	Priority at Traffic Signals .....	70
7.2.1	Phase Splitting .....	71
7.2.2	Preferential Treatment .....	71
7.2.3	Simulation .....	73
8.0	BUSWAY LIGHTING .....	76
9.0	CONCLUSION .....	77
10.0	REFERENCES .....	79

## List of Tables

Table 2.1	Total Annual Cost Comparison Based on 625,000 Pop. Level . . . . .	4
Table 2.2	Technical and Operating Fact for Ottawa Transitway . . . . .	6
Table 2.3	Total Daily Transit Trips to Work By Allegheny County Workers . . . . .	7
Table 2.4	PAT Fiscal Performance for Selected Years . . . . .	7
Table 2.5	Key Performance Indicators for Brisbane for 1991 and 2011 . . . . .	12
Table 2.6	Physical Characteristics of Busways Surveyed . . . . .	22
Table 2.7	Passenger Boarding Times by City and Fare Collection Arrangements . . . . .	22
Table 2.8	Maximum Observed Peak Hour Bus Flow, Available Passenger Places and Passenger Flows at Peak Load Points on Selected Busways . . . . .	23
Table 4.1	Similar Types of Bus Lanes and Busways . . . . .	35
Table 4.2	Level of Service for Bus Stops . . . . .	37
Table 4.3	Values of Percent Failure and Associated One-Tail Normal Variate, $Z_a$ . . . . .	38
Table 4.4	Capacity Analysis for Pittsburgh Busway . . . . .	39
Table 5.1	Recommended Cross-section Widths for Median At-grade Busways Without Overtaking Facilities Carrying More than 60 Buses/hour . . . . .	45
Table 5.2	Recommended widths of Bike Lanes . . . . .	57
Table 7.1	Safe Stopping Distance and Detector Setback . . . . .	74

## List of Figures

Figure 2.1	Ottawa Transitway Station .....	5
Figure 2.2	Runcorn's Busway .....	10
Figure 2.3	Runcorn Busway Alignment .....	11
Figure 2.4	Brisbane City Past and Expected Growth in Population, Vehicle Trips/day and Vehicle km/day .....	13
Figure 2.5	Arterial Street Busway Plan .....	15
Figure 2.6	Intersection Busway Grade Separation .....	15
Figure 2.7	The Kizilay Bus Stop with no Overtaking Facility, Ankara, Turkey .....	17
Figure 2.8	Off-line Bays for Belo Horizonte Busway .....	18
Figure 2.9	Lateral Busway Using One Half of a Dual Roadway, Istanbul, Turkey .....	19
Figure 2.10	Bus Ordering Assembly Area, Assis, Brazil .....	20
Figure 2.11	Median Busway, Sao Paulo Brazil .....	21
Figure 3.1	South Dade Busway Configuration .....	26
Figure 3.2	South Dade Busway Collision Diagrams .....	28
Figure 4.1	Feasibility of Busway Along Exiting Road .....	30
Figure 4.2	Operating Speeds for Selected Busways .....	31
Figure 4.3	Relationship between Line-haul Throughput and Passenger Transfer Demand	32
Figure 4.4	Trunk and Feeder Service in Curitiba, Brazil .....	32
Figure 4.5	Bus Ordering Technique .....	33
Figure 4.6	Off-board Ticketing, Curitiba, Brazil .....	34
Figure 5.1	Typical Busway Cross-section in New Roadways or Abandoned right-of-way	41
Figure 5.2	Typical Busway Configuration .....	42
Figure 5.3	Typical Bus stop Layout ,Belo Horizonte, Brazil .....	43
Figure 5.4	Typical Bus Stop Layout, Sao Paulo, Brazil .....	43
Figure 5.5	Median At-grade Busway, Curitiba, Brazil .....	44
Figure 5.6	Median At-grade Busway, Belo Horizonte, Brazil .....	44
Figure 5.7	Median At-grade Busway Cross-section .....	45
Figure 5.8	Typical Cross-section of a Side-aligned At-grade Busway, Miami, FL .....	46
Figure 5.9	Side-aligned At-grade Busway at Station Area with Overtaking Facility, Miami, FL .....	46
Figure 5.10	Different Locations of a Busway Stop .....	48
Figure 5.11	Ottawa Transitway Station .....	49
Figure 5.12	South Dade Busway Station, Miami, FL .....	50
Figure 5.13	Lights at Busway Stations .....	50
Figure 5.14	Bike locker .....	51
Figure 5.15	Dual Bike Locker .....	51
Figure 5.16	Bike Rack .....	52
Figure 5.17	Vending Machine at Bus Stops .....	52
Figure 5.18	Communication Facilities at South Dade Busway .....	53



Figure 5.19	Route Information at South Dade Busway Stop . . . . .	55
Figure 5.20	Electronic Transit Information Panel at a Bus Stop . . . . .	55
Figure 5.21	Shelter Design Example to Meet ADA Requirements . . . . .	56
Figure 5.22	Wheelchair Lift in Operation . . . . .	56
Figure 5.23	Light for Bike Lanes at Intersections . . . . .	58
Figure 5.24	Vertical and horizontal Illumination . . . . .	59
Figure 5.25	Vertical and Horizontal Clearance for Busways . . . . .	60
Figure 6.1	Typical Cross-section of Conventional Flexible Pavement . . . . .	61
Figure 6.2	Typical Cross-section of Full Depth Asphalt Pavement . . . . .	61
Figure 6.3	Typical Cross-section of CRAM . . . . .	62
Figure 6.4	Typical Cross-section of a Rigid Pavement . . . . .	62
Figure 6.5	Cross-section for Busway Flexible Pavement . . . . .	63
Figure 6.6	Cross-section for Busway rigid Pavement . . . . .	63
Figure 6.7	Cross-section for Bus Pad Rigid Pavement . . . . .	64
Figure 6.8	Concrete Bus Pad at Bus Stops . . . . .	64
Figure 7.1	Sign at the Entrance of South Dade Busway . . . . .	66
Figure 7.2	Busway Crossing Sign at an At-grade Intersection, Miami, FL . . . . .	66
Figure 7.3	“STOP HERE ON RED” Sign, Miami, FL . . . . .	67
Figure 7.4	Bike Lane Sign along the Busway . . . . .	67
Figure 7.5	Pavement Marking at the Entrance of South Dade At-grade Busway . . . . .	68
Figure 7.6	Pavement Marking at the Entrance of the Busway in Hong Kong . . . . .	69
Figure 7.7	“BUS ONLY” Pavement Marking at South Dade Busway At-grade Busway Intersection . . . . .	69
Figure 7.8	South Dade Busway Center Line Pavement Marking . . . . .	70
Figure 7.9	Method of Phase-splitting to reduce Bus Delay at Traffic Signals . . . . .	63

## 1.0 INTRODUCTION

The basic traffic and transit goals should be to improve the speed, reliability, and capacity of bus operations (TCRP Report 26). Bus speed and capacities depend on how frequent the bus stops are placed, where the bus stops are located, traffic conditions along the busway, and whether buses can pass and overtake each other. Bus travel times and speeds are important to the transit passenger, transit operator, traffic engineer, and transportation planner. The transit passenger wants a quick and dependable trip while, the transit operator measures and analyzes bus speeds to set, monitor, and refine schedules; estimates vehicle requirements; and plans new routes and services. The traffic engineer uses bus speed to assess the impacts of traffic control and bus priority treatments. The transportation planner uses speeds to quantify congestion and provide input to transit demand and modeling process.

Busway transit with the physical separation of buses and other traffic, is a true urban mass rapid transit option. Comparable to Light Rapid Transit (LRT), busway transit offers the possibility of introducing a mass transit system at a relatively low cost. It is important to distinguish busway transit from other bus priority measures which are more limited in their scope. When a new town is to be built, the opportunity can sometime be taken to provide a busway which will go nearer to houses, shops and workplaces than conventional public transit services or in some case than private automobiles, giving the bus an advantage over other private modes of transportation. As car ownership increases congestion on streets, the busway will remain free from congestion at all times and this will give more powerful encouragement for the use of public transportation.

At-grade busways can be a major component of strategies designed to make better use of existing transit facilities with relatively low capital expenditures. The objective of at-grade busways is to attract auto drivers or other transit users from major traffic corridors by improving comfort, economy, travel time, and quality of transit services and providing express services that collect transit riders from residential neighborhoods and parking facilities.

The main advantages of at-grade busway transit systems include the following (Shen et al., 1997):

- **Flexibility** - Since buses can approach and leave a busway at intermediate points, many routes effectively serve the passenger catchment area, with significantly fewer passenger transfers than would be required with a fixed guided system. Busway transit can also closely match capacity and service quality to changing passenger demands. In most cases, they can provide one seat trips.
- **Self-enforcement** - Because a busway physically separates buses from general traffic, busways are virtually self-enforcing and are therefore superior to traditional "paint-and-sign" bus lane priorities.

- **Incremental Development** - Busway transit can be implemented in stages and sections of even a few hundred meters, whereas rail transit requires a depot and significant route length before it can attract many passengers. Busways can be expanded incrementally and can be enhanced and implemented in phases by adding physical separation from general traffic causing a minimum disturbance to traffic.
- **Low Construction Costs** - Busways may be implemented at a relatively lower cost by using existing or abandoned right-of-way or a street median. Moreover, the busway technology is less complicated than the rail technology, thus lower maintenance and operating costs. Also, there is no need to buy special transit vehicles for the busway, existing fleet bus can be used.
- **Implementation Speed** - A busway may be implemented relatively quickly since special legislation is seldom necessary and the track and vehicles are inherently less complex than those of rail systems. Nevertheless, negotiations with existing operators can be politically sensitive and protracted.

While it is important that the general public understands the technical aspects of at-grade busways, it is even more important that the potential users become aware of the enhanced quality of services provided by a busway system and its attractiveness in terms of shorter commuting time, speed and minimal environmental impact.

This report focuses on the planning and design issues related to at-grade busway transit systems with at-grade intersections. While, the literature review of several at-grade busway systems in North and South America, Europe, Australia, and other development countries is presented in **Section 2**, this section is considered to be a follow up for a previous project entitled: "At-grade Busway Study", **Section 3** presents issues associate with the implementation of at-grade busway, as well as a the latest safety statistics for South Miami-Dade Busway. **Sections 4** and **5** present planning and design aspects that should be taken into considerations with planning for an at-grade busway system. Choosing the proper type of pavement and traffic control devices are presented in **Sections 6** and **7**, respectively. As lighting is considered to be an important factor to enhance the operations of the busway, as well as the safety of its users, several considerations are presented in **Section 8**. In the remainder of this document the term busway is often used interchangeably with at-grade busway.

## **2.0 LITERATURE REVIEW**

### **2.1 Ottawa, Canada**

Ottawa has the most successful extensive busway system in North America. The region consists of 11 rural and urban municipalities with a metropolitan region population of 650,000 persons. Ninety percent of the population resides within the urban areas. Employment is dominated by the federal government which accounts for 22% of all jobs in the region and half of the 28% of all jobs that are located in the downtown area. Due to an anticipated increase in the metropolitan population, employment and increase in the transit ridership, the transit operating agency's (OC Transpo) task was to develop a rapid transit plan for the region. Attracting the commuter was the key to success as they made up the single largest group of period travelers (Bonsall 1989).

OC Transpo adopted a two-phase approach. First, it made every effort to increase the efficiency and use of the existing bus system in the region. This includes efforts to spread out the peak period and the implementation of various bus priority measures. OC Transpo's consultant suggested that the region would be best served by an outside-in transit development strategy. This entailed building the rapid transit lines from the outside relying initially on surface street operations in the central area. The downtown segment was the most expensive to construct and was therefore deferred in favor of less costly construction in the corridor leading to the downtown. The near term benefit/cost ratios were much higher for the relatively inexpensive outer segments than for the costly CBD links. Also, forecasts of future transit use indicated that the building of a costly tunnel or any other grade-separated facility in the downtown area could be safely deferred for 20 to 25 years (USDOT, 1992).

By using the outside-in approach Ottawa was able to begin the building of three segments of the busway with the largest net benefits, meaning the congested travel corridors leading to downtown. The choice of a specific technology was strongly influenced by the outside-in approach. As such, the technologies considered were limited to systems that could operate at-grade on downtown streets. This produced two viable options, a busway or a light rail system. Based on a transit system that can handle up to 15,000 passenger/hr/direction and can operate at-grade in the downtown area, the following four rapid transit alternatives were investigated: (USDOT, 1992)

(1) A busway system using standard buses. The busway operations should include semi-express and local stopping services and are designed to minimize transfers by combining feeder and line-haul routes whenever possible.

(2) A bus transitway system with the same characteristics as (1), except that articulated buses are used wherever there is sufficient projected use to maintain a minimum ten-minute peak period headway.

(3) An LRT system with standard bus feeder routes.

(4) An LRT system identical to (3), except that articulated buses are used rather than standard buses whenever demand is sufficient to use them without reducing peak period headways below 10 minutes.

These four alternatives were then compared using the following criteria; capital and operating costs, level of service, staging flexibility, and environmental impact. OC Transpo gave the heaviest weight to the total annual system cost (USDOT, 1992). The total annual costs (1989 dollars) for the four alternatives were obtained by adding total annual operating costs to the annualized costs of each component of capital cost as shown in **Table 2.1**. The busway using articulated buses proved to be the least expensive with an annual cost of \$117 million. The LRT with standard feeder and local service with an annual cost of \$140 million was the most expensive alternative. The lower operating costs of the busway alternative are due to its close demand/capacity relationship and savings from the interlining of buses between routes on the busway. With the rail system, the opportunity to short turn trains is limited so that the train capacity exceeds the demand except in the downtown area. In the case of the busway, the use of many different bus routes produces a greater opportunity to adjust the overall system capacity to match the demand as it varies along the transitway. The lower operating cost of the best busway to the best LRT alternative reflects the fact that busway alternatives can achieve a better match between demand and capacity (USDOT, 1992).

**Table 2.1 - Total Annual Cost Comparison Based on 625,000 Population Level  
(Millions of 1989 US Dollars)**

Cost	Busway		Light Rail	
	Standard Bus	Articulated Bus	Standard Bus	Articulated Bus
<b>Annual Operating Costs</b>	\$93.93	\$83.67	\$91.83	\$84.42
<b>% of Low Cost Alternative</b>	112%	100%	110%	101%
<b>Annual Capital Costs</b>	\$32.11	\$32.95	\$48.73	\$49.54
<b>% of Low Cost Alternative</b>	97%	100%	148%	150%
<b>Total Costs</b>	<b>\$126.04</b>	<b>\$116.62</b>	<b>\$140.56</b>	<b>\$133.97</b>
<b>% of Low Cost Alternative</b>	108%	100%	121%	115%

The busways are designed so that Ottawa's Transitway system will be able to accommodate a large increase in passenger demand in the future. System planners originally designed the busways so that they could be converted to light rail which was up-gradable to heavy rail, if the future levels of ridership make such conversion is necessary. The proposed CBD bus tunnel is also being designed to permit conversion to heavy rail.

Busway stations provide passenger loading and unloading, protection from inclement weather, and information services. Fares are collected on board the buses. However, over 75 percent of the passengers use monthly passes and cash passengers must pay the exact fare as drivers do not provide change. Fares vary by time of the day and area served.

Station platforms on the grade-separated portions of the busway are 55 m. long, providing sufficient space for up to three buses to load and unload passengers at the same time. Winters are quite bitter in Ottawa, thus each station consists of a series of small shelters linked by covered walkways as shown in **Figure 2.1**. The shelters are designed to accommodate different types of buses operated by OC Transpo. Shelter door openings are designed in such a way that the buses' front and rear doors line up with the shelter doorways. During the cold Ottawa winters the shelters are heated for the comfort of waiting passengers.

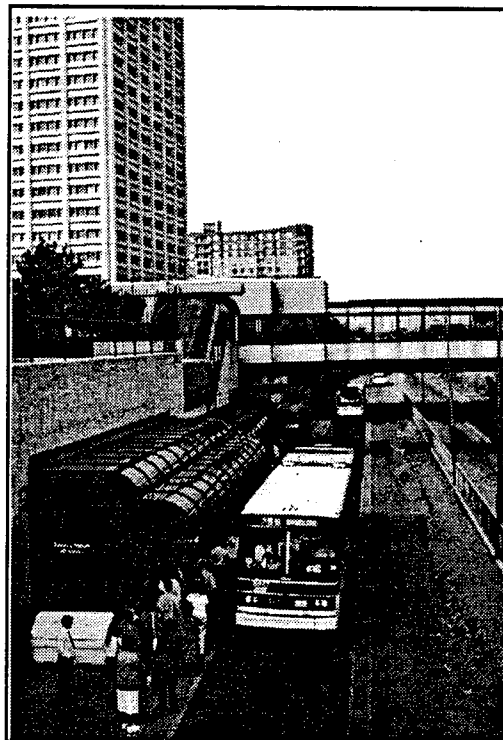

**Figure 2.1 - Ottawa Transitway Station**

The busway services in Ottawa include a mixture of different route types. Some is exclusive busway service operating along the busway and stopping at each station as rapid transit service. Other routes operate on both the surface and part or all of the busway. Technical and operation characteristics of the Ottawa transitway is shown in **Table 2.2**.

**Table 2.2 - Technical and Operating Fact for Ottawa Transitway**

<b>TECHNICAL FACTS</b>	
<b>Length</b>	
Exclusive right-of-way	19.6 km
Priority lanes	9.7 km
Mixed traffic	3.3 km
<b>Total</b>	<b>32.6 km</b>
<b>Stations</b>	
Number of Stations	23 stations
Platforms	6 m wide x 55 m long
<b>Roadway Width</b>	
Mainline	13 m (2-lane, 8 m roadway with 2.5 m shoulders)
Stations	17 m (2 platform service lanes, and two passing lanes)
<b>Park and Ride Spaces</b>	1535 parking spaces (4 park-and-ride lots)
<b>OPERATIONAL FACTS</b>	
<b>Ridership</b>	
Weekday passenger volume	200,000 passengers
Peak hour passenger volume	10,000 Passengers/hour/direction
<b>Bus Service</b>	
Number of daily buses	700 buses
Number of buses/peak hour/direction through CBD	190 buses
Express routes	78 routes
Local routes	46 routes
Trunk route	7 routes

Source: OC Transpo Fact Sheet, 1996.

## 2.2 Pittsburgh, PA

The Port Authority of Allegheny County (PAAC), through its Port Authority Transit Division (PAT) is the first transit operator in the United States that has built and operated exclusive busways. Pittsburgh is one of the nation's most important transit market (*Development Along a Busway, a Case Study of Development along the East Busway in Pittsburgh, Pennsylvania, 1996*). In 1977, PAT opened a 3.8-mile South Busway and in 1983, it opened the 6.8-mile Martin Luther King, Jr. East Busway. A third busway, the 8.1-mile Airport Busway/Wadash HOV facility is under construction and scheduled for completion in the year 2000.

In the 1980, Pittsburgh was ranked the seventh highest metropolitan area with journey-to-work transit mode split of 11%. The central city of Pittsburgh is relatively compact (55 square miles) and has relatively high population and deployment densities. High densities and low levels of auto ownership are translated into high levels of transit use. Pittsburgh is ranked as the eleventh highest ridership in the nation with 88.9 million annual unlinked trips in 1985 (UMTA, 1987). While Pittsburgh was ranked the seventh highest metropolitan area with journey-to-work transit mode split of 11%, the transit ridership and modal share started to decline as presented in **Table 2.3** and PAT has experienced growing financial problems as shown in **Table 2.4**.

**Table 2.3 - Total Daily and Transit Trips to Work by Allegheny County Workers**

Work trips	Number			Percentage Change		
	1960	1970	1980	60-70	70-80	60-80
<b>Total Daily</b>	617,900	617,200	664,600	-0.1%	7.7%	7.6%
<b>Transit</b>	133,335	109,551	98,231	-17.8%	-10.3%	-26.3%
<b>Percent Transit</b>	21.60%	17.70%	14.80%	-17.7%	-16.7%	-31.5%

Source: U.S. Census, Population and Housing, 1960, 1970, 1980.

**Table 2.4 - PAT Fiscal Performance for Selected Years (millions of 1989 dollars)**

	1966	1971	1976	1981	1986
<b>Farebox Recovery</b>	89.6%	64.8%	50.8%	49.1%	44.1%
<b>Total Revenue</b>	\$ 103.10	\$ 90.20	\$ 74.50	\$ 77.60	\$ 81.70
<b>Fare Revenue</b>	\$ 99.20	\$ 86.80	\$ 71.50	\$ 75.40	\$ 73.70
<b>Total Expenses</b>	\$ 110.70	\$ 133.90	\$ 1,407.00	\$ 153.50	\$ 167.00
<b>Operating Deficit</b>	\$ 7.70	\$ 43.70	\$ 66.20	\$ 76.00	\$ 85.30

Source: PAT Annual Report 1970-1986.



In August of 1968, three rapid transit facilities were approved as part of a countywide rapid transit system. The building of two exclusive busways was recommended to serve corridors south and east of the CBD. The busway proposal appeared because rail advocates were unable to agree on the technology (heavy rail, sky bus and LRT) to be used.

### ***South Busway***

The 3.8-mile, two-lane exclusive South Busway was opened in 1977 to bypass severe congestion at the Liberty tunnel which is considered the major roadway link between the CBD and the South Hills area. 1.7 miles of the South Busway in South Hills consist of exclusive two fourteen feet wide one-way lanes with curbs on each side. The remaining 2.1 miles are shared with the trolley.

Before the South Busway was opened, buses experienced difficulties in operating on local streets due to the hilly terrain of South Hills area. In order to avoid steep grades, the South Busway was built parallel to N&W railroad tracks on virtually a flat grade. Buses on the South Busway save from six to 11 minutes over buses before the opening of the busway. Due to the operation of the South Busway, PAT was able to eliminate more than 160 bus trips per day from the congested streets of South Hills (US DOT, Jan 1992).

The ridership of the South Busway exceeded all expectations, where ridership increased 16% from routes using the busway. A total of 17 routes uses the busway, including the new service routes added after its opening. The exclusive segment averages approximately 400 bus trips per direction per day.

### ***East Busway***

Due to a seven-mile backup at the peak periods, plans were set to rebuild and repair the Penn Lincoln Parkway. It was estimated that to rebuild the parkway and add a third tube to the tunnel would take seven years. The proposed reconstruction would also severely disrupt traffic, thus, the East Busway was a compromise.

Original plans for the East Busway assumed the exclusive use of an abandoned rail right-of-way. Then, the busway was squeezed into the right-of-way leaving room for two Conrail tracks, providing a safe operation for Conrail trains (US DOT, Jan 1992).

The construction of the East Busway involved relocating and rebuilding the Conrail tracks and widening the right-of-way at several locations. The construction also includes replacing the four tracks by two new tracks, two-lane busway, building a separation wall between the railroad and the busway, relocating utilities, lowering the track bed, reconstructing vehicle and pedestrian overpasses, building bus ramps, and providing stairs and ramps to enable passengers to reach below-grade busway stations.

The original plan for the East Busway was an 8-mile (12.8 km) facility from downtown Pittsburgh to Swissvale, but due to Swissvale's residents concerns about noise, pollution and safety at the below-grade busway stations that would be fully invisible from streets, the busway was reduced to 6.8 miles. Thus, the new East Busway connects downtown Pittsburgh and the eastern suburbs of Wilkinsburg.

The East Busway is served by 31 PAT bus routes. Twenty-nine of these are express or flyer services and only two are busway routes which stop at all busway stations (US DOT, Jan 1992). After the opening of the East Busway, 17 existing express routes were shifted onto the busway right-of-way. Most of the flyer and express routes stop at only two of the six East Busway stations. Flyer routes serve outlying suburban communities located closer to the eastern terminus of the busway. A rider to Downtown from the eastern terminus in Wilkinsburg, which used to take from 20 to 60 minutes depending on the weather and traffic conditions, now takes between a nine and 13 minutes depending on the number of passenger stops.

Fifty-seven developments along and near the busway were constructed since the opening of the East Busway in 1983. Six of these developments are shopping centers or office and warehouse complexes with a total of 61 tenants, and 47 are new developments (*Development Along a Busway, a Case Study of Development along the East Busway in Pittsburgh, Pennsylvania, 1996*).

These developments are adjacent to or within a 1,500 foot radius from the busway stations (5.7 minutes walking at 3 miles/hour (4.8 km/hr)). Forty-four developments are adjacent to or near stations and 13 are greater than 1,500 feet (450 m). The most common uses for the developments along the East Busway are retail, office, residential, and medical. Although there are a number of manufacturers located along the East Busway, their number is declining due to the reduced importance of direct rail access for many industries and the preference of new manufacturers to locate in Greenfield areas (*Development Along a Busway, a Case Study of Development Along the East Busway in Pittsburgh, Pennsylvania, 1996*). The total value of the development along the busway is \$302 million, of which \$248 million (76%) is new construction. The development clustered at stations accounts for 58% of the total investment (\$176 million).

### 2.3 Runcorn, UK

In 1964, the town of Runcorn and its surrounding areas was designated as a New Town. An increase in the population from 30,000 in 1964 to 100,000 in 1990 was expected (NATO 1976). Due to the increase in population, a proposal was made to have a specially reserved route for rapid transit service that would serve as a spine to the neighboring communities. The suggested busway was intended to provide a fully integrated public transit service with different activities in the town and in such a way it would also provide a level of service competitive with private vehicles. The New Town was planned around the busway, which has the shape of a number eight, shown in **Figure 2.2**, centered on newly developed shopping and commercial areas. The original town, which formed the starting point for the growth of the New Town was mainly in the area covered by the western loop while the new part of the town is now shaped around the eastern loop.

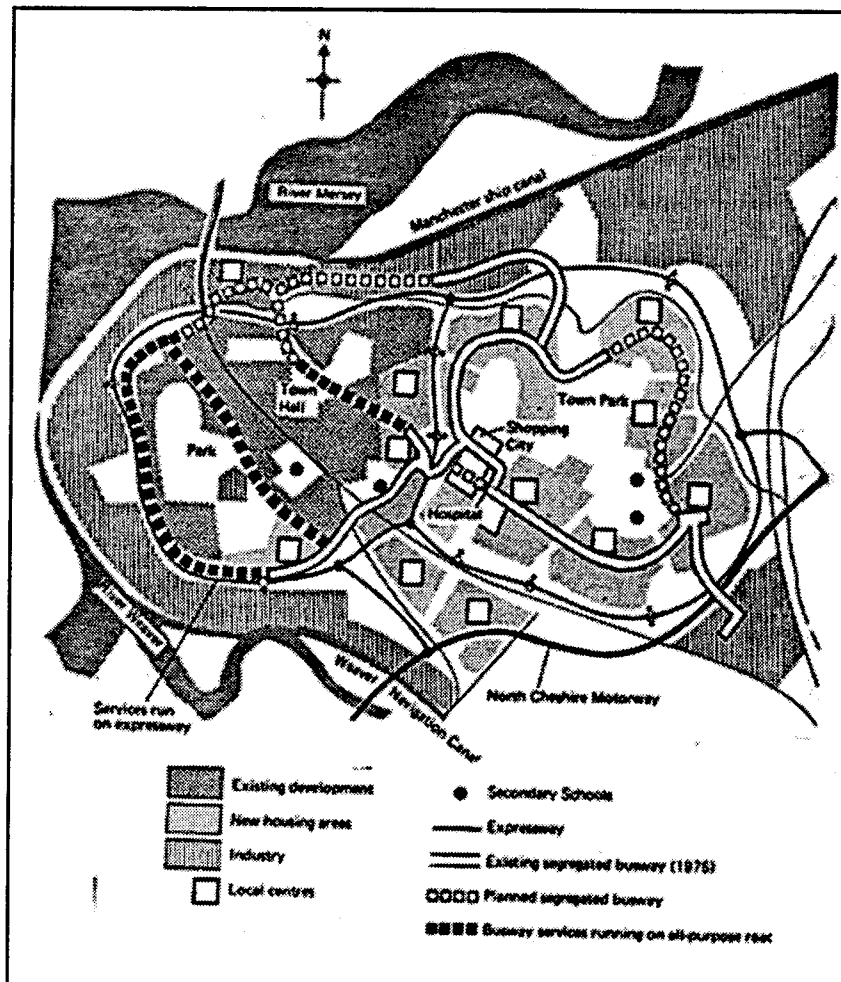
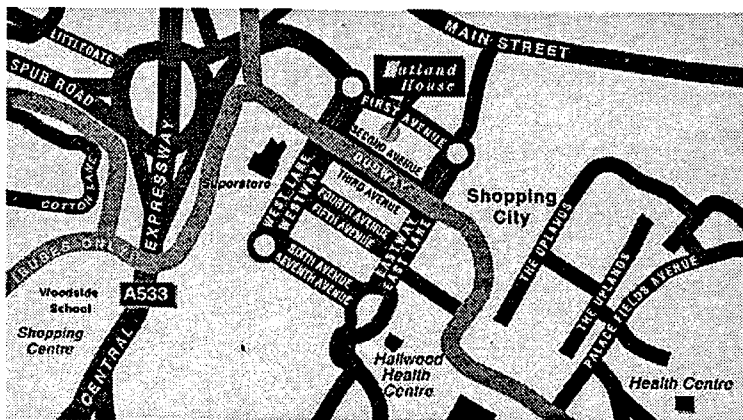

Figure 2.2 - Runcorn's busway

The 7.5-mile (12-km) phase of the busway started operation in Spring 1973. It linked five new residential developments, two industrial areas, and the town shopping area. The complete busway consists of 19 km of separated roadway and 8 km of all-purpose roads. Approximately, 0.625 miles (1 km) of the busway in the shopping area is elevated, while the rest of the busway is at-grade with the exception of grade separation at some major intersections. About 64% of the busway alignment is in an exclusive right-of-way, 14% on an expressway where buses operate with other traffic, and the remaining 22% on local roads where buses share the right-of-way with general traffic. **Figure 2.3** shows part of the Runcorn's busway.

Within the eastern loop, local communities with a population of about 8,000 are centered on the busway bus stop, which is usually near local shops, a primary school and other facilities. Walking distances to the bus-stops were kept short where 90% of the working population is living within five minutes walk time to the nearest stop. The integration of the separated busway track into the city structure has enabled the area to be served by shorter total length of bus routes than if buses were operated on a conventional road network. The average speed of buses on the busway is approximately 19.5 mph (31 km/hr) compared to 12 mph (19 km/hr) for buses on conventional roads. This higher speed and shorter route length enable the frequency of the bus service to be 2.5 times higher on the busway than on conventional roads for the same operating costs.



**Figure 2.3 - Runcorn Busway Alignment.**

In order to encourage the use of the buses, planners determined the following:

- Automobile parking is located further from major land use than corresponding bus service stops, including residential areas.
- Bus frequency levels are 5 - 7 minutes during the off-peak hours for 80 percent of all passengers.
- There is a maximum 5-minute walk to bus stops.

The total construction cost of the entire busway is \$15 million (1973) including the land costs. About 90% of the construction costs are attributed to the grade separate and the elevated sections of the busway.

## 2.4 Brisbane City, Queensland

Brisbane City has a good public transport system with both train and bus services. No new rail extension of any note planned with the City, and the bus system is increasingly impacted by traffic congestion, which reduces the level of service to passengers and increases costs (Travel Smart, 1994). Thus, the Brisbane City Council has plans to double the proportion of public transport usage by the year 2011, as presented in **Table 2.5**. The key to increasing the use of bus systems is to improve their speed, frequency, reliability and comfort and to ensure providing bus service to the CBD and to new employment areas in Brisbane.

**Table 2.5 - Key Transport Performance Indicators for Brisbane for 1991 and 2011**

Characteristics	1991	2011	% Chg.
Average vehicle speed (km/h)	41.5	34.7	16%
Vehicle travel (million km/day)	19.1	27.6	44%
Vehicle travel (1000 hrs/day)	461	796	72%
Vehicle operating costs (million \$/day)	5.1	8.1	58%
Cost of travel time (million \$/day)	6.8	11.8	74%
Total vehicle emissions (1000 tonnes/year)	223	380	70%
Costs of accidents (million \$/day)	174	251	44%

*Source: Travel Smart Traffic Reduction Strategy, Brisbane City, 1994*

By studying the travel data of 1991 and 2011, the City of Brisbane concluded that the public transport share of peak period travel has to increase by 25% from the existing modal split of 24% to a future 30%. Otherwise, the land use and livable city goals will not be achieved and both people and jobs will migrate to communities outside Brisbane to avoid congestion, resulting in creating suburban development rather than livable urban development. This will not only will increase traffic congestion that leads to more urban sprawl but also the resulting environmental, energy, safety and social costs will reduce the future economic development in Brisbane. In order to avoid this, half the peak hour transit riders and the majority of Brisbane residents traveling into the CBD in 2011 have to use bus system because the rail system itself will not meet the needs. **Figure 2.4** shows the past and expected growths in population, vehicle trips per day, and vehicle

km per day. It can be concluded from this figure that the car usage is increasing faster than the population.

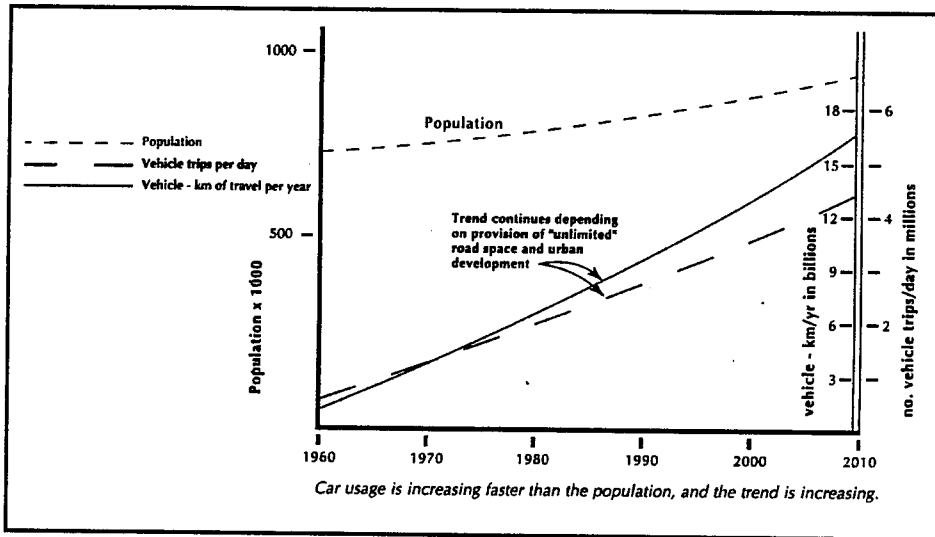

**Figure 2.4 - Brisbane City Past and Expected Growths in Population, Vehicle Trips/day and Vehicle Km/day**

*Source: Travel Smart Traffic Reduction Strategy, Brisbane City, 1994*

Brisbane officials found that the only way to provide a fast, convenient and reliable transit service in these circumstances, as well as to ensure effective public transportation, is to create a region-wide system or network of transit priority that can be implemented quickly enough to influence new land use development. This rapid transit network must be capable of incremental implementation and be of relatively low cost so as to be as responsive as possible to growing road congestion and new opportunities to influence changing land use patterns. It must also be compatible with the generally low density nature of most new urban areas in Brisbane while providing efficient service to nodal developments in the CBD area and other transit oriented centers.

Accordingly, a series of actions had been taken to provide the bus system in Brisbane with greater reliability and travel speeds by initiating various bus priority measures in the form of bus lanes and special traffic signal procedures. Building a busway alone, will not produce the required modal split improvements (McCormick, June 1995). Thus, the busway construction program must be supported by appropriate land use and transportation policy changes and operation of an expanded busway express bus system.

A conceptual busway network was identified to establish the basic feasibility and cost for Brisbane's public transport approach. The construction costs of the network are estimated at about \$600 million and it would be built over a 20-year period. When complete, the total length of the busway network will be 29 miles (46 km) with 51 stations. The entire stations will be accessible by disabled

passengers. Bikeways will be added to the busway corridors whenever feasible. Special bus and HOV lanes are undertaken with the beginning of the busway construction. Within the 2011 time frame, the technologies employed in the rapid bus system will include:

- Buses in mixed traffic flow.
- Rapid bus services in bus/HOV lanes with and without other priority treatments.
- Rapid transit bus service on exclusive busways.

As in Ottawa, it appears that a decision to build the busway system will cost Brisbane and Queensland taxpayers less than the “do nothing alternative” and at the same time will contribute Brisbane’s 2011 objectives. It was found that by year 2011, the busway will save tax payers about \$60 million. In addition, the busway strategy will avoid another \$50 million annually in the urban sprawl and pollution costs. Other benefits of the busway include a reduction of 62% in the amount of emissions and the creation of 21,000 employments per years of during the construction of the busway.

### **Brisbane’s Busway Description**

The busway in Brisbane has two general forms depending on the nature of the corridor in which the busway is located. For high speed operation (80 km/h), the busway typically consists of two 3.5 meter lanes in addition to two 0.5 meter paved shoulders. At stations, the cross section is widened to provide two 11.5 ft (3.5 m) stopping lanes and two 12.3 ft (3.75 m) through lanes. A central barrier is installed to discourage at grade crossing of the busway by pedestrians. The average platform width varies from 13.1 to 19.7 ft (4.0 to 6.0 m) depending upon local conditions and shelter arrangements. At stations, acceleration and deceleration lanes are also provided to enhance the high speed operation.

In low speed urban arterials where the busway operates in a speed comparable with the adjacent general traffic, different design standards are used. The busway consists of two 12.3 ft (3.75 m) lanes and between two 11.5 ft (3.5 m) curbed landscaped medians. At stations, the medians are paved to provide the platforms while buses use the opposing lanes to pass a stopped bus as shown in **Figure 2.5**.

The arterial busway can accommodate low volume turns across its right-of-way and at-grade signalized intersections. Signal preemption of transit is used to improve transit operation. At high volume intersections grade separation of the busway movement is justified and shown in **Figure 2.6**.

High frequency bus services running the full length of the corridor and stopping at each station are provided. Passengers access this service by walking or cycling to the station, transferring from feeder buses and by using park-and-ride and kiss-and-ride facilities located along the corridor.

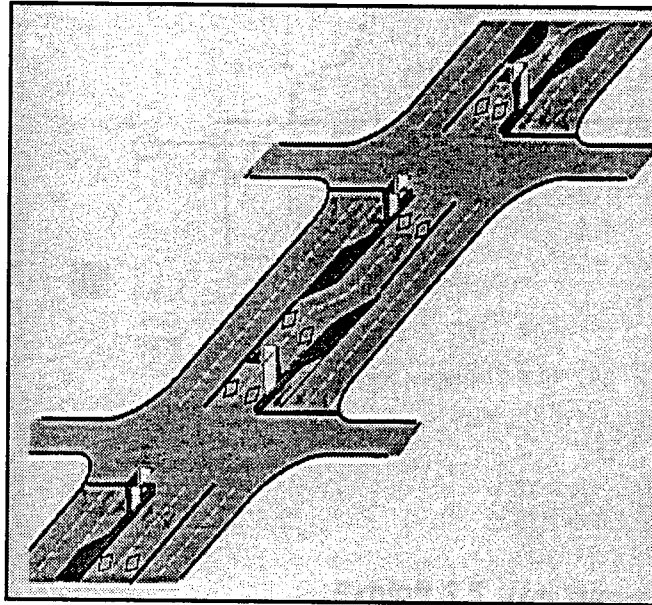

**Figure 2.5 - Arterial Street Busway Plan**  
*Source: McCormick, June 1995*

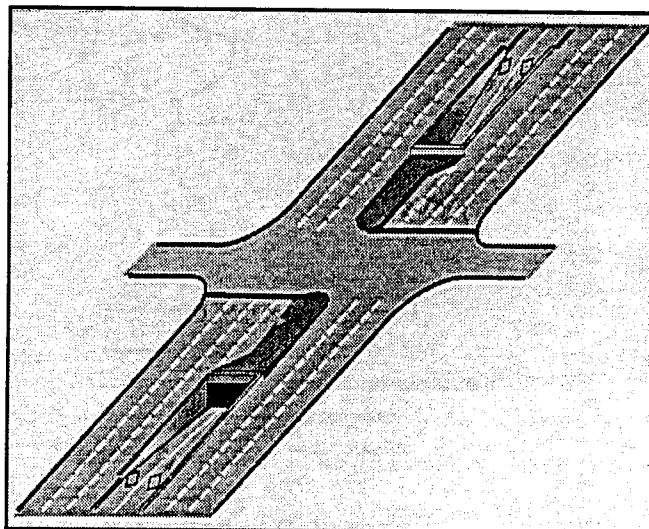

**Figure 2.6 - Intersection Busway Grade Separation**  
*Source: McCormick, June 1995*



## **Brisbane's Busway Operating Concept**

The busway provides unlimited flexibility to tailor the transit operation to suit corridors and regional needs. Buses can operate on and off the busway right-of-way and therefore offer the opportunity to link feeder and line haul express services to reduce the need for passengers to transfer.

The typical busway operation configuration consists of a high frequency service running the full length of the corridor and stopping at each station. Passengers access this service as they would a light rail service by walking or cycling to the stations, transferring from feeder buses and by using park-and-ride facilities where provided (McCormick, June 1995).

The busway basic service is supplemented by other high frequency bus routes that typically pick up and drop off the majority of their passengers at on street locations away from the immediate busway corridor. Such services may operate only over some sections of the busway to take advantage of the high operating speed of the busway and/or to serve particular stations and trip generators long the busway corridors. The service types will include:

- All stop routes which operate from one end of the busway to other providing a service similar to that of conventional rapid transit.
- Feeder bus service which serve each of the busway stations and all stop service in the same way as they would serve a rail system.
- Express bus routes which pick up passengers at bus stops in residential areas and/or at park-and-ride lots and then enter the busway and operate in a skip station mode to their ultimate destination (usually CBD).
- Reserve direction express services which operate from a major transfer stations on the busway in a skip station or all stops mode along the busway and then directly to major employment centers remote from the busway corridor.
- Regular on street services that make use of a section of the busway to avoid congested areas.

## 2.5 Abidjan, Cote D'Ivoire

The busway in Abidjan was implemented as part of a comprehensive traffic management program, including an Urban Traffic Control System. The lateral 2-lane busway is located on a dual 2-lane roadway across the CBD. The busway has on-line stops with no special operational features. Single-deck buses are operated on the busway. The functioning of the busway is unsatisfactory since long bus queues form at busy stops during the P.M. peak period. Passenger waiting areas at some bus stops are inadequate and safety barriers have deteriorated due to poor maintenance (TRRL 329, 1991).

## 2.6 Ankara, Turkey

Ankara's busway is a median busway system that is located in the middle of a busy roadway that connects to the CBD. The busway performance is greatly influenced by the intersections. Conflicts and general traffic congestion occasionally require the intervention of police and bus inspectors to manage traffic (TRRL 329, 1991).

Buses are separated from other traffic on both sides by a raised islands and 1.5 m high fences as shown in **Figure 2.7**. The number of buses operating along the busway is low in relation to passengers demand and so average bus occupancy is high, and bus overcrowding causes long delays at some stops.

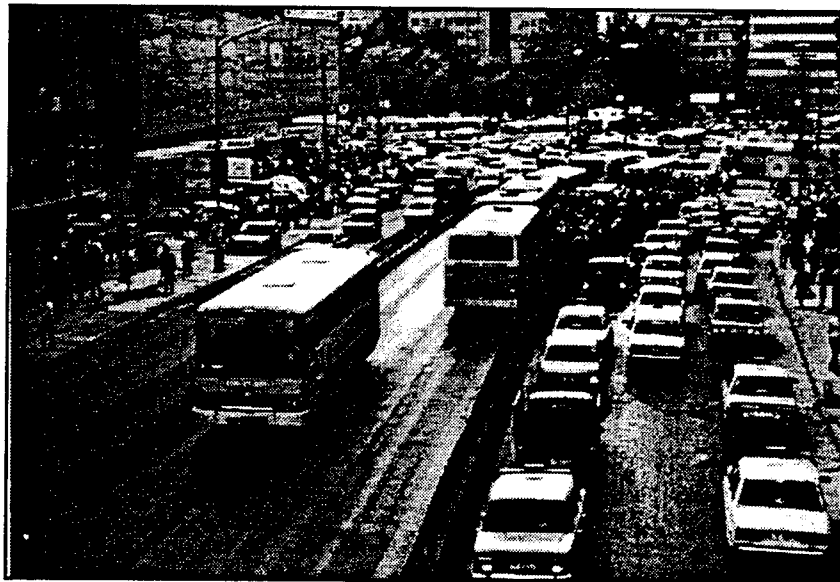
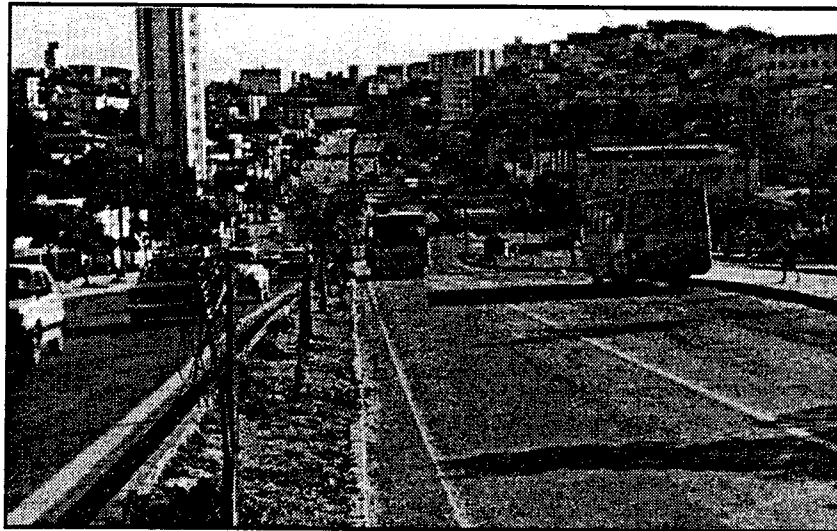

**Figure 2.7 - The Kizilay Bus Stop, Ankara, Turkey with no Overtaking Facility**

*Source: TRRL 329, 1991*

## 2.7 Belo Horizonte, Brazil

A purpose built, median busway links the city center with low-income suburbs (TRRL 329, 1991). At the city center where the busway ends, buses have exclusive use of the lower level of a double-deck tunnel through a hill to link the busway with the CBD. The busway has an off-line station which permits overtaking as shown in **Figure 2.8**. The busway is separate from the general traffic by landscaping islands of varying width. Bus services are operated by various companies under a coordinated municipal policy. Buses are color coded according to the line type (express, semi-express and local).



**Figure 2.8 - Off-Line Bays, Belo Horizonte**

*Source: TRL, 1993*

## 2.8 Istanbul, Turkey

The Taksim-Zincirlikuyu busway is an exclusive CBD busway in the middle of general traffic lanes. Buses are separated from general traffic by a continuous 1.5 m high fence (see **Figure 2.9**). Although some private operators are permitted to use the busway, the majority of the buses using the busway are operated by a public bus company. Over 80 bus routes use the busway and all share the same stops which result in disorderly stops and bus congestion. Some bus services run nearly empty while others are overloaded. As overtaking is not possible, overloaded buses delay empty buses. Traffic signals at some intersections allocate short green times to the busway causing delays and bus clustering, which in turn aggravates problems at bus stops (TRRL 329, 1991).



**Figure 2.9 - Lateral Busway Using One Half of a Dual Roadway,  
Istanbul, Turkey**  
*Source: TRL, 1993*

## **2.9 Porto Alegre, Brazil**

The Assis Brasil busway, shown in **Figure 2.10**, is located on a radial corridor which connects the CBD with suburbs. At bus stops, staggered on-line passenger platforms minimize road width requirements. Between bus stops, busway running sections are separated from general traffic by heavy studs (TRRL 329, 1991).

Bus services are operated by private companies which function under a municipally regulated regime. Single deck buses of various sizes are used by the operators. In peak periods, some companies use passenger trailers towed by conventional buses to increase capacity. Urban bus services use the busway while minibus and inter-urban buses use the general traffic lanes. During the P.M. peak period, buses enter the busway in the same sequence as the bus bays within the stops. This technique is known as bus ordering.

The busway was physically neglected due to political factors and due to fund shortages. The physical conditions of the busway road surface, platforms and shelters have deteriorated over the years. Operationally, the busway carries high bus and passenger volumes but the throughput is constrained by a bus stop at a busy suburban center (Obirici) where large volumes of passengers board buses in the evening peak period.

The Farrapos median busway links the CBD with other major suburbs and with the Assis Brazil busway. The Farrapos busway runs parallel to the Porto Alegre metro. One end of the busway is located at the edge of the city center where extensive traffic management measures have been implemented, including a bus street of disperse buses to local terminals. Although the busway carries high bus volumes, passenger transfer demands are relatively light along its length. Design and operational characteristics are similar to those for the Assis Brazil busway.

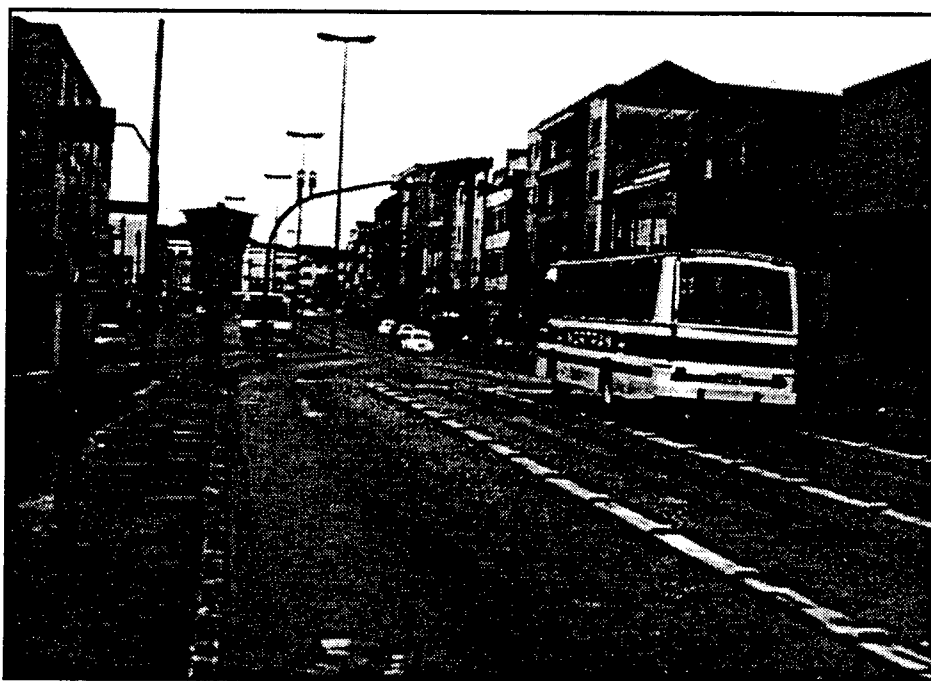

**Figure 2.10 - Bus Ordering Assembly Area, Assis Brazil Porto Alegre, Brazil**

*Source: TRRL 329, 1991*

## **2.10 Sao Paulo, Brazil**

The Avenida 9 de Julho/Santo Amora Busway, shown in **Figure 2.11**, extends along a radial corridor to the southwest of the city center. The busway is discontinuous for two short sections. One through a tunnel where there is inadequate width for the full busway/road cross the section and one through an underpass. A key function is that overtaking lanes are provided at all bus stops which minimize delays and enables semi-express bus services to operate on the busway without stopping.

Pedestrian and passenger movements along the busway are controlled by guard rails and signals. The median has chain-link fencing to discourage pedestrian crossing. Within the bus stop areas, buses in opposing directions are separated by concrete barriers. Between stops, the busway tracks are separated from general traffic by heavy road studs.



**Figure 2.11 - Median Busway, Sao Paulo, Brazil**  
*Source: TRL, 1993*

Bus services including double deck and trolley buses are operated by both state and private bus companies in a regulated environment. The busway management is handled by the state bus company. Over 150 bus routes use sections of the busway. One of the main problems of the busway is the lack of information at bus stops. One of the two non-overtaking bus stops causes congestion where buses queue to access the stop during the evening peak period.

**Tables 2.6, 2.7 and 2.8** provide a summary for the surveyed busway in this report.

**Table 2.6 - Physical Characteristics of Busways Surveyed**

City	Location (Km)	Length	Avg. Stop Spacing (M)	Avg. Junc. Spacing (M)	Special Features
Abidjan	Blvd De La Republique	1.27	400	160	None
Ankara	Besevler-dikimevi	3.6	310	410	None
Belo Horizonte	Av. Cristiano Machado	8.57	610	920	Overtaking at Stops
Curitiba	Eixo Sul	9.5	430	430	Trunk & Feeder
Istanbul	Taksim-Zincirlikuyu	2.27	310	410	None
Porto Alegre	Assis Brasil	4.5	580	410	Bus Ordering
Port Alegre	Farrapos	2.8	560	390	Bus Ordering
Sao Paulo	Av.9 De Julho/s.amaro	7.9	600	530	Overtaking at Stops

Source: TRRL 329, 1991

**Table 2.7 - Passenger Boarding Times by City and Fare Collection Arrangements**

City	Lost Time (Sec)	Time/pax (Sec)	Entry Arrangement	Fare Collection Method
Abidjan	10.3	0.9	Free Entry	Turnstile
Bangkok	9.8	1.2	Free Entry	Conductor
Belo Horizonte	5.2	1.5	Free Entry	Turnstile
Sao Paulo	8.6	1.3	Free Entry	Turnstile
Ankara	23.0	1.8	Driver Supervised	pay Box
Hong Kong	13.1	1.7	Driver Supervised	Pay Driver
Istanbul	9.3	2.3	Driver Supervised	Pay Box
Singapore	8.4	2.2	Driver Supervised	Pay Driver

Source: TRRL 329, 1991

**Table 2.8 - Maximum Observed Peak Hour Bus Flows, Available Passenger Places and Passenger Flows at Peak Load Points on Selected Busways**

City/Scheme	Period (Direction) a= Alighting b= Boarding	Bus Flows (P/h/d)	Bus Available Passenger Places Driver Supervised			Actual Passenger Flows (P/h/d)
			Seated	Nominal	Crush	
Abidjan	AM(a)	204	4,800	20,200	24,200	16,000
	PM(b)	197	4,500	19,600	23,500	19,500
Ankara	AM(b)	91	3,200	7,300	9,300	7,300
	PM(a)	91	3,200	7,300	9,300	6,500
Belo Horizonte	AM(b)	216	8,000	19,200	22,500	15,800
	PM(a)	205	7,600	18,200	21,300	14,500
Curitiba	AM(b)	94	4,100	11,400	13,400	9,900
	PM(a)	80	3,500	9,800	11,500	7,000
Istanbul	AM(b)	169	5,300	12,800	15,900	10,700
	PM(a)	143	4,600	11,000	13,600	7,300
Assis Brasil	AM(a)	326	16,300	33,600	37,900	26,100
	PM(b)	260	13,100	27,000	30,500	18,300
Farapos	AM(a)	378	19,100	39,400	44,500	15,300
	PM(b)	304	15,200	31,300	35,300	17,500
Sao Paulo	AM(a)	230	9,100	20,300	24,000	18,600
	PM(b)	221	8,600	19,400	23,000	20,300

Source: TRRL 329, 1991



### 3.0 AT-GRADE BUSWAY SAFETY

Similar to light rail transit (LRT) systems, at-grade busways can provide a safe mode of transportation in terms of total accidents or accidents per mile travel. Like other public transportation modes, accidents produce problems of the public image and create transit agency liability. Thus, appropriate actions should be taken during the planning, design and operation of at-grade busways to minimize conflicts. The purpose of this chapter is to provide information to facilitate the safe, orderly and integrated movement of traffic on the busways and adjacent roads, and to provide guidance and warnings needed for safe operation of individual elements of at-grade busways.

At-grade busways are similar in operation to exclusive LRT with at-grade automobile, bicycle and/or pedestrian crossings. Thus, some of the safety considerations can be adopted by at-grade busways. The following section presents an overview of the possible accidents on at-grade busway right-of-ways followed by an overview of possible solutions to minimize the possibility of accident rates.

#### 3.1 Overview of Accident Types and Possible Solutions

Safety problems are given important concerns in any transit system and any accident may impact the ridership due to problems with the public image. Expected accident causes for at-grade busways are as follows: (TCRP 17, 1996)

##### 3.1.1 Side-Aligned At-Grade Busway

- 1- Pedestrians trespass on side-aligned at-grade busway right-of-ways where no sidewalk is provided. This design disrupts the normal pedestrian travel pattern. *Solution: Install fence or install sidewalk if none exists.*
- 2- Pedestrians jaywalk across at-grade busway right-of-ways due to the absence of sidewalks on both sides of the side-aligned at-grade busways. *Solution: Install fence to separate the busway right-of-way or provide curbside landscaping, bollards, or barriers.*
- 3- Pedestrians and motorist confusion about which way the busway vehicle is approaching. *Solution: Busway vehicle should operate with headlight on all the time and install internally illuminated signs displaying the front or side view of a bus and the direction of approach.*
- 4- Side-aligned two-way at-grade busways operating on a two-way street may cause confusion to motorists, especially at night when the headlight of an approaching busway vehicle appears on the right-hand side of the road. *Solution: Replace side running with*

*median operations.*

- 5- Motorists make illegal left turns across the busway immediately after the termination of their left turn green arrow. As a result, they might be unaware of a busway vehicle approaching the intersection at a higher speed. Solution: *Improve enforcement and install active BUS COMING signs.*
- 6- Motorists violate the right-turn red arrow and may be unaware of a busway vehicle approaching the intersection from the left-hand side. Solution: *Improve enforcement and install active BUS COMING signs.*
- 7- Red time extension due to multiple busway vehicle preemption may make motorists who are waiting to cross the busway tracks to become impatient. Solution: *Limit multiple bus preemption within the same cycle.*
- 8- Complex intersection geometry may cause confusion to motorists, pedestrians and bicyclists and complicate their decision-making about crossing busway intersections. Solution: *Simplify roadway geometry and use traffic signals or other active controls to restrict motor vehicle movements while a busway vehicle crosses the intersection.*

### **3.1.2 Median At-Grade Busways**

- Lack of safe, clearly defined pedestrian crossings at stations, intersections and mid-block locations may be a source of hazards to pedestrians. Solution: *Define pedestrian pathways; design stations to prevent random crossings of the busway lanes, install safety islands; and install pedestrian automatic gates, swing gates, bedstead barriers, or z-crossings.*
- Lack of passenger waiting areas. Solution: *Provide a sufficient passenger waiting areas to handle the maximum expected number of passengers at the peak periods.*
- Motorists violating traffic signals at perpendicular at-grade crossings try to beat busway vehicles to the intersection, especially when the busway vehicles are moving at relatively low speed. Solution: *Improve enforcement, provide a left-turn phase after a through busway vehicle phase, and/or install active BUS COMING signs.*
- Motorists making left-turns blocking the busway right-of-way. Solution: *Coordinate traffic signal phasing and timing at intersections and provide sufficient left-turn storage pockets.*
- Motorist confusion between the busway signals and general traffic signals especially left-turn signals. Solution: *Provide busway signals that are clearly distinguishable from traffic*

signals and whose indications are meaningless to motorists and pedestrians.

### 3.2 Alignment Consideration

Good alignment choices and design geometry are essential for safe busway operation. The busway alignment must be chosen carefully with full consideration to general traffic and pedestrian travel patterns and roadway operating conditions. When the geometry is poor, traffic devices may provide relatively little safety benefits.

### 3.3 Intersection Design and Control

Intersection design and controls should clearly define and control conflicts between busway vehicles and adjacent road users. Left turns across the busway right-of-way affect both the capacity and the safety of at-grade busways. Thus, left turns should either be provided and protected or prohibited and redirected. Traffic signal controls should always be carefully coordinated with the roadway geometry.

### 3.4 Safety Analysis of the South Miami-Dade Busway, Miami, FL

The South Miami-Dade Busway is an 8.2-mile (13 km), separate, at-grade roadway for the exclusive use of buses and emergency vehicles. The busway was built in an abandoned railroad right-of-way located to the west of US 1, as shown in **Figure 3.1**. Buses operate on two exclusive at-grade 12-foot (3.6 m) lanes with a 4-foot (1.2-m) buffer in between. At station areas, the width of the busway increases from 28 feet to 52 feet (8.5 to 16 m) to allow express buses to bypass other local buses alighting and boarding passengers at the stations (Shen et al., 1997).

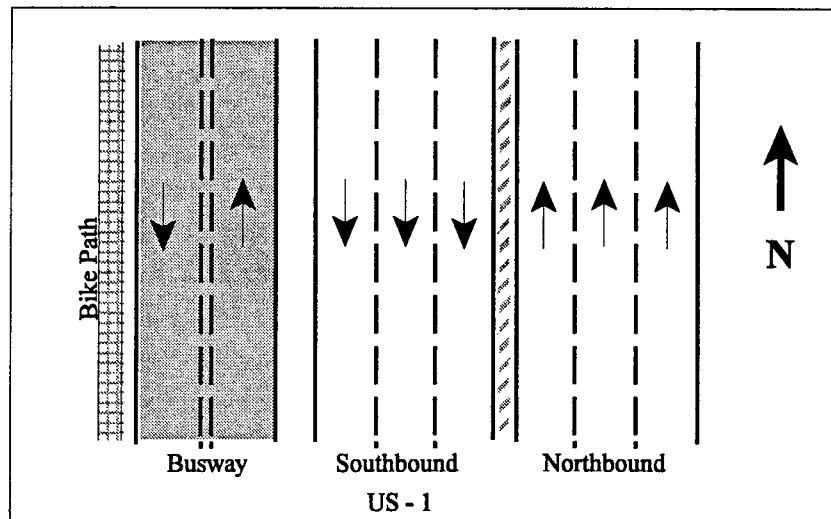

**Figure 3.1 - South Dade Busway Configuration**

The busway intersects with 20 major signalized intersections, of which 11 are within a 50 to 80 feet (15.25 to 24.5 m) separation distance between the busway and the pavement edge of US 1. At these intersections, the busway and US 1 operate as a single signalized intersection (combined intersection). In order to operate the busway safely, exclusive right turn lanes with right turn signals along the US 1 southbound were added at most of the intersections to provide an exclusive right turn movement (Fowler 1995). Another safety measure was the conversion of northbound left turns to restrictive protection phasing. Due to the close separation distance between the busway and the US 1 edge of pavements a portable message sign was installed during the early periods of operation with NO TURN ON RED indication, which warn the motorists with the new signal configurations and the operation of the busway. Side street operations were also converted to directionally separated phasing. Programmable signal heads were installed at the side streets to prevent motorist confusion between busway and US 1 signal heads.

Advanced vehicle motion detectors are installed on the at-grade busway to allow express buses to travel from Dadeland South Station to Cutler Ridge Station without stopping. The advanced vehicle detectors are placed at 600 feet (183 m) and 375 feet (114.5 m) before the intersection to allow an approaching bus, if arriving during the allowable preemption window, to proceed through the intersection without stopping (Fowler 1995). Sufficient time is given for the preemption phase to terminate and clear before a bus reaches the dilemma zone. Thus, express buses can travel the entire length of the at-grade busway without making a local stop.

Since the beginning of the South Dade Busway operation in February of 1997, 25 accidents occurred, of which 19 accidents were classified as vehicle collisions and the remaining 6 as non-collisions with passenger injury. **Figure 3.2** shown the number of accidents, directions of both transit vehicle and other vehicles involved, types of transit vehicle, and number of injuries.

As shown in **Figure 3.2**, most of the accidents occurred where the busway is far from US 1 (from 250 ft (76 m) to 400 ft (122 m)). Also, most of the vehicles involved in accidents with transit vehicles were heading east toward US 1. From this we can conclude that people are not used to the existence of the busway at the locations of the accidents. Also, the occurrence of more than one traffic signal, one for the busway and one for US 1, may have caused no fusion for some drivers when they have different light indications.

Two out of the six non-collision accidents occurred when the transit vehicle driver was trying to avoid a vehicle crossing the busway and the other one when trying to avoid a pedestrian.

Reviewing the causes for accidents, the following suggesting may be done:

- Increase the motorists crossing the busway with coming transit vehicles by installing active BUS COMING signals at the intersection.

- Avoid the installation of multiple signals to reduce the motorists' confusion between the busway signal and US 1 signal.
- Install pedestrian signal with clear indication when to cross. Also, to install pedestrian signals with indications LOOK BOTH SIDES BEFORE CROSSING.
- 

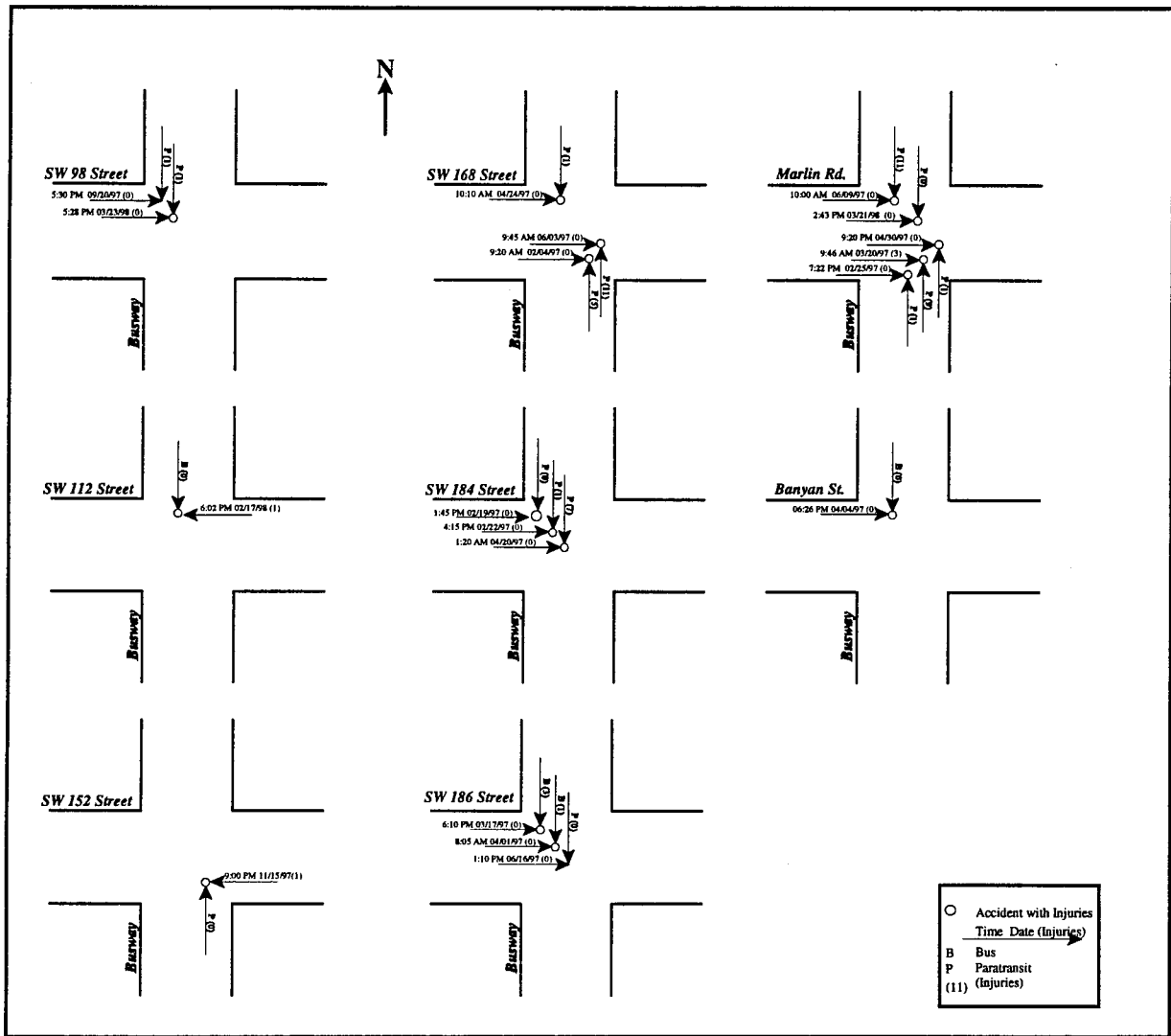

Figure 3.2 - South Dade Busway Collision Diagrams

## 4.0 BUSWAY PLANNING

### 4.1 Introduction

In planning a busway system, it is important to distinguish between a basic busway as a traffic management measure to meet short-term traffic objectives, and a bus-based mass transit system, including special operational measures, to meet medium-long term objectives.

There are more than forty busway exits worldwide (TRRL 329, 1991). Only half of the cities that have busways have developed them in a systematic and comprehensive manner as part of the city's mass transit network. The best example of is the busway system in Curitiba and Ottawa, where the busway is the backbone of the public transit system radiating from the CBD to where the city growth is focused.

There is no value in providing bus priority measures where transit service is poor, costly, or nonexistent; where there are neither buses nor congestion; or, where the community has no desire to maintain and improve bus services or to enforce bus priority measures.

Planning and implementing bus priority measures requires: (HCM 1994)

- A reasonable concentration of bus services;
- High degree of bus and vehicle congestion;
- Suitable streets and roadway geometry; and
- Community willingness to support public transport and enforce regulations.

Thus, it is necessary to have a demand policy management to support the allocation of the required right-of-way. When passenger demand is high, the number of passengers that can be transported along the busway is substantially more than those transported by private vehicles along the same right-of-way. When allocating a right-of-way for a busway, its use must be justified. If the bus flow on the busway is relatively low for the majority of time, this can lead to future elimination of the busway. The trade-off between the general traffic flow and the bus flow is presented in **Figure 4.1**. Case four in **Figure 4.1** is when the busway may be implemented as the road is already running near capacity and the allocation of bus lanes would not benefit other road users unless additional capacity was provided.

The main objectives of implementing bus priority measures are:

- Relieve congestion;
- Alleviate existing bus service deficiencies;
- Buses can operate at higher speeds;

- Achieve attractive and reliable bus service;
- Serve demonstrated existing demand;
- Provide reserve capacity for future growth in bus trips;
- Attract auto drivers;
- Relate long-range transit improvements and downtown development programs; and
- Have reasonable construction and operational costs.

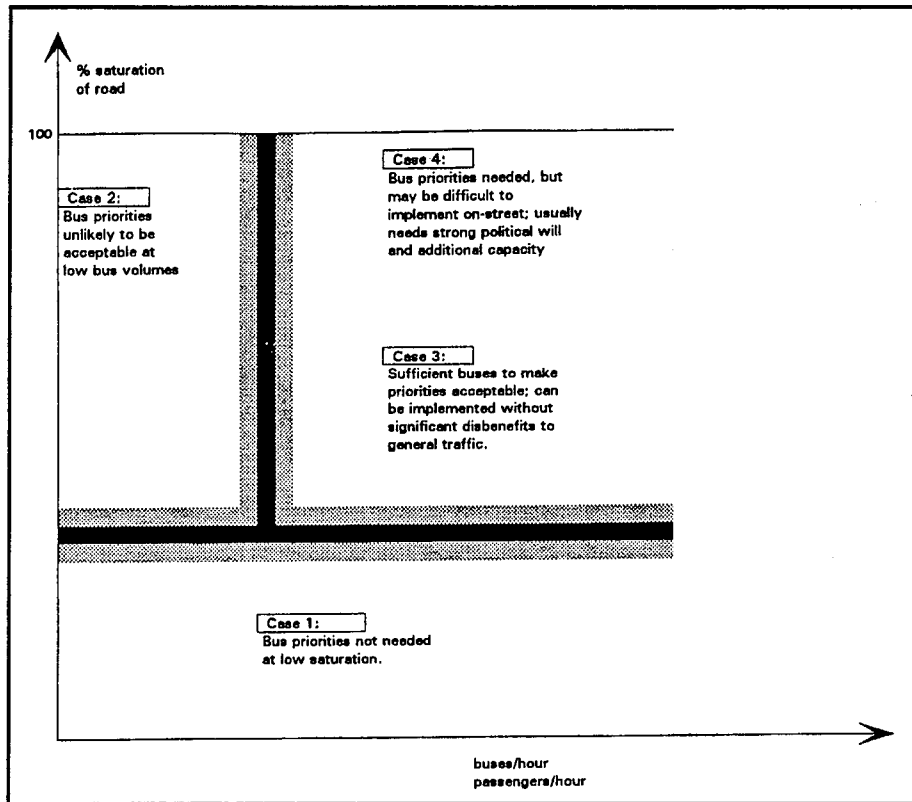

**Figure 4.1 - Feasibility of Busway Along Existing Road**

*Source: Design Guidelines for Busway Transit, TRL 1993*

The key factors of implementing a busway as a bus priority measure are:

- The intensity and growth prospects of the CBD;
- The historical and potential future reliance on public transportation;
- Street width, configuration, continuity, and congestion;
- The suitability of existing streets for an exclusive busway;
- Bus operating speed and service reliability;
- Availability of alternative routes for displaced auto traffic;
- Locations of major employment centers in relation to bus services;
- Express and local bus routing patterns;

- Bus passenger loading requirements along curbs; and
- Community attitudes and resources.

## 4.2 Busway Performance

The performance of the busway depends mainly on the bus and passenger flow relationship as well as the operating speed of the buses on the busway right-of-way. **Figure 4.2** shows the operating speeds for selected busways. Accordingly, the bus and passenger flow and the operating speed of the buses depends on the existence of some busway features discussed below.

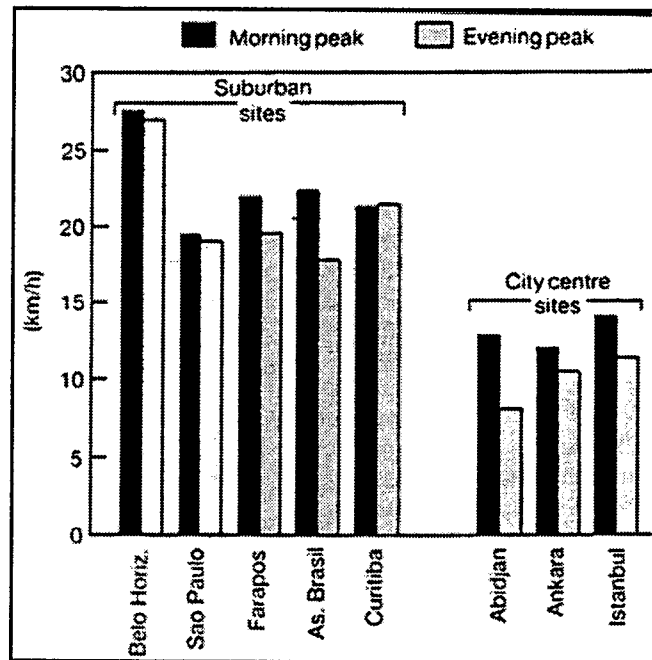

**Figure 4.2 - Operating Bus Speeds for Selected Busways.**

Source: TRRL 329, 1991

### 4.2.1 Effect of Special Operational Measures

Various techniques that may be implemented to enhance the performance of a busway include: (TRRL 329, 1991)

- **Bus Overtaking Facilities at Stops:** Bus overtaking facilities can be provided in several ways to offer a powerful mean of enhancing the performance. Overtaking facilities permit express, semi-express and non-stopping bus services to pass by other buses boarding and alighting passengers at stops. The provision of the overtaking facilities increases the



throughput and decreases the bus trip time to match service characteristics to passenger demands. The relationship between the line-haul throughput and passenger demand is shown in **Figure 4.3**.

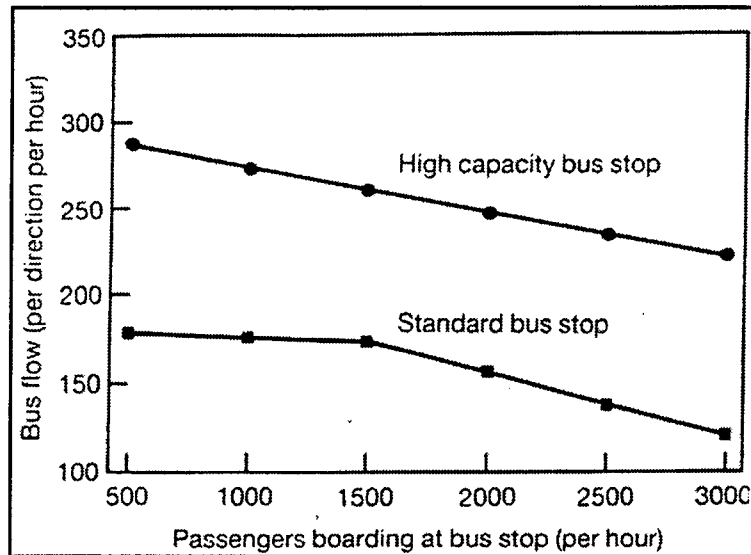

**Figure 4.3 - Relationship between Line-haul Throughput and Passenger Transfer Demand**  
*Source: TRRL 329, 1991*

- Trunk-and-feeder Operations:** Curitiba is the only known busway system to operate exclusively with trunk-and-feeder services, see **Figure 4.4**. Although such operations were also introduced in Porto Alegre, the scheme was subsequently removed due to difficulties related to private sector operating concessions and to passenger resistance to enforced interchanging. A successful trunk-and feeder system necessitates integrated fares and ticketing in order to permit "free passenger transfer between feeder and trunk buses.

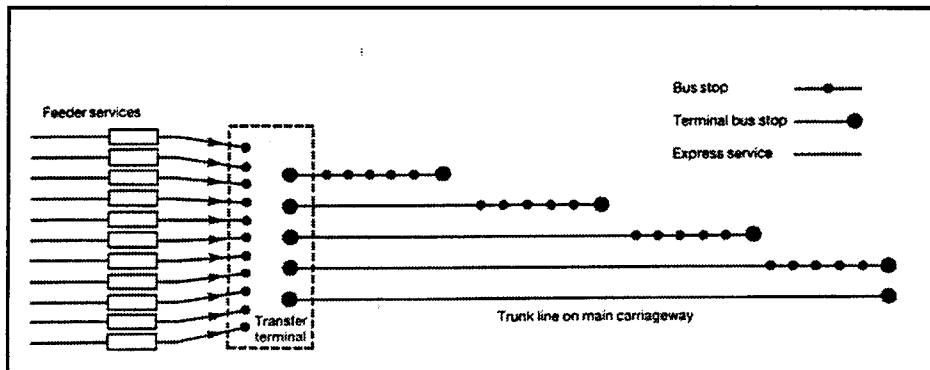

**Figure 4.4 - Trunk and Feeder Service in Curitiba, Brazil**

- Bus Ordering:** COMONOR is a technique which involves assembling buses into conveyors at the start of a busway in a sequence corresponding to the route and stand order at individual bus stops along the busway. The principle is to minimize delays by having groups of buses start and stop almost simultaneously (similar to cars of a train). The first operational system was introduced in Sao Paulo and subsequently COMONOR was applied in Porto Alegre on Assis Brasil and Farrapos. However, the technique was found to be too difficult to sustain operationally and was superseded by events in Sao Paulo and evolved into "bus ordering" in Porto Alegre.

With bus ordering shown in **Figure 4.5**, each bus route and bus is allocated to one of three groups A-B-C and, for the outbound movement during the evening peak (the predominantly critical boarding direction), buses are arranged, as far as possible, in the correct order at the beginning of the busway. Buses can be ordered using manually-controlled gantry-mounted traffic signals as in Porto Alegre. This technique enables Assis Brasil to accommodate up to 18,300 passengers/hour/direction (pphpd), without bus overtaking facilities or other special measures. Analyses suggest that at high passenger transfer demands, bus ordering might increase bus and passenger throughput by 10%, with a reduction of travel time through the bus stop area of the order of 25-40%.

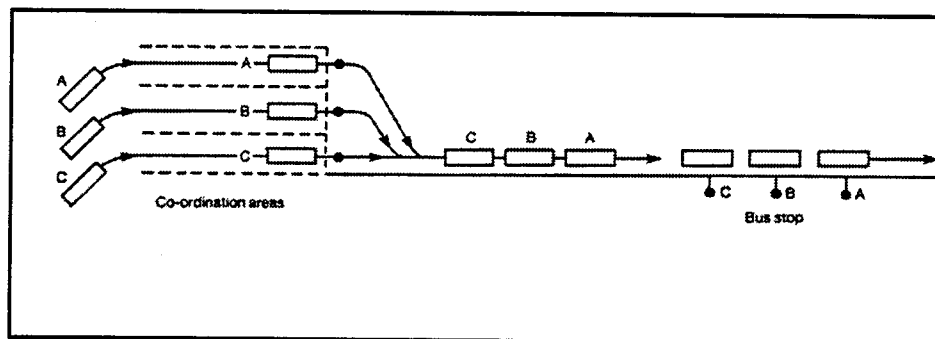

**Figure 4.5 - Bus Ordering Technique.**

Source: TRRL 329, 1991

- Use of High-capacity Buses:** The use of high-capacity buses such as articulated can increase passenger line-haul throughput, provided passengers board and alight efficiently at critical bus stops. Line-haul throughput is broadly proportional to bus capacity and bus flow, subject to passenger transfer capacity constraints at busy bus stops.
- Off-board Ticketing:** Where entry to a bus is unobstructed by fare collection or ticket validation, boarding times per passenger are lower (about 1 second/passenger) than where entry is restricted. Consequently, off-board ticketing offers the possibility to reduce passenger service time and thereby to reduce bus dwell time and increase commercial

speed. Although the potential benefits will depend on the existing situation and future fare collection, ticketing and boarding arrangements, analyses suggest that bus travel time through the stop might typically be reduced by about 20-25%. The only known busway with off-board ticketing is Curitiba, as shown in **Figure 4.6**.

- **Traffic Signal Techniques to Favor Bus Movements:** Various techniques are available to favor buses. Including: selective detection and demand dependent stages. However, more sophisticated biasing techniques would be required with high bus flow since buses would continuously call for priority.
- **Bus Dwell Time Limitation:** Occasional very long bus dwell times at a stop were observed at several locations to have a very adverse effect on the throughput and service reliability (Gardner, 1991). If staff could be assigned to limit bus dwell times in busy periods, the more severe disturbances might be avoided.

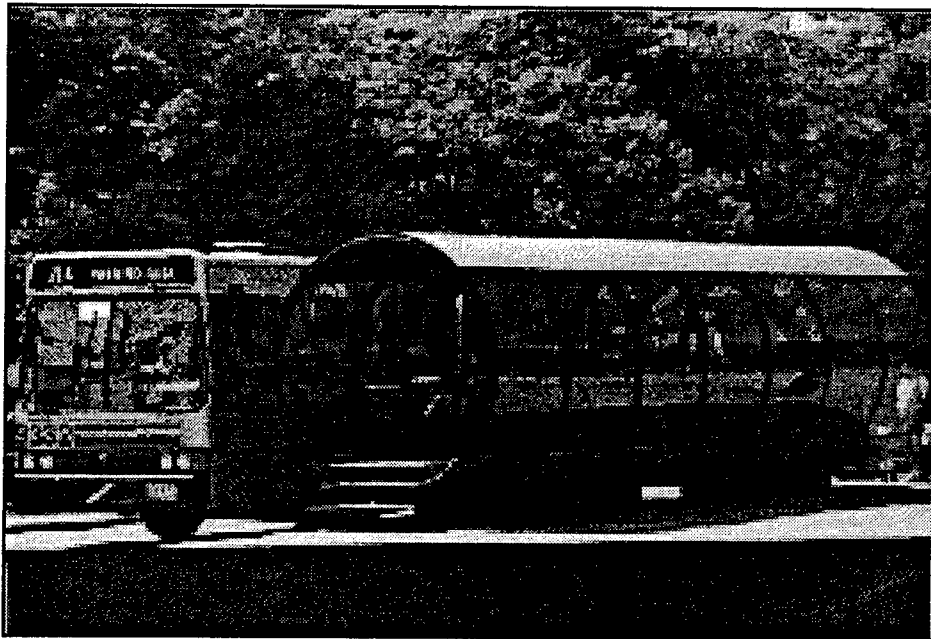

**Figure 4.6 - Off-board Ticketing, Curitiba, Brazil.**

*Source: Major 1997*

### **4.3 Capacity of At-Grade Busways**

This section focuses on the capacity of at-grade busways where bus movements are impacted by traffic control signals and patterns of passenger boarding and alighting. As bus capacity deals with the movement of both people and transit vehicles, the capacity of a bus priority treatment depends upon the size and configuration of the vehicles, and how often they operate. It also reflects the

interactions between passenger traffic concentrations and transit vehicle flow. Operating policy is also one of the factors that affects the busway capacity that specifies service frequencies, minimum separation between successive transit vehicles, and allowable passenger loading.

Several studies were done focusing on the capacity of bus lanes which has a similar concept to at-grade busways. The main difference among the three types of bus lanes, presented in **Table 4.1**, is the availability of the adjacent lane for buses to pass other buses, right-turn queue and other bus lane obstructions. **Table 4.1** also shows the corresponding busway to each bus lane configuration. Type 1 bus lanes are similar to a busway with no overtaking facility, where both cannot pass other buses loading and unloading passengers in the station areas. A type 2 bus lane is similar to a busway with overtaking facilities, where buses can pass other buses loading and unloading passengers at bus stops. A type 3 bus lane has no similar busways as busways consist of only two lanes (one each direction) and buses are not allowed to use the opposite direction to pass other buses. Thus, busways can use the same formulas used to calculate the capacity of bus lanes.

**Table 4.1 - Similar Types of Bus Lanes and Busways**

Type	Bus Lane Configurations	Similar Busways
1	No use of adjacent lane for buses to pass other buses, right-turn queue and other bus lane obstructions	Busway with no overtaking facility
2	Partial use of adjacent lane for buses to pass other buses, right-turn queue and other bus lane obstructions	Busway with overtaking facility
3	Full use of adjacent lane for buses to pass other buses, right-turn queue and other bus lane obstructions	N/A

Various formulas to estimate the capacity of bus berth, bus stop or bus route are presented in the Highway Capacity Manual (HCM 1994). These formulas show how the number of buses that can be accommodated at a given stop relate to the dwell times at stops, the clearance times between successive buses and the amount of green time per signal cycle.

The general formula provided by the HCM to calculate the capacity of the bus lane for a single bus lane where buses may not pass each other, which similar to a busway with no overtaking facility is:

$$C_B = \frac{(g/C)3600RN_b}{(g/C)D+t_c}$$

Where:	$C_B$	=	buses per hour per channel per berth.
	$D$	=	bus dwell time at stop (sec).
	$t_c$	=	clearance time (headway) between buses (sec), usually 10 to 15 seconds.
	$N_b$	=	number of effective berths.
	$R$	=	reductive factor to account for variations in dwell times and arrival. Assumed in the HCM to be 0.833 for buses for service level E.
	$g$	=	effective green time per cycle (sec).
	$C$	=	cycle length (sec).

This formula reflects near-side stops and was assumed to be a reasonable approximation for the far side stops.

The factor "R" takes into account the variations in dwell times. Maximum capacity was assumed to have a 30% failure: i.e.  $R = 0.833$ . The "R" values were calibrated based on a dwell time coefficient of variation of about 0.4 to 0.5.

#### 4.3.1 Development of Revised Capacity Estimates

The basic bus berth capacity equation was formulated to provide a more precise treatment of bus dwell time variability (TCRP 26, 1997). The resulting equations were as follows for uninterrupted and interrupted flow conditions, they assume that:

##### *Unsignalized*

$$C_b = \frac{3600}{t_c + D + Z_a C_v D}$$

##### *Signalized*

$$C_b = \frac{(g / C) 3600}{t_c + (g / c) D + Z_a C_v D}$$

This equation assumes that the time spent loading and discharging passengers on both the green and red phases are proportional to the green time per cycle, respectively.

Where:

$C_b$	=	capacity of a berth in buses per hour.
$t_c$	=	clearance time between buses, (i.e. 10 to 15 sec).

- D = average (mean) dwell time (sec).
- g/C = effective green time per signal cycle.
- S<sub>D</sub> = standard deviation of dwell time (sec).
- Z<sub>a</sub> = one-tail normal variate corresponding to probability that queue will not form from behind bus stops.

The percentage failure represents the probability that bus stop capacity is exceeded (queue forms behind a bus stop), and is keyed to Level-Of-Service in **Table 4.2** (Table 12-17 of HCM). The value Z<sub>a</sub>, from basic statistics, represents the area under one "tail" of the normal curve beyond the acceptable level of probability of a queue forming at the bus stop, and thus represents the probability that a queue will not form behind the bus stop. Typical values of Z<sub>a</sub> for various failure rates are shown in **Table 4.3**.

**Table 4.2 - Level of Service for Bus Stops**

LOS	R Value	Effective sec/hr (3,600 R)	Index LOS E = 1.00	Approx. Probability of Queues forming Behind Bus Stop
A	0.400	1,200	0.40	1
B	0.500	1,800	0.60	2.5
C	0.667	2,400	0.80	10
D	0.750	2,700	0.90	20
E	0.833	3,000	1.00	30
Capacity E-Perfect Conditions	1.000	3,600		50

Source: HCM 1994, Transit Capacity, Table 12-17.

**Table 4.3 - Values of Percent Failure and Associated One-Tail Normal Variate,  $Z_a$**

Failure (%)	$Z_a$
0.01	2.330
2.50	1.960
5.00	1.645
7.50	1.440
10.00	1.280
15.00	1.040
20.00	0.840
25.00	0.675
30.00	0.525
50.00	0.000

*Source: Final Report, TCRP A-7, 1996.*

The previous formulas indicate the following: (TCPR 26, 1997)

- Capacity decreases as the mean dwell time increases.
- Capacity increases as the  $g/C$  ratio increases.
- The increase in the capacity is not directly proportional to the increase in  $g/C$  because some of the clearance time,  $T_c$ , is not affected by the  $g/C$ .
- Capacity decreases as the variability in dwell time increases. For the same mean dwell time, bus lane capacity would be greater for a stream of buses with similar dwell times, than for buses whose dwell time is much higher or lower than the average. Thus, the mixing of bus routes at a bus stop that experience long dwell times (such as park-and-ride) with those that experience short dwell times (such as local service) may reduce the overall capacity of the busway.
- Capacity reflects the level of failure that is accepted.

#### **4.3.2 Capacity Adjustment for the Availability of Overtaking Facilities**

When all buses stop at every curbside bus stop in an on-line busway station, the availability of an overtaking or an off-line station becomes necessary only for lane obstruction passing. The ability of express buses to pass other buses boarding and alighting passengers at bus stops improves the bus speed and the busway capacity. Thus, the corresponding increase in the capacity of at-grade busways ranges between 50 and 100 percent depending on the following:

- 1- The length of deceleration and acceleration lanes.
- 2- Number of berths at each bus stop.
- 3- The distance between the busway stop and an intersection.
- 4- The capacity of buses operating on the busway (minibus, standard bus, or articulated bus).
- 5- Existence of advanced vehicle detectors which allow express buses to travel part of or the entire length of the busway without stopping.
- 6- Level of training and experience of the drivers.

The following is an example of the capacity analysis for Pittsburgh Busways.

**Table 4.4 - Capacity Analysis for Pittsburgh Busway**

DESIGN SPEED (MPH)	MINIMUM STOPPING SIGHT DISTANCE		SAFE STOPPING SIGHT DISTANCE	
	S.S.D. (Ft.)	CAPACITY (Buses/Hr)	S.S.D. (Ft.)	CAPACITY (Buses/Hr)
30	375	380	220	610
40	615	320	360	530
50	915	275	540	455
60	1,275	240	750	400

Source: *Capacity Analysis of Exclusive Busway/HOV/Carpool Facilities*, Houston Transit Consultant, December 1981.

#### 4.4 Bus Stop Capacity

Due to the complexity of bus and passenger interactions at stops, it is impossible to specify a single set of bus stop capacities. Simulation can be used sometimes to test particular options based on local behavior. In this section, some indicative performance figures for various busway stop layouts and operating regimes are presented. These layouts are the come out of an empirically-based spreadsheet calculation procedure using observed passenger demand profiles and behavior, and bus operating characteristics.

The busway stops can be one of the following:

- Two-bay bus stops where buses can use either of them. Buses can also leave the station in any order depending on the loading time;
- Three-bay stops where either buses can use any bay or buses allocated to specific bays



(A-B-C);

- Four-bay bus stops where buses are assigned to one or two groups of bays. Each bus allocated to two bays (AA-BB); or
- six-bay stops where buses are assigned to one of two groups each of which is allocated to three bays (AAA-BBB ).

Busway stop capacity also depends on the following:

- Improved boarding/alighting conditions (fare collection methods);
- The use of high capacity buses;
- Bus ordering, buses are assembled into the correct route order before entering the stop;  
or
- Trunk-and-feeder services.

## 5.0 DESIGN GUIDELINES FOR AT-GRADE BUSWAYS

### 5.1 Introduction

This section of the report discusses the at-grade busway infrastructure components in detail including; right-of-way, bus stops, shelters, bus bays, intersection layout, traffic signal priority, and the above-mentioned busway operational measures. A typical at-grade busway should include two through exclusive bus only lanes with an optional two extra lanes at the station areas to allow express buses to bypass other buses boarding and alighting passengers. Deciding whether to install a median or a side-aligned busway mainly depends on the existing right-of-way configuration, as well as, the characteristics of the corridor on which the busway will be installed.

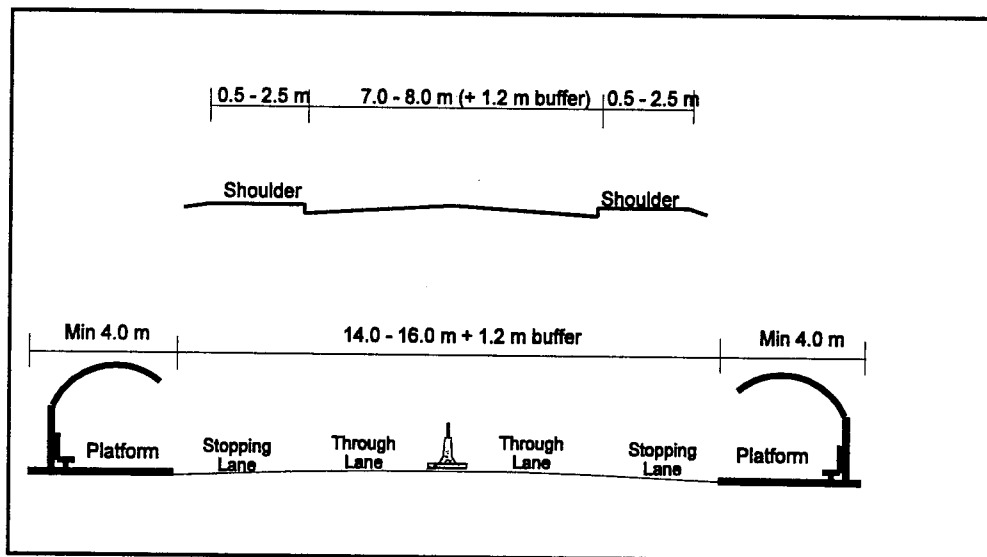

Figure 5.1 - Typical Busway Cross-section in New Roadways or Abandoned Right-of-Way.

### 5.2 Right-of-Way Characteristics

At-grade busways can be introduced along existing roads, using abandoned or sharing railway right-of-way, or they can be purpose-built. Along an existing road, a busway can run in the middle of the roadway (median busway) or along the curb (lateral busway or curbside busway). **Figure 5.2** presents different busway alignments. A purpose-built busway can accommodate dedicated at-grade bus only roads (e.g., Runcorn New Town, UK), an abandoned railway right-of-way can be modified for the busway operation (e.g., Miami, FL). A busway can also share the right-of-way with other modes of transit in part of its alignment (South Busway, Pittsburgh), and a dedicated right-of-way along a new road (e.g., Avenida Cristiano Machado, Belo Horizonte, Brazil).

### 5.2.1 Median At-grade Busway Cross-section

The insertion of a new busway in an existing roadway is a difficult issue that arises over the allocation of road space between the conflicting demands of different road users. In many cases, there are insufficient right-of-ways to add two more exclusive busway lanes. Thus, a median at-grade busway usually consists of an exclusive two-lane roadway, one lane in each direction, reserved for the use of buses. Unless, there is enough right-of-ways near the intersections, two extra lanes (one each direction) can be added as an overtaking facility at the station area. Otherwise, the buses on the busway have to operate in the same order from beginning to the end of the busway. **Figures 5.3, 5.4, 5.5 and 5.6** show different median busway alignments. The total width of the busway is a function of its design speed. **Table 5.1** represents some of the recommended lane width and different separation dimensions shown in **Figure 5.7**.

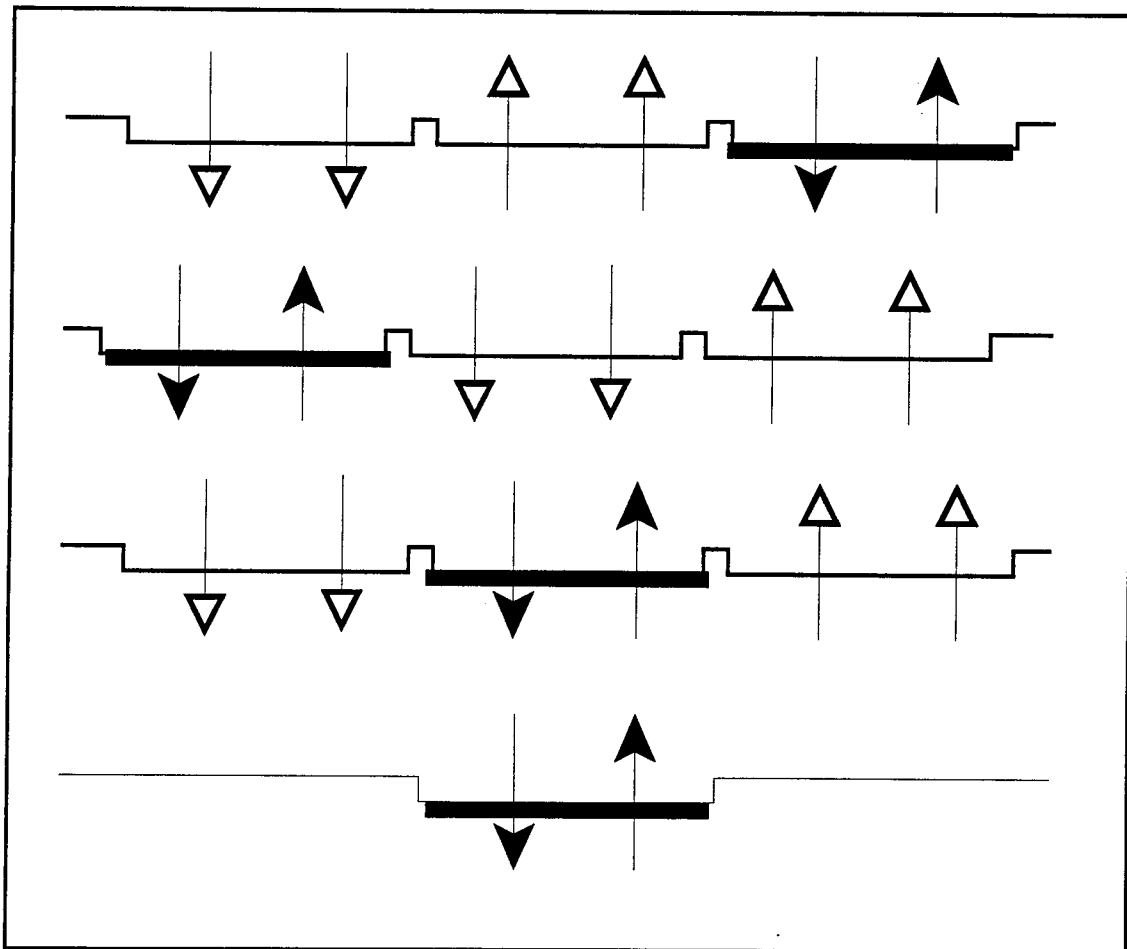

Figure 5.2 - Typical Busway Configuration

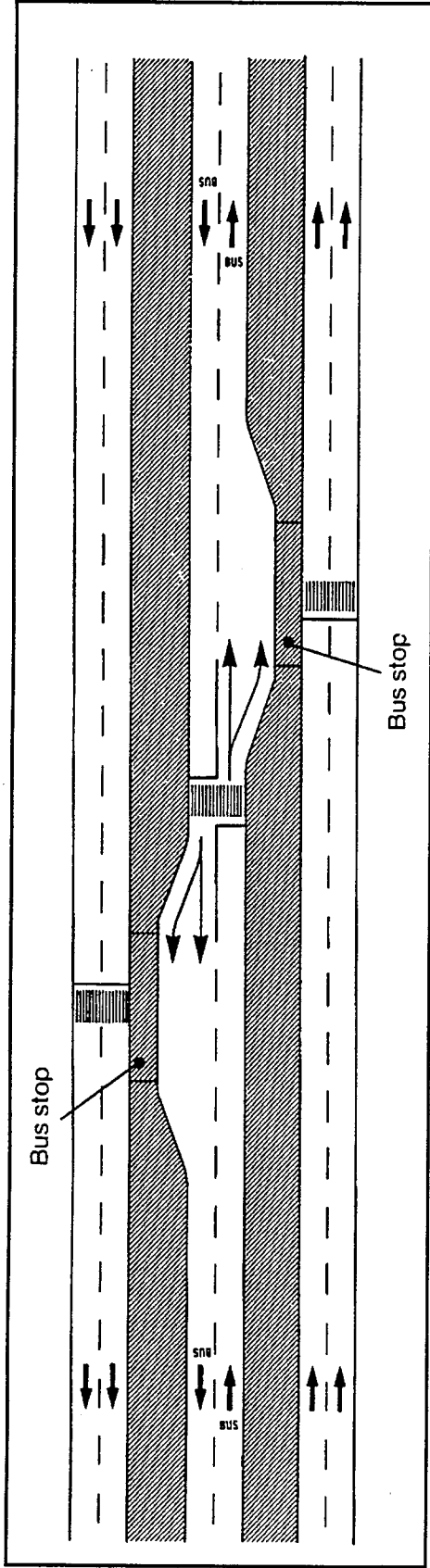

Figure 5.3 - Typical Bus Stop Layout, Avenida Cristiano Machado, Belo Horizonte, Brazil

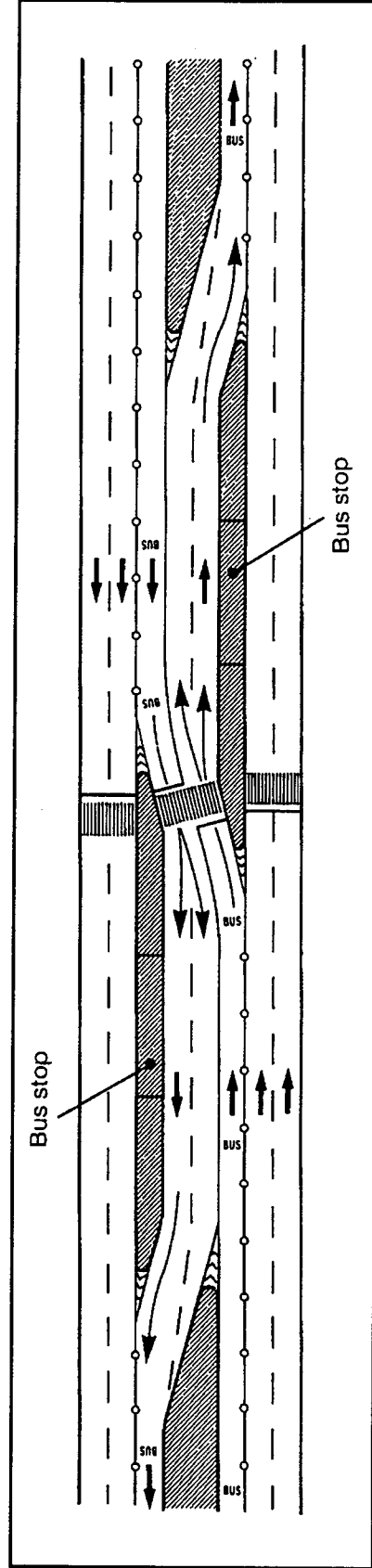
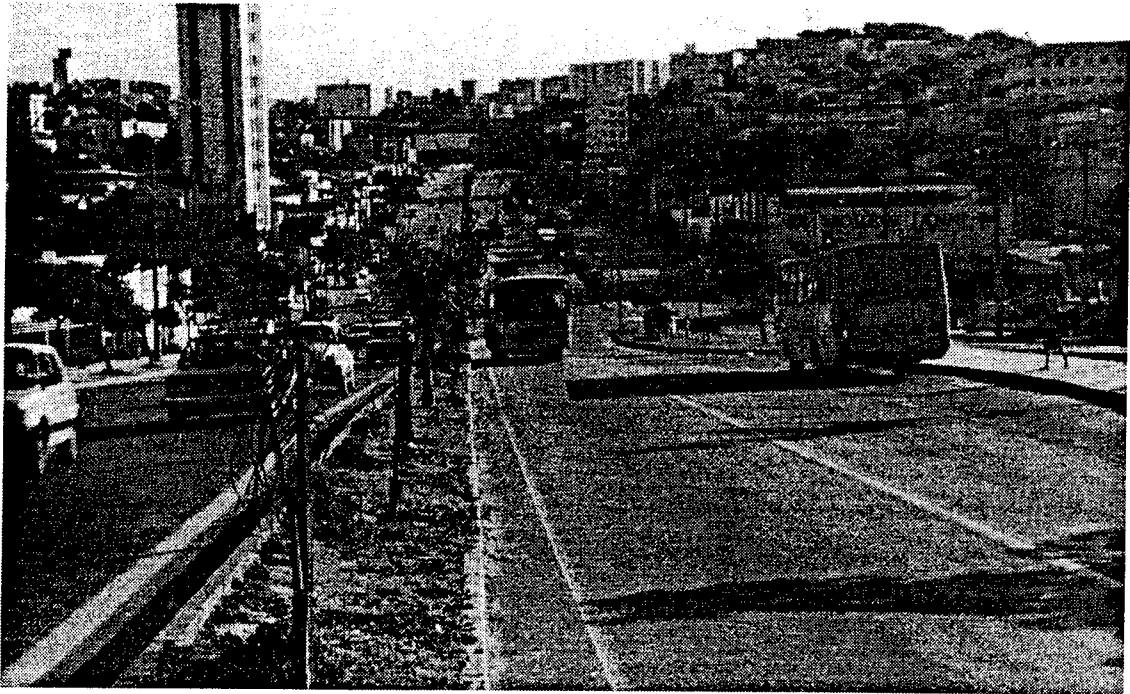

Figure 5.4 - Typical Bus Stop Layout, Avenida 9 de Julho, Sao Paulo, Brazil



**Figure 5.5 - Median At-Grade Busway, Curitiba, Brazil**

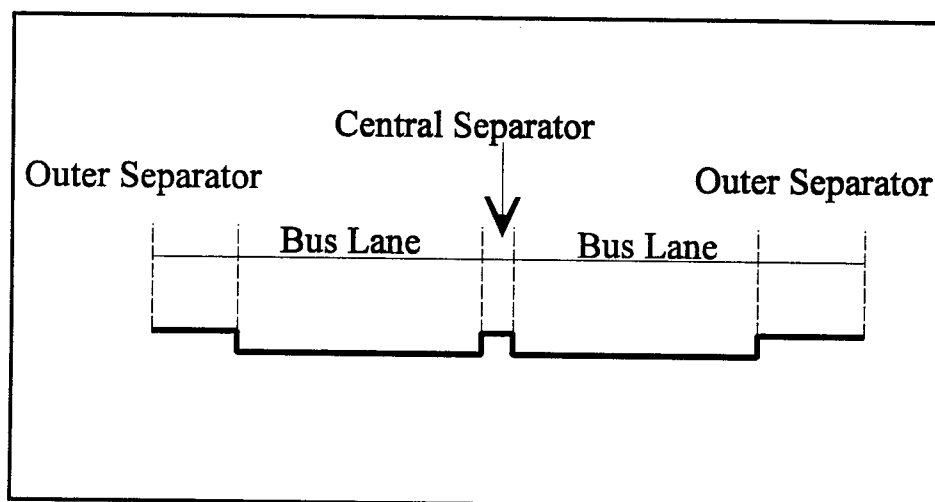

**Figure 5.6 - Median At-Grade Busway, Belo Horizonte, Brazil**

**Table 5.1 - Recommended Cross-section Widths for Median At-grade Busways with No Overtaking Facilities Carrying More Than 60 Buses/Hour.**

Design Speed (km/h)	Width (m)			
	Bus Lane	Central Separator	Outer Separator	Total Width
100	4.00	0.40	0.75	10.30
80	3.75	0.40	0.50	9.30
60	3.25	0.40	0.30	7.90
40	3.00	0.40	0.20	7.20

Source: TRL 1993.

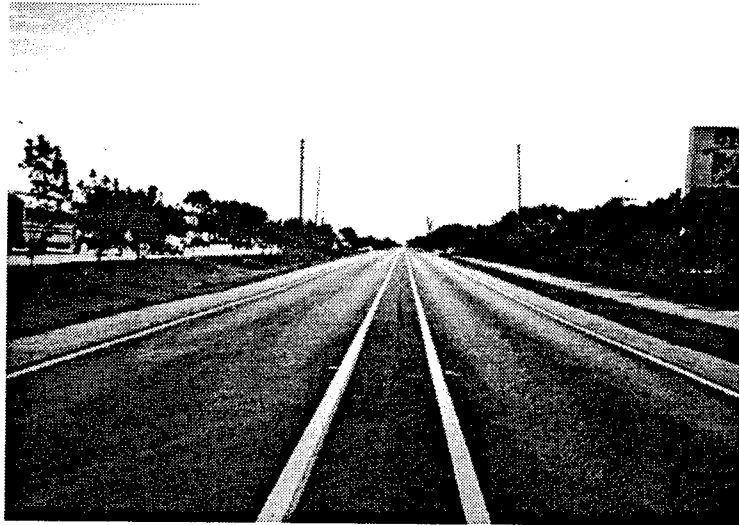

**Figure 5.7 - Median At-Grade Busway Cross-section.**

### 5.2.2 Side-Aligned At-grade Busway Cross-section

A Side-aligned at-grade busway is usually planned and installed in newly constructed corridors where the right-of-way needed is reserved and driveways for businesses are permitted at the busway side. Typically, a side aligned busway consists of an exclusive two lane roadway, one lane each direction, reserved for the use of buses as shown in **Figure 5.8**. For high speed operation of 50 mph (80 km/hr) lane width may vary from 9.9 to 13 ft (3 to 4 m) depending on the space available. If the right-of-way permits, an extra four feet (1.2 m) separation distance (buffer) between the two directions may be placed. Shoulders may also vary from 1.6 ft to 8 ft (0.5 m to 2.5 m). At stations, two extra lanes (one each direction) are placed. This will result in one stopping

lane and one through lane. This cross-section will allow non-stop or express buses to pass by other buses loading and unloading passengers at stations as shown in **Figure 5.9** (South Miami-Dade Busway in Miami, Florida). A fence is usually installed at the station area to separate the two direction of traffic and to prevent passengers from crossing the busway within the station area. Typically, the cross-section at the station area varies from 75 ft to 85 ft (23 m to 26 m) including a 13-ft (4-m) station platform for each direction.



**Figure 5.8 - Typical Cross-section of a Side-aligned At-grade Busway, Miami, FL**  
*Source: LCTR Photo Collection*

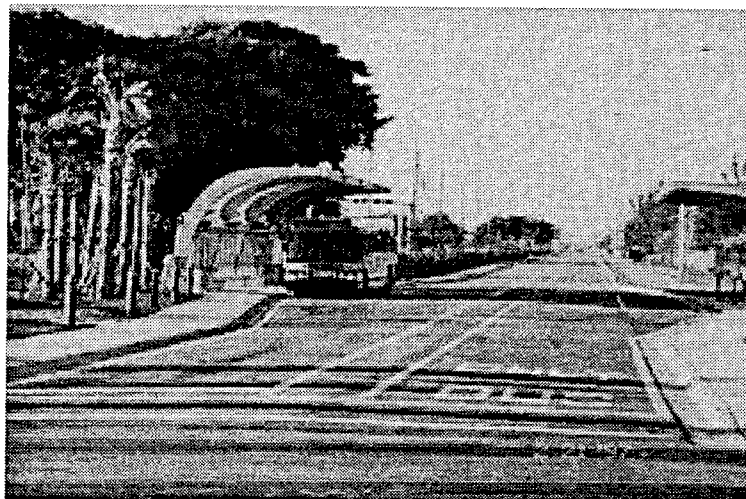

**Figure 5.9 - Side-aligned At-grade Busway at Station Area with Overtaking Facility, Miami, Florida**  
*Source: LCTR Photo Collection*

### 5.3 Bus Stop Characteristics

The provision and subsequent spacing of bus stops are dependent on the purpose and the design speed of the busway. If the busway is to service as a rapid transit corridor between a remote residential zone and a central business district (CBD), few if any stops would be provided. If however the busway travels through passenger catchment areas, stop spacing is considered to be: (Held, 1990)

- close (0.3 to 0.625 mile) where passengers would walk to stops;
- intermediate (0.625 to 0.94 mile) where passengers would ride other buses to stops; and
- long (0.94 to 2.8 miles) where passengers would drive private vehicles to stops.

These distances compared to standard on-road stop spacing usually in the order of 820-985 ft (250-300 m). It should be noted that close and possibly intermediate stop spacing would prevent buses from attending Class A busway design speeds in the order of 62.5 mph (100 km/hr).

The design of bus stops should be such that delays associated with loading and unloading affects only the bus in question. Thus, ideally either bus bays or overtaking facilities should be provided into the bus stop design if the right-of-way permits.

Passenger security is a major issue in bus stop design and location, because the design and location of the bus stop can positively or negatively influence a bus patron's perception of that bus stop. Landscaping, walls, billboards, and solid structures can restrict sight lines and provide spaces to hide. Thus, transit agencies should carefully review which amenities are to be included at a bus stop and consider any factors that may influence security.

#### 5.3.1 Bus Stop Location

At-grade busway stops like any other bus stops can be located at the near side or the far side of an intersection as well as mid-block. Several considerations should be taken into account when determining the location of a busway stop. **Figure 5.10** shows some of the considerations when locating a busway stop. These considerations are important when the volume of buses joining and leaving the busway alignment from and to local streets is relatively high. Typically, Case II is used for mid-block at-grade busway stops, but Case I and Case III may be implemented at intersections where bus volume joining or exiting the busway is high, respectively. Buses will have time to wait for the green light to make a right turn instead of blocking the way for express buses.

- **Advanced Vehicle Detectors** - When Planning to install advanced vehicle detectors on the busway to detect and allow express buses on the at-grade busway to travel the entire length or part of the busway without stopping at intersections, it is recommended to locate



the busway stops at the far side of the intersection. If the station is located at the near side of the intersection, local buses will be detected and will obey the busway stop located at the near side of the intersection while having a green signal to cross the intersection. Thus, causing an extensive delay for side street traffic crossing the busway.

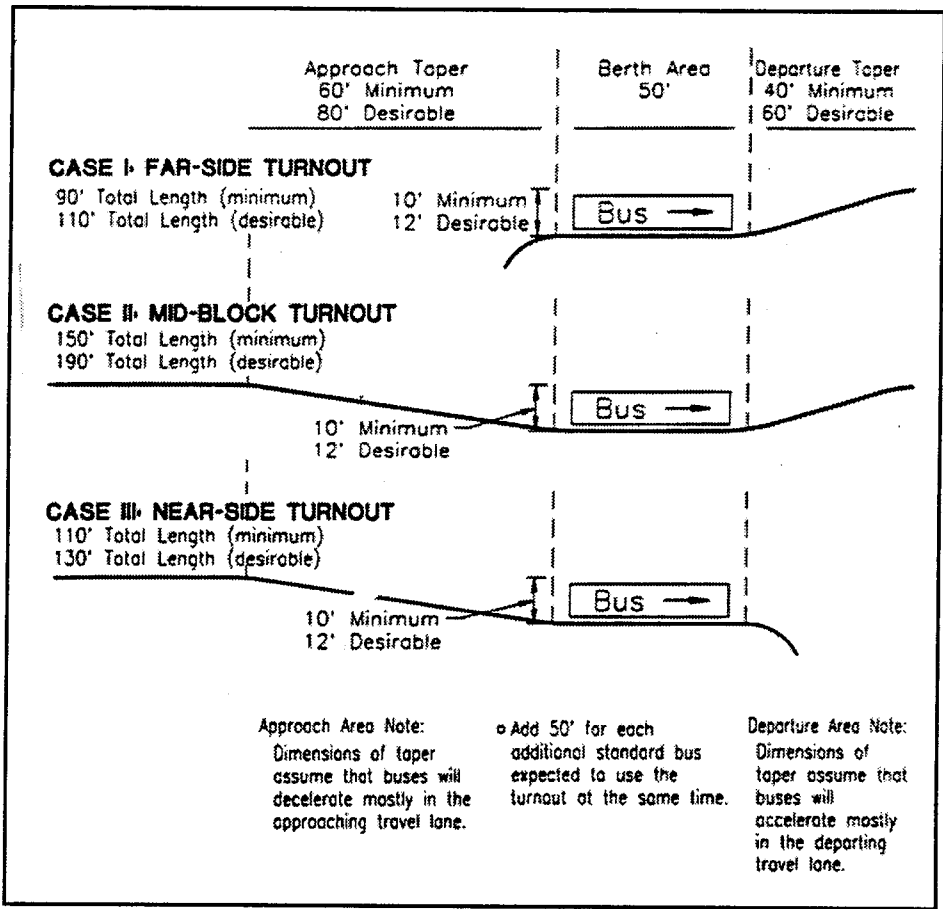

**Figure 5.10 - Different Locations of a Busway Stop**  
 Source: MST, January 1996

- **No Overtaking Facilities** - If overtaking facilities are not provided along the busway, it is recommended to locate the bus stops at the near side of the intersections. Especially if bus volume is high, locating the bus stops at the far side of the intersection might result in bus back-ups that may block the intersection causing delay to side street traffic. If it is necessary to locate a bus stop at the far side of the intersection, bus stops should be located at a sufficient distance from the intersection to allow a space for expected buses arriving at the intersection. The only draw back of this solution is increasing the walking distance to transit riders to go to and from the bus stop to their destination.

### 5.3.2 Station Amenities

Certain passenger comfort features should be included in the design of all busway stations. Other features may be provided only under certain conditions. The materials that are used for the construction of bus stop amenities should be weather resistant and withstand continual use, and can be easily maintained. Primarily, wood, concrete, glass, and plastics are used at the bus stops. The types of amenities that are to be provided are the following:

- **Bus Stop Shelters** - The area used by passengers waiting for a bus, boarding or alighting from a bus, should be provided with shelter at each loading bay, as shown in **Figure 5.11**, to protect riders from rain, snow, cold weather during winter, or direct sunshine during warm weather. Full platform canopies may be considered when there are high levels of passenger activity to the extent that boarding passengers cannot be accommodated within the shelter area or when buses are not assigned to a certain bay at the bus stop, as shown in **Figure 5.12**. In most instances, the estimated number of passengers boarding has the greatest influence on what type of shelters to be used. Other factors that can influence the size of the shelter include availability of the right-of-way width, utility pole locations, existing structures, and maintaining proper circulation distances around existing site features.
- **Benches** - Benches provide comfort and convenience at bus stops. Benches are usually installed on the basis of existing or projected ridership figures. Benches should be installed at each bus stop for elderly and disabled passengers. The location of benches should be coordinated with existing shelters and shade trees, street lighting, and ADA mobility clearance.



Figure 5.11 - Ottawa Transitway Station

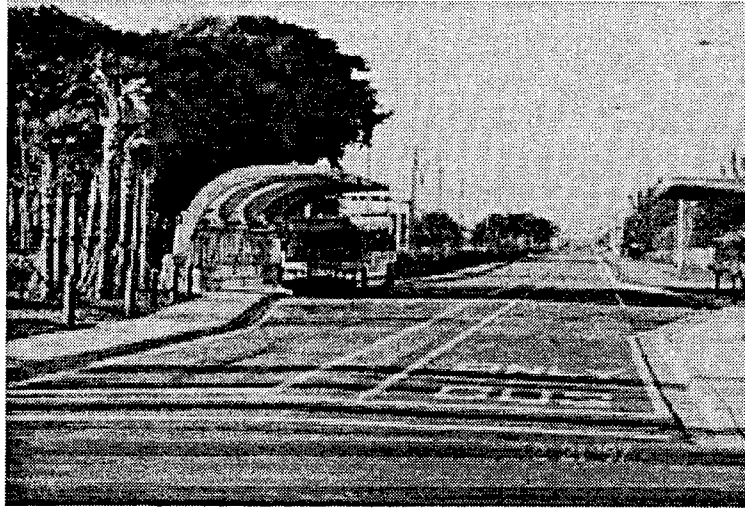

**Figure 5.12 - South Dade Busway Station, Miami, Florida**

*Source: LCTR Photo Collection*

- **Lighting** - Lighting affects bus patrons' perception of safety and security at a bus stop. Good lighting can enhance a waiting passenger's sense of comfort and security. On the other hand, poor lighting may encourage unintended use of the facility by non-bus patrons, especially after hours. Sufficient lighting should be provided to ensure adequate visibility when the facility is in operation. Illumination requirements are often a policy of individual transit agencies, however, installing lighting that provides between two to five foot candles is the general recommendation. Such illumination should be sufficient for reading, to avoid injury due to physical hazards and to discourage crime. **Figure 5.13** shows a location for lighting pole at a bus stop.

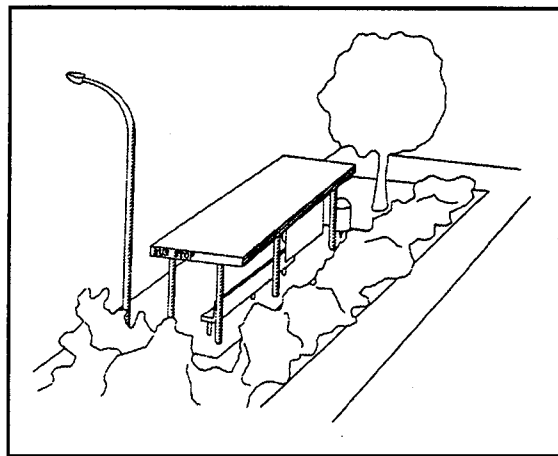

**Figure 5.13 - Lights at Busway Stations.**

*Source: TCRP 19, 1996*

- **Bicycle Storage Facilities** - Bicycle storage facilities, such as bike lockers and bike racks, may be provided at bus stops for the convenience of bicyclists using transit. Before creating a bicycle storage facility, planners should consider the location, type of rack and the number of racks to be installed (**Figures 5.14, 5.15, and 5.16**). Proper storage of bicycles can reduce the amount of visual clutter at a stop by confining bikes to one area. Bike storage area should be located away from other pedestrian or patron activities to improve safety and reduce congestion. Also, the location of bike storage facilities should be located with existing on-site lighting. Paved access should be provided between the bike storage area and the bus stop, and should be constructed with non-slip concrete or asphalt that is properly drained.

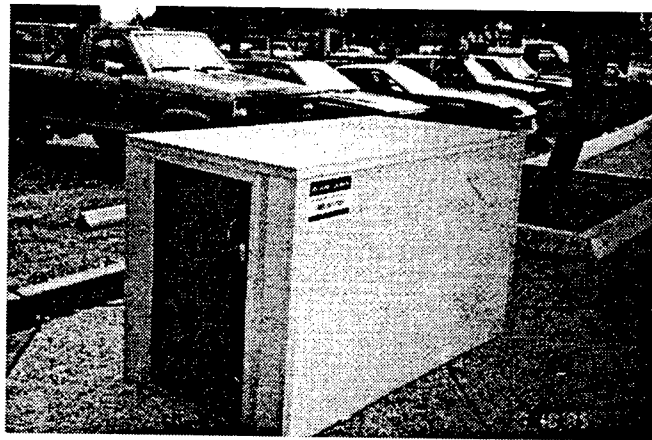

**Figure 5.14 - Bike Locker**

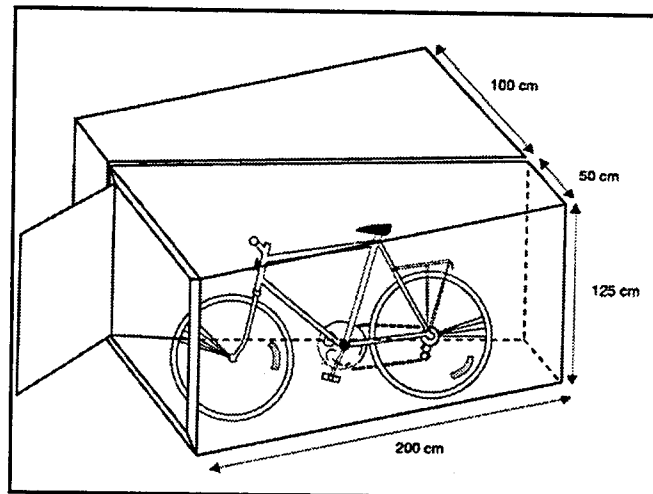

**Figure 5.15 - Bike Locker**



**Figure 5.16 - Bike Rack**

*Source: Technical Handbook of Bikeway Design, 1992*

- **Vending Machines** - The vending machines can provide passengers with the reading material while they wait for the bus. Vending machines should be located so that they do not obstruct accessibility causing inconvenience. Also, they should be properly maintained to avoid the accumulation of trash in the form of news papers (see **Figure 5.17**).



**Figure 5.17 - Vending Machines at Bus Stops**

*Source: TCRP 19, 1996*

- **Trash Receptacles** - Trash receptacles can improve the appearance of a bus stop by providing a place to dispose of trash. The receptacle should be located in an area where it will not get direct sunlight which can develop the foul odor and must be emptied regularly.
- **Shopping Cart Storage Area** - Proper storage is needed for shopping carts at bus stops near commercial shopping areas. Because bus stops normally do not have storage facilities for shopping carts, carts often litter the area around the stop and along the sidewalk accessing the stop.
- **Communications** - Telephones at bus stops are not required under ADA, but if telephones are in place, they shouldn't obstruct access to the facility. Phones should be suitable for users with hearing impairments. At least one phone should be accessible for wheelchair users. Telephone directories can also be made available. Pay telephones may be provided at all bus stops with off-street bus facilities. They create a feeling of security for the commuters and will be handy in the emergency time. A direct line to transit information should also be considered. (see Figure 5.18).



**Figure 5.18 - Communication Facilities at South Dade  
Busway**

*Source: LCTR Photo Collection*

## 5.4 Customer Information at Bus Stops

Many transit agencies took steps to increase and improve transit service information at bus stops (TCRP 17, 1996). Transit service information at bus stops is important to transit users and can effectively increase ridership by retaining existing riders and potentially attracting new riders to the transit system. The service information may include:

- Schedule information
- Route maps
- System maps
- Fare information

These displays may range from small display panels affixed to the bus stop sign supports to large displays employing color graphics depicting route and system maps and other information that can be useful to transit riders. As a result of various studies and surveys it was decided that it would be an effective way to adopt a pictograph to identify a bus stop with route numbers and special messages provided with each route (see **Figure 5.19**). The transit information telephone number can be displayed on all bus stop signs. Route and passenger information can be displayed in various ways. A flag sign is the most common method used by transit agencies to display information. The installation of schedule holders or schedule and route information on the shelters are also commonly used. The actual displays mounted on the sign can include the transit agency logo, route numbers available at the stop, type of route (local or express), and destinations for a limited number of stops. Scheduled holders are included at sites with large passenger volumes. The schedule holders can be mounted on the flag sign inside a shelter. Interior panels of shelters can also be used for posting route and schedule information. Side panels may be large enough to display the entire system map and can include backlighting for display at night. Some recommendations for route or patron information display are as follows:

- Provide updated information when changes are made to routes and schedules.
- Consider the quality and appearance of the information displays.
- Follow the ADA clearance, mobility, and visual guidelines for access of information by individuals with impairments. According to RTD, 1988 the amenities that have to be provided for the bus stops include:

- **Transit information** - Bulletin boards or kiosks may be provided, and maintained with the maps and schedules of the rail and bus lines that serve the station. Fare information may also be posted. Appropriate signage can be provided to clearly indicate the other mode station access points and direction to bus lines from all rail access points. The individual line route and schedule information should be provided at each bay for the lines serving that bay. This information should be updated within 24 hours of any service change.



**Figure 5.19 - Route Information at South Dade Busway Stops**

*Source: LCTR Photo Collection*

- **Advanced Technology Applications** - The use of technology to inform users through video displays, electronic signage and programmed audio announcements are suitable for high-volume facilities with relatively controlled environments. (see **Figure 5.20**)



**Figure 5.20 - Electronic Transit Information Panel at a Bus Stop**

*Source: TCRP 17, 1996*



## 5.5 Elderly and Disabled Requirements

All stations should be designed to provide easy access to the elderly and the disabled. Appropriate curb cuts and ramps should be made where required to meet the accessing needs. The minimum dimensions for a bus stop pad and shelter is presented in **Figure 5.21**. Since most of the transit buses are equipped with wheelchair lifts (see **Figure 5.22**), located at the front or the rear door, bus stop design has to allow for either possibility.

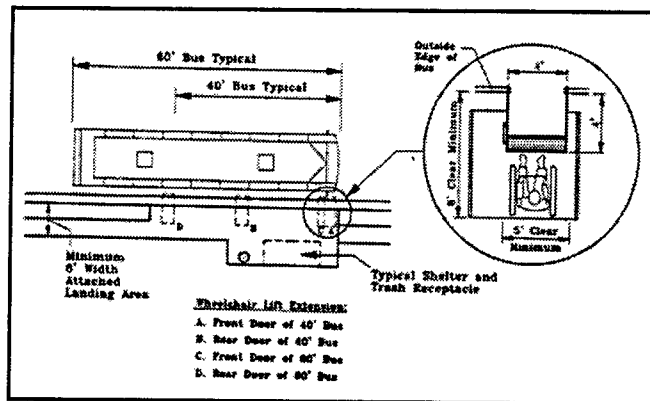

**Figure 5.21 - Shelter Design Example to Meet ADA Requirements**

*Source: TCRP 19, 1996*



**Figure 5.22 - Wheelchair Lift in Operation**

*Source: TCRP 19, 1996*

## 5.6 Bike Path

Many cyclists are discouraged from traveling on bikes. The road network includes major obstacles difficult to negotiate on two wheels and does not allow sufficient space for bicycles. Providing a bikeway along busways can provide a safe environment for cyclists wherever the right-of-way permits or when a new busway is under construction. Bike path along a busway are suitable for bicycle travel, linking two or more locations. Also, bike paths can be connected to other bike trails or bike lanes in the area forming a bikeway network.

- **Right-of-Way** - Bike path along a busway can be designed to be used by more than one group (pedestrian, joggers, wheelchair users, etc.). However, in urban areas where bicycle and/or pedestrian traffic volumes are high, the risk of conflict and accidents increases and the efficiency of bicycle travel is reduced. In this case, it is desirable to separate cyclists from pedestrians. A minimum separation distance should be provided between the busway and the bike lanes. The width of the bike path depends primarily on the volume of bicycles using the bike lane. **Table 5.2** presents the suggested widths of bike lanes.

**Table 5.2 - Recommended Widths of Bike Paths**

Traffic Volume	Configuration	Width
< 1,500 cyclists/day	Unidirectional	2.25 m
	Bidirectional	2.75 m
> 1,500 cyclists/day	Unidirectional	2.50 m
	Bidirectional	3.00 m

Source: *Technical Handbook of Bikeway Design, Québec, 1992.*

- **Obstacles** - Various elements may hinder the construction of roadside bicycle paths, including mail boxes, billboards, steep side slopes, private access roads, and signage. These obstacles are easy to work around or move, but must be taken into account when planning for a bike path along a busway. Roadside poles, such as electrical lines, street lights, etc., present some major obstacles for cyclists. Thus, it is desirable to provide a separation distance of at least 1 meter (3 feet) between roadside poles and bike lanes.
- **Road Irregularities** - Due to the lack of shock absorbers and the low volume tires, bicycles do not cushion cyclists very well against impact. Thus, the quality of the bike lane riding surface is very important. The following measure should be taken into consideration:
  - Public utility installations such as manholes cover, sumps, and gates chambers must be level with the surface of the traveled way.

- Control joints must be inspected.
  - The surface must be maintained regularly to remove sand, earth, and other matters that may cause skidding.
  - Surface irregularities which may make riding uncomfortable bumpy or lead to drainage problems must be eliminated.
  - Drainage grates must have narrow opening and be oriented perpendicular to the riding surface, to prevent bicycle tires from slipping into them.
- **Lighting** - Effective lighting is an essential element of safe travel on bike paths in the darkness or evenings. The horizontal light should be strong enough to enable the cyclists to follow the bike paths easily, to spot any obstacles and to read surface markings. An effective vertical light should enable cyclists to read road signs and spot other cyclists coming from the opposite direction (**Figure 5.23**). At intersections, the vertical illumination level should ensure that cyclists are clearly visible to motorists. The bike path should be illuminated to the same level as the street for a distance of 25 meters on either side of the intersection (**Figure 5.24**).

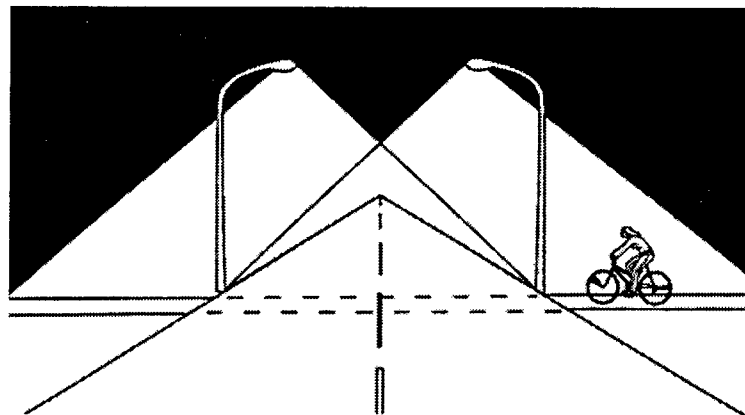

**Figure 5.23 - Light for Bike Paths at Intersections**  
 Source: *Technical Handbook of Bikeway Design, 1992.*

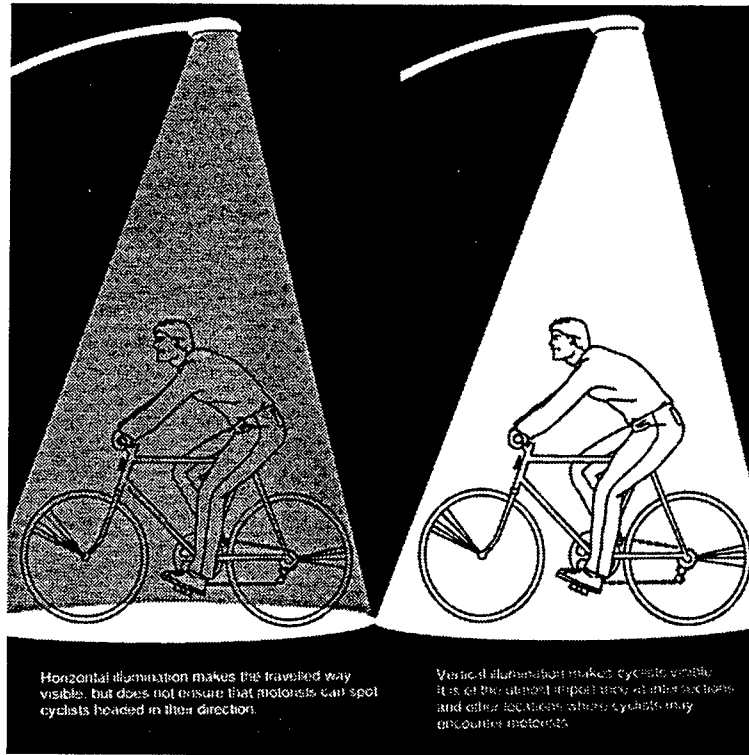

**Figure 5.24 - Vertical and Horizontal Illumination**  
 Source: *Technical Handbook of Bikeway Design*, 1992.

### 5.7 Horizontal and Vertical Clearances for Buses

A minimum of 2 feet horizontal clearance should be provided between the curb and any lateral obstruction along the busway. While in station areas, 5 feet minimum clearance should be provided. Obstacles within the station area should not conflict with the movement of passengers. Vertical clearance should be determined according to the type of buses operating on the busway. In the case of standard-sized buses, the minimum clearance is 14' 6".

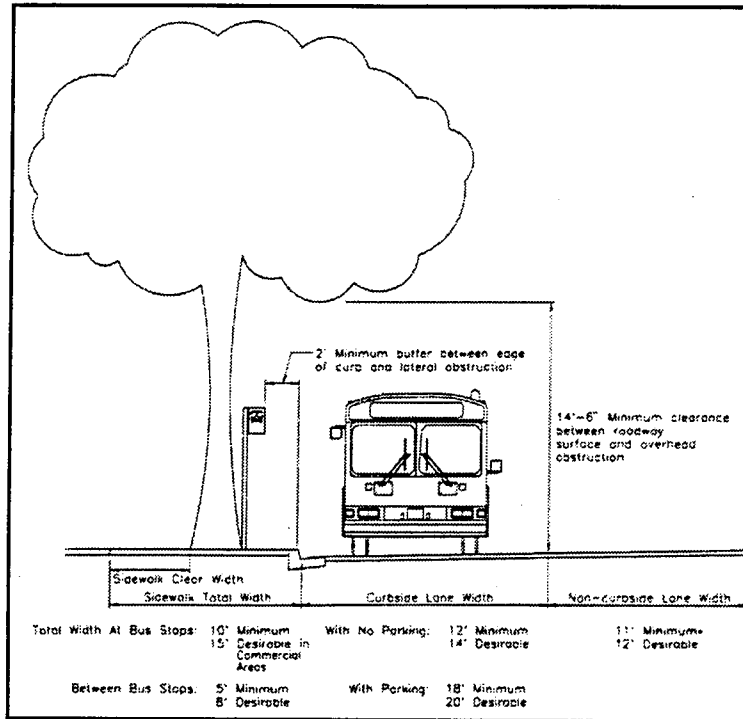

**Figure 5.25 - Vertical and horizontal Clearance for Busways**

Source: MST, January 1996

## 6.0 PAVEMENT DESIGN

The process of selecting the proper pavement type is complex and hard to define. In the final analysis the selection process is an economic decision, although all engineering factors must be properly and carefully considered in such an analysis (AASHTO 1993). Depending on economy and the models chosen to analysis all the engineering factors, the pavement type yielding the highest benefit/cost ratio would be the proper choice.

### 6.1 Types of Pavements

There are two major types of pavements: Flexible or asphalt pavements and rigid or concrete pavements.

1. **Flexible Pavements:** Flexible pavements are constructed of bituminous and regular materials. There are types of construction have been used for flexible pavements: *conventional flexible pavements, full-depth asphalt pavement, and contained rock asphalt mat (CRAM)*. The typical cross-section for the three types of the flexible pavement are shown in Figures 6.1, 6.2 and 6.3.

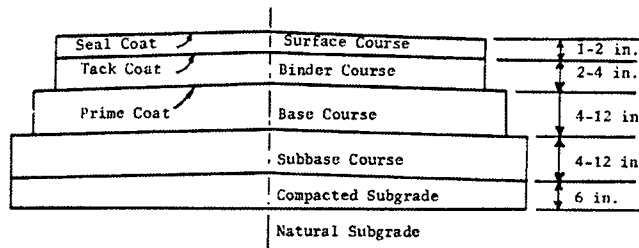

**Figure 6.1 - Typical Cross-section of Conventional Flexible Pavement**

Source: Huang 1993

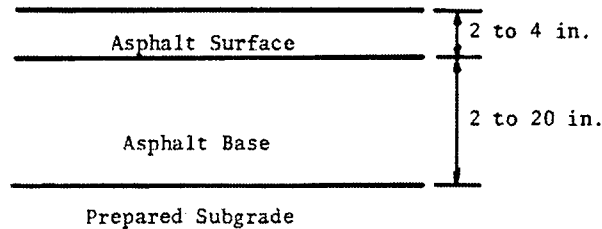

**Figure 6.2 - Typical Cross-section of Full Depth Asphalt Pavement**

Source: Huang 1993

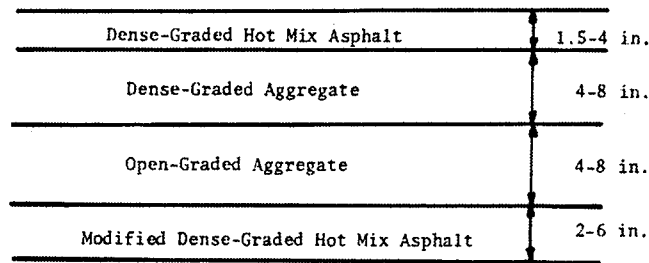

**Figure 6.3 - Typical Cross-section of CRAM**

*Source: Huang 1993*

2. **Rigid Pavements:** Rigid Pavements are constructed of portland cement concrete. **Figure 6.4** shows a typical cross section for rigid pavements. In contrast to flexible pavements, rigid pavements are placed either directly on the prepared subgrade or on a single layer of granular or stabilized material.

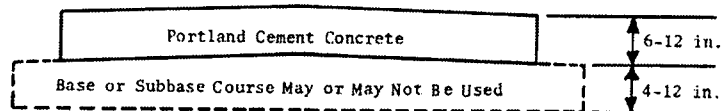

**Figure 6.4 - Typical Cross-section of a Rigid Pavement**

*Source: Huang 1993*

## 6.2 Design Factors

Design factors can be divided into four categories as follows: (Huang 1993)

- **Traffic and Loading:** Traffic and loading to be considered including axle loads, the number of load repetition, tires contact area, and vehicle speeds.
- **Environment:** The environmental factors that influence pavement design include temperature and precipitation, both affecting the elastic moduli of the various layers. The damage caused by both temperature and precipitation during a month or a season is evaluated and summed throughout the year to determine the design life.

- **Materials:** The properties of material must be specified, so that the responses of the pavement, such as stresses, strains, and displacements in the critical components, can be determined. These responses are then used with the failure criteria to predict whether failure will occur.
- **Failure Criteria:** A number of failure criteria, each directed to specific type of stresses, must be established.

Typically, the busway roadway surface can either be paved with asphalt or concrete depending on the bus traffic volume, environment, and construction and maintenance costs. A typical roadway pavement with a side slope of 2% and 7% slope of the curb can be used for at-grade busways. The thickness of the pavement layers depends upon the average daily traffic volume and the resistance value of the base soil. The preferred pavement at station areas should be made of reinforced concrete to handle the additional stresses from the frequent stopping of heavy buses. Bus pads may be installed during busway construction or rehabilitation, or may be installed as a separate project. The detailed cross-section of busways and bus pads pavement thickness and slope are shown in Figures 6.5, 6.6, and 6.7. The benefit of installing concrete bus pads shown in Figure 6.8 at bus stops is to reduce maintenance and pavement damage.

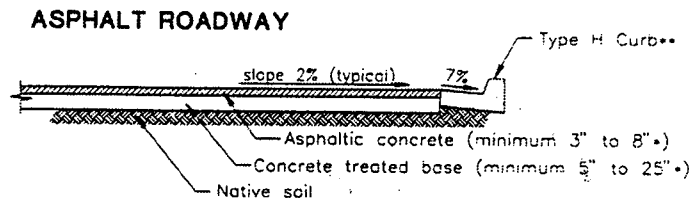

**Figure 6.5 - Cross-section for Busway Flexible Pavement**

Source: MST, January 1996

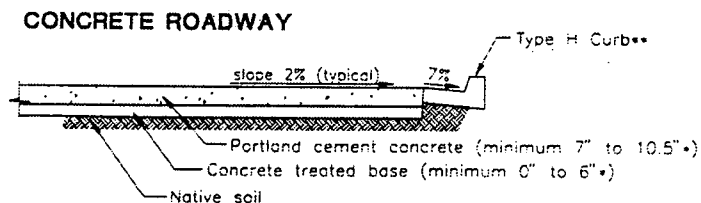

**Figure 6.6 - Cross-section for Busway Rigid Pavement**

Source: MST, January 1996



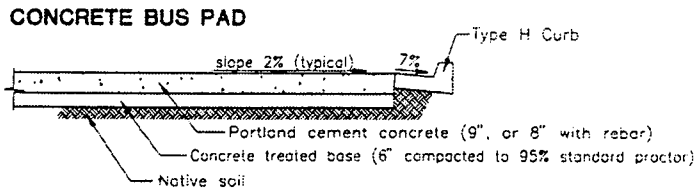

**Figure 6.7 - Cross-section for Bus Pad Rigid Pavement**  
*Source: MST, January 1996*

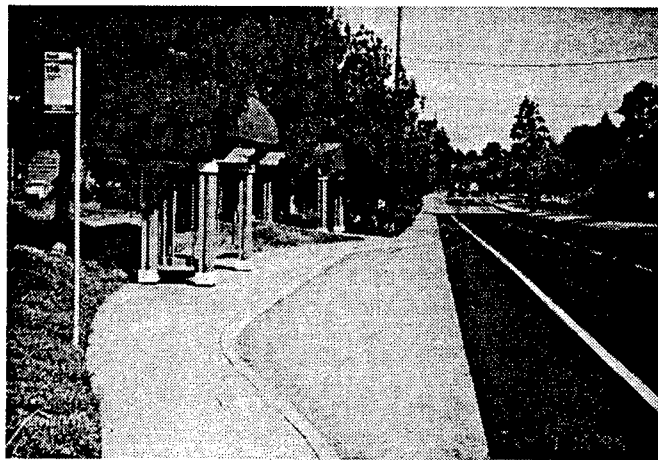

**Figure 6.8 - Concrete Bus Pad at Bus Stops**  
*Source: TCRP 19, 1996*

## 7.0 TRAFFIC CONTROL DEVICES

### 7.1 Busway Signing and Pavement Marking

The capability of roadways to safely and efficiently serve vehicular traffic is dependant to a large extent on adequacy of traffic control devices. The majority of motorists drive in an orderly and safe manner, provided they are given reliable regulatory, warning, and guide information (Brockenbrough and Boedecker 1996).

The need to provide advanced warning for unusual roadway, roadside, operational, and environmental conditions has resulted in the development of a wide diversity of devices. The majority of these devices can be categorized as warning signs containing different symbols and legends. Other warning devices include flashing beacons, rumble strips, pavement surface treatments, and pavement markings. Device complexity ranges from simple passive warning signs to devices that are activated by vehicle speed, headway, or presence on one or more approaches to a potentially hazardous roadway element (MUCTD).

Signing and pavement markings along the busway alignment and at-grade intersections have an important function in providing guidance and information for transit vehicle drivers and other road users.

#### 7.1.1 Signing

In the design of warning signs, it is important to remember that the signs are designed to draw attention to themselves through contrast, color, shape, composition, reflection, and illumination with a simple message providing a clear and understandable instruction to the motorists. Sign size, symbol size, lettering size, and placement should be such to allow adequate time for proper response. Standard sign letters are prescribed in the *Standard Alphabets for Highway Signs*, which should be used to develop lettering size and style. Sections 2C-1, 2C2, and 2C-40 of *Manual of uniform Traffic Control Devices (MUTCD)* contain information that must be followed in the design of warning signs. In addition, Sec. 1A-7 of *MUTCD* lists additional publications and documents that provide requisite information for the proper design of warning signs.

Establishing the need for supplemental devices requires identifying the problem locations and performing a safety and/or operational analysis. Deficient locations can be identified by traffic safety management system, citizen complaints, employee observations, and/or safety analysis (Brockenbrough and Boedecker 1996).

For at-grade busways, a "DOT NOT ENTER" sign may be installed at both end of the busway and at each busway crossing as shown in **Figure 7.1**. The role of this sign is to minimize the motorists'

confusion between the busway right-of-way and general traffic right-of-way. This is essential where the busway alignment is close to the general traffic roadway. Also, the installation of "BUSES CROSSING", shown in **Figure 7.2**, or "BUSWAY CROSSING" signs should be installed on the streets crossing the at-grade busway to warn them with the busway operations. Another type of sign that should be installed with the implementation of side-aligned busways and where there is a close separation distance between the busway and the parallel general traffic roadway and the existence of more than traffic signals for the side streets is the "STOP HERE ON RED" sign shown in **Figure 7.3**. It will reduce the motorists' confusion of the existence of multiple stop bars and multiple signals.

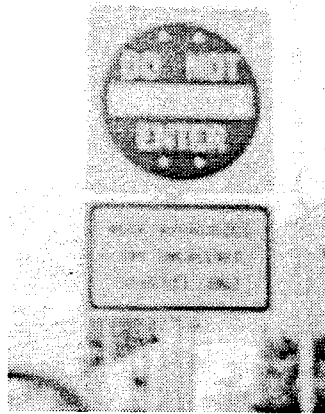

**Figure 7.1 - Sign at the Entrance of South Dade Busway**

*Source: LCTR Photo Collection*

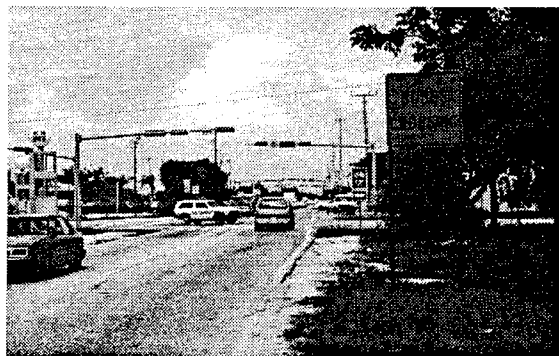

**Figure 7.2 - Busway Crossing Sign at an At-grade Intersection, Miami FL**

*Source: LCTR Photo Collection*

Other information signs may be installed along the busway alignment such as speed limit for buses, bike lanes and bike trails (see Figure 7.4), etc.



**Figure 7.3 - "STOP HERE ON RED" Sign, Miami, FL**  
*Source: LCTR Photo Collection*

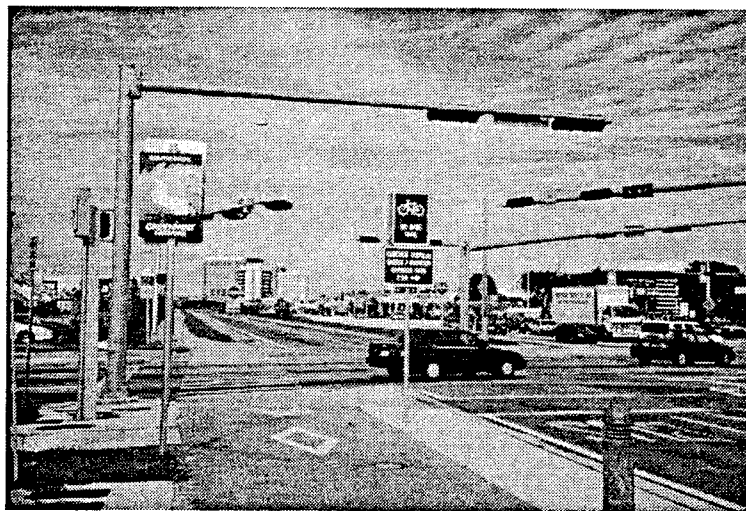
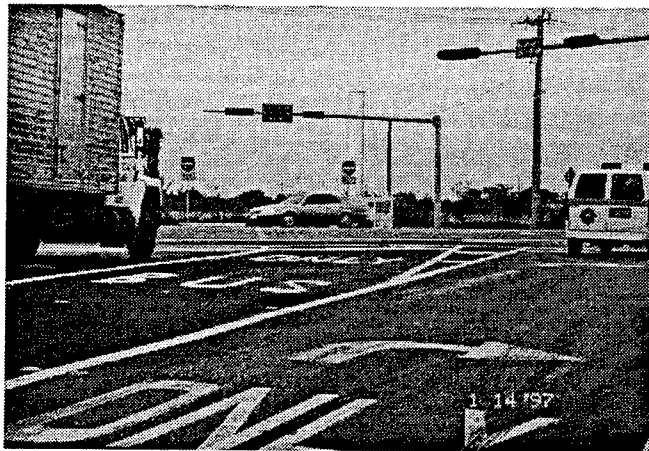

**Figure 7.4 - Bike Lane Sign along South Dade Busway**  
*Source: LCTR Photo Collection*

### 7.1.2 Pavement Marking

Pavement markings are used to supplement other traffic control devices such as signs, signals and other markings. Markings have limitations. Thus, visibility of the markings can be limited by snow, debris and water on or adjacent to the marking. However, under most roadway conditions, markings provide important information while allowing minimal diversions of attention from the roadway. Pavement marking can enhance roadway delineation with the addition of audible and tactile features such as bars, differential surface profiles, raised pavement markings, or other devices which may alert the road user that a delineation on the roadway is being traversed.

The entrance to the busway should be clearly marked to warn the motorists of the exclusiveness right-of-way for the busway. A "BUS ONLY" pavement marking indication may be used, as well as the installation of "DO NOT ENTER". **Figures 7.5 and 7.6**, show examples of the pavement marking at the entrance of the busway in Miami and Hong Kong, respectively.



**Figure 7.5 - Pavement Marking at the Entrance of South Dade At-grade Busway**

Similarly, at each at-grade intersection the "BUS ONLY" pavement marking should be marked as shown in **Figure 7.7** which will help motorists' for distinguish between the busway right-of-way and the general traffic roadway.

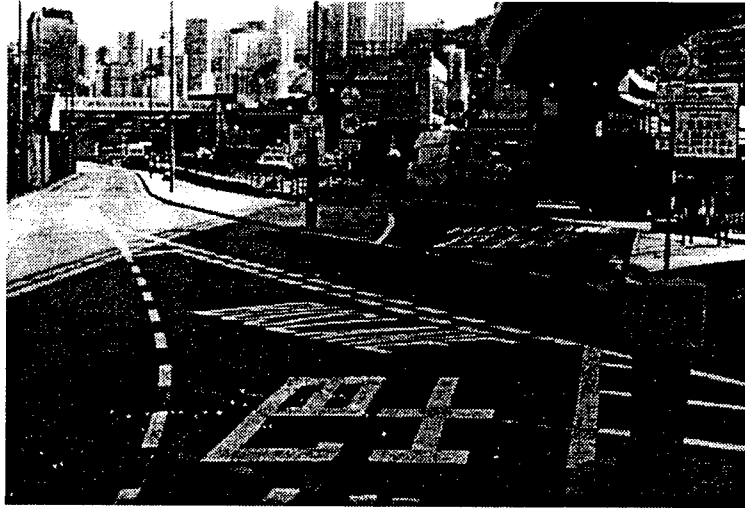
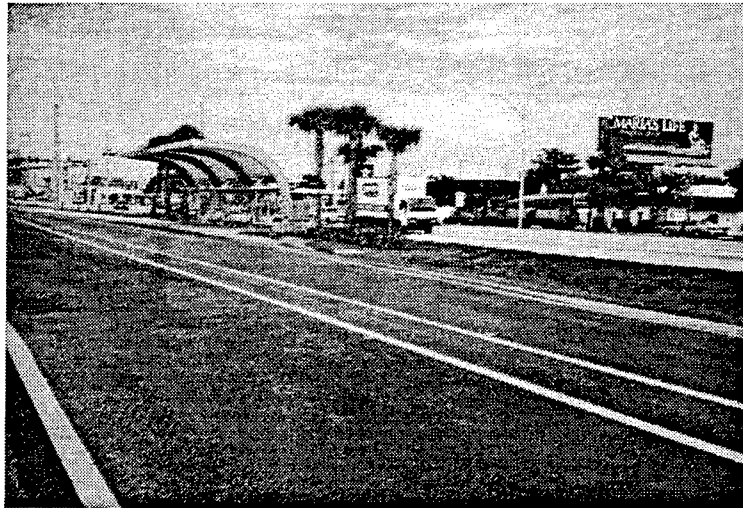

**Figure 7.6 - Pavement Marking at the Entrance of the Busway in Hong Kong**



**Figure 7.7 - "BUS ONLY" Pavement Marking at South Dade Busway At-grade Intersection**

Pavement markings along the busway itself should consist of center line and curb marking. The center line provides important guidance to bus drivers as it separates traffic traveling in opposite directions. It is recommended that the center line consists of two normal solid yellow lines which indicate that passing is prohibited (see **Figure 7.8**).



**Figure 7.8 - South Dade Busway Center Line Pavement Marking**

*Source: LCTR Photo Collection*

## **7.2 Priority at Traffic Signals**

A large amount of traffic delays in urban areas are due to the conflict at road intersections. At intersections controlled by traffic signals, there may still be a delay of up to one cycle caused by the signals themselves. Since urban bus routes typically pass through many signal-controlled intersections, the cumulative effect of such intersection delays on the overall journey can be substantial and can lead to excessive bunching and bus irregularity. Strategies for awarding priority to transit vehicles have been developed and tested in the field using computer simulation over the past 20 to 30 years.

If signal cycle time is generally long, the effect of the delays at some intersections may be seriously destructive. One method of reducing delays is to provide short cycle times at intersections carrying an appreciable busway flow. Shorting the cycle length along an arterial reduces stopped time delay to both transit and private vehicles (Urbanik 1997). In some situations, short cycles can increase the capacity of a signal-controlled intersection. Thus, all traffic, not only buses will benefit. However, if a cycle is too short that the capacity becomes insufficient to pass all the traffic arriving at the intersection, the delays to all traffic, including buses, will rise rapidly. The merit of shorting the cycle length must be weighed against the capacity reduction along the arterial (Urbanik 1997). Thus, implementing bus priority treatments will benefit buses from shorter delay at intersections due to shorter cycle time. On the other hand, the non-priority traffic would lose due to lower capacity resulting in the use of a less-than-optimum cycle time.

### **7.2.1 Phase Splitting**

Another method of decreasing the delay to buses is to split the bus green period into two as shown in **Figure 6.1**. This technique can be applied to isolated signals or to appropriate intersections in a network, and to both fixed-time or vehicle-actuated signals. Splitting phases refers to splitting a transit signal phase into multiple phases whose total time equals its original duration. This reduces the cycle length for the transit vehicle's approach, without altering the overall intersection cycle length.

If the green phase containing the bus flow is split into two short green periods separated by two phases for non-bus flow, the maximum delay to buses can be almost halved, and their clustering reduced. The cost is negligible and the total capacity of the intersections is slightly reduced. To obtain a full benefit, buses must be able to cross the intersection during the first green phase following their arrival at the intersection.

### **7.2.2 Preferential Treatment**

The use of bus priority signals is a method of providing preferential treatment to buses using the busway by altering the signal timing plan to favor buses on other traffic disturbing the bus flow. If individual buses are detected on a busway, they can be given a priority as they arrive at an intersection. This may require the installation of vehicle detectors on the busway lanes approaching an intersection. Vehicle detectors are primary requisites of actuated signal control, as they sense vehicular demand and relay the data to the local intersection controller or master controller so that appropriate signal indications may be displayed. The selection of the type, design and installation of various types of detectors is a function of the operational requirements and physical layout of at-grade busway intersections.



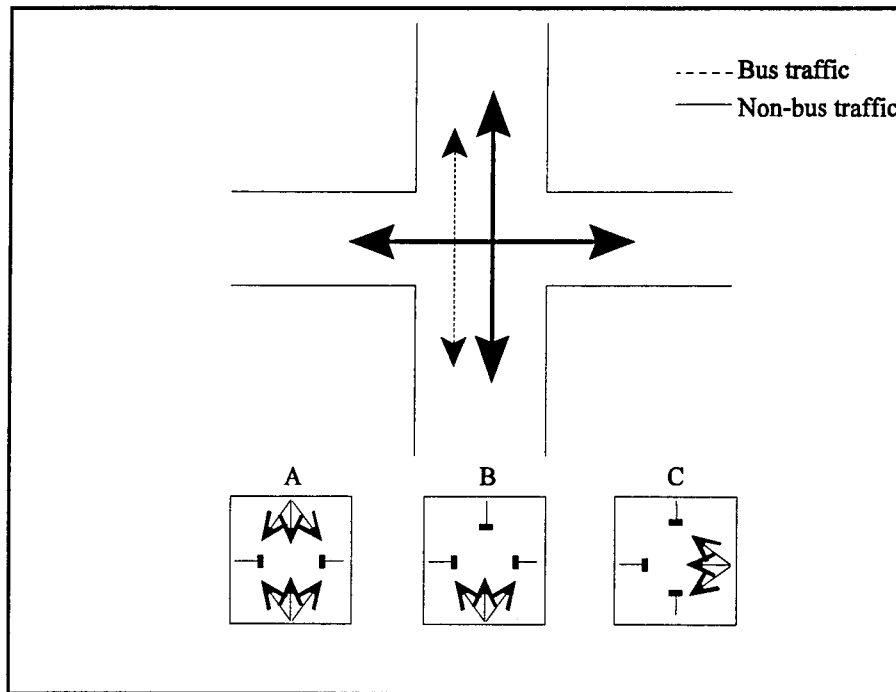

**Figure 7.9 - Method of Phase-Splitting to Reduce Bus Delay at Traffic Signals**

There are several signal priority techniques that can be used to favor buses on other vehicular traffic. (Al-Sahili 1995))

**Green Extension and Red Truncation:** Green extensions and red truncations are forms of active priority which steal green time from cross-street approaches to be added to the end and beginning of the transit approach's green phase, respectively. This means extending the green phase beyond its normal setting to allow the bus to pass the intersection. If the signal phase serving the bus operating in a through lane approach the intersection is already green, then the green can be extended past its normal end time. This extension is usually limited to a maximum value. Hounsell (1995) found that the use of green extensions alone, without red reduction had the best overall impact upon traffic.

**Phase Recall:** This priority treatment advances the busway green phase by prematurely terminating all other non-bus phases. This may be considered by providing a minimum green time for the phase to be prematurely terminated. If the signal phase is red, then the green will return earlier than normal.

**Phase Skipping:** To facilitate the provision of the bus priority phase, one or more nonpriority phases may be omitted from the normal phase sequence.

**Compensation:** One may choose to compensate for the time lost from the other non-bus phase in the next cycle to limit the adverse effects that priority traffic has caused to nonpriority traffic.

**Conditional versus Unconditional:** Active priority measures can be grouped into conditional and unconditional priorities. Unconditional priority is the provision of signal priority each time it is requested, after all other vehicular and pedestrian safety-required intervals are satisfied. In some cases, preemption is disruptive to cross-street traffic, thus, it would be better to subject preemption to certain conditions. These selective conditions determine when or if the signal priority will be granted to the busway traffic. Thus, in a conditional priority scheme, a transit vehicle is not necessarily given priority at an intersection every time priority is requested. Instead, the well-being of cross-streets are considered before priority is granted to transit vehicles' approaching transit vehicles.

Several parameters must be established before signal priority can be effectively granted to buses (Bowen 1994). The degree of intersection saturation below which priority may be granted is a highly important parameter. If this value is too high, the usefulness of green extensions or red reductions will be lost when used in heavily congested environments. In addition, the intersection level-of-service (LOS) may be further sacrificed through the excessive use of signal priority. However, if this value is set too low, buses which could have benefitted from signal priority will not be granted a green extension or red reduction. The frequency of bus arrival should also be considered in the appropriate signal priority strategies. For example, in London when buses were operated with one minute headway, providing green extensions only was identified as the optimum strategy. When operating at headways shorter than one minute, adjusting signal timing to allow for bus progression was recommended.

### **Location of Detectors**

Many state and local agencies have established policies and standards related to the longitudinal location (setback of detectors relative to stop bar). Ideally, the detector location should consider the speed, type and volume of approaching vehicles as well as the type of controller unit.

**Table 7.1** presents a range of suggested detector setbacks. The values were determined as a function of the deceleration rate, reaction time and deceleration distance. This table is more conservative than that used by many agencies in that it is based on a deceleration rate of 10 ft/s<sup>2</sup> (3 m/sec<sup>2</sup>) rather than 12 ft/s<sup>2</sup> (3.66 m/sec<sup>2</sup>).

Table 7.1 - Safe Stopping Distance and Detector Setback

Speed <sup>a</sup> , V		Decel. Time, t (sec)	Reac. Dist., R (ft)	Decel. Dist., D (ft)	Total Dist., S (ft)	Detector Setback (ft)
mph	ft/sec					
15	22.0	2.2	22.0	24.2	46.2	45
20	29.3	2.9	29.3	42.9	72.2	50
25	36.7	3.7	36.7	67.3	104.0	105
30	44.0	4.4	44.0	96.8	140.8	140
35	51.3	5.1	51.3	131.6	182.9	180
40	58.7	5.9	58.7	172.3	231.0	230
45	66.0	6.6	66.0	217.8	283.8	<i>b</i>
50	73.3	7.3	73.3	268.6	341.9	<i>b</i>
55	80.7	8.1	80.7	325.6	406.3	<i>b</i>
60	88.0	8.8	88.0	387.2	475.2	<i>b</i>
65	95.3	9.5	95.3	454.1	549.4	<i>b</i>

<sup>a</sup> Design speed or high-pace speed

<sup>b</sup> Use multiple detectors or volume-density modules

Where:

Deceleration rate,  $d$  = 10 ft/s<sup>2</sup>  
 Deceleration time,  $t$  =  $V/d$ , seconds  
 Speed,  $V$  = ft/s  
 Reaction time,  $r$  = 1 s  
 Reaction distance,  $R$  =  $r \times Vt$ , ft  
 Deceleration distance,  $D$  =  $\frac{1}{2} Vt$ , ft  
 Safe stopping distance,  $S$  =  $R + D$ , ft  
 =  $r \times V + \frac{1}{2} Vt$

### 7.2.3 Simulation

Several simulation models and field experiments with signal preemption have been conducted in the United States and Europe since the early 1960s. Simulation showed increasing bus delay savings when signal priority was used with decreasing intersection saturation levels (Hounsell 1995). Vincent et al.(1978) used a microscopic bus priority assessment simulation (BUSPAS) program to test five preemption control strategies at an intersection. They examined green extensions only; green extension, red truncation, and no compensation; green extension, red

reduction and compensation; red reduction and no compensation; and red reduction and compensation.

Jacobson and Sheffi (1980) developed an analytical model of delay at isolated signalized intersections with a bus preemption scheme. The model treated the beginning time of the green period as a random variable, the density function of which was developed. The model also assumed a Poisson arrival process for the vehicles approaching the intersection. Four cases were analyzed including; no preemption and minimization of total person delay; no preemption and minimization of total vehicle delay; preemption and minimization of total person delay; and preemption and minimization of total vehicle delay.

In 1985, Smith developed a bus signal preemption algorithm for the New Jersey Department of Transportation to be incorporated into the NETSIM simulation model. The study tested advancing or extending green while still maintaining a minimum side-street green plan. The preemption process resulted in saving of 6.2 vehicle-hours and 9.2 passenger-hours over the peak hour.

Benevelli et al. (1983) conducted a study on bus signal preemption using the urban traffic control system/bus priority signal model, which is a microscopic traffic simulation model that was developed by FHWA.

Using TRAF-Netsim to test the effectiveness of active signal priority, Al-Sahili (1995) found that arterial traffic suffered from overall increased delays whenever signal priority was initiated. Since the arterial traffic was rather high, upon receiving signal priority, signal progression along the arterial was lost, resulting in increased downstream intersection delay. Therefore, along heavily traveled arterials, signal progression, rather than signal priority, appear to be of prime importance.

The sensitivity of transit signal priority success to the ratio of arterial and cross-street traffic selected for the analysis were 2:1, 3:1 and 5:1. Simulation results indicated that negative impacts introduced through the various signal priority techniques are significant at low volume ratios (2:1), but significant at high volume ratios (5:1). However, benefits from signal priority in terms of reduced bus travel times and delays decreased with increasing volume ratios because at high volume ratios, signals are already timed to favor the bus approaches.

Accordingly, the success of transit signal priority appears to depend on:

- Traffic characteristics at intersection where priority is used.
- Transit service characteristics.
- Geometry of intersections.

## 8.0 BUSWAY LIGHTING

Properly designed and installed roadway lighting can result in significant reductions in nighttime traffic accidents, act as deterrent to crime, increase commercial activity, and improve aesthetic value. The requirement for adequate visibility is essential for safe traffic operations during both day and night operation. Visibility can be divided into three classifications: perception, recognition, and decision making. Effective lighting can aid these tasks by providing the quality of light required by human eye to increase its visual acuity (Brockenbrough and Boedecher 1996).

Busway lighting can adopt the same lighting specifications for major roadways. The area classifications (commercial, residential, and intermediate) also depict the lighting design needs for lighting along a busway. Traffic volume, number of pedestrians, at-grade intersections, turning movements, signalization, and unusual geometric are some elements that make lighting on streets and busways desirable.

To determine if the roadway lighting is warranted, the analytical approach developed by the National Cooperative Highway Research Program (NCHRP Report 152) can be used. This approach is used to obtain a quantitative measure of the effect of the roadway characteristics on driver visual information needs. After rating all the characteristics, the scores are summed to obtain an overall measure of driver information needs. This method is flexible and permits modifications to fit local needs.

The net safety benefit from increasing visibility is influenced by the hazard posed by the roadway lighting or its support acting as a fixed object. If roadway illumination is not warranted, or if it is installed wrong, there is a strong possibility that traffic hazards will be increased rather than reduced by providing illumination. The *Roadside Design Guide* (by AASHTO) requires the lighting designer not only to produce an effective, efficient lighting system but also to consider removing the hazards inherent in such a system. The following points should be considered to increase the safety due to lighting installations:

- Remove the hazard from the right-of-way
- Locate the hazard in a place less likely to be struck
- Provide a breakaway support
- Provide a barricade

There are several tested and approved devices by the Federal Highway Administration (FHWA) for the breakaway structure of the light poles. These devices should be used as prescribed, but it is up to the designer to use the proper device in the particular situation

## 9.0 CONCLUSION

1. At-grade busways can be an integral part of the countywide rapid transit improvement plans. Thus it is important to distinguish busway transit from other bus priority measures which are limited in their scope.
2. Only half of the cities that have busways have developed them in a systematic and comprehensive manner as part of the city's mass transit network.
3. At-grade busways can be a major component of strategies planning and designed to make better use of existing transit facilities with relatively low capital expenditures.
4. At-grade busways can be implemented as part of traffic management programs.
5. Several approaches can be used in the implementation of at-grade busways (outside-in or inside-out). The choice of a specific approach for a city is strongly influenced by the level of congestion, availability of current right-of-ways, availability of funds, and current and future transportation plans.
6. At-grade busways can be a fully integrated service with existing and projected activities in a city and in such a way it can provide a level of service competitive to private vehicles.
7. At-grade busways can provide a fast, convenient and reliable transit service to ensure effective public transportation and to create a region wide system or network of transit priority that can be quickly enough to influence new land use developments.
8. Safety problems for at-grade busways should be given important concerns during the planning and design periods. Any accident may impact the ridership due to problems with the public image.
9. Intersection design and controls should clearly define and control conflicts between busway vehicles and adjacent road users. Also, Traffic signal controls should be carefully coordinated with the roadway geometry.
10. It is necessary to have a demand policy management to support the allocation of the required right-of-way.
11. The performance of the busway depends mainly on the relationship between the bus and passenger flow, as well as the operating speed of the buses on the busway right-of-way.
12. Various techniques may be used to enhance the performance of at-grade busways.

13. Bus stops should be located in a way that will not affect the capacity of at-grade intersections.
14. Amenities at busway stops should be considered during planning and design as they provide passengers with comfort, convenience and sense of security.
15. The choice of the busway pavement depends on the economy and the models chosen to analyze all the engineering factors involved.
16. Pavement markings, signs and other traffic control devices along at-grade busways will provide safety for both transit and vehicular traffic.
17. Properly designed and installed roadway lighting results in significant reduction in nighttime traffic accidents, act as deterrent to crime, increase commercial activity, and improve aesthetic value along busways.

## 10. REFERENCES

AASHTO, *Guide for Design of Pavement Structures*, Washington, D.C., 1993.

Al-Sahili, K. and W. Taylor. Evaluation of Bus Priority signal Strategies in Ann Arbor, Michigan. Transportation Research Board, National Research Council, *Transportation Research Record* 1554, 1995, pp. 74-79.

Benevelli, D. A., A. E. Radwan, and J. W. Hurley, Jr. Evaluation of a Bus Preemption Strategy by Use of Computer Simulation. In *Transportation Research records 906*, TRB, National Research Council, Washington, D.C., 1983, pp. 60-67.

Bonsall, John, 1989. *Transitways: The Ottawa-Carleton Experience*. Ottawa-Carleton Regional Transit Commission, June 1989.

Brockenbrough, R. and K. Boedecker. *Highway Engineering Handbook: Building and Rehabilitation the Infrastructure*. McGraw-Hill, 1996.

Bus Priority Systems. NATO Committee on the Challenges of Modern Society, CCMS Report 45, Transportation and Research Laboratory, London, 1976.

Capacity Analysis of Exclusive Busway/HOV/Carpool Facilities, Houston Transit Consultant, December 1981.

Design Guidelines for Busway Transit. Transport Research Laboratory, Overseas Center, TRL, *Overseas Road note 12*, 1993.

Designing for Transit: A manual for Integrating Public Transportation and land Use in Monterey County. Monterey-Salinas Transit (MST), California, January 1996.

Fowler, Brian C. The South Dade Busway. In the 1995 Compendium of Technical Papers, ITE 65<sup>th</sup> Annual Meeting, ITE, 1995, pp. 508 - 511.

Gardener, G., P. Cornwell and J. Cracknell. The performance of Busway Transit in Development Cities. Transport and road Research Laboratory, *Research Report 329*, 1991.

Guidelines for the location and Design of Bus Stops. Transportation Research Board, National Research Council, Washington, D.C., *TCRP Report 19*, 1996.

High Occupancy Vehicle Project Case Studies: Historical Trends and Project Experiences, August 1992, USDOT 1992.



Highway Capacity Manual (HCM) Special Report Third Edition. Transportation Research Board, National Research Council, Washington, D.C., 1994.

Hounsell, N. B., and J. P. Wu. Public Transport Priority in Real-Time Traffic Control Systems. Applications of Advanced Technologies in Transportation Engineering, pp. 71-75, June, 1995.

Huang, Y. Pavement Analysis and Design. Prentice Hall, Englewood Cliffs, New Jersey 07632, 1993.

Increasing the Productivity of the Nation's Urban Transportation Infrastructure: Measures to Increase Transit Use and Carpooling, January 1992, USDOT 1992.

Jacobson, J. and Y. Sheffi. Analytical model of Traffic delays Under Signal Preemption: Theory and Application. Presented at the 59<sup>th</sup> Annual Meeting of the Transportation Research Board, Washington, D.C., 1980.

Jacques, K. and H. Levinson. Operational Analysis of Bus Lanes on Arterials, *TCPR Report 26*, 1997

Korve, Hans W., Jose I. Farran, and Douglas M. Mansel. Integration of Light Rail Transit into City Streets, *TCRP Report 17*, 1996.

Major, M. J. Brazil's Busways. *Journal of Mass Transit, Vol. 23, No. 3, 1997.* pp.26-34.

Manual of Uniform Traffic Control Devices (MUCTD) for Streets and Highways. U.S. Department of Transportation, Federal Highway Administration.

McCormick, R. A Busway Strategy for Brisbane City, Volume 1, June 1995.

Shen, D., H. Elbadrawi, F. Zhao, and D. Ospina. At-grade Busway Study. National Urban Transit Institute, December 1997.

Travel Smart. A Traffic Reduction Strategy for Brisbane. The Brisbane City Council, 1994.

Technical Handbook of Bikeway Design: Planning, Design and Implementation. Canadian International Development Agency, Quebec, 1992.

Urbanik II, Thomas and R. W. Holder. Evaluation of Priority Techniques for High Occupancy Vehicles on Arterial Streets. Texas Transportation Institute, Texas A&M university, July, 1997.

Wohlwill, D. E. Development Along A Busway: Case Study of Development Along the Martin

Luther King, Jr. East Busway in Pittsburgh, Pennsylvania. Port Authority of Allegheny County, Pittsburgh, PA, 1996.

Vincent, R. A., B. R. Copper and K. Wood. Bus Actuated Signal Control at Isolated Intersections: simulation Studies of Bus Priority, Report 814. Transportation and Road Research Laboratory, Crowthorne, Berkshire, United Kingdom, 1978.