

Timely, Dynamic, and Spatially Accurate Roadway Incident Information to Support
Real-Time Management of Traffic Operations

Final Report

**Prepared by:
University of Florida**

June 2020

DISCLAIMER

The opinions, findings, and conclusions expressed in this publication are those of the authors and not necessarily those of the State of Florida Department of Transportation.

The contents of this report reflect the views of the authors, who are responsible for the facts and the accuracy of the information presented herein. This document is disseminated under the sponsorship of the U.S. Department of Transportation's University Transportation Centers Program, in the interest of information exchange. The U.S. Government assumes no liability for the contents or use thereof.

METRIC CONVERSION CHART

SYMBOL	WHEN YOU KNOW	MULTIPLY BY	TO FIND	SYMBOL
LENGTH				
in	inches	25.4	millimeters	mm
ft	feet	0.305	meters	m
yd	yards	0.914	meters	m
mi	miles	1.61	kilometers	Km
mm	millimeters	0.039	inches	in
m	meters	3.28	feet	ft
m	meters	1.09	yards	yd
km	kilometers	0.621	miles	mi
AREA				
in²	square inches	645.2	square millimeters	mm ²
ft²	square feet	0.093	square meters	m ²
yd²	square yard	0.836	square meters	m ²
ac	acres	0.405	hectares	ha
mi²	square miles	2.59	square kilometers	km ²
mm²	square millimeters	0.0016	square inches	in ²
m²	square meters	10.764	square feet	ft ²
m²	square meters	1.195	square yards	yd ²
ha	hectares	2.47	acres	ac
km²	square kilometers	0.386	square miles	mi ²
VOLUME				
fl oz	fluid ounces	29.57	milliliters	mL
gal	gallons	3.785	liters	L
ft³	cubic feet	0.028	cubic meters	m ³
yd³	cubic yards	0.765	cubic meters	m ³
mL	milliliters	0.034	fluid ounces	fl oz
L	liters	0.264	gallons	gal
m³	cubic meters	35.314	cubic feet	ft ³
m³	cubic meters	1.307	cubic yards	yd ³

NOTE: volumes greater than 1000 L shall be shown in m³

TECHNICAL REPORT DOCUMENTATION PAGE

1. Report No.		2. Government Accession No.		3. Recipient's Catalog No.	
4. Title and Subtitle Timely, Dynamic, and Spatially Accurate Roadway Incident Information to Support Real-Time Management of Traffic Operations				5. Report Date May 2020	
				6. Performing Organization Code	
7. Author(s) I. Bejleri, Y. Zhang, L. Zhai, X. Yan				8. Performing Organization Report No.	
9. Performing Organization Name and Address University of Florida 418 Architecture Building Gainesville, FL 32611				10. Work Unit No. (TRAVIS)	
				11. Contract or Grant No. BDV31-977-111	
12. Sponsoring Agency Name and Address Florida Department of Transportation 605 Suwannee Street, MS 30 Tallahassee, FL 32399				13. Type of Report and Period Covered Final Report April 2019 – June 2020	
				14. Sponsoring Agency Code	
15. Supplementary Notes					
16. Abstract At present, Florida Department of Transportation (FDOT) District 5 obtains incident Computer-Aided Dispatch (CAD) information from Florida Highway Patrol (FHP) only for selected interstates in the district through its Transportation Management Center (TMC) system. The lack of incident information on other roadways prevents FDOT from implementing a real-time responsive and proactive traffic operation management system. For incident information on other roadways, CAD systems at public safety answering points (PSAPs) are the best data sources available. However, FDOT lacks an effective communication method to receive incident information from PSAPs in a timely manner. To address this issue, the research team conducted fundamental research to support real-time incident information sharing between PSAPs and FDOT. Specifically, we reviewed related documents, interviewed, and surveyed PSAPs in District 5 to understand the current practice of incident information management. We also reviewed best professional practices in the country on traffic-incident-related information sharing between transportation agencies and PSAPs, based on which, we identified three common approaches for incident information sharing: dedicated workstation, CAD-to-TMC integration, and information exchange hub. By conducting a feasibility analysis using a cost-benefit framework, we found that the best approach to achieve district-wide or statewide incident information sharing is through an information exchange hub. Between the two options to receive incoming information into the exchange system, the industry standard HTTP POST method is superior to the email/text method. To support the successful implementation of a district-wide or even statewide incident information sharing system, the research team identified a list of data elements that FDOT should request from PSAPs, proposed an architecture for the exchange system, and developed a three-phase implementation plan that includes development of the system prototype, followed by a pilot phase, and it is completed by an expansion phase. The proposed solution creates opportunities for greater data accuracy and integration improvements that can lead to new efficacies in incident management and traffic operations far beyond the objectives of this research.					
17. Key Word Traffic incident management, interagency data sharing, CAD integration, roadway incident, traffic operations				18. Distribution Statement No restrictions	
19. Security Classify. (of this report) Unclassified		20. Security Classify. (of this page) Unclassified		21. No. of Pages 130	22. Price

ACKNOWLEDGEMENTS

The research team would like to thank the FDOT District 5 project managers Jeremy Dilmore and Tushar Patel for their vision, leadership, and support for this research.

Special thanks to Claudia Paskauskas for her day-to-day management of the project, guidance, assistance, patience, encouragement, prompt response, and support throughout this research.

We also would like to thank Sheryl Bradley for sharing her expansive expertise and domain knowledge in traffic incident management, answering all our questions, helping in interfacing with the stakeholders, and for her enthusiasm for this research.

Thanks to John Hope and other District 5 staff for providing information and feedback on SunGuide CAD integration.

The research team would like to thank Grady Carrick for his thoughtful input and insights and for sharing his in-depth knowledge in traffic incident response and management and CAD integration knowledge, both in Florida and at the national level.

Finally, many thanks to the PSAP staff of District 5 agencies that provided information and input during site interviews and via the online survey.

The authors are grateful to the FDOT research office for providing the funding support to make this research possible.

EXECUTIVE SUMMARY

Departments of transportation need timely information about the location, type, and severity of roadway incidents in order to respond rapidly to clear the roadway, prevent secondary events (e.g., secondary crashes), reduce congestion, and assist emergency services to save lives. One of the barriers to this aspirational rapid response is the lack of timely knowledge about the existence of such events. In Florida, the Florida Department of Transportation (FDOT) District 5, located in central Florida, faces the same challenges: how to get timely information about several hundreds of such incidents occurring daily in the District's roadway system.

Currently, the District obtains timely alerts about a very small portion of such events, primarily those that occur on interstates. This information comes to the District's Traffic Management Center (TMC) system (named SunGuide) from the Florida Highway Patrol's (FHP) Computer-Aided Dispatch (CAD) system. Incident information on other roadways reported by local law enforcement agencies is not available to the District in an organized, timely, accurate, and streamlined fashion. The lack of a real-time, unified, spatially accurate, and dynamic information stream on all the District roadways prevents the District from implementing a real-time, responsive, and proactive traffic operation management system at the district-wide scale.

CAD systems that support public safety answering points (PSAPs) are the best data sources available for the District to obtain incident information on other roadways. PSAPs handle all 911 calls, dispatch local law enforcement and fire agencies, and communicate with external stakeholders on an as-needed basis. PSAPs are the source from which agencies first receive information about roadway incidents, and so they are critical information sources for Traffic Incident Management (TIM). Nevertheless, District 5 and FDOT lack an effective communication method to receive incident information from PSAPs in a timely manner. The goal of this research is to thus explore feasible solutions to achieve a real-time incident information sharing between PSAPs and District 5 and FDOT. More specially, it aims to identify a district-wide suitable information exchange system for District 5 and provide recommendations for implementation.

To this end, we first examined the current TIM data practice of FDOT and other key stakeholders in District 5, including over 80 police and fire agencies and their CAD and 911 systems. Specifically, we conducted an extensive review of documents related to traffic incident procedures, standards, and stakeholders in the District, conducted on-site interviews at four PSAPs, and distributed an online survey to all PSAPs in the District. These efforts helped document the incident response data flow within FDOT and PSAPs, their respective data needs, and the CAD data elements available at PSAPs. We further reviewed best professional practices across the United States on traffic-incident-related information sharing between transportation agencies and PSAPs. The review included CAD integration project reports and other relevant documents accessible online and summarized three typical approaches of incident information sharing between DOTs and public safety agencies in the United States. The professional practice review also provided some insights on potential solutions to the barriers that are impeding interagency incident information sharing systems.

The following are the major findings from the interviews, the survey, and the document review process.

First, we found that almost all the *critical* data elements that FDOT needs for incident response are available in all CAD systems in the District that responded to the survey. They include dates and times of incidents, geolocation, incident types, injury severity, dispatch information, and notes about roadway blockage and vehicles involved. PSAPs indicated their willingness to share information with FDOT, as well as their interest in receiving information from FDOT, especially from traffic cameras. Only one out of the 26 PSAPs that responded indicated potential financial concerns for enhancing their CAD system and raised security concerns to share their information with FDOT.

Second, we found that broadly speaking, data security is the most common concern for interagency information sharing. Other barriers to establishing an interoperable data-sharing system include existence of multiple proprietary CAD systems, inconsistency in data standards, and potential for sharing duplicated incident records.

Based on all the findings above, we concluded that a feasible solution to support the information sharing should possess the following characteristics: (a) support a large number of participating agencies, (b) request that PSAPs share a minimal and critical set of data elements and avoid requesting personally identifiable information (PII) data in order to ease security concerns, (c) have the ability to handle duplicate records, (d) do not create additional work for the PSAP staff, (e) enable FDOT to share traffic camera information because receiving verified incident information from FDOT is the greatest motivation for PSAPs to participate, and (f) for PSAPs to share their information may require enhancements of their CAD systems and, therefore, consideration should be given to solutions that are low cost.

To determine the most feasible solution for District 5, we considered three candidate approaches for incident information sharing identified from the best practices review: dedicated workstations, CAD-to-TMC integration, and information sharing hub. A dedicated workstation solution displays CAD information from public safety agencies on a dedicated workstation physically located inside a transportation agency. The CAD-to-TMC integration sends real-time CAD data feeds directly to TMC's information system. Florida's FHP CAD integration into SunGuide is an example of such system. Last, the information sharing hub is a solution where the participating sharing PSAPs and DOTs post their information into a single computer system that serves as a hub that can share the information with interested recipients.

To evaluate which of these approaches can better support a district-wide and eventually a statewide exchange system, we conducted a feasibility analysis comparing the advantages and drawbacks of these approaches. To guide the feasibility analysis, we developed a cost-benefit framework that considered evaluation criteria for both benefits and costs. Benefits include: (a) connectivity: the ability for stakeholders to effectively exchange information; (b) speed: timely access and transfer of shared information; (c) data quality: ability to analyze, link, improve, and work with reliable data; and (d) expandability: the ability of the system to expand over time to a district and statewide solution. Cost criteria include considerations for (a) initial cost to FDOT

and PSAPs and (b) respective long-term maintenance cost. Each benefit item was scored on a scale of three values: 2 – solution provides the benefit, 1 – solution provides the benefit with constraints, and 0 – solution does not provide the benefit. Each cost item was scored on the same scale with 2 – high cost, 1 – medium cost, and 0 – low cost. Each cost-benefit criterion can be weighted to support its relative importance. Finally, the overall benefit and cost score for each approach is determined as the weighted average of all benefit items or cost items, and the cost-benefit ratio is calculated for each approach.

The result of the feasibility analysis suggests that the best approach to achieve district-wide or statewide incident information sharing is through an information exchange hub approach. This approach can enable timely and reliable information sharing with low cost and can provide this information not to just FDOT, but also to PSAPs. It also enables FDOT to share their information with all interested PSAPs by posting it on the exchange hub rather than sending it individually to various PSAPs. We identified two potential methods to push the PSAP's information into the exchange hub: (a) utilizing HTTP POST, which is an industry standard method that uses a secure HTTP protocol to post encrypted information to a receiving server and (b) the email/text method, in which PSAP's CAD system sends emails or text messages to registered user's devices (FDOT staff). Between these two options, the HTTP POST solution is preferred and recommended because it delivers standardized incident data in a more reliable manner considering directness, speed and contents, requires minor enhancements on participating PSAPs' CAD systems, and it is more sustainable in the long run.

The dependency on information from PSAP's CAD systems is the biggest challenge, if not the only challenge, for the proposed information exchange system that is out of DOT's control. FDOT can control the exchange system data storage and data sharing and should use this as an opportunity to draw the cooperation of the PSAPs. If PSAPs are willing to share their information and if any security concerns are explained and addressed, the outstanding item that may prevent collaboration would be the need for funding to support CAD enhancements. Although the cost for such enhancement should be minimal or even not applicable (could be accommodated as part of software maintenance), it may be necessary to explore funding avenues to support PSAP's CAD software enhancement. Florida Traffic Records Coordinating Committee that manages federal funds for traffic records improvements in the state may be a suitable and interested funding source. If the cost of CAD enhancement could be unexpectedly high, an alternative backup strategy is to ask the PSAPs to share the information using methods that may be currently available in their current CAD system, such as emails and texts, and expand the functionality of the exchange system to build adapters to standardize the incoming information of various formats and share it on the platform.

Based on the research findings, the research team proposes three major recommendations for implementing a district-wide incident information sharing system.

First, we have identified a list of data elements that FDOT should request from PSAPs. About half of the data elements are required and deemed critical to support FDOT incident response. They include incident dates and times, incident type, location, dispatch information, and

respective updates. The second part of the data elements proposed is optional and contains information about road blockage, dispatch arrival times, alternative location description methods, and description of vehicles involved. The second set is recommended as optional to reduce the burden on PSAP's CAD enhancement effort, although from an automated data sharing perspective, not much additional effort is required to include the optional elements in PSAP's CAD data sharing, either via the HTTP POST method, or via email. We recommend that FDOT should strongly encourage PSAPs to share the optional data elements once a general agreement to share the critical data elements is established. The detailed data dictionary is included in this report.

Second, we have proposed a high-level architecture for the exchange system. At the core of a system would be a relational database hosted on a server computer. The system would contain a software component that will process the incoming HTTP POSTs (or email/text alerts) and store the information in the database. The system should include a web-based viewer to display the shared information and should be accessible both on mobile and desktop devices. In addition, the system would include a mechanism to post out the information to interested subscribers via HTTP POST and email/text.

Third, a successful implementation of a district-wide or statewide incident information sharing system needs to be strategized carefully. We propose approaching the implementation in three phases. In phase one, develop a simplified prototype of the exchange system that includes all the components of the system that have no dependencies on PSAPs but that use the expected data elements from PSAPs. Consider implementing the HTTP POST method as it is less expensive and more reliable than the email/text method even for the prototype. In phase two, utilize the prototype to reach out to one or two more proactive PSAPs to demonstrate the working of the system and the benefits to PSAP's participation. Conduct a pilot project with the selected PSAP. Encourage the PSAP to present the provided specifications to their CAD vendor to assess the potential cost for CAD enhancement. In the third phase, use the pilot project as a model to expand the system by gradually reaching out to the rest of PSAPs in the District.

Finally, we would like to point out that the district-wide, and eventually the state-wide central exchange system proposed, provides a unique opportunity that can have greater positive implications beyond the immediate needs of FDOT for a timely response to roadway incidents. The proposed system will create new opportunities to link CAD, crash and other roadway incident data, enforcement, EMS, and injured patient data in a new way that has not been done before. This would lead to major improvements in roadway incident data quality, timeliness, and reliability. Such a linkage will provide FDOT and other stakeholders in the state new avenues for advanced analytics that can inform decision making and that can elevate safety and traffic management improvements and performance to higher levels of effectiveness to reduce congestion and save lives.

TABLE OF CONTENTS

	Page
DISCLAIMER	ii
METRIC CONVERSION CHART.....	iii
TECHNICAL REPORT DOCUMENTATION PAGE	iv
ACKNOWLEDGEMENTS.....	v
EXECUTIVE SUMMARY.....	vi
TABLE OF CONTENTS	x
LIST OF FIGURES	xii
LIST OF TABLES.....	xiv
LIST OF ACRONYMS	xv
1 INTRODUCTION	1
1.1 Problem Statement	1
1.2 Research Objectives	1
1.3 Research Framework.....	2
1.4 Report Organization	4
2 ASSESSMENT OF CURRENT PRACTICE	5
2.1 The Review Process.....	5
2.2 Incident Response Data Flow	5
2.3 Data Needs	11
2.4 Survey of PSAP’s CAD Data.....	12
3 INCIDENT INFORMATION SHARING APPROACHES	30
3.1 Dedicated Workstations.....	32
3.2 CAD-to-TMC Integration.....	32
3.3 Information Sharing Hub.....	33
4 FEASIBILITY OF POTENTIAL SOLUTIONS.....	38

4.1	Considerations for a Feasible Solution.....	38
4.2	Barriers to Information Sharing and Potential Solutions.....	39
4.3	Feasibility Analysis.....	41
5	RECOMMENDATIONS	51
5.1	Shared Data Elements	51
5.2	Proposed System Architecture.....	55
5.3	Implementation Strategy	57
6	GREATER VISION.....	61
	REFERENCES	62
	APPENDIX.....	63
	Appendix 1: Interview Questionnaire	63
	Appendix 2: Online Survey	74
	Appendix 3: Selected PSAPs’ Dispatch and Transfer Diagrams	99
	Appendix 4. Vendor Active 911 Capabilities	103
	Appendix 5: Technical Specifications For CAD Vendors.....	105
	Appendix 6: Current Positioning Methods Supporting PSAP.....	112

LIST OF FIGURES

Figure 1-1 Research Framework.....	3
Figure 2-1 PSAP's Incident Response Data Flow.....	6
Figure 2-2 FHP Centers Service Areas and FDOT District Boundaries	9
Figure 2-3 FDOT's Data Flow.....	10
Figure 2-4 Number of Responses by County	13
Figure 2-5 Response Rate by County	13
Figure 2-6 PSAP Dispatch Distribution	14
Figure 2-7 PSAPs' 911 Vendor Distribution	14
Figure 2-8 Fire CAD Vendors	15
Figure 2-9 LE CAD Vendors	16
Figure 2-10 Sources for Incident Information	17
Figure 2-11 911 Incident ID.....	18
Figure 2-12 Data Elements in 911 CAD Spills.....	18
Figure 2-13 Data Elements Captured in CAD	18
Figure 2-14 Types of Location Information.....	19
Figure 2-15 Location Data Element	20
Figure 2-16 The Maximum Number of Records on Location Information	20
Figure 2-17 The Availability of Vehicle Information	21
Figure 2-18 The Availability of Road Blockage Information	21
Figure 2-19 Direction of traffic.....	22
Figure 2-20 The Linkage between the LE Record and the Fire Record for the Same Incident.....	23
Figure 2-21 Frequency of Creating Duplicate Records	23
Figure 2-22 Frequency of Dispatching More than One Unit for the Same Incident	24
Figure 2-23 Method of Handling Duplicate Records	24
Figure 2-24 LE PSAPs Dispatch by Incident Types.....	25
Figure 2-25 Fire PSAPs Dispatch by Incident Types	26
Figure 2-26 Status of Contact with FDOT and RTMC.....	27
Figure 2-27 Frequency of Communication Methods Used.....	27

Figure 2-28 Interest in Receiving Incident Information from FDOT	28
Figure 2-29 Preferred Method(s) of Receiving Information from FDOT	29
Figure 3-1 Washington State CAD-TMC System Architecture	33
Figure 3-2 Oregon Interconnect System Architecture.....	35
Figure 3-3 ARIS Integration with RADS	36
Figure 3-4 How RTIMIS Works	37
Figure 5-1 Proposed Architecture for the Exchange System.....	56
Figure 5-2 Architecture of the Exchange System Prototype	58
Figure A3-1 Legends and Sample Diagram	99
Figure A3-2 PSAPs’ Dispatch and Transfer Diagram – Flagler County.....	99
Figure A3-3 PSAPs’ Dispatch and Transfer Diagram – Osceola County.....	100
Figure A3-4 PSAPs’ Dispatch and Transfer Diagram – Seminole County.....	101
Figure A3-5 PSAPs’ Dispatch and Transfer Diagram – Sumter County.....	102
Figure A4-1 Active 911 Data Flow.....	103
Figure A6-1 Example of How Cellular Tower Triangulation Works	113
Figure A6-2 Identifying Location of Emergency Callers.....	114

LIST OF TABLES

Table 1-1 Benefits of Establishing an Interoperable Data Sharing System	2
Table 2-1 FHP Regional Communication Centers in Florida	8
Table 2-2 FDOT's Data Needs.....	11
Table 3-1 Incident Information Sharing Practices Reviewed.....	31
Table 4-1 Definitions of the Values.....	43
Table 4-2 Current Capability to Share Incident Information Externally	45
Table 4-3 Cost Benefit Comparison Framework.....	47
Table 5-1 Requested Data Elements for Sharing	53
Table 5-2 Additional Recommended Data Elements for Sharing	54
Table A1-1 Example of Your Agency's Duties	66
Table A1-2 Your Agency's Duties	66
Table A1-3 Roadway and Traffic Event Types and the Dispatch Code	68
Table A1-4 Reference Answers	68
Table A1-5 Example Answers of Data Flow	69
Table A1-6 Summary Table of Data Collected from Other Sources	70
Table A1-7 Summary Table of Data Disseminated to Other Agencies	70
Table A5-1 Required Data Elements.....	110
Table A5-2 Additional Recommended Data Elements	111

LIST OF ACRONYMS

ATMS	Advanced Traffic Management Software
CAD	Computer-Aided Dispatch
CJIS	Criminal Justice Information Services
EMS	Emergency Medical Services
EPHI	Electronic Protected Health Information
DOT	Department of Transportation
D5	District 5
EMS	Emergency Medical Services
FDOT	Florida Department of Transportation
FHP	Florida Highway Patrol
FMRCC	Ft. Myers Regional Communication Center
FIPS	Federal Information Processing Standards
FISMA	Federal Information Security Management Act
FOT	Field Operational Test
HIPAA	Health Insurance Portability and Accountability Act
HTTPS	Hypertext Transfer Protocol Secure
IRB	Institutional Review Board
IRIS	Intelligent Roadway Information System
ITS	Intelligent Transportation Systems
JRCC	Jacksonville Regional Communication Center
LWRCC	Lake Worth Regional Communication Center
MOU	Memorandum of Understanding
MRCC	Miami Regional Communication Center
MUTCD	Manual on Uniform Traffic Control Devices
NIEM	National Information Exchange Model
OIS	Oregon Interoperability Service
ORCC	Orlando Regional Communication Center

PHI	Protected Health Information
PII	Personal Identifiable Information
PSAP	Public Safety Answering Point
SSL	Secure Sockets Layer
RADS	Regional Archived Data System
RITIS	Regional Integrated Transportation Information System
RTMC	Regional Transportation Management Center
RTIMIS	Real-Time Traffic Incident Management Information System
SBU	Sensitive But Unclassified
TBRCC	Tampa Bay Regional Communication Center
TIC	Traffic Information Center
TIM	Traffic Incident Management
TLS	Transport Layer Security
TRCC	Tallahassee Regional Communication Center

1 INTRODUCTION

1.1 Problem Statement

The Manual on Uniform Traffic Control Devices (MUTCD, <https://mutcd.fhwa.dot.gov/>) defines a traffic incident as “an emergency road user occurrence, a natural disaster, or other unplanned event that affects or impedes the normal flow of traffic.” Examples of traffic incidents are traffic crashes, roadway debris, vehicle disablements, vehicle fires, medical emergencies, traffic enforcement actions, and a myriad of other events that meet the definition. Traffic incident management (TIM) is universally recognized among agencies and organizations that respond to traffic incidents as the operational approach to deal with these events. TIM consists of a planned and coordinated multidisciplinary process to detect, respond to, and clear traffic incidents so that traffic flow may be restored as safely and quickly as possible.

Florida Department of Transportation (FDOT) Regional Traffic Management Centers (RTMC) are the centers for managing traffic operations on selected roadways at the FDOT District level. RTMCs are staffed by FDOT contract personnel 24/7 in every district of the state, utilizing an advanced traffic management software (ATMS) called SunGuide. Incident detection is an important first step in TIM, obtained from a variety of sources such as intelligent transportation system (ITS) field instruments like roadway cameras and traffic sensors, computer-aided dispatch (CAD) integration with the Florida Highway Patrol (FHP), crowdsource data integration like Waze, telephone calls from public agencies, and from Road Rangers (Florida’s safety service patrols). Except for occasional telephone calls to the center, The RTMCs currently do not have an effective way to receive incident information from local public safety agencies. To address this limitation, FDOT District 5 needs a real-time interagency information exchange system with relevant stakeholders in TIM (hereafter referred to as “the exchange system”).

1.2 Research Objectives

The goal of this project was to explore feasible solutions to achieve a real-time roadway incident information sharing between FDOT, local law enforcement agencies, fire departments, and potentially other TIM stakeholders (hereafter referred to as “incident information sharing”). While this research is focused on FDOT District 5, the findings are expected to benefit other RTMCs and districts in Florida and serve as a framework for the state.

The purpose of this project is twofold:

- Develop an understanding of current public safety roadway incident information management within FDOT District 5, including over 80 police and fire agencies, their CAD and 911 systems.

- Conduct a feasibility analysis and provide recommendations to develop a real-time, unified, consistent, spatially accurate, and dynamically updated information stream of district-wide roadway incidents, to support the District’s traffic operations mission.

The implementation of the exchange system can help FDOT improve the completeness and accuracy of traffic incident data:

- At present, FDOT obtains incident information mainly on freeways, but infrequently on other state roads and arterials. The exchange system can improve the geographic extent and agency diversity of FDOT’s traffic incident data sources.
- Public safety agencies have the most accurate time-based information for roadway incidents. Accessing this accurate information in a streamlined fashion can improve information timeliness and accuracy.

Beyond data improvements, establishing an interoperable data sharing system with local public safety agencies is expected to have several benefits that are depicted in Table 1-1. Ultimately, it is expected to reduce congestion and secondary incidents.

Table 1-1 Benefits of Establishing an Interoperable Data Sharing System

Benefits to Public Safety Agencies	Benefits to Transportation Agencies
Increase officer safety during incident response.	Improved notifications, awareness, and verification of incidents.
Minimal cost or changes to law enforcement processes.	Can mobilize DOT response resources faster.
Reduce coordination time for dispatch/communications centers.	Overall improvements to incident response and clearance time.
Improved capabilities for performance measures.	Depth and accuracy of data for performance analysis.
	Improved traveler information

1.3 Research Framework

The research is structured in three main tasks that aim at addressing the research goals by following the research framework illustrated in Figure 1-1 below. By reviewing the current practice of incident data sharing in District 5 and various approaches of incident sharing in

other states, the research team put together feasibility options for a real-time interagency information exchange system and provided recommendations based on a cost-benefit analysis.

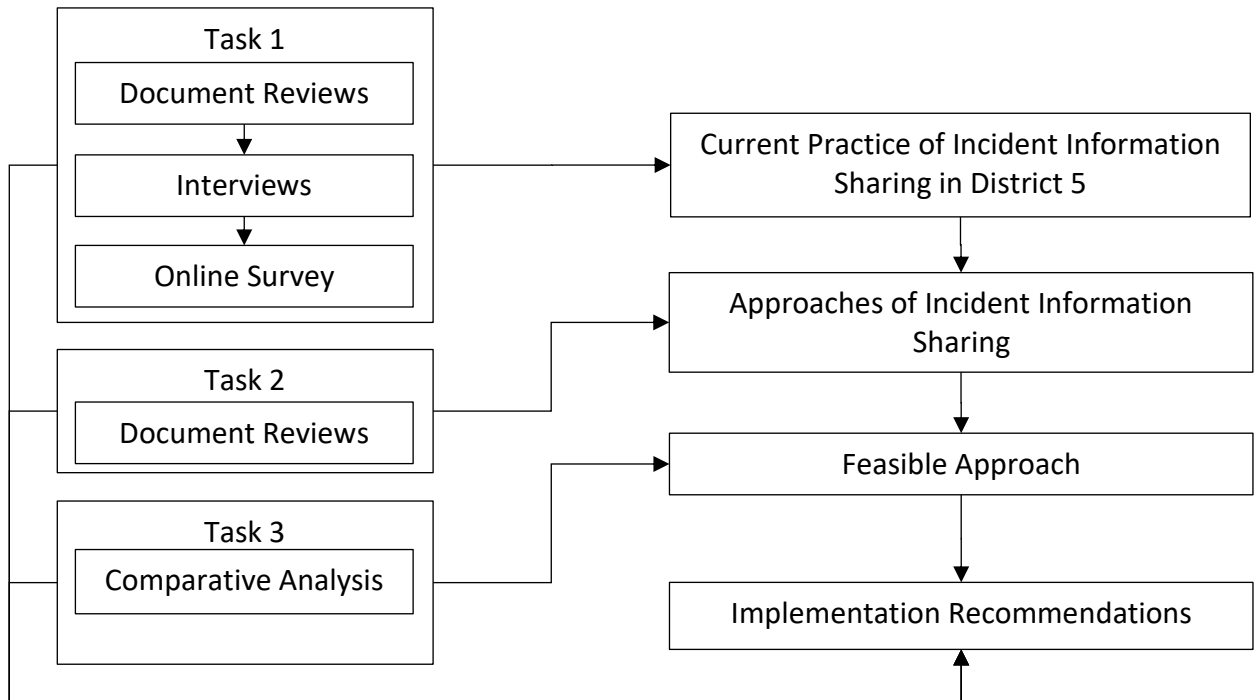

Figure 1-1 Research Framework

1.3.1 Task 1 – Review of the current practice in District 5

The goal of Task 1 was to review the current TIM data practice of FDOT and other key stakeholders in District 5. It aimed to understand these agencies’ operations, types of data collected, data management practices, communication among systems and information exchange with other agencies in the district.

The research team established three objectives to support this goal:

- Objective 1: Identify key TIM stakeholders in District 5 and understand these stakeholders’ data collection and information exchange process when a traffic incident happens.
- Objective 2: Understand the data each key stakeholder needs and determine data they might contribute to interagency information exchange.
- Objective 3: Evaluate potential obstacles to the establishment of an interoperable data sharing system between public safety and transportation agencies in District 5.

1.3.2 Task 2 – Review of literature and best practices

The goal of Task 2 was to learn from existing knowledge, solutions, and experience in the roadway incident response, relevant coordinated information sharing and management. The review of practices intended to support the following objectives:

- Objective 4: Summarize the current approaches that DOTs use to receive real-time traffic incident data from law enforcement agencies and fire departments and identify options to inform the feasibility analysis.
- Objective 5: Synthesize the barriers for implementing an incident information sharing system in District 5 and discuss solutions for implementing a statewide information sharing system in the future.

1.3.3 Task 3 – Feasibility analysis and recommendations

The purpose of Task 3 was to compare the advantages and drawbacks of interagency incident information sharing approaches identified in Task 2 and make recommendations for implementing of a real-time incident information sharing system to facilitate TIM response in District 5. This task included an evaluation framework for the comparative analysis of potential costs and benefits involved with each approach. The findings of this task are expected to benefit other districts in the state.

Task 3 aimed to fulfil the following objectives:

- Objective 6: Compare incident information sharing approaches based on a cost-benefit comparison framework and identify the most feasible approach for District 5.
- Objective 7: Propose a suitable exchange system for District 5 and provide recommendations for implementation.

1.4 Report Organization

Chapter 2 presents all findings related to the current practice of incident information sharing in District 5. Chapter 3 introduces three common approaches of incident information sharing and a qualitative comparative analysis of these approaches. Chapter 4 discusses the feasibility of potential solutions and Chapter 5 provides recommendations for implementation.

2 ASSESSMENT OF CURRENT PRACTICE

This chapter discusses the current practice of incident information sharing in District 5, including data flows, data needs, and survey results. This information is synthesized from review of documents, on site interviews and an online survey.

2.1 The Review Process

We began with a review of documents related to traffic incident procedures, standards, and stakeholders in District 5. Beyond the Florida Open Roads agreement, no formal agreements exist between area agencies as it relates to the conduct of traffic incidents. Where there are overlapping jurisdictions on roadway segments, decisions on response and investigative responsibilities are typically informal agreements between enforcement agencies that are implemented by communications center staff. Fire and EMS responsibilities typically follow jurisdictional boundaries. Towing and recovery operations are geographically defined by enforcement agency contracts or written zone assignments.

Based on these documents, we identified representative stakeholders as interview candidates and developed an interview questionnaire (see Appendix 1). We conducted on-site interviews with four agencies: City of Apopka PSAP, Volusia County PSAP, City of Orlando PSAP, and the FHP Orlando Regional Communication Center (ORCC). This list provides a sampling of dispatch centers on all three levels (state, county, and city). Two city sites (Orlando PSAP and Apopka PSAP) are included because Apopka PSAP has a unique arrangement: it not only dispatches for Apopka PD and Fire but also dispatches for Maitland PD.

Based on these reviews, we identified Public Safety Answering Points (PSAPs) as the candidate stakeholders for information exchange with FDOT. PSAPs handle all 911 calls, dispatch local law enforcement and fire agencies, and communicate with external stakeholders on an as-needed basis. PSAPs are the source from which responsible agencies first receive information about roadway incidents, therefore they are critical information management centers for TIM.

2.2 Incident Response Data Flow

2.2.1 PSAPs' Data Flow

PSAPs are the first to receive incident notifications that are reported through 911 calls, and they communicate with both callers and other agencies directly. PSAPs are usually equipped with CAD systems, so electronic reports of incidents are usually available in PSAPs as soon as an incident is reported. These characteristics make PSAPs the best sources of roadway incident information for FDOT.

Figure 2-1 shows the typical data flow of a PSAP that dispatches for both law enforcement agencies and fire departments. When a caller calls 911, the 911 system automatically detects the calling number and the caller's location (the methods of positioning the caller's location is discussed in Appendix 6. Many CAD systems have the capability to receive "911 spills", which means they can automatically transfer the information from the 911 system into their own system. The call taker then collects incident information from the caller while recording all the information in the CAD system(s). Incident records in CAD systems can always be updated as more information is obtained or verified by responders or call takers. If an incident is located outside of a PSAP's service area, the call taker transfers the call to the appropriate PSAP. Otherwise, the dispatcher dispatches appropriate responders to the scene. In some PSAPs, the same staff member serves plays the roles of both the call taker and the dispatcher (e.g. Apopka PSAP).

While 911 systems are the first to receive incident notifications, they are read-only systems, whereas CAD systems can provide more data elements with the most up-to-date information. Overall, CAD systems provide more complete information for traffic incident response.

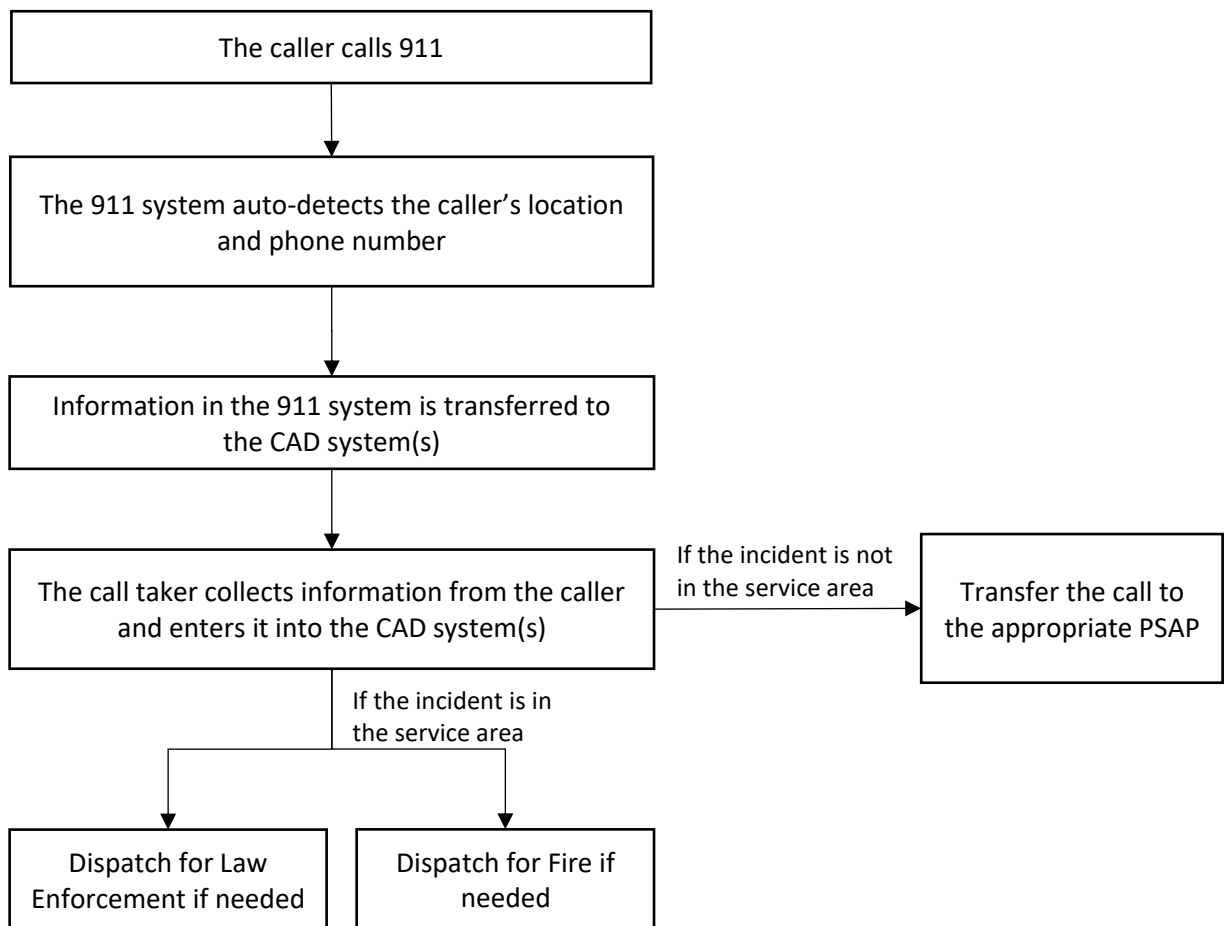

Figure 2-1 PSAP's Incident Response Data Flow

PSAPs that dispatch for both Law Enforcement (LE) and Fire Rescue use either one CAD system or two separate CAD systems to manage two types of responders – one LE and one fire rescue (e.g. Orlando PSAP). Regardless, the standard practice is to generate two separate records due to the difference in data needs for LE vs Fire response.

Based on reviewing documents and information on each PSAP websites, we developed one diagram for each county in DISTRICT 5 to document all PSAPs in the county, their co-location information, agencies they dispatch or transfer calls to, and the service area of these responding agencies (Appendix 3). These diagrams only include key TIM stakeholders that are of interest to this project: PSAPs, law enforcement agencies, fire departments, and FHP. As shown in the diagrams, for an incident that requires both fire and law enforcement units, it is common for two PSAPs to be involved, one dispatched for fire and the other dispatched for law enforcement. This was important to highlight because it can lead to duplicate alerts for the same incident. The issue of duplicates is discussed later in this report.

Because of the significant number of agencies and transfer routes between agencies in Orange County, transfer routes are excluded from the Orange County’s diagram to improve readability. Furthermore, for the purposes of this project, the inclusion of the transfers is not critical because no CAD event is created in the first PSAP call recipient if the PSAP transfers the call to another PSAP.

2.2.2 FDOT’s Data Flow

There are 7 FHP regional communication centers (RCC) in Florida (see Table 2-1). FHP regional communications centers do not have PSAPs. Instead, they are notified of incidents by *FHP calls, troopers’ report through radio, as well as 911 calls transferred from PSAPs. PSAPs do not dispatch for FHP centers, because FHP centers have their own dispatchers (also called Regional Duty Officers). Like almost every public safety agency, the FHP creates a CAD incident for each call and, records important information in the data fields. The FHP CAD stores this information in a centralized relational database. A unique capability of the FHP CAD is the display of basic information for active incidents. The date, time, location, and event type are presented in a tabular form on a public-facing web page¹. Similarly, that event information is pushed via XML to a common FDOT server, along with comments and other data fields¹.

¹ https://www.flhsmv.gov/fhp/traffic/live_traffic_feed.html

Table 2-1 FHP Regional Communication Centers in Florida

Troop(s)	FHP Regional Center	Service Area
A and H	Tallahassee (TRCC) Leon County	Bay, Calhoun, Escambia, Franklin, Gadsden, Gulf, Holmes, Jackson, Jefferson, Leon, Liberty, Madison, Okaloosa, Santa Rosa, Taylor, Wakulla, Walton, Washington
B and G	Jacksonville (JRCC) Duval County	Alachua, Baker, Bradford, Clay, Columbia, Dixie, Duval, Flagler, Gilchrist, Hamilton, Lafayette, Levy, Marion, Nassau, Putnam, St. Johns, Suwannee, Union
C	Tampa (TBRCC) Hillsborough County	Citrus, Hernando, Hillsborough, Pasco, Pinellas, Polk, Sumter
D	Orlando (ORCC) Orange County	Brevard, Lake, Orange, Osceola, Seminole, Volusia
E	Miami (MRCC) Dade County	Dade, Monroe
F	Ft. Myers (FMRCC) Lee County	Charlotte, Collier, DeSoto, Glades, Hardee, Hendry, Highlands, Lee, Manatee, Sarasota
K and L	Lake Worth (LWRCC) Palm Beach County	Broward, Indian River, Martin, Okeechobee, Palm Beach, St. Lucie, and Florida Turnpike

As shown in Figure 2-2, the service areas of FHP Regional Centers do not completely align with FDOT’s district boundaries. The inconsistency in boundaries means that most FDOT districts need access to the information sent from multiple FHP centers as well as a mechanism to identify incidents in their own districts. Currently, the FDOT server consolidates a filtered list of FHP CAD events and makes it accessible to all RTMCs. RTMCs request FHP data from the common FDOT server and their SunGuide systems receive the data as FHP alerts. Each district may have multiple SunGuide installations and each RTMC’s SunGuide system has its own setting to filter FHP alerts by roadway and county.

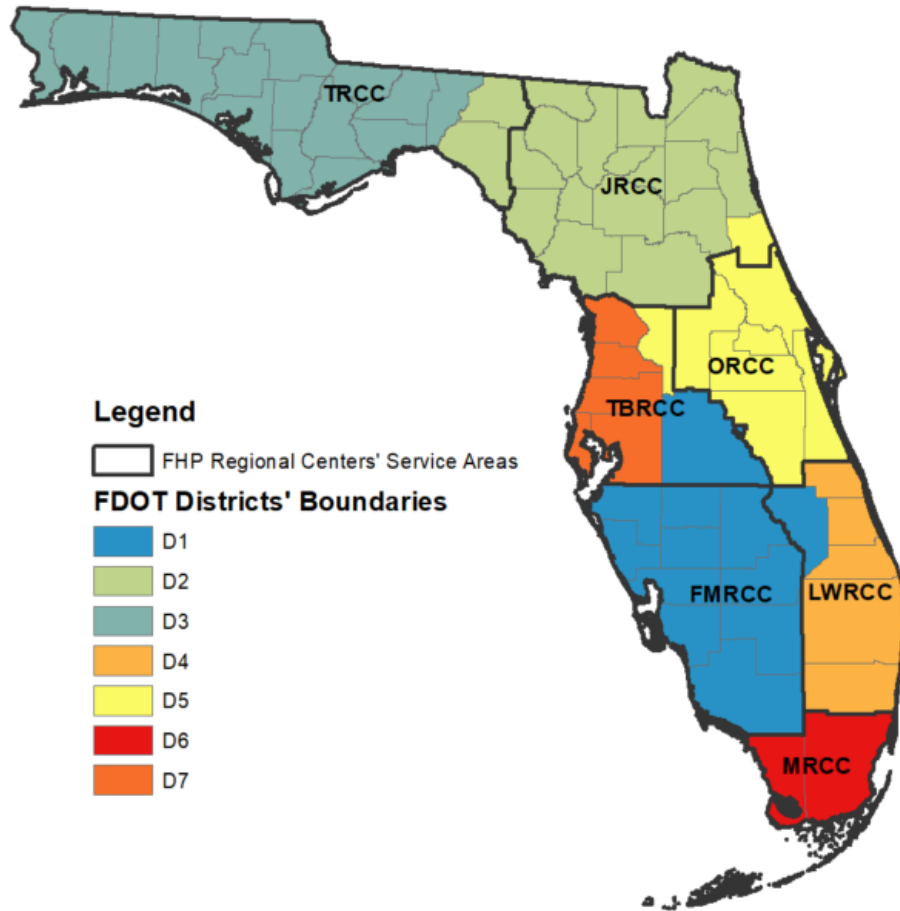

Figure 2-2 FHP Centers Service Areas and FDOT District Boundaries

*Turnpike is not shown on the map. It is covered by Florida Turnpike Enterprise and FHP's LWRCC

Upon receiving an FHP alert, an RTMC operator can create a new SunGuide event from the alert, incorporating its information into an existing SunGuide event or dismissing the alert if not relevant. If Road Rangers encounter an incident when they are on patrol, they will also notify the RTMCs. RTMCs manage detailed information for each traffic incident. They are also responsible for initiating response plans and contacting other agencies as needed, as well as disseminating information to other outlets such as the 511 system. Figure 2-3 shows how FDOT receives and disseminates roadway incident information.

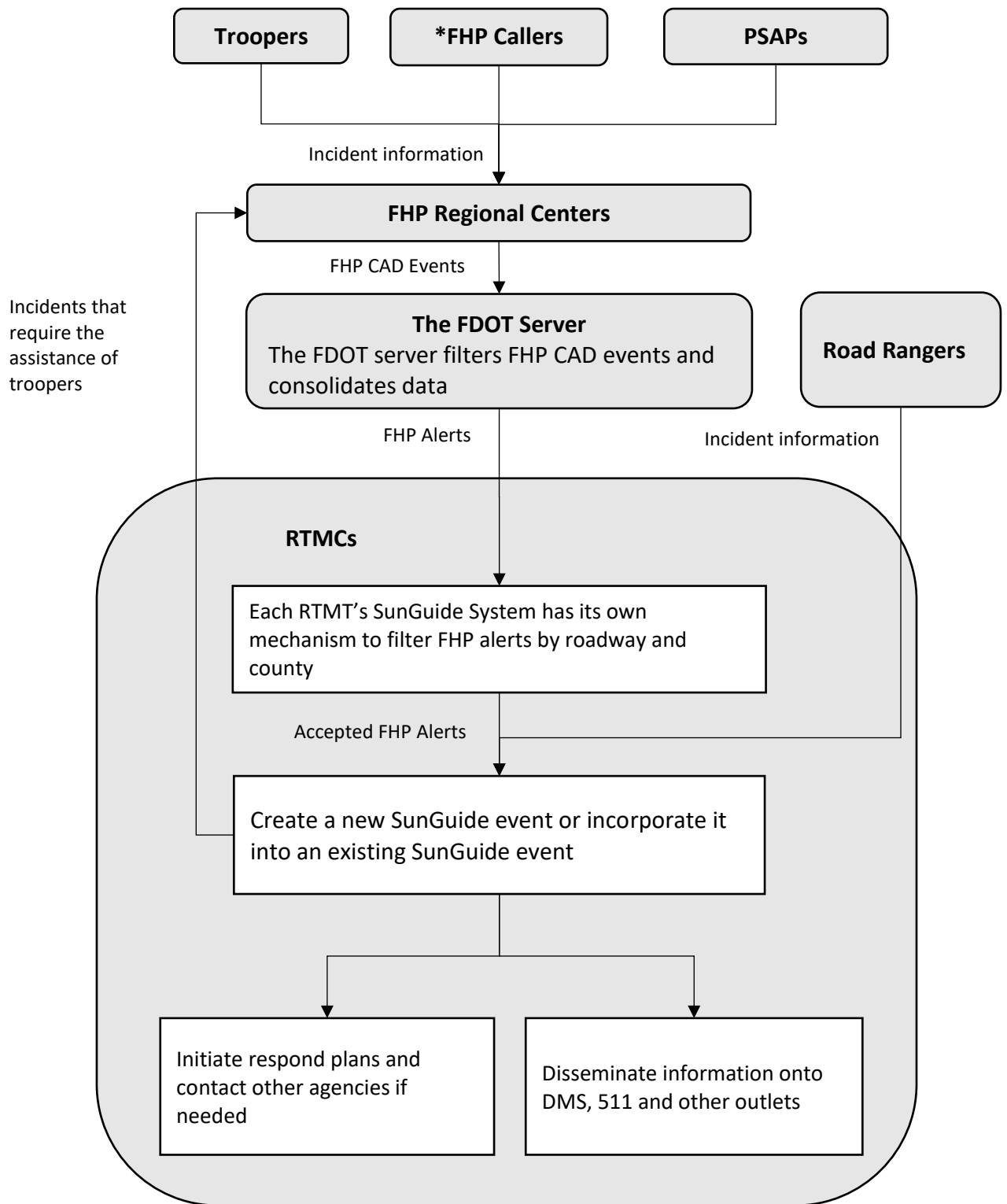

Figure 2-3 FDOT's Data Flow

2.3 Data Needs

2.3.1 FDOT's data needs

FDOT needs alerts and information on incidents that are reported through 911 calls. Table 2-2 shows the data items needed by FDOT that could be provided by PSAPs.

Table 2-2 FDOT's Data Needs

Item Number	FDOT's Data needs	Description
1	The name of the PSAP	
2	Type of the PSAP	Dispatch for Law Enforcement, Fire, or both.
3	Date of the incident	
4	Time of the incident	
5	Location of the incident	
6	Roadway incident types	Any incidents with fatality Crash with injury Crash without injury Crash with road blockage Crash without road blockage Debris on roadway with road blockage Debris on roadway without road blockage Disabled vehicle with road blockage Disabled vehicle without road blockage Vehicle Fire with injury Vehicle Fire without injury Vehicle Fire with road blockage Vehicle Fire without road blockage Vegetation Fire with road blockage Vegetation Fire without road blockage Hazardous Materials with road blockage Hazardous Materials without road blockage
7	Dispatch information of fire departments and law enforcement agencies	Date of dispatch, time of dispatch, time of arrival, time of incident closed
8	Blocked lanes	
9	Vehicle description	Vehicle type, vehicle color, vehicle make, vehicle model, vehicle year.

Items 1-5 and item 8 are essential information that is always collected by PSAPs' CAD systems. For Item 6, PSAPs have dispatch codes that reflect the incident types, but the classification of

incident types varies by CAD system and is usually different from that of FDOT's. Item 8 and Item 9 might not be collected in designated data fields in all CAD systems, but they are likely available in the incident comment fields.

2.3.2 PSAP's Data Sources

Typically call takers gather incident information from two sources: the 911 system, and the caller.

Most 911 systems have street addressing information loaded into their systems and so street addresses for residences and businesses are validated and automatically populated. For a 911 call from a landline, the 911 system reports the street address associated with the caller's landline number with good accuracy. However, the majority of 911 calls about traffic incidents are from cell phones. For cell phone calls, there are two levels of available location accuracy. The first one, called 'Phase I location', represents the location of the closest cell tower, which could be miles from the actual caller. The 'Phase II location' is an estimated caller's location using the tower triangulation method and is more accurate than Phase I location, but it is still not accurate enough to include detailed location information such as the direction of traffic. More detailed information about the location accuracy of 911 Phase I location and Phase II location is provided in Appendix 6.

The call taker always verifies the incident location with the caller. Locating roadway incidents relies on roadway identification, the direction of traffic, and an offset from the nearest intersecting roadway. This could be complicated when incidents occur on roadway segments between intersections. Therefore, it is not uncommon for a caller to report a vague or incorrect incident location.

Inaccurate location information can lead to inefficient or delayed response. For instance, in the case of an incident that occurred on a freeway, sometimes PSAPs would dispatch two units in two different directions because they cannot verify the direction of traffic information. With a real-time information exchange system between the FDOT and PSAPs, FDOT will be able to receive incident notifications much earlier in the process so that they can confirm the incident location using live traffic cameras promptly and help PSAPs establish a more efficient response.

2.4 Survey of PSAP's CAD Data

To develop a more detailed understanding of the CAD data elements available at PSAPs, we conducted an online survey directed to all PSAPs in the district. The survey study was approved by the Institutional Review Board (IRB) at the University of Florida. Soon after that, the District 5 traffic incident management (TIM) coordinator sent out the recruitment email with the survey link to the chiefs of police in District 5 and followed up with a reminder email a few days later. The target survey audience was the Public Safety Answering Points (PSAPs) in District 5. The survey was developed on the Qualtrics platform. The questionnaire is provided as Appendix 2. The following sections present a synthesis of relevant survey results.

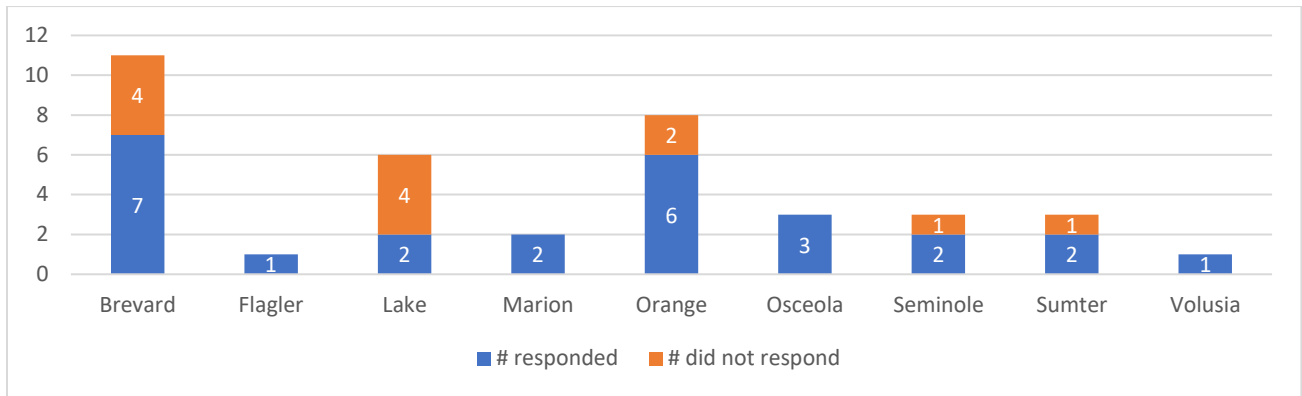

Figure 2-4 Number of Responses by County

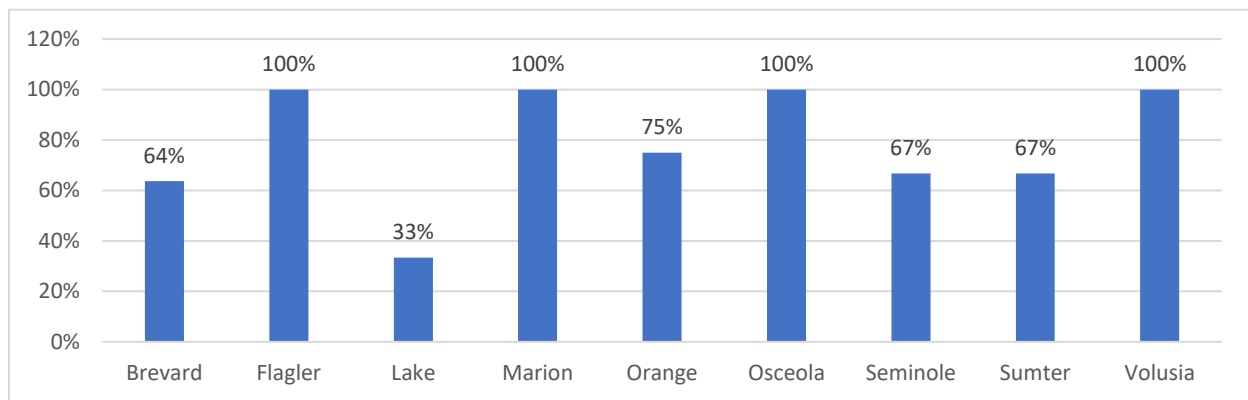

Figure 2-5 Response Rate by County

The research team identified 38 PSAPs in District 5 based on each county’s 911 plan. We received 26 effective survey responses, 25 of which are 100% completed. The effective response rate is thus 68.4%. The responding agencies cover all counties in District 5. The response counts and rates by county are shown in Figure 2-4 and Figure 2-5. The following subsections summarize the survey results.

2.4.1 Type of PSAPs

Among the 26 participants, 11 PSAPs dispatch for both LE and Fire, 8 PSAPs dispatch for LE only, 7 PSAPs dispatch for Fire only (Figure 2-6).

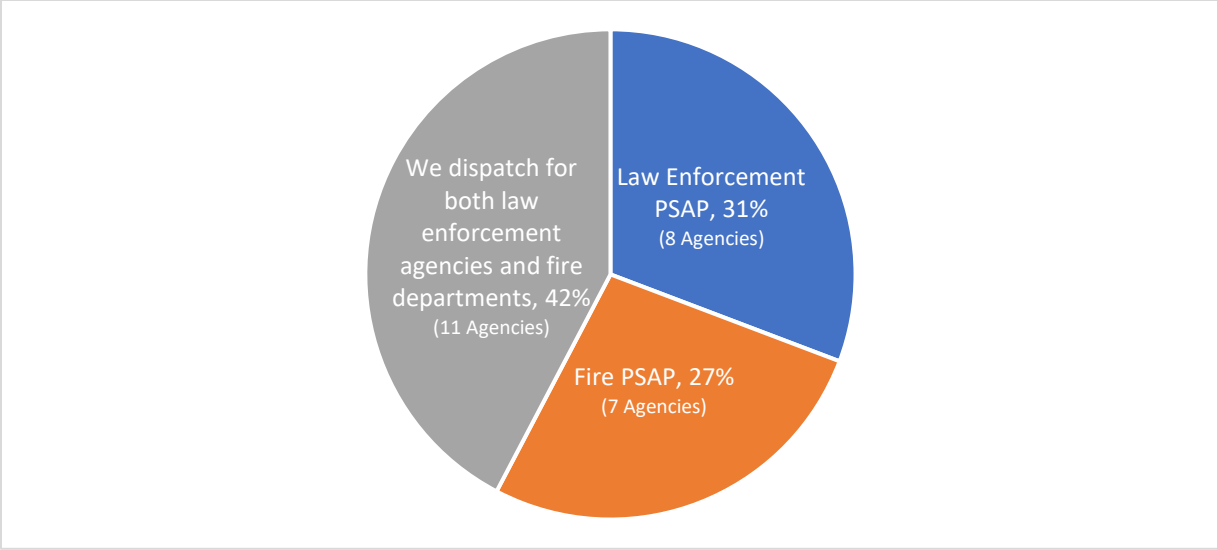

Figure 2-6 PSAP Dispatch Distribution

2.4.2 911 and CAD Vendors

2.4.2.1 911 Vendors

- For 911 systems, PSAPs that participated in this survey currently use the products of four different vendors. 80% of the respondents are using West Corporation’s Intrado Viper. (Figure 2-7)
- PSAPs in one county do not necessarily use the same 911 system. Answers given by survey respondents in Osceola County, Orange County and Brevard County showed some inconsistencies.

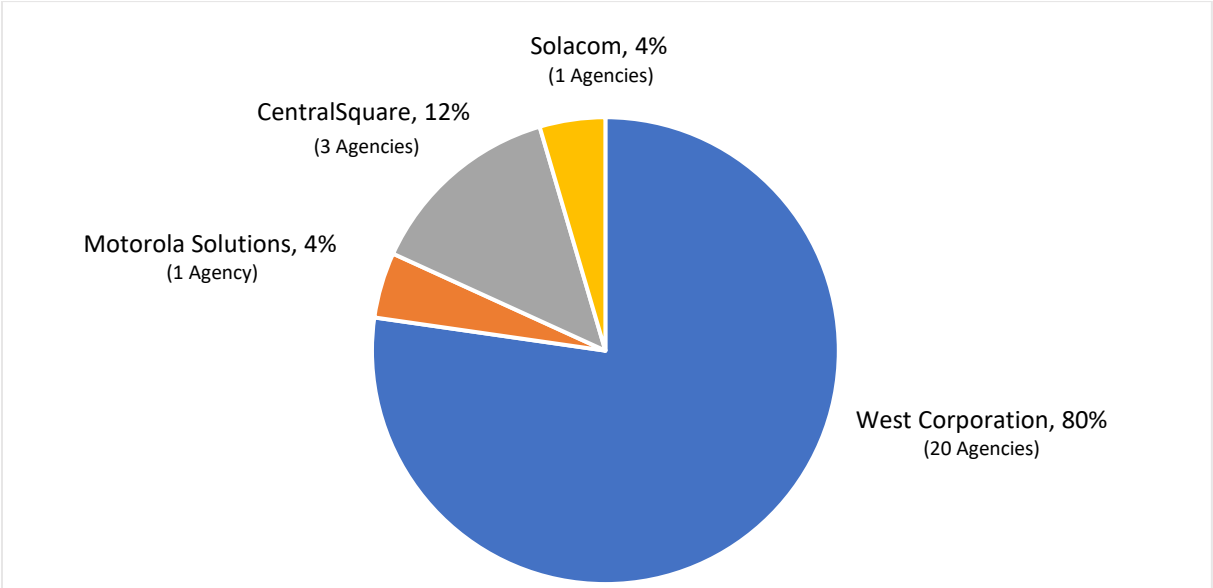

Figure 2-7 PSAPs’ 911 Vendor Distribution

2.4.2.2 CAD Vendors

- There are 4 vendors of Fire CAD and 6 vendors of LE CAD serving PSAP agencies in District 5. Tyler Technologies and CentralSquare serve the majority of PSAPs in the District. (Figure 2-8 and Figure 2-9)
- Among the 11 PSAPs that dispatch for both LE and Fire, only Apopka PD PSAP uses two different CADs. St. Cloud PD PSAP uses two instances of the same CAD, while the other 9 PSAPs use the same dispatch system for LE and Fire. These nine PSAPs are Volusia County SO Communication Center Primary PSAP, Osceola County SO Primary PSAP, Cocoa PD Primary PSAP, Indialantic PD Primary PSAP, Flagler County Primary PSAP, Melbourne PD Primary PSAP, Satellite Beach PD primary PSAP, Kissimmee PD PSAP and Marion County Public Safety Communications Primary PSAP.

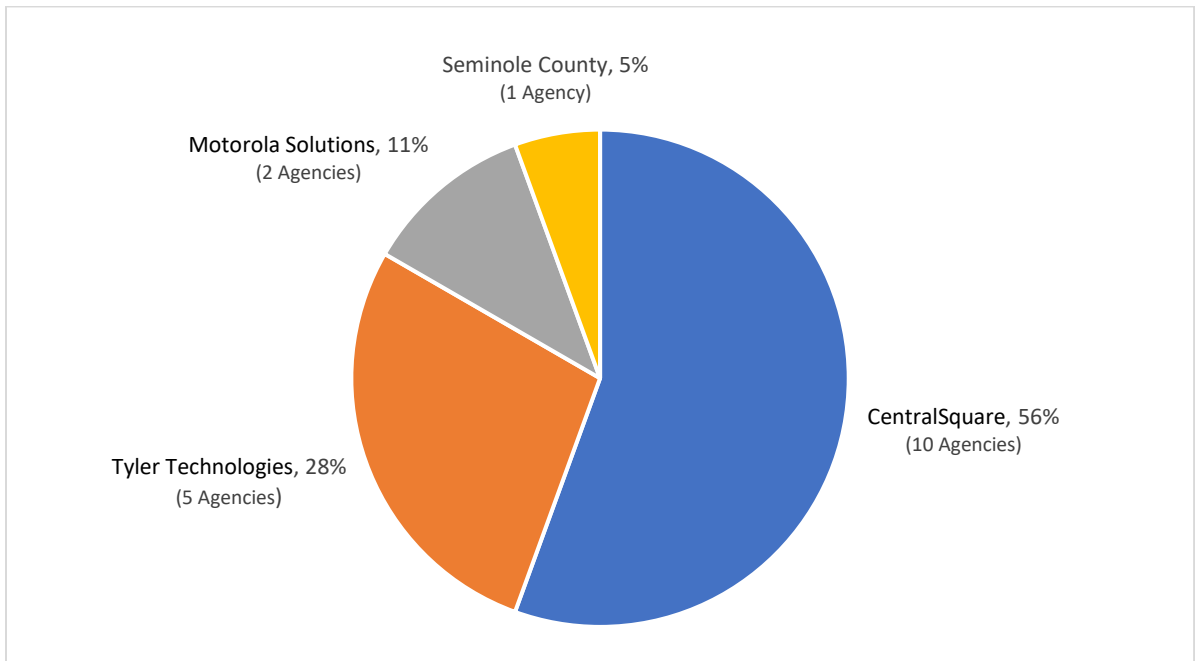

Figure 2-8 Fire CAD Vendors

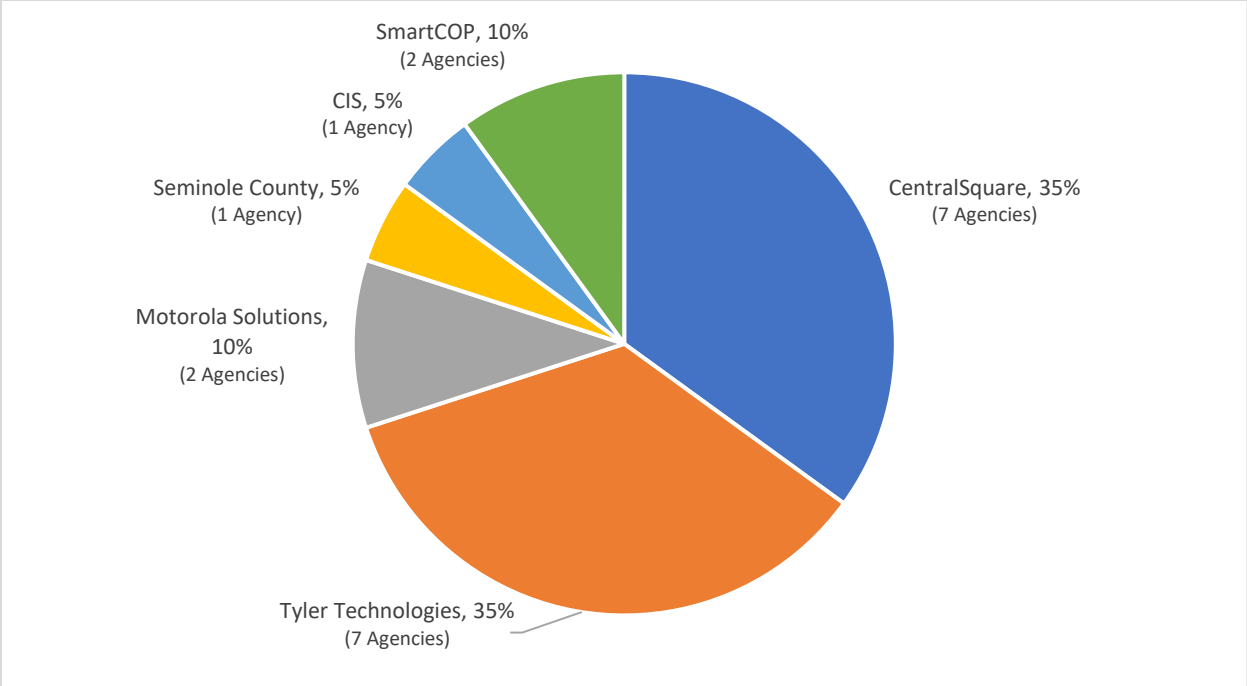

Figure 2-9 LE CAD Vendors

2.4.3 Information Sources

- The majority of respondents receive incident notifications from 911 calls, LE non-emergency calls, FHP and 911 texts. Only 35% of respondents receive notifications from the road rangers or FDOT. No respondents receive notifications from social media or apps. (Figure 2-10)
- Brevard County listed alarm companies and other outside agencies as their additional sources for incident information. Kissimmee PD also receives incident information from citizen complaint reporting emails (seeitsayit@kissimmee.org).

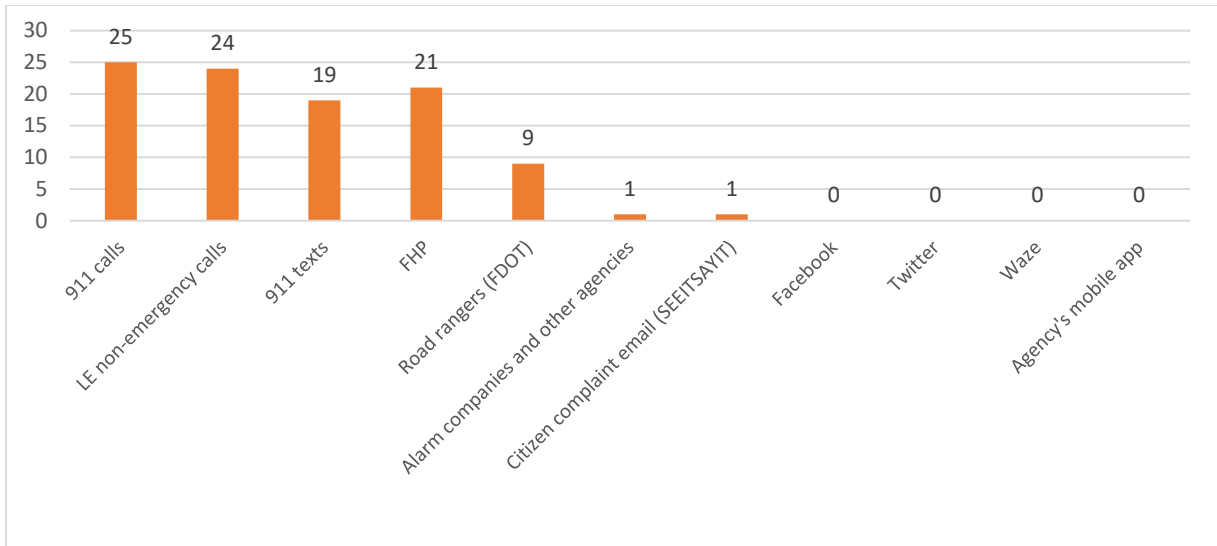

Figure 2-10 Sources for Incident Information

2.4.4 Data Elements

2.4.4.1 General Data Elements

- Although 15 PSAPs have unique incident IDs in their 911 systems, only 10 of them include 911 incident IDs in their 911 spill. (Figure 2-11)
- Rockledge PD PSAP is the only respondent whose CAD does not support automatic data transfer from their 911 system. The other PSAPs all have 911 spills and transfer ALI information, which is the auto-detected location of the caller. Date and time of 911 call is also usually included in 911 spills. (Figure 2-12)
- All PSAPs' CADs capture time of incident, time of dispatch, time of arrival, time of incident closed and location information. Eustis PD PSAP is the only agency that does not have CAD incident ID. Apopka PD PSAP is the only agency that captures the date of incident in their CAD. (Figure 2-13)

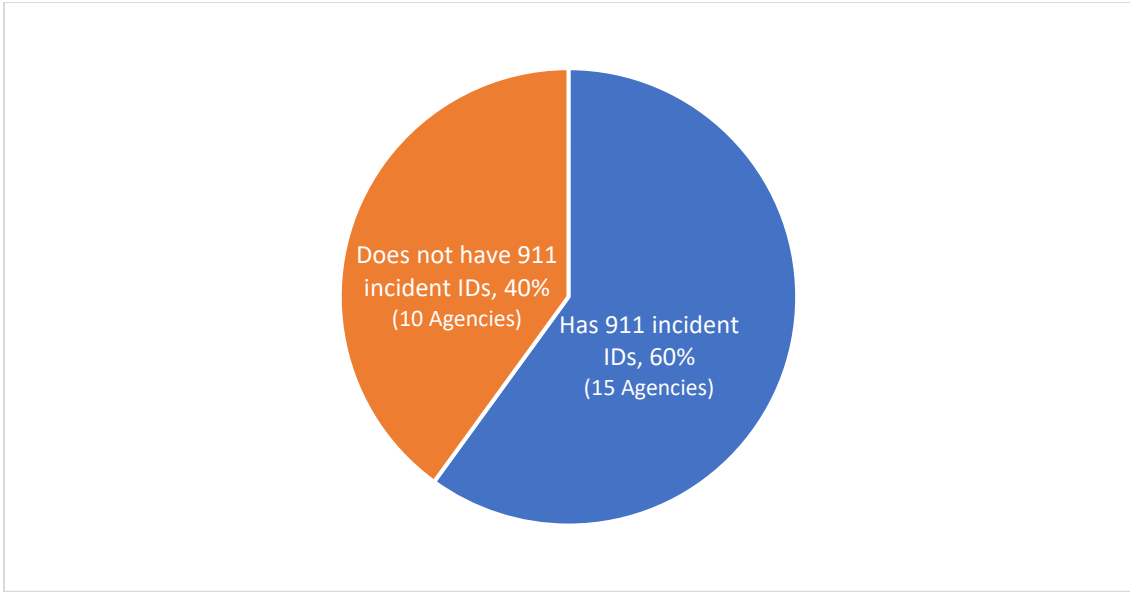

Figure 2-11 911 Incident ID

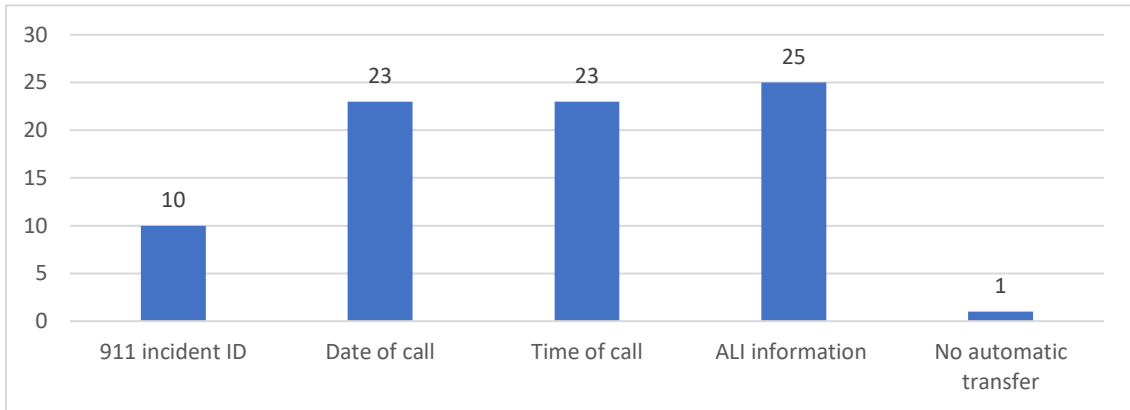

Figure 2-12 Data Elements in 911 CAD Spills

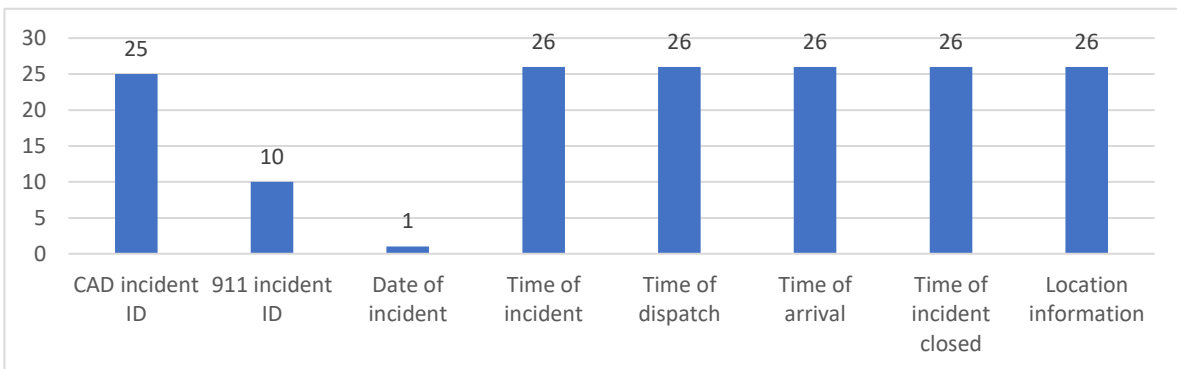

Figure 2-13 Data Elements Captured in CAD

2.4.4.2 Location Information

- All respondents can detect the street address of the caller, but this may not necessarily be the location of the incident. Sumter County Fire/EMS Secondary PSAP is the only respondent that does not collect other types of location information in their CAD besides caller’s street address. Most respondents also capture updated location information in their CADs. Some PSAPS also receive location information from the RapidSOS, but it may not be integrated into CAD due to network security concerns. (Figure 2-14)

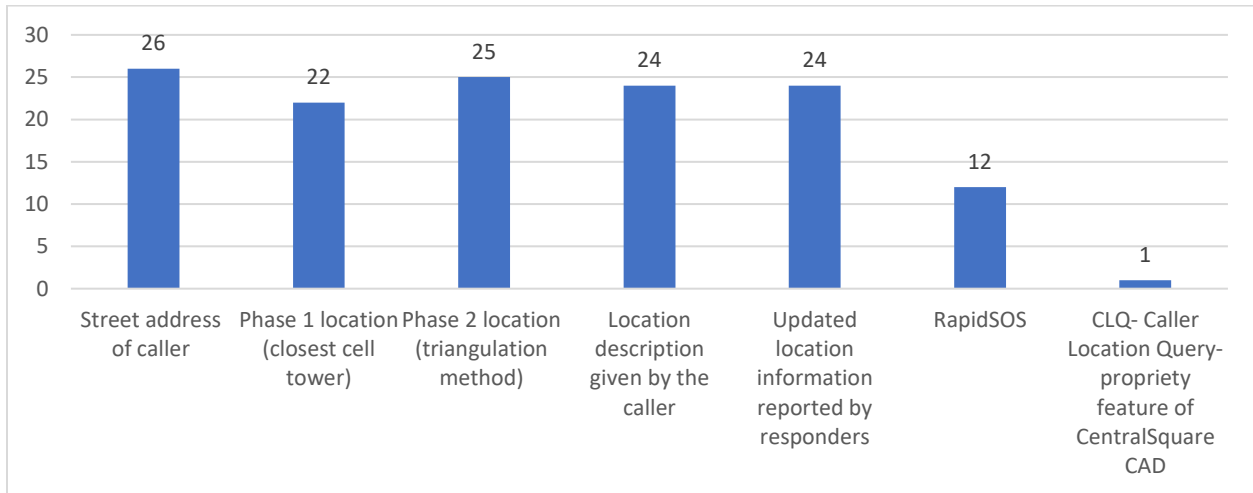

Figure 2-14 Types of Location Information

- All respondents record location in the street address format. Most agencies also record location in latitude and longitude except for Eustis PD and Rockledge PD. Another method of recording location is by specifying the street name and the distance to a reference intersection. This method is widely used for crash reports recorded by law enforcement. However, 12 PSAPs only capture the street names of the closest intersection, but not the distance to the intersection, which makes it difficult to pinpoint incident locations using intersections as the reference points. Note, however, this information is complementary to the street address of the caller. (Figure 2-15)

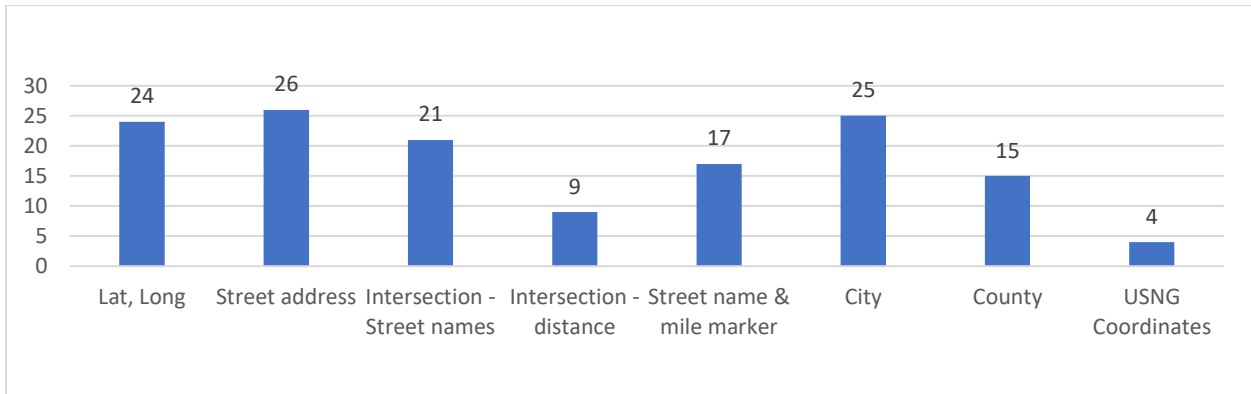

Figure 2-15 Location Data Element

- When asked about the number of records on location information kept in their CADs, Orange County SO is the only respondent that keeps two records: the first record of incident location and the latest one. The other PSAPs either overwrite their location information whenever they get an update or keep all the update instances. (Figure 2-16)

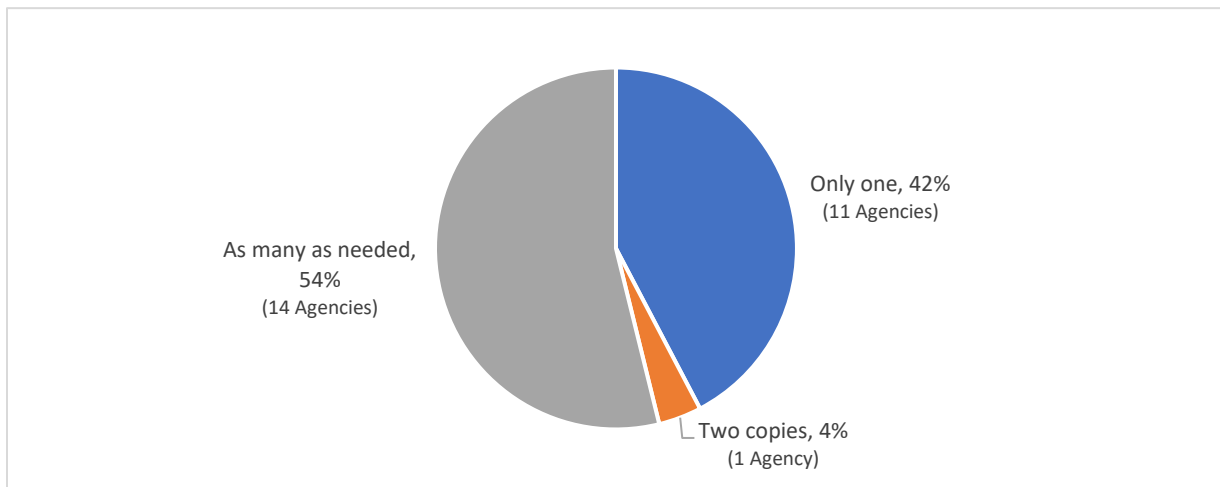

Figure 2-16 The Maximum Number of Records on Location Information

2.4.4.3 Vehicle Information

About 73% of respondents capture vehicle information and they all collect information on vehicle type, make and model. They also collect vehicle color information except for Apopka PD. Apopka PD PSAP has two CADs, and vehicle information is only captured in their LE CAD. (Figure 2-17)

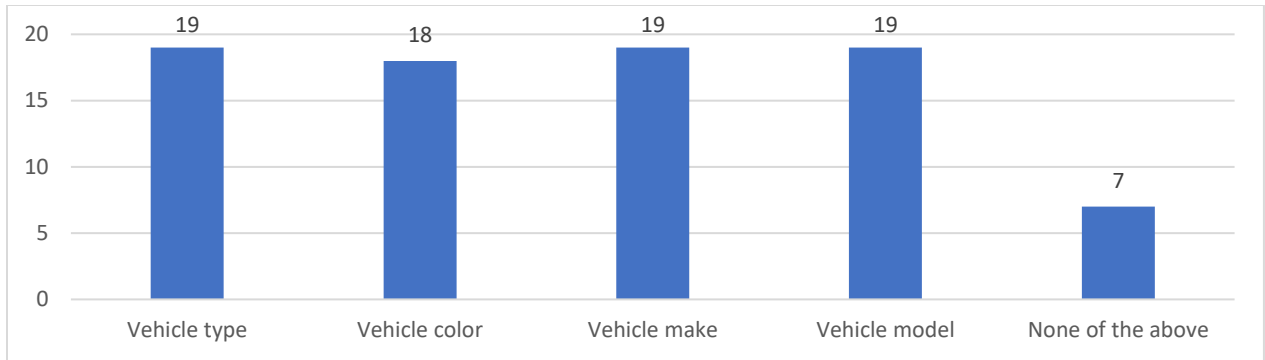

Figure 2-17 The Availability of Vehicle Information

2.4.4.4 Road Blockage Information

Road blockage information is generally not captured in designated fields in PSAPs' CADs. Orlando Fire PSAP and Indialantic PD PSAP are the only two respondents that record road blockage information. (Figure 2-18)

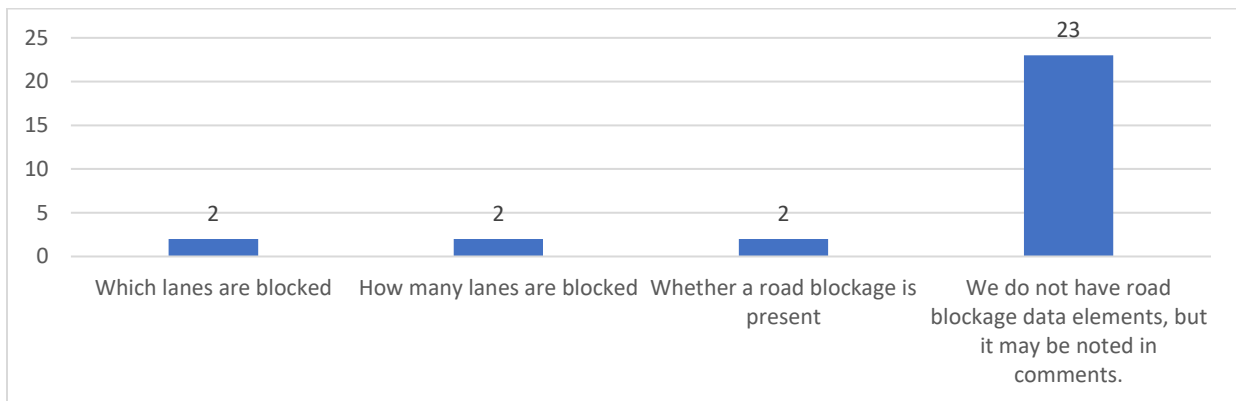

Figure 2-18 The Availability of Road Blockage Information

2.4.4.5 Direction of traffic

Only 6 PSAPs capture the direction of traffic in a designated field and they use 4 different CAD vendors. 12 respondents said they usually collect the direction of traffic information but store it in a comment field. (Figure 2-19)

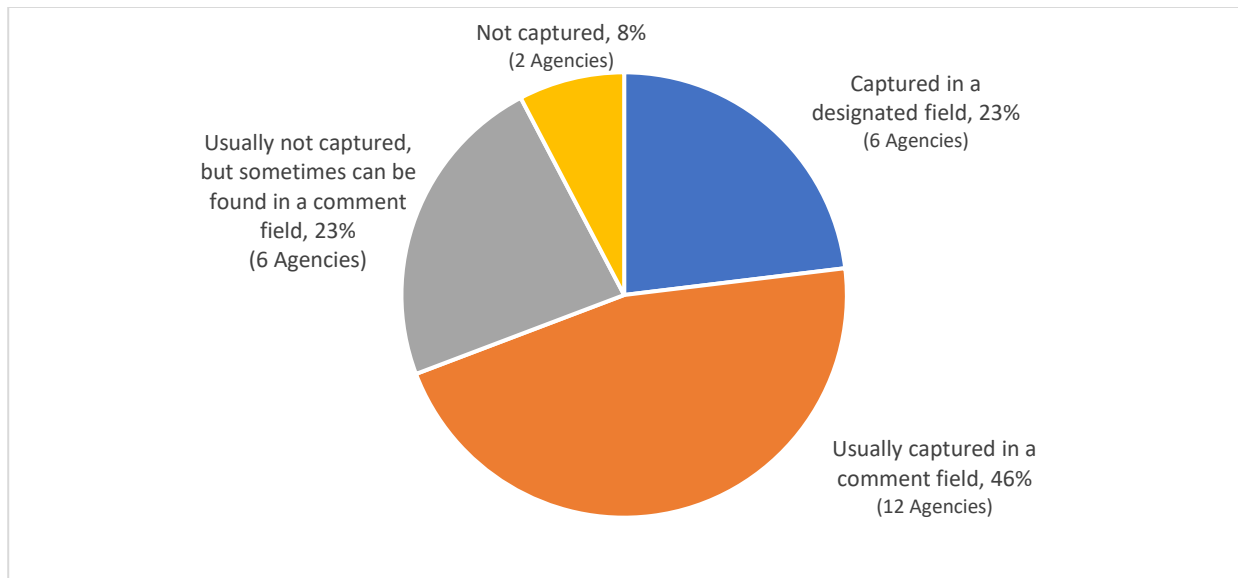

Figure 2-19 Direction of traffic

2.4.5 Handling of Duplicate Records

Ideally, FDOT would like to avoid receiving duplicate reports for the same incident from a PSAP. However, it is not uncommon for PSAPs to generate multiple records for the same incidents due to two reasons: (1) For an incident that requires the assistance from both LE and Fire, two CAD dispatch events would be generated; (2) PSAPs routinely receive multiple 911 calls and while the call takers do their best to determine if such calls are in reference to the same incident, occasionally duplicate records get created unintentionally. The following provides a summary of survey results about the handling of the multiple records:

- For cases when PSAPs dispatch for both LE and Fire, the LE CAD event and the Fire CAD event for the same incident are linked together. The most common approach to link the two records is by using a common CAD ID or a CAD ID spawned from the other, followed by using the caller’s telephone number. No respondents use 911 incident IDs to link two records, even though they are unique and therefore could be better identifiers than caller numbers. Apopka PD and Melbourne PD do not link their Fire CAD events and LE CAD events at all. (Figure 2-20)

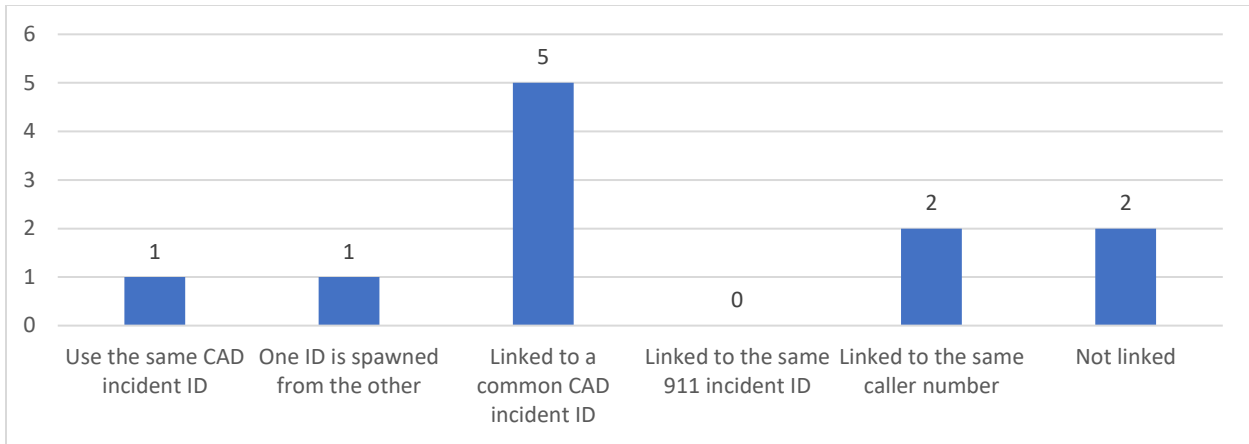

Figure 2-20 The Linkage between the LE Record and the Fire Record for the Same Incident

- Although only 8% of respondents never create duplicate records (Figure 2-21), 46% of the agencies do not dispatch more than one unit for the same incident when they have duplicate records (Figure 2-22). The results implicate that PSAPs have mechanisms to examine duplicate records and minimize the chances of dispatching duplicate units.

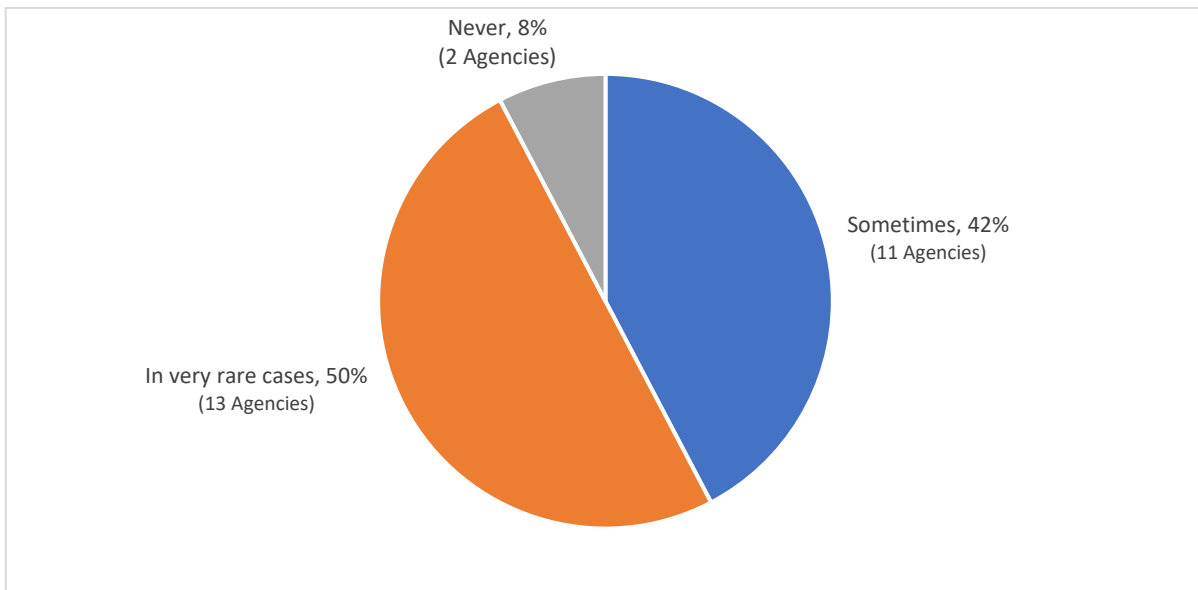

Figure 2-21 Frequency of Creating Duplicate Records

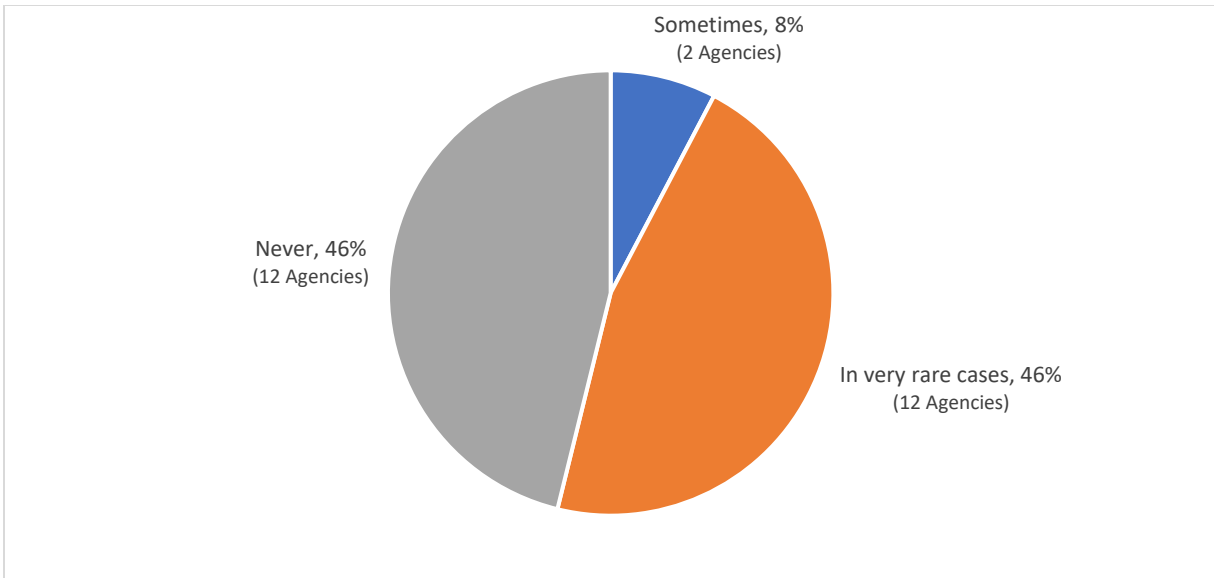

Figure 2-22 Frequency of Dispatching More than One Unit for the Same Incident

- Figure 2-23 summarizes how respondents currently address duplicate CAD records. The most common approach is to only keep one record (about 85% of the respondents). A main concern with this approach is that the information in the duplicate record(s) may be not be entered into designated data fields in an organized way. This could potentially make it more difficult for data processing.

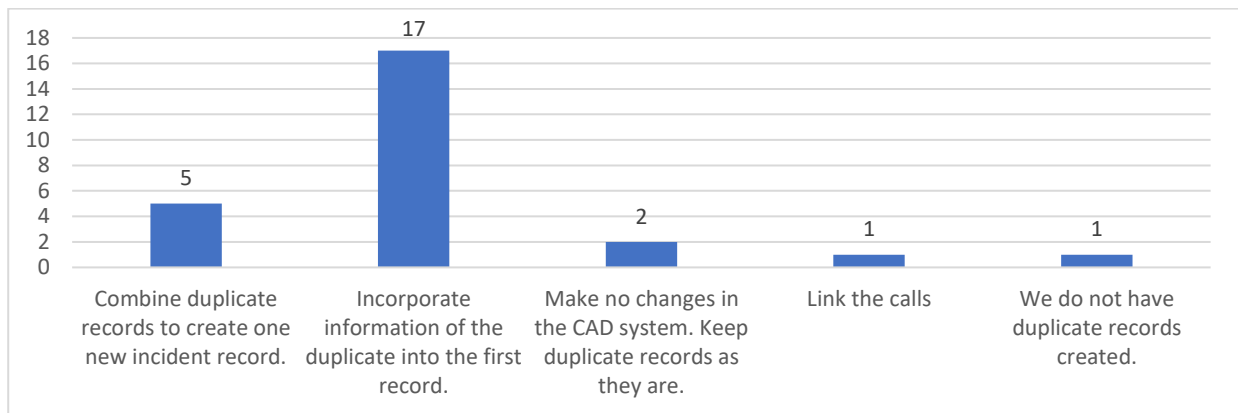

Figure 2-23 Method of Handling Duplicate Records

2.4.6 Incident Types

A CAD system creates a record for an incident only when the PSAP is responsible for dispatching respondents to it. The survey provided a list of incident types of interest to FDOT and asked PSAPs to check the incident types for which they dispatch units to the scene. Results show that Fire PSAPs respond to all incidents involving fire, hazardous materials, injuries, or fatality, while LE PSAPs respond to all incidents involving road blockage, injuries, or fatality. For incidents

without road blockage or injuries, LE CADs provide better sources of information than Fire CADs. (Figure 2-24 and Figure 2-25)

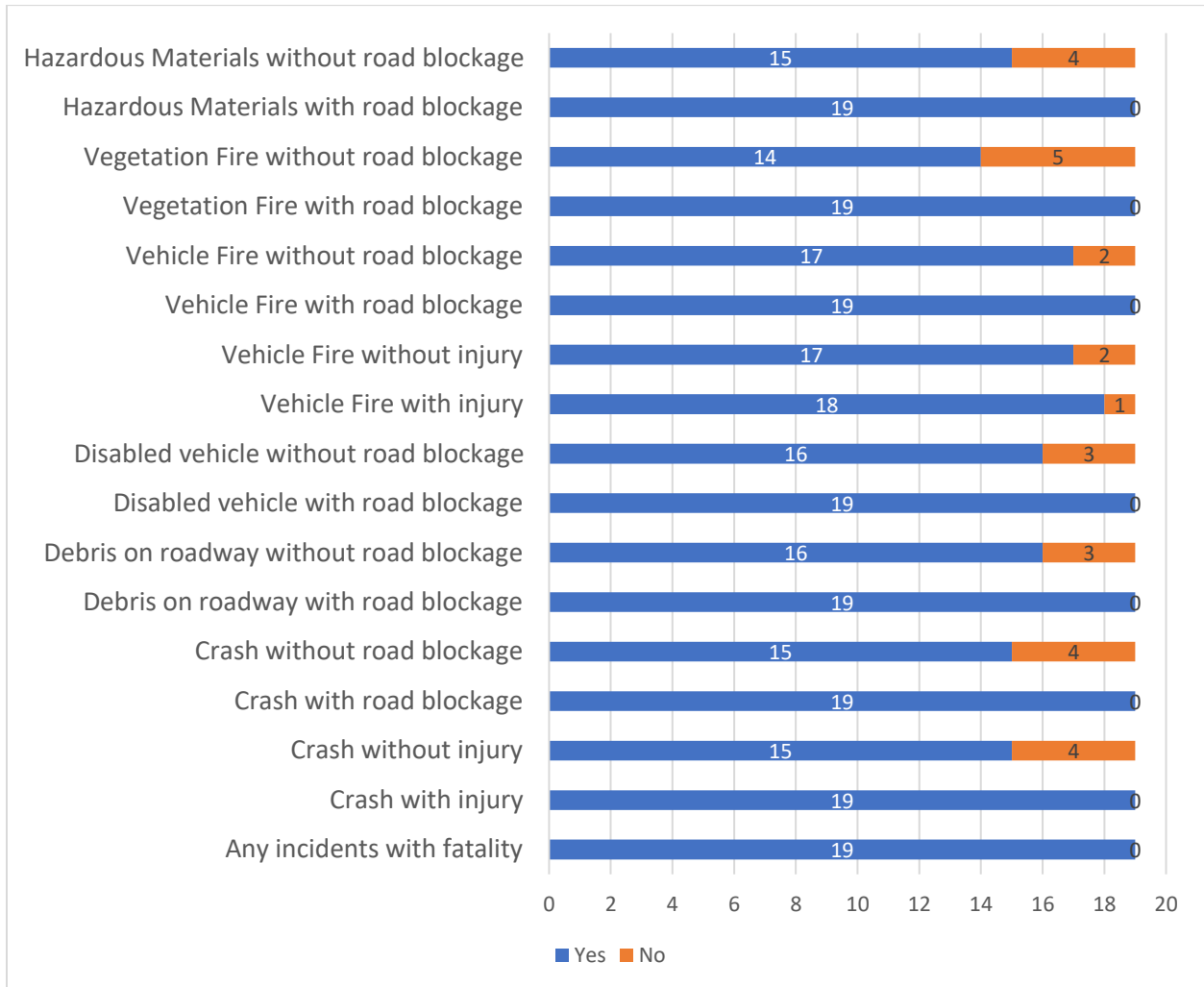

Figure 2-24 LE PSAPs Dispatch by Incident Types

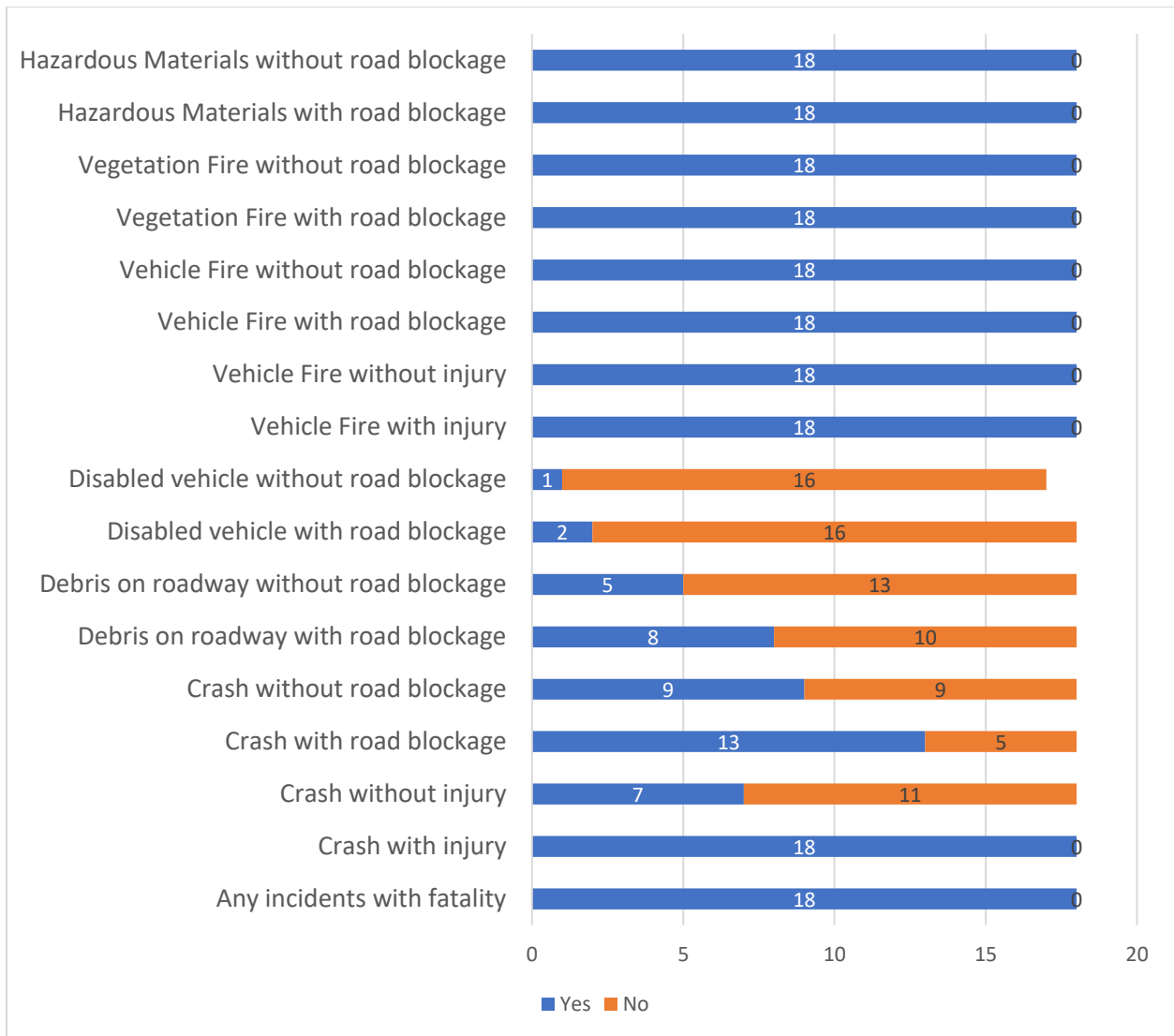

Figure 2-25 Fire PSAPs Dispatch by Incident Types

2.4.7 Information sharing with FDOT and RTMC

2.4.7.1 Contact of FDOT

- When asked about contacts with RTMCs, about 46% of the respondents stated that they had no contact with any RTMC. However, when asked about their communication method with FDOT and RTMC, only 8% respondents stated that they had no contact with FDOT and RTMC. Figure 2-26 and Figure 2-27 Based on 911 plans, most PSAPs transfer calls to FHP, and it might be the reason why some PSAPs checked phone calls as their communication method but claimed to have no contact with any RTMC in the previous question.

- As shown in Figure 2-27, besides the two PSAPs which do not communicate with FDOT in any way, all the other respondents contact FDOT via phone calls. Lake County EMS PSAP and Seminole County EMS PSAP stated that they used Mutualink - a dedicated workstation - to communicate with FDOT. Two other uncommon communication methods are paging system (only used by Seminole County EMS PSAP) and teletype (only used by Eustis PD PSAP). It is worth noting that Lake County EMS PSAP and Eustis PD currently do not actively share any information with FDOT currently, even though they claimed to do so in the survey.

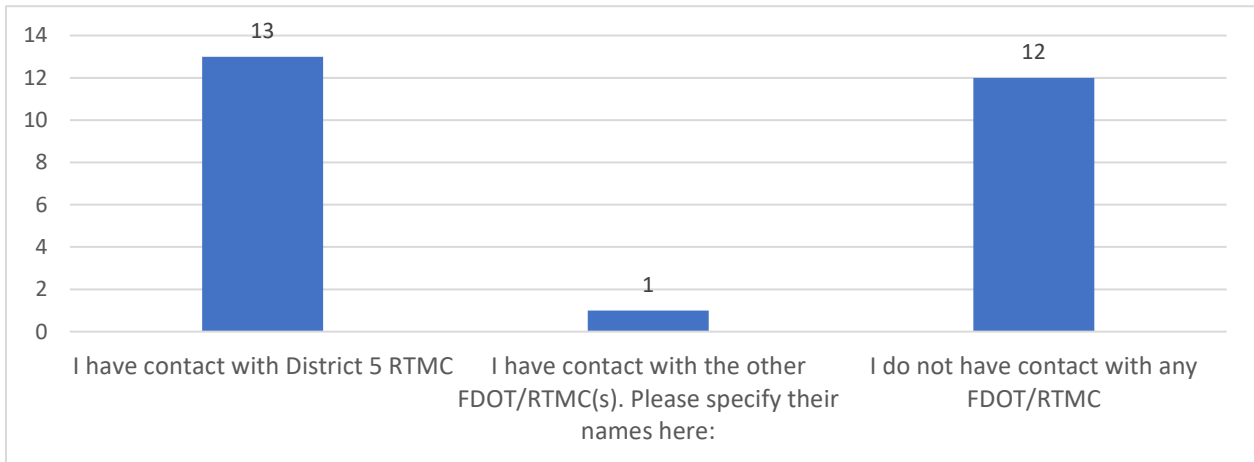

Figure 2-26 Status of Contact with FDOT and RTMC

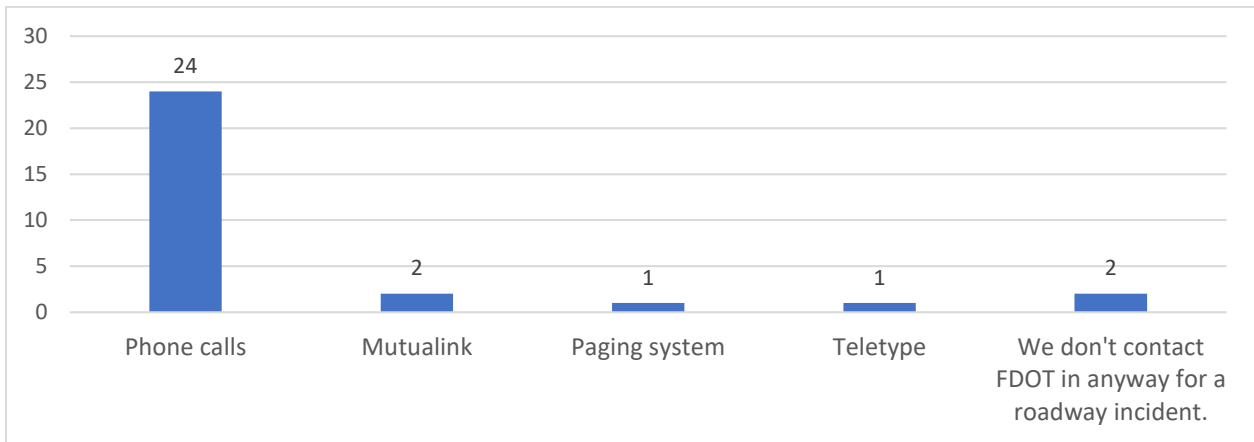

Figure 2-27 Frequency of Communication Methods Used

2.4.7.2 Traffic Camera Data from FDOT

- All respondents expressed interest in getting traffic camera data from FDOT, which is consistent with our findings from on-site visits referenced in Task 1. 70% of the respondents chose to receive traffic camera data automatically, with or without a filter, while 19% respondents would rather contact FDOT and RTMC directly to ask for support as needed instead of receiving automatic data feed. (Figure 2-28) Brevard County

Fire/Rescue Secondary PSAP is already using traffic camera data, but the respondent did not specify how they are receiving such information from FDOT. Melbourne PD Primary PSAP is interested in receiving traffic camera data but is discouraged by their previous failed attempts. Here is a direct quote from Melbourne PD Primary PSAP’s respondent: “We have pushed for more integration with FDOT as well as County and City run traffic camera access, only to be denied and limited in the Melbourne area”. Melbourne PD Primary PSAP later expressed their interest in gaining access to traffic camera data in the open-ended question.

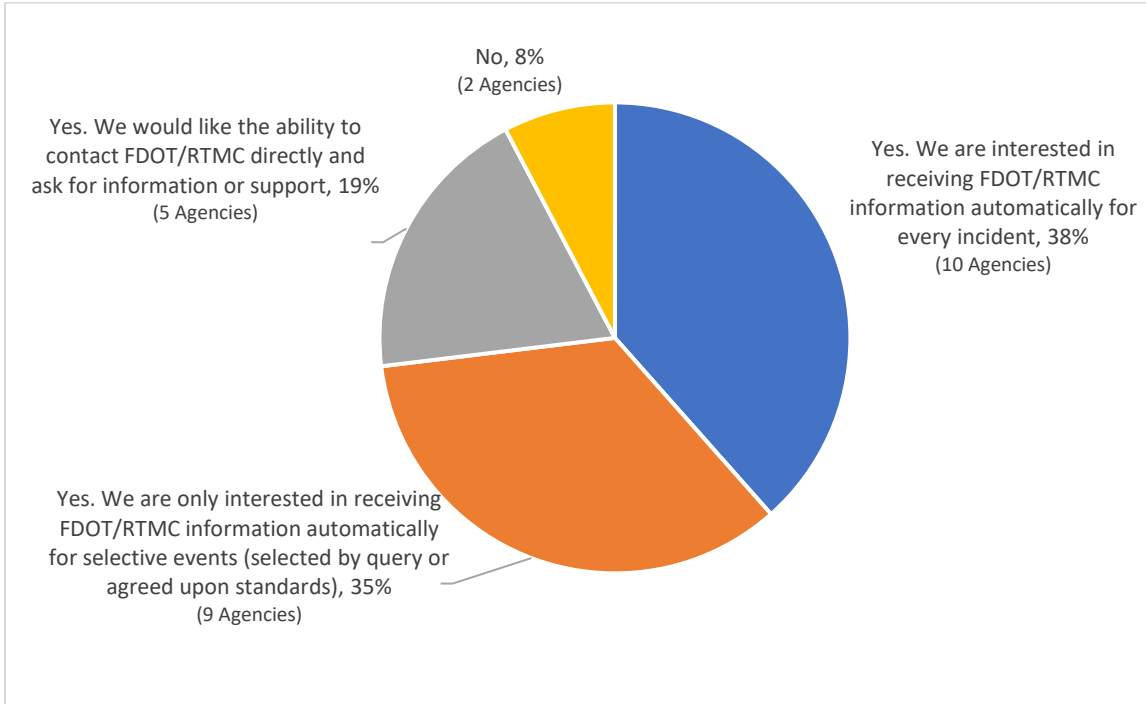

Figure 2-28 Interest in Receiving Incident Information from FDOT

- The survey also asked PSAPs about their preferred method of receiving information from FDOT (Figure 2-29). Live video feeds are the most popular choice among respondents. Some PSAPs prefer to gain access to all traffic cameras, while some PSAPs would rather only receive video feeds for the incident scene. Screenshots and verbal/text descriptions are also acceptable for some PSAPs.

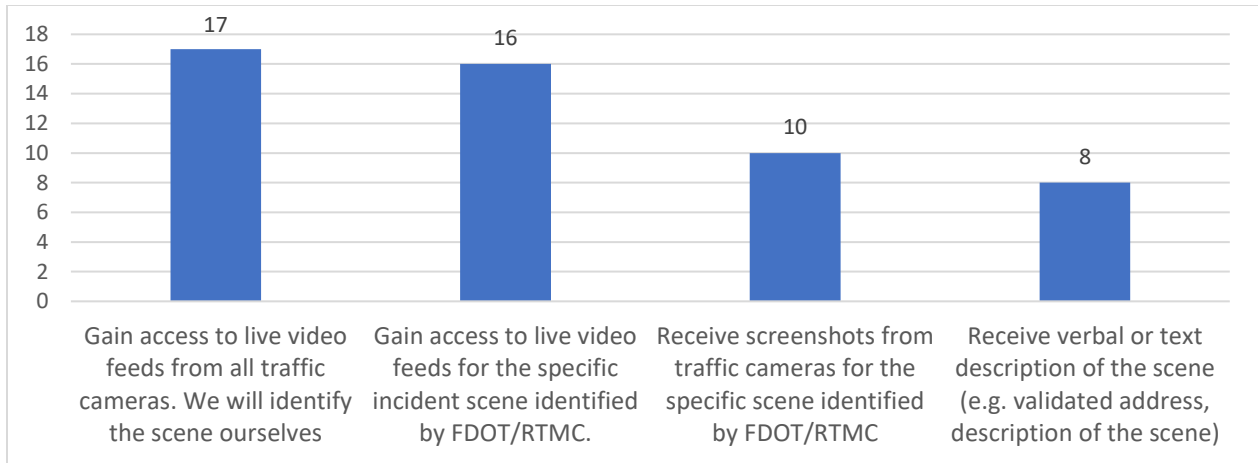

Figure 2-29 Preferred Method(s) of Receiving Information from FDOT

2.4.8 Comments

- Flagler County PSAP expressed two concerns for the implementation of interagency incident information sharing: financial concerns with CAD vendor programming and configuration, and secure VPN tunnel and CJIS agreements.
- Orlando Fire PSAP recommended having FDOT talk groups.
- Seminole County Fire/EMS Secondary PSAP expressed interest in receiving accurate information on (1) direction of traffic, (2) the number of lanes blocked, (3) if the incident is off the roadway, and (4) the ETA of dispatched road rangers/FHP units
- Orange County SO Primary PSAP is about to implement a new CAD, so their survey answers might no longer be applicable later this year.

3 INCIDENT INFORMATION SHARING APPROACHES

The research team reviewed CAD integration project reports and other relevant documents accessible online and summarized three typical approaches of incident information sharing between DOTs and public safety agencies in the United States. Table 3-1 reviewed cases including the name of participating DOT, public safety agencies, project description and adopted information sharing approach. The sections below provide a description of these approaches.

Table 3-1 Incident Information Sharing Practices Reviewed

DOT	Public Safety Agency	Project Description	Approach
Arizona DOT	Arizona Department of Public Safety	A dedicated workstation at the ADOT TIC displaying AZDPS CAD data	Dedicated Workstation
Washington State DOT	Washington State Patrol	A field operational test to compare performance of the following two approaches: (1) A dedicated workstation at the WSDOT TMC displaying the WSP CAD data (2) Automated data feed from WSP's CAD to the WSDOT's lane closure system (CARS)	
Utah DOT	Utah Highway Patrol	A field operational test: the information sharing is facilitated by CAD-to-CAD inter-agency service requests and the CAD-to-ATMS interagency ATMS message	
	Salt Lake City Police Department		
	Salt Lake City Fire Department		
	Valley Emergency Communications Center		
	Utah Transit Agency		
Minnesota DOT	Minnesota State Patrol	Integrated MSP's Integraph CAD with the MnDOT's CARS lane closure/event management system (2008)	
	Minnesota State Patrol	A real-time XML data feed from MSP to the MnDOT's Intelligent Roadway Information System (IRIS) (2013)	
Texas DOT	Austin Police Department	Integrated APD CAD with the TXDOT TMC LoneStar ATMS	
California DOT	California Highway Patrol	CHP provides CDOT near real-time data on events occurring on the state highway system through a xml media data feed	
Arizona	Phoenix Fire	Arizona implemented a data warehouse called the Regional Archived Data System (RADS). RADS includes filtered CAD data from the Phoenix and Mesa Fire	Information Sharing Hub
	Mesa Fire		
Oregon DOT	Oregon State Police	Oregon implemented a common data exchange system called the Oregon Interoperability Service (OIS)	
	Deschutes County PSAP		
	Hood River County PSAP		
	Other PSAPs (planned)		
Virginia DOT	Virginia State Patrol	Virginia implemented a Real-time Traffic Incident Management Information System (RTIMIS)	
	Albemarle County PSAP		
	Other local PSAPs (planned)		

3.1 Dedicated Workstations

Setting a dedicated workstation in the TMC is a commonly used approach to share CAD information with operators at DOT. A dedicated workstation is an appliance that displays CAD data from public safety agencies and is used solely for interagency information sharing. Typically, one TMC has one dedicated workstation. TMC operators can view or access CAD data logs on the workstation, but they need to enter incident information into their own system manually. Arizona Department of Public Safety, Washington State Patrol, and the Utah Highway Patrol all shared CAD data with their state DOT through this approach. Currently, District 5 uses an off-the-shelf interoperable workstation system called Mutualink to share incident-specific traffic camera views with a few PSAPs through screen projections.

The main drawback of using dedicated workstations is that operators can only view CAD data from the dedicated workstations. Products like Mutualink can project the screen of the primary workstation to other devices by using screen scraping of the CAD screen, but they do not give operators the ability to actively search for information on these devices. No CAD data feed can be automatically transferred to the TMC's system through the dedicated workstation approach.

3.2 CAD-to-TMC Integration

The second approach is to send real-time CAD data feeds directly to TMC's intelligent transportation system (ITS). Florida, Minnesota, Texas, Washington State, Utah, and California adopted this approach, which allows direct incident information sharing between the CADs in public safety agencies and DOT's management or information center (see Table 3-1). Participating public safety agencies need to modify their CADs to be connected to the state's transportation management system. Figure 3-1 is retrieved from the final report of the Field Operational Test (FOT) in Washington, and it shows the original design of their integrated CAD-TMC system (Science Applications International Corporation, 2006). In this design, the World Wide Web serves as an interface to connect WSP CAD and the WSDOT TMC CARS database with other CAD systems such as Skagit County EMS CAD, but Skagit County EMS did not participate in the FOT. The integration between WSP CAD and WSDOT's CARS was successfully implemented using commercial technology (Science Applications International Corporation, 2006).

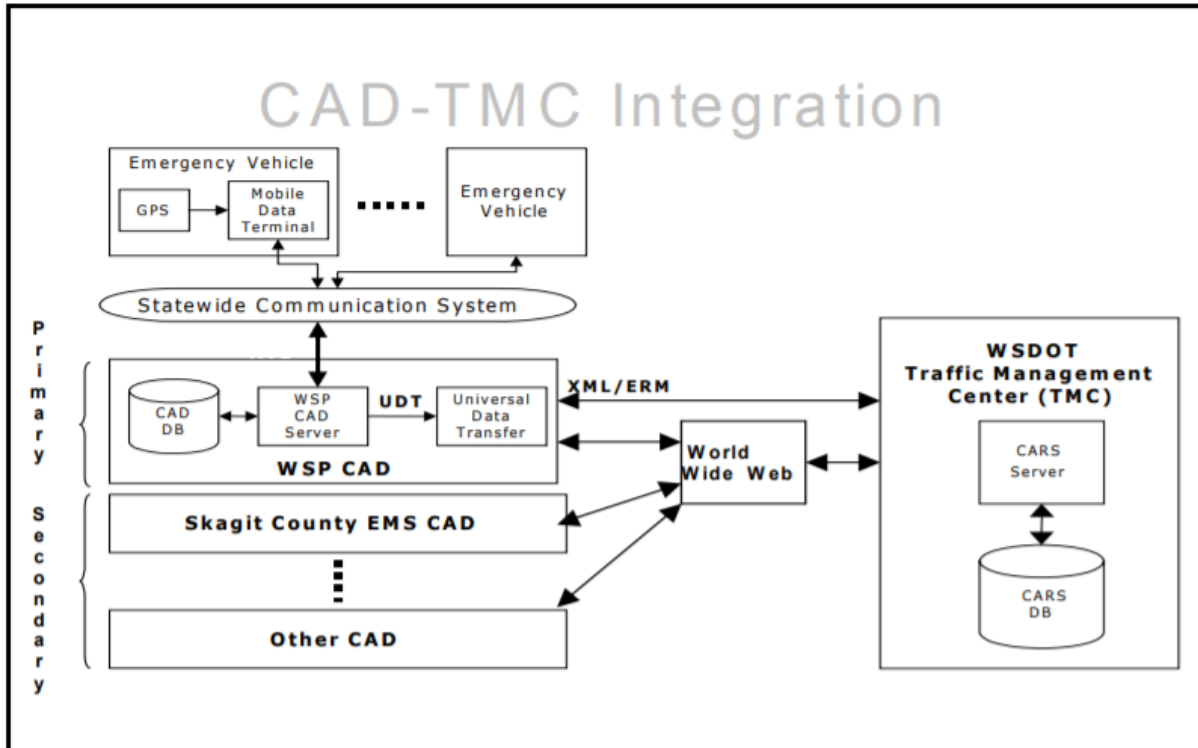

Source: Incorporated from: Legg, Bill, WSDOT, "APPLICATION FOR RFA Number DTFH61-02-X-00062, Computer-Aided Dispatch- Traffic Management Center Integration Field Operational Test," p. 16.

Figure 3-1 Washington State CAD-TMC System Architecture

3.2.1 Florida FHP/FDOT CAD Integration

As discussed in Chapter 2, FDOT has already achieved CAD integration with FHP. FHP Regional Centers push near real-time incident information to a single FDOT server, which filters FHP CAD events, consolidates data, and distributes FHP alerts to all RTMCs in Florida. The FDOT server acts as a data processing hub that allows one-way communication from FHP centers to RTMCs, but currently there is not a similar hub that allows incident information sharing among FDOT, local public safety agencies and other TIM stakeholders such as EMS and towing companies.

This approach works for posting information from CAD to DOT (one way), but not ideal for information sharing among multiple agencies, which is why some states have established an information sharing hub to achieve real-time data exchange among multiple agencies

3.3 Information Sharing Hub

The third approach of incident information sharing is by building an information sharing hub or platform that connects all participating agencies' CADs and the transportation management system. The following four examples demonstrate different ways to implement this approach.

3.3.1 CentralSquare CAD-to-CAD (Tellus Aware)

Tellus Aware is a platform that includes a set of connectors and a data hub that integrate with all the leading Computer Aided Dispatch systems. According to the old Tellus website, CADs supported by the Tellus platform included TriTech, Superior, Motorola, Tyler New World, Hexagon and more. Connectors were also available for RMS systems, P25 radios, video, and audio devices. In 2019, Tellus Safety Solutions (previously named FATPOT Technologies) was acquired by CentralSquare (Westrope, 2019). At the time of the writing of this report, the original Tellus website is no longer accessible. CentralSquare is now offering a similar product called CAD-to-CAD but it is unclear which systems it supports (<https://www.centralsquare.com/public-safety/cad>).

The advantage of using products like CentralSquare CAD-to-CAD is that they already have connectors for some major CAD software vendors and a functional platform to support more connectors as needed. The major disadvantages of using an existing product are data security and the dependency on a specific vendor and their proprietary software.

3.3.2 Oregon – A centralized text message service

The Oregon Interconnect System (OIS) is built on the original ODOT/OSP CAD Interconnect System, which was an external interface between the Oregon DOT and Oregon State Police's CADs (Figure 3-2). OIS is designed to expand the functionality of the ODOT/OSP CAD Interconnect System and provides a centralized text message service between Oregon State Police, ODOT traffic operations centers, and PSAPs. The OIS can not only automatically send and receive information when an incident is reported, but also updates on incident information. The plan is to first connect the PSAPs along the US 97 corridor in Central Oregon to OIS, and then connect other 911 Centers in the State. As of February 2015, the Deschutes County and the Hood River County 911 CADs were both connected to the system (McGill, 2015).

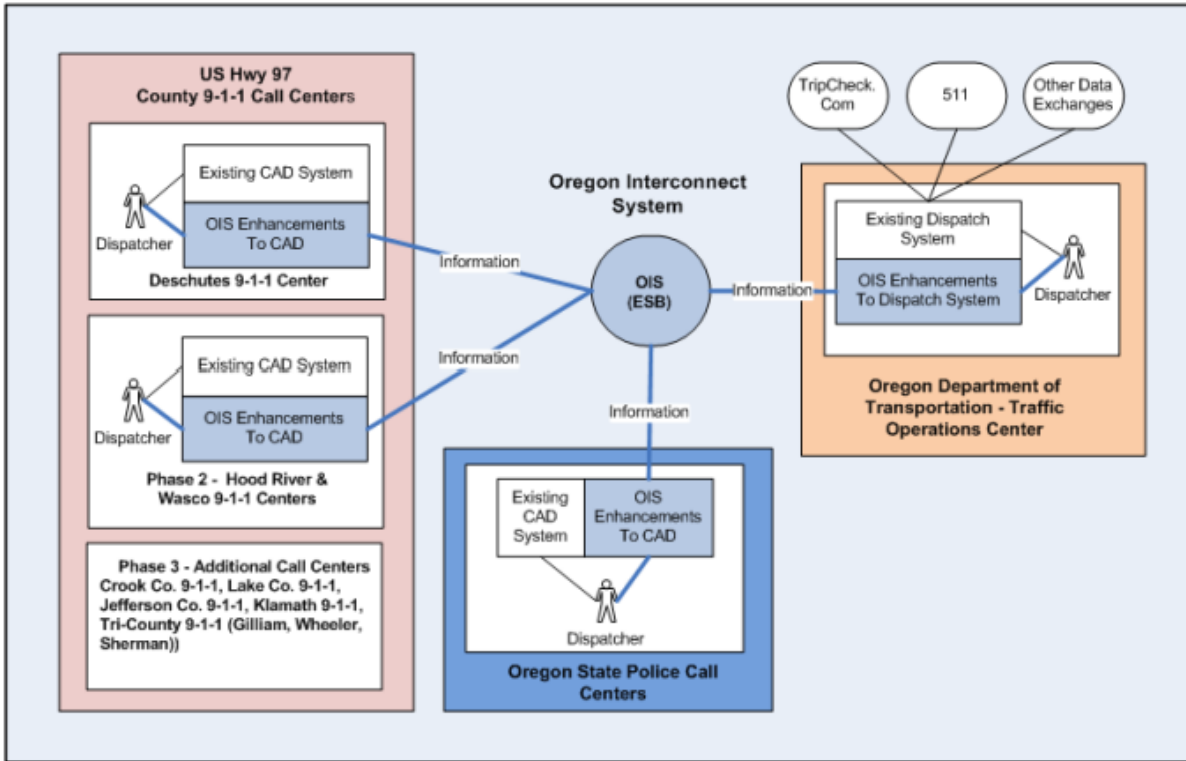

Figure 3-2 Oregon Interconnect System Architecture
 (Oregon Department of Transportation, 2013)

3.3.3 Arizona – RADS

The Regional Archive Data System (RADS) is a processing engine and data archival system of ITS data in the greater Phoenix metropolitan area (Figure 3-3). RADS is capable of collecting filtered CAD data from CADs and the regional ITS system -- AZTech Regional Information System (ARIS), formatting and tagging data from multiple sources, storing collected data in a focused repository and fusing data to generate useful information products to support traffic incident management.

AZTech develops and operates both ARIS and RADS. It is a partnership including 25 partners (e.g. Arizona DOT and the Maricopa County DOT) in the Phoenix Metropolitan area that “guides the application of Intelligent Transportation System (ITS) technologies for managing regional traffic” (Arizona Department of Transportation, 2018).

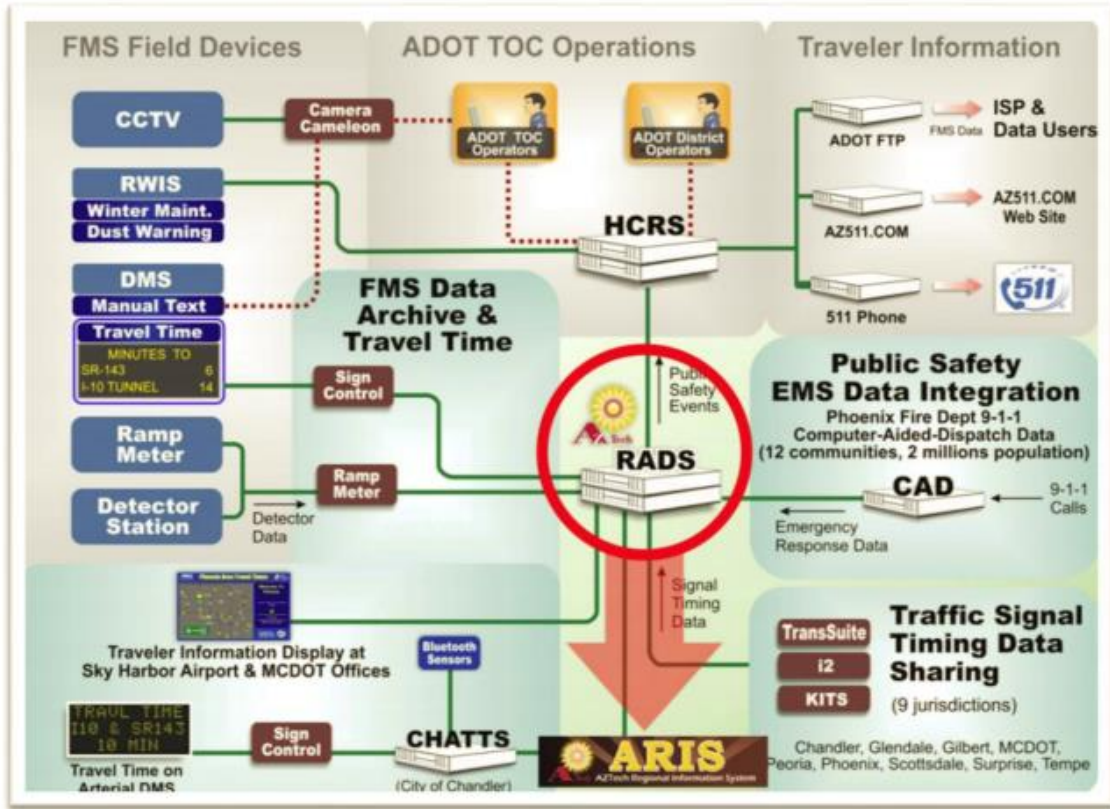

Figure 6. ARIS Integration with Regional Archive Data System

Figure 3-3 ARIS Integration with RADS (Saleem, n.d.)

3.3.4 Virginia – RTIMIS

The Real-Time Traffic Incident Management Information System (RTIMIS) is an interagency real-time data sharing system with automated data extraction, data filtering and data injection (Figure 3-4). Virginia State Patrol and Albemarle County PSAP are already connected to RTIMIS, the Virginia DOT plans to include other local public agencies in the RTIMIS and build a RTIMIS web application, but both objectives had not been fulfilled yet at the time the I-95 Corridor Coalition Computer Aided Dispatch Workshop in April 2018 (Cowherd, 2018).

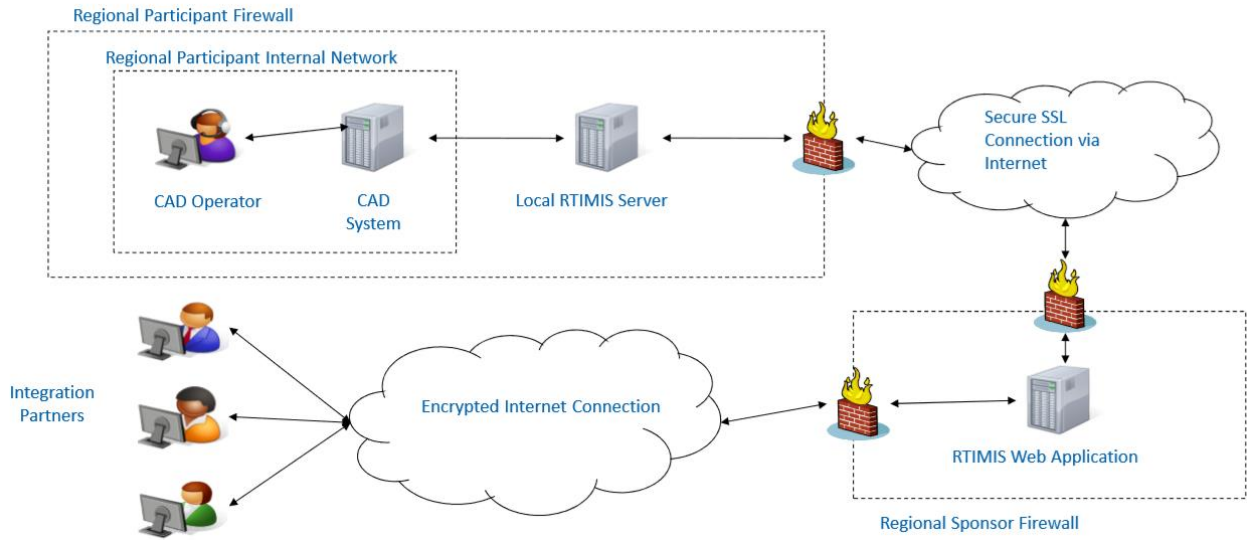

Figure 3-4 How RTIMIS Works

4 FEASIBILITY OF POTENTIAL SOLUTIONS

In this section we provide some considerations for a feasible solution, discuss potential barriers and solutions to overcome them, and conduct a feasibility analysis of the three potential approaches.

4.1 Considerations for a Feasible Solution

While the solution that uses a dedicated workstation at TMC offices can provide timely PSAP incident information to TMC, TMC operators must physically sit at the workstation to receive the information, rather than receiving the information on their computers or workstations. Additionally, this solution is not suitable for TMCs that are unable to acquire a dedicated workstation, an issue which is more pronounced in rural areas.

The direct CAD-TMC integration method works well for one-to-one information exchange but presents added complexity for multiple agency incident information exchange.

The information sharing hub method allows information exchange between all participating CAD systems and the TMC through a central information exchange hub. This model seems to scale well for multiagency information exchange and does not have the physical limitations of the dedicated workstation solution. However, the implementation of this method varies widely, and careful consideration should be given to the adaptation of this method to meet TMC needs.

The suitable solution for the District should consider the following requirements:

- Support incident information exchange from multiple LE and Fire CAD systems across many agencies
- Establish a *required* shared minimal list of incident data elements and the corresponding data dictionary that are essential for the TMC response. This may include incident type, location, time, injury severity, dispatch information, etc.
- Additional information of interest can be set up as *optional*. This may include vehicle type and color, the direction of traffic, road blockage (number of lanes blocked), ETA of dispatched units, etc.
- Avoid (at least initially) including personal information in the shared data elements list (for both the required and optional elements) because it may trigger the need for special data security and networking solutions and add much more technical and legal complexity, especially if access to personal information is not useful for incident response.
- Encourage PSAPs to minimize the sharing of duplicate records.
- Consider that some duplicate records will be missed by PSAPs. The solution should include a method to detect and handle duplicate records to avoid an unnecessary response. However, consider that suspected duplicates will likely need to be pushed

through for visual confirmation to ensure it is not a secondary incident e.g. a secondary crash.

- The solution should not create additional work for PSAP call takers and dispatchers. Rather the information sharing should happen in the background.
- Allow FDOT to share incident information (e.g. traffic camera information) with PSAPs
- Provide flexibility in sharing DOT traffic camera information with PSAPs because different PSAPs may need to access camera information differently.
- The sharing of PSAP's information may require enhancements of their CAD systems and therefore consideration should be given to solutions that are low cost.

4.2 Barriers to Information Sharing and Potential Solutions

Based on the survey results and the review of practices in other states (Table 3-1), we have identified some barriers and potential solutions for establishing an interagency incident information sharing system in District 5.

4.2.1 Data Security

Data security is the most common concern for interagency information sharing. This section summarizes the commonly adopted data encryption standards and different approaches for sharing selective data in the current practice.

4.2.1.1 Standards

The CJIS Compliance

If a law enforcement agency decides to share Personal Identifiable Information (PII) with FDOT, both agencies need to have a written agreement stating that they will both comply with CJIS's security standards. For instance, CJIS requires a minimum of 128-bit encryption with adequately complex keys for the storage and usage of PII. Operators at TMCs would also be required to complete security training within the first six months of being authorized to handle CJIS data and additional training. At the time of writing, all DISTRICT 5 TMC operators are CJIS certified.

The HIPAA regulations

The HIPAA Privacy Rule was issued by the United States Department of Health and Human Services to restrict the use and disclosure of Protected Health Information (PHI). HIPAA Security Rule extends the HIPAA Privacy Rule to ensure that electronic protected health information (ePHI) is properly secured from a breach in transit or at rest. Fire departments are required by law to follow these HIPAA regulations.

FIPS 140-2

FIPS 140-2 (Security Requirements for Cryptographic Modules) is a set of minimum-security requirements for data encryption that are mandatory for federal government departments or other agencies that use sensitive but unclassified (SBU) information.

Applicability of one or more of these data security related standards will depend on the data elements that will be shared for the purpose of improving incident response.

4.2.1.2 Sharing selected data

Besides data encryption, another way to protect sensitive data is to avoid sharing data fields that may contain PII.

The first approach we found from the review of current practices is to let operators at each agency determine what entries should be shared, and to which agencies the information should be sent. The operators would also be responsible for screening received entries and decide whether to bring that entry into their systems. The Oregon Interconnect System adopted this approach. In Utah's FOT, most participating agencies chose this option. Though a very flexible approach to share data, this approach creates additional workloads for the operators. As shown in Utah's FOT, very few events were transferred to Utah's CAD-TMC integrated system.

Another option is to keep the number of shared data elements to a necessary minimum. For example, in Utah, the Valley Emergency Communications Center (VECC) only sent event type and location to the integrated system. As a result, UDOT operators had to contact VECC in some other way for any additional information on the incident or use their traffic cameras to verify the direction of traffic information.

Finally, during our on-site visits in District 5, the PSAP agency staff expressed interest in sharing information as long as no additional work was added to the current work process. It is important, however, to include all the essential data fields that FDOT will need for a rapid and timely response.

4.2.2 Connecting with Different Proprietary Systems

Currently there are 10 different CAD systems from 6 vendors in FDOT District 5 (based on survey responses received to date). Although recent mergers in the CAD systems industry may lead to a reduction of CAD systems vendors and architectures to be considered in the District, it is highly likely that the number of CAD systems will remain large enough to make the data sharing process complex.

4.2.3 Discrepancy in Data Standards

The interviews confirmed that DOT, law enforcement agencies and fire departments use different data standards. We did not find detailed information on how the common data standard is set up for previous CAD integration projects, but the documents we reviewed indicate that all information sharing systems which enable automatic data feeds to ITS or

information sharing hub have a mechanism to standardize input data. According to Virginia DOT's summary of their project, information on their data feed is limited by the identifiable data fields that are available in the CAD system.

4.2.4 Conflicts When Receiving Multiple Reports

If RTMCs in Florida can receive real-time incident information from local public safety agencies, they will inevitably receive some duplicate incident reports for the same incidents. This is because when an incident requires both Fire and LE's responding units, it is very likely that two PSAPs or the Fire CAD and LE CAD system in one PSAP will both generate a CAD event and send an alert to FDOT. Moreover, the survey results show that PSAPs sometimes unknowingly create duplicate CAD events for the same incident. The majority of PSAPs will combine or link duplicate records together once they detect them, but currently, it may be difficult to avoid RTMCs receiving duplicate initial alerts. Therefore, the information exchange system must have the ability to automatically detect duplications and resolve potential data conflicts from multiple sources.

4.2.5 Promoting Participation

One big challenge of achieving interagency incident information sharing is to motivate more public agencies to join the project. Survey results suggest that the greatest motivation for PSAPs to participate is to receive verified incident information and dispatch information from FDOT. Upon receiving an incident alert, FDOT can use traffic cameras to help PSAPs verify incident information such as the location and direction of traffic. Sharing dispatch information is also helpful for more efficient interagency coordination. Therefore, consideration should be given development of any necessary formalized agreement such as a memorandum of understanding (MOU) among partners. Developing a memorandum of understanding (MOU) and establishing a maintenance plan are also important for addressing any concerns that PSAPs may have regarding their roles and responsibilities and the feasibility of implementing and managing a statewide incident information exchange system.

Another potential motivation for PSAPs is the ability to communicate with other participating PSAPs. However, we cannot confirm their potential interest in PSAP-to-PSAP communication in this study. PSAP-to-PSAP information exchange was not an objective of this research.

Only one agency expressed a financial concern related to their ability to share information with DOT. This suggests that PSAPs might be more likely to join the incident information exchange if some financial support is provided for any necessary CAD enhancement, should they be necessary depending on the chosen information exchange approach.

4.3 Feasibility Analysis

In Chapter 3, we summarized three main approaches for incident information sharing based on current practice: dedicated workstations, CAD-to-TMC integration, and information sharing hub. This section develops a framework to compare the advantages and drawbacks of these

approaches and presents the results in a cost-benefit comparison matrix (Table 4-3). The framework for *benefits* consists of 12 items organized in 4 evaluation criteria:

- Connectivity – ability for stakeholder to exchange information
- Speed - timely access/transfer of shared information
- Data quality – ability to analyze, link, improve and work with reliable data
- Expandability - ability of the system to expand over time to a district and statewide solution

The *cost* part of the framework consists of 8 cost items organized in two evaluation criteria:

- Initial cost – include cost for development of the exchange platform (hardware & software) and the software cost of enhancement of CAD systems and the Sunguide
- Maintenance cost – typical hardware and software long term maintenance cost

Each item is scored on a scale of 0 to 2 to indicate how well an approach can provide a certain benefit, or its relative cost compared with other approaches. Table 4-1 below summarizes the score and their definitions.

Table 4-1 Definitions of the Values

Value	Definitions	
	For Benefit Items	For Cost Items
0	This approach cannot provide this benefit	Low cost
1	This approach can provide this benefit with certain constraints	Medium cost
2	This approach can provide this benefit	High cost

A weight can be assigned to each item based on its importance in the decision-making process. The weights are determined by the research team at this time but can be adjusted by FDOT if needed in the future. The overall benefit or cost score for each approach is determined as the weighted average of all benefit items or cost items respectively, and the cost-benefit ratio is calculated for each approach. The sections below describe the assignment of values of cost and benefit for each approach. The complete list of items and the comparison results are presented in Table 4-3.

4.3.1 Dedicated Workstations

While using a dedicated workstation requires a relatively low cost in software upgrade and maintenance, it does not directly transfer CAD information automatically to TMC’s system. Moreover, when only one workstation is installed at the TMC, operators cannot access CAD data instantly, which can result in additional delays. Technically, virtual platforms can enable operators to remotely access another agency’s system, but due to cybersecurity concerns or high cost to enable specialized software to enable such connections, this option is not considered as part of the research. The information displayed on dedicated workstations will likely be different and formatted differently, which makes it difficult for TMC operations to easily utilize the information in a standardized fashion. As the number of participating agencies increase, the hardware cost, differences in the information displayed, and the data transfer delays associated with retrieving incident information from dedicated workstations will also increase significantly. Therefore, the research team does not recommend using this approach for district-wide or statewide incident information sharing.

4.3.2 CAD-TMC Integration

The CAD-TMC integration approach can send automatic CAD data feeds to FDOT in real-time and has proven to be an effective solution for FDOT to receive CAD data from FHP. The main concern of this approach is that it requires a data connection between FDOT and every other participating agency, which means 38 data connections are required for District 5 to receive incident information from all PSAPs in the District. The number of required data connection can increase exponentially in the case of a statewide incident information sharing system which would support multi-district communications. Another drawback of this approach is that CAD-TMC integration does not allow PSAPs (or other participating TIM stakeholders) to communicate with each other. Though this is not the focus of this project, the capability to

support real-time data sharing between all TIM stakeholders is a desirable feature that can facilitate multiagency collaboration in TIM and other emergency management functions.

4.3.3 Information Exchange Hub

In the information exchange hub approach, the incoming information can flow to the exchange platform either through a web transfer protocol (e.g. using HTTP POST method) or via email/text. Regardless of the information input method, the outgoing information can be shared with FDOT and other PSAPs in a standardized way via a web viewer and through direct subscription to the exchange system. The sections below provide a comparative analysis of the two options for obtaining incoming information:

HTTP POST Option

In this solution, all participating agencies would use the HTTP protocol to post the data to the information sharing platform. HTTP protocol is commonly used for secure communication over a computer network. When establishing an HTTP connection, data exchange between the client and the server are encrypted in both directions using TLS or SSL. If adopting this method, PSAPs would need to include a feature in their CAD system to automatically post incident data via HTTP to the exchange server. The use of HTTP POST method is quite standard in the current industry and this feature is rather simple to implement. This method offers FDOT an opportunity to obtain real-time CAD data feed in a standardized format including incident alerts and incident updates. The standardized format ensures the consistency of the outgoing information through the web viewer and optionally through a subscription model.

The actual cost of adding this feature to a CAD system is expected to be low. It is not uncommon that a simple feature of this size could be included in the PSAPs maintenance plan with their CAD vendors to cover software enhancement and may not cost any additional money. Even if some cost will be involved, the expense will be per feature, not per agency. That is, once a vendor implements this feature, it can be available to all their client agencies in the district that are using the same CAD system. It should be noted that, should a cost be involved, despite it being low, there could be funding avenues that agencies can explore through grants or other potential incentives available at the state or federal level for improvement of data quality and timeliness.

In conclusion, the research team estimates a low to medium cost for this item because: (1) only a minor system enhancement is required; (2) the same enhancement can be adopted by all PSAPs which use the same CAD system.

The Email/Text option

The second data format for obtaining the CAD alerts and updates into the exchange system is to obtain the data via email or text messages. At the time of this writing, we have confirmed eight PSAPs have the capability to share incident information via emails and texts (see Table 4-2). These agencies use CAD systems from three (out of six) vendors: CentralSquare,

TylerTechnologies, and SmartCOP. They currently provide CAD systems to 21 PSAPs (out of 26 survey respondents). District 5 responders are already receiving roadway incident alerts shared via email or paging systems from Seminole County Fire/EMS Secondary PSAP and Volusia County Sheriff's Office Communications Center Primary PSAP. The information is sent to Active 911 – a third party server- and can be accessed by FDOT responders via mobile devices (see Appendix 4).

Though we cannot confirm if all CAD systems for the same vendor have the same capability to share incident information externally, we cautiously assume that the majority of PSAPs in District 5 can share incident information with FDOT responder via email/text without any system enhancement. Based on this assumption, we estimate the CAD enhancement cost of this solution would be zero in this comparative analysis.

Table 4-2 Current Capability to Share Incident Information Externally

County	PSAPs in D5	CAD Vendor Name	Current Capability to Share Incident Information Externally via: (Y/N)		
			HTTPS	Email	Text
Marion	Marion County Public Safety Communications Primary PSAP	CentralSquare	X	X	X
Orange	Apopka Police Department Primary PSAP	Seminole County Sheriff's Office (XCAD)			
		SmartCOP		X	X
Orange	Orlando Fire Department Secondary PSAP	Tyler Technologies		X	X
Orange	Orlando Police Department Primary PSAP	Tyler Technologies		X	X
Seminole	Seminole County Fire/EMS Secondary PSAP	CentralSquare		X	X
Sumter	Sumter County Fire/EMS Secondary PSAP	CentralSquare		X	X
Sumter	Sumter County Sheriff's Office Primary PSAP	SmartCOP		X	X
Volusia	Volusia County Sheriff's Office Communications Center Primary PSAP	CentralSquare (Tiburon)		X	X

Currently, District 5 staff is already receiving roadway incident alerts from Seminole County Fire/EMS Secondary PSAP and Volusia County Sheriff's Office Communications Center Primary PSAP using a similar solution. These two PSAPs' CAD systems send automated messages to a third-party server via emails or paging systems. The server processes CAD data and then send it to FDOT's devices through an app called Active 911 (see Appendix 4). If FDOT adopts the emails/texts solution, we envision a server with customized parsers to process data from different CAD systems. The server will be able to send standardized incident data to a web viewer, the SunGuide system and other subscribers.

The main drawback of the incoming information in email or text format is that the exchange system would need to have adapters for each CAD system and update such adapters over time.

Therefore, while there may not be any cost for getting incoming information into the exchange system (assuming email subscription will be free of charge), processing the different email/text streams coming from different CAD systems presents several challenges. They include different data dictionaries, slower communication or speed could fluctuate, would be much more costly, less predictable (some agencies may not provide the service) and less sustainable compared to the HTTP POST option.

Table 4-3 Cost Benefit Comparison Framework

Incident Information Sharing Approach Evaluation Items and Weights			Dedicated Workstations		CAD-TMC Integration		Information Exchange Hub			
							HTTP POST		Email/Text	
Benefit	Items	Weight	Value	Description	Value	Description	Value	Description	Value	Description
Connectivity	Enables FDOT to receive real-time information from public safety agencies	2	2	Yes	2	Yes	2	Yes	2	Yes
	Enables public safety agencies to receive real-time information from FDOT	2	0	No	2	Yes	2	Yes	2	Yes
	Enables participating public safety agencies to exchange information with each other	2	0	No	0	No	2	Yes	2	Yes
Speed	Allows TMCs to view information in real time	2	2	Yes	2	Yes	2	Yes	2	Yes
	Gives all operators immediate access to shared information	2	1	CAD data is only available on the workstations	2	Yes	2	Yes	2	Yes
	Enables immediate information transfer to TMC' system	1	1	Manual entry required	2	Yes	2	Yes	2	Yes

Table 4-3 Cost Benefit Comparison Framework (continued)

Incident Information Sharing Approach Evaluation Items and Weights			Dedicated Workstations		CAD-TMC Integration		Information Exchange Hub			
							HTTP POST		Email/Text	
Data quality	The readability of CAD data	2	1	Readable, but not standardized	2	Yes	2	Yes	1	Readable, but not standardized
	Ability to analyze the information	1	1	Medium	1	Medium	2	High	1	Medium
	Potential for broader data quality improvements (e.g. e-crash)	1	1	Medium	1	Medium	2	High	1	Medium
	Potential to link the data to related data	1	2	Medium	2	Medium	2	High	1	Medium
	Potential to include other data sources (e.g. towing company, EMS)	1	1	Medium	1	Medium	2	High	2	High
Expandability	The ability to expand to include new partners	1	1	Medium	1	Medium	2	High	2	High
Benefits Summary			1.06		1.56		2.00		1.72	
Cost	Items	Weight	Value	Description	Value	Description	Value	Description	Value	Description
Initial Cost	CAD upgrade	1	1	Medium	2	High	1	Medium	0	Low
	Development of the information sharing platform	1	0		0		1	Medium	2	High
	SunGuide upgrade	1	0		1	Medium	1	Medium	1	Medium
	Hardware	1	2	Workstations	0	Use existing server	1	New server	1	New server

Table 4-3 Cost Benefit Comparison Framework (continued)

Incident Information Sharing Approach Evaluation Items and Weights			Dedicated Workstations		CAD-TMC Integration		Information Exchange Hub			
							HTTP POST		Email/Text	
Maintenance Cost	CAD system enhancement for adding a new partner whose CAD system does not support the exchange system yet	1	2	High. CAD upgrade and adding a new workstation.	2	High. CAD upgrade and SunGuide upgrade.	1	Medium. CAD upgrade.	1	Medium. A new parser in the exchange system.
	Adding a new partner whose CAD system supports the exchange system	1	1	Medium. Adding a new workstation.	0		0		0	
	Maintenance of the central system	1	0	Low	1	Medium. Maintenance of the SunGuide	1	Medium. Maintenance of the exchange system	1	Medium. Maintenance of the exchange system
	Regular hardware maintenance	1	1	Medium	0	Low	0	Low	0	Low
Cost Summary			1.4		1.2		1.2		1.2	
Cost-benefit Ratio			0.75		1.3		1.67		1.44	

Based on the results of this analysis supported by the comparison matrix, the research team recommends the information exchange hub as the most feasible approach of the three options for building a district-wide and eventually a statewide exchange system. This approach can enable timely and reliable information sharing with low cost and can provide this information not to just FDOT but also to PSAPs. It also enables FDOT to share their information with all interested PSAPs by posting it on the exchange hub rather than sending it individually to various PSAPs.

Between the two options for obtaining the incoming information into the exchange hub, the HTTP POST can deliver standardized incident data in a more reliable and instantaneous manner, and therefore it is our recommended solution. Upon assessing the cost of PSAPs for enhancing their CAD system with the ability to post incident alerts and updates into the exchange hub, FDOT should weigh in whether to pursue the HTTP POST approach, retreat to the email/text option, or consider a hybrid model that may include supporting both data formats for ingesting the incoming information into the exchange system.

5 RECOMMENDATIONS

Based on the research findings, the research team provides three major recommendations for implementing a district-wide incident information sharing system: (a) a proposed list of shared data elements that FDOT should request from PSAPs, (b) a high-level architecture for the exchange system, and (c) a three-step strategy to approach the implementation

5.1 Shared Data Elements

One key issue that can affect the success of the exchange system or data sharing in general has to do with the data elements that PSAPs would be requested to share. This includes the sensitivity of the data being shared, the number of the data elements, and the sharing frequency. As discussed in Chapter 2, concerns about CJIS Compliance is one key factor that could discourage PSAPs from joining the information exchange system and complicate the implementation process. Specifically, the sharing of personal identifiable information (PII) is a big concern. Given PII is not critical for FDOT's timely incident response and traffic incident management, we recommend that no data elements containing PII are requested from PSAPs.

Another important factor is to look for data elements that are absolutely required for FDOT's needs versus those that could be optional. The required list should consider data elements that are useful for incident response and that are also available in the PSAP's CAD system. As we learned from the interviews, PSAPs could be reluctant to share if the process will require additional work by the CAD operators and call takers.

Based on findings from the user survey and considering the FDOT needs, we recommend that FDOT requests from PSAPs the data elements presented in Table 5-1 and Table 5-2. Table 5-1 presents the *required* data elements. Table 5-2 presents *additional recommended* data elements, which are optional. The tables include information about the data type and the domain values for each data element.

Data elements are identified as required elements if they provide critical information for FDOT to generate an incident response or provide essential information for the exchange system to identify, link, and filter records. For example, PSAP NAME and CAD INCIDENT ID are required elements because they are essential for identifying uniquely each incoming alert. DATE OF THE INCIDENT and TIME OF THE INCIDENT are needed for the identification of potential duplicate incident alerts. UPDATED DATE and UPDATE TIME are needed for identifying the latest update of an incident and are not applicable to new incident alerts. To gather information about the nature of roadway incidents, we recommend using six variables to capture different incident types and two variables to capture the injury severity of the incident. The majority of the required data elements are currently collected by all PSAPs which participated in our survey, except for LATITUDE and LONGITUDE which is provided by 24 of 26 survey participants (see Chapter 2). The only location element that all survey participants collect is the STREET

ADDRESS. Regardless, we strongly recommend LATITUDE and LONGITUDE to be listed a required data element given its paramount importance for incident response. It is likely that, with improvement of 911 and CAD technology, this information will eventually be ubiquitous among PSAPs.

The optional recommended data elements are selected based on FDOT data requirements (Table 5-2). They provide helpful information for FDOT to identify incidents and establish response in a timelier manner but are not as essential or commonly available as the required data elements.

It should be noted that from an automated data sharing perspective, not much additional effort is required to include the optional elements in data sharing either via the HTTP POST method or via email. At the time of discussion with PSAP, the FDOT should strongly encourage PSAPs to share the optional data elements once a general agreement to collaborate is established.

Table 5-1 Requested Data Elements for Sharing

Category	Name	Data Type	Domain Values	Description
IDs	PSAP NAME	string	PSAP's name	Name of the PSAP which sends this alert
	RESPONDING AGENCY NAME	string	[Agency 1], [Agency 2] ...	Name of the responding agencies such as law enforcement
	CAD INCIDENT ID	string	CAD Incident ID	CAD incident ID
	AGENCY CASE NUMBER	string	Agency case number	The case number assigned to the event report
Incident Time	DATE OF THE INCIDENT	date	YYYYMMDD	The date on which this incident happened
	TIME OF THE INCIDENT	time	HHMMSS	The time of day when this incident happened
	CREATED DATE	date	YYMMDD	The date on which this incident record is created, only applicable for new incident alerts
	CREATED TIME	time	HHMMSS	The time of day when this incident record is created, only applicable for new incident alerts
	UPDATED DATE	date	YYYYMMDD	The date on which this incident record is created, only applicable for incident updates
	UPDATED TIME	time	HHMMSS	The time of day when this incident record is created, only applicable for incident updates
Dispatch	DISPATCH DATE	date	YYYYMMDD	Dispatch date of the first responding unit
	DISPATCH TIME	time	HHMMSS	Dispatch time of the first responding unit
	DEPARTURE DATE	date	YYYYMMDD	The date on which the last responding unit leaves the scene, only applicable for incident updates
	DEPARTURE TIME	time	HHMMSS	The time of day when the last responding unit leaves the scene, only applicable for incident updates
Incident Type	CRASH	Boolean	{Y, N}	Whether this is a crash incident
	HAZARDOUS MATERIALS	Boolean	{Y, N}	Whether hazardous materials are involved
	VEGETATION FIRE	Boolean	{Y, N}	Whether a vegetation fire is involved
	VEHICLE FIRE	Boolean	{Y, N}	Whether a vehicle fire is involved
	DISABLED VEHICLE	Boolean	{Y, N}	Whether any disabled vehicle is involved
	DEBRIS ON ROADWAY	Boolean	{Y, N}	Whether there is debris on roadway
Injury Severity	INJURY	Boolean	{Y, N}	Whether the incident results in any injury
	FATALITY	Boolean	{Y, N}	Whether the incident results in any fatality
Location	LATITUDE	float	(24.3959, 31.0035)	The latitude of the incident location
	LONGITUDE	float	(-87.6265, -79.8198)	The longitude of the incident location
	STREET ADDRESS	string	A valid street address in Florida	The location of the incident location
Others	REMARK	string		Additional information and comments

Table 5-2 Additional Recommended Data Elements for Sharing

Category	Name	Data Type	Domain Values	Description
Dispatch	ESTIMATED ARRIVAL DATE	date	YYMMDD	Estimated dispatch date of the first responding unit
	ESTIMATED ARRIVAL TIME	time	HHMMSS	Estimated dispatch time of the first responding unit
	ARRIVAL DATE	date	YYMMDD	Actual arrival date of the first responding unit, only applicable for incident updates
	ARRIVAL TIME	time	HHMMSS	Actual arrival time of the first responding unit, only applicable for incident updates
Road Blockage	ROAD BLOCKAGE	Boolean	{Y, N}	The existence of road blockage
	NUMBER OF LANES BLOCKED	integer	(1, 9)	The number of lanes blocked due to the incident
	BLOCKED LANES	string	N1D1; N2D2... Ni = {1, 2, 3, 4, 5, 6, 7, 8, 9} Di = {L, R, T}	Identify the lanes that are currently blocked. Ni is a one-digit integer that refers to the lane number, D marks if the lane is a left-turn lane (L), right-turn lane (R) or through lane (T)
	DIRECTION OF TRAFFIC	string	(N, S, W, E)	The direction of traffic
	INTERSECTION - STREET NAME N/S	string	A valid street name located in Florida	The street name of the northbound/southbound roadway crossing the closest intersection to the incident location
	INTERSECTION - STREET NAME W/E	string	A valid street name located in Florida	The street name of the westbound/eastbound roadway crossing the closest intersection to the incident location
	INTERSECTION-MILEAGE	integer		The distance from the incident location to the closest intersection in miles
	USNG COORDINATES	string	A valid USNG value located in Florida	The US National Grid value of the incident location
	STREET NAME	String	A valid street name located in Florida	The street name of the roadway on which the incident is located. This is to be used in combination with the Mile Marker variable.
	MILE MARKER	integer	(1, 900)	The closest mile marker to the incident location
	CITY	string	A valid city name in Florida	The name of the city where the incident is located
COUNTY	string	A valid county name in Florida	The name of the county where the incident is located	
Vehicle Description	VEHICLES	string	([Type1], [Color1], [Make1], [Model1], [Year1]); ([Type2], [Color2], [Make2], [Model2], [Year2]);	Information about involved vehicles. If a field is unknown, leave it blank.

5.2 Proposed System Architecture

The feasibility analysis in Section 4.3 concluded that the best way to achieve incident information sharing among a large number of participating agencies is through an information sharing hub, which processes, stores and manages incident data gathered from all available sources. In this section, we propose a high-level architecture for the information sharing system which we are referring as the exchange system (see Figure 5-1).

The core of the exchange system is an information sharing platform, which consists of an incoming message processor, an relational database, an outgoing message processor, and a web-based viewer. The PSAPs, after obtaining incident information through a variety of different sources, are expected to post the required incident information to the exchange hub. SunGuide can also be one of the sources that should be able to post information in the exchange system. Once the messages are posted into the exchange system, they are processed and stored in the relational database. As soon as the data is stored in the database, a message processor can push the data to recipients such as PSAPs or SunGuide, or any participating agency that can choose to become a subscriber of the exchange system and receive automatic data feeds via HTTP POST, email or text. Other TIM stakeholders such as EMS or towing companies can also become participating agencies.

The information can be viewed via a web-based viewer in real-time by any authorized agency. The web-based viewer can be formatted to be accessed by various devices such as mobile phones, tablets, laptops, and desktop computers.

Currently, the incident information subsystem in SunGuide has plug-ins to pull Waze information and receive FHP CAD data. In this version of the proposed architecture, the existing data flow between Waze, FHP CAD, and FDOT remains unchanged. Considerations could be given in the future on whether to make any changes to the existing information flow once the exchange system becomes a reality. One alternative could be that Waze and FHP CAD information can be sent directly to the information sharing platform, given that SunGuide can be a subscriber of the exchange system. While this approach will help create a consistent information flow for all incident information from all sources, FDOT should consider the pros and cons of this alternative before taking any actions.

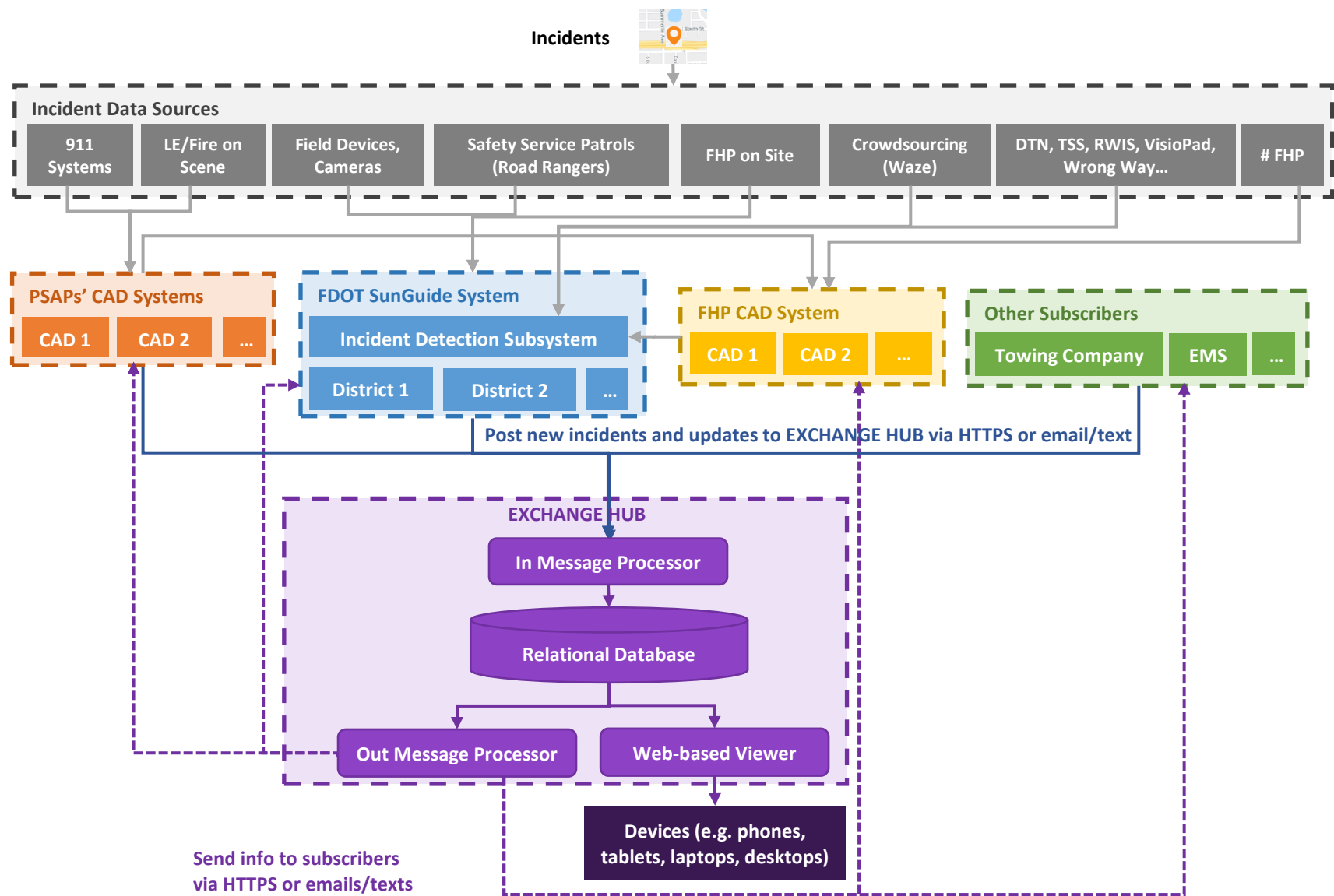

Figure 5-1 Proposed Architecture for the Exchange System

5.3 Implementation Strategy

In the previous section, we concluded that an exchange hub would be the most feasible solution for implementing a district-wide or even statewide incident information sharing system. However, the implementation of this solution needs to be carefully strategized to ensure success. The dependency of incoming information from PSAP's CAD systems is the major, if not the only, challenge for implementation. FDOT can control the exchange system data storage and data sharing and should use this as an opportunity to draw the cooperation of the PSAPs. We suggest to divide the implementation in three steps or phases: First, develop a prototype of the exchange system, followed by developing a pilot project with one or two PSAPs that use the same CAD system, and finally, gradually start including the rest of PSAPs in the district.

5.3.1 The Prototype Phase

The proposed architecture shown in Figure 5-1 above can be condensed into a simpler diagram shown in Figure 5-2 below. The entire portion of the incoming messages can be simply represented by an incoming message generator that can simulate alerts and updates coming from PSAPs either via HTTP POSTs or via email or text. The core of the exchange system – the information collection and sharing platform – receives and processes incident information from a data source, stores the information into a relational database, visualizes information on the web-based viewer, and sends data to subscribers. The incoming information can be simulated through a simple message generator software routine that would send to the database of the system sample CAD data determined in the section Shared Data Elements above. Likewise, the posting of information out of the system can be easily programmed to push information to simulated subscribers.

This condensed representation clearly shows that the exchange system can, in fact, be entirely developed and tested independent of PSAPs. FDOT should consider developing a functional prototype of this system as the first step toward implementation for three reasons: a) it can be used as a proof of concept to demonstrate to PSAPs the benefits of information sharing by demonstrating concretely how the system would work and what will be required from them; b) assuming the Exchange platform is selected as the solution for implementation, this part of the system has to be built regardless whether the incoming alerts come via HTTP POST or email/text; c) the functional prototype would be easily converted to an operational system by replacing the incoming message generator with the actual data feeds coming from PSAP's HTTP POSTs or emails/text. From the cost perspective, this portion of the system represents an expense that must happen regardless, assuming the Exchange platform is selected as the solution for implementation. Eventually, the prototype can be enhanced and solidified once PSAPs have agreed to come on board to develop a fully operational system.

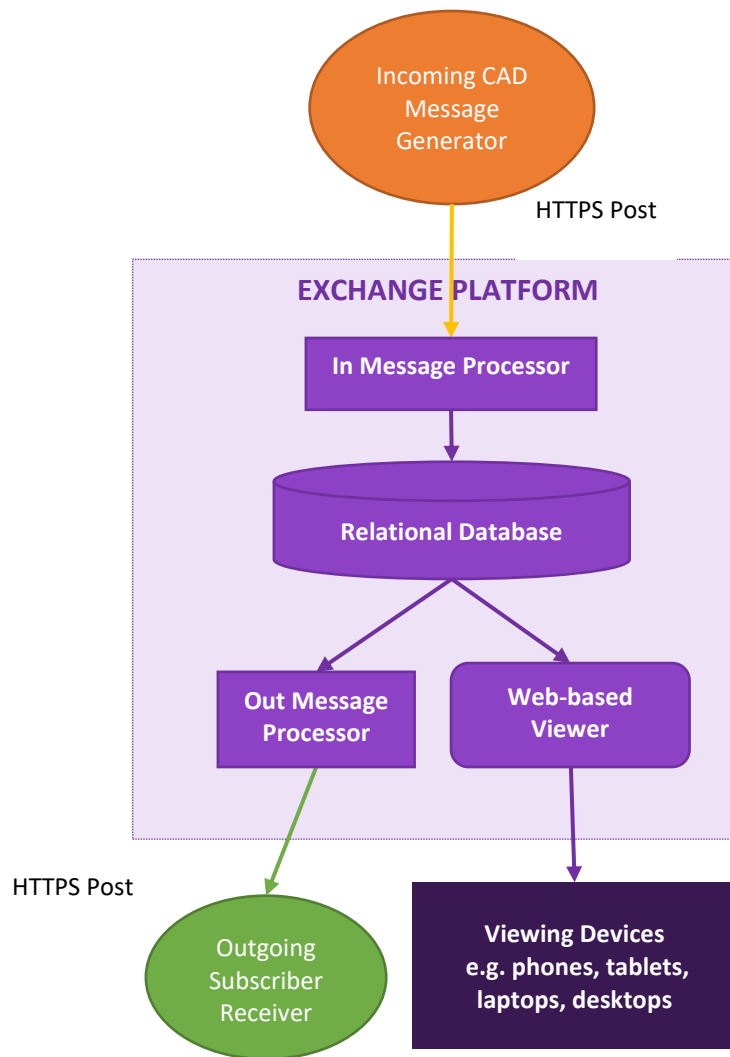

Figure 5-2 Architecture of the Exchange System Prototype

5.3.2 The Pilot Project Phase

Once a functional information sharing platform is in place, the second step is to reach out to PSAPs and eventually invite one or two PSAPs to participate in a pilot project. Before implementing the project, the research team recommends FDOT discussing an MOU with the PSAP(s) to clarify: (1) the data elements that will be shared by each party; (2) the data elements that will be sent to each subscriber; (3) each party's role in this arrangement.

FDOT should reach out to PSAPs that are the most proactive in the interagency incident information exchange effort. After the presentation of the prototype, it will be necessary for the participating PSAP to obtain cost quotes from their CAD vendors to implement posting of the required data elements using the HTTPS Post method. Specifications for CAD vendors for implementing the recommended HTTPS POST method are provided in Appendix 5. Specs include examples that can help vendors implement the requirements. As shown by the specs, the implementation of the HTTP POST is simple and should require minimal effort to accomplish. While this enhancement of the CAD system is very simple and should either be free (could be handled as part of the maintenance agreement) or

very low cost, based on the review of CAD integration practice in other states, the research team recommends exploring a grant or other funding sources to support the PSAP CAD enhancement as a backup. A potential funding source could be the Florida Traffic Records Coordinating Committee (<http://www.fltrafficrecords.com/>), which manages federal funds aimed at improving traffic records in the county. An exchange system as it is proposed here will play a big role in improving traffic records in the state, such as data accuracy, timeliness, and especially data integration, which has been a major challenge for the state agencies around the country.

Once the pilot project is completed, this feature can be applied without any additional cost to other agencies that may be using the same CAD system simply by a CAD software update (once the MOU as described above is in place). So far, the survey results have identified 6 CAD vendors currently serving 26 PSAPs in District 5, with two major vendors serving more than half the PSAPs. Note that the CAD HTTP POST feature is expected to occur behind the scene and unsupervised and as such will not add any additional responsibility for PSAP staff.

The research team recommends the following criteria for choosing an ideal participant for the pilot project:

- (1) This PSAP is driven to participate in this effort to improve the efficiency of TIM.
- (2) This PSAP can provide critical incident information on major FDOT roads in District 5.
- (3) The cost for the addition of the required CAD enhancement is reasonable and affordable.
- (4) Ideally, this PSAP is using a CAD system from the major CAD vendors in the district although PSAP willingness to participate should drive the selection given that any CAD vendor should be able to enhance their system as requested.
- (5) If two PSAPs are selected for the pilot project, it would be best if they are using the same CAD system so the pilot project can be completed faster and at a lower cost.

If the cost of CAD enhancement is deemed too high, the alternative plan is to ask the PSAP(s) to share information using any existing method their CAD system supports. As discussed in Section 5.2, that may be through emails and/or text messages. In such case, the exchange system will require to develop an adapter for each CAD system and somehow come up with a standardized set of data elements for sharing and web-viewing.

At some point District 5 should consider how the SunGuide could interact with the exchange system e.g. if it could serve both as a data source and it can also be a subscriber of the exchange system. Both the FDOT and PSAP(s) can access data in the exchange system on the web-based viewer in real-time. The information sharing platform should also include a module to handle potential duplicates of the same incident.

The pilot project will enable District 5 to evaluate the performance of the exchange system, the associated costs, and any implementation challenges in a real-world setting and thus, will help to better prepare for the next phase, the system expansion with the rest of PSAPs.

5.3.3 The Expansion Phase

We recommend a gradual expansion of the exchange system. First, FDOT should gain a better understanding of current practice in District 5 by following up with the 12 PSAPs that did not respond to our survey in this project. Next, FDOT can prioritize the invitations to PSAPs based on their willingness to participate, the significance of their incident information to TIM response, and the costs of CAD enhancement. Note that during the expansion phase, there is not much more work on the exchange system itself. That is one of the advantages of this approach. The main work during the expansion phase is with each PSAPs enhancing their CAD system to share the data.

Expansion beyond District 5 can be done in a similar fashion. Other districts can start reaching out to their PSAPs by demonstrating the exchange system of District 5. The exchange system can serve the entire state. The critical thing is to have more PSAPs join and post their information to the system.

6 GREATER VISION

Finally, the district-wide and eventually a state-wide central exchange system approach proposed, provides a unique opportunity that can have greater positive implications beyond the immediate needs of FDOT for a timely response to roadway incidents. For years, Florida and other states have struggled with the problem of linking all relevant information related to crash events such as linking police reports with EMS reports with trauma patient records, i.e. linking data from “crash site to bed side”. In absence of common identifiers, the traditional method to link such data, referred to as probabilistic linkage, tries to match the various databases based on multiple common data fields and typically get a 50-65% success rate. By reporting all roadway incidents to a central database, the proposed exchange system will offer new opportunities to create event universal identifiers for any roadway incident event which can then be used as the common identifier to link all relevant data related to the lifecycle of that event including CAD, crash, Road Ranger, enforcement, EMS, and injured patient trauma or hospital records. This linkage method, that is based on common primary identifiers, is referred to as the deterministic method, and it can lead to a much higher degree of success in data linkage and integration. This linkage of data would lead to major improvement in roadway incident data quality, timeliness, and reliability, which in return will create opportunities for increased data depth, timeliness, and accuracy for performance analysis, currently not possible. Such linkage will provide FDOT and other stakeholders in the state new avenues for advanced analytics that can inform decision making, and that can elevate safety and traffic management to higher levels of efficacies in incident response and traffic operations far beyond the objectives of the this research, to ultimately reduce congestion and save lives.

REFERENCES

- Active911. (2019, November 19). *Active911 Documentation*. Retrieved from http://wiki.active911.com/wiki/index.php/Active911_Documentation
- Arizona Department of Transportation. (2018). *2018 Arizona Statewide ITS Architecture*. Retrieved from apps.azdot.gov: <https://apps.azdot.gov/files/ITS-Architecture/html/inv/el164.htm>
- Cowherd, S. (2018). Real-time Traffic Incident Management Information System (RTIMIS). *I-95 Corridor Coalition Computer Aided Dispatch Workshop*.
- Federal Communications Commission. (2020, January 28). *Wireless 911 Service*. Retrieved from https://www.fcc.gov/sites/default/files/911_wireless_services.pdf
- Frank van Diggelen, P. E. (2015). The World's first GPS MOOC and Worldwide Laboratory using Smartphones. 361-369.
- McGill, G. (2015). *Project: Oregon Interoperability Service*. Salem, OR: Oregon Department of Transportation. Retrieved from <https://transportationops.org/publications/oregon-interoperability-service-award-application-and-project-summary>
- Oregon Department of Transportation. (2013, November 30). *Oregon interoperability service (OIS) project*. Retrieved from State Library of Oregon : <https://digital.osl.state.or.us/islandora/object/osl:10793>
- Pew Research Center. (2019, June 12). *Mobile Fact Sheet*. Retrieved from <https://www.pewresearch.org/internet/fact-sheet/mobile/>
- Saleem, F. (n.d.). *AZTech Regional Information System (ARIS)*. Retrieved from Aztech: <http://www.aztech.org/projects/aris.htm>
- Science Applications International Corporation. (2006). *Computer-Aided Dispatch – Traffic Management Center Field Operational Test: Washington State Final Report*. Springfield: The National Technical Information Service.
- Tiwari, A. (2017). *How Does Turning On WiFi Improve The Location Accuracy Of A Device?* Retrieved from <https://www.scienceabc.com/innovation/how-does-turning-on-wifi-improve-the-location-accuracy-of-a-device.html>
- Tracki. (2020). *How GPS Tracker Works and Cell Phone Tower Triangulation Accuracy*. Retrieved from <https://tracki.com/pages/how-gps-tracker-works-and-cell-phone-tower-triangulation-accuracy>
- Westrope, A. (2019, May 24). *New CentralSquare Acquisition to Unify CAD Systems*. Retrieved from Government Technology: <https://www.govtech.com/biz/New-CentralSquare-Acquisition-to-Unify-CAD-Systems.html>
- Wikipedia. (2020, April 11). *Enhanced 9-1-1*. Retrieved from Wikipedia: https://en.wikipedia.org/wiki/Enhanced_9-1-1

APPENDIX

Appendix 1: Interview Questionnaire



Please read this document carefully before you decide to participate in this research study. **Your participation is voluntary, and you can decline to participate or withdraw consent at any time, with no consequences.**

Study Title:

Timely, Dynamic, and Spatially Accurate Roadway Incident Information to Support Real-Time Management of Traffic Operations

Person(s) conducting the research:

Principal Investigator: Ilir Bejleri, Ph.D.

*Associate Professor, Co-Director, Geoplan Center
Department of Urban and Regional Planning,
University of Florida
439 Architecture Building,
Gainesville, Florida 32611
Phone: (954) 214-7885
Email: ilir@ufl.edu*

Project Manager:

*Jeremy Dilmore, P.E.
Title: TSMO Project Engineer
Florida Department of Transportation District 5
Address: MS 562,
791 South Woodland Blvd
Deland, FL 32720
Phone: 386-943-5360
Email: Jeremy.Dilmore@dot.state.fl.us*

Purpose of the research study:

Responding to highway incidents is an important public safety function and one that is inherently dangerous for responders and other drivers. Each year, dozens of police, fire, EMS, transportation, and towing professionals are killed when struck by vehicles at incidents. A real-time information exchange system would enable FDOT to detect and verify incidents earlier, which can speed response and ultimately clearance of incidents. With better information, transportation agencies can put messages on electronic highway signs, or dispatch Road Rangers to help with traffic control. RTMC CCTV verification would also ensure that appropriate first responders are dispatched.

This survey is designed to identify the role of your agency in taking calls for roadway incidents and how they are subsequently dispatched and/or shared with other agencies. Coordination, cooperation, and communication is key to increasing safety for responders and reducing secondary crashes that also injure innocent drivers approaching scenes.

What you will be asked to do in the study:

In this interview, you will be asked to answer questions about the traffic incident management procedures and data management at your agency. The interviews will be recorded with your consent. You can withdraw your consent for the recording at any time during the interview.

Time required:

This is a one-time interview, the duration of which is expected to be no longer than 2 hours.

Risks and benefits:

There are no risks or discomforts anticipated. There are no direct benefits of participation for you

Confidentiality:

Personal information collected about you will only include your name, job title, responsibilities and contact information at work. Information collected about you will be stored in computers with security passwords. Paper-based records will be kept in a secure location. Only certain people have the legal right to review these research records, and they will protect the secrecy (confidentiality) of these records as much as the law allows. These people include the researchers for this study, certain University of Florida officials, and the Institutional Review Board (IRB; an IRB is a group of people who are responsible for looking after the rights and welfare of people taking part in research). Otherwise, your research records will not be released without your permission unless required by law or court order.

Once this research study is completed, any information that could identify you might be removed from any identifiable private information collected and that, after such removal, the information could be used for future research studies or distributed to another investigator for future research studies without additional informed consent from you or your legally authorized representative. Researchers will take appropriate steps to protect any information they collect about you. However, there is a slight risk that information about you could be revealed inappropriately or accidentally. If the results of this research are published or presented at scientific meetings, your identity will not be disclosed.

You are free to withdraw your consent and to stop participating in this study at any time without consequence. You can decline to answer any question you don't wish to answer. If you withdraw, your information will be discarded.

Source(s) of funding for the research: *Florida Department of Transportation*

Withdrawal from the study:

You are free to withdraw your consent and to stop participating in this study at any time without consequence. You can decline to answer any question you don't wish to answer. If you withdraw, your information will be used or discarded. Researchers will not withdraw you from the study.

If you wish to discuss the information above or any discomforts you may experience, please ask questions now or contact one of the research team members listed at the top of this form.

If you have any questions regarding your rights as a research subject, please contact the Institutional Review Board (IRB02) office (098 PSY Bldg., University of Florida; Box 112250; (352) 392-0433 or irb2@ufl.edu.)

Do you voluntarily consent to participate in this study? If so, we will proceed.

Interview Questions

1. We would like to understand your agency’s role and duties in traffic incident management (TIM).
Please fill out Table A1-2 below. Table A1-1 shows an example that can be used as a reference.

Table A1-1 Example of Your Agency’s Duties

Agency Name	Duties	Collaborate with other agencies on this duty? (Name(s) of agencies)
e.g. Fire/Rescue	e.g. Protecting the incident scene	e.g. Law enforcement
	e.g. Suppressing fires	
	e.g. Providing emergency medical care	e.g. EMS
	e.g. Serving as incident commander	e.g. Law enforcement
	e.g. Providing initial HAZMAT response and containment	
	e.g. Providing traffic control until law enforcement or DOT arrival	e.g. Law enforcement

Table A1-2 Your Agency’s Duties

Agency Name	Duties	Collaborate with other agencies on this duty? (Name(s) of agencies)

2. We would like to understand your agency's standard procedure of responding to a traffic incident.

2.1. We have listed some typical steps in a traffic incident response. The number assigned to each step reflects its sequence in the timeline. Please assign numbers to the steps that apply to your agency's TIM timeline. Add any additional steps as needed (see the example below)

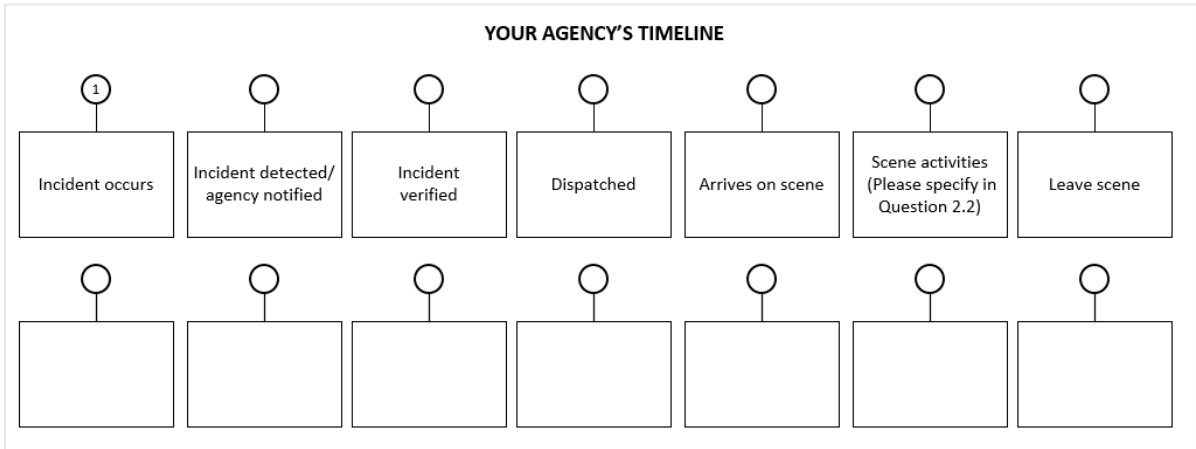

Figure A1-1 Agency's Timeline

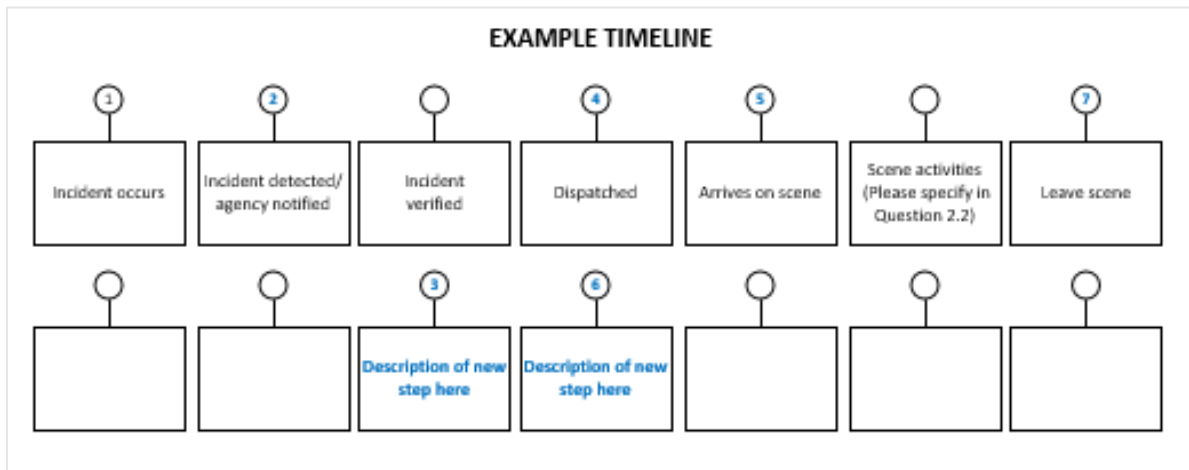

Figure A1-2 Example of Agency's Timeline

2.2 Please list the activities that your agency is responsible for or typically performs at the scene of a traffic incident.

2.3 Please answer the following questions that are applicable to your agency.

a. How are you notified of incidents (detection)?

b. What steps do you take to verify incidents? (i.e., what details do you collect from callers about the incident, confirm multiple callers, check with other agencies, etc.)

c. What are the primary factors that determine if you dispatch units to an incident or turn it over to another agency?

3. Please list below the roadway/traffic event types and the dispatch code for your agency. Or, if you have a file with this information, please email this file to nicolezhang@ufl.edu

Table A1-3 Roadway and Traffic Event Types and the Dispatch Code

ROADWAY EVENT TYPE	DISPATCH CODE
e.g. Crash	e.g. signal 4

4. Please fill out the following table to help us better understand the data flow at your agency. We are looking for a typical use case. Feel free to expand and adjust the table as needed. Also please consult your agency IT staff or CAD vendor if needed. Step numbers should refer to your agency timeline from question 2.1.

Table A1-4 Reference Answers

DESCRIPTION	HOW	FORMAT	SOURCE(S) / REFER-TO
A. Date of Incident	A. Phone Calls	A. XML	A. Self/On-view
B. Time of Incident	B. Radio	B. HTML	B. Public
C. Date Incident Detected	C. Text	C. CVS	C. PD
D. Time Incident Detected	D. Email	D. TSV	D. SO
E. Location – ANI/ALI	E. CAD System	E. XLS/XLSX	E. Fire/Rescue
F. Location – GPS	F. Face-to-face	F. dBase	F. PSAP
G. We Convert Location to LAT/LONG	communication	G. MS Access	G. EMS
H. We Do Not Convert Location to LAT/LONG	G. Other	H. ODS	H. FDOT
I. Dispatched Unit ID		I. TXT	I. Towing and Recovery
J. Date Arrived		J. DOC	J. Hazardous Materials Contractors
K. Time Arrived		K. Hand-written notes	K. 511
L. Date Departed		L. Other	L. Hospital
			M. FHP

DESCRIPTION	HOW	FORMAT	SOURCE(S) / REFER-TO
M. Time Departed N. Event Type O. Urgency P. Injuries Q. Road Blockage R. Author S. County T. Others			N. Other

Table A1-5 Example Answers of Data Flow

STEP NUMBER	DATA COLLECTED/RECEIVED			
	Description	How	Format	Source(s)
e.g. 2	A	E	A	E
e.g. 2	B	E	A	E
e.g. 6	Driver information	B, F	J, K	A

Table A1-6 Summary Table of Data Collected from Other Sources

STEP NUMBER	DATA COLLECTED/RECEIVED			
	Description	How	Format	Source(s)

Table A1-7 Summary Table of Data Disseminated to Other Agencies

STEP NUMBER	DATA DISSEMINATED/SENT TO OTHER AGENCIES			
	Description	How	Format	Refer to

5. Is there a standard incident data document/dictionary that your agency follows? (e.g. APCO/NENA 2.105.1-2017: NG9-1-1 Emergency Incident Data Document (EIDD))

- Yes. (Please email the document to nicolezhang@ufl.edu)
- No

6. Can you share with us some sample data (minus any personal information) that illustrate the data described in question #3?

- Yes. (Please email the document to nicolezhang@ufl.edu)
- No

7. What is the name/brand of your dispatch software (or 911 software)? Please check all that applies.

- Superior ONESolution CAD
- TriTech Zuercher Suite
- TriTech Inform Public Safety Suite
- TriTech IMC public safety software
- Tyler Technologies TPS
- Tyler New World
- Spillman Flex
- Spillman Nova
- Spillman Ally
- SmartCOP MCT
- Zoll RescueNet FireRMS

Others

None

8. Do you have an introduction/overview document of the CAD system that you are using? It will help us understand the system's functions, compatibility with other software, interface, etc.

Yes. (Please email the document to nicolezhang@ufl.edu)

No

9. In the response event, is there any type of data (or systems/software) that you need, yet currently do not have?

10. Which roadway types do you respond to? Please list some of the most important roadways below.

Interstates, e.g. I-4

US Roads

State Roads

County Roads

Local Roads

Others

11. Do you foresee any obstacles in sharing roadway incident-related information with FDOT's communications/dispatch center?

12. What are some feasible methods at present for your agency to communicate or share dispatch information with DOT (e.g. text, email ...)?

13. This question is about the Regional Transportation Management Centers (RTMC):

13.1 Do you know of the RTMCs in Florida?

Yes

No

13.2 Do you have contacts with any RTMC?

I have contact with District 5 RTMC

I have contact with other RTMC (type name below)

I do not have contact with any RTMC

14. Are there things FDOT can do to improve the flow of information and coordination to improve response and clearance of incidents?

15. Is there anything else that you can share with us that would be useful for this study?

Please provide your contact information below, so we can reach out if we have follow-up questions.

Agency Name: _____

Participant's Name: _____

Participant's Title: _____

Email: _____

Phone number: _____

Thank you!

Appendix 2: Online Survey



DISTRICT 5-Survey Questionnaire

Start of Block: Consent Form

Research Study Title:

Timely, Dynamic and Spatially Accurate Roadway Incident Information to Support Real-Time Management of Traffic Operations

Persons conducting this research

Project Manager: Jeremy Dilmore, P.E.
District 5, Florida Department of Transportation
Email: Jeremy.Dilmore@dot.state.fl.us

Principal Investigator: Ilir Bejleri, Ph.D.
University of Florida
Email: ilir@ufl.edu

Purpose of this research study

Responding to highway incidents is an important public safety function, and one that is inherently dangerous for responders and other drivers. Each year, dozens of police, fire, EMS, transportation, and towing professionals are killed when struck by vehicles at incidents. A real-time information exchange system would enable Florida Department of Transportation (FDOT) to detect and verify incidents earlier, which can shorten response and road clearance time. With better information, transportation agencies can put messages on electronic highway signs, or dispatch Road Rangers to help with traffic control. RTMC CCTV verification would also ensure that the appropriate first responders are dispatched to the correct location. Coordination, cooperation, and communication is key to increasing safety for responders and reducing secondary crashes that also injure innocent drivers.

This survey is designed to help FDOT understand how PSAPs gather and store key information about roadway incidents, in order to explore inter-agency information exchange options between PSAPs and FDOT.

What you will be asked to do in this study

In this survey, you will be asked to answer questions about the traffic incident response procedures and data management at your agency.

Time required

This survey is expected to take between 10 and 20 minutes to complete.

Risks and benefits

There are no risks or discomforts anticipated. There is no compensation for your participation in this survey.

Confidentiality

No identifiable private information will be collected during this survey. You are free to withdraw your consent and to stop participating in this study at any time without consequence. You can decline to answer any question you don't wish to answer. If you withdraw, your survey answers will be discarded.

Source of funding for this study

Florida Department of Transportation

Withdrawal from this study

You are free to withdraw your consent and to stop participating in this study at any time without consequence. You can decline to answer any question you don't wish to answer. Some questions are needed for selecting the appropriate questions for you to answer later, so the only way to skip these questions is to withdraw from the survey entirely. If you withdraw, your answers will be discarded and never be used in the study.

If you wish to discuss the information above or any discomforts you may experience, please contact one of the research team members listed at the top of this form. If you have any questions regarding your rights as a research subject, please contact the Institutional Review Board (IRB02) office (352-392-0433 or irb2@ufl.edu.)

- Yes, I consent. Please start survey.
- No, I do not consent.

End of Block: Consent Form

Start of Block: General Agency Questions

SECTION 1: AGENCY INFORMATION

1. What is the name of your agency?

- Brevard County Sheriff's Office Primary PSAP
- Brevard County Fire/Rescue Secondary PSAP
- Rockledge Police Department PSAP
- Palm Bay Police Department Primary PSAP
- Indialantic Police Department Primary PSAP
- Cocoa Police Department Primary PSAP
- Cocoa Beach Police Department Primary PSAP
- Satellite Beach Police Department Primary PSAP
- Melbourne Police Department Primary PSAP
- Indian Harbor Beach Police Department Primary PSAP
- Titusville Police Department Primary PSAP
- Flagler County Primary PSAP
- Lake County Sheriff's Office Primary PSAP
- Eustis Police Department Primary PSAP
- Groveland Police Department Primary PSAP
- Leesburg Police Department Primary PSAP
- Mount Dora Police Department Primary PSAP
- Lake County EMS Secondary PSAP
- Marion County Public Safety Communications Primary PSAP
- Ocala Police Department Primary PSAP
- Apopka Police Department Primary PSAP
- Orange County Sheriff's Office Primary PSAP
- Orange County Fire/Rescue Secondary PSAP
- Orlando Police Department Primary PSAP
- Orlando Fire Department Secondary PSAP

- Reedy Creek Improvement District Secondary PSAP
- Winter Garden Police Department Primary PSAP
- Winter Park Police Department Primary PSAP
- Osceola County Sheriff's Office Primary PSAP
- St. Cloud Police Department PSAP
- Kissimmee Police Department PSAP
- Seminole County Sheriff's Office Primary PSAP
- Winter Springs Police Department Primary PSAP
- Seminole County Fire/EMS Secondary PSAP
- Sumter County Sheriff's Office Primary PSAP
- Wildwood Police Department Primary PSAP
- Sumter County Fire/EMS Secondary PSAP
- Volusia County Sheriff's Office Communications Center Primary PSAP
- Our PSAP is not listed here. Please specify the name of your PSAP:

- We are dispatched by another agency's PSAP. Please specify the name of this PSAP:

Skip To: End of Survey If Q1 = We are dispatched by another agency's PSAP. Please specify the name of this PSAP:

2. Are you a Law Enforcement PSAP or a Fire PSAP?

- Law Enforcement PSAP
- Fire PSAP
- We dispatch for both law enforcement agencies and fire departments

End of Block: General Agency Questions

Start of Block: 911 AND CAD System Questions

SECTION 2: 911 SYSTEM AND CAD SYSTEM(S)

3. What is the name of your 911 system?

- Intrado Viper - West Corporation
 - Guardian 911 solution -- Solacom
 - Other, please specify: _____
-

4. Please check all the sources from which you receive roadway incident notifications.

- 911 calls
 - 911 texts
 - Law enforcement agencies' non-emergency calls
 - Road rangers (FDOT)
 - FHP
 - Facebook
 - Waze
 - Twitter
 - Agency's mobile app. Please specify: _____
 - Others, please specify: _____
-

5. Does your 911 system generate a unique identifier for each 911 incident call (911 incident ID)?

- Yes
 - No
-

Display This Question:

If Q2 = We dispatch for both law enforcement agencies and fire departments

6. How many CAD systems do you use?

- We use the same CAD system for Law Enforcement and Fire.
- We use the same CAD system for Law Enforcement and Fire, but separate instances of it.
- We use one CAD system for Law Enforcement and another CAD system for Fire.
- We don't use any CAD system.

Skip To: End of Block If Q6 = We don't use any CAD system.

Display This Question:

If Q6 = We use the same CAD system for Law Enforcement and Fire.

Or Q2 = Law Enforcement PSAP

Or Q2 = Fire PSAP

Or Q6 = We use the same CAD system for Law Enforcement and Fire, but separate instances of it.

7. What is the name of your CAD system?

- CentralSquare CAD Enterprise
- CentralSquare CAD Pro
- Tyler Incode
- Tyler New World
- Spillman Flex
- Spillman Nova
- Spillman Ally
- SmartCAD by SmartCOP
- Tiburon
- Other, please specify: _____

Q6 != We use the same CAD system for Law Enforcement and Fire.

And Q6 != We use the same CAD system for Law Enforcement and Fire, but separate instances of it.

- We don't use any CAD system.

Skip To: End of Block If Q7 = We don't use any CAD system.

Display This Question:

If Q6 = We use one CAD system for Law Enforcement and another CAD system for Fire.

7.1 What is the name of your Law Enforcement CAD system?

- CentralSquare CAD Enterprise
 - CentralSquare CAD Pro
 - Tyler Incode
 - Tyler New World
 - Spillman Flex
 - Spillman Nova
 - Spillman Ally
 - SmartCAD by SmartCOP
 - Tiburon
 - Other, please specify: _____
-

Display This Question:

If Q6 = We use one CAD system for Law Enforcement and another CAD system for Fire.

7.2 What is the name of your Fire CAD system?

- CentralSquare CAD Enterprise
 - CentralSquare CAD Pro
 - Tyler New World
 - Spillman Flex
 - Spillman Nova
 - Spillman Ally
 - SmartCAD by SmartCOP
 - Zoll
 - Other, please specify: _____
-

Display This Question:

If Q6 = We use the same CAD system for Law Enforcement and Fire.

Or Q2 = Law Enforcement PSAP

Or Q2 = Fire PSAP

Or Q6 = We use the same CAD system for Law Enforcement and Fire, but separate instances of it.

8. What data elements are automatically transferred from your 911 system to your CAD system? Please check all that apply.

- 911 Incident ID
 - Date of call
 - Time of call
 - Incident Location
 - Others, please specify: _____
 - ☒ We don't have automatic transfer of information from 911 system to our CAD system
-

Display This Question:

If Q6 = We use one CAD system for Law Enforcement and another CAD system for Fire.

8.1 What data elements are automatically transferred from your 911 system to your Law Enforcement CAD system? Please check all that apply.

- 911 Incident ID
 - Date of call
 - Time of call
 - Incident Location
 - Others, please specify: _____
 - ☒ We don't have automatic transfer of information from 911 system to our Law Enforcement CAD system
-

Display This Question:

If Q6 = We use one CAD system for Law Enforcement and another CAD system for Fire.

8.2 What data elements are automatically transferred from your 911 system to your Fire CAD system?
Please check all that apply.

- 911 Incident ID
- Date of call
- Time of call
- Incident Location
- Others, please specify: _____
- We don't have automatic transfer of information from 911 system to our Fire CAD system

Display This Question:

If Q6 = We use the same CAD system for Law Enforcement and Fire.

Or Q2 = Law Enforcement PSAP

Or Q2 = Fire PSAP

Or Q6 = We use the same CAD system for Law Enforcement and Fire, but separate instances of it.

9. Which of the following data elements does your CAD system capture? Please check all that apply.

- CAD incident ID
- 911 Incident ID
- Time of incident
- Time of dispatch
- Time of arrival
- Time of incident closed
- Location information

Display This Question:

If Q6 = We use one CAD system for Law Enforcement and another CAD system for Fire.

9.1 Which of the following data elements does your Law Enforcement CAD system capture? Please check all that apply.

- CAD incident ID
 - 911 Incident ID
 - Date of incident
 - Time of incident
 - Time of dispatch
 - Time of arrival
 - Time of incident closed
 - Location information
-

Display This Question:

If Q6 = We use one CAD system for Law Enforcement and another CAD system for Fire.

9.2 Which of the following data elements does your Fire CAD system capture? Please check all that apply.

- CAD incident ID
 - 911 Incident ID
 - Date of incident
 - Time of incident
 - Time of dispatch
 - Time of arrival
 - Time of incident closed
 - Location information
-

Display This Question:

If Q6 = We use the same CAD system for Law Enforcement and Fire.

Or Q2 = Law Enforcement PSAP

Or Q2 = Fire PSAP

Or Q6 = We use the same CAD system for Law Enforcement and Fire, but separate instances of it.

10. What road blockage information does your CAD system capture? Please check all that apply.

- Which lanes are blocked
 - How many lanes are blocked
 - Whether a road blockage is present (without any specific lane information)
 - ☒ We do not have road blockage data elements, but it may be noted in comments.
-

Display This Question:

If Q6 = We use one CAD system for Law Enforcement and another CAD system for Fire.

10.1 What road blockage information does your Law Enforcement CAD system capture? Please check all that apply.

- Which lanes are blocked
 - How many lanes are blocked
 - Whether a road blockage is present (without any specific lane information)
 - ☒ We do not have road blockage data elements, but it may be noted in comments.
-

Display This Question:

If Q6 = We use one CAD system for Law Enforcement and another CAD system for Fire.

10.2 What road blockage information does your Fire CAD system capture? Please check all that apply.

- Which lanes are blocked
 - How many lanes are blocked
 - Whether a road blockage is present (without any specific lane information)
 - ☒ We do not have road blockage data elements, but it may be noted in comments.
-

Display This Question:

If Q2 = We dispatch for both law enforcement agencies and fire departments

11. When you dispatch units from both Law Enforcement and Fire for a roadway incident, how do you link the Law Enforcement CAD record with the Fire CAD record?

- The Law Enforcement CAD record and the Fire CAD record have the same incident ID.
 - The Law Enforcement CAD record and the Fire CAD record have their own incident IDs, but they are linked to each other through another common incident ID created in CAD.
 - The Law Enforcement CAD record and the Fire CAD record have their own incident IDs, but they are linked to the same 911 incident ID.
 - The Law Enforcement CAD record and the Fire CAD record have their own incident IDs, but they are linked to the same caller number.
 - The Law Enforcement CAD record and the Fire CAD record have their own incident IDs, and they are not linked to each other in anyway.
 - Other, please specify: _____
 - I don't know.
-

Display This Question:

If Q6 = We use the same CAD system for Law Enforcement and Fire.

Or Q2 = Law Enforcement PSAP

Or Q2 = Fire PSAP

Or Q6 = We use the same CAD system for Law Enforcement and Fire, but separate instances of it.

12. Are there cases when you unknowingly create duplicate records in your CAD system for the same incident?

- Yes, sometimes.
 - Yes, in very rare cases.
 - Never.
-

Display This Question:

If Q6 = We use one CAD system for Law Enforcement and another CAD system for Fire.

12.1 Are there cases when you unknowingly create duplicate records in your Law Enforcement CAD system for the same incident?

- Yes, sometimes.
 - Yes, in very rare cases.
 - Never.
-

Display This Question:

If Q6 = We use one CAD system for Law Enforcement and another CAD system for Fire.

12.2 Are there cases when you unknowingly create duplicate records in your Fire CAD system for the same incident?

- Yes, sometimes.
 - Yes, in very rare cases.
 - Never.
-

Display This Question:

If Q6 = We use the same CAD system for Law Enforcement and Fire.

Or Q2 = Law Enforcement PSAP

Or Q2 = Fire PSAP

Or Q6 = We use the same CAD system for Law Enforcement and Fire, but separate instances of it.

13. Are there cases when you dispatch more than one unit for the same incident because of duplicate records in your CAD system?

- Yes, sometimes.
 - Yes, in very rare cases.
 - Never.
-

Display This Question:

If Q6 = We use one CAD system for Law Enforcement and another CAD system for Fire.

13.1 Are there cases when you dispatch more than one unit for the same incident because of duplicate records in your Law Enforcement CAD system?

- Yes, sometimes.
 - Yes, in very rare cases.
 - Never.
-

Display This Question:

If Q6 = We use one CAD system for Law Enforcement and another CAD system for Fire.

13.2 Are there cases when you dispatch more than one unit for the same incident because of duplicate records in your Fire CAD system?

- Yes, sometimes.
 - Yes, in very rare cases.
 - Never.
-

Display This Question:

If Q6 = We use the same CAD system for Law Enforcement and Fire.

Or Q2 = Law Enforcement PSAP

Or Q2 = Fire PSAP

Or Q6 = We use the same CAD system for Law Enforcement and Fire, but separate instances of it.

14. How do you handle duplicate records in your CAD system when you realize they are for the same incident?

- Combine duplicate records to create one new incident record.
 - Incorporate information of the duplicate into the first record.
 - Make no changes in the CAD system. Keep duplicate records as they are.
 - Other, please specify: _____
-

Display This Question:

If Q6 = We use one CAD system for Law Enforcement and another CAD system for Fire.

14.1 How do you handle duplicate records in your Law Enforcement CAD system when you realize they are for the same incident?

- Combine duplicate records to create one new incident record.
 - Incorporate information of the duplicate into the first record.
 - Make no changes in the CAD system. Keep duplicate records as they are.
 - Other, please specify: _____
-

Display This Question:

If Q6 = We use one CAD system for Law Enforcement and another CAD system for Fire.

14.2 How do you handle duplicate records in your Fire CAD system when you realize they are for the same incident?

- Combine duplicate records to create one new incident record.
- Incorporate information of the duplicate into the first record.
- Make no changes in the CAD system. Keep duplicate records as they are.
- Other, please specify: _____

SECTION 3: INCIDENT LOCATIONS

Display This Question:

If Q6 = We use the same CAD system for Law Enforcement and Fire.

Or Q2 = Law Enforcement PSAP

Or Q2 = Fire PSAP

Or Q6 = We use the same CAD system for Law Enforcement and Fire, but separate instances of it.

15. What types of location information are captured in your CAD system? Please check all that apply.

- Street address of caller – if the caller uses a landline
 - Phase 1 location (closest cell tower) – if the caller uses a cellphone
 - Phase 2 location (triangulation method) – if the caller uses a cellphone
 - Location description given by the caller
 - Updated location information reported by dispatched units once they arrive on scene
 - Location pushed by RapidSOS from connected devices (e.g. cell phones, vehicles)
 - Others, please specify: _____
-

Display This Question:

If Q6 = We use one CAD system for Law Enforcement and another CAD system for Fire.

15.1 What types of location information are captured in your Law Enforcement CAD system? Please check all that apply.

- Street address of caller – if the caller uses a landline
- Phase 1 location (closest cell tower) – if the caller uses a cellphone
- Phase 2 location (triangulation method) – if the caller uses a cellphone
- Location description given by the caller
- Updated location information reported by dispatched units once they arrive on scene
- Location pushed by RapidSOS from connected devices (e.g. cell phones, vehicles)
- Others, please specify: _____

Display This Question:

If Q6 = We use one CAD system for Law Enforcement and another CAD system for Fire.

15.2 What types of location information are captured in your Fire CAD system? Please check all that apply.

- Street address of caller – if the caller uses a landline
- Phase 1 location (closest cell tower) – if the caller uses a cellphone
- Phase 2 location (triangulation method) – if the caller uses a cellphone
- Location description given by the caller
- Updated location information reported by dispatched units once they arrive on scene
- Location pushed by RapidSOS from connected devices (e.g. cell phones, vehicles)
- Others, please specify: _____

Display This Question:

If Q6 = We use the same CAD system for Law Enforcement and Fire.

Or Q2 = Law Enforcement PSAP

Or Q2 = Fire PSAP

Or Q6 = We use the same CAD system for Law Enforcement and Fire, but separate instances of it.

16. Does your CAD system store the following location data elements? Please check all that apply.

- Latitude and longitude
 - Street address
 - The street names of the closest intersection
 - The distance to the closest intersection
 - Street name and mile marker
 - City name
 - County name
 - US National Grid Coordinates
 - Others, please specify: _____
-

Display This Question:

If Q6 = We use one CAD system for Law Enforcement and another CAD system for Fire.

16.1 Does your Law Enforcement CAD system store the following location data elements? Please check all that apply.

- Latitude and longitude
 - Street address
 - The street names of the closest intersection
 - The distance to the closest intersection
 - Street name and mile marker
 - City name
 - County name
 - US National Grid Coordinates
 - Others, please specify: _____
-

Display This Question:

If Q6 = We use one CAD system for Law Enforcement and another CAD system for Fire.

16.2 Does your Fire CAD system store the following location data elements? Please check all that apply.

- Latitude and longitude
 - Street address
 - The street names of the closest intersection
 - The distance to the closest intersection
 - Street name and mile marker
 - City name
 - County name
 - US National Grid Coordinates
 - Others, please specify: _____
-

Display This Question:

If Q6 = We use the same CAD system for Law Enforcement and Fire.

Or Q2 = Law Enforcement PSAP

Or Q2 = Fire PSAP

Or Q6 = We use the same CAD system for Law Enforcement and Fire, but separate instances of it.

17. To shorten response time, it's also important to know which side of the road the incident is located at (e.g. southbound/northbound). Is the direction of traffic captured in your CAD system?

- Yes, it is captured in a designated field.
 - Yes, it is usually captured in a comment field.
 - It is usually not captured, but sometimes can be found in a comment field.
 - No, it's not captured in our CAD system.
-

Display This Question:

If Q6 = We use one CAD system for Law Enforcement and another CAD system for Fire.

17.1 To shorten response time, it's also important to know which side of the road the incident is located at (e.g. southbound/northbound). Is the direction of traffic captured in your Law Enforcement CAD system?

- Yes, it's available in a designated field.
 - Yes, it is usually captured in a comment field.
 - It is usually not captured, but sometimes can be found in a comment field.
 - No, it's not captured in our Law Enforcement CAD system.
-

Display This Question:

If Q6 = We use one CAD system for Law Enforcement and another CAD system for Fire.

17.2 To shorten response time, it's also important to know which side of the road the incident is located at (e.g. southbound/northbound). Is the direction of traffic captured in your Fire CAD system?

- Yes, it's available in a designated field.
 - Yes, it is usually captured in a comment field.
 - It is usually not captured, but sometimes can be found in a comment field.
 - No, it's not captured in our Fire CAD system.
-

Display This Question:

If Q6 = We use the same CAD system for Law Enforcement and Fire.

Or Q2 = Law Enforcement PSAP

Or Q2 = Fire PSAP

Or Q6 = We use the same CAD system for Law Enforcement and Fire, but separate instances of it.

18. When the location information is updated, how many copies of locations does your CAD system keep?

- Only one. When location information is updated, it overwrites the original one
 - Two copies maximum. One is the first location information recorded, the other is the latest updated location (if any).
 - As many as needed. Whenever location information is updated, it generates a new copy of the location with a new timestamp.
-

Display This Question:

If Q6 = We use one CAD system for Law Enforcement and another CAD system for Fire.

18.1 When the location information is updated, how many copies of locations does your Law Enforcement CAD system keep?

- Only one. When location information is updated, it overwrites the original one
- Two copies maximum. One is the first location information recorded, the other is the latest updated location (if any).
- As many as needed. Whenever location information is updated, it generates a new copy of the location with a new timestamp.

Display This Question:

If Q6 = We use one CAD system for Law Enforcement and another CAD system for Fire.

18.2 When the location information is updated, how many copies of locations does your Fire CAD system keep?

- Only one. When location information is updated, it overwrites the original one
- Two copies maximum. One is the first location information recorded, the other is the latest updated location (if any).
- As many as needed. Whenever location information is updated, it generates a new copy of the location with a new timestamp.

SECTION 4: INCIDENT TYPES

Display This Question:

If Q2 = We dispatch for both law enforcement agencies and fire departments

Or Q2 = Law Enforcement PSAP

19.1 Do you dispatch Law Enforcement for the following incident types? Please provide a response for each incident type.

	Yes	No
Any incidents with fatality		
Crash with injury		
Crash without injury		
Crash with road blockage		
Crash without road blockage		
Debris on roadway with road blockage		
Debris on roadway without road blockage		

Disabled vehicle with road blockage		
Disabled vehicle without road blockage		
Vehicle Fire with injury		
Vehicle Fire without injury		
Vehicle Fire with road blockage		
Vehicle Fire without road blockage		
Vegetation Fire with road blockage		
Vegetation Fire without road blockage		
Hazardous Materials with road blockage		
Hazardous Materials without road blockage		

Display This Question:

If Q2 = We dispatch for both law enforcement agencies and fire departments

Or Q2 = Fire PSAP

19.2 Do you dispatch Fire for the following incident types? Please provide a response for each incident type.

	Yes	No
Any incidents with fatality		
Crash with injury		
Crash without injury		
Crash with road blockage		
Crash without road blockage		
Debris on roadway with road blockage		
Debris on roadway without road blockage		
Disabled vehicle with road blockage		
Disabled vehicle without road blockage		
Vehicle Fire with injury		
Vehicle Fire without injury		
Vehicle Fire with road blockage		
Vehicle Fire without road blockage		
Vegetation Fire with road blockage		

Vegetation Fire without road blockage		
Hazardous Materials with road blockage		
Hazardous Materials without road blockage		

SECTION 5: VEHICLE DESCRIPTION

Display This Question:

If Q6 = We use the same CAD system for Law Enforcement and Fire.

Or Q2 = Law Enforcement PSAP

Or Q2 = Fire PSAP

Or Q6 = We use the same CAD system for Law Enforcement and Fire, but separate instances of it.

20. Which of the following vehicle information does your CAD system capture? Please check all that apply.

- Vehicle Type
- Vehicle Color
- Vehicle Make
- Vehicle Model
- None of the above

Display This Question:

If Q6 = We use one CAD system for Law Enforcement and another CAD system for Fire.

20.1 Which of the following vehicle information does your Law Enforcement CAD system capture? Please check all that apply.

- Vehicle Type
 - Vehicle Color
 - Vehicle Make
 - Vehicle Model
 - None of the above
-

Display This Question:

If Q6 = We use one CAD system for Law Enforcement and another CAD system for Fire.

20.2 Which of the following vehicle information does your Fire CAD system capture? Please check all that apply.

- Vehicle Type
- Vehicle Color
- Vehicle Make
- Vehicle Model
- None of the above

End of Block: 911 AND CAD System Questions

Start of Block: Communication with FDOT

SECTION 6: INTERACTION WITH FLORIDA DEPARTMENT OF TRANSPORTATION (FDOT) DISPATCH/COMMUNICATION CENTERS (I.E. REGIONAL TRANSPORTATION MANAGEMENT CENTER (RTMC))

21. Do you have contact with any FDOT/RTMC? Please check all that apply.

- I have contact with District 5 RTMC
 - I have contact with the other FDOT/RTMC(s). Please specify their names here:

 - I do not have contact with any FDOT/RTMC
-

22. Do you foresee any obstacles in sharing roadway incident related information with FDOT/RTMC?

- Yes. Please specify: _____
 - No
-

23. What methods do you currently use to contact FDOT/RTMC? Please check all that apply.

- Phone calls
- Mutualink (<https://mutualink.net/our-solution/products/>)
- Others. Please specify: _____
- We don't contact FDOT in anyway for a roadway incident.

24. With access to numerous traffic cameras, FDOT/RTMC can often provide helpful information for PSAPs. Is your agency interested in receiving such information from FDOT/RTMC?

- Yes. We are interested in receiving FDOT/RTMC information automatically for every incident.
- Yes. We are only interested in receiving FDOT/RTMC information automatically for selective events (selected by query or agreed upon standards).
- Yes. We would like the ability to contact FDOT/RTMC directly and ask for information or support.
- No. Please tell us why: _____

Skip To: Q26 If Q24 = No. Please tell us why:

25. How would you like to receive the information from FDOT/RTMC? Please check all that apply.

- Gain access to live video feeds from all traffic cameras. We will identify the scene ourselves.
- Gain access to live video feeds for the specific incident scene identified by FDOT/RTMC.
- Receive screenshots from traffic cameras for the specific scene identified by FDOT/RTMC.
- Receive verbal or text description of the scene (e.g. validated address, description of the scene).

26. Is there anything else that you can share with us that would be useful for this study?

End of Block: Communication with FDOT

Start of Block: Submit Survey

This is the last page of the survey. Please be aware that once you click the "Submit" button, you can no longer edit your response using this link.

End of Block: Submit Survey

Appendix 3: Selected PSAPs' Dispatch and Transfer Diagrams

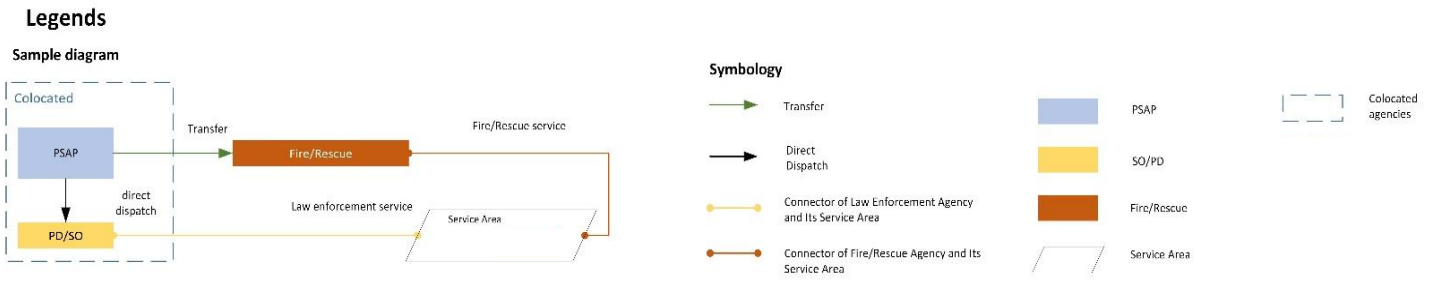

Figure A3-1 Legends and Sample Diagram

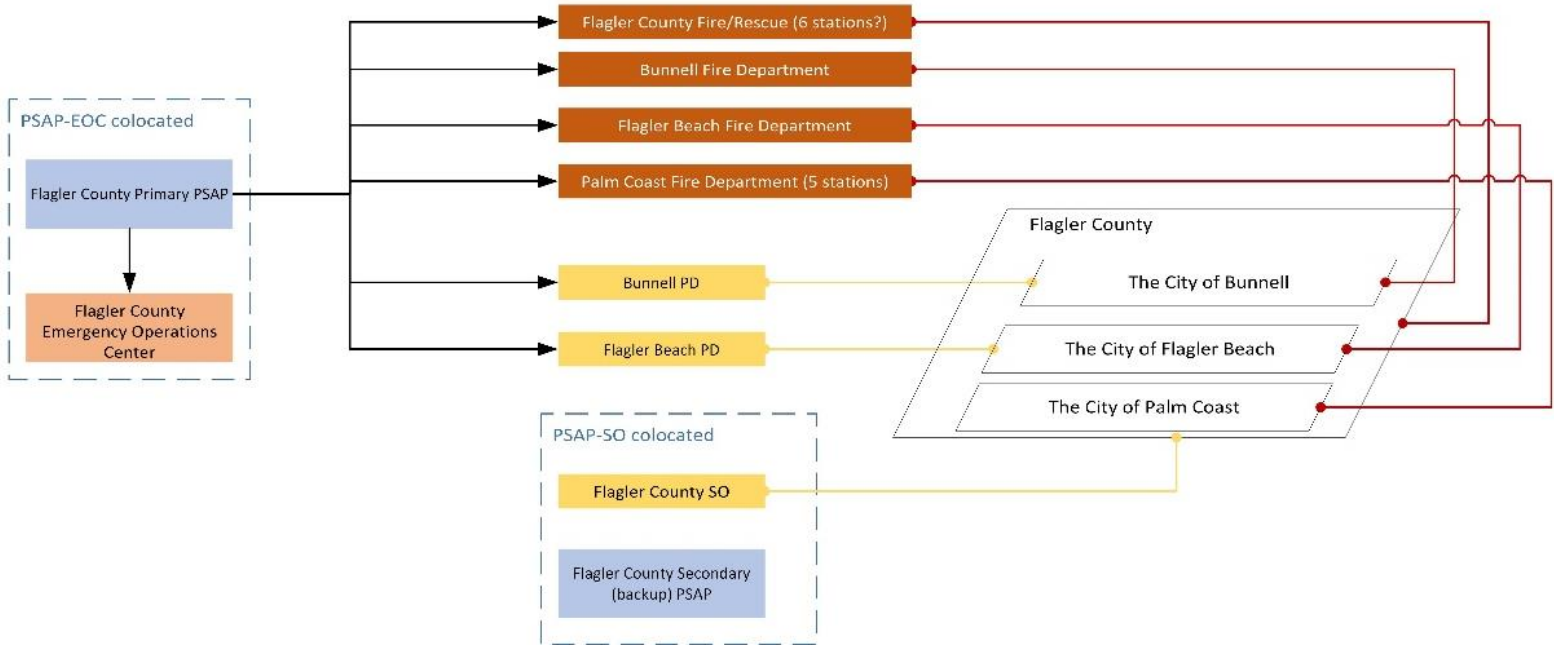

Figure A3-2 PSAPs' Dispatch and Transfer Diagram – Flagler County

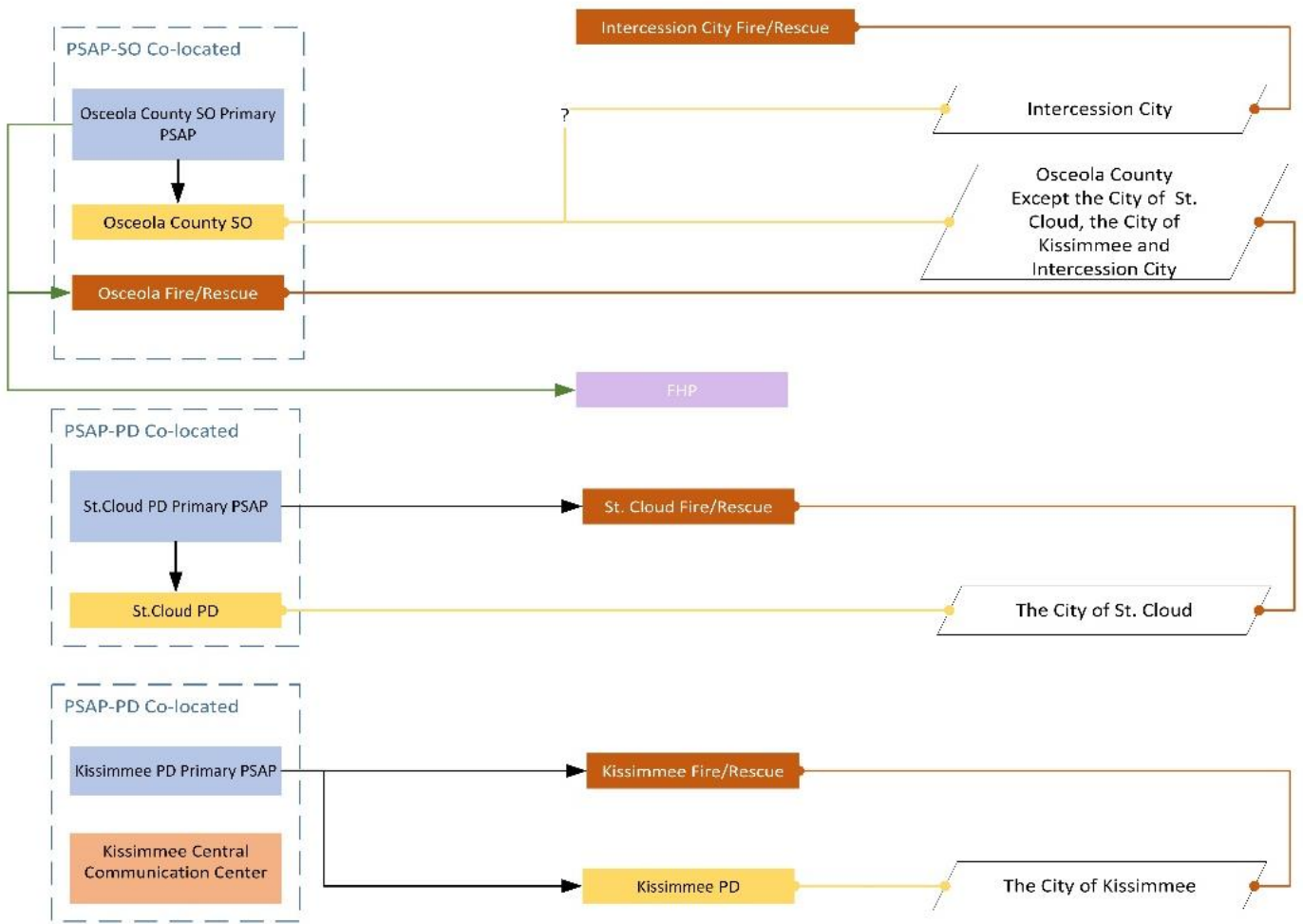

Figure A3-3 PSAPs' Dispatch and Transfer Diagram – Osceola County

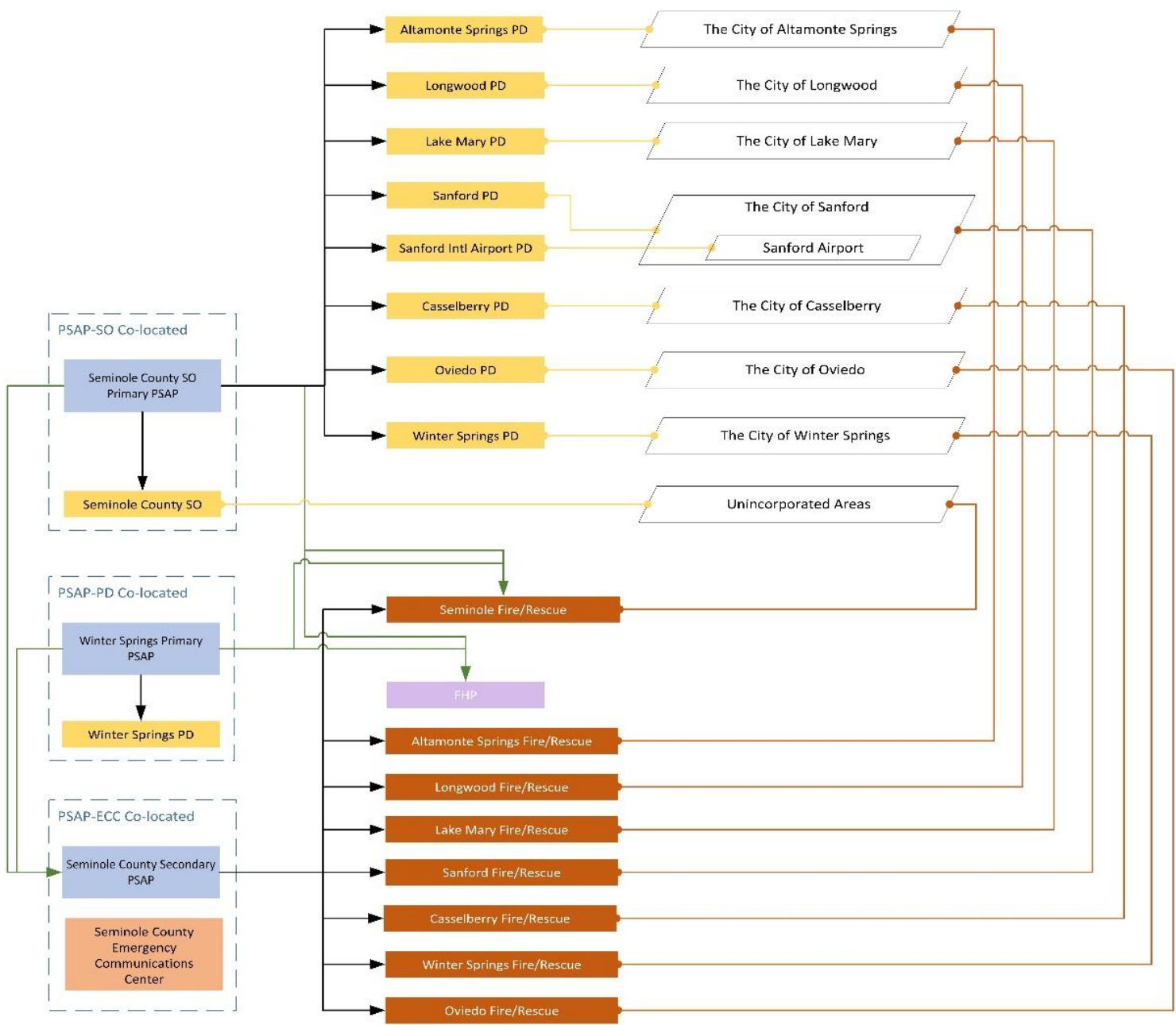

Figure A3-4 PSAPs' Dispatch and Transfer Diagram – Seminole County

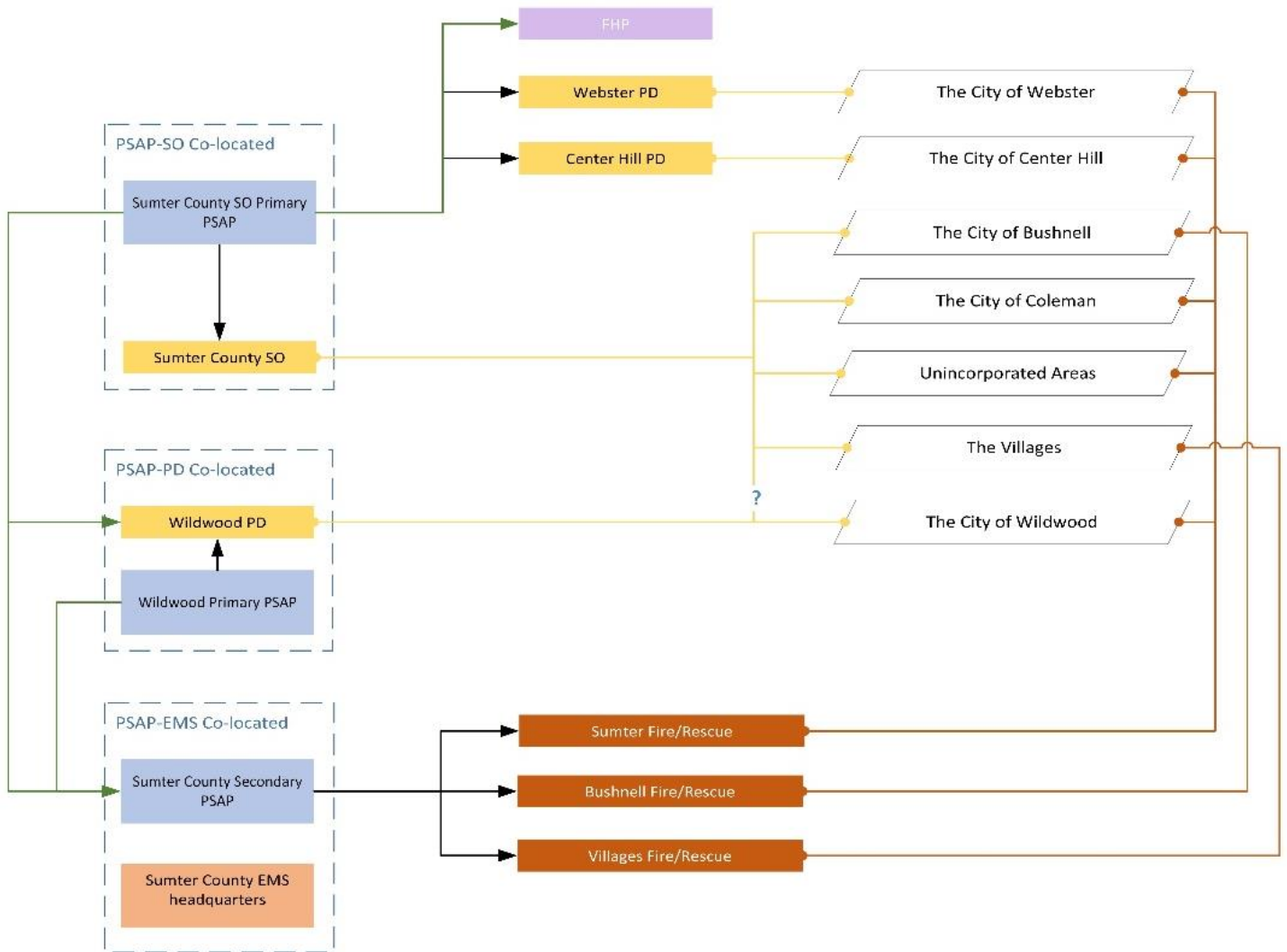

Figure A3-5 PSAPs' Dispatch and Transfer Diagram – Sumter County

Appendix 4. Vendor Active 911 Capabilities

We reviewed the information of the Active 911 vendor provided on their website. This section presents a summary of our understanding of how their service works. As a cautionary note, we did not find clear documentation of the processes described below but rather synthesized it ourselves based on disparate sources of information.

Active 911 is a commercial product that helps first responders, or emergency response agencies, view CAD alerts on their individual workstations or personal devices. The first responders can also share their GPS positions with the dispatch centers using the Active 911 app. Active 911 also allows users to choose the time and location criteria for determining a duplicate alert and the automated action they would like the system to take with such duplicates.

Active 911 has two servers. They can receive information from CAD systems via SMTP (Simple Mail Transfer Protocol) and SNPP (Simple Network Paging Protocol), respectively. Figure A4-1 illustrates the typical data flow of Active 911. In this example, CAD A sends call information to Active 911 via email, while CAD B does so via a paging system. To identify the messages sent by each agency, Active 911 assigns a unique email address to Agency A's active 911 account and a unique paging ID to Agency B's account. Messages generated from different CAD systems have different formats, so for every dispatch center, Active 911 needs to build a unique parser in the server to process its CAD data. The servers then send standardized CAD data to emergency response agencies or first responders' devices through the Active 911 app. For agencies whose CAD systems are unable to send automated messages, Active 911 encourages them to use standardized format or the Cadpage format (Active911, 2019).

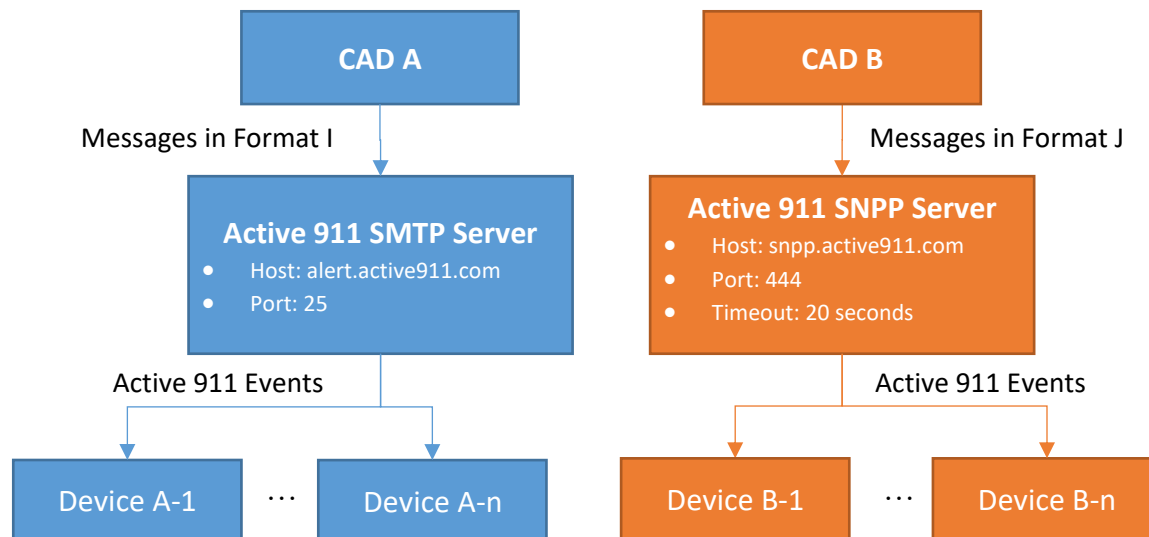

Figure A4-1 Active 911 Data Flow

Thought Active 911 is mainly designed to facilitate information sharing inside an agency, it can be used for interagency information sharing. For instance, the Seminole County and Volusia County set FDOT up as an emergency response agency in their CAD system and “dispatch” FDOT on Active

911 for all roadway incidents. This way, FDOT can receive the same alerts through the Active 911 application as other dispatched response agencies or first responders.

Active 911 adopts 256-bit TLS encryption and other encryption protocols, but its security setting is not sufficient for handling HIPPA data¹.

Appendix 5: Technical Specifications For CAD Vendors

PSAP CAD Information Sharing with the Exchange Platform via the HTTP POST Method

1. Vendors need to populate an XML or JSON content with the appropriate incident data following the specifications in Table A5-1 (required) and Table A5-2 (optional) below. Examples are provided below in both XML and JSON.
2. Use an HTTP POST request to send the content to the exchange server. Web request implementations and syntax could vary with programming language but typically involve constructing and submitting an HTTP POST request with the XML or JSON roadway incident data as its content. A brief C# example is provided below.
3. Optional: Listening for a response is not required but desirable to check successful delivery and processing (status 200 ok).

IMPLEMENTATION EXAMPLES

XML payload:

```
<RoadwayIncidentData>
  <PsapName>SamplePSAP</PsapName>
  <RespondingAgencyName>SampleAgency</RespondingAgencyName>
  <CadIncidentId>Sample1153</CadIncidentId>
  <AgencyCaseNumber>CaseNumber123</AgencyCaseNumber>
  <DateOfIncident>20200531</DateOfIncident>
  <TimeofIncident>135211</TimeofIncident>
  <CreateDate>20200531</CreateDate>
  <CreateTime>135552</CreateTime>
  <UpdateDate />
  <UpdateTime />
  <DispatchDate>20200531</DispatchDate>
  <DispatchTime>135748</DispatchTime>
  <DepartureDate>20200531</DepartureDate>
  <DepartureTime>144822</DepartureTime>
  <Crash>Y</Crash>
  <HazardousMaterials>N</HazardousMaterials>
  <VegetationFire>N</VegetationFire>
  <VehicleFire>Y</VehicleFire>
  <DisabledVehicle>Y</DisabledVehicle>
  <DebrisOnRoadway>Y</DebrisOnRoadway>
  <Injury>Y</Injury>
  <Fatality>N</Fatality>
  <Latitude>25.325974</Latitude>
  <Longitude>-84.626554</Longitude>
  <StreetAddress>5032 SampleStreet, AFloridaCity, FL, 12345</StreetAddress>
  <Remark>Additional info and comments</Remark>
  <EstimatedArrivalDate>20200531</EstimatedArrivalDate>
  <EstimatedArrivalTime>141448</EstimatedArrivalDate>
  <ArrivalDate>20200531</ArrivalDate>
  <ArrivalTime>141612</ArrivalTime>
  <RoadBlockage>Y</RoadBlockage>
  <NumberOfLanesBlocked>2</NumberOfLanesBlocked>
  <BlockedLanes>1L;2T</BlockedLanes>
  <DirectionOfTravel>S</DirectionOfTravel>
  <NorthSouthIntersectingStreet>NS DemoStreet, AFloridaCity,
FL</NorthSouthIntersectingStreet>
  <EastWestIntersectingStreet>EW OtherStreet, AFloridaCity,
FL</EastWestIntersectingStreet>
  <IntersectionMileage>0.31</IntersectionMileage>
  <UsngCoordinates>16RGP3891703152</UsngCoordinates>
  <StreetName>SampleStreet, AFloridaCity, FL</StreetName>
  <MileMarker>332</MileMarker>
  <City>AFloridaCity</City>
  <County>AFloridaCounty</County>
  <Vehicles>
    <string>Blue Volvo sedan</string>
    <string>Red pickup truck</string>
  </Vehicles>
</RoadwayIncidentData>
```

JSON payload:

```
{
  "PsapName": "SamplePSAP",
  "RespondingAgencyName": "SampleAgency",
  "CadIncidentId": "Sample1153",
  "DateOfIncident": "20200531",
  "TimeofIncident": "135211",
  "CreateDate": "20200531",
  "CreateTime": "135552",
  "UpdateDate": "",
  "UpdateTime": "",
  "DispatchDate": "20200531",
  "DispatchTime": "135748",
  "DepartureDate": "20200531",
  "DepartureTime": "144822",
  "Crash": "Y",
  "HazardousMaterials": "N",
  "VegetationFire": "N",
  "VehicleFire": "Y",
  "DisabledVehicle": "Y",
  "DebrisOnRoadway": "Y",
  "Injury": "Y",
  "Fatality": "N",
  "Latitude": 25.325974,
  "Longitude": -84.626554,
  "StreetAddress": "5032 SampleStreet, AFloridaCity, FL, 12345",
  "Remark": "Additional info and comments",
  "EstimatedArrivalDate": "20200531",
  "EstimatedArrivalTime": "141448",
  "ArrivalDate": "20200531",
  "ArrivalTime": "141612",
  "RoadBlockage": "Y",
  "NumberOfLanesBlocked": 2,
  "BlockedLanes": "1L;2T",
  "DirectionOfTravel": "S",
  "NorthSouthIntersectingStreet": "NS DemoStreet, AFloridaCity, FL",
  "EastWestIntersectingStreet": "EW OtherStreet, AFloridaCity, FL",
  "IntersectionMileage": 0.31,
  "UsngCoordinates": "16RGP3891703152",
  "StreetName": "SampleStreet, AFloridaCity, FL",
  "MileMarker": 332,
  "City": "AFloridaCity",
  "County": "AFloridaCounty",
  "Vehicles": [
    "blue Volvo sedan",
    "red Ford pickup"
  ]
}
```

C# HTTP POST example using JSON payload:

```
// serialize the RoadwayIncidentData object to JSON
var jsonContent = new
StringContent(JsonSerializer.Serialize(roadwayIncidentData),Encoding.UTF8,"application/json");
jsonContent.Headers.ContentType = new
MediaTypeHeaderValue("application/json");

// create an instance of the System.Net.Http.HttpClient class
var httpClient = new HttpClient();
var uri = new
System.Uri("https://s4.geoplan.ufl.edu/RoadwayIncidentExchange/notify");

// submit an asynchronous POST request
var response = await httpClient.PostAsync(uri, jsonContent);

// check that the POST request succeeded
if (response.StatusCode == HttpStatusCode.OK) {...}
```

C# RoadwayIncidentData Class:

```
public class RoadwayIncidentData
{
    public string PsapName { get; set; }
    public string RespondingAgencyName { get; set; }
    public string CadIncidentId { get; set; }
    public string AgencyCaseNumber { get; set; }
    public string DateOfIncident { get; set; }
    public string TimeofIncident { get; set; }
    public string CreateDate { get; set; }
    public string CreateTime { get; set; }
    public string UpdateDate { get; set; }
    public string UpdateTime { get; set; }
    public string DispatchDate { get; set; }
    public string DispatchTime { get; set; }
    public string DepartureDate { get; set; }
    public string DepartureTime { get; set; }
    public string Crash { get; set; }
    public string HazardousMaterials { get; set; }
    public string VegetationFire { get; set; }
    public string VehicleFire { get; set; }
    public string DisabledVehicle { get; set; }
    public string DebrisOnRoadway { get; set; }
    public string Injury { get; set; }
    public string Fatality { get; set; }
    public decimal Latitude { get; set; }
    public decimal Longitude { get; set; }
    public string StreetAddress { get; set; }
    public string Remark { get; set; }
    public string EstimatedArrivalDate { get; set; }
    public string EstimatedArrivalTime { get; set; }
    public string ArrivalDate { get; set; }
    public string ArrivalTime { get; set; }
    public string RoadBlockage { get; set; }
    public int NumberOfLanesBlocked { get; set; }
    public string BlockedLanes { get; set; }
    public string DirectionOfTravel { get; set; }
    public string NorthSouthIntersectingStreet { get; set; }
    public string EastWestIntersectingStreet { get; set; }
    public decimal IntersectionMileage { get; set; }
    public string UsngCoordinates { get; set; }
    public string StreetName { get; set; }
    public int MileMarker { get; set; }
    public string City { get; set; }
    public string County { get; set; }
    public List<string> Vehicles { get; set; }
}
```

Table A5-1 Required Data Elements

Category	Name	JSON/XML Attribute	Data Type	Domain Values	Description
IDs	PSAP NAME	PsapName	string	PSAP's name	Name of the PSAP which sends this alert
	RESPONDING AGENCY NAME	RespondingAgencyName	string	[Agency 1], [Agency 2] ...	Name of the responding agencies such as law enforcement, fire etc
	CAD INCIDENT ID	CadIncidentId	string	CAD incident ID	CAD incident ID
	AGENCY CASE NUMBER	AgencyCaseNumber	string	Case number ID	Case number ID associated with the CAD incident ID
Incident Time	DATE OF THE INCIDENT	DateOfIncident	string	YYYYMMDD	The date on which this incident happened
	TIME OF THE INCIDENT	TimeofIncident	string	HHMMSS	The time of day when this incident happened
	CREATED DATE	CreateDate	string	YMMMDD	The date on which this incident record is created, only applicable for new incident alerts
	CREATED TIME	CreateTime	string	HHMMSS	The time of day when this incident record is created, only applicable for new incident alerts
	UPDATED DATE	UpdateDate	string	YYYYMMDD	The date on which this incident record is created, only applicable for incident updates
	UPDATED TIME	UpdateTime	string	HHMMSS	The time of day when this incident record is created, only applicable for incident updates
Dispatch	DISPATCH DATE	DispatchDate	string	YYYYMMDD	Dispatch date of the first responding unit
	DISPATCH TIME	DispatchTime	string	HHMMSS	Dispatch time of the first responding unit
	DEPARTURE DATE	DepartureDate	string	YYYYMMDD	The date on which the last responding unit leaves the scene, only applicable for incident updates
	DEPARTURE TIME	DepartureTime	string	HHMMSS	The time of day when the last responding unit leaves the scene, only applicable for incident updates
Incident Type	CRASH	Crash	char(1)	{Y, N}	Whether this is a crash incident
	HAZARDOUS MATERIALS	HazardousMaterials	char(1)	{Y, N}	Whether hazardous materials are involved
	VEGETATION FIRE	VegetationFire	char(1)	{Y, N}	Whether a vegetation fire is involved
	VEHICLE FIRE	VehicleFire	char(1)	{Y, N}	Whether a vehicle fire is involved
	DISABLED VEHICLE	DisabledVehicle	char(1)	{Y, N}	Whether any disabled vehicle is involved
	DEBRIS ON ROADWAY	DebrisOnRoadway	char(1)	{Y, N}	Whether there is debris on roadway
Injury Severity	INJURY	Injury	char(1)	{Y, N}	Whether the incident results in any injury
	FATALITY	Fatality	char(1)	{Y, N}	Whether the incident results in any fatality
Location	LATITUDE	Latitude	string	(24.395932, 31.003545)	The latitude of the incident location
	LONGITUDE	Longitude	string	(-87.626521, -79.819864)	The longitude of the incident location
	STREET ADDRESS	StreetAddress	string	A valid street address in FL	The location of the incident location
Others	REMARK	Remark	string		Additional information and comments

Table A5-2 Additional Recommended Data Elements

Category	Name	JSON/XML Attribute	Data Type	Domain Values	Description
Dispatch	ESTIMATED ARRIVAL DATE	EstimatedArrivalDate	string	YYMMDD	Estimated dispatch date of the first responding unit
	ESTIMATED ARRIVAL TIME	EstimatedArrivalTime	string	HHMMSS	Estimated dispatch time of the first responding unit
	ARRIVAL DATE	ArrivalDate	string	YYMMDD	Actual arrival date of the first responding unit, only applicable for incident updates
	ARRIVAL TIME	ArrivalTime	string	HHMMSS	Actual arrival time of the first responding unit, only applicable for incident updates
Road Blockage	ROAD BLOCKAGE	RoadBlockage	char(1)	{Y, N}	The existence of road blockage
	NUMBER OF LANES BLOCKED	NumberOfLanesBlocked	string	(1, 9)	The number of lanes blocked due to the incident
	BLOCKED LANES	BlockedLanes	string	N1D1; N2D2... Ni = {1, 2, 3, 4, 5, 6, 7, 8, 9} Di = {L, R, T}	Identify the lanes that are currently blocked. Ni is a one-digit integer that refers to the lane number, D marks if the lane is a left-turn lane (L), right-turn lane (R) or through lane (T)
	DIRECTION OF TRAVEL	DirectionOfTravel	string	(N, S, W, E)	The direction of travel
	INTERSECTION - STREET NAME N/S	NorthSouthIntersectingStreet	string	A valid street name located in Florida	The street name of the northbound/southbound roadway crossing the closest intersection to the incident location
	INTERSECTION - STREET NAME W/E	EastWestIntersectingStreet	string	A valid street name located in Florida	The street name of the westbound/eastbound roadway crossing the closest intersection to the incident location
	INTERSECTION-MILEAGE	IntersectionMileage	integer		The distance from the incident location to the closest intersection in miles
	USNG COORDINATES	UsngCoordinates	string	A valid USNG value located in Florida	The US National Grid value of the incident location
	STREET NAME	StreetName	String	A valid street name located in Florida	The street name of the roadway on which the incident is located. This is to be used in combination with the Mile Marker variable.
	MILE MARKER	MileMarker	string	(1, 900)	The closest mile marker to the incident location
	CITY	City	string	A valid city name in Florida	The name of the city where the incident is located
COUNTY	County	string	A valid county name in Florida	The name of the county where the incident is located	
Vehicle Description	VEHICLES	EstimatedArrivalDate	Collection of strings	["<Color1> <Type1> <Make1> ", "<Color2> <Type2> <Make2> "]...	Information about involved vehicles. If a field is unknown, leave it blank.

Appendix 6: Current Positioning Methods Supporting PSAP

Incident location is the most critical information for effective dispatch in TIM. As discussed in Section 2.2, CAD system reports incident location based on the auto-detected caller's location identified by the 911 system and caller's verification. While 911 systems can identify the street address of landlines in the Automatic Location Identification database with good accuracy, their accuracy in detecting locations of cell phone callers vary depending on callers' cellphones (smartphones and non-smartphones), settings on the cellphones (turning on and off location features) and their adjacency to cell towers. This appendix discusses typical position methods to locate cellphones and the accuracy FDOT can expect from CAD location information for 911 calls from cellphones.

There are three positioning methods to track the location of a caller: Global Positioning System (GPS), Wi-Fi tracking, and cellular tower triangulation. Global Positioning System (GPS), Wi-Fi tracking require that callers have a smartphone while cellular tower triangulation works for all cellphones. According to a survey by Pew Research Center, the share of people that own smartphones is 81%, and the share of any kind of cellphone is 96% in 2019 (Pew Research Center, 2019).

GPS positioning method uses more than three satellites to find the location of a device that can receive satellite signals. Satellite can measure the distance from the satellite to the device so that the possible locations of a device are on a sphere centered at a single satellite. When two spheres intersect, the possible locations of the device can be scaled down to a circle. When the circle intersects with a third sphere, the possible location becomes two points. The point closer to the earth is the location of the device. GPS-enabled smartphones typically have an accurate range within a 5-meter (16 ft) radius under the open sky (Frank van Diggelen, 2015). However, the accuracy can get worse when the user is inside a multiple story building or surrounded by tall buildings or trees.

Wi-Fi tracking uses the location database of the Wi-Fi access point to determine the location of smartphones within its range. The accuracy is about 100-300 feet if the location of access points has been stored in the database, and the Wi-Fi feature on the smartphone is enabled (Tiwari, 2017). GPS and Wi-Fi tracking can collect more accurate information than cellular tower triangulation, but they can only be enabled on a smartphone.

The "Phase II location" in the 911 system is identified through cell tower triangulation method. Cell tower triangulation uses multiple cell towers to calculate the distance between towers and the cellphone. The accuracy depends on how many towers the cellphone can detect. A single tower can only determine that the location of a cellphone is on the fringe of a circle as shown in Figure A6-1 (Tracki, 2020), so the method works poorly in rural areas with few cellphone tower coverages. If the call is made in an urban center where towers are abundant, the accuracy could be about 300-feet. If there is no tower coverage by any service provider, people cannot make the call.

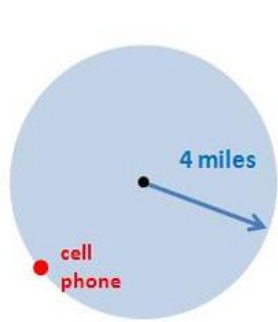

Cell phone detected within a certain distance of a single tower.

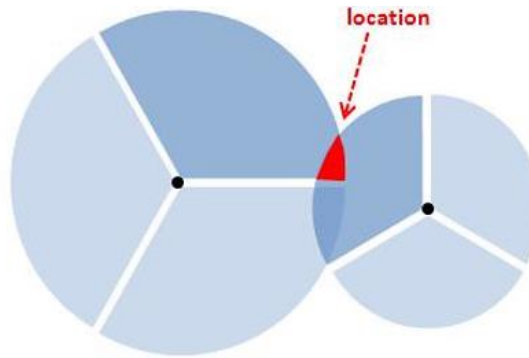

Cell phone detected within a certain distance of two towers with directional antennae.

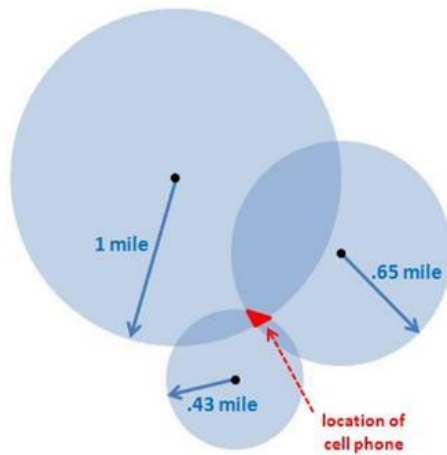

Triangulation – cell phone detected within a certain radius of each of 3 cell towers – the area where each cell tower overlaps the phone is where it is pinpointed.

Figure A6-1 Example of How Cellular Tower Triangulation Works (Tracki, 2020)

In order to allow local emergency responders to be dispatched quickly to help all callers with meaningful and accurate location information, Phase I E911 rules issued by Federal Communications Commission (FCC) require wireless service providers to provide the location of the cell tower. Phase II E911 rules require wireless service providers to transmit the location of a wireless 911 call by GPS and other methods. Phase II generally requires the accuracy to be within 50 to 300 meters, depending on the type of technology used. It also requires the accuracy to be incrementally improved through 2024 (Federal Communications Commission, 2020). Figure A6-2 shows how Phase I and Phase II are incorporated in identifying the location of emergency callers.

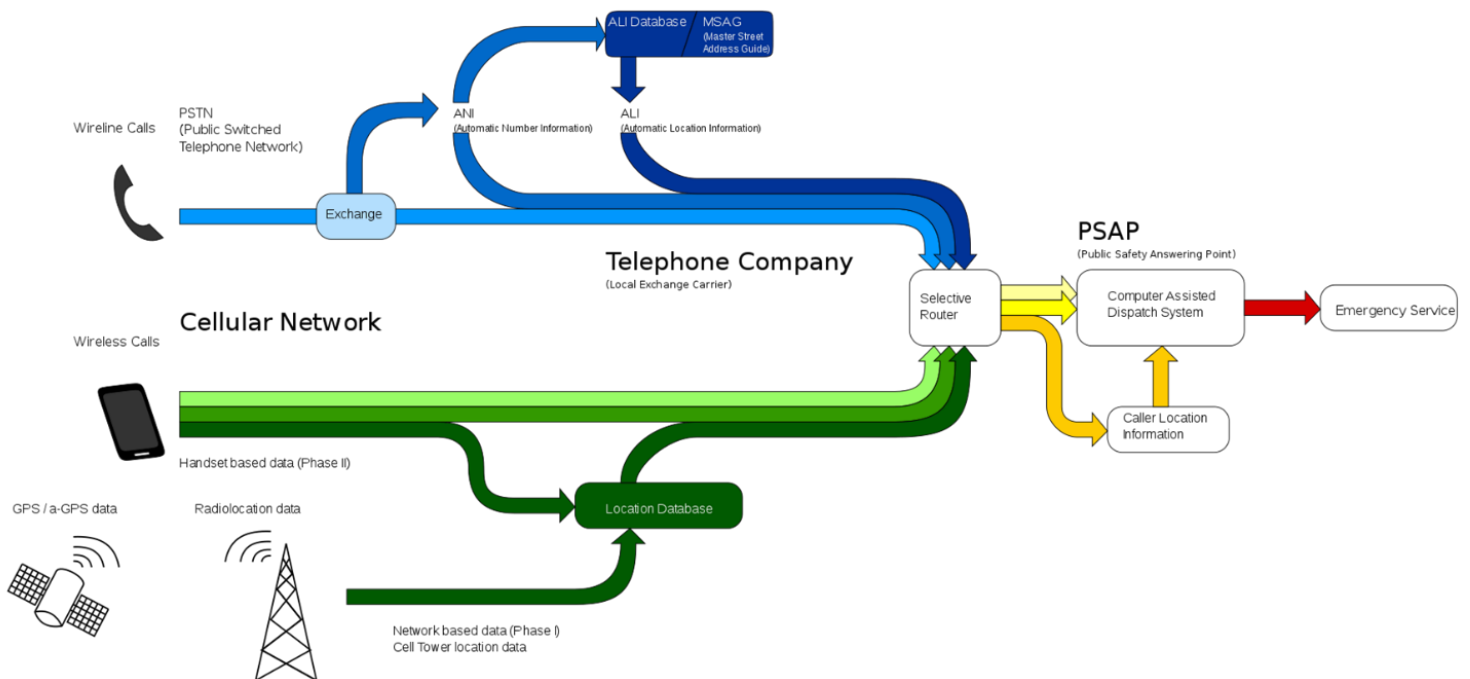

Figure A6-2 Identifying Location of Emergency Callers (Wikipedia, 2020)

In summary, the accuracy of the autodetected caller's location is better when caller is using a smartphone with GPS location service and Wi-Fi service turned on, less blockage in the air between the caller and the satellites, more than three cellular towers reaching the caller. Depending on the situation, PSAPs can get the pinpointed location of the caller, or just the location of the cellular tower, which could be miles away from the caller.