

SOUTHERN PLAINS
TRANSPORTATION CENTER

**Impact of Deicing Salts
on Corrosion Rates of MSE Reinforcement
– Phase 2**

Joseph Waugh
Priyantha W. Jayawickrama, Ph.D.
Hoyoung Seo, Ph.D., P.E.
Sangwook Bae, Ph.D., P.E.

SPTC14.1-36-F-II

**Southern Plains Transportation Center
201 Stephenson Parkway, Suite 4200
The University of Oklahoma
Norman, Oklahoma 73019**

DISCLAIMER

The contents of this report reflect the views of the authors, who are responsible for the facts and accuracy of the information presented herein. This document is disseminated under the sponsorship of the Department of Transportation University Transportation Centers Program, in the interest of information exchange. The U.S. Government assumes no liability for the contents or use thereof.

TECHNICAL REPORT DOCUMENTATION PAGE

1. REPORT NO. SPTC14.1-36-F Phase 2	2. GOVERNMENT ACCESSION NO.	3. RECIPIENTS CATALOG NO.	
4. TITLE AND SUBTITLE Impact of Deicing Salts on Corrosion Rates of MSE Reinforcement – Phase 2		5. REPORT DATE November 20, 2019	
		6. PERFORMING ORGANIZATION CODE	
7. AUTHOR(S) Rahul Muduganti, Priyantha W. Jayawickrama, Sangwook Bae and Hoyoung Seo		8. PERFORMING ORGANIZATION REPORT	
9. PERFORMING ORGANIZATION NAME AND ADDRESS Texas Tech Center for Multidisciplinary Research in Transportation Texas Tech University Box 41023 Lubbock, Texas 79409		10. WORK UNIT NO.	
		11. CONTRACT OR GRANT NO. DTRT13-G-UTC36	
12. SPONSORING AGENCY NAME AND ADDRESS Southern Plains Transportation Center 201 Stephenson Pkwy, Suite 4200 The University of Oklahoma Norman, OK 73019		13. TYPE OF REPORT AND PERIOD COVERED Final June 2014 – November 2019	
		14. SPONSORING AGENCY CODE	
15. SUPPLEMENTARY NOTES University Transportation Center			
16. ABSTRACT SPTC Project 14.6-36: Phase II involved a detailed laboratory study in which rates of corrosion were measured in MSE steel reinforcement specimens embedded in a granular MSE backfill. Two separate gradations, AASHTO standard gradation for MSE backfill and AASHTO NO.57 of one selected crushed limestone source obtained from Vulcan materials in Brownwood, Texas were included in this phase of the study. The materials were subjected to repeated cycles of saturation (inundation) and desaturation (drainage) and changes in rates of corrosion as well as changes in electrochemical properties and moisture content were monitored continuously. Tests were conducted with fresh water (RO water) only and with a saline solution followed by fresh water. The above saturation-desaturation regime was adopted to simulate exposure to runoff from deicing salt applications and/or coastal flooding followed by flushing out of salt by rain water that percolate through backfill. All tests were conducted in replicates of two. The resistivity of the coarse granular backfill under fully saturated conditions was found to be higher than that of the standard backfill. However, the factor that had the greatest impact on the rate of corrosion was the material's ability to drain quickly. The coarse granular backfill responded more readily when saline water was introduced. But it also recovered more quickly during subsequent cycles of fresh water saturation-desaturation cycles.			
17. KEY WORDS MSE backfill; corrosivity; Electrochemical properties; electrical resistivity, corrosion rate		18. DISTRIBUTION STATEMENT No restrictions. This publication is available at www.sptc.org and from the NTIS.	
19. SECURITY CLASSIF. (OF THIS REPORT) Unclassified	20. SECURITY CLASSIF. (OF THIS PAGE) Unclassified	21. NO. OF PAGES 62	22. PRICE

SI* (MODERN METRIC) CONVERSION FACTORS				
APPROXIMATE CONVERSIONS TO SI UNITS				
SYMBOL	WHEN YOU KNOW	MULTIPLY BY	TO FIND	SYMBOL
LENGTH				
in	inches	25.4	millimeters	Mm
ft	feet	0.305	meters	m
yd	yards	0.914	meters	m
mi	miles	1.61	kilometers	km
AREA				
in ²	square inches	645.2	square millimeters	mm ²
ft ²	square feet	0.093	square meters	m ²
yd ²	square yard	0.836	square meters	m ²
ac	acres	0.405	hectares	ha
mi ²	square miles	2.59	square kilometers	km ²
VOLUME				
fl oz	fluid ounces	29.57	milliliters	mL
gal	gallons	3.785	liters	L
ft ³	cubic feet	0.028	cubic meters	m ³
yd ³	cubic yards	0.765	cubic meters	m ³
NOTE: volumes greater than 1000 L shall be shown in m ³				
MASS				
oz	ounces	28.35	grams	g
lb	pounds	0.454	kilograms	kg
T	short tons (2000 lb)	0.907	megagrams (or "metric ton")	Mg (or "t")
TEMPERATURE (exact degrees)				
°F	Fahrenheit	5 (F-32)/9 (F-32)/1.8	Celsius or	°C
ILLUMINATION				
fc	foot-candles	10.76	lux	lx
fl	foot-Lamberts	3.426	candela/m ²	cd/m ²
FORCE and PRESSURE or STRESS				
lbf	poundforce	4.45	newtons	N
lbf/in ²	poundforce per square inch	6.89	kilopascals	kPa
APPROXIMATE CONVERSIONS FROM SI UNITS				
SYMBOL	WHEN YOU KNOW	MULTIPLY BY	TO FIND	SYMBOL
LENGTH				
mm	millimeters	0.039	inches	in
m	meters	3.28	feet	ft
m	meters	1.09	yards	yd
km	kilometers	0.621	miles	mi
AREA				
mm ²	square millimeters	0.0016	square inches	in ²
m ²	square meters	10.764	square feet	ft ²
m ²	square meters	1.195	square yards	yd ²
ha	hectares	2.47	acres	ac
km ²	square kilometers	0.386	square miles	mi ²
VOLUME				
mL	milliliters	0.034	fluid ounces	fl oz
L	liters	0.264	gallons	gal
m ³	cubic meters	35.314	cubic feet	ft ³
m ³	cubic meters	1.307	cubic yards	yd ³
MASS				
g	grams	0.035	ounces	oz
kg	kilograms	2.202	pounds	lb
Mg (or "t")	megagrams (or "metric ton")	1.103	short tons (2000 lb)	T
TEMPERATURE (exact degrees)				
°C	Celsius	1.8C+32	Fahrenheit	°F
ILLUMINATION				
lx	lux	0.0929	foot-candles	fc
cd/m ²	candela/m ²	0.2919	foot-Lamberts	fl
FORCE and PRESSURE or STRESS				
N	newtons	0.225	poundforce	lbf

*SI is the symbol for the International System of Units. Appropriate rounding should be made to comply with Section 4 of ASTM E380. (Revised March 2003)

Acknowledgements

The authors wish to thank the Southern Plain Transportation Center (SPTC) for their sponsorship of this study. Also, we would like to thank West Texas Paving and Vulcan Materials company for the assistance they provided in procuring MSE backfill used in this study. We would like to extend special thanks Ricardo Rendon-Bernot for his role in developing an automatic data acquisition system. The authors thank Ms. Kim Harris for her administrative support throughout the project.

Impact of Deicing Salts on Corrosion Rates of MSE Reinforcement

Final Report-Part II November 2019

by

Rahul Muduganti
Graduate Research Assistant
Department of Civil, Environmental, and Construction Engineering
Texas Tech University

Priyantha W. Jayawickrama, Ph.D.
Associate Professor
Department of Civil, Environmental, and Construction Engineering
Texas Tech University

Sang-Wook Bae, Ph.D., P.E.
Assistant Professor
Department of Civil, Environmental, and Construction Engineering
Texas Tech University

and

Hoyoung Seo, Ph.D., P.E.
Assistant Professor
Department of Civil, Environmental, and Construction Engineering
Texas Tech University

**Southern Plains Transportation Center
201 Stephenson Pkwy, Suite 4200
The University of Oklahoma
Norman, OK 73019**

Table of Contents

Chapter 1 – Introduction	1
1.1 General Background	1
1.2 Research Objectives	2
1.3 Research Approach	2
1.4 Report Organization	2
Chapter 2 – Literature Review	4
2.1 General Overview	4
2.2 MSE Wall Backfill	4
2.3 Measurement of Corrosion Rate in Laboratory	6
Chapter 3 – Experimental Program	8
3.1 General Overview	8
3.2 Equipment Setup:	8
3.3 Material Characteristics Tests	14
3.4 Moisture Content Measurements on Backfill Materials:	19
3.5 Resistivity Measurements for Backfill Materials:	21
3.6 Corrosion Rate Measurements on Backfill Materials:	22
Chapter 4 – Results and Data Analysis	26
4.1 General Overview	26
4.2 Moisture Content Results and Data Analysis	26
4.3 Resistivity Results and Data Analysis:	28
4.4 Corrosion Rate Results and Data Analysis:	38
Chapter 5 – Conclusions and Recommendations	45
5.1 General Overview	45
5.2 Conclusions	45
5.3 Recommendations	46
References	48

List of Figures

Figure 1. Open-Circuit Potential of the Cell (Carino 1999);	6
Figure 2. Texas Tech Box Schematic	10
Figure 3. Texas Tech Box Views.....	10
Figure 4. Geotextile Laid in Texas Tech Box.....	11
Figure 5. Top View of Experimental Setup	12
Figure 6. Side View of Experimental Setup	12
Figure 7. Experimental Setup.....	13
Figure 8. Saltwater Preparation.....	14
Figure 9. Sieve Shakers.....	15
Figure 10. Particle Size Distribution For AASHTO No.57 and AASHTO Standard Materials.....	16
Figure 11. Ph Measured Using Gropro	18
Figure 12. Moisture Sensors	20
Figure 13. Arduino Mega 2560 Device	21
Figure 14. Terminal Connectors Used To Complete Electrical Connections Between Electrodes and Resistivity Measuring Instrument	22
Figure 15. Polarization Resistance Electrodes.....	23
Figure 16. Polarization Resistance Electrodes.....	24
Figure 17. Moisture Content Comparison Between AASHTO Standard and AASHTO No.57 Gradations	27
Figure 18. Resistivity Comparison Between AASHTO Standard and AASHTO No.57 Gradations Inundated With RO Water.....	30
Figure 19. Resistivity Comparison Between AASHTO Standard Backfill Inundated with RO Water	31
Figure 20. Resistivity Comparison Between AASHTO Standard and AASHTO No.57 Gradations Inundated With Saltwater.....	33
Figure 21. Resistivity Comparison Between AASHTO No.57 Inundated with Saltwater .	34
Figure 22. Resistivity Comparison For AASHTO Standard Gradation Inundated with Saltwater.....	35
Figure 23. Resistivity Comparison For AASHTO No. 57 Gradation Inundated with RO and Saltwater.....	36
Figure 24. Resistivity Comparison For AASHTO Standard Gradation Inundated with RO vs Saltwater.....	37
Figure 25. Corrosion Rates Comparison Between AASHTO Standard and AASHTO No.57 Gradations Inundated With RO Water.....	39
Figure 26. Corrosion Rate Comparison For Aashto No.57 Gradation Inundated With RO Water.....	40
Figure 27. Corrosion Rate Comparison Between AASHTO Standard and AASHTO No.57 Gradations Inundated With Saltwater and RO Water.....	41
Figure 28. Corrosion Rate Comparison for AASHTO No. 57 Gradation Inundated in RO and Saltwater.....	43
Figure 29. Corrosion Rate comparison for AASHTO Standard Gradation inundated in RO and Saltwater	44

List of Tables

Table 1. Recommended Limits of Electrochemical Properties for Reinforced Fills with Steel Reinforcement (FHWA 2009b) 4

Table 2. Limiting Corrosion Rates for Galvanized and Residual Carbon Steel in Moderately Corrosive Backfill with Controlled Electrochemical Properties (Fhwa 2009b) 5

Table 3. Specifications of Texas Tech Box Compartments 9

Table 4. Number of Boxes Representing Each Corrosive Environment..... 11

Table 5. AASHTO No. 57 Material Gradation 16

Table 6. AASHTO Standard Material Gradation 17

Table 7. Ph from AASHTO T-289 Test Method..... 17

Table 8. Chloride and Sulfate Contents in Backfill..... 19

Table 9. Volumetric Moisture Content Relations Between Two Gradations During Saturated-Conditions 28

Table 10. Resistivity Relations Between Two Gradations During Saturated-Drained Conditions Inundated with RO Water 31

Table 11. Resistivity Relations Between No.57 and standard Gradations Inundated with Saltwater 34

Table 12. Resistivity Relationships for No.57 Inundated With RO and Saltwater 36

Table 13. Resistivity Comparison for AASHTO Standard Gradation Inundated with ROVs Saltwater..... 37

Table 14. Corrosion Rate Relations between Two Gradations During Saturated-Drained Conditions Inundated with RO Water 40

Table 15. Corrosion Rate Relations Between Two Gradations During Saturated-Drained Conditions Inundated with Saltwater 42

Table 16. Corrosion Rate Comparison for AASHTO No. 57 Gradation Inundated in RO and Saltwater..... 43

Table 17. Corrosion Rate Comparison for AASHTO Standard Gradation Inundated in RO and Saltwater..... 44

Executive Summary

SPTC Project 14.6-36 examined corrosion rates of MSE steel reinforcement specimens embedded in granular MSE backfill. Of special interest in this study was the exposure of the reinforcing elements to runoff from deicing salt applications and/or coastal flooding and its impact on rates of corrosion. This research study was completed in two separate phases. This report documents the work completed in Phase II of the research.

SPTC Project 14.6-36: Phase II involved a detailed laboratory study in which rates of corrosion were measured in MSE steel reinforcement specimens embedded in a granular MSE backfill. Two separate gradations, AASHTO standard gradation for MSE backfill and AASHTO NO.57 of one selected crushed limestone source obtained from Vulcan materials in Brownwood, Texas were included in this phase of the study. The materials were subjected to repeated cycles of saturation (inundation) and desaturation (drainage) and changes in rates of corrosion as well as changes in electrochemical properties and moisture content were monitored continuously. Half of the tests were conducted with fresh water (RO water) only while the remaining half was exposed to a saline solution followed by fresh water. The above saturation-desaturation regime was adopted to simulate exposure to runoff from deicing salt applications and/or coastal flooding followed by flushing out of salt by rain water that percolate through backfill. All tests were conducted in replicates of two.

The key findings from the SPTC Project 14.6-36: Phase II are as follows: (a) A very significant difference was observed in moisture retention behavior of the two gradations of the same material. This resulted in corresponding changes in electrical resistivity and rates of corrosion. For this reason, the overall rates of corrosion in steel specimens embedded in the coarse granular backfill was significantly lower. While the electrical resistivity of the AASHTO No. 57 was 8-9 times higher than that of AASHTO standard material during full saturation, they were different by a factor of 30-45 under drained conditions. The difference in rates of corrosion was similar. During saturation cycles, corrosion rates were different in the two materials by a factor of 4-8 whereas during desaturation cycles they were different by a factor of 90-145. (b) Introduction of saline water had a dramatic impact in lowering electrical resistivity and increasing corrosion rates in both materials. The initial corrosion rates measured in AASHTO No. 57 material saturated with saline water was 73 times that measured in the same material with fresh water. The corresponding increase in material with standard gradation was only 10-11. This can be explained based on the fact that the material with standard gradation does not drain as efficiently. Therefore, when saline water is introduced, the fresh water that is retained in the material helps in diluting it and attenuating its effect on corrosion rates. However, on the other hand,

the coarse granular material, AASHTO No.57 showed much better capability to recover during subsequent cycles of inundation with fresh water. Accordingly, the corrosion rates measured after 3 cycles of fresh water, were only two times as large when compared with fresh water saturation. For AASHTO standard gradation, the corresponding ratio was approximately 4.

Chapter 1 – Introduction

1.1 General Background

Mechanically stabilized earth (MSE) structures provide support to many civil engineering infrastructure systems, particularly those used in the transportation sector such as bridge abutments and freeways. Due to its rapid construction speed, cost effectiveness, and aesthetic appeal these structures are used widely in almost all parts of U.S.A. Use of galvanized steel reinforcements is common in MSE wall construction because of their high strength and stiffness as well as robustness during installation. These reinforcements are embedded within MSE soil backfill during the construction process and are subjected to tensile forces during their service period. One major drawback in the use of steel reinforcement is its susceptibility to corrosion, especially in those environments where they are prone to salt exposure. The rate of corrosion in the steel reinforcement is an important design consideration because it determines the design life of the MSE wall system.

Organizations like the United States Department of Transportation/Federal Highway Administration (USDOT/FHWA) proclaim corrosive potential of a backfill material is evaluated by resistivity (ρ), pH, chlorides (Cl⁻), sulfates (SO₄²⁻), and organic content. In MSE walls soil backfill is used as a standard backfill material but if MSE walls are exposed to saltwater inundations because of marine water flooding's or deicing salts according to USDOT FHWA backfill can have grains up to 1.0in size (AASHTO No.57 gradation) for easy drainage of saltwater. The conventional method of evaluating the resistivity an important parameter to measure the corrosive potential of a MSE backfill is through AASHTO T 288-12 which is only concerned with the resistivity of the backfill in a fully saturated condition. Such a tests approach completely ignores the drainage potential of the coarse backfills (AASHTO No. 57 gradation). Also, after saltwater inundation in sand backfills (AASHTO Standard gradation) will retain some of the salt leading to drastic increase in the corrosion rate while the coarse aggregate readily drains out most of the water and limits further corrosion on steel reinforcement. These after effects of inundations needed to be evaluated, quantified and appropriate relationships must be established between drained and fully saturated conditions.

1.2 Research Objectives

The main objectives of this research study can be summarized as follows:

- To capture the drainage potential of AASHTO No.57 backfill when compared to AASHTO standard backfill.
- To quantify and compare the effects of salts intrusion on MSE reinforcements when AASHTO standard and AASHTO No.57 backfill are used.
- To quantify and compare AASHTO Standard materials resistivity and corrosion rates during fresh and saltwater inundations.
- To quantify and compare AASHTO No.57 materials resistivity and corrosion rates during fresh and saltwater inundations.

1.3 Research Approach

In order to achieve those objectives the selected backfill materials with their reinforcements are subjected to periodic inundations with RO water, and corrosion rates and resistivity readings are measured simultaneously. In this manner, the influence of the backfill gradation on electrical resistivity of backfill materials and rates of corrosion of steel reinforcements embedded in them are monitored for both saturated and drained conditions. In addition, parallel testing will be conducted where backfill materials are inundated with one cycle of saltwater and three consecutive cycles of fresh water to simulate field conditions where saltwater enters into MSE backfill through deicing salts or coastal flooding and later washed out by rainwater. The respective corrosion rate and resistivity readings are compared to determine the impact of saltwater intrusion into the MSE backfill. The trends exhibited by the backfill materials as the inundations progress in each corrosion environment are monitored and quantified.

1.4 Report Organization

This report consists of five chapters. Chapter 2 includes a literature review on documents consisting covering areas such as MSE backfills recommended limits for electrochemical properties, moderately corroding MSE reinforcements corrosion limits, the concepts regarding corrosion rates and resistivity measurement techniques. The experimental program procedure performed by Texas Tech University research team is described in detail in Chapter 3. Chapter

4 explains the results and trends obtained from the experimental program. Chapter 5 provides conclusions obtained from the results and recommendations from the research study.

Chapter 2 – Literature Review

2.1 General Overview

This chapter begins with discussing a national publication document which specifies the different parameters and their test methods to determine them in order to evaluate the corrosive potential of a MSE backfill. Later, the chapter specifies the corrosion limits for a steel specimen in a moderately corroding fill material. The chapter concludes with the concepts used in measuring corrosion rates and resistivity measurements.

2.2 MSE Wall Backfill

Most of the MSE walls are designed and constructed under the regulatory guidelines of United States Department of Transportation Federal Highway Administration (USDOT FHWA). A program from the USDOT FHWA called The National Highway Institute (NHI), published course document (Fhwa 2009b) provides the electrochemical properties which evaluate the corrosive potential of an MSE backfill along with its limiting values and an appropriate test to determine them.

Table 1. Recommended Limits of Electrochemical Properties for Reinforced Fills with Steel Reinforcement (FHWA 2009b)

Parameter	Criteria Limitations	Test Method
Resistivity	> 3000 ohm-cm	AASHTO T-288
pH	> 5 and < 10	AASHTO T-289
Chlorides	< 100 PPM	ASTM D4327
Sulfates	< 200 PPM	ASTM D4327
Organic Content	1% maximum	AASHTO T-267

From NHI published course document (FHWA 2009b) the limiting corrosion rates for galvanized steel and residual carbon steel in a moderately corrosive backfill material having the controlled electrochemical property limits as mentioned in Section 2.2 of this chapter are summarized in Table 2.

Table 2. Limiting Corrosion Rates for Galvanized and Residual Carbon Steel in Moderately Corrosive Backfill with Controlled Electrochemical Properties (FHWA 2009b)

For zinc/side:	0.58 mils/year (15 $\mu\text{m}/\text{year}$) (first two years)
For zinc/side:	0.16 mils/year (4 $\mu\text{m}/\text{year}$) (thereafter)
For residual carbon steel/side:	0.47 mils/year (12 $\mu\text{m}/\text{year}$) (thereafter)

In the process of galvanization when iron and zinc rod are in an electrolyte and electrodes are connected to an electrical conductor zinc undergoes oxidation while iron undergoes reduction. The half-cell potential of an electrode is the factor which drives the half-cell reactions to oxidation or reduction. The standard half-cell potential is measured with respect to a reference electrode under a unit concentration of solutions at standard temperature (Guy 1976). Higher the half-cell potential higher the tendency to lose electrons and to act as anodes in their respective electrolytic cell. The standard half-cell potential of zinc is -0.76V (Fontana 1986) and standard half-cell potential of carbon steel is -0.44V (Carino 1999) thus, leading zinc to act as an anode. In MSE reinforcements the same steel specimen act as both anode and cathode.

Assume an electrolytic cell where zinc electrode is connected to an iron electrode through an external circuit and standard solution of zinc ions are in contact with standard solutions of iron ions through a salt bridge. The electrons flow from zinc to iron electrode through external circuit depleting zinc electrode and iron ions get deposited on the iron electrode from the electrons through the external circuit. The difference between those two electrodes half-cell potential is known as the open circuit potential of the cell.

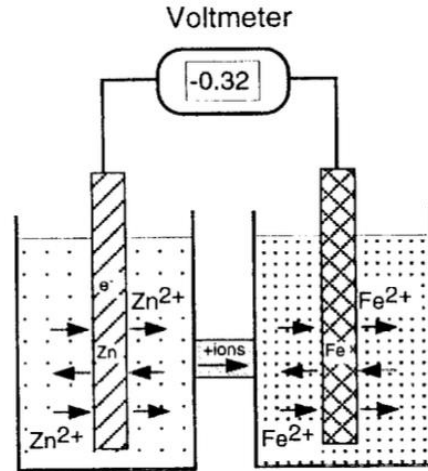

Figure 1. Open-Circuit Potential of the Cell (Carino 1999);

2.3 Measurement of Corrosion Rate in Laboratory

Polarization Resistance is a faster and non-destructive way of measuring corrosion rate. In an equilibrium cell, a potentiostat is used to apply small external potential and measures the current caused by that external potential. For, small deviations about open circuit potential the change in voltage ΔE and Δi exhibit a linear relationship. Thus, polarization resistance is defined as the slope of a potential versus current density plot. (“ASTM G59 - 97(2014) Standard Test Method for Conducting Potentiodynamic Polarization Resistance Measurements” n.d.)

$$R_p = \frac{\Delta E}{\Delta i} \quad (4)$$

Polarization resistance and corrosion current density can be related to Stern – Geary coefficient B.

$$i_{corr} = \frac{B}{R_p} \quad (5)$$

R_p is ohm-cm², i_{corr} is $\mu A/cm$ and B is in V. from (“ASTM G59 - 97(2014) Standard Test Method for Conducting Potentiodynamic Polarization Resistance Measurements” n.d.)

From the NHI manual, the conversion factor or Stern-Geary coefficient B for the steel reinforcements can be assumed as 0.035V in order to obtain average data (FHWA 2009a).

Faraday's Law states that the quantity of a substance produced or consumed at an electrode is proportional to the amount of electric charge passing through the electrode. Thus, from the Faraday's law corrosion rate is given by the following equation as

$$CR = 3.27 \times 10^{-3} \frac{icorrEW}{\rho} \quad (6)$$

EW is the equivalent weight of the electrode, ρ is the density of corroding material in g/cm³. ("ASTM G59 - 97(2014) Standard Test Method for Conducting Potentiodynamic Polarization Resistance Measurements" n.d.)

Castro et al. 1996 concluded that Activated Titanium Reference electrode has low impedance for moderate to high frequencies which makes these embedded electrodes ideal for polarization resistance. It also specifies that in the moist environment the activated titanium reinforcement provides a long-term stability. The conventional Copper-copper electrodes cannot be used since significant errors can occur because of high resistance during dry conditions.

Sagues et al. 1998 conducted saltwater contamination on a laboratory placed backfill materials and concluded that saltwater has increased the corrosion rate by one order of magnitude in both galvanized and plain steel specimens. They have used polarization resistance method to measure the corrosion rate and titanium plate as the reference electrode. The document states that saltwater contamination at year zero can compromise the project 10 times earlier.

Chapter 3 – Experimental Program

3.1 General Overview

This research aimed to quantify the drainage characteristics advantage of AASHTO No. 57 gradation over AASHTO Standard gradation and to compare how those two gradations of the same material impact corrosion rate in MSE reinforcements during saturated-drained cases. Also, the experimental plan included measurement of the effects of salts intrusion on steel reinforcements when these two gradations are used as MSE backfills.

In order to achieve those goals these two backfill materials are subjected to periodic inundations with RO water, and simultaneously corrosion rates and resistivity readings are measured. Here how the gradation of backfill is going to affect the corrosion rate and resistivity measurements in saturated-drained cases is monitored. Also, other sets of boxes are inundated with one cycle of saltwater and consecutive RO water cycles to replicate the field condition when saltwater entered into MSE walls through deicing salts or coastal flooding's and later washed out by rainwater. The respective corrosion rate and resistivity readings are compared with their counterpart boxes which are exposed to pure RO water. The trends exhibited by the backfill materials as the inundations progress in each corrosion environments are monitored and quantified.

This chapter begins with the experimental setup developed to measure the corrosion rates, moisture content and resistivity readings for each corrosive environment. Later this chapter discusses the process of evaluating corrosion potential of graded backfill materials by conducting characterization tests, then leads to the procedure how moisture content readings are measured. Followed by procedure adopted to measure resistivity measurements through backfill materials and ends with the corrosion rate measuring test method in steel reinforcements.

3.2 Equipment Setup:

Texas Tech Box:

In order to measure corrosion rates in MSE reinforcements and resistivity through backfill material simultaneously, Texas Tech research team had designed a glass box called

Texas Tech Box. The box consists of one bottom compartment and two top compartments one for resistivity measurements and other top compartment is for corrosion rate measurements. Bottom compartment consists of two valves (inlet and outlet valve). The outlet valve is placed at the base of the bottom compartment and the inlet valve is placed on the side wall of the bottom compartment. During inundations water enter Texas Tech box through the inlet valve, then into bottom compartment and through holes they enter into top compartments. The resistivity top compartment and bottom compartment share 7 holes. Corrosion rate top compartment and bottom compartment share 18 holes. Each hole has a diameter of 3/8 inch. All box walls have a thickness of 3/4 inch glass. Outlet and internal valves have an internal diameter of 1/4 inch.

Table 3. Specifications of Texas Tech Box Compartments

	Length	Width	Height	Volume
Bottom Compartment	31.75 cm (12.5in)	20.32 cm (8 in)	6.35 cm (2.5in)	4096.76 cm ³
Resistivity Top Compartment	9.525 cm (3.75in)	20.32 cm (8 in)	13.97 cm (5.5in)	2703.86 cm ³
Corrosion Rate Top Compartment	20.32 cm (8 in)	20.32 cm (8 in)	13.97 cm (5.5in)	5768.24 cm ³

In the resistivity top compartment, there are two stainless steel plates which act as electrodes. In order to determine the resistivity of that backfill, the box factor of resistivity top compartment is calculated by the following equation

$$\text{Box Factor} = \frac{\text{Area of Electrode}}{\text{Distance between Electrodes}}$$

$$\text{Box Factor of Resistivity Top Compartment} = \frac{3.75" * 5.5"}{8"} = 2.578" = 6.54\text{cm}$$

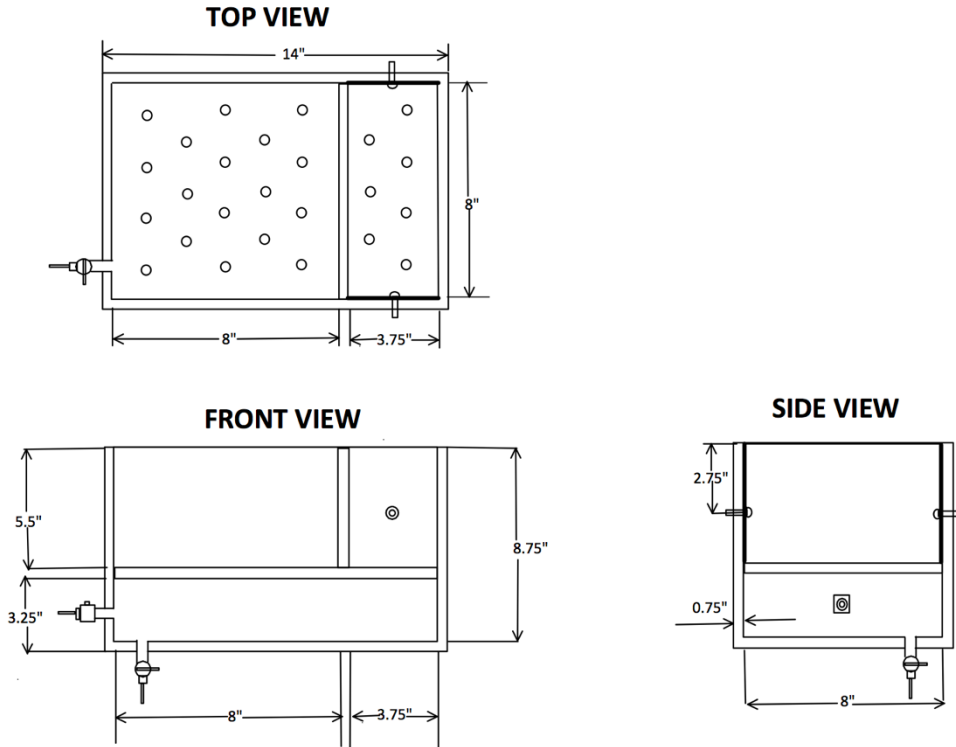
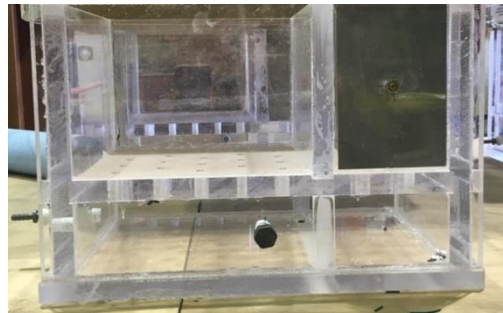

Figure 2. Texas Tech Box Schematic



a. Texas Tech Box Isometric View



b. Texas Tech Box Front View



c. Texas Tech Box Top View

Figure 3. Texas Tech Box Views

Geotextile is laid on the base of top compartments in order to prevent flushing of fines during drainage. The edges of Geotextile were sealed to the box using a water-resistant sealant, Flex Seal.

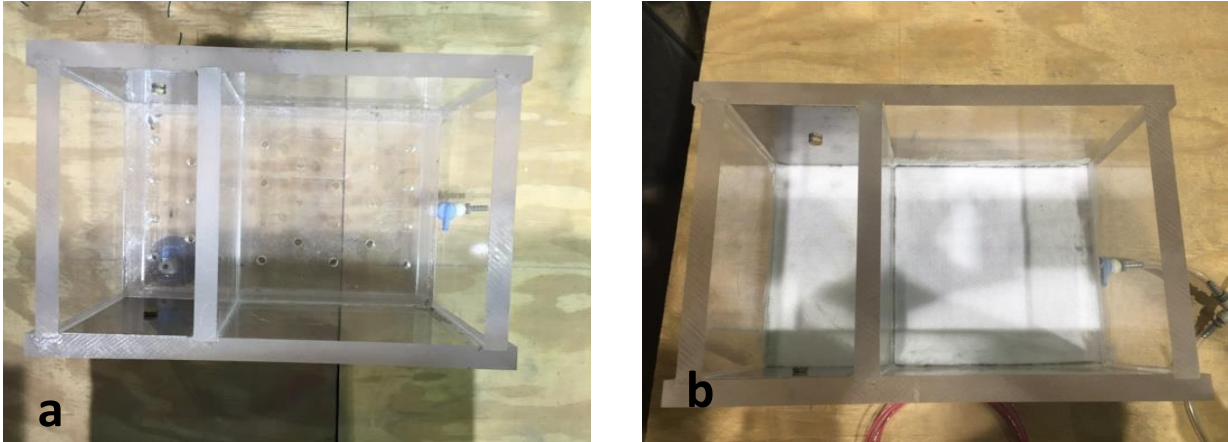

Figure 4. Geotextile Laid in Texas Tech Box

(a) Texas Tech box without Geotextile, (b) Texas Tech box with Geotextile

We have a total of eight boxes, out of which every two boxes represent a unique corrosive environment as described in the following table.

Table 4. Number of Boxes Representing Each Corrosive Environment

	Saltwater (0.6% Salt)	RO Water
AASHTO No. 57 (Coarse Backfill)	2	2
AASHTO Standard (Sand Backfill)	2	2

Moisture sensors were placed in two boxes, one in AASHTO Standard backfill and other in AASHTO No. 57 backfill to monitor the moisture content variations during inundations. In the following figure, MC represents box used to measure moisture content readings whereas CR&R represents boxes used to measure corrosion rate and resistivity readings. Overhead tanks have a capacity of 275 gallons and the hosing between boxes have a diameter of 1/4". Water tanks have a head of 7' from the inlet valves of boxes.

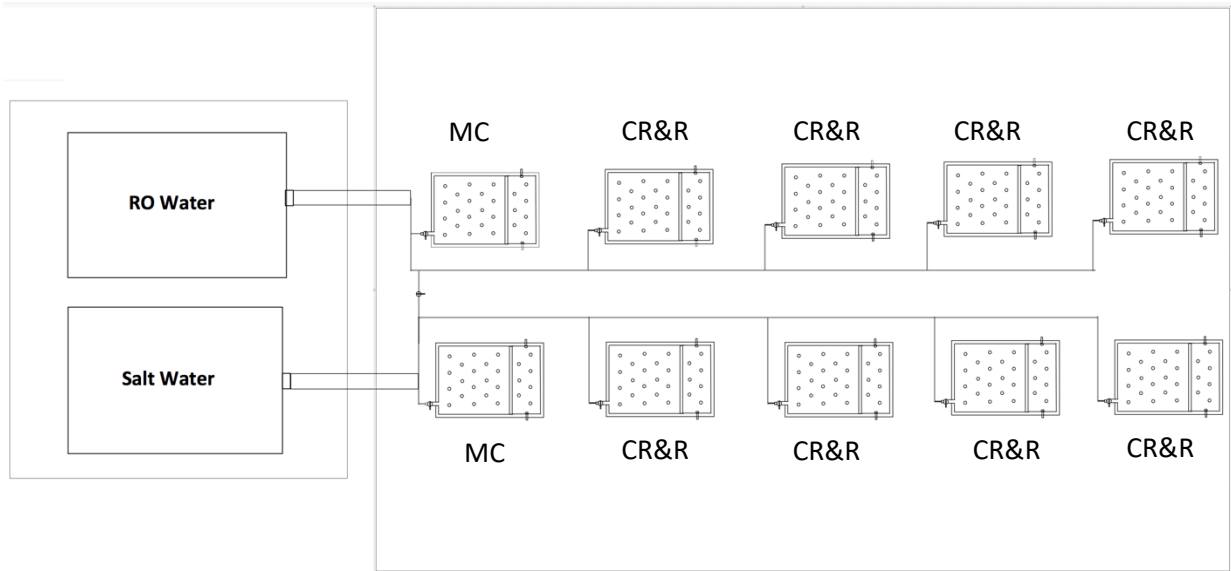

Figure 5. Top View of Experimental Setup

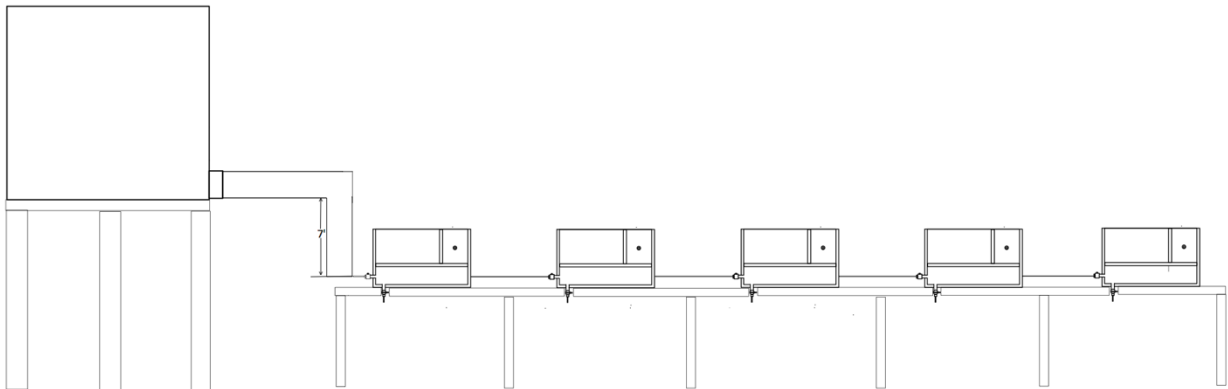

Figure 6. Side View of Experimental Setup



(a)



(b)



(c)

Figure 7. Experimental Setup; (a) Complete Setup, (b) Texas Tech box with AASHTO No.57, (c) Texas Tech box with AASHTO Standard

Saltwater was prepared by adding 0.6% of salt in weight to RO water. Small batches of water were mixed with salts in temporary tanks using mixers and later we did pump the saltwater to the overhead tank. Suresoft pool salt was used because of its high solubility. A power drill with a mixer attachment was used to dissolve the salts.



(a)



(b)



(c)



(d)

Figure 8. Saltwater Preparation

(a) Driller used to dissolve salts, (b) Salt used to prepare saltwater, (c) Pump used to transfer water to the overhead tank, (d) Saltwater after all salts dissolved

3.3 Material Characteristics Tests

As mentioned in Chapter 2, in order to evaluate corrosion potential of graded backfill materials characterization tests such as resistivity, pH, water-soluble sulfates and chlorides needed to be performed as per FHWA-NHI Courses No. 132042 and 132043. Thus, pH of the graded backfill was determined using AASHTO T-289 test method. In order to perform tests on water-soluble sulfates and chlorides tests in backfill materials first, sulfates and chlorides are extracted from the soil using FDOT method and later ASTM D4327 test is performed on the extracted water.

Matching Desired Gradation:

Source materials for the research project were brought from the local stockpile at Vulcan materials and it mostly comprises of limestone. The soil backfill material selected for this part of the research used two different gradation-requirements based on AASHTO Number 57 (No. 57) and AASHTO Standard materials. The particle size distribution data for AASHTO Standard and AASHTO No.57 were plotted in the figure along with their gradation limitations. AASHTO No. 57 gradation was prepared using Gilson TS-1 instrument and AASHTO Standard material was prepared using 12” sieve shaker. Vulcan’s material AASHTO No. 57 and AASHTO Standard gradations are specified in Table 5 and 6, respectively.

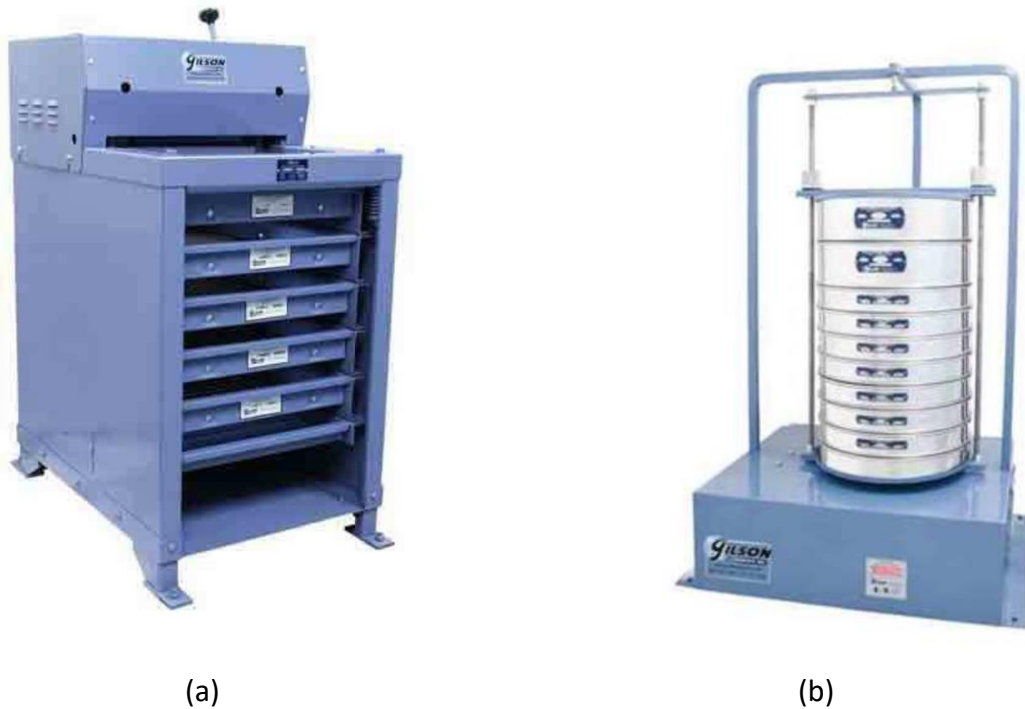

(a) Gilson TS-1 Instrument, (b) 12-in Sieve Shaker

Figure 9. Sieve Shakers

Figure 10. Particle Size Distribution for AASHTO No.57 and AASHTO Standard Materials

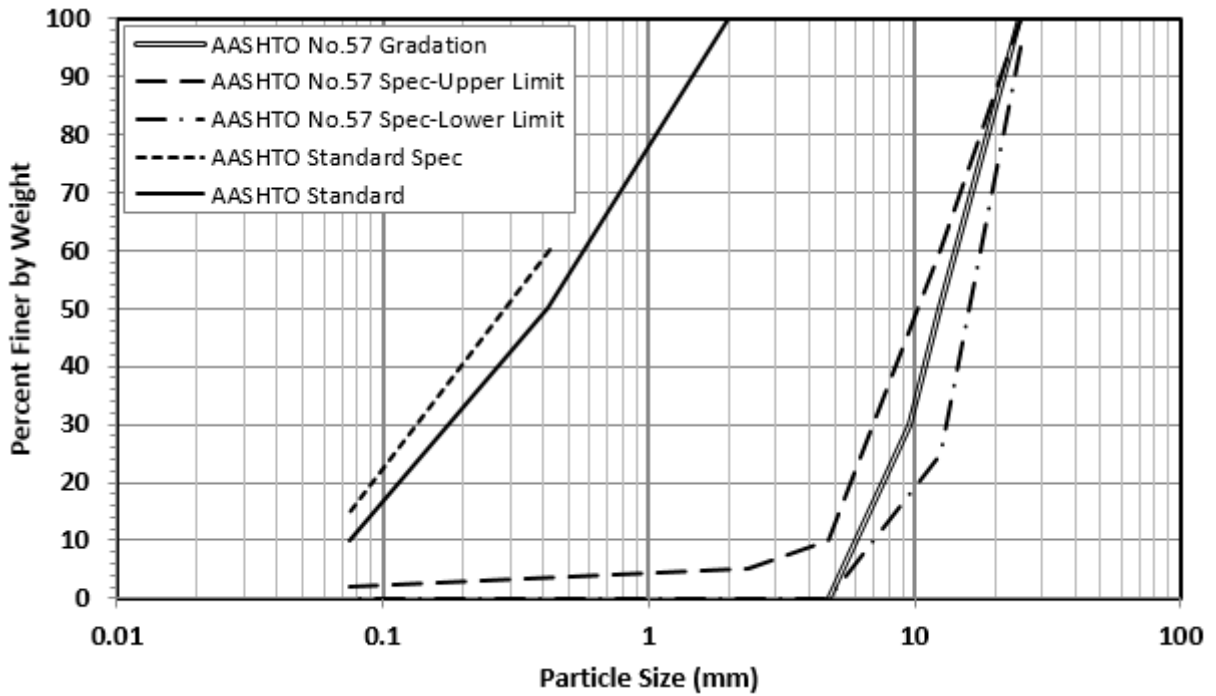

Table 5. AASHTO No. 57 Material Gradation

Gradation Criteria	AASHTO No. 57 Gradation (%)
Passing 25 mm (1 in.) sieve	100
Between 25 mm (1 in.) and 12.5 mm (1/2 in.) sieve	50
Between 12.5 mm (1/2 in.) and 9.51 mm (3/8 in.) sieve	20
Between 9.51 mm (3/8 in.) and 4.76 mm (No. 4) sieve	30
Passing 4.76 mm (No. 4) sieve	0

Table 6. AASHTO Standard Material Gradation

Gradation Criteria	AASHTO Standard Gradation (%)
Passing 2mm (No. 10) sieve	100
Between 2 mm (No. 10) and 0.420 mm (No. 40) sieve	50
Between 0.420 mm (No. 40) and 0.075 mm (No. 200) sieve	40
Passing 0.075 (No. 200) sieve	10

pH of MSE backfill (AASHTO T-289):

As per the AASHTO T-289 test method, 30 grams of material passing No. 10 sieve (AASHTO Standard gradation material) were added with 30ml of distilled water, allowing it to stand for one hour. In between for every 10-15 minutes, the soil solution is mixed with a glass rod. After an hour GroPro probe was calibrated for pH and submerged into the topmost part of the solution, and a pH value was measured. This is the standard test procedure for sand materials using AASHTO T-289 test method, but we have another gradation which is AASHTO No. 57 where if we crush the material to No. 10 sieve as specified in AASHTO manual our material eventually becomes AASHTO Standard gradation thus Texas Tech research team had decided to test 300grams of AASHTO No.57 gradation mixed with 300ml of distilled water so, that we can evenly involve all size grains in the test and repeated the same AASHTO T-289 which was performed for AASHTO Standard gradation. (AASHTO 1991)

Table 7. pH from AASHTO T-289 Test Method

	pH from AASHTO T-289 Test Method
AASHTO Standard Gradation	8.91
AASHTO No. 57 Gradation	9.68

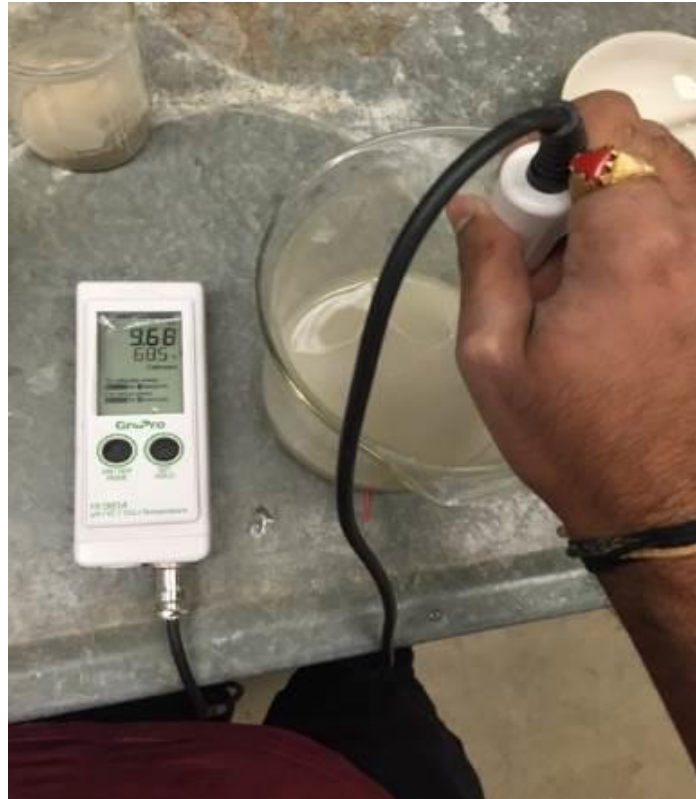

Figure 11. pH measured using GroPro

Sulfates and Chlorides in MSE Backfill:

According to FHWA-NHI Courses, No. 132042 and 132043 water soluble sulfates and chlorides in MSE backfill was measured using ASTM D4327 but this method doesn't specify how to extract water-soluble minerals from the backfill material thus Texas Tech researchers adopted FDOT method for extracting. 100grams of AASHTO standard material is diluted to 300ml of distilled water, then the solution is shaken vigorously for 20seconds and after 1-hour repeat agitation. Later we allowed it to stay still for 15 hours and solution is filtered through Whatman No.41 filter paper. This solution is tested using ASTM D4327-11. For AASHTO No. 57 Texas Tech researchers took 300grams of backfill and mixed it with 300ml of distilled water ("Florida Method of Test For Sulfate in Soil and Water" 2016), ("Florida Method of Test For Chloride in Soil and Water" 2016)and tested it following ASTM D4327-11 test method. ("ASTM D4327 - 17 Standard Test Method for Anions in Water by Suppressed Ion Chromatography" n.d.)

Table 8. Chloride and Sulfate Contents in Backfill

	Chloride Content in ppm	Sulfate Content in ppm
AASHTO Standard Gradation	57.0	340.95
AASHTO No. 57 Gradation	16.55	37.65

3.4 Moisture Content Measurements on Backfill Materials:

For moisture content measurements Decagon Devices EC-5 moisture sensors are used. Since sensor is made up of metal embedding the sensor in resistivity compartment or corrosion rate compartment might affect the resistivity or corrosion environment of backfill medium thus we had decided to use two more additional boxes (one for AASHTO Standard and one for AASHTO No. 57 materials) and placed those sensors in corrosion rate measuring compartment since it is big enough for sensor detection range. Sensors are placed along mid-height and mid-distance from walls in the corrosion rate measuring compartment. Data logger Em5b is used to store data from multiple EC-5 sensors and using ECHO utility software the frequency at which readings needed to be taken or how long and other user settings are can be altered. Later data from Em5b data logger using ECHO utility software moisture content readings for each sensor are transferred into the computer and using excel plots for change in moisture content during saturated-drained conditions are plotted. Moisture sensors provide volumetric moisture content data. Moisture content readings are recorded at every 2minutes frequency. Box saturation period is 4hours and the draining period is 20 hours later the inundation cycle repeats with same saturated-drained time periods for the next day.



Figure 12. Moisture Sensors

- (a) EC-5 Moisture Sensor, (b) Moisture Sensor Embedded in corrosion rate measuring compartment, (c) Data Logger EC-5 is used to store data and change measurements frequency

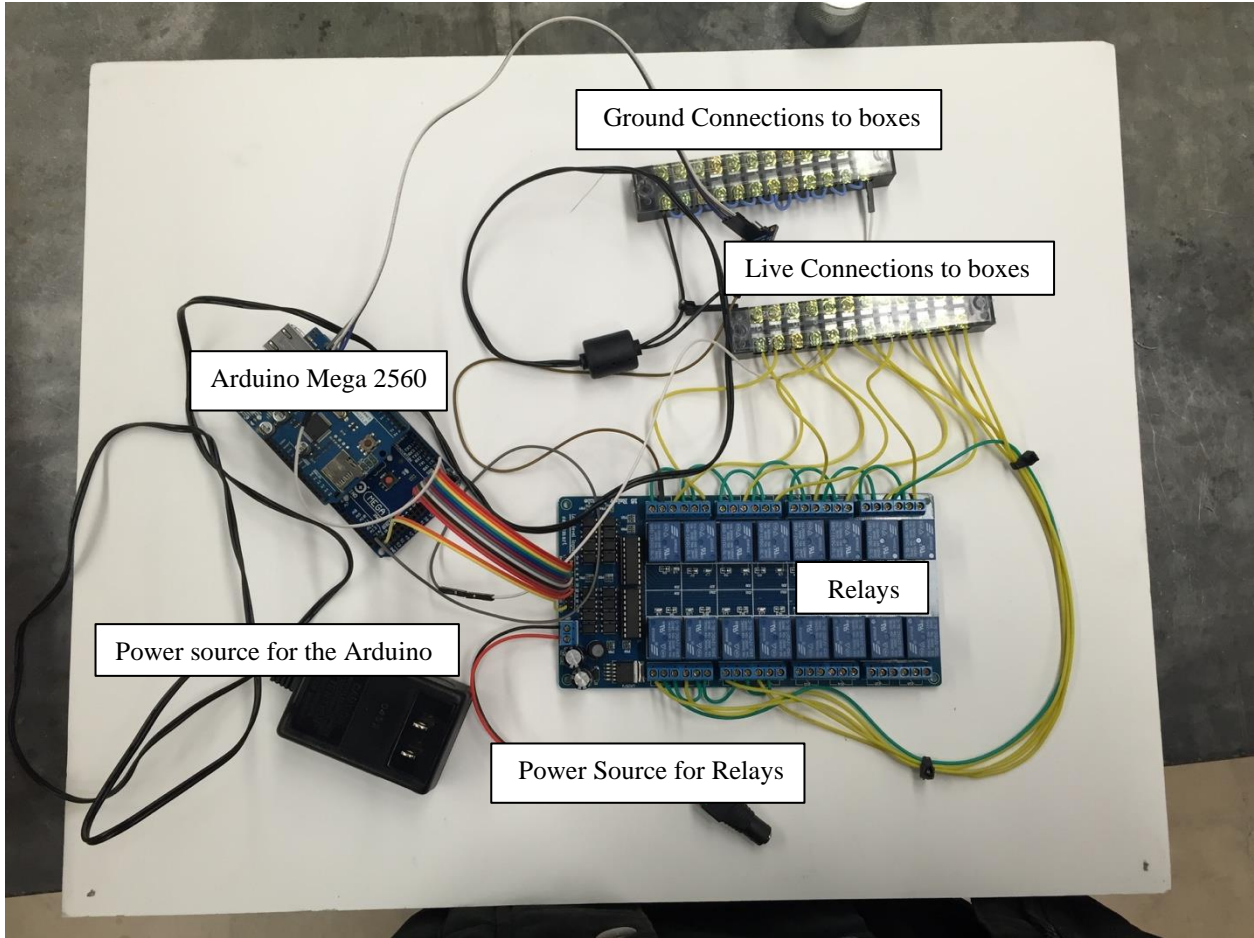

Figure 13. Arduino Mega 2560 Device

3.5 Resistivity Measurements for Backfill Materials:

Arduino Mega 2560 device is developed by Texas Tech research team in order to measure resistivity through a backfill material at frequent intervals. Arduino Mega 2560 component allow the user to compile new instructions such as data logging frequency, Overall experiment time period, input box factor value and time taken to measure each box resistivities. Resistivity of a backfill material during saturated (water fills all the voids)-drained conditions is calculated when relay apply a 12V across electrodes and measures current between those electrodes and send it to Arduino component. Then, Arduino component calculates resistivity from current, voltage and box factor parameters. This resistivity data then stored in memory card.

Terminal connectors were used to complete electrical connections between electrodes

and Arduino mega 2560 device (one electrode is connected to live connection and another electrode is connected to ground connection). Arduino software is used to compile any changes to the device. Later through memory card reader data is transferred to the computer and Microsoft Excel is used to process the data and plot graphs. U & O shaped terminal connectors are used to complete electrical connections between the electrodes and Arduino Mega 2560 device. Resistivity readings are taken at every one-hour frequency. Box saturation period is 4hours and the draining period is 20 hours later the inundation cycle repeats with same saturated-drained time periods for next day.

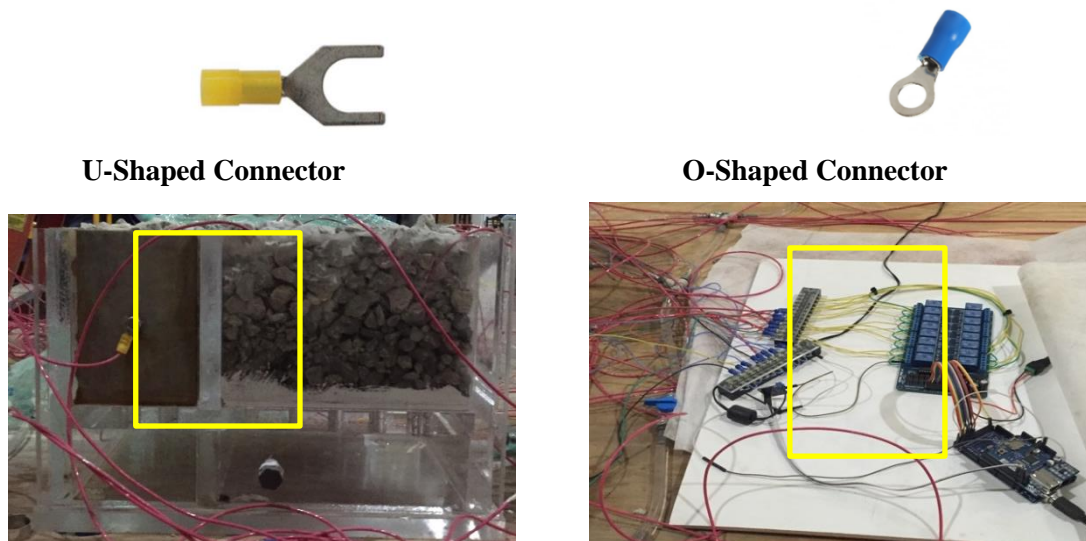
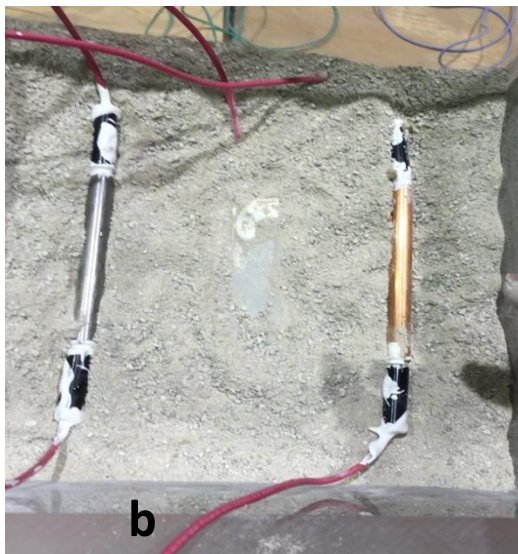
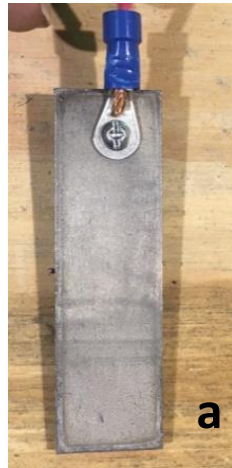

Figure 14. Terminal connectors used to complete electrical connections between electrodes and resistivity measuring instrument

3.6 Corrosion Rate Measurements on Backfill Materials:

A three-cell electrode system is adopted in order to perform polarization resistance method and to determine corrosion rates on steel reinforcements. Here steel rod is used as working electrode, titanium plate is used as a reference electrode and the copper rod is used as counter electrode. The steel rod is categorized as 12L14 carbon steel with a yield strength of 60ksi. Whereas titanium plate is of grade 2 and C101 grade copper rod is used. All these electrodes are placed along mid-height of box compartment. The distance between electrodes

center to center and distance between the center of the electrode to box walls is 2 inches. Steel and copper rods are of 3/8" diameter. In order to maintain an electrical connection all rods are drilled at top and banana pin with an electrical wire is inserted into that void. A water-resistant sealant called flex seal is used to seal those connections to prevent these connections to get in contact with water during inundations. For titanium plate, a hole is drilled at one side of the plate and using a screw-bolt mechanism and O type terminal connector a connection was made and sealed with flex seal.



(a) Titanium plate electrical connection using bolt-screw mechanism and O-shaped terminal connector, (b) Final Electrodes setup in AASHTO Standard Material, (c) Final Electrodes setup in AASHTO No.57 Material

Figure 15. Polarization Resistance Electrodes

One side of these electrical wire is connected to electrodes and other side Gamry cell connections. These cell connections go into multiplexer cell channels. A multiplexer connects up to eight electrochemical cells to one Gamry Potentiostat. Gamry ECM8 multiplexer is used and connected to a potentiostat (pstat 1).

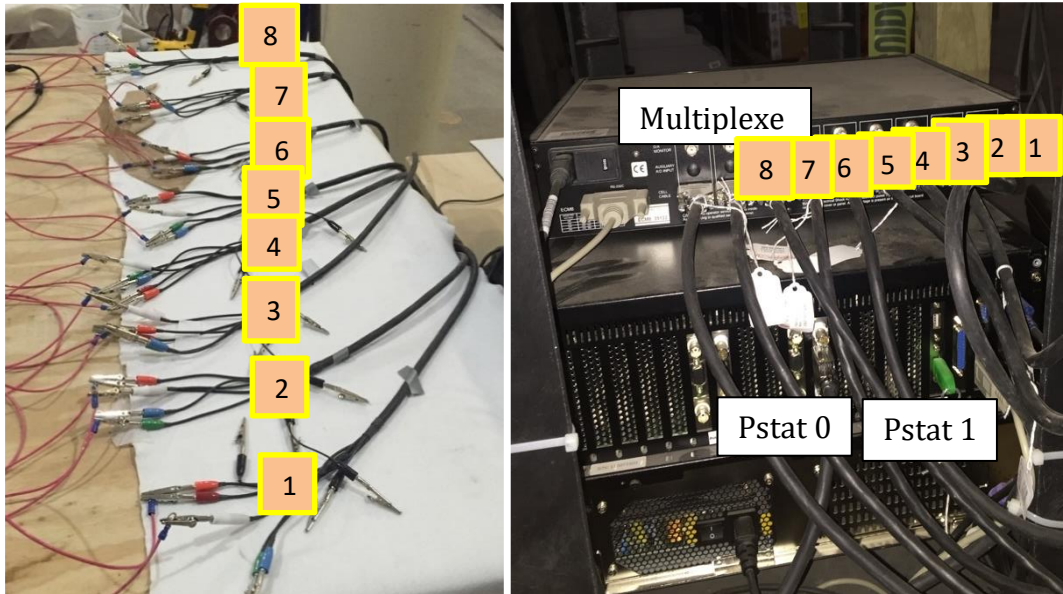

Figure 16. Polarization Resistance Electrodes

- (a) Electrical connections from electrodes to Gamry cell cables each label determine the channel in the multiplexer, (b) Gamry Equipment Multiplexer and the two potentiostats

Gamry Framework software is used to provide user instructions to the instrument and Gamry Echem Analyst is used to process the data. In Gamry Framework software in order to perform polarization resistance test using a multiplexer for all 8 boxes Multiplexer Rp/Ec Trend experiment is performed. Area of steel specimens in all boxes, the equivalent weight of steel, the density of steel specimens, the frequency at which curves needed to be plotted, total experiment time and speed at which scan rate needed to be done are all added as an input in Gamry software. The area of steel specimens in contact with the electrolyte is the area we need to input in framework software. This area is the total surface area of the rod excluding top and

bottom face area. As inundations, progress and saturation-drained cycles start to occur polarization resistance curves are being plotted at one curve per every hour frequency. Box saturation period is four hours and the draining period is 20 hours. This inundation-drainage cycle repeats several times, with the same time periods for each cycle.

Chapter 4 – Results and Data Analysis

4.1 General Overview

This chapter discusses the results and data analysis discovered from the experimental program performed by Texas Tech University's research team. The chapter begins with presenting the data from moisture sensors which are placed in additional two Texas Tech boxes and then discusses the results and data analysis for resistivity tests which are measured through AASHTO Standard and AASHTO No. 57 backfills. The chapter concludes with the data obtained from corrosion rate measurements on steel reinforcements which were exposed to different corrosive environments as mentioned in Chapter 3. In this chapter, data is accompanied by detailed explanations which reflect the measured readings and trends exhibited by backfills. In this chapter, AASHTO No. 57 is described as coarse material and AASHTO Standard is described as fine material.

4.2 Moisture Content Results and Data Analysis

As described in Chapter 3, the moisture sensors and steel reinforcement specimens are placed in separate compartments within the boxes as these metal sensors can interfere with the corrosive environment of backfill materials. One sensor is used for AASHTO Standard gradation and another sensor is used for AASHTO No. 57 gradation. These sensors are placed at mid-height and mid-distance from box walls in the big compartment. Moisture content readings were recorded at 2 minutes intervals as the backfill materials were subjected to repeated cycles saturation (inundation) and desaturation (draining).

The following plot provides data for volumetric Moisture content readings vs time. The readings were taken for four inundation cycles consisting of four saturated conditions and four drained conditions.

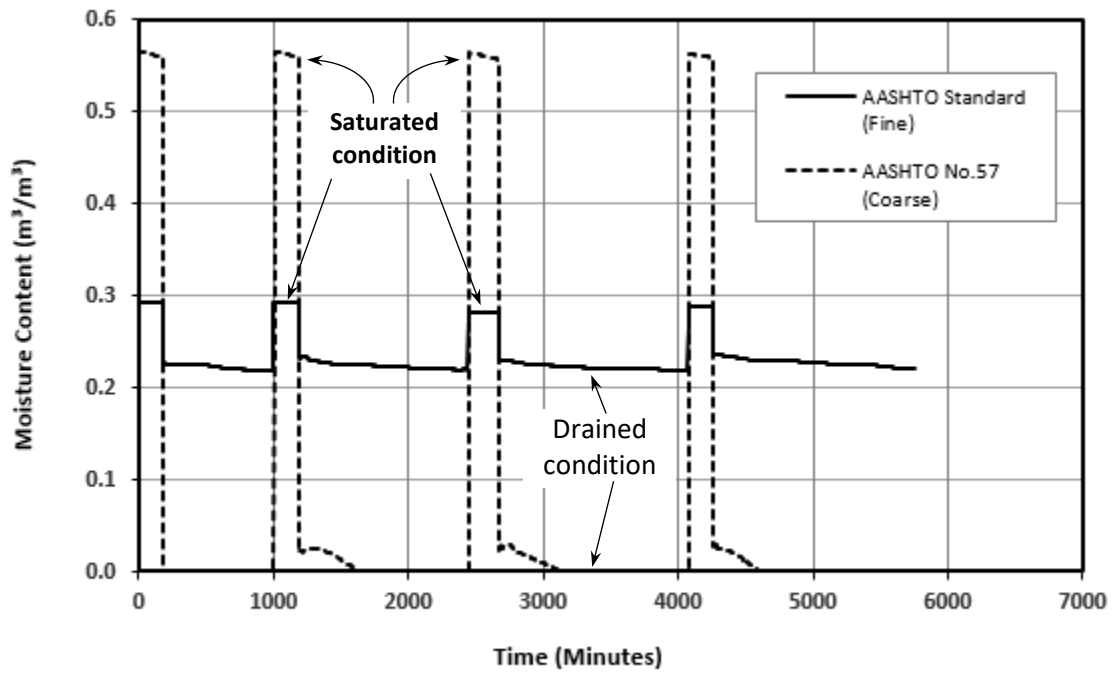

Figure 17. Moisture Content Comparison between AASHTO Standard and AASHTO No.57 Gradations

During the saturation period, No.57 gradation holds more water content than standard gradation, but when water starts to drain there is a significant drop in moisture content for No. 57. Whereas, AASHTO Standard material might drain a small quantity of water. These relations are quantified and presented in the table. From the plot at day 1 moisture sensor detects $0\text{m}^3/\text{m}^3$ volumetric moisture content thus relation for drained No.57 to other cases at day 1 are not calculated in the table. There is no significant change in moisture content readings from day 1 to day 4. Also for standard material, there is no considerable change in moisture content values during their drainage period of 20 hours. The change in moisture content in the standard material is approximately 25% from saturated to the drained case. In No.57 material moisture content at the saturated case is 22 times that of the drained case.

Table 9. Volumetric Moisture Content Relations Between Two Gradations During Saturated-Conditions

Day 1	% Difference during Saturation between Standard & No.57	92.5%
Day 1	Initial Drainage case MC relation for No.57 times Standard material	N/A
Day 1	For No. 57 gradation MC relation for initial Drained and Saturated	N/A
Day 1	% Difference between standard material initial drained & saturation	29.8%
Day 1	% Difference Between initial and final Drained case for Standard	2.7%
Day 2	% Difference during Saturation between Standard & No.57	92.2%
Day 2	Initial Drainage case MC relation for No.57 times Standard material	9.4 times
Day 2	For No. 57 gradation MC relation for initial Drained and Saturated	25.4 times
Day 2	% Difference between standard material initial drained & saturation	28.5%
Day 2	% Difference Between initial and final Drained case for Standard	3.5%
Day 3	% Difference during Saturation between Standard & No.57	99.3%
Day 3	Initial Drainage case MC relation for No.57 times Standard material	11.2 times
Day 3	For No. 57 gradation MC relation for initial Drained and Saturated	22.4 times
Day 3	% Difference between standard material initial drained & saturation	24.3%
Day 3	% Difference Between initial and final Drained case for Standard	3.1%
Day 4	% Difference during Saturation between Standard & No.57	95.5%
Day 4	Initial Drainage case MC relation for No.57 times Standard material	9.0 times
Day 4	For No. 57 gradation MC relation for initial Drained and Saturated	18.1 times
Day 4	% Difference between standard material initial drained & saturation	24.2%
Day 4	% Difference Between initial and final Drained case for Standard	4.8 %

4.3 Resistivity Results and Data Analysis:

The resistivity of a backfill material at frequent intervals is measured by Arduino Mega 2560 device. In this section, the resistivity measurements for AASHTO standard and AASHTO No. 57 materials are discussed first when they were inundated with RO water. Secondly, we

discuss the resistivity measurements made on the same two materials when they were subjected to inundation with one cycle of saltwater and 3 consecutive cycles of RO water. In this chapter RO water inundated AASHTO No. 57 is stated as coarse type material and AASHTO Standard is stated as fine type material. Saltwater inundated AASHTO No. 57 is stated as salt coarse type material and AASHTO Standard is stated as salt fine type material.

Case 1: Two Backfills inundated with RO water

The RO water saturated time period is represented by troughs (or valleys) in the resistivity curves. In the saturated case on Day 1, resistivity measured for AASHTO No.57 is 8.67 times to that measured for AASHTO standard. It should be noted that, even though the materials with different gradations were obtained from the same source, the material with standard gradation has a larger percentage of fine particles. These fine grained particles have large surface area coated with minerals. When this backfill material is inundated with water, large amounts of minerals go into solution resulting in lower resistivity than in the case of No. 57 material that have much larger particles.

In the drained case at day 1 resistivity through AASHTO No.57 material is 45.6 times to that of resistivity through AASHTO standard material. In AASHTO No.57 material when drainage has started from moisture sensor data approximately 93% of water has been drained resulting in only 7% of saturated water content which is probably coated with the grains is carrying current when 12V potential is applied on the electrodes by Arduino device resulting in high resistivity value whereas in standard gradation from moisture sensor data only 23% is drained and there is a considerable amount of water (77%) and dissolved ions still present in the box to carry current between electrodes resulting in much lower resistivity values.

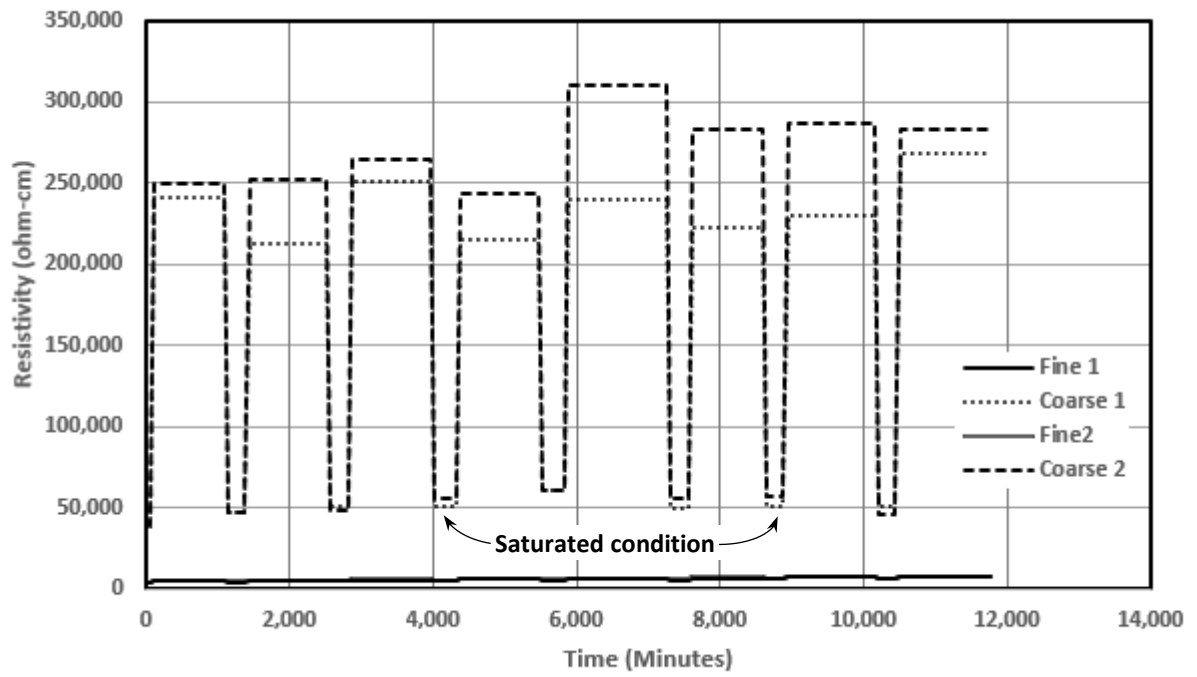

Figure 18. Resistivity Comparison between AASHTO Standard and AASHTO No.57 Gradations Inundated with RO Water

Table 10. Resistivity Relations between two gradations during saturated-drained conditions inundated with RO water

		Multiplier Factor
Day 1	Saturation Std to No.57	8.7 times
Day 1	Drained Std to No.57	45.6 times
Day 2	Saturation Std to No.57	9.6 times
Day 2	Drained Std to No.57	39.8 times
Day 3	Saturation Std to No.57	9.2 times
Day 3	Drained Std to No.57	41.2 times
Day 4	Saturation Std to No.57	10.4 times
Day 4	Drained Std to No.57	36.3 times
Day 5	Saturation Std to No.57	10.4 times
Day 5	Drained Std to No.57	39.8 times
Day 6	Saturation Std to No.57	8.8 times
Day 6	Drained Std to No.57	34.5 times
Day 7	Saturation Std to No.57	8.6 times
Day 7	Drained Std to No.57	33.2 times
Day 8	Saturation Std to No.57	6.9 times
Day 8	Drained Std to No.57	31.8 times

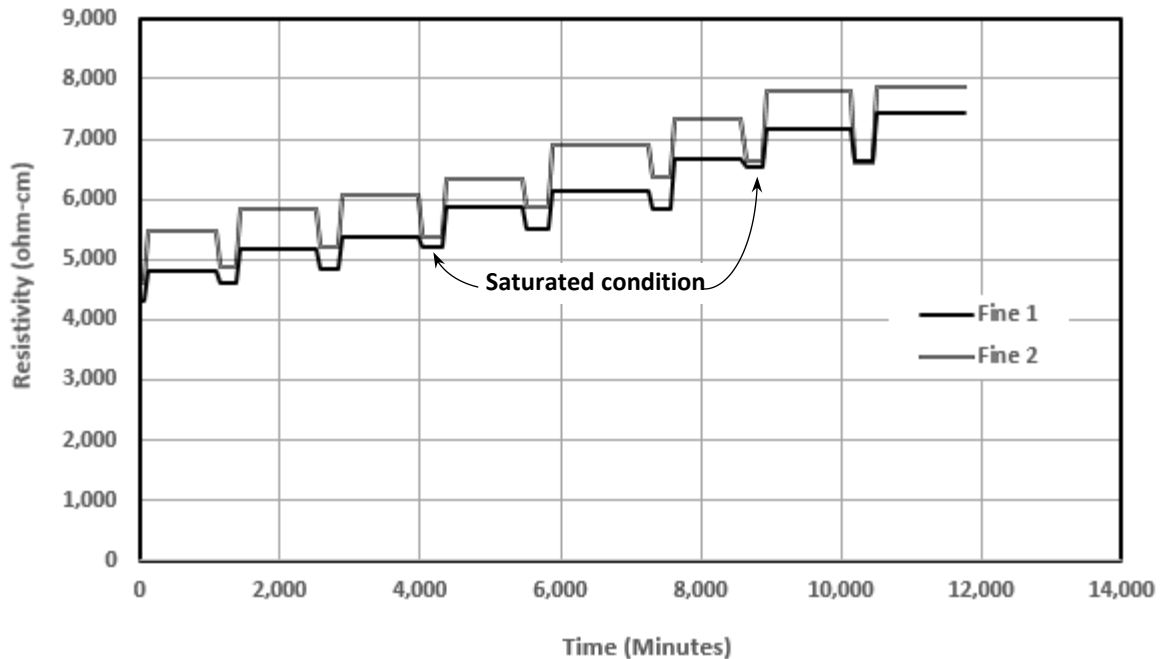

Figure 19. Resistivity Comparison between AASHTO Standard backfill inundated with RO Water

As AASHTO standard material start to expose towards more and more inundations the salts which are coated to the grains get dissolved in the water during saturation period and during drainage, water along with their dissolved salts are also washed out of box resulting in higher resistivities for next inundation cycle. After 8 cycles of inundations, the resistivity of the standard material is increased by 43% in drained conditions. After 8 cycles of inundations, the resistivity of the standard material is increased by 44% in saturated condition. Thus, exposure of backfill material to RO water inundations help backfill material develop non-conducting characteristics by flushing out all naturally occurring salts.

Case 2: Two Backfills are inundated with saltwater

In this case, boxes are inundated with 1 cycle of saltwater which has 0.6% salt concentration and then subjected to 3 RO water cycles. Later again 4th inundation cycle is inundated with saltwater and then subjected to 3 RO water cycles. In the plot red background represent inundation with saltwater during saturation period whereas blue background represents RO water inundation during their saturation period.

In AASHTO No.57 during saltwater inundation the resistivity at saturation condition is very low but after saltwater has drained the resistivity has increased 18 times. Even though there is a considerable amount of salt present in the box, the electrolyte was drained to carry current between electrodes is responsible for this situation. Later, when it is inundated with pure RO water the resistivity has decreased because of increase in water content and previously retained salts had led to increase in paths to transfer current between electrodes but this resistivity is not as low as previous (saltwater) cycle saturated case resistivity this is because of drainage characteristics of No.57 gradation which easily flushed out some salts during first cycle drainage period. Later when second cycle water is allowed to drain now the resistivity is increased higher than cycle 1 drained resistivity because now again some amount of salt is being flushed out. This pattern continued for consecutive RO water inundations where backfill flushed out salts and increased its resistivity until the second cycle of saltwater inundated boxes. Later, 2nd cycle of saltwater and there consecutive RO water inundations also exhibit the same trend where resistivity's drops and later starts to climb.

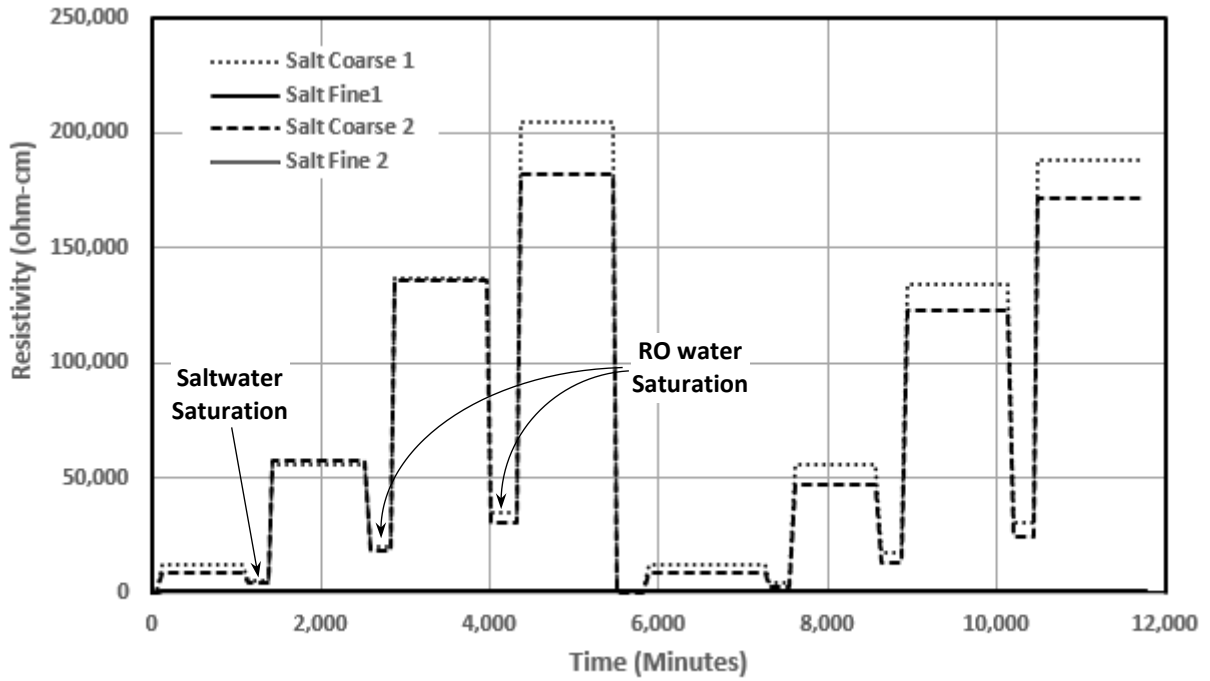

Figure 20. Resistivity comparison between AASHTO Standard and AASHTO No.57 gradations inundated with saltwater

Table 11. Resistivity Relations between No.57 and Std Gradations Inundated with Saltwater

		Multiplier Factor
Day 1	Saturation Std to No.57	1.0 time
Day 1	Drained Std to No.57	14.5 times
Day 2	Saturation Std to No.57	12.1 times
Day 2	Drained Std to No.57	65.4 times
Day 3	Saturation Std to No.57	20.4 times
Day 3	Drained Std to No.57	141.5 times
Day 4	Saturation Std to No.57	32.9 times
Day 4	Drained Std to No.57	195.1 times
Day 5	Saturation Std to No.57	0.7 times
Day 5	Drained Std to No.57	11.2 times
Day 6	Saturation Std to No.57	3.9 times
Day 6	Drained Std to No.57	7.3 times
Day 7	Saturation Std to No.57	17.5 times
Day 7	Drained Std to No.57	149.5 times
Day 8	Saturation Std to No.57	31.3 times
Day 8	Drained Std to No.57	194.6 times

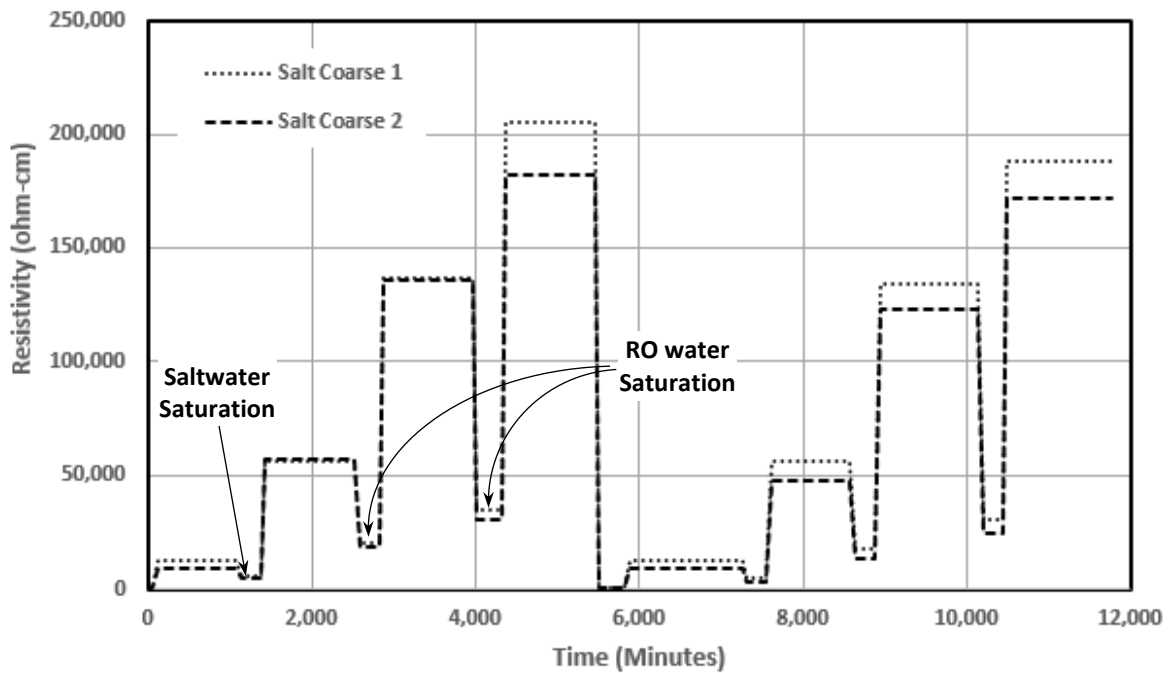

Figure 21. Resistivity comparison between AASHTO No.57 inundated with saltwater

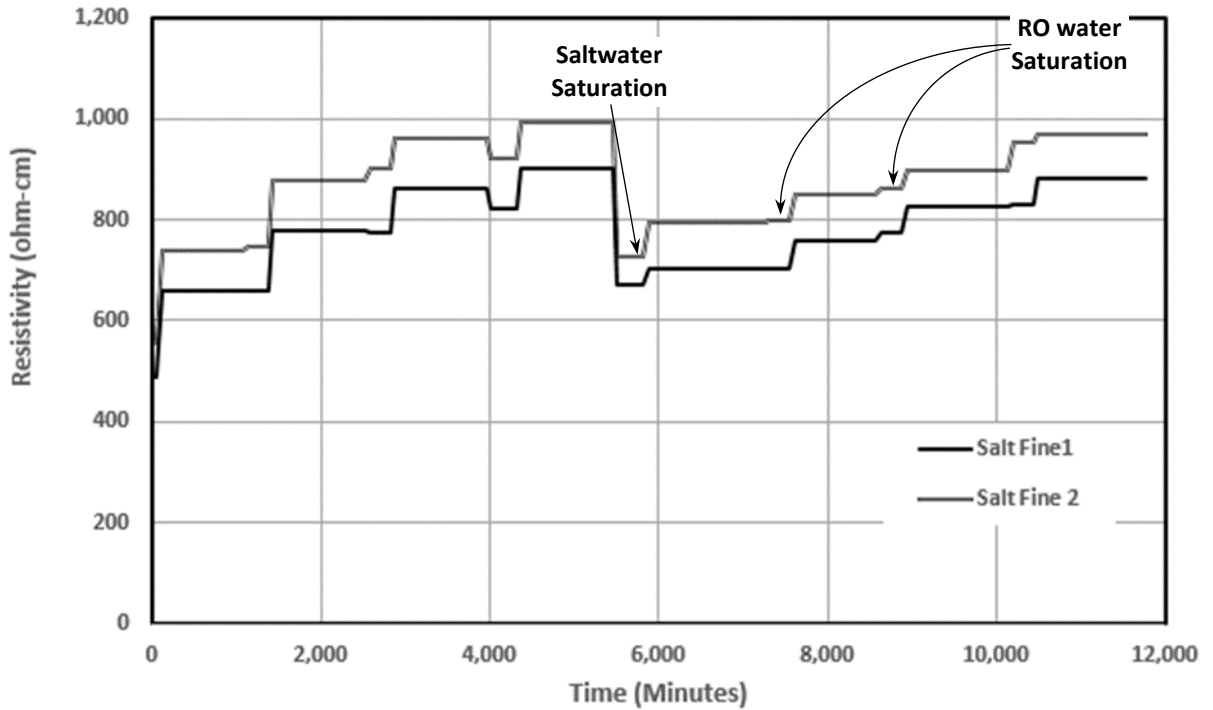

Figure 22. Resistivity comparison for AASHTO Standard Gradation inundated with saltwater

AASHTO Standard gradation exhibits a similar trend to what we observed in AASHTO No.57, but the increase in resistivity in day one inundation from saturated case to drained case is only 35% percent whereas the increase in resistivity for No.57 gradation is 18times. This happens since standard gradation is not as efficient as No.57 gradation in flushing out saltwater as stated from the moisture sensor data. Also, during 2nd saltwater inundation, the resistivity is not as low as 1st saltwater saturation resistivity and this is because after 3rd RO water inundation and drainage the gradation still holds a considerable amount of RO water not allowing complete saltwater to fill its voids.

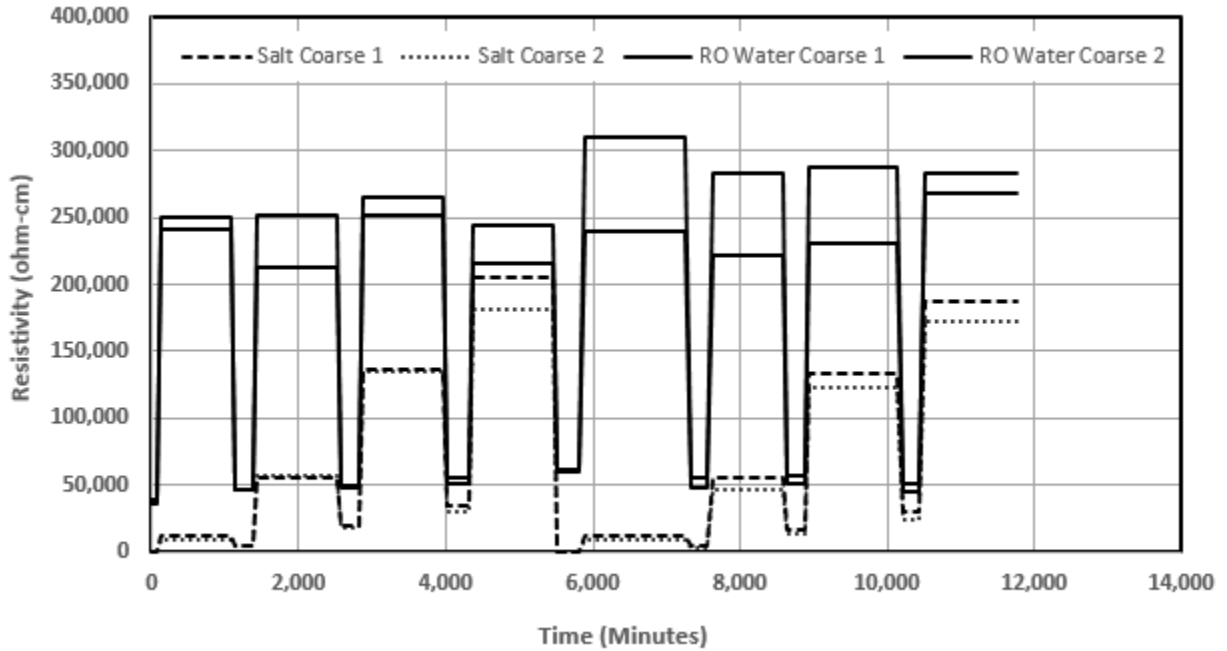

Figure 23. Resistivity comparison for AASHTO No. 57 Gradation inundated with RO and Saltwater

Table 12. Resistivity Relationships for No.57 inundated with RO and saltwater

		Multiplier Factor
Day 1	Saturation salt to RO	85.0 times
Day 1	Drained salt to RO	27.7 times
Day 2	Saturation salt to RO	10.2 times
Day 2	Drained salt to RO	4.1 times
Day 3	Saturation salt to RO	2.6 times
Day 3	Drained salt to RO	1.8 times
Day 4	Saturation salt to RO	1.9 times
Day 4	Drained salt to RO	1.2 times
Day 5	Saturation salt to RO	127.7 times
Day 5	Drained salt to RO	31.0 times
Day 6	Saturation salt to RO	18.2 times
Day 6	Drained salt to RO	5.0 times
Day 7	Saturation salt to RO	4.2 times
Day 7	Drained salt to RO	2.1 times
Day 8	Saturation salt to RO	1.8 times
Day 8	Drained salt to RO	1.4 times

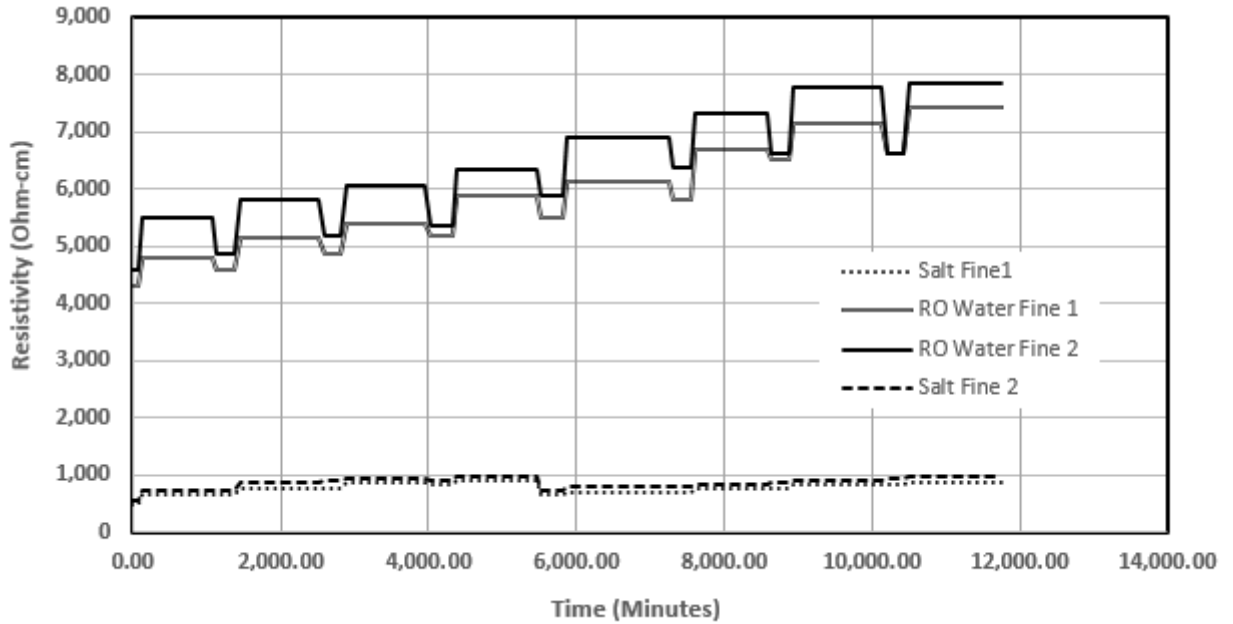

Figure 24. Resistivity comparison for AASHTO Standard Gradation inundated with RO vs Saltwater

Table 13. Resistivity comparison for AASHTO Standard Gradation inundated with RO vs Saltwater

		Multiplier Factor
Day 1	Saturation salt to RO	8.2 times
Day 1	Drained salt to RO	7.2 times
Day 2	Saturation salt to RO	6.5 times
Day 2	Drained salt to RO	6.3 times
Day 3	Saturation salt to RO	5.9 times
Day 3	Drained salt to RO	6.0 times
Day 4	Saturation salt to RO	5.9 times
Day 4	Drained salt to RO	6.2 times
Day 5	Saturation salt to RO	7.8 times
Day 5	Drained salt to RO	8.8 times
Day 6	Saturation salt to RO	7.7 times
Day 6	Drained salt to RO	8.3 times
Day 7	Saturation salt to RO	7.7 times
Day 7	Drained salt to RO	8.3 times
Day 8	Saturation salt to RO	6.8 times
Day 8	Drained salt to RO	7.9 times

4.4 Corrosion Rate Results and Data Analysis:

Corrosion rates of steel reinforcements at frequent intervals is measured by a Gamry instrument where potentiostat is coupled to a multiplexer. A multiplexer connects up to eight electrochemical cells to one Gamry Potentiostat. In this section first, the corrosion rates of steel specimens inundated to pure RO water are discussed and later corrosion rates of steel specimens subjected to one cycle of saltwater and 3 consecutive cycles of pure RO water is compared with the pure RO water inundated case. In this chapter RO water inundated AASHTO No. 57 is stated as coarse type material and AASHTO Standard is stated as fine type material. Saltwater inundated AASHTO No. 57 is stated as salt coarse type material and AASHTO Standard is stated as salt fine type material.

Case 1: Two Backfills inundated with RO water

In the drained case at day 1 resistivity through AASHTO No.57 material is 45.6 times to that of resistivity through AASHTO standard material. In AASHTO No.57 material when drainage has started from moisture sensor data approximately 93% of water has been drained resulting in only 7% of saturated water content which is probably coated with the grains is carrying current when 12V potential is applied on the electrodes by Arduino device resulting in high resistivity value whereas in standard gradation from moisture sensor data only 23% is drained and there is a considerable amount of water (77%) and dissolved ions still present in the box to carry current between electrodes resulting in much lower resistivity values.

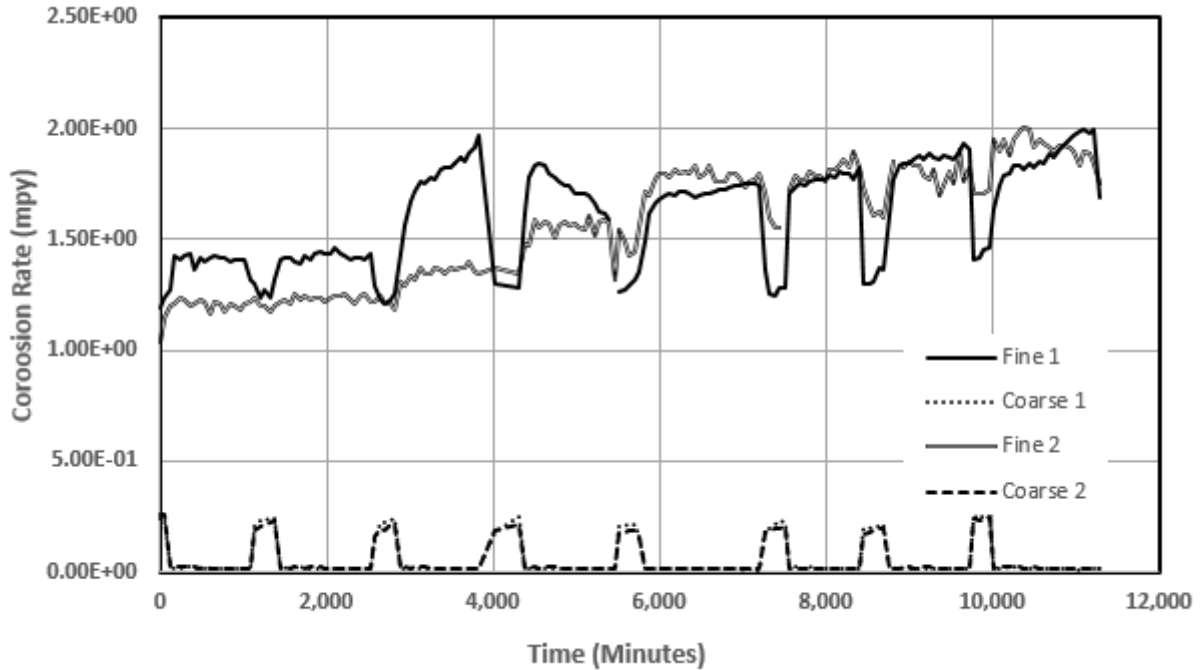

Figure 25. Corrosion Rates comparison between AASHTO Standard and AASHTO No.57 gradations inundated with RO Water

At day one, saturated period corrosion rates on AASHTO standard steel specimens is 4.63 times that of corrosion rates on AASHTO No.57 steel specimens. At day one, drained period corrosion rates on AASHTO standard steel specimens is 90.97 times as that of corrosion rates on AASHTO No.57 steel specimens. This considerable increase in corrosion rate difference is because of superior drainage characteristics of AASHTO No.57 over AASHTO Standard gradation. Even though the resistivity of standard material at the drained case is higher than its saturated case, the corrosion rate of standard material at drained conditions is higher than the corrosion rate of standard materials at saturated conditions. Availability of oxygen is an important parameter which controls the rate of corrosion reactions. In AASHTO standard completely saturated condition dissolved oxygen in water is the only source of oxygen to participate in corrosion reactions whereas, in drained condition, only 23% of water is drained allowing some pores to trap some oxygen from the atmosphere and have higher corrosion rates.

Table 14. Corrosion Rate Relations between two gradations during saturated-drained conditions inundated with RO water

		Multiplier Factor
Day 1	Saturation No.57 to Std	4.6 times
Day 1	Drained No.57 to Std	91.0 times
Day 2	Saturation No.57 to Std	5.2 times
Day 2	Drained No.57 to Std	91.7 times
Day 3	Saturation No.57 to Std	5.8 times
Day 3	Drained No.57 to Std	92.1 times
Day 4	Saturation No.57 to Std	6.2 times
Day 4	Drained No.57 to Std	119.2 times
Day 5	Saturation No.57 to Std	7.8 times
Day 5	Drained No.57 to Std	144.7 times
Day 6	Saturation No.57 to Std	8.1 times
Day 6	Drained No.57 to Std	145.2 times
Day 7	Saturation No.57 to Std	8.3 times
Day 7	Drained No.57 to Std	125.7 times
Day 8	Saturation No.57 to Std	7.4 times
Day 8	Drained No.57 to Std	125.2 times

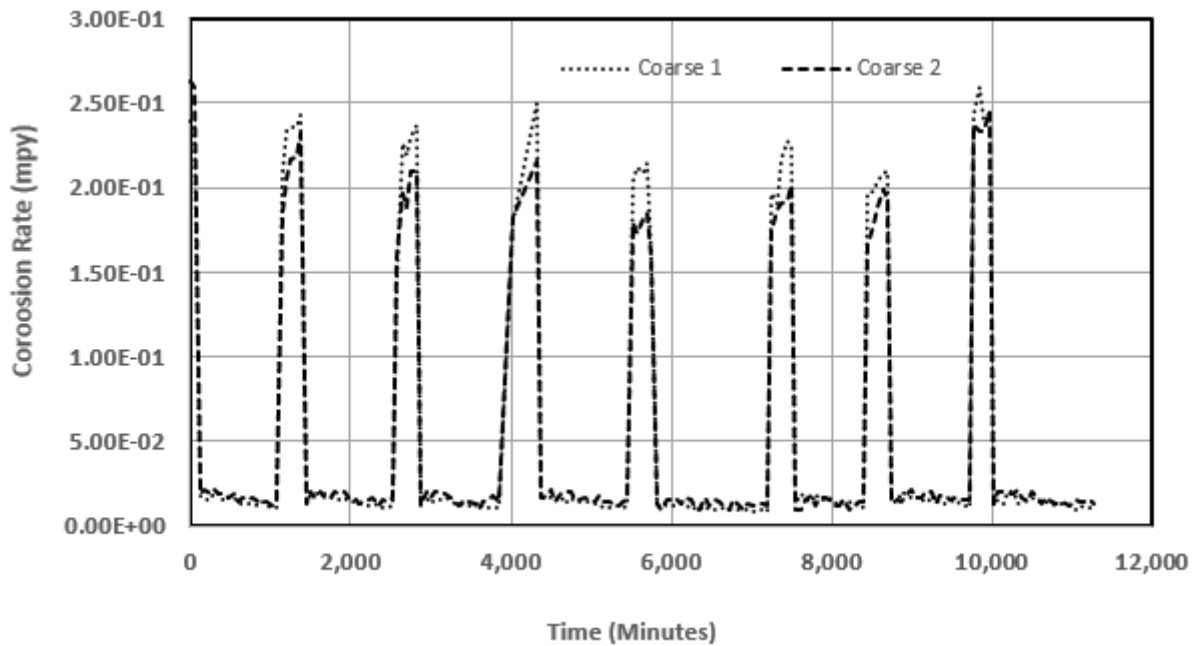

Figure 26. Corrosion Rate comparison for AASHTO No.57 Gradation inundated with RO Water

There is not a significant change in the corrosion rate values for AASHTO No.57 gradation. During the saturation period, corrosion rate values are high and during drainage, since it drains approximately 93% of moisture the corrosion value decreases exponentially.

Case 2: Two Backfills inundated with Saltwater

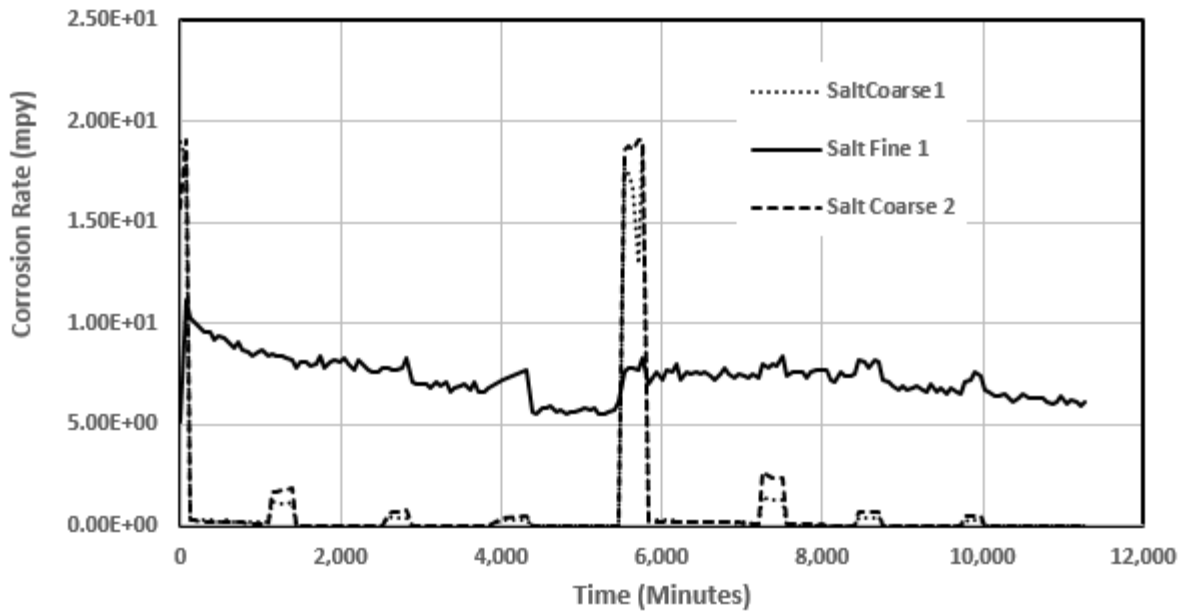

Figure 27. Corrosion Rate comparison between AASHTO Standard and AASHTO No.57 gradations inundated with saltwater and RO water

From the plot at day 1 saturation period with saltwater, the corrosion rate for the steel specimens in AASHTO No.57 material is higher than the corrosion rate for the steel specimens in AASHTO standard material. From the moisture sensor data during saturation period AASHTO No.57 holds double the moisture as that of AASHTO standard gradation. Thus, when the box is saturated with saltwater AASHTO No.57 material holds double the quantity of dissolved salts resulting in higher corrosion rates.

From the data, we can see AASHTO No.57 can flush considerable amount of salts during each drainage cycle whereas AASHTO standard cannot flush those salts. In AASHTO No.57 after drainage of saltwater at day 1 even though it contains some salts coated to the

grains since all of the water has drained the corrosion rate value has decreased exponentially and when the box is again flooded with RO water and all those coated salts start to dissolve in water and result in a higher corrosion rate.

Table 15. Corrosion Rate Relations between two gradations during saturated-drained conditions inundated with Saltwater

		Multiplier Factor
Day 1	Saturation No.57 to Std	0.6 times
Day 1	Drained No.57 to Std	63 times
Day 2	Saturation No.57 to Std	4.6 times
Day 2	Drained No.57 to Std	168.14 times
Day 3	Saturation No.57 to Std	10.52 times
Day 3	Drained No.57 to Std	269.6 times
Day 4	Saturation No.57 to Std	18.9 times
Day 4	Drained No.57 to Std	318.4 times
Day 5	Saturation No.57 to Std	0.2 times
Day 5	Drained No.57 to Std	43.0 times
Day 6	Saturation No.57 to Std	3.5 times
Day 6	Drained No.57 to Std	161.5 times
Day 7	Saturation No.57 to Std	11.0 times
Day 7	Drained No.57 to Std	269.0 times
Day 8	Saturation No.57 to Std	13.6 times
Day 8	Drained No.57 to Std	332.5 times

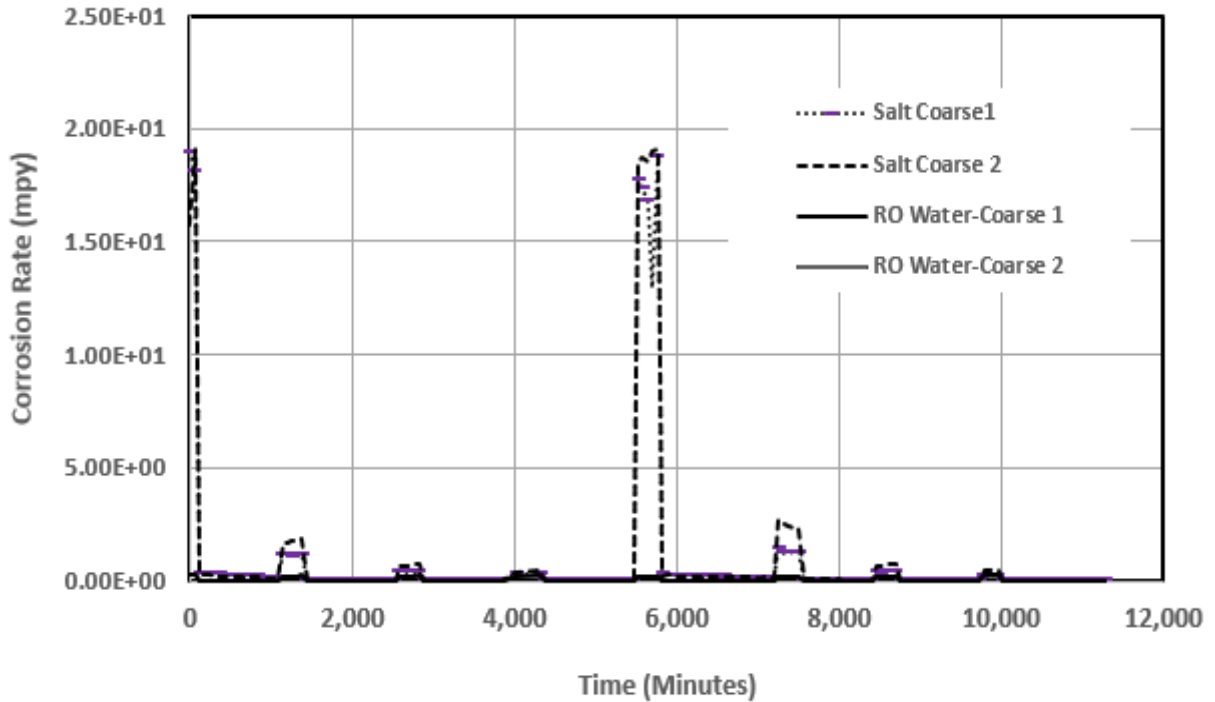

Figure 28. Corrosion Rate comparison for AASHTO No. 57 Gradation inundated in RO and Saltwater

Table 16. Corrosion Rate comparison for AASHTO No. 57 Gradation inundated in RO and Saltwater

		Multiplier Factor
Day 1	Saturation RO to salt	73.7 times
Day 1	Drained RO to salt	9.3 times
Day 2	Saturation RO to salt	8.2 times
Day 2	Drained RO to salt	2.4 times
Day 3	Saturation RO to salt	3.6 times
Day 3	Drained RO to salt	2.0 times
Day 4	Saturation RO to salt	2.1 times
Day 4	Drained RO to salt	1.1 times
Day 5	Saturation RO to salt	101.6 times
Day 5	Drained RO to salt	15.9 times
Day 6	Saturation RO to salt	11.8 times
Day 6	Drained RO to salt	4.2 times
Day 7	Saturation RO to salt	3.9 times
Day 7	Drained RO to salt	1.3 times
Day 8	Saturation RO to salt	2.1 times
Day 8	Drained RO to salt	1.1 times

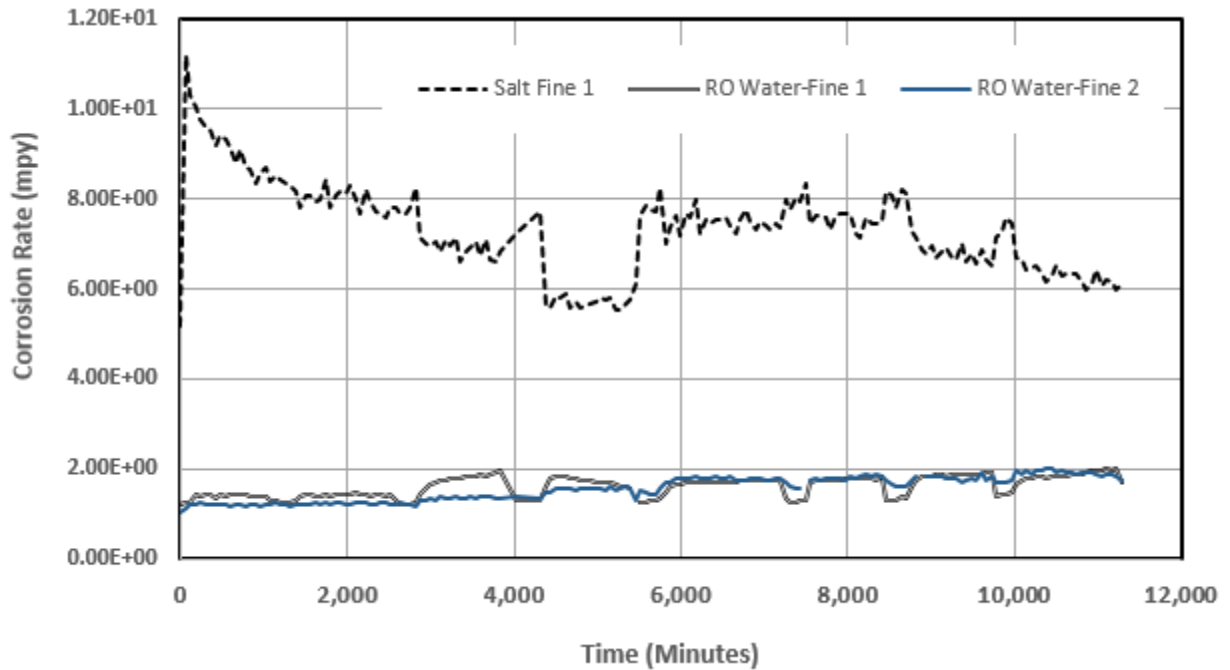

Figure 29. Corrosion Rate comparison for AASHTO Standard Gradation inundated in RO and Saltwater

Table 17. Corrosion Rate comparison for AASHTO Standard Gradation inundated in RO and Saltwater

		Multiplier Factor
Day 1	Saturation RO to salt	10.8 times
Day 1	Drained RO to salt	6.9 times
Day 2	Saturation RO to salt	6.8 times
Day 2	Drained RO to salt	6.6 times
Day 3	Saturation RO to salt	6.6 times
Day 3	Drained RO to salt	4.9 times
Day 4	Saturation RO to salt	5.3 times
Day 4	Drained RO to salt	3.7 times
Day 5	Saturation RO to salt	4.0 times
Day 5	Drained RO to salt	4.2times
Day 6	Saturation RO to salt	5.1 times
Day 6	Drained RO to salt	4.4 times
Day 7	Saturation RO to salt	5.1 times
Day 7	Drained RO to salt	3.8 times
Day 8	Saturation RO to salt	4.3 times
Day 8	Drained RO to salt	3.3 times

Chapter 5 – Conclusions and Recommendations

5.1 General Overview

This report contains results obtained from a research study that investigated the effects of grain size on electrical resistivity of MSE backfill and rates of corrosion of steel reinforcements embedded in the backfill. In order to accomplish these goals testing was carried out on two AASHTO gradations prepared from the same source material. Based on the results of this research, the following conclusions and recommendations were developed.

5.2 Conclusions

The data clearly showed that water-soluble sulfates and chlorides provide a direct relation to resistivities. The water-soluble sulfates and chlorides for AASHTO Standard gradation are 340.95 and 56.85ppm respectively whereas for AASHTO No.57 gradation water-soluble sulfates and chlorides is 37.65ppm and 16.55ppm. The resistivity readings for day 1 saturated case AASHTO standard material is 4592 ohm-cm and AASHTO No.57 material is 39836 ohm-cm. This provides the reason that even though both gradations are prepared from the same source the for AASHTO standard finer grains which have a larger contact area with the distilled allow more sulfates and chlorides to get dissolved in water eventually leading to higher corrosion rates (lower resistivities) than their counterpart gravel type AASHTO No.57 material.

During drained cases for boxes inundated with RO water from moisture sensors data standard material drains only 23% of its moisture whereas No.57 gradation drains 93% of its moisture resulting in four-fold increase in electrical resistivity. The absence of electrolyte (water) has caused this effect.

As AASHTO standard material are subjected to increased number of inundation cycles, the minerals attached to the grains get dissolved in the water during the saturation phase and get flushed out during the drainage phase resulting in higher resistivities for next inundation cycle. After 8 cycles of inundation and drainage, the resistivity of the standard material is increased by 43%. After 8 cycles of inundations, the resistivity of the standard material is increased by 44% in saturated condition. Thus, exposure of backfill material to RO water

inundations help backfill material develop non-conducting characteristics by flushing out all naturally occurring minerals.

In standard material, even though the resistivity of standard material at the drained case is higher than its saturated case, the corrosion rate of standard material at drained conditions is higher than the corrosion rate of standard materials at saturated conditions. Availability of oxygen is an important parameter which controls the rate of corrosion reactions. In AASHTO standard completely saturated condition dissolved oxygen in water is the only source of oxygen to participate in corrosion reactions whereas, in drained condition, only 23% of water is drained allowing some pores to trap some oxygen from the atmosphere and have higher corrosion rates.

In saturation period with saltwater contrary to RO water results, the corrosion rate for the steel specimens in AASHTO No.57 material is higher than the corrosion rate for the steel specimens in AASHTO standard material. From the moisture sensor data during saturation period AASHTO No.57 holds double the moisture as that of AASHTO standard gradation. Thus, when the box is saturated with saltwater AASHTO No.57 material holds double the quantity of dissolved salts resulting in higher corrosion rates.

In RO water inundated boxes after one cycle of RO water AASHTO standard material, the corrosion rate was increased by 9.3% due to increase in availability of oxygen and decrease in 23% of moisture content whereas AASHTO No.57 material the corrosion rate was decreased by 94.4 percent. This state the drainage characteristic advantage of AASHTO No.57 over AASHTO standard material in RO water inundations.

In saltwater inundated boxes after one cycle of saltwater and three consecutive cycles of RO water AASHTO standard material, the corrosion rate has decreased by 45.35% whereas AASHTO No.57 material the corrosion rate was decreased by 99.9 percent. This state the drainage characteristic advantage of AASHTO No.57 over AASHTO standard material in saltwater inundations.

5.3 Recommendations

From the experimental results, it is always efficient to use AASHTO No.57 gradation over AASHTO standard material in order to decrease the effects of corrosion on steel reinforcements. Not a considerable amount of moisture has been drained for AASHTO standard material in 20 hours drainage period. Future work can be done with longer drainage

SPTC 14.1-36 Phase 2

intervals and simultaneously monitoring corrosion rate, resistivity and moisture content readings.

References

- AASHTO. 1991. “Standard Method of Test for Determining PH of Soil for Use in Corrosion Testing, Single User PDF Download | AASHTO Bookstore.” 1991.
https://bookstore.transportation.org/item_details.aspx?ID=827.
- ASTM D4327 - 17 Standard Test Method for Anions in Water by Suppressed Ion Chromatography. n.d. Accessed May 14, 2018.
<https://www.astm.org/Standards/D4327.htm>.
- ASTM G59 - 97(2014) Standard Test Method for Conducting Potentiodynamic Polarization Resistance Measurements.” n.d. Accessed May 14, 2018.
<https://www.astm.org/Standards/G59.htm>.
- ASTM G59 - 97(2014) Standard Test Method for Conducting Potentiodynamic Polarization Resistance Measurements.” n.d. Accessed May 14, 2018.
<https://www.astm.org/Standards/G59.htm>.
- Carino, Nicholas J. 1999. “Nondestructive Techniques to Investigate Corrosion Status in Concrete Structures.” *Journal of Performance of Constructed Facilities* 13 (3): 96–106.
[https://doi.org/10.1061/\(ASCE\)0887-3828\(1999\)13:3\(96\)](https://doi.org/10.1061/(ASCE)0887-3828(1999)13:3(96)).
- Castro, P., A. A. Sagüés, E. I. Moreno, L. Maldonado, and J. Genescá. 1996. “Characterization of Activated Titanium Solid Reference Electrodes for Corrosion Testing of Steel in Concrete.” *CORROSION* 52 (8): 609–17. <https://doi.org/10.5006/1.3292151>.
- FHWA. 2009a. “CORROSION/DEGRADATION OF SOIL REINFORCEMENTS FOR MECHANICALLY STABILIZED EARTH WALLS AND REINFORCED SOIL SLOPES.” <https://www.fhwa.dot.gov/engineering/geotech/pubs/nhi09087/nhi09087.pdf>.
- FHWA. 2009b. “Design and Construction of Mechanically Stabilized Earth Walls and Reinforced Soil Slopes – Volume I.”
<https://www.fhwa.dot.gov/engineering/geotech/pubs/nhi10024/nhi10024.pdf>.
- Fontana, Mars G. (Mars Guy). 1986. *Corrosion Engineering*. McGraw-Hill.
- Guy, A G. 1976. “ESSENTIALS OF MATERIALS SCIENCES.”
<https://trid.trb.org/view/62805>.
- Sagues, Alberto A, Juan Rossi, Randall J Scott, Jose A Pena, Tanya Simmons, 7 Authors, Alberto A Sagoes, Jose A Pefia, and Tonya Simmons. 1998. “INFLUENCE OF CORROSIVE INUNDATION ON THE CORROSION RATES OF GALVANIZED TIE STRIPS IN MECHANICALLY STABILIZED EARTH WALLS.”

<http://sagues.myweb.usf.edu/Documents/FDOT Arch/0510686-INFL CORR INUND MSE OCR.pdf>.