



Catch Basins and Manholes

PRODUCTS, INSTALLATION,
AND SETTLEMENT AND HEAVE
MITIGATION



September 2021
Report No. 2021RIC04

Prepared by: Derek Tompkins, Principal Investigator
American Engineering Testing

To request this document in an alternative format, such as braille or large print, call [651-366-4718](tel:651-366-4718) or [1-800-657-3774](tel:1-800-657-3774) (Greater Minnesota) or email your request to ADArequest.dot@state.mn.us. Please request at least one week in advance.

Technical Report Documentation Page

| | | | |
|--|--|---|-----------|
| 1. Report No. MN 2021RIC04 | 2. | 3. Recipients Accession No. | |
| 4. Title and Subtitle Catch Basins and Manholes: Products, Installation, and Settlement and Heave Mitigation | | 5. Report Date September 2021 | |
| | | 6. | |
| 7. Author(s) Brynley Nadziejka Waller, Derek Tompkins | | 8. Performing Organization Report No. | |
| 9. Performing Organization Name and Address American Engineering Testing 550 Cleveland Avenue N. St. Paul, MN 55114 | | 10. Project/Task/Work Unit No. | |
| | | 11. Contract (C) or Grant (G) No. (c) 1047617 | |
| 12. Sponsoring Organization Name and Address Local Road Research Board Minnesota Department of Transportation Office of Research & Innovation 395 John Ireland Boulevard, MS 330 St. Paul, Minnesota 55155-1899 | | 13. Type of Report and Period Covered Final Report | |
| | | 14. Sponsoring Agency Code | |
| 15. Supplementary Notes https://www.mndot.gov/research/reports/2021/2021RIC04.pdf | | | |
| 16. Abstract (Limit: 250 words) Practices for constructing and repairing catch basins and manholes vary across Minnesota municipalities and counties. There are a variety of products available for building a catch basin or manhole, sealing structure joints, and helping reduce infiltration and intrusion. Currently, there is very little documentation on the local experience with catch basins and manholes in Minnesota as most resources are promotional literature or articles from industry publications. The Minnesota Department of Transportation (MnDOT) Local Road Research Board (LRRB) initiated this project to document best practices for managing the effects of settlement and heave at catch basins and manholes. However, in response to feedback from municipalities indicating that settlement and heave were not dominant issues, the focus of the study was broadened to include more general municipal experiences and best practices with catch basins and manholes. This project included developing and distributing a survey to Minnesota municipalities and summarizing the results, reviewing municipal specifications and product promotional literature, and interviewing industry and municipal professionals about their experiences with catch basins and manholes. This guide provides foundational information to help Minnesota municipalities select and implement appropriate materials and methods for catch basin and manhole installation/maintenance. The two hypothetical field scenarios presented will assist public works and city engineers in constructing new structures or maintaining and repairing existing structures. These scenarios demonstrate, in a general way, how the information in this guide can be applied to new construction and repair projects. | | | |
| 17. Document Analysis/Descriptors Catch basins, Manholes, Drainage, Public works departments, Best practices | | 18. Availability Statement No restrictions. Document available from: National Technical Information Services, Alexandria, Virginia 22312 | |
| 19. Security Class (this report) Unclassified | 20. Security Class (this page) Unclassified | 21. No. of Pages 48 | 22. Price |

Catch Basins and Manholes: Products, Installation, and Settlement and Heave Mitigation

FINAL REPORT

Prepared by:

Brynley Nadziejka Waller
Derek Tompkins

American Engineering Testing, Inc.

September 2021

Published by:

Minnesota Department of Transportation
Office of Research & Innovation
395 John Ireland Boulevard, MS 330
St. Paul, Minnesota 55155-1899

This report represents the results of research conducted by the authors and does not necessarily represent the views or policies of the Minnesota Department of Transportation or American Engineering Testing. This report does not contain a standard or specified technique.

The authors, the Minnesota Department of Transportation, and American Engineering Testing do not endorse products or manufacturers. Trade or manufacturers' names appear herein solely because they are considered essential to this report

ACKNOWLEDGMENTS

The authors thank the members of the Technical Advisory Panel, Greg Kilgore, Ess Brothers; Pete Moen, city of Brooklyn Center; Nathan Kaderlik and Dave Goergen, city of Edina; and Bill Graham, city of New Brighton, for their review and comments on the project work. The contributions of project Technical Liaison Steve Bot, city St. Michael, were particularly appreciated.

The authors would also like to thank Paul Scheid, Eull's Manufacturing; John Olson, city of Hutchinson; and Carter Schulze, city of Eden Prairie, for contributing their time and expertise to this project.

Finally, the authors would like to thank the project coordinator, Thomas Johnson-Kaiser, for his assistance in all project activities.

TABLE OF CONTENTS

- CHAPTER 1: Introduction 1**
 - 1.1 Project objectives 1
 - 1.2 Report structure 1
 - 1.3 Disclaimer 1

- CHAPTER 2: Municipal Specification Review 2**
 - 2.1 Base, Barrel, and Cone Section Construction 2
 - 2.2 Chimney Construction 5
 - 2.3 Catch Basin and Manhole Rehabilitation 10

- CHAPTER 3: Construction and Repair Product Review 12**
 - 3.1 HDPE and EPP Rings 12
 - 3.2 Infi-Shield Uni-band 13
 - 3.3 Flex Seal Utility Sealant 13
 - 3.4 I&I Barrier and Sealant 14
 - 3.5 Eull’s Manhole Shield 15
 - 3.6 Alignment Barrier 16
 - 3.7 Gator Wrap 16

- CHAPTER 4: Settlement and Heave Mitigation 18**

- CHAPTER 5: Survey Response Summary 20**

- CHAPTER 6: Municipal Catch Basin/Manhole Experiences 23**
 - 6.1 Product experience 23
 - 6.2 Areas Of Focus In The Field 26
 - 6.3 Where To Focus Repairs 27

- CHAPTER 7: Installation Considerations 29**
 - 7.1 Scenario A – New structure 29

| | |
|---|-----------|
| 7.2 Scenario B – Maintenance and repair | 32 |
| CHAPTER 8: Conclusion | 35 |
| REFERENCES..... | 36 |

LIST OF FIGURES

| | |
|--|----|
| Figure 1. Manhole graphic with structure components labeled..... | 2 |
| Figure 2. Example of precast concrete (top) doghouse and (bottom) barrel..... | 4 |
| Figure 3. Excerpt of specification for precast base slab [5]. | 4 |
| Figure 4. Concrete adjustment rings. | 6 |
| Figure 5. HDPE adjustment rings..... | 6 |
| Figure 6. Excerpt of specification for manhole cone and chimney construction [15]..... | 6 |
| Figure 7. Application of underground utility mortar. | 8 |
| Figure 8. Application of HDPE ring sealant. | 8 |
| Figure 9. Example of chimney requirements for mitigating infiltration in sanitary sewer manholes [1] .. | 10 |
| Figure 10. Application of SpectraShield in a manhole..... | 11 |
| Figure 11. Installation of (a) circular and (b) rectangular (with frame) EPP rings..... | 12 |
| Figure 12. Infi-Shield Uni Band installed on manhole casting..... | 13 |
| Figure 13. (a) Flex Seal being applied to a manhole chimney interior; (b) Chimney interior after Flex Seal application. | 14 |
| Figure 14. Placement of I&I Barrier in manhole chimney and related components..... | 15 |
| Figure 15. Alignment Barrier on cone with Gator Wrap placed around part of the flange..... | 17 |
| Figure 16. Compacted backfill surrounding manhole. | 18 |
| Figure 17. Vibratory plate compactor being used to compact backfill around catch basin. | 18 |
| Figure 18. HDPE ring being installed. | 23 |
| Figure 19. Steel riser ring installed in manhole frame..... | 23 |
| Figure 20. Curtain grouting from inside the structure. | 25 |

| | |
|--|----|
| Figure 21. Curtain grouting from outside the structure. | 26 |
| Figure 22. Televising device entering manhole..... | 28 |
| Figure 23. (a) application of Flex Seal Utility Sealant; (b) installation of I&I Barrier. | 31 |
| Figure 24. Sewer televising footage. | 32 |
| Figure 25. New manhole structure before backfilling. | 34 |

LIST OF TABLES

| | |
|--|----|
| Table 1. Comparing specified ring count and height by municipality | 9 |
| Table 2. Comparing specified ring count and height by municipality | 30 |

LIST OF ABBREVIATIONS

| | |
|-------|---|
| MnDOT | Minnesota Department of Transportation |
| LRRB | Local Road Research Board |
| AET | American Engineering Testing, Inc. |
| CEAM | City Engineers Association of Minnesota |
| HDPE | High Density Polyethylene |
| EPP | Expanded Polypropylene |
| UUM | Underground Utility Mortar |

EXECUTIVE SUMMARY

The Minnesota Department of Transportation (MnDOT) Local Road Research Board (LRRB) initiated this project to document best practices for managing the effects of settlement and heave at catch basins and manholes. However, in response to feedback from municipalities indicating that settlement and heave were not dominant issues, the focus of the study was broadened to include more general municipal experiences and best practices with catch basins and manholes.

This project included developing and distributing a survey to Minnesota municipalities and summarizing the results, reviewing municipal specifications and product promotional literature, and interviewing industry and municipal professionals about their experiences with catch basins and manholes.

Major conclusions from this study are as follows:

- In many cities, settlement and heave are not the predominant catch basin and manhole issues. Initial construction issues are an equal, if not more pressing, concern, according to survey results and interviews.
- The reviewed municipal specifications indicate that catch basin and manhole construction methods are generally similar, the primary differences being chimney detail and recommendations for rehabilitation (where present).
- Reviewed specifications indicate that backfill compaction is the first means by which to mitigate the effects of heave and settlement, and proper use of some products can help prevent infiltration/intrusion if manhole or catch basin adjustment rings are damaged.
- There are a wide array of products available to help mitigate infiltration, including internal and external seals and barriers, bonding materials, joint wraps, and drain tile. Interviewed municipal and industry professionals emphasized that it is critical to select the proper materials for a structure and ensure that those materials are applied appropriately in the field.

This guide provides foundational information to help Minnesota municipalities select and implement appropriate materials and methods for catch basin and manhole installation/maintenance. The two hypothetical field scenarios presented will assist public works and city engineers in constructing new structures or maintaining and repairing existing structures. These scenarios demonstrate, in a general way, how the information in this guide can be applied to new construction and repair projects.

CHAPTER 1: INTRODUCTION

Practices for constructing and repairing catch basins and manholes vary across Minnesota municipalities and counties. There are a variety of products available for building a catch basin or manhole, sealing structure joints, and helping reduce infiltration and intrusion. Currently, there is very little documentation on the local experience with catch basins and manholes in Minnesota, as most resources are promotional literature or articles from industry publications.

To address this documentation gap, the Minnesota Department of Transportation (MnDOT) Local Road Research Board (LRRB) initiated a project to produce a report that discusses the experiences of Minnesota municipalities with catch basins and manholes, documents available products, and discusses settlement and heave mitigation near catch basins and manholes. An early outcome of the study was that settlement and heave are not the predominant issues in many cities in Minnesota. This shifted the focus of the work to identifying and cataloguing a wider range of common issues and the best practices for addressing those problems.

1.1 PROJECT OBJECTIVES

The project objective was to produce a report that details installation techniques that prevent settlement or heave near catch basins and manholes, documents Minnesota municipal experiences with catch basins and manholes, and lists available catch basins and manhole products.

1.2 REPORT STRUCTURE

The remainder of the report documents the project work in the chapters listed below.

- Chapter 2. Municipal Specification Review
- Chapter 3. Construction and Repair Product Review
- Chapter 4. Settlement and Heave Mitigation
- Chapter 5. Survey Response Summary
- Chapter 6. Municipal Catch Basin/Manhole Experiences
- Chapter 7. Installation Considerations
- Chapter 8. Conclusions

1.3 DISCLAIMER

While performing the literature review, the project team discovered that American Engineering Testing (AET) had performed testing of Ladtech, Inc., products on three occasions from 1998 to 2015 (AET Project Nos. 05-00175, 05-04911, and 05-06572). The project team was unaware of these efforts when proposing and performing the work of this project. Should the project team uncover additional contracted work for product manufacturers, those efforts will be disclosed as soon as possible.

CHAPTER 2: MUNICIPAL SPECIFICATION REVIEW

The effort reviewed specifications and/or details from the municipalities describing materials and methods used to construct manhole and catch basin doghouse, barrel, and cone sections (Figure 1) For the benefit of additional perspective, three municipalities outside of Minnesota were included in the review. Specifications from the following municipalities and organizations are referenced in this literature review, with citations corresponding to documents reviewed for that municipality: Andover [1, 2]; Blaine [3, 4]; Chanhassen [5]; Duluth [6, 7]; Edina [8]; Fargo, ND [9, 10]; Grand Forks, ND [11]; Green Bay, WI [12]; Hastings, MN [13]; Mankato, MN [14]; Minneapolis, MN [15]; Plymouth, MN [17, 18]; Rochester, MN [19]; Saint Paul, MN [20]; and the City Engineers Association of Minnesota (CEAM) [21].

The review determined that the specifications were generally similar, the primary differences being chimney detail and recommendations for rehabilitation (where present). The following sections describe general features of the municipal specifications, with citations so that interested readers can investigate specific recommendations.

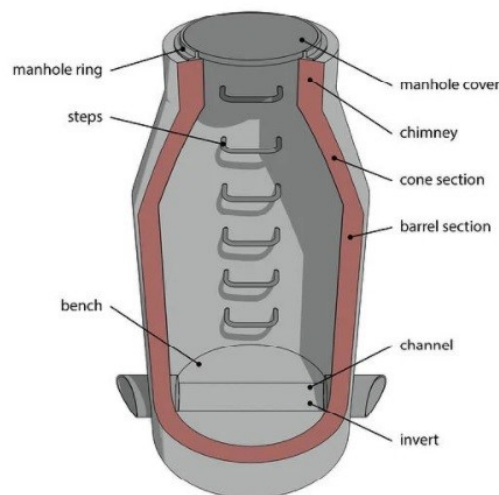

Figure 1. Manhole graphic with structure components labeled.

2.1 BASE, BARREL, AND CONE SECTION CONSTRUCTION

The reviewed specifications include three types of material for the base, barrel, and cone sections of manhole and catch basin structures: pre-cast reinforced concrete, cast-in-place concrete, and manhole blocks/bricks. All 15 of the specifications reviewed approve of the use of pre-cast reinforced concrete for the doghouse and barrel; when explicitly approved, pre-cast concrete is often the default. Cast-in-place concrete is called out in five specifications [12, 13, 14, 18, 20, 21]. Six specifications allow for bricks/blocks to be used but only at the engineer's discretion [5, 10, 13, 16, 18, 20, 21].

2.1.1 Pre-cast and Cast-In-Place Concrete Structures

The reviewed specifications all list pre-cast concrete barrel and cone sections as the preferred, if not the only, method (Figure 2). Some specifications allow for the whole structure be made using cast-in-place concrete if called for in the plans and approved by the engineer [12, 21]. Requirements for the concrete used for manhole and catch basin structures vary by city and depending on whether the concrete is pre-cast or cast-in-place. The specifications discussed pre-cast concrete using the following standards for mix design.

- ASTM C-478, which is cited by 7 municipalities and CEAM [2, 8, 9, 10, 12, 13, 20, 21]
- MnDOT Mix 3F52, which is cited once [5]
- MnDOT 3622, which is cited once [6, 7]
- MnDOT 2506, which is cited once [21]

For city specifications describing wet-cast units, the mix design was unspecified, however air content was limited to 5-8 percent [13, 21]. For cast-in-place concrete, the reviewed specifications alluded to the following standards for mix design.

- MnDOT Mix 3G52, which was cited once [20].
- MnDOT 2461, Table 2461-6, which was cited by 2 municipalities [13, 21].
- Internal municipal mix designs with required 28-day compressive strength of 3900 psi [13]

Many cities list pre-cast base slabs as the preferred method or as an acceptable method. An exception is the CEAM specifications, which only allows for a pre-cast base slab with engineer approval, otherwise the base slab is cast-in-place [21]. A few cities allow for cast-in-place base slabs if included in the plans [12, 13]. The standard thickness for pre-cast or cast-in-place base slabs is 5 to 6 inches, and the thickness can change based on the depth of the slab. Three reviewed cities provided guidelines for required base slab thickness given the depth of the structure (Figure 3) [5, 16, 17, 18].

The diameter of the structure can also affect the thickness of the base slab. While the diameter of the structure barrel can change based on the diameter of the pipe(s) that intersect the doghouse, the most common inside diameter of a manhole is 48 inches, with a cone section that tapers to a 27-inch top opening. Catch basins can be either circular or rectangular. When rectangular, the standard dimensions are 2 feet by 3 feet, and when circular, the inside diameter is usually 30 to 48 inches with a 27-inch top opening. When a cone section is not used, the circular structure will often have a flat top slab with a 27-inch opening cut into the slab.

In addition to base slab thickness and diameter guidance, some cities provide guidelines for barrel section wall thickness based on the structure diameter [16]. In general, the standard wall thickness is 5 inches for pre-cast or cast-in-place manholes and catch basins. The barrel joints are often required to be tongue-and-groove type and self-centering [9, 10, 13].

The details for how to make a manhole or catch basin watertight vary somewhat by city, but certain components are commonly required. One component is rubber or all-weather butyl O-ring gaskets in the joints between barrel sections. Two gasket standards listed in the reviewed specifications are ASTM

C-443 and MnDOT 3726 Type B [20]. Cities also sometimes require an additional seal around the barrel and cone joints. The following sealing products are specified by municipalities.

- RAM-NEK (preformed flexible plastic gasket coils) in joints [1, 11]
- Infi-Shield Gator Wrap or an approved product whose performance is judged by the municipality to be functionally equivalent to Gator Wrap (6-inch width, stretchable, self-shrinking, intra-curing halogenated base rubber with a minimum thickness of 30 mils) [17]
- Cretex internal manhole joint seals in high ground water areas [5]
- Water barrier wrap meeting ASTM C-877 in a 12-inch width on all joints [19]

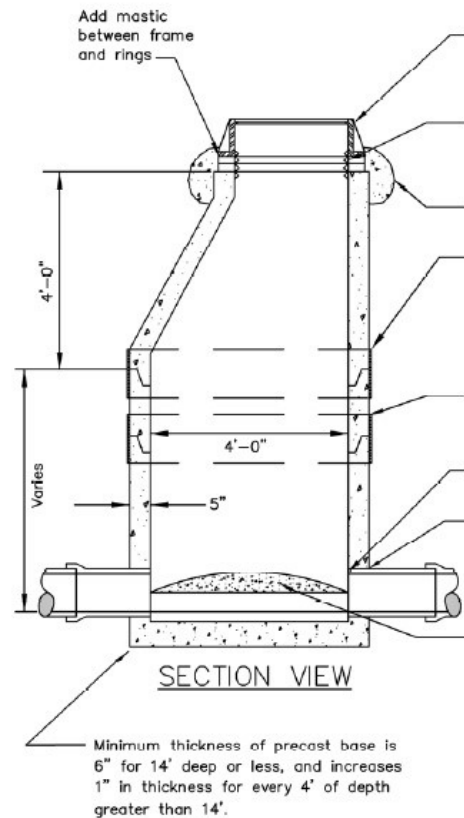

Figure 2. Example of precast concrete (top) doghouse and (bottom) barrel.

Figure 3. Excerpt of specification for precast base slab [5].

The specifications for how to make pipe connections in manholes and catch basins watertight vary in terms of requirements and provided detail.

Finally, other uncommon features of concrete manholes and catch basins include the requirement that the doghouse of a structure be wrapped in geotextile fabric [2]. Another uncommon requirement is grouting the doghouse of a structure inside and outside, which is required by a few municipalities for storm sewer catch basins and manholes [2, 5, 18].

2.1.2 Block Manhole Structures

The CEAM standards allow for block construction of catch basins and manholes where it is not possible to construct the structure with pre-cast manhole sections [21]. Six cities (including one outside of Minnesota) also consider manhole blocks for construction, if approved by the engineer or by special provision. The following items summarize general features of specifications for block manholes.

- Pre-cast blocks that meet ASTM C-139, which is cited by 2 municipalities [10, 13].
- Structure walls must be 6" to 8" thick, which is cited by 4 municipalities [10, 16, 18, 20].
- Blocks are placed with mortar. The standards for mortar used in the reviewed specifications include:
 - Mortar that is 1 part Portland cement and 2 parts sand, by volume [10].
- Joints between the blocks are ½" to 3/8" thick and filled with mortar [16, 20]
- Exterior of the block section is plastered with ¼" to ½" mortar [5, 13, 18].
- Coal tar epoxy is applied to the exterior of the block section, which is cited once [20].
- Interior of the block section is plastered with ½" mortar [16, 18].
- Gaps in the blocks are sealed using Flex Seal or approved equal, which is cited once [18].

2.2 CHIMNEY CONSTRUCTION

The project team observed that the feature of manholes and catch basins specifications with the most variation is the chimney/adjustment ring section. The project identified four elements of chimney construction that varied by municipality.

- Type of adjustment rings allowed
- Number of rings and/or height of the stack of rings
- Material used to bond the rings to the structure and casting
- Infiltration mitigation product (if used)

The following subsections provide more detail on these features of chimney construction.

2.2.1 Types of Adjustment Rings

There are two types of rings cited by municipalities: pre-cast concrete rings and engineered polymer rings (Figure 4, Figure 5). The engineered polymer rings are typically either high-density polyethylene (HDPE) or expanded polypropylene (EPP) rings. The characteristics of HDPE/EPP rings are outlined in detail in the Construction and Repair Product chapter of this document. The reviewed specifications cited the following rings.

- Pre-cast concrete rings only [1, 2, 3, 4, 8, 12, 13, 14, 15, 16].
- HDPE/EPP/engineered polymer rings only [6, 7, 11].
- Pre-cast concrete rings or engineered polymer rings (Figure 6) [5, 19, 21].
- Engineered polymer rings primarily, with a note that concrete rings were considered with engineer approval [9, 10, 17, 18].
- Manhole bricks are used to adjust the final grade of the structure, and manhole bricks are used in combination with concrete riser blocks for bigger adjustments [20].



Figure 4. Concrete adjustment rings.



Figure 5. HDPE adjustment rings.

The survey of Minnesota municipal engineers conducted during this project found that 40% of the respondents favored HDPE rings in repairs and 21% of respondents stated that HDPE rings were less successful in repairs. Concrete rings were favored by 56% of respondents and were found to be less successful by 55% of respondents.

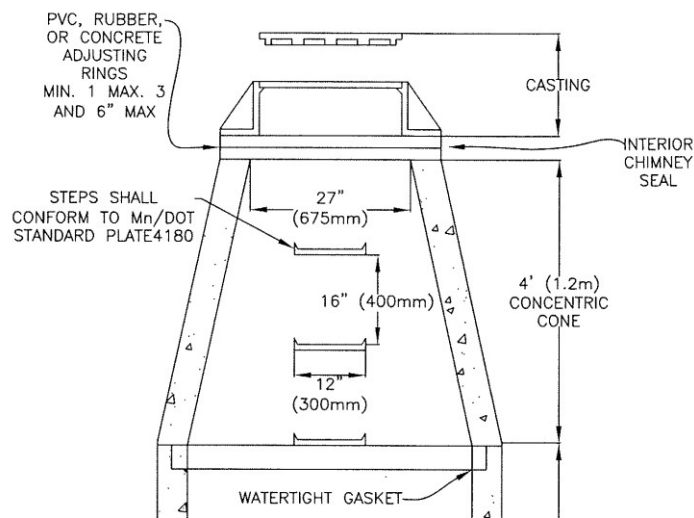

Figure 6. Excerpt of specification for manhole cone and chimney construction [15]

2.2.2 Bonding Material

Improper mortar selection is one of the leading causes of structure failure according to both municipal interviewees and survey responses. Multiple survey responses emphasize the importance of selecting the appropriate underground mortar for installation, as do interviewed industry and municipal professionals.

The material used to bond the rings with each other, the barrel, or the the casting depends on the type of ring being used.

If concrete rings are used, mortar is placed between the rings, between the bottom ring and the structure top, and between the top ring and the casting. Most of the specifications that call for concrete rings require that the rings be set in ¼" - ½" mortar. Some specifications require a coat of mortar on the outside of the rings, as well. Mortar standards and descriptions in the reviewed specifications include ASTM C-270; MnDOT 2506.2B; Type M Masonry Cement and Sand Mortar; Type N mortar; Type S mortar; and Non-shrinking grout.

The traditional way of making mortar in the field relies on the laborer to mix the correct amounts of sand, Portland cement, and lime, and provide sufficient air entrainment. ASTM C270 provides 28-day compressive strength, water retention, and air content requirements for mortar Types M, S, N, and O. The strength and water retention requirements are given as minimum required values. The air content requirements are maximum allowed values. Air entrainment is important and ASTM C270 does not require a minimum air content in order to meet the specification. Due to the generality of ASTM C270, many types of mortar are able to meet this specification.

- Type M mortar is used by some of the reviewed municipalities in concrete manhole and catch basin construction. ASTM C270 requires 2500 psi at 28 days.
- Type S mortar is required by ASTM C270 to achieve 1800 psi compressive strength at 28 days.
- Type N mortar is not air entrained and is meant for above-grade brick construction, or "brick set", rather than for below grade construction. The life span of underground structure built using Type N mortar is 1-3 years. The compressive strength requirement at 28 days is 750 psi per ASTM C270.
- Type O mortar is required by ASTM C270 to have 350 psi compressive strength at 28 days.

Another type of mortar used in Minnesota is TCC Spec Mix underground utility mortar (TCC UUM), which is the result of a collaboration between MnDOT, Eull's Manufacturing and Twin City Concrete. TCC UUM is composed of Portland cement, hydrated lime, mason sand, and air entrainment in the correct proportions to meet ASTM C270, ASTM C387, and MnDOT 2506.2B and 3107.2A.1. The laborer adds water per instructions to produce the mortar. UUM is made to be used with underground precast concrete or brick manhole and catch basin construction in areas that experience freeze-thaw conditions (Figure 7). UUM has 8-9% air content and, depending on mortar proportions, can achieve 28-day compressive strength of up to 5050 psi according to the product specification sheet.



Figure 7. Application of underground utility mortar.



Figure 8. Application of HDPE ring sealant.

For HDPE/EPP rings, the manufacturer’s sealant or a butyl or polyurethane sealant are usually called for. Some specifications only require sealant between the structure and the bottom ring and the top ring and the casting, while others require sealant in all chimney joints (Figure 8).

Wood shims are explicitly banned in 6 of the reviewed specifications, regardless of the type of rings used [1, 2, 3, 4, 5, 6, 7, 16, 21]. Two municipalities do not allow steel shims, and one those limitations on steel shims is only for when HDPE rings are used [9, 10, 16]. Fine adjustments to grade and slope often need to be made using thin and/or tapered rings. One municipality allows for mortar to be used to do fine casting grade adjustments [20].

2.2.3 Number of Rings and Chimney Height

Table 1 is provided to efficiently compare specified number of rings and chimney height across the municipal specifications reviewed in this project. St. Paul is excluded from Table 1, as St. Paul specifies the use of manhole bricks for adjustments 6 inch or less and a combination of cast-in-place concrete riser blocks and manhole bricks for adjustments between 7 and 17 inches.

Table 1. Comparing specified ring count and height by municipality

| City/Specification | Minimum height/# of rings | Maximum height/# of rings |
|--------------------------------------|--|---|
| Andover | 2 rings | 1' |
| Blaine | 2-0.2' rings | 5-0.2' rings |
| CEAM | 2-2" rings | 6-2" rings |
| Chanhassen | 2-2" rings | 3 rings |
| Edina | -- | 2' |
| Duluth | -- | 6" |
| Fargo | 3-2" rings | -- |
| Grand Forks | 2 rings | -- |
| Green Bay | -- | 4" for plastic rings, concrete rings used if adjustment >4" |
| Hastings | 2 rings | 6 rings |
| Mankato | 1 ring | 6"/3 rings |
| Minneapolis | 1-2" ring | 8" including mortar |
| Plymouth – storm sewer structures | 4" min; min of 1-2" ring below casting | 12" |
| Plymouth – sanitary sewer structures | 4" min; 4" or 6" ring used for adjustments of 8" or more | 12" |
| Rochester | 2" min | 8"/2 rings |

2.2.4 Infiltration Mitigation Products

Nine of the reviewed specifications require an external or internal seal be applied or infiltration mitigation product be installed when completing the chimney portion of a sewer structure, especially for sanitary sewer structures (Figure 9). Some cities describe the use of specific products, while other cities have a general requirement for an external and/or internal seal. As outlined below, the specifications detail many different requirements and/or products for infiltration mitigation.

- I&I Barriers for sanitary sewer manholes [5,13,17].
- I&I Barriers for storm sewer structures [13].
- I&I Barrier or Cretex chimney seal for sanitary sewer manholes [9].
- I&I Barrier or Infi-Shield Uni-band for sanitary sewer structures [8].
- Infi-Shield Uni-band for sanitary sewer structures [1, 5, 13].
- Infi-Shield Uni-band for storm sewer structures [13].
- DOW Corning 700 industrial grade sealant between manhole cover and casting frame for sanitary sewer manholes [6].
- External rubber sleeve installed around rings for sanitary sewer manholes in unpaved areas [6].
- Internal chimney seal for sanitary sewer manholes [15].
- Internal water barrier meeting ASTM D4976 in paved areas and an external seal meeting ASTM C923 extending 3" minimum below the top of the pre-cast cone in nonpaved areas, for storm and sanitary sewer manholes [19].

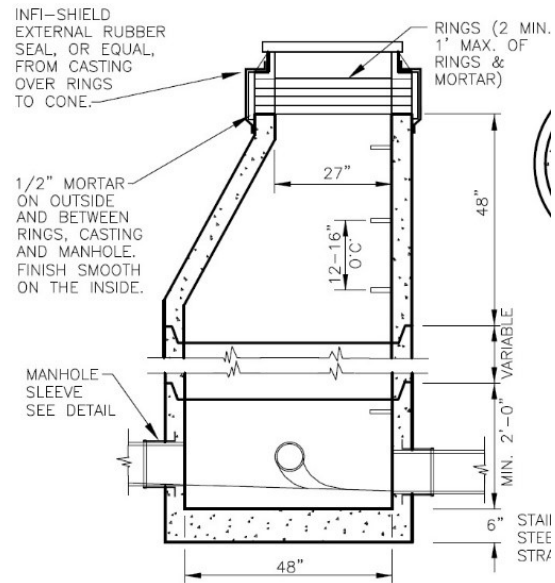

Figure 9. Example of chimney requirements for mitigating infiltration in sanitary sewer manholes [1]

2.3 CATCH BASIN AND MANHOLE REHABILITATION

Three of the reviewed municipalities have a specification for manhole and/or catch basin rehabilitation [12, 13, 20]. General methods for replacing the chimney or cleaning, sealing, and lining the barrel and cone sections are described below.

2.3.1 Cleaning and Lining Sewer Structures

Two of the specifications cite cleaning requirements and all three cite interior lining requirements, which are summarized as follows.

- Prevent material from entering the sewer lines; placing a cover over the inverts is required by one municipality [12].
- Thoroughly clean the interior of the structure, removing anything that would prevent a good bond between the existing manhole interior and the liner material, like grease, oil or loose or protruding material [12,13].
- Remove and replace grout on doghouse, inverts, and, and walls [13].
- Fix infiltration problems and other gaps in the walls with patching material, like chemical grouting [12, 13].
- Seal sanitary sewer manhole joints with 1.5" Kent-Seal No 2 or equal [12].
- After cleaning and sealing structure interior, apply liner to the walls [12, 13].
- The lining materials cited include a cementitious liner at least ½" thick [12]; Quadex Dynastone or SpectraShield [13]; or a formed/poured concrete liner for brick manholes that is 3" to 6" thick [20] (Figure 10).



Figure 10. Application of SpectraShield in a manhole.

2.3.2 Structure Reconstruction

One of the specifications outlines steps for reconstructing brick and pre-cast concrete manholes [20]. The following steps describe the reconstruction of a pre-cast concrete manhole.

- Remove existing casting, rings, and brick riser to necessary depth
- Salvage cone section if possible, must meet ASTM C-478
- Insert pre-cast concrete riser section beneath cone section, 12" thick minimum
- O-ring rubber gaskets meeting ASTM C443 in pre-cast section joints
- Adjust to grade using manhole bricks and cast-in-place concrete riser, if >7"
- Shim frame to match grade using a minimum of ½" mortar

The specifications describing rehabilitation practices outline the reconstruction of a brick manhole as follows.

- Remove existing casting, rings, and brick riser to 6' or as indicated on plans/by the engineer
- Protect underlying brick portion of the structure during reconstruction and keep invert free of debris
- Place 12" thick pre-cast or cast-in-place concrete base ring on at least 1" thick bed of mortar on top of underlying brick section of structure
- Place 4' concentric access cone on concrete base ring with 2 strips of RAM-NEK or approved equal between concrete ring and base of cone
- Install steps to match existing steps
- Adjust to grade using manhole bricks and cast-in-place concrete riser, if >7"
- Shim frame to match grade using ½" mortar minimum

CHAPTER 3: CONSTRUCTION AND REPAIR PRODUCT REVIEW

The project survey of Minnesota municipal engineers identified HDPE rings, Infi-Shield Uni-band, and concrete rings as the most commonly used products for manhole and catch basin construction and repair. Other products relevant to this study – based on either additional survey comments or municipal specifications – include EPP rings, Eull’s Manhole Shield, Flex Seal Utility Sealant, and I&I Barrier and Sealant. The following sections provide a general overview for readers who may be unfamiliar with the range of products available to municipal engineers.

3.1 HDPE AND EPP RINGS

HDPE and EPP rings are available as a substitute for the concrete adjustments rings and manhole bricks traditionally used to grade catch basin and manhole castings and frames [23, 24, 25, 26, 27]. The life expectancy of HDPE and EPP rings is 100 years and 50 years, respectively. Both types of rings are resistant to road salt and hydrogen sulfide, as well as HMA paving temperatures. Circular and rectangular EPP rings are shown in Figure 11.

The rings are lightweight (relative to other construction materials) and, therefore, require little equipment to install. One municipal engineer in the resources alluded to the weight of EPP rings as mitigating a work safety concern, as the use of EPP rings is less strenuous for the workers than working with concrete rings [22].

HDPE and EPP rings as thin as ¼” are available to make grade adjustments, and slope rings can be used to adjust the pitch of the casting. However, one survey respondent mentioned that HDPE rings are difficult to use because of the offset of most castings and the limited ability to manipulate the final elevation, pitch, and grade.



Figure 11. Installation of (a) circular and (b) rectangular (with frame) EPP rings

3.2 INFI-SHIELD UNI-BAND

The Infi-Shield Uni-band external seal is made by Seal Systems, Inc. [28, 29]. The Uni-band seal (Figure 12) is used to prevent infiltration. The seal overlaps the casting of the manhole or catch basin, fully covers the adjustment rings, and overlaps the top of the cone or top slab of the structure. The sealing material is made of ethylene propylene diene monomer (EPDM) rubber and is installed as one seamless piece. There is a pre-formed 90° angle (“L” shape) in the rubber that is placed at the intersection of the manhole/catch basin casting and the sides of the adjustment rings.



Figure 12. Infi-Shield Uni Band installed on manhole casting.

The seal between the rubber and the structure is strengthened with the use of both a primer that leaves a tacky residue when it dries and with non-hardening butyl mastic tape. The primer is first applied where the tape will go. A 2-3"-wide strip of butyl mastic tape is placed between the seal and the casting, and a 2"-wide strip of the tape is placed at the bottom of the side section of the seal, where the rubber overlaps with the cone or top slab.

To install the Infi-Shield, the laborer must dig down five inches and clean the side of the cone section all the way around so that the seal adheres properly. The casting also needs to be clean for the Infi-Shield to adhere when the material is brought up over the casting flange.

Infi-Shield is favored in repairs by 32% of survey respondents, while 10% of respondents found it be to less successful in their experience.

3.3 FLEX SEAL UTILITY SEALANT

Flex Seal Utility Sealant, produced by Sealing Systems, Inc (SSI), is product that can be used to seal catch basin adjustment rings and chimney joints (Figure 13). It is made of plural component aromatic urethane and creates a seal on the inside of the chimney. Flex Seal Utility Sealant is acid resistant and will hold up to hydrogen sulfide and road salt.

Based on the instructions provided by SSI, preparation of the substrate before applying Flex Seal is critical. SSI provides a detailed instructional document outlining the steps that need to be taken depending on the material that the Flex Seal will be applied to. Certain materials, such as SpeedCrete, Quick Plug, and Speed Pave, should not be used because Flex Seal will not bond. SSI also provides detailed installation instructions for after the area has been prepped and cleaned appropriately [30, 31, 32]:

- A primer is applied to the cleaned structure surface and becomes tacky within 30-60 minutes.
- The Flex-Seal Utility Sealant must be applied within three hours of the primer becoming tacky.
- Parts A and B of the sealant material are thoroughly mixed using a power drill with a paint mixer.
- The sealant is applied with a paint brush (Figure 13).
- Each batch of sealant will be workable for about 20 minutes.

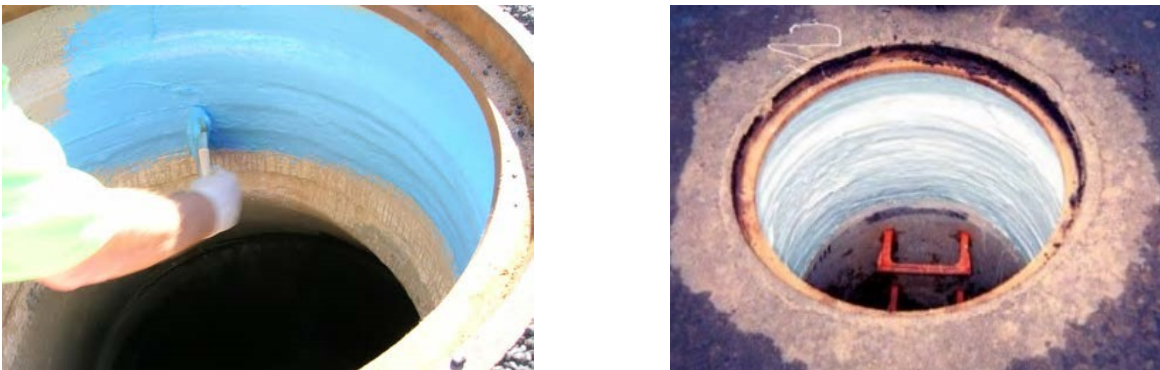

Figure 13. (a) Flex Seal being applied to a manhole chimney interior; (b) Chimney interior after Flex Seal application.

One survey respondent noted that Flex-Seal has been successful as a preventative measure for up to 10 years.

3.4 I&I BARRIER AND SEALANT

The I&I Barrier, produced by Strike Products, is made of polyethylene and is water and penetration resistant and illustrated in Figure 14 [34]. It creates an interior wall within the adjustment rings that is intended to prevent water infiltration into manholes and catch basins. The general method for installing the barrier is as follows [34]:

- The top surface of the doghouse/manhole cone is cleaned.
- I&I sealant is applied to the surface, and the barrier is set on the sealant.
- Rings are stacked around the barrier using mortar/sealant in between the rings and to seal the outside of the stack. The barrier extends above the top ring.
- Sealant is placed on the top ring and the casting/frame is set on that sealed ring.

- A watertight “Cap ‘n Seal” cover is available to fit into the barrier under the casting for extra infiltration prevention in flood-prone or heavy rainfall areas.

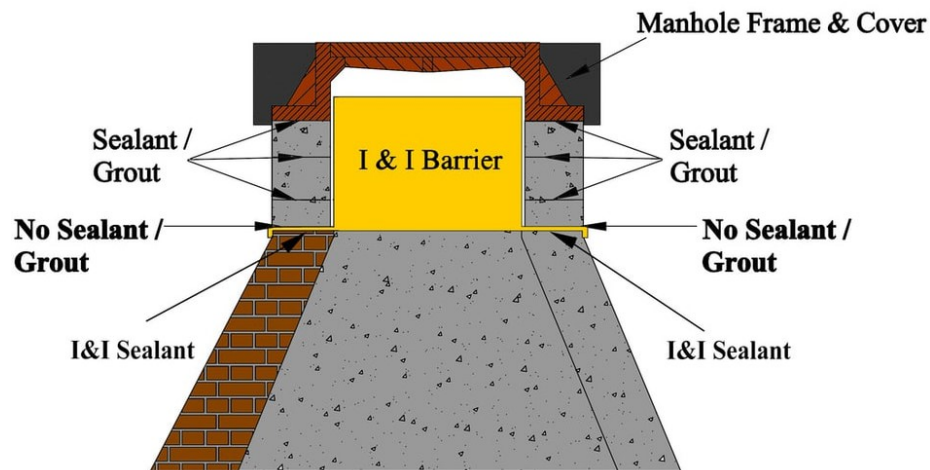

Figure 14. Placement of I&I Barrier in manhole chimney and related components.

The project survey indicated that 12% of respondents favored I&I Barriers, whereas 5% have found them to be less successful. Two respondents commented that while they use I&I Barriers for sanitary manholes, they have yet to find a good product for catch basins because of frequently having to deal with staggered rings.

3.5 EULL’S MANHOLE SHIELD

The Eull’s Manhole Shield is the system that Eull’s Manufacturing recommends for installing manhole chimneys. A survey respondent also commented that this is a product they favor for repairs. The method requires four components:

- Concrete adjustment rings
- Strike Products I&I Barrier and Sealant
- Appropriate underground utility mortar
- High impact, chemical and water-resistant plastic shims

The top surface of the concrete base structure is cleaned off. I&I Sealant is applied to the clean surface, and the I&I Barrier is placed on the area with sealant. The concrete adjustment rings are placed over the barrier so that the hollow, cylindrical part of the barrier is in the middle of the rings (forms an interior wall).

Underground utility mortar is applied between each ring and on the outside of the rings once the stack is complete to help seal the chimney. Plastic shims are placed as needed to adjust the slope of the casting to match the slope of the road. The barrier extends slightly higher than the top ring, but the casting still sits on the top ring [33].

3.6 ALIGNMENT BARRIER

The Alignment Barrier is a low-density polyethylene adjustment ring guide produced by Ess Brothers and Sons, Inc. and is illustrated in Figure 15 [36]. The purpose of the Alignment Barrier is to ensure that the adjustment rings used to build the chimney are properly aligned when stacked. It can be used with concrete or HDPE adjustment rings and comes in three sizes to accommodate different manhole diameters and chimney heights. To install the Alignment Barrier [36]:

- Clean and dry the top surface of the manhole cone.
- Cut the barrier's vertical sleeve to the desired height.
- Apply non-hardening butyl mastic at least ½" wide around bottom surface of the barrier flange.
- Secure the Alignment Barrier to the top of the cone.
- Build the chimney by placing the adjustment rings so that the vertical sleeve goes through the center of the rings.

3.7 GATOR WRAP

Gator wrap is a joint-sealing product made by SSI for manholes, catch basins, and pipes and is illustrated in Figure 15 [36]. The seal is made of 30 mil thick, stretchable, halogenated-based rubber on the front side and 30 mil thick, cross-linked re-enforced butyl adhesive on the back side, for a total thickness of 60 mil. When two ends of the seal are overlapped, a cross-link and fused bond is formed between the rubber and butyl adhesive. The seal applies inward pressure on the structure joint that works to prevent water and soil intrusion [37].

SSI recommends the following for gator wrap installation [37]:

- Clean around joint to be sealed with a wire brush and whisk broom and remove any protruding edges around the joint. Area needs to be dry and free of dirt before seal is applied.
- Remove first foot of paper backing from the adhesive side of the seal. Center and place the gator wrap around the joint. Continue removing the paper backing as the wrap is applied to the entire joint.
- Make sure the two ends of the wrap overlap by 6". Do not stretch the material in the overlap area.
- Cut excess material using a utility knife.
- Use a rubber mallet or hand-held roller to flatten the gator wrap around the whole joint.



Figure 15. Alignment Barrier on cone with Gator Wrap placed around part of the flange.

CHAPTER 4: SETTLEMENT AND HEAVE MITIGATION

The original goal of this project was to research best practices related to managing the effects of settlement and heave at catch basins and manholes. However, the project survey of Minnesota municipal engineers found that frost heave and settlement were lesser concerns for respondents relative to other construction-related issues. As a result, the project objectives were adjusted to account for a wider scope of activities/products related to catch basin and manhole construction.

However, given the original objective, the project team recorded instances in reviewed specifications that specifically outline practices for preventing settlement and heave and those methods. Generally, the reviewed specifications require that backfilling be performed as soon as possible [5, 8, 12] or, if the structure is cast-in-place concrete or bricks/blocks laid in mortar, soon after a minimum 3-day cure for the placed concrete/mortar (Figure 16, Figure 17) [20]. The backfill material should be deposited in a way that does not injure the pipes or structures [5, 8, 12]. Some specifications indicate that backfill for manholes and catch basins shall meet MnDOT 3149.2.D.2 Granular Backfill [35] or MnDOT 2503 and 2506 [8].

Some specifications describe backfill materials – for instance, that they be free of cinders; ashes; organics; boulder stones or rocks larger than 6"; and frozen material [12]. Others limit the top-size of aggregate or other material to 2 inches in the upper foot of the finished grade [8]. For over-excavated areas adjacent to a manhole base and under the pipe, the use of 1¼" crushed rock backfill was required in one specification to prevent settlement and support the pipe [9].



Figure 16. Compacted backfill surrounding manhole.



Figure 17. Vibratory plate compactor being used to compact backfill around catch basin.

While there is general agreement on backfill lifts and compaction effort, items are outlined below to distinguish small differences, where present.

- Backfill in traveled portions of the street shall be deposited in 1' lifts using a vibratory compactor for granular material and a sheep's foot roller for cohesive material [8].
- Backfill outside of traveled portions of the streets shall be done with 3' lifts maximum [8].

- Backfill should be placed in uniform loose layers up to 12" thick and backfill within a roadbed shall meet MnDOT 2105.3 F1 [21].
- Backfill around and outside of structures shall be compacted to the extent necessary to prevent future settlement by tamping or other means approved by the engineer [9].
- For backfilling above the pipes, backfill should be compacted to 95% of standard proctor density up to the top 3' of material. The top 3' of material should be compacted to 100% of standard proctor density [5].
- Top 3' of material compacted to at least 95% of modified proctor density. Below 3' shall be compacted to 90% modified proctor density [12].

Finally, we note that separate compaction requirements are listed for cold weather conditions in one specification [12].

While compaction is the first means to mitigate the effects of heave and settlement, proper use of some of the above-mentioned products can help prevent infiltration/intrusion if manhole or catch basin adjustment rings are damaged. When frost heave or other events damage manhole or catch basin rings, the surrounding material and water can enter the structure through openings that have formed. The migration of sediment leaves voids in the subsurface surrounding the structure [38]. When those voids collapse, settlement occurs, and settlement can damage the overlying pavement or other surficial structures. As discussed in section 2, the Infi-Shield Uni-band, Flex Seal, I&I Barrier, and Gator Wrap, when installed correctly, can be utilized as a preventative measure against the infiltration of water and sediment [38].

CHAPTER 5: SURVEY RESPONSE SUMMARY

The first task for the project was creating and distributing a brief survey to Minnesota cities and counties to begin gathering data about their experiences with catch basins and manholes. The survey questions regarded the following topics.

- Catch basin and manhole statistics for the city/county
 - Annual budget for catch basin/manhole repairs
 - Number of catch basins/manholes in the municipality
 - Number of catch basins/manholes repaired in the last year
- Common causes of catch basin and manhole failure
- Products that are favored for repairs
- Products that are less successful for repairs
- Resources used to obtain information on catch basin/manhole repairs

The project team received 83 responses to the survey and those responses are summarized below. A complete record of the survey data can be found in Appendix A.

Survey question one asked respondents approximately how many catch basins and manhole are in their municipality. Many of the respondents (33.7%) work in municipalities with 2000-7000 catch basins and manholes. Similar numbers of respondents work in municipalities with less than 500 (21.7%), 500-2000 (22.9%), and 7000+ (21.7%) catch basins and manholes.

Survey question two asked approximately how many catch basins/manholes have been repaired in the respondent's municipality in the last year. Over 60% of respondents have repaired 50 or fewer catch basins/manholes in the last year. Of the remaining respondents, 18.1% have repaired 100-300 and 14.5% have repaired 50-100 in the last year. Less than 10% of the responding municipalities have repaired 300+ catch basins/manholes in the last year.

Survey question three asked the respondents to rank causes of catch basin/manhole failure from most to least common. The survey identified the following causes of failure.

- Seasonal frost heave
- Initial construction issues
- Damage from neighboring construction, pavement issues, or traffic
- Product and/or product installation issues

Seasonal frost heave is ranked as the most common cause of failure by 32.9% of respondents, but by a slim margin as initial construction issues are considered the most common cause by 27.3% of respondents. Damage from neighboring construction, pavement issues, or traffic is considered the most common problem by 21.0% and product and/or product installation issues is considered the most common problem by 18.8% of respondents.

Survey questions four and five focused on products used for catch basin and manhole repairs. Question four listed 11 products and asked respondents to select which products they favor for repairs and to provide additional details if necessary. Survey respondents identified the following products.

- Strike I/I Barrier
- Gator Wrap
- Infi-Shield
- Flex Seal
- Other Type of Chimney Seal
- HDPE Rings
- Concrete Rings
- Aqua Seal
- SpinCast (concrete)
- SpeedCrete
- SpectraShield Liner

Of the products provided in the survey question, concrete rings, HDPE rings, and Infi-Shield are the most favored products for catch basin and manhole repairs. Over 50% of respondents use concrete rings, just over 40% use HDPE rings, and over 30% use Infi-Shield. All other products had at least about 10% of respondents indicating that they favor it for repairs. The survey comments identified the following additional products.

- Cement meant for underground use
- Eull's Manhole Shield
- Inexpensive geotextile wrap similar to silt fence material
- Butyl sealant between rings
- Avanti Grout for high water table or deep infrastructure (expensive but seems to be effective)
- Quakex Geokrete geopolymer

Question five provided the same list of products as question 4 and asked which products have been less successful for repairs and provided a comments field for more details. Of the products provided in the survey question, concrete rings, HDPE rings, and SpeedCrete are more often less successful for repairs. Concrete rings appear to be the least successful, as 55.4% of respondents selected that option, compared to 21.4% selecting HDPE rings, and 17.9% selecting SpeedCrete. Some of the more detailed additional comments for this question include the following quotes:

- "Read the manufacturers warning for SpeedCrete and know how long it is supposed to last. Demand that workers power wash the structure first and remove all loose debris and leave the surface damp/wet when making repairs. When pouring the doghouse, pour all the way around, make a good seal, and do not back fill for at least 72 hours in order to give the mud time to set before trying to get compaction."
- "HDPE rings are difficult to use due to the offset of most castings and the limited ability to manipulate the final fit including elevation, pitch, and grade to fit the road/curb."

- “Flex-Seal as a preventative measure has been successful for 5-10 years so far.”

Survey question six asked how much of the municipality’s annual budget is dedicated to catch basin/manhole repairs. The majority (61.5%) of the respondents work in municipalities that spend \$1-50k on catch basins and manhole repairs annually. Those that spend \$50-100k made up 13.3% of respondents, and those that spend \$100-200k made up 16.9%. Less than 10% spend more than \$200k annually on catch basin and manhole repairs.

Finally, question seven listed four categories of possible sources of catch basin/manhole repair information and asked which the respondent has used. The four categories listed were online sales information; agency reports (incl LRRB 2001 report); internal city documents; and “other.” There was a comment box for respondents to specify what “other” resources are used.

Online sales information is used by 36.7% of respondents and internal city documents are used by 20.0%. Only 6.7% of respondents utilize agency reports. A variety of other resources are used by 76.7% of respondents, including but not limited to the following items.

- MnDOT spec on catch basin installation
- APWA
- In-house experience
- Looking to other city’s methods and specifications
- Using the experience of the person applying the repair product
- Information from expos, conferences, and demos
- Personal experience and staff input
- Trial and error
- Manufacturers sales force

The data from the survey was used to identify resources and products to research and review. As stated above, the fact that initial construction issues are nearly as common as seasonal frost issues in Minnesota motivated a broader research focus than originally planned. Because the results show that seasonal frost is still an issue that municipalities are dealing with, documented methods for mitigating settlement and heave are included above in Chapter 4 of this report. Other common issues and best practices discussed in interviews with engineers and public work professionals are included next in Chapter 6.

CHAPTER 6: MUNICIPAL CATCH BASIN/MANHOLE EXPERIENCES

The project team interviewed industry and municipal professionals to add more detailed examples of best practices and common issues to the data collected from the survey responses. The following sections summarize those discussions.

6.1 PRODUCT EXPERIENCE

6.1.1 Adjustment Rings

Based on the interviews that the project team conducted, plastic and concrete rings appear to be used in equal measure, and both have a good chance of long-term success if installed properly. Each product has advantages and drawbacks.

When discussing concrete rings, the challenging weight of the rings and lack of easy maneuvering came up as drawbacks, while ease of ring stacking and casting slope adjustment were advantages. The importance of using the proper type of mortar when installing concrete rings was emphasized during one of the interviews and is discussed in section 6.2.

For plastic rings, workers find them to be light and easy to maneuver. However, building the chimney with plastic rings can be challenging because plastic rings need to be installed straight up from the cone to the casting, and some have found it difficult to make the necessary offset and slope adjustments, even with the tapered plastics rings (Figure 18). Plastic rings have been known to compress or crack prematurely because the way the rings are positioned to match the slope of the pavement makes the rings more vulnerable to load. A less common issue is plastic rings slipping off the cone. Finally, it was mentioned that in a few instances the modular gaps in the plastic rings filled with water, and the water was then in direct contact with the casting for an extended period, which was damaging to the casting.



Figure 18. HDPE ring being installed.



Figure 19. Steel riser ring installed in manhole frame.

One interviewee oversees the use of steel riser rings for adjusting the grade of manholes located in the middle of roadways, especially during mill and overlay construction (Figure 19). Steel riser rings attach to the top of the existing manhole frame and are purchased to match the existing structure diameter, so the original casting cover will fit over the riser ring. As it was explained in the interview, using steel rings during paving projects allows for paving right up to the manhole and eliminates needing to cut away a square of pavement around each manhole later to bring it to grade.

6.1.2 Infiltration Prevention Products

6.1.2.1 Infi-Shield

The Infi-Shield came up in more than one interview when discussing the importance of proper initial installation of products. The following comments were made:

- To properly install the Infi-Shield, the contractor must dig down five inches and clean all the way around the side of the cone before adhering the Infi-Shield to the side of the cone.
- The casting needs to be clean for the Infi-Shield to adhere properly when the material is brought up over the casting flange.
- The Infi-Shield's tight fit over the adjustment rings and casting makes it difficult to install. They have experience with contractors cutting the Infi-Shield sleeve to make it easier to cover the casting and rings and then patching the slit with concrete.

6.1.2.2 I&I Barrier

- The I&I Barrier has been a successful infiltration prevention product for municipalities.
- The ease of installation compared to alternatives is one reason that it is preferred.
- To properly install an I&I Barrier, it is critical that the top surface of the cone be thoroughly cleaned so the sealant can bond fully to the concrete.
- Installing Gator Wrap, or similar product, around the bottom of the barrier will help seal the base of the barrier to the cone.

6.1.3 Lining Products

Municipalities have reported using SpectraShield for an interior structure lining because of SpectraShield's application thickness and flexibility. SpectraShield is a spray-on lining composed of modified polyurea that adheres well to concrete, brick, and steel.

Curtain grouting is a method of plugging leaks in structures by injecting grout into the soil surrounding the structure [39]. Curtain grouting works as follows:

- The injected grout creates an impermeable gel-soil matrix that helps prevent water from entering the structure.
- The gel-soil matrix encapsulates the structure, which can be advantageous if the structure has many leaks and/or many potential points of infiltration, such as brick or block structures.
- Two types of material can be used: acrylic gel grout or expansive polyurethane foam.

- The material can be injected from inside or outside of the structure.

To curtain grout from inside the structure, equally spaced holes are drilled in rows throughout the whole structure (Figure 20). The chosen material is prepped per instructions and injected into the lowest drilled hole until material starts coming out of an adjacent drilled hole. Material is injected into that adjacent hole and the other holes in the row until that row is complete. The process is repeated with the remaining rows of holes, working from the bottom to the top of the structure. Once all holes have been injected, patch the holes with quick-set mortar.

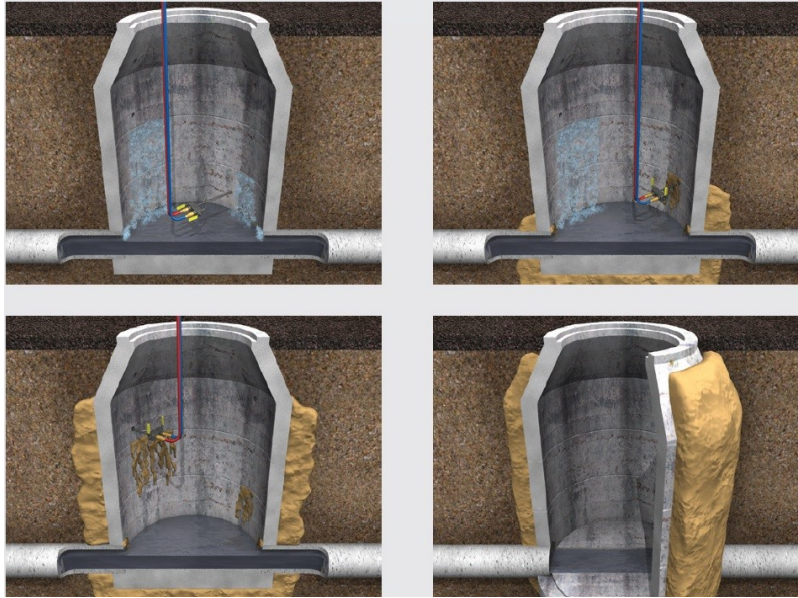

Figure 20. Curtain grouting from inside the structure.

To curtain grout a structure from ground level, drill holes in the pavement or ground around the structure (Figure 21). After mixing the chosen grouting material per instructions, insert the injection probe in the drilling hole and begin injecting grout at the bottom of the structure. Inject a thorough amount of grout, then pull the probe up two to three feet and inject grout. Continue injecting grout into the drilled holes around the structure until the structure is fully encapsulated.

A combination of curtain grouting and SpectraShield linings has been a successful combination of products for sanitary structures according to a municipal contact interviewed during this project.

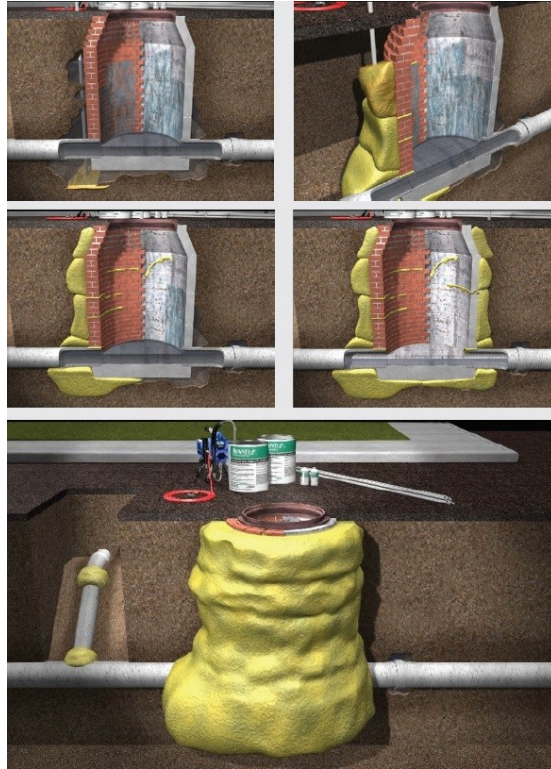

Figure 21. Curtain grouting from outside the structure.

6.1.4 Drain Tile

Drain tile is used by some to mitigate the effects of frost action in the top three feet of ground. The drain tile is installed alongside storm sewer structures. On new construction projects, the tile is installed along the street edge just outside the curb, and on reconstruction projects the tile is installed just inside the curb. The product typically used, according to a municipal contact, is half perforated pipe or standard plastic agricultural drain tile. The tile is used as a conduit to run the groundwater into the catch basins. In addition, inlets are installed between property lines for sump pump flow.

6.2 AREAS OF FOCUS IN THE FIELD

The municipal contacts interviewed by the project team identified what they look for in the field as work-quality indicators.

6.2.1 Appropriate Mortar

The type of mortar being used and how it is applied are important indicators of how soon structures will need repairs after initial construction. An industry contact made the following remarks:

- Using mortar made specifically for underground, utility applications is critical for the structure to have a long lifespan.

- Seeing Type N mortar on a manhole or catch basin construction site, for example, can be a red flag as Type N mortar is not air-entrained and is not suited for utility structures.
- Underground utility mortar, Type M mortar, or Type S mortar are air-entrained and better suited for utility structures.
- Using one of these types of mortar to fill adjustment ring and pipe joints thoroughly and uniformly is important for structure longevity and looking at the quality of the mortar work in the field is an important indicator of workmanship.
- The mortar set time should be monitored by an inspector. The mortar should not be too dry when used.

6.2.2 Adjustment Ring Thickness

Seeing only undersized adjustment rings on the job site is a possible problem. When installing a manhole or catch basin chimney, using fewer rings means having fewer joints and fewer opportunities for installation issues. When only thin adjustment rings are available on a job site, it is likely that more rings will be used for the chimney than would be needed if thicker rings are also available. Assuming concrete rings are the same price per inch regardless of the thickness of the ring, the price for a chimney made with 2-3" rings would be the same as a chimney made with 3-2" rings. However, the structure with fewer rings has a better chance of lasting longer. Table 1 lists the minimum and maximum number of rings/height of chimney allowed by the municipalities reviewed for this report.

6.2.3 Initial Construction Issues

A municipal contact identified two initial construction issues that can cause paving problems during later stages of construction.

1. It is important to confirm that the concrete forms around catch basins are installed correctly. They have experience on job sites with contractors being sloppy with the forms, using sticks as props instead of proper materials, and resorting to piling up concrete around the catch basin casting, which is an issue for the pavers during later stages of construction. Proper initial installation of the concrete forms can prevent future problems.
2. If the dip of the catch basin is too severe, the gutter line will also dip more than intended to match the catch basin. This will cause uneven pavement later and excess pavement in the trough created by the severe dip will often slough off into the catch basin.

6.3 WHERE TO FOCUS REPAIRS

Municipalities need to decide where focus repair efforts each year. One municipal contact interviewed by the project team described the strategy that has been successful for them. This municipality looks at the recorded amount of water consumed in a defined area and compares it to the amount of wastewater system inflow from that same area. The ratio of consumption to wastewater inflow is calculated to estimate how much unintended inflow and infiltration is happening in that defined area. Once areas with higher-than-expected inflow are identified, the municipality uses CCTV televising

inspections of manholes and catch basins in those areas to confirm what the data is indicating (Figure 22, Figure 24).



Figure 22. Televising device entering manhole.

CHAPTER 7: INSTALLATION CONSIDERATIONS

This chapter describes catch basin/manhole example scenarios that require decisions about installation and/or repair. Products and processes relevant to the scenarios are discussed. The idea is not to dictate which choices are correct but rather to provide a demonstration of things to consider and questions to ask when faced with similar scenarios.

7.1 SCENARIO A – NEW STRUCTURE

Situation: New catch basin is being installed as part of city road reconstruction.

Utility structure construction decisions will depend on many particulars, including the municipality or county specifications, the experiences of those involved, the structure's intended function, and the surrounding area.

7.1.1 Type and Number of Adjustment Rings

The type of adjustment rings will need to be chosen.

Based on the survey results and interviews, concrete rings and HDPE/EPP rings both have advantages and disadvantages. The reviewed specifications show that in Minnesota there are municipalities that specific one type of adjustment ring be used and municipalities that allow for either.

Concrete adjustment rings:

- Concrete rings are a widely-known product that utility contractors are familiar with installing.
- With proper initial installation and appropriate mortar, concrete rings can last up to 25-30 years.
- According to a municipal contact, concrete rings also have the advantage of being easy to use when building chimneys to offset castings and when needing to adjust the pitch of the casting to match the slope of the pavement.
- The same municipal contact also cited the heavy weight of concrete rings as a disadvantage as it makes transport and installation awkward and a safety hazard.

HDPE/EPP rings:

- HDPE/EPP rings are lightweight (a 6" thick ring is less than 20 lb.) which makes transportation and installation convenient and safe for workers.
- With proper installation, the manufacturers of HDPE and EPP rings promote a product life of 50-100 years.
- One disadvantage is the HDPE/EPP rings need to be installed in a straight stack, which means they cannot be used to build a chimney to an offset casting.
- Another disadvantage is that the tapered rings used for adjusting the pitch of the casting can be tricky to install.

The anticipated height of the chimney should meet the requirements of the governing specifications. Many municipalities have minimum and/or maximum requirements for chimney height and/or number of rings. Table 2, which reproduces Table 1 from above, compares the specified ring count and height by municipality. If the plans for the structure do not meet the relevant requirements, consider adjusting the plans for the barrel sections to shorten or lengthen the chimney adjustment, as needed.

Table 2. Comparing specified ring count and height by municipality

| City/Specification | Minimum height/# of rings | Maximum height/# of rings |
|--------------------------------------|--|---|
| Andover | 2 rings | 1' |
| Blaine | 2-0.2' rings | 5-0.2' rings |
| CEAM | 2-2" rings | 6-2" rings |
| Chanhassen | 2-2" rings | 3 rings |
| Edina | -- | 2' |
| Duluth | -- | 6" |
| Fargo | 3-2" rings | -- |
| Grand Forks | 2 rings | -- |
| Green Bay | -- | 4" for plastic rings, concrete rings used if adjustment >4" |
| Hastings | 2 rings | 6 rings |
| Mankato | 1 ring | 6"/3 rings |
| Minneapolis | 1-2" ring | 8" including mortar |
| Plymouth – storm sewer structures | 4" min; min of 1-2" ring below casting | 12" |
| Plymouth – sanitary sewer structures | 4" min; 4" or 6" ring used for adjustments of 8" or more | 12" |
| Rochester | 2" min | 8"/2 rings |

An additional consideration is the thickness of the adjustment rings. As discussed in section 6.2, a red flag that an interviewee looks for in the field is undersized adjustment rings. When fewer rings are used to build a chimney, there are fewer joints, and this reduces the chances of installation error and infiltration.

7.1.2 Bonding Material

Once the type of adjustment ring has been decided, the type of material used to bond the rings to each other, the top of the cone, and the casting needs to be chosen.

For concrete rings, mortar is used as the bonding material. Section 2.2.2 discusses mortar that is appropriate for underground utility applications in more detail, and section 6.2 includes an industry contact's views on choosing a type of mortar. TCC underground utility mortar, Type M mortar, and Type S mortar are all air-entrained and used by Minnesota municipalities.

For HDPE/EPP rings, the manufacturer's installation instructions and multiple reviewed specifications call for butyl sealant strips/rope to be used between the top of the cone and the bottom ring and between the top ring and the casting.

7.1.3 Infiltration Prevention

A third consideration is whether an infiltration prevention product will be installed. The survey responses, interviews, and specifications provide examples of external and internal ring barriers.

Multiple reviewed Minnesota municipal specifications require external barriers, according to both reviewed specifications and interviews. Infi-Shield Uni-band is an external barrier that is applied around the outside of the adjustment rings and is discussed above in sections 3.2 and 6.1.2.1.

Internal barriers came up in the survey responses, interviews, and municipal specifications. Examples of internal barriers are Flex-Seal Utility Sealant (section 3.3) and the I&I Barrier (sections 3.4 and 6.1.2.2) (Figure 23). One survey comment positively reviewed the Flex-Seal Utility Sealant, saying that the product has worked for them as a preventative measure for 5-10 years. A municipal contact commented that the I&I Barrier was their preferred product due to the ease of installation.



Figure 23. (a) application of Flex Seal Utility Sealant; (b) installation of I&I Barrier.

7.1.4 Frost Action

If frost action is a known issue around the project site, another consideration is frost action mitigation. As discussed in Chapter 4, when frost heave or other events damage manhole or catch basin rings, the surrounding material and water can enter the structure through openings that have formed. The migration of sediment creates voids in the subsurface surrounding the structure [38]. When those voids collapse, settlement occurs, and settlement can damage the overlying pavement or other surficial structures. As discussed in section 2, the Infi-Shield Uni-band, Flex Seal, I&I Barrier, and Gator Wrap, when installed correctly, can be utilized as a preventative measure against the infiltration of water and sediment [38]. Section 6.1.4 discusses the installation of drain tile alongside storm sewer structures as a frost heave mitigation strategy.

7.2 SCENARIO B – MAINTENANCE AND REPAIR

Situation: Existing sanitary manhole has infiltration problems and is scheduled to be repaired. Visual inspection confirms that infiltration is primarily due to cracks in the pre-cast concrete barrel sections below the cone.

As discussed in section 6.3, visual inspection is not the only way to determine where repairs are needed. Another method is to use the ratio of water consumption to wastewater inflow for sections of a city to determine which areas have a higher likelihood of needing repairs and focusing inspection efforts in those areas. Visual or CCTV inspections can be used in the high-inflow areas to confirm whether structure repairs are needed (Figure 22, Figure 24).

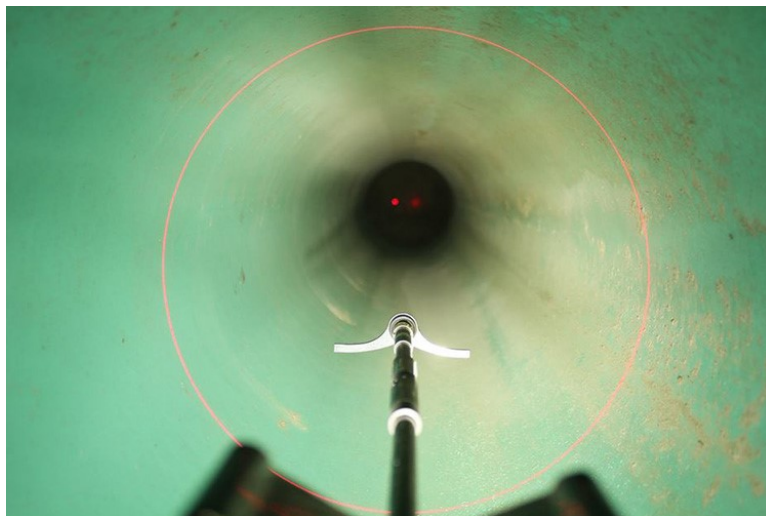

Figure 24. Sewer televising footage.

Visual and/or CCTV inspections can be used to characterize the severity and location of infiltration in a structure (i.e., is the infiltration coming from cracks in the barrel or from the barrel joints).

Based on the severity of the infiltration, the condition of other structures in the area, and the budget and time available, among other factors, the municipal engineer would then decide whether the structure will be rehabilitated or replaced.

7.2.1 Rehabilitation

Catch basin/manhole rehabilitation is discussed in more detail in section 2.3.

When rehabilitating a catch basin or manhole, the general order of operations is:

1. Thoroughly clean structure interior.
2. Patch leaks and remove and replace any deteriorated mortar/grout, as applicable.
3. Apply sealant per manufacturer's instructions.

Numerous internal seal application instructions emphasize the importance of thoroughly cleaning the interior of the structure. Cleaning is critical for a good bond between the sealant and the structure. Examples of cleaning methods are power washing and air blasting.

Materials that can be used to patch leaks in concrete barrel sections include concrete, mortar, and chemical grouting like Avanti Grout. If the joints are leaking, a butyl rope sealant like Kent Seal is used by some municipalities.

Survey responses, interviews, and specifications describe a number of options to seal structures against infiltration.

Internal seals available (not a comprehensive list):

- SpectraShield
- Cementitious seal
- Quadex Dynastone
- Poured concrete liner 3-6" thick for brick manholes
- I&I Barrier
- Flex Seal Utility Sealant

External seals available (not a comprehensive list):

- Curtain grouting
- Infi-Shield Uni Band

7.2.2 Replacement

Catch basin/manhole replacement is discussed in more detail in section 2.3.2 (Figure 25).



Figure 25. New manhole structure before backfilling.

The general order of operations for catch basins/manhole replacement are as follows:

- Remove existing casting, rings, and riser/barrel sections to necessary depth.
- Insert pre-cast concrete riser sections beneath cone section as needed to reach the necessary grade.
- O-ring rubber gaskets are often required in pre-cast section joints.
- Build chimney to grade using adjustment rings.
- Shim frame to match ground slope using mortar or shims, as required.

Some construction considerations are:

- Will the barrel section joints be sealed with a butyl product like Gator Wrap or Kent Seal (or other rope mastic) to help prevent infiltration?
- What type of adjustment ring will be used? Refer to Scenario A for a discussion of concrete and HDPE/EPP rings.
- Will an infiltration prevention product be installed with the adjustment rings? Refer to Scenario A for a discussion of possible products.
- How will the rings be shimmed, if needed? Shimming is discussed in more detail in section 2.2.2.
- Will a seal/liner be applied to the structure to help prevent infiltration? Refer to section 7.3.1 for a list of available sealing products.

CHAPTER 8: CONCLUSION

This project included developing and distributing a survey to Minnesota municipalities and summarizing the results, reviewing municipal specifications and product promotional literature, and interviewing industry and municipal professionals about their experiences with catch basins and manholes.

Major conclusions from this study are as follows:

- In many cities, settlement and heave are not the predominant catch basin and manhole issues. Initial construction issues are an equal, if not more pressing, concern, according to survey results and interviews.
- The reviewed municipal specifications indicate that catch basin and manhole construction methods are generally similar, the primary differences being chimney detail and recommendations for rehabilitation (where present).
- Reviewed specifications indicate that backfill compaction is the first means by which to mitigate the effects of heave and settlement, and proper use of some products can help prevent infiltration/intrusion if manhole or catch basin adjustment rings are damaged.
- There are a wide array of products available to help mitigate infiltration, including internal and external seals and barriers, bonding materials, joint wraps, and drain tile. Interviewed municipal and industry professionals emphasized that it is critical to select the proper materials for a structure and ensure that those materials are applied appropriately in the field.

This guide provides foundational information to help Minnesota municipalities select and implement appropriate materials and methods for catch basin and manhole installation/maintenance. The two hypothetical field scenarios presented will assist public works and city engineers in constructing new structures or maintaining and repairing existing structures. These scenarios demonstrate, in a general way, how the information in this guide can be applied to new construction and repair projects.

REFERENCES

- [1] City of Andover, Minnesota. (n.d.). (Internet), Section 300 – Sanitary Sewer Details (PDF), details revised on different dates. Retrieved from <https://www.andovermn.gov/DocumentCenter/View/947/Section-300-Sanitary-Sewer-Details?bidId=>
- [2] City of Andover, Minnesota. (n.d.). (Internet), Section 400 – Storm Sewer Details (PDF), details revised on different dates. Retrieved from <https://www.andovermn.gov/DocumentCenter/View/948/Section-400-Storm-Sewer-Details?bidId=>
- [3] City of Blaine, Minnesota. (n.d.). (Internet), Sanitary Sewer (All Detail Plates) (PDF), detail revision dates not included. Retrieved from <https://www.blainemn.gov/DocumentCenter/View/5393/Sanitary-Sewer-All-Detail-Plates-PDF>
- [4] City of Blaine, Minnesota. (n.d.). (Internet), Storm Drainage (All Detail Plates) (PDF), detail revision dates not included. Retrieved from <https://www.blainemn.gov/DocumentCenter/View/5394/Storm-Drainage-All-Detail-Plates-PDF>
- [5] City of Chanhausen, Minnesota. (n.d.). (Internet), Standard Specifications & Detail Plates, detail revision dates not included. Retrieved from <https://www.ci.chanhausen.mn.us/436/Standard-Specifications-Detail-Plates>
- [6] City of Duluth, Minnesota. (2019). (Internet), Sanitary Sewer Details (PDF). Retrieved from <https://duluthmn.gov/media/7294/2019-sanitary-sewer-details-binder.pdf>
- [7] City of Duluth, Minnesota. (2019). (Internet), Storm Sewer Details (PDF). Retrieved from <https://duluthmn.gov/media/7295/2019-storm-detail-binder.pdf>
- [8] City of Edina, Minnesota. (2019-January) (Internet), Sanitary Sewer & Storm Sewer Structures. Retrieved from <https://www.edinamn.gov/362/Standard-Plates-Specifications>
- [9] City of Fargo, North Dakota. (2015). (Internet), City of Fargo Specifications – Sanitary Sewers (PDF). Retrieved from https://download.fargond.gov/0/2015_sanitary_sewers.pdf
- [10] City of Fargo, North Dakota. (2014). (Internet), City of Fargo Specifications – Storm Sewers (PDF). Retrieved from https://download.fargond.gov/0/2014_storm_sewers.pdf
- [11] City of Grand Forks, North Dakota. (2020-February). (Internet), Standard Plates for Construction (PDF). Retrieved from <https://www.grandforksgov.com/home/showdocument?id=34429>
- [12] City of Green Bay, Wisconsin. (2020). (Internet), Standard Specifications & Construction Standards for Public Works Construction (PDF). Retrieved from <https://greenbaywi.gov/DocumentCenter/View/4947/Standard-Specifications-and-Construction-Standards-for-Public-Works-Construction-2020-Edition-PDF>
- [13] City of Hastings, Minnesota. (2015). (Internet), Standard Infrastructure Specifications (PDF). Retrieved from <https://www.hastingsmn.gov/home/showdocument?id=1474>
- [14] City of Hastings, Minnesota. (n.d.). (Internet), City of Hastings Standard Plates (PDF), plates revised on different dates. Retrieved from <https://www.hastingsmn.gov/home/showdocument?id=6095>

- [15] City of Mankato, Minnesota. (2018). (Internet), City of Mankato Standard Plates – 2018 (PDF). Retrieved from <https://www.mankatomn.gov/home/showdocument?id=1004>
- [16] City of Minneapolis, Minnesota. (2020-January). (Internet), Standard Specifications & Detail Plates. Retrieved from http://www2.minneapolismn.gov/publicworks/plates/public-works_plates-home
- [17] City of Plymouth, Minnesota. (2020-January). (Internet), *Standard Specifications for Sanitary Sewer Construction (PDF)*. Retrieved from <https://www.plymouthmn.gov/home/showdocument?id=20710>
- [18] City of Plymouth, Minnesota. (2020-January). (Internet), Standard Specifications for Storm Sewer Construction (PDF). Retrieved from <https://www.plymouthmn.gov/home/showdocument?id=20712>
- [19] City of Rochester, Minnesota. (n.d.). (Internet), Sanitary & Storm Sewer Structures (PDF), detail plate revision dates vary. Retrieved from <https://www.rochestermn.gov/home/showdocument?id=27536>
- [20] City of Saint Paul, Minnesota. (Internet), Sewers & Appurtenances 2000 Series. Retrieved from <https://www.stpaul.gov/departments/public-works/standard-plates/sewers-appurtenances>
- [21] City Engineers Association of Minnesota. (2018). (Internet), Standard Specifications. Retrieved from [https://www.ceam.org/vertical/Sites/%7BD96B0887-4D81-47D5-AA86-9D2FB8BC0796%7D/uploads/download_redline_version_\(002\).pdf](https://www.ceam.org/vertical/Sites/%7BD96B0887-4D81-47D5-AA86-9D2FB8BC0796%7D/uploads/download_redline_version_(002).pdf)
- [22] R. Wahlen. (2014-September). *Evaluation of Expanded Polypropylene (Foam) Adjustment Rings for Manhole Grade Adjustment*. Minneapolis, MN: University of Minnesota, Center for Transportation Studies, Minnesota Local Technical Assistance Program.
- [23] Ladtech, Inc. (2018). (Internet), Products: HDPE Manhole Rings. Retrieved from <http://ladtech.com/hdpe-manhole-rings/>
- [24] Ladtech, Inc. (2018). (Internet), Products: Catch Basins. Retrieved from <http://ladtech.com/catch-basins/>
- [25] Ladtech, Inc. (2018). (Internet), *Installation Guide – English Instructions (PDF)*. Retrieved from <http://ladtech.com/wp-content/uploads/2018/01/install.pdf>
- [26] Cretex Specialty Products. (2019). (Internet), PRO-RING Advantages. Retrieved from <https://www.cretexseals.com/wp-content/uploads/2019/02/PRO-RING-Features-Benefits-2019-web-email-qualityF.pdf>
- [27] Cretex Specialty Products. (2019-November). (Internet), *PRO-RING Brochure*. Retrieved from https://www.cretexseals.com/wp-content/uploads/2019/11/PRO-RING-Brochure-11-2019-UD_11122019-web.pdf
- [28] Sealing Systems, Inc. (2019). (Internet), Infi-Shield Uni-Band Installation Procedures (PDF). Retrieved from <http://ssisealingsystems.com/pdf/infi-shield-uni-band-installation-instructions.pdf>
- [29] Sealing Systems, Inc. (2019). (Internet), Infi-Shield Uni-Band Specification for Manhole Adjustment Rings – Patent #7,789,586 (PDF). Retrieved from <http://ssisealingsystems.com/pdf/infi-shield-uni-band-specifications.pdf>
- [30] Sealing Systems, Inc. (2019). (Internet), Flex-Seal Utility Sealant-Prep and Cleaning (PDF). Retrieved from <http://ssisealingsystems.com/pdf/flex-seal-prep-and-cleaning.pdf>

- [31] Sealing Systems, Inc. (2019). (Internet), *Flex-Seal Utility Sealant Installation Instructions* (PDF). Retrieved from <http://ssisealingsystems.com/pdf/flex-seal-installation-brochure.pdf>
- [32] Sealing Systems, Inc. (2019). (Internet), *Flex-Seal Utility Sealant Brochure* (PDF). Retrieved from http://ssisealingsystems.com:60080/b416c5b5c3202c0a4438bf84b2e730669a9658cb/3b74436b-df2c-7909-8d45-f964d9664796/tap2_C4jB5c_dec/flex-seal-brochure.pdf
- [33] Eull's Manufacturing. (2019). (Internet), *Specifications-Eulls-Manhole-Shield* (PDF). Retrieved from <https://eullsmfg.com/wp-content/uploads/2019/01/Specifications-Eulls-Manhole-Shield.pdf>
- [34] Strike Products. (n.d.). (Internet), *Products: I/I Barriers*. Retrieved from <https://www.striketool.com/i--i-barrier.html>
- [35] City of Duluth, Minnesota. (2019-April). (Internet), *Construction Standards 2019*. Retrieved from https://duluthmn.gov/media/7290/2019-construction-standard_final_rev05april2019.pdf
- [36] G. Kilgore. (2020-October 26). Ess Brothers and Sons, Inc., Loretto, MN, email message to author, Alignment barrier and gator wrap documents and picture.
- [37] Sealing Systems, Inc. (2019). (Internet), *Infi-Shield Gator Wrap*. Retrieved from <http://ssisealingsystems.com/gator-wrap.html>
- [38] S. Bot. (2020-November 30). City of St. Michael, MN, email message to author, The use of products to mitigate the effects of frost heave/ring deterioration.
- [39] Avanti. (2019-November). (Internet), *Curtain Grouting* (PDF). Retrieved from <https://www.avantigrout.com/component/zoo/category/curtain-grouting?Itemid=1241>