

385.0973
Un386ord
79/20.1

Report No. FRA/ORD-79/20.1

To: G. W. Hise

CPF
for comment
Albino

FLYWHEEL ENERGY STORAGE SWITCHER

STUDY SUMMARY AND DETAILED DESCRIPTION OF ANALYSIS

AiResearch Manufacturing Company of California
2525 W. 190th Street

Torrance, California 90509



ASSOCIATION OF AMERICAN
RAILROADS
R & T LIBRARY
RESEARCH AND TEST DEPARTMENT
WASHINGTON, DC 20001

ASSOCIATION OF AMERICAN
RAILROADS
TTC
TECHNICAL LIBRARY
RESEARCH AND TEST DEPARTMENT
PUEBLO, CO 81001

APRIL 1979

FINAL REPORT

Document is available to the public through the
National Technical Information Service
Springfield, Virginia 22161.

Prepared for

U.S. DEPARTMENT OF TRANSPORTATION
FEDERAL RAILROAD ADMINISTRATION
OFFICE OF RESEARCH AND DEVELOPMENT
WASHINGTON, D.C. 20590

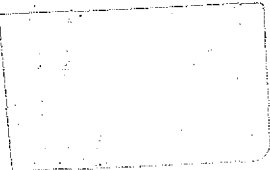

NOTICE

This document is disseminated under the sponsorship of the Department of Transportation in the interest of information exchange. The United States Government assumes no liability for its contents or the use thereof.

The United States Government does not endorse products of manufacturers. Trade or manufacturer's names appear herein solely because they are considered essential to the object of this report

TJ 541
A47

1. Report No. FRA/ORD-79/20.1		2. Government Accession No.		3. Recipient's Catalog No.	
4. Title and Subtitle FLYWHEEL ENERGY STORAGE SWITCHER Volume I--Study Summary and Detailed Description of Analysis				5. Report Date April 1979	
				6. Performing Organization Code	
7. Author(s) L.M. Cook, W.T. Curran, R. McConnell, A.K. Smith				8. Performing Organization Report No. 79-15651-1	
9. Performing Organization Name and Address AiResearch Manufacturing Company of California 2525 W. 190th Street Torrance, California 90509				10. Work Unit No. (TRAIS)	
				11. Contract or Grant No. DOT-FR-777-4247-1	
12. Sponsoring Agency Name and Address U.S. Department of Transportation Federal Railroad Administration Office of Research and Development Washington, D.C. 20590				13. Type of Report and Period Covered Final Report for period Sept 77 to Jan 1979	
				14. Sponsoring Agency Code RRD12	
15. Supplementary Notes Volume II (Report No. FRA/ORD-79/20.2), 363 pages, contains appendixes that comprise field data developed during switchyard and locomotive test phases.					
16. Abstract An indepth study of the application of flywheel energy storage to the railroad switchyard locomotive was conducted to determine the practicality and viability of such a system. The system, as originally conceived, required the use of separately excited fraction motors, and a major task of the study was to test separately excited version of the Electro-Motive Division's D77 traction motor. The attractiveness of the system is very dependent on the operational scenario of the switching locomotive. Therefore, the study examined the operation of locomotives at three flatyards: Dillard (Southern Railway System), Baldwin (Seaboard Coast Line), and Whitefish (Burlington Northern). Also, a large amount of data concerning the operating environment of switching locomotives was collected. It was concluded early in the study that a boxcar was required to carry the energy storage unit because no room existed on the locomotive. This, combined with the increased auxiliary load, results in the same energy consumption with or without the FESS system, for a typical flatyard operation in spite of the energy recuperated and reused. Brake maintenance savings, although significant, are not sufficient to give an attractive return on investment.					
17. Key Words Transportation Regenerative braking Railroads Energy conservation Energy Storage Flatyards Flywheels				18. Distribution Statement	
19. Security Classif. (of this report) Unclassified		20. Security Classif. (of this page) Unclassified		21. No. of Pages 329	

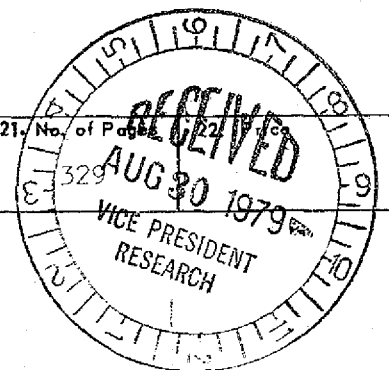

385.0973
Un386ord

Engines - 3

PREFACE

This final report summarizes the results of the Flywheel Energy Storage Switcher study. It is submitted to the Federal Railroad Administration by the AiResearch Manufacturing Company of California, a division of The Garrett Corporation, in accordance with U.S. Department of Transportation Contract No. DOT-FR-777-4247.

The Flywheel Energy Storage Switcher Study represents the efforts of the AiResearch Manufacturing Company of California, assisted in the hardware testing by Motor Coils Manufacturing. The continued assistance and guidance of the Federal Railroad Administration (FRA) contracting officer's technical representative, Mr. William F. Cracker; the Lawrence Berkeley Laboratory (LBL), Engineering Sciences Department systems analyst, Mr. Robert K. Abbott; and several members of the FRA and LRL staffs were invaluable to the successful completion of the study.

Major contributions were made by many U.S. railroads, who contributed comprehensive information that was used to establish and maintain the necessary data base. In addition, the following railroads made a significant contribution to the study by allowing the use of their flatyards for data collection:

- Burlington Northern (BN)
- Seaboard Coast Line (SCL)
- Southern Railway System (SRS)

Specifically, the assistance of Mr. T. C. Gilbert (SRS), Mr. R. J. Morris (BN), and Mr. J. Prosser (SCL) was greatly appreciated.

Southern Railway System also allowed the use of their test facilities to investigate locomotive performance, and they provided two EYD D77 traction motors for test purposes.

The Southern Pacific Transportation Company made available an SW1500 locomotive at their Taylor Yard facility to enable the equipment installation drawings to be made.

The final report comprises two volumes, as follows:

Volume No.	Title
I	Study Summary and Detailed Description of Analysis
II	Field Data

9174

METRIC CONVERSION FACTORS

Approximate Conversions to Metric Measures

Symbol	When You Know	Multiply by	To Find	Symbol
LENGTH				
in	inches	2.5	centimeters	cm
ft	feet	30	centimeters	cm
yd	yards	0.9	meters	m
mi	miles	1.6	kilometers	km
AREA				
in ²	square inches	6.5	square centimeters	cm ²
ft ²	square feet	0.09	square meters	m ²
yd ²	square yards	0.8	square meters	m ²
mi ²	square miles	2.6	square kilometers	km ²
	acres	0.4	hectares	ha
MASS (weight)				
oz	ounces	28	grams	g
lb	pounds	0.45	kilograms	kg
	short tons (2000 lb)	0.9	tonnes	
VOLUME				
tsp	teaspoons	5	milliliters	ml
Tbsp	tablespoons	15	milliliters	ml
fl oz	fluid ounces	30	milliliters	ml
	cups	0.24	liters	l
pt	pints	0.47	liters	l
qt	quarts	0.95	liters	l
gal	gallons	3.8	liters	l
ft ³	cubic feet	0.03	cubic meters	m ³
yd ³	cubic yards	0.76	cubic meters	m ³
TEMPERATURE (exact)				
°F	Fahrenheit temperature	5/9 (after subtracting 32)	Celsius temperature	°C

¹ in 2.54 (exactly). For a and more detailed tables, see NBS Misc. Publ. 286, Units of Weights and Measures, Price \$2.25. E Catalog No. C13 10 286.

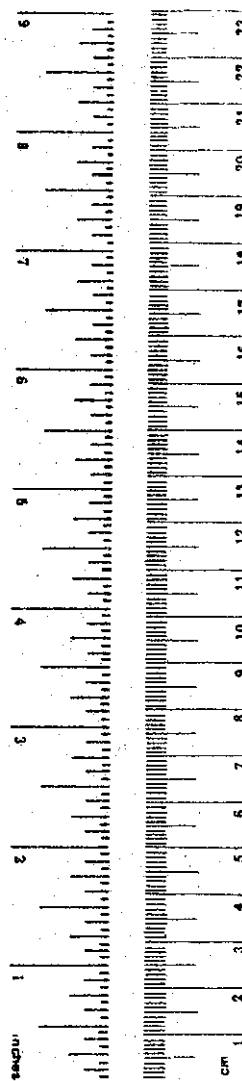

Approximate Conversions from Metric Measures

Symbol	When You Know	Multiply by	To Find	Symbol
LENGTH				
mm	millimeters	0.04	inches	in
cm	centimeters	0.4	inches	in
m	meters	3.3	feet	ft
m	meters	1.1	yards	yd
km	kilometers	0.6	miles	mi
AREA				
cm ²	square centimeters	0.16	square inches	in ²
m ²	square meters	1.1	square yards	yd ²
km ²	square kilometers	0.4	square miles	mi ²
ha	hectares (10,000 m ²)	2.5	acres	
MASS (weight)				
g	grams	0.035	ounces	oz
kg	kilograms	2.2	pounds	lb
t	tonnes (1000 kg)	1.1	short tons	
VOLUME				
ml	milliliters	0.03	fluid ounces	fl oz
l	liters	2.1	pints	pt
l	liters	1.06	quarts	qt
l	liters	0.26	gallons	gal
m ³	cubic meters	35	cubic feet	ft ³
m ³	cubic meters	1.3	cubic yards	yd ³
TEMPERATURE (exact)				
°C	Celsius temperature	9/5 (then add 32)	Fahrenheit temperature	°F

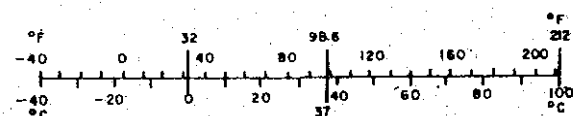

CONTENTS

<u>Section</u>		<u>Page</u>
1	SUMMARY	1
	Field Data Acquisition	1
	Systems Analysis	2
	Traction Motors	2
	Economic Analysis	2
	Alternate Configurations	3
	Conclusions and Recommendations	3
2	FESS STUDY INTRODUCTION	4
	Introduction	4
	Program Rationale	4
	Program Outline	5
	Program Methodology	12
	Format of Final Report	12
3	FIELD DATA ACQUISITION, TASK I	14
	Scenario Tests	14
	Data Gathering	14
	Scenario Data Reduction	16
	Scenario Test Data Summary	21
	Scenario Formulation	40
	Fuel Consumption Comparison	41
	Locomotive Performance Tests	41
4	SYSTEM ANALYSIS	56
	Introduction	56
	Basic System Elements	56
	SW1500 Locomotive	56
	ACT-I Energy Storage Unit (ESU)	67
	Flywheel Energy Storage Capacity	67
	Flywheel Assembly	67
	Safety Features	72
	Gyroscopic Effects	76
	Input-Output Machine	76
	Computer Simulation	78
	Series Motor Model	78
	Series Motor Model Validity	89
	FESS Yodel	91
	FESS Model Validity	97
	Use of the Models	102
	Preliminary Analysis (Task IIB)	102
	Concept A	104
	Concept B	104

CONTENTS (Continued)

<u>Section</u>	<u>Page</u>
Selected Concept	104
Indepth System Analysis (IIC)	104
System Description	109
System Hardware	109
System Control	119
Energy Management	119
Motoring Control	125
Braking Control	126
Control Analysis	126
System Operation	134
System Performance	135
Risk Analysis	135
System Costs and Credits	136
Initial Costs	137
Annual Costs and Credits	138
5 TRACTION MOTORS	
Analysis/Design	141
Unmodified Motors	150
Tests of Unmodified Motors	150
Traction Motor Modifications	151
Test of Modified Motors	151
Test Configuration	151
Yo-Load Saturation Test	157
Load Saturation Tests	166
Performance	175
Heat Run Test Data	182
Traction Motor Thermal Analysis	182
Thermal Analysis Details	182
Thermal Performance	185
Main Field Coil Optimization	193
Results of Traction Motor Task	201
6 ECONOMIC ANALYSIS AND RESULTS	202
Economic Analysis Techniques	202
Office of Management and Budget Circular A-94	202
Railroad Revitalization and Regulatory Reform (4R) Act-1975	203
Sensitivity Analyses 1 and 2	203
Inflation	203
General Price Level	204
Diesel Fuel	204
Maintenance	205
Engineering Economics Computer Program	205
Input Data	205

CONTENTS (Continued)

<u>Section</u>		<u>Page</u>
	Output Data	207
	Economical Analysis Results	207
7	ALTERNATE CONFIGURATIONS	213
	Configuration Descriptions	213
	Economic Analysis	213
8	CONCLUSIONS AND RECOMMENDATIONS	224
	Conclusions	224
	Recommendations	225
9	REFERENCES	226

Appendixes

APPENDIX A:	INSTRUMENTATION	A-1
APPENDIX B:	END PRODUCT SOFTWARE	B-1
APPENDIX C:	FESS ECONOMICS PROGRAM LISTING	C-1
APPENDIX D:	FESS BASELINE CONCEPT ECONOMICS ANALYSIS	D-1
APPENDIX E:	ALTERNATE CONFIGURATIONS	E-1

ILLUSTRATIONS

Figure

1	Flywheel Energy Storage Switcher Study Methodology	13
2	Instrumentation Block Diagram	15
3	Scenario Test Data Reduction Process	17
4	Portion of Meta IV Strip Chart	19
5	Computer Program Block Diagram for Scenario Data Processing	70
6	Scenario Data Reduction Program Printout	22

ILLUSTRATIONS (Continued)

<u>Figure</u>		<u>Page</u>
7	Scenario Data Reduction Program Statistical Summary	24
8	Dillard Yard Data Summary	27
9	Baldwin Yard Data Summary	28
10	Whitefish Yard Data Summary	29
11	Combined Data Summary (Armature Current vs Active Time)	30
12	Combined Data Summary (Speed Less than Abscissa Value vs Active Time)	31
13	Combined Data Summary (Speed vs Active Time)	32
14	Dillard Yard Peak Speed Distribution	33
15	Baldwin Yard Peak Speed Distribution	34
16	Whitefish Yard Peak Speed Distribution	35
17	Combined Total Peak Speed Distribution	36
18	Southern Railway System Dillard Yard Annual Average	37
19	Southern Railway Dillard Yard Test Period Activity	37
20	Seaboard Coast Line Baldwin Yard Annual Average	38
21	Seaboard Coast Line Baldwin Yard, Test Week Activity	38
22	Burlington Northern Whitefish Yard Annual Average	39
23	Burlington Northern Whitefish Yard Test Period Activity	39
24	Locomotive Speed Distribution Characteristic	
25	Locomotive Armature Current Distribution Characteristic	43
26	SW1500 Load Box Test, Engine and Generator Performance, Locomotive 2302	47
27	Load Box Data, Speed vs Throttle	48
28	Locomotive Fuel Consumption, Load Box Test, Locomotive 2302	49

ILLUSTRATIONS (Continued)

<u>Figure</u>		<u>Page</u>
29	Load Box Data, Generator Voltage vs Engine Speed	50
30	Load Box Data, Field Current vs Engine Speed	51
	Engine Generator Response Time	52
32	Data Roll No. 1	53
33	Data Roll No. 2	54
34	Data Roll No. 3	55
35	SW1500 Locomotive	56
36	SW1500 Locomotive General Arrangement	57
37	12-645E Engine Performance (Data from Electro-Motive Division, General Motors Corporation, Curve SC2980, March 5, 1974)	60
38	D32 Generator Characteristics (Data from Electro-Motive Division, General Motors Corporation, Curve 2689, October 25, 1968)	62
39	Characteristics of D77 Traction Motor at 260 kw (Data from Electro-Motive Division, General Motors Corporation, Curve SC-2673, November 20, 1966)	63
40	Simplified Schematic of SW1500 Locomotive	64
	Wheel Spin Protection Circuit	66
42	Energy Storage Unit	68
43	ACT-1 Flywheel Design	69
44	Disc Bore Stress Range, With and Without Shrink Fit	73
45	Modified Goodman Diagram Showing Benefits of Shrink Fit on Fatigue Life	74
46	Computer Model Standard SW1500	79
47	SW1500 Simulator Output, Fetch Mode	91
48	SW1500 Simulator Output, Switching Mode	85

ILLUSTRATIONS (Continued)

<u>Figure</u>		<u>Page</u>
49	Reverse Run Test Data (Start 1261)	90
50	Reverse Run Comparison of Model and Test Data	92
51	Diesel Characteristics	93
52	Forward Run Test Data (Start 1329)	94
53	Test Data Compared to Computer Model	95
54	Computer Model FESS	96
55	FESS Simulator Output, Switching Mode	98
56	Armature Circuit Connections	101
57	Simplified System Schematic of Concept A1	105
58	Simplified System Schematic of Concept A2	106
59	Simplified System Schematic of Concept B1	107
60	Simplified System Schematic of Concept B2	108
61	Typical FESS System Efficiencies	110
62	Energy Storage Unit (ESU) Modified for FESS Application	111
63	Energy Storage Unit Lubricating Oil Circuit Design for FESS Application	112
64	Typical U.S. Boxcar	
65	Characteristics of Proposed Field Supply Alternator	114
66	Reliability Growth of Proposed Field Supply Alternator for Commercial Aircraft Application	115
67	Outline of Field Supply Alternator	116
68	Space Available for Installation of Auxiliary Alternator	117
69	Younting Bracket for Alternator and Gearbox	117
70	27-Point Control Jumper	120
71	Auxiliary Power Jumper	122

ILLUSTRATIONS (Continued)

<u>Figure</u>		<u>Page</u>
72	Main Power Jumper	123
73	Traction Motor Field Power Supply	123
74	Air Brake and Electrical Equipment Compartment	124
75	Flywheel Assembly Mechanical Losses vs Speed	124
76	Tractive Effort Control Logic	125
77	Braking Effort Control Logic	127
78	Electric Brake Interface With Friction Brake	128
79	Equivalent Circuit of FESS Concept A2	129
80	077 Traction Motor Saturation Curve	130
81	Flywheel Machine Saturation Curve	132
82	Existing D77 Traction Motor	142
83	Separately Excited, Shunt-Wound Traction Motor with Compensating Pole Face Winding	144
84	Separately Excited, Shunt-Wound Uncompensated Traction Motor	148
85	No-Load Saturation Characteristics Unmodified D77 Traction Motors	152
86	Unmodified Series-Wound D77 Traction Motor Characteristics	153
97	Replacement Shunt Field Coil	154
88	Replacement Interpole Coil	155
89	Separately Excited Traction Motor Test Schematic	156
90	No-Load Saturation Characteristics Modified D77 Traction Motors	159
91	Total Rotational Losses vs Generator Excitation from No-Load Saturation Test of Modified Traction Motor and Generator	163

ILLUSTRATIONS (Continued)

<u>Figure</u>		<u>Page</u>
92	Effect of Conductor Temperature and Speed on Armature Winding Eddy Factor	169
93	Effect of Armature Reaction	171
94	Load Saturation Characteristics of D77 Traction Motor	
95	Unmodified Series-Wound D77 Traction Motor Characteristics (356 kw, 62:15 Gear Ratio, 40-in. Wheel, 75°C)	176
96	Typical Excitation vs Armature Current Characteristics	178
97	Excitation vs Load Characteristics for Minimum Loss at a Given Speed	179
98	Modified Shunt-Wound D77 Traction Motor Characteristics	181
99	Thermal Nodal Network for D77 Motor	186
100	Thermal Nodal Network for D77 Motor	187
101	Thermal Nodal Network for D77 Motor (Interpole Area)	187
102	D77 Motor Average Field Coil Surface Temperature Modified	190
103	Modified D77 Motor Average Field Conductor Temperature	190
104	Modified D77 Motor Interpole Average Coil Surface Temperature	191
105	Modified D77 Motor Interpole Average Conductor Temperature	191
106	Modified D77 Motor Armature Average Temperature	192
107	Predicted D77 Motor Winding Temperature (96°F Cooling Air)	194
108	Main Field Coil Section	195
109	Insulation Details Main Field Coil	196
110	Thermal Optimization of Main Field Coil	197
111	Effect of Number of Turns and Interturn Clearance on Winding Space Factor	198

ILLUSTRATIONS (Continued)

<u>Figure</u>		<u>Page</u>
112	Main Field Coil Construction	199
113	Projected Cost of Diesel Fuel	204
114	Economics Program Flow Chart	206
115	Baseline Concept A2, One Boxcar	208
116	Baseline Concept A2, Two Boxcars	209
117	Baseline Concept A2, Three Boxcars	210
118	Baseline Concept A2, Four Boxcars	211
119	Modified Concept A1, One Boxcar	214
120	Modified Concept A1, Two Boxcars	215
121	Modified Concept A1, Three Boxcars	216
122	Series Motors Concept, One Boxcar	217
123	Series Motors Concept, Two Boxcars	218
124	Series Motors Concept, Three Boxcars	219
125	Series Motors Concept, Four Boxcars	220
126	Series Motors Concept, Five Boxcars	221
127	Series Motors Concept, Six Boxcars	222
128	Chopper-Controlled Dynamics Brake	223

TABLES

1	Specific Cost Factors	11
2	Instrumented Parameters	14
3	Scenario Test Yards	16
4	Scenario Data Reduction Program Printout Headings	23

TABLES (Continued)

<u>Table</u>		<u>Page</u>
5	Scenario Data Summary	25
6	Scenario Data Summary	26
	Fuel Consumption Comparison	44
8	Locomotive Performance Tests Instrumented Parameters	46
9	General Data of SW1500 Locomotive	59
10	D77 Traction Motor Ratings in SW1500 Locomotive	61
11	Engine Speed Control Trainlines	65
12	ACT-1 Energy Storage Flywheel Summary of Losses	70
13	Acceleration/Deceleration Tests, Cut Consist	89
14	SW1500 Model Input Deck Description	103
15	FESS Card Input	103
16	Proposed Contact Identification of 27-Point Control Plug and Receptacle for FESS Equipment	121
17	Locomotive Modification Cost	137
18	Boxcar Installation Cost	138
19	Performance of Series Traction Motor (D77 Series-Wound Traction Motor With Interpoles)	145
20	Performance of Fully Compensated, Separately Excited, Shunt-Wound Traction Motor With Interpoles	146
21	Performance of Uncompensated, Separately Excited, Shunt-Wound Traction Motor With Interpoles	149
22	Traction Motor History	150
23	Unmodified D77 Traction Motor Resistances	151
24	No-Load Saturation Data, Modified Traction Motor	158
25	Calculated vs Measured No-Load Saturation Characteristics	100
26	Rotational Loss Data No-Load Saturation Test	161

TABLES (Continued)

<u>Table</u>		<u>Page</u>
27	D77 Traction Motor (Modified) No-Load Loss Distribution at 1000 rpm	164
28	Brush Design Data, D77 Traction Motor	165
29	Friction and Windage Losses, kw at 1000 rpm	166
30	Load Saturation Test Data	167
31	Modified D77 Traction Motor Resistances	168
32	Loss Distribution From Load Saturation Test Data	174
33	D77 Series Motor Performance Characteristics	175
34	Modified D77 Separately Excited Motor Performance Characteristics	180
35	Heat Run No. 1 Test Data, Modified D77 Traction Motor	183
36	Heat Run No. 2 Test Data, Modified D77 Traction	
37	Steady-State Thermal Conditions	185
	Modified D77 Traction Motor Steady-State Temperature Test Condition	188
39	Fluid Capacity Rate Elements	189
40	Traction Motor Thermal Study Summary	200
41	Summary of Inflation Rates	203
42	Flatyard Characteristics	212

SECTION 1

SUMMARY

Within the last six years, the AiResearch Manufacturing Company of California, a division of The Garrett Corporation, has developed a number of flywheel energy storage units (ESU's) for use on transit cars such as those currently in service for the New York City Transit Authority. With the arrival of the energy crisis, attention has been focused on the application of this new technology to other fields, and several ESU-equipped vehicles are in various stages of design and/or development. These include a bus and advanced concept train for the Department of Transportation; a postal van for the United States Postal Service; and a battery/flywheel passenger automobile for the Department of Energy.

AiResearch, in conjunction with the Federal Railroad Administration, identified the switchyard operation as the most likely candidate for short-term energy storage because the operating cycle of the switching locomotive involves repeated accelerating and braking with short periods between these operations.

A three-phase program was developed to quantify the costs and benefits of the flywheel energy storage switcher (FESS) system:

Phase I--System Analysis, Economic Analysis, and Bench Testing

Phase II--Design, Hardware Fabrication, Testing

Phase III--Demonstration

A Phase I contract, awarded to AiResearch in September 1977, specified that the system must "...utilize available hardware and existing knowledge...". Thus, FESS is based on applying the Advanced Concept Train (ACT-1) ESU to the General Motors Corporation Electro-Motive Division SW1500 switching locomotive.

FIELD DATA ACQUISITION

To establish a firm data base for subsequent computer simulations and energy calculations, operations at the following three representative classification yards were monitored: (a) Dillard yard of the Southern Railway System, (b) Baldwin yard of the Seaboard Coast Line, and (c) Whitefish yard of the Burlington Northern Railroad.

Continuous recordings, over 24-hr periods, were made of the following parameters:

- (a) Speed
- (b) Time
- (c) Traction motor current
- (d) Brake pipe pressure
- (e) Direction

From these data, statistical data reduction techniques were used to derive a typical scenario for a switching locomotive's duty cycle. The most significant finding of this part of the study was that the switching locomotive typically spends more than 50 percent of the time idle.

To determine the internal operating characteristics of the locomotive, static testing of an SW1500 locomotive was performed with the assistance of Southern Railway System. This allowed determination of (a) engine fuel consumption and power levels, and (b) generator power output.

SYSTEMS ANALYSIS

A preliminary systems analysis identified four possible ESU/locomotive configurations, and one was chosen for detailed analysis. The chosen configuration consists of an SW1500 with modified traction motors and an unmotored boxcar that houses two ESU's (two are required so that the ACT I flywheel electrical machine current rating can be matched to the locomotive traction motor rating).

Computer models of the existing and proposed FESS switchyard operations were developed and validated using the field and locomotive data described above.

An indepth analysis of the chosen configuration confirmed technical feasibility and quantified the costs and benefits associated with the scheme. For the chosen configuration and scenario, it was found that, due to the parasitic loads associated with the system, energy saving is almost negligible, and without careful energy management by the operator (in terms of when to use and not to use the flywheel), the FESS system could result in an increase in fuel consumption. Savings still result from a reduction in brake shoe wear. These results are directly related to the low utilization of the equipment capability.

TRACTION MOTORS

The original concept identified by AiResearch involved the use of a separately excited motor based on the General Motors Corporation Electro-Motive Division D77 traction motor. A significant portion of the study was devoted to testing a motor with this configuration to confirm design values and feasibility. A separately excited shunt-field coil design having 98 turns evolved from this effort. The performance of the modified motor was found to be equivalent to that of the unmodified motor with the exception that optimum performance is developed at slightly higher armature current and slightly lower excitation for the same tractive effort requirements at a given speed. Improvements in interpole coil design were incorporated in the modified machine to accommodate increased armature current. This change reduced interpole losses and interpole temperatures.

ECONOMIC ANALYSIS

The high initial cost of the FESS system and the low monetary value of the brake shoe maintenance reduction combined to show a return on investment (ROI) that was positive only in the largest of yards with well-above-average productivity.

ALTERNATE CONFIGURATIONS

In view of the poor economic return for the chosen configuration, an attempt was made to reduce the cost of the system by adopting more simple methods of achieving the same result. No financially viable configuration was identified.

CONCLUSIONS AND RECOMMENDATIONS

The basic conclusion reached is that flywheel energy storage techniques are not applicable to railroad switchyard operation for two reasons:

- Existing operating costs of yards are relatively low.
- Equipment utilization is low.

In spite of rejection of the FESS concept, it is recommended that full documentation of the computer models (an optional task) be considered for other applications beyond the present study.

Also, it must be recommended that Phases II and III not be pursued.

SECTION 2

FESS STUDY INTRODUCTION

INTRODUCTION

The Flywheel Energy Storage Switcher (FESS) is a three-phase program related to the recuperation of energy on a switchyard locomotive. It covers the system analysis, fabrication, testing, and demonstration of such a locomotive, and incorporates a flywheel energy storage unit (ESU). The project was defined from the beginning to "utilize only available hardware and existing knowledge to design, fabricate, and test the system." The three phases of the program were defined as follows:

Phase I--System analysis, economic analysis, and bench testing

Phase II--Design, hardware fabrication, testing

Phase III--Demonstration

The intent of this Phase I study, therefore, was to establish the feasibility and to quantify the benefits of recuperating braking energy from a switching locomotive for short-term storage and subsequent reuse during the next operating cycle. Such energy is presently dissipated in the form of heat by the friction braking system. It was recognized at the outset that it was necessary to understand the operating conditions and duties of a typical switching locomotive to quantify the potential energy saving to be accrued from FESS. A test plan was formulated by AiResearch and approved by the Federal Railroad Administration (FRA) to determine the following:

- (a) The internal operating parameters of the locomotive
- (b) The daily operational pattern of switching locomotives

The FESS study began with measurements at three flatyards: Dillard (Southern Railway System), Baldwin (Seaboard Coast Line), and Whitefish (Burlington Northern) where the data vital to the study were collected.

Concurrent with the data gathering task, the feasibility of modifying the most common traction motor in use in the U.S. (the General Motors Corporation Electro-Motive Division (EMD) Model D77) was investigated with the assistance of Motor Coils Manufacturing. The Southern Railway System loaned two motors for this task.

preliminary analysis of the total system configuration was also carried out at an early stage in the study to identify the most attractive concept and to concentrate the major resources of the study on that favored concept.

PROGRAM RATIONALE

Over the past few years, critical shortages of oil and its derivatives have been of major concern to the U.S. Government, with no alleviation expected in

the near future. The dependency of the economy on the consumption of oil has reached alarming proportions. The United States imports about 44 percent of the oil it consumes--a percentage that continues to increase. A major effort is underway now to reduce this dependency by exploring and investigating alternate sources of power to circumvent the use of petroleum and its byproducts.

During the past six years, AiResearch Manufacturing Company of California has devoted a major portion of company-funded IR&D programs to the development and implementation of energy saving devices. One of these--the flywheel--has recently completed testing for commercial application as an energy storage device in the New York City Transit Authority rail system. The use of flywheels for energy storage is beneficial in situations where the duty cycle is one of acceleration/deceleration and energy is dissipated in braking friction, or where energy that could be conserved is ultimately wasted because there is no effective means of storing the energy. For example, when a train must ascend steep grades, usually more than one locomotive is required to produce the tractive effort to negotiate the incline. Once having ascended the grade, the potential energy that could be conserved during descent is dissipated in heat, either in the friction brakes or in a resistor bank if dynamic braking is employed. AiResearch recently completed a study of the use of wayside flywheels to store potential energy. The flywheels are speeded up during the conversion of potential energy to kinetic energy during the dynamic braking cycle. The stored energy is used later to provide power to assist another locomotive to ascend the grade.

Another potential candidate for flywheel energy storage and energy conservation was in the freight classification yard of fully loaded freight cars to makeup trains. In the majority of U.S. flat classification yards, a yard locomotive goes to the receiving area and couples to a cut of 20 to 35 freight cars. This cut is withdrawn to a classification ladder that connects to numerous tangent distribution or classification tracks, leading ultimately to the makeup (or departure) section of the yard. The yard locomotive typically accelerates the cut of cars to a speed of 5 to 10 mph and then applies full braking to reduce the train speed. As the train accords out from the compressed drive condition to a fully extended coupler, yardmen uncouple the lead part (car or cars) of the cut. This released part is destined to be set in a particular block or class track. As the cut car proceeds along the ladder, it is switched into the proper classification track. The car proceeds along this track until it couples into the train section being made up on this particular track. As soon as this car clears the initial switch, the switchman signals clearance to the locomotive engineer, who repeats the cycle until the last of the cut is released. The locomotive then returns to the incoming yard section, retrieves another cut of cars, and repeats the entire cycle.

During the period of high acceleration and deceleration, the performance of the yard locomotive is characterized by maximum noise emission, and generally by significant smoke emission. This is a result of operation at very poor efficiency of the locomotive's diesel engine. Negative aspects associated with this operation include:

- (a) Fuel Consumption--The diesel electric locomotives are operating in their worst fuel consumption regime at these low vehicle speeds.

- (b) Noise--Operation of the power plant in this mode is outside normally acceptable limits.
- (c) Smoke--The fuel mismatch for the engine is at its worst, so resulting generated smoke and pollutant volumes are high and in some areas (notably California) well beyond the legal limits.

A possible solution to these freight yard problems is the application of flywheel energy storage technology to the yard classification locomotive. A prototype flywheel system now has completed revenue service demonstration on two New York subway cars and a preproduction version also completed its demonstration program on the advanced concept trains.

PROGRAM OUTLINE

The FESS program was conducted by AiResearch and consisted of performing the seven work tasks specified in the contract statement of work (SOW). The specific work tasks completed during this program are summarized in the following SOW paragraphs:

Task I -- Field Data Acquisition

- A Test Plan shall be submitted and approved by the COTR prior to the initiation of testing
- B. Field Data--Visits shall be made to an appropriate number (3) of switching yards of the participating railroads where locomotive(s) shall be instrumented to test and determine, in conjunction with appropriate railroad personnel, the following:
 - 1. A realistic operational scenario for railroad yard switching that shall be used in the analyses.
 - 2. The acceleration and deceleration characteristics of an existing SW1500 locomotive.
 - 3. Monitor performance parameters (operating characteristics and power flow parameters) that will provide for a satisfactory correlation between the computer model and the actual operation of an existing SW1500 locomotive.

Task II--System Analysis

A Performance Requirements

The system analysis will establish a realistic and definitive set of performance requirements for flywheel - locomotive system. This will be accomplished from analysis of existing equipment capabilities and analysis of field data describing the actual work. The field data will be examined not only to establish the average conditions for the application, but also extreme worst case conditions.

B. Preliminary Analysis

The contractor shall conduct a preliminary system analysis to establish the most advantageous system configuration within the limits of existing conventional hardware components (e.g., SW1500 locomotive, ACT-1 flywheel unit). As a minimum the following two configurations will be considered:

- a) The flywheel in trailing car with the locomotive modified for separately excited traction motors.
- b) The flywheel in trailing car with the trailing car modified with separately excited traction motors and with the locomotive basically unmodified.

Any additional configurations besides a) and b) above should be identified within 30 days from the start of Task II 9 (Preliminary Analysis) and shall be approved by the COTR prior to further analysis. An optimum configuration shall not be addressed in Phase I. This preliminary system analysis shall make basic assumptions concerning critical elements of system such as control system, traction motors, installation features, etc. These assumptions should be stated and risks identified. Each element of the system shall be defined in terms of their performance requirements, the tolerances, component description, and features of installation. Each system configuration considered shall be described in terms of theory of operation, configuration analysis showing trade-offs, performance characteristics and limits, and functional block diagrams.

Practical applications in switch yards and/or on mainline railroads shall be identified for each system configuration. These analyses shall utilize the realistic operational scenario generated under Field Data Acquisition (Task I). At the conclusion of this task, the contractor shall conduct a program review to discuss the results of the preliminary analysis, to recommend a system configuration for further analysis under Task II C (In-depth System Analysis), and to discuss the status of other tasks underway. The contractor shall obtain COTR approval of the recommended configuration before proceeding with Task II C.

C. In-Depth System Analysis

I. System Analysis

The Contractor shall conduct an in-depth system analysis of only the approved configuration. This system analysis shall include elements of the control system, installation analysis, and traction motors as they pertain to systematically investigating the technical effectiveness, risks, costs and economic benefits in a quantitative way. The resultant system configuration description should be much more complete and detailed than the initial description and should include schematic diagrams, control system flow diagrams, and layout sketches.

Drawings shall be completed in accordance with the provisions of attachment B, Technical Data Requirements.

The analyses shall include but not be limited to the following considerations:

- a. The effect of varying the number of cars in a switching cut from 10 to 40 cars and the train weight from 460 tons to 2460 tons.
- b. The effect of Two equipment configurations:
 - 1) Time sharing a trailing car containing the fly-wheel installation with locomotive.
 - 2) Constant coupled units (locomotive and trailing car).
- c. The effect of requiring the system design to include adjustment capabilities to account for different numbers of cars/ cut, different yard operation procedures, and various duty cycles.
- d. The effect of modifying the baseline operational scenario defined in Field Data Acquisition (Task 1) to maximize benefits.

2. Control Analysis

In conjunction with the system analysis of the approved configuration, a conceptual analysis/design effort shall be undertaken on the control system. This effort shall be in sufficient depth to establish feasibility of the control system and to allow the economic benefits and technical risks to be assessed. This analysis shall include but not be limited to consideration of the following questions:

- a. Is **it** feasible for the control system to be designed with automatic or manual adjustments or to be programmed to provide optimum operation under various train load conditions;
- b. Is **it** feasible for the control system to be designed to maximize the tractive effort of each individual traction motor;
- c. Is **it** feasible to utilize the flywheel as an additional power source giving the integrated system a power potential greater than an unmodified locomotive;
- d. Is **it** feasible to vary the power sharing between the flywheel and the prime source as a function of some train variable (e.g., number of cars/cut or cut weight);

- e. How is tractive effort/ton maximized;
 - f. How is spin/slide control accomplished;
 - g. How is the operation of the existing friction brake system blended with the dynamic brake system; and
 - h. How is the operation of the diesel generator blended with the flywheel system?
3. Installation Analysis
In conjunction with the system analysis of the approved configuration, a preliminary installation analysis/design effort shall be undertaken. This effort shall include layout sketches of the major components in sufficient detail to establish feasibility of the design and to allow the economic benefits and technical risks to be assessed.
4. Computer Simulation
A computer simulation model shall be developed as necessary for the approved system configuration. Field test data shall be used to verify in the model the operational parameters associated with the existing locomotive(s). This model shall be used in the analyses and shall be capable of use in evaluating system performance as well as establishing design parameters. The model shall be able to accommodate variations in operating parameters, including, but not limited to:
- a. Variations in the number of cars and loads in a cut to be switched.
 - b. Variations in the switching operation time due to different throttle settings and train speeds.
 - c. Variations in the typical duty cycle, including effects of switch yard geometry.
 - d. Variations in traction motor characteristics.

Task III - - Traction Motor Analysis/Design

- A. The General Motors EMD Model D77 locomotive traction motor shall be analyzed for conversion to separate field excitation.
- B. In conjunction with the analysis, the preliminary electrical/mechanical design necessary to implement the conversion shall be accomplished.

Drawings shall be completed in accordance with the provisions of attachment B, Technical Data Requirements.

Task IV--Traction Motor Modification.

- A. Traction Motors - Two General Motors EMD Model D77 locomotive traction motors shall be obtained from one of the participating railroads and modified to run with separate field excitation.
- B. Restoration of the traction motors to their original configuration will be done as a result of the written instructions from the Contracting Officer.

Task V--Traction Motor Bench Test

- A. The contractor shall submit a detailed test plan and obtain the COTR's approval prior to the initiation of testing.
- B. The traction motors shall be bench tested to establish operational integrity and performance characteristics before and after modification. These tests shall be conducted in a "back-to-back" test rig. The bench tests shall be designed to provide information that will:
 - a. Quantify the tractive effort before and after modification.
 - b. Assist in correlating the dynamic braking potentially attainable from an SW1500 locomotive incorporating modified traction motors with the braking characteristics of an existing SW1500 locomotive.
 - c. Assist in determining how rapidly an SW1500 locomotive incorporating modified traction motors can go from an accelerating mode to a dynamic braking mode.

Task VI--Economic Analysis

The cost/benefit and application for each design configuration analyzed in Task II-B (Preliminary Analysis), shall be determined and quantified. This analysis shall be based on or include the impact of switching yard data generated by Task I (Field Data Acquisition). The life cycle cost analysis will be made weighing the relative cost-benefits to be expected from each equipment configuration. Life cycle cost in this sense includes all costs incident to planning, engineering, fabrication, installation, operation, maintenance, training, and provisioning of a system. This analysis shall be refined for the approved configuration as further data becomes available during the in-depth system analysis (Task II-C).

The economic analysis will be based on four different guidelines as to provide full insight in cost considerations and allow a direct comparison with the Wayside Energy Storage System (WESS) Program (Reference 1).

Reference 1. Wayside Energy Storage Study, AiResearch Manufacturing Company of California, 78-15180, June, 1978.

These guidelines will include the "4R" Act, the O.M.B. Circular A-94, one sensitivity study representing a best estimate of future inflation, and a sensitivity study using inflation rates favorable for FESS deployment. Specific cost factors for these four methods of analysis are shown in Table 1.

TABLE 1
SPECIFIC COST FACTORS

Guideline	Computation Technique	Discount or R.O.I	Inflation			General Price From 1983 Inflation
			Diesel Fuel	Electricity	Maintenance	
4R Act	Internal Rate of Return	Output	Constant	Constant	Constant	Constant
OMB A-94	NPV-Constant	10 percent	2 percent*	1 percent*	2 percent*	Constant
Sensitivity (Best Guess)	Internal Rate of Return	Output	2 percent*	1 percent*	2 percent*	6 percent
Sensitivity (High Bound)	Internal Rate of Return	Output	4 percent*	1 percent*	2 percent*	6 percent

*Relative to general price level.

The economic analysis will provide the following:

- (1) Perform the four economic analyses as per Table 1 above. The analyses will be done manually, or by a computer, or a combination of the two. Tabulated data will be generated for all four analyses.
- (2) The data from the four analyses will be reviewed,
- 3 A detailed analysis of the significant data will be prepared. The other output data will be compared to the significant data, and a description of the economic comparisons will be made.

- (4) This economic analysis will allow a direct comparison by FRA with the Wayside Energy Storage System program.

Task VII--Optional Requirement - Computer Program Documentation

The computer model developed under Task II, C, 4 of the Statement of Work shall be modified so that it can be used as a tool by interested parties for predicting benefits for various classification yard applications and different switching practices. The operating software program will include all parameters necessary to derive the benefits of the recommended flywheel-locomotive system for a particular railroad yard application.

The computer model must be capable of evaluating the flywheel-locomotive system in various railroad yard applications. The model shall be able to accommodate variations in operating parameters, including but not limited to:

- (a) Variations in number of cars and loads in a cut to be switched
- (b) Variations in the switching operation time due to different throttle settings and train speeds
- (c) Variations in the typical duty cycle including the effects of switch yard geometry
- (d) Variations in traction motor characteristics

The model shall be well-suited to study energy savings, operating, and performance evaluation.

References to the above-listed study tasks are made throughout this final report to show the specific efforts that have been directed toward each one.

PROGRAM METHODOLOGY

A logic diagram of the methodology followed by AiResearch in performing the Phase I program is shown in Figure 1. As shown, the program logically consisted of three major areas of effort and each had a built-in FRA approval stage, culminating in the engineering economics analysis (Task VI).

FORMAT OF FINAL REPORT

The sheer volume of material generated during the 16-month Flywheel Energy Storage Switcher Phase I Study has necessitated publishing this report in two volumes. Volume 1 contains the details of the system analysis, and descriptions of the locomotive and traction motor testing. Volume 2 contains the field data obtained from the three yards visited. These data were ultimately used to determine a typical switching locomotive's duty cycle.

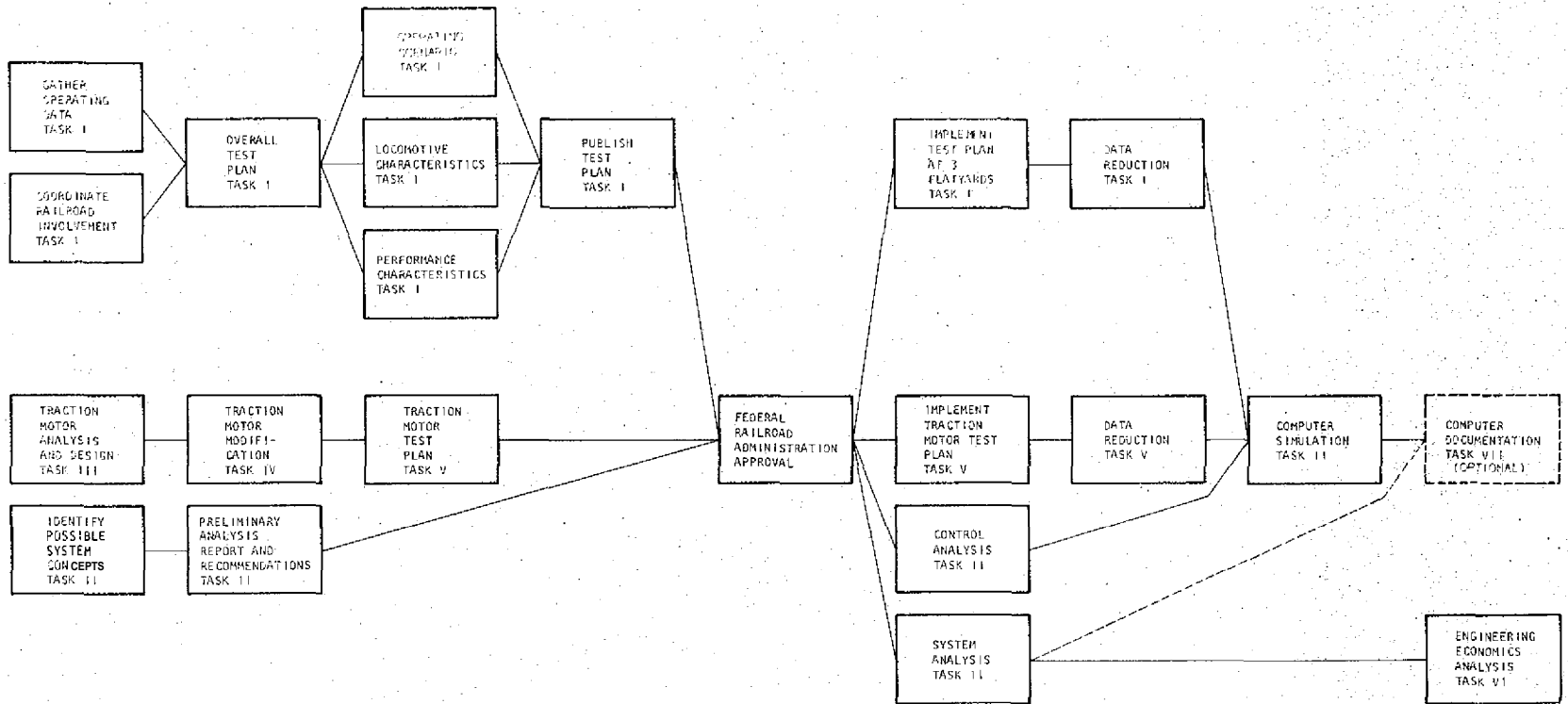

Figure 1. Flywheel Energy Storage Switcher Study Methodology

SECTION 3

FIELD DATA ACQUISITION, TASK 1

One of the critical steps in determining the viability of a flywheel-assisted switcher locomotive was to determine the required operational characteristics and duty cycles that are currently employed by existing switcher locomotives. To determine these parameters, a test program was formulated to evaluate the following:

- (a) The operational duty cycle (or scenario) at three separate switchyards
- (b) The acceleration and deceleration characteristics of a commonly used locomotive

SCENARIO TESTS

Data Gathering

The switchyards to be included in the scenario tests were determined by relying on the experience of senior railroad personnel to identify the flatyards with maximum activity. The duration of testing was set at a minimum of 24 continuous hours at each of three test sites. The parameters to be monitored during each test were selected on the basis of usefulness in developing the final scenario. Due to the large mass of data that would be obtained, a digital sampling and recording technique was implemented to facilitate the use of computer-aided reduction processes.

The instrumented parameters shown in Table 2 were selected to provide the numerical evaluation of the operational duty cycle. The onboard instrumentation package was arranged as shown in the instrumentation block diagram of Figure 2. A detailed description of the instrumentation package is contained in Appendix A

TABLE 2

INSTRUMENTED PARAMETERS

Parameter	Transducer	Range
Locomotive speed	Axle generator	50 mph
Locomotive acceleration	Accelerometer	± 3 mphps
Brake cylinder pressure	Pressure transducer	150 psi
Traction motor current	Current shunt	1200 amp
Sanding control signal	Trainline 23 voltage divide	74 vdc
Wheelslip relay actuation	Trainline 10 voltage divide	74 vdc
Locomotive direction	Trainline 8 and 9 voltage divider	74 vdc

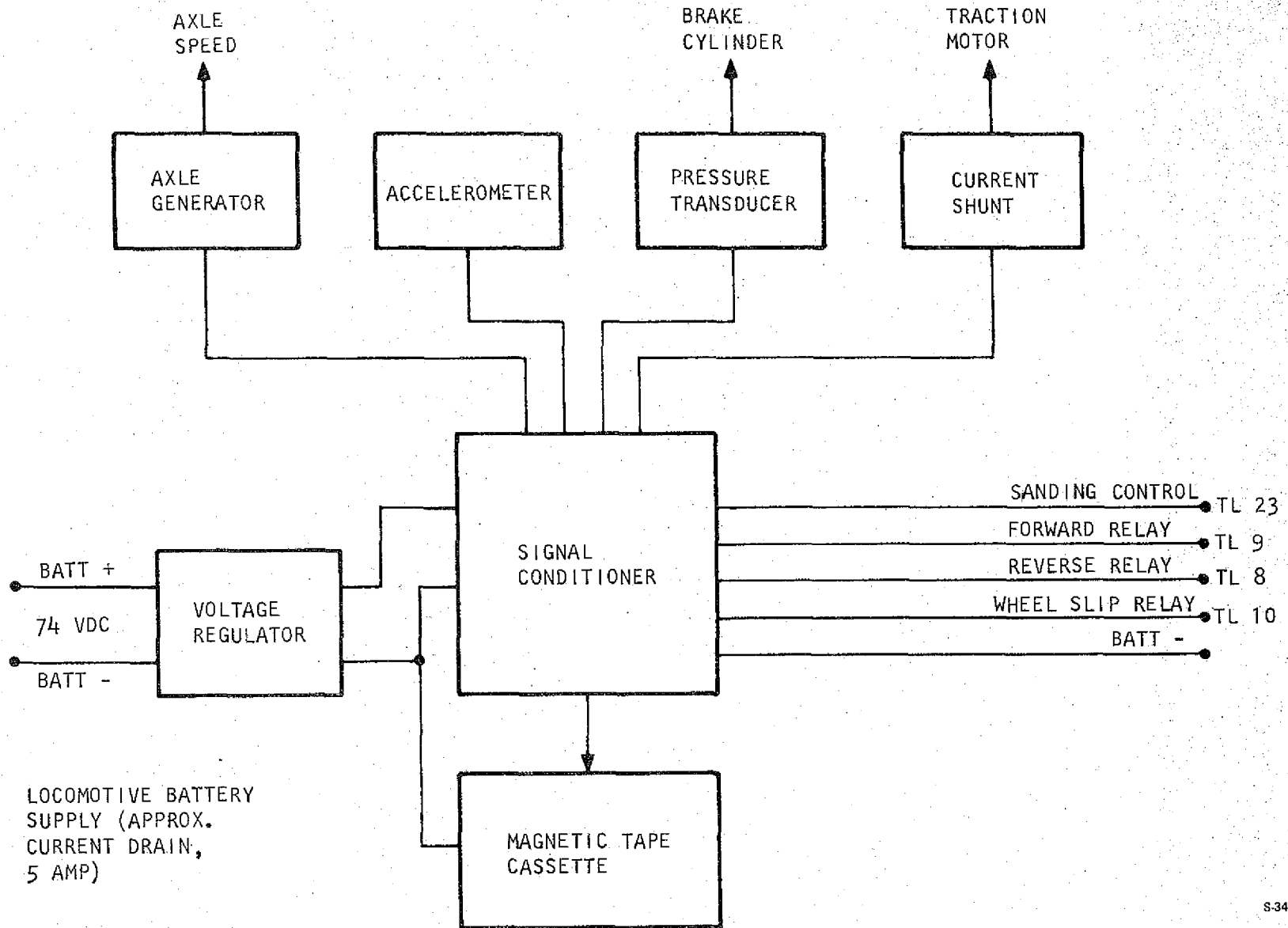

S-34174

Figure 2. Instrumentation Block Diagram

The test procedure for the scenario tests consisted merely of installing the instrumentation onboard a locomotive at each flatyard and then monitoring the activity and movements during a period of at least 24 continuous hours. The details of this test plan are contained in AiResearch Report 77-14536A (Reference 2).

In addition to the data recorded on tape, additional information was obtained in the form of switch lists. These lists represent the cars handled by each switcher locomotive during the three test periods; however, the procedures in each yard differed enough to prevent any detailed comparison of switch list data. The switch lists for each yard are contained in Volume 2 of this report.

The scenario tests were conducted at the three yards listed in Table 3 without major incidents or interference with the normal modes of operation.

TABLE 3
SCENARIO TEST YARDS

Railroad	Yard	Location	Test Dates
Southern Railway System	Dillard	Savannah, Ga.	Feb 2 to 4, 1978
Seaboard Coast Line	Baldwin	Jacksonville, Fla.	Feb 8 to 10, 1978
Burlington Northern	Whitefish	Whitefish, Mont.	Feb 15 to 17, 1978

Scenario Data Reduction

At the conclusion of the scenario tests, all of the tape recorded data were contained on nine digital tape cassettes. Due to the cassette tape format and configuration, it was necessary to process the information as illustrated in Figure 3. This apparent long processing chain was due principally to the use of existing equipment and is not necessarily a requirement for the basic method with completely compatible equipment. Several problems were encountered that consumed considerably more calendar time than originally anticipated.

Initially, the availability of the Gould recorder, which also was used for the playback function, was unpredictable due to conflicts with other FESS testing as well as other program users.

Each of the data tapes was sampled early in the reduction process to confirm successful data transfer. This was accomplished by the initial version

Reference 2. Testing and Data Collection Plan to Define Operating Scenario of Flatyard Switch Engine, AiResearch Report 77-14536A, AiResearch Manufacturing Company of California, December 1977.

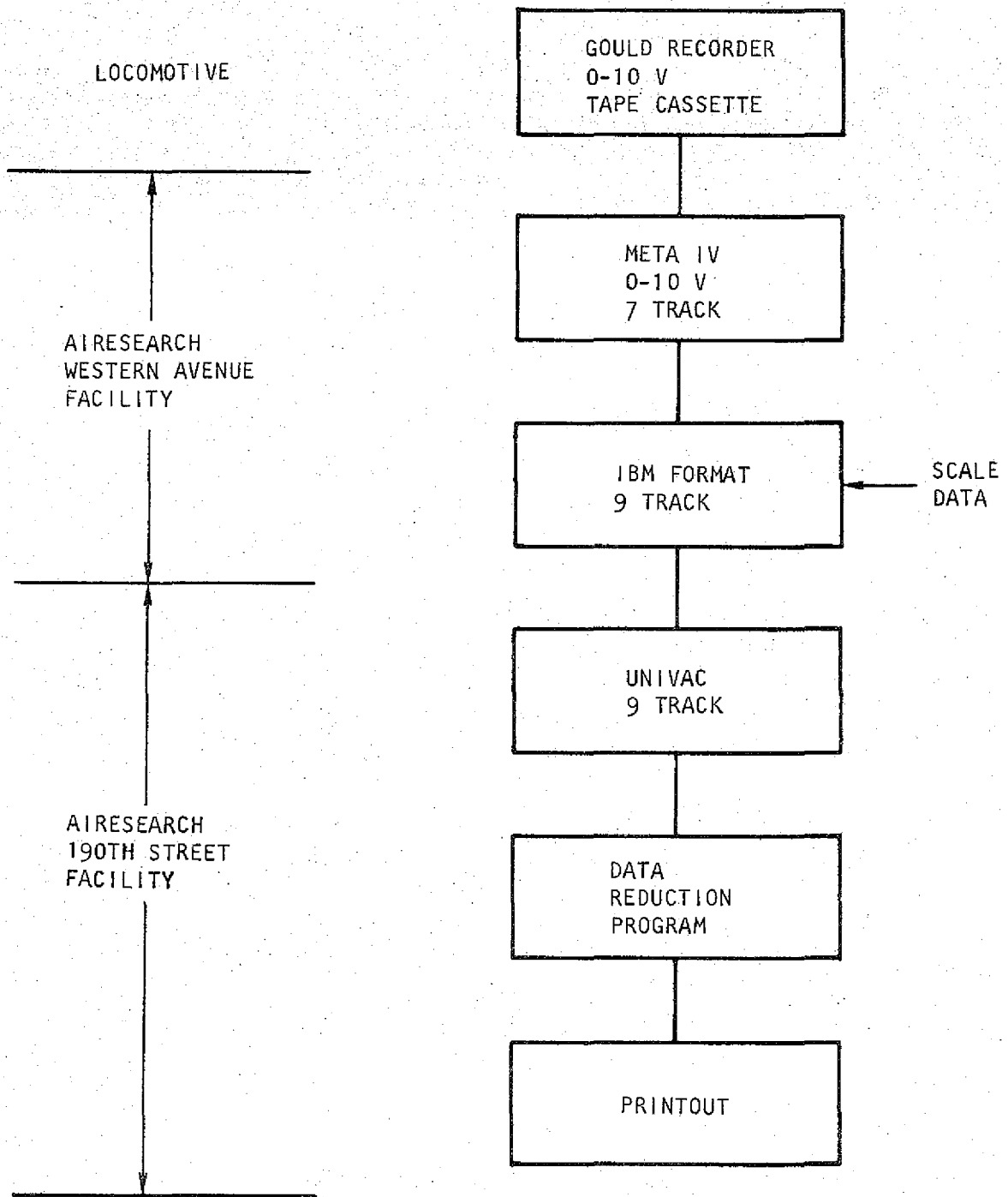

S-34184

Figure 3. Scenario Test Data Reduction Process

of the data reduction program by reading a short span of data at the beginning of the final nine track tapes. In addition, the Meta IV computer was used to generate a strip chart recording of recorded velocity and direction information. These charts were used during the remainder of the program as a "road map" to the recorded data and to explain apparent anomalies and odd conditions. A typical portion of this recording is shown in the upper two traces of Figure 4.

The second problem encountered was the loss of data apparently caused by lack of hardware compatibility between the two computer facilities. After discovery of this problem, the regeneration of some of the nine track tapes was required. Eventually these problems were identified and sorted out to allow complete reduction of all recorded data.

All recorded parameters, with the exception of locomotive acceleration, were used in the final reduction process. The accelerometer recordings contained a high noise content apparently due to structural vibration of the locomotive. Although it may have been possible to devise a filtering technique in the reduction process, alternate methods of estimating acceleration were used where required.

The final form of the data reduction program allowed a sequential listing of the available data; however, because a large mass of data was to be handled, it was necessary to summarize the various inputs. The method selected is illustrated in Figure 5.

The digitized data input of the locomotive speed signal is processed by a digital filter that compares the indicated speed to parameters based on armature current and brake pressure. This step was required to eliminate influence of occasional noise spikes on the final data. The operation of this filter is illustrated by comparison of the lower trace of Figure 4, which is the filter output, to the upper trace of the figure, which is the original digitized data. The sampling period of the original data was once per second. As it can be seen, the principle influence is removal of the high amplitude and short time duration spikes.

As soon as a valid speed trace has been obtained, the reduction program calculates the following parameters on a sample-by-sample basis:

- (a) Distance travelled
- (b) Motor and generator operating conditions based on published characteristics of armature current and speed
- (c) Generator output energy
- (d) Braking energy imposed by the locomotive
- (e) Fuel consumption of the engine based on published characteristics

As a technique to condense the data, but still maintain visibility as to locomotive activity, a line printout is obtained whenever the distance

-- 08 AUG 78--

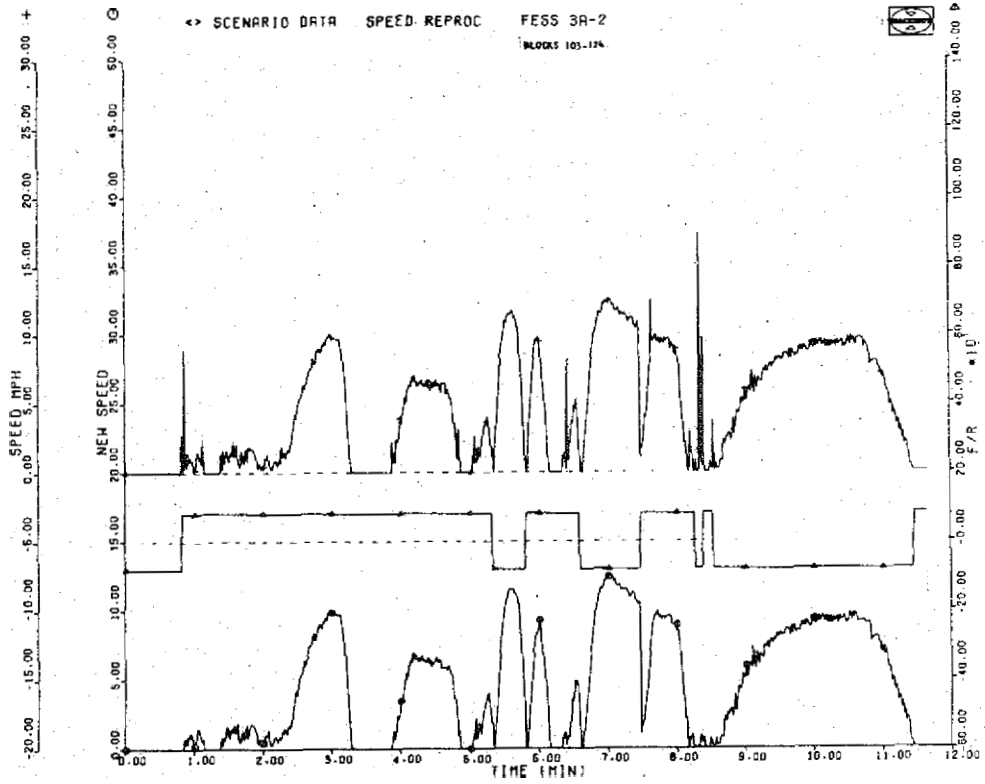
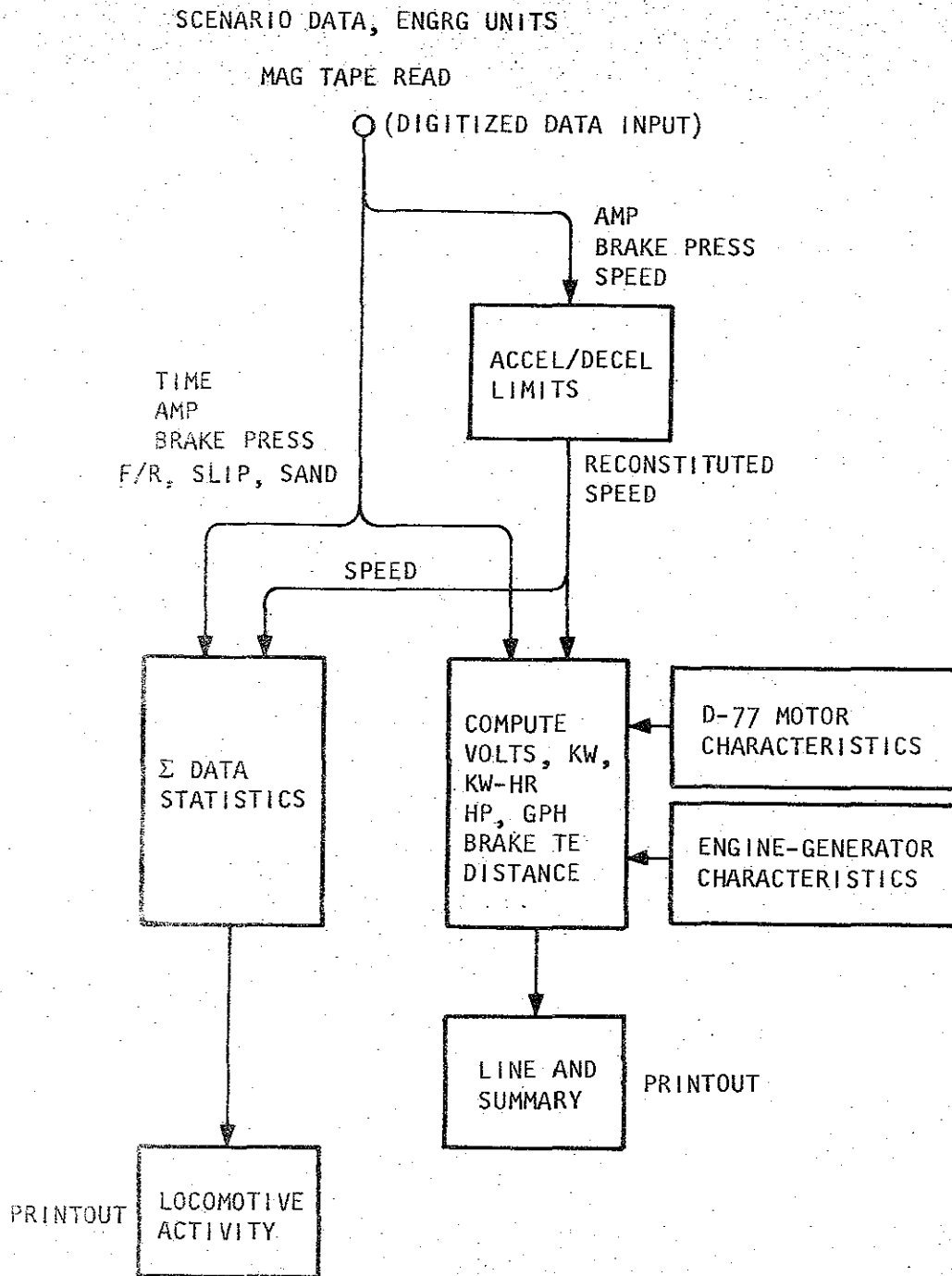

Figure 4. Portion of Meta IV Strip Chart



S-34175

Figure 5. Computer Program Block Diagram for Scenario Data Processing

travelled by the locomotive exceeds a net value of 500 ft. A typical printout obtained from reading a data tape is shown in Figure 6. Table 4 defines the column headings.

At the end of the data printout, a summary line is printed representing the combined accumulations of the previous lines. The final level of summary for the data tape, which was also accumulated as the tape was processed, is shown in Figure 7. This summary presents a statistical accumulation of the various parameters shown that allow the data from separate yards to be combined into an average operating profile. For the purpose of describing the overall duty cycle, the locomotive and its equipment, the velocity distribution and armature current distribution data have proven to be the most valuable.

Scenario Test Data Summary

The results of the data reduction of all recorded tapes are shown in Tables 5 and 6. These tables have been arranged to summarize the locomotive activity at each test site as well as the combined total of all three yards. In addition, the distribution data for each yard and the combined total have been plotted in Figures 8 to 13. Complete reduction program outputs are contained in Volume 2 of this report.

Some of the more significant factors revealed by the data summary are as follows:

- (a) Active time of the locomotive ranged between 41 to 61 percent with an overall average of 50 percent.
- (b) The braking energy available for regeneration averaged 25 percent of the energy output by the generator. This is disappointingly low when considering the use of a flywheel energy storage system.
- (c) The speed profile data indicate very little activity at speeds in excess of 15 mph. The average speed, after the bulk of idle time has been removed, was slightly less than 4 mph.
- (d) Less than 10 percent of the active time is spent in excess of the traction motor current rating, so there exists a great margin of thermal capability for the usage.

In addition to the data automatically processed, the total quantities of locomotive movements were manually measured from the speed-time "road map" previously described. These data have been used to determine mean values for kicking speeds and movement quantities. Figures 14 to 17 illustrate these data.

To ensure that the data collected at the three test sites were obtained during typical operating days, each yard was asked to submit data reflecting the car quantities processed during the past year and during the test period. These data are shown in Figures 18 to 23. Source information for these graphs is contained in Volume 2 of this report. In each of the three tests, the average car quantities were not grossly different than the previous year's average.

LOCATION (FEET)	DIR	FL TIME (MIN)	IDL TIME (MIN)	DIST TRAV (FEET)	MAX MPH	KWHR G	KWHR H	GAL	DE #	BLK #	LN #	TAPE TIME HRS MIN SEC
0.	*	.000	.000	0.	.00	.00	.00	.00	01	1	1	6 53 11
-515.	*	7.117	4.767	515.	12.39	.67	.04	.51	01	14	12	7 0 18
-1020.	*	.533	.000	505.	11.62	.05	.00	.04	01	15	12	7 0 50
-1525.	*	.617	.000	505.	10.10	.23	.00	.06	01	16	17	7 1 27
-2035.	*	.863	.000	510.	13.34	.56	.00	.08	01	17	14	7 1 56
-2541.	*	.483	.000	506.	13.25	.02	.00	.03	01	18	11	7 2 26
-3043.	*	.483	.000	502.	14.94	.71	.42	.09	01	19	8	7 2 54
-2533.	-	15.980	10.133	921.	13.22	1.42	2.40	1.09	100	48	10	7 18 56
-2026.	-	.717	.000	507.	9.39	.07	.00	.05	100	49	21	7 19 19
-1515.	-	.690	.000	510.	11.02	.31	.42	.06	100	50	25	7 20 15
-2031.	*	6.600	.483	1506.	12.41	9.35	2.66	1.13	100	63	5	7 26 51
-2535.	*	.533	.000	504.	12.30	.42	.03	.07	100	64	5	7 27 23
-3049.	*	.517	.000	515.	12.88	4.02	.00	.34	100	65	4	7 27 54
-3550.	*	.483	.000	501.	12.76	1.37	.00	.14	100	66	1	7 28 23
-4057.	*	.517	.000	507.	11.63	1.39	1.55	.14	100	66	32	7 28 54
-3556.	-	3.717	.017	821.	9.74	8.21	5.11	.40	100	73	31	7 32 37
-3041.	-	19.450	12.283	3344.	17.20	22.40	14.72	2.99	101	110	14	7 53 8
-2541.	-	1.067	.000	500.	13.46	.67	1.73	.12	101	112	14	7 54 12
-2033.	-	1.450	.000	980.	15.45	2.47	2.15	.28	101	115	5	7 55 39
-2536.	*	4.283	.000	858.	10.67	34.69	.65	3.14	101	123	6	7 59 56
-3037.	*	2.700	.000	500.	3.82	24.37	.01	2.17	101	128	8	8 2 38
-3540.	*	2.617	.000	503.	4.29	24.11	.00	2.15	101	133	5	8 5 15
-4043.	*	1.750	.000	503.	10.21	13.44	.05	1.22	101	136	14	8 7 32
-4545.	*	.750	.000	502.	8.12	4.12	.28	.36	101	137	27	8 8 17
-5047.	*	3.333	.000	1002.	8.12	13.45	4.79	1.31	101	144	3	8 11 37
-4543.	-	2.717	.000	801.	6.84	14.31	4.50	1.30	102	149	6	8 14 20
-4041.	-	3.533	.000	924.	8.47	14.16	4.04	1.39	102	155	26	8 17 52
-3540.	-	4.150	.000	1251.	9.40	12.51	5.52	1.31	102	163	19	8 23 37
-3039.	-	1.417	.000	518.	10.35	1.07	.88	.18	102	166	8	8 25 2
-2535.	-	2.767	.000	1597.	15.99	6.71	3.30	.71	102	171	14	8 27 48
-3054.	*	.917	.000	722.	19.50	1.96	1.35	.21	102	173	5	8 28 43
-3419.	-	5.250	2.533	406.	15.31	.12	1.10	.34	102	182	32	8 33 58

>>>> SUMMARY TIME (HRS) GEN KWHR BLK KWHR TOTAL GAL MILES TRAV
 1.62 219.34 57.75 24.0 4.6

* STATUS= 0 BLOCK # = 182 LINE # = 32 TAPE # = 118684

>> END TAPE READ/PRINT >>

Figure 6. Scenario Data Reduction Program Printout

TABLE 4

SCENARIO DATA REDUCTION PROGRAM PRINTOUT HEADINGS

Column	Heading	Definition
1	LOCATION (FEET)	Net distance from starting point at beginning of data tape.
2	DIR	Direction of locomotive travel when 500-ft marker was crossed.
3	EL TIME (MIN)	Elapsed time from starting point of data tape in minutes.
4	IDL TIME (MIN)	Idle time accumulated since last 500-ft marker. Idle time accumulation is not started until 1 min after speed is below 1/2 mph and brake pressure is greater than 20 psi.
5	DIST TKAV (FEET)	Total distance travelled since last 500-ft marker. This will indicate sum of forward and reverse movements.
6	MAX MPH	Maximum speed obtained since last 500-ft marker.
7	KWR G	Calculated energy output by main generator of locomotive in kilowatt-hours.
8	KWR B	Calculated energy absorbed by locomotive wheels during braking.
9	GAL	Calculated gallons of fuel consumed since last 500-ft marker.
10	DE#	Data entry number manually set into recorder when data were collected. Used for correlation to test log books.
11	BLK#	Block number of data tape.
12	LN#	Line number of data tape.
13	-- TAPE TIME -- HRS MIN SEC	Indicates recorded value of time at which 500-ft marker is crossed. Value indicated will be modified if recorder had been turned off or placed in standby mode.

>>TAPE IDENTIFICATION < 118684 > BLOCK 1 TO 100 150355 15:03:55
 ---LOCOMOTIVE ACTIVITY---ACCUMULATED TIME (MINUTES) RUN TOTAL 97.1

ARM AMPS >30 34
 >200 = 27.1
 >500 = 21.6
 >1000 = 15.4
 BRAKE PSI >10 = 12.2 (SPR >0.5)
 >30 = 8.3
 SLIP RELAY ON = 0.0 <SECONDS>
 SAND ON = 28.4
 SPEED (MPH) >0.5 = 49.7
 >2.0 = 41.5
 >4.0 = 28.2
 >6.0 = 20.8
 >8.0 = 13.9
 >10.0 = 8.0
 >15.0 = 1.0
 >20.0 = .1
 CRUISE TIME = 9.5 (MPH >8. AND ARM AMPS <200.)
 IDLE TIME = 30.2 (1 MIN AFTER MPH <0.5 AND PSI >20.)

---- ACTIVITY RATIOS (EXCLUDES IDLE TIME)

16.5 %	TIME BETWEEN	0.5 AND	MPH	11.1
26.7 %		2. AND 4.	MPH	17.4
14.9 %		4. AND 6.	MPH	10.0
13.8 %		6. AND 8.	MPH	7.3
11.9 %		8. AND 10.	MPH	9.0
14.2 %		10. AND 15.	MPH	9.5

24.6 % BRAKING
 55.0 % ACCEL
 71.8 % OF TIME SANDING DURING BRAKING AND ACCEL

---- IDLE TIME = 31.1 % OF TOTAL

OFIN

Z4

Figure 7. Scenario Data Reduction Program Statistical Summary

TABLE 5
SCENARIO DATA SUMMARY

FESS Tape	Yard, RR	Log Book Data				Data Tape Summary						Average Calculations			
		Elapsed Time, min	No Record, min	Recorded Time, min	Run Time, min	Gen, kw-hr	Brk, kw-hr	Total Fuel, gal	Miles Travel	Idle Time, min	Cruise Time, min	kw-hr/ gal	Average mph w/o Idle	Active Time, min	Brk kw-hr/ Gen kw-hr
1b	Dillard SRR	1490	224	1266	525.6 97.2	941.14 219.34	178.21 57.75	105.3 24.0	34.6	44.0 30.2	48.1 9.5	8.94 9.14	3.92 4.12	481.6 67.0	0.19 0.26
2		407	15	392	349.9	695.97	198.69	78.9	26.6	91.7	64.6	8.82	6.18	258.2	0.29
3a		636	52	584	533.4	647.08	260.86	85.2	27.6	166.1	65.7	7.59	4.51	367.3 23.7	0.40 0.65
3b					27.2	15.11	9.8	2.9	2.1	3.5	6.9	5.21	5.3		
	Total	2533	291 (11%)	2242	1533.3	2518.6	705.3	256.3	92.4	335.5	194.8	8.50	4.63	1197.8	0.28
4	Baldwin SCL	440	53	387	447.6	538.8	203.15	70.2	23.6	65.9	39.0	7.68	3.71	381.7	0.38
5a		1017	385	632	402	628.82	119.08	74.4	19.8	102.3	27.1	8.45	3.96	299.7	0.19
5b			42	311	216.6	335.6	60.82	39.4	13.6	38.0	21.2	8.52	4.57	178.6	0.18
6					262.8	314.4	96.01	44.5	11.0	24.5	20.6	7.07	2.77	238.3	0.31
	Total		(27%)	1330	1329	1817.6	479.1	228.5	68.0	230.7	107.9	7.95	3.71	1098.3	0.26
7	Whitefish BN	1020	457	563	467.4	390.5	56.01	60.3	10.9	22.0	0.2	6.48	1.47	445.4	0.14
8		120	50	70		40.45	13.55	5.5	5.6	0.5	16.7	7.35	9.55	35.2	0.33
9		260	25	235		93.44	27.02	16.0	11.1	37.1	36.5	5.84	7.02	94.9	0.29
	Total	1400	532 (38%)	868	638.47 177	524.39	96.58	81.8	27.6	59.6	53.4	6.41	2.88	575.5	0.18
Totals		5743	1303 23%	4440	3497.4	4860.6	1280.94	1606.6	188.0	625.8	356.1	8.01	3.93	2871.6	0.26

25

TABLE 6
SCENARIO DATA SUMMARY

FESS Tape No.	Active Time, min	Speed Profile, mph								Armature Current Profile, amp				Speed Histogram, mph					
		>0.5	> 2	> 4	> 6	> 8	> 10	> 15	> 20	> 30	> 200	> 500	> 1000	0.5 -2	2 -4	4 -6	6 -8	8 -10	10 -15
a	481.6	371.4	320.1	222.2	128.8	60.7	29.4	3.6	1.4	270.4	204.5	113.9	9.7	66.5	126.7	121.8	88.1	40.5	33.7
b	67.0	49.7	41.5	28.2	20.8	13.9	8.0	1.0	6.1	34	27.3	21.8	15.4	11.1	17.9	10.0	9.3	8.0	9.5
2	258.2	207.4	193.9	163.5	129.2	86.7	56.0	29.2	9.7	128.9	87.5	58.2	21.8	16.8	38	42.6	52.9	38.2	33.3
3a	367.3	271.1	235.2	191.3	141.5	87.0	43.9	0.5	0.1	181.5	124.0	62.3	9.4	48.5	59.5	67.6	73.8	58.4	58.8
3b	23.7	17.2	16	14.5	11.2	7.4	4.7	0	0	10.8	4.4	1.0	0	1.7	2.0	4.5	5.2	3.7	6.5
	1197.8	916.8	806.7	619.7	431.5	255.7	142.0	34.3	11.3	625.6	444.7	257.2	56.3	144.6	244.1	246.5	229.3	148.8	141.8
	100%	77	67	52	36	21	12	3	1	52	37	21	5	12	20	21	19	12	12
4	381.7	269.6	219.4	168.1	115.3	59.1	21.4	1.4	0.1	174.4	128.1	56.1	5.5	71.0	72.5	74.8	79.8	53.4	28.3
5a	259.7	225.8	177.8	125.6	81.4	43.1	23.6	4.5	3.3	156.9	127.4	74.3	5.7	63.8	69.2	58.7	51.0	25.8	25.5
5b	178.5	136.3	110.1	86.9	60.6	37.3	21.4	6.5	1.4	90.5	70.5	33.2	4.6	39.3	30.4	34.5	30.5	20.9	19.5
6	238.3	168.9	133.1	98.5	60.8	29.6	14.7	1.5	0.1	107.5	77.8	35.7	0.2	50.5	48.9	53.2	43.9	21.0	18.6
	1098.2	800.6	640.4	479.1	318.1	169.1	81.1	13.9	4.9	529.3	403.8	199.3	16.0	219.6	221	221.2	205.2	121.1	91.9
	100%	73	58	44	29	15	7	1	0.5	48	37	18	1	20	20	20	19	11	8
7	445.4	346.1	131.6	10.7	0.9	0.2	0	0	0	274.2	164.2	94.2	9.0	276.2	155.5	12.5	0.9	0.5	0
8	35.2	31.3	31.1	28.2	26.3	23.8	21.3	3.1	0	21.1	11.3	0.8	0	0.18	3.2	2.22	2.75	2.78	20.6
9	94.9	71.1	70.2	61.4	52.5	41.7	33.0	8.7	1.2	44.8	20.4	7.7	0.6	1.0	11.9	11.8	14.5	11.6	32.6
	575.5	448.5	232.9	100.3	79.7	65.7	54.3	11.8	1.2	340.1	195.9	102.7	9.6	277.4	170.6	26.5	18.2	14.9	53.2
	100%	78	40	17	14	11	9	2	0	59	34	18	2	48	30	5	3	3	9
	2804.5	2165.9	1680.0	1199.1	829.3	490.5	277.4	60.0	17.4	1495.0	1044.4	559.2	81.9	641.6	635.7	494.2	452.7	284.8	286.9
	100%	77	60	43	30	17	10	2	1	53	37	20	3	23	23	18	16	10	10

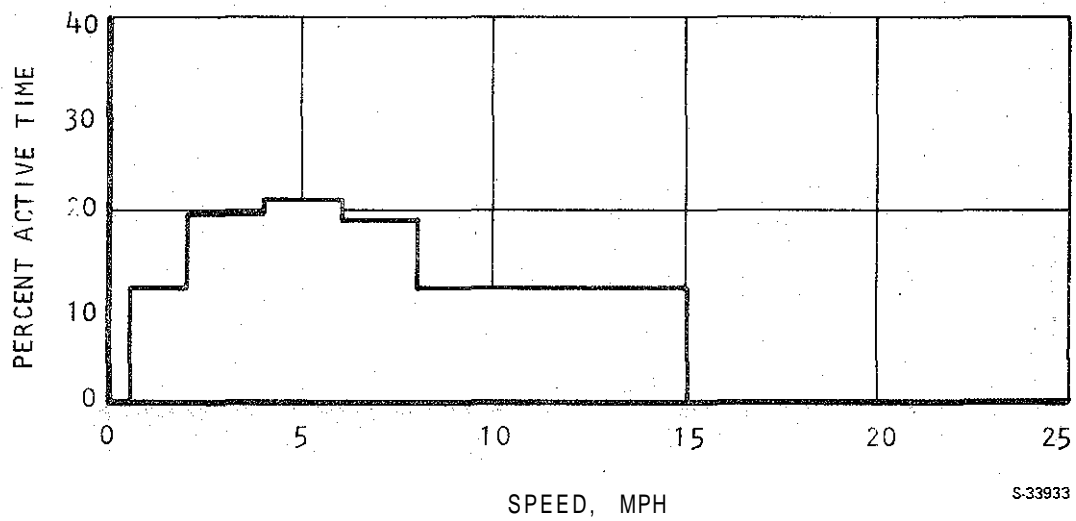
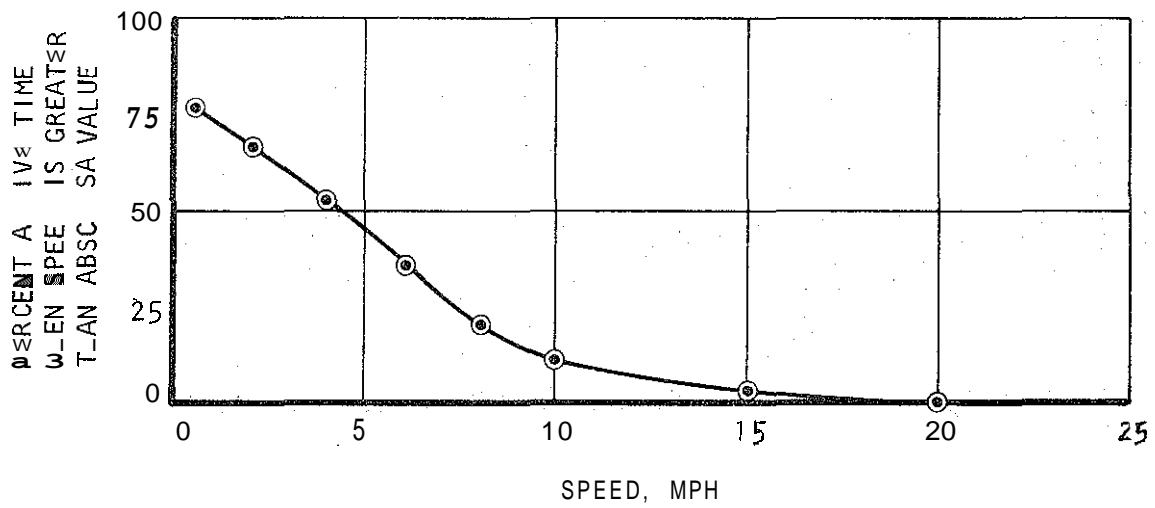
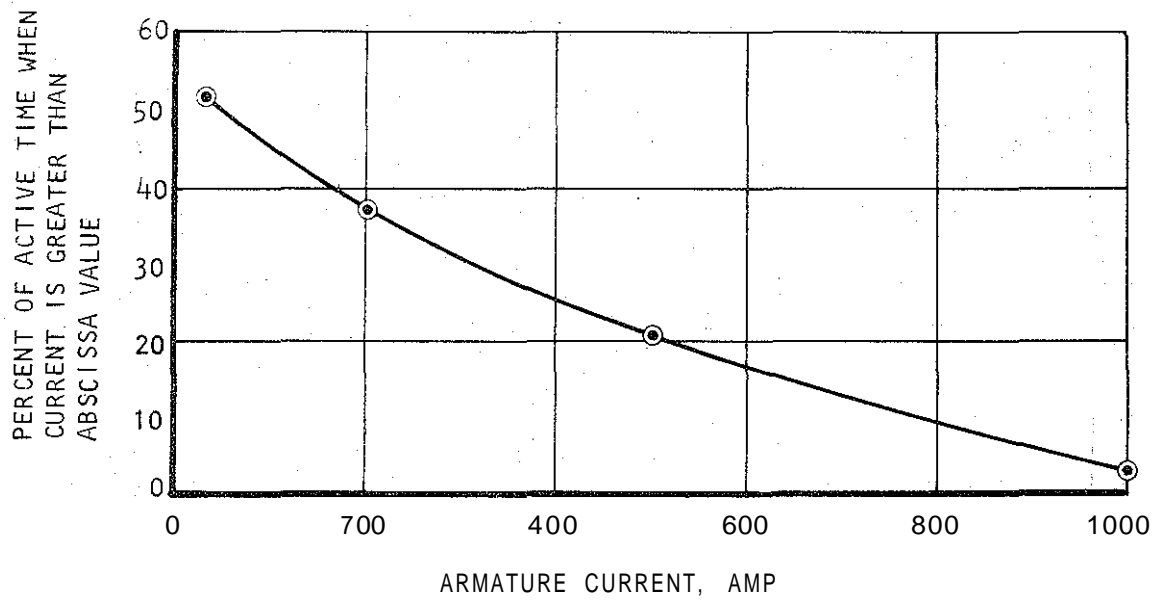

S-33933

Figure 8. Dillard Yard Data Summary

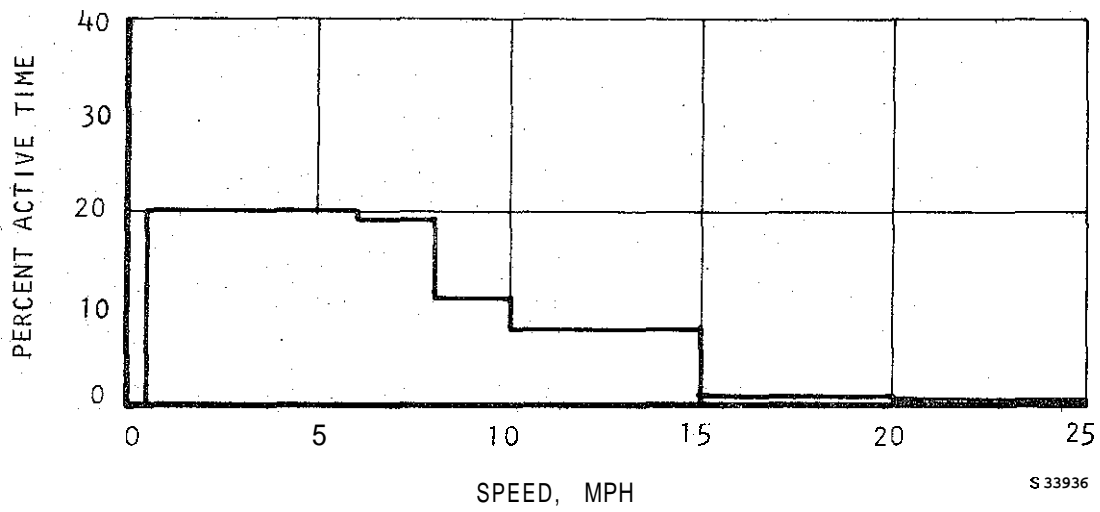
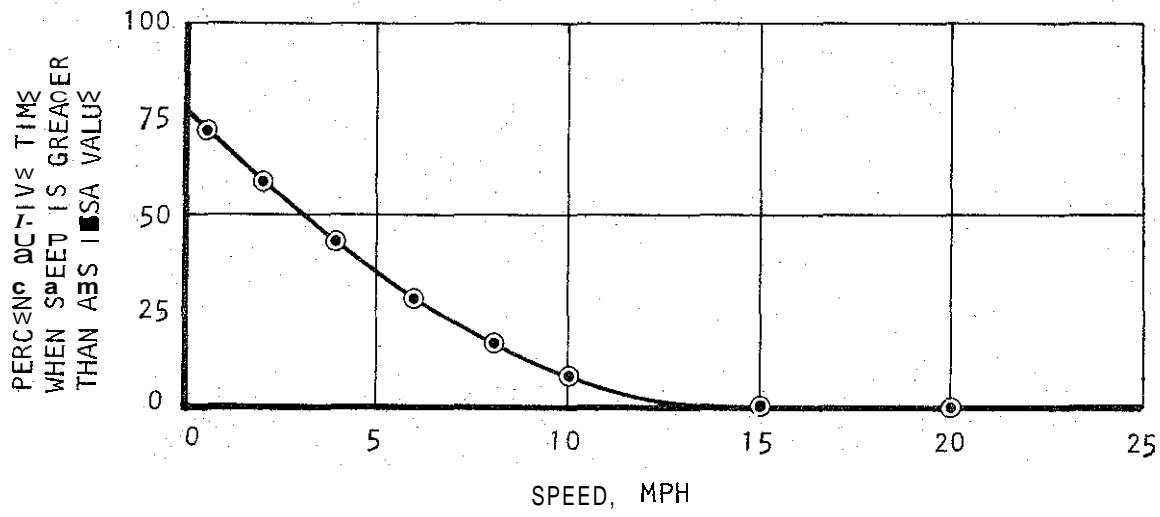
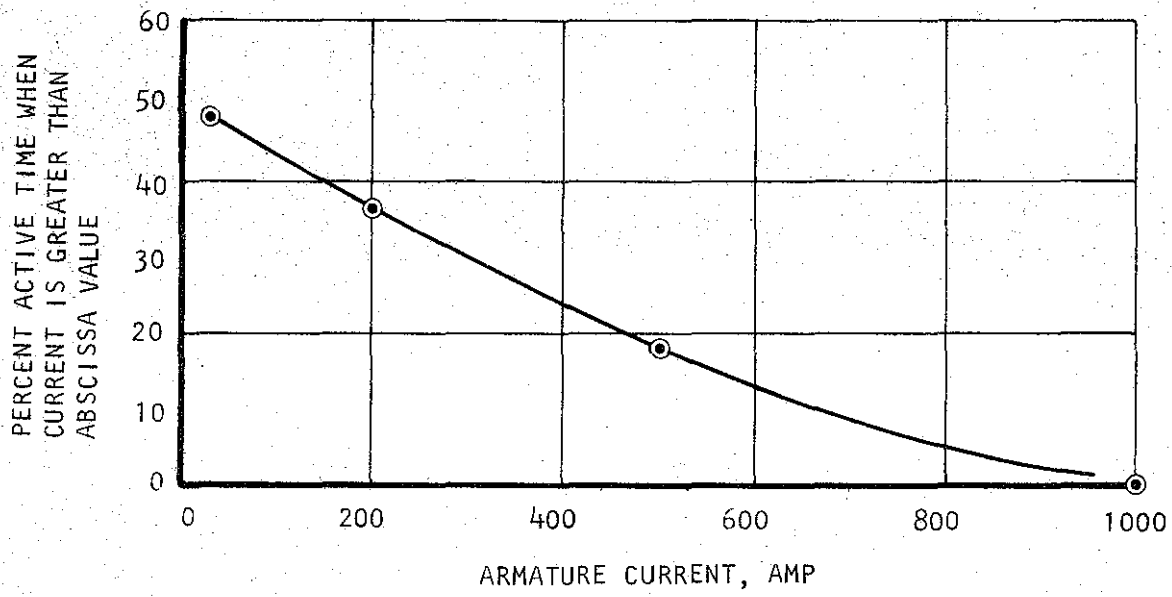

S 33936

Figure 9. Baldwin Yard Data Summary

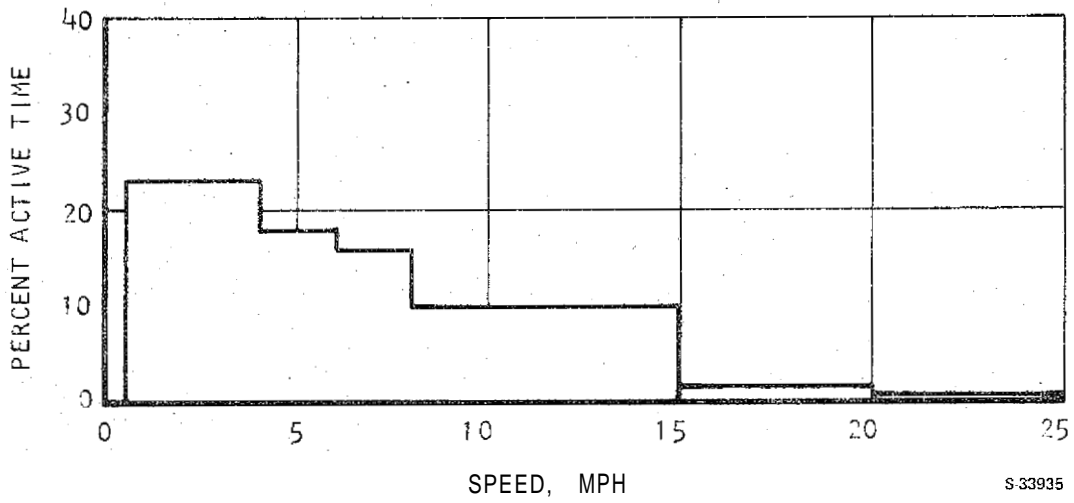
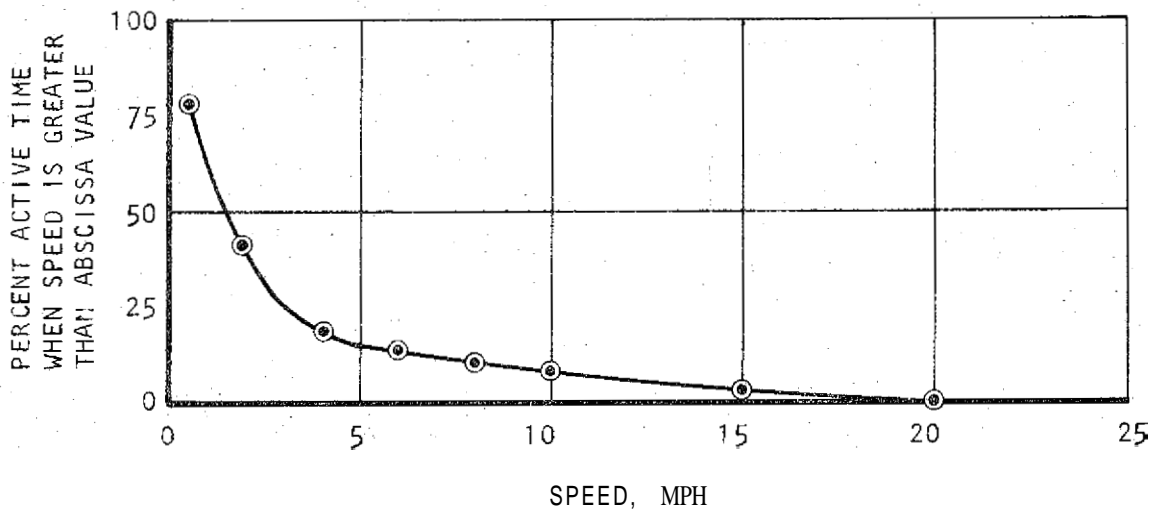
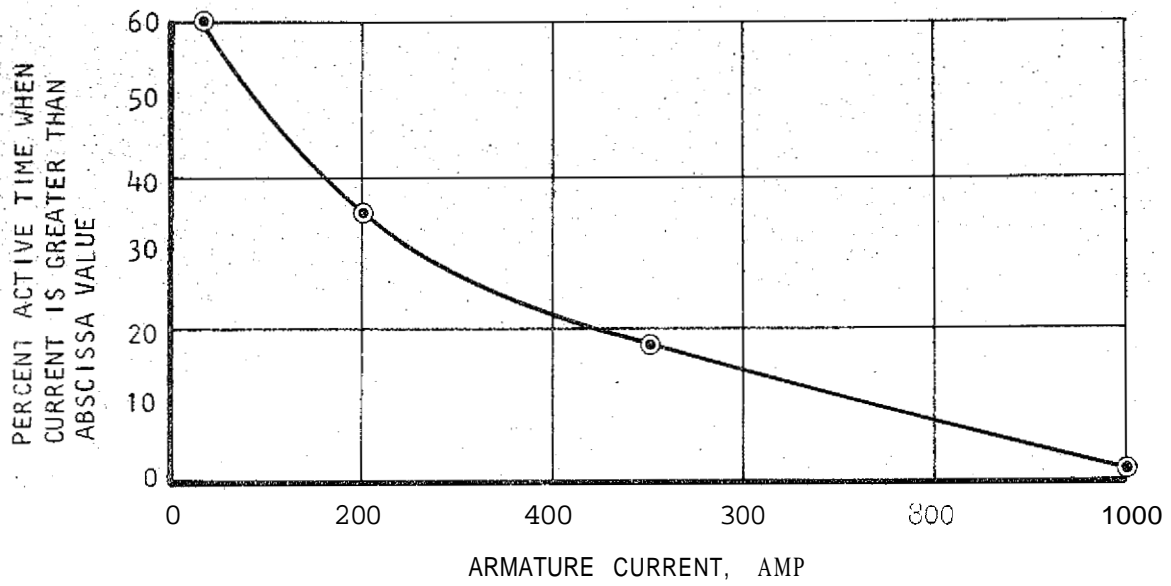

S-33935

Figure 10. Whitefish Yard Data Summary

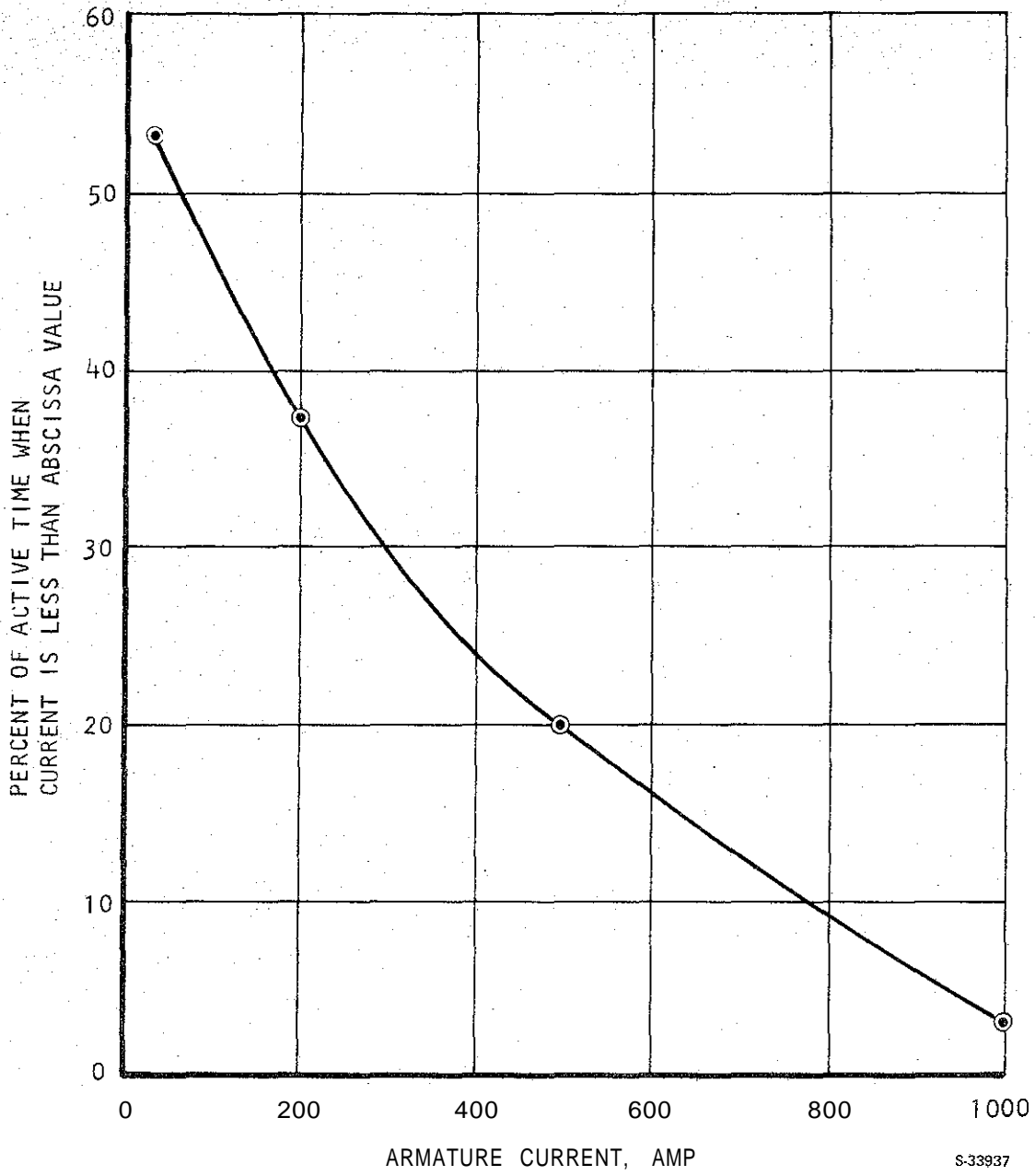

Figure 11. Combined Data Summary (Armature Current vs Active Time)

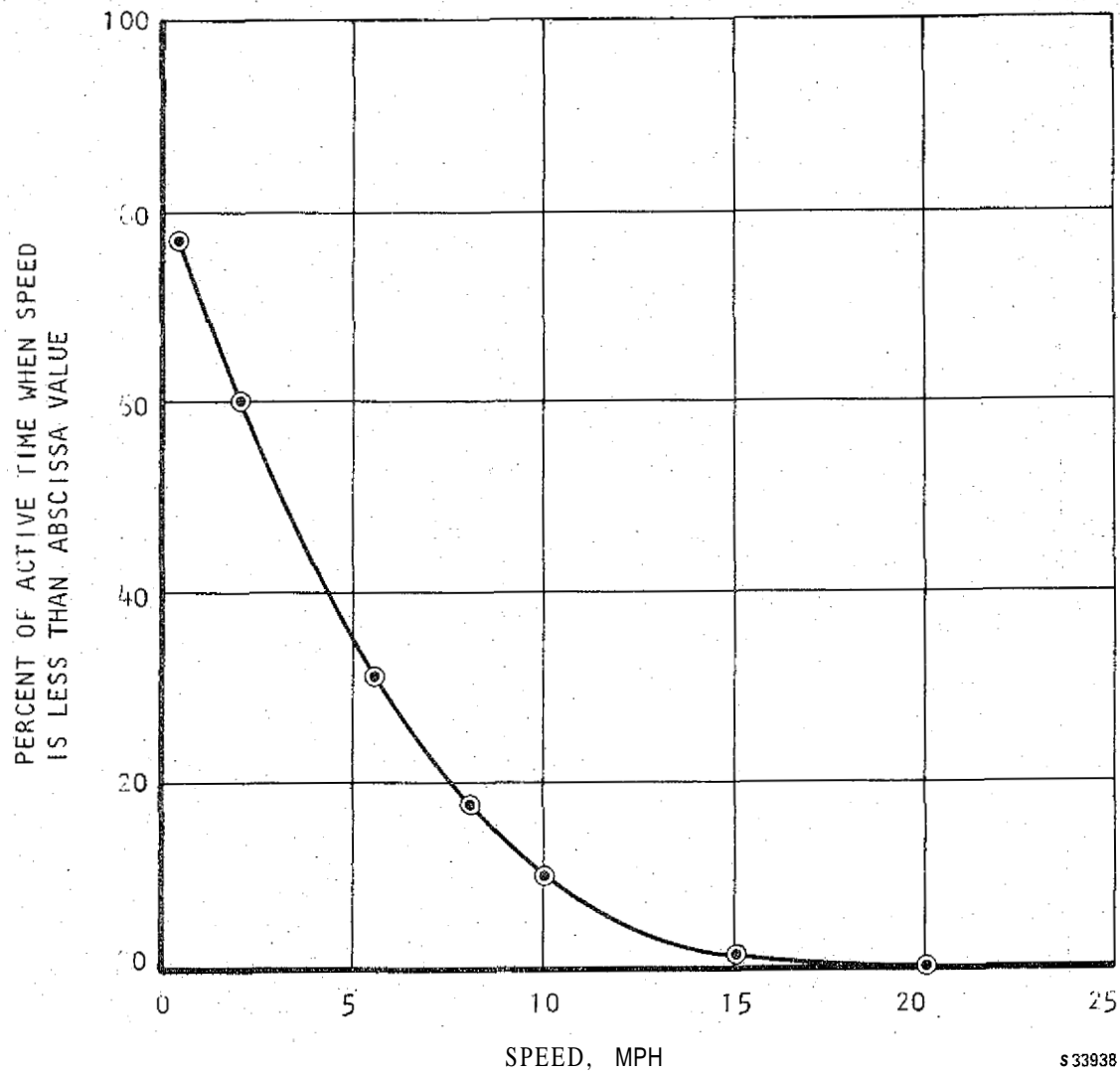

Figure 12. Combined Data Summary (Speed Less than Abscissa Value vs Active Time)

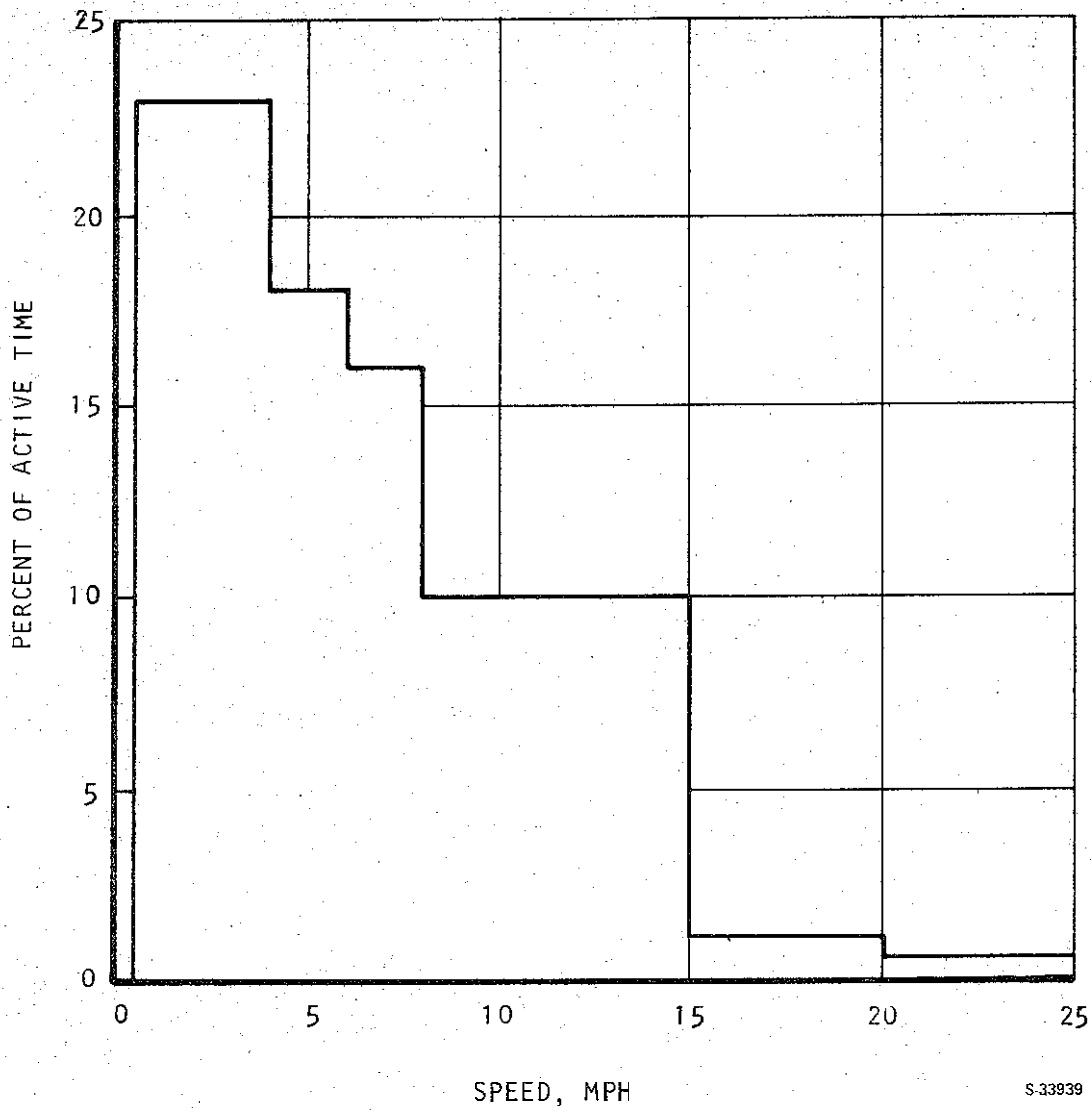
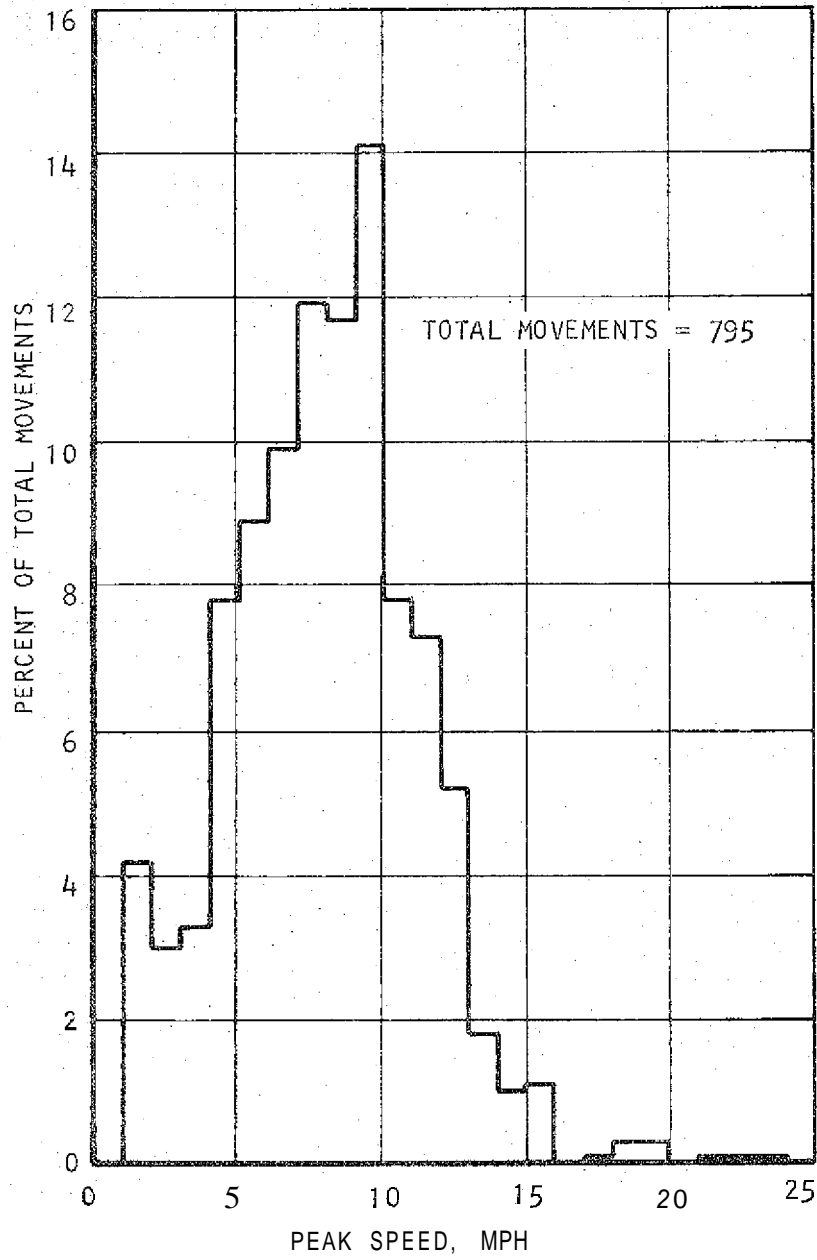
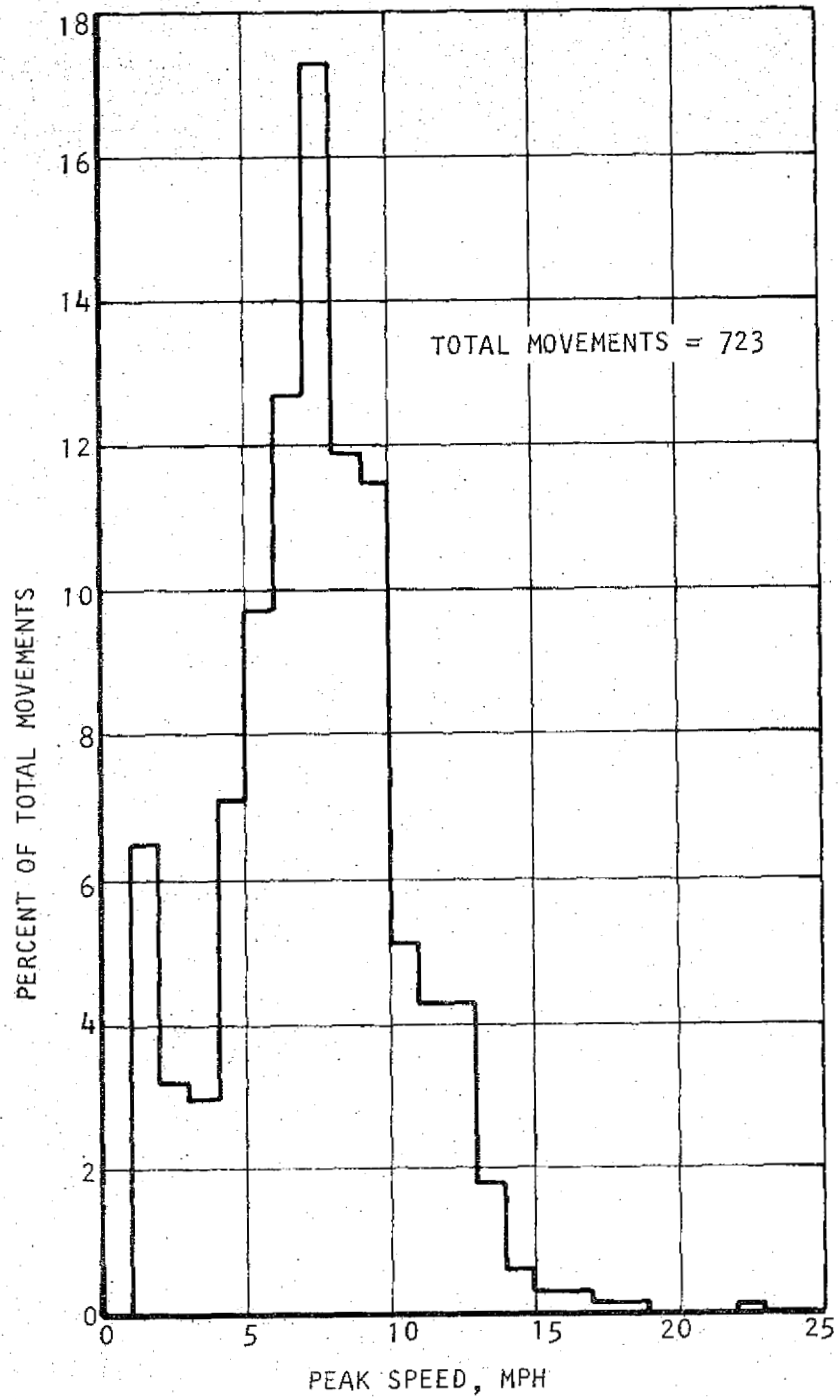

Figure 13. Combined Data Summary (Speed vs Active Time)



S34179

Figure 14. Dillard Yard Peak Speed Distribution



S-34178

Figure 15. Baldwin Yard Peak Speed Distribution

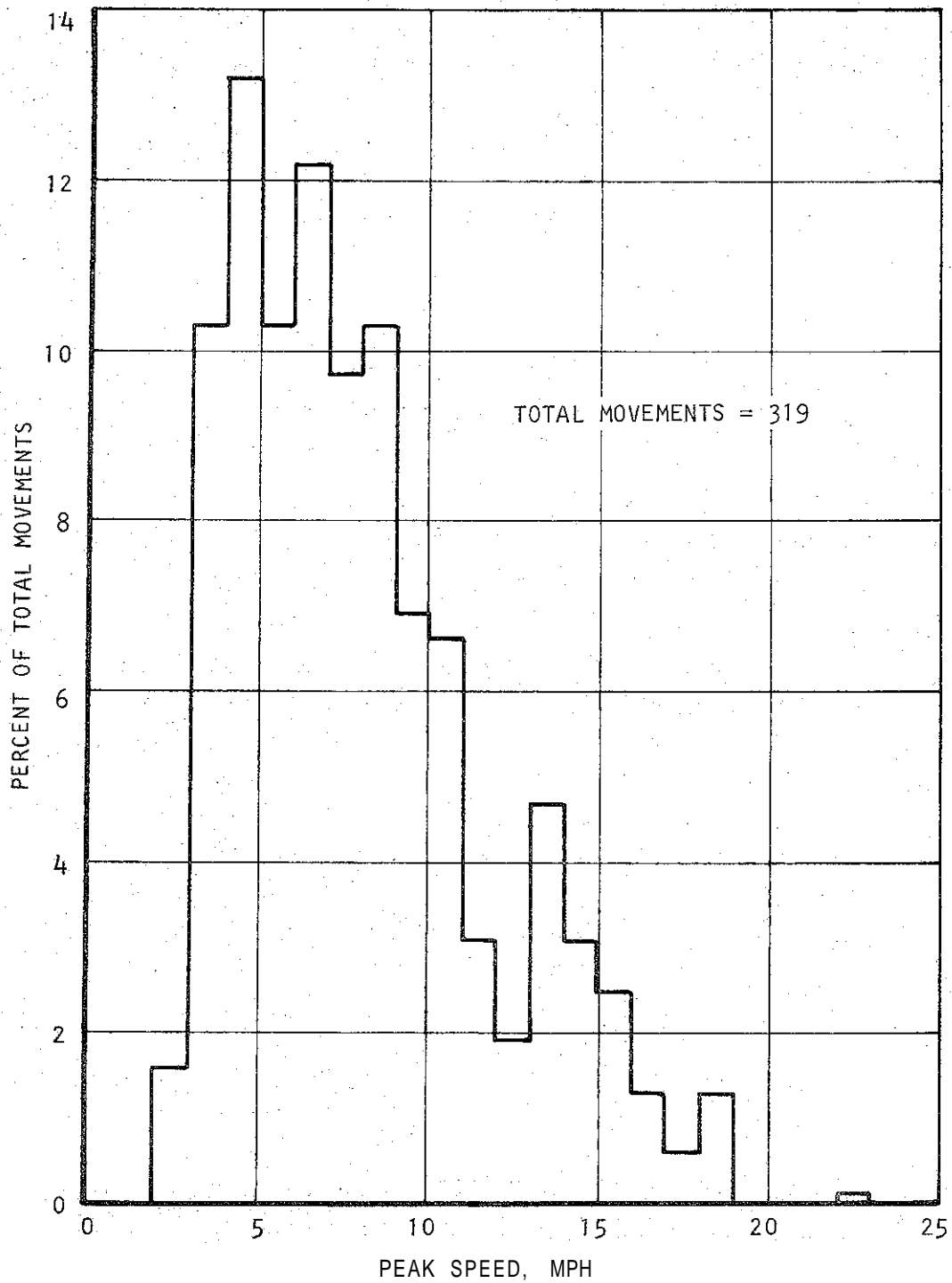

S34180

Figure 16. Whitefish Yard Peak Speed Distribution

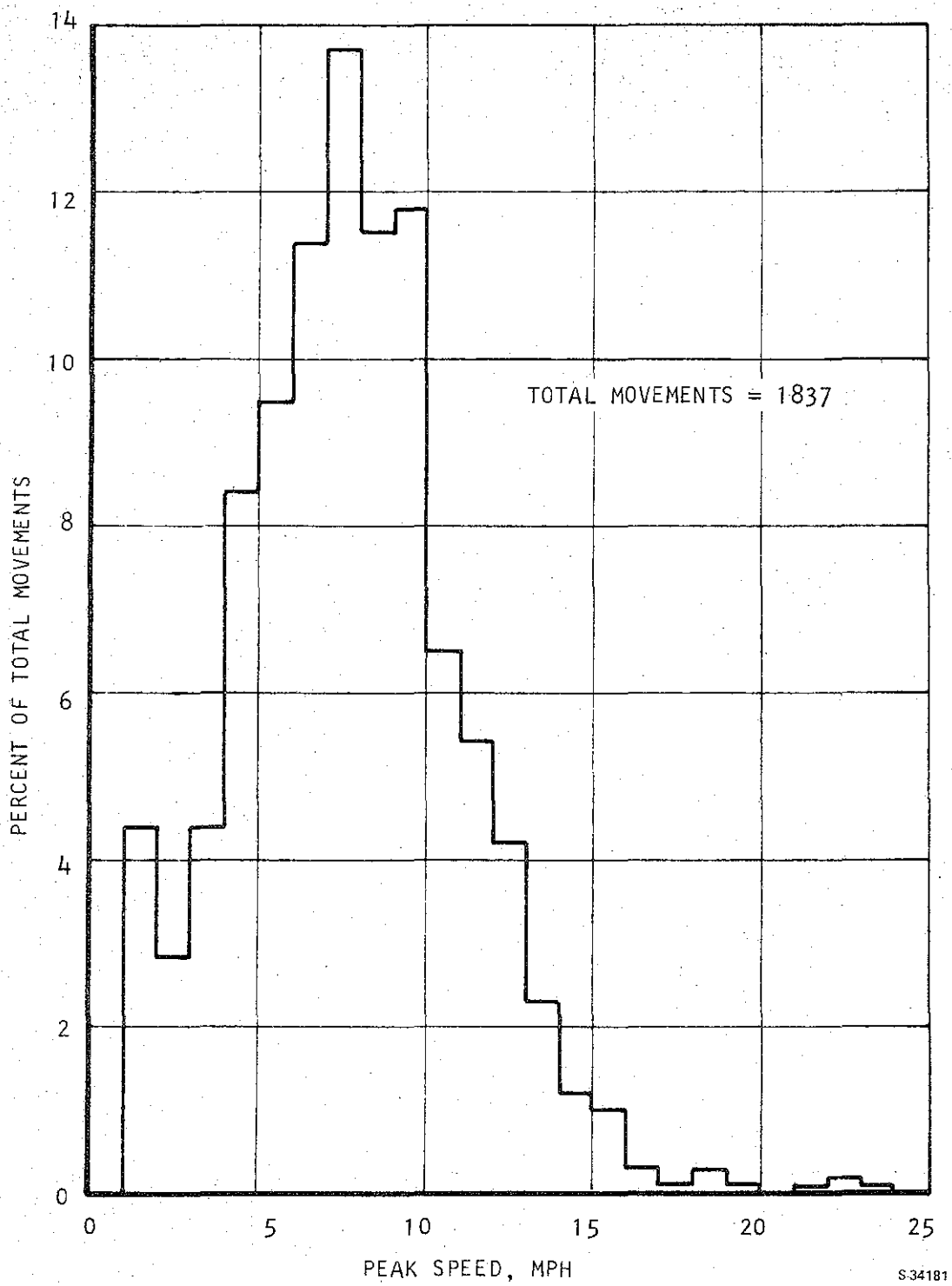
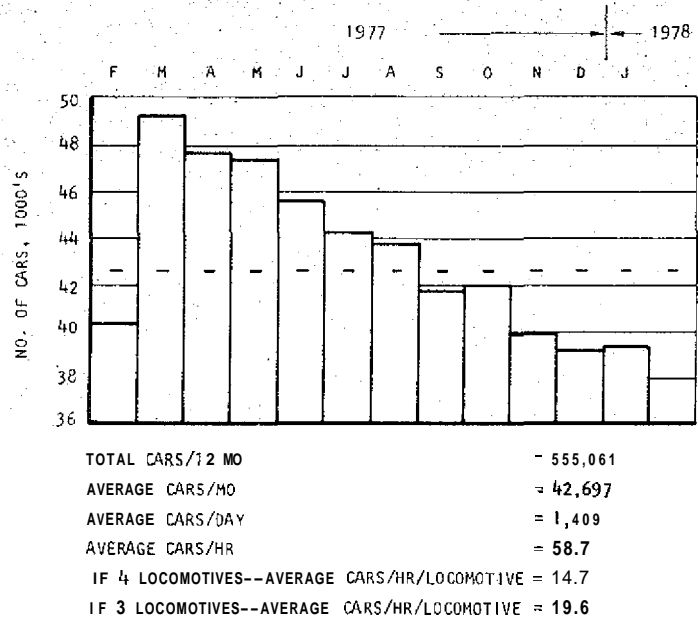
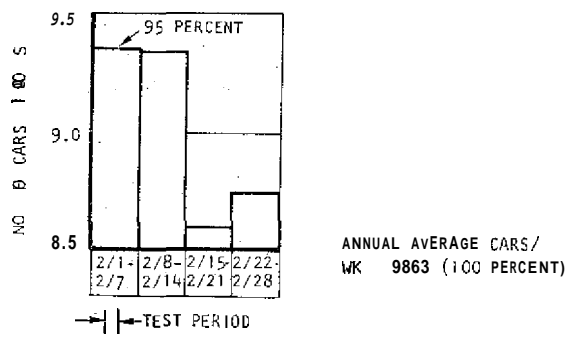

Figure 17. Combined Total Peak Speed Distribution



DATA FROM SOUTHERN RAILWAY
 SYSTEM DILLARD YARD,
 3-14 AND 4-18-78
 S 33944

Figure 18. Southern Railway System Dillard Yard Annual Average



DATA FROM SOUTHERN
 RAILWAY SYSTEM
 4-18-78
 S 33947

Figure 19. Southern Railway Dillard Yard Test Period Activity

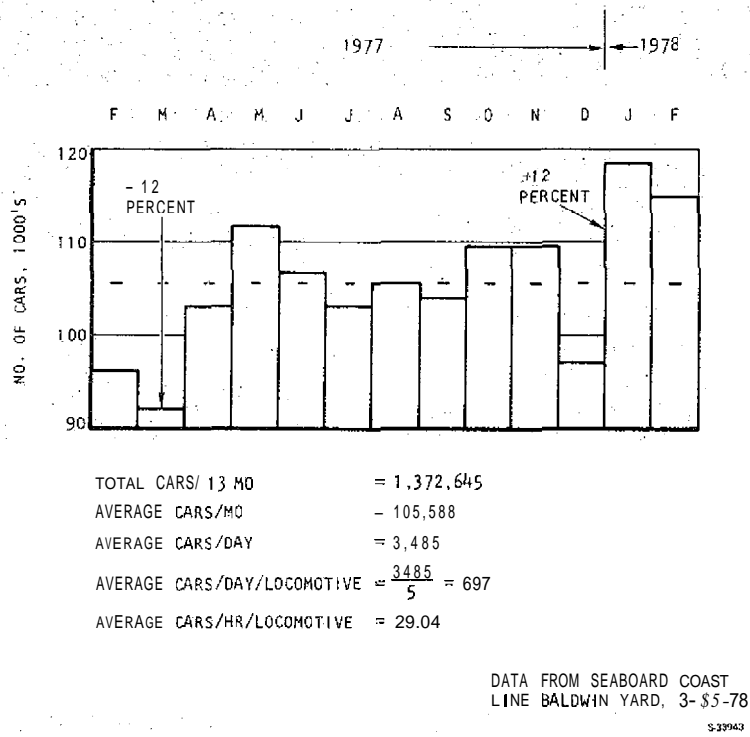

Figure 20. Seaboard Coast Line Baldwin Yard Annual Average

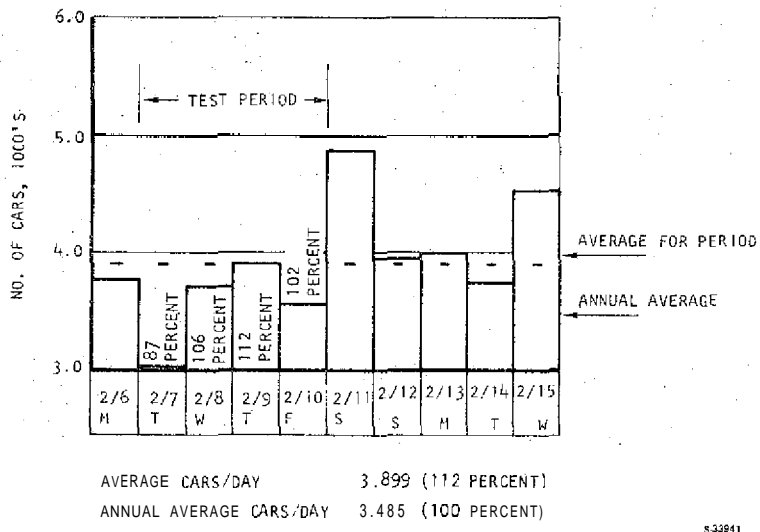
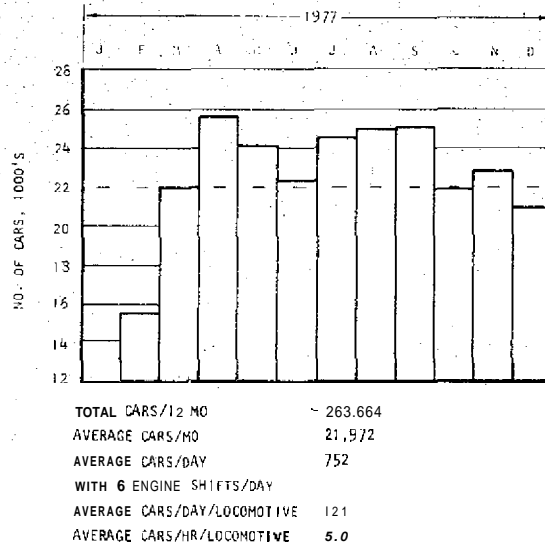
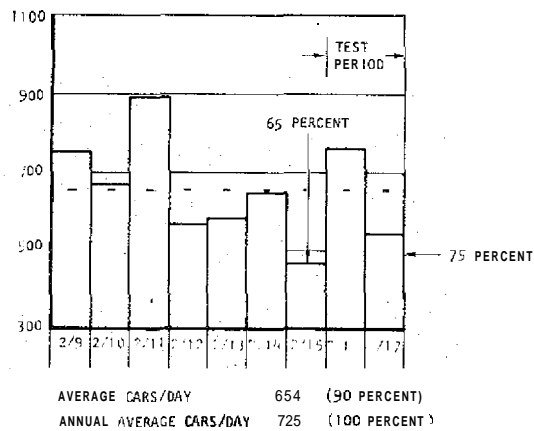

Figure 21. Seaboard Coast Line Baldwin Yard, Test Week Activity



DATA FROM BURLINGTON
NORTHERN WHITEFISH
YARD MARCH 1978
S-33040

Figure 22. Burlington Northern Whitefish Yard Annual Average



DATA FROM BURLINGTON
NORTHERN WHITEFISH YARD
THROUGH CARS/DAY = 45
(ANNUAL AVERAGE)
S-33924

Figure 23. Burlington Northern Whitefish Yard Test Period Activity

Scenario Formulation

The primary objective of the scenario tests was to create a data base from which the operational duty cycle could be determined. Also, the format of the scenario had to be compatible with the computer simulation of the switching locomotive that is described in Section 4. The ground rule for determining the scenario was to match as many of the tested average parameters as practical. The following description details this procedure.

(a) Based on logbook and recorded data, the active time was set at 50 percent.

(b) From switch list data (contained in Volume 2), the cars processed per day were:

Dillard Yard	348/30.8 cars/hr
Baldwin Yard	613/31 cars/hr
Whitefish Yard	498/26 cars/hr

Overall Average = 402 cars/24 hr

(c) From logbook data and observers experience:

2 cars/kick
22 cars/fetch

(d) The kicking cycles required:

$$\frac{402 \text{ cars}}{22 \text{ cars/fetch}} \approx 18 \text{ fetches}$$

(e) The total movement quantity should be:

Dillard Yard	795/30.8 moves/hr
Baldwin Yard	723/31 moves/hr
Whitefish Yard	319/26 moves/hr

Overall Average = 491 moves/24 hr

For a fetch of 22 cars and assuming 2 forward moves and 1 reverse move for every 2 kicks, the kicking moves will total 15 moves/fetch or 270 moves kicking. Therefore, the sum of fetching and other miscellaneous moves should total approximately 220.

(f) The primary technique for matching the test data in terms of energy transfer was to select a set of computer runs that matched the speed and armature current distribution data. This was accomplished by an iterative trial and error method. The runs tabulated below provide a reasonable match to the data. This is not the only combination, but is considered a suitable match for the fuel consumption comparison.

<u>Type</u>	<u>Quantity</u>	<u>No. of Cars</u>	<u>Peak Speed, mph</u>	<u>Distance, ft.</u>
Kicking	18	22	7.5	NA
Fetching	8	22	5.8	2300
Fetching	8	22	6.8	2400
Fetching	65	22	9.8	1000
Fetching	13	22	11.0	3800
Fetching	30	10	15.1	1100

The preceding detailed computer runs are contained in Volume 2. The comparisons of the speed and armature distribution data of the scenario runs and the test data are shown in Figure 24.

The scenario simulation speed distribution characteristic differs from the test data primarily in the low speed (less than 4 mph) region. This is attributed to *the* relatively small number of computer runs used in the scenario simulation. The area of difference could have been represented by many very low speed runs that do not have a significant influence on total energy expended or recovered. To make up for this difference, however, the selected computer runs result in a speed distribution that is slightly higher in the remainder of the characteristic where the energy content is more significant.

The armature current distribution characteristic resulting from the formulated scenario is represented by the data points plotted on the test data characteristics of Figure 25. The differences between test data and computer simulation data are primarily due to the relatively small number of computer runs used as well as the small number of data points used to construct the characteristic.

Fuel Consumption Comparison

When a set of computer runs that matched the test data had been identified, the task of determining the fuel consumption of the standard and the flywheel-assisted configurations was accomplished. The various components of fuel usage are shown in Table 7. The resulting fuel differences are essentially zero. Even with the assumption that the flywheel system is not energized on nonprofitable moves, the savings achieved during the kicking merely offsets the additional losses of the idling period.

LOCOMOTIVE PERFORMANCE TESTS

It was necessary to develop a basis for evaluating the accuracy of the computer model because the primary evaluation technique for the FESS program was to use a computer simulation of the switching locomotive. This evaluation described in Section 4) was to be based on actual test data. During June, 1978,

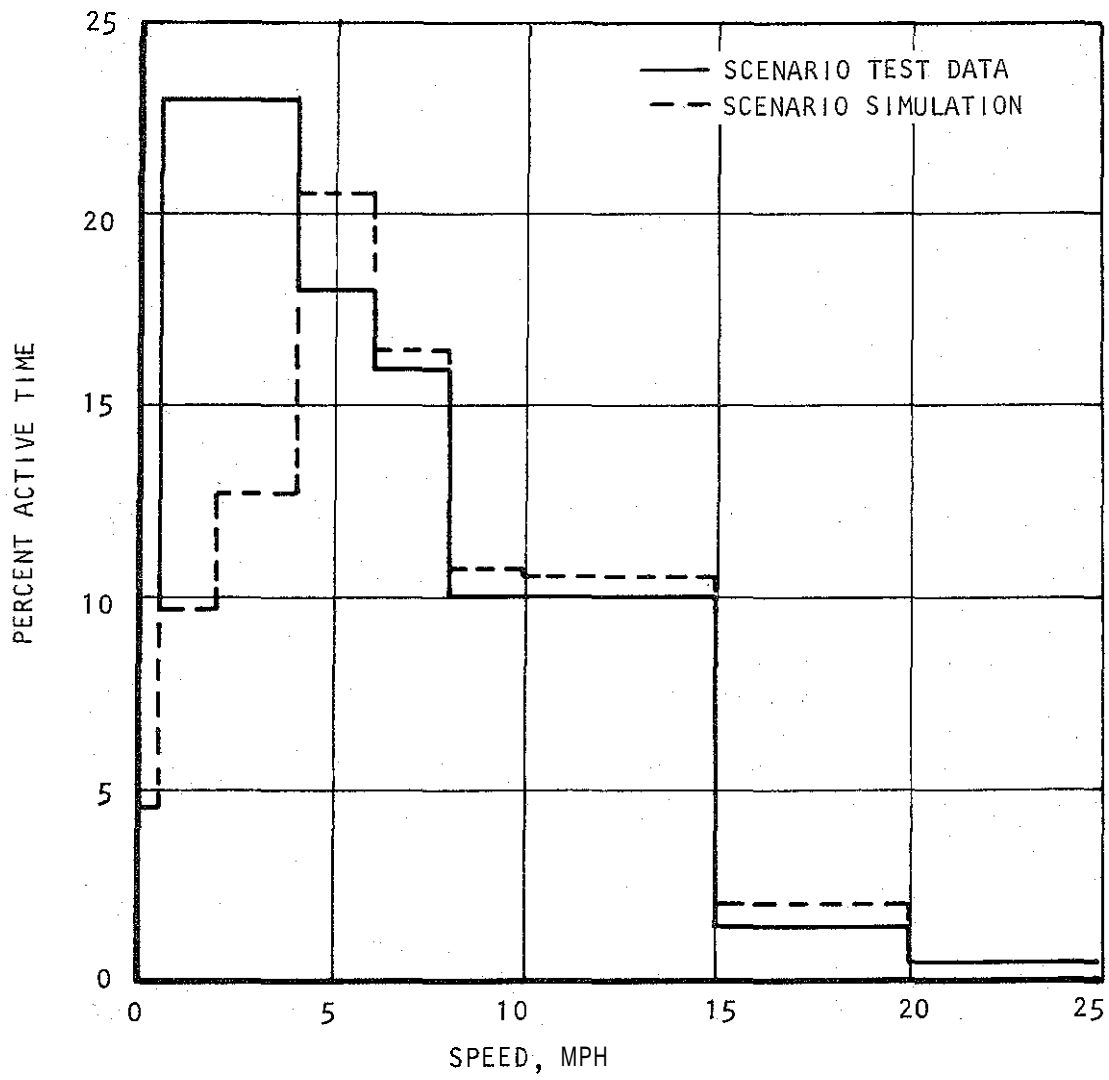

S-34176

Figure 24. Locomotive Speed Distribution Characteristics

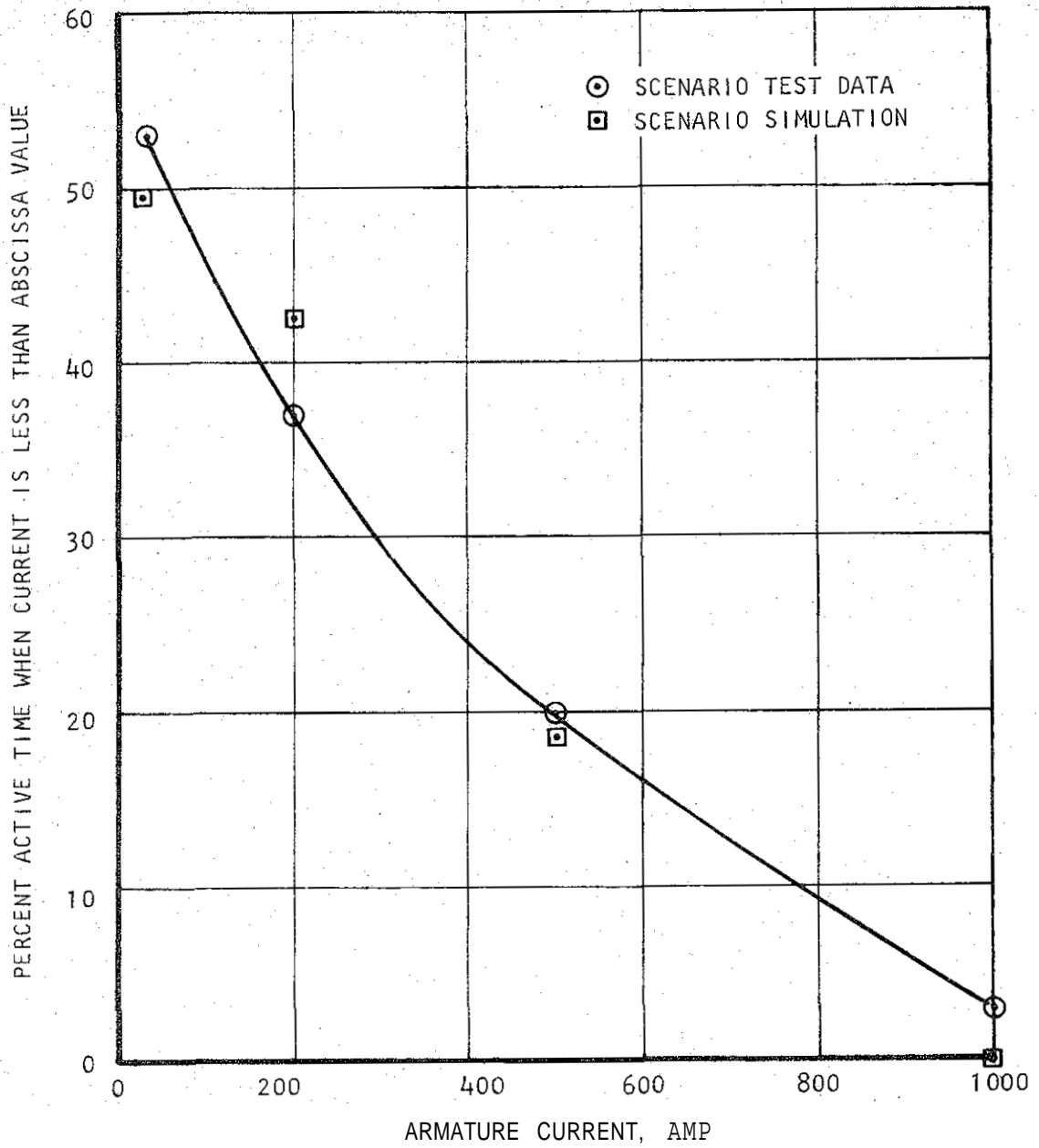

S34182

Figure 25. Locomotive Armature Current Distribution Characteristic

TABLE 7
FUEL CONSUMPTION COMPARISON

Operating Mode	Standard Locomotive		Flywheel System		Gallons Saved
	Time, min	Fuel, gal	Time, min	Fuel, gal	
Idle, 12 hr	720	45.6	720	48	-2.4
<u>Fetching, 3.4 hr</u>					
Cars x Dist x Speed x Runs					
22 x 2300 x 5.8 x 8	44.3	6.74	45.0	6.89 ³	-0.15
22 x 2400 x 6.8 x 8	38.3	6.82	37.2	6.943	-0.12
22 x 1000 x 9.8 x 2	4.0	1.27	3.9	1.20	+0.07
Idling between moves	117.0	7.41	117.0	7.8	-0.4
<u>Kicking, 3.6 hr</u>					
22 x NA x 7.5 x 18	122.9	36.7	117.0	32.9	+3.8
Idling between moves	93.0	5.9	99.0	6.6	-0.7
<u>Misc. Moves, 5.0 hr</u>					
22 x 3800 x 11.0 x 13	63.1	19.9	66.2	19.3	+0.6
22 x 1000 x 9.8 x 63	126.0	40.1	122.5	37.5	+2.6
10 x 1100 x 15.1 x 30	41.7	17.2	42.0	16.0	+1.2
Idling between moves	70.0		70.0	4.7	-0.3
<u>Flywheel Startup to 50 Percent</u>					
6 times/24 hr	--	0	--	3.8	-3.8
Totals	440.3	192.0	1439.8	191.6	0.4
1. Fuel rate = 3.8 gph. 2. Fuel rate = 4.0 gph. 3. Flywheel system deenergized.		$\frac{\text{Gallons saved}}{\text{Cars switched}} = \frac{0.4}{396} = 0.001$			

24

the locomotive tests to supply this data were conducted at the Atlanta, Georgia facilities of the Southern Railway System. The locomotive used for testing was an SW1500 with SRS No. 2302. This locomotive was also used during the scenario tests at Savannah, Georgia. The test plan is described in AiResearch Report 78-15055 (Reference 3).

The parameters instrumented during the performance tests are shown in Table 8. The details of the instrumentation package are described in Appendix A.

The locomotive was stationary during the initial testing, but the main generator was connected to a resistive load bank. This method is a standard technique for evaluating the performance of the diesel engine and main generator. For the FESS program test plan, the engine was operated to obtain a stabilized thermal condition. The engine was then operated in each available throttle notch to establish the steady-state operating parameters at power output, fuel flow, engine speed, and control characteristics.

The resulting power vs speed characteristic is shown in Figure 26, which also shows the equivalent published characteristic. In general the characteristics are similar; however, there is a displacement in engine speed and power output between the two curves. These differences can probably be attributed to the age and state of control in calibration of the tested locomotive. The engine speed vs throttle characteristic of Figure 27 depicts the tested and published characteristics of these parameters.

The output power vs fuel flow characteristics are shown in Figure 28. A slight variation that shows a greater fuel flow for the tested locomotive was found.

The relationships of generator volts, battery field current, and engine speed obtained during the tests are shown in Figures 29 and 30. There were no published characteristics available for comparison; however, the apparent control range of the battery field could have allowed a better match of the generator power vs engine speed characteristics if the controls had been slightly adjusted. No control adjustments were made for the FESS program.

The response times of the engine-generator combination were recorded as the engine was accelerated and decelerated with single notch steps. Although some data scatter were obtained, the results are shown in Figure 31.

All of the preceding test characteristics were developed from the test data and are considered representative of the tested configuration. However, under dynamic conditions, the traction motors can present different loads that will tend to vary or distort these characteristics.

Following the load box test, the locomotive was subjected to various conditions of acceleration and deceleration with different loads. Various runs from this data set were used in the detail development of the computer model and its validation. Figures 32, 33, and 34 show typical data obtained during these tests.

Reference 3. Performance Test Plan for SW1500 Locomotive, AiResearch Report 78-15055, AiResearch Manufacturing Company of California, May 2, 1978.

TABLE 8
LOCOMOTIVE PERFORMANCE TESTS
INSTRUMENTED PARAMETERS

Vehicle Parameters	Transducer Type	Range
Acceleration	Servo accelerometer	+3 mphps
Speed	GE Tachometer	50 mph
Direction	Trainline 8 and 9 voltage divider	74 vdc
Engine Parameters		
Fuel flow (Inlet-return)	Turbine flowmeter	150 gph
Engine speed	Photoelectric sensor	1000 rpm
Main Generator Parameters		
Battery field current	Current shunt	75 adc
Output voltage	Voltage divider	1200 vdc
Output current	Current shunt	3000 adc
Traction Motor Parameters		
Armature voltage	Voltage divider	74 vdc
Armature current	Current shunt	1200 adc
Suspension displacement	Cable potentiometer	+1 in.
Control Parameters		
Throttle position	Cable potentiometer	Notch 0-8
Brake cylinder pressure	Pressure transducer	150 psi
Wheel slip relay actuation	Trainline 10 voltage divider	74 vdc
Sander valve actuation	Trainline 23 voltage divider	74 vdc

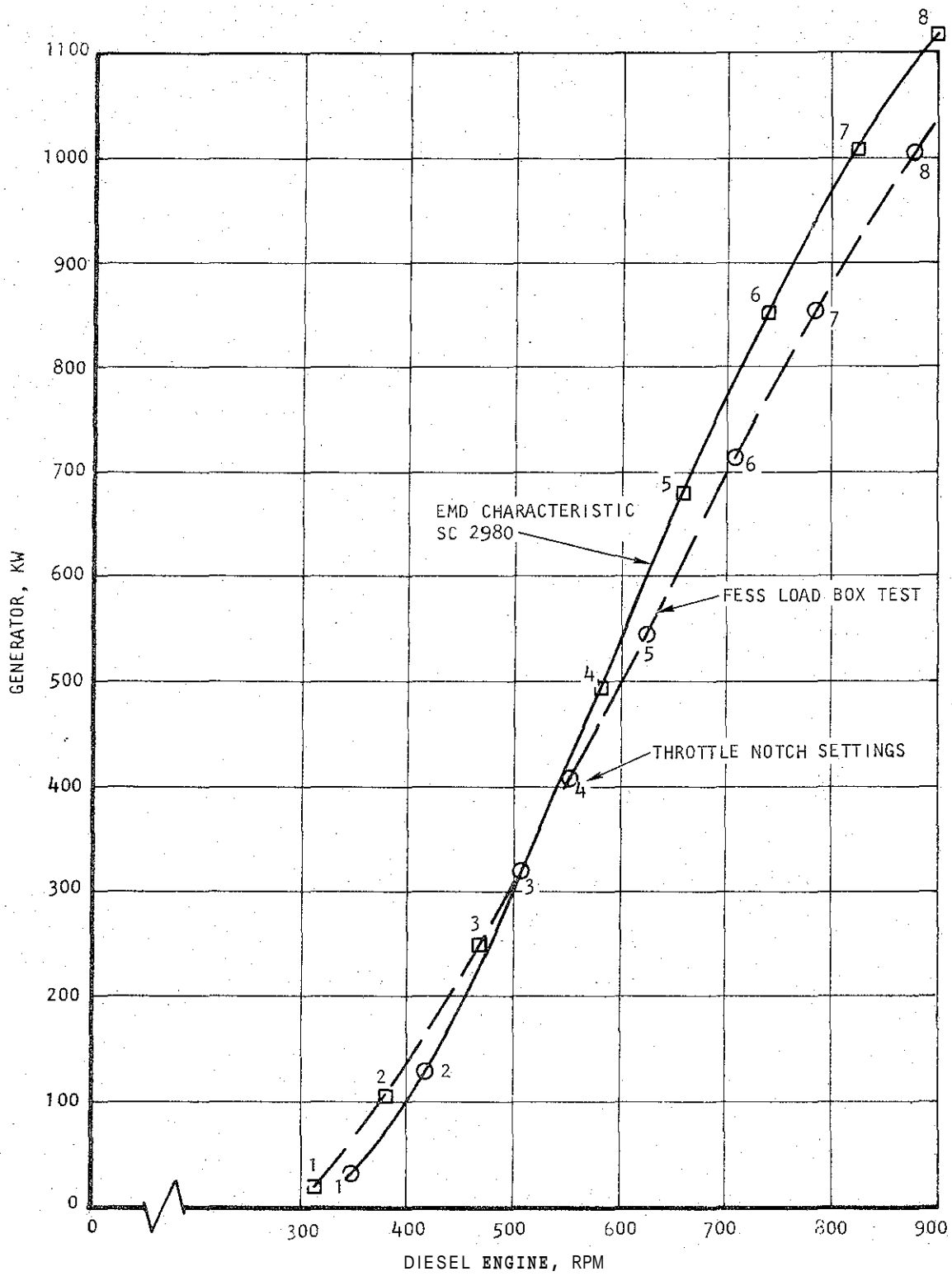

S34232

Figure 26. SW1500 Load Box Test, Engine and Generator Performancs, Locomotive 2302

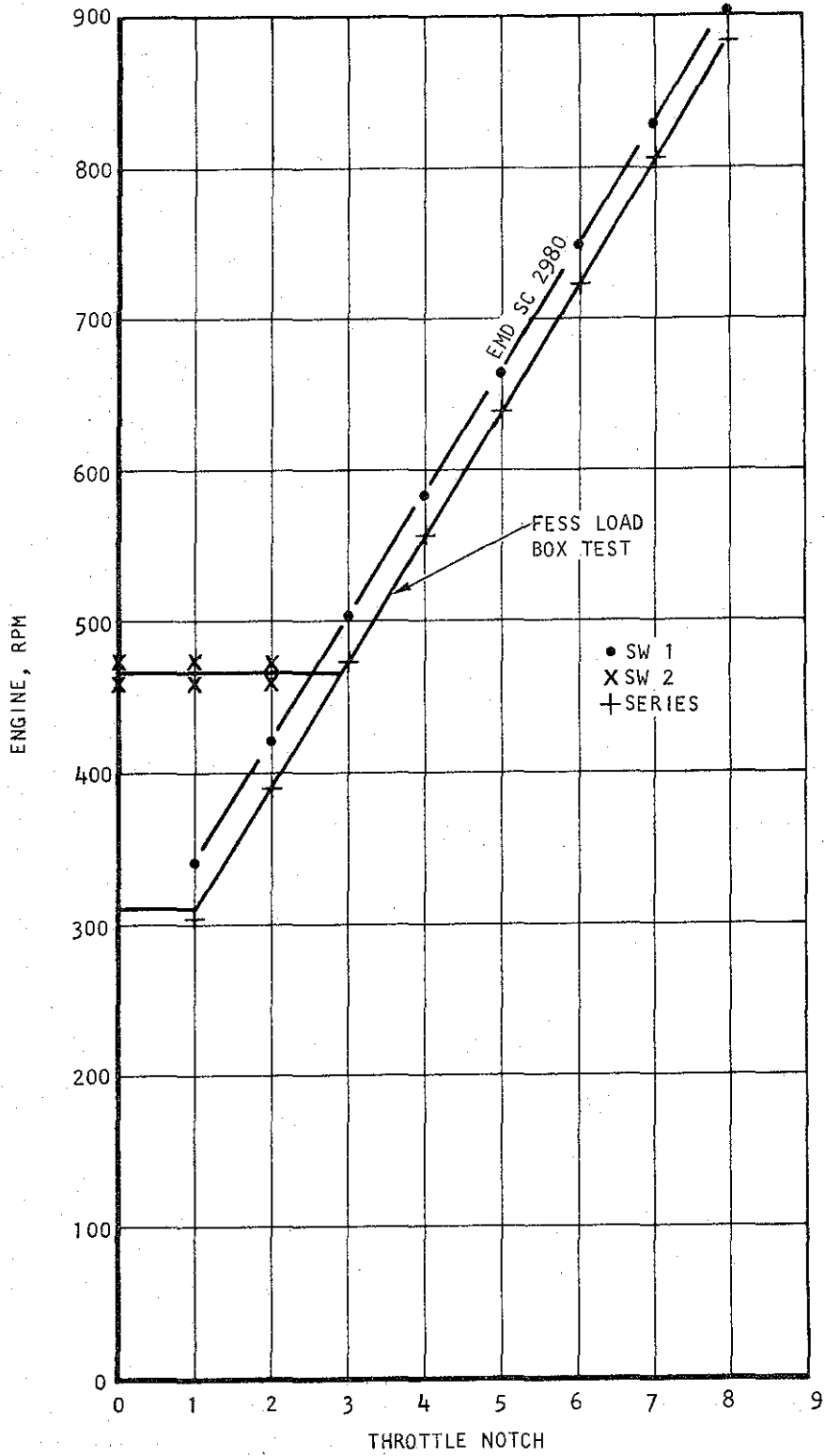

S-34233

Figure 27. Load Box Data, Speed vs Throttle

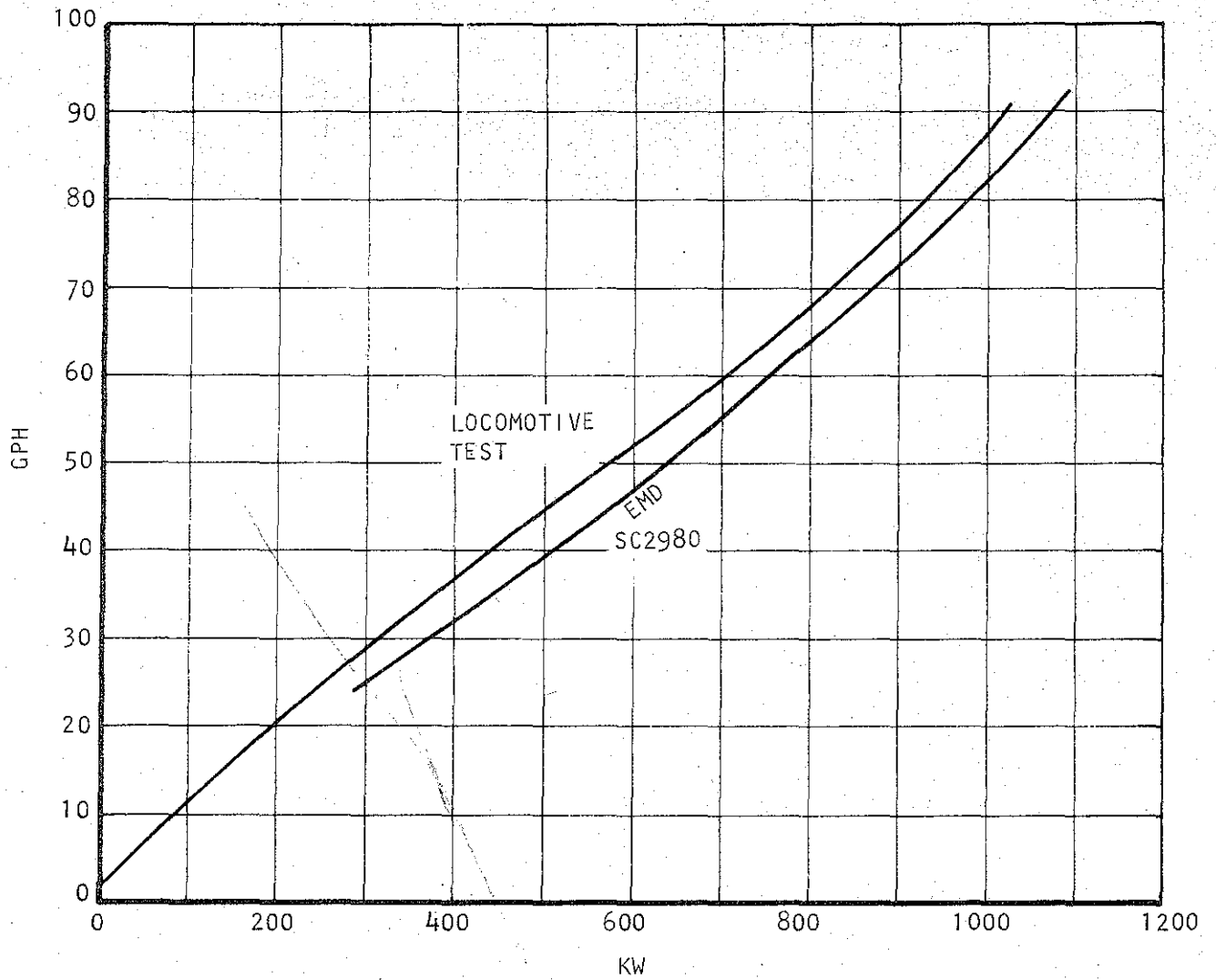

S-34235

Figure 28. Locomotive Fuel Consumption, Load Box Test, Locomotive 2302

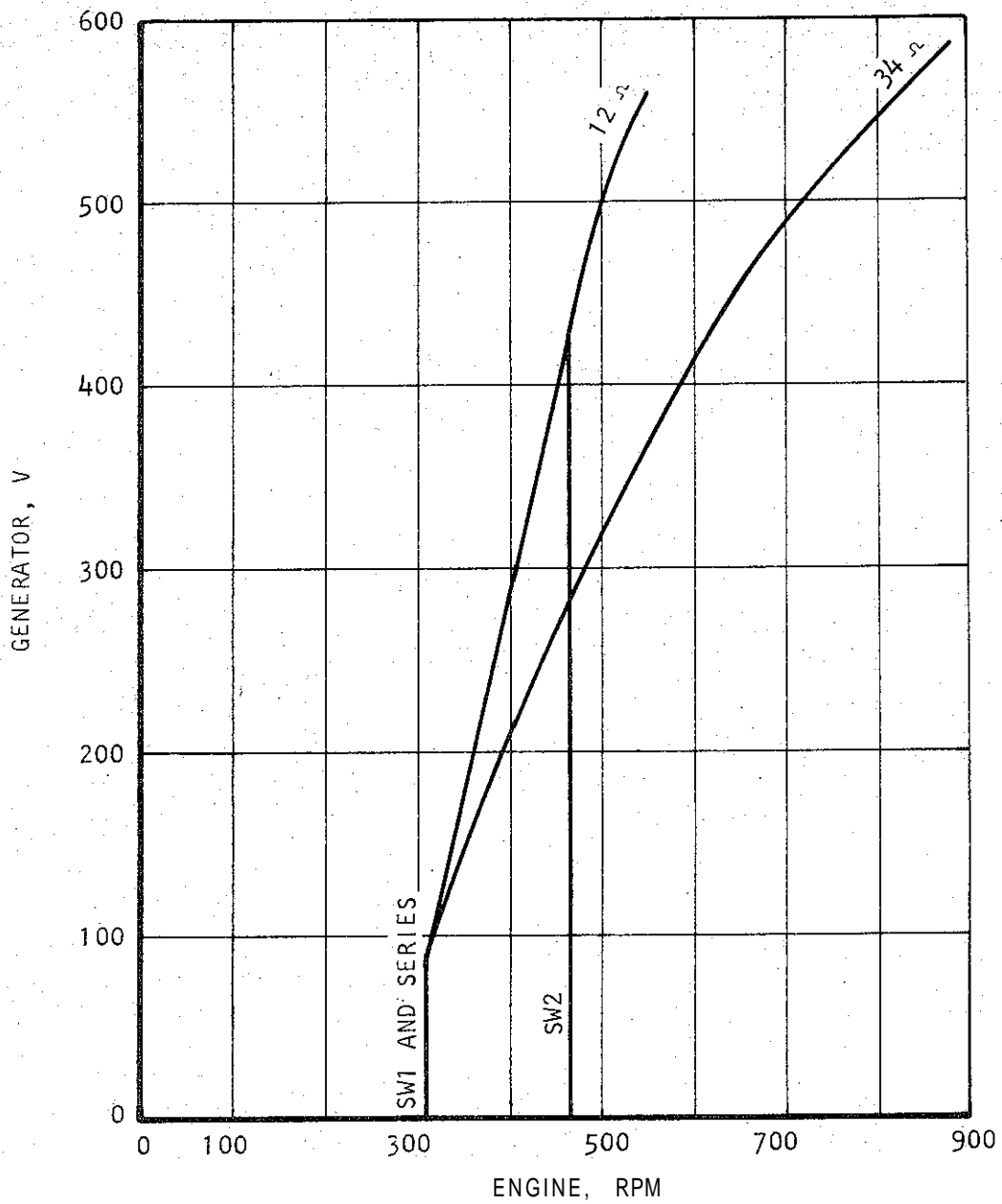

S 34237

Figure 29. Load Box Data, Generator Voltage vs Engine Speed

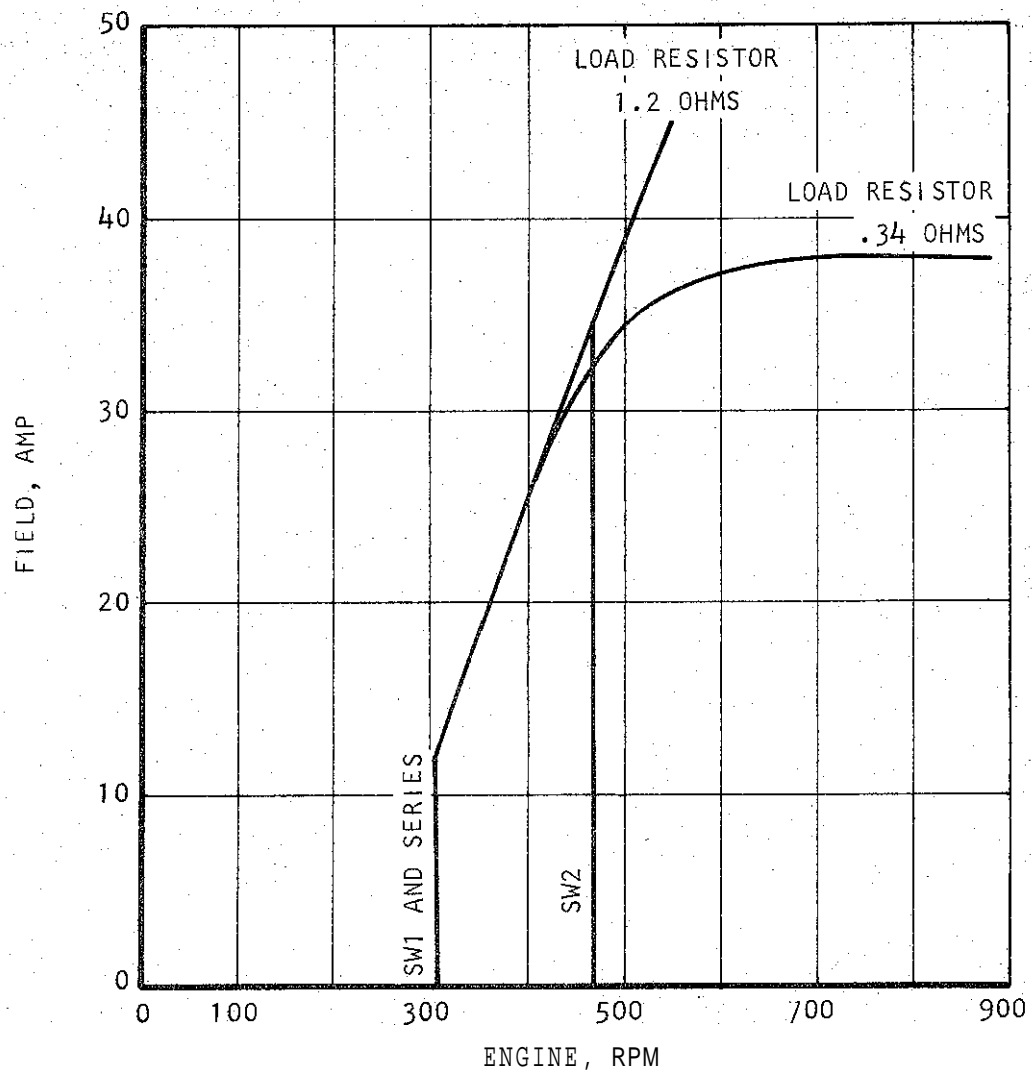

S 34236

Figure 30. Load Box Data, Field Current vs Engine Speed

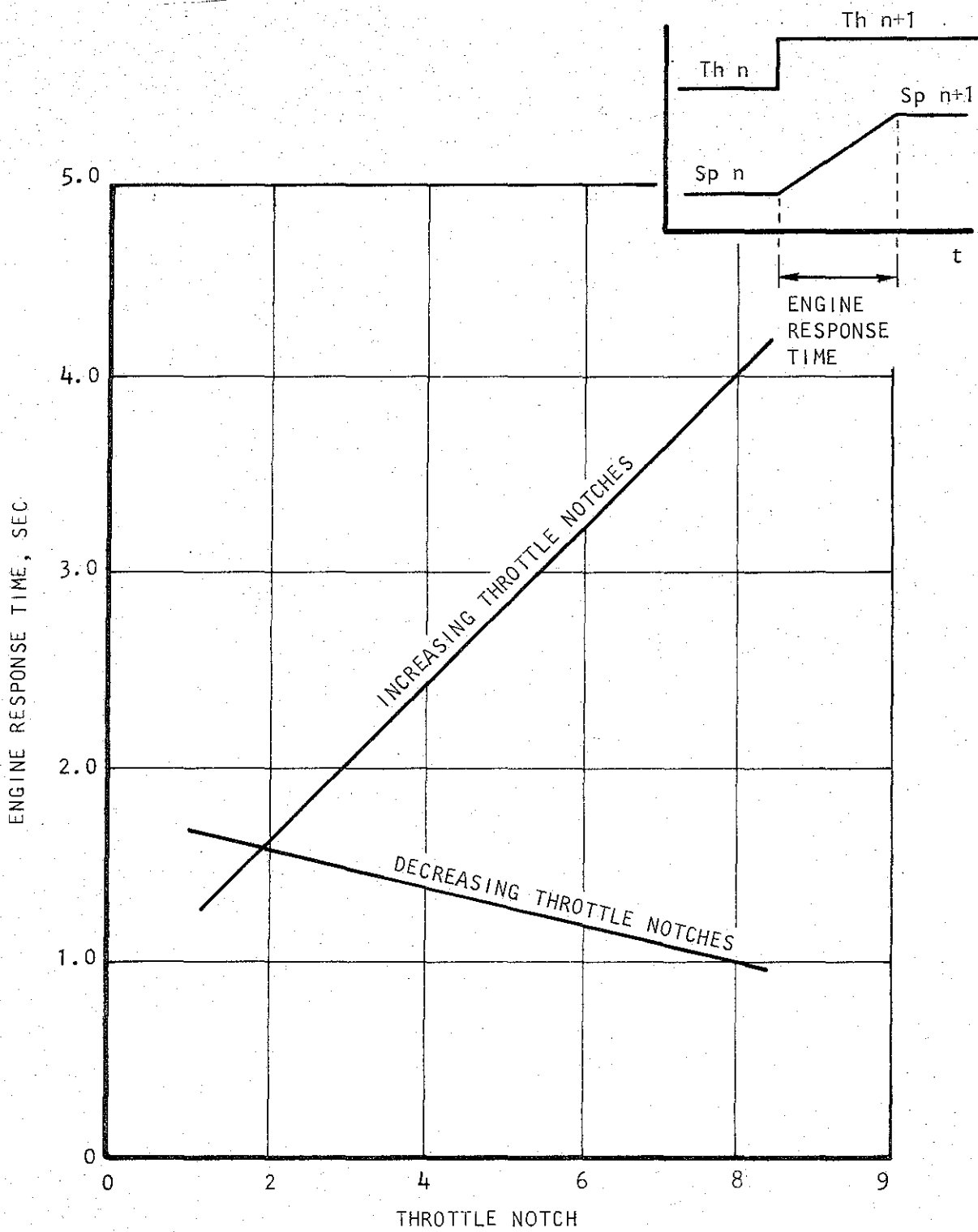

S-34234

Figure 31. Engine Generator Response Time

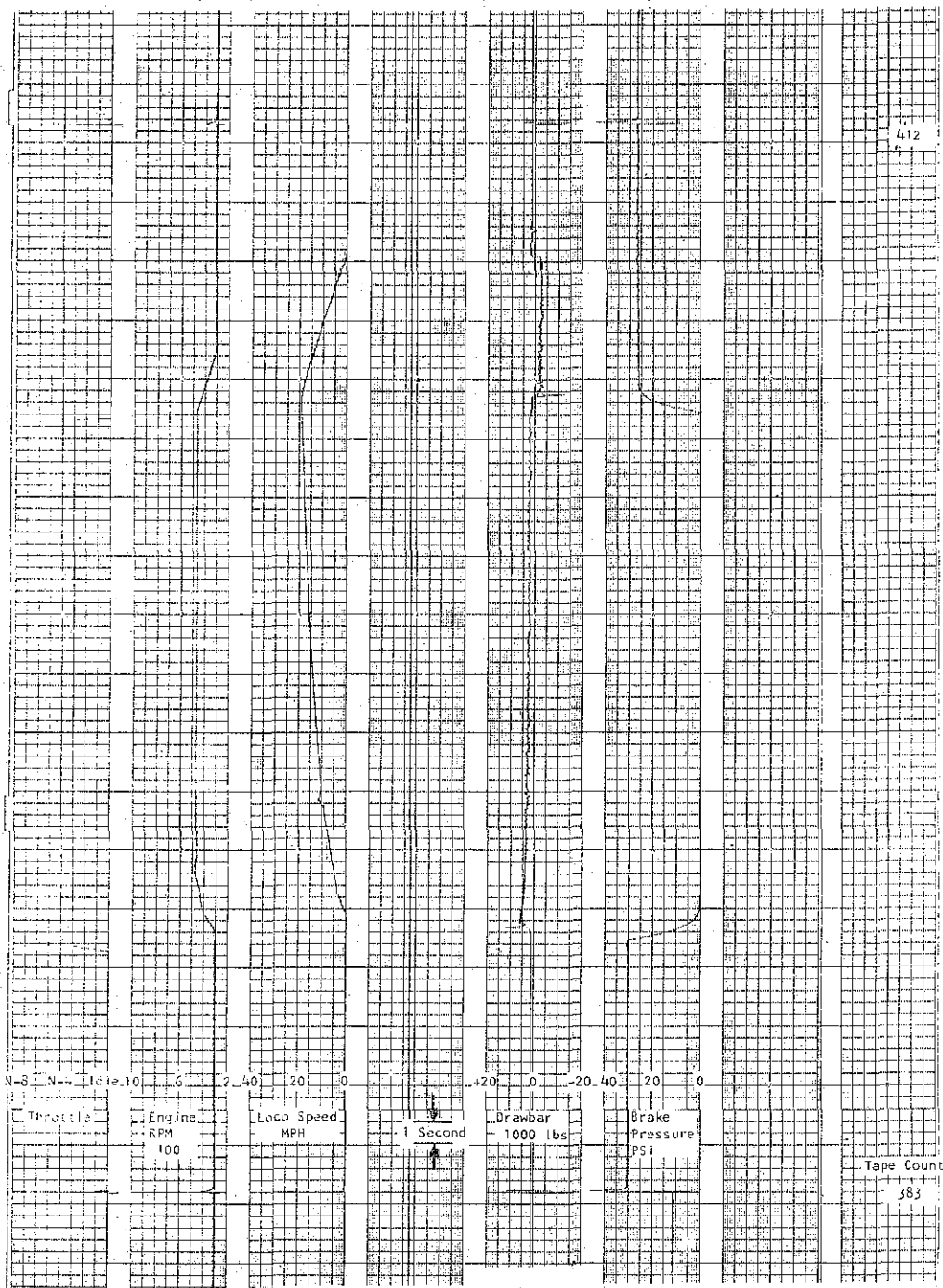

Figure 32. Data Roll No. 1

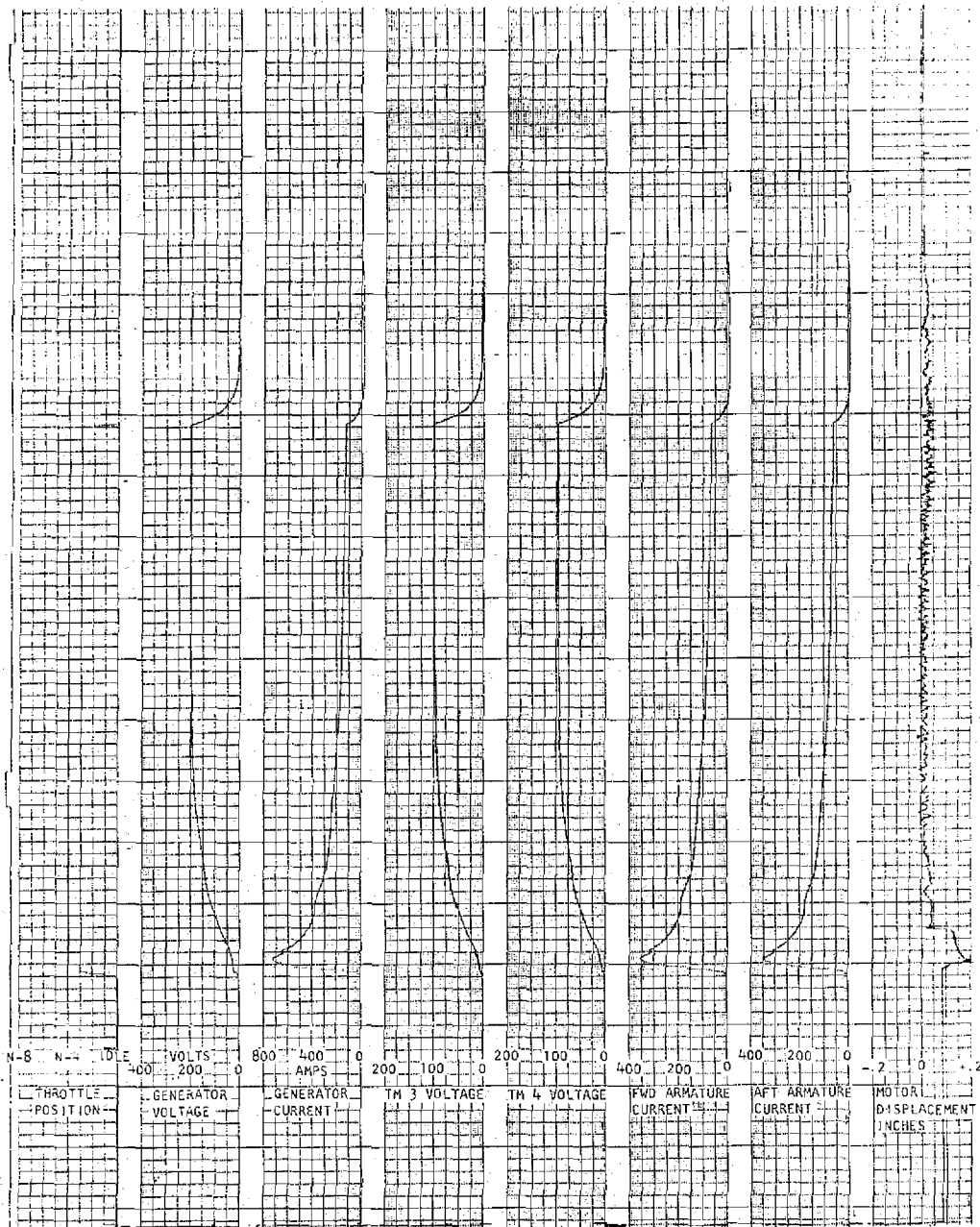
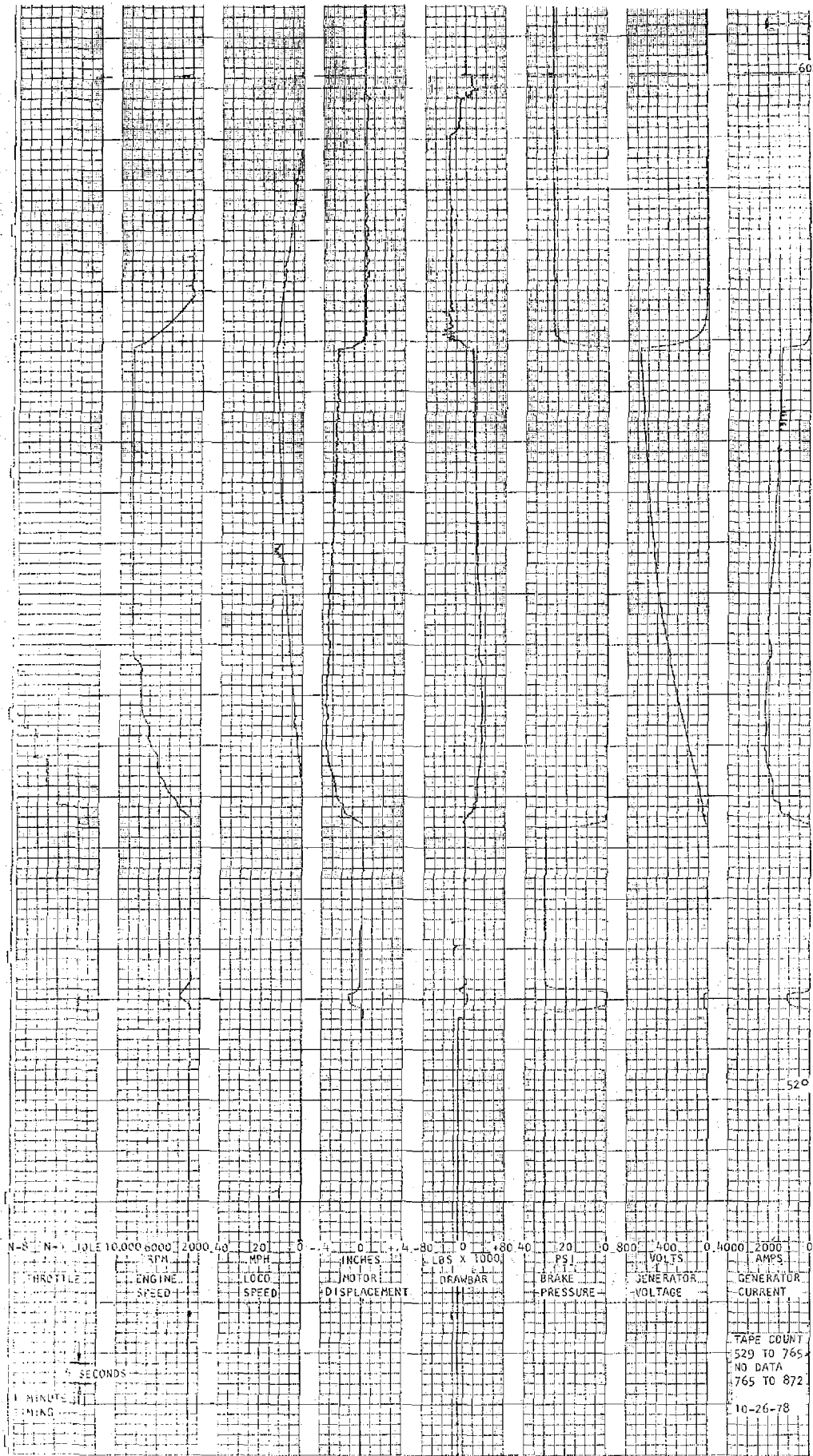

Figure 33. Data Roll No. 2



S 34276

Figure 34. Data Roll No. 3

SECTION 4

SYSTEM ANALYSIS

INTRODUCTION

The goal of the system analysis was to establish the most advantageous configuration using the two basic system elements defined in the contract SOW. These elements were the EMD SW1500 locomotive and the AiResearch ACT-? Energy Storage Unit (ESU). To define this superior configuration, a preliminary analysis identified four alternate concepts that were evaluated on a relative rather than absolute basis. The performance requirements of the system were identified concurrently with the preliminary analysis where subsequent, indepth analyses could be performed on a firm data base.

BASIC SYSTEM ELEMENTS

SW1500 Locomotive

The SW1500 locomotive has been manufactured by EMD since 1968 (see Figures 35 and 36). Another locomotive choice could have been the SW1000. This

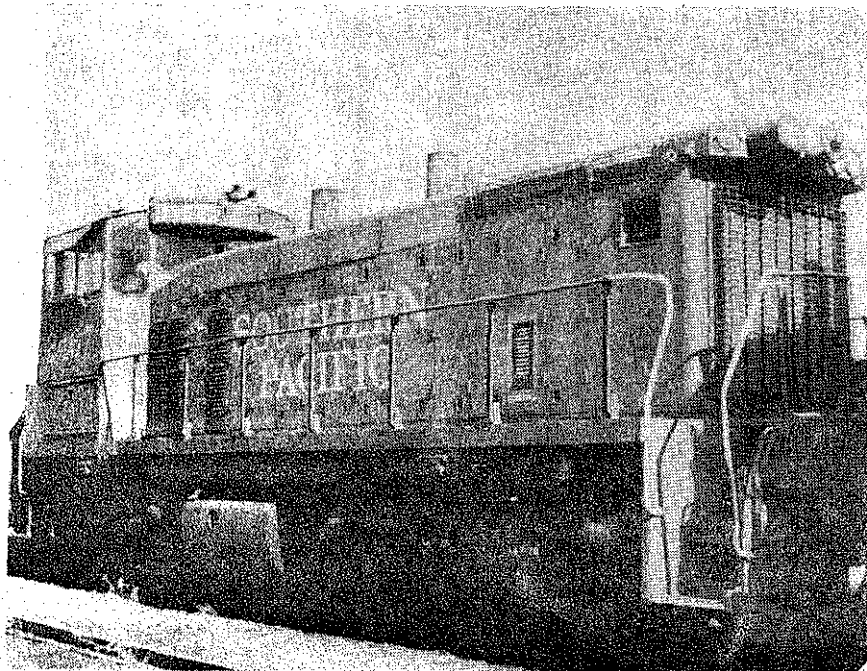

F-29051

Figure 35. SW1500 Locomotive

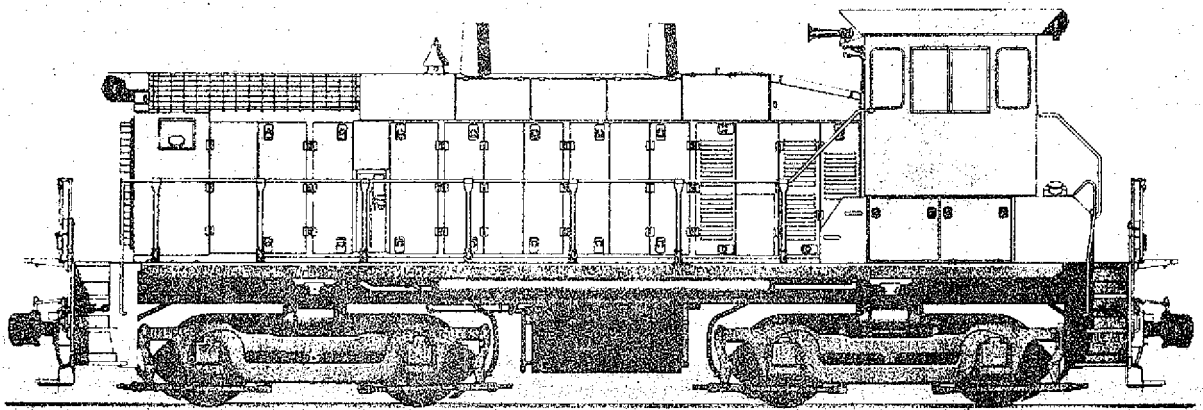

139 19

a. SIDE ELEVATION

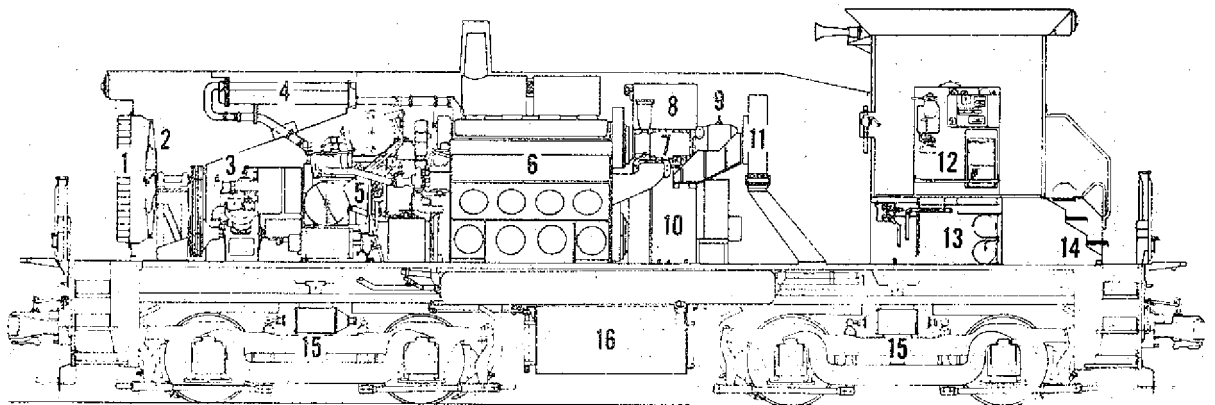

139 20

b. CROSS SECTION

- | | | |
|---------------------------------------|--------------------------------|---|
| 1. COOLING SYSTEM SHUTTERS | 6. 645E DIESEL ENGINE | 12. CONTROL CONSOLE |
| 2. FAN SHROUD AND SAND BOXES LOCATION | 7. ENGINE BLOWER | 13. AIR BRAKE EQUIPMENT AND ELECTRICAL SWITCHGEAR |
| 3. AIR COMPRESSOR | 8. ENGINE OIL BATH AIR FILTERS | 14. BATTERY BOX AND SAND BOXES |
| 4. RADIATORS | 9. AUXILIARY GENERATOR | 15. TRUCK |
| 5. EQUIPMENT RACK | 10. MAIN GENERATOR | 16. FUEL TANK |
| | 11. TRACTION MOTOR BLOWER | |

DATA AND ILLUSTRATIONS OBTAINED FROM
 SW1000-SW1500 OPERATOR'S MANUAL,
 2ND EDITION, GENERAL MOTORS CORPORATION,
 ELECTRO-MOTIVE DIVISION, SEPTEMBER 1968.

Figure 36. SW1500 Locomotive General Arrangement.

locomotive was introduced in 1966, and is also manufactured by EMD. The basic difference in the two locomotives is the engine size; the SW1000 has a smaller 1000 hp engine. In terms of broad principles, the system analysis described below is applicable to both locomotives. Only detail changes would be required to accommodate a model change.

Specific information on the SW1500 locomotive that is relevant to the study is contained in Table 9.

1. Diesel Engine

The engine performance characteristic published by EMD is shown in Figure 37. The brake horsepower is the total mechanical power output of the diesel engine and includes power to the main generator, auxiliary generator, air compressor, and radiator cooling fan. The traction horsepower is the input to the main generator. The specific fuel consumption curve relates to total engine power output, that is, the brake horsepower.

2. Main Generator

The main generator on the locomotive is a Model D32 manufactured by EMD. The generator is directly connected to the diesel engine by a flexible coupling. The engine rotates the generator to develop a rated 600 vdc output voltage at 1700 amp.

The generator is a multifield machine having the following windings:

- (a) Starting Winding--The starting winding is energized by the locomotive battery during engine start to motor the generator and crank the engine.
- (b) Interpole Winding--The interpole winding is provided to assist commutation of armature current.
- (c) Compensating Pole Face Winding--This winding provides compensation for armature reaction and maintains uniform air gap flux distribution.
- (d) Differential Winding--This winding is connected in series with the armature circuit to buck the main field. This produces a droop in output voltage with load current, and alters the generator characteristics so a relatively small change in separate excitation will provide control of generator output power.
- (e) Battery Field Winding--The battery field winding is a separately excited shunt field winding connected to the battery and auxiliary generator circuit. The battery field is controlled by the load regulator, which serves to maintain a constant horsepower demand on the engine for any ampere demand within the capability of the generator and load regulator.

TABLE 9

GENERAL DATA OF SW1500 LOCOMOTIVE

Data from Electro-Motive Division, General Motors Corporation, SW1000-SW1500 Operator's Manual, 2nd Edition, September, 1968.	
Wheels	
Arrangement	B - B
Diameter	40 in.
Diesel Engine	
Model	12645E
Power	1500 hp
Cylinder arrangement	45 deg v
Cylinder bore and stroke	9-1/10 in. x 10 in.
Maximum speed	900 rpm
Idling speed (standby)	330 rpm
Idling speed (working)	493 rpm
Main Generator	
Model	D32
Rating	1700 amp at 600 v
Output	Direct current
Voltage control	Field excitation
Traction Motors	
Model	D77
Type	Series field, self-excited
Continuous rating	850 #1 amp
Cooling airflow per motor	1400 cfm
Connection	Permanent series/parallel
Gear ratio	62:15
Maximum speed (armature limit)	71 mph
Locomotive Weight (maximum)	250,000 lb
Consumable supplies	
Sand	30 cu ft
Fuel, basic	600 U.S. gal
--extra	1100 U.S. gal

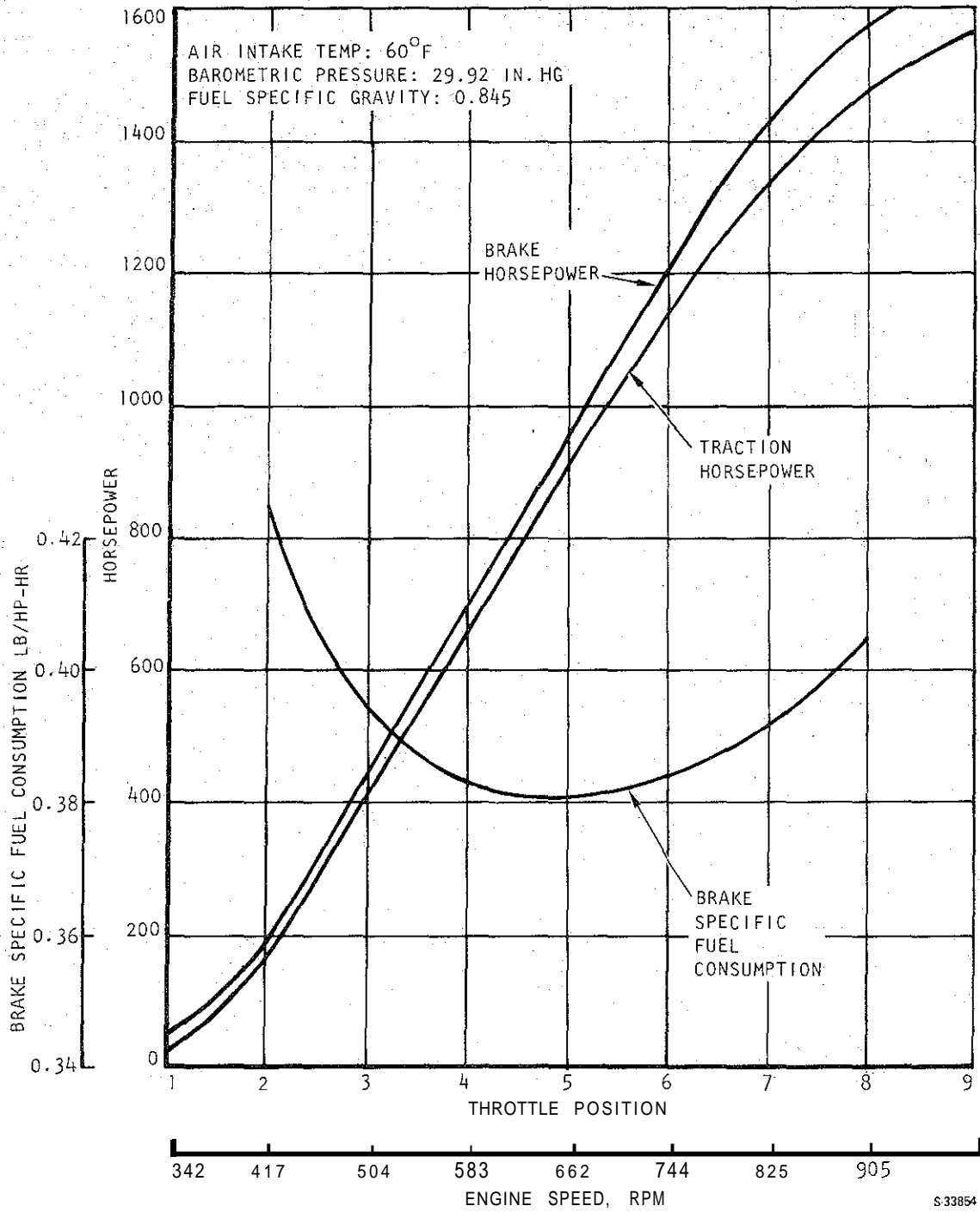

Figure 37. 12-645E Engine Performance (Data from General Motors Corporation, Electro-Motive Division, Curve SC2980, March 5, 1974)

(f) Shunt Field Winding--A small portion of generator output is fed back and used to excite the shunt field. This field is used to adjust generator characteristics in relation to the number and connection of motors powered by the generator.

Figure 38 shows the characteristics of a D32 generator which reflects the traction power available from the diesel engine between maximum current and maximum voltage limitations.

3. Traction Motors

The four traction motors are standard D77 models used on most BMD road and switching locomotives. D77 models are series field, self-excited traction motors. The characteristics of the motor used in the SW1500 locomotive are shown in Figure 39. As installed in the SW1500 locomotive, the traction motors are air cooled at 1400 cfm/motor at maximum engine speed from a single engine-driven blower, giving a continuous current rating of 850 amp. Short term ratings are given in Table 10.

TABLE 10

U77 TRACTION MOTOR RATINGS IN SW1500 LOCOMOTIVE

Duration	Current, Amp	Speed, mph
Continous	850	10.7
1 hr	890	9.8
30 min	965	8.7
15 min	1065	7.4

A more detailed description of the traction motor is given in Section 5 of this report.

4. Power and Control Circuits

The simplified power schematic in Figure 40 shows that the traction motors are connected in permanent series/parallel. This arrangement reduces the size of the generator required to supply the motors. For example, if the four traction motors were all connected in parallel, the generator would have to be capable of delivering 3400 amp at low locomotive speeds. If all traction motors were connected in series, a generator capability of 2200 v would be required at high speeds. Therefore, the series/parallel connection represents a compromise often made in diesel locomotive practice.

Power control is achieved by the load regulator, which is a plate-type rheostat driven by a hydraulically operated vane motor.

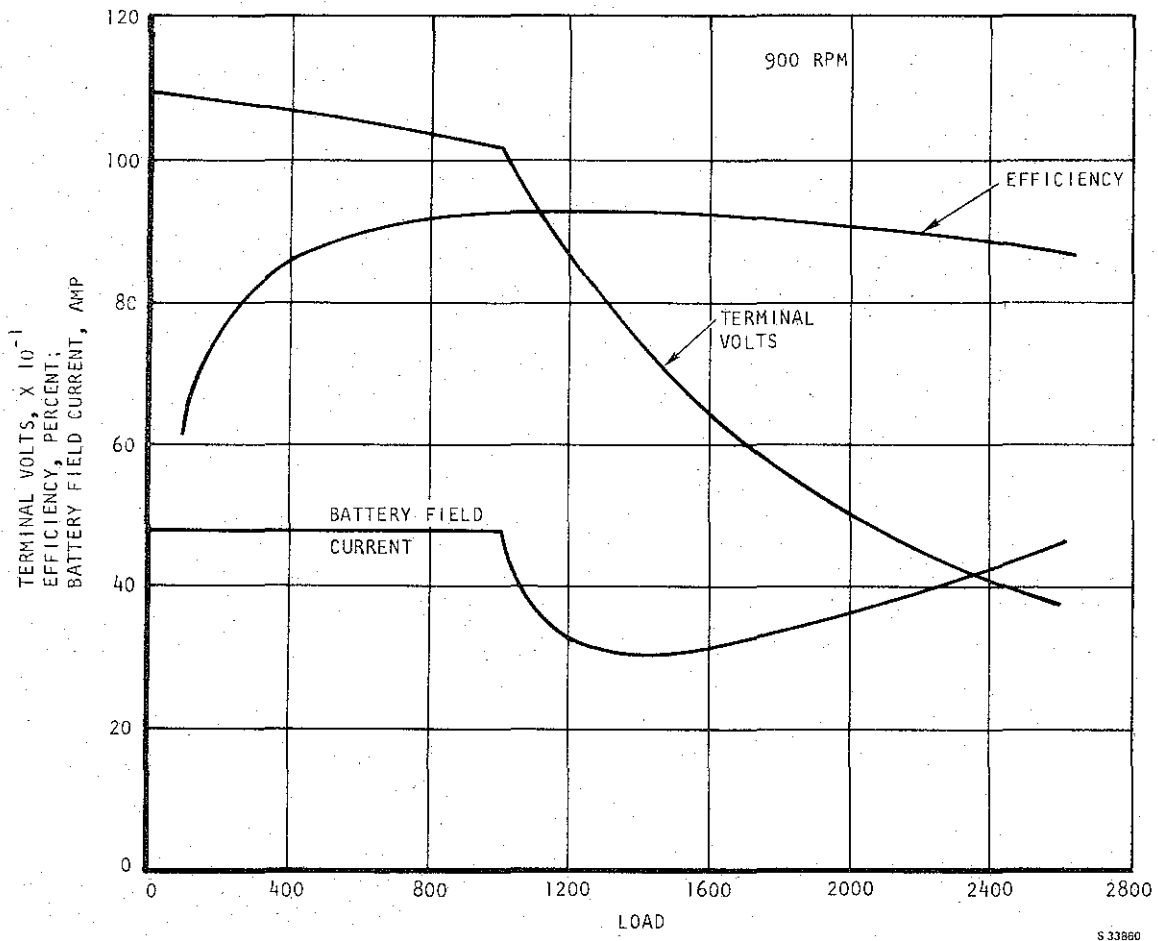

Figure 38. D32 Generator Characteristics (Data from Electro-Motive Division, General Motors Corporation, Curve 2689, October 25, 1978)

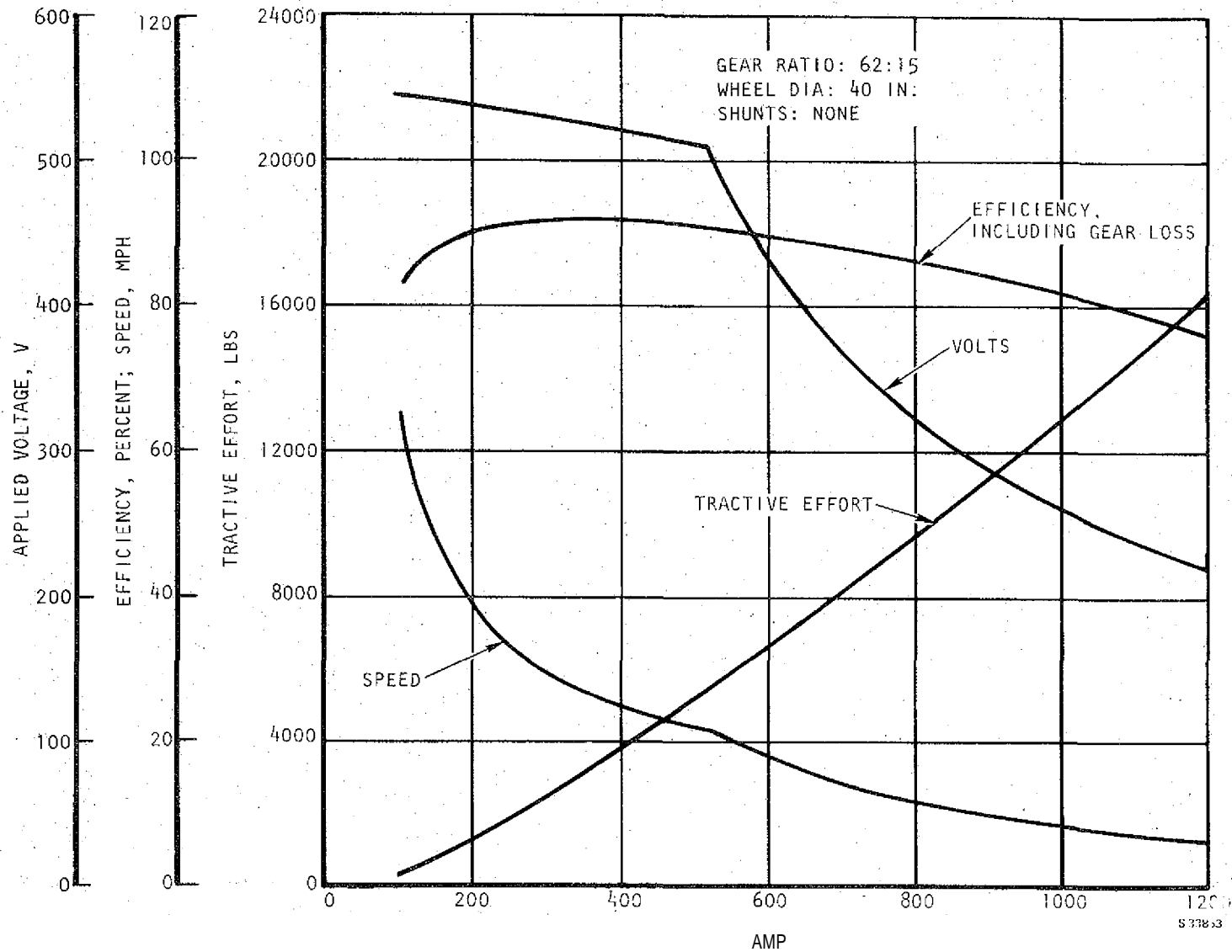
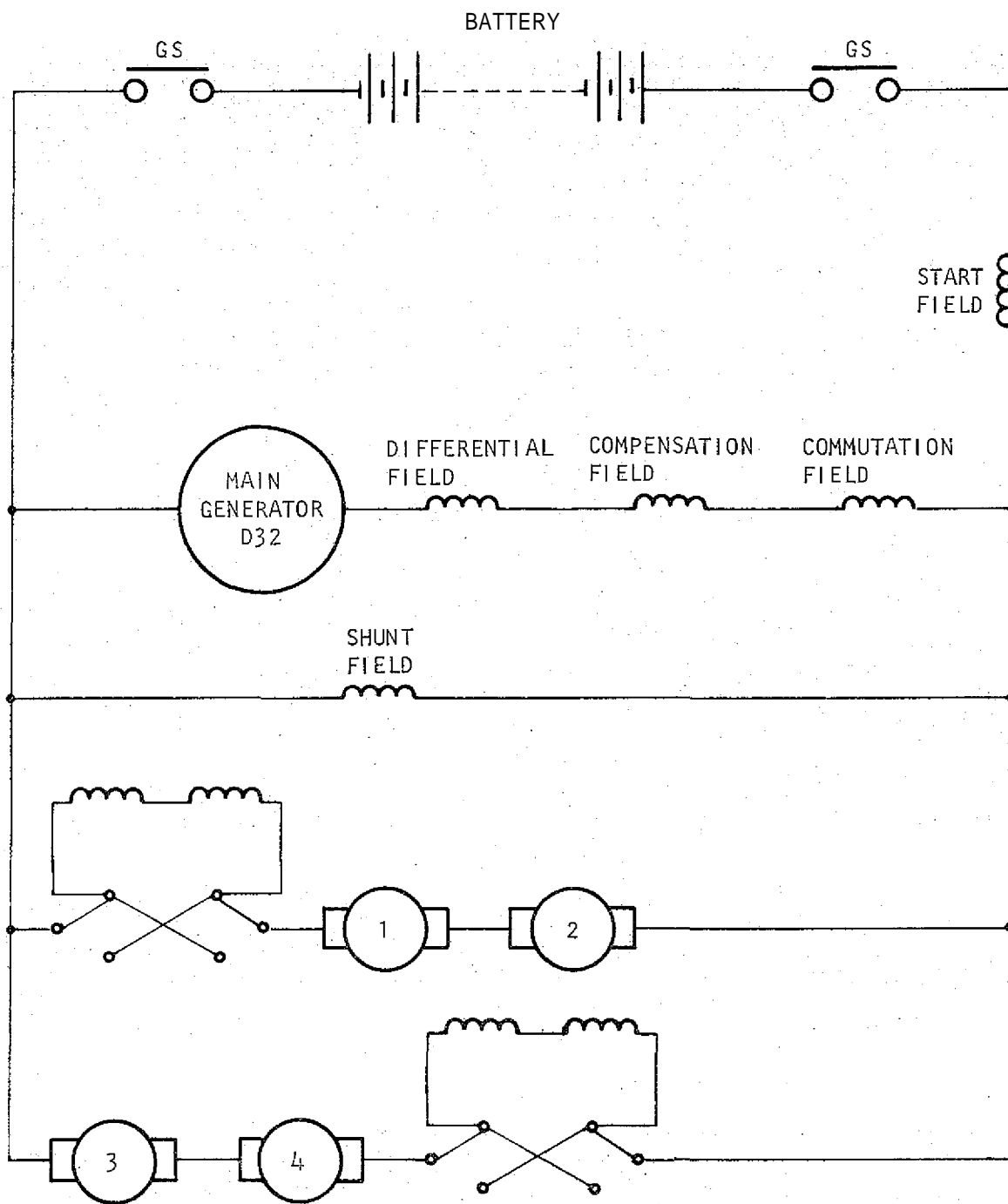

Figure 39. Characteristics of D77 Traction Motor at 260 kw (Data from General Motors Corporation, Electro-Motive Division, Curve SC2673, November 20, 1966)



S 33834

Figure 40. Simplified Schematic of SW1500 Locomotive

A pilot valve in the engine governor controls a flow of engine oil under pressure to drive the vane motor clockwise or counterclockwise, thereby positioning the rheostat brush arm and regulating the output of the main generator by varying excitation of the generator field. Control of generator field excitation results in control of the load on the engine. Load control on the engine (by the governor) permits the governor to maintain engine speed with regulation of power at the correct level for a given speed.

The pilot valve in conjunction with the load regulator requires the engine to assume a predetermined load for each throttle position by controlling the loading of the main generator through the battery field.

Engine speed is controlled using four control solenoids fed from relays controlled by the operator's throttle control. These feeds are trainlined, as shown in Table 11, to give multiple unit control of engines when required.

TABLE 11

ENGINE SPEED CONTROL TRAINLINES

Throttle Position	Throttle Relays Energized	Engine Speed	Trainlines Energized
Stop	D	-	3
1	None	315	None*
2	A	395	15
3	C	480	7
4	AC	560	15, 7
5	BCD	650	12, 7, 3
6	ABCD	735	15, 12, 7, 3
7	BC	815	12, 7
8	ABC	900	15, 12, 7

*None of the four "engine speed" trainlines.

5. Braking System

The SW1500 locomotive is equipped with a standard 26 NL-type air brake.

6. Wheel Spin/Slide Control

Wheel spin is detected by means of wheel spin relays connected in a bridge circuit around each pair of series-connected traction motors (Figure 41). In this circuit, differential wheel spin between a pair of axles is detected by the presence of sufficient differential voltage to pick up a wheel spin relay. When a wheel spin is detected, a wheel spin light is illuminated in the cab and a battery field contactor opened to reduce main generator excitation. Thus, locomotive power on all motors is reduced until sufficient adhesion is regained to reduce the spin, decrease the differential voltage, drop out the spin relay, reclose the battery field contactor, and restore locomotive power to the previous level of output.

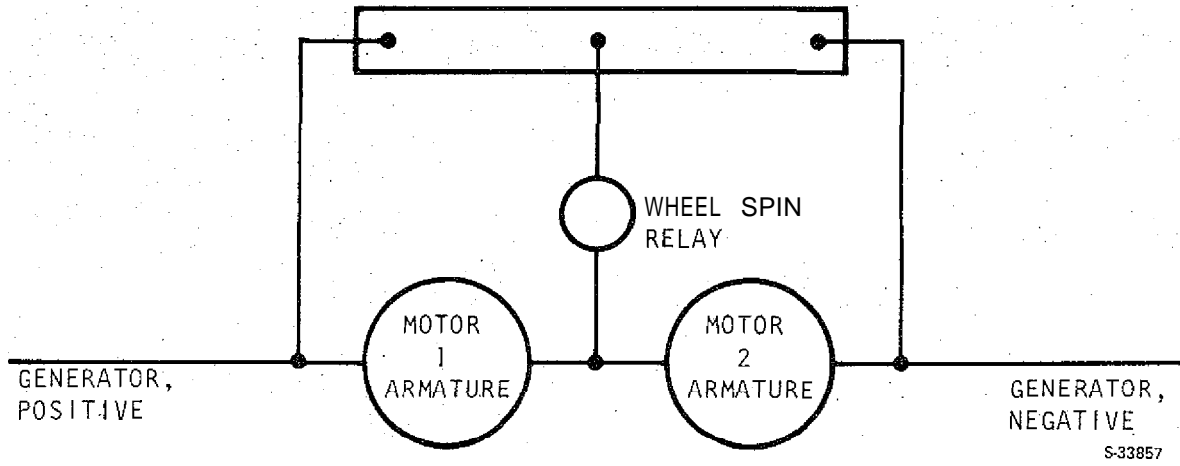

Figure 41. Wheel Spin Protection Circuit

In the event of synchronous spin of both axles on a truck, the wheel spin bridge circuits will not receive any differential voltage and the wheel spin relays will not pick up. However, when a synchronous spin condition develops on a single truck, the increase on motor speed will result in a current decrease in each of the spinning motors. The generator voltage and current will increase in the pair of nonspinning motors. The differential current between the motor pairs resulting from this condition will pick up a differential current relay. This relay performs the same functions as the differential voltage sensing relays, and results in the removal of all tractive effort until sufficient adhesion is regained to reduce the differential current below the dropout value of the differential current wheel spin relay.

Synchronous spin of all four axles on the locomotive is undetectable by the wheel spin bridge on differential current circuits, and no automatic protection is provided on the SW1500 locomotive for correction of this condition.

When wheel spin conditions are encountered, the engineer can use the sanding switch to apply sand which improves adhesion conditions, or if the locomotive is equipped with automatic sanding circuits, these circuits can apply sand when spin conditions are detected.

Wheel slide protection during friction braking is not provided. Although during the data gathering tasks it was noted that the friction brake forces were relatively low (approximately 35,000 lb for a 250,000-lb locomotive), the requirement for 14-percent adhesion does not result in an unacceptable number of slides.

ACT-1 ENERGY STORAGE UNIT (ESU)

The ESU in Figure 42 shows the ACT-1 energy storage unit as designed for the ACT-1 and NYCTA applications. This unit consists of a single ACT-1 type of flywheel assembly with its gearbox and electrical machine. This unit accepts the electrical energy transmitted from the traction motor during braking and stores it as mechanical energy in the form of a rotating mass. On demand, this mechanical energy is transformed back to electric power and delivered to the locomotive traction motors so the locomotive may be accelerated initially without the use of power from the diesel engine. Modifications to the ESU for the FESS application are described later.

The flywheel also provides direct mechanical drive to a large blower and an auxiliary alternator. The alternator is the prime source for the motor field power during normal operation.

Flywheel Energy Storage Capacity

There is an optimum range of energy storage capacity for the flywheels for rapid transit systems. This defines the storage capacity and not the FESS application to which the ESU is now being applied. This capacity is a function of the vehicle weight and the average velocity profile over which the vehicle will be operated. It was determined that a flywheel capacity of 4.5 kw-hr (12×10^6 ft-lb) was optimum for the ACT-1 unit.

Flywheel Assembly

The AiResearch flywheel design employs the laminated disc concept illustrated in Figure 43. The rotor uses a bearing and seal arrangement similar to that developed for the NYCTA R-32 car energy storage flywheel. The shaft provides a backbone for supporting the disc laminations. The laminations are installed with a thermal differential expansion to the shaft that results in a prestressed fit after assembly. Support plates are located at the rotor ends to act as a secondary bearing in the event of roller bearing failure.

Testing of the NYCTA and ACT-1 energy storage flywheels has produced data for system and component losses that have been used to derive improvements in component operation. A 50-percent improvement has been achieved on the first unit tested. An additional improvement of 20 percent from the present loss value also is expected.

The losses for the current ACT-1 design modified for the FESS application are summarized by component in Table 12.

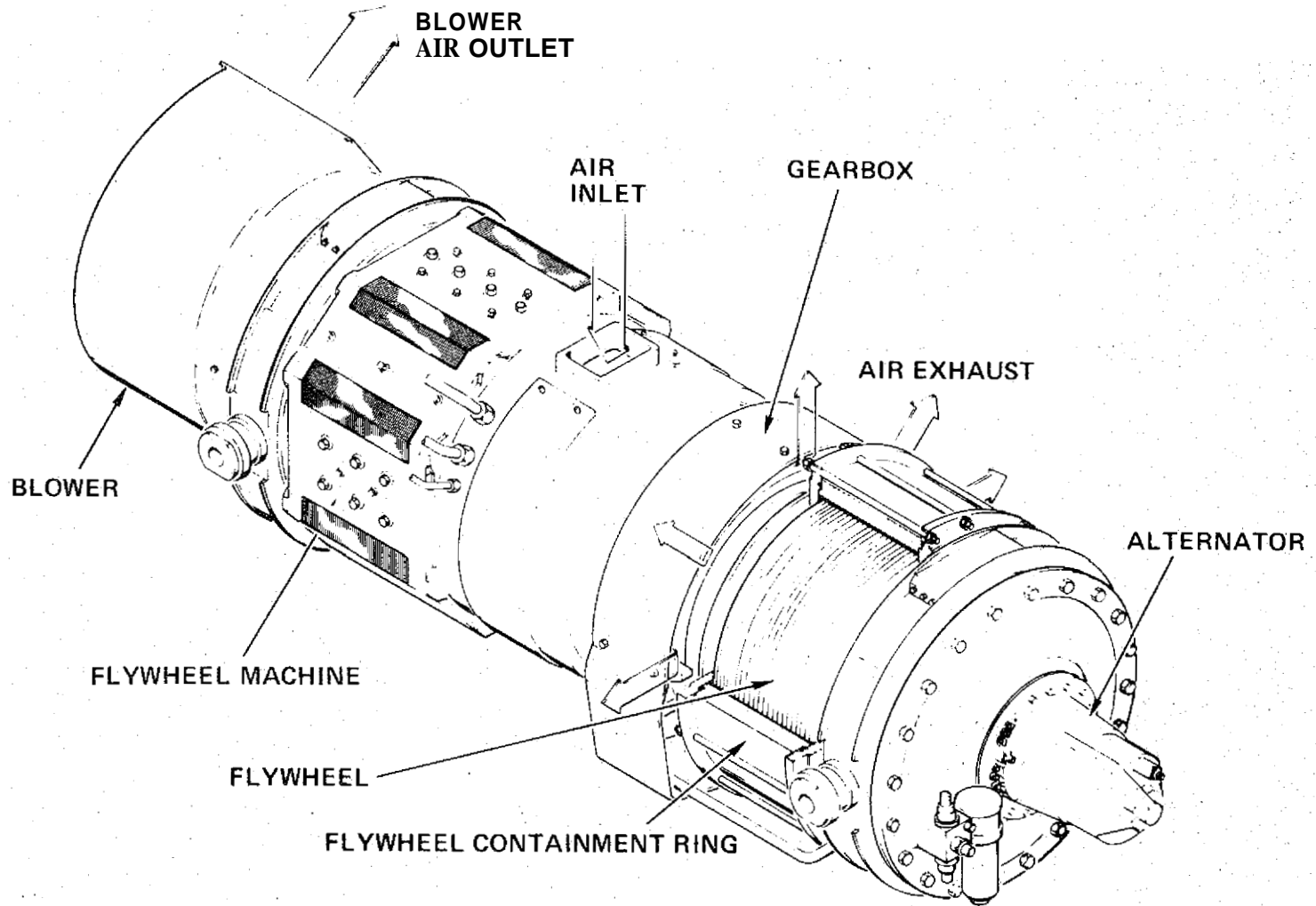

SPA5719-14

S-34143

Figure 42. Energy Storage Unit

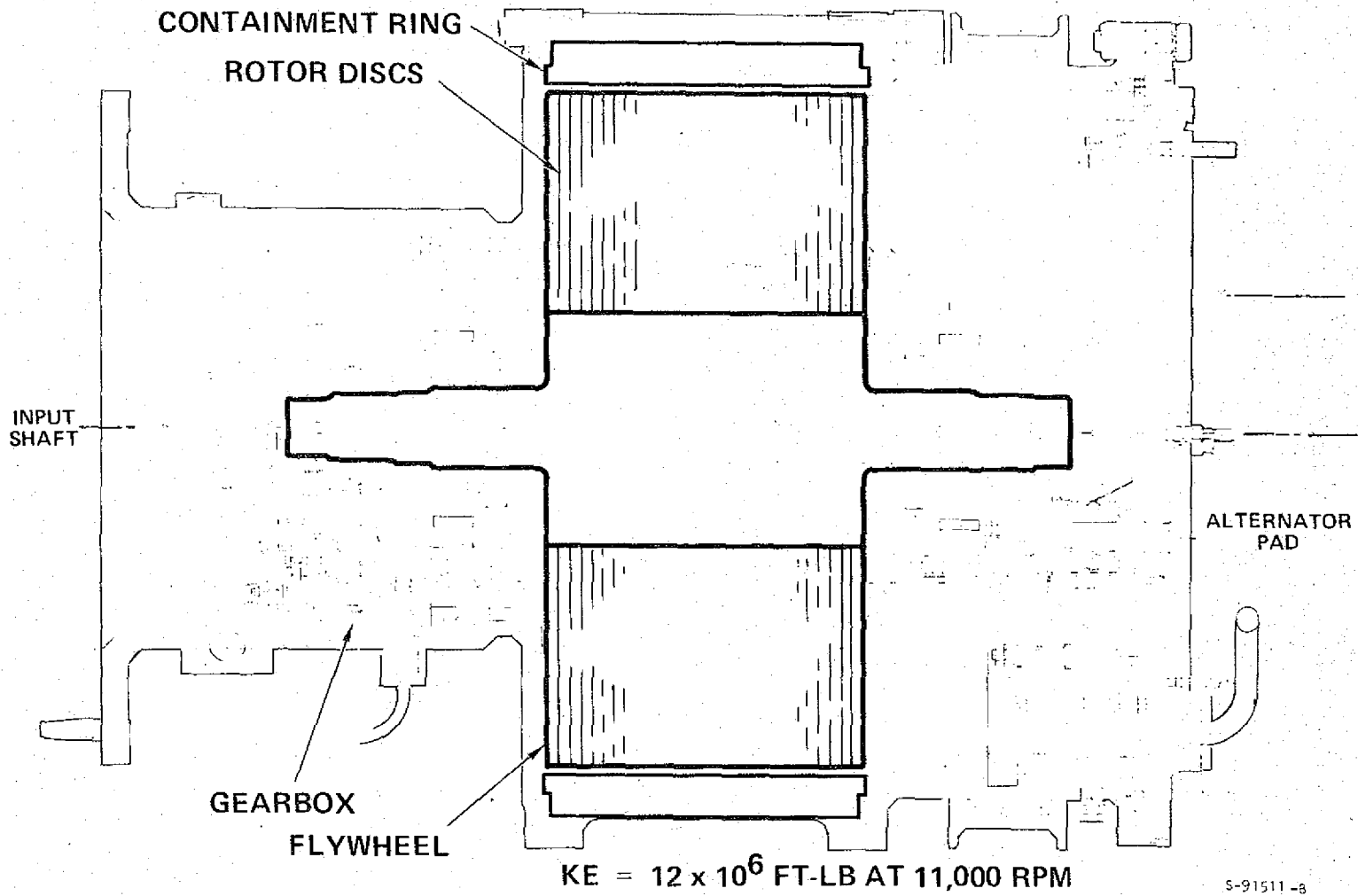

Figure 43. ACT-1 Flywheel Design

TABLE 12

ACT-1 ENERGY STORAGE FLYWHEEL SUMMARY OF LOSSES

Mechanical Losses at 100-percent rpm	Loss, hp
Windage, flywheel	2.0
Rotor bearings (2)	2.0
Rotor seals (2)	2.7
Planetary gears (no load)	0.5
Planetary bearing (6)	1.0
Lubrication and vacuum pump	1.7
Accessory gears	<u>0.3</u>
Total	9.7

1. Bearings

The flywheel rotor is supported by two roller bearings. The rings and rollers are made from 52100 steel, which provides adequate strength and hardness at the design operating temperatures. The roller bearings will be provided with thrust capability, eliminating the need for additional thrust ball bearings and thereby minimizing mechanical losses. The design objective is a 110,000-hr B-10 fatigue life for the bearings that provides a margin for any unforeseen loading or operation conditions.

Lateral thrust arising from acceleration, deceleration, or minor misalignment of the flywheel is reacted by flanges on one of the roller bearings with machined cages. The planetary gears transmitting the power between the motor and the flywheel are supported by roller bearings.

2. Seals

The two shaft seals are of conventional design, which is typical of many applications used at AiResearch for high-speed machinery. The seals are of the radial type with a hardened surface rotor that runs adjacent to the carbon face. A surface velocity of 190 ft/sec maximum is well within the operating regime of this type of seal. An operating life of greater than 25,000 hr is expected for this seal.

3. Gears

The flywheel drives the motor-generator through a planetary gear train at a gear ratio of 3 to 1. The gears are of the conventional spur-gear type and are designed to operate reliably for 25,000 hr.

4. Lubrication and Vacuum System

The lubrication system provides lubrication and cooling for bearings, seals, and gears. An air-to-oil heat exchanger removes the heat losses from the lube oil. The lubricant used is MIL-1-23699, which is a synthetic oil used in turbine engines operating under severe temperature and load conditions. This

system contains a filter and relief valve to provide properly conditioned oil to the various lubrication points. Lubrication of the bearings is performed by oil jets. The system is designed to minimize oil splash and reduce oil churning losses.

The lubrication and vacuum pump is similar to the pump used on the NYCTA and ACT-1 energy storage flywheels, but is removable while the ESU is on the car. The pump is made from two internal gear pumping elements and is typical of lubrication pumps used in aircraft jet engines and gas turbines. The expected life is a minimum of 25,000 hr.

5. Rotor Stresses

The shaft and the laminations are proportioned to take maximum advantage of the direction in which the centrifugal stress is applied. The shaft is stressed compressively by the discs and is lightly loaded from the centrifugal forces at maximum speeds. The resulting cyclic loads on the shaft surface are well below the fatigue limit for conventional materials.

The laminations are made from alloy steel formed by hot rolling from billets. The plate thickness is selected to provide optimum containment weight and resistance to buckling. The laminations are heat-treated to obtain a combination of maximum fatigue strength and ductility. Nondestructive testing of the laminations is enhanced by the thin plate design, which can be inspected ultrasonically. Overspeed testing of each disc will further evaluate material properties. AiResearch experience with these inspection methods has provided a high degree of product reliability in rotating machinery.

The laminations are the most highly stressed components in the rotor. The maximum disc stress with no central hole would be approximately one-half that of a disc with a center hole; however, no practical method exists to assemble a laminated disc of this configuration and to retain it in a rotor without introducing stress concentration effects such as tiebolt holes that would increase the local stress approximately to the levels in the disc with a central hole. In addition, a design of this type would not have the intrinsic rotor integrity provided by a large central shaft.

For the material selected, the maximum disc stress and corresponding average tangential stress must be limited to a level that will provide adequate margins of safety on yield and disc burst speed; however, the limiting criterion for a material exposed to many duty cycles of fluctuating stresses is fatigue strength. Assuming an 8-hr/day, 6-day/week utilization, the flywheel will experience 72,000 cycles during a 1-year period. The speed will range from 70 to 100 percent, therefore, half the full stress range is experienced during each cycle. If the maximum stress range experienced is reduced during a duty cycle, the fatigue life of the disc is increased. The stress range in the disc laminations is reduced by introducing a residual stress in the discs with a shrink fit on assembly. The shrink fit creates a residual tensile tangential stress and a residual compressive radial stress at the disc bore at zero speed. At operating speed, the shrink pressure and radial stress is nearly zero, and only the tangential stress remains at the bore. Using the effective Hencky-von Mises bore stress, the beneficial effect of the shrink fit on the disc bore

stress range is illustrated in Figure 44. The maximum stress range experienced by a disc with an 8-in. bore diameter, and a shrink fit designed to prevent separation of the disc from the shaft over the operating speed range, is approximately 15 percent of the stress range experienced by a similar disc with no shrink fit. To assess the effect on fatigue life, a constant-life or modified Goodman diagram should be used. Figure 45 is a modified Goodman diagram for AISI 4340 steel at an ultimate strength of 200 ksi.

The stresses introduced in the shaft due to rotational speed and shrink **fit** are much lower than those in the discs, and adequate life margins can be achieved with relative ease.

The cyclic bending stresses imposed on the shaft due to gyroscopic moments from the flywheel are relatively low for the design approach used by AiResearch because of the large shaft diameter and bearing span.

5. Rotor Dynamics

A critical speed analysis of the flywheel rotor shows that no rotor critical speeds occur in the operating speed range. The required effective bearing stiffness has been determined to position the first two rigid-body critical speeds below the minimum operating speed.

The effective bearing stiffness, damping, and bearing configuration is optimized to locate the critical speeds out of the operating speed range. This effective stiffness is achieved by introducing mechanically resilient bearing supports. AiResearch has found this approach highly successful in many rotating machinery applications, including the energy storage flywheel for NYCTA. The resilient mounts reduce the rotor-generator vibration and increase the tolerance to rotor unbalance.

7. Containment Shield

Under normal conditions, the stress level in the disc should eliminate the possibility of failure from static overload or fatigue; however, after all inspections and production screening processes are performed, manufacturing flaws that could grow to critical size during operation could exist.

The incorporation of a containment shield is, therefore, a requirement of the flywheel system. The shield is of forged steel, 1.5 in. thick.

The containment shield must be capable of protection against projectiles resulting from structural failure of the rotor that may occur during normal operation. A study made of various designs to determine the system weight of the respective designs showed that the prestressed-bore, laminated rotor with a lightweight containment shield resulted in the least system weight.

Safety Features

AiResearch has considered the safety aspects of the energy storage unit in a public transit vehicle. These considerations are carried through to the FESS application even though there is no passenger involvement. The safety

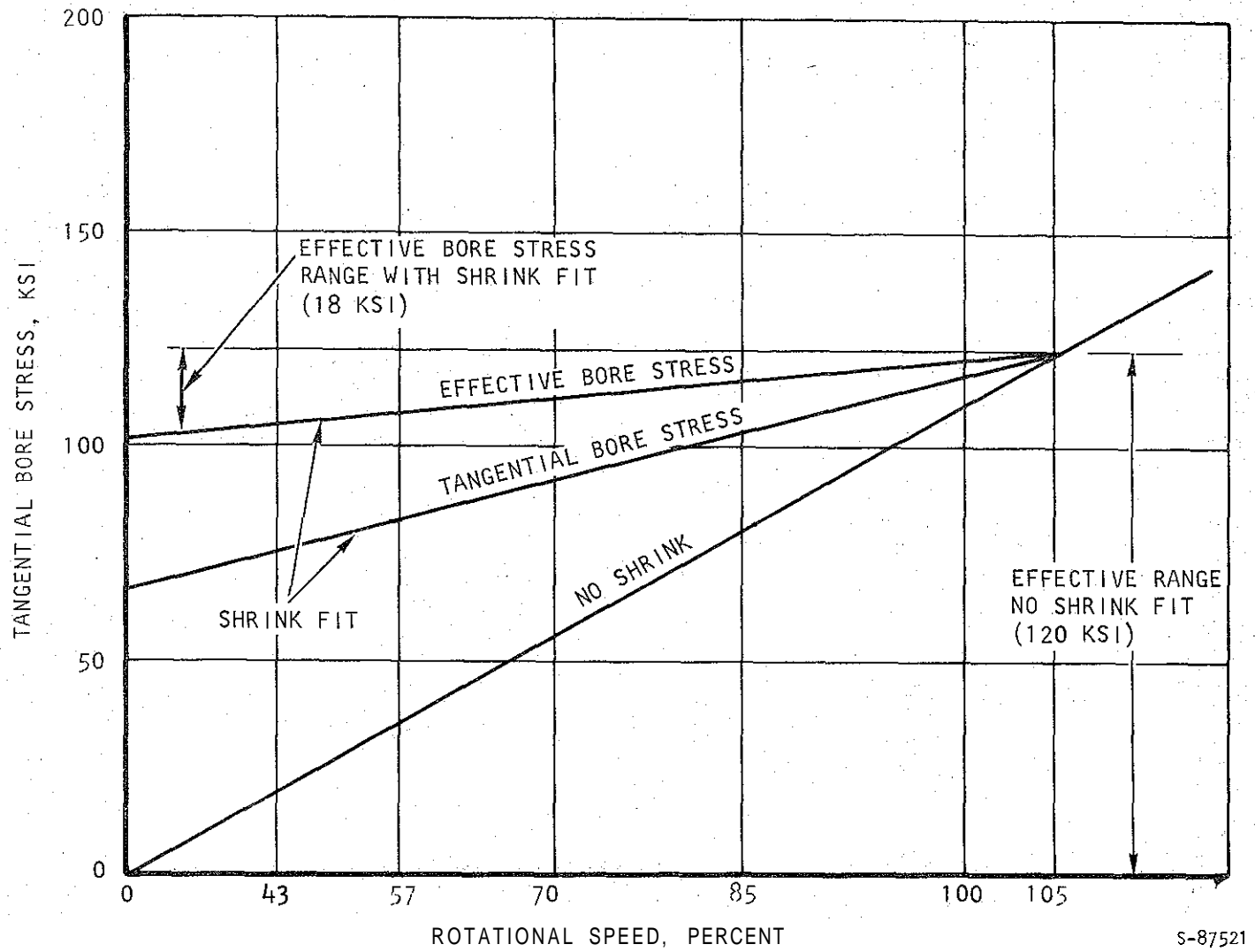

Figure 44. Disc Bore Stress Range, With and Without Shrink Fit

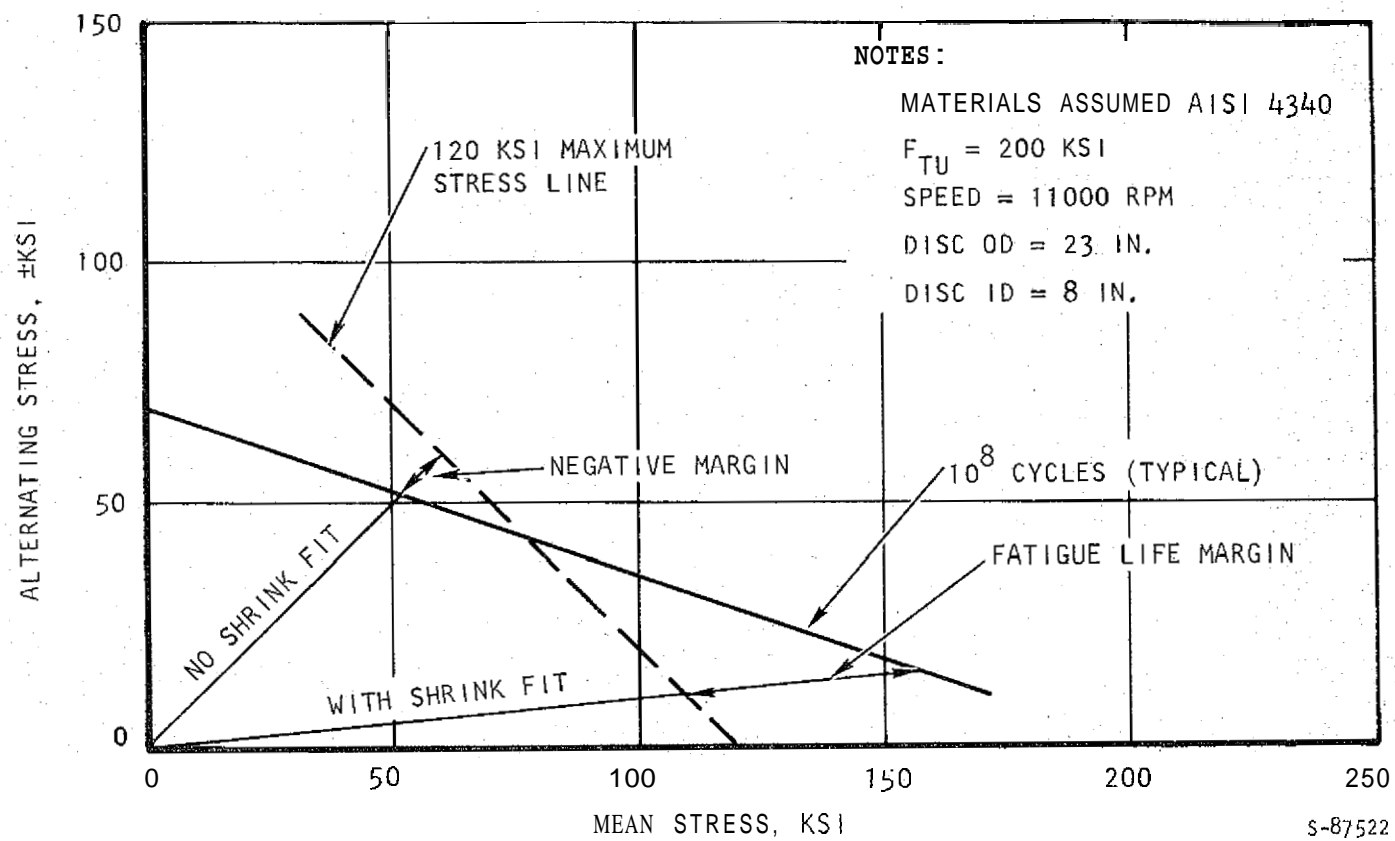

Figure 45. Modified Goodman Diagram Showing Benefits of Shrink Fit on Fatigue Life

aspects are summarized below. Although the energy storage unit stores a large amount of energy, it can be designed to be safe using the following conservative, achievable, low-risk design practices:

- Conservative design stress levels to ensure that no rotor failure occurs
- Identification of the most severe types of failure and analysis of their potential hazard
- Containment of the rotor for rotor failure, bearing failure, or accidental vehicle impact
- Elaborate inspection and test techniques to ensure proper material and fabrication quality
- Safety devices to prevent unsafe operation

AiResearch has designed, developed, and produced over 3.5 million pieces of high-speed rotating equipment, and most of them are used in man-rated vehicles. Each new design is subjected to extensive verification of design safety, including burst testing. AiResearch has accumulated a vast knowledge of the theory and test data that allows design safety optimization, including rotor containment, of a high-speed rotating device such as the energy storage unit.

The material selected for the flywheel is optimal (based on cyclic fatigue, high strength, and fracture toughness) and within the constraints of reasonable cost for material and fabrication. In addition, the multiple disc design is inherently safe because of the following considerations:

- Simultaneous fracture of all the discs is exceedingly remote; hence, only a small portion of the stored energy is dissipated in a burst.
- The flywheel cannot be oversped because the discs will lose their radial contact with the shaft, and thus the shaft will not transmit further torque to the discs.
- Failure of one disc will serve as a brake for the rotor, and the rest of the stored energy will be dissipated slowly as heat.
- The disc material has high ductility that allows the discs to creep rather than fracture in the event of rotor overheating.

The laminated flywheel design provides important safety features with respect to the possibility of a triaxial hub burst of the rotor caused by a defect that is normally undetectable during flywheel operation. The use of many stacked laminations limits the kinetic energy release to a minor fraction of the available kinetic energy in the complete flywheel. Particle containment is achieved through the use of a lightweight high-strength ductile housing material. Momentum transfer to the surrounding structure is limited to the translation and rotation caused by burst of the lamination. The triggering effect of the subsequent unbalance and shock can then employ a braking device

to decelerate the flywheel. The shock loads are limited to a value established by shear pins located in two girth rings that surround the propulsion unit. This arrangement prevents the main mounts from being loaded to failure in the event of rotor seizure.

Gyroscopic Effects

Although the flywheel possesses a relatively large angular momentum when spinning at its design speed of 11,000 rpm, the resultant gyroscopic forces will not have an adverse effect on car performance or flywheel component life.

Since the spin axis of the flywheel will be parallel to the longitudinal axis of the car, no gyroscopic moment will be developed by angular movement of the car about this axis (roll). Considering the case of car motion about the pitch axis (e.g., car front-end up, car rear-end down) and assuming that the ends of a 50-ft-long car are moving up and down at an amplitude of ± 6 in. at a frequency of 1 oscillation per second, it can be shown that a gyroscopic moment of 2654 lb-ft will be developed. This moment will increase the side loading on the four ESU mounts by 514 lb per mount, which is less than 30 percent of the load on the mounts from the ESU weight, and is well within design limits.

In the case of a car negotiating a turn of 145-ft radius at a speed of 33 mph, a vertical load of 685 lb will be developed at each mount. This load is approximately 40 percent of that due to ESU weight alone, and again is well within design limits particularly since speeds of this magnitude are not achieved within the switchyard.

Comparing these forces to the empty car weight of 50,000 lb and the maximum loaded weight of 123,000 lb, it can be seen that the gyroscopic forces do not present a problem.

Input-Output Machine

The following is a description of the input-output machine that is coupled to the flywheel.

1. Rating

The machine has a rating of 610 kw, 1200 v, 540 amp, 2730- to 3900-rpm range. The peak rating is 1020 kw, 1200 v, 900 amp as a motor; and 540 kw, 600 v, 900 amp as a generator.

2. Type of Machine

The input-output machine is a separately excited shunt with pole face winding to compensate the armature reaction. The frame is fully laminated to give good commutation under all steady-state and transient load conditions.

3. Insulation

The insulation of the armature and stator winding is Class 200. It consists of Kapton (polyimide film) insulated copper wire, with Kapton ground insulation in the armature and pole face winding, and mica paper insulation on shunt and interpole coils. The other insulation materials are glass tapes, either untreated or treated with high-temperature EI-staged resins. The armature is vacuum-pressure impregnated into solventless silicon resin; after partial curing, it is dipped into the same resin and then fully cured. The stator windings are impregnated and dipped in the same silicon resin and cured. After mounting and connecting the coils into the stator, the whole stator is dipped into a high-temperature polyester resin and cured. Nomex and flexible mica sheets are used on supports.

4. Armature

The armature consists of low-silicon steel laminations pressed on a solid shaft. End-support rings keep the laminations under uniform pressure. The commutator is of the ring-nut type, with a spring ring to give it elasticity in axial direction, and to prevent overstresses under all speed and temperature conditions. The slot wedges are machined from glass laminate impregnated with high-temperature polyester to prevent delamination of wedges. The end bands are made from parallel-filament (weftless) glass fibers held together by B-shaped resin. It is wound hot with a high preload over the end turns and then cured. The armature conductors are TIG-welded to the risers in such a fashion that the copper of the commutator bars is not overheated during the welding operation. After the resin treatment, the commutator is finish-turned and the copper bars are beveled.

5. Stator

The magnetic active portion of the stator is made up of octagonal-shaped laminations with the same axial length as the armature. End plates of the same shape are on the commutator end bell and other side; after pressing the stator stack, eight tiebars are welded between the two end plates to make a stator housing. The main pole seats, bearing fits, shield registers, brush-holder supports, etc., are machined concentric to each other to ensure a uniform air gap. The precise circumferential positioning of the main poles and interpoles is assured by recesses in the stator laminations into which the poles **fit**.

The shunt field windings are fitted to the main poles and then mounted into the stator. Then the interpole coils are mounted on the poles, the pole face winding is inserted in the pole face, and all the coils are connected to each other and to the motor leads.

6. Bearings and Seals

Roller bearings are used--the one on the commutator is locked against a shoulder with a locking ring; the other is floating. The seals are of the labyrinth type. The bearings and seals are lubricated with a suitable grease that will withstand all temperature conditions. No regreasing between overhauls will be necessary.

7. Brushes and Brushholders

The brushes will be of the split type with an elastic pad on top to distribute the spring pressure evenly and to dampen any vibrations. The brush springs will be of constant force over the whole useful brush length. The holders are mounted to insulated radial studs that are mounted to the brushholder lugs on the stator. Positioning of the brushholder lugs is from the pole recesses of the stator to ensure perfect neutral position.

8. Ventilation

The machine is ventilated with filtered air entering from the air inlet or the noncommutator side. This ensures a clean motor free of contamination, including carbon dust. The air is distributed by means of an inlet baffle, which gives the right amount of air to the stator and rotor. The rotor air distribution gives the optimum cooling to end turns, armature core, and under the commutator.

COMPUTER SIMULATION

Two computer programs were constructed: (1) a simulation of the standard SW1500 locomotive, and (2) a modified version that provides for energy storage and recovery. These programs have been used to generate various performance profiles under a wide range of operating conditions. The standard SW1500 simulator has been exercised in test profiles that have been directly compared with data taken during actual tests of an SW1500 in Atlanta. The results indicate a good overall representation by the model in both the ballistic sense and the fundamental electrical parameters, and also in fuel consumption calculations.

The models simulate the locomotive to a fine level of detail. The major parameters are provided as printout at 1-sec intervals (internal computation takes place at 0.1-sec intervals) and include such quantities as: acceleration, speed, drag force, total tractive effort, motor parameters (rotational speed, current, voltage, torque), main generator operation, diesel engine primary performance parameters (brake horsepower, rotational speed, fuel consumption) and others. The simulator for the standard SW1500 responds to an input profile of locomotive throttle notch setting vs time. Although not shown in the printouts provided here, considerably more detail internal to the programs can be accessed such as motor iron and copper losses, efficiency and gearbox losses, Davis drag components, etc.

The format of the digital programs of these models is arranged so they can be easily reconfigured to run 4-axle and 6-axle vehicles with the existing motor subroutines. Other motor designs may be substituted using the same motor subroutine format.

Series Motor Model

The standard SW1500 model functions are shown in general terms in the block diagram of Figure 46. The detailed printout includes parameters corresponding to those recorded during actual tests of the SW1500. Therefore, the model performance can be evaluated by direct comparison of time profiles of actual test data and overall fuel consumption for a given task.

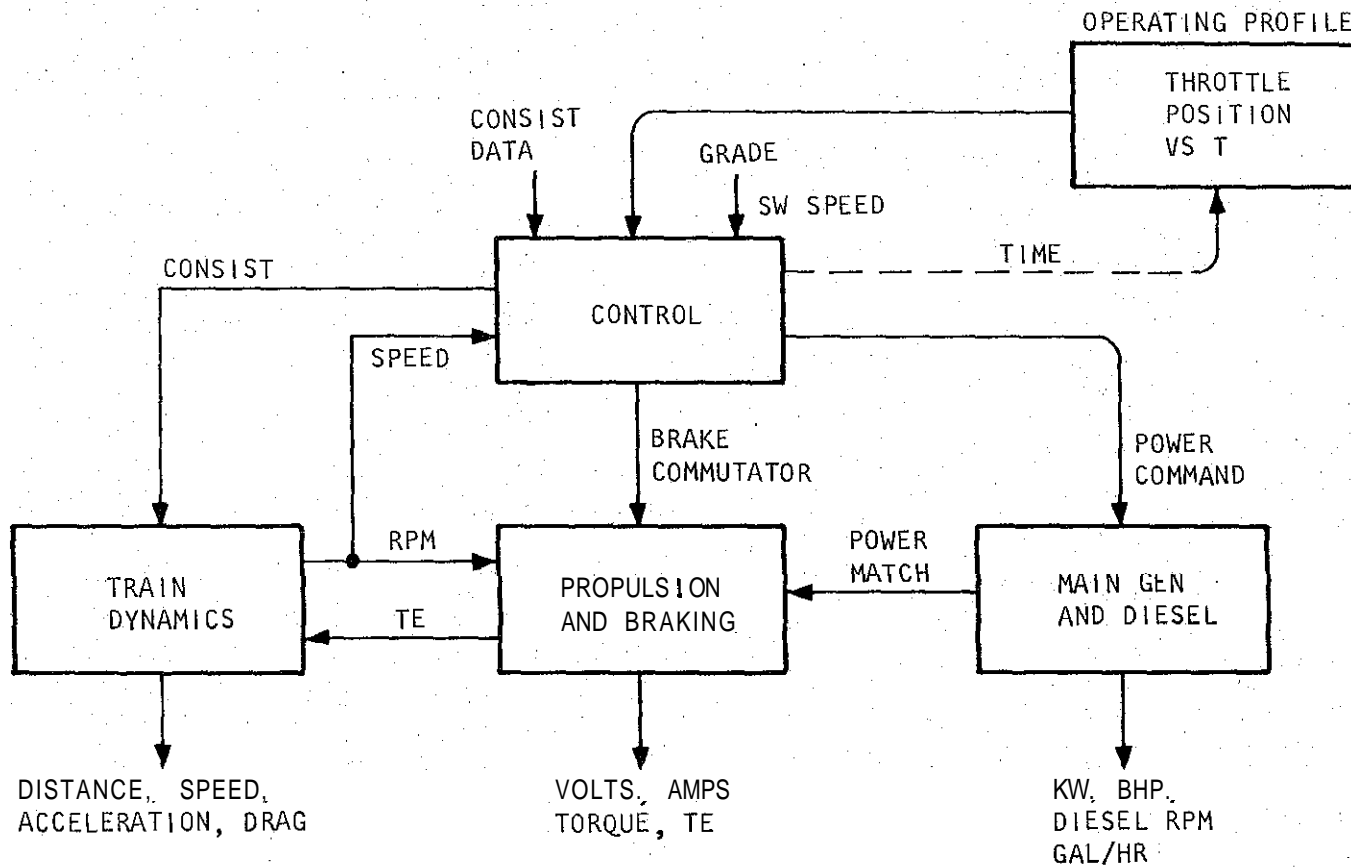

RUN SUMMARY DATA: TIME, DISTRIBUTION, KW-HR, GAL, RMS AMP

S-34173

Figure 46. Computer Model Standard SW1500

The input card deck for the model is straightforward in terms of train consist, locomotive gearbox ratio, motor operating temperature, throttle notch vs time profile, etc. The deck consists of nine data cards as shown in Figure 47, sheet 1 (bottom inset). The model can be run in a car kicking mode and in a cut fetching mode and can simulate a variety of operating conditions using the throttle notch profile as the variable input.

Examples of the model operating in fetch mode and switching mode are shown in the computer printout sheets of Figures 47 and 48, respectively. The first page of the printout reflects the input card deck so that the output performance data may be examined in proper context. To simplify the input deck structure, the characteristic data for traction motors, main generator, and diesel are stored as separate subroutines internal to the program. The simulator responds to the throttle notch vs time profile in the same way as the real locomotive does. Braking is initiated when throttle notch command is negative.

The model incorporates the major time constants of the machine. These include the rate of increase in engine speed for a change in throttle setting (which is dependent on the engine speed) and braking tractive effort ramp rate. Electrical transient data due to system inductance, resistance, and capacitance ratios are not simulated. The characteristic lags can be observed in the second-by-second printout vs throttle setting, and in the drive/brake transition. Currents and volts in the printout are per motor. Tractive effort (TE) as shown includes Davis drag, air brake, and traction motors output at the wheels (including gearbox and motor losses). The drag shown is Davis drag only, in pound-force at the wheels. The diesel engine rotational speed (DSL-RPM) and fuel consumption shown in Figures 47 and 48 reflect the road test data collected at Inman Yard, Atlanta, June 26 and 27, 1978.

The fetch mode printout of Figure 47 takes the model through an acceleration phase, then a short run at constant speed, and finally braking to a stop with locomotive brake, all on level track. The model also can accommodate coasting (engine idling and no brake) and the effects of grade. Figure 48 shows two cycles of a switching operation starting with 16 cars and kicking 2 at a time, ending with 12 cars.

The run summary in Figure 47, sheet 4, is self-explanatory and shows total time and distance, total fuel consumed, and rms current per motor. The final item in the printout is the statistical summary, which is generated in the same format as that used in summarizing the scenario tapes data reduction. This data may be combined into a daily operating composite, providing one method of comparison of daily yard operation. The summary for the switching example is similar. There are intermediate run summaries for each set of cars switched out and a trip summary. Usually, the printout would continue until all cars in the cut are switched out; the example in Figure 48 was terminated on a time limit for brevity.

>>>> SW 1500 (4 077'S SERIES-PARALLEL) AIR-BRAKING ONLY <<<<

05 JAN 79 08141132

	DRAG COEFFS		WEIGHT	LBS	# AXLES	# CARS
	K1=	K2=	VEHICLE	TOTNL	PER CAR	
LOCOMOTIVE >	.0300	.2880	24000.	20000.	4.	
FREIGHT CARS	.0450	.0450	10000.	10000.	4.	22.

LOCOM GR =62./15. WHEEL DIA=40.0 INCHES GEAR BX EFF = .970 TM TEMP =160. C

THROTTLE POSITION PROFILE ----

THRTL NOTCH =	2.	3.	5.	1.	-0.	-0.	-0.	-0.
TIME (SEC)=	.0	8.0	12.0	50.0	70.0	120.0	300.0	370.0

DIESEL RPM RAMP RATE = 21.0 RPM/SEC (ABOVE NX=4)
MAX BRAKE TE = -20000. LBS

BRK RAMP TIME = 3.0 SEC
BRK RELEASE = .8 MPH

SPEED (MPH)

START	KICK	GRADE	CARS/KICK
.0	.0	.0	0.

PGM CONTROL

DELTA T = .1000 SEC
 PRINT INTERVAL = 1.0000 SEC
 TIME LIMIT = 120.00 SEC
 PRINT LEVEL = 3. (ZERO IS MIN)
 DIAGNOSTIC START = .00 SEC
 DIAGNOSTIC INTERVAL = .000 SEC
 LOOP CNTR = 0 (PRNT IF = 1)

RUN DECK (9 data Cards)

*RUN WTC-3400-25047b-703-0100,177,2
 *ASG-A WTC-02.
 *ASG-T 3.
 *XGT WTC-02,LCMIS/2R

```
>>>> SW 1500 ( 4 077'S SERIES-PARALLEL AIR-BRAKING ONLY <<<<
.030 .288 24000. 20000. 4.
.045 .045 10000. 10000. 4. 22.
62. 40. .97 160.
2. 3. 5. 1. -.01 -.01 -.01
0. 8.0 12.0 50. 70. 120. 300. 370.
21. -20000. 3. 0.8
0. -.01
0.1 1.0 129. 3.
```

Figure 47. SW1500 Simulator Output, Patch Mode (Sheet 1 of 4)

T (SEC)	MPH	FEET	MPH/SEC	TELE (PS)	DRAG	T/W/MTR	PPH	AMPS	VOLTS	GEAKW	HPP	DSL-PPH	GAL/HR	T-NO	SAND
0.00	0.0	0.0	0.000	0.0	-2670.0	0.0	0.0	10.0	0.0	0.0	20.0	300.0	0.00	0.	
1.00	0.2	0.1	0.254	33248.3	-4386.6	1911.2	7.9	799.8	36.0	115.12	187.7	336.0	12.66	2.	
2.00	0.5	0.7	0.263	34401.3	-4401.5	4032.6	16.8	820.9	43.1	141.58	236.2	376.0	16.78	2.	
3.00	0.7	1.0	0.252	32760.7	-4417.0	7463.7	25.9	791.5	48.5	153.39	254.3	390.6	18.12	2.	
4.00	1.0	2.8	0.229	29666.0	-4431.3	3545.6	34.3	735.3	52.1	153.24	253.8	390.0	18.10	2.	
5.00	1.2	4.4	0.209	27169.2	-4444.5	3285.4	41.9	689.6	55.5	153.04	253.3	390.0	18.07	2.	
6.00	1.4	6.4	0.193	25031.1	-4456.7	3044.5	48.9	653.2	58.5	152.93	252.9	390.0	18.05	2.	
7.00	1.6	8.5	0.179	23269.0	-4468.0	2882.6	55.4	622.5	61.4	152.85	252.7	390.0	18.04	2.	
8.00	1.8	11.0	0.168	21785.7	-4478.7	2729.5	61.4	596.2	64.1	152.78	252.5	390.0	18.03	2.	
9.00	1.9	13.8	0.173	22658.3	-4489.2	2821.3	67.3	612.0	68.9	168.57	277.1	428.0	19.31	3.	
10.00	2.1	16.7	0.180	23448.1	-4500.2	2944.5	73.4	626.2	73.8	184.76	302.1	465.0	20.65	3.	
11.00	2.3	20.0	0.171	22264.9	-4511.3	2776.5	79.6	604.3	76.6	185.20	302.7	465.0	20.69	3.	
12.00	2.5	23.4	0.162	21062.8	-4521.4	2658.9	85.3	583.9	79.3	185.16	302.5	465.0	20.68	3.	
13.00	2.6	27.2	0.172	22555.1	-4532.4	2815.0	91.1	611.0	84.7	207.11	336.0	486.0	23.05	5.	
14.00	2.8	31.1	0.183	23979.3	-4543.7	2964.2	97.3	636.3	90.5	230.27	370.8	567.0	25.50	5.	
15.00	3.0	35.4	0.193	25245.9	-4555.9	3097.1	103.8	658.6	96.3	253.74	405.4	528.0	27.95	5.	
16.00	3.2	39.9	0.202	26375.7	-4568.7	3215.9	110.6	678.3	102.3	277.52	439.8	549.0	30.39	5.	
17.00	3.4	44.7	0.225	29538.0	-4582.6	3546.0	118.0	735.4	110.7	325.66	512.9	570.0	34.07	5.	
18.00	3.6	49.9	0.248	32427.7	-4598.2	3847.9	126.2	788.7	119.3	376.42	590.2	591.0	37.96	5.	
19.00	3.9	55.4	0.266	34856.5	-4615.3	4102.1	135.1	832.9	126.0	426.59	667.6	612.0	41.86	5.	
20.00	4.2	61.3	0.282	36876.5	-4633.8	4313.9	144.6	869.2	136.9	475.89	744.8	633.0	45.74	5.	
21.00	4.4	67.6	0.274	35642.0	-4652.9	4187.6	154.3	847.6	142.6	483.54	754.6	635.0	46.23	5.	
22.00	4.7	74.3	0.282	34111.0	-4671.3	4030.4	163.6	820.5	147.7	484.74	754.4	635.0	46.21	5.	
23.00	5.0	81.4	0.251	32735.5	-4689.2	3889.3	172.6	796.0	152.6	485.79	754.3	635.0	46.20	5.	
24.00	5.2	88.9	0.241	31434.1	-4706.6	3755.9	181.1	772.6	157.2	485.83	754.1	635.0	46.19	5.	
25.00	5.5	96.7	0.232	30255.3	-4723.4	3635.1	189.4	751.2	161.7	485.85	753.8	635.0	46.18	5.	
26.00	5.7	104.9	0.224	29182.6	-4739.7	3525.3	197.3	731.7	166.0	485.87	753.6	635.0	46.17	5.	
27.00	5.9	113.4	0.217	28261.8	-4755.6	3425.1	205.0	713.7	170.2	485.89	753.4	635.0	46.16	5.	
28.00	6.1	122.2	0.210	27287.6	-4771.0	3331.7	212.4	697.2	174.2	485.76	753.0	635.0	46.14	5.	
29.00	6.3	131.3	0.203	26435.3	-4786.1	3244.7	219.6	683.0	177.6	485.76	752.8	635.0	46.13	5.	
30.00	6.5	140.7	0.197	25649.2	-4800.9	3164.5	226.5	669.8	181.3	485.78	752.6	635.0	46.12	5.	
31.00	6.7	150.4	0.191	24920.1	-4815.3	3090.2	233.3	657.5	184.7	485.60	752.5	635.0	46.12	5.	
32.00	6.9	160.4	0.186	24241.3	-4829.4	3021.1	239.8	645.9	188.0	485.82	752.4	635.0	46.11	5.	
33.00	7.1	170.7	0.181	23607.3	-4843.2	2956.7	246.2	635.1	191.3	485.84	752.3	635.0	46.11	5.	
34.00	7.3	181.2	0.177	23013.4	-4856.7	2896.4	252.4	624.9	194.4	485.87	752.2	635.0	46.10	5.	
35.00	7.4	192.0	0.172	22455.5	-4870.0	2839.8	258.5	615.2	197.5	485.89	752.1	635.0	46.10	5.	
36.00	7.6	203.1	0.168	21930.2	-4883.0	2786.5	264.4	606.1	200.4	485.91	752.0	635.0	46.09	5.	
37.00	7.8	214.3	0.164	21434.4	-4895.8	2736.3	270.2	597.4	203.4	485.94	751.9	635.0	46.09	5.	
38.00	7.9	225.9	0.161	20965.4	-4908.4	2688.9	275.9	589.2	206.2	485.96	751.8	635.0	46.09	5.	
39.00	8.1	237.6	0.157	20521.0	-4920.8	2644.0	281.4	581.3	209.0	485.98	751.8	635.0	46.08	5.	
40.00	8.3	249.6	0.154	20098.9	-4932.9	2601.4	286.8	573.8	211.7	486.01	751.7	635.0	46.08	5.	
41.00	8.4	261.9	0.151	19697.5	-4944.9	2560.9	292.1	566.7	214.4	486.03	751.6	635.0	46.08	5.	
42.00	8.6	274.3	0.148	19315.0	-4956.7	2522.4	297.3	559.9	217.0	486.05	751.6	635.0	46.07	5.	
43.00	8.7	287.0	0.145	18949.5	-4968.4	2485.7	302.5	553.3	219.6	486.07	751.5	635.0	46.07	5.	
44.00	8.9	299.8	0.143	18599.5	-4979.9	2450.5	307.5	547.1	222.1	486.10	751.5	635.0	46.07	5.	
45.00	9.0	312.9	0.140	18264.7	-4991.2	2416.8	312.4	541.1	224.6	486.12	751.4	635.0	46.07	5.	
46.00	9.1	326.2	0.138	17943.9	-5002.4	2384.7	317.2	535.3	227.0	486.14	751.4	635.0	46.06	5.	
47.00	9.3	339.7	0.135	17636.3	-5013.4	2353.9	321.9	529.7	229.4	486.16	751.3	635.0	46.06	5.	
48.00	9.4	353.4	0.133	17340.9	-5024.3	2324.3	326.6	524.4	231.8	486.18	751.3	635.0	46.06	5.	
49.00	9.5	367.3	0.131	17057.0	-5035.0	2295.9	331.2	519.2	234.1	486.20	751.2	635.0	46.06	5.	
50.00	9.7	381.4	0.129	16783.8	-5045.6	2268.6	335.7	514.3	236.4	486.22	751.2	635.0	46.06	5.	
51.00	9.8	395.6	0.036	4157.6	-5053.1	957.2	338.9	284.3	181.0	205.78	346.7	488.8	23.80	1.	
52.00	9.8	410.0	-0.004	-842.6	-5054.4	437.7	339.4	186.0	130.2	96.90	172.5	326.3	11.62	1.	
53.00	9.8	424.3	-0.012	-1540.2	-5053.5	365.1	339.0	170.4	119.8	81.67	150.0	310.0	9.80	1.	
54.00	9.7	438.6	-0.012	-1534.6	-5052.5	365.6	338.6	170.5	119.7	81.68	150.0	310.0	9.80	1.	
55.00	9.7	452.9	-0.012	-1529.1	-5051.6	366.1	338.2	170.6	119.7	81.68	150.0	310.0	9.80	1.	

Figure 47. Continued (Sheet 2 of 4)

T (SEC)	MPH	FEET	MPH/SEC	TE (L/S)	DRAG	TQ/MPH	RPM	AMPS	VOLTS	GEN KW	HPP	OSL-RPM	GAL/HR	T-INCH	SAND
55.10	9.7	454.3	-.012	-1528.5	-5051.5	366.1	336.2	170.7	119.7	81.69	150.0	310.0	9.80	1.	
56.00	9.7	467.2	-.012	-1523.5	-5050.6	366.5	337.8	170.8	119.6	81.69	150.0	310.0	9.80	1.	
57.00	9.7	481.4	-.012	-1518.0	-5049.7	367.0	337.4	170.9	119.5	81.70	150.0	310.0	9.80	1.	
58.00	9.7	495.7	-.012	-1512.5	-5048.7	367.5	337.0	171.0	119.5	81.70	150.0	310.0	9.80	1.	
59.00	9.7	509.9	-.012	-1507.0	-5047.8	368.0	336.6	171.1	119.4	81.71	150.0	310.0	9.80	1.	
60.00	9.7	524.1	-.012	-1501.5	-5046.8	368.4	336.2	171.2	119.3	81.72	150.0	310.0	9.80	1.	
61.00	9.7	538.3	-.011	-1496.0	-5045.9	368.9	335.8	171.3	119.3	81.72	150.0	310.0	9.80	1.	
62.00	9.7	552.4	-.011	-1490.5	-5044.9	369.4	335.4	171.4	119.2	81.73	150.0	310.0	9.80	1.	
63.00	9.6	566.6	-.011	-1485.1	-5044.0	369.9	335.0	171.5	119.2	81.73	150.0	310.0	9.80	1.	
64.00	9.6	580.7	-.011	-1479.6	-5043.1	370.3	334.6	171.6	119.1	81.74	150.0	310.0	9.80	1.	
65.00	9.6	594.9	-.011	-1474.2	-5042.1	370.8	334.2	171.7	119.0	81.75	150.0	310.0	9.80	1.	
66.00	9.6	609.0	-.011	-1468.7	-5041.2	371.3	333.8	171.8	119.0	81.75	150.0	310.0	9.80	1.	
67.00	9.6	623.0	-.011	-1463.3	-5040.3	371.7	333.4	171.9	118.9	81.76	150.0	310.0	9.80	1.	
68.00	9.6	637.1	-.011	-1457.9	-5039.4	372.2	333.1	172.0	118.8	81.76	150.0	310.0	9.80	1.	
69.00	9.6	651.2	-.011	-1452.5	-5038.5	372.7	332.7	172.1	118.8	81.77	150.0	310.0	9.80	1.	
70.00	9.6	665.2	-.011	-1447.1	-5037.6	373.1	332.3	172.2	118.7	81.78	150.0	310.0	9.80	1.	
71.00	9.5	679.2	-.040	-5232.5	-5036.0	-20.4	331.6	10.0	8.5	.34	21.6	302.0	4.07	-0.	
72.00	9.5	693.2	-.040	-5229.1	-5032.8	-20.4	330.2	10.0	8.5	.34	21.6	302.0	4.07	-0.	
73.00	9.4	707.1	-.089	-11890.6	-5027.8	-20.4	328.1	10.0	8.4	.34	21.6	302.0	4.07	-0.	
74.00	9.3	720.9	-.140	-18547.9	-5018.8	-20.3	324.3	10.0	8.4	.33	21.6	302.0	4.07	-0.	
75.00	9.2	734.5	-.191	-25200.9	-5005.6	-20.3	318.6	10.0	8.3	.33	21.5	302.0	4.07	-0.	
76.00	9.0	747.8	-.193	-25184.7	-4990.1	-20.2	311.9	10.0	8.1	.32	21.5	302.0	4.07	-0.	
77.00	8.9	760.8	-.193	-25168.5	-4974.7	-20.1	305.2	10.0	8.0	.32	21.5	302.0	4.07	-0.	
78.00	8.6	773.6	-.193	-25152.6	-4959.4	-20.1	298.5	10.0	7.9	.31	21.5	302.0	4.07	-0.	
79.00	8.4	786.0	-.193	-25137.4	-4944.2	-20.1	291.8	10.0	7.7	.31	21.4	302.0	4.06	-0.	
80.00	8.2	798.2	-.193	-25122.3	-4929.1	-20.1	285.1	10.0	7.6	.30	21.4	302.0	4.06	-0.	
81.00	8.0	810.1	-.192	-25107.2	-4914.1	-20.1	278.4	10.0	7.5	.30	21.4	302.0	4.06	-0.	
82.00	7.8	821.7	-.192	-25092.4	-4899.2	-20.1	271.7	10.0	7.3	.29	21.4	302.0	4.06	-0.	
83.00	7.6	833.0	-.192	-25077.6	-4884.4	-20.1	265.1	10.0	7.2	.29	21.3	302.0	4.06	-0.	
84.00	7.4	844.1	-.192	-25062.9	-4869.7	-20.1	258.4	10.0	7.1	.28	21.3	302.0	4.06	-0.	
85.00	7.2	854.9	-.192	-25048.3	-4855.1	-20.1	251.7	10.0	6.9	.28	21.3	302.0	4.06	-0.	
86.00	7.1	865.4	-.192	-25033.8	-4840.6	-20.1	245.0	10.0	6.8	.27	21.3	302.0	4.06	-0.	
87.00	6.9	875.6	-.192	-25019.4	-4826.2	-20.1	238.4	10.0	6.7	.27	21.2	302.0	4.06	-0.	
88.00	6.7	885.5	-.192	-25005.1	-4811.9	-20.1	231.7	10.0	6.5	.26	21.2	302.0	4.05	-0.	
89.00	6.5	895.1	-.192	-24991.0	-4797.8	-20.1	225.1	10.0	6.4	.26	21.2	302.0	4.05	-0.	
90.00	6.3	904.5	-.191	-24976.9	-4783.7	-20.1	218.4	10.0	6.3	.25	21.2	302.0	4.05	-0.	
91.00	6.1	913.6	-.191	-24962.9	-4769.7	-20.1	211.6	10.0	6.1	.24	21.1	302.0	4.05	-0.	
92.00	5.9	922.4	-.191	-24949.0	-4755.8	-20.1	205.1	10.0	6.0	.24	21.1	302.0	4.05	-0.	
93.00	5.7	930.9	-.191	-24935.3	-4742.1	-20.1	198.5	10.0	5.9	.23	21.1	302.0	4.05	-0.	
94.00	5.5	939.1	-.191	-24921.6	-4728.4	-20.1	191.8	10.0	5.7	.23	21.1	302.0	4.05	-0.	
95.00	5.3	947.1	-.191	-24908.0	-4714.8	-20.1	185.2	10.0	5.6	.22	21.0	302.0	4.05	-0.	
96.00	5.1	954.8	-.191	-24894.5	-4701.4	-20.1	178.6	10.0	5.5	.22	21.0	302.0	4.05	-0.	
97.00	5.0	962.2	-.191	-24881.2	-4688.0	-20.1	171.9	10.0	5.3	.21	21.0	302.0	4.04	-0.	
98.00	4.8	969.3	-.191	-24867.9	-4674.7	-20.1	165.3	10.0	5.2	.21	21.0	302.0	4.04	-0.	
99.00	4.6	976.1	-.191	-24854.7	-4661.5	-20.1	158.7	10.0	5.1	.20	20.9	302.0	4.04	-0.	
100.00	4.4	982.7	-.190	-24841.7	-4648.5	-20.1	152.1	10.0	4.9	.20	20.9	302.0	4.04	-0.	
101.00	4.2	989.0	-.190	-24828.7	-4635.5	-20.1	145.5	10.0	4.8	.19	20.9	302.0	4.04	-0.	
102.00	4.0	995.0	-.190	-24815.8	-4622.6	-20.1	138.9	10.0	4.7	.19	20.9	302.0	4.04	-0.	
103.00	3.8	1000.7	-.190	-24803.0	-4609.9	-20.1	132.3	10.0	4.5	.18	20.8	302.0	4.04	-0.	
104.00	3.6	1006.2	-.190	-24790.4	-4597.3	-20.1	125.7	10.0	4.4	.18	20.8	302.0	4.04	-0.	
105.00	3.4	1011.3	-.190	-24777.8	-4584.6	-20.1	119.1	10.0	4.3	.17	20.8	302.0	4.04	-0.	
106.00	3.2	1016.2	-.190	-24765.3	-4572.1	-20.1	112.5	10.0	4.1	.17	20.8	302.0	4.03	-0.	
107.00	3.0	1020.8	-.190	-24752.9	-4559.8	-20.1	105.9	10.0	4.0	.16	20.7	302.0	4.03	-0.	
108.00	2.9	1025.2	-.190	-24740.7	-4547.5	-20.1	99.3	10.0	3.9	.15	20.7	302.0	4.03	-0.	
109.00	2.7	1029.2	-.190	-24728.5	-4535.3	-20.1	92.7	10.0	3.7	.15	20.7	302.0	4.03	-0.	
110.00	2.5	1033.0	-.189	-24716.4	-4523.2	-20.1	86.1	10.0	3.6	.14	20.7	302.0	4.03	-0.	

Figure 47. Continued (Sheet 3 of 4)

T (SEC)	MPH	FEET	MPH/SEC	TE (LBS)	DRAG	TQ/MTR	RPM	AMPS	VOLTS	GENK%	BHP	USL-RPM	GAL/HR	T-NCH	SAND
110.00	2.5	1033.3	-	189-24715.2	-4522.0	-20.1	85.5	10.0	3.6	.14	20.7	302.0	4.03	-0.	
111.00	2.3	1036.5	-	189-24704.4	-4511.2	-20.1	79.5	10.0	3.5	.14	20.7	302.0	4.03	-0.	
112.00	2.1	1039.7	-	189-24692.5	-4499.3	-20.1	73.0	10.0	3.3	.13	20.6	302.0	4.03	-0.	
113.00	1.9	1042.6	-	189-24680.7	-4487.5	-20.1	66.4	10.0	3.2	.13	20.6	302.0	4.03	-0.	
114.00	1.7	1045.3	-	189-24669.0	-4475.8	-20.1	59.8	10.0	3.1	.12	20.6	302.0	4.03	-0.	
115.00	1.5	1047.7	-	189-24657.4	-4464.3	-20.1	53.2	10.0	2.9	.12	20.6	302.0	4.02	-0.	
116.00	1.3	1049.8	-	189-24645.9	-4452.8	-20.1	46.7	10.0	2.8	.11	20.5	302.0	4.02	-0.	
117.00	1.2	1051.6	-	189-24634.5	-4441.3	-20.1	40.1	10.0	2.1	.11	20.5	302.0	4.02	-0.	
118.00	1.0	1053.2	-	189-24623.2	-4430.0	-20.1	33.6	10.0	2.5	.10	20.5	302.0	4.02	-0.	
119.00	.6	1054.5	-	189-24612.0	-4418.8	-20.1	21.0	10.0	2.4	.10	20.5	302.0	4.02	0.	

>>> RUN SUMMARY ...
 TIME(SEC) FEET GAL RMS AMPS BRK KWHR GEN KWHR # CARS
 120.0 1055.4 .636 439.7 2.58 5.80 22.

05 JAN 79 0814310J

---- LOCOMOTIVE ACTIVITY -- ACCUM TIME (MINUTES): RUN TOTAL = 2.00

ARM AMPS >30 = 1.18
 >200 = .86
 >500 = .83
 >1000 = .00

SPEED (MPH) >0.5 = 1.96
 >2.0 = 1.72
 >4.0 = 1.37
 >6.0 = 1.07
 >8.0 = .71
 >10. = .00
 >15. = .00
 >20. = .00

---- ACTIVITY RATIOS

12.2 % TIME BETWEEN 0.5 AND 2. MPH
 17.2 % 2. AND 4. MPH
 15.3 % 4. AND 6. MPH
 17.8 % 6. AND 8. MPH
 35.6 % 8. AND 10. UP"
 .0 % 10. AND 15. MPH
 .0 % 15. AND 20. MPH
 .0 % > 20. MPH

43.1 % ACCEL
 39.8 % BRAKE

FIN

Figure 47. Continued (Sheet 4 of 4)

>>> SW 1500 (4 077'S SERIES=PARALLEL) AIR-BRAKING ONLY <<<<

05 JAN 79 10106159

	DD DRAG COEFS		WEIGHT	LRS	# AXLES	# CARS
	K1*	K2*	VEHICLE	ROTNL	PER CAR	
LOCOMOTIVE >	.0300	.2880	248000.	20000.	4.	
FREIGHT CARS	.0450	.0450	108000.	10000.	4.	16.

LOCOM GR =62./15. WHEEL DIA=40.0 INCHES GEAR BX EFF = .970 TM TEMP =160. C

THROTTLE POSITION PROFILE ----

THRTL NOTCH =	3.	5.	8.	10.	15.	20.	25.	30.
TIME (SEC)=	0.	8.0	12.0	20.0	65.0	100.0	200.0	201.0

DIESEL RPM RAMP RATE = 21.0 RPM/SEC (ABOVE NX=4)
MAX BRAKE TE = -36000. LRS

BRK RAMP TIME = 3.0 SEC
BRK RELEASE = .8 MPH

SPEED (MPH)

START	KICK	% GRADE	CARS/KICK
0.	7.5	0.0	2.

PGM CONTROL

DELTA I = .1000 SEC
PRINT INTERVAL =1.0000 SEC
TIME LIMIT = 80.00 SEC
PRINT LEVEL = 3. (ZERO 15 MIN)
DIAGNOSTIC START = .00 SEC
DIAGNOSTIC INTERVAL = .000 SEC
LOOP CNTR = 0 (PRNT IF =1)

RUN DECK

WRUP WTC,3400-256476-/03-0100,177,2

WASG,A WTC=02.

WASG,T 3.

WXGT WTC=02,LCMIS/2H

>>> SW 1500 (4 077'S SERIES=PARALLEL) AIR-BRAKING ONLY <<<<

.030	.288	248000.	20000.	4.				
.045	.045	108000.	10000.	4.	16.			
62.	15.	40.	.97	160.				
3.	5.	8.	-.01	-.01	-.01	-.01		
0.	8.	12.	20.	65.	100.	200.	201.	
21.	-36000.	3.	0.8					
0.	7.5		2.					
0.1	1.0	80.	3.					

WFIN

Figure 48. SW1500 Simulator Output, Switching Mode (Sheet 1 of 4)

T(SEC)	RPM	FEET	HP/SEC	TE (LBS)	DRAG	TQ/HP	RPM	AHPS	VOLTS	GENK	HHP	OSI-RPM	GAL/HR	T-NCH	SAND
.00	.0	.0	.000	.0	-2670.0	.0	.0	10.0	.0	.00	20.0	300.0	.60	0.	
1.00	.3	.2	.340	33433.0	-3269.3	3814.3	10.5	782.8	37.0	115.81	188.7	338.0	12.93	0.	
2.00	.6	.4	.341	33528.5	-3284.1	3825.7	22.2	784.8	45.4	142.45	237.0	376.0	16.84	0.	
3.00	1.0	2.1	.334	32766.6	-3299.2	3748.1	34.1	771.2	53.2	164.04	270.9	414.0	18.99	0.	
4.00	1.3	3.8	.321	31495.0	-3313.9	3617.5	45.5	748.1	60.3	180.33	296.0	452.0	20.29	0.	
5.00	1.6	5.9	.299	29186.1	-3328.2	3379.0	56.4	705.4	66.0	186.34	305.0	465.0	20.85	0.	
6.00	1.9	8.5	.271	26498.6	-3341.4	3109.9	66.3	659.2	70.5	185.97	304.2	465.0	20.80	0.	
7.00	2.2	11.5	.249	24370.2	-3353.6	2881.2	75.4	622.3	74.6	185.81	303.7	465.0	20.76	0.	
8.00	2.4	14.9	.231	22635.8	-3364.9	2702.1	83.7	591.4	78.5	185.69	303.4	465.0	20.74	0.	
9.00	2.6	18.6	.241	23674.5	-3376.1	2811.2	91.9	610.3	85.1	207.65	336.8	446.0	23.10	0.	
10.00	2.9	22.6	.251	24662.0	-3387.9	2915.1	100.4	628.0	91.9	230.82	371.5	507.0	25.56	0.	
11.00	3.1	27.0	.259	25513.3	-3400.3	3004.8	109.2	643.2	98.8	254.31	406.1	528.0	28.00	0.	
12.00	3.4	31.8	.267	26253.6	-3413.3	3083.1	118.4	656.3	105.9	278.11	440.5	549.0	30.42	0.	
13.00	3.7	37.0	.294	29031.5	-3427.1	3373.2	128.0	704.4	115.9	326.45	513.9	570.0	34.12	0.	
14.00	4.0	42.7	.319	31458.1	-3442.5	3627.0	138.7	749.8	125.8	377.20	591.0	591.0	38.00	0.	
15.00	4.3	48.8	.340	33523.6	-3459.3	3843.4	150.1	787.9	136.0	428.52	668.1	612.0	41.88	0.	
16.00	4.7	55.4	.358	35193.7	-3477.3	4018.9	162.2	818.5	146.3	479.05	745.6	633.0	45.78	0.	
17.00	5.0	62.5	.367	36116.0	-3496.3	4116.7	174.8	835.4	156.3	522.30	813.0	654.0	48.97	0.	
18.00	5.4	70.1	.375	36844.3	-3516.0	4194.4	187.7	848.7	166.3	564.71	878.8	675.0	52.08	0.	
19.00	5.8	78.3	.381	37470.3	-3536.3	4261.6	200.8	860.2	176.5	607.24	944.5	696.0	55.18	0.	
20.00	6.2	87.1	.386	37946.9	-3557.3	4313.3	214.1	869.0	186.6	648.75	1009.9	717.0	58.47	0.	
21.00	6.5	96.4	.370	36282.7	-3578.3	4142.5	227.3	839.8	194.1	652.12	1011.9	717.0	58.60	0.	
22.00	6.9	106.3	.354	34726.6	-3598.7	3962.9	239.9	812.3	201.2	653.76	1011.4	717.0	58.57	0.	
23.00	7.3	116.7	.340	33309.4	-3618.5	3837.7	252.0	786.9	208.0	654.72	1011.3	717.0	58.56	0.	
24.00	7.6	127.5	.301	28418.8	-3637.7	3331.4	263.6	697.1	209.4	584.02	901.8	670.3	53.17	0.	
25.00	7.8	138.8	.263	25691.9	-3648.1	2970.7	269.8	286.4	147.3	168.74	287.9	436.8	19.87	0.	
* CAPS REMAINING = 14. (KICKED 2.)															
26.00	7.8	150.2	-.100	-9346.1	-3232.6	-11.8	269.9	-25.9	-16.4	1.70	-81.3	296.7	-.52	0.	
27.00	7.6	161.5	-.237	-21337.7	-3224.3	-11.8	264.3	-25.9	-16.2	1.57	-79.7	296.7	-.45	0.	
28.00	7.3	172.5	-.374	-33322.4	-3208.9	-11.8	253.9	-25.9	-15.7	1.62	-76.5	296.7	-.31	0.	
29.00	6.9	182.9	-.449	-39300.8	-3167.3	-11.8	239.1	-25.9	-14.9	1.54	-71.9	296.7	-.10	0.	
30.00	6.4	192.7	-.449	-39278.4	-3164.9	-11.8	223.5	-25.9	-14.1	1.46	-66.9	296.7	.12	0.	
31.00	6.0	201.8	-.449	-39256.3	-3142.8	-11.8	207.9	-25.9	-13.3	1.38	-61.9	296.7	.34	0.	
32.00	5.5	210.2	-.449	-39234.6	-3121.1	-11.8	192.3	-25.9	-12.5	1.29	-57.0	296.7	.57	0.	
33.00	5.1	218.0	-.448	-39213.3	-3099.8	-11.8	176.8	-25.9	-11.7	1.21	-52.0	296.7	.79	0.	
34.00	4.6	225.2	-.448	-39192.4	-3078.9	-11.8	161.2	-25.9	-10.9	1.13	-47.0	296.7	1.01	0.	
35.00	4.2	231.6	-.448	-39171.8	-3058.4	-11.8	145.6	-25.9	-10.1	1.04	-42.1	296.7	1.23	0.	
36.00	3.7	237.5	-.448	-39151.7	-3038.2	-11.8	130.1	-25.9	-9.3	.96	-37.1	296.7	1.45	0.	
37.00	3.3	242.6	-.447	-39131.9	-3018.4	-11.8	114.5	-25.9	-8.5	.88	-32.2	296.7	1.67	0.	
38.00	2.8	247.1	-.447	-39112.5	-2999.0	-11.8	99.0	-25.9	-7.7	.79	-27.2	296.7	1.89	0.	
39.00	2.4	251.0	-.447	-39093.5	-2980.0	-11.8	83.4	-25.9	-6.9	.71	-22.2	296.7	2.12	0.	
40.00	2.0	254.2	-.447	-39074.8	-2961.3	-11.8	67.9	-25.9	-6.1	.63	-17.3	296.7	2.34	0.	
41.00	1.5	256.7	-.447	-39056.5	-2943.0	-11.8	52.4	-25.9	-5.2	.54	-12.3	296.7	2.56	0.	
42.00	1.1	258.6	-.446	-39038.6	-2925.1	-11.8	36.9	-25.9	-4.4	.46	-7.4	296.7	2.78	0.	
43.00	.6	259.8	-.399	-34301.0	-2907.8	-20.1	21.6	10.0	2.3	.09	20.4	296.7	4.02	0.	

>>> RUN SUMMARY ***
 TIME(SEC) FEET GAL RMS AHPS BRK KWHR GEN KWHR ■ CARS
 44.0 260.4 .254 560.9 1.35 2.51 14.

Figure 48. Continued (Sheet 2 of 4)

T (SEC)	MPH	FEET	MPH/SEC	TE (LHS)	DRAG	TOT/MTR	RPM	AMPS	VOLTS	GENKWH	H-P	DSL-RPM	GAL/HR	T-INCH	SAWD
0.00	0.0	0.0	-0.134	0.0	-2894.8	-20.1	0.0	10.0	2.1	.08	24.4	250.0	4.02	0.	
1.00	0.0	-0.0	-0.016	-2752.7	-2670.0	-8.6	0.0	10.0	1.9	.07	20.4	244.0	4.02	3.	
2.00	0.2	0.1	.387	33638.6	-2891.5	3796.4	6.8	779.7	34.2	106.53	175.2	326.0	11.84	3.	
3.00	0.6	0.6	.379	33145.1	-2906.2	3746.6	20.1	170.9	43.2	133.30	222.4	364.0	15.66	3.	
4.00	1.0	1.4	.375	32700.0	-2921.0	3701.9	33.3	173.0	52.7	159.31	263.4	402.0	18.60	3.	
5.00	1.3	3.4	.356	31036.2	-2935.6	3530.5	46.0	732.6	59.9	175.45	288.4	440.0	19.89	3.	
6.00	1.7	5.1	.335	29174.2	-2949.7	3338.4	58.1	698.3	66.8	186.65	305.4	465.0	20.88	3.	
7.00	2.0	8.3	.302	26239.4	-2962.8	3034.8	69.2	648.2	71.8	186.24	304.5	465.0	20.92	3.	
8.00	2.3	11.5	.275	23981.0	-2974.9	2801.4	79.3	608.6	76.0	186.02	304.0	465.0	20.78	3.	
9.00	2.5	15.0	.254	22169.1	-2986.1	2614.2	88.5	576.1	80.7	185.87	303.6	465.0	20.75	3.	
10.00	2.8	18.9	.252	22096.4	-2996.7	2407.8	97.1	575.0	86.3	198.55	322.9	477.4	22.12	5.	
11.00	3.1	23.7	.263	23087.3	-3007.8	2711.9	106.1	593.2	93.4	221.67	357.7	494.6	24.58	5.	
12.00	3.3	27.9	.273	23936.8	-3019.5	2801.4	115.4	608.6	100.6	245.00	392.3	519.6	27.03	5.	
13.00	3.6	33.0	.282	24671.8	-3031.7	2879.1	125.0	621.9	108.0	268.69	426.7	540.6	29.46	5.	
14.00	3.9	38.5	.302	26516.7	-3044.6	3072.1	135.0	654.5	117.1	306.55	463.1	561.6	32.57	8.	
15.00	4.2	44.4	.331	29078.2	-3058.8	3339.8	146.0	698.5	127.9	357.30	560.5	582.6	36.46	8.	
16.00	4.5	50.8	.355	31147.7	-3074.5	3556.5	157.8	737.1	138.4	408.18	637.2	603.6	40.33	8.	
17.00	4.9	57.7	.376	32920.2	-3091.4	3742.5	170.5	770.2	149.2	459.80	714.4	624.6	44.21	8.	
18.00	5.3	65.2	.390	34111.7	-3109.4	3868.2	183.8	792.3	160.0	506.97	786.5	646.6	47.72	8.	
19.00	5.7	73.3	.398	34863.5	-3128.2	3948.3	197.5	806.2	170.5	549.99	852.5	666.6	50.84	8.	
20.00	6.1	81.9	.405	35481.0	-3147.7	4014.5	211.4	817.7	181.2	592.69	918.3	687.6	53.94	8.	
21.00	6.5	91.1	.411	36000.8	-3167.9	4070.6	225.6	827.4	192.0	635.30	984.3	708.6	57.06	8.	
22.00	6.9	100.9	.403	35191.6	-3188.4	3988.6	239.9	813.2	201.1	654.27	1012.3	717.0	58.63	-0.	
23.00	7.3	111.4	.385	33584.1	-3208.5	3823.6	253.6	784.5	208.8	655.29	1012.2	717.0	58.62	-0.	
24.00	7.7	122.3	.284	23441.2	-3227.4	2771.5	266.4	603.5	201.1	485.45	751.2	623.6	46.06	0.	
25.00	7.8	133.7	.058	4815.9	-3235.4	836.7	271.7	263.4	139.2	146.90	253.8	390.1	18.10	0.	
# CARS REMAINING = 12. (KICKED 2.1)															
26.00	7.8	145.2	-.140	-11332.2	-2818.1	-11.9	270.7	-25.8	-16.4	1.69	-84.5	296.7	-0.66	0.	
27.00	7.6	156.5	-.296	-23322.6	-2808.4	-11.9	263.4	-25.8	-16.1	1.66	-82.2	296.7	-0.56	0.	
28.00	7.2	167.4	-.452	-35306.1	-2792.0	-11.9	250.6	-25.8	-15.5	1.59	-78.2	296.7	-0.36	0.	
29.00	6.7	177.6	-.507	-38884.1	-2770.0	-11.9	233.5	-25.8	-14.6	1.50	-72.7	296.7	-0.14	0.	
30.00	6.2	187.1	-.507	-38862.0	-2747.9	-11.9	215.8	-25.8	-11.7	1.41	-66.9	296.7	0.12	0.	
31.00	5.7	195.8	-.506	-38840.3	-2726.2	-11.9	198.3	-25.8	-12.8	1.32	-61.2	296.7	0.38	0.	
32.00	5.2	203.8	-.506	-38819.1	-2705.0	-11.9	180.7	-25.8	-11.9	1.22	-55.4	296.7	0.64	0.	
33.00	4.7	211.1	-.506	-38798.3	-2684.2	-11.9	163.1	-25.8	-11.0	1.13	-49.6	296.7	0.89	0.	
34.00	4.2	217.6	-.506	-38778.0	-2663.9	-11.9	145.5	-25.8	-10.0	1.04	-43.9	296.7	1.15	0.	
35.00	3.7	223.4	-.505	-38758.1	-2644.0	-11.9	128.0	-25.8	-9.1	.94	-38.1	296.7	1.41	0.	
36.00	3.2	228.4	-.505	-38738.6	-2624.5	-11.9	110.4	-25.8	-8.2	.85	-32.4	296.7	1.66	0.	
37.00	2.7	232.7	-.505	-38719.5	-2605.4	-11.9	92.9	-25.8	-7.3	.76	-26.6	296.7	1.92	0.	
38.00	2.2	236.3	-.505	-38700.9	-2586.8	-11.9	75.4	-25.8	-6.4	.66	-20.9	296.7	2.18	0.	
39.00	1.7	239.1	-.504	-38682.7	-2568.6	-11.9	57.8	-25.8	-5.5	.57	-15.1	296.7	2.43	0.	
40.00	1.2	241.1	-.504	-38665.0	-2550.9	-11.9	40.3	-25.8	-4.6	.48	-9.4	296.7	2.69	0.	
41.00	0.7	242.5	-.481	-36326.8	-2533.6	-20.1	22.8	10.0	2.4	.09	20.4	296.7	4.02	0.	

>>>> RUN SUM, ##,
 TIME (SEC) FEET GAL RMS AMPS BRK KWHR GEN KWHR # CARS
 41.9 243.0 .228 533.8 1.22 2.23 12.

<>< TRIP SUMMARY ##
 TIME (SEC) FEET GAL RMS AMPS BRK KWHR GEN KWHR # CYCLES
 85.9 503.5 .462 547.8 2.57 4.74 2.

--- LOCOMOTIVE ACTIVITY --- ACCUM TIME (MINUTES), RUN TOTAL = 1.43

05 JAN 79 10107143

Figure 48. Continued (Sheet 3 of 4)

ARM AMPS >30 = .82
 >200 = .82
 >500 = .78
 >1000 = .00

SPEED (MPH) >0.5 = 1.34
 >2.0 = 1.08
 >4.0 = .69
 >6.0 = .37
 >8.0 = .00
 >10. = .00
 >15. = .00
 >20. = .00

---- ACTIVITY RATIOS

18.0 % TIME BETWEEN 0.5 AND 2. MPH
 27.4 % 2. AND 4. MPH
 22.5 % 4. AND 6. MPH
 25.7 % 6. AND 8. MPH
 .0 % 8. AND 10. MPH
 .0 % 10. AND 15. MPH
 .0 % 15. AND 20. MPH
 .0 % > 20. MPH

57.3 % ACCEL
 40.6 % BRAKE

*FIN

Figure 48. Continued (Sheet 4 of 4)

Series Motor Model Validity

&

Data retrieved from yard operation of an instrumented switcher locomotive engine were used as the basis for establishing the validity of the computer model. For purposes of this report, a pair of acceleration/deceleration runs in two directions was selected as representative of the locomotive performance.

The particular test data are from tape reel II starting at tape counts 1261 and 1329. The first is an upgrade run in reverse, to approximately 16 mph, then braking to a stop using approximately 6 to 7 psi air brake. The parameters used as the basis for comparison to the simulator are: throttle notch, diesel engine rotational speed, traction motor current, traction motor voltage, and locomotive speed. The recorded data played back in engineering units are shown in Figure 49. The consist was locomotive plus caboose and 10 cars at 613 tons total, as shown in Table 13.

TABLE 13

ACCELERATION/DECELERATION TESTS, CUT CONSIST

Car Identification	Loaded/Empty	Tons
ACL 38761	L	77
SAN 638	E	23
SOU 98039	E	23
SOU 65295	L	84
SOU 550303	L	81
NATX 18623	E	23
CIR 2123	E	23
UP 451241	L	71
SAN 551027	E	23
GATX 126940	E	<u>23</u>
		451
Caboose		38
Locomotive		<u>124</u>
	Total	613
June 26, 1978		

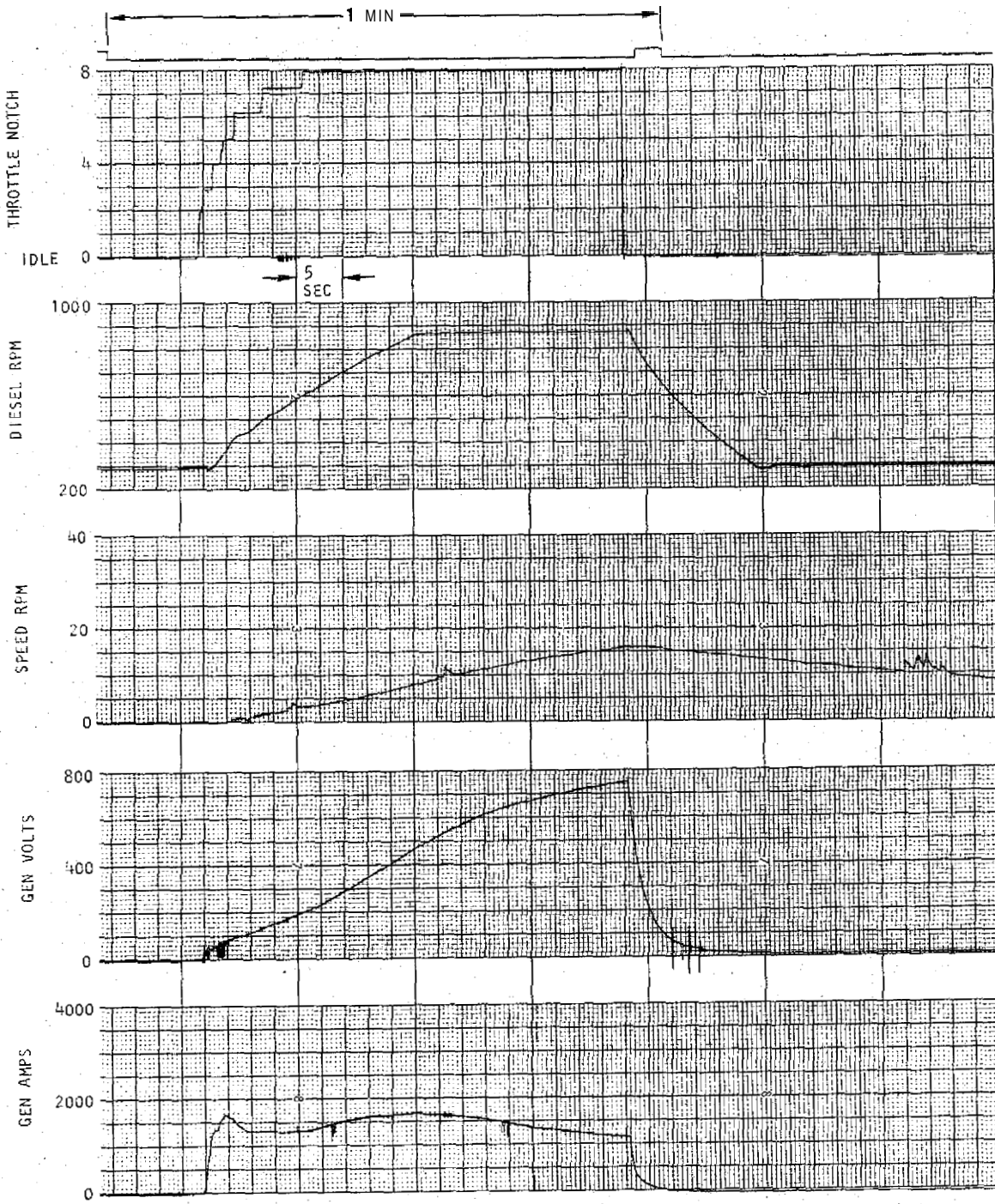

S-34196

Figure 49. Reverse Run Test Data (Start 1261)

Initial runs of the model were made using diesel and generator characteristics derived from the load box test data. However, the computer-plotted output from the model did not match the generator current curve, as shown at the bottom of Figure 49, in the 0 to 8 mph region. It also became evident that an appreciable grade was present by comparing the speed curves (acceleration and deceleration) of the model and the test data. These parameters were varied until a reasonable match was obtained as shown in Figure 50 for the reverse run starting at tape footage count 1261. The computer-plotted data comprise the simulator model, the dash lines are data replotted from Figure 49. The basic input to the computer model is throttle notch vs time taken from the test run.

It was determined that the grade for the reverse run was +0.5 percent at this location. A comparison of the published data for the diesel with the load box test and the road test data is shown in Figure 51. According to the comparison, the response of the power unit to throttle notch was quite different for a dynamic load, in the low speed region, as opposed to the fixed resistive load in the load box test.

The same consist was run in the forward direction (downgrade). Test data starting at tape count 1329 are shown in Figure 52, and comparison with the model is shown in Figure 53. The plot data for the model in Figure 53 were run at -0.4 percent grade average for the run. The downgrade run was considerably longer and it is assumed that some grade change was encountered in the extended part of the run. The motor current curve was not as good a match on the downgrade run, which indicates that the assumed loading characteristic (Figure 51) is influenced by the higher motor voltage.

The overall match is good and the sensitivity to grades and power loading demonstrates the integrity of the model.

FESS MODEL

The SW1500 with two ACT-1 flywheels is an expanded version of the series motor model. Computation was expanded to include operation of the field power supply as an added control subsystem, powered by a 400-Hz, 150-kva alternator driven from the forward line shaft of the diesel engine. This power takeoff is included as an added load on the engine and varies with the demands for field power. In addition, the necessary cooling for the traction motors during dynamic braking is presented as a load on the alternator that reaches an estimated 15 kw maximum. A steady 1.5-kw load is assumed to be supplied via the alternator for controls auxiliary power. All of these items are reflected in an increased total power output and fuel consumption of the FESS configuration as compared with the standard SW1500 model. The FESS simulator also accommodates the additional control system transitions from flywheel-powered to main generator power acceleration when the flywheel energy is depleted; and the transition from electric to air brake when the flywheel speed reaches its upper limit.

The logic required for controlling a real-world system is contained within the program and represents a first design iteration for the controls configuration. A block diagram of the FESS model is shown in Figure 54.

11 JAN 79

SW 1500 * * <10 CARS+CAB> TP CNT 1261-1329

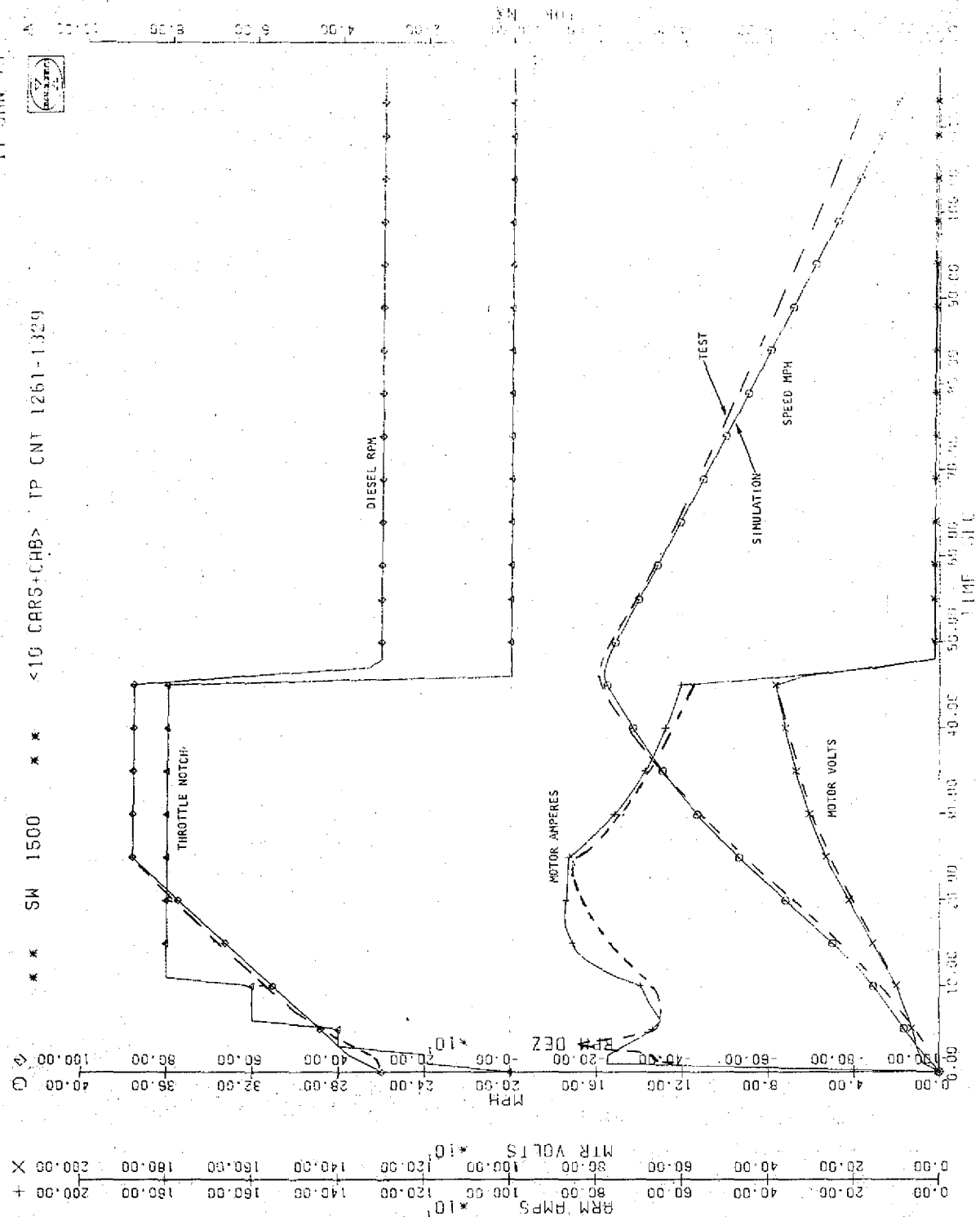
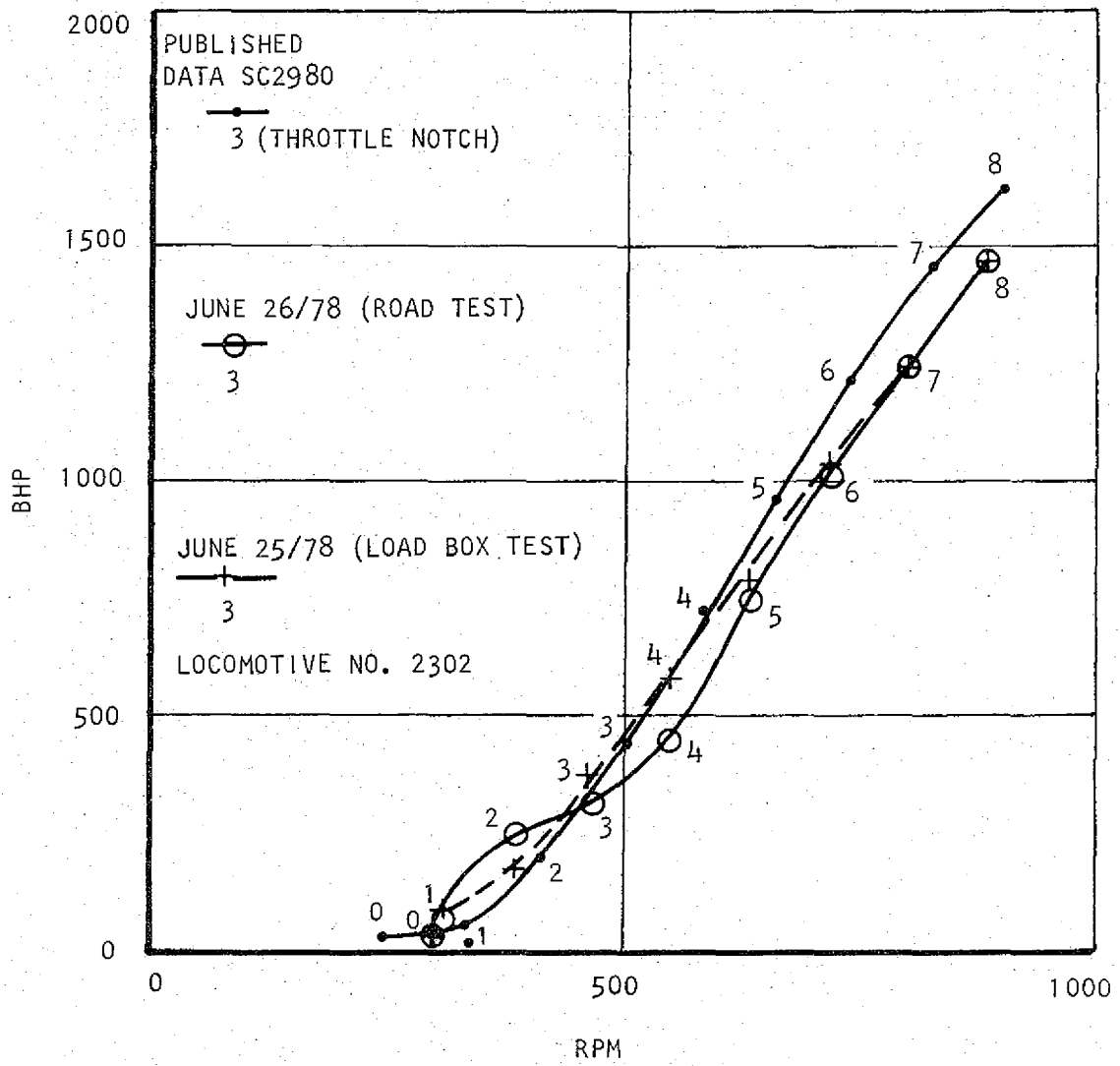

Figure 50. Reverse Run Comparison of Mode and Test Data



S-34177

Figure 51. Diesel Characteristics

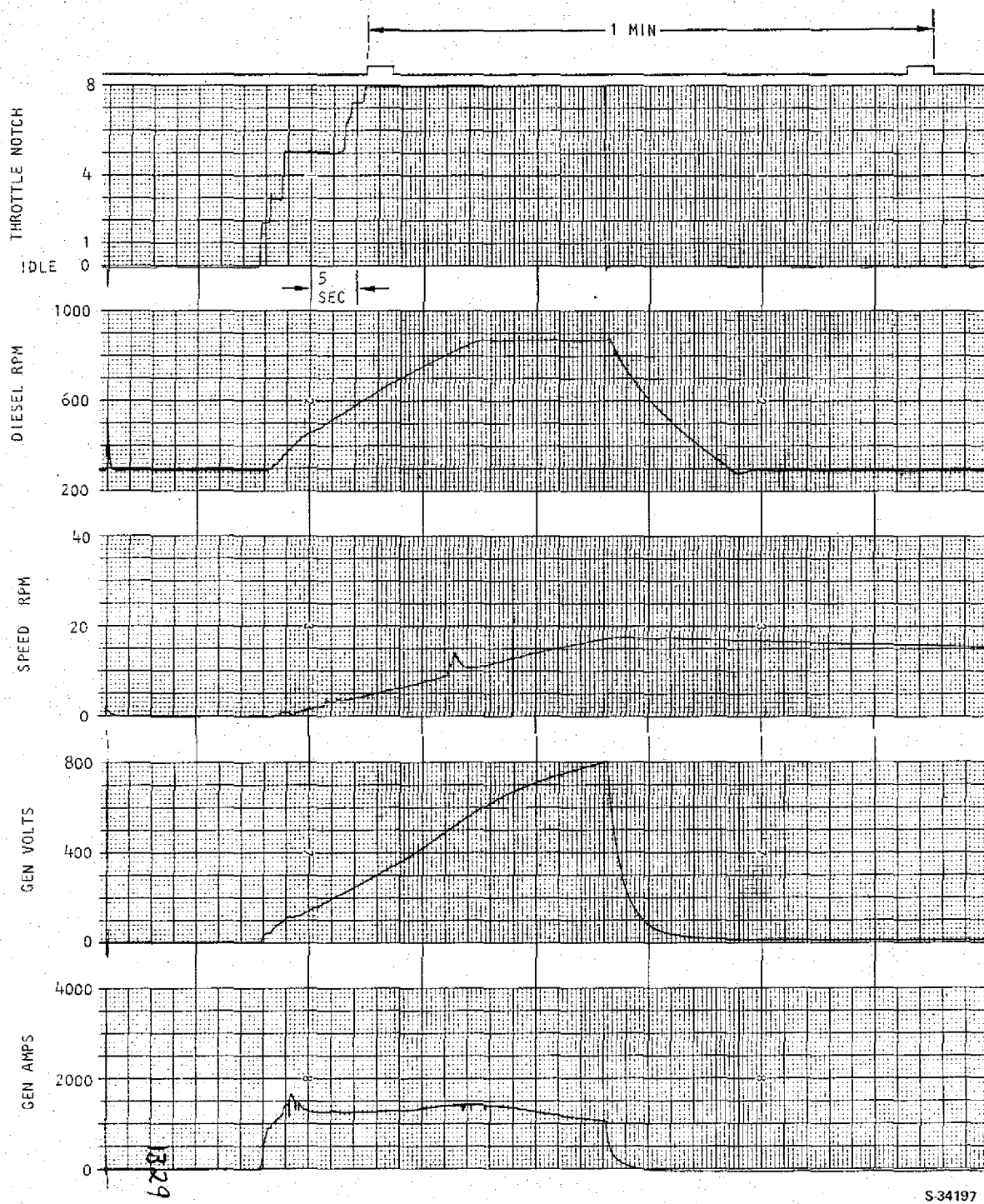

Figure 52. Forward Run Test Data (Start 1329)

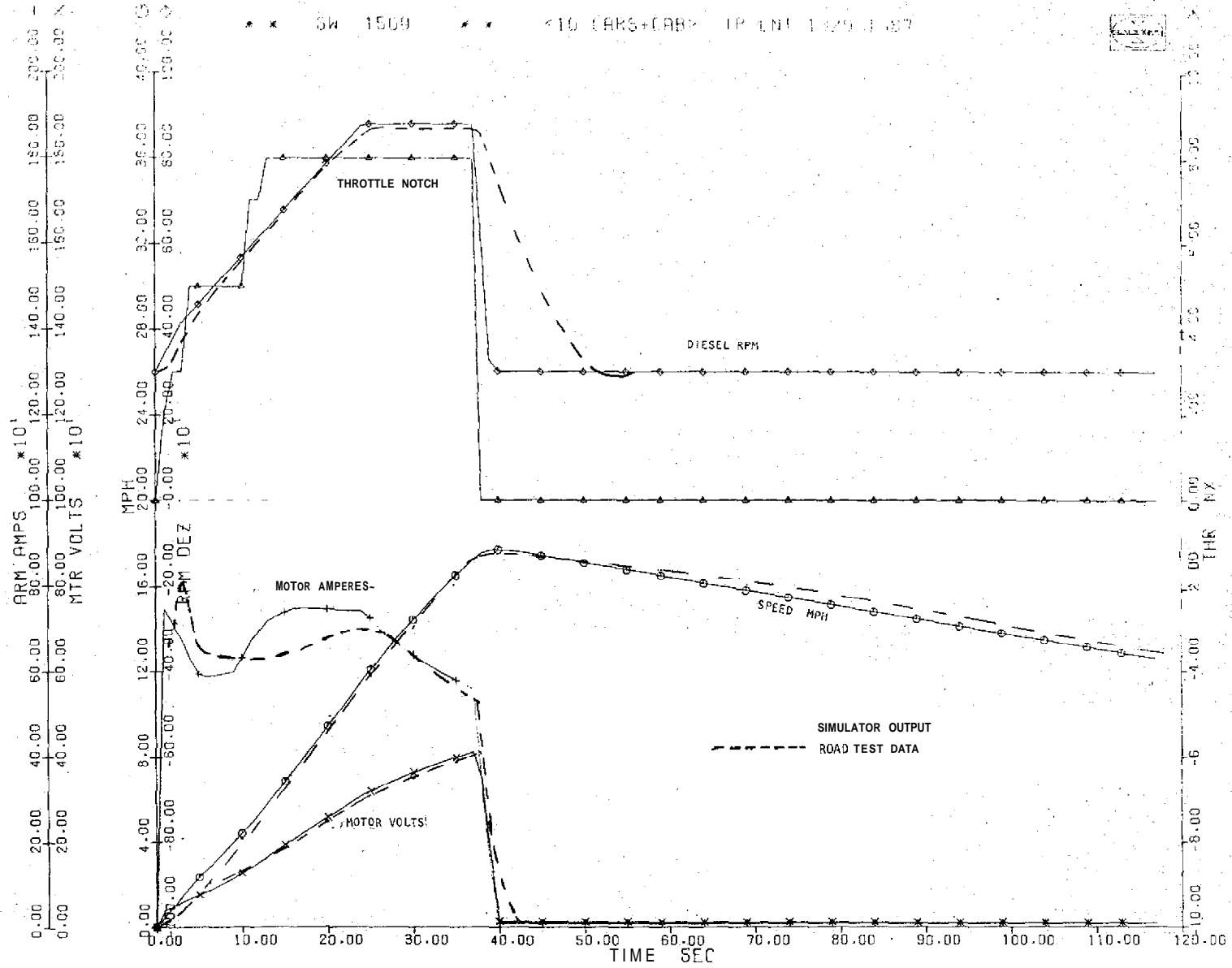
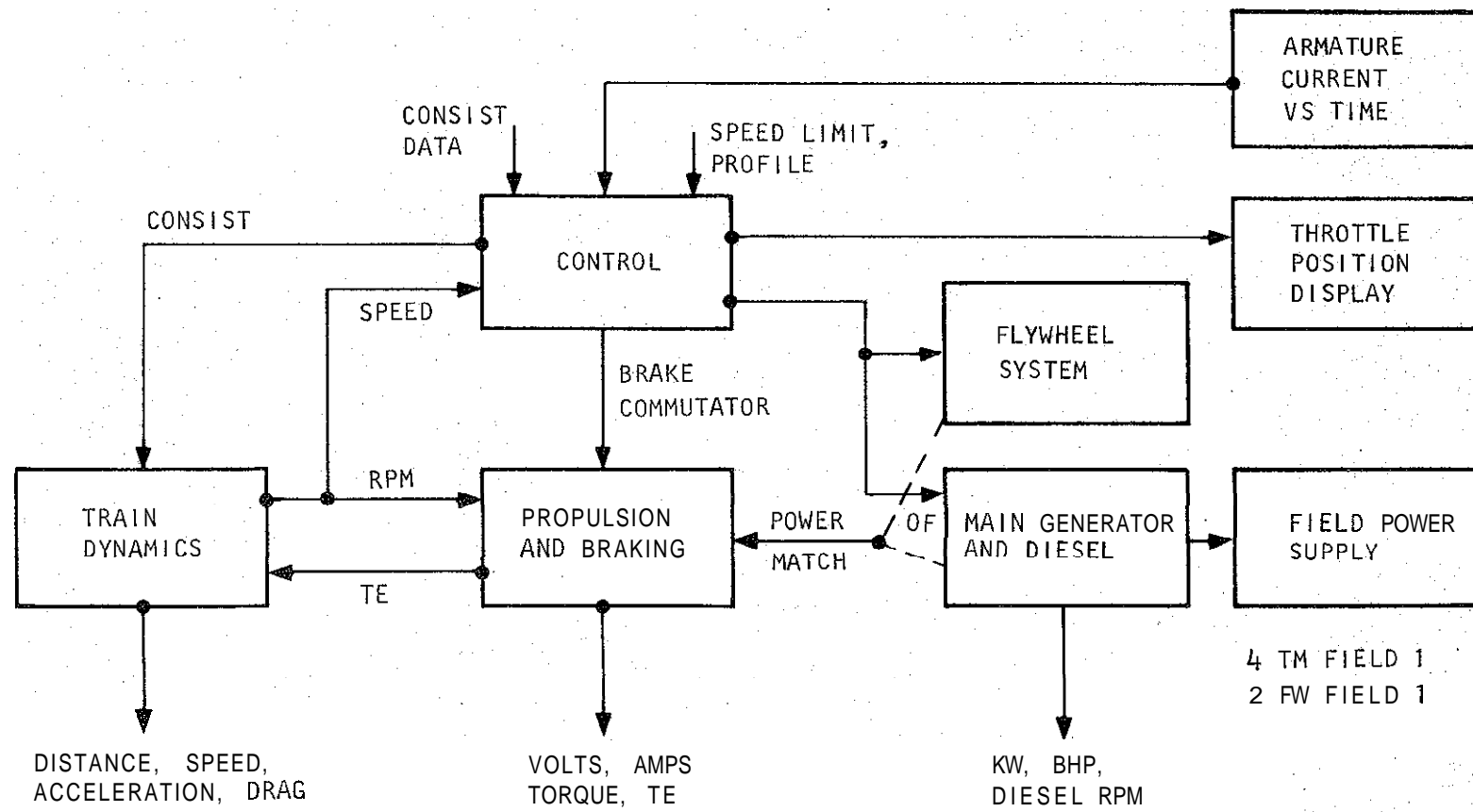

Figure 53. Forward Run Comparison of Model and Test Data



4 TM FIELD 1
2 FW FIELD 1

S 34185

RUN SUMMARY DATA: TIME, DISTRIBUTION, KW-HRS,
GAL, RMS AMP

Figure 54. Computer Model FESS

The computer input deck is similar to the SW1500 model with added parameters to accommodate changes in the basic size and speed of the flywheel design. An example of the basic input (10 card) deck is shown in the lower inset of Figure 55, sheet 1, and the associated computer printout is shown in Figure 55, sheets 1, 2, and 3.

A comparison of Figure 48, sheets 2 and 3, with Figure 55, sheets 2 and 3, showing essential operating parameters, will demonstrate the difference in response of the two systems in a similar operating profile. In particular, the diesel engine loading profile is quite different due to the energy supplied by the flywheel in the FESS model during acceleration to the time the flywheel is depleted to its lower limit. All armature currents and voltages are shown on a per-motor basis in these printouts. The armature circuit connections for the two models are shown in Figure 56, and it is assumed that the parallel sets share current equally. Hence, flywheel machine armature current is half of traction motor armature current, and main generator current equals traction motor current in the FESS model.

To accommodate the requirement for the separately excited motors' and the flywheel motors' field power, a shaft-driven alternator is incorporated into the FESS model. The model also incorporates auxiliary power usage for controls and for motor cooling during dynamic braking. This shows as increased fuel consumption for FESS as compared with the standard model in the braking phase. The alternator is engine shaft-driven so these auxiliaries show as a power demand on the diesel engine, which is reflected in the second-by-second data printout of Figure 55, sheets 2 and 3. Thus, some of the fuel saving gained when using the flywheel for acceleration is lost during dynamic braking.

In the Figure 55 printout, it will be noted that the motor field current is the same as the armature current, producing essentially the same operation as the series motor configuration. Other field schedules could be used, but for the purpose of performance comparison of the SW1500 and FESS, this was considered acceptable. Even with different field coil turns, the field power requirement would be unchanged, and as a convenience, the shunt field version of the D77 motor subroutine (which removes the field voltage drop from the armature circuit) was used. In addition, keeping the field current proportional to armature current (rather than using full field at low speed) reduces field power demand and represents a more efficient mode of operation.

The same program is used for running fetch mode, with a slight alteration of the input card deck. For example, switching speed is set to a negative value and the two blank cards, shown in Figure 55, sheet 1 inset, are filled with armature current vs time profile data. Calling for a specific negative armature current initiates dynamic braking at the desired level.

FESS Model Validity

The validity of the standard SW1500 model has been established as acceptable through comparison of ballistic and electrical performance with real-world tests. The FESS model uses the component subroutines from the SW1500 model and is an extension, using an added motor model of the same format (proven accurate with existing real-world test data for the ACT-1 ESU).

>>>> SW 1500 A-2 CONFIGIN <<<<<

05 JAN 79 13:12:139

	NO BEAR COEFF	WEIGHT	LBS	# AXLES	# CARS
	F1*	F2*	VEHICLE	PER CAR	
OBJECTIVE >	.0300	.2000	240000.	20000.	4.
EFFICIENT CARS	.0450	.0450	100000.	10000.	4.

CONSIST STARTING TONS = 986.

L CRR GR = 62.715. WHEEL DIA = 40.0 INCHES GEAR RA FFP = .970 TM TEMP = 160. C

>> MACHINE PARAMETERS ---
MAX WPT = 10.000 INERTIA (FT.LB.SEC² REF MOTOR SHAFT) = 140.
3793.0 2655.0 160.0

SYSTEM CONTROL IS (2) ACT FW MACHINES
OPERATING IN PARALLEL INTO (4) D-17 TM
IN SERIES

>> OPERATING ENVELOPE ---
NO. ACC. AMPS 100.0
AW = 36000. LBS 15000.0

BRK REL = 1.0 MPH
MAX TRACTION = 1200.0 KW
FW START = 3000.0 MPH
AUX PWR = 1.500 KW

SPEED (MPH)	START	FLICK	# GRADE	CARS/FICK
	.1	7.0	.00	2.

RM PROFILE (FEET)	---	---	---	---	---	---	---	---
ARM AMPS =	.0	.0	.0	.0	.0	.0	.0	.0
TIME (SEC) =	.0	.0	.0	.0	.0	.0	.0	.0

PRM CONTROL DELTA T = .1000 SFC
PRINT INTERVAL = 1.0000 SEC
TIME LIMIT = 50.00 SEC
PRINT LEVEL = 3. (ZERO IS MIN)

RUN DECK

SW WTC=1400-251476-703-100,177
WAS(1) WTC=12.
XGL1 WTC=02,LEPRW/2

(10 data cards)

>>>> SW 1500 A-2 CONFIGIN <<<<<						
.030	.200	240000.	20000.	4.		
.045	.045	100000.	10000.	4.	16.	
62.	15.	40.	.97	160.		
3793.	2655.	150.	140.			
800.	1.5.	-36000.	15000.	1.	1200.	3000. 1.5
0.	7.	0.	2.			
0.1	1.0	50.	3.			

(2 blank cards)

Figure 55. FESS Simulator Output, Switching Mode (Sheet 1 of 3)

TIME SEC	SPEED MPH	DIST FEET	NET TQ LBS	U 77 ARM I	FWD I	RPM	KWHR	ACT ARM I	FWD I	RPM	VOLTS	KW	GEN ARM I	RPM	DIFSEL RMP	GPH	ALT HP	SAND	SYS DRV	THR NCH
0.0	0.0	0.0	0.0	50.0	0.0	2.937	0.0	0.0	3000.0	0.0	0.0	0.0	0.0	0.0	0.0	0.0	0.0		FW	0.
1.0	0.0	0.0	207.2	150.0	150.0	0.0	2.935	-75.0	0.7	2998.9	21.0	3.2	0.0	339.6	49.0	6.4	29.0		FW	8.
2.0	0.0	0.0	4633.7	250.0	250.0	0.0	2.932	-125.0	1.1	2997.4	32.0	8.1	0.0	343.2	52.0	6.6	32.0		FW	3.
3.0	0.1	0.1	16097.7	350.0	350.0	2.8	2.928	-175.0	1.6	2995.2	48.0	16.8	0.0	345.6	57.0	6.8	37.0		FW	2.
4.0	0.2	0.3	15016.6	450.0	450.0	6.8	2.921	-225.0	2.2	2992.0	69.0	30.9	0.0	348.7	63.0	7.0	43.0		FW	2.
5.0	0.4	0.7	20465.1	550.0	550.0	12.7	2.912	-275.0	3.0	2987.2	95.0	52.4	0.0	352.7	71.0	7.3	51.0		FW	2.
6.0	0.6	1.5	26021.7	650.0	650.0	20.5	2.898	-325.0	3.9	2980.3	128.0	83.3	0.0	357.5	80.0	7.6	60.0		FW	2.
7.0	0.9	2.6	31616.2	750.0	750.0	30.4	2.879	-375.0	5.0	2970.2	168.0	125.7	0.0	363.0	91.0	8.0	71.0		FW	3.
8.0	1.2	4.1	34336.5	800.0	800.0	42.0	2.852	-400.0	6.0	2956.4	207.0	165.4	0.0	366.1	97.0	8.3	77.0		FW	3.
9.0	1.6	6.2	34320.6	800.0	800.0	54.2	2.821	-400.0	6.9	2940.2	241.0	192.9	0.0	366.2	97.0	8.3	77.0		FW	3.
10.0	1.9	8.6	34304.5	800.0	800.0	66.3	2.786	-400.0	7.8	2921.9	276.0	220.5	0.0	366.2	97.0	8.3	77.0		FW	3.
11.0	2.3	11.9	34288.1	800.0	800.0	78.4	2.747	-400.0	8.7	2901.4	310.0	248.0	0.0	366.3	97.0	8.3	77.0		FW	3.
12.0	2.6	15.5	34271.5	800.0	800.0	90.6	2.704	-400.0	9.6	2878.7	344.0	275.5	0.0	366.3	97.0	8.3	77.0		FW	3.
13.0	3.0	19.7	34254.7	800.0	800.0	102.7	2.658	-400.0	10.6	2853.7	379.0	303.1	0.0	353.5	72.0	7.3	52.0		FW	3.
14.0	3.3	24.3	34237.6	800.0	800.0	114.8	2.613	-300.0	11.5	2829.7	413.0	330.6	-200.0	424.9	218.0	13.2	52.0	GEN	3.	
15.0	3.7	29.5	34220.3	800.0	800.0	126.9	2.578	-200.0	12.3	2810.9	448.0	358.0	-400.0	475.3	366.0	20.7	52.0	GEN	4.	
16.0	4.0	35.1	34202.7	800.0	800.0	139.0	2.556	-100.0	13.1	2798.4	482.0	385.5	-600.0	526.9	525.0	29.1	53.0	GEN	4.	
17.0	4.4	41.3	34184.9	800.0	800.0	151.1	2.546	-0.0	13.8	2793.0	516.0	413.0	-800.0	581.9	706.0	38.8	53.0	GEN	4.	
18.0	4.7	48.0	34166.9	800.0	800.0	163.2	2.545	15.0	14.7	2792.8	551.0	440.4	-831.0	602.4	771.0	42.2	53.0	GEN	4.	
19.0	5.1	55.2	34148.6	800.0	800.0	175.3	2.545	15.0	15.8	2792.9	585.0	467.8	-831.0	616.3	815.0	44.5	53.0	GEN	4.	
20.0	5.4	62.9	34130.1	800.0	800.0	187.4	2.546	15.0	16.9	2793.0	619.0	495.2	-831.0	630.2	859.0	46.8	53.0	GEN	4.	
21.0	5.8	71.1	34111.4	800.0	800.0	199.4	2.546	15.0	18.1	2793.1	653.0	522.6	-831.0	644.1	903.0	49.1	54.0	GEN	4.	
22.0	6.1	79.9	34092.5	800.0	800.0	211.5	2.546	15.0	19.2	2793.3	688.0	550.0	-831.0	657.9	947.0	51.3	54.0	GEN	5.	
23.0	6.5	89.1	34073.1	800.0	800.0	223.5	2.547	15.0	20.5	2793.6	722.0	577.4	-831.0	672.1	991.0	53.7	54.0	GEN	5.	
24.0	6.8	98.4	34053.8	800.0	800.0	235.6	2.547	15.0	21.9	2793.9	756.0	604.7	-831.0	686.6	1035.0	56.2	55.0	GEN	5.	
25.0	7.2	109.1	34033.9	800.0	800.0	247.5	2.548	15.0	21.9	2794.2	758.0	515.4	-711.0	641.2	894.0	48.6	41.0	GEN	0.	
26.0	7.4	119.8	34014.2	800.0	800.0	255.4	2.548	15.0	17.5	2794.4	637.0	242.2	-411.0	506.7	459.0	25.5	16.0	GEN	0.	
27.0	7.4	130.6	34004.5	800.0	800.0	257.6	2.548	15.0	4.6	2794.3	179.0	14.3	-111.0	349.4	64.0	7.0	3.0	GEN	0.	
# CARS REMAINING = 14. (KICKED 2.)																				
28.0	7.4	141.5	34001.7	800.0	800.0	256.1	2.549	110.0	9.9	2794.7	394.0	92.9	0.0	271.1	27.0	4.4	7.0		FW	-2.
29.0	7.2	152.1	34005.4	800.0	800.0	250.2	2.571	260.0	15.0	2807.1	587.0	336.0	0.0	325.8	45.0	6.0	25.0		FW	-3.
30.0	6.9	162.4	34007.9	800.0	800.0	239.2	2.611	280.0	14.2	2828.8	565.0	351.8	0.0	335.4	48.0	6.3	28.0		FW	-3.
31.0	6.5	172.2	34002.5	800.0	800.0	227.8	2.650	280.0	13.3	2849.4	535.0	335.0	0.0	334.9	48.0	6.3	28.0		FW	-3.
32.0	6.2	181.6	34005.2	800.0	800.0	216.4	2.685	280.0	12.3	2868.7	505.0	318.2	0.0	353.6	73.0	7.4	53.0		FW	-3.
33.0	5.4	190.4	34009.2	800.0	800.0	205.0	2.719	280.0	11.4	2886.6	475.0	301.4	0.0	353.6	72.0	7.3	52.0		FW	-3.
34.0	5.5	199.4	34007.4	800.0	800.0	193.6	2.750	280.0	10.5	2903.2	445.0	284.7	0.0	353.5	72.0	7.3	52.0		FW	-3.
35.0	5.2	206.7	34005.8	800.0	800.0	182.2	2.780	280.0	9.6	2918.5	415.0	267.9	0.0	353.4	72.0	7.3	52.0		FW	-3.
36.0	4.9	214.1	34002.4	800.0	800.0	170.8	2.806	260.0	8.9	2932.5	386.0	251.2	0.0	353.4	72.0	7.3	52.0		FW	-3.
37.0	4.6	221.0	34002.2	800.0	800.0	159.4	2.831	280.0	8.1	2945.3	356.0	234.5	0.0	353.3	72.0	7.3	52.0		FW	-2.
38.0	4.2	227.4	34001.2	800.0	800.0	148.1	2.853	260.0	7.3	2956.8	326.0	217.8	0.0	353.3	72.0	7.3	52.0		FW	-2.
39.0	3.9	233.0	34000.4	800.0	800.0	136.7	2.873	260.0	6.6	2967.1	296.0	201.1	0.0	353.3	72.0	7.3	52.0		FW	-2.
40.0	3.6	238.9	34000.4	800.0	800.0	125.4	2.890	280.0	5.8	2976.2	266.0	184.4	0.0	353.2	72.0	7.3	52.0		FW	-2.
41.0	3.2	243.9	34000.5	800.0	800.0	114.0	2.908	280.0	5.1	2984.0	236.0	167.7	0.0	353.2	72.0	7.3	52.0		FW	-2.
42.0	2.9	248.4	34000.3	800.0	800.0	102.7	2.919	280.0	4.4	2990.7	207.0	151.0	0.0	353.2	72.0	7.3	52.0		FW	-2.
43.0	2.6	252.6	34000.3	800.0	800.0	91.3	2.930	280.0	3.6	2996.2	177.0	134.3	0.0	353.2	72.0	7.3	52.0		FW	-2.
44.0	2.3	256.1	34000.5	800.0	800.0	80.0	2.938	280.0	2.9	3000.6	147.0	117.6	0.0	353.1	72.0	7.3	52.0		FW	-2.
45.0	1.9	259.1	34000.0	800.0	800.0	68.7	2.944	280.0	2.2	3003.7	117.0	101.0	0.0	353.1	72.0	7.3	52.0		FW	-2.
46.0	1.6	261.8	34000.0	800.0	800.0	57.3	2.948	280.0	1.5	3005.7	88.0	84.3	0.0	353.1	71.0	7.3	51.0		FW	-1.
47.0	1.3	263.9	34000.4	800.0	800.0	46.0	2.950	280.0	0.7	3006.5	58.0	67.7	0.0	353.1	71.0	7.3	51.0		FW	-1.
48.0	1.0	265.5	34000.4	800.0	800.0	34.7	2.949	260.0	0.1	3006.2	30.0	47.7	0.0	351.8	69.0	7.2	49.0		FW	-1.
49.0	0.7	266.8	34000.1	800.0	800.0	26.1	2.947	115.0	0.1	3005.3	15.0	10.2	0.0	342.8	52.0	6.6	32.0		FW	0.

>>>> FLD. SENSED ...

TIME (SEC)	FLEET	GAL	RMS AMPS	RMS AMPS	ARK	KWHR	GEN	KWHR	FW	KWHR	# CARS
49.3	297.0	.218	628.8	250.4	1.17	1.56	.01	14.			

Figure 55. Continued (Sheet 2 of 3)

TIME SEC	SPL MPH	DIST FEET	NFT LBS	TF	ARM I	FLD I	PPM	KWHR	ARM I	FLD I	HMM	VOLTS	KW	ARM I	RPM	RHP	GPH	HP	SAND	SYS DRV	THR NCH
0.0	.7	.0	.0		50.	140.0	24.8	2.947	70.	.0	3005.0	7.	3.8	0.	338.9	49.	6.4	29.		FW	0.
1.0	.7	1.0	-219.3		150.	150.0	23.8	2.944	-75.	1.4	3003.7	49.	7.4	0.	339.7	49.	6.4	29.		FW	0.
2.0	.7	2.0	4392.8		250.	250.0	24.2	2.940	-125.	2.1	3001.7	75.	18.8	0.	343.2	52.	6.6	32.		FW	1.
3.0	.8	3.1	9853.8		350.	350.0	26.7	2.934	-175.	2.9	2998.5	101.	35.4	0.	345.6	57.	6.8	37.		FW	1.
4.0	.9	4.3	15362.6		450.	450.0	31.2	2.925	-225.	3.7	2993.6	129.	58.0	0.	348.8	63.	7.0	43.		FW	2.
5.0	1.1	5.8	20810.8		550.	550.0	38.0	2.911	-275.	4.6	2986.6	161.	88.8	0.	352.7	71.	7.3	51.		FW	2.
6.0	1.4	7.6	26367.0		650.	650.0	46.9	2.891	-325.	5.6	2976.7	200.	130.0	0.	357.5	80.	7.6	60.		FW	2.
7.0	1.7	9.9	31960.9		750.	750.0	58.1	2.865	-375.	6.9	2962.8	245.	184.1	0.	363.1	91.	8.0	71.		F	3.
8.0	2.1	12.7	34680.5		800.	800.0	71.3	2.829	-400.	8.1	2944.4	290.	231.9	0.	366.2	97.	8.3	77.		FW	3.
9.0	2.5	16.0	34663.9		800.	800.0	85.1	2.788	-400.	9.1	2923.1	329.	263.1	0.	366.3	97.	8.3	77.		FW	3.
10.0	2.9	20.0	34647.0		800.	800.0	98.9	2.743	-400.	10.2	2899.3	368.	294.4	0.	366.4	97.	8.3	77.		FW	3.
11.0	3.3	24.5	34629.8		800.	800.0	112.6	2.693	-400.	11.4	2873.0	407.	325.6	0.	366.5	97.	8.3	77.		FW	3.
12.0	3.7	29.6	34612.3		800.	800.0	126.4	2.640	-370.	12.5	2844.2	446.	356.8	-79.	398.9	160.	10.7	53.		GEN	4.
13.0	4.1	35.3	34594.5		800.	800.0	140.1	2.593	-270.	13.5	2818.7	485.	388.0	-260.	450.5	293.	17.0	53.		GEN	4.
14.0	4.5	41.6	34576.5		800.	800.0	153.9	2.557	-170.	14.5	2799.5	524.	419.2	-460.	507.0	460.	25.5	53.		GEN	4.
15.0	4.9	48.4	34558.2		800.	800.0	167.6	2.536	-70.	15.5	2787.6	563.	450.4	-660.	565.2	652.	35.9	53.		GEN	4.
16.0	5.3	55.8	34539.6		800.	800.0	181.3	2.529	14.	16.4	2764.1	602.	481.5	-828.	622.6	835.	45.5	53.		GEN	4.
17.0	5.7	63.8	34520.8		800.	800.0	195.0	2.529	14.	17.7	2784.1	641.	512.7	-828.	638.4	885.	48.1	54.		GEN	4.
18.0	6.0	72.4	34501.6		800.	800.0	208.7	2.530	14.	19.1	2784.1	680.	543.8	-828.	654.1	935.	50.7	54.		GEN	5.
19.0	6.4	81.6	34482.2		800.	800.0	222.4	2.530	14.	20.4	2784.3	719.	574.9	-828.	670.0	985.	53.4	54.		GEN	5.
20.0	6.8	91.3	34462.5		800.	800.0	236.1	2.530	14.	22.0	2784.4	757.	606.0	-828.	686.4	1035.	56.2	55.		GEN	5.
21.0	7.2	101.6	26100.7		650.	650.0	249.5	2.530	14.	21.8	2784.6	752.	488.9	-678.	627.1	850.	46.3	38.		GEN	0.
22.0	7.4	112.4	9552.1		350.	350.0	257.9	2.531	14.	16.9	2784.7	617.	215.9	-378.	492.7	417.	23.3	14.		GEN	0.
23.0	7.5	123.4	-3101.9		50.	50.0	259.9	2.530	14.	2.9	2784.5	115.	5.8	-78.	327.4	45.	6.1	3.		GEN	0.
# CARS REMAINING = 12. (KICKED 2.)																					
24.0	7.4	134.3	-10830.5		-250.	250.0	258.1	2.532	125.	11.1	2785.4	136.	116.8	0.	274.9	28.	4.5	8.		FW	-2.
25.0	7.2	145.0	-27788.1		-550.	550.0	250.9	2.558	275.	15.3	2799.6	594.	360.8	0.	333.4	47.	6.2	27.		FW	-3.
26.0	6.8	155.3	-28326.6		-560.	560.0	238.3	2.598	280.	14.2	2821.6	563.	350.4	0.	335.4	48.	6.3	28.		FW	-3.
27.0	6.5	165.1	-28310.4		-560.	560.0	225.4	2.636	280.	13.1	2842.1	529.	331.5	0.	334.8	48.	6.3	28.		FW	-3.
28.0	6.1	174.2	-28294.4		-560.	560.0	212.6	2.671	280.	12.1	2861.0	495.	312.7	0.	353.6	72.	7.4	52.		FW	-3.
29.0	5.7	182.9	-28278.7		-560.	560.0	199.8	2.704	280.	11.0	2878.5	462.	293.8	0.	353.5	72.	7.3	52.		FW	-3.
30.0	5.3	191.0	-28263.2		-560.	560.0	187.0	2.734	280.	10.0	2894.6	428.	275.0	0.	353.5	72.	7.3	52.		FW	-3.
31.0	5.0	198.6	-28247.9		-560.	560.0	174.2	2.762	280.	9.2	2909.2	394.	256.2	0.	353.4	72.	7.3	52.		FW	-3.
32.0	4.6	205.6	-28232.9		-560.	560.0	161.4	2.787	280.	8.3	2922.3	361.	237.4	0.	353.4	72.	7.3	52.		FW	-2.
33.0	4.2	212.1	-28218.1		-560.	560.0	148.6	2.809	280.	7.4	2934.1	327.	218.6	0.	353.3	72.	7.3	52.		FW	-2.
34.0	3.9	218.1	-28203.5		-560.	560.0	135.9	2.829	280.	6.6	2944.5	294.	199.8	0.	353.3	72.	7.3	52.		FW	-2.
35.0	3.5	223.5	-28189.2		-560.	560.0	123.1	2.847	280.	5.7	2953.5	260.	181.0	0.	353.2	72.	7.3	52.		FW	-2.
36.0	3.1	228.3	-28175.1		-560.	560.0	110.3	2.861	280.	4.9	2961.1	227.	162.2	0.	353.2	72.	7.3	52.		FW	-2.
37.0	2.8	232.7	-28161.2		-560.	560.0	97.6	2.873	280.	4.1	2967.4	193.	143.5	0.	353.2	72.	7.3	52.		FW	-2.
38.0	2.4	236.5	-28147.6		-560.	560.0	84.8	2.883	280.	3.2	2972.4	160.	124.7	0.	353.1	72.	7.3	52.		FW	-2.
39.0	2.0	239.7	-28134.2		-560.	560.0	72.1	2.890	280.	2.4	2976.0	126.	106.0	0.	353.1	72.	7.3	52.		FW	-2.
40.0	1.7	242.5	-28121.0		-560.	560.0	59.3	2.895	280.	1.6	2978.3	93.	87.2	0.	353.1	71.	7.3	51.		FW	-1.
41.0	1.3	244.6	-28108.0		-560.	560.0	46.6	2.897	280.	.8	2979.3	59.	68.5	0.	353.1	71.	7.3	51.		FW	-1.
42.0	.9	246.3	-26442.3		-530.	530.0	33.9	2.896	265.	.1	2979.0	28.	46.5	0.	351.8	69.	7.2	49.		FW	-1.
43.0	.7	247.4	-9512.2		-230.	230.0	24.2	2.894	115.	.0	2978.0	12.	9.5	0.	342.8	52.	6.6	32.		FW	0.

>>> RUN SUMMARY ...

TIME(SEC)	FEET	GAL	RMS	AMPS	RMS	AMPS	BRK	KWHR	GEN	KWHR	FW	KWHR	# CARS
43.4	247.7	.179	612.4	251.0	1.06	1.21							12.

<< << TRIP SUMMARY ...

TIME(SEC)	FEET	GAL	RMS	AMPS	RMS	AMPS	BRK	KWHR	GEN	KWHR	FW	KWHR	# CYCLES
92.7	514.7	.396	621.2	251.0	2.22	2.77							2.

Figure 55. Continued (Sheet 3 of 3)

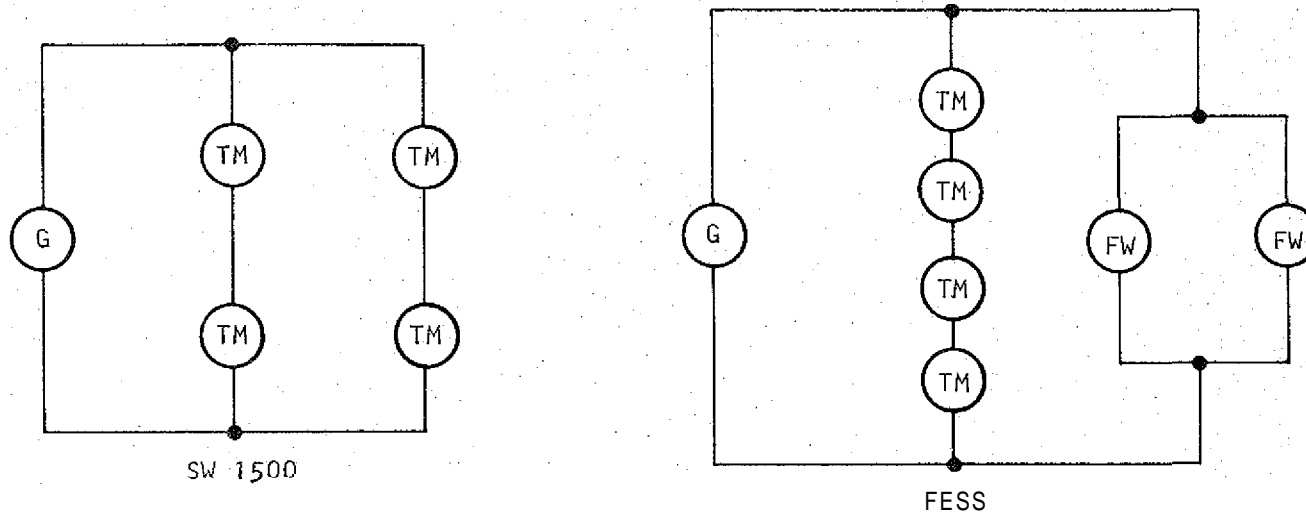

G = GENERATOR
TM = TRACTION MOTOR
FW = FLYWHEEL MACHINE
NOTE: FIELD CONNECTIONS NOT SHOWN

S-34186

Figure 56. Armature Circuit Connections

The auxiliary loads including the field power supply and added cooling are probably not more than 20 percent in error. These are, in any case, only second-order increments in the range of 40 to 90 hp absolute. Therefore, it is essentially of the same merit as the SW1500 model.

USE OF THE MODELS

Model flexibility is exercised through variations in input deck data; however, changes in basic system component characteristics can be readily accommodated by substitution of the respective subroutines. In general, the component subroutines contain stored data sets defined by real-world test data. These data sets can be altered without any basic modification of the subroutine format.

Tables 14 and 15 show variations that may be entertained by alterations of data in the input card decks. The card decks illustrated in Figures 47 (sheet 1), 48 (sheet 1), and 55 (sheet 1) also show the control cards that are used with the UNIVAC 1100 system. The programs are written in FORTRAN V and are compatible with minor modifications down to level IV G.

A list of programs and subroutines related to the simulator models is given in Appendix B.

PRELIMINARY ANALYSIS (TASK IIB)

This Phase I study of a yard-switching locomotive incorporating a flywheel energy storage unit has been structured to establish the most advantageous system configuration within the limits of existing conventional hardware components (i.e., SW1500 locomotive and ACT-1 flywheel unit) by means of a preliminary system analysis, as defined in the contract SOW.

The following two basic configurations were considered in the analysis:

- (a) The flywheel energy storage unit in a trailing car with the locomotive modified for separately excited traction motors
- (b) The flywheel energy storage unit in a trailing car with the trailing car having separately excited traction motors and the locomotive basically unmodified

It was not the purpose of the preliminary analysis to establish an optimum configuration. No additional configurations other than the specified alternatives were identified at this stage in the study.

The FESS concepts previously analyzed in AiResearch Report 78-15053 (Reference 4), are summarized below.

Reference 4. Analysis Report, Flywheel Energy Storage Switcher, AiResearch Report 78-15053, AiResearch Manufacturing Company of California, June, 1978.

TABLE 14
SW1500 MODEL INPUT DECK DESCRIPTION

Card 1	Title card (all literal).
Cards 2, 3	Define the consist.
Card 4	Defines the locomotive configuration and mean traction motor operating temperature.
Cards 5, 6	Define operating profile for fetch mode.
Card 7	Defines system response rates.
Card 8	Declares kicking or fetching mode; if kicking, it defines kick speed and number of cars per kick.
Ca-d 9	Program control for run duration and printout options.

TABLE 15
FESS CARD INPUT

Card 1	Title.
Cards 2, 3	Consist definition.
Card 4	Locomotive configuration and traction motor mean temperature.
Card 5	Flywheel configuration.
Card 6	System operating levels and auxiliary load level.
Card 7	Declares kicking or fetching mode; if kicking, it defines kick speed and number of cars per kick.
Cards 8, 9	Defines operating profile for fetch mode.
Card 10	Program control for run duration and printout options.

Concept A

The basic Concept A1 system schematic is shown in Figure 57. In this system, the diesel engine, main dc generator, and the basic friction brake system are existing SW1500 locomotive equipment. The traction motors are modified by the replacement of the existing series-wound main field coils with low-current main field coils that are excited from a separate source. No changes to the magnetic circuit or armature of the traction motor are required. The auxiliary alternator has been added to the engine-driven auxiliaries, and the locomotive controls modified for operation with the energy storage unit. The flywheel energy storage unit is installed in a trailing car. Suitable power and control interconnections are provided between the locomotive and trailing car. The limitation on the performance of this system was found to be the flywheel machine continuous current rating of 540 amp. To overcome this limitation, Concept A2, shown diagrammatically in Figure 58, was developed.

Concept B

The basic Concept B1 system schematic is shown in Figure 59, and consists of an SW1500 locomotive with the addition of an auxiliary alternator, a series/parallel switch for the traction motors, an isolation switch, a necessary modification of locomotive controls for operation with an energy storage unit, and four separately excited traction motors installed on a trailing car. The trailing car is also provided with a friction brake system.

System elements are the same as described for Concept A, but the energy storage unit must drive a larger blower to supply cooling air to the traction motors on the trailing car. All field power supplies are installed on the trailing car. One field power supply unit with individual controls for each separately excited traction motor and one field power supply for each energy storage unit are provided.

As in Concept A1, Concept B1 was found to be limited in performance by the flywheel machine rating, and therefore Concept B2 shown in Figure 60 was developed.

Selected Concept

Based on the preliminary data available. AiResearch recommended that Concept A2 should be chosen for an indepth system analysis. FRA concurred with this recommendation, and the indepth analysis (Task 11c) was directed to Concept A2.

INDEPTH SYSTEM ANALYSIS (TASK 11C)

Concept A2 consists of a General Motors Electro-Motive Division (EMD) SW1500 switching locomotive and a nonmotored boxcar containing two ACT-1 energy storage units (Figure 58). The two vehicles are coupled, using a standard Association of American Railroads (AAR) coupler and electrical/air connections.

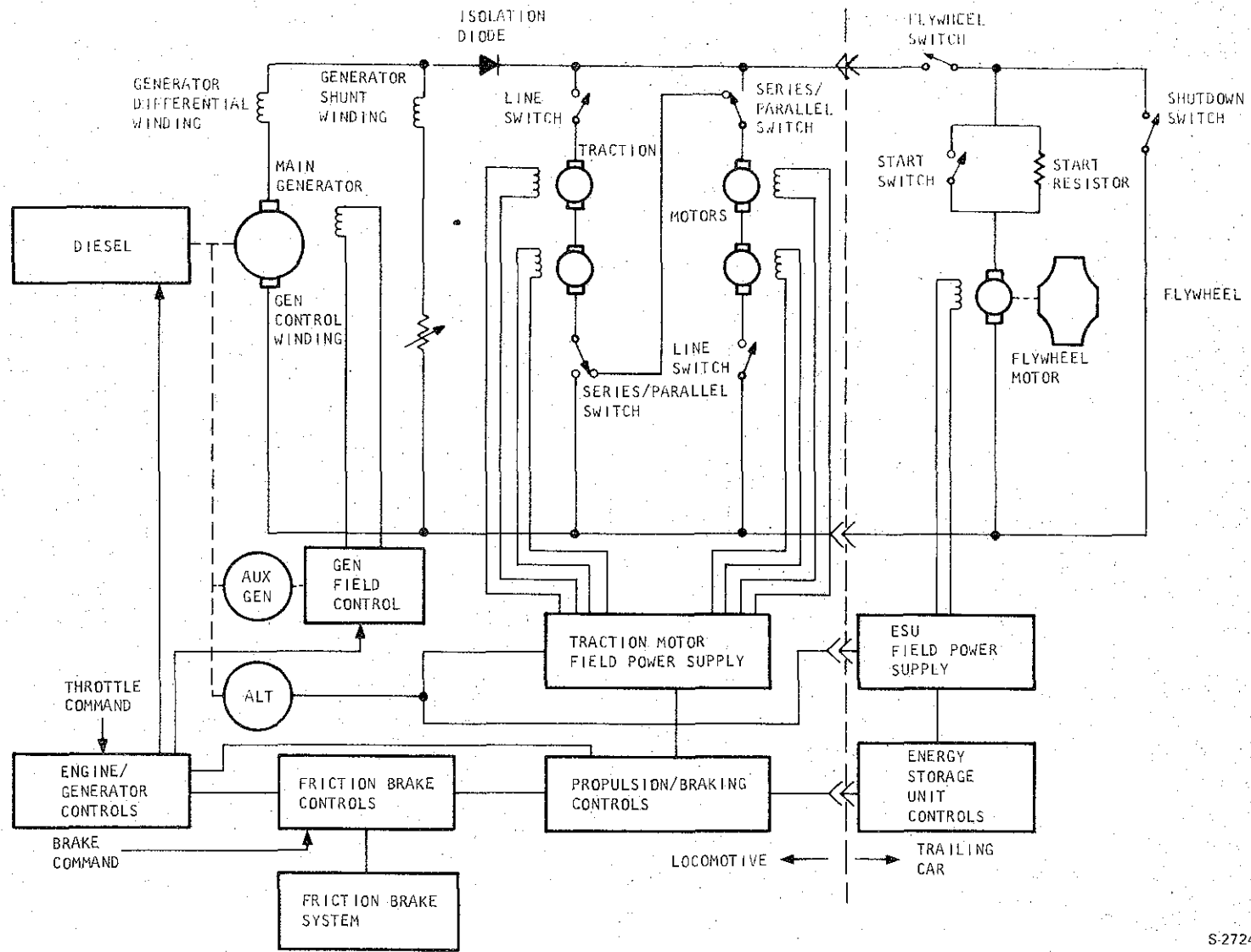

S-27244

Figure 57. Simplified System Schematic--Concept 41

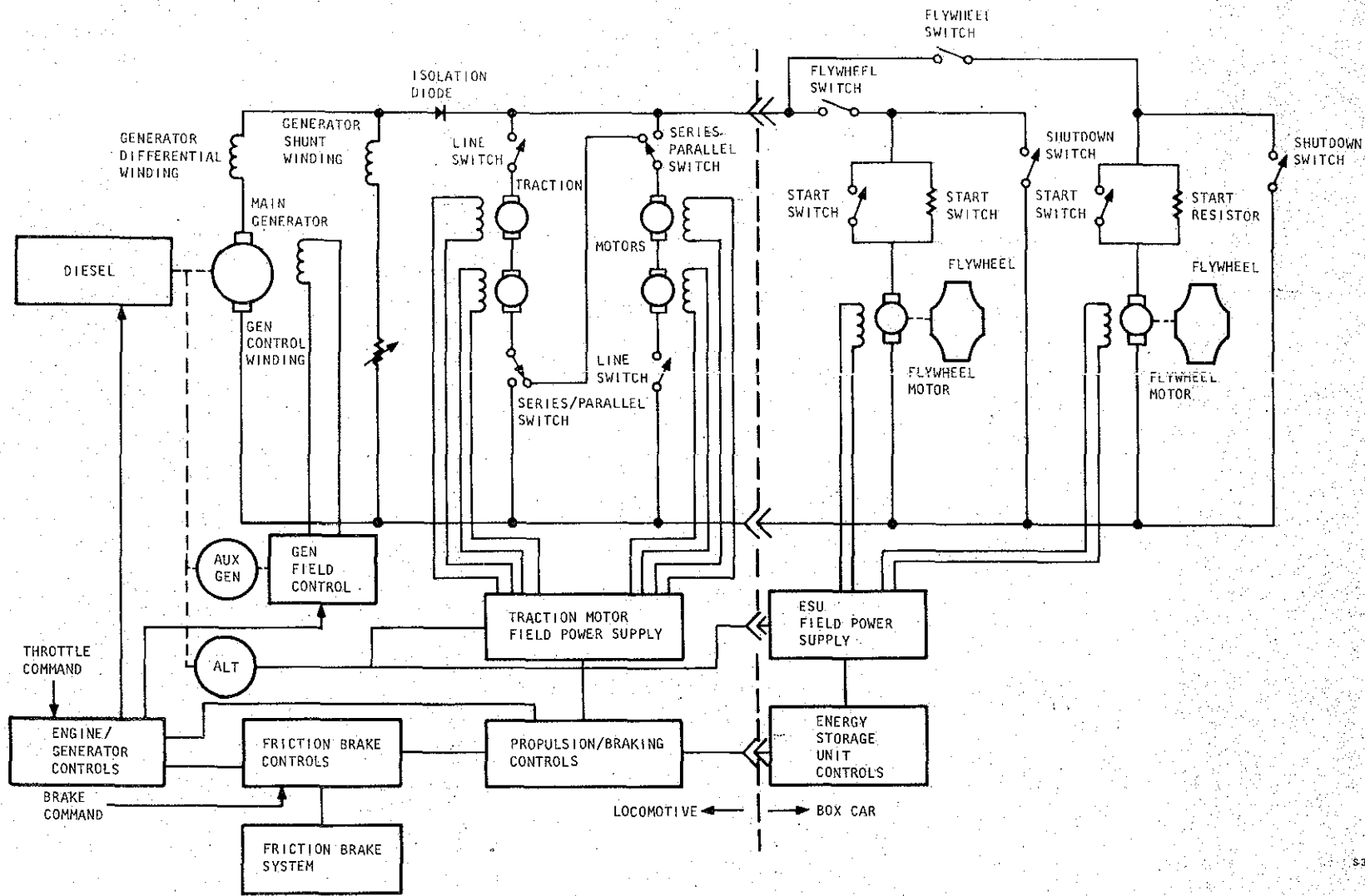
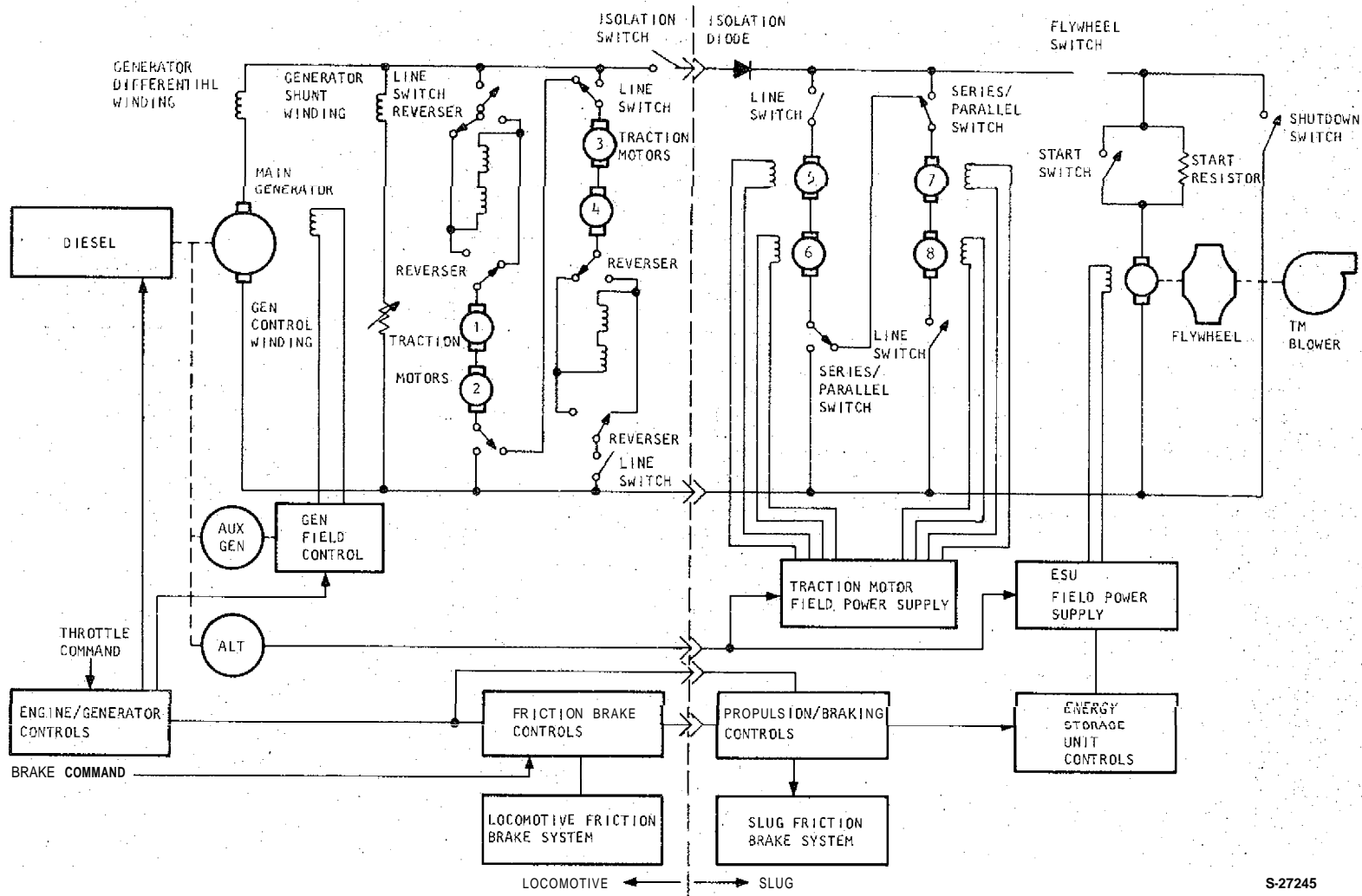
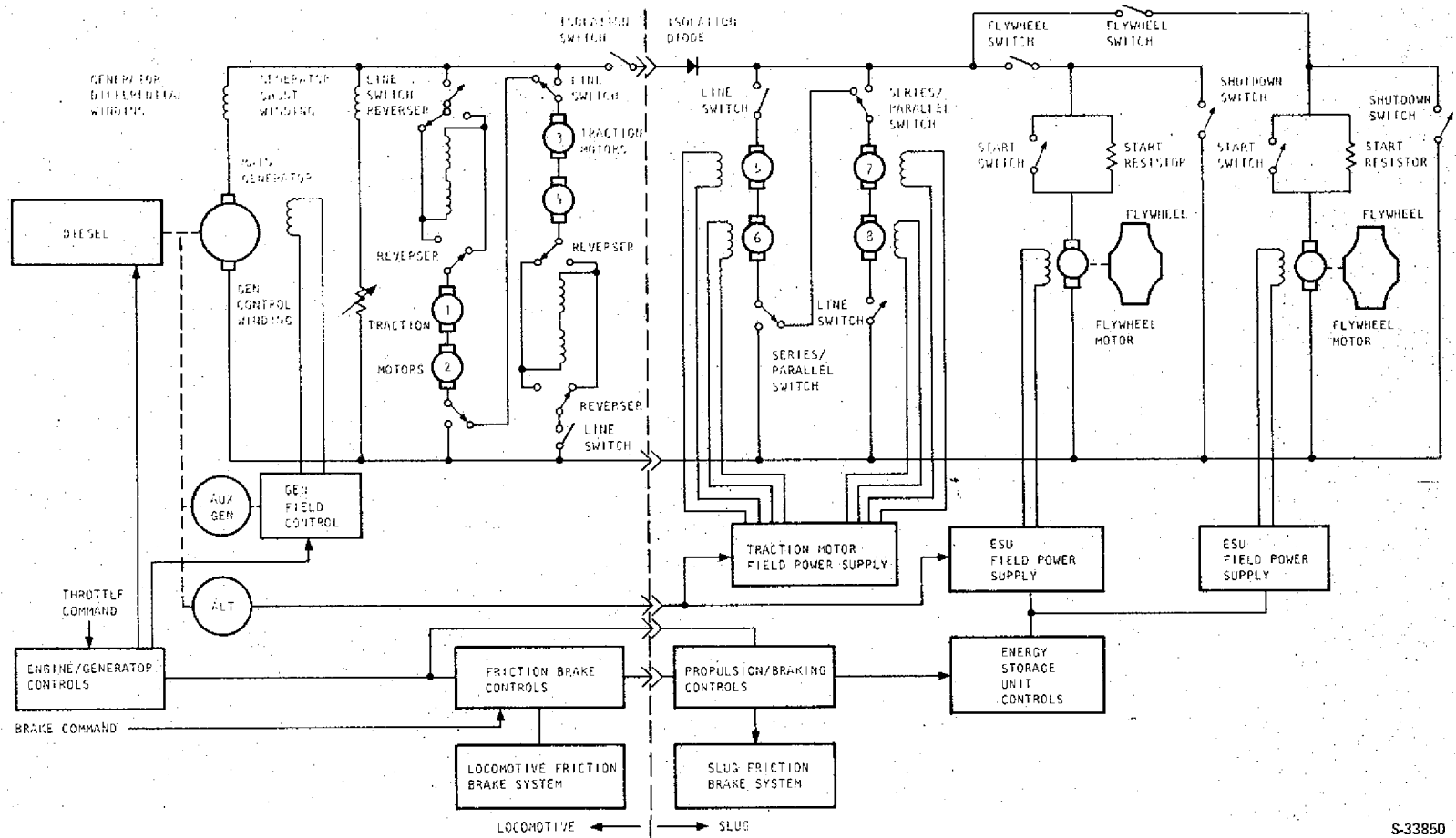

Figure 58. Simplified System Schematic--Concept A2



S-27245

Figure 59. Simplified System Schematic--Concept B1



S-33850

Figure 60. Simplified System Schematic--Concept B2

System Description

The system has two basic operating modes, motoring and braking. Since the motors are modified EMD D77 traction motors, they are of the low field current, separately excited type. During motoring the power source may be the diesel engine, the flywheel (via intervehicle electrical connections), or a combination of both. The power source for a given condition depends on the stored energy level and the energy management policy adopted. The flow of current from the flywheel machines to the main generator is prevented by the use of isolation diodes between the generator and traction motor units. During braking the traction motors, now acting as separately excited generators, are driven by the locomotive wheels and the current is fed to the flywheel machines increasing the flywheel speed and storing the braking energy. The speeds of the two flywheels are kept approximately the same by flywheel machine field adjustment. Current passage to the generator is again prevented by the isolation diodes.

Upon receipt of a command to transition from an accelerating mode to a braking mode, the traction motor field currents are increased slightly to raise the armature voltage above that of the main generator. This action reverse-biases the isolation diode and the generator field current and the output current are reduced to zero. During the same interval, the initial level of armature current in the flywheel machine could be either positive or negative. However, due to the increasing traction motor voltage, the current will increase in a negative direction until the commanded current level is obtained. The primary controls for the braking mode are the traction motor field currents used to set the operating voltage level as a function of speed, and the flywheel motor field current used to regulate armature current. Once the generator current has been reduced to zero, the generator voltage can be held at some level below the traction motor armature voltage. The transition from braking to acceleration will essentially be the reverse of the process described above.

The component efficiencies of the system shown in Figure 61 are generalizations since efficiency varies with load and duty cycle. It can be noted that the approximate round-trip efficiency is 67 percent. In a normal duty cycle, delays between deceleration and acceleration will be minimized; therefore, flywheel spinning losses have been neglected.

In the computer simulation, actual values of component efficiency based on load including spinning losses were used to calculate fuel savings.

System Hardware

Although existing, unmodified system hardware will not be described in this report, references will be made to the modifications of the control of such hardware.

1. Energy Storage Units

The ESU's to be installed in the trailing boxcar are based on the ACT-1 ESU's modified for this application (the modified ESU is shown in Figure 62).

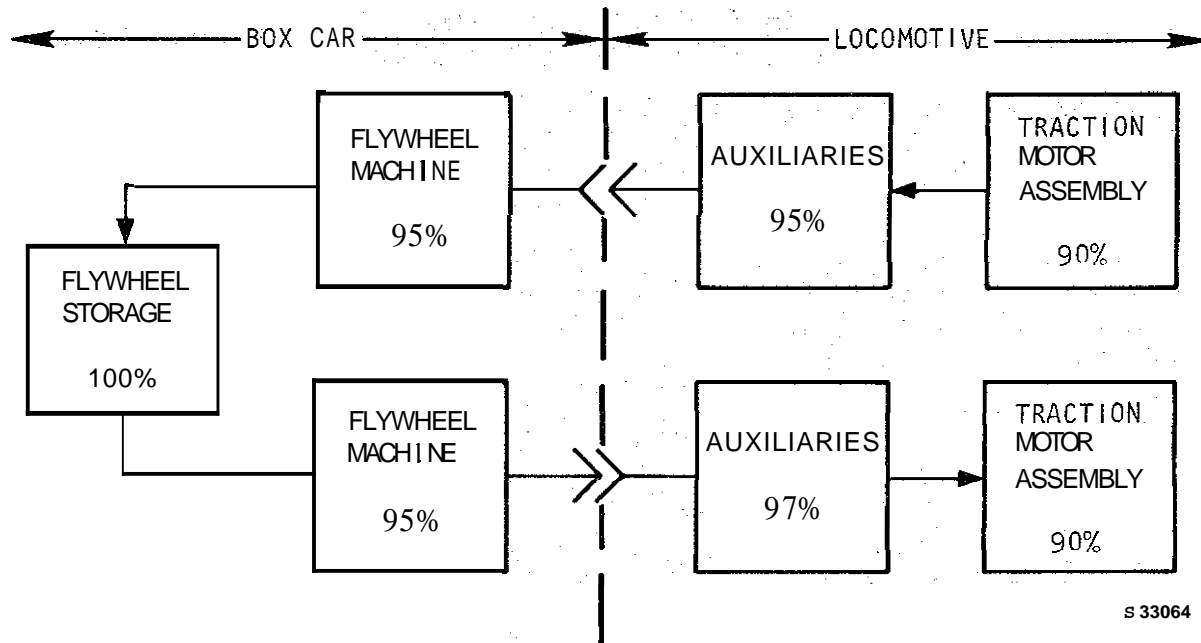

Figure 61. Typical FESS System Efficiencies

a. Modifications to Standard ESU

Minor modifications are required on the standard ACT-1 ESU for suitability to the FESS application. The oil-cooled auxiliary alternator used in the ACT-1 installation to provide field power for the flywheel machine is not required for the FESS installation since field power is obtained from the diesel engine-driven, auxiliary alternator on the locomotive by means of jumper cables. This arrangement has the advantage of reducing the number of rotating machines, but does preclude the charging of the flywheel from a single external source that may have been operationally convenient. Removal of this alternator will entail blanking off the oil ports used for alternator cooling. The revised lubricating oil circuit design is shown in Figure 63.

The turbocooler used in the ACT-1 installation for air conditioning is not required for FESS. As with the alternator removal, the oil ports will have to be bridged to preserve the integrity of the oil circuits.

The standard ESU blower is used to cool the flywheel machine and traction motors on ACT-1, but the only cooling requirement in the FESS application is for the flywheel machine. This means that a smaller blower can be used in this application, again minimizing the energy drain on the flywheel.

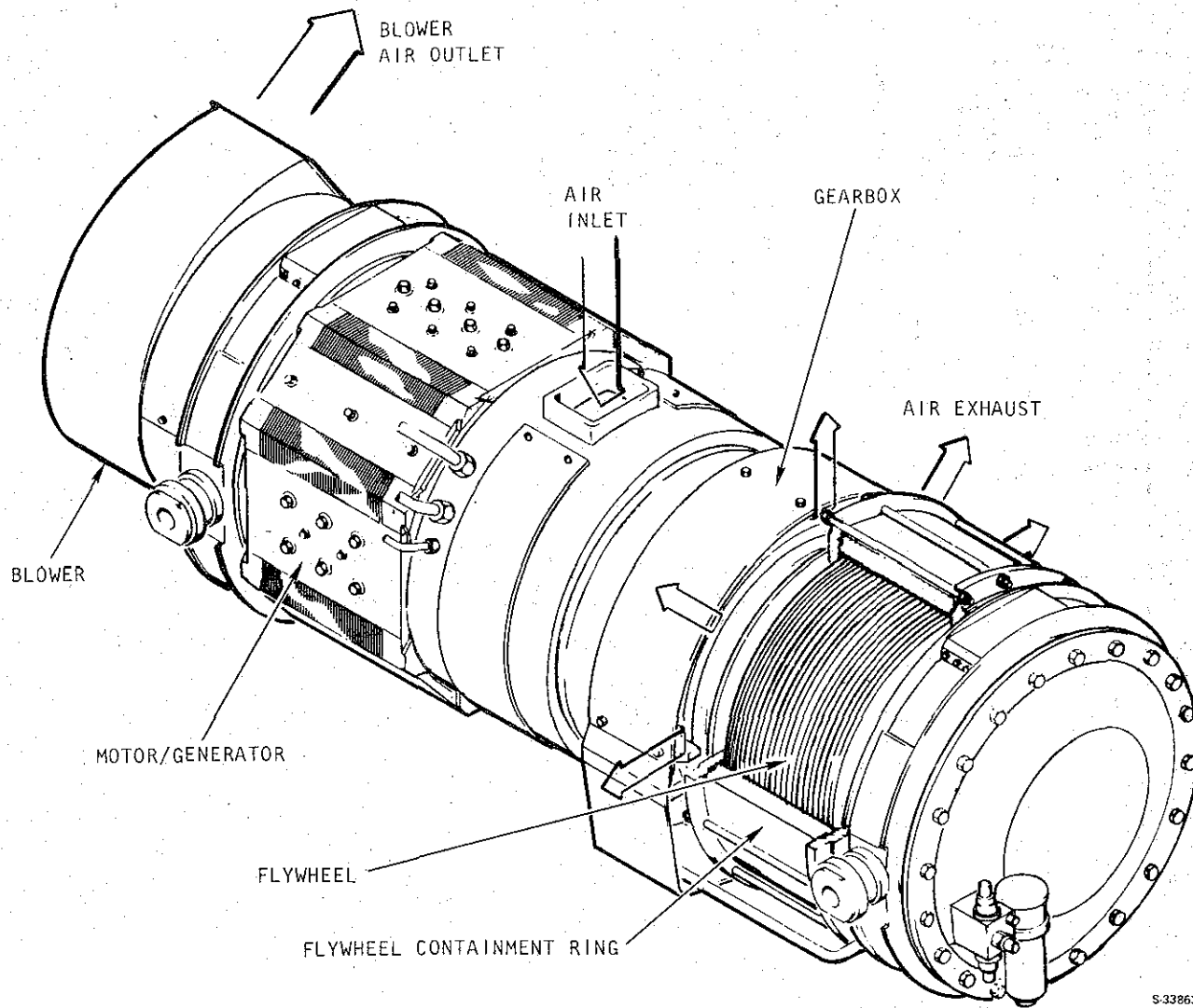

S-33863

Figure 62. Energy Storage Unit (E80) Modified for FESS Application

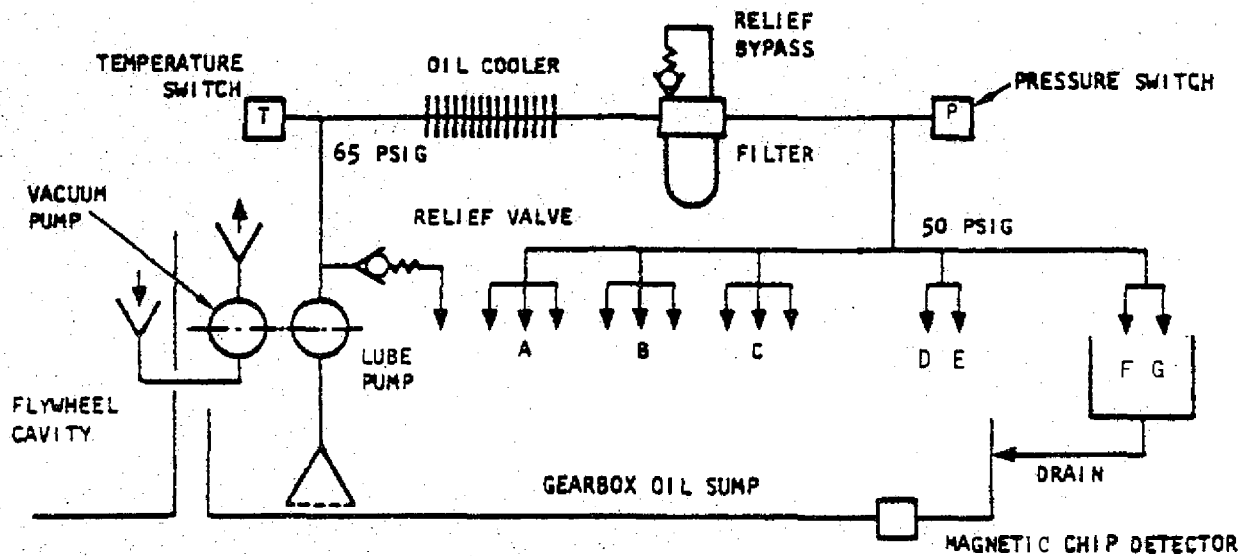

LOCATION		JET DIA, IN.	GPM PER JET	NO. OF JETS	TOTAL GPM
A	OUTBOARD PLANET BEARING	0.030	0.13	3	0.39
B	INBOARD PLANET BEARING	0.030	0.13	3	0.39
C	SUN GEAR	0.037	0.20	3	0.60
D	ROLLER BEARING	0.073	0.80	1	0.80
E	RESILIENT MOUNT	0.037	0.20	1	0.20
F	ROLLER BEARING	0.073	0.80	1	0.80
G	RESILIENT MOUNT	0.037	0.20	1	0.20
TOTAL					3.38 GPM

Figure 63. Energy Storage Unit Lubricating Oil Circuit Design for FESS Application

b. Installation

Installation requirements for the ESU are relatively simple, The major requirements are:

- (a) Cooling air to be filtered and ducted
- (b) Cable runs to be in accordance with normal safe practice

- (c) ESU mechanical mounts to be able to withstand accelerations associated with switching (3 g longitudinal, 2 g lateral)
- (d) Ease of access for maintenance of ESU and control system
- (e) Storage of special maintenance parts

A typical boxcar is shown in Figure 64.

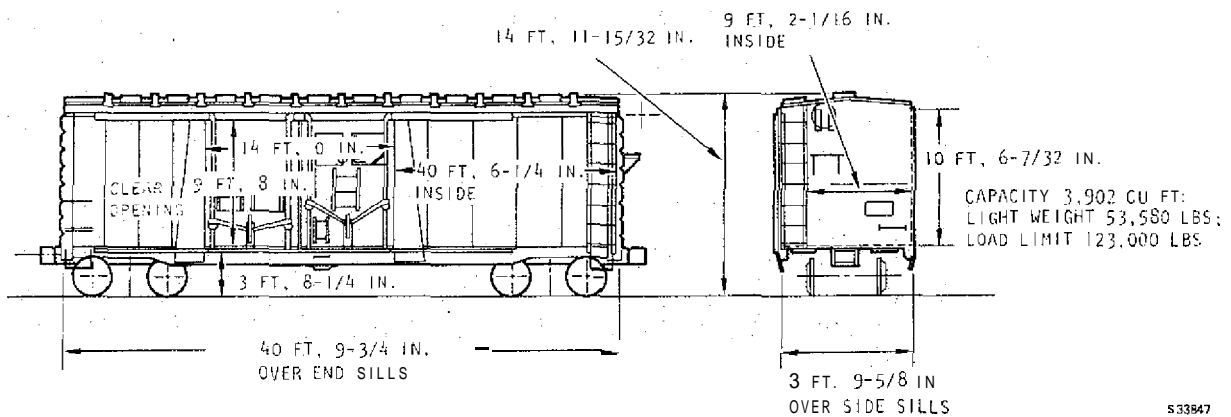

Figure 64. Typical U.S. Boxcar

2. Locomotive Equipment and Modifications

a. Traction Motors

The modifications of the traction motors to 97 turn main fields with improved interpoles is described in detail later in this report.

b. Field Supply Alternator

The power source required for the traction motor and flywheel machine fields will be an engine-driven alternator. The power requirements are as follows:

Traction motor field supplies (including field forcing)	60 kw
Flywheel machine field supplies (including field forcing)	20 kw
Total	80 kw

Considering alternator efficiency and assuming a 0.6 power factor, the alternator is required to deliver 150 kva over the entire 493/900 rpm engine speed range. This performance requirement can be met by the alternator used by Garrett on the gas turbine-electric (GTE) cars. The characteristics of the proposed field alternator (Figure 65) show that the machine when operated from 4,930 to 9,000 rpm through a 10:1 speed increases gearbox and pulley systems and is able to produce a minimum of 150 kva at the minimum operating speed.

This alternator was used successfully on the GTE cars and has seen extensive service on commercial craft. With more than 20 million hours of service experience, the alternator has a proven reliability record. It is not sensitive to environment and has given consistent performance. Maintenance is simplified and reliability assured by the lack of brushes, commutators, and slip rings. The growth of the mean-time-between-failure (MTBF) as used on 707/720 aircraft is shown in Figure 66.

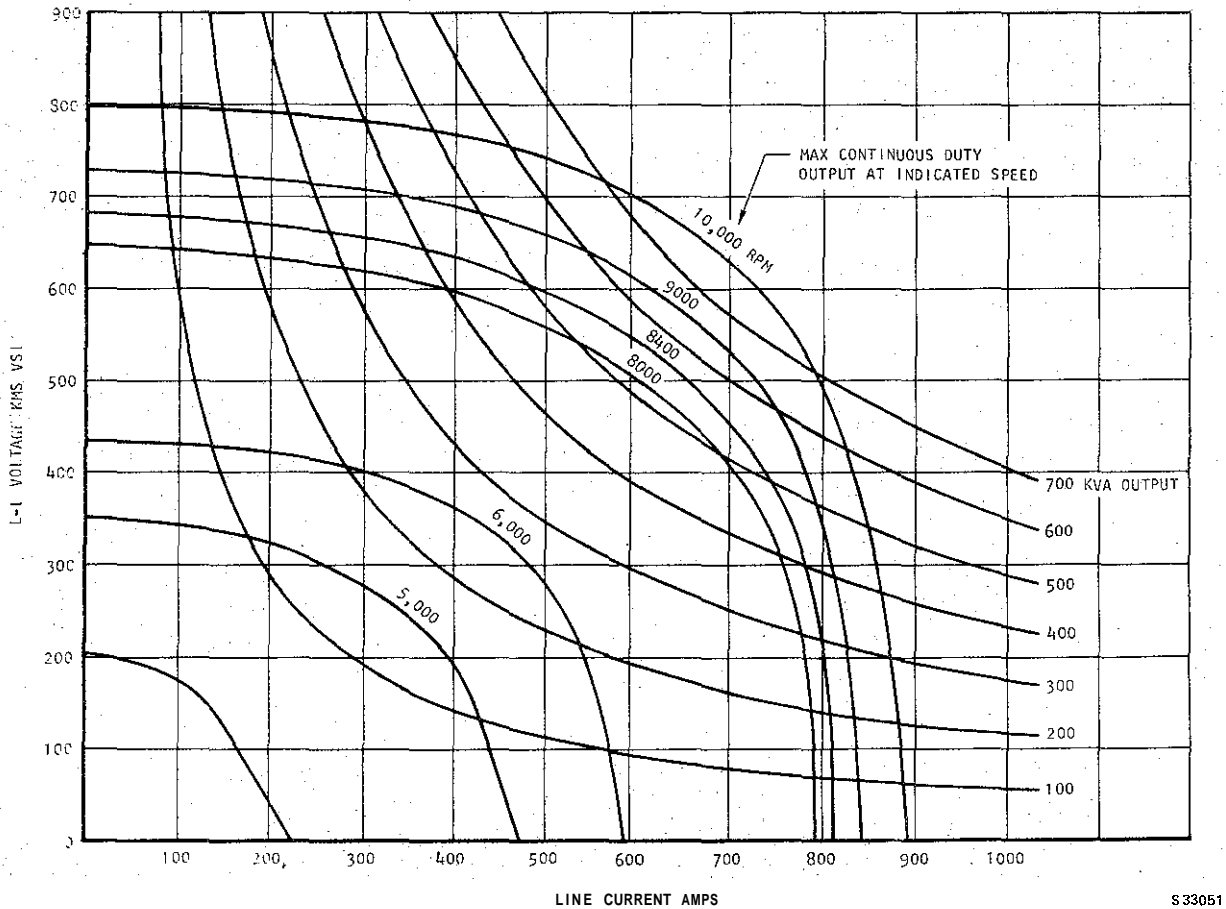

Figure 65. Characteristics of Proposed Field Supply Alternator

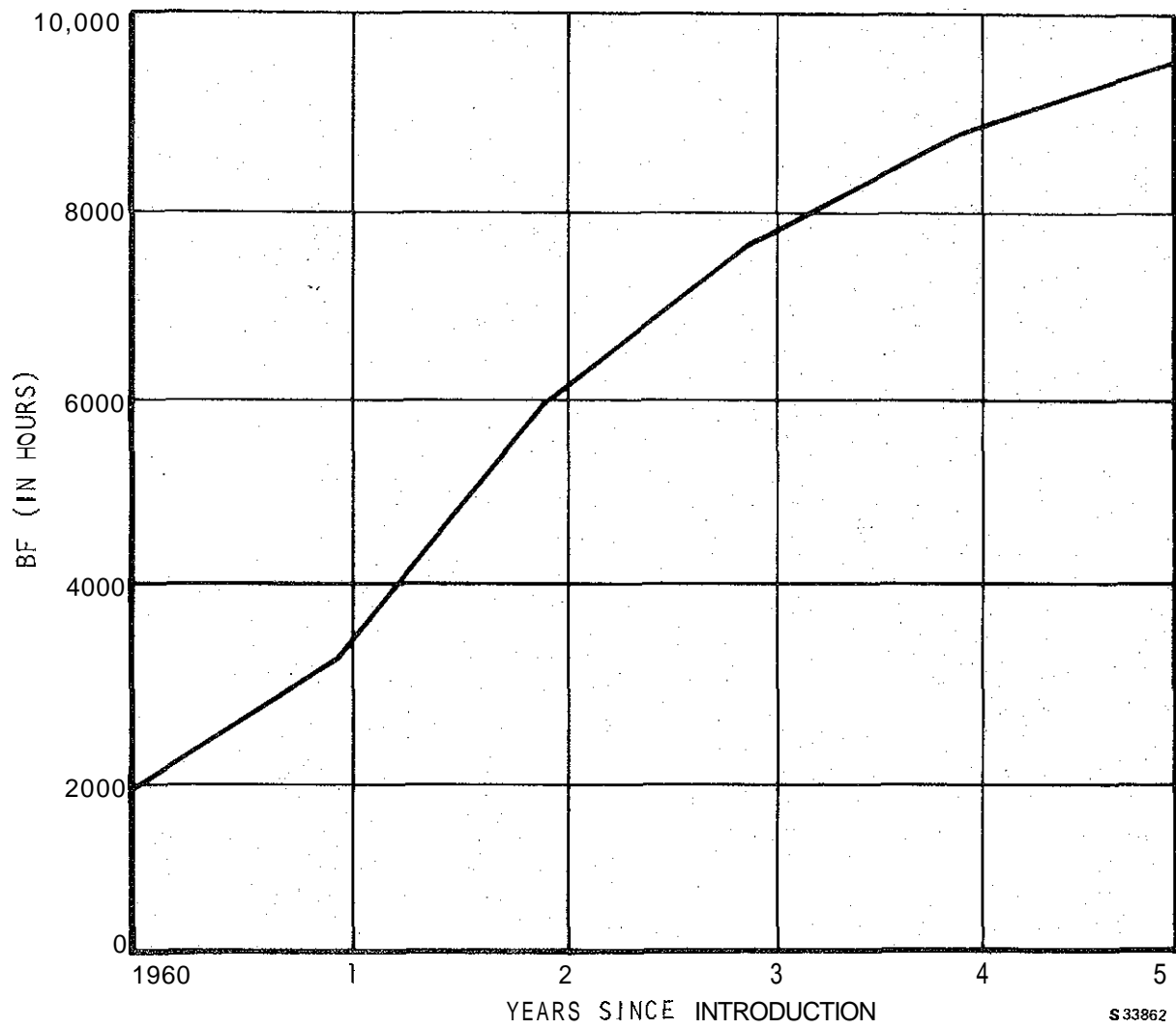
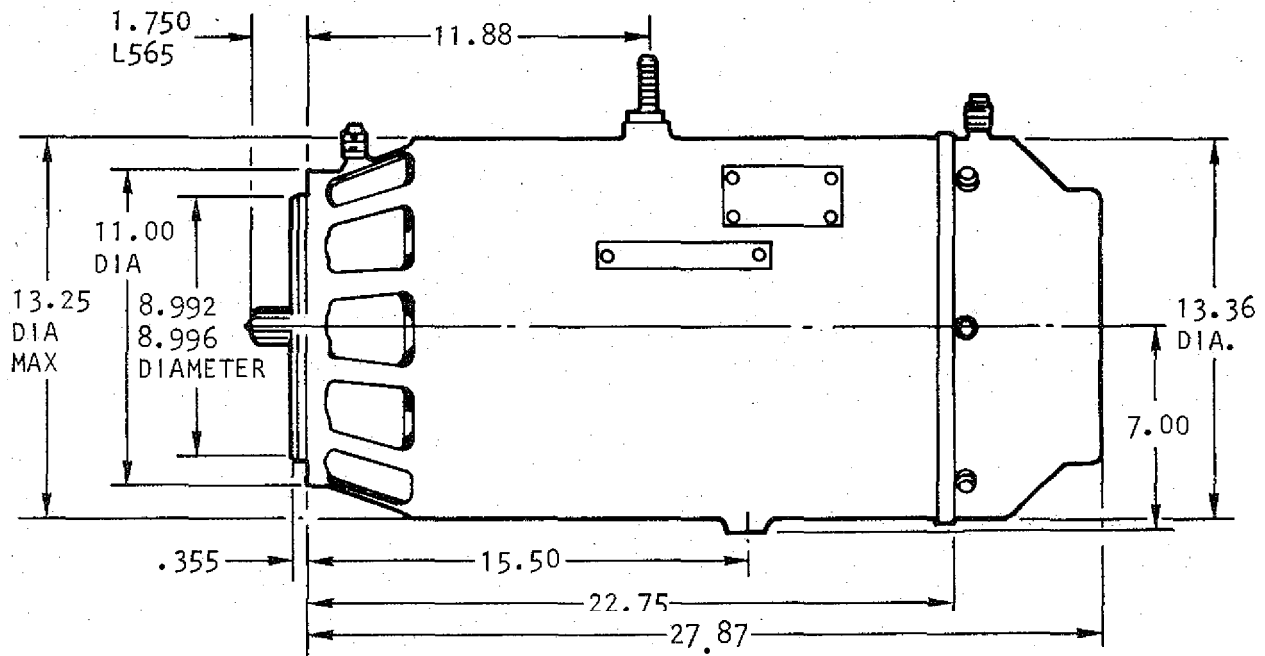

Figure 66. Reliability Growth of Proposed Field Supply Alternator for Commercial Aircraft Application

The major components of the generator are the main generator, the exciter generator, a rotating rectifier assembly, and associated mechanical parts. The exciter of the generator consists of a stationary dc field and a rotating ac armature. The ac output of the exciter is fed into a three-phase, full-wave silicon rectifier assembly mounted in the center of the generator shaft. The dc output from the rectifier assembly is supplied directly to the rotating field of the main generator.

Regulation of the generator ac output voltage is accomplished by controlling the strength of the exciter dc field. A transistorized or magnetic amplifier voltage regulator directs the output voltage by sensing and comparing this voltage with a referenced value to obtain an error signal. This signal is amplified and used to control the current supplied to the exciter field winding.

The alternator (shown in Figure 67) is to be installed above the main and auxiliary generators in the space shown in Figure 68, the location of the speed increasing gearbox. The alternator and gearbox will be mounted off the existing bracket shown in Figure 69. A general arrangement of the installation is shown in Drawing SK6999.



S-33066

DIMENSIONS IN INCHES

Figure 67, Outline of Field Supply Alternator

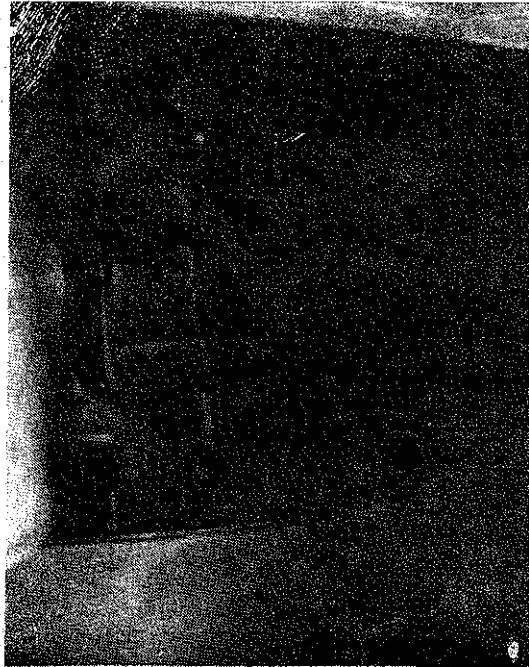

F-29050

Figure 68. Space Available for Installation of Auxiliary Alternator

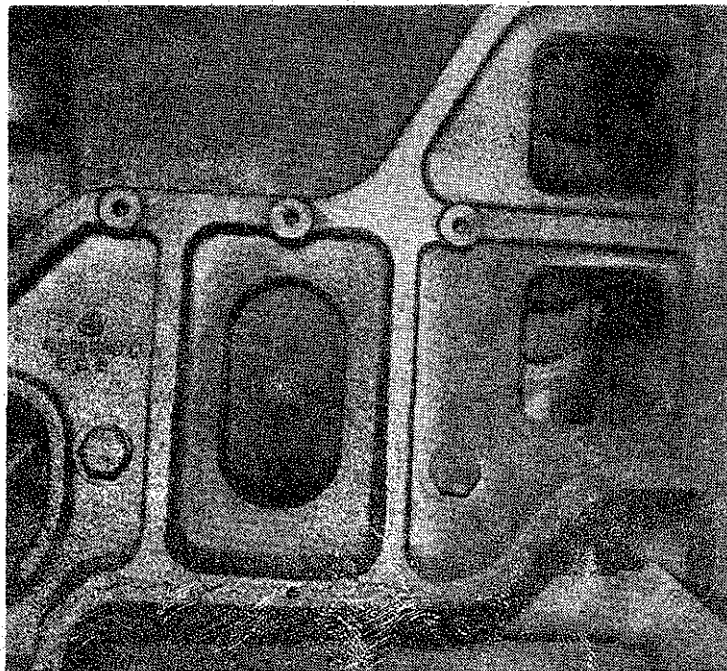

F-29052

Figure 69. Mounting Bracket for Alternator and Gearbox

REVISIONS		DATE	APPROVED
NO.	DESCRIPTION		

This drawing contains designs and other information which are the property of THE GABBETT CORPORATION. It is to be used only for the purposes for which it was prepared and is not to be reproduced, stored in a retrieval system, or transmitted in any form or by any means, electronic, mechanical, photocopying, recording, or by any information storage and retrieval system, without the prior written permission of THE GABBETT CORPORATION.

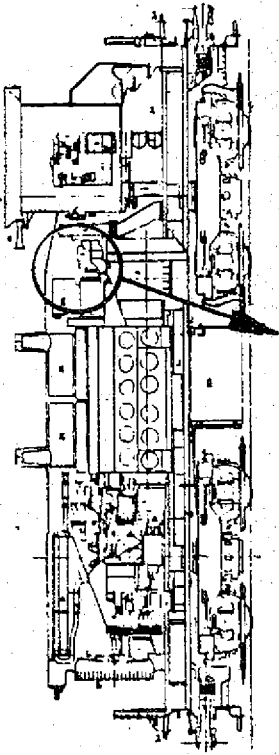

FIELD SUPPLY ALTERNATOR

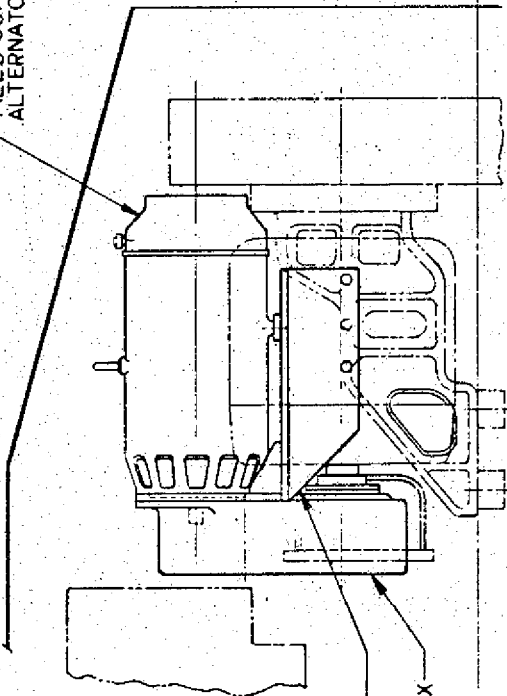

SUPPORT BRACKET
GEAR BOX

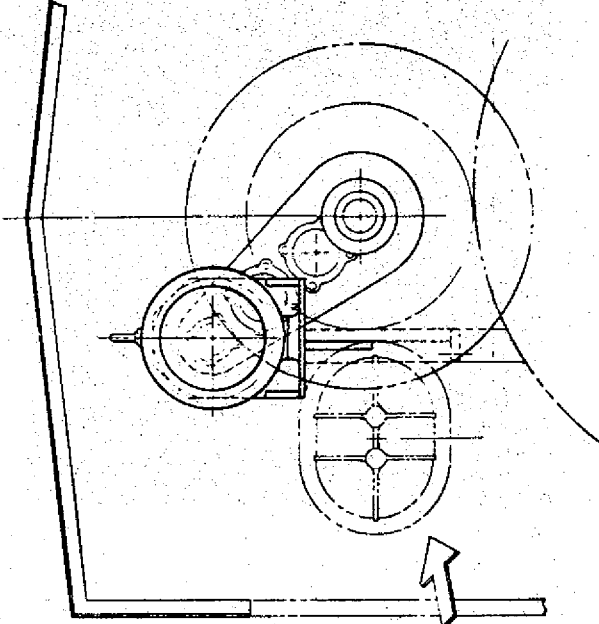

ACCESS

AIRRESEARCH MANUFACTURING COMPANY OF CALIFORNIA A DIVISION OF THE GABBETT CORPORATION TORRANCE, CALIFORNIA		ALTERNATOR, FIELD SUPPLY, INSTALLATION IN LOCOMOTIVE SW1500 (FESS)	
CONTRACT NO. PREPARED BY: <i>J. A. ...</i> 790110	DRAWING NO. C 70210	PART NO. SK69999	SHEET / OF / 1 / 1
UNLESS OTHERWISE SPECIFIED: SURF CONTROL PER EC&G STD INTERPRETATIONS PER ASME DIMENSIONAL MARKING PER ASME	REGION DATE REVISIONS APPROVED DESIGN SUPERVISOR PROJECT ENGINEER GOVERNMENT AGENCY	SCALE	
MATERIAL FINISH TOLERANCES		PART IDENTIFY	
REQ'D. NEXT ASSY. USED ON APPLICATION		SCALE	

c. Jumper Cables

Jumper cables are required to connect the locomotive and boxcar electrically and will conform to the requirements of AAR Specification, Section 7-4-2-1. The jumper cables are as follows:

- (a) Control--Standard 27-point plugs and receptacles shown in Figure 70 will be mounted in the AiResearch-designated standard positions in order to utilize the existing jumper equipment. Spare wires will be used by new control functions. A list of the proposed function allocations is contained in Table 16; these will be approved by AiResearch before being implemented.
- (b) Auxiliary Power--The field power supply jumper cables of the flywheel machine will be standard AiResearch 30-amp capacity, currently used for external supplies for locomotive lighting. Two cables in parallel will be used to achieve the necessary current capacity. These items are detailed in Figure 71.
- (c) Main Power--To provide for the 1000-amp jumper requirement for main power, it is proposed that the AiResearch dynamic brake field loop plug and receptacle be used (Figure 72).

d. Field Control Unit

The optimum field control unit is shown in Figure 73. The operating current and voltage were selected because a transformer is not required, allowing the cost of the modification of the motors to be offset by the cost of the transformer.

The field control units will be mounted in the electrical compartment under the cab, with the power device heat sinks mounted in cutouts in the traction motor cooling air ducts. The space available for this installation is shown in Figure 74.

SYSTEM CONTROL

Energy Management

Although relatively small, the spinning losses associated with the flywheel vary as the square of the speed (Figure 75). Therefore, at 70-percent speed there are approximately 55 percent of the losses at 100-percent speed. In order to minimize these losses, it is proposed that the flywheel be maintained at as low a speed as possible. This is achieved when energy is taken out of the flywheel at the start of an acceleration at the maximum power level. Upon reaching the flywheel minimum speed, diesel power will take over to supply the traction motors and maintain the flywheel at its minimum speed. Because there is no way of knowing the weight of the locomotive and cars to be braked, energy will be passed to the flywheel from the initiation of braking. As the flywheel reaches maximum speed, if sufficient energy is available due to braking, the brakes will be applied to complete the braking duty. This system inherently takes account of changes in train weight thereby avoiding the need for costly and complex control logic.

TABLE 16

PROPOSED CONTACT IDENTIFICATION OF 27-POINT
CONTROL PLUG AND RECEPTACLE FOR FESS EQUIPMENT

Receptacle Point	Function	Code
1	Power Reduction Setup	PRS
2	Alarm Signal	SG
3	Engine Speed	DV
4	Negative	N
5	Spare (Emergency Sanding)	ES
6	Generator Field	GF
7	Engine Speed	CV
8	Forward	FO
9	Reverse	RE
10	Wheel Slip	WS
11	Brake Hold Off/Generator Excitation Inhibit	BH*
12	Engine Speed	BH
13	Positive Control/Fuel Pump	PC/FP
14	Excitation Set Up on G.E. Units	SN
15	Engine Speed	AV
16	Engine Run	ER
17	Electric Brake	EB
18	Braking Effort Command	BECP*
19	Second Negative	NN
20	Dynamic Brake	BG
22	Compressor	CC
23	Sanding	SA
24	Brake Control/Power Reduction Control	BC/PRC
25	Headlight	HL
26	Separator Blow-Down/Remote Reset	SV/RR
27	Braking Effort Command	BECN*

*FESS Proposal

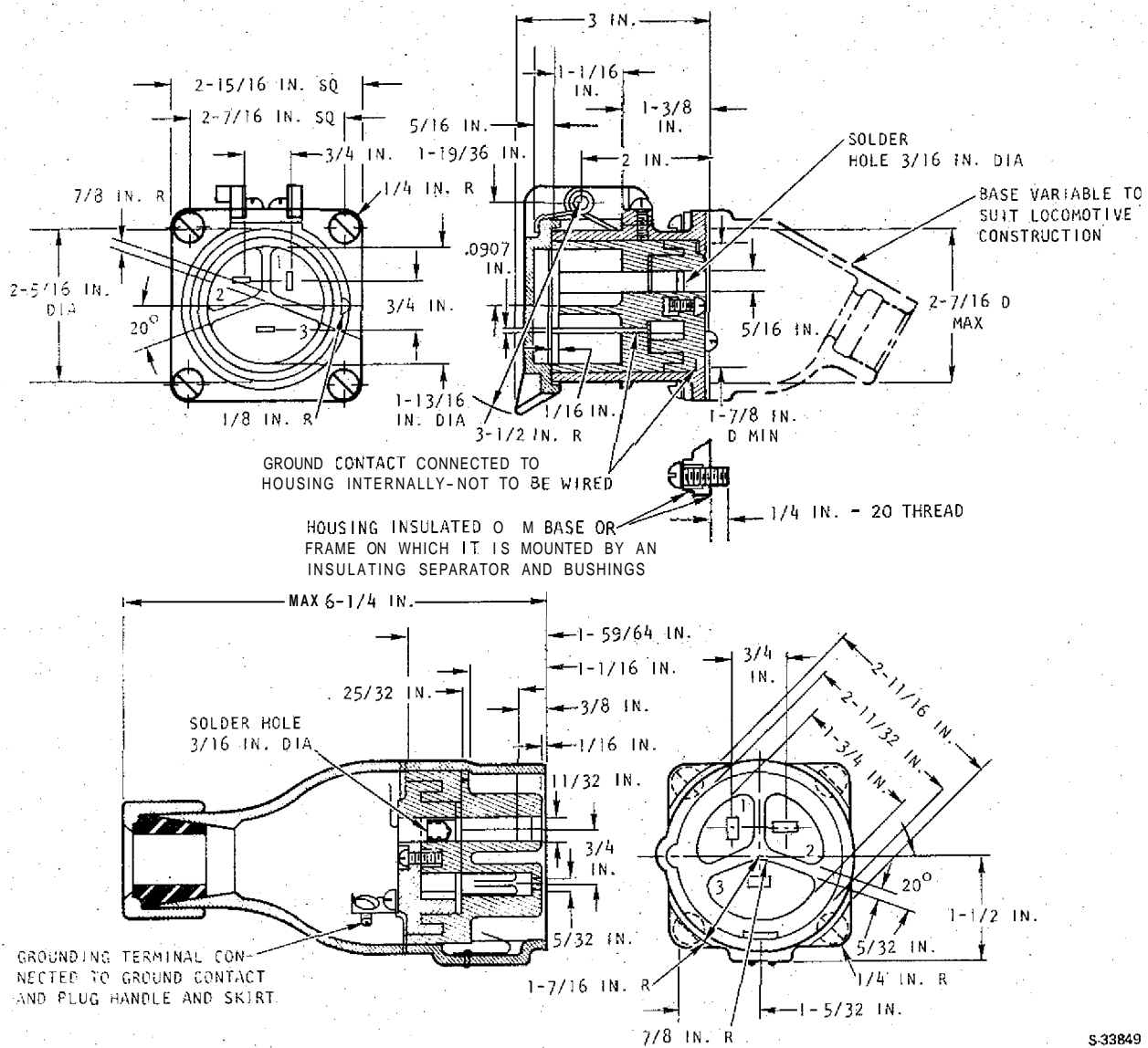

S-33849

Figure 71. Auxiliary Power Jumper

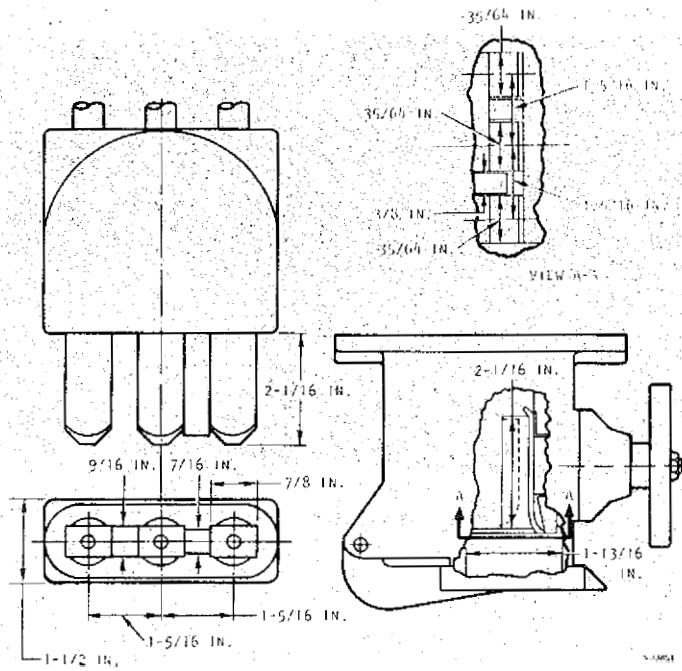

Figure 72. Main Power Jumper

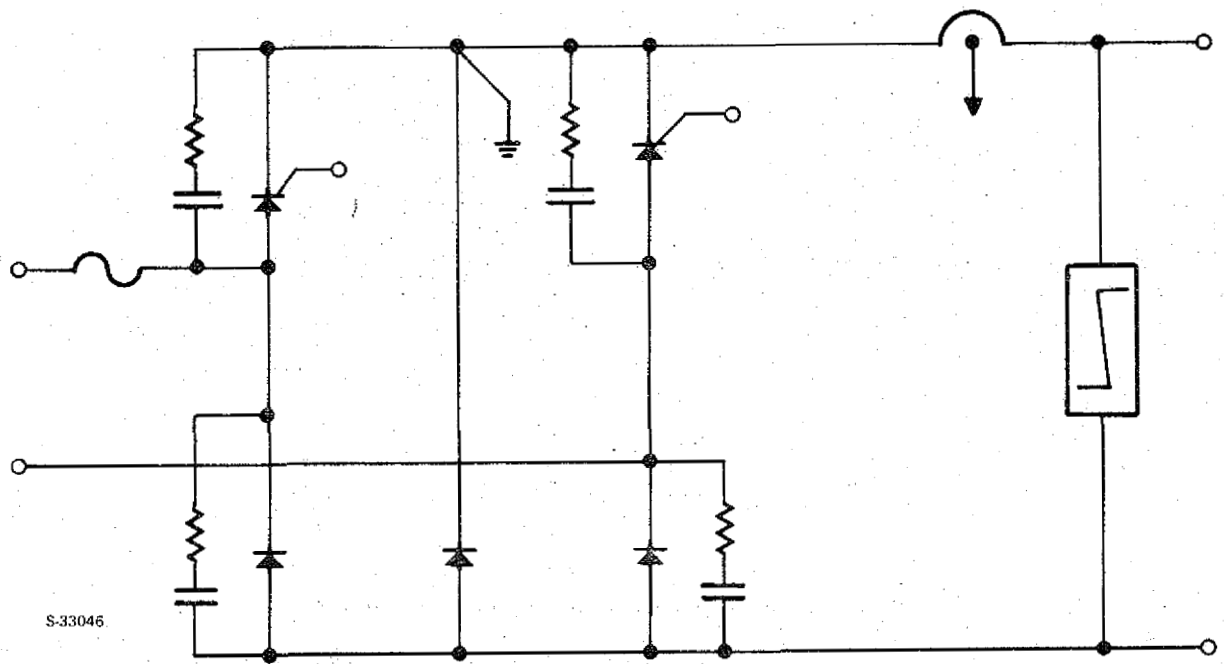
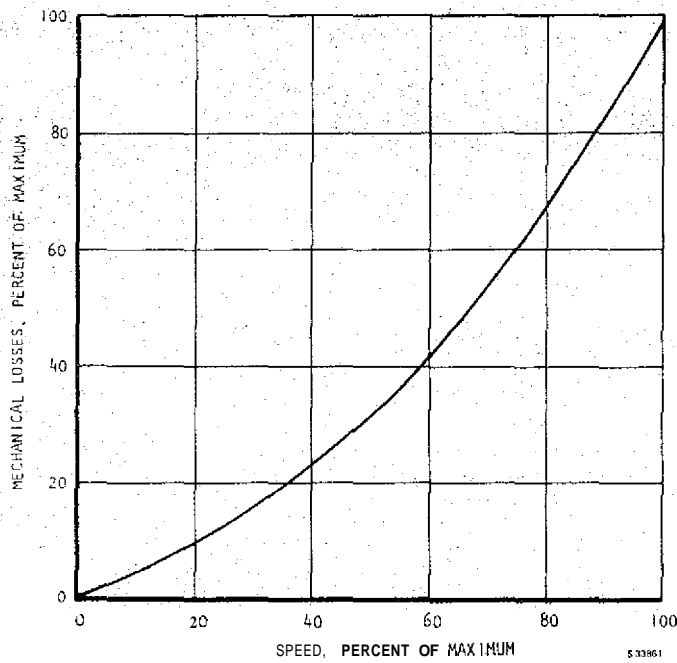

Figure 73. Traction Motor Field Power Supply



F-29760

Figure 74. Air Brake and Electrical Equipment Compartment



F-29761

Figure 75. Flywheel Assembly Mechanical Losses vs Speed

Motoring Control

The motoring control logic diagram is shown in Figure 76. At the motoring command, the traction motor fields will be turned fully on until armature current is detected. At that time the field current will be reduced to maintain a constant ampere-turn/armature current ratio to the locomotive base speed, maintaining a series motor characteristic. The notch communication to the load regulator position will be intercepted if the flywheel has usable energy available. The flywheel machine field will be turned on and increased until the equivalent generator output current/voltage is achieved. To compensate for the decrease in flywheel speed, the field current of the flywheel machine is increased, enabling the constant volt-amp product to be maintained over the full flywheel machine speed range.

A closed-loop control continuously monitors the armature current to ensure that the required output is being delivered to the traction motors. As the flywheel approaches minimum speed, the generator volts are allowed to rise to the required level until the isolation diode is forward-biased, and the generator supplies power to the traction motors. At this time, the flywheel machine field current is maintained at a level where the machine, now acting as a motor, takes sufficient power to maintain the flywheel at its minimum speed, 53 hp.

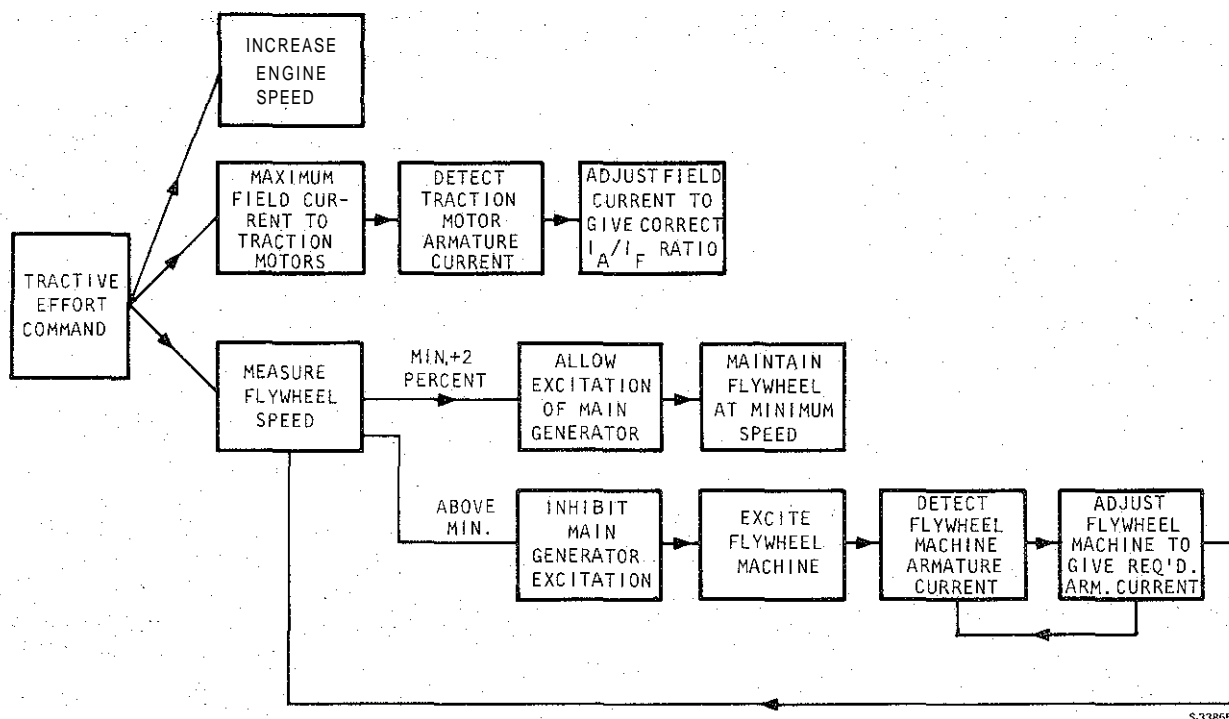

Figure 76. Tractive Effort Control Logic

Braking Control

The braking control logic diagram is shown in Figure 77.

The objective during brake is for the operator to be unaware of the source of the braking power. This is accomplished by using a pressure transducer in the existing air brake system (Figure 78). This transducer will be located in the train pipe so a signal proportional to the train pipe reduction can be used to determine the braking current necessary. Upon detection of the braking power, an electrically operated valve will be energized to prevent air pressure buildup in the brake cylinders. The system is basically fail-safe in terms of power equipment, but to accommodate stray feeds to the brake hold-off valve or seizure of brake hold-off valve, a separate lever operated manually should be provided at the operator's location to enable the hold-off valve to be bypassed. The feed to the brake hold-off valve will be derived from a relay in the boxcar, ensuring that the valve can only be energized when the boxcar is available. Operating instructions would call for the brake hold-off bypass lever to be in the "bypass" position whenever the locomotive is not operating with the boxcar.

This modification will be easy to achieve since the air brake equipment is located directly beneath the cab as shown in Figure 73, and has the advantage of requiring minimum alteration to operating techniques. This means a minimum of operator retraining is required; a factor, which though expensive, is often overlooked.

The flywheel machine is capable of maintaining control of braking effort by matching traction motor speed variations with an adjustment of its field. Thus, there is no need for the generator field to be varied with locomotive speed from the nominal value, determined by the drop in brake pipe pressure, because the flywheel machine field current variation will be referenced to maintaining a constant armature current. Therefore, stability problems caused by traction motor and flywheel machines attempting to control the machine simultaneously are avoided.

Control Analysis

1. Motoring

The locomotive performance analysis will be based on a 1050-amp armature current, the probable maximum accelerating current, which defines the base speed (the limit of constant current operation) to be 8 mph (Figure 79). At 8 mph, the applied motor voltage has to be 250 v per motor. This results in a 1000-v output requirement from the flywheel machine even at its minimum operating speed of 2655. With the armature and brush drops (15 v and 3 v, respectively), a field current of 48 amp at minimum speed is required. Although this is above the continuous rating of the field, **it** is within the capability of the flywheel.

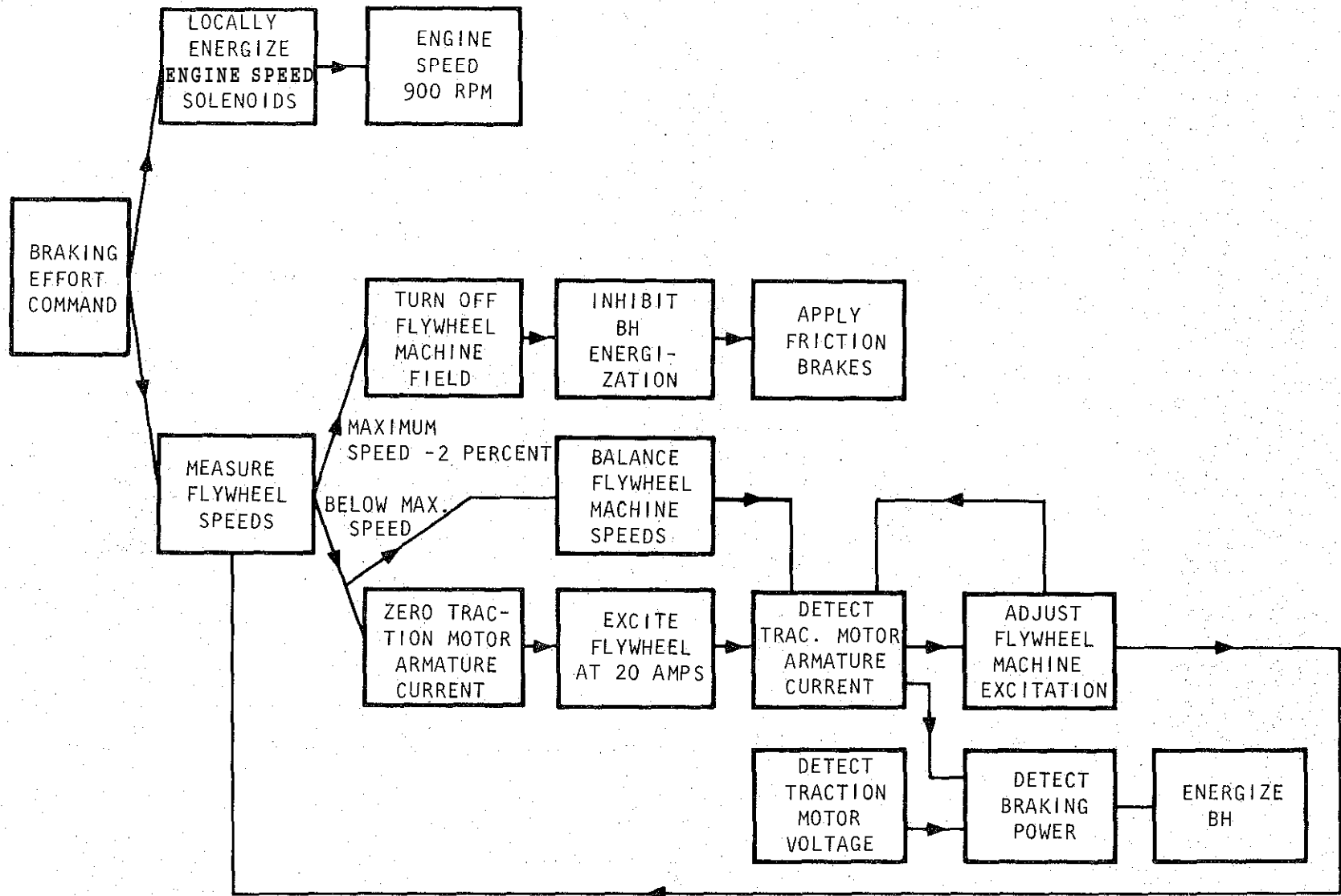

S-33852

Figure 77. Braking Effort Control Logic

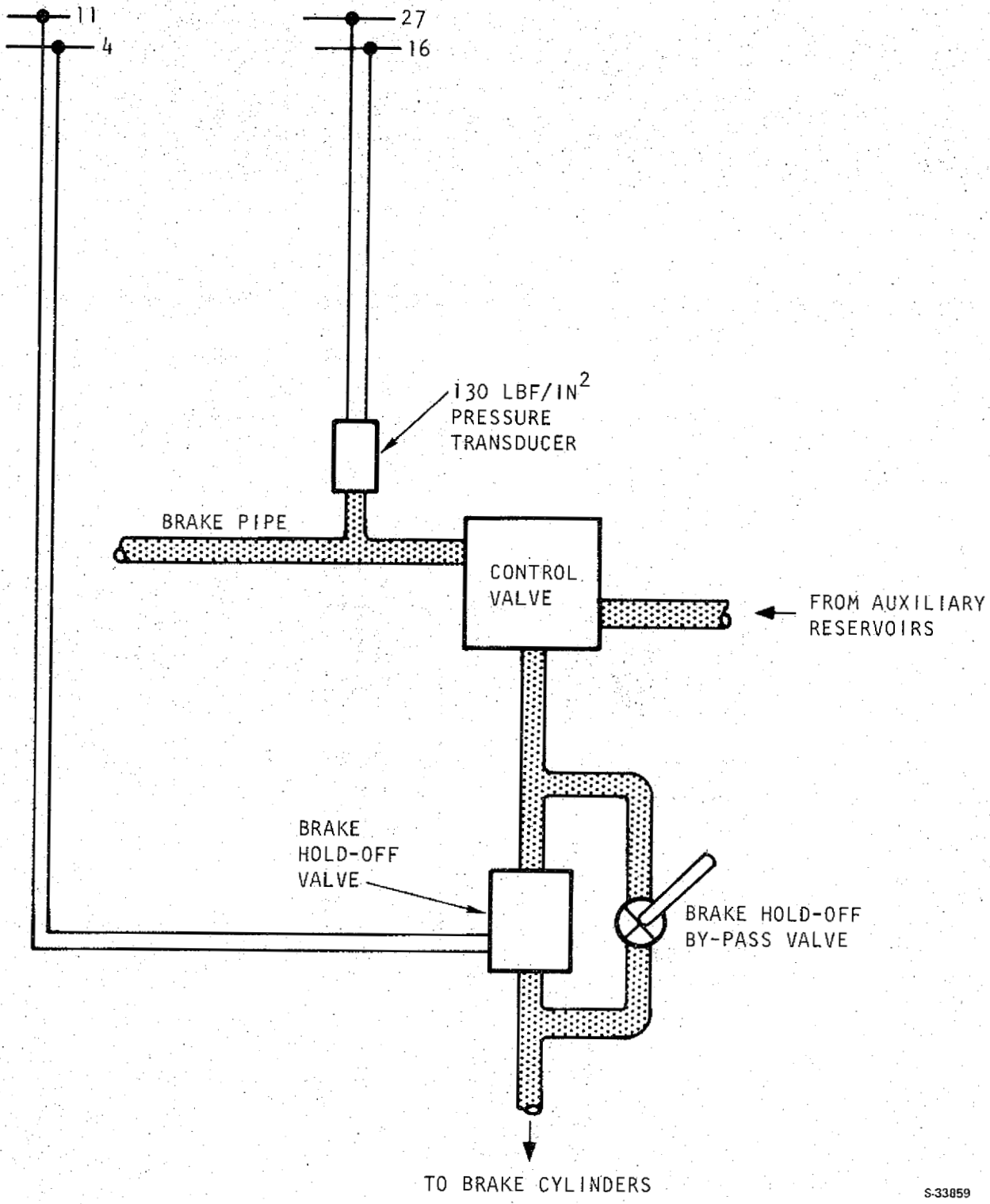

S-33059

Figure 78, Electric Brake Interface with Friction Brake

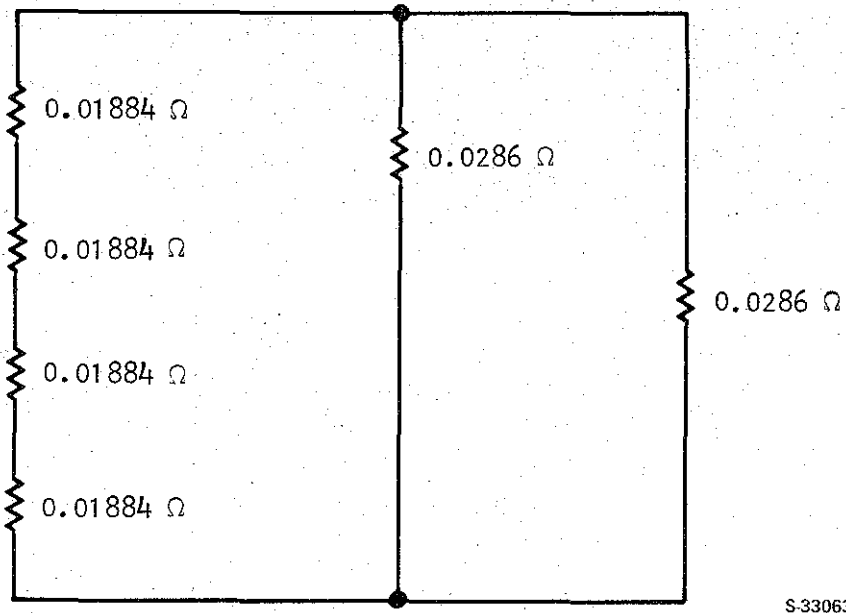

Figure 79. Equivalent Circuit of FESS Concept A2

From the above analysis, it is clear that each of the flywheel machines is able to supply 525 amp over the operating range of the traction motor, up to base speed at any voltage necessary to 1000 v. The operation above base speed at reduced current is not usual during switching duty, therefore its importance is limited. By the time the locomotive and boxcar (and any coupled cars) achieve relatively high speeds, the flywheel is already at minimum speed and does not contribute to the energy delivered to the locomotive wheels.

2. Braking

The scenario data and the SRI report (Reference 5) suggest that a switching locomotive typically brakes from 8 mph. Simplification of the control scheme will result if the traction motor field current can be maintained constant and the braking effort controlled by the adjustment of the flywheel machine alone.

3. Equivalent Circuit

The equivalent armature circuit of the machine, neglecting brush resistance but including interpoles, is shown in Figure 80.

Total circuit resistance is 0.08966 ohms, which results in a 98-v drop at 1050 amp. Brush losses are calculated at 3 v per brush set for a 15-v total brush loss, and a circuit voltage drop of 109 v.

Reference 5. Railroad Classification Yard Technology, a Survey and Assessment, Stanford Research Institute Report, January 1977.

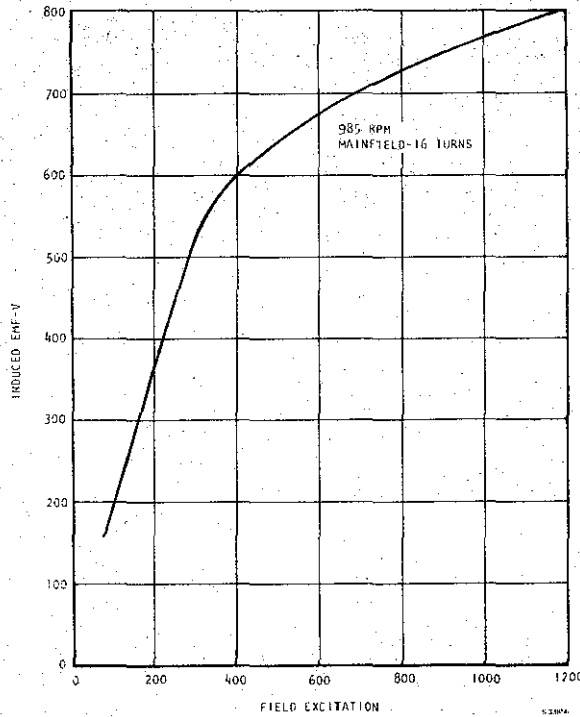

Figure 80. D77 Traction Motor Saturation Curve

Assuming a constant 1050 amp in the traction motor fields, the minimum brake speed is determined by the speed at which the 109-v drop cannot be overcome.

4. Traction Motor Control

At a locomotive speed of 8 mph, a 40-in. diameter wheel, and a 62:15 gear ratio, the motor speed is 277.87 rpm. For a field current of 1050 amp, the induced emf is 220 v as seen in Figure 80.

The minimum brake speed (N) is:

$$10^9 = \frac{N}{277.87} \times 220 \times 4$$

$$N = 34.4 \text{ rpm}$$

$$\text{Wheel speed} = \frac{15}{62} \times 34.4 = 8.326 \text{ rpm}$$

$$\text{Locomotive speed} = \frac{40}{2 \times 12} \times 2 \pi \times \frac{8.326}{60} \times \frac{60}{88} = 0.99 \text{ mph}$$

Therefore, the maximum braking current of 1050 amp is available from 8 mph to 0.99 mph, resulting in less than 2-percent loss of available energy.

5. Flywheel Machine Control

To confirm the range of flywheel machine control (i.e., field current) adequate for this duty, the approach adopted is to consider the two extreme cases of brake entry at almost maximum flywheel speed (unlikely) and minimum flywheel speed. The test of the adequacy of the flywheel machine control will be based on a traction motor armature and field current of 1050 amp, and a brake entry speed of 8 mph. Under these conditions, the total generated emf is 4×220 percent 880 v. The back emf of the flywheel machine must not exceed $880 - 109 = 771$ v.

At minimum flywheel speed the volts per rpm become 290, and the saturation curve (Figure 81) gives a field current of 26 amp.

At maximum speed the volts per rpm become 203.3, and the saturation curve gives a field current of 16.5 amp. Therefore the braking duty is within the control regime of the flywheel machine field current, with the traction motor field maintained constant at 1050 amp.

6. Locomotive Power Enhancement

It is obvious there is scope for increasing the locomotive power within the traction motor capability. This could be achieved by placing a voltage source, such as the flywheel machine, in series with the main generator. The benefits of this arrangement in the switching mode are minimal since, for the most part, the locomotive is not horsepower limited. Furthermore, the time that the flywheel could be used to boost power is so short the possibility of locomotive power enhancement was not pursued.

7. Tractive Effort Control

It is possible to compensate for the weight transfer that occurs when the traction motors apply torque using separately excited traction motors with a separate field supply for each motor. Since the weight transfer that occurs, neglecting truck friction and suspension hysteresis, is a function of torque only, weight transfer compensation becomes a simple matter of arranging the outputs from the four field power supplies in fixed ratios automatically reversed, depending on the direction selected. This simple procedure allows the tractive effort per ton of locomotive to be maximized without increasing the probability of wheel spin.

The performance of a switching locomotive is not closely tied to available adhesion due to the copious use of sand to enhance traction conditions at the wheel/rail interface. Therefore, the benefit of weight transfer compensation on a switching locomotive is virtually impossible to quantify.

Similarly, the introduction of a complex system of load weighing to account for locomotive weight loss as consumable supplies such as sand and fuel are used, is considered unnecessary. The variation in locomotive weight from 100 to 0 percent consumable supplies is only 5 percent.

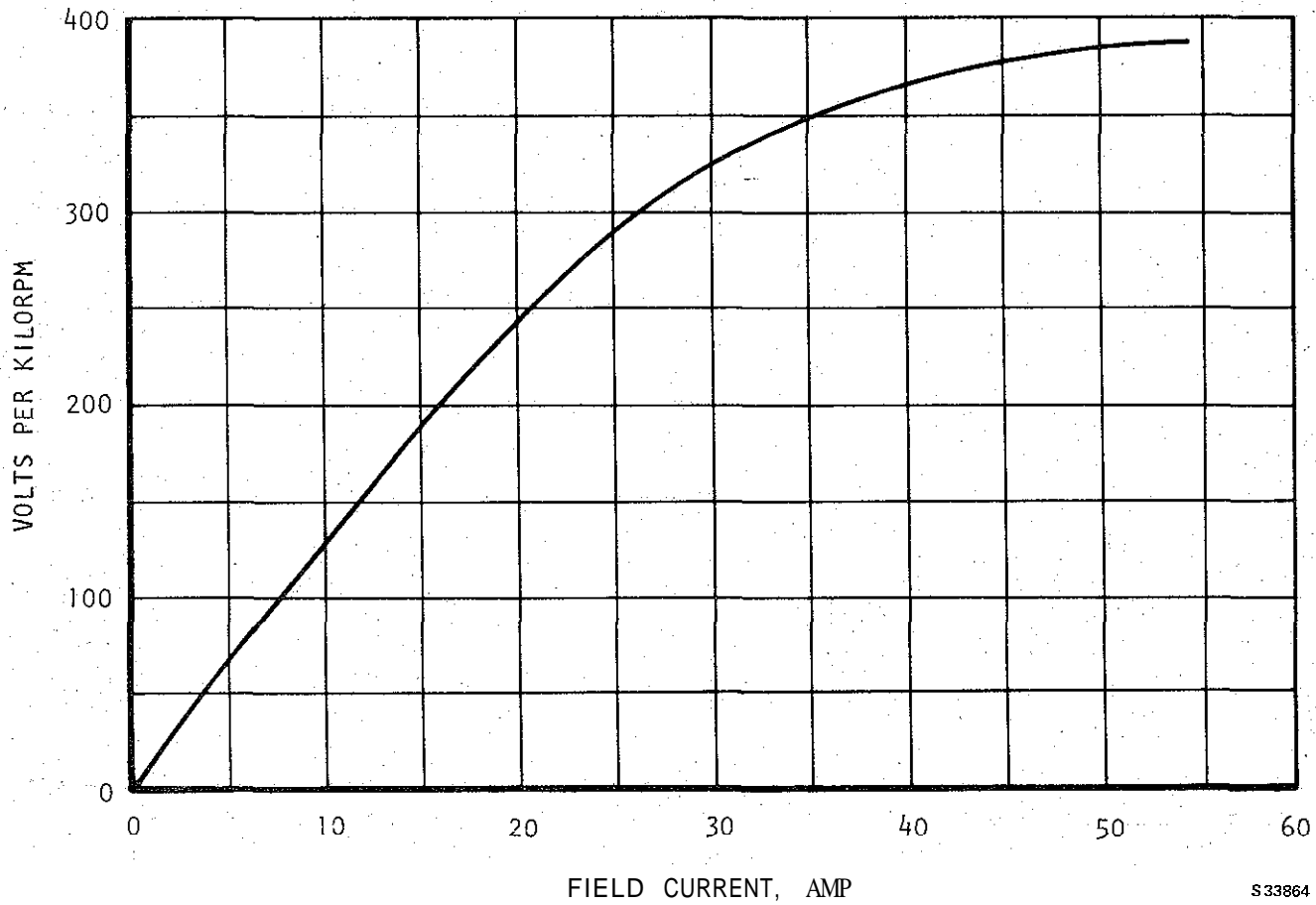

S33864

Figure 81. Flywheel Machine Saturation Curve

8. Spin/Slide Protection (Optional)

This basic operating concept would consist of sensing the rapid increase or decrease in wheel velocity due to spin or slide, respectively, and taking the necessary corrective action. Tractive or braking effort would then be reapplied in a controlled manner so the wheel/rail velocities would become synchronous in minimal time to achieve high efficiency.

Each axle would be equipped with a pulse-type speed pickup mounted from the reduction gearbox. A frequency-to-dc converter of the sample-and-hold type develops a dc voltage proportional to wheel velocity and is operational down to velocities of a few miles per hour. Filtering is necessary to smooth the output and prevent false trips because of noise, resulting in a small time delay before the spin/slide condition is detected.

Since the motors are in series, detection of spin/slide would be on a total locomotive basis, with the filtered dc speed signal being fed to a rate-sensing circuit of the electronic flywheel type. This differentiating circuit performs the following functions: (1) senses when the wheel acceleration or deceleration exceeds about 2 mph/sec and puts out a protective trip signal, and (2) removes the protective trip signal only when the wheel velocity again is essentially synchronous with that of the rail.

The rate-sensing method has numerous advantages over the differential wheel speed schemes, including the following:

- (a) Detection of spin/slide is based on rate only, and hence does not require a specific speed error to develop before taking action.
- (b) Speed errors in tachometer signals due to tolerances and temperature drift have negligible effect on protective action. Since speed signals are not compared directly, variations in wheel diameters only slightly affect the 2 mph/sec trip point rate. This value could vary from 1.5 to 2.5 with no change in performance.
- (c) No special circuits are required to handle either random or synchronous slides of all wheels on a locomotive.
- (d) The rate-sensing method results in lower wheel/rail slip velocities and higher operating efficiency.

If wheel spin is detected during acceleration, the tractive effort command is automatically reduced to zero to allow the wheel to recover synchronous speed. Once this occurs, the tractive effort is restored. If wheel slide is detected during deceleration, the brake effort command and any dynamic braking are automatically reduced to zero to allow the wheel to recover synchronous speed, and once this happens the brake effort command is restored by adaptive control.

If the tractive braking effort is returned to the same level from which the spin/slide occurred, the result will be another trip. Repetitive dumping with low efficiency will take place until adhesion improves or the command

value is reduced. Adaptive control serves to overcome this problem by progressively reducing the tractive effort command to a level compatible with the available adhesion. Typical operation of an adaptive control scheme is as follows:

- (a) Each time a dump occurs, the command signal is reduced to a certain percentage (e.g., 85 percent of its value by means of a bucking voltage signal).
- (b) At the end of the dump, the command returns rapidly to the 85-percent point, and then ramps up at a slow preset rate toward the initial 100-percent value.
- (c) A second dump immediately drives the command down to the 70-percent region, where it ramps upward at the same preset rate toward the initial 100-percent point.
- (d) Successive dumps reduce the command to a level slightly below the available adhesion in such a way that the number of dumps is minimized and efficiency is maximized. The reapplication percentage and ramp-up rates are selected for optimum efficiency under specified adhesion conditions.

Although the AiResearch proposal allows the adoption of this advanced spin/slide system, it is not considered economically sound to apply it to the switching locomotive since the motors are connected in series, and a rapid reduction in field current may tend to a flashover condition on other machines. This wheelslip protection scheme is ideally applied to locomotives with motors in permanent parallel or in multiple series/parallel groupings.

SYSTEM OPERATION

Details of the FESS system operation will vary from switching yard to switching yard, and from railroad to railroad. The purpose of this study was to provide a flexible system able to be accommodated and absorbed by a railroad, with minimum impact on the existing operation. The major variable concerned the number of boxcars required in relation to the number of locomotives modified out of the total population of switching locomotives in the yard. If the railroad can dedicate a certain proportion of their switchers to the actual switching duty, and use the remainder exclusively for train makeup and other duties, then a significant saving in first cost can be realized on a "per car switched" basis. In order to allow the benefit of dedicated switching locomotives to be demonstrated, the economics program plots ROI against cars switched per day with variables, such as number of locomotives modified and number of boxcars required, inputted to produce families of curves.

Apart from the task of coupling the boxcar and ESU together, which would be infrequent in the idealized case, there should be no impact on the actual switching operation. Costs and savings associated with the implementation of FESS are discussed later in this document.

Simulations carried out in previous studies (Reference 5) indicated that the stages of flatyard operations are generally well-balanced, and no single activity acts as a bottleneck to the flow of cars through the yard. For example, an increase in the switching rate at most flatyards would not significantly increase yard capacity or reduce car-detention time unless train arrival and departure processing activities were also increased.

Since the existing operation tends to be adhesion limited (attested to by the amount of sand found in switching yards), it is clear that no significant impact on productivity could be realized by an improved motor rating or braking rate. Methods of increasing the effective working adhesion, such as individual axle control, would not have a significant impact on the operation since the use of sand increases the adhesion level up to 50 percent, compared with relatively small increases (15 percent) due to individual axle control.

SYSTEM PERFORMANCE

Computer model simulations described earlier in this section were conducted to establish the following:

- (a) Fuel consumption of the existing system
- (b) Fuel consumption of a FESS A2 system with the same performance level (cars switched/day) as the existing system

The above approach allows the railroad to optimize its operation on the basis of productivity or energy consumption, whichever is considered to be the more important.

At the cooling air flow rate available in the SW1500, it has been determined that the continuous rating of the D77 traction motor is 850 amp. It is at this rate that the limitation on the motoring performance of the FESS system has been reached. In brake, the performance is again limited by the traction motor rating, although if the motor rating were increased more than slightly (e.g., increasing the airflow), it would be necessary to consider the impact of the available adhesion level assumed.

The existing switching system is generally limited by adhesion in both motoring and braking, which has led to the adoption of operating methods that recognize this constraint. Prominent among these methods is the copious use of sand to prevent slip/slide when the adhesion level temporarily falls. This is an extremely cost-effective method of dealing with an intermittent problem, and is recognized in the switching yard as well-suited to the application. However, if the separately excited motor configurations were applied to road locomotives, it would be recommended that the optional spin/slide protection system be included in the package.

RISK ANALYSIS

The hardware required for the FESS system can be considered as either existing or state of the art. Existing hardware which is to be used to implement the FESS system includes the following items.

- (a) D77 traction motor manufactured by EMD and modified as demonstrated. The control of the machine will ensure that the series characteristic, flux to armature current ratio consistent with the existing conditions, is maintained and the operating conditions of the motor unaltered.
- (b) ACT-1 energy storage unit manufactured by the Garrett Corporation with only minimal modifications. Following extensive final running on the ACT-1 vehicles, sufficient experience has been gained to ensure that production hardware will achieve an acceptable level of reliability.
- (c) The field supply alternator available from the Garrett Corporation is a proven machine, having operated reliably in the traction environment of the GTE cars.

New hardware required for the FESS concept, which is available within the state of the art, is limited to the field control unit which supplies power to the traction motor field. This type of power supply is common and falls within the area of expertise of Garrett. No particular risk can be assigned to this yet-to-be-designed hardware.

The main area of risk comes from the system integration required to incorporate the SW1500 locomotive, modified D77 traction motor, ACT-1 ESU, field supply alternator, and field control units into a viable working unit within a specified budget. The following are identified points of interface:

- (a) Motoring control--Translation of the operator's engine power demand into a flywheel machine current
- (b) Braking control--Translation of the operator's braking effort demand into a flywheel machine current
- (c) Field control--Maintaining the flux/armature ratio consistent with the series field characteristic, taking into account field saturation

The short-term technical risk associated with this product can be confidently stated to be minimal. While every effort will be made to preserve the impressive reliability record of the locomotive, it is probable that by introducing new and different hardware into the locomotive, its reliability will suffer. The front-end engineering effort would be directed to minimize that impact.

SYSTEM COSTS AND CREDITS

All system costs and credits are in 1978 dollars, and are based on locomotive/ESU quantities in excess of 50. Although the figures are not sensitive to quantities above 20, below this figure the cost per unit rises dramatically. The annual costs and credits are not related to the quantities produced.

Initial Costs

1. Locomotive Modification

The estimated cost of the locomotive modification is shown in Table 17.

TABLE 17
LOCOMOTIVE MODIFICATION COST

Item	Cost
Traction motor modification kit	\$ 11,000
Auxiliary alternator (AIResearch PN SC938398)	15,000
Field power supplies	30,000
Electronic control unit	12,000
Jumper cables	5,000
Control modifications	10,000
Installation labor	25,000
Miscellaneous	10,000
Total	\$118,000

Of the \$118,000 estimated for the modification cost, \$68,000 (59 percent of the total) has been estimated to within ± 5 percent. This leaves only \$50,000 as a rough order-of-magnitude estimate, of which \$10,000 (9 percent of the total) is miscellaneous. Therefore, the total cost figure is considered to have sufficient accuracy for the purposes of this study.

2. Boxcar Installation

The estimated cost of the total boxcar installation is shown in Table 18. Of the \$4215,500 estimated for the total installation cost, \$180,000 (85 percent of the total) is confirmed as the probable production cost of two ACT-1 ESU's in large quantity production. Therefore, the total cost of the installation is considered accurate.

TABLE 18

BOXCAR INSTALLATION COST

Item	Cost
Basic boxcar	\$ 15,000
Two ACT-1 ESU's (modified)	180,000
Electronic control unit	8,000
Jumper cables	5,000
Installation labor	2,500
Miscellaneous	5,000
Total	\$215,500

Annual Costs and Credits

1. Energy Storage Unit Maintenance--Boxcar Installation

Extensive theoretical analyses of the application of ACT-1 ESU's to New York have resulted in the generation of the following maintenance costs attributable to the ESU's:

Labor	\$0.03135/car mi
Material	<u>0.00495/car mi</u>
Total	\$0.363/car mi

A fleet of 6,700 cars covers an average mileage of 305×10^6 miles. Therefore, the average annual cost of ESU maintenance (schedule and failure modes) becomes \$1,600 for one ESU per car. On the basis that maintenance cost is time-related rather than mileage-related, it will be assumed that the annual cost of maintenance of the two ESU's in the boxcar will be \$3,000.

2. Locomotive

a. Field Supply Alternator Maintenance

The alternator to be used in the FESS scheme has been involved in extensive rail traction service in the Garrett GTE cars currently operating in Long Island, New York. Experience to date indicates that the air cooled version of the alternator will be an extremely low cost maintenance item. Assuming a major rebuild every 10 years, the average maintenance cost is estimated at \$550 per annum.

b. Locomotive Brake Maintenance

In order to derive the maintenance savings attributed to reduction in friction brake use, the starting point was data supplied by the Southern Railway. Brake shoes cost \$7.15 each, and it is estimated that it takes 30 minutes to change 16 shoes every 8.5 days. The total cost per year for brake shoe maintenance is \$9,376 per locomotive. Brake shoe wear is generally proportional to the kinetic energy to be converted to heat. For average conditions, this can be translated to car stops. The typical scenario (Table 7) shows a locomotive making 4348 car stops per day, 3996 car stops with the ESU in service. Since the electric brake is only operative to 1 mph, the percentage of the kinetic energy still to be translated into heat is given by:

$$1 - \frac{(7.5^2 - 1^2)}{7.52} = 1.78 \text{ percent}$$

Therefore, the saving in brake shoe maintenance due to the FESS system is estimated at:

$$\frac{3996}{43483} \times 0.9822 = 90.2 \text{ percent of the brake shoe maintenance.}$$

This gives an annual maintenance saving of \$8,464.

c. Control System Interface Equipment Maintenance

It is recognized that the introduction of additional control equipment to the locomotive will result in additional costs, such as:

- Retraining of maintenance personnel
- Purchase and maintenance of new test equipment
- Increased spares holding

It is almost impossible to quantify this cost without involving a specific case study including railroad policy, local labor agreements, etc. However, an allowance of \$500 per locomotive will be made in the locomotive maintenance costs to cover the above.

d. Summary of Locomotive Maintenance

The net locomotive maintenance saving becomes

$$\$8,464 - 550 - 500 = \$7,414.$$

The maintenance data are based on an average switching locomotive owned by the Southern Railway. The scenario data derived in Section 3 of this report indicated that an average Southern locomotive switches 396 cars per day, 350 days per year. Therefore, the net savings in locomotive maintenance can be estimated at \$0.054 per car switched.

3. Fuel Savings

Fuel savings on a "gallons per car switched" basis are calculated by the computer simulations referred to earlier in this section for the chosen scenario. The fuel cost used in this study at 1978 levels is \$0.42 per gallon.

4. Productivity

An attempt was made to determine whether it would be economically attractive to switch cars at a faster rate, thereby improving productivity.

Simulations carried out in previous studies (Reference 5) indicated that "the stages of flat-yard operations are generally well-balanced and no single activity acts as a bottleneck to the flow of cars through the yard. For example, an increase in the switching rate at most flat yards would not significantly increase yard capacity or reduce car-detention time unless train arrival and departure processing activities are also increased."

Observations made in this study indicate that a locomotive typically spends at least 50 percent of its time idle. Therefore, to complete a task faster would simply lead to more idle time. Since incoming and outgoing traffic times are determined by factors outside the classification yard (such as line capacity, availability of cars, availability of road locomotives, etc.), it is clear that the classification yard must be considered as an essential service industry to the main task of transporting cars from point A to point B. The inefficient use of resources, such as locomotives idling 50 percent of the time, is a necessary characteristic of switchyard operation.

The conclusion reached in this study is that locomotives and crews must always be available to cater to the peaks of work. The only incentive to increase switching rates would be the elimination of complete locomotives or complete three-shift days. With the small population of locomotives considered (up to six per yard), this would require a 15-percent (minimum) increase in switching rate. This could be more easily achieved without FESS. Since electric brake is not required, the traction motors could be run at higher currents in motoring, and higher braking levels could be achieved using air brakes. Generally, the railroads do not aim for these high acceleration and deceleration rates since switch rate is not the critical factor in overall yard productivity.

SECTION 5

TRACTION MOTORS

The program plan called for analysis of the General Motors EMD Model D77 locomotive traction motor for conversion to separate field excitation, and development of a preliminary electrical/mechanical design necessary to implement the conversion. The plan also required the testing of two traction motors to establish operational integrity and performance characteristics before and after modification. The tests were intended to quantify the tractive effort before and after modification, assist in correlating the dynamic braking potentially attainable from an SW1500 locomotive incorporating modified traction motors with the braking characteristics of an existing SW1500 locomotive, and assist in determining how rapidly an SW1500 locomotive incorporating modified traction motors can go from an accelerating mode to a dynamic braking mode.

This section reports the results of activities conducted under Task III, Traction Motor Analysis/Design; Task IV, Traction Motor Modification; and Task V, Traction Motor Bench Test.

ANALYSIS/DESIGN

An analysis of the conversion of the EMD Model D77 locomotive traction motor to separate field excitation was performed. The first configuration evaluated was that of a fully compensated, separately excited, shunt-wound, traction motor with interpoles and pole face compensating windings. The development of this design is presented in the following discussion.

Figure 82 shows details of the series-wound traction motor with interpoles. This design configuration is the result of years of development by EMD to provide increased power in the same basic frame. Note that the series field windings are designed with parallel coil sides. Space between the series coil sides and the commutating coils on the interpoles is partially filled with baffles and additional baffles are installed between the pole tips to control the distribution of air to the various areas of the machine and to maintain the high velocity airflow required to obtain good heat transfer from the coil surfaces. When viewed from the end, the central sections of the series coils on the main poles are seen to extend in a radial direction almost from the pole tip to the frame. The commutating windings also extend over the full length of the interpoles. These windings utilize a very large fraction of the available volume within the machine.

Conversion of this machine to a separately excited machine requires a number of tradeoffs to design an acceptable configuration within the existing frame. As seen in Figure 82, the space available is extremely limited. This limitation in available space is much more severe than anticipated and introduces a number of difficulties in the design of a fully compensated, separately excited, shunt-wound configuration within the existing motor frame.

To provide space for the compensating pole face windings on the main poles, it is necessary to reduce the size of the main pole shunt field windings.

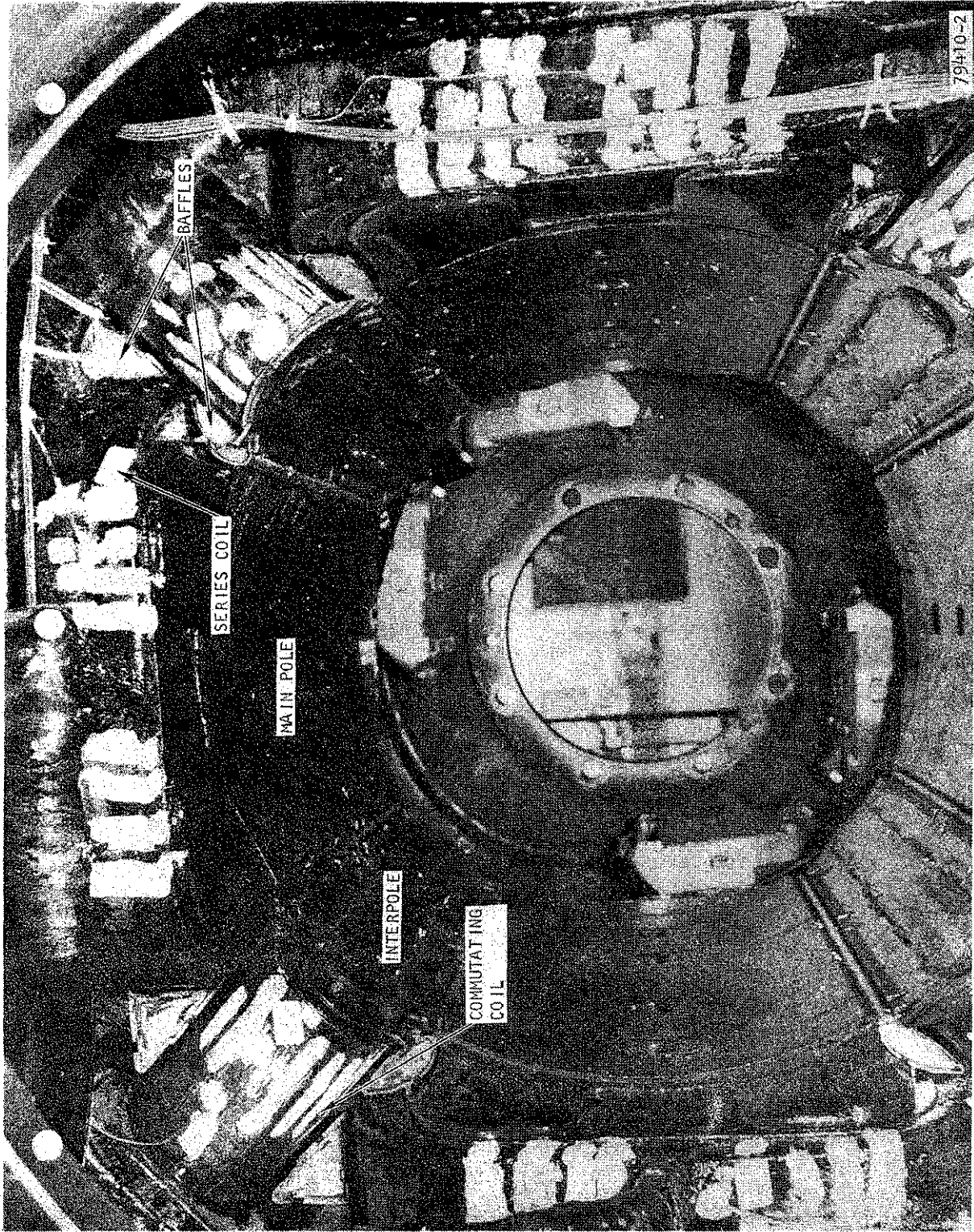

Figure 82. Existing D77 Traction Motor

Reduction in the main pole air gap reduces the excitation required from the main pole separately excited shunt field windings. This reduction in excitation required from the shunt field permits a reduction in the size of the shunt field coil and reduces the shunt coil losses. The pole face compensating winding neutralizes, or partially neutralizes, the cross-magnetizing ampere-turns of the armature and permits a reduction in the ampere-turns in the commutating winding on the interpoles. Concentration of the reduced commutation coils near the interpole tip provides additional space near the frame for the shunt field coils on the main poles.

Figure 83 shows the design that has evolved as a result of these trade-offs. The following modifications are required:

- Replacement of the existing main field poles with a new main pole and separable tooth pole to provide a reduced main air gap and slots for the pole face compensating winding
- Replacement of the existing series field winding with a separately excited shunt field winding
- Replacement of the existing commutating winding with a new commutating winding concentrated near the pole tip
- Installation of a new compensating winding in the main pole faces
- Modification of motor interconnections
- Development of a new baffle configuration

Tables 19 and 20 show the results of analysis of the performance of the series traction motor and the separately excited, fully compensated traction motor. These tables show that the efficiency of the fully compensated separately excited shunt-wound machine is comparable to that of the series-wound machine.

The use of the compensating pole face winding greatly reduces the leakage flux from the interpole and the useful interpole flux is made more nearly proportional to armature current. The compensating pole face winding reduces distortion of the motor air gap flux, producing a more uniform volts-per-commutator bar. It also reduces saturation in the commutating flux path and improves commutation at high armature current. These features are advantageous in certain applications, as in high-speed road locomotive and rapid transit propulsion systems.

The analysis of the D77 motor modification in the preceding description and the preliminary design work performed indicate that development of the fully compensated separately excited shunt-wound modified D77 motor with interpoles will require appreciable nonrecurring engineering effort. The required additional effort results from the need for iterative electromagnetic, mechanical, insulation, and thermal design and analysis to develop an acceptable design within the restrictions of the available motor frame design. It was estimated that the cost of this approach would be several times the cost allowable for economic application in energy storage switch engine applications.

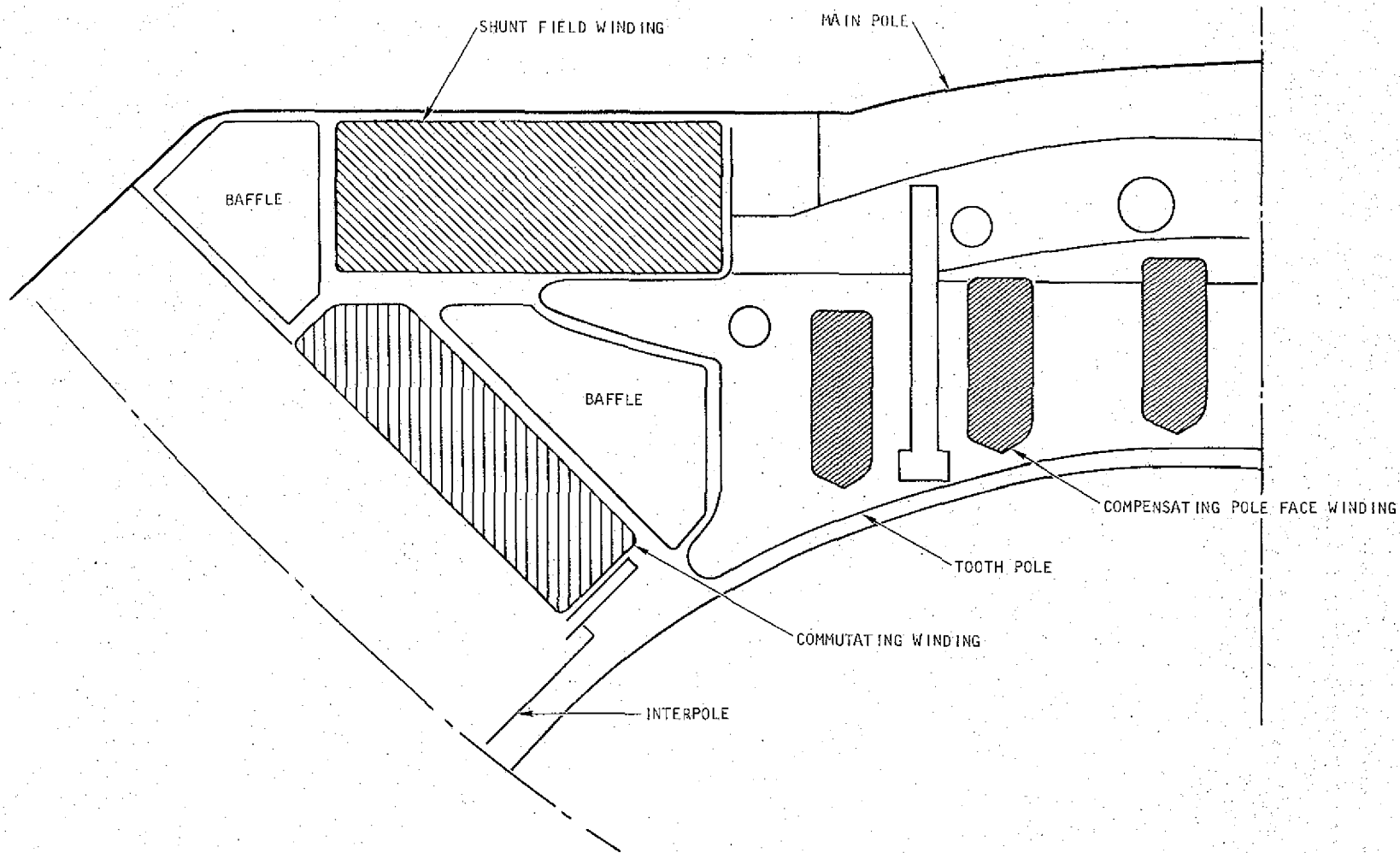

S-25473

Figure 83. Separately Excited, Shunt-Wound Traction Motor with Compensating Pole Face Winding

TABLE 19

PERFORMANCE OF SERIES TRACTION MOTOR
(D77 SERIES-WOUND TRACTION MOTOR WITH INTERPOLES)

Armature Current, amp	Terminal Voltage, v	Armature Circuit Input Power, kw	Speed, rpm	Output Torque, lb-ft	Output Power, kw	Separately Excited Field Power, kw	Efficiency, percent
1105	319.6	353.2	347	6171	304.1	0	86.1
690	523.7	361.4	695	3409	336.4	0	93.1
510	705.2	359.7	1042	2302	340.6	0	94.7
420	878.0	368.8	1389	1779	350.8	0	95.1
360	1037.2	373.4	1737	1440	355.2	0	95.1
320	1178.1	377.2	2084	1210	358.1	0	95.0
290	1285.9	372.9	2431	1023	353.0	0	94.7

TABLE 20

PERFORMANCE OF FULLY COMPENSATED, SEPARATELY EXCITED,
SHUNT-WOUND TRACTION MOTOR WITH INTERPOLES

Armature Current, amp	Terminal Voltage, v	Armature Circuit Input Power, kw	Speed, rpm	Output Torque, lb-ft	Output Power, kw	Separately Excited Field Power, kw	Efficiency,* percent
1105	309.7	342.2	347	6116	301.3	19.6	82.7
690	523.7	361.4	695	3440	339.4	8.26	91.5
510	705.2	359.7	1042	2313	342.2	3.16	94.2
420	878.0	368.9	1389	1785	351.9	1.87	94.9
360	1037.2	373.4	1737	1444	356.0	1.26	95.0
320	1178.7	377.2	2084	1213	358.7	0.940	94.9
290	1285.9	372.9	2431	1024	353.5	0.706	94.6
*Based on field power supply efficiency of 88 percent.							

The major factor contributing to this increased cost is the complexity introduced by the compensating pole face winding. If the compensating pole winding is eliminated and a simple, noncompensated, separately excited, shunt-wound traction motor is considered, minimum changes to the motor, which can be implemented at considerably lower costs, are required.

Figure 84 shows a cross-sectional view of an alternative uncompensated separately excited design. Inspection of this figure shows that it involves a simple replacement of the series field winding on the main pole with a shunt field winding on the same pole. No changes to the magnetic structure are involved. The poles and air gap are unchanged. Minor changes in baffle design and interconnections are required. These changes can be incorporated at minimum cost. Table 21 shows the analytical results of the performance of this uncompensated separately excited design.

Both the compensated and uncompensated separately excited machine designs adequately provide means for the control of power exchange between the traction motors and energy storage flywheel. Reference to Tables 20 and 21 at the same armature current and speed indicates that the uncompensated separately excited machine has the same high-speed efficiency as the compensated machine and has slightly better low-speed performance.

Separately excited shunt-wound machines designed for operation from solid-state power supplies utilize laminated poles and fully laminated frames to reduce iron losses resulting from harmonics in the motor flux. In the FESS application, the traction motor armatures are supplied with smooth dc voltages from rotating machine generators. The fields are supplied from phase-delay-rectifiers operating in series with the output of an auxiliary generator. The inductance of the shunt field winding limits the ripple in excitation current to a relatively low value. Therefore, it is unnecessary to laminate the main poles of the machine.

The solid iron frame of the D77 permits the generation of eddy currents that prevent rapid rates of change in motor flux. Because rapid rates of change in flux are prevented by the solid frame of the D77, advantages resulting from improved transient load commutation with compensating pole face windings cannot be realized. Improvement in motor commutation under high-speed field weakened conditions, resulting from the use of compensating pole face windings, are significant in high-speed road locomotive and rapid transit applications. The FESS application utilizes the traction motors at full field and low speeds for the greater portion of the locomotive operation.

The most significant advantages of the pole face compensating winding, therefore, can be only partially realized in the FESS application. The advantages of the fully compensated machine over those of the uncompensated machine are not considered sufficient to offset the disadvantages of lower efficiency, complexity of assembly, and increased cost.

On the basis of the results of the analytical work described above, the uncompensated, separately excited, shunt-wound friction motor with interpoles has been selected for use in the FESS system.

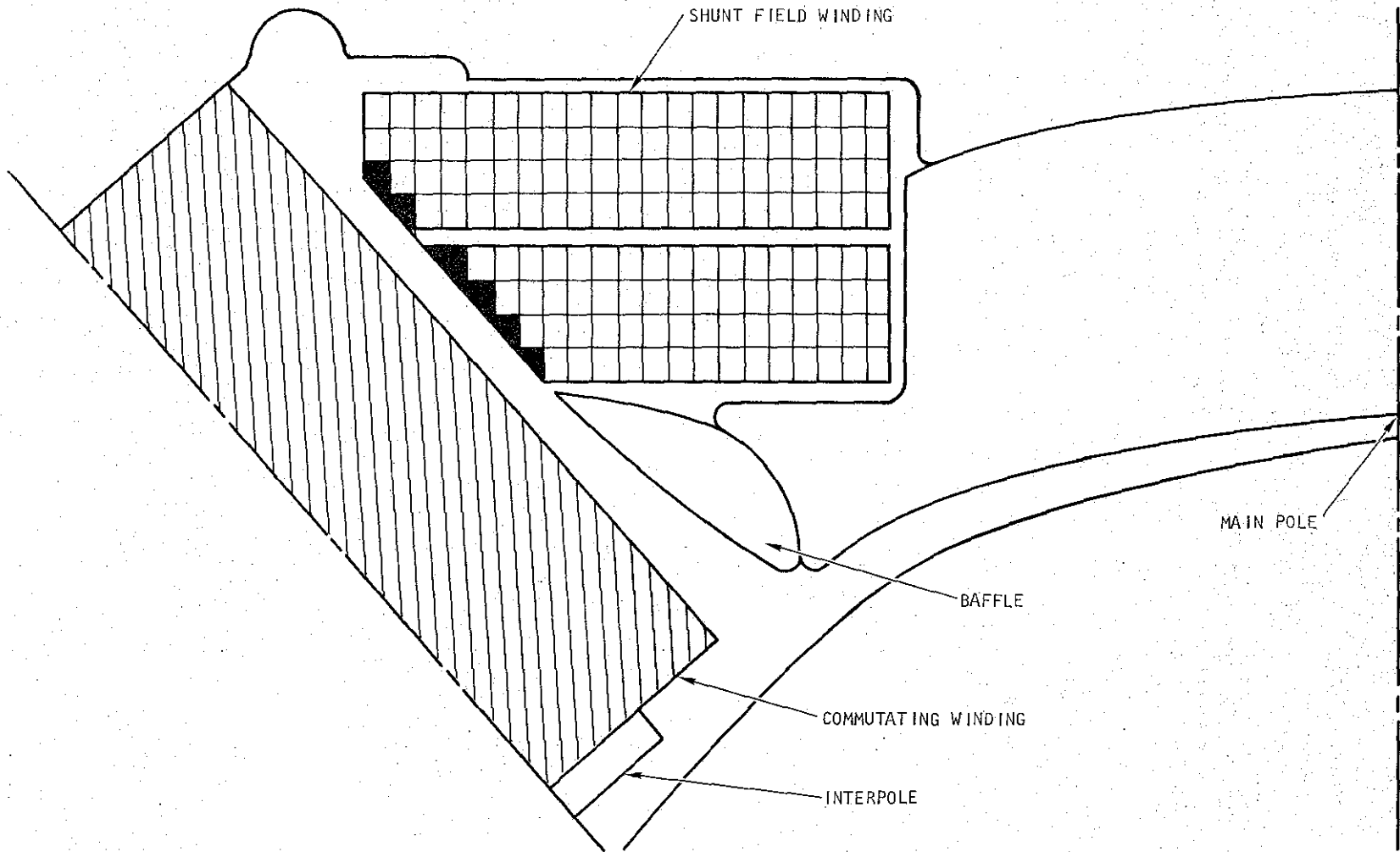

S-25446

Figure 84. Separately Excited, Shunt-Wound Uncompensated Traction Motor

TABLE 21

PERFORMANCE OF UNCOMPENSATED, SEPARATELY EXCITED,
SHUNT-WOUND TRACTION MOTOR WITH INTERPOLES

Armature Current, amp	Terminal Voltage, v	Armature Circuit Input Power, kw	Speed, rpm	Output Torque, lb-ft	Output Power, kw	Separately Excited Field Power, kw	Efficiency,* percent
1105	300.7	332.2	347	5994	295.3	10.5	85.8
690	523.7	361.4	695	3454	340.9	5.76	92.6
510	705.2	359.7	1042	2319	343.1	2.86	94.5
420	878.0	368.8	1389	1787	352.5	1.92	95.0
360	1037.2	373.4	1737	1445	356.4	1.40	95.0
320	1178.7	377.2	2084	1214	359.1	1.10	94.9
290	1285.9	372.9	2431	1025	353.8	0.869	94.6

*Based on field power supply efficiency of 88 Percent.

UNMODIFIED MOTORS

Two General Motors EMD Model D77 traction motors were made available to the program by the Southern Railway System. The history of these motors is shown in Table 22.

TABLE 22
TRACTION MOTOR HISTORY

Motor Serial Number	Original Service Date	Overhaul Date	Accumulated Mileage	Remarks
71121661	1972	1-8-76	404,151	
		10-31-77	539,858	Armature replaced with C75E296 having 109,626 mi accumulated service at installation.
69311094	11-3-71	2-27-76	326,636	First record of motor original service date unknown. Armature replaced with C69G375 remanufactured by National Coils.
		10-25-77	478,480	

TESTS OF UNMODIFIED MOTORS

The two unmodified traction motors were installed on a test stand at Motor Coil Manufacturing in North Braddock, Pennsylvania. Winding resistance and insulation resistance measurements were made with the motors cold. Tests were run to establish the no-load saturation and performance characteristics of the machines. Heat runs also were performed on the machines. Table 23 shows the results of the resistance measurements. The measured winding resistances were within the ± 2 percent range specified by the manufacturer except for the inter-pole winding resistance of one machine, which was found to be 2.6 percent above the specified resistance band. The insulation resistance of both machines was greater than 10 megohms.

Figure 85 shows the no-load saturation characteristics of one machine. The characteristics of the second machine were found to be equivalent within the limits of instrumentation accuracy and the hysteresis characteristics of these machines.

TABLE 23

UNMODIFIED D77 TRACTION MOTOR RESISTANCES

Circuit	Serial Number	
	71-L2-4661*	69-J1-1094*
Interpole	0.005865	0.005205
Main field	0.007584	0.007200
Armature	0.01031	0.01003

* Resistance corrected to 20°C.

Figure 86 shows the performance characteristics with 40-in. wheels, a reduction gear ratio of 62/15, and an assumed reduction gear efficiency of 96 percent. Excellent agreement is seen between the published performance data and the performance based on motor tests.

Heat run test data indicated that the 850-amp continuous current rating at 1400 cfm results in acceptable motor temperature rises. The thermal time constants of the interpole and main field windings as established from test data are 22 and 27 min, respectively, at 1260 cfm.

These test results indicate that the operational integrity of the unmodified motors is good and that the performance is in agreement with published characteristics. The thermal test also disclosed that the unmodified interpole winding temperatures are the highest temperatures in the machine.

Figure 86 quantifies the tractive effort of the unmodified machine.

TRACTION MOTOR MODIFICATIONS

After completion of the unmodified traction motor tests, the motors were modified to the separately excited, low field current configuration. In addition, the interpole coils were replaced with coils having increased conductor area to reduce interpole losses and lower interpole temperatures. Figures 87 and 88 define the replacement coils installed in the modified motors.

TEST OF MODIFIED MOTORS

Test Configuration

Figure 89 is a schematic diagram of the test configuration showing instrumentation and control as installed for the tests using the electrical supply of loss test circuit with a booster generator. This circuit was used to perform no-load saturation tests, establish load saturation characteristics, and perform heat runs on the modified machines.

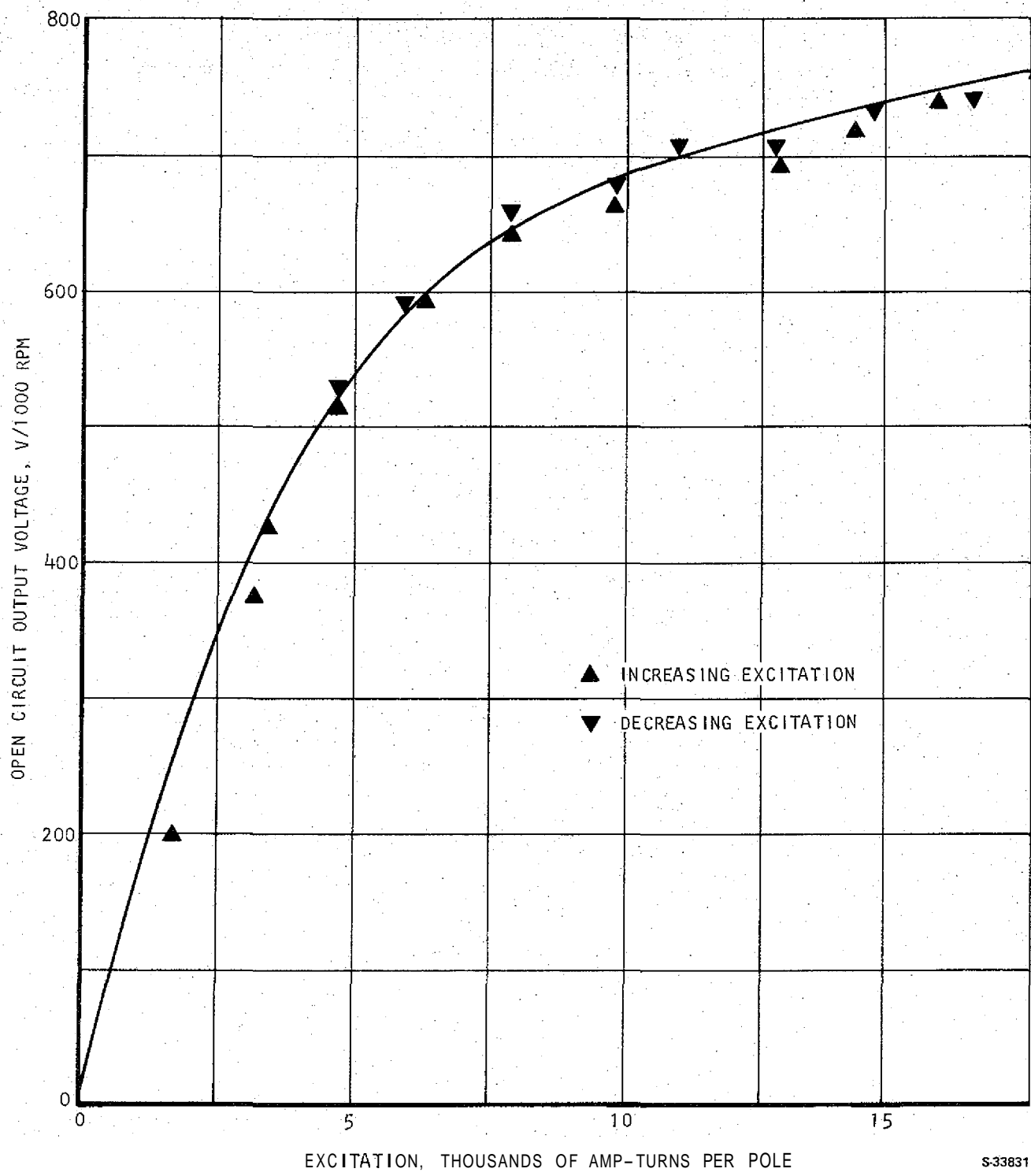
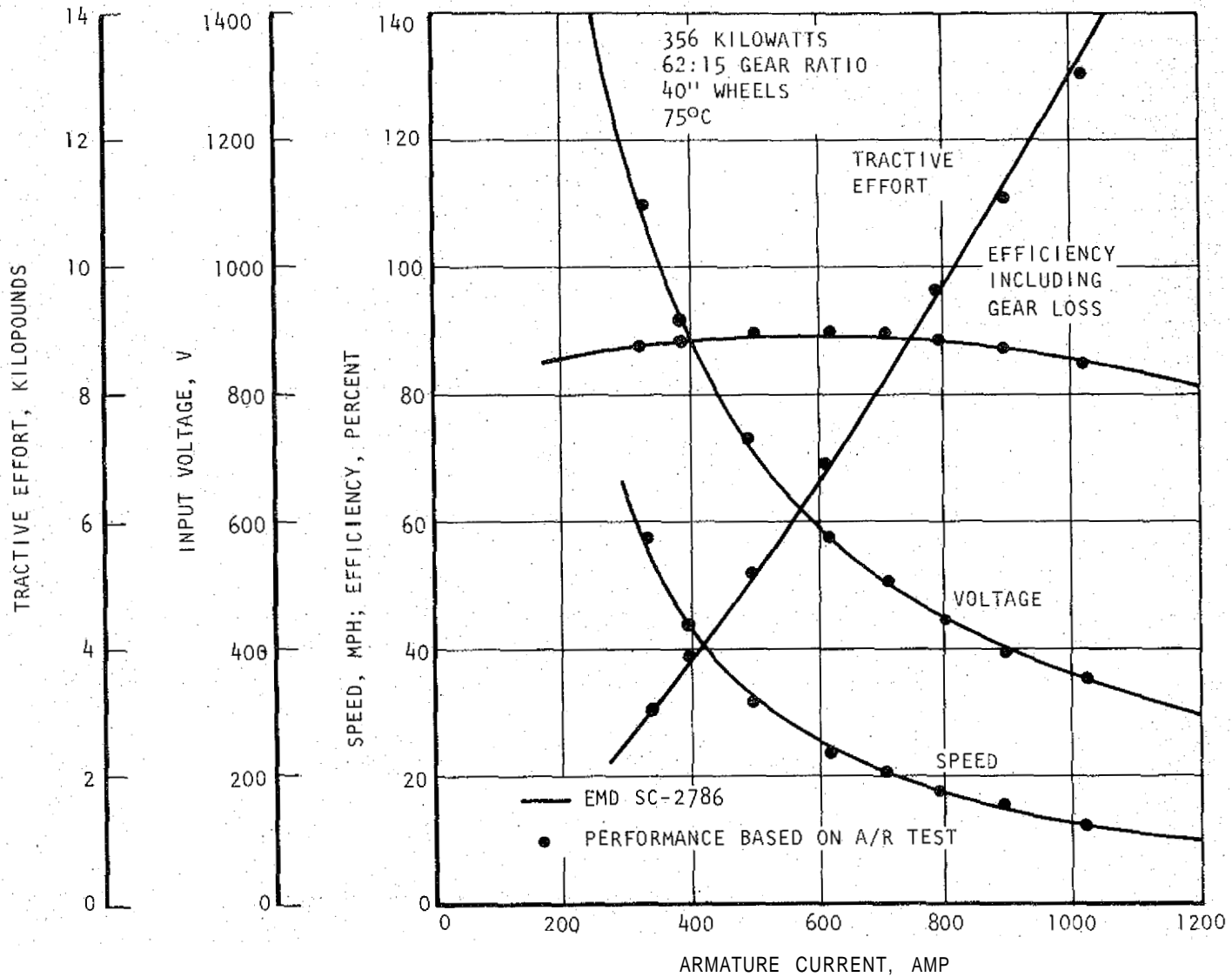

Figure 85. No-Load Saturation Characteristics Unmodified D77 Traction Motors



S-33815

Figure 86. Unmodified Series-Wound D77 Traction Motor Characteristics

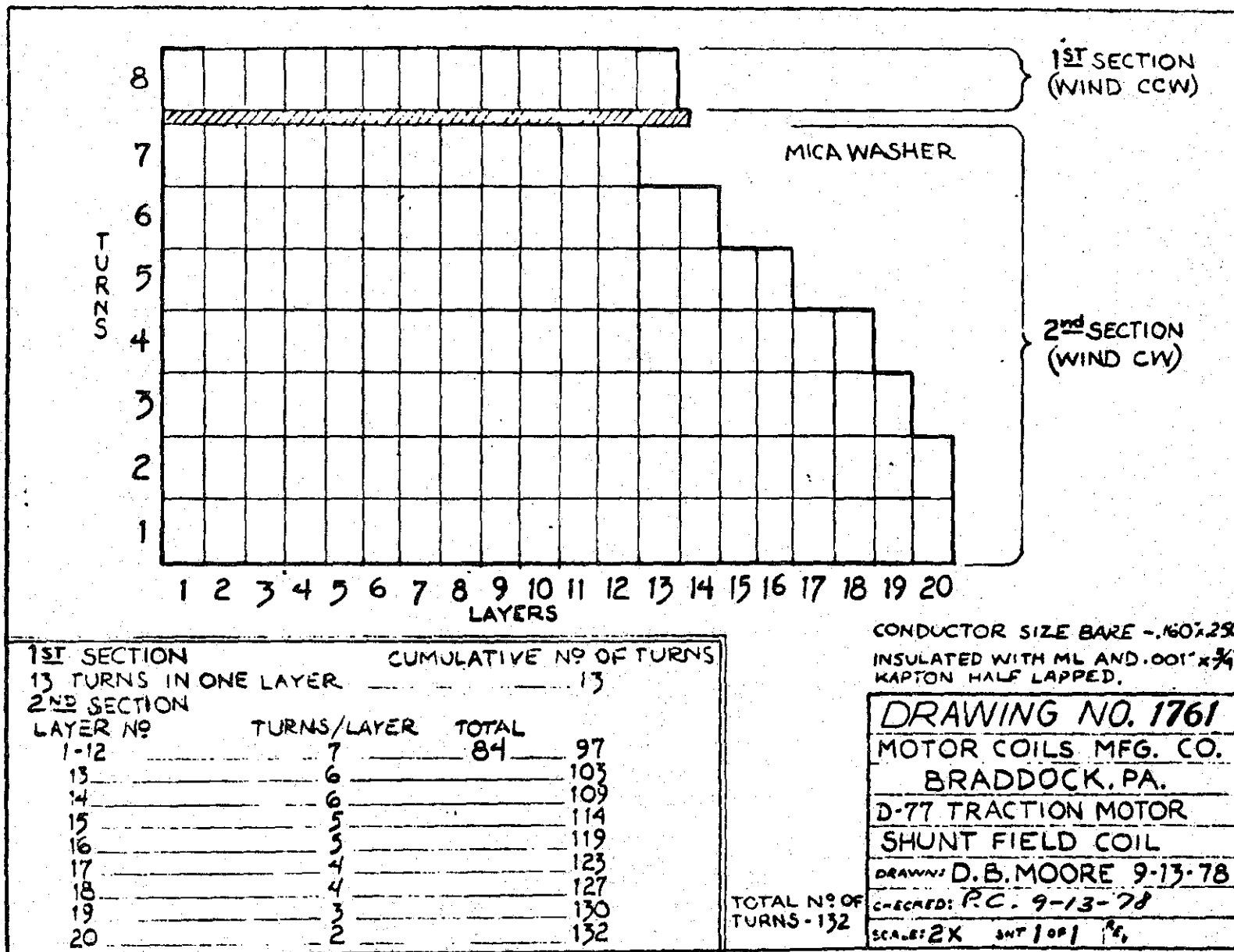

Figure 87. Replacement Shunt Field Coil

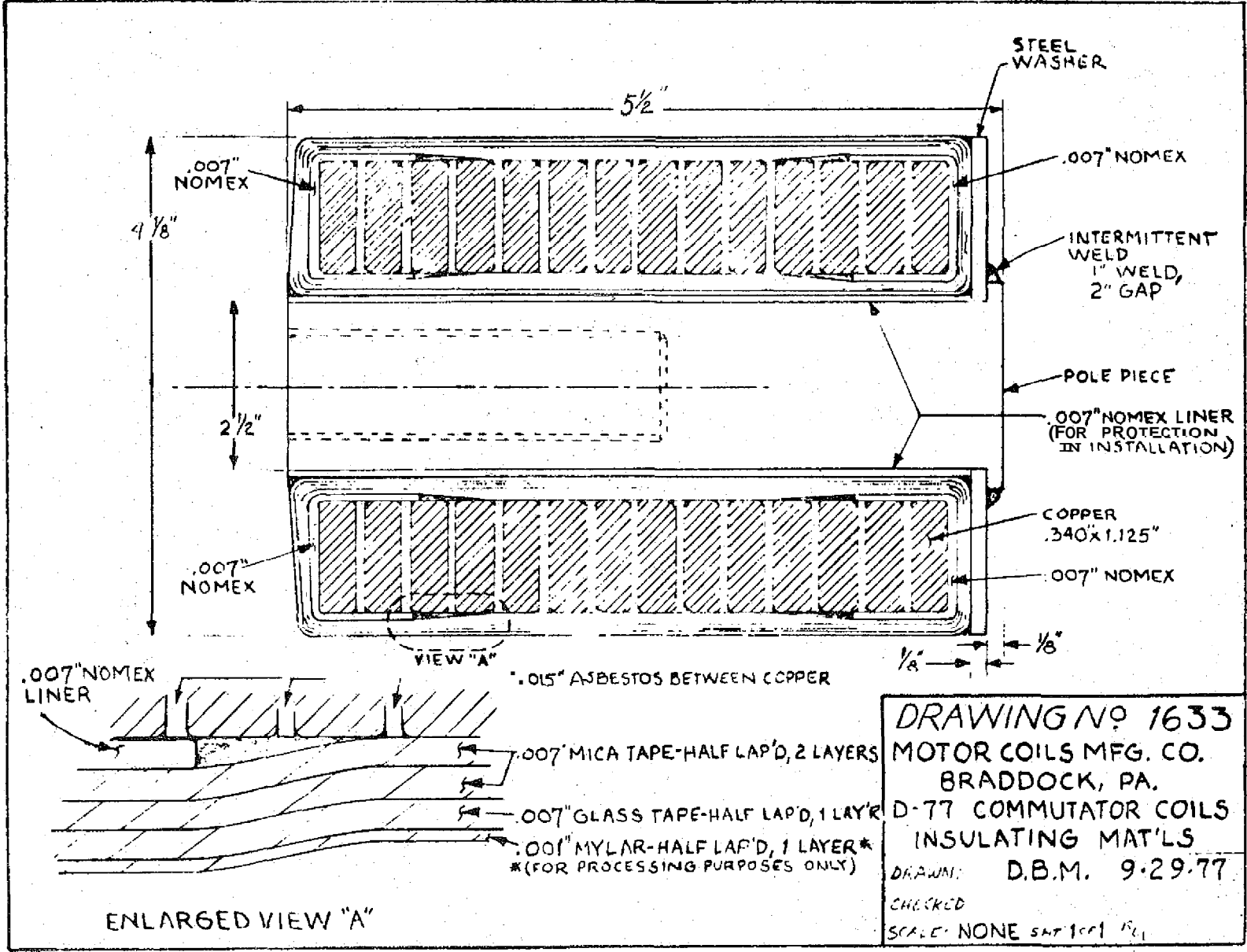
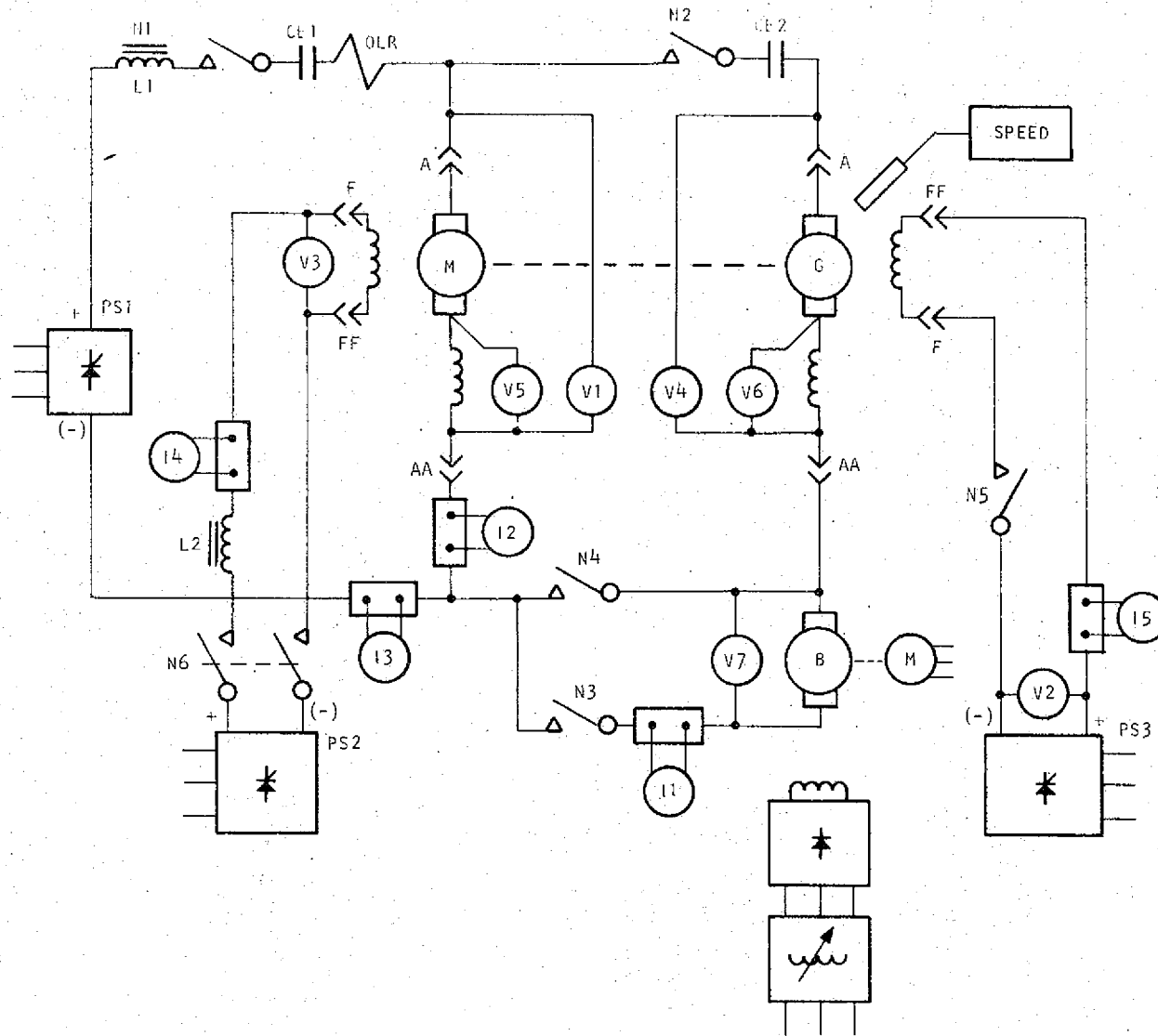

Figure 88. Replacement Interpole Coil



S-33826

Figure 89. Separately Excited Traction Motor Test Schematic

Yo-Load Saturation Test

Table 24 shows the no-load saturation test data for the modified D77 traction motor in columns 1 to 8. The measured speed was determined by use of a counter connected to a magnetic speed sensor which develops 60 pulses per revolution. With a 1-sec counting interval, this arrangement provides direct reading digital speed indication. A check of the motor speed with a stroboscope speed indicator showed that the instrumentation was operating properly. Therefore, corrected speed is the indicated speed as shown in columns 8 and 9. The generator excitation shown in column 10 is the product of the generator field current (column 6) and the number of turns per pole on the modified main field coils (132). The open circuit generator output voltage shown in column 4 is normalized to 1000 rpm speed and is shown in column 11.

The no-load saturation characteristics of the machine are shown in Figure 90. Because these characteristics agree with those observed on the unmodified machine and the modification work should not have resulted in any change, only one of the modified machines was tested for no-load saturation characteristics. These characteristics may be represented by the expression:

$$E' = \frac{aF}{F + b} \quad (1)$$

where E' is the open circuit voltage per kilorpm

F is the excitation in ampere-turns

a is an empirical constant (947.9)

b is an empirical constant (3738)

These constants were selected to give 490 v/kilorpm at 4,000 ampere-turns and 690 v/kilorpm at 10,000 ampere-turns. Table 25 is a comparison between the measured and simulated characteristics. Excellent agreement is seen between the measured and computed results at normal operating excitation levels.

1. Rotational Losses

Table 24 provides the data necessary to compute the power input required to drive the motor and generator. The armature circuit resistance losses in the motor are small under no-load saturation test conditions. As a consequence, the entire motor input power is equal to the rotational losses of the machines. With the generator open-circuited, the actual supply current (column 1) and motor armature current (column 3) are identical. The average of the two measured currents multiplied by the motor voltage (column 2) is taken as the motor input power and is shown as the total rotational loss in column 2 of Table 26. Column 3 of Table 26 shows the motor excitation, which is the product of motor field current (column 7 of Table 24) and the 132 turns per pole of the main field windings.

TASLE 24

NO-LOAD SATURATION TEST DATA, MODIFIED TRACTION MOTOR

NO.	SUPPLY CURRENT	MOTOR VOLTAGE	MOTOR ARMATURE CURRENT	GENERATOR VOLTAGE	MOTOR FIELD VOLTAGE	GENERATOR FIELD CURRENT	MOTOR FIELD CURRENT	INDICATED SPEED RPM	CORRECTED SPEED RPM	GENERATOR EXCITATION AMPERE TURNS	OPEN CIRCUIT VOLTAGE @ 1000 RPM
1	2	3	4	5	6	7	8	9	10	11	
1	14	616	15	9	28	0	44	1002	1002	0	8.98
2	14	614	16	296	28	16	44	1010	1010	2112	293
3	16	613	17	489	28	30	43	1006	1006	3960	486
4	19	608	20	593	29	44	42	1003	1003	5808	591
5	21	607	23	651	29	59	42	1002	1002	7788	650
6	26	605	25	693	29	74	42	999	999	9768	694
7	30	603	29	727	29	89	42	999	999	11748	728
8	34	601	34	752	29	103	42	1022	1022	13596	736
9	39	599	38	776	29	119	42	1022	1022	15709	759
10	43	597	43	792	29	133	42	997	997	17556	794
11	34	602	33	723	33	103	48	982	982	13596	736
12	30	604	30	701	33	90	48	990	990	11880	708
13	27	605	26	673	33	75	48	963	963	9900	699
14	23	609	23	640	33	60	48	968	968	7920	661
15	18	616	17	489	33	30	48	941	941	3960	520
16	14	617	14	8	33	0	47	986	986	0	8.11
17											
18											
19											
20											
21											

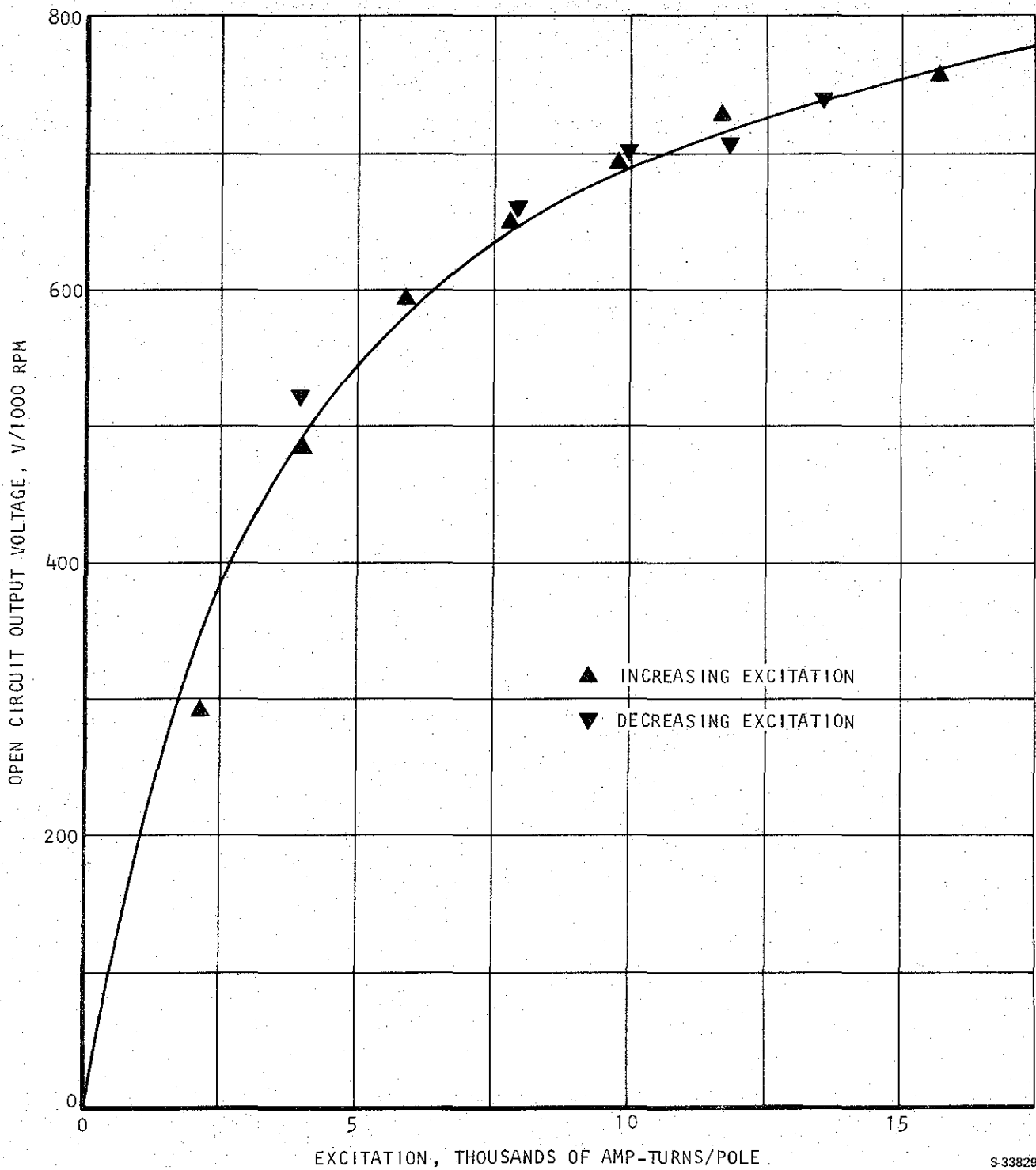

Figure 90. No-Load Saturation Characteristics Modified D77 Traction Motors

TABLE 25

CALCULATED VS. MEASURED NO-LOAD SATURATION CHARACTERISTICS

a = 947.94

b = 3738

	Generator Excitation, ampere-turns	Open Circuit Voltage at 1000 rpm	Calculated Open Circuit Voltage at 1000 rpm	Voltage Error, v	Voltage Error, percent
No.	10	11	12	13	14
1	0	8.98	0	-8.98	-100
2	2112	293	342	49.2	16.8
3	3960	486	488	1.6	0.34
4	5808	591	577	-14.3	-2.4
5	7788	650	641	-9.5	-1.5
6	9768	694	686	-8.4	-1.2
7	11748	728	719	-8.9	-1.2
8	13596	736	744	7.5	1.0
9	15709	759	766	6.7	0.9
10	17556	794	782	-12.5	-1.6
11	13596	736	744	7.5	1.0
12	11880	708	721	13.1	1.8
13	9900	699	688	-10.9	-1.6
14	7920	661	643	-17.0	-2.5
15	3960	520	488	-32.4	-6.2
16	0	8.11	0	-8.1	-100

TABLE 26

ROTATIONAL LOSS DATA NO-LOAD SATURATION TEST

	Generator Excitation, ampere-turns	Total Rotational Loss, kw	Motor Excitation, ampere-turns	Speed, rpm	Open Circuit Voltage at 1000 rpm, v
No.	1	2	3	4	5
1	0	8.93	5810	1002	8.98
2	2112	9.20	5810	1010	293
3	3960	10.10	5680	1006	486
4	5808	11.80	5540	1003	591
5	7788	13.30	5540	1002	650
6	9768	15.40	5540	999	694
7	11748	17.80	5540	999	728
8	13596	20.40	5540	1022	736
9	15709	23.00	5540	1022	759
10	17556	25.60	5540	997	794
11	13596	20.20	6340	982	736
12	11880	18.10	6340	990	708
13	9900	16.00	6340	963	699
14	7920	14.00	6340	968	661
15	3960	10.80	6340	941	520
16	0	8.63	6200	986	8.11

Figure 91 shows the total rotational losses vs generator excitation for operation at an average speed of 1010 (997 to 1022) rpm and an average motor excitation of 5600 (5540 to 5810) ampere-turns per pole. These essentially constant conditions for these parameters are from lines 1 to 10 of Table 26. If the generator is operated at an excitation of 5540 ampere-turns per pole, both motor and generator will be operating at essentially the same conditions and the total rotational losses of 11.6 kw may be assumed to divide equally between the two machines. When the generator excitation is reduced to zero, the total rotational loss reduces to 8.78 kw. This change has little effect on motor losses, so it may be considered to require the same 5.8 kw as required for operation with the generator at 5540 ampere-turns per pole. The difference between the 8.78 kw total rotational loss and the 5.8 kw rotational loss required by the motor is the generator friction and windage of 2.98 kw, which remains when the generator excitation is reduced to zero. This may be assumed to equal the motor friction and windage loss for identical machines. The difference between the total rotational loss of the motor of 5.80 kw and the motor friction and windage loss of 2.98 kw is the motor iron loss at 1000 rpm and an excitation of 5540 ampere-turns per pole. Table 27 summarizes these no-load losses in the motor and generator for the unexcited and excited generator conditions as described above.

2. Iron Losses

The iron losses in the machine may be described by the equation:

$$P_{FE} = \left(\frac{K_1}{N} + K_2 \right) \frac{E^2}{1000} \quad (2)$$

where P_{FE} is the iron loss in kilowatts

N is the speed in rpm

E is the air gap voltage in volts

K_1 and K_2 are iron loss constants for the machine

The iron loss constants for the machine have been calculated from motor design data and material characteristics and are 5.86 and 2.289×10^{-3} for K_1 and K_2 , respectively.

Equation (1) may be used to calculate the air gap voltage for the excitation level of 5540 ampere-turns and a speed of 1010 rpm as follows:

$$E = \frac{947.9 \times 5540}{5540 + 3378} \times \frac{1010}{1000} = 572 \text{ v} \quad (3)$$

At this excitation level, Table 25 indicates that the calculated voltage should be increased about 2 percent. This correction results in an air gap voltage of 583 v for the given conditions, and a calculated iron loss from Equation (2) of 2.75 kw. This calculated iron loss agrees quite well with the

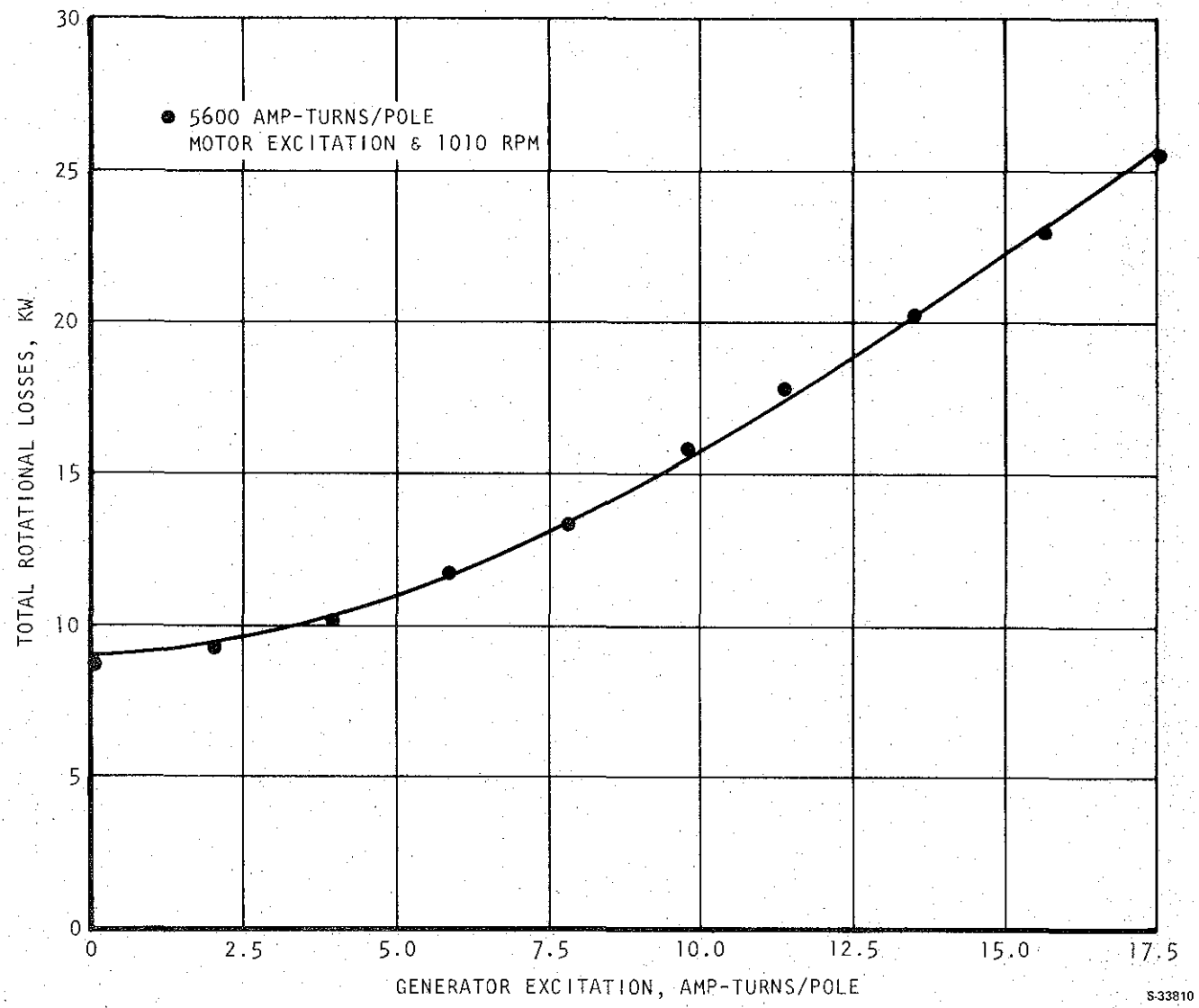

Figure 91. Total Rotational Losses vs Generator Excitation from No-Load Saturation Test of Modified Traction Motor and Generator

TABLE 27

D77 TRACTION MOTOR (MODIFIED)
NO-LOAD LOSS DISTRIBUTION AT 1000 RPM

	Motor	Generator	Total
Excitation, ampere-turns	5540	0	---
Friction and windage, kw	2.98	2.98	5.96
iron loss, kw	<u>2.82</u>	0	<u>2.82</u>
Total rotational, kw	5.80	2.98	8.78
Excitation, ampere-turns	5540	5540	---
Friction and windage, kw	2.98	2.98	5.96
iron loss, kw	<u>2.82</u>	<u>2.82</u>	
Total rotational	5.80	5.80	11.60

2.82 kw shown in Table 27 as derived from test data. Constants K1 and K2 are adjusted as follows to match the test data:

$$K1 = \frac{2.82}{2.75} \times 5.86 = 6.01 \quad (4)$$

$$K2 = \frac{2.82}{2.75} \times 2.289 \times 10^{-3} = 2.35 \times 10^{-3} \quad (5)$$

3. Friction and Windage Losses

Brush friction losses may be calculated from the expression:

$$P_{BF} = 5.9184 \times 10^{-6} w l n P \mu N D \quad (6)$$

where P_{BF} is the brush friction loss in kw/motor

w is the brush width in inches

l is the axial length of the brush in inches

n is the number of brushes per motor

μ is the coefficient of friction between brush and commutator

N is the motor speed in rpm

D is the commutator diameter in inches

Table 28 shows the brush design data used in the calculation of brush friction losses for the D77 traction motor.

TABLE 28

BRUSH DESIGN DATA
D77 TRACTION MOTOR

w	Width, in.	0.625
l	Length, in.	2.0
β	Pressure, psi	6.5
n	Number of brushes	12
μ	Coefficient of friction	0.15
D	Commutator diameter, in.	15.81

The calculated brush friction losses, using the data of Table 28, are 1.368 kw/motor at 1000 rpm.

Bearing friction may be calculated from the expression:

$$P_{BRG} = 7.398 \times 10^{-7} q N \quad (7)$$

where P_{BRG} is the bearing loss in kw
 q is the bearing drag in oz-in.
 N is the motor speed in rpm

Windage loss may be calculated from the expression:

$$P_w = k_w N^2 \quad (8)$$

where P_w is the windage loss in kw
 k_w is the windage loss coefficient

The loss coefficient (k_w) is estimated to be 5.217×10^{-7} from tests of similar machines.

The sum of the calculated brush friction, bearing friction, and windage loss should equal the 2.98 kw as derived from *fesf* at 1000 rpm. Table 29 shows the calculated friction and windage losses at 1000 rpm as compared with the test value. The calculated value is less than that established by test. The calculated losses are adjusted to match total friction and windage losses as

shown in Table 29. The major increase in the adjusted losses is in the brush friction loss. This increase in brush friction may be the result of operation with an unseasoned, clean, new commutator surface that has not yet acquired a burnished low friction film.

TABLE 29
 FRICTION AND WINDAGE LOSSES, KW AT 1000 RPM

	Calculated Loss, kw	Adjusted Loss, kw	Effect of Speed
Brush friction	1.368	2.08	Linear with speed
Bearing friction	0.074	0.122	Linear with speed
Windage loss	0.522	0.782	Speed squared
Total losses	1.964	2.98	--

Load Saturation Tests

Load saturation tests were performed to establish the effect of load on the performance of the motor. Table 30 shows the measured load saturation test data as recorded. Analysis of the test data has shown that the indicated speed exceeds the actual speed that could exist for certain test conditions. Therefore, it was necessary to adjust the speed prior to additional data reduction. It appears that the speed instrumentation counter input signal threshold was set too low and that some noise was counted as motor speed. The principal noise source was the three pulse-per-cycle noise on the solid-state power suppliers shown in Figure 89. At high power levels, one or more of these pulses apparently added to the counter each cycle of supply frequency. One pulse per second is equivalent to a speed of one revolution per minute. Three pulses per cycle at 60 cycles per second, therefore, are equivalent to 180 rpm if each noise pulse is detected by the counter. Thus, speed errors may be 60, 120, or 180 rpm. Column 15 of Table 30 shows the corrected speed resulting from evaluation of the data.

The effect of load on the performance of the motor is to introduce voltage drops between the motor input terminals and the internal voltage of the machine and to increase the magnetomotive force (mmf) under one pole tip and to decrease it under the other pole tip of each pole. As a consequence of saturation, the increase in mmf results in less than proportional increase in magnetic flux where the load current produced mmf is aiding the main field flux. This increase in flux is less than the reduction in flux that occurs under the pole tip where the armature reaction mmf is bucking the main field flux. As a result of this effect, the average flux per pole is reduced, which is equivalent to additional voltage drop. These effects are considered in greater detail in the following paragraphs.

TABLE 30

LOAD SATURATION TEST DATA

NO.	TIME	MOTOR VOLTAGE volts ac	GENERATOR FIELD VOLTAGE volts ac	GENERATOR INTERPOLE VOLTAGE volts ac	GENERATOR ARMATURE CURRENT amps ac	GENERATOR FIELD CURRENT amps ac	INDICATED SPEED RPM	GENERATOR VOLTAGE volts ac	MOTOR FIELD VOLTAGE volts ac	MOTOR INTERPOLE VOLTAGE volts ac	MOTOR ARMATURE CURRENT amps ac	MOTOR FIELD CURRENT amps ac	SUPPLY CURRENT amps ac	BOOSTER VOLTAGE volts ac	CORRECTED SPEED
1	2	3	4	5	6	7	8	9	10	11	12	13	14	15	
1	821	80	11.1	3.40	722	102.4	226	49.0	47.4	3.87	835	77.1	115	—	106
2	823	164	58.5	4.23	884	93.8	422	136	48.2	4.91	1029	77.1	143	—	242
3	825	340	57.8	4.61	914	89.7	606	312	48.9	5.17	1022	76.9	113	30.2	486
4	835	445	57.8	4.74	925	88.0	722	419	49.0	5.50	1055	76.0	120	29.4	662
5	837	569	62.5	4.96	933	92.1	998	543	51.0	5.61	1039	78.0	115	29.6	818
6	845	569	34.2	4.95	902	49.0	1144	543	30.9	5.73	1015	47.4	125	29.5	964
7	851	577	25.4	5.01	893	36.9	1415	539	23.3	6.00	1043	36.5	140	38.0	1235
8	852	578	19.7	4.56	813	29.2	1632	539	18.9	5.77	1010	30.4	151	40.6	1452
9	900	577	15.6	4.85	844	23.0	2012	528	15.1	5.96	994	24.9	159	—	1832
10	905	566	12.6	4.93	844	18.6	2308	508	12.5	6.25	1030	21.3	175	63.8	2128
11	921	573	21.7	5.42	915	33.7	1503	513	20.8	6.63	1044	35.2	130	61.0	1323
12	922	581	19.4	4.31	725	30.2	1443	529	20.9	5.05	796	34.9	74	53.3	1263
13	931	578	29.5	4.53	752	46.3	1086	527	30.2	5.07	817	49.6	60	53.0	966
14	935	580	36.9	4.52	751	51.9	1012	526	36.9	4.93	797	60.1	51	53.0	892
15	938	577	59.1	4.55	758	90.6	987	527	57.5	4.95	810	90.0	50	52.9	807
16	941	581	57.3	2.25	380	85.1	867	547	59.2	2.41	401	90.1	28	34.4	807
17	945	577	40.5	2.10	369	58.8	979	563	39.0	2.33	405	58.9	36	14.4	919
18	949	582	33.9	2.02	366	49.1	1036	576	32.6	2.31	410	49.6	44	7.75	976
19	958	582	23.1	1.91	356	33.6	1223	581	22.4	2.20	405	35.2	45	2.16	1163

1. Resistance Drops

The resistance of the interpole winding, armature winding resistance, and brush drop all contribute to the effect of load on performance. The resistance of the windings was measured at a known temperature using a Kelvin bridge to obtain precise values of winding resistance. The results of these measurements are shown in Table 31.

TABLE 31
MODIFIED D77 TRACTION MOTOR RESISTANCES

Circuit	Serial Number	
	71-L2-4661*	69-J1-1094*
Interpole	0,004738	0.004724
Main field	0.5351	0,5394
Armature	0.01031	0.01003

*Resistance corrected to 20°C.

The resistances shown in Table 31 are corrected for temperature using the expression:

$$r_t = r_{20} \left(\frac{234.5 + t}{234.5 + 20} \right) \quad (9)$$

where r_t is the resistance at temperature t

r_{20} is the resistance at 20°C

t is the average winding temperature in °C

The product of the armature current and the sum of all resistances in series with the motor armature is the voltage drop resulting from the dc load current at low speed. As the speed of the machine increases, alternating current is induced in the armature conductors. This alternating current results in eddy current losses in the armature conductors, which increase the effective resistance of the armature. This effect is accounted for by the introduction of an eddy factor (EF), which is a function of speed (frequency) and armature conductor temperature (resistivity). Armature design data were used to develop the EF for the D77 armature resistance. This multiplier of the dc or ohmic resistance of the armature is shown in Figure 92.

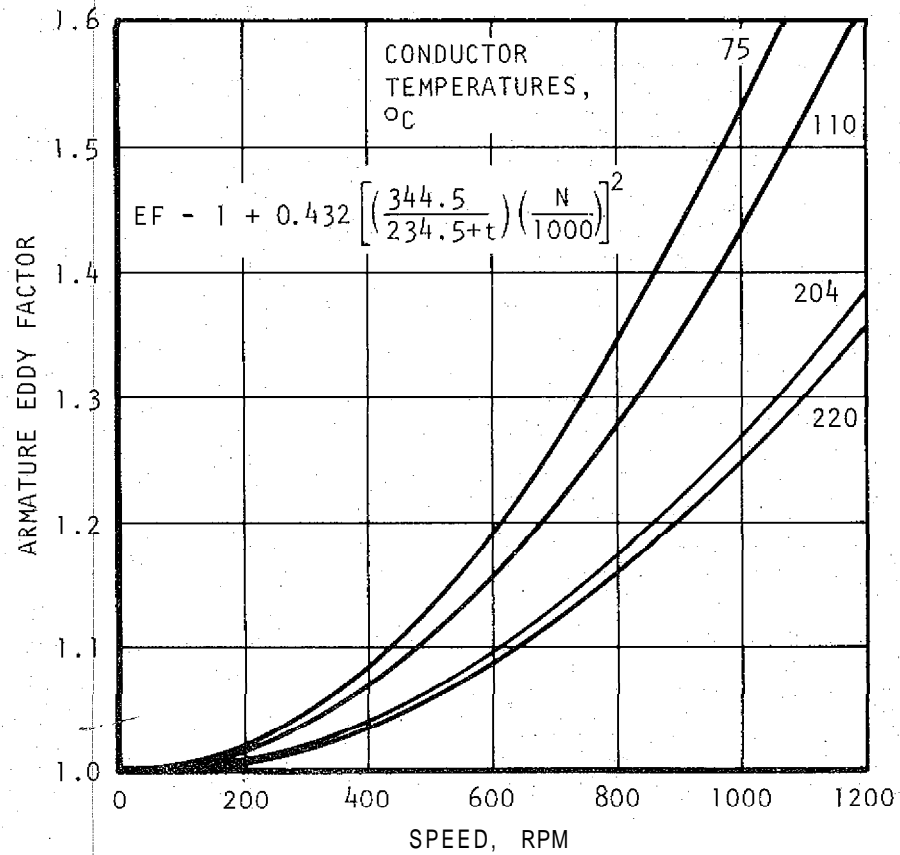

NO.	SPEED, RPM	TEMPERATURE, °C			
		75	110	204	220
1	0	1.000	1.000	1.000	1.000
2	100	1.005	1.004	1.003	1.002
3	200	1.021	1.017	1.011	1.010
4	300	1.048	1.039	1.024	1.022
5	400	1.086	1.069	1.043	1.040
6	500	1.134	1.108	1.067	1.062
7	600	1.193	1.156	1.096	1.089
8	700	1.262	1.212	1.131	1.122
9	800	1.343	1.276	1.171	1.159
10	900	1.434	1.350	1.216	1.201
11	1000	1.535	1.432	1.267	1.248
12	1200	1.771	1.622	1.384	1.357
13	1400	2.049	1.847	1.523	1.486
14	1600	2.370	2.106	1.583	1.535
15	2000	3.141	2.728	2.067	1.993

S-33809

Figure 92. Effect of Conductor Temperature and Speed on Armature Winding Eddy Factor

An additional voltage drop is the brush drop. The brush drop is given by the equation:

$$V_B = E_B + I_A R_B \quad (10)$$

where V_B is the brush drop in volts

E_B is the brush contact drop in volts

R_B is the effective brush resistance in ohms

I_A is the armature current in amperes

The brush contact resistance is assumed to be 0.00217 ohms and the brush contact drop is assumed to be 2.5 v.

2. Armature Reaction

Armature reaction resulting from load current flowing in the motor armature of an uncompensated motor results in an increase in the mmf on one pole tip and a decrease in the mmf on the other. If there were no saturation, the average magnetic flux would remain constant. When the mmf increases on one pole tip, saturation results in a less than proportional increase in flux under this half of the pole, which fails to compensate for the decrease under the other half of the pole. Figure 93 shows this effect. It has been shown that the no-load voltage (E') may be written:

$$E' = \frac{aF}{F + b} \quad (11)$$

Load current (I_A) results in an armature reaction mmf equal to (δ) where:

$$\delta = k_A I_A \quad (12)$$

The average voltage (E) under load may be approximated by the expression:

$$E = \frac{1}{2\delta} \left\{ \int_0^{F+\delta} \frac{aF}{(F+b)} dF - \int_0^{\delta-F} \frac{aF}{(F+b)} dF \right\} \quad \delta > F \quad (13)$$

or

$$E = \frac{1}{2\delta} \int_{F-\delta}^{F+\delta} \frac{aF}{(F+b)} dF \quad \delta \leq F \quad (14)$$

$$E = a \left\{ \frac{F}{\delta} + \frac{b}{2\delta} \ln \left(\frac{b+\delta-F}{b+\delta+F} \right) \right\} \quad \delta > F \quad (15)$$

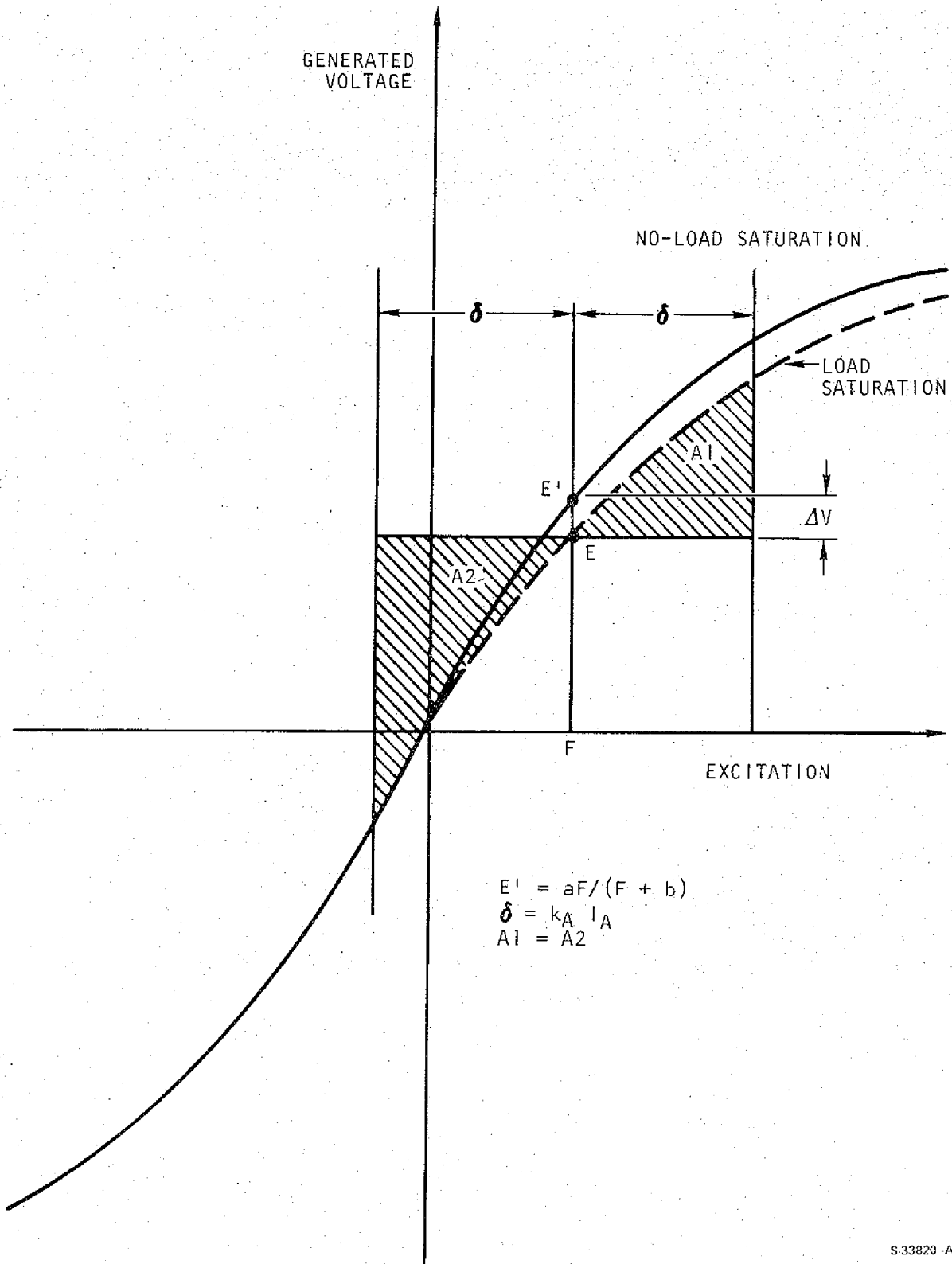

Figure 93. Effect of Armature Reaction

or

$$E = a \left\{ 1 + \frac{b}{2\delta} \ln \left(\frac{b - \delta + F}{b + \delta + F} \right) \right\} \quad \delta \leq F \quad (16)$$

Figure 94 shows calculated load saturation characteristics (E) vs (F) with (I_A) as a parameter for $k_A = 6.5$. This constant (k_A) has been selected to best fit the experimental data,

This curve is derived from the load saturation test measurements shown in Table 31. Table 32 shows the corrected speed (column 1), the motor excitation (column 2), the motor back emf (column 3), the normalized motor back emf at 1000 rpm (column 4), the motor armature current (column 5), and motor air gap power (column 6).

Columns 7 through 11 show the corresponding generator parameters. Instrumentation correction factors have been applied to the voltages and currents shown in Table 31 prior to calculation of the items in Table 32. The back emf of the motor and generator, as shown in Table 32, are based on these corrected values and on the measured resistances of the armature corrected for the estimated armature temperature at the test condition. The armature temperature is estimated on the basis of observed interpole and field winding temperature by resistance. Eddy factors from figure 92 are applied for the armature temperature and speed conditions at the time of measurement. Interpole drops are as measured and shown in Table 31. Brush drops are calculated and included in the total drop to establish the back emf. Corrected speed values are used to normalize the back emf of motor and generator.

3. Load Saturation Characteristics from Test Data

The motor back emf at 1000 rpm from column 4 vs motor excitation from column 2 of Table 32 defines the load saturation characteristics of the motor. Corresponding parameters define that of the generator.

4. Rotational Losses Under Load

The difference between the air gap power output of the motor and the air gap power input of the generator is the total rotational loss. This loss is calculated for each condition as shown in Table 32 (column 12).

5. Stray Load Losses

The friction and windage losses, motor iron losses, and generator iron losses are calculated from the equations developed herein from actual test data. These losses are shown in Table 32 on a per-machine basis in columns 13, 14, and 15, respectively. The total rotational losses minus the sum of the friction and windage losses and the iron losses for both machines, divided by two, is the stray load loss as shown in column 16 of Table 32. This loss divided by the motor input power calculated from corrected motor voltage and current is shown in column 17 as the stray load loss for the motor in percent of motor input. The average of the stray load losses of column 17 is 1.9 percent.

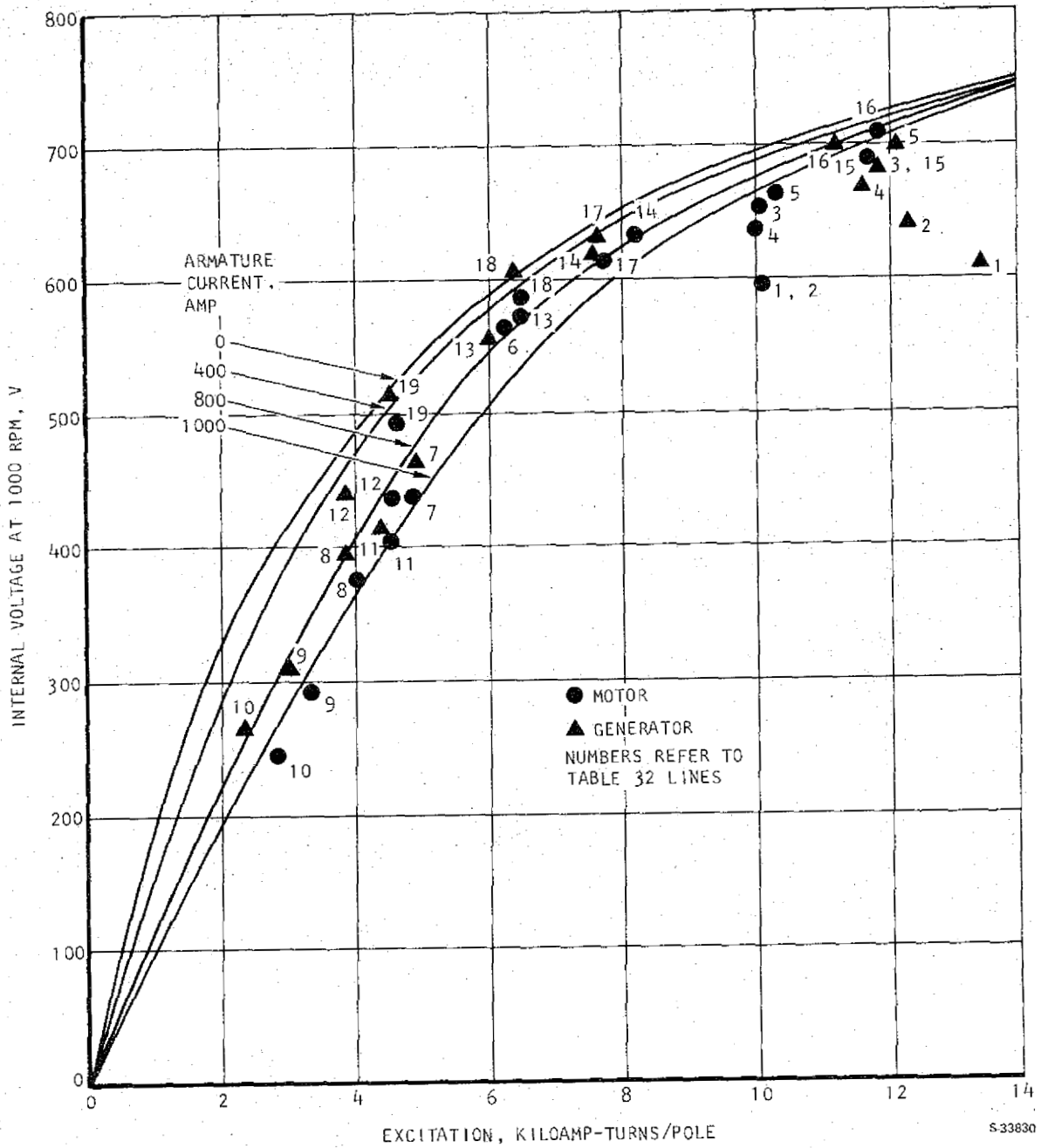

Figure 94. Load Saturation Characteristics of D77 Traction Motor

TABLE 32

LOSS DISTRIBUTION FROM LOAD SATURATION TEST DATA

No.	Speed, rpm	Motor Excitation, ampere-turns	Motor Back emf, v	Motor Back emf at 1000 rpm, v	Motor Current, amp	Motor Air Gap Power, kw	Generator Excitation, ampere-turns	Generator Back emf, v	Generator Back emf at 1000 rpm, v	Generator Current, amp	Generator Air Gap Power, kw	Total Rotational Loss, kw	Friction and Windage Loss, kw	Motor Iron Loss, kw	Generator Iron Loss, kw	Stray Load Loss, kw	Stray Load loss in Motor, percent
1	106	10180	63.1	596	835	52.7	13520	64.3	606	724	46.5	6.18	0.24	0.24	0.24	2.61	3.90
2	242	10180	143	592	1029	14.7	12380	155	640	887	137	9.98	0.58	0.56	0.65	3.81	2.25
3	486	10150	318	653	1022	32.5	11840	334	687	917	306	18.41	1.25	1.48	1.64	6.40	1.83
4	662	10030	420	635	1055	44.3	11620	443	669	928	411	32.20	1.78	2.02	2.24	12.2	2.59
5	818	10300	543	663	1039	56.4	12160	570	696	936	533	30.82	2.32	2.86	3.15	10.1	1.70
6	984	6260	541	561	1015	54.9	6470	571	592	905	516	32.57	2.84	2.51	2.80	10.8	1.86
7	1235	4820	544	440	1043	56.7	4870	570	462	896	511	56.26	3.90	2.13	2.35	22.0	3.64
8	1452	4013	542	373	1010	54.7	3850	571	393	815	466	81.55	4.83	1.90	2.72	33.9	5.80
9	1832	3290	533	291	994	53.0	3040	568	310	847	481	48.92	6.64	1.60	1.82	16.1	2.80
10	2130	2810	513	241	1030	52.8	2460	554	261	847	469	58.97	8.21	1.36	1.59	19.8	3.33
11	1323	4650	537	406	1044	56.1	4450	547	413	918	502	59.23	4.27	1.39	2.06	23.3	3.89
12	1263	4600	554	439	796	44.1	3990	556	440	727	404	37.07	4.02	2.18	2.20	12.3	2.66
13	966	6547	554	574	817	45.3	6110	552	571	754	416	36.70	2.85	2.63	2.61	12.9	2.72
14	892	7930	557	625	797	44.4	7640	550	617	753	414	30.06	2.58	2.82	2.75	9.67	2.09
15	807	11880	555	688	810	45.0	11960	550	682	760	418	31.08	2.28	3.02	2.97	10.3	2.19
16	807	11890	570	706	401	229	11230	561	695	381	214	14.78	2.29	3.18	3.08	1.98	0.85
17	919	7770	565	615	405	229	7760	577	628	370	213	15.53	2.67	2.84	2.96	2.19	0.93
18	976	6550	570	584	410	234	6480	590	604	367	217	17.20	2.88	2.77	2.96	2.85	1.19
19	1163	4650	569	490	405	231	4540	596	512	357	213	17.31	3.61	2.44	2.67	2.79	1.18

Performance

The preceding discussion has established all of the parameters necessary to determine the performance of the D77 traction motor in the unmodified series-connected configuration or in the modified shunt-connected configuration. This section first calculates the performance of the unmodified machine from test data and compares it with published data from the manufacturer. Then the performance of the modified machine is calculated from test data to indicate the effect of the modification on performance.

1. Performance of Unmodified D77 Traction Motors

The performance of the unmodified D77 traction motor has been calculated from the test data. The results of these calculations are shown in Table 33. The calculations are made for the condition of a constant 356-kw input power to the motor. Reduction gear efficiency has been calculated from data on similar gears. Figure 95 shows the tractive effort vs current and speed vs current performance characteristics of the machine as defined by the manufacturer (EMD Curve SC-2786). The voltage vs current characteristic is fixed by the constant power input constraint. Also shown in Figure 95 is the efficiency, including gear losses vs current as calculated from the tractive effort, speed, and input power defined on this curve. These characteristics are the baseline performance characteristics of the motor and gear. The characteristics shown in

TABLE 33

D77 SERIES MOTOR PERFORMANCE CHARACTERISTICS
(356 kw, 62:15 ratio, 40-in. wheels, 75°C, 16 turns/coil)

Armature Current, amp	Tractive Effort, lb	Speed, mph	Voltage, v	Reduction Gear Efficiency, percent	Efficiency Including Gears, percent	Output Power at Rail, hp
1020	12960	11.7	350	98.7	84.3	402
895	11030	14.0	399	98.4	86.3	412
797	9560	16.5	448	98.5	87.8	419
704	8170	19.5	507	98.4	88.9	424
618	6890	23.3	577	98.3	89.5	427
495	5100	31.6	721	97.9	89.8	428
400	3760	42.4	892	97.2	89.0	424
325	2740	56.9	1097	96.0	87.0	415

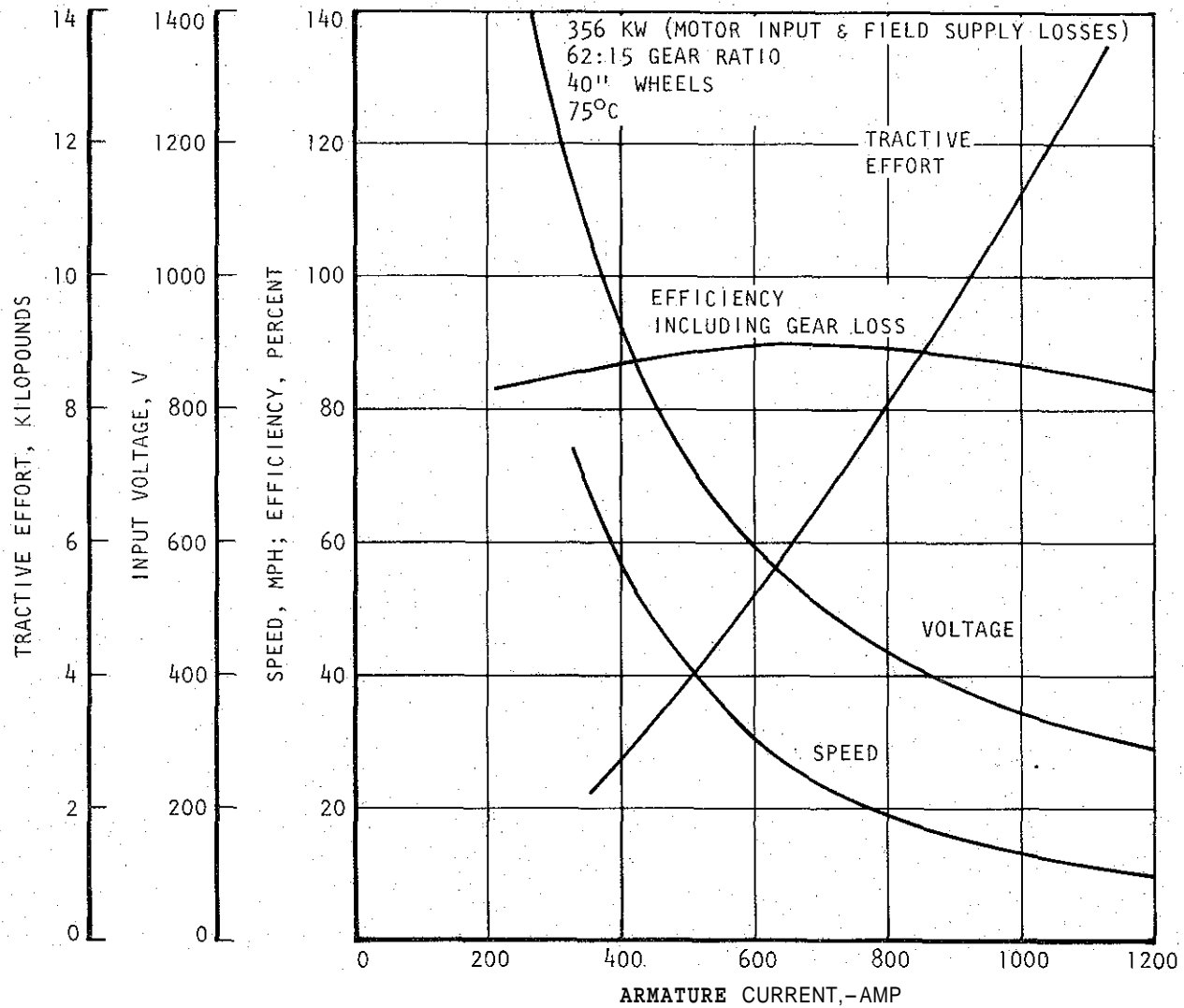

Figure 95. Unmodified Series-Wound D77 Traction Motor Characteristics (356 kw, 62:15 Gear Ratio, 40-in. Wheel, 75°C)

Table 33, which are based on the test results, have been added to Figure 95. Excellent agreement is seen between the baseline and measured characteristics. The published performance characteristics are verified as representative of actual motor performance for the series-connected machine. The performance parameters established from test data also may be considered to be verified for use in system analysis, because they produce results that agree with expected performance.

2. Performance of Modified Traction Motors

The motor data developed in the preceding subsection and validated by comparison of calculated performance with published performance data for the series motor have been used to calculate the performance of the modified motor. The modified motor field losses must be separately supplied. These field losses and the losses in the field power supply (alternator and rectifier) must be included in the input to the motor in order to compare the performance of the modified machine with the baseline characteristics. In the series-connected machine, the main field winding must operate at armature current. At full armature current, the main field winding must be capable of dissipating full armature current losses in the winding. The field losses increase with the current squared but the resulting flux increase is limited by saturation, so operation at high armature current is inefficient. In the separately excited machine, an additional degree of freedom is introduced and excitation may be controlled independent of armature current. Figure 96 shows the effect on the motor losses and tractive effort of a tradeoff between armature current and field excitation. As the armature current is increased, the armature copper loss, the interpole loss, and the brush drop increase. At the same time, the main field loss and iron loss decrease. Figure 96 shows that at constant input power and speed an optimum excitation exists that will result in minimum losses, maximum efficiency, maximum tractive effort, and maximum output power. Figure 97 shows optimum excitation vs armature current for constant power input to motor and field supply losses. Also shown in Figure 97 is the 100-percent field condition equivalent to that of the series machine.

Table 34 shows the calculated performance of the modified D77 traction motor for constant input power to the motor plus field supply losses with optimum excitation applied to the motor. Field power supply losses are based on 85-percent field power supply efficiency. Reduction gear efficiencies, as shown, are included. These data are shown in Figure 98.

Figures 95 and 98 provide a direct comparison of the performance of the unmodified and modified machines for constant power input at 75°C winding temperatures. At light load (low current), the field power supply losses are small and most of the power is delivered to the motor armature circuit. The voltage vs current characteristics, therefore, are practically identical. At higher current, the modified motor input voltage is slightly less than that of the unmodified motor at the same current. Operation of the modified motor at reduced excitation and higher armature current for a given power input on speed results in a shift of the tractive effort curve to the right, an increase in the speed curve, and an increase in the efficiency curve. At the same tractive effort and input power with optimum excitation, the modified machine

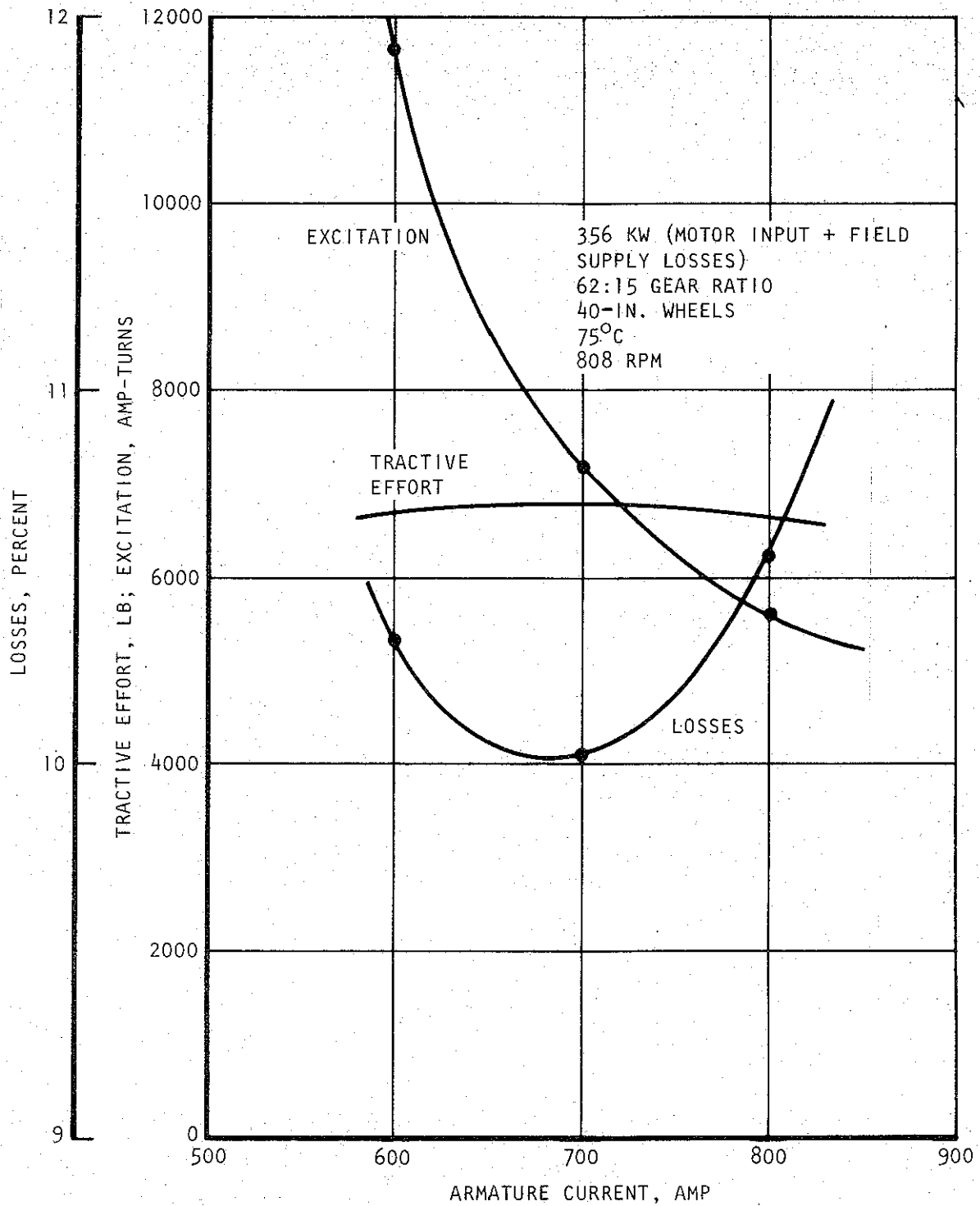

S-33814

Figure 96. Typical Excitation vs Armature Current Characteristics

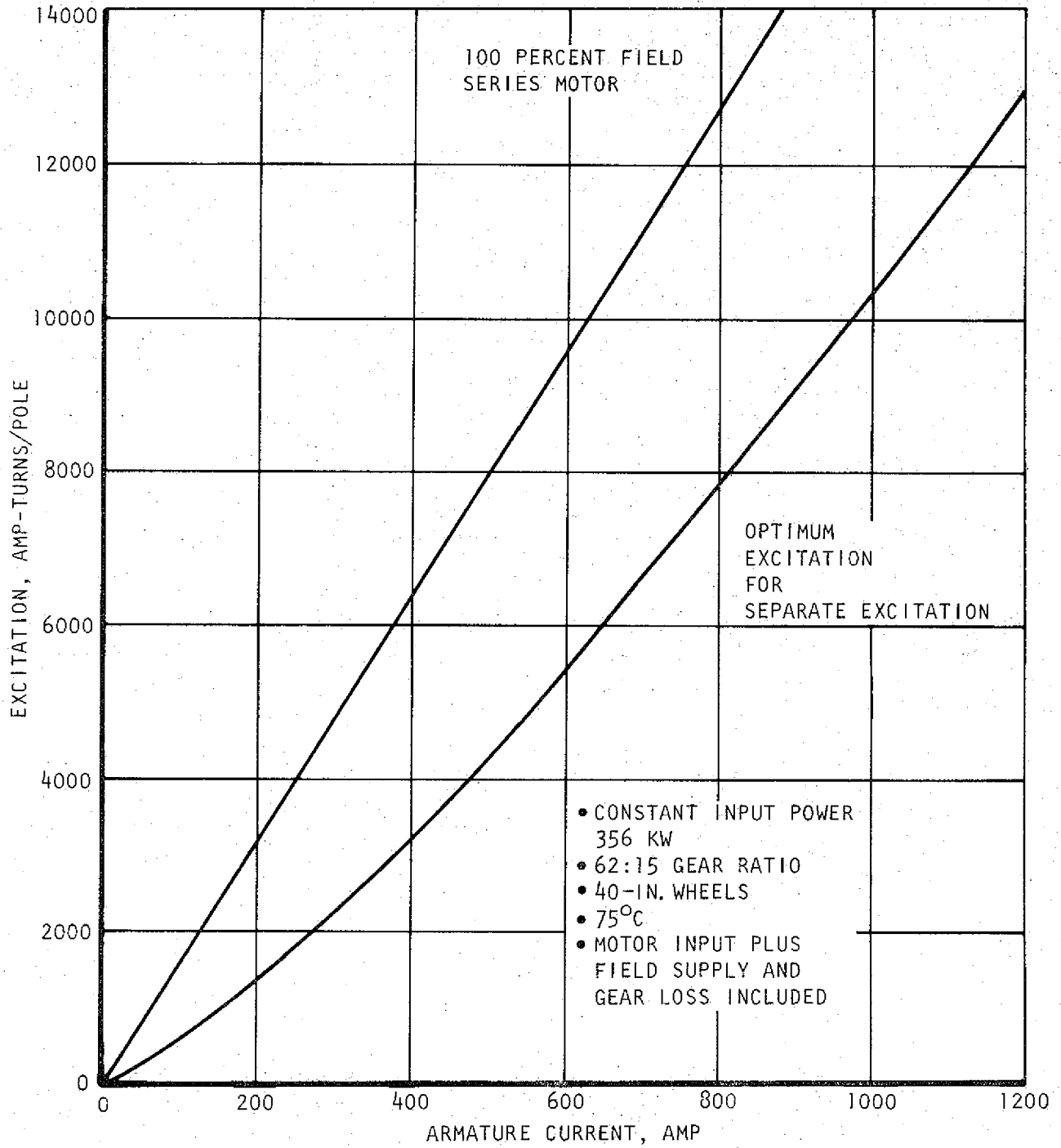

Figure 97. Excitation vs Load Characteristics for Minimum Loss at a Given Speed

S33811

TABLE 34

MODIFIED D77 SEPARATELY EXCITED MOTOR PERFORMANCE CHARACTERISTICS
 (356 kw,* 62:15 ratio, 40-in. wheels, 75°C, 132 turns/coil)

Armature Current, amp	Optimum Excitation		Tractive Effort, lb	Speed, mph	Voltage, v	Reduction Gear Efficiency, percent	Efficiency Including Gears, percent	Output Power at Rail, hp
	Current, amp (132 turns)	mmf, ampere-turns						
1100	97.1	12800	13170	11.7	318	98.7	85.7	409
1000	76.6	10110	11150	14.0	351	98.6	87.4	417
900	67.6	8930	9640	16.5	392	98.5	88.6	423
800	59.8	7890	8203	19.5	442	98.4	89.5	427
700	54.1	7150	6930	23.3	506	98.3	90.1	430
600	39.2	5170	5110	31.6	591	97.9	90.2	430
500	31.2	4120	3770	42.4	709	97.2	89.4	427
400	27.0	3560	2760	56.9	890	96.0	87.7	418

* Total motor input + field supply losses.

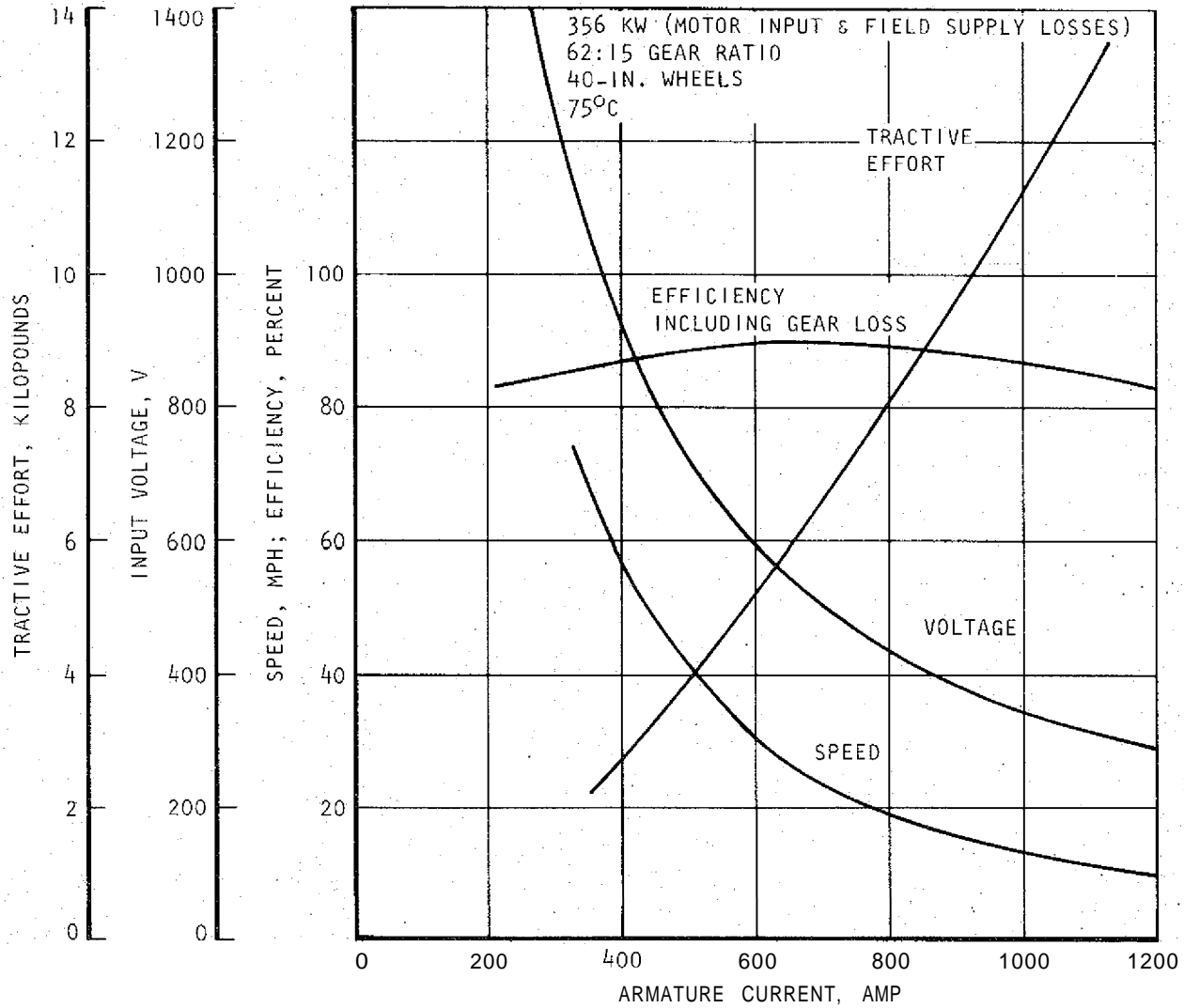

533821

Figure 98. Modified Shunt-Wound D77 Traction Motor Characteristics

operates at higher armature current than the unmodified machine, but at the same speed and efficiency. Therefore, both machines operate at the same overall performance level, but with a different distribution of internal losses.

Heat Run Test Data

The two motors were operated back-to-back at the conditions shown in Tables 35 and 36 until steady-state temperatures were obtained. Temperatures of the winding surfaces were measured and recorded. Average winding temperatures were established by resistance determined from voltmeter and ammeter readings. Average armature temperature after shutdown was determined by resistance measurement and commutation/brush interface temperature after shutdown was measured by a thermocouple. Airflow to the machine was adjusted and measured as the pressure drop across the motors and air temperatures were. Extensive temperature data obtained during these tests have been reduced and are included in the following subsection. The thermal time constants of the main field and interpole windings as determined from tests of the modified machine are 73 and 23 min, respectively, at 3130 cfm. The increase in thermal impedance of the shunt-wound multiterminal coil that results from turn insulation is significantly greater than the effect of airflow on the cooling rate and explains the increase in time constant for this coil. The modified interpole winding has increased heat capacity and increased cooling capacity, and therefore, has a time constant similar to the unmodified coil. The significant results of the heat run are that the thermal capability of the interpole winding was greatly improved by the use of a larger size conductor and that some improvement in the thermal design of the shunt field winding of the modified machine is required. The following subsection provides detailed temperature time history data from heat run 2 to illustrate the thermal condition of the machine as modified with a prototype shunt field design.

TRACTION MOTOR THERMAL ANALYSIS

A thermal analysis of the modified D77 traction motor was performed. The purpose of the analysis was to establish a digital computer thermal model for the evaluation and optimization of the motor performance in terms of thermal rating. The thermal model was correlated with laboratory test data to verify and improve its accuracy. The study has shown that the thermal modeling technique presented herein is a valid tool for thermal design of the traction motor. The test conditions on the machine were taken from heat run 2 (line 24, Table 36). Analysis of the test data resulted in the thermal conditions, airflow, and loss distribution as shown in Table 37.

Thermal Analysis Details

The analysis was performed using the AiResearch Thermal Analyzer Computer Program. The program analyzes a thermal network model that considers conduction, convection, cooling airflow, and radiation. The heat dissipation (I^2R) as a function of temperature was accounted for in the program. A detailed model was created for the analysis and is presented in Figures 99 to 101. The calculated steady-state temperatures based on the test condition of the D77 motor are presented in Tables 38 and 39. The measured temperatures and the calculated temperatures at the critical areas of the motor are presented in Figures 102 to 105.

TABLE 35

HEAT RUN NO. 1 TEST DATA
MODIFIED D77 TRACTION MOTOR

	TIME	MOTOR VOLTAGE Volts dc	GENERATOR FIELD VOLTAGE Volts dc	GENERATOR INTERPOLE VOLTAGE Volts dc	GENERATOR ARMATURE CURRENT amps dc	GENERATOR FIELD CURRENT amps dc	INDICATED SPEED RPM	GENERATOR VOLTAGE Volts dc	MOTOR FIELD VOLTAGE Volts dc	MOTOR INTERPOLE VOLTAGE Volts dc	MOTOR ARMATURE CURRENT amps dc	MOTOR FIELD CURRENT amps dc	SUPPLY CURRENT amps dc
NO.	1	2	3	4	5	6	7	8	9	10	11	12	13
1	12:60	513	743	5.37	920	95.3	881	505	74.1	5.47	1035	94.5	42
2	12:05	577	75.3	5.83	1035	93.8	944	507	75.2	6.14	1101	93.5	62
3	12:10	580	78.0	5.77	967	94.7	959	513	77.1	6.02	1025	93.8	60
4	12:18	580	81.3	5.81	939	95.5	1008	510	80.7	6.06	990	94.9	50
5	12:20	577	83.6	5.89	962	97.3	1006	508	81.1	6.29	1016	94.7	53
6	12:25	572	84.1	6.29	973	95.4	970	505	81.2	6.31	1013	94.9	54
7	12:30	571	87.8	6.23	961	97.4	1023	503	83.6	6.44	999	94.5	56
8	12:35	572	88.7	6.05	929	96.2	1050	503	85.1	6.44	993	94.9	55
9	12:43	569	91.8	6.25	943	96.5	1031	502	85.9	6.47	974	94.6	54
10	12:50	571	96.1	6.20	931	98.7	1026	504	88.4	6.55	998	95.1	55
11	13:00	571	90.1	6.31	932	91.2	1016	506	83.9	6.70	990	89.6	57
12	13:06	572	83.3	6.22	910	84.3	1008	505	79.6	6.40	950	85.3	52
13	13:10	578	83.2	5.86	870	84.3	1073	512	79.7	6.13	907	85.5	45
14	13:16	566	83.3	6.16	900	84.7	981	500	79.6	6.38	958	85.7	53
15	13:26	570	84.1	5.95	882	85.3	1013	503	80.1	6.12	933	86.4	47
16	13:30	567	92.5	6.48	960	94.1	985	502	83.2	6.64	990	89.4	59
17	13:35	565	91.1	6.40	950	91.9	984	498	83.2	6.71	1000	89.2	60
18	13:40	568	91.4	6.47	945	91.7	988	501	83.7	6.75	998	89.5	64
19	13:50	568	91.5	6.32	918	90.8	994	501	83.6	6.59	962	89.1	55
20	14:00	572	93.2	6.59	951	91.7	1041	508	84.2	6.90	1004	89.3	68
21	14:05	570	93.8	6.43	917	91.4	997	509	84.1	6.72	985	89.2	62

TABLE 36

HEAT RUN NO. 2 TEST DATA
MODIFIED D77 TRACTION MOTOR

NO.	TIME	MOTOR VOLTAGE Volts dc	GENERATOR FIELD VOLTAGE Volts dc	GENERATOR INTERPOLE VOLTAGE Volts dc	GENERATOR ARMATURE CURRENT Amps dc	GENERATOR FIELD CURRENT Amps dc	INDICATED SPEED RPM	GENERATOR VOLTAGE Volts dc	MOTOR FIELD VOLTAGE Volts dc	MOTOR INTERPOLE VOLTAGE Volts dc	MOTOR ARMATURE CURRENT Amps dc	MOTOR FIELD CURRENT Amps dc	SUPPLY CURRENT Amps dc	BOOSTER VOLTAGE Volts dc
1	2	3	4	5	6	7	8	9	10	11	12	13	14	
1	10:25	578	55.7	4.73	809	79.2	981	518	53.4	6.09	1062	80.2	90	55
2	10:30	565	63.3	6.80	1105	85.2	1009	508	53.4	7.91	1233	78.5	124	57.1
3	10:35	561	63.2	6.61	1050	83.9	1040	515	53.8	7.70	1155	77.4	140	49.7
4	10:40	565	65.1	6.84	1055	84.4	1011	517	53.8	8.20	1210	76.4	146	49.6
5	10:45	563	64.9	7.10	1052	82.8	1014	517	53.8	8.55	1210	75.4	150	49.8
6	10:50	567	65.6	7.03	1035	82.7	1034	518	54.0	8.75	1180	74.6	145	49.9
7	10:55	564	66.0	7.16	1052	82.0	1026	516	55.0	9.18	1230	75.5	175	49.7
8	11:00	570	70.5	7.32	1060	85.6	1027	522	57.6	9.10	1185	78.2	150	50.1
9	11:05	574	71.1	7.14	1030	85.1	1015	523	57.7	9.01	1183	77.4	140	51.5
10	11:10	571	71.4	7.15	1035	85.3	1012	525	58.6	9.22	1185	77.8	145	51.2
11	11:20	575	74.2	7.10	1018	85.3	1021	526	60.7	9.20	1150	79.1	133	52.4
12	11:30	556	74.6	7.39	1044	84.8	984	511	61.0	9.47	1160	78.5	143	51.7
13	11:40	557	73.8	7.44	1036	82.9	1018	510	61.0	9.50	1152	77.6	140	51.5
14	11:50	562	75.1	7.38	1030	82.6	1022	513	61.9	9.25	1133	78.3	144	51.5
15	12:01	559	77.7	7.51	1035	85.3	972	510	64.3	9.25	1145	80.3	135	51.7
16	12:11	562	78.2	7.45	1015	84.9	980	513	64.9	9.45	1172	80.3	133	54.0
17	12:20	566	79.5	7.50	1035	85.5	987	515	65.5	9.40	1150	80.5	137	55.4
18	12:30	561	79.5	7.60	1030	84.6	1021	507	66.2	9.32	1136	80.9	124	54.9
19	12:45	557	82.0	7.61	1035	85.2	950	505	67.6	9.57	1159	82.0	135	-
20	12:53	560	82.7	7.63	1020	85.7	960	510	67.7	9.40	1150	81.4	135	55.1
21	13:08	560	81.6	7.51	1003	84.1	979	508	67.6	9.33	1135	81.0	134	55.0
22	13:20	557	81.9	7.70	1038	83.7	992	500	67.6	9.78	1185	80.5	150	55.0
23	13:37	560	81.6	7.60	1020	83.6	979	509	68.0	9.35	1135	80.8	135	55.3
24	13:42	552	81.3	7.89	1053	83.8	978	500	68.0	9.90	1205	81.0	145	55.0

Figure 102 presents the average surface temperature of the main field coil at the cooling air inlet end (commutator end) and the cooling air outlet end. The measured temperatures are based on four thermocouples reading at each end of the coil. Each thermocouple is bonded on the center of end turn

TABLE 37

STEADY-STATE THERMAL CONDITIONS

Cooling airflow	2800 cfm
Cooling air temperature	96°F
Motor speed (corrected)	858 rpm
Armature current	1053 amp
Power dissipation summary	
Interpole	8.34 kw at 169°C
Main field	6.81 kw at 223°C
Armature cu	27.43 kw at 248°C
Brush drop	7.1 kw
Armature tooth	10.6 kw
Armature iron	3.12 kw
Main pole face	5.58 kw

surface. Figure 103 shows the average field conductor temperatures that were calculated by resistance measurement. Figure 104 is the average surface temperature of the interpole coil. The measurement technique is similar to the main field coil. The average interpole conductor temperature measured by resistance method is presented in Figure 105. Figure 106 shows the average armature conductor temperatures that were calculated by resistance measurement after shutdown.

Examination of the results reveals that the thermal model has demonstrated a good agreement between the test data and the analytically computed results. Therefore, the thermal model can be used for the prediction of the hot-spot winding temperature and thermal performance of the traction motor.

Thermal Performance

The thermal analysis model of the as-modified traction motor validated by test data has been used to investigate the effect of airflow and main field coil design changes on the thermal performance of the motor.

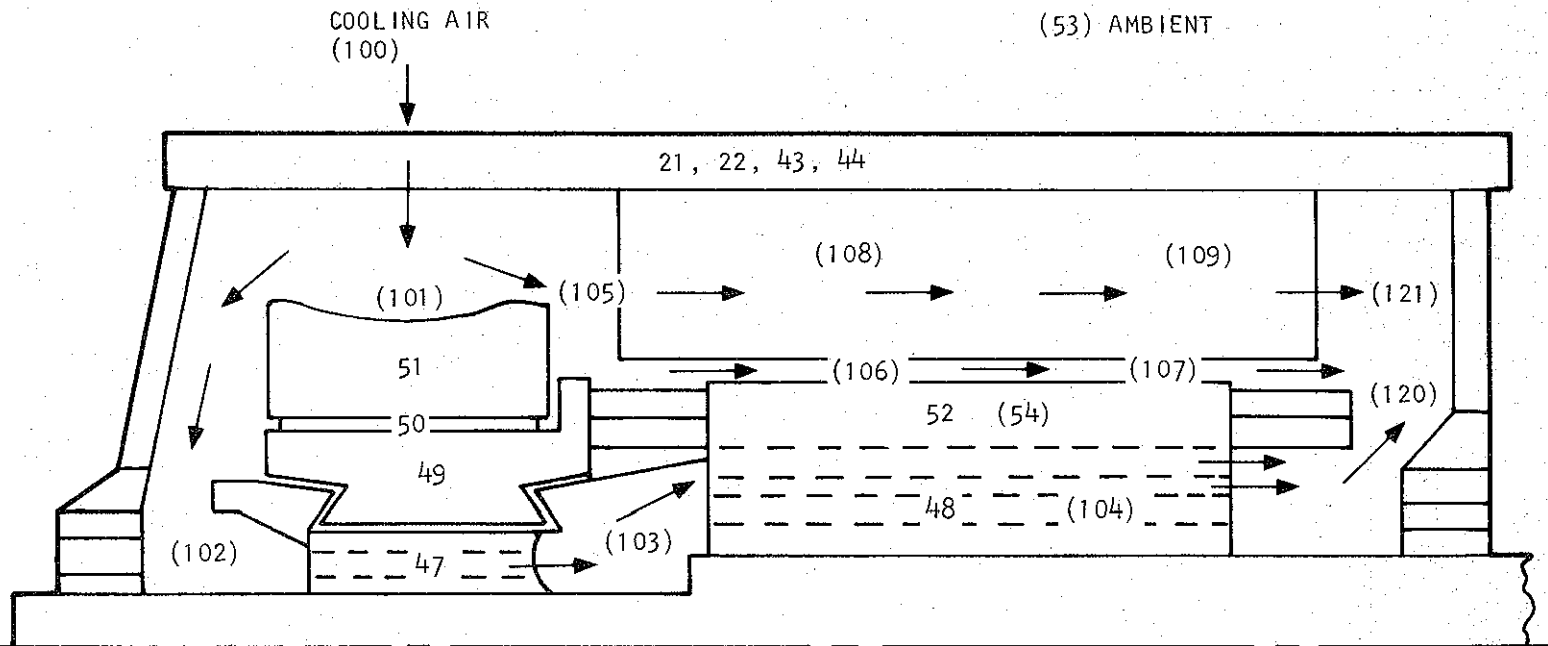

NOTES: NODES 49, 50 COMMUTATOR
 51 BRUSH
 52 ARMATURE WINDING
 54 ARMATURE TOOTH
 48 ARMATURE BACK IRON
 100-101-102--104 COOLING AIRFLOW THROUGH ARMATURE BACK IRON
 100--107 COOLING AIR THROUGH GAP
 100--109 COOLING AIR BETWEEN FIELD AND INTERPOLE

S-33801

Figure 99. Thermal Nodal Network for D77 Motor

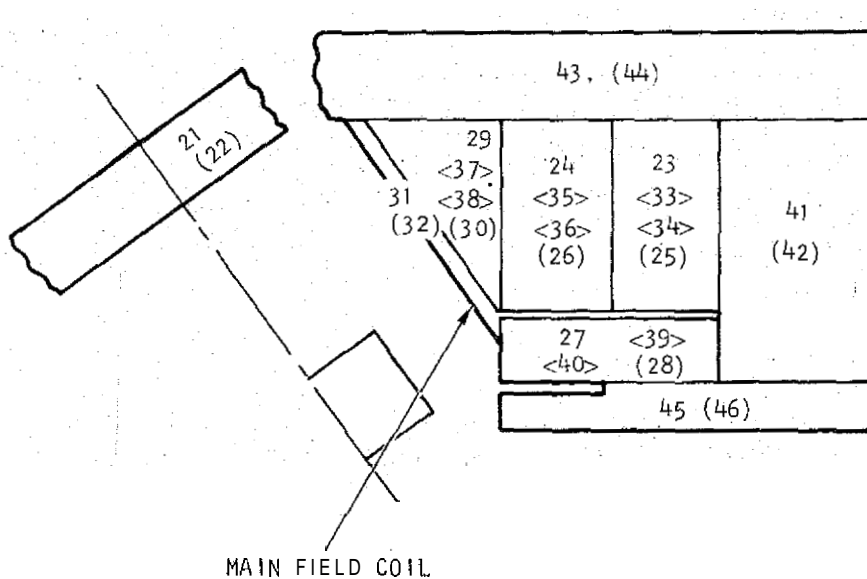

NOTES: NODES 23, 24, 29 INLET AIR END END-TURN
 25, 26, 30 OUTLET AIR END END-TURN
 31, 32 INSULATION
 33 TO 40 WINDING
 41 TO 46 HOUSING OR IRON

S-33802

Figure 100. Thermal Nodal Network for D77 Motor

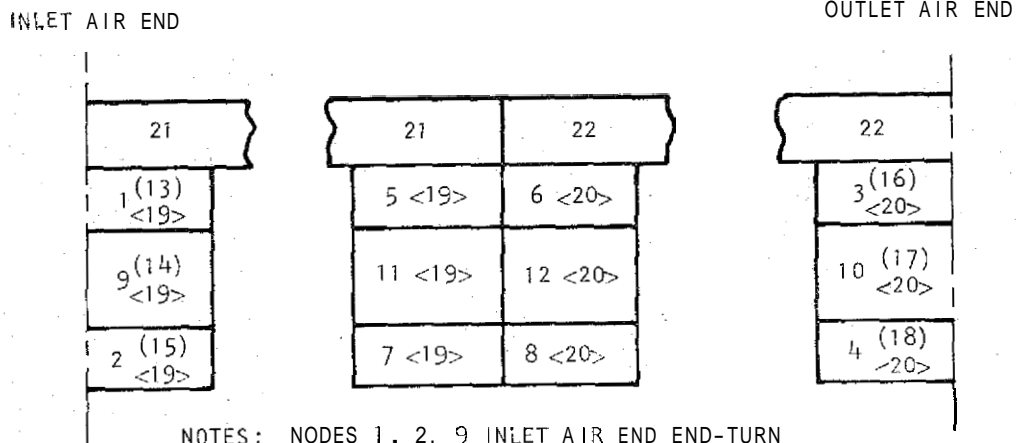

NOTES: NODES 1, 2, 9 INLET AIR END END-TURN
 3, 4, 10 OUTLET AIR END END-TURN
 13 TO 18 END TURN INSULATION
 5, 6, 7, 8, 11, 12 WINDING
 19 TO 22 BACK IRON

S-33800

Figure 101. Thermal Nodal Network for 077 Motor (Interpole Area)

TABLE 38

MODIFIED D77 TRACTION MOTOR STEADY-STATE
TEMPERATURE TEST CONDITION

STEADY STATE SOLUTION

NO. OF ITER. = 3 DTEMP = 1.0000 ACCEL = 1.0000

NODE NO.	TEMP. F	HEAT IN. WATT	PRCV	CRIT	KN	TEMP. C
1	342.12	34.2248	.000000	.0000	200.00000	172.27
2	295.33	32.0430	.000000	.0000	200.00000	146.28
3	349.71	34.5792	.000000	.0000	200.00000	176.50
4	313.21	32.8767	.000000	.0000	200.00000	156.22
5	341.27	116.0321	.000000	.0000	200.00000	171.80
6	347.27	116.9815	.000000	.0000	200.00000	175.14
7	294.10	-108.5705	.000000	.0000	200.00000	145.60
8	307.98	110.7660	.000000	.0000	200.00000	153.31
9	350.92	52.0461	.000000	.0000	200.00000	177.17
10	359.50	52.6476	.000000	.0000	200.00000	181.93
11	352.15	176.6316	.000000	.0000	200.00000	177.85
12	358.53	178.1457	.000000	.0000	200.00000	181.40
13	204.41	.0000	.000000	.0000	.11000	95.77
14	216.17	.0000	.000000	.0000	.11000	102.31
15	186.30	.0000	.000000	.0000	.11000	85.71
16	220.51	.0000	.000000	.0000	.11000	104.72
17	232.16	.0000	.000000	.0000	.11000	111.19
18	206.44	.0000	.000000	.0000	.11000	96.90
19	271.80	.0000	.000000	.0000	60.00000	133.21
20	282.75	.0000	.000000	.0000	60.00000	139.29
21	271.12	.0000	.000000	.0000	60.00000	132.83
22	277.29	.0000	.000000	.0000	60.00000	136.26
23	484.78	67.3041	.000000	.0000	.90000	251.53
24	494.65	68.0755	.000000	.0000	.90000	257.01
25	492.53	67.9100	.000000	.0000	.90000	256.84
26	503.88	68.7981	.000000	.0000	.90000	262.15
27	335.11	17.2030	.000000	.0000	.90000	168.38
28	365.31	17.9339	.000000	.0000	.90000	185.16
29	421.46	51.9690	.000000	.0000	.90000	216.36
30	433.91	52.7807	.000000	.0000	.90000	223.27
31	485.65	.0000	.000000	.0000	.11000	85.35
32	241.55	.0000	.000000	.0000	.11000	116.41
33	480.41	77.9470	.000000	.0000	.90000	249.10
34	482.57	78.1440	.000000	.0000	.90000	250.31
35	494.03	79.1867	.000000	.0000	.90000	256.67
36	498.40	79.5847	.000000	.0000	.90000	259.10
37	409.99	59.6439	.000000	.0000	.90000	209.98
38	415.08	60.0298	.000000	.0000	.90000	212.81
39	354.00	20.5686	.000000	.0000	.90000	178.87
40	363.62	20.8397	.000000	.0000	.90000	184.22
41	285.26	.0000	.000000	.0000	60.00000	140.69
42	295.51	.0000	.000000	.0000	60.00000	148.38
43	275.77	.0000	.000000	.0000	60.00000	135.42
44	282.06	.0000	.000000	.0000	60.00000	138.91
45	285.86	349.0000	.000000	.0000	60.00000	141.02
46	298.89	349.0000	.000000	.0000	60.00000	148.26
47	159.47	.0000	.000000	.0000	15.00000	70.80
48	304.36	390.0000	.000000	.0000	15.00000	151.30
49	415.74	.0000	.000000	.0000	200.00000	213.18
50	419.76	984.0000	.000000	.0000	1.00000	215.41
51	226.82	.0000	.000000	.0000	4.50000	103.22
52	459.51	3429.0000	.000000	.0000	200.00000	237.49
53	40.00	.0000	-1.000000	1.0000	1.00000	26.65
54	419.00	1325.0000	.000000	.0000	15.00000	214.99

FLUID CAPACITY RATE ELEMENTS

TABLE 39

FLUID CAPACITY RATE ELEMENTS

STREAM NO.= 1 NODE NO.= 100 INLET TEMP.= 96.00

SECTION	NODE NO.	TOUT	FLOW	RHOF	HEAT IN.
1	101	104.36	1470.0000	.0708	.000000

FLUID CAPACITY RATE ELEMENTS

STREAM NO.= 2 NODE NO.= 101 INLET TEMP.= 104.36

SECTION	NODE NO.	TOUT	FLOW	RHOF	HEAT IN.
1	102	105.22	592.0000	.0703	.000000
2	103	106.10	592.0000	.0702	.000000
3	104	150.73	592.0000	.0674	.000000

FLUID CAPACITY RATE ELEMENTS

STREAM NO.= 3 NODE NO.= 101 INLET TEMP.= 104.36

SECTION	NODE NO.	TOUT	FLOW	RHOF	HEAT IN.
1	105	104.88	878.0000	.0703	.000000

FLUID CAPACITY RATE ELEMENTS

STREAM NO.= 4 NODE NO.= 105 INLET TEMP.= 104.88

SECTION	NODE NO.	TOUT	FLOW	RHOF	HEAT IN.
1	106	166.87	454.0000	.0666	.404789
2	107	231.73	454.0000	.0602	1.260794

FLUID CAPACITY RATE ELEMENTS

STREAM NO.= 5 NODE NO.= 105 INLET TEMP.= 104.88

SECTION	NODE NO.	TOUT	FLOW	RHOF	HEAT IN.
1	108	127.74	424.0000	.0689	.000000
2	109	149.13	424.0000	.0663	.000000

FLUID CAPACITY RATE ELEMENTS

STREAM NO.= 6 NODE NO.= 120 INLET TEMP.= 175.32

SECTION	NODE NO.	TOUT	FLOW	RHOF	HEAT IN.
1	121	175.58	1470.0000	.0624	.000000

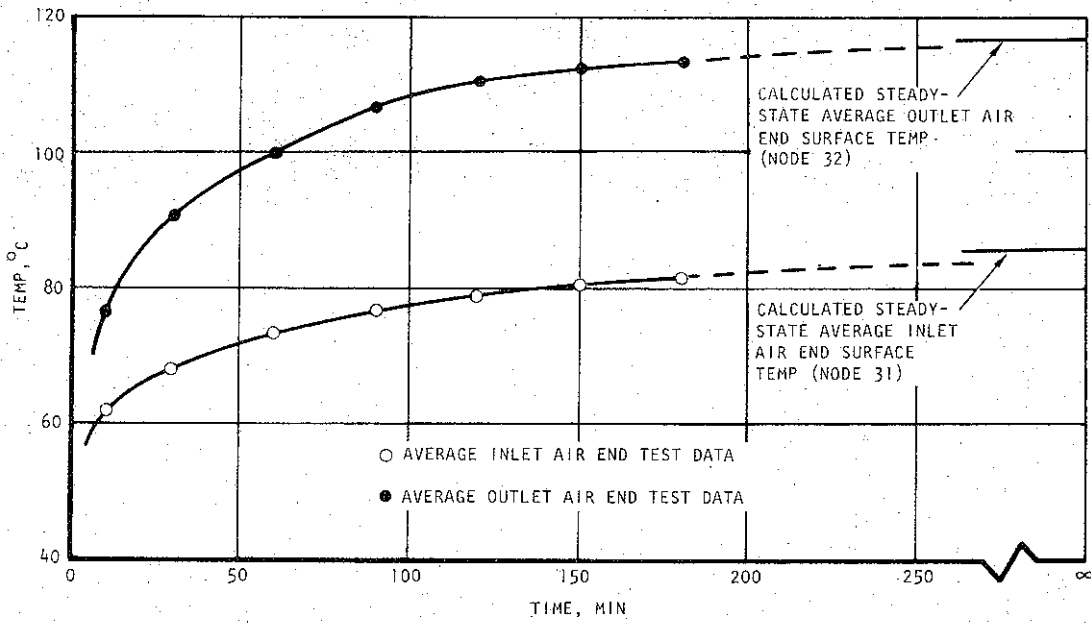

533819

Figure 102. D77 Motor Average Field Coil Surface Temperature Modified

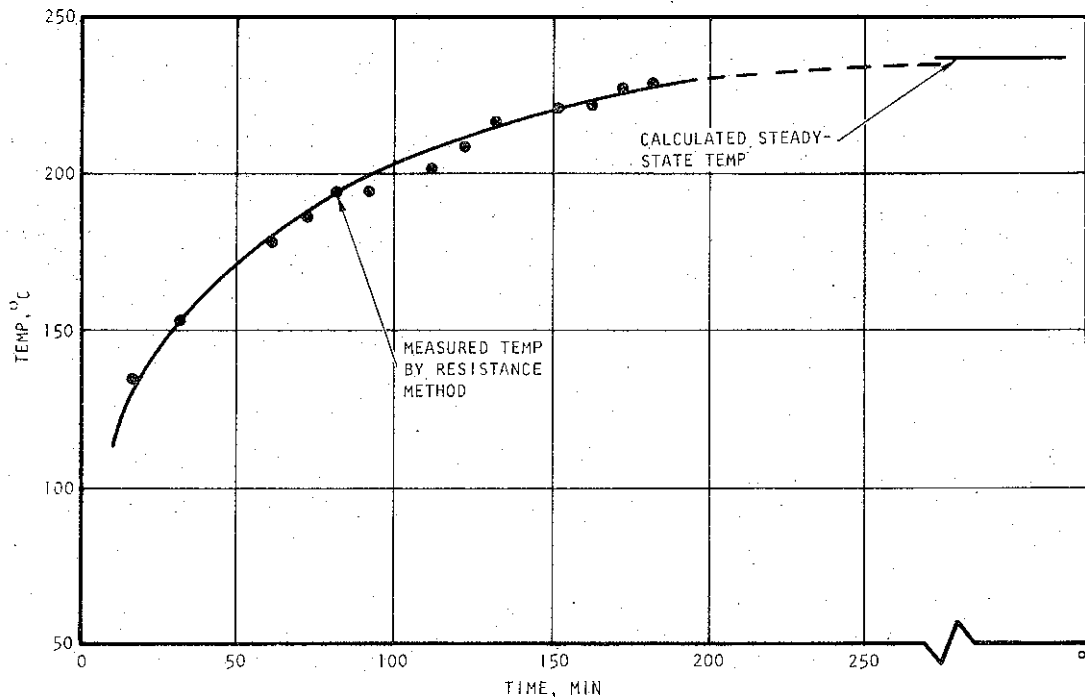

533817

Figure 103. Modified D77 Motor Average Field Conductor Temperature

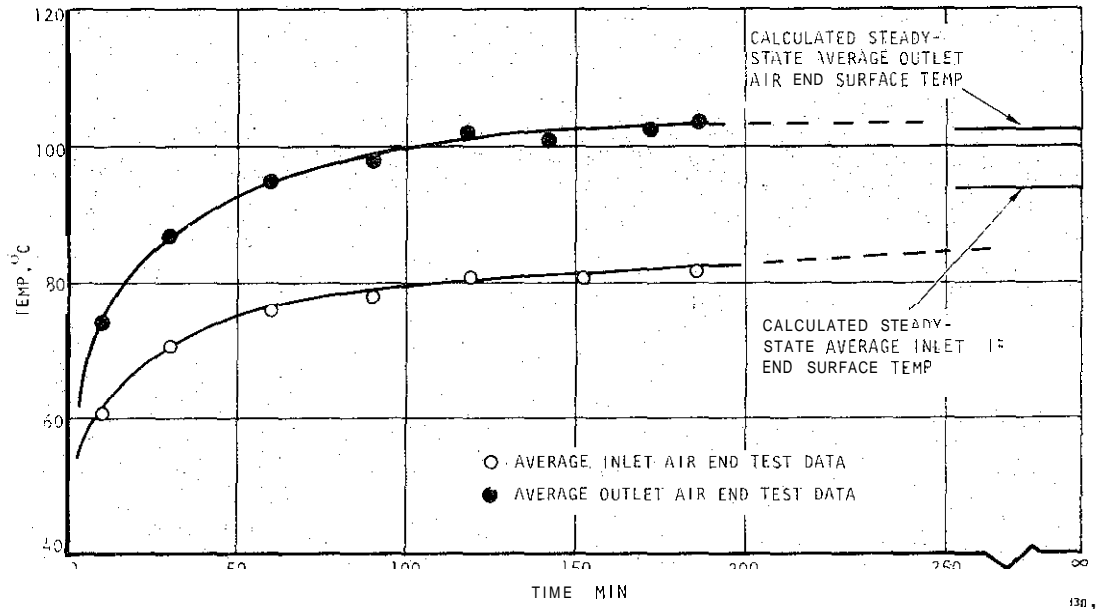

Figure 104. Modified D77 Motor Interpole Average Coil Surface Temperature

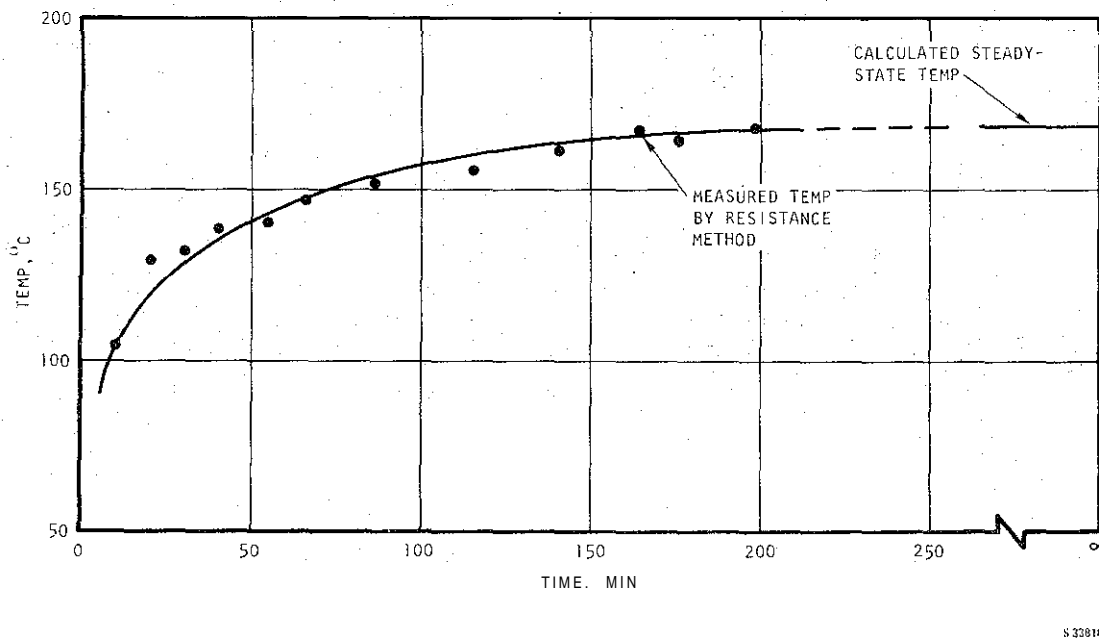

Figure 105. Modified D77 Motor Interpole Average Conductor Temperature

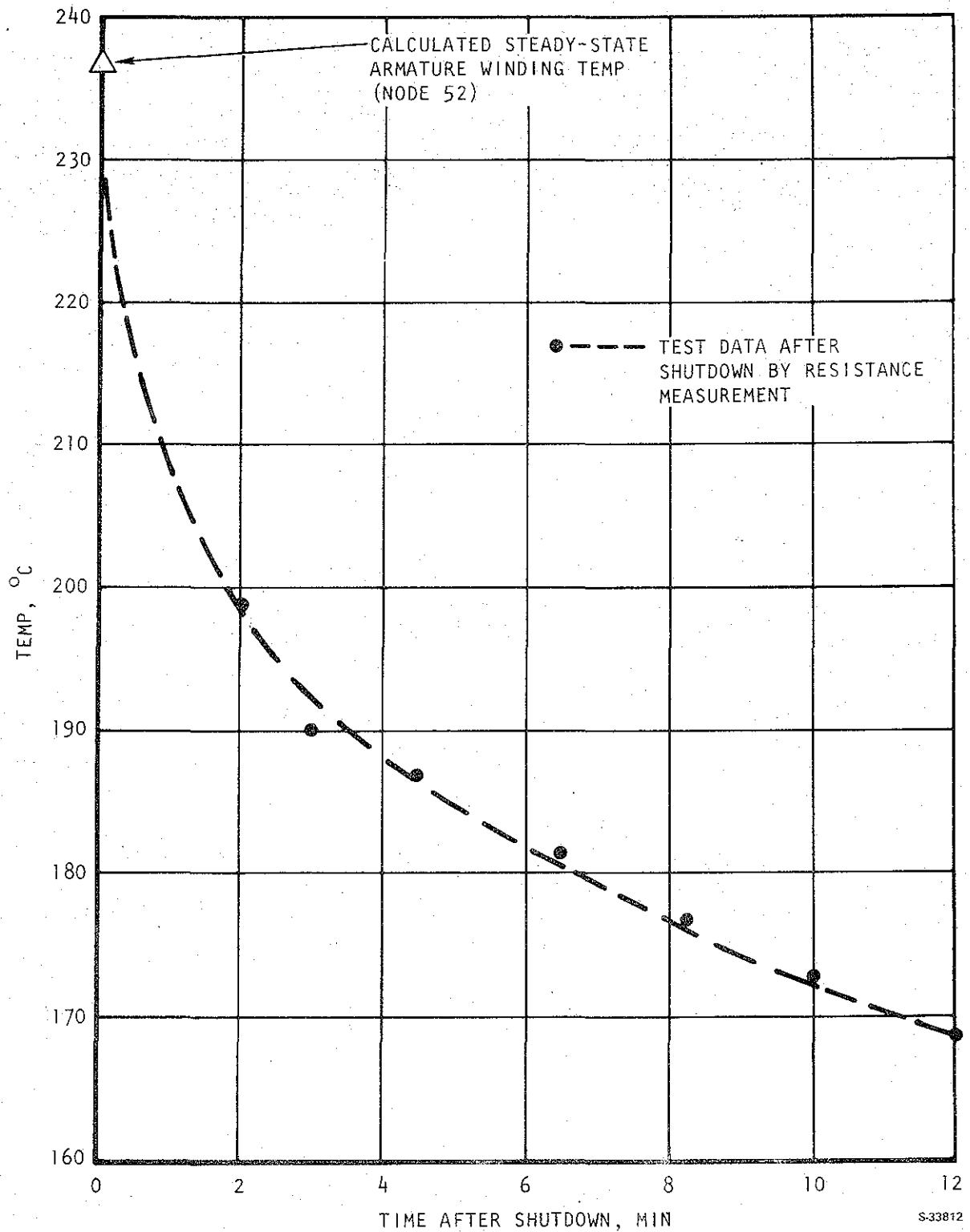

Figure 106. Modified D// Motor Armature Average Temperature

Figure 107 shows the effect of motor cooling airflow rate on interpole and main field temperatures. Inspection of this figure shows that increased airflow has little effect on winding temperatures in the as-modified machine for the test conditions specified.

Inspection of Figure 107 discloses that reduction in main field coil temperatures required that the coil be optimized.

MAIN FIELD COIL OPTIMIZATION

A 132-turn shunt field coil was designed, fabricated, and installed in two D77 traction motors. The coil was fabricated to match the dimensions of the standard motor. It utilized Kapton turn insulation and an external insulation system identical to that of the standard coil as manufactured by Motor Coils Manufacturing. The coil was designed as a low-current (100 amp), moderate voltage (100 v) replacement for the standard coil. The purpose of this coil was to provide benchmark thermal data on the performance of such a multilayer, multiturn coil in a D77 traction motor. No detail drawings of the machine were available to AiResearch, and detail thermal analysis without drawings or test data was not considered to be an effective approach. The approach followed was to design, fabricate, install, and test the above coil for minimum cost in money and time, and the resulting test data were used for coil optimization.

Figure 108 shows a simplified section of the coil as manufactured. Additional details of the insulation system are provided in Figure 109. These details were used to define the baseline thermal model of the as-modified-as-tested motor.

Figure 110 shows three techniques for improvement of the thermal performance of the main field windings. The first involves the installation of a metal filler plate along the coil sides to provide increased thermal conductivity for the conduction of heat from the coil to the cooling surface. This technique is similar to that employed in machines using a 7-turn, 9-turn, 2-section, main field winding in the series machine. No problem or development is required to incorporate this improvement in production coils. The second technique takes advantage of the fact that the separately excited main field coils in the shunt-wound machine are operated from an isolated power supply and so are not subjected to full armature circuit voltages and switching transients that require high insulation levels in the series machine. The baseline coil is grossly over-insulated and significant reduction in insulation thickness to ground can be obtained without loss of electrical integrity. However, until operating history can be obtained on the separately excited machines with such main field windings, it is not considered prudent to reduce the insulation system to the minimum electrical requirements because the insulation system provides considerable mechanical support for the windings and it also provides mechanical protection for the internal insulation. A reduction of 0.016 in., therefore, is considered as the maximum reduction to make from the established design at this time. The third technique increases the coil fill factor (percent of the coil space occupied by copper) by the use of improved production tooling to control the buildup of the winding. A conservative reduction of 0.005 in the inter-turn space is assumed around

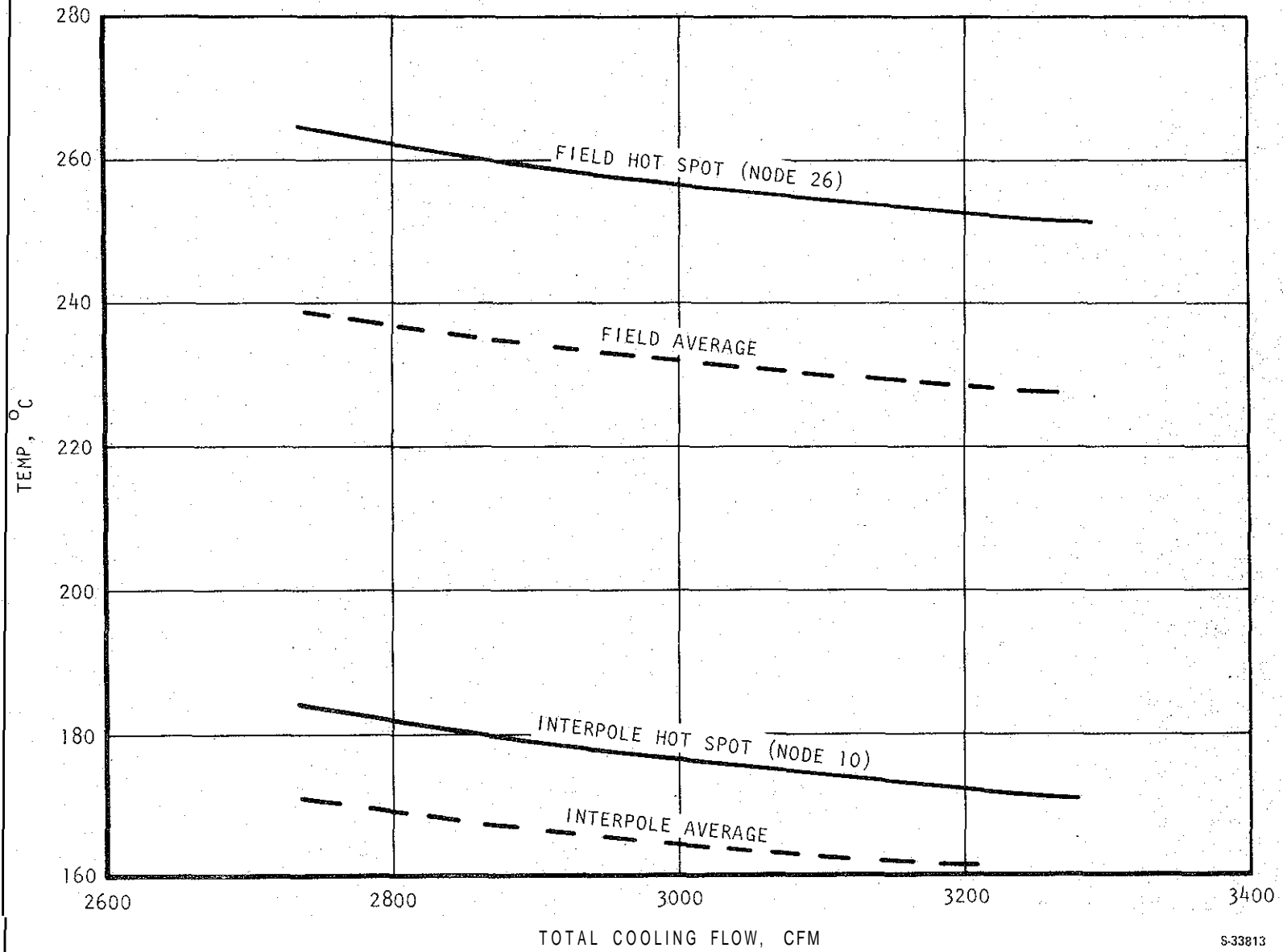

S33813

Figure 107. Predicted D77 Motor Winding Temperature (96°F Cooling Air)

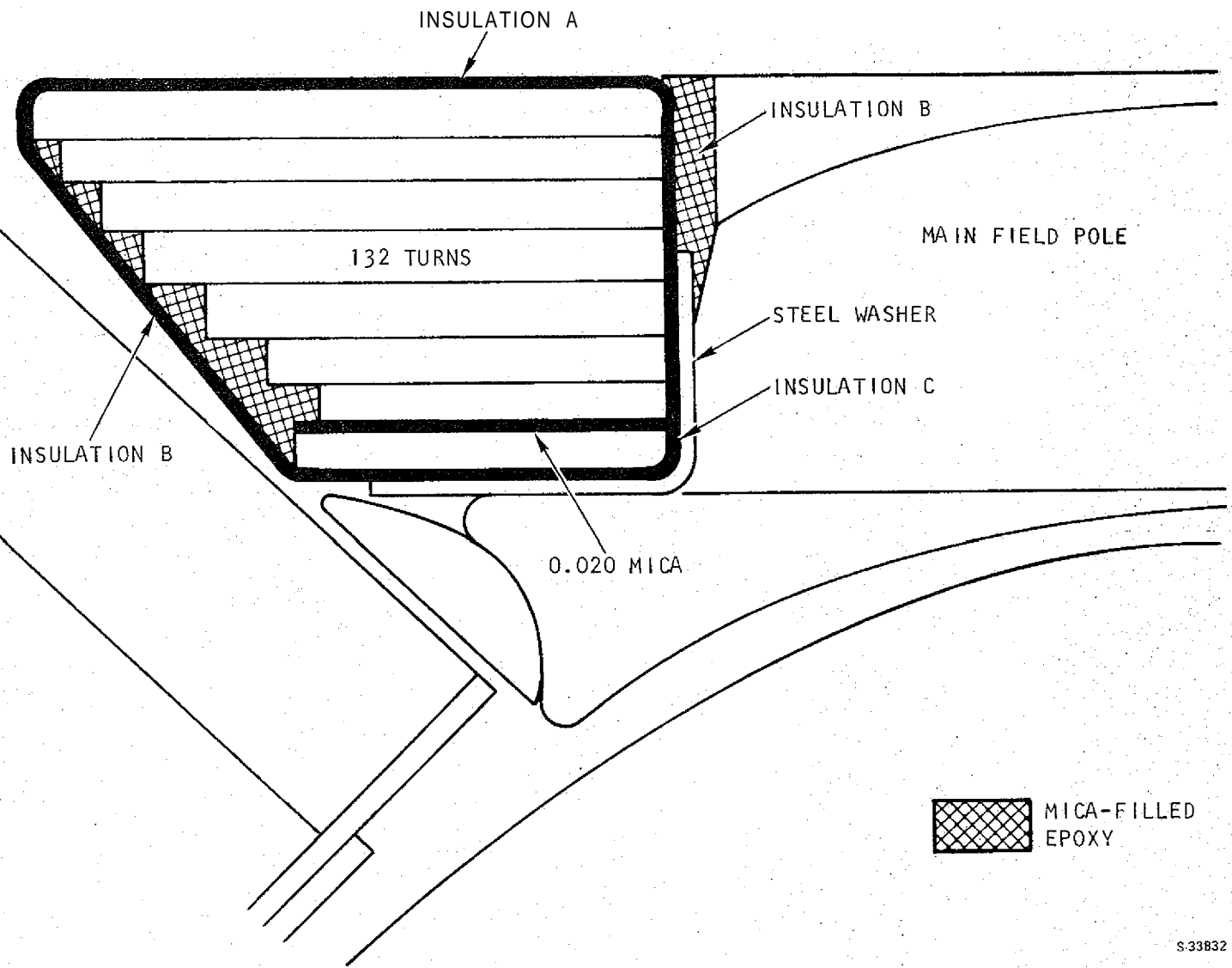

Figure 108. Main Field Coil Section

S-33832

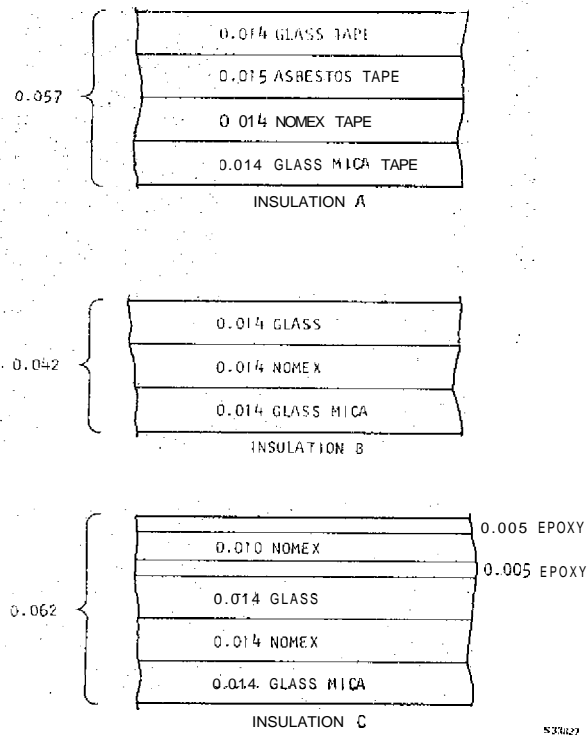
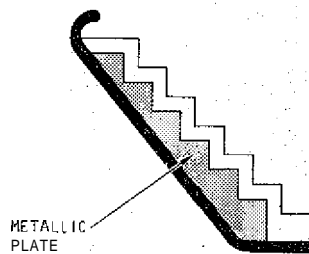

Figure 109. Insulation Details Main Field Coif



- REDUCED THERMAL IMPEDANCE ON AIR SIDE OF COIL
 - REDUCED COIL INSULATION 0.016 IN.
 - INCREASED COIL FILL FACTOR
 - IMPROVED TOOLING
 - REDUCED TURNS
- 5.1382P A

Figure 110. Thermal Optimization of Main Field Coif

each turn. In addition, a reduction in the number of turns will reduce the number of layers of insulation that impede heat transfer and will reduce the losses in the coil.

Figure 111 shows the effect of a reduction in the number of turns and a reduction in the inter-turn space on the fill fraction. A 132-turn coil (existing shunt field coil design) and a 98-turn coil design are shown.

The thermal model of the D77 was utilized to investigate the effectiveness of these techniques. Figure 112 identifies the main field coil construction for specific thermal model cases.

Case 1A is the as-tested configuration with the as-tested airflow and loss distribution. Case 1B is the same as 1A, except that the airflow is increased. Case 1C is the same as 1A, except that additional airflow is provided. The speed and losses are as-tested for all three of these cases. These are the same cases shown in Figure 107.

The results of the thermal analysis are summarized in Table 40.

Case 2 shows the effect of a reduction in the number of turns on the thermal performance for the same conditions as case 1A, which are the as-tested conditions. Inspection of Table 40 shows that the main field hot-spot temperature has been reduced from 262° to 228°C and the average winding temperature has been reduced to 209°C.

Additional reduction in temperature is shown to result if the turns are reduced and, in addition, insulation thickness also is reduced as shown in Figure 112. When both changes are accomplished, the thermal model indicates that the main field hot-spot temperature is reduced to 217°C and the average main field temperature is reduced to 199°C. Interpole winding temperatures are only 181°C hot spot and 168°C average. Armature temperature, however, is high (237°C) because operation of the motor at 858 rpm results in a high armature eddy factor.

Case 4 shows that if the motor speed is reduced to base speed of 372 rpm (10.7 mph), the armature losses and temperature are reduced to an acceptable 191°C at the higher armature current level of 1129 amp. With an excitation of 11,800 ampere-turns per pole, this performance is identical to that of the series machine at 1056 amp. All winding temperatures are acceptable.

Case 5A shows the effect of reduction in airflow from that of the road locomotive to that of the switcher. At this airflow, load must be reduced. Case 5B reduces load to a level where 85 percent of the losses of case 5A are developed and case 5C reduces load to a level where 80 percent of the losses of case 5A are developed.

Acceptable temperatures are shown for case 5C. The performance of the separately excited switches at these conditions is acceptable and exceeds that of the unmodified series machine, which is limited by interpole temperature to about 850 amp load current at 1400 cfm.

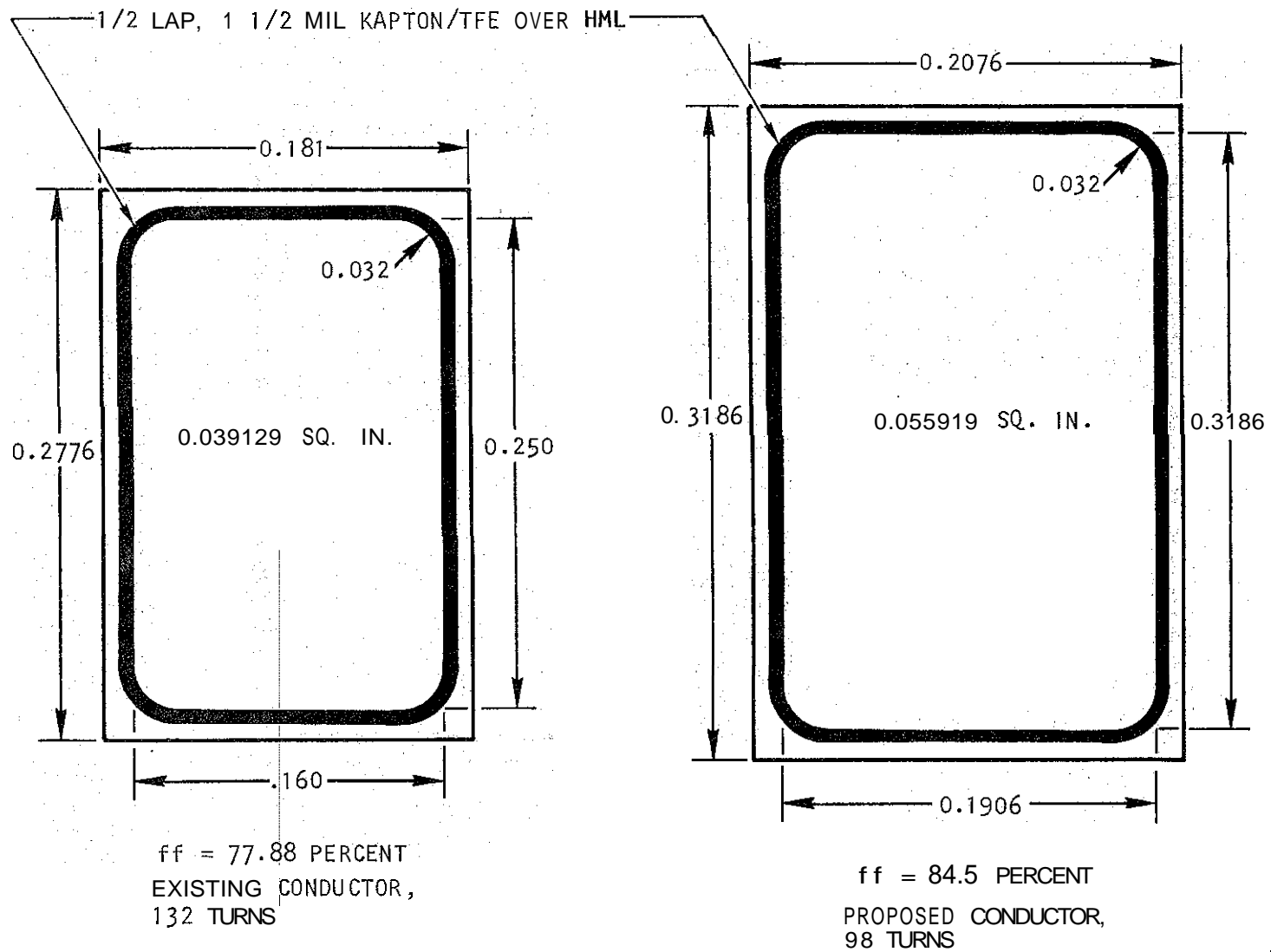

S 33796

Figure 111. Effect of Number of Turns and Interturn Clearance on Winding Space Factor

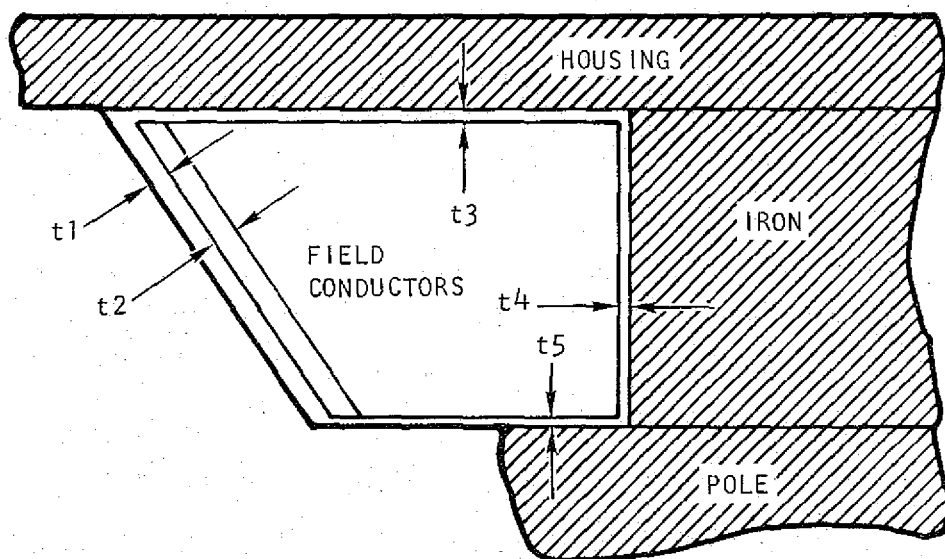

- CASE 1
- 79 PERCENT CU-FILLED WIRE
 - $t_1 = 0.042$; $t_3 = 0.057$
 - T2 (AVERAGE EPOXY MICA FILLER) = 0.264
 - $t_4 = 0.062$; $t_5 = 0.146$
- CASE 2 SAME AS CASE 1 WITH 85 PERCENT CU-FILLED WIRE
- CASE 3
- 85 PERCENT CU-FILLED WIRE
 - TO
 - $t_1 = 0.026$; $t_3 = 0.041$
- CASE 5
- $t_2 = 0.125$; $t_4 = 0.046$
 - $t_5 = 0.146$

NOTE: DIMENSIONS ARE IN INCHES.

S-33798

Figure 112. Main Field Coil Construction

TABLE 40

TRACTION MOTOR THERMAL STUDY SUMMARY
(COOLING AIR AT (96°F))

Case No.	Configuration (see Figure 112) for description)	Conditions				Main Field Winding Temperature, °C		Interpole Winding Temperature, °C		Armature Winding Temperature, °C
		Airflow, cfm	Speed, rpm	Armature Current, amp	Excitation, ampere-turns	Hot Spot	Average	Hot Spot	Average	Average
1A	As-tested	2800	858	1056	11000	262	237	182	170	237
1B	As-tested	3000	858	1056	11000	257	232	176	164	232
1C	As-tested	3200	858	1056	11000	252	218	172	161	227
2	Reduced turn (98)	2800	858	1056	11000	228	209	181	168	237
3	Reduced turn (98) plus reduced insulation thermal resistance	2800	858	1056	11000	217	199	181	168	237
4		2800	372	1129	11800	213	195	190	175	191
5A		1400	372	1129	11800	265	243	265	243	249
5B		1400	372	1040	10880	217	201	215	199	217
5C		1400	372	1010	10550	202	187	200	185	206

*--

RESULTS OF TRACTION MOTOR TASK

Traction motor performance data obtained from tests have been used to develop models for the analysis of the performance of unmodified and modified traction motors. The performance model for the series model predicts performance that agrees with the established characteristics. This validates the data for use in the analysis of system performance.

A prototype separately excited main field coil was designed, manufactured, and installed in two D77 traction motors. Testing of the modified motors provided the thermal data necessary for development of a thermal model of the machine and optimization of the coil design.

An optimized coil design resulting from this effort is shown to have 98 turns. Performance of the separately excited machine is equivalent to that of the series machine, but with a different distribution of losses. Operation of the separately excited machine is most effective at reduced excitation levels and increased armature current levels when compared with the series machine.

Increases in interpole conductor size improve the thermal capability of the machine.

SECTION 6

ECONOMIC ANALYSIS AND RESULTS

The potential benefits of flywheel energy storage are largely economic. Although reduced fuel consumption is a desirable material goal, no particular social benefit results from the deployment of FESS. The major savings are locomotive fuel, energy, and reduced locomotive maintenance. On a time-consistent basis, these savings must be compared with the initial investment and maintenance costs for the flywheel system equipment.

The comparison of savings to cost has been performed by using several accepted economic techniques. The FESS can be considered economically viable if (1) the savings sufficiently exceed costs to provide a reasonable return on invested capital, including interest charges, and (2) the savings compensate for the uncertainties associated with the introduction of new technology.

ECONOMIC ANALYSIS TECHNIQUES

To simplify the calculation of return on investment (ROI) in the economic analysis, it was assumed that all investments were made in year zero of the 20-year economic life of the system. Year zero is defined as 1982 for the purpose of this study since this would be the earliest a production FESS system could be deployed. Savings were calculated at the mid-year point for each of the 20 years.

The economic techniques to be employed in this study were agreed upon with FRA at an early stage when an attempt was made to assess the viability of the FESS concept using the techniques with which industry and government are most familiar. These techniques are described below.

Office of Management and Budget Circular A-94

This is a net present worth or net present value technique. As the name implies, this technique is concerned with assessing the value of monies spent or saved in future years in terms of today's money value; however, this is not a method for dealing with inflation. OMB A-94 allows relative inflation to be taken into account. Inflation factors are shown in Table 41.

A crucial discussion to be considered concerns the rate at which future monies should be discounted. OMB A-94 dictates that a 10-percent rate be used. This represents an estimate of the average rate of return for private investment before taxes and after inflation. However, railroads typically realize only a 5 to 6 percent rate of return, and therefore the applicability of the OMB A-94 guidelines to FESS is questionable. For this reason, the results derived from this technique were not used as the baseline case.

TABLE 41

SUMMARY OF INFLATION RATES

Analysis Technique	Diesel Fuel	Maintenance	General Price Level
OMS A-94	2	2	0
4R Act	0	0	0
Sensitivity 1	8	8	6
Sensitivity 2	10	8	6

Railroad Revitalization and Regulatory Reform (4R) Act-1975

The purpose of the Railroad Revitalization and Regulatory Reform (4R) Act was to provide financial assistance to the U.S. railroads, enabling them to invest in essential new projects, such as track maintenance, track reconfiguration, etc. It was considered prudent to assess the benefit of FESS using the guidelines of the 4R Act, even though FESS could probably not qualify for 4R assistance as the legislation is currently structured.

Because the 4R Act guidelines make no allowance for general or relative inflation, AiResearch feels that the results do not reflect accurate world conditions. Therefore, the results from this technique were not used as the baseline case.

Sensitivity Analyses 1 and 2

These analyses were recommended by AiResearch as being "real-world" because inflation was taken into account, producing an output based on current dollars. The analyses, like the 4R Act, employ ROI techniques, with the exception of inflation recognition. The inflation factors for the two analyses are shown in Table 41.

Sensitivity analysis 1 is considered to be the most realistic scenario, so it was used as the baseline case for the economic analyses.

INFLATION

In this type of study, the choice of inflation factor is a crucial decision when the year of decision is 1982, and the hardware is designed for a 20-year economic life. Many different components make up the total costs and annual savings; historically, each of these components has increased in cost at different rates relative to the general price level (GPL).

General Price Level

When inflation factors were formulated in November 1977, the GPL was rising at 6 percent per year. Today the GPL is rising at 9 percent per year, but the inflation rate of 6 percent has been used for this study.

Diesel Fuel

Diesel fuel inflation is difficult to predict because it is subjected to international political pressure. A report by A. D. Little (Reference 6) suggests that diesel fuel will probably escalate at 2 to 4 percent rate above the GPL over the next 25 years. Figure 113 is based on a 2 percent differential inflation rate, and 2 percent above GPL is considered to be the most realistic estimate for fuel inflation (Reference 7).

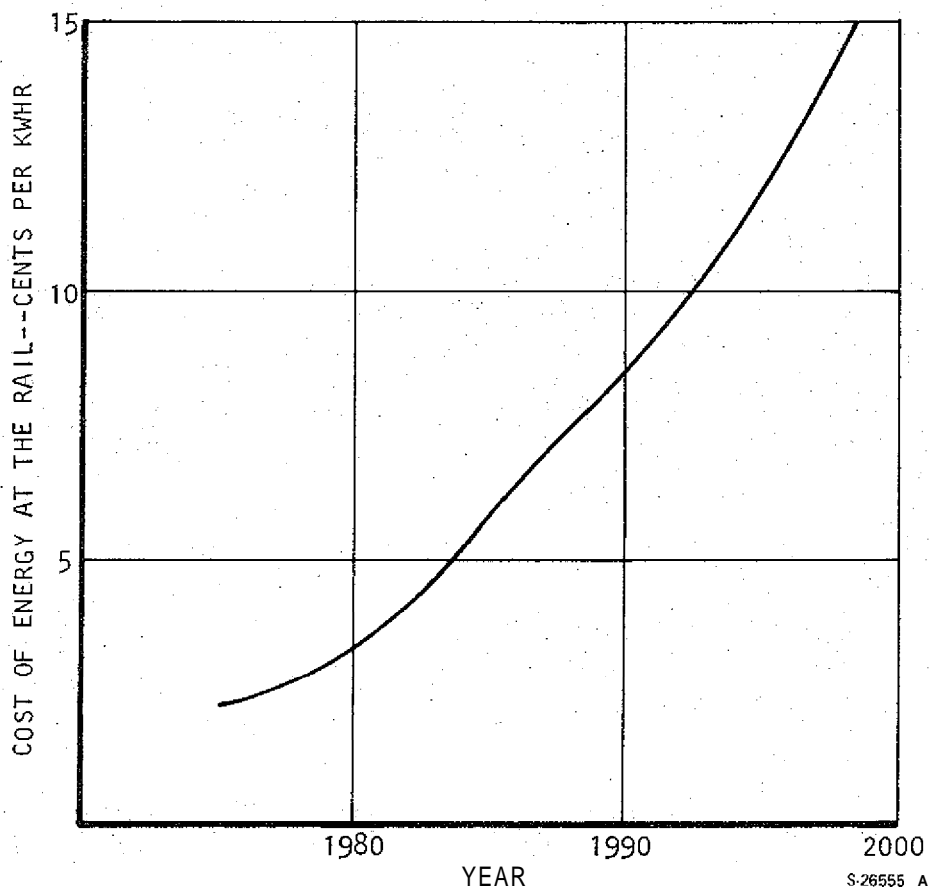

Figure 113. Projected Cost of Diesel Fuel

Reference 4. Schwarm, E. G., Energy Costs for Railroad Electrification, final Report prepared by A. D. Little, Inc., under contract to DOT-TSC, May 1977.

Reference 7, An Evaluation of the Costs and Benefits of Railroad Electrification, Draft Report, Federal Railroad Administration, Washington D.C.

Maintenance

The Department of Commerce (Bureau of Labor) projections of increased costs in manufacturing and nonmanufacturing industry have historically shown an increase of 2 percent above GPL in maintenance costs. This increase has been assumed for the life of FESS.

ENGINEERING ECONOMICS COMPUTER PROGRAM

In order to handle the large number of calculations required for the four economic analyses of FESS, a computer program has been written for the Univac 1100 system. Figure 114 shows a simplified flow chart for this program, and Appendix C gives a program listing. The input and output data of this program are briefly described below.

Input Data

The first card is a title card in which 80 alphanumeric characters can be used for job identification purposes. As described below, other input data are inputted in a namelist form:

COMOD--Initial cost for one locomotive modification

BXCOS--Initial cost of one boxcar

ESUCOS--Initial cost of two ESU's

LBCMTC--Maintenance cost of one locomotive per cars switched

ESUMTC--Annual maintenance cost of ESU per boxcar

FULSAV--Fuel savings in gallons per cars switched

NBBBX--Number of quantities of boxcars considered

NLLOC--Number of quantities of locomotives considered

NCARS--Number of quantities of cars switched

BXC--Array for numbers of boxcars considered

LCC--Array for numbers of locomotives considered

CARSD--Array for numbers of cars switched

DISCON--Discount rate

IPR--2 0 gives diagnostic printout
= 0 no diagnostic printout

NYRCN--Life of project in years

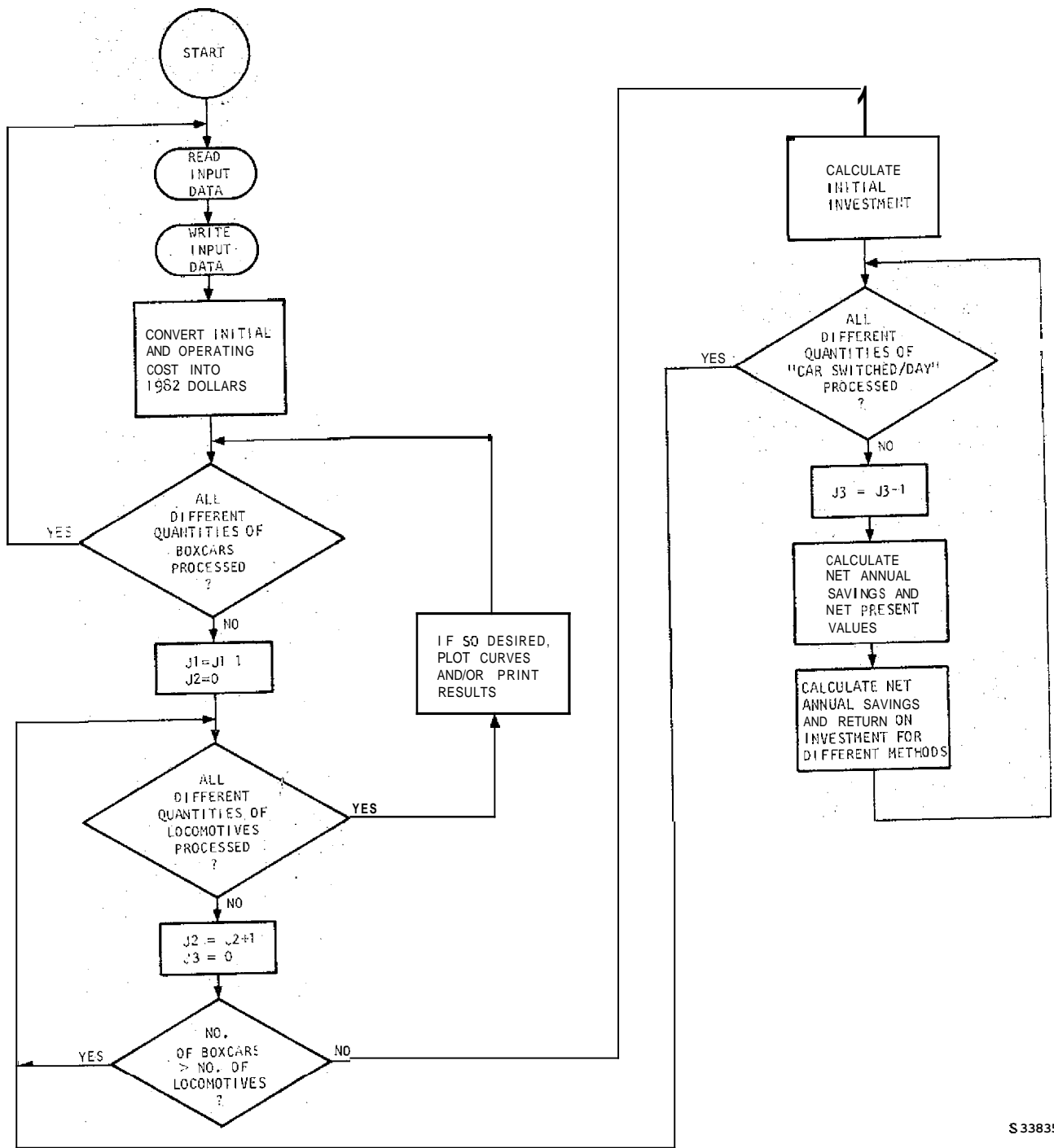

S 33835

Figure 114. Economics Program Flow Chart

IPL0T-- = 1. generates Calcomp plots
= 0. no Calcomp plots

FACT--Scale factor for Calcomp plots
= 1. for full size

IRPT--= 1. prints output
= 0. no printout

CWEIT--Average car weight in tons

YMAX--Maximum value (in percent) of the Y-axis to be used in Calcomp plots

Output Data

The first page of the printout shows the input data used in the run. Subsequent pages show the following variables printed as a function of number of cars switched for a given number of boxcars and a given number of locomotives.

- (a) Net present value (NPV) in thousands of dollars
- (b) Initial cost in thousands of dollars
- (c) Return on invest in percent using the 4R method
- (d) Return on investment in percent using sensitivity 1 analysis
- (e) Return on investment in percent using sensitivity 2 analysis

ECONOMICAL ANALYSIS RESULTS

The results of the Concept A2 economic analysis are contained in Appendix D, using sensitivity 1 as the baseline. This is presented graphically in Figures 115 through 118 where the calculated ROI is plotted against the numbers of cars switched per day in a given yard. The numbers of locomotives requiring modification to the FESS configuration to switch the given number of cars per day is given as the third variable on each plot. The fourth variable taken into account is the number of boxcars required for each yard, a factor dependent on locomotive utilization, which in turn is dependent on yard topography, labor agreements, available work, etc. Due to the difficulty in arriving at a general set of universal rules which could be used to evaluate FESS in any application, the results are plotted to enable any interested party to plot their own particular circumstances on the graphs.

The data collection task described in Section 2 of this report provided the parameters for the three flatyards visited (Table 42).

BASELINE CONCEPT A2

SENSITIVITY 1

NO. OF BOX CARS = 1

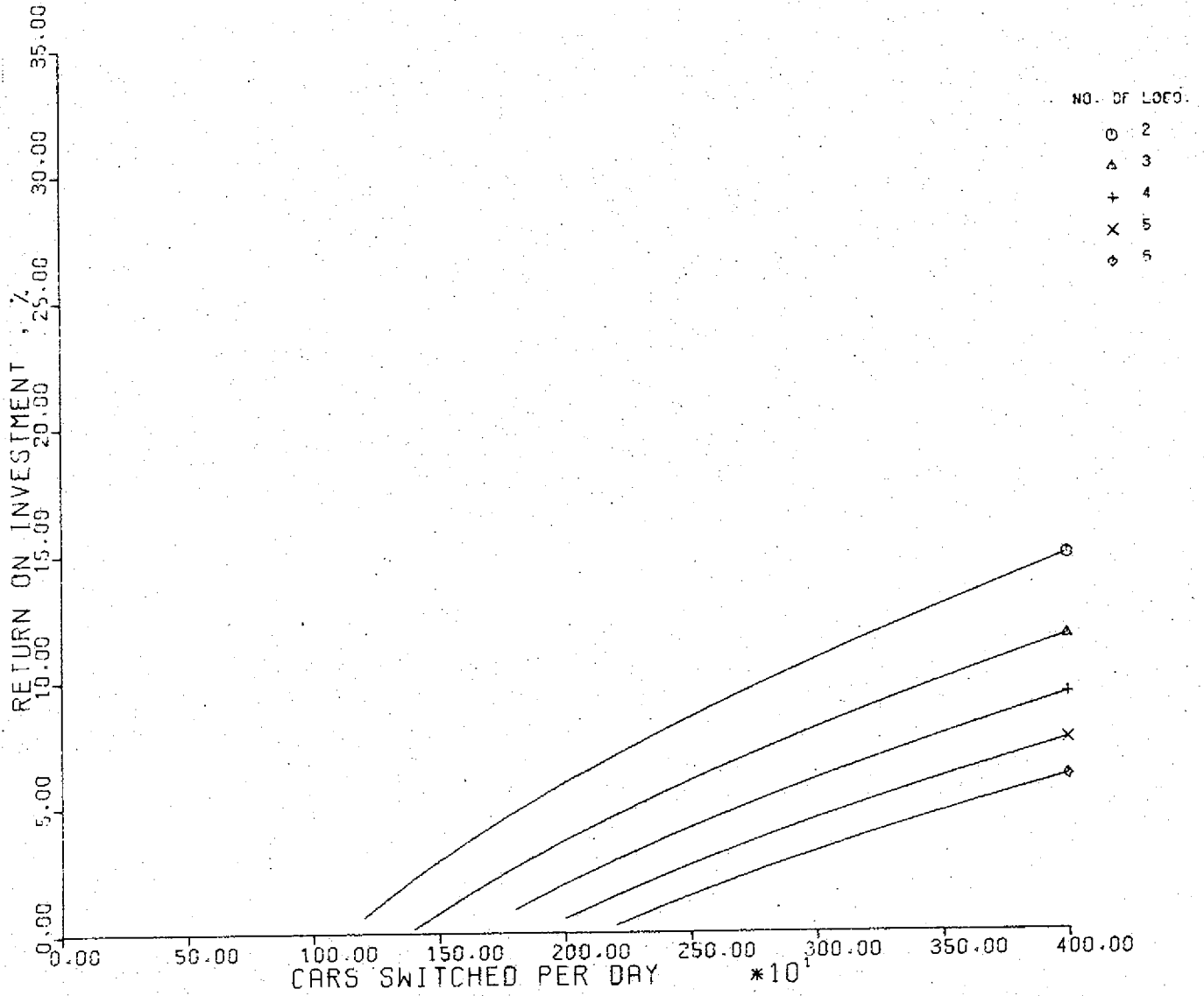

Figure 115. Baseline Concept A2, One Boxcar

BASELINE CONCEPT A2

SENSITIVITY 1

NO OF BOX CARS = 2

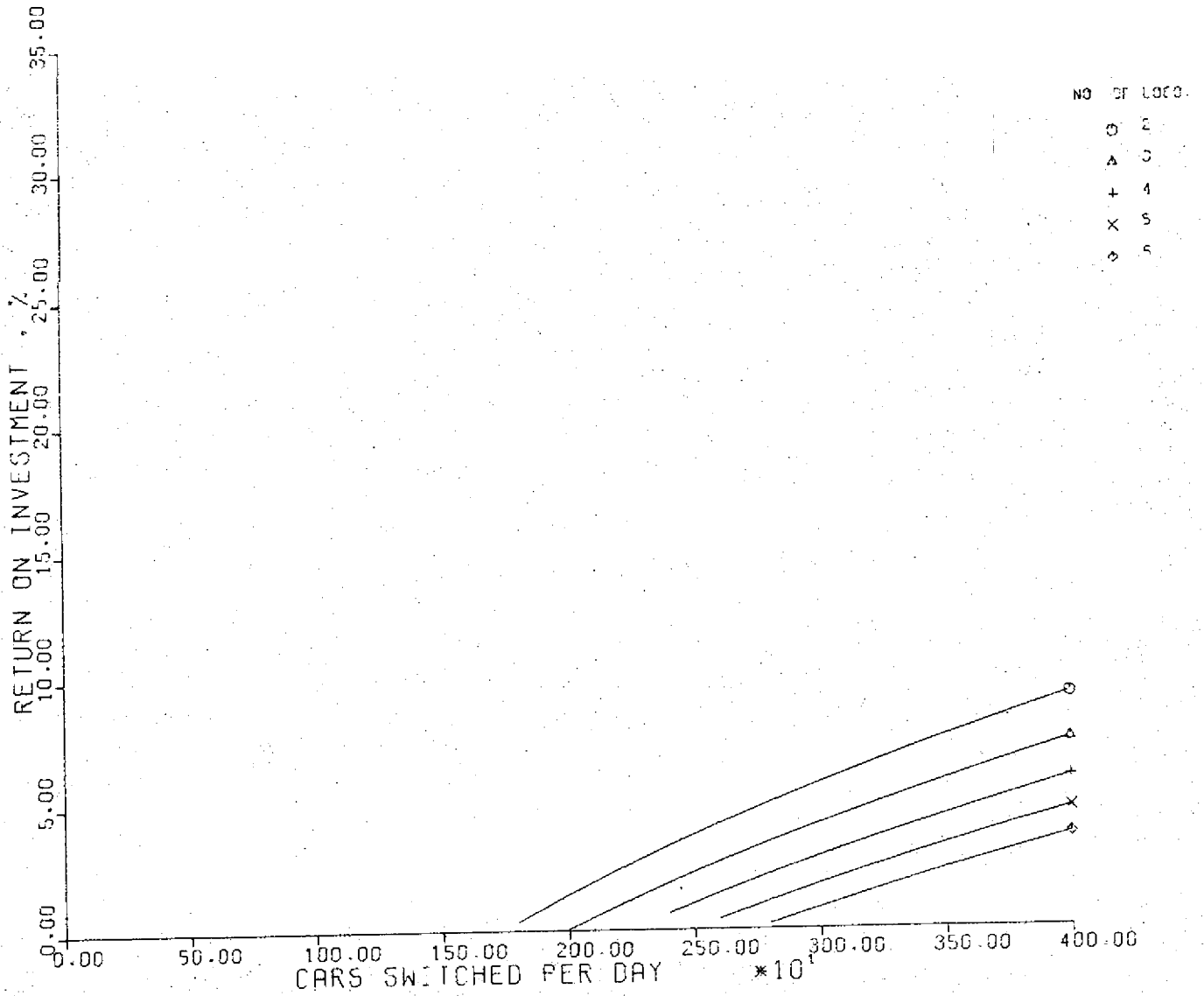

Figure 116, Baseline Concept A2, Two Boxcars

BASELINE CONCEPT A2

SENSITIVITY 1

NO. OF BOX CARS = 3

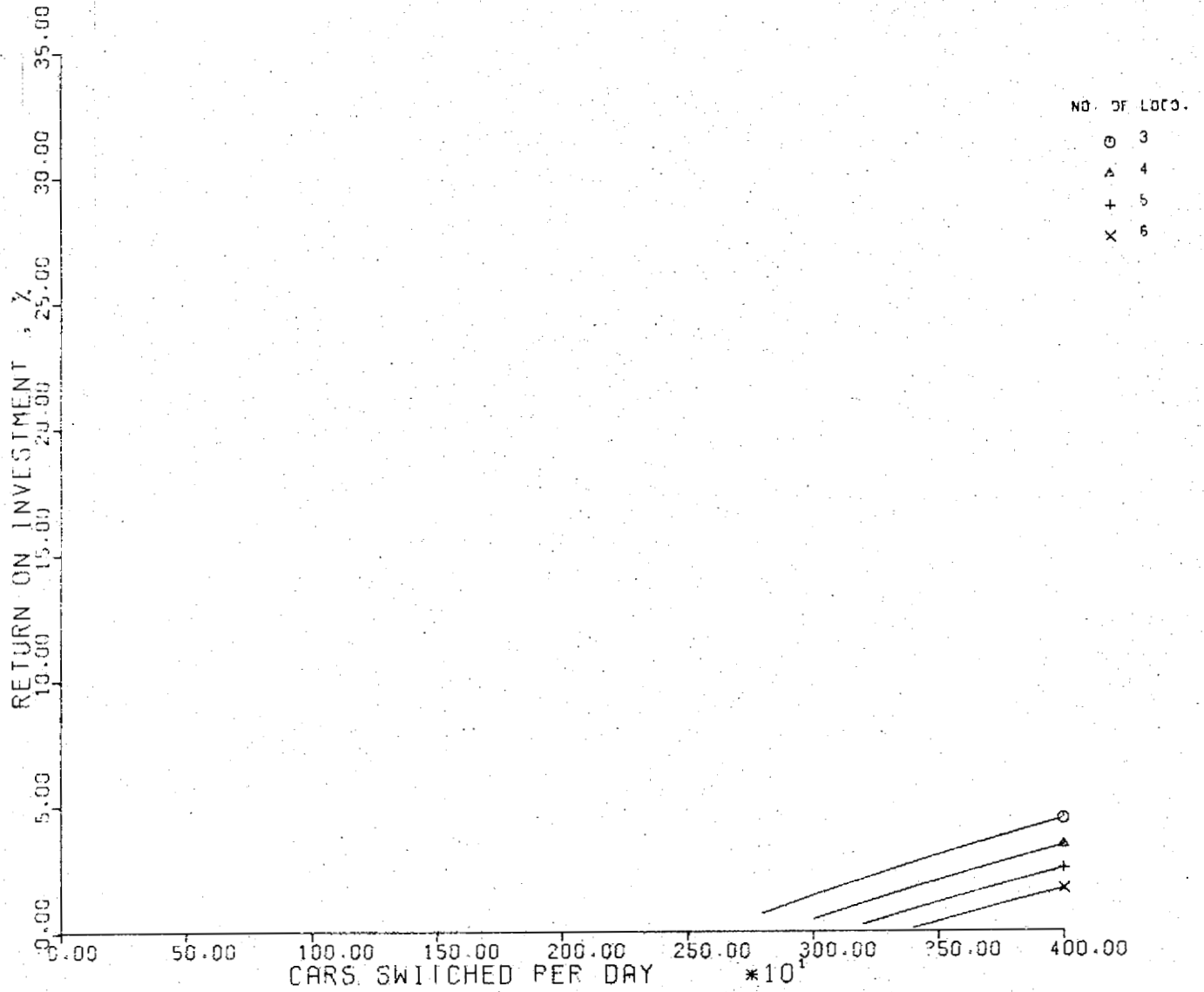

Figure 117. Baseline Concept A2, Three Boxcars

BASELINE CONCEPT A2

SENSITIVITY 1

NO. OF BOX CARS = 4

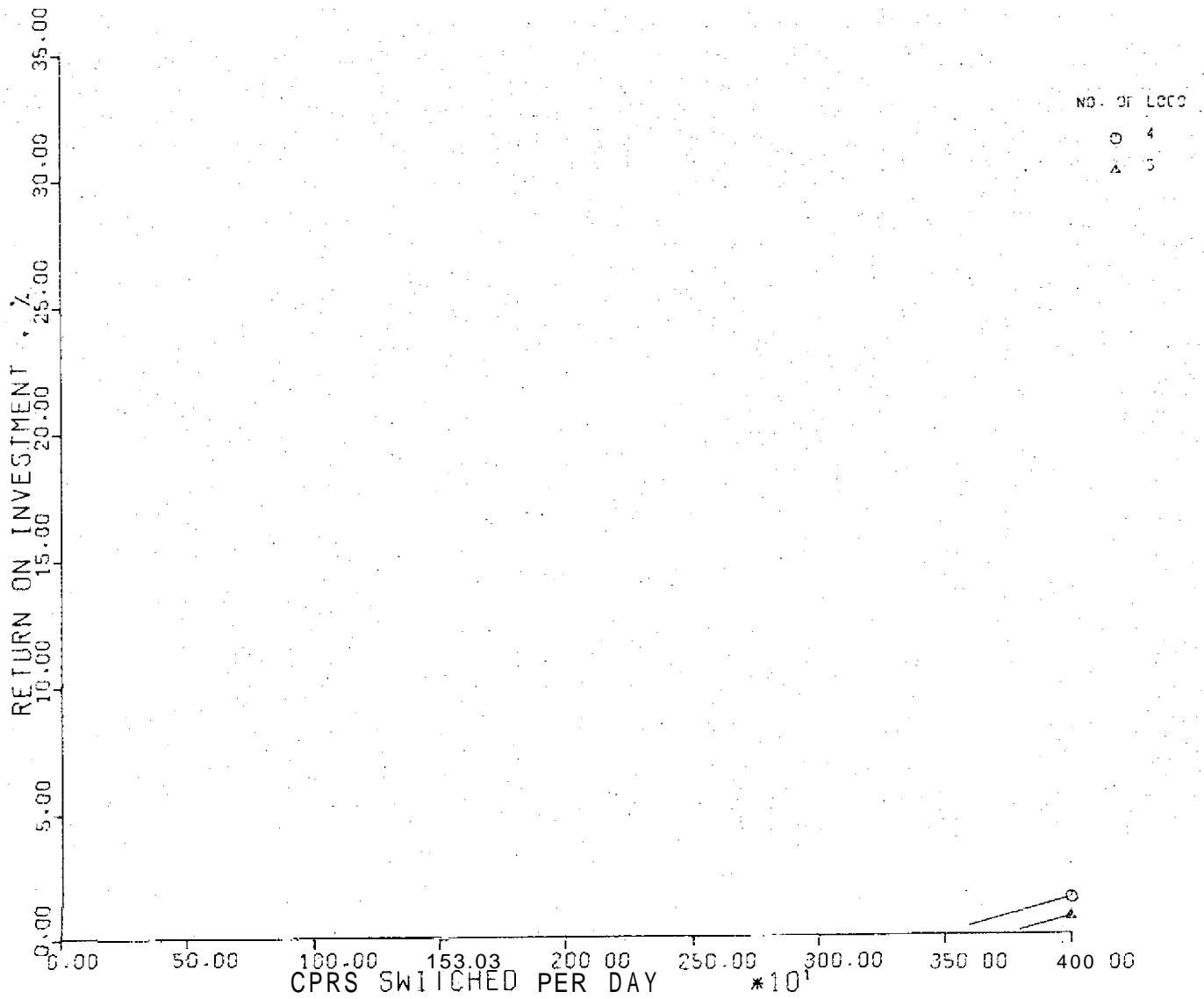

Figure 118. Baseline Concept A2, Four Boxcars

TABLE 42

FLATYARD CHARACTERISTICS

	Dillard	Baldwin	Whitefish
Cars/day	1409	3485	725
Locomotives/yard	3 or 4	5 or 6	3 or 2

Applying the data obtained from Table 42 to the results of Figures 115 through 118, a conclusion is reached that even in a most optimistic case (the number of ESU-equipped boxcars less the numbers of locomotives), the ROI would not exceed 5, and would probably be negative. Therefore, the obvious conclusion is that FESS Concept A2 is economically unattractive.

SECTION 7

ALTERNATE CONFIGURATIONS

CONFIGURATION DESCRIPTIONS

During the concluding efforts of the indepth system analysis, preliminary economic analysis results made it apparent that the Concept A2 economic viability was marginal for two reasons: (1) without careful energy management by the operator, the lack of fuel saving could alter to increased fuel usage, and (2) a high initial cost was associated with the concept. In an attempt to retrieve the situation, AiResearch considered alternate configurations that were aimed at reducing the cost of the most expensive items: the locomotive modification and the ESU's. The following three alternate flywheel configurations were identified and are described in Appendix E:

- o Concept A2 (modified)
- Concept A1 (modified)
- Series motors concept

Furthermore, because it has been clearly demonstrated that the energy savings identified are negligible and the benefits identified result solely from brake maintenance reduction, it is obvious that similar benefits would result from the use of a dynamic brake if it could maintain braking effort at a low speed (1 mph). The chopper-controlled dynamic brake is such a system, and it is also described in Appendix E.

ECONOMIC ANALYSIS

It was considered that this cursory analysis of alternate configurations was more useful than a conventional sensitivity analysis on a proposal which was so clearly uneconomic. The detailed results of the economic analysis of each configuration are given in Appendix E. From these data, the baseline analysis results are plotted in Figures 119 through 121 for Concept A1 (modified), Figures 122 through 127 for the series motors concept, and Figure 128 for the chopper-controlled dynamic brake.

An economic analysis of Concept A2 (modified) was unnecessary because the only difference between A2 and A2 (modified) was a less than 1-percent reduction in the locomotive modification cost.

It can be seen that none of the alternate configurations are attractive, and it has been concluded that the switchyard locomotive operation costs are so small to run that high-cost modifications cannot be justified. The low utilization factor of the equipment also precludes taking a financial credit for any possible increase in productivity that could have resulted from enhanced equipment performance, because this would have been absorbed by an increase in the utilization factor.

CONCEPT A1 (MODIFIED)

SENSITIVITY 1

NO. OF BOX CPRS = 1

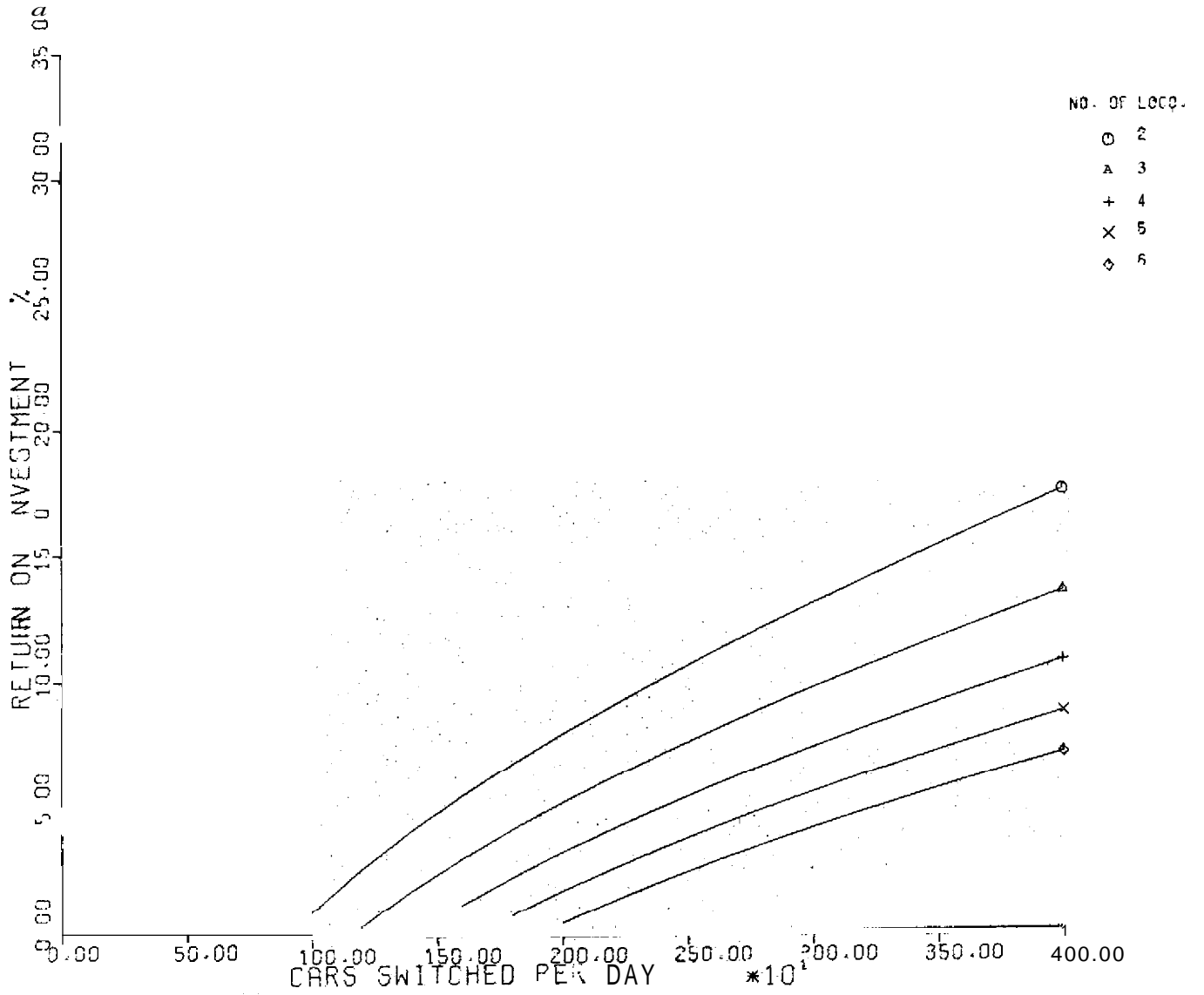

Figure 119. Modified Concept A1, One Boxcar

CONCEPT A1 (MODIFIED)

SENSITIVITY 1

NO. OF BOX CARS - 2

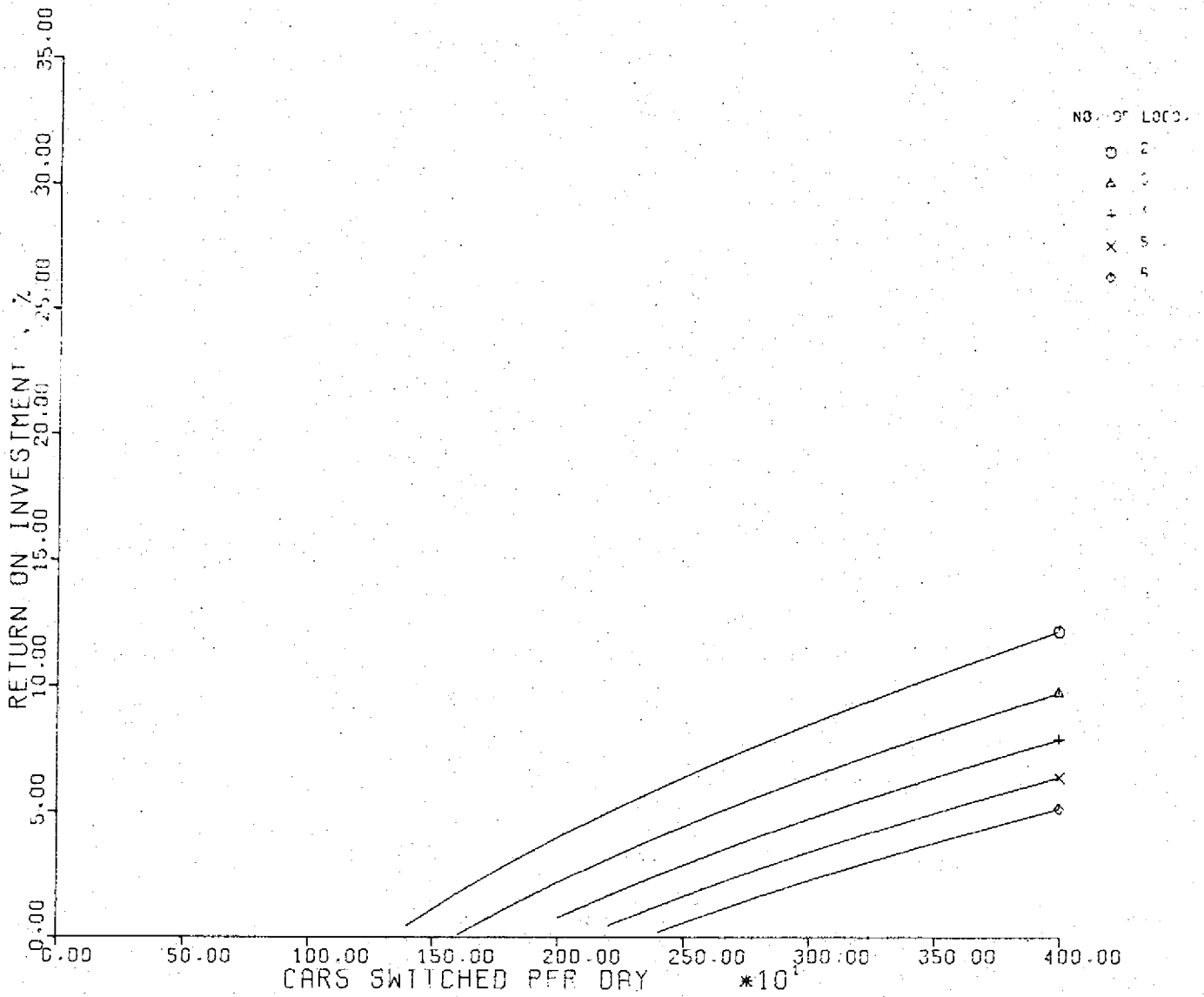

Figure 120. Modified Concept A1, Two Boxcars

CONCEPT A1 (MODIFIED)

SENSITIVITY 1

NO. OF BOX CARS = 3

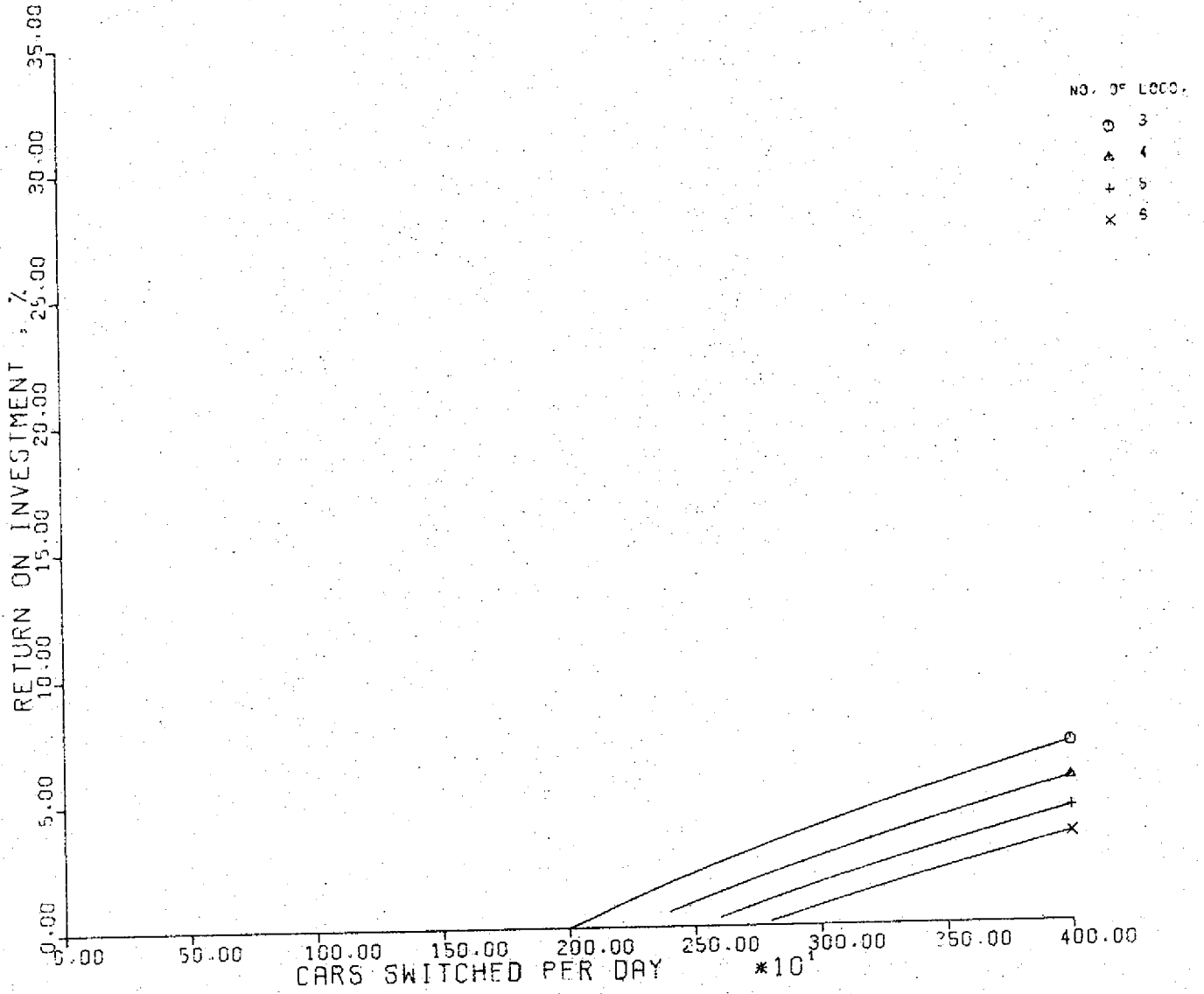

Figure 121. Modified Concept A1, Three Boxcars

SERIES MOTORS CONCEPT

SENSITIVITY 1

NO. OF BOX CARS - 1

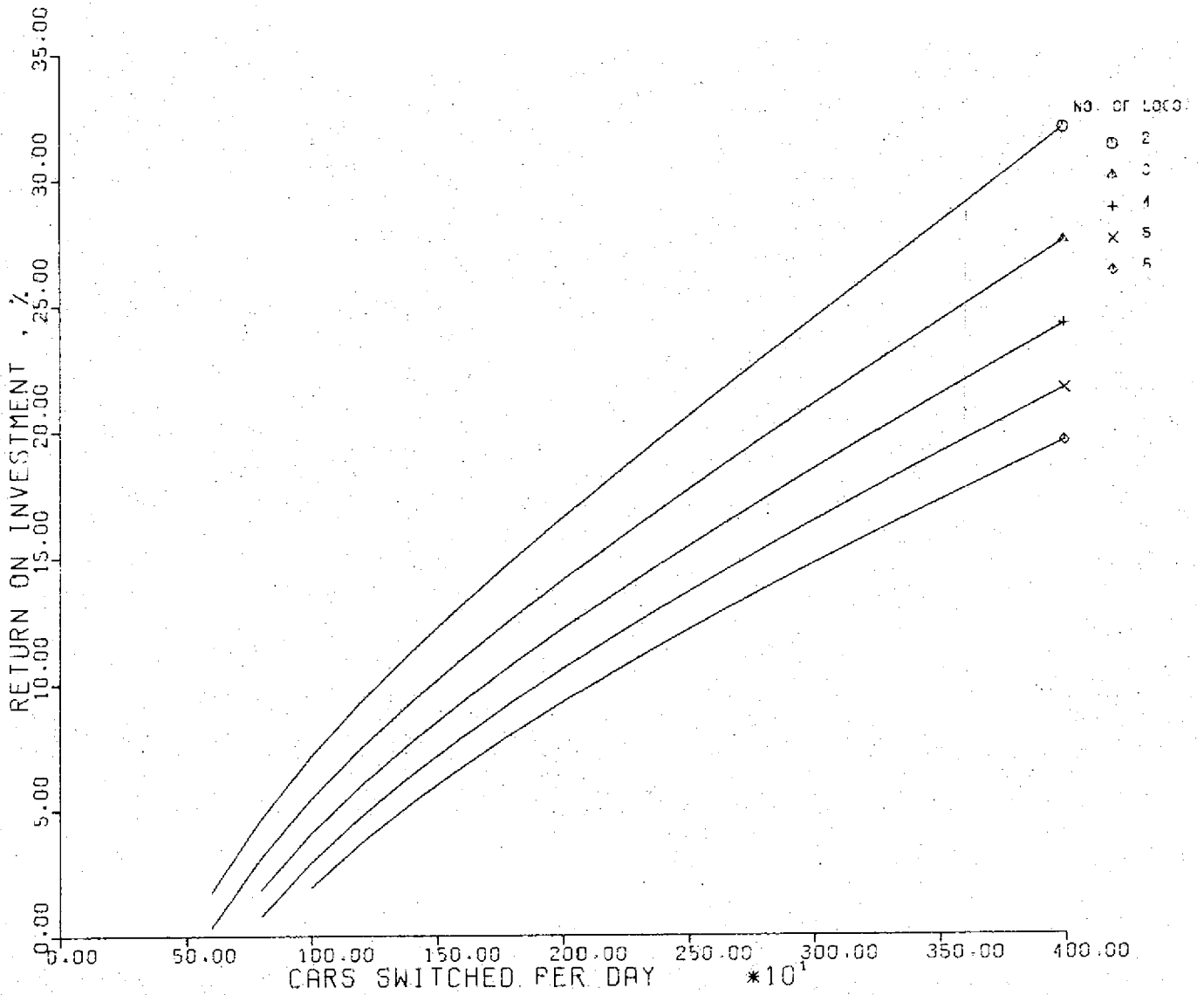

Figure 122. Series Motors Concept, One Boxcars

SERIES MOTORS CONCEPT

SENSITIVITY 1

NO. OF BOX CARS = 2

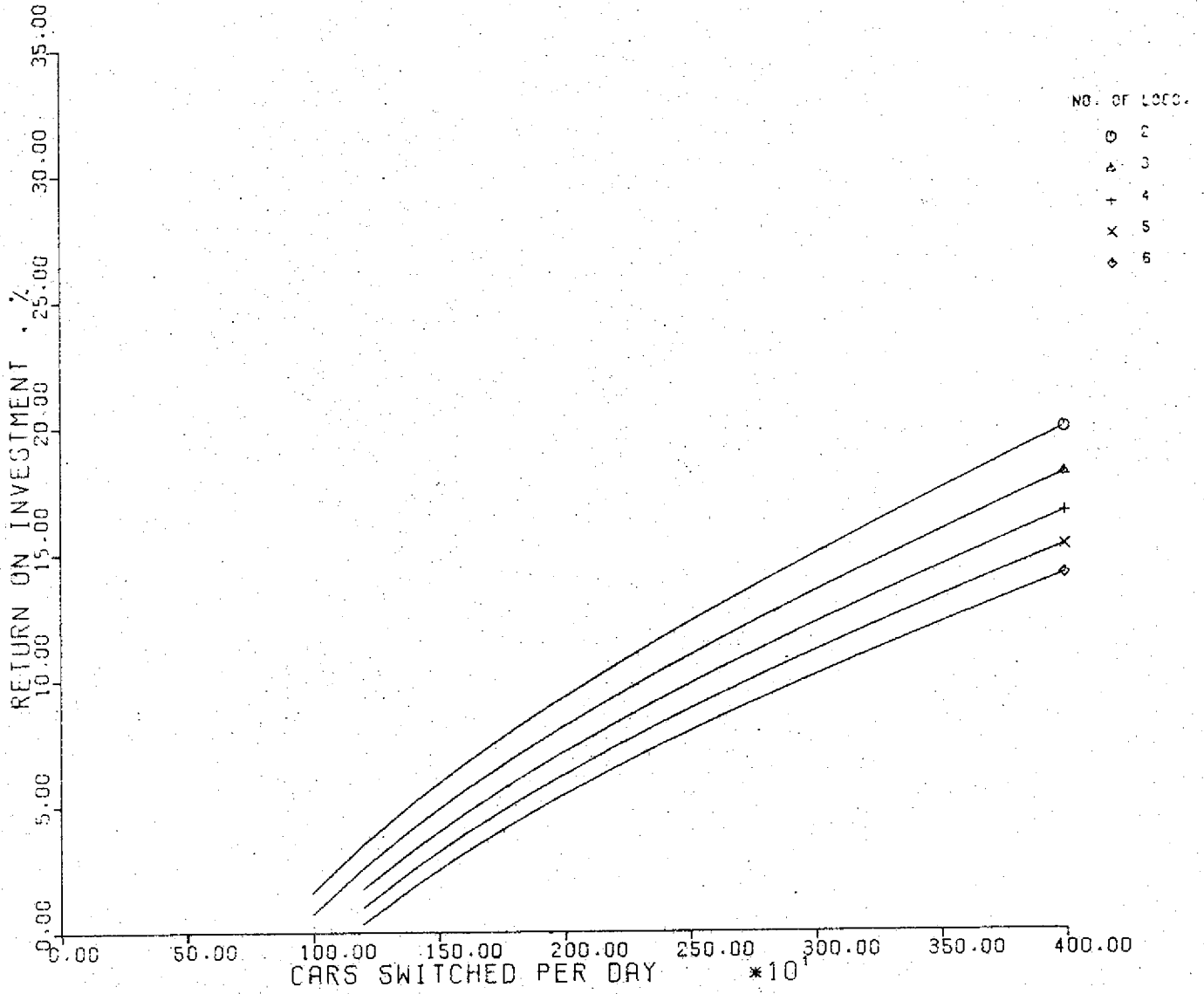

Figure 123. Series Motors Concept, Two Boxcars

SERIES MOTORS CONCEPT

SENSITIVITY 1

NO. OF BOX CARS - 3

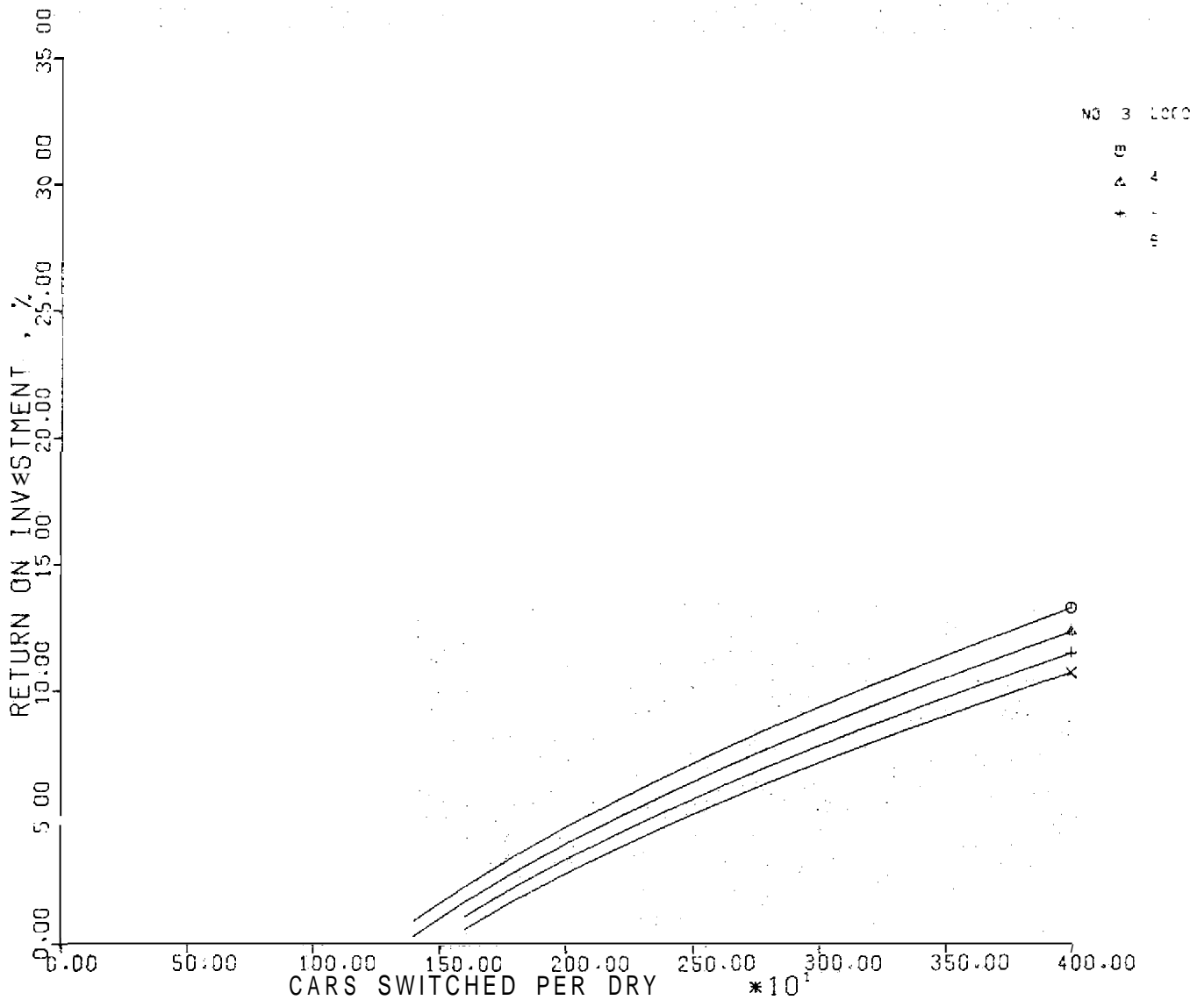

Figure 124. Series Motors Concept, Three Boxcars

SERIES MOTORS CONCEPT

SENSITIVITY .

NO. OF BOX CARS = 4

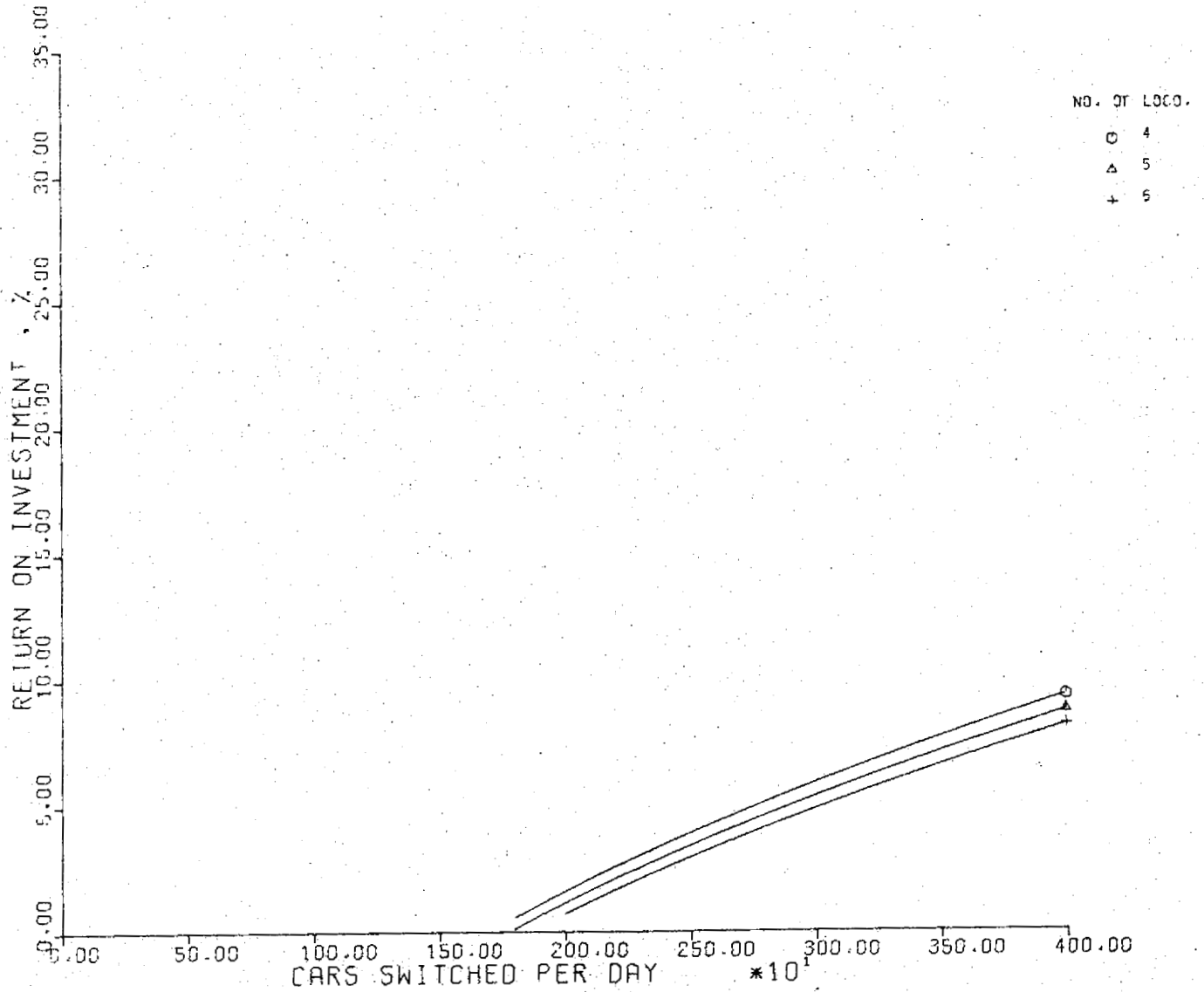

Figure 125. Series Motors Concept, Four Boxcars

SERIES MOTORS CONCEPT

SENSITIVITY 1

NO. OF BOX CARS = 5

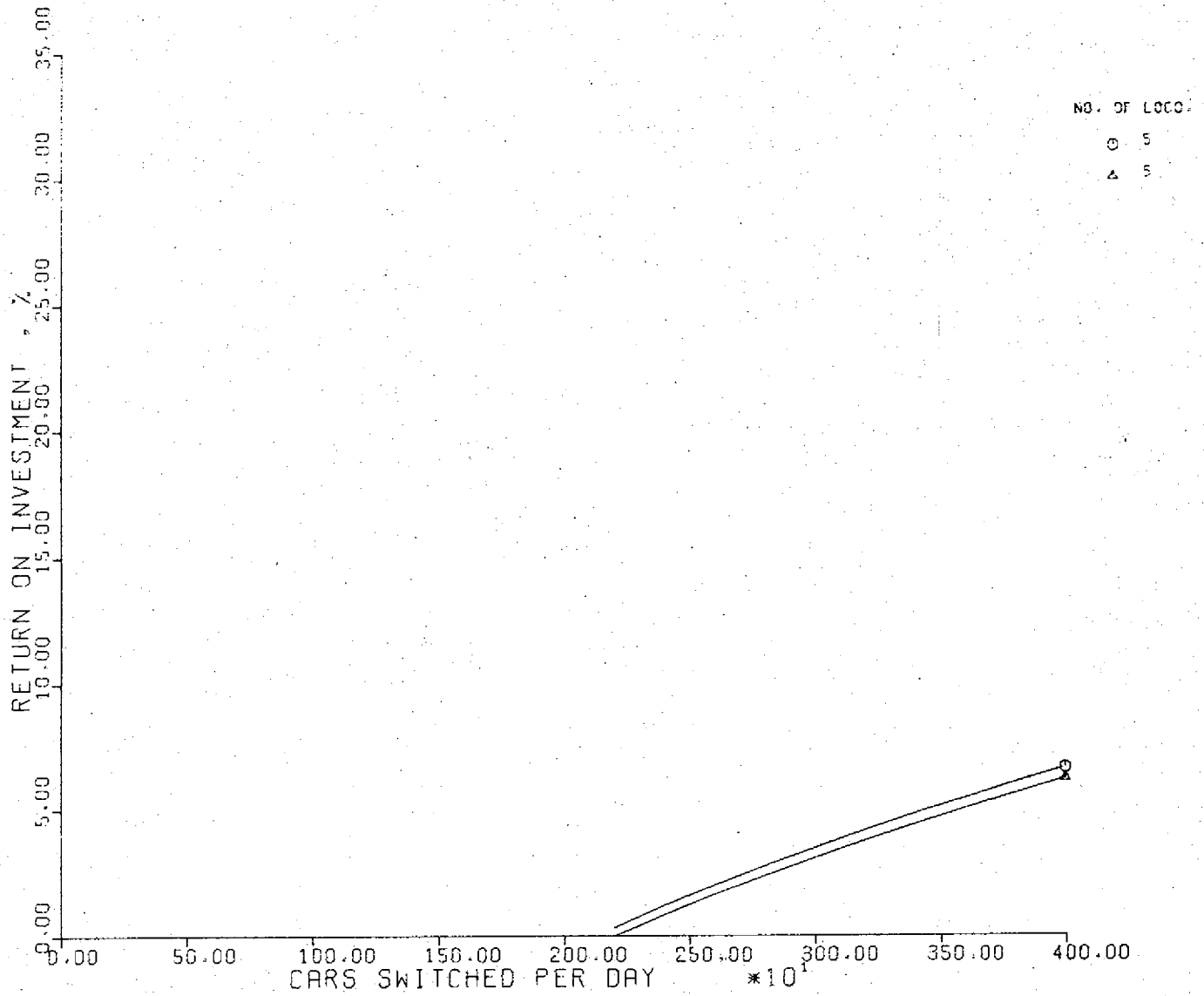

Figure 126. Series Motors Concept, Five Boxcars

SERIES MOTORS CONCEPT

SENSITIVITY 1

NO: OF BOX CARS = 6

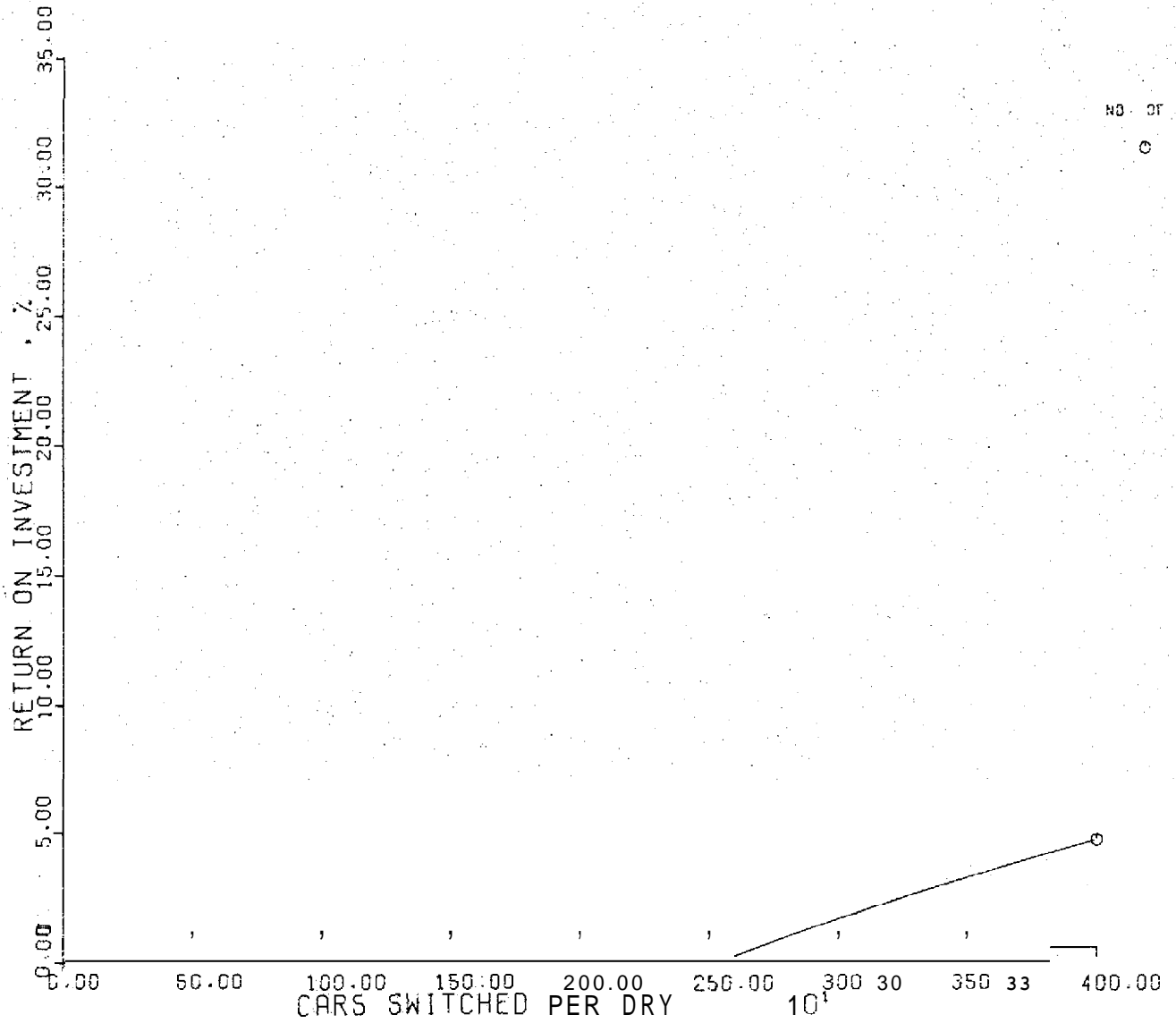

Figure 127. Series Motors Concept, Six Boxcars

CHOPPER CONTROLLED DYNAMIC BRAKE

SENSITIVITY 1

NO. OF BOX CARS = 1

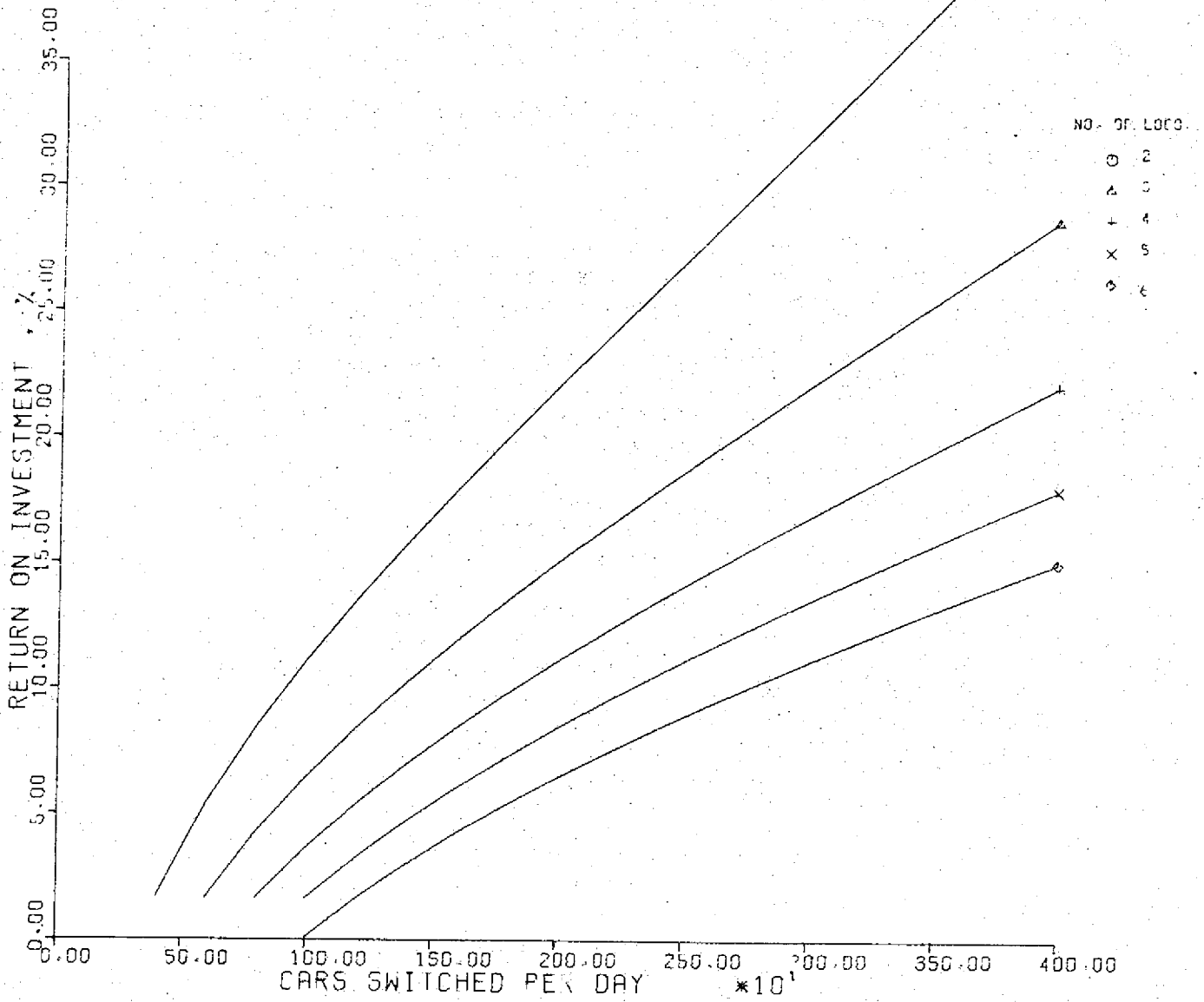

Figure 128. Chopper-Controlled Dynamics Brake

SECTION 8

CONCLUSIONS AND RECOMMENDATIONS

The completion of Phase I of the flywheel energy storage switcher program has resulted in the quantification of the costs involved in, benefits derived from, and technical feasibility of short-term energy storage as applied to the operating environment of the switching locomotive. On this basis, the concept has been found to be economically unattractive, although technical feasibility was confirmed. Alternate configurations were considered and some were found to improve the economics, although the concept is, at best, marginally valuable.

The specific conclusions and recommendations of this 16-month FESS study are given below.

CONCLUSIONS

- (a) The recuperation of braking energy from a switching locomotive, its short-term storage, and subsequent reuse cannot be achieved in an economically attractive way using existing equipment.
 - (b) The overall energy consumption of the existing switching operation is very low and, therefore the energy savings, which can be realized only during the short switching period, are also low and usually balanced by an increase in parasitic loads.
 - (c) The study has resulted in the quantification of the duty cycle for a typical switching locomotive, which shows that the equipment is generally underutilized because of the nature of the work.
 - (d) The modification of the EMD 077 traction motor to a separately excited, low-current field configuration has been shown to be technically feasible. This modified motor may have applications beyond the FESS concept.
 - (e) The operating costs of the switching locomotive are so low that high investment programs (in which only 5 percent of the locomotive cost are involved) cannot generally be justified by maintenance or energy savings. The locomotive population is generally small (usually less than six locomotives per yard), and therefore a minor increase in the potential productivity cannot be accomplished by a reduction in the size of the locomotive fleet. This is generally in agreement with the conclusions reached by the Stanford Research Institute (Reference 5).
 - (f) The computer models developed for this study may have potential for application to other railroad activities, since the model uses the internal parameters of the locomotive to generate a train's performance.
-

RECOMMENDATIONS

- (a) The traction motors made available by the Southern Railway System should be reconverted to the standard configuration and returned to service. SRS may wish to retain certain features of the modified motor, such as the improved interpole.
- (b) The proposed Phases II and III of the FESS program should not be pursued, since the concept has been shown to save little energy and to be economically unattractive.
- (c) The optional task in the contract (Article V, Computer Program Documentation) should be considered for use in other research projects since this comprehensive train model has a virtually universal application.
- (d) The scenario data reduced for FESS purposes have been fully described in this report. It is possible that other requirements may exist for further data reduction, and it is recommended that this possibility be investigated by FRA.
- (e) Because the feasibility of separately exciting the most common traction motor in U.S. railroad service has been confirmed, it is recommended that the application of this motor beyond the FESS concept be pursued.

SECTION 9

REFERENCES

- Wayside Energy Storage Study, AiResearch Manufacturing Company of California, AiResearch Report 78-15180, June 1978.
2. Testing and Data Collection Plan to Define Operating Scenario of Flat-yard Switch Engine, AiResearch Report 77-14536A, AiResearch Manufacturing Company of California, December 1977.
 3. Performance Test Plan for SW1500 Locomotive, AiResearch Report 78-15055, AiResearch Manufacturing Company of California, May 2, 1978.
 4. Preliminary Analysis Report, Flywheel Energy Storage Switcher, AiResearch Report 78-15053, AiResearch Manufacturing Company of California, June 1978.
 5. Railroad Classification Yard Technology, A Survey and Assessment, Stanford Research Institute, January 1977.
 6. Schwarm, E. G., Energy Costs for Railroad Electrification, Final Report prepared by A. D. Little, Inc., under contract to DOT-TSC, May 1977.
 7. "An Evaluation of the Costs and Benefits of Railroad Electrification," Draft Report, Federal Railroad Administration, Washington, D. C.

APPENDIX A
INSTRUMENTATION

SCENARIO TESTS

The switching locomotive was instrumented to record data on digital cassettes for future retrieval. The data was recorded at a rate of 1 scan per second, and scanned at a rate of 200 channels per second. Prior to the test, a calibration of each channel was recorded on the digital cassette. An event marker provided a stop and start marker for each individual test. Figure A-1 illustrates the data acquisition systems; Table A-1 lists the instrumentation required for data acquisition and calibration; Table A-2 shows the sensor locations for the recorded signals. All of these, except the accelerometer and brake pressure transducer, are standard locomotive equipment.

Retrieval of recorded data was accomplished using a Gould 6000 communications interface in conjunction with a standard RS-232 teletype. Calibration data recorded on the digital cassette provided the necessary scale factors to convert the printout digital data to engineering units. Figure A-2 is an illustration of the data recovery system, and Table A-3 lists the test equipment used for data recovery.

LOCOMOTIVE TESTS

Description

The switching locomotive was instrumented to record data on analog magnetic tape for future retrieval, and on an oscillograph for quick-look monitoring of tape recorder outputs and selected parameters. Figure A-3 is a block diagram of the onboard data acquisition system. A description of this equipment is given in Table A-4.

Retrieval of taped data was usually accomplished by playback on an eight-channel recorder as shown in Figure A-4. Data reduction was then continued, using the analog information provided from these playbacks. This playback equipment is described in Table A-5.

The bandwidth resolution, the sensors, and the sensitivity ranges of the recording equipment are summarized in Table A-6. A summary of the parameters recorded, and the instrumentation used for the performance tests is shown in Table 4-7.

A section of the locomotive wiring diagram shows the connection points for the voltage and current measurements (see Figure A-5). Note that measured motor voltage is actually motor armature voltage plus brush drop. True motor voltage is calculated to include the field voltage drop.

Calibration

1. Current

The current shunts have a 50-mv output for rated current input. They have been calibrated and certified by the AiResearch metrology laboratory.

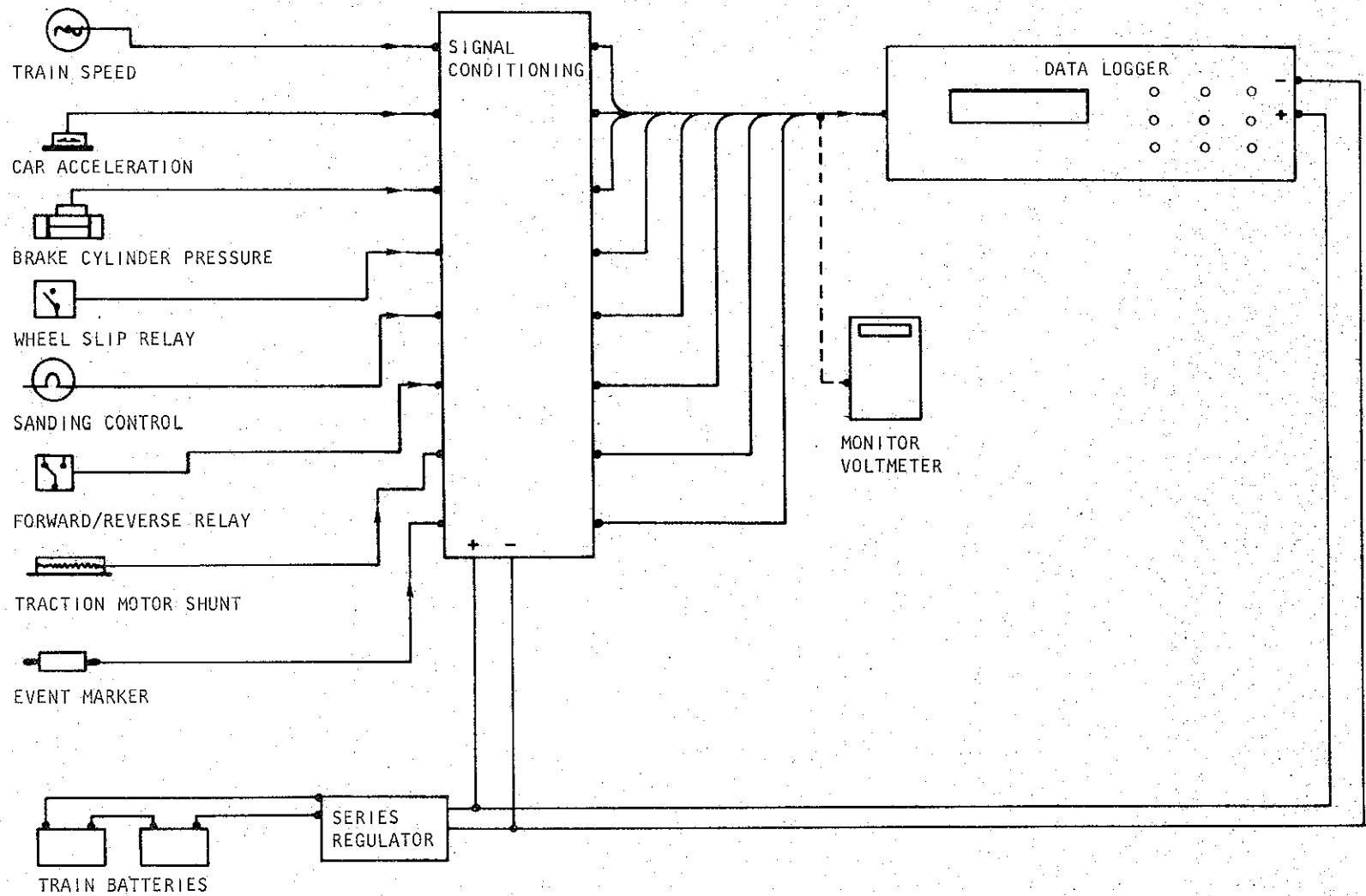

Figure A-1. Data Acquisition Systems

TABLE A-1

DATA ACQUISITION SYSTEM AND CALIBRATION INSTRUMENTATION

Item No.	Instrument Description	Model No.	Manufacturer	Response Range	Sensitivity	Calibration	Notes
1	Digital data logger	6100	Gould, Inc.	1 to 200 channels per second scan rate.	± 10 mv to 10 v		
2	Shunt isolation amplifiers	LSK 36895	AiResearch	Dc to 15 kHz	.1 mv min.	50 mv = 5.0 v	
3	Current shunts	Supplied by locomotive manufacturer		0 to 500 Hz	.1 mv min.	50 mv = 1000A	
4	Buffer/divider card	LSK 36521 (modified)	AiResearch	0 to 5 kHz	.1 v min.	75 v in = 5.0 v out	Used to condition FWD/REV, wheel slip, and sensing signals
5	Pressure transducer	217	Taber	0 to 100 Hz	0 to 200 psig .1 psig min.	75 psig = 5.0 V _{out}	
6	Strain gage card	LSK 36530	AiResearch	0 to 10 kHz	.01 mv min.	AiResearch certified	
7	Linear accelerometer	LSBC-.2S	Schaevitz	0 to 40 Hz	0 to $\pm .25$ g .001 g min.	.25 g = 10.0 v	
8	Accelerometer conditioning card	LSK 36530 (modified)	AiResearch	0 to 10 kHz	.01 mv min.	AiResearch certified	
9	Speed alternator (frequency to voltage transducer)	MM 24	General Electric	300 Hz	5 Hz	160 Hz = 50 mph	Supplied by locomotive manufacturer
10	Frequency to dc converter	LSK 36525 (modified)	AiResearch	0 to 10 kHz	5 Hz min	160 Hz = 5.00 v	
11	Signal conditioning power supply and chassis	LSK 36896	AiResearch	N/A	N/A	N/A	
12	Low voltage calibrator	DVC 8500	DATEL	Dc	.1 mv min.	AiResearch certified	
13	Digital multimeter	3476B	Hewlett-Packard	Dc to 10 kHz	.1 mv min.	AiResearch certified	
14	Frequency counter	CF601R	Anadex	1 Hz to 99,999 Hz	± 1 count	AiResearch certified	
15	Pressure gage	1850	Ashcroft	N/A	1.0 psig 0 to 200 psig	AiResearch certified	

TABLE A-2

SENSOR LOCATIONS

Parameter	Test Point
Train speed	Signal from an alternator mounted on the rear axle, right side.
Train accelerator	Signal derived from a linear 0.25 g accelerator mounted on a wooden baseplate, taped to the cab floor.
Brake cylinder pressure	A pressure transducer was hooked into a pressure tap on the rear-axle brake cylinder on the left side of the engine.
Traction motor current	Picked up shunt signal across terminals of the current meter mounted in the cab console,
Sanding control	Signal across sanding light on control console.
Forward/reverse relay	Signal from forward/reverse switch in cab control console.
Wheel slip relay	Signal across wheel slip light on instrument console in engine cab

TABLE A-3

DATA RECOVERY SYSTEM TEST EQUIPMENT

Item	Instrument	Model	Sensitivity	Range	Description
1	Digital data logger	Gould 6100 system	1 mv to 10 v	Scan rate: 1 to 200 channels per sec	Data storage on digital cassette 300A
2	Communications interface	Gould 6000 system	--	110 to 1200 baud ASC11 format	Microprocessor-controlled data logger command station
3	Teletypewriter	Teletype Corporation, Model 43	--	30 character per sec 132 column serial data terminal	Provide printout data from data logger, and supply commands to interface
4	Power supply	Hewlett Packard 5274B	--	0 to 60 vdc 0 to 15 adc	Supply operating power to data logger and communications interface

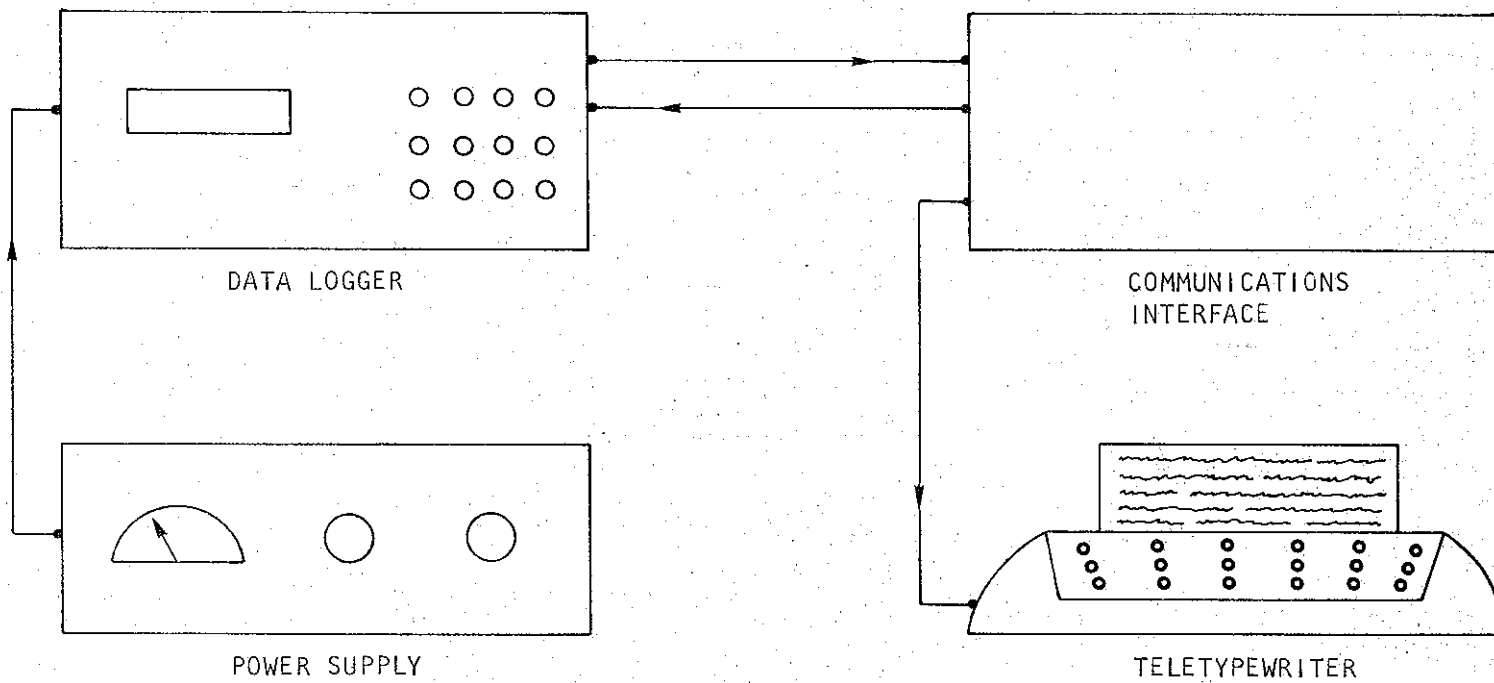

S-34264

Figure A-2. Data Recovery System

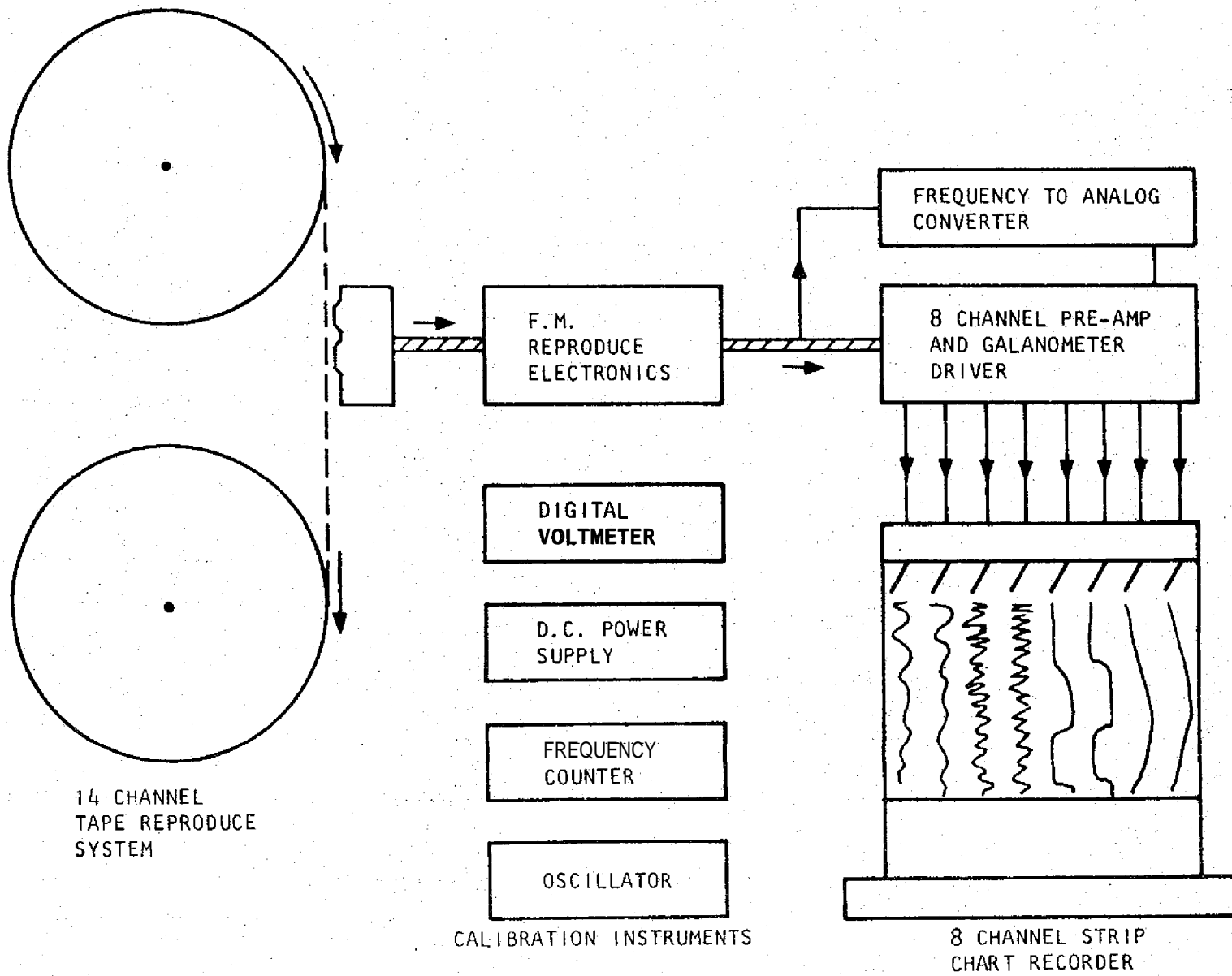
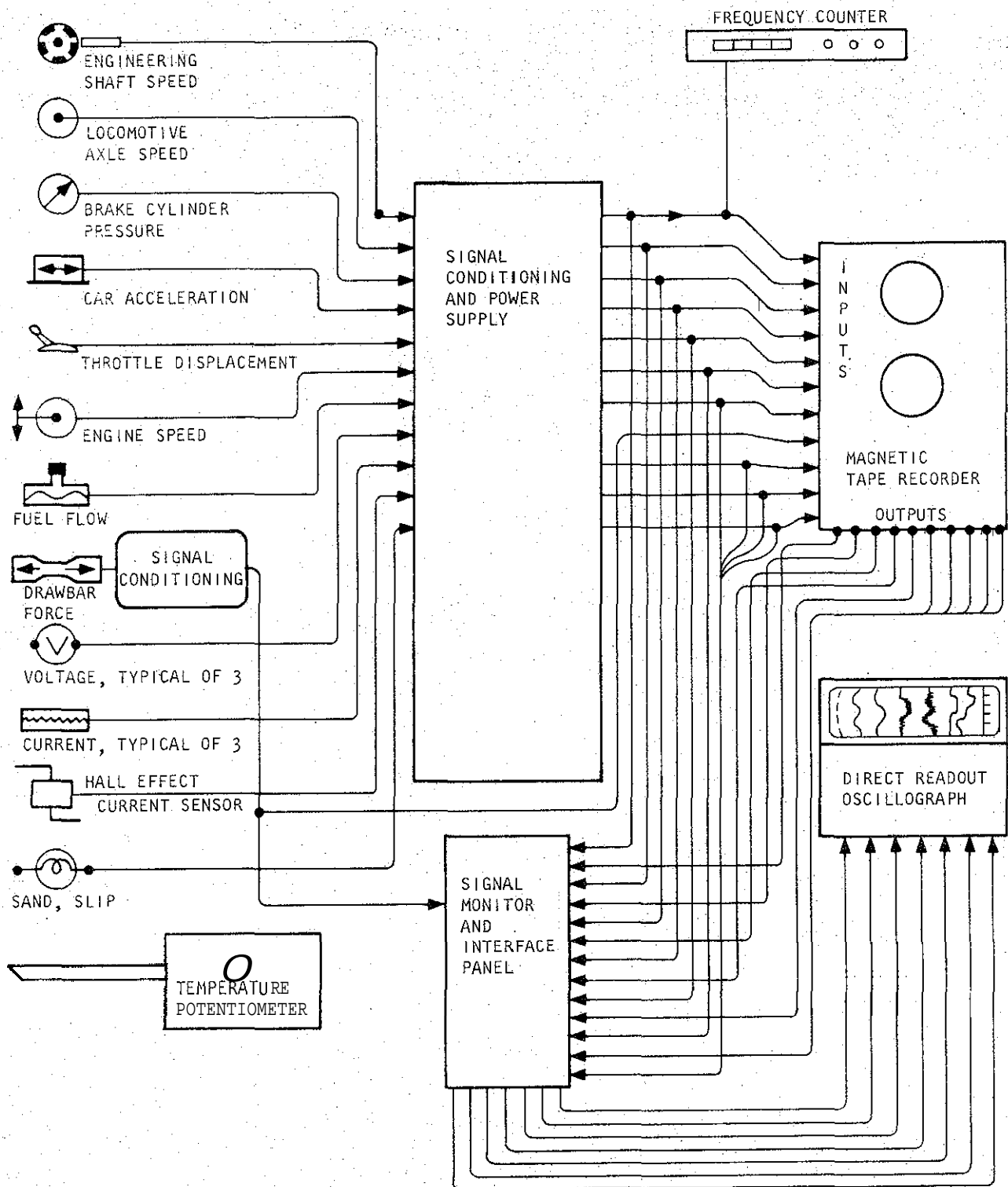

Figure A-3. Onboard Data Acquisition System Block Diagram

TABLE A-4

DATA ACQUISITION SYSTEM INSTRUMENTATION

Item No.	FESS Instrumentation Description	Model No.	Manufacturer	Response Range	Sensitivity	Calibration	Notes
1	Oscillograph recorder, 18 channel	5-134	Bell and Howell	0 to 1000 Hz	≈ 2.5 v per in.	0 to 2 in. for F.S. signal	
2	Tape recorder	3600	Sangamo	0 to 10 kHz	≈ 10 mv min.	± 5 v F.S. signal	
3	Strain gage signal conditioning	LSK 36530	AiResearch	0 to 10 kHz	≈ 10 μ v min.	Depends on sensor	
4	General signal conditioning	LSK 36896	AiResearch	0 to 1 kHz	N/A	± 5 v F.S. signal	Provides buffering for voltages and accelerates
5	Speed and signal conditioning	LSK 36925	AiResearch	0 to 1 kHz	$\approx \pm 0.1$ mph and $\approx \pm 1.0$ ft	0 to 50 mph	
6	Linear accelerometer	LSBC-.25	Schaevitz	0 to 40 Hz	$\approx .001$ g min.	5 v = .25 g	
7	Current shunts	PR1000	Quality Electric	0 to 500 Hz	≈ 0.1 mv min.	50 mv = 3000A, 1000A, and 100A	
8	Current shunt isolators	6271A LSK 36895	AiResearch	15 kHz	≈ 0.5 percent of F.S.	50 mv = 5 v	
9	Voltage dividers	LSK 36521	AiResearch	0 to 1 kHz	≈ 0.5 v min.	1000 v and 500 v = 5 v	0.1 percent resistive divider
10	Calibration high voltage power supply	408A	Fluke	500 to 5000 v	1.0 v	AiResearch certified	
11	Calibration frequency counter	CF501R	Anadex	1 Hz to 99,999 Hz	± 1 count	AiResearch certified	
12	Calibration oscillator	204C	Hewlett Packard	5 Hz to 1.2 MHz	± 1 percent	AiResearch certified	
13	Calibration rms voltmeter	427A	Hewlett Packard	0.01 v to 300 v 10 Hz to 1 MHz	≈ 0.5 mv min.	AiResearch certified	
14	Millivolt calibrator	DVC 8500	Datel	Dc	0.1 mv	AiResearch certified	
15	Calibration dc voltmeter	3475B	Hewlett Packard	0 to 1000 v	0.1 mv	AiResearch certified	
16	Inverter	1K60-752001	Nova	Dc to 60 Hz	N/A	N/A	
17	Oscilloscope	503	Tektronix	Dc to 1 MHz	10 mv min.	AiResearch certified	
18	Linear displacement	R14046	R.I. Controls	Dc to 50 Hz	≈ 1.0 v per in.	3 in. F.S.	
19	Turbine flowmeters	AW8-4	Cox	Dc to 10 Hz	.25 gpm min.	AiResearch certified	
20	Optical speed sensor	13135	Spectral Dynamics Corp.	Dc to 5 kHz	N/A	N/A	
21	Temperature potentiometer	8693	Leads and Northrop	Dc -250 to 500°F	.5°F min.	AiResearch certified	
22	Drawbar force gage		Supplied and calibrated by Southern Railway				
23	Pressure transducer	217	Taber	Dc to 100 Hz 0 to 200 psig	.1 psig min.	AiResearch certified	
24	Current sensor, hall effect	CT 100LS	Ohio Semitronics Inc.	Dc to 10 kHz	1A (min.) 0-100A range	AiResearch certified	



S 34294

Figure A-4. Retrieval of Taped Data System

TABLE A-5

DATA RECOVERY SYSTEM INSTRUMENTATION

Item	Instrument	Model	Sensitivity	Range	Description
1	Magnetic tape recorder/reproducer	Sangamo 3600	0.5 to 10 v peak for full deviation	3-3/4 ips - 0 to 625 Hz 7-1/2 ips - 0 to 1250 Hz 15 ips - 0 to 2500 Hz	14-channel FM reproduce medium band system
2	Strip chart recorder	Beckman-Offner Type Dynograph	1.0 mv/mm max.	0 - 200 Hz \pm 20 percent	8-channel writing oscillograph
3	Digital voltmeter	Doric-DS 100	0.1 mv to 1000v	-	Dc voltmeter
4	Dc power supply	Lambda LS 513	100 μ v to 40 v	-	Precision, programmable, digital adjust
5	Frequency counter	Anadex CF601R	\pm 1	1 Hz to 99.999 kHz	Digital counter
6	Oscillator	Hewlett-Packard 204B	\pm 1% of scale	5 Hz to 560 kHz	Solid state, battery-operated
7	Frequency	Anadex P1-408R	9.01 v RMS threshold voltage	5 Hz to 51.2 kHz	Frequency to analog converter with zero suppression

TABLE A-6.

PARAMETER CALIBRATION RANGES

Parameter	Calibration Range	Calibration
Voltaques	1000 v = F.S. (750 v = 9.000 v)	Resistive divider (0.01 percent resistors) fluke power supply and Hewlett Packard digital multimeter voltmeter
Currents	1000 A = 50 mv	Certified current shunt Datel mv calibrator
Speed	0 to 50 mph	Anadex oscillator and Anadex counter
Oscillograph Records	5 v = 2 in.	Datel mv calibrator and H.P. digital multi- meter
Tape Recorder	+5 v = F.S. (+40 percent deviation on FM)	Datel mv calibrator and H.P. digital multi- meter
Fuel Flows	.25 to 2.5 GPM	Anadex counter and oscillator
Pressure	0 to 50 psig	Wallace and Tiernan pressure gage

TABLE A-7

PERFORMANCE TEST PARAMETERS AND INSTRUMENTATION

Recorded Parameter	Load Box Tests		Accel/Decel Tests		Simulated Switching	
V, main gen.	T	0	T	0	T	0
V, arm. 3			T	0	T	0
V, arm, 4			T	0	T	0
Amp, main gen.	T	0	T	0	T	0
Amp, arm-fwd			T	0	T	0
Amp, arm-rear			T	0	T	0
Amp, gen. fld.	T	0				
Fuel flow-inlet	T				T	
Fuel flow-return	T				T	
Engine speed	T		T		T	
Locomotive speed			T	0	T	0
Press, brake cylinder			T	0	T	0
Throttle position	T	0	T	0	T	0
Motor displacement			T	0	T	0
Sanding			T	0		
Wheel slip			T	0		
Drawbar force			T		T	

T = Recorded on magnetic tape.

3 = Recorded on oscillograph paper.

A-12

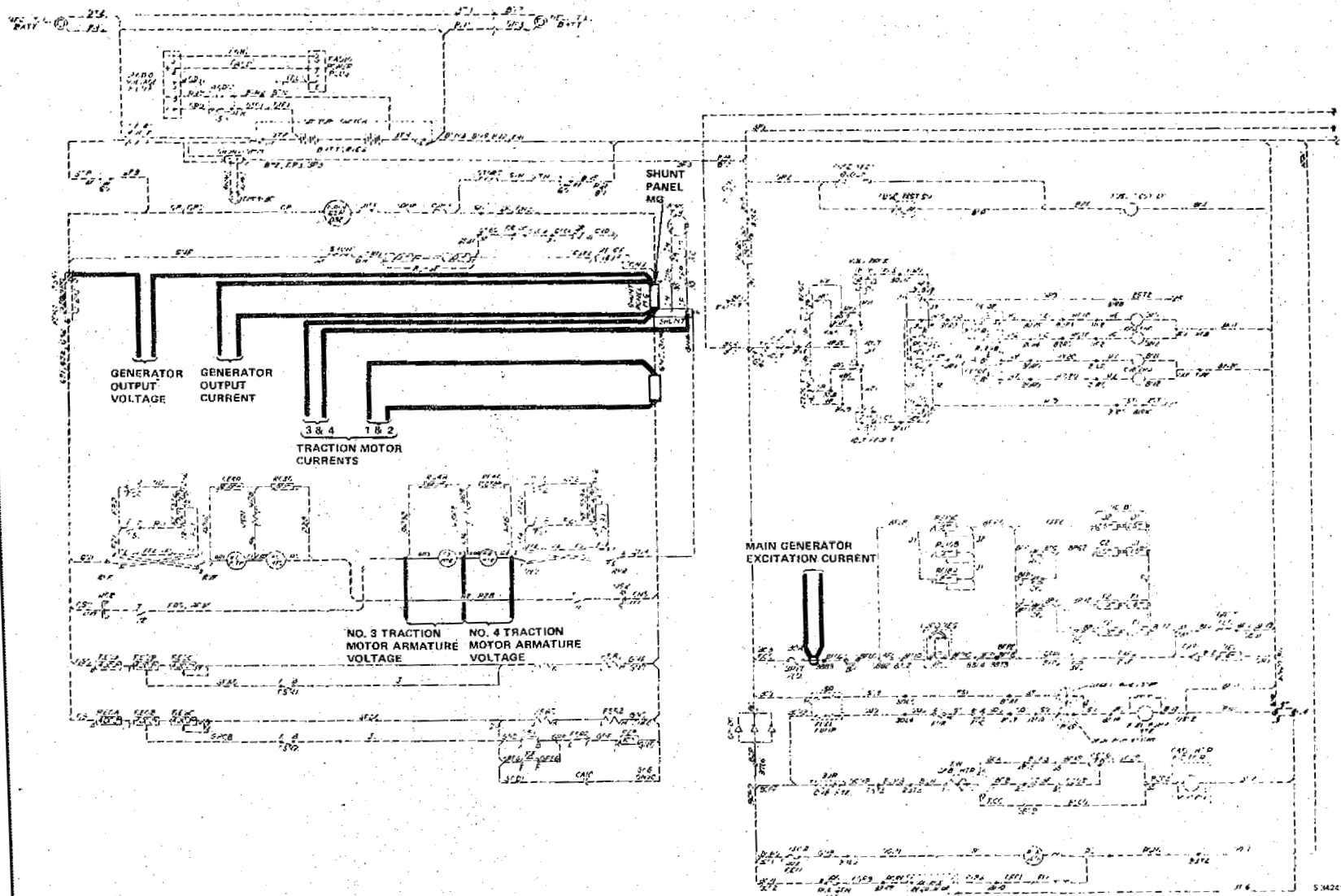

Figure A-5. Locomotive Wiring Diagram

534221

Shunt signal conditioning is calibrated by inserting a precision power supply in place of the current shunt. This input signal is varied from 3 to 50 mv, and the output is read on a calibrated digital voltmeter. The gain of the signal-conditioning amplifiers is adjusted as necessary to provide the correct output,

2. Voltage

The voltage divider cards were calibrated with a precision high voltage power supply for input and a calibrated digital voltmeter for output. This provided a voltage calibration ratio. Since the divider are made up of precision resistors, this ratio is constant. Subsequent field calibrations require only a two-point check with zero volts input and line voltage input,

3. Fuel Flow

The output of the turbine-type flowmeters was recorded directly as a frequency vs fuel flow. No amplitude calibration was required. For data reduction the signal was played back into a frequency counter, and flow was determined from a calibrated graph relating frequency to fuel flow. The fuel temperatures were also recorded to allow for volume flow corrections.

4. Speed

Engine shaft and locomotive speeds were both recorded as ac signals which related directly to rpm. The locomotive speed was calculated from the wheel and wheel circumference rpm's.

5. Rake Cylinder Pressure

A pressure transducer was connected to an output port in the brake cylinder of the left rear locomotive axles. The transducer was calibrated in the laboratory using a pressure source and a gage. 4 simulated calibration was then performed using a known precision resistor to unbalance the transducer-sensing bridge. This imbalance was related to the output from an applied pressure source. Field calibration was then carried out using a precision resistor to simulate an applied pressure.

6. Displacement

Throttle position and motor reaction displacement were instrumented, utilizing precision linear displacement potentiometers. The potentiometers were calibrated using a vernier scale to relate inches of displacement to potentiometer output.

The throttle position potentiometer was instrumented to give a recorded indication of throttle position during a series of tests. The motor reaction displacement potentiometer was attached at a point between the traction motor and the locomotive frame. This indicated motor reaction due to varying torque.

7. Sanding--Wheel Slip

These parameters were recorded simply as on-off signals to indicate occurrences of sanding or wheel slip.

8. Drawbar Force

The equipment used for this measurement, the instrumented drawbar, and the calibration signal was supplied by Southern Railway. The parameter was recorded on magnetic tape as an analog signal.

APPENDIX B

END PRODUCT SOFTWARE

The following list is an inventory of debugged and operating digital computer programs developed and/or modified for use on the FESS study program. Table B-1 relates to the scenario tests. Table R-2 relates to the simulators used to produce the comparative performance study for the SW1500 and the 47 configuration (dual flywheel system). The lists do not include UNIVAC 1100 system standard support software. Tables B-1 and R-2 represent approximately 3200 Fortran card images.

TARLF B-1

SCENARIO SOFTWARE

Program Identification	Contents		
.BLKRD	Prints selected regions of 9 track mag tape which contains scenario test data in engineering units		
.EVELYN	Converts 9 track ASCII to 9 track field data		
.BLKST/3	Scenario data reduction and statistical summaries from 9 track field data tapes (.BLKST/3N for Whitefish data)		
Supporting Subroutines	Contents		Calling Element
.SPDCR2	Digital filter for loco speed	.BLKST/3	
.YARD	Yard operation's printout and summary	.BLKST/3	
.GENKW	D32 generator efficiency	.YARD	
.DEZL	645E diesel chdracteristic and fuel consumption	.YARD	
.BRKFC	Air brake chacacteristic TE vs pressure	.YARD	
.EHPG	Loco amperes, speed converted to horsepower based on D77 characteristic	.YARD	

TABLE B-2
SIMULATION MODEL SOFTWARE

Program Identification	Contents	
<p>.LCMST/2B</p> <p>.LCMFW/2</p> <p>.PLU40</p>	<p>SW1500 model (D77 motors, 032 generator, 12-545 diesel) throttle profile control configuration. Operates in car kicking or cut fetching modes.</p> <p>A2 configuration (SW1500 with 2 energy storage fly-wheels). Current profile control configuration. Operates in car kicking or cut fetching modes.</p> <p>Plots 5 variables on Calcomp plotter.</p>	
Supporting Subroutines	Contents	Calling Element
.PD77SR	D77 motor model (using Pittsburgh test data for saturation curve)	.LCMST/2B
.PD77SH	Shunt field version of .PD77SR	.LCMFW/2
.DRAGL	Modified Davis drag computation	*
.DEZLL	Diesel characteristic and fuel consumption (also .DEZLL/A, .DEZLL/S)	.LCMST/2B
.GENKW	032 generator characteristic	*
.GNLM	032 envelope limits (voltage, hp, current)	*
.TRNZL	Drive/brake transition	.LCMST/2B
.RAMPY	Ramp control	.LCMFW/2; TRNZC
.LSTAT	Statistical data summary	.LCMST/2B
.ESUI	Energy storage FW motor model	.LCMFW/2
.DEZLF	Similar to .DEZLL/S	.LCMFW/2
.CP/3D	3D curve look up (for iron losses)	.ELOSM
.ELOSM	Motor losses (basic curve data are stored in respective model)	.PD77SR, .PD77SH, .ESUI
.RMSUM	Data accumulator for rms quantities	
.PSHLN	Draws dashed line from X, Y coord data	.PLU40
.DTMHP2L	Prints dates and time as required	*

*Subroutine used by both .LCMFW/2 and .LCMST/2B

APPENDIX C

FESS ECONOMICS PROGRAM LISTING

```

009*FESS(1),MAIN
1      C
2      C   FLYWHEEL ENERGY STORAGE SYSTEM (FESS)
3      C   ENGINEERING ECONOMICS ANALYSIS
4      C
5      PARAMETER NP1=4,NP2=10,NP3=20,NP4=10
6      REAL*4 LOCMT1,LOCMT2,NAS,NPV,LOCC,LOCNO
7      DIMENSION SACPB2(4),UNIT(4)
8      COMMON /NUMP/ BOXC(NP4),LOCC(NP2),CARSD(NP3)
9      COMMON /COST / COSMOD,BOXCOS,ESUCOS,LOCMT1,ESUMT1,BOXMT1,FULSAV
13     COMMON /COST2/ COSMD2,BOXCS2,ESUCS2,LOCMT2,ESUMT2,BOXMT2,FULSV2
11     COMMON /PEPNT/ XIR(4,4)
12     COMMON /SAVE/ NAS(30,4),NPV(30),ROI(NP3,NP2,3),LOCNO(NP2),FACT
13     * ,STAR(NP3,NP2,3),YMAX
14     COMMON /SAV2/ SINV(NP2),XPV(NP3,NP2),CWEIT,FULOLA,NYRCON
15     COMMON /INDX / J1,JK,NCARS,IFLG,NOLOC
16     COMMON /ITITL / TITLE(14)
17     EQUIVALENCE (LOCMT2,SACPB2(1))
18     EQUIVALENCE (ACARS,UNIT(1)),(ABOXC,UNIT(2)),(ABOXD,UNIT(3)),
19     * (ACARSD,UNIT(4))
20     DATA CONV1/350./,CONV2/0.42/,IPLOT/0/,IRPT/0/
21     I FORMAT(13A6,A2)
22     NAMLIST /INPUT/ COSMOD,BOXCOS,ESUCOS,LOCMT1,ESUMT1,BOXMT1,FULSAV,
23     1 NOBOX,NOLOC,NCARS, BOXC, LOCC, CARSD,DISCON,IPR,NYRCON,IPLOT,FACT
24     2,IRPT,CWEIT,YMAX
25     CALL NINTRO(1,E-20,100)
26     RATE1=1.06**4
27     RATE2=1.08**4
28     2C READ (5,1,END=999) TITLE
29     READ(5,INPUT)
30     IFLG=0
31     *WRITE(6,INPUT)
32     C
33     C
34     C   CONVERT COST TO 1982 DOLLARS
35     C
36     COSMD2=COSMOD*RATE1
37     BOXCS2=BOXCOS*RATE1
38     ESUCS2=ESUCOS*RATE1
39     LOCMT1=LOCMT1*CONV1
40     LOCMT2=LOCMT2*RATE2
41     ESUMT2=ESUMT1*RATE2
42     BOXMT2=BOXMT1*RATE2
43     FULSV2=FULSAV*CONV2*RATE2*CONV1
44     FULOLA=FULSAV*CONV1*CONV2
45     DO 200 J1=1,NOBOX
46     ABOXC=BOXC(J1)
47     ABOXD=ABOXC
48     JK=0
49     DO 190 J2=1,NOLOC
50     ALOCC=LOCC(J2)
51     IF (ABOXC.GT.ALOCC) GO TO 190
52     JK=JK+1
53     LOCNO(JK)=ALOCC
54     SINVB2=ALOCC*COSMD2+ABOXC*(BOXCS2+ESUCS2)
55     SINV(JK)=SINVB2
56     DO 180 J3=1,NCARS
57     ACARSD=CARSD(J3)
58     SSAB2=ACARS*LOCMT2+ABOXC*(BOXMT2+ESUMT2)+ACARSD*FULSV2
59     OO 30 I=1,4

```

```

61      IF (I.NE.1)  NAS(1,I)=NAS(1,I)-SINV82
62      30 CONTINUE
63      NPV(1)=SSAV82/(1.+DISCON)**0.5-SINV82
64      DO 50 I=2,NYRCON
65          XI=I
66          XI=XI-0.5
67          XII=XI-0.5
68          NAS(I,1)=0.
69          OF 40 K=1,4
70          NAS(I,1)=NAS(I,1)+SACP82(K)*UNIT(K)*(1.+XIF(K,1))**XII
71      40 CONTINUE
72      NPV(I)=NPV(I-1)+NAS(I,1)/(1.+DISCON)**XI
73      50 CONTINUE
74      XPV(J3,JK)=NPV(NYRCON)*SINV82
75      DO 100 J=2,4
76          DO 75 I=2,NYRCON
77              NAS(I,J)=0.
78              XI=I
79              XI=XI-0.5
80              XII=XI-0.5
81              LO 70 K=1,4
82              NAS(I,J)=NAS(I,J)+SACP82(K)*UNIT(K)*(1.+XIR(K,J))**XII
83      70 CONTINUE
84      75 CONTINUE
85      JJ=1
86      CALL ROMINV(NAS(JJ,J),NYRCON,XROI,SINV82,IPP,ISTAR)
87      ROI(J3,JK,J-1)=100.*XROI
88      STAR(J3,JK,J-1)=* *
89      IF (ISTAR.EQ.1) STAR(J3,JK,J-1)=* * *
90      100 CONTINUE
91      180 CONTINUE
92      190 CONTINUE
93      IF (IPLOT.NE.0) CALL PLOTG
94      IF (IRPT.NE.0) CALL REPORT
95      200 CONTINUE
96      GO TO 20
97      999 STOP
98      END

```

009755(1),R0N1RV

```
1 C * * CASHFLOW ANALYSIS * * ROI PROGRAM CARL HEINZ * * GARRETT CORP.
2 SUBROUTINE ROIINV(CASFLO,NYR,ROI,SIIV90,IPR,ISTAR)
3 C a * * 10 YEAR DISCOUNTING
4 C * *
5 C * * CASFLO(I)=CASHFLOW FOR THE I*TH YEAR.
6 C * * NYR= TOTAL NO. OF YEARS CONSIDERED.
7 C * * CONVG = CONVERGENCE TOLERANCE USED IN ITERATION LOOP.
8 C * * ROI = RETURN ON INVESTMENT.
9 C * * ROISS = GUESS FOR ANSWER FRACTION FORM(NOT PERCENTAGE)
10 C * * DCF(I) = DISCOUNTED CASHFLOW FOR I*TH YEAR.
11 C * * DCFDES = 0.0 = ZERO DISCOUNTED CASH FLOW AT END OF NYR YEARS.
12 C * * ITLIM = MAXIMUM NUMBER OF ITERATIONS ALLOWED FOR CONVERGENCE.
13 DIMENSION CASFLO(50),DCF(50),IT(10),XX(2),YY(2)
14 C * * READ IN DATA: 1ST CARD CONTAINS (1) NYR, (2) DCFDES,
15 C * * AND (3) CONVG.
16 C * * CONVG=INPUT CONVERGENCE TOLERANCE. IF NOT INPUT THIS TOLERANCE
17 C * * IS AUTOMATICALLY DETERMINED.
18 C * * WHEN GUESSING ROISS IT IS BETTER TO GUESS LOW (IF POSSIBLE).
19 ISTAR=0
20 ITLIM=27
21 C** DCFDES=0.0 DCFDES SET BY SUBR ARGUMENT
22 DCFDES=SIIV90
23 C * * CONTROL CARD FORMAT * *
24 1 FORMAT(15,5X,2F10.0)
25 C * * READ CONTROL CARD.
26 C** 5 READ(5,1,END=9999)NYR,ROISS,CONVG
27 KOUNT=0
28 C * * READ IN CASHFLOW FOR EACH YEAR (8F10.0) FORMAT
29 C * * DATA CARD(S) FORMAT. * *
30 2 FORMAT(8F10.0)
31 C * * QEAO DATA.
32 C** READ(5,2)(CASFLO(I),I=1,NYR I
33 C * *
34 IF(IPR.NE.0)
35 WRITE(6,4)NYR,(CASFLO(I),I=1,NYR)
36 4 FORMAT(1H1//20X,'ROI CASHFLOW ANALYSIS',//5X,'NUMBER OF YEARS=',I10
37 1//5X,'NET CASH FLOW PER YEAR='/(10F12.2))
38 C * * SPECIAL EXPERIMENTAL GUESS ROUTINE FOR ROI FOR WESS PROGRAM.
39 IF(ABS(SIIV90).LT.0.001) GO TO 175
40 STAND= 100./SIIV90
41 DUMSUM=
42 DO 170 I=1,NYR
43 170 DUMSUM=DUMSUM+STAND*CASFLO(I)
44 IF((DUMSUM=100.).LT.0.0)GO TO 175
45 ROISS=DUMSUM/(NYR)
46 ROISS=ROISS*0.001
47 GO TO 180
48 175 CONTINUE
49 ROISS=-.01
50 180 CONTINUE
51 ROISS=100.*ROISS
52 IF((ABS(ROISS).GT.1.E-12).AND.(IPR.GT.0))WRITE(6,3)ROISS
53 3 FORMAT(/5X,'GUESS FOR ROI=',F15.3,' PERCENT'///)
54 CONVG=0.0
55 IF(ABS(CONVG).GT.1.E-10)GO TO 27
56 FMAX=0.0
57 DO 11 J=1,NYR
58 11 IF(ABS(CASFLO(J)).GT.FMAX)FMAX=ABS(CASFLO(J))
59 CONVG=0.000015*FMAX
```

```

60          GO TO 13
61      27 CONVG=CONVGT
62      13 IF (IPR.GT.0)WRITE(6,12)CONVG
63      12 FORMAT('          CONVERGENCE TOLERANCE=',G17.6)
64      C
65      C *
66      C
67          ROI=ROI*GSS
68      47 CONTINUE
69          IT(1)=1
70          XX(1)=ROI
71      10 CONTINUE
72          DO 20 I=1,NYR
73              XP=I
74              XP=XP-0.5
75      C * * XP=XP-0.5          : THIS ALLOW FOR MID YEAR DISCOUNTING.
76      20 DCF(I)=CASHFLO(I)/(1.0+ROI)**XP
77          DCFACT=0
78          DO 21 I=1,NYR
79      21 DCFACT=DCFAC+DCF(I)
80          IF (IT(1).EQ.1)YY(1)=DCFAC
81          IF (IT(1).NE.2)GO TO 7
82          XX(2)=ROI
83          YY(2)=DCFAC
84          DYDX=(YY(2)-YY(1))/(XX(2)-XX(1))
85          IF (DYDX.GE.0.0)GO TO 8
86      7 CONTINUE
87          IF (IPR.GT.0)WRITE(6,6) DCFDES, DCFAC,ROI
88      6 FORMAT('          DCF DESIRED=',G16.6,'          DCF ACTUAL=',G16.6,'          ROI=',
89      1 G16.6)
90          ROISAV=ROI
91          CALL ITPAT($25,$50,ROI,DCFAC,DCFDES,IT,1,CONVG,ITLIM)
92      C * * CONVERT FROM FRACTION TO PERCENT.
93          PROI=100.*ROI
94          IF (IPR.GT.0)WRITE(6,5)PROI
95      51 FORMAT('/5X'          THE ROI FOR SEQUENCE OF NET CASH FLOWS IS:'
96      1,2X,F10.3,' PERCENT')
97          RETURN
98      C** GO TO 5
99      C * * YOU CANNOT LOSE MORE THEN 100 %.
100      25 IF (ROI .LT. -0.9) ROI=-0.9
101          IF (ROI .GT. 9.999999) ROI=9.999998
102      C * * IF (ROI .GT. 9.9999999) ROI=9.999998          # LIMITS PROFIT TO 1000%
103          GO TO 10
104      C**50 GO TO 5
105      50 CONTINUE
106          ISTAR=1
107          RETURN
108      8 ROITEM=99999.
109          IF (ROI .GT. 0.01)ROITEM=0.5*ROI
110          IF (ROI .GT.0.0 .AND.ROI.LE.0.01)ROITEM=-.01
111          IF (ROI .LE.0.0)ROITEM=.85*ROI -0.149997
112          IF ((KOUNT.GE.10).AND.(IPR.NE.0))WRITE(6,9)ROITEM,KOUNT
113          IF (ROITEM.EQ.99999.)WRITE(6,9) ROITEM,KOUNT
114          IF (ROITEM.EQ.99999.)STOP
115      9 FORMAT('/' * * * ROITEM=',G16.6,'          KOUNT=',I10,' * * *//')
116          KOUNT=KOUNT+1
117          IF (KOUNT.GT.7 ) GO TO 9999
118          ROI=ROITEM
119          IF (IPR.GT.0)WRITE(6,19)ROITEM

```

```

120      IS FORMAT(' NEW GUESS FOR ROI=','G16.6,' PROVIDED AUTOMATIC BY PROGRA
121      [M'])
122      GO TO 47
123      9999 IF (IPR.EQ.0) GO TO 9996
124      WRITE(6,9997)SIIV90
125      9997 FORMAT('      SUM INITIAL INVESTMENTS 1990 $=','G16.6,' ** CHECK CAS
126      IN FLOW ***)
127      WRITE(6,4)NYR,(CASFLO(I),I=1,NYR)
128      WRITE(6,9998) KOUNT
129      WRITE(6,9998) KOUNT,ROI
130      999P FORMAT('      *** CANNOT GET A GOOD GUESS FOR ROI  NEXT CASE PLEASE
131      | ***/' KOUNT=','I10' BAD VALUE OF ROI=','G16.6,/'
132      2' *** CHANGE ROI TO MINUS 99.99 PERCENT ***/')
133      9996 ROI=-.9999
134      ISTAR=1
135      RETURN
136      E N D

```

009*FESS(1),PLOT

```
1 C
2 C PLOT ROI (RETURN ON INVESTMENT) VS CARS SWITCHED PER DAY FOR A
3 C GIVEN NUMBER OF BOX CARS.
4
5 SUBROUTINE PLLTC
6 PARAMETER NP1=4, NP2=10, NP3=20, NP4=10
7 REAL*4 NAS, NPV, LOCC, LOCNO
8 COMMON /SAVE/ NAS(30,4), NPV(30), ROI(NP3, NP2, 3), LOCNO(NP2), FACT
9 * , STAR(NP3, NP2, 3), YMAX
10 COMMON /NUMR/ BOXC(NP4), LOCC(NP2), CARSD(NP3)
11 COMMON /TITL/ TITLE(14)
12 COMMON /INDX / J1, JK, NCARS, IFLG, NOLOC
13 DIMENSION LABX(4), LABY(4), Y(NP3), XA(3), YA(3), X(NP3)
14 DATA JFLG /0/, XSL /500./, YSL/5.0/, XPAG/0./, YPAG/0./, KOUNT/1/
15 DATA LABX /'CARS S', 'WITCHE', 'D PER', 'DAY' //
16 DATA LABY /'RETURN', ' Oh IN', 'VESTME', 'NT', '%'/
17 DATA XA, YA /0., 0., 1., 0., 0., 1./
18 IF(JFLG.NE.0) GO TO 10
19 CALL PLOTS(0,0,0)
20 CALL FACTOR(FACT)
21 JFLG=1
22 CALL PLOT(2., -5., -3)
23 10 IF(KOUNT.GT.3) GO TO 20
24 YPAG=YPAG+2.
25 KOUNT=KOUNT+1
26 GO TO 30
27 20 CALL PLOT(XL+2.5, -40., -3)
28 XPAG=0.
29 YPAG=2.
30 KOUNT=2
31 30 CALL PLOT(XPAG, YPAG, -3)
32 XL=CARSD(NCARS)/XSL
33 YL=YMAX/YSL
34 CALL AXIS(0., 0., LABX, -24, XL, 0., 0., XSL)
35 CALL AXIS(0., 0., LABY, 24, YL, 90., 0., YSL)
36 YPAG=YL+1.
37 SIZE=XL/80.
38 VALUE=BOXC(J1)
39 CALL SYMBOL(0., YPAG, SIZE, TITLE, 0., 80)
40 CALL SYMBOL(.5, YPAG-0.30, SIZE, 13HSENSITIVITY 1, 0., 13)
41 CALL SYMBOL(3., YPAG-0.3, SIZE, 18HNO. OF BOX CARS = , 0., 18)
42 CALL NUMBER(999., 999., SIZE, VALUE, 0., -1)
43 XK=XL+0.65
44 YK=YL-0.5
45 SZ=0.08
46 CALL SYMBOL(XK-0.55, YK, SZ, 12HNO. OF LOCC., 0., 12)
47 DO 50 J=1, JK
48 I=0
49 DO 40 K=1, NCARS
50 YPOT=ROI(K, J, 2)
51 IF(YPOT.LT.0.) GO TO 40
52 I=I+1
53 Y(I)=YPOT
54 X(I)=CARSD(K)
55 40 CONTINUE
56 II=1
57 IF(II.LE.1) GO TO 50
58 Y(II+1)=0.
59 Y(II+2)=YSL
60 X(II+1)=0.
61 X(II+2)=XSL
62 CALL LINE(X, Y, II, 1, 0, INTEQ)
63 CALL LINE(X(II), Y(II), I, 1, -1, J)
64 XK=XK-0.25
65 YK=YK-0.25
66 XA(1)=XK
67 YA(1)=YK
68 CALL LINE(XA, YA, 1, 1, -1, J)
69 XK=XK+0.25
70 CALL NUMBER(XK, YK, SZ, LOCNO(J1, 0., -1)
71 50 CONTINUE
72 RETURN
73 END
```

009*FESS(1),REPORT

```
1 SUBROUTINE REPORT
2 PARAMETER NP1=4, NP2=10, NP3=20, NP4=10
3 REAL*4 LOCMT, NAS, NPV, LOCC, LOCNO
4 COMMON /NUMB/ BOXC(NP4), LOCC(NP2), CARSD(NP3)
5 COMMON /COST / COSMOD, BOXCOS, ESUCOS, LOCMT, ESUMTC, BOXMT, FULSAV
6 COMMON /SAVE / NAS(30,4), NPV(30), ROI(NP3, NP2, 3), LOCNO(NP2), FACT
7 * , STAR(NP3, NP2, 3), YMAX
8 COMMON /SAV2/ SINV(NP2), XPV(NP3, NP2), CWEIT, FULDLA, NYRCON
9 COMMON /INX / J1, JK, NCARS, IFLG, NOLOC
10 COMMON /TITL / TITLE(14)
11 IF (IFLG, NE, 0) GO TO 80
12 IFLG=1
13 WRITE(6,1)
14 WRITE(6,2) TITLE
15 WRITE(6,3) CARSD(1), CARSD(NCARS)
16 WRITE(6,4) CWEIT
17 WRITE(6,5) LOCC(1), LOCC(NOLOC)
18 WRITE(6,6) FULSAV
19 WRITE(6,7) NYRCON
20 WRITE(6,8) COSMOD
21 WRITE(6,9) BOXCOS
22 WRITE(6,10) ESUCOS
23 WRITE(6,11) LOCMT
24 WRITE(6,12) ESUMTC
25 WRITE(6,13) FULDLA
26 80 DO 100 I=1, JK
27 WRITE(6,14) TITLE
28 WRITE(6,15) BOXC(J1)
29 WRITE(6,16) LOCNO(I)
30 WRITE(6,17)
31 DO 60 J=1, NCARS
32 XNPV=XPV(J, I)/1.E+3
33 XINV=SINV(I)/1.E+3
34 WRITE(6,18) CARSD(J), XNPV, XINV, (ROI(J, I, K), STAR(J, I, K), K=1, 3)
35 60 CONTINUE
36 100 CONTINUE
37 1 FORMAT(1H1, 10X, 'FLY WHEEL ENERGY STOWAGE SWITCHER'///)
38 2 FORMAT(2X, 'ANALYSIS: ', 13A6, 420)
39 3 FORMAT(2X, 'YARD DATA '///2X, 'CARS SWITCHED PER DAY :', F5.0, '-
40 *', F5.0/)
41 4 FORMAT(7X, 'AVERAGE CAR WEIGHT :', F4.0, ' TONS//)
42 5 FORMAT(7X, 'NO. OF LOCOMOTIVES :', F3.0, '- ', F3.0//)
43 6 FORMAT(7X, 'FUEL SAVING (GAL/CAR SW) :', F6.3//)
44 7 FORMAT(7X, 'LIFE OF PROJECT :', I3, ' YEARS//)
45 8 FORMAT(///2X, 'INITIAL INVESTMENT SUMMARY (1978 $)--PER UNIT'//
46 * 7hr LOCOMOTIVE MODIFICATION :', F7.0//)
47 9 FORMAT(7X, 'PROVISION OF BOX CAR :', F7.0//)
48 10 FORMAT(7X, 'PROVISION OF 2 ESU'S :', F7.0//)
49 11 FORMAT(///2X, 'CHANGE IN ANNUAL COSTS AND CREDITS (1978 $)
50 * '/// 7X, 'LOCOMOTIVE MAINTENANCE :', F7.3, ' PER CAR SWITCHED
51 *//)
52 12 FORMAT(7X, 'ESU MAINTENANCE :', F7.0, ' PER BOX CAR//)
53 13 FORMAT(7X, 'FUEL SAVING :', F7.4, ' PER CAR SWITCHED
54 *//)
55 14 FORMAT(1H1, 10X, 'SUMMARY OF FESS ECONOMICS'///2X, 'ANALYSIS: ', 13A6, 4
56 * 2//)
57 15 FORMAT(2X, 'NO. OF BOX CARS :', F4.0//)
58 16 FORMAT(2X, 'NO. OF LOCOMOTIVES: ', F4.0//)
59 17 FORMAT(//25X, 'OMB A=94 :', 14X, 'RETURN ON INVESTMENT %'//2X, 'CARS SW
```

```

60      HITCHED/DAY      16 X1000)      4R METHOD  SENSITIVITY  SENSITIV
61      ZITY:/22X,*NPV  INIT COST*(21X,11*,13X,*2*/28X,1*(1982 $)*/)
62      18 FORMAT(7X,F5.0,8X,F7.2,2X,F7.2,6X,F6.2,1X,A2,4X,F6.2,1X,A2,4X,F6.2
63      *,1X,A2)
64      RETURN
65      END

```

009*FESS11).BLK(AT

```

1      HLOCK DATA
2      PARAMETER NP1=4, NP2=10, NP3=20, NP4=10
3      REAL*4 LOCNO, NAS, NPV
4      COMMON /PERCENT/ XIR(4,4)
5      COMMON /SAVE/ NAS(30,4), NPV(30), RQI(NP3, NP2, 3), LOCNO(NP2), FACT
6      *, STAR(NP3, NP2, 3), YMAX
7      DATA FACT/1.0/
8      DATA XIR / 0.02 , 0.02 , 0.02 , 0.02 ,
9      * 0.0 , 0.0 , 0.0 , 0.0 ,
10     * 0.08 , 0.08 , 0.08 , 0.08 ,
11     * 0.08 , 0.08 , 0.08 , 0.10 /
12     END

```

*FIN

APPENDIX D

FESS BASELINE CONCEPT ECONOMICS ANALYSIS

FLYWHEEL ENERGY STORAGE SWITCHER

ANALYSIS: BASELINE CONCEPT A2
YARD DATA

CARS SWITCHED PER DAY	:	200.--4000.
AVERAGE CAR WEIGHT	:	50. TONS
NO. OF LOCOMOTIVES	:	2.-- 6.
FUEL SAVING (GAL/CAR SW)	:	.001
LIFE OF PROJECT	:	20 YEARS

INITIAL INVESTMENT SUMMARY (1978 \$)--PER UNIT

LOCOMOTIVE MODIFICATION	:	\$118000.
PROVISION OF BOX CAR	:	\$35500.
PROVISION OF 2 ESUS	:	\$180000.

CHANGE IN ANNUAL COSTS AND CREDITS (1978 \$)

LOCOMOTIVE MAINTENANCE	:	18.900 PER CAR SWITCHED
ESU MAINTENANCE	:	-3000. PER BOX CAR
FUEL SAVING	:	.1470 PER CAR SWITCHED

SUMMARY OF FESS ECONOMICS

ANALYSIS: BASELINE CONCEPT A2

NO. OF BOX CARS : 1.

NO. OF LOCOMOTIVES: 2.

CARS SWITCHED/DAY	DMP A-94 (% X1000)		RETURN ON INVESTMENT %		
	NPV	INIT COST (1982 \$)	4R METHOD	SENSITIVITY 1	SENSITIVITY 2
200.	11.25	570.01	-15.93 **	-.98 **	-.98 **
400.	64.19	570.01	-.98 **	-9.67	-9.64
600.	117.12	570.01	-11.32 **	-5.78	-5.76
800.	170.06	570.01	-10.18	-3.13	-3.11
1000.	223.00	570.01	-8.25	-1.06	-1.04
1200.	275.94	570.01	-6.64	.67	.69
1400.	328.87	570.01	-5.23	2.18	2.20
1600.	381.81	570.01	-3.97	3.53	3.55
1800.	434.75	570.01	-2.82	4.77	4.79
2000.	487.69	570.01	-1.75	5.91	5.93
2200.	540.62	570.01	-.75	6.99	7.00
2400.	593.56	570.01	.20	8.00	8.02
2600.	646.50	570.01	1.10	8.96	8.98
2800.	699.44	570.01	1.96	9.89	9.90
3000.	752.37	570.01	2.80	10.78	10.79
3200.	805.31	570.01	3.60	11.64	11.65
3400.	858.25	570.01	4.38	12.47	12.47
3600.	911.19	570.01	5.15	13.29	13.30
3800.	964.12	570.01	5.89	14.08	14.10
4000.	1017.06	570.01	6.62	14.86	14.88

SUMMARY OF FESS ECONOMICS

ANALYSIS: BASELINE CONCEPT A2

NO. OF BOX CARS : 1.

NO. OF LOCOMOTIVES: 3.

CARS SWITCHED/DAY	DPR A-94 (\$ X 1000)		RETURN ON INVESTMENT %		
	NPV	INIT COST (1982 \$)	4R METHOD	SENSITIVITY 1	SENSITIVITY 2
200.	11.25	718.98	-15.52 **	-0.98 **	-0.98 **
400.	64.19	718.98	y **	-11.07	-11.04
600.	117.12	718.98	-1.00 **	-7.33	-7.31
800.	170.06	718.98	-11.73	-4.80	-4.78
1000.	223.00	718.98	-9.91	-2.84	-2.82
1200.	275.94	718.98	-8.39	-1.21	-1.19
1400.	328.87	718.98	-7.08	.20	.22
1600.	381.81	718.98	-5.90	1.46	1.48
1800.	434.75	718.98	-4.84	2.60	2.62
2000.	487.69	718.98	-3.86	3.65	3.67
2200.	540.62	718.98	-2.95	4.63	4.65
2400.	593.56	718.98	-2.09	5.55	5.57
2600.	646.50	718.98	-1.27	6.42	6.44
2800.	699.44	718.98	-.49	7.26	7.27
3000.	752.37	718.98	.25	8.05	8.07
3200.	805.31	718.98	.97	8.82	8.84
3400.	858.25	718.98	1.68	9.56	9.58
3600.	911.19	718.98	2.33	10.28	10.29
3800.	964.12	718.98	2.98	10.97	10.99
4000.	1017.06	718.98	3.62	11.65	11.67

SUMMARY OF FEAS ECONOMIC

ANALYSIS: BASELINE CONCEPT A2

NO. OF BOX CARS : 1.

NO. OF LOCOMOTIVES: 4.

CARS SWITCHED/DAY	BASE A-94		RETURN ON INVESTMENT *		
	NPV (\$ X1000)	INIT COST (1982 \$)	4R NET400	SENSITIVITY 1	SENSITIVITY 2
200.	11.25	867.95	-15.52 **	-.98 **	-.98 **
400.	64.19	867.95	-.98 **	-6.59 **	-7.56 **
600.	117.12	867.95	-.98 **	-6.54	-7.52
800.	170.06	867.95	-2.69 **	-6.10	-6.09
1000.	223.00	867.95	-11.19	-4.22	-4.21
1200.	275.94	867.95	-9.74	-2.60	-2.64
1400.	328.87	867.95	-8.48	-1.31	-1.31
1600.	381.81	867.95	-7.37	-.12	-.10
1800.	434.75	867.95	-6.37	.96	.98
2000.	487.69	867.95	-5.45	1.95	1.97
2200.	540.62	867.95	-4.59	2.87	2.84
2400.	593.56	867.95	-3.79	3.73	3.74
2600.	646.50	867.95	-3.03	4.54	4.56
2800.	699.44	867.95	-2.31	5.31	5.33
3000.	752.37	867.95	-1.62	6.05	6.06
3200.	805.31	867.95	-.97	6.75	6.77
3400.	858.25	867.95	-.33	7.43	7.45
3600.	911.19	867.95	.28	8.09	8.11
3800.	964.12	867.95	.88	8.72	8.74
4000.	1017.06	867.95	1.45	9.34	9.36

SUMMARY OF FESS ECONOMICS

ANALYSIS: BASELINE CONCEPT A2

NO. OF BOX CARS : 1.

NO. OF LOCOMOTIVES: 5.

CARS SWITCHED/DAY	OMP A-94 (\$ *1000)		RETURN ON INVESTMENT %		
	NPV	INIT COST (1982 \$)	4H METHOD	SENSITIVITY 1	SENSITIVITY 2
200.	11.25	1016.93	-15.52 **	-.98 **	-.98 **
400.	64.19	1016.93	-.98 **	-1.08 **	-1.09 **
600.	117.12	1016.93	-.98 **	-9.53	-9.51
800.	170.06	1016.93	-1.02 **	-7.16	-7.14
1000.	223.00	1016.93	-12.22	-5.33	-5.31
1200.	275.94	1016.93	-10.82	-3.82	-3.81
1400.	328.87	1016.93	-9.62	-2.53	-2.51
1600.	381.81	1016.93	-8.55	-1.38	-1.37
1800.	434.75	1016.93	-7.59	-.35	-.33
2000.	487.69	1016.93	-6.71	.59	.61
2200.	540.62	1016.93	-5.90	1.47	1.48
2400.	593.56	1016.93	-5.13	2.28	2.30
2600.	646.50	1016.93	-4.42	3.05	3.07
2800.	699.44	1016.93	-3.74	3.78	3.80
3000.	752.37	1016.93	-3.09	4.47	4.49
3200.	805.31	1016.93	-2.47	5.14	5.16
3400.	858.25	1016.93	-1.88	5.77	5.79
3600.	911.19	1016.93	-1.31	6.39	6.41
3800.	964.12	1016.93	-.75	6.98	7.00
4000.	1017.06	1016.93	-.22	7.56	7.57

SUMMARY OF FESS ECONOMICS

ANALYSIS: BASELINE CONCEPT A2

NO. OF BOX CARS : 1.

NO. OF LOCOMOTIVES: 6.

CARS SWITCHED/DAY	OPTION A-94 (\$ 1000)		RETURN ON INVESTMENT %		
	NPV	INIT COST (1982 \$)	4R METHOD	SENSITIVITY 1	SENSITIVITY 7
200.	11.25	1165.90	-15.52 **	-.98 **	-.98 **
400.	64.19	1165.90	-.98 **	-.98 **	-.98 **
600.	117.12	1165.90	-.98 **	-10.36	-10.34
800.	170.06	1165.90	-.98 **	-8.04	-8.02
1000.	223.00	1165.90	-1.84 **	-6.26	-6.25
1200.	275.94	1165.90	-11.73	-4.80	-4.78
1400.	328.87	1165.90	-10.56	-3.54	-3.53
1600.	381.81	1165.90	-9.53	-2.43	-2.42
1800.	434.75	1165.90	-8.60	-1.44	-1.42
2000.	487.69	1165.90	-7.75	-.53	-.51
2200.	540.62	1165.90	-6.97	.31	.33
2400.	593.56	1165.90	-6.24	1.10	1.11
2600.	646.50	1165.90	-5.56	1.83	1.85
2800.	699.44	1165.90	-4.91	2.53	2.55
3000.	752.37	1165.90	-4.29	3.19	3.21
3200.	805.31	1165.90	-3.70	3.82	3.84
3400.	858.25	1165.90	-3.14	4.43	4.44
3600.	911.19	1165.90	-2.59	5.01	5.03
3800.	964.12	1165.90	-2.07	5.57	5.59
4000.	1017.06	1165.90	-1.56	6.11	6.13

D-6

SUMMARY OF FEASIBILITY ECONOMICS

ANALYSIS: BASELINE CONCEPT A2

NO. OF BOX CARS : 2.

NO. OF LOCOMOTIVES: 2.

CARS SWITCHED/DAY	COST A-94 (in \$1000)		RETURN ON INVESTMENT %		
	NPV	INIT COST (1982 \$)	4 METHOD	SENSITIVITY 1	SENSITIVITY 2
200.	-30.44	842.07	-99.99 **	-99.99 **	-99.99 **
400.	22.50	842.07	-9.98 **	1.00 **	-9.98 **
600.	75.43	842.07	-9.98 **	-11.05	-11.02
800.	128.37	842.07	, **	-7.76	-7.73
1000.	181.31	842.07	-12.34	-5.46	-5.43
1200.	234.25	842.07	-10.65	-3.64	-3.62
1400.	287.16	842.07	-9.24	-2.13	-2.11
1600.	340.12	842.07	-8.01	-1.81	-1.79
1800.	393.06	842.07	-6.92	.37	.39
2000.	446.00	842.07	-5.93	1.43	1.45
2200.	498.93	842.07	-5.01	2.42	2.44
2400.	551.87	842.07	-4.16	3.33	3.35
2600.	604.81	842.07	-3.36	4.19	4.21
2800.	657.75	842.07	-2.60	5.00	5.02
3000.	710.68	842.07	-1.88	5.77	5.79
3200.	763.62	842.07	-1.19	6.51	6.53
3400.	816.56	842.07	-.53	7.22	7.24
3600.	869.50	842.07	.11	7.91	7.92
3800.	922.43	842.07	.73	8.57	8.58
4000.	975.37	842.07	1.33	9.21	9.22

0-7

SUMMARY OF FESS ECONOMICS

ANALYSIS: BASELINE CONCEPT A2

NO. OF BOX CARS : 2.

NO. OF LOCOMOTIVES: 3.

CARS SWITCHED/DAY	OPR A-94 (% X1000)		RETURN ON INVESTMENT %		
	NPV	INIT COST (1982 \$)	4R METHOD	SENSITIVITY I	SENSITIVITY 2
200.	-30.44	991.04	-99.99 **	-99.99 **	-99.99 **
400.	22.50	991.04	-9.98 **	9 **	-9.98 **
600.	75.43	991.04	-9.98 **	-11.93 **	-11.96 **
800.	128.37	991.04	-9.98 **	-8.88	-8.77
1000.	181.31	991.04	-1.24 **	-6.56	-6.54
1200.	234.25	991.04	-11.74	-4.81	-4.70
1400.	287.18	991.04	-10.33	-3.35	-3.33
1600.	340.12	991.04	-9.20	-2.68	-2.66
1800.	393.06	991.04	-8.15	-1.95	-1.93
2000.	446.00	991.04	-7.20	.07	.08
2200.	498.93	991.04	-6.33	1.06	1.07
2400.	551.87	991.04	-5.52	1.87	1.89
2600.	604.81	991.04	-4.76	2.68	2.70
2800.	657.75	991.04	-4.05	3.45	3.47
3000.	710.65	991.04	-3.37	4.18	4.19
3200.	763.62	991.04	-2.72	4.87	4.89
3400.	816.56	991.04	-2.10	5.53	5.55
3600.	869.50	991.04	-1.51	6.17	6.19
3800.	922.43	991.04	-0.93	6.79	6.80
4000.	975.37	991.04	-0.38	7.38	7.40

SUMMARY OF FEAS ECONOMICS

ANALYSIS: BASELINE CONCEPT A2

NO. OF BOX CARS 1 2.

NO. OF LOCOMOTIVES: 4.

CARS SWITCHED/DAY	OPER A-94 (\$ M1000)		RETURN ON INVESTMENT		
	NPV	INIT COST (1982 \$)	ARR METHOD	SENSITIVITY 1	SENSITIVITY 2
200.	-30.44	1140.02	-99.99 **	-99.99 **	-99.99 **
400.	22.50	1140.02	-15.93 **	-1.74 **	-1.98 **
600.	75.43	1140.02	-9.98 **	-1.74 **	-1.27 **
800.	128.37	1140.02	-9.94 **	-9.67	-9.64
1000.	181.31	1140.02	-9.99 **	-7.48	-7.48
1200.	234.25	1140.02	-11.32 **	-5.78	-5.78
1400.	287.18	1140.02	-11.32	-4.36	-4.34
1600.	340.12	1140.02	-10.18	-3.13	-3.11
1800.	393.06	1140.02	-9.16	-2.04	-2.02
2000.	446.00	1140.02	-8.25	-1.06	-1.04
2200.	498.93	1140.02	-7.41	-.16	-.14
2400.	551.87	1140.02	-6.64	.61	.61
2600.	604.81	1140.02	-5.91	1.45	1.47
2800.	657.75	1140.02	-5.23	2.18	2.20
3000.	710.68	1140.02	-4.58	2.87	2.89
3200.	763.62	1140.02	-3.97	3.53	3.55
3400.	816.56	1140.02	-3.39	4.16	4.18
3600.	869.50	1140.02	-2.82	4.77	4.79
3800.	922.43	1140.02	-2.27	5.35	5.37
4000.	975.37	1140.02	-1.75	5.91	5.93

SUMMARY OF FESS ECONOMICS

ANALYSIS: BASELINE CONCEPT A2

NO. OF BOX CARS : 2.

NO. OF LOCOMOTIVES: 5.

CARS SWITCHED/DAY	OFR 4-94 (% X1000)		RETURN ON INVESTMENT %		
	NPV	INIT COST (1982 \$)	4R METHOD	SENSITIVITY 1	SENSITIVITY 2
200.	-30.44	1288.99	-99.99 **	-99.99 **	-99.99 **
400.	22.51	1288.99	-15.55 **	-1.00 **	-1.99 **
600.	75.43	1288.99	-9.98 **	-1.00 **	-1.00 **
800.	128.37	1288.99	-9.98 **	-10.41	-10.39
1000.	181.31	1288.99	-9.98 **	-3.27	-3.25
1200.	234.25	1288.99	-1.24 **	-6.61	-6.59
1400.	287.19	1288.99	-12.12	-5.22	-5.20
1600.	340.12	1288.99	-11.01	-4.83	-4.81
1800.	393.06	1288.99	-10.03	-2.97	-2.95
2000.	446.00	1288.99	-9.14	-2.02	-2.00
2200.	498.93	1288.99	-8.34	-1.15	-1.13
2400.	551.87	1288.99	-7.53	-.34	-.32
2600.	604.81	1288.99	-6.88	.41	.43
2800.	657.75	1288.99	-6.22	1.12	1.13
3000.	710.68	1288.99	-5.60	1.76	1.80
3200.	763.62	1288.99	-5.01	2.42	2.43
3400.	816.56	1288.99	-4.45	3.02	3.04
3600.	869.51	1288.99	-3.91	3.60	3.62
3800.	922.43	1288.99	-3.39	4.16	4.17
4000.	975.37	1288.99	-2.89	4.69	4.71

D-10

SUMMARY OF FESS ECONOMICS

ANALYSIS: BASELINE CONCEPT A2

NO. OF BOX CARS : 2.

NO. OF LOCOMOTIVES: 6.

CARS SWITCHED/DAY	OMB 4-94 (\$ 1000)		RETURN ON INVESTMENT %		
	NPV	INIT COST (1982 \$)	4R METHOD	SENSITIVITY 1	SENSITIVITY 2
200.	-30.44	1437.96	-99.99 **	-99.99 **	-99.99 **
400.	22.50	1437.96	-15.57 **	-9.98 **	-9.98 **
600.	75.43	1437.96	-9.98 **	-9.98 **	-9.98 **
800.	128.37	1437.96	-9.98 **	-11.07	-11.04
1000.	181.31	1437.96	-9.98 **	-8.97	-8.94
1200.	234.25	1437.96	-1.00 **	-7.33	-7.31
1400.	287.18	1437.96	-4.40 **	-5.97	-5.95
1600.	340.12	1437.96	-11.71	-4.80	-4.78
1800.	393.06	1437.96	-10.77	-3.77	-3.75
2000.	446.00	1437.96	-9.91	-2.84	-2.82
2200.	498.93	1437.96	-9.12	-2.00	-1.98
2400.	551.87	1437.96	-8.39	-1.21	-1.19
2600.	604.81	1437.96	-7.71	-.48	-.47
2800.	657.75	1437.96	-7.08	.28	.22
3000.	710.68	1437.96	-6.48	.95	.86
3200.	763.62	1437.96	-5.91	1.46	1.48
3400.	816.56	1437.96	-5.38	2.04	2.06
3600.	869.50	1437.96	-4.84	2.60	2.62
3800.	922.43	1437.96	-4.34	3.14	3.15
4000.	975.37	1437.96	-3.85	3.65	3.67

SUMMARY OF FEES ECONOMICS

ANALYSIS: BASELINE CONCEPT A2

NO. OF BOX CARS : 3.

NO. OF LOCOMOTIVES: 3.

CARS SWITCHED/DAY	JOB A-94 (\$ X1000)		RETURN ON INVESTMENT %		
	NPV	INIT COST (1982 \$)	4R METHOD	SENSITIVITY 1	SENSITIVITY 2
200.	-72.13	1263.11	-99.99 **	-99.99 **	-99.99 **
400.	-19.19	1263.11	-99.99 **	-99.99 **	-99.99 **
600.	33.74	1263.11	-.98 **	-.98 **	-.98 **
800.	86.68	1263.11	-.98 **	-1.56 **	-1.63 **
1000.	139.62	1263.11	-.98 **	-2.78	-2.75
1200.	192.56	1263.11	-.98 **	-4.76	-4.73
1400.	245.49	1263.11	-2.31 **	-6.16	-6.13
1600.	298.43	1263.11	-11.74	-4.81	-4.79
1800.	351.37	1263.11	-10.64	-3.64	-3.62
2000.	404.31	1263.11	-9.69	-2.61	-2.59
2200.	457.24	1263.11	-8.82	-1.67	-1.65
2400.	510.18	1263.11	-8.01	-.81	-.79
2600.	563.12	1263.11	-7.27	-.01	.01
2800.	616.06	1263.11	-6.58	.73	.75
3000.	668.99	1263.11	-5.93	1.43	1.45
3200.	721.93	1263.11	-5.31	2.10	2.12
3400.	774.87	1263.11	-4.77	2.73	2.75
3600.	827.81	1263.11	-4.16	3.33	3.35
3800.	880.75	1263.11	-3.62	3.91	3.93
4000.	933.68	1263.11	-3.10	4.47	4.48

SUMMARY OF FESS ECONOMICS

ANALYSIS: BASELINE CONCEPT A2

NO. OF POX CARS :

3.

NO. OF LOCOMOTIVES:

4.

CARS SWITCHED/DAY	OMB A-94 (\$ (1000) NPV NET COST (1982 \$)		RETURN ON INVESTMENT % 4R METHOD SENSITIVITY SENSITIVITY		
				1	2
200.	-72.13	1412.08	-99.99 **	-99.99 **	-99.99 **
400.	-19.19	1412.08	-99.99 **	-99.99 **	-99.99 **
600.	33.74	1412.08	9 **	-.98 **	-.98 **
800.	86.68	1412.08	-.98 **	-1.03 **	-1.04 **
1000.	139.62	1412.08	-.98 **	-10.46	-10.43
1200.	192.56	1412.08	-.98 **	-8.47	-8.45
1400.	245.49	1412.08	-1.07 **	-6.90	-6.88
1600.	298.43	1412.08	-12.46	-5.58	-5.56
1800.	351.37	1412.08	-11.40	-4.45	-4.42
2000.	404.31	1412.08	-10.46	-3.43	-3.41
2200.	457.24	1412.08	-9.61	-2.52	-2.50
2400.	510.18	1412.08	-8.83	-1.66	-1.66
2600.	563.12	1412.08	-8.11	-.91	-.89
2800.	616.06	1412.08	-7.44	-.19	-.17
3000.	668.99	1412.08	-6.81	.49	.51
3200.	721.93	1412.08	-6.21	1.13	1.15
3400.	774.87	1412.08	-5.64	1.74	1.76
3600.	827.81	1412.08	-5.10	2.32	2.34
3800.	880.75	1412.08	-4.58	2.86	2.90
4000.	933.68	1412.08	-4.08	3.41	3.43

SUMMARY OF FFSS ECONOMICS

ANALYSIS: BASELINE CONCEPT A2

NO. OF HOV CARS : 3.

NO. OF LOCOMOTIVES: 5.

CARS SWITCHED/DAY	OMB A-94 (\$ X1000)		RETURN ON INVESTMENT %		
	NPV	INIT COST (1982 \$)	4R METHOD	SENSITIVITY 1	SENSITIVITY 2
200.	-72.13	1561.05	-99.99 **	-99.99 **	-99.99 **
400.	-19.19	1561.05	-99.99 **	-99.99 **	-99.99 **
600.	33.74	1561.05	-21.96 **	-.98 **	-.98 **
800.	86.68	1561.05	-.98 **	-.98 **	-.99 **
1000.	139.62	1561.05	-.98 **	-11.06	-11.03
1200.	192.56	1561.05	-.98 **	-9.10	-9.08
1400.	245.49	1561.05	-.99 **	-7.56	-7.54
1600.	298.43	1561.05	-1.83 **	-6.27	-6.25
1800.	351.37	1561.05	-12.05	-5.15	-5.13
2000.	404.31	1561.05	-11.13	-4.16	-4.14
2200.	457.24	1561.05	-10.30	-3.27	-3.25
2400.	510.18	1561.05	-9.54	-2.45	-2.43
2600.	563.12	1561.05	-8.84	-1.70	-1.68
2800.	616.06	1561.05	-8.19	-.99	-.97
3000.	668.99	1561.05	-7.57	-.33	-.31
3200.	721.93	1561.05	-6.99	.29	.31
3400.	774.87	1561.05	-6.44	.88	.90
3600.	827.81	1561.05	-5.92	1.45	1.46
3800.	880.75	1561.05	-5.41	1.98	2.00
4000.	933.68	1561.05	-4.93	2.50	2.52

D-14

SUMMARY OF FESS ECONOMICS

ANALYSIS: BASELINE CONCEPT A2

NO. OF BOX CARS : 3.

NO. OF LOCOMOTIVES: 6.

CARS SWITCHED/DAY	OMR 61-94 (\$ X1000)		RETURN ON INVESTMENT %		
	NPV	INIT COST (1982 \$)	4R METHOD	SENSITIVITY 1	SENSITIVITY 2
200.	-72.13	1710.02	-99.99 **	-99.99 **	-99.99 **
400.	-19.19	1710.02	-99.99 **	-99.99 **	-99.99 **
600.	33.74	1710.02	-15.93 **	-.98 **	-.98 **
800.	86.68	1710.02	-.98 **	-.98 **	-.98 **
1000.	139.62	1710.02	-.98 **	-11.59	-11.57
1200.	192.56	1710.02	-.98 **	-9.67	-9.64
1400.	245.49	1710.02	-.98 **	-8.14	-8.12
1600.	298.43	1710.02	-1.08 **	-6.87	-6.85
1800.	351.37	1710.02	-11.32 **	-5.78	-5.76
2000.	404.31	1710.02	-11.73	-4.81	-4.79
2200.	457.24	1710.02	-10.92	-3.93	-3.91
2400.	510.18	1710.02	-10.18	-3.13	-3.11
2600.	563.12	1710.02	-9.45	-2.39	-2.37
2800.	616.06	1710.02	-8.85	-1.71	-1.69
3000.	668.99	1710.02	-8.25	-1.06	-1.04
3200.	721.93	1710.02	-7.68	-.45	-.44
3400.	774.87	1710.02	-7.15	.12	.14
3600.	827.81	1710.02	-6.64	.67	.69
3800.	880.74	1710.02	-6.15	1.20	1.21
4000.	933.68	1710.02	-5.68	1.70	1.72

SUMMARY OF FESS ECONOMICS

ANALYSIS: BASELINE CONCEPT A2

NO. OF BOX CARS : 4.

NO. OF LOCOMOTIVES: 4.

CARS SWITCHED/DAY	OMR A-94 (\$ X1000)		RETURN ON INVESTMENT 4		
	P	INIT COST (1982 \$)	4R METHOD	SENSITIVITY 1	SENSITIVITY 2
200.	-113.82	1684.14	-99.99 **	-99.99 **	-99.99 **
400.	-60.88	1684.14	-99.99 **	-99.99 **	-99.99 **
600.	-7.95	1684.14	-99.99 **	-99.99 **	-99.99 **
800.	44.99	1684.14	-.98 **	-.98 **	-.98 **
1000.	97.93	1684.14	-.98 **	-.99 **	-1.00 **
1200.	150.87	1684.14	-.98 **	-11.05	-11.02
1400.	203.80	1684.14	-.98 **	-9.22	-9.19
1600.	256.74	1684.14	-.98 **	-7.76	-7.73
1800.	309.68	1684.14	-1.31 **	-6.53	-6.50
2000.	362.62	1684.14	-12.34	-5.46	-5.43
2200.	415.55	1684.14	-11.45	-4.50	-4.48
2400.	468.49	1684.14	-10.65	-3.64	-3.62
2600.	521.43	1684.14	-9.92	-2.86	-2.84
2800.	574.37	1684.14	-9.24	-2.13	-2.11
3000.	627.30	1684.14	-8.61	-1.45	-1.43
3200.	680.24	1684.14	-8.01	-.81	-.79
3400.	733.18	1684.14	-7.45	-.20	-.19
3600.	786.12	1684.14	-6.92	.37	.39
3800.	839.06	1684.14	-6.41	.91	.93
4000.	891.99	1684.14	-5.93	1.43	1.45

SUMMARY OF FESS ECONOMICS

ANALYSIS: BASELINE CONCEPT A2

NO. OF BOX CARS : 4.

NO. OF LOCOMOTIVES: 5.

ARS SWITCHED/DAY	OMR 6-94 (\$ X1000)		RETURN ON INVESTMENT		
	NPV	INIT COST (1982 \$)	4R METHOD	SENSITIVITY 1	SENSITIVITY 2
200.	-113.82	1833.12	-99.99 **	-99.97 **	-99.99 **
400.	-60.88	1833.12	-99.99 **	-99.99 **	-99.99 **
600.	-7.95	1833.12	-99.99 **	-99.99 **	-99.99 **
800.	44.99	1833.12	-.98 on	-.98 **	-.98 **
1000.	97.93	1833.12	-.98 **	-.98 **	-.98 **
1200.	150.87	1833.12	9 **	-11.55	-11.52
1400.	203.80	1833.12	-.98 **	-9.74	-9.72
1600.	256.74	1833.12	-.98 **	-8.30	-8.28
1800.	309.68	1833.12	-1.03 **	-7.09	-7.07
2000.	362.62	1833.12	-3.35 **	-6.04	-6.01
2200.	415.55	1833.12	-12.01	-5.10	-5.09
2400.	468.49	1833.12	-11.22	-4.25	-4.23
2600.	521.43	1833.12	-10.50	-3.48	-3.46
2800.	574.37	1833.12	-9.84	-2.77	-2.75
3000.	627.30	1833.12	-9.22	-2.10	-2.08
3200.	680.24	1833.12	-8.64	-1.48	-1.46
3400.	733.18	1833.12	-8.09	-.89	-.87
3600.	786.12	1833.12	-7.57	-.33	-.31
3800.	839.06	1833.12	-7.07	.21	.22
4000.	891.99	1833.12	-6.60	.71	.73

SUMMARY OF FESS ECONOMICS

ANALYSIS: BASELINE CONCEPT A2

NO. OF BOX CARS : 4.

NO. OF LOCOMOTIVES: 6.

CARS SWITCHED/DAY	ONR A-94 (\$ A1000)		RETURN ON INVESTMENT %		
	NPV	INIT COST (1982 \$)	4R METHOD	SENSITIVITY 1	SENSITIVITY 2
200.	-113.82	1982.09	-99.99 **	-99.99 **	-99.99 **
400.	-60.88	1982.09	-99.99 **	-99.99 **	-99.99 **
600.	-7.95	1982.09	-99.99 **	-99.99 **	-99.99 **
800.	44.99	1982.09	-.98 **	-.98 **	-.98 **
1000.	97.93	1982.09	-.98 **	-.98 **	-.98 **
1200.	150.87	1982.09	-.98 **	-11.93 **	-11.96 **
1400.	203.80	1982.09	-.98 **	-10.22	-10.19
1600.	256.74	1982.09	-.98 **	-8.80	-8.77
1800.	309.68	1982.09	-.99 **	-7.63	-7.58
2000.	362.62	1982.09	-1.28 **	-6.56	-6.54
2200.	415.55	1982.09	-12.51 **	-5.64	-5.62
2400.	468.49	1982.09	-11.74	-4.81	-4.79
2600.	521.43	1982.09	-11.03	-4.05	-4.03
2800.	574.37	1982.09	-10.38	-3.35	-3.33
3000.	627.30	1982.09	-9.77	-2.69	-2.67
3200.	680.24	1982.09	-9.20	-2.08	-2.06
3400.	733.18	1982.09	-8.66	-1.59	-1.48
3600.	786.12	1982.09	-8.15	-.95	-.93
3800.	839.06	1982.09	-7.66	-.43	-.41
4000.	891.99	1982.09	-7.20	.07	.08

SUMMARY OF FESS ECONOMICS

ANALYSIS: BASELINE CONCEPT A2

NO. OF BOX CARS : 5.

NO. OF LOCOMOTIVES: 5.

CARS SWITCHED/DAY	OMB A-94 (\$ X1000)		RETURN ON INVESTMENT %		
	NPV	INIT COST (1962 \$)	4R METHOD	SENSITIVITY 1	SENSITIVITY 2
200.	-155.51	2105.18	-99.99 **	-99.99 **	-99.99 **
400.	-102.57	2105.18	-99.99 **	-99.99 **	-99.99 **
600.	-49.64	2105.18	-99.99 **	-99.99 **	-99.99 **
800.	3.30	2105.18	-28.01 **	-15.52 **	-15.52 **
1000.	56.24	2105.18	-.98 **	-.98 **	-.98 **
1200.	109.18	2105.18	-.98 **	-.98 **	-.98 **
1400.	162.11	2105.18	-.98 **	-11.93 **	-11.90
1600.	215.05	2105.18	-.98 **	-10.26	-10.23
1800.	267.99	2105.18	-.98 **	-8.91	-8.88
2000.	320.93	2105.18	-.98 **	-7.76	-7.73
2200.	373.86	2105.18	-1.13 **	-6.76	-6.74
2400.	426.80	2105.18	-7.54 **	-5.87	-5.85
2600.	479.74	2105.18	-11.97	-5.06	-5.04
2800.	532.68	2105.18	-11.29	-4.33	-4.30
3000.	585.62	2105.18	-10.65	-3.64	-3.62
3200.	638.55	2105.18	-10.06	-3.01	-2.99
3400.	691.49	2105.18	-9.51	-2.41	-2.39
3600.	744.43	2105.18	-8.98	-1.85	-1.83
3800.	797.37	2105.18	-8.49	-1.32	-1.30
4000.	850.30	2105.18	-8.01	-.81	-.79

SUMMARY OF FESS ECONOMICS

ANALYSIS: BASELINE CONCEPT A2

NO. OF BOX CARS : 5.

NO. OF LOCOMOTIVES: 6.

CARS SWITCHED/DAY	OMB A-94 (\$ X1000)		RETURN ON INVESTMENT %		
	NPV	INIT COST (1982 \$)	4R METHOD	SENSITIVITY 1	SENSITIVITY 2
200.	-155.51	2254.15	-99.93 **	-99.99 **	-99.99 **
400.	-102.57	2254.15	-99.99 **	-99.99 **	-99.99 **
600.	-49.64	2254.15	-99.99 **	-99.99 **	-99.99 **
800.	3.30	2254.15	-27.73 **	-15.52 **	-15.52 **
1000.	56.24	2254.15	-.98 **	-.98 **	-.98 **
1200.	109.18	2254.15	-.98 **	-.98 **	-.98 **
1400.	162.11	2254.15	-.98 **	-2.95 on	-3.32 **
1600.	215.05	2254.15	-.98 **	-10.67	-10.64
1800.	267.99	2254.15	-.98 **	-9.33	-9.31
2000.	320.93	2254.15	-.98 **	-8.20	-8.17
2200.	373.86	2254.15	-1.01 **	-7.21	-7.19
2400.	426.80	2254.15	-1.64 **	-6.33	-6.31
2600.	479.74	2254.15	-12.41	-5.54	-5.52
2800.	532.68	2254.15	-11.74	-4.81	-4.79
3000.	585.62	2254.15	-11.11	-4.14	-4.12
3200.	638.55	2254.15	-10.53	-3.51	-3.49
3400.	691.49	2254.15	-9.98	-2.42	-2.90
3600.	744.43	2254.15	-9.47	-2.37	-2.35
3800.	797.37	2254.15	-8.98	-1.85	-1.83
4000.	850.30	2254.15	-8.52	-1.35	-1.33

SUMMARY OF FESS ECONOMICS

ANALYSIS: BASELINE CONCEPT A2

NO. OF BOX CARS : 6.

NO. OF LOCOMOTIVES: 6.

CARS SWITCHED/DAY	OMB A-94 (\$ X1000)		RETURN ON INVESTMENT *		
	NPV	INIT COST (1982 \$)	4R METHOD	SENSITIVITY 1	SENSITIVITY 2
200.	-197.20	2526.22	-99.99	**	-99.99 **
400.	-144.26	2526.22	-99.99	**	-99.99 **
600.	-91.33	2526.22	-99.99	**	-99.99 **
800.	-38.39	2526.22	-99.99	**	-99.99 **
1000.	14.55	2526.22	-15.52	**	-16.33 **
1200.	67.49	2526.22	-.93	**	-.98 **
1400.	120.42	2526.22	-.98	**	-27.10 **
1600.	173.36	2526.22	-.98	**	-1.63 **
1800.	226.30	2526.22	-.98	**	-11.02
2000.	279.24	2526.22	-.98	**	-9.75
2200.	332.17	2526.22	-.98	**	-8.67
2400.	385.11	2526.22	-.98	**	-7.73
2600.	438.05	2526.22	-1.07	**	-6.89
2800.	490.99	2526.22	-2.31	**	-6.13
3000.	543.93	2526.22	-12.34		-5.42
3200.	596.86	2526.22	-11.74		-4.79
3400.	649.80	2526.22	-11.18		-4.19
3600.	702.74	2526.22	-10.65		-3.62
3800.	755.68	2526.22	-10.16		-3.09
4000.	808.61	2526.22	-9.60		-2.59

FIN

APPENDIX E

ALTERNATE CONFIGURATIONS

INTRODUCTION

The following applications of technology developed during the FESS and other related programs were considered in an attempt to identify a viable energy saving or productivity increasing concept.

CONCEPT A2 (MODIFIED)

System Description

Concept A2 (modified) is shown in principle in Figure E-1. The variation from Concept A2 is the traction motors that are unmodified D77 models with the fields excited at high current and low voltage from an externally controlled supply. A simplified schematic diagram of the field power supply is shown in Figure E-2.

The rationale behind this concept is the engineering effort that is concentrated in the provision of the field power supply rather than being split between the traction motor modification and the field power supply.

System Costs

The system costs identified here are based on those derived for Concept A2. Only variations are described in detail.

1. Initial Locomotive Modification

The \$11,000 estimated for the traction motor modification in Concept A2 is saved, but is offset by an increase in the cost of the four field power supplies from 830,000 to \$40,000. Therefore, the total locomotive modification cost for Concept A2 (modified) is \$117,000.

It is not possible to quantify the benefit (or penalty) of not modifying the standard traction motor from the viewpoint of traction motor interchangeability, spares holding, etc.

2. Boxcar Installation

The boxcar cost remains unaltered at \$215,000.

Annual Costs and Credits

The locomotive and boxcar maintenance costs are the same as those derived for Concept A2, as the fuel consumption is.

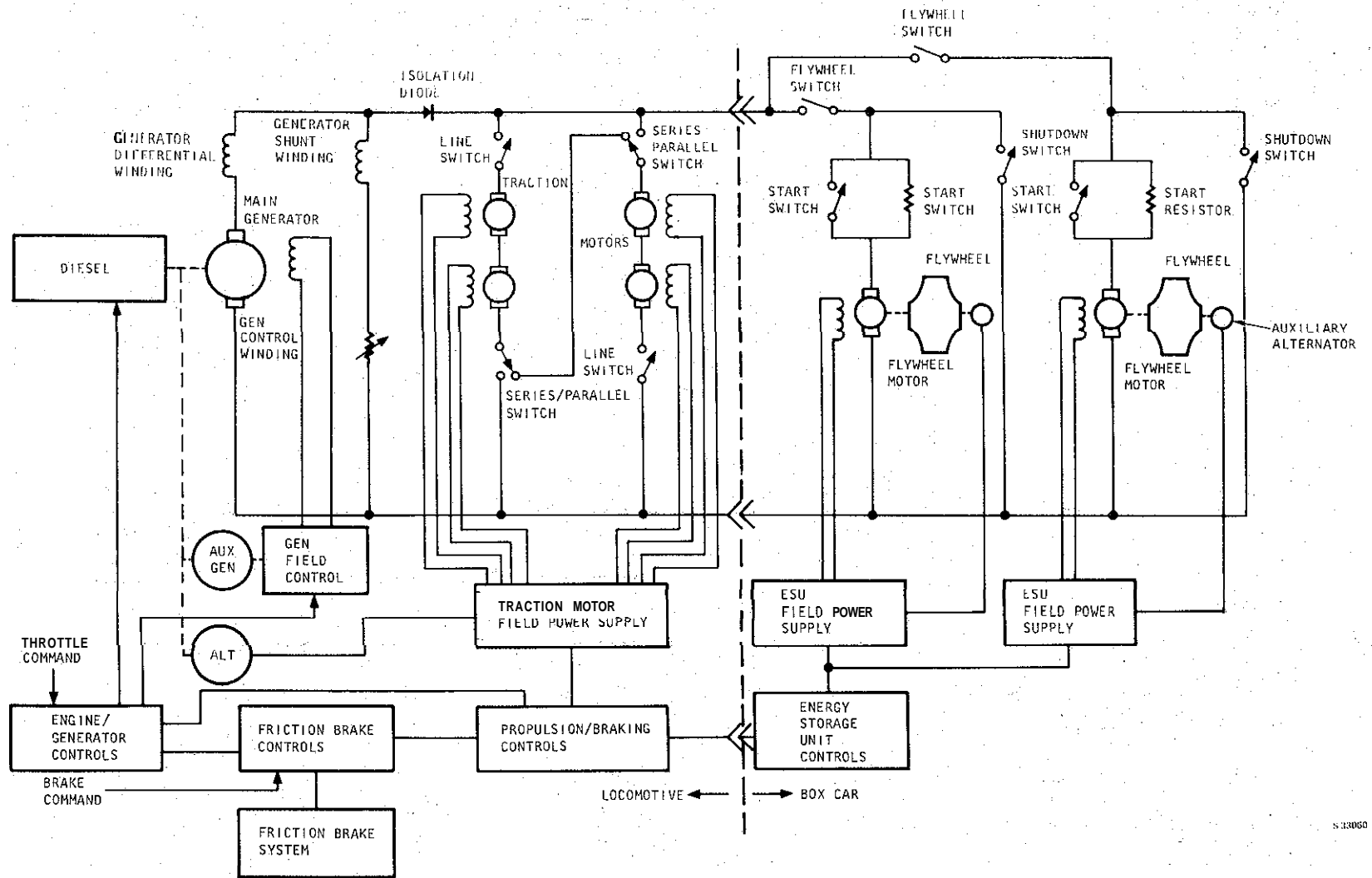

Figure E-1. Concept A2 (Modified)

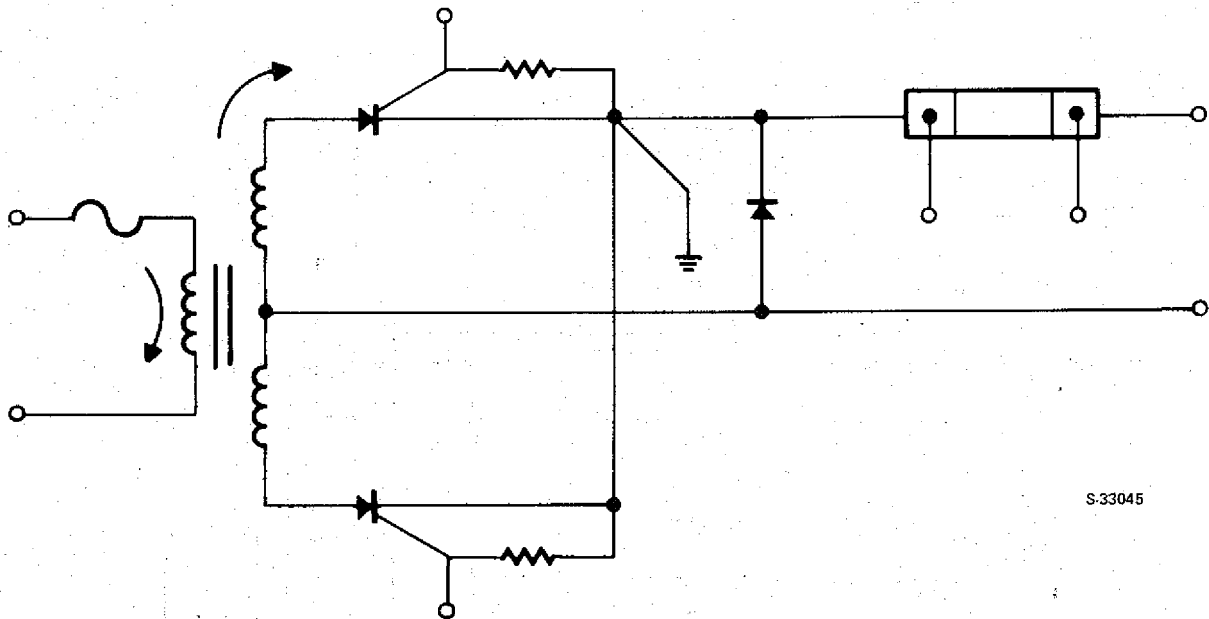

Figure E-2. Field Power Supply for Concept A2 (Modified)

Economic Analysis

It can be seen that the only saving resulting from Concept A2 (modified) compared to Concept A2 is a saving of less than 1 percent in the initial cost of the locomotive modification. Therefore, the results of the economic analysis of Concept A2 (modified) are not significantly different from Concept A2, and Concept A2 (modified) is considered to be economically unattractive.

CONCEPT A1 (MODIFIED)

System Description

Concept A1 (modified) is based on Concept A2 (modified), but utilizes only one ESU with a higher capacity flywheel machine (the energy storage capacity of the ESU having already been shown to be adequate). The proposed flywheel machine, which has yet to be designed, would be rated at 850 amp (continuous) as the traction motors are. The system schematic is conceptually the same as Figure 57 contained in the main body of this report.

System Costs

1. Initial Locomotive Modification

The locomotive modification costs are the same as those for Concept A2 (modified), that is, \$117,000.

2. Boxcar Installation

It is estimated that the cost of the ESU, complete with a larger capacity machine, would be \$120,000, thereby resulting in a total boxcar installation cost of \$155,000.

Annual Costs and Credits

1. Locomotive

The locomotive maintenance costs are the same as Concept A2 (modified). The fuel consumption would be reduced compared to Concept A2, due to the reduction of the boxcar weight now that only one ESU is used. The flywheel machine is significantly larger, so this will offset the weight saving due to the elimination of one ESU. However, the reduction in fuel consumption is negligible because the reduction in weight would be approximately 1 percent of the combined locomotive and boxcar weight, which represents an even lesser proportion of the total average system weight.

2. Boxcar

The 5S.J maintenance will be \$1,600/year.

Economic Analysis

The preceding data were input to the FESS economics program. The results are contained in the following pages. From these, it can be seen that for a typical locomotive, switching 395 cars/day, the ROI is only positive (but less than 1 percent) when the number of boxcars assumed is unrealistically low. Therefore, it was concluded that Concept A1 (modified) was uneconomic.

SUMMARY OF FESS ECONOMICS

ANALYSIS: CONCEPT A1 (MODIFIED)

NO. OF BOX CAPS : 1.

NO. OF LOCOMOTIVES: 3.

CAHS SWITCHED/DAY	OMB A-94 (% X1000)		RETURN ON INVESTMENT %		
	V	INIT CUST (1982 \$)	4R METHOD	SENSITIVITY 1	SENSITIVITY 2
200.	30.70	643.23	-.94 **	-.98 **	-1.72 **
400.	83.64	643.23	-15.42	-8.77	-8.75
600.	136.58	643.23	-12.43	-5.55	-5.54
800*	189.52	643.23	-10.26	-3.22	-3.21
1000.	242.45	643.23	-8.52	-1.35	-1.34
1200.	295.39	643.23	-7.05	.23	.25
1400.	348.33	643.23	-5.75	1.63	1.64
1600.	401.27	643.23	-4.58	2.88	2.90
1800.	454.20	643.23	-3.51	4.03	4.05
2000.	507.14	643.23	-2.51	5.09	5.11
2200.	560.08	643.23	-1.58	6.09	6.11
2400.	613.02	643.23	-.70	7.04	7.05
2600.	665.95	643.23	.14	7.93	7.95
2800.	718.89	643.23	.94	8.79	8.81
3000.	771.83	643.23	1.72	9.62	9.64
3200.	824.77	643.23	2.46	10.42	10.44
3400.	877.70	643.23	3.19	11.19	11.21
3600.	930.64	643.23	3.89	11.95	11.96
3800.	983.58	643.23	4.58	12.68	12.70
4000.	1036.52	643.23	5.25	13.40	13.41

SUMMARY OF FESS ECONOMICS

ANALYSIS: CONCEPT A1 (MODIFIED)

NO. OF BOX CARS : 1.

NO. OF LOCOMOTIVES: 4.

CARS SWITCHED/DAY	OMR A-94 (\$ X1000)		RETURN ON INVESTMENT %		
	NPV	INIT COST (1982 \$)	4R METHOD	SENSITIVITY 1	SENSITIVITY 2
200*	30.70	792.20	-.98 **	-.98 **	-.98 **
400.	83.64	792.20	-.98 **	-10.06	-10.04
600.	136.58	792.20	-1.06 **	-6.96	-6.94
800.	189.52	792.20	-11.66	-4.72	-4.71
1000.	242.45	792.20	-10.00	-2.94	-2.93
1200.	295.39	792.20	-8.60	-1.44	-1.42
1400.	348.33	792.20	-7.38	-.12	-.11
1600.	401.27	792.20	-6.28	1.05	1.07
1800.	454.20	792.20	-5.28	2.13	2.14
2000.	507.14	792.20	-4.36	3.12	3.13
2200.	560.08	792.20	-3.50	4.04	4.06
2400.	613.02	792.20	-2.69	4.91	4.93
2600.	665.95	792.20	-1.92	5.73	5.75
2800.	718.89	792.20	-1.18	6.52	6.54
3000.	771.83	792.20	-.48	7.27	7.29
3200.	824.77	792.20	.20	8.00	8.01
3400.	877.70	792.20	.85	8.69	8.71
3600.	930.64	792.20	1.48	9.37	9.39
3800.	983.58	792.20	2.10	10.03	10.05
4000.	1036.52	792.20	2.70	10.67	10.69

SUMMARY OF FESS ECONOMICS

ANALYSIS: CONCEPT A1 (MODIFIED)

NO. OF BOX CARS : 1.

NO. OF LOCOMOTIVES: 5.

CAWS SWITCHED/DAY	OMR A-94 (\$ X1000)		RETURN ON INVESTMENT %		
	NPV	IKIT COST (1982 \$)	4R METHOD	SENSITIVITY 1	SENSITIVITY 2
200.	30.70	941.18	-.98 **	-.98 **	-.98 **
400.	83.64	941.18	-.98 **	-11.09	-11.08
600.	136.58	941.18	-.98 **	-4.08	-6.06
800.	189.52	941.18	-5.84 **	-5.92	-5.90
1000.	242.45	941.18	-11.17	-4.20	-4.18
1200.	295.39	941.18	-9.83	-2.75	-2.74
1400.	348.33	941.18	-8.66	-1.50	-1.48
1600.	401.27	941.18	-7.61	-.37	-.35
1800.	454.20	941.18	-6.66	.65	.66
2000.	507.14	941.18	-5.79	1.58	1.60
2200.	560.08	941.18	-4.97	2.46	2.47
2400.	613.02	941.18	-4.21	3.28	3.29
2600.	665.95	941.18	-3.49	4.05	4.07
2800.	718.89	941.18	-2.80	4.78	4.80
3000.	771.83	941.18	-2.15	5.49	5.51
3200.	824.77	941.18	-1.52	6.16	6.17
3400.	877.70	941.18	-.92	6.81	6.82
3600.	930.64	941.18	-.33	7.43	7.45
3800.	983.58	941.18	.24	8.04	8.06
4000.	1036.52	941.18	.79	8.63	8.64

SUMMARY OF FESS ECONOMICS

ANALYSIS: CONCEPT A1 (MODIFIED)

NO. OF HOX CARS : 1.

NO. OF LOCOMOTIVES: 6.

CARS SWITCHED/DAY	OHM A-94 (\$ X1000)		RETURN ON INVESTMENT %		
	NPV	INIT COST (1982 \$)	4R METHOD	SENSITIVITY 1	SENSITIVITY 2
200.	30.70	1090.15	-.98 **	-.98 **	-.98 **
400.	83.64	1090.15	-.98 **	-11.95 **	-11.94 **
600.	136.58	1090.15	-.98 **	-9.01	-8.99
800.	189.52	1090.15	-1.07 **	-6.90	-6.88
1000.	242.45	1090.15	-12.13	-5.23	-5.22
1200.	295.39	1090.15	-10.83	-3.83	-3.82
1400.	348.33	1090.15	-9.70	-2.62	-2.60
1600.	401.27	1090.15	-8.70	-1.54	-1.52
1800.	454.20	1090.15	-7.78	-.56	-.54
2000.	507.14	1090.15	-6.95	.34	.36
2200.	560.08	1090.15	-6.17	1.17	1.19
2400.	613.02	1090.15	-5.44	1.96	1.97
2600.	665.95	1090.15	-4.75	2.69	2.71
2800.	718.89	1090.15	-4.10	3.39	3.41
3000.	771.83	1090.15	-3.48	4.05	4.07
3200.	824.77	1090.15	-2.89	4.69	4.71
3400.	877.70	1090.15	-2.32	5.30	5.32
3600.	930.64	1090.15	-1.77	5.89	5.91
3800.	983.58	1090.15	-1.24	6.46	6.48
4000.	1036.52	1090.15	-.72	7.01	7.03

SUMMARY OF FESS ECONOMICS

ANALYSIS: CONCEPT A1 (MODIFIED)

NO. OF BOX CARS : 7.

NO. OF LOCOMOTIVES: 2.

CARS SWITCHED/DAY	OMB A-94 (\$ X1000)		RETURN ON INVESTMENT %		
	NPV	INIT COST (1982 \$)	4R METHOD	SENSITIVITY 1	SENSITIVITY 2
200.	8.47	690.57	-15.52 **	-.98 **	-.98 **
400.	61.41	690.57	-.98 **	-11.09	-11.07
600.	114.34	690.57	-1.01 **	-7.22	-7.20
800.	167.28	690.57	-11.58	-4.64	-4.62
1000.	220.22	690.57	-9.72	-2.64	-2.62
1200.	273.16	690.57	-8.17	-.97	-.96
1400.	326.09	690.57	-6.83	.46	.48
1600.	379.03	690.57	-5.64	1.74	1.76
1800.	431.97	690.57	-4.56	2.91	2.92
2000.	484.91	690.57	-3.56	3.98	3.99
2200.	537.84	690.57	-2.63	4.97	4.99
2400.	590.78	690.57	-1.75	5.91	5.93
2600.	643.72	690.57	-.92	6.80	6.82
2800.	696.66	690.57	-.13	7.65	7.67
3000.	749.59	690.57	.63	8.46	8.48
3200.	802.53	690.57	1.36	9.24	9.26
3400.	855.47	690.57	2.07	10.00	10.02
3600.	908.41	690.57	2.76	10.73	10.75
3800.	961.35	690.57	3.42	11.45	11.47
4000.	1014.28	690.57	4.08	12.14	12.16

SUMMARY OF FESS ECONOMICS

ANALYSIS: CONCEPT A1 (MODIFIED)

NO. OF BOX CARS : 2.

NU. OF LOCOMOTIVES: 3.

CARS SWITCHED/DAY	OMB A-94 (\$ X1000)		RETURN ON INVESTMENT %		
	NPV	INIT COST (1982 \$)	4R METHOD	SENSITIVITY 1	SENSITIVITY 2
200.	8.47	839.55	-15.52 **	-.98 **	-.98 **
400.	61.41	839.55	-.98 **	-4.57 **	-5.18 **
600.	114.34	839.55	-1.13 **	-8.48	-8.46
800.	167.28	839.55	-4.10 **	-5.99	-5.97
1000.	220.22	839.55	-11.05	-4.07	-4.05
1200.	273.16	839.55	-9.57	-2.48	-2.47
1400.	326.09	839.55	-8.30	-1.12	-1.10
1600.	379.03	839.55	-7.18	.09	.11
1800.	431.97	839.55	-6.16	1.19	1.20
2000.	484.91	839.55	-5.22	2.19	2.21
2200.	537.84	839.55	-4.35	3.12	3.14
2400.	590.78	839.55	-3.54	4.00	4.01
2600.	643.72	839.55	-2.77	4.82	4.84
2800.	696.66	839.55	-2.04	5.60	5.62
3000.	749.59	839.55	-1.34	6.35	6.37
3200.	802.53	839.55	-.67	7.07	7.09
3400.	855.47	839.55	-.02	7.76	7.78
3600.	908.41	839.55	.60	8.43	8.44
3800.	961.35	839.55	1.20	9.07	9.09
4000.	1014.28	839.55	1.79	9.70	9.72

SUMMARY OF FESS ECONOMICS

ANALYSIS: CONCEPT A1 (MODIFIED)

NO. OF BOX CARS : 2.

NO. OF LOCOMOTIVES: 4.

CARS SWITCHED/DAY	OMR A-94 (\$ X1000)		RETURN ON INVESTMENT %		
	NPV	INIT CUST (1982 \$)	4R METHOD	SENSITIVITY 1	SENSITIVITY 2
200.	8.47	988.52	-15.52 **	-.98 **	-.98 **
400.	61.41	988.52	-.98 **	-1.05 **	-1.06 **
600.	114.34	988.52	-.98 **	-9.50	-9.48
800.	167.28	988.52	-1.03 **	-7.08	-7.06
1000.	220.22	988.52	-12.12	-5.22	-5.20
1200.	273.16	988.52	-10.70	-3.69	-3.67
1400.	326.09	988.52	-9.48	-2.38	-2.36
1600.	379.03	988.52	-8.40	-1.22	-1.20
1800.	431.97	988.52	-7.42	-.17	-.16
2000.	484.91	988.52	-6.53	.78	.80
2200.	537.84	988.52	-5.71	1.67	1.68
2400.	590.78	988.52	-4.94	2.49	2.51
2600.	643.72	988.52	-4.21	3.27	3.29
2800.	696.66	988.52	-3.52	4.01	4.03
3000.	749.59	988.52	-2.87	4.71	4.73
3200.	802.53	988.52	-2.24	5.38	5.40
3400.	855.47	988.52	-1.64	6.03	6.05
3600.	908.41	988.52	-1.06	6.65	6.67
3800.	961.35	988.52	-.50	7.25	7.27
4000.	1014.28	988.52	.05	7.84	7.85

SUMMARY OF FESS ECONOMICS

ANALYSIS: CONCEPT A1 (MODIFIED)

NO. OF HOV CARS : 2.

NO. OF LOCOMOTIVES: 5.

CARS SWITCHED/DAY	OMB A-94 (\$ X1000)		RETURN ON INVESTMENT %		
	NPV	INIT COST (1982 \$)	4R METHOD	SENSITIVITY 1	SENSITIVITY 2
200.	8.47	1137.49	-15.52 **	-23.81	-23.74
400.	61.41	1137.49	-.98 **	-.98 **	-.98 **
600.	114.34	1137.49	-.98 **	-10.36	-10.34
800.	167.28	1137.49	-.98 **	-7.99	-7.97
1000.	220.22	1137.49	-2.17 **	-6.18	-6.16
1200.	273.16	1137.49	-11.63	-4.70	-4.68
1400.	326.09	1137.49	-10.45	-3.42	-3.41
1600.	379.03	1137.49	-9.41	-2.30	-2.29
1800.	431.97	1137.49	-8.47	-1.30	-1.28
2000.	484.91	1137.49	-7.61	-.38	-.36
2200.	537.84	1137.49	-6.82	.47	.49
2400.	590.78	1137.49	-6.08	1.27	1.28
2600.	643.72	1137.49	-5.39	2.01	2.03
2800.	696.66	1137.49	-4.73	2.71	2.73
3000.	749.59	1137.49	-4.11	3.38	3.40
3200.	802.53	1137.49	-3.51	4.02	4.04
3400.	855.47	1137.49	-2.94	4.63	4.65
3600.	908.41	1137.49	-2.40	5.22	5.24
3800.	961.35	1137.49	-1.87	5.79	5.81
4000.	1014.28	1137.49	-1.35	6.34	6.36

SUMMARY OF FESS ECONOMICS

ANALYSIS: CONCEPT A1 (MODIFIED)

NO. OF BOX CARS : 2.

NO. OF LOCOMOTIVES: 6.

CARS SWITCHED/DAY	OMB A-94 (\$ X1000)		RETURN ON INVESTMENT %		
	NPV	INIT COST (1982 \$)	4R METHOD	SENSITIVITY 1	SENSITIVITY 2
200.	8.47	1286.46	-15.52 **	-24.34 **	-24.29
400.	61.41	1286.46	-.98 **	-.98 **	-1.72 **
600.	114.34	1286.46	-.98 **	-11.09	-11.07
800.	167.28	1286.46	-15.42	-8.77	-8.75
1000.	220.22	1286.46	-1.05 **	-7.00	-6.98
1200.	273.16	1286.46	-12.43	-5.55	-5.54
1400.	326.09	1286.46	-11.28	-4.31	-4.30
1600.	379.03	1286.46	-10.26	-3.22	-3.21
1800.	431.97	1286.46	-9.35	-2.25	-2.23
2000.	484.91	1286.46	-8.52	-1.35	-1.34
2200.	537.84	1286.46	-7.76	-.53	-.51
2400.	590.78	1286.46	-7.05	.23	.25
2600.	643.72	1286.46	-6.38	.95	.97
2800.	696.66	1286.46	-5.75	1.63	1.64
3000.	749.59	1286.46	-5.15	2.27	2.29
3200.	802.53	1286.46	-4.58	2.88	2.90
3400.	855.47	1286.46	-4.03	3.47	3.49
3600.	908.41	1286.46	-3.51	4.03	4.05
3800.	961.35	1286.46	-3.00	4.57	4.59
4000.	1014.28	1286.46	-2.51	5.09	5.11

SUMMARY OF FESS ECONOMICS

ANALYSIS: CONCEPT A1 (MODIFIED)

NO. OF POX CAPS : 3.

NO. OF LOCOMOTIVES: 3.

CAPS SWITCHED/DAY	OMB A-94 (\$ X1000)		RETURN ON INVESTMENT %		
	NPV	INIT COST (1962 \$)	4R METHOD	SENSITIVITY 1	SENSITIVITY 2
200.	-13.77	1035.86	-99.99 **	-99.99 **	-99.99 **
400.	39.17	1035.86	-.98 **	-.98 **	-.98 **
600.	92.11	1035.86	-.98 **	-11.09	-11.07
800.	145.05	1035.86	-.98 **	-3.36	-8.28
1000.	197.98	1035.86	-1.82 **	-6.27	-6.25
1200.	250.92	1035.86	-11.58	-4.64	-4.62
1400.	303.86	1035.86	-10.29	-3.26	-3.24
1600.	356.80	1035.86	-9.17	-2.05	-2.03
1800.	409.73	1035.86	-8.17	-.97	-.96
2000.	462.67	1035.86	-7.26	.00	.02
2200.	515.61	1035.86	-6.42	.91	.92
2400.	568.55	1035.86	-5.64	1.74	1.76
2600.	621.49	1035.86	-4.91	2.53	2.55
2800.	674.42	1035.86	-4.21	3.27	3.29
3000.	727.36	1035.86	-3.56	3.98	3.99
3200.	780.30	1035.86	-2.93	4.65	4.67
3400.	833.24	1035.86	-2.33	5.29	5.31
3600.	886.17	1035.86	-1.75	5.91	5.93
3800.	939.11	1035.86	-1.19	6.51	6.53
4000.	992.05	1035.86	-.65	7.09	7.11

SUMMARY OF FESS ECONOMICS

ANALYSIS: CONCEPT A1 (MODIFIED)

NO. OF BOX CARS : 3.

NO. OF LOCOMOTIVES: 4.

CARS SWITCHED/DAY	OMB A-94 (\$ X1000)		RETURN ON INVESTMENT %		
	NPV	INIT COST (1982 \$)	4R METHOD	SENSITIVITY - 1	SENSITIVITY 2
200.	-13.77	1184.83	-99.99 **	-99.99 **	-99.99 **
400.	39.17	1184.83	- .98 **	- .98 **	- .98 **
600.	92.11	1184.83	- .98 **	-11.88	-11.85
800.	145.05	1184.83	- .98 **	-9.15	-9.13
1000.	197.98	1184.83	-1.62 **	-7.16	-7.14
1200.	250.92	1184.83	-12.45	-5.57	-5.55
1400.	303.86	1184.83	-11.26	-4.23	-4.21
1600.	356.80	1184.83	-10.11	-3.06	-3.04
1800.	409.73	1184.83	-4.14	-2.02	-2.00
2000.	462.67	1184.83	-8.26	-1.08	-1.06
2200.	515.61	1184.83	-7.46	-.21	-.19
2400.	568.55	1184.83	-6.71	.60	.62
2600.	621.49	1184.83	-6.00	1.35	1.37
2800.	674.42	1184.83	-5.34	2.06	2.08
3000.	727.36	1184.83	-4.71	2.74	2.75
3200.	780.30	1184.83	-4.12	3.38	3.39
3400.	833.24	1184.83	-3.54	3.99	4.01
3600.	886.17	1184.83	-2.99	4.58	4.60
3800.	939.11	1184.83	-2.46	5.15	5.16
4000.	992.05	1184.83	-1.95	5.69	5.71

E-17

SUMMARY OF FESS ECONOMICS

ANALYSIS: CONCEPT A1 (MODIFIED)

NO. OF BOX CARS : 3

NO. OF LOCOMOTIVES: 5.

CARS SWITCHED/DAY	OMB A-94 (\$ X1000)		RETURN ON INVESTMENT %		
	NPV	INIT COST (1982 \$)	4R METHOD	SENSITIVITY 1	SENSITIVITY 2
ZOO.	-13.77	1333.81	-99.99 **	-99.99 **	-99.99 **
400.	39.17	1333.81	-.98 **	-.98 **	-.98 **
600.	92.11	1333.81	-.98 **	-1.65 **	-1.71 **
800.	145.05	1333.81	-.98 **	-9.88	-9.86
1000.	197.98	1333.81	-.98 **	-7.93	-7.91
1200.	250.92	1333.81	-1.55 **	-6.37	-6.36
1400.	303.86	1333.81	-11.98	-5.07	-5.05
1600.	356.80	1333.81	-10.92	-3.93	-3.91
1800.	409.73	1333.81	-9.98	-2.91	-2.90
2000.	462.67	1333.81	-9.12	-2.00	-1.98
2200.	515.61	1333.81	-8.34	-1.16	-1.14
2400.	568.55	1333.81	-7.61	-.38	-.36
2600.	621.49	1333.81	-6.93	.35	.37
2800.	674.42	1333.81	-6.30	1.04	1.06
3000.	727.36	1333.81	-5.69	1.69	1.70
3200.	780.30	1333.81	-5.12	2.30	2.32
3400.	833.24	1333.81	-4.57	2.89	2.91
3600.	886.17	1333.81	-4.04	3.46	3.48
3800.	939.11	1333.81	-3.53	4.00	4.02
4000.	992.05	1333.81	-3.04	4.53	4.54

SUMMARY OF FESS ECONOMICS

ANALYSIS: CONCEPT A1 (MODIFIED)

NO. OF BOX CARS : 3.

NO. OF LOCOMOTIVES: 6.

CARS SWITCHED/DAY	OMB A-94 (\$ 1000)		RETURN ON INVESTMENT %		
	NPV	INIT COST (1982 \$)	4R METHOD	SENSITIVITY 1	SENSITIVITY 2
200.	-13.77	1482.78	-99.94 **	-99.99 **	-99.99 **
400.	39.17	1482.78	-.98 **	-.98 **	-.98 **
600.	92.11	1482.78	-.98 **	-1.05 **	-1.06 **
800.	145.05	1482.78	-.98 **	-10.52	-10.50
1000.	197.98	1482.78	-.98 **	-8.61	-8.59
1200.	250.92	1482.78	-1.03 **	-7.08	-7.06
1400.	303.86	1482.78	-10.68 **	-5.80	-5.78
1600.	356.80	1482.78	-11.62	-4.68	-4.66
1800.	409.73	1482.78	-10.70	-3.69	-3.67
2000.	462.67	1482.78	-9.87	-2.80	-2.78
2200.	515.61	1482.78	-9.10	-1.98	-1.96
2400.	568.55	1482.78	-8.40	-1.22	-1.20
2600.	621.49	1482.78	-7.74	-.51	-.49
2800.	674.42	1482.78	-7.12	.15	.17
3000.	727.36	1482.78	-6.53	.78	.80
3200.	780.30	1482.78	-5.98	1.38	1.40
3400.	833.24	1482.78	-5.45	1.95	1.97
3600.	886.17	1482.78	-4.94	2.49	2.51
3800.	939.11	1482.78	-4.45	3.02	3.04
4000.	992.05	1482.78	-3.98	3.52	3.54

SUMMARY OF FESS ECONOMICS

ANALYSIS: CONCEPT A1 (MODIFIED)

NO. OF BOX CARS : 4.

NO. OF LOCOMOTIVES: 4.

CARS SWITCHED/DAY	OMM A-94 (\$ X1000)		RETURN ON INVESTMENT %		
	NPV	INIT COST (1982 \$)	4R METHOD	SENSITIVITY 1	SENSITIVITY 2
200.	-36.00	1381.15	-99.99 **	-99.99 **	-99.99 **
400.	16.94	1381.15	-15.52 **	-.98 **	-.98 **
600.	69.87	1381.15	-.98 **	-14.31	-1.02 **
800.	122.81	1381.15	-.98 **	-11.09	-11.07
1000.	175.75	1381.15	-.98 **	-8.91	-8.89
1200.	228.59	1381.15	-1.01 **	-7.22	-7.20
1400.	281.62	1381.15	-9.25 **	-5.83	-5.81
1600.	334.56	1381.15	-11.58	-4.64	-4.62
1800.	387.50	1381.15	-10.60	-3.58	-3.56
2000.	440.44	1381.15	-9.72	-2.64	-2.62
2200.	493.38	1381.15	-8.91	-1.77	-1.75
2400.	546.31	1381.15	-8.17	-.97	-.96
2600.	599.25	1381.15	-7.48	-.23	-.21
2800.	652.19	1381.15	-6.83	.46	.48
3000.	705.13	1381.15	-6.22	1.12	1.14
3200.	758.06	1381.15	-5.64	1.74	1.76
3400.	811.00	1381.15	-5.08	2.34	2.36
3600.	863.94	1381.15	-4.56	2.91	2.92
3800.	916.88	1381.15	-4.05	3.45	3.47
4000.	969.81	1381.15	-3.56	3.98	3.99

SUMMARY OF FESS ECONOMICS

ANALYSIS: CONCEPT A1 (MODIFIED)

NO. OF BOX CARS : 4.

NO. OF LOCOMOTIVES: 5.

CARS SWITCHED/DAY	OMB A-94 (\$ X1000)		RETURN ON INVESTMENT %			
	NPV	INIT COST (1982 \$)	4R METHOD	SENSITIVITY 1	SENSITIVITY 2	
200.	-36.00	1530.12	-99.99	**	-99.99	**
400.	16.94	1530.12	-15.52	**	-9.98	**
600.	69.87	1530.12	-9.98	**	9	**
800.	122.81	1530.12	-9.98	**	-11.69	-11.67
1000.	175.75	1530.12	9	**	-9.54	-9.52
1200.	228.69	1530.12	-9.98	**	-7.89	-7.87
1400.	281.62	1530.12	-1.32	**	-6.52	-6.50
1600.	334.56	1530.12	-12.24		-5.35	-5.33
1800.	387.50	1530.12	-11.28		-4.32	-4.30
2000.	440.44	1530.12	-10.42		-3.39	-3.34
2200.	493.38	1530.12	-9.64		-2.55	-2.53
2400.	546.31	1530.12	-8.92		-1.78	-1.76
2600.	599.25	1530.12	-8.24		-1.05	-1.03
2800.	652.19	1530.12	-7.61		-.38	-.36
3000.	705.13	1530.12	-7.02		.26	.28
3200.	758.06	1530.12	-6.46		.87	.88
3400.	811.00	1530.12	-5.92		1.44	1.46
3600.	863.94	1530.12	-5.41		1.99	2.01
3800.	916.88	1530.12	-4.92		2.52	2.54
4000.	969.81	1530.12	-4.46		3.03	3.04

SUMMARY OF FESS ECONOMICS

ANALYSIS: CONCEPT A1 (MODIFIED)

NO. OF BOX CARS : 4.

NO. OF LOCOMOTIVES: 6.

CAHS SWITCHED/DAY	OMB A-94 (\$ X1000)		RETURN ON INVESTMENT %		
	NPV	INIT COST (1982 \$)	4R METHOD	SENSITIVITY 1	SENSITIVITY 2
200.	-36.00	1679.09	-99.99 **	-99.99 **	-99.99 **
400.	16.94	1679.09	-15.52 **	-.98 **	-.98 **
600.	69.87	1679.09	-.98 **	-.98 **	-.98 **
800.	122.81	1679.09	-.98 **	-4.57 **	-5.1A **
1000.	175.75	1679.09	-.98 **	-10.11	-10.09
1200.	228.69	1679.09	-1.13 **	-8.48	-8.46
1400.	281.62	1679.09	-1.02 **	-7.14	-7.12
1600.	334.56	1679.09	-4.10 **	-5.99	-5.97
1800.	387.50	1679.09	-11.89	-4.98	-4.96
2000.	440.44	1679.09	-11.05	-4.07	-4.05
2200.	493.38	1679.09	-10.28	-3.24	-3.23
2400.	546.31	1679.09	-9.57	-2.48	-2.47
2600.	599.25	1679.09	-8.92	-1.78	-1.76
2800.	652.19	1679.09	-8.30	-1.12	-1.10
3000.	705.13	1679.09	-7.72	-.50	-.48
3200.	758.06	1679.09	-7.18	.09	.11
3400.	811.00	1679.09	-6.66	.65	.67
3600.	863.94	1679.09	-6.16	1.19	1.20
3800.	916.88	1679.09	-5.68	1.70	1.72
4000.	969.81	1679.09	-5.22	2.19	2.21

SUMMARY OF FESS ECONOMICS

ANALYSIS: CONCEPT A1 (MODIFIED)

NO. OF BOX CARS : 5.

NO. OF LOCOMOTIVES: 5.

CARS SWITCHED/DAY	OMB A-94 (\$ X1000)		RETURN ON INVESTMENT %		
	NPV	INIT COST (1982 \$)	4R METHOD	SENSITIVITY 1	SENSITIVITY 2
200.	-58.23	1726.44	-99.99 **	-99.99 **	-99.99 **
400.	-5.30	1726.44	-99.99 **	-99.99 **	-99.99 **
600.	47.64	1726.44	-.98 **	-.98 **	-.98 **
800.	100.58	1726.44	-.98 **	-1.00 **	-1.00 **
1000.	153.52	1726.44	-.98 **	-11.00	-11.07
1200.	206.45	1726.44	-.98 **	-9.29	-9.27
1400.	259.39	1726.44	-.98 **	-7.85	-7.83
1600.	312.33	1726.44	-1.21 **	-6.64	-6.62
1800.	365.27	1726.44	-12.45	-5.58	-5.56
2000.	418.20	1726.44	-11.58	-4.64	-4.62
2200.	471.14	1726.44	-10.78	-3.76	-3.76
2400.	524.08	1726.44	-10.06	-3.00	-2.99
2600.	577.02	1726.44	-9.39	-2.28	-2.26
2800.	629.95	1726.44	-8.76	-1.61	-1.59
3000.	682.89	1726.44	-8.17	-.97	-.96
3200.	735.83	1726.44	-7.61	-.38	-.36
3400.	788.77	1726.44	-7.09	.19	.21
3600.	841.70	1726.44	-6.58	.73	.75
3800.	894.64	1726.44	-6.10	1.25	1.27
4000.	947.58	1726.44	-5.64	1.74	1.76

SUMMARY OF LESS ECONOMICS

ANALYSIS; CONCEPT A1 (MODIFIED)

NO. OF BOX CARS : 5.

NO. OF LOCOMOTIVES: 6.

CAWS SWITCHED/DAY	OMB A-94 (\$ X1000)		RETURN ON INVESTMENT %		
	NPV	INIT COST (1982 \$)	4R METHOD	SENSITIVITY 1	SENSITIVITY 2
200.	-58.23	1875.41	-99.99 **	-99.99 **	-99.99 **
400.	-5.30	1875.41	-99.99 **	-99.99 **	-99.99 **
600.	47.64	1875.41	-.98 **	-.98 **	-.98 **
800.	100.58	1875.41	-.98 **	-.98 **	-.98 **
1000.	153.52	1875.41	-.98 **	-11.58	-11.55
1200.	206.45	1875.41	-.98 **	-9.80	-9.78
1400.	259.39	1875.41	-.98 **	-8.38	-8.36
1600.	312.33	1875.41	-1.01 **	-7.18	-7.16
1800.	365.27	1875.41	-2.40 **	-6.14	-6.12
2000.	418.20	1875.41	-12.11	-5.21	-5.20
2200.	471.14	1875.41	-11.34	-4.38	-4.36
2400.	524.08	1875.41	-10.62	-3.61	-3.59
2600.	577.02	1875.41	-9.96	-2.90	-2.88
2800.	629.95	1875.41	-9.35	-2.24	-2.22
3000.	682.89	1875.41	-8.77	-1.62	-1.60
3200.	735.83	1875.41	-8.23	-1.04	-1.02
3400.	788.77	1875.41	-7.71	-.48	-.47
3600.	841.70	1875.41	-7.22	.04	.06
3800.	894.64	1875.41	-6.75	.55	.57
4000.	947.58	1875.41	-6.30	1.03	1.05

SUMMARY OF FESS ECONOMICS

ANALYSIS: CONCEPT A1 (MODIFIED)

NO. OF BOX CAPS : 6.

NO. OF LOCOMOTIVES: 6.

CARS SWITCHED/DAY	OMB b-94 (\$ X1000)		RETURN ON INVESTMENT %		
	NPV	INIT COST (1982 \$)	4R METHOD	SENSITIVITY	SENSITIVITY Z
200.	-80.47	2071.72	-99.99	**	-99.99 **
400.	-27.53	2071.72	-99.99	**	-99.99 en
600.	25.41	2071.72	-15.52	**	-.98 **
800.	78.34	2071.72	-.98	**	-.98 **
1000.	131.28	2071.72	-.98	**	-1.09 **
1200.	184.22	2071.72	-.98	**	-11.09
1400.	237.16	2071.72	-.98	**	-9.56
1600.	290.09	2071.72	-.98	**	-8.30
1800.	343.03	2071.72	-1.01	**	-7.22
2000.	395.97	2071.72	-1.82	**	-6.27
2200.	448.91	2071.72	-12.30		-5.41
2400.	501.84	2071.72	-11.58		-4.62
2600.	554.78	2071.72	-13.91		-3.92
2800.	607.72	2071.72	-10.29		-3.26
3000.	660.66	2071.72	-9.72		-2.64
3200.	713.59	2071.72	-9.17		-2.05
3400.	766.53	2071.72	-8.66		-1.50
3600.	819.47	2071.72	-8.17		-.97
3800.	872.41	2071.72	-7.70		-.47
4000.	925.34	2071.72	-7.26		.00

FIN

SERIES MOTORS CONCEPT

System Description

The series motors concept is based on the use of standard dynamic brake techniques using unmodified traction motors. The traction motor fields, having been separated from the armatures, are connected in series with each other across the main generator. Traction motor excitation is controlled by using the main generator field to control the voltage, and therefore the current, applied across the fields.

The single ESU with increased capacity flywheel machine identified in Concept A1 (modified) will be applied to this concept; however, a power supply, now required for the flywheel machine field, will be taken from an ESU-driven alternator.

A simplified system schematic is shown in Figure E-3.

System Costs

1. Initial Locomotive Modification

An estimate of the locomotive modification cost is given in Table E-1.

Table E-1

COST OF LOCOMOTIVE MODIFICATION FOR SERIES MOTORS CONCEPT

Element	Cost, \$
Switchgear	5,000
Jumper cables	4,000
Control modifications	15,000
Installation labor	15,000
Miscellaneous	<u>5,000</u>
Total	44,000

2. Boxcar Installation

The boxcar installation cost will be the same as Concept A1 (modified) except that an ESU-driven alternator is required at an estimated cost of \$6,000, giving a total boxcar installation cost of \$161,000.

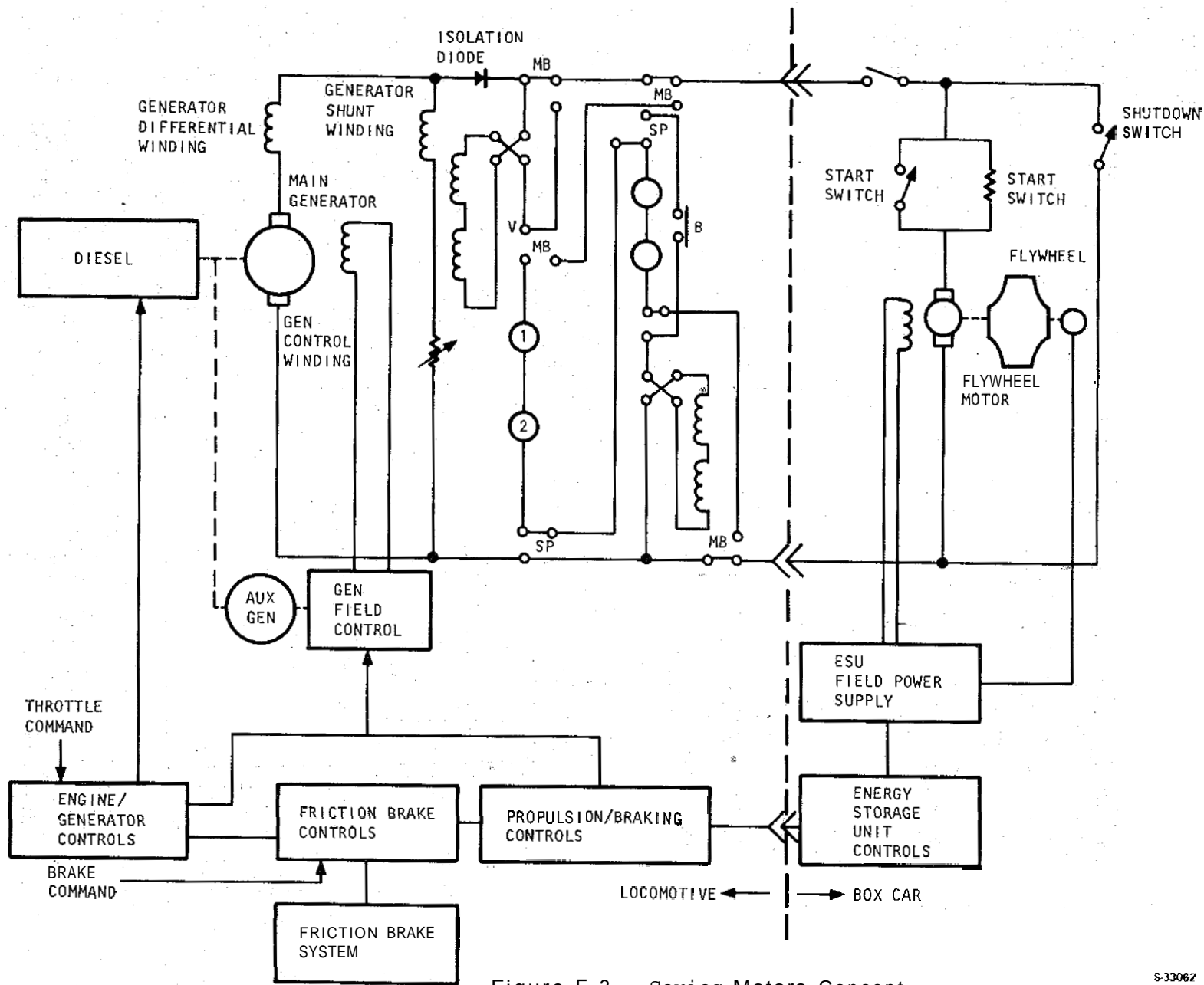

Figure E-3. Series Motors Concept

Annual Costs and Credits

1. Locomotive

The locomotive maintenance costs will be the same as those for Concept A1, except for the following:

- (a) The additional maintenance cost allowed for the electronic equipment will not be required.
- (b) The additional maintenance cost allowed for the field power supply alternator will not be required.
- (c) An allowance of \$200 per year will be made for the maintenance of the additional contactors and control equipment required.

Therefore, the maintenance saving becomes \$0.06 per car switched.

The fuel consumption is reduced compared to other concepts due to the elimination of the diesel-engine-driven field power supply alternator. The fuel saving for this concept is estimated at 0.016 gal/car switched.

2. Boxcar

The maintenance cost of the boxcar will be the same as that for Concept A1 (modified).

Economic Analysis

The preceding data were input to the FESS economics program. The results are contained in the pages that follow.

For the typical locomotive usage, the series motors concept shows an ROI that is less than 5 percent, the actual figure being dependent on the ratio of boxcars to locomotives. It is clear, however, that this concept, in common with the other flywheel options, is not economically attractive.

FLYWHEEL ENERGY STORAGE SWITCHER

ANALYSIS: SERIES MOTORS CONCEPT
YARD DATA

CARS SWITCHED PER DAY	:	200.--4000.
AVERAGE CAR WEIGHT	:	50. TONS
NU. OF LOCOMOTIVES	:	2.-- 6.
FUEL SAVING (GAL/CAR S ²)	:	.016
LIFE OF PROJECT	:	20 YEARS

INITIAL INVESTMENT SUMMARY (1978 \$)--PER UNIT

LOCOMOTIVE MODIFICATION	:	44000.
PROVISION OF HOA CAR	:	35000.
PROVISION OF ESU	:	126000.

CHANGE IN ANNUAL COSTS AND CREDITS (1978 \$)

LOCOMOTIVE MAINTENANCE	:	21,000 PER CAR SWITCHED
ESU MAINTENANCE	:	-1600. PER HOA CAR
FUEL SAVING	:	2.3520 PER CAR SWITCHED

SUMMARY OF FEBS ECONOMICS

ANALYSIS: SERIES MOTORS CONCEPT

NO. OF BOX CARS : 1.

NO. OF LOCOMOTIVES: 2.

CARS SWITCHED/DAY	OMB A-94 (\$ X1000)		RETURN ON INVESTMENT 2 4R METHOD SENSITIVITY SENSITIVITY		
	NPV	INIT COST (1982 \$)		1	2
200.	42.67	314.36	-0.98 **	-8.50	-8.22
400.	107.57	314.36	-9.22	-2.10	-1.86
600.	172.47	314.36	-5.64	1.74	1.97
800.	237.38	314.36	-2.91	4.67	4.90
1000.	302.28	314.36	-0.61	7.13	7.36
1200.	367.18	314.36	1.42	9.30	9.54
1400.	432.08	314.36	3.27	11.29	11.52
1600.	496.99	314.36	5.00	13.13	13.37
1800.	561.89	314.36	6.65	14.88	15.12
2000.	626.79	314.36	8.22	16.56	16.80
2200.	691.69	314.36	9.75	18.19	18.43
2400.	756.60	314.36	11.24	19.77	20.01
2600.	821.50	314.36	12.71	21.33	21.57
2800.	886.40	314.36	14.16	22.87	23.11
3000.	951.30	314.36	15.59	24.39	24.63
3200.	1016.21	314.36	17.02	25.90	26.15
3400.	1081.11	314.36	18.45	27.41	27.66
3600.	1146.01	314.36	19.88	28.92	29.17
3800.	1210.91	314.36	21.31	30.44	30.69
4000.	1275.82	314.36	22.76	31.96	32.21

SUMMARY OF FESS ECONOMICS

ANALYSIS: SERIES MOTORS CONCEPT

NO. OF BOX CARS : 1.

NO. OF LOCOMOTIVES: 3.

CARS SWITCHED/DAY	UPH A-94 (\$ X1000)		RETURN ON INVESTMENT % 4R METHOD SENSITIVITY		
	NPV	INIT COST (1982 \$)		1	2
200.	42.67	369.91	-0.98 **	-9.52	-9.23
400.	107.57	369.91	-10.35	-3.32	-3.08
600.	172.47	369.91	-6.93	.36	.59
800.	237.38	369.91	-4.34	3.14	3.37
1000.	302.28	369.91	-2.18	5.45	5.68
1200.	367.18	369.91	-.29	7.47	7.76
1400.	432.08	369.91	1.42	9.30	9.53
1600.	496.99	369.91	3.00	11.00	11.23
1800.	561.89	369.91	4.50	12.59	12.82
2000.	626.79	369.91	5.92	14.11	14.34
2200.	691.69	369.91	7.28	15.56	15.80
2400.	756.60	369.91	8.61	16.97	17.21
2600.	821.50	369.91	9.90	18.35	18.58
2800.	886.40	369.91	11.17	19.69	19.93
3000.	951.30	369.91	12.42	21.02	21.26
3200.	1016.21	369.91	13.65	22.33	22.57
3400.	1081.11	369.91	14.87	23.63	23.87
3600.	1146.01	369.91	16.09	24.92	25.16
3800.	1210.91	369.91	17.31	26.20	26.45
4000.	1275.82	369.91	18.52	27.49	27.73

SUMMARY OF FESS ECONOMICS

ANALYSIS: SERIES MOTORS CONCEPT

NO. OF BOX CARS : 1.

NO. OF LOCOMOTIVES: 4.

CARS SWITCHED/DAY
 OMB 9-94
 (6 *1000)
 NPV INIT COST
 (1982 \$)

RETURN ON INVESTMENT %
 4R METHOD SENSITIVITY SENSITIVITY
 1 2

200.	42.67	425.45	-.98 **	-10.37	-10.09
400.	107.57	425.45	-11.29	-4.33	-4.09
600.	172.47	425.45	-7.99	-.78	-.55
800.	237.38	425.45	-5.51	1.89	2.11
1000.	302.28	425.45	-3.45	4.09	4.31
1200.	367.18	425.45	-1.67	6.00	6.23
1400.	432.08	425.45	-.06	7.72	7.95
1600.	496.99	425.45	1.42	9.30	9.53
1800.	561.89	425.45	2.80	10.78	11.01
2000.	626.79	425.45	4.11	12.18	12.41
2200.	691.69	425.45	5.37	13.52	13.75
2400.	756.60	425.45	6.57	14.81	15.04
2600.	821.50	425.45	7.75	16.06	16.29
2800.	886.40	425.45	8.89	17.27	17.51
3000.	951.30	425.45	10.01	18.46	18.70
3200.	1016.21	425.45	11.11	19.63	19.87
3400.	1081.11	425.45	12.20	20.79	21.03
3600.	1146.01	425.45	13.27	21.93	22.17
3800.	1210.91	425.45	14.34	23.06	23.30
4000.	1275.82	425.45	15.40	24.19	24.43

SUMMARY OF FESS ECONOMICS

ANALYSIS: SERIES MOTORS CONCEPT

NO. OF BOX CARS : 1.

NO. OF LOCOMOTIVES: 5.

CARS SWITCHED/DAY	OPP A-94 (\$ X1000)		RETURN ON INVESTMENT %		
	NPV	INIT COST (1982 \$)	4R METHOD	SENSITIVITY 1	SENSITIVITY 2
200.	42.67	481.00	-0.98	-11.19	-10.83
400.	107.57	481.00	-12.10	-5.19	-4.96
600.	172.47	481.00	-8.88	-1.74	-1.51
800.	237.38	481.00	-6.49	.83	1.06
1000.	302.28	481.00	-4.52	2.95	3.17
1200.	367.18	481.00	-2.81	4.78	5.00
1400.	432.08	481.00	-1.28	6.41	6.64
1600.	496.99	481.00	.12	7.91	8.14
1800.	561.89	481.00	1.42	9.31	9.53
2000.	626.79	481.00	2.65	10.62	10.85
2200.	691.69	481.00	3.82	11.87	12.10
2400.	756.60	481.00	4.94	13.06	13.29
2600.	821.50	481.00	6.02	14.22	14.45
2800.	886.40	481.00	7.07	15.34	15.57
3000.	951.30	481.00	8.10	16.43	16.67
3200.	1016.21	481.00	9.11	17.50	17.74
3400.	1081.11	481.00	10.09	18.55	18.79
3600.	1146.01	481.00	11.07	19.59	19.83
3800.	1210.91	481.00	12.03	20.61	20.85
4000.	1275.82	481.00	12.98	21.62	21.86

SUMMARY OF FEAS ECONOMICS

ANALYSIS: SERIES MOTORS CONCEPT

NO. OF POA CARS : 1.

NO. OF LOCOMOTIVES: 5.

CARS SWITCHED/DAY	OMB A-94 (\$ 1000)		RETURN ON INVESTMENT %		
	NPV	INIT COST (1982 \$)	4R METHOD	SENSITIVITY 1	SENSITIVITY 2
200.	42.67	536.55	-0.98 **	-11.75	-11.47
400.	107.57	536.55	-5.00 **	-5.95	-5.71
600.	172.47	536.55	-9.66	-2.58	-2.35
800.	237.38	536.55	-7.33	-0.07	.15
1000.	302.28	536.55	-5.43	1.97	2.19
1200.	367.18	536.55	-3.78	3.73	3.96
1400.	432.08	536.55	-2.32	5.30	5.53
1600.	496.99	536.55	-0.98	6.73	6.96
1800.	561.89	536.55	.26	8.06	8.29
2000.	626.79	536.55	1.42	9.31	9.53
2200.	691.69	536.55	2.52	10.49	10.71
2400.	756.60	536.55	3.59	11.61	11.84
2600.	821.50	536.55	4.59	12.70	12.93
2800.	886.40	536.55	5.58	13.74	13.98
3000.	951.30	536.55	6.53	14.76	14.99
3200.	1016.21	536.55	7.47	15.76	15.99
3400.	1081.11	536.55	8.38	16.73	16.96
3600.	1146.01	536.55	9.28	17.68	17.92
3800.	1210.91	536.55	10.16	18.63	18.86
4000.	1275.82	536.55	11.03	19.55	19.79

SUMMARY OF FESS ECONOMICS

ANALYSIS: SERIES MOTORS CONCEPT

NO. OF BOA CARS : 2.

NO. OF LOCOMOTIVES: 3.

CARS SWITCHED/DAY	OMB A-94 (% A1000)		RETURN ON INVESTMENT %		
	NPV	INIT COST (1982 \$)	4H METHOD	SENSITIVITY 1	SENSITIVITY 2
200.	26.43	573.16	-.98 **	-.98 **	-.98 **
400.	85.34	573.16	-.98 **	-7.91	-7.62
600.	150.24	573.16	-11.05	-4.07	-3.82
800.	215.14	573.16	-8.55	-1.39	-1.14
1000.	280.04	573.16	-6.57	.75	.99
1200.	344.95	573.16	-4.88	2.56	2.79
1400.	409.85	573.16	-3.40	4.15	4.38
1600.	474.75	573.16	-2.05	5.59	5.82
1800.	539.65	573.16	-.82	6.91	7.14
2000.	604.56	573.16	.33	8.14	8.37
2200.	669.46	573.16	1.42	9.30	9.54
2400.	734.36	573.16	2.45	10.41	10.64
2600.	799.26	573.16	3.45	11.47	11.70
2800.	864.17	573.16	4.40	12.49	12.72
3000.	929.07	573.16	5.33	13.48	13.71
3200.	993.97	573.16	6.23	14.44	14.68
3400.	1058.87	573.16	7.11	15.38	15.61
3600.	1123.78	573.16	7.97	16.30	16.53
3800.	1188.68	573.16	8.82	17.20	17.44
4000.	1253.58	573.16	9.65	18.08	18.32

SUMMARY OF FESS ECONOMICS

ANALYSIS: SERIES MOTORS CONCEPT

NO. OF BOX CARS : 2.

NO. OF LOCOMOTIVES: 4.

CARS SWITCHED/DAY	OMB A-94 (\$ X1000)		RETURN ON INVESTMENT %		
	NPV	INIT COST (1982 \$)	4R METHOD	SENSITIVITY 1	SENSITIVITY 2
200.	20.43	628.71	-.98 **	-.98 **	-.98 **
400.	85.34	628.71	-.98 **	-2.50	-8.22
600.	150.24	628.71	-11.67	-4.73	-4.48
800.	215.14	628.71	-9.22	-2.10	-1.86
1000.	280.04	628.71	-7.28	-.02	.22
1200.	344.95	628.71	-5.64	1.74	1.97
1400.	409.85	628.71	-4.20	3.26	3.52
1600.	474.75	628.71	-2.91	4.67	4.90
1800.	539.65	628.71	-1.72	5.95	6.18
2000.	604.56	628.71	-.61	7.13	7.36
2200.	669.46	628.71	.43	8.25	8.48
2400.	734.36	628.71	1.42	9.30	9.54
2600.	799.26	628.71	2.36	10.31	10.55
2800.	864.17	628.71	3.27	11.29	11.52
3000.	929.07	628.71	4.15	12.22	12.46
3200.	993.97	628.71	5.00	13.13	13.37
3400.	1058.87	628.71	5.83	14.02	14.25
3600.	1123.78	628.71	6.65	14.88	15.12
3800.	1188.68	628.71	7.44	15.73	15.97
4000.	1253.58	628.71	8.22	16.56	16.80

E-37

SUMMARY OF FESS ECONOMICS

ANALYSIS: SERIES MOTORS CONCEPT

NO. OF BOX CARS : 2.

NO. OF LOCOMOTIVES: 5.

CARS SWITCHED/DAY	DPM A-94 (\$ X1000)		RETURN ON INVESTMENT %		
	NPV	INIT COST (1982 \$)	4R METHOD	SENSITIVITY 1	SENSITIVITY 2
200.	20.43	684.26	-0.98 **	-0.98 **	-0.98 **
400.	85.34	684.26	-0.98 **	-9.03	-8.75
600.	150.24	684.26	-12.21	-5.32	-5.07
800.	215.14	684.26	-9.81	-2.74	-2.50
1000.	280.04	684.26	-7.92	-0.70	-0.47
1200.	344.95	684.26	-6.32	1.01	1.25
1400.	409.85	684.26	-4.92	2.51	2.75
1600.	474.75	684.26	-3.66	3.86	4.09
1800.	539.65	684.26	-2.51	5.10	5.33
2000.	604.56	684.26	-1.44	6.24	6.47
2200.	669.46	684.26	-0.44	7.32	7.55
2400.	734.36	684.26	0.51	8.33	8.57
2600.	799.26	684.26	1.42	9.30	9.54
2800.	864.17	684.26	2.29	10.23	10.47
3000.	929.07	684.26	3.13	11.13	11.36
3200.	993.97	684.26	3.94	12.00	12.23
3400.	1058.87	684.26	4.73	12.84	13.07
3600.	1123.78	684.26	5.50	13.66	13.90
3800.	1188.68	684.26	6.25	14.46	14.70
4000.	1253.58	684.26	6.99	15.25	15.49

SUMMARY OF FESS ECONOMICS

ANALYSIS: SERIES MOTORS CONCEPT

NO. OF BOX CARS : 2.

NO. OF LOCOMOTIVES: 6.

CARS SWITCHED/DAY	GMR A-94 (\$ x1000)		RETURN ON INVESTMENT %		
	NPV	INIT COST (1982 \$)	4R METHOD	SENSITIVITY 1	SENSITIVITY 2
200.	20.43	739.81	-0.98 **	-0.98 **	-0.98 **
400.	85.34	739.81	-0.98 **	-9.52	-9.23
600.	150.24	739.81	-8.02 **	-5.86	-5.61
800.	215.14	739.81	-10.35	-3.32	-3.08
1000.	280.04	739.81	-8.49	-1.32	-1.09
1200.	344.95	739.81	-6.93	.36	.52
1400.	409.85	739.81	-5.56	1.82	2.05
1600.	474.75	739.81	-4.34	3.14	3.37
1800.	539.65	739.81	-3.22	4.34	4.57
2000.	604.56	739.81	-2.18	5.45	5.68
2200.	669.46	739.81	-1.21	6.49	6.72
2400.	734.36	739.81	-.29	7.47	7.70
2600.	799.26	739.81	.58	8.41	8.64
2800.	864.17	739.81	1.42	9.30	9.53
3000.	929.07	739.81	2.23	10.17	10.40
3200.	993.97	739.81	3.00	11.00	11.23
3400.	1058.87	739.81	3.76	11.80	12.04
3600.	1123.78	739.81	4.50	12.59	12.82
3800.	1188.68	739.81	5.21	13.36	13.59
4000.	1253.58	739.81	5.92	14.11	14.34

SUMMARY OF FESS ECONOMICS

ANALYSIS: SERIES MOTORS CONCEPT

NO. OF BOX CARS : 3.

NO. OF LOCOMOTIVES: 3.

CARS SWITCHED/DAY	OMB-A-94 (6 X 1000)		RETURN ON INVESTMENT %		
	NPV	INIT COST (1982 \$)	4R METHOD	SENSITIVITY 1	SENSITIVITY 2
200.	-1.80	776.42	-99.99 **	=99.99 **	-15.52 **
400.	63.10	776.42	-1.98 **	-11.62	-11.25
600.	128.00	776.42	-1.01 **	-7.25	-6.96
800.	192.91	776.42	-11.41	-4.46	-4.19
1000.	257.81	776.42	-9.43	-2.33	-2.08
1200.	322.71	776.42	-7.80	-.58	-.33
1400.	387.61	776.42	-6.40	.93	1.17
1600.	452.52	776.42	-5.15	2.27	2.51
1800.	517.42	776.42	-4.01	3.49	3.72
2000.	582.32	776.42	-2.97	4.61	4.84
2200.	647.22	776.42	-2.00	5.65	5.88
2400.	712.13	776.42	-1.08	6.63	6.87
2600.	777.03	776.42	-.21	7.56	7.80
2800.	841.93	776.42	.62	8.45	8.69
3000.	906.83	776.42	1.42	9.30	9.54
3200.	971.74	776.42	2.19	10.12	10.36
3400.	1036.64	776.42	2.93	10.92	11.15
3600.	1101.54	776.42	3.65	11.69	11.93
3800.	1166.44	776.42	4.36	12.44	12.68
4000.	1231.35	776.42	5.04	13.16	13.41

SUMMARY OF FESS ECONOMICS

ANALYSIS: SERIES MOTORS CONCEPT

NO. OF BOX CARS : 3.

NO. OF LOCOMOTIVES: 4.

CARS SWITCHED/DAY	DMS A-94 (\$ X1000)		RETURN ON INVESTMENT %		
	NPV	INIT COST (1982 \$)	4R METHOD	SENSITIVITY 1	SENSITIVITY 2
200.	-1.50	831.97	-99.99 **	-99.99 **	-33.08
400.	63.10	831.97	-.98 **	-11.80 **	-11.65
600.	128.00	831.97	-.98 **	-7.70	-7.41
800.	192.91	831.97	-11.86	-4.94	-4.68
1000.	257.81	831.97	-9.91	-2.85	-2.60
1200.	322.71	831.97	-8.31	-1.13	-.89
1400.	387.51	831.97	-6.93	.35	.59
1600.	452.52	831.97	-5.71	1.66	1.90
1800.	517.42	831.97	-4.60	2.85	3.09
2000.	582.32	831.97	-3.59	3.95	4.18
2200.	647.22	831.97	-2.64	4.96	5.20
2400.	712.13	831.97	-1.74	5.92	6.15
2600.	777.03	831.97	-.90	6.82	7.06
2800.	841.93	831.97	-.10	7.68	7.92
3000.	906.83	831.97	.68	8.51	8.74
3200.	971.74	831.97	1.42	9.30	9.54
3400.	1036.64	831.97	2.14	10.07	10.39
3600.	1101.54	831.97	2.83	10.81	11.05
3800.	1166.44	831.97	3.51	11.54	11.77
4000.	1231.35	831.97	4.17	12.24	12.46

SUMMARY OF FESS ECONOMICS

ANALYSIS: SERIES MOTORS CONCEPT

NO. OF BOX CARS : 3.

NO. OF LOCOMOTIVES: 5.

CARS SWITCHED/DAY	OHR A-94 (% X1000)		RETURN ON INVESTMENT 1 4K METHOD		
	NPV	IRIT COST (1982 \$)	SENSITIVITY 1	SENSITIVITY 2	
200.	-1.80	887.52	-99.99 **	-99.99 **	-33.32
400.	63.10	887.52	-.98 **	-2.37 **	-11.27 **
600.	128.00	887.52	-.99 **	-8.12	-7.83
800.	192.91	887.52	-12.28	-5.39	-5.13
1000.	257.81	887.52	-10.36	-3.33	-3.08
1200.	322.71	887.52	-8.78	-1.63	-1.39
1400.	387.61	887.52	-7.43	-.18	.06
1600.	452.52	887.52	-6.23	1.11	1.35
1800.	517.42	887.52	-5.14	2.27	2.51
2000.	582.32	887.52	-4.15	3.34	3.58
2200.	647.22	887.52	-3.22	4.34	4.57
2400.	712.13	887.52	-2.35	5.27	5.50
2600.	777.03	887.52	-1.53	6.15	6.36
2800.	841.93	887.52	-.75	6.99	7.22
3000.	906.83	887.52	.00	7.79	8.02
3200.	971.74	887.52	.72	8.56	8.79
3400.	1036.64	887.52	1.42	9.30	9.54
3600.	1101.54	887.52	2.09	10.02	10.26
3800.	1166.44	887.52	2.75	10.72	10.96
4000.	1231.35	887.52	3.38	11.40	11.64

SUMMARY OF FESS ECONOMICS

ANALYSIS: SERIES MOTORS CONCEPT

NO. OF BOX CARS : 3.

NO. OF LOCOMOTIVES: 6.

ARS SWITCHED/DAY	OMB A-94 (a x1000)		RETURN ON INVESTMENT % 4R METHOD		
	NPV	INIT COST (1982 \$)		SENSITIVITY 1	SENSITIVITY 2
200.	-1.80	943.07	-99.99 **	-99.99 **	-33.53
400.	63.10	943.07	-0.98 **	-1.31 **	-2.32 **
600.	128.00	943.07	-1.24 **	-8.50	-8.22
800.	192.91	943.07	-10.18 **	-5.81	-5.55
1000.	257.81	943.07	-10.77	-3.77	-3.52
1200.	322.71	943.07	-9.22	-2.10	-1.86
1400.	387.61	943.07	-7.89	-.67	-.43
1600.	452.52	943.07	-6.71	.60	.83
1800.	517.42	943.07	-5.64	1.74	1.97
2000.	582.32	943.07	-4.66	2.79	3.02
2200.	647.22	943.07	-3.76	3.76	3.99
2400.	712.13	943.07	-2.91	4.67	4.90
2600.	777.03	943.07	-2.10	5.53	5.76
2800.	841.93	943.07	-1.34	6.35	6.58
3000.	906.83	943.07	-.61	7.13	7.36
3200.	971.74	943.07	.09	7.88	8.11
3400.	1036.64	943.07	.77	8.60	8.84
3600.	1101.54	943.07	1.42	9.30	9.54
3800.	1166.44	943.07	2.05	9.98	10.21
4000.	1231.35	943.07	2.67	10.64	10.87

SUMMARY OF FESS ECONOMICS

ANALYSIS: SERIES MOTORS CONCEPT

NO. OF BOX CARS : 4.

NO. OF LOCOMOTIVES: 4.

CARS SWITCHED/DAY	OMB A-94 (% \$1000)		RETURN ON INVESTMENT %		
	NPV	INIT COST (1982 \$)	4R METHOD	SENSITIVITY 1	SENSITIVITY 2
200.	-24.04	1035.23	-99.99 **	-99.99 **	-99.99 **
400.	40.87	1035.23	9 **	-0.98 **	-0.98 **
600.	105.77	1035.23	-0.98 **	-10.26	-9.92
800.	170.67	1035.23	-1.01 **	-7.25	-6.96
1000.	235.57	1035.23	-11.98	-5.07	-4.81
1200.	300.48	1035.23	-10.37	-3.33	-3.08
1400.	365.35	1035.23	-9.00	-1.86	-1.01
1600.	430.28	1035.23	-7.80	-0.58	-0.33
1800.	495.18	1035.23	-6.73	.57	.81
2000.	560.09	1035.23	-5.75	1.62	1.86
2200.	624.99	1035.23	-4.85	2.59	2.82
2400.	689.89	1035.23	-4.01	3.49	3.72
2600.	754.79	1035.23	-3.22	4.33	4.57
2800.	819.70	1035.23	-2.47	5.14	5.37
3000.	884.60	1035.23	-1.76	5.90	6.14
3200.	949.50	1035.23	-1.08	6.63	6.87
3400.	1014.41	1035.23	-0.42	7.43	7.57
3600.	1079.31	1035.23	.21	8.01	8.25
3800.	1144.21	1035.23	.82	8.67	8.90
4000.	1209.11	1035.23	1.42	9.30	9.54

SUMMARY OF FESS ECONOMICS

ANALYSIS: SERIES MOTORS CONCEPT

NO. OF BOX CARS : 4.

NO. OF LOCOMOTIVES: 5.

CARS SWITCHED/DAY	DPR A-94 (% X1000)		RETURN ON INVESTMENT %		
	NPV	INIT COST (1982 \$)	4R METHOD	SENSITIVITY 1	SENSITIVITY 2
200.	-24.04	1090.78	-99.99 **	-99.99 **	-99.99 **
400.	40.87	1090.78	-.98 **	-.98 **	-.98 **
600.	105.77	1090.78	-.98 **	-10.57	-10.24
800.	170.67	1090.78	-.99 **	-7.59	-7.30
1000.	235.57	1090.78	-12.32	-5.44	-5.17
1200.	300.48	1090.78	-10.72	-3.72	-3.46
1400.	365.38	1090.78	-9.37	-2.26	-2.01
1600.	430.28	1090.78	-8.19	-1.00	-.75
1800.	495.18	1090.78	-7.13	.14	.38
2000.	560.09	1090.78	-6.17	1.17	1.41
2200.	624.99	1090.78	-5.29	2.12	2.36
2400.	689.89	1090.78	-4.46	3.01	3.24
2600.	754.79	1090.78	-3.69	3.84	4.07
2800.	819.70	1090.78	-2.95	4.63	4.86
3000.	884.60	1090.78	-2.25	5.37	5.61
3200.	949.50	1090.78	-1.58	6.09	6.32
3400.	1014.41	1090.78	-.94	6.78	7.01
3600.	1079.31	1090.78	-.32	7.44	7.67
3800.	1144.21	1090.78	.27	8.08	8.31
4000.	1209.11	1090.78	.85	8.70	8.93

SUMMARY OF FESS ECONOMICS

ANALYSIS: SERIES MOTORS CONCEPT

NO. OF BOX CARS : 4.

NO. OF LOCOMOTIVES: 6.

CARS SWITCHED/DAY	OMB A-94 (\$ X1000)		RETURN ON INVESTMENT %		
	NPV	INIT COST (1982 \$)	4R METHOD	SENSITIVITY 1	SENSITIVITY 2
200.	-24.04	1146.33	-99.00 **	-99.99 **	-99.99 **
400.	40.87	1146.33	9 **	-9.98 **	-9.98 **
600.	105.77	1146.33	-9.98 **	-10.87	-10.53
800.	170.67	1146.33	-9.98 **	-7.91	-7.12
1000.	235.57	1146.33	-11.35 **	-5.78	-5.51
1200.	300.48	1146.33	-11.05	-4.07	-3.82
1400.	365.38	1146.33	-9.72	-2.64	-1.39
1600.	430.28	1146.33	-8.55	-1.39	-1.14
1800.	495.18	1146.33	-7.51	-.27	-.03
2000.	560.09	1146.33	-6.57	.75	.99
2200.	624.99	1146.33	-5.69	1.69	1.92
2400.	689.89	1146.33	-4.88	2.56	2.79
2600.	754.79	1146.33	-4.12	3.38	3.61
2800.	819.70	1146.33	-3.40	4.15	4.38
3000.	884.60	1146.33	-2.71	4.88	5.12
3200.	949.50	1146.33	-2.05	5.59	5.82
3400.	1014.41	1146.33	-1.43	6.26	6.49
3600.	1079.31	1146.33	-.82	6.91	7.14
3800.	1144.21	1146.33	-.24	7.53	7.77
4000.	1209.11	1146.33	.33	8.14	8.37

SUMMARY OF FESS ECONOMICS

ANALYSIS: SERIES MOTORS CONCEPT

NO. OF BOX CARS : 5

NO. OF LOCOMOTIVES: 5.

ARS SWITCHED/DAY	OMB A-94 (\$ X1000)		RETURN ON INVESTMENT %		
	NPV	INIT COST (1982 \$)	4R METHOD	SENSITIVITY 1	SENSITIVITY 2
200.	-46.27	1294.04	-99.99 **	-99.99 **	-99.99 **
400.	18.63	1294.04	-15.52 **	-9.98 **	-9.98 **
600.	83.53	1294.04	-.98 **	-1.14 **	-1.64 **
800.	148.44	1294.04	-.98 **	-9.55	-9.23
1000.	213.34	1294.04	-1.01 **	-7.25	-6.96
1200.	278.24	1294.04	-12.35	-5.47	-5.19
1400.	343.15	1294.04	-10.98	-3.99	-3.73
1600.	408.05	1294.04	-9.79	-2.72	-2.47
1800.	472.95	1294.04	-8.75	-1.59	-1.35
2000.	537.85	1294.04	-7.80	-.58	-.33
2200.	602.76	1294.04	-6.94	.35	.59
2400.	667.66	1294.04	-6.14	1.21	1.45
2600.	732.56	1294.04	-5.39	2.01	2.25
2800.	797.46	1294.04	-4.68	2.77	3.01
3000.	862.37	1294.04	-4.01	3.49	3.72
3200.	927.27	1294.04	-3.38	4.17	4.40
3400.	992.17	1294.04	-2.77	4.82	5.06
3600.	1057.07	1294.04	-2.18	5.45	5.68
3800.	1121.98	1294.04	-1.62	6.05	6.28
4000.	1186.88	1294.04	-1.08	6.63	6.87

SUMMARY OF FESS ECONOMICS

ANALYSIS: SEPIES MOTORS CONCEPT

NO. OF BOX CARS : 5.

NO. OF LOCOMOTIVES: 6.

CARS SWITCHED/DAY	OMB A-94 (\$ X1000)		RETURN ON INVESTMENT %		
	NPV	INIT COST (1982 \$)	4R METHOD	SENSITIVITY 1	SENSITIVITY 2
200.	-46.27	1349.59	-99.99 **	-99.99 **	-99.99 **
400.	18.63	1349.59	-15.52 **	-.98 **	-.98 **
600.	83.53	1349.59	-.98 **	-1.04 **	-1.25 **
800.	148.44	1349.59	-.98 **	-9.81	-9.49
1000.	213.34	1349.59	-.99 **	-7.52	-7.23
1200.	278.24	1349.59	-11.92 **	-5.75	-5.48
1400.	343.15	1349.59	-11.26	-4.29	-4.13
1600.	408.05	1349.59	-10.09	-3.03	-2.78
1800.	472.95	1349.59	-9.05	-1.92	-1.67
2000.	537.85	1349.59	-8.11	-.91	-.67
2200.	602.76	1349.59	-7.25	.00	.25
2400.	667.66	1349.59	-6.47	.85	1.09
2600.	732.56	1349.59	-5.73	1.65	1.89
2800.	797.46	1349.59	-5.03	2.39	2.63
3000.	862.37	1349.59	-4.37	3.10	3.34
3200.	927.27	1349.59	-3.75	3.77	4.01
3400.	992.17	1349.59	-3.15	4.41	4.65
3600.	1057.07	1349.59	-2.57	5.03	5.26
3800.	1121.98	1349.59	-2.02	5.62	5.86
4000.	1186.88	1349.59	-1.49	6.20	6.43

SUMMARY OF FESS ECONOMICS

ANALYSIS: SERIES MOTORS CONCEPT

NO. OF BOX CARS : 6.

NO. OF LOCOMOTIVES: 6.

CARS SWITCHED/DAY	OMB A-94 (\$ X1000)		RETURN ON INVESTMENT %		
	NPV	INIT COST (1982 \$)	4R METHOD	SENSITIVITY 1	SENSITIVITY 2
200.	-68.50	1552.85	-99.99 **	-99.99 **	-99.99 **
400.	-3.60	1552.85	-99.99 **	-99.99 **	-15.52 **
600.	61.30	1552.85	-.98 **	-.98 **	-.98 **
800.	126.20	1552.85	-.98 **	-11.62	-11.25
1000.	191.11	1552.85	-.98 **	-9.12	-8.89
1200.	256.01	1552.85	-1.01 **	-7.25	-6.96
1400.	320.91	1552.85	-12.21 **	-5.74	-5.46
1600.	385.81	1552.85	-11.41	-4.46	-4.19
1800.	450.72	1552.85	-10.37	-3.33	-3.08
2000.	515.62	1552.85	-9.43	-2.33	-2.08
2200.	580.52	1552.85	-8.58	-1.42	-1.17
2400.	645.42	1552.85	-7.80	-.58	-.33
2600.	710.33	1552.85	-7.08	.20	.44
2800.	775.23	1552.85	-6.40	.93	1.17
3000.	840.13	1552.85	-5.75	1.62	1.86
3200.	905.03	1552.85	-5.15	2.27	2.51
3400.	969.94	1552.85	-4.57	2.89	3.13
3600.	1034.84	1552.85	-4.01	3.49	3.72
3800.	1099.74	1552.85	-3.48	4.06	4.29
4000.	1164.64	1552.85	-2.97	4.61	4.84

FIN

CHOPPER CONTROLLED DYNAMIC BRAKE

System Description

From the results obtained in this study, it is clear that energy savings are minimal at best, and negative at worst. The only positive benefit identified has been the saving in brake maintenance brought about by the use of electric, rather than friction, brakes. This saving could be realized by the use of a series chopper, as shown in Figure E-4.

In this scheme, full braking effort can be maintained to less than 1 mph. In conventional dynamic brake schemes (i.e., without a chopper), the braking effort falls rapidly at a relatively high speed (24 mph in a typical U.S. road locomotive). Available extended range features successively short out sections of the dynamic brake resistor, but this is not effective below approximately 10 mph. The chopper can be used to maintain the armature current and hence the braking effort at a sensibly constant level until the output voltage of the motors can no longer overcome the voltage drops in the circuit. This condition occurs at approximately 1 mph with four D77 traction motors that have a 62:15 gear ratio and a 40-in. diameter wheel.

System Cost

1. Initial

The only initial cost is the modification of the locomotive, because the boxcar is no longer required. This modification has an ROM cost as shown in Table E-2.

TABLE E-2

COST OF LOCOMOTIVE MODIFICATION FOR CHOPPER-CONTROLLED DYNAMIC BRAKE

Element	Cost, \$
Chopper and resistor grids	40,000
Control modifications	15,000
Jumper cables	4,000
Installation labor	15,000
Miscellaneous	<u>10,000</u>
Total	84,000

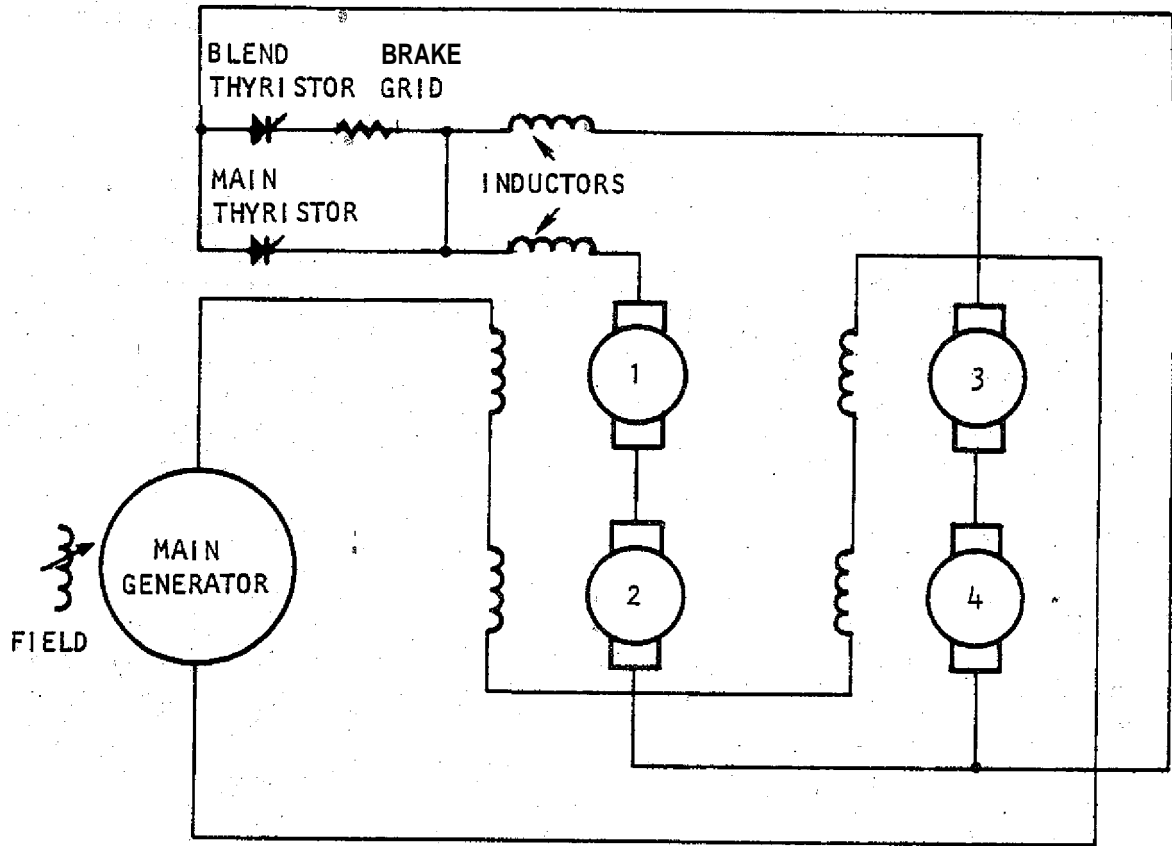

S-33833

Figure E-4. Simplified Schematic, Chopper-Controlled Dynamic Brake

2. Annual Costs and Credits

The saving in brake maintenance will be higher for this concept because the dynamic brake is available for all stops. However, an allowance is required for the maintenance of the chopper, and an RCM estimate of \$1,000 per year has been made. Therefore, the net saving in locomotive maintenance becomes \$0.059 per car switched.

Economic Analysis

The preceding data were input to the FESS economics program. The results are contained in the following pages.

For the typical locomotive, **it** can be seen that the ROI is 8.4 percent. Although this is significantly higher than the ROI for any other concept, **it** is still much too low to be worth considering.

FLYWHEEL ENERGY STORAGE SWITCHER

ANALYSIS: CHOPPER CONTROLLED DYNAMIC BRAKE YARD DATA

CARS SWITCHED PER DAY	:	200.--4000.
AVERAGE CAR WEIGHT	:	50. TONS
NO. OF LOCOMOTIVES	:	2.-- 6.
FUEL SAVING (GAL/CAR SW)	:	.000
LIFE OF PROJECT	:	20 YEARS

INITIAL INVESTMENT SUMMARY (1978 \$)--PER UNIT

LOCOMOTIVE MODIFICATION	:	84000.
PROVISION OF BOX CAR	:	0.
PROVISION OF ESU	:	0.

CHANGE IN ANNUAL COSTS AND CREDITS (1978 \$)

LOCOMOTIVE MAINTENANCE	:	20.650	PER CAR SWITCHED
ESU MAINTENANCE	:	0.	PER BOX CAR
FUEL SAVING	:	.0000	PER CAR SWITCHED

SUMMARY OF FESS ECONOMICS

ANALYSIS: CHOPPER CONTROLLED DYNAMIC BRAKE

NO. OF BOX CARS : 1.

NO. OF LOCOMOTIVES: 2.

CARS SWITCHED/DAY	OMB A-94 (% X1000)		4R METHOD	RETURN ON INVESTMENT %	
	NPV	INIT COST (1982 \$)		SENSITIVITY 1	SENSITIVITY 2
200.	57.39	212.10	-10.84	-3.84	-3.84
400.	114.79	212.10	-5.75	1.62	1.62
600.	172.18	212.10	-2.24	5.38	5.38
800.	229.57	212.10	.60	8.43	8.43
1000.	286.96	212.10	3.09	11.09	11.09
1200.	344.36	212.10	5.35	13.50	13.50
1400.	401.75	212.10	7.47	15.76	15.76
1600.	459.14	212.10	9.49	17.91	17.91
1800.	516.54	212.10	11.45	19.99	19.99
2000.	573.93	212.10	13.36	22.02	22.02
2200.	631.32	212.10	15.25	24.02	24.02
2400.	688.71	212.10	17.12	26.01	26.01
2600.	746.11	212.10	19.00	27.99	27.99
2800.	803.50	212.10	20.87	29.97	29.97
3000.	860.89	212.10	22.76	31.96	31.96
3200.	918.29	212.10	24.66	33.97	33.97
3400.	975.68	212.10	26.59	35.99	35.99
3600.	1033.07	212.10	28.54	38.04	38.04
3800.	1090.46	212.10	30.51	40.12	40.12
4000.	1147.86	212.10	32.52	42.23	42.23

SUMMARY OF FESS ECONOMICS

ANALYSIS: CHOPPER CONTROLLED DYNAMIC BRAKE

NO. OF BOX CARS : 1.

NO. OF LOCOMOTIVES: 3.

CARS SWITCHED/DAY	OMB 4-94 (% X1000)		RETURN ON INVESTMENT %		
	NPV	INIT COST (1982 \$)	4R METHOD	SENSITIVITY 1	SENSITIVITY 2
200.	57.39	318.14	-1.20 **	-6.66	-6.66
400.	114.79	318.14	-8.84	-1.69	-1.69
600.	172.18	318.14	-5.75	1.62	1.62
800.	229.57	318.14	-3.32	4.24	4.24
1000.	286.96	318.14	-1.24	6.46	6.46
1200.	344.36	318.14	.60	8.43	8.43
1400.	401.75	318.14	2.29	10.23	10.23
1600.	459.14	318.14	3.86	11.91	11.91
1800.	516.54	318.14	5.35	13.50	13.50
2000.	573.93	318.14	6.77	15.02	15.02
2200.	631.32	318.14	8.15	16.49	16.49
2400.	688.71	318.14	9.49	17.91	17.91
2600.	746.11	318.14	10.80	19.30	19.30
2800.	803.50	318.14	12.09	20.67	20.67
3000.	860.89	318.14	13.36	22.02	22.02
3200.	918.29	318.14	14.62	23.36	23.36
3400.	975.68	318.14	15.87	24.69	24.69
3600.	1033.07	318.14	17.12	26.01	26.01
3800.	1090.46	318.14	18.37	27.33	27.33
4000.	1147.86	318.14	19.62	28.65	28.65

SUMMARY OF FESS ECONOMICS

ANALYSIS: CHOPPER CONTROLLED DYNAMIC BRAKE

NO. OF BOX CARS : 1.

NO. OF LOCOMOTIVES: 4.

CARS SWITCHED/DAY	OMB A-94 (\$ X1000)		RETURN ON INVESTMENT %		
	NPV	INIT COST (1982 \$)	4R METHOD	SENSITIVITY 1	SENSITIVITY 2
200.	57.39	424.19	-3.38 **	-8.52	-8.52
400.	114.79	424.19	-10.84	-3.84	-3.84
600.	172.18	424.19	-7.98	-.77	-.77
800.	229.57	424.19	-5.75	1.62	1.62
1000.	286.96	424.19	-3.88	3.63	3.63
1200.	344.36	424.19	-2.24	5.38	5.38
1400.	401.75	424.19	-.76	6.97	6.97
1600.	459.14	424.19	.60	8.43	8.43
1800.	516.54	424.19	1.88	9.80	9.80
2000.	573.93	424.19	3.09	11.09	11.09
2200.	631.32	424.19	4.24	12.32	12.32
2400.	688.71	424.19	5.35	13.50	13.50
2600.	746.11	424.19	6.42	14.65	14.65
2800.	803.50	424.19	7.47	15.76	15.76
3000.	860.89	424.19	8.49	16.85	16.85
3200.	918.29	424.19	9.49	17.91	17.91
3400.	975.68	424.19	10.47	18.96	18.96
3600.	1033.07	424.19	11.45	19.99	19.99
3800.	1090.46	424.19	12.41	21.01	21.01
4000.	1147.86	424.19	13.36	22.02	22.02

SUMMARY OF FESS ECONOMICS

ANALYSIS: CHOPPER CONTROLLED DYNAMIC BRAKE

NO. OF BOX CARS : 1.

NO. OF LOCOMOTIVES: 5.

CARS SWITCHED/DAY	OMB A-94 (\$ X1000)		RETURN ON INVESTMENT %		
	NPV	INIT COST (1982 \$)	4R METHOD	SENSITIVITY 1	SENSITIVITY 2
200.	57.39	530.24	-0.98 **	-9.91	-9.91
400.	114.79	530.24	-12.31	-5.42	-5.42
600.	172.18	530.24	-9.59	-2.50	-2.50
800.	229.57	530.24	-7.49	-0.25	-0.25
1000.	286.96	530.24	-5.75	1.62	1.62
1200.	344.36	530.24	-4.24	3.25	3.25
1400.	401.75	530.24	-2.88	4.70	4.70
1600.	459.14	530.24	-1.63	6.04	6.04
1800.	516.54	530.24	-0.48	7.27	7.27
2000.	573.93	530.24	0.60	9.43	8.43
2200.	631.32	530.24	1.63	9.53	9.53
2400.	688.71	530.24	2.61	10.58	10.58
2600.	746.11	530.24	3.55	11.58	11.58
2800.	803.50	530.24	4.46	12.56	12.56
3000.	860.89	530.24	5.35	13.50	13.50
3200.	918.29	530.24	6.21	14.42	14.42
3400.	975.68	530.24	7.05	15.32	15.32
3600.	1033.07	530.24	7.88	16.20	16.20
3800.	1090.46	530.24	8.69	17.06	17.06
4000.	1147.86	530.24	9.49	17.91	17.91

E-57

SUMMARY OF FESS ECONOMICS

ANALYSIS: CHOPPER CONTROLLED DYNAMIC BRAKE

NO. OF BOX CARS : 1.

NO. OF LOCOMOTIVES: 6.

CARS SWITCHED/DAY	OMB A-91 (\$ X1000)		RETURN ON INVESTMENT %		
	NPV	INIT COST (1982 \$)	4R METHOD	SENSITIVITY 1	SENSITIVITY 2
200.	57.39	636.29	-0.98 **	-11.01	-11.01
400.	114.79	636.29	-1.20 **	-6.66	-6.66
600.	172.18	636.29	-10.84	-3.84	-3.84
800.	229.57	636.29	-8.84	-1.69	-1.69
1000.	286.96	636.29	-7.18	.08	.08
1200.	344.36	636.29	-5.75	1.62	1.62
1400.	401.75	636.29	-4.48	2.99	2.99
1600.	459.14	636.29	-3.32	4.24	4.24
1800.	516.54	636.29	-2.24	5.38	5.38
2000.	573.93	636.29	-1.24	6.46	6.46
2200.	631.32	636.29	-.30	7.47	7.47
2400.	688.71	636.29	.60	8.43	8.43
2600.	746.11	636.29	1.46	9.35	9.35
2800.	803.50	636.29	2.29	10.23	10.23
3000.	860.89	636.29	3.09	11.09	11.09
3200.	918.29	636.29	3.86	11.91	11.91
3400.	975.68	636.29	4.61	12.72	12.72
3600.	1033.07	636.29	5.35	13.50	13.50
3800.	1090.46	636.29	6.07	14.27	14.27
4000.	1147.86	636.29	6.77	15.02	15.02

BFIN

