

Infrasound Avalanche Monitoring: Enhanced monitoring in Little Cottonwood Canyon, Utah

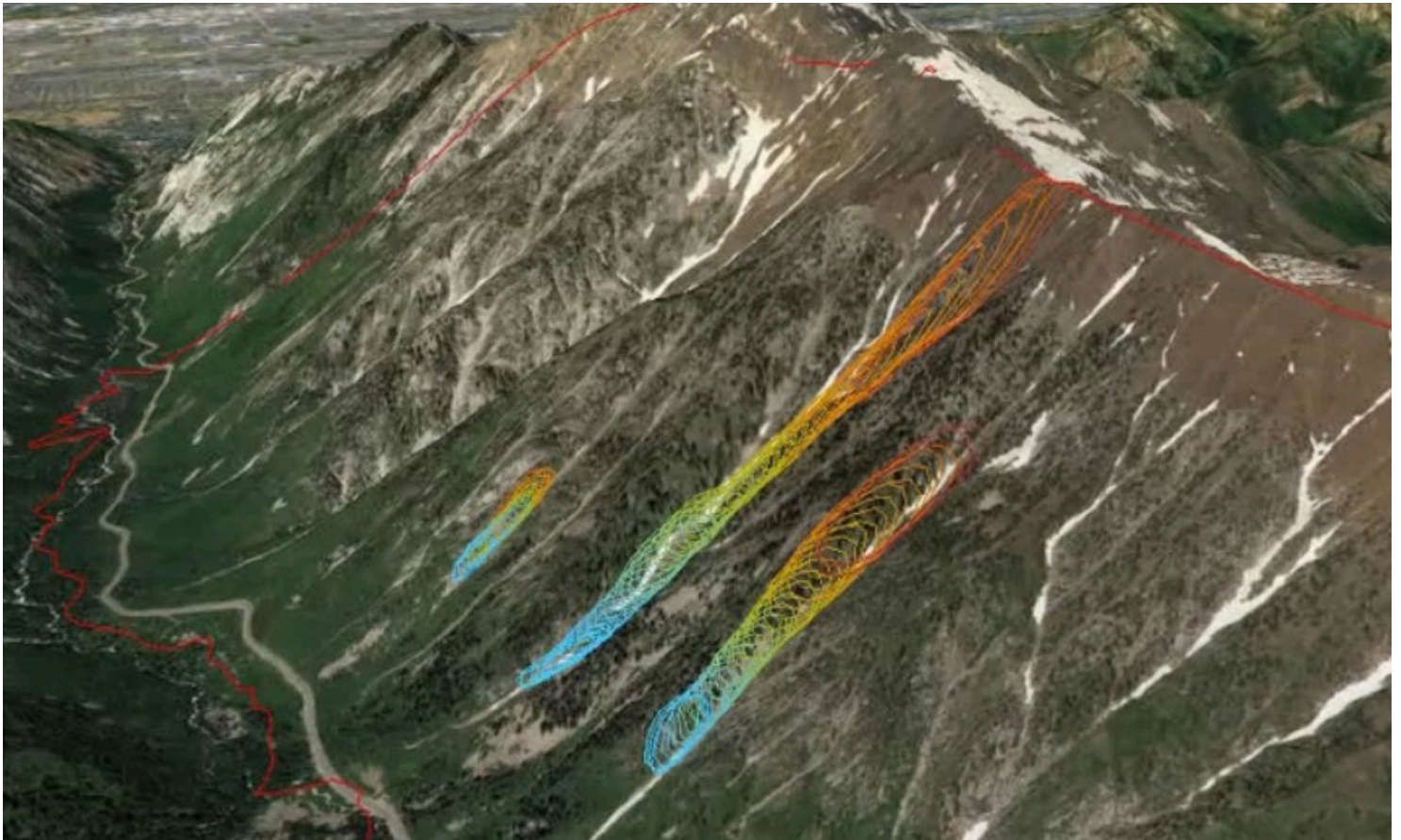

APPLIED RESEARCH &
INNOVATION BRANCH

Jeffrey Johnson
Hans Peter Marshall
Jacob Anderson



COLORADO
Department of Transportation

The contents of this report reflect the views of the authors, who are responsible for the facts and accuracy of the data presented herein. The contents do not necessarily reflect the official views of the Colorado Department of Transportation or the Federal Highway Administration. This report does not constitute a standard, specification, or regulation.

Technical Report Documentation Page

1. Report No. CDOT-2021-10		2. Government Accession No.		3. Recipient's Catalog No.	
4. Title and Subtitle Infrasound Avalanche Monitoring: Enhanced monitoring in Little Cottonwood Canyon, Utah				5. Report Date June 2021	
				6. Performing Organization Code	
7. Author(s) Jeffrey B Johnson ¹ (jeffreybjohnson@boisestate.edu) Hans-Peter Marshall ¹ (hpmarshall@boisestate.edu) Jacob F Anderson ¹ (jacobanderson152@boisestate.edu)				8. Performing Organization Report No.	
9. Performing Organization Name and Address ¹ Department of Geosciences, Boise State University, Boise, ID 83725				10. Work Unit No. (TRAVIS)	
				11. Contract or Grant No. 5337.05	
12. Sponsoring Agency Name and Address Colorado Department of Transportation - Research 2829 W. Howard Pl. Denver CO, 80204				13. Type of Report and Period Covered Final	
				14. Sponsoring Agency Code	
15. Supplementary Notes Prepared in cooperation with the US Department of Transportation, Federal Highway Administration Steven Clark stevenclark@utah.gov , Project Champion Jamie Yount, CDOT, Jamie.yount@state.co.us , Co-Champion Mark Saurer, UDOT, msaurer@utah.gov Damian Jackson, UDOT, djackson@utah.gov					
16. Abstract The work is a continuation of a 2017-2018 TARP project, which focused on testing infrasound sensor technology and deployment optimization of infrasound stations for monitoring of snow avalanches in Little Cottonwood Canyon (LCC), Utah. The goals of this project were to develop software and hardware solutions to permit (cell) telemetry of synthesized infrasound data products. Toward this objective we designed, installed, maintained, and processed data from a three-station network of infrasound arrays in LCC for both the 2019-2020 and 2020-2021 seasons. The installation in 2020-2021, together with a partnership with Snowbound Solutions LCC, was an operational system designed to provide near real-time tools to forecasters in Little Cottonwood Canyon. This project concluded with a successful transfer of R&D to an applied system suitable for commercial purposes.					
17. Keywords CDOT, Colorado, infrasound, Little Cottonwood Canyon			18. Distribution Statement This document is available on CDOT's website https://www.codot.gov/programs/research		
19. Security Classif. (of this report) Unclassified		20. Security Classif. (of this page) Unclassified		21. No. of Pages 22	22. Price

Infrasound Avalanche Monitoring: Enhanced monitoring in Little Cottonwood Canyon, Utah (CDOT 5337-05)

Johnson, J.B., Anders, J.F., Marshall, H.P. (Boise State University)

Contents of this report:

- 1) Project Description**
- 2) Background**
- 3) Personnel and Roles**
- 4) Project objectives and Status**
- 5) Project Objective #1 and #2**
 - a) Hardware Overview**
 - b) Software Overview**
- 6) Project Objective #3**
- 7) Project Objective #4**
- 8) Recommendations Moving Forward**
- 9) Publications and References Cited**

1) Project Description:

This work is a continuation of a Transportation Pooled Fund Program Project (TARP TPF-5337-02; 2/2017-6/2019), which was entitled ‘Infrasound Avalanche Detection: comparison study of multiple new technologies’. The project that is featured in this report is ‘Infrasound Avalanche Monitoring: Enhanced monitoring in Little Cottonwood Canyon, Utah’. In the current work we further explore infrasound sensor technology and deployment optimization of infrasound stations for monitoring of snow avalanches. The goals met by this project were to develop software and hardware solutions to permit (cell) telemetry of synthesized infrasound data products. Toward this objective we designed, installed, maintained, and processed data from a three-station network of infrasound arrays in LCC for both the 2019-2020 and 2020-2021 seasons. The installation in 2020-2021, together with a partnership with Snowbound Solutions LLC, resulted in an operational system capable for providing near real-time tools to forecasters in Little Cottonwood Canyon. This project concluded with a successful transition of research-focused infrasound technology to an applied system suitable for commercial purposes.

2) Background

Infrasound, or low frequency sound waves below the threshold of human sensitivity, are used by scientists and practitioners to detect, locate, quantify, and understand geophysical events including volcanoes, earthquakes, storms, debris flows, and *snow avalanches*. Infrasound sensing is particularly appropriate for the study of snow avalanches because much of their sound energy is generated in the infrasound frequency band, whose energy can propagate long distances with minimal signal attenuation [e.g., **Bedard, 1997**]. Infrasound monitoring instrumentation can be situated several kilometers from an avalanche permitting safe deployment locations for both hardware and personnel. Furthermore, infrasound may be collected in real-time and utilized at night and during periods of inclement weather when a view to the avalanche source is not possible [e.g., **Havens et al., 2014**].

The value of infrasound monitoring for snow avalanches has been recognized in Little Cottonwood Canyon (LCC), Utah for more than 15 years. Intermountain Labs (IML; <http://www.intermountainlabs.com/>) led the initial effort to design and maintain a robust infrasound network in LCC capable of surveilling slide paths that could potentially impact a 3 km section of SR-211, a heavily-used road access corridor to popular Utah ski resorts [Yount et al., 2008]. They deployed three stations, referred to in this report as LCC1, LCC2, and LCC3, adjacent to and easily accessible to the highway. These sites permitted identification of both snow avalanche occurrence and associated explosive mitigation work. This system has operated reliably for many years, but ongoing maintenance, coupled with the availability of improved sensor and telemetry technologies, signal processing developments, and web-based applications, has prompted our recent efforts to improve upon the system.

Boise State University (BSU) has received two rounds of funding from TARP to explore infrasound applications for the snow avalanche community. The first grant, completed in 2019 focused on comparing sensor types and replicating and improving upon IML avalanche location algorithms (which are proprietary). A second round of funding permitted additional work focused largely on development of an operational system. The LCC component of the project replicated the deployment topology of the IML setup, in order to assess effectiveness, and also leverage the site permissions already granted to UDOT. These LCC1, LCC2, and LCC3 sites are adequate for monitoring a particularly exposed section of SR-211, but are not necessarily optimal for monitoring the entire transportation corridor. A map of these stations, used by both the IML system and by our group, is provided in Figure 1.

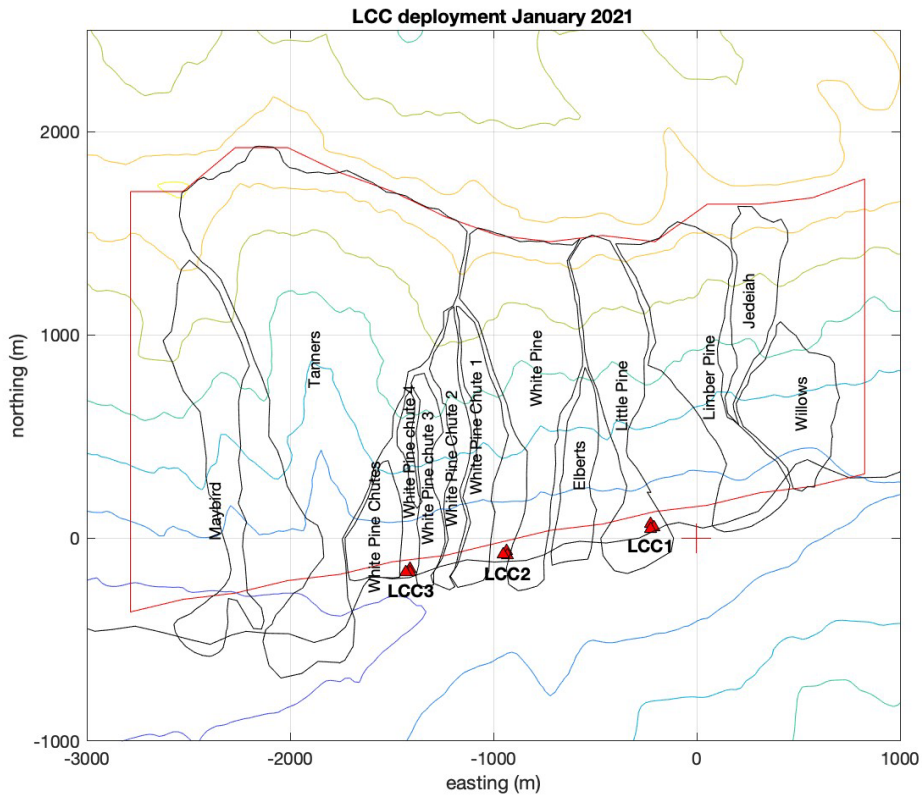
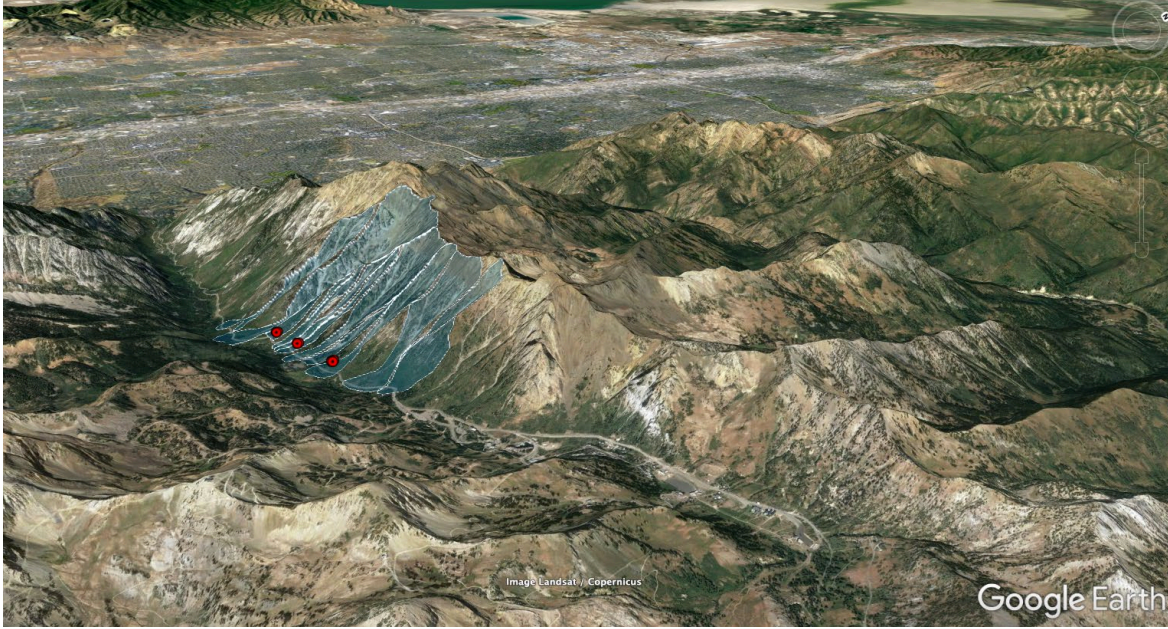

Figure 1 – (top) oblique perspective view from Alta and Snowbird ski resorts at head of valley toward Salt Lake City urban corridor in background. LCC1, LCC2, and LCC3 stations are red symbols. (bottom) Plan view of station deployment showing names of monitored slide paths.

3) Personnel and Roles

Boise State University has research groups in their geophysics program focused both on infrasound technology and on avalanche and snow physics. This project is led by Drs. Jeffrey Johnson, Jake Anderson, and Hans-Peter Marshall who are geophysicists in the Department of Geosciences. Professors Johnson and Marshall are regular teaching/research faculty and have largely focused their TARP efforts on software development, project management, and dissemination of results. Dr. Anderson is a research professor and his effort focused primarily on telemetry and hardware solutions.

The work during the 2020-2021 season has been facilitated by collaboration with Snowbound Solutions (<https://snowboundsolutions.com/>) staff, Dr. Scott Havens and Clark Corey. Both Snowbound and BSU shared field efforts and data analysis strategies and worked together to optimize technology transfer from BSU to Snowmbound.

This work would not have been possible without active involvement from current and former UDOT forecasters including Mark Saurer, Bill Nalli, and Damian Jackson, who provided vital data, including avalanche reporting, and information about the functionality of the long-lived IML system. Along with other forecasters, including Steven Clark, Dan Costaschuk, Lauren Delaney, Brett Korpela and Shawn Lambert, they also provided essential help in the field including hardware maintenance.

Jeffrey Johnson prepared this report with input from collaborators Anderson, Marshall, and Havens. Johnson is responsible for the contents of this report and any questions can be referred to him.

4) Project Objectives and Status:

Four principal objectives, listed below, were addressed in the TARP project 'Infrasound Avalanche Monitoring: Enhanced monitoring in Little Cottonwood Canyon (LCC), Utah'.

Objective #1: Development of software and hardware infrastructure to permit (cell) telemetry of synthesized infrasound data products. *This objective was met.* Both hardware and software are now mature and the technology was transferred to Snowbound.

Objective #2: Deployment of proof-of concept telemetered station(s) from the LCC sites and return avalanche detection data. *Our results exceeded the expectations of this objective.* Three operational stations delivered array data from LCC in 2021; data return excellent. An additional test deployment was realized in Milford Road, New Zealand [**Watson et al., in rev.**].

Objective #3: Installation and maintenance of an expanded six-station infrasound network of arrays optimally situated to monitor a larger stretch of SR-210. *This objective is still in progress.* Quick-deploy array hardware is ready to go, but installation was problematic during pandemic; an installation is still possible during winter 2021-2022 season

Objective #4: Campaign-style experimentation during which activity is recorded optically and/or multi-spectrally and mapped to relate physical manifestation of avalanche to the infrasound radiation. *We met the expectations of this objective.* Integrated visual-infrasound study was carried out and published in the Journal of Geophysical Research [**Johnson et al., 2021**]

Details of each of these are project objectives are outlined in the next sections.

5) Project Objectives #1 and #2 - Development of software and hardware infrastructure to permit (cell) telemetry of synthesized infrasound data products – and - deployment of proof-of-concept telemetered station data from the LCC sites and return avalanche detection data

The primary focus of this project was to replicate and improve upon the IML system of avalanche detection in LCC. Both hardware and software are now mature and their technologies have been transferred through peer-reviewed journal publications [**Johnson et al., 2018; Johnson et al., 2021; Watson et al., in rev.**], as well as through presentations at conferences (International Snow Science Workshop, Innsbruck, Austria (2018)), invited talks to the snow avalanche community (e.g., Colorado Snow and Avalanche Workshop, Breckenridge, CO (2019) and Utah Snow and Avalanche Workshop, Salt Lake City, UT (2019), and in regular status reports to the TARP members during virtual meetings.

a) Hardware efforts have involved integration of infrasound monitoring transducers with data acquisition and telemetry systems. The hardware technology transfer to Snowbound Solutions LCC includes solutions implemented primarily during the 2020-2021 winter season. As in previous studies we used the low-cost calibrated infrasound transducers (infraBSU version #2; <https://sites.google.com/boisestate.edu/infravolc/infrabsu/version-2?authuser=0>) developed at Boise State University. These sensors are robust and reliable using MEMS transducers and customized capillary assemblies to pass sound above 0.1 Hz. The sensors are built at a cost of about \$400 per unit and are used as part of a three-sensor distribution to provide beamforming capabilities. Beamforming permits identification of low-intensity avalanche sounds and directional constraints. For avalanche studies we optimized infrasound arrays as three-element distributions of sensors distributed with about a 25-m aperture (see Figure 2).

Station Layout

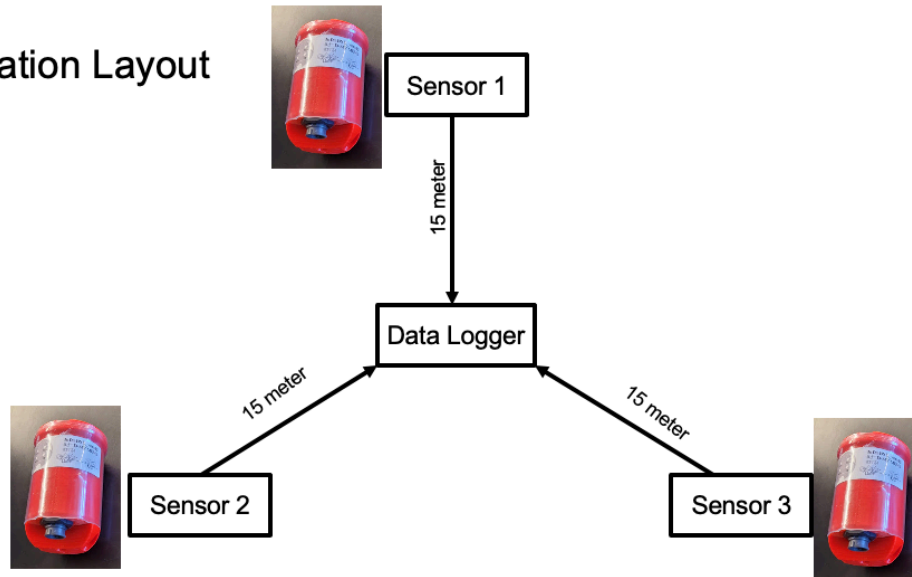
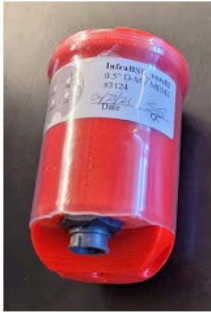

Figure 2 – Schematic of three element infrasound array using infraBSU version #2 infrasonic microphones. In the field these sensors are separated from the central datalogger by cables of length ~15 m. These cables and the sensors are located at ground level and covered by snowpack, which does not generally interfere with infrasound. Precise location of sensors is measured with GPS and is necessary to perform proper source location constraints.

Analog output from the three-element infrasound arrays is digitized with three-channel seismic-style dataloggers capable of amplifying signal and digitizing continuously at 100 Hz using 24-bit resolution. DataCube loggers by DiGOS (<https://digos.eu/>) have proven capable and reliable since we started monitoring infrasound in LCC. In 2019-2020 and in 2020-2021 we integrated and tested DataCube loggers with DataCube communication modules (Figure 2) using cell phone telemetry to relay data to cloud-based servers (both Boise State University and Amazon Web Service). Direct cost of DiGOS hardware at each station is about \$2000 per logger and \$1500 per communication module.

Avalanche Monitoring Instrumentation

Sensor:
infraBSU microphone



Data Logger:
DiGOS Datacube-3



Telemetry:
DiGOS CCUBE



Figure 3 – Hardware used at each station. Three microphones (left) are connected by cable to a central data logger (middle), which is co-located with the telemetry unit (right). The logger and telemetry unit are housed in a weather-proof enclosure and mounted on the power tower (Figure 4).

A single avalanche monitoring station entails three microphones, digitization and telemetry hardware, and a power system (Figure 4). In 2020-2021 we partnered with Snowbound Solutions to construct three stations with robust solar power systems capable of running the station throughout the winter. The logger and telemetry module were powered with a 210 Amp-hour battery bank and 100 Watt solar panel, while the sensors used a separated shared battery of 55 Amp-hour capacity. Tower and power system design was developed by Snowbound Solutions partners.

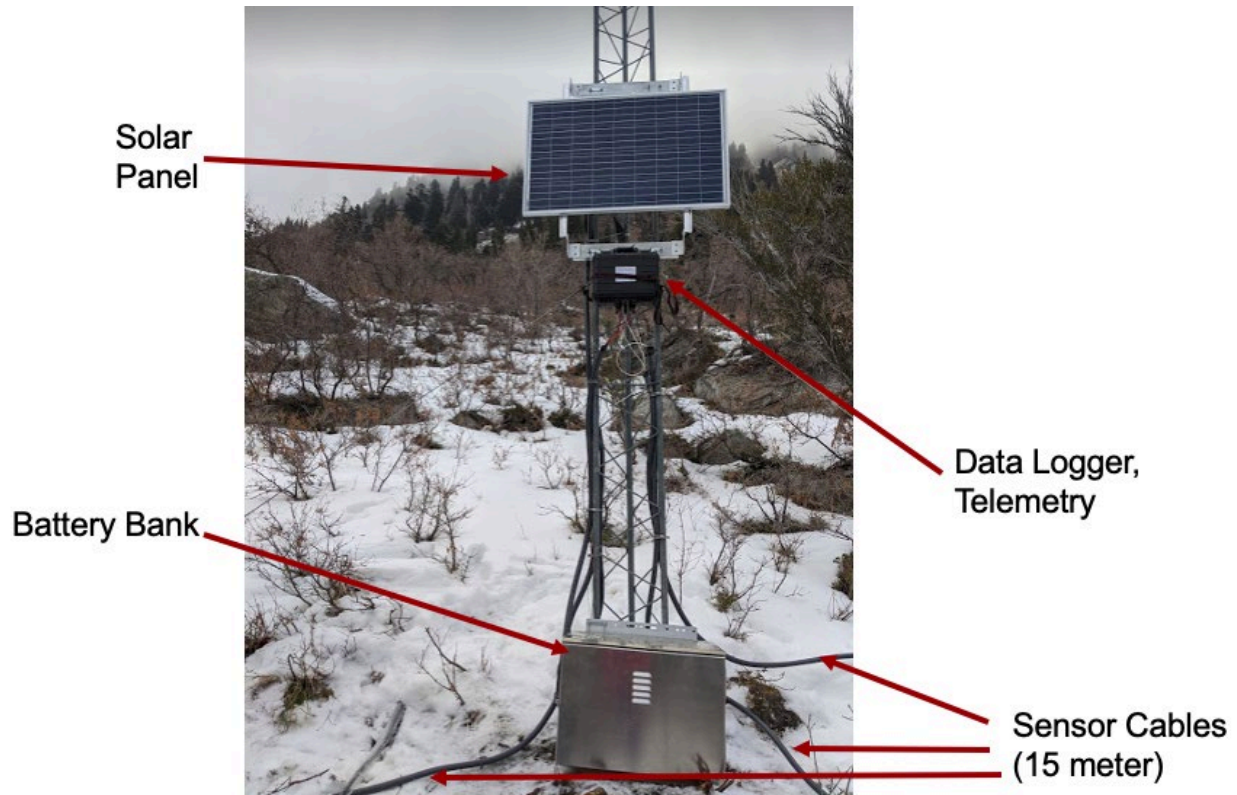

Figure 4 – Station tower at LCC3 designed to keep 100 Watt solar panel above snow pack. Logger and telemetry module are in 30 x 20 x 15 cm black box situated directly beneath the solar panel.

Cell telemetry is available in LCC and was used to relay infrasound waveform data in near real time to cloud-based servers. Three stations, each with three sensors, operated independently. Data throughput of the three arrays was approximately $24 \text{ bit} \times 3 \text{ channels} \times 3 \text{ stations} \times 100 \text{ Hz} = 4000 \text{ Bytes/s}$. Data drops occurred occasionally as cell connectivity was lost. Re-establishment of a link occurred autonomously and was made more robust as the season went on. All data were also stored locally aboard the loggers at each station.

b) Software - Data were analyzed in real-time according to the workflow in Figure 5. Software developed by BSU was converted to Python by Snowbound Solutions and embedded with the Amazon Web Service (AWS) data repositories. Real-time analyses resulted in signal identification, localization, and alerts, including event pages. The alerts system is an ongoing developmental focus led by Snowbound Solutions with continuing input from the BSU group.

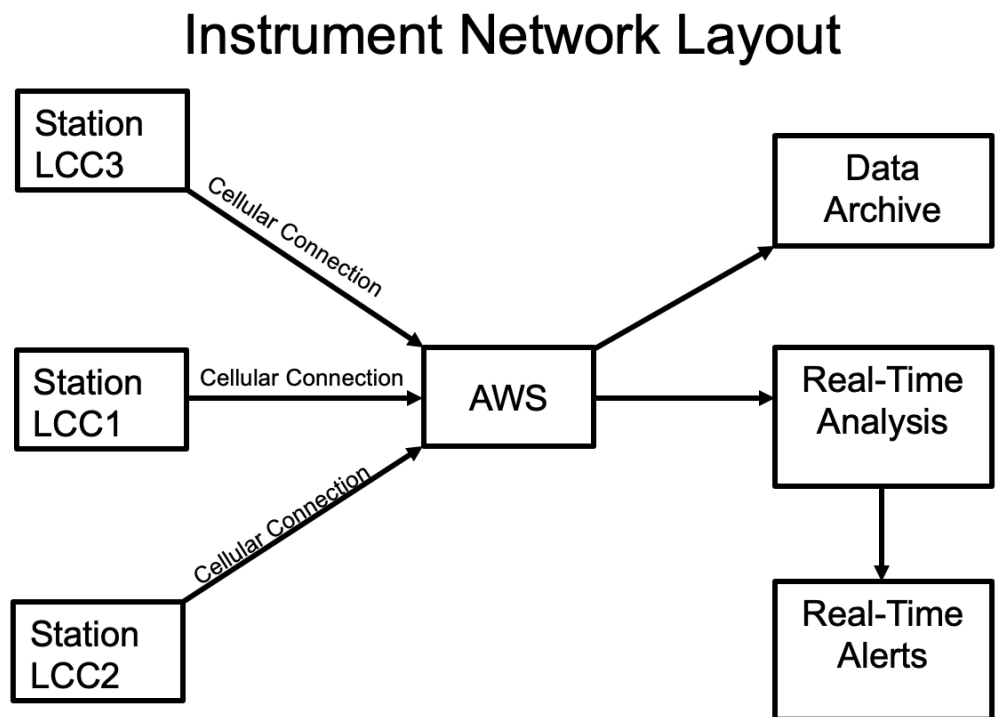

Figure 5 – Workflow schematic for three station network (LCC1-3) and general processing.

Algorithms for multi-array avalanche localization are detailed in **Johnson et al. (2018)** and **Johnson et al. (2021)** and are summarized only briefly here. The location of avalanches employed by these studies and by the original IML system [**Yount et al., 2008**], require coincident detections from at least two infrasound arrays (see workflow schematic in Figure 6). While a single array is processed independently to infer that there may be a candidate source, another array is needed to confirm and ultimately locate the avalanche. Improvements made in the last few seasons of data acquisition and signal processing analysis have permitted enhanced detection and localization of sources.

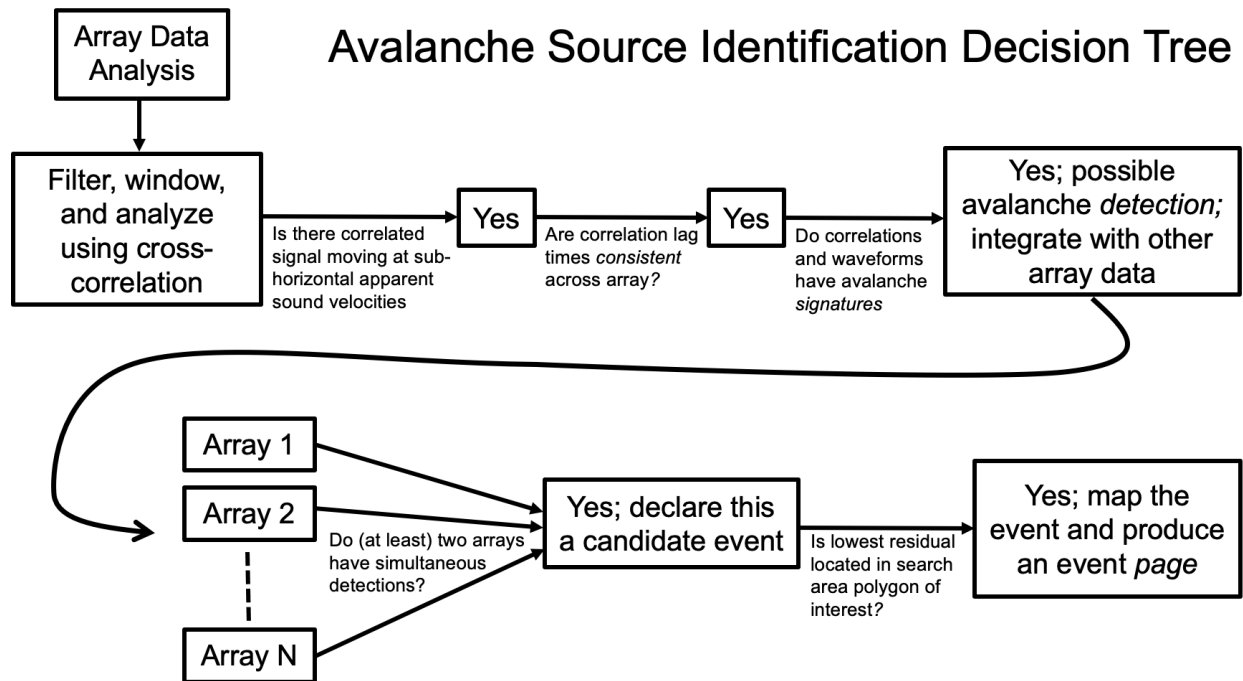

Figure 6 – Decision tree used to identify and map an avalanche of interest.

The workflow is designed to optimize avalanche detections and minimize false positives. For LCC avalanche data, which can be obscured by vehicular noise and explosive triggers, we have optimized analysis windows and filter bands (generally 5 Hz infrasound and above). Data are analyzed in overlapping 5 s time windows and similarity of signal is measured across all microphones in an array (top row of Figure 6). The output of an analysis for an entire day, for example, can be used to demonstrate the presence of avalanche signals. Other optimization strategies are discussed in **Johnson et al. (2018)** and **Johnson et al. (2021)**. This workflow permits expansion of additional stations within a network of arrays. Event identification simply requires any two arrays in a multi-array network to concurrently detect signal.

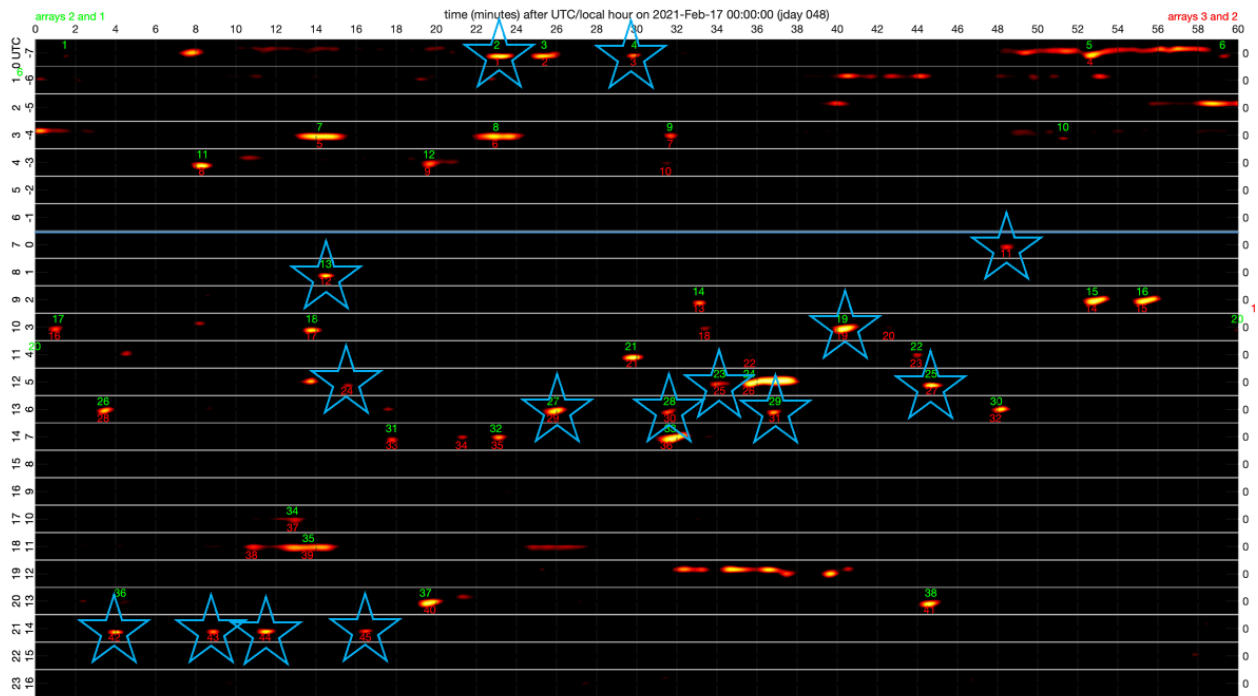

Figure 7 – An analysis of 24 hours of avalanche data from 17-Feb-2021 highlighting avalanches identified with station LCC2. Each line represents an hour of activity and each ‘hot spot’ indicates the timing and duration of a probable avalanche. Numbers correspond to detected avalanches using a subset of arrays (either LCC1 and LCC2; green, or LCC2 and LCC3; red). More than 40 avalanches are detected on this day corresponding to a powerful local storm (snowfall rate is shown in lower time series). Blue stars in top panel indicate those events detected and located using the IML installations.

An assessment of the effectiveness of the detection algorithms is made by comparing BSU/Snowbound hardware and processing algorithms with the detections made by the IML system operational since 2006 [Yount et al., 2008]. On 17 February 2021, for instance (see Figure 7), avalanches that were detected by IML (using their arrays 1 and 2) consisted primarily of events occurring within the network. Approximately 30 *additional* avalanche events were identified by the BSU/Snowbound system, many of which were outside the network (meaning that they are confirmed as avalanches, but not precisely locatable). Many of these extra-network detections are listed in the operational forecaster’s catalog. Avalanche locations, derived from infrasound, move downslope and can be mapped as a time lapse series of sources (Figure 8).

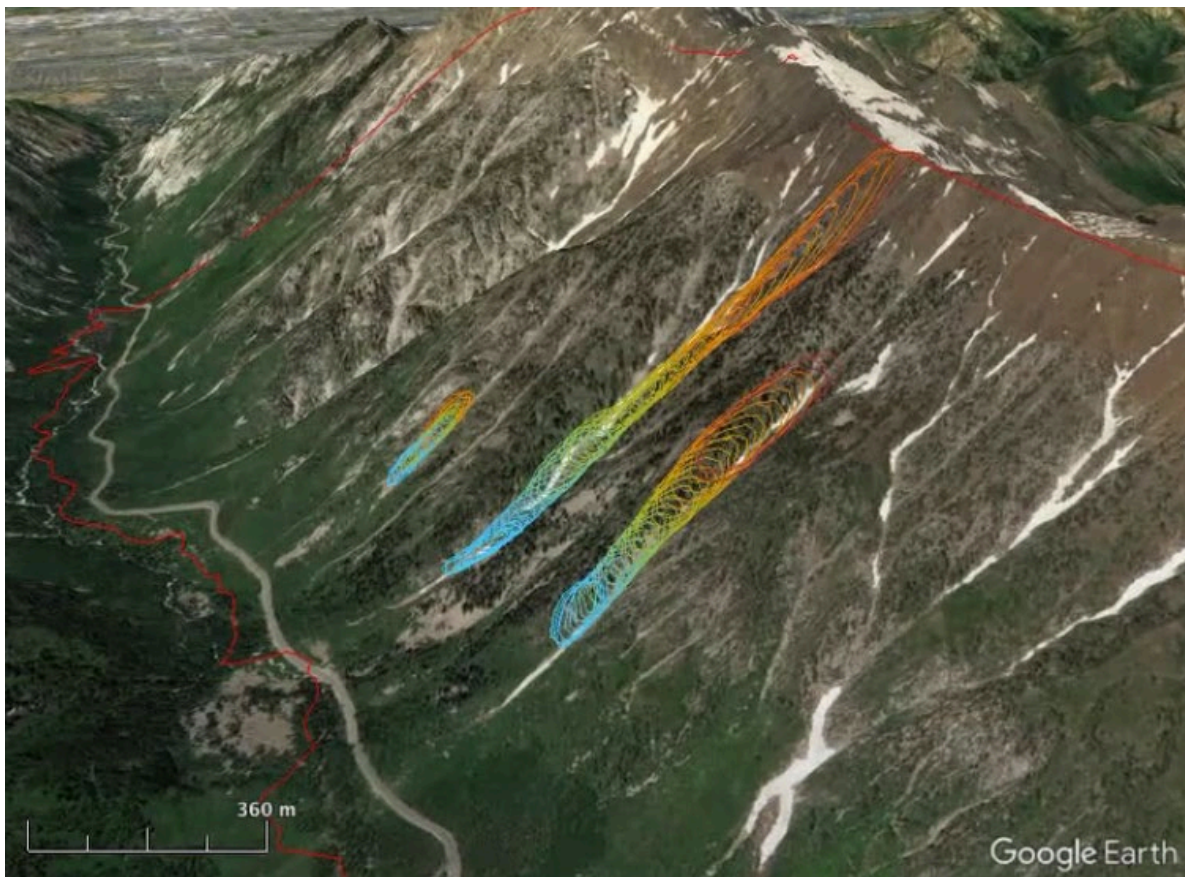

Figure 8 – Three mapped avalanches occurring in LCC within the network of LCC1, LCC2, and LCC3. Color indicates time progression and polygon size indicates source dimension uncertainty.

Location of avalanches is carried out for events occurring within the network, meaning that precise locations can be made for avalanches located between stations. An example perspective view of three well-located events may be seen in Figure 8. For processing telemetered data, near real-time maps and signal energetics can be quantified and posted using Snowbound Solutions' *SnowObs Visualization* pages (Figure 9). This information, along with text alerts, is being made available in near-real time for forecasters.

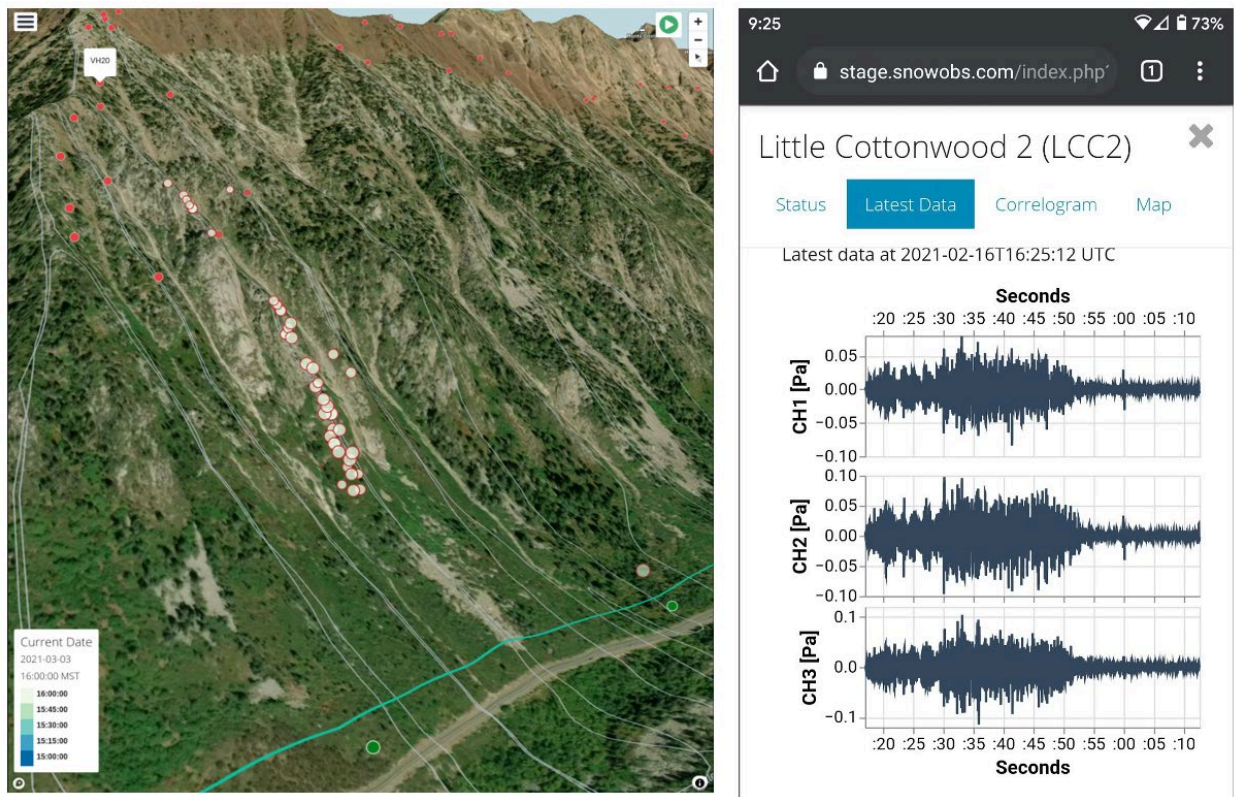

Figure 9 – SnowObs visualization showing a 3D avalanche detection map (left) and mobile interface corresponding to avalanche signal (right). These tools are under development by Snowbound Solutions with input and feedback from UDOT forecasters.

6) Project Objective #3 -Installation and maintenance of an expanded six-station infrasound network of arrays optimally situated to monitor a larger stretch of SR-210.

The 2020-2021 telemetered network of arrays performs well for identifying and locating avalanches within the network. This means that avalanches located within an approximate 5 km² region north of the SR-210 corridor, and both west of LCC1 and east of LCC2 are well-triangulated. For events occurring outside of network (refer to Figure 10) detections are possible, but precise locations cannot be well triangulated. The solution for more comprehensive source localization outside of the LCC1, LCC2, and LCC3 domain is to add additional stations (blue triangles in Figure 10).

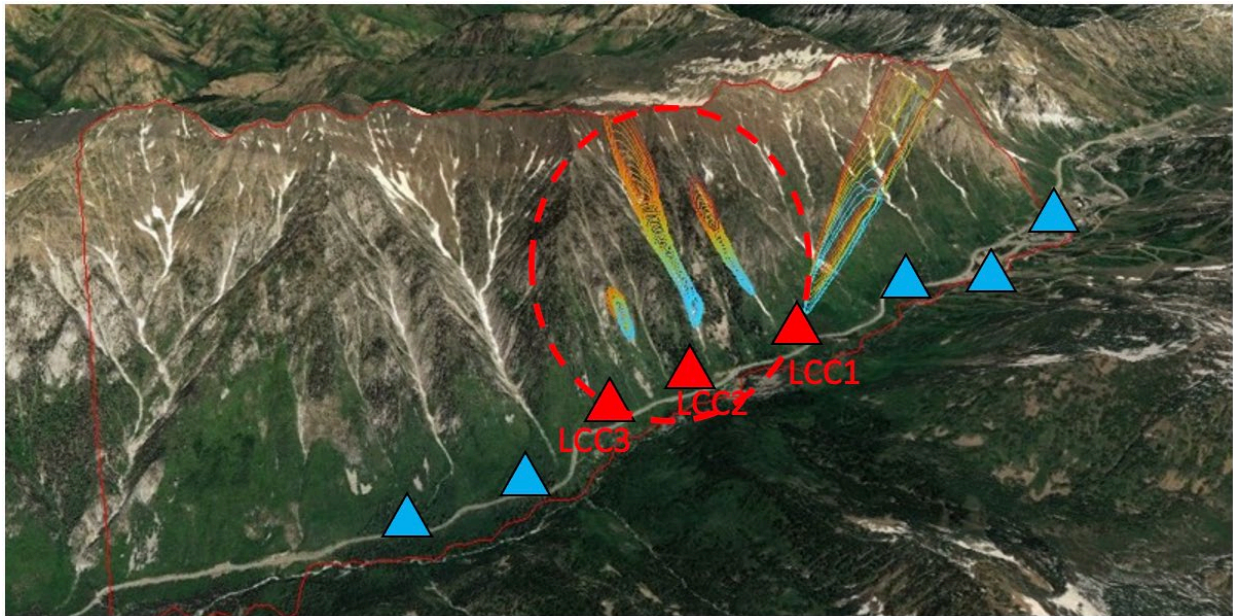

Figure 10 – Example of four avalanches detected by LCC and locations mapped using multiple arrays (LCC1, LCC2, or LCC3; red triangles). The area enclosed by the red circle indicates locations made in-network. If an avalanche occurs outside the network the location uncertainty will be larger as indicated by the avalanche depicted furthest to the right. Expanding the size of the network requires additional stations, such as those proposed by the blue triangles.

Designing and implementing an expanded network in LCC may be desirable given the large number of avalanches that occur outside of the LCC1-to-LCC3 network. The first step to inform network topology is to conduct a campaign deployment using portable loggers, internal batteries, and no telemetry. This was planned for 2020-2021, but was not implemented due to pandemic-related logistical issues. Despite this, hardware is developed and now in hand to support a broader survey of additional sites within LCC; we have developed *quick-deploy boxes* in which loggers, microphones, and cables may be set up within about 30 minutes. These systems will run unattended for ten days and can be used to assess suitability of additional stations within the LCC network. ***Although this grant is formally concluded in June 2021 we intend to follow up with campaign efforts during the 2021-2022 season.*** This data may be used by Snowbound Solutions to consider whether an expanded network of permanent stations is warranted.

7) Project Objective #4 - Campaign-style experimentation during which activity is recorded optically and/or multi-spectrally and mapped to relate physical manifestation of avalanche to the infrasound radiation.

Fundamental research in avalanche science is a primary motivator of the TARP-funded project. The team has published both a BSU-led operations paper [Johnson et al., 2018] as well as a detailed peer-reviewed journal article focused on improved understanding of the dynamics of snow avalanches detected using infrasound technologies [Johnson et al., 2021]. This second paper, published in the Journal of Geophysical Research, made use of integrated video and infrasound observations to quantify acoustic source strength of the avalanche source and locate the portion of the avalanche most responsible for the infrasound source. The focus of the study was on avalanches triggered by explosions and the team used infrasound array analysis to distill signals from explosions, topographic echoes (from explosions), and the avalanche signals themselves (Figure 11). They also assessed source energetics and discussed the threshold of detection for infrasound sensing located at various distances.

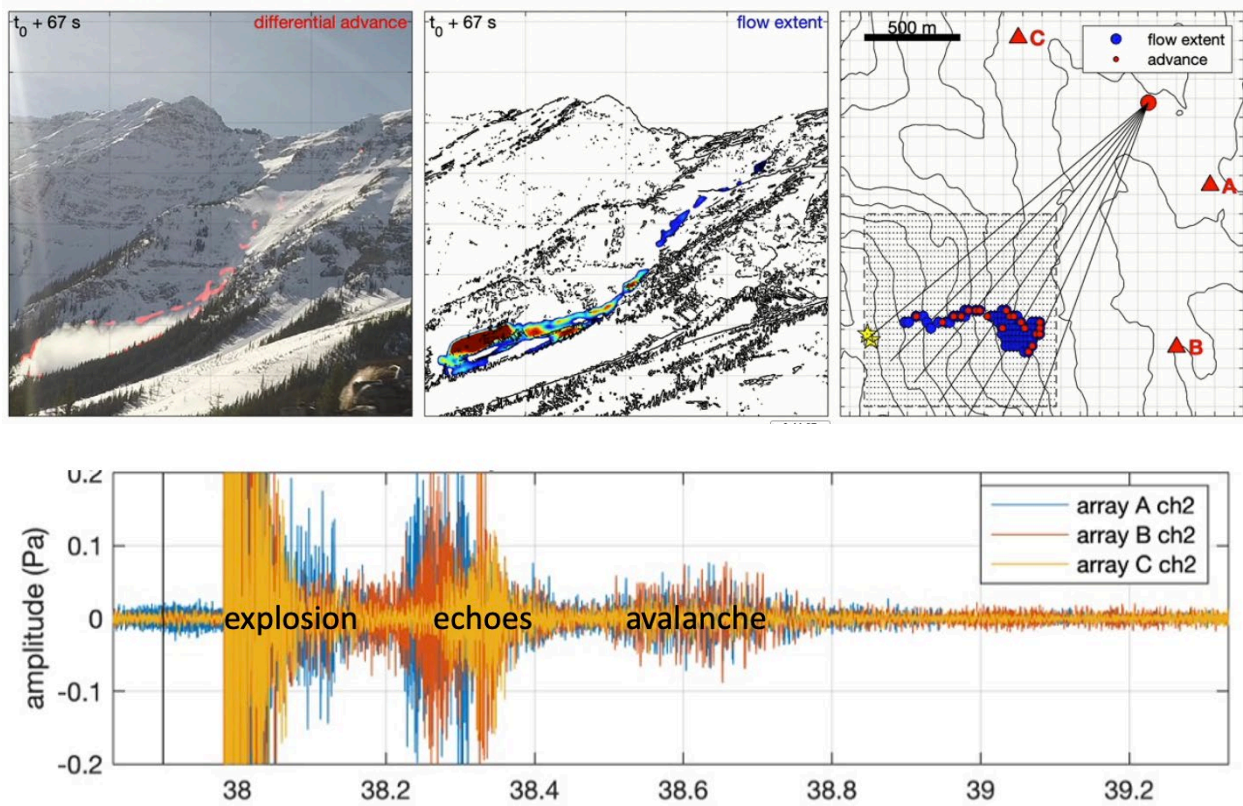

Figure 11 – Figure reproduced from animation in **Johnson et al. (2021)**. Upper panels show a snapshot in time of a triggered avalanche. Bottom panel shows the waveforms and the interpreted sources associated with this event

This study further discussed optimal deployment strategies and sensor distances to resolve and map the downslope movement of avalanches. Further work is advisable to continue multi-disciplinary observations with the goal of relating infrasound recordings to snow avalanche intensity and style. *Opportunities for pursuing this work in LCC canyon are being explored through scientific grant funded opportunities.*

8) Recommendations Moving Forward:

Based upon comparisons between the BSU and IML network of infrasound arrays we assert that there is a performance improvement in the BSU system (Figure 7), which uses only three-element arrays, but employs modern sensors and new digital processing strategies. Detection of avalanches with the BSU system during a test period in February 2017, including many small events, resulted in nearly all those listed in the LCC forecasters' logs. Detections were made both outside and inside the network, where locations, along with critical location uncertainties, are provided [e.g., **Johnson et al., 2018**]. Both the BSU and IML system use multi-array location algorithms, and both systems appear to outperform the Infrasound Detection of Avalanches (IDA) system (<https://www.wyssenavalanche.com>), which is an alternative system on the market that is best for detecting, but not mapping, 'large dry-snow and mixed-type avalanches' (see evaluation in **Mayer et al. (2020)**).

The upcoming 2021/2022 season will focus on tailoring the operational capabilities of the infrasound system. Snowbound Solutions will be working closely with UDOT forecasters to implement alerting, detection summaries, mobile mapping capabilities and estimating how close to the road an avalanche came. At the conclusion of the 2021/2022 season, the infrasound monitoring system will be the next commercially available infrasound system and ready for expansion to other areas. BSU individuals will remain involved in this project in a software consulting role and through infrasound sensor provision. Their infrasound hardware and telemetry systems (less than \$5000 per array; not including power system) is the lowest cost solution on the market. Combined with ease of deployment, robust sensor design, and support from Snowbound Solutions we see the BSU system as an appropriate solution for monitoring snow avalanches in LCC and beyond.

Future work for BSU will also involve continuing fundamental science research focused on avalanche physics and the analysis of infrasound to better constrain avalanche dynamics. Infrasound is proven as a powerful technology to quantify avalanche characteristics [e.g., **Johnson et al., 2021**] and continuing multi-disciplinary studies, involving camera work, drone surveys, seismic and radar surveillance will be illuminating as campaign-style experiments.

9) Publications and References Cited

* (indicates research product sponsored in part by this project)

Bedard, A.J. (1997). Avalanche Detection Using Atmospheric Infrasound. Final Report Winter 1994-1995 for CDOT-DTD-R-97.4

Havens, S., Marshall, H.-P., Johnson, J. B., & Nicholson, B. (2014). Calculating the velocity of a fast-moving snow avalanche using an infrasound array. *Geophysical Research Letters*, *41*(17), 6191–6198. <https://doi.org/10.1002/2014GL061254>

*Johnson, J.B., Anderson, J.F., Marshall, H.P., Havens, S., Watson, L.M. (2021), Snow Avalanche Detection and Source Constraints Made Using a Networked Array of Infrasound Sensors, *Journal of Geophysical Research Earth Surfaces*, <https://doi.org/10.1029/2020JF005741>

*Johnson, J. B., Marshall, H. P., Loo, S. M., Nalli, B., Saurer, M., Havens, S., et al. (2018). Detection and tracking of snow avalanches in Little Cottonwood Canyon, Utah using multiple small-aperture infrasound arrays. *Proceeding of International Snow Science Workshop, Innsbruck, Austria, 7–12 October 2018*.

Mayer, S., van Herwijnen, A., Ulivieri, G., & Schweizer, J. (2020). Evaluating the performance of an operational infrasound avalanche detection system at three locations in the Swiss Alps during two winter seasons. *Cold Regions Science and Technology*, *173*(December 2019), 102962. <https://doi.org/10.1016/j.coldregions.2019.102962>

*Watson, L.M., Carpenter, B., Thompson, K., Johnson, J.B. (in rev.), Using local infrasound arrays to detect plunging snow avalanches along the Milford Road, New Zealand (Aotearoa), *Natural Hazards*

Yount, J., Naisbitt, A., Scott, E. D., & Laboratories, I. (2008). Operational Highway Avalanche Forecasting Using the Infrasonic Avalanche. In *International Snow Science Workshop Proceedings, Whistler, BC* (pp. 268–276).