





December 1990  
Vol. 54, No. 3



U.S. Department  
of Transportation  
**Federal Highway  
Administration**

# Public Roads

A Journal of High Transportation and Development

Main Library, M-493.3  
Main Library, M-493.3  
JAN 24 1991  
JAN 24 1991  
Main Library, M-493.3  
Main Library, M-493.3  
JAN 24 1991  
JAN 24 1991



# Public Roads

A Journal of Highway Research and Development



December 1990  
Vol. 54, No. 3

COVER: Aerial shot of the Smart Corridor—a heavily instrumented stretch along the Santa Monica Freeway between Santa Monica and Los Angeles.

**U.S. Department of Transportation**  
Samuel K. Skinner, *Secretary*

**Federal Highway Administration**  
Thomas D. Larson, *Administrator*

**Office of Research and Development**  
Charles L. Miller, *Associate Administrator*

*Editorial Staff*  
Anne N. Barsanti  
William Zaccagnino

*Advisory Board*  
R.J. Betsold, T.J. Pasko, G.M. Shrieves

## IN THIS ISSUE

### Articles

#### **Intelligent Vehicle-Highway Systems: Moving America Into the 21st Century**

by Frank Mammano and John Baxter ..... 225

#### **The Highway Safety Information System**

by Forrest M. Council and Jeffrey F. Paniati ..... 234

#### **Leaching Test Studies Using Extraction Procedure Toxicity Test and Toxicity Characteristic Leaching Procedure**

by Shuang-Ling Chong, John Peart, W. Clayton Ormsby, and Michael S. Griffith ..... 241

#### **Upgrade of the FOIL Pendulum Test Capability**

by Allen G. Hansen ..... 249

### Departments

**Recent Publications** ..... 255

**Technology Applications** ..... 259

**New Research** ..... 261

### NOTICE

The United States Government does not endorse products or manufacturers. Trade or manufacturers' names appear herein solely because they are considered essential to the object of an article.

*Public Roads* (ISSN 0033-3735) is published quarterly by the Office of Research and Development, Federal Highway Administration (FHWA), 400 Seventh Street SW, Washington, DC 20590. Second class postage paid at Washington, DC and additional mailing offices.

POSTMASTER: Send address changes to *Public Roads*, HRD-10, FHWA, 6300 Georgetown Pike, McLean, VA 22101-2296.

*Public Roads, A Journal of Highway Research and Development*, is sold by the Superintendent of Documents, U.S. Government Printing Office (GPO), Washington, DC 20402, for \$6 per year (\$1.50 additional for foreign mailing) or \$2 per single copy (50 cents additional for foreign mailing). Check or money order should be made payable and sent directly to the GPO. Subscriptions are available for 1-year periods. Free distribution is limited to public officials actually engaged in planning and constructing highways and to instructors of highway engineering. At present, there are no vacancies on the free mailing list.

The Secretary of Transportation has determined that the publication of this periodical is necessary in the transaction of the public business required by law of this Department.

**Contents of this publication may be reprinted. Mention of source is requested.**

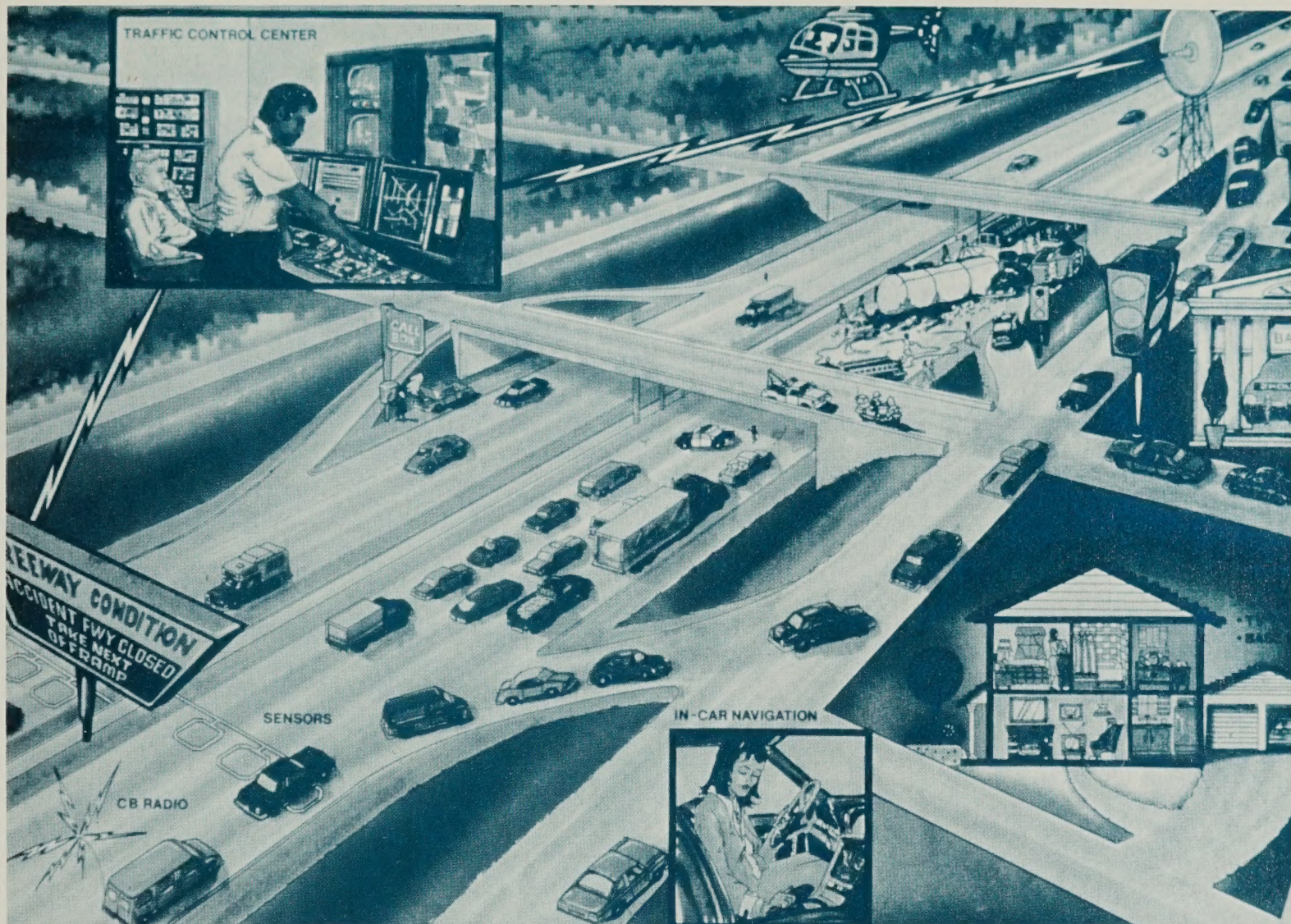

# Intelligent Vehicle-Highway Systems: Moving America Into the 21st Century

by Frank Mammano and John Baxter

## Introduction

Today's highway system has undergone tremendous change and growth. Since 1956, road travel has more than tripled to almost 1.9 trillion vehicle-miles. At the same time, road and street mileage has seen only modest growth: from 1970 to 1985, vehicle population grew 63 percent while road mileage increased 5 percent.

The result of these growing demands on the road system has been an increase in traffic congestion. In 1987, drivers experienced 2 billion vehicle-hours of delay on urban freeways (an increase of 60 percent since 1984). Studies of top U.S. cities estimate total economic losses due to congestion at approximately \$42 billion per year. In fact, two-thirds of all urban interstate traffic is experiencing severe congestion (defined as travel under 35 mi/h [56 km/h]).

Accidents on the Nation's highway system result annually in more than 47,000 fatalities and 3.5 million injuries. According to 1987 Fatal Accident Reporting System data, most fatalities (36 percent) are off-road accidents, followed by angle collisions (18 percent) and head-on collisions (17 percent). Although these accidents result from human, environmental, or vehicular factors, most are the result of human error.

What does the future hold? Current studies estimate that travel will double to 3.8 trillion vehicle-miles by 2020. Assuming no major improvements are made, a 400- to 500-percent increase in delay is possible by 2005, resulting in 10 billion vehicle-hours of delay. More than 100,000 fatalities per year are possible by 2020, projecting today's rates. Also the driving population is aging. Today, 1 driver in 8 is older than 65. By 2020, 1 in 5—or 20 percent of the driving population—will be over 65.

## Pathfinder

Traffic congestion is a major—and growing—problem nationwide; moreover, it is expected that total travel will continue to grow in the future. Pathfinder, an in-vehicle navigation system, is an experimental project aimed at improving traffic flow. The project tests the feasibility of using the latest technological devices to aid motorists in avoiding adverse traffic conditions. Specifically, Pathfinder provides drivers of specially equipped cars with up-to-date information about accidents, congestion, highway construction, and alternative routes. Pathfinder is a cooperative project of the Federal Highway Administration, the California Department of Transportation, and General Motors Corporation.

The Pathfinder system is being tested to see how drivers could benefit by receiving on-board information through a computerized mapping device on a monitor display. A control center manages the communication, detecting traffic density and vehicle speeds, and transmitting that information to the equipped vehicles via an electronic map shown on the display screen. The system helps motorists find the most efficient route to their destinations.

Pathfinder will be tested in the Smart Corridor,<sup>1</sup> a 13-mi (21-km) stretch along the Santa Monica Freeway between Santa Monica and Los Angeles. The corridor is one of the most heavily traveled areas in the country and includes freeway service roads and five major parallel arterial roads.

As shown in figure 1, the Pathfinder system has three elements:

- Vehicle system hardware which provides information to drivers.
- Centrally located computers which collect and process data from various sources.
- A communications system which transmits data to and from vehicles.

### Vehicle system

Pathfinder's vehicle hardware is based upon an Etak Travepilot, a navigational device that displays electronic road maps on a TV-type monitor mounted on the dashboard. While driving, the vehicle's position on the screen remains constant and the map moves

<sup>1</sup>The Smart Corridor is a cooperative project to fight congestion with state-of-the-art traffic management equipment and techniques. The project consists of automated traffic surveillance, interactive signal control, direct-access, real-time traffic information, improved emergency response, and the study of drivers' motivation.

accordingly. A driver can zoom the display in and out to show particular areas of interest. In addition, a driver can enter a destination and have it displayed on the map. The map data are stored on a computer disk located in the vehicle trunk.

A separate processor collects and sorts congestion data which are then presented to the driver via symbols on the map display, written messages, and audio messages through standard radio speakers.

### Central system

At the central location, a computer is used to process congestion data from arterial streets, freeways, and Pathfinder vehicles. Other information (e.g., police accident reports and information on ongoing maintenance and construction activities) can also be provided to the computer. The data are sorted, compiled into a list of locations and congestion levels, and broadcast to all vehicles.

### Communication system

Each minute, the central system broadcasts area-wide congestion and location data to all Pathfinder vehicles. Also once each minute, a vehicle's position data, direction, and speed are transmitted back to the central system.

### Evaluation

After the Pathfinder system has been installed and tested, the California Department of Transportation will evaluate the system by loaning Pathfinder vehicles to various types of drivers—e.g., commuters and salespersons. Information will be collected on how drivers perceive and use the data and which modes of presentation are preferred. Drivers will also make recommendations as to how larger-scale systems can be implemented in the future.

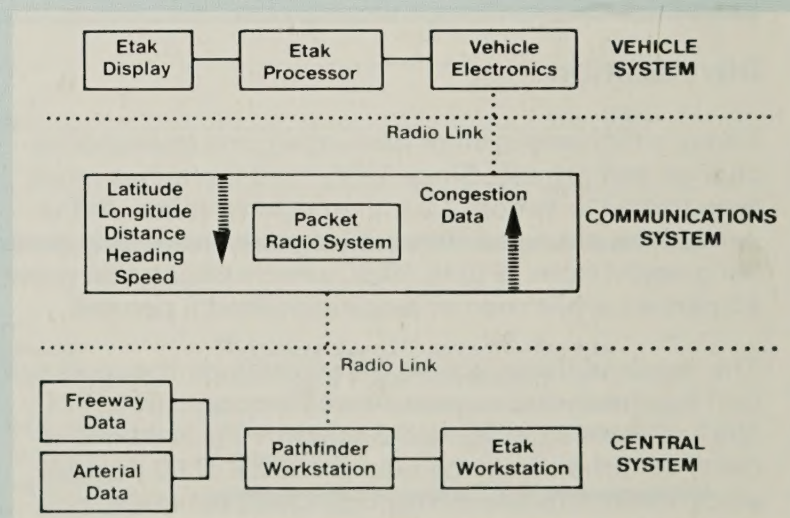

Figure 1.—Elements of the Pathfinder system.

Engineers therefore need to look for ways to increase driver mobility while simultaneously increasing safety. The President's National Transportation Policy recognizes these issues by including four strategies to address future surface transportation needs:

- Build new capacity.
- Manage travel demand.
- Increase operational efficiency.
- Advance new technologies.

The solution to future surface transportation needs will be the balanced application of all four of these strategies. However, the remainder of this article discusses the one strategy with the potential to effectively handle much of the need for increased mobility and safety—advancing new technologies. Collectively, these technologies are known as intelligent vehicle-highway systems (IVHS), or smart cars and smart highways.

## Intelligent Vehicle-Highway Systems

IVHS represent the marriage of the vehicle, the driver, and the highway to improve system efficiency and driver safety; realizing this marriage involves the development and application of advanced technologies. There are four elements of IVHS: advanced traffic management systems (ATMS), advanced traveler information systems (ATIS), commercial vehicle operations (CVO), and advanced vehicle control systems (AVCS). See figure 2.

### Advanced traffic management systems

Much like the air traffic controller at an airport, ATMS are intended to monitor, control, and manage traffic. They are the "umbrella" under which the other elements operate, providing the communication link between the roadway, the vehicle, and the traveler. ATMS receive information—either digitally or verbally—concerning traffic conditions from various sources, including vehicle detectors, traffic signals, police and emergency personnel, and individual vehicles.

ATMS "fuse" these data to provide real-time information (i.e., the data are processed and transmitted almost instantaneously). This information is, in turn, used to control and manage traffic by adjusting traffic signals, alerting incident management personnel, and displaying current traffic conditions to travelers (including automobile and commercial vehicle drivers and transit operators) through changeable message signs, highway advisory radio, and on-board displays/voice systems.

Although similar to today's traffic management centers, ATMS will be distinguished from them because they will:

- Work in real-time.
- Use algorithms to predict congestion and implement countermeasures.

## Intelligent Vehicle-Highway Systems

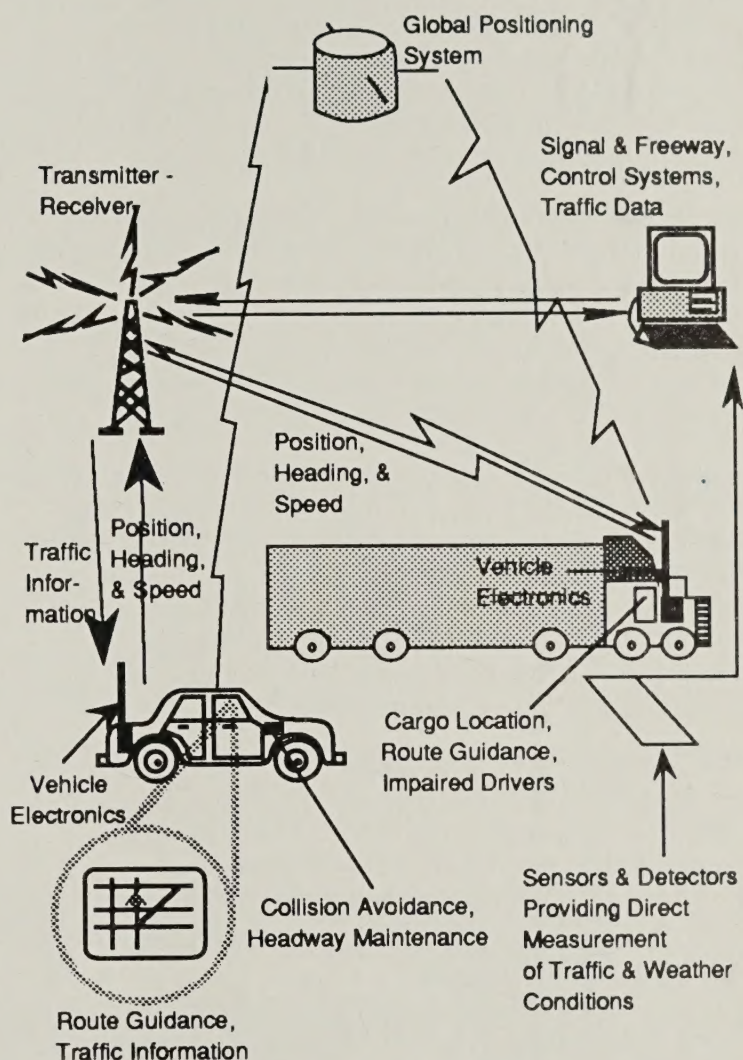

Figure 2.—Elements of the IVHS.

- Use area-wide surveillance and detection to develop optimal solutions.
- Coordinate control of freeways and arterials.
- Be able to cover multiple jurisdictions.
- Provide rapid response to incidents.
- Provide information to individual vehicles.

ATMS should substantially reduce congestion. In fact, total reduction in delays from ATMS is currently estimated at 10 to 35 percent. The greatest potential for reduced delay is through improved incident management strategies—1 minute saved in clearing an incident reduces the duration of congestion by at least 4 to 5 minutes. ATMS also help reduce accidents by improving traffic conditions.

## HELP System

Various users need heavy vehicle data. For example Federal, State, and local governments are involved in disparate programs to support highway planning and design activities, as well as size and weight enforcement and tax administration. Private industry relies on such information as the Rate Bureau's Continuous Traffic Survey to monitor industry activity levels and support financial planning. Private carriers, too, must monitor vehicles and loads to ensure effective operational management.

Although many of these data collection activities entail substantial effort, the data produced have inconsistencies among States, sources, and over years. Or the data have important elements missing, such that much of the data are not directly useful. Moreover, some data sources remain proprietary and unavailable for general use.

Envisioned as a means of developing integrated technical solutions to many of these problems, a heavy vehicle electronic license plate (HELP) system was created that could automatically weigh, classify, and identify heavy vehicles at strategic locations. The resulting data could then be stored, processed, and retrieved to provide government and the trucking industry with useful and consistent information.

Several States are involved in the HELP system, including Arizona, California, Idaho, Iowa, Minnesota, Nevada, New Mexico, Oregon, Pennsylvania, Virginia, and Washington, as well as the Port Authorities of New York and New Jersey.

## Crescent Project

A multi-State demonstration and evaluation project, known as the Crescent project, is being implemented to test the HELP system. The Crescent project involves installation of various elements of the fully developed system in a group of western States and Canada.

The three main technologies that will probably form the basis of the Crescent project are automatic vehicle identification, weigh-in-motion, and automatic vehicle classification. Roadside stations equipped with some or all of these technologies will be linked to State and regional computers.

## Automatic vehicle identification

Automatic vehicle identification (AVI) refers to techniques that uniquely identify vehicles as they pass specific points on the highway, without requiring any action by the driver or an observer. Recent advances in vehicle detection and data processing techniques have made the application of AVI systems both technically and economically feasible.

Currently, AVI approaches can be divided into ground-based and satellite-based systems. Satellite systems offer the possibility of continuous monitoring; ground-based systems will only identify vehicles at fixed locations on the highway system. Because ground-based systems generally are less costly than satellite-based systems, they are prime contenders for the first-generation HELP system.

One of the aims of the HELP system is to develop a standard specification for an AVI system which will serve the purposes of all end users, including the trucking industry as well as State and Federal Government agencies. To reproduce this specification, a technology testing and appraisal program is being conducted. There has been only a very limited amount of experience to date with highway-based AVI systems. Figure 3 illustrates the AVI element of the Crescent project.

## Weigh-in-motion

Weigh-in-motion is now an established technology in the United States and throughout the world. With weigh-in-motion systems, in-pavement sensors can detect and transmit the axle and gross weights of vehicles as they are traveling along the highway. A wide variety of systems is available, ranging from low-speed weigh-in-motion devices to several full highway-speed systems, each with a different level of capability and cost.

Unlike AVI systems which need to be standardized to ensure compatibility among different States and manufacturers, weigh-in-motion system designs do not require a uniform approach. Each State could choose its own system, or group of systems, to achieve its HELP system applications. Thus, with weigh-in-motion, the task of the HELP system is to set out the alternatives and develop a minimum performance specification based on user needs.



The possible alternatives for weigh-in-motion within the HELP system are:

- Bending plate systems.
- Shallow weighscale systems.
- Deep pit weigh scales.
- Bridge systems.
- Piezo systems.
- Capacitive systems.

### Automatic vehicle classification

Automatic vehicle classification (AVC) forms the third key technology which will be used at HELP roadside stations. Classified traffic data provide basic information widely used in highway network design, maintenance, and management. AVC systems within HELP offer the possibility for collecting these data reliably, continuously, and inexpensively.

Automatic vehicle classification systems are comprised of the following elements:

- Sensors, which provide data on the presence or passage of the vehicle to be classified.
- Detectors, which receive signals from the sensors and condition them before passing them on to a processor.

- A processor, which performs the basic calculations of vehicle length, number of axles, etc., from which vehicle class is determined.
- A recorder, which stores and manipulates data into the presentation format.

General requirements for sensors are that they be low cost, easy to install, and—above all—reliable. Several technologies are available which meet these requirements in specific applications. The last three elements are normally combined in the roadside unit. The use of solid-state electronic elements, with microprocessor control and memory data storage, has reduced design and reliability problems in these areas.

As with weigh-in-motion systems, the approach adopted towards AVC within the HELP system is to develop a minimum performance specification to define minimum standards of classification accuracy, counting accuracy, reliability, and durability. This specification will be based on reviews of work undertaken in previous related projects.

The HELP system represents a major step forward in the use of information technology in transportation. It is also a pioneering cooperative effort between the public and private sectors. If the Crescent demonstration project is successful, it may lead to regional and national implementations of a HELP system, with potential applications for both government and industry.

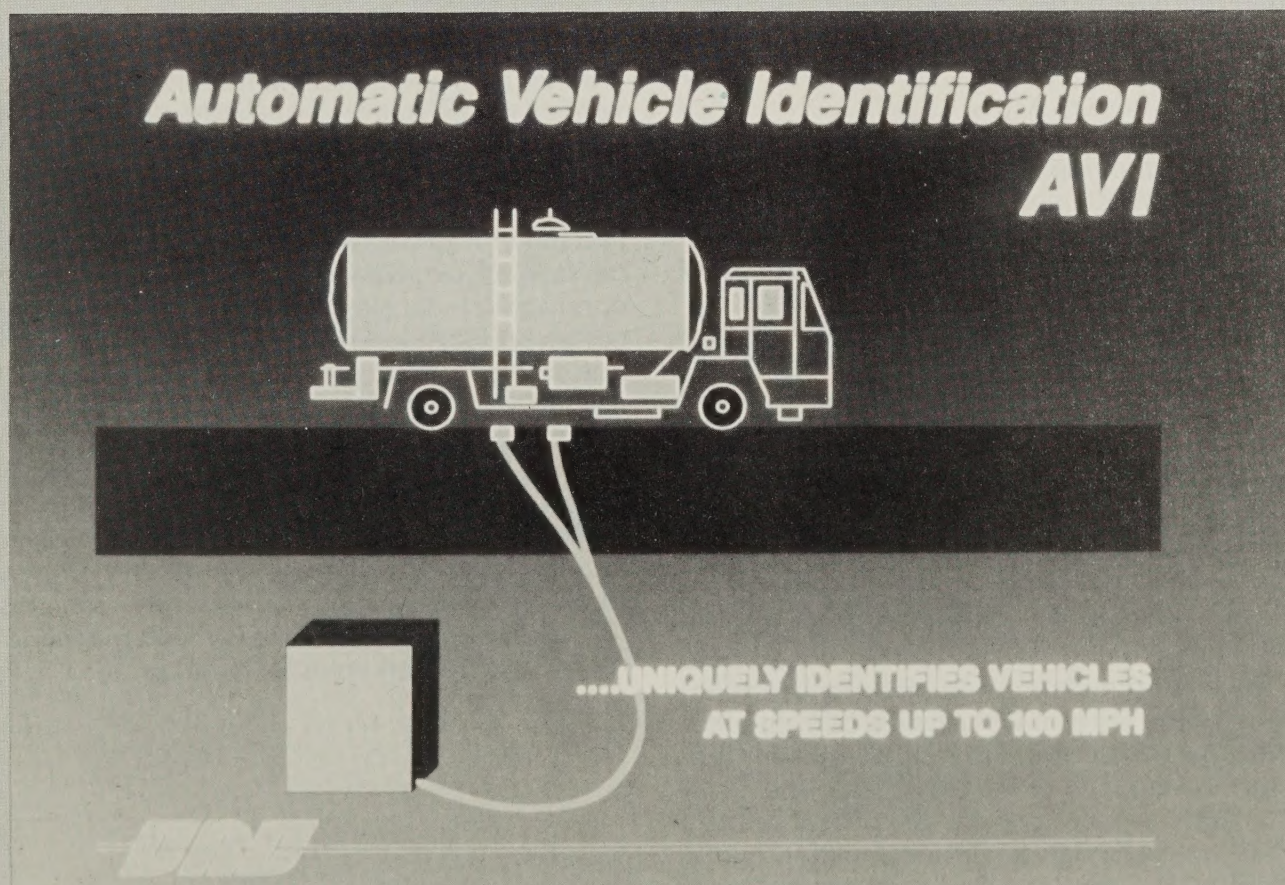

Several U.S. metropolitan areas are developing state-of-the-art traffic management centers, including Los Angeles, Anaheim, Phoenix, Seattle, Minneapolis, Chicago, New York and Detroit. Ongoing operational tests (i.e., tests conducted under real-world conditions) to evaluate the latest technologies include the Smart Corridor project along 13 mi (21 km) of the Santa Monica freeway in Los Angeles and the 128-mi (206-km) INFORM system corridor on Long Island, New York.

Many research needs involve enhancing existing technologies rather than developing new ones. All of the following research areas are needed to achieve the maximum potential of ATMS: improved traffic detection techniques, adaptive and interactive traffic signal controls, expert systems, communication technologies, real-time traffic assignment and simulation models, and research on driver behavior issues, as well as other research and development (R&D).

### **Advanced traveler information systems**

The second IVHS element, ATIS, addresses how the driver will receive information from ATMS. The objective is to provide travelers in both urban and rural areas with information on current traffic and road conditions, vehicle location and navigation information, safety warning messages, and other services.

Current traffic and road conditions will be provided to the traveler via computer terminals at work or home (useful for pretrip planning and flexible, personalized transit service for the elderly and handicapped), changeable message signs, highway advisory radio, or on-board display/voice systems. This information, combined with navigation and location information, will be used by travelers to select the optimal routes to their destinations.

ATIS are not only designed for use in urban areas. In rural areas, they could provide travelers with safety warnings of unusual road geometrics, accidents ahead, or adverse weather conditions. The systems could also supplement road signs with on-board sign displays activated by roadside transmitters. Other ATIS services could include information on parking, tourist areas, hotel/motel accommodations, and service stations.

To use ATIS, a base map of a street network will be contained (along with other services) on a read-only-memory compact disc in the vehicle; possibly, the map might instead be broadcast from ATMS. The on-board navigation device will determine current vehicle location in relation to the base map through either a satellite positioning system, electronic reference beacons, or a "dead-reckoning" system which determines location by measuring distance and direction from a known starting point. Drivers will receive current location and traffic information on the map display, and a route guidance system will direct drivers around congested areas via the map display, a directional arrow display, and/or a voice system. Vehicle location and speed information will periodically be sent back to ATMS, which will use this information to update the status of individual links on the network.

The potential benefits of ATIS are very similar to those of ATMS—i.e., reductions in travel times and comparable reductions in fuel use and vehicle emissions. ATIS also will reduce "hot spots" by allowing drivers to utilize more of the road network capacity, which in turn will reduce accidents and improve commercial vehicle efficiency. In addition, safety benefits will be realized from on-board sign displays and safety advisory and warning systems (e.g. limited site distance, environmental and weather conditions, roadway hazards, and accidents and hazardous spills).

Elements of ATIS technology are being evaluated through two current operational tests—Pathfinder and TravTek. R&D needs for ATIS technology include identifying traveler information requirements, developing a system communication interface, researching human factors issues, in-vehicle safety advisory and warning systems, and developing algorithms to provide vehicle routing and optimal traffic flow.

### **Commercial vehicle operations**

In recent years, global competition has forced companies in the United States to change the way they do business. Companies must provide faster, more reliable, more cost-effective services, using techniques such as just-in-time manufacturing and distribution. IVHS offer benefits in line with these objectives. By applying IVHS to CVO, the efficiency of commercial vehicles, public service vehicles, and even passenger vehicles will be enhanced. Commercial vehicles—for economic reasons—will be the first to use IVHS technologies on a wide-scale basis. In fact, many have already begun to do so.

Several IVHS technologies are applicable to CVO including automatic vehicle identification, automatic vehicle classification, automatic vehicle location, automatic cargo identification, automatic driver identification, and weigh-in-motion. With the exception of weigh-in-motion, all of these technologies use a receiver and transmitter to send signals via satellites (or possibly roadside beacons) to identify and locate commercial vehicles, allow dispatchers and drivers to communicate directly, and provide necessary information to regulatory agencies. Automatic vehicle identification and automatic vehicle location are already being used by commercial vehicles and passenger cars in toll facilities, thereby increasing toll capacity and decreasing driver delay. Billings are mailed to the driver on a periodic basis. Weigh-in-motion devices use detectors embedded in the pavement to monitor and regulate commercial vehicles in motion; these devices are already being used to monitor traffic growth and vehicle loadings.

Potential benefits of CVO technologies include increased productivity, increased safety, improved emergency response, improved fleet regulation, and improved traffic conditions.

Current operational testing of a CVO technology is being performed on the Crescent Demonstration Project, which is part of the Heavy Vehicle Electronic License Plate (HELP) Program. Future R&D in the CVO area will focus on vehicle identifiers, a hazardous materials tracking algorithm, driver identification systems, and a bridge height clearance sensor.

### Advanced vehicle control systems

The final IVHS element, AVCS, has the most long-term potential, but presents the greatest challenge. The objective of AVCS is to develop various technologies that help the driver perform vehicle control functions. AVCS areas include driver warning and assistance, obstacle avoidance, and automatic steering/headway control.

Driver warning and assistance includes radar technology to detect objects in driver blind spots, infrared imaging to enhance driver visibility at night or during inclement weather, anti-lock braking, etc. Some of these earlier technologies, such as anti-lock brakes, have already been developed and are being used.

Obstacle/crash avoidance and automatic steering/headway control involve radar and other technologies to alert the driver of potentially hazardous obstacles (i.e., other vehicles or roadside obstacles). If no action is taken by the driver, automatic braking would be applied. Automatic steering/headway control requires dedicated highways that can monitor and control vehicle speed, headway (platooning), and lateral movement.

Major AVCS research efforts include California's Program on Advanced Technology for the Highway (PATH). Started in 1986, the goal of this \$56-million program is to demonstrate automation, navigation, and electrification technologies. AVCS technology development efforts are also under way in other States.

Early AVCS technologies will provide the driver with warnings and assistance to enhance driver safety. Later technologies involving dedicated highways and vehicle control could dramatically reduce congestion. Future R&D will concentrate on automatic braking systems, lateral guidance systems, headway control, speed control, lane changing control, and transition logic from manual to automatic controls.

## Challenges

As with any new system development, there are many challenges facing IVHS. Besides conducting the needed R&D noted above, IVHS developers need to examine institutional issues, standardize system elements, ensure system reliability, address potential liability, and—most importantly—focus on public acceptance. The challenges thus do not end with engineering the system. Rather, the objective is to proceed with a multidisciplinary approach that transcends political and jurisdictional boundaries and gains the support of the traveling public.

## Public-Private Partnership

Given the various industrial, technological, commercial, and other factors involved in IVHS, the public sector cannot, by itself, develop IVHS technologies. Development must instead be a cooperative public-private partnership involving governments (Federal, State, and local), universities, private industry (automotive, communications, electronics, etc.), and trade associations.

The foundation for this public-private partnership was laid with *Mobility 2000*, an informal group of government, university, and industry representatives created to promote the use of advanced technologies to improve highway safety and mobility. Additionally, a national IVHS organization—the Intelligent Vehicle-Highway Society of America (IVHS AMERICA)—is now being formed to pursue the advancement of IVHS technology in the United States. IVHS AMERICA is scheduled to be established by January 1, 1991 and will incorporate the activities of *Mobility 2000*.

## Summary

IVHS show promise for increased safety: by 2010, they could save an estimated 11,500 lives and prevent 442,000 injuries annually. They also show promise for reducing urban congestion, resulting in improved travel times and improved economic productivity.

Many IVHS technologies are already being adopted by the highway industry. However, there are still many challenges ahead before the full potential of IVHS can be achieved, including technological, institutional, and public acceptance issues. A public-private partnership is needed to meet these challenges. *Mobility 2000* laid the foundation for this partnership, and IVHS-AMERICA will coordinate future efforts.

The Federal Highway Administration will continue to sponsor IVHS-related research and will be an active participant in IVHS AMERICA. Through these efforts, and the efforts of industry, academia, and other governmental organizations, IVHS will help address the safety and mobility issues facing our Nation as we move into the 21st century.

## TravTek

General Motors Corporation, the Federal Highway Administration, the American Automobile Association, the Florida Department of Transportation, and the City of Orlando are working together to develop a travel technology (TravTek) project for the entire Orlando area. The TravTek system uses prototype, in-vehicle information equipment that will provide motorists with up-to-date traffic information and directions to destinations. The system will also offer information on area attractions, accommodations, and services.

TravTek equipment will be installed in about 75 general-use GM rental cars and about 25 vehicles used by high mileage local drivers, such as salespersons. While traveling the Orlando area, drivers of these vehicles will receive continuous reports about congested routes to avoid. As new information becomes available on traffic incidents (accidents, disabled vehicles, construction and maintenance activities, etc.), drivers will be offered alternative routes that reflect the shortest travel times on the highway network.

The in-vehicle TravTek device will consist of a video screen, a microcomputer, and a radio for data communications. The video monitor may display:

- Maps of the Orlando area graphically representing traffic congestion locations, incidents, and services information.
- Text information about traffic incidents or available services.
- Route guidance instructions using simple graphic cues, such as directional arrows.

When drivers select their destinations, the TravTek processor uses travel times to determine the best routes. TravTek uses both graphic displays and a synthesized voice to give information to drivers. In addition to receiving route instructions, drivers can view services available in the Orlando area. On the video monitor, service stations, hotels, motels, restaurants, or tourist attractions may be indicated on a map display or viewed as textual information. Drivers also may call listed establishments using a dedicated cellular telephone.

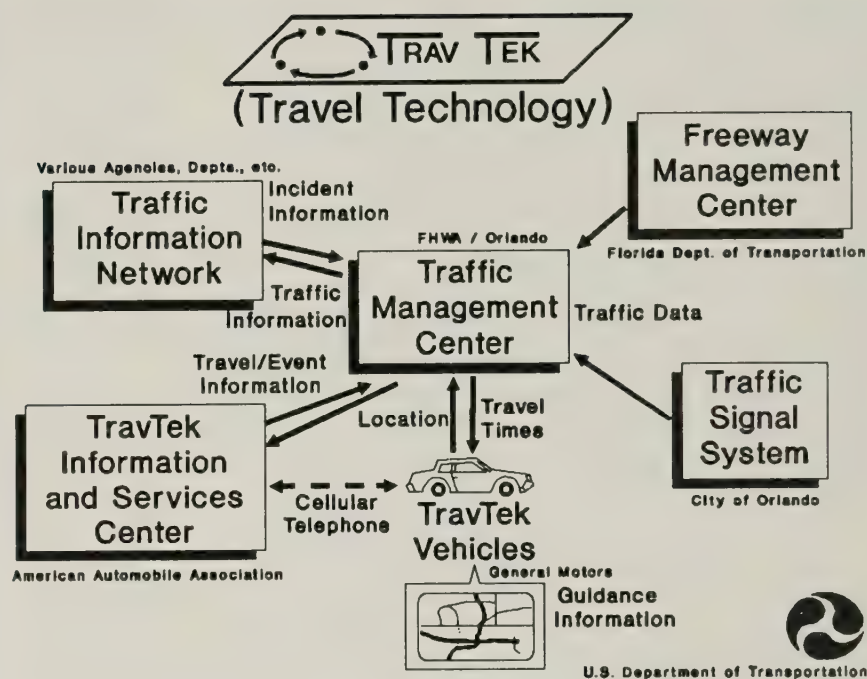

Figure 4.—Elements of TravTek.

A traffic management center will combine and sort the traffic-related information received from the various sources throughout the Orlando metropolitan area making up the traffic information network, for example:

- Orlando's centralized traffic signal system.
- Florida Department of Transportation's freeway management systems.
- American Automobile Association's TravTek Information and Service Center.
- Area police agencies.
- Various departments responsible for maintenance and construction activities.
- TravTek vehicles.

Incident information—including travel times on affected routes—will be estimated from the fused data and transmitted to the TravTek vehicles. The in-vehicle TravTek processor then will determine if the driver's selected route is affected, calculate a new route, and inform the driver that a revised routing is available.

Figure 4 illustrates the various elements of TravTek.

## Bibliography

*Advanced Vehicle/Highway Systems and Urban Traffic Problems*, Staff Paper, Science, Education, and Transportation Program, Office of Technology Assessment, Congress of the United States, September, 1989.

Conroy, Patrick J. "Transportation's Technology Future—Prospects for Energy and Air Quality Benefits," *TR News*, Transportation Research Board, Washington, DC, May-June, 1990.

*Evaluation of Travel Demand Management Measures to Relieve Congestion*, Publication No. FHWA-SA-90-005, U.S. Department of Transportation, Federal Highway Administration, Washington, DC, February 1990.

*Executive Summary—Mobility 2000 Workshop on Intelligent Vehicles and Highway Systems*, Communications-500, Texas Transportation Institute, The Texas A&M University System, Dallas, TX, March 19-21, 1990.

*Intelligent Vehicle-Highway Systems*, brochure, U.S. Department of Transportation, Federal Highway Administration, Washington, DC.

*Heavy Vehicle Electronic License Plate (HELP) Program Executive Summary*, Castle Rock Consultants, April 1989.

Judycki, Dennis C. *Managing Mobility and Traffic*, presentation at Intertraffic 90, Amsterdam, April 23, 1990.

Leasure, William. *Safety Benefits of IVHS Technology*, presentation for the Washington, DC Section, Institute of Transportation Engineers meeting, College Park, MD, June 1990.

*Mobility 2000 Final Report of the Working Group on Advanced Driver Information Systems*, Texas Transportation Institute, The Texas A&M University System, College Station, TX, March, 1990.

*Mobility 2000 Final Report of the Working Group on Advanced Vehicle Control Systems*, Texas Transportation Institute, The Texas A&M University System, College Station, TX, March, 1990.

*Mobility 2000 Final Report of the Working Group on Advanced Traffic Management Systems*, Texas Transportation Institute, The Texas A&M University System, College Station, TX, March, 1990.

*Mobility 2000 Report of the Working Group on Commercial Vehicle Operations*, Texas Transportation Institute, The Texas A&M University System, College Station, TX, March, 1990.

*Our Nation's Highways—Selected Facts and Figures*, Publication No. FHWA-PL-90-024, U.S. Department of Transportation, Federal Highway Administration, Office of Highway Information Management, Washington, DC, 1990.

*PATHFINDER—In-Vehicle Navigation System*, Publication No. FHWA-RD-89-196, U.S. Department of Transportation, Federal Highway Administration, Washington, DC, June 1989.

*A Program for the Advancement of Intelligent Vehicle/Highway Systems (IVHS)*, U.S. Department of Transportation, Federal Highway Administration, Washington, DC, April 1989.

*Report to Congress on Intelligent Vehicle-Highway Systems*, Publication No. DOT-P-37-90-1, U.S. Department of Transportation, Office of the Secretary of Transportation, Washington, DC, March 1990.

*Smart Cars, Smart Highways—Toward More Efficient, Safer Driving*, Highway/Vehicle Technology Committee, Highway Users Federation, Washington, DC.

*Traffic Congestion—Federal Efforts to Improve Mobility, United States General Accounting Office: Report to the Chairman, Subcommittee on Transportation and Related Agencies*, Publication No. GA/PEMD-90-2, Committee on Appropriations, U.S. Senate, Washington, DC, December 1989.

*Travel Technology—An Advanced Motorist Information Demonstration*, brochure, U.S. Department of Transportation, Federal Highway Administration, Washington, DC.

**Frank Mammano** is an electronics engineer in the Intelligent Vehicle-Highway Systems Research Division, Office of Safety and Traffic Operations Research and Development, Federal Highway Administration (FHWA). Mr. Mammano has been involved in research on the growing urban and suburban traffic congestion problem in the United States. He serves as project manager of the Pathfinder project which applies advanced technology to metropolitan area congestion problems. He has a bachelor of Electrical Engineering and a master of Civil Engineering (Transportation) from the Catholic University of America.

**John Baxter** is a highway engineer in the Office of Traffic Operations and Intelligent Vehicle Highway Systems, Operational Test Branch, FHWA. Mr. Baxter's previous assignments were in the Office of Implementation at the Turner Fairbank Highway Research Center and in the Utah and Michigan division offices. He has a bachelor of science and a master degree in engineering from Clemson University, and is a registered professional engineer in Utah.

### TRAFFIC ACCIDENT REPORT

POLICE ACCIDENT NO. INCIDENT NUMBER

Sheet \_\_\_\_\_ of \_\_\_\_\_ Sheets

OH Number or Name of Highway or Street \_\_\_\_\_ POLICE \_\_\_\_\_ COUNTY \_\_\_\_\_ TOWNSHIP OR CITY \_\_\_\_\_

1 At Intersection (Y/N) \_\_\_\_\_ (Number or Name of Intersecting Highway or Street) \_\_\_\_\_

2 If Not at Intersection (Circle One) N E S W O (Nearest Highway, Street, Bridge, Milepost, or Other Landmark) \_\_\_\_\_

DATE OF ACCIDENT: MO / DAY / YR \_\_\_\_\_ TIME OF ACCIDENT: \_\_\_\_\_ A.M. / P.M.

CIRCLE ONE OR MORE: TYPE OF REPORT: 1. Conventional, 2. Death, 3. Animal, 4. Private Property, 5. Hit and Run, 6. Supplementary. 1. Fatal, 2. Injury, 3. Property Damage, 4. Arrest, 5. Interstate/Expressway.

MOTOR VEHICLES INVOLVED: DAY OF THE WEEK: M T W T F S S

PASSENGERS AND/OR WITNESSES: NAME, Last, First, MI. ADDRESS, CITY, STATE

VEHICLE MAKE, MODEL, YEAR, COLOR, CLASSIFICATION, RESTRICTIONS, STATE, LICENSE NUMBER

TRUCK DATA: NO. OF AXLES, NO. OF TRAILERS, TRAILER

VEHICLE OWNER: OWNER'S ADDRESS, VEHICLE REMOVED BY

DRIVER'S NAME, PEDESTRIAN, REGALYCLIST, DRIVER'S ADDRESS, DRIVER'S LICENSE NUMBER, VEHICLE MAKE, MODEL, TRUCK DATA, VEHICLE OWNER, OWNER'S ADDRESS, VEHICLE REMOVED BY

DAMAGE TO PROPERTY: NAME OF OWNER OF PROPERTY, NATURE OF DAMAGE

TIME OF ACCIDENT: MONTH / DAY / YEAR, A.M. / P.M.

ARREST NAME, Last, First, SECTION NUMBER, TICKET NUMBER

OFFICER OF INVESTIGATING OFFICER: ID NUMBER, BEATZONE, COURT DATE, REVIEWING OFFICER

SEATING IN VEHICLE: 1-9 positions, ENCLOSED PASSENGERS, EXPOSED PASSENGERS

SAFETY EQUIPMENT USE: 0. UNKNOWN, NOT STATED; 1. SAFETY BELTS USED; 2. SAFETY BELTS NOT USED; 3. HELMET USED; 4. HELMET PRESENT NOT USED; 5. CHILD RESTRAINT USED; 6. CHILD RESTRAINT USED NOT BELTED; 7. CHILD RESTRAINT PRESENT NOT USED; 8. AIR BAG ACTIVATED



# The Highway Safety Information System

by Forrest M. Council and Jeffrey F. Paniati

## Introduction

Highway engineers and administrators continually face decisions concerning highway safety—decisions ranging from the safety impacts of proposed programs or policies to the design of a section of highway. Often, decisions are made based primarily on engineering judgment or on accident data alone. Consistent, rational decisions, however, result when sound analysis methods are applied to good data bases. These data bases must include not only accident information, but also information concerning roadway geometrics at accident and non-accident locations, traffic volumes specific to vehicle types, intersection configura-

tions and traffic controls present, and hardware and obstacles that appear on the roadsides. Data bases must be computerized and linkable to allow variables from several files to be combined rapidly and inexpensively.

## The Need

Both Federal and State Governments need to measure the level of highway safety, although their specific emphases differ somewhat. At the Federal level, the Federal Highway Administration (FHWA) is concerned with formulating new policies and verifying existing ones concerning the impacts of roadway geometrics, hardware, and traffic guidance treatments on the safety of the Nation's highway system.

At the State level, the major emphasis is on selecting alternative designs for construction, identifying hazardous locations for treatment, deciding among possible safety treatments, and making safety improvements on reconstruction projects.

Both Federal and State Governments generally measure safety in terms of accident frequency or rate as related to or caused by certain factors which can be modified by highway engineers. These factors include geometrics, traffic control, guidance systems, and roadside hardware. State and Federal Governments require quick access to high-quality accident, roadway, and traffic data.

To meet this need, many States have, for the past decade, been moving toward high-quality data in linkable computer files. Until recently, however, the FHWA had no such system available for its own use. Although certain national safety data bases exist, they are accident-based: that is, they provide detailed information on specific vehicles and drivers, but no information about the highway system and its characteristics.

What the FHWA needs is a location-based system which provides specific information on both failures (i.e., locations where accidents occur) and successes (i.e., accident-free locations). Without this information, it is virtually impossible to determine the factors resulting in success or failure—such differentiation is the essential nature of safety research.

### A Solution

In 1983, the FHWA initiated a study with the Texas Transportation Institute to assess the ability of existing data bases to meet FHWA highway safety analysis needs. (1)<sup>1</sup> The study examined a wide range of data bases and found that no single data base could meet *all* highway safety data needs. However, it did conclude that integrated State accident, roadway design, and traffic volume data files could provide much of the needed information at a reasonable cost. Special studies could be used to collect additional data, not on State files, on an as-needed basis. Based on this concept, the FHWA and the University of North Carolina Highway Safety Research Center (HSRC) have acquired State data for a new highway safety data base—the Highway Safety Information System (HSIS).

The HSIS uses raw data already collected by a select group of States. These data undergo a series of quality control checks, are prepared in a standard format, and are merged. The merged data are then used in analyses.

The HSIS was not designed to combine the data from all participating States into one large data base. There is no common system of variable definitions applied across all States. There are differences in variable names for similar variables, and large differences in the category labels for the same variable. For example, an accident-type variable can have only a few basic categories in some States and as many as 20 different categories in others. Thus, to combine different States' data for the same variable would mean moving to a lowest common denominator definition in which a great amount of data information and specificity would be lost.

Consequently, the HSIS was developed to maintain the integrity of each State's mergeable files. This type of system provides several advantages for problem analysis:

- Each State's data set can be examined to determine which possesses the most appropriate data variables, categories, sample sizes, and linkages.
- State-by-State analyses can be done using the appropriate data for each State.
- The results can be compared across States to check for consistency and/or differences.

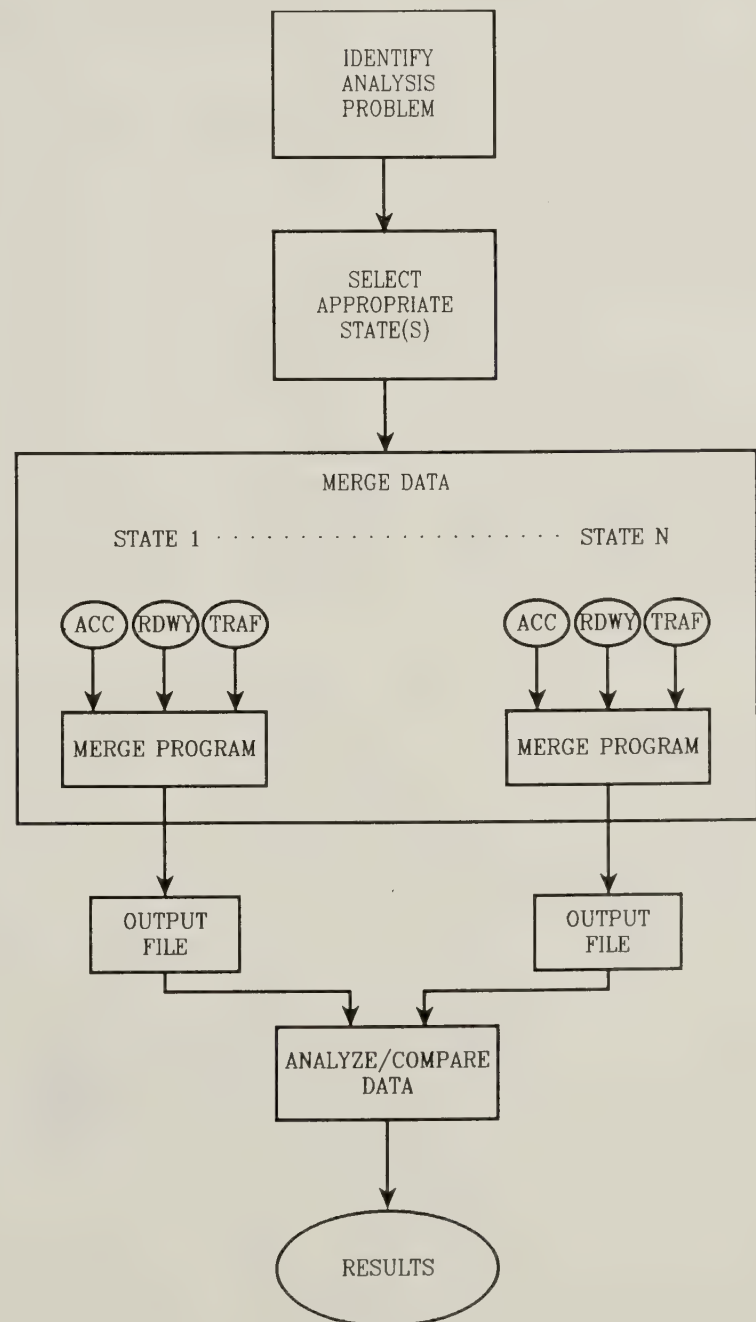

Figure 1.—Flowchart of the HSIS problem analysis process.

<sup>1</sup>Reference identified on page 240.

Consistent results could be generalized to other locations in the Nation. Differing results could lead to closer examination of why these differences exist. This in turn could provide more insight as to where research results would be most accurately applied. The results could be customized by location and/or related administrative guidelines or regulations issued for various areas of the country. Figure 1 provides a flow chart of the problem analysis process.

## The Participating States

After selecting the system design, system developers devoted significant effort to the choice of the five States to be included in the HSIS. The selection process included a review of information on data quality and quantity for all 50 States, telephone interviews with several States, and site visits to the most promising ones. The primary criteria used in the selection process were the range, quantity, and quality of data variables collected.

### Range of data variables

Working with FHWA staff, the HSRC developed a list of projected critical future analysis issues. This list was supplemented by input on safety research needs from safety researchers in the National Cooperative

Highway Research Program, the Transportation Research Board, and other safety analysts. When completed, the list of critical variables was compared to variables available in the States.

### Quantity of data variables

To assess the quantity of data available, the HSRC collected information from the potential States on the number of records in each of the files of interest, including:

- The number of accidents per year that could be linked with roadway inventory information.
- The number of miles of roadway included in the State's computerized roadway inventory system.
- The number of miles of roadway for which traffic count information was routinely collected, updated, and computerized.
- The sample size of data in any other special files (e.g., intersection or guardrail inventories).

### Quality of data variables

Because a history of data use by the State and/or outside research agencies was felt to be a strong indicator of potential data quality, the HSRC project staff relied on each State's

own assessment of its data quality as well as the project staff's knowledge of past research activities using the State's data. Significant weight was also placed on whether a State had developed *and used* a computerized data-merging system. Although several States attach some form of roadway information to accident data in order to identify high-hazard locations, only a few States have true data-merging systems. Such systems allow users to identify locations based on roadway inventory variables and then attach accident and traffic data to these locations. This full-merge capability ensures that a State's data files can be successfully linked. States that have invested the large amounts of funding needed to develop and maintain such a system would be expected to have used their data more often than States without this capability, and the more data are used, the higher the expected quality.

### State selection

Eight States were selected for more detailed evaluation. This evaluation included careful study of data quality and quantity and the identification of problems with merging data. As shown on figure 2, Utah, Minnesota, Illinois, Michigan, and Maine were finally

## HIGHWAY SAFETY INFORMATION SYSTEM (HSIS)

Figure 2.—Map of participating States.





Table 1.—HSIS data quantity

	Accidents/ year	Roadway mileage
Illinois	160,000	16,000
Maine	40,000	22,000
Michigan	145,000	10,000
Minnesota	70,000	60,000
Utah	50,000	50,000
Pennsylvania	150,000	

selected for inclusion in the prototype HSIS. In addition, the accident data for Pennsylvania are currently being captured by the FHWA for future inclusion in the system. Table 1 indicates the quantity of data available in the selected States. The table shows the number of police-reported mergeable accidents per year along with the number of miles of roadway to which these accidents can be linked.

The prototype HSIS was not designed to be a statistically valid sample; it is not nationally representative in terms of providing a random sample of all types of accident and roadway situations. The HSIS does not aim to provide national safety estimates—the National Accident Sampling System already serves this purpose. Rather, the HSIS will acquire quality data on a large number of variables, accident circumstances, and roadway locations for problem analysis.

The States currently in the system are not geographically spread across the United States; however, the roadway sections included do cover terrain types ranging from relatively level terrain with its inherent roadway geometrics to mountainous sections with critical curvature and roadsides. Thus, if an analysis requires certain terrain or types of locations, the analysis file can be restricted to those locations in the HSIS States that meet the specific criteria.

## The Data Files

The primary files from each of these States include accident files, roadway inventory files, and traffic files. Certain States provide additional useful information as well. Table 2 shows the files from each of the States.

## Data File Processing

So as to produce data files that could be easily manipulated by computer for problem analysis, it was decided early on to convert all raw data files to a Statistical Analysis System (SAS) format. SAS data formats identify each variable by a unique name, enabling the variable to be retrieved by name only rather than by position.

By providing these SAS formats for each variable, the output generated by the SAS program is easily readable. This means that the analyst can use the data directly from the computer without having to refer to a data dictionary for each of the variables being used. It is also much easier to program such operations as cross-tabulations, regression analyses, or frequency counts.

In addition to naming each variable, each of the variable categories was labeled with a brief 16 character description (SAS maximum) and an expanded description extracted from the States' documentation. These descriptions provide the analyst with more information about the variable of interest.

Once the files were formatted and labeled, a series of quality control checks was run for each of the files within each of the States. Single- and multi-variate tables were generated for the variables within each of the files. The HSRC analysts then examined each table to identify variables with unusual amounts of uncoded or unknown data, variables where the data were not consistent, and variables where two data elements that measured essentially the same parameter were inconsistent. When potential problems were found, the State liaison was contacted to determine if these

Table 2.—Files available from HSIS States

	Utah	Minnesota	Illinois	Maine	Michigan
Accident	X	X	X	X	X
Roadway inventory	X	X	X	X	X
Traffic volumes	X	X	X	X	X
Roadway geometrics	X		X		X
Intersection data	X	X			X
Guardrail					X

problems could be corrected or if they would need to be highlighted as a potential problem in future analyses.

## The Guidebooks

The aforementioned data conversion, quality control, and consistency check all contributed to the development of HSIS data guidebooks. The detailed guidebooks will make the individual HSIS State files useful in future analysis efforts. The guidebooks provide enough information to allow both analysts and programmers to determine whether a specific analysis effort is possible. The guidebooks list all available variables and, for each, provide detailed definitions of each category, identify potential biases in the data, and supply

information on available sample sizes. As future analyses are completed, the guidebooks will be modified to document solutions to some of the problems in the variables and/or highlight additional issues relevant to future research. The guidebooks are bound in looseleaf for easy updating and are organized into four sections as described below.

### Section A. basic description

Section A of each guidebook provides an overall description of the individual State's data system and an overview of the types of data residing in each of the files. Details are noted concerning which variables should be used with caution in future analyses and which variables may be more appropriate

than others for certain types of activities. The points presented in the section are then summarized and information on key State contact persons is given. For example, in the discussion of the accident file accuracy and coverage for one of the States, the text notes:

...comparison of accident diagram with accident type revealed that the accident diagram variable provides the general nature of the accident without reference to what is involved. For example, for those accidents coded as head-on in the accident diagram variable (which one might assume means head-on with a second moving vehicle), 18 percent were coded as collision with fixed objects and 12 percent

ACCDIGM	ACCIDENT DIAGRAM	(SAS Format Name - ACCDIGF)
01	= 'REAR END'	Rear end
02	= 'SIDESWIPE PASSNG'	Sideswipe - Passing
03	= 'LEFT TURN'	Left turn into oncoming traffic
04	= 'RAN OFF RD LEFT'	Ran off road - Left side
05	= 'RIGHT ANGLE'	Right angle
06	= 'RIGHT TURN'	Right turn into cross-street traffic
07	= 'RAN OFF RD RGHT'	Ran off road - Right side
08	= 'HEAD ON'	Head on
09	= 'SIDESWIPE OPPOS'	Sideswipe - Opposing
10	= 'OTHER' Other	
98	= 'NOT STATED'	Not stated
99	= 'UNKNOWN'	Unknown
<p>NOTE: See discussion in writeup -- this variable does not indicate "what" is struck, only "how" something is struck. Also, large number of records (20%) coded "Other".</p>		
ACCTYPE	ACCIDENT TYPE	(SAS Format Name - ACCTYPF)
01	= 'COLL OTH VEH'	Collision with other motor vehicle
02	= 'COL VEH OTH RDWY'	Collision with motor vehicle in other roadway
03	= 'COLL PRK VEH'	Collision with parked motor vehicle
04	= 'COLL TRAIN'	Collision with railroad train
05	= 'COL BICYCLIST'	Collision with bicyclist
06	= 'COLL PEDEST'	Collision with pedestrian
07	= 'COLL ANIMAL'	Collision with animal
08	= 'COLL FIXOBJ'	Collision with fixed object
09	= 'COLL OTH OBJ'	Collision with other object
10	= 'OVERTURN'	Overturn
11	= 'FIRE/EXPLOSION'	Fire or explosion
12	= 'SUBMERSION'	Submersion
90	= 'OTHER' Other	

Figure 3.—Sample of the SAS format information included in the guidebook.

were coded as collision with parked vehicle in the accident type variable. . . . Clearly, if the analyst is interested in what is struck (e.g. another vehicle) in what fashion (e.g. head-on), then some combination of both variables should be used.

### Section B. SAS formats

Section B includes SAS format names and category labels for each variable in individual State's files. The variable descriptions include notes regarding any potential consistency, coding, or quality problems. In this way, any problems that might produce biases are highlighted during the planning process before the initial computer runs are made. (See figure 3.)

### Section C. single-variable tabulations

Section C of the guidebook provides single-variable tabulations for many key variables in each file. These tables show an estimate of available sample size and indicate data consistency across years. The tables will be updated each year as the new data come in and allow the FHWA to provide quick answers to routine questions. For example, the tables show how many accidents involving utility poles occur each year for every State in the data base and indicate the direction of change in frequency over time.

The tables can also be used to assess the adequacy of the sample

size for a particular analysis. For example, an analyst might be asked to investigate accidents involving truck tractors with semitrailers. Figure 4 shows that truck tractors with semitrailers represent only 1.72 percent of the total number of accident-involved vehicles over the 3-year period in this State. However, there are an average of 2,300 of these vehicles in accidents each year, an adequate sample size for many analyses.

### Section D. computer programs

Section D includes programs written to process and merge the variables as well as programs which combine files to calculate basic accident rates. These merging programs provide a framework which can be later modified to conduct similar analysis efforts.

## A Cooperative Effort

Key to the successful development of the HSIS was the continued cooperation of the participating States. The State liaisons provided the raw data files as well as consulting expertise and input on individual data variables when data quality issues were raised. The liaisons attended an initial workshop during which they advised the FHWA on how the system could best be developed using their data and what problems and issues needed to be overcome given the basic proposed design. Later, the State liaisons reviewed and commented on their own State's guidebook. They also took copies of the guidebooks back to their States for further review.

TYPE_VEH (ACV-VEHIC-TYPE TYPE OF VEHICLE)				
ACCYR (ACD-YEAR-OCCURRED)				
FREQUENCY				
PERCENT				
ROW PCT				
COL PCT				
	85	86	87	TOTAL
AUTOMOBILE	99951 24.61 34.54 71.99	95115 23.42 32.87 70.72	94335 23.23 32.60 71.03	289401 71.26
AUTO WITH TRAIL	260 0.06 36.93 0.19	253 0.06 35.94 0.19	191 0.05 27.13 0.14	704 0.17
TRUCK/TRK TRACT	3021 0.74 37.87 2.18	2660 0.65 33.34 1.98	2297 0.57 28.79 1.73	7978 1.96
<b>TRU/TRAT W/SEMI</b>	<b>2514</b> 0.62 36.07 1.81	<b>2262</b> 0.56 32.46 1.68	<b>2193</b> 0.54 31.47 1.65	<b>6969</b> <b>1.72</b>
TRU/TRAT W/TWIN	35 0.01 31.82 0.03	30 0.01 27.27 0.02	45 0.01 40.91 0.03	110 0.03
TRU/TRAT W/OTHER	392 0.10 37.44 0.28	329 0.08 31.42 0.24	326 0.08 31.14 0.25	1047 0.26
PICKUP TRUCK	13239 3.26 30.55 9.54	14826 3.65 34.21 11.02	15272 3.76 35.24 11.50	43337 10.67
TOTAL	138839 34.18	134499 33.12	132808 32.70	406146 100.00

Figure 4.—Sample of single-variable table from the guidebook.

To this point, the FHWA has received the primary benefit from this cooperative effort—a usable, roadway-based safety data system. However, the project has also provided useful information to the participating States, including information on data inconsistencies and potential problems with individual data elements and SAS-formatted files and programs. Since some States are now moving to SAS formatting, they will use the HSIS SAS files and programs to reduce the amount of work needed. In the future, it is anticipated that these States will be key players in providing potential problem analysis to the FHWA. Any reports prepared from these data will be given to the States for their own use.

## Conclusion

The HSIS provides the flexibility to analyze a large number of safety problems, ranging from basic problem identification issues to multivariate modeling efforts to predict future accidents from roadway characteristics and traffic factors. The HSIS is a major highway safety analysis tool for the FHWA and other highway analysts and researchers. A computerized multi-State data base of accident, roadway inventory, and traffic information, the HSIS is user friendly in

terms of formatting and flexible in terms of the numerous ways in which its files can be manipulated and merged for a specific analysis problem. The HSIS will be an important companion to existing national data bases and will provide information and analysis capabilities not previously available. As with all data bases, however, its ultimate value will depend on the research and analysis in which it is used: the challenge now rests with the users.

*Further discussion of the types of analyses which can be conducted with the HSIS will be included in the next issue of Public Roads. The article will cover results from completed HSIS analysis efforts, other potential applications for HSIS data, the status of the FHWA's HSIS demonstration project, potential enhancements to the system, and information on how interested users can access HSIS data.*

## Reference

- (1) K.K. Mak and L.I. Griffin. *Assessment of Existing Data Bases for Highway Safety Analysis*, Publication No. FHWA/RD-85/117, Federal Highway Administration, Washington, DC, November 1985.

**Forrest M. Council** is deputy director of the University of North Carolina Highway Safety Research Center. He is currently the principal investigator on the study involving the maintenance, enhancement, and analytical use of the Highway Safety Information System (HSIS) for the Federal Highway Administration (FHWA). Since 1968, his work at the research center has involved roadway safety using State data files. He served as principal investigator for the project in which the HSIS was developed.

**Jeffrey F. Paniati** is a highway research engineer in the Information and Behavioral Systems Division, Office of Safety and Traffic Operations Research and Development, FHWA. Mr. Paniati is the manager of the Highway Safety Information System. He is a 1985 graduate of the FHWA Highway Engineer Training Program and is a professional engineer registered in the Commonwealth of Virginia.

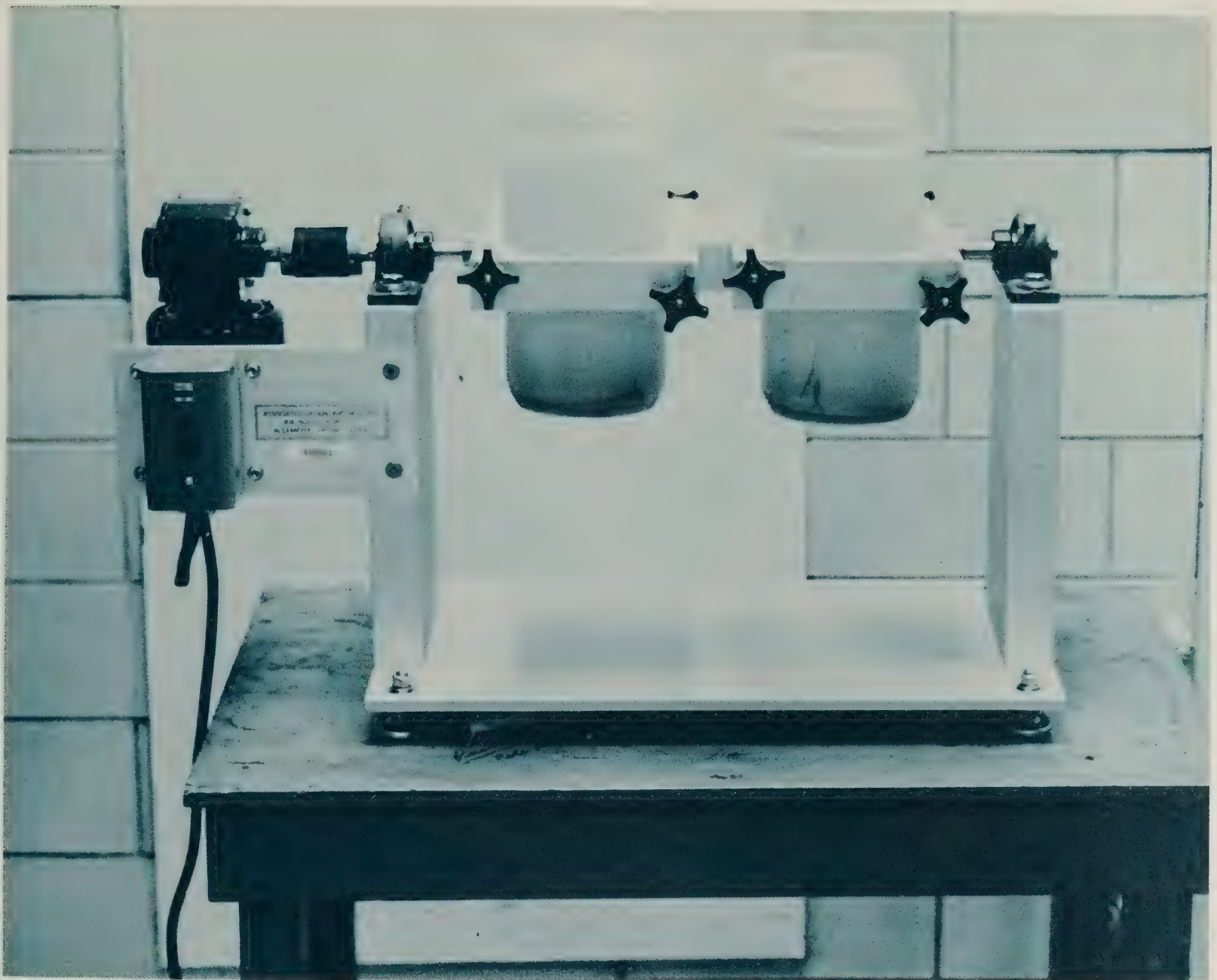

# Leaching Test Studies Using Extraction Procedure Toxicity Test and Toxicity Characteristic Leaching Procedure

by Shuang-Ling Chong, John Peart,  
W. Clayton Ormsby, and Michael S. Griffith

## Introduction

As more steel bridges are maintained through surface cleaning and repainting, more and more paint and abrasive residues are accumulating. These residues are potentially hazardous in view of State and Federal regulations, since many of the old paint formulations contained lead, hexavalent chromium, and other materials that are now regulated as toxic metals. Disposal of the residues will be costly. Currently, the estimated cost

of hazardous waste disposal ranges from \$300 to \$500 per ton; this is about 5 to 10 times more expensive than nonhazardous waste disposal at a sanitary landfill. To repaint the old bridges in the United States will generate, for example, approximately 200,000 tons per year of lead-contaminated abrasive residues.<sup>1</sup> These already substantial disposal costs have become even higher since a new disposal land ban requiring stabilization treatment prior to disposal was legislated in August 1990.

<sup>1</sup>From B.R. Appleman's NCHRP Synthesis 20-09 "Bridge Paint: Removal, Containment, and Disposal," in press.

Disposal costs can be contained somewhat by ensuring proper classification of hazardous wastes. Correct classification in turn requires a reliable, precise method for determining the leachable metal concentration of various solid wastes. This article reviews the results obtained through use of two widely employed leaching methods.

## Background

In November 1984, the Environmental Protection Agency (EPA) specified the maximum concentrations of eight different metals (arsenic, barium, cadmium, chromium, lead, mercury, selenium, and silver) that can be disposed of in a landfill. Presence of any of these metals in excess of the prescribed concentrations makes a waste hazardous. Presence at lesser concentrations makes the waste nonhazardous and allows it to be disposed of in a sanitary (class B) landfill. In August 1990, more stringent EPA regulations went into effect. (1)<sup>2</sup> Under the Land Disposal Restriction for Third Scheduled Wastes, the maximum leachable levels of various metals allowable after treatment by a demonstrated technology must be reduced to extremely low values.

To meet these strict requirements, a reliable and precise method is needed for determining the leachable metal concentrations of various solid wastes. Two methods have been devised by the EPA—the Extraction Procedure Toxicity Test (EPTox), promulgated in 1984 to extract leachable organics and metals from solid wastes, and the Toxicity Characteristic Leaching Procedure (TCLP), proposed in 1986 to replace EPTox. (2,3) On March 29, 1990, the EPA finalized use of TCLP in its hazardous waste identification regulations: its use has been mandatory since September 1990. (4)

Although both EPTox and TCLP have advantages and disadvantages, little information is available for making a detailed comparison of the two methods. Some evaluations of these methods have, however, been made for extracting paint residues. (5,6,7) Many of these studies point to EPTox's questionable reliability and precision; this has undoubtedly caused some wastes to be incorrectly classified as hazardous which in turn has led to increased disposal costs for the States. Studies have also shown that TCLP gives higher results than EPTox, resulting at times in a hazardous classification for wastes that EPTox testing had classified as nonhazardous. Thus, using TCLP is insurance against hazardous see page.

The objective of this investigation was to compare the EPTox and TCLP extraction methods by measuring metal concentrations in leachates from separate samples of various abrasive paint residues. This comparison included evaluating the precision and reproducibility of the two methods using data sets obtained from various participating analytical laboratories.

## Experimental Procedure

The study consisted of a round robin test conducted at three laboratories. Nine abrasive paint residues were collected from various Pennsylvania bridge maintenance operations. Each residue was carefully blended; from each, .25 in (6.35 mm) of oversize material was removed. Next, the residues were split using the Jones splitter technique to obtain representative samples for each of the laboratories. (8) At each laboratory, portions of each sample were leached by the EPTox and TCLP methods and the lead concentrations in the leachates were determined by atomic absorption spectroscopic analysis. Additionally, chromium and zinc concentrations were determined by the Federal Highway Administration (FHWA) Materials Division Paint Laboratory.

## Comparison of the EPTox and TCLP Tests

### EPTox test

The EPTox method is designed to adjust the level of acidity (pH value) of the leachate of a waste sample to  $5.0 \pm 0.2$  with a frequent addition of 0.5 Normal acetic acid during the extraction. The adjustment is made for at least 6 hours before an overnight extraction and for an additional 4 hours afterwards. The EPA established the acidic extraction with the pH based upon the values that may be obtained in the natural leaching condition of organic wastes disposed of in a sanitary landfill. These values would not apply in segregated landfills where no organic disposal was allowed. The techniques used in the EPTox analysis raise several problems, including the following:

- The pH adjustment is laborious and very time consuming.
- The pH value of a leachate during overnight leaching may reach a value much above 5.0 for an extensive period of time. This time length represents more than half the total leaching time; the leaching in a higher pH condition would create a large error compared with leaching at a lower pH.

Many laboratories have found that the data obtained with the EPTox method are difficult to reproduce given the tedious and at times uncontrollable pH adjustments. Tinklenberg, for example, found no correlation of the results obtained by the five different acetic acid addition methods examined. (7)

### TCLP test

The TCLP method was developed as a simpler, more accurate, and less expensive substitute for EPTox. In the TCLP method, a rapid test is initially made to determine the acidity of a sample before its extraction. This pH level determines which of two extracting fluids will be

<sup>2</sup>Italic numbers in parentheses identify references on page 245.

used. In most cases, a sodium acetate buffer solution (pH = 5.0) is used; for extremely alkaline samples, a fixed amount of acetic acid solution (pH = 2.88) is used. As the pH value with buffering can be maintained fairly constant even with the presence of alkaline and/or acidic materials, this buffering provides a more steady pH condition. State department of transportation laboratory personnel have concluded that this extraction method gives higher levels of lead than EPTox, resulting in leachates with higher measured concentrations of the regulated materials. (5)

## Results and Discussion

### Statistical analysis of round robin tests for lead

Results of the round robin tests for lead are given in table 1 and figure 1. These results were evaluated using analysis of variance procedures (table 2). (9) Because laboratory 3 did not run duplicate determinations, the method of unweighted means was used for its analysis. (10) An examination of the results in table 2 reveals that significant differences between the

Table 1.—Results of round robin tests for lead

Sample No.	Test 1 EPTox, ppm			Test 2 TCLP, ppm		
	Lab 1	Lab 2	Lab 3	Lab 1	Lab 2	Lab 3
1	1.8	1.5	8.8	6.9	6.6	7.5
2	3.1	1.5	0.4	22.0	6.9	20.2
		2.1	0.2		16.6	
3	5.8	2.6	1.0	25.0	16.1	25.0
		5.6	4.0		25.8	
4	19.0	5.4	4.0	25.0	26.8	34.0
		17.9	9.9		32.4	
5	4.0	7.4	0.7	11.0	18.3	16.0
		7.7	1.0		17.2	
6	5.4	6.1	3.2	13.0	12.5	13.0
		4.9	2.4		11.7	
7	5.2	6.2	1.5	0.7	1.7	1.5
		6.1	1.5		1.6	
8	9.7	7.8	3.3	23.0	26.9	25.0
		7.5	2.3		25.8	
9	13.0	18.6	13.8	1.5	1.8	2.0
		18.5	5.5		1.5	

ppm = parts per million

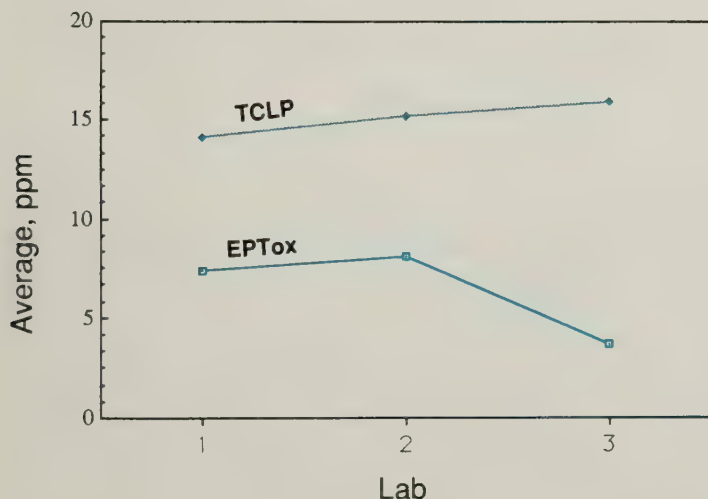

Figure 1.—Laboratory averages for lead using TCLP and EPTox.

Table 2.—Analysis of variance: EPTox and TCLP results for lead

Laboratory 1						
Source	Sum of squares	DF <sup>a</sup>	Mean square	F ratio <sup>b</sup>	F05 <sup>c</sup>	F01 <sup>d</sup>
Method	207.40	1	207.40	3.24 <sup>e</sup>	4.50	8.53
Error	1024.06	16	64.0			
Total	1231.46	17				
Laboratory 2						
Source	Sum of squares	DF <sup>a</sup>	Mean square	F ratio <sup>b</sup>	F05 <sup>c</sup>	F01 <sup>d</sup>
Method	458.68	1	458.68	6.39 <sup>*</sup>	4.16	7.44
Error	2439.26	34	71.74			
Total	2897.94	35				
Laboratory 3						
Source	Sum of squares	DF <sup>a</sup>	Mean square	F ratio <sup>b</sup>	F05 <sup>c</sup>	F01 <sup>d</sup>
Method	897.60	1	897.60	18.36 <sup>**</sup>	4.24	7.77
Error	1222.49	25	48.40			
Total	2120.09	26				

<sup>a</sup>DF = Degree of freedom.

<sup>b</sup>F Ratio = Fisher F ratio.

<sup>c</sup>F05 = 5-percent level of significance.

<sup>d</sup>F01 = 1-percent level of significance.

<sup>e</sup>Not significant.

<sup>\*</sup>Significant at the 5-percent level.

<sup>\*\*</sup>Significant at the 1-percent level.

Table 3—Concentrations of lead, chromium, and zinc in the leachate of abrasive paint residues

Sample No.	Test 1 EPTox, ppm			Test 2 TCLP, ppm		
	Pb	Cr	Zn	Pb	Cr	Zn
1	1.5	0.1	0.8	6.6	0.5	2.0
	1.5	0	0.9	6.9	0.5	2.0
2	2.1	0	4.9	16.6	0.3	6.6
	2.6	0	5.7	16.1	0.3	6.5
3	5.6	0	2.4	25.2	0.4	6.1
	5.4	0	2.2	25.8	0.4	5.7
4	19.5	0	25.9	26.8	0	62.5
	17.9	0	23.5	32.4	0.1	71.2
5	7.4	0	50.1	18.3	0	40.2
	7.7	0	56.9	17.2	0.1	52.3
6	6.1	0	50.0	12.5	0	56.9
	4.9	0	30.4	11.7	0	58.6
7	6.2	0	118.0	1.7	0.1	199.0
	6.1	0	119.0	1.6	0	199.0
8	7.8	0	23.5	26.9	0.1	35.6
	7.5	0.1	19.3	25.8	0.1	31.9
9	18.6	0	58.5	1.8	0	131.0
	18.5	0	77.1	1.5	0.1	140.0

ppm = parts per million

TCLP and EPTox methods were found for laboratories 2 and 3. Results for laboratory 1 did not show a significant difference between the two methods at the 5 percent significance level. More complete replication could possibly have improved the sensitivity of the analysis resulting in a significant difference "effect." (See later results and discussion in carefully replicated lead, chromium, and zinc tests).

Table 4.—Analysis of variance: EPTox and TCLP determinations for lead, chromium, and zinc

Source	Sum of Squares	DF <sup>a</sup>	Mean Square	F Ratio <sup>b</sup>	F05 <sup>c</sup>	F01 <sup>d</sup>
<b>Lead</b>						
Sample	1122.055	8	140.257	252.842**	2.51	3.71
Test	395.347	1	395.347	712.694**	4.41	8.28
Sample x Test	1075.101	8	134.388	242.261**	2.51	3.71
Error	9.985	18	0.555			

Source	Sum of Squares	DF <sup>a</sup>	Mean Square	F Ratio <sup>b</sup>	F05 <sup>c</sup>	F01 <sup>d</sup>
<b>Chromium</b>						
Sample	0.301	8	0.038	22.542**	2.51	3.71
Test	0.218	1	0.218	130.667**	4.41	8.28
Sample x Test	0.247	8	0.031	18.542**	2.51	3.71
Error	0.030	18	0.002			

Source	Sum of Squares	DF <sup>a</sup>	Mean Square	F Ratio <sup>b</sup>	F05 <sup>c</sup>	F01 <sup>d</sup>
<b>Zinc</b>						
Sample	85684.381	8	10710.548	343.868**	2.51	3.71
Test	5329.000	1	5329.000	171.091**	4.41	8.28
Sample x Test	8040.095	8	1005.012	32.267**	2.51	3.71
Error	560.650	18	31.147			

<sup>a</sup>DF = Degree of freedom.  
<sup>b</sup>F Ratio = Fisher F ratio.  
<sup>c</sup>F05 = 5-percent level of significance.  
<sup>d</sup>F01 = 1-percent level of significance.  
 \*\*Significant at the 1-percent level.

Table 5.—Standard Deviations: Duplicate Difference Method, ppm

Element	Test 1	Test 2
Lead	0.50	0.49
Chromium	0.03	0.05
Zinc	6.67	4.22

ppm = parts per million

### Statistical analysis of results on lead, chromium, and zinc tests.

Concentrations of lead, chromium, and zinc in the leachates of paint residues are given in table 3. Variance analysis of these results, comparing EPTox and TCLP tests, are given in table 4. As expected, there were significant differences among the materials tested. Further, the analysis for lead revealed a significant interaction effect between test method and sample as shown in figure 2a. The observation that different samples respond differently to the two tests is important, demonstrating that the tests cannot be correlated and are dependent on the inherent nature of the test sample and its response to different leaching regimens.

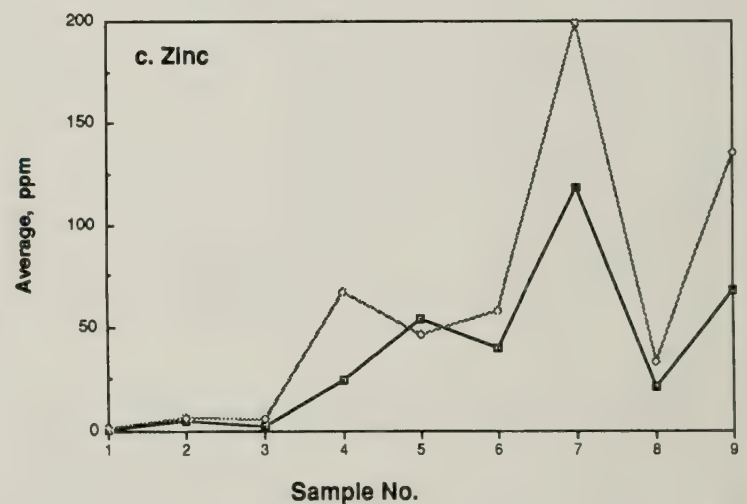
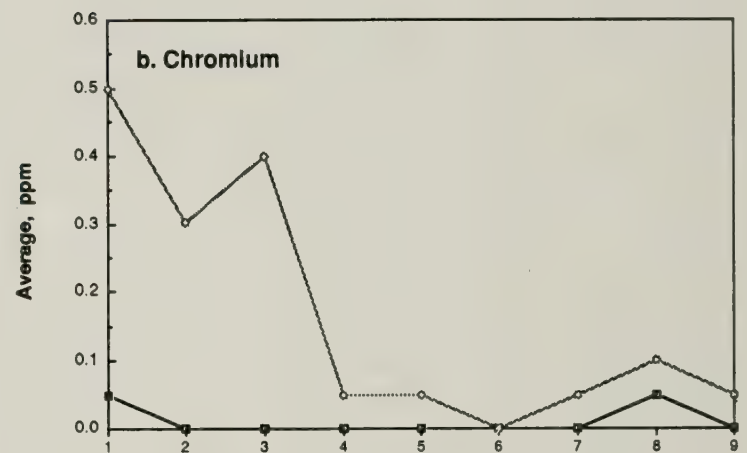
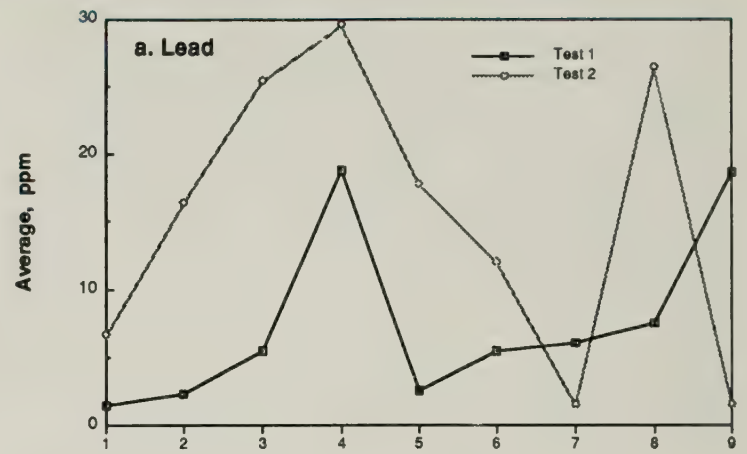

Figure 2.—Sample averages for EPTox (test 1) and TCLP (test 2).

### Analysis of variance

As with lead, significant differences were found for chromium and zinc both between test methods and between samples (table 4). Similarly, significant interactions for "samples x test" were found (figures 2b and 2c).



## Precision—lead, chromium, and zinc

Standard deviations for lead, chromium, and zinc analyses were calculated using the duplicate difference method table 5. (11) All values from table 3 were used except the duplicate difference for lead for sample number 4 (TCLP); this difference was rejected based on outlier tests. (12) The standard deviations for a given element are quite similar for the two tests. However, since the absolute values for TCLP tests are almost all considerably higher than the EPTox tests, the TCLP test would give a lower percent standard deviation.

The high standard deviation values for zinc may be attributable to excessive uncontrollable variations. These variations are likely given the extensive sample dilution needed to obtain concentrations in the linear range for atomic absorption analysis.

## Conclusions and Recommendations

- Round robin tests generally showed significant differences between the TCLP and EPTox methods. Future round robin tests should involve more laboratories (perhaps 10) and include replicated experiments on at least 3 test samples. Also, rigorous sampling procedures should be followed.<sup>3</sup>
- Generally speaking, TCLP tests resulted in much higher concentrations of lead than did EPTox tests. Reversals were noted, however. These reversals (interactions) did not appear to be significant in the round robin tests, but were found to be significant in the more closely controlled tests on lead, chromium, and zinc run by the FHWA.
- The interaction phenomenon prevents using TCLP tests to predict EPTox results and vice versa.
- Compared to EPTox, applying TCLP to abrasive paint residue would generally result in more materials being classified as hazardous (lead and chromium exceeding concentrations of 5 ppm) than if the EPTox were used.
- Precision calculations on FHWA results gave values with reasonable standard deviations for lead and chromium. Standard deviations for zinc were very high, possibly reflecting errors arising from the dilution procedure required in the atomic absorption determinations.

## Acknowledgments

The authors wish to thank Pittsburgh Mineral & Environmental Technology for preparing the abrasive paint samples and the Pennsylvania Department of

<sup>3</sup>As in all analyses, the method of sampling and the homogeneity of the sample tested is critical in obtaining accurate and reproducible leaching results. The sampling method and the number of samples taken dictate if the analytical results are truly representative of the abrasive paint debris in question. The EPA's recommend waste sampling requirements are described in reference (13); illustrative examples of the method's application have been described by Tinklenberg and Smith. (14)

Transportation laboratories for their participation in the round robin testing protocol.

## References

- (1) "Land Disposal Restrictions for Third Scheduled Wastes; Proposed Rule," *Federal Register*, Vol. 54, No. 224, 1989, p. 48372.
- (2) "Hazardous Waste Management System; Identification and Listing of Hazardous Waste," Appendix II: EPToxicity Test Procedure, *Federal Register*, Vol. 45, No. 98., 1980, p. 33127.
- (3) "Hazardous Waste Management System; Land Disposal Restriction," Appendix I to Part 268: Toxicity Characteristic Leaching Procedure (TCLP), *Federal Register*, Vol. 51, No. 216, 1986, p. 40643.
- (4) "Hazardous Waste Management System; Identification and Listing of Hazardous Waste: Toxicity Characteristics Revisions," *Federal Register*, Vol. 55, No. 61, 1990, p. 11798.
- (5) D. Friedman. "Toxicity Levels and Test Procedures," *Proceedings of the SSPC Symposium on Lead Paint Removal*, Publication No. SSPC 88-01, February 29 - March 1, 1988, p. 14.
- (6) K.A. Trimber and S. Solomon. "Analysis of Leachable Lead on Bridges of the Port Authorities of New York and New Jersey." *Proceedings of the SSPC Symposium on Lead Paint Removal*, Publication No. SSPC 88-01, February 29 - March 1, 1988, p. 133.
- (7) G. Tinklenberg. "EPTox: Michigan's Experience," *Proceedings of the SSPC Symposium on Lead Paint Removal*, Publication No. SSPC 88-01, February 29 - March 1, 1988, p. 175.
- (8) P.M. Gy. *Sampling of Particulate Materials—Theory and Practice*, Elsevier Scientific Publishing Co., New York, 1982.
- (9) SYSTAT. SYSTAT, Inc., Evanston, IL, 1987.
- (10) J. Neter, W. Wasserman, and M.H. Kutner. *Applied Linear Statistical Models*, Richard D. Irwin, Inc., Homewood, IL, 1985.
- (11) W.J. Youden. *Statistical Methods for Chemists*. John Wiley & Sons, Inc., New York, 1951.
- (12) W.J. Dixon and F.J. Massey. *Introduction to Statistical Analysis*, McGraw Hill Book Co., Inc., New York, 1957.
- (13) U.S. Environmental Protection Agency, Office of Solid Waste, Emergency Response. *Test Method for Evaluating Solid Wastes-Physical/Chemical Methods, 3rd Edition*. Publication No. SW-846, Washington, DC, November 1986.
- (14) G. Tinklenberg and L. Smith. "The Criticality of Sampling and Quality Control for Hazardous Waste Testing," *Journal of Protective Coatings and Linings*, Vol. 7, No. 4, April 1990, pp. 36-44.

## The FHWA Corrosion Control Laboratory

The increasing environmental regulations on open abrasive blasting and the containment, transport, and disposal of paint removal debris containing toxic levels of lead and chromium have resulted in added capabilities and increased demand for the FHWA Corrosion Control Laboratory services. Currently, the laboratory—located in McLean, Virginia, at the Turner-Fairbank Highway Research Center—can address both short-response materials problems (failure investigations) and the design and implementation of staff studies to develop and evaluate new materials. Additionally, the laboratory provides quick in-house support to research in the FHWA's High Priority National Program Area "Steel Bridge Coatings."

### Failure Analysis

The laboratory can evaluate the coating and corrosion condition of field structures and determine the quality of coating application. In case of premature coating failures, field investigation and laboratory analysis are performed to identify the failure mechanism and determine repair or replacement options.

The FHWA's scanning electron microscope and X-ray fluorescence analysis facility is useful in determining the cause of these failures (figure 3). This determination of cause helps States obtain compensation for the losses incurred. Such services have been performed in association with coating failure on the Nachez Trace and Chicamauga Dam Bridges.

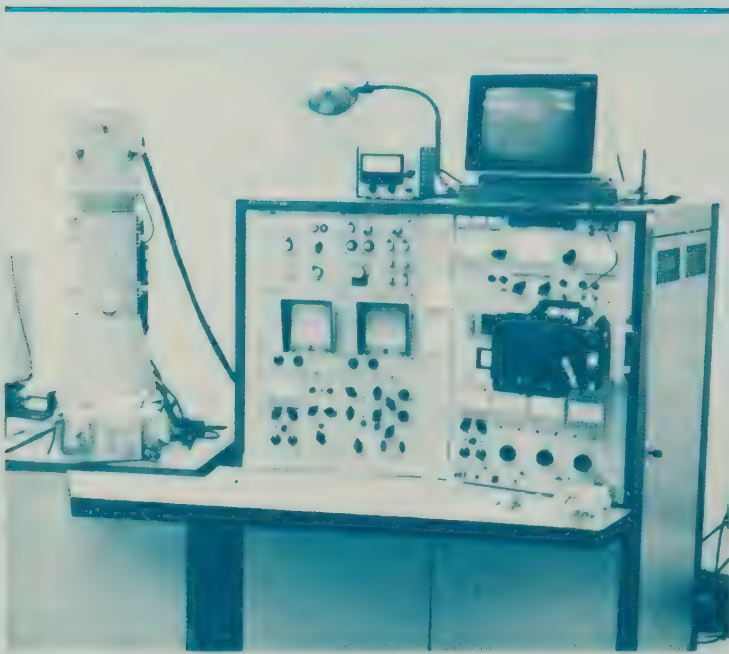

Figure 3.—Scanning electron microscope.

### Material Characterization

The laboratory can identify the chemical composition of dried coating films and liquid paints and their components. Liquid paints can also be characterized by their physical, rheological, and application properties. In this function, the laboratory is participating in the paint proficiency round robin testing sponsored by the American Association of State Highway and Transportation Officials Materials Reference Laboratory. The properties determined during this testing are weight per gallon, viscosity, pigment content/volatile content, and set-to-touch and dry-through times.

The laboratory performs vehicle and solvent identification and fingerprinting of liquid paints to ensure that material sources, quality, and original qualified formulations are not changed. The FHWA's infrared spectrometer and gas chromatograph instruments are used; this atomic absorption instrumentation is valuable in identifying coating pigment components and heavy metal content of leachates resulting from toxicity testing (figure 4).

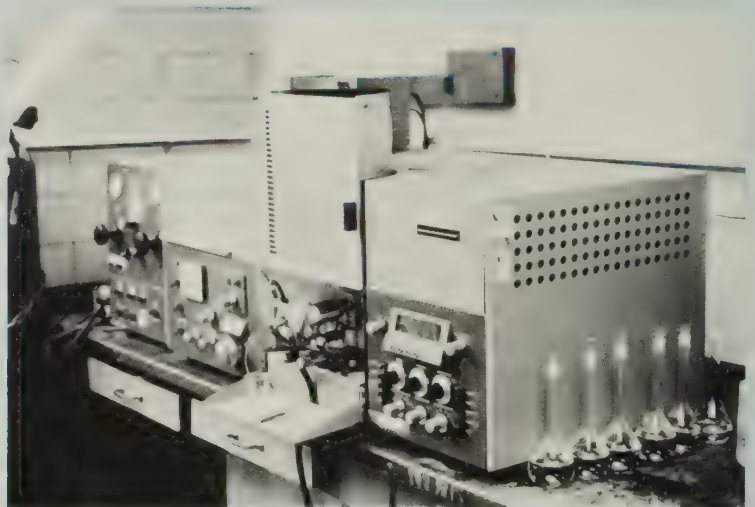

Figure 4.—Atomic absorption spectrometer.

Currently, the laboratory is examining mineral blasting abrasives sampled from different bridge painting operations for soluble salt content and particle size distribution. High salt concentrations result in the contamination of the cleaned substrate; this in turn may cause premature failure of the coating due to osmotic blistering. The correct particle size distribution of the blasting abrasive is critical to the cleaning rate and may affect the ulti-

mate cleanliness of heavily pitted steel. Additionally, heavy concentrations of large-size particles result in excessive profiles which may reduce coating performance.

## Toxicity Testing

The laboratory can also characterize abrasive paint debris from bridge repainting operations for the heavy metal content of their water leachates. As described in the article, these determinations can be

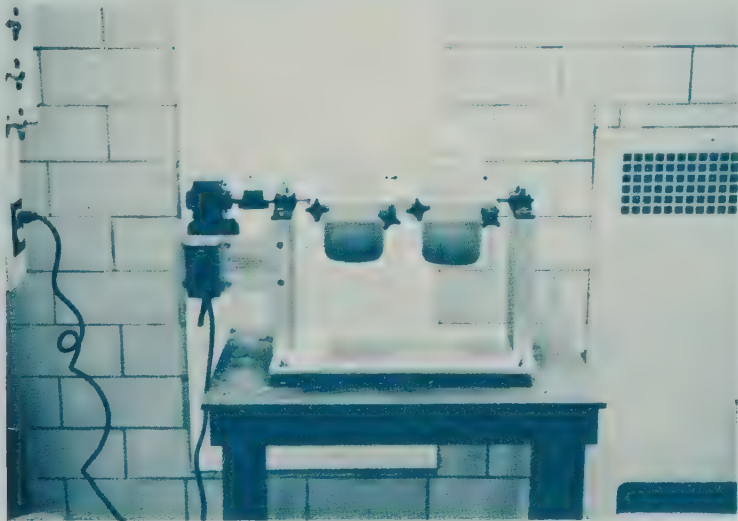

Figure 5.—Leaching apparatus.

made using either of the Environmental Protection Agency leaching procedures, the Extraction Procedure Toxicity Test (EPTox) or Toxicity Characteristic Leaching Procedure (TCLP). The leaching apparatus used in these tests is shown in figure 5.

## Accelerated Corrosion Testing

The noncompliant high-volatile organic compound containing coatings now used to protect bridges from corrosion must be replaced by high-performance, high-solid materials that meet environmental standards. The selection process requires that the laboratory perform accelerated corrosion testing regimens to evaluate the performance of the candidate paint and corrosion protection systems. UV-condensation, salt fog, freeze-thaw, and pressurized water immersion testing regimens are available for these evaluations (figures 6 and 7). A staff study has been designed and is being implemented to evaluate application and corrosion protection performance properties of commercially available replacement materials that meet environmental regulations with respect to toxic material and volatile organic compound content.

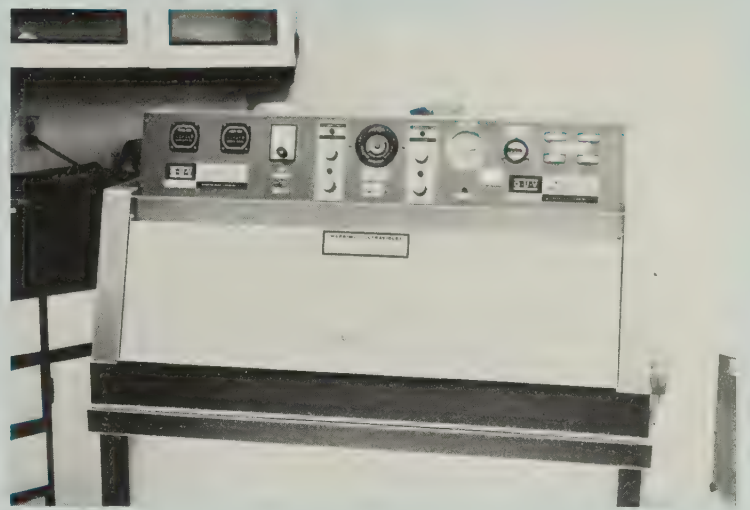

Figure 6.—Ultraviolet-condensation tester.

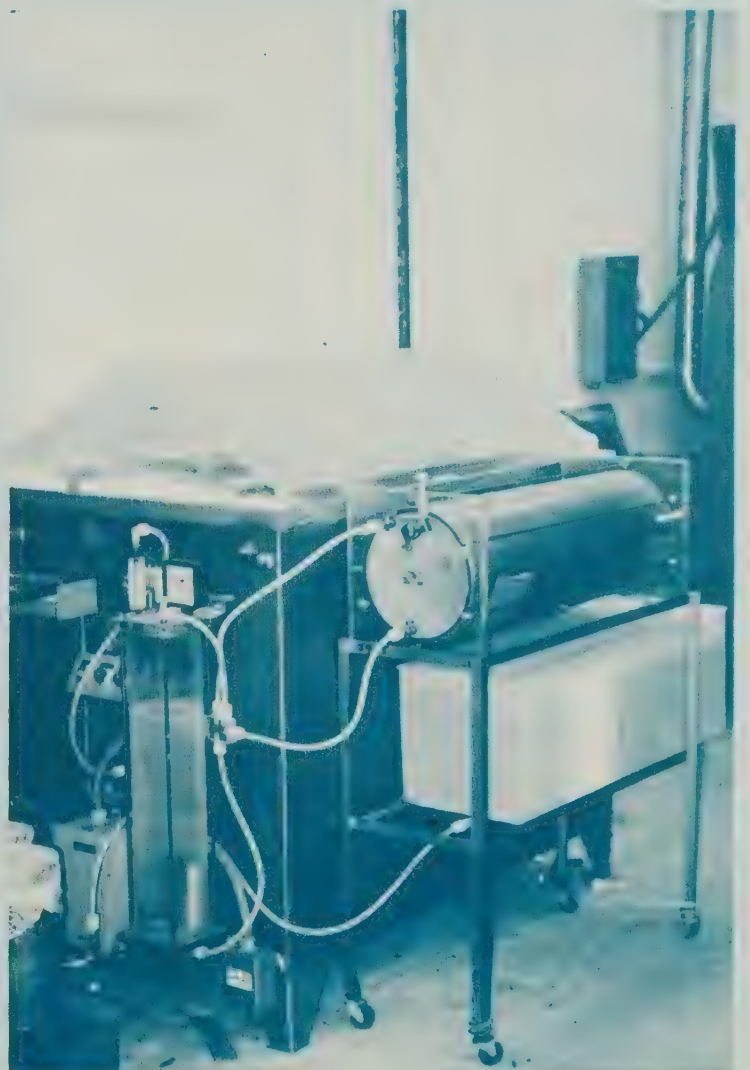

Figure 7.—Salt fog tester.

## Electrochemical Techniques

The Corrosion Control Laboratory is equipped with an EG&G Princeton Applied Research Model 272/273 Potentiostat/Galvanostat with supporting computer and software to perform corrosion measurements using various electrochemical techniques (figure 8). With this equipment, Tafel plots, polarization resistance, anodic and cathodic potentiodynamic polarization, cyclic polarization, and AC impedance corrosion measurements can be made. A current staff study is using these techniques, along with concrete ponding experiments to study the relative corrosion rates of deicers on steel rebars in concrete. Research plans are being formulated to employ impedance techniques to evaluate alternate rebar coatings to study the problem of coated rebar corrosion on the Florida Keys bridges as well as to evaluate bridge coatings.



Figure 8.—Corrosion measurement system.

**Shuang-Ling Chong** is a research chemist in the Materials Division, Office of Engineering and Highway Operations Research and Development (R&D), Federal Highway Administration (FHWA). Her 20 years' research experience covers photolysis, ion-molecule reactions, fractionation and characterization of organic materials in fossil fuels and petroleum, and identification of toxic organics and metals in coal combustion residues. She is currently conducting staff research in paint testings and evaluation of low-volatile organic compound compatible coating systems.

**John Peart** is also a research chemist in the FHWA's R&D Materials Division. He is the program manager for the High Priority National Program Area "Steel Bridge Coatings" which addresses FHWA's research effort in the corrosion control of steel highway structures.

**W. Clayton Ormsby**, a supervisory research chemist in the FHWA's R&D Materials Division, has 25 years of experience in materials research with the FHWA. He also has been active in the Organisation for Economic Co-operation and Development and Public Law 480 studies on waste utilization, fly ash, and cement. Before joining the FHWA, Dr. Ormsby spent 10 years with the National Bureau of Standards (now the National Institute for Standards and Technology) as a ceramic engineer and physical chemist.

**Michael S. Griffith** is a mathematical statistician in the Information and Behavioral Systems Division, Office of Safety and Traffic Operations Research and Development, FHWA. His current work involves data from the Highway Safety Information System. Using classical and Bayesian statistical methods, Mr. Griffith conducts analysis for highway safety research.

# Upgrade of the FOIL Pendulum Test Capability

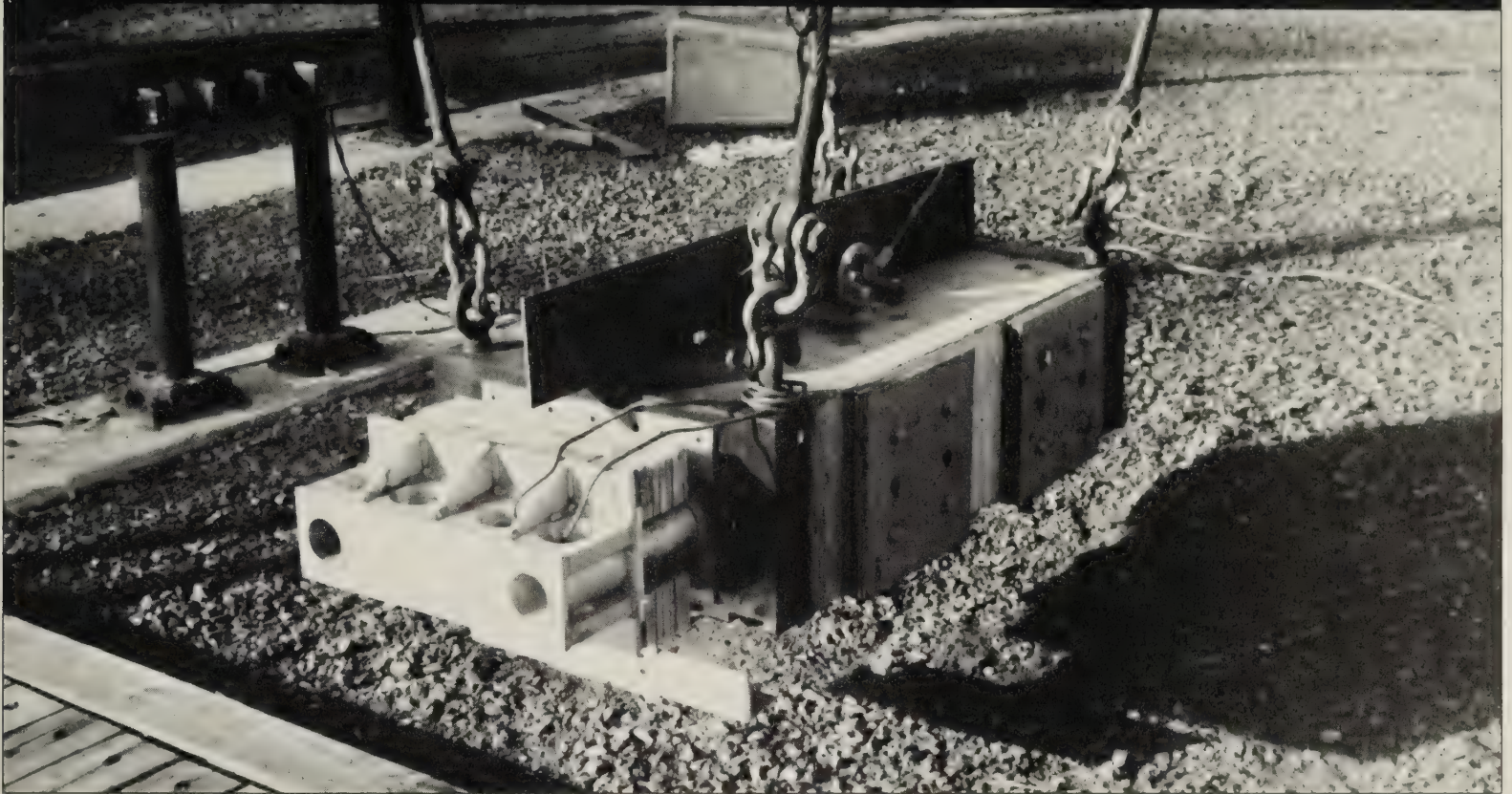

by Allen G. Hansen

## Introduction

In 1985, the Federal Highway Administration's (FHWA's) Office of Safety and Traffic Operations Research and Development opened the Federal Outdoor Impact Laboratory (FOIL) at the Turner-Fairbank Highway Research Center in McLean, Virginia. This facility was designed to evaluate roadside safety hardware when impacted by small vehicles at low and high speeds. To accomplish this, the FOIL features a unique, reusable surrogate (or bogie) vehicle which can simulate the impact of a small car at both low and high speeds in breakaway tests. Also, a pendulum system designed to simulate low-speed impacts of a 2,250-lb (1 020-kg) vehicle was moved to the FOIL to

provide additional surrogate test capability for narrow roadside objects such as sign and luminaire supports.

The pendulum system had previously been used to certify luminaire support breakaway performance under the 1975 American Association of State Highway and Transportation Officials (AASHTO) criteria. However, the pendulum design had certain limitations. The most significant of these was its crushable nose system which caused a momentary unrealistically high force on the target hardware. In some cases, the force caused the breakaway mechanism to activate early, thereby enabling some devices to pass the specification—a result that might not have occurred with automobile testing.

Another limitation was the lack of damping in the pendulum mass which was made of steel. After impact, the mass continued to vibrate, introducing error into the accelerometer measurements. Also, when the pendulum was moved to the FOIL, a mounting system for luminaire and sign supports was not provided. Instead, only direct burial devices such as guardrail posts could be evaluated. Finally, the pendulum design included a steel sweeper plate which simulated the effect of a vehicle undercarriage passing over the remaining stub of an article being tested. This plate often bent when impacting the remaining stub of the support, allowing the pendulum to pass over the impact area. A strong undercarriage could have significantly slowed the pendulum or possibly stopped it.

These limitations severely restricted the pendulum's use as a surrogate test vehicle. Further, in 1985, AASHTO adopted new criteria for evaluating roadside hardware. These criteria included the specification of an 1,800-lb (817-kg) vehicle for small car crash test certification, thereby making the old pendulum unsuitable for this testing due to its weight. To mitigate these limitations and meet the new AASHTO criteria, the FHWA issued a contract to design, install, and validate the operation of an upgraded pendulum system. (1)<sup>1</sup>

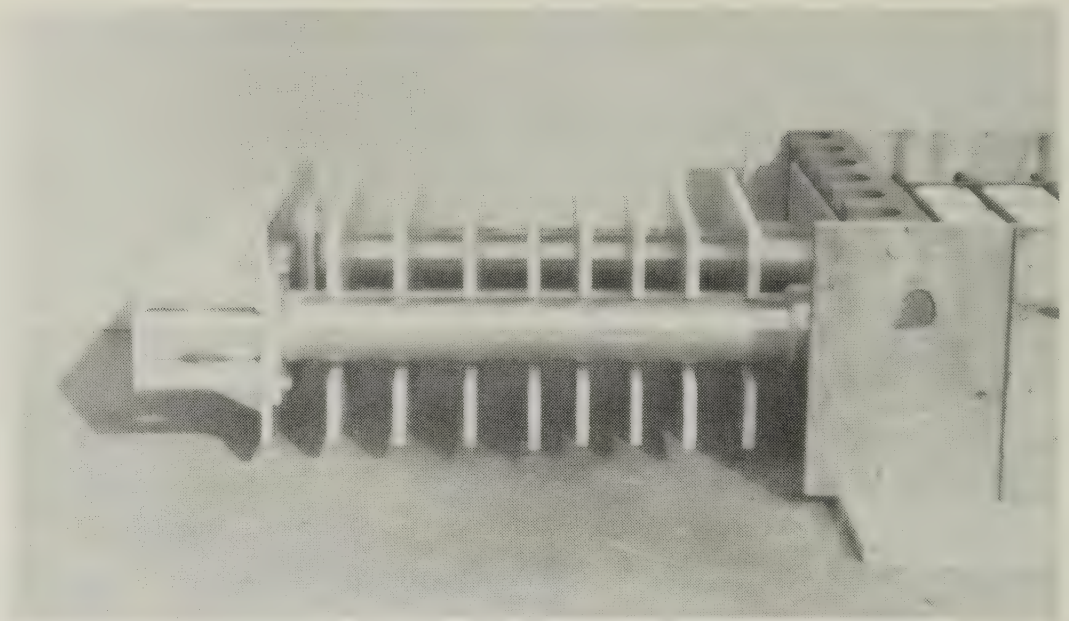

Figure 3.—Sliding nose design.

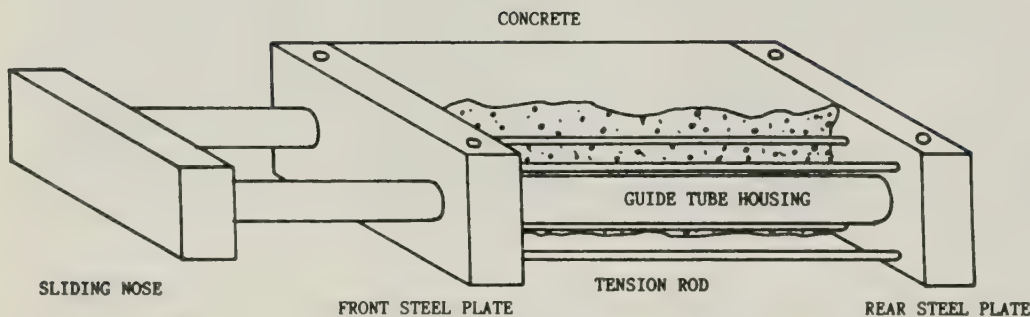

Figure 1.—Schematic of the new pendulum.

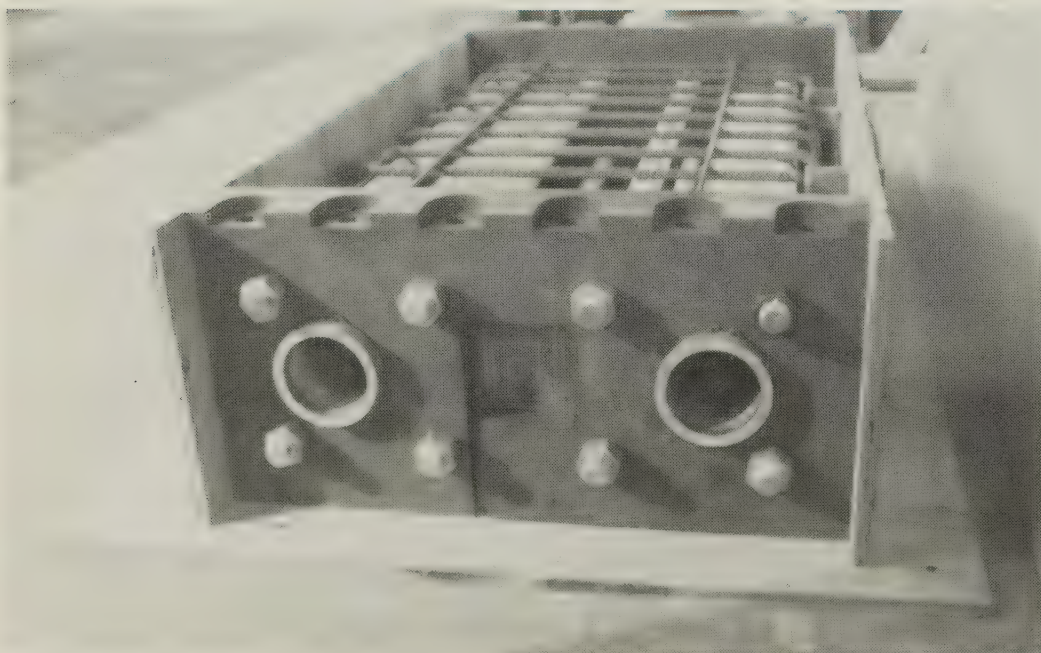

Figure 2.—Pendulum mass.

## System Design

The upgraded pendulum system has been designed to overcome all of the limitations of the previous system and to adhere to AASHTO's new 1,800-lb (817-kg) weight specifications. The design has used features already incorporated into the FOIL bogie test vehicle whenever possible, minimizing the need for both additional spare parts and a more comprehensive validation testing program. The features of this new design are described below.

### Mass design

The pendulum has been constructed in a sandwich configuration of dissimilar materials to damp out the vibrations due to impact. A concrete central mass has been used with steel front and rear plates as shown conceptually in figures 1 and 2. The steel plates are connected by nose guide tube housings and steel all-thread rods that are pretensioned to keep the concrete in compression. The concrete was cast between the plates; after curing, the pretension rods were tightened to specification. The heavy steel end plates spread the impact loads over the face of the

<sup>1</sup>Italic numbers in parentheses identify references on page 254.

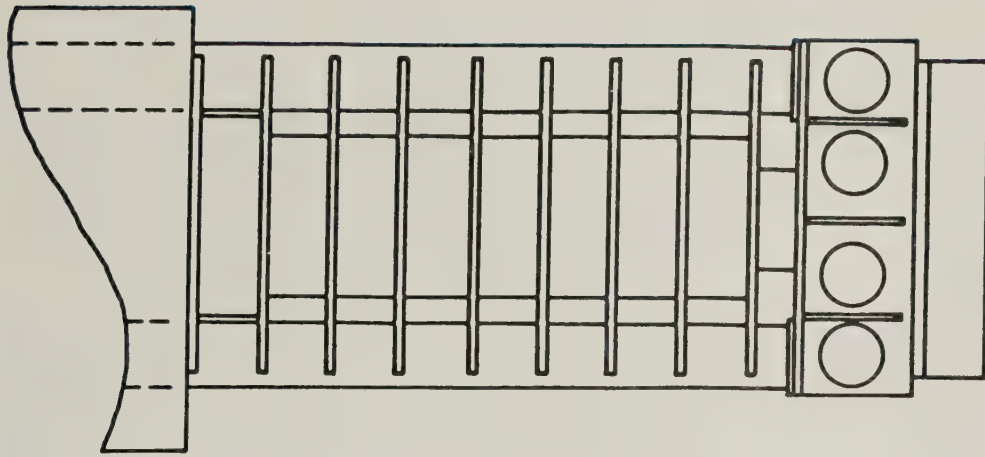

Figure 4.—Schematic of honeycomb nose cartridge placement.

pendulum and also provide attachment points for the sweeper plate, suspension cables, transducers, and other accessories.

### Sliding nose design

The sliding nose design was selected to eliminate the momentary unrealistically high force on the target seen in the earlier design (figure 3). The system is identical to the FOIL bogie nose, with the guide tubes fixed to the nose and allowed to slide into the body of the pendulum. Vehicle crush is modeled with honeycomb cartridges separated with phenolic spacers (figure 4). Because these parts are all interchangeable with the FOIL bogie, no additional spare parts need to be inventoried.

### Sweeper plate design

Two sweeper plates have been provided for the new pendulum. The first is identical to the bogie sweeper and uses a steel angle attached to a perforated plate to replicate a moderate strength vehicle undercarriage. The second sweeper simulates a very strong undercarriage; it has been designed to shear from the pendulum mass at a load of 50,000 lb (23 000 kg) (figure 5). This load level was selected to provide the greatest strength possible without endangering the integrity of the new pendulum mass.

The front of the sweeper is made of removable aluminum blocks of different thicknesses so that the sweeper's height can be adjusted.

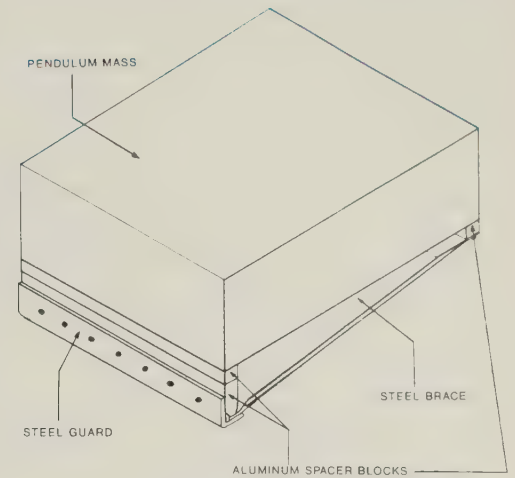

Figure 5.—Rigid sweeper plate design.

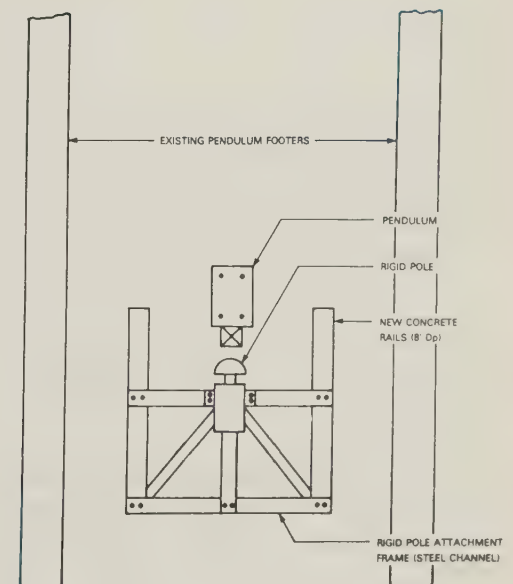

Figure 6.—Test article mounting system.

The blocks are braced with a reinforced steel plate which also protects them from secondary impacts into test article stubs that may remain on the foundation or in the ground as the pendulum continues to swing after the initial impact.

### Test article mounting system

A rigid mounting system has been provided as part of the pendulum upgrade (figure 6). It can accommodate a rigid instrumented pole

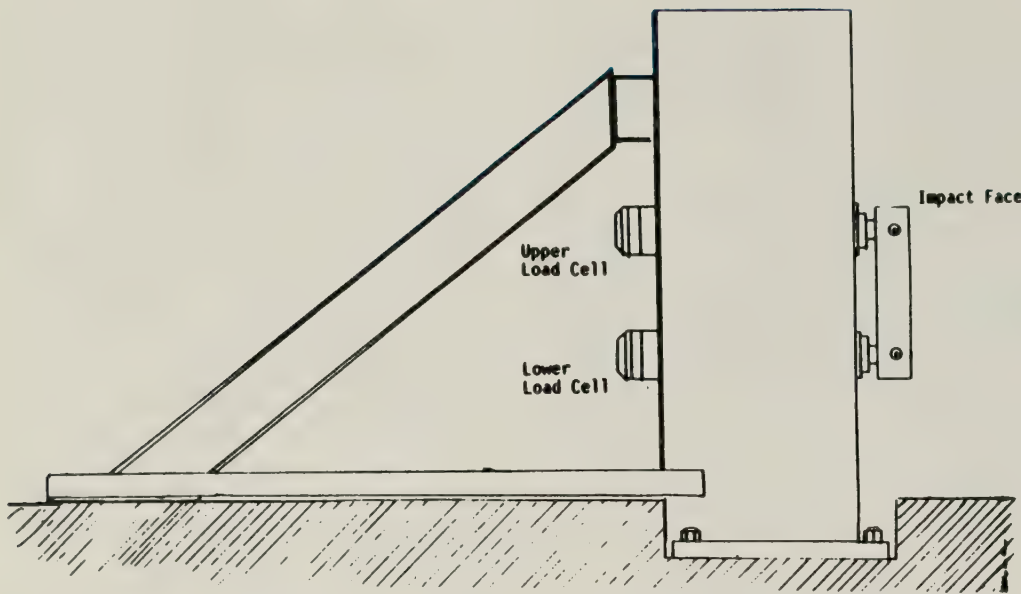

Figure 7.—Schematic of rigid instrumented pole.

for pendulum performance validation in addition to sign and luminaire supports. The mounting system consists of front and rear main cross beams, each supported by two upper and two lower diagonal braces. The main beams are also coupled with a span beam to minimize the deflection of the front beam when luminaire or sign supports are mounted.

The steel frame mounts between two concrete foundations. These foundations run longitudinally next to the path of the pendulum so as not to interfere with direct burial device testing (which can be conducted by removing the steel frame).

### System Validation

Validation of the pendulum upgrade included pendulum crush characterization using a rigid instrumented pole and proof-of-concept tests using the new sweeper plate design. (2)

### Crush characterization

To characterize the dynamic performance of the pendulum, three tests were conducted using a rigid instrumented pole. The pole was

designed to measure vehicle crush characteristics at low speed (figure 7). The impact face of this device consists of a semicircular section of extra heavy walled pipe attached to two connecting rods. Each rod end is fastened to a load cell so that the impact force can be monitored.

Table 1.—Pendulum rigid sweeper plate stub test summary

Test number	Impact speed (ft/s)	Maximum force (lb)
90P010	7.2	10,500
90P011	14.6	58,200
90P012	22.8	75,400

1 ft/s = 0.305 m/s  
1 lb = 0.454 kg

Table 2.—Pendulum rigid sweeper plate anchor base luminaire support test summary

Test number	Vehicle	Sweeper plate	Velocity change (ft/s)
87F068	Bogie	Current	10.2
90P013	Pendulum	Rigid	16.3

1 ft/s = 0.305 m/s

The time histories of force versus displacement using the load cell data from the rigid instrumented pole and double-integrated accelerometer data from the pendulum have been averaged together; figure 8 compares these data to averaged

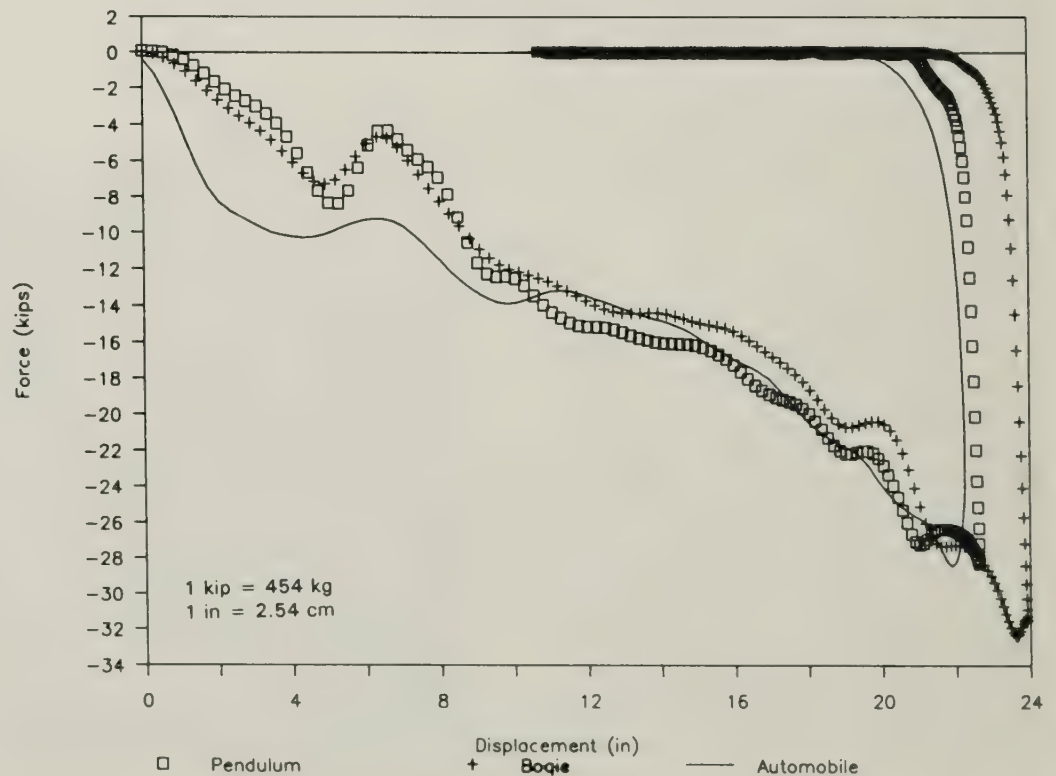

Figure 8.—Average vehicle force versus displacement.



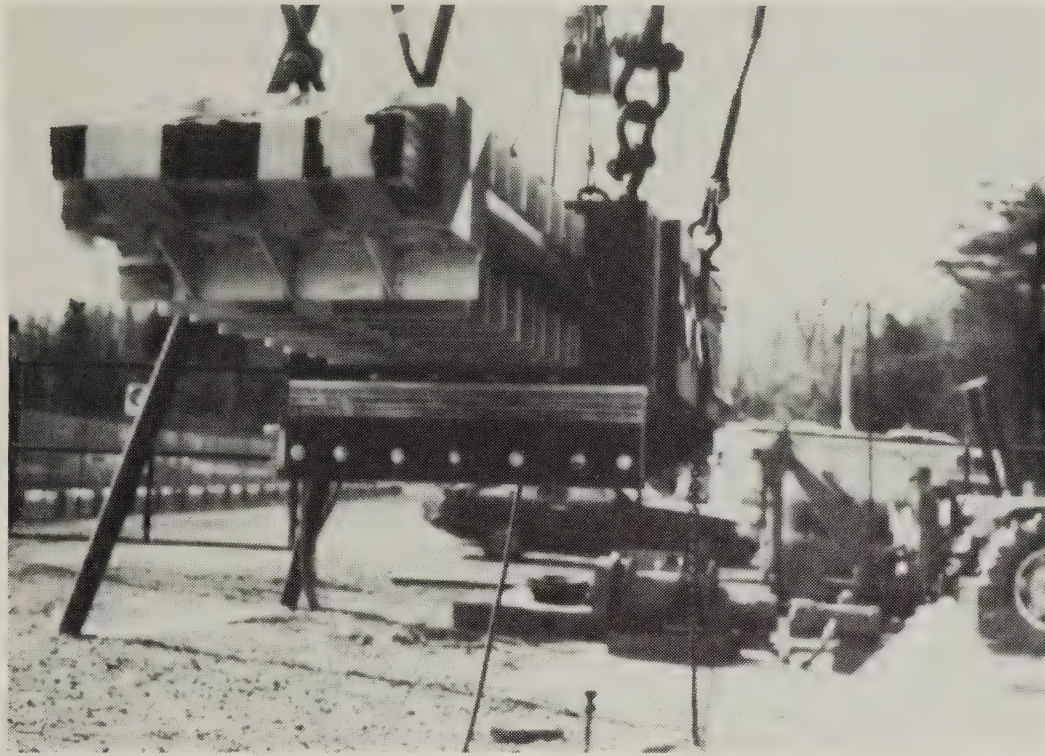

Figure 9.—Pendulum with rigid sweeper plate attached.

FOIL bogie results and averaged 1979 Volkswagen Rabbit results. (The crushable noses on the bogie and pendulum were designed to simulate impact into a 1979 Rabbit.)

The data show that the maximum crush and maximum force of the pendulum compare quite favorably with the automobile: both are somewhat less than the bogie. However, the differences in maximum values are rarely important with breakaway devices, because these high force levels are not reached when a device breaks away with a reasonable change in velocity. A more realistic comparison is at lower force-displacement values.

Figure 8 shows that the pendulum and bogie force-displacement characteristics are almost identical, and significant differences only appear when the bogie continues to crush to a greater depth, achieving high force levels. In addition, both the bogie and the pendulum only deviate from the automobile at low

displacements. These differences between the surrogate and the automobile have been documented previously and have been accepted as reasonable for FOIL testing.

#### Sweeper plate tests

Four tests were performed with the new rigid sweeper plate attached to the pendulum body (figure 9). In three of these tests, a rigid stub attached to the pendulum foundation was impacted. In the first two tests, the pendulum sweeper plate impacted the rigid stub and bounced back. In the third test, the sweeper plate hit the rigid stub, momentarily pushing the stub and the mounting foundation back about 0.8 in (2.0 cm). The sweeper then sheared away at the indicated force level, with the foundation and stub returning to their normal rest position. Test results are summarized in table 1.

These three tests revealed that the sweeper does indeed break away from the pendulum when impacting a very strong target. However, the breakaway force level for the new sweeper design (which uses the specified grade five bolts) is 50 per-

cent greater than the design load of 50,000 lb (22 700 kg). This greater load caused the entire rigid mounting structure to shift momentarily.

For the last rigid sweeper plate test, an anchor base luminaire support—identical to that used in a previous FOIL bogie test—was impacted at 20 mi/h (8.9 m/s). The results are presented in table 2 and include the data from the previous test in which the bogie sweeper plate design was used. The velocity change is significantly higher for the test in which the rigid sweeper plate was installed. This indicates that a significant increase in velocity change can be expected if a vehicle with a strong undercarriage impacts a luminaire support with a strong stub.

## Conclusions

- Because the crush characteristics of the upgraded pendulum are very similar to those of the bogie and an automobile, the pendulum is another surrogate method of determining the low-speed breakaway performance of sign and luminaire supports.
- The FOIL's upgraded pendulum system provides a highly efficient way of testing sign and luminaire supports at 20 mi/h (8.9 m/s), thus keeping the cost of testing to a minimum. The system meets all criteria in the AASHTO specifications for 1,800-lb (817-kg) class vehicle testing.

- The new pendulum system also provides a cost-efficient method of impact testing components of breakaway structures; thereby reducing the cost of these devices during the research and development stages.

## References

(1) A. Hansen, J. Hinch, N. Santelli, C. Hott, C. Brown, and N. Totani. *Development of Additional Federal Outdoor Impact Laboratory (FOIL) Facilities, Final Report—Vol. II: Validation of the*

*FOIL Pendulum Upgrade*, Publication No. FHWA-RD-90-085, Federal Highway Administration, Washington, DC, June 1990.

(2) C. Hott, C. Brown, and N. Totani. *Crush Characteristics of the 1800-lb Pendulum*, Publication No. FHWA-RD-90-059, Federal Highway Administration, Washington, DC, March 1990.

**Allen Hansen** is a mechanical engineer and director of the Engineering Systems Division of The Scientex Corporation. He currently manages and is the principal investigator on several highway safety research projects being conducted for the Federal Highway Administration.

# Recent Publications

The following are brief descriptions of selected publications recently published by the Federal Highway Administration, Office of Research and Development (R&D). The Office of Engineering and Highway Operations Research and Development includes the Structures Division, Pavements Division, and Materials Division. The Office of Safety and Traffic Operations R&D includes the Intelligent Vehicle-Highway Systems Research Division, Design Concepts Research Division, and Information and Behavioral Systems Division. All publications are available from the National Technical Information Service (NTIS). In some cases, limited copies of publications are available from the R&D Report Center.

When ordering from the NTIS, include the PB number (or the publication number) and the publication title. Address requests to:

National Technical Information Service  
5285 Port Royal Road  
Springfield, Virginia 22161

Requests for items available from the R&D Report Center should be addressed to:

Federal Highway Administration  
R&D Report Center, HRD-11  
6300 Georgetown Pike  
McLean, Virginia 22101-2296  
Telephone: (703) 285-2144

**Pollutant Loadings and Impacts from Highway Stormwater Runoff,**  
Vol. I: Design Procedure,  
Publication No. FHWA-RD-88-006

**Vol. II: Users Guide for Interactive Computer Implementation of Design Procedure, Publication No. FHWA-RD-88-007**

**Vol. III: Analytical Investigation and Research Report, Publication No. FHWA-RD-88-008**

**Vol. IV: Research Report Data Appendix, Publication No. FHWA-RD-88-009**

## by Materials Division

These publications document an investigation dealing with the characterization of stormwater runoff pollutant loads from highways, and the prediction of water quality impacts.

Study results are based on monitoring data from 993 individual storm events at 31 highway runoff sites in 11 States. Impact prediction is based on a methodology previously developed and applied to urban runoff and adapted for highway runoff applications.

Volume I provides a step-by-step procedure for computing the estimated impact on water quality of a stream or lake exposed to highway runoff. Guidance is provided for evaluating if a water quality problem will result and the degree of pollution control required to mitigate impacts to acceptable levels.

Volume II is a users guide for an interactive computer procedure for estimating the impact on water quality of a stream or lake exposed to highway runoff. The program provides evaluation guidance for potential water quality problems and the degree of pollution control required. The computer program is based on the methodology presented in volume I of the report.

Volume III describes the procedures used to assemble and analyze the data base and reports the results of these analyses. Included in this document are statistical summaries of the data base, along with a description of procedures used to predict pollutant discharges from highway sites and the impact that they have on receiving waters.

Volume IV provides a tabulated summary of all of the monitored data on storm rainfall, runoff volume, and pollutant concentrations. Data were recorded in spreadsheet format on microcomputer disks. Master copies of these disks are available in both "Lotus 1-2-3" and "Excel" spreadsheet documents.

These publications may only be purchased from the NTIS.

Vol. I (PB No. 90-257551/AS, Price code: A04.)

Vol. II: (PB No. 90-257544/AS, Price code: A03.)

Vol. III: (PB No. 90-257569/AS, Price code: A08.)

Vol. IV: (PB No. 90-257577/AS, Price code: A07.)

**Safety Implications of Various Truck Configurations, Vol. I: Technical Report, Publication No. FHWA-RD-89-018**

**by Design Concepts Research Division**

This study examined truck size and weight limits in order to determine their effects on design and configuration, their performance capabilities, and safety implications.

The study shows the manner in which size and weight rules influence the safety-related performance of vehicles designed to increase productivity. By treating a number of projected size and weight scenarios, the study developed a basis for generalizing to sets of principles that can be used in evaluating the possible safety consequences of changes in size and weight regulations.

This volume is the first in a series of three. The other two are Vol. II: Appendixes, Publication No. FHWA-RD-89-019, and Vol. III: Summary Report, Publication No. FHWA-RD-89-085.

Limited copies of this publication are available from the R&D Report Center. Copies may also be purchased from the NTIS. (PB No. 90-244138/AS, price code: A12.)

**Field Evaluation of Edgeline Widths, Publication No. FHWA-RD-89-111**

**by Design Concepts Research Division**

This report documents an evaluation of the safety and cost effectiveness of 8-in (20-cm) wide edgelines on two-lane rural roads compared with 4-in (10-cm) wide edgelines. In order to assess the incremental benefits attributable to the wider lines, a before-and-after experimental design with a control group was developed. With the assistance of State highway departments in Alabama, Maine, Massachusetts, New Mexico, Ohio, South Dakota, and Texas, over 2,000 mi (3 200 km) of two-lane rural roads were restriped with either 8-in (20-cm) or 4-in (10-cm) edgelines.

Using log-linear modeling and conventional statistical analysis techniques, the accident data collected over a 2- to 3-year period *before* the edgelines were applied were compared with accident data collected over a 1- to 2-year period *after*. Based on the available data, there is little evidence to suggest that the 8-in (20-cm) edgelines produce an incremental accident reduction compared to 4-in (10-cm) edgelines on two-lane rural roads with average daily traffic volumes between 5,000 and 10,000.

The analysis revealed that the wider edgelines were more effective under certain conditions and that they could be a cost-effective alternative to 4-in (10-cm) edgelines. Finally, the report gives suggestions as to when and where 8-in (20-cm) edgelines should be applied on two-lane rural roads.

This publication may only be purchased from the NTIS. (PB No. 90-266503/AS, Price code: A04.)

**Construction Costs and Safety Impacts of Work Zone Traffic Control Strategies, Vol. I: Final Report, Publication No. FHWA-RD-89-209**

**by Information and Behavioral Systems Division**

Research was performed to determine total costs (construction and road-user costs) and safety impacts associated with traffic control through work zones on rural four-lane, divided highways using single-lane closure (SLC) versus two-lane, two-way traffic operations (TLTWO). An informational guide for use in selecting cost-effective traffic control strategies was also prepared.

Construction data were collected from 51 construction projects in 11 States, and traffic capacity delay studies were conducted at 25





projects in 10 States. In all, construction projects were studied in 16 different States.

A total of seven types of construction projects were analyzed for the two traffic control alternatives. The construction type was the most important aspect affecting the selection of the most cost-effective traffic control strategy. The average daily traffic for the projects ranged from approximately 10,000 to 30,000. For the projects studied, there were no significant differences in accident rates between the two traffic control alternatives.

Guidelines are presented for selection of SLC versus TLTWO, including a simplified procedure to estimate road-user costs for SLC and TLTWO traffic control strategies.

This research report is the first volume of this, two-volume series. The second volume is the informational guide (Publication No. FHWA-RD-89-210.)

This publication may only be purchased from the NTIS. (PB No. 90-246778/AS, Price code: A08.)

**Levels of Service in Shared-Permissive Left-Turn Lane Groups at Signalized Intersections, Publication No. FHWA-RD-89-228**

**by Intelligent Vehicle-Highway Systems Research Division**

This study's objective was to evaluate and improve the 1985 Highway Capacity Manual (HCM) model for estimating the impact of shared-permissive left-turn movements on lane group saturation flow.

The study was based upon a nationwide data collection effort that yielded 15-minute samples taken at 45 intersection approaches (25 intersections) in 4 regional areas. Field measurements included prevailing and ideal saturation flow rates for each period, critical portions of the green phase as defined in the 1985 HCM, subject and opposing flow rates, lost times, and

other critical information. Only 22 percent of the data was used in model evaluations and calibrations because there were insufficient off-peak queues to yield saturation flow rate measurements.

The resulting analysis documents unique characteristics which apply to single-lane approaches and recommends simplified regression models for use in chapter 9 of the 1985 HCM. The model structure of the 1985 HCM does not appear to describe single-lane approach behavior adequately.

For multilane approaches, the general logic of the 1985 HCM appears to be correct, but simplified regression equations based on this logic can improve the accuracy of saturation flow rate predictions.

This publication may only be purchased from the NTIS. (PB No. 90-256074/AS, Price code: A08.)

## Development of Strength in Cements,

Vol. I: Interim Report 1986-1987,  
Publication No. FHWA-  
RD-90-015

Vol. II: Interim Report 1987-1988,  
Publication No. FHWA-  
RD-90-016

### by Materials Division

Volume I of the report describes an investigation of approaches for regulating the setting time of belite cement containing  $C_3A$  and  $C_4AF$ . It was found that belite-rich cement must have at least twice as much alite as tricalcium aluminate to avoid a flash setting. The report also deals with the development of a phase diagram for  $Ca_2SiO_4$  and  $Ba_2SiO_4$  ( $Ca_2SiO_4$ - $Ba_2SiO_4$ ) in the temperature range from 25 to 1 450 °C. The report treats specifically the X-Phase, ( $Ca_{1.52}Ba_{0.48}SiO_4$ ) and T-Phase, ( $Ca_{0.69}Ba_{1.31}SiO_4$ ) which according to their compositions are located between belite and  $Ba_2SiO_4$  in the

$Ca_2SiO_4$ - $Ba_2SiO_4$  system. Studies of the hydraulic reactivities and strength development of X-Phase and T-Phase are presented.

Volume II summarizes the researchers' studies for 1987 through 1988 and includes hydrated fly ash results from the hydration of free-lime-rich (approximately 40 weight percent) fly ash from the GACKO power plant. Also treated are the results of combining: hydrated fly ash (70 weight percent) plus silica fume (30 weight percent), hydrated fly ash (70 weight percent) plus silica fume (20 or 10 weight percent) and portland cement (10 or 20 weight percent), and hydrated fly ash (70 weight percent) plus portland cement (30 weight percent).

Figures in the report illustrate the relative percentages of ettringite and the carbonate, oxide, hydroxide, and sulfate of calcium plus that of portland cement (where used in a hydration) at the various hydration agings from 0 to 90 days.

These publications are in a series of six by the Federal Highway Administration: FHWA/RD-80/128, FHWA/RD-83/049, FHWA/RD-86/002, FHWA/RD-87/028, FHWA/RD-90-015, and FHWA/RD-90-016.

These publications may only be purchased from the NTIS.

Vol. I: (PB No. 90-268525/AS,  
Price code: A04.)

Vol. II: (PB No. 90-268533/AS,  
Price code: A03.)

## Performance Evaluation of an On-Board Data Acquisition System, Publication No. FHWA-RD-90-018

### by Design Concepts Research Division

This report contains the results of a test performed to evaluate an on-board data acquisition system in a crash test environment. The test was performed at the Federal Outdoor Impact Laboratory (FOIL) located in McLean, Virginia. Data collected by the on-board system was compared to data collected by the current FOIL system. The former posed no physical barriers for use at the FOIL and the data collected compared well with the data from the current FOIL system.

This publication may only be purchased from the NTIS. (PB No. 90-204561/AS, Price code: A03.)

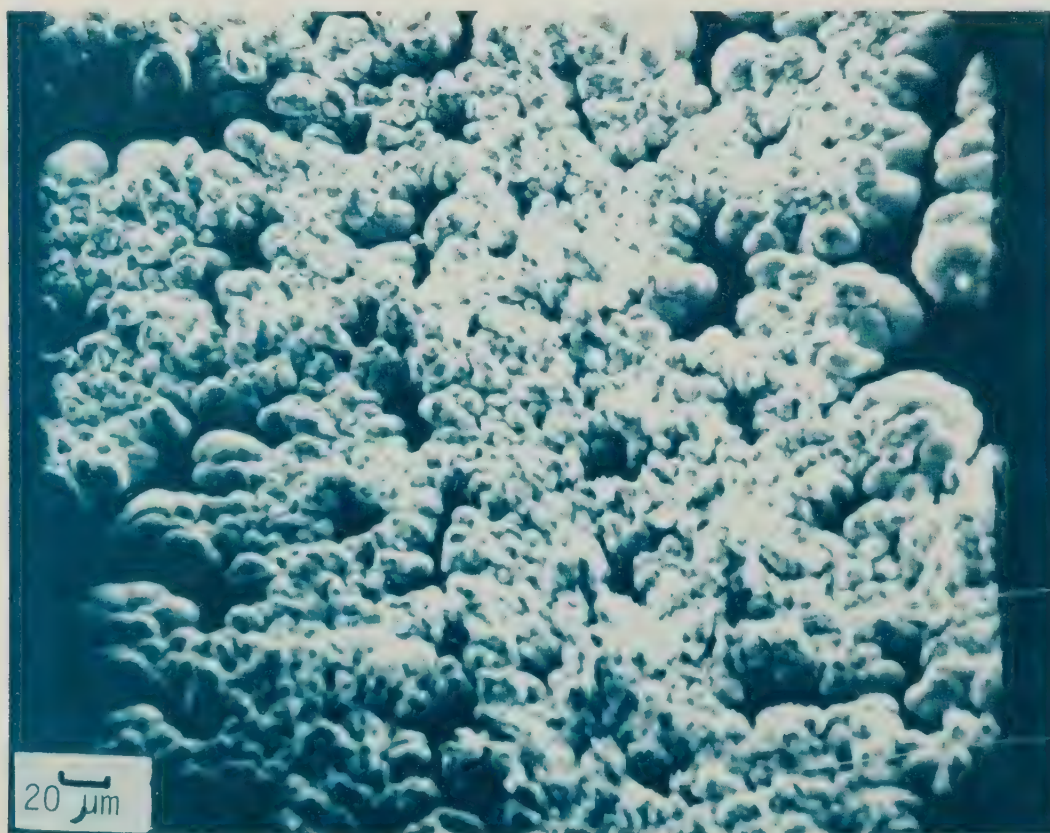

# Technology Applications

The following are brief descriptions of selected items that have been completed recently by State and Federal highway units in cooperation with the Office of Technology Applications, Office Safety and System Applications, Federal Highway Administration. Some items by others are included when they are of special interest to highway agencies. All publications are available from the National Technical Information Service (NTIS). In some cases, limited copies of publications are available from the R&D Report Center.

When ordering from the NTIS, include the PB number (or the publication number) and the publication title.

#### Address requests to:

**National Technical Information Service**  
5285 Port Royal Road  
Springfield, Virginia 22161

Requests for items available from the R&D Report Center should be addressed to:

**Federal Highway Administration**  
R&D Report Center, HRD-11  
6300 Georgetown Pike  
McLean, Virginia 22101-2296  
Telephone: (703) 285-2144

**Synthesis of Safety Research:  
Adverse Environmental Conditions, Publication No.  
FHWA-TS-89-046**

**by Office of Technology Applications**

This synthesis provides background information on the detrimental effects of adverse environmental conditions on safety and traffic operations. A wide variety of treatments has been used to mitigate safety and operational problems due to rain, fog, snow, ice, dust, and other conditions. These treatments and their effectiveness are discussed. A reference list is also provided for readers who wish more detailed information on a particular study.

Overall, on an annual basis, nearly 25 percent of the total accidents in the United States may be related to adverse environmental conditions. While no accurate figures are available, it is estimated that adverse conditions exist for less than 10 percent of the time. Consequently, a driver's accident risk is much greater during adverse environmental conditions than during normal driving conditions.

Several treatments have been found to be effective in reducing reoccurring adverse environmental problems in selected areas. Most of the adverse environmental problems occur randomly at any location and over time. Additional efforts in driver training and in-vehicle and roadside guidance warning systems are needed to solve the overall problem.

Limited copies of this publication are available from the R&D Report Center. Copies may also be





purchased from the NTIS. (PB No. 90-246760, Price code: A03 for paper, A01 for microfiche.)

**Maintenance of Aggregate and Earth Roads, Publication No. FHWA-TS-90-035**

**by Washington State Department of Transportation**

Road maintenance is characterized as the continuing care of the roadway until improvements are identified and undertaken. Within the scope of recurrent and deferred maintenance activities, opportunities are identified to improve cost effectiveness of surfacing and ditch maintenance and to reduce future capital improvements.

Planning, scheduling, and performing roadside ditch, travelway, and shoulder maintenance requires knowledge and expertise. Basic maintenance approaches and concepts are suggested and new considerations proposed for aggregate, earth, and native-surfaced roads.

Limited copies of this publication are available from the R&D Report Center.

**Work Zone Traffic Control Information Catalog, Publication No. FHWA-TS-028**

**by Office of Technology Applications**

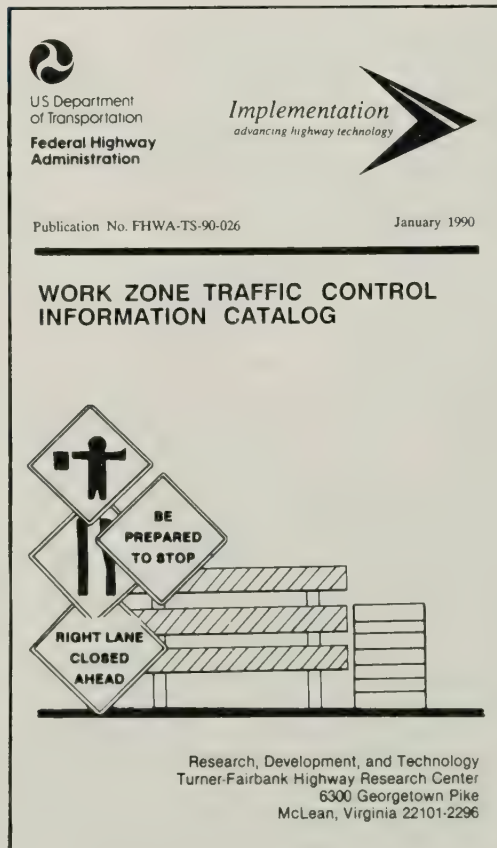

Limited copies of this publication are available from the R&D Report Center. Copies may also be purchased from the NTIS. (PB No. 90-1569289/AS, Price code: A03.)

**1991 Technology Transfer Calendar, Publication No. FHWA-TS-90-052**

**by Office of Technology Applications**

A 1991 Technology Transfer calendar has been developed to illustrate the various products and services available from, or sponsored by, the Federal Highway Administration (FHWA). This year's calendar adopts the National Transportation Policy's theme of *Moving America Together Into the 21st Century*. Thirteen featured products and 13 practical "Did You Know..." items promote research and technology areas such as Geographical Information Systems, the WALK ALERT National Pedestrian Safety Program, the Bridge Welding Code, the Arterial Analysis Package, Drainable Pavement Systems, and much more.

The calendar highlights industry convention dates and also describes how to obtain additional project information.

The 1991 Technology Transfer calendar will be distributed to all FHWA offices, State highway agencies, and Rural Technical Assistance Program centers. Limited copies are also available from the



The following new research studies reported by the FHWA's Office of Research and Development are sponsored in whole or in part with Federal highway funds. For further details on a particular study, please note the kind of study at the end of each description for:

- FHWA Staff and Administrative Contract Research contact Public Roads.
- Highway Planning and Research (HP&R) contact the performing State highway or transportation department.
- National Cooperative Highway Research Program (NCHRP) contact the Program Director, NCHRP, Transportation Research Board, 2101 Constitution Avenue, NW, Washington, DC 20418.
- Strategic Highway Research Program (SHRP) contact the SHRP, 818 Connecticut Avenue, NW, 4th floor, Washington, DC 20006.

## NCP Category A—Highway Safety

### A.1: Traffic Control for Safety

**Title:** Assessment and Improvement of Motorist Understanding of Traffic Control Devices (NCP No. 4A1C0182)

**Objective:** Identify areas where educational efforts might improve driver comprehension of complex signs, signals, and pavement markings. Test a representative sample of subjects based on geographic region, age, sex, education, driving experience, ethnic background, and linguistic ability.

**Performing Organization:** Texas A&M University, College Station, TX 77843

**Funding Agency:** Texas State Department of Highways and Public Transportation

**Expected Completion Date:** August 1993

**Estimated Cost:** \$259,180 (HP&R)

**Title:** Evaluation of Steady Burn Lights for Traffic Control in Highway Work Zones—Phase II (NCP No. 4A1E0282)

**Objective:** Test drums with high-intensity sheeting with and without steady burn lights in work zones involving lane closures, crossovers, and curved alignment on four-lane divided highways. Measure speed, lateral placement, acceleration noise, weaving, traffic conflicts, and driver preference. Collect data day

and night under dry, rainy, and foggy conditions. A total of 107 subjects will drive an instrumented vehicle through the study area.

**Performing Organization:** University of Cincinnati, Cincinnati, OH 45221

**Funding Agency:** Ohio Department of Transportation

**Expected Completion Date:** April 1992

**Estimated Cost:** \$245,000 (HP&R)

## NCP Category B—Traffic Operations

### B.1: Traffic Management Systems

**Title:** Development of Alternative Vehicle Detectors (NCP No. 4B1D0082)

**Objective:** Develop and evaluate a detection method that will minimize or eliminate the need for installing sensing devices and connecting cables in pavement.

**Performing Organization:** California Department of Transportation, Sacramento, CA 95807

**Expected Completion Date:** May 1993

**Estimated Cost:** \$259,000 (HP&R)

### **B.3: Motorist-Highway System Interactions**

**Title: Older Driver Perception-Reaction Time for Intersection Sight Distance and Object Detection (NCP No. 3BA0152)**

**Objective:** Investigate older driver perception-reaction time in analytical and empirical studies to determine the appropriate values for use in highway design equations. Evaluate older driver perception-reaction time in a variety of intersection situations and hazardous object encounters. Identify alternate models for highway design equations.

**Performing Organization:** Comsis Corporation, Silver Spring, MD 20910

**Expected Completion Date:** February 1993

**Estimated Cost:** \$370,000 (FHWA Administrative Contract)

**Title: TRAVTEK Traffic Management Center Systems Manager (NCP No. 3B3B5082)**

**Objective:** Provide traffic, motorist services, and tourism information and route guidance to operators of 100 test vehicles equipped with an in-vehicle TravTek device. Route guidance will reflect real-time traffic conditions in the TravTek traffic network. The project involves the following partners: Orlando, Florida Department of Transportation, the Federal Highway Administration, General Motors/Hughes, and the American Automobile Association.

**Performing Organization:** Farradyne Systems, Inc., Rockville, MD 20852

**Expected Completion Date:** December 1992

**Estimated Cost:** \$680,000 (FHWA Administrative Contract)

**Title: In-Vehicle Safety Advisory and Warning Systems (NCP No. 3B3B5072)**

**Objective:** Determine a cost-effective highway-vehicle communication technology and an in-vehicle system to inform the driver of roadway safety hazards. Develop permanent and portable systems for use at hazardous sites. Select, install, and field test appropriate technology. Frequently encountered hazards include stopped school buses, moving maintenance zones, and poor roadway or environmental conditions.

**Performing Organization:** Hughes Aircraft Company, Fullerton, CA

**Expected Completion Date:** September 1992

**Estimated Cost:** \$560,655 (FHWA Administrative Contract)

---

## **NCP Category C—Pavements**

### **C.2: Evaluation of Flexible Pavements**

**Title: Upgrading Marginal Aggregates for use in Asphalt Concrete Pavements (NCP No. 4C2A2542)**

**Objective:** Establish practical field operations for the treatment of aggregates with a portland cement coating and for the use of this modified aggregate in hot-mixed asphalt concrete. Examine the economic feasibility of the process.

**Performing Organization:** Texas A&M University, Texas Transportation Institute, College Station, TX 77843

**Funding Agency:** Texas State Department of Highways and Public Transportation

**Expected Completion Date:** August 1992

**Estimated Cost:** \$190,000 (HP&R)

### **C.3: Field and Laboratory Test Methods**

**Title: Evaluation of a Piezoelectric Weigh-in-Motion System (NCP No. 4C3A1782)**

**Objective:** Determine the accuracy, reliability, and survivability of piezoelectric weigh-in-motion systems placed in various pavement types under actual traffic conditions. Install systems adjacent to each of the four Strategic Highway Research Program general pavement study sites in Connecticut.

**Performing Organization:** Connecticut Department of Transportation, Wethersfield, CT 06109

**Expected Completion Date:** June 1993

**Estimated Cost:** \$295,000 (HP&R)

**Title: Establishment of a Pavement Research Facility at the Louisiana Transportation Center (NCP No. 4C3C1182)**

**Objective:** Establish a pavement research facility at the Louisiana Transportation Center. Construct an accelerated pavement loading facility to simulate traffic loads. Facility will be similar to the one at the Turner-Fairbank Highway Research Center.

**Performing Organization:** Louisiana Transportation Research Center, Baton Rouge, LA 70804

**Funding Agency:** Louisiana Department of Transportation

**Expected Completion Date:** December 1992

**Estimated Cost:** \$1,764,000 (HP&R)

#### C.4: Pavement Management Strategies

##### Title: Implementation of Illinois Pavement Feedback System (NCP No. 4C4C3212)

**Objective:** Implement the Illinois pavement feedback system (IPFS). Correct discrepancies between the management file and the IPFS data base. Incorporate pavement roughness into data bases and analysis procedures. Improve predictive equations and develop ad hoc management reports.

**Performing Organization:** Illinois Transportation Resources Consortium, Evanston, IL 60201 and Illinois Department of Transportation

**Funding Agency:** Illinois Department of Transportation

**Expected Completion Date:** June 1992

**Estimated Cost:** \$309,000 (HP&R)

#### NCP Category D—Structures

##### D.1: Bridge Design

##### Title: Automated Culvert Design and Drafting (NCP No. 4D1D1122)

**Objective:** Develop a software system to combine the design analysis and drafting for box culverts similar to the BRADD-2 system for bridges. Tasks include familiarization with the Pennsylvania Department of Transportation criteria, preliminary system development, conceptual design, detailed design of software, verification testing, implementation training, acceptance testing, final report, and maintenance of system for 2 years.

**Performing Organization:** Michael Baker, Jr. Inc., Beaver, PA 15009

**Funding Agency:** Pennsylvania Department of Transportation

**Expected Completion Date:** July 1995

**Estimated Cost:** \$300,000 (HP&R)

##### D.2: Bridge Management

##### Title: Monitoring Program for PA's Demonstration Timber Bridge Program (NCP No. 4D2B1062)

**Objective:** Monitor 17 post-tensioned timber bridges composed of solid hardwood laminates, steel/hardwood composite bridges, and stressed glue-laminated hardwoods constructed under PennDOT's Demonstration Timber Bridge Program, during preconstruction, construction, and post-construction phases in order to arrive at a set of recommendations for designers, contractors, and maintenance engineers of modern timber bridges.

**Performing Organization:** West Virginia University, Morgantown, WV 26506

**Funding Agency:** Pennsylvania Department of Transportation

**Expected Completion Date:** August 1995

**Estimated Cost:** \$300,000 (HP&R)

##### Title: Development of a Comprehensive Bridge Management System for Texas (NCP No. 4D2D1142)

**Objective:** Develop and implement, in a least one district, a comprehensive bridge management system that meets the needs and resources of the Texas State Department of Highways and Public Transportation.

**Performing Organization:** Texas A&M University, Texas Transportation Institute, College Station, TX 77843

**Funding Agency:** Texas State Department of Highways and Public Transportation

**Expected Completion Date:** August 1992

**Estimated Cost:** \$328,000 (HP&R)

##### D.4: Corrosion Protection

##### Title: Structural Integrity of Epoxy-Coated Bars (NCP No. 4D4C0222)

**Objective:** Evaluate the performance of epoxy-coated rebars under conditions that simulate the corrosive environment and structural conditions in which they are typically used.

**Performing Organization:** University of Texas, Austin, TX 78712

**Funding Agency:** Texas State Department of Highways and Public Transportation

**Expected Completion Date:** September 1993

**Estimated Cost:** \$348,000 (HP&R)

##### Title: Corrosion Protection for Post-Tensioned Tendons and Cable-Stay Systems (NCP No. 4D4C0232)

**Objective:** Obtain long-term corrosion protection. Determine the effect of suspended deleterious components of grout. Determine methods to improve consolidation and reasonable inspectability of all types of tendons. Provide design and construction procedures for lubricated tendons.

**Performing Organization:** University of Texas, Austin, TX 78712

**Funding Agency:** Texas State Department of Highways and Public Transportation

**Expected Completion Date:** September 1994

**Estimated Cost:** \$636,000 (HP&R)

## NCP Category E—Materials and Operations

### E.2: Cement and Concrete

**Title:** Design and Construction of an Environmentally Controlled Test Facility for Portland Cement Concrete (NCP No. 4E2A1163)

**Objective:** Build an enclosure and test bed for a test facility to house large-scale structures and test them in a controlled environment. Designed to be built in stages, the enclosure and test bed will be built under this phase—humidity and temperature control will be added later.

**Performing Organization:** Center for Transportation Research, Austin, TX 78705

**Funding Agency:** Texas State Department of Highways and Public Transportation

**Expected Completion Date:** August 1991

**Estimated Cost:** \$229,000 (HP&R)

### E.3: Geotechnology

**Title:** Bridge Foundation Research: Dynamic Pile Monitoring, KARST Conditions and Flowable Backfill (NCP No. 4E3A0742)

**Objective:** Develop an implementation plan for the routine use of dynamic pile monitoring equipment. Prepare a guide to help identify and solve problems associated with KARST conditions. Prepare specifications for the use of flowable backfills.

**Performing Organization:** Pennsylvania Department of Transportation, Harrisburg, PA 17120

**Expected Completion Date:** June 1993

**Estimated Cost:** \$250,000 (HP&R)

### E.5: Highway Maintenance

**Title:** Incorporation of Maintenance Consideration in Highway Design (NCP No. 5E5F1142)

**Objectives:** Determine the current practice of incorporating maintenance concerns into highway design and identify successful techniques, weaknesses, and needed improvements. Recommend a design process that incorporates maintenance implications. List and describe design details that create maintenance problems and the improvements that overcome them.

**Performing Organization:** Daniel, Mann, Johnson, and Mendenhall, Los Angeles, CA 90010

**Expected Completion Date:** August 1992

**Estimated Cost:** \$190,000 (NCHRP)

### E.8: Construction Control and Management

**Title:** Procedures and Data for Determining Contract Completion Time (NCP No. 4E8C2192)

**Objective:** Develop a rational procedure for estimating contract completion time using detailed project characteristics, production quantities, and production rates.

**Performing Organization:** Texas A&M University, Texas Transportation Institute, College Station, TX 77843

**Funding Agency:** Texas State Department of Highways and Public Transportation

**Expected Completion Date:** August 1992

**Estimated Cost:** \$185,000 (HP&R)

#### Errata

On page 196 in the September 1990 issue of *Public Roads*, the value of EXP in equation 5 should read:

$$\text{EXP} = 0.040 - 0.433(Y_s/B) + 0.0566 \log(D_{S,bed}/Y) + 0.142 \log(Y/B) + 0.0116(D_{r,pier}/B)$$

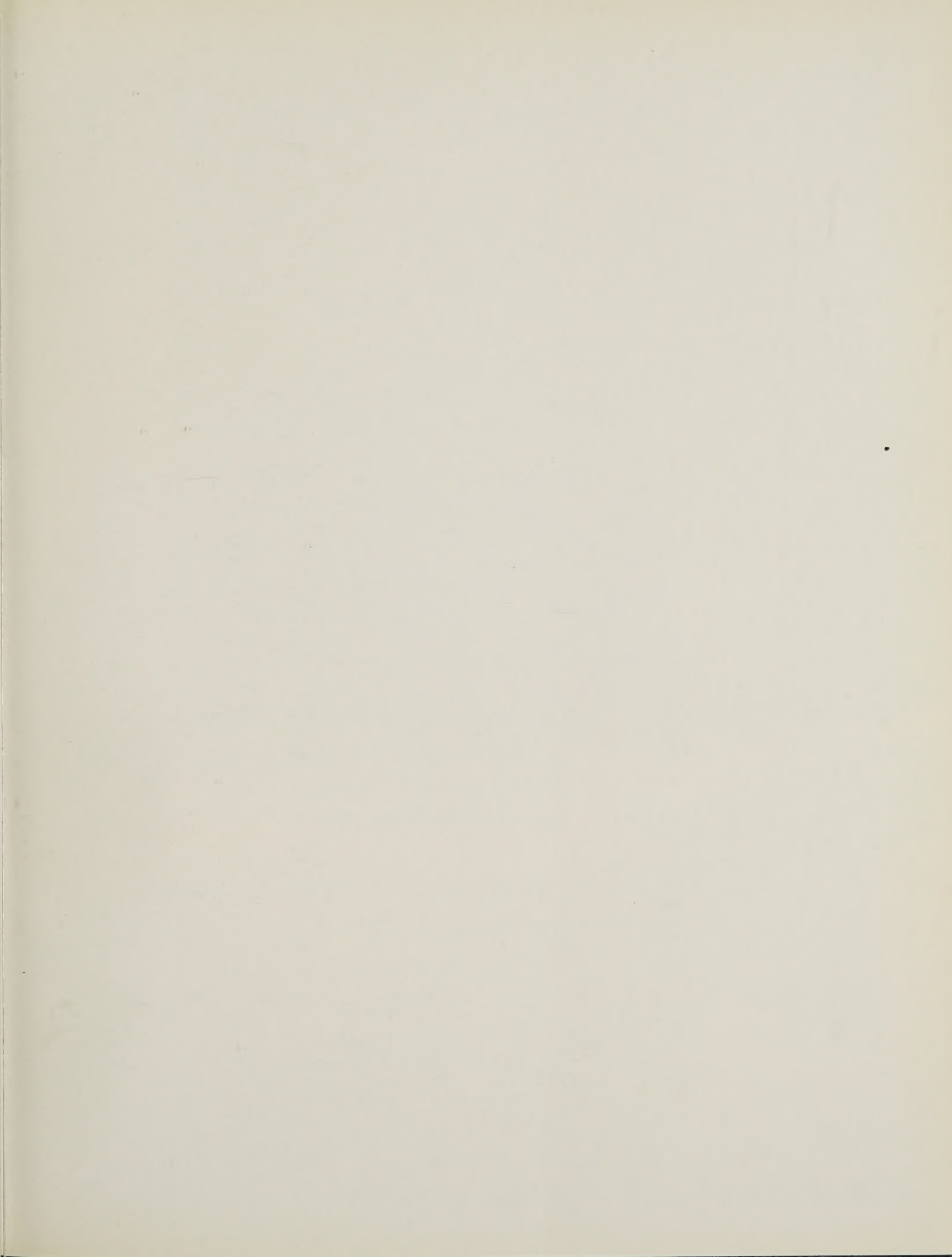

US. Department  
of Transportation

**Federal Highway  
Administration**

400 Seventh St., S.W.  
Washington, D.C. 20590

Official Business  
Penalty for Private Use \$300

Second Class Mail  
Postage and Fees Paid  
Federal Highway Administration  
ISSN No. 0033-3735

# **In this issue**

**Intelligent Vehicle-Highway  
Systems: Moving America Into  
the 21st Century**

**The Highway Safety Information  
System**

**Leaching Test Studies Using  
Extraction Procedure Toxicity Test  
and Toxicity Characteristic  
Leaching Procedure**

**Upgrade of the FOIL Pendulum  
Test Capability**

**Public Roads**

A Journal of Highway Research and Development

