





# PUBLIC ROADS

A JOURNAL OF HIGHWAY RESEARCH



UNITED STATES DEPARTMENT OF AGRICULTURE  
BUREAU OF PUBLIC ROADS



VOL. 10, NO. 9



NOVEMBER, 1929



A FEDERAL-AID ROAD IN PENNSYLVANIA

# PUBLIC ROADS

## A JOURNAL OF HIGHWAY RESEARCH

UNITED STATES DEPARTMENT OF AGRICULTURE

BUREAU OF PUBLIC ROADS

CERTIFICATE: By direction of the Secretary of Agriculture, the matter contained herein is published as administrative information and is required for the proper transaction of the public business

The reports of research published in this magazine are necessarily qualified by the conditions of the tests from which the data are obtained. Whenever it is deemed possible to do so, generalizations are drawn from the results of the tests; and, unless this is done the conclusions formulated must be considered as specifically pertinent only to the described conditions

VOL. 10, NO. 9

NOVEMBER, 1929

R. E. ROYALL, Editor

### TABLE OF CONTENTS

|   | Page |
|---|------|
| Earth Pressure Experiments on Culvert Pipe - - - - -                        | 153  |
| Appendix I.—Notes Relative to Vertical Pressures on Pipe Culverts - - - - - | 165  |
| Appendix II.—Stresses and Deflections of Pipe Culverts - - - - -            | 169  |

### THE BUREAU OF PUBLIC ROADS

Willard Building, Washington, D. C.

#### REGIONAL HEADQUARTERS

Mark Sheldon Building, San Francisco, Calif.

#### DISTRICT OFFICES

|  |   |
|--|---|
| DISTRICT No. 1. Oregon, Washington, and Montana.<br>Box 3900, Portland, Oreg.                                  | DISTRICT No. 7. Illinois, Indiana, Kentucky, and Michigan.<br>South Chicago Post Office Bldg., Chicago, Ill.  |
| DISTRICT No. 2. California, Arizona, and Nevada.<br>Mark Sheldon Building, San Francisco, Calif.               | DISTRICT No. 8. Louisiana, Alabama, Georgia, Florida, Mississippi,<br>South Carolina, and Tennessee.<br>Box J, Montgomery, Ala.                             |
| DISTRICT No. 3. Colorado, New Mexico, and Wyoming.<br>301 Customhouse Building, Denver, Colo.                  | DISTRICT No. 9. Connecticut, Maine, Massachusetts, New Hamp-<br>shire, New Jersey, New York, Rhode Island,<br>and Vermont.<br>Federal Building, Troy, N. Y. |
| DISTRICT No. 4. Minnesota, North Dakota, South Dakota, and<br>Wisconsin.<br>410 Hamm Building, St. Paul, Minn. | DISTRICT No. 10. Delaware, Maryland, North Carolina, Ohio, Penn-<br>sylvania, Virginia, and West Virginia.<br>Willard Building, Washington, D. C.           |
| DISTRICT No. 5. Iowa, Kansas, Missouri, and Nebraska.<br>8th Floor, Saunders-Kennedy Building, Omaha,<br>Nebr. | DISTRICT No. 11. Alaska.<br>Goldstein Building, Juneau, Alaska.   |
| DISTRICT No. 6. Arkansas, Oklahoma, and Texas.<br>1912 Fort Worth National Bank Building, Fort<br>Worth, Tex.  | DISTRICT No. 12. Idaho and Utah.<br>Fred J. Kiesel Building, Ogden, Utah.   |

Owing to the necessarily limited edition of this publication it will be impossible to distribute it free to any persons or institutions other than State and county officials actually engaged in planning or constructing public highways, instructors in highway engineering, and periodicals upon an exchange basis. Others desiring to obtain PUBLIC ROADS can do so by sending 10 cents for a single number or \$1 per year (foreign subscription \$1.50) to the Superintendent of Documents, United States Government Printing Office, Washington, D. C.

# EARTH PRESSURE EXPERIMENTS ON CULVERT PIPE

RESULTS OF RESEARCH BY THE UNIVERSITY OF NORTH CAROLINA IN COOPERATION WITH THE NORTH CAROLINA HIGHWAY COMMISSION AND THE UNITED STATES BUREAU OF PUBLIC ROADS

By G. M. BRAUNE, Dean of School of Engineering; WILLIAM CAIN, Professor Emeritus of Mathematics; and H. F. JANDA formerly Professor of Highway Engineering, of the University of North Carolina<sup>1</sup>

EXPERIMENTS relating to earth pressures on culvert pipe were initiated at the University of North Carolina in 1923 in cooperation with the North Carolina State Highway Commission. The additional cooperation of the Bureau of Public Roads was obtained in 1925. The object of the experiments was to secure data for use in the design of highway culverts. There is no exact method of determining the behavior of an elastic pipe culvert under the variable loads produced by granular fill material. Deformations in the culvert produced by the load result in a rearrangement of the material producing the deformation. This rearrangement of material is affected by the cohesive and frictional qualities of the soil.

Since the problem did not lend itself to analysis without experimentation it was decided to make field tests to determine the earth pressure on culvert pipe, to ascertain the elastic behavior of the pipe under these loads, and to attempt to correlate the field data with

Other experimental work relative to earth pressures has been performed (see bibliography at end of report), but the application of earth pressures to culvert pipe has been confined to the two projects noted above. In both of these the method of approaching the problem has differed somewhat from that used at the University of North Carolina.

The tests at Chapel Hill were conducted on 20 and 30 inch pipe of various materials, using sand and clay fills. In all tests of the first series the pipe was placed in what is termed "the condition of 50 per cent projection"—that is, only one-half of the circumference of the pipe was exposed to the fill. In the first portion of this series the fill was placed over the pipe exposed in this manner, and later conditions were modified by placing and compacting a portion of the fill and then excavating a narrow trench to expose the pipe (in condition of 50 per cent projection). The trench was then back filled and the fill completed in the usual manner. This was called the "trench condition."

The most pertinent data were obtained in the second series of tests in which the entire surface of the pipe

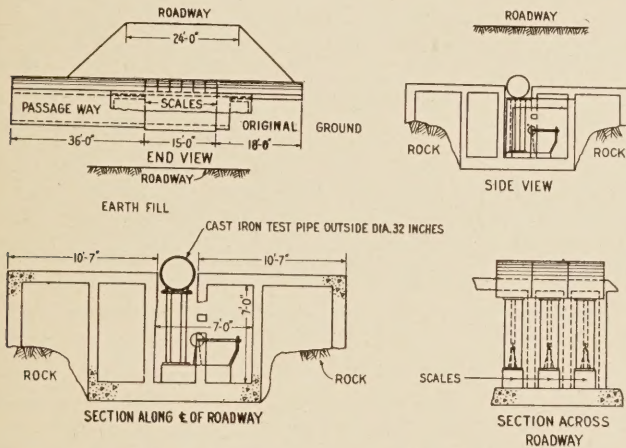

FIGURE 1.—ARRANGEMENT OF TEST APPARATUS FOR TESTS UNDER CONDITION OF 50 PER CENT PROJECTION

laboratory tests in such a manner as to provide design data.

Dean Anson Marston of Iowa State College, at Ames, Iowa, has conducted large scale experiments for several years, along lines similar to the work at Chapel Hill.

Experiments to determine earth pressures on culvert pipe have been made near Farina, Ill., under the auspices of the American Railway Engineering Association.

<sup>1</sup> Valuable personal aid and criticism has been furnished by Frank H. Page, Charles M. Upham, C. N. Connor, G. W. Hutchinson, F. E. Schnepfe, R. T. Giles, E. H. Kivett, F. C. Pritchett, and W. E. Hawkins, of the North Carolina State Highway Commission; A. T. Goldbeck, E. F. Kelley, George W. Davis, and A. L. Gemeny, of the United States Bureau of Public Roads; T. F. Hickerson, of the University of North Carolina; Milo S. Ketchum, of the University of Illinois; and R. W. Crum, of the Iowa State Highway Commission.

Materials for use in the experiments were supplied by the Portland Cement Association; the National Tube Co., of Atlanta, Ga.; the American Casting Co., of Birmingham, Ala.; the Armo Culvert and Flume Manufacturers Association; and the Standard Sand and Gravel Corporation, of Gravel Pit, N. C.

Recognition is due the research fellows who have performed a major portion of the work and the collection of data at the experimental station. The following men have served as research fellows: J. G. Wardlaw, jr., and L. B. Aull, jr., 1923-24; H. McC. Holmes, jr., and Harry Cantey, 1924-25; W. C. Johnson and W. McK. Franklin, 1926-27; and E. G. Dobbins and H. A. Schmitt, 1927-28.

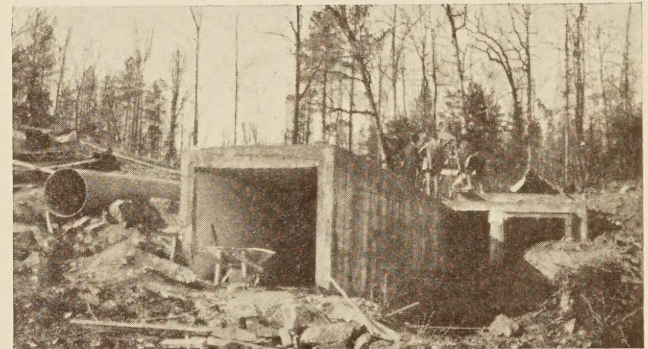

FIGURE 2.—THE HOUSING CULVERT UNDER CONSTRUCTION

was exposed to the fill and information was obtained not only as to the load on the pipe but also as to the radial earth pressure and the deflection of the pipe.

## ARRANGEMENT OF APPARATUS DESCRIBED

A site suitable for the experiments was found about 1 mile south of Chapel Hill, N. C. This site was easily accessible, was quite near an excellent supply of sand and clay for filling material, and required comparatively small quantities of fill to reach the desired height of embankment. The profile of the original ground permitted a good location for the test apparatus and for the formation of embankment up to 20 feet in height, or greater if desired.

The original apparatus was designed to simulate field conditions and measure vertical earth pressure only. The upper half of the pipe surface was to be exposed to earth pressure—a condition hereafter referred to as 50 per cent projection—and the pipe was to be supported by weighing apparatus so arranged as to permit observers working beneath the pipe. Figures 1, 2, 3, and 4 indicate the general arrangement.

The housing for the weighing apparatus (fig. 2) consisted of a reinforced concrete box culvert 58.5 feet long, 7 feet wide, with a clear height of 7 feet. Sufficient excavation was made for the housing culvert to allow the test pipe being placed at the desired elevation.

The weighing apparatus which was placed inside the culvert box consisted of four platform scales, each having a capacity of 30,000 pounds, designed and constructed especially for these experiments. They have been calibrated a number of times during the experiment and are thought to be accurate. Steel columns

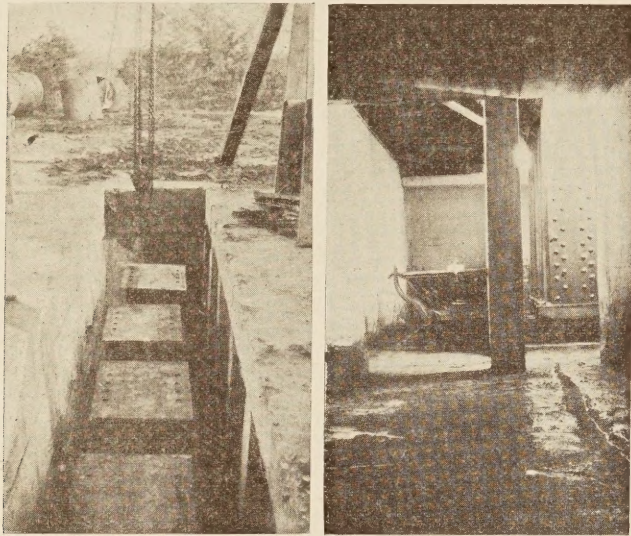

FIGURE 3.—TOPS OF COLUMNS FOR SUPPORTING PIPE IN CONDITION OF 50 PER CENT PROJECTION AND INSIDE OF HOUSING CULVERT

(fig. 3) extending up to the roof of the weighing chamber were supported on the scale platform, and the test pipes were placed on top of these columns.

The columns were only 5 feet 4 inches long, but in order to prevent any appreciable deformation they were designed with an excessive cross-sectional area so as to keep the unit stress below 1,000 pounds per square inch. The concrete roof of the weighing chamber had a slot (fig. 3) large enough to permit the insertion of the test pipe. Resting on the columns were the four joints of pipe, held in place by small angles bolted to the columns (figs. 1 and 4) and spaced sufficiently far apart to allow free deflection of the pipe. In order that uniform conditions might be obtained, the pipe was extended beyond the test sections so as to cover the entire width of the fill and was supported on the concrete slab. Each section of test pipe was 2½ feet long.

In conducting the tests it was necessary to differentiate between active and passive pressures. The movement of the scale platform during a weighing operation as calculated from the movement of the balance arm was only 0.00007 inch (and some of this was perhaps taken up in the elasticity of the lever), but there was a very slight movement of the platform. Therefore, in order to record active pressure, the tendency of the movement of the scale platform would have to be in a downward direction. This condition was obtained by running the counterpoise out so that the beam was always down and the platform up. When the readings were taken the poise was run in until the beam just began to rise. Thus the mass of the earth tended to move down and was supported in part by its friction and

cohesion, the vertical earth pressure exerted upon the pipe being observed on the scales.

In determining passive pressures the poise was kept in, thus allowing the platform to be deflected down. In making a reading the counterpoise was moved out to the point of balance and the scale platform tended to move up, and was resisted not only by the weight of the earth but also by its friction and cohesion.

CHARACTERISTICS OF FILL MATERIAL DETERMINED

Sand was used as the first filling material because of its homogeneous character and relatively low coefficient of cohesion. Its more uniform character makes it better than clay or other materials as a standard substance for comparison of the behavior of the various kinds of pipe under the different conditions of installation. Clay was used as a filling material later in order to compare the effects produced by the two different materials.

The sand was obtained from the bed of a creek about a half mile from the experiment site. It had angular grains, was of a reddish-brown appearance, and was well graded. During the tests, physical characteristics of the sand were determined at suitable intervals. The properties of the different samples varied but little and the average values are in Table I.

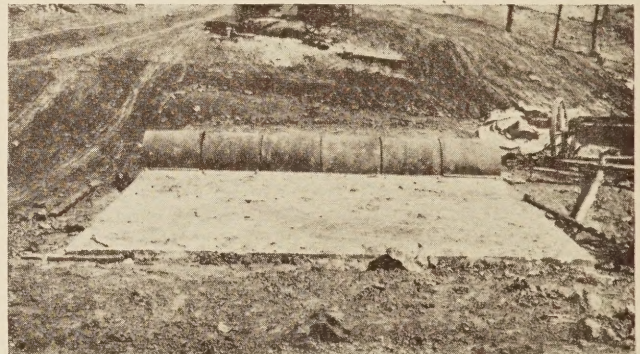

FIGURE 4.—PIPE IN POSITION FOR 50 PER CENT PROJECTION TEST

TABLE 1.—Average test values of sand used in fill

|  |            |       |
|--|------------|-------|
| Weight per cubic foot, loose (shoveled).....   | pounds..   | 80.7  |
| Weight per cubic foot, well shaken (deposited in 3-inch layers and shaken by hand to refusal)..... | pounds..   | 104.2 |
| Elutriation loss.....  | per cent.. | 8.5   |

MECHANICAL ANALYSIS

| Sieve No. | Cumulative percentage retained | Sieve No. | Cumulative percentage retained | Sieve No.        | Cumulative percentage retained |
|-----------|--------------------------------|-----------|--------------------------------|------------------|--------------------------------|
| 3.....    | 1.3                            | 14.....   | 37.3                           | 65.....          | 96.8                           |
| 4.....    | 3.6                            | 20.....   | 51.2                           | 100.....         | 98.5                           |
| 6.....    | 6.7                            | 28.....   | 72.0                           | 150.....         | 99.0                           |
| 8.....    | 12.7                           | 35.....   | 87.8                           | 200.....         | 99.3                           |
| 10.....   | 23.0                           | 48.....   | 94.3                           | Passing 200..... | .7                             |

|  |      |
|--|------|
| Specific gravity.....  | 2.59 |
| Percentage of solids, material tamped, 9 per cent moisture..         | 57.6 |
| Percentage of solids, material well shaken, 9 per cent moisture..... | 50.8 |
| Percentage of solids, material loose, 9 per cent moisture..          | 43.5 |
| Percentage of air voids, material loose.....                         | 45.4 |
| Percentage of air voids, materials well shaken.....                  | 36.2 |
| Percentage of air voids, material tamped.....                        | 27.7 |

The clay used in constructing the fills of that material was obtained from a nearby borrow pit. The physical characteristics as determined at suitable intervals are given in Table 2.

TABLE 2.—Average test values of clay used in fill

|  |      |
|--|------|
| Percentage of clay as determined by elutriation.....               | 43.9 |
| Cementation test (number of blows necessary to cause failure)..... | 160  |

SIEVE ANALYSIS ON RESIDUE LEFT AFTER ELUTRIATION

| Sieve No. | Cumulative percentage retained | Sieve No. | Cumulative percentage retained | Sieve No.         | Cumulative percentage retained |
|-----------|--------------------------------|-----------|--------------------------------|-------------------|--------------------------------|
| 8.....    | 0                              | 30.....   | 8.7                            | 100.....          | 34.3                           |
| 14.....   | 1.0                            | 65.....   | 25.8                           | Retained on 200.. | 55.9                           |

Weight per cubic foot, determined by weighing a cubic foot of soil as cut from each 1-foot increment in placing fill, 121 pounds.

SAND FILL USED FOR FIRST TESTS

The pipe used in this test was of cast iron and had an inside diameter of 30 inches and a barrel thickness of 1 inch. The four test sections were placed as previously described (50 per cent submerged below the concrete roof), care being taken to see that the scales were in proper working order and that the pipe sections were centered. Approximately 1 inch of clearance was allowed between the pipe and the concrete roof slab, and about half an inch was allowed between the pipe sections. A canvas tarpaulin was spread over the pipe sections and tucked around them in such a manner as to prevent water and sand from coming through the cracks. This was done carefully to avoid any restraint upon the movement of the sections.

Sand was filled around the pipe until it was level with the top, being done with hand shovels to prevent

pressure on the pipe at this point was the difference between the initial tare weights and the final weights as indicated by the scales. Filling was continued in increments of 1 foot, the material being hauled upon the fill in wagons and dumped. Each layer was carefully brought to grade and leveled, control being maintained by a bench mark referenced to the top of the

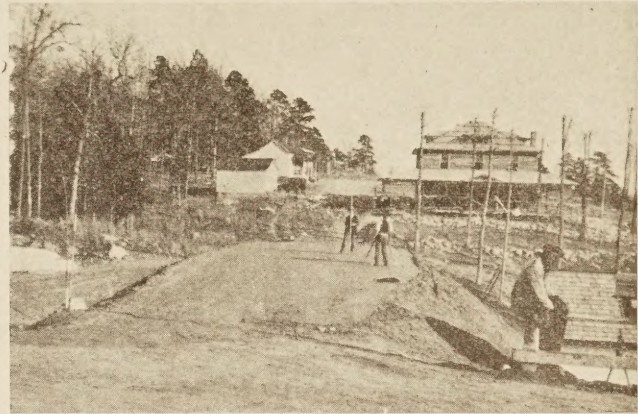

FIGURE 6.—CHECKING FILL ELEVATION

pipe sections. The height of fill was considered as so many feet above the top of the pipe, a 10-foot fill meaning 10 feet above the top of the pipe and not above the concrete slab where it actually started. The active pressures were determined for each increment of fill height, as described for the fill when level with the top of pipe.

A roadway width of 24 feet was maintained throughout the construction of the fill and, except during actual work on the fill or during pressure observations, a tarpaulin was kept over the surface in order to prevent appreciable variations in the moisture content. This tarpaulin was used in all tests except in the determination of time and weather effects.

Filling was started June 11, 1924, and was completed at a height of 20 feet on October 1, 1924. Readings were taken at various intervals as the fill was removed, and recorded in the same manner as those obtained while the fill was being placed.

Figure 5 shows the results of this first test in graphic form. The scale readings were converted into pounds per lineal foot by dividing each reading by the length of the pipe sections, 2½ feet, and then computing the average for the four sections. The curve shows the height of fill plotted against the pressure on the pipe. The weight of the material directly over the culvert as computed from the actual weight per cubic foot is also shown plotted on the same scale.

Assuming  $W$  equals the weight of the prism of earth directly over the culvert pipe and  $P$  equals the pressure transmitted to the scales, a ratio,  $K = \frac{P}{W}$  may be determined for the different heights of fill. For a fill of 4 feet,  $K$  approaches unity and decreases as the height of fill increases. For a fill of 20 feet  $K$  becomes 0.807.

The curves show that for equal heights of fill the pressures during removal were greater than during the filling. This was because the pipe was already deflected during removal. The pressure upon the top of the pipe was lessened as the earth was removed and the pipe tended to recover its original shape. It was partially restrained by the passive pressure of the prism of

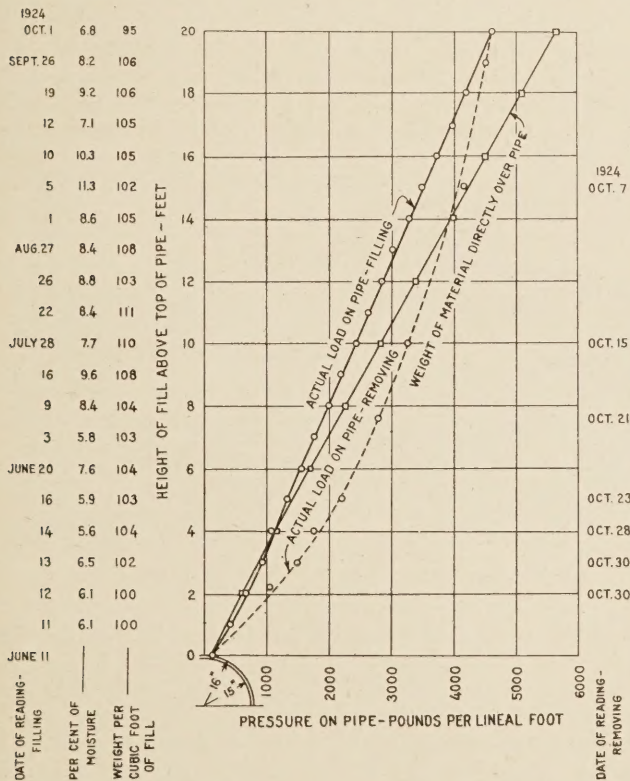

FIGURE 5.—RESULTS OF TESTS WITH SAND FILL ON CAST-IRON PIPE—50 PER CENT PROJECTION

a displacement of the sections. Each scale was balanced by running the counterpoise in, and the pressure was then observed and recorded. The actual active

earth. Thus, the pipe acted as a compressed spring and exerted an upward pressure until the passive pressure could be overcome. Equilibrium between the "spring" pressure of the pipe and the passive pressure of the soil was maintained throughout the removal of the fill.

TESTS WITH CLAY FILL AND 50 PER CENT PROJECT ON MADE

The apparatus used in this test was the same as that used in the preceding sand-fill test, the same 30-inch cast-iron pipe being used.

The procedure for obtaining the scale pressures was also the same as in the preceding test. However, after the 3-foot level had been reached, the clay was rolled at each 1-foot increment by a 4-ton road roller. It was not rolled before the 3-foot level had been reached because of the danger of displacing the pipe. It was not practical to maintain a uniform width of roadway by filling on the slopes at each increment in height, as with the sand; so the bottom of the fill was made sufficiently

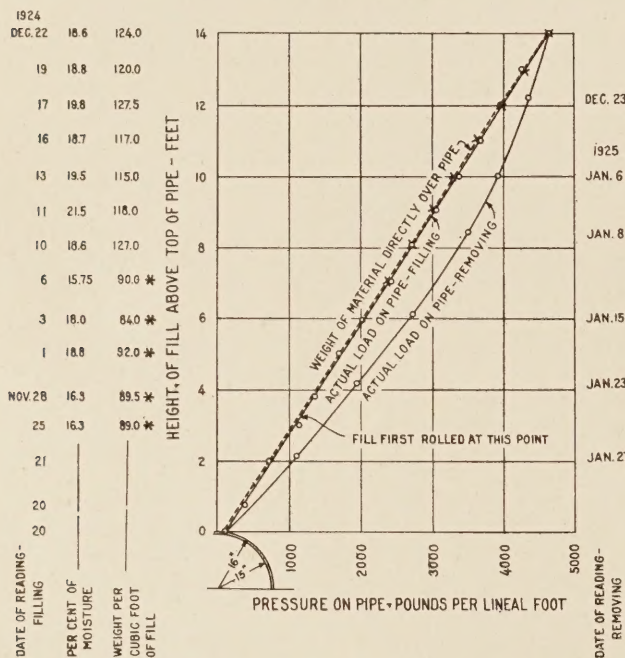

FIGURE 7.—RESULTS OF TESTS WITH CLAY FILL ON CAST-IRON PIPE—50 PER CENT PROJECTION. WEIGHTS INDICATED BY STAR OBTAINED BY AN APPROXIMATE METHOD AND NOT USED IN CALCULATIONS, OTHER WEIGHTS OBTAINED BY WEIGHING SAMPLE CUT FROM EMBANKMENT

wide to permit a 1½ to 1 slope, giving a roadway width of 23 feet at the completed height of fill.

Filling was started on November 20, 1924, and was completed on December 22, 1924. A height of 14 feet was reached.

The removal of the fill was started as soon as the filling was completed and was done in 2-foot decrements. The earth pressure transmitted to the scales was determined at each decrement. This operation was completed on January 27, 1925.

Figure 7 shows that the pressure on the pipe in this test was approximately equal to the weight of the earth directly over it. The variation was almost negligible, and so, for this test,  $K=1$ .

The pressures during removal of the fill were greater than during the filling at equal heights, as in the first test and for the same reason.

TRENCH CONDITION RESULTS IN REDUCTION OF PRESSURE ON PIPE

A second test with clay filling material was performed upon cast-iron pipe in what was termed the "trench condition." The trench condition is that in which pipe

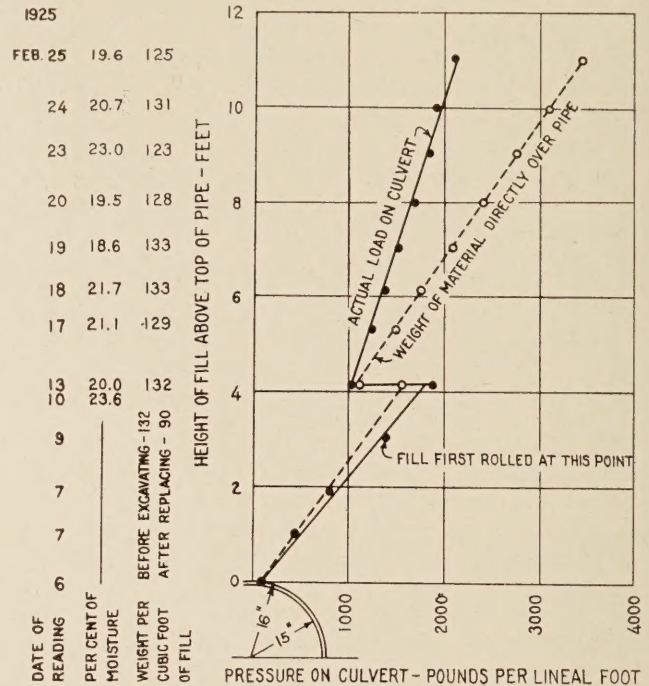

FIGURE 8.—RESULTS OF TESTS WITH CLAY FILL ON CAST-IRON PIPE—50 PER CENT PROJECTION, TRENCH CONDITION

is installed with its upper surface below the level of the ground alongside. To insure proper seating of the pipe sections and to avoid installing the sections in a narrow trench, the following procedure was adopted. The clay fill was built to a height of 4.15 feet above the

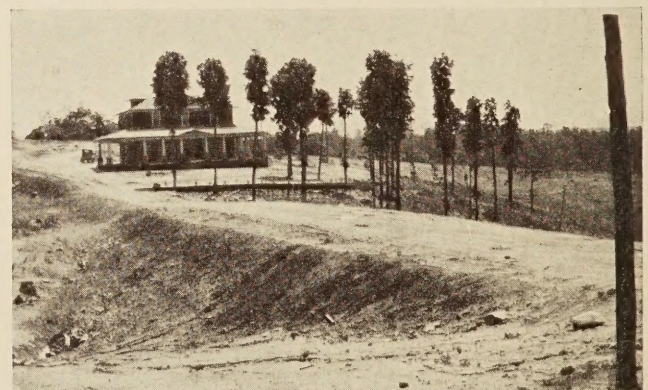

FIGURE 9.—CONDITION OF FILL AT END OF TIME AND WEATHER TESTS

top of the pipe and a trench 3.5 feet wide was dug to expose the entire length of pipe under the fill. The trench was then back filled loosely by hand until the level of the 4.15-foot fill was reached. From this point the filling was carried on by teams and wheelers until a height of 11.05 feet had been reached. The last 6 inches of fill placed was sand.

As in the preceding test, this fill was rolled, and the effect of live loads was also observed. It was found that the vertical pressures on the pipe were less in the trench condition than in the preceding 50 per cent projection condition test, using the same filling material.



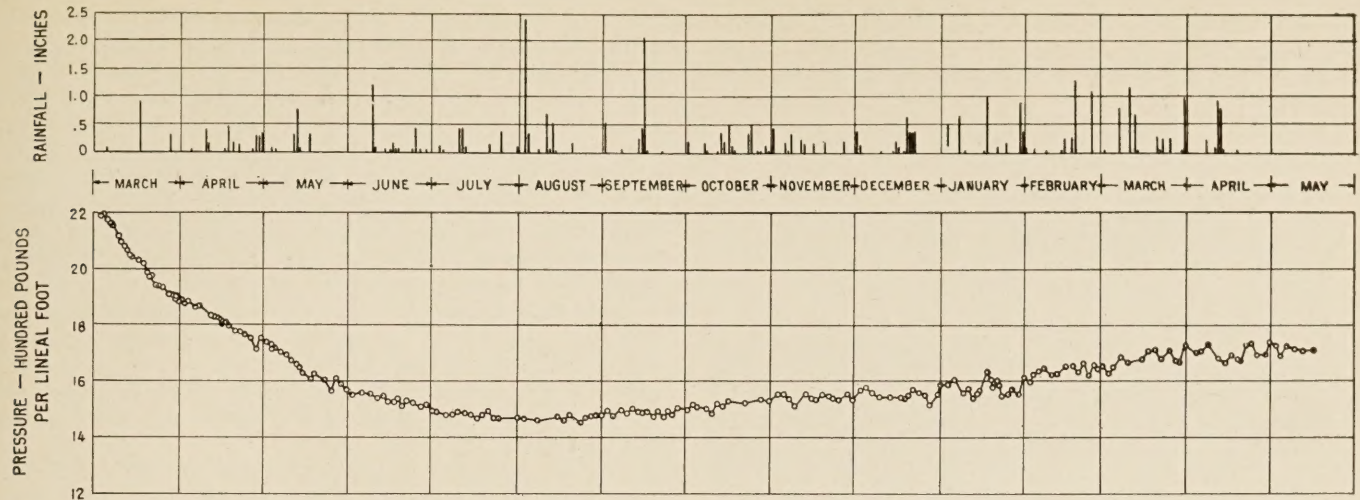

FIGURE 10.—EFFECT OF TIME AND WEATHER ON PRESSURE EXERTED ON CAST-IRON PIPE, CLAY FILL 11.05 FEET DEEP, 50 PER CENT PROJECTION, TRENCH CONDITION

This is clearly shown by a comparison of Figures 7 and 8.

TIME AND WEATHER TESTS MADE

On the completion of the fill in the trench condition test it was decided to allow the fill to remain in place for one year to study the effect of time and weather upon the earth pressures transmitted to the pipe. The test was begun February 25, 1925, and extended through May, 1926.

The pressures decreased from March 3, 1925, to the middle of August, when a total decrease of 33 per cent had taken place. After that time a slow increase occurred, until at the conclusion of the test approximately one-third of the lost pressure had been recovered.

The rapid decrease in pressure may be attributed to the drying and shrinking of the initially saturated clay, resulting from the summer's unusually low rainfall. The increase in pressure is probably the result of a slow failure of the trench and of an increase in moisture content of the clay during the fall and winter months.

Variations in the rainfall have but little effect, if any, upon the pressure, as shown in Figure 10.

CONCENTRATED LOADS APPLIED THROUGH FILL

Because of the lack of data concerning the transmission of pressure through soils, especially that of live loads through embankments to culvert pipe, it was decided to investigate the additional pressure due to traffic.

At each observation of the pressure on both the clay fills with the 50 per cent projection and the 50 per cent projection with trench condition, a 4-ton road roller was moved along the center line of the roadway over the test sections, from a point where no effect upon the scales was perceptible to a point where the effect had disappeared, halting at intermediate positions, usually 2 feet apart, for a complete observation of the earth pressure transmitted to the scales.

To conform with the other data tabulated the increases were calculated in pounds per lineal foot of pipe. Up to the 8-foot level, the two inside scales received much greater increases in pressure than the two outside scales; and since it was desirable to obtain the maximum effect, the two scales nearest the center line were averaged. Above the 8-foot level, all four scales were averaged because the increments were approximately the same.

It was found that there was a residual pressure on the pipe after the passing of the roller for the first 50 per cent projection condition but not for the trench

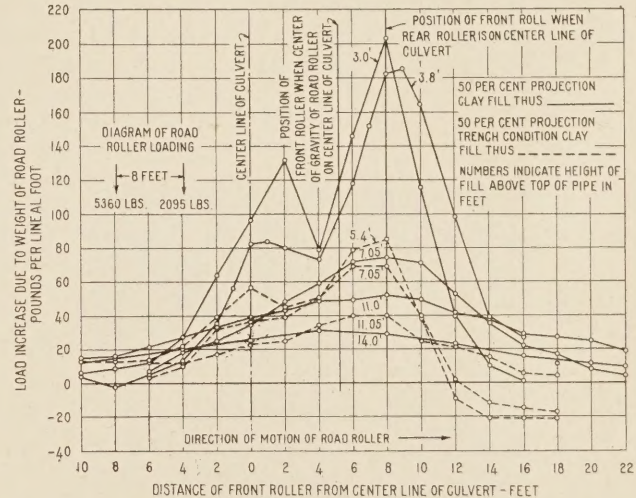

FIGURE 11.—RESULT OF LIVE LOAD TESTS WITH 4-TON ROLLER

condition. Representative curves for both 50 per cent projection conditions are shown in Figure 11, using the average increment in pounds per lineal foot as ordinates and the position of the front roller of the road roller, with reference to the center line of the culvert, as abscissas. The maximum increase of pressure occurred when the rear or heavy roller was directly over the center line of the culvert. The increase in pressures for low fills is quite marked.

For the trench condition the increase was not marked unless one of the rollers was over the trench. (Fig. 11.) It appeared that after the passage of the roller over the 7.05 and 5.4 foot fills, trench condition, there was less pressure than before. No reasonable explanation for this phenomenon has been discovered.

SECOND SERIES OF TESTS OUTLINED

On completion of the 50 per cent projection tests the results indicated the importance of continuing the experiments according to a well-defined outline. The work suggested was as follows:

1. All pipe to be placed under the fill in a 100 per cent projection condition.

2. Vertical pressures to be measured by means of scales.

3. Radial pressures to be measured by means of soil-pressure cells.

4. Pipe of various degrees of rigidity to be used so that deflections under the fill loads would be varied



FIGURE 12.—FILL STEPPED BACK TO PREVENT ARCH ACTION OF THE SOIL OVER PIPE

from practically zero to the maximum permissible, without causing failure.

5. Two sizes of pipe to be tested.

The clay fill used in the time-and-weather tests was removed to the level of the top of the box culvert for a distance of 12 feet on each side of the test pipe and

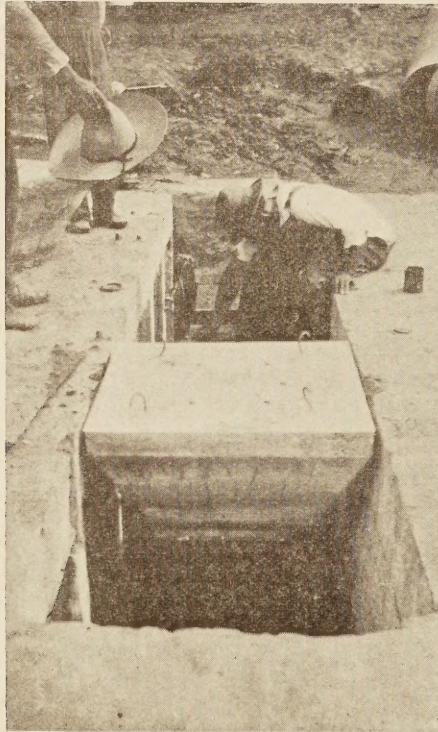

FIGURE 13.—ARRANGEMENT FOR PIPE SUPPORT IN 100 PER CENT PROJECTION TESTS

the sides were stepped back on a slope of  $45^\circ$  as shown in Figure 12, to prevent any tendency of the filling material to wedge or arch over the pipe. The scales were removed, cleaned, and recalibrated, and then replaced with the columns, as in the former tests.

Since the columns were designed to support the pipe in the 50 per cent projection tests it was necessary to raise the support to the level of the top of the chamber for the 100 per cent condition. Concrete caps were placed on top of the columns, and were made to fill the opening with clearance enough to permit vertical motion without touching the sides of the slot. (Fig. 13.) A sheet of canvas was placed across the column caps with sufficient overlap onto the adjoining slab to prevent sand and water from entering the weighing chamber.

The test sections were carefully placed on the column caps so as to insure an independent movement of each section. Blank sections of the same type as the test sections were placed at each end so as to produce the effect of a continuous pipe across the entire fill.

New Goldbeck soil-pressure cells of the improved brass type were attached to the test sections by means of small steel brackets and  $\frac{1}{4}$ -inch bolts, as shown in Figure 14. The bolts extended through the walls

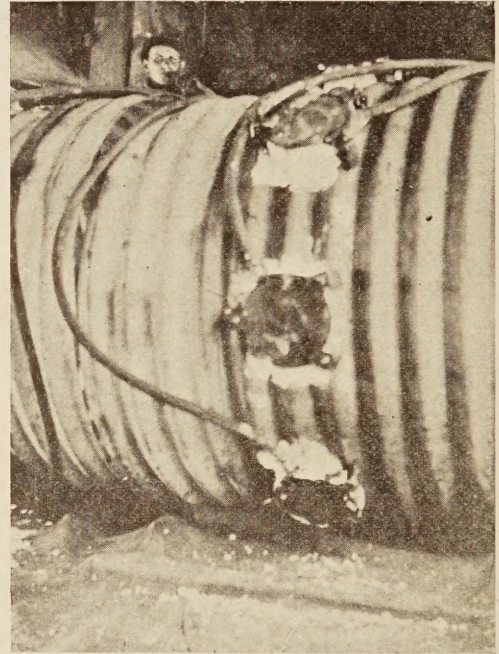

FIGURE 14.—POSITION OF PRESSURE CELLS ON CORRUGATED METAL PIPE

of the pipe, except in the case of the cast iron, solid plug, and concrete sections. In these cases the cells were bolted to light sheet-metal bands which were securely fastened around the pipe. The cells were placed on a circumference of each section spaced at  $45^\circ$ , the one at the bottom point being omitted.

The location and notation of the cells Nos. 1 to 7 are shown by Figure 15. Cell No. 4 measures vertical pressure at the top of the pipe; Nos. 2 and 6, the horizontal pressure; Nos. 3 and 5, the pressure at  $45^\circ$  from the vertical, on the upper side of the pipe; and Nos. 1 and 7, at the same angle from the vertical, on the under side of the pipe. The cells were not countersunk, hence their top surfaces were  $1\frac{1}{4}$  inches above the plane of the supporting surface. Flexible connections consisting of heavy rubber hose were used to convey air and the electric wiring to the edge of the slot. From this point  $\frac{1}{4}$ -inch metal pipes led to the indicating instruments in the chamber below.

Each cell was provided with a separate connection and was entirely independent of all others.

The deflections were measured with a special Browne & Sharpe inside pipe micrometer, reading to one-thousandth of an inch. The deflections of the 30-inch pipe were measured on six diameters; the horizontal, the vertical, and at 30° and 60°, respectively, from the vertical on each side of the pipe. These diameters are shown in Figure 15, and are designated DD', AA', BB', FF', CC', and EE'. Indentions were drilled at these points for the insertion of the ends of the micrometer. In the case of all the 20-inch pipe

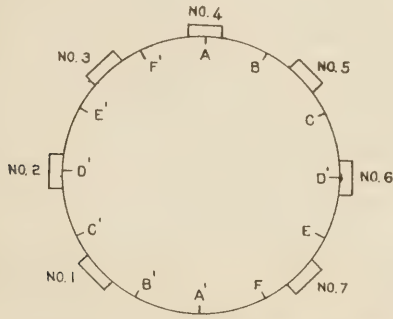

FIGURE 15.—ARRANGEMENT OF PRESSURE CELLS ON PIPE CIRCUMFERENCE

and the 30-inch concrete pipe, only the horizontal and vertical deflections were read.

The tests on the various pipes were made under as nearly similar conditions as possible. The fill was made of the same sand used in the earlier tests and was placed in the fill with drag pans. The teams moved in a direction parallel to the pipe until the 1-foot level was reached. Up to this level the sand was thrown around and over the pipe by hand and lightly tamped with shovel handles. After the 1-foot level had been reached the teams traveled in a direction at right angles to the length of the pipe.

The fill was built in 1-foot increments with a roadway width of 24 feet. The side slopes were constructed by allowing the material to fall freely over the shoulders. At each foot of height the fill was leveled off to within 0.05 ± foot of the nominal height. A Y-level was used for controlling the grade. Unusual care was taken to prevent material being piled above the elevation at which the next set of readings was to be taken. A maximum fill height of 12 feet was used for all the tests.

Scale readings indicating total vertical load, cell pressures indicating radial pressures, and diameter measurements indicating deflections were recorded for each foot of fill placed and at intervals of 2 or 4 feet while it was being removed. The scale counterpoise was kept on the outer end of the beam and brought in to the balancing point when a reading was taken, thus recording the active pressure.

The weight of the filling material was determined from a sample obtained by driving into the fill a steel cylinder of 1/8-cubic foot capacity and sharpened on the lower edge.

The percentage of moisture present in the fill was determined from a sample, of not less than 500 grams, taken from the material present in the cylinder when a weight sample was taken. The tarpaulin used in covering the fill eliminated appreciable variations in the moisture content.

DATA SHOWS RELATION BETWEEN HEIGHT OF FILL AND DEFLECTION AND LOAD ON PIPE

Tests were made on the various types of pipe listed below:

1. 30-inch, smooth iron (thickness, 0.109 inch).
2. 30-inch, corrugated metal (thickness, 0.105 inch).
3. 30-inch, steel tube (thickness, 0.349 inch).
4. 30-inch, cast iron (thickness, 1 inch).
5. 30-inch, concrete (thickness, 2½ inches).
6. 32-inch, solid plug.
7. 20-inch, smooth iron (thickness, 0.076 inch).
8. 20-inch corrugated metal (thickness, 0.079 inch).
9. 20-inch, solid plug.

The solid plug sections were obtained by filling the 20-inch steel tube sections and the 30-inch cast-iron sections with concrete.

The data taken in the field for each foot of fill consisted of 4 scale readings; 7 cell readings for each section, making a total of 28, and 6 diameters of each section, making a total of 24. Table 3 summarizes this field data, and is arranged in the order in which the tests were run.

The four scale readings were added and the sum divided by 10 to obtain the load per lineal foot. The values obtained with the fill level with the top of the pipe were adopted as zero readings and were used as tare values to be subtracted from the succeeding values.

The outside diameters of the pipe listed as 30-inch pipe vary from 29 inches for the concrete to 32 inches for the solid plug and the cast-iron pipe. In order to have a uniform basis for comparison and for plotting, the scale readings were converted to a value equivalent to a pipe of 30 inches outside diameter by simple proportion.

The deflections were determined for each pipe by comparing the measured diameter under different

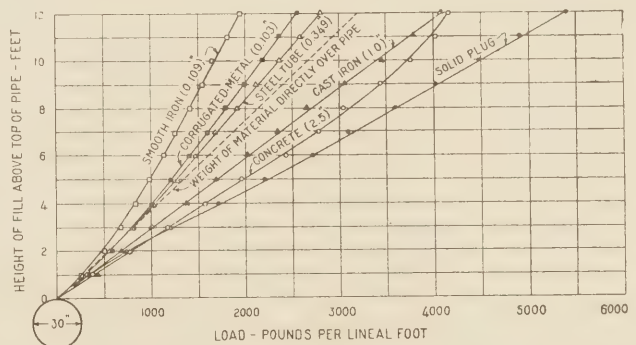

FIGURE 16.—VERTICAL LOADS TRANSMITTED TO 30-INCH PIPE (CORRECTION MADE FOR VARIATION FROM 30 INCHES), 100 PER CENT PROJECTION CONDITION, BY VARIOUS HEIGHTS OF SAND FILL. NUMBERS IN PARENTHESES INDICATE THICKNESS.

heights of fill with the diameter recorded for the fill level with top of pipe. If the diameter was greater or less than the value when the fill was at the top of the pipe, it was called plus or minus, respectively. The deflections for the four sections in each test were averaged to obtain the final values.

Some of the cell readings were unmistakably erratic, and it was decided to use the following method in obtaining the final representative values. All cells in the same relative position were considered in one group—for example, the eight cells in positions 1 and 7.

TABLE 3.—Results of field tests on various pipe, 100 per cent projection, sand fill

SMOOTH IRON  
[Diameter 30 inches, 0.109 inch thick]

| Height of fill | Actual weight over pipe  | Scale reading            | Ratio scale reading to actual weight | Scale reading corrected to 30-inch diameter | Deflection of diameters |        |        |        |        |        | Cell pressures |      |      |     | Moisture     | Weight per cubic foot |
|----------------|--------------------------|--------------------------|--------------------------------------|---|-------------------------|--------|--------|--------|--------|--------|----------------|------|------|-----|--------------|-----------------------|
|                |                          |                          |                                      |   | F-F'                    | A-A'   | B-B'   | C-C'   | D-D'   | E-E'   | 1, 7           | 2, 6 | 3, 5 | 4   |              |                       |
| <i>Feet</i>    | <i>Lbs. per lin. ft.</i> | <i>Lbs. per lin. ft.</i> | <i>K</i>                             |   |                         |        |        |        |        |        |                |      |      |     |              |                       |
| Mid-point      | 72.2                     | 92.5                     | 1.27                                 | 92.5  | -0.204                  | -0.234 | -0.036 | +0.204 | +0.218 | +0.027 |                |      |      |     |              |                       |
| Top of pipe=0  | 144.3                    | 133.0                    | 1.08                                 | 133.0                                       | 0                       | 0      | 0      | 0      | 0      | 0      |                |      |      |     | Per cent 4.8 | Pounds 105.0          |
| 1              | 267.5                    | 232.5                    | .87                                  | 232.5                                       | -.094                   | -.108  | -.002  | +.092  | +.037  | +.002  | 0.9            | 1.4  | 1.5  | 1.0 | 6.2          | 109.0                 |
| 2              | 535.0                    | 480.0                    | .90                                  | 480.0                                       | -.171                   | -.261  | -.054  | +.189  | +.019  | +.062  | 1.3            | 2.4  | 2.3  | 2.2 | 5.8          | 106.0                 |
| 3              | 802.0                    | 673.5                    | .84                                  | 673.5                                       | -.223                   | -.383  | -.098  | +.246  | +.248  | +.105  | 1.7            | 3.2  | 3.0  | 3.1 |              | 106.5                 |
| 4              | 1,070.0                  | 839.5                    | .78                                  | 839.5                                       | -.265                   | -.435  | -.132  | +.292  | +.318  | +.143  | 2.3            | 3.8  | 3.0  | 3.5 | 5.7          |                       |
| 5              | 1,337.5                  | 978.0                    | .73                                  | 978.0                                       | -.285                   | -.477  | -.149  | +.315  | +.353  | +.163  | 3.4            | 4.0  | 3.2  | 3.8 |              |                       |
| 6              | 1,605.0                  | 1,120.5                  | .70                                  | 1,120.5                                     | -.313                   | -.535  | -.179  | +.349  | +.403  | +.191  | 3.7            | 4.9  | 3.7  | 3.9 | 5.2          |                       |
| 7              | 1,872.5                  | 1,261.0                  | .67                                  | 1,261.0                                     | -.338                   | -.583  | -.179  | +.375  | +.444  | +.212  | 4.4            | 5.5  | 4.3  | 5.4 |              |                       |
| 8              | 2,140.0                  | 1,406.0                  | .66                                  | 1,406.0                                     | -.360                   | -.630  | -.202  | +.403  | +.484  | +.234  | 5.0            | 5.8  | 4.7  | 4.9 | 5.0          | 105.0                 |
| 9              | 2,407.5                  | 1,548.5                  | .64                                  | 1,548.5                                     | -.384                   | -.678  | -.234  | +.473  | +.517  | +.250  | 4.6            | 6.5  | 4.7  | 5.4 | 5.9          | 103.0                 |
| 10             | 2,675.0                  | 1,647.5                  | .62                                  | 1,647.5                                     | -.412                   | -.731  | -.255  | +.461  | +.569  | +.285  | 5.2            | 7.1  | 5.2  | 5.8 |              |                       |
| 11             | 2,942.5                  | 1,811.0                  | .61                                  | 1,811.0                                     | -.425                   | -.758  | -.267  | +.471  | +.585  | +.287  | 5.7            | 7.7  | 5.8  | 6.3 | 5.2          | 104.0                 |
| 12             | 3,210.0                  | 1,949.0                  | .61                                  | 1,949.0                                     | -.455                   | -.812  | -.290  | +.504  | +.631  | +.310  | 5.6            | 8.3  | 6.5  | 6.7 |              |                       |
| 12             | 3,210.0                  | 1,955.0                  | .61                                  | 1,955.0                                     | -.462                   | -.825  | -.296  | +.514  | +.646  | +.318  | 7.9            | 9.2  | 6.7  | 7.3 |              |                       |
| 12             | 3,210.0                  | 1,941.5                  | .61                                  | 1,941.5                                     | -.470                   | -.841  | -.302  | +.520  | +.656  | +.322  | 5.7            | 8.5  | 7.6  | 6.9 |              |                       |
| 8              | 2,140.0                  | 1,482.5                  | .69                                  | 1,482.5                                     | -.467                   | -.835  | -.302  | +.515  | +.653  | +.321  | 4.9            | 7.1  | 5.3  | 5.2 | 4.7          | 106.5                 |
| 4              | 1,070.0                  | 984.5                    | .92                                  | 984.5                                       | -.464                   | -.830  | -.300  | +.514  | +.653  | +.324  | 3.0            | 5.3  | 4.0  | 4.9 | 6.0          | 105.0                 |
| Top of pipe=0  | 0                        | 64.5                     | 1.00                                 | 64.5  | -.347                   | -.590  | -.274  | +.299  | +.571  | +.252  |                |      |      |     | 4.2          |                       |

CORRUGATED METAL<sup>1</sup>

[Diameter 31.5 inches, 0.103 inch thick]

|               |         |         |      |         |        |        |        |        |        |        |      |     |     |      |  |         |           |
|---------------|---------|---------|------|---------|--------|--------|--------|--------|--------|--------|------|-----|-----|------|--|---------|-----------|
| Mid-point     | 79.2    | 112.3   | 1.42 | 106.9   | -0.005 | -0.007 | -0.006 | +0.006 | +0.016 | +0.005 |      |     |     |      |  | (1) 6.3 | (1) 104.0 |
| Top of pipe=0 | 0       | 0       | 0    | 0       | 0      | 0      | 0      | 0      | 0      | 0      |      |     |     |      |  | a 9.2   | b 103.5   |
| 1             | 281.0   | 318.8   | 1.14 | 308.6   | -.021  | -.054  | -.020  | +.023  | +.047  | +.023  | 2.2  | 2.2 | 1.7 | 1.2  |  | a 8.1   | b 107.0   |
| 2             | 562.1   | 610.5   | 1.08 | 581.5   | -.038  | -.098  | -.036  | +.043  | +.078  | +.040  | 3.7  | 2.9 | 2.4 | 2.9  |  | a 7.5   | b 99.0    |
| 3             | 843.1   | 847.3   | 1.00 | 806.9   | -.049  | -.124  | -.049  | +.055  | +.104  | +.053  | 3.1  | 3.4 | 2.7 | 3.1  |  | a 6.6   | b 103.5   |
| 4             | 1,124.2 | 1,057.5 | .94  | 1,007.2 | -.058  | -.149  | -.053  | +.074  | +.128  | +.065  | 5.9  | 3.9 | 3.1 | 4.1  |  | a 5.7   | b 105.0   |
| 5             | 1,405.2 | 1,270.3 | .90  | 1,209.8 | -.074  | -.183  | -.069  | +.086  | +.155  | +.072  | 6.9  | 4.6 | 3.8 | 4.8  |  | a 7.2   | b 104.0   |
| 6             | 1,686.3 | 1,474.8 | .87  | 1,404.6 | -.086  | -.209  | -.078  | +.099  | +.177  | +.090  | 7.7  | 4.9 | 4.2 | 5.4  |  | a 6.6   | b 103.5   |
| 7             | 1,967.3 | 1,676.0 | .85  | 1,596.2 | -.099  | -.239  | -.095  | +.112  | +.200  | +.102  | 8.8  | 5.7 | 5.0 | 6.1  |  | a 5.7   | b 102.5   |
| 8             | 2,248.4 | 1,887.5 | .84  | 1,797.7 | -.111  | -.269  | -.106  | +.123  | +.224  | +.114  | 10.5 | 5.7 | 5.3 | 6.9  |  | a 6.1   | b 105.0   |
| 9             | 2,529.4 | 2,083.5 | .82  | 1,984.4 | -.122  | -.292  | -.117  | +.134  | +.243  | +.124  | 11.7 | 6.8 | 5.7 | 7.6  |  | a 5.7   | b 107.5   |
| 10            | 2,810.5 | 2,285.3 | .81  | 2,186.1 | -.137  | -.324  | -.127  | +.149  | +.274  | +.139  | 12.6 | 7.9 | 6.5 | 8.5  |  | a 7.9   | b 103.5   |
| 11            | 3,091.5 | 2,476.0 | .80  | 2,358.2 | -.145  | -.345  | -.138  | +.162  | +.300  | +.148  | 13.0 | 7.2 | 6.8 | 9.3  |  | a 6.1   | b 102.5   |
| 12            | 3,372.6 | 2,690.0 | .80  | 2,561.9 | -.162  | -.379  | -.145  | +.179  | +.322  | +.162  | 13.1 | 8.1 | 7.6 | 10.5 |  | a 5.7   | b 105.0   |
| 8             | 2,248.4 | 2,116.5 | .94  | 2,015.8 | -.161  | -.381  | -.145  | +.179  | +.322  | +.165  | 9.5  | 6.1 | 6.4 | 8.5  |  | a 6.2   | b 107.5   |
| 4             | 1,124.2 | 1,438.3 | 1.28 | 1,370.3 | -.152  | -.364  | -.141  | +.171  | +.311  | +.161  | 4.0  | 4.2 | 5.6 | 5.7  |  | a 7.2   | b 112.5   |
| Top of pipe=0 | 0       | 72.3    |      | 68.9    | -.029  | -.102  | -.034  | +.041  | +.083  | +.048  |      |     |     |      |  | a 5.7   | b 107.5   |

STEEL TUBE<sup>1</sup>

[Diameter 30 inches, 0.349 inch thick]

|               |         |         |      |         |       |       |       |       |       |       |     |     |     |     |  |         |         |
|---------------|---------|---------|------|---------|-------|-------|-------|-------|-------|-------|-----|-----|-----|-----|--|---------|---------|
| Mid-point     | 77.2    | 113     | 1.54 | 111.3   |       |       |       |       |       |       |     |     |     |     |  | (1)     | (1)     |
| Top of pipe=0 | 144.3   | 280.8   | 1.94 | 280.8   | 0     | 0     | 0     | 0     | 0     | 0     |     |     |     |     |  | b 4.7   | b 105.0 |
| 1             | 267.5   | 303.1   | 1.13 | 303.1   | -.014 | -.033 | -.014 | +.014 | +.025 | +.012 | 0.8 | 2.0 | 1.7 | 1.3 |  | b 3.9   | b 106.5 |
| 2             | 535.0   | 560.8   | 1.05 | 560.8   | -.024 | -.067 | -.024 | +.023 | +.044 | +.021 | .7  | 2.7 | 2.4 | 2.4 |  | a 8.3   | a 108.5 |
| 3             | 802.5   | 816.0   | 1.02 | 816.0   | -.037 | -.081 | -.038 | +.044 | +.066 | +.030 | .9  | 3.0 | 3.2 | 3.0 |  |         |         |
| 4             | 1,070.0 | 1,019.5 | .95  | 1,019.5 | -.040 | -.100 | -.040 | +.056 | +.080 | +.042 | 1.3 | 3.6 | 3.6 | 3.7 |  | b 5.5   | a 106.5 |
| 5             | 1,337.5 | 1,287.5 | .96  | 1,287.5 | -.053 | -.103 | -.052 | +.062 | +.080 | +.042 | 1.3 | 4.2 | 4.4 | 3.7 |  |         |         |
| 6             | 1,605.0 | 1,470.8 | .92  | 1,470.8 | -.054 | -.112 | -.053 | +.077 | +.093 | +.035 | 1.8 | 4.4 | 5.1 | 4.4 |  | b 7.6   |         |
| 7             | 1,872.5 | 1,679.3 | .89  | 1,679.3 | -.063 | -.131 | -.062 | +.087 | +.111 | +.043 | 1.9 | 4.7 | 5.9 | 4.8 |  |         |         |
| 8             | 2,140.0 | 1,900.3 | .89  | 1,900.3 | -.079 | -.174 | -.064 | +.097 | +.156 | +.076 | 2.0 | 5.1 | 6.1 | 5.3 |  | b 5.0   |         |
| 9             | 2,407.5 | 2,107.8 | .88  | 2,107.8 | -.085 | -.195 | -.075 | +.100 | +.170 | +.090 | 2.4 | 5.5 | 7.2 | 5.6 |  | a 7.5   |         |
| 10            | 2,675.0 | 2,351.0 | .88  | 2,351.0 | -.101 | -.220 | -.084 | +.121 | +.194 | +.096 | 2.4 | 6.3 | 8.1 | 6.4 |  |         |         |
| 11            | 2,942.5 | 2,569.0 | .87  | 2,569.0 | -.107 | -.239 | -.094 | +.123 | +.211 | +.111 | 3.2 | 6.9 | 8.5 | 6.7 |  | b 6.6   | b 102.5 |
| 12            | 3,210.0 | 2,795.0 | .87  | 2,795.0 | -.117 | -.261 | -.090 | +.139 | +.234 | +.122 | 3.6 | 8.2 | 8.8 | 7.5 |  | b 105.5 |         |
| 8             | 2,140.0 | 2,241.5 | 1.05 | 2,241.5 | -.119 | -.267 | -.106 | +.141 | +.244 | +.128 | 2.0 | 6.2 | 7.8 | 6.5 |  | a 6.7   | b 103.5 |
| 4             | 1,070.0 | 1,526.8 | 1.42 | 1,526.8 | -.117 | -.250 | -.084 | +.137 | +.230 | +.116 | .8  | 3.3 | 5.4 | 4.8 |  | a 4.9   | b 105.5 |
| Top of pipe   | 0       | 44.3    |      |         | -.010 | -.219 | -.012 | +.024 | +.043 | +.026 |     |     |     |     |  | b 4.5   | b 105.5 |

See footnotes at end of table.

The eight readings were listed in order of magnitude and the median determined by taking the average of the middle two. The highest and lowest value of the eight values listed were then compared with the median and the one closest to the median was retained and all values numerically more distant from the median were discarded. The remaining values were averaged and the result recorded.

The loads on the 30-inch pipe of various types are shown graphically in Figure 16. The values plotted

were those obtained by reducing the scale readings of all the pipe to a value equivalent to a 30-inch diameter. Figure 17 shows the vertical loads for the 20-inch pipe. Figures 16 and 17 show that, except for the first few feet of fill, the load carried increases with the height of fill at a uniform rate. A study of these two sets of curves also indicates a direct relation between the vertical load and the flexibility of the pipe.

Figures 18 and 19 show the load-deflection relation of the various pipes. For the more rigid pipes this

TABLE 3.—Results of field tests on various pipe, 100 per cent projection, sand fill—Continued

CAST IRON  
[Diameter 32 inches, 1.0 inch thick]

| Height of fill | Actual weight over pipe | Scale reading | Ratio scale reading to actual weight | Scale reading corrected to 30-inch diameter | Deflection of diameters |        |        |        |        |        | Cell pressures |      |      |      | Moisture | Weight per cubic foot |       |
|----------------|-------------------------|---------------|--------------------------------------|---|-------------------------|--------|--------|--------|--------|--------|----------------|------|------|------|----------|-----------------------|-------|
|                |                         |               |                                      |   | F-F'                    | A-A'   | B-B'   | C-C'   | D-D'   | E-E'   | 1, 7           | 2, 6 | 3, 5 | 4    |          |                       |       |
| Mid-point      | 81.3                    | 65.0          | 0.80                                 | 61.0  | -0.001                  | -0.004 | -0.005 | -0.009 | +0.003 | -0.001 |                |      |      |      |          |                       |       |
| Top of pipe=0  | 163.0                   | 0             | 1.55                                 | 237.0                                       | 0                       | 0      | 0      | 0      | 0      | 0      |                |      |      |      |          | 6.7                   | 103.5 |
| 1              | 285.3                   | 430.0         | 1.51                                 | 410.5                                       | -0.005                  | -0.006 | -0.003 | +0.003 | +0.005 | +0.001 | 1.1            | 0.7  | 1.5  | 1.2  |          |                       |       |
| 2              | 570.6                   | 730.0         | 1.28                                 | 685.0                                       | -0.009                  | -0.014 | -0.007 | +0.008 | +0.012 | +0.004 | 1.6            | 1.4  | 2.3  | 2.6  |          |                       |       |
| 3              | 855.0                   | 1,062.5       | 1.24                                 | 995.0                                       | -0.012                  | -0.021 | -0.009 | +0.012 | +0.021 | +0.009 | 1.9            | 1.7  | 2.5  | 3.9  | 13.0     |                       | 104.0 |
| 3              | 855.0                   | 1,063.0       | 1.24                                 | 997.0                                       | -0.012                  | -0.022 | -0.009 | +0.019 | +0.022 | +0.010 | 2.0            | 1.8  | 3.2  | 3.9  | 7.1      |                       |       |
| 4              | 1,141.2                 | 1,445.0       | 1.27                                 | 1,365.0                                     | -0.016                  | -0.030 | -0.013 | +0.016 | +0.028 | +0.013 | 2.1            | 2.0  | 3.4  | 5.0  |          |                       |       |
| 5              | 1,426.5                 | 1,806.0       | 1.26                                 | 1,690.0                                     | -0.021                  | -0.039 | -0.017 | +0.022 | +0.038 | +0.017 | 2.4            | 2.1  | 4.2  | 6.4  | 6.5      |                       | 103.0 |
| 6              | 1,711.8                 | 2,160.5       | 1.26                                 | 2,000.1                                     | -0.025                  | -0.048 | -0.020 | +0.027 | +0.046 | +0.021 | 3.7            | 2.8  | 5.8  | 7.7  |          |                       |       |
| 7              | 1,997.1                 | 2,500.5       | 1.25                                 | 2,318.9                                     | -0.027                  | -0.057 | -0.023 | +0.032 | +0.054 | +0.028 | 3.9            | 2.7  | 5.1  | 9.2  | 6.2      |                       | 103.0 |
| 8              | 2,202.4                 | 2,831.0       | 1.24                                 | 2,628.7                                     | -0.033                  | -0.065 | -0.027 | +0.036 | +0.062 | +0.029 | 3.6            | 2.9  | 6.1  | 10.8 |          |                       |       |
| 9              | 2,567.8                 | 3,265.0       | 1.27                                 | 3,045.0                                     | -0.038                  | -0.077 | -0.034 | +0.041 | +0.073 | +0.034 | 4.3            | 3.5  | 7.3  | 15.6 | 7.3      |                       | 108.0 |
| 10             | 2,853.1                 | 3,680.0       | 1.29                                 | 3,424.7                                     | -0.043                  | -0.088 | -0.038 | +0.046 | +0.082 | +0.040 | 4.5            | 3.8  | 8.2  | 14.8 |          |                       |       |
| 11             | 3,138.4                 | 4,028.0       | 1.28                                 | 3,780.0                                     | -0.048                  | -0.098 | -0.042 | +0.051 | +0.091 | +0.044 | 5.5            | 4.1  | 8.9  | 16.2 | 9.3      |                       | 110.0 |
| 12             | 3,423.7                 | 4,350.0       | 1.27                                 | 4,080.0                                     | -0.057                  | -0.107 | -0.045 | +0.048 | +0.101 | +0.049 | 5.3            | 4.1  | 9.4  | 17.9 | 12.0     |                       | 105.0 |
| 10             | 2,853.1                 | 3,679.5       | 1.29                                 | 3,700.0                                     | -0.049                  | -0.103 | -0.043 | +0.055 | +0.098 | +0.048 | 3.8            | 2.8  | 9.8  | 17.4 | 6.9      |                       | 110.0 |
| 8              | 2,282.4                 | 3,504.0       | 1.53                                 | 3,280.0                                     | -0.051                  | -0.096 | -0.043 | +0.050 | +0.092 | +0.045 | 2.8            | 2.3  | 7.6  | 15.8 | 8.7      |                       | 111.0 |
| 6              | 1,711.8                 | 2,915.0       | 1.70                                 | 2,725.0                                     | -0.041                  | -0.085 | -0.036 | +0.045 | +0.082 | +0.041 | 2.0            | 2.0  | 7.8  | 14.0 | 6.1      |                       | 103.0 |
| 4              | 1,141.2                 | 2,113.5       | 1.85                                 | 1,995.0                                     | -0.031                  | -0.066 | -0.028 | +0.039 | +0.065 | +0.032 | 1.6            | 1.0  | 4.8  | 11.5 |          |                       | 106.0 |
| 2              | 570.6                   | 990.5         | 1.73                                 | 928.0                                       | -0.016                  | -0.033 | -0.011 | +0.020 | +0.034 | +0.017 | 0.9            | 0.7  | 5.0  | 4.3  |          |                       | 107.0 |
| Top of pipe    | 163.0                   | 117.0         | 0.72                                 | 109.0                                       | -0.004                  | -0.008 | -0.002 | +0.008 | +0.012 | +0.006 |                |      |      |      |          | 8.6                   | 111.0 |

CONCRETE

[Diameter 29 inches, 2½ inches thick]

|               |         |         |      |         |        |  |  |        |  |  |     |     |     |      |      |     |  |       |
|---------------|---------|---------|------|---------|--------|--|--|--------|--|--|-----|-----|-----|------|------|-----|--|-------|
| Top of pipe=0 | 0       | 0       |      | 0       |        |  |  | 0      |  |  |     |     |     |      |      |     |  | 110.0 |
| 1             | 258.6   | 378.5   | 1.46 | 391.5   | +0.001 |  |  | +0.002 |  |  | 1.5 | 2.2 | 1.9 | 1.6  | 9.2  |     |  |       |
| 2             | 517.2   | 752.5   | 1.45 | 778.5   | +0.002 |  |  | +0.005 |  |  | 1.5 | 2.4 | 2.1 | 2.6  | 14.6 |     |  | 114.0 |
| 3             | 775.8   | 1,183.0 | 1.53 | 1,223.8 | 0.000  |  |  | +0.006 |  |  | 2.0 | 2.8 | 2.2 | 4.0  |      |     |  |       |
| 4             | 1,034.4 | 1,521.0 | 1.47 | 1,573.5 | -0.001 |  |  | +0.007 |  |  | 1.7 | 2.7 | 2.5 | 5.2  | 8.6  |     |  | 106.0 |
| 5             | 1,290.0 | 1,900.5 | 1.47 | 1,966.1 | -0.002 |  |  | +0.012 |  |  | 2.1 | 3.1 | 3.7 | 6.9  |      |     |  |       |
| 6             | 1,548.6 | 2,340.5 | 1.51 | 2,421.2 | -0.004 |  |  | +0.011 |  |  | 2.1 | 3.8 | 4.1 | 8.4  | 9.2  |     |  | 109.0 |
| 7             | 1,807.2 | 2,692.0 | 1.49 | 2,785.0 | -0.005 |  |  | +0.014 |  |  | 2.4 | 3.9 | 4.7 | 9.9  |      |     |  |       |
| 8             | 2,065.8 | 2,946.0 | 1.43 | 3,048.1 | -0.011 |  |  | +0.019 |  |  | 2.3 | 4.4 | 4.3 | 11.0 |      |     |  |       |
| 9             | 2,324.4 | 3,331.5 | 1.43 | 3,446.4 | -0.019 |  |  | +0.027 |  |  | 2.9 | 4.8 | 4.6 | 13.2 |      |     |  |       |
| 10            | 2,583.0 | 3,620.0 | 1.40 | 3,745.0 | -0.025 |  |  | +0.033 |  |  | 3.0 | 5.1 | 4.8 | 13.1 |      |     |  |       |
| 11            | 2,841.6 | 3,885.5 | 1.37 | 4,019.5 | -0.032 |  |  | +0.045 |  |  | 3.2 | 4.9 | 4.7 | 13.2 |      |     |  |       |
| 12            | 3,100.2 | 4,021.0 | 1.30 | 4,160.0 | -0.058 |  |  | +0.075 |  |  | 3.8 | 5.6 | 6.6 | 12.5 | 10.0 |     |  | 115.0 |
| 12            | 3,100.2 | 4,066.0 | 1.31 | 4,207.0 | -0.060 |  |  | +0.091 |  |  | 4.1 | 5.7 | 6.2 | 14.1 |      |     |  |       |
| 12            | 3,100.2 | 2,774.0 | 0.89 | 2,865.0 |        |  |  |        |  |  | 2.3 | 5.4 | 7.1 | 12.2 |      |     |  |       |
| 12            | 3,100.2 | 2,015.5 | 0.67 | 2,805.0 |        |  |  |        |  |  | 2.5 | 5.4 | 6.2 | 11.6 |      |     |  |       |
| 12            | 3,100.2 | 1,166.0 | 0.38 | 1,206.0 |        |  |  |        |  |  | 1.8 | 4.4 | 4.9 | 6.2  |      |     |  |       |
| 12            | 3,100.2 | 357.5   | 0.12 | 369.0   |        |  |  |        |  |  | 1.0 | 4.0 | 2.8 | 4.4  |      |     |  |       |
| 8             | 2,065.8 | 409.5   | 0.19 | 423.0   | -0.031 |  |  | +0.059 |  |  | 1.0 | 3.8 | 2.8 | 7.2  |      |     |  |       |
| 4             | 1,034.4 | 273.5   | 0.27 | 282.5   | -0.029 |  |  | +0.051 |  |  | 1.2 | 3.4 | 1.7 | 5.9  |      |     |  |       |
| Top of pipe   | 0       | -190.5  |      | 197.0   | -0.030 |  |  | +0.049 |  |  |     |     |     |      |      | 8.7 |  | 112.0 |

SOLID CONCRETE PLUG

[Diameter, 32 inches]

|               |         |         |       |         |  |  |  |  |  |  |     |     |      |      |     |  |  |       |
|---------------|---------|---------|-------|---------|--|--|--|--|--|--|-----|-----|------|------|-----|--|--|-------|
| Mid-point     | 81.3    | 101.5   | 1.25  | 93.8    |  |  |  |  |  |  |     |     |      |      |     |  |  |       |
| Top of pipe=0 | 163.0   | 308.0   | 1.89  | 304.0   |  |  |  |  |  |  |     |     |      |      |     |  |  |       |
| 1             | 285.3   | 343.0   | 1.21  | 322.0   |  |  |  |  |  |  | 1.0 | 1.5 | 2.1  | 1.3  |     |  |  |       |
| 2             | 570.6   | 806.0   | 1.41  | 756.0   |  |  |  |  |  |  | 1.1 | 1.8 | 2.9  | 2.6  | 6.1 |  |  |       |
| 3             | 859.9   | 1,296.5 | 1.51  | 1,215.5 |  |  |  |  |  |  | 0.7 | 1.6 | 3.7  | 4.0  |     |  |  |       |
| 4             | 1,141.2 | 1,831.0 | 1.60  | 1,717.0 |  |  |  |  |  |  | 1.2 | 2.0 | 4.6  | 5.2  | 5.3 |  |  | 100.0 |
| 5             | 1,426.5 | 2,358.0 | 1.65  | 2,210.0 |  |  |  |  |  |  | 1.1 | 2.2 | 5.9  | 7.0  |     |  |  |       |
| 6             | 1,711.8 | 2,902.0 | 1.69  | 2,721.0 |  |  |  |  |  |  | 0.9 | 1.9 | 6.8  | 7.0  |     |  |  |       |
| 7             | 1,997.1 | 3,300.0 | 1.65  | 3,094.0 |  |  |  |  |  |  | 1.2 | 2.4 | 7.8  | 8.0  | 5.2 |  |  | 105.0 |
| 8             | 2,282.4 | 3,840.5 | 1.68  | 3,600.0 |  |  |  |  |  |  | 1.2 | 2.3 | 8.8  | 10.0 |     |  |  |       |
| 9             | 2,567.8 | 4,291.0 | 1.67  | 4,023.0 |  |  |  |  |  |  | 1.1 | 2.8 | 10.4 | 10.8 |     |  |  |       |
| 10            | 2,853.1 | 4,775.0 | 1.67  | 4,477.0 |  |  |  |  |  |  | 1.4 | 3.0 | 11.1 | 12.2 |     |  |  |       |
| 11            | 3,138.4 | 5,242.5 | 1.67  | 4,915.0 |  |  |  |  |  |  | 1.2 | 3.0 | 12.9 | 14.9 | 4.7 |  |  | 103.0 |
| 12            | 3,423.7 | 5,758.0 | 1.68  | 5,398.0 |  |  |  |  |  |  | 1.3 | 3.3 | 12.9 | 14.8 |     |  |  |       |
| 12            | 3,423.7 | 2,335.0 | 0.68  | 2,181.0 |  |  |  |  |  |  | 1.4 | 3.3 | 7.4  | 10.6 |     |  |  |       |
| 12            | 3,423.7 | 801.0   | 0.23  | 751.0   |  |  |  |  |  |  | 1.2 | 3.6 | 3.9  | 6.8  |     |  |  |       |
| 12            | 3,423.7 | -73.0   | -0.21 | -68.5   |  |  |  |  |  |  | 1.4 | 3.5 | 2.3  | 3.9  |     |  |  |       |
| 12            | 3,423.7 | -362.0  | -0.10 | -339.0  |  |  |  |  |  |  | 1.1 | 3.5 | 1.5  | 1.9  |     |  |  |       |
| 12            | 3,423.7 | +201.5  | +0.05 | +188.5  |  |  |  |  |  |  | 1.5 | 4.0 | 2.5  | 4.3  |     |  |  |       |
| 12            | 3,423.7 | -860.0  | -0.26 | -805.0  |  |  |  |  |  |  | 1.8 | 3.7 | 0.7  | 0.5  |     |  |  |       |
| 12            | 3,423.7 | -760.0  | -0.22 | -713.0  |  |  |  |  |  |  | 1.6 | 3.3 | 0.8  | 0.7  |     |  |  |       |
| 12            | 3,423.7 | -627.0  | -0.18 | -586.0  |  |  |  |  |  |  | 1.3 | 3.4 | 0.8  | 0.3  |     |  |  |       |
| 8             | 2,282.4 | -636.0  | -0.19 | -597.0  |  |  |  |  |  |  | 1.3 | 2.8 | 1.0  | 0.9  | 4.7 |  |  | 105.0 |
| 4             | 1,141.2 | -655.0  | -0.19 | -613.0  |  |  |  |  |  |  |     |     |      |      |     |  |  |       |
| Top of pipe   | 163.0   | -613.0  | -0.19 | 574.0   |  |  |  |  |  |  |     |     |      |      |     |  |  |       |
| Mid-point     | 81.3    | -628.5  | -0.18 | -588.0  |  |  |  |  |  |  |     |     |      |      |     |  |  |       |

See footnotes at end of table.

TABLE 3.—Results of field tests on various pipe, 100 per cent projection, sand fill—Continued

SMOOTH IRON  
[Diameter 20 inches, 0.076 inch thick]

| Height of fill in feet | Actual weight | Scale reading | Ratio scale reading to actual weight<br>K | Scale reading corrected to 20-inch diameter | Deflection of diameters |        | Cell pressures |          |     | Moisture | Weight per cubic foot |
|------------------------|---------------|---------------|---|---|-------------------------|--------|----------------|----------|-----|----------|-----------------------|
|                        |               |               |   |   | A-A'                    | D-D'   | 2, 6           | Ground   | 4   |          |                       |
| Top of pipe=0          | 0             | 0             |   | 0   |                         |        |                |          |     |          |                       |
| 1                      | 177.6         | 160.5         | 0.90                                      | 160.5                                       | -0.014                  | +0.104 | 2.0            | (10) 3.0 | 1.1 | 4.7      | 105.0                 |
| 2                      | 355.2         | 316.0         | .89                                       | 316.0                                       | -.145                   | +.147  | 2.9            | 4.9      | 2.9 | 5.8      |                       |
| 3                      | 532.8         | 457.0         | .86                                       | 457.0                                       | -.209                   | +.185  | 3.6            | 5.4      | 3.4 |          |                       |
| 4                      | 710.4         | 547.5         | .77                                       | 547.5                                       | -.262                   | +.204  | 4.2            | 6.1      | 3.4 |          | 103.0                 |
| 5                      | 888.0         | 624.5         | .70                                       | 624.5                                       | -.311                   | +.287  | 5.1            | 7.3      | 4.2 |          |                       |
| 6                      | 1,065.6       | 706.5         | .67                                       | 706.5                                       | -.338                   | +.303  | 5.2            | 8.0      | 3.7 | 7.2      |                       |
| 7                      | 1,243.2       | 792.5         | .64                                       | 792.5                                       | -.384                   | +.356  | 5.8            | 7.8      | 4.2 |          |                       |
| 8                      | 1,420.8       | 859.5         | .64                                       | 859.5                                       | -.405                   | +.366  | 6.1            | 9.0      | 4.5 | 6.3      | 100.0                 |
| 9                      | 1,598.4       | 925.0         | .58                                       | 925.0                                       | -.442                   | +.396  | 6.4            | 9.8      | 4.8 |          |                       |
| 10                     | 1,776.5       | 1,009.0       | .57                                       | 1,009.0                                     | -.477                   | +.424  | 7.1            | 10.6     | 5.0 |          |                       |
| 11                     | 1,953.6       | 1,098.0       | .56                                       | 1,098.0                                     | -.533                   | +.480  | 8.0            | 12.1     | 5.3 |          |                       |
| 12                     | 2,131.2       | 1,176.0       | .55                                       | 1,176.0                                     | -.543                   | +.480  | 8.0            | 12.6     | 5.4 | 5.7      | 105.0                 |
| 12                     | 2,131.2       | 1,176.0       | .55                                       | 1,176.0                                     | -.553                   | +.493  | 8.3            | 12.9     | 5.6 |          |                       |
| 8                      | 1,420.8       | 966.0         | .68                                       | 966.0                                       | -.549                   | +.492  | 7.2            | 9.5      | 5.0 |          |                       |
| 4                      | 710.4         | 681.0         | .96                                       | 681.0                                       | -.555                   | +.487  | 5.8            | 6.2      | 3.7 | 6.2      | 105.0                 |
| Top of pipe=0          | 0             | 0             |   | 0   | -.283                   | +.304  |                |          |     |          |                       |

CORRUGATED  
[Diameter 21 inches, 0.076 inch thick]

|               |         |         |      |         |        |        |     |          |     |      |       |
|---------------|---------|---------|------|---------|--------|--------|-----|----------|-----|------|-------|
| Top of pipe=0 | 0       | 0       |      | 0       |        |        |     |          |     |      |       |
| 1             | 187.2   | 252.2   | 1.35 | 240.0   | -0.017 | +0.018 | 1.6 | (10) 2.8 | 1.9 | 9.8  | 106.0 |
| 2             | 374.4   | 486.0   | 1.30 | 463.0   | -.045  | +.045  | 2.3 | 3.7      | 3.0 |      |       |
| 3             | 561.6   | 586.5   | 1.03 | 558.0   | -.054  | +.057  | 2.8 | 4.1      | 3.2 |      |       |
| 4             | 748.8   | 784.5   | 1.05 | 746.0   | -.099  | +.070  | 3.3 | 4.7      | 4.1 |      |       |
| 5             | 936.0   | 963.5   | 1.03 | 917.0   | -.091  | +.088  | 3.9 | 4.9      | 4.1 | 8.5  | 105.0 |
| 6             | 1,123.2 | 1,148.5 | .99  | 1,065.0 | -.109  | +.103  | 4.6 | 5.2      | 4.5 |      |       |
| 7             | 1,310.4 | 1,276.0 | .97  | 1,215.0 | -.127  | +.119  | 4.9 | 5.9      | 5.1 | 8.6  | 106.5 |
| 8             | 1,497.6 | 1,405.0 | .94  | 1,338.0 | -.141  | +.134  | 5.2 | 6.3      | 5.5 |      |       |
| 9             | 1,684.8 | 1,547.5 | .92  | 1,472.0 | -.163  | +.150  | 5.7 | 6.8      | 6.2 |      |       |
| 10            | 1,872.0 | 1,715.5 | .92  | 1,632.0 | -.193  | +.176  | 6.5 | 7.7      | 6.7 |      |       |
| 11            | 2,059.0 | 1,872.5 | .91  | 1,781.0 | -.212  | +.196  | 7.0 | 7.2      | 7.3 |      |       |
| 12            | 2,246.4 | 2,069.5 | .92  | 1,968.0 | -.233  | +.212  | 6.7 | 7.4      | 7.5 | 10.0 | 112.5 |
| 8             | 1,497.6 | 1,757.0 | 1.17 | 1,672.0 |        |        | 5.3 | 6.0      | 7.7 | 9.2  | 115.0 |
| 4             | 748.8   | 1,299.0 | 1.73 | 1,235.0 |        |        | 2.5 | 3.8      | 5.7 | 8.2  |       |
| Top of pipe=0 | 0       | 0       |      | 0       |        |        |     |          |     |      | 111.0 |

SOLID CONCRETE PLUG  
[Diameter, 20 inches]

|               |         |         |      |         |  |  |     |      |      |      |       |
|---------------|---------|---------|------|---------|--|--|-----|------|------|------|-------|
| Top of pipe=0 | 0       | 0       |      | 0       |  |  |     |      |      |      |       |
| 1             | 177.6   | 204.5   | 1.15 | 204.5   |  |  | 2.1 | 3.0  | 1.5  | 7.6  | 106.0 |
| 2             | 355.2   | 438.5   | 1.23 | 438.5   |  |  | 2.2 | 3.6  | 2.1  |      |       |
| 3             | 532.8   | 719.5   | 1.35 | 719.5   |  |  | 2.3 | 4.4  | 3.5  |      |       |
| 4             | 710.4   | 1,016.5 | 1.43 | 1,016.5 |  |  | 2.7 | 5.1  | 4.4  |      |       |
| 5             | 888.0   | 1,291.0 | 1.45 | 1,291.0 |  |  | 2.4 | 4.8  | 6.1  | 7.7  |       |
| 6             | 1,065.6 | 1,524.5 | 1.43 | 1,524.5 |  |  | 2.3 | 6.1  | 5.9  |      |       |
| 7             | 1,243.2 | 1,735.0 | 1.39 | 1,735.0 |  |  | 2.6 | 5.9  | 6.8  | 8.2  |       |
| 8             | 1,420.8 | 1,949.0 | 1.37 | 1,949.0 |  |  | 3.7 | 5.8  | 7.6  |      |       |
| 9             | 1,420.8 | 1,975.0 | 1.39 | 1,975.0 |  |  | 3.7 | 6.8  | 10.4 |      |       |
| 9             | 1,598.4 | 2,221.5 | 1.39 | 2,221.5 |  |  | 3.7 | 7.7  | 9.3  | 6.5  |       |
| 10            | 1,776.0 | 2,433.0 | 1.37 | 2,433.0 |  |  | 3.4 | 8.3  | 10.7 |      |       |
| 11            | 1,953.6 | 2,678.5 | 1.37 | 2,678.5 |  |  | 3.7 | 6.9  | 11.5 | 7.9  | 107.5 |
| 12            | 2,131.2 | 2,933.5 | 1.38 | 2,933.5 |  |  | 3.4 | 10.6 | 12.5 | 12.0 |       |
| 12            | 2,131.2 | 2,954.5 | 1.39 | 2,954.5 |  |  | 3.2 | 10.8 | 13.3 |      |       |
| 12            | 2,131.2 | 2,934.0 | 1.38 | 2,934.0 |  |  | 4.1 | 11.1 | 17.0 |      |       |
| 12            | 2,131.2 | 2,989.0 | 1.40 | 2,989.0 |  |  | 4.3 | 10.0 | 16.3 |      |       |
| 8             | 1,420.8 | 2,233.0 | 1.57 | 2,233.0 |  |  | 3.9 | 6.6  | 13.5 |      |       |
| 4             | 710.4   | 217.0   | 1.71 | 1,217.0 |  |  | 3.1 | 5.2  | 8.2  | 8.1  |       |
| Top of pipe=0 | 0       | 0       |      | 0       |  |  |     |      |      |      |       |

<sup>1</sup> Average results from two tests on different pipe. In the last two columns the runs are indicated by a and b.  
<sup>2</sup> Only one deflection read.  
<sup>3</sup> Section No. 2 cracked along bottom.  
<sup>4</sup> Section No. 2 cracked half way across top and Section No. 1 cracked on bottom.  
<sup>5</sup> All cracks widened and material spalled off.  
<sup>6</sup> Section No. 3 cracked on top and bottom and section No. 4 cracked on bottom.  
<sup>7</sup> Pipe dropped 1/40 inch.  
<sup>8</sup> Section on south end cracked and pipe dropped 1/20 inch.  
<sup>9</sup> Pipe dropped 1/40 inch.

<sup>10</sup> Pipe dropped 1/2 inch, all cracks closing.  
<sup>11</sup> Pipe dropped 0.1 inch in 45 minutes.  
<sup>12</sup> Pipe dropped 0.2 inch in 30 minutes.  
<sup>13</sup> Pipe dropped 0.3 inch in 30 minutes.  
<sup>14</sup> Pipe dropped 0.4 inch in 30 minutes.  
<sup>15</sup> Pipe dropped 0.4 inch in 12 hours.  
<sup>16</sup> Pipe dropped 0.8 inch in 45 minutes.  
<sup>17</sup> Readings taken 2 hours after previous reading.  
<sup>18</sup> Reading taken 12 hours after previous reading.  
<sup>19</sup> Cell on ground at level of bottom of pipe and measuring vertical pressure.

relation plots approximately as a straight line throughout, whereas the deflections of the more flexible pipe increase rapidly at first and then more slowly as the side pressure increases.

Figure 20 shows graphically the variation in radial pressure on a rigid and on a flexible pipe. On the rigid pipe the pressure is high at the top and low at the sides. On the flexible pipe the pressure is slightly higher on the sides than on the top. This variation in pressure on the two pipes is to be expected when it is realized that the flexible pipe acquires its strength through side support.

**ATTEMPT MADE TO CORRELATE FIELD DATA AND LABORATORY METHODS**

Upon completion of the field tests experiments were undertaken in an attempt to correlate the field data with laboratory methods, in hope of providing some rational basis for design of culvert pipe. Two different procedures were undertaken—first, an attempt was made to produce in the laboratory the same radial pressures on the pipe as were found to exist in the field; second, it was attempted to produce in the laboratory the radial deflections obtained in the field.

To reproduce the radial pressures a timber box, 2½ feet wide, ¾ feet long, and 3½ feet high, inside dimensions, was designed suitable for holding a filling material and a test section of the pipe. The box was constructed of 2½-inch oak timbers bolted together.

The radial pressures were indicated by soil-pressure cells fastened on the test pipe at 45° intervals around

For the purpose of producing the same side pressures as in the field, the ends of the box were arranged on rollers so they were free to be pushed out by the deflection of the pipe under load. This outward motion was opposed by heavy box-car springs. The resistance of these springs compared to the passive side pressure in the field. Loads were applied by a testing machine

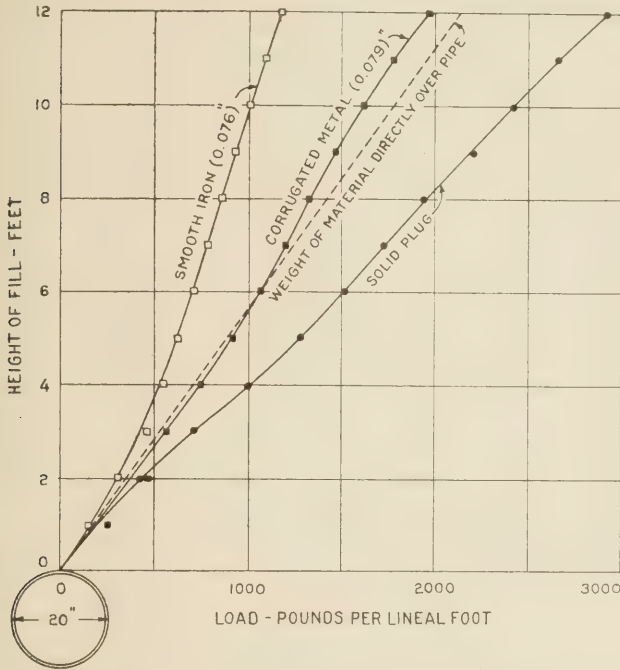

FIGURE 17.—VERTICAL LOADS TRANSMITTED TO 20-INCH PIPE (CORRECTION MADE FOR VARIATION FROM 20 INCHES), 100 PER CENT PROJECTION CONDITION, BY VARIOUS HEIGHTS OF SAND FILL. NUMBERS IN PARENTHESES INDICATE THICKNESS

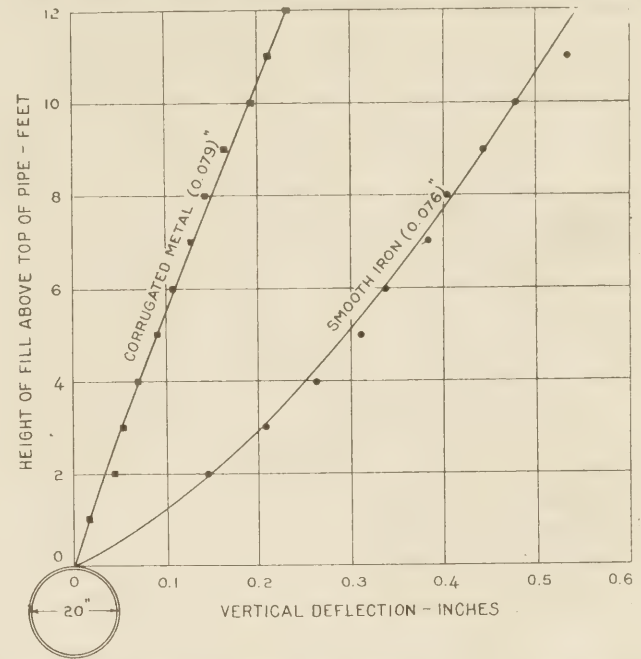

FIGURE 19.—RELATION BETWEEN HEIGHT OF FILL AND DEFLECTION FOR 20-INCH PIPE, 100 PER CENT PROJECTION AND SAND FILL. NUMBERS IN PARENTHESES INDICATE THICKNESS OF PIPE

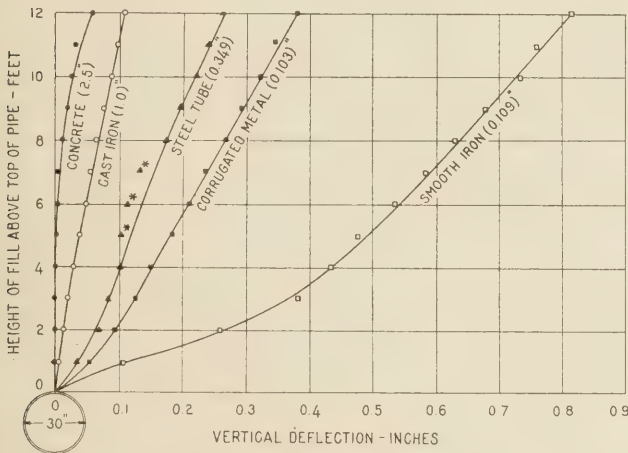

FIGURE 18.—RELATION BETWEEN HEIGHT OF FILL AND DEFLECTION FOR 30-INCH PIPE, 100 PER CENT PROJECTION CONDITION AND SAND FILL. NUMBERS IN PARENTHESES INDICATE THICKNESS OF PIPE.

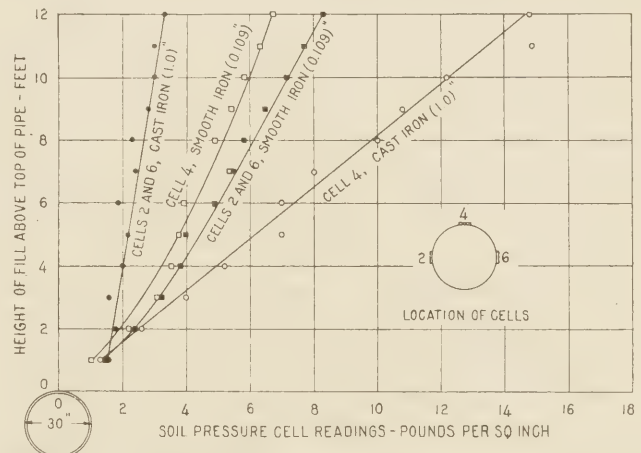

FIGURE 20.—RESULTS OF SOIL-PRESSURE CELL READINGS ON A RIGID AND A FLEXIBLE 30-INCH PIPE, 100 PER CENT PROJECTION, SAND FILL. NUMBERS IN PARENTHESES INDICATE THICKNESS OF PIPE

its circumference. Holes were bored in the sides of the box for the flexible air hose and electric wires leading to the pressure cells. The pipe was placed in the box with its length at right angles to the sides and with its bottom resting on the bottom of the box. The filling material was a well-graded dry sand and was placed around the pipe and to a depth of 6 inches over it. The top of the box through which loads were to be applied was made of 2½-inch oak timber reinforced with ½-inch steel plates.

to the top of the box through an I-beam leverage system.

The tests were made on a section of smooth iron pipe 30 inches in diameter and having a thickness of 0.109 inch, and also on a section of steel tube 30 inches in diameter with a thickness of 0.349 inch. There was a wide discrepancy between the pressures and deflections obtained by this method and those obtained in the field, and it was decided that field conditions could not be simulated with the apparatus.

**A SECOND METHOD OF SIMULATING FIELD CONDITIONS PRODUCES UNSATISFACTORY RESULTS**

A new apparatus was devised (fig. 22) in an attempt to produce the same radial deflection as found in the field by applying restraint at the 30° point and a load on the top of the pipe. It was desired to compare this load with the load producing the same deflections in the field.

Oak timbers were placed along the outside of the test pipe parallel to its longitudinal axis and spaced 30° apart. The timbers were held in place by 3/4-inch steel radial rods threaded at each end and supplied with lock nuts, which had bearing on the longitudinal

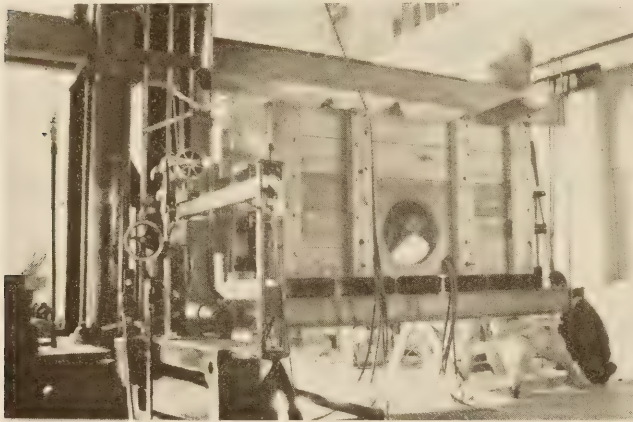

FIGURE 21.—APPARATUS USED IN TEST WITH SAND BEARING

timbers. By tightening or loosening the nuts, the desired radial deflections could be induced in the test pipe. Loads were applied to the top of the pipe by means of a cantilever arrangement. Tests were made on a 30-inch steel tube having a thickness of 0.349 inch.

A vertical load corresponding to a fill height of 6 feet was first applied, and the horizontal deflection was adjusted to the corresponding field value. The load was then increased to produce the vertical deflection corresponding to a 6-foot fill. With these two diameters corresponding to the field values, an attempt was made to adjust the other 30° diameters to correspond with the field values. After a number of manipulations it was found impossible to get the desired deflections.

No further attempt was made to correlate the field data with a laboratory method, with the idea of obtaining a practical rational design for culvert pipes, but a suggested procedure may be found under the heading "Application of results to design of rigid pipe discussed."

Because of the theoretical as well as the practical significance, some data were obtained to determine the resulting changes in the scale reading values effected by lowering the test pipes through small increments. These experiments were performed only on the concrete pipes and the solid plugs.

**APPLICATION OF RESULTS TO DESIGN OF RIGID PIPE DISCUSSED**

A study of the data obtained from these experiments indicates that the magnitude of the earth pressure transmitted to the pipe is to a large degree a function of the flexibility or deflection of the pipe. If the pipe is of such rigidity that its deflection is equal to the settlement of the adjacent fill, the value of *K*—ratio of the earth pressure to the weight of the earth prism

directly over the pipe—will be unity; that is, the load carried by the pipe will be equal to the weight of the prism of earth vertically above the pipe. If this rigidity is increased, the load carried will also be increased whereas if the rigidity is decreased the earth pressure transmitted to the pipe will be decreased.

Comparing Figure 18, which shows the relation between height of earth fill and the vertical deflections for the five types of pipe arranged in their order of flexibility, and Figure 16, which shows the relation between height of earth fill and the pressures, we obtain a graphical proof of this conclusion.

In discussing the influence of the results of this investigation upon the design of culvert pipe, it is necessary to divide culverts into two types, which must be separately considered. The first type, known as rigid-type culverts, may be defined as those culverts made of such material that their structural failure is evidenced by fracture of the material. The second, flexible-type culverts, are those culverts made of such material that their structural failure is not evidenced by fracture of the material but rather by extreme change in shape or cross section.

For the rigid-type culverts a method of design may be used based on data obtained from this investigation. This method of design, is based upon the assumption that the limiting or ultimate load from a 2 or 3 point bearing test when multiplied by some factor will equal the limiting or ultimate load in actual embankment conditions.

The relation between vertical deflections and embankment loads per lineal foot of pipe for the 30-inch cast-iron pipe is shown in Table 3 and Figure 18.

Figure 23 shows the deflections obtained for the same pipe under a 3-point bearing load. The ratios of em-

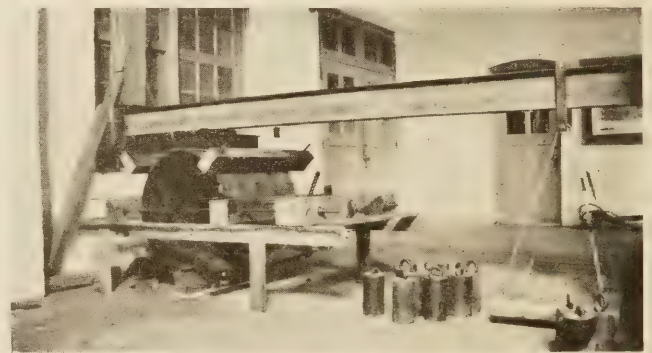

FIGURE 22.—APPARATUS USED IN MULTIPLE-POINT LOADING

bankment loads to the 3-point bearing loads and are shown in Table 4.

TABLE 4.—Ratios of load on 30-inch cast-iron pipe to 3-point bearing load producing equal deflections

| Equal deflections | Height of fill | Weight of earth per lineal foot of pipe directly over pipe | Pressures per lineal foot of pipe | Load per lineal foot of pipe from 3-point bearing test | Ratio of weight of earth to 3-point bearing load | Ratio of earth pressure to 3-point bearing load |
|-------------------|----------------|--|-----------------------------------|--|--|---|
| Inches            | Feet           | Pounds   | Pounds                            | Pounds   |  |   |
| 0.014             | 2              | 571  | 730                               | 375  | 1.523  | 1.95  |
| .030              | 4              | 1,141  | 1,445                             | 775  | 1.472  | 1.80  |
| .048              | 6              | 1,712  | 2,160                             | 1,275  | 1.343  | 1.73  |
| .065              | 8              | 2,283  | 2,831                             | 1,700  | 1.295  | 1.69  |
| .088              | 10             | 2,853  | 3,680                             | 2,250  | 1.268  | 1.64  |
| .107              | 12             | 3,424  | 4,350                             | 2,725  | 1.256  | 1.62  |



Using a proper ratio or factor the ultimate strength of any rigid pipe as determined by the 3-point bearing test can be converted into its equivalent load-carrying capacity for earth embankments.

It is possible to calculate the ratio of the load under 3-point loading to the weight of earth over pipe pro-

show that there is no one factor that can be used to determine field loading from laboratory loading. This is due to the fact that the structural strength of flexible pipe in the 2 or 3 point bearing test is only a part of its load-carrying capacity, the remaining portion being due to side support which is developed as passive pressure on the sides of the pipe.

From this investigation it seems reasonable to conclude that had the embankments been carried to sufficient height to cause structural failure of the flexible types of pipe, this failure would have resulted from excessive deflection. If this is true, then the logical method of design for pipes of this type must be based upon a law of deflections, which might be obtained from data observed on a large number of actual installations.

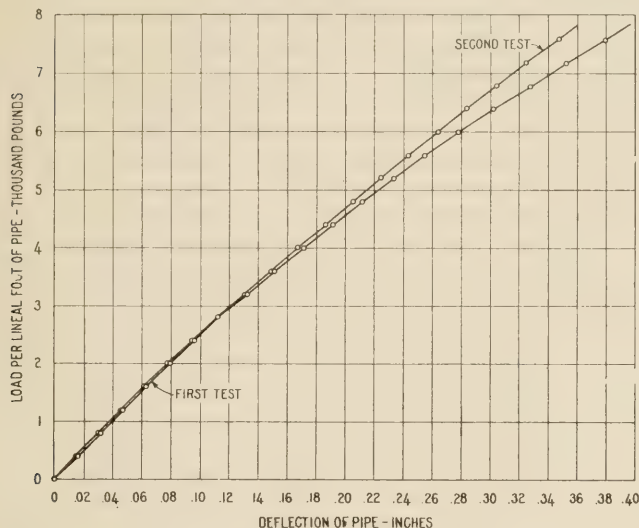

FIGURE 23.—DEFLECTIONS OF 30-INCH PLAIN CAST-IRON PIPE, 1 INCH THICK AND 25 FEET LONG UNDER 3-POINT LOADING

ducing the same deflection  $\left(\frac{P}{W}\right)$ , with equation 17 of Appendix II, which is given as

$$(1.06 - q) = \frac{e_E}{e_p} \times \frac{1.8}{K} \times \frac{P}{W}$$

In this equation,

$$q = \frac{1 - \sin \phi}{1 + \sin \phi} = \text{ratio of lateral load to vertical load.}$$

$e_E$  = vertical deflection of pipe due to embankment load.

$e_p$  = vertical deflection from 3-point bearing load.

$K$  = ratio of earth pressure sustained by pipe to weight of earth prism directly over the pipe.

$P$  = load per lineal foot of pipe obtained from 3-point bearing method.

$W$  = weight of embankment per lineal foot of pipe.

If we assume for the internal angle of friction,  $\phi = 42^\circ$ ,  $q$  becomes 0.2.

Applying equation 17 with above assumptions, making  $e_E = e_p$  and noting that  $K = 1.27$  for cast-iron pipe, we obtain for the ratio

$$\frac{P}{W} = 0.607, \text{ or } \frac{W}{P} = 1.65.$$

This value is larger than those obtained from the experimental data as given in Table 4, and is, of course, dependent on the assumed value of  $\phi$ .

This method gives a maximum height of fill with no consideration of a proper factor of safety. Since the reliability of this method depends upon the uniformity of the material of which the pipe is composed, it seems logical to suggest that some factor of safety be used in determining the safe height of fill for rigid pipe when designed according to this method.

**ADDITIONAL DATA NEEDED TO DESIGN FLEXIBLE TYPES OF PIPE**

The above method can not be applied to flexible types of pipe. Three-point bearing tests on flexible pipe when compared with actual embankment loads

**APPENDIX I**

**NOTES RELATIVE TO VERTICAL PRESSURES ON PIPE CULVERTS**

By WILLIAM CAIN, Professor Emeritus of Mathematics, University of North Carolina

An apparatus for determining the coefficients of friction and cohesion of earth is shown in Figure 1, where the pull  $Q'$ , starting at zero, finally attains the value  $Q$  pounds, when shear of the sand (or earth) along the surface  $AB$  of one square foot is "impending." Let  $P_n$  be the total normal load on this area  $AB$  and for the case where the pull  $Q'$  is less than  $Q$ , let  $f'$  equal friction per unit of  $P_n$  and  $c'$  equal the cohesion per unit area ( $AB$ ). Then an approximate load—friction—cohesion relation is expressed by the formula,

$$Q' = f'P_n + c' \text{-----(1)}$$

Figure 1B represents the case where the pull has reached its maximum,  $Q$ , and the coefficients  $f'$  and  $c'$  have likewise reached their maximum values,  $f$  and  $c$ , called respectively the coefficients of friction and cohesion.

We have now

$$Q = fP_n + c \text{-----(2)}$$

As  $Q'$  varies from 0 to  $Q$ ,  $f'$  and  $c'$  vary from 0 to  $f$ ,  $c$ , but the relative variation of  $f'$  and  $c'$  is unknown. For

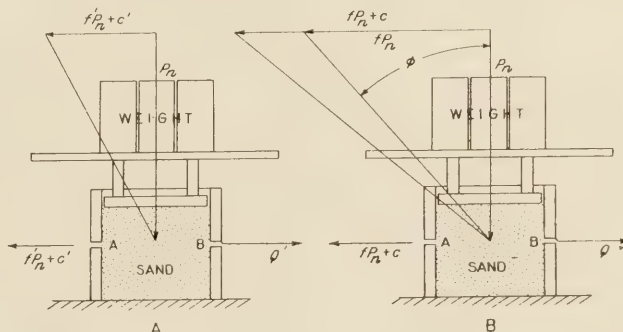

FIGURE 1.—DIAGRAM USED IN DISCUSSING COHESION AND FRICTION

example, if  $Q' = \frac{1}{2}Q$ ,  $f'$  and  $c'$  may not be  $\frac{1}{2}f$ ,  $\frac{1}{2}c$ , respectively, but Equation 1 must always hold. In experimenting with the apparatus shown in Figure 1, the values of  $Q$  have been recorded for a succession of loads  $P_n$  and the results plotted as shown in Figure 2 for a typical case, the values of  $P_n$  being laid off as abscissas and the corresponding values of  $Q$  as ordinates. A straight

line can be drawn to nearly pass through the plotted points and represented by the equation,

$$Q = \tan \phi P_n + b \text{-----} (3)$$

This fact has been noted by English and French experimenters (1).<sup>1</sup>

It is desirable that the earth or sand used in the experiment be homogeneous or readjustments of the grains may occur in increasing the pulls. This homogeneity may possibly be attained by simply shaking before applying the loads, but it seems that it could more certainly be accomplished by a uniform tamping, say, with one of the weights.

By comparing equations 2 and 3, it is seen that  $f = \tan \phi = \text{slope of straight line}$ , and  $c$ , the coefficient

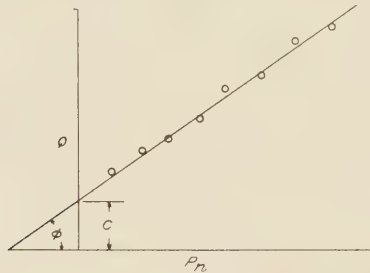

FIGURE 2.—GRAPHICAL REPRESENTATION OF RELATION BETWEEN  $\phi$  AND  $P_n$

of cohesion is equal to  $b$ , the intercept on the axis of  $Q$ . The angle  $\phi$  is called the angle of friction or the angle of internal friction. It is always less than the angle of repose when  $c$  is not zero, being equal to it only when  $c=0$ , corresponding to perfectly dry, clean sand. By measuring the  $y$ -intercept and computing  $\tan \phi$  from the diagram, the values of  $c$  and  $f$  can be found for sand, or earth containing any mixture of sand and clay, and with various percentages of moisture. Tests made on the bank sand used for the fill over the pipe culverts, showed that as the percentage of moisture increased from 0.4 to 10.9 per cent  $c$  varied from 10 to 30 pounds per square foot, and  $\phi$  varied from  $42^\circ$  to  $45^\circ$ . For the clay filling with 21 per cent moisture,  $Q$  was 41 degrees and  $c$  was 225 pounds per square foot.

Although the formula  $Q' = f'P_n + c'$  approximately expresses the relation between pressure and shear resistance in earth fills, experiments disclose that this shear resistance does not develop before there is appreciable tangential displacement along a plane of rupture. Prior to rupture any granular material behaves like an imperfectly elastic body with low modulus of elasticity. Within such body, stresses depend upon deformation. Hence the proper treatment of the problem is to treat the system—culvert and fill—as a statically indeterminate combination of elastic bodies.

In order to get a rough conception of existing conditions one can disregard the elasticity of the fill and introduce a variable coefficient of friction along more or less arbitrary planes starting with a value of zero for no deformation and increasing to full value when displacements are important enough to produce shear.

UNEQUAL SETTLEMENT IN FILLS DISCUSSED

Let us next consider an embankment of earth (fig. 3) having a level surface and a level foundation, either

rigid or uniformly compressible, the earth extending indefinitely in all directions. Imagine the earth divided by vertical planes so as to make prisms  $h$  feet high and 1 foot square in cross section. Then, if  $w$  is the average weight in pounds per cubic foot of the earth, the weight of each prism is  $wh$  pounds. This weight is transmitted vertically to the foundation. There is a horizontal or lateral earth pressure  $E$  on each vertical plane which is given by a known formula (5).<sup>2</sup>

Under the conditions assumed, there is no sliding along vertical planes and thus no friction or cohesion can be exerted in a vertical direction along them. But, suppose the foundation under one of these prisms to give way entirely, then its weight is almost wholly transmitted to the sides through the friction,  $Ef$  and the cohesion,  $ch \times 1$ , exerted upward on each of the inclosing vertical sides of the prism. The theory is similar to that used in the design of bins or for tunnels in earth excavated by use of poling boards.

Again, if the foundation gives a minute amount, but more in some places than others, then some of the weight of the prisms that sink most will be transferred to the sides, though the full friction and cohesion may not be exerted. The vertical pressures on a culvert are not uniform, even for the width of the roadway, but for this central position of greatest height, it is on the side of safety to assume the weight vertically transmitted, as it should be near the center of this portion. This will be assumed in the following discussion, where the vertical pressure on one lineal foot of pipe, just under the center of the roadway, is alone considered.

Let us next consider the case of the pipe culvert shown in Figure 4. Assume the concrete walls, just touching the pipe, to be rigid and let the outside diameter of the pipe be  $b$  feet. On account of the compression of the earth varying with the depth, the weight of

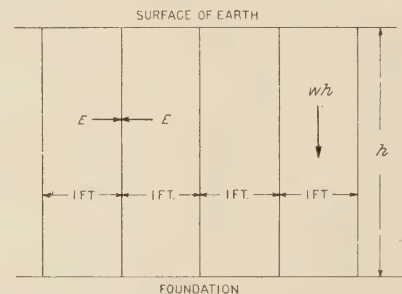

FIGURE 3.—EARTH EMBANKMENT DIVIDED INTO PRISMS

earth per cubic foot varies nearly uniformly from the earth surface to the top of the pipe in the distance,  $h$  feet. Therefore the average weight,  $w$ , will be that at about the depth  $h/2$ , and the weight of earth vertically over the pipe will be  $wbh$ . It is difficult to ascertain  $w$ . It is always greater than the measured weight of earth as deposited because of the compression. The value can not be determined by removing the fill to a depth of  $h/2$  and weighing a sample as clayey earth tends to recover its shape when the load is removed—in fact, the clay experimented with acted as if it was perfectly elastic. The weight,  $w$ , also increases with  $h$ ; however, in the theory which follows,  $w$  is always assumed to be the true average for the height, though necessarily in plotting the results of experiments for sand, only the weights of the earth, well shaken, as first deposited, were

<sup>1</sup> Italic numbers in parentheses refer to bibliography at end of article.

<sup>2</sup> See equation 2 on p. 183 involving both  $c$  and  $f$ . When  $c$  equals zero the equation reduces to the familiar Rankine formula.

plotted. Let us call  $KW$  the vertical pressure actually sustained on a horizontal plane of width  $b$  through the top of the pipe. For the case represented by Figure 4, the pipe deflects under its load, the prism of earth vertically over it sinks, and it then exerts friction and cohesion, in amount,  $f'E+c'h$ , along the vertical sides of the prism. Hence, part of the weight of the prism is held up by the earth outside of the pipe and  $KW < wbh$ .

Unfortunately, we have no means of estimating  $f'$  and  $c'$ . They increase with the deflection and, thus, with the height of fill; but they can never exceed the limiting values  $f$  and  $c$ . It is not even tacitly assumed that the vertical sides of the prism are surfaces of rupture. The surfaces of rupture are unknown and would be of no use if they were known. It is only stated that the condition for equilibrium of this vertical prism is,  $KW = wbh - 2(f'E + c'h)$ .

Again, nothing is said of the distribution of  $KW$  upon the horizontal plane on which it acts. It is not uniformly distributed, but it is symmetrically placed as regards the top of the pipe. The simple theory used does not require a knowledge of how the transfer of load to the vertical sides is effected, nor what path it follows outside the prism; but if we imagine the prism over the pipe to be divided up into thin vertical prisms; then, in going from a vertical plane through the top of the pipe

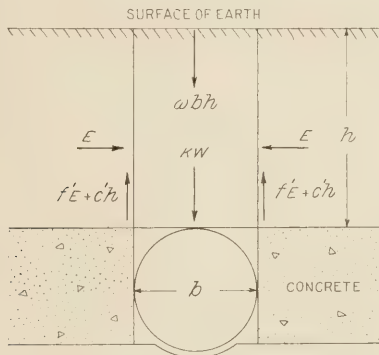

FIGURE 4.—SKETCH SHOWING PIPE RIGIDLY SUPPORTED WITH CONCRETE AT THE SIDES AND EARTH FILL ON TOP

toward the sides, each little prism transfers a part of its weight to the next prism through friction and cohesion and transfers, besides, the load transferred to it, so that the sides of the prism vertically over the pipe ultimately receive the total transfer, which amounts to  $2(f'E+c'h)$ . These general remarks are made to explain similar actions in other cases that follow.

VARIOUS CULVERT CONDITIONS ANALYZED

Let us now consider the cases shown in Figures 5, 6, and 7, where the pipe is entirely surrounded by earth. The supposed sliding along the planes  $BD, B'D'$  equals the difference in deflection,  $e-e'$ . In Figure 5, when  $h=0, e=0$  and the sliding of the earth to the right of  $BD$  is downward and in amount,  $e'-e=e'$ , and the coefficients of friction and cohesion are  $f', c'$ , corresponding; for, as proved by the experiments made in connection with Figure 1,  $f'$  and  $c'$  vary with  $e'-e$  or the amount of sliding.

Next, suppose  $h$  to increase from  $h=0$  to  $h=h'$  ( $h'$  represents height of fill where  $e'$  is equal to  $e$  as shown in Figure 6) and  $f'$  and  $c'$  are both zero, since now there is no sliding along  $BD$ . For the case of Figure 7, where  $h > h', e > e'$ , as  $h$  increases beyond the limit  $h', e-e'$  increases from zero and  $f'$  and  $c'$  increase from zero (at  $h=h'$ ) to the values  $f'$  and  $c'$ , corresponding

to the height,  $h$ , and the sliding,  $e-e'$ . The coefficients  $f', c'$ , can not exceed  $f, c$  (see Eq. 2), for which  $e-e'=0.35$  inch, as shown by experiments with the apparatus illustrated in Figure 1, since the sliding reached that amount just before continuous motion was attained when  $f'$  and  $c'$  attained their maximum values,  $f, c$ . Thus, as the height of fill increases, the values of  $f'$  and  $c'$  vary, passing through zero at  $h=h'$  and then increasing as  $h$  further increases, but rarely reaching the maxima  $f$  and  $c$ , since the sliding,  $e-e'=0.35$  inch is rarely attained for a culvert pipe.

The modified bin formula (5, p. 210) would apply to the case of Figure 8 if  $f'$  and  $c'$  were known, which is,

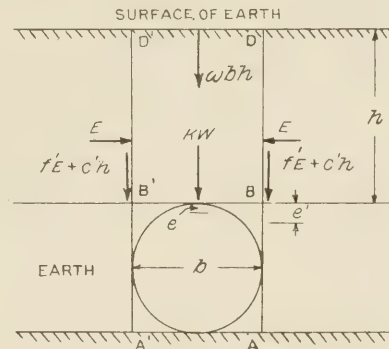

FIGURE 5.—CONDITION OF FILL WHERE  $h < h'$

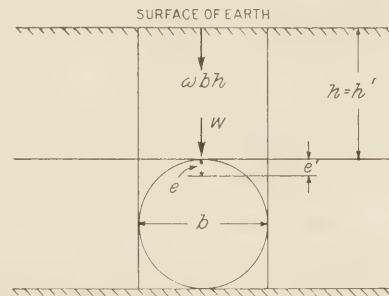

FIGURE 6.—CONDITION OF FILL WHERE  $h = h'$

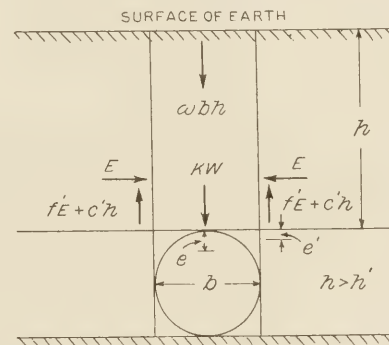

FIGURE 7.—CONDITION OF FILL WHERE  $h > h'$

unfortunately, not the case. This formula, for  $c=0$ , for a long pipe, reduces to,

$$Vb = \frac{wb^2}{2K'} \bar{f}' \left( 1 - e^{-\frac{2K'f'}{b}h} \right)$$

Where  $V$  = vertical unit pressure at top of pipe in pounds per square foot,  
 $b$  = mean diameter of pipe in feet,  
 $h$  = depth of fill over pipe in feet,  
 $w$  = weight of earth in pounds per cubic foot,  
 $f'$  = coefficient of friction actually exerted along  $BD, B'D'$  of Figure 7,

$k'$  = ratio of horizontal to vertical unit pressure,  
 $K$  is used as previously defined, and  
 $e = 2.71828$ , the Napierian base.

In the experiment on a smooth 30-inch iron pipe, thickness 0.109 inch, 100 per cent projection, for which  $w = 106$  pounds per cubic foot, on assuming  $k'f' = 0.13$ , this formulal reduces to,

$$\Gamma b = 2,550 \left( 1 - \frac{1}{e^{0.109h}} \right)$$

The results from this formula agree very well with those given by the weighing apparatus from  $h = h' = 2$  feet to  $h = 12$  feet.

For the bank sand,  $\phi = 42^\circ$ , therefore  $f' = \tan \phi = 0.900$  and  $k' = \frac{1 - \sin \phi}{1 + \sin \phi} = 0.2$ , by Rankine's formula; then  $k'f' = 0.18$  and the resulting formula does not agree with the experiments. The discrepancy was very much greater for a thick cast-iron pipe, where  $k'f'$  had to be assumed equal to 0.04 for the vertical pressures to agree with those given by the weighing apparatus. The mean diameter of the pipe was 30 inches, and its thickness 1 inch, so that its deflection was very small. Hence  $e - e'$  is very small and it should be expected

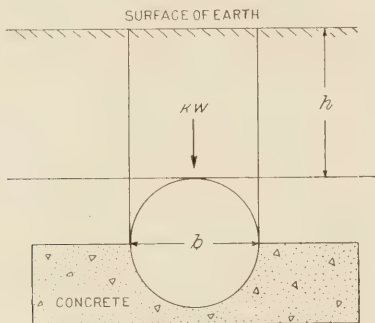

FIGURE 8.—DIAGRAM USED TO ILLUSTRATE EFFECT OF SIDE SUPPORT

that  $f'$  would be smaller than  $\tan \phi$ . Thus, if  $k'f' = 0.2f' = 0.04$ , then  $f' = 0.2$ , which is much less than the maximum value,  $\tan \phi = 0.9$ .

This is in agreement with the contention that  $f'$  can not be assumed equal to  $\tan \phi$ , but that it varies with the amount of sliding along the walls  $BD$ ,  $B'D'$ , and thus varies with  $h$ . Assuming  $f'$  to be constant in the formula, assuming an average value for the depth of fill considered, and the formula is not exact for any depth. For the cast-iron pipe, it was found from the results with the weighing apparatus that the depth of fill for which the vertical pressure on the top of the pipe was exactly equal to the weight of earth above it was 3 to 4 feet. Thus,  $h' = 3$  feet to 4 feet, for which depth,  $f' = 0$ .

When a thick cast-iron pipe or a solid plug was entirely buried, it was found that there was no limit to the value of  $h'$ , so that the case of Figure 5 was alone in evidence. In that case, for an assumed average  $f'$ , the sign of  $f'$  must be changed. The formula is easily written and reduced, but, as for the previous case ( $h > h'$ ), to apply it, the value of  $f'$  (or  $k'f'$ ) must be known. As this depends on the relative deflection,  $e' - e$ , it is unknown, and the formula is of little value for design.

In Figure 8, the pipe is supported on its lower half by concrete. In this case, for equal values of  $h$ , the value of  $e'$  should be about half the value shown in

Figure 5, since  $e'$  represents the compression of the column of earth from  $B$  to the concrete. As before, when  $e' > e$ , then  $KW > wbh$ . The support given the pipe by the concrete under it is advisable in practice to avoid breaking, particularly with an irregular foundation. If there is no concrete under the pipe, but vertical walls of concrete extend up to the mid-point, the case is similar to some of the 50 per cent projection, tests except that in the tests, the walls did not touch the pipe which was supported by columns and not by earth. For the case of Figure 8, where the pipe rests on a cradle of concrete; or, as in the experiments, where concrete walls only are used,  $h'$  must be greater than in the case of Figure 6, for since  $e' = e$ , the shorter column of earth from  $B$  to the concrete wall, will require a greater weight and therefore a greater  $h$  to compress it the same amount. But, as  $e$  increases with  $h$ , the  $h'$  for Figure 8 will be less than double that for Figure 6.

Figure 7 represents a most important case, where  $h > h'$  and consequently  $e > e'$ . Therefore the prism of earth vertically over the pipe sinks more than the earth outside of this prism, hence part of the weight of this prism is transferred outside, the reasoning being precisely that pertaining to Figure 4 and,

$$KW = wbh - 2(f'E + c'h)$$

The load actually on the top of the pipe,  $KW$ , is less than the weight of earth,  $wbh$ , vertically over it. The values of  $f'$  and  $c'$  vary with the height  $h$ . Thus their values, from certain finite values when  $h$  is small, diminish to zero for  $h = h'$  and then increase with  $h$ .

There are many cases recorded of broken pipes, but it has been stated that a corrugated pipe under a 40-foot fill, although badly deformed, yet preserved a channel for the water. Evidently, nearly all the weight of earth over the pipe was transferred to the sides. This theory shows that it is advisable in practice either to build walls of concrete or compacted gravel on either side of a pipe culvert and touching it, or, at least, to compact the earth very thoroughly on either side and under the pipe.

**THEORETICAL CONCLUSIONS SUPPORTED BY EXPERIMENTAL DATA**

The theory for arch culverts is very similar to that for pipes,  $e'$  being the compression of a vertical column of earth just outside the arch reaching from the top of the abutment to the level of the upper side of the crown and  $e$  being the deflection of the crown. Then, as for the pipe, according as  $h < h'$ ,  $h = h'$ ,  $h > h'$ , we shall have  $KW > wbh$ ,  $KW = wbh$ ,  $KW < wbh$ , respectively, where  $b$  is the span of the extrados and  $KW$  is the actual vertical load transmitted to the horizontal plane of width  $b$  passing through the highest point of the extrados. With our present knowledge,  $h'$  can only be found by experiment.

The above conception of the interaction of pipe culverts and fills is sustained by the experiments with sand filling conducted at Chapel Hill, N. C., in 1924-1927.

As the sand in the interior of the fill must necessarily have been compressed by the weight of the material above it, it must weigh more per cubic foot than originally; or  $w$  is somewhat greater than was assumed for the well shaken sand. If this correction could be made, the effect would be to diminish  $h'$  and the line representing the weights of earth vertically above the pipe would more nearly coincide with the curve of vertical pressures on the pipe up to  $h = h'$ .

In the experiments, the weights recorded on the scales included the weight of earth over the pipe up to the level of the crown. This weight was subtracted to obtain  $KW$ , the actual vertical pressure on the plane through the top of the pipe,  $b$  feet wide. Then the experiments proved, as theory indicates, that for

$$\begin{aligned} h < h', & KW > wbh, K > 1, \\ h = h', & KW = wbh, K = 1, \\ h > h', & KW < wbh, K < 1. \end{aligned}$$

For the clay filling the weights per cubic foot were roughly the same for a cube of the earth cut from the

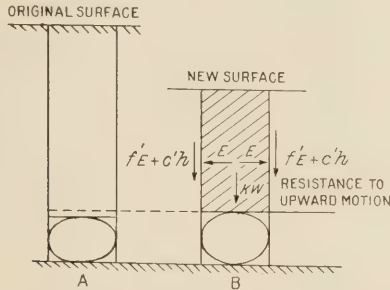

FIGURE 9.—DIAGRAM USED IN DISCUSSING PRESSURE ON PIPE DURING PLACING AND REMOVAL OF FILL

top of the rolled fill as for the earth when the fill had been removed to any level. The clay recovered its original shape. In fact, as a heavy road roller passed over it, the clay was seen to sink an inch or more and then rise to its original level. Of course, for any fill, the weight per cubic foot in the interior is greater than at the surface after rolling, on account of the compression, but this is not shown by the weighing of a cube of earth cut out at the level to which the fill was removed, on account of the recovery of shape. The trench condition called for placing the pipe in a trench about 3.5 feet wide and extending 4.15 feet above the top of the pipe and then filling in with loose earth and completing the fill as usual. The pressures are less than before because of the increased sinking of the earth over the pipe, causing rubbing along vertical planes, so that much of the weight of the earth vertically over the pipe is transferred by friction and cohesion to the sides.

When both sand and clay fill was being removed, the vertical pressures recorded on the scales was greater than when the fill was being raised for any given height. To explain this, suppose the distorted pipe in Figure 9A not to have its elasticity impaired; then as earth is removed (fig. 9B), the pipe will tend to recover its form. To effect this, the pipe will have to push up the (shaded) mass of earth vertically over it; but this is resisted, not only by the weight of this mass, but also by the resistance to upward motion,  $2(Ef' + c'h)$ , along its sides due to friction and cohesion, which always oppose the motion. It is plain now that an increase in the vertical pressure on the pipe, for the same  $h$ , in lowering the fill over that in raising it, could have been predicted.

All of the preceding results show that the deflection of the pipe is a leading factor in the theory of the vertical pressure actually exerted on the pipe. Its influence should be more pronounced the thinner the pipe. The simple theory advanced has a practical value in showing that the case of Figure 7 is the least advantageous one in that there is less of the weight of the earth over the

pipe transferred to the sides than for the cases illustrated by Figures 4 and 8. At least  $90^\circ$  of the circumference of any pipe should bear on the ground or on concrete, and any earth under it or on its sides should be well tamped. The conditions shown in Figure 8 are very favorable, particularly if the side walls are carried up as high as the pipe.

For sewer trenches cut out of consolidated ground, a working space on either side of the pipe will necessarily have to be allowed; but, otherwise, the trench should be as narrow as possible. Thus, in Figure 7, let the vertical planes tangent to the pipe represent the sides of the trench in consolidated ground; then, since  $e'$  is the deflection of the hard ground, caused only by the part of the weight of the loose earth filled in over the pipe that is transferred to the sides,  $e'$  is practically zero, and the weight transferred is a maximum. But, as the width of the trench increases,  $e'$  will increase, since, now, it represents the deflection of loose earth; the weight transferred will decrease (by the preceding theory) and thus, the load actually carried by the pipe increases. It is thus highly desirable in practice to make the trench as narrow as a proper working space will allow and to have its sides vertical.

## APPENDIX II

### STRESSES AND DEFLECTIONS OF PIPE CULVERTS

By WILLIAM CAIN, Professor Emeritus of Mathematics, University of North Carolina

The pressure cell readings give pressures over a small area and not average values over a much larger area; they are sometimes erratic; still they give information of great value. Thus, although  $a_1$ , the unit load at the crown of the pipe as determined by cell 4 reading (fig. 1), exceeds  $Kwh$ , as given by the weighing machine by from 0 to 50 per cent for the various pipes tested, nevertheless the variation in lateral stress on a vertical plane is clearly indicated by cell readings 1 and 7, 2 and 6, 3 and 5;  $a_2$ , the unit lateral stress diminishing in going up or down from the ends of the horizontal diameter somewhat as represented in the diagram.

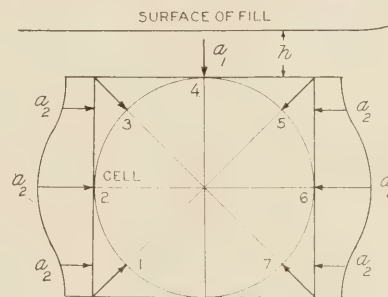

FIGURE 1.—DISTRIBUTION OF HORIZONTAL PRESSURE ON SIDE OF PIPE

As a cell reading gives the normal component in pounds per square inch, let  $n$  equal this normal component at cell 3, then to find  $a_2$  consider the right prism of earth ABC of Figure 2, with a length of 1 inch perpendicular to the plane of the drawing and the sides AB and BC 1 inch in length. Then  $AC = \sqrt{2}$  inches. The prism is considered as having no weight (to correspond to infinitesimal dimensions). Resolving the three forces in equilibrium perpendicular to AC, we have,

$(a_1 + a_2) \cos 45^\circ = n\sqrt{2}$ , since  $\cos 45^\circ = \frac{1}{\sqrt{2}}$ , we have

$$a_2 = 2n - a_1 \tag{1}^1$$

The component of the stress on AC acting parallel to AC is carried by the friction of earth on cell. At the level of cells 3 or 5, the value of  $a_1$  was taken as the reading of cell 4 approximately.

The same formula for  $a_2$ , the unit pressure on a vertical plane applies to readings of cells 1 and 7. However, if we use the full vertical pressure at this depth for the value of  $a_1$ , the value of  $a_2$  is negative in half the cases. It is then certain that this full value of  $a_1$  is never exerted over this lower part of the pipe.

In view of the uncertainties,  $a_2$  was assumed to vary somewhat as in Figure 1, though for ease of computation, the forces acting on the pipe are taken as in Figure 3. Here, for brevity,  $w' = Kw$ ,  $a = \cos \phi_1$ ,  $ON = ra$ . Then, the vertical unit load,  $Kwh = w'h$ , acts on the pipe from B to A and the vertical reaction acts on the pipe from A to J, though both are drawn as if acting on horizontal planes. Similarly, the average lateral

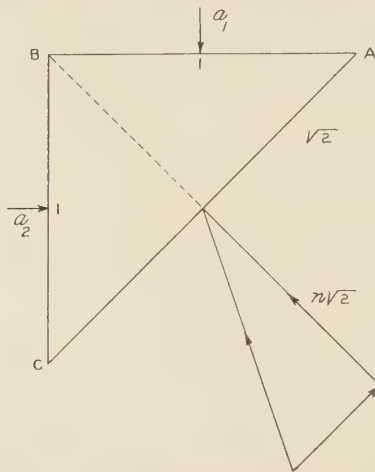

FIGURE 2.—PRESSURES ON ELEMENTARY PRISM OF FILL

thrust,  $q'Kwh = qw'h$ , acts along the pipe from I to J, though drawn as if acting on a vertical plane.

No lateral stress is assumed to act on BI or JD. When  $\phi_1 = \text{BOI} = \text{DOJ}$  is less than  $30^\circ$ , the error is small for IB and negligible for JD, under which the earth is not well tamped, so that on JD, there is very little horizontal or vertical pressure.

In the formulas to be derived for thin circular pipes of 1-inch length let,

- $r$  = mean radius in inches,
- $b = 2r$  = mean diameter in inches,
- $t$  = thickness of pipe in inches,
- $I = \frac{1}{12}bt^3$  = moment of inertia of a normal section of a pipe about its neutral axis,
- $h$  = height in inches from top of pipe to surface of fill,
- $w$  = weight in pounds per cubic inch of earth fill,
- $K$  = ratio of weight of earth actually sustained by the upper half of pipe to the weight of earth vertically over it,
- $w' = Kw$ , so that the actual vertical load on pipe, assumed uniformly distributed on a horizontal plane through the top of the pipe, is,  $Kwh = w'h$  per square inch,

$q$  = ratio of lateral load to vertical load, hence,  
 $qw'h$  = horizontal load in pounds per square inch on a vertical plane,

$E$  = modulus of elasticity of pipe in pounds per square inch,

The loads being symmetrical with respect to the vertical diameter, the thrusts  $R_1$  and  $R_2$  at B and D are horizontal.

$M_B$ ,  $M_C$ , and  $M_D$  represent moments at B, C, and D, counter clockwise moments being taken as positive.

The moment of  $R_1$  about C =  $R_1 \times \text{BF} = R_1 (r - r \cos \phi)$ , which is likewise the moment about C' =  $R_1 \times \text{BE}$ , if  $\phi = \text{BOC}'$ ; for then,  $(r - r \cos \phi) = \text{BO} + \text{OE}$ , since  $\phi$  is now an obtuse angle.

The moment of the vertical load about C is,

$-w'h \times \text{CF} \times \frac{1}{2}\text{CF} = -w'h \times r \sin \phi \times \frac{1}{2}r \sin \phi = -\frac{1}{2}w'hr^2 \sin^2 \phi$ . For C' the load on BAC' is that on BA minus the reaction on AC'. As the latter balances the load on CA, the moment about C' is the same as that about C or  $-\frac{1}{2}w'hr^2 \sin^2 \phi$  (clockwise and therefore negative). For any point C'' on JD, where  $\phi = \text{BOC}''$ , the vertical load on BAC'' equals the vertical load on BI, since the reaction on AJ balances the load on AI. The load on BI =  $w'hr \sin \phi$  and its lever arm about C'' is  $(\frac{1}{2}r \sin \phi_1 - r \sin \phi)$ , so that its moment about C'' is,  $w'hr^2 \sin \phi_1 (\frac{1}{2} \sin \phi_1 - \sin \phi)$ . This gives a positive or counter-clockwise moment when C'' is to the right of the vertical through the center of gravity of the load on BI and a negative moment when C'' is to the left of this vertical, as should be the case.

For the lateral forces; the load on BIC =  $qw'h (r \cos \phi_1 - r \cos \phi)$ , and its lever arm about C is,  $\frac{1}{2}(r \cos \phi_1 - r \cos \phi)$ , so that its moment about C is  $-\frac{1}{2}qw'hr^2$

$(a - \cos \phi)^2$ , on substituting for brevity  $a = \cos \phi_1$ . When  $\phi = \text{BOC}'$ , the same formula applies, since  $(r \cos \phi_1 - r \cos \phi) = \text{NO} + \text{OE} = \text{NE}$ . For a point C'' on JD ( $\phi = \text{BOC}''$ ), the lateral load on BAC'' is the total,  $qw'h$ .  $\text{GN} = 2qw'hr \cos \phi_1$ , and its lever arm is  $\text{OK} = r \cos \phi$ , giving a moment about C'',  $2qw'har^2 \cos \phi$ , which is negative since  $\cos \phi$  is negative.

In summing the moments for the entire arc BAD, the limits of the integrations must be carefully attended to. The sum is,

$$\int_0^\pi M d\phi = \int_0^\pi M_B d\phi + \int_0^\pi R_1 r (1 - \cos \phi) d\phi - \int_0^{\pi-\phi_1} \frac{1}{2} w'hr^2 \sin^2 \phi d\phi + \int_{\pi-\phi_1}^\pi w'hr^2 \sin \phi_1 \left( \frac{1}{2} \sin \phi_1 - \sin \phi \right) d\phi - \int_{\phi_1}^{\pi-\phi_1} \frac{1}{2} qw'hr^2 (a^2 - 2a \cos \phi + \cos^2 \phi) d\phi + \int_{\pi-\phi_1}^\pi 2 qw'ahr^2 \cos \phi d\phi \tag{2}$$

This expression, which is proportional to the relative rotation of the cross sections of the pipe at B and D is zero, since these sections, on account of symmetry about a vertical diameter, remain vertical.

Thus,  $\int_0^\pi M d\phi = 0$

<sup>1</sup> This same formula is a special case of the general formula 31, p. 83 of Cain's Earth Pressure Walls and Bins.

Further, the horizontal displacement of B as to D is zero. In the displacement theory (see any book on arch theory) the origin is always taken at the end supposed free and the moment at each point, C, C' or C'', is multiplied by the ordinate at that point perpendicular to the supposed displacement. Thus, if D is regarded as the fixed end and B as the free end, the ordinate in question is the vertical distance from B to C (or C' or C''),  $r(1 - \cos \phi)$ ; and the theory gives the displacement of B relative to D as,

$$\frac{1}{EI} \int_0^\pi Mr(1 - \cos \phi) ds = \frac{r^2}{EI} \int_0^\pi M(1 - \cos \phi) d\phi = 0,$$

since,  $ds = d(r\phi) = rd\phi$ .

Since,  $\int_0^\pi M d\phi = 0$ , this reduces to

$$\int_0^\pi M \cos \phi d\phi = 0 \dots\dots\dots (3)$$

Similarly, the horizontal displacement of B as to A, regarded as fixed, is

$$\frac{r^2}{EI} \int_0^{\frac{\pi}{2}} M \cos \phi d\phi \dots\dots\dots (4)$$

Lastly, by the same rule, the decrease of the vertical diameter is,

$$e_E = - \frac{r^2}{EI} \int_0^\pi M \sin \phi d\phi \dots\dots\dots (5)$$

We now proceed to integrate Equation 2, placed equal to zero, giving:

$$\begin{aligned} \pi M_B + R_1 r \left[ \phi - \sin \phi \right]_0^{\pi} - \frac{1}{2} w' hr^2 \left[ \frac{\phi}{2} - \frac{1}{4} \sin 2\phi \right]_0^{\pi - \phi_1} \\ + w' hr^2 \sin \phi_1 \left[ \frac{\sin \phi_1}{2} \phi + \cos \phi \right]_{\pi - \phi_1}^{\pi} \\ - \frac{1}{2} qw' hr^2 \left[ a^2 \phi - 2a \sin \phi + \frac{\phi}{2} + \frac{1}{4} \sin 2\phi \right]_{\phi_1}^{\pi - \phi_1} \\ + 2qw' hr^2 \cos \phi_1 \left[ \sin \phi \right]_{\pi - \phi_1}^{\pi} = 0. \end{aligned}$$

On reducing, noting that  $\sin(\pi - \phi) = \sin \phi_1$ ,  $\cos(\pi - \phi_1) = -\cos \phi_1$ ,  $\sin(2\pi - 2\phi_1) = -\sin 2\phi_1$ ,  $2\sin \phi_1 \cos \phi_1 = \sin 2\phi_1$ . we find,

$$\begin{aligned} \pi M_B + R_1 r \pi + w' hr^2 \left[ -\frac{\pi}{4} + \frac{\phi}{4} (1 + 2 \sin^2 \phi_1) + \frac{3}{8} \sin^2 \phi_1 \right. \\ \left. - \sin \phi_1 - qw' hr^2 \left[ \left( a^2 + \frac{1}{2} \right) \frac{\pi - 2\phi_1}{2} + \frac{3}{4} \sin 2\phi_1 \right] \right] = 0 \dots (6) \end{aligned}$$

Next, to evaluate equation 3, multiply each term to the right of the integral sign in equation 2 by  $\cos \phi$ , integrate, and place the sum = 0.

$$\begin{aligned} \left[ M_B \sin \phi + R_1 r \left( \sin \phi - \frac{\phi}{2} - \frac{1}{4} \sin 2\phi \right) \right]_0^{\pi} - \left[ 1/6 w' hr^2 \sin^3 \phi \right]_{\pi - \phi_1}^{\pi} + w' hr^2 \sin \phi_1 \left[ \frac{1}{2} \sin \phi_1 \sin \phi - \frac{1}{2} \sin^2 \phi \right]_{\pi - \phi_1}^{\pi} \\ - 1/2 qw' hr^2 \left[ a^2 \sin \phi - a \left( \phi + \frac{\sin 2\phi}{2} \right) + 1/3 \sin \phi \left( 2 + \cos^2 \phi \right) \right]_{\phi_1}^{\pi - \phi_1} + 2qw' hr^2 a \left[ \frac{\phi}{2} + \frac{\sin 2\phi}{4} \right]_{\pi - \phi_1}^{\pi} = 0. \end{aligned}$$

$$\therefore -R_1 r \frac{\pi}{2} - 1/6 w' hr^2 \sin^3 \phi_1 + qw' hr^2 a \frac{\pi}{2} = 0$$

$$\therefore R_1 = w' hr \left[ -\frac{\sin^3 \phi_1}{3\pi} + qa \right] \dots\dots\dots (7)$$

On substituting this value of  $R_1$  in equation 6 and reducing, we derive

$$\begin{aligned} \pi M_B = w' hr^2 \left[ 1/3 \sin^3 \phi_1 + \sin \phi_1 + \frac{\pi}{4} - \frac{\phi_1}{4} (1 + 2 \sin^2 \phi_1) \right. \\ \left. - \frac{3}{8} \sin 2\phi_1 \right] - qw' hr^2 \left[ a\pi - \frac{\pi - 2\phi_1}{2} \left( a^2 + \frac{1}{2} \right) - 3/4 \sin 2\phi_1 \right] \dots\dots\dots (8) \end{aligned}$$

As a check, place  $\phi_1 = 0$ ,  $a = \cos \phi_1 = 1$ , then equations 7 and 8 reduce to well-known formulas.

Also for  $\phi_1 = \frac{\pi}{2}$ ,  $a = 0$  and equations 7 and 8 agree with an independent solution for no lateral load.

But the most complete check was obtained by verifying the relation

$$\int_0^{\frac{\pi}{2}} M \cos \phi d\phi + \int_{\frac{\pi}{2}}^{\pi} M \cos \phi d\phi = \int_0^{\pi} M \cos \phi d\phi = 0$$

by actually integrating between the limits indicated the first two terms and proving that this sum is equal to zero.

The increase in the horizontal diameter by equation 4 is

$$\Delta X = \frac{2r^2}{EI} \int_0^{\frac{\pi}{2}} M \cos \phi d\phi$$

which is also equal to

$$- \frac{2r^2}{EI} \int_{\frac{\pi}{2}}^{\pi} M \cos \phi d\phi,$$

as just seen,

$$\begin{aligned} \Delta X = \frac{2r^2}{EI} \left[ \int_0^{\frac{\pi}{2}} \left[ M_B \cos \phi + R_1 r (\cos \phi - \cos^2 \phi) \right] d\phi - \frac{1}{2} \right. \\ \left. w' hr^2 \int_0^{\frac{\pi}{2}} \sin^2 \phi \cos \phi d\phi - \frac{1}{2} qw' hr^2 \int_{\phi_1}^{\frac{\pi}{2}} \left[ a^2 \cos \phi \right. \right. \\ \left. \left. - 2a \cos^2 \phi + \cos^3 \phi \right] d\phi \right] \end{aligned}$$

The general integrals of these terms have already been given, so that it is readily verified that

$$\begin{aligned} \Delta X = \frac{2r^2}{EI} \left[ M_B + 0.215 R_1 r - 0.167 w' hr^2 - qw' hr^2 \left[ \frac{a^2}{2} - \frac{a\pi}{4} \right. \right. \\ \left. \left. + 1/3 + \frac{a\phi_1}{2} + \frac{1}{4} a \sin 2\phi_1 - \frac{1}{2} \sin \phi_1 (a^2 + 2/3 \right. \right. \\ \left. \left. + 1/3 \cos^2 \phi_1) \right] \right] \dots\dots\dots (9) \end{aligned}$$

We have, finally, to derive a general formula for vertical deflection, or decrease in vertical diameter, by effecting the integrations of equation 5,

$$e_E = - \frac{r^2}{EI} \int_0^{\pi} M \sin \phi d\phi.$$

The separate terms in equation 2 were each multiplied by  $\sin \phi$  to the right of the integral signs; then, integrating,





plane at the level of cell 2 is,  $\frac{h+r}{h}$  (cell 4 reading)

$$\therefore \text{average } q = 0.75 \frac{(\text{cell 2 reading})}{\frac{h+r}{h}(\text{cell 4 reading})}$$

Thus, for  $h=120$  inches,  $r=15$  inches,

$$\text{Average } q = \frac{2}{3} \frac{\text{cell 2 reading}}{\text{cell 4 reading}}$$

The weight of the sand used in the fill is 107 pounds per cubic foot

$$\therefore w = 0.0615 \text{ pounds per cubic inch.}$$

The height of fill above the pipe was taken as 10 feet;

$$\therefore h = 120 \text{ inches and } wh = 7.38,$$

$$b = \text{mean diameter of pipe in inches, } W = whb,$$

$$t = \text{thickness of pipe in inches; } I = \frac{1}{12}bt^3.$$

It was assumed that—

$E = 27,000,000$  pounds per square inch for iron;

$E = 30,000,000$  pounds per square inch for steel;

$E = 10,000,000$  pounds per square inch for cast iron.

The results are given in Table 1.

There was a firm belief with the experimenters that the earth as placed under the pipe gave practically no bearing or reaction for perhaps  $30^\circ$  to  $40^\circ$  on either side. Hence the assumption,  $\phi_1 = 30^\circ$ , which, it is seen from Table 1, gives nearly equal values of  $q$ , whether it is computed from Equation 13, using the experimental  $\Delta X$ , or from Equation 14 with the experimental  $e_E$ . The use of Equation 11 gives practically consistent results also (see columns 10 and 11) which differ only by 4 to 6 per cent from those given in columns 7 and 9 of Table 1.

In discussing the results, let us assume for simplicity,  $\phi_1 = 0$ , or the distribution of forces as shown in Figure 4. Then, up to some height of fill, corresponding to a very small deflection of the pipe, only active horizontal earth thrust is exerted. If we assume for the sand fill with 5 per cent moisture an internal angle of friction <sup>3</sup> of  $\phi = 42^\circ$ , the ratio of lateral to vertical unit pressure, by Rankine's formula is,

$$q = \frac{1 - \sin \phi}{1 + \sin \phi} = 0.2.$$

<sup>3</sup> The symbol,  $\phi$ , has been used in connection with polar coordinates of Figure 3. It is used here as the customary symbol for angle of internal friction.

TABLE 1.—Comparison of calculated and measured values of  $q$  for 10-foot fill and  $\phi_1$  equals  $30^\circ$  in equations 13 and 14, and  $\phi_1$  equals 0 in Equation 11

| Kind of pipe                         | Diameter | Thickness | $K$  | $\frac{KWb^3}{96EI}$ | Experimental $\Delta x$ | $q$ by Equation 13 | Experimental $e_E$ | $q$ by Equation 14 | $q$ from Equation 11 |                 | Average $q$ from cells |
|--------------------------------------|----------|-----------|------|----------------------|-------------------------|--------------------|--------------------|--------------------|----------------------|-----------------|------------------------|
|                                      |          |           |      |                      |                         |                    |                    |                    | By aid of $\Delta X$ | By aid of $e_E$ |                        |
| 1                                    | 2        | 3         | 4    | 5                    | 6                       | 7                  | 8                  | 9                  | 10                   | 11              | 12                     |
|                                      | Inches   | Inch      |      |                      |                         |                    |                    |                    |                      |                 |                        |
| Steel tube, first test <sup>1</sup>  | 30       | 0.349     | 0.76 | 0.446                | 0.149                   | 0.71               | 0.172              | 0.67               | 0.67                 | 0.61            | 0.43                   |
| Steel tube, second test <sup>1</sup> | 30       | .349      | 1.00 | .586                 | .259                    | .60                | .267               | .60                | .56                  | .54             | .90                    |
| Smooth iron <sup>1</sup>             | 30       | .109      | .62  | 13.20                | .569                    | 1.00               | .751               | 1.00               | .96                  | .94             | .81                    |
| Smooth iron <sup>1</sup>             | 20       | .076      | .58  | 7.22                 | .424                    | .98                | .477               | .99                | .94                  | .93             | .98                    |
| Cast iron                            | 30       | 1.00      | 1.29 | .096                 | .082                    | .18                | .088               | .14                | .14                  | .08             | .17                    |

<sup>1</sup> In the University of Illinois Bulletin No. 22, April 28, 1908, the results of tests of cast iron are given. The modulus of elasticity of strips, 2 by 24 inches, cut out of cast-iron pipes and tested in cross-breaking, varied from 9,900,000 to 14,500,000 pounds per square inch; but when the pipe itself was subjected to a concentrated load and the exact formula for deflection was used,  $E$  varied from 6,500,000 to 14,300,000, averaging 10,000,000 pounds per square inch. The latter value especially applies here.

Now, as the height of fill increases, the experiments show that the vertical diameter decreases and the horizontal diameter increases, so that for a little less than  $45^\circ$  above and below the ends of the horizontal diameter, the sides of the pipe spread horizontally and thus cause a horizontal passive resistance or reaction of the earth, which increases with the deflection. But when the intensity of this horizontal reaction is equal to the intensity of the vertical load on the pipe, or  $q=1$ , then from Figure 4, we have liquid pressure, so that there are no bending moments in the pipe and no deflection except that due to the tangential stress which causes a decrease in diameter of  $2 \frac{Kwhr^2}{Et}$ , which is very small and negligible. Thus, we have the inconsistency that

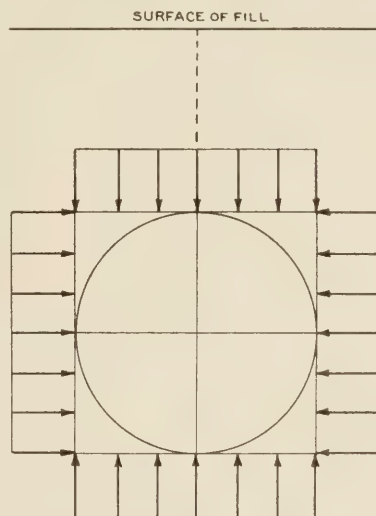

FIGURE 4.—EQUAL DISTRIBUTION OF PRESSURE ON PIPE IN FOUR DIRECTIONS

when  $q=1$ , theory gives only a minute deflection, absolutely negligible, whereas experiment records a large deflection both vertically and horizontally. The explanation is simple.

The theory treats the passive resistances as if they were active forces, always in contact with the pipe, and following up any inward movement, and that the vertical loads on the pipe remain the same, so that as  $q$  approaches 1, the sides move inward and the top rises, and when  $q=1$ , the pipe returns to its original position; whereas the passive resistances are caused entirely by the lowering of the crown and the spreading of the sides, and since the earth is imperfectly

elastic, there can be but little inward motion of the earth, so that the passive earth resistance does not (and can not) act as if it was an active thrust to restore the pipe to its original circular form; besides the supposed rise at the crown would be resisted not only by  $KW$ , but, in addition, by the friction and cohesion acting along the sides of the vertical prism of earth directly over the pipe which always act opposed to the motion.

All the formulas for moments, thrusts and deflections are correct for  $q$  less than some unknown value,  $q_1$ , corresponding to a maximum deflection. For  $q > q_1$ , all the formulas are inapplicable, since, as we

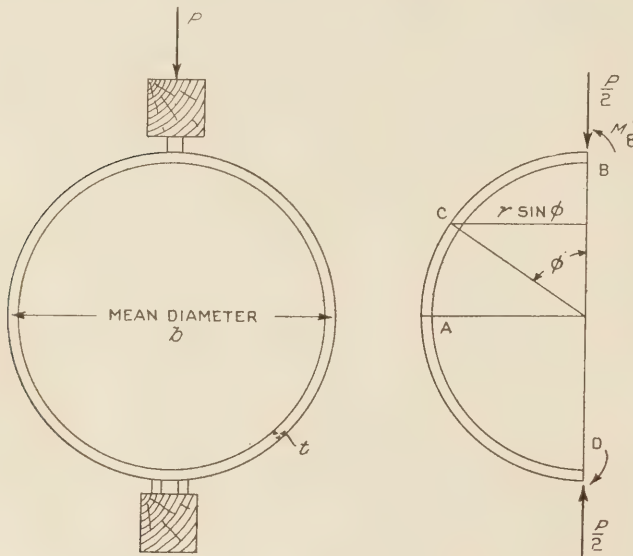

FIGURE 5.—FORCES ACTING ON PIPE IN 3-POINT METHOD OF TESTING

have seen, this involves a rise of the crown of the pipe, which is impossible.

To clarify ideas, let us assume, as  $h$  increases, that  $K$  remains constant, but that  $q$  varies with  $h$  according to the parabolic law,  $q^2 = ch$ . Then, putting,  $\frac{KWb^4}{96EI} = A$ , a constant, we can write for the deflection,

$$e_E = Ah(1 - q) = A(h - \sqrt{c}h^{\frac{3}{2}}).$$

This is a maximum when  $\frac{de_E}{dh} = 0$ , or, when,

$$1 - \frac{3}{2}\sqrt{ch} = 0, \therefore 1 - \frac{3}{2}q_1 = 0, \text{ or, } q_1 = \frac{2}{3}.$$

This is a plausible law of variation and value of  $q_1$ , but it is only roughly approximate.

A linear variation,  $q = ah$ , would lead to  $q_1 = \frac{1}{2}$ . The first law seems more probable, and until more definite information is attainable, it may be assumed that when  $q$  is less than 0.67, that all the formulas are correct (for the hypothesis), but that when  $q$  is greater than 0.67, they are inapplicable.

However, as in all cases of a maximum, the results vary very little near the maximum value, perhaps the limit  $q$ , can be extended to, say, 0.7. Such a limit would rule out the computations of Table 1 for both the "smooth iron" pipes for which values of  $q$  equal to 1 were derived. These should be ruled out likewise because the limit of elasticity has been considerably

exceeded, and, in fact, the breaking point nearly reached, as computation shows,  $q$  can not be greater than 1, for it entails the absurdity that a passive resistance should exceed the weight which produces it and actually overcome this weight and cause the top of the pipe to rise higher than its original circular position.

A preferable method for finding  $q$  is to compare the deflection  $e_p$  for a pipe under a single load  $P$  (fig. 5), using the three point laboratory method, with the deflection after the pipe is placed in the fill.

In Figure 5, the moment at any point C is,

$$M = M_E - \frac{P}{2} r \sin \phi.$$

Since, from symmetry, the sections at A and B do not rotate,

$$\int_0^{\pi/2} M d\phi = 0; \text{ giving}$$

$$M_B = \frac{Pr}{\pi} = 0.318 Pr \text{----- (15)}$$

The decrease in vertical diameter, by Equation 5, is

$$e_p = -\frac{2r^2}{EI} \int_0^{\pi/2} M \sin \phi d\phi = -\frac{2r^2}{EI} \int_0^{\pi/2} \left( M_B - \frac{P}{2} r \sin \phi \right) \sin \phi d\phi = +\frac{2r^2}{EI} \left[ M_B \int_0^{\pi/2} \cos \phi d\phi + \frac{Pr}{2} \int_0^{\pi/2} \left( \frac{\phi}{2} - \frac{\sin 2\phi}{4} \right) d\phi \right]$$

$$\therefore e_p = \frac{2r^2}{EI} \left[ -M_B + \frac{Pr\pi}{8} \right] = 0.150 \frac{Pr^3}{EI} = \frac{0.150}{8} \frac{Pb^3}{EI} \text{----- (16)}$$

On dividing Equation 14 by this equation and solving

$$(1.06 - q) = \frac{e_E}{e_p} \frac{1.8}{K} \frac{P}{W} \text{----- (17)}$$

Thus,  $E$ ,  $I$ , and  $b$  have been eliminated, so that a value of  $q$  computed from this equation should prove more accurate than one as estimated by the previous method. The results, by use of this formula, gave almost exactly the values of  $q$  of the table for the various tests on the "steel tube," though the stress-strain curve was somewhat curved. For the 30-inch cast iron pipe, 1 inch thick, the derived value of  $q$  was  $-0.05$ . This impossible negative value is perhaps partly due to the very small deflection, but mainly to the fact that the tube was not circular, the inner diameter varying in various directions from 29.716 inches to 29.792 inches.

On solving Equation 17 for  $KW$ , there is found,

$$KW = \frac{e_E}{e_p} \frac{1.8P}{1.06 - q} \text{----- (17 A)}$$

When  $q$  and the ratio,  $\frac{e_E}{e_p}$ , are known, this formula enables one to compute  $KW$ , or the vertical load actually sustained by the pipe. For small deflections of the pipe, only active horizontal earth thrust is exerted. Thus, if Rankine's formula is used, for  $\phi = 42^\circ$ , then  $q = 0.2$ . For large deflections, passive resistance is experienced and  $q$  is increased.

UNIT STRESS DISCUSSED

Let us assume compression positive, tension negative; then, if  $P$  is the tangential stress on a certain section of the pipe, 1 inch long, and  $M$  is the bending moment where the neutral axis crosses it, then the usual formula for the unit stress at the extrados or the intrados is,

$$f = \frac{P}{t} \pm \frac{6M}{t^2} \dots\dots\dots (18)$$

Since  $M$  has been assumed positive when counter clockwise, the upper sign will refer to the extrados, the lower to the intrados. When all dimensions are given in pounds, the stresses are in pounds per square inch.

Usually, the first term ( $\frac{P}{t}$ ) can be neglected in comparison with the second, or that due to bending stress. The latter will be tension at the intrados at B and D (fig. 3), but tension at the extrados at section A. The values of  $M_B$ ,  $M_D$ ,  $M_A$ , are given in Equation 12, which may be utilized to find the height of fill corresponding to a given stress,  $f$  pounds per square inch, for a given pipe. Thus the unit stress at the bottom of the pipe is,

$$f = \frac{6M_D}{t^2} = \left[ 0.356 - 0.242q \right] 6Kwh \frac{1}{(t/r)^2} \dots\dots (19)$$

The bank sand constituting the fill varied in its properties according to the amount of moisture and the degree of tamping, but when moderately tamped, the earth containing 5 per cent moisture, there was found  $\phi = 45^\circ$ ,  $c = 10$  to 20 pounds per square foot. For the clay filling with 21 per cent moisture,  $\phi = 41^\circ$ ,  $c = 225$  pounds per square foot.

The value of  $K$  can only be obtained by experiment for a particular earth, but for the bank sand used, a good idea of its variation can be had by comparing values of  $\frac{t}{r}$  and  $K$  as given in Table 2.

A graph showing these values of  $K$  plotted against the corresponding values of  $(t/r)$  will enable a safer judgment to be made in case  $K$  for a new earth has to be estimated.

As to the values of  $q$  to assume, the only reliable ones, as given in Table 1, are those pertaining to the steel tube,  $q = 0.60$ ,  $q = 0.71$ . These happen to lie near the supposed maximum, 0.67; so that the value  $q = 0.67$  will be used in the last formula.

TABLE 2.—Comparison of values of  $\frac{t}{r}$  and  $K$  for a 10-foot fill

| Kind of pipe     | Diameter |       | $\frac{t}{r}$ | $K$  |
|------------------|----------|-------|---------------|------|
|                  | Inches   | Inch  |               |      |
| Smooth iron..... | 30       | 0.109 | 0.0073        | 0.62 |
| Smooth iron..... | 20       | .076  | .0076         | .58  |
| Steel tube.....  | 30       | .349  | .0233         | .88  |
| Cast iron.....   | 30       | 1.000 | .0667         | 1.29 |
| Solid plug.....  | 30       | ..... | .....         | 1.67 |
| Solid plug.....  | 20       | ..... | .....         | 1.37 |

For a steel pipe, assume a safe stress of  $f = 20,000$  pounds per square inch.

For the sand fill, as before,  $w = 0.0615$  pounds per cubic inch.

$H =$  height of fill in feet  $\therefore h = 12 H$ .

Equation 19 reduces to,

$$H = \frac{23,300 t^2}{K r^2} \dots\dots\dots (20)$$

Thus, for  $K = 1$ ,  $t = 0.5$  inch,  $r = 15$  inches,  $H = 25.9$  feet.

For the steel tube,  $K = 0.88$ ,  $t = 0.349$  inch,  $r = 15$  inches.

Whence  $H = 14.3$  feet is the height of fill giving the stress in the pipe of 20,000 pounds per square inch.

For the clay filling used in some of the earlier experiments, weighing 120 pounds per cubic foot ( $w = 0.0694$  pounds per cubic inch), Equation 19 reduces to,

$$H = \frac{20,600 t^2}{K r^2} \dots\dots\dots (21)$$

For the clay filling,  $K$  was greater than for sand and, to be on the safe side, it had best be assumed equal to or greater than unity.

The sole experiment on the 30-inch cast-iron pipe, 1 inch thick, involved only active earth thrust; but if we assume, as the height of fill (and deflection) increases, that  $q$  increases up to the limit 0.67, as before, and likewise assume a safe tension of 8,000 pounds per square inch, then the values of  $H$  as given by Equations 20 and 21 are reduced in the ratio 8 to 20 or 4 to 10. Of course such formulas are approximate, and it is highly desirable to make a record of failures for use in amending them.

BIBLIOGRAPHY

1. AMERICAN RAILWAY ENGINEERING ASSOCIATION COMMITTEE ON MASONRY, LOADS ON CULVERTS IN FILLS, Extract from Committee report, Engineering News-Record, March 19, 1925, p. 487.
2. BASQUIN, THE CIRCULAR DIAGRAM OF STRESSES AND ITS APPLICATION TO THE THEORY OF INTERNAL FRICTION, Journal of the Western Society of C. E., vol. XVII, p. 815.
3. BELL, A. L., THE LATERAL PRESSURE AND RESISTANCE OF CLAY AND THE SUPPORTING POWER OF CLAY FOUNDATIONS, Minutes of Proc. Inst. C. E., vol. CXVIX.
4. BRAUNE, G. M., EARTH PRESSURES ON CULVERT PIPES, PUBLIC ROADS, vol. 7, No. 11, January 1927, p. 222-229.
5. CAIN, WILLIAM, EARTH PRESSURES, RETAINING WALLS, AND BINS. John Wiley and Son, 1916. p. 287.
6. CAIN, WILLIAM, EXPERIMENTS ON RETAINING WALLS AND PRESSURE ON TUNNELS, trans. A. S. C. E., vol. LXXII, 1912. p. 403-474.
7. CAIN, WILLIAM, COHESION IN EARTH, trans. Am. Soc. C. E., vol. LXXX, 1916, p. 1315.
8. FELD, JACOB, LATERAL EARTH PRESSURES AND DISCUSSIONS, Trans. A. S. C. E., vol. LXXXVI, 1923, p. 1448-1598.
9. FRANKLIN, W. M., AND JOHNSON, W. C., EXPERIMENTS TO DETERMINE EARTH PRESSURE ON CULVERT PIPE, 1927, masters thesis in the library of the University of North Carolina.
10. GOLDBECK, A. T., TESTS TO DETERMINE PRESSURE DUE TO HYDRAULIC FILLS, Engineering News-Record, vol. 80, April 18, 1918, p. 758-760.
11. HOLMES, H. C., AND CANTEY, HARRY, VERTICAL EARTH PRESSURES ON CULVERT PIPE, 1926, masters thesis in the library of the University of North Carolina.
12. GOODRICH, E. P., LATERAL EARTH PRESSURES AND RELATED PHENOMENA, Trans. A. S. C. E., vol. LIII, 1904, p. 272-321.
13. GRIFFITH, J. H., FRICTION AND COHESION OF SOILS, Proc. A. S. C. E., vol. 48, March 1922, p. 565.
14. KETCHUM, M. S., WALLS, BINS, AND GRAIN ELEVATORS, McGraw-Hill book company, 1911, p. 556.
15. LEYGUE, M. S., NOUVELLE RECHERCHE SUR LA POUSSEE DES TERRES, Annales des Ponts et Chaussées, 1885, Part II, p. 788.
16. MARSTON, A., SCHLICK, W. J. AND CLEMMER, H. F., THE SUPPORTING STRENGTH OF SEWER PIPE IN DITCHES AND METHODS OF TESTING SEWER PIPE IN LABORATORIES TO DETERMINE THEIR ORDINARY SUPPORTING STRENGTH. Iowa Engineering Experiment Station Bulletin No. 47, 1917.
17. MARSTON, A., AND ANDERSON, A. O., THE THEORY OF LOADS ON PIPES IN DITCHES, AND TESTS OF CEMENT AND CLAY DRAIN TILE AND SEWER PIPE. Iowa Engineering Experiment Station, Bulletin No. 31, February, 1913.
18. PAUL, C. H., CORE STUDIES IN HYDRAULIC FILL DAMS OF THE MIAMI CONSERVANCY DISTRICT. Trans. A. S. C. E., 1922, p. 1181-1236.

19. RESAL, POUSSE DES TERRES, PART II, THEORIE DES TERRES COHERENTES, Paris, 1910, p. 327.
20. SCHLICK, S. J., SUPPORTING STRENGTH OF DRAIN TILE AND SEWER PIPE UNDER DIFFERENT PIPE-LAYING CONDITIONS. Iowa Engineering Experiment Station, Bulletin No. 57, April, 1920.
21. SCHMITT, H. A., AND DOBBINS, E. G., A COMPARISON OF LABORATORY AND FIELD DATA RELATIVE TO PRESSURE ON CULVERT PIPE, 1928, masters' thesis in the library of the University of North Carolina.
22. SPANGLER, M. G., A PRELIMINARY EXPERIMENT ON THE SUPPORTING STRENGTH OF CULVERT PIPES IN AN ACTUAL EMBANKMENT. Iowa Engineering Experiment Station, Bulletin, No. 76, 1926.
23. SPANGLER, M. G., MASON, CLYDE; WINFREY, ROBLEY. EXPERIMENTAL DETERMINATIONS OF STATIC AND IMPACT LOADS TRANSMITTED TO CULVERTS. Iowa Engineering Experiment Station, Bulletin No. 79, 1926.
24. TALBOT, A. N., TESTS OF CAST-IRON AND REINFORCED CONCRETE CULVERT PIPE, University of Illinois Bulletin No. 22, 1908.
25. TRAUTWINE, J. C., THE CIVIL ENGINEER'S POCKET BOOK, Philadelphia, Trautwine Co., 1919, p. 1528.
26. UNIVERSITY OF ILLINOIS BULLETIN No. 22, April, 1908, p. 11 to 18.
27. WARDLAW, J. G., AND AULL, L. B., VERTICAL EARTH PRESSURES ON CULVERT PIPE, 1924, masters' thesis in the library of the University of North Carolina.

## ROAD PUBLICATIONS OF BUREAU OF PUBLIC ROADS

*Applicants are urgently requested to ask only for those publications in which they are particularly interested. The Department can not undertake to supply complete sets nor to send free more than one copy of any publication to any one person. The editions of some of the publications are necessarily limited, and when the Department's free supply is exhausted and no funds are available for procuring additional copies, applicants are referred to the Superintendent of Documents, Government Printing Office, this city, who has them for sale at a nominal price, under the law of January 12, 1895. Those publications in this list, the Department supply of which is exhausted, can only be secured by purchase from the Superintendent of Documents, who is not authorized to furnish publications free.*

### ANNUAL REPORTS

Report of the Chief of the Bureau of Public Roads, 1924.  
Report of the Chief of the Bureau of Public Roads, 1925.  
Report of the Chief of the Bureau of Public Roads, 1927.  
Report of the Chief of the Bureau of Public Roads, 1928.

### DEPARTMENT BULLETINS

No. \*136D. Highway Bonds. 20c.  
220D. Road Models.  
257D. Progress Report of Experiments in Dust Prevention and Road Preservation, 1914.  
\*314D. Methods for the Examination of Bituminous Road Materials. 10c.  
\*347D. Methods for the Determination of the Physical Properties of Road-Building Rock. 10c.  
\*370D. The Results of Physical Tests of Road-Building Rock. 15c.  
386D. Public Road Mileage and Revenues in the Middle Atlantic States, 1914.  
387D. Public Road Mileage and Revenues in the Southern States, 1914.  
388D. Public Road Mileage and Revenues in the New England States, 1914.  
390D. Public Road Mileage and Revenues in the United States, 1914. A Summary.  
407D. Progress Reports of Experiments in Dust Prevention and Road Preservation, 1915.  
463D. Earth, Sand-Clay, and Gravel Roads.  
\*532D. The Expansion and Contraction of Concrete and Concrete Roads. 10c.  
\*583D. Reports on Experimental Convict Road Camp, Fulton County, Ga. 25c.  
\*660D. Highway Cost Keeping. 10c.  
\*670D. The Results of Physical Tests of Road-Building Rock in 1916 and 1917.  
\*691D. Typical Specifications for Bituminous Road Materials. 10c.  
\*724D. Drainage Methods and Foundations for County Roads. 20c.  
1216D. Tentative Standard Methods of Sampling and Testing Highway Materials, adopted by the American Association of State Highway Officials and approved by the Secretary of Agriculture for use in connection with Federal-aid road construction.  
1259D. Standard Specifications for Steel Highway Bridges, adopted by the American Association of State Highway Officials and approved by the Secretary of Agriculture for use in connection with Federal-aid road work.  
1279D. Rural Highway Mileage, Income, and Expenditures 1921 and 1922.  
1486D. Highway Bridge Location.

### DEPARTMENT CIRCULARS

No. 94C. T. N. T. as a Blasting Explosive.  
331C. Standard Specifications for Corrugated Metal Pipe Culverts.

### TECHNICAL BULLETIN

No. 55. Highway Bridge Surveys.

### MISCELLANEOUS CIRCULARS

No. 62M. Standards Governing Plans, Specifications, Contract Forms, and Estimates for Federal-Aid Highway Projects.  
93M. Direct Production Costs of Broken Stone.  
\*109M. Federal Legislation and Regulations Relating to the Improvement of Federal-Aid Roads and National-Forest Roads and Trails. 10c.

### SEPARATE REPRINTS FROM THE YEARBOOK

No. 914Y. Highways and Highway Transportation.  
937Y. Miscellaneous Agricultural Statistics.  
1036Y. Road Work on Farm Outlets Needs Skill and Right Equipment.

### TRANSPORTATION SURVEY REPORTS

Report of a Survey of Transportation on the State Highway System of Connecticut.  
Report of a Survey of Transportation on the State Highway System of Ohio.  
Report of a Survey of Transportation on the State Highways of Vermont.  
Report of a Survey of Transportation on the State Highways of New Hampshire.  
Report of a Plan of Highway Improvement in the Regional Area of Cleveland, Ohio.  
Report of a Survey of Transportation on the State Highways of Pennsylvania.

### REPRINTS FROM THE JOURNAL OF AGRICULTURAL RESEARCH

Vol. 5, No. 17, D- 2. Effect of Controllable Variables upon the Penetration Test for Asphalts and Asphalt Cements.  
Vol. 5, No. 19, D- 3. Relation Between Properties of Hardness and Toughness of Road-Building Rock.  
Vol. 5, No. 24, D- 6. A New Penetration Needle for Use in Testing Bituminous Materials.  
Vol. 6, No. 6, D- 8. Tests of Three Large-Sized Reinforced-Concrete Slabs Under Concentrated Loading.  
Vol. 11, No. 10, D-15. Tests of a Large-Sized Reinforced-Concrete Slab Subjected to Eccentric Concentrated Loads.

\* Department supply exhausted.

UNITED STATES DEPARTMENT OF AGRICULTURE

BUREAU OF PUBLIC ROADS

CURRENT STATUS OF FEDERAL AID ROAD CONSTRUCTION

AS OF

OCTOBER 31, 1929

| STATE          | COMPLETED MILEAGE | UNDER CONSTRUCTION   |                      |         |                    | APPROVED FOR CONSTRUCTION |                      |               |                    | BALANCE OF FEDERAL-AID FUNDS AVAILABLE FOR PROJECTS | STATE          |
|----------------|-------------------|----------------------|----------------------|---------|--------------------|---------------------------|----------------------|---------------|--------------------|---|----------------|
|                |                   | Estimated total cost | Federal aid allotted | MILEAGE |                    | Estimated total cost      | Federal aid allotted | MILEAGE       |                    |   |                |
|                |                   |                      |                      | Initial | Stage <sup>1</sup> |                           |                      | Initial       | Stage <sup>1</sup> |   |                |
| Alabama        | 2,057.1           | \$ 3,115,518.33      | \$ 1,540,542.44      | 134.3   | 21.0               | 155.3                     | \$ 193,007.98        | \$ 163,984.10 | 34.1               | 34.1  | Alabama        |
| Arizona        | 837.7             | 3,023,419.20         | 2,485,535.02         | 115.7   | 80.3               | 196.0                     | 321,979.73           | 141,072.92    | 11.8               | 13.0  | Arizona        |
| Arkansas       | 1,757.6           | 3,435,582.25         | 1,611,976.49         | 189.4   | 32.4               | 191.8                     | 1,112,510.52         | 413,114.76    | 29.7               | 29.7  | Arkansas       |
| California     | 1,744.2           | 8,105,239.97         | 3,795,318.32         | 229.0   | 11.2               | 240.2                     | 1,450,301.75         | 247,301.75    | 2.4                | 16.9  | California     |
| Colorado       | 1,143.3           | 4,713,707.75         | 2,502,749.49         | 186.3   | 44.5               | 230.8                     | 772,175.31           | 321,390.91    | 4.1                | 16.9  | Colorado       |
| Connecticut    | 229.3             | 1,469,404.69         | 453,708.57           | 16.4    | 16.4               | 16.4                      |                      |               |                    | 4.1   | Connecticut    |
| Delaware       | 213.3             | 1,326,553.90         | 585,435.96           | 52.5    | 52.5               | 52.5                      |                      |               |                    | 19.2  | Delaware       |
| Florida        | 467.0             | 3,251,617.50         | 1,379,311.13         | 142.0   | 24.3               | 166.3                     | 1,619,961.23         | 72,047.38     | .8                 | 6.6   | Florida        |
| Georgia        | 2,597.3           | 3,017,244.77         | 1,379,311.13         | 142.0   | 24.3               | 166.3                     | 1,619,961.23         | 72,047.38     | .8                 | 6.6   | Georgia        |
| Idaho          | 1,164.7           | 1,146,023.06         | 688,048.96           | 73.5    | 10.2               | 83.8                      | 257,500.00           | 152,500.00    | 14.1               | 28.3  | Idaho          |
| Illinois       | 1,995.0           | 16,472,887.17        | 7,290,150.60         | 475.5   | 475.5              | 475.5                     | 528,000.00           | 284,000.00    | 18.3               | 18.3  | Illinois       |
| Indiana        | 1,304.0           | 8,983,685.23         | 4,214,492.29         | 273.1   | 273.1              | 273.1                     | 359,700.00           | 179,850.00    | 12.0               | 12.0  | Indiana        |
| Iowa           | 3,039.0           | 3,390,853.00         | 1,409,759.97         | 34.5    | 91.5               | 126.2                     | 478,584.45           | 227,252.38    | 29.5               | 33.0  | Iowa           |
| Kansas         | 2,636.1           | 5,461,747.00         | 2,469,137.34         | 34.7    | 23.9               | 364.5                     | 171,957.42           | 85,978.70     | 15.3               | 21.4  | Kansas         |
| Kentucky       | 1,335.4           | 4,969,742.11         | 2,376,431.52         | 278.1   | 24.3               | 302.4                     |                      |               | 6.1                | 6.1   | Kentucky       |
| Louisiana      | 1,335.4           | 3,543,990.25         | 1,764,235.49         | 150.0   | 150.0              | 150.0                     | 52,952.10            | 26,476.05     | 5.6                | 5.6   | Louisiana      |
| Maine          | 502.1             | 2,153,369.54         | 902,399.29           | 51.0    | 2.0                | 53.0                      | 274,976.40           | 109,925.68    | 10.4               | 10.4  | Maine          |
| Maryland       | 624.3             | 1,438,907.50         | 689,338.85           | 54.7    | 3.0                | 57.7                      | 233,972.40           | 27,773.64     | 6.7                | 6.7   | Maryland       |
| Massachusetts  | 620.7             | 3,690,786.91         | 1,052,145.99         | 49.5    | 2.8                | 52.3                      | 1,842,000.00         | 756,723.31    | 41.2               | 53.6  | Massachusetts  |
| Michigan       | 1,541.3           | 10,383,356.02        | 4,442,064.23         | 252.9   | 13.3               | 266.2                     | 900,788.77           | 16,110.00     | 11.1               | 48.3  | Michigan       |
| Minnesota      | 3,954.1           | 5,659,756.32         | 1,853,797.96         | 252.7   | 102.2              | 354.9                     |                      |               |                    |   | Minnesota      |
| Mississippi    | 1,755.1           | 3,652,917.43         | 1,572,535.69         | 140.8   | 17.4               | 158.2                     | 154,441.12           | 51,895.79     | 2.5                | 2.5   | Mississippi    |
| Missouri       | 2,284.0           | 9,619,301.96         | 3,891,776.79         | 149.3   | 132.5              | 281.8                     | 1,265,343.00         | 695,127.01    | 104.8              | 129.1   | Missouri       |
| Montana        | 1,536.0           | 6,715,502.19         | 3,950,226.24         | 491.5   | 26.2               | 517.7                     | 1,391,599.33         | 631,253.26    | 29.4               | 67.5  | Montana        |
| Nebraska       | 3,590.4           | 5,954,644.91         | 2,869,821.85         | 312.0   | 158.2              | 470.2                     |                      |               |                    |   | Nebraska       |
| Nevada         | 1,132.5           | 1,078,172.91         | 867,766.71           | 100.9   | 108.9              | 208.9                     |                      |               |                    |   | Nevada         |
| New Hampshire  | 344.0             | 550,445.68           | 163,444.87           | 8.2     | 3.1                | 11.3                      |                      |               |                    |   | New Hampshire  |
| New Jersey     | 489.6             | 3,733,703.37         | 796,560.00           | 53.1    | 53.1               | 53.1                      | 1,395,389.48         | 214,230.00    | 14.3               | 14.3  | New Jersey     |
| New Mexico     | 1,893.3           | 2,803,022.94         | 1,775,554.44         | 149.3   | .7                 | 150.0                     | 271,285.96           | 170,353.69    | 25.8               | 25.8  | New Mexico     |
| New York       | 2,304.5           | 85,206,017.76        | 5,632,330.55         | 376.8   |                    | 376.8                     | 3,574,119.02         | 534,790.00    | 35.6               | 35.6  | New York       |
| North Carolina | 1,744.1           | 1,321,591.55         | 659,957.26           | 79.4    | 17.1               | 96.5                      | 232,387.09           | 116,193.53    | 19.5               | 20.6  | North Carolina |
| North Dakota   | 4,075.5           | 1,852,567.62         | 745,294.75           | 289.1   | 113.5              | 402.6                     | 1,259,869.85         | 644,068.44    | 211.5              | 387.8   | North Dakota   |
| Ohio           | 2,124.4           | 13,134,669.05        | 4,218,420.15         | 240.8   | 13.3               | 254.1                     | 5,390,065.67         | 1,419,501.62  | 50.1               | 75.8  | Ohio           |
| Oklahoma       | 1,816.6           | 3,473,610.65         | 1,892,402.94         | 107.1   | 29.5               | 135.7                     | 1,190,565.08         | 595,929.03    | 32.1               | 53.9  | Oklahoma       |
| Oregon         | 1,150.2           | 2,048,711.50         | 1,173,377.17         | 110.4   | 35.9               | 146.3                     | 1,109,290.70         | 669,953.94    | 61.4               | 86.6  | Oregon         |
| Pennsylvania   | 2,189.4           | 15,177,094.69        | 3,834,770.59         | 236.9   | 14.1               | 251.0                     | 2,539,375.88         | 648,498.67    | 42.4               | 42.4  | Pennsylvania   |
| Rhode Island   | 172.1             | 1,424,602.88         | 404,118.70           | 21.1    | 21.1               | 21.1                      | 62,478.20            | 23,505.99     | 1.8                | 1.8   | Rhode Island   |
| South Carolina | 1,874.7           | 2,928,639.87         | 1,015,839.51         | 108.7   | 22.3               | 131.0                     | 222,098.58           | 122,154.18    | 27.9               | 74.5  | South Carolina |
| South Dakota   | 3,450.4           | 3,392,997.18         | 1,809,822.56         | 388.8   | 62.5               | 451.4                     |                      |               |                    |   | South Dakota   |
| Tennessee      | 1,207.7           | 2,345,335.98         | 1,055,962.98         | 88.4    | 88.4               | 88.4                      | 208,835.70           | 104,417.85    | 10.8               | 10.8  | Tennessee      |
| Texas          | 6,239.7           | 18,975,945.47        | 8,014,853.19         | 619.5   | 273.7              | 892.2                     | 689,541.29           | 327,883.03    | 2.9                | 28.0  | Texas          |
| Utah           | 937.5             | 1,757,993.44         | 1,175,949.04         | 67.8    |                    | 67.8                      | 319,624.61           | 184,502.20    | 9.3                | 9.3   | Utah           |
| Vermont        | 239.8             | 1,359,327.69         | 500,507.53           | 27.3    | 3.1                | 27.3                      | 869,671.79           | 398,479.91    | 25.9               | 35.1  | Vermont        |
| Virginia       | 1,402.5           | 1,753,556.90         | 943,707.05           | 76.5    | 29.8               | 106.3                     | 445,795.46           | 225,000.00    | 20.3               | 31.2  | Virginia       |
| Washington     | 885.5             | 5,502,914.35         | 1,962,600.00         | 113.4   |                    | 113.4                     |                      |               |                    |   | Washington     |
| West Virginia  | 662.8             | 4,107,331.67         | 1,671,409.86         | 92.3    | 34.7               | 127.0                     | 142,197.17           | 171,093.59    | 6.3                | 6.3   | West Virginia  |
| Wisconsin      | 2,136.7           | 8,321,585.54         | 3,581,113.26         | 282.1   | 19.2               | 301.3                     | 153,618.54           | 100,660.55    | 22.6               | 22.6  | Wisconsin      |
| Wyoming        | 1,717.2           | 1,630,653.96         | 1,062,575.45         | 190.3   | 23.2               | 183.5                     | 247,259.61           | 247,259.61    | 18.6               | 16.5  | Wyoming        |
| Hawaii         | 39.5              | 402,251.10           | 137,426.82           | 6.6     |                    | 6.6                       |                      |               |                    |   | Hawaii         |
| TOTALS         | 80,588.0          | 250,269,799.99       | 101,670,979.47       | 8,322.2 | 1,631.0            | 9,953.2                   | 33,195,280.38        | 12,143,044.87 | 1014.6             | 1551.2  | TOTALS         |

<sup>1</sup>The term stage construction refers to additional work done on projects previously improved with Federal aid. In general, such additional work consists of the construction of a surface of higher type than was provided in the initial improvement.



