



U.S. DEPARTMENT OF AGRICULTURE
BUREAU OF PUBLIC ROADS

Public Roads

VOL. 2, NO. 14

WASHINGTON, D. C.

JUNE, 1919



ONE OF THE ROADS IN DELAWARE'S NEW HIGHWAY SYSTEM

Owing to the necessarily limited edition of this publication it will be impossible to distribute it free to any persons or institutions other than State and county officials actually engaged in the planning or construction of highways, instructors in highway engineering, periodicals upon an exchange basis, and Members of both Houses of Congress. Others desiring to obtain "Public Roads" can do so by sending 15 cents for a single number or \$1.50 for annual subscription to the Superintendent of Documents, Government Printing Office, Washington, D. C.

U. S. DEPARTMENT OF AGRICULTURE

BUREAU OF PUBLIC ROADS

PUBLIC ROADS

TABLE OF CONTENTS

	Page.
Secretary Houston Discusses Federal Road Commission Bill	3
Federal Aid Work in Delaware	6
<i>By A. R. Losh</i>	
Suggestions for Contractors on Concrete Road Construction	15
<i>By Clyde E. Learned</i>	
Federal Aid Record	18
Road Making at Front in France	21
<i>By F. G. Eason</i>	
Bonding New Cement-Mortar and Concrete to Old	26
<i>By W. E. Rosengarten</i>	
Commercial Sizes of Crushed Stone Aggregates	35
<i>By F. H. Jackson and C. W. Mitman</i>	



U. S. DEPARTMENT OF AGRICULTURE
BUREAU OF PUBLIC ROADS
PUBLIC ROADS

TABLE OF CONTENTS

ADDITIONAL COPIES
OF THIS PUBLICATION MAY BE PROCURED FROM
THE SUPERINTENDENT OF DOCUMENTS
GOVERNMENT PRINTING OFFICE
WASHINGTON, D. C.
AT
15 CENTS PER COPY
SUBSCRIPTION PRICE, \$1.50 PER YEAR.



SECRETARY HOUSTON DISCUSSES FEDERAL ROAD COMMISSION BILL

SECRETARY HOUSTON, in response to a communication from a city chamber of commerce requesting his views regarding the creation of a Federal highway commission and the wisdom of taking the Federal supervision of highways from the Department of Agriculture and placing it under such a commission, has sent the following reply:

"I have your letter of May 2 in which you state that your chamber of commerce has been asked to adopt a resolution calling on the Congress of the United States to create a Federal highway commission and that you note that such resolution has been adopted by a number of commercial organizations, including the United States Chamber of Commerce. You ask for an expression of my views on the matter and particularly whether, in my opinion, it would be wise to take the Federal supervision of highways from the Department of Agriculture and place it under such a commission as that proposed.

FUNDAMENTAL CONSIDERATION,

"Before expressing my views, it might be well for me to point out certain fundamental considerations which should be borne in mind in determining any sound policy of highway administration and development: (1) The roads in each section of the country are of varying degrees of importance in the service which they render or may render to the particular locality, to the State, and to the Nation as a whole. (2) This is a big country and the traffic conditions and needs vary greatly from section to section. (3) The State highway departments, being in immediate touch with local conditions, are best able to classify the roads properly on the basis of the economic purpose which they may serve. (4) The Federal Government, under the present Bankhead Federal Aid Road Act, is cooperating in the improvement of the roads of greatest importance, the classification of which is fixed by the State highway departments; and (5) when this classification has been carefully made and by agreement between the highway departments of adjoining States, the roads of first importance generally meet at State boundaries, and, therefore, become interstate highways of nation-wide utility. The Federal Government, under the present law, is aiding the State highway departments in the classification of their roads on the basis of importance and needs, and Federal aid is rapidly being extended for their improvement, on projects submitted by the States and approved by this department.

FEDERAL COMMISSION NOT NEEDED.

"Having those points in mind, I have been unable to see the need for the creation of a separate Federal highway commission or the wisdom of substituting for the present cooperative program a plan which would commit or limit the Federal Government to the construction of two federally owned and maintained trunk lines in each State of the Union. There was a bill introduced in the Senate of the United States on February 13, 1919, embodying these suggestions. This proposed legislation provides for a Federal highway commission of five, each receiving a salary of \$10,000 a year, whose duty, among other things, would be to establish, construct, and maintain a system of highways 'to comprise not less than two main trunk line roads in each State, and joining the national highway system in the adjacent States and countries.' The commission is given the power to select the trunk-line roads to be constructed after having requested the State highway departments to recommend routes. The Federal Government is to assume the maintenance of these roads. The commission is furthermore empowered to take over the work of all existing Federal agencies relating to highway transportation and 'to purchase, lease, rent, operate, and maintain such motor and other transportation facilities as it may deem necessary in performance of its duties under this act.'

OPERATION OF PRESENT LAW.

"In July, 1916, the Bankhead Road Act was passed. It provided appropriations out of the Federal Treasury, to be matched by equal sums from the States, for the construction of roads, and provided further that no State should receive any of the money appropriated unless it had a highway department with adequate powers. The law placed the administration of the act in the hands of the Secretary of Agriculture, in cooperation with the 48 State highway departments. It was enacted only a short time before we entered the European war and its operation was necessarily greatly interfered with by the disturbed conditions. There were also certain features of the law that made its smooth administration difficult. After the cessation of hostilities, with the approval of the President, I requested Congress to make a large additional appropriation to aid the States in highway construction and also to make certain amendments to the law, the necessity for which experience had demonstrated. Congress, through the Bankhead amendment to the post-office

appropriation bill, provided an additional appropriation of \$209,000,000 and substantially made the amendments suggested.

"Under existing legislation there is no special obstacle, so far as I can see, to the construction, in the different States of the Union, of those roads which serve the greatest economic needs. In the first place, the definition of the kind of roads that can be constructed has been greatly broadened, and in the second place, the limitation on the Federal contribution for any one road has been increased from \$10,000 to \$20,000 a mile.

COOPERATION WITH STATES.

"Following this legislation, the regulations governing the administration of the act and the standards for plans, specifications, and estimates have been modified and one of the most successful former State highway engineers in the country has been placed in immediate charge of the Federal aid road work. He has at his disposal a considerable staff of local and district engineer aids and no pains will be spared to provide any further Federal assistance that may be needed. The machinery provided by the Bankhead amendment includes not only the Federal Bureau of Public Roads, one of the largest and most effective organizations of its kind in the world, but also the 48 State highway departments, the two agencies working in close cooperation. It is also a part of the plan to have an advisory committee, composed of representatives of the State highway departments, selected by the American Association of State Highway Officials with due regard to geographic considerations, to work in intimate touch with the Federal Bureau, meeting with its officers at stated periods and at such other times as may be necessary. This machinery, in effect, is an expert national commission intimately in touch through its various parts with all sections of the Union, having no other purpose than that of serving the public interest. It is difficult to see what need there can be for additional machinery.

STATE OFFICIALS SELECT ROADS.

"Very properly the Bankhead Act places on the highway authorities of the several States responsibility, in large measure, for selecting the roads to be constructed. Obviously the local authorities are in a better position to judge what roads would serve the largest economic needs than any group of men sitting in Washington would be. It is the duty of the Federal Bureau, with its district engineers, to see that the provisions of the law are complied with. It is giving, and will continue to give, all possible assistance to the State authorities in all their technical problems, as well as in the planning of State systems and in the classification of roads. It has

been the policy of the department from the outset, in order to prevent haphazard action, to have the State highway authorities prepare and present tentative State systems of roads. It was apparent that a rigid system, not subject to modifications as conditions might require, would be inadvisable. Each State authority has worked out a system and, in general, it is being followed in the development of projects and the construction of roads. In a number of instances systems in general terms have been adopted by State legislatures. Of course, in formulating these systems the engineers gave due regard to interstate connections; that is, to roads connecting the system of one State with that of another, and it is difficult to see why, as progress is made, the construction of through roads will not follow, as a matter of course.

OBSTACLES IN WAY OF NEW PLAN.

"It seems scarcely likely, in view of the fact that nearly \$300,000,000 are now available out of the Federal Treasury, that the Congress, in the light of the financial situation, will make additional large appropriations; and it would be impossible without creating many complications to divert the existing appropriations from the purposes and plans already under way under the cooperative arrangements with the States. A considerable part of the available appropriations has already been formally tied up under agreements with State departments and contracts for large sums have been let. Additional large amounts are being pledged monthly. Every State has accepted the Federal act and many of them have by law directed its agencies to cooperate with the Secretary of Agriculture. A number of the States have large sums available for cooperation, in many instances much in excess of what is necessary to meet the requirements of the Federal act, and other States are preparing greatly to increase their appropriations. These State laws and arrangements can not easily be changed and perhaps would not be. After the original act was passed, more than a year elapsed before many of the States were able to secure legislative action which would enable them to comply with the Federal law and to begin the construction of roads. With the passage of the amendment carrying a large additional appropriation, there arose a necessity for further legislative action in some of the States. It seems to me that instead of asking for more or different legislation we should now proceed actively and vigorously with the construction of roads under existing arrangements.

NOTHING GAINED BY COMMISSION.

"I am convinced that nothing material would be gained by the proposed change. Much would be lost. As has been pointed out, many complications

would be introduced. The creation of a commission would entail unnecessary additional administrative expenditures and the commission could not do anything that can not now be done more effectively by the existing cooperative machinery. There would also be a radical change of policy. I do not think that the people of the States will be willing to substitute for the present policy of developing roads on the principle of serving the largest economic purposes that policy advocated by those whose interest is in two main or trunk-line automobile roads in each State, nor do I think that they would be willing, even if it were legal or practicable, to have existing funds diverted from the present or contemplated projects, worked out with the aid of the State highway departments, solely to the construction of such roads. The largest service will be rendered, not only to farmers, but, in the long run, also to urban people, by following the principle of constructing roads of the greatest economic importance, selected after careful consideration by the State agencies having adequate knowledge and approved by the Federal department. It seems to me clear also that, as the work proceeds, we shall have roads which will be equally serviceable not only to those interested immediately in long-distance automobile travel and motor-truck transportation, but also to those interested in getting their farm produce to the market in the easiest and the most effective manner and in the transportation of the mails. I have no prejudice against any sort of road except a bad road, or against any sort of construction except wasteful and unsubstantial construction. If traffic conditions require heavy construction, then I am in favor of it; and in any case, under the law, the construction must be substantial.

GOOD RESULTS OF BANKHEAD LAW.

"The road-construction movement is growing very rapidly. The Federal aid road act has done much to promote it. It has stimulated financial aid and has caused many State legislatures to create central highway departments. Experience has brought about amendments to the law and helpful changes in administration. Comprehensive road programs have been inaugurated. They are being pushed vigorously. They will result, in a shorter time than most people imagine, not only in a network of good, substantial roads in the various States of the Union, but also in the requisite interstate highways.

WHY INTRODUCE COMPLICATIONS?

"Why at this stage introduce complications and embarrassments? Why should not the friends of the movement for roads to serve the people cooperate? It is difficult for me to see why all who are animated by high public spirit in their thinking

concerning highways should not cooperate in the development of present programs and in the perfection of the existing processes and machinery, instead of attempting to overthrow them. I believe that many of those who are backing the proposed change do not know the facts and are not aware of existing conditions and possibilities."

\$6,500,000 FOR DALLAS ROADS.

Dallas County, Tex., on May 24, voted by an overwhelming majority to issue road bonds to the amount of \$6,500,000. The commissioners and advisory board will determine at an early date the initial expenditure to be made from this amount. The plan submitted to the people with the proposition provides for a complete belt line around the county, with 12 roads radiating out from Dallas to all sections, and in addition 6 intermediate roads connecting the radial highways. The proposal showed the location of each of these roads, its construction, location of culverts and approaches, the cost of each section and of the improvements upon it.

The system provides for 332 miles of road, and in addition feeder roads amounting to about 100 miles will be improved by the decrease in maintenance expense. Federal aid amounting to \$250,000 had been allowed to Dallas County for its highway development, and a large number of motor trucks will be assigned to assist in the construction work.

This Dallas bond issue was by far the largest amount ever submitted in any county in Texas, and it is one of the largest voted anywhere in the country. The result of the vote was looked for with great interest by Texas people, and the big majority by which the proposal carried is expected to have a favorable influence in State election in November on an issue of \$75,000,000 for road construction.

Many counties near to Dallas have voted bond issues for large amounts. Collin County voted \$3,000,000; Hunt, \$2,000,000; Denton, \$1,650,000; Titus, \$1,500,000; Kaufman, \$1,450,000; Rockwell, \$800,000; and Ellis, \$250,000. Tarrant County will soon vote on a proposed issue of \$3,500,000, and there are several other counties which have pending issues.

COUNTY TO SPEND \$2,000,000.

Washington County, Miss., now has available over \$2,000,000 for highway improvement. There is an unexpended balance of about \$800,000 from a bond issue of \$950,000 voted three years ago, while it was recently decided by a large majority at a special election to issue an additional amount of \$1,250,000 for road building.

DELAWARE'S FEDERAL AID WORK

By A. R. LOSH, Acting District Engineer, Bureau of Public Roads.



REDUCING AN 11 PER CENT GRADE TO 5 PER CENT ON DELAWARE PROJECT NO. 1A.

THE policy followed by the State highway department of Delaware in the selection of Federal aid projects has been to place the Federal funds on the trunk highways of the State system. As only a small portion of the State highway system has been constructed, it has been possible to select as Federal aid projects the most important roads of the State. A further policy of the department has been to place as large a mileage as practicable on the Federal aid program so as to insure in a measure the future maintenance of the roads. As a result of this policy, and due to the fact that the Delaware

apportionment is comparatively small, the Federal fund allotted to projects has been but a small percentage of their total cost.

The Federal aid allotment to the State for the first three years of the original Federal aid, amounting to \$48,965.10, was assigned to projects 1A and 2, and is but 4.1 per cent of their estimated cost. The Federal aid act as amended provides \$130,349.55 for the first three fiscal years ending June 30, 1919. Projects have been submitted in excess of this sum as shown in the following table.

DELAWARE FEDERAL AID PROJECTS.

Project.		Length in miles.	Roadway.		Estimated total cost.	Federal aid allotted.	
No.	Road.		Type.	Width.		Amount.	Per cent total cost.
1A	Philadelphia Pike.....	5.72	Brick	19	\$639,349.59	\$28,550.00	4.46
1B	do.....	.492	do.....	40	83,116.72	4,500.00	5.41
2	Laurel-Bridgeville.....	11.6	Plain cement concrete.....	16	537,827.40	20,415.10	3.79
3	Greenwood-Farmington.....	4	do.....	16	137,601.73	36,000.00	26.16
4	Delmar-Laurel.....	4.39	do.....	16	177,936.00	40,000.00	22.47
5	Farmington-Harrington.....	5.96	do.....	16	210,143.11	54,000.00	25.69
Total.....					1,785,974.55	183,465.10	10.272



LOWERING TELEPHONE WIRE CONDUITS ON DELAWARE FEDERAL AID PROJECT NO. 1. NOTE THE TEMPORARY CABLE ON THE RIGHT.

The State highway department is concentrating its efforts at the present time on building the trunk highways of the State system. In anticipation of future heavy motor-truck traffic, the building program provides for substantial improved types and only high-grade work. Generally these roads pass through agricultural sections and for that reason it is possible to make the design and location on broad engineering principles and without greatly disturbing existing permanent improvements.

RIGHTS-OF-WAY.

On all trunk highways the minimum right-of-way taken is 60 feet. The Philadelphia Pike, Federal aid projects Nos. 1A and 1B, has a right-of-way of 80 feet. This width was taken in anticipation of future suburban development along the project. As it serves the industrial section between Wilmington and Philadelphia, a large portion of property adjacent to this highway is being developed for residential purposes. The last State legislature passed a law enabling the State highway department to construct roads through incorporated towns. On roads through towns and adjacent to cities rights-of-way of 80 feet will be established in order to insure sufficient width for traffic ways and allow for future planting and parking as may be found desirable.

STANDARD ROAD SECTIONS.

The road sections typical of the Delaware project are shown in figure 1. It will be noted that the sections are quite wide beyond the edges of the improved roadway. The section for project 1A provides in addition to the 19 feet of brick and concrete, macadam shoulders from 4 to 8 feet in width. On project 1B the middle of the roadway is occupied by two electric railway tracks and to accommodate traffic the roadway has been widened to 40 feet between curbs. Projects 2 and 4 have earth shoulders 6 feet wide, while projects 3 and 5 have shoulders 8 feet wide. The reason for this difference is that on projects 2 and 4 the soil is quite sandy and the shoulders of this material would not be suitable for traffic, while on the other two projects the soil is of such a nature as to make it practical to maintain an earth roadway on each side of the concrete.

The special section shown with an improved roadway of only 10 feet in width is to be used where the present traffic is light but where an improved road is needed to develop the country served. It is proposed to build the improved roadway for one line of traffic, using the shoulders, which are to be 11 feet wide, for passing, and, if desired, for horse-drawn vehicles. If traffic increase warrants a wider roadway the same can be provided readily by the addi-

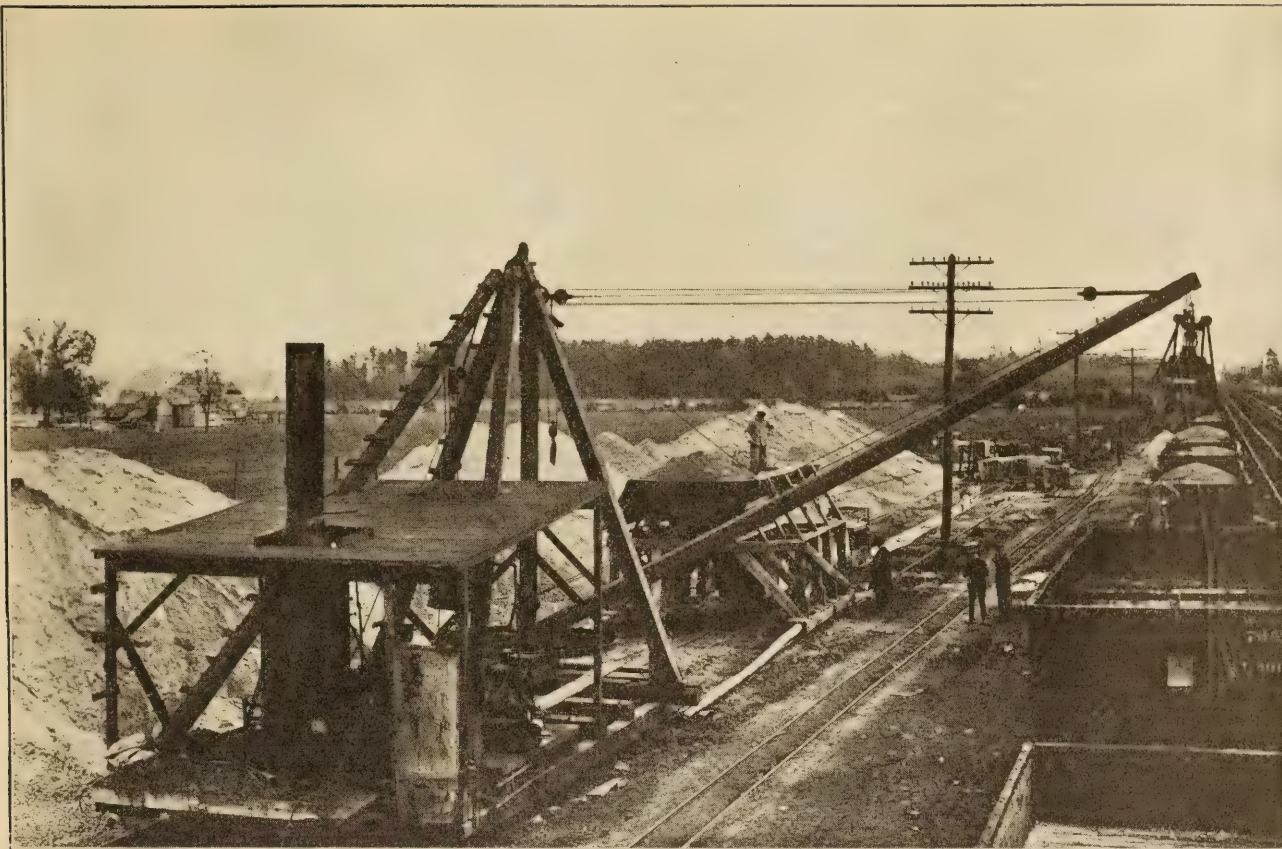

DERRICK CAR, CLAM-SHELL BUCKET, AND MOVABLE BINS ON WIDE GAUGE TRACK, DELAWARE FEDERAL AID PROJECT NO. 4.

tion of concrete slabs to one or both sides of the 10-foot roadway. Generally the improved width of 10 feet will be of bituminous macadam on a slag base. This section is especially adaptable at this time to the east-and-west State highways and to State aid highways on which the counties cooperate in the cost of the construction.

ALIGNMENT.

Alignment receives very careful study of all roads improved by the State. Little attention is given to existing roads, which were laid out generally along property lines. The practice of the State highway department is to build on long tangents and easy curves, going to considerable expense where necessary to secure such a line. One of the State highways has a tangent 14 miles long; other tangents of several miles in length are not infrequent. Curves of more than 2 degrees are exceptions to the general practice of the State. The maximum curvature on the present established State highway is 6 degrees. As a result of this practice a great many relocations are necessary. Generally it has been found that the saving in the cost of construction due to the saving in distance on the relocated line is sufficient to pay for the new right of way and property damages.

119883—19—2

This is not, however, considered as a limiting factor in deciding upon locations. On Federal aid project No. 2 there are several relocations that have been quite expensive to make and with very little saving in construction cost. On one of these where the saving in length is small the relocation has required moving a house, several farm buildings, and the building of a 20-foot span concrete arch with heavy earth embankments. This was done in order to avoid two dangerous curves and the placing of the roadway over a mill pond dam, as was the case with the old road.

The maximum gradient for Delaware State highways is 6 per cent. This maximum occurred on project No. 1A where, before improvement, the grade was 11 per cent. This particular piece of work required the removal of a large amount of rock.

DRAINAGE.

Road drainage often presents difficult problems. On project No. 1 there is ample fall, and means for surface drainage are provided readily, except occasionally where special outlets are necessary. Under-drainage, in this case, is much more difficult, because of the nature of the soil. Special tile drains are provided on long grades where there is danger that ground water will flow under the roadway, or at other

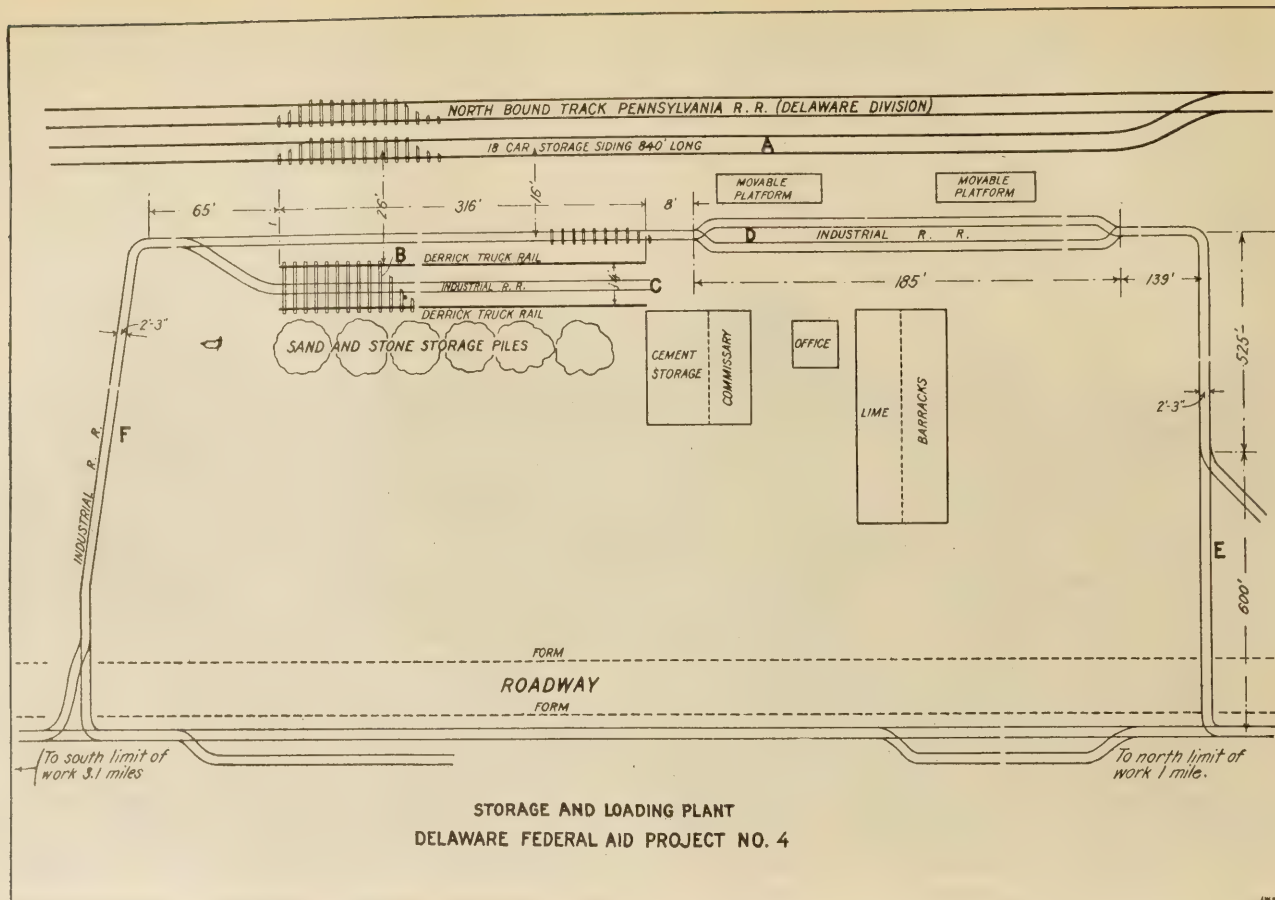

places where seepage may occur. Lateral drains at an angle of about 60° with the roadway are constructed 50 to 75 feet apart on these long grades on project No. 1. These drains consist of 4-inch tile laid with open joints and covered with crushed stone to the surface of the subgrade.

On other projects, especially in southern Delaware, underdrainage gives little trouble, as the soil is of a sandy nature and does not retain storm water readily. On account of the low grades encountered in this section special outlet channels often are necessary. On many of the adjacent farm lands special channels have been provided for drainage purposes, and these are often used as outlets for the road drainage. Many of these special drainage channels have been constructed and maintained by special taxes levied on the benefited property. Where these waterways cross the highways careful study is given, so that ample openings may be left for these special channels. The elevation of culvert floors receives special attention with the view of providing sufficient fall for future drainage development and to prevent ponding of storm water.

Bridges and culverts usually are constructed of reinforced concrete. For waterways of 7 square feet or less reinforced concrete pipe generally is specified. Vitrified tile is used occasionally instead of reinforced concrete pipe. All pipe culverts are protected with concrete headwalls. Reinforced concrete box culverts and beam spans are used for openings of from 3 to 18 feet in length. For longer spans T girders and arches of reinforced concrete are used. The clear roadway for culverts and bridges varies from 32 to 40 feet in width. All such struc-

tures on project No. 1 have roadways of 40 feet. Substantial reinforced concrete guard rails and hub guards are provided on all spans of more than 6 feet. It is the practice to place the bridge floors below the finished subgrade so that the roadway or pavement may be constructed over the structure without any change in general construction features.

PROJECT NO. 1.

Delaware's first project, No. 1, known as the Philadelphia Pike, is the most heavily traveled highway in Delaware. It begins at the eastern corporation line of Wilmington and extends northeast to the Delaware-Pennsylvania line, a distance of 6.21 miles. The preliminary investigations of the State highway department showed that this road was receiving in 1917 an average of 35,000 gross tons per week. Locally, the project serves sections principally utilized for residential purposes. There are also a number of industrial developments to be served, and it is thought that these will increase in the future.

As a State highway it will serve as an outlet to northern markets for the products of the agricultural sections of Delaware. Traffic from this source will greatly increase with the completion of the State highway from Wilmington south. The project is also a very important interstate highway carrying a greater portion of the through north-and-south traffic. Traffic from Philadelphia to the south by way of Baltimore and the Maryland system of roads to the Shenandoah Valley, by way of Washington and Richmond, or by way of Cape Charles and Norfolk would pass over this project. Due to



FINISHING THE SUBGRADE ON DELAWARE PROJECT NO. 4. NO MATERIALS LOST AND THE SUBGRADE UNIFORM.

its importance in this respect, the State highway department has used every effort to secure its early improvement.

COST UNUSUALLY HIGH.

Contracts for section A, 5.72 miles, were awarded in May, 1917, and amounted to \$639,349.59. While the price of road is unusually high, \$111,774.23 per mile, it should be borne in mind that these contracts were let during war times in a section of the United States where labor was in great demand and that being a road of comparatively wide section the quantities of work to be performed are larger than ordinarily. Earth excavation and borrow amount to 53,000 cubic yards and in addition to this 14,500 cubic yards of rock excavation are required. Prices for the earth excavation were \$1.62 and \$2 and the rock \$3.72 and \$5 per cubic yard. Concrete base was awarded at \$14 and \$14.25 per cubic yard and vitrified brick (not including base) \$2.50 to \$3.50 per square yard. The unusual hazards due to war conditions undoubtedly affected the prices of the work.

The typical section illustrates the character of the improvement. It is the standard semimonolithic brick pavement. The specifications for the base require a 1:2½:5 concrete with the addition of 0.1 cubic feet of hydrated lime per bag of cement. A mix of one minute in the drum and a minimum of 15 revolutions also is required. The 1-inch cement-sand cushion course is in 1:3 proportions and the grout filler 1:1½ proportions.

Specifications for the brick require a wire-cut vitrified paving block which will lose not more than 22 per cent in weight when submitted to the stand-

ard rattler test. On one contract Bessemer brick is used and in the other one Clydesdale. Plant inspection and test of the brick were made by the State highway department. Check tests from field samples also were made. The requirements of the specifications for hand piling of brick were waived by the State highway department to facilitate the rapid handling of freight cars, and the contractors dumped the blocks on the roadside. The brick were dumped from trucks against a sloping bulkhead, which it is believed greatly reduced the amount of spalling. The results of this method were satisfactory.

SECURING SMOOTH FINISH.

In laying the cement-sand cushion course, care was taken to eliminate all inequalities of the base and secure a smooth finished surface. To accomplish this, "finish grade" was marked on the curbs at intervals of 10 feet.

Because of the great changes in grades in a number of places it was necessary to lower much of the long-distance telephone cables in conduit along the project. Serious objections were made by the owners of these lines to making such changes during the stress of war times, as it was feared interruptions of the service might result. In some cases the conduits were lowered as much as 13 feet. Temporary cable lines were put up to by-pass the work. Blasting on the heavy rock work was done within 8 feet of the conduit without injury to the tile.

The material from the old roadway, mostly surface-treated macadam, is being used as shoulder material for the new construction. As rapidly as sections of the project are completed they are opened

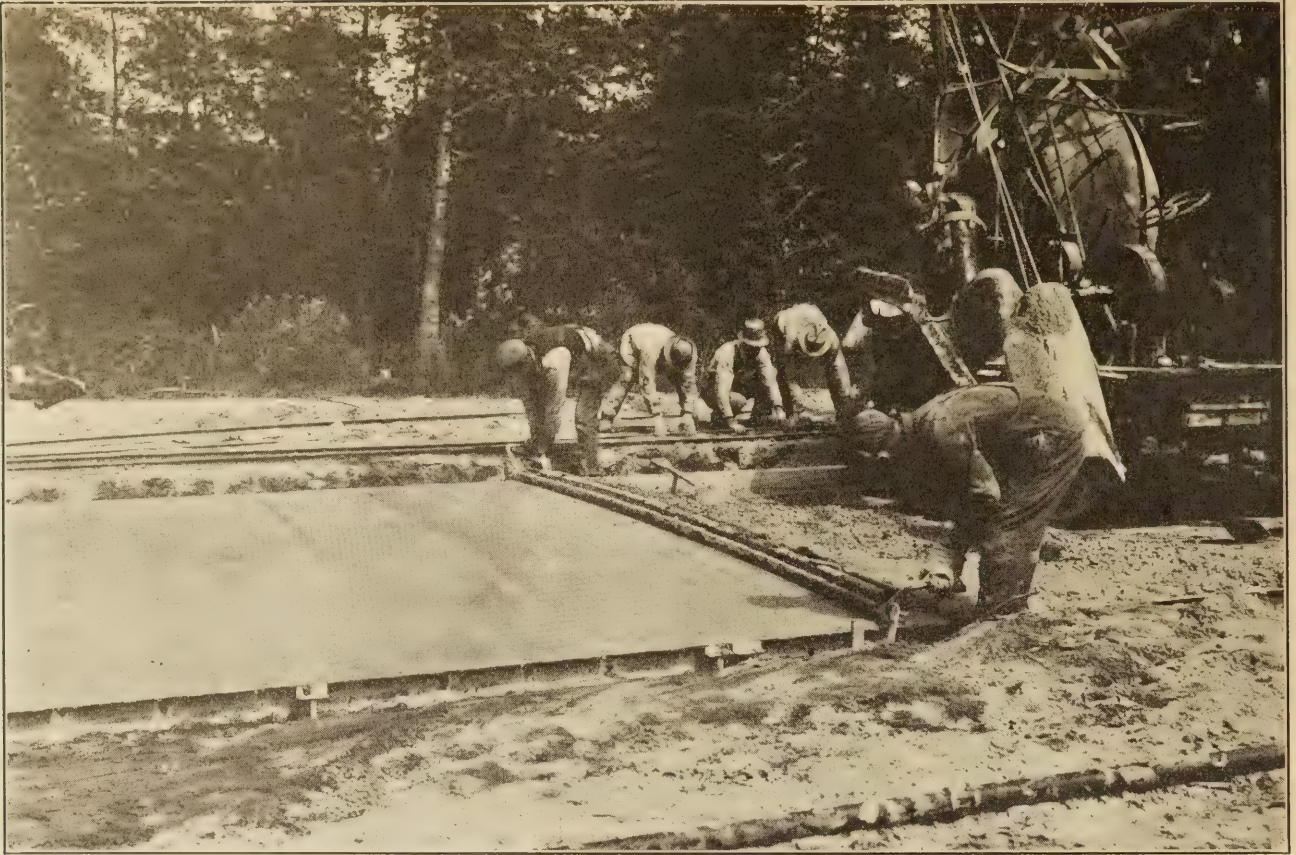

THE 400-POUND TEMPLATE IN USE ON DELAWARE FEDERAL AID PROJECT NO. 4.

to traffic, so as to relieve as much as possible the lighter built detour roads.

Section 1B of this project, being 0.492 mile in length, was not placed under contract until April of this year. The State highway department expects the completion of the entire project by August of this year.

PROJECT NO. 2.

The State's second project is a part of the main north-and-south State highway and extends from Bridgeville to Laurel, a distance of 11.52 miles. Contract for this work was awarded in May, 1918, for the sum of \$537,827.40. The project serves locally an agricultural community, but when the highway is completed to Wilmington this project will be a portion of an important through line for traffic from southern Delaware, the Eastern Shore of Maryland, and through traffic by way of Cape Charles and Norfolk.

The country through which the road passes is quite flat. Earthwork amounts to about 5,000 cubic yards per mile, and the contract price is \$1.50 per cubic yard. The contract price on concrete roadway is \$17.50 per cubic yard.

This project and project No. 4 are identical as to type and standard of construction.

The specifications for the concrete require the proportions of 1 : 2 : 4 with the addition of 0.1 cubic foot hydrated lime per bag of cement. The use of hydrated lime is based on extensive experiments conducted by the State highway department. Mixing must be carried on for a period of at least one and a half minutes with a minimum speed of the drum of

15 revolutions per minute. The practice is to use the minimum amount of water which will give a concrete that can be properly worked and finished.

Special attention is given to securing a smooth, compact, uniform finish. To obtain this the concrete is worked down with shovels immediately ahead of the template, which is worked forward with the usual sawing motion. Practice has been to develop a heavy template. The template used this season weighs 400 pounds for a 16-foot roadway. By using a template of this weight it is not lifted readily from the side forms and consequently in working forward it cuts a fairly uniform surface.

USE SPECIAL FINISHING BELT.

For removing excess water and for finishing the concrete surface the standard practice of using a roller and belt is followed. For the past year a special arrangement for the finishing belt has been used in Delaware. It is a bow-belt 10 inches wide and 17 feet long attached to two 3 by $\frac{5}{8}$ inch boards bowed so that the apex of the arc is 3 feet above the four-ply belt. Rubber belting is preferred to canvas, as the latter is liable to warp out of shape. C. S. Gale, engineer of construction for the State highway department must be given considerable credit for this form of belt finisher, and also for the heavier template now being used.

Joints are placed in concrete roadways only as construction features. At the end of each day's work a joint is made by finishing the concrete against a bulkhead cut to conform to the finished cross section of the road. Through this bulkhead



USING THE SPECIALLY DEvised 10-INCH BOW BELT ON DELAWARE FEDERAL AID PROJECT NO. 4.

five $\frac{1}{2}$ inch steel bars 4 feet long are extended for half their length into the concrete. These bars are coated with asphalt before being placed in the concrete. When the work is resumed the bulkhead is removed and the new concrete placed against the old, embedding the exposed portions of the bars. The joint thus formed is simply held in a vertical plane, the bars acting merely as dowels, allowing opening of the joint in a horizontal plane but no separation of the slabs vertically.

ROADS OPENED AFTER 30 DAYS.

The finished concrete is first protected by canvas and then with 2 inches of wet earth for 14 days. Concrete roadways are not opened to traffic until 30 days have elapsed from the time the concrete was placed.

Construction methods on this project are along the lines usually followed in this type of roadway. Grading generally has been completed, except for subgrade finishing, well in advance of the placing of concrete. Coarse aggregate is delivered by rail and a clam shell bucket is used for unloading the cars. The material is stock piled or placed in a bin which discharges directly into trucks. The stone is stock piled along one side of the road on the shoulder so as not to interfere with setting forms. Sand is hauled from a local pit and dumped on the subgrade as needed. A loader is used instead of wheelbarrows to measure and deliver the aggregate to the mixer skip. When not mixing concrete this loader is sometimes used for loading sand from the pit or for loading excavation or borrow into trucks.

PROJECT NO. 4.

Project No. 4 is practically a continuation of project No. 3, extending from Laurel to the Delaware-Maryland line. A portion of this, however, was built before Federal aid was applied for and is not a part of the Federal-aid project. Contract for this work was awarded in May, 1918, at a contract price of \$237,400 for 6.3 miles.

The general plans and specifications are the same as for project No. 2, but the method of construction differs materially. All materials are received at a central storage and loading plant and are sent direct to the mixer in batch units by means of industrial railway equipment. A general plan of this storage and loading plant is shown in the accompanying drawing.

Stone and sand are received in open cars on the railroad siding (track "A") and are unloaded by means of a clam-shell bucket and derrick working on track "B." The material, if for immediate use, is placed in the bins, which are also operated on track "B" or placed in storage piles for future use. Cement is also received on track "A," and if for immediate use is unloaded onto movable platforms that can be quickly set up conveniently near the car. If the cement is for future use, it is placed in the cement storehouse, from which it is placed on temporary platforms for use as needed.

A train to be loaded receives sand and stone on track "C" by passing under the material bins, where the proper amount of each material is dumped into batch boxes. Each car carries two boxes, and a box holds a batch of aggregate. Cement and lime

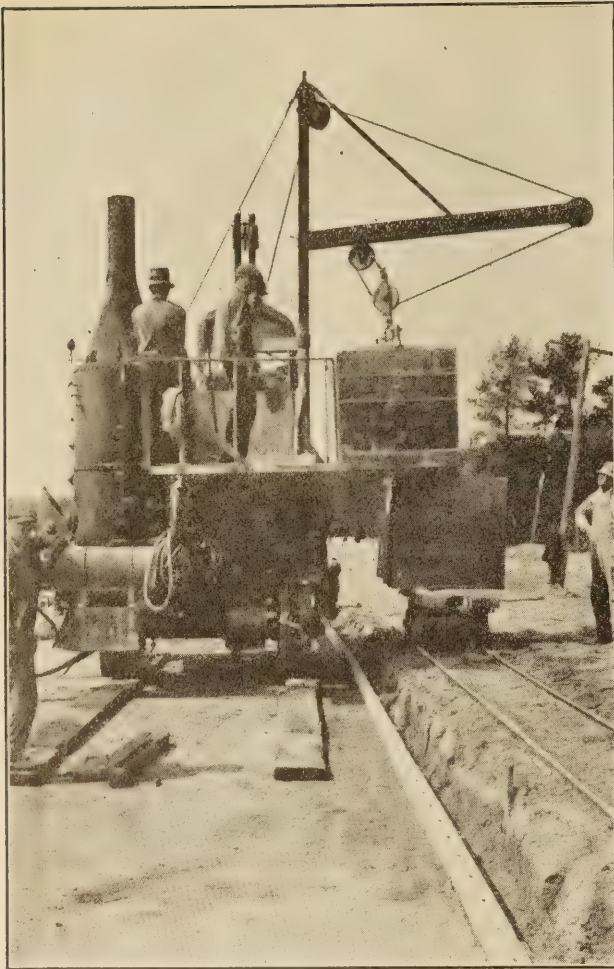

HOISTING A BATCH FOR DUMPING INTO THE MIXER DRUM
ON DELAWARE FEDERAL AID PROJECT NO. 4.

are received from track "D", the cement being left in bags until the mixer is reached. Tracks "E" or "F" are used to reach the mixer, depending upon its location.

Upon reaching the mixer the boxes are hoisted from the cars and dumped directly into the mixer drum. The time required for making the hitch, hoisting and dumping the box, and replacing it in the car is one and one-half minutes. The mixer is an ordinary machine remodeled to handle the boxes. The skip has been taken off, but the skip hoist is used to raise the boxes. The mast is an extra heavy 5-inch iron pipe filled with cement mortar and the boom is made up of two 6-inch channels. The mast is stepped into a casting over a worm gear and can be turned through an angle of 160° . This special attachment for handling the boxes was put together by the contractor. The hitch for lifting the boxes is simply a yoke with links on each end which engage strap-iron hooks on the boxes.

The advantages and disadvantages of this method of handling and transporting materials for road construction are generally well known. All special equipment, such as batch boxes, mixer hoist, and stone bins, were made by the contractor and used with his regular construction equipment.

At the present time the contractor has a force of 67 men and the following equipment: One concrete

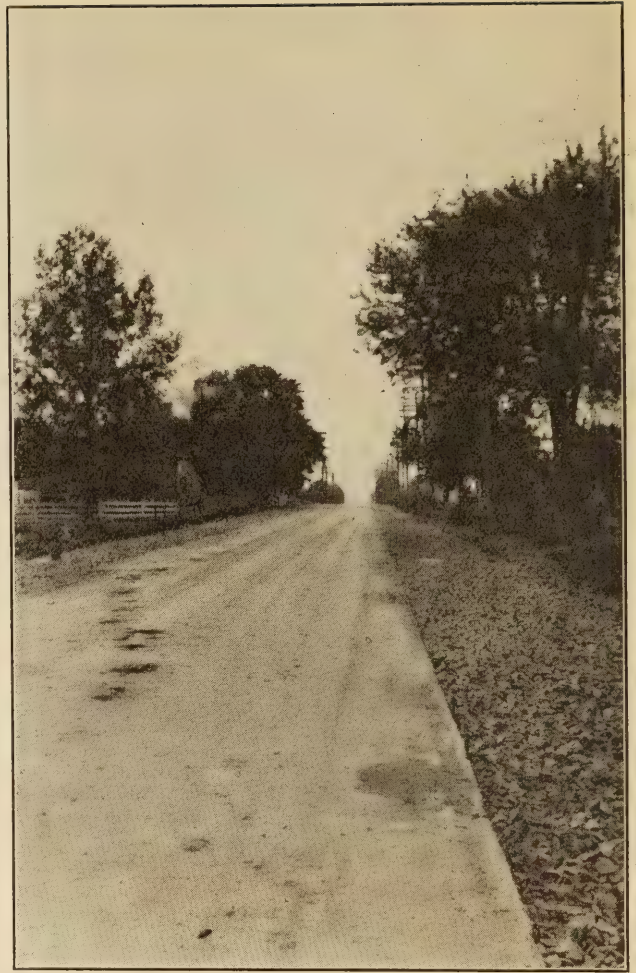

EIGHTEEN-INCH BRICK, MACADAM SHOULDERS, UNFINISHED,
ON DELAWARE FEDERAL AID PROJECT NO. 1.

mixer of 1 cubic yard capacity, 2 gasoline dinky engines, 42 cars, 84 loading boxes, $3\frac{1}{2}$ miles narrow-gauge railway, 1 steam roller, 10 teams, 2,500 linear feet steel side forms, and in addition the loading-plant equipment.

PRICES THIS YEAR ARE LOWER.

Projects Nos. 3 and 5 have been awarded recently at the prices given in Table No. 1. Some of the unit prices on this work are worthy of note in comparison with prices on similar work awarded last year (projects 2 and 4). The price for excavation was \$0.676 per cubic yard and the price for cement roadway was \$13.50 per cubic yard. These are about 45 per cent and 70 per cent respectively of last year's prices.

Recent changes in Delaware practice for the construction of concrete roads are principally the following: Use of the bow belt for finishing, using a 10-inch rubber belt; use of a 400-pound template with a minimum face of 8 inches, and requiring a batch meter for mixers on all new contracts.

At the present time the State highway department is revising its standard specifications and these are among the changes that will be made. The question of using a roller of larger diameter for finishing the concrete is now being considered, as is also the use of more rigid types of steel forms.

SUGGESTIONS FOR CONTRACTORS ON CONCRETE ROAD CONSTRUCTION

By CLYDE E. LEARNED, Highway Engineer, Bureau of Public Roads.

THE following notes and suggestions, compiled from long observation and practice in the construction of concrete highways, are offered with the view to affording aid to contractors and others engaged in such work.

Never attempt to build a concrete pavement unless you already have built one or have in your organization at least one good foreman thoroughly acquainted with this type of construction.

Troublesome equipment, especially the principal items such as the mixer and the pump, often will cause delays that are more costly than interest on new equipment. Therefore, in all cases where used equipment is employed, it is advisable to see that all is thoroughly overhauled and put into good running order before starting work. If the job is a large one, especially if isolated from repair shops, it usually will pay to consider carefully the purchase of new mixer and pump.

The cables on the mixer, as well as various parts on the mixer, the pumps, and other machines, are subject to rapid wear. To avoid delays caused by the breakage of such parts, spares should be kept on hand or under order at all times.

Have on hand at all times a list of repair parts and the nearest agencies for each machine.

CAREFUL OVERHAULING SAVES MONEY.

Keep all nuts on the mixer tightened and use plenty of oil and grease. It is money well spent to have the machinist spend ample time in carefully overhauling, cleaning, and adjusting all machines on the job.

Use a well-laid loop in feeding the mixer. By laying a 3 by 6 foot platform in front of the skip and by properly placing the runways a large skip can be loaded in a surprisingly short time.

In soft ground it will be necessary to provide runways for the wheelbarrow men and for the mixer itself. In fact, it is always better to have runways, but where they are used ample room should be provided at the skip for turning and there should be no drops onto or off of the runways.

Have the material that is distributed on the road ahead of the mixer properly placed, as considerable delay is caused when wheelbarrow men have to wheel materials a long distance.

Place a reliable man in charge of receiving and placing materials and do not depend upon the teamsters or the truck drivers to allocate them properly.

Dump wagons and trucks often cut up the subgrade, with the result that more or less material may be lost in the ruts. This loss can be largely eliminated by having a laborer fill any ruts where a load is to be dumped.

TAKE CARE OF THE SUBGRADE.

Many contractors do not pay enough attention to the preparation of the subgrade or to taking care of it after it has once been shaped up, with the result that they have costly delays at the mixer and much unnecessary expense in reshaping the subgrade. If enough care is exercised in these particulars it usually is possible to eliminate the one or two men working on the grade ahead of the mixer.

Figure the proper spacing of the loads before cement is piled along the road ahead of the mixer.

Have the cement dumped on the opposite side of the road from the pipe line.

Shake out and tie up cement sacks as they are used. A man will shake enough cement out of the bags to more than pay his wages.

Have the sacks gathered up every night rather than left in piles along the road.

Have boards placed under any cement that is to be left out over night and have enough canvas on hand to cover it in case of rain.

If side forms are to be used, grade the road so that the shoulders will not interfere with placing them.

Where wooden side forms are to be used over and over it will save money to cap them with angle irons.

If motor trucks are used for hauling, it generally will be advisable for them to back in to dump their loads.

ECONOMY IN USE OF TRUCKS.

For hauling the materials for a concrete road it is more economical to use trucks with a capacity of from 3½ to 5 tons than trucks of a smaller capacity unless local soil conditions make the operation of such large trucks inadvisable.

A small-capacity truck often proves economical for hauling cement, as it can be driven between the material piles on the road and has comparatively little tendency to damage the subgrade.

Before buying a pump do a little figuring, taking into consideration the size, length, and condition of the pipe line to be used, the maximum vertical height to which water is to be raised, the amount of water that will be required, and the source from which it must be obtained. When the supply is from a deep bored well it will be necessary to provide an

extra pump for lifting the water from the well. This should be a deep-well pump connected to an appropriate engine. It is used to pump the water into the storage tank or reservoir from which the high-pressure pump draws the water for the mixer.

Do not use less than a 2-inch pipe line, and discard all defective lengths and rethread all poor ends before laying it.

WATER REQUIREMENTS.

The water requirements will vary from 20 gallons to as much as 60 gallons per minute. This includes water for the concrete mixing, for wetting the subgrade, and one stream for curing the concrete. Usually one stream is not enough to keep the green concrete in good condition, so it will often be necessary to resort to night pumping to provide enough water for this purpose.

The following tables will be of assistance in determining the size of pump required for most conditions:

TABLE I.

Water required per minute.	Loss in friction head (in feet) in 2-inch pipe.			
	1 mile.	2 miles.	3 miles.	4 miles.
20 gallons.....	51	102	153	204
30 gallons.....	110	220	330	440
40 gallons.....	194	388	582	776
50 gallons.....	296	592	888	1,184
60 gallons.....	468	936	1,404	1,872

To the loss in head in the above table it will be necessary to add the vertical height that the water is to be pumped and to make allowance for angles and valves.

The theoretical horsepower required to raise water to different heights is given in the following table:

TABLE II.

Per minute.	Height to be raised (in feet).					
	100	200	300	400	500	600
20 gallons.....	0.50	1.00	1.50	2.00	2.50	3.00
30 gallons.....	.75	1.50	2.25	3.00	3.75	4.50
40 gallons.....	1.00	2.00	3.00	4.00	5.00	6.00
50 gallons.....	1.25	2.50	3.75	5.00	6.25	7.50
60 gallons.....	1.50	3.00	4.50	6.00	7.50	9.00

Multiply theoretical horsepower by 4 for deliveries of 30 gallons per minute or less and by 3 for deliveries of from 30 to 125 gallons per minute.

Example.

Required, 40 gallons per minute; maximum distance to be pumped = 2 miles, up a hill 100 feet in height.

From Table I:	
Loss in head in pipe line.....	= 388 feet.
Vertical height up hill.....	= 100 feet.
Estimated loss of head in valves, elbows, etc..	= 20 feet.
Total head.....	= 508 feet.
From Table II:	
Theoretical horsepower required.....	= 5 horsepower.
Actual horsepower required for engine and pump, three times theoretical horsepower...	= 15 horsepower.

RELIEF VALVES TO PREVENT DAMAGE.

The vertical distance from the water surface to the pump should not exceed 20 feet, and a foot valve should be placed on the end of the suction pipe. To prevent damage from excessive pressure in the line all pumps should be provided with relief valves.

Provide a 1-inch hose from pipe line to mixer.

At the pump provide a check valve in the main pipe line, and between it and the pump put in a tee with a short nipple, on which a globe valve is set. Open the globe valve before starting the pump, allowing the water to discharge into the air at this point. Close the valve as the engine gets up speed.

Globe valves should be provided in the pipe line about every 1,000 feet apart, 2-inch to 1-inch tees from 200 to 300 feet apart, and unions about 500 feet apart.

The insert for the mixer should be made up as follows: A 1-inch short nipple, a 1-inch globe valve, and another 1-inch short nipple, to which the mixer hose is coupled.

The hose for wetting down the concrete usually is 1-inch size, as it is easy to drag around. The inserts are made by using a 1-inch nipple, then a 1-inch square-head cock, and then another 1-inch short nipple. About a dozen of these inserts should be provided, and they should be moved from place to place as the progress of the work requires.

CARE IN LAYING PIPE LINE.

In laying the pipe line eliminate sharp sags and raises as much as possible, for air pockets at the high points will cause much trouble. If an extra tee is placed at each high point, a nipple inserted and a valve attached, the air pockets can be blown off readily. Provide a similar outlet at all low spots in order that the pipe may be drained if occasion requires.

Two men can lay 1,500 to 2,000 feet of good pipe a day.

If the size of the job warrants it a blacksmith shop will save considerable time. Provide it with a blacksmith's outfit, a strong bench vise, a drill press, and a supply of various sizes of round and flat iron.

Use white lead or a mixture of graphite and machine oil for connecting pipe line. Machine oil is preferable if the pipe is to be taken apart frequently.

When a split or a leak occurs in the pipe line mark it with red lead, so that it will be noticed, and cut out the defective section before laying the pipe again.

Provide a good grade of 1-inch hose for general use on the work.

The following list of tools and supplies are recommended for repair work on the concrete mixer and pipe line:

Hinge pipe vise and bench (light and movable).

NEW NEBRASKA ROAD LAWS.

Pipe cutter, pipe dies, and holder.
 Breast drill, with assortment of bits.
 Cold cutters, cold chisels, and hacksaws.
 Wrenches—monkey, Stillson, Westcotts, open-end,
 etc.
 Hose menders and couplings.
 Pliers and end-cutting nippers.
 Rubber packing, electric tape, and candle wicking.
 Assortment of carriage and machine bolts.
 Extra supply of valves, tees, ells, unions, couplings, nipples, plugs, and reducers.
 Rolls of 18-gauge wire for bundling cement sacks.

PEOPLE LIKE GOOD ROADS.

Outagamie County, Wis., in 1916 voted a bond issue of \$700,000 for the construction of a system of concrete roads. The issue was not large enough to complete the system, but the roads built proved so successful in educating the public that the county board in 1917 issued additional bonds to the amount of \$260,000 for highway work, and recently a resolution was passed by the board for a third issue, of \$160,000. At the end of this year Outagamie will have 75 miles of concrete roads.

A BIG PROGRAM FOR 1919.

From March 20 to May 2 contracts were awarded by the Pennsylvania State highway department for 249.11 miles of the State highway system. Bids will be opened June 17 for 65 miles, in various parts of the State, and contracts will be let for an additional 150 miles before July 15. This will make a total mileage of 464.12 of main State highways contracted for and on which work will be done this year. In addition construction work is under way on 137.46 miles for which the contracts were let in 1917 and 1918, bringing the total length of roads completed or under way this year to over 601 miles.

It is asserted that this work will break all records for highway expenditure and length of construction planned. The contract price for the 195 miles of road for which contracts were let from March 20 to May 2 is \$7,277,634.68. The roads are 18 feet wide. Practically all the roads are concrete, reinforced concrete, or bituminous surface.

TO BUILD PAVED HIGHWAY.

The board of revenue of Jefferson County, Ala., is considering the construction of 20 to 30 miles of permanent paved highway this year. The road will have a concrete base with brick, asphalt or other surface. The county now has about \$300,000 in its road and bridge fund and expects to receive as much more State and Federal aid. The question of issuing county bonds to the amount of \$5,000,000 is being considered.

The 1919 Nebraska Legislature passed several important laws relating to highways. The most important provides for a system of State highways, to include 79 new road sections in addition to 9 previously laid out, to be constructed and improved with State and Federal funds. The State engineer is required by January 1, 1920, to file with each county clerk a map showing all the State highways within the county. The State highways department will build the roads. The counties are required to maintain them and to provide markers. Provision was made for dividing the State into project districts, with not more than five counties to a district.

The use of the State highways is prohibited to motor vehicles over 7½ feet wide or 12 feet high, and vehicles with a load limit exceeding 600 pounds for each inch width of wheel tire are also barred. A truck carrying over 7,000 pounds combined load on any one wheel can not use the highways without special permission of the State highways board. Advertising signs upon or along the State highways are forbidden except by written permission of the board and after a fee ranging from 25 cents to \$5 is paid.

Motor-license fees were raised. Twenty-five per cent of the fees received are set aside for the county road dragging fund, the balance deposited with the State treasurer to the credit of the State highway fund to be expended for road improvement in the county from which it is collected.

A State-aid road fund was created and a tax of 3 mills levied for the years 1919 and 1920. Appropriations were made from this fund for each of the two years to the amount of \$1,546,631 to match an equal amount of Federal-aid funds.

The legislature authorized the publication of the Monthly Highway Report, the first number of which appeared in May.

BONDS FOR HIGHWAY.

Sussex County, Del., will issue bonds to the amount of \$500,000 to construct a concrete road across the county from Lewes and Rehoboth Beach to the Maryland line.

GOOD ROADS IN ALABAMA.

According to the records in the office of State Highway Commissioner Keller, of Alabama, nearly every county in the State has taken advantage of State aid in the building of roads, and a rapidly increasing number have taken up the Federal-aid proposition. Only one county has not yet taken up State or Federal aid. A large amount of road work is under way or planned in Alabama, and the year will see a large mileage added to the improved highways of the State.

11,326 MILES OF FEDERAL-AID ROADS IN APPROVED PROJECTS

IN MAY new records were made in the number of new Federal-aid projects approved, in the number of project agreements executed, and in the estimated cost of the projects and the amount of Federal aid asked and allowed. In 123 new project statements approved and in revision of two previously approved the Federal aid asked amounts to \$6,428,418.79 for roads estimated to cost \$15,203,873.06, and which will have a mileage of 762.943. Agreements were executed for 81 projects and modifications made in 21 projects previously executed. The aggregate length of the roads embraced in these agreements is 670.342 miles and the estimated cost \$6,400,912.05. Total Federal aid allowed is \$3,907,232.66.

The figures for both statements approved and agreements signed during the month show 226 projects with a mileage of 1,433.342, an estimated road cost of \$23,604,785.11. The total Federal aid involved amounts to \$10,335,651.45.

Since the Federal-aid law was passed, 1,186 projects for 11,326.356 miles of road have been approved. The estimated cost of these projects is \$108,059,783.40, and they call for Federal aid to the amount of \$42,929,483.83. The total number of agreements executed up to June 1 was 617 for 5,286.125 miles of road, with a total Federal-aid allowance of \$19,521,162.27, and an estimated cost of roads of \$47,425,729.28.

The estimated cost of roads in the applications for Federal aid received in May is \$19,192,135.05, almost one-sixth of that of all the applications since the first one was received under the law.

In the number of project statements approved during May, Georgia and Ohio were the leading States, the former with 17 and the latter with 16 projects. In the amount of Federal aid involved Ohio led, with a total of \$884,800, and Pennsylvania

followed, with requests for a total of \$822,871.60 for 6 projects. These States were also leaders in the estimated cost of the roads, the figures being \$2,881,479.38 and \$2,135,861.05. The Ohio cost is for 77.93 miles of road and Pennsylvania's for 40.87 miles. Nebraska's projects have the greatest aggregate mileage, 104.55, with the total for Georgia, 103.20, almost as great.

In five States the estimated cost of the projects approved amounts to more than \$1,000,000. In addition to Ohio and Pennsylvania they are Maryland, California, and Washington, while the Georgia amount is above \$900,000. These six States represent the East, the Middle West, the South, and the Pacific coast, indicating the country-wide movement of the road-building program.

The average cost of the Pennsylvania roads included in the projects approved is \$52,260 a mile. On one project the average will be \$59,323. One Ohio project will average about \$58,560 a mile.

The largest project approved during the month, in cost and Federal aid involved, is for 11.6 miles of bituminous and concrete road in Luzerne County, Pa., the estimated cost of which is \$618,124, for which \$232,000 of Federal aid is requested. Another Pennsylvania project, 7.6 miles of concrete in Berks and Schuylkill Counties, will cost \$426,750, and an allowance for it of \$157,471.60 is asked. A 25-mile earth road in Mendocino County, Calif., is estimated to cost \$387,805, with Federal aid of \$193,902.50.

In the agreements executed during the month Federal aid to the amount of \$1,192,386.26 was allowed to 11 Pennsylvania projects, estimated to cost \$2,770,550.43. They represent 61.16 miles of highway. New Jersey and Nebraska are second and third in amount of Federal aid allowed, \$256,666.28 and \$249,419.59, respectively, for roads estimated to cost \$570,369.53 and \$502,839.20.

RECORD OF FEDERAL-AID PROJECTS IN MAY, 1919.

State.	Project No.	County.	Length in miles.	Type of construction.	Project statement approved.	Project agreement signed.	Estimated cost.	Federal aid.
Alabama.....	22	Colbert.....	0.69	Gravel, bituminous surface treatment, or chert or slag macadam, bituminous surface treatment.	May 27	\$10,511.87	\$5,255.93
	37	Jackson.....	May 5	1 478.13	1 639.07
	38	Lawrence.....	7.38	Gravel.....	May 26	49,779.77	24,889.88
	41	Pike.....	6.89	Sand-clay.....	May 27	30,946.35	15,473.17
	43	Covington.....	4.12	do.....	May 7	33,440.00	16,720.00
	46	Jackson.....	6.00	Macadam.....	May 19	28,589.13	14,294.56
	47	Butler.....	3.37	Sand-clay.....	May 31	26,438.78	13,219.39
	48	Barbour.....	8.66	do.....	May 12	41,583.30	20,791.65
Arizona.....	8	Maricopa.....	6.84	Concrete or bituminous.....	May 1	207,888.12	103,944.06
California.....	14	Mendocino.....	25.00	Earth.....	May 9	387,805.00	193,902.50
	15	Monterey.....	1.03	Bridge and concrete.....	May 31	304,062.00	152,031.00
	16	Humboldt.....	2.80	Earth.....	May 29	43,073.25	21,536.62
	17	Del Norte.....	7.91	do.....	do.....	241,802.00	120,901.00
	18	Humboldt.....	7.94	Concrete.....	May 27	142,883.40	71,441.70
Colorado.....	9	Larimer.....	19.014	Earth.....	May 23	89,924.95	44,962.47
Connecticut.....	3	New London.....	7.83	Bituminous macadam.....	May 8	256,145.23	128,072.61
	5	Fairfield.....	11.183	Bituminous.....	May 7	315,810.00	157,905.00
Florida.....	13	Orange.....	8.67	Concrete.....	May 12	153,370.80	76,685.40
	14	Santa Rosa.....	5.923	Brick or concrete.....	May 5	166,408.66	83,204.33
	15	De Soto.....	3.26	Concrete.....	May 26	51,570.67	20,000.00
	16	do.....	.67	do.....	do.....	11,798.80	5,899.40
Georgia.....	14	Floyd.....	7.444	Topsoil.....	May 26	28,524.39	14,000.00
	17	Harris.....	19.95	Earth, surfaced with topsoil in part.....	do.....	107,725.98	53,500.00
	24	Cherokee.....	2 2.05	Gravel and topsoil.....	May 2	2 12,137.55	2 7,700.00
	35	Whitfield.....	5.80	Gravel.....	May 24	54,188.67	27,094.33
	55	Walker.....	24.30	do.....	May 7	144,762.13	72,381.06
	56	Gwinnett.....	11.50	Sand-clay.....	May 26	60,759.27	30,379.63
	59	Jackson.....	4.00	do.....	May 5	21,769.00	10,884.50

¹ Modified agreement. Estimated cost and Federal-aid allowance reduced from original figures by the amounts given.
² Modified agreement. Mileage or amounts given are increases over the original figures.

RECORD OF FEDERAL-AID PROJECTS IN MAY, 1919—Continued.

State.	Project No.	County.	Length in miles.	Type of construction.	Project state-ment approved.	Project agree-ment signed.	Estimated cost.	Federal aid.
Georgia	60	Stephens	11.20	Sand-clay	May 7		\$51,218.64	\$25,000.00
	61	Wilkes	2.10	Concrete	May 16		58,167.67	29,083.83
	62	do.	.60	do.	May 10		16,587.12	8,293.56
	63	do.	.60	do.	May 13		15,869.37	7,934.68
	64	Glynn	4.49	Brick or concrete	May 6		108,820.80	54,410.40
	65	Dade	2.00	Gravel	do.		32,418.98	15,000.00
	66	McDuffie	.89	Sand-clay	May 5		11,073.96	5,536.98
	67	Green		2 bridges and approaches	May 6		63,176.48	31,588.24
	69	Franklin	11.90	Sand-clay	May 16		55,633.16	27,816.58
	70	Morgan	7.00	Concrete	do.		106,843.18	53,421.59
	71	Catoosa	7.70	Gravel	May 23		45,499.81	22,749.90
	72	Elbert	10.00	Sand-clay	May 16		51,154.71	25,577.35
	73	Richmond		Concrete bridge and approaches	do.		12,584.00	6,292.00
Idaho	11	Elmore	28.00	Gravel	May 29		262,823.00	131,411.50
Iowa	8	Decatur	9.80	Graded earth	May 9		60,320.90	30,000.00
	20	Monroe	8.25	Earth	do.		48,639.07	24,000.00
Kansas	4	Shawnee		Concrete	May 13			1 37,400.82
	11	Sedgwick		do.	do.			1 35,776.99
	17	Geary		Brick	do.			1 4,320.50
	25A	Wyandotte	2.50	Concrete			89,134.58	37,500.00
	26	Rice	7.31	Brick or concrete	May 23		337,720.90	109,650.00
Kentucky	3	Rowan	7.756	Graded and drained earth		May 27	73,775.88	36,887.94
Louisiana	25	Ouachita		Gravel	May 29		1 4,271.00	1 9,484.07
	29	Franklin	10.47	do.	May 27		101,635.93	50,000.00
Maryland	8A	Talbot	3.11	Concrete	May 31		100,085.70	50,042.85
	12A	Frederick	2.007	do.	May 8		59,008.40	29,504.20
	15	Baltimore	5.36	do.	May 2		196,812.00	98,406.00
	17	Harford	4.50	do.	May 6		142,890.00	71,445.00
	18	Cecil	2.08	do.	May 2		80,506.25	40,253.12
	20	Dorchester	2.15	do.	May 23		65,976.60	32,988.30
	22	Caroline	5.16	do.	May 2		214,445.00	103,200.00
	26	Baltimore	7.37	do.	May 19		233,750.00	116,875.00
	27	do.	.93	do.	May 29		73,975.00	18,600.00
	29	Worcester	4.55	do.	do.		176,000.00	88,000.00
	30	do.	4.30	do.	do.		169,400.00	84,700.00
Massachusetts	4	Essex		Bituminous macadam	May 1			1 2,210.22
	8	Worcester	7.016	do.	May 24		180,638.09	90,319.04
	11	Middlesex	4.849	Bituminous	May 16		158,212.45	79,106.22
	19	Bristol	2.116	Concrete	May 27		83,442.15	41,721.07
	20	Middlesex	2.909	Bituminous	May 26		77,505.45	38,752.72
Michigan	8	Allegan	.008	Bituminous macadam	May 22			1 9,199.56
	9B	Washtenaw	.124	Concrete or brick	May 5		7,715.40	2,480.00
	16B	do.	.373	Concrete, asphaltic concrete, or brick	do.		23,777.16	7,460.00
	21	Kalamazoo		Concrete	May 22		1 24,488.81	1 15,999.08
	24	Berrien		Macadam, surface treated	May 5		1 36,588.66	1 14,719.41
	25	Delta and Schoolcraft	8.128	do.	May 22		140,522.14	70,261.07
Minnesota	16	Anoka	20.46	Crushed rock	May 31		256,193.95	128,096.97
	23	Dakota	6.00	Concrete, brick, or asphalt	May 20		260,000.00	100,000.00
	26	Todd	4.80	Gravel	May 21		30,537.69	10,000.00
	27	Douglas		do.	May 27		1 4,730.62	1 22,781.96
	44	Sherburne	4.50	Asphalt, brick, or concrete	May 27		136,688.03	68,344.01
Mississippi	5	Rankin	5.787	Gravel	May 31		53,482.94	26,741.47
	17	Hinds	4.119	do.	do.		30,950.38	15,000.00
	36	Walthall	9.239	do.	do.		53,734.50	26,000.00
Missouri	11	Callaway		do.	May 23		1 9,088.60	1 4,544.30
	19	Jackson	2.40	Bituminous	May 10		89,809.41	44,904.70
Montana	3	Carbon	2.69	Gravel	May 2		17,550.77	8,775.38
	5	Big Horn	2.02	do.	do.		12,532.46	6,266.23
	6	Dawson	7.50	Gravel and shale surface	May 5		21,939.66	10,969.83
	7	do.	9.00	Gravel	May 2		21,367.83	10,683.91
Nebraska	2	Richardson, Omaha, Otoe		1 mile gravel, rest earth	May 27		1 60,032.50	1 30,016.25
	12	Logan		Graded and drained earth	May 22		1 6,168.68	1 3,084.34
	23	Sheridan	14.83	Gravel	do.		71,763.12	35,881.56
	25	Burt and Washington	33.30	Earth	May 31		107,792.65	53,896.32
	26	Gage and Jefferson	29.72	do.	May 5		72,839.89	35,419.94
	28	Chase and Hays	16.90	do.	May 5		51,480.00	25,740.00
	28	Cass and Otoe	26.19	do.	May 5		71,369.00	35,634.50
	29	Butler	37.67	do.	May 22		112,973.36	54,486.68
	38	Frontier	12.10	do.	May 7		29,480.00	14,740.00
	39	Dawson	28.50	do.	May 23		48,840.00	24,420.00
	41	Dundy	13.60	do.	May 2		40,480.00	20,240.00
	45	Sioux	8.25	Sand-clay	May 12		45,804.00	22,902.00
	60	Hall and Howard	25.20	Earth	May 29		56,980.00	28,490.00
Nevada	9	Washoe	5.42	Concrete or bituminous	May 31		161,299.74	80,634.87
	21	do.	1.00	Concrete	May 5		42,958.30	20,000.00
	22	Eureka	6.30	Gravel	May 23		89,900.53	44,950.26
New Hampshire	21	Cheshire and Coos	3.59	do.	May 5		15,413.86	7,706.93
	23	Hillsborough	2.09	Gravel or macadam	May 26		29,984.46	14,992.23
	27	Grafton and Hillsborough	1.515	do.	do.		30,000.00	15,000.00
	38	Hillsborough	1.30	Bituminous	May 29		14,194.29	7,097.14
New Jersey	5	Atlantic	3.873	Concrete	May 15		146,091.00	65,740.95
	6	do.	5.867	do.	do.		222,382.85	100,072.28
	8	Cape May	2.025	do.	May 16		74,211.74	33,395.28
	9	do.	3.575	do.	do.		127,683.94	57,457.77
	11	Atlantic	4.418	do.	May 16		183,864.59	88,360.00
New Mexico	4	Valencia	20.62	Graded earth, surfaced where needed	May 13		74,258.74	37,134.37
	19	Luna	10.25	Gravel	May 27		60,236.00	30,118.00
New York	8	Wayne		Bituminous macadam or concrete	May 5		1 41,990.00	1 20,995.00
	22	Broome	4.20	Bituminous	May 9		105,000.00	52,500.00
	24	Herkimer	2.26	do.	May 12		56,500.00	28,250.00
	25	Madison and Oneida	5.70	Concrete	do.		151,470.00	75,735.00
	26	Steuben	3.50	do.	do.		106,300.00	53,150.00
	28	Wyoming	7.90	do.	do.		247,900.00	121,950.00
North Carolina	17	Wilkes	17.60	do.	May 6		101,386.08	25,000.00
	24	Wake		Concrete	May 5		1 62,029.55	1 39,894.77
	33	Montgomery	10.78	Topsoil	May 6		22,222.40	5,000.00
	35	Forsythe	1.87	Concrete	May 12		50,335.87	26,400.00
	42	Stanly	11.68	Sand-clay or gravel	May 29		62,392.00	16,700.00
	43	Beaufort	2.20	Concrete	May 26		79,651.11	39,825.00
	44	Granville	4.569	Sand-clay	May 27		31,362.10	15,500.00
North Dakota	32	Cass	.34	2 bridges	May 26		41,250.77	20,625.33
	43	Bottineau	10.00	Gravel	May 12		23,850.75	11,925.37

1 Modified agreement. Mileage or amounts given are increases over the original figures.

RECORD OF FEDERAL-AID PROJECTS IN MAY, 1919—Continued.

State.	Project No.	County.	Length in miles.	Type of construction.	Project statement approved.	Project agreement signed.	Estimated cost.	Federal aid.
Ohio	5	Lake		Reinforced concrete or brick monolithic.		May 8	\$12,830.00	\$3.00
	23A	Stark	4.83	Brick		May 31	240,000.00	81,580.00
	23B	do.	3.21	do.		do.	162,000.00	54,220.00
	35	Portage	8.46	Macadam	May 24	do.	245,300.00	84,600.00
	40	Medina	4.73	Bituminous or concrete	May 16	do.	153,000.00	75,000.00
	41	Trumbull	9.897	Macadam or concrete	May 24	do.	348,000.00	80,000.00
	42	Seneca	4.28	Bituminous, concrete, or brick	May 24	do.	179,000.00	42,800.00
	43	Ottawa	7.14	Concrete	May 20	do.	238,000.00	71,500.00
	44	Lorain	2.70	Brick or concrete	May 19	do.	133,000.00	50,000.00
	45	do.	1.21	Concrete	May 16	do.	49,500.00	6,500.00
	49	Morgan	3.26	Macadam	May 29	do.	82,000.00	41,000.00
	51	Sandusky	5.76	Brick or bituminous	May 19	do.	337,000.00	86,400.00
	52	Huron	1.28	Brick	May 24	do.	51,000.00	17,000.00
	55	Miami	3.59	Concrete	May 19	do.	106,000.00	20,000.00
	57	Shelby	3.04	do.	May 24	do.	96,000.00	35,000.00
	58	do.	3.52	do.	do.	do.	106,000.00	35,000.00
	60	Holmes	10.00	Macadam	do.	do.	414,079.38	100,000.00
	65	Hancock	6.04	Brick, asphalt, or concrete	May 19	do.	243,600.00	90,000.00
	80	Washington	3.026	Concrete	May 29	do.	100,000.00	50,000.00
Oklahoma	9	Le Flore		Bridge	May 19	do.	38,500.00	19,250.00
	10	do.		3 bridges	May 26	do.	129,536.00	64,768.00
	11	McClain and Pottawatomie		Bridge	May 29	do.	200,000.00	100,000.00
Oregon	10	Baker	18.80	Earth		May 26	91,258.36	38,129.18
	12	Yamhill	2.75	Macadam		do.	39,986.95	14,993.47
	18	Polk	7.00	Hard surface	May 7	do.	217,963.00	93,548.00
	19	Marion	4.18	Concrete or bituminous	May 12	do.	99,895.11	49,947.55
Pennsylvania	13	Armstrong	4.10	Reinforced concrete		May 8	216,792.29	82,000.00
	20A	Adams, Cumberland, York	5.21	Concrete or bituminous		May 5	225,348.47	104,200.00
	21	Lehigh	6.64	Concrete		May 9	264,111.85	132,055.92
	22	Monroe	4.45	do.		do.	155,790.14	77,895.07
	23	Greene	6.49	do.		do.	358,039.05	129,800.00
	24A	Warren	5.09	do.		May 12	224,104.38	101,800.00
	25	Adams and Franklin	5.70	do.		May 23	205,181.20	102,590.60
	26	Elk	5.62	do.		do.	274,093.60	112,400.00
	27	Allegheny	8.22	Bituminous		May 12	487,638.08	164,400.00
	28	Mercer	4.53	Concrete		May 9	170,280.04	85,140.02
	29	Pike	5.60	Bituminous concrete		do.	219,809.31	109,904.65
	30	Bradford	6.00	Concrete		May 12	327,401.07	120,000.00
	31	Center	6.10	Bituminous and brick		May 16	291,060.00	122,000.00
	32	Chester	4.10	Concrete		May 15	181,720.00	82,000.00
	33	Luzerne	11.60	Bituminous and concrete		do.	618,134.00	232,000.00
	34	Berks and Schuylkill	7.60	Concrete		May 16	426,758.00	157,471.60
	35	Tioga	4.98	do.		May 12	260,150.00	99,600.00
Rhode Island	3	Washington		Bituminous macadam		May 21		1,844.00
South Carolina	8	Bamberg		Sandy-clay		May 31	19,101.40	6,740.75
	17	Calhoun	2.22	3 bridges		May 10	18,423.51	9,211.75
	24	Spartanburg	1.90	Asphalt		May 19	55,192.50	27,596.25
Texas	17	Mason	24.877	Sand-clay and gravel		May 23	42,384.97	20,000.00
	28	Morris	10.70	Sand-clay		May 22	64,342.83	32,171.41
	36	Caldwell	15.67	Gravel		do.	127,680.65	35,000.00
	39	Dallas	9.125	Concrete		May 12	365,469.20	58,000.00
	62	Foard	14.564	Gravel and sand-clay		May 22	32,379.34	14,616.89
	63	Fannin	7.12	Gravel		May 31	54,863.88	26,357.07
	75	Falls	1.10	do.		May 22	11,957.64	5,978.82
	78	Freestone	17.22	Gravel and sand-clay		do.	57,044.52	28,522.26
	80	Harris	9.269	Concrete and macadam		May 27	91,283.26	25,000.00
	81	Freestone	2.79	Gravel or macadam		May 23	40,421.58	20,000.00
Utah	34	Utah	5.74	Concrete		May 29	194,784.93	97,392.46
Virginia	20	Southampton	8.315	Gravel		May 29	183,140.54	91,570.27
	23	Charles City	4.14	do.		May 13	18,824.30	9,412.15
	30	Roanoke	2.27	Macadam		May 29	33,634.15	16,817.07
	33	Nelson	2.68	do.		May 13	34,936.00	17,468.00
Washington	17	Whatcomb	3.60	Concrete		May 12	99,812.90	49,906.45
	18	Skagit	5.57	Gravel		do.	61,380.55	30,690.27
	19	Jefferson	3.49	do.		do.	46,999.15	23,499.57
	20	Spokane	7.80	Gravel or macadam		May 27	81,051.98	40,525.99
	21	Grant	4.89	do.		do.	42,642.71	21,321.35
	22	Spokane	4.50	Concrete		do.	118,597.60	59,298.80
	23	do.	3.88	do.		May 26	108,618.84	54,309.42
	24	King	6.42	do.		May 21	187,484.00	93,742.00
	25	Thurston	7.00	do.		do.	213,075.50	46,537.75
	26	Grays Harbor	3.17	do.		May 23	85,360.00	42,680.00
West Virginia	20	Doddridge	.57	do.		May 23	20,353.30	6,700.00
	22	Hancock	1.05	Brick on concrete base		May 5	24,851.75	10,500.00
	23	Kanawha		Asphaltic concrete		May 23		10,000.00
	25	Lincoln	4.50	Concrete		May 16	89,503.01	40,600.00
	27	Barbour	3.14	Macadam		May 15	59,614.50	29,000.00
	28	Tyler	1.50	Concrete		do.	40,903.00	20,451.50
	37	Marion	.76	do.		May 12	32,979.92	15,200.00
	38	Fayette	6.00	Bituminous		do.	103,248.20	44,200.00
	42	Raleigh	5.24	do.		May 31	53,674.86	26,766.00
	43	do.	1.43	do.		May 29	17,180.02	8,590.01
	44	Mercer	6.00	Macadam		do.	80,707.20	40,350.00
Wisconsin	31	Taylor	3.52	Earth		May 27	216,194.06	5,398.02
	42	Rock	12.89	Concrete		do.	164,854.98	19,198.99
	46	Waushara	10.187	Earth		do.	32,912.50	10,970.83
	49	Waupaca	9.54	Earth, surfaced in part		do.	31,986.09	10,662.03
	51	Columbia	5.05	Gravel or macadam		May 31	72,613.24	24,204.41
	53	Vilas and Iron	13.51	Earth and gravel		May 7	69,518.73	23,172.91
	65	Winnebago	.25	Concrete		May 31	5,154.20	1,718.07
	68	Wood	4.63	Gravel		May 22	24,943.16	8,314.39
	72	Dodge and Jefferson	3.53	do.		May 21	38,417.01	12,805.67
	73	Forest	4.47	do.		May 13	23,997.39	7,999.13
	75	Price	6.06	Gravel and earth		May 22	21,436.41	7,145.47
	81	Trempealeau	4.74	Gravel		May 12	68,266.11	22,755.37
	82	Vernon	2.96	Bituminous		May 14	46,207.41	15,402.47
	91	Rusk	6.80	Earth		May 24	26,639.14	8,879.71
Wyoming	20	Sheridan		Concrete or asphaltic		May 9	152,481.09	131,054.81
	36	Albany	15.00	Natural gravel		May 31	29,915.60	14,957.80
Total	227		1,433.352				23,604,785.11	10,335,651.45

¹ Modified agreement. Mileage or amounts given are increases over the original figures.

² Revised project statement. Figures given show amount of increases over the original statement.

ROAD MAKING AT FRONT IN FRANCE

By F. G. EASON, Senior Drainage Engineer, Bureau of Public Roads, Captain Company A, 317th Engineers, U. S. A.

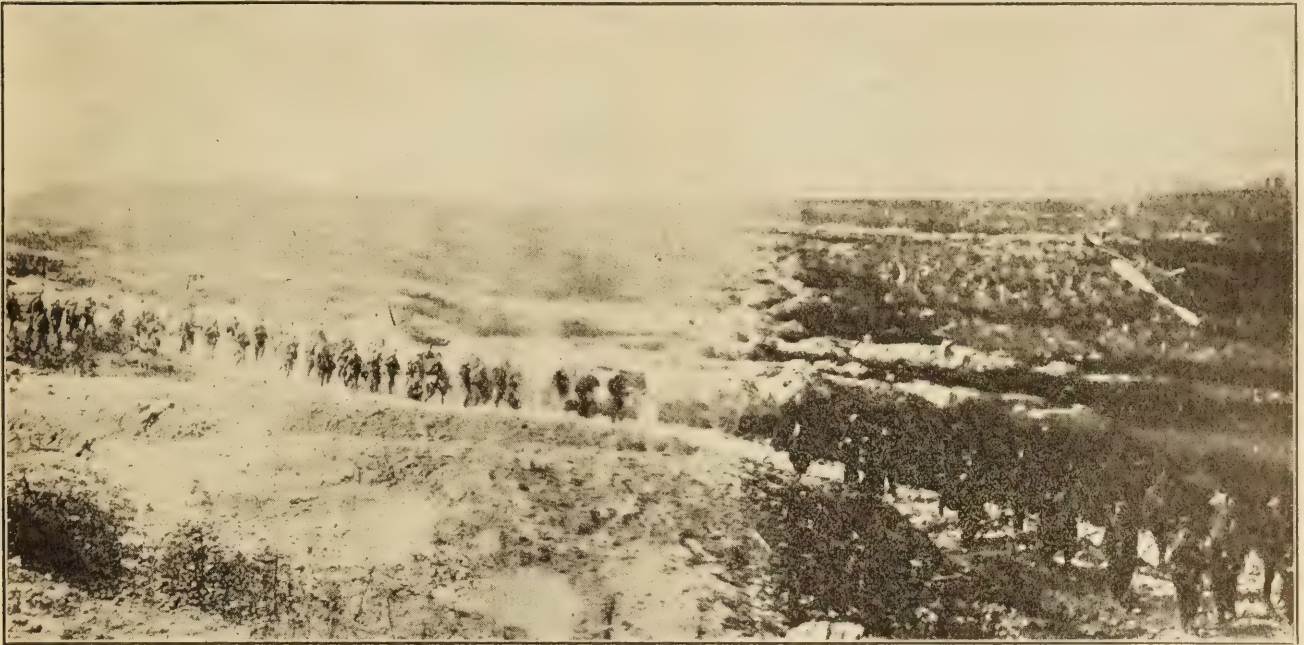

THE ROAD THROUGH NO MAN'S LAND, FOREST OF ARGONNE.

IT was very instructive, as well as interesting, to attend the 188 various schools conducted in France by the Army for the purpose of imparting the best methods of constructing roads and other engineering works at the front during active operations. It was also most amusing to see the way all of these technical methods were "shot to pieces" under actual working conditions at the front. It resolved itself into a question of simply doing the best one could with what happened to be at hand in the shortest space of time.

The golden rule in the Army is "do it now." Never mind how or with what, do it. And it is in just such instances that the American engineer on the front was enabled to put over the big jobs by bringing into play his remarkable faculties of ingenuity and resourcefulness coupled with quick action; all of which combined made him a winner and helped to break down the German war machine.

Imagine arriving at a section of the front new to you and your men and receiving orders that a certain piece of road must be opened at once. The road, surroundings, and materials are all unknown to you. That calls for quick reconnoissance to get a line on the work.

WORK BY THE "TOUCH SYSTEM."

This article will deal primarily with road construction during active operations at the front in mobile warfare, as this was the phase of fighting mostly encountered by the Americans. This will,

of course, not be applicable to the conditions of fighting in France which obtained for four years before the Germans were driven from the trenches and compelled to resort to the former style of warfare.

It is rather difficult to draw a mental picture of conditions at the front during the advance of a big drive. Everyone must have impressions from childhood of the day the big circus came to town; everything was bustle, noise, crowds, and seeming confusion. Things at the front were in very much the same shape; the country unfamiliar, the location of units not known, the roads impassable in nearly all instances from either density of traffic or large shell holes and mine craters. The incoming shells and aeroplane bombs only tended to make matters worse and add to the confusion. This was the usual condition under which the road engineer had to work and if it happened to be night on a road you had never seen the task became almost hopeless and about all that could be done was to fill shell holes by the "touch system," for, of course, no lights were allowed.

During such times and under such conditions as those just described road work resolved itself into a question not of building or repairing but simply one of keeping the roads open in any manner possible so that the continuous stream of ambulances, ammunition and supply trucks, artillery, motorcycles and automobiles could pass on uninterruptedly. To this end many expedients were resorted to for obtaining material and repairing the roads.

YAWNING MINE HOLES TO BE FILLED.

The French roads are justly famous. The prevailing type is the water-bound macadam, and in normal times these are kept in a wonderful state of repair by the most painstaking methods of maintenance done under the patrol system. This does not apply in a measure to conditions at the front, for there it was not possible to give the roads such attention, and the constant heavy traffic played havoc with them. Through "no-man's land" the roads have been practically obliterated by constant shell fire and mines, and it was there that the engineers had their hardest work. It was, of course, quite necessary that the roads across this stretch be opened up at once.

Almost without exception the main roads across "no-man's land" had been mined by the Germans, and upon their retreat the mines were set off, blowing the road off the map and leaving gaping holes 30 to 50 feet deep and with a diameter of about 100 feet. In such a case the only thing to do was to construct an entirely new road around the crater until things had quieted down a bit, and then go back and either fill the hole or bridge it. Then, upon getting back to the old road, the chief trouble would be with shell holes in the road. These varied all the way from 2 feet to 20 feet deep and a diameter of 3 to 30 feet. This called for quick filling methods, with any hard material at hand, and right here was where one of the greatest difficulties arose: that of getting proper materials for filling these numerous holes. If one were lucky enough to have a few trucks bringing up rock from the rear, things would run along smoothly enough, but this was more often the exception than the rule.

GERMAN SHELLS FURNISH MATERIAL.

The houses in the French villages are almost without exception built of stone with a rather dry mortar. These houses were, for the most part, shot to pieces, so that the stones were available for use in filling these holes along the roads, and the engineers did not hesitate to use this material wherever possible.

The Germans were not sparing with the use of concrete on their trenches, dugouts, and "pill-boxes." These were in many cases torn up to obtain material for road work. When this was resorted to there was nothing left but the steel-rod reinforcement.

There are, in many sections of the Argonne Forest and the adjoining country to the east, a substratum of clay with rocks ranging in size from a man's fist to his head. In sections where the shelling had been heavy, large quantities of these rocks would be blown out of the ground and others left loosened up in the holes. These were used when nothing else could be

had. It was no uncommon sight to see men in the fields along the roads collecting these rocks in sand bags, sacks, boxes, and on sheets of corrugated iron, for filling the holes in the roads. Other sources of materials were stone fences along the roads, roofing tile, sand bags filled with earth, etc.

There was one thing that could be found on the front without fail during active operations, and that was rain. Some of the roads through the Forest of Argonne and surrounding country that were of minor importance suddenly became of great importance during a drive, and had to be opened up. These were given the same kind of attention as the other roads except in cases where the soil was a very sticky clay, in which case it usually was necessary to corduroy. The same scouting around for suitable material would occur again, but usually it was found. A company of pioneer engineers has constructed in half a day 75 to 100 yards of corduroy road in addition to scouting around for the material.

WORKED 96 HOURS AT A STRETCH.

In passing, it might be stated that it was very disheartening to finish up a section of road and then have to go back and do the work all over again as a result of new shell holes. The work had to go on day and night. In some cases it could be done only at night, for where the enemy had direct observations, large bodies of men working on a road were almost certain to draw fire.

This also was one place where the eight-hour law was not strictly enforced. Working day and night for 72 to 96 hours was not an uncommon occurrence, and at the end of such a stretch, the ground or a hard board felt pretty good in lieu of a bed.

All big offensives slowed down after a few days of hard fighting and a lull in operations ensued. This gave the engineers an opportunity to secure some much-needed rest and to do some road work of a little more permanent nature than the rough work just described. Things got on a more normal basis and then the engineers opened up and operated quarries or brought up materials from the rear. There are several of these quarries in the Argonne country with a good quality of limestone which was used quite extensively on the roads in that section. There is also in this section a poor quality of soft-clay rock which outcrops on the hillsides. This was used considerably to fill holes and as a temporary measure did very well. Under constant heavy traffic and wet conditions it would break down and turn to mud in two or three days and it would have to be shoveled out and replaced.

HOW THEY BLEW UP BRIDGES.

The Germans are a very ingenious people, at least so far as the art of war is concerned, and they never

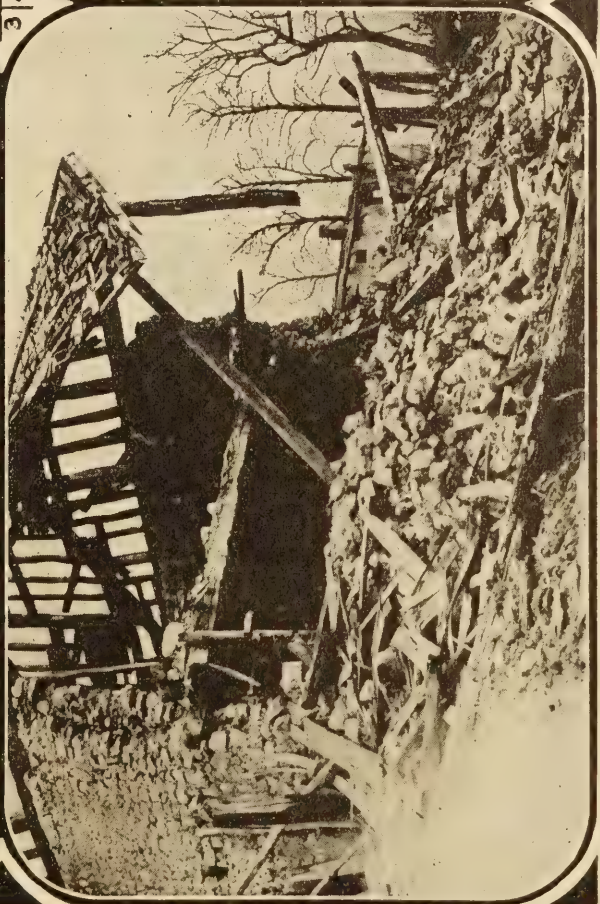
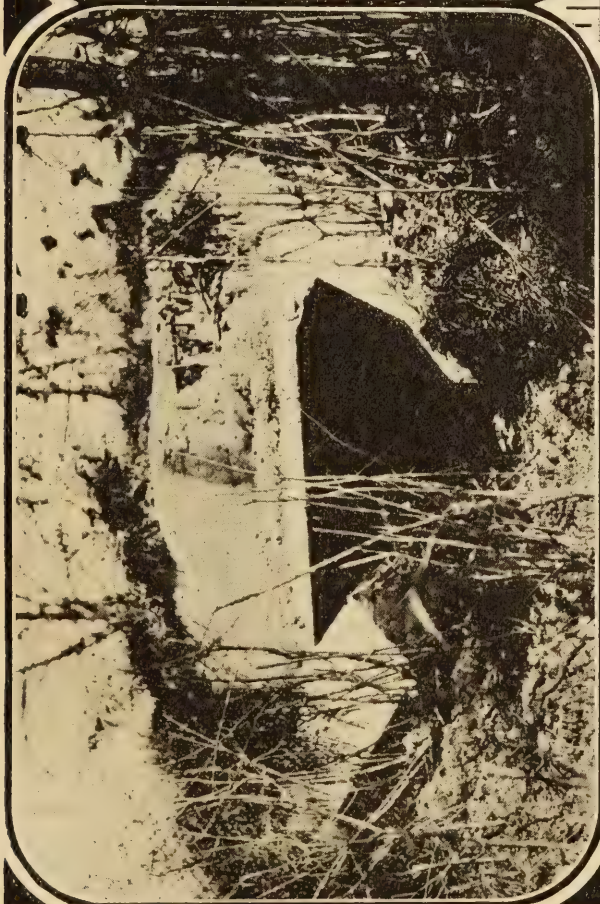
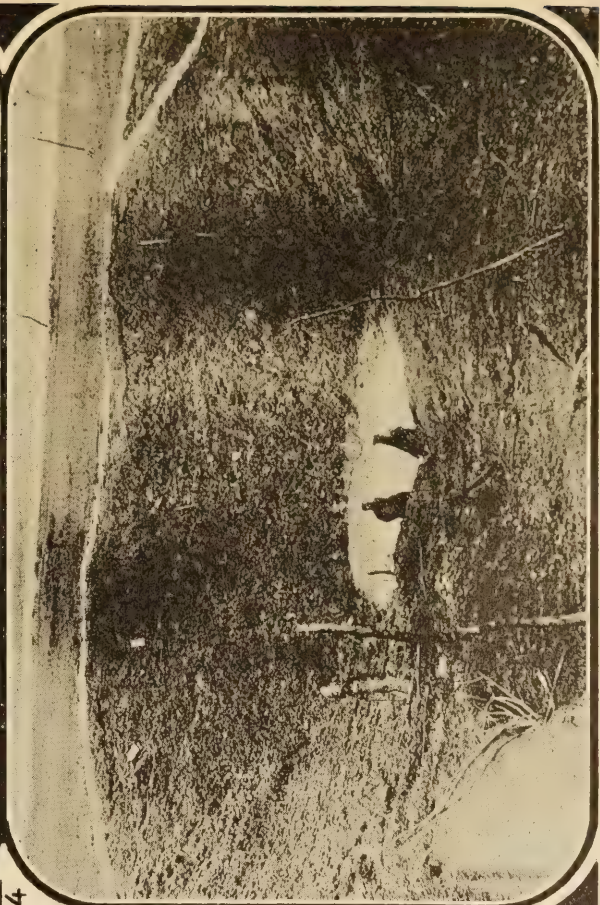
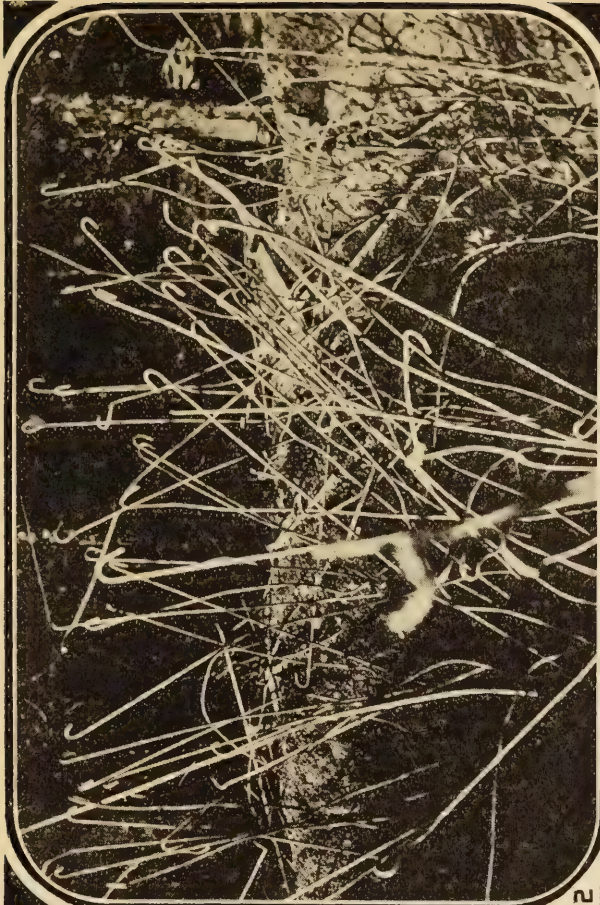

1 2
3 4

1. GERMAN PILL BOX IN MACHINE GUN POSITION, FOREST OF ARGONNE, BEFORE IT WAS BROKEN UP BY AMERICAN ENGINEERS FOR MATERIALS FOR ROAD CONSTRUCTION, AND,
 2. SHOWING STEEL REINFORCEMENT, ALL THAT WAS LEFT. 3. HOUSE SHOWING RESULTS OF GERMAN SHELL FIRE, WHICH ALSO FURNISHED MATERIAL FOR REPAIRING ROADS,
 4. ROAD IN THE ARGONNE FOREST AFTER IT WAS HIT BY A GERMAN SHELL.

overlooked anything that hindered the enemy in his advance. To this end the roads were mined and bridges destroyed. One rather novel method of destroying the small bridges consisted in making a girdle of from 12 to 15 hand grenades around each pile, under the bridge, putting a cap in one of them and connecting them up to a battery. Upon firing, the pile would be cut off and down came the bridge. The hand grenades used for this purpose were those with the handle for throwing, called by the American doughboys "potato mashers." This is cited merely to show one instance of where the Boche used his head.

In order to handle the endless stream of traffic at the front, the plan of one-way traffic now in vogue in some of the cities was adopted and proved quite successful. The routes of travel would, of course, have to be worked out hurriedly and many a poor truck driver has had to drive all over the world to get to his destination of a few kilometers, as he would have to follow the route of travel on the one-way roads and that was not always in the direction he wanted to go.

Unless a man was on staff or some special duty which carried him to different parts of the front, the knowledge he gained was confined solely to the immediate vicinity in which he was working. This is true to a remarkable extent. It is surprising what little one knew of what was going on around him during active operations. His vision was quite restricted, and limited only to the immediate part of the front in which he happened to be. As to what was going on in other parts of the line he was utterly oblivious and knew nil. Those in the rear, in the S. O. S., and in the States knew far more concerning the general operations. This makes it rather difficult to generalize, and what has been written is confined to the Forest of Argonne section.

LACK OF TRANSPORTATION.

The Americans in the big Argonne-Meuse offensive of September 26 to November 11, 1918, fought under many great disadvantages. Many of the men had never before been in a battle and things were bound to be confused at times. However, one of the greatest disadvantages was lack of transportation. This tied up certain phases of work very materially at times. A company of pioneer engineers is supposed to have two motorcycle side cars, four bicycles, and the usual quota of wagons, water carts, rolling kitchens, etc., with 41 head of horses and mules. Companies that had 10 horses to pull their equipment were lucky and motor transportation or bicycles were unknown. But in spite of all obstacles and set-backs the Americans had the fighting spirit and the determination to drive the Germans back, and they did it.

GOOD ROADS IN TEXAS.

Highway building in Texas is at its highest tide since impetus was given to it by State and Federal aid. It is estimated by the State highway engineers that more than \$20,000,000 worth of roads are now under construction. Bond issues in counties and subdivisions of counties are of weekly occurrence and the agitation for good roads is so general that enthusiasts believe that all the State highways in Texas will soon be built and maintained in a high state of usefulness.

Representative C. O. Laney, the author of the \$75,000,000 road bond amendment which the people will vote on next November, estimates that \$200,000,000 will be available for road construction in the State during the next 5 years if road bonds contemplated are issued. Counties in the State have already voted or now have pending road bonds amounting to \$23,670,000, the State will receive Federal aid money amounting to about \$9,000,000 this year with approximately \$20,000,000 allotted for the next three years. The voting of the \$75,000,000 will greatly stimulate the further issuance of county bonds during the five-year period.

SAVE A CENT A MILE.

The commissioner of highways of Milwaukee County, Wis., estimates from statistics he has compiled that the improved roads of that county save \$2,500 a day to the people who use them. The statistics are based on a census of the traffic taken periodically during the last four years. This census is made by selecting 52 points scattered throughout the county, and making seven counts at each point, one for every day of the week. The count is not made on consecutive days, but at various periods from April to November, so as to arrive at average conditions. This census is taken to determine the durability of certain types of pavement, according to the amount of traffic per square yard. It shows that about 25,000 vehicles of all kinds travel the highways each day. Traffic on the road has increased about 42 per cent a year during the four years in which the survey has been made.

ILLINOIS BOND ISSUE VALID.

The Supreme Court of Illinois has decided, in a test suit, that the \$60,000,000 road bond issue approved by the voters last November is valid. The suit was a friendly one, brought that a decision from the court might be secured which would remove all doubt as to the validity of the bonds, so there would be nothing in the way of carrying out the program of road building authorized by the vote.

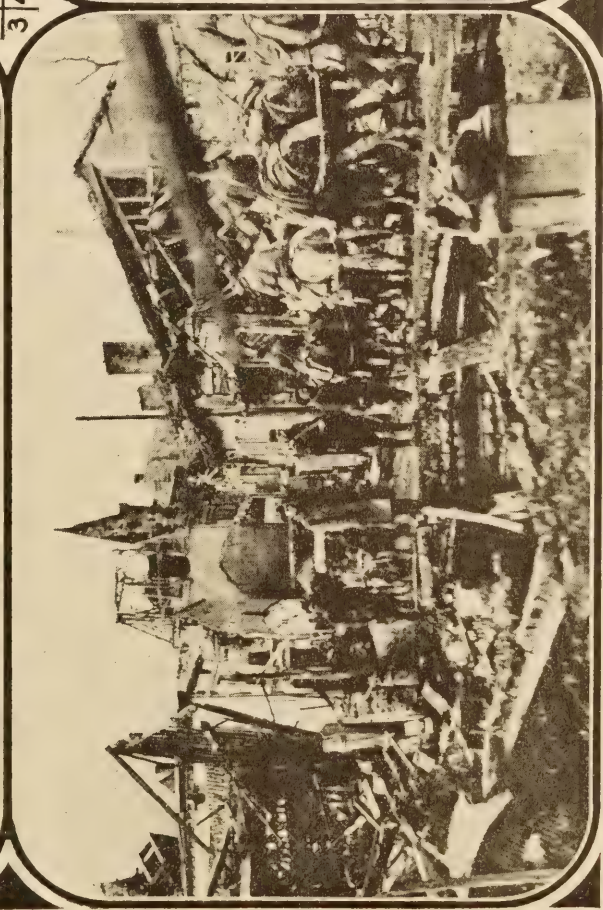
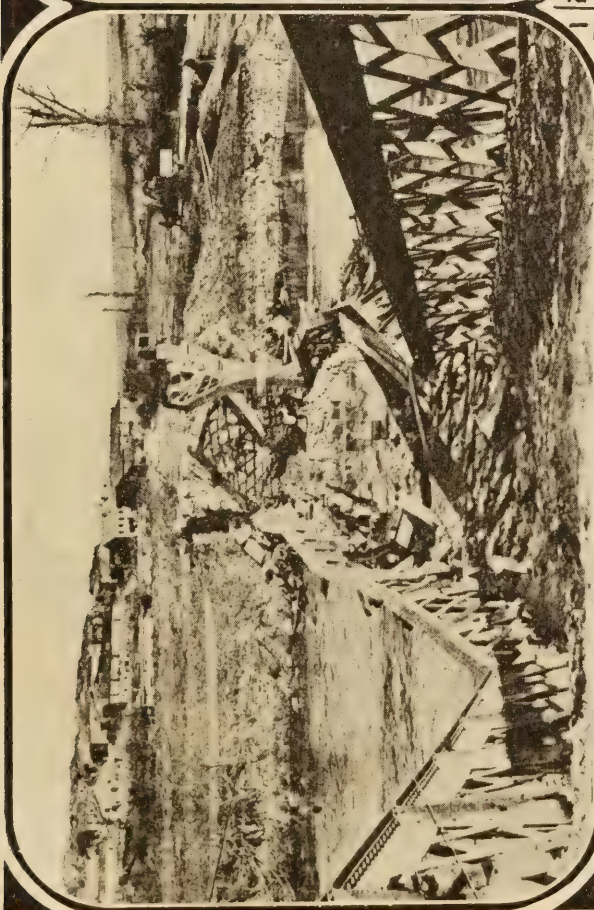
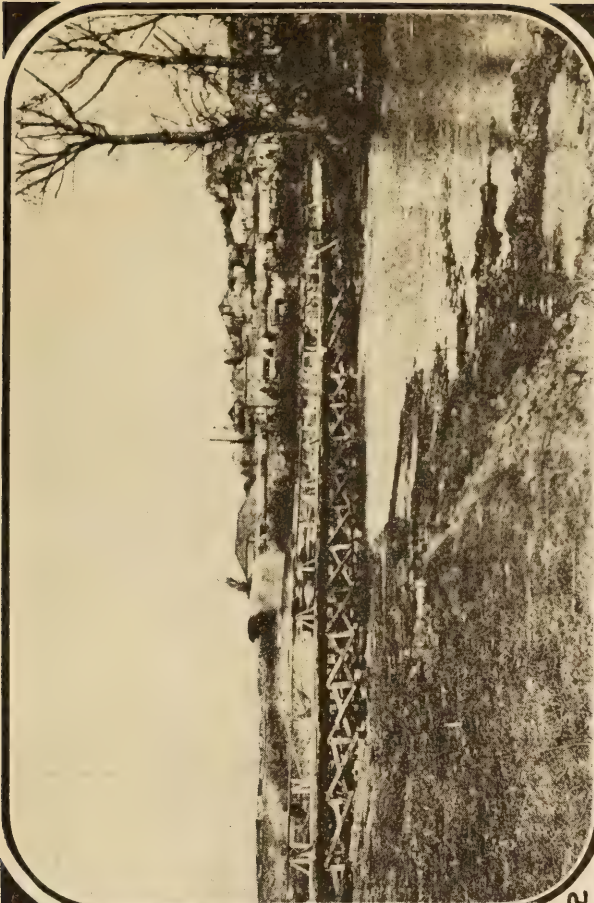

12
34

1. SHOWING GERMAN DEMOLITION OF A BRIDGE OVER THE AIRE RIVER, BETWEEN ST. JERVIN AND MARCY. 2. HASTY BRIDGE CONSTRUCTION, SHOWING BRIDGE OVER THE AIRE, IN THE SAME VICINITY, BUILT, BY AMERICAN ENGINEERS. 3. REMAINS OF GRANDPRE AFTER SHELLING. 4. BRIDGE AT GRANDPRE DEMOLISHED BY GERMANS AND HASTY RECONSTRUCTION ABOVE THE RUINS BY AMERICANS.

BONDING NEW CEMENT-MORTAR AND CONCRETE TO OLD IN TESTS

By W. E. ROSENGARTEN, U. S. Highway Engineer, Bureau of Public Roads.

IT FREQUENTLY is necessary in construction and repair work to join fresh concrete to old or to concrete which has partially set. In order to obtain definite data on the relative value of various methods of increasing the bond an extensive series of tests was planned and carried out in the Engineering Research Laboratory of the Bureau of Public Roads. This series included:

I. Tests on the bond strength in tension of a 1:2 mortar in the form of the standard tension briquette.

II. Tests on the bond strength in cross bending of a 1:3:1½ concrete in 4 by 4 by 14 inch prisms bonded to concrete slabs.

III. Tests on the bond strength in shear of a 1:3:1½ concrete in specimens in the form of 8-inch diameter cylindrical disks, 2 inches high.

IV. Tests on the permeability or water-tightness of the joints formed by various bonding methods. The same specimens were used in this series as in the shear tests.

CONCLUSIONS DRAWN FROM TESTS.

As a result of these tests the following conclusions may be drawn:

Tension.—It may be safely stated that the ability of fresh mortar to adhere to older material decreases rapidly as the old sets up. Where the older material has set for 24 hours before adding the fresh, the bonding strength is but 44 per cent of that of monolithic construction. Further ageing of the old mortar causes a slight decrease in the bonding ability, which at 7 days is 39 per cent of the original, and at 28 days has reduced to 35.5 per cent.

The bond of new concrete to old can, however, be increased by various methods, which include treatment of the old surface, the use of a bonding medium, and care in handling the new concrete.

The old surface can be treated to increase the bond either by roughing with a steel tool or by a treatment of dilute hydrochloric acid (1:10 concentrated acid and water). The acid acts on the cement particles, dissolving them and leaving the clean surfaces of the aggregate. The remaining salts should be washed off thoroughly. Roughing the surface increases the strength of bond 20 per cent, and the acid treatment increases it 13 per cent, except in the case of the tests where the old concrete has aged 7 days, in which case there appears an unexplainable detriment to the bond due to the acid

treatment. Combining both roughening and then treating with acid gives but a slightly greater bonding ability than either by itself.

The application of a thin layer of cement butter as a bonding medium has a decided effect in increasing the adhesive strength. An additional 25 per cent in strength is developed by the addition of the cement-butter layer. If the cement-butter layer is allowed to stand one hour prior to adding the fresh mortar, an additional 3 per cent may be added to the strength. The use of a proprietary compound mixed in with the neat cement butter appears to be of little additional value.

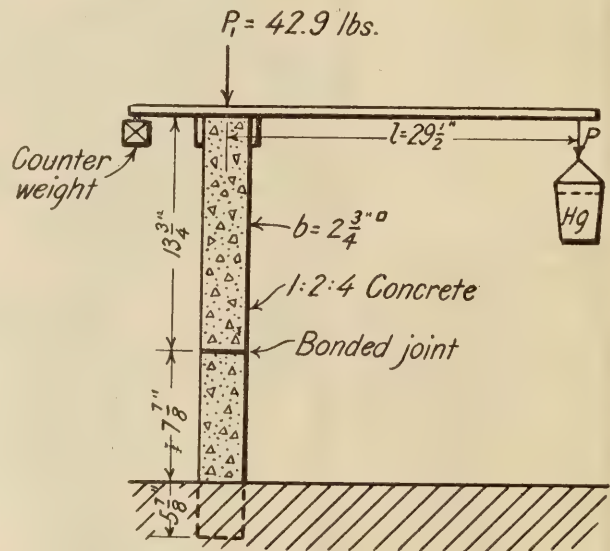

FIG. 1

METHOD USED BY MESNAGER.

The hard tamping of the new mortar against the old, thus forcing it into the pores, has a tendency to increase the strength of bond about 8 per cent.

The broken surface showed a greater bond than either the plain molded or natural surface, as might have been expected. The roughing of the two latter characters of surface had the effect of placing them on a par with the broken surfaces.

The ability to bond to the molded and natural surfaces appeared about equal. A tendency, however, is noted in the case of the surface molded against forms toward a decrease in the strength as the age of old concrete increases, while the natural surface appears to remain fairly constant after the concrete has aged 24 hours.

The effect on the bond of wetting the old mortar surface is hard to determine from the results of these tests. It is at present the usual practice to wet the old work thoroughly before attempting to bond fresh mortar to it. In about half the above tests this appears to have a detrimental effect, decreasing the bond strength about 10 per cent, while the other half shows it to have increased the bond strength 5 per cent.

The use of a bituminous bonding material is of little value.

The use of sodium silicate appears to have an effect on the bonding strength.

Cross-bonding.—The use of the hydrochloric acid wash on the concrete specimens appears to give a slightly greater bond than does the mechanical roughing of the surface. In the case of the mortar briquettes the opposite was the case.

The old concrete surface wetted develops a bond of only a little over one-fifth the strength of the monolithic concrete, roughing the surface or giving it a hydrochloric acid treatment increases the strength one-sixth and the application of a cement-butter layer adds an additional one-fifth.

The results of this series of tests show the wetting of the concrete to be beneficial. The suggested theory that the cement particles are drawn into the old dry concrete by capillary action, thus increasing the bond, does not appear to be borne out by the tests. This may be due possibly to the fact that in Test II—G, H, and I, page 33—the cement butter had insufficient water, and in Tests II—J, K, and L—where the cement milk was used, there was an excess of water.

The ability of the fresh concrete to adhere to the old decreased rapidly during the early stages of setting of the old concrete, from 100 per cent to about 30 per cent in the first 24 hours. After the old concrete has taken its final set the decrease with the age is very slight.

In general, it appears that (a) by careful treatment new concrete can be made to adhere to old with a strength equal to 60 per cent of monolithic concrete. If a greater bond than this is desired it will be necessary to resort to dowels drilled into the old concrete.

(b) If no special treatment is given the old concrete other than cleaning off foreign substances before adding the fresh concrete, a bond of but 20 per cent of the monolithic concrete is developed.

(c) The surface of the old concrete can be roughened or treated with a 1:10 dilute solution of hydrochloric acid which will increase the bond by 20 per cent of the strength of the monolithic concrete.

(d) A bonding medium of a thin layer of neat cement butter spread over the surface of the old concrete will increase the bond 20 per cent of the strength of the monolithic concrete.

(e) Tamping the fresh concrete hard against the old concrete, forcing the cement into the pores, increases the bond 5 per cent of the strength of the monolithic concrete.

It must be remembered that the above conclusions refer to a rich concrete—namely, 1:2/3:1-1/3, and that for leaner mixes the percentages very likely would be increased.

Shear.—The shearing strength of a joint is greatly increased by a treatment of the surface of the old concrete, and although it may slightly increase the cost of the work, the added effect would certainly seem desirable.

Permeability.—The results of this series show that there is no danger of leakage at a joint made in concrete of a mixture as rich as 1:2/3:1-1/3, under pressures up to 40 pounds per square inch; when the surface of the old concrete has been treated.

FORMER TESTS NOT NUMEROUS.

Engineering literature indicates that tests on bond were not very numerous. A brief synopsis of several series of tests on bonding new concrete to old, of which records have been found, are included here in order that they may be compared with the results of this investigation.

Since tests on bond strength have not been standardized the results will be comparative rather than absolute. The strengths of bonded specimens are therefore compared with the strength of monolithic specimens in order to obtain a measure of the degree of perfect bond attained by various methods. The strength of the monolithic specimens is considered the limit which may be reached by the various methods of bonding.

TESTS BY M. MESNAGER.

A record of an interesting series of bond tests by M. Mesnager, a Frenchman, was published in 1907. He used specimens of 1:2:4 concrete. The old concrete portion of the specimens was cast in a horizontal position and cured under a damp cloth. After 7 days and 30 days the second half of the specimen was cast on the end of the first half, which was stood in a vertical position, the concrete being well rammed. The connecting surface was left plain just as it came from the forms, with no additional scoring or marking. This surface, on one-half of the specimens, was well wetted before adding the new concrete, while on the remainder the surface was washed with cement grout.

The completed specimens were stored under wet cloths for 28 days and then tested as a cantilever by the method indicated in figure 1. The specimen was firmly set 5½ inches into a fixed grip. The lower arm and bucket balanced by the counterweight were clamped on the upper end of the specimen and the load applied by pouring mercury into

the bucket. Nearly all the specimens first broke some distance above the joint. The loading device was reattached to the remaining portion and again tested until failure occurred at the joint. The tension in the outer fiber was figured from the following formula.

- T = tension in outer fiber;
- P = weight of mercury;
- P^1 = weight of lever arm, bucket and counter-balance = 42.9 pounds;
- l = lever arm of P about the specimen;
- b = side of section of the specimen = $2\frac{3}{4}$ inches;

$$T = \frac{Pl\frac{b}{12}}{b^4} - \frac{P+P_1}{b^2} = \frac{6Pl}{b^3} - \frac{P+P_1}{b^2}$$

The results of the tests made are shown in the following tables:

AGE OF OLD CONCRETE, 7 DAYS.

	Specimen No.	Tests on each specimen.	"P"—breaking load in pounds.	"T"—tension in outer fiber, pounds per square inch.	Remarks.
Plain joint.....	1	a	3.5	24	Broke $\frac{7}{8}$ inch above joint. ¹
		b	3.5	24	Broke at joint.
	2	a	12.2	97	Do.
	3	a	8.7	67	Do.
Average.....				87	
Grouted joint..	4	a	23.4	191	Broke 8 inches above joint.
		b	24.3	198	Broke 4 inches above joint.
		c	25.6	209	Broke at joint.
	5	a	21.9	178	Broke $1\frac{1}{2}$ inches above joint.
		b	21.6	175	Broke at joint.
	6	a	24.8	202	Broke $1\frac{1}{4}$ inches above joint.
	b	24.6	200	Broke at joint.	
Average.....				193	

AGE OF OLD CONCRETE, 30 DAYS.

	Specimen No.	Tests on each specimen.	"P"—breaking load in pounds.	"T"—tension in outer fiber, pounds per square inch.	Remarks.
Plain joint.....	7	a	24.5	199	Broke $7\frac{1}{2}$ inches above joint.
		b	24.9	202	Broke 4 inches above joint.
		c	21.2	171	Broke at joint.
	8	a	13.9	111	Broke $10\frac{1}{2}$ inches above joint.
		b	19.1	154	Broke at joint.
	9	a	17.7	142	Do.
Average.....				163	
Grouted joint..	10	a	21.5	174	Broke $11\frac{1}{4}$ inches above joint.
		b	24.6	200	Broke $9\frac{1}{2}$ inches above joint.
		c	29.0	234	Broke $2\frac{1}{2}$ inches above joint.
		d	19.7	159	Broke at joint.
	11	a	5.5	91	Broke $8\frac{3}{4}$ inches above joint. ²
		b	26.5	216	Broke $4\frac{1}{2}$ inches above joint.
		c	31.6	259	Broke 2 inches above joint.
		d	36.7	302	Broke at joint.
	12	a	24.3	198	Broke 10 inches above joint.
		b	27.8	227	Broke $5\frac{1}{2}$ inches above joint.
		c	26.6	217	Broke $2\frac{1}{2}$ inches above joint.
	Average.....				219

¹ Disregard No. 1 as faulty joint.

² Disregard test 11-a.

The general conclusions drawn were that a grouted joint is an aid and that hard tamping adds appreciably to the bonding strength, since the new concrete was tamped with much greater force in the case of the 30-day specimens than it was with those in which the old concrete had aged but 7 days.

TESTS BY R. B. PERRY.

Following these tests Raymond B. Perry carried on a similar series of tests as a thesis for a civil engineer's degree at the Case School of Applied Science, which were published in 1908. The specimens were of the same dimensions as those made by M. Mesnager, but were of 1:2 mortar, as it was considered that a more uniform set of specimens could be obtained and that in practice the treated surface usually is one in which a mortar has flushed to the surface. The mortar was put in the forms wet and only tamped sufficiently to get out the air. The old halves of the specimens were all allowed to cure for 14 days, being kept moist. A new half was then bonded to an old half and kept moistened for an additional 21 days before testing. The load was applied in this case by pouring sand instead of mercury into the bucket. All of the cemented specimens broke at the joint. A set of full-length specimens was cast and tested after 21 days. These all broke at the center.

Various methods of increasing the bond were employed and the results in each case equated to the proportional strength of the monolithic specimens. The results of the tests, as reported, are given in the following tables:

Specimen No.	Method of treating joint.	"T"—tension in outer fiber, pounds per square inch.	(a) Average.	(b) Average of 3 nearest tests.	Per cent of (a) to full strength.	Per cent of (b) to full strength.
A1	Ends roughened with cold chisel—cuts $\frac{1}{4}$ to $\frac{1}{2}$ inch deep.....	158	124	125	49	49
A2		123				
A3		87				
A4		124				
A5		128				
B1	End smooth but covered with a cement paste $\frac{3}{8}$ inch.....	119	133	125	53	49
B2		131				
B3		207				
B4		82				
B5		124				
C	End moistened only. All broke in handling.					
D1	End roughened as in A, and covered with cement paste as in B....	279	237	229	94	90
D2		211				
D3		237				
D4		225				
D5		227				
E1	End cleaned and solution of Ransomite applied, then washed off. Thin cement grout rubbed in and $\frac{1}{4}$ inch cement paste....	232	101	228	76	90
E2		128				
E3		220				
E4		231				
E5		146				
F1	End cut with groove on neutral axis $\frac{7}{8}$ inch wide, $\frac{1}{4}$ inch deep, groove straight angles to cross arm.....	173	133	127	53	50
F2		133				
F3		120				
F4		128				
F5		110				
G1	Full length prism, $27\frac{3}{4}$ inches, tested after 21 days.....	255	252	254	100	100
G2		230				
G3		249				
G4		271				
G5		257				

The conclusions drawn from the above tests were—

1. The bond existing at a smooth joint is very slight.
2. About one-half the strength of concrete is developed in a joint bonded by—
 - (a) Roughing the surface;
 - (b) Applying layer of cement paste;
 - (c) By cutting a bonding groove.
3. When the joint is both roughened and a cement paste applied, 90 per cent of full strength is developed.
4. A solution like "Ransomite" takes the place of roughing.

TESTS BY E. P. GOODRICH.

Another series of tests on bonding new concrete to old was reported a year later by E. P. Goodrich. The test specimens in this case were the standard cement briquettes. One set of specimens was molded and broken after 24 hours, the halves being used as the old portion to which the fresh mortar was bonded. Another set of briquettes was molded with a thin strip inserted at the small one-inch cross section. The resulting smooth surface was roughened with a sharp steel tool to imitate the roughing done in practice with the pickaxe or blunt chisel. A 1:2 (by weight) cement mortar was used. All the specimens were cured in air to approximate more nearly actual working conditions. The new mortar was added to the old half specimens after they had aged for 24 hours and 7 days. All specimens were broken at the end of 30 days from time of binding. The results of the tests are shown in the table below:

Treatment of old surface before adding fresh mortar.	Broken surface.		Smooth surface roughened.	
	24 hours.	7 days.	24 hours.	7 days.
Dry.....	161 ¹ H 126 92	\$ 285 313-314 343	162 205,149 80	¹ H 15 15
Soaked 10 minutes in water.....	¹ H 60 60	138 218-189	165 90,154	¹ H 44 44
Grouted, dipped end in creamy cement.	380 315-347 ¹ H	347 280-276 200	98 43,100 160	¹ H ¹ H ¹ H
HCl, treated with 1:10 solution HCl and washed clean.	68 ¹ H 112 155	126 175-174 221	87 232-141 105	83 51-53 44
"Bondsit" powder, 5 pounds to 10 gallons water used as HCl above (a sulphuric acid).	30 60,45 4	152 105-117 95	79 54,67 68	172 26,104 114
Average.....	147	207	122	69

Whole briquettes—363, 384, 309, 438, 415, 304, 427.
Average, 377.
¹H—Denotes break in handling.

The conclusions drawn by Mr. Goodrich were:

- (a) Since best results were obtained from the natural fracture, it points to a purely mechanical bond or one with little cementitious action.
- (b) Practically no bond is developed on the surface molded against the form and which had dried for 7 days.

(c) Thorough soaking of work is essential. In the 7-day smooth surface, grouted bond, water was absorbed so rapidly from the grout as to render it an actual detriment. However, in 24 hours and 7 days, rough surface, soaked, would lead one to suppose there is a possibility of using too much water. This was thought possible in the laboratory but not in practice. The use of dry cement sprinkled over the old surface dampened is of questionable value.

(d) A coat of grout is advantageous, after first having soaked the old concrete thoroughly.

(e) The acid treatment when the old concrete has aged but 24 hours is of little value.

(f) The acid treatment is advantageous on surfaces molded against forms and having dried for seven days.

(g) The acid treatment gives more consistent results than other methods.

(h) It is difficult to explain why the rough surface, 7-day specimens were stronger than the 24-hour specimens, unless small particles were loosened and still clung to the damp surface and were brushed off the dry 7-day surface.

TESTS BY J. L. MINER.

J. L. Miner carried out a series of tests at the Lafayette College for the purpose of determining the comparative strength of different joints in bonding new concrete to old. The first half of beams were allowed to set for 48 hours before adding the remaining half. All beams were broken at the end of two months. Three kinds of aggregate and mixes were used.

Mix No. 1.—Clean, sharp bank sand $\frac{1}{4}$ inch to dust, and crushed dolomitic limestone passing $1\frac{1}{4}$ -inch and retained on $\frac{1}{4}$ -inch screen, in the proportion of 1:2:3, using 8 per cent of water and mixed by hand.







Mix No. 2.—Crushed dolomitic limestone screenings under $\frac{1}{4}$ inch, and crushed dolomitic limestone passing $1\frac{1}{2}$ -inch and retained on $\frac{1}{4}$ -inch screen, in the proportion of 1:1 $\frac{3}{4}$:3 $\frac{1}{4}$, using 10 per cent of water.

Mix No. 3.—Clean, sharp bank sand, $\frac{1}{4}$ -inch to dust, and gravel from pit along the Delaware River above Easton, all passing 2 $\frac{1}{4}$ -inch and retained on $\frac{1}{16}$ -inch screen, in the proportion of 1:1:4, using 7 $\frac{1}{2}$ per cent of water.

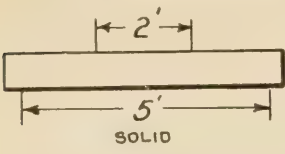
The concrete was well rammed with a $\frac{3}{4}$ -inch round iron bar with a nut on the end. The loadings were in increments of 200 pounds, and the deflections noted each time. The breaking load was recorded and the modulus of rupture figured. The beams were tested on a 5-foot span with the load

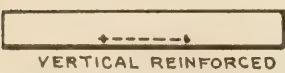
applied at two points, one 12 inches each side of the center.

The results of the tests are given in the following table:

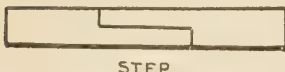
	Kind of joint.	Mix No. 1.		Mix No. 2.		Mix No. 3.	
		Pounds.	Average.	Pounds.	Average.	Pounds.	Average.
	A Solid.....	{ 2,200 3,100 3,400 }	3,275	{ 1,700 2,950 1,850 }	1,775	{ 2,900 3,700 3,000 }	3,200
	B Dovetail.....	{ 1,400 1,900 1,800 }	1,700	{ 1,350 1,350 }	1,350		
	C Vertical roughened.....	{ 750 1,050 }	900				
	D { Vertical reinforced, two 1/4-inch rods 18 inches long with nuts on either end, 1 1/2 inches from bottom, 2 inches from sides.....					{ 2,900 3,100 3,700 }	3,233
	E Scarf (1/3 length of beam).....	{ 2,150 2,300 2,450 }	2,300	{ 1,850 1,900 1,750 }	1,833		
	F Scarf washed with oxalic acid (1/3 length of beam).....			{ 2,150 2,250 }	2,200	{ 3,900 2,900 3,500 }	3,433
	G Scarf washed with cement (1/3 length of beam).....					{ 3,200 2,700 3,700 }	3,200
	H Step, 18 inches long.....			{ 800 550 }	675		

The conclusions drawn from the tests were that the reinforced was the strongest end the scarf joint next strongest. Scrubbing the old surface with oxalic acid helped to increase strength slightly.

TEST OF H. ST. G. ROBINSON.

A paper by H. St. G. Robinson, Institute of Civil Engineers in London, tells of a series of tests on the adhesion of new concrete to old. Prisms of concrete were tested as cantilevers. Six specimens of each kind of joint were tested. All were cast at the same time and the artificial joint made 7 days later, and the set tested 28 days after their manufacture.

Considering the solid prism as 100 per cent efficient, the various methods of bond showed the following degrees of efficiency:

	Per cent.
(a) Face wetted only.....	38.3
(b) Face roughened and wetted.....	56.2
(c) Face roughened and grouted.....	85.5
(d) Face treated with acid, cleaned, and new concrete applied.....	82.0

PRESENT SERIES OF TESTS.

In the light of the foregoing, the present series of tests was planned and carried out in the concrete research laboratory of the Bureau of Public Roads, to determine the value of various methods of bonding new concrete to old.

SERIES I—TENSION.

The simplest and most direct means of testing the bond of new concrete to old was by use of the standard tensile cement test, specimens having a 1 inch square section at the plane of bonding. A 1:2 mortar of Portland cement and sand was used in order to develop sufficient strength to cause the specimens to break at the joint and not in the mass itself. In actual practice three general types of surfaces of old concrete to which new concrete is to be joined may be encountered. They are, first, a broken surface, second, a molded surface, as against a wood form, and, third, a natural surface, as a

TABLE No. 1.

Series I. Bonding new cement mortar to old.

[Tension tests, standard 1:2 mortar briquettes, age of bonded joint, 28 days.]

Bonding method.		Broken surface, age of old half of specimen.			Molded surface, age of old half of specimen.			Natural surface, age of old half of specimen.		
Surface.	Medium.	1 day.	7 days.	28 days.	1 day.	7 days.	28 days.	1 day.	7 days.	28 days.
A	Dry.....	1 H } 1 H } 154	247 } 274 } 234	238 } 306 } 288	278 } 305 } 310	182 } 198 } 192	1 H } 168 } 174	191 } 171 } 181	167 } 173 } 208	207 } 218 } 227
B	Wet.....	154 } 218 } 256	281 } 248 } 270	321 } 144 } 216	345 } 230 } 236	213 } 184 } 199	180 } 113 } 116	164 } 189 } 202	226 } 222 } 243	186 } 188 } 192
C	Soaked.....	293 } 274 } 304	295 } 221 } 233	257 } 204 } 233	250 } 225 } 250	231 } 184 } 194	121 } 106 } 113	252 } 197 } 199	201 } 204 } 262	221 } 143 } 186
D	Wet.....	333 } 402 } 432	249 } 399 } 476	278 } 382 } 396	279 } 290 } 315	203 } 237 } 254	128 } 155 } 157	201 } 230 } 283	294 } 317 } 355	221 } 193 } 256
E	Wet.....	473 } 352 } 434	542 } 423 } 506	429 } 430 } 460	309 } 401 } 424	263 } 326 } 340	161 } 163 } 180	329 } 316 } 356	423 } 302 } 353	292 } 259 } 330
F	Roughened and wet.....	493 } 261 } 276	551 } 217 } 241	500 } 257 } 257	438 } 285 } 276	358 } 284 } 274	210 } 234 } 241	384 } 284 } 277	353 } 248 } 263	330 } 235 } 229
G	do.....	284 } 445 } 451	274 } 471 } 483	240 } 322 } 371	438 } 445 } 451	403 } 480 } 455	395 } 417 } 427	286 } 391 } 424	301 } 429 } 420	247 } 399 } 398
H	do.....	402 } 399 } 411	363 } 434 } 410	296 } 401 } 371	471 } 364 } 359	483 } 346 } 310	471 } 346 } 310	495 } 354 } 344	429 } 344 } 386	427 } 386 } 302
I	HCl washed.....	398 } 450 } 448	214 } 230 } 226	398 } 426 } 437	394 } 428 } 415	174 } 210 } 202	333 } 350 } 351	351 } 401 } 391	385 } 386 } 386	313 } 345 } 379
K	Wet.....	497 } 450 } 459	233 } 453 } 434	486 } 443 } 407	443 } 401 } 391	221 } 352 } 346	370 } 336 } 298	421 } 288 } 289	252 } 307 } 310	204 } 240 } 239
L	Dry.....	82 } 84 } 84	66 } 77 } 81	82 } 90 } 89	87 } 93 } 89	68 } 68 } 74	71 } 80 } 79	74 } 74 } 77
M	Wet.....	86 } 417 } 422	100 } 430 } 478	95 } 378 } 430	99 } 396 } 409	87 }	163 } 171 } 171	255 } 288 } 286	188 } 216 } 286	215 } 398 } 356
N	Wet.....	426 } 216 } 224	538 } 219 } 227	472 } 238 } 255	431 }	208 } 219 } 229	180 } 107 } 130	314 } 145 } 199	141 } 155 } 174
P	Dry.....	237 }	246 } 203 } 197	269 }	262 }	150 } 1 H } 132 } 141	274 }	242 } 242 } 258	226 }
Q	Wet.....	223 }	90 } 92 } 92	151 }	274 }
R	HCl washed.....	249 } 266 } 264	242 } 251 } 258	281 }	246 } 267 } 264	125 } 166 } 174

¹H. break in handling.

TABLE No. 2.

Series I. Bonding new concrete to old.

Tension tests on standard 1:2 mortar briquettes.

Per cent of perfect bond.

[Based on average strength of whole briquette = 570 at 28 days.]

Bonding method.		Broken surface.			Molded surface.			Natural surface.			
Surface.	Medium.	Age of old mortar at time of bonding.									
		1 day.	7 days.	28 days.	1 day.	7 days.	28 days.	1 day.	7 days.	28 days.	
A	Dry.....	Per cent.	Per cent.	Per cent.	Per cent.	Per cent.	Per cent.	Per cent.	Per cent.	Per cent.	
B	Wet.....	27.0	41.0	50.5	54.4	33.7	30.5	31.7	36.5	39.8	
C	Soaked.....	44.9	47.4	37.9	41.4	34.9	20.3	35.5	42.6	33.7	
D	Wet.....	53.3	40.9	40.9	43.8	34.0	19.8	34.9	46.0	32.6	
E	do.....	75.8	83.5	69.5	55.3	44.5	27.5	49.7	62.0	44.9	
F	do.....	76.2	88.2	80.7	74.4	59.6	31.6	62.5	57.0	50.0	
G	Roughened and wet.....	48.4	42.3	48.6	46.1	40.2	
H	do.....	79.2	79.8	75.0	74.4	69.8	
I	do.....	72.1	71.9	65.1	63.0	54.4	60.4	55.3	59.3	
J	HCl washed.....	78.6	39.7	76.7	72.8	35.4	61.6	68.6	67.7	66.5	
K	Wet.....	80.5	76.1	71.5	68.6	60.6	52.3	50.7	54.4	41.9	
L	Dry.....	Thin layer bitumen No. 12032.....	14.7	14.2	15.6	15.6	13.0	13.9	13.5	
M	Wet.....	Thin layer cement butter, stand 1 hour.....	74.0	83.8	75.4	71.7	30.0	50.1	63.4	
N	do.....	Soaked with 10 per cent solution of sodium silicate.....	39.3	39.8	44.7	40.2	22.8	34.9	30.5	
P	Dry.....	do.....	34.5	24.7	45.3	
Q	Wet.....	Thin layer bitumen No. 12032.....	16.1	
R	HCl washed.....	46.3	45.2	46.3	30.5	
		57.9	57.1	57.2	61.2	47.6	39.8	51.5	52.8	49.3

smooth glossy upper surface where old concrete work has ended.

The age of the old concrete also has an effect on the extent of the bond developed and therefore fresh mortar was bonded to half briquettes which had aged 1 day, 7 days, and 28 days.

The broken surface was obtained by molding briquettes in the ordinary manner and breaking them just prior to bonding. The halves were used separately, to which the fresh mortar was bonded. The molded surface was formed by placing thin wet wood partitions across the 1-inch section of the molds. Upon removing the specimens from the molds they parted into halves, presenting a flat surface similar to that formed by the ordinary wooden form boards. The natural surface was obtained by standing the briquette molds on end and closing in the sides of the molds, up to the 1-inch cross section, with pieces of plate glass. The mortar was then tamped into the lower half of the mold and allowed to set up under damp cloths.

When the original half specimens had cured the first 24 hours in damp air and the remainder of the time under water, the surface was treated by the various methods and then placed in one end of the briquette molds and fresh mortar added, tamping in the usual manner, except when otherwise noted. The bonded specimens were stored for 24 hours in damp air and 27 days under water. The water in the storage tank was changed occasionally. All specimens were tested when the age of the bond was 28 days.

BONDING METHODS.

The treatment of the old surface to form the bonding joint was as follows:

Method "A."—The half specimens were allowed to dry in the air of the laboratory for 24 hours, except in the case of the 24-hour tests, which were stored in the damp closet overnight and allowed to dry in the laboratory air about 4 hours before adding the fresh mortar.

Method "B."—The half specimen was removed from the water-storage tank, excess water mopped off and fresh mortar added.

Method "C."—Similar to "B," except excess water was allowed to stand on bonding surface.

Method "D."—The half specimen was treated as in "B" and then a $\frac{1}{16}$ -inch layer of cement butter (cement and water mixed to plastic consistency) was spread over the surface of the joint prior to adding the fresh mortar.

Method "E."—Similar to "D" except that the fresh mortar was tamped hard into the remaining half of the mold with the end of a knife handle.

Method "F."—For this set the molded and natural surfaces of the old half specimens were entirely roughened by nicking with the corner of a cold chisel, brushed off clean, and the fresh mortar added.

Method "G."—Similar to "F," except that a $\frac{1}{16}$ -inch layer of cement butter was spread before adding fresh mortar.

Method "H."—Similar to "F," except that a thin layer of dry cement was sprinkled over the surface prior to adding the fresh mortar.

Method "I."—The surface of the old half was treated with a dilute solution of hydrochloric acid (1 part concentrated HCl to 10 parts water). This was allowed to set for several minutes, the surface then thoroughly washed and a $\frac{1}{16}$ -inch layer of cement butter added before molding the remaining half of the specimen.

Method "K."—The old half specimen was given a $\frac{1}{16}$ -inch layer of a proprietary compound, made by mixing the compound, a powder, and cement in the proportion of 1:20, with water. The remaining half of specimen was then molded as in the previous cases.

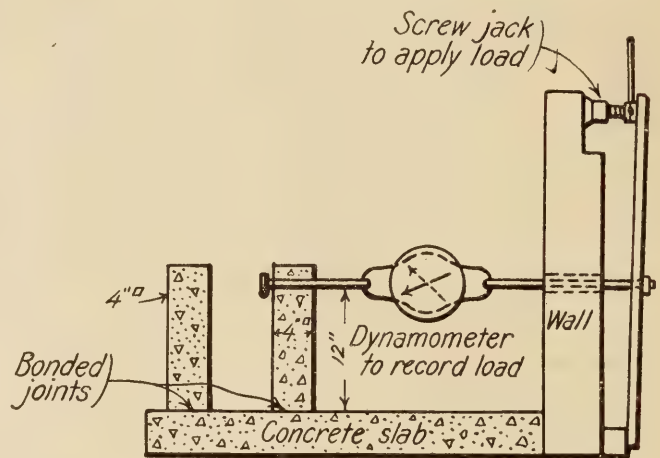

FIG. 2

METHOD OF MAKING BENDING TESTS.

Method "L."—The old surface was dried as in "A" and a thin layer of hot bitumen spread over the joint. The fresh mortar was then applied.

Method "M."—The set was treated similarly to "Method D," except that after spreading the $\frac{1}{16}$ -inch cement-butter layer, it was allowed to stand one hour before adding the new mortar.

Method "N."—The old surface was given a thorough soaking with a 10 per cent solution of sodium silicate.

Method "P."—Similar to "N," except that the old half was first allowed to dry as in "A."

Method "Q."—Similar to "L," except that the old half was not dried, but used as it came from the water-storage tanks.

Method "R."—The old surface was treated with a dilute HCl solution, as described under "Method I," and the fresh mortar added. No cement cream was used in this case.

Tables Nos. 1 and 2 on the foregoing page give the results of the tests of this series.

SERIES II—BENDING.

Realizing that the results obtained from mortar tension specimens with but a 1-inch-square breaking area have their limitations when applied to concrete construction, a series of tests were made on columns of concrete 4 by 4 by 14 inches bonded to a concrete slab. The wood forms were removed from the columns after 48 hours. The specimens were kept under a damp cloth for two weeks and in the laboratory air for two weeks. All were tested when the age of the bond was 28 days.

A 1:2/3:1-1/3 mix of Portland cement, sand passing a 1/4-inch screen, and gravel retained on a 1/2-inch and passing a 3/8-inch screen were used. The slabs were cast on edge and the surface upon which the columns were set was formed by the sides of wood molds. The roughened surfaces were formed by entirely chipping off the old surface with a cold chisel until the clean stone surfaces were exposed. The hydrochloric-acid treatment was similar to that mentioned on the series of tests on the tensile briquettes. The cement butter, made by mixing cement and water to a plastic consistency, was spread over the surface of the old concrete to a thickness of approximately 1/8 inch.

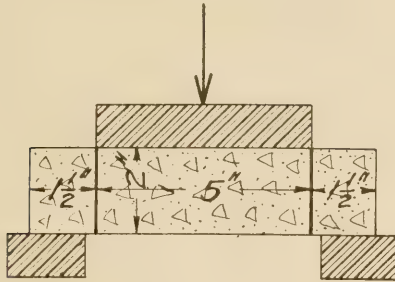

METHOD OF MAKING SHEAR TEST AT JOINT

The results of the small tensile briquette tests seemed to indicate that there might be a possible advantage in having the old concrete dry before adding the fresh concrete, a rational explanation being that the fine particles of cement are drawn into the pores of the old concrete with the water by capillary action, thus knitting together the old and new. In the tests G, H, and I of Series II, the effectiveness of the 1/8-inch layer of cement cream was impaired by the rapid withdrawal of the moisture into dry concrete. In order to overcome this and at the same time secure the possible advantage of the capillary action in assisting the bond tests, J, K, and L were made, using a wash of cement milk (equal parts by weight of cement and water) on the dry surface of the old concrete, followed by the 1/8-inch layer of cement butter. In order to obtain the effect of the age of the old concrete in its early stages of setting on the bond, the series of tests "M," below, were made. The first column was cast simultaneously with the slab. The next five were cast on the slab at later intervals, as shown in the table.

The tests were made in bending by pulling over the columns, as indicated in figure 2. The load was applied by the slow uniform turning of a screw jack, and was measured by means of a Chatillon dynamometer, having a maximum hand to indicate the breaking load.

The strength of a monolithic column of concrete, under a bending test similar to the above was obtained by casting a column 4 by 4 inches by 4 feet long. The column was held firmly between metal jaws and allowed to project 14 inches. The bending test then was made with a 12-inch lever arm similar to the other tests. The results of these tests are given in the following table:

SERIES II—BONDING NEW CONCRETE TO OLD.

Bending tests on 1:2/3:1-1/3 concrete.

(4 by 4 inch column bonded to slab and tested on 12 inch lever arm; age of bonded joint, 28 days.)

	Bonding method.		Age of old concrete.	Breaking load.		Per cent strength of monolithic specimen.
	Surface.	Medium.		Each test.	Average.	
A	{ Roughened and wet.	1/8-inch layer cement butter.	Approximate 2 months.	250 295 355	300	57.7
B	Wet.....	do.....	do.....	170 275 235 380	227	43.6
C	HCl washed.....	do.....	do.....	315 275	323	62.1
D	Roughened.....	do.....	do.....	180 175 250	202	38.8
E	Wet.....	do.....	do.....	110 115 120	115	22.1
F	HCl washed.....	do.....	do.....	210 236 185	210	40.4
G	{ Roughened dry.	do.....	do.....	220 280 215	238	45.7
H	Dry.....	do.....	do.....	185 165 290	175	33.6
I	{ HCl washed and dry.	do.....	do.....	235 200	242	46.5
J	{ Roughened dry.	Cement milk and 1/8-inch layer cement butter.	do.....	190 230 205 135	208	40.0
K	Dry.....	do.....	do.....	140 H H	137	26.5
L	{ HCl washed dry.	do.....	do.....	170 H 175	172	33.1
M	Monolithic.....	do.....	0 hours.....	460	100.0
M	Wet.....	do.....	1 1/2 hours.....	370	80.5
M	do.....	do.....	2 1/2 hours.....	375	81.5
M	do.....	do.....	3 1/2 hours.....	175	37.0
M	do.....	do.....	4 1/2 hours.....	310	67.4
M	do.....	do.....	24 hours.....	140	30.4
N	do.....	1/8-inch cement butter	do.....	130	28.3
O	HCl washed.....	do.....	do.....	255 480	55.5
Specimen ...	Monolithic.....	do.....	do.....	585 495	520	100.0

¹ H indicates a break while removing the forms from the specimen.

SERIES III—SHEAR.

In practice a joint between old and new concrete may be called upon frequently to withstand a shearing stress. In order to learn the resistance to this character of stress by various methods of bonding, specimens were made and tested for shear. The materials and mix were the same as used in Series II on bending. Concrete rings 2 inches high, having an outside diameter of 8 inches and an inner diameter of approximately 5 inches, were molded; galvanized iron rings were used for the inner and outer forms, making a smooth surface. When these had aged 1 day in damp air and 6 days in water, the inner surface of the ring was treated by the various methods and the center hole filled with concrete. The completed specimens then were stored 1 day in damp air, 3 days under water, and 10 days in air.

A total of eight specimens was made. The treatment of the inner surface of the ring just prior to adding the fresh concrete in the center was as follows: Nos. 1 and 2 were untreated except for thorough wetting. No. 3, the inner surfaces were treated with dilute hydrochloric acid and washed. Nos. 4 and 5 were spread with a one-sixteenth inch layer of cement paste; the surface of Nos. 6 and 7 was first roughened with the corner of a cold chisel until 50 per cent of it was covered with nicks one-sixteenth inch deep, and then washed clean. Specimen No. 8 was a solid disk 8 inches in diameter and 2 inches high.

The specimens were tested by supporting on a metal ring having 6-inch diameter hole. A 5-inch diameter bearing block was placed upon the specimen and the load applied as indicated in the accom-

APPARATUS FOR PERMEABILITY TEST

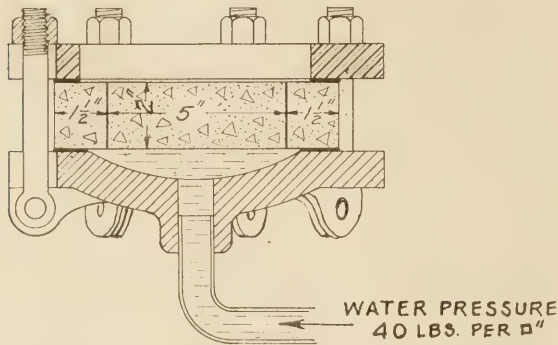

panying sketch. The results of the tests are given in the following table:

TESTS ON SHEARING STRENGTH.

Age of joint, 14 days.

Specimen No.	Treatment of bonding surface.	Total load.	Unit shear, pounds per square inch.	Percent strength of solid disk.
1	Plain, wet.....	{ 8,500	265	29
2				
3	HCl washed.....	{ 15,770	495	51
4				
5	Plain, $\frac{1}{8}$ -inch layer cement butter.....	{ 17,700	557	59
6				
7	Roughened, wet.....	{ 22,570	706	74
8				
8	Solid disk.....	33,440	979	100

It will be seen from the above table that the shearing strength of the 1:2 $\frac{2}{3}$ 1 $\frac{1}{2}$ concrete used in these tests is close to 1,000 pounds per square inch. Fresh concrete bonded to an old smooth surface develops but 29 per cent of total shearing strength. The treatment of the surface against which fresh concrete is to be placed increased the shearing strength of the joint considerably. The hydrochloric-acid treated surface developed 51 per cent of the shearing strength of the solid disk, the coating of cement cream 59 per cent, and the roughened surface 74 per cent. It is possible that a still greater strength could have been attained had the latter two treatments been combined.

The results of these tests should be conservative, as in all cases the outer ring cracked at the time the center plug of concrete pushed out.

SERIES IV—PERMEABILITY.

In connection with the above tests it was desired to obtain the watertightness of the joints formed by the various methods of bonding. A series of tests was run using the shear specimens after the bonded joints had aged one day in damp air, three days under water, and three days in the air of the laboratory. The concrete disks were clamped in an apparatus shown in the accompanying sketch and a water pressure applied to the under side of the specimen. A water pressure of 40 pounds per square inch was applied with the result shown in the following table:

Age of joint, seven days.

Specimen No.	Treatment of bonding surface.	Water pressure of 40 pounds per square inch.	
		Applied.	Leakage.
		Hours.	Grams.
1	Plain, wet.....	{ 1	7.5
2			
3	HCl washed.....	{ 5	0
4			
5	Plain, $\frac{1}{8}$ -inch layer cement butter.....	{ 3	0
6			
7	Roughened, wet.....	{ 17	0
8			

Both specimens 1 and 2, in which the joint was untreated except for wetting just previous to adding the fresh concrete, showed slight leakage. Specimen No. 1 showed leakage at 2 points, apparently from small air holes in the ring. The amount of leakage was not weighed, but was slightly in excess of specimen No. 2, which appeared to leak at but one place along the joint. None of the other specimens showed any sign of leakage. The solid disk, specimen No. 8, used in the shear test was not tested for permeability, as the results of the other specimens indicated the watertightness of the class of concrete used.

VIRGINIA ROAD BUILDING.

According to State Highway Commissioner George P. Coleman, of Virginia, road projects to cost \$3,105,929 are either under contract or being surveyed in that State. This budget includes road maintenance and reconstruction as well as new highway construction and the work of convicts, and it is more than double any previous annual total for roads in the history of Virginia. It has been financed by Federal, State, county, and private funds, and is exclusive of what counties may spend on roads not embraced in the State or county systems.

In addition to the amount to be expended as outlined, there will be \$1,600,000 Federal-aid money available this year, which the State has no fund to meet. The extent to which individual counties can raise funds to meet the requirements under the Federal law has not yet been ascertained.

THE COMMERCIAL SIZES OF CRUSHED STONE AGGREGATES

A Survey of the Present Practice in the States of Ohio, Kentucky, Tennessee, North Carolina, and Georgia

By F. H. JACKSON, Assistant Testing Engineer, and C. W. MITMAN, formerly Aid in Mineral Technology.

THE survey of crushing plant practice inaugurated by the Bureau of Public Roads early in 1917, for the purpose of securing data to be used in the development of a system of standard sizes and uniform nomenclature of crushed stone products, was continued during the past summer in the States of Ohio, Kentucky, Tennessee, North Carolina, and Georgia.

The information secured in the New England and Middle Atlantic States during the 1917 survey was published in the June, 1918, number of PUBLIC ROADS, together with a set of proposed tentative standard sizes based upon an analysis of the data obtained. In the present report the information obtained has been arranged in the same manner as in the article referred to. The deductions made will therefore be comparable.

PLANTS VISITED.

Of the 65 stone crushing plants inspected in the last field season, 34 are located in the western half of the State of Ohio and extend from the edge of Lake Erie southward to the Ohio River. Although stone-crushing plants can be found in almost every county in the western half of Ohio, there are certain centers in which activities are more or less concentrated. These are in the counties of Erie, Sandusky, Lucas, Hancock, Putnam, Allen, Franklin, Clark, Montgomery, and Hamilton. At least two plants were visited in each one of these centers, while in Lucas, Hardin, Montgomery, and Allen counties three plants were visited. The rock quarried throughout the State is a dolomitic limestone, occurring in perfectly horizontal beds varying in thickness from 3 inches to 5 and 6 feet and lying within 6 inches to 2 feet of the surface.

Six plants were visited in Kentucky, four of which are located in the vicinity of Louisville and two in the western part of the State. All of the plants crush limestone of the same character as that found in Ohio.

Five plants were visited in Tennessee. Four of these are located within a radius of 20 miles of Nashville and one located near Chattanooga. The rock crushed is a limestone of good quality when it can be obtained free from bands of shale or "rotten rock" as it is called locally.

Six plants were visited in Georgia, all located within a 50-mile zone of Atlanta. Three of these crushed granite as a by-product to the stone-block industry. Two crushed a bastard limestone and one a granitic gneiss rock. All the plants visited have a small output and (with the exception of one of the plants crushing limestone), make crushed stone almost an incidental industry.

Seven crushing plants were visited in North Carolina, distributed north and south of an imaginary line extending from Asheville to Raleigh. All the plants crush granite rock, two making the crushing industry incidental to the stone block and monumental stone industry.

PROCEDURE.

As pointed out in the article in PUBLIC ROADS referred to above, the most important element in the equipment of a crushing plant, in so far as quality of grading is concerned, is the screen. Screening methods therefore were given first consideration in the study of each plant. The data collected included the length over all, diameter, pitch, and speed of revolution of each screen, the number of screens in operation, and the length and diameter of each section of screen. If gravity or pulsating screens were used, their dimension, pitch, and size of holes in each compartment was obtained; the nominal diameter (or dimensions, if square holes) of each section of the screen at the time of inspection was recorded, together with the total length of each section having the same size holes. In addition, information was obtained pertaining to crushing and elevating machinery such as would present a complete flow sheet of operations.

The general condition and operation of the plant as a whole was noted and recorded. A record was made of each commercial size of crushed stone produced, including the name under which each size is sold, and the limits in size within which each grade is supposed to lie.

Finally, a sample of each commercial grade, available at the time of inspection, was obtained, and a mechanical analysis of each sample was made on the spot. Samples of grades smaller than one-fourth inch were mailed to Washington for mechanical analysis. The size of sample used in making each analysis was based upon the maximum size stone

present as recommended by the First Conference of State Testing Engineers and Chemists and given in United States Department of Agriculture Bulletin No. 555.

TABLE I.

Diameter of maximum size stone.	Approximate weight of sample to use.
<i>Inches.</i>	<i>Pounds.</i>
0.5	10
1.0	10
1.5	10
2.0	20
2.5	40
3.0	70
3.5	100

SCREENING METHODS IN USE.

All the plants visited are equipped with revolving screens, but a few in Ohio have in addition pulsating screens installed in various stages of the operation. Revolving screens, in the majority of cases, are used to obtain the larger sized products, while the smaller grades are obtained with the pulsating screens. The cost of maintenance of pulsating screens is high and as far as could be determined the only reason for installing them was that, for a limited space, a larger screening area could be obtained as compared with the revolving screen.

In its simplest form the pulsating screen consists of two or three rectangular frames constructed of wood and hung one beneath the other, each frame having a perforated metal or woven-wire screen attached to the under side. The three frames are in turn hung in a frame work and rocked to and fro by means of eccentrics. If a three-tier screen is used the upper has the largest perforations and the lowest the finest. All grades discharge from the screen opposite to the feeding end. These screens may be set either in a horizontal position or may be inclined, combining, in the latter case, the principles of the gravity screen and pulsating screen.

GENERAL RESULTS OBTAINED.

In discussing the results obtained during the last field season the same general order will be followed as in the original report. The tables included have therefore been arranged in the same form, and give relatively the same information as the corresponding tables in the first report.

In Table II the results of the mechanical analyses of the crushed stone products of the plants visited are given, together with those factors in screen design and operation which might presumably influence the actual sizes of the products. An analysis of these results leads, in general, to the same conclusions as were noted last year. Thus, variations in pitch and speed of revolving screens, contrary to the general idea, appear to affect the grading very little. Likewise, it may be noted that, except in a very general way, the dimensions of the

screens themselves have little influence on the sizes of the products. This, of course, does not mean that, in any individual case, the diameter, pitch, or speed of the screen does not influence the grading of the material produced. It does seem to indicate, however, that there are other influences at work which overshadow the effect of these variables.

As has been previously pointed out, the rate of feeding the stone into the screen, which, of course, varies continually during the screening operation and therefore can not be recorded, probably influences the grading to a marked degree.

OHIO REQUIREMENTS STANDARD.

In Ohio, practically all the operators are producing stone nominally in accordance with the State requirements for size. These requirements have been standard for some years, and, inasmuch as limestone is quarried throughout the State under practically the same conditions, it would seem that to produce these sizes revolving screens of the same diameter of perforations should be used in the various plants. As a matter of fact, Table I shows that this is far from true. For instance, of the 12 plants in the State producing the Ohio No. 1 standard size limestone ($2\frac{1}{2}$ - $3\frac{1}{2}$ inches or $2\frac{1}{2}$ -4 inches), or its equivalent, by means of revolving screens, one plant has 2-inch holes in its screen retaining the product, two plants have $2\frac{1}{4}$ -inch holes, six have $2\frac{1}{2}$ -inch holes, two have $2\frac{3}{4}$ -inch holes and one has 3-inch holes. Likewise, in the case of the No. 2 Ohio standard size ($2\frac{1}{2}$ - $1\frac{1}{2}$ inches), in the 11 plants producing this material the same relative variations in size of perforation may be noted.

How these variations in plant installation affect the actual sizes of the product may be gathered from the tabulated mechanical analyses and will be discussed later. Suffice to say that even in a State where standard sizes for broken stone used in road construction have been in use for a number of years, revolving screens with 13 different sizes of holes are used to produce three grades of stone.

SCREENING EFFICIENCY GREATER.

For the purpose of making comparisons between the nominal and actual sizes of product, Table III was prepared. This table is exactly the same in form as Table IV in last year's report. The interpretation of the results obtained therefore may be made in a similar manner.

It is interesting to note that the average efficiency of screening operations is somewhat greater among the plants visited this year than among those in New England and the Middle Atlantic States. As recorded in the original report, 34 per cent of all the plants visited in 1917 produced the ordinary commercial sizes with less than 5 per cent variations from the nominal size of perforations in their retain-

reasons for these discrepancies are the same as brought out in the previous article, namely, faulty chute construction, overflowing bins, etc.

SPECIFICATIONS PURELY THEORETICAL.

As explained in last year's report, the reason for analyzing the data obtained in this manner is to secure figures based on actual screening operations, which might be used in framing practical specifications for stone sizes. The average specification covering the size of crushed stone products is purely theoretical. It usually requires stone graded between certain fixed limits without any allowance for imperfect screening. It is the custom, therefore, of most operators to use screens with openings slightly larger than those specified, so as to obtain approximately the sizes desired. This custom results in the production of more or less indefinitely graded products, which sometimes do, but much more frequently do not, meet the letter of the specification. A study of the results given in Table I will show to what extent this is true.

It was in order that operators might be able to use screens with perforations the sizes specified and still secure, with reasonable care, products which conform to definite specification requirements that the system of tolerances given in the June, 1918, number of **PUBLIC ROADS** was suggested. This system calls, in general, for products graded between certain fixed limits as determined by laboratory screens, but allows as much as 5 per cent to be retained on the larger screen, and as much as 15 per cent to pass the smaller screen. It also provides, in general, that not less than 25 per cent nor more than 75 per cent shall be retained on a screen with perforations of as nearly as possible an exact intermediate size.

TOLERANCES SHOULD NOT BE REDUCED.

It was felt that for most types of construction in which broken stone is used, products meeting this specification would be satisfactory. They would, moreover, be literally meeting the specification and at the same time would possess the advantage of being practical from the standpoint of the operator. This system of specifying has been used in New York State for a number of years. The only other scheme which has been proposed to care for the situation is the one in use by the State of Pennsylvania. In the specifications of this State, revolving plant screens are used as the basis for determining the sizes required. The results of using this method, insofar as the actual grading of the products obtained is concerned, has been previously discussed.

The information obtained during the 1918 survey would indicate that, from the standpoint of present efficiency in production, the tolerances suggested last year may not be reduced without eliminating

the products of a considerable proportion of the plants involved. Before considering a more rigid specification, it is therefore necessary to presuppose increased efficiency in operation. Whether the increased cost involved in increasing efficiency would be justified is a question. In the opinion of the writers it could only be justified in cases where exceptionally well-graded stone is required.

UNIFORMITY IN NOMENCLATURE.

Referring again to Table II, it will be noted that, with the exception of the State of Ohio, there is practically no uniformity in the nomenclature used in designating crushed-stone products. The State of Ohio has, for some years, used a standard system of stone sizes, each size being designated by a number. The majority of the crushing plants in Ohio which were visited use the State system of numbers in designating their product. This is about as far, however, as the uniformity extends, because even the operators who use the same nomenclature do not always use the same screens for obtaining nominally the same product, nor do the products themselves have always the same grading. This latter point is brought out in Table IV, in which the actual sizes of crushed-stone products sold by plants using the State nomenclature are compared.

That portion of the mechanical analysis included between the vertical lines in each subdivision gives the proportion of the total product which meets the State requirements for size. Some extremely wide variations from the State requirements are shown. The general tendency is to produce larger stone than that specified. This table shows that just 3 out of the 35 products indicated meet the State requirements for size as called for by the number under which each is sold. In the writers' opinion, this table furnishes about as convincing an argument against the practice of specifying definite limits for stone sizes as could be desired.

One point in connection with the standardization of stone sizes which has not been discussed is the effect of character of stone on the maximum size allowable in various types of construction. It is recognized, for instance, that the sizes should be somewhat larger in the case of limestone than where granite or trap is used. It may be necessary, therefore, to modify the proposed system of sizes to cover this point.

GENERAL CONCLUSIONS AND SUGGESTIONS.

As a result of the field investigations carried on during the past summer it is possible to indorse the eight conclusions summarized in the article appearing in the June, 1918, number of **PUBLIC ROADS**. It is felt that the necessity for standardizing stone sizes has been demonstrated. It is recognized by both producer and consumer alike, and in the

writer's opinion it should be possible very soon to reach some basis of understanding along the lines indicated which will result in the general adoption of a series of standard sizes to be used throughout the country. Numerous operators in the course of these investigations have stated that if a standard system of sizes were adopted they would be able to turn out a better grade of product than is now possible.

The ideal crushing and screening plant operation is one in which the crusher is always crushing stone, the elevator is always elevating stone, and the screen is always receiving and screening a fixed quantity of stone. It is of course practically impossible to keep the crusher operating continuously, so that there are always intermittent periods when the screen is running practically empty. At other periods it is heavily loaded, and between the two extremes the amount of stone in the screen is constantly fluctuating. This is undoubtedly one of the principal reasons for variations in the grading of the screened products. To remedy this condition, it might be found advantageous to install a hopper at the charging end of the screen from which stone could be fed at a definite rate into the screen. Knowing the rate of feed of stone from the hopper to the screen, the speed and pitch of the latter can be adjusted so as to insure the very best possible grading. The size of the hopper need not be larger than is necessary to secure a constant supply of stone from the screen, even should the crusher run idle for a few moments. The elevator would of course discharge stone directly into the hopper instead of into the screen.

NEW JERSEY'S 1920 PROGRAM.

State Highway Commissioner Thompson, of New Jersey, has submitted to the State commission a tentative construction plan for 1920. It proposes the building of 61 miles of State highways, at an estimated cost of \$4,107,688, with \$150,000 additional for rights of way. The construction work planned for the present season, including both the 1918 and the 1919 programs, amounts to 100 miles. Commissioner Thompson regards the estimates as conservative, and that they probably exceed considerably the actual cost of construction, as they make no allowance for decreased cost of labor and materials.

The commissioner estimated that on March 31 the net available assets at the command of the highway department were \$10,493,366, from which amounts, for administration, outstanding contracts, the estimated cost of the 1919 program, and other expenses, aggregates \$5,894,263. This will leave \$4,599,104 for the 1920 construction.

FROM AUTOMOBILE LICENSES.

The fees for automobile licenses will materially increase the road funds in Massachusetts this year. The commissioner in charge of licenses estimates that the year's receipts will amount to about \$2,500,000. All the fund above the expenses of the department will be available for highway work.

TABLE III.
Efficiency of plant screening.

State.	Number of plants.	Approximate size of product.	Proportion of plants showing the following variations from nominal size.			
			Less than 5 per cent.	Less than 10 per cent.	Less than 15 per cent.	Over 15 per cent.
Ohio.....	15	4 to 2½ inches.....	34	68	74	26
	19	2½ to 1½ inches.....	16	42	63	37
	16	1½ to ¾ inch.....	31	50	63	37
	22	¾ to ½ inch.....	50	68	73	27
	72	Average.....	33	57	68	32
Georgia.....	3	2 to 1½ inches.....	67	100	100
	4	1½ to ¾ inch.....	25	75	75	25
	6	¾ to ½ inch.....	67	67	67	33
	13	Average.....	54	77	77	23
North Carolina....	7	2½ to 1½ inches.....	43	57	79	21
	7	1½ to ¾ inch.....	43	71	100	0
	4	¾ to ½ inch.....	25	100	100	0
	18	Average.....	39	72	92	8
	103	General average....	37	62	73	27

TABLE IV.

Plant No.	Known as—	Mechanical analysis.								
		Per cent over 3 inches.	Per cent between—						Per cent under ¼ inch.	
			3 and 2½ inches.	2½ and 2 inches.	2 and 1½ inches.	1½ and 1 inch.	1 and ¾ inch.	¾ and ½ inch.		½ and ¼ inch.
5.....		40	28	32						
9.....		52	36	12						
10.....		18	82	4						
11.....		73	23	4						
12.....	1	34	30	30	6					
13.....		36	40	24						
18.....		82	13	5						
20.....		47	44	9						
21.....		87	13							
23.....		75	25							
5.....				38	56	6				
9.....			6	91	3					
10.....			12	47	40	1				
12.....				47	33	19	1			
13.....	2		11	60	29					
18.....				36	47	12	5			
20.....			5	34	37	24				
21.....			36	47	12	5				
23.....					60	40				
5.....					30	61	9			
9.....					46	53	1			
10.....					17	52	27	4		
12.....					12	52	27	9		
13.....	3				1	49	32	18		
20.....					2	80	16	2		
21.....					2	83	15			
9.....						16	20	34	26	4
10.....							5	28	63	4
11.....							11	82	7	
12.....									36	40
13.....	4							10	47	43
18.....						54	18	21	7	
20.....							33	60	7	
21.....						42	27	18	13	
29.....							6	67	15	12

THE MAN WHO SAVES.

- He erects a bulwark against sickness or adversity.
- He builds a bridge to the better job.
- He takes in hand a tool to grasp opportunity.
- He sets up a ladder to climb in the world.
- He gains control over money and things.
- He trains himself for growing responsibility.
- He Buys War Savings Stamps.

BUY W. S. S.

ROAD PUBLICATIONS OF BUREAU OF PUBLIC ROADS.

NOTE.—Application for the free publications in this list should be made to the Chief of the Division of Publications, U. S. Department of Agriculture, Washington, D. C. Applicants are urgently requested to ask only for those publications in which they are particularly interested. The Department can not undertake to supply complete sets, nor to send free more than one copy of any publication to any one person. The editions of some of the publications are necessarily limited, and when the Department's free supply is exhausted and no funds are available for procuring additional copies, applicants are referred to the Superintendent of Documents, Government Printing Office, this city, who has them for sale at a nominal price, under the law of January 12, 1895. Those publications in this list, the Department supply of which is exhausted, can only be secured by purchase from the Superintendent of Documents, who is not authorized to furnish publications free. In applying for these publications the name of the series as well as the number of the publication should be given, as "Bureau of Public Roads Bulletin No. 32."

REPORTS

- Report of the Director of the Office of Public Roads for 1916.
- Report of the Director of the Office of Public Roads for 1917.
- Report of the Director of the Bureau of Public Roads for 1918.

OFFICE OF PUBLIC ROADS BULLETINS.

- *Bul. 28. The Decomposition of the Feldspars (1901) 10c.
- 32. Public Road Mileage Revenues and Expenditures in the United States in 1904. 15c.
- *37. Examination and classification of Rocks for Road Building, including Physical Properties of Rocks with Reference to Their Mineral Composition and Structure. (1911.) 15c.
- *43. Highway Bridges and Culverts. (1912.) 15c.
- *45. Data for Use in Designing Culverts and Short-span Bridges. (1913.) 15c.
- *48. Repair and Maintenance of Highways (1913). 15c.

DEPARTMENT BULLETINS.

- *Dept. Bul. 53. Object-Lesson and Experimental Roads and Bridge Construction of the U. S. Office of Public Roads, 1912-13. 5c.
- 105. Progress Report of Experiments in Dust Prevention and Road Preservation, 1913.
- 136. Highway Bonds.
- 220. Descriptive Catalogue of Road Models of Office of Public Roads.
- 230. Oil Mixed Portland Cement Concrete.
- 249. Portland Cement Concrete Pavements for Country Roads.
- 257. Progress Report of Experiments in Dust Prevention and Road Preservation, 1914.
- *284. Construction and Maintenance of Roads and Bridges, from July 1, 1913, to December 31, 1914. 10c.
- 314. Methods for the Examination of Bituminous Road Materials.
- 347. Methods for the Determination of the Physical Properties of Road-Building Rock.
- *348. Relation of Mineral Composition and Rock Structure to the Physical Properties of Road Materials. 10c.
- 370. The Results of Physical Tests of Road-Building Rock.
- 373. Brick Roads.
- 386. Public Road Mileage and Revenues in the Middle Atlantic States.
- 387. Public Road Mileage and Revenues in the Southern States.
- 388. Public Road Mileage and Revenues in the New England States.
- 389. Public Road Mileage and Revenues in the Central, Mountain, and Pacific States, 1914.
- 390. Public Road Mileage in the United States. A summary.
- 393. Economic Surveys of County Highway Improvement.
- 407. Progress Reports of Experiments in Dust Prevention and Road Preservation, 1915.
- 414. Convict Labor for Road Work.
- 463. Earth, Sand-Clay, and Gravel Roads.
- 532. The Expansion and Contraction of Concrete and Concrete Roads.
- 537. The Results of Physical Tests of Road-Building Rock in 1916, including all Compression Tests.
- 555. Standard Forms for Specifications, Tests, Reports, and Methods of Sampling for Road Materials.
- 583. Report on Experimental Convict Road Camp, Fulton County, Ga.
- 586. Progress Reports of Experiments in Dust Prevention and Road Preservation, 1916

*Department supply exhausted

- Dept. Bul. 660. Highway Cost Keeping.
- 670. The Results of Physical Tests of Road-Building Rock in 1916 and 1917.
- 691. Typical Specifications for Bituminous Road Materials.
- 704. Typical Specifications for Nonbituminous Road Materials.
- 724. Drainage Methods and Foundations for County Roads.

OFFICE OF PUBLIC ROADS CIRCULARS.

- Cir. 89. Progress Report of Experiments with Dust Preventatives, 1907.
- *90. Progress Report of Experiments in Dust Prevention, Road Preservation and Road Construction 1908. 5c.
- *92. Progress Report of Experiments in Dust Prevention and Road Preservation, 1909. 5c.
- *94. Progress Reports of Experiments in Dust Prevention and Road Preservation, 1910. 5c.
- Progress Reports of Experiments in Dust Prevention and Road Preservation, 1911.
- *99. Progress Reports of Experiments in Dust Prevention and Road Preservation, 1912. 5c.
- *100. Typical Specifications for Fabrication and Erection of Steel Highway Bridges. (1913.) 5c.

OFFICE OF THE SECRETARY CIRCULARS.

- Sec. Cir. *49. Motor Vehicle Registrations and Revenues, 1914. 5c.
- 52. State Highway Mileage and Expenditures to January 1, 1915.
- 59. Automobile Registrations, Licenses, and Revenues in the United States, 1915.
- 62. Factors of Apportionment to States under Federal Aid Road Act Appropriation for the Fiscal Year 1917.
- 63. State Highway Mileage and Expenditures to January 1, 1916.
- 65. Rules and Regulations of the Secretary of Agriculture for Carrying out the Federal Aid Road Act.
- 72. Width of Wagon Tires Recommended for Loads of Varying Magnitude on Earth and Gravel Roads.
- 73. Automobile Registrations, Licenses, and Revenues in the United States, 1916.
- 74. State Highway Mileage and Expenditures for the Calendar Year 1916.
- 77. Experimental Roads in the Vicinity of Washington, D. C.

FARMERS' BULLETIN.

- F. B. 338. Macadam Roads.
- 505. Benefits of Improved Roads.
- 597. The Road Drag.

YEARBOOK SEPARATES.

- Y. B. Sep. *638. State Management of Public Roads; Its Development and Trend. 5c.
- 727. Design of Public Roads.
- 739. Federal Aid to Highways.

REPRINTS FROM THE JOURNAL OF AGRICULTURAL RESEARCH.

- Vol. 5, No. 17, D-2. Effect of Controllable Variables Upon the Penetration Test for Asphalts and Asphalt Cements.
- Vol. 5, No. 19, D-3. Relation Between Properties of Hardness and Toughness of Road-Building Rock.
- Vol. 5, No. 20, D-4. Apparatus for Measuring the Wear of Concrete Roads.
- Vol. 5, No. 24, D-6. A New Penetration Needle for Use in Testing Bituminous Materials.
- Vol. 6, No. 6, D-8. Tests of Three Large-Sized Reinforced-Concrete Slabs under Concentrated Loading.
- *Vol. 10, No. 5, D-12. Influence of Grading on the Value of Fine Aggregate Used in Portland Cement Concrete Road Construction. 15c.
- Vol. 10, No. 7, D-13. Toughness of Bituminous Aggregates.
- Vol. 11, No. 10, D-15. Tests of a Large-Sized Reinforced-Concrete Slab Subjected to Eccentric Concentrated Loads.

*Department supply exhausted.

