



U.S. Department  
of Transportation  
**Federal Highway  
Administration**

# **The Application of Various Digital Subscriber Line (xDSL) Technologies to ITS: Traffic Video Field Assessments**

**June 1999**

**ITS Joint Program Office**

REPRODUCED BY:  
U.S. Department of Commerce  
National Technical Information Service  
Springfield, Virginia 22161

**NTIS**

**Notice**

**This document is disseminated under the sponsorship of the Department of Transportation in the interest of information exchange. The United States Government assumes no liability for its contents or use thereof.**

**Technical Report Documentation Page**

1. Report No.  FHWA-OP-99-039		2. Government Accession No.		3. Recipient's Catalog No.	
4. Title and Subtitle The Applications of Various Digital Subscriber Line (xDSL) Technologies to ITS: Traffic Video Field Assessments				5. Report Date  6-12-99	
				6. Performing Organization Code	
7. Author(s) Keith Biesecker, Giles Charleston				8. Performing Organization Report No.	
9. Performing Organization Name and Address Mitretek Systems 7525 Colshire Drive McLean, VA				10. Work Unit No. (TRAVIS)	
				11. Contract or Grant No.	
12. Sponsoring Agency Name and Address				13. Type of Report and Period Covered	
				14. Sponsoring Agency Code	
15. Supplementary Notes					
<p>16. Abstract</p> <p>Various digital subscriber line (xDSL) technologies are those methods used to implement high-speed data services (e.g., 2 Mbps Frame Relay) on a twisted pair (wire) communications medium. They are also considered strong candidates for rapidly deploying Intelligent Transportation Systems (ITS) services over existing communications infrastructure. For example, xDSL technologies provide the potential to integrate full motion traffic video over the twisted pair currently used by many traffic control systems.</p> <p>Commercially available xDSL products and services exist, and field trials have occurred for the more popular applications, including Internet access and video on-demand. However, ITS applications such as freeway surveillance video were untested. Although xDSL technologies offer great potential for ITS, they remain largely unknown to the transportation community, and further evaluation was required.</p> <p>This paper documents the final phase of a Federal Highway Administration (FHWA) study to assess the application of xDSL technologies to ITS, particularly their use of traffic video. This is an addendum to "The Application of Various Digital Subscriber Line (xDSL) Technologies to ITS: Traffic Video Laboratory Assessments"--an earlier report that provides a general understanding of the various DSL technologies and describes the concept of xDSL-based traffic video. This supplement documents the field testing of an xDSL-based traffic video prototype that was built during the laboratory studies. In addition to validating laboratory findings, field tests were used to demonstrate the prototype's capabilities in an operational environment.</p>					
17. Key Words digital subscriber line (DSL), traffic video, Intelligent Transportation Systems (ITS), field test				18. Distribution Statement	
19. Security Classif. (of this report)		20. Security Classif. (of this page)		21. No. of Pages  86	22. Price



**MITRETEK** PRODUCT

---

MP 1999-50

---

# **The Application of Various Digital Subscriber Line (xDSL) Technologies to ITS: Traffic Video Field Assessments**

**June 1999**

Keith Biesecker  
Giles Charleston

**MITRETEK**  
S Y S T E M S

**Center for Telecommunications and Advanced Technology  
McLean, Virginia**



# **The Application of Various Digital Subscriber Line (xDSL) Technologies to ITS: Traffic Video Field Assessments**

**June 1999**

Keith Biesecker  
Giles Charleston

**Sponsors:** Federal Highway Administration      **Contract No.:** DTFH61-95-C-00040

**Dept. No.:** Q020      **Project No.:** 099818B5-0A

**MITRETEK**  
S Y S T E M S  
**Center for Telecommunications and Advanced Technology**  
McLean, Virginia





## ABSTRACT

Various digital subscriber line (xDSL) technologies are those methods used to implement high-speed data services (e.g., 2 Mbps Frame Relay) on a twisted pair (wire) communications medium. They are also considered strong candidates for rapidly deploying Intelligent Transportation Systems (ITS) services over existing communications infrastructure. For example, xDSL technologies provide the potential to integrate full motion traffic video over the twisted pair currently used by many traffic control systems.

Commercially available xDSL products and services exist, and field trials have occurred for the more popular applications, including Internet access and video on-demand. However, ITS applications such as freeway surveillance video were untested. Although xDSL technologies offer great potential for ITS, they remain largely unknown to the transportation community, and further evaluation was required.

This paper documents the final phase of a Federal Highway Administration (FHWA) study to assess the application of xDSL technologies to ITS, particularly their use for traffic video. This is an addendum to "*The Application of Various Digital Subscriber Line (xDSL) Technologies to ITS: Traffic Video Laboratory Assessments*" – an earlier report that provides a general understanding of the various DSL technologies and describes the concept of xDSL-based traffic video. This supplement documents the field testing of an xDSL-based traffic video prototype that was built during the laboratory studies. In addition to validating laboratory findings, field tests were used to demonstrate the prototype's capabilities in an operational environment.

**Suggested Keywords:** digital subscriber line (DSL), traffic video, Intelligent Transportation Systems (ITS), field test



## **ACKNOWLEDGMENTS**

The authors wish to thank the hosts and supporting personnel from each of two field test sites. From the city of Alexandria, Virginia: David L. Jones P.E., Traffic Signal Systems Engineer; Juan Carrasco, Computer Room Specialist; Jose Wood, Computer Room Operator; Eric May and Walter Shepherd, Traffic Signal Technicians; Ernie “Cowboy” Clagette, Ronnie Campbell, and Andy Nguyen, Traffic Signal Service Workers. From the city of Fairfax, Virginia: Ron Schillingburg, Street Division Superintendent; James Burney, Signs and Signals Supervisor; James Dodson and Richard White, Traffic Signal and Computer Technicians; Johnny Greer and Patrick Lacour, Signal Technicians, Bruce Canton and David Vito, Signal Technician Helpers.

Their contributions were essential for rapidly deploying the field prototypes, establishing adequate test facilities, and assisting with our evaluation efforts.



## TABLE OF CONTENTS

<b>SECTION</b>	<b>PAGE</b>
1. Introduction	1-1
1.1 Purpose	1-1
1.2 Scope	1-1
1.3 Organization	1-2
2. Prototype Deployments	2-1
2.1 Pre-Deployment Considerations	2-1
2.1.1 Prototype Selection	2-1
2.1.2 Site Selection	2-2
2.2 City of Alexandria Deployment	2-4
2.2.1 Communications Infrastructure	2-4
2.2.2 Deployment	2-5
2.3 City of Fairfax Deployment	2-9
2.3.1 Communications Infrastructure	2-9
2.3.2 Deployment	2-9
3. Prototype Performance Evaluations	3-1
3.1 Methodology	3-1
3.1.1 Systems Parameter Settings	3-1
3.1.2 Quantitative and Qualitative Observations	3-5
3.2 Field Assessments	3-7
3.2.1 SDSL Prototype in Alexandria	3-7
3.2.2 SDSL Prototype in Fairfax	3-13
4. Conclusions	
4.1 Field Assessments	4-1
4.2 Demonstration	4-1
4.3 Summary	4-2
Bibliography	BI-1
Appendix A SDSL Prototype Design	A-1
Appendix B Performance Evaluation Results – Alexandria	B-1
Appendix C Performance Evaluation Results – Fairfax	C-1
Glossary	GL-1



## LIST OF FIGURES

<b>FIGURE</b>	<b>PAGE</b>
2-1 Centralized Traffic Control Architecture	2-2
2-2 Distributed Traffic Control Architectures	2-2
2-3 SDSL Prototype	2-3
2-4 Centralized Traffic Control Architecture	2-4
2-5 SDSL Prototype Installation, Alexandria	2-6
2-6 Twisted Pair Used to Provision the DSL Circuit in Alexandria	2-7
2-7 Taps Removed from the Twisted Pair in Alexandria	2-8
2-8 SDSL Prototype Installation, Fairfax	2-10
2-9 Twisted Pair Used to Provision the DSL Circuit in Fairfax	2-11
3-1 Terminal Session to the Encoder	3-2
3-2 xDSL Modem Performance Statistics	3-5
3-3 Video Motion Statistics	3-6
3-4 Traffic Controller GUI	3-6
3-5 Video Quality (Alexandria vs. Laboratory); Throughput = 384 kbps	3-11
3-6 Video Motion (Alexandria vs. Laboratory); Throughput = 384 kbps	3-11
3-7 Video Quality (Fairfax vs. Laboratory); Throughput = 384 kbps	3-16
3-8 Video Motion (Fairfax vs. Laboratory); Throughput = 384 kbps	3-16





## LIST OF TABLES

<b>TABLE</b>	<b>PAGE</b>
3-1 SDSL Throughput = 384 kbps; Alexandria	3-8
3-2 Video Motion (f/s) while Maintaining “Good” Video Quality (Alexandria vs. Laboratory)	3-12
3-3 SDSL Throughput = 384 kbps; Fairfax	3-13
3-4 Video Motion (f/s) while Maintaining “Good” Video Quality (Fairfax vs. Laboratory)	3-17



## EXECUTIVE SUMMARY

### INTRODUCTION

Various digital subscriber line (xDSL) technologies are methods used to implement high-speed data services on a twisted pair (wire) communications medium. They are also candidates for rapidly deploying Intelligent Transportation Systems (ITS) services over existing communications infrastructure. However, as emerging technologies, they remain largely unknown to the transportation community, and proof-of-concept studies were needed to establish their use within ITS.

This paper documents the final phase of a Federal Highway Administration (FHWA) study to assess the application of xDSL technologies to ITS, particularly their use for traffic video. This last phase involved field testing an xDSL prototype that was built during laboratory testing. In addition to validating laboratory findings, these field efforts were used to demonstrate the prototype's capabilities in an operational environment.

The field testing has been completed and comprises the basis for the findings in this report – an addendum to “*The Application of Various Digital Subscriber Line (xDSL) Technologies to ITS: Traffic Video Laboratory Assessments*”. The laboratory assessments document provides a general understanding of the various DSL technologies and describes the concept of xDSL-based traffic video. Additionally, much of the information presented within this report is supplemental, and the laboratory assessments document should be reviewed for a comprehensive understanding of the subject matter in this report.

As with lab tests, emphasis during field testing was placed on evaluating the end-to-end operation and performance of the xDSL-based traffic video prototype – the concept system. Evaluations included the same quantitative and qualitative assessments as those performed in the lab. In this case, they were used to establish how the prototype performed within the given field environment.

### PROTOTYPE DEPLOYMENTS

While the laboratory efforts involved prototypes based on both symmetric and asymmetric technologies (i.e., the RADSL and SDSL prototypes), the field efforts involved assessment of only the SDSL prototype. This selection was made for reasons discussed in this report.

Two sites were selected for field testing activities, one within the city of Alexandria, Virginia, and the other within the city of Fairfax, Virginia. The locations were selected in part for the willingness of the associated transportation agencies to host these activities. Additionally, both sites are within close proximity of our research facilities and staff, and

both use an owned infrastructure in a centralized architecture – ideal conditions for rapid deployment of the prototype. The city of Alexandria happened to have more appropriate facilities for demonstrating the prototype and therefore became our primary test site.

For each test site, we present an overview of the communications infrastructure and discuss deployment of the SDSL prototype within these infrastructures. Deployments included installing SDSL and base system components, provisioning DSL circuits, and testing the systems for proper operation. At both test sites, we were able to deploy the prototype in less than a day.

## **PROTOTYPE PERFORMANCE EVALUATIONS**

Our approach to evaluating the SDSL prototypes in the field was similar to that used for laboratory tests. However, as opposed to the laboratory assessments, which took into account over 25 different twisted pair scenarios, each field test site had one twisted pair to consider – that which was available. Still, the various permutations created over 90 test cases for each of the field sites.

Results from these recent assessments show that the SDSL prototype functions well in a field environment. The prototype performs in a manner similar to that we observed during laboratory tests, and in general, the field assessments substantiate our laboratory findings. At both field test sites, we were able to maximize the DSL throughput and subsequently optimize the video motion/quality relation. We were able to achieve this level of performance since the prototypes were deployed over relatively simple DSL circuits (i.e., short wire runs within centralized architectures). As discussed within this report, these better-case scenarios permitted less complicated deployments. Regardless, under identical system configurations and using similar infrastructures, the performance results from our field testing efforts closely resemble those obtained in the laboratory.

We therefore conclude that results from other laboratory test cases (over 600) provide a good approximation of the prototype’s performance under similar conditions in the field. This includes using the SDSL prototype within standard twisted pair infrastructures (e.g. ANSI #3) and those infrastructures with DSL impairments, such as near-end cross talk (NEXT).

## **SUMMARY**

In addition to validating laboratory findings, the field testing efforts demonstrated the capabilities of an xDSL-based traffic video prototype. They have also exemplified the ability to rapidly deploy such a system.

The city of Alexandria has considered the prospect of installing more DSL-based traffic video cameras and is currently in the midst of a study to determine the feasibility and scope of such a deployment. The Alexandria and Fairfax field tests have also drawn the attention of Virginia Department of Transportation (VDOT) officials who are now

observing these efforts closely for any insight to similar application within other jurisdictions.

Several formal and informal demonstrations of the prototypes have raised interest from other parties as well, including consultants to the city of Baltimore, Maryland. The City has made a commitment to have 30 traffic video cameras up and running by October of this year and are interested in using the DSL approach to achieve this goal. They are currently in the process of testing a system based on a prototype we developed.

Although the FHWA studies (both laboratory and field) focused on traffic video, the numbers and types of high-speed data-intensive applications will grow and subsequently increase the demand on transportation communication systems. The ability to support such applications on existing infrastructure provides an alternative to those with communications problems that originate from financial constraint or infrastructure limitations. It also provides an option for those planning to lease or install new communication systems (e.g., fiber optic systems).

xDSL technologies show great potential for their application to ITS. The field testing efforts have validated the concept of xDSL-based traffic video, but more importantly, they have effectively demonstrated the value of this technology to the transportation community.



## SECTION 1

### INTRODUCTION

Various digital subscriber line (xDSL) technologies are methods used to implement high-speed data services on a twisted pair (wire) communications medium. They are also candidates for rapidly deploying Intelligent Transportation Systems (ITS) services over existing communications infrastructure. However, as emerging technologies, they are rapidly evolving and remain largely unknown to the transportation community, and proof-of-concept studies were needed to help establish their application within ITS. As part of a Federal Highway Administration (FHWA) task, Mitretek Systems conducted such activities.

#### 1.1 PURPOSE

Commercially available xDSL products and services exist, and systems are in place to support the more popular small business and residential applications, including Internet access and video on-demand. However, ITS applications such as freeway surveillance video were untested. This paper documents the field testing of an xDSL-based traffic video prototype that was built during earlier laboratory studies. In addition to validating laboratory findings, these field efforts were used to demonstrate the prototype's capabilities in an operational environment.

#### 1.2 SCOPE

The xDSL concept studies were conducted in two phases: an initial laboratory testing phase that was performed in Mitretek's Advanced Telecommunications Laboratory (ATL), and a supplemental field testing phase conducted at sites within the cities of Alexandria and Fairfax, Virginia. The field testing has been completed and comprises the basis for the findings in this report – an addendum to *"The Application of Various Digital Subscriber Line (xDSL) Technologies to ITS: Traffic Video Laboratory Assessments"*. The laboratory assessments document provides a general understanding of the various DSL technologies and describes the concept of xDSL-based traffic video. Additionally, much of the information presented within this report is supplemental, and the laboratory assessments document should be reviewed for a comprehensive understanding of the subject matter in this report.

As with the laboratory assessments, emphasis during field testing was placed on evaluating the end-to-end operation and performance of the xDSL-based traffic video prototype – the concept system. Field test evaluations included the same quantitative and qualitative assessments as those performed in the lab. In this case, they were used to establish how the prototype performed within the given field environment.

### **1.3 ORGANIZATION**

This document is divided into three additional sections and three appendices:

- Section 2 addresses the prototype deployment at two field test sites
- Section 3 describes our evaluation methodology and provides results from the evaluation of the prototype at the two field test sites
- Section 4 summarizes the field testing activities
- Appendix A describes the symmetric DSL (SDSL) prototype used in field testing efforts
- Appendix B presents detailed results from the evaluation of the SDSL prototype deployed within the city of Alexandria, Virginia
- Appendix C presents detailed results from the evaluation of the SDSL prototype deployed within the city of Fairfax, Virginia



## SECTION 2

### PROTOTYPE DEPLOYMENTS

The first element of field testing involved deploying the prototype. This section discusses our pre-deployment considerations and the specifics regarding deployment of an xDSL prototype at each of two test sites.

#### 2.1 PRE-DEPLOYMENT CONSIDERATIONS

Prior to deployment, we went through an exercise to select the appropriate prototype for field testing and suitable locations at which to test. The following subsections address these considerations.

##### 2.1.1 Prototype Selection

While the laboratory efforts involved prototypes based on both symmetric and asymmetric technologies (i.e., the RADSL and SDSL prototypes), the field efforts involved assessment of only the SDSL prototype. This selection was made for the following reasons:

- Sophisticated features of the DSL Access Multiplexer (DSLAM) used in the SDSL prototype allow the collection of detailed system performance statistics. Similar data is not available from the RADSL prototype.
- Although the SDSL prototype's maximum attainable throughput is less than that of the RADSL prototype, the SDSL prototype allows a much broader range of throughputs – increments of 64kbps to 2048kbps. The RADSL prototype offers only three rates: 1536, 2304, 6144 kbps. The flexibility of the SDSL prototype can be used to optimize the distance-throughput threshold for the given twisted pair.
- We encountered occasional codec synchronization problems when laboratory testing the RADSL prototype at its maximum throughput of approximately 6 Mbps. The RADSL modems (and other test equipment) were on short-term consignment, and we were unable to resolve the issue and adequately test the 6 Mbps configuration within the time allocated for laboratory testing (this configuration was not used in the laboratory assessments). Regardless, the next highest throughput at which the RADSL prototype would reliably operate (2304 kbps) was not significantly more than that achieved with the SDSL prototype.

*[Note: We are not stating that the RADSL prototype will not operate reliably at 6Mbps, just that we did not have time to resolve the problem for both laboratory and field assessments.]*

The SDSL prototype is the more flexible deployment alternative and provides more complete performance data for potential users. The design of this prototype is described in Appendix A.

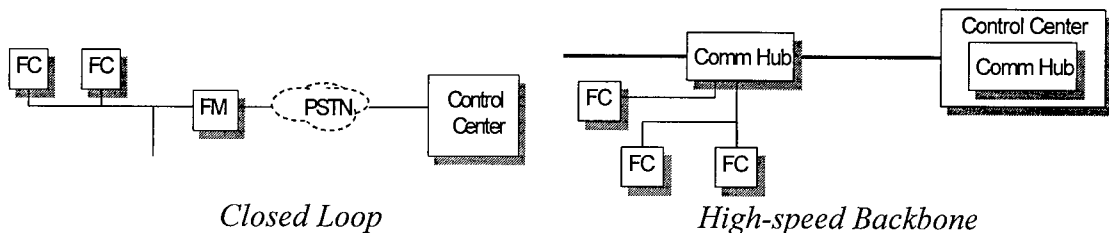
### 2.1.2 Site Selection

Two sites were selected for field testing activities, one within the city of Alexandria, Virginia, and the other within the city of Fairfax, Virginia. The locations were selected in part for the willingness of the associated transportation agencies to host these activities. Additionally, both sites are within close proximity of our research facilities and staff, and both use an owned infrastructure in a centralized architecture – ideal conditions for rapid deployment of the prototype.

Using an owned infrastructure reduces coordination problems. There is no leasing agreement with which to contend, no concerns regarding DSL service offerings (i.e., available data rates), etc. While a DSL solution using leased services is possible, the potential for logistical difficulties among the testing party (us), the host, and the leasing entity would have restricted field testing activities. It was also much less costly to test the prototype within an owned infrastructure.



**Figure 2-1. Centralized Traffic Control Architecture**



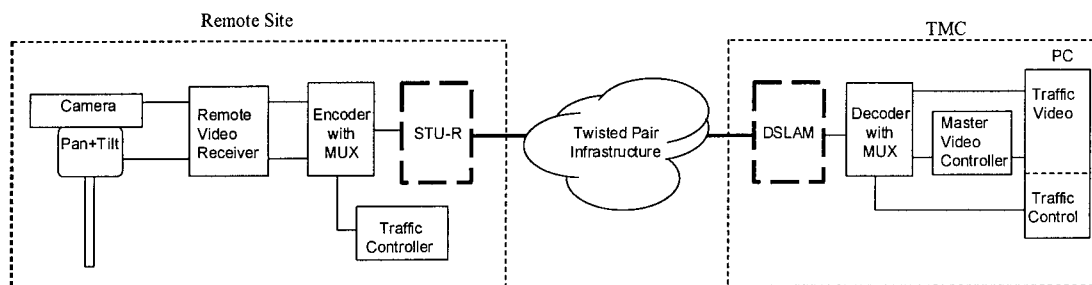
**Figure 2-2. Distributed Traffic Control Architectures**

The centralized architecture, as illustrated in Figure 2-1, provides direct access to remote traffic control facilities and introduces fewer infrastructure concerns than either distributed architecture (Figure 2-2). Any problems that might exist could be handled directly by the controlling organization – in this case, our field testing hosts. We might also have tested the prototype over a tail-circuit, such as that between remote site and communications hub within a high-speed distributed architecture, but we did not find a participant with current interest and readily available resources.

While infrastructure conditions and close proximity heavily influenced the selection of test sites, we also had requirements of the candidate hosts.

**Schedule:** With regards to a testing schedule, we requested that the prototype remain operational until we could gather enough data to complete the assessments. After which, the host could either take down the prototype or leave it operational until needed elsewhere by FHWA. To date, both sites continue to use the prototypes.

**Application:** The host could use the prototype as desired (e.g., surveillance, incident detection) when not in use during evaluations. The application was of no significance so long as it did not impede deployment, significantly disrupt the assessment schedule, threaten to cause legal or organizational problems, or require us to provide more equipment than that we had available.



**Figure 2-3. SDSL Prototype**

**Equipment and Facilities:** FHWA provided all prototype equipment including: the DSLAM and STU-R; the encoder and decoder with communications multiplexers; the traffic camera with pan & tilt unit, remote video receiver (RVR), and master video controller (MVC); the traffic controller (Alexandria test-site only); and all necessary cabling and mounting hardware. While we also provided a PC to control various prototype components and collect statistics during assessments, the host was required to provide a PC for system control when the assessments were not in progress. Refer to Appendix A (and/or the laboratory assessments document) for details regarding the functions of these base system and SDSL system components.

The host was asked to provide a separate video monitor for qualitative observations. They were also asked to provide adequate space within the TMC for the DSLAM, decoder, and MVC. Rack mounting equipment was preferable but not necessary. They were also asked to provide a NEMA enclosure (with power) at the remote site for the encoder, the traffic controller, and the STU-R.

**Twisted Pair:** The host could select the remote installation site as long as it was within the operational distance limits of the prototype. In the case of the SDSL prototype, this limit was just over 5 miles. The remote site was to have access to at least one dedicated twisted pair that runs to the TMC facility – the SDSL prototype requires a dedicated pair. This pair could

not run through any intermediate switching facilities. Patch panels or crossover boards (as would be used in traffic controller cabinets) were acceptable, but switching equipment would have required additional SDSL equipment.

As part of provisioning a circuit, field technicians were asked to perform a simple continuity test and verify connectivity between the TMC and the remote site. Noise level and other circuit tests were unnecessary and line conditioning was discouraged. Although the conditioning could improve performance, we wanted to observe system performance when the prototype was deployed without modifications to the infrastructure. A significant benefit of the xDSL technologies and an xDSL-based traffic video system is the ability to use the infrastructure that one has available – without modifications.

We did ask that technicians review the outside cable plant (OCP) and identify any bridged taps along the pair. This information is important if one later chooses to remove the taps and optimize system performance. An unnecessary step – as just indicated – since the prototype will function with the taps, but a relatively minor and quick adjustment.

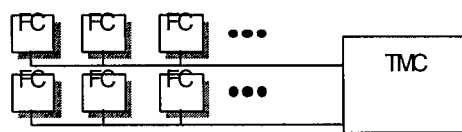
Transportation organizations within the cities of Alexandria and Fairfax not only met our criteria; they also showed significant interest. The city of Alexandria happened to have more appropriate facilities for demonstrating the prototype and therefore became our primary test site.

## 2.2 CITY OF ALEXANDRIA DEPLOYMENT

In the following subsections, we present an overview of the communications infrastructure in Alexandria. Then, we discuss deployment of the SDSL prototype within this infrastructure.

### 2.2.1 Communications Infrastructure

The city of Alexandria owns the communications infrastructure they use for traffic control operations and monitoring. The architecture is centralized, as illustrated in Figure 2-4, with the TMC located within City Hall. The OCP consists of 19-gauge twisted pair wire and covers an area of approximately 16 square miles distributed across some 100 street intersections.



**Figure 2-4. Centralized Traffic Control Architecture**

From the TMC – referred to as *the traffic computer room* by Alexandria traffic personnel – several twisted pairs fan out through the OCP to the field controllers (FC), which operate many traffic lights and a few loop detectors. The connections between field controllers and the traffic computer room are not as direct as Figure 2-4 might imply. The 19-gauge twisted pairs, within either 25- or 12-pair bundles, pass through multiple wiring cabinets along the city streets. Within these cabinets, the twisted pairs either terminate at a field controller or continue to subsequent cabinets until either reaching a controller or terminating on a crossover board. This arrangement creates the potential for a great number of bridged taps and splices (see section 2.1.5 of the laboratory assessments document for further description of these and other impairments). As we will show, the bridged taps can impede DSL transmissions and subsequently degrade performance of the prototype.

### **2.2.2 Deployment**

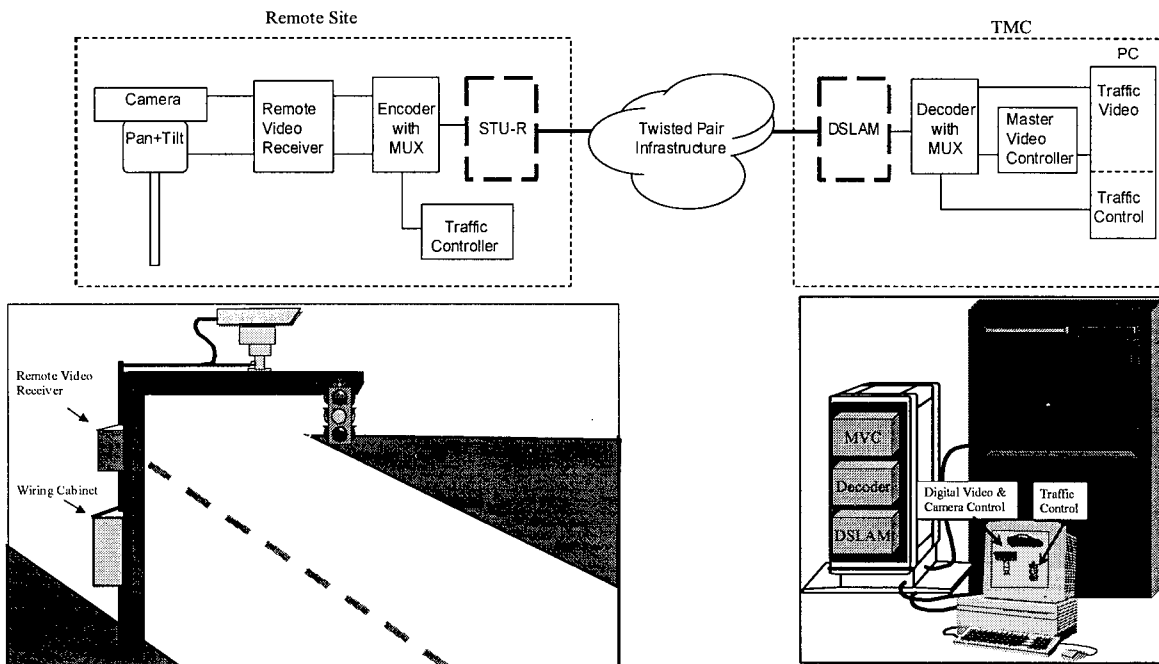
Prior to deployment, the prototype was reassembled in our lab, configured as it was during laboratory assessments, and tested for proper operation. Technical descriptions of the prototype's SDSL and base system components, as well as their configuration (i.e., parameter settings), can be found in Appendix A.

After a brief (and successful) laboratory test, we packed the equipment and shipped it to the field site for installation. Deployment of the SDSL prototype included installing SDSL and base system components, provisioning a DSL circuit, and testing the system for proper operation.

#### **Prototype Installation**

Installation was completed in phases. First, the prototype's SDSL system components were installed; the DSLAM was rack-mounted at the TMC, and the STU-R was placed in a wiring cabinet at the remote location. Next, the prototype's base system components (traffic video, codec, and traffic control) were installed.

- The traffic camera and pan & tilt unit were mounted on the traffic signal's horizontal mast, as shown in Figure 2-5. The host was given the choice of mounting location and style. While unconventional, this mount was efficient, economical, functional, and served the purpose of this effort. The remote receiver was pole-mounted. The MVC was rack-mounted within the TMC.
- The encoder was placed in the wiring cabinet at the remote location, and the decoder was rack-mounted within the TMC.
- The traffic controller was placed in the wiring cabinet at the remote location. The TMC counterpart to the controller is the PC.

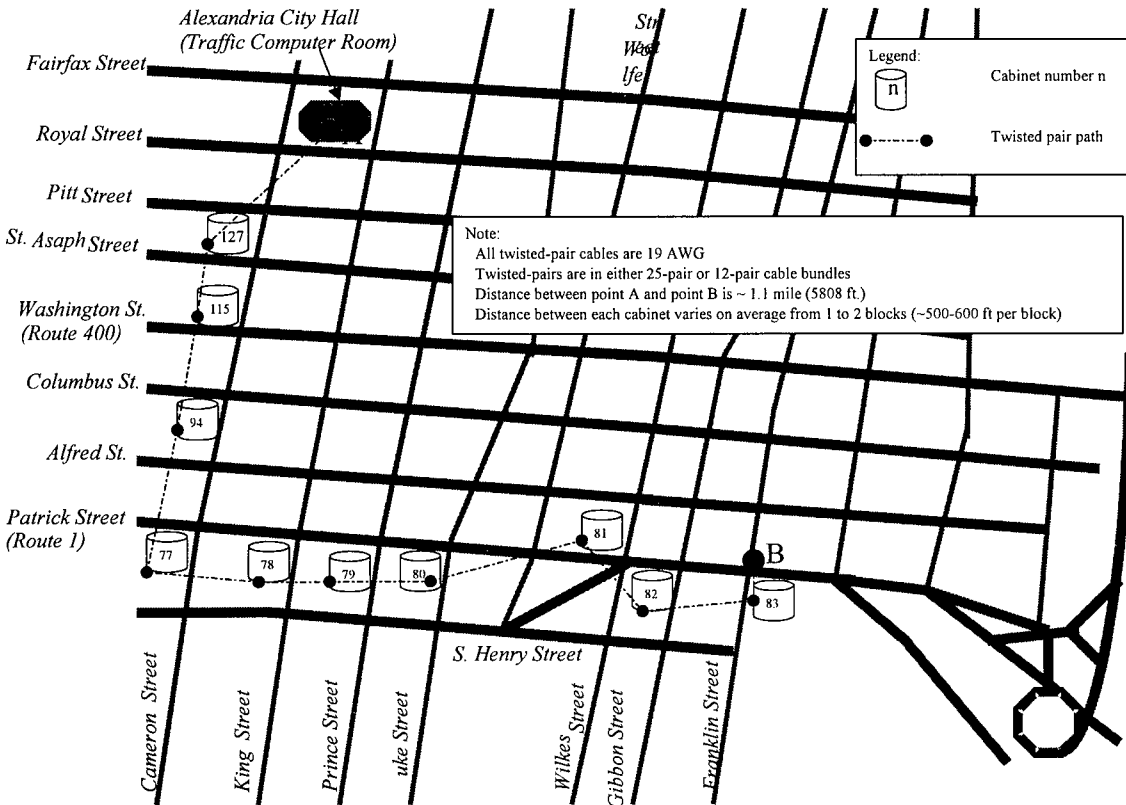


**Figure 2-5. SDSL Prototype Installation, Alexandria**

All base system components were connected to each other; however, the connections between SDSL and base system components (i.e., DSLAM to decoder and STU-R to encoder) were not made at this time. This connection would be established after successfully provisioning a circuit for the digital subscriber line. Refer to Appendix A for details on these interfaces.

### **Circuit Provisioning**

As noted previously, Alexandria personnel selected the remote location. In this case, it was well within the SDSL prototype's distance limitations. Figure 2-6 shows the path of the twisted pair used to provision the SDSL circuit. The pair runs through several cabinets until reaching the intersection of Franklin Street and Patrick Street. The distance between the TMC (point A) and this intersection (point B) is approximately 1.1 miles.



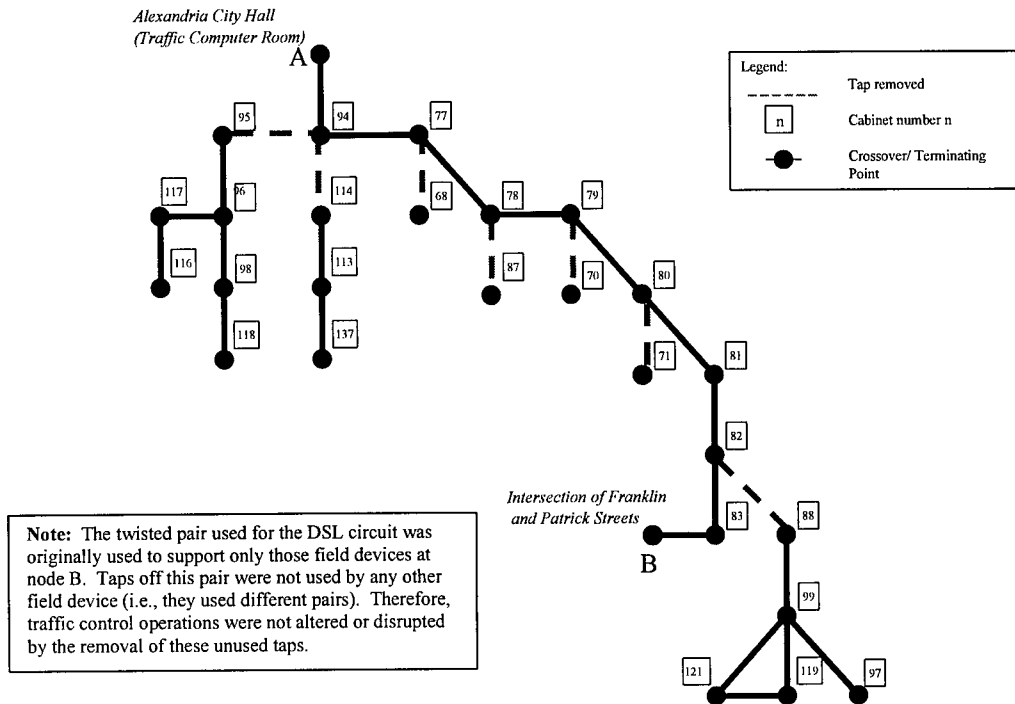
**Figure 2-6. Twisted Pair Used to Provision the DSL Circuit in Alexandria**

A major advantage of the xDSL technologies is their ability to function within the infrastructure that one has available – without modification. However, it’s helpful to test the twisted pair prior to provisioning DSL circuits. There are sophisticated methods for testing, but these techniques require the use of specialized and expensive equipment. Without such resources, we simply had the field technicians run a continuity test to identify a twisted pair between the remote site and the TMC. Technicians in Alexandria were also able to determine if the pair was “clean” (i.e., had a relatively low level of noise on the line).

After field technicians identified the twisted pair to be used, we connected the SDSL system components (STU-R and DLSAM) to either end of the line. The STU-R and the DSLAM were powered and attempted synchronization – beginning at a maximum throughput of 2048 kbps and scaling back until synchronization was achieved. The SDSL equipment achieved synchronization at 1120 kbps – a rate that was much lower than expected. Both theory and our

laboratory assessment results predict that at such a short distance (1.1 miles), we should be able to achieve synchronization at the maximum throughput.

While testing for continuity, we did not adequately review the OCP. Upon further review, we identified seven bridged taps along the twisted pair we were using for the DSL circuit (Figure 2-7).



**Figure 2-7. Taps Removed from the Twisted Pair in Alexandria**

These taps introduce a large amount of attenuation by increasing the effective loop distance several miles. They also introduce harmonics and reflections that reduce the DSL receiver signal margin and subsequently lessen the attainable throughput. While splices (occurring at each wiring cabinet and possibly at locations between) also introduce reflections and harmonics, their impact on the margin is much less. For a description of the potential impairments to DSL transmissions (e.g., crosstalk, loading coils, etc.), refer to the laboratory assessments document, section 2.1.5.

Not much can be done about the splices in such an infrastructure, but the taps can easily be removed. Field technicians removed the seven unnecessary taps in just under 30 minutes, and the DSL throughput increased from 1120 to 2048 kbps – full capacity.



## **Prototype Testing**

Once the SDSL system component was operational, we introduced the base system components. This only required connecting DTE ports between STU-R and encoder, and between DSLAM and decoder. Once connected, the encoder and decoder synchronized and the prototype became operational. *[Note: clocking required to maintain synchronization between codecs was provided by the SDSL equipment, as described in section 5.1 of the laboratory assessments document]*

The video signal was successfully transmitted; camera control functions were operational; and traffic controller telemetry was accurate and continuous. SDSL system parameter settings (e.g., throughput) were changed, and the prototype remained operational. Base system parameter settings affecting video motion and video quality were changed, and the prototype remained operational. We did not exhaustively test all possible SDSL and base system parameter settings, only those that we used during our evaluation (discussed in section 3.1, Methodology).

In less than a day, we were able to deploy the SDSL prototype without any major difficulties. Once convinced the prototype would remain operational, we were ready for the performance evaluation of the prototype. This evaluation is discussed in section 3.2.1 and Appendix B.

## **2.3 CITY OF FAIRFAX DEPLOYMENT**

In the following subsections, we present an overview of the communications infrastructure in Fairfax and discuss deployment of the SDSL prototype within this infrastructure.

### **2.3.1 Communications Infrastructure**

Like the city of Alexandria, the city of Fairfax owns the communications infrastructure they use for traffic control operations and monitoring. The architecture is centralized and the TMC is located inside the City's property yard facility. The 15-year-old OCP consists of 19-gauge twisted pair wire in either 12- or 25-pair bundles.

### **2.3.2 Deployment**

Prior to deployment, a second prototype was assembled in our lab, configured as it was during laboratory assessments, and briefly tested for proper operation. Once tested, the prototype was shipped to the field site for installation. As in Alexandria, deployment of the SDSL prototype included installing SDSL and base system components, provisioning a DSL circuit, and testing the system for proper operation.

## Prototype Installation

The installation process was similar to that for Alexandria. First, the prototype's SDSL system components were installed; the DSLAM was rack-mounted at the TMC, and the STU-R was placed in a wiring cabinet at the remote location. Next, the prototype's base system components (traffic video and codec) were installed.

- The traffic camera and pan & tilt unit were mounted on the traffic signal's horizontal mast, as shown in Figure 2-8. Again, the mount is unconventional, but it was efficient, economical, and functional. The remote receiver was placed in the wiring cabinet. Since we were provided much more space in this wiring cabinet than the one used in Alexandria, we did not need to pole-mount the remote receiver. The MVC was rack-mounted within the TMC.
- The encoder was placed in the in the wiring cabinet at the remote location, and the decoder was rack-mounted within the TMC.

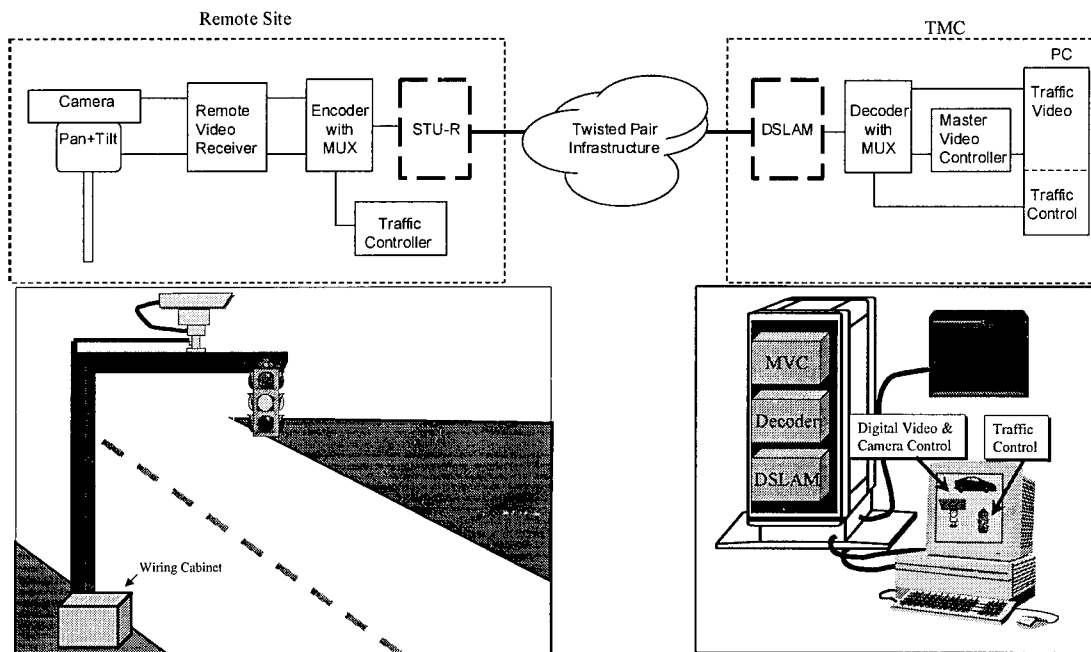


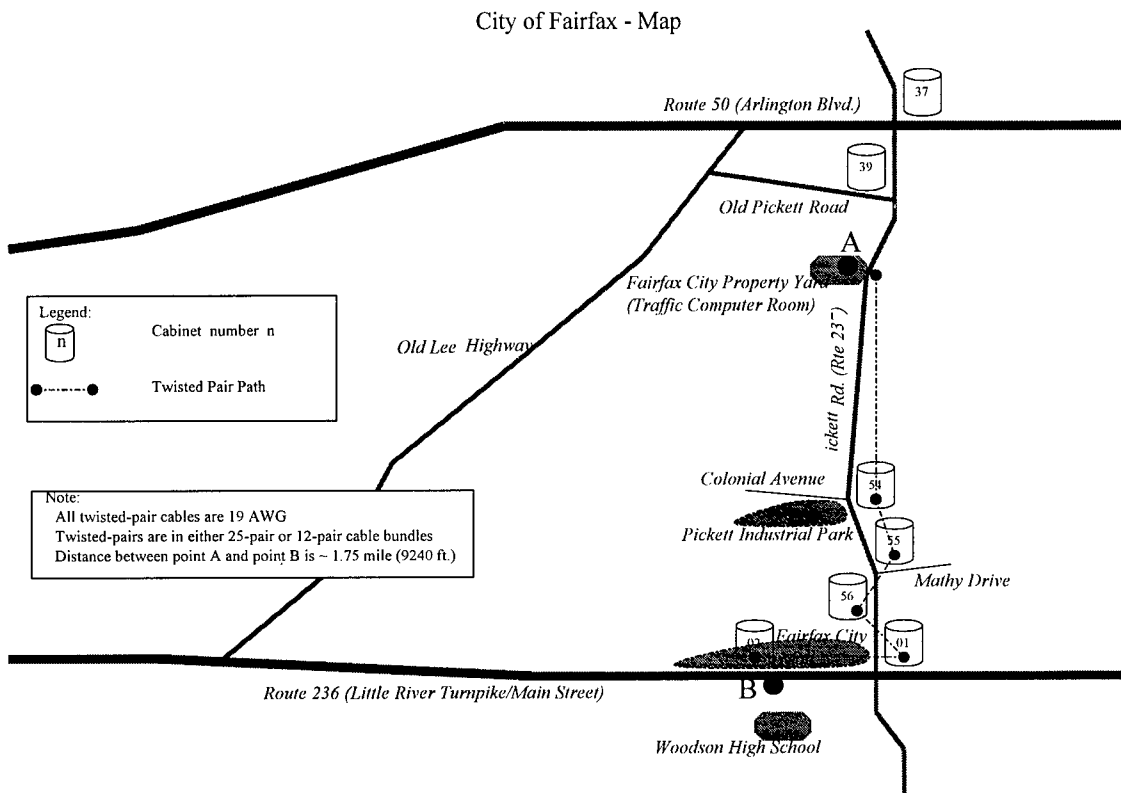
Figure 2-8. SDSL Prototype Installation, Fairfax

This deployment did not include a traffic controller; the equipment was unavailable. However, this was not critical to the prototype's video capabilities or to our evaluation. We simply could not gather statistics on field device telemetry at this site. This data would be provided by the prototype in Alexandria.

All base system components were connected to each other, but the connections between the SDSL and base system components (i.e., DSLAM to decoder and STU-R to encoder) were not made at this time. These connections would be established after successfully provisioning a circuit for the digital subscriber line. Refer to Appendix A for details on these interfaces.

### Circuit Provisioning

Fairfax personnel selected the remote location. Like the location in Alexandria, it was well within the SDSL prototype's distance limitations. Figure 2-9 shows the path of the twisted pair used to provision the SDSL circuit. The pair runs through several cabinets until reaching the entrance to the Fair City Mall along Route 236. The distance between the TMC (point A) and this intersection (point B) is approximately 1.75 miles.



**Figure 2-9. Twisted Pair Used to Provision the DSL Circuit in Fairfax**

While not necessary, it's useful to test the twisted pair prior to provisioning a DSL circuit. As in Alexandria, we asked the field technicians to run a continuity test and identify a twisted pair between the remote site and the TMC. Having encountered the minor problem with bridged taps

in Alexandria, we placed more emphasis on reviewing the OCP and were able to avoid similar problems.

After a pair was identified, we connected the SDSL system components (STU-R and DLSAM) to either end of the line. The STU-R and the DSLAM were powered and synchronized at the maximum throughput of 2048 kbps – as expected. Reliable communication at this rate exemplifies the prototype’s ability to overcome an aging infrastructure.

### **Prototype Testing**

Once the SDSL system component was operational, we introduced the base system components by connecting DTE ports between STU-R and encoder, and between DSLAM and decoder. The encoder and decoder synchronized and the prototype became operational.

The video signal was successfully transmitted; camera control functions were operational; and traffic controller telemetry was accurate and continuous. SDSL system parameter settings (e.g., throughput) were changed, and the prototype remained operational. Base system parameter settings affecting video motion and video quality were changed, and the prototype remained operational.

Again, we were able to deploy an SDSL prototype without any major difficulties in less than one day. Once convinced the prototype would remain operational, we were ready for the performance evaluation of the prototype. This evaluation is discussed in section 3.2.2 and Appendix C.

## SECTION 3

### PROTOTYPE PERFORMANCE EVALUATIONS

This evaluation was not a detailed analysis on the relative performance of vendor specific DSL equipment – equipment that is based on a particular modulation technique or adheres to a particular standard. It was a study to determine if and how xDSL technologies, and in particular our SDSL concept prototype, could be used for traffic video. Having tested the SDSL prototype in the laboratory, we reestablished a methodology to evaluate this prototype in the field.

#### 3.1 METHODOLOGY

Our approach to evaluating the SDSL prototypes in the field was similar to that used for laboratory tests. However, as opposed to the laboratory assessments, which took into account over 25 different twisted pair scenarios, each field test site had one twisted pair to consider – that which was available between the remote location and the TMC. Refer to sections 2.2 and 2.3 for descriptions and illustrations of the twisted pair used in the Alexandria and Fairfax deployments.

The video source (i.e., the traffic event viewed by camera) was also different from that used during the laboratory assessments. For the field tests, we were able to use live traffic video as opposed to recorded traffic video displayed on a large screen monitor. While not significant to the relative performance of the prototype, this did provide for a better baseline video quality – as expected.

##### 3.1.1 Systems Parameter Settings

The SDSL prototype has a number of variable system parameters. Some involve its DSL system component while others involve base system components.

##### SDSL System Parameters

The SDSL systems' variable parameters are described in Appendix A. That of particular interest to our effort is the system information rate (i.e., throughput), which is defined as the rate of the SDSL transmission (i.e., the line rate) less the SDSL overhead. The throughputs we used are as follows:

- SDSL throughput = 384, 768, 1152, 1536, and 2048 kbps

While the SDSL system offers symmetric throughputs in increments of 64 kbps, we selected fairly common ¼ T1 increments (384 kbps) and the E1 rate (2048 kbps). These are the same as those used for the laboratory assessments.

### Base System Parameters

For the purpose of this study, the most benign base system component is the traffic controller. The function of this unit was to provide nominal field controller telemetry – a communications link to verify proper and continual controller operation during the evaluation process. As with the laboratory assessments, we did not alter controller telemetry parameters. The unit was configured to communicate asynchronously at 9.6 kbps.

Variations in some video system component settings could impact performance slightly. However, these settings are not applicable in the video system’s standard operational mode.

The most significant base system component to influence the performance of the prototypes is the video encoder/decoder (codec), and in particular, the encoder’s resolution, quantization, and screen-cropping parameter settings. Each can be manipulated to improve video quality at the expense of video motion, or vice versa.

The encoder settings were configured via terminal session, as illustrated in Figure 3-1.

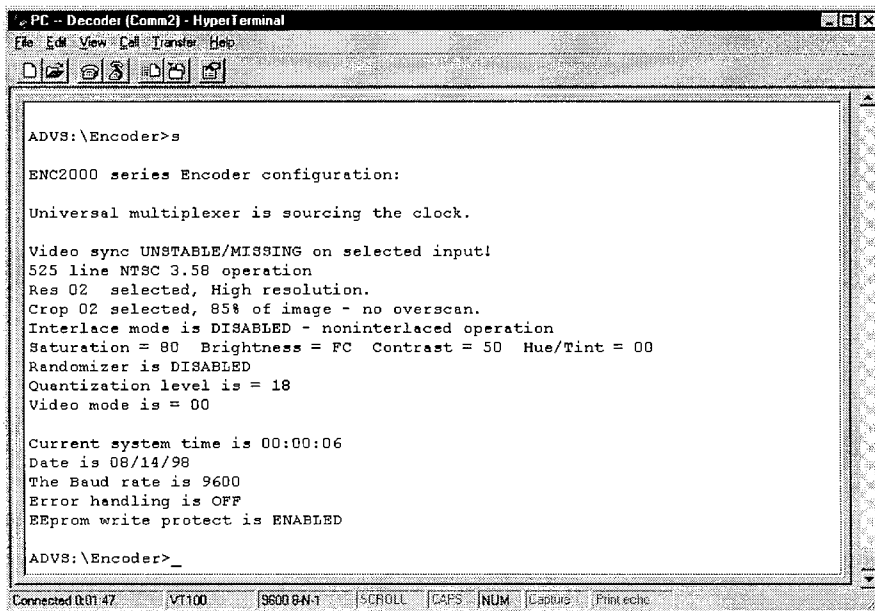


Figure 3-1. Terminal Session to the Encoder

- The encoder has a vertical resolution of 480 lines/frame at 60 Hz. The horizontal resolution is variable and was set to one of three possible values.
  - Resolution = High: 560 pixels/line (laser disc quality)
  - Resolution = Standard: 280 pixels/line (VCR quality)
  - Resolution = Low: 140 pixels/line

The resolution setting is inversely proportional to the achievable frame rate (video motion).

- The encoder's quantization factor (q-factor) defines the relative quantization level – an element affecting the distinction between individual pixels. While there are 256 available q-factor settings, we selected the following values.
  - q-factor = 18: no noticeable distinction between pixels
  - q-factor = 28: little noticeable distinction between pixels
  - q-factor = 38: noticeable distinction between pixels

The q-factor has a direct relationship to the amount of compression achieved and is directly proportional to the achievable frame rate – the more compression, the poorer the video quality, but the faster the video motion, and vice versa.

- The encoder's screen-cropping factor determines the number of pixels per video frame that are included in the image being compressed (i.e., it defines the region of view in which most image processing occurs). There are six available screen-cropping settings from which to choose, but we selected the more common.
  - Screen-cropping factor = 85% standard video: The entire visible image area is processed, excluding the over-scanned areas around the edges of the picture (some monitors display blanked video around the edged – a normal procedure)
  - Screen-cropping factor = 63% standard video: The center window of the screen is processed

The screen-cropping factor is inversely proportional to the frame rate.

Many more codec permutations could be created by introducing variations on additional parameters (e.g., saturation, brightness, contrast, tint), but such parameters have relatively little impact on video quality and video motion compared to resolution, quantization, and screen-cropping. While we couldn't possibly review all permutations of these three parameters either, we selected an adequate range with which to demonstrate the concept. Additionally, these were the same settings used in the laboratory assessments and allowed us to validate findings from these earlier efforts.

It should also be noted that the parameters and parameter settings are particular to this device and would be different for other codec systems. From the perspective of this project, the codecs and other base system components are interchangeable with similar devices on the market. We selected the prototype component systems for reasons discussed in section 4 of the laboratory assessments document.

## Baseline Parameter Settings

Some of the decisions on system parameter settings were affected by earlier studies of compressed traffic video. The FHWA telecommunications analysis<sup>1</sup> discusses the quality of video required to support real-time traffic operations for Maryland's Chesapeake Highway Advisory Routing Traffic (CHART) system. Using an H.261 encoding scheme, researchers were able to obtain 15 frames per second over leased fractional T1 lines. The analyses suggest that compressed video transmitted at 384 kbps would be sufficient to perform CHART operator job functions. CHART officials subsequently selected this rate as a minimum requirement for compressed video.

Our studies do not attempt to confirm or dispute the validity of this requirement. We did however use the results from this study to establish a baseline for our compressed video transmissions – a baseline that was used to identify the lower bound on our system parameter settings. As in the laboratory assessments, with the xDSL modem-pair information rate (i.e., throughput) set to 384 kbps, we were able to achieve 15 frames per second with the following encoder settings: q-factor = 38, resolution = Low, and screen-cropping factor = 63 percent. We began observations at this lower limit and worked toward higher quality video.

We could have created an endless number of permutations with additional encoder settings (e.g., q-factor, screen-cropping, as well as saturation, brightness, contrast, and tint) or xDSL system settings (e.g., BER threshold, S/N margins, etc.) However, our objective was to demonstrate the feasibility of an xDSL transmission system and not to exhaustively evaluate every system permutation. We manipulated those parameters that have the most significant impact on video quality and video motion and selected ranges within those items to adequately demonstrate the concept. The selected permutations of the system settings noted above comprise the 90 test cases we devised for each of the field test sites.

---

<sup>1</sup> "A Case for Intelligent Transportation System (ITS) Telecommunications Analysis", pub. No. FHWA-JPO-97-0015



### 3.1.2 Quantitative and Qualitative Observations

For each of the field test cases established, we conducted limited qualitative and quantitative observations – identical to those made during laboratory assessments.

#### Quantitative Observations

Our quantitative observations included the following:

- xDSL modem performance statistics, as illustrated in Figure 3-2
  - MrGn: The near-end and far-end receiver signal margin, or the received signal to noise ratio (SNR) less a relative receiver SNR reference value (dB)
  - XmtPW: The near-end and far-end transmit signal power level (dBm)
  - RxGn: The near-end and far-end receiver gain level (dB)

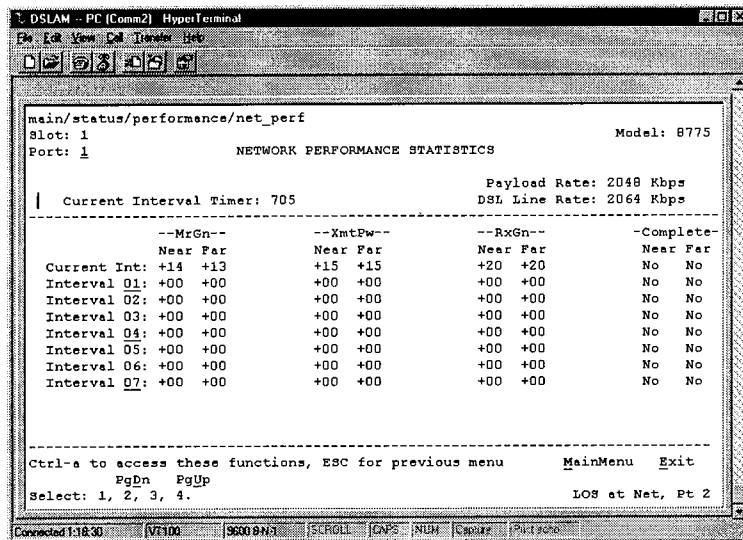


Figure 3-2. xDSL Modem Performance Statistics

- xDSL modem error statistics.
  - ES: Errored seconds, or the seconds during which one or more extended super frame (ESF) error events occurred
  - SES: Severely errored seconds, or the seconds during which more than 320 CRC error events or at least 1 out-of-frame (OOF) events occurred
  - FEBE: Far end block errors, errors reported by the remote equipment

Statistics for a single test case offer little, but a collection of such statistics clearly illustrates relative performance of the prototype under varying conditions.

The modem information rate (i.e., throughput) and its constituent video signal and control data throughput were also collected.

- Video Motion: The received video frame rate (frames per second or f/s) was collected via the codec component (Figure 3-3). Video motion refers to the smoothness of subject motion. Full motion is defined as 30 f/s in the US, but the level of video motion required for a given application is subjective and not an issue of this study.

```

PC - Decoder (Comm2) - Hyperterminal
File Edit View Local Transfer Help

Universal multiplexer is sourcing the clock.

Video sync UNSTABLE/MISSING on selected input!
525 line NTSC 3.58 operation
Res 02 selected, High resolution.
Crop 02 selected, 85% of image - no overscan.
Interlace mode is DISABLED - noninterlaced operation
Saturation = 80 Brightness = FC Contrast = 50 Hue/Tint = 00
Randomizer is DISABLED
Quantization level is = 28
Video mode is = 00

Current system time is 19:04:22
Date is 08/14/98
The Baud rate is 9600
Error handling is OFF
EEPROM write protect is ENABLED

ADVS:\Encoder>sp
Average fields per second, last 2 seconds = 030
Average fields per second, last 15 seconds = 030
Average fields per second, last 60 seconds = 030

ADVS:\Encoder>_

```

**Figure 3-3. Video Motion Statistics**

- Traffic Control Operations: A simple assessment to determine if there was accurate and continual telemetry between our PC and our traffic controller. This observation was conducted by monitoring the telemetry from the traffic controller GUI (Figure 3-4). This observation was not made for the system deployed within the city of Fairfax since a traffic controller was not part of the prototype used at this test site.

```

RUN
T 8 x 16
Date: 8/22/98
#01 - Test Local 01
LOCAL STATUS - CONTROLLER UNIT
SEQ: 00 FULL FUNCTION EPAC
RING ----> RING 1 RING 2 PHS..12345678 90123456
TIMERS MGRN 10 RED RST C/N .0..... <-- PHASE
or STATES WALK 2 VEH CCCC..... STATUS
PASS 4 MGRN 0 MANUAL FREE <-- COORD
MAX1 30 H/O ..... 00000000 <-- OTHER

T MGRN-Min Grn AINI-Ad Init PASS-Passage S GAP OUT LST CAR
I MX1-Max No#1 MX2-Max No#2 EGAP-Eff Gap T GRN RST RED REST
M TBR -Time B4 TTR -Time To CBR -Cars B4 A MAX OUT WLK HLD
E WALK-Walk PCLR-Ped Clr T FORCE WLK RST
R YEL -Yel Chg RED -Red Clr RRVT-Red Rev E

Monitor Led Report Console Page 1 of 3
Press [ESC] to exit to prior MENU.

```

© Eagle Traffic Control Systems, Siemens Energy & Automation, Inc.

**Figure 3-4. Traffic Controller GUI**

## **Qualitative Observations**

Our only qualitative observation was a perception of the received video image. For each test case, we provided a limited and subjective assessment of the video quality. Video quality refers to the perceived video resolution – a function of encoder resolution, q-factor, and screen-cropping settings as well as pixel tint, saturation, brightness, and contrast values. We identified the video quality from each test case as one of nine relative values from “poor-” to “good+”.

While such assessments are normally conducted among large test groups, we were limited to two researchers. As with most individuals, we held a highly subjective opinion on quality of video. Regardless, this assessment was fairly consistent, was relative to our baseline video quality (established as discussed in section 3.1.1), and provided some perspective on system performance.

Having reestablished the criteria used to observe the SDSL prototype in the field, we then conducted our assessments.

## **3.2 FIELD ASSESSMENTS**

For each field deployment, either Alexandria or Fairfax, we configured the prototype’s system components with the baseline settings – xDSL modem throughput is 384 kbps and encoder q-factor, resolution, and screen cropping factors are 38, low, and 63 percent, respectively. We started observations at this lower limit and worked toward higher quality video adjusting SDSL and base system parameter settings as discussed in the methodology (Section 3.1). The various permutations created over 90 test cases at each of the field sites.

As explained in the methodology, our quantitative observations included: SDSL modem performance and error statistics, modem information rate (i.e., throughput), traffic controller telemetry, and video motion. Our qualitative observations involved video quality.

### **3.2.1 SDSL Prototype in Alexandria**

This section presents results from the evaluation of the SDSL prototype that was deployed within the city of Alexandria. The evaluation was conducted using the system parameter settings defined in section 3.1.1, and the twisted pair supporting the prototype is detailed in section 2.2. Complete findings from these assessments are provided in Appendix B.

### **Field Assessment Results**

The following information summarizes qualitative and quantitative observations from the various test cases. Results are grouped by increasing SDSL modem throughput.

- SDSL Throughput = 384 kbps

Video quality and video motion observations are summarized in Table 3-1.

**Table 3-1. SDSL Throughput = 384 kbps; Alexandria**

Encoder Settings			Video Quality	Video Motion
Video Quantization Factor	Video Resolution	Screen Cropping Ratio		
38	Low	63%	Poor-	15
38	Low	85%	Poor-	10
38	Standard	63%	Fair	10
38	Standard	85%	Fair-	8
38	High	63%	Fair+	6
38	High	85%	Good-	4
28	Low	63%	Poor	15
28	Low	85%	Poor	10
28	Standard	63%	Fair	8
28	Standard	85%	Fair	6
28	High	63%	Good	5
28	High	85%	Good	3
18	Low	63%	Fair-	10
18	Low	85%	Fair-	9
18	Standard	63%	Fair+	7
18	Standard	85%	Fair+	5
18	High	63%	Good+	4
18	High	85%	Good	3

As with laboratory assessment results, our field observations reveal that regardless of q-factor and screen cropping settings, the encoder’s resolution must be at or above the “standard” setting in order to achieve fair to good video. The prototype was able to achieve a maximum of 15 f/s only when the encoder resolution setting was “low” and the q-factor was “28” or higher, which yields poor video quality. Good video quality was obtained at rates between 3 to 5 f/s.

- SDSL Throughput = 768 kbps

Specific observations (similar to those presented in Table 3-1) are tabulated in Appendix B.

Similar to the results obtained at 384 kbps, the observations at 768 kbps reveal that in order to achieve a fair to good video quality, the encoder resolution setting must be at or above “standard” – regardless of the other parameters’ settings. The video motion data show an increase in the achievable frame rate. The prototype was able to reach a maximum frame rate of 30 f/s (full-motion video), but at the expense of decent video quality. Good video quality could only be maintained at rates between 6 to 12 f/s.

- SDSL Throughput = 1152 kbps

Specific observations are tabulated in Appendix B.

Video quality observations were consistent with those viewed previously. Fair to good quality is obtainable with a “standard” or better resolution setting. Once again, we measured improved video motion – under certain circumstances reaching 30 f/s with fair quality video. However, good quality could be maintained only at rates within the range of 8 to 15 f/s.

- SDSL Throughput = 1536 Kbps

Specific observations are tabulated in Appendix B.

As expected, the video quality was again consistent with earlier observations. Fair to good video quality requires an encoder resolution setting at or above “standard”. The prototype is able to achieve between 15 and 30 f/s under most system parameter settings, but the better quality video is observed when the frame rate is between 10 and 15 f/s.

- SDSL Throughput = 2048 Kbps

Specific observations are tabulated in Appendix B.

Observed video quality follows the trend from previous test cases. Fair to good quality requires an encoder resolution setting at or above “standard” – regardless of the other parameters’ settings. There were several configurations that allowed for full-motion video (30 f/s); some with good video quality. The lowest frame rate observed is 12 f/s, but this is only when the video is of its highest quality.

General observations of the SDSL prototype deployed in Alexandria are as follows:

- SDSL performance and error statistics: These statistics (as defined in section 3.1.2) allowed us to assess the operation of the SDSL equipment as the system parameter settings varied. As the throughput was increased, near-end and far-end transmit powers increased to compensate for decreasing receiver gains and subsequent drops in the SNR. Throughout all test cases, the SNR never dropped below 11 dB – a substantial margin for sustained and reliable operation. We did not observe any communication errors (FEBE, ES, and SES).
- SDSL modem information rate (throughput): Although this was a predetermined system parameter setting, we monitored real-time throughput for any significant deviation – perhaps due to modem compensations. No significant or sustained deviations were observed.

- Traffic control operations: The SDSL modems were able to maintain synchronization throughout all tests, hence, traffic controller telemetry remained operational.
- Video motion: The frame rate was affected by the available system throughput – the greater the throughput the smoother the motion. For any given throughput, the motion was also affected by the prototype’s encoder settings (e.g., resolution, q-factor, screen cropping). Values set to achieve better video quality subsequently reduced motion. However, with sufficient throughput, the quality was optimized without noticeably affecting the motion. For details, refer to Appendix B
- Video quality: The quality was based primarily on the prototype’s encoder settings and remained independent of the system throughput. Throughput had no significant impact on the quality. Refer to Appendix B for details.

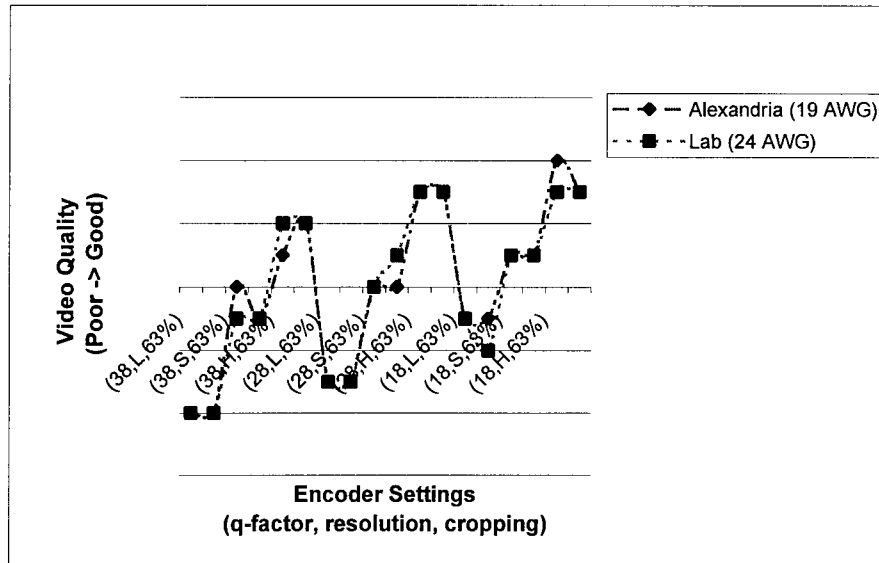
### **Comparing Field Assessment and Laboratory Assessment Results**

The following briefly describes a comparison between results obtained during field assessments in Alexandria, and those obtained during laboratory assessments. The intent of this comparison was to help validate the prototype’s performance during the more than 600 laboratory test cases. While we could not directly validate all laboratory test cases, we could establish a benchmark for comparison, and if highly correlated, speculate that results from the remaining lab test cases were fairly accurate.

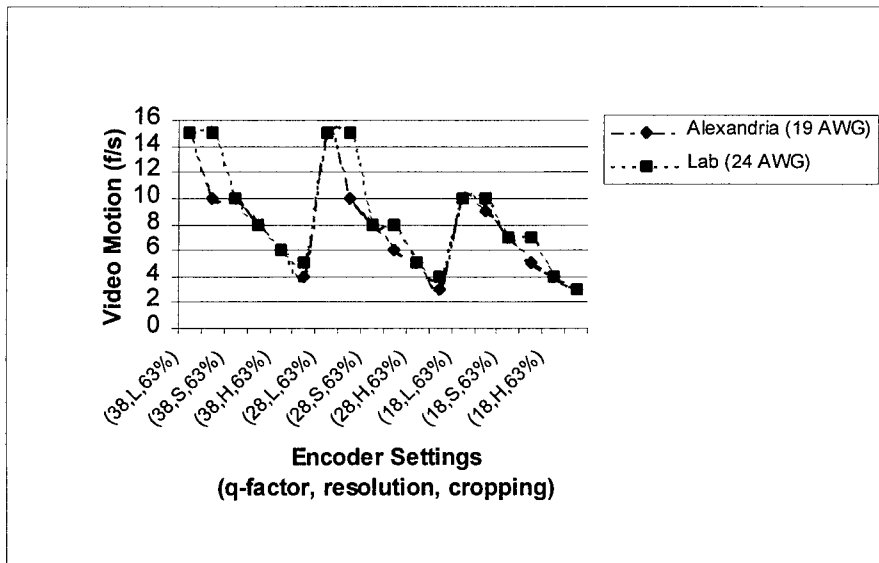
A precise benchmark comparison between laboratory and field test results was difficult due to discrepancies in their respective system configurations. There is no exact match between the twisted pair configuration encountered in the field and any of the configurations supported by the line simulator. First, the SDSL prototype deployed within the city of Alexandria used 19-gauge wire – like many other municipalities, Alexandria has a 19-gauge twisted pair infrastructure. The laboratory configurations included only simulated 24- and 26-gauge wire – the line simulator used for laboratory assessments could only support 24 or 26 AWG. Secondly, the distances of twisted pair wire were slightly different. Laboratory assessments were performed using wire distances in increments of 1 mile. As described in section 2.2, the distance of the twisted pair used for the prototype in Alexandria is approximately 1.1 miles.

The laboratory test scenario that most resembled the scenario in the field was a 24-gauge point-to-point 1-mile configuration. While the field test scenario involved 19-gauge wire (which enables greater loop-reach than 24-gauge wire), it also involved a slightly longer distance. The compromise of lower wire gauge for longer loop reach has the effect of equalizing the Alexandria field test cases and these particular lab test cases. For the purpose of establishing a benchmark, the 1-mile point-to-point laboratory test cases were more than adequate for comparison.

Under identical system parameter settings, laboratory assessments of the 24 AWG point-to-point scenarios at 1 mile showed results similar to those obtained during field tests. Figures 3-5 and 3-6 illustrate comparisons of video quality and video motion for the SDSL prototypes (laboratory tested and field tested) while operating at a throughput of 384 kbps.



**Figure 3-5. Video Quality (Alexandria vs. Laboratory); Throughput = 384 kbps**



**Figure 3-6. Video Motion (Alexandria vs. Laboratory); Throughput = 384 kbps**

Figure 3-5 shows the quality to be nearly identical for both implementations (field and lab). Any variance is most likely due to a subjective opinion of video quality. The video motion data in Figure 3-6 also show close similarity. The variance in these data is due more to random traffic flow than to differences in the twisted pair infrastructures.

Similar plots for data collected at system throughputs of 768, 1152, 1536, and 2048 kbps are provided in Appendix B, section B.2. For a detailed view of the data points refer to the tables provided in section B.1 and the tables in provided in Appendix A of the laboratory assessments document.

As illustrated in table 3-2 and the many figures in Appendix B, the relatively high degree of correlation was consistent across test cases. The two closely related configurations (field and lab) under identical system parameter settings provided similar frame rates while maintaining similar video quality.

**Table 3-2. Video Motion (f/s) while Maintaining “Good” Video Quality (Alexandria vs. Laboratory)**

<i>Wire Gauge [AWG]</i>	<i>SDSL Throughput [Kbps]</i>	<i>Twisted Pair Distance [miles]</i>	
19 <sup>2</sup> (Alexandria)	384	1 <sup>3</sup>	4
	768	1	8
	1152	1	12
	1536	1	15
	2048	1	15
24 <sup>4</sup> (laboratory)	384	1	4
	768	1	8
	1152	1	10
	1536	1	13
	2048	1	15

Occasionally, the field system performed better than the laboratory prototype and vice versa, but there were no significant discrepancies. Other system performance statistics (e.g. MrGn, XmtPW, RxGn) were also similar.

This strong correlation helps substantiate our laboratory findings for these particular point-to-point test cases. It also establishes our benchmark for comparison between laboratory and field test results. Therefore, we can infer that laboratory results provide a good estimate of the performance one can achieve under various infrastructure conditions and systems parameter settings. This includes using the SDSL prototype within standard twisted pair configurations (e.g. ANSI #3) and those configurations impaired with near-end cross talk (NEXT). Refer to the laboratory assessments document for a complete list of laboratory test cases and their associated results.

<sup>2</sup> Wire gauge utilized during field assessments in Alexandria, Virginia.

<sup>3</sup> Actual distance is approximately 1.1 miles

<sup>4</sup> Wire gauge simulated during laboratory assessments.



### 3.2.2 SDSL Prototype in Fairfax

This section presents results from the evaluation of the SDSL prototype that was deployed within the city of Fairfax. The evaluation was conducted using the system parameter settings defined in section 3.1.1, and the twisted pair supporting the prototype is detailed in section 2.3. Complete findings from these assessments are provided in Appendix C.

#### Field Assessment Results

The following information summarizes qualitative and quantitative observations from the various test cases. Results are grouped by increasing SDSL modem throughput.

- SDSL Throughput = 384 kbps

Video quality and video motion observations are summarized in Table 3-3.

**Table 3-3. SDSL Throughput = 384 kbps; Fairfax**

Encoder Settings				
<i>Video Quantization Factor</i>	<i>Video Resolution</i>	<i>Screen Cropping Ratio</i>	<i>Video Quality</i>	<i>Video Motion</i>
38	Low	63%	Poor-	15
38	Low	85%	Poor-	10
38	Standard	63%	Fair-	10
38	Standard	85%	Fair-	8
38	High	63%	Good-	6
38	High	85%	Good-	4
28	Low	63%	Poor	14
28	Low	85%	Poor	10
28	Standard	63%	Fair	8
28	Standard	85%	Fair	7
28	High	63%	Good	5
28	High	85%	Good	3
18	Low	63%	Poor+	10
18	Low	85%	Poor+	9
18	Standard	63%	Fair+	6
18	Standard	85%	Fair+	6
18	High	63%	Good+	4
18	High	85%	Good	3

Our field observations reveal that regardless of q-factor and screen cropping settings, the encoder’s resolution must be at or above the “standard” setting in order to achieve fair to good video. The prototype was able to achieve a maximum of 15 f/s only when the encoder resolution setting was “low” and the q-factor was “28” or higher, which yields poor video quality. Good video quality was obtained at rates between 3 to 5 f/s. All of these results were consistent with those obtained in Alexandria.

- SDSL Throughput = 768 kbps

Specific observations (similar to those presented in Table 3-3) are tabulated in Appendix C.

Observations again indicate that a fair to good video quality could only be achieved with the encoder resolution setting at or above “standard” – regardless of the other parameters’ settings. The video motion data show an increase in the achievable frame rate – as much as 30 f/s but with poor quality. Good video quality could only be maintained at a rate within the range of 6 f/s to 10 f/s. These are all similar to results obtained in Alexandria.

- SDSL Throughput = 1152 kbps

Specific observations are tabulated in Appendix C.

Video quality observations were consistent with those viewed previously. Fair to good quality is obtainable with a “standard” or better resolution setting. Once again, we measured improved video motion that occasionally reached 30 f/s with fair quality video. Good quality could be maintained at rates at or below 15 f/s.

- SDSL Throughput = 1536 kbps

Specific observations are tabulated in Appendix C.

As expected, the video quality was consistent with earlier observations. Fair to good video quality requires an encoder resolution setting at or above “standard”. The prototype is able to achieve between 15 and 30 f/s under most system parameter settings, but the better quality video is observed when the frame rate is at or below 15 f/s.

- SDSL Throughput = 2048 kbps

Specific observations are tabulated in Appendix C.

Observed video quality follows the trend from previous test cases. Fair to good quality requires an encoder resolution setting at or above “standard”. Many configurations allowed for full-motion video (30 f/s); some with good video quality. The lowest frame rate observed is 10 f/s, but the video at this rate was of its highest quality.

General observations of the SDSL prototype deployed in Fairfax are as follows:

- SDSL performance and error statistics: These statistics (as defined in section 3.1.2) allowed us to assess the operation of the SDSL equipment as the system parameter settings varied. Data collected were similar to that obtained for the Alexandria deployment. As throughput increased, near-end and far-end transmit powers increased to compensate for decreasing receiver gains and related drops in the SNR. Throughout all test cases, the SNR never dropped below 10 dB – a margin similar to that maintained in Alexandria and more than adequate for sustained and reliable operation. We observed no communication errors (FEBE, ES, and SES).
- SDSL modem information rate (throughput): As done in Alexandria, we monitored real-time throughput. No significant or sustained deviations were observed.
- Traffic control operations: These observations were not made since a traffic controller was not part of the prototype used at this test site.
- Video motion: As with the test cases in Alexandria, the frame rate was affected by the available system throughput – the greater the throughput the smoother the motion. For any given throughput, the motion was also affected by the prototype’s encoder settings (e.g., resolution, q-factor, screen cropping). Values set to achieve better video quality subsequently reduced motion. With sufficient throughput, the quality was optimized without noticeably affecting the motion. Refer to Appendix C for details.
- Video quality: Quality was based on the prototype’s encoder settings and remained independent of the system throughput. Throughput had no significant impact on the quality. For details, refer to Appendix C.

### **Comparing Field Assessment and Laboratory Assessment Results**

The following provides a brief comparison of the results obtained during field assessments in Fairfax, and those obtained during laboratory assessments. As with the comparison of results from Alexandria, the intent of this comparison was to validate laboratory assessment findings. Again, we could not directly validate all laboratory test cases, but we could establish our benchmark for comparison.

There is no exact match between the twisted pair configuration encountered in the field and any of the configurations supported by the line simulator. Therefore, a precise benchmark comparison between laboratory and Fairfax field test results was not possible. The SDSL prototype deployed within the city of Fairfax used 19-gauge wire – like Alexandria – while laboratory configurations included only simulated 24- and 26-gauge wire. Additionally, the distances of twisted pair wire were slightly different. Laboratory assessments were performed using wire distances in increments of 1 mile. As described

in section 2.3, the distance of the twisted pair used for the prototype in Fairfax is approximately 1.75 miles.

The laboratory test scenario that most resembled the scenario in the field was a 24-gauge point-to-point 2-mile configuration. For the purposes of establishing a benchmark comparison, the 2-mile point-to-point laboratory test cases were more than adequate.

Under identical system parameter settings, laboratory assessments of the 24 AWG point-to-point scenarios at 2 miles showed results similar to those obtained during field tests. Figures 3-7 and 3-8 illustrate comparisons of video quality and video motion for the SDSL prototypes (laboratory tested and field tested) while operating at a throughput of 384 kbps.

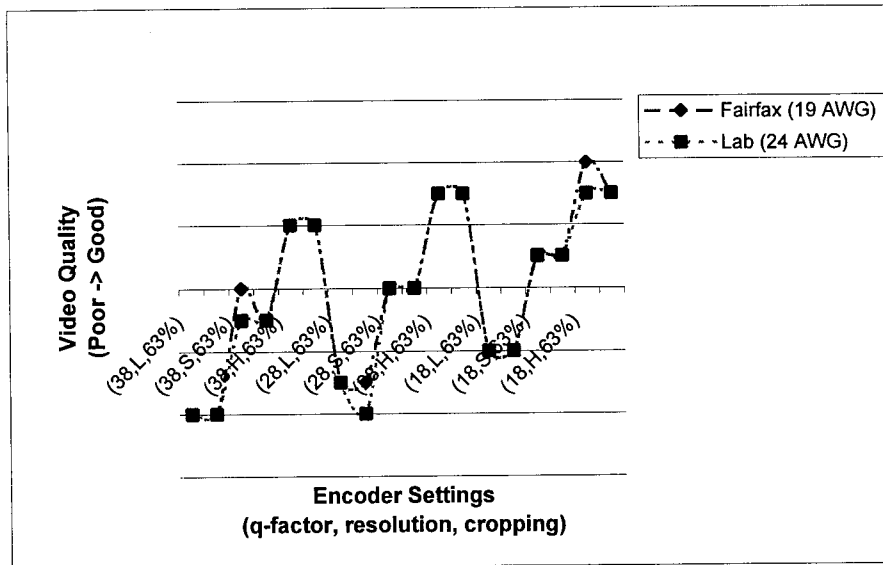


Figure 3-7. Video Quality (Fairfax vs. Laboratory); Throughput = 384 kbps

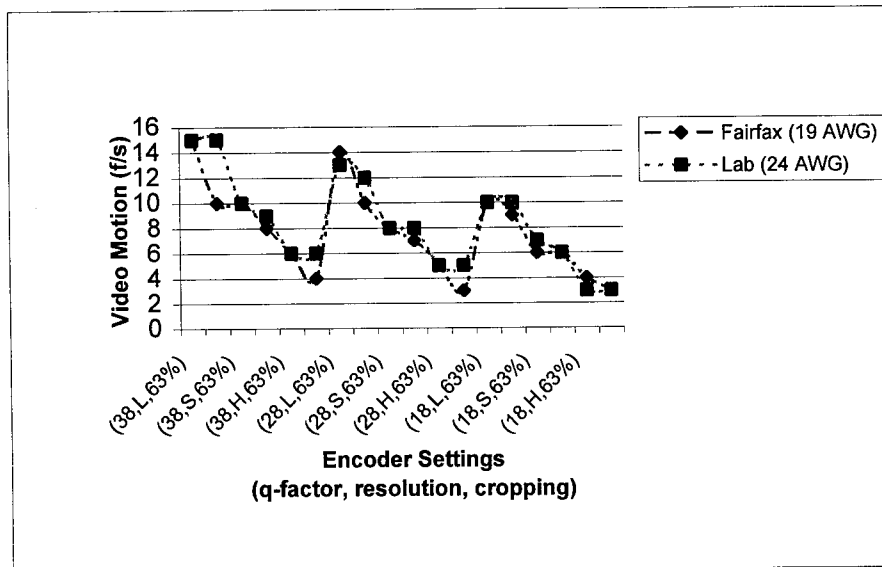


Figure 3-8. Video Motion (Fairfax vs. Laboratory); Throughput = 384 kbps

Figure 3-7 shows a similar quality for both implementations (field and lab). As with the assessments in Alexandria, any variance is likely due to a subjective opinion of video quality. The video motion data in Figure 3-8 also show a good similarity. Again, the variation in these data is due more to random traffic flow than to differences in the twisted pair infrastructures.

Similar plots for data collected at system throughputs of 768, 1152, 1536, and 2048 kbps are provided in Appendix C, section C.2. For a detailed view of the data points refer to the tables provided in section C.1 and the tables in provided in Appendix A of the laboratory assessments document.

Results shown in table 3-4, as well as the many figures in Appendix C, illustrate the high degree of correlation across test cases.

**Table 3-4. Video Motion (f/s) while Maintaining “Good” Video Quality (Fairfax vs. Laboratory)**

<i>Wire Gauge [AWG]</i>	<i>SDSL Throughput [Kbps]</i>	<i>Twisted Pair Distance [miles]</i>	
19 <sup>5</sup> (Fairfax)	384	2 <sup>6</sup>	3
	768	2	7
	1152	2	10
	1536	2	10
	2048	2	15
24 <sup>7</sup> (laboratory)	384	2	4
	768	2	8
	1152	2	10
	1536	2	13
	2048	2	15

The two similar configurations (field and lab) under identical system parameter settings provided comparable frame rates while maintaining comparable video quality. Other system performance statistics (e.g. MrGn, XmtPW, and RxGn) were also similar. As observed in Alexandria, the field system occasionally performed better than the laboratory prototype, and vice versa, but there were no significant discrepancies.

This correlation helps validate the laboratory findings for these particular point-to-point test cases. It also establishes our benchmark for comparison between laboratory and Fairfax field test results. These data further substantiate our conclusion that results from the remaining laboratory test cases provide a good approximation of the prototype’s performance. Refer to the laboratory assessments document for a complete list of laboratory test cases and their associated results.

<sup>5</sup> Wire gauge utilized during field assessments in Fairfax, Virginia.

<sup>6</sup> Actual distance is approximately 1.75 miles

<sup>7</sup> Wire gauge simulated during laboratory assessments.



## SECTION 4

### CONCLUSIONS

The following conclusions are derived from not only the field test results, but also the experience of deploying the SDSL prototypes within the field. It is important to note that this report is an addendum to the laboratory assessments document. Much of the information presented within is supplemental, and the laboratory document should be reviewed for a comprehensive understanding of the subject matter in this report.

#### 4.1 FIELD ASSESSMENTS

Our recent evaluations have shown that the SDSL traffic video prototype functions well in a field environment. The prototype performs in a manner similar to that we observed during laboratory tests, and in general, the field assessments substantiate our laboratory findings.

At both field test sites, we were able to maximize the DSL throughput and subsequently optimize the video motion/quality relation. We were able to achieve this level of performance since the prototypes were deployed over relatively simple DSL circuits (i.e., short wire runs within centralized architectures). As discussed in section 2, these better-case scenarios permitted less complicated deployments. Regardless, under identical system configurations and using similar infrastructures, the performance results from our field testing efforts closely resemble those obtained in the laboratory. Occasionally, the field system performed better than the laboratory prototype and vice versa, but there were no significant discrepancies.

The strong correlation helps substantiate our laboratory findings. Additionally, we conclude that results from other laboratory test cases (over 600) provide a good approximation of the prototype's performance under various infrastructure conditions and systems parameter settings. This includes using the SDSL prototype within standard twisted pair infrastructures (e.g. ANSI #3) and those infrastructures with DSL impairments, such as near-end cross talk (NEXT).

As discussed in the laboratory assessments document, if choosing to deploy an xDSL solution, there will be some additional infrastructure-, equipment-, operational-, and service-related issues to address. Ultimately, such considerations will be influenced by where and for whom the system is deployed.

## **4.2 DEMONSTRATION**

In addition to validating laboratory findings, the field testing efforts effectively demonstrated the capabilities of an xDSL-based traffic video prototype in an operational environment. They have also exemplified the ability to rapidly deploy such a system.

The city of Alexandria has considered the prospect of installing more DSL-based traffic video cameras and is currently in the midst of a study to determine the feasibility and scope of such a deployment. The Alexandria and Fairfax field tests have also drawn the attention of Virginia Department of Transportation (VDOT) officials who are now observing these efforts closely for any insight to similar application within other jurisdictions.

On 19 April 1999, Mitretek demonstrated the prototype in Alexandria as part of the “Enabling Technologies” session at the ITS America annual conference. This presentation, as well as a number of informal demonstrations, has raised interest from other parties, including consultants to the city of Baltimore, Maryland. The City has made a commitment to have 30 traffic video cameras up and running by October of this year and are interested in using the DSL approach to achieve this goal. They are currently in the process of testing a system based on the RADSL prototype we developed.

## **4.3 SUMMARY**

Although the FHWA studies (both laboratory and field) focused on traffic video, the numbers and types of high-speed data-intensive applications will grow and subsequently increase the demand on transportation communication systems. The ability to support such applications on existing infrastructure provides an alternative to those with communications problems that originate from financial constraint or infrastructure limitations. It also provides an option for those planning to lease or install new communication systems (e.g., fiber optic systems).

xDSL technologies show great potential for their application to ITS. The field testing efforts have validated the concept of xDSL-based traffic video, but more importantly, they have effectively demonstrated the value of this technology to the transportation community.



## BIBLIOGRAPHY

Biesecker, K., and Charleston, G., "The Application of Various Digital Subscriber Line (xDSL) Technologies to ITS: Traffic Video Laboratory Assessments", Mitretek Systems, 28 February 1999.

Biesecker, K., Charleston, G., and Kain, C., "The Application of Various Digital Subscriber Line Technologies to Intelligent Transportation Systems", Mitretek Systems, *The Telecommunications Review*, pp. 65-76, 1998.

Biesecker, K. and Kain, C., "ITS Video and High Speed Data over Telephone Lines", ITS America 8<sup>th</sup> Annual Meeting and Exposition, April 1998.

Cohu, Inc., *Model 3500 DSP Interline Transfer Color Camera – Installation and Operating Instructions*, Revision 2, March 1997.

Cohu, Inc., *MPC Master and Remote Control Panels – Installation and Operating Instructions*, Revision 3, April 1994.

Consultronics, *DLS 400 ADSL Wireline Simulator – Operating and Reference Manual*, Revision 7, June 1998.

Consultronics, *DLS 90 ADSL Wireline Simulator – Operating and Reference Manual*, Revision 7, December 1996.

Eagle Traffic Control Systems, Siemens Energy & Automation, Inc., *EPAC300 Actuated Controller Unit*, Revision C.12, June 1996.

Enerdyne Technologies, Inc., *ADVS® Compatible Compressed Digital Video Encoders and Decoders with Universal Communications Multiplexer - User Manual*, Fourth Edition, March 1998.

Hawley, George T., "Systems Considerations for the use of xDSL Technology for Data Access", *IEEE Communications*, pp. 56-60, March 1997.

Paradyne Corporation, *DSL Source Book*, 1997.

Paradyne Corporation, *Hotwire 8600 Digital Subscriber Line Access Multiplexer (DSLAM) - Installation Guide*, Document No. 8600-A2-GN20-30, February 1998.

Paradyne Corporation, *Hotwire Management Communications Controller (MCC) Card - User's Guide*, Document No. 8000-A2-GB29-00, April 1998.

Paradyne Corporation, *Hotwire 8775 MSDSL Termination Unit - User's Guide*, Document No. 8775-A2-GB20-00, March 1998.

Paradyne Corporation, *Hotwire Model 7975 MSDSL Stand Alone Termination Unit - User's Guide*, Document No. 7975-A2-GB20-10, April 1998.

Pelco, *PT570P/PT570-24 Series Pan and Tilts Installation/Operation Manual*, Revision C330M-F, April 1997.

U.S. Department of Transportation Federal Highway Administration, *ITS Architecture: Physical Architecture*, January 1997.

U.S. Department of Transportation Federal Highway Administration, *Communications Handbook for Traffic Control Systems*, 1993.

U.S. Department of Transportation Federal Highway Administration, *ITS Telecommunications: Public or Private? A Cost Trade-off Methodology Guide*, Pub. No. FHWA-JPO-97-0014, 1997.

U.S. Department of Transportation Federal Highway Administration, *A Case for Intelligent Transportation System (ITS) Telecommunications Analysis*, Pub. No. FHWA-JPO-97-0015, 1997.

U.S. Department of Transportation Federal Highway Administration, *ITS Telecommunications Requirements, Options, and Policy Implications*, 1993.

WaiLAN Communications, Inc., *AGATE 700 CO/CP User's Guide*, Version V2.2, 1998.

## APPENDIX A

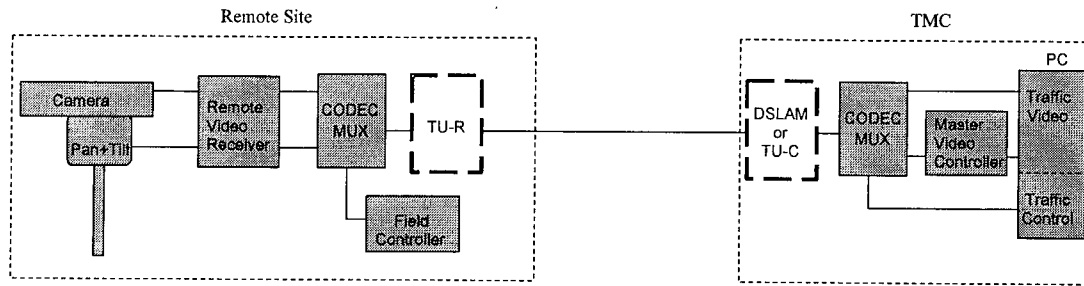
### SDSL PROTOTYPE DESIGN

The SDSL prototype consists of base system components and SDSL system components. This appendix describes these components and their function(s) as part of this prototype. To better understand the concept behind this traffic video prototype, refer to section 3 of the laboratory assessments document.

#### A.1 BASE SYSTEM COMPONENTS

After conducting various product surveys, we obtained, installed, and tested the components to be used in the prototype's base system. This equipment comprises traffic video and traffic control systems in use today and was used to create the conditions under which the prototype was evaluated.

Figure A-1 highlights base system components of the SDSL prototype. We refer to this configuration as base system #2 – an arrangement used to evaluate those xDSL technologies that utilize baseband portions of the twisted pair spectrum for high-speed data communication, such as SDSL. [Note: the RADSL prototype uses a different base system – base system #1, which is described in the laboratory assessments document].



**Figure A-1. Base System #2 Configuration**

At the remote site, the camera and pan & tilt unit are controlled by the remote video receiver. The video receiver passes analog video between the camera and the encoder, and it provides full duplex video control data between the pan & tilt and camera units and a communications multiplexer within the encoder. This base system also integrates traffic controller (field device) communications via the encoder's multiplexer. The encoder compresses and digitizes the analog video signal, multiplexes this with any video control data or traffic controller telemetry, and provides this integrated data stream to the xDSL modem at the remote site (i.e., the TU-R). The TU-R then exchanges data with its counterpart (TU-C or DSLAM) at the TMC.

At the TMC, the data stream is provided to the decoder. The decoder decompresses the video signal and returns it to an analog form, and any multiplexed video or traffic control data is separated. Traffic control data is sent to a traffic control device – in our case a desktop computer using a DOS based controller application. The video control data is passed to the master video controller, which is in turn governed by the same desktop

computer. The analog video signal is passed to a monitoring device – the desktop computer (with a video capture board) and/or a video monitor.

If the termination point for the circuit happens to be an intermediate communications hub and not the TMC, the SDSL equipment would be placed at the hub location, and the decoder and video control/display equipment would be located at the TMC. A communications service (e.g., a SONET) along the backbone facilities would be used to complete the circuit between hub and TMC.

The following sections more precisely describe the equipment we used to establish base system #2. If one were to use equipment other than that we selected, the general concept would remain the same.

### **A.1.1 Traffic Video Component**

The function of the traffic video component is to provide our video source. We made a deliberate attempt to use some of the more common traffic video equipment on the market; that specifically designed for traffic video. This was done to avoid any false conclusions that the video equipment was specifically designed to be used with any of the xDSL system components. This equipment could have been that from most any traffic video system deployed today; the concept would remain the same.

#### **Equipment**

The traffic video system, as represented in Figure A-1, comprises the following:

- Traffic Camera: Cohu, Inc. 3500 Series High Performance CCD Color Camera with DSP capabilities. This device has several parameter settings that are available on most of today's video camcorders, including an 8:1 digital zoom, auto-back-light compensation, auto-tracking or sample-and-hold white balance, integration and shuttering, etc. The camera uses a single 39-pin connector for multiple interfaces to the remote video receiver: an RS-170 interface for analog video, an RS-422 interface for DSP camera control, and an analog interface for mechanical camera control.



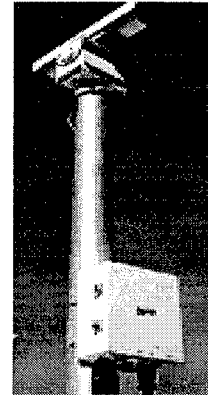
© Cohu, Inc.

**Figure A-2. Traffic Video Camera and Pan & Tilt Unit**

- Pan & Tilt Unit: Pelco, Inc. PT570P Medium Duty Pan Tilt. This is one of the more common models used by both Pelco and Cohu. It features worm-gear final drives to

minimize backlash and wind-drift and is sealed for all weather use. It uses 120 VAC and has a 40 lb maximum load. The unit has a 14-pin analog interface for communications with the remote video receiver.

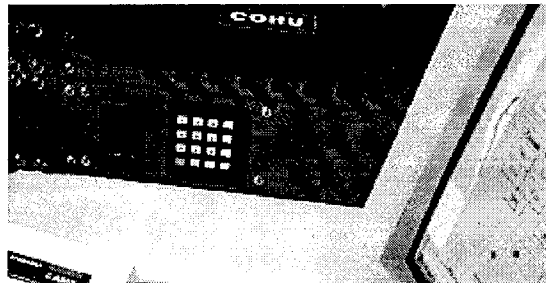
- Remote Video Receiver: Cohu, Inc. MPC Receiver within a NEMA-4 rated environmental enclosure. This unit can be mounted on a pole or other location up to 500 feet from the camera site and up to 50 feet (further if using RS-422) from the enclosure with the encoder, TU-R, etc. As described previously, the receiver uses a single 39-pin connector for multiple video and control interfaces with the camera. The receiver has a 14-pin analog interface for communications with the pan & tilt unit, an RS-232 interface for full duplex communication with the encoder's multiplexer, and an RS-170 BNC interface for analog video to the encoder.



© Cohu, Inc.

**Figure A-3. Pole-mounted Remote Video Receiver, Camera, and Pan & Tilt Unit**

- Master Controller: Cohu, Inc. MPC Control Panel. This unit provides an operator interface to the video system and is located within the TMC. It has an integrated control panel that includes: a keypad and a display to enter various camera and monitor selection commands, an integrated joystick to control pan & tilt operation, toggle switches to control camera functions (e.g., zoom), and several LEDs to indicate system status (e.g., camera power, communications error).



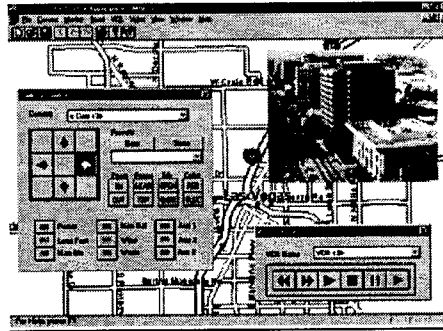
© Cohu, Inc.

**Figure A-4. Master Controller**

The master controller has a DB9 RS-232 interface for full duplex communication with the encoder's multiplexer, and a similar interface for communication with the PC. It can be operated by its integrated control panel or Cohu's PC-based Camera Administration & Monitoring Software CAMS™ program (discussed below).

- PC: Dell Inspiron laptop computer with Pentium™ processor and a Windows 98™ operating system. The PC houses Cohu's CAMS 2.0 software, a windows based application that will manage and control video system equipment through a graphical user interface (GUI). The software provides the ability to map a complex system and control components by clicking on representative icons displayed within the map. It provides all the functionality of the control panel on the master controller and more

(e.g., DSP camera functions such as digital zoom). The PC has full duplex communications with the master controller through one of its serial ports. While we provided this PC to control various prototype components and collect statistics during field assessments, the field test hosts were required to provide a PC for system control when the assessments were not in progress.



© Cohu, Inc.

**Figure A-5. CAMS GUI**

## **Component Testing**

To test the video system independently and verify proper operation of equipment, we connected the camera and pan & tilt unit to the remote video receiver. We then directly connected the remote video receiver to the master controller and the master controller to the PC. We powered these components, entered a default configuration (for a one-camera system) into the master controller, and tested various pan & tilt and camera functions as allowed by the control panel on the master controller. All tests were successful and indicated no problems with our analog video or camera control transmissions.

We later installed the CAMS software on the laptop PC and connected the PC to the master controller. Using the CAMS GUI, we performed various camera and pan & tilt operations. These tests were also successful and indicated no problems with our analog video or camera control transmissions.

Although there are many parameter settings, once we established a suitable video quality baseline (as discussed in Section 3.1, Methodology), we did not adjust these settings – such variations were not essential to our assessments.

### **A.1.2 Video Encoder/Decoder “codec” Component**

Digitization and compression of the video signal and multiplexing of the traffic and camera control communications were handled by two codecs. The codecs are manufactured by Enerdyne Technologies, Inc., and more specifically described as video encoder and decoder with built-in multiplexers. This equipment was selected in part for its use and familiarity within the ITS domain. Additionally, it has interfaces compatible with the rest of our base system components and provides flexibility for the wide range of assessment test cases, as discussed in section 3.1.1.

When considering the video encoding used in our prototypes, it's important to recall that this effort is not a performance evaluation of the codec system or the M-JPEG encoding scheme that it employs. It is not a comparison of technical issues such as M-JPEG vs. H.261 or MPEG1, or interframe vs. intraframe encoding. These issues are independent of the xDSL transmission technology and considerations for those implementing such systems. Our focus is placed on the transmission technology – xDSL. From the perspective of this particular project, the codecs and other base system components are interchangeable with similar devices on the market.

## Equipment

The video encoder/decoder component, as represented in Figure A-1, comprises of the following:

- **Encoder:** Enerdyne ENC2000R2 encoder equipped with the Universal Communications Multiplexer (UCM). This unit digitizes and compresses any of the following analog video signals: NTSC composite (color), PAL composite (color), EIA170 (monochrome), and CCIR (monochrome). The UCM, a single circuit board housed inside the encoder chassis, provides three configurable full-duplex asynchronous serial data channels, a voice communication channel, and control channels. All of which are multiplexed with the compressed video into a single data stream compatible with standard telecommunications interfaces.

A single video source may be connected at the input video port (VIDEO). The analog board converts the input signal to a digital format where it is compressed by a digital board and routed to the UCM. The UCM combines the compressed video with any serial data that may be present (such as EIA-/RS-232 serial data or digitized voice data) and passes the multiplexed data to the transmission facility. If an external CSU/DSU is utilized, the multiplexed data is available on the DTE serial port compatible with EIA-530 or V.35 telecommunications interfaces, as illustrated in Figures A-6 and A-7. If an optional T1 or dual T1 internal CSU is installed, the DTE serial port is non-functional and the interface to the telecommunications network is via one (T1) or two (dual T1) RJ48 connectors.

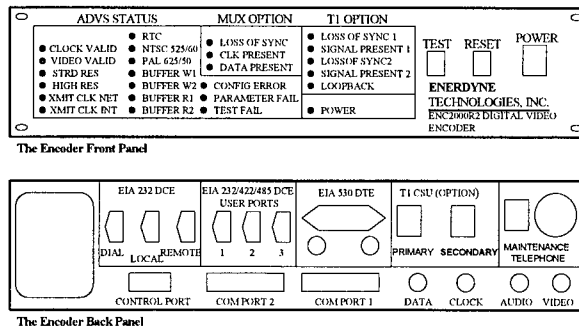
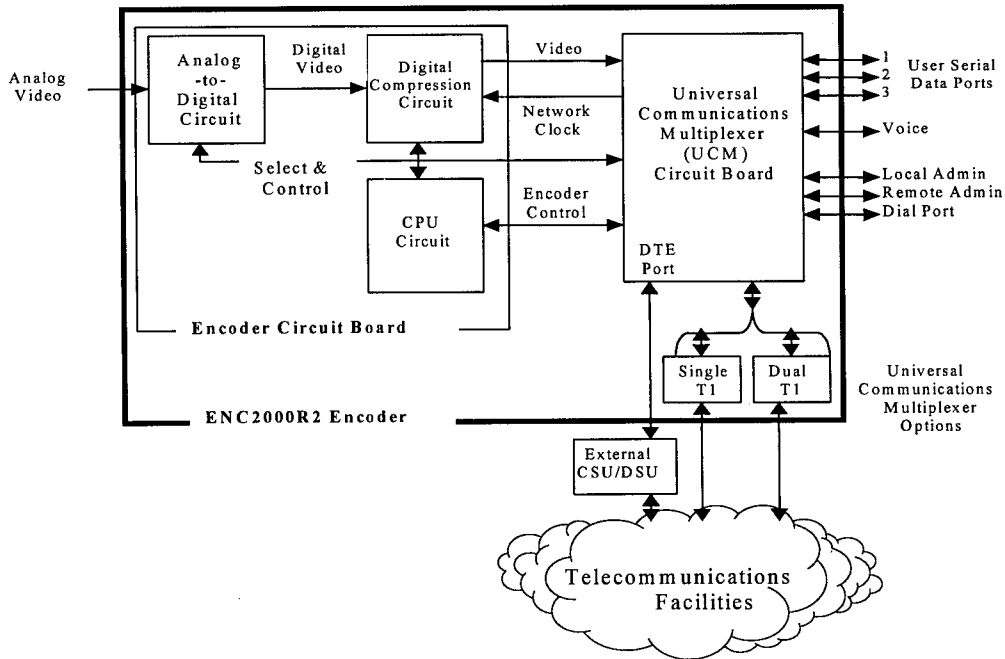
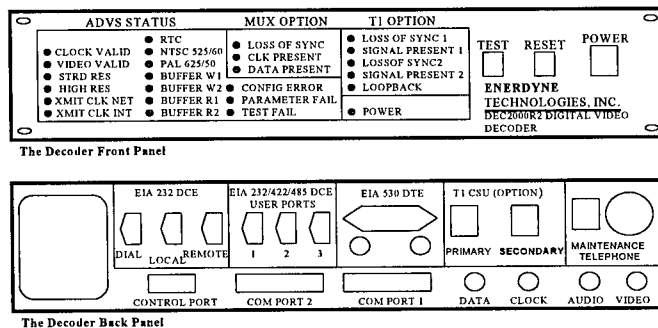


Figure A-6. External Overview of the Video Encoder



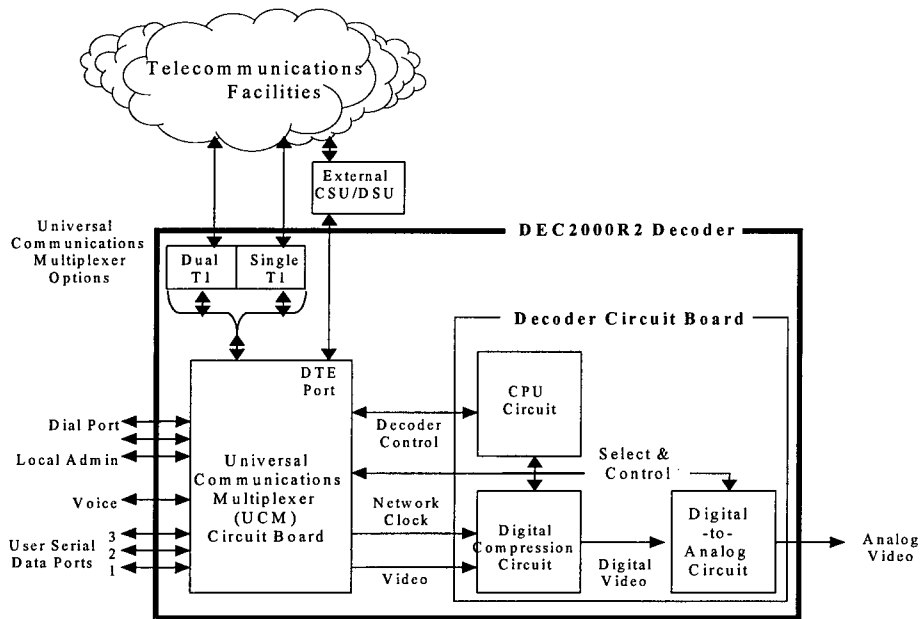
**Figure A-7. Functional Block Diagram of the Video Encoder**

Decoder: Enerdyne DEC2000R2 decoder similarly equipped with the Universal Communications Multiplexer (UCM). This unit receives digitized video from the encoder via the optional T1 interface or through the DTE port if an external CSU/DSU is used. The UCM on the decoder extracts user data that has been multiplexed with the video signal by the encoder and passes this user data to the three user data ports as appropriate. The UCM also provides the compressed digital video and the network clock signals to the decoder's digital board. Here the video data is decompressed and sent to the CPU as a 24-bit video signal. It is then converted to an NTSC or PAL analog video signal and passed to the output video port (VIDEO) for display (Figures A-8 and A-9).



**Figure A-8. External Overview of the Video Decoder**

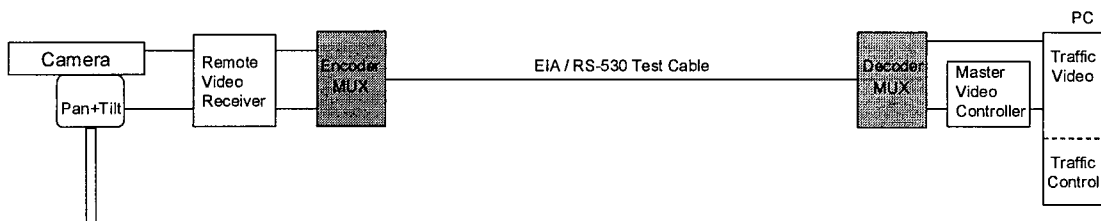




**Figure A-9. Functional Block Diagram Representation of the Video Decoder**

### Component Testing

To inspect the encoder and decoder for proper operation, we used a test cable between these units (connected to the video system as shown in Figure A-10) to run bench testing procedures as outlined in Chapter 5 of the user manual. Refer to the Enerdyne Technologies entry in the Bibliography. All tests were successful and indicated no problems with our digital video transmissions or multiplexed camera control communications.



**Figure A-10. Bench Testing the Video Codecs**

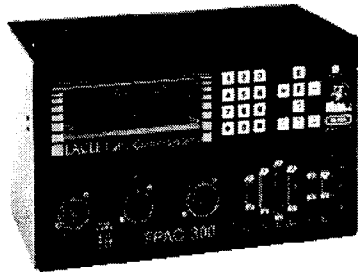
### A.1.3 Traffic Controller Component

The function of the traffic controller component is to provide the mechanism for our 4 kHz baseband communications. As with the selection of the traffic video equipment, we made a deliberate attempt to use a fairly common field device; in this instance a NEMA TS2 Type 2 traffic controller from Eagle Traffic Control Systems. This selection was made to demonstrate the proper operation of a true field device within our concept system and to avoid the generalities of using two generic devices (e.g., PCs) for our baseband communications. The field device could have been one of several types (e.g., ramp meter controller, dynamic message sign (DMS)) and from various manufacturers. The concept remains the same. [Note: The deployment within the city of Fairfax did not include a traffic controller; the equipment was unavailable.]

#### Equipment

The traffic controller component, as illustrated in Figure A-1, comprises of the following:

Traffic Controller: Eagle Traffic Control Systems EPAC300 series controller.



© Eagle Traffic Control Systems, Siemens Energy & Automation, Inc.

**Figure A-11. EPAC300 NEMA TS2 Type2 Traffic Controller**

This unit is a fully actuated controller that complies with both NEMA TS 1-1989 and TS 2-1992 actuated controller standards. Interfaces include the standard DB15 SDLC port (port 1), DB25 RS232 terminal port (port 2), as well as DB9 RS232 and FSK modem telemetry ports (ports 3) and the A, B, and C circular ports used for backward compatibility with TS1 devices. This unit also has a backlit LCD and alphanumeric keypad from programming. The EPAC300 communicates with a desktop PC through its telemetry port.

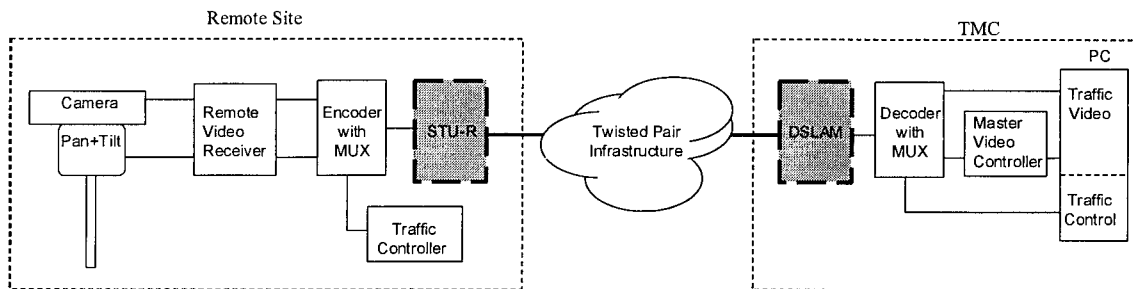
- PC: Dell Inspiron desktop personal computer (same as that described previously). The PC is used to emulate basic traffic management functions (Alexandria only). It houses a demo version of Eagle's Monitor and Report Console (MARC) software, a DOS-based application that provides for telemetry between the PC and the traffic controller. The software provides the ability to remotely control various aspects of the controller, such as vehicle and pedestrian phases, timing rings, etc. The PC has full duplex communications with the traffic controller through one of its serial ports.

## Component Testing

To verify proper operation the traffic controller itself, we merely powered the unit and varied parameters manually using the built-in control panel. To test if we could remotely control the unit on a dedicated circuit, as would be used in a centralized traffic control architecture, we connected the traffic controller (via its RS232 telemetry port) directly to an encoder user port. The PC (via its serial port) was connected to the associate user port on the decoder. With the codecs functioning, we had a dedicated connection and were able to use the MARC software to vary EPAC300 parameters as before. Since the function of the traffic controller in our study was simply to demonstrate undisturbed and simultaneous field device operation, we did not extensively test the functionality of this traffic controller component.

## A.2 INTEGRATING SDSL SYSTEM COMPONENTS

The function of the SDSL system (highlighted in Figure A-12) is to provide the communications between those base system components at the remote site and those at the TMC site (or the transmission facilities of an intermediate communications hub). SDSL systems use a single twisted pair to provide symmetric communications at rates in excess of 2 Mbps.



**Figure A-12. SDSL Prototype**

The remote site component of the SDSL prototype is constructed as follows.

- The camera uses a single 39-pin connector for multiple interfaces to the remote video receiver: an RS-170 interface for analog video, an RS-422 interface for DSP camera control, and an analog interface for mechanical camera control.
- The pan & tilt unit has a 14-pin analog interface for communications with the remote video receiver.
- The remote video receiver has an RS-170 BNC interface for analog video to the encoder and an RS-232 interface for full duplex camera control communications with the encoder's multiplexer (user port #1)
- The traffic controller (used in Alexandria only) has an RS-232 interface for full duplex communications with the encoder's multiplexer (user port #2).
- The encoder has an RS-530 to V.35 interface for integrated communications with the remote SDSL unit (STU-R), which is in turn connected to the twisted pair infrastructure.

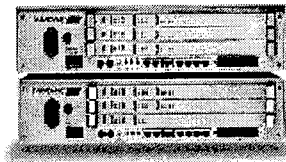
The TMC component of the SDSL prototype is constructed as follows.

- The twisted pair is connected to the DSLAM, which has a V.35 to RS-530 interface for integrated communications with the decoder.
- The decoder has an RS-170 BNC interface for analog video to both the PC's video capture board and a video monitor. The decoder's multiplexer has two RS-232 interfaces; one for camera control communications with the master video controller and the other for traffic controller communications with the PC.
- The master video controller also has an RS-232 interface for full duplex communications with the PC.
- The PC houses Cohu's CAMS 2.0 software, a windows-based application that will manage and control video system equipment through a graphical user interface (GUI). The PC also contains Eagle's Monitor and Report Console (MARC) software, a DOS-based application that provides for telemetry between the PC and the traffic controller.

The specific SDSL equipment used for this prototype was selected as a result of the aspects discussed in section 5 of the laboratory assessments document. Other SDSL equipment might also have worked for this prototype; regardless, the concept remains the same.

### Equipment

- DSLAM: Paradyne Corporation's Hotwire 8600 DSLAM chassis. This unit houses up to three line cards and supports a stackable design configuration for future growth. A 50-pin punch-down block provides access to the twisted pair infrastructure. Each individual line card provides the DTE interface(s). Our SDSL prototype utilized the following line cards:

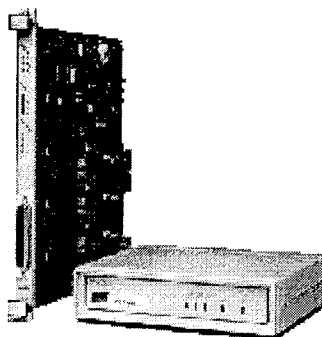


© Paradyne Corporation

**Figure A-13. SDSL Prototype's DSLAM**

- Hotwire management communications controller (MCC) card: This card manages all of the DSL cards within the DSLAM chassis providing alarm monitoring, system status, port status, etc. Only one MCC card is needed per stack (with a maximum of six chassis per stack).
- Hotwire 8775 termination unit: Paradyne Corporation's Multirate Symmetrical Digital Subscriber Line (M/SDSL) line card. This card uses a CAP line coding technique operating over the 3 kHz to 400 kHz portion of a twisted pair's frequency spectrum. The card has four DTE ports, each providing for a symmetric communications channel; each for a separate twisted pair. The card can automatically configure a channel for the maximum throughput supported by the associated local loop. Throughput is also selectable in increments of 64 kbps to a maximum of 2048 kbps (E1).

- **STU-R:** Paradyne Corporation's Hotwire 7975 termination unit. This stand-alone unit has functions similar to those of the 8775 M/SDSL line card, but it has only one DTE port. It is the line card's counterpart in the field. This unit can also be connected back-to-back without the need of a DSLAM (i.e., with another 7975 unit functioning as an STU-C).



© Paradyne Corporation

**Figure A-14. SDSL Prototype's M/SDSL Line Card and STU-R**

### **Component Testing**

Before integrating the SDSL and base systems, we installed and configured the SDSL equipment as an individual system. The M/SDSL line card (via DSLAM) was connected to the STU-R with a short test wire. The DSLAM, M/SDSL line card, and STU-R were appropriately configured and powered. We then verified synchronization and proper communications between the units with management statistics provided by the MCC card via terminal session.

A twisted-pair simulator was introduced in place of the test wire, and we again verified synchronization and proper operation as twisted pair infrastructure configurations were varied. All tests were successful and indicated no problems with our SDSL system.

### **Prototype Testing**

Once operational, we introduced the SDSL system to the base system components. This only required connecting DTE ports between STU-R and encoder, and between DSLAM and decoder.

As a complete system, the only concern with this integration was the synchronization between codecs over the new digital subscriber line. Proper clocking is required to maintain synchronization between the codecs. We used the SDSL system to source the clock, but our original attempt to integrate the SDSL system failed. After properly configuring the M/SDSL line card, STU-R, and codec DTE ports (e.g., receive and transmit clock polarity, DTR and RTS leads, etc.) we were able to synchronize the codecs.

The video signal was successfully transmitted; camera control functions were operational; and traffic controller telemetry was accurate and continuous. SDSL system parameter settings (e.g., throughput) were changed, and the prototype remained operational. Base system parameter settings affecting video motion and video quality were changed, and the prototype remained operational. The simulated twisted pair infrastructure was changed; the SDSL modems compensated for the change, and the prototype returned to operation. We did not exhaustively test all possible SDSL and base system parameter settings, only those that we used during our evaluation (discussed in section 3.1, Methodology).

## APPENDIX B

### PERFORMANCE EVALUATION RESULTS – ALEXANDRIA

This appendix presents results from the evaluation of the SDSL prototype that was deployed within the city of Alexandria. The evaluation was conducted using the system parameter settings defined in section 3.1.1, and the twisted pair supporting the prototype is detailed in section 2.2. Results from these field tests are also compared to laboratory assessment findings.

#### B.1 FIELD ASSESSMENT RESULTS

The following information summarizes qualitative and quantitative observations from the various field test cases. Results are grouped by increasing SDSL modem throughput.

##### B.1.1 SDSL Modem Information Rate (Throughput) = 384 kbps

- SDSL line rate = 400 kbps
- SDSL throughput = 384 kbps (SDSL line rate less SDSL overhead)
- Codec throughput = 378 kbps (SDSL throughput less codec overhead)

Note: In the SDSL prototype, codec throughput accounts for traffic video, traffic video control, and traffic controller transmissions.

Note: Unless specifically indicated, the traffic controller operations were accurate and continual during these tests.

**Table B-1. SDSL Throughput = 384 kbps**

Encoder Settings			<i>Video Quality</i>	<i>Video Motion (f/s)</i>
<i>Video Quantization Factor</i>	<i>Video Resolution</i>	<i>Screen Cropping Ratio</i>		
38	Low	63%	Poor-	15
38	Low	85%	Poor-	10
38	Standard	63%	Fair	10
38	Standard	85%	Fair-	8
38	High	63%	Fair+	6
38	High	85%	Good-	4
28	Low	63%	Poor	15
28	Low	85%	Poor	10
28	Standard	63%	Fair	8
28	Standard	85%	Fair	6
28	High	63%	Good	5
28	High	85%	Good	3

Encoder Settings				
<i>Video Quantization Factor</i>	<i>Video Resolution</i>	<i>Screen Cropping Ratio</i>	<i>Video Quality</i>	<i>Video Motion (f/s)</i>
18	Low	63%	Fair-	10
18	Low	85%	Fair-	9
18	Standard	63%	Fair+	7
18	Standard	85%	Fair+	5
18	High	63%	Good+	4
18	High	85%	Good	3

**B.1.2 SDSL Modem Information Rate (Throughput) = 768 kbps**

- SDSL line rate = 784 kbps
- SDSL throughput = 768 kbps (SDSL line rate less SDSL overhead)
- Codec throughput = 756 kbps (SDSL throughput less codec overhead)

Note: In the SDSL prototype, codec throughput accounts for traffic video, traffic video control, and traffic controller transmissions.

Note: Unless specifically indicated, the traffic controller operations were accurate and continual during these tests.

**Table B-2. SDSL Throughput = 768 kbps**

Encoder Settings				
<i>Video Quantization Factor</i>	<i>Video Resolution</i>	<i>Screen Cropping Ratio</i>	<i>Video Quality</i>	<i>Video Motion (f/s)</i>
38	Low	63%	Poor+	30
38	Low	85%	Poor-	15
38	Standard	63%	Fair	15
38	Standard	85%	Fair-	12
38	High	63%	Good-	10
38	High	85%	Good-	8
28	Low	63%	Poor+	30
28	Low	85%	Poor	15
28	Standard	63%	Fair+	15
28	Standard	85%	Fair	10
28	High	63%	Good-	10
28	High	85%	Good	7
18	Low	63%	Fair-	15
18	Low	85%	Poor+	15
18	Standard	63%	Good-	12
18	Standard	85%	Good-	8
18	High	63%	Good	8
18	High	85%	Good+	6



**B.1.3 SDSL Modem Information Rate (Throughput) = 1152 kbps**

- SDSL line rate = 1552 kbps
- SDSL throughput = 1152 kbps (SDSL line rate less SDSL overhead)
- Codec throughput = 1134 kbps (SDSL throughput less codec overhead)

Note: In the SDSL prototype, codec throughput accounts for traffic video, traffic video control, and traffic controller transmissions.

Note: Unless specifically indicated, the traffic controller operations were accurate and continual during these tests.

**Table B-3. SDSL Throughput = 1152 kbps**

Encoder Settings				
<i>Video Quantization Factor</i>	<i>Video Resolution</i>	<i>Screen Cropping Ratio</i>	<i>Video Quality</i>	<i>Video Motion (f/s)</i>
38	Low	63%	Poor-	30
38	Low	85%	Poor-	30
38	Standard	63%	Fair-	30
38	Standard	85%	Fair-	15
38	High	63%	Good	15
38	High	85%	Good-	10
28	Low	63%	Poor	30
28	Low	85%	Poor-	30
28	Standard	63%	Fair	17
28	Standard	85%	Fair	15
28	High	63%	Good	15
28	High	85%	Good	10
18	Low	63%	Poor+	30
18	Low	85%	Poor	17
18	Standard	63%	Good	15
18	Standard	85%	Fair+	12
18	High	63%	Good+	12
18	High	85%	Good+	8

**B.1.4 SDSL Modem Information Rate (Throughput) = 1536 kbps**

- SDSL line rate = 1552 kbps
- SDSL throughput = 1536 kbps (SDSL line rate less SDSL overhead)
- Codec throughput = 1512 kbps (SDSL throughput less codec overhead)

Note: In the SDSL prototype, codec throughput accounts for traffic video, traffic video control, and traffic controller transmissions.

Note: Unless specifically indicated, the traffic controller operations were accurate and continual during these tests.

**Table B-4. SDSL Throughput = 1536 kbps**

Encoder Settings			Video Quality	Video Motion (f/s)
Video Quantization Factor	Video Resolution	Screen Cropping Ratio		
38	Low	63%	Poor-	30
38	Low	85%	Poor-	30
38	Standard	63%	Fair-	30
38	Standard	85%	Fair-	17
38	High	63%	Good	15
38	High	85%	Good-	15
28	Low	63%	Poor	30
28	Low	85%	Poor	30
28	Standard	63%	Fair	30
28	Standard	85%	Fair	15
28	High	63%	Good	15
28	High	85%	Good	11
18	Low	63%	Poor+	30
18	Low	85%	Poor+	30
18	Standard	63%	Good-	15
18	Standard	85%	Good-	15
18	High	63%	Good+	15
18	High	85%	Good+	10

**B.1.5 SDSL Modem Information Rate (Throughput) = 2048 kbps**

- SDSL line rate = 2064 kbps
- SDSL throughput = 2048 kbps (SDSL line rate less SDSL overhead)
- Codec throughput = 2016 kbps (SDSL throughput less codec overhead)

Note: In the SDSL prototype, codec throughput accounts for traffic video, traffic video control, and traffic controller transmissions.

Note: Unless specifically indicated, the traffic controller operations were accurate and continual during these tests.

**Table B-5. SDSL Throughput = 2048 kbps**

Encoder Settings			Video Quality	Video Motion (f/s)
Video Quantization Factor	Video Resolution	Screen Cropping Ratio		
38	Low	63%	Poor-	30
38	Low	85%	Poor-	30
38	Standard	63%	Fair-	30

<b>Encoder Settings</b>				
<i>Video Quantization Factor</i>	<i>Video Resolution</i>	<i>Screen Cropping Ratio</i>	<i>Video Quality</i>	<i>Video Motion (f/s)</i>
38	Standard	85%	Fair	30
38	High	63%	Good	29
38	High	85%	Good-	15
28	Low	63%	Poor	30
28	Low	85%	Poor	30
28	Standard	63%	Fair	30
28	Standard	85%	Fair+	30
28	High	63%	Good	15
28	High	85%	Good	15
18	Low	63%	Poor+	30
18	Low	85%	Fair-	30
18	Standard	63%	Good-	30
18	Standard	85%	Good	15
18	High	63%	Good+	15
18	High	85%	Good+	12

## B.2 COMPARING FIELD ASSESSMENT AND LAB ASSESSMENT RESULTS

Figures B-1 through B-10 illustrate comparisons of video quality and video motion for the SDSL prototypes (laboratory tested and field tested) while operating at throughputs of 384, 768, 1152, 1536, and 2048 kbps.

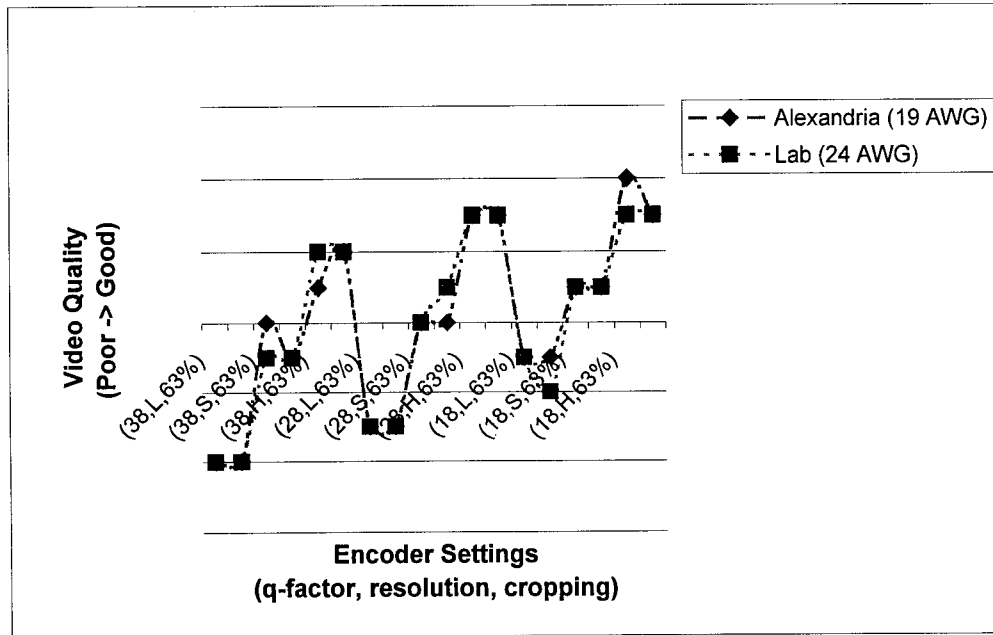


Figure B-1. Video Quality (Alexandria vs. Laboratory); Throughput = 384 kbps

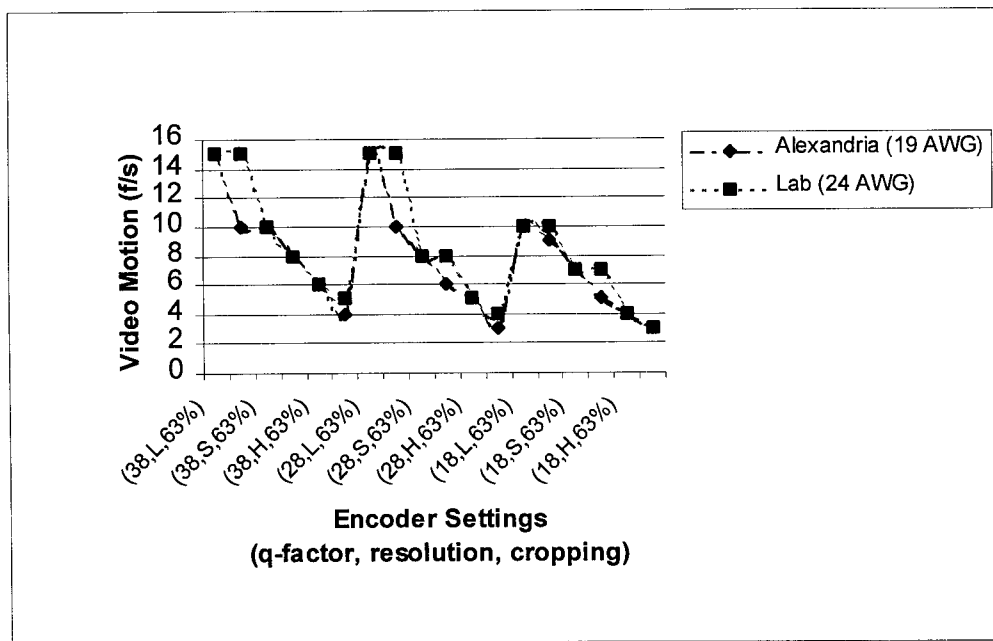


Figure B-2. Video Motion (Alexandria vs. Laboratory); Throughput = 384 kbps

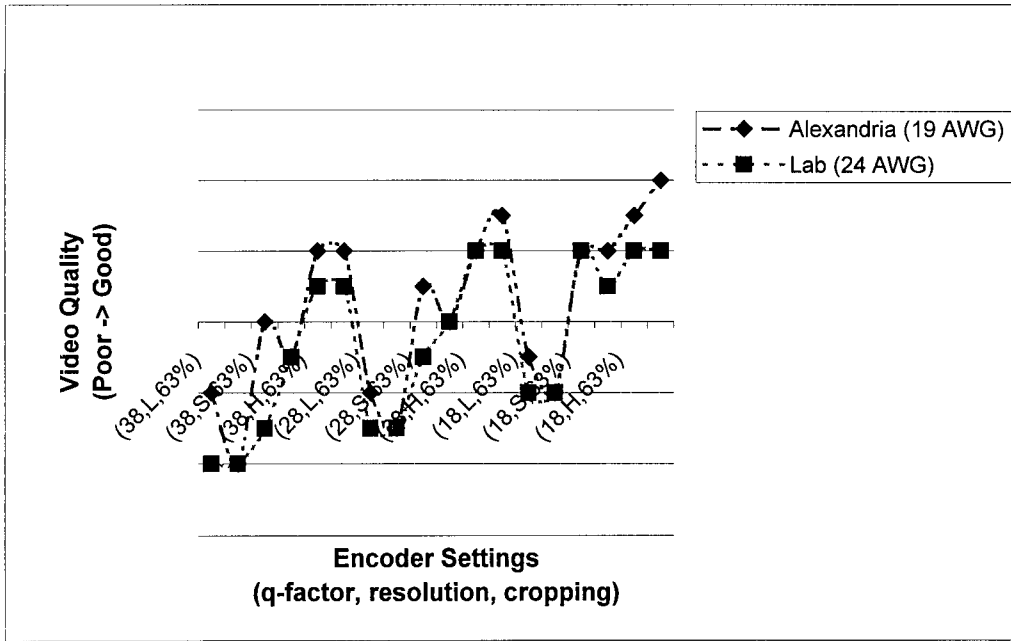


Figure B-3. Video Quality (Alexandria vs. Laboratory); Throughput = 768 kbps

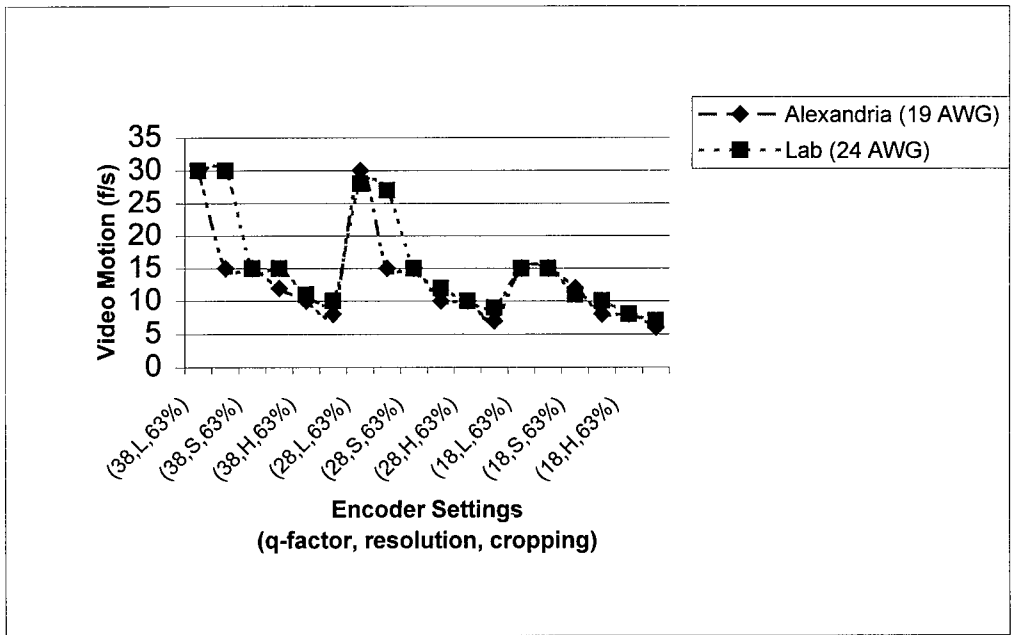


Figure B-4. Video Motion (Alexandria vs. Laboratory); Throughput = 768 kbps

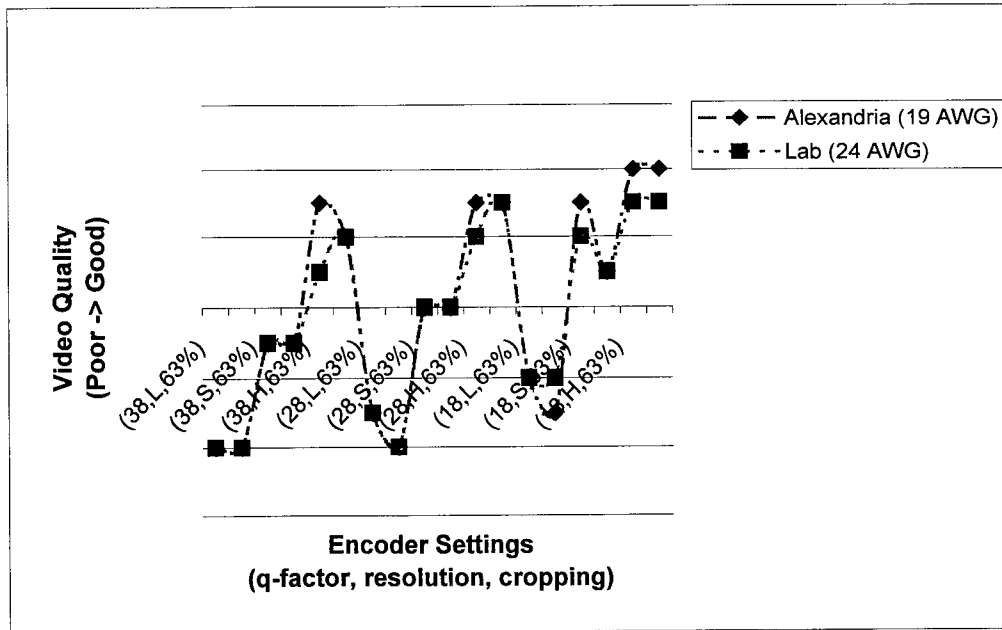


Figure B-5. Video Quality (Alexandria vs. Laboratory); Throughput = 1152 kbps

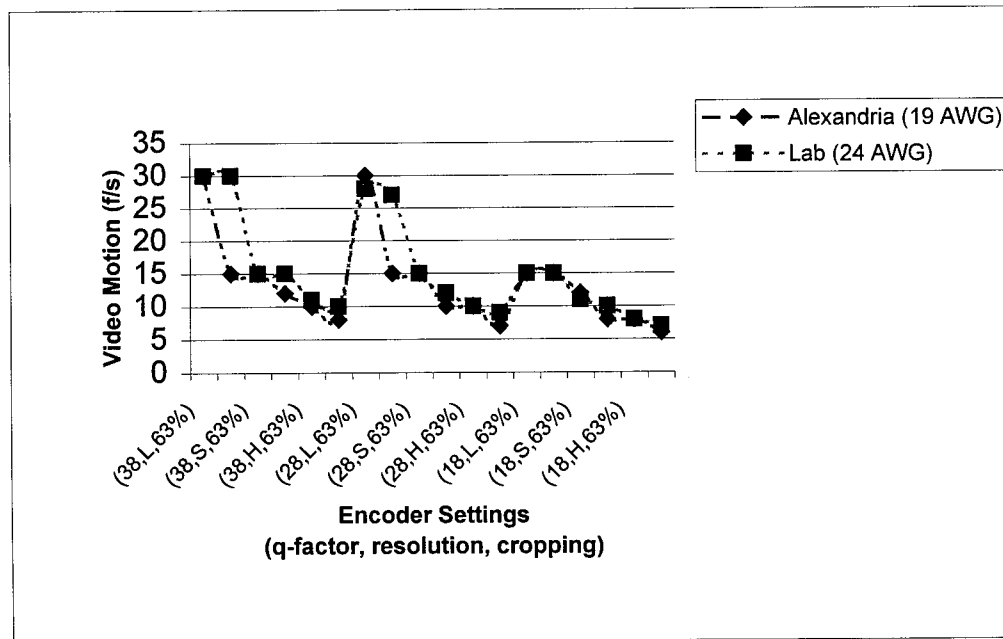


Figure B-6. Video Motion (Alexandria vs. Laboratory); Throughput = 1152 kbps

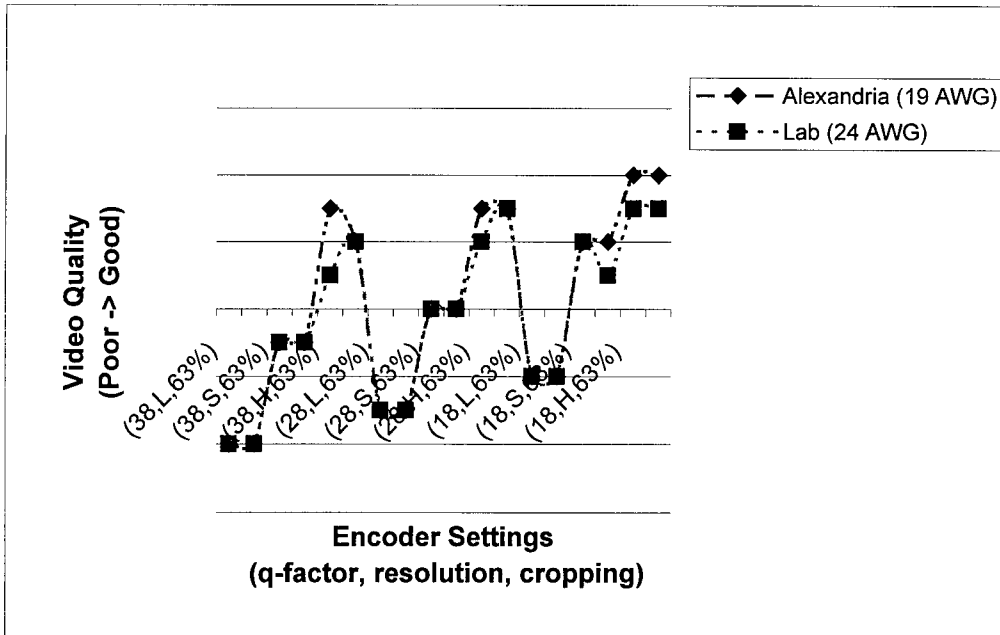


Figure B-7. Video Quality (Alexandria vs. Laboratory); Throughput = 1536 kbps

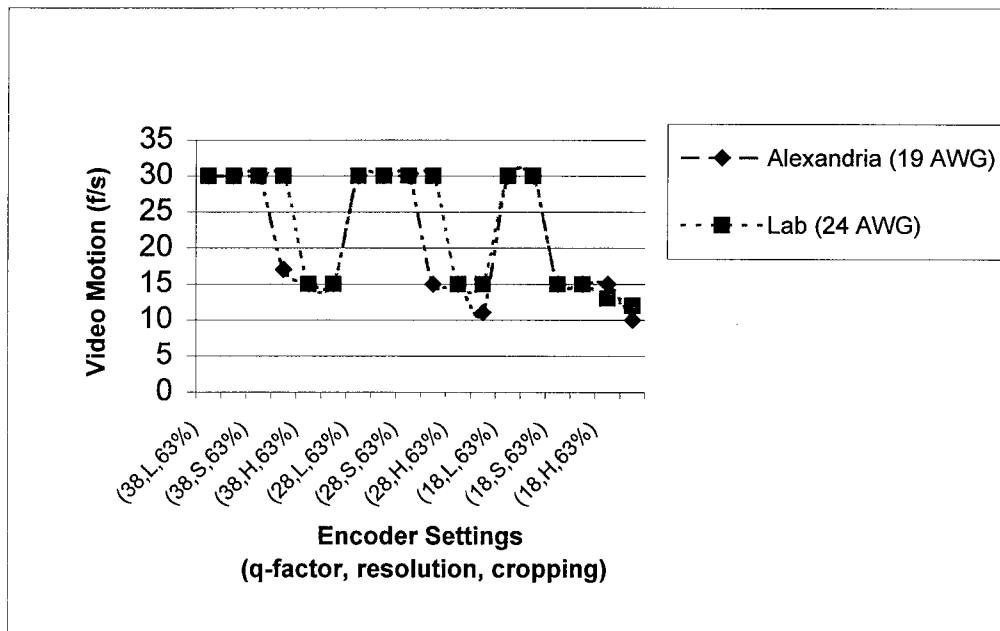


Figure B-8. Video Motion (Alexandria vs. Laboratory); Throughput = 1536 kbps

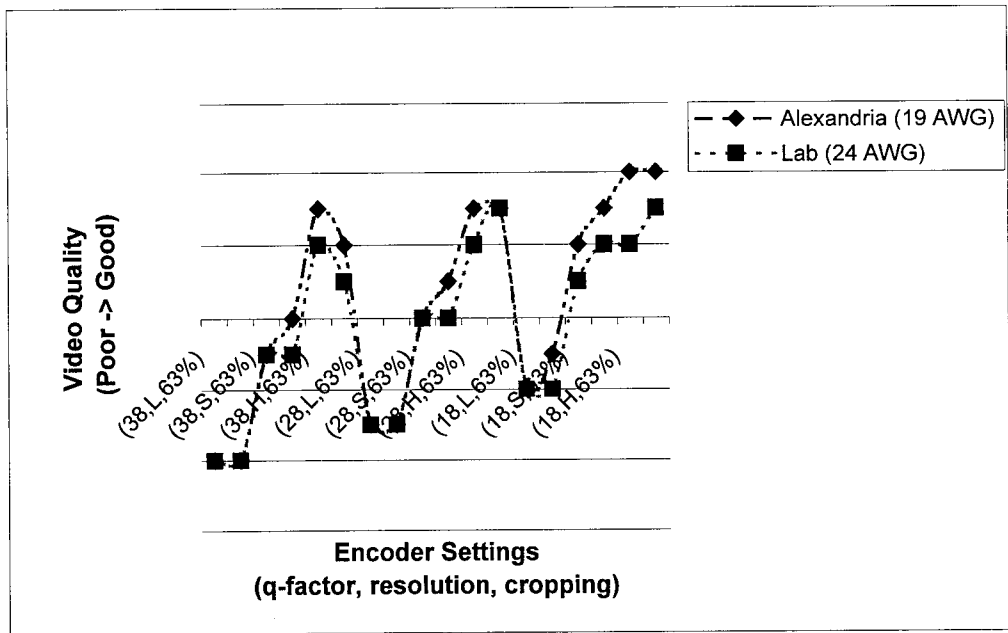


Figure B-9. Video Quality (Alexandria vs. Laboratory); Throughput = 2048 kbps

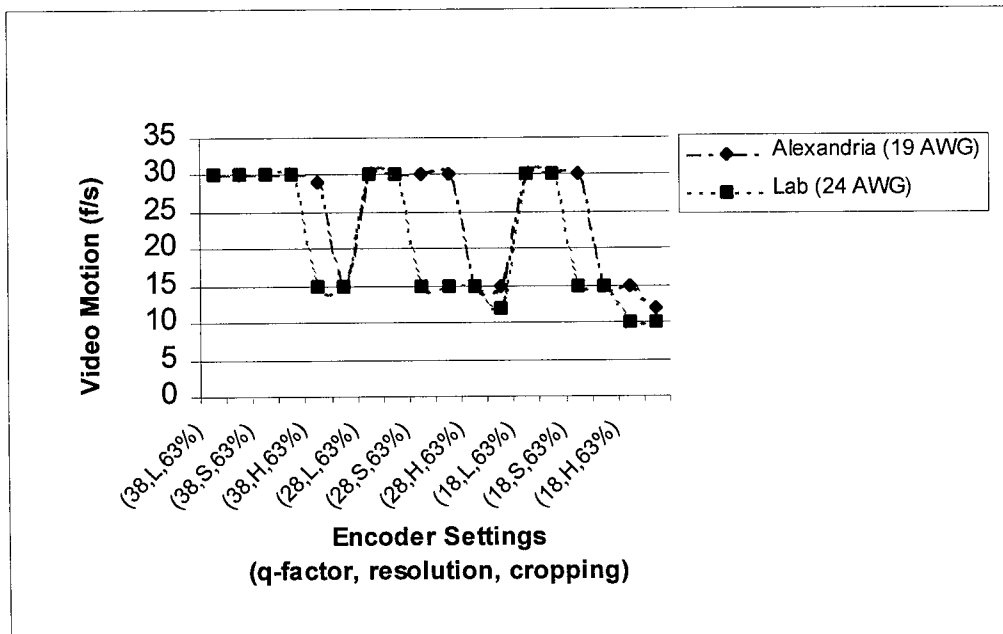


Figure B-10. Video Motion (Alexandria vs. Laboratory); Throughput = 2048 kbps



## APPENDIX C

### PERFORMANCE EVALUATION RESULTS – FAIRFAX

This appendix presents results from the evaluation of the SDSL prototype that was deployed within the city of Fairfax. The evaluation was conducted using the system parameter settings defined in section 3.1.1, and the twisted pair supporting the prototype is detailed in section 2.3. Results from these field tests are also compared to laboratory assessment findings.

#### C.1 FIELD ASSESSMENT RESULTS

The following information summarizes qualitative and quantitative observations from the various field test cases. Results are grouped by increasing SDSL modem throughput.

##### C.1.1 SDSL Modem Information Rate (Throughput) = 384 kbps

- SDSL line rate = 400 kbps
- SDSL throughput = 384 kbps (SDSL line rate less SDSL overhead)
- Codec throughput = 378 kbps (SDSL throughput less codec overhead)

Note: In the SDSL prototype, codec throughput accounts for traffic video, traffic video control, and traffic controller transmissions.

Note: Unless specifically indicated, the traffic controller operations were accurate and continual during these tests.

**Table C-1. SDSL Throughput = 384 kbps**

Encoder Settings				
<i>Video Quantization Factor</i>	<i>Video Resolution</i>	<i>Screen Cropping Ratio</i>	<i>Video Quality</i>	<i>Video Motion (f/s)</i>
38	Low	63%	Poor-	15
38	Low	85%	Poor-	10
38	Standard	63%	Fair-	10
38	Standard	85%	Fair-	8
38	High	63%	Good-	6
38	High	85%	Good-	4
28	Low	63%	Poor	14
28	Low	85%	Poor	10
28	Standard	63%	Fair	8
28	Standard	85%	Fair	7
28	High	63%	Good	5
28	High	85%	Good	3

Encoder Settings				
<i>Video Quantization Factor</i>	<i>Video Resolution</i>	<i>Screen Cropping Ratio</i>	<i>Video Quality</i>	<i>Video Motion (f/s)</i>
18	Low	63%	Poor+	10
18	Low	85%	Poor+	9
18	Standard	63%	Fair+	6
18	Standard	85%	Fair+	6
18	High	63%	Good+	4
18	High	85%	Good	3

### C.1.2 SDSL Modem Information Rate (Throughput) = 768 kbps

- SDSL line rate = 784 kbps
- SDSL throughput = 768 kbps (SDSL line rate less SDSL overhead)
- Codec throughput = 756 kbps (SDSL throughput less codec overhead)

Note: In the SDSL prototype, codec throughput accounts for traffic video, traffic video control, and traffic controller transmissions.

Note: Unless specifically indicated, the traffic controller operations were accurate and continual during these tests.

**Table C-2. SDSL Throughput = 768 kbps**

Encoder Settings				
<i>Video Quantization Factor</i>	<i>Video Resolution</i>	<i>Screen Cropping Ratio</i>	<i>Video Quality</i>	<i>Video Motion (f/s)</i>
38	Low	63%	Poor-	30
38	Low	85%	Poor-	15
38	Standard	63%	Fair	15
38	Standard	85%	Fair-	10
38	High	63%	Good-	10
38	High	85%	Good-	7
28	Low	63%	Poor	30
28	Low	85%	Poor	15
28	Standard	63%	Fair	15
28	Standard	85%	Fair	10
28	High	63%	Good	10
28	High	85%	Good	7
18	Low	63%	Poor+	15
18	Low	85%	Poor+	15
18	Standard	63%	Fair+	10
18	Standard	85%	Fair+	7
18	High	63%	Good+	8
18	High	85%	Good	5

### C.1.3 SDSL Modem Information Rate (Throughput) = 1152 kbps

- SDSL line rate = 1552 kbps
- SDSL throughput = 1152 kbps (SDSL line rate less SDSL overhead)
- Codec throughput = 1134 kbps (SDSL throughput less codec overhead)

Note: In the SDSL prototype, codec throughput accounts for traffic video, traffic video control, and traffic controller transmissions.

Note: Unless specifically indicated, the traffic controller operations were accurate and continual during these tests.

**Table C-3. SDSL Throughput = 1152 kbps**

Encoder Settings			Video Quality	Video Motion (f/s)
Video Quantization Factor	Video Resolution	Screen Cropping Ratio		
38	Low	63%	Poor-	30
38	Low	85%	Poor-	30
38	Standard	63%	Fair-	30
38	Standard	85%	Fair-	15
38	High	63%	Good-	15
38	High	85%	Fair+	10
28	Low	63%	Poor	30
28	Low	85%	Poor	30
28	Standard	63%	Fair	15
28	Standard	85%	Fair	12
28	High	63%	Good	15
28	High	85%	Good	10
18	Low	63%	Fair-	30
18	Low	85%	Poor+	15
18	Standard	63%	Fair+	15
18	Standard	85%	Fair+	12
18	High	63%	Good	10
18	High	85%	Good	7

### C.1.4 SDSL Modem Information Rate (Throughput) = 1536 kbps

- SDSL line rate = 1552 kbps
- SDSL throughput = 1536 kbps (SDSL line rate less SDSL overhead)
- Codec throughput = 1512 kbps (SDSL throughput less codec overhead)

Note: In the SDSL prototype, codec throughput accounts for traffic video, traffic video control, and traffic controller transmissions.

Note: Unless specifically indicated, the traffic controller operations were accurate and continual during these tests.

**Table C-4. SDSL Throughput = 1536 kbps**

<b>Encoder Settings</b>				
<i>Video Quantization Factor</i>	<i>Video Resolution</i>	<i>Screen Cropping Ratio</i>	<i>Video Quality</i>	<i>Video Motion (f/s)</i>
38	Low	63%	Poor-	30
38	Low	85%	Poor-	30
38	Standard	63%	Fair-	30
38	Standard	85%	Fair-	15
38	High	63%	Good	15
38	High	85%	Good-	15
28	Low	63%	Poor	30
28	Low	85%	Poor	30
28	Standard	63%	Fair	30
28	Standard	85%	Fair	15
28	High	63%	Good	15
28	High	85%	Good	10
18	Low	63%	Fair-	30
18	Low	85%	Poor+	30
18	Standard	63%	Good-	15
18	Standard	85%	Fair+	15
18	High	63%	Good+	15
18	High	85%	Good	10

**C.1.5 SDSL Modem Information Rate (Throughput) = 2048 kbps**

- SDSL line rate = 2064 kbps
- SDSL throughput = 2048 kbps (SDSL line rate less SDSL overhead)
- Codec throughput = 2016 kbps (SDSL throughput less codec overhead)

Note: In the SDSL prototype, codec throughput accounts for traffic video, traffic video control, and traffic controller transmissions.

Note: Unless specifically indicated, the traffic controller operations were accurate and continual during these tests.

**Table C-5. SDSL Throughput = 2048 kbps**

<b>Encoder Settings</b>				
<i>Video Quantization Factor</i>	<i>Video Resolution</i>	<i>Screen Cropping Ratio</i>	<i>Video Quality</i>	<i>Video Motion (f/s)</i>
38	Low	63%	Poor-	30
38	Low	85%	Poor-	30
38	Standard	63%	Fair-	30

<b>Encoder Settings</b>				
<i>Video Quantization Factor</i>	<i>Video Resolution</i>	<i>Screen Cropping Ratio</i>	<i>Video Quality</i>	<i>Video Motion (f/s)</i>
38	Standard	85%	Fair-	30
38	High	63%	Good	28
38	High	85%	Good-	15
28	Low	63%	Poor	30
28	Low	85%	Poor	30
28	Standard	63%	Fair	30
28	Standard	85%	Fair	30
28	High	63%	Good	15
28	High	85%	Good	15
18	Low	63%	Poor+	30
18	Low	85%	Poor+	30
18	Standard	63%	Fair+	30
18	Standard	85%	Fair+	15
18	High	63%	Good+	15
18	High	85%	Good	10

## C.2 COMPARING FIELD ASSESSMENT AND LAB ASSESSMENT RESULTS

Figures C-1 through C-10 illustrate comparisons of video quality and video motion for the SDSL prototypes (laboratory tested and field tested) while operating at throughputs of 384, 768, 1152, 1536, and 2048 kbps.

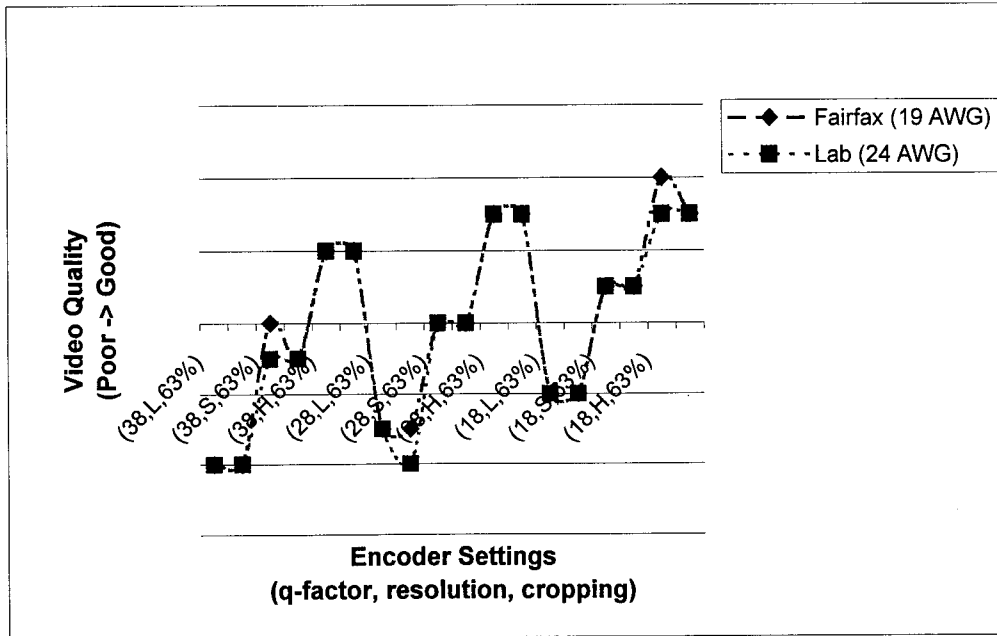


Figure C-1. Video Quality (Fairfax vs. Laboratory); Throughput = 384 kbps

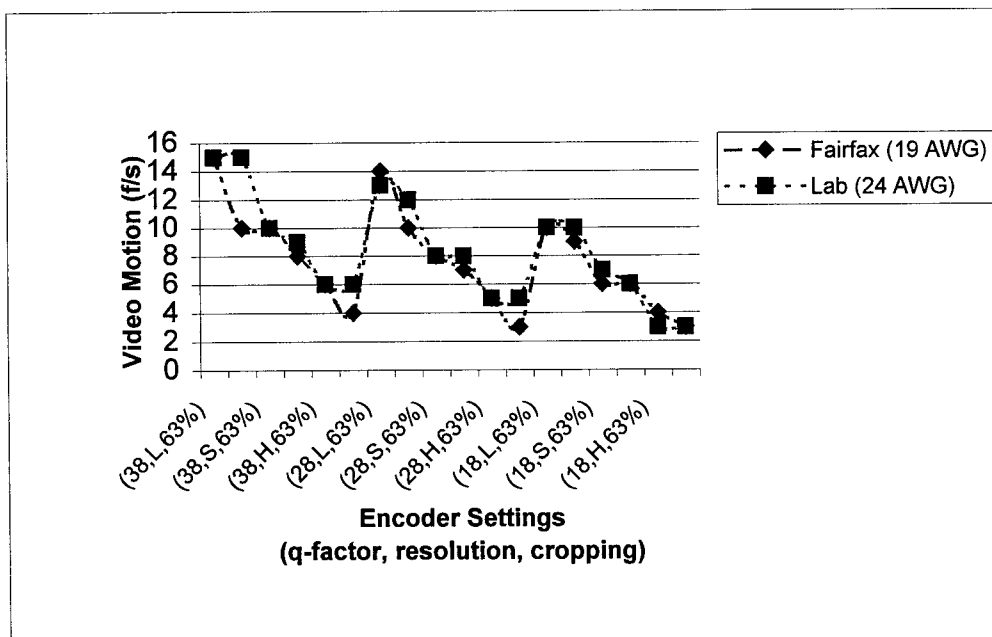


Figure C-2. Video Motion (Fairfax vs. Laboratory); Throughput = 384 kbps

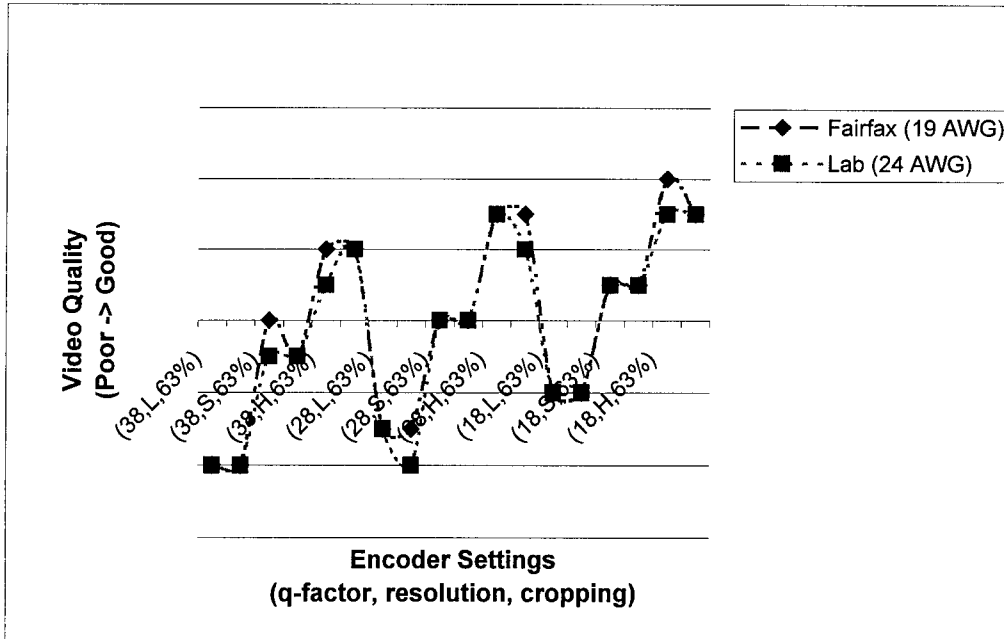


Figure C-3. Video Quality (Fairfax vs. Laboratory); Throughput = 768 kbps

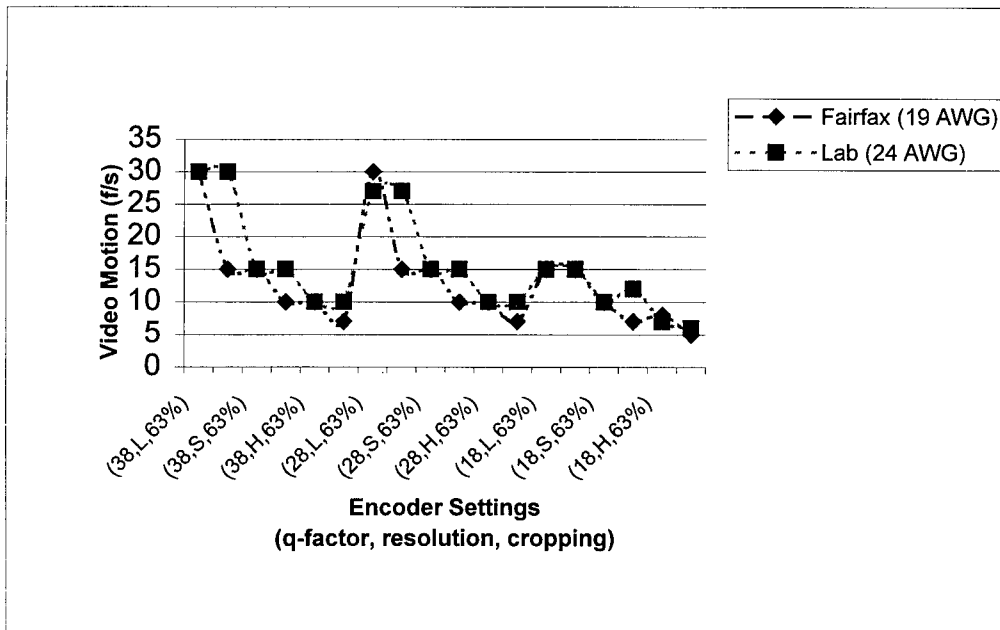


Figure C-4. Video Motion (Fairfax vs. Laboratory); Throughput = 768 kbps

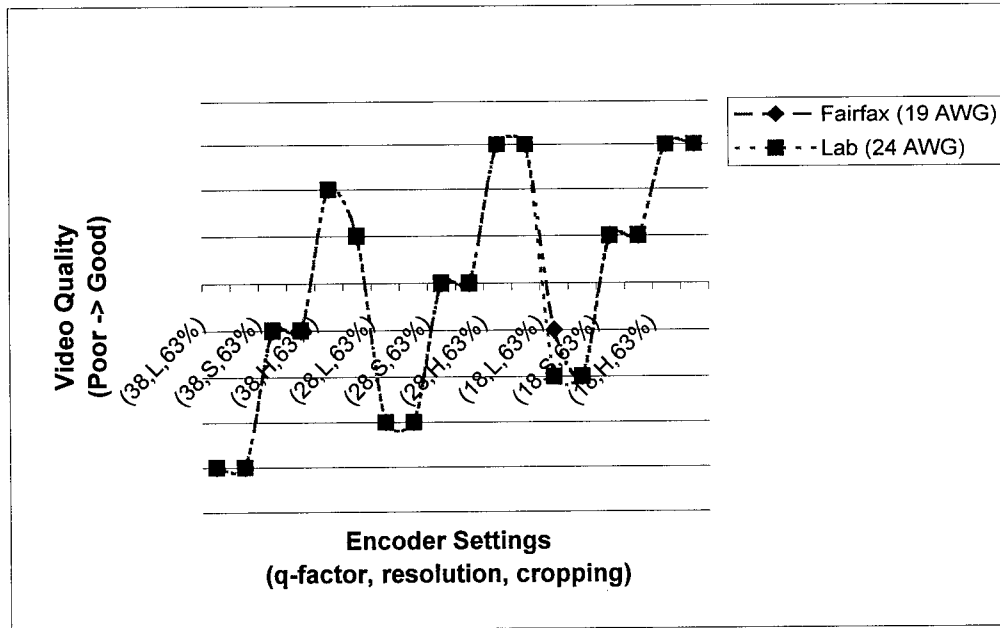


Figure C-5. Video Quality (Fairfax vs. Laboratory); Throughput = 1152 kbps

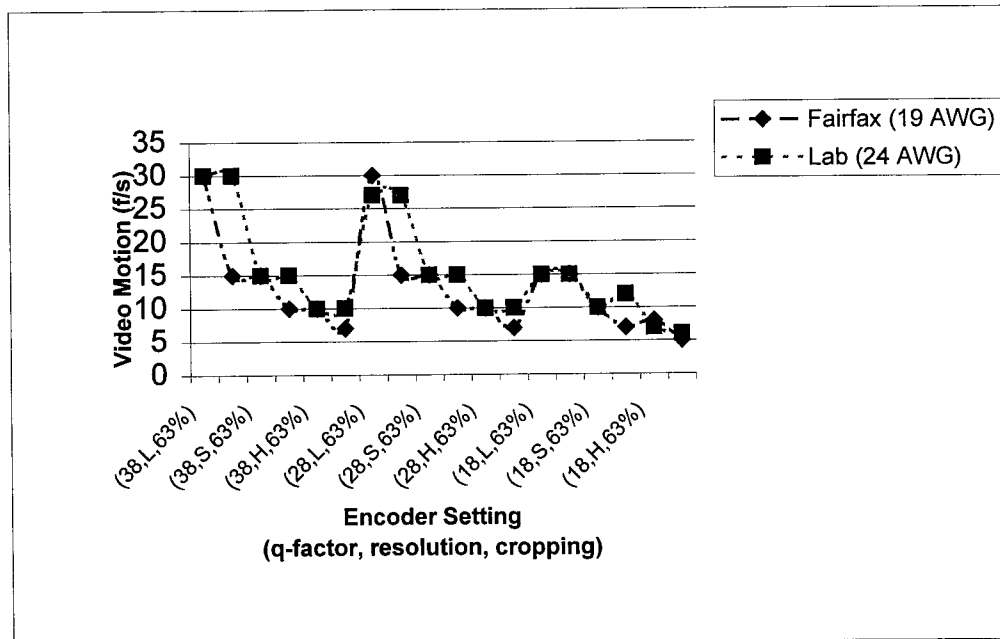


Figure C-6. Video Motion (Fairfax vs. Laboratory); Throughput = 1152 kbps



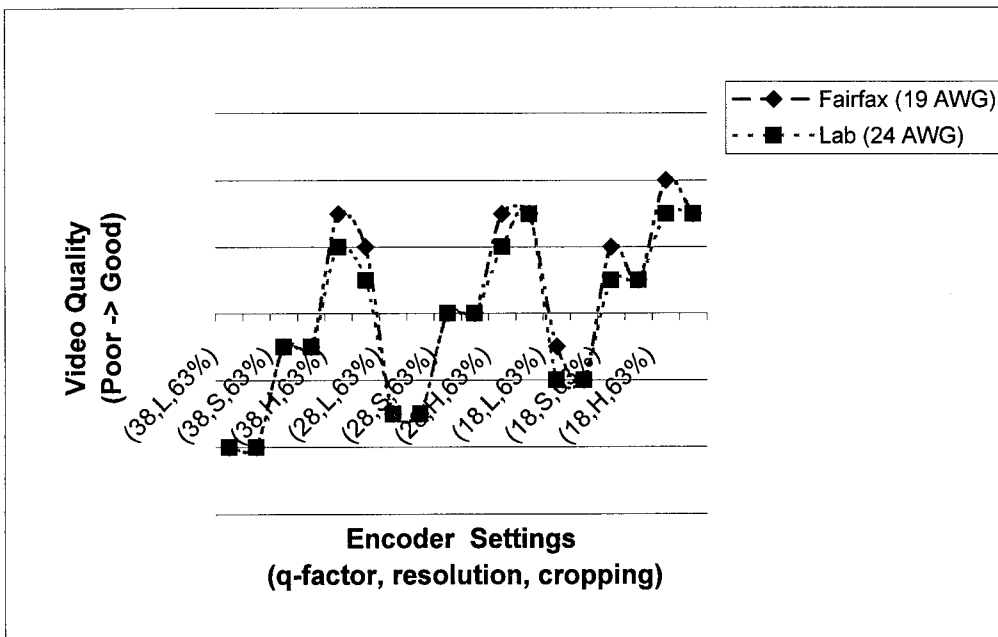


Figure C-7. Video Quality (Fairfax vs. Laboratory); Throughput = 1536 kbps

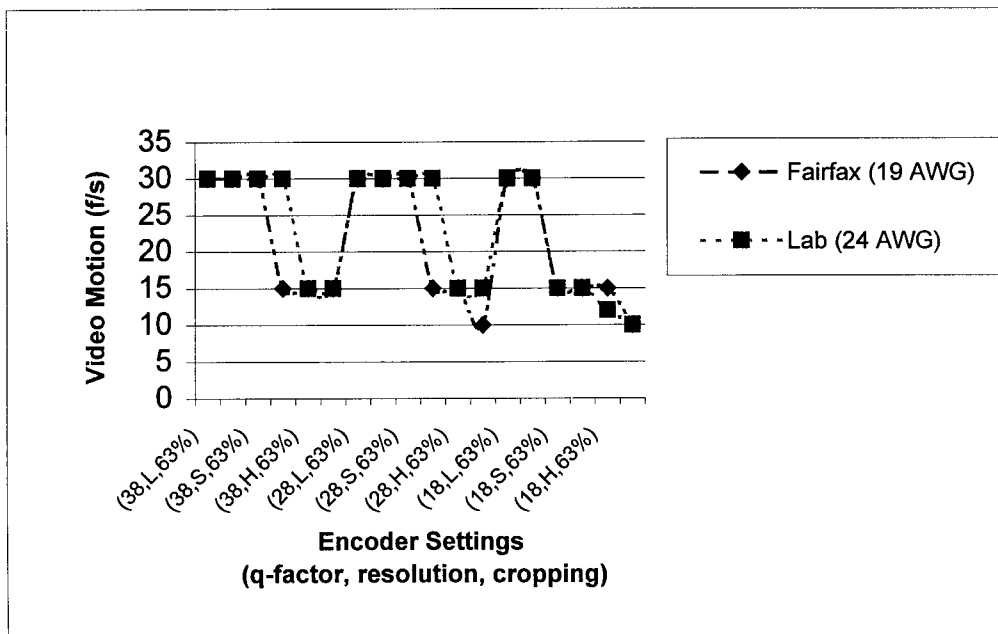


Figure C-8. Video Motion (Fairfax vs. Laboratory); Throughput = 1536 kbps

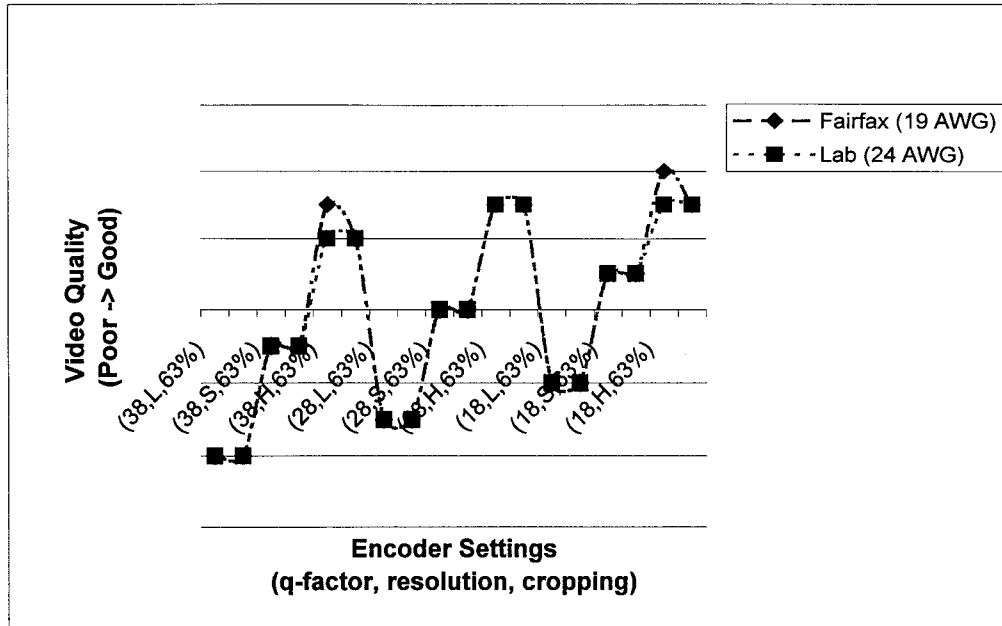


Figure C-9. Video Quality (Fairfax vs. Laboratory); Throughput = 2048 kbps

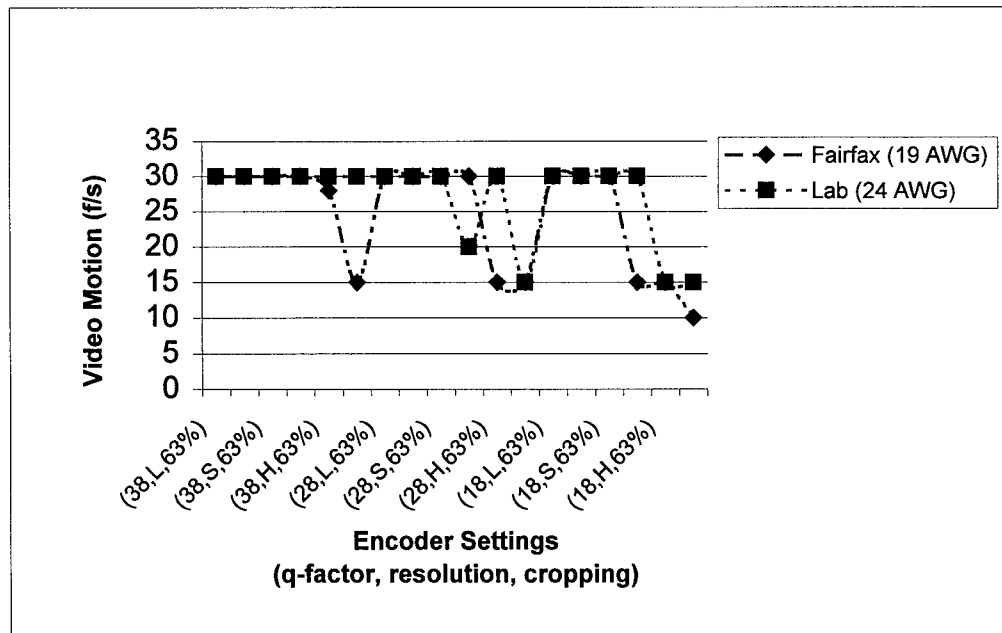


Figure C-10. Video Motion (Fairfax vs. Laboratory); Throughput = 2048 kbps

## GLOSSARY

<b>ADSL</b>	Asymmetric Digital Subscriber Line
<b>AM</b>	Amplitude Modulation
<b>AMI</b>	Alternate Mark Inversion
<b>ANSI</b>	American National Standards Institute
<b>ATL</b>	Advanced Telecommunications Laboratory
<b>ATM</b>	Asynchronous Transfer Mode
<b>ATU-C</b>	Asymmetric Transmission Unit- Central Office End
<b>ATU-R</b>	Asymmetric Transmission Unit- Remote End
<b>AWG</b>	American Wire Gauge
<b>BER</b>	Bit Error Rate
<b>CAMS</b>	Camera Administration & Monitoring Software (Cohu, Inc.)
<b>CAP</b>	Carrierless Amplitude Phase Modulation
<b>CCTV</b>	Closed Circuit TV
<b>CDSL</b>	Consumer DSL
<b>CHART</b>	Chesapeake Highway Advisory Routing Traffic
<b>Codec</b>	COder/DECoder
<b>CO</b>	Central Office
<b>CPE</b>	Customer Premises Equipment
<b>CRC</b>	Cyclic Redundancy Check
<b>CSA</b>	Carrier Serving Area, between the Central Office and the home, approximately 12,000 feet in the U.S. phone network
<b>dB</b>	Decibel
<b>dBm</b>	Decibel power level referred to 1 mW
<b>DCE</b>	Data Communication Equipment
<b>DDS</b>	Digital Data Service
<b>DLC</b>	Digital Loop Carrier
<b>DMT</b>	Dual Multi Tone
<b>DOT</b>	Department Of Transportation
<b>DSL</b>	Digital Subscriber Line
<b>DSLAM</b>	DSL Access Multiplexer
<b>DS1</b>	Digital Signal Level 1. Transmission Standard interface for digital data used by T1 transmission lines. DS1 operates at 1.544 Mbps.
<b>DS3</b>	Digital Signal Level 3. Transmission Standard interface for digital data used by T3 transmission lines. DS3 operates at 44.736 Mbps and consists of 28 DS1 channels plus overhead.
<b>DTE</b>	Data Terminal Equipment
<b>DTR</b>	Data Terminal Ready
<b>DWMT</b>	Discrete Wavelet Multitone
<b>E1</b>	European Standard for high-speed digital transmission operating at 2.048 Mbps.
<b>E3</b>	European Standard for high-speed digital transmission operating at 34 Mbps.
<b>ES</b>	Errored Second
<b>ESF</b>	Extended Super Frame

<b>FC</b>	Field Controller
<b>FEBE</b>	Far End Block Error
<b>FEXT</b>	Far End Cross Talk
<b>FHWA</b>	Federal Highway Administration
<b>FTTC</b>	Fiber To The Curb
<b>FTTH</b>	Fiber To The Home
<b>GUI</b>	Graphical User Interface
<b>HDSL</b>	High-bit-rate Digital Subscriber Line
<b>HFC</b>	Hybrid Fiber Coax
<b>IDSL</b>	ISDN DSL
<b>IP</b>	Internet Protocol
<b>ISDN</b>	Integrated Services Digital Network
<b>ITS</b>	Intelligent Transportation Systems
<b>ITU</b>	International Telecommunications Union
<b>JPEG</b>	Joint Photographic Experts Group
<b>LAN</b>	Local Area Network
<b>LEC</b>	Local Exchange Carrier
<b>LED</b>	Light Emitting Diode
<b>MARC</b>	Eagle's Monitor and Report Console (Eagle TCS, Siemens Inc.)
<b>MCC</b>	Management Communications Controller
<b>MDF</b>	Main Distribution Frame
<b>M-JPEG</b>	Motion JPEG
<b>MPEG</b>	Motion Picture Expert Group
<b>M/SDSL</b>	Multi-rate SDSL
<b>MVC</b>	Master Video Controller
<b>NEMA</b>	National Electrical Manufacturers Association
<b>NEXT</b>	Near End Cross Talk
<b>OOF</b>	Out Of Frame
<b>PBX</b>	Private Branch eXchange
<b>PDA</b>	Personal Data Assistant
<b>POTS</b>	Plain Old Telephone Service
<b>PSTN</b>	Public Switched Telephone Network
<b>PVC</b>	Permanent Virtual Circuit
<b>OC-1</b>	Optical Carrier, level 1. The counterpart of STS-1, the basic rate (51.84 Mbps) on which SONET is based. A direct, electrical-to-optical mapping of the STS-1 signal with frame synchronous scrambling. Higher levels of OC-x are multiples of OC-1.
<b>OC-3</b>	Optical Carrier, level 3. A rate of approximately 155 Mbps (3 times one OC-1) at which a signal is transmitted over fiber-optic cable.
<b>OCP</b>	Outside Cable Plant
<b>QAM</b>	Quadrature Amplitude Modulation
<b>RADSL</b>	Rate Adaptive Digital Subscriber Line
<b>RTS</b>	Request To Send
<b>RTU-C</b>	RADSL Transmission Unit- Central Office End
<b>RTU-R</b>	RADSL Transmission Unit- Remote Office End

<b>RVR</b>	Remote Video Receiver
<b>S-HDSL</b>	Single-pair HDSL
<b>SDSL</b>	Symmetric Digital Subscriber Line
<b>SES</b>	Severed Errored Second
<b>SNMP</b>	Simple Network Management Protocol
<b>SNR</b>	Signal to Noise Ratio
<b>SONET</b>	Synchronous Optical Network
<b>STS-1</b>	Synchronous Transport Signal, level 1. The basic rate of transmission, 51.84 Mbps, of a SONET frame carried on an electrical interface.
<b>STU-C</b>	SDSL Transmission Unit- Central Office End
<b>STU-R</b>	SDSL Transmission Unit- Remote Office End
<b>SVC</b>	Switched Virtual Circuit
<b>T1</b>	An AT&T digital T-carrier facility used to transmit a DS-1 formatted digital signal at 1.544 Mbps
<b>T3</b>	An AT&T digital T-carrier facility used to transmit a DS3-formatted digital signal at approximately 45 Mbps.
<b>TMC</b>	Traffic Management Center
<b>TMS</b>	Traffic Management Subsystem
<b>UDSL</b>	Universal DSL
<b>VDOT</b>	Virginia Department of Transportation
<b>VDSL</b>	Very high bit rate Digital Subscriber Line
<b>V.35</b>	ITU-T standard for a high-speed, 34-pin, DCE/DTE interface.
<b>WAN</b>	Wide Area Network
<b>2B1Q</b>	2 Binary 1 Quarternary

