

Report No. FHWA-RD-75-48

A REVIEW OF ENGINEERING EXPERIENCES WITH EXPANSIVE SOILS IN HIGHWAY SUBGRADES

D.R. Snethen and others

U.S. Army Engineer Waterways Experiment Station



June 1975
Interim Report

FOR EXHIBIT ONLY
Please Do Not Remove

This document is available to the public
through the National Technical Information
Service, Springfield, Virginia 22161

Prepared for
FEDERAL HIGHWAY ADMINISTRATION
Offices of Research & Development
Washington, D.C. 20590

NOTICE

This document is disseminated under the sponsorship of the Department of Transportation in the interest of information exchange. The United States Government assumes no liability for its contents or use thereof.

The contents of this report reflect the views of the U. S. Army Engineer Waterways Experiment Station, which is responsible for the facts and the accuracy of the data presented herein. The contents do not necessarily reflect the official views or policy of the Department of Transportation. This report does not constitute a standard, specification, or regulation.

The United States Government does not endorse products or manufacturers. Trade or manufacturers' names appear herein only because they are considered essential to the object of this document.

Sufficient copies of this report are being distributed by FHWA bulletin to provide a minimum of two copies to each regional office, two copies to each division office and four copies to each State highway agency. Direct distribution is being made to the division offices.

1. Report No. FHWA-RD-75-48		2. Government Accession No. PB 248658/As		3. Recipient's Catalog No.	
4. Title and Subtitle A REVIEW OF ENGINEERING EXPERIENCES WITH EXPANSIVE SOILS IN HIGHWAY SUBGRADES				5. Report Date June 1975	
				6. Performing Organization Code	
7. Author(s) Donald R. Snethen, Frank C. Townsend, Lawrence D. Johnson, David M. Patrick, Philip J. Vedros				8. Performing Organization Report No.	
9. Performing Organization Name and Address Soil Mechanics Division Soils and Pavements Laboratory U. S. Army Engineer Waterways Experiment Station P. O. Box 631, Vicksburg, MS 39180				10. Work Unit No. (TRAIS) FCP 34D1-132	
				11. Contract or Grant No. Intra-Government Purchase Order No. b-1-0195	
12. Sponsoring Agency Name and Address Offices of Research and Development Federal Highway Administration U. S. Department of Transportation Washington, D. C. 20590				13. Type of Report and Period Covered Interim Report	
				14. Sponsoring Agency Code M-0222	
15. Supplementary Notes FHWA Contract Manager - Preston C. Smith (HRS-21)					
16. Abstract Volume change resulting from moisture variations in expansive soil subgrades is estimated to cause damage to streets and highways in excess of \$1.1 billion annually in the United States. Expansive soils are so areally extensive within parts of the United States that alteration of the highway routes to avoid the material is virtually impossible. This report presents the results of a review of current literature combined with details of experiences of selected state highway agencies on procedures for coping with problems associated with expansive soil subgrades. The report discusses the geologic, mineralogic, physical, and physicochemical properties which influence the volume change characteristics of expansive soils. Currently used techniques for sampling, identifying, and testing expansive materials are reviewed and discussed. Treatment alternatives for the prevention or reduction of detrimental volume change of expansive soil subgrades beneath new and existing pavements are presented and discussed.					
17. Key Words Expansive soils Highways Soil moisture Subgrades			18. Distribution Statement This document is available to the public through the National Technical Information Service, Springfield, VA 22161		
19. Security Classif. (of this report) Unclassified		20. Security Classif. (of this page) Unclassified		21. No. of Pages 137	22. Price

PREFACE

The study of the methodology for prediction and minimization of detrimental volume change of expansive soils in highway subgrades is a 4-yr investigation funded by the Department of Transportation, Federal Highway Administration, under Intra-Government Purchase Order No. 4-1-0195, Work Unit No. FCP 34D1-132.

The work was initiated during June 1974 by the Soils and Pavements Laboratory (S&PL) of the U. S. Army Engineer Waterways Experiment Station (WES), Vicksburg, Mississippi. Dr. Donald R. Snethen, Research Group, Soil Mechanics Division (SMD), was the principal investigator during the period of this report. The work reported herein was performed by Dr. Snethen; Dr. Frank C. Townsend, Chief, Laboratory Research Facility, SMD, Dr. Lawrence D. Johnson, Research Group, SMD; Dr. David M. Patrick, Engineering Geology Research Facility, Engineering Geology and Rock Mechanics Division; and Mr. Philip J. Vedros, Special Projects Branch, Pavement Investigation Division, S&PL. The investigation was accomplished under the direct supervision of Mr. Clifford L. McAnear, Chief, SMD, and under the general supervision of Mr. James P. Sale, Chief, S&PL.

Director of WES during the conduct of this portion of the study and preparation of the report was COL G. H. Hilt, CE. Technical Director was Mr. F. R. Brown.

TABLE OF CONTENTS

	<u>Page</u>
PREFACE	ii
CONVERSION FACTORS, U. S. CUSTOMARY TO METRIC (SI) UNITS OF MEASUREMENT	vi
INTRODUCTION	1
PROPERTIES OF EXPANSIVE SOILS	4
Geology	4
Mineralogy	26
Physical Properties	32
Physicochemical Properties	47
Microscale Mechanisms	48
SAMPLING, IDENTIFICATION, AND TESTING OF EXPANSIVE SOILS	52
Sampling Techniques	53
Laboratory Identification and Testing Techniques	56
PRECONSTRUCTION TECHNIQUES FOR MINIMIZING DETRIMENTAL VOLUME CHANGE OF EXPANSIVE SOIL SUBGRADES	70
Introduction	70
Methods of Controlling Volume Change of Expansive Soils	70
Summary	95
POSTCONSTRUCTION TECHNIQUES FOR MINIMIZING DETRIMENTAL VOLUME CHANGES OF EXPANSIVE SOIL SUBGRADES	98
Introduction	98
Remedial Methods for Treating Expansive Soil Subgrades	98
Summary	103
PAVEMENT DESIGN AND CONSTRUCTION METHODS FOR HIGHWAYS ON EXPANSIVE SOIL SUBGRADES	104
Introduction	104
State Highway Agency Practices	104
Maintenance Procedures	109
SUMMARY	111
REFERENCES	114

LIST OF FIGURES

1 First order physiographic provinces within the continental United States	11
2 Distribution of potentially expansive materials in the United States: FHWA Regions 1, 3, and 5	13,14

3	Distribution of potentially expansive materials in the United States: FHWA Region 4	15,16
4	Distribution of potentially expansive materials in the United States: FHWA Region 6	17,18
5	Distribution of potentially expansive materials in the United States: FHWA Regions 7 and 8	19,20
6	Distribution of potentially expansive materials in the United States: FHWA regions 9 and 10	21,22
7	Typical structural configurations of clay minerals	28
a	Deflocculated clay mineral associations showing surface water (illite) and surface and interlayer water (montmorillonite)	34
9	Molding water content versus dry density and particle orientation	37
10	X-radiograph of undisturbed clay shale sample	42
11	Correlation of percent swell, liquid limit, and dry unit weight	68
12	Typical construction of moisture barriers used by the Colorado Department of Highways	74
13	Membrane section on Kaycee Project showing moisture buildup under center portion of roadway from hydrogenesis	76
14	Percentage of expansion for various placement conditions under a 1-psi surcharge	90
15	Total uplift pressure caused by wetting for various placement conditions	90
16	Effects of method of compaction on swell pressure saturation	92
17	Electrochemical stabilization experiment, Friant-Kern Canal, California	100

LIST OF TABLES

1	Tabulation of Potentially Expansive Materials in the United States	23,24
2	Typical Values of Free Swell for Common Clay Minerals	33
3	Cation Exchange Capacities of Clay Minerals	49
4	Natural Microscale Mechanisms Causing Volume Change in Expansive Soils	50

5 Indirect Techniques for Identification/Classification of Expansive Soils	58
6 Direct Techniques for Quantitatively Measuring Volume Change of Expansive Soils	62
7 Methods for Volume Change Control Using Additives	81

CONVERSION FACTORS, U. S. CUSTOMARY TO METRIC (SI)
UNITS OF MEASUREMENT

U. S. customary units of measurement used in this report can be converted to metric (SI) units as follows:

Multiply	By	To Obtain
inches	2.54	centimeters
feet	0.3048	meters
miles (U. S. statute)	1.609344	kilometers
square feet	0.092903	square meters
square yards	0.8361274	square meters
gallons (U. S. liquid)	3.785412	cubic decimeters
pounds (mass)	0.4535924	kilograms
tons (2000 lb)	907.185	kilograms
pounds (mass) per square foot	4.882429	kilograms per square meter
pounds (mass) per cubic foot	16.0185	kilograms per cubic meter
pounds (force) per square inch	6894.757	pascals
tons (force) per square foot	95.7606	kilonewtons per square meter
Fahrenheit degrees	5/9	Celsius or Kelvin degrees"

* To obtain Celsius (C) temperature readings from Fahrenheit (F) readings, use the following formula: $C = (5/9)(F - 32)$. To obtain Kelvin (K) readings, use: $K = (5/9)(F - 32) + 273.15$.

A REVIEW OF ENGINEERING EXPERIENCES WITH EXPANSIVE
SOILS IN HIGHWAY SUBGRADES

INTRODUCTION

1. Volume change resulting from moisture variations in expansive soil subgrades is estimated to cause damage to streets and highways in excess of \$1.1 billion annually,¹ particularly in the western, central, and southeastern United States. A 1972 survey² of the highway departments in the 50 states, District of Columbia, and Puerto Rico indicated that 36 states have expansive soils within their geographical jurisdiction. Expansive soils are so areally extensive within parts of the United States that alteration of the highway routes to avoid the material is virtually impossible. In addition, the currently used procedures for the design and construction of pavements on expansive soils do not systematically consider the variety of factors and conditions which influence volume change as evidenced by the continued occurrence of warped and cracked pavements in areas where expansive soils exist. Thus more accurate methods are needed for identifying, testing, and treating expansive clays to improve highway design, construction, and maintenance techniques.

2. The U. S. Army Engineer Waterways Experiment Station (WES) has recently undertaken a 4-yr study entitled "Development of Methodology for Prediction and Minimization of Detrimental Volume Change of Expansive Clays in Highway Subgrades," sponsored by the Federal Highway Administration (FHWA). The study has as its major objectives (a) the establishment of physiographic areas of similar natural sources and manifestations of swelling behavior, (b) the development of expedient procedures for identifying expansive clays, (c) the development of testing procedures for quantitatively (amount and rate of volume change) describing the behavior of expansive clays, (d) the development and evaluation of innovative technologies for prevention of detrimental swell under new and existing pavements, and (e) the development of recommended design criteria, construction procedures, and

specifications for the economical construction of new pavements and maintenance or reconstruction of existing pavements on expansive clays. All of the major objectives involve specific problems which have been studied by numerous independent and university researchers and state highway agencies. In order to **fully** understand the problems and the solutions afforded them by the various individuals and agencies concerned, a technical literature review and state highway agency contact program was undertaken. The information for the technical literature review was assembled with the aid of three major computer information retrieval systems; namely, Highway Research Information Service (HRIS), National Technical Information Service (NTIS), and the Defense Documentation Center (DDC) facilities. The state highway agency contacts were limited to those states having a greater distribution and frequency of occurrence of problems with expansive soils as specified by the FHWA. A total of fourteen state highway agencies located in the western and central United States were contacted. Subsequent to preliminary discussions eleven of these agencies were visited to discuss in detail their problems with expansive soils. The literature review and information derived from the agency contacts provide an updated summary of engineering experiences with expansive soils in highway subgrades. The information collected also provided guidance for detailing specific research topics included in this study. This report represents the results of the efforts expended on the review of current literature combined with details of experiences of various state highway agencies in coping with the problem of expansive soils.

3. The purpose of this report is to present a summary of technologies used to identify, test, and treat expansive clays. The report discusses the geologic, mineralogic, physical, and **physicochemical** properties of expansive materials. Currently used techniques for identifying and testing expansive materials are categorized and evaluated with respect to the applicability to highway **engineering**. Treatment techniques used in research studies and routine construction practice are presented and discussed. State highway agency practices with regard to construction guidelines and specifications for highways on

expansive clays are presented. General conclusions are drawn with regard to success of techniques discussed.

PROPERTIES OF EXPANSIVE SOILS

Geology

4. The origin and distribution of expansive materials in the United States are generally a function of the geologic history, sedimentation, and present local climatic conditions. These three factors, acting individually or in combination, have contributed to the formation of earth materials which may present serious design and construction problems by the sorption of water and resulting increase in the volume of the material. The term "expansive material" as used here signifies any earth materials which exhibit significant volume changes in the presence of water.

5. These expansive materials may be subdivided into three categories on the basis of physical characteristics. These are expansive argillaceous rocks, expansive argillaceous sediments, and expansive argillaceous soils. This subdivision is geologic in context and relates more to sedimentologic aspects and the geologic history than to mineralogy or to the amount of volume change exhibited by the material. The term "argillaceous" signifies that the material contains considerable clay-size particles which are usually necessary for volume change to occur.

6. The term "argillaceous rocks" refers to relatively hard, indurated clay shales or clay stones which have been buried, consolidated, and at least partially cemented. Argillaceous sediments include those materials of Mesozoic age or younger that have not been sufficiently buried, consolidated, or cemented to be included in the category of rocks. This is an arbitrary basis and materials exist for which it is difficult to make this distinction. The argillaceous soils or residual soils refer to the altered materials which have formed upon existing rocks or sediments. These residual soils may owe their expansive character to the parent material and/or to the weathering processes under which the soils were formed. Although each category of material possesses different intrinsic properties, each may exhibit varying

degrees of expansion due to the presence of active clay minerals in the material.

7. The active clay minerals include montmorillonite, mixed-layer combinations of montmorillonite and other clay minerals, and under some conditions chlorites and vermiculites. Kaolinites and illites are usually not considered active although they may contribute to expansive properties if sufficient amounts are present in the material. The mineralogical aspects of the problem are discussed in more detail under "Mineralogy." Expansiveness caused by minerals other than montmorillonite is discussed under "Mineralogy." In general, the distribution of expansive materials is controlled by those conditions which facilitate the formation, accumulation, and preservation of montmorillonite.

Formation

8. The following conditions, either individually or in combination, lead to the formation or origin of expansive materials: (a) weathering, (b) diagenetic alteration of preexisting minerals, and (c) hydrothermal alteration. Of these conditions, weathering and diagenesis are probably the more important. For example:

- a. Montmorillonite will form from the weathering of volcanic ash or primary silicate minerals such as feldspars, pyroxenes, or amphiboles under those conditions which result in the retention of bases and silica within the weathering system. These conditions are promoted by insufficient leaching of the soil profile by downward moving water due to low permeability, and excessive evaporation in regions of aridity.³
- b. The distinction between diagenesis and weathering, although somewhat vague, is between alteration which occurs at depth (diagenesis) or within the top few feet of the soil profile (weathering). Both involve similar chemical and physical processes and both occur in and as a result of groundwater. The diagenetic formation of montmorillonite results from the devitrification of volcanic ash particles or shards which have accumulated as sediments in sedimentary basins.⁴ The shards are more or less amorphous, range in size from sand to clay, and are chemically quite unstable. The instability and the composition, which is often intermediate between rhyolite and basalt and thus rich in silica as well as bases, usually lead to the formation of montmorillonite. The shards may occur intermixed with other land- or basin-derived

sediments or as relatively pure discrete layers several feet thick. Discrete layers of volcanic ash which have altered to montmorillonite are termed bentonite.

Accumulation

9. Sedimentary accumulations of montmorillonite originate in those areas which receive land-derived montmorillonite and/or volcanic ash sediments. The areas must either lie near or be **stream-connected** to land areas where montmorillonite was formed by weathering and/or lie sufficiently near volcanic areas such that volcanic ash sediments can be carried either in the air or by streams to the areas of accumulation.

10. The energy conditions at the depositional areas must be conducive to the deposition and accumulation of essentially silt- and clay-size particles. These conditions may exist in several types of sedimentary environments. The principal controlling conditions are relatively flat gradients and minimum wave energies. The following tabulation shows typical sedimentary environments suitable for the accumulation of volcanic ash and montmorillonite clay:

<u>Sedimentary Environments</u>		
<u>Marine</u>	<u>Mixed</u>	<u>Continental</u>
Neritic	Deltaic	Lacustrine
Bathyl		Floodplain
Abyssal		Bolson (Playa)

11. The pertinent characteristics of the environments listed in the tabulation relate to the size and shape of the sedimentary deposit. The marine environments, particularly the bathyl and abyssal, may be **areally** extensive, while the continental environments are limited **areally** and may even consist of isolated deposits.

Preservation

12. The preservation of sedimentary deposits of montmorillonite involves all those factors which may affect the material from the time that it was deposited until it is exposed at the earth's surface; basically, this falls within the limits of diagenesis. The diagenetic factors that may affect a sedimentary deposit consist of the following: (a) deep burial resulting in high lithostatic (overburden) pressure,

(b) temperature increases resulting from the burial, (c) chemical effects produced by pore solutions, and (d) time exposed to high pressures.⁵

13. These diagenetic factors that have contributed to the formation of montmorillonite by the devitrification of volcanic ash may with sufficient time and burial ultimately lead to the destruction of the mineral, whether produced originally from ash or by weathering of volcanic ash. Thus the older rocks (Paleozoic and older) exhibit considerably less montmorillonite than Mesozoic- or Cenozoic-age rocks. These older rocks consist mainly of nonswelling illite and chlorite clay minerals. It is believed that with time and burial the montmorillonite structure is altered and an illitelike structure is produced. Also, the Paleozoic rocks exhibit mixed-layer combinations of montmorillonite and other clay minerals which are the result of diagenesis.

Weathering^{3,6}

14. Physical and chemical weathering of argillaceous sediments and rocks results in changes in the properties of these materials which may affect their expansiveness. The zone of weathering and property alteration may vary in depth from a few inches to tens of feet. The actual thickness of the weathering zone is generally dependent upon climate and topography. The weathering processes which may affect volume change are discussed in the following paragraphs.

15. Physical weathering. The two most important physical weathering processes are stress release due to past or current overburden removal and cyclic wetting and drying. Stress release is simply particle reorientation resulting from removal of external loads. Cyclic wetting and drying is a physicochemical process in that water is adsorbed on clay mineral surfaces during wet periods and is removed by evaporation during dry periods. The process contributes to the development of cracks and may disrupt the organization of double-layer water on and in the expandable clay minerals. The extent to which wetting and drying affect volume change depends upon the in situ nature of the materials and the type of minerals present. For sediments this process may actually decrease the potential volume change by disrupting double-layer water. Argillaceous rocks, however, may exhibit

an increase in volume change since the process contributes to breaking down the rock by cracking and the admission of water. Generally, weathering of this type results in an increase in plasticity for the argillaceous rock.

16. Chemical weathering. The chemical weathering processes are those which produce a change in the chemical constituency of the material. The changes may be small, such as the exchange of interlayer cations on clay minerals, or large, involving the destruction of mineral constituents and the formation of new mineral types. Those chemical weathering processes believed to be important in this study are as follows:

- a. Cation exchange. Cation exchange will occur in the zone of weathering when a chemical energy gradient exists between the groundwater and the clay minerals. The gradient, if present, tends to affect a replacement of the cations on clay minerals by cations in the groundwater. The existence of the energy gradient is dependent upon size of, charge of, and concentration differences between the ions in the groundwater and those on clay minerals. The replacing power of the common cations generally decreases in the following order: magnesium, calcium, potassium, and sodium. This means that other parameters being equal, magnesium will replace calcium easier than calcium will replace magnesium. The replacement may be partially a function of clay mineral type and therefore the replacement series may not hold for all cases. A case in point is potassium which on some clays is tightly bonded and is removed with difficulty. The type cation in the groundwater and on the clay minerals in argillaceous rocks or sediment may be quite variable. The cations present in groundwater are dependent generally upon present climate. Sodium is commonly associated with arid climates whereas calcium and magnesium tend to predominate under wetter conditions; furthermore, the arid climates usually exhibit higher cation concentration in groundwater than the wetter climates. The cations commonly present on montmorillonite are calcium, magnesium, and sodium. These may occur in variable proportions but generally one cation will predominate. The type of cation is determined by the chemistry of the environment of formation, chemistry of parent material, and the chemical effects produced during diagenesis. Often, but not exclusively, montmorillonite derived from volcanic ash devitrification in marine environments carries sodium, whereas montmorillonite of

similar origin produced in nonmarine environments carries calcium or magnesium.

- b. Solution. Groundwater moving through the sediments or rocks may possess sufficient acidity that the more soluble minerals such as calcite or gypsum are removed by solution. This process decreases rock strength and also permits the entry of moisture to the clay minerals.
- c. Oxidation. The presence of oxygen or oxidizing agents in groundwater may oxidize mineral components such as pyrite, which is unstable in a high pH environment: The oxidation of the mineral results in its removal, an increase in void space, and possibly the formation of new mineral types.

17. New mineral formation.⁷ The chemical weathering processes of oxidation and solution may, in certain circumstances, result in the formation of new mineral types which are more stable in the weathering environment. The new mineral types generally have specific gravities lower than the original minerals and often are hydrated. This results in an increase in the volume of the material and is expressed at the surface by heaving. The volumetric increases caused by new mineral formation for four weathering reactions are given in the following tabulation:⁸

<u>Original Mineral</u>	<u>New Mineral</u>	<u>Volume Increase of Crystalline Solids, %</u>
Illite	Alunite	8
Illite	Jarosite	10
Calcite	Gypsum	60
Pyrite	Melanterite	536

The volume increases are based upon a material consisting of 100 percent original material.

Distribution of expansive materials

18. The following discussion involves the characteristics, compositions, and distribution of expansive materials in the continental United States. The sources of this information include data provided by state highway agencies, geologic and soil maps published by various Government agencies and private organizations, and the

combined experiences of geologists and engineers within the Soils and Pavements Laboratory, WES.

19. The discussion of expansive materials has been categorized by physiographic province. Figure 1 illustrates the first-order physiographic provinces that were selected to form the basis of the presentation. The areal distribution and degree of expansiveness of expansive materials within the United States are shown in Figures 2-6 and described in Table 1. The information pertaining to the physiographic provinces is preliminary as presented in this report. Further details and discussions of the provinces will be presented in a subsequent report.

20. The distribution of expansive materials shown in Figures 2-6 has been categorized on two bases: (a) degree of expansiveness and (b) expected frequency of occurrence of expansive materials. The bases for categorization are qualitative. Three major sources of information formed the bases for classificational decisions. Firstly, the reported occurrences of expansive materials as indicated in published literature or other sources of data which revealed actual problems or failures due to expansive materials.⁹ These sources were not necessarily limited to highway subgrades. Secondly, materials maps provided summaries of illustrated earth material properties pertinent to this study.¹⁰ Reference 10 was used to delineate areas of argillaceous materials, and the soils surveys¹¹ were used to substantiate suspected occurrences of expansive materials. Third, geologic maps and cross sections were used to identify and delineate areas of argillaceous rocks and sediments which were believed to possess expansive properties. 12-20

21. These three general sources were combined to produce four mapping categories that reflect the degree of expansiveness and expected frequency of occurrence. The four categories are as follows:

1. Highly expansive and/or high frequency of occurrence.
2. Medium. Moderately expansive and/or moderate frequency of occurrence.

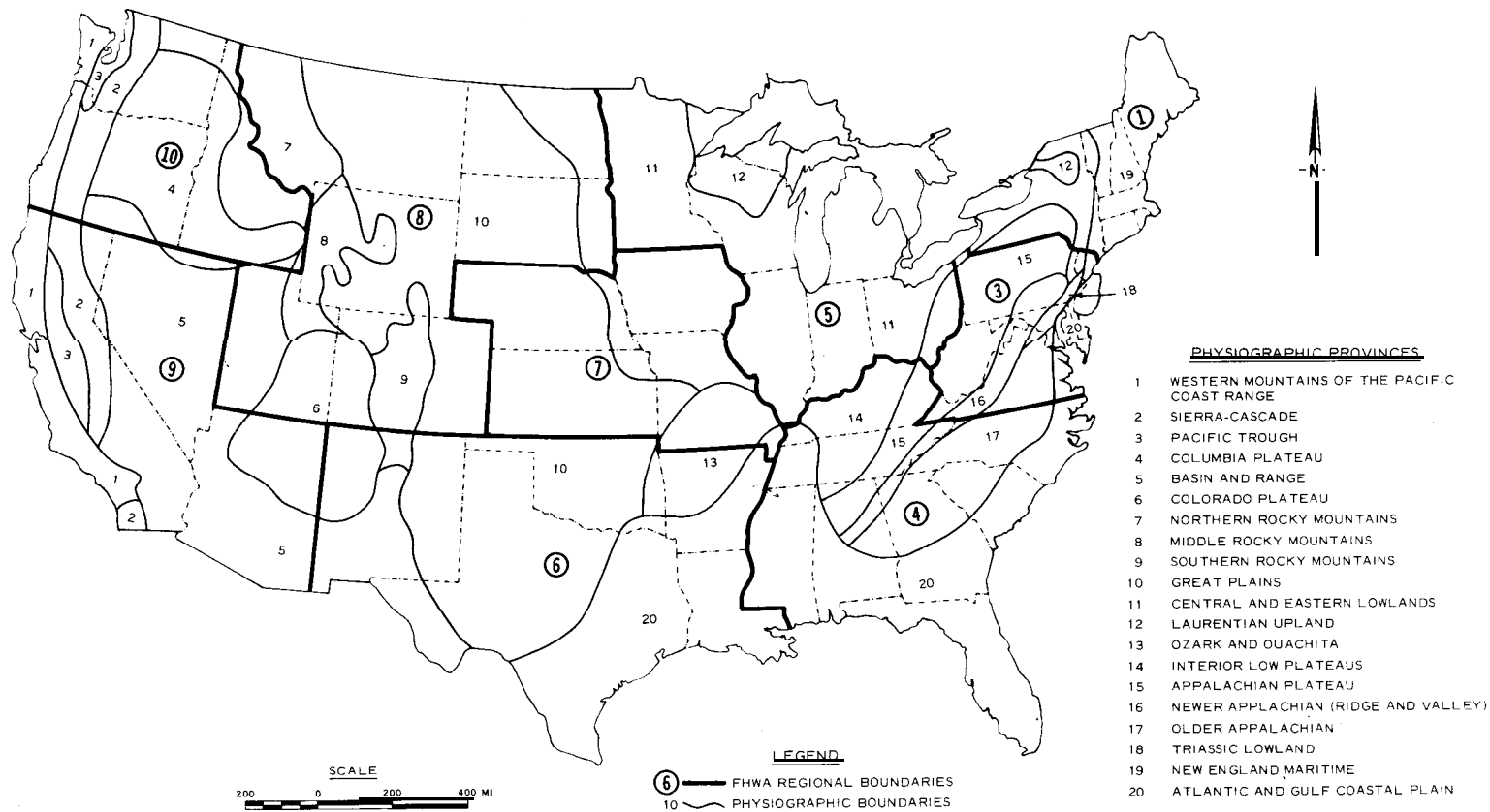

Figure 1. First order physiographic provinces within the continental United States

3. Low. Generally of low expansive character, and/or low frequency of occurrence.
 4. Nonexpansive. These areas are mainly underlain by materials which, by their physical makeup, do not exhibit expansive properties and which, upon weathering, do not develop expansive soils.
22. The following premises guided the map categorization:
- a. Any area underlain by argillaceous rocks, sediments, or soils will exhibit some degree of expansiveness.
 - b. The degree of expansiveness is a function of the amount of expandable clay minerals present.
 - c. Generally, the Mesozoic and Cenozoic rocks and sediments contain significantly more montmorillonite than the Paleozoic (or older) rocks.
 - d. Areas underlain by rocks or sediments of mixed textural compositions (e. g., sandy shales or sandy clays) or shales or clays interbedded with other rock types or sediments are considered on the basis of geologic age and the amount of argillaceous material present.
 - e. Generally those areas lying north of the glacial boundary are categorized as nonexpansive due to the cover of glacial drift. Whether the drift itself is expansive is a function of drift texture and the mineralogy of the source material. The till deposited in Montana and the Dakotas is partially composed of material derived from expansive, Cretaceous shales in this region; thus this till may show considerably more expansive properties than tills in other regions. Also, the argillaceous sediments deposited in Pleistocene lakes may be of such texture and mineralogy that they also possess limited expansive properties.
 - f. From a regional standpoint, those soils derived from the weathering of igneous and metamorphic rocks are considered nonexpansive. These soils may contain some expansive clay minerals but their concentration and the general soil texture preclude appreciable volume change. Also, in temperate areas these soils are usually limited in thickness.
 - g. The categorization does not consider climate or other environmental aspects. These subjects will be addressed in a later report.
 - h. Argillaceous rocks or sediments originally composed of expandable-type clay minerals do not exhibit significant volume change when subjected to tectonic folding, deep burial, or metamorphism.

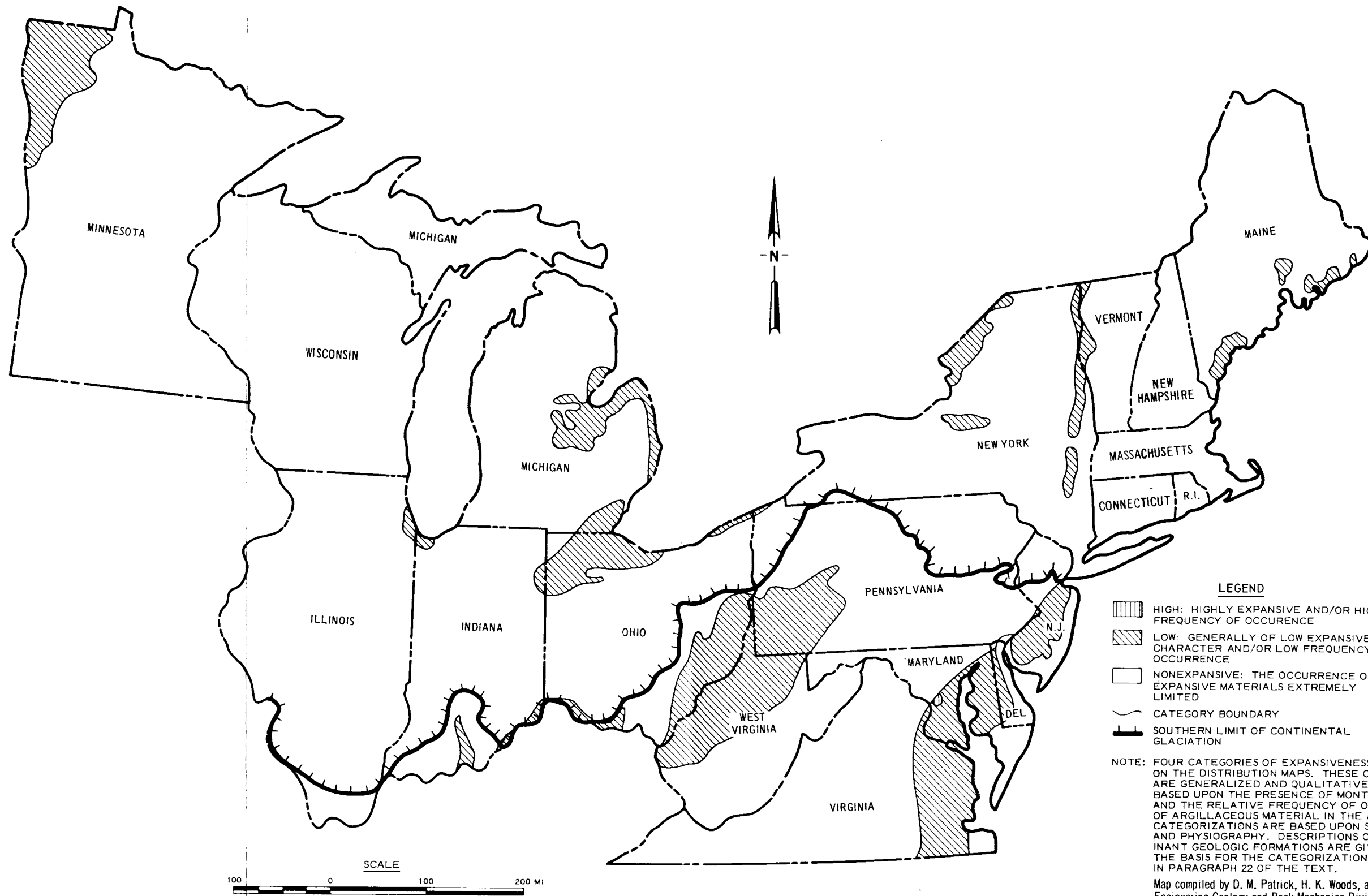

Figure 2. Distribution of potentially expansive materials in the United States: FHWA Regions 1, 3 and 5

LEGEND



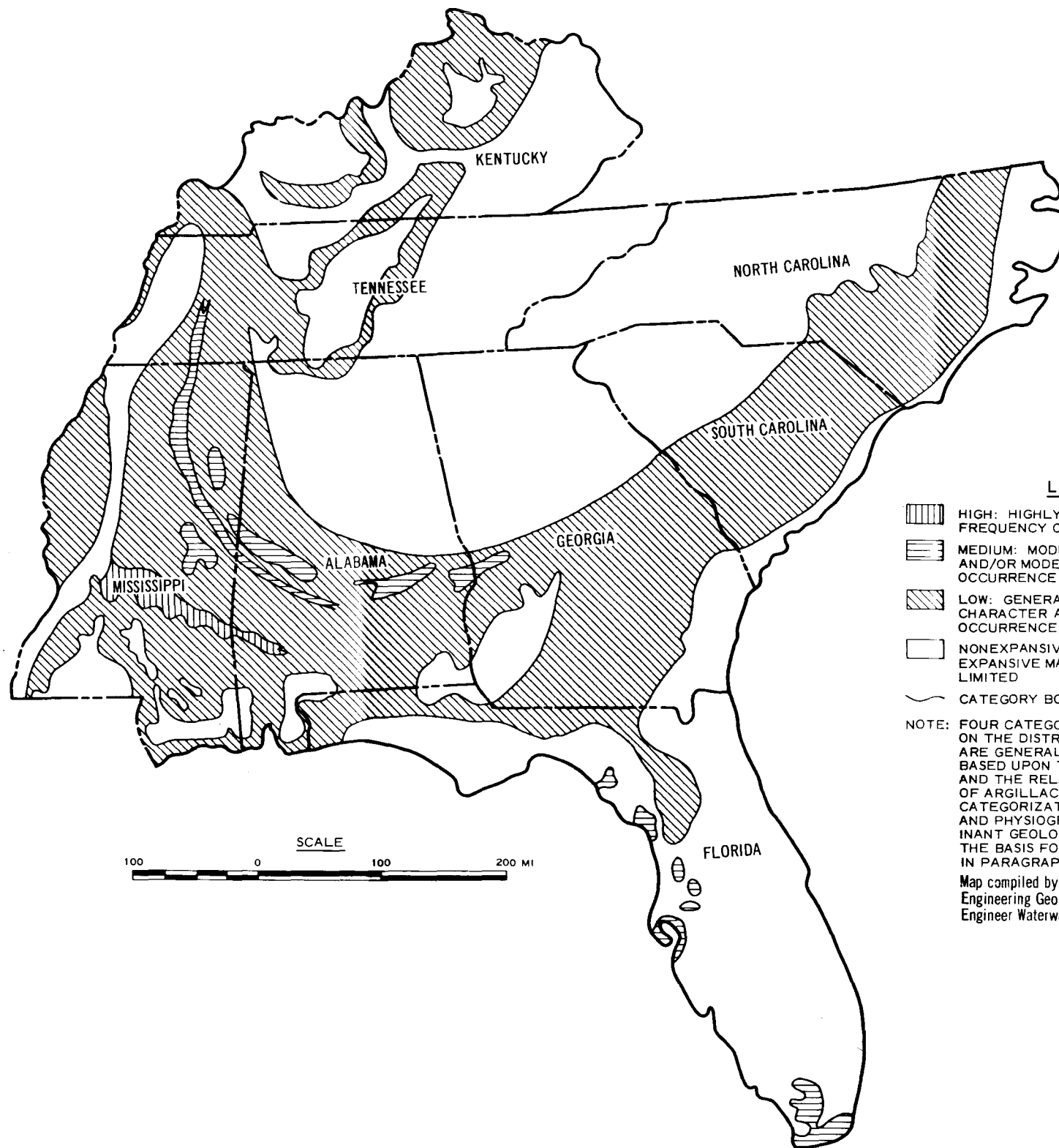

- HIGH: HIGHLY EXPANSIVE AND/OR HIGH FREQUENCY OF OCCURRENCE
- LOW: GENERALLY OF LOW EXPANSIVE CHARACTER AND/OR LOW FREQUENCY OF OCCURRENCE
- NONEXPANSIVE: THE OCCURRENCE OF EXPANSIVE MATERIALS EXTREMELY LIMITED
- CATEGORY BOUNDARY
- SOUTHERN LIMIT OF CONTINENTAL GLACIATION

NOTE: FOUR CATEGORIES OF EXPANSIVENESS ARE SHOWN ON THE DISTRIBUTION MAPS. THESE CATEGORIES ARE GENERALIZED AND QUALITATIVE AND ARE BASED UPON THE PRESENCE OF MONTMORILLONITE AND THE RELATIVE FREQUENCY OF OCCURRENCE OF ARGILLACEOUS MATERIAL IN THE AREA. MAJOR CATEGORIZATIONS ARE BASED UPON STRATIGRAPHY AND PHYSIOGRAPHY. DESCRIPTIONS OF THE PREDOMINANT GEOLOGIC FORMATIONS ARE GIVEN IN TABLE 1. THE BASIS FOR THE CATEGORIZATION IS EXPLAINED IN PARAGRAPH 22 OF THE TEXT.

Map compiled by D. M. Patrick, H. K. Woods, and Frederick L. Smith, Engineering Geology and Rock Mechanics Division, U. S. Army Engineer Waterways Experiment Station, Vicksburg, Ms.



LEGEND

-  HIGH: HIGHLY EXPANSIVE AND/OR HIGH FREQUENCY OF OCCURRENCE
-  MEDIUM: MODERATELY EXPANSIVE AND/OR MODERATE FREQUENCY OF OCCURRENCE
-  LOW: GENERALLY OF LOW EXPANSIVE CHARACTER AND/OR LOW FREQUENCY OF OCCURRENCE
-  NONEXPANSIVE: THE OCCURRENCE OF EXPANSIVE MATERIALS EXTREMELY LIMITED
-  CATEGORY BOUNDARY

NOTE: FOUR CATEGORIES OF EXPANSIVENESS ARE SHOWN ON THE DISTRIBUTION MAPS. THESE CATEGORIES ARE GENERALIZED AND QUALITATIVE AND ARE BASED UPON THE PRESENCE OF MONTMORILLONITE AND THE RELATIVE FREQUENCY OF OCCURRENCE OF ARGILLACEOUS MATERIAL IN THE AREA. MAJOR CATEGORIZATIONS ARE BASED UPON STRATIGRAPHY AND PHYSIOGRAPHY. DESCRIPTIONS OF THE PREDOMINANT GEOLOGIC FORMATIONS ARE GIVEN IN TABLE 1. THE BASIS FOR THE CATEGORIZATION IS EXPLAINED IN PARAGRAPH 22 OF THE TEXT.

Map compiled by D. M. Patrick, H.K. Woods, and Frederick L. Smith, Engineering Geology and Rock Mechanics Division, U. S. Army Engineer Waterways Experiment Station, Vicksburg, Ms.

Figure 3. Distribution of potentially expansive materials in the United States: FHWA Region 4

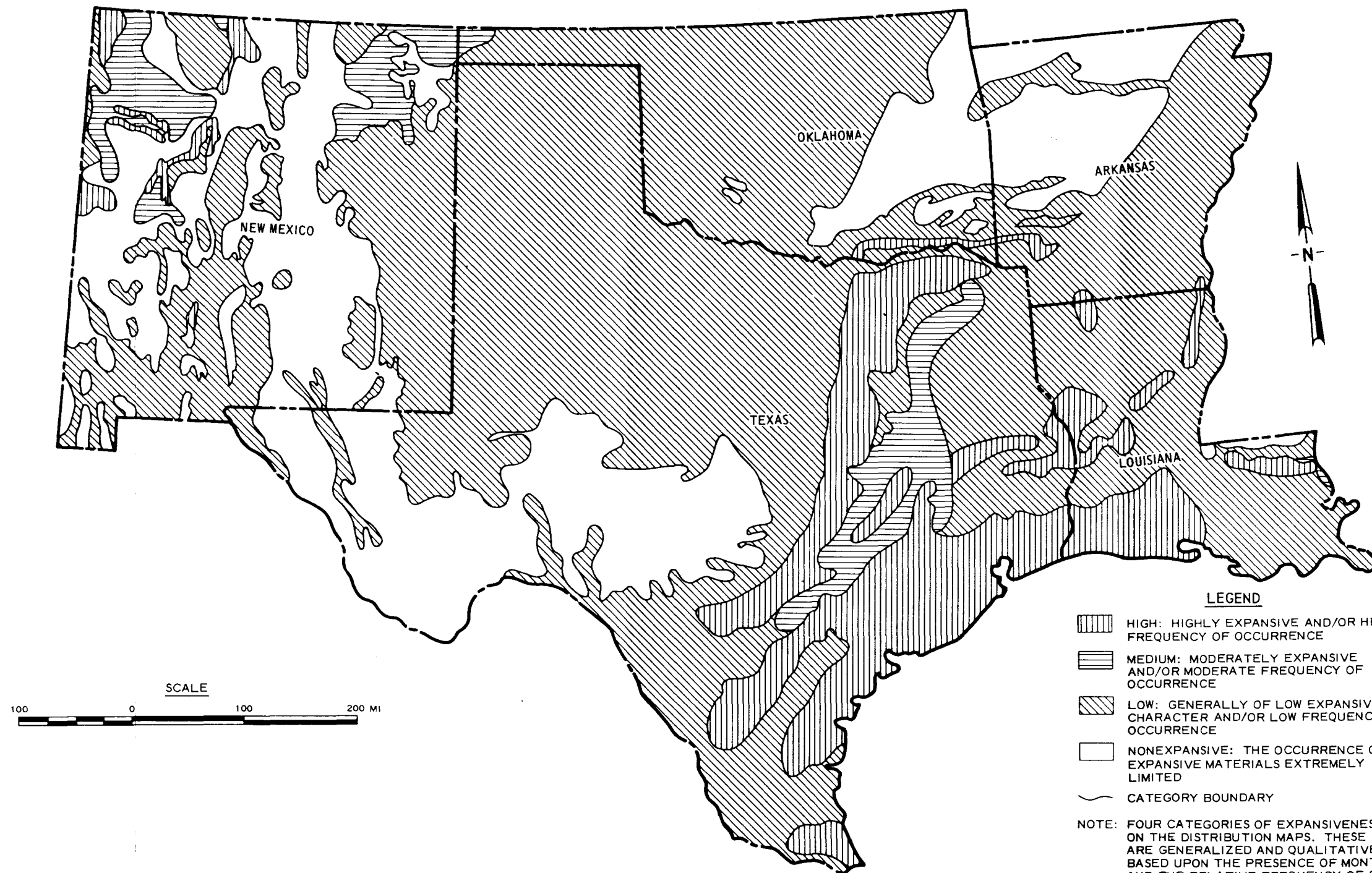







Figure 4. Distribution of potentially expansive materials in the United States: FHWA Region 6

LEGEND

-  HIGH: HIGHLY EXPANSIVE AND/OR HIGH FREQUENCY OF OCCURRENCE
-  MEDIUM: MODERATELY EXPANSIVE AND/OR MODERATE FREQUENCY OF OCCURRENCE
-  LOW: GENERALLY OF LOW EXPANSIVE CHARACTER AND/OR LOW FREQUENCY OF OCCURRENCE
-  NONEXPANSIVE: THE OCCURRENCE OF EXPANSIVE MATERIALS EXTREMELY LIMITED
-  CATEGORY BOUNDARY

NOTE: FOUR CATEGORIES OF EXPANSIVENESS ARE SHOWN ON THE DISTRIBUTION MAPS. THESE CATEGORIES ARE GENERALIZED AND QUALITATIVE AND ARE BASED UPON THE PRESENCE OF MONTMORILLONITE AND THE RELATIVE FREQUENCY OF OCCURRENCE OF ARGILLACEOUS MATERIAL IN THE AREA. MAJOR CATEGORIZATIONS ARE BASED UPON STRATIGRAPHY AND PHYSIOGRAPHY. DESCRIPTIONS OF THE PREDOMINANT GEOLOGIC FORMATIONS ARE GIVEN IN TABLE 1. THE BASIS FOR THE CATEGORIZATION IS EXPLAINED IN PARAGRAPH 22 OF THE TEXT.

Map compiled by D. M. Patrick, H. K. Woods, and Frederick L. Smith, Engineering Geology and Rock Mechanics Division, U. S. Army Engineer Waterways Experiment Station, Vicksburg, Ms.

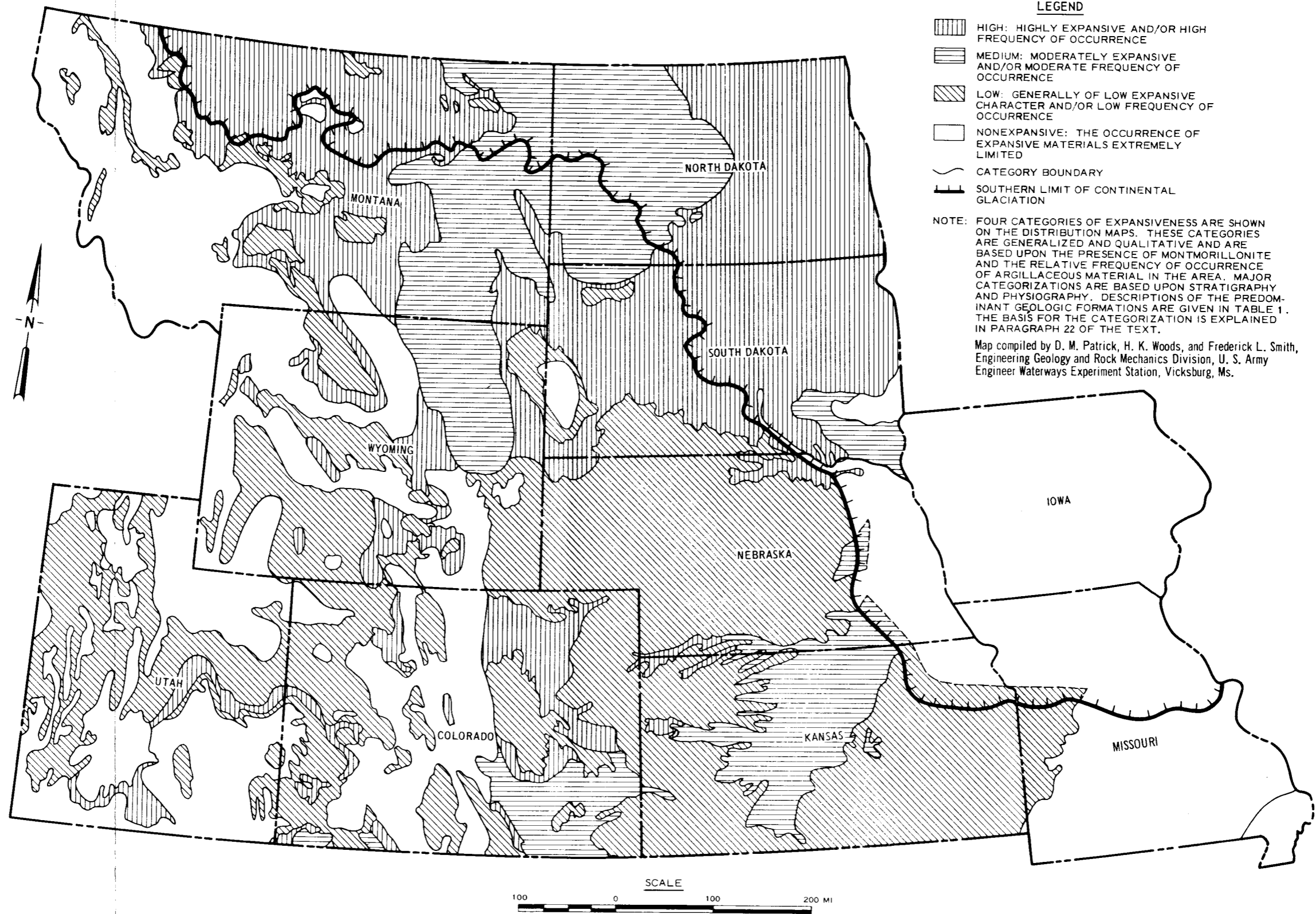
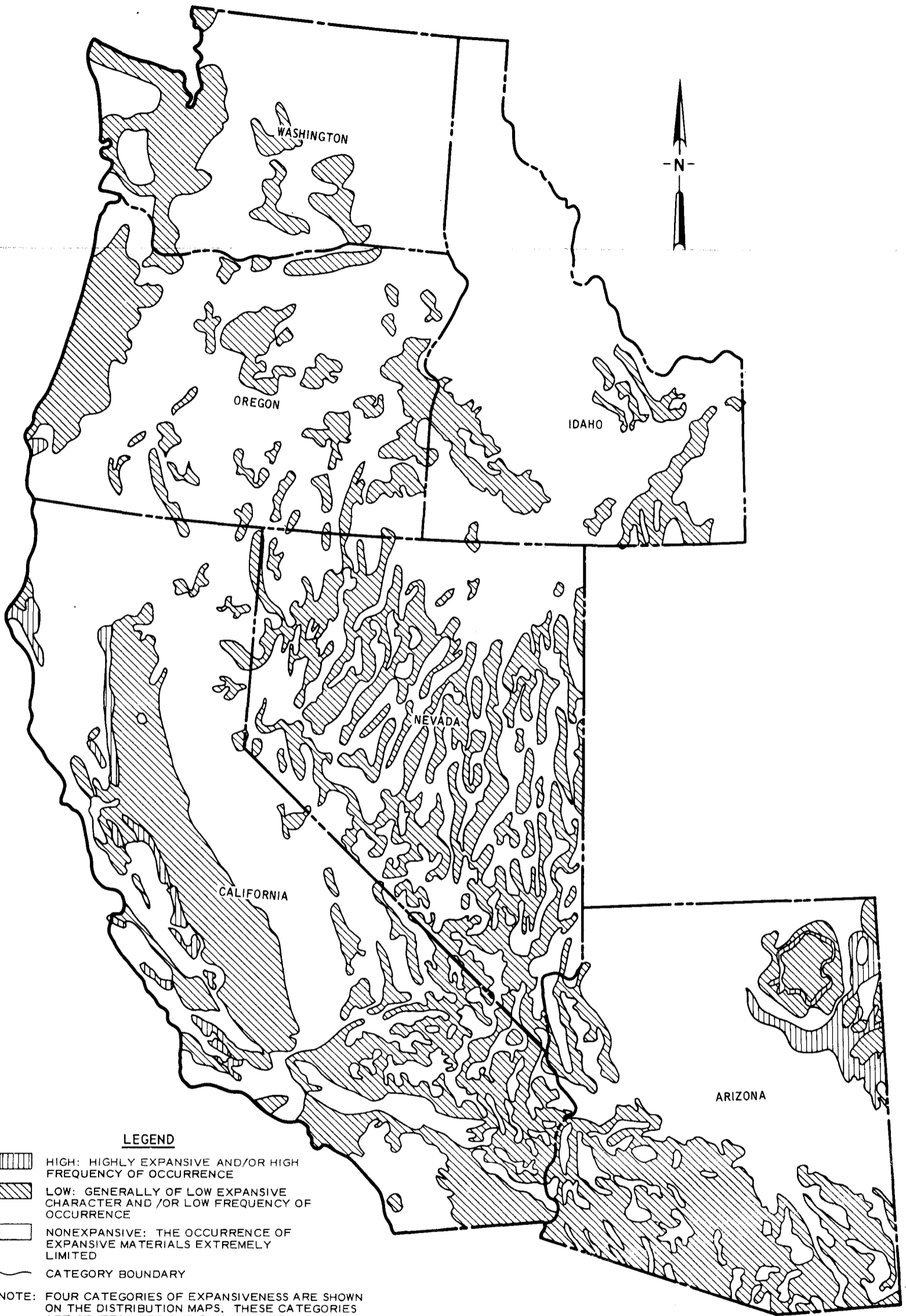





Figure 5. Distribution of potentially expansive materials in the United States: FHWA Regions 7 and 8



LEGEND

-  HIGH: HIGHLY EXPANSIVE AND/OR HIGH FREQUENCY OF OCCURRENCE
-  LOW: GENERALLY OF LOW EXPANSIVE CHARACTER AND /OR LOW FREQUENCY OF OCCURRENCE
-  NONEXPANSIVE: THE OCCURRENCE OF EXPANSIVE MATERIALS EXTREMELY LIMITED
-  CATEGORY BOUNDARY

NOTE: FOUR CATEGORIES OF EXPANSIVENESS ARE SHOWN ON THE DISTRIBUTION MAPS. THESE CATEGORIES ARE GENERALIZED AND QUALITATIVE AND ARE BASED UPON THE PRESENCE OF MONTMORILLONITE AND THE RELATIVE FREQUENCY OF OCCURRENCE OF ARGILLACEOUS MATERIAL IN THE AREA. MAJOR CATEGORIZATIONS ARE BASED UPON STRATIGRAPHY AND PHYSIOGRAPHY. DESCRIPTIONS OF THE PREDOMINANT GEOLOGIC FORMATIONS ARE GIVEN IN TABLE 1. THE BASIS FOR THE CATEGORIZATION IS EXPLAINED IN PARAGRAPH 22 OF THE TEXT. HAWAII AND ALASKA NOT INCLUDED.

Map compiled by D. M. Patrick, H. K. Woods, and Frederick L. Smith, Engineering Geology and Rock Mechanics Division, U. S. Army Engineer Waterways Experiment Station, Vicksburg, Ms.

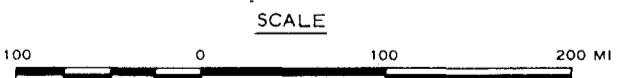

Figure 6. Distribution of potentially expansive materials in the United States: FHWA Regions 9 and 10

Table 1
 Tabulation of Potentially Expansive Materials in the United States

No.*	Physiographic Province		Predominant Geologic Unit	Geologic Age	Location of Unit	Map** Category	Remarks
	Name						
1	Western Mountains of the Pacific Coast Range	Reefridge	Miocene	CA	1	The Tertiary section generally consists of interbedded sandstone, shale, chert, and volcanics	
		Monterey	Miocene	CA	1		
		Rincon	Miocene	CA	1		
		Tumbler	Miocene	CA	1		
		Tyee	Eocene	OR	3		
		Umpqua	Paleocene-Eocene	OR	3		
		Puget Gp	Miocene	WA	3	Interbedded sandstones and shales with some coal seams	
2	Sierra Cascade	Cascade Gp	Pliocene	OR	4	Predominate material is volcanic	
		Columbia Gp	Miocene*	WA	4		
		Volcanics	Paleozoic to Cenozoic	NV	4		
		Volcanics	Paleozoic to Cenozoic	CA	4		
3	Pacific Trough	Troutdale	Pliocene	WA	3	Great Valley materials characterized by local areas of low swell potential derived from bordering mountains. Some scattered deposits of bentonite	
		Santa Clara	Pleistocene	CA	3		
		Riverbank	Pleistocene	CA	3		
4	Columbia Plateau	Volcanics	Cenozoic	WA, OR, ID, NV	4	Some scattered bentonites and tuffs	
5	Basin and Range	Valley fill materials	Pleistocene	OR, CA, NV, UT, AZ, NM, TX	3	Playa deposits may exhibit limited swell potential. Some scattered bentonites and tuffs	
		Volcanics	Tertiary	OR, CA, NV, UT, AZ, NM, TX	3		
6	Colorado Plateau	Greenriver	Eocene	CO, UT, NM	3	Interbedded sandstones and shales	
		Wasatch	Eocene	CO, UT, NM	3		
		Kirkland shale	Upper Cretaceous	CO, UT, NM, AZ	2		
		Lewis shale	Upper Cretaceous	CO, UT, NM, AZ	2		
		Mancos	Upper Cretaceous	CO, UT, NM, AZ	1		
		Mowry	Upper Cretaceous	CO, UT, NM, AZ	1		
		Dakota	Jurassic-Cretaceous	CO, UT, NM, AZ	3		
		Chinle	Triassic	NM, AZ	1		
		7	Northern Rocky Mountains	Montana Gp	Cretaceous		MT
Colorado Gp	Cretaceous			MT	1	Locally some siltstone	
Morrison	Jurassic			MT	3	Shales, sandstones, and limestones	
Sawtooth	Jurassic			MT	3		
8	Middle Rocky Mountains	Windriver	Eocene	WY, MT	3		
		Fort Union	Eocene	WY, MT	3		
		Lance	Cretaceous	WY, MT	1		
		Montana Gp	Cretaceous	WY, MT	1		
		Colorado Gp	Cretaceous	WY, MT	1		
		Morrison	Jurassic-Cretaceous	WY, MT	3		
9	Southern Rocky Mountains	Metamorphic granitic rocks	Precambrian	WY	4	Montana and Colorado Gps may be present locally with some Tertiary volcanic and minor amounts of Pennsylvania limestone (sandy or shaly). Some mixtures of metamorphic rocks with sands and gravels of Poison Canyon fm	
		Metamorphic granitic rocks	Precambrian	CO	4		
		Metamorphic granitic rocks	Precambrian to Cenozoic	NM	4		
10	Great Plains	Lance	Pliocene	WY	1	Generally nonexpansive but bentonite layers are locally present	
		Fort Union	Pliocene	WY, MT	2		
		Thermopolis	Pliocene	WY, MT	1		
		Montana Gp	Cretaceous	WY, MT, CO, NM	1		
		Colorado Gp	Cretaceous	WY, MT, CO, NM	1		
		Mowry	Cretaceous	WY, MT, CO, NM	1		
		Morrison	Cretaceous	WY, MT, CO, NM	3		
		Ogallala	Pliocene	WY, MT, CO, NM, SD, NE, KS, OK, TX	3		
		Wasatch	Eocene	MT, SD	3		
		Dockum	Triassic	CO, NM, TX	3		
		Permian Red Beds	Permian	KS, OK, TX	3		
		Virgillian Series	Pennsylvanian	NE, KS, OK, TX, MO	3		
		Missourian Series	Pennsylvanian	KS, OK, TX, MO	3		
		Desmonian Series	Pennsylvanian	KS, OK, TX, MO	3		
11	Central and Eastern Lowlands	Glacial lake deposits	Pleistocene	ND, SD, MN, IL, IN, OH, MI, NY, VT, MA, NE, IA, KS, MO, WI	3	Some Paleozoic shales locally present which may exhibit low swell	
12	Laurentian Uplands	Keveanawan	Cambrian	NY, WI, MI	4	Abundance of glacial material of varying thickness	
		Huronian	Cambrian	NY, WI, MI	4		
		Laurentian	Cambrian	NY, WI, MI	4		
13	Ozark and Ouachita	Fayetteville	Mississippian	AR, OK, MO	3	May contain some montmorillonite in mixed layer form	
		Chickasaw Creek	Mississippian	AR, OK, MO	3		
14	Interior Low Plains	Meramac Series	Mississippian	KY	3	Interbedded shale, sandstone, and limestone	
		Osage	Mississippian	KY, TN	3		
		Kinderhook	Mississippian	KY, TN	3		
		Chester Series	Mississippian	KY, IN	3		
		Richmond	Upper Ordovician	KY, IN	3		
		Maysville	Upper Ordovician	KY, IN	3		
		Eden	Upper Ordovician	KY, IN	3		

(Continued)

* Refer to map of physiographic provinces, Figure 1.

** Numerical map categories correspond as follows: 1 - high expansion, 2 - medium expansion, 3 - low expansion, and 4 - nonexpansive.

Table 1 (Concluded)

Physiographic Province No.	Name	Predominant Geologic Unit	Geologic Age	Location of Unit	Map Category	Remarks
15	Appalachian Plateau	Dunkard Gp	Pennsylvanian-Permian	AL, TN, KY, VA, WV, MD, PA, NY	3	Interbedded shale, sandstone, limestone, and coal
16	Newer Appalachian (Ridge and Valley)	Catoctin Gp	Precambrian	AL, GA, TN, NC, VA, WV, MD, PA	4	Metamorphosed rocks
		Lynchburg Gp	Precambrian	AL, GA, TN, NC, VA, WV, MD, PA	4	
		Switt Run Gp	Precambrian	AL, GA, TN, NC, VA, WV, MD, PA	4	
17	Older Appalachian	Carolina Slate Gp	Paleozoic	AL, GA, NC, SC, VA, MD	4	Metamorphosed and intrusive rocks
		Kings Mountain Gp	Paleozoic	AL, GA, NC, SC, VA, MD	4	
		Brevard Gp	Paleozoic	AL, GA, NC, SC, VA, MD	4	
18	Triassic Lowland	Newmark Gp	Triassic	PA, MD, VA	4	
19	New England Maritime	Glacial Till	Pleistocene and Ordovician through Devonian	ME, NH, VT, MA, CT, RI, NY	4	Glacial deposits underlain by non-expansive rocks. Local areas of clay could cause some swell potential
20	Atlantic and Gulf Coastal Plain	Talbot and Wicomico Gps	Pleistocene	NC, SC, GA, VA, MD, DE, NJ	4	Interbedded gravels, sands, silts, and clays
		Lumbee Gp	Upper Cretaceous	NC, SC	3	Sand with intermixed sandy shale
		Potomac Gp	Lower Cretaceous	DC	3	Sand with definite shale zones
		Arundel Fm	Lower Cretaceous	DC	1	
		Continental and marine coastal deposits	Pleistocene to Eocene	FL	4	Sands underlain by limestone, local deposits may show low swell potential
		Yazoo	Paleocene through Pleistocene	AL, GA, FL, MS, LA, TN	1	A complex interfacing of gravel, sand, silt, and clay. Clays show varying swell potential
		Porters Creek	Pleistocene	LA, MS, TN, KY	4	A mantle of uniform silt with essentially no swell potential
		Selma	Pleistocene	LA, MS, TN, KY	4	
		Loess	Pleistocene	LA, MS, TN, KY	4	
		Mississippi alluvium	Recent	LA, MS, AR, MO	3	Interbedded stringers and lenses of sands, silts, clays, marl, and chalk
		Beaumont-Prairie Terraces	Pleistocene	LA, MS, TX	1	
		Jackson, Claiborne, Midway	Paleocene	LA, MS	1-3	
		Navarre, Taylor, Austin	Upper Cretaceous	TX	1-2	
Eagleford, Woodbine	Upper Cretaceous	TX	3			
Washita	Lower Cretaceous	TX	1-3			
Fredricksburg	Lower Cretaceous	TX	3			
Trinity	Lower Cretaceous	TX	4			

- i. Volcanic areas consisting mainly of extruded basalts and kindred rocks may also contain tuffs and volcanic ash deposits which have devitrified and altered to montmorillonite.
- j. Areas along the glaciated boundary may have such a thin cover of drift that the expansive character of the materials under the drift may predominate.

Mineralogy

23. 'Expansive, argillaceous rocks, sediments, and soils generally owe their expansive character to their constituent clay mineral suite, past and present loading history, and to their natural and imposed aqueous environments. Swelling may also be due to chemical processes acting on certain nonclay minerals which result in the formation of new minerals of lesser density. The volume changes exhibited by argillaceous materials are related to the interactions of various intrinsic and external factors of varying intensities acting alone or in unison upon the system. This section deals with the effects produced by the mineral components and relationships between the minerals and the aqueous environment.

Clay mineralogy²¹⁻²⁶

24. The clay minerals comprise a group of hydrous aluminosilicate minerals belonging to the phyllosilicate and double chain, inosilicate groups. The minerals in these groups are characterized by small grain size, large surface area, and unbalanced electrical charges. Structurally, the phyllosilicates are mainly platelike whereas the inosilicates are tubular in shape. The clay minerals that are of most concern with respect to volume change are in the phyllosilicate group. The extent to which water is imbibed is a function of the structural configuration, clay mineral size, and water chemistry.

25. Structurally, the phyllosilicates consist of three general configurations which are distinguished by the arrangements of the aluminum octahedral and silica tetrahedral layers. The aluminum octahedral layer or gibbsite layer consists of aluminum and/or magnesium

ions in sixfold coordination with hydroxyl or oxygen. The silica tetrahedral layer has silicon ions in fourfold coordination with oxygen. These three configurations may be further subdivided on the basis of ionic substitutions within both structural layers, e.g., aluminum for silicon, and iron or magnesium for aluminum. Clay minerals which have aluminum or trivalent ions in the octahedral layers are termed di-octahedral, whereas those which contain magnesium or divalent ions are termed trioctahedral.

26. The clay minerals are classified in the following fashion:
 - a. Two-layer clays consist of one silica tetrahedral layer bonded to one aluminum octahedral layer. Kaolinite is the common mineral, in which the octahedral layer contains mainly aluminum; serpentine consists of a magnesium-rich octahedral layer.
 - b. Three-layer clays have one octahedral layer bonded between two tetrahedral layers; examples of this type are illite, vermiculite, and montmorillonite. The term montmorillonite, as used here, indicates the dioctahedral magnesium bearing member of the smectite group. These minerals may occur as di- or trioctahedral.
 - c. Mixed-layer clays consist of interstratifications of the two- and three-layer clay minerals previously described. The mixing may be regular or random. Examples of regular mixing include chlorite, a three-layer plus octahedral layer repetition. Another common regular mixed-layer clay is montmorillonite-chlorite. The randomly mixed-layer clays consist of any of many possible combinations.

The structural configurations of these three classes of clay minerals are shown in Figure 7.

27. The small grain size and resulting large surface area are due to the clay mineral's origin by weathering or diagenetic alteration of preexisting minerals. In these processes alteration begins at very small centers or points on the grain surfaces and eventually spreads throughout the grain. The resultant alteration product may have crystallographic continuity throughout the surface but lacks physical continuity. Thus the size of the clay mineral is inherited from the size of the initial weathering center.

<u>CATEGORY</u>	<u>THICKNESS</u>	<u>CONFIGURATION</u>	<u>EXAMPLE</u>
2-LAYER CLAY MINERALS	7Å	 OCTAHEDRAL TETRAHEDRAL	KAOLINITE
3-LAYER CLAY MINERALS	10-15Å	 TETRAHEDRAL OCTAHEDRAL TETRAHEDRAL	ILLITE VERMICULITE MONTMORILLONITE
MIXED-LAYER CLAY MINERALS: REGULAR	14Å	 OCTAHEDRAL TETRAHEDRAL OCTAHEDRAL TETRAHEDRAL	CHLORITE
	26-29Å	 MONTMORILLONITE CHLORITE MONTMORILLONITE CHLORITE	INTERLAYERED MONTMORILLONITE AND CHLORITE
RANDOM	VARIABLE	 MONTMORILLONITE CHLORITE CHLORITE MONTMORILLONITE MONTMORILLONITE	MIXED-LAYER MONTMORILLONITE AND CHLORITE

Figure 7. Typical structural configurations of clay minerals

28. Those clay minerals exhibiting high volume change do so because of electrical charge characteristics, degree of crystallinity, and size. Clay minerals possessing internally unbalanced electrical charges due to lattice substitutions maintain electrical balance by cations located on the surfaces and edges of the minerals. These cations may be easily hydrated and thus affect the development of double-layer water on the clay. The effects of degree of crystallinity on swelling may depend upon the particular clay mineral. Generally, the effects of size are such that volume change is increased when clay mineral size is decreased.

- a. Montmorillonite. The clay mineral montmorillonite, although dioctahedral, usually contains some magnesium substituted for aluminum in the octahedral layer. This substitution results in a lattice charge deficiency which is neutralized by the presence of cations such as Na^+ , Ca^{++} , or Mg^{++} on interlayer positions. Although these ions possess ionic radii that would permit occupancy of the space within the hexagonal opening at the surface of the tetrahedral layers, the ions are hydrated and as a result of increased ionic radii must occupy space on and above the tetrahedral layers. Such a position props adjacent layers apart and permits access of more water to interlayer positions. Since the interlayer ions balance charge deficiencies in the octahedral layer, the ions are weakly held and thus may be removed by ion exchange. Ordinarily, montmorillonite exists as extremely small particles with dimension on the order of a few tens of Angstrom units.
- b. Vermiculite. As a preface to the discussion of the swelling vermiculites and chlorites, it should be emphasized that these materials are not the common examples of megascopic minerals associated with the metamorphic rocks, but rather are fine-grained weathering and diagenetic alteration products that have formed from preexisting mica, illite, chlorite, and vermiculite. These fine-grained chlorites and vermiculites possess properties similar to those of montmorillonite, particularly with respect to swelling and cation exchange. The similarities complicate mineral identification, and it is quite likely that swelling chlorites and vermiculites have been identified as montmorillonites in routine X-ray analyses. Another source of confusion stems from the fact that these minerals often occur as mixed-layer interstratifications with montmorillonite or other clay minerals. The clay

vermiculites are three-layer clay minerals exhibiting a wide variety of physical properties and variable chemical constituencies. Charge deficiencies or excesses may exist in both tetrahedral and octahedral layers. The net charge is negative and usually balanced by interlayer Mg^{++} , Na^+ , or K^+ ions. Aluminum may substitute for silicon in some vermiculite, whereas other vermiculites contain no tetrahedral aluminum. The former varieties are more similar to the coarse-grained vermiculite, whereas the latter resemble montmorillonite. The interlayer cations are hydrated and control the extent to which the mineral expands.

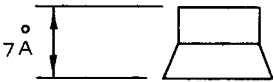
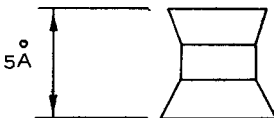
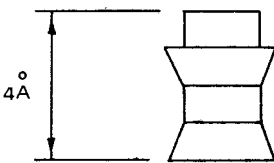
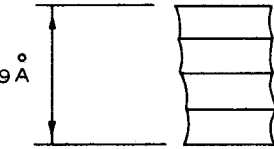
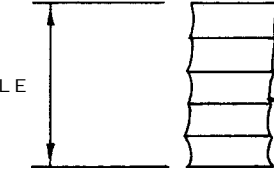
- c. Chlorite. The fine-grained chlorite may be considered a regular mixed-layer interstratification of a di- or trioctahedral three-layer clay and one octahedral-type layer containing magnesium. Apparently, the amount of swelling exhibited by this material is dependent upon the continuity of this octahedral-type layer. As with vermiculite, the swelling chlorites often occur in mixed-layer associations with other clay minerals.
- d. Mixed-layer types. Regular and random mixed-layer combinations of montmorillonite, chlorite, and vermiculite with other clays may be of importance in contributing to expansiveness. Generally, the amount of expansion would be in proportion to the amount of montmorillonite or other expansive clay minerals present in the mixed layer association. As stated elsewhere, the amount of montmorillonite present in the Paleozoic rocks is usually significantly less than that in the Mesozoic and Tertiary rocks; however, this mineral may be present as a mixed-layer component and thus contribute to the expansiveness of these older rocks.
- e. Kaolinite. The clay mineral kaolinite exhibits very minor interlayer swelling. This is explained by the virtual absence of ionic substitution in either the tetra- or octahedral layers which results in more or less complete electrical neutrality and the absence of compensating cations. Also, the individual two-layer structures are more tightly bonded together by the opposing electrical charges on the adjacent octa- and tetrahedral layers. Therefore, the volume change exhibited by this mineral is mainly due to water sorbed on the periphery of individual grains.
- f. Illite. This three-layer clay mineral also exhibits very minor interlayer swelling. This results from the presence of nonhydrated K^+ ions in interlayer positions within the hexagonal openings of the tetrahedral layer. The K^+ satisfies charge deficiencies residing mainly on

the tetrahedral layer and is thus tightly bonded. These characteristics effectively preclude the admission of significant amounts of water between the unit layers.

Clay mineral-water interaction 21-23,27

29. The electrical charges exhibited by clay mineral grains are caused by the following: (a) charge deficiencies due to ionic substitution within the lattice, (b) broken bonds at grain edges, (c) imperfections within the lattice, and (d) the polar nature of ions exposed at clay surfaces. This last cause includes the negative electrical charge of oxygen in the silicon tetrahedral layer and a positive charge due to the hydroxyl portion in the aluminum octahedral layer. Lattice imperfections and broken bonds may produce either a positive or negative charge, whereas ionic substitution usually results in a negative charge.

30. The magnitude and location of these electrical charges are different for the various clay minerals and are fundamental in explaining the ability of some minerals to imbibe significantly more water than others. Water associated with the clay minerals consists of three types:

- a. Hydroxyl or bound water. This water forms a part of the octahedral layer and cannot be removed by heating at temperatures below 400°C for most clay minerals.
- b. Interlayer water. This is double-layer water which occurs between clay mineral surfaces in some clays. It is gradually removed by heating up to 150-200°C.
- c. Pore water. This water occurs in the open spaces between grains and also constitutes the more tightly bound double-layer water on grain surfaces. This water is essentially removed by drying at room temperatures and completely removed by heating at approximately 100°C.

31. The clay minerals which exhibit appreciable expansion or shrinkage are called expansive clay minerals and include montmorillonite, vermiculite, chlorite, and mixed-layer combinations of these minerals with each other or with other clay minerals. Halloysite, the tubular, hydrous member of the kaolinite group may also exhibit expansive properties. Kaolinite and illite generally do not exhibit volume

change to the extent of montmorillonite, vermiculite, or chlorite and are called nonswelling clay minerals. Table 2 lists some representative free swell data for the common clay minerals.

32. The distinctions between swelling and nonswelling clays and between interlayer and pore water are illustrated in Figure 8. The clay particles are represented in the deflocculated state. The lower diagram shows a three-layer swelling clay such as vermiculite or montmorillonite with water in interlayer and pore areas, while the upper diagram shows a nonswelling clay such as illite with surrounding pore water.

33. The double-layer water adsorbed between clay layers in expandable clays and the water adsorbed on the surfaces of other clays possess properties which are somewhat different from those of the water in pore spaces. The double-layer water exhibits a certain degree of crystallinity which is not a property of the pore water. The crystallinity is greatest adjacent to the clay mineral itself and decreases outward from the mineral surface. The thickness of the oriented water and whether the decrease in crystallinity is gradual or abrupt appears to be dependent upon the nature of the clay mineral and the type cation present. Montmorillonite exhibits larger thicknesses of oriented water than the other clay minerals. Those cations which enhance the orientation are those whose hydrated or nonhydrated size can be accommodated within the water structure, for example, sodium and lithium fit, whereas calcium and magnesium do not.

Physical Properties

34. Physical properties of expansive soils which determine the behavioral characteristics of the material have been enumerated and defined in a multitude of publications. In many cases, attempts have been made to isolate the individual properties and explain the behavior on the basis of a single property or a combination of single property contributions. However, in both the laboratory and field situations, the actual behavior is a function of combinations and interrelationships

Table 2
Typical Values of Free Swell for Common
Clay Minerals (From Reference 22)

<u>Clay Mineral</u>	<u>Free Swell, * %</u>
Sodium montmorillonite	1400-2000
Calcium montmorillonite	45-145
Vermiculite**	--
Chlorite**	--
Illite	60-120
Kaolinite	5-60
Halloysite	70
Mixed layer typet	

* Test data based on swell in water of 10 cc of dried, crushed material passing No. 30 sieve and retained on the No. 50 sieve.

** Free swell is variable and dependent on size and crystallinity.

† Free swell is variable and dependent on amount of expandable clay minerals present.

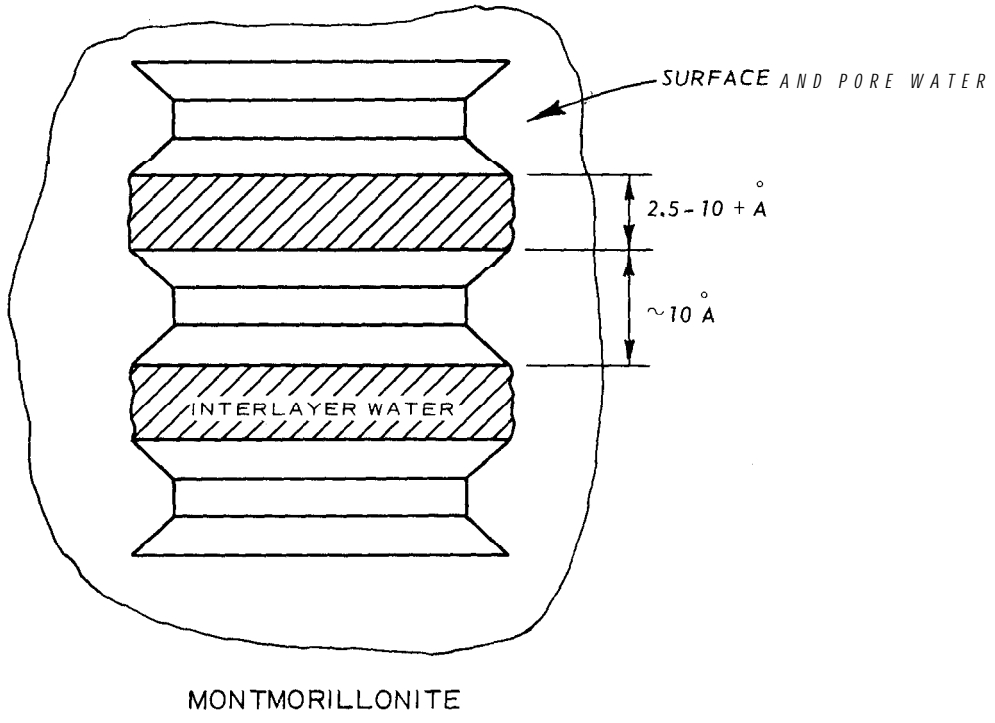
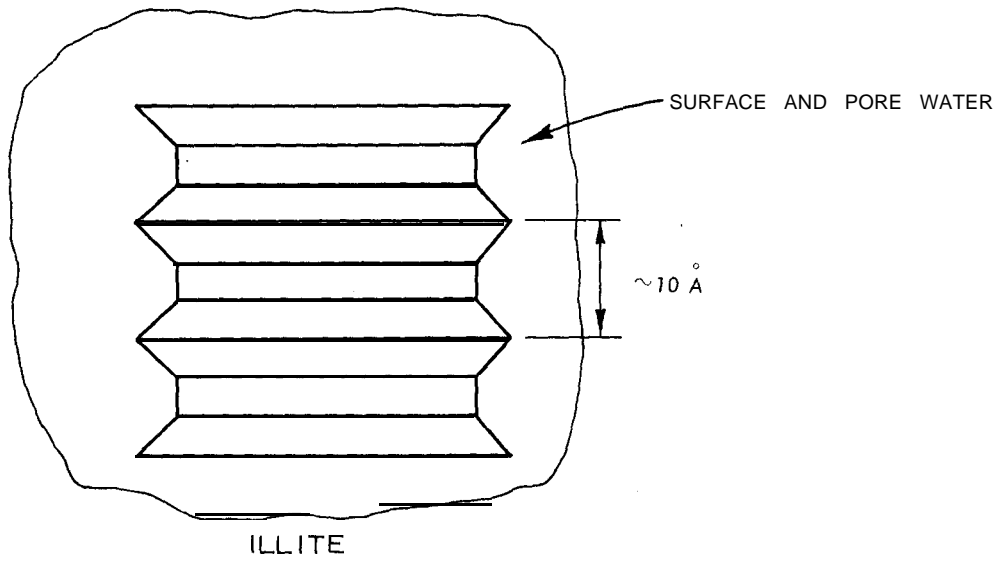

Figure 8. Deflocculated clay mineral associations showing surface water (illite) and surface and interlayer water (montmorillonite)

among the properties. The following discussions are based on a twofold categorization of the physical properties in order to point out and explain some of these interrelationships: (1) the intrinsic properties of the materials which contribute to or influence the actual volume change and apply to both laboratory and in situ materials and (2) the properties, or more precisely, the ambient environmental conditions which enhance the probability and magnitude of expansivity and apply more to in situ materials.

Intrinsic properties

35. The intrinsic properties which influence the behavior of expansive materials are presented in the following paragraphs. Confinement, time, and temperature are not intrinsic properties as defined in the previous paragraph; however, they are factors which influence the role of the intrinsic properties in determining the amount and rate of volume change in both laboratory and in situ conditions and as such are discussed under this general topic.

36. Soil Composition.^{21,28-43} This includes the type and amount of clay mineral within the soil and the size and specific surface area of the clay minerals. The type and amount of clay mineral are the intrinsic factors which determine whether or not the material will expand. In other words, the potential for volume change rests on the mineralogic composition; and the remaining intrinsic factors, combined with the ambient environmental conditions, determine the extent or magnitude of volume change.

37. The size of the clay mineral particles in expansive materials affects volume change by controlling the development of double-layer water on the particle periphery. Generally, small particle sizes result in large effective surface areas which permit considerable thicknesses of double-layer water to surround the individual particles. This is particularly important for clay minerals which do not exhibit interlayer swelling since the expansivity of the materials is almost entirely due to sorption of peripheral water. Clay mineral size is not an independent parameter, but often is a characteristic of the specific clay mineral. For example, montmorillonite occurs as extremely small

particles which may be considered colloid. In the completely dispersed, deflocculated condition, sizes on the order of a few unit cells may be present. On the other hand, kaolinite may occur as rather large particles which may be of a fine silt size. Chlorite, vermiculite, illite, and mixed-layer clays are generally intermediate in size between montmorillonite and kaolinite. In summary, clay mineral size and specific surface area are inversely proportional such that surface area increases with decreasing mineral particle size from kaolinite to montmorillonite.

38. Dry density. ^{28,41,43-49} The dry density is an important factor in determining the magnitude of volume change. The swell or swelling pressure of an expansive soil increases with increasing dry density for constant moisture content. The reason, simply stated, is that higher densities result in closer particle spacing, therefore causing greater particle interaction. This particle interaction, or more precisely, double-layer water interaction, results in higher osmotic repulsive forces and a greater volume change. This holds true for both remolded and undisturbed materials. Another important and somewhat indirect influence of dry density on volume change is its interrelationships with some of the other intrinsic factors. For example, the dry density of a material, particularly compacted soils, will influence the soil fabric (interparticle arrangement). Details of the influence have been described by Pacey⁵⁰ and Seed and Chan⁵¹ and are depicted in Figure 9. For a given compaction effort and at low initial moisture contents, a less oriented fabric is obtained. As the moisture content increases, the soil fabric is more oriented.

39. Soil fabric. ^{27,31,33,41,43,50,51} The soil fabric refers to the orientation or arrangement in space of the constituent particles. In the case of argillaceous sediments and rocks, the fabric consists of the arrangements of the platelike clay minerals with each other and with the nonclay components. The type of clay mineral arrangement present will influence the amount and to some degree the direction (lateral or vertical) of volume change exhibited by an expansive material. The fabrics exhibited by argillaceous sediments and rocks are

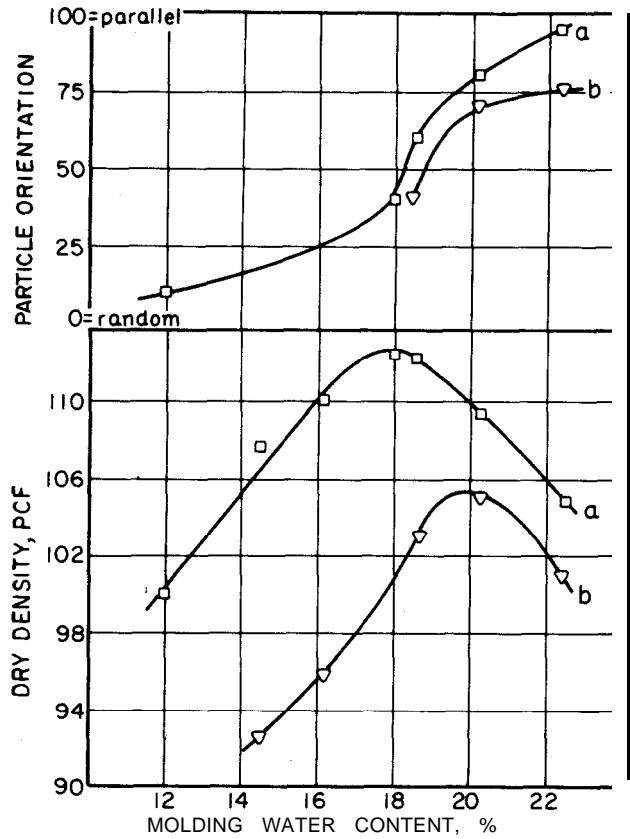

a. BOSTON BLUE CLAY
(FROM REFERENCE 50)

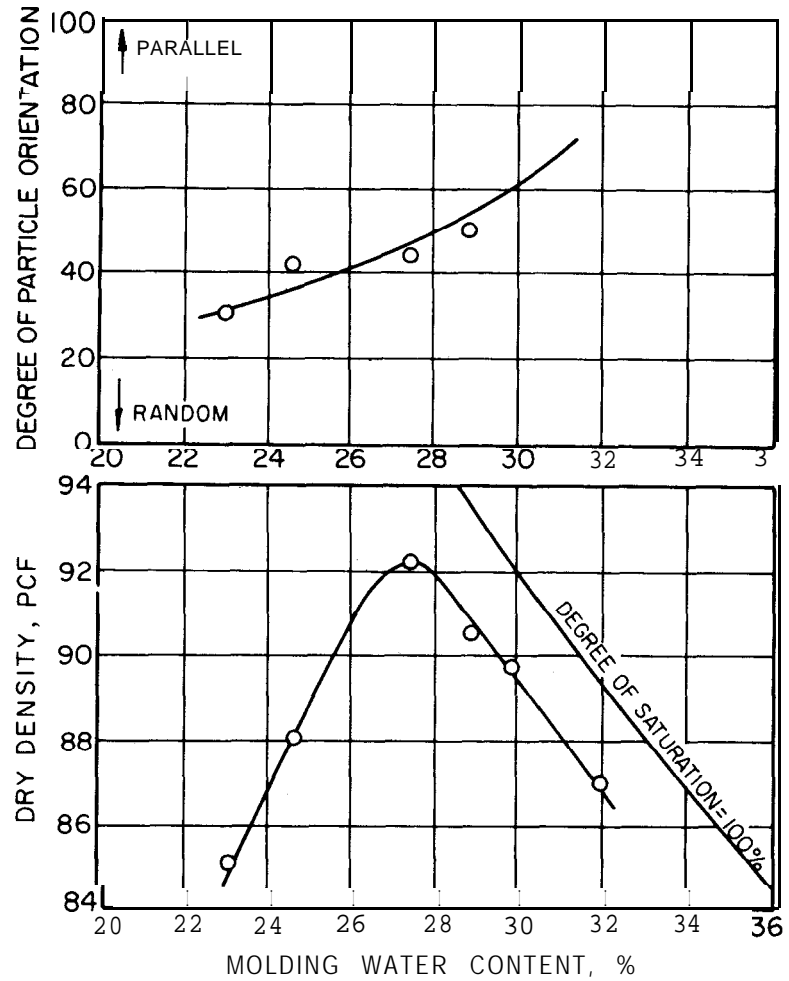

b. COMPACTED SAMPLES OF
KAOLINITE (FROM REFERENCE 51)

Figure 9. Molding water content versus dry density and particle orientation

complex, variable, difficult to observe, and have not been specifically categorized in an acceptable manner. Individual clay mineral platelets generally occur in either agglomerated or nonagglomerated arrangements. Agglomerated arrangements consist of independent groups of platelets which may be associated in several ways, while nonagglomerated arrangements are void of discernible groups and the fabric is uniform throughout.

40. The individual clay mineral platelets within either of these two arrangements may exist as individual units of the smallest size (dispersed) or as small booklets of individual units with **face-to-face** contacts of the individual units (aggregated). If the dispersed or aggregated units exist with no points of contact with other units and are surrounded by double-layer water, the association is denoted as deflocculated. A flocculated association is one in which the dispersed or aggregated units are in contact with adjacent units.

41. Generally, sediments and sedimentary rocks exhibit observable fabrics which may be categorized with respect to geometry alone without regard to whether **OR** not the individual units are surrounded by double-layer water. These fabrics may be either parallel or **random**. The parallel fabric implies that a majority of the clay platelets are in an aggregated parallel arrangement which is usually parallel to bedding. The random fabric implies a less oriented arrangement of clay platelets.

42. Pore water properties. ^{34,40,41,43,52,53} The phenomenon of volume change in expansive soils is the direct **result** of the availability and variation in the quantity of water in the soil. Therefore, the properties of the water will have a significant influence on the expansive behavior. The volume change of expansive soils is primarily due to the hydration of the clay minerals or, more precisely, the adsorption of water molecules to the exterior and interior surfaces of the clay mineral to balance the inherent charge deficiency of the particle. The degree of hydration is influenced by the amount and type of ions adsorbed on the particle and the amount and type of ions in the pore fluids. Pore fluids containing high concentrations of

cations, i.e., soluble salts, tend to reduce the magnitude of volume change of an expansive soil. On the other hand, pore fluids with low ionic concentrations may actually leach out the charge balancing cations and cementing agents and render the soil more susceptible to volume change.

43. Confinement. 28,29,31-33,44,54-59 The application of a surcharge or external load to an expansive material will obviously reduce the amount of volume change that is likely to occur. In the laboratory measurement of swelling pressure, less than 1 percent deformation of the testing device may result in large errors in magnitude of the swelling pressure. For in situ conditions, the presence of a layer of nonexpansive overburden material may eliminate the probability of damage from the underlying expansive material. It may be noted that confinement has its greatest influence on expansive soils in a stress-related sense (swelling pressure). The greater the confinement, the greater the stress and the smaller the deformation. Generally, the load applied by a pavement is far less than that required to maintain minimal deformation; therefore, problems with expansive clays in highway subgrades are more related to deformation.

44. Time. 28,32,33,44,55,57-59 The influence of time on volume change is another interrelated property which has its major impact on the rate at which expansion occurs. The time to the first occurrence of volume change and the rate of expansion are functions of the permeability of the soil and the availability of water. Expansion occurs as soon as moisture is made available and continues until an equilibrium condition is reached with regard to the source of **water** or the hydration of the clay minerals.

45. Permeability. 54,57,60-62 As indicated in the previous discussion on the influence of time on volume change, the permeability plays an important role in the time rate of volume change. The permeability is a function of the initial moisture content, dry density, and soil fabric. For compacted soils, the permeability is greater at the lower moisture contents and dry densities and decreases to some relatively constant value at about the optimum moisture content. Above

optimum, the permeability is essentially constant. The obvious reason for this minimum permeability near the optimum moisture content and maximum dry density is that the voids available for moisture movement are at a minimum because of the close particle spacing. Above optimum, the interaction of the double-layer water also minimizes the voids necessary for moisture movement. For in situ expansive soils, the permeability is normally enhanced by such structural discontinuities as fissures, fractures, and desiccation cracks.

46. Temperature. ^{29,44,63,64,} The influence of temperature is primarily limited to its effect on the viscosity and specific gravity of the adsorbed water. Increases in temperature tend to depress the double-layer water, while temperature decreases result in double-layer expansion. Of more importance is the influence of temperature on the movement of moisture, both vapor and liquid, as a result of thermal gradients within the soil mass. Water vapor at a higher temperature will migrate toward a cooler area in an effort to equalize the thermal energy in the system. Liquid moisture movement by thermal gradients occurs as a thermoosmotic film analogous to electroosmotic flow.

47. Structure. ^{55,58,65-67} The structure of argillaceous sediments and rocks includes those features or discontinuities which contribute to the nonhomogeneity of the material. Of most concern with respect to volume change are fracture zones, fissures, cracks, and micro- and macrofaults. The structural discontinuities may exhibit variable orientations in space and originate as a result of stress conditions which have developed in the natural sediments or rock mass. The conditions which contribute to fracturing and faulting include desiccation, stress release during unloading, and possibly tectonic loading. The structures, if not cemented, provide avenues for the introduction of moisture into the expansive soil. Their occurrence is generally concentrated in the upper layers within a few feet of the surface. However, if the upper material is removed, new structures will appear in the new shallow zones. This implies that the discontinuities existed in the lower zone prior to overburden removal, but did not open until the overburden pressure was reduced. Figure 10 shows X-radiographs ⁶⁸

of approximately the upper 6 ft* of Pierre shale ((K) from southeastern Colorado. ^{69,70} The radiographs reveal the extent of fracturing in this material. Some of the fractures have been filled with gypsum cement {denoted GF). The notation FO refers to a fossil shell.

48. Cementation. ^{56,71-74} Cementation refers to the adhesive action of mineral cements which coat and bond the particulate constituents together in sedimentary rocks. The presence or absence of these cements may determine whether a particular material should be classified as a rock or a sediment. It seems logical that materials exhibiting a high degree of cementation would possess less expansive properties than materials lacking cements. The presence of cement produces two effects: the development of bonds between points of contact which decrease the likelihood of the displacement of adjacent particles and the coating of individual particles which reduces the ability of the clay minerals to imbibe water.

49. The common cementing agent may either be crystalline or amorphous and consists of CaCO_3 (calcite), iron oxides or hydroxides (hematite or goethite), and various forms of silica. The degree of resistance to weathering and strength decreases in the order of silica, iron, and carbonate. The carbonates, however, probably comprise the most common cement in sedimentary rocks. Siliceous cements are commonly associated with bentonites and other rocks which contain montmorillonite derived from the devitrification of volcanic ash. In these cases the devitrification of the ash produces silica in excess of that necessary to produce montmorillonite. The excess silica may be removed from the zone of alteration and redeposited elsewhere in the system by ground-water. The redeposited silica produces indurated zones in the sedimentary sequence.

50. Whether carbonate cements would enhance or retard the volume change exhibited in a highway subgrade is dependent upon the elevation of the grade with respect to natural ground surface, and the

* A table of factors for converting U. S. customary units of measurement to metric (SI) units is presented on page 7.

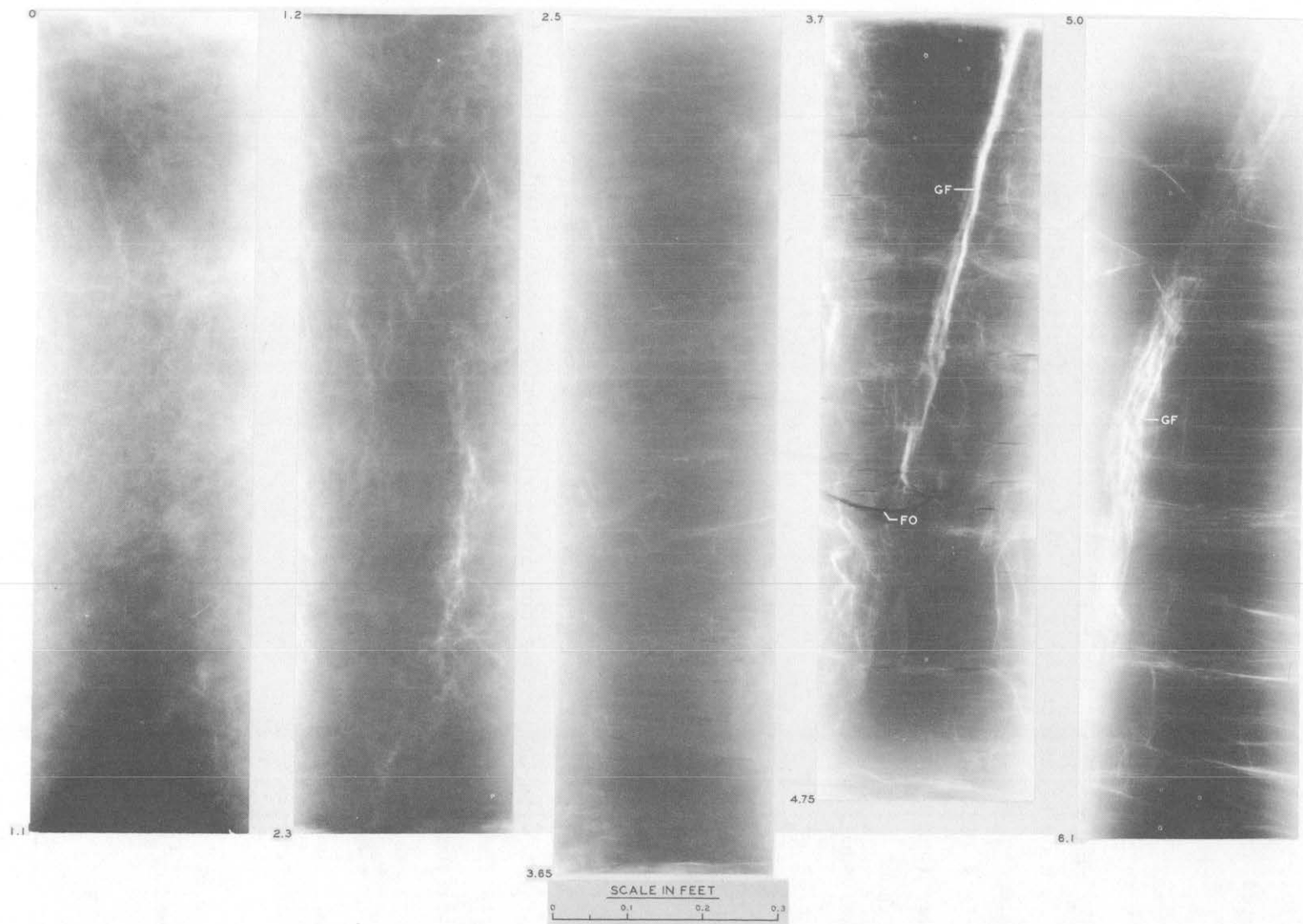

Figure 10. X-Radiograph of undisturbed clay shale sample

ambient climatic conditions because the carbonate minerals are easily weathered in moist climates. The exposure of fresh material in a cut would contribute to the removal of carbonate cements and thus increase the probability of moisture imbibition and volume change.

51. Some argillaceous sedimentary rocks possess a degree of soundness and induration indicative of cementation, but do not exhibit appreciable mineral cements. These have been referred to as compaction shales (as opposed to cementation shales). The induration is apparently derived from bonds which have developed at contact points between individual clay mineral particles. These bonds are probably time-related and have developed by diagenesis (diagenetic bonds). This phenomenon is a characteristic of older rocks and occurs during and because of the recrystallization of the clay minerals, i. e., montmorillonite altering to illite. These bonds, as well as the concomitant changes, tend to decrease the possibility of volume change in the material.

52. Diagenetic effects.^{43,73} Long-term physical and chemical alterations of materials as a result of changes in overburden conditions or groundwater environment are generally termed diagenetic factors. The diagenetic factors are generally reflected in such phenomena as inter-particle bonding due to recrystallization of the contacts between clay minerals under high overburden stress conditions or by cementation of particles as a result of precipitation of cementing agents from the groundwater. In general, the differences in behavior of expansive soils between the undisturbed and remolded states are related to the presence of diagenetic bonds.

I Environmental conditions

53. The environmental conditions which influence volume change are presented in the following paragraphs.

54. Soil profile.^{30,39,43,45,55,57,59,60,66} The properties of the soil profile which may enhance or influence volume change include the total layer thickness, variations in the thickness, depth below ground surface, and the presence of lenses and layers of more permeable materials. Obviously, the thicker the layer of expansive soil, the greater the total potential volume change providing a source of moisture

is available throughout the layer. Variations in thickness of the layer will result in variations of the magnitudes of volume change, or more precisely, differential volume change. Differential expansion, just like differential settlement, is the major problem with regard to damage to structures. The depth of the layer below ground surface may actually be a positive influence since the deeper the material, the greater the confinement on the expansive soil. In addition, the deeper the material, the less likely the expansive soil will be affected by seasonal moisture variations. The presence of lenses or layers of higher permeability will provide avenues for the ingression of water. In fact, a mass of soil which requires that moisture must move from its extremities will take much longer to develop its total volume because as the moisture is introduced and expansion occurs, the avenues of moisture transfer are somewhat decreased. Lenses or layers of more porous material within the mass tend to overshadow this advantage since they are a relatively continuous source of moisture.

55. Depth of desiccation. 30,31,39,48,55-57,65,66 The depth of desiccation is important to the magnitude and rate of volume change. The thickness of the desiccated layer represents the material in which a moisture deficiency exists. In addition, the layer normally has a large number of avenues (desiccation cracks) available for movement of moisture into the material. The depth of desiccation is generally defined as the depth to which a difference exists between the equilibrium moisture content profile resulting from minimal loss of moisture to the atmosphere (evaporation) and the ambient soil moisture content profile in which the soil stratum is in equilibrium with its environment (climate and overburden). In simpler terms, the depth of desiccation is that depth to which evaporation influences are reflected in the soil moisture content profile. Generally, the hotter and drier the climate, the greater the depth of desiccation. Changes in the overburden conditions and the proximity of the groundwater table have an important influence on the depth of desiccation. To date, no absolute method exists for defining the value.

56. Depth of seasonal moisture variation. 30,39,43,55,57,62,75-78

This comprises some thickness of the surface material which is influenced by seasonal variations in climatic conditions. As would be expected, the greater depths of seasonal moisture change occur in areas in which the seasonal climatic changes are greatest, i.e., long droughts followed by excessive rainfalls. Ambient temperature conditions also influence the depth of seasonal variations. During colder seasons, moisture from the lower, warmer zones will accumulate closer to the surface and dissipate back to depths during the warmer seasons. Seasonal moisture variations have been reported to depths of 10-12 ft. In temperate and semiarid climatic conditions, the depth is normally between 5 to 7 ft. Seasonal moisture variations are relatively constant for given climatic conditions; however, the general trend is toward accumulation of total moisture content. In other words, the seasonal variations will occur within a relatively constant limit while cumulatively increasing the total moisture content to some equilibrium value which is dependent on the type and physical condition of the expansive material. It seems obvious then that the volume change is a seasonal variation function with the total amount being an accumulation with time.

57. Vegetative cover. ^{29,30,39,60,61} Vegetation such as trees, shrubs, and some grasses are conducive to moisture movement or depletion by transpiration. In areas where vegetation is removed and structures such as pavements are replaced, the moisture that was being used by the vegetative cover will tend to accumulate beneath the structure and enhance the volume change. Vegetation with large root systems located in close proximity to pavements (i.e., city streets) will result in differential moisture conditions and thus differential volume change.

58. Surface drainage characteristics. ^{33,61,78,79} Poor surface drainage leads to moisture accumulation or ponding which can provide a source of moisture for expansive subgrades by infiltration through the verge slopes. Poor surface drainage is a frequent problem associated with highways on expansive soils and occurs in cut, grade, and uphill sides of transition sections. The extent of the infiltration is a function of the transverse and longitudinal gradients in the ditches and the

type of material in the section. The problem could be eliminated by moving the ditches as far away as possible from the highway and assuring proper gradients so that the surface water can be removed.

59. Modes of moisture transfer.^{29,43} In situ soils are generally considered to be a three-phase system; that is, soil particles, water, and air. In such a system it is possible for water to move either in the liquid phase or vapor phase, or a combination of both. For water to move in either phase, there must be a driving force within the system to provide a mode of transfer. These modes are generally described as gravity, capillarity, and thermal gradients. Gravitational movement of water is primarily limited to the liquid phase in which differential heads will cause the moisture to seek an equilibrium condition. Examples of gravitational movement are simple infiltration of surface water, lateral seepage from available sources, and the upward movement of the groundwater table. Transfer of water by capillarity is again primarily limited to the liquid phase. The nature of clay soils, which possess extremely fine pore openings, and the surface tension effects of water combine to imbibe moisture from the groundwater level. The zone of capillary rise is the layer of material directly above the submerged material within the influence of the groundwater table and can extend upward from the groundwater table for considerable distances depending on the effective pore sizes of the soil. If pavements are constructed within this zone of capillary rise, then a continuous source of water is available to the expansive subgrade. Moisture transfer as a result of thermal gradients is applicable to both the liquid and vapor phases, with the vapor phase predominant. The placement of a structure over an expansive soil will alter its ambient temperature conditions, generally decreasing the subgrade temperature. Water vapor at a higher temperature in the surrounding area will migrate to the cooler area in an effort to equalize the thermal energies of the system. As the vapor moves into the cooler area, it will condense and form a source of free water. This is the basis of hydrogenesis as described by Brakey.^{80,81} The movement of liquid water by thermal gradients occurs as a thermoosmotic film and is similar in nature to electroosmotic flow.

60. Sources of water. 29,30,39,43,54,55,57,60 Descriptions of the modes of moisture transfer in paragraph 59 discussed some of the possible sources of water which cause volume change. Infiltration of rainfall through the pavement proper (i.e., porous material or cracks) or through the verge slopes is the primary source of free water. This is evident from the fact that seasonal moisture variations are directly dependent on the frequency and amount of rainfall. Lateral or vertical migration of moisture from sources such as the groundwater table is another possible source of free water. These are the naturally occurring sources of water; however, variations can be caused by man through such activities as irrigation, which could influence surface infiltration and groundwater conditions. Faulty or leaking subsurface utilities (i.e., water or sewage) could adversely affect ambient moisture conditions. Impoundment of reservoirs could have profound effects on groundwater conditions.

Physicochemical Properties

61. Important physicochemical properties which influence the behavioral characteristics of expansive soils include the ionic environment (ions adsorbed on the clay minerals and present in the pore water) and the exchange capacities of the clay minerals. Influence of ionic concentrations in the pore water were discussed in paragraph 42.

Adsorbed ions. 21,27,34,40,43,52

62. The adsorbed cations on clay minerals influence the degree of volume change through their hydration properties. The cations attach themselves to the clay particles as a result of the charge deficiency of the particles. In the presence of water, the ions hydrate and increase in size. Common ions, in order of increasing ionic radii, which can be adsorbed on clay minerals are Na^+ , Ca^{++} , Mg^+ , and K^+ . The smaller the ionic radius, the greater the amount of hydration the ion undergoes and thus the greater the volume change that is likely to occur. Hence, the fact that sodium-montmorillonites will undergo a greater volume change than calcium-montmorillonites.

Cationexchange capacity^{21,27,34,50}

63. The cation exchange capacity (CEC) is a measure of the adsorption characteristics of clay minerals and is an indicator of the type and amount of free cations that are adsorbed on the swelling behavior of expansive clays. The CEC is usually defined as the total amount of exchangeable cations a soil is capable of adsorbing, expressed in milliequivalents per 100 grams of soil. Researchers have found that all clay soils possess a CEC value. Several factors result in variations of the CEC of a given soil: particle size, temperature, availability and concentrations of ions in solution, clay mineral structure, and isomorphic substitution.

64. In general, there are three major causes for cation exchange of clay minerals: (a) broken bonds around the edges of the clay mineral, (b) substitution within the lattice structure of the clay mineral, and (c) replacement of the hydrogen of exposed hydroxyls by cations which may be exchangeable. Some representative CEC values for various clay minerals are presented in Table 3. In general, the expansive properties of clay minerals increase with increasing CEC.

Microscale Mechanisms

65. The development of an understanding of the microscale mechanisms is somewhat hampered by the lack of an adequate description of the mechanisms and the role they play in making an expansive clay "expansive." The mechanisms listed in Table 4 are those which have been described in the literature. These should not be confused with the physical factors previously described which influence the magnitude and rate of volume change.

66. Throughout the literature these mechanisms have been given varying degrees of responsibility for the causes of expansivity. Actually, with a reasonable knowledge of the clay-water system, it is hard to imagine anything other than a combination of the mechanisms being responsible for volume change. The problem is determining the contribution of each mechanism toward the total phenomenon. The

Table 3
Cation Exchange Capacities of Clay Minerals
(From Reference 21)

<u>Clay Mineral</u>	<u>CEC Milliequivalents per 100 g</u>
Kaolinite	3-15
Halloysite, 2 H ₂ O	5-10
Montmorillonite	80-150
Illite	10-40
Vermiculite	100-150
Chlorite	10-40

Table 4

Natural Microscale Mechanisms Causing Volume Change in Expansive Soils

Mechanism	Explanation	Influence on Volume Change
Osmotic repulsion	Pressure gradients developed in the double-layer water due to variations in the ionic concentration in the double layer. The greatest concentration occurs near the clay particle and decreases outward to the boundary of the double layer	The double-layer boundary acts as an osmotic membrane when exposed to an external source of free water; that is, it tries to draw the water into the double layer to reduce the ionic concentration. The result is an increase in the double-layer water volume and the development of repulsive forces between interacting double layers. The net result is an increase in the volume of the soil mass
Clay particle attraction	Clay particles possess a net negative charge on their surfaces and edges which result in attractive forces for various cations and in particular for dipolar molecules such as water. This makes up the major "holding" force for the double-layer water	In an effort to satisfy the charge imbalance, the volume of water in the double layer will continue to increase until a volume change of the soil mass occurs
Cation hydration	The physical hydration of cations substituted into or attached to the clay particle	As the cations hydrate, their ionic radii increase, resulting in a net volume change of the soil mass
London-van der Waal forces	Secondary valence forces arising from the interlocking of electrical fields of molecule associated with movements of electrons in their orbits. The phenomenon frequents molecules in which the electron shells are not completely filled	The interlocking of electrical fields causes a charge imbalance which creates an attractive force for molecules such as water
Capillary imbibition	Movement of water into a mass of clay particles resulting from surface tension effects of water and air mixtures in the pores of the clay mass. Compressive forces are applied to the clay particles by the menisci of the water in the pores	As free water becomes available to the clay mass, the pore water menisci begin to enlarge and the compressive forces are relaxed. The capillary film will enlarge and result in a volume change or supply water for one of the other mechanisms
Elastic relaxation	A readjustment of clay particles due to some change in the diagenetic factors	Volume change results from particle reorientation and/or changes in soil structure due to changes in the diagenetic factors

general inference of the literature is that the major portion of the volume change is attributable to four of the six mechanisms: osmotic repulsion, clay particle attraction, cation hydration, and capillary imbibition. The remaining two mechanisms are recognized to be present but are of a lesser consequence and somewhat more difficult to explain physically. The influences of the four major mechanisms are generally combined and described as the total soil suction, a term taken from the soil physicist. Total soil suction is the sum of the osmotic suction and matrix suction. Quantitatively, the osmotic suction includes the osmotic repulsion mechanism and matrix suction, the remaining three major mechanisms. The magnitude and rate of volume change of expansive clays may be estimated from the magnitude and rate of change of soil suction as indicated by moisture diffusion theories using specified field conditions and soil suction-void ratio-water content relationships. In light of this ability to estimate the magnitude and rate of volume change, a considerable effort has been expended to develop instrumentation to measure total soil suction and its independent components. This approach, measurement of soil suction and correlation with the various influencing factors, appears to hold promise for verifying the microscale mechanisms. The testing procedures for independently measuring total, osmotic, and **matric** suction are relatively simple and straightforward. Once the soil suction components and the physical and physicochemical properties have been evaluated, the possibility exists for developing a better understanding of the interrelationships between the mechanisms causing volume change and the physical parameters influencing volume change.

SAMPLING, IDENTIFICATION, AND TESTING OF EXPANSIVE SOILS

67. Expansive soils are distinguishable from other soils by their ability to swell from imbibition of moisture with resulting volume change. An acceptable approach to evaluate the behavior of expansive soil subgrades involves a subsurface soil investigation of the route, identification of the potentially expansive soils, and estimation of the in situ volume change behavior of the expansive soils. Based on this information a suitable and economical soil treatment and pavement design can be selected. The subsurface soil investigation will define the physical limits of the materials and the relative vulnerability of the soils for volume change with respect to ambient conditions, and will provide soil samples for laboratory testing. Identification of the expansive soils will indicate the soil strata that possess the highest potential for volume change. Soil samples from these strata may be selected for laboratory tests from which data can be collected to describe the in situ volume change behavior of the expansive soils and form the basis for the best possible designs based on current technology.

68. The nature of volume change beneath pavements in the vertical direction often takes the form of a general upward movement beginning shortly after the start of construction and continuing until an equilibrium subgrade moisture condition is achieved. Cyclic expansion-contractions of the subgrade soils usually occur at the perimeter of pavements which are related to the rainfall and evapotranspiration. Local expansion may also occur from ponding and poor drainage. Cuts in highway sections may lead to local heaving due to removal of surcharge pressure and subsequent increase in the moisture deficiency of the subgrade soils.

69. The amount and rate of volume change that actually accumulates in an expansive foundation soil is a complex function of many factors that have previously been discussed. Therefore, to make an accurate estimate of the in situ behavior, some consideration should be given to as many of the influencing factors as possible, both technological and economical. The economic factors are variable from location to location

and are outside the scope of this effort. The technological aspects will be discussed in succeeding sections based on the current state of the art.

70. Numerous procedures have been developed for identifying and predicting volume change or vertical heave for conditions that account for some of the field-related factors. Identification procedures are usually concerned with maximum potential swell based on composition for some known soil structure and loading conditions. Procedures for quantifying heave usually attempt to simulate important in situ conditions and often require swell data from some type of one-dimensional consolidation swell test.

Sampling Techniques

71. The sampling of soils in general is for the purpose of delineating the horizontal and vertical boundaries of the specific elements of a given profile and to provide laboratory specimens from which such data as classification, strength, consolidation, or other pertinent properties, can be determined. For a given project, good exploratory information can be combined with experience and engineering judgment to give an overview of the behavior of the structure on its foundation. For the design of highways in expansive soil areas, the judicious use of good exploration and sampling techniques is extremely important.

72. Exploration in and sampling of expansive materials is particularly important because of the nature of the materials involved. Expansive soils vary from medium to firm materials, such as the Prairie Terrace formations of Louisiana, to very hard rock materials, such as the Pierre or Mancos shales of the Northern and Central Plains areas. Complementary to the varying degrees of firmness are large variations of in situ moisture content, i.e., from less than 5 percent for some of the shale materials to near or above the plastic limit for some of the softer materials. Finally, such structural discontinuities as fissures, slickensides, and bedding planes can make sample recovery a near impossible task. With such a variety of field-related problems and the

ever-present requirement for minimal disturbance, it is obvious that a variety of sampling techniques must be available to the engineer to obtain good undisturbed samples.

73. The application of currently available sampling techniques is dependent on the variables discussed in the previous paragraph as well as the type of tests that are planned. For simply delineating the subsurface conditions, classification testing (i.e., specific gravity, grain-size distribution, Atterberg limits) and for physicochemical testing, auger borings can provide the necessary type and amount of sample. For compaction tests and test methods for defining effects of soil stabilizers which require larger sample quantities, large borings or pit samples can provide the required amount. Thus far, the discussion has been limited to tests which require disturbed samples. For tests such as consolidation (including swell and swell pressure) and strength undisturbed samples are required.

Undisturbed sampling techniques ^{82,83}

74. Undisturbed sampling techniques generally used in expansive clays and shales include push-tube and rotary core barrel samplers. push-tube samplers consist of thin-walled, seamless, stainless steel tubes (2.0-5.0 in. ID) that are advanced into the soil by hydraulic or falling weight systems. Variations of the push-tube samplers involve the use of pistons within the sampling tube to take advantage of the vacuum created during sampling. The simplest form of push-tube does not have a piston; instead, the driving head is affixed to the sampling tube and has a pressure release valve (ball type) to bleed off the compressed air and to close and form a vacuum on the sample during withdrawal of the sampler. A second variation is the free piston or semifixed piston push-tube sampler in which the piston is held at the lower end of the sampling tube during insertion of the sampler and allowed to rest on the sample during the push. In this way, the vacuum is again used only during the withdrawal of the sampler. The third variation is the fixed-Piston push-tube sampler in which the piston is connected or fixed to the drill rig during the push and the vacuum assists during the pushing of the sampler as well as during the withdrawal. push-tube samplers

are best suited for medium-stiff or stiff clays which are free of gravels or small rocks which could damage the leading edge of the tube.

75. Rotary core barrel samplers may be categorized as double-barrel or single-barrel. The double-barrel type, such as Denison, Pitcher, or WES samplers, consists of an outer barrel with a cutter shoe to advance the sampler and an inner barrel with a cutter edge to fine-trim and contain the sample. A single-barrel rotary core sampler is simply a core barrel with a cutter shoe; usually with a diamond head, to advance and contain the sample. The double-barrel samplers are best suited for hard soils and soils containing gravel. Single-barrel samplers are best suited to sampling rock.

Sample disturbance

76. The subject of sample disturbance is particularly important when sampling and testing expansive materials. The disturbance which occurs during sampling is primarily limited to the extremities of the sample and is the result of frictional resistance between the sample tube and the soil. In most cases this is of minor consequence and can be minimized by controlling the angle of the cutting edge and reducing the frictional resistance between the sample and the sampler. The reduction of the resistance within the sampler can be achieved by the application of lubricant such as silicon or Teflon sprays, by polishing the inner surface, or by plating the inner surface, i.e., chrome plating.

77. A second and probably more problematic type of disturbance, at least with respect to the magnitude of measured volume change, is the stress relief a sample undergoes when it is extruded from the sampler, sealed, and then stored prior to testing. This type of disturbance will allow some particle reorientation due to stress relief and may even result in volume change if the environment is conducive to moisture accumulation. The effect of this type of disturbance can be reduced by testing the material in rings cut directly from the sampler or using a sampler consisting of a series of rings. If this is not feasible, then the sample should be stored in the sampler until the testing program is ready to begin. If this is not possible and the sample must be extruded and sealed, then the exposure time should be an absolute minimum and the

sealer material of the highest quality available. When required, it is generally recommended that samples of expansive soils be stored under conditions similar to the in situ environment. However, information on the effects of storing samples of expansive soil prior to testing is extremely limited and requires further clarification.

Laboratory Identification and Testing Techniques

78. The purpose of identification and testing of expansive soils is to qualitatively and quantitatively describe the volume change behavior of the soils. The obvious need for qualitative identification is to forewarn the engineer during the planning stages of the potential for volume change and to generally classify the potential with regard to the probable severity. Quantitative testing is necessary to obtain measurable properties for predicting or estimating the magnitude of volume change the material will experience in order to ascertain approximate treatment and/or design alternatives. With this in mind, a threefold categorization of identification and testing techniques is possible.

- a. Indirect techniques in which one or more of the related intrinsic properties are measured and complemented with experience to provide indicators of potential volume change. These may be grouped according to soil composition; physicochemical, physical, and index properties; and currently used soil classification systems.
- b. Direct techniques which involve actual measurement of volume change in an odometer-type testing apparatus. These are generally grouped into swell or swell pressure tests depending on the need for deformation or stress-related data.
- c. Combination techniques in which data from the indirect and direct techniques are correlated either directly or by statistical reduction to develop general classifications with regard to probable severity.

79. The following discussions are an attempt to define the techniques published in the literature with regard to the categories previously described. As would be expected, the available techniques are quite varied and numerous, and in some cases categorical delineation may be subjective.

Indirect techniques

80. Discussion in earlier sections of the report indicated a large number of intrinsic properties and ambient conditions which influence volume change. Hence, the variety of indirect techniques for qualifying potential volume change is just as numerous and varied. Table 5 defines and describes a majority of the published techniques.

81. An indication of the potentially expansive nature of earth materials may be deduced in the field by examination of exposures of the material and by simple field tests. The outcrop appearance of highly expansive materials is usually quite distinctive after desiccation. The surfaces exhibit polygonal shrinkage areas and cracking which reflect the percentage of clay and possibly the presence of expandable clay minerals. The size of the polygons is also indicative in that the smaller the polygons, the higher the amount of clay. The extreme case of a material composed of sodium-montmorillonite results in a desiccation surface which possesses the size and texture of popcorn. This "popcorn" texture is common on outcrops of bentonite and other rocks rich in montmorillonite.

82. The reaction of a presumed expansive material with water may also be informative. The extent to which the material slakes, disintegrates, and is dispersed in water gives some indication of its thirst for water and also its cementation. Materials which slake immediately upon the introduction of water and which, when stirred, become almost completely dispersed, may be highly expandable. Again, sodium-montmorillonite slakes readily and is easily dispersed.

83. The accurate identification and study of clay minerals and their expandable properties must be accomplished in the laboratory. The common techniques used are relatively routine and are described in Table 5. Many private and governmental organizations have the personnel and equipment to perform these identification analyses. Probably the most important technique is X-ray diffraction (XRD). This method is relatively fast, uses small amounts of material, permits accurate identification, and may provide a semiquantitative estimation of the amount of expandable clay minerals present,

Table 5

Indirect Techniques for Identification/Classification of Expansive Soils

Indicator Group	Property and/or Method	Reference	Description																																		
Soil composition	Clay mineralogy by X-ray diffraction	79, 84-89	Measure of diffraction characteristics of clay minerals when exposed to x-radiation. Procedure permits qualitative and semiquantitative identification of clay mineral components based on structural differences between the clay minerals. Solvation techniques identify expansive clay minerals																																		
	Clay mineralogy by differential thermal analysis (DTA)	79, 89, 90	Identification is based upon exothermic and/or endothermic reactions which occur at particular temperatures. The type of reaction and temperature are functions of mineralogy. Heating rates, grain size, and sample size influence results. Multicomponent samples are difficult to analyze																																		
	Clay mineralogy by infrared radiation	89	Measure of selective absorption of infrared radiation by hydroxyls in clay minerals. Fair indicator, but not conclusive																																		
	Clay mineralogy by dye adsorption	89, 91	Qualitative indicator based on selective adsorption of different types of dyes by different clay minerals. Accuracy decreases if more than one mineral is present																																		
	Clay mineralogy by dielectric dispersion	92, 93, 94	Measure of the radiofrequency electric properties of clay-water systems. Dispersion is the measure of the dielectric constant at two frequencies. Good indicator of type and amount of clay minerals. Some problems evolve when mixtures of different expandable minerals are present in the soil																																		
Physicochemical	Cation exchange capacity	34, 40, 41, 52, 53	Measure of the ion adsorption properties of clay minerals. CEC increases from a minimum for keolinite to a maximum for montmorillonite. Good indicator of hydration properties of clay minerals																																		
	Exchangeable cations	34, 40, 41, 52, 53	Measure of the type of cations adsorbed on the clay minerals. Does not directly relate to swell potential but rather to the expected degree of swell from ion hydration																																		
Physical	Colloidal content from hydrometer analysis	7, 95	Measure of percent by dry weight basis of particles less than 1 micron in size. Indicator of amount of clay but no reference to type of mineral. Not conclusive																																		
	Specific surface area of clay particles	29, 34, 35, 36, 42	Measure of available clay mineral surface area for hydration. Fair indicator of amount of clay mineral and to some extent the type, since montmorillonite minerals are very fine and result in large specific surface areas for given samples																																		
	Soil fabric by electron microscopy	51, 89, 96, 97	No direct measure of swell potential. Primarily used for studies of the influence of soil fabric on volume change																																		
	Structure by X-radiography	68, 98	Good for determining the extent of cracks and fractures of undisturbed materials which will influence moisture movement. No direct measure of swell potential																																		
Index properties	Atterberg limits	29, 33, 43, 56, 99-115	Measures of the plasticity and shrinkage characteristics of cohesive soils. Liquid limit (LL) and plastic index (PI) correlate reasonably well with swell potential primarily because there are good correlations between them and the type and amount of clay minerals present. For shrinkage limit and shrinkage index (LL-SL) the property of volume reduction is correlated with swell potential because of similarities between the phenomena. Some of the published classifications based on Atterberg limits are:																																		
			<table border="1"> <thead> <tr> <th rowspan="2">Degree of Expansion</th> <th colspan="2">Reference 103</th> <th colspan="2">Reference 113</th> </tr> <tr> <th>PI</th> <th>Shrinkage Index</th> <th>Shrinkage Index</th> <th>Reference 102 LL</th> </tr> </thead> <tbody> <tr> <td>Low</td> <td><12</td> <td><15</td> <td><20</td> <td>20-35</td> </tr> <tr> <td>Medium</td> <td>12-23</td> <td>15-30</td> <td>20-30</td> <td>35-50</td> </tr> <tr> <td>High</td> <td>23-32</td> <td>30-60</td> <td>30-60</td> <td>50-70</td> </tr> <tr> <td>Very high</td> <td>>32</td> <td>>60</td> <td>>60</td> <td>70-90</td> </tr> <tr> <td>Extra high</td> <td>--</td> <td>--</td> <td>--</td> <td>>90</td> </tr> </tbody> </table>	Degree of Expansion	Reference 103		Reference 113		PI	Shrinkage Index	Shrinkage Index	Reference 102 LL	Low	<12	<15	<20	20-35	Medium	12-23	15-30	20-30	35-50	High	23-32	30-60	30-60	50-70	Very high	>32	>60	>60	70-90	Extra high	--	--	--	>90
Degree of Expansion	Reference 103		Reference 113																																		
	PI	Shrinkage Index	Shrinkage Index	Reference 102 LL																																	
Low	<12	<15	<20	20-35																																	
Medium	12-23	15-30	20-30	35-50																																	
High	23-32	30-60	30-60	50-70																																	
Very high	>32	>60	>60	70-90																																	
Extra high	--	--	--	>90																																	
	Linear shrinkage	114-116	Measure of shrinkage from a given moisture content. Reasonably good indication of swell potential																																		
Soil classification system	AACHO	117	A-6 and A-7 and borderline soils to A-4, A-6, and A-7 generally have high swell potentials																																		
	SCC	118-122	Pedological classification system in which the vertisol order is by expansive soils																																		

84. For initial, routine reconnaissance testing, three XRD analyses are recommended. These analyses include:

- a. Bulk sample. The XRD analysis of the bulk sample identifies the overall composition and is a basis for estimating the relative amount of clay minerals present in the sample. This usually does not allow for very precise identification of individual clay mineral types.
- b. Sedimented-oriented clay-size fraction (-4 micrometers). This provides for more detailed identification of the clay mineral components but may not detect montmorillonite in the presence of vermiculite or chlorite.
- c. Solvated, sedimented-oriented clay-size fraction. The addition of a polar, organic alcohol such as ethylene glycol or glycerol to the sedimented clay will expand the structural lattices of montmorillonite and expansive chlorites and vermiculites and thus permit the identification of these minerals. Other techniques such as heating must be used to distinguish between montmorillonite, expandable vermiculites, or expandable chlorites if these latter two types are not in a mixed-layer combination.

85. Generally, after these initial analyses have been made, subsequent samples from the same formation or area may be studied by XRD of the solvated sample alone.

86. The most widely used indicator group for identification/classification of expansive soils is the index property group. It involves properties that are routinely determined by most agencies, and experience has shown that the volume change behavior correlates reasonably well with liquid limit, plasticity index, and shrinkage limit. In most state highway agencies, a combination of observed Atterberg limits and prior experience with materials within a given area are the primary identification methods used for expansive soils. For example, in Louisiana if the liquid limit is below 50, the resulting distress from expansive soils will be minimal and no special treatment is required. If the liquid limit is between 50 and 70, then some type of treatment, usually lime, is deemed necessary. If the liquid limit is above 70, then the material is discarded for use in fills. Other state highway agencies rely on plasticity index; for example, in Kansas if the plasticity index is below 15, then minimal ^{*}problems are anticipated. If

the plasticity index is between 15 and 35, moderate problems are expected and some minimal treatment is considered. If the plasticity index is greater than 35, the material must be treated to minimize the problem or discarded. The South Dakota Department of Transportation has correlated Atterberg limits (liquid limits) with the Soil Conservation--Service Pedological Soil Surveys and developed a map showing the distribution of soils within specified limits of the liquid limit and use this as an indicator of potential volume change.

87. In summary, it is evident from the literature that only a few of the indirect techniques are capable of general application for the recognition of the potential volume change of expansive soils. Several procedures are available for defining the clay mineral constituents and thus a reasonable indication of swell potential. The index properties have shown reasonable correlations with swell potential; however, general application is somewhat hindered by the relative degrees of volume change from one area to another. In other words, the swell potential in one area defined by a given range of index properties may cause minimal problems, while the same limit may indicate serious problems in another area. This points to the possible need for identification techniques for physiographic areas in which the mechanisms of volume change are basically similar and the variations in ambient environmental conditions are minimal.

Direct techniques

08. The direct techniques include all those methods which quantitatively assess the volume change characteristics of expansive soils. In their basic forms, the measured volume change characteristics are swell and swelling pressure. The applied loads and structural rigidity generally determine which of the characteristics (deformation or stress) control the design of a specific structure. The measurement of these characteristics is accomplished by the use of odometer-type testing procedures. If the deformation (swell) characteristics are required, the specimen on which the information is desired is loaded to some seating load or some surcharge pressure determined by experience or related to overburdened conditions, then inundated and allowed to swell to

equilibrium. The ratio of deformation to original height is defined as the percent swell. If the stress characteristics (swelling pressure) are required, the specimen is loaded to some seating load or predetermined surcharge pressure, then inundated and a load applied to maintain a constant volume. This load defines the swelling pressure. An alternate procedure that has been used for defining swelling pressure is to allow the specimen to swell, then apply enough load to return the specimen to its original height. The combination of these basic variables (testing method) with the factors which influence the laboratory measurement of volume change have made the standardization of testing procedures somewhat complicated. Table 6 defines and describes some of the various published procedures in which the swell and swelling pressure of both undisturbed and remolded soils have been measured.

89. Krazynski⁴⁴ has defined and described the laboratory related variables which influence the measurement of volume change as:

- a. Initial moisture content.
- b. Initial dry density.
- c. Soil fabric.
- d. Surcharge load.
- e. Solution characteristics.
- f. Time allowed for swell.
- g. Curing time for remolded samples.
- h. Stress history (loading sequence).
- l. Sample size and shape.
- j. Temperature.

It is his opinion that a reliable and reproducible test, for the direct measurement of volume change should standardize at least eight of the ten variables. Loading sequence and temperature are not necessary because, as described in the previous paragraph, the loading sequence can determine which basic characteristic is being measured, and the variations in laboratory temperatures are usually minimal. Ideally, a standard method should consider each of the above factors as well as simulate the expected loading conditions that the structure will undergo. To date, no reliable procedure has been developed to adequately simulate

Table 6
Direct Techniques for Quantitatively Measuring Volume Change of Expansive Soils

Method	Reference	Description,
Navy method	123	Odometer test on remolded or undisturbed samples in which deformations under various surcharges are measured to develop a surcharge versus percent swell curve. The surcharge versus percent swell curve is related to the depth of clay versus percent swell curve from which the magnitude of volume change is calculated as the area under the curve
Potential vertical rise (PVR)	125, 126	The correlation of measured volumetric swell of a triaxial specimen (all around pressure of 1 psi) with classification test data (LL, PI, SR, and percent soil binder) to determine the Family Number (predetermined correlations) for the soil. The vertical pressures at the midpoints of strata are calculated and used in conjunction with Family Curves to obtain percent volumetric swell under actual loading conditions in each strata. The linear swell is take" as one-third of the volumetric swell which is cumulatively summed to calculate the potential vertical rise
Noble method	124	Odometer test on statically compacted samples (total four, two initial moisture contents under two surcharge pressures) measuring deformation. Previously correlated data are consulted to determine the magnitude of volume change with changing loading and initial moisture conditions
Double odometer	39, 55, 127, 128, 129	Odometer test in which two adjacent undisturbed samples are subjected to differing loading conditions. One sample is inundated and allowed to swell to equilibrium, then consolidation-tested using routine procedures. The second sample is consolidated-tested using routine procedures at its natural moisture content (NMC). The virgin portion of the NMC curve is adjusted to coincide with the swell-consolidation curve, and relationships from consolidation theory are used to estimate volume change
Simple odometer	130	Odometer test using one undisturbed sample which is loaded to its in situ overburden pressure the" unloaded to a seating load, inundated, and allowed to swell to equilibrium, the" consolidation-tested using routine procedures. Analytical procedures are same as double odometer method
Sampson, Schuster, and Budge	131	Odometer test in which two undisturbed or remolded samples are subjected to different loading conditions. One sample is loaded to the testing machine capacity (32 tsf reported) and consolidated to equilibrium, inundated, unloaded to 0.1 tsf, and allowed to swell to equilibrium. The second sample is loaded to its in situ overburden pressure, inundated, unloaded to the planned structure load, and allowed to swell to-equilibrium. The swelling index and changes in void ratio and consolidation theory are used to determine amount of volume change
Lambe and Whitman	132	Odometer test in which undisturbed or remolded samples are consolidation-tested using routine procedures including rebound. Effective stresses are calculated before and after testing, and the associated void ratio changes are determined. From this $\Delta e/l + e_o$ or $\Delta H/H^*$ versus depth curves are plotted. Magnitude of volume change is equal to area under the curve
Sullivan and McClelland (constant volume swell)	57, 133, 134, 135	Odometer test in which a" undisturbed sample is loaded to its in situ overburden pressure, inundated, and swell pressure measured by maintaining constant volume, then unloaded to a light seating load and the swell measured. Changes in void ratio are taken from the curve corresponding to the initial and final effective stress conditions of the in situ soil. Consolidation theory is used to estimate volume change
Komornik, Wiseman, and Ben-Yaacob	136	Odometer test on undisturbed samples in which swell is measured under corresponding overburden pressures to develop depth versus percent swell curve. Magnitude of volume change is equal to area under curve
Wong and Yong	66	Same as previous procedure except that a" additional surcharge equal to the pore water suction at hydrostatic conditions is added. Same analytical procedures
Expansion Index (Orange County)	44	Odometer test on compacted samples measuring volume change under 1-psi surcharge
Third cycle expansion pressure test	137	Used in conjunction with standard R-value test. Swelling pressure is measured at the end of the third cycle of volume change development (i.e., swell pressure is developed and relieved twice, then measured after developing the third time)

* Δe = change in void ratio; e_o = initial void ratio; ΔH = change in height; A = height.

the ambient environmental conditions which influence volume change.

90. The measured swell and swelling pressures using conventional techniques are generally conservative because of the method by which water is made available to the specimen. It is highly unlikely that the in situ soil mass would have a sufficient source of water to completely saturate the soil and satisfy the soil's "thirst" for water immediately.

91. Since highway subgrade loading conditions are minimal, the swell rather than the swelling pressure is the controlling characteristic. Some state highway agencies use some form of odometer swell test with a minimal surcharge to define the volume change of expansive soils. Generally, the data are used to quantitatively assess the volume change for the determination of appropriate treatment techniques and is seldom used directly in the design of pavement.

92. The time rate^{129,138-141} of development of volume change is a factor which current testing procedures are not capable of defining or simulating. Estimates are generally made by using consolidation theory and are somewhat questionable. Recent advances have been made through the use of finite difference¹³⁸ and finite element techniques and applying diffusion theory to the problem. These techniques appear promising; however, further experience will be required to substantiate their accuracy.

Combination techniques

93. Combination techniques involve the correlation of indirect and direct techniques to provide better classification groups with regard to severity of volume change and develop quantitative estimation techniques for ultimate volume change. Commonly used correlation parameters include Atterberg limits (liquid limit, plastic index, **shrinkage** limit), colloidal content, activity, and swell or swelling pressures from odometer-type tests under various loading conditions. Generally the techniques result in a categorization of the relative severity of volume change; however, in some cases prediction equations are obtained from ^{Statistical} comparison of measured properties. The following paragraphs present some of the more widely published techniques with brief descriptions of their application.

94. Bureau of Reclamation method.²⁸ This method involves the direct correlation of observed volume change with colloidal content, plastic index, and shrinkage limit. The measured volume change is taken from odometer swell tests using 1 psi surcharge pressures from air-dry to saturation. The degree of expansion and limits of correlated properties are shown in the following tabulation:

<u>Date from Index Tests</u>			<u>Probable Expansion</u>	<u>Degree of Expansion</u>
<u>Colloid Content</u>	<u>PI</u>	<u>SL</u>		
<u>%-1 μm</u>	<u>%</u>	<u>%</u>	<u>%</u>	
<15	<18	>15	<10	Low
13-23	15-28	10-16	10-20	Medium
20-31	25-41	7-12	20-30	High
>28	>35	<11	>30	Very high

Experience has shown that this method correlates reasonably well with expected behavior and provides a good indicator of potential volume change. The major criticisms of the method are that the colloidal content indicates amount but not the type of clay constituents and that the hydrometer test is not a routine test in many agency laboratories.

95. Altmeyer method.¹¹² In a discussion to Holtz's paper presenting the USBR method, Altmeyer brought out the major criticisms to the method and suggested a method based on correlations between percent swell and the shrinkage limit and linear shrinkage. The percent swell is determined in an odometer test on compacted samples (90% standard AASHTO T-99 density) under 650-psf surcharge. The results of his recommendations are tabulated as follows:

<u>Linear Shrinkage</u>	<u>Shrinkage Limit</u>	<u>Probable Swell</u>	<u>Degree of Expansion</u>
<u>%</u>	<u>%</u>	<u>%</u>	
<5	>12	<0.5	Noncritical
5-8	10-12	0.5-1.5	Marginal
>8	<10	>1.5	Critical

One minor criticism to this method is its lack of application to in situ behavior since the data were collected on remolded samples.

96. Seed, Woodward, and Lundgren method.^{106,142} The swell potential of an expansive soil is defined from correlations of percent swell from odometer tests using laboratory prepared and compacted samples

(maximum dry density and optimum moisture content, AASHTO T-99) under 1-psi surcharge with percent clay size ($-2\mu\text{m}$) and soil activity. A statistical relationship is defined for swell potential in terms of clay content and activity and compared with measured volume change. Using appropriate charts, the swell potential may be categorized as follows:

<u>Swell Potential</u> %	<u>Degree of</u> <u>Expansion</u>
0-1.5	Low
1.5-5	Medium
5-25	High
>25	Very high

Experience has shown fair results with regard to actual conditions. One criticism of the method is that the volume change was measured on samples prepared from commercial grade clay minerals and may not sufficiently represent in situ material behavior because of the varied composition of most soils.

97. PVC (Federal Housing Administration).¹⁴³ The potential volume change (PVC) of a material is based on a field testing device (PVC meter) developed for the FHA in which the swelling index (swelling pressure under 200-psf surcharge at the end of 2 hr) is defined and correlated with the PVC rating. The degree of expansion related to PVC rating is:

<u>PVC Rating</u>	<u>Degree of</u> <u>Expansion</u>
0-2	Noncritical
2-4	Marginal
4-6	Critical
>6	Very Critical

The method has not been widely accepted because of some of the inherent inconsistencies in the testing procedure and the somewhat empirical testing system.

98. Ladd and Lambe method.¹⁰² In an effort to increase the applicability of the PVC method, additional correlations were made between the percent swell under 200-psf surcharge (rather than swelling pressure) and the plasticity index, moisture content at 100 percent humidity, and the volume change occurring between the field moisture

equivalent and the shrinkage limit. Using these parameters, a combined PVC rating was determined and the resulting degree of expansion categories are as follows:

<u>PVC (Combined)</u>	<u>Degree of Expansion</u>
<2	Noncritical
2-4	Marginal
3-6	Critical
>6	Very critical

One apparent shortcoming is that the sample must be run in the PVC meter; therefore, the additional parameters are not advantageous. In fact, the method is somewhat more complicated because of the extra data required.

99. Chen method.¹⁰⁵ In an effort to simplify the USBR method (i.e., eliminate the need for hydrometer analysis) and to provide some relative measure of soil density, a correlation was made between odometer swell data (undisturbed sample under 0.5-*tsf* surcharge) and percent passing the No. 200 sieve, liquid limit, and standard penetration resistance. The resulting classification of the degree of expansion is as follows:

<u>Laboratory and</u>		<u>Field Data</u>		Probable	Degree of <u>Expansion</u>
< No. 200	LL %	Std Penetration	Blows per foot	Expansion %	
<30	<30	<10		<1	Low
30-60	30-40	10-20		1-5	Medium
60-95	40-60	20-30		3-10	High
>95	>60	>30		>10	Very high

Although attempts have been made to correlate density with standard penetration and have been quite successful in cohesionless materials, the extrapolation to cohesive materials (especially overconsolidated clays) has not been very meaningful.

100. Sorochnik method.⁵⁶ The correlation involves relating the swelling index (void ratio, e , after free expansion divided by the initial sample void ratio, e_o) to the plasticity index. The resulting degrees of expansion with regard to correlated parameters are as follows:

Swelling Index, e/e_0					Degree of Expansion
15 < PI < 20	20 < PI < 25	25 < PI < 30	30 < PI < 35	35 < PI < 40	
a.12	<1.11	a.09	<1.08	a.07	Nonswelling
1.12-1.23	1.11-1.21	1.09-1.19	1.08-1.17	1.07-1.15	Slight
1.23-1.39	1.21-1.30	1.19-1.28	1.17-1.25	1.15-1.22	Medium
1.39	>1.30	a.28	a.25	>1.22	High

The method considers two of the properties important to volume change; however, an expansion test must be conducted to use the method.

101. Vijayvergiya and Ghazzaly method.¹⁰⁸ The method defines a swell index for an expansive soil as the ratio of the natural water content to liquid limit and correlates it with odometer swell (0.1-*tsf* surcharge) and swell pressure data. Rather than a specific degree of expansion, limits of probable swell and swelling pressure are defined as shown in the following tabulation:

<u>Natural Water Content</u> <u>Liquid Limit</u>	<u>Probable Swell Pressure</u> <u><i>tsf</i></u>	<u>Probable Swell, %</u>
>0.5	<0.3	<1
0.37-0.5	0.3-1.25	1-4
0.25-0.37	1.25-3.0	4-10
<0.25	>3.0	>10

The method is based on data collected from a wide variety of samples and is very simple to use, i.e., all that is required is the natural water content and liquid limit. However, experience with regard to application of the method is relatively limited.

102. Vijayvergiya and Sullivan method.¹⁴⁴ The method is correlation of odometer swell data (1-*psi* surcharge) with liquid limit and dry density. Here again, degree of expansion is not defined; instead, a family of curves relating the parameters with quantitative volume change (Figure 11). The basic material data for the correlation is good; however, experience with application of the system is somewhat limited.

103. Nayak and Christensen method.¹⁰⁹ The method involves the development of two statistical relationships, one for swell and the other for swelling pressure, in terms of plasticity index, percent clay

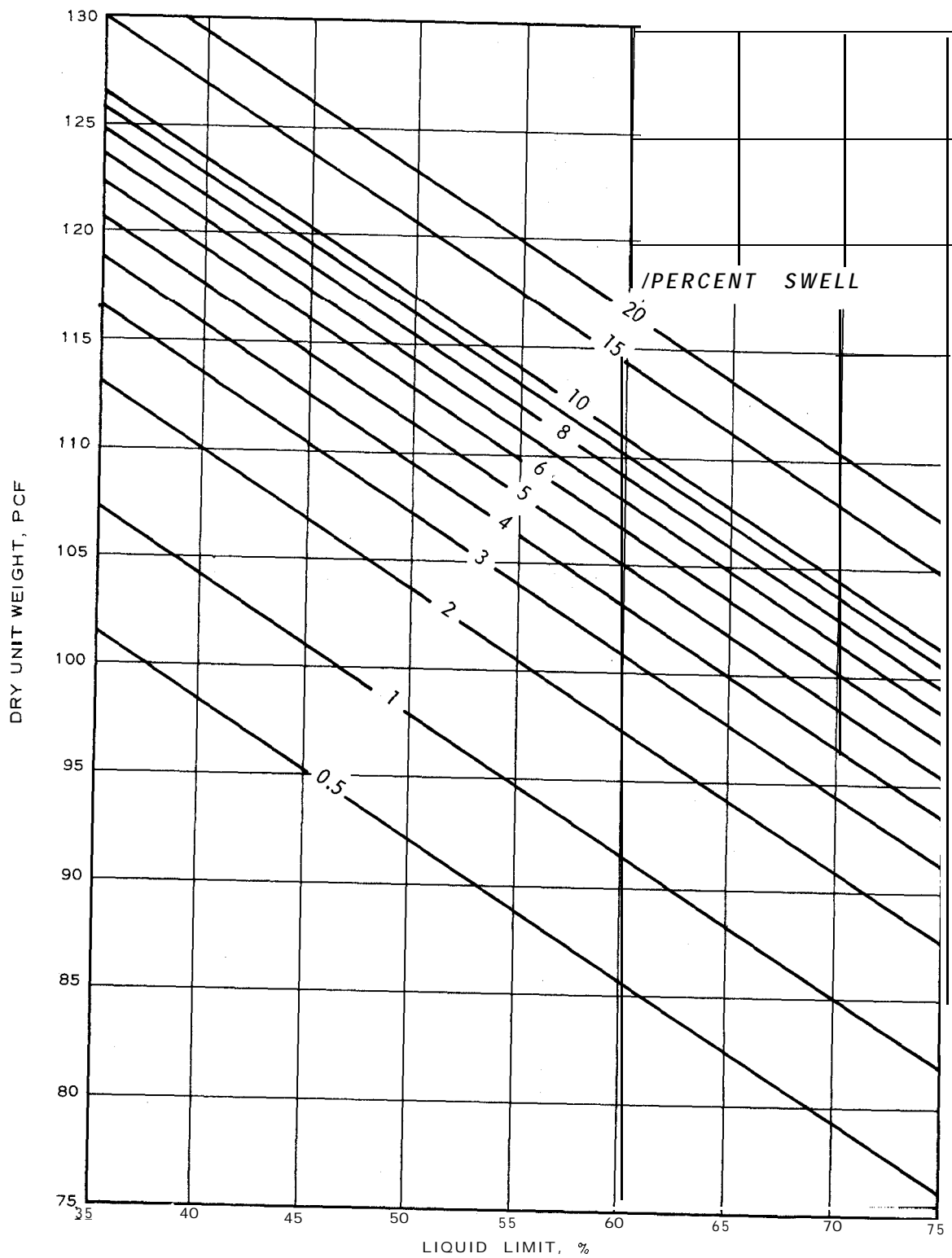

Figure 11. Correlation of percent swell, liquid limit, and dry unit weight (from Reference 144)

content, and initial moisture content. The developed relationships are:

$$S_p = (2.29 \times 10^{-2})(PI)^{1.45} \frac{C}{w_1} + 6.38$$

where

S_p = predicted swell percentage

PI = plasticity index, percent

C = clay content, percent

w_1 = initial moisture content

and

$$P_n = (3.5817 \times 10^{-2})(PI)^{1.12} \frac{C}{2} + 3.7912$$

where

P_p = predicted swelling pressure, psi

The correlation with measured odometer data was very good. Here again, experience with the method outside the area of its development is somewhat limited.

104. Komornik and David method.¹⁴⁵ This is another statistical comparison of measured data which provides a relationship for predicting swelling pressure using liquid limit (LL), natural dry density (γ_d), and natural moisture content (w_i). The relationship for predicted swelling pressure is:

$$\log P = -2.132 + 0.0208(LL) + 0.000665(\gamma_d) - 0.0269(w_i)$$

The dry density and swelling pressure are in kg/cm^2 .

105. As with the direct and indirect techniques, no universally applicable technique has been described for an accurate assessment of the potential volume change. However, experiences within localized areas have indicated reasonably good results using many of the techniques previously described.

PRECONSTRUCTION TECHNIQUES FOR MINIMIZING DETRIMENTAL
VOLUME CHANGE OF EXPANSIVE SOIL SUBGRADES

Introduction

106. During the past decade, the methods reported for controlling or limiting detrimental volume changes in subgrades has changed little. In 1964, a literature review on swelling soils¹⁴⁶ by the Colorado State Highway Department identified the following courses of action for dealing with the problem:

- a. Removal of expansive soil and replacement with nonexpansive soil.
- b. Application of surcharge pressure.
- c. Preventing access of water to the soil.
- d. Prewetting the soil.
- e. Stabilization by chemical admixtures.
- f. Mechanical stabilization.

107. Since that time few, if any, additional methods have been added to the list, and every major literature review or conference on swelling soils^{29,43,147-150} has reiterated these remedies. However, an examination of the literature of the past decade reveals that enormous strides and many innovative techniques have been developed for applying these methods, with literally hundreds of documents published. While it is impossible to tabulate and review all these publications, the following paragraphs summarize various projects and general conclusions concerning these methods.

Methods of Controlling Volume Change of Expansive Soils

Removal of expansive soil and replacement with nonexpansive soil

108. Removal of natural expansive subgrade material and replacement with a nonexpansive material is a most obvious method of eliminating swell problems. In some cases this approach may be economical *if*

the expansive stratum is thin and replacement materials are available. Unfortunately, this is generally not the case, and the excavation and replacement solution is extended only to a depth which will reduce swelling to a tolerable minimum. Hence the required depth of excavation depends upon the expansiveness of the soil and the anticipated weight of backfill and structure which counteract the uplift forces of the swelling soil. The selection of the particular nonexpansive backfill material is critical. Holtz¹⁵¹ suggests that replacement soils be impervious as pervious soils may create conditions conducive to the collection of water or the condensation of moisture from the air through hydrogenesis.

109. Holtz²⁸ describes repairs made to the Mohawk and Wellton Canals by removing the subgrade soil and replacing it with a sand-gravel material before reconstructing the lining. The gravel was not highly compacted so that some compression of the gravel would occur, thereby relieving part of the expansive force.

110. McDowell¹²⁵ reports construction of a large building on a 50-ft deposit of Del Rio clay in which the clay was excavated to a depth of 6 ft and backfilled with a nonexpansive material. In another case reported by McDowell¹⁵² a 2- to 3-ft layer of expansive soil overlying rock was stripped off and replaced by compacted crushed rock fill.

111. Contrary to these aforementioned successes using excavation and replacement methods, the Colorado Department of Highways has reported dismal failures using this technique.^{81,153-155} In these cases, swelling subgrades were subexcavated a depth of 2 ft and backfilled with various gradations and types of granular material. Unfortunately, the pervious granular material permitted the entrance of moisture through surface runoff and hydrogenesis, and swelling occurred. It was found that open-graded gravels were the worst offenders of the gradations tested.

112. South Dakota's experience¹⁵⁶ indicated that limited undercutting and recompaction of the subgrade (6-18 in.) did not solve their pavement warping problems. However, on I-90, 2 percent lime was added to a cushion gravel and base course gravel to reduce the PI from 10-20 to less than 10 and placed directly on the untreated subgrade. The

results showed that although several warped pavements have developed, the overall serviceability index of the project is good.¹⁵⁷ Likewise, on I-95 east of Cactus Flat, it was determined that a 4-in. layer of lime-treated gravel cushion gave as good as or better protection to the subgrade for retention of the construction moisture and density at a lower cost than did lime stabilization of the upper 6 in. of subgrade with 3 percent RC-1 being mixed in the upper 3 in. to form a moisture barrier.¹⁵⁶ These experiences suggest that lime treatment of the gravels may eliminate problems encountered by the Colorado Department of Highways. However, it would appear that sufficient fines for lime reaction must be present in the base course gravels and a fairly impervious material should result for this method to be effective.

113. Experiences of the Wyoming State Highway Department concerning the use of untreated gravel bases placed directly on the subgrade have been similar to those of the Colorado Department of Highways.^{158,159} The experimental project on I-25 south of Kaycee resulted in moisture accumulations in the granular base course followed by heaving. Originally, roads built in Wyoming were constructed using gravel (with fines) bases with some surfacing, and heaving was not a major problem. However, with the advent of heavier loads and faster speeds of modern traffic, clean gravel bases and gentle side slopes with several feet of exposed gravel base became common practice. The result was swelling soil problems. Initial reactions were to thicken the gravel section; however, the thicker the section and better the gravel, the higher the heaves. In some cases a gravel with fines was used with some retardation of the swelling.

Application of surcharge pressure

114. Loading the expansive soil with pressure greater than the swelling pressure is a method by which swelling can be prevented. However, pavement loads are generally insufficient to prevent expansion, and this method is usually applied in the case of large buildings or structures imposing high loads. Sallberg³¹ mentions that pavement designs developed by the California Division of Highways are based partly on the requirement that the pavement weigh enough to prevent expansion

of the subgrade. The use of this method obviously is limited to swelling soils with low expansive pressures, and a careful balancing of swell pressures and pavement weights is required.

Preventing access of water to the soil

115. Since the change in moisture content is the main factor influencing the volume change of swelling soils, it is obvious that if the soil could be isolated from any moisture changes, volume change could be reduced or minimized. In this context, waterproof membranes are becoming an increasingly promising method for limiting access of water and minimizing moisture changes.

116. Holtz²⁸ describes the use of a one-quarter-in. semiblow, hot-sprayed asphalt membrane used between the concrete lining and subgrade soil on the Friant-Kern Canal in California.

117. The Colorado Department of Highways^{80,81,153-155,159-161} has observed considerable success with asphaltic membranes in controlling moisture changes and heaving. The Clifton-West experimental test program on I-70 concluded that the two sections using three-eighths-in.-thick, catalytically blown asphalt membranes outperformed other preventative measures tested. Test sections on State Highway 96 near Ordway to evaluate full-depth stabilized base mixtures showed that after 7 yrs, none of the sections were close to failure even though some sections were designed for only 3 yrs of service. Test sections on US Hwy 40 west of Elk Springs showed that sections constructed with a 3-1/2-in. or thicker asphalt-stabilized base and membrane-lined ditches were performing well. However, sections constructed with a 4-in. wearing surface with no base and sections constructed with a 12-in.-thick clay base enveloped with catalytically blown asphalt membranes had experienced both structural and heaving failures. Brakey⁸¹ suggested that enveloped clay sections may be effective if properly constructed, but sufficient support may not be economically gained when compared with full depth asphalt.

118. The Colorado Department of Highways has two basic approaches for using moisture barriers with swelling soils⁸⁰ as illustrated in Figure 12. These are either a full-depth asphalt laid directly on the

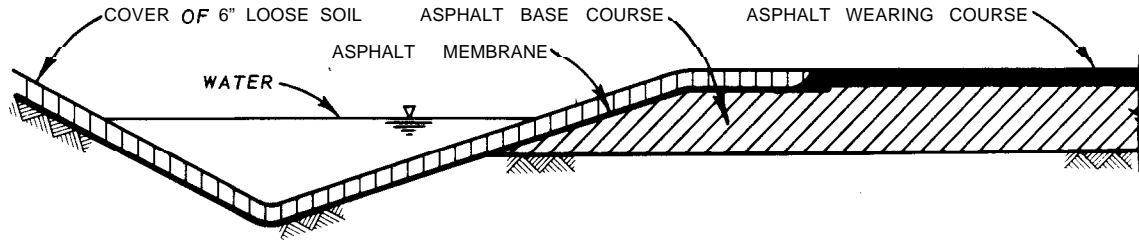

FULL-DEPTH ASPHALT PAVEMENT WITH LINED DITCHES

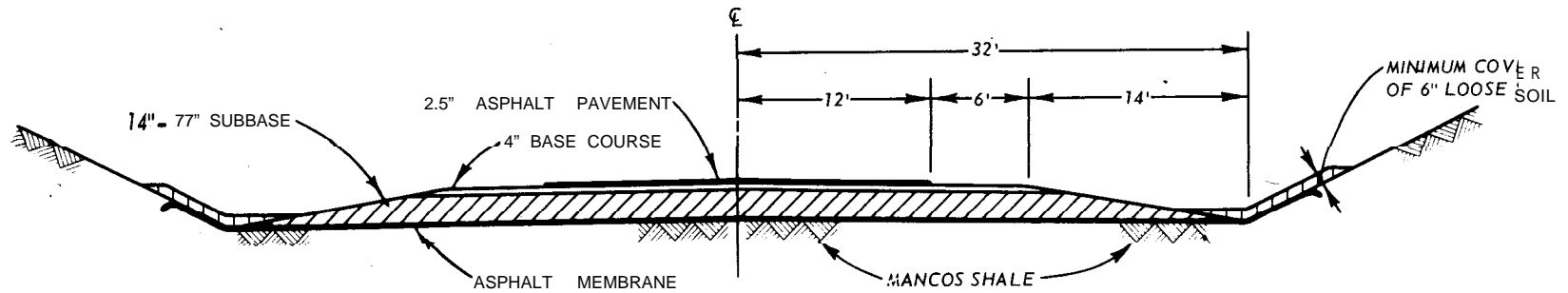

CONTINUOUS ASPHALT MEMBRANE APPLIED TO SUBGRADE AND DITCHES

Figure 12. Typical construction of moisture barriers used by the Colorado Department of Highways (from Reference 80)

swelling subgrade with asphalt-lined ditches and backslopes or asphalt membranes between the swelling subgrade and the road subbase. The full-depth asphalt section provides an impermeable support material which eliminates moisture accumulation by hydrogenesis or surface runoff. The asphalt membrane permits moisture to accumulate in the base and subbase, but prevents it from seeping downward into the subgrade; instead, the water merely drains off to the side ditches.

119. The use of moisture barriers in an experimental section was evaluated by the South Dakota Department of Transportation on US Hwy 12 over the Pierre shale.¹⁶² The upper 6 in. of the subgrade was treated with a mixture of lime and RC-1 asphalt to form the waterproof cover. In addition, a polyethylene plastic blanket was placed vertically to a depth of 4 ft at a distance of 20 ft either side of the center line, just inside the shoulder line. The results indicated that there were no significant differences in moisture contents of sections with moisture barriers and those without. Apparently, the polyethylene plastic cutoff was not placed deep enough and the fractured nature of the shale permitted moisture to move underneath the wall. There were more moisture fluctuations in the areas with the moisture barrier, and the riding surface was better in areas without the moisture barrier. The moisture seemed to be higher and fluctuated more in the area close to the barrier itself, indicating that a thermal change may be causing condensation near the plastic cutoff.

120. The Mississippi State Highway Department used a moisture barrier of an asphalt membrane placed at the rate of 1 gal/yd² in a test section on State Highway 475 constructed over Yazoo clay.¹⁶³⁻¹⁶⁵ While the companion control sections experienced severe distortion during the 34-month observation period, the bituminous membrane provided a very effective means of waterproofing the roadway and preventing any detrimental swell. It had been feared that capillary rise would make the membrane ineffective, but apparently moisture migration in the Yazoo clay is not due to capillary rise; rather, it is controlled by surface runoff and cracks and fissures in the clay.

121. The Arizona Department of Transportation like the Colorado

Department of Highways has used membranes and/or full-depth asphalt roadways. These moisture barriers have proven to be a fairly good solution, particularly in arid regions.¹⁶⁶

122. The Wyoming State Highway Department tried plant-mixed asphaltic bases over granular subbases and experienced problems similar to those of the Colorado Department of Highways. Specifically, moisture accumulated in the granular layer which subsequently infiltrated the expansive subgrade causing heaves. However, the use of full-depth plant-mixed bases and asphaltic membranes has produced an economical, effective means of preventing moisture migration to the subgrade by surface moisture.¹⁵⁸

123. On the Kaycee-South experimental section of I-25, the Wyoming State Highway Department placed a section consisting of 2-in. plant-mixed asphalt concrete surface course, an 8-in. hot-mixed asphalt-stabilized base, and a variable section (minimum 3 ft) of select soft sandstone base over the expansive Cody shale. A plastic membrane (unsealed at either edge) was placed in either ditch section part way up in the select sandstone base, Figure 13. In the companion nonmembrane section, a considerable increase in moisture occurred at the select sandstone base and clay subgrade interface. Likewise, in the membrane sections under the driving lane (where no membrane was placed) significant

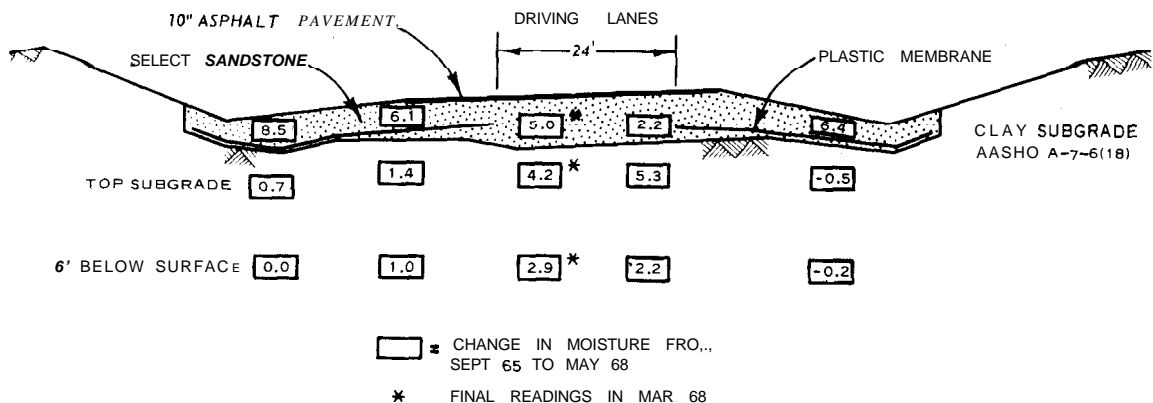

Figure 13. Membrane section on Kaycee Project showing moisture buildup under center portion of roadway from hydrogenesis. Membrane kept shoulder area dry (from Reference 159)

moisture accumulations occurred leading to upheavals. However, under the plastic membrane the moisture increase was less than 1 percent, with moisture accumulations of 2-8 percent occurring above the membrane in the sandstone base course. ¹⁵⁹

124. On the Upton-New Castle test section on US Hwy 16 overlying shale similar to the Pierre and on the Upton-Ten Sleep test section on US Hwy 16 overlying the Cody shale, the Wyoming State Highway Department used catalytically blown asphalt membrane to minimize moisture changes. Asphalt membrane was placed completely across the subgrade to the bottom of the side ditches and up the backslope to a horizontal distance of 18 in. Results showed that no significant changes in moisture content occurred, and the pavement was virtually free of any significant expansive soil upheavals. ¹⁵⁹

125. An evaluation of moisture barrier sealants by the University of Wyoming for the State Highway Department ¹⁶⁷ showed that Peneprime and a catalytically blown asphalt with P_2O_5 additive were effective sealants. However, a product, B D Quat 2 Coco, and silicone 772, were not effective. Peneprime when heated to 250°F penetrated remolded compacted clay specimens a depth of 1 in. at assimilated application rates of 0.35 gal/yd². The catalytically blown asphalt when heated to 400°F and applied at a rate of 1.44 gal/yd² formed a 1/4-in.-thick membrane resembling a tire inner tube. The B D Quat 4 Coco was intended to coat the soil particles with a water repellent film. However, when applied as a concentrated surface treatment, the Coco formed a gel when it contacted water; the water eventually penetrated the gel, causing swelling. When the Coco was mixed with water, a gel formed and no penetration of the soil occurred. Silicone 772 is used as a waterproofing agent for exterior wall and roofing products. However, it does not adhere well to soil particles, and cracking occurred during laboratory tests.

Prewetting the soil

126. The objective of prewetting is to allow desiccated swelling soils to reach equilibrium prior to placement of the roadway or structure. The most commonly applied method for accelerating swelling by this technique is ponding. ^{29, 138} The questions of how long the

material should be ponded and to what depth the moisture should penetrate to be effective are still unknown.

127. One of the earliest, more notable highway ponding projects was on US Hwy 81 north of Waco, Texas, over Wilson clay loam which is developed from the Taylor marl.¹⁵² In 1948, two areas were ponded; one site had 4-in.-diam holes drilled to a depth of 8 ft on 5-ft centers; at the second site, 4-in.-diam holes were drilled to a depth of 7.5 ft on 6-ft centers. The holes were backfilled with sand or gravel to minimize sloughing of the walls and filled with water daily for 4 months. Most of the water entered the upper 3.5 ft of soil, and the quantity added was so small compared to the volume of soil being wetted that some parts of the soil were still below the shrinkage level 2 months after filling of the holes began. To expedite the swelling process, two areas were ponded for approximately 3 months. In the 40 days prior to ponding, there was no evidence of surface heave resulting from the daily filling of the holes with water. However, after 3 days of ponding the surface rose 1 in. Several experiments to accelerate water movement from the holes were tried. In one experiment, pressures of 25-90 psi were applied in sealed holes. Two comparison experimental sections, one with 4-in.-diam holes 8 ft deep on 5-ft centers and one without any holes, were both ponded. All these experiments concluded that the holes were of little value in wetting the soil and that ponding was more effective. The apparent reason for this conclusion was that the blocky-structured natural clay afforded easy penetration of the water. Hence it was recommended that ponding be completed prior to any grading which may alter the natural fissures.

128. In 1958 a section of I-35 north of Waco, again crossing the lower member of the Taylor marl, was ponded for 22-41 days. Results of the project showed that the water did not penetrate more than 4 ft downward during a ponding period of 24 days. Nevertheless after several days of ponding, the moisture contents at the 20-ft depth level increased. Results of this ponding show that after 7 yr of service, only 2 of the 15 ponded sections have become rough, while several unponded sections in the same area have heaved and been overlaid or replaced.¹⁵²

129. Based upon these Texas Highway Department projects, McDowell¹⁵² feels that ponding of approximately 30 days is recommended. After ponding, lime stabilization may be required to provide a firm working platform and to decrease evaporation and dry weather cracking of the underlying subgrade.¹²⁴

130. Ponding of foundations for building sites and highway sub-grades have been reported by McDowell,¹²⁵ Watt and Steinburg,¹⁶⁸ Blight,¹⁶⁹ Dawson,¹⁷⁰ and Haynes.¹⁷¹ In the two examples cited by McDowell^{125,152} the foundation soils were ponded for 30 days, followed by lime stabilization to provide a working platform and decrease any dry weather cracking and evaporation. Results were successful. Some success was reported by Dawson¹⁷⁰ who flooded the foundation trenches for a building on expansive clay. After 4 months of ponding, penetration of water into the soil was found to be very limited. Nevertheless, the subsequent heave of the structure proved to be less than that observed for similar structures in the area.

131. Haynes and Mason¹⁷¹ report a prewetting technique in which 6-in.-wide, 3-ft-deep trenches on a 10- by 30-ft grid were filled to a depth of 1 ft with lime and backfilled with gravel. Water with a surfactant Kyro E0 was placed in the trenches for about 1 month. At this time the soil had reached the required prewetted moisture content corresponding to the fully swelled condition and the floor slab was placed with no subsequent heave problems.

132. Ponding of a 27-ft-deep cut on US Hwy 90 west of San Antonio, Texas, in the Taylor formation was accomplished in 1970.^{168,172} An area from 3 ft up the backslope across the main lanes, median, and shoulders was ponded for 45 days. It was observed that little water reached below 3 ft due to the lack of a fissured system in the clay, and the source of swelling was primarily in the upper 4 ft. In one of the ponds a surfactant was used, but no perceptible difference in the surface and depth elevations or moisture readings was observed. This, plus the fact that the surfactant-water combination was toxic to goldfish, led to its discontinuance. The areas were lime-stabilized after drainage to hold the moisture. At this time, a road condition survey of the ponded and

adjacent areas of US Hwy 90 is inconclusive as to the effectiveness of the ponding. However, it appears that the ponded sections have required less maintenance work.

133. The Mississippi State Highway Department conducted an experimental cut and fill ponding section on State Highway 475 overlying Yazoo clay.¹⁶³⁻¹⁶⁵ The entire section was undercut 3 ft below finished subgrade elevation, a grid of 6-in.-diam sand drains 20 ft deep (laboratory tests showed swelling to 20 ft could be anticipated) on 5-ft centers constructed, and the section ponded for 140 days. After drainage the section was brought to grade and the upper 6 in. stabilized with 7 percent lime. The lime stabilization extended from ditch to ditch to prevent future desiccation. Moisture content determination at various depths under the section proved to be inconclusive; however, it was concluded that the permeability of the remolded fill clay was so low that ponding was not effective in reducing the swell potential. Ponding was effective in the cut area. However, performance data indicate that all experimental sections, including an asphaltic membrane section, have required no maintenance, while the companion control sections have experienced considerable distortion. Apparently, the moisture barrier consisting of an asphalt membrane is an effective method for construction, in this material.

Stabilization by chemical admixtures

134. Chemical stabilization has been used as a method for altering the clay structure or clay-water combination to prevent or minimize swelling of expansive clays. Literally hundreds of chemicals or additives have been tried. Cementation by lime, lime-fly ash, and cement has been used. Ion exchange (addition of divalent and trivalent salts), cation fixation in expanding lattice clays (with potassium), deactivation of sulfates (with calcium chloride), waterproofing (silicones, asphalts), cementation (silicates, carbonates, lignins; phosphoric acid), and alteration in permeability and wetting properties (surface active agents, wetting agents) have all been attempted or used to reduce the expansive properties of swelling clays. However, due to mixing problems, economics, effectiveness, and practicability, none of these are recommended for

Table 7
Methods for Volume Change Control Using Additives (from Reference 173)

Method of Additive	Effects on Soil	Method of Application	Comments	Reference
Lime treatment	Reduce or eliminate swelling by ion exchange, flocculation, cementation, alteration of clay minerals	Remove, mix, replace or mix-in-place	Only suitable for shallow depths	174
			Mixing difficult in highly plastic clays	175
		Deep-plow	Delay between initial addition of lime and final mixing and placement improves ease of handling and compaction	176 177 178
			2-6 percent lime usually required	179
Cement treatment	Reduce or eliminate swelling by cementation, ion exchange, and alteration of clay minerals	Lime slurry injection: lime piles	Treat depths to 36 in. Can use conventional equipment. Requires careful quality control	
		Mixing-in-place: piles and walls	Controversial. Limited by slow lime diffusion rate. May be effective in fissured material.	180 181
			Not yet investigated. Might be suitable in highly plastic soils for treatment to large depth. Could use dry lime, lime mortar, or slurry.	*
Chemicals:	Various effects have been measured or hypothesized, including:	Usually remove, mix, and replace or mix-in-place. In some instances spraying or injection is used. Electroosmosis may be useful in special cases. Diffusion may be effective	Cement may be less effective than lime in highly plastic clays	183
			Mixing in place	Mixing difficult in highly plastic clays. Deep-plow method not yet investigated (?). Reduction in swelling noticeable for cement contents >4-6 percent. No excavation and backfilling required. Has been used for construction of piles and walls. Better, more economical equipment needed.
Hydroxides	Reduced plasticity		Problems of mixing or injection may be significant	185
Chlorides	Improved compaction		No chemical additives for control of volume change appear to be available that are effective, permanent and economically competitive with lime or cement when large volumes of soil must be treated	186
Phosphoric acid	Reduced swell		Calcium chloride may be effective at least temporarily in soils with expanding lattice clays. It may be useful in soils with a high sulfate content	187
Carbonates	Waterproofing		A number of proprietary formulations have been marketed. The beneficial effects of these materials have not generally been documented	188
Sulfates	Preservation of soil structure			189
Lignins	Increased strength			190
Siliconates	Increased or decreased permeability			191
Asphalts				192
Quaternary ammonium chloride				193
Proprietary: "Compaction aids"				194
Other				195

* See Reference 182 for technique utilizing portland cement.

large-scale routine treatment of swelling soils.¹⁷³ Lime continues to be the most widely used and most effective additive for stabilization of expansive clays.^{167,173} Table 7, excerpted from Mitchell,¹⁷³ summarizes the use of various chemical additives for controlling volume change.

135. The University of Wyoming evaluated approximately 17 different additives for stabilizing an expansive clay on I-80 west of Laramie.¹⁶⁷ Effectiveness was evaluated by volume expansion tests using a CBR mold and swell pressure tests using a 4-in.-diam Proctor mold.

Briefly, the following additives were evaluated:

- a. Alcohols and formaldehyde. Isopropyl alcohol caused the soil to become friable and reduced the swelling as much as lime for a short period of time. Negative results were obtained with a lime-isopropyl alcohol slurry in an attempt to migrate dissolved lime into the clay. Ethyl alcohol and formaldehyde also reduced swelling, but the tests showed that this reduction was only temporary.
- b. B D Quat 2 CoCo. This agent is a quaternary ammonium chloride and was added to the soil in an attempt to form a water-repellent film covering the clay. Gelation occurs when CoCo is added to water. Addition of concentrated CoCo-water mixture to the soil caused the soil to become friable. Reduction in swell compared favorably with lime, but, as with lime, good mixing is required.
- c. Reten. Reten 210 and Reten A-1 are synthetic, water-soluble polymers; the former is cationic while the latter is anionic. They are used as flocculants in sewage treatment and, as expected, when they were added to the soil, a spongy, friable mixture was obtained. However, when very slight amounts were added to water, unmanageable gelation occurred, thereby precluding any migration and ease of mixing.
- d. Nalcolyte. Nalcolyte 605 and 675 are a cationic poly-electrical organic coagulant and a water-soluble polymer flocculant, respectively. Nalcolyte 605 caused the soil to become friable, but failed to reduce swell. Nalcolyte 675 behaved similar to Reten with a considerable loss in density observed.
- e. Silicone. Silicone 770 and 772 are silicone resin concentrates used for waterproofing masonry, and a water-soluble sodium methyl siliconate used as a dispersing agent in clays and ceramics, respectively. For the percentages tested, silicone 770 failed to provide any appreciable swell reductions. Silicone 772 at 3 percent

produced results nearly comparable to lime, but at 0.5 percent little swell reduction was obtained.

- f. Sodium and magnesium chlorides. At application rates of 0.5-2 percent by dry weight, only slight improvements were observed.
- g. Phosphoric acid. Phosphoric acid in amounts of 1, 2, and 3 percent by dry weight was added to the soil. When the acid was added to the moist soil instead of being added directly to the mixing water, the soil became friable. However, no reduction in swell was obtained.
- h. "N" sodium silicate. This agent is a concentrated silicate solution which would hopefully cause ion substitution and thereby eliminate swelling. Several mixing possibilities were attempted, but because of the many variables involved, i.e., polymer size and concentration, pH of water, temperature, calcium or aluminum ions added, and the amount of water used in mixing, the mixing combinations are innumerable. Only slight reductions in swell were obtained for the mixing combinations tried.
- i. Emulsified asphalt SS-K. Asphalt mixed with the mixing water in amounts of 1, 2, 3, and 5 percent by dry weight increased friability, but did not significantly decrease the swell.
- j. Kerosene. Kerosene, when placed on the surface of compacted specimens, was observed to penetrate the soil quickly. However, after the kerosene had completely penetrated the sample, rapid volume increases approaching 10 percent were observed when water was placed on the surface.

Results of this program showed that none of these agents reduced the swell as effectively as lime.¹⁶⁷

136. The South Dakota Department of Transportation constructed an experimental road section to evaluate the field performance of various stabilizing agents.¹⁹⁶ A test road composed of a 2-in. Class F mat and a 5-in. base course, with 3-6 in. of standard subbase and select soil varying in thickness from 6-18 in., was placed over stabilized sections of Pierre shale. The stabilizing agents and percentages added to the subgrade were:

- a. Lime, 6 percent.
- b. Lime-asphalt, 6 percent plus 4 percent RC-1.
- c. Phosphoric acid plus ferric sulfate, 5 percent plus 2 percent.

- d. PDC Formula (4:2:1; lime:Portland cement:soy flour),
5 percent.

Results of this experimental project show that all of the stabilizing agents altered the physical characteristics to some degree, with lime having a more permanent effect in lowering these characteristics. CBR ratings showed that after 4 yr the phosphoric acid section had a value only slightly higher than untreated soil. Conversely, lime, lime plus RC-1, and the PDC formula, in that order, caused significant CBR increases. Serviceability ratings of the stabilized sections except for the phosphoric acid were better than those of the standard design section. Lime-treated sections had the best ratings, while PDC and lime plus RC-1 followed very closely. The use of stabilizing agents in 1964 changed the average initial cost per mile from \$67,500 for untreated soil to \$85,200 per mile for lime, \$93,300 per mile for lime plus RC-1, \$95,700 for PDC formula, and \$120,600 per mile for phosphoric acid plus ferric sulfate. It was concluded from the study that phosphoric acid was not effective as a stabilizing agent of the Pierre shale, and that the effect of the PDC formula was due to the lime-cement combination of the formula rather than the soy flour additive.

Methods of lime treatment

137. Lime continues to be the most effective and most widely used additive for treating expansive soils. Initially, lime treatment was confined to the upper few inches of subgrade, perhaps primarily to achieve strength benefits and not so much to treat the expansive problem. Recently, efforts have been directed toward stabilizing or modifying deeper layers. In addition to conventional mix in-place or batch mixing, other methods for incorporating lime include electrical, drill-hole, pressure, and deep-plow.

138. Electrical. The use of an electrical potential to increase the rate of lime migration was evaluated in the laboratory by the University of Wyoming.¹⁹⁷ Lime slurry (7 parts water:1 part lime) was placed on top of a compacted specimen and an electrical current of 1-4 amps placed across the slurry and sample for 15 min. The results showed that little lime or few calcium ions migrated into the soil, and this

method was abandoned. Electroosmotic methods were reported by the Louisiana Department of Highways¹⁹⁸ with similar results. Lime slurry (10 percent by volume) was placed in a trench between steel electrodes, and an electrical gradient ranging from 0.75 to 2.0 volts/cm was applied for durations ranging from 75 to 1584 hr. Water movement was satisfactory, but no appreciable amount of lime migrated and the method was abandoned.¹⁹⁹

139. Drill-hole. This technique consists basically of drilling holes into the subgrade and backfilling with a lime slurry or lime slurry-sand mixture. Once placed in the holes, the lime migrates or diffuses into the soil system, initiating the soil-lime reactions. However, this diffusion process can be quite slow, and time may be required before a substantial quantity of the soil is affected²⁰⁰ unless a system of cracks and fissures extends to the depth of the hole. The drill-hole technique has been used for remedial measures and new construction by a number of highway agencies.

140. The Oklahoma Department of Highways²⁰¹ has reported numerous successful instances of drilled-hole lime applications. Typically, 9-in.-diam, 30-in.-deep holes on 5-ft centers have been backfilled with lime slurry.

141. Experiences of the Colorado Department of Highways using drilled-hole lime techniques have proven quite successful.²⁰² Generally, 12-in.-diam holes with depths ranging from 6-20 ft, depending upon the extent of treatment desired, on a 5- by 6-ft grid or 5-ft centers, are used. Experience showed that slurries of more than 1 lb of lime per gallon of water result in less lime and water migration. Holes at least 12 in. in diameter are recommended as smaller holes do not provide sufficient water and soaking areas and are more costly. The mechanism of stabilization observed shows that lime does not migrate over 2-3 in. from the periphery of the hole and mostly at the bottom of the shaft (lime is slightly soluble in water and rapidly settles out of the slurry). The swelling potential is reduced due to the moisture increases in the soil (similar to ponding action) and stress relief. Stress relief allows dry material away from the hole to expand laterally into the hole, thereby

reducing the vertical swell component. From these considerations, it would appear that lime is of little benefit to the technique; however, experiments suggest that water migration is more effective when water is added as a lime slurry than as water alone. Backfilling the holes with sand or gravel permits excess moisture accumulated in the base and sub-base courses by hydrogenesis to be drained evenly into the subgrade instead of collecting unevenly and causing uneven heaving.

142. Efforts by the Louisiana Department of Highways to use drill-hole lime stabilization to improve the strength and stability of a fill were unsuccessful.²⁰³ In this case, a half bag of lime (25 lb) was placed in 9-in.-diam holes, 18 or 24 in. deep on 3-ft centers, while one bag of lime (50 lb) was placed in 36- or 48-in.-deep holes on 5-ft centers. Results obtained by test pits showed little or no lime migration from the hole periphery after 1 yr.

143. In a remedial measure, the South Dakota Department of Transportation¹⁵⁷ placed a lime slurry composed of 1 part lime, 1 part water, and 1 part sand into 4-ft-deep holes placed on 5-ft centers (no hole size given) into an expansive subgrade of Pierre shale clay. Results showed some reduction in the frequency and sharpness of the bumps. With time a definite improvement in serviceability index was noted for these sections over companion untreated areas. These studies and field sections show that lime migration from the drill hole was quite limited and restricted to the periphery of the hole. Success using this technique arises from (a) an increase in moisture content of the surrounding subgrade due to migration of the water (aided by lime) from the hole and (b) stress relief of lateral expansive pressure, thereby reducing upward swell pressures.

144. Lime slurry pressure injection. In an attempt to obtain greater distribution of lime in swelling subgrades, the technique of lime slurry pressure injection (LSPI) was developed. The technique consists of pumping lime slurry under pressures of up to 200 psi, depending upon soil conditions, through hollow injection rods into the subgrade. The injection rods penetrate the soil in approximately 12-in. intervals, and the slurry, 2.5-3.0 lb of lime per gallon of water, is

injected into refusal. Refusal is defined as (1) soil will not take additional slurry, (2) slurry is running freely either around the pipe or out of previous injection holes, or (3) the slurry has fractured the surface and is flowing. A wetting agent is often added to the slurry to assist in migration, and spacings of 3-5 ft on centers is common.²⁰⁴⁻²⁰⁶ The lime slurry left on the surface immediately following injection is mixed into the top 4-6 in. of soil and recompact.

145. The Louisiana Department of Highways has reported results^{199,203} of a LSPI experiment used on a hydraulic fill on I-55. Lime slurry, either 0.5 percent lime by weight or 1.5 percent lime by weight, was injected on 5-ft centers to depths of either 5, 10, or 20 ft. Injection was made every 8-1/2 in. of depth. During the process, various quantities of lime slurry would break out of the soil at distances ranging from 1-5 ft from the injection point, and an estimated 2-30 percent of the lime slurry was lost at these "breakout" points. Disturbed and undisturbed samples and test pit observations approximately 2 and 4 yr after injection revealed that the lime distribution was stratified in nature. The lime slurry flowed through fissures caused by the pressure, fracturing the silty soils or preexisting voids. Little penetration into the heavier clays occurred, and bulging of the highly plastic material allowed the slurry to go around the injector. The area of treatment, after 4 yr, extended 1/2-1-1/2 in. above and below the slurry seam, and no active lime was available for further reactions with the surrounding soil. There was little increase in the unconfined compressive strength of samples, and no lessening of subsidence due to LSPI was observed.

146. Wright^{204,205} also observed that when lime slurry is injected into heavy clays, the slurry migrates through available fractures and fissures in the soil, creating a network of lime seams. The added moisture may cause a noticeable swell of 2-8 in. at the time of injection, depending upon the original moisture content of the soil. This preswell is beneficial as the lime seams and upper 4- to 6-in. stabilized layer create moisture barriers which assist in maintaining a constant moisture content, and thus eliminate subsequent cracking and

swelling. Because of the lime seam effect, the quality of the LSPI cannot be evaluated by conventional tests, i.e., Atterberg limits, pH, swell, or strength tests, on recovered samples.

147. Ingles and Neil¹⁸⁰ evaluated lime and cement grouting at seven sites in Australia. Two lime-water grouts, 1:1 and 1:2 by weight, and a comparison cement grout, 1:1, were injected under pressure into the soil via sealed 4-in. auger holes ranging from 3 to 8 ft deep. Visual inspection of recovered cores showed that the grout penetrated fissures and not pores. In this context, dry-season grouting, when desiccation cracks are most prevalent, enhances grout penetration. Post-grouting results indicated that surface movements occurred shortly after grouting due to the moisture being added, but that surface level fluctuations in montmorillonitic soils and total swell were reduced by 50 percent over untreated areas. By comparison, cement grouting was less satisfactory with surface movements in the montmorillonitic soil being reduced by 10 percent.

148. In a recent publication (1975), Thompson and Robnett²⁰⁶ summarized that although there are conflicting reports concerning the effectiveness of LSPI, it seems logical to conclude that LSPI may be an effective swell control procedure under certain circumstances. The condition most favorable to the achievement of successful LSPI treatment of expansive soils is the presence of an extensive fissure and crack network into which the lime slurry can be successfully injected. The treatment mechanisms explaining LSPI effectiveness, i.e., prewetting, development of soil-lime moisture barriers, effective swell restraint with the formation of limited quantities of soil-lime reaction products, all have validity.

149. Deep-plow lime stabilization. Conventional soil-lime construction techniques are normally limited to maximum depths of 8-12 in. With these lift thicknesses, typical soil stabilization equipment is capable of pulverization, blending, and mixing required for high quality soil-lime mixtures. However, if greater depths of stabilization are required in one lift, these conventional techniques are inadequate. Thompson¹⁷⁹ describes successful use of deep-plow lime stabilization to

stabilize lifts 24 in. thick and suggests that the technique may possibly be extended to 36-in. lifts.

150. The technique pioneered by the Oklahoma Department of Highways²⁰⁷ in 1966 consists of (a) plowing the roadway to a depth of 1 ft prior to spreading the lime, (b) spreading the lime required for stabilization of the layer, (c) mixing the lime and soil with three passes of the plow to a depth of 2 ft, (d) spraying water over the roadbed after initial dry mixing, (e) final mixing using a deep ripper, (f) compacting the 2-ft depth of stabilized material in one lift using either sheepsfoot or vibratory sheepsfoot rollers, and (g) a final compaction and test rolling using a 50-ton roller making six passes. A special three-toothed ripper attachment with a trapezoidal shaped shoe-plow bolted to the teeth was used for ripping operations. Densities taken at various depths, 0-8 in., 8-16 in., and 16-24 in., revealed that adequate densities, >95 percent AASHTO T-99, were obtained at all depths. Examination of the profile during density investigations revealed that a fairly equal distribution of lime was obtained in the upper 16 in. with a lesser amount being observed in the lower 8 in.

151. Thompson¹⁸³ cites examples of deep-plowing operations at the Fort Worth Regional Airport and in Illinois. In Illinois, the lime was disked into the upper layer and "turned over" using a moldboard plow. He emphasizes that quality requirements, i.e., lime content, pulverization, mixing, and compaction, should be carefully coordinated for successful results.

Mechanical stabilization (compaction control)

152. Considerable experimental evidence exists^{51,95,142,208-210} that the conditions of compaction have a considerable effect on the swelling characteristics of compacted expansive soils. Figures 14 and 15 from Holtz and Gibbs illustrate some of the influences. These results show that an increase in molding water content for a given density decreased the swell and swell pressure. However, an increase in density at any given water content may increase or decrease the swell, depending on the range of densities involved (generally, an

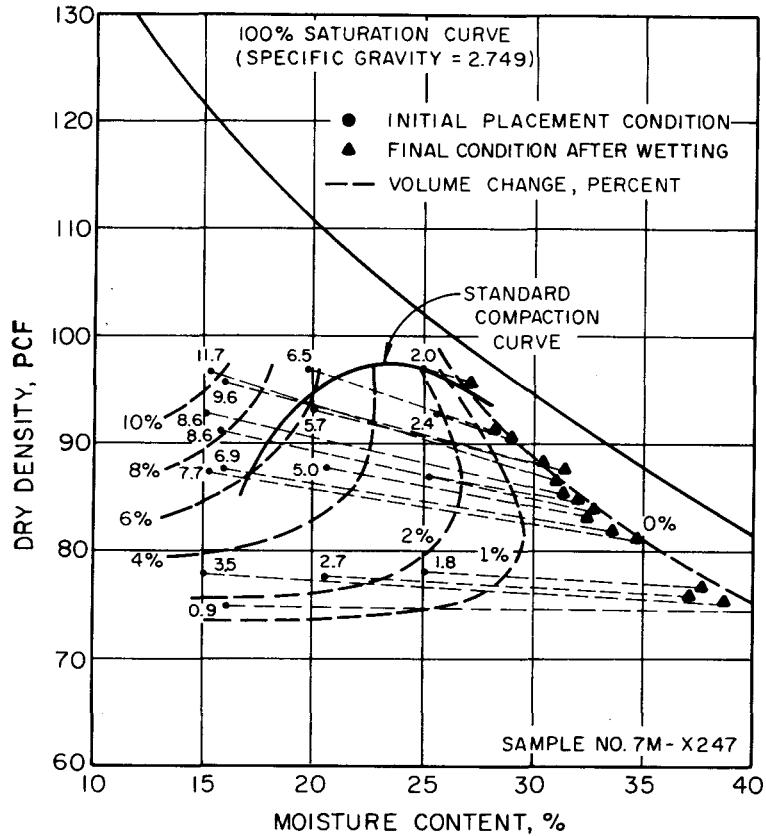

Figure 14. Percentage of expansion for various placement conditions under a 1 psi surcharge (from Reference 95)

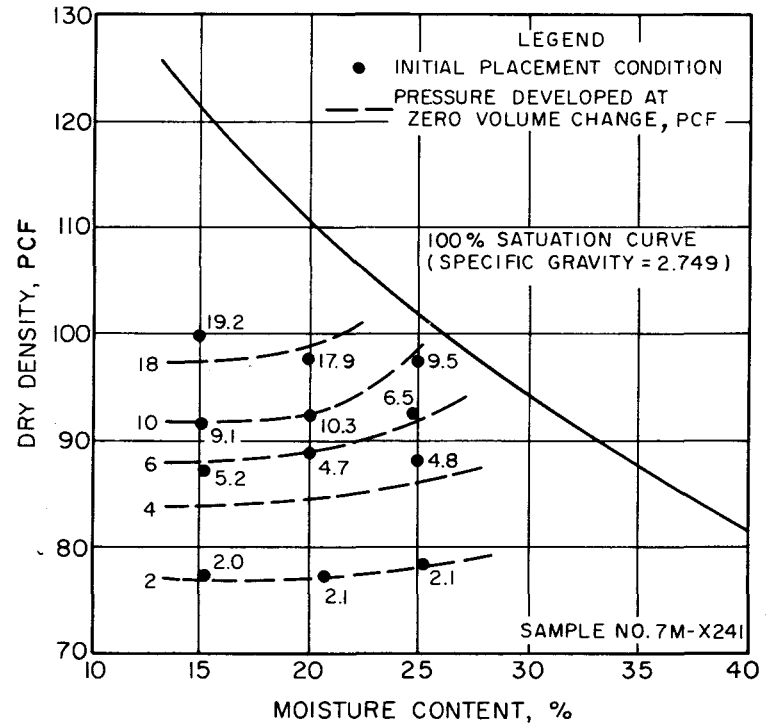

Figure 15. Total uplift pressure caused by wetting for various placement conditions (from Reference 95)

increase in density causes an increase in swell). Hence low densities and high water contents are conducive to smaller expansion. Seed and Chan⁵¹ observed that soils compacted dry of optimum exhibit higher swelling characteristics and swell to higher water contents than do samples at the same density compacted wet of optimum.

153. The method of compaction also influences swelling characteristics of compacted swelling soils. An expansive soil with a dispersed, (deflocculated) structure swells less than one with a flocculated structure for the same water content and density. Seed et al.¹⁴² have shown in Figure 16 that kneading compaction leads to dispersed structures and less swell than static compaction and flocculated structure.

154. From these considerations, the swell or swell pressure can be reduced by compacting the soil to medium or low densities at water contents above optimum. Compaction equipment producing a kneading action and corresponding dispersed structure, such as a sheep's foot roller, would be most appropriate. Obviously, if high strengths were important, low densities wet of optimum are impractical as this condition is conducive to low strengths and subsequent deformations.

155. Johnson²⁹ cites examples by the Omaha²¹¹ and Kansas City²¹² Districts of the U. S. Army Corps of Engineers using moisture and density control methods for minimizing soil heave. In these Districts, water contents 2-5-1/2 percent above optimum and compaction to 88-93 percent of standard density were successful in controlling heave.

156. Léer²¹³ describes North Dakota Highway Department experiences using compaction control to minimize expansive subgrade problems. Prior to 1967, standard compaction for earthwork was to compact the subgrade to 90 percent of the AASHTO T-180 maximum dry density and use a minimum water content of 75 percent of optimum. These criteria resulted in compacting the soil to fairly low water contents, which was conducive to swell. Since 1967, compaction specifications have been changed to 85 percent of AASHTO T-180 maximum dry density and a minimum water content of optimum. These new compaction standards and the use of continuously reinforced concrete pavements have virtually eliminated pavement roughness in expansive soil areas.

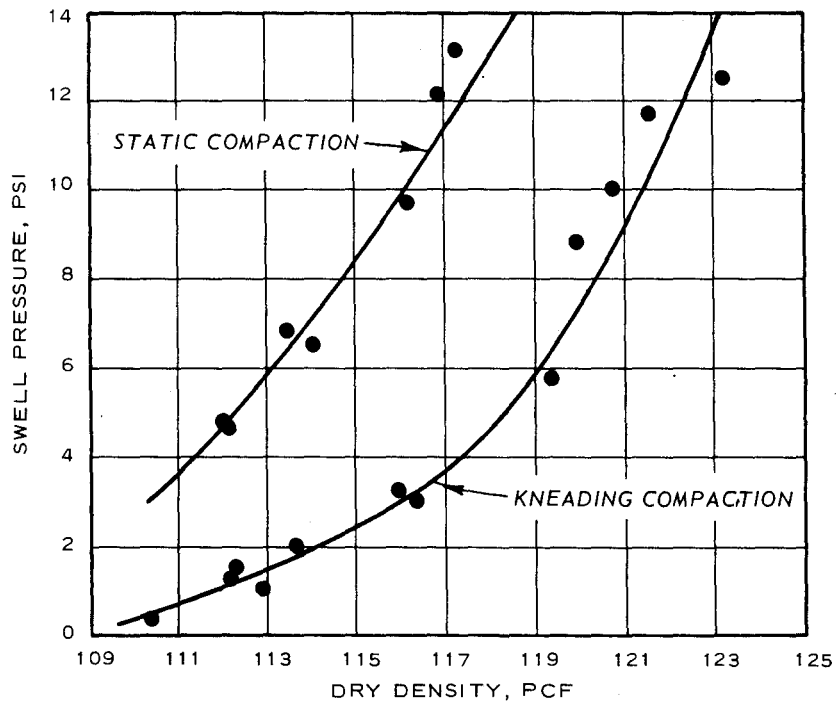

a. PITTSBURG SANDY CLAY

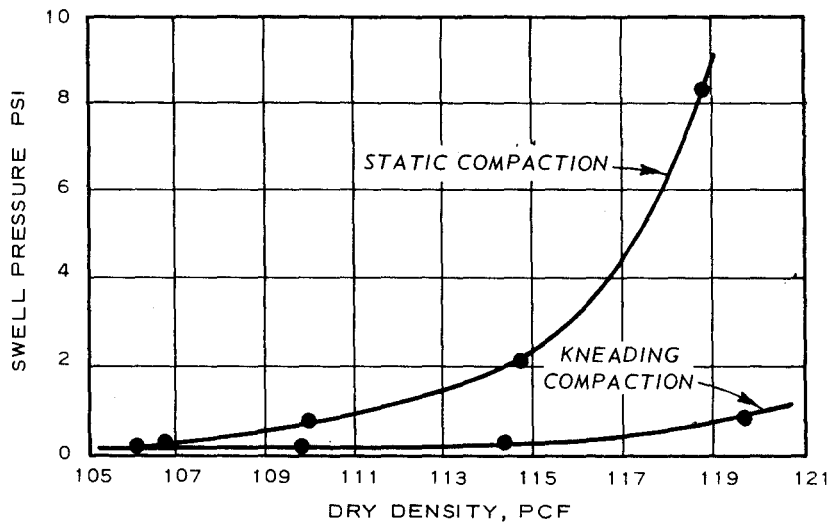

b. VICKSBURG SILTY CLAY

Figure 16. Effects of method of compaction on swell pressure saturation (from Reference 142)

157. The South Dakota Department of Transportation¹⁵⁶ used specifications requiring that the upper 3 ft of the subgrade in both cuts and fills be constructed of weathered soil selected for that purpose. The 3- to 6-ft zone of the entire subgrade is to be constructed of normal soil using higher water contents and lower density minimum requirements than the underlying embankment. Subsequent field tests revealed that it was not always practical to hold the water content to 3 percentage points above optimum, and the heavy construction equipment usually compacted the soil above the target low density of 92 percent of AASHTO T-99. The specifications were revised to set a minimum density of the upper 6 ft of subgrade to 92 percent AASHTO T-99 with a target density of 95 percent. The corresponding water content was set at not lower than optimum with a target content of 3 percentage points above optimum. Preliminary conclusions based on roughness index checks indicate that the special moisture-density controls have retarded the adverse effects of the expansive soil.

158. The Wyoming State Highway Department¹⁵⁸ has experimented with subexcavation and replacing the material with moisture and density control. In areas where the interbedded layers intersect the subgrade, a more uniform subgrade is obtained, and many of the short, choppy heaves often produced by this formation are eliminated. However, they feel that use of moisture density control in hard shales places moisture in areas where it ordinarily would not reach and that a better approach is to prevent moisture intrusion. The problem is that the material used in laboratory determinations of compaction curves is limited to minus No. 4 sieve material. However, the material in the field never is broken up this fine. Specifying water contents above laboratory determined optimum water contents places a granular acting fill at water contents far above field condition optimum. The result is shale fragments or clay "clods" dry on the inside with free water in the voids. This results in an unstable condition which can cause internal breakdowns or expansion after surfacing even if the surface moisture is kept out.

159. Experience of the Colorado Department of Highways²¹⁴

concerning construction in arid regions with or without moisture or density control has shown that satisfactory fills can be constructed with swelling soils if there is good moisture-density control. Often the expense of moisture-density control for the entire depth of high fills is not economically justified where water is at a premium. However, a comparison of two similar roadways, one constructed with moisture density control and the other without, shows that 33 percent of the distress observed in the latter occurred in fills, while no distress was observed in fills of the former. By incorporating sufficient moisture in the upper layers and avoiding construction of dry fills, successful results can be obtained. The suggested depth of moisture-density control below grade for cuts and tops of fills for interstate and primary highways are as follows:

<u>Plasticity Index</u>	<u>Depth of Treatment, ft</u>
10-20	2
20-30	3
30-40	4
40-50	5
>50	6

A slightly different set of guidelines are used for secondary and state highways:

<u>Plasticity Index</u>	<u>Depth of Treatment, ft</u>
10-30	2
30-50	3
>50	4

Heat treatment

160. Heat treatment as a technique of modifying expansive soils for minimizing volume change has not been studied or applied extensively in the United States.¹⁷³ Nevertheless, it is well known that heating can cause considerable alteration of the mineralogical and hence physical and engineering properties of clays. Aylmore et al.²¹⁵ observed that swelling characteristics may be reduced significantly by heating to +200°C.

161. Uppal²¹⁶ reports field heat treatment experiments on Indian Black Cotton Soils using the Irvine machine, a mobile furnace manufactured in collaboration with the Australian government. The machine consists of two units on pneumatic-tired wheels, a tractor, and a trailer having a total weight of about 20 tons. Heating of the soil is from two bottomless chambers lined with fire brick at the top. The two chambers are separated by a gap of about 4 ft, which houses a mechanism for turning over the soil burnt in the first chamber. Firing is accomplished by burning fuel oil through jets under a pressure of 10 psi.

162. Initial efforts with the machine resulted in a baked crust, 3/4 in. thick, as the flames did not penetrate the soil and were merely reflected. To increase the depth of penetration, the soil was broken up to a depth of 4 in., which produced burnt clods of 2-in. size. The technique was found to be quite uneconomical, costing about the same as hauling aggregate 30 miles or 2.5 times the cost of conventional 5 percent lime stabilization. Nevertheless, the technique may have some promise in emergency or hasty construction.

Summary

163. Based upon these case histories, it is obvious that excavation and replacement techniques are not a panacea unless the entire or sufficient depths of expansive stratum can be removed so that swelling is negligible or tolerable. Unfortunately, this is seldom the case. Replacement should be with relatively impervious materials to avoid providing moisture access routes to the swelling subgrade.

164. The technique of applying heavy loads to counteract swelling pressures has generally not been applied to pavements as pavement weights are usually insufficient.

165. Moisture barriers have widespread usage as an effective means for controlling volume changes. In cases such as arid regions where surface moisture, either runoff or from hydrogenesis, is the source of infiltration, asphaltic membranes or full-depth asphalt pavements are effective. However, in cases where capillary moisture or high

water tables preclude effective sealing of the expansive subgrade from moisture accumulations, membranes obviously will be ineffective. Asphaltic products appear to be the most widely used material for membranes. To be effective, complete sealing across ditches and up the backslopes is required.

166. Ponding has been successfully used in Texas and Mississippi to increase subgrade moisture contents and thereby minimize subsequent swelling. Successful ponding requires presence of an extensive network of fissures and cracks. Relatively impermeable natural clays or fills probably will not respond well to this technique. The use of holes, sand drains, or trenches without ponding generally is ineffective; however, where used in conjunction with ponding, they may be of some benefit. Lime stabilization after ponding is often used to provide a working platform and impermeable moisture barrier to prevent desiccation of the ponded areas. Some provisions should be made to prevent moisture loss subsequent to ponding, i.e., a return of soil to a preponded condition.

167. Lime continues to be the most effective and widely used additive for reducing swelling characteristics of expansive clays. In addition to conventional shallow mix in-place or batch mix surface treatment, drill-hole lime, LSPI, and deep-plow techniques have been used successfully. Field studies show that lime migration from the drill holes is limited to the periphery of the hole. The primary benefit arises from an increase in moisture content of the surrounding subgrade (lime aids the migration of water) and stress relief of lateral expansive pressures.

168. Although controversial, LSPI is an effective swell control procedure under certain circumstances. Conditions most favoring successful treatment are the presence of extensive fissures and cracks into which the slurry can be injected. Its effectiveness is attributed to prewetting, development of soil-lime moisture barriers, and the formation of limited quantities of soil-lime reaction products.

169. Deep-plow techniques have demonstrated that lifts up to 24 and 36 in. can be successfully mixed with lime and compacted.

170. Compaction of the soil to low or medium densities at water

contents above optimum can reduce the swell pressures or volume change of compacted clays. Compaction equipment producing a kneading action and corresponding dispersed structure, such as a sheepsfoot roller, are appropriate. As an alternative to requiring good moisture-density compaction control for an entire high fill, experience indicates that good moisture-density control, particularly minimum moisture contents of optimum, in the upper several feet is successful in alleviating swelling problems.

POSTCONSTRUCTION TECHNIQUES FOR MINIMIZING DETRIMENTAL
VOLUME CHANGES OF EXPANSIVE SOIL SUBGRADES

Introduction

171. Postconstruction techniques used for rectifying unserviceable pavements due to subgrade expansion are generally in the categories of pavement maintenance or maintenance stabilization. Pavement maintenance includes:

- a. Mudjacking.
- b. Overlay.
- c. Excavate and replace.
- d. Drainage improvements.
- e. Membrane placement.

while maintenance stabilization includes:

- f. Drill-hole lime.
- g. LSPI.
- h. Electrokinetic or osmotic stabilization.
- i. Ion migration.

Remedial Methods for Treating Expansive
Soil Subgrades

Pavement maintenance

172. Mudjacking, overlaying, and excavation and replacement are techniques used to improve the rideability of the pavement. However, these methods merely apply a "bandage" and do not treat the cause. Generally, drainage improvements and/or membrane placement are used in conjunction with mudjacking, overlaying, and excavation and replacement to prevent further swell once corrective action has been taken.

Maintenance stabilization

173. Drill-hole lime, LSPI, electrokinetic stabilization, and ion migration are remedial techniques for combating swelling subgrades. In the cases of drill-hole lime and LSPI, holes are drilled through the pavement surface and the treatment applied. These two techniques

have been discussed in detail in paragraphs 139 and 144 as preconstruction techniques. Electrokinetic stabilization and ion migration are two maintenance techniques which have received only localized use.

Electrokinetic stabilization

174. In 1935, L. Casagrande²¹⁷ observed and reported an irreversible hardening of clay soils as the result of passing an electrical direct current using aluminum electrodes through the clay. The hardening was attributed to replacement of Na^+ ions in the diffuse double layer by Al^{+++} ions, to a reduction in water content by electroosmosis, and to aluminates formed in the soil pores. The concept of this technique is to use electrical current to move stabilizing chemicals through the soil mass, irreversibly alter the clay and/or clay water system, and thereby reduce the expansiveness of the clay. The method has considerable attractiveness as a remedial technique since the pavement structure and in-place material do not require removal and reworking. As a remedial technique, the electrodes and chemicals are added outside the shoulders and migrate beneath the pavement.

175. Holtz²⁸ describes an attempt to stabilize a section of the Friant-Kern Canal by electrochemical methods. Figure 17 shows the layout and details of the trial section. Perforated aluminum pipe anodes were placed 6 ft deep at 30-ft intervals along the toe of the slope. Iron wellpoint cathodes, 25 ft long, were also placed at 30-ft intervals at the top of the slope. A chemical distribution system provided a 1:1 mixture of 7 percent potassium chloride solution and 3 percent aluminum chloride solution at the anodes. These chemicals were selected from detailed electrochemical tests on the calcium-beidellite soil at the site. The purpose of adding the chemical compounds was to provide potassium, which has a greater fixing power in the expanding lattice, and aluminum for stabilizing purposes. The applied voltage was maintained at about 40 volts and the amperage varied from about 40 amps at the start of the test to about zero at the end of the test 5-1/2 months later. Although postexperiment test results were somewhat irregular, they indicated that favorable stabilization took place only within about 4 ft from the anodes. This was manifested principally in a decrease

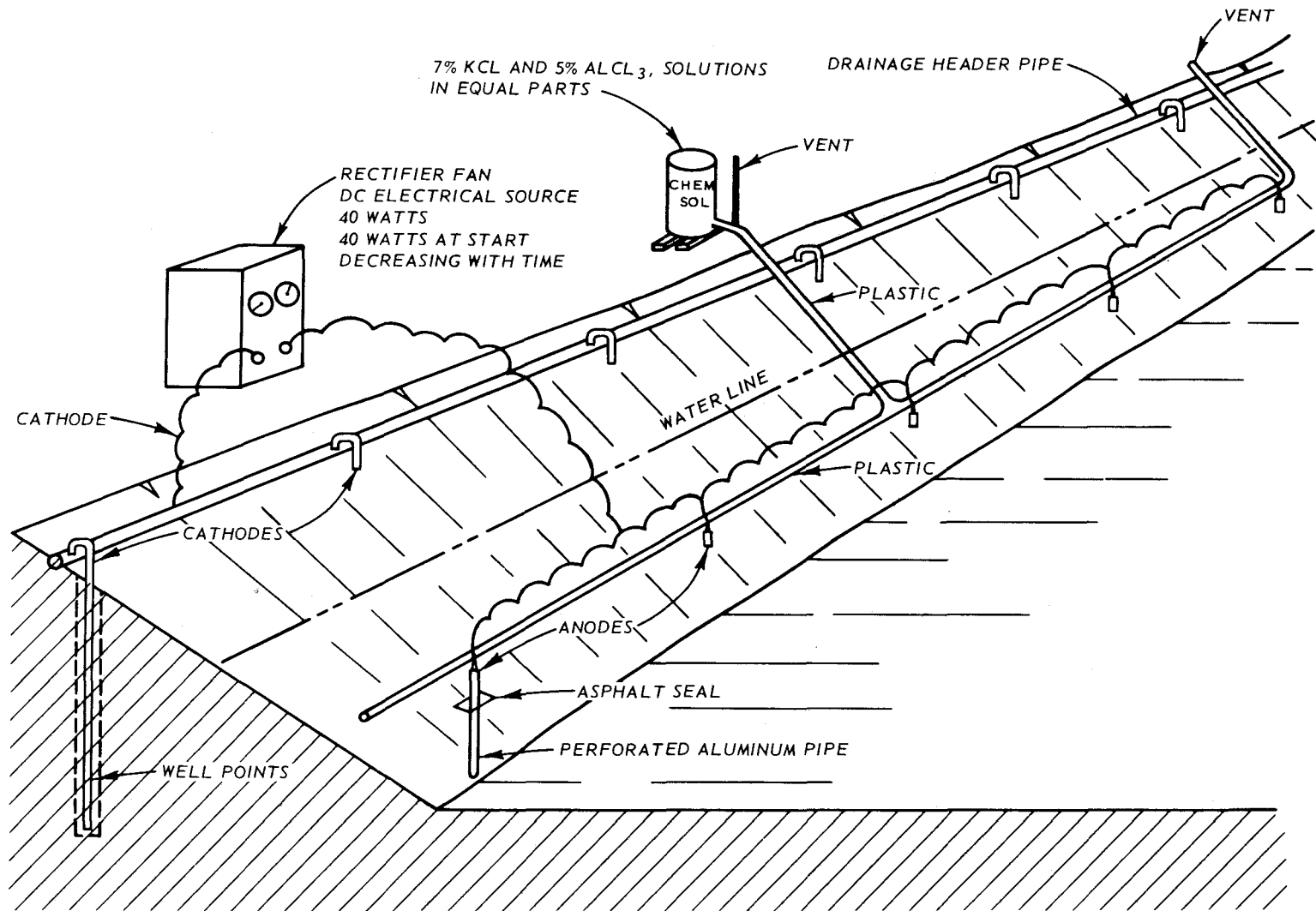

Figure 17. Electro-chemical stabilization experiment, Friant-Kern Canal, California (from Reference 28)

in exchangeable sodium cations and increased potassium cations and probable stabilizing effects of aluminum. While some strength was undoubtedly added to the slope by this treatment, it was considered inadequate to prevent heaving of the concrete lined sections.

176. In a review of electrokinetic phenomena, Zaslavsky and Ravina²¹⁸ report that aluminum anodes have been shown to have an irreversible stabilizing effect on clay soils, while anodes of other metals are less effective. The introduction of aluminum salt solutions into the soil was shown to be less effective. Generally their review of various laboratory research by others showed that maximum strengthening was usually obtained after 30 kwhr per cubic meter of soil.

177. Esrig's²¹⁹ laboratory experiments on electrokinetic stabilization of an illitic clay using calcium ions with carbon rod anodes and steel or brass mesh for cathodes showed a generally increasing strength with increasing times of treatment. It was concluded that these strength gains were the result of variations in soil-moisture content and ion exchange with essentially no apparent chemical cementation occurring.

178. The most complete application of electrokinetic stabilization for reducing swelling under highways was conducted by O'Bannon for the Arizona Department of Transportation^{220,221} on the montmorillonitic Chinle clay. In laboratory studies evaluating aluminum versus steel electrodes, and calcium chloride, calcium chloride plus magnesium chloride, aluminum chloride, calcium chloride plus magnesium chloride plus aluminum chloride, potassium chloride, and sodium chloride solutions, it was found that potassium chloride and steel electrodes were consistently the most effective electrode-chemical combination for treatment of the Chinle. Further testing established that 4-5 percent by weight of commercial grade potassium chloride was the optimum percentage. In an attempt to increase the rate of penetration of the potassium chloride solution into the clay, several wetting agents were evaluated. These included Aerosol OT (sodium dioctyl sulfosuccinate); Aerosol AY (sodium diamyl sulfosuccinate), C-61 (ethanolated alkylqucinidineamine complex), propanol alcohol, and Ultra Wet. The results of laboratory

and field tests showed that C-61 and Aerosol AY were promising, with C-61 being the most effective and recommended for usage. From these considerations, a field test section using various electrode arrangements and methods of adding potassium chloride to the clay were evaluated. Site one used horizontal electrodes and solution wells (6 in. in diameter, 18 in. deep in subgrade, on 5-ft centers); site two used horizontal electrodes, and the base course was flooded with the chemical solution; and site three used horizontal electrodes and a central trench cut 18 in. deep in the subgrade and filled with potassium chloride solution. Evaluation of these sites showed that the solution wells provided the greatest uniformity, depth, and economy of treatment. It was recommended that No. 8 rebar or equivalent should be used as the anode, while the cathodes should be No. 4 bars. If vertical electrodes are used, they should extend the entire depth of the section to be treated, while horizontal electrodes should be placed approximately at a depth of one-half the total thickness of the section to be treated. A voltage gradient of 0.6-1.0 volt per inch is suggested. Application of these criteria have proven effective in reducing heaving in the Chinle.

179. O'Bannon's ²²² laboratory experiments using 10-40 percent montmorillonite plus 90-60 percent kaolinite subjected to potassium chloride electrokinetic stabilization showed that the mechanism of electrokinetic stabilization was to permanently alter the mineralogical characteristics of montmorillonite. The potassium ion possesses the correct size and coordination properties so that it can easily enter the basal sheet and become fixed. The result of this alteration is a reduction in expansive pressure by a factor ranging from 2 to 8.

Ion migration

180. A patented technique held by Ion Tech, Inc., of Daly City, California, has been successfully used for treating landslides and expansive soil problems. ^{223,224} The technique consists of treating the clay mineral with a concentrated chemical solution. The chemical solution added depends upon the clay minerals present and the groundwater. After selection of the appropriate chemical, the solution is applied to the clay through cracks and/or drill holes. Success is due to

replacement of the original cations on the clay by those of the additive solution, thereby altering the clay properties. The conditions necessary for successful ion exchange treatment of landslides are (a) a clearly defined plane or zone of failure, (b) clay minerals along this zone, (c) saturation of the clay, and (d) cracks and/or borings for the introduction of chemicals.

181. Laboratory tests reported by Arora and Scott²²³ members of Ion Tech, show a substantial reduction in expansion of a compacted control and a treated sample submerged in deionized water and in 7 percent chemical solution, respectively. A reported case history showed a 55 percent reduction in expansion. In this case, expansive clays underlying a housing project were treated by applying chemicals in 1-1/2-in.-diam holes on 5-ft centers around the houses (no depth given) and seasonal damages were effectively ended.

Summary

182. Consideration of these case histories and laboratory research indicate that electrokinetic stabilization is a viable remedial technique for reducing the expansiveness of montmorillonitic-rich clays. The addition of potassium chloride plus a wetting agent under an electrical gradient provides potassium ions for collapsing the clay lattice and altering the expansive potential of these clays. However, it is doubtful that other clays can be treated by this technique. Apparently aluminum anodes can provide some hardening of various clays. Nevertheless this hardening is generally confined to localized areas near the anode. Electrode spacing, current and voltage gradients, and concentration of potassium ion solution will vary with site and would need to be established prior to treatment.

183. Ion migration techniques are patented and have had few trials in reducing swelling of expansive clays. Further documentation and experience are needed before this method can be recommended. It should be remembered that numerous chemicals have been tried for stabilizing clays with lime being the most effective.

PAVEMENT DESIGN AND CONSTRUCTION METHODS FOR
HIGHWAYS ON EXPANSIVE SOIL SUBGRADES

Introduction

184. There are a wide variety of current design and construction practices being used by the states for highway construction over expansive clay subgrades. The variety of designs reflects the differences in subgrade soil, environmental conditions, availability of road-building materials, and traffic. The criteria for using special treatments in design are generally tempered by past experience with a combination of measures aimed at minimizing moisture changes or minimizing the effects of such changes.

State Highway Agency Practices

185. Current design techniques used by the state highway agencies within the area of concern of this project are defined and described in the following paragraphs. These are practices actually used in the design and construction of pavements, whereas the previous section involved the treatment techniques primarily from the standpoint of research and to a lesser extent, common practice.

Kansas^{150,225,226}

186. Current engineering practices include treatment with lime and the utilization of positive design features and construction control. Current lime treatment practice for concrete pavements involves modification of the top 6 in. of the subgrade with hydrated lime when swell potentials in excess of 2 percent, as measured in an odometer swell test with 1-psi surcharge, are encountered. An identical procedure is used for flexible pavements in areas of eastern Kansas where past performance has been adversely affected by nonuniform subgrades with differential swell characteristics. Any added soil support which is realized by this lime modification procedure is reflected in thinner design sections. Lime application rates are generally 5 percent by weight.

Utilization of positive design features and construction control to minimize the degree to which swell potential is realized include the following:

- a. Specifications normally require that soil moisture under concrete pavements at the time of compaction be maintained between optimum and 5 percent above optimum (MR-0) for the soil in the top 18 in. of the subgrade. Moisture control for flexible pavements is not as strict; the lower bound is specified as 5 percent below optimum (MR-5).
- b. In both rigid and flexible pavements in cuts of weathered shales, the soils are subgraded to a depth of 12 in. and a width of 2 ft beyond the road surface. An additional 6 in. is scarified and recompact to 95 percent of standard AASHTO T-99 density with moisture controls as specified in the standard specifications, either MR-0 or MR-5. The subgraded material is replaced with the same density and moisture requirements providing a total of 18 in. of uniform material through the cut. The same density and moisture controls are specified for the top 18 in. of embankment sections.
- c. For control of surface and subsurface water, a typical design roadway section places the bottom of the ditch 3 ft below the shoulder point. Also, subsurface interceptor drains are used to control subsurface water in cut sections.

Arizona^{150,225,227}

187. Approximately 99 percent of the highways in the expansive clay areas have been completed so the main problem at the present time is to control the expansion and volume changes prior to performing maintenance. Present design requirements for new construction, if needed, utilizes a full-depth asphalt section over a bituminous membrane placed on the subgrade. The membrane extends over the width of the roadway, shoulder, cut ditches, and up the back slope. Design section also requires wide shoulder slopes and good drainage in cut ditches. A structural number of 2 is assigned expansive soils in the AASHTO design equation.

Louisiana²²⁸

188. Design policy in the State of Louisiana provides that special provisions are required for subgrade materials having a liquid

limit above the value of 50. For material with a liquid limit of 50 and below, a normal design would be specified for embankment construction. The soils design engineer will specify either moisture-density control or lime treatment for soils with a liquid limit range of from 50 to 70. Moisture control will be at optimum or 2 percent above optimum, and if this creates a too wet subgrade condition, then lime treatment (about 3 percent) will be required for the upper 2-3 ft of the embankment. Materials with liquid limits above 70 will not normally be used in the roadway but may be used in nonloading areas of the embankment such as the shoulders. Lime treatment of the upper 2-3 ft of the embankment will be required if this higher liquid limit material must be used.

Colorado^{150,225,229}

189. General design guidelines for highways on expansive clay subgrades in Colorado involve (a) avoiding cut sections and using fill sections at all times, if possible; (b) keeping moisture from infiltrating into the subgrade by using asphaltic membranes or full-depth pavement layers; and (c) where cut sections are used, the ditch should be placed at least 25 ft from the shoulder and undercut the subgrade and recompact to AASHTO T-99 specifications with strict moisture-density control. The tabulation in paragraph 159 defines the guidelines for depth of undercut for interstate and primary roads and for secondary and state roads.

Mississippi^{150,230}

190. The State of Mississippi is incorporating various experimental items such as asphalt membranes, moisture-density control, replacement of material, and lime treatment for new construction now in progress; and some of these techniques may be incorporated into design procedures in the future. Highways are presently designed using the AASHTO equation in which coefficients of relative strength per inch of thickness are assigned the materials used in the layers. Lime stabilization, which increases the coefficient of relative strength of this layer and reduces the expansive properties, would be considered the only approach at the present time to the expansive soil problem. Lime content will generally range from about 4 to 8 percent.

South Dakota 150,225,231

191. For primary and high type roads, design procedures incorporate undercutting, moisture and density control, and lime stabilization. These procedures are used under asphalt or concrete roadways; however, where areas have indicated extremely unstable characteristics from past performances, an asphalt-surfaced roadway will be specified. This is primarily for easier maintenance. The asphalt pavements are full-depth asphalt (12-13 in. thick) placed directly on the treated subgrade. South Dakota has stopped constructing jointed concrete pavements and is building continuous reinforced pavements. The embankment under both rigid and flexible pavements is treated the same where expansive soils are encountered. The specification requires that the upper 3 ft of the subgrade in both cuts and fills is to be constructed of weathered soil. This is accomplished by undercutting the subgrade soil in 3-ft increments to a depth of 6 ft. The top 3 ft of subgrade material that was removed and stockpiled is placed in the bottom of the excavation and compacted to about 92 to 95 percent of AASHTO T-99 density at moisture contents just above optimum. The remaining 3 ft of material is compacted in place with the same density and moisture requirements. Approximately 5-6 percent of lime is added to the top 6-in. layer of this material. The undercut and backfill in the lower 3 ft is from shoulder line to shoulder line whereas the upper 3 ft of backfill material is from toe to toe of the embankment. For secondary roads, only 3 ft of material is undercut and replaced, extending from toe to toe of the embankment.

Wyoming 150,225,232,233

192. Where expansive soils are encountered in Wyoming, general practice in design involves undercutting the subgrade to a maximum depth of 5 ft and recompacting the material at moisture contents between minus 4 percent and plus 2 percent of AASHTO T-99 optimum. Swell pressure tests are determined on subgrade soils to determine the required thickness necessary to prevent volume change. The use of full-depth asphalt sections placed directly on grade are being used to help prevent infiltration into the subgrade. Asphalt membranes are also being

used with the full-depth asphalt to protect the subgrade shoulders and ditches from intrusion of water. Removal and replacement of the expansive material with a nonexpansive soil may be specified in design if this is feasible. Stage surfacing is also used, if possible. Cost of each alternate design is considered, and the most economical one is used.

Oklahoma 225,234,235

193. Pavement design in Oklahoma is based on the Oklahoma Soil Index (OSI) which is derived from the Atterberg limits and grain-size distribution of the subgrade material. Lime modification is routinely used in areas where expansive soils are predominant. Lime percentages used are generally between 4 and 6 percent, and the strength of the lime-modified layer is accounted for in the design method. The lime treatment increases the OSI, which reduces the thickness required. Typical pavement sections used in expansive soil areas are 24 in. of select borrow or 24 in. of lime-modified subgrade under 4 in. of black base and 9 in. of reinforced concrete pavement. Flexible pavements are usually 4-1/2 in. of asphaltic concrete over 9 in. of black base on a 6-in. lime-modified subgrade layer.

Montana 150,225,236

194. Special provisions are included in the specifications which require that subexcavated clay shale and shale materials be placed in the lower portions of the subexcavated areas and in the embankment not within the top 3 ft. The clay shale materials are compacted between 92 to 98 percent of AASHTO T-99 density at about 2 percent above optimum moisture. The top 3 ft of backfill material is low swell material, and moisture and density controls are also required on this material.

California 150,225,237

195. Design procedures for portland cement concrete pavements in California incorporate the expansive pressure and linear expansion tests to determine the moisture adjustment necessary in the subgrade and required overburden to overcome the expansive pressure. The pavement thickness is designed accordingly. Some districts in the state use lime treatment in the upper 6-12 in. of the subgrade material, and

this is reflected in a thinner design section. For flexible pavements, a more uniform swelling of the soil occurs, and little concern is given in design to these pavements.

Utah^{150,225,238}

196. Special provisions for processing the shale subgrades are provided in the specifications to subexcavate 4-5 ft of the shale material and replace with a good borrow material. Existing shale subgrade material is scarified and compacted at about 2 percent above optimum moisture and 96 percent of AASHTO T-99 density.

Texas^{150,239}

197. Design of highways in Texas over expansive clay areas utilizes lime treatment in the top 6-12 in. of the subgrade. Moisture and density control is also specified for the untreated subgrade soils.

North Dakota^{150,225}

198. Expansive clays do not cause much concern in North Dakota, but some problems have developed under jointed concrete pavements. Because of this, continuous reinforced concrete pavements are specified, and the subgrade soils are placed with strict moisture (above optimum) and density control.

Maintenance Procedures

199. Differential or localized swell in either high volume change soils or high swell soils results in pavement surface distortion. The surface becomes rough, bumpy, and cracked in most cases. Criteria for maintenance is usually when the condition of the surface becomes unsuitable for public use. Most state highway agencies use similar maintenance procedures to correct the problem. Pavements that are badly damaged are removed and replaced with a more suitable material. Leveling and overlaying is the general procedure used by most highway departments. Some of the more troublesome areas have been overlayed a number of times so that the thickness of asphalt pavement is measured in feet rather than inches. Some sealing of cracks and joints is performed on concrete pavements. Where the concrete slabs have heaved,

the slabs may be leveled by "slab jacking" or in some cases leveled by applying water in holes that have been drilled in the slabs. The Arizona Department of Transportation has been using a rubberized asphalt membrane sprayed over the existing roadway and shoulders prior to over-laying to prevent infiltration of surface water.

SUMMARY

200. This report, which is based on a review of literature combined with experiences of the state highway agencies contacted, provides an updated summary of the properties which influence volume change of expansive soils, techniques used for identification and testing of expansive soils, and pre- and postconstruction treatment techniques for expansive soil subgrades. Some of the more important points concerning expansive soils and the topics discussed within the report are summarized in the following paragraphs.

201. Expansive soils are areally extensive in many regions of the United States. The origin and distribution of expansive soils are functions of their past geologic condition. Expansive soils are formed as a result of weathering (either physical or chemical), diagenetic alteration, and/or hydrothermal alteration of existing materials. The distribution of potentially expansive soils has been defined and maps prepared showing relative degrees of expansivity based on geologic conditions pertinent to the formation, accumulation, and preservation of the materials. These factors have been combined with experiences of state highway agencies to provide a summary of potential problem areas.

202. The clay minerals which exhibit appreciable volume change with variations in moisture content include montmorillonite, vermiculite, chlorite, and mixed-layer combinations of these minerals with one another or with other clay minerals. These clay minerals exhibit volume change because of electrical charge characteristics, degree of crystallinity, and particle size. The mineralogic composition of expansive soils determines whether the soil has a potential for volume change, and the physical and environmental factors control the amount of volume change that the soil will undergo.

203. The amount of volume change exhibited by an expansive soil is influenced by the intrinsic properties (both physical and physico-chemical) of the material and the environmental conditions prevailing at a specific site. The laboratory and in situ behaviors of expansive soils are functions of numerous interrelationships among the intrinsic

properties and environmental conditions.

204. The sampling of expansive soils is complicated by the wide variations of the in situ conditions associated with the materials. Generally, the sampling programs performed by the state highway agencies include shallow auger borings and a limited number of undisturbed samples. In addition, the capabilities for undisturbed sampling have not been developed to the extent required to provide a sufficient number of good samples for testing. This lack of adequate undisturbed sampling combined with poor quality samples reduces the effectiveness of any direct testing method used to estimate potential volume change. The influence of storage of expansive soil samples for extended periods is not fully understood; however, it is generally considered to be detrimental to the quality of the sample. Therefore, testing should be completed as soon as possible after sampling.

205. Identification of potentially expansive soils can be accomplished by numerous methods as described in Table 5. Many of these methods provide qualitative assessments of the type and amount of clay mineral present. Most of the state highway agencies rely on index property tests and experience to identify expansive soils. A large variety of combination techniques exist which correlate index properties and probable volume change. No generally applicable technique is currently available; however, local experiences with many of these correlations have been successful.

206. The quantitative measurement of potential volume change is essential for estimating the amount of in situ swell. Odometer tests for measuring swell and swelling pressure are the most widely used. However, available testing procedures are quite varied with respect to placement conditions, loading conditions, surcharge pressures, time allowed for swell, and interpretation of results. Many state highway agencies do not use a test of this nature for estimating in situ volume change. Even in those states which use some type of direct testing technique, the results are often not considered in the pavement design procedures or in the selection of a treatment alternative.

207. Based on case histories describing preconstruction

treatment alternatives, the more successful techniques include membranes, ponding, lime treatment, subgrade compaction control, and positive surface drainage. No generally applicable guidelines exist which define the material properties and environmental conditions for which a specific treatment alternative performs best. Guidelines of this type would enhance the selection of a suitable alternative by considering the performance of the alternative under varying conditions as well as the cost of the alternative.

208. Postconstruction treatment techniques are generally limited to pavement maintenance procedures (i.e., mudjacking, leveling and overlaying, and local excavation and replacement). Application of lime in drill holes has been successfully used as a remedial treatment on a limited basis. Some possible techniques for remedial treatment include electrokinetic stabilization and ion migration. Experience with these techniques is somewhat limited and will require further investigation with regard to probable success and relative cost. It is generally accepted that the cost of electrokinetic stabilization is prohibitive; however, with the rapidly increasing cost of construction materials it may be feasible if a sufficient reduction in volume change can be obtained.

REFERENCES

1. Jones, D. E., Jr., and Holtz, W. G., "Expansive Soils - The Hidden Disaster," Civil Engineering, American Society of Civil Engineers, Vol 43, No. 8, Aug 1973, pp 49-51.
2. Lamb, D. R. and Hanna, S. J., "Summary of Proceedings of Workshop on Expansive Clays and Shales in Highway Design and Construction," FHWA-RD-73-72, May 1973, Federal Highway Administration, Washington, D. C.
3. Keller, W. D., The Principles of Chemical Weathering, Lucas Bros., Columbia, Mo., 1962, p 65.
4. Pettijohn, F. J., Sedimentary Rocks, 2d ed., Harper, New York, 1957, p 331.
5. Weaver, C. E. and Beck, K. C., "Clay Water Diagenesis During Burial: How Mud Becomes Gneiss," Geologic Society of America Special Paper 13A, 1971.
6. Carrol, D., Rock Weathering, Plenum Press, New York, 1970.
7. Millot, G., Geology of Clays (translated from French by W. R. Farrand and H. Paquet), Springer-Verlag, 1970, p 86.
8. Shamburger, J. H. et al., "Design and Construction of Shale Embankments: Survey of Problem Areas and Current Practices," FHWA-RD-75-61, Vol I (in preparation), Jun 1975, Federal Highway Administration, Washington, D. C.
9. Witczak, M. W., "Relationships Between Physiographic Units and Highway Design Factors," Report 132, 1972, National Cooperative Highway Research Program, Highway Research Board, Washington, D. C.
10. Belcher, D. J. et al., "Map - Origin and Distribution of United States Soils," 1946, The Technical Development Service, Civil Aeronautics Administration, and the Engineering Experiment Station, Purdue University, Lafayette, Ind.
11. U. S. Department of Agriculture, Soil Survey Bulletins, Washington, D. C.
12. U. S. Geological Survey, Geologic Map of North America, 1965, Washington, D. C.
13. American Association of Petroleum Geologists, Geologic Highway Map: Mid-Atlantic Region, 1970, Tulsa, Okla.
14. _____, Geologic Highway Map: Northern Rocky Mountain Region, 1972, Tulsa, Okla.
15. _____, Geologic Highway Map: Mid-Continent Region, 1966, Tulsa, Okla.
16. _____, Geologic Highway Map: Pacific Southwest Region, 1968, Tulsa, Okla.

17. American Association of Petroleum Geologists, Geologic Highway Map: Texas, 1973, Tulsa, Okla.
18. _____, Geologic Highway Map: Pacific Northwest Region 1973, Tulsa, Okla.
19. _____, Geologic Highway Map: Southern Rocky Mountain Region, 1967, Tulsa, Okla.
20. U. S. Geological Survey and State Geological Survey Geological Maps for Alabama, Arizona, Florida, Georgia, Louisiana, Mississippi, New Mexico, Oklahoma, and Utah.
21. Grim, R. E., Clay Mineralogy, McGraw-Hill, New York, 1968.
22. _____, Applied Clay Mineralogy, McGraw-Hill, New York, 1962.
23. Gillot, J. G., Clay in Engineering Geology, Elsevier Press, London, 1968.
24. Weaver, C. E. and Pollard, L. D., The Chemistry of Clay Minerals, Elsevier Press, London, 1973.
25. Deer, W. A., Howie, R. A., and Zussman, J., Rock Forming Minerals, Volume 3: Sheet Silicates, Longmans, Green, and Co., Ltd., London, 1967.
26. Grimshaw, R. W., The Chemistry and Physics of Clays and Allied Ceramic Materials, 4th ed., Wiley-Interscience, New York, 1971.
27. Van Olphen, H., An Introduction to Clay Colloid Chemistry, Wiley-Interscience, New York, 1963, pp 93-95.
28. Holtz, W. G., "Expansive Clays - Properties and Problems," Quarterly, Colorado School of Mines, Vol 54, No. 4, Oct 1959, pp 89-125.
29. Johnson, L. D., "Review of Literature on Expansive Clay Soils," Miscellaneous Paper S-69-24, June 1969, U. S. Army Engineer Waterways Experiment Station, CE, Vicksburg, Miss.
30. Jennings, J. E., "The Theory and Practice of Construction on Partly Saturated Soils as Applied to South African Conditions," Proceedings, First International Research and Engineering Conference on Expansive Clay Soils, Texas A&M University, College Station, Tex., 1965, pp 345-363.
31. Sallberg, J. R. and Smith, P. C., "Pavement Design over Expansive Clays: Current Practices and Research in the United States," Proceedings, First International Research and Engineering Conference on Expansive Clay Soils, Texas A&M University, College Station, Tex., 1965, pp 208-238.
32. Parcher, J. V. and Liu, P., "Some Swelling Characteristics of Compacted Clays," Journal, Soil Mechanics and Foundations Division, American Society of Civil Engineers, Vol 91, No. SM3, May 1965.
33. Ladd, C. C., "Mechanisms of Swelling by Compacted Clay," Water Tensions; Swelling Mechanisms; Strength of Compacted Soil, Bulletin

- No. 245, pp 10-26, Jan 1959, Highway Research Board, National Academy of Sciences - National Research Council, Washington, D. C.
34. Gupta, S. N., Gupta, B. N., and Shukla, K. P., "Physico-Chemical Properties of Expansive Clays in Relation to Their Engineering Behavior," Proceedings, Third Regional Conference on Soil Mechanics and Foundation Engineering, Haifi, Israel, Vol 1, Sep 1967, pp 84-89.
 35. Coughlan, K. J., Fox, W. E., and Hughes, J. D., "Aggregation in Swelling Clay Soils," Australian Journal of Soil Research, Vol 11, No. 2, Sep 1973, pp 133-141.
 36. Greene-Kelly, R., "The Specific Surface Areas of Montmorillonites," Clay Mineral Bulletin, Vol 5, 1964, pp 392-400.
 37. Cooling, L. F., "Some Foundation Problems in Great Britain," Building Research Congress, London, 1951, pp 157-164.
 38. Escario, V., Saez, J., and Fisicas, L. C., "Measurement of the Properties of Swelling and Collapsing Soils Under Controlled Suction," Proceedings, Third International Research and Engineering Conference on Expansive Clay Soils, Haifi, Israel, Aug 1973, pp 195-200.
 39. Jennings, J. E., "A Comparison Between Laboratory Prediction and Field Observation of Heave of Buildings on Desiccated Subsoils," Proceedings, Fifth International Conference on Soil Mechanics and Foundation Engineering, Paris, Vol 1, 1961, pp 689-692.
 40. Grim, R. E., "Physico-Chemical Properties of Soils: Clay Minerals," Journal, Soil Mechanics and Foundations Division, American Society of Civil Engineers, Vol 85, SM2, Apr 1959, pp 1-17.
 41. Alpan, I., "The Geotechnical Properties of Soils," Earth Science Review, Vol 6, No. 1, Feb 1970, pp 5-49.
 42. Diamond, S. and Kinter, E. B., "Surface Areas of Clay Minerals as Derived from Measurements of Glycerol Retention," Clays and Clay Minerals; Proceedings, Fifth National Conference on Clay and Clay Minerals, National Academy of Sciences - National Research Council Publication 566, 1958, pp 334-347.
 43. Woodward-Clyde and Associates, "A Review Paper on Expansive Clay Soils," Vol 1, 1968, Los Angeles, Calif.
 44. Krazynski, L. M., "The Need for Uniformity in Testing of Expansive Clays," Proceedings, Workshop on Expansive Clays and Shales in Highway Design and Construction, D. R. Lamb and S. J. Hanna, ed., prepared for Federal Highway Administration, Washington, D. C., Vol 1, May 1973, pp 98-128.
 45. Chen, F. H., "The Basic Physical Property of Expansive Soils," Proceedings, Third International Research and Engineering Conference on Expansive Clay Soils, Haifi, Israel, Aug 1973, pp 17-25.
 46. Alpan, I., "An Apparatus for Measuring the Swelling Pressure in

- Expansive Soils," Proceedings, Fourth International Conference on Soil Mechanics and Foundation Engineering, Vol 1, 1957, pp 3-5.
47. Komornik, A. and Livneh, A., "Influence of Granular Constituents on the Swelling Characteristics of Expansive Clays," Proceedings, Second International Research and Engineering Conference on Expansive Clay Soils, Texas A&M University, College Station, Tex., Aug 1969, pp 279-290.
 48. Blomquist, G. C. and Portigo, H. M., "Moisture, Density, and Volume Change Relationships of Clay Soils Expressed as Constants of Proportionality," Highway Research Board Bulletin No. 313, 1961, pp 78-91.
 49. Russell, H. W., Worsham, W. B., and Andrews, R. K., "Influence of Initial Moisture and Density on the Volume Change and Strength Characteristics of Two Typical Illinois Soils," Highway Research Board Proceedings, Vol 26, 1946, pp 544-550.
 50. Pacey, J. G., Jr., The Structure of Compacted Soils, M.S. Thesis, 1956, Massachusetts Institute of Technology, Cambridge, Mass.
 51. Seed, H. B. and Chan, C. K., "Structure and Strength Characteristics of Clay," Journal, Soil Mechanics and Foundations Division, American Society of Civil Engineers, Vol 85, SM5, Oct 1959, pp 87-128.
 52. Bayer, L. D. and Winterkorn, H. F., "Sorpton of Liquids by Soil Colloids II," Soil Science, Vol 40, 1935, pp 403-419.
 53. Mitchell, J. K., "Influence of Mineralogy and Pore Solution Chemistry on the Swelling and Stability of Clays," Proceedings, Third International Research and Engineering Conference on Expansive Clay Soils, Haifi, Israel, Vol II, Aug 1973, pp 11-26.
 54. Donaldson, G. W., "The Occurrence of Problems of Heave and the Factors Affecting Its Nature," Proceedings, Second International Research and Engineering Conference on Expansive Clay Soils, Texas A&M University, College Station, Tex., Aug 1969, pp 25-36.
 55. Jennings, J. E. and Kerrich, J. E., "The Heaving of Buildings and the Associated Economic Consequences, with Particular Reference to the Orange Free State Goldfields," Civil Engineer in South Africa, Vol 4, No. 11, Nov 1962, pp 221-248.
 56. Sorochank, E. A., "Certain Regularities of the Swelling of Soils," Journal, Soil Mechanics and Foundation Engineering, Indian National Society, Vol 9, No. 3, Jul 1970, pp 293-304.
 57. Jennings, J. E., "The Prediction of Amount and Rate of Heave Likely to be Experienced in Engineering Construction on Expansive Soils," Proceedings, Second International Research and Engineering Conference on Expansive Clay Soils, Texas A&M University, College Station, Tex., Aug 1969, pp 99-109.
 58. Abelev, Yu. M., Sazhin, V. S., and Burov, E. S., "Deformational Properties of Expansive Soil," Expansive Clays - Properties and

- Engineering Problems; Proceedings, Third Asian Conference on Soil Mechanics and Foundation Engineering, Haifi, Israel, Vol 1, 1967, pp 57-59.
59. Matyas, E. L. and Radhakrishna, H. S., "Volume Change Characteristics of Partially Saturated Soils," Geotechnique, Vol 18, No. 4, Dec 1968, pp 432-446.
 60. Donaldson, G. W., "A Study of Level Observations on Buildings as Indications of Moisture Movements in the Underlying Soil," Moisture Equilibria and Moisture Changes in Soils Beneath Covered Areas, Butterworth, Australia, 1965, pp 156-163.
 61. _____, "The Prediction of Differential Movement on Expansive Soils," Proceedings, Third International Research and Engineering Conference on Expansive Clay Soils, Haifi, Israel, Aug 1973, pp 289-293.
 62. DeBruijn, C. M. A., "Moisture Redistribution in Southern African Soils," Proceedings, Eighth International Conference on Soil Mechanics and Foundation Engineering, Moscow, Vol 4, 1973, pp 37-44.
 63. Cedergren, H. R., Seepage, Drainage, and Flow Nets, Wiley, New York, 1968, pp 28-43.
 64. Russam, K., "An Investigation of Soil-Moisture Conditions at Three Airfields in Southern Rhodesia," Rhodesian Engineer, July 1960.
 65. Black, W. P. M., Croney, D., and Jacobs, J. C., "Field Studies of the Movements of Soil Moisture," Road Research Technical Paper No. 41, 1958, Department of Scientific and Industrial Research, Road Research Laboratory, London.
 66. Wong, H. Y. and Yong, R. M., "A Study of Swelling and Swelling Force During Unsaturated Flow in Expansive Soils," Proceedings, Third International Research and Engineering Conference on Expansive Clay Soils, Haifi, Israel, Aug 1973, pp 143-151.
 67. Jennings, J. E. B. and Williams, A. A. B., "Problems of Pavements and Earthworks on Heavy Clays in Tropical Climates," Proceedings, Conference on Civil Engineering Problems Overseas, The Institution of Civil Engineers, London, 1960, pp 237-242.
 68. Krinitzsky, E. L., Radiography in the Earth Sciences and Soil Mechanics, Plenum Press, New York, 1970.
 69. Windom, J. E. et al., "Material Property Investigation for Project Middle Gust, Events I, II, and III; Subsurface Exploration and Laboratory Test Results," Technical Report S-73-10, Report 1, Oct 1973, U. S. Army Engineer Waterways Experiment Station, CE, Vicksburg, Miss.
 70. Knott, R. A., Vispi, M. A., and Farrell, W. J., "Material Property Investigation for Project Middle Gust, Events IV and V; Subsurface Exploration and Laboratory Test Results," Technical Report S-73-11, Report 1, Oct 1973, U. S. Army Engineer Waterways Experiment Station, Vicksburg, Miss.

71. DeBruijn, C. M. A., Jr., "Swelling Characteristics of a Transported Soil Profile at Leeuhof Vereeniging (Transvaal)," Proceedings, Fifth International Conference on Soil Mechanics and Foundation Engineering, Paris, Vol, 1961, pp 43-49.
72. Mielenz, R. C. and King, M. E., "Physical-Chemical Properties and Engineering Performance of Clays," Proceedings, National Conference on Clays and Clay Technology, California Division of Mines Bulletin 169, 1955, pp 196-254.
73. Obermeier, S. F., "Evaluation of Laboratory Techniques for Measurement of Swell Potential of Clays," Proceedings, Workshop on Expansive Clays and Shales in Highway Design and Construction, D. R. Lamb and S. J. Hanna, ed., prepared for Federal Highway Administration, Washington, D. C., Vol 1, May 1973, pp 214-254.
74. Yong, R. N. and Warkentin, B. P., Introduction to Soil Behavior, Macmillan, New York, 1966.
75. Aitchison, G. D., "Problems of Soil Mechanics and Construction on Soft Clays and Structurally Unstable Soils," Proceedings, Eighth International Conference on Soil Mechanics and Foundation Engineering, Moscow, Vol 3, Aug 1973, pp 169-170.
76. Barden, L., Madedor, A. O., and Sides, G. R., "Volume Change Characteristics of Unsaturated Clay," Journal, Soil Mechanics and Foundations Division, American Society of Civil Engineers, Vol 95, SMI, Jan 1969, pp 33-50.
77. Kassiff, G., Baker, R., and Ovadia, Y., "Swell-Pressure Relationships at Constant Suction Changes," Proceedings, Third International Research and Engineering Conference on Expansive Clay Soils, Haifi, Israel, Aug 1973, pp 201-208.
78. Shaw, L. K., and Haliburton, T. A., "Evaluation of Collected Data 1966-1969: Subgrade Moisture Variations," Interim Report VIII, Feb 1970, School of Civil Engineering, Oklahoma State University, Stillwater, Okla.
79. Hardy, R. M., "Identification and Performance of Swelling Soil Types," Canadian Geotechnical Journal, Vol 11, No. 2, May 1965, pp 141-166.
80. Brakey, B. A., "Road Swells: Causes and Cures," Civil Engineering, American Society of Civil Engineers, Vol 40, No. 12, Dec 1970.
81. _____, "Moisture Stabilization by Membranes, Encapsulation, and Full Depth Paving," Proceedings, Workshop on Expansive Clays and Shales in Highway Design and Construction, D. R. Lamb and S. J. Hanna, ed., prepared for Federal Highway Administration, Washington, D. C., Vol 2, May 1973, pp 155-189.
82. Office, Chief of Engineers, Department of the Army, "Soil Sampling," Engineer Manual EM 1110-2-1907, 31 Mar 1972, Washington, D. C.
83. American Association of State Highway and Transportation Officials,

- "Manual on Foundation Investigation," 1967, Washington, D. C.
84. Lambe, T. W. and Martin, R. T., "Composition and Engineering Properties of Soil," Highway Research Board Proceedings, Vol 32, 1953, pp 576-588.
 85. Novais-Ferreira, H. and Horta da Silva, J. A., "Luanda Expansive Clays and Laboratory Appreciation Criteria," Proceedings, Third International Research and Engineering Conference on Expansive Clay Soils, Haifi, Israel, Aug 1973, pp 53-59.
 86. Carroll, D., "Clay Minerals and a Guide to Their X-ray Identification," Special Paper 126, 1970, Geological Society of America.
 87. Brown, G., ed., The X-ray Identification and Crystal Structures of Clay Minerals, Mineralogical Society (Clay Minerals Group), London, 1961.
 88. Buck, A. D., "Quantitative Mineralogical Analysis by X-ray Diffraction," Miscellaneous Paper C-72-2, Feb 1972, U. S. Army Engineer Waterways Experiment Station, CE, Vicksburg, Miss.
 89. Rich, C. I. and Kunze, G. W., ed., Soil Clay Mineralogy, University of North Carolina Press, Raleigh, 1964.
 90. Mackenzie, R. C., ed., The Differential Thermal Investigation of Clays, Mineralogical Society (Clay Minerals Group), London, 1957.
 91. Kacker, K. P. and Sen Gupta, D. P., "Prediction of Swelling Potential and Compression Index of Soils by Dye Adsorption," Journal, Indian Society of Soil Science, Vol 14, No. 3, 1966, pp 151-159.
 92. Basu, R. and Arulanandan, K., "A New Approach to the Identification of Swell Potential of Soils," Proceedings, Workshop on Expansive Clays and Shales in Highway Design and Construction, D. R. Lamb and S. J. Hanna, ed., prepared for Federal Highway Administration, Washington, D. C., May 1973, pp 315-340.
 93. _____, "A New Approach to the Identification of Swell Potential of Soils," Proceedings, Third International Research and Engineering Conference on Expansive Clay Soils, Haifi, Israel, Aug 1973, p 1-11.
 94. Sridharan, A. and Venkatappa Rao, G., "Effective Stress Theory of Shrinkage Phenomena," Canadian Geotechnical Journal, Vol 8, No. 4, Nov 1971, pp 503-513.
 95. Holtz, W. G. and Gibbs, H. J., "Engineering Properties of Expansive Clays," Proceedings, American Society of Civil Engineers, Vol 80, Separate No. 516, Oct 1954.
 96. Ravina, I., "Swelling of Clays, Mineralogical Composition, and Microstructure," Proceedings, Third International Research and Engineering Conference on Expansive Clay Soils, Haifi, Israel, Aug 1973, pp 61-63.
 97. Sankoran, K. S. and Venkateshwar, Rao, "A Microscopic Model of Expansive Clay," Proceedings, Third International Research and

- Engineering Conference on Expansive Clay Soils, Haifi, Israel, Aug 1973, pp 65-71.
98. Haase, M. C., "X-radiography of Unopened Soil Cores," Miscellaneous Paper 3-918, Aug 1967, U. S. Army Engineer Waterways Experiment Station, CE, Vicksburg, Mississippi
 99. Kantey, B. A. and Brink, A. B. A., "Laboratory Criteria for the Recognition of Expansive Soils," South African National Building Institute Bulletin No. 9, Dec 1952, pp 25-28.
 100. Lytton, R. L., "Expansive Clay Roughness in the Highway Design System," Proceedings, Workshop on Expansive Clays and Shales in Highway Design and Construction, D. R. Lamb and S. J. Hanna, ed., prepared for Federal Highway Administration, Washington, D. C., Vol 2, May 1973, pp 129-149.
 101. Gil, A. C., "Contribution to the Study of Expansive Clays of Peru," Proceedings, Second International Research and Engineering Conference on Expansive Clay Soils, Texas A&M University, College Station, Tex., Aug 1969, pp 183-193.
 102. Ladd, C. C. and Lambe, T. W., "The Identification and Behavior of Compacted Expansive Clays," Proceedings, Fifth International Conference on Soil Mechanics and Foundation Engineering, Parish, Vol 1, 1961, pp 201-205.
 103. Raman, V., "Identification of Expansive Soils from the Plasticity Index and the Shrinkage Index Data," The Indian Engineer, Calcutta, Vol 11, No. 1, Jan 1967, pp 17-22.
 104. Gibbs, H. J., "Criteria for Identifying Expansive Soils and Relation of Expansion to In-Place Density and Moisture Content," Proceedings, Workshop on Swelling Soils in Highway Design and Construction, Denver, Colo., Sep 1967.
 105. Chen, F. H., "The Use of Piers to Prevent the Uplifting of Lightly Loaded Structures Founded on Expansive Soils," Proceedings, First International Research and Engineering Conference on Expansive Clay Soils, Texas A&M University, College Station, 1965, pp 152-171.
 106. Seed, H. B., Woodward, R. J., Jr., and Lundgren, R., "Prediction of Swelling Potential for Compacted Clays," Journal, Soil Mechanics and Foundations Division, American Society of Civil Engineers, Vol 88, No. SM3, Jun 1962, pp 53-87.
 107. Dakshanamurthy, V. and Raman, V., "A Simple Method of Identifying an Expansive Soil," Soils and Foundations, Japanese Society of Soil Mechanics and Foundation Engineering, Vol 13, No. 1, Mar 1973, pp 97-104.
 108. Vijayvergiya, V. N. and Ghazzaly, O. I., "Prediction of Swelling Potential for Natural Clays," Proceedings, Third International Research and Engineering Conference on Expansive Clay Soils, Haifi, Israel, Aug 1973, pp 227-234.

109. Nayak, N. V. and Christensen, R. W., "Swelling Characteristics of Compacted Expansive Soils," Clays and Clay Minerals, Vol 19, No. 4, 1974, pp 251-261.
110. Anderson, K. O. and Thomson, S., "Modification of Expansive Soils of Western Canada with Lime," Proceedings, Second International Research and Engineering Conference on Expansive Clay Soils, Texas A&M University, College Station, Tex., Aug 1969, pp 175-182.
111. Livneh, M., Kassiff, G., and Wiseman, G., "The Use of Index Properties in the Design of Pavements on Expansive Clays," Proceedings, Second International Research and Engineering Conference on Expansive Clay Soils, Texas A&M University, College Station, Tex., Aug 1969, pp 218-234.
112. Altmeyer, W. T., "Discussion of Engineering Properties of Expansive Clays," Proceedings, American Society of Civil Engineers, Vol 81, Separate No. 658, Mar 1955, pp 17-19.
113. Ranganatham, B. V. and Satyanarayana, B., "A Rational Method of Predicting Swelling Potential for Compacted Expansive Clays," Proceedings, Sixth International Conference on Soil Mechanics and Foundation Engineering, Vol 1, 1965, pp 92-96.
114. Ring, G. W. III, "Shrink-Swell Potential of Soils," Public Roads, Vol 33, No. 6, Feb 1965, pp 97-105.
115. Snethen, D. R., "Visit to Texas Highway Department and with Representatives of Center for Highway Research," Memorandum for Record, 26 Sep 1974, Soil Mechanics Division, Soils and Pavements Laboratory, U. S. Army Engineer Waterways Experiment Station, CE, Vicksburg, Miss.
116. Texas Highway Department, Manual of Testing Procedures (100 Series).
117. American Association of State Highway and Transportation Officials, "The Classification of Soils and Soil-Aggregate Mixtures for Highway Construction Purposes," M145-73, Specifications, Part 1, 11th ed., 1974.
118. Soil Conservation Service, Soil Classification: A Comprehensive System (7th Approximation), U. S. Government Printing Office, Washington, D. C., 1960; and 1967, 1968, and 1970 Supplements.
119. _____, Soil Series of the United States, Puerto Rico, and the Virgin Islands: Their Taxonomic Classification, U. S. Government Printing Office, Washington, D. C., 1972.
120. _____, Soil Taxonomy: A Basic System of Soil Classification for Making and Interpreting Soil Surveys, U. S. Department of Agriculture Handbook No. 436 (in press), U. S. Government Printing Office, Washington, D. C.
121. Philipson, W. R., Arnold, R. W., and Snagrey, G. A., "Engineering Values from Soil Taxonomy," Highway Research Board Record No. 426 1973, pp 39-49.

122. Arnold, R. W., "Soil Engineers and the New Pedological Taxonomy," Highway Research Board Record No. 426, 1973, pp 50-54.
123. Department of the Navy, Bureau of Yards and Docks, "Soil Mechanics, Foundations and Earth Structures," Design Manual DM-7, 1971, Washington, D. C.
124. Noble, C. A., "Swelling Measurements and Prediction of Heave for a Lacustrine Clay," Canadian Geotechnical Journal, Vol III, No. 1, Feb 1966, pp 32-41.
125. McDowell, C., "The Relation of Laboratory Testing to Design for Pavements and Structures on Expansive Soils," Quarterly, Colorado School of Mines, Vol 54, No. 4, Oct 1959, pp 127-153.
126. Smith, A. W., "Method for Determining the Potential Vertical Rise, PVR," Proceedings, Workshop on Expansive Clays and Shales in Highway Design and Construction, D. R. Lamb and S. J. Hanna, ed., prepared for Federal Highway Administration, Washington, D. C., May 1973, pp 189-206.
127. Jennings, J. E. B. and Knight, K., "The Prediction of Total Heave from the Double Oedometer Test," Symposium on Expansive Clays, The South African Institute of Civil Engineers, 1957-1958, pp 13-19.
128. Burland, J. B., "The Estimation of Field Effective Stresses and the Prediction of Total Heave Using a Revised Method of Analyzing the Double Oedometer Test," The Civil Engineer in South Africa, Vol 4, No. 7, Jul 1962, pp 133-137.
129. Knight, K. and Greenburg, J. A., "The Analysis of Subsoil Moisture Movement During Heave and Possible Methods of Predicting Field Rates of Heave," The Civil Engineer in South Africa, Vol 12, No. 2 Feb 1970, pp 27-32.
130. Jennings, J. E. et al., "An Improved Method for Predicting Heave Using the Oedometer Test," Proceedings, Third International Research and Engineering Conference on Expansive Clay Soils, Haifi, Israel, Vol 2, Aug 1973, pp 149-154.
131. Sampson, E., Jr., Schuster, R. L., and Budge, W. D., "A Method of Determining Swell Potential of an Expansive Clay," Proceedings, First International Research and Engineering Conference on Expansive Clay Soils, Texas A&M University, College Station, Tex., 1965, pp 225-275.
132. Lambe, T. W. and Whitman, R. V., "The Role of Effective Stress in the Behavior of Expansive Soils," Quarterly, Colorado School of Mines, Vol 54, No. 4, 1959, pp 33-61.
133. DeBruijn, C. M. A., Jr., "The Mechanism of Heaving," Transactions, South African Institution of Civil Engineers, Vol 5, Sep 1955, pp 273-278.
134. Simons, N. E., Discussion of "The Heaving of Buildings and

- Associated Economic Consequences with Particular Reference to the Orange Free State Goldfields," by J. E. Jennings and J. E. Kerrick, The Civil Engineer in South Africa, Vol 5, No. 5, May 1963, pp 129-130.
135. Sullivan, R. A. and McClelland, B., "Predicting Heave of Buildings on Unsaturated Clay," Proceedings, Second International Research and Engineering Conference on Expansive Clay Soils, Texas A&M University, College Station, Tex., Aug 1969, pp 404-420.
 136. Komornik, A., Wiseman, G., and Ben-Yaacob, Y., "Studies of In Situ Moisture and Swelling Potential Profiles," Proceedings, Second International Research and Engineering Conference on Expansive Clay Soils, Texas A&M University, College Station, Tex., Aug 1969.
 137. California Department of Highways, "Method of Test for Evaluating the Expansive Potential of Soils Underlying Portland Cement Concrete Pavements," Test Method No. California 354-B.
 138. Lytton, R. L. and Watt, W. G., "Prediction of Swelling in Expansive Clays," Research Report 118-4, Sep 1970, Center for Highway Research, The University of Texas at Austin.
 139. De Wet, J. A., "The Time-Heave Relationship for Expansive Clays," Symposium in Expansive Clays, Transactions, South African Institute of Civil Engineers, Dec 1957, pp 20-26.
 140. Blight, G. E., "The Time Rate of Heave of Structures on Expansive Clays," Moisture Equilibria and Moisture Changes in Soils, Symposium in print, Butterworth, Australia, 1965, pp 78-88.
 141. Richards, B. G., "Theoretical Transient Behaviour of Saturated and Unsaturated Soils Under Load and Changing Moisture Conditions," Technical Paper No. 16, 1973, Division of Applied Geomechanics, Commonwealth Scientific and Industrial Research Organization, Australia.
 142. Seed, H. B., Mitchell, J. K., and Chan, C. K., "Study of Swell and Swell Pressure Characteristics of Compacted Clays," Highway Research Board Bulletin No. 313, 1962, pp 12-39.
 143. Lambe, T. W., "The Character and Identification of Expansive Soils," Soil PVC Meter, Publication 701, Dec 1960, Federal Housing Administration, Washington, D. C.
 144. Vijayvergiya, V. N. and Sullivan, R. A., "Simple Technique for Identifying Heave Potential," Proceedings, Workshop on Expansive Clays and Shales in Highway Design and Construction, D. R. Lamb and S. J. Hanna, ed., prepared for Federal Highway Administration, Washington, D. C., Vol 1, May 1973, pp 275-294.
 145. Komornik, A. and David, D., "Prediction of Swelling Pressure of Clay," Journal, Soil Mechanics and Foundations Division, American Society of Civil Engineers, Vol 95, SM1, Jan 1969, pp 209-225.
 146. Colorado State Department of Highways, A Review of Literature on Swelling Soils, 1964.

147. Proceedings, First International Research and Engineering Conference on Expansive Clay Soils, Texas A&M University, College Station, Tex., 1965.
148. Proceedings, Second International Research and Engineering Conference on Expansive Clay Soils, Texas A&M University, College Station, Tex., Aug 1969.
149. Proceedings, Third International Research and Engineering Conference on Expansive Clay Soils, Haifi, Israel, Aug 1973.
150. Lamb, D. R. and Hanna, S. J., ed., Proceedings, Workshop on Expansive Clays and Shales in Highway Design and Construction, prepared for Federal Highway Administration, Washington, D. C., May 1973.
151. Holtz, W. G., "Volume Change in Expansive Clay Soils and Control by Lime Treatment," Proceedings, Second International Research and Engineering Conference on Expansive Clay Soils, Texas A&M University, College Station, Tex., Aug 1969, pp 157-174.
152. McDowell, C., "Remedial Procedures Used in the Reduction of Detrimental Effects of Swelling Soils," Proceedings, First International Research and Engineering Conference on Expansive Clay Soils, Texas A&M University, College Station, Tex., Aug 1965, pp 239-254.
153. Gerhardt, B. B., "Soil Modification Highway Projects in Colorado," Proceedings, Workshop on Expansive Clays and Shales in Highway Design and Construction, D. R. Lamb and S. J. Hanna, ed., prepared for Federal Highway Administration, Washington, D. C., Vol 2, May 1973, pp 33-48.
154. Merten, F. K. and Brakey, B. A., Asphalt Membranes and Expansive Soils, Asphalt Institute Information Series No. 145 (IS 145), May 1968.
155. Gerhardt, B. B. and Safford, M. C., "Clifton - Highline Canal Experimental Project, I70-1 (14) 33," Final Report, 1973, Colorado Highway Department.
156. McDonald, E. B., "Review of Highway Design and Construction Through Expansive Soils (I95 - Missouri River West for 135 Miles)," Proceedings, Workshop on Expansive Clays and Shales in Highway Design and Construction, D. R. Lamb and S. J. Hanna, ed., prepared for Federal Highway Administration, Washington, D. C., Vol 2, May 1973, p 230.
157. _____, "Lime Research Study - South Dakota Interstate Routes (16 Projects)," Final Report, Dec 1969, South Dakota Highway Department.
158. Diller, D. G., "Expansive Soils in Wyoming Highways," Proceedings, Workshop on Expansive Clays and Shales in Highway Design and Construction, D. R. Lamb and S. J. Hanna, ed., prepared for Federal Highway Administration, Washington, D. C., Vol 2, May 1973, p 250.

159. Brakey, B. A. and Carroll, J. A., "Experimental Work Design, and Construction of Asphalt Bases and Membranes in Colorado and Wyoming," Paper presented at 1971 Annual Meeting, Association of Asphalt Paving Technologists, Oklahoma City, Okla., 1971.
160. Brakey, B. A., "Use of Asphalt Membranes to Reduce Expansion in Certain Types of Expansive Soils," Paper presented at 53d Annual Meeting of American Association of State Highway Officials, Salt Lake City, Utah, Oct 1967.
161. Brakey, B. A., "Use of Asphalt Membranes to Reduce Expansion in Certain Types of Expansive Soils," Paper presented at Highway Engineer Conference, University of Colorado, Boulder, Colo., 1968.
162. McDonald, E. B., "Experimental Moisture Barrier and Waterproof Surface," Final Report, Oct 1973, South Dakota Department of Transportation.
163. Teng, T. C., Mattox, R. M., and Clisby, M. B., "A Study of Active Clays as Related to Highway Design," Final Report, 1972, Mississippi State Highway Department.
164. _____, "Mississippi's Experimental Work on Active Clays," Proceedings, Workshop on Expansive Clays and Shales in Highway Design and Construction, D. R. Lamb and S. J. Hanna, ed., prepared for Federal Highway Administration, Washington, D. C., Vol 2, May 1973, pp 1-27.
165. Teng, T. C. and Clisby, M. B., "Experimental Highway Construction Techniques for the Active Clays in Mississippi," Paper presented at National ASCE Transportation Engineering Specialty Conference, Montreal, 1974.
166. Morris, G. P., "Arizona's Experience with Swelling Clays and Shales," Proceedings, Workshop on Expansive Clays and Shales in Highway Design and Construction, D. R. Lamb and S. J. Hanna, ed., prepared for Federal Highway Administration, Washington, D. C., Vol 2, May 1973, p 283.
167. Lamb, D. R. et al., "Roadway Failure Study No. II: Behavior and Stabilization of Expansive Clay Soils," Final Report to Wyoming Highway Department, Aug 1967, University of Wyoming, Laramie, Wyo.
168. Watt, W. G. and Steinburg, M. L., "Measurements of a Swelling Clay in a Poned Cut," Research Report 118-6, Oct 1974, Center for Highway Research, The University of Texas at Austin.
169. Moisture Equilibria and Moisture Changes in Soils, Symposium in print, Butterworth, Australia, 1965.
170. Dawson, R. F., "Modern Practices Used in the Design of Foundations for Structures on Expansive Soils," Quarterly, Colorado School of Mines, Vol 54, No. 4, Oct 1959.
171. Haynes, J. H. and Mason, R. C., "Subgrade Soil Treatment at Apparel Mart, Dallas, Texas," Proceedings, First International Research and Engineering Conference on Expansive Clay Soils,

- Texas A&M University, College Station, Tex., 1965, pp 172-182.
172. Steinberg, M. L., "Continuing Measurements of a Swelling Clay in a Poned Cut," Research Report 118-8, Aug 1973, Center for Highway Research, The University of Texas at Austin.
 173. Mitchell, J. K. and Raad, L., "Control of Volume Changes in Expansive Earth Materials," Proceedings, Workshop on Expansive Clays and Shales in Highway Design and Construction, D. R. Lamb and S. J. Hanna, ed., prepared for Federal Highway Administration, Washington, D. C., May 1973, p 200.
 174. California Division of Highways, "Lime-Soil Stabilization Study-- A Selected Literature Review," Materials and Research Report 632 812-1, 1967.
 175. Diamond, S. and Kinter, E. B., "Mechanisms of Lime Stabilization," Public Roads, 1966, pp 260-273.
 176. Herrin, M. and Mitchell, H., "Lime-Soil Mixtures," Highway Research Board Bulletin 304, 1961.
 177. Jones, C. W., "Stabilization of Expansive Clay Using Hydrated Lime and Portland Cement," Highway Research Board Bulletin No. 193, 1958, pp 40-47.
 178. Mitchell, J. K. and Hooper, D. R., "Influence of Time Between Mixing and Compaction on Properties of a Lime-Stabilized Expansive Clay," Highway Research Board Bulletin 304, 1961.
 179. Thompson, M. R., "Deep-Plow Lime Stabilization for Pavement Construction," Transportation Engineering Journal, American Society of Civil Engineers, Vol 98, No. TE2, May 1972, pp 311-323.
 180. Ingles, O. G. and Neil, R. C., "Lime Grout Penetration and Associated Moisture Movements in Soil," Research Paper No. 138, 1970, Division of Applied Geomechanics, C.S.I.R.O., Australia.
 181. Lundy, H. L., Jr., and Greenfield, B. J., "Evaluation of Deep In Situ Soil Stabilization by High Pressure Lime Slurry Injection," Highway Research Board Record No. 235, 1968, pp 27-35.
 182. Sherard, J. L., "Mixing-In-Place Soil and Portland Cement," Journal, Soil Mechanics and Foundations Division, American Society of Civil Engineers, No. SM6, Nov 1969, pp 1357-1363.
 183. Highway Research Board, "Soil Stabilization with Portland Cement," Highway Research Board Bulletin 292, 1961.
 184. Moh, Z., "Soil Stabilization with Cement and Sodium Additives," Journal, Soil Mechanics and Foundations Division, American Society of Civil Engineers, Vol 88, No. SM6, Dec 1962, pp 81-105.
 185. Katti, R. K. and Barve, A. G., "Effect of Inorganic Chemicals on the Consistency of an Expansive Soil Sample," Highway Research Board Bulletin No. 349, 1962, pp 1-8.
 186. Blaser, H. D. and Scherer, O. J., "Expansion of Soils Containing

- Sodium Sulfate Caused by Drop in Ambient Temperatures," Highway Research Board Special Report No. 103, 1969.
187. Hoover, J. M. et al., "Soil Organic Cationic Chemical Lignin," Highway Research Board Bulletin No. 241, 1960, pp 1-13.
 188. Freitag, D. R. and Kozan, G. R., "An Investigation of Soil Waterproofing and Dust Proofing Materials," Highway Research Board Bulletin No. 282, 1961, pp 13-27.
 189. Anday, M. C., "An Experiment with Paczyme," Final Report, Nov 1970, Virginia Highway Research Council.
 190. Landrum, H. W., Jordan, G. W., and Patrick, R. L., "Evaluation of Paczyme as a Stabilizing Agent for Secondary Roads," Final Report, 1971, Research Project 170-4, North Carolina State Highway Commission.
 191. Larutan Corporation, "Paczyme Means Better Roads at Less Cost," Anaheim, California.
 192. "Composition for Compacting Soil," U. S. Patent No. 3,404,068, 1968.
 193. Zel Chemical Company, "Reynolds Road Packer 2-3-5," Portland, Oreg.
 194. Central Chemical Company, "The Central System of Soil Stabilization," Fresno, Calif.
 195. Ion Tech, Inc., "The Ion Tech Method," 1970, Daly City, Calif.
 196. South Dakota Department of Transportation, "Experimental Stabilization - Expansive Clay Shale," Four Year Report, Apr 1969.
 197. Lamb, D. R. et al., "Roadway Failure Study No. I: Final Report," Aug 1966, prepared for Wyoming Highway Department by University of Wyoming, Laramie, Wyo.
 198. Louisiana Department of Highways, "In Situ Stabilization of Soils at Depth," Interim Progress Report No. 1, Research Project 63-75, Aug 1964.
 199. Higgins, C. M., "High Pressure Lime Injection," Research Report 17, Research Project 63-75, Aug 1965, Louisiana Department of Highways.
 200. Robnett, Q. L., Jamison, G. F., and Thompson, M. R., "Technical Data Base for Stabilization of Deep Soil," Technical Report TR-70-84, Apr 1971, Air Force Weapons Laboratory, Kirtland Air Force Base, N. Mex.
 201. "Subgrade Improved with Drill Lime Stabilization," Rural and Urban Roads, Oct 1963.
 202. Colorado Department of Highways, "Lime-Shaft and Lime-Tilled Stabilization of Subgrades in Colorado Highways," Interim Report, 1967.
 203. Higgins, C. M., "Lime Treatment at Depth," Research Report 41, Final Report, June 1969, Louisiana Department of Highways.

204. Wright, P. J., "Lime Slurry Pressure Injection Tames Expansive Clays," Civil Engineering, American Society of Civil Engineers, Oct 1973.
205. Wright, P. J., Personal Communication.
206. Thompson, M. R. and Robnett, Q. L., "Pressure Injection Lime Treatment of Swelling Soils," Paper presented at 54th Annual Meeting, Transportation Research Board, Washington, D. C., Jan 1975.
207. Hartronft, B. C., Buie, L. D., and Hicks, F. P., "A Study of Lime Treatment of Subgrades to Depths of 2 Feet," 1969, Research and Development Division, Oklahoma Department of Highways.
208. Seed, H. B., Lundgren, R., and Chan, C. K., "Effect of Compaction Method on Stability and Swell Pressure of Soils," Highway Research Bulletin No. 93, 1954, p 33.
209. Gizienski, S. F. and Lee, L. J., "Comparison of Laboratory Swell Tests to Small Scale Field Tests," Proceedings, First International Research and Engineering Conference on Expansive Clay Soils, Texas A&M University, College Station, Tex., 1965, pp 108-119.
210. Kassiff, G. et al., "Studies and Design Criteria for Structures on Expansive Clays," Proceedings, First International Research and Engineering Conference on Expansive Clay Soils, Texas A&M University, College Station, Tex., 1965, pp 276-301.
211. U. S. Army Engineer District, Omaha, CE, Letter to U. S. Army Engineer Waterways Experiment Station, CE, Vicksburg, Miss., "Subject: Review and Analysis of Structures on Expansive Clays," Dec 1967, Omaha, Nebr.
212. U. S. Army Engineer District, Kansas City, CE, Letter to U. S. Army Engineer Waterways Experiment Station, CE, Vicksburg, Miss., "Subject: Review and Analysis of Structures on Expansive Clays," Dec 1967, Kansas City, Mo.
213. Leer, D. K., "Problems of High Volume Change Soils in North Dakota," Proceedings, Workshop on Expansive Clays and Shales in Highway Design and Construction, D. R. Lamb and S. J. Hanna, ed., prepared for Federal Highway Administration, Washington, D. C., Vol 2, May 1973, p 256.
214. Colorado Department of Highways, "Embankment Construction Without Moisture-Density Control," Interim Report, 1967.
215. Aylmore, L. A. G., Quirk, J. P., and Sills, I. D., "Effects of Heating on the Swelling of Clay Minerals," Highway Research Board, Special Report No. 103, 1969.
216. Uppal, H. L., "Modification of Expansive Soils for Use in Road Work," Proceedings, Second International Research and Engineering Conference on Expansive Clay Soils, Texas A&M University, College Station, Tex., pp 421-430.

217. Casagrande, L., "Review of Past and Current Work on Electro-Osmotic Stabilization of Soils," Harvard Soil Mechanics Series 45, Dec 1953.
218. Zaslavsky, D. and Ravina, I., "Review and Some Studies in Electrokinetic Phenomena," Moisture Equilibria and Moisture Changes in Soils, Symposium in print, Butterworth, Australia, 1965, p 55.
219. Esrig, M., "Electrokinetic Stabilization of an Illitic Clay," Journal, Soil Mechanics and Foundations Division, American Society of Civil Engineers, Vol 93, No. SM3, May 1967, pp 109-128.
220. O'Bannon, C. E., "Stabilization of Chinle Clay by Electro-Osmotic Treatment," Phase Two Report to Arizona Department of Transportation, Feb 1973.
221. _____, "Stabilization of Chinle Clay by Electro-Osmosis and Base Exchange of Ions," Final Report to Arizona Department of Transportation, Feb 1973.
222. _____, Stabilization of Montmorillonite Clay by Electro-Osmosis and Base Exchange of Ions, Ph. D. Dissertation, Oklahoma State University, Stillwater, Okla., Jul 1971.
223. Arora, H. S. and Scott, J. B., "Chemical Stabilization of Landslides by Ion Exchange," California Geology, May 1974.
224. Mearns, R., Camey, R., and Forsyth, R., "Evaluation of the Ion Exchange Landslide Correction Technique," Highway Research Report, Jan 1973, California Highway Department.
225. Proceedings, Workshop on Swelling Soils in Highway Design and Construction, Federal Highway Administration, Denver, Colo., Sep 1967.
226. Kansas Highway Department, "Standard Specifications," 1973.
227. Arizona Highway Department, "Standard Specifications," 1969, and Supplement Specifications, 1974.
228. Louisiana Training Brochure, "Volume Changes in Embankments."
229. Colorado Highway Department, "Standard Specifications," 1971, and planned revision to Section 203.
230. Little, W. S., "Roadway Design," Paper Presented to Asphalt Pavement Seminar, Mississippi State University, University, Miss. 1974.
231. South Dakota Highway Department, "Standard Specifications," 1969, and "Special Provisions for Subgrade Construction," 1969.
232. Nolan, P. R., "Thickness Design for Flexible Pavement," 1970, Wyoming State Highway Department.
233. Wyoming Highway Department, "Standard Specifications," 1971.
234. Oklahoma Highway Department, "Standard Specifications," 1967.
235. Haliburton, T. A., "Subgrade Moisture Variations," Final Report, Aug 1970, Oklahoma State University, Stillwater, Okla.

236. Montana Highway Department, "Standard Specifications," 1970.
237. California Highway Department, "Highway Design Manual," Oct 1974.
238. Marchino, J. L., "State of the Art Study, Mancos Shale and Swelling Soils," Mar 1971, Utah Department of Highways.
239. Texas Highway Department, "Standard Specifications," 1972.

