

DOT/FAA/TC-19/13

Federal Aviation Administration
William J. Hughes Technical Center
Aviation Research Division
Atlantic City International Airport
New Jersey 08405

Requirements Definition Study and Gap Analysis for Future Guidance and Control Displays as Part of NextGen SESAR

March 2019

Technical Report

This document is available to the U.S. public through the National Technical Information Services (NTIS), Springfield, Virginia 22161.

This document is also available from the Federal Aviation Administration William J. Hughes Technical Center at actlibrary.tc.faa.gov.



U.S. Department of Transportation
Federal Aviation Administration

NOTICE

This document is disseminated under the sponsorship of the U.S. Department of Transportation in the interest of information exchange. The U.S. Government assumes no liability for the contents or use thereof. The U.S. Government does not endorse products or manufacturers. Trade or manufacturers' names appear herein solely because they are considered essential to the objective of this report. The findings and conclusions in this report are those of the author(s) and do not necessarily represent the views of the funding agency. This document does not constitute FAA policy. Consult the FAA sponsoring organization listed on the Technical Documentation page as to its use.

This report is available at the Federal Aviation Administration William J. Hughes Technical Center's Full-Text Technical Reports page: actlibrary.tc.faa.gov in Adobe Acrobat portable document format (PDF).

1. Report No. DOT/FAA/TC-19/13	2. Government Accession No.	3. Recipient's Catalog No.
4. Title and Subtitle REQUIREMENTS DEFINITION STUDY AND GAP ANALYSIS FOR FUTURE GUIDANCE AND CONTROL DISPLAYS AS PART OF NEXTGEN SESAR		5. Report Date March 2019
		6. Performing Organization Code ANG-E271
7. Author(s) Uijt De Haag, M. Adami, T. Theunissen, E	8. Performing Organization Report No.	
9. Performing Organization Name and Address ANG-E271 Robert McGuire WJH FAA Technical Center Atlantic City Int'l Airport, NJ 08405		10. Work Unit No. (TRAIS)
		11. Contract or Grant No.
12. Sponsoring Agency Name and Address Small Airplane Standards Branch FAA Central Regional Office 901 Locust St Kansas City , MO 64106		13. Type of Report and Period Covered Technical Report
		14. Sponsoring Agency Code AIR-714
<p>15. Supplementary Notes</p> <p>The FAA William J. Hughes Technical Center Aviation Research Division COR was Robert McGuire. Context and targeted results of FAA Energy Management Sponsored Research David G. Sizoo, FAA Aircraft Certification, Flight Test Pilot</p> <p>The three cornerstones that lay the foundation for FAA Flight Controls and Mechanical Systems sponsored research are angle of attack, energy management, and flight path control. The FAA Small Airplane Standards Branch and the Policy and Innovation Division have sponsored a comprehensive portfolio of R&D projects to integrate these three topics.</p> <p>These three areas are clearly inter-related. Our approach has been to first extensively study angle of attack. The results of that research were policy that brought innovative and inexpensive angle of attack awareness to general aviation. The knowledge gained from the research also contributed to incorporating angle of attack details in FAA publications such as the Pilot's handbook of Aeronautical Knowledge, and the Airplane Flying handbook.</p> <p>The second focus area for research, energy management, is absolutely critical for controlling flight path. The research undertaken in this project with Ohio University was meant to explore novel ways of measuring and presenting energy information to the pilot. Preliminary results from the FAA sponsored work were published in a 2014 IEEE paper titled "An Energy Management Display for General Aviation Safety Enhancements" (978-1-4799-5001-0/14 written by Adami,T.; Uijt de Haag, M.; Theunissen E.; Sizoo, D.; McGuire, R.)</p> <p>This work laid the foundation for other energy management and flight path control research sponsored by the FAA. Follow on work includes Trajectory Energy Management policy development for electric and Vertical Take-off and landing VTOL vehicles as well as adding an Energy Management Chapter in the FAA's Airplane Flying Handbook written by Juan Merkt, David Sizoo, and Peter Rouse. In April 2017, we briefed the Chairman of the NTSB on the impact of energy management on fatal accidents at the Loss of Control Forum in Washington, DC.</p> <p>The Ohio University research discussed in this report also set the stage for incorporating Energy Management in teaching and measuring pilot skills. Juan Merkt and Dave Sizoo briefed the FAA Airman Certification Standards Working Group (ACSWG) in Washington Dc on September 25, 2019. As a result, the FAA is updating the training standards with energy concepts.</p> <p>The research described in this report fits into the overall FAA research portfolio to develop policy integrating Energy Management, Angle of Attack, and Flight Path Control.</p>		
<p>16. Abstract</p> <p>This project studied advanced cockpit displays, and included the design of a new, energy-based, synthetic vision display. A simulator was constructed for pilot opinion studies, and flight instructors and students from Ohio University participated and provided feedback. Concepts such as energy management, conflict probing, and path-based navigation guidance were studied and implemented. A mobile "rig" was designed and constructed to enable flight testing aboard a general aviation aircraft.</p> <p>Valuable feedback was provided by the flight instructors and students, and the mobile rig was tested by an Ohio University pilot and by an FAA test pilot. The results were promising, and recommendations on future work are provided at the end of this report.</p>		

<p>17. Key Words</p> <p>General aviation; Cockpit displays; Energy Management Primary Flight Display</p>		<p>18. Distribution Statement</p> <p>This document is available to the U.S. public through the National Technical Information Service (NTIS), Springfield, Virginia 22161. This document is also available from the Federal Aviation Administration William J. Hughes Technical Center at actlibrary.tc.faa.gov.</p>	
<p>19. Security Classif. (of this report)</p> <p>Unclassified</p>	<p>20. Security Classif. (of this page)</p> <p>Unclassified</p>	<p>21. No. of Pages</p> <p>51</p>	<p>22. Price</p>

TABLE OF CONTENTS

	Page
EXECUTIVE SUMMARY	VIII
1. INTRODUCTION	1
2. BACKGROUND	1
3. GAP ANALYSIS	1
3.1 Identified Gaps	2
4. SIMULATOR DESIGN AND CONSTRUCTION	2
4.1 Simulator Structure	2
4.2 Simulator Software	3
5. EMPFD PILOT-EVALUATION STUDY	4
5.1 EMPFD Training Materials	4
5.2 EMPFD Study Setup	4
5.3 Pilot Evaluation Study (Round 1)	6
5.3.1 Pilot Evaluation Study Scenario	6
5.3.2 Pilot Evaluations	6
5.4 Pilot Evaluation Study (Round 2)	8
6. ENERGY-BASED DISPLAY FOR GA	9
6.1 Energy-based Synthetic Vision Display	10
6.1.1 Energy Cues	11
6.1.2 Path and Energy-Based Approach Guidance	13
6.1.3 Guidance from the Downwind Leg	14
6.1.4 Pilot Interaction on Downwind Leg	14
6.1.5 Implementation Example	15
6.2 Simulator Evaluation and Flight Tests	20
6.2.1 Flight Testing	22
7. CONCLUSIONS AND FUTURE WORK	29
8. REFERENCES	29

APPENDICES

A—ENERGY CUES

B—SIMULATOR CAD DRAWING

C—PILOT STUDY RECRUITMENT

D—X-PLANE® SIMULATION ENVIRONMENT

E—MOBILE RIG

LIST OF FIGURES

Figure		Page
1	Ohio University part-task simulator	3
2	Vertical profile for preliminary EMPFD testing	5
3	EMPFD as driven by Microsoft FSX	6
4	Vertical profile commanded vs. achieved	9
5	Flight parameters in a moving atmosphere (no vertical wind component)	10
6	Basic display symbology	11
7	Straight-level flight, no acceleration	12
8	Geometry describing synthetic vision-based path guidance	14
9	Initial position near KOJC (PFD)	15
10	Blue color indicates path available	16
11	Green color indicates path calculated	16
12	Entry point to approach path (PFD)	16
13	Approach path with map (MFD)	17
14	Nearing approach path (PFD)	17
15	Continuing toward approach path	17
16	Exocentric view of approach path	18
17	Approach path calculated	18
18	Turning onto base leg	19
19	Turning onto final	19
20	Tunnel capture after extreme descent	20
21	Sagetech AHRS	21
22	Mobile Delphins design concept	21
23	Ohio version of the mobile rig	22
24	Ground-test vehicle	22
25	Tunnel available	23
26	Tunnel drawn	24
27	Intercepting the tunnel	25
28	Inside the tunnel	26
29	Runway in view	27
30	Final moments before landing	28

LIST OF ACRONYMS

AHRS	Attitude heading reference system
CD&R	Conflict detection and resolution
CDA	Continuous descent approach
CDU	Control display unit
CFI	Certified flight instructor
EMPFD	Energy Management Primary Flight Display
FPM	Flight path marker
FPV	Flight path vector
FSX	Flight Simulator X
GA	General aviation
GAJSC	GA Joint Steering Committee
GNC	Global Navigation Chart
HiL	Human-in-the-loop
IAS	Indicated airspeed
KOJC	Johnson County Executive Airport
LOC	Loss of control
MCP	Mode control panel
NextGen	Next Generation Airspace
PFD	Primary flight display
PFPA	Potential flight path angle
SVS	Synthetic vision system

EXECUTIVE SUMMARY

The goal of this project was to develop a synthetic vision display for general aviation (GA) that includes energy cues to improve pilots' awareness of the aircraft energy state during the approach phase of flight.

An Energy Management Primary Flight Display with an additional perspective flight path display (highway-in-the-sky) was developed for this research effort. The display presents an intercept-tunnel that is to be followed by the pilot on a curved approach to the runway. In addition, a range of energy cues is available for the pilots to efficiently manage control effort.

The Energy Management Primary Flight Display was tested on a flight simulator and in aircraft flight testing. These flight tests showed the advantages of energy-state cues, and approach-path guidance.

The display is intended for deployment in GA aircraft to aid pilots during the approach phase of flight and has been tested in both a fixed-base simulator and in actual flight tests, with promising results. Other phases of flight, including arrival and landing, should be addressed in further studies.

1. INTRODUCTION

The initial goal for this project was to identify advanced cockpit display concepts for the Next Generation Airspace system, and to implement and test those concepts in a part-task flight simulator. A simulator was constructed, software was developed, and informal pilot studies were conducted. The scope of the project shifted after those initial studies, and emphasis was placed on developing a synthetic vision display for general aviation (GA) that includes energy cues to improve pilots' awareness of the aircraft energy state during the approach phase of flight. Simulator studies were de-emphasized, and a mobile display "rig" was assembled centered around a portable attitude heading reference system (AHRS) unit and a miniature PC.

The display software was a modified version of Delphins, designed and programmed by Erik Theunissen. The energy cues were partially motivated by the Energy Management Primary Flight Display (EMPFD) developed by Anthony Lambregts. The simulator was constructed at Ohio University, and replicated a commercial airliner flight deck. It was also flexible enough to be used for GA operations by swapping out the flight controls. Microsoft® Flight Simulator X® (FSX) or X-Plane® created the displays and provided out-the-window views on the large-screen displays. Ohio University developed interface software between the components and implemented the calculations of many of the energy cues.

2. BACKGROUND

Loss of control (LOC) is the leading cause of general aviation (GA) accidents, according to findings of the GA Joint Steering Committee (GAJSC). Main contributors to LOC are lack of awareness of the energy state and the angle-of attack, and margins from published limits of the aircraft. As part of their assessment, the GAJSC developed a GA Safety Plan and identified a list of safety enhancements. Several of these safety enhancements address the improvement of the pilot's energy-state awareness (e.g., better awareness of the aircraft's angle-of-attack) and tools to help in achieving a stabilized approach and landing. In addition to a detailed explanation of the GA synthetic vision system (SVS) concept and the added energy awareness cues, this report discusses the human-in-the-loop (HiL) evaluation and flight test of the proposed concepts.

3. GAP ANALYSIS

A literature and standards search was performed to broaden the insights in the Next Generation Airspace (NextGen) concepts and identify potential innovative display solutions, apart from Energy Management Primary Flight Display (EMPFD) and Conflict Probes, which could fill gaps in NextGen guidance and control displays. FAA documents, including the NextGen Implementation Plan (March 2011) and NextGen Concept of Operations (Version 3.0), were used to help identify and define scenarios to test these potential solutions.

Given the constraints of the NextGen Airspace vision, off-nominal conditions will inevitably lead to situations in which there will not be enough time to renegotiate trajectories before loss of separation occurs. Therefore, it is important to provide pilots with the right information to help avoid or mitigate loss of separation.

3.1 IDENTIFIED GAPS

The gap analysis identified three gaps that exist with respect to information needed by pilots to effectively manage the NextGen airspace:

1. Conflict prediction and resolution support in the tactical domain
2. Lack of integration of conflict detection and resolution (CD&R) with Global Navigation Chart (GNC) system
3. Lack of pilot and CD&R system awareness of how aircraft performance constraints impact the available maneuver margin for conflict prevention

Gap 1 exists between the time-to-conflict, but the situation can be resolved through trajectory negotiation and the time-to-conflict at which the traffic-collision-avoidance system starts to provide collision-avoidance guidance. Gap 2 exists because of a lack of integration of CD&R data within the GNC system, thereby forcing the pilot to spend valuable time manually entering conflict-resolution data. Gap 3 follows from Gap 2, and exists because of the lack of pilot and CD&R system awareness of how aircraft performance constraints impact the available maneuver margin for conflict prevention.

4. SIMULATOR DESIGN AND CONSTRUCTION

A part-task simulator was constructed to conduct pilot-opinion studies of the proposed display technologies. Ohio University visited with Delft University partners to receive training in the configuration and operation of the Delphins software package, to get familiarized with the flight-deck simulator hardware, and to discuss scenarios to be tested. The design was modeled after the flight deck of a commercial airliner, and includes five 17-inch touchscreen displays and three large-screen monitors for an out-the-window view.

4.1 SIMULATOR STRUCTURE

Ohio University engineers designed the simulator display console, worked with OTP Industrial Solutions in Columbus, Ohio to develop a computer-aided drafting drawing of the structure (figure B-1 in appendix B). OTP delivered the parts in a kit, and the console was assembled in Ohio. A pair of airplane cockpit seats from a retired Boeing 737 were purchased from the Airline Pilot's Historical Society (see figure 1). A wooden platform was constructed on which to build the simulator, and cardboard was fastened to the bottom to allow the entire assembly to be slid across the floor as necessary.

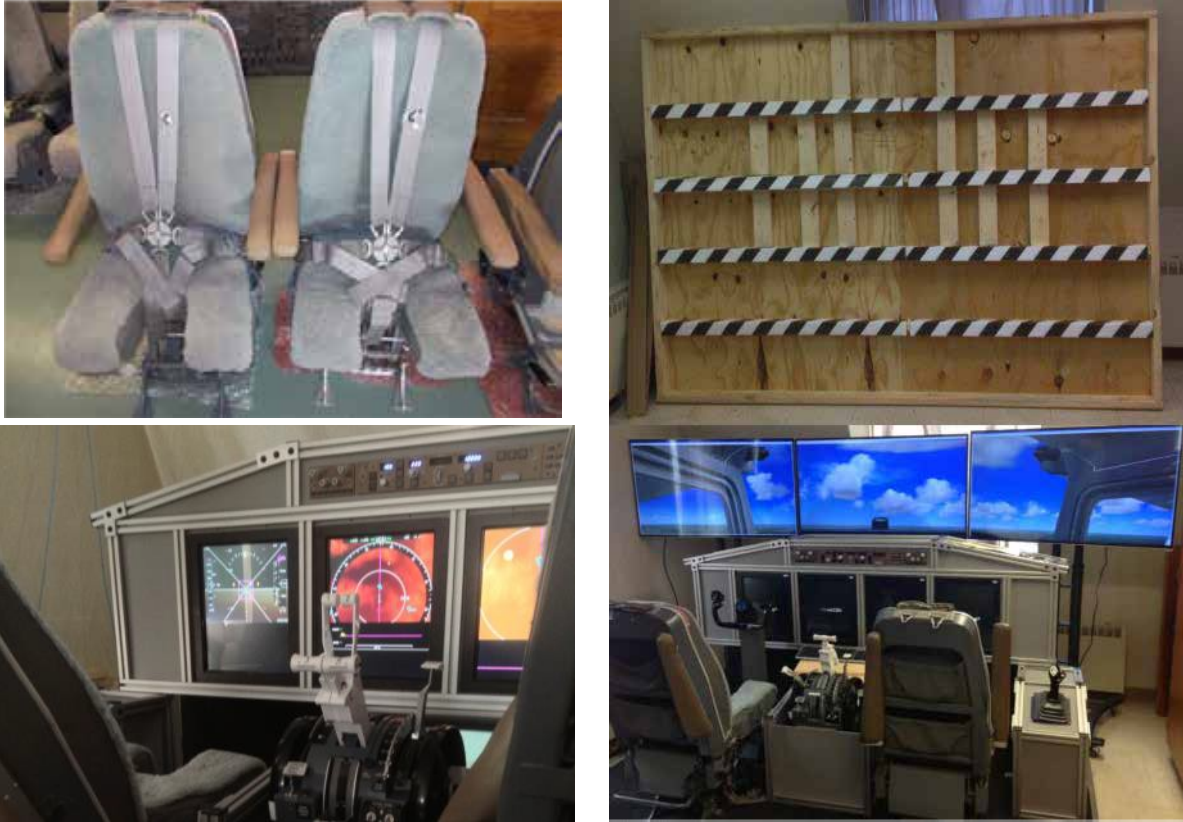

Figure 1. Ohio University part-task simulator

The configuration shown in the figure includes five 17-inch displays, a side-stick for pitch and roll control, a throttle quadrant, a mode control panel (MCP), a control display unit (CDU), and two electronic flight instrument system control panels. Each display was run by a dedicated PC, and the system was networked using TCP/IP protocol allowing for ease of configuration.

4.2 SIMULATOR SOFTWARE

All the flight display software was based on Delphins, which takes input from the flight-dynamics model and creates the images seen on the displays. Delphins also includes a built-in flight dynamics model, and can be interfaced with FSX or X-Plane to provide an out-the-window view. The system can also use FSX or X-Plane to propagate the flight dynamics, and Ohio University developed interface software for both cases. After the project shifted to the GA display, it was necessary to shift from the built-in flight dynamics model to models included in FSX (and later X-Plane). The main reason for this was to evaluate the EMPFD under full manual control and to make an elevator trim control available to the pilots.

The interface between FSX and Delphins was written by Ohio University and relies heavily on a library called FSUIPC that maps the variables in FSX to accessible memory locations. Using these library routines, the initial condition of the aircraft (position, velocity, etc.) is set, and the outputs of the FSX vehicle model are passed to Delphins for display. The X-Plane interface is in the form of a plug-in and uses datarefs that point to more than 400 variables propagated by X-Plane.

5. EMPFD PILOT-EVALUATION STUDY

An informal pilot evaluation of the baseline EMPFD was conducted first. Preparation for this consisted of two main tasks: 1) creation of an overview document of the Total Energy Control System and the EMPFD, along with pilot training materials for the human-in-the-loop (HiL) testing and 2) installation and configuration of the EMPFD software and associated hardware in the simulator. Preliminary input for the EMPFD overview and training materials was provided by Anthony Lambregts. A working meeting was held with Chief Pilot Jamie Edwards to go through details of the control algorithm and associated display and to get input on how to best convey the necessary information to prospective pilot study participants.

The simulator was reconfigured for manual mode testing of the EMPFD. For manual mode testing, the EMPFD was driven by the outputs of FSX, enabling the evaluation of control cues provided by the display. Pilot test subjects flew straight-in approaches that included multiple energy-state transitions (see figure 2), alternately using the EMPFD and a conventional primary flight display (PFD) to change states. Pilot comments were gathered and documented to obtain a first-impression opinion of the EMPFD.

5.1 EMPFD TRAINING MATERIALS

An overview document describing the essential concepts of the EMPFD was produced and delivered to the FAA. A PowerPoint™ presentation was developed to help train pilots participating in the study. Before the tests, a one-hour training session was provided, which included video captures of the display, an overview of the essential concepts, and an introduction to the symbology.

5.2 EMPFD STUDY SETUP

The interface software enabled the activation of speed, altitude, and heading bugs on the EMPFD at predefined distances from the runway threshold. Pilots were tasked with performing an approach in a simulated Cessna 172 SP. A closed-circuit camera was mounted to capture the pilot activity and comments, and real-time video of the simulated flights (both from the camera, and directly from the EMPFD) were displayed on two large-screen TVs in the lab and saved for later review.

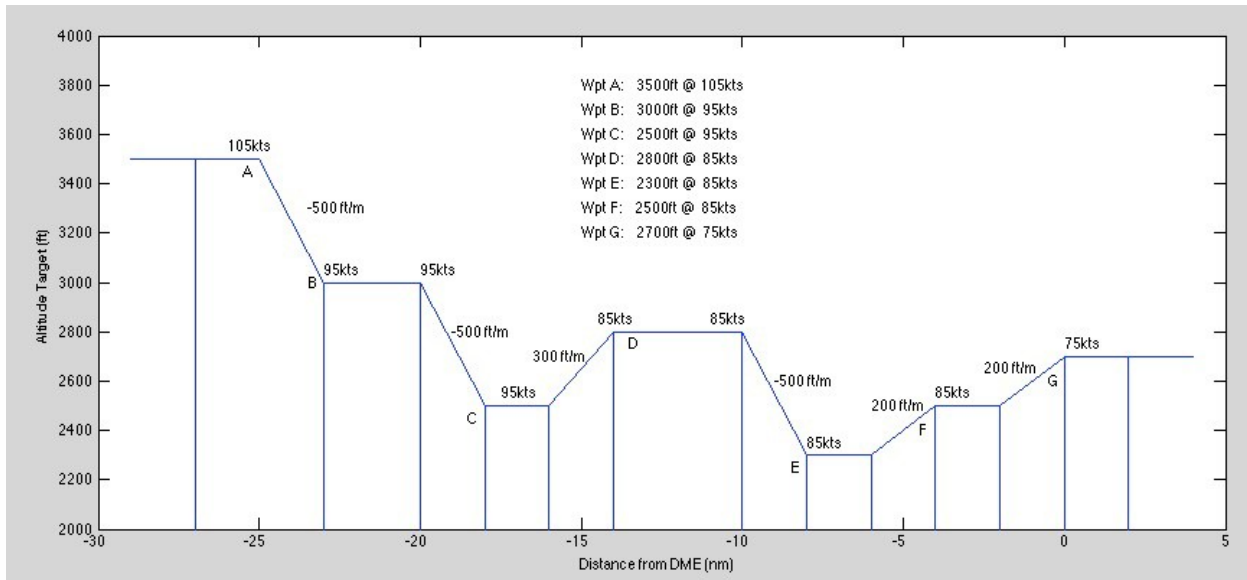

Figure 2. Vertical profile for preliminary EMPFD testing

The simulation configurations were saved as FSX .flt files. They began in straight-and-level flight, approximately 15 NM from the runway, with the aircraft close to the runway heading and the heading autopilot on so that the pilot could focus on the speed and altitude. In one case, the pilots were provided energy cues by the modified EMPFD, and in the other case they were provided no energy cues.

As shown in figure 3, the presence of the bugs activated energy bars next to the speed and altitude tapes. The initial study evaluated whether or not pilots could use the energy cues to efficiently transition between altitude and speed targets. Chief pilot Jamie Edwards and Ohio University School of Aviation chairman and pilot Bryan Branham flew the modified EMPFD and provided valuable configuration feedback.

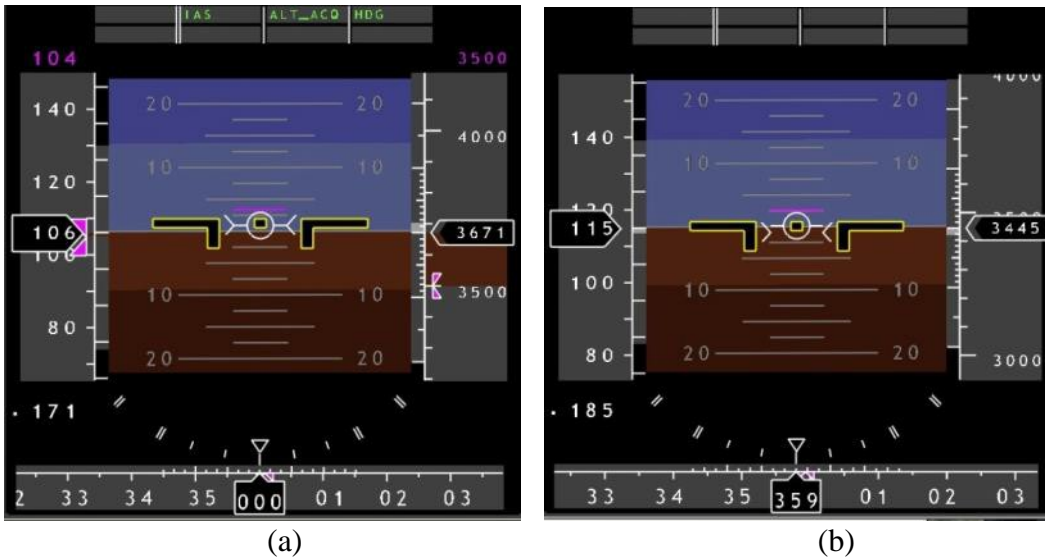

Figure 3. (a) EMPFD configuration with speed, altitude, and heading bugs activated; the bugs were set only to provide cues to the pilot; no altitude or speed autopilots were engaged; (b) EMPFD configuration without speed and altitude bugs

5.3 PILOT EVALUATION STUDY (ROUND 1)

The pilot evaluation study of the EMPFD included two Ohio University School of Aviation pilots who were introduced to the concepts and implementation of the EMPFD on the simulator, and flew a flight profile similar to the one in figure 2.

5.3.1 Pilot Evaluation Study Scenario

The profile featured seven waypoints with specific energy targets, and the pilots were instructed to arrive at the waypoints as close to that energy condition as possible. These tests were meant to evaluate the efficacy of the energy bars (see figure 3) at providing guidance cues for the pilot as the aircraft moved through a series of energy-state changes. Flight test cards were developed to provide specific procedures to help normalize the test runs, enabling evaluation and comparison of flight-technical error with and without the use of the energy bars.

5.3.2 Pilot Evaluations

Three pilots participated in the study; their backgrounds and opinions of the displays are summarized below.

5.3.2.1 Nick Gamrath

Nick Gamrath is a Certified Flight Instructor (CFI) with an instrument rating and a commercial pilot's license. He has more than 270 hours in a Piper Warrior III and 20–30 hours in a Piper Arrow.

First trial without standard PFD:

“Not much different than what we’re used to. Trim for a given airspeed and increase/decrease power to climb/descend until the bar hits the desired FPM. As airspeed changes, pitch control is necessary to increase or decrease to desired airspeed (pitch down to increase; pitch up to decrease). Once airspeed is attained, power is adjusted to maintain that climb/descent and airspeed.”

Second trial with modified EMPFD:

“Same concepts apply, except the energy bars provide a quick reference to how effective your power/pitch changes are, and allow you to predict more accurately where those power/pitch settings will take you.”

Notes:

“Some pilots familiar with current PFDs were used to seeing ‘trend bars’ during turning flight. The bar will travel to a given setting to indicate your rate of turn. I feel because of this that the energy bar concept is not totally foreign, and would allow for an easier transition to this type of display. The specific numbers and calculations that the energy bars indicate would not necessarily be vital for a GA pilot to know, but it would be important to understand that matching up with the error indication will eventually bring the aircraft to its desired airspeed/altitude. Used in this way, it would be ideal for a pilot that needs to ‘stay ahead of the aircraft,’ and would allow him to accurately predict power/pitch settings.”

5.3.2.2 Dylan Ewing

Dylan Ewing is a fourth-year student pilot and flight-team captain. He has more than 250 hours of flying in a Piper Warrior III, a Piper Arrow, a Cessna 152, and a Cessna 150.

Comments:

- Flew climbs and descents at changing and steady airspeeds.
- New concept to understand. I don’t usually think of kinetic and potential energy while flying.
- Makes small transitions (and corrections) easier to see. Too high and too slow or too low and too fast.
- Maybe good as a standalone instrument on MFD instead of on PFD.
- Makes pilot more aware of physics of flight.
- Uses in power off/engine out gliding performance?
- Quick calculation of distance in that situation?
- Help notice small changes in airspeed and attitude.

5.3.2.3 Mike Braasch

Mike Braasch is a Professor of Electrical Engineering and Computer Science at Ohio University and holds a private pilot's license.

Comments:

Dr. Braasch provided valuable comments regarding the EMPFD training and talked about the emergence of 4D navigation to deal with crowded airspace, emphasizing the importance of arriving at the right place at the right time. "Target altitude and speeds will be part of it. How about pilots who need to switch between multiple air frames? Wouldn't it be nice if they didn't have to spend the first 20 hours getting used to the way the airplane works? These cues can help the low-time pilots avoid the overshoot."

5.4 PILOT EVALUATION STUDY (ROUND 2)

One Ohio University CFI and two aviation students were invited to participate in the next round of study; some representative results of those tests are shown in figure 4.

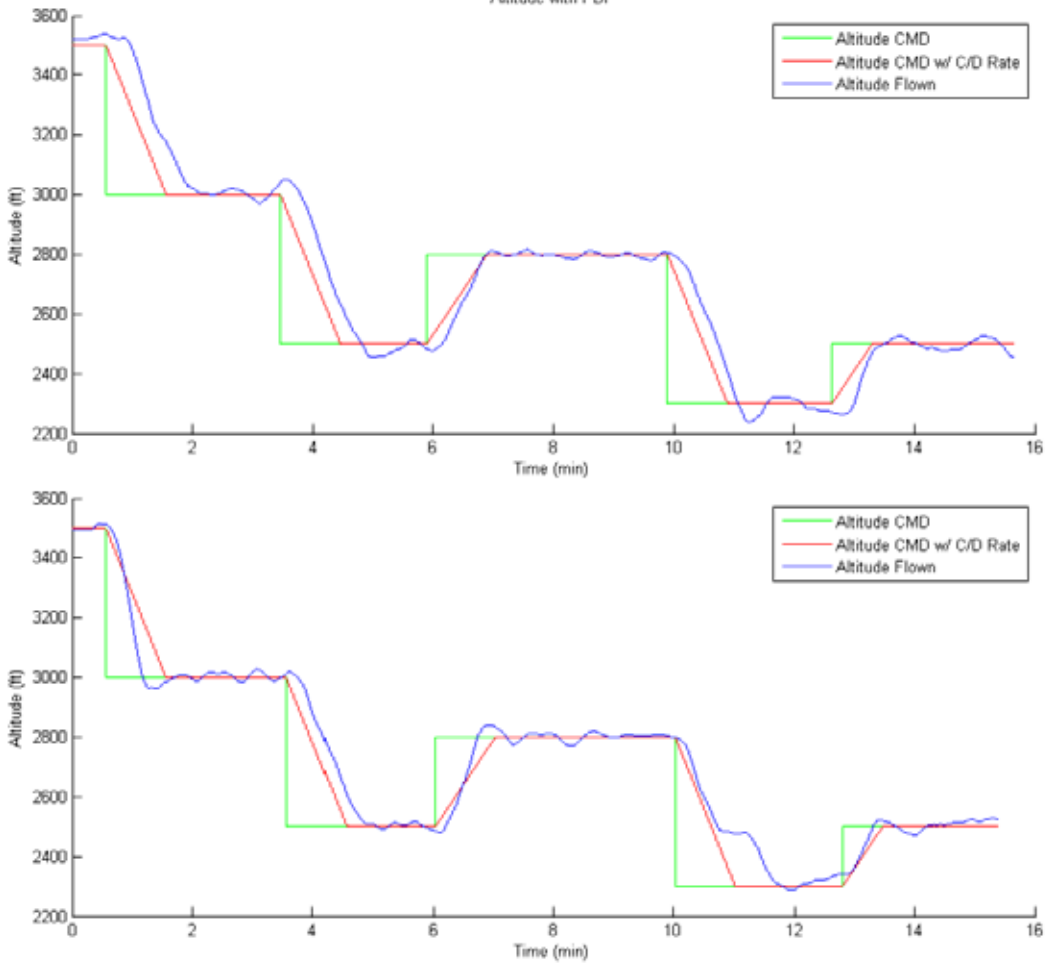

Figure 4. Vertical profile commanded vs. achieved

6. ENERGY-BASED DISPLAY FOR GA

Ohio University Avionics Engineering Center personnel hosted Robert McGuire and Dave Sizoo of the FAA on April 2–3, 2013. The task was refocused to emphasize design and implementation of an energy-based display for GA that included path-based guidance during the approach phase. The main decisions resulting from those discussions were:

1. Move to a synthetic vision system (SVS) display, and a navigation display and vertical profile display (VPD) with conflict probes.
2. Include the 3D tunnel on the display for those cases in which a trajectory (nominal or for emergency purposes) is defined. If possible, remove the leading lines of the tunnel (indicated by the arrows) because they could lead to a “cross” being shown as an artifact.
3. Reuse parts of the symbology used in the EMPFD and consider others:

- Include potential flight path angle (PFPA)_{max}, but also add a PFPA_{min}. Maybe even indicate the point in between for “half-throttle.”
- Make the speed trend and the vertical speed similar in terms of symbology; re-evaluate scaling as done in the EMPFD.
- Check how to move the energy information to the center of the display around the flight path vector (FPV) similar to the airspeed error ribbon.
- Keep the PFPA.
- Consider including envelope-protection information, such as angle-of-attack, similar to the A380 (on the airspeed tape) or the Boeing 787 (whiskers for maximum pitch).
- It may be necessary for some symbology to be turned off. Depending on what is required, symbology may be activated.

6.1 ENERGY-BASED SYNTHETIC VISION DISPLAY

This section describes a new aircraft cockpit display implementation that combines a pathway-in-the-sky with energy-based guidance cues. The goal is to provide GA pilots the information they need to fly a stabilized approach and arrive on the runway centerline at the proper altitude (potential energy) and speed (kinetic energy). Figure 5 illustrates the state variables, including track ξ , true heading ψ , sideslip angle β , velocity v , wind-velocity v_w , angle-of-attack α , pitch θ , and flight path angle γ .

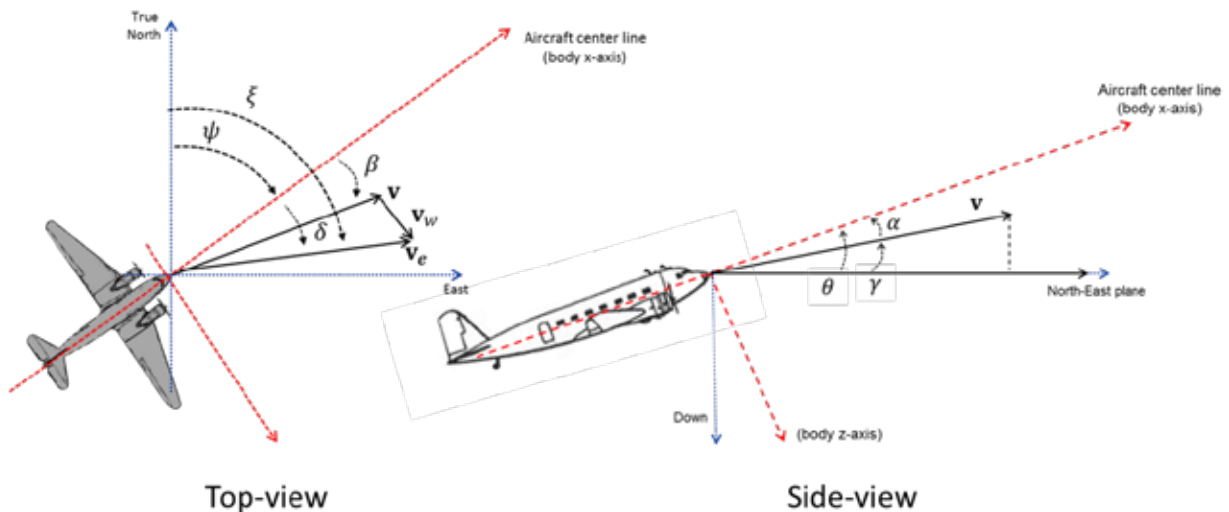

Figure 5. Flight parameters in a moving atmosphere (no vertical wind component)

An SVS with an additional perspective flight path display (pathway-in-the-sky), such as the one described in [10], forms the foundation of the current research. The display presents an intercept tunnel to be followed by the pilot on a curved approach to the runway. In addition, a range of energy cues are available for GA pilots to efficiently manage control effort.

First, the glide path along the extended centerline of the selected runway is visualized on the PFD. Upon visual acquisition of this path, the pilot can choose to have the system compute and

display an intercept tunnel from the current position to the glide path along the extended centerline and can use a flight path marker (FPM) to assess the aircraft motion with respect to the lateral and vertical path constraints. To assess the deviation of the current energy state from the desired energy state, a PFPA indicator is included. The PFPA is an acceleration cue (along the flight path), and is scaled such that it indicates a change of flight path at the current power setting while holding speed constant.

In addition to the PFPA, the display includes the maximum and minimum PFPA to make pilots aware of the safety margins when applying maximum thrust and idle thrust. Finally, the display includes an indication of pitch limits with respect to the critical stall (v_s) and never-exceed (v_{NE}) velocities.

6.1.1 Energy Cues

The basic symbology set that is proposed for the SVS PFD in this paper is shown in figure 6. In addition to the waterline that indicates the pitch angle, θ , the display includes the FPM. The FPM is driven by the aircraft velocity vector indicated by “v” in figure 5, and includes both a vertical component (the flight path angle γ) and a lateral component (the track angle ξ). This symbology was also included on the 1979 implementation of the Klopstein HUD format evaluated by the Calspan Advanced Technology Center [11].

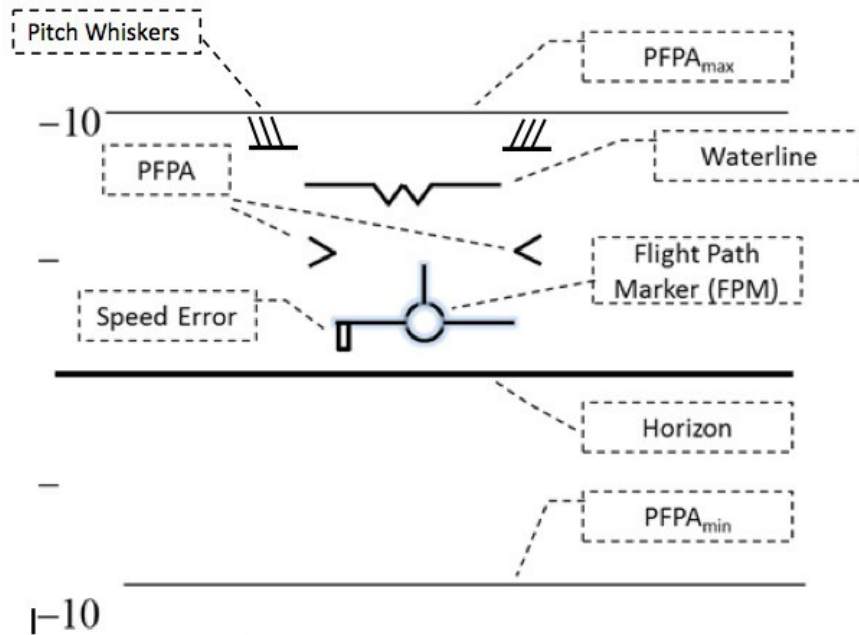

Figure 6. Basic display symbology

Similar to Klopstein and the EMPFD, the display also includes a PFPA, or g_p , indicated by a double caret with respect to the FPM symbol. g_p is a measure of the attainable FPM at the current throttle setting. It is the FPM the airplane attains when the rate of change of the velocity is reduced to zero by applying only elevator/pitch control. Given a FPM depicting a flight path angle g , the PFPA is given by:

$$g_p = g + \frac{\dot{v}}{g}, \quad (1)$$

where \dot{v} is the acceleration along the flight path, and g is local gravity. Note that $g_p = g$ when there is no acceleration along the flight path. The example in figure 6 shows the aircraft climbing with a flight path angle of approximately 2° . At the same time, the aircraft is accelerating as the PFPA, indicated by the carets, is larger than indicated by the FPM. The PFPA is 6° and indicates the attainable FPM at the current speed and the current throttle setting. Two additional lines indicate the maximum PFPA ($g_{p_{\max}}$) and minimum PFPA ($g_{p_{\min}}$), and correspond to the FPM attainable at maximum and minimum throttle, respectively.

Symbology depicting the $g_{p_{\max}}$ can provide energy-awareness cues by converting the maximum acceleration of the aircraft along the flight path to a maximum achievable flight-path angle. Hence, $g_{p_{\max}}$ is given by:

$$g_{p_{\max}} = n + \frac{v_{\max}}{g} \quad (2)$$

and can be calculated for various altitudes and power settings. For example, a Cessna 172 on the downwind leg of an approach at 2100 RPM and 85kts can accelerate at approximately 1kts/s by applying full power. Assuming an initial condition of level flight, this yields a $PFPA_{\max}$ approximately equal to 3° . Figure 7 shows an example with a zero FPM and zero PFPA, indicating no acceleration along the flight path. The carets are aligned with the FPM, and both sit on the horizon.

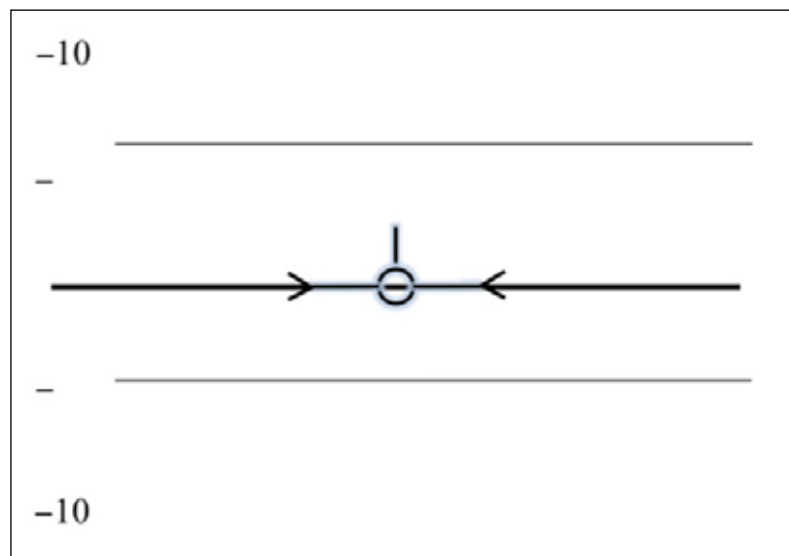

Figure 7. Straight-level flight, no acceleration

Acceleration cues are also indicated by the PFPA using appropriate scaling with respect to the pitch tape. For example, the proper throttle setting for capturing a 3° glide slope from level flight

is found by reducing the throttle until the PFPA is equal to -3° , while pushing the stick forward almost simultaneously to maintain constant speed.

A small bar on the left wing of the FPM in figure 6 represents the speed error and indicates the difference between the indicated airspeed (IAS) and the selected airspeed (target). Additionally, the pitch whiskers provide a dynamic representation of the pitch attitude at the critical angle-of-attack, and will be at or above the waterline if that angle is exceeded.

6.1.2 Path and Energy-Based Approach Guidance

In addition to a symbology set that provides the pilot with better energy-state awareness, the GA display discussed in this paper includes a pathway-in-the-sky to provide the GA pilot with awareness of the desired flight path during the arrival and approach procedure. The pilot can follow this desired path by lining up the FPM with the center of the path and monitoring his energy using the energy cues provided by the display.

When getting close to the destination airport, the glide path along the extended centerline of the selected runway will be generated automatically. The system can further compute and display an intercept tunnel that represents the standard arrival procedure consisting of a downwind leg, a base leg, and the final approach segment (see figure 8). The blue line through AB represents the final approach segment, positioned above the extended centerline with a glideslope indicated by γ_1 . At point B'', the aircraft must have reached the final approach speed (v_{REF}). The line from D to C is the downwind leg at a constant height h_3 , parallel to the runway at a distance dd_2 .

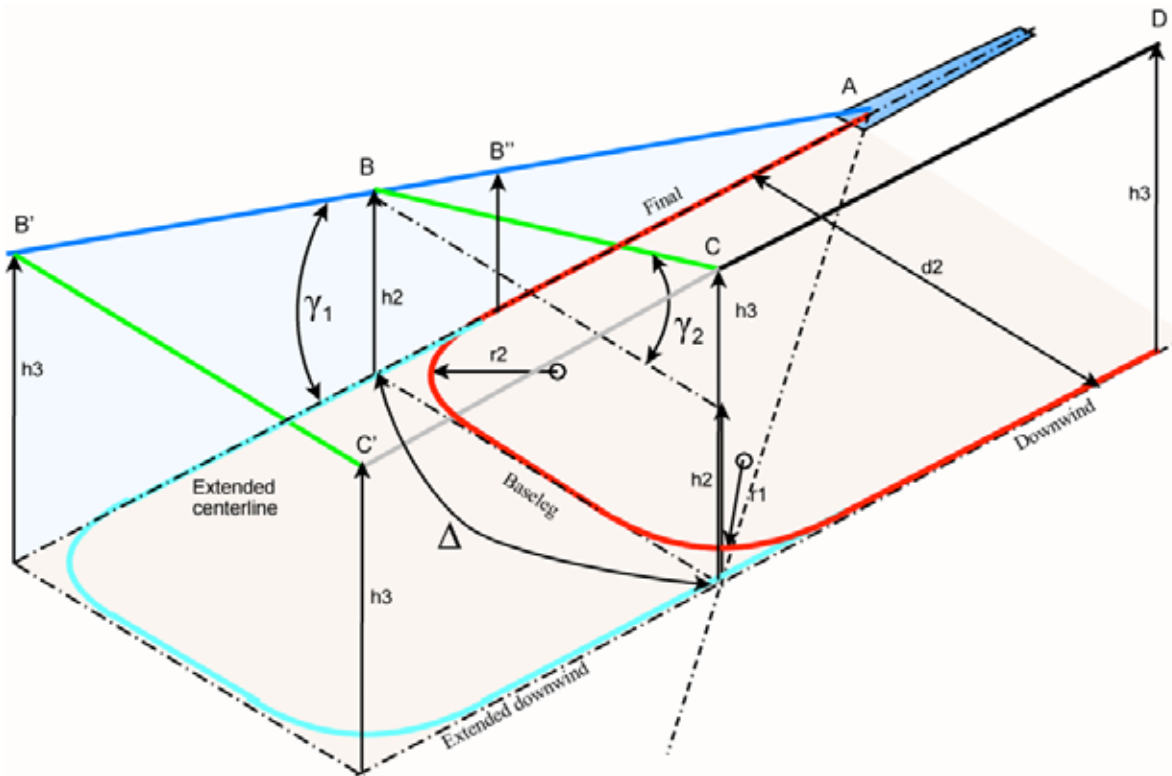

Figure 8. Geometry describing synthetic vision-based path guidance

6.1.3 Guidance from the Downwind Leg

Pathway-based guidance to point A can be provided to a pilot on the downwind leg. The conventional procedure for capture is to turn to base leg, with the base leg defined by point C lying on a line that has a 45° angle (Δ in figure 8) relative to the extended centerline. In this case, the location of point C is determined by d_2 . The height h_2 at B is determined by the glideslope (γ_1) of the final segment and given by:

$$h_2 = d_2 \tan \gamma_1 \quad (3)$$

The glideslope that must be flown when on base leg (γ_2) is determined by the height during the downwind leg according to:

$$\gamma_2 = \tan^{-1} \frac{h_3 - h_2}{d_2} \quad (4)$$

The turn radius to go from downwind to base leg (r_1) is determined by the roll angle and the speed on the downwind leg. The turn radius to go from base leg to final (r_2 is determined by the roll angle and speed on final, assuming that base leg is used to reduce the speed to final approach speed). Given these dependencies, the whole path can be generated dynamically if distance d_2 and height h_3 are defined. Various rules can be defined to choose these two parameters.

Example rules for distance d_2 choice:

- Spatially defined limit
- Turn-radius defined limit based on current velocity and maximum bank angle
- Turn-radius defined limit based on specified velocity and maximum bank angle (i.e., rules for height h_2 choice)
- Current altitude
- Specified height above ground for downwind leg

Additional constraints imposed on the base leg, such as maximum glideslope angle or maximum vertical speed, may require extension of the downwind leg and, therefore, a reduction of the 45° angle. This extension is indicated by the portion of the cyan line from $B\phi$ to $B\phi$ in figure 8. Procedurally, it may be required to limit the maximum extension. These parameters are configurable by the user for a customized approach.

6.1.4 Pilot Interaction on Downwind Leg

When on downwind, the pilot selects a runway, and the system dynamically generates a tunnel based on the constraints defined in the previous section. After generation of the intercept tunnel, the pilot can use the FPM to maneuver the aircraft in the direction of the intercept point. This enables the pilot to steer the aircraft to and along the path, and the PFFPA allows the pilot to assess

deviation from the desired energy state and provides guidance for setting power. Max- and Min-PFPA limits provide awareness of safety margins. The final stabilized approach from point B to point A in figure 8 is constrained to provide 1) a minimum distance, 2) a minimum glide path, and 3) a reference speed. Note that in the current implementation, the target speed at point B is $W_{REF} + 3\text{kts}/-0\text{kts}$, and at point A the tolerance is reduced to $+1\text{kts}/-0\text{kts}$. This introduces the concept of an energy funnel, which requires an increase in speed tolerance closer to the runway.

6.1.5 Implementation Example

Johnson County Executive Airport (KOJC) in Olathe, KS was selected to evaluate the functionality of the dynamically generated approach path. A button on the virtual MCP was used to command the computation and depiction of a dynamically generated intercept tunnel. Once the simulation was started, the approach path generation function tested whether the criteria were met to generate an approach path. If this was the case, the INTC button on the MCP changed colors, from black to blue. Figure 9 shows the SVS PFD at that position.

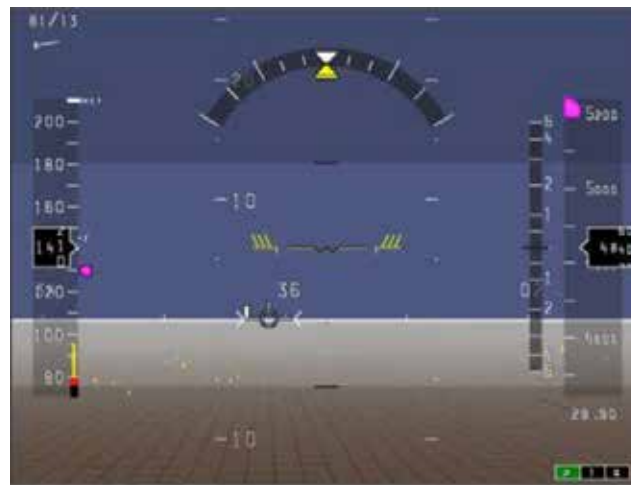

Figure 9. Initial position near KOJC (PFD)

In the example shown here, the routes were selected such that, initially, the distance from the aircraft to the airport was larger than the criterion used by the approach path function. However, for the scenario shown here, the aircraft continues along the route for which, at a certain point, all criteria are met, and the INTC button turns blue (see figure 10). To generate an approach path, the pilot has to press the INTC button. This will change the color from blue to green (figure 11), indicating that the path has been successfully computed. The downwind leg of the path is generated only up to a certain distance from the runway threshold (point D in figure 4). If the aircraft has not reached this point, the entry point of the path will be ahead of the aircraft, and the pilot must fly towards it. If the aircraft is beyond this point, the path will start from the aircraft's current location once the command to generate a path has been issued.

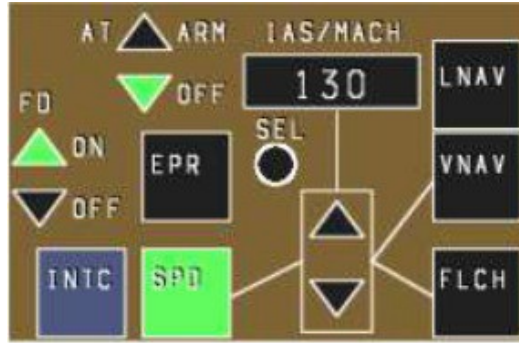

Figure 10. Blue color indicates path available

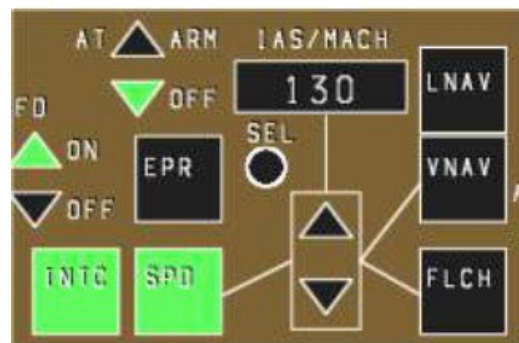

Figure 11. Green color indicates path calculated

The SVS PFD in figure 12 shows the entry point of the dynamically generated path located ahead of Ownship. The corresponding MFD in figure 13 shows the strategic view of the same situation. In this example, it is overlaid on top of a map, but typically that map is omitted. Figures 14 and 15 show the SVS PFD as Ownship gets closer.



Figure 12. Entry point to approach path (PFD)



Figure 13. Approach path with map (MFD)



Figure 14. Nearing approach path (PFD)

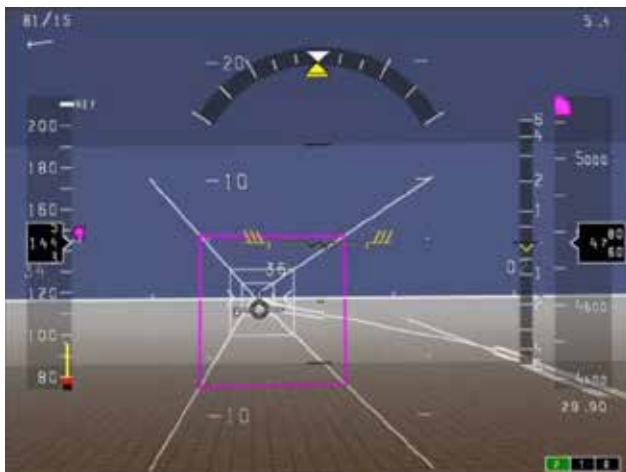

Figure 15. Continuing toward approach path

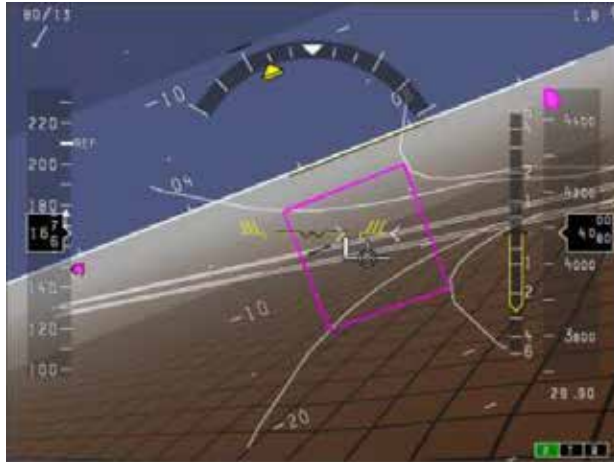

Figure 18. Turning onto base leg

Figure 19 shows Ownship turning onto final. Vertical speed is approaching 4000 FPM, and IAS is 195kts and accelerating. Once the turn onto final is completed, Ownship transitions from the almost 10° glideslope on base leg to the 3° glideslope on final. In the situation depicted in figure 20, Ownship is at 270 ft above ground level with an IAS of 192kts and decelerating. Note that these are initial simulation results. In, HiL simulations and flight tests, the constraints discussed above on the glideslope, vertical speed, and target airspeed along the flight path are considered. Regardless, the energy cues provided ample awareness of the developing energy state.

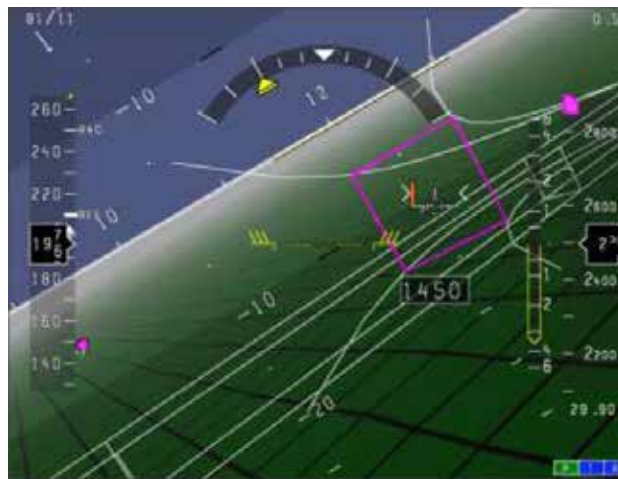

Figure 19. Turning onto final

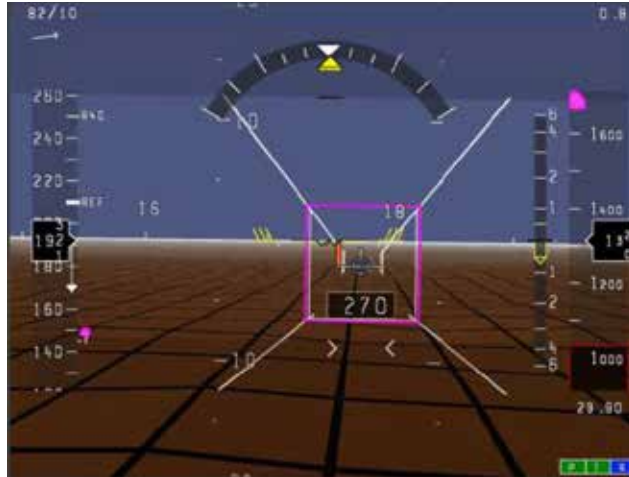

Figure 20. Tunnel capture after extreme descent

The general idea behind the concepts is to provide a sufficiently accurate preview of the future target state so the pilot can use optimal open-loop control. This should be reflected in a power setting that is initially very close to the one required to arrive at the intercept point at the desired speed. Also, in case of the geometry shown in figure 8, minimal changes in power should be required during the intercept. With the additional (energy-based) information about margins, it should be straightforward to detect situations that are safe (i.e., sufficient margin), those that warrant more attention (close to the margins), and those that cannot be maintained/executed.

6.2 SIMULATOR EVALUATION AND FLIGHT TESTS

The concepts discussed above were implemented in both an HiL simulation environment and as an avionics function onboard a representative GA aircraft using a portable attitude heading reference system (AHRS) and a miniature PC. Mobile platform development focus shifted from testing the display concepts in the simulator to testing with a mobile rig. The mobile rig was built around a Sagatech Clarity SV AHRS system that provided roll, pitch, yaw angles, and GPS location (see figure 21). The AHRS system was supported by a software development kit, and a programmed interface to Delphins. A Surface Pro 2[®] was loaded with Delphins, and interfaced with the Sagatech. The main drawback of the tablet was poor visibility in direct sunlight. For this reason, two 7-inch first-person view monitors and an Intel[®] NUC PC were purchased and connected, as seen in figure 22.



Figure 21. Sagatech AHRS

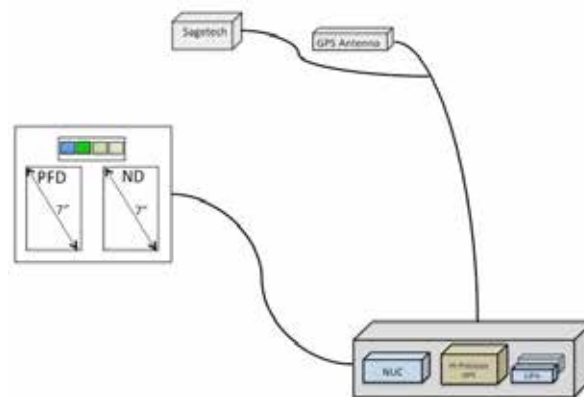

Figure 22. Mobile Delphins design concept

Two versions of the mobile testbed were assembled for parallel testing by David Sizoo in Kansas City and by Ohio University participants. Each setup used the same type of hardware, and each had an identical copy of Delphins installed. Figure 23 shows the setup used by Ohio. The button bar across the top was the interface, and included start/stop, zoom, and other functions as needed. It also included the button to draw the intercept tunnel when it was available. The power supply at the bottom ran the NUC computer (bottom right) and could be powered by a 12V or 28V cigarette lighter, AC power, or batteries. The Sagatech Clarity was initially tested on a motorcycle (see figure 24) to capture some of the dynamics that would take place in the airplane. The results were promising, and a fourth interface program was developed by Ohio University to run the AHRS unit with Delphins.



Figure 23. Ohio version of the mobile rig

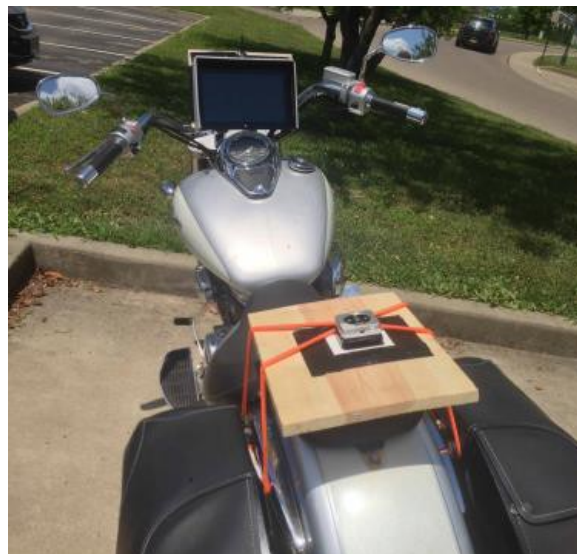

Figure 24. Ground-test vehicle

6.2.1 Flight Testing

Flight testing of the mobile rig was performed to evaluate functionality of the path-based guidance cues. The AHRS unit does not provide any airspeed information, and therefore was not well-suited to many of the energy-based cues. Future work should consider incorporation of an airspeed measurement or improved estimate.

6.2.1.1 Ohio Flight Test – 8-7-15

The Ohio University version of the rig was tested aboard the Beechcraft Bonanza. The flight data were saved and can be replayed, but the drawing of the tunnel was not captured, so replay of the

flight data does not include the drawing of the tunnel because Delphins was unaware if the flight was live or recorded. Future versions should include the pilot's inputs to the system (i.e., when the tunnel was drawn). The figures below are screenshots from the flight video taken in August 2015 by Ohio University. The flight videos were provided to the FAA and showed the functionality of many of the display's features.

Figure 25 shows that the blue button has been activated, indicating a tunnel is available. Using the button bar, the pilot can request the tunnel to be drawn, and the blue button turns green. The tunnel can be seen on the NAV display in figure 26, but cannot be seen clearly on the PFD.



Figure 25. Tunnel available



Figure 26. Tunnel drawn

Figure 27 shows Ownship intercepting the tunnel from the left side. Note that the speed bug is set to 115 kts, and the airspeed indicator shows more than 120 kts. The relatively small speed error is indicated by the ribbon growing out of the left wing, indicating excess speed. In figure 28, the tunnel has been captured and the speed error has been reduced.



Figure 27. Intercepting the tunnel



Figure 28. Inside the tunnel

Figure 29 shows the runway coming into view during another approach (note the speed and altitude bugs were not set for this trial to focus on the tunnel only). Figure 30 shows the final moments before touchdown.



Figure 29. Runway in view



Figure 30. Final moments before landing

6.2.1.2 FAA Flight Test—August, 2015

The mobile rig was flown by FAA test pilot David Sizoo on August 16, 2015 to evaluate the path-based guidance and energy cues. An offset in the altitude was present as an artifact of ground testing that limited the utility of the energy cues, but the flight proceeded regardless because of time constraints. An email was received November 12, 2015 containing feedback from Mr. Sizoo. His comments were as follows:

- “I did not exercise the test cards that Erik developed. Rather, I just flew 4 patterns at KOJC. I intend to fly the cards on the next flight after some of the bugs are fixed.”
- “As Tony and I discussed before I got airborne, the Altitude display had a bias. On the ground at KOJC (field elevation of 1076 ft), the Delphics showed 3320 ft. Also I think the airspeed showed 136 kts with 0 kts Groundspeed.”
- “When on downwind, I generated a path. On the Delphics Nav Display, the path overshot the runway. (I saw this same issue with X-plane) and took a picture that I

sent to Tony. If I followed this path on the PFD, it took me to a parallel offset (approximately 5–10 runway widths to the west of runway 18 at KOJC).”

- “The P T R cues do not indicate as briefed by Tony. For example, I understood that the R would change from Black when within 5 miles longitudinally, and 2 miles laterally from the runway IF you were within a 25 degree cone from the runway. (TONY-did I get this right??) Anyway, this was not the case in flight.”
- “It was very difficult to hand fly to remain within the Pathway boxes. Maybe this is a box size issue? When flying from base to final and trying to stay in the path box on the PFD, I was unsuccessful. I usually deviated out the top of the box.”

7. CONCLUSIONS AND FUTURE WORK

After studies performed using the EMPFD reaffirmed the advantages of energy-state cues, a synthetic vision display was developed providing approach-path guidance and energy-state awareness cues. The display is intended for deployment in GA aircraft to aid pilots during the approach phase of flight and has been tested in both a fixed-base simulator and in actual flight tests, with promising results. Other phases of flight, including arrival and landing, should be addressed in further studies.

A specific scenario under consideration for future work consists of a Continuous Descent Approach (CDA) with Merging and Spacing on a closely spaced parallel runway. Based on discussions with the FAA, the gap analysis described earlier was expanded to consider the effects of low required navigation performance values and increased use of CDA. These issues are not only of interest in terms of NextGen—they are relevant in today's cockpits as well, especially during off-nominal conditions. Experiments should measure the accuracy with which the open-loop control actions are performed. Less accuracy means more corrections later and can result in overshoots and oscillations of target speed and/or altitude. Awareness of the proximity to the margins can be assessed by introducing unsafe situations. Basing this on actual accidents and incidents should provide sufficient realism and an indication of whether the proposed guidance may have made a difference.

Part of this work was presented at the AIAA/IEEE 33rd Digital Avionics Systems Conference (DASC) [10].

8. REFERENCES

1. Lambregts, T.A., Rademaker, R., Theunissen, E. (2008). *A New Ecological Primary Flight Display Concept*. Proceedings from the IEEE Digital Avionics Systems Conference (DASC), St. Paul, MN.
2. General Aviation Joint Steering Committee, (2011). 10 Years of Accidents and Causal Factors, *Sport Aviation*, p. 10.
3. FAA. (2012). *NextGen Implementation Plan*. U.S. Department of Transportation Federal Aviation Administration, March 2012.

4. "Operation Concept for the Next Generation Air Transportation System (NextGen)," CONOPS, Concepts of Operations Document, Version 3.0, October 1, 2009.
5. Lambregts, T.A., Tadema, J., Rademaker, R.M., Theunissen, E., (2009). *Defining Maximum Safe Maneuvering Authority in 3D Space Required for Autonomous Integrated Conflict Resolution*. Proceedings from the Digital Avionics Systems Conference, Orlando, FL.
6. Rademaker, R., Theunissen, E., and Lambregts, T.A. (2010). *Maximizing the Use of the Vertical Maneuver Space for Conflict Prevention and Resolution*. Proceedings from the IEEE Digital Avionics Systems Conference (DASC), Salt Lake City, UT.
7. Tadema, J., Theunissen, E., Lambregts, T.A. (2009). Exploring the Potential of Energy and Terrain Awareness Information in a Synthetic Vision Display for UAV Control. *Enhanced and Synthetic Vision*, 7328(1) 732809–732809. doi:10.1117/12.819257.
8. Theunissen, E. (1997). *Integrated Design of a Man-Machine Interface for 4-D Navigation*. Amsterdam, Netherlands: Delft University Press.
9. Monagan, S.J. and Smith, R.E. (1981). *Head-Up-Display Flight Tests*. Proceedings from the Fifth Advanced Aircrew Display Symposium, Naval Air Test Center, Patuxent River, MD.
10. Adami, T.M., de Haag, M.U., Theunissen, E., Sizoo, D., McGuire, R. (2014). *An energy management display for general aviation safety enhancements*. Paper presented at the Digital Avionics Systems Conference (DASC), 2014 IEEE/AIAA 33rd, Colorado Springs, CO.

APPENDIX A—ENERGY CUES

A.1. QUICKENING THE FLIGHT PATH ANGLE

To avoid potential PIOs, the flight path angle marker is “quickened” as:

$$g_{\text{quickened}} = g + 0.25q \quad (\text{A-1})$$

A.2. ACCELERATION CUES

$$\ddot{h} = \frac{T \cos a \cos b - D - mg \sin g}{m} \quad (\text{A-2})$$

$$g_p = g + \frac{\ddot{h}}{g} \quad (\text{A-3})$$

For propeller-driven aircraft, the thrust-to-weight ratio is given by:

$$\frac{T}{W} = \frac{\eta_p P}{\epsilon V} \quad (\text{A-4})$$

where η_p is propulsive efficiency at true airspeed V , and P is engine power. Thrust is then:

$$T = \frac{\eta_p P}{\epsilon V} \quad (\text{A-5})$$

and the maximum thrust at a given prop-setting and airspeed is:

$$T_{\text{max}} = \frac{\eta_p P_{\text{max}}}{\epsilon V} \quad (\text{A-6})$$

The acceleration at maximum thrust is:

$$\ddot{h}_{\text{max}} = \frac{T_{\text{max}} \cos a \cos b - D - mg \sin g}{m} \quad (\text{A-7})$$

so that the maximum PFPA is:

$$g_{p\text{max}} = g + \frac{\ddot{h}_{\text{max}}}{g} \times \quad (\text{A-8})$$

The flight path angle that will cause the speed to reach stall speed v_{s_0} in a given time interval can drive the maximum and minimum thrust settings T_{\min} and T_{\max} . Assuming no change in total energy, the kinetic energy lost and potential energy gained are related by the change in speed and altitude. For example, if the aircraft is traveling at an initial speed of v_{i_0} , and the speed that is being protecting against is the stall speed v_{s_0} the corresponding change in height is:

$$\Delta h = \frac{v_{s_0}^2 - v_{i_0}^2}{2g} \quad (\text{A-9})$$

Because $\dot{h} = v \sin g$, the following expression can be formed:

$$v_{s_0}^L = \frac{\dot{h}_s^2}{\sin^2 g_s} \quad (\text{A-10})$$

Substituting equation (6) into (5), and solving for g_s yields:

$$g_s = \sin^{-1} \sqrt{\frac{\dot{h}_s^2}{2g\Delta h + v_{i_0}^2}} \quad (\text{A-11})$$

Also, at constant vertical speed:

$$\dot{h} = \frac{Dh}{Dt} \quad (\text{A-12})$$

So, for a given time interval Δt , an \dot{h} is obtained from Eq. 8 that will cause the aircraft to lose enough kinetic energy to reach stall speed, and the associated flight path angle from Eq. 7. For example, a 1975 Citabria 7GCAA has a nominal stall speed v_{s_0} equal to 44 kts and a $v_{\text{REF}} = 57.8$ kts. To provide an indication of the FPA that will cause airspeed to drop from v_{REF} to v_0 , the required change in altitude is first computed using (5) as $\Delta h = 62.5$ ft. This value of Δh and a time interval $\Delta t = 10$ s results in a vertical speed equal to $\dot{h}_{10s} = 3720$ ft/m. Finally, equation (7) is used to find the critical flight path angle $\gamma_{10s} = 4.8^\circ$. A similar calculation indicates that a potential stall within 5s would result from a FPA of $\gamma_{5s} = 9.7^\circ$.

The maximum pitch is calculated as

$$q_{\max} = g_{P_{\max}} + a \quad (\text{A-13})$$

APPENDIX B—SIMULATOR CAD DRAWING

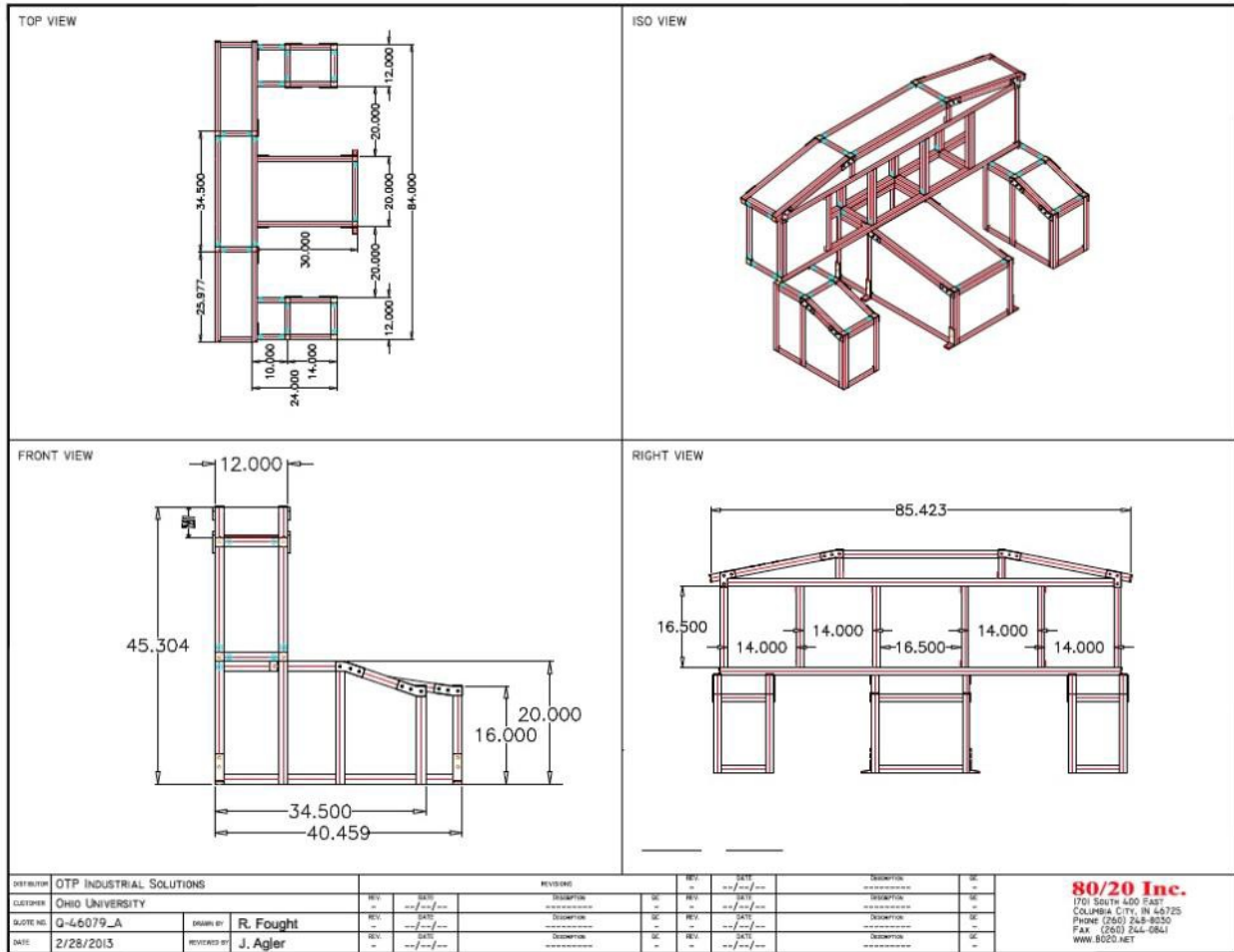

Figure B-1. Simulator drawing

APPENDIX C—PILOT STUDY RECRUITMENT

Recruitment for pilot subjects began, and approximately a half-dozen candidates were identified. They consisted of several aviation students, an instructor, and a retired airline pilot from the local area.

Pilots Needed for Display Study

The Avionics Engineering Center at Ohio University is running a study with support from the Federal Aviation Administration (FAA) to evaluate advanced cockpit display concepts for aircraft in the NextGen Airspace. As the skies get more crowded, more responsibility will be given to pilots to maintain safety and avoid collisions. Ideas like conflict probing and energy management have become the focus of new research, and engineers at OU have built a fixed-base, part-task simulator on the third floor of Stocker Center to conduct pilot-opinion studies on new implementations of these ideas. You can help by participating in the study. It will take about two hours, and will include 1/2 hour briefing, one hour in the simulator, and 1/2 hour to complete a questionnaire and provide other feedback. You can help make tomorrow's skies safer for everyone!

All experience levels welcome. Contact Tony Adami (adami@ohio.edu) to participate.



Tony Adami
adami@ohio.edu
740-593-1590

Figure C-1. Pilot study flyer

APPENDIX D—X-PLANE® SIMULATION ENVIRONMENT

Hot Keys





The issue of re-starting X-Plane each time a small change in the interface code is required was addressed through the implementation of hotkeys. X-Plane provides the functional framework to use hotkeys, and the user must write the code. Several other hotkeys have been implemented and will be described in the software instructions.

Hotkeys may be used to interface with Delphins, as shown in table 1. Be sure that X-Plane is the active window to use the hot keys. These hotkeys override the built-in functionality of the keys under X-Plane and may not be chosen optimally. Further investigation and feedback are encouraged.

Table D-1. Hotkeys

Hot Key	Function	Notes
T	Says Hello World	
M	Increase navigation display	
N	Decrease navigation display	
J	Toggle RNP tapes	
K	Increase ANP	
L	Decrease ANP	
R	Reload the configuration	
G	Reset Position	
W	W button on CDU	
D	Start to record data	
Z	Re-load Delphins	
V	Generate intercept tunnel	
S	Increase speed cmd	
T	Decrease speed cmd	
A	Increase alt cmd	
E	Decrease alt cmd	

APPENDIX E—MOBILE RIG

 A small, black, square-shaped computer (NUC) sitting on a wooden surface. A black cable is plugged into the top, and another black cable is plugged into the side.	 A rectangular, silver-colored power adapter with a power cord on one end and a connector on the other.	 A black power adapter with several cables connected to it, including a yellow and black braided cable, a black power cord, and a black cable with a connector.
<p>NUC Computer Running Windows 7 and Delphins</p>	<p>NUC AC Power Adapter</p>	<p>Mobile Power Adapter With Cables</p>
 A black, rectangular display stand with a handle on top and a base.		 A black, rectangular display stand with a handle on top and a base, viewed from the opposite side.
<p>Display Stand</p>		
 Two small, black, rectangular displays sitting on a wooden surface. A keyboard is positioned in front of them. Several black cables are connected to the displays and keyboard.	 A black power adapter with a blue label, connected to a power cord and several other cables.	
<p>Displays and Button Strip With Cables</p>	<p>Display Power Adapter</p>	

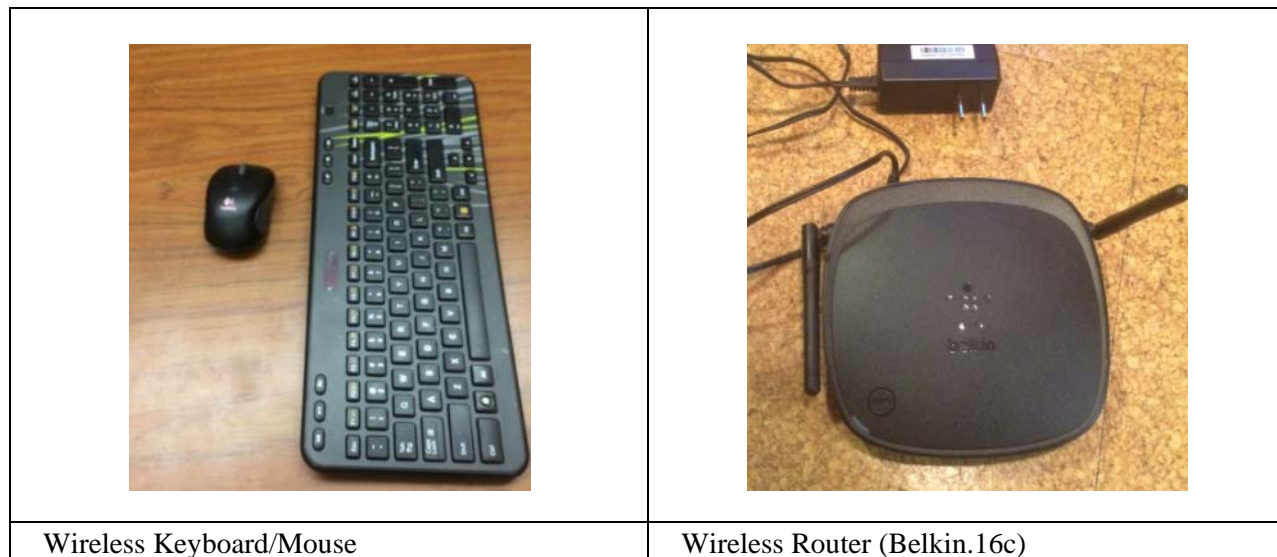

E.1. HARDWARE SETUP

The Delphins display system as configured runs on an Intel® Next Unit of Computing (NUC) computer, and can interface with X-Plane® or with a Sagetech ClaritySV AHRs. A hardware setup document was provided to the FAA to help with initial assembly. Figure E-1 shows the connections, and detailed assembly instructions were also provided. The video is transmitted from the NUC computer to the monitors via HDMI. The cables should be attached as shown. Figure E-2 shows an excerpt from the hardware setup instructions.

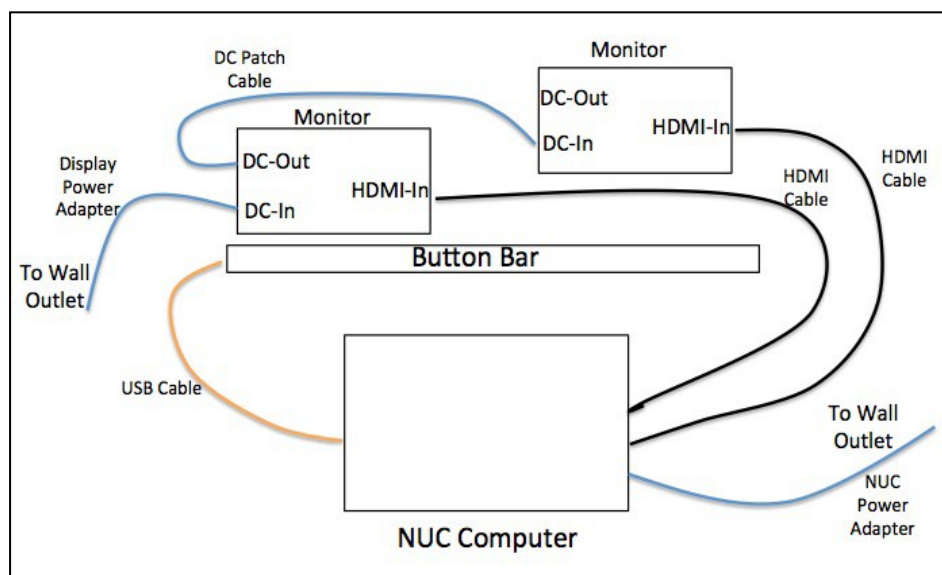

Figure E-1. Schematic diagram of assembled rig

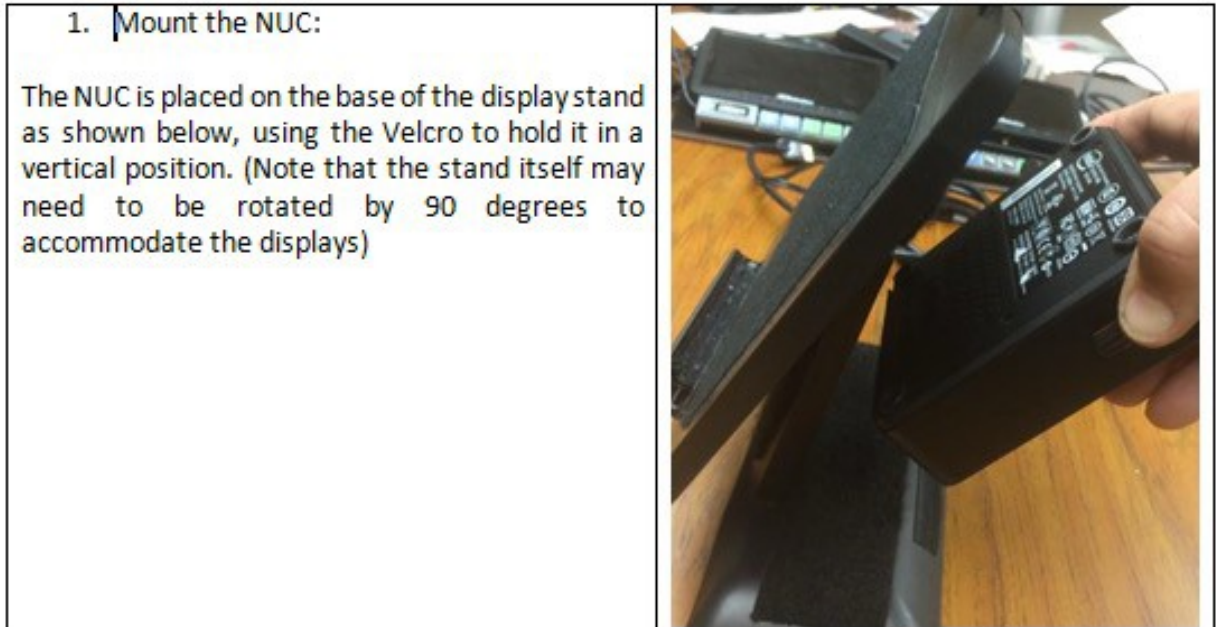

Figure E-2. Excerpt from hardware setup instructions

E.2. SOFTWARE SETUP

A software setup document detailing the process of getting Delphins running with X-Plane driving the displays, and some of the features of the user interface were delivered to the FAA. Note that the software setup document also includes detailed instructions for an initial flight. Figure E-3 shows an excerpt from that document.

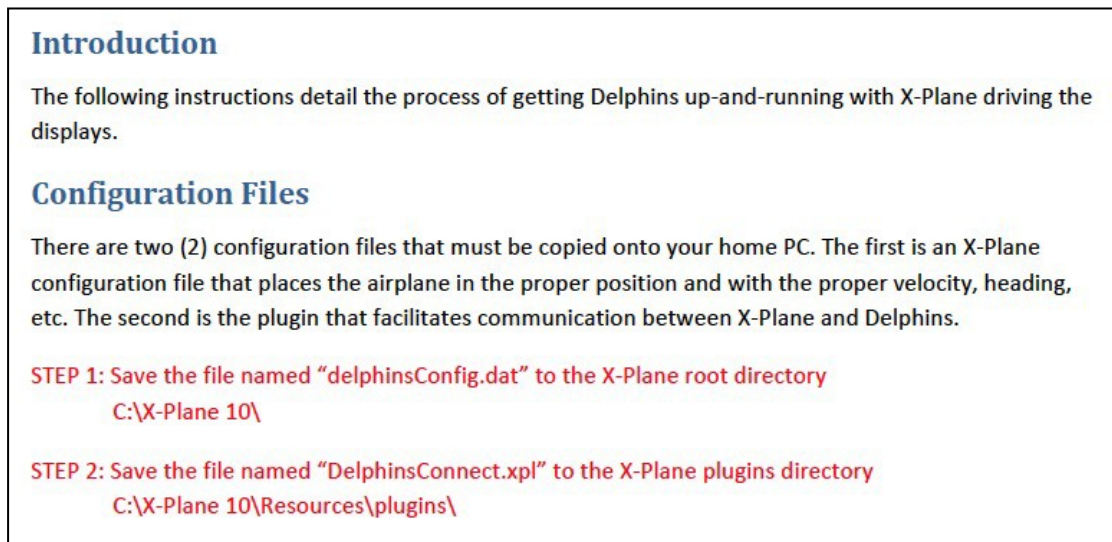

Figure E-3. Excerpt from software setup instructions

E.3. BUTTONS

A button bar (see figure E-4) is provided for the pilot to interface with Delphins in flight. The functions include such tasks as starting and stopping Delphins, and increasing and decreasing the range of the navigation display .

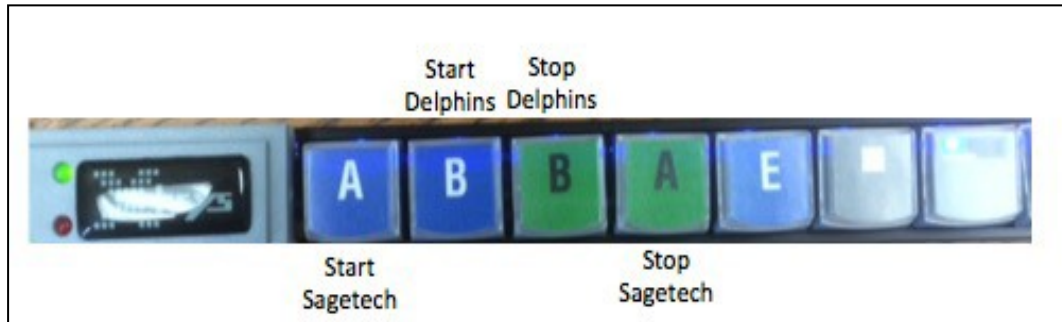

Figure E-4. Button bar to run Delphins

E.4. DELPHINS

Many of the features of Delphins are user-configurable. The interface for the user is a series of configuration files (plain text), which enable the program features. These configuration files are located below the Delphins root directory.

The Delphins software is installed in the directory Desktop\XplaneDelphins. The directory structure is important because the configuration files are sorted by category in various directories. The top-level structure is shown in figure E-5. The subdirectory call “maintun” contains configuration files that apply to the system as a whole, and is divided into airports, configurations, flight plans, and more (see figure E-6).

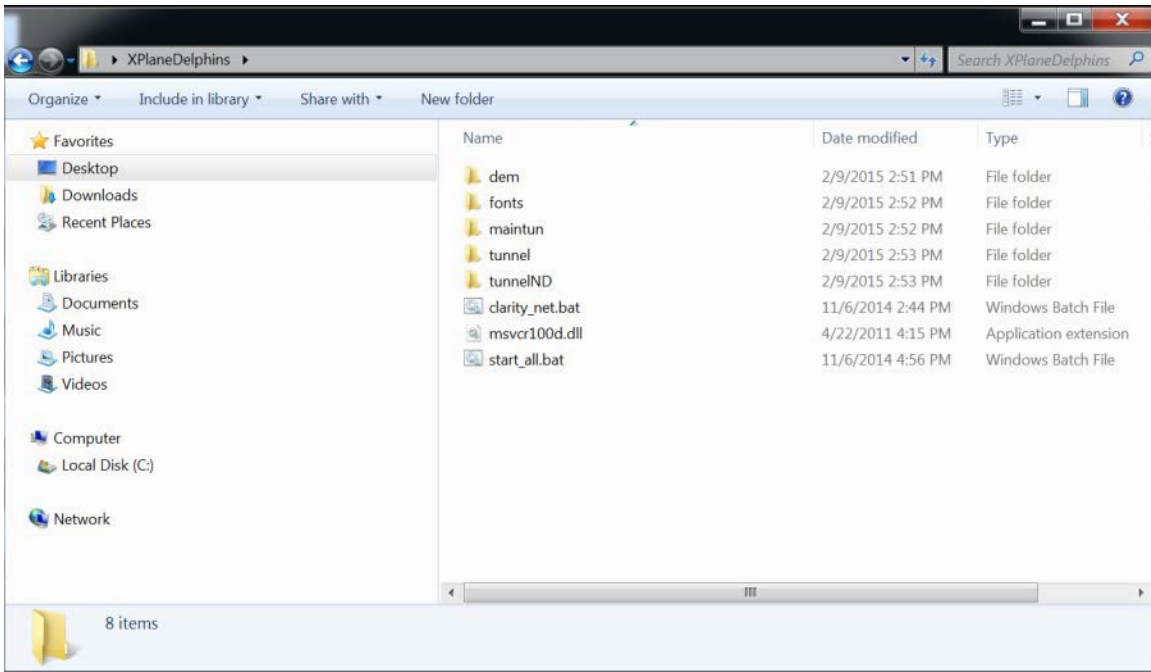

Figure E-5. Delphins directory structure (1)

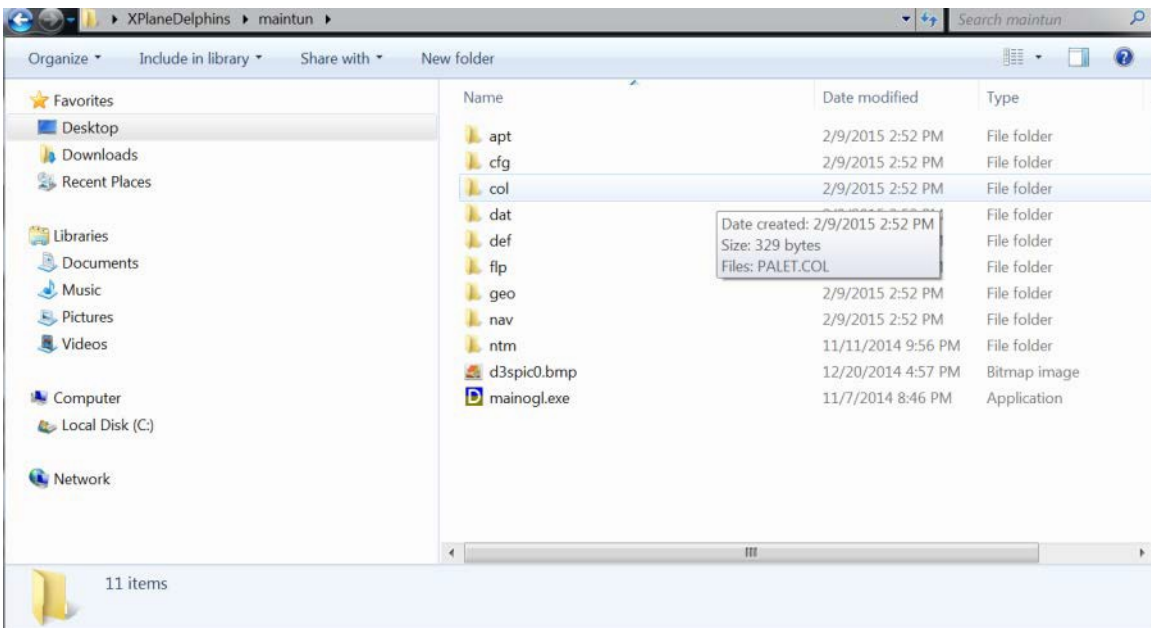

Figure E-6. Delphins directory structure (2)

The 'cfg' subdirectory of maintun is shown in figure E-7. The very important “stations.cfg” and “dynapr.cfg” are located there.

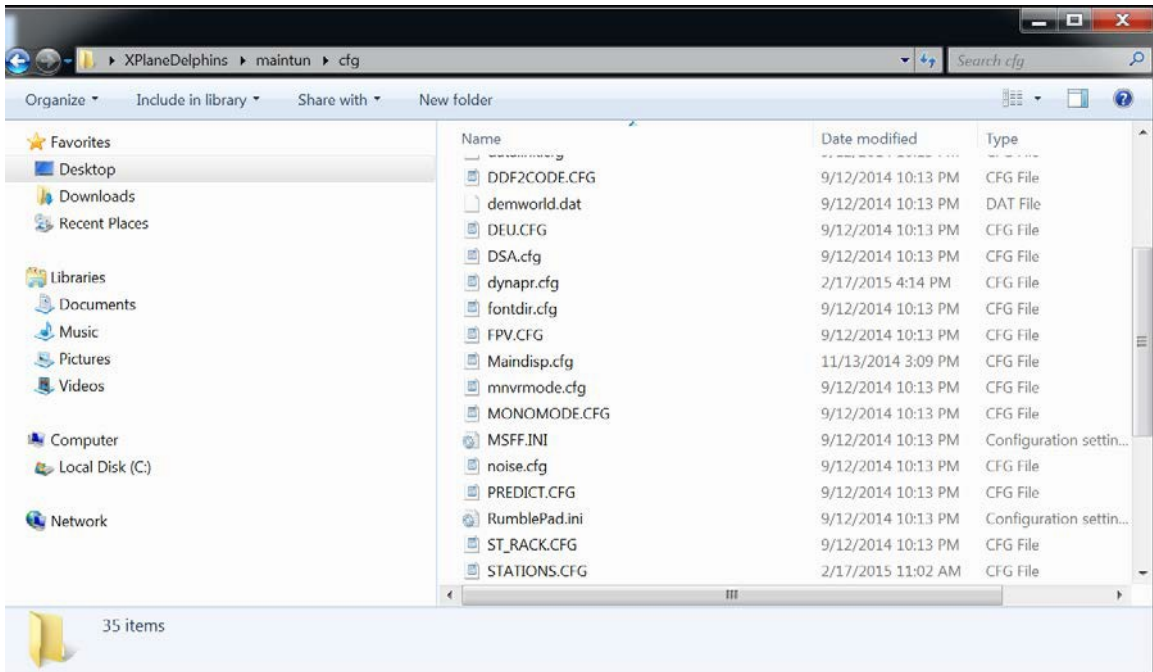

Figure E-7. Delphins directory structure (3)

E.5. KNOWN BUGS AND ISSUES

Table E-1. FAQ and issue list

Issue	Solution
X-Plane must be started first, and Delphins must be started before X-Plane [®] is finished loading.	Start X-Plane and then start Delphins while X-Plane is loading. Delphins will wait for X-Plane and then will show the displays.
Sometimes the green "B" button on the button bar does not perform as expected, and Delphins will not shut down.	
The "Z" hotkey is broken in the latest version. Delphins will reload but will not receive any data from X-Plane.	
Occasionally, the data stream is interrupted for an unknown reason, and the Delphins display appears only sparsely populated.	