

Dynamic Performance of Cantilevered Sign Trusses for Fatigue

Hunter Senior, M.S.
Caroline Bennett, Ph.D., P.E.
William Collins, Ph.D., P.E.
Jian Li, Ph.D., P.E.
Mark Ewing, Ph.D.
Matt Fadden, Ph.D., P.E.

The University of Kansas



Appendices Table of Contents

Appendices Table of Contents.....	i
Appendices List of Tables.....	ii
Appendices List of Figures.....	iii
Appendix A1.....	1
A1.1: Y-Component of Velocity Behind Large Sign at V=30 mph (13.4 m/s).....	1
A1.2: Y-Component of Velocity Behind Large Sign at V=61.2 mph (27.4 m/s).....	7
A1.3: Y-Component of Velocity Behind Large Sign at V=105mph (46.9 m/s).....	13
A1.4: Y-Component of Velocity Behind Medium Sign at V=30 mph (13.4 m/s).....	19
A1.5: Y-Component of Velocity Behind Medium Sign at V=61.2 mph (27.4 m/s).....	25
A1.6: Y-Component of Velocity Behind Medium Sign at V=105mph (46.9 m/s).....	31
A1.7: Y-Component of Velocity Behind Small Sign at V=30 mph (13.4 m/s).....	37
A1.8: Y-Component of Velocity Behind Small Sign at V=61.2 mph (27.4 m/s).....	43
A1.9: Y-Component of Velocity Behind Small Sign at V=105mph (46.9 m/s).....	49
Appendix A2.....	55
A2.1: Large Sign Velocity Profile at V=30 mph (13.4 m/s).....	55
A2.2: Large Sign Velocity Profile at V=61.2 mph (27.4 m/s).....	57
A2.3: Large Sign Velocity Profile at V=105mph (46.9 m/s).....	59
A2.4: Medium Sign Velocity Profile at V=30 mph (13.4 m/s).....	61
A2.5: Medium Sign Velocity Profile at V=61.2 mph (27.4 m/s).....	63
A2.6: Medium Sign Velocity Profile at V=105mph (46.9 m/s).....	65
A2.7: Small Sign Velocity Profile at V=30 mph (13.4 m/s).....	67
A2.8: Small Sign Velocity Profile at V=61.2 mph (27.4 m/s).....	69
A2.9: Small Sign Velocity Profile at V=105mph (46.9 m/s).....	71
Appendix A3.....	73
Appendix B.....	85

Due to file size, the full report without appendices is available in a separate file located at:

<https://kdotapp.ksdot.org/kdotlib/kdotlib2.aspx>

or by contacting the KDOT Library at KDOT#Research.Library@ks.gov.

Appendices List of Tables

Table A3.1: Displacements at V=30 mph (13.4 m/s).....	73
Table A3.2: Top Box-Connection Stresses at V=30 mph (13.4 m/s).....	74
Table A3.3: Bottom Box-Connection Stresses at V=30 mph (13.4 m/s).....	75
Table A3.4: Pole Stresses at V=30 mph (13.4 m/s).....	76
Table A3.5: Displacements at V=61.2 mph (27.4 m/s).....	77
Table A3.6: Top Box-Connection Stresses at V=61.2 mph (27.4 m/s).....	78
Table A3.7: Bottom Box-Connection Stresses at V=61.2 mph (27.4 m/s).....	79
Table A3.8: Pole Stresses at V=61.2 mph (27.4 m/s).....	80
Table A3.9: Displacements at V=105mph (46.9 m/s).....	81
Table A3.10: Top Box-Connection Stresses at V=105mph (46.9 m/s).....	82
Table A3.11: Bottom Box-Connection Stresses at V=105mph (46.9 m/s).....	83
Table A3.12: Pole Stresses at V=105mph (46.9 m/s).....	84

Appendices List of Figures

Figure A1.1:	Y-component of velocity for the large sign at $V=30$ mph (13.4 m/s) at a distance = $0.5h$ behind the sign	1
Figure A1.2:	Y-component of velocity for the large sign at $V=30$ mph (13.4 m/s) at a distance = $0.75h$ behind the sign	1
Figure A1.3:	Y-component of velocity for the large sign at $V=30$ mph (13.4 m/s) at a distance = $1.0h$ behind the sign	2
Figure A1.4:	Y-component of velocity for the large sign at $V=30$ mph (13.4 m/s) at a distance = $1.25h$ behind the sign	2
Figure A1.5:	Y-component of velocity for the large sign at $V=30$ mph (13.4 m/s) at a distance = $1.5h$ behind the sign	3
Figure A1.6:	Y-component of velocity for the large sign at $V=30$ mph (13.4 m/s) at a distance = $1.75h$ behind the sign	3
Figure A1.7:	Y-component of velocity for the large sign at $V=30$ mph (13.4 m/s) at a distance = $2.0h$ behind the sign	4
Figure A1.8:	Y-component of velocity for the large sign at $V=30$ mph (13.4 m/s) at a distance = $2.25h$ behind the sign	4
Figure A1.9:	Y-component of velocity for the large sign at $V=30$ mph (13.4 m/s) at a distance = $2.5h$ behind the sign	5
Figure A1.10:	Y-component of velocity for the large sign at $V=30$ mph (13.4 m/s) at a distance = $2.75h$ behind the sign	5
Figure A1.11:	Y-component of velocity for the large sign at $V=30$ mph (13.4 m/s) at a distance = $3.0h$ behind the sign	6
Figure A1.12:	Y-component of velocity for the large sign at $V=61.2$ mph (27.4 m/s) at a distance = $0.5h$ behind the sign	7
Figure A1.13:	Y-component of velocity for the large sign at $V=61.2$ mph (27.4 m/s) at a distance = $0.75h$ behind the sign	7
Figure A1.14:	Y-component of velocity for the large sign at $V=61.2$ mph (27.4 m/s) at a distance = $1.0h$ behind the sign	8
Figure A1.15:	Y-component of velocity for the large sign at $V=61.2$ mph (27.4 m/s) at a distance = $1.25h$ behind the sign	8

Figure A1.16: Y-component of velocity for the large sign at $V=61.2$ mph (27.4 m/s) at a distance = 1.5h behind the sign	9
Figure A1.17: Y-component of velocity for the large sign at $V=61.2$ mph (27.4 m/s) at a distance = 1.75h behind the sign	9
Figure A1.18: Y-component of velocity for the large sign at $V=61.2$ mph (27.4 m/s) at a distance = 2.0h behind the sign	10
Figure A1.19: Y-component of velocity for the large sign at $V=61.2$ mph (27.4 m/s) at a distance = 2.25h behind the sign	10
Figure A1.20: Y-component of velocity for the large sign at $V=61.2$ mph (27.4 m/s) at a distance = 2.5h behind the sign	11
Figure A1.21: Y-component of velocity for the large sign at $V=61.2$ mph (27.4 m/s) at a distance = 2.75h behind the sign	11
Figure A1.22: Y-component of velocity for the large sign at $V=61.2$ mph (27.4 m/s) at a distance = 3.0h behind the sign	12
Figure A1.23: Y-component of velocity for the large sign at $V=105$ mph (46.9 m/s) at a distance = 0.5h behind the sign	13
Figure A1.24: Y-component of velocity for the large sign at $V=105$ mph (46.9 m/s) at a distance = 0.75h behind the sign	13
Figure A1.25: Y-component of velocity for the large sign at $V=105$ mph (46.9 m/s) at a distance = 1.0h behind the sign	14
Figure A1.26: Y-component of velocity for the large sign at $V=105$ mph (46.9 m/s) at a distance = 1.25h behind the sign	14
Figure A1.27: Y-component of velocity for the large sign at $V=105$ mph (46.9 m/s) at a distance = 1.5h behind the sign	15
Figure A1.28: Y-component of velocity for the large sign at $V=105$ mph (46.9 m/s) at a distance = 1.75h behind the sign	15
Figure A1.29: Y-component of velocity for the large sign at $V=105$ mph (46.9 m/s) at a distance = 2.0h behind the sign	16
Figure A1.30: Y-component of velocity for the large sign at $V=105$ mph (46.9 m/s) at a distance = 2.25h behind the sign	16

Figure A1.31: Y-component of velocity for the large sign at $V=105$ mph (46.9 m/s) at a distance = 2.5h behind the sign	17
Figure A1.32: Y-component of velocity for the large sign at $V=105$ mph (46.9 m/s) at a distance = 2.75h behind the sign	17
Figure A1.33: Y-component of velocity for the large sign at $V=105$ mph (46.9 m/s) at a distance = 3.0h behind the sign	18
Figure A1.34: Y-component of velocity for the medium sign at $V=30$ mph (13.4 m/s) at a distance = 0.5h behind the sign	19
Figure A1.35: Y-component of velocity for the medium sign at $V=30$ mph (13.4 m/s) at a distance = 0.75h behind the sign	19
Figure A1.36: Y-component of velocity for the medium sign at $V=30$ mph (13.4 m/s) at a distance = 1.0h behind the sign	20
Figure A1.37: Y-component of velocity for the medium sign at $V=30$ mph (13.4 m/s) at a distance = 1.25h behind the sign	20
Figure A1.38: Y-component of velocity for the medium sign at $V=30$ mph (13.4 m/s) at a distance = 1.5h behind the sign	21
Figure A1.39: Y-component of velocity for the medium sign at $V=30$ mph (13.4 m/s) at a distance = 1.75h behind the sign	21
Figure A1.40: Y-component of velocity for the medium sign at $V=30$ mph (13.4 m/s) at a distance = 2.0h behind the sign	22
Figure A1.41: Y-component of velocity for the medium sign at $V=30$ mph (13.4 m/s) at a distance = 2.25h behind the sign	22
Figure A1.42: Y-component of velocity for the medium sign at $V=30$ mph (13.4 m/s) at a distance = 2.5h behind the sign	23
Figure A1.43: Y-component of velocity for the medium sign at $V=30$ mph (13.4 m/s) at a distance = 2.75h behind the sign	23
Figure A1.44: Y-component of velocity for the medium sign at $V=30$ mph (13.4 m/s) at a distance = 3.0h behind the sign	24
Figure A1.45: Y-component of velocity for the medium sign at $V=61.2$ mph (27.4 m/s) at a distance = 0.5h behind the sign	25

Figure A1.46: Y-component of velocity for the medium sign at V=61.2 mph (27.4 m/s) at a distance = 0.75h behind the sign	25
Figure A1.47: Y-component of velocity for the medium sign at V=61.2 mph (27.4 m/s) at a distance = 1.0h behind the sign	26
Figure A1.48: Y-component of velocity for the medium sign at V=61.2 mph (27.4 m/s) at a distance = 1.25h behind the sign	26
Figure A1.49: Y-component of velocity for the medium sign at V=61.2 mph (27.4 m/s) at a distance = 1.5h behind the sign	27
Figure A1.50: Y-component of velocity for the medium sign at V=61.2 mph (27.4 m/s) at a distance = 1.75h behind the sign	27
Figure A1.51: Y-component of velocity for the medium sign at V=61.2 mph (27.4 m/s) at a distance = 2.0h behind the sign	28
Figure A1.52: Y-component of velocity for the medium sign at V=61.2 mph (27.4 m/s) at a distance = 2.25h behind the sign	28
Figure A1.53: Y-component of velocity for the medium sign at V=61.2 mph (27.4 m/s) at a distance = 2.5h behind the sign	29
Figure A1.54: Y-component of velocity for the medium sign at V=61.2 mph (27.4 m/s) at a distance = 2.75h behind the sign	29
Figure A1.55: Y-component of velocity for the medium sign at V=61.2 mph (27.4 m/s) at a distance = 3.0h behind the sign	30
Figure A1.56: Y-component of velocity for the medium sign at V=105 mph (46.9 m/s) at a distance = 0.5h behind the sign	31
Figure A1.57: Y-component of velocity for the medium sign at V=105 mph (46.9 m/s) at a distance = 0.75h behind the sign	31
Figure A1.58: Y-component of velocity for the medium sign at V=105 mph (46.9 m/s) at a distance = 1.0h behind the sign	32
Figure A1.59: Y-component of velocity for the medium sign at V=105 mph (46.9 m/s) at a distance = 1.25h behind the sign	32
Figure A1.60: Y-component of velocity for the medium sign at V=105 mph (46.9 m/s) at a distance = 1.5h behind the sign	33

Figure A1.61: Y-component of velocity for the medium sign at $V=105$ mph (46.9 m/s) at a distance = 1.75h behind the sign	33
Figure A1.62: Y-component of velocity for the medium sign at $V=105$ mph (46.9 m/s) at a distance = 2.0h behind the sign	34
Figure A1.63: Y-component of velocity for the medium sign at $V=105$ mph (46.9 m/s) at a distance = 2.25h behind the sign	34
Figure A1.64: Y-component of velocity for the medium sign at $V=105$ mph (46.9 m/s) at a distance = 2.5h behind the sign	35
Figure A1.65: Y-component of velocity for the medium sign at $V=105$ mph (46.9 m/s) at a distance = 2.75h behind the sign	35
Figure A1.66: Y-component of velocity for the medium sign at $V=105$ mph (46.9 m/s) at a distance = 3.0h behind the sign	36
Figure A1.67: Y-component of velocity for the small sign at $V=30$ mph (13.4 m/s) at a distance = 0.5h behind the sign	37
Figure A1.68: Y-component of velocity for the small sign at $V=30$ mph (13.4 m/s) at a distance = 0.75h behind the sign	37
Figure A1.69: Y-component of velocity for the small sign at $V=30$ mph (13.4 m/s) at a distance = 1.0h behind the sign	38
Figure A1.70: Y-component of velocity for the small sign at $V=30$ mph (13.4 m/s) at a distance = 1.25h behind the sign	38
Figure A1.71: Y-component of velocity for the small sign at $V=30$ mph (13.4 m/s) at a distance = 1.5h behind the sign	39
Figure A1.72: Y-component of velocity for the small sign at $V=30$ mph (13.4 m/s) at a distance = 1.75h behind the sign	39
Figure A1.73: Y-component of velocity for the small sign at $V=30$ mph (13.4 m/s) at a distance = 2.0h behind the sign	40
Figure A1.74: Y-component of velocity for the small sign at $V=30$ mph (13.4 m/s) at a distance = 2.25h behind the sign	40
Figure A1.75: Y-component of velocity for the small sign at $V=30$ mph (13.4 m/s) at a distance = 2.5h behind the sign	41

Figure A1.76: Y-component of velocity for the small sign at V=30 mph (13.4 m/s) at a distance = 2.75h behind the sign	41
Figure A1.77: Y-component of velocity for the small sign at V=30 mph (13.4 m/s) at a distance = 3.0h behind the sign	42
Figure A1.78: Y-component of velocity for the small sign at V=61.2 mph (27.4 m/s) at a distance = 0.5h behind the sign	43
Figure A1.79: Y-component of velocity for the small sign at V=61.2 mph (27.4 m/s) at a distance = 0.75h behind the sign	43
Figure A1.80: Y-component of velocity for the small sign at V=61.2 mph (27.4 m/s) at a distance = 1.0h behind the sign	44
Figure A1.81: Y-component of velocity for the small sign at V=61.2 mph (27.4 m/s) at a distance = 1.25h behind the sign	44
Figure A1.82: Y-component of velocity for the small sign at V=61.2 mph (27.4 m/s) at a distance = 1.5h behind the sign	45
Figure A1.83: Y-component of velocity for the small sign at V=61.2 mph (27.4 m/s) at a distance = 1.75h behind the sign	45
Figure A1.84: Y-component of velocity for the small sign at V=61.2 mph (27.4 m/s) at a distance = 2.0h behind the sign	46
Figure A1.85: Y-component of velocity for the small sign at V=61.2 mph (27.4 m/s) at a distance = 2.25h behind the sign	46
Figure A1.86: Y-component of velocity for the small sign at V=61.2 mph (27.4 m/s) at a distance = 2.5h behind the sign	47
Figure A1.87: Y-component of velocity for the small sign at V=61.2 mph (27.4 m/s) at a distance = 2.75h behind the sign	47
Figure A1.88: Y-component of velocity for the small sign at V=61.2 mph (27.4 m/s) at a distance = 3.0h behind the sign	48
Figure A1.89: Y-component of velocity for the small sign at V=105 mph (46.9 m/s) at a distance = 0.5h behind the sign	49
Figure A1.90: Y-component of velocity for the small sign at V=105 mph (46.9 m/s) at a distance = 0.75h behind the sign	49

Figure A1.91: Y-component of velocity for the small sign at V=105 mph (46.9 m/s) at a distance = 1.0h behind the sign	50
Figure A1.92: Y-component of velocity for the small sign at V=105 mph (46.9 m/s) at a distance = 1.25h behind the sign	50
Figure A1.93: Y-component of velocity for the small sign at V=105 mph (46.9 m/s) at a distance = 1.5h behind the sign	51
Figure A1.94: Y-component of velocity for the small sign at V=105 mph (46.9 m/s) at a distance = 1.75h behind the sign	51
Figure A1.95: Y-component of velocity for the small sign at V=105 mph (46.9 m/s) at a distance = 2.0h behind the sign	52
Figure A1.96: Y-component of velocity for the small sign at V=105 mph (46.9 m/s) at a distance = 2.25h behind the sign	52
Figure A1.97: Y-component of velocity for the small sign at V=105 mph (46.9 m/s) at a distance = 2.5h behind the sign	53
Figure A1.98: Y-component of velocity for the small sign at V=105 mph (46.9 m/s) at a distance = 2.75h behind the sign	53
Figure A1.99: Y-component of velocity for the small sign at V=105 mph (46.9 m/s) at a distance = 3.0h behind the sign	54
Figure A2.1: Velocity profile below the sign, for the large sign and a wind speed of V=30 mph (13.4 m/s).....	56
Figure A2.2: Velocity profile below the sign, for the large sign and a wind speed of V=61.2 mph (27.4 m/s).....	58
Figure A2.3: Velocity profile below the sign, for the large sign and a wind speed of V=105 mph (46.9 m/s).....	60
Figure A2.4: Velocity profile below the sign, for the medium sign and a wind speed of V=30 mph (13.4 m/s).....	62
Figure A2.5: Velocity profile below the sign, for the medium sign and a wind speed of V=61.2 mph (27.4 m/s).....	64
Figure A2.6: Velocity profile below the sign, for the medium sign and a wind speed of V=105mph (46.9 m/s).....	66

Figure A2.7:	Velocity profile below the sign, for the small sign and a wind speed of 30 mph (13.4 m/s).....	68
Figure A2.8:	Velocity profile below the sign, for the small sign and a wind speed of 61.2 mph (27.4 m/s).....	70
Figure A2.9:	Velocity profile below the sign, for the small sign and a wind speed of V=105mph (46.9 m/s).....	72
Figure B.1:	Schematic of model sign used in wind tunnel testing at the University of Kansas	85
Figure B.2:	KDOT standard detail for cantilevered structural sign supports	85
Figure B.3:	KDOT standard detail for cantilevered structural sign supports	86
Figure B.4:	KDOT standard detail for cantilevered structural sign supports	86

Appendix A1

A1.1: Y-Component of Velocity Behind Large Sign at V=30 mph (13.4 m/s)

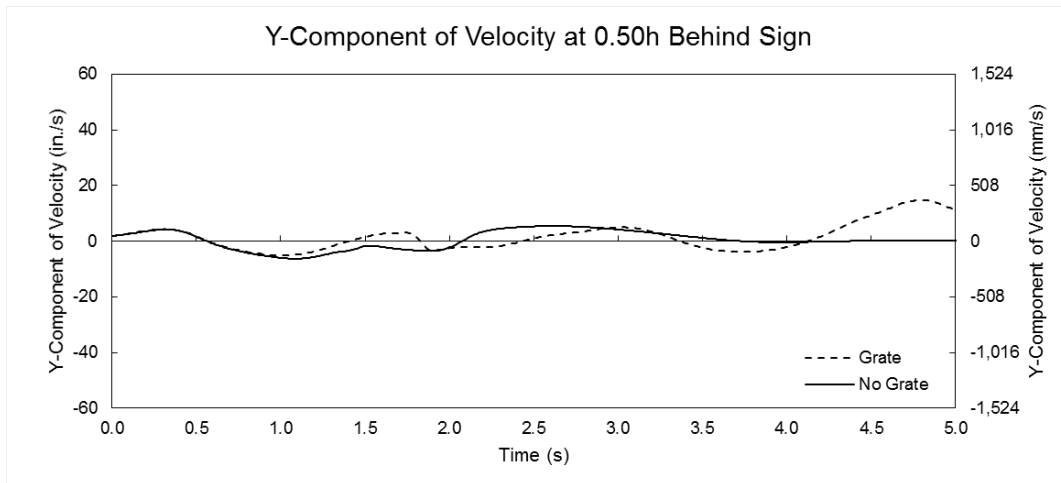

Figure A1.1: Y-component of velocity for the large sign at V=30 mph (13.4 m/s) at a distance = 0.5h behind the sign

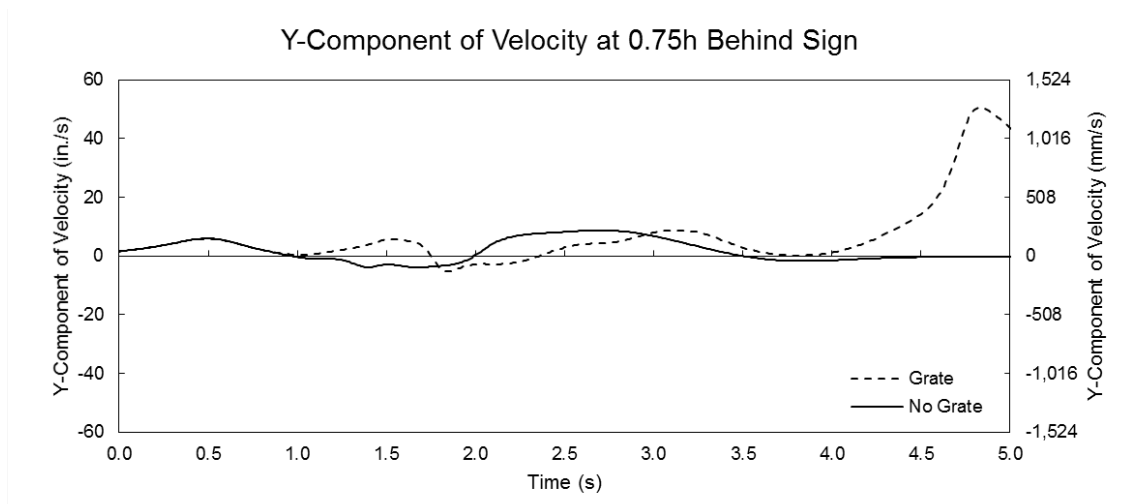

Figure A1.2: Y-component of velocity for the large sign at V=30 mph (13.4 m/s) at a distance = 0.75h behind the sign

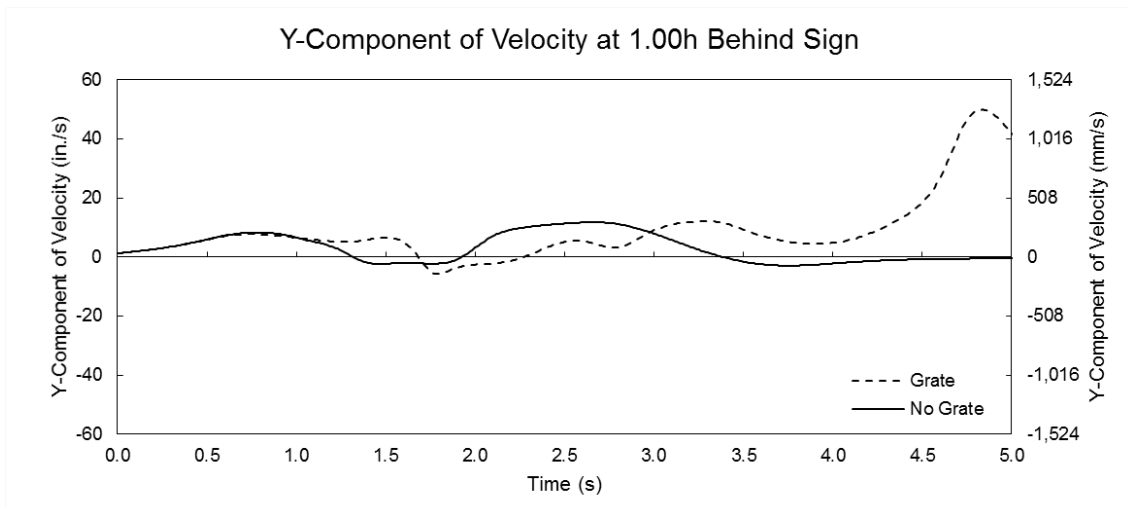

Figure A1.3: Y-component of velocity for the large sign at V=30 mph (13.4 m/s) at a distance = 1.0h behind the sign

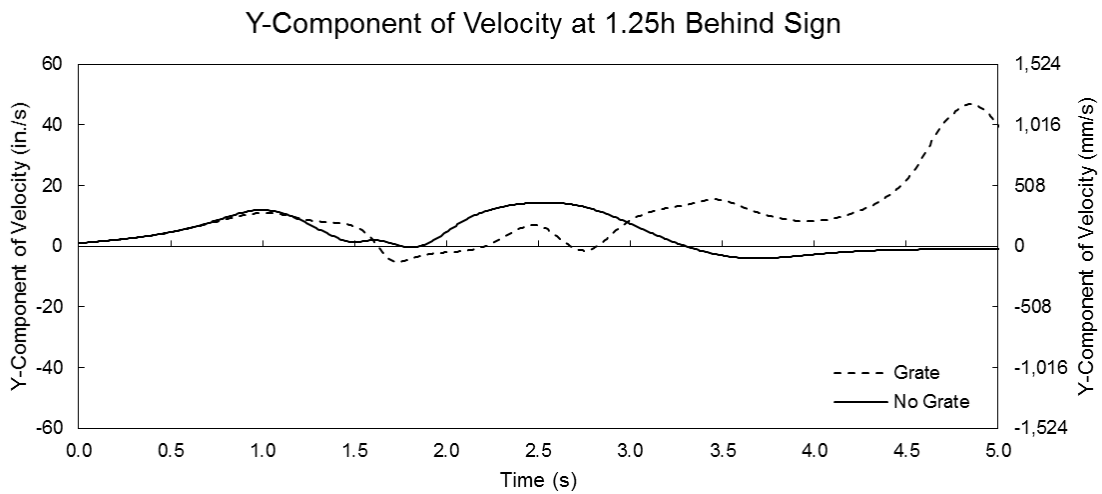

Figure A1.4: Y-component of velocity for the large sign at V=30 mph (13.4 m/s) at a distance = 1.25h behind the sign

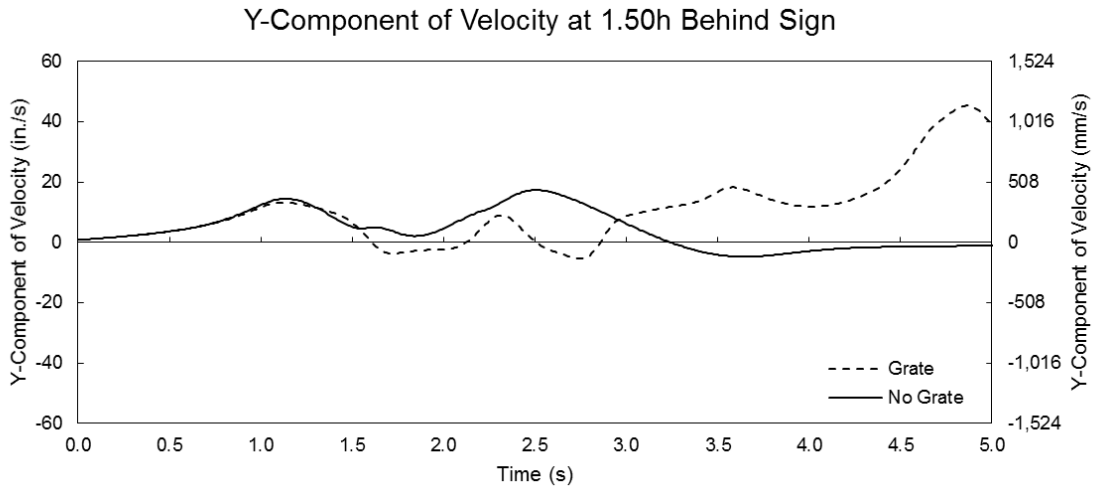

Figure A1.5: Y-component of velocity for the large sign at V=30 mph (13.4 m/s) at a distance = 1.5h behind the sign

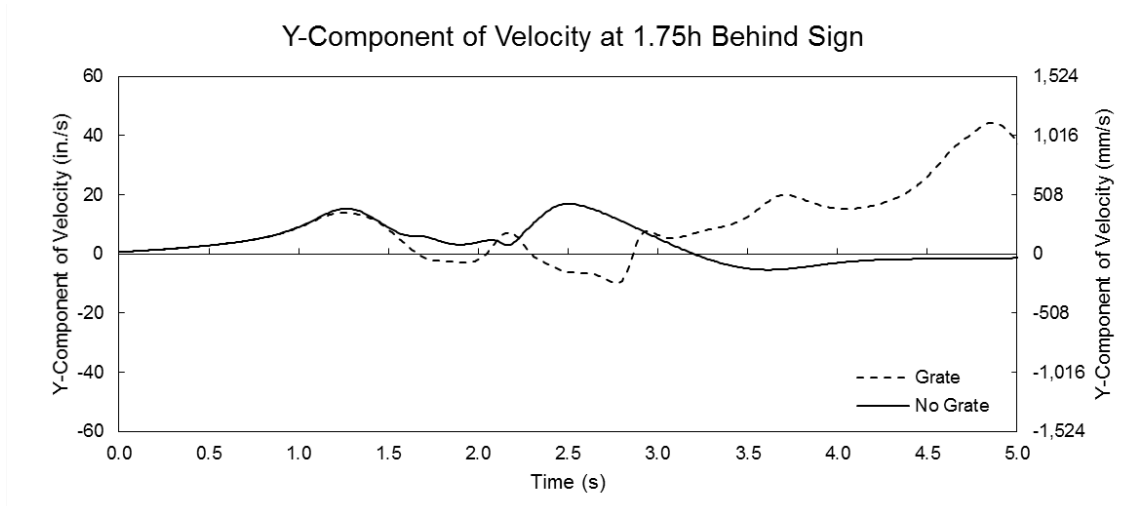

Figure A1.6: Y-component of velocity for the large sign at V=30 mph (13.4 m/s) at a distance = 1.75h behind the sign

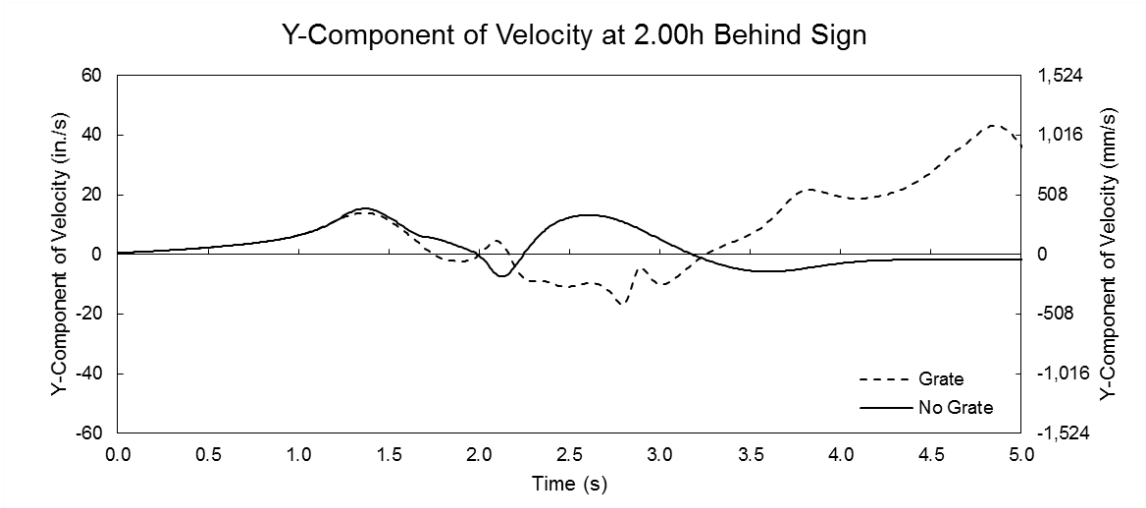

Figure A1.7: Y-component of velocity for the large sign at V=30 mph (13.4 m/s) at a distance = 2.0h behind the sign

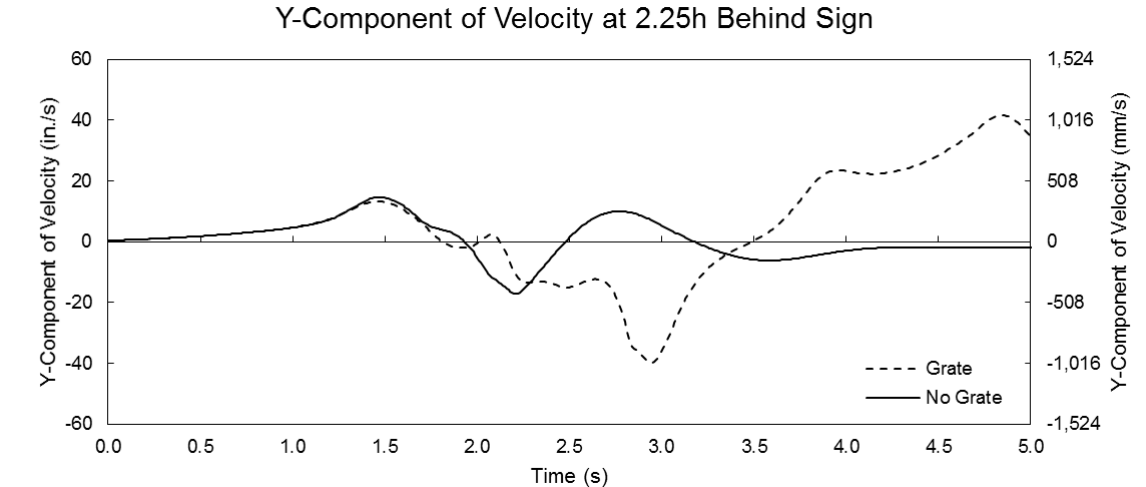

Figure A1.8: Y-component of velocity for the large sign at V=30 mph (13.4 m/s) at a distance = 2.25h behind the sign

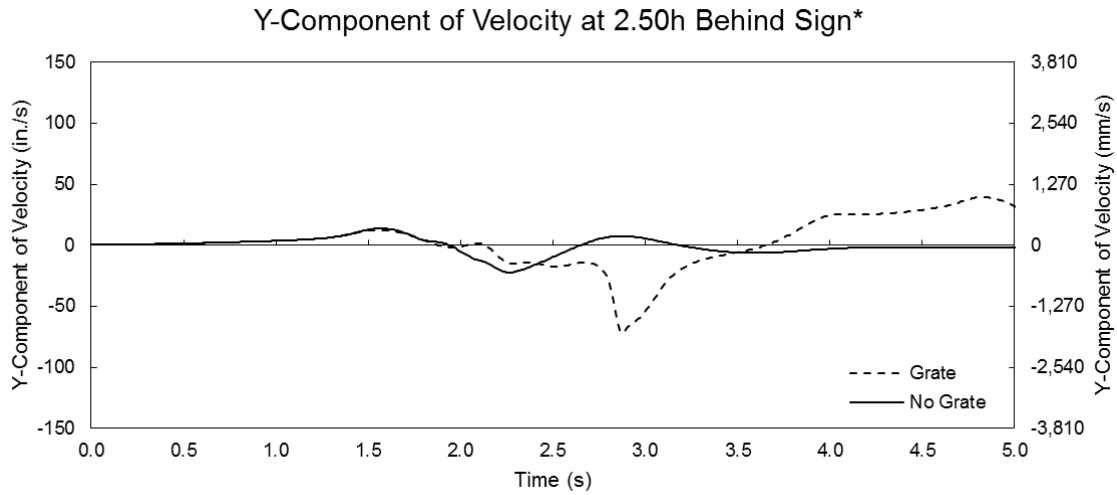

Figure A1.9: Y-component of velocity for the large sign at V=30 mph (13.4 m/s) at a distance = 2.5h behind the sign

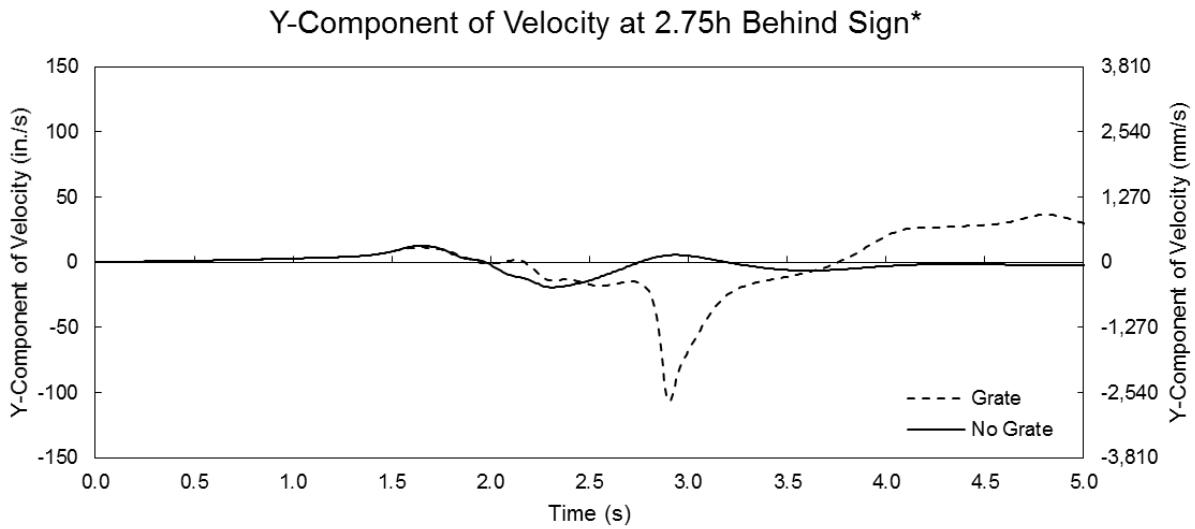

Figure A1.10: Y-component of velocity for the large sign at V=30 mph (13.4 m/s) at a distance = 2.75h behind the sign

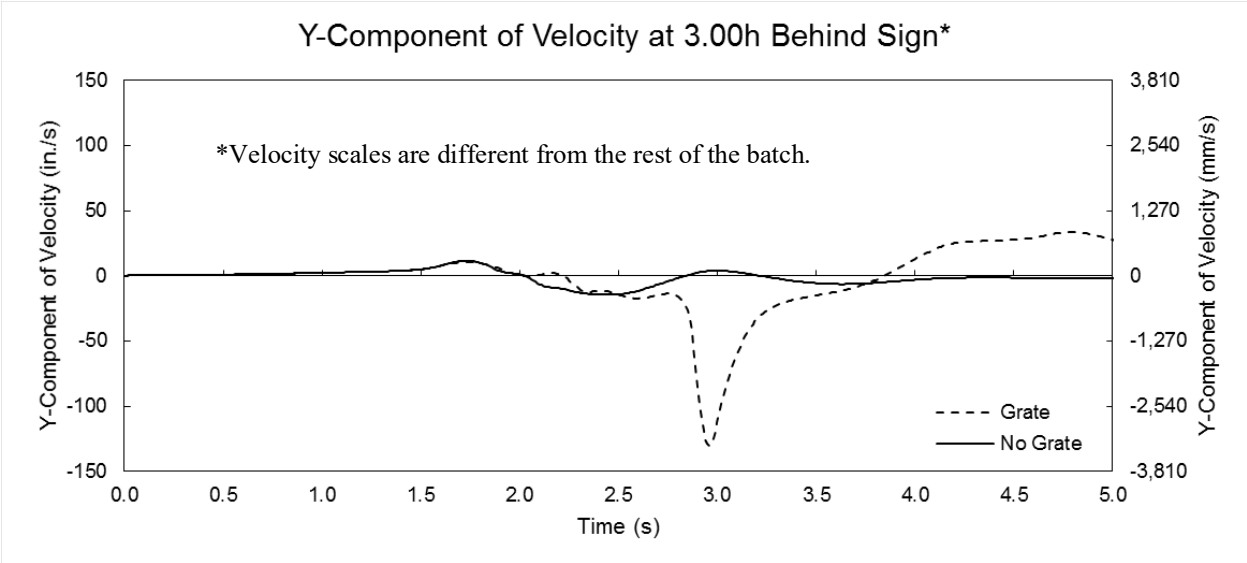

Figure A1.11: Y-component of velocity for the large sign at V=30 mph (13.4 m/s) at a distance = 3.0h behind the sign

A1.2: Y-Component of Velocity Behind Large Sign at V=61.2 mph (27.4 m/s)

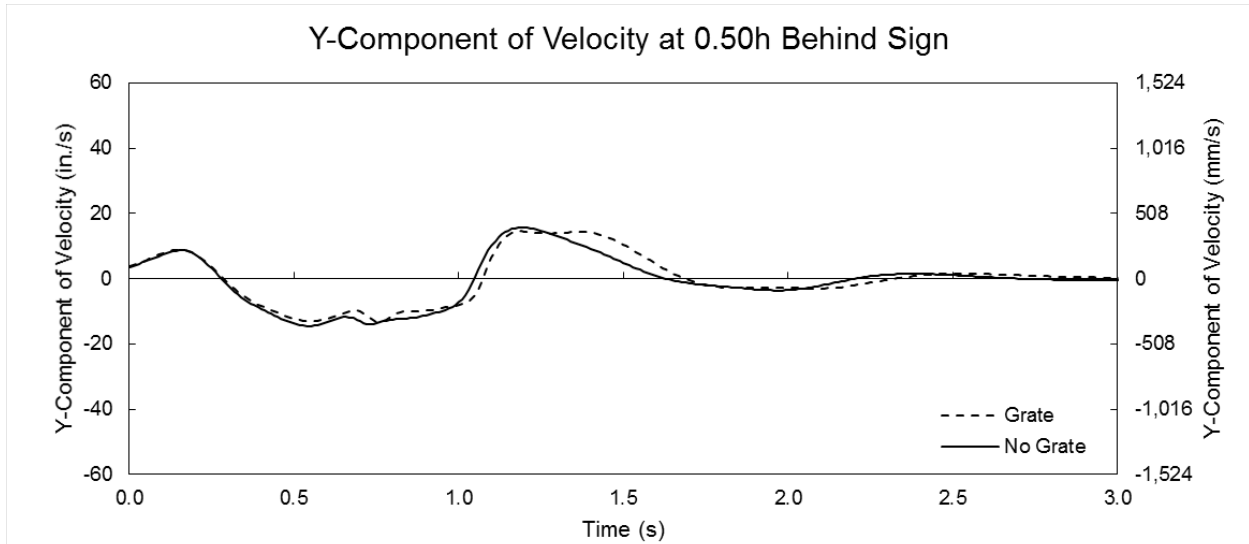

Figure A1.12: Y-component of velocity for the large sign at V=61.2 mph (27.4 m/s) at a distance = 0.5h behind the sign

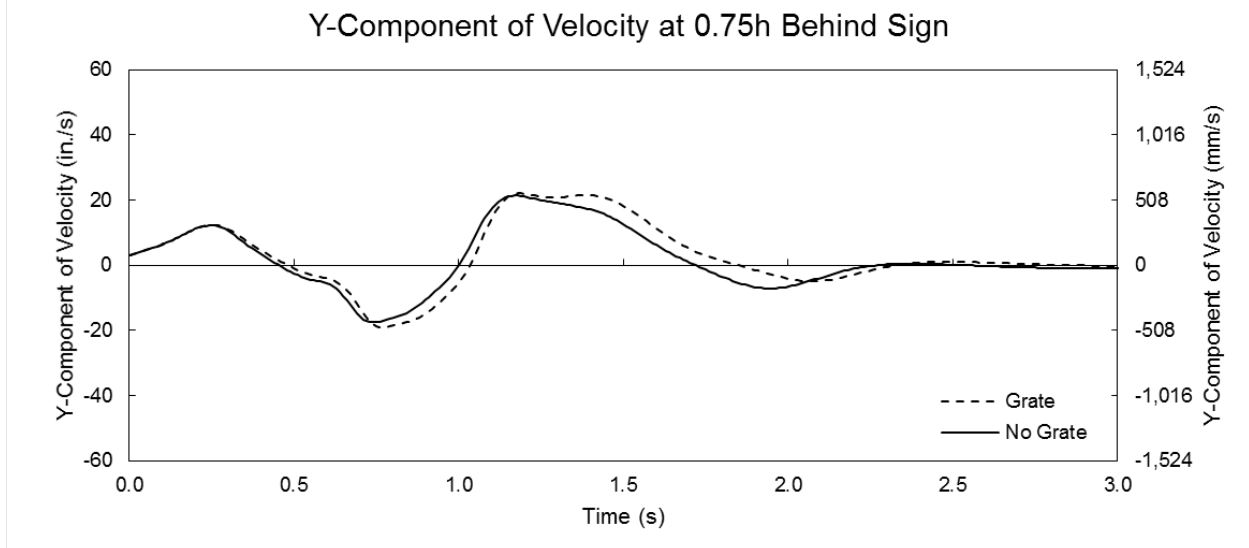

Figure A1.13: Y-component of velocity for the large sign at V=61.2 mph (27.4 m/s) at a distance = 0.75h behind the sign

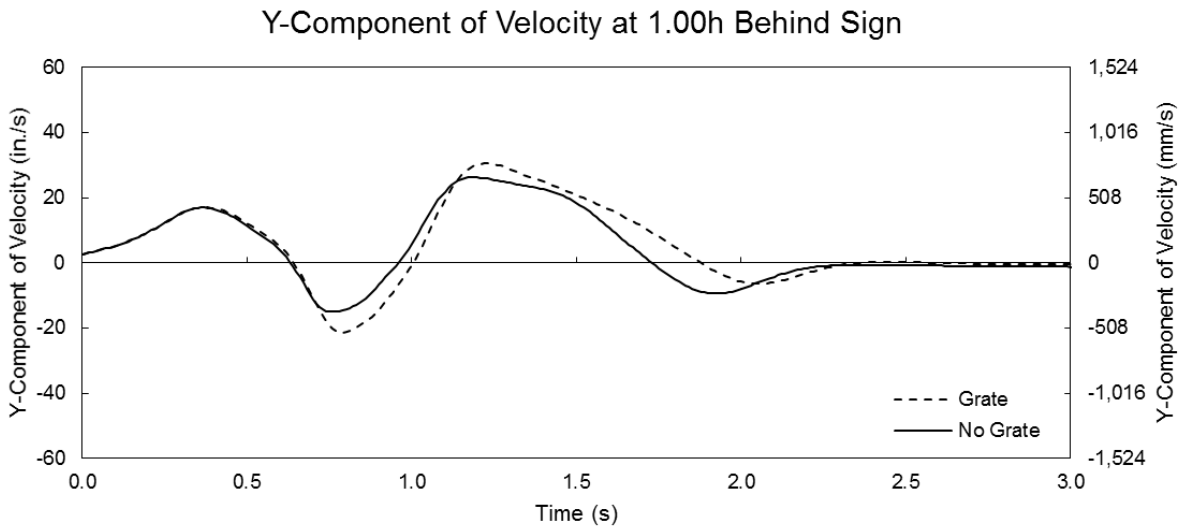

Figure A1.14: Y-component of velocity for the large sign at V=61.2 mph (27.4 m/s) at a distance = 1.0h behind the sign

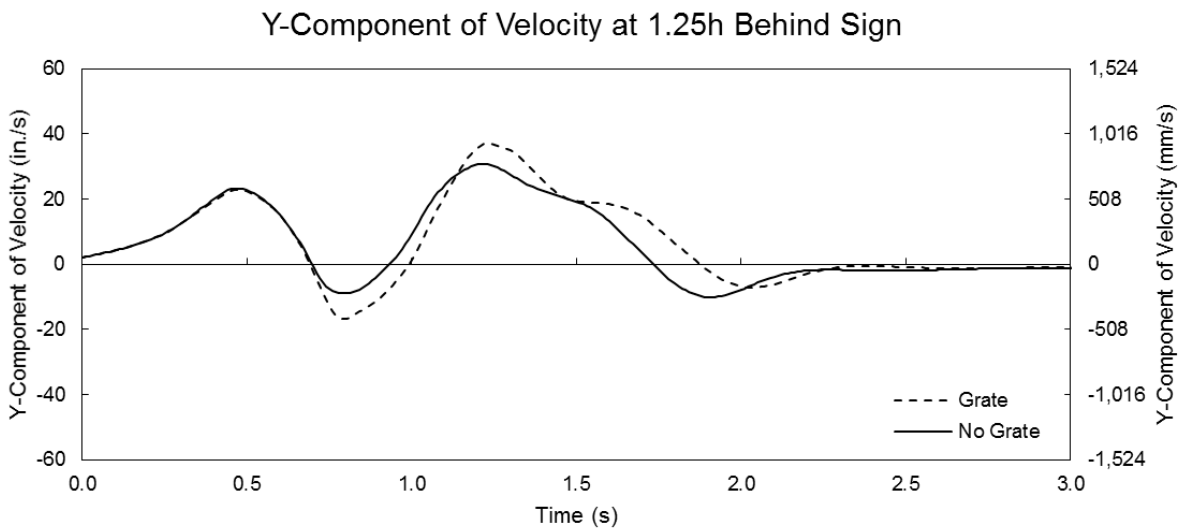

Figure A1.15: Y-component of velocity for the large sign at V=61.2 mph (27.4 m/s) at a distance = 1.25h behind the sign

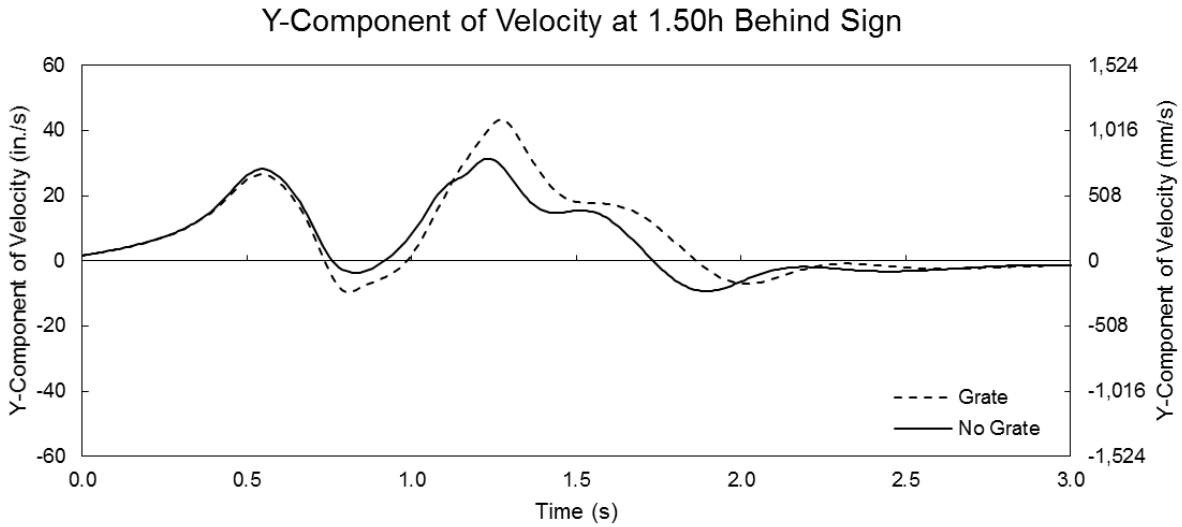

Figure A1.16: Y-component of velocity for the large sign at V=61.2 mph (27.4 m/s) at a distance = 1.5h behind the sign

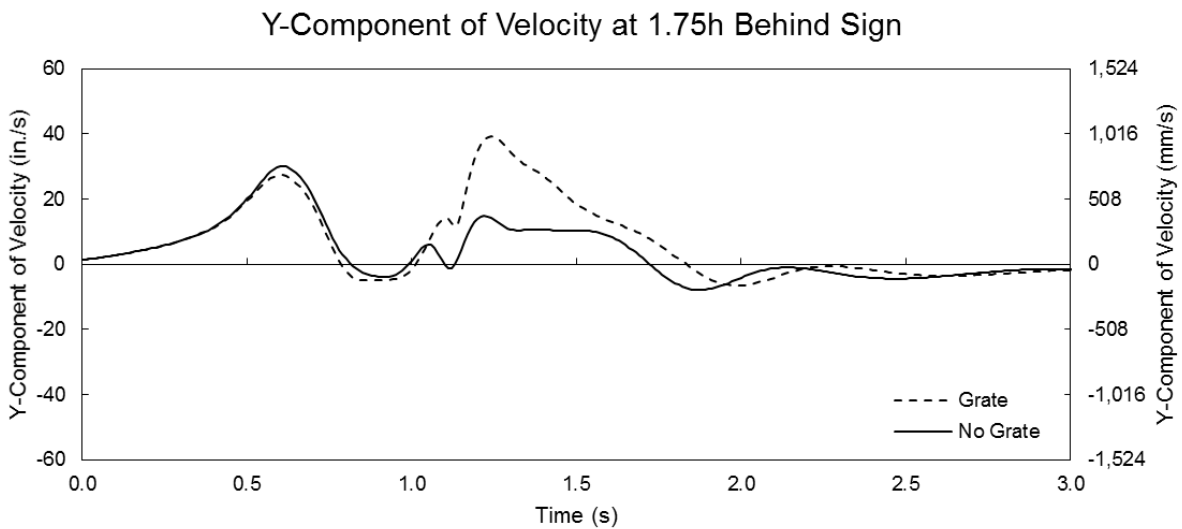

Figure A1.17: Y-component of velocity for the large sign at V=61.2 mph (27.4 m/s) at a distance = 1.75h behind the sign

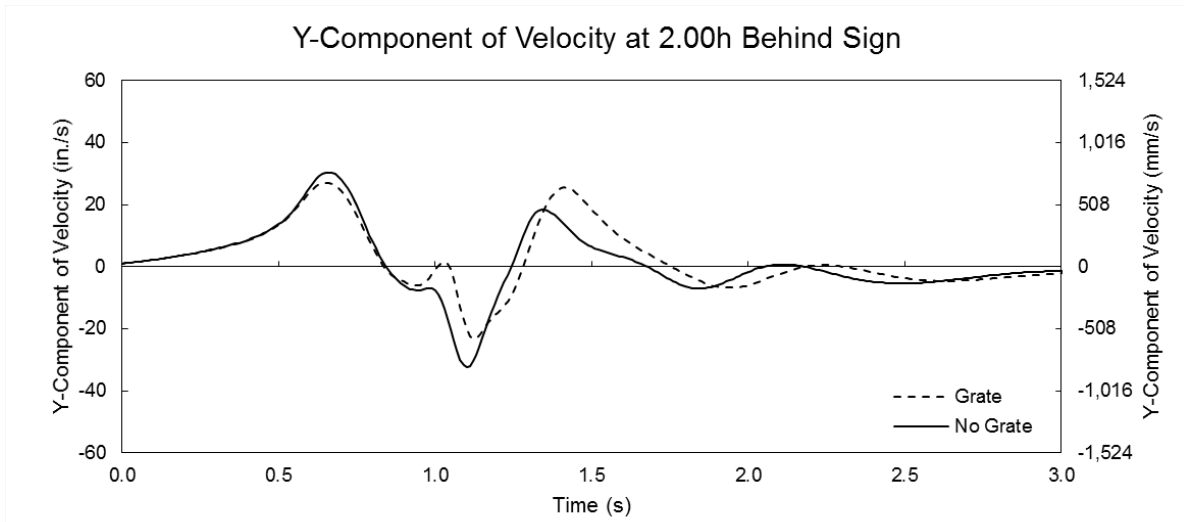

Figure A1.18: Y-component of velocity for the large sign at $V=61.2$ mph (27.4 m/s) at a distance = 2.0h behind the sign

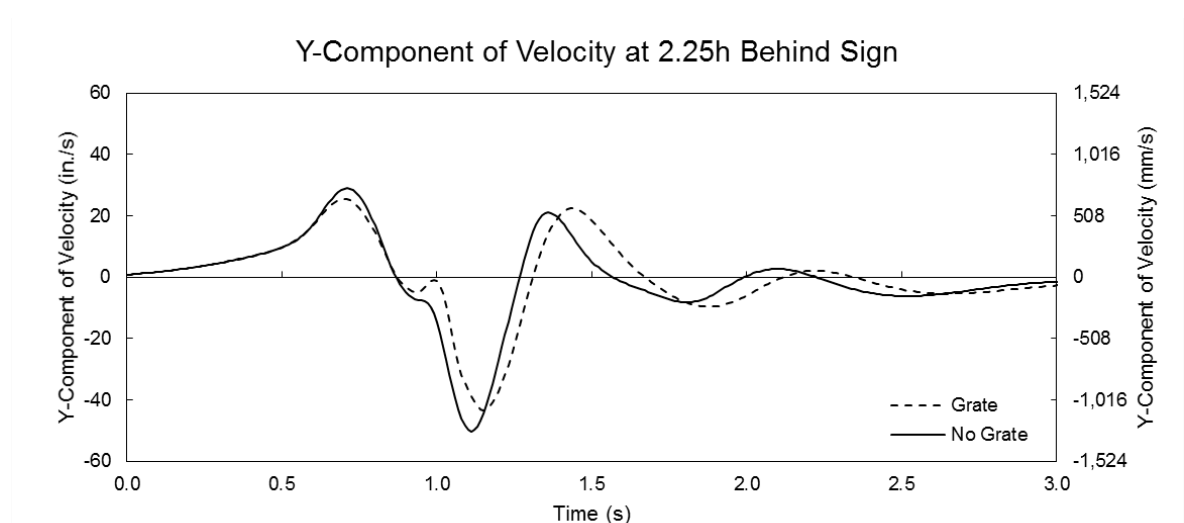

Figure A1.19: Y-component of velocity for the large sign at $V=61.2$ mph (27.4 m/s) at a distance = 2.25h behind the sign

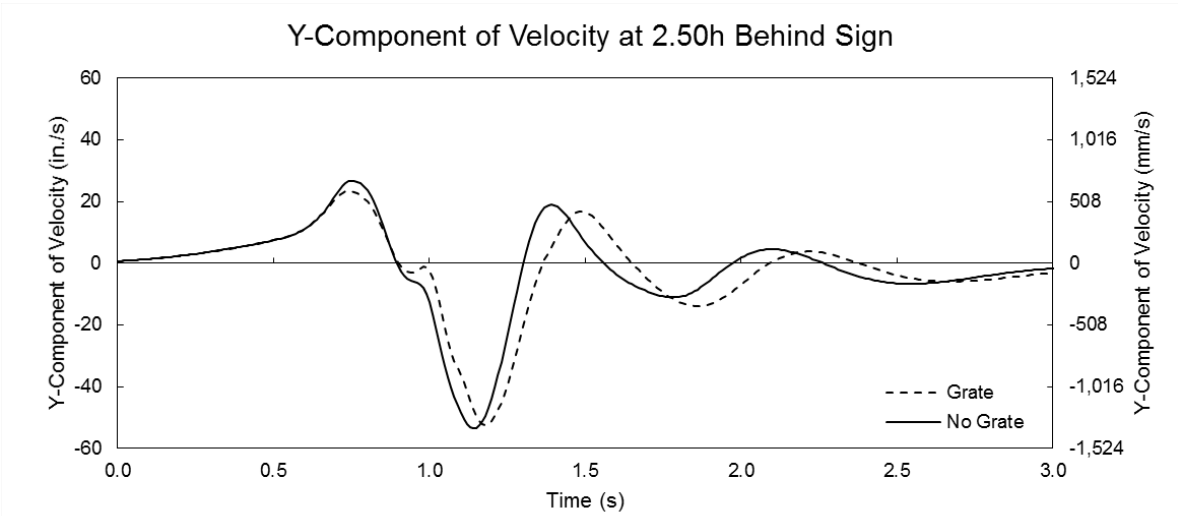

Figure A1.20: Y-component of velocity for the large sign at V=61.2 mph (27.4 m/s) at a distance = 2.5h behind the sign

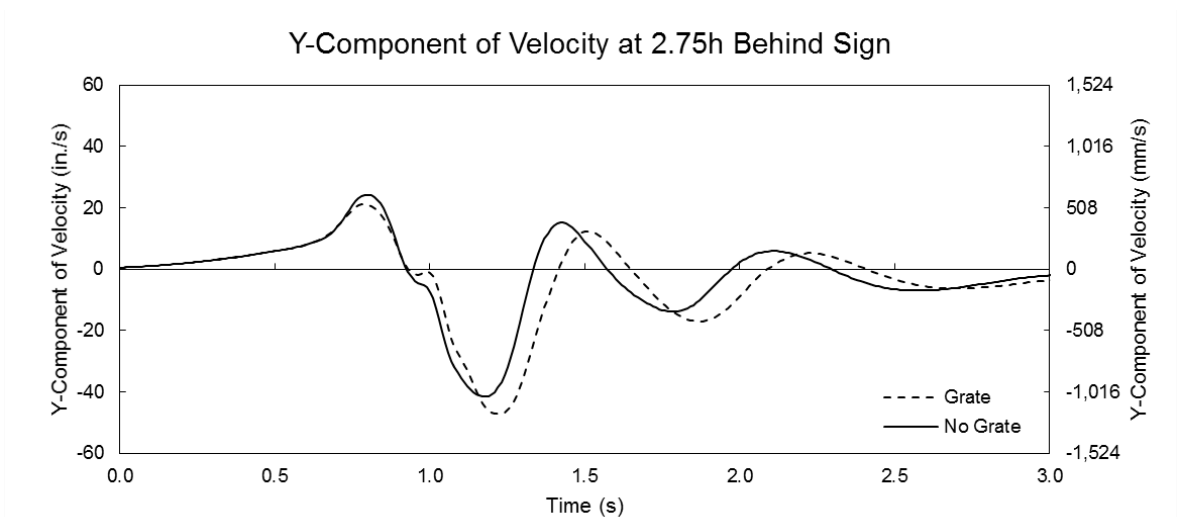

Figure A1.21: Y-component of velocity for the large sign at V=61.2 mph (27.4 m/s) at a distance = 2.75h behind the sign

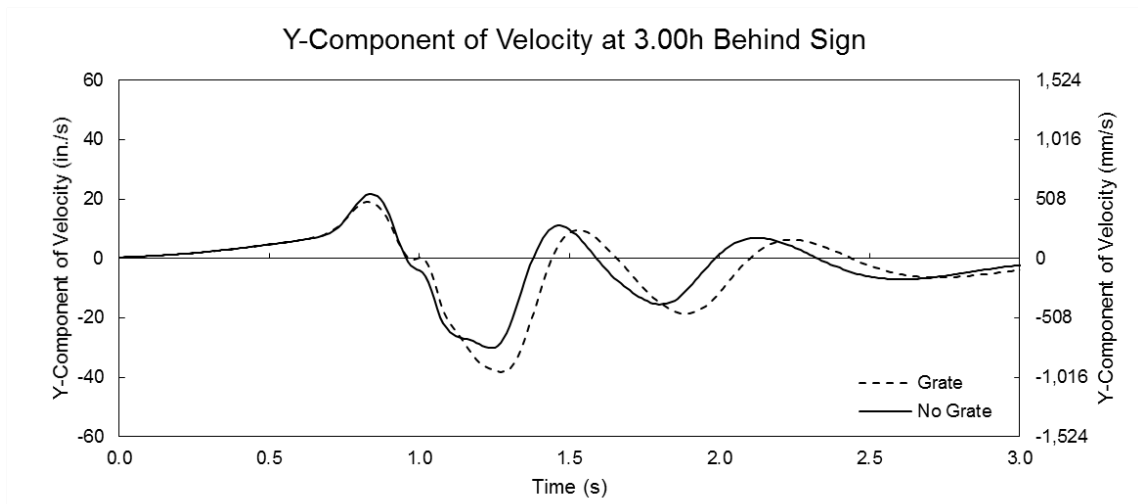

Figure A1.22: Y-component of velocity for the large sign at $V=61.2$ mph (27.4 m/s) at a distance = $3.0h$ behind the sign

A1.3: Y-Component of Velocity Behind Large Sign at V=105mph (46.9 m/s)

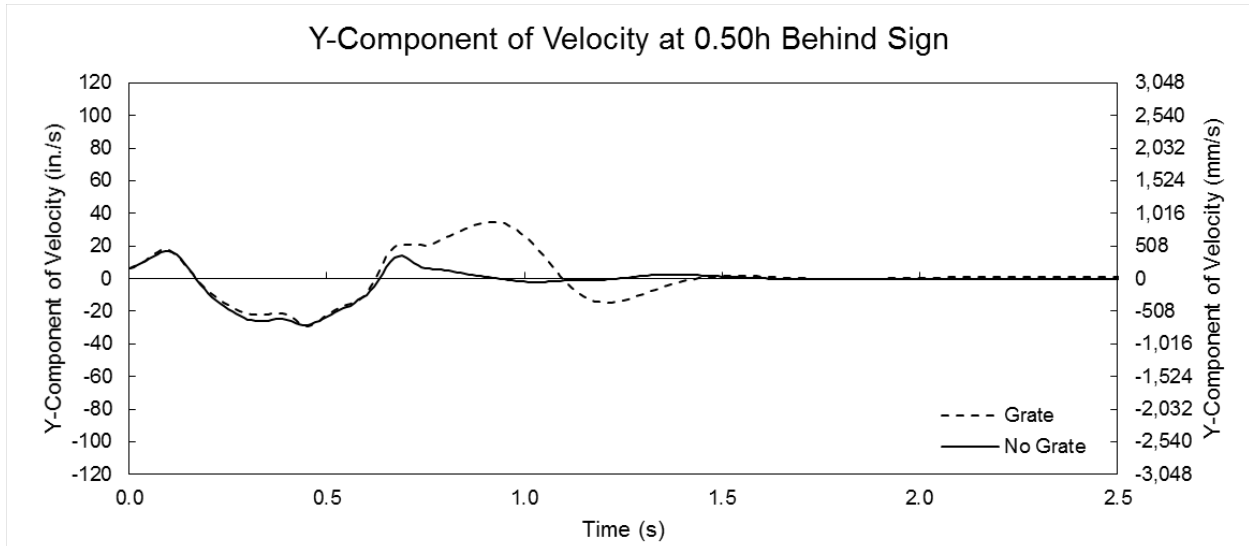

Figure A1.23: Y-component of velocity for the large sign at V=105 mph (46.9 m/s) at a distance = 0.5h behind the sign

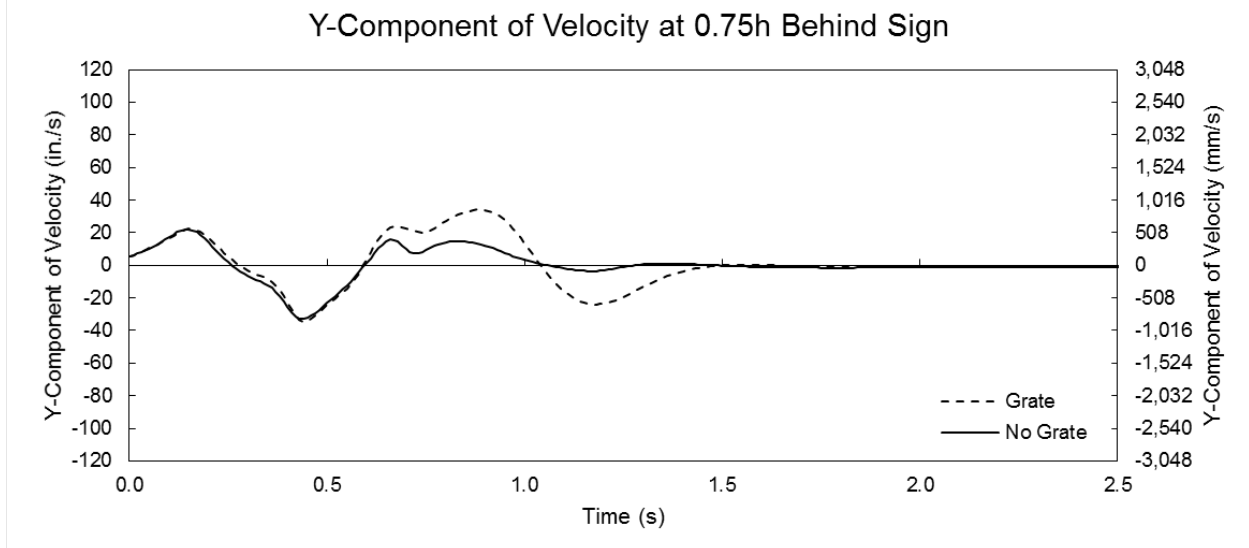

Figure A1.24: Y-component of velocity for the large sign at V=105 mph (46.9 m/s) at a distance = 0.75h behind the sign

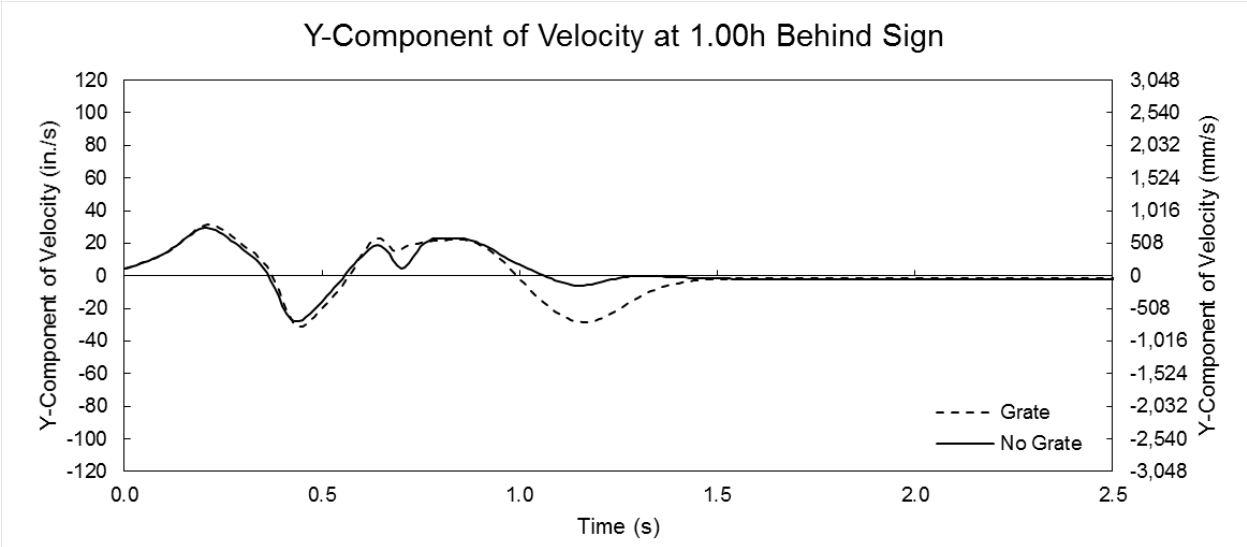

Figure A1.25: Y-component of velocity for the large sign at V=105 mph (46.9 m/s) at a distance = 1.0h behind the sign

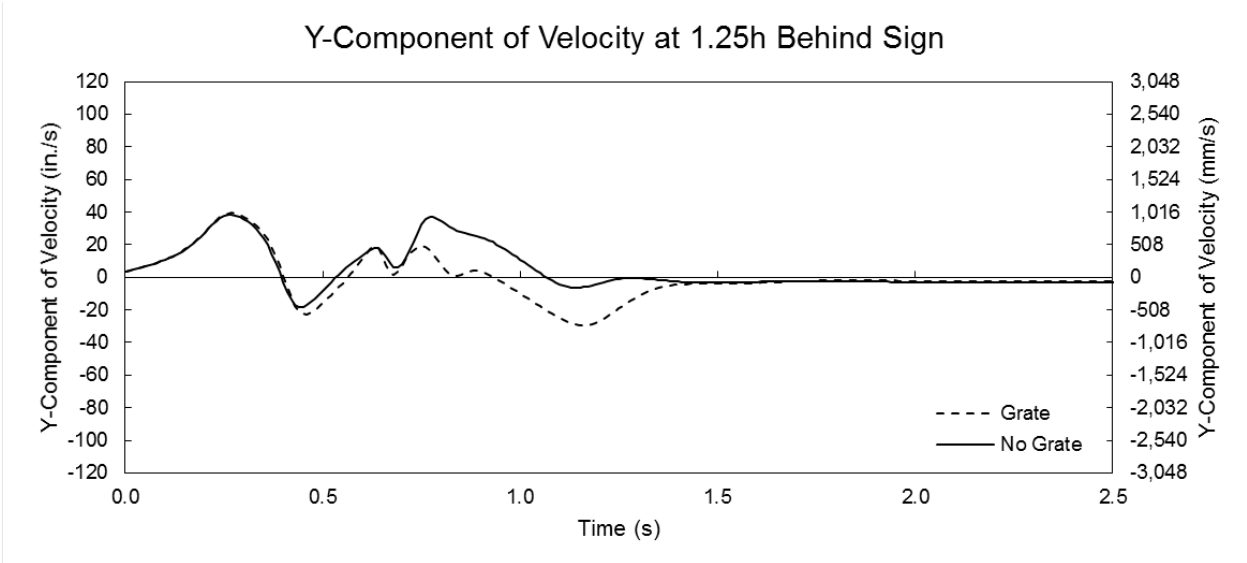

Figure A1.26: Y-component of velocity for the large sign at V=105 mph (46.9 m/s) at a distance = 1.25h behind the sign

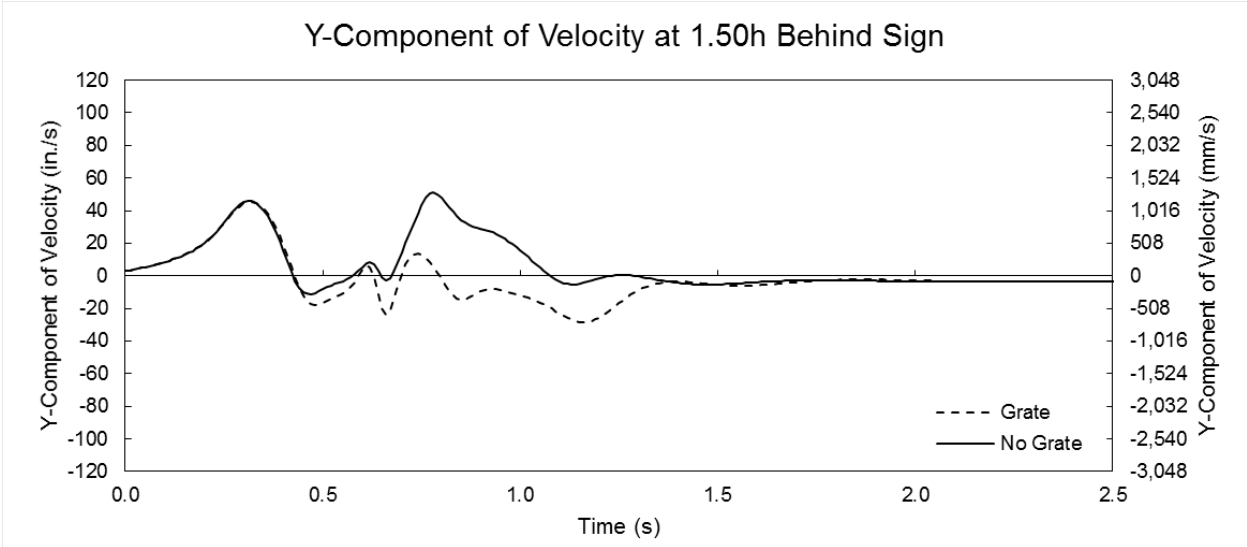

Figure A1.27: Y-component of velocity for the large sign at V=105 mph (46.9 m/s) at a distance = 1.5h behind the sign

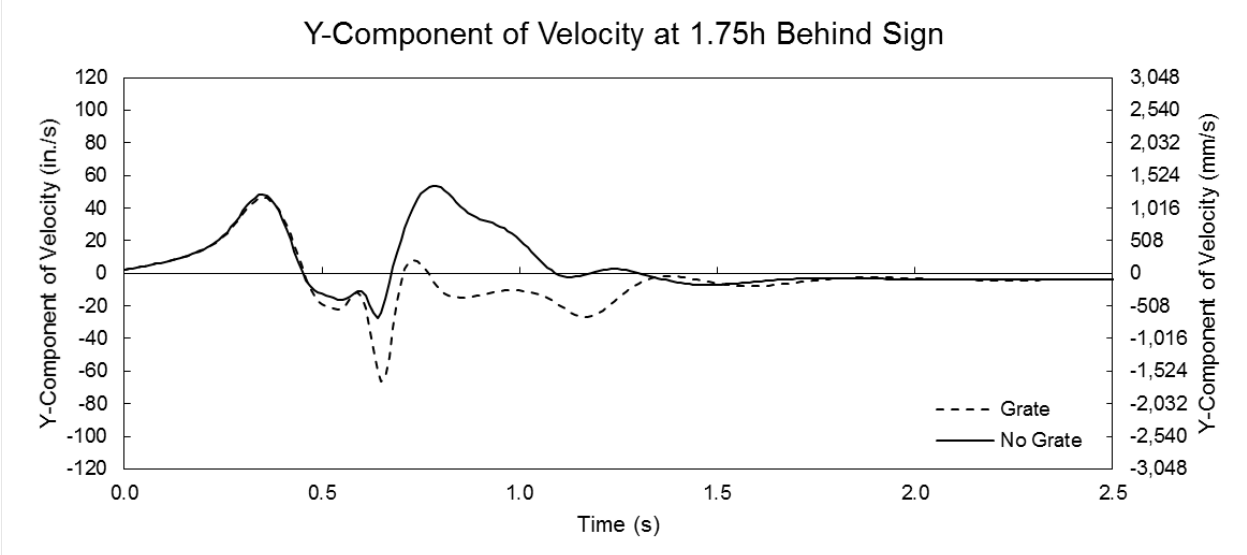

Figure A1.28: Y-component of velocity for the large sign at V=105 mph (46.9 m/s) at a distance = 1.75h behind the sign

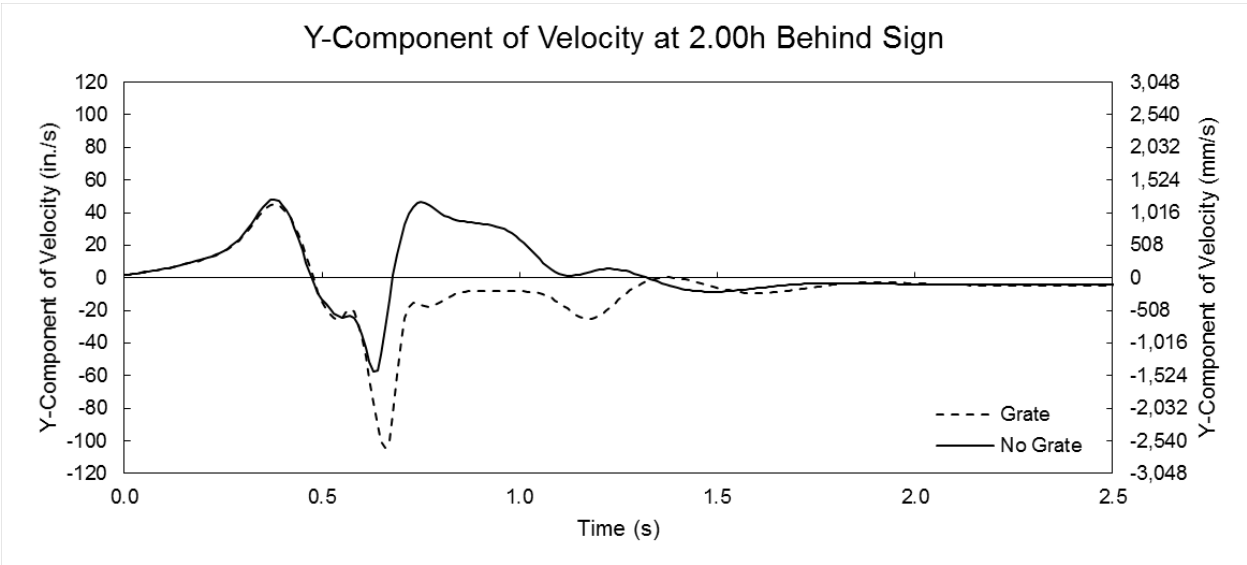

Figure A1.29: Y-component of velocity for the large sign at V=105 mph (46.9 m/s) at a distance = 2.0h behind the sign

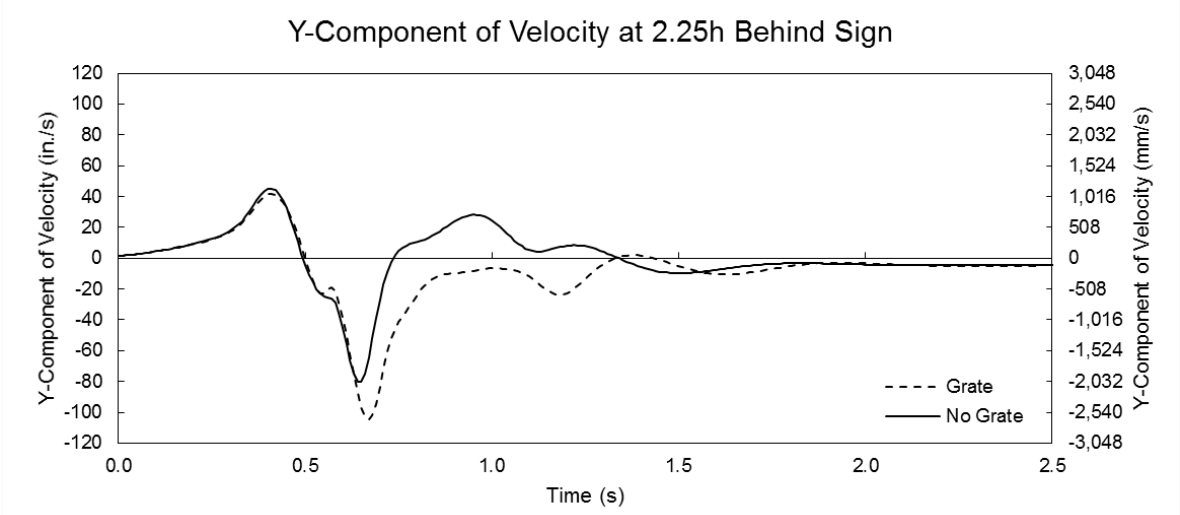

Figure A1.30: Y-component of velocity for the large sign at V=105 mph (46.9 m/s) at a distance = 2.25h behind the sign

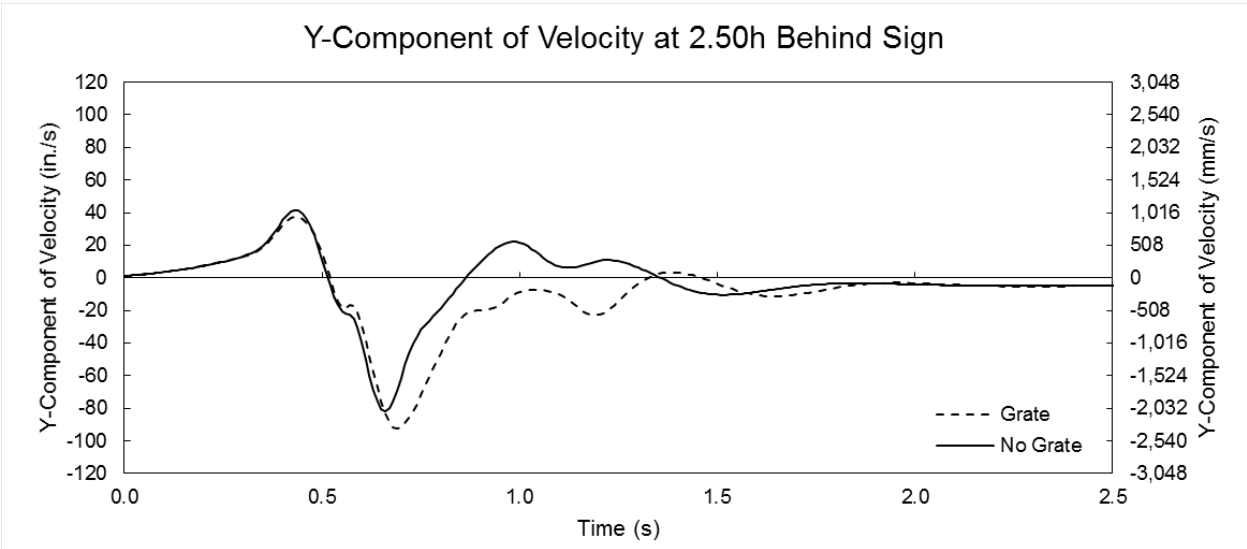

Figure A1.31: Y-component of velocity for the large sign at V=105 mph (46.9 m/s) at a distance = 2.5h behind the sign

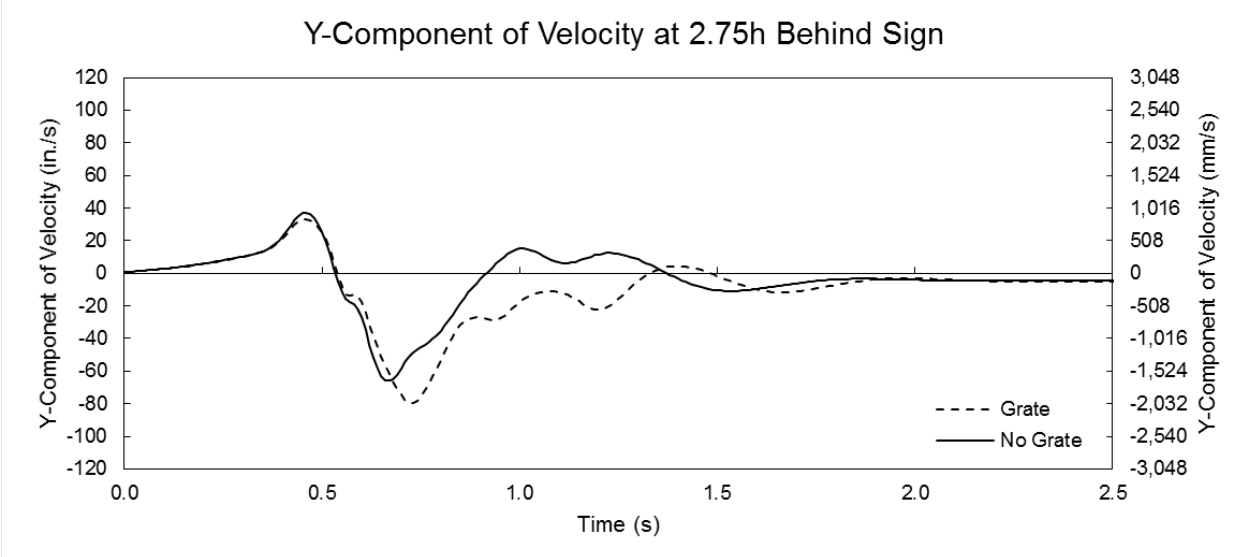

Figure A1.32: Y-component of velocity for the large sign at V=105 mph (46.9 m/s) at a distance = 2.75h behind the sign

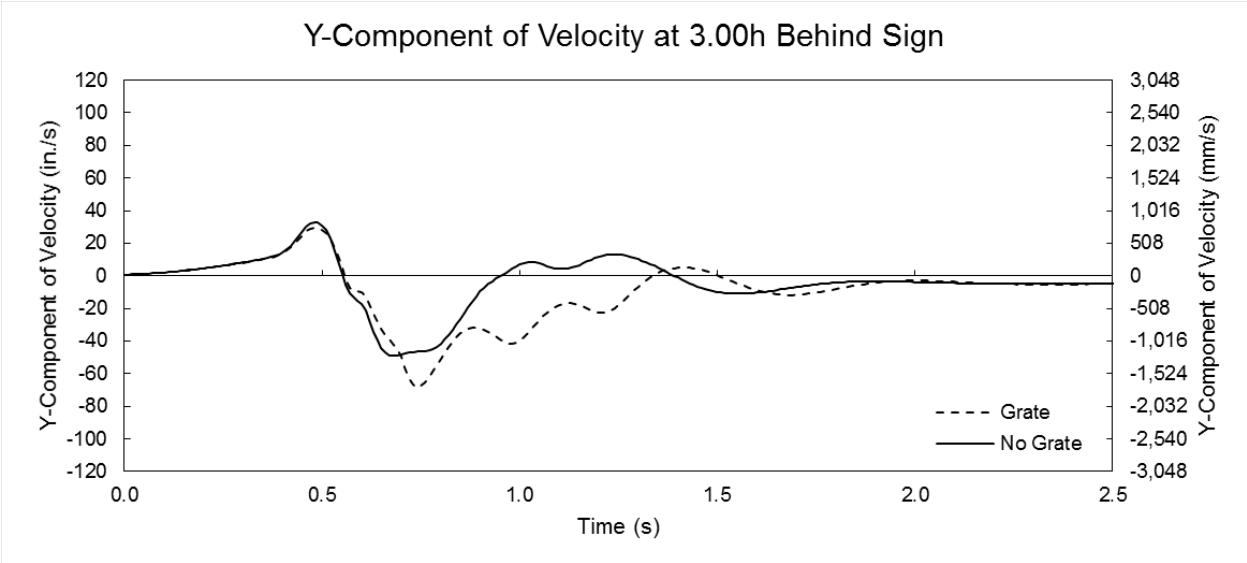

Figure A1.33: Y-component of velocity for the large sign at V=105 mph (46.9 m/s) at a distance = 3.0h behind the sign

A1.4: Y-Component of Velocity Behind Medium Sign at V=30 mph (13.4 m/s)

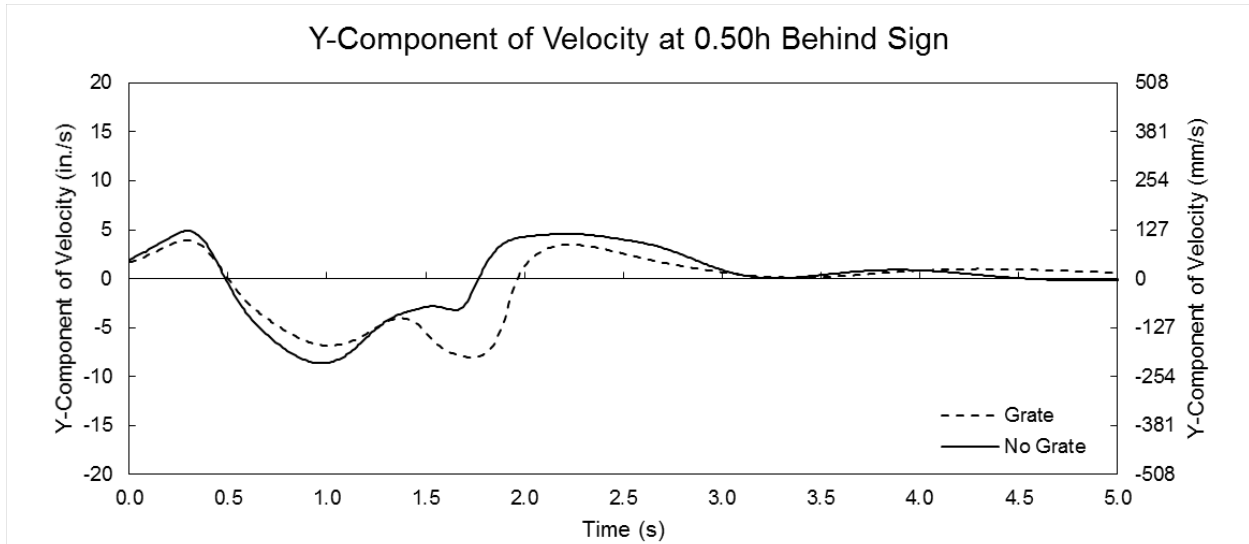

Figure A1.34: Y-component of velocity for the medium sign at V=30 mph (13.4 m/s) at a distance = 0.5h behind the sign

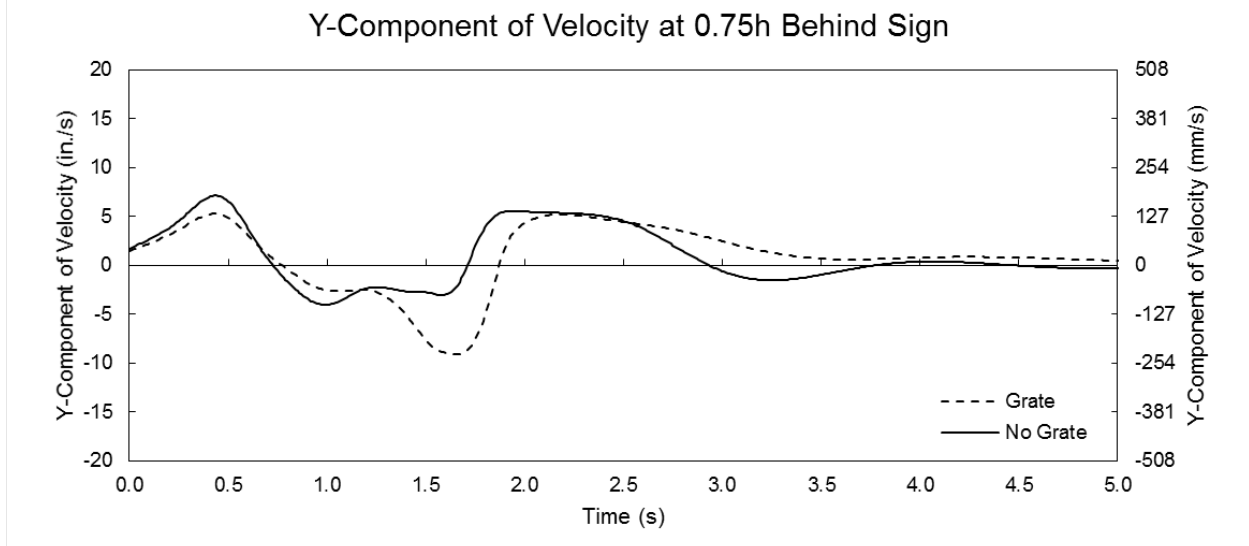

Figure A1.35: Y-component of velocity for the medium sign at V=30 mph (13.4 m/s) at a distance = 0.75h behind the sign

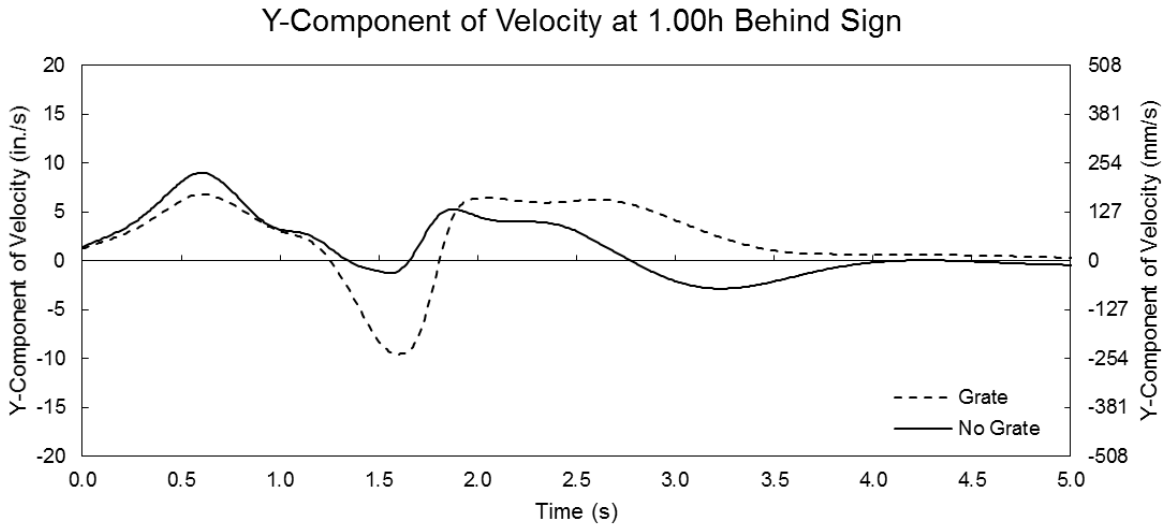

Figure A1.36: Y-component of velocity for the medium sign at V=30 mph (13.4 m/s) at a distance = 1.0h behind the sign

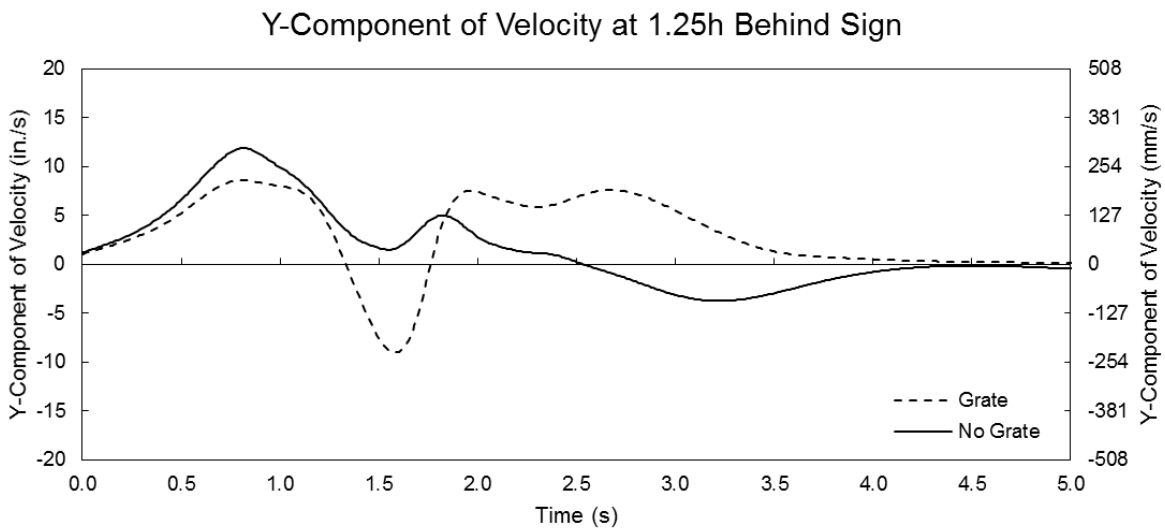

Figure A1.37: Y-component of velocity for the medium sign at V=30 mph (13.4 m/s) at a distance = 1.25h behind the sign

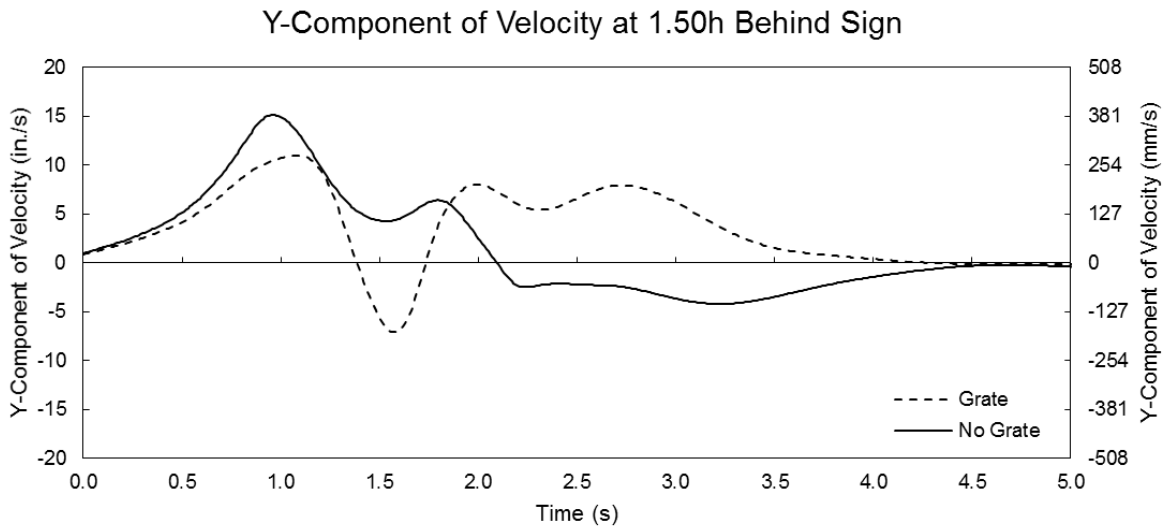

Figure A1.38: Y-component of velocity for the medium sign at V=30 mph (13.4 m/s) at a distance = 1.5h behind the sign

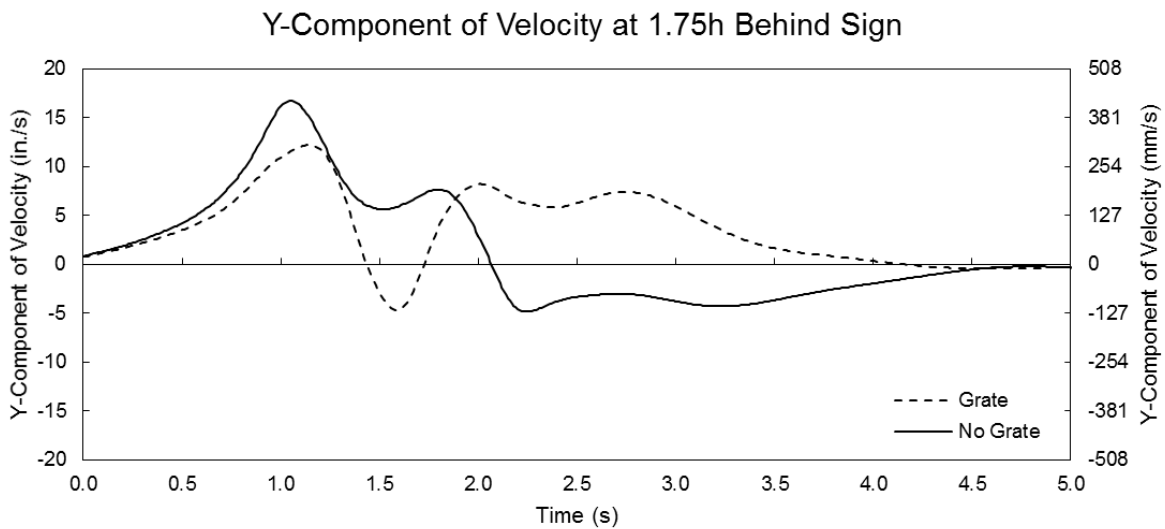

Figure A1.39: Y-component of velocity for the medium sign at V=30 mph (13.4 m/s) at a distance = 1.75h behind the sign

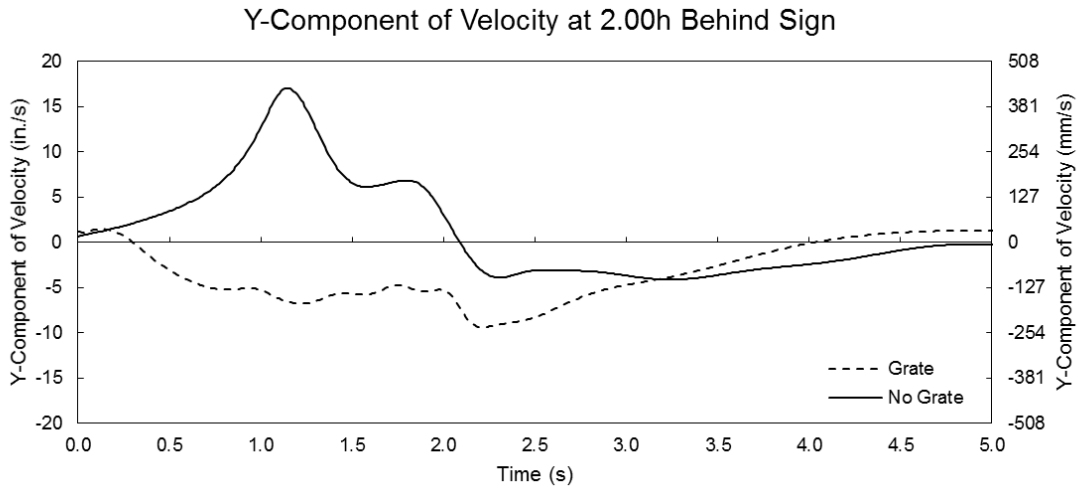

Figure A1.40: Y-component of velocity for the medium sign at V=30 mph (13.4 m/s) at a distance = 2.0h behind the sign

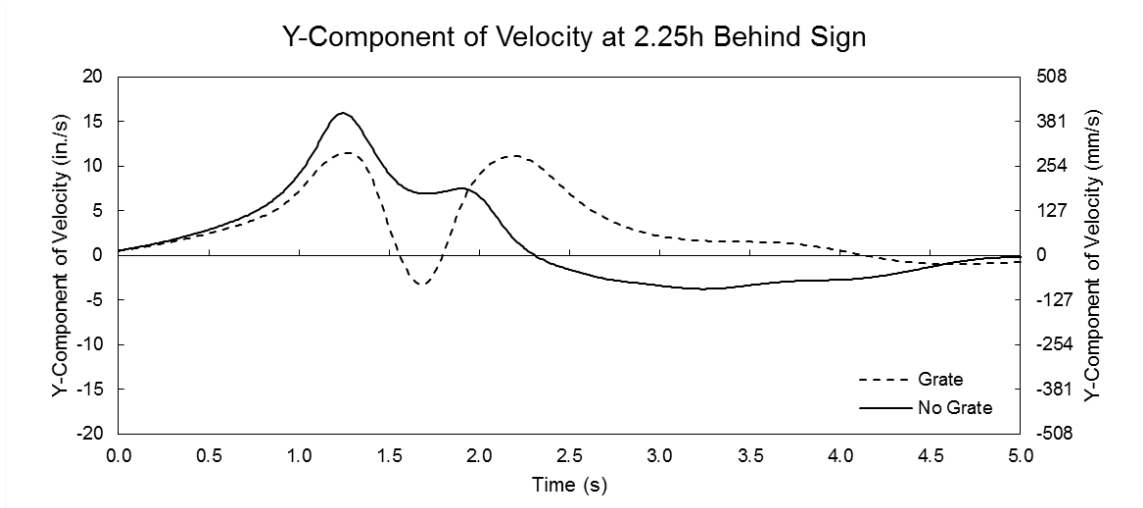

Figure A1.41: Y-component of velocity for the medium sign at V=30 mph (13.4 m/s) at a distance = 2.25h behind the sign

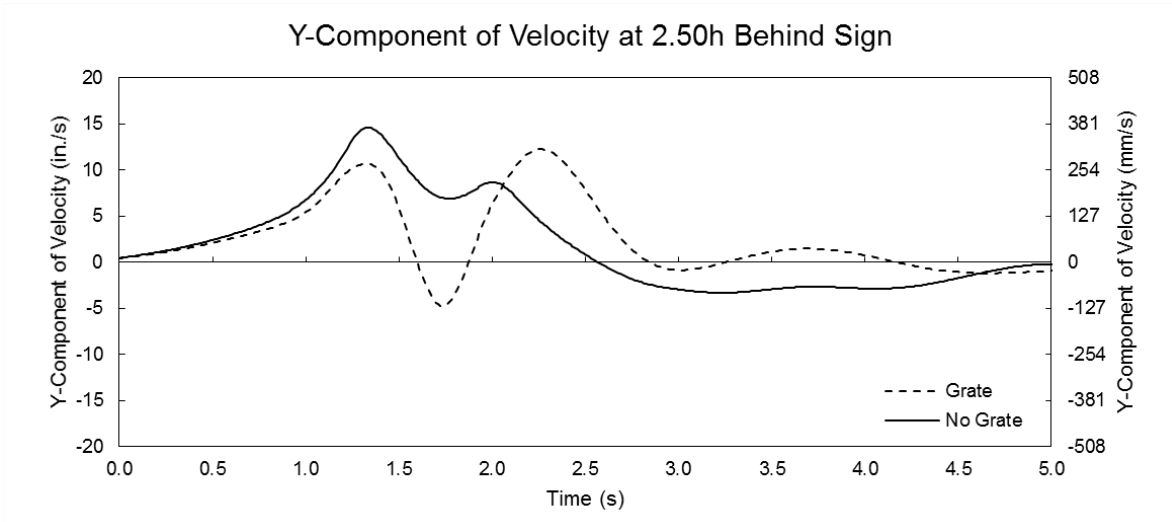

Figure A1.42: Y-component of velocity for the medium sign at V=30 mph (13.4 m/s) at a distance = 2.5h behind the sign

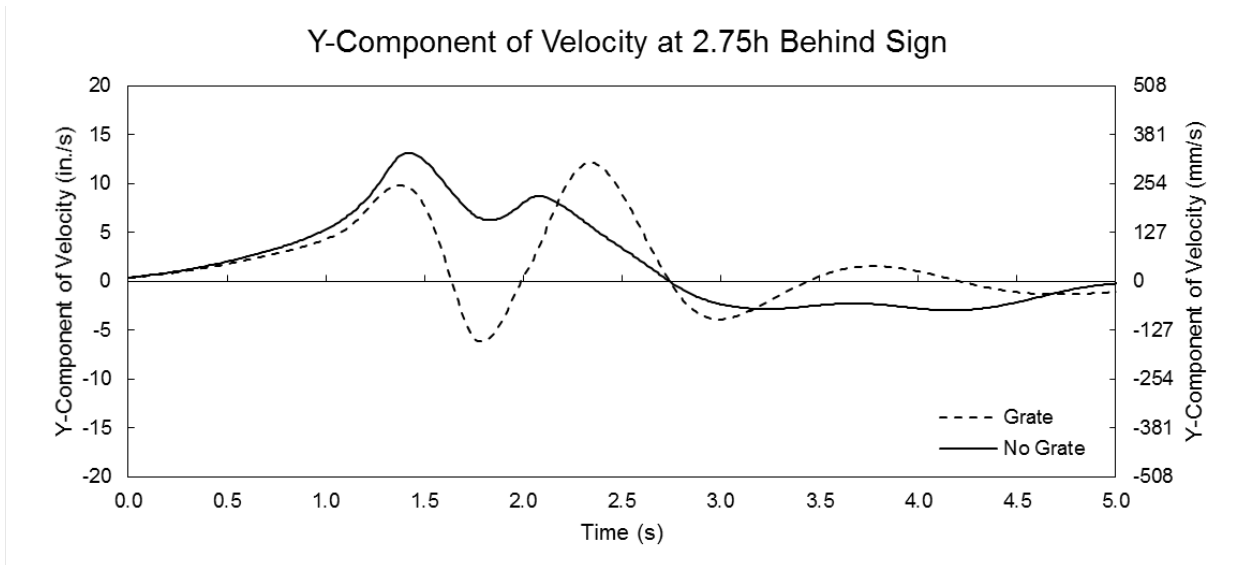

Figure A1.43: Y-component of velocity for the medium sign at V=30 mph (13.4 m/s) at a distance = 2.75h behind the sign

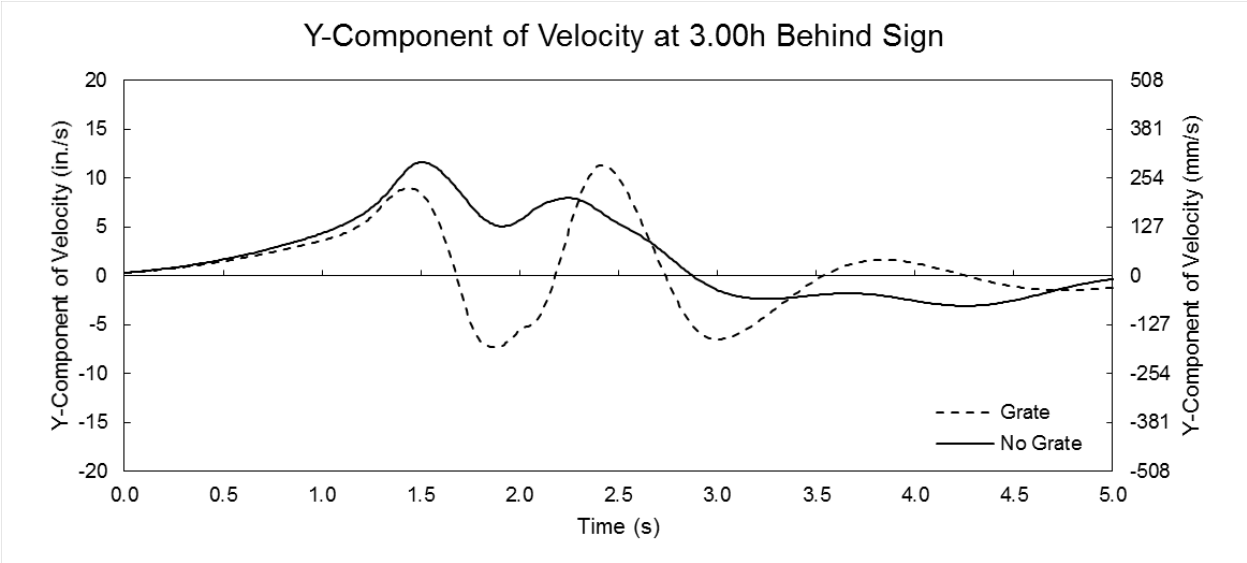

Figure A1.44: Y-component of velocity for the medium sign at V=30 mph (13.4 m/s) at a distance = 3.0h behind the sign

A1.5: Y-Component of Velocity Behind Medium Sign at V=61.2 mph (27.4 m/s)

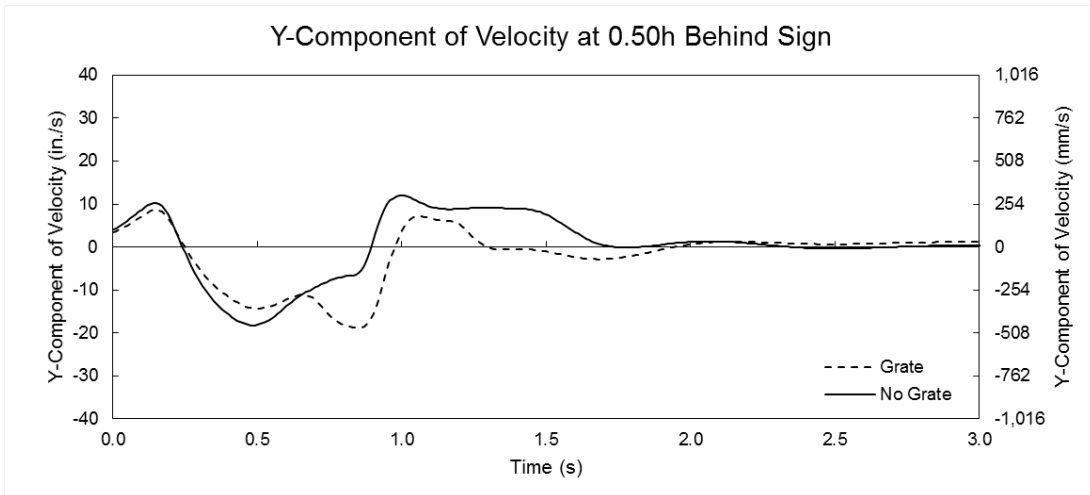

Figure A1.45: Y-component of velocity for the medium sign at V=61.2 mph (27.4 m/s) at a distance = 0.5h behind the sign

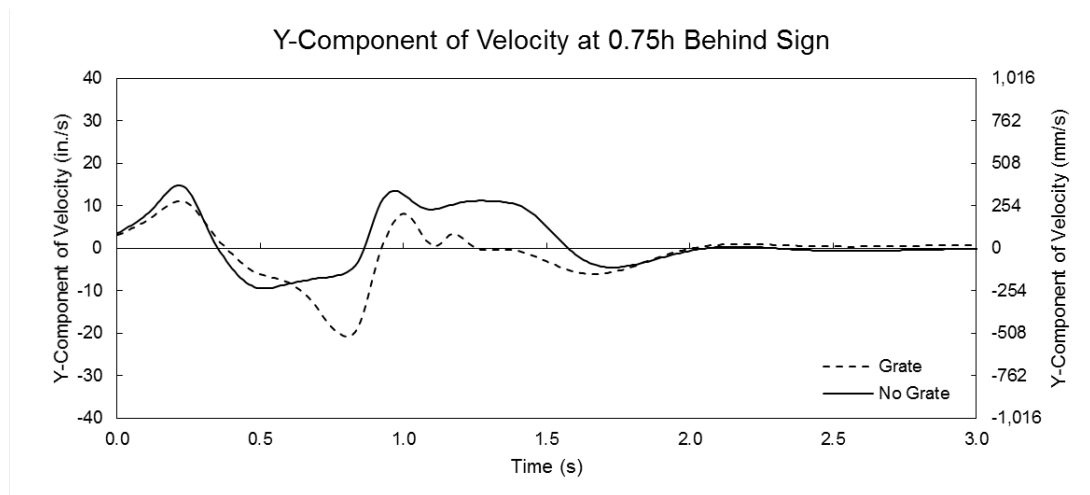

Figure A1.46: Y-component of velocity for the medium sign at V=61.2 mph (27.4 m/s) at a distance = 0.75h behind the sign

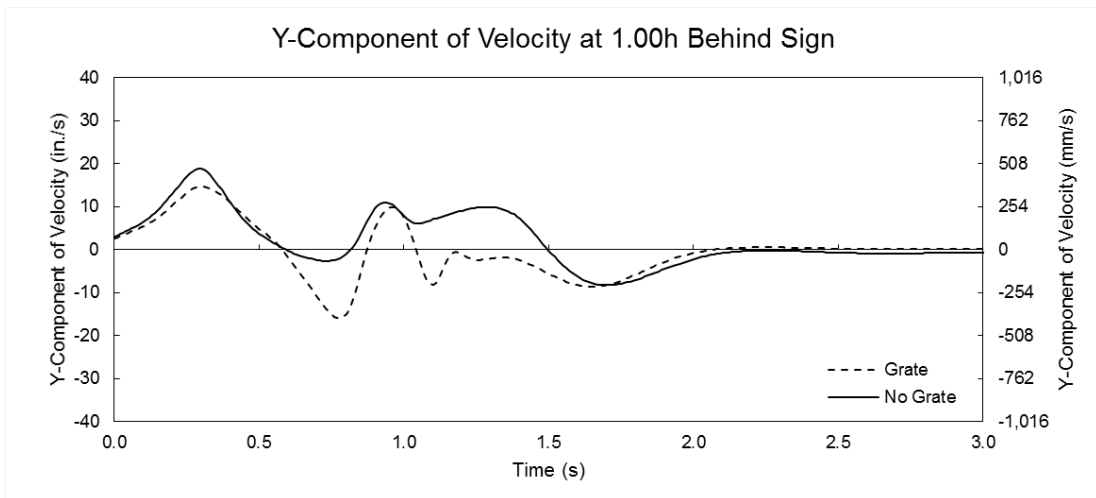

Figure A1.47: Y-component of velocity for the medium sign at V=61.2 mph (27.4 m/s) at a distance = 1.0h behind the sign

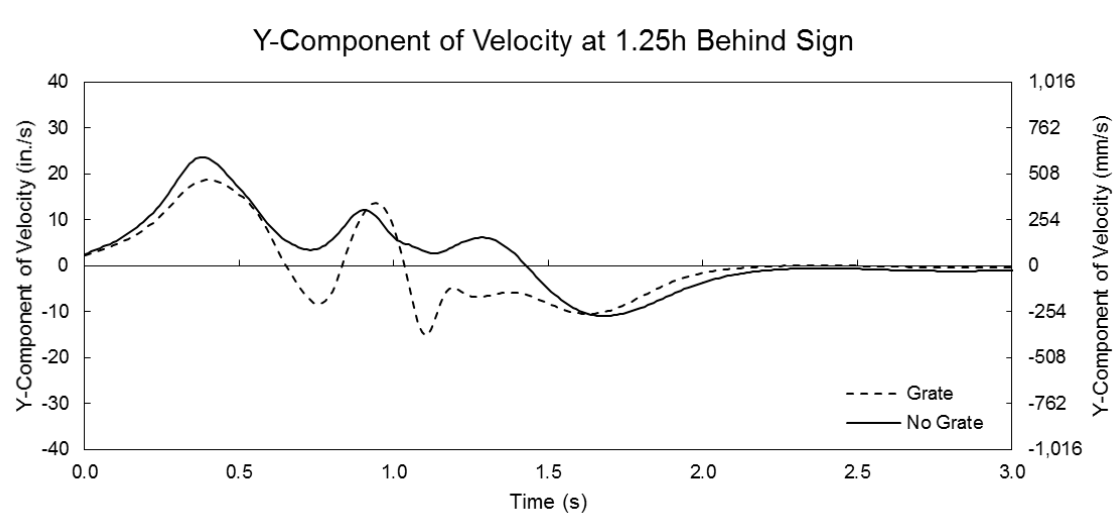

Figure A1.48: Y-component of velocity for the medium sign at V=61.2 mph (27.4 m/s) at a distance = 1.25h behind the sign

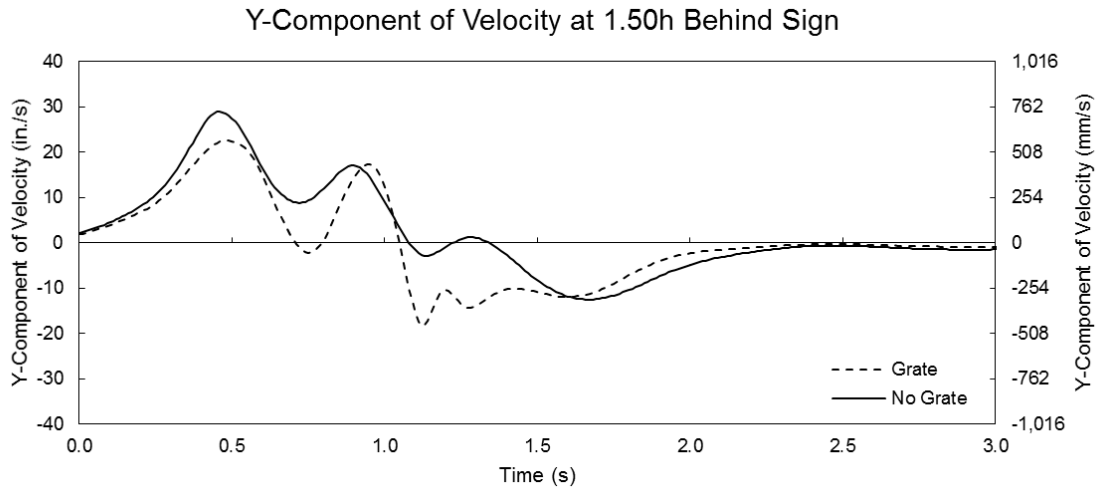

Figure A1.49: Y-component of velocity for the medium sign at V=61.2 mph (27.4 m/s) at a distance = 1.5h behind the sign

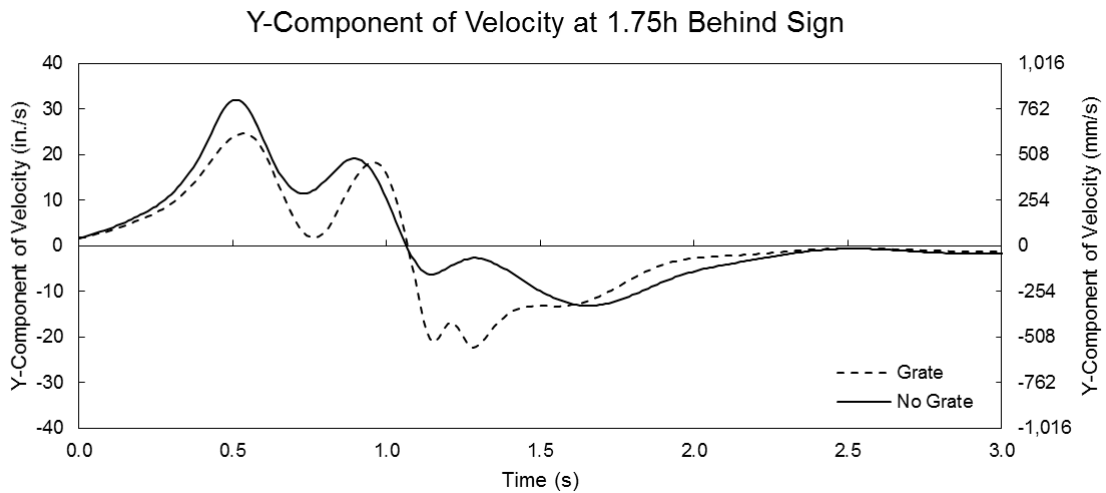

Figure A1.50: Y-component of velocity for the medium sign at V=61.2 mph (27.4 m/s) at a distance = 1.75h behind the sign

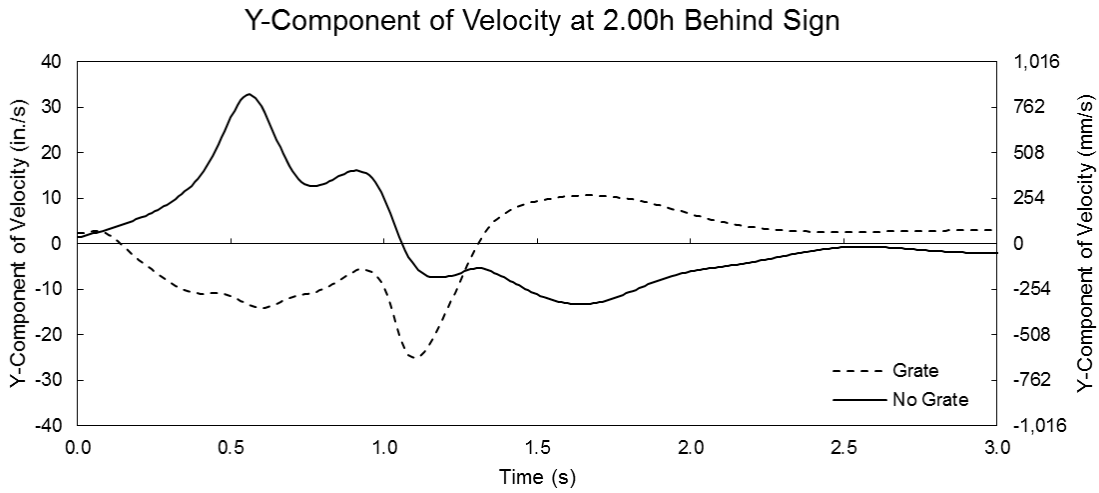

Figure A1.51: Y-component of velocity for the medium sign at V=61.2 mph (27.4 m/s) at a distance = 2.0h behind the sign

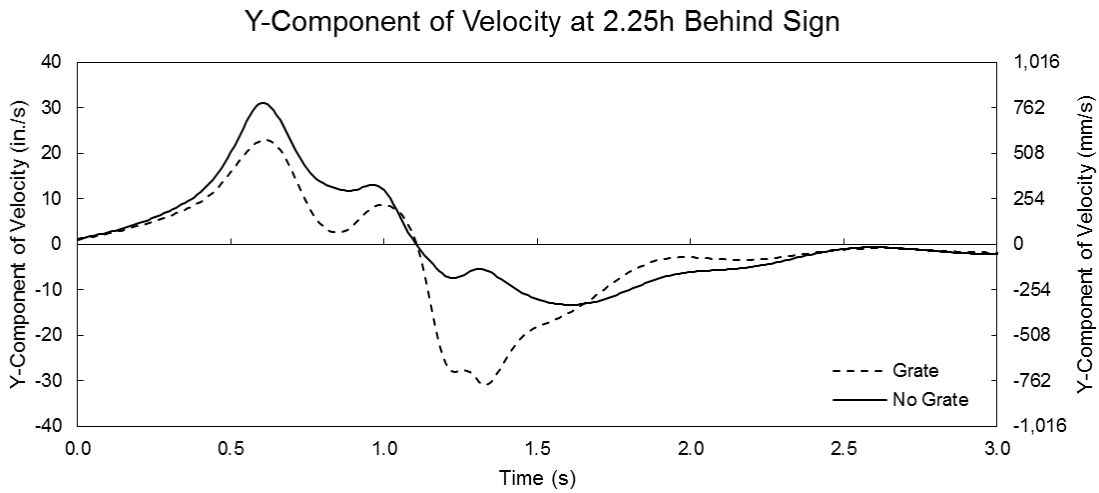

Figure A1.52: Y-component of velocity for the medium sign at V=61.2 mph (27.4 m/s) at a distance = 2.25h behind the sign

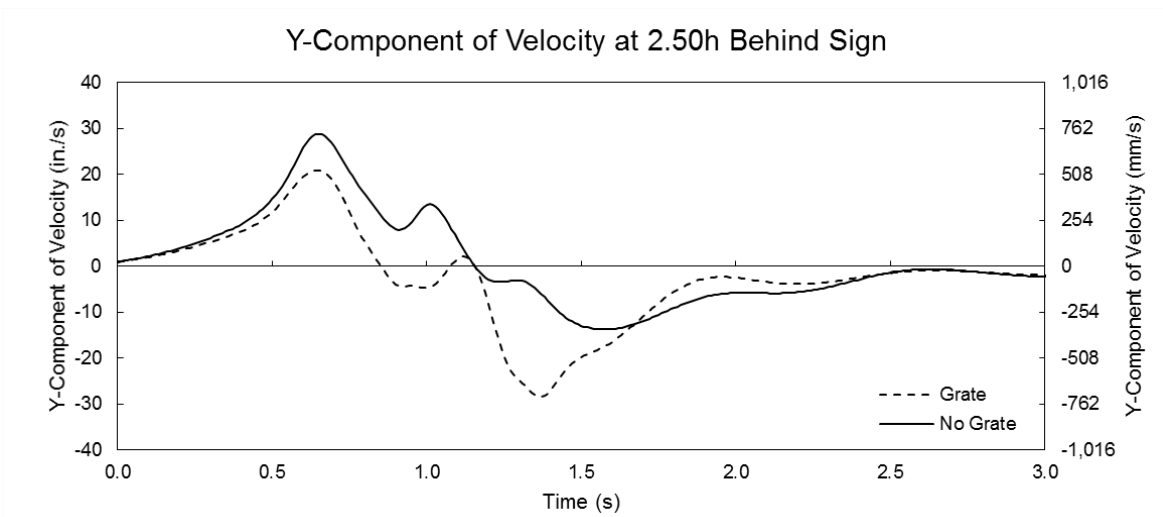

Figure A1.53: Y-component of velocity for the medium sign at V=61.2 mph (27.4 m/s) at a distance = 2.5h behind the sign

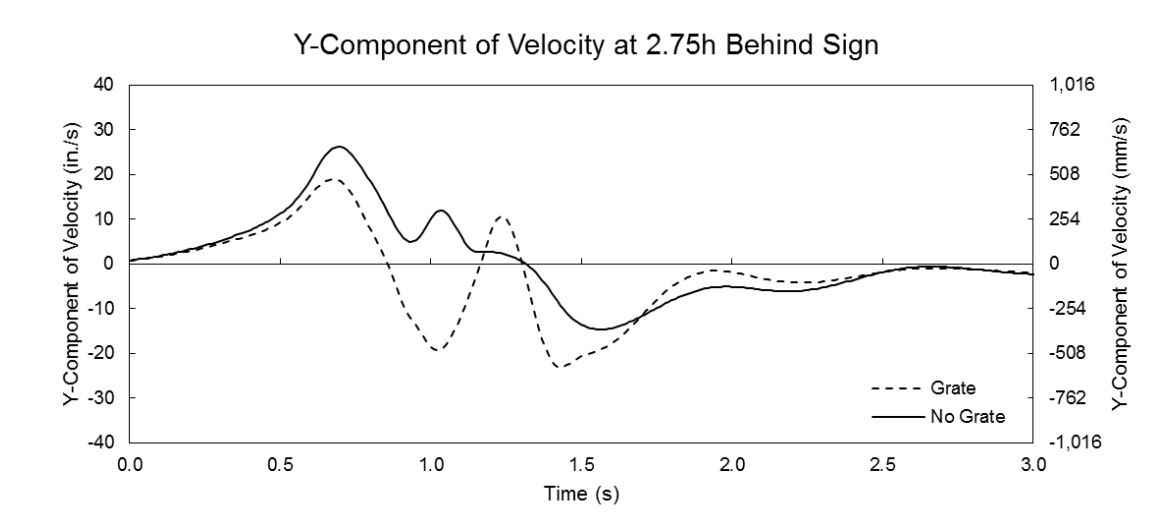

Figure A1.54: Y-component of velocity for the medium sign at V=61.2 mph (27.4 m/s) at a distance = 2.75h behind the sign

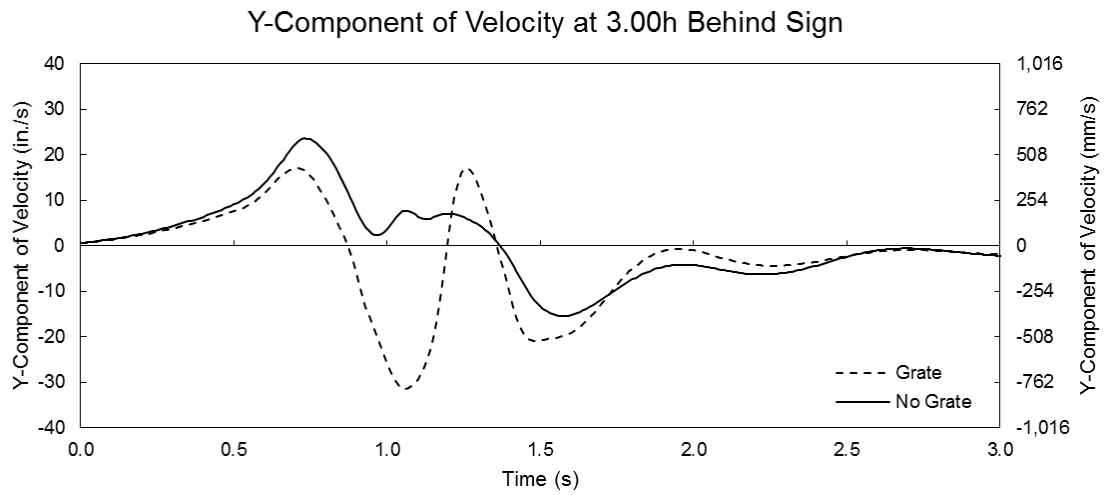

Figure A1.55: Y-component of velocity for the medium sign at V=61.2 mph (27.4 m/s) at a distance = 3.0h behind the sign

A1.6: Y-Component of Velocity Behind Medium Sign at V=105mph (46.9 m/s)

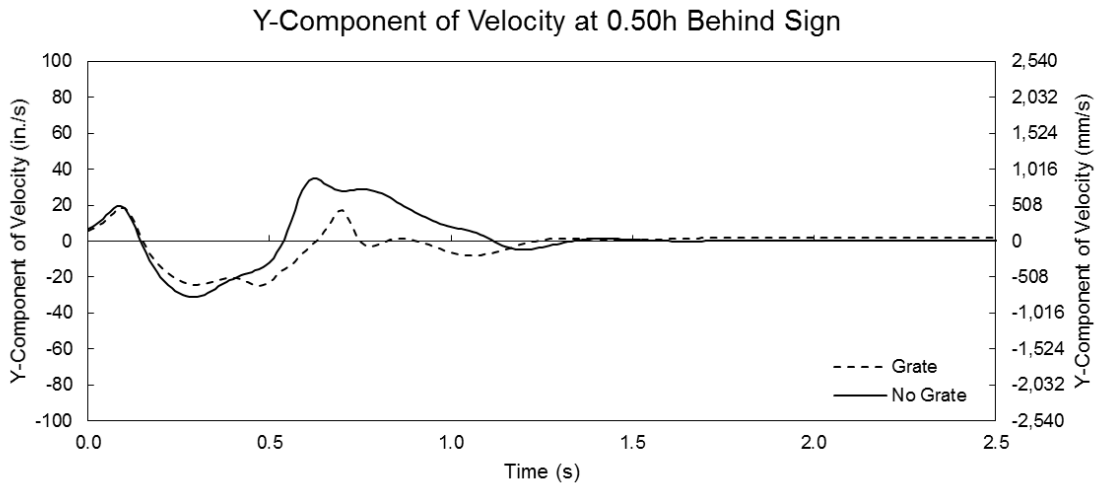

Figure A1.56: Y-component of velocity for the medium sign at V=105 mph (46.9 m/s) at a distance = 0.5h behind the sign

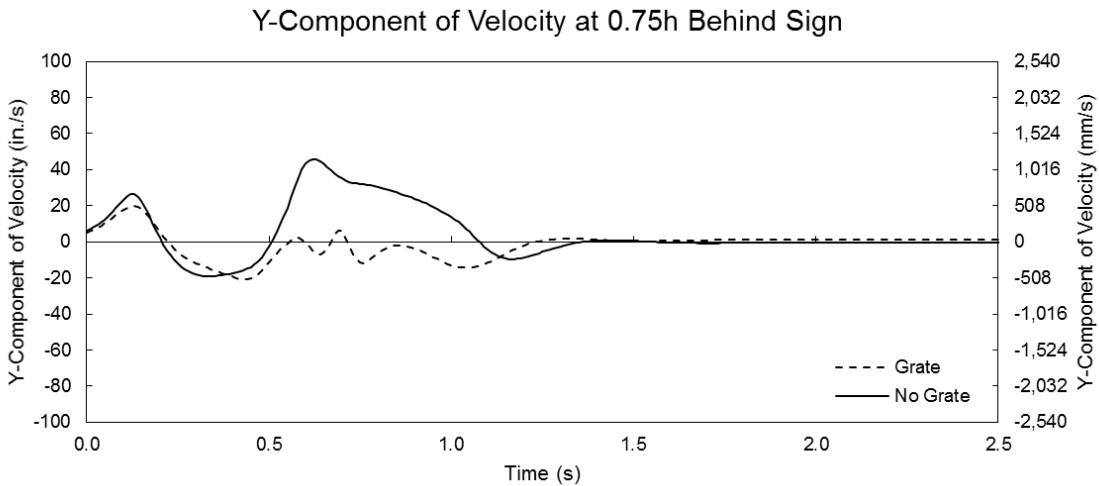

Figure A1.57: Y-component of velocity for the medium sign at V=105 mph (46.9 m/s) at a distance = 0.75h behind the sign

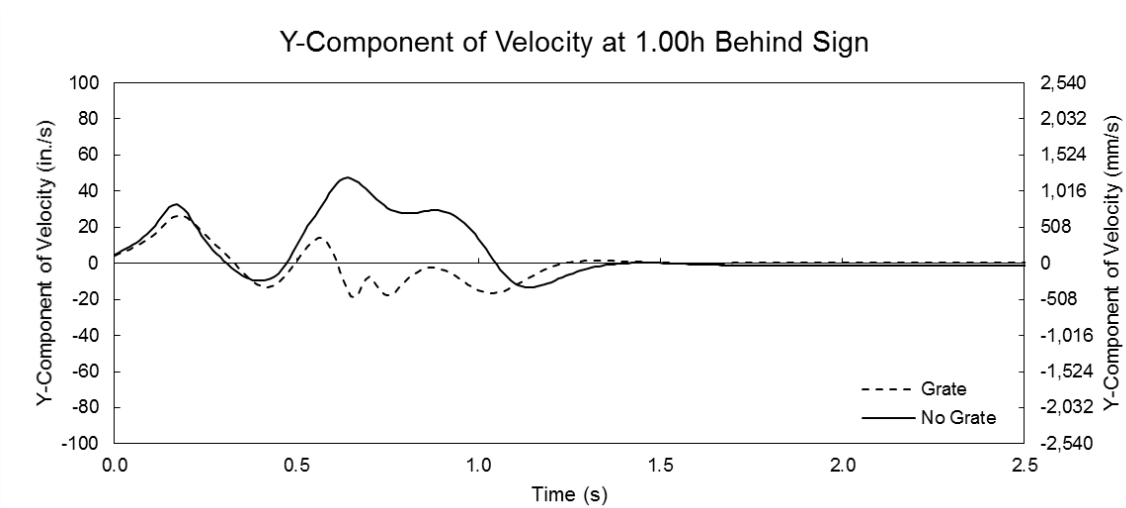

Figure A1.58: Y-component of velocity for the medium sign at V=105 mph (46.9 m/s) at a distance = 1.0h behind the sign

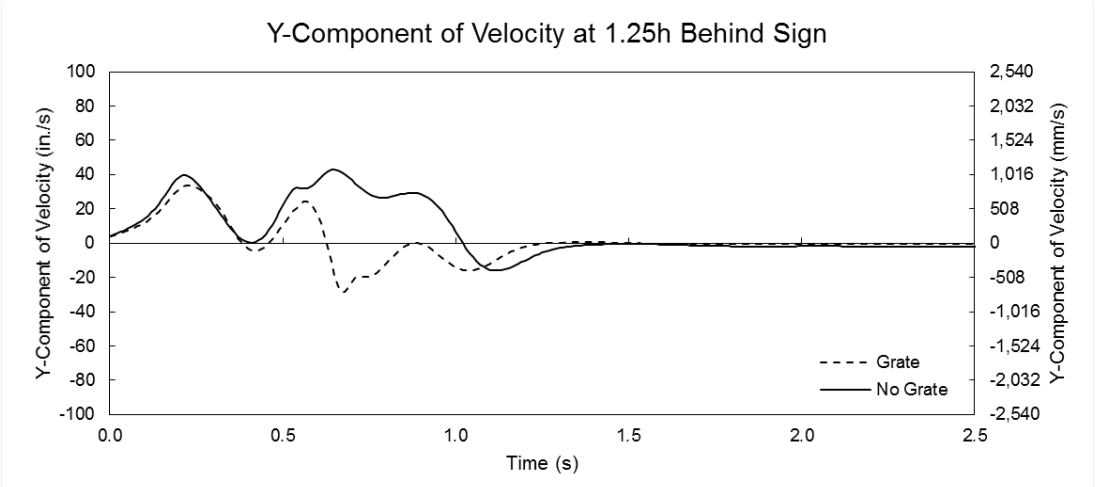

Figure A1.59: Y-component of velocity for the medium sign at V=105 mph (46.9 m/s) at a distance = 1.25h behind the sign

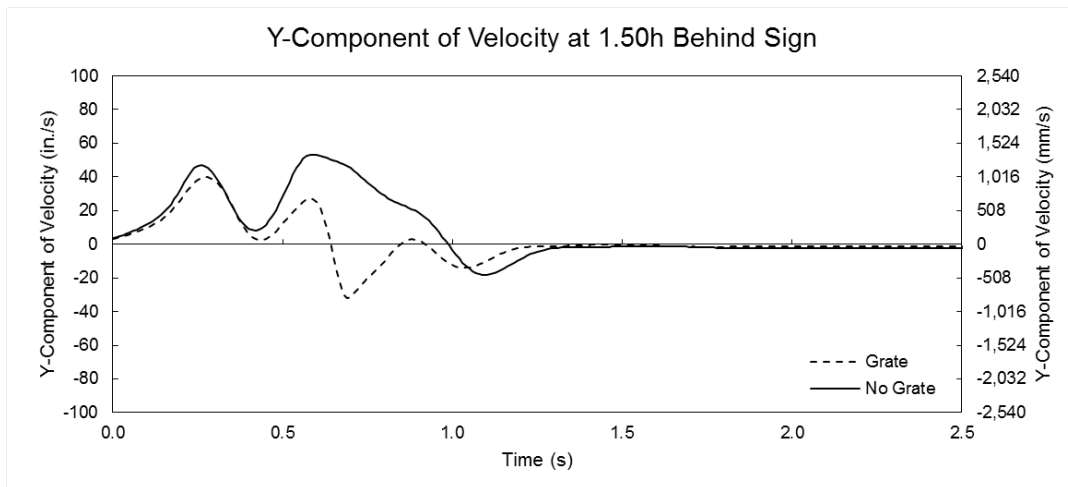

Figure A1.60: Y-component of velocity for the medium sign at V=105 mph (46.9 m/s) at a distance = 1.5h behind the sign

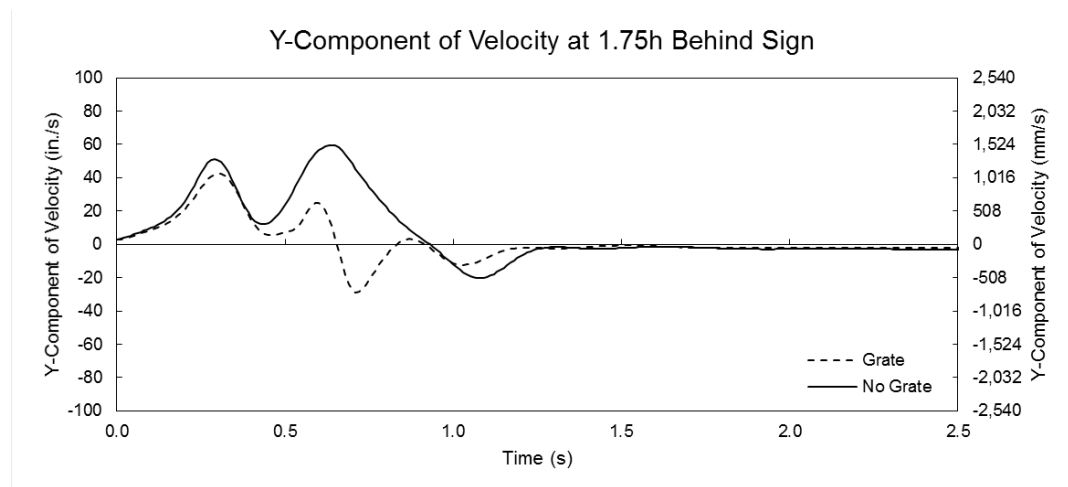

Figure A1.61: Y-component of velocity for the medium sign at V=105 mph (46.9 m/s) at a distance = 1.75h behind the sign

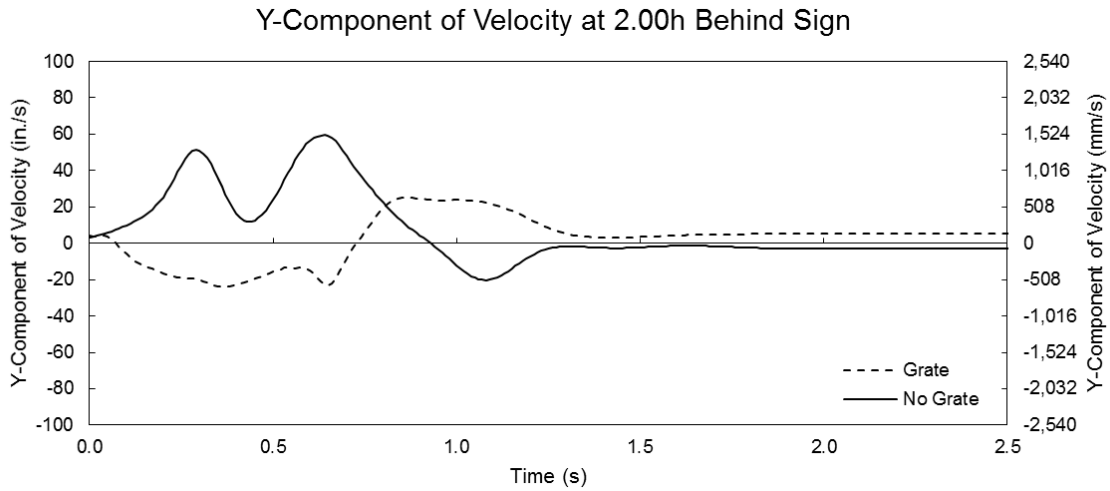

Figure A1.62: Y-component of velocity for the medium sign at V=105 mph (46.9 m/s) at a distance = 2.0h behind the sign

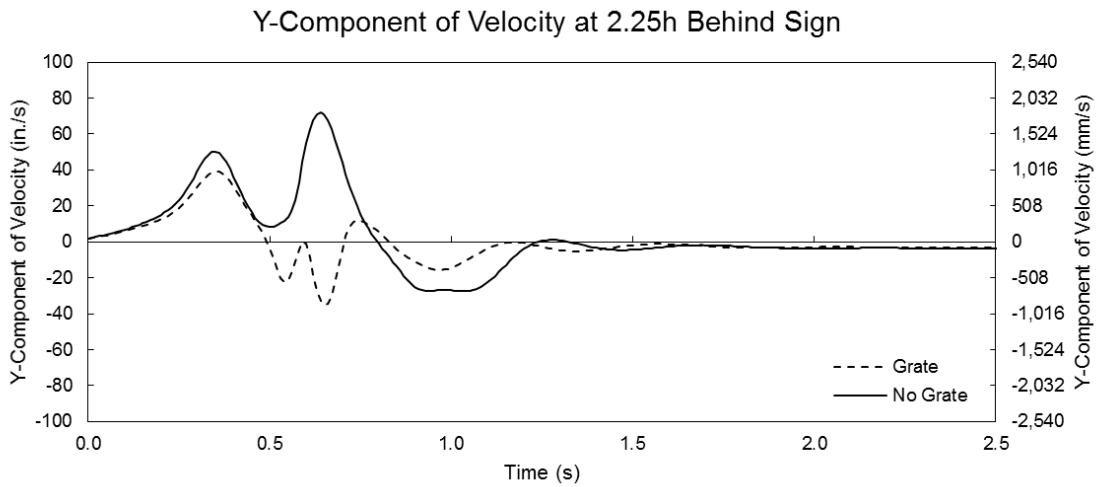

Figure A1.63: Y-component of velocity for the medium sign at V=105 mph (46.9 m/s) at a distance = 2.25h behind the sign

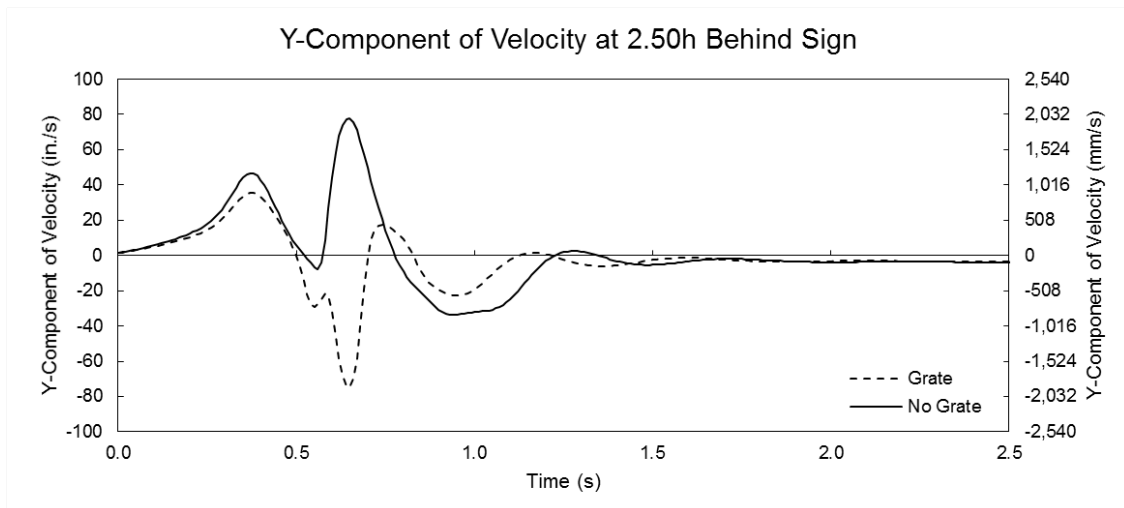

Figure A1.64: Y-component of velocity for the medium sign at V=105 mph (46.9 m/s) at a distance = 2.5h behind the sign

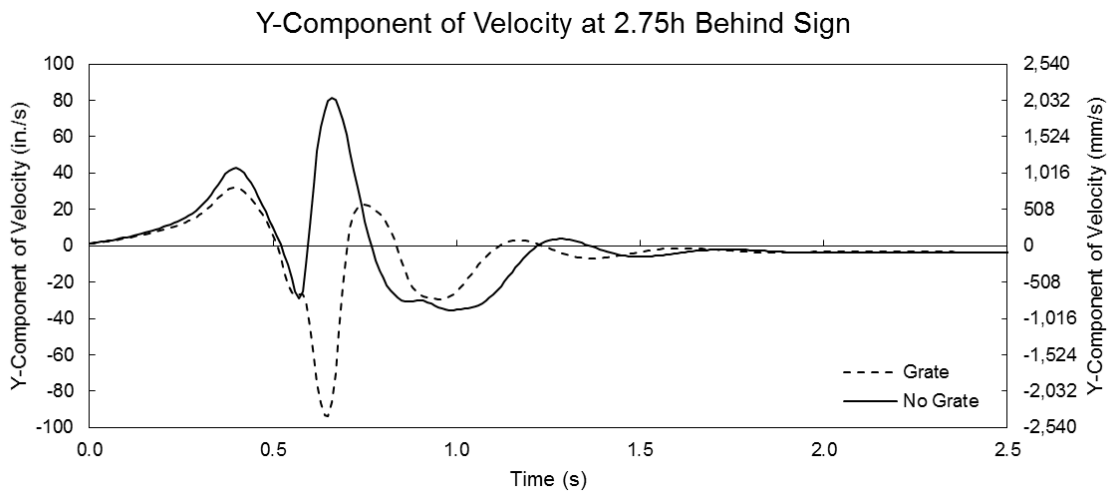

Figure A1.65: Y-component of velocity for the medium sign at V=105 mph (46.9 m/s) at a distance = 2.75h behind the sign

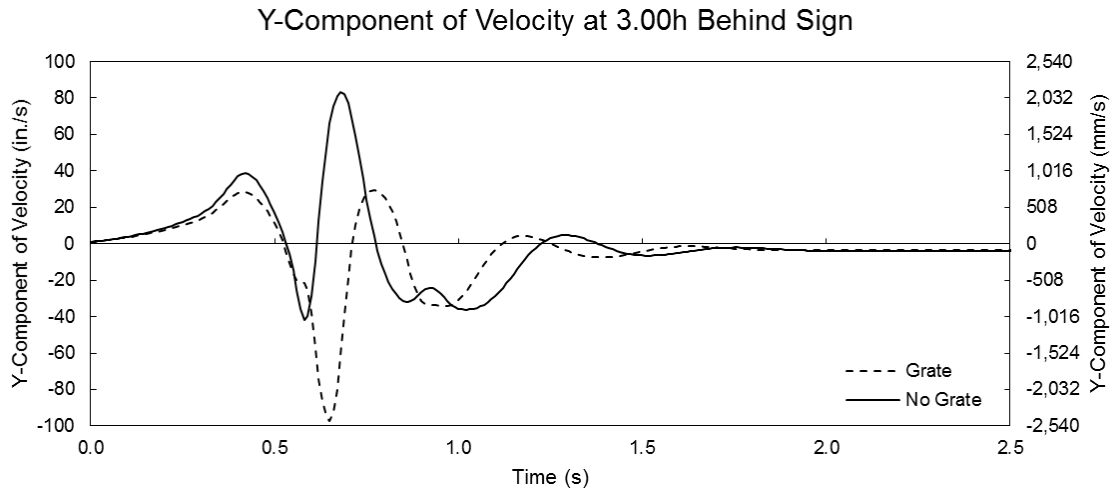

Figure A1.66: Y-component of velocity for the medium sign at V=105 mph (46.9 m/s) at a distance = 3.0h behind the sign

A1.7: Y-Component of Velocity Behind Small Sign at V=30 mph (13.4 m/s)

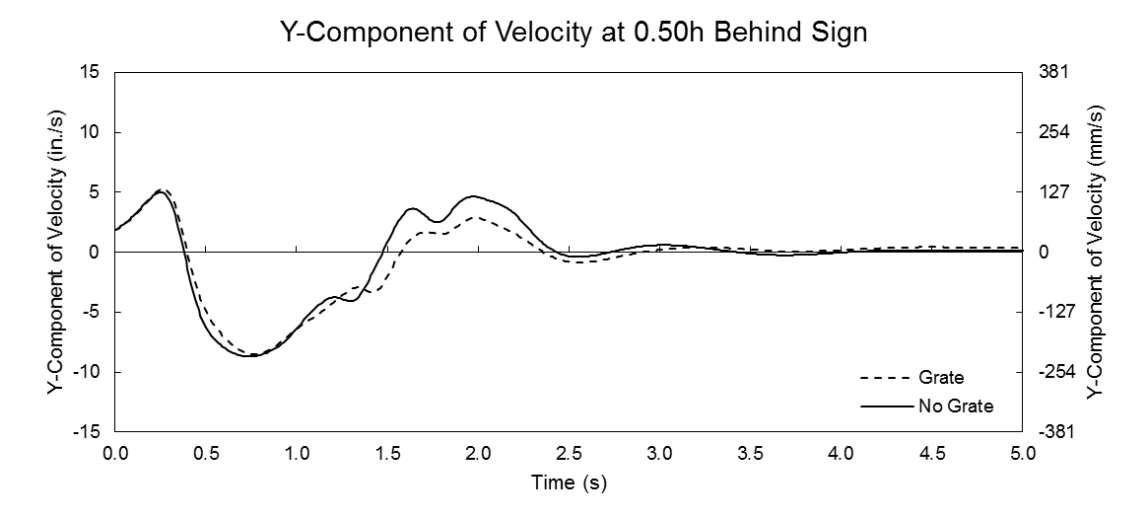

Figure A1.67: Y-component of velocity for the small sign at V=30 mph (13.4 m/s) at a distance = 0.5h behind the sign

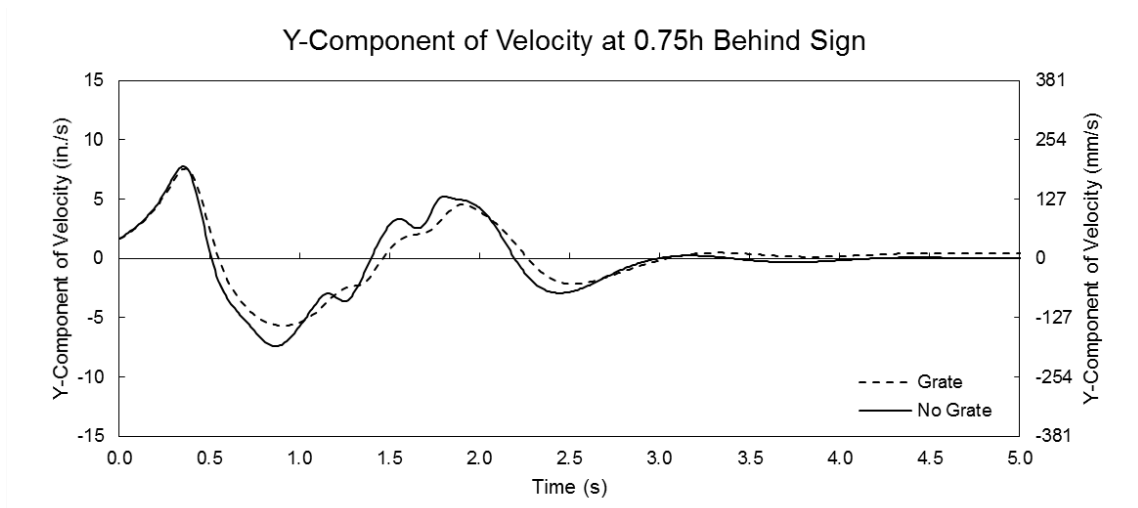

Figure A1.68: Y-component of velocity for the small sign at V=30 mph (13.4 m/s) at a distance = 0.75h behind the sign

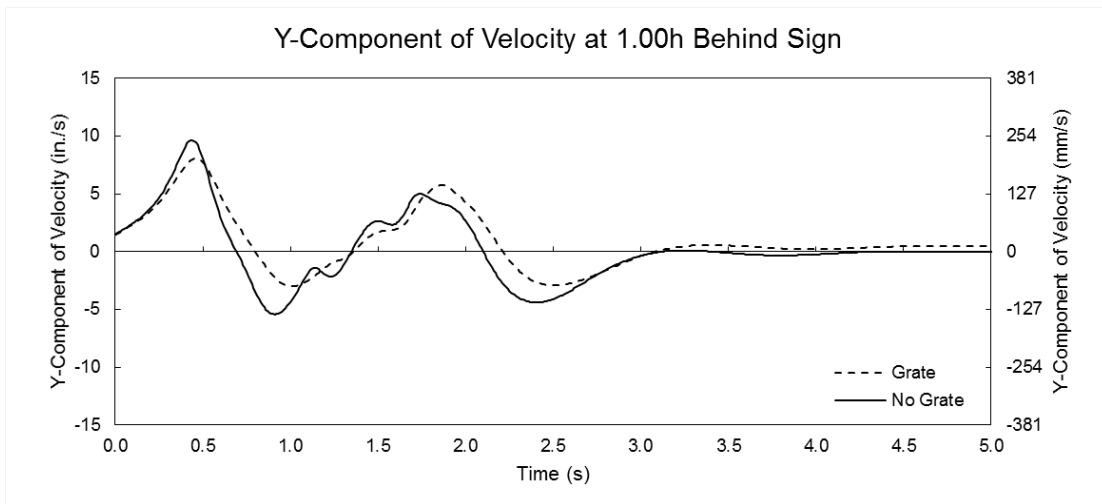

Figure A1.69: Y-component of velocity for the small sign at V=30 mph (13.4 m/s) at a distance = 1.0h behind the sign

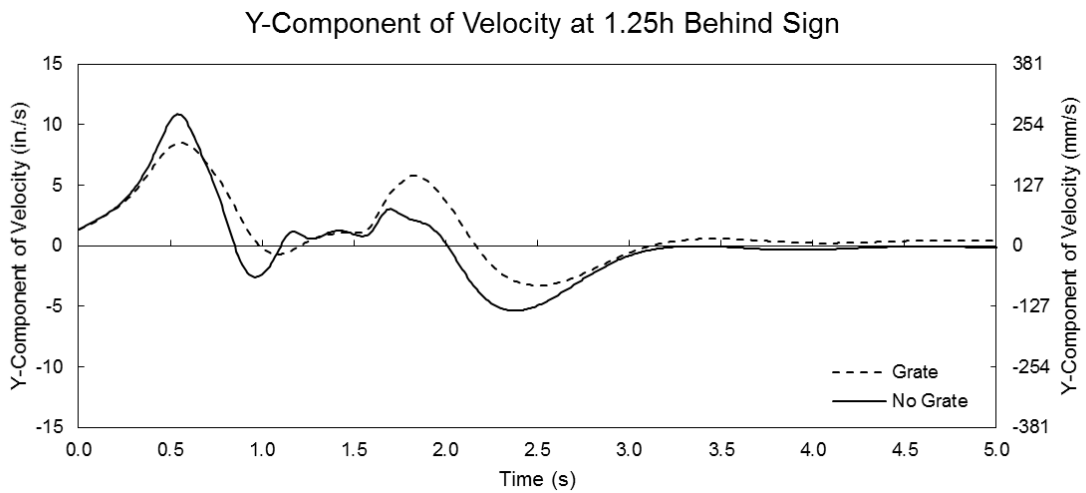

Figure A1.70: Y-component of velocity for the small sign at V=30 mph (13.4 m/s) at a distance = 1.25h behind the sign

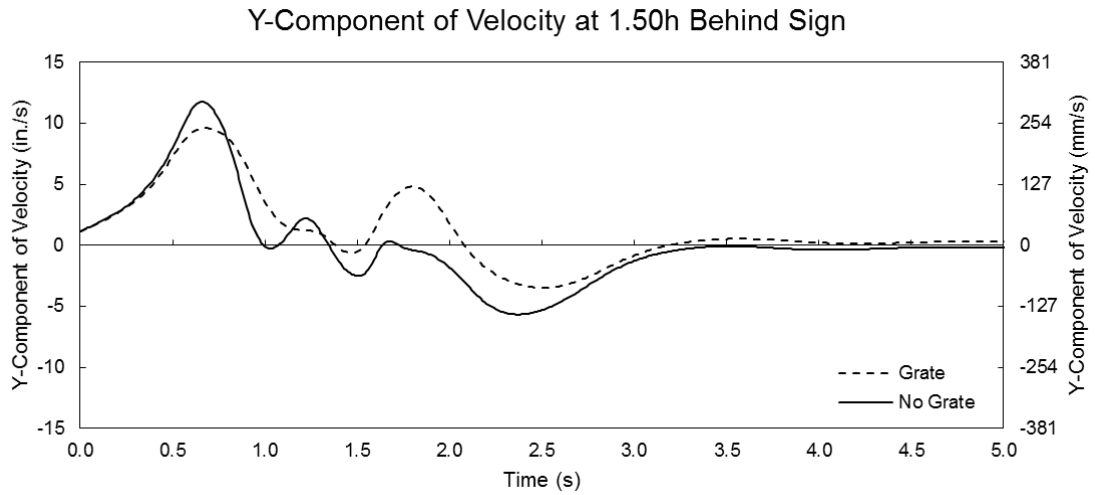

Figure A1.71: Y-component of velocity for the small sign at V=30 mph (13.4 m/s) at a distance = 1.5h behind the sign

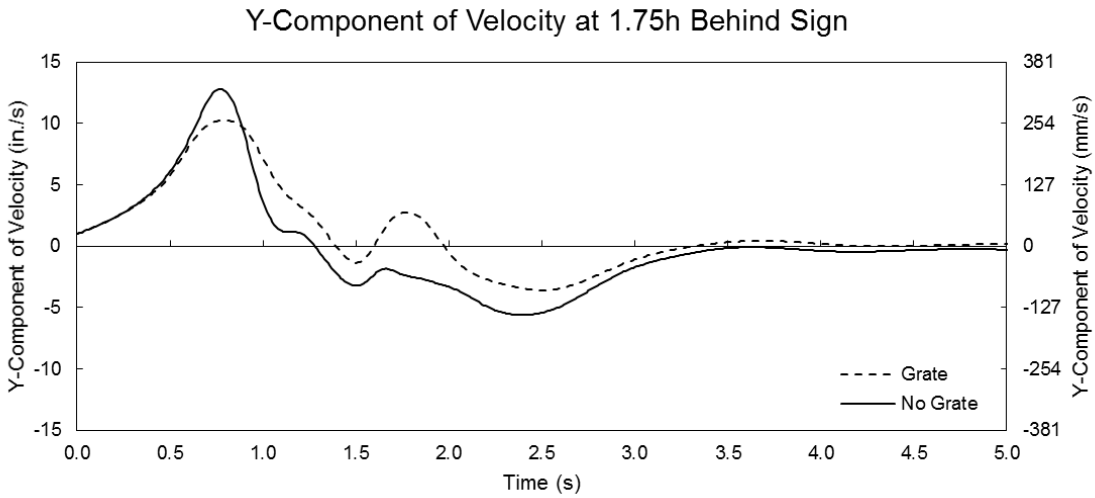

Figure A1.72: Y-component of velocity for the small sign at V=30 mph (13.4 m/s) at a distance = 1.75h behind the sign

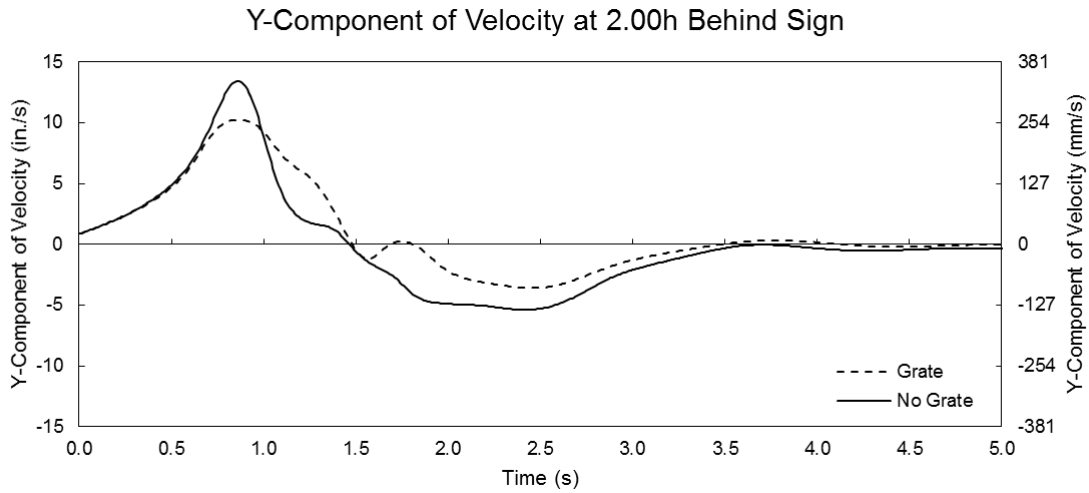

Figure A1.73: Y-component of velocity for the small sign at V=30 mph (13.4 m/s) at a distance = 2.0h behind the sign

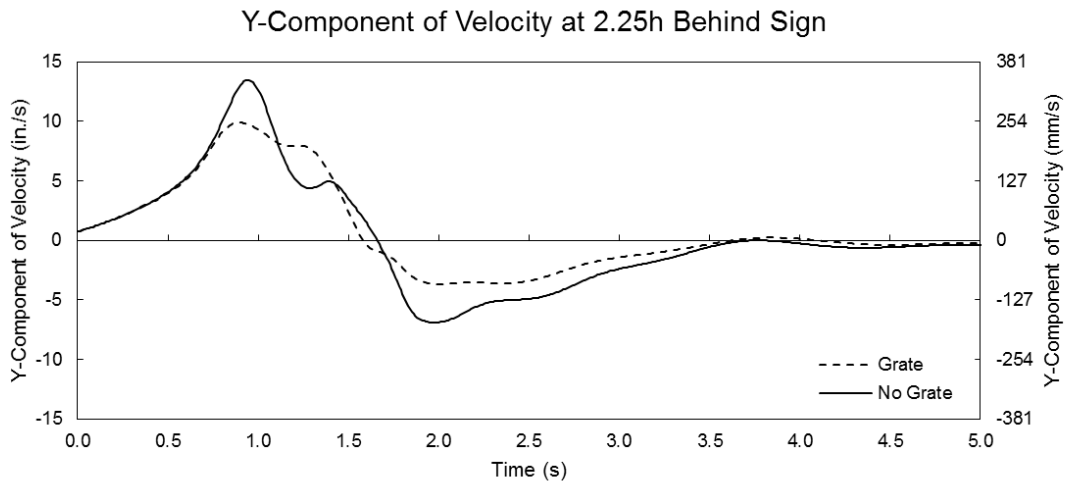

Figure A1.74: Y-component of velocity for the small sign at V=30 mph (13.4 m/s) at a distance = 2.25h behind the sign

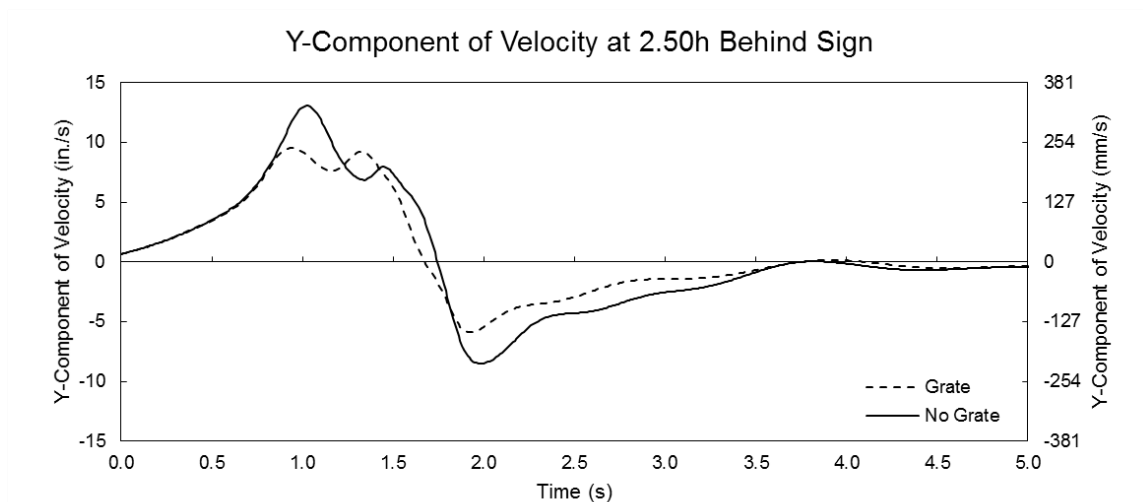

Figure A1.75: Y-component of velocity for the small sign at V=30 mph (13.4 m/s) at a distance = 2.5h behind the sign

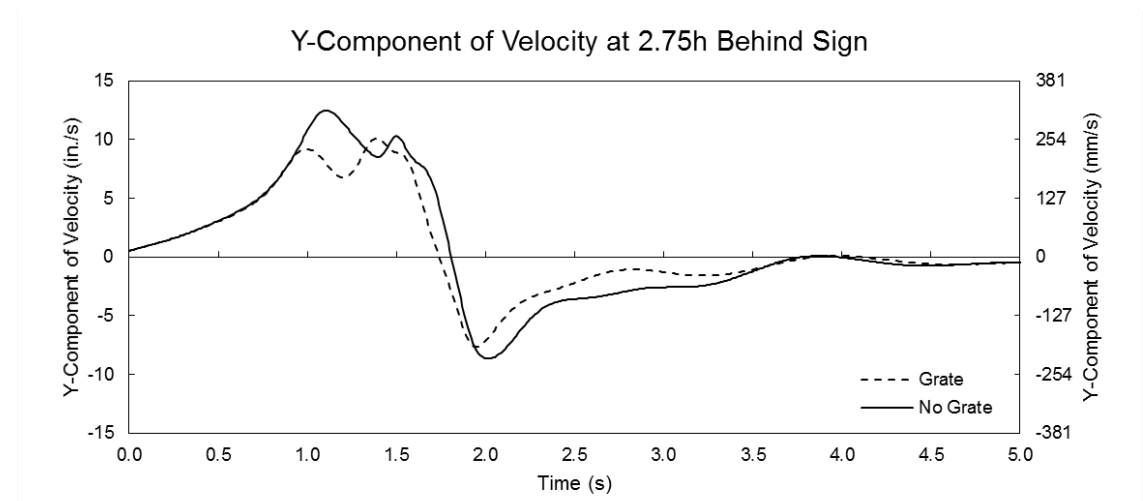

Figure A1.76: Y-component of velocity for the small sign at V=30 mph (13.4 m/s) at a distance = 2.75h behind the sign

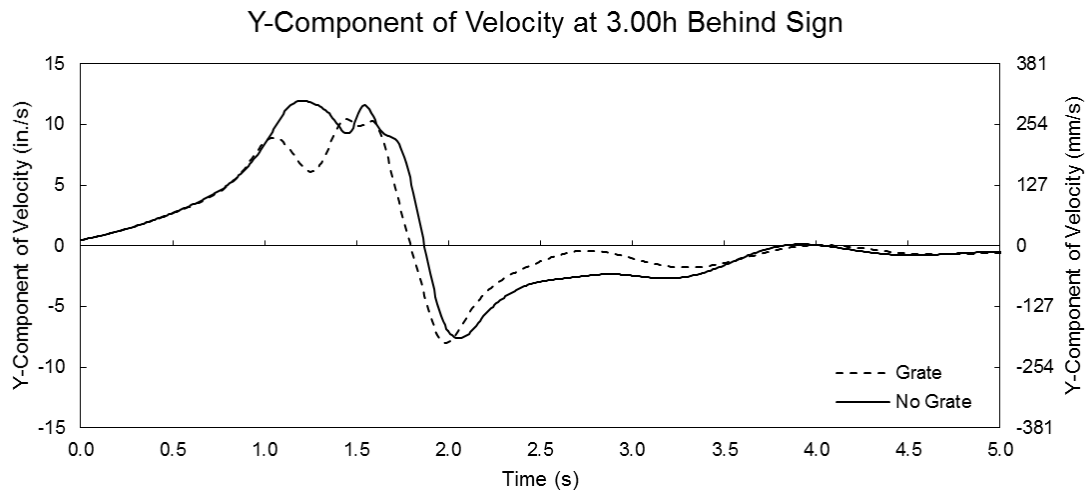

Figure A1.77: Y-component of velocity for the small sign at V=30 mph (13.4 m/s) at a distance = 3.0h behind the sign

A1.8: Y-Component of Velocity Behind Small Sign at V=61.2 mph (27.4 m/s)

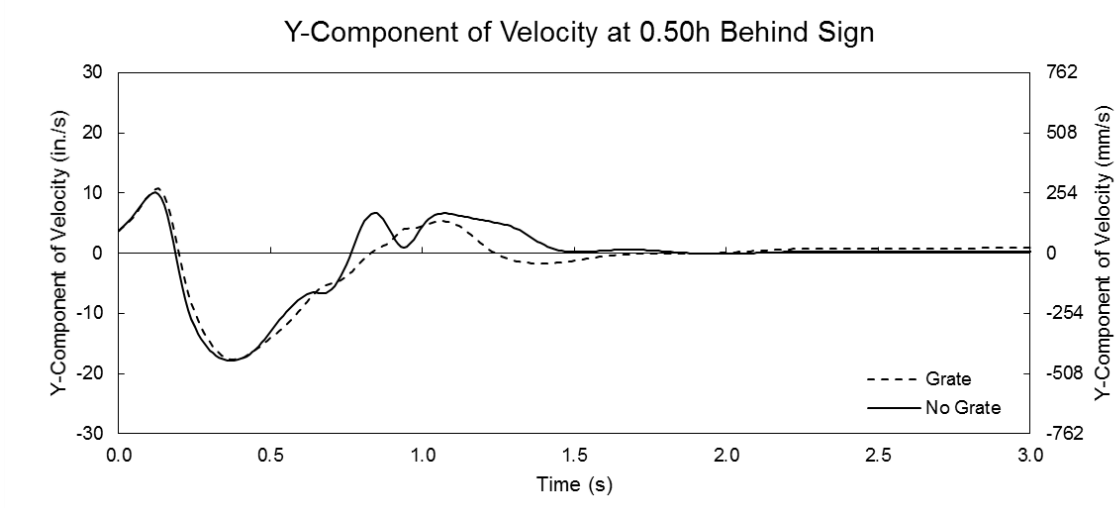

Figure A1.78: Y-component of velocity for the small sign at V=61.2 mph (27.4 m/s) at a distance = 0.5h behind the sign

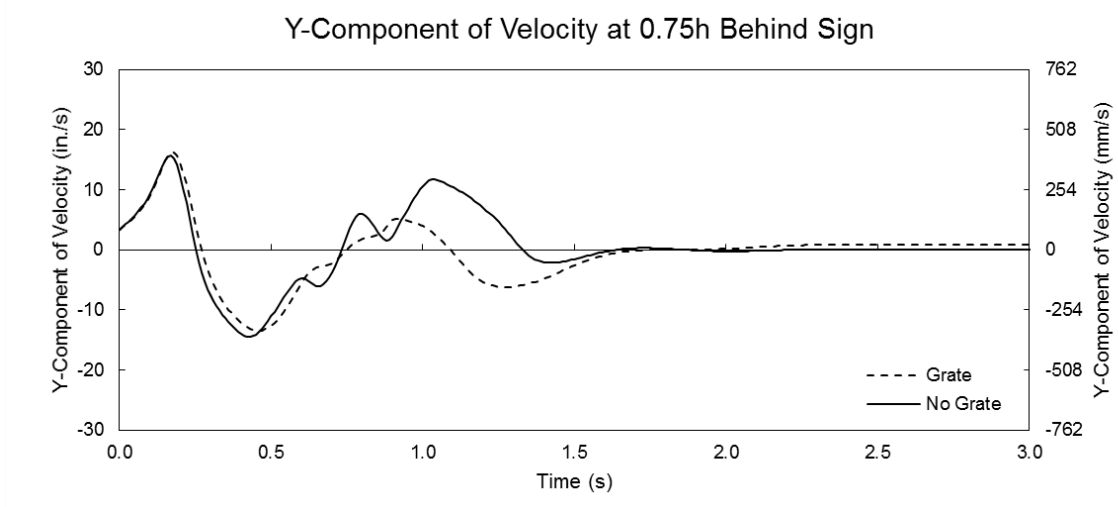

Figure A1.79: Y-component of velocity for the small sign at V=61.2 mph (27.4 m/s) at a distance = 0.75h behind the sign

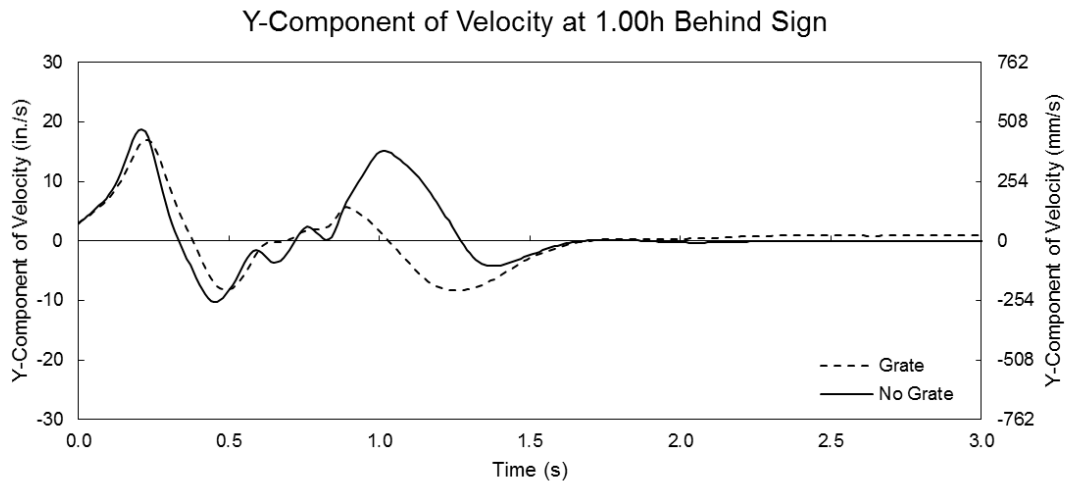

Figure A1.80: Y-component of velocity for the small sign at V=61.2 mph (27.4 m/s) at a distance = 1.0h behind the sign

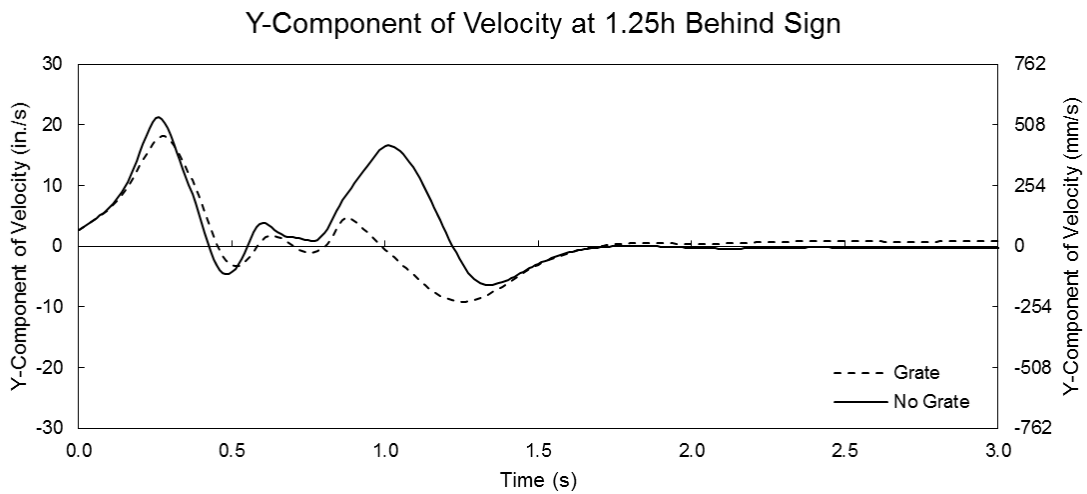

Figure A1.81: Y-component of velocity for the small sign at V=61.2 mph (27.4 m/s) at a distance = 1.25h behind the sign

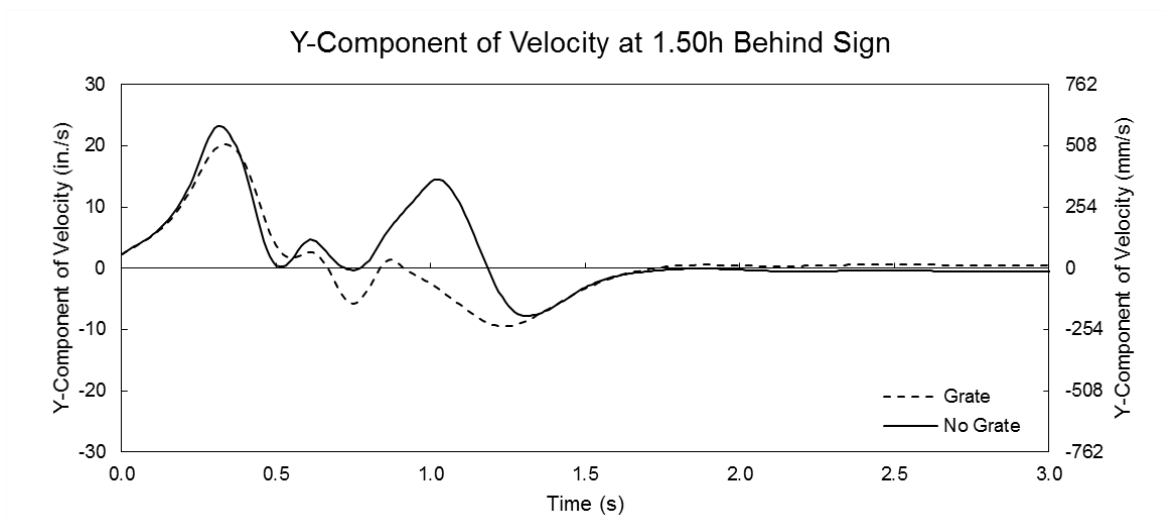

Figure A1.82: Y-component of velocity for the small sign at V=61.2 mph (27.4 m/s) at a distance = 1.5h behind the sign

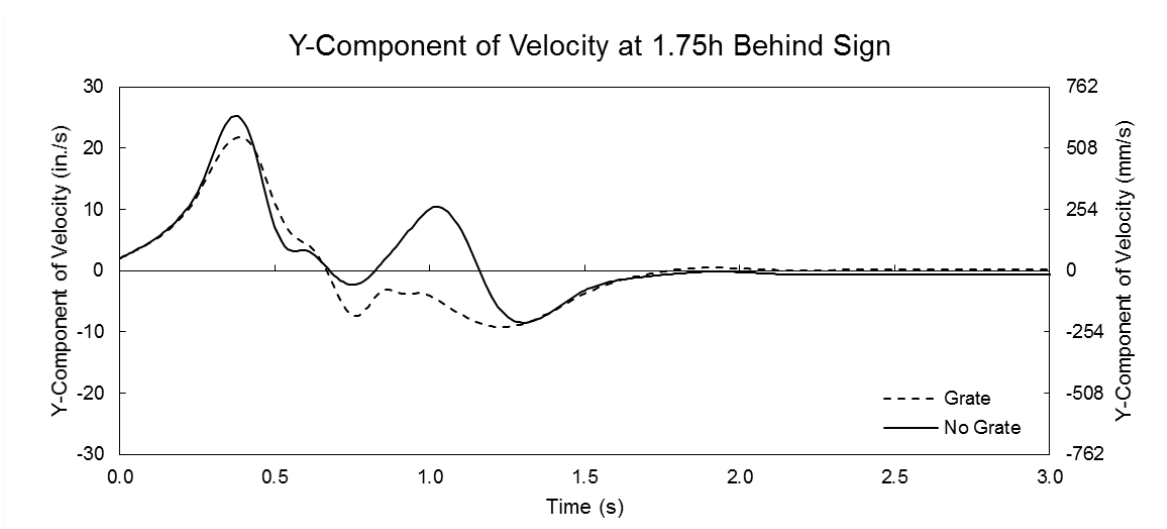

Figure A1.83: Y-component of velocity for the small sign at V=61.2 mph (27.4 m/s) at a distance = 1.75h behind the sign

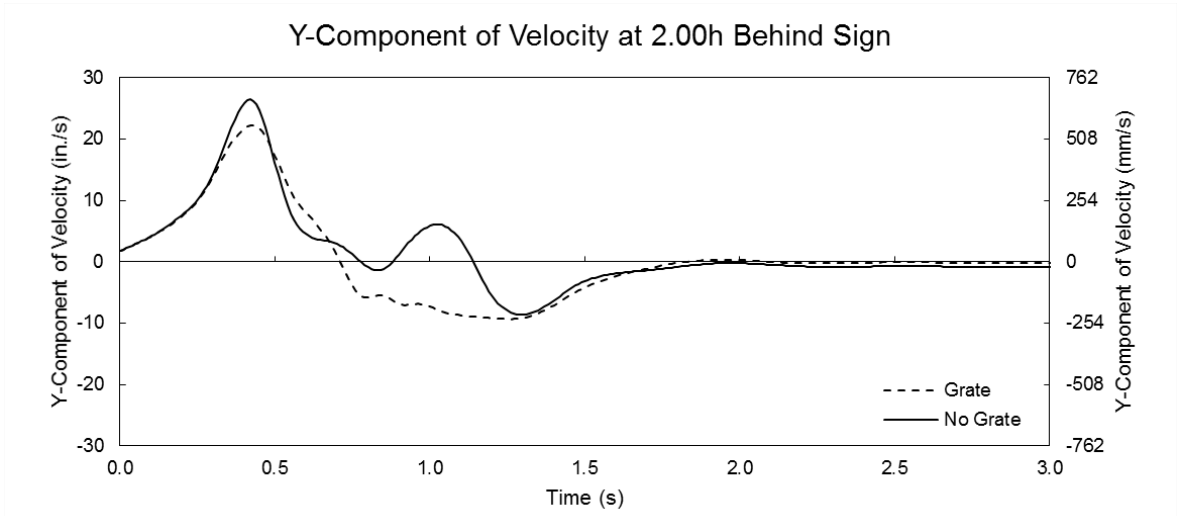

Figure A1.84: Y-component of velocity for the small sign at V=61.2 mph (27.4 m/s) at a distance = 2.0h behind the sign

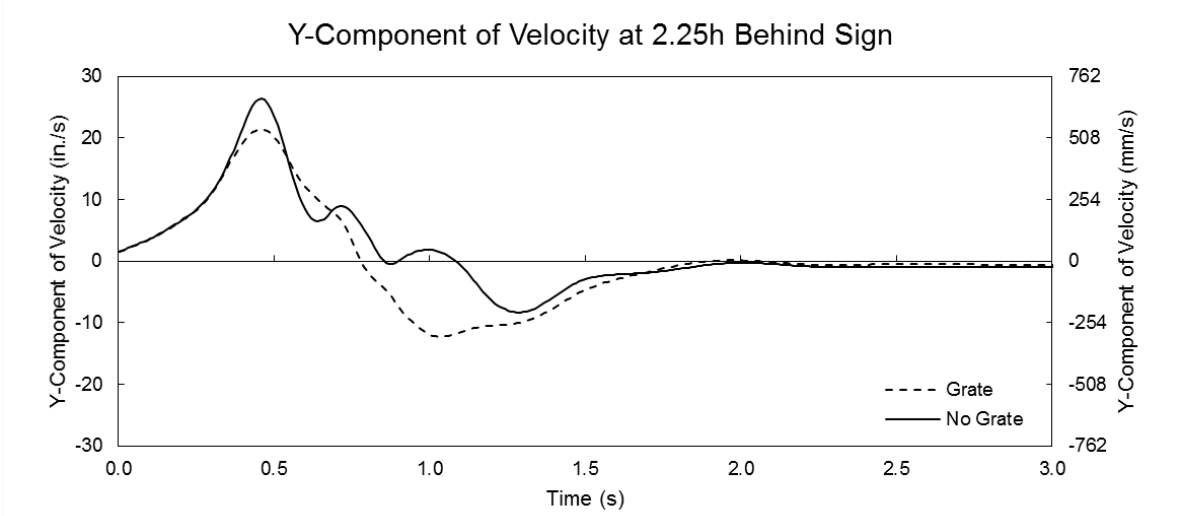

Figure A1.85: Y-component of velocity for the small sign at V=61.2 mph (27.4 m/s) at a distance = 2.25h behind the sign

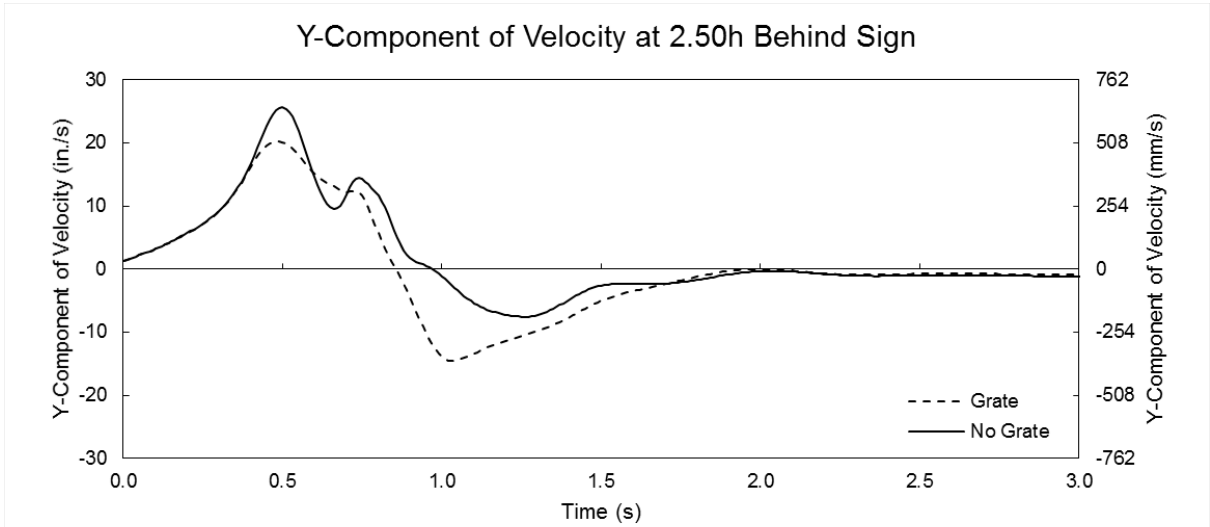

Figure A1.86: Y-component of velocity for the small sign at V=61.2 mph (27.4 m/s) at a distance = 2.5h behind the sign

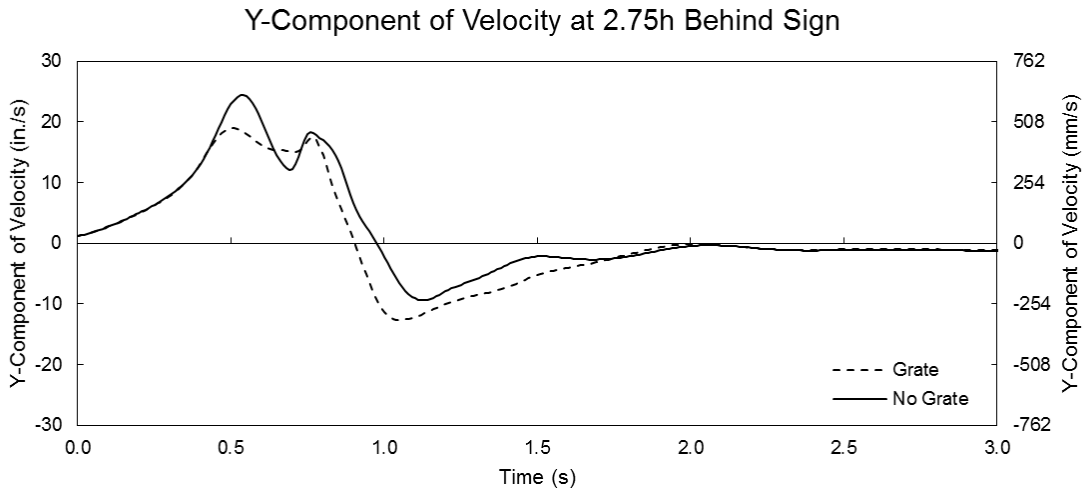

Figure A1.87: Y-component of velocity for the small sign at V=61.2 mph (27.4 m/s) at a distance = 2.75h behind the sign

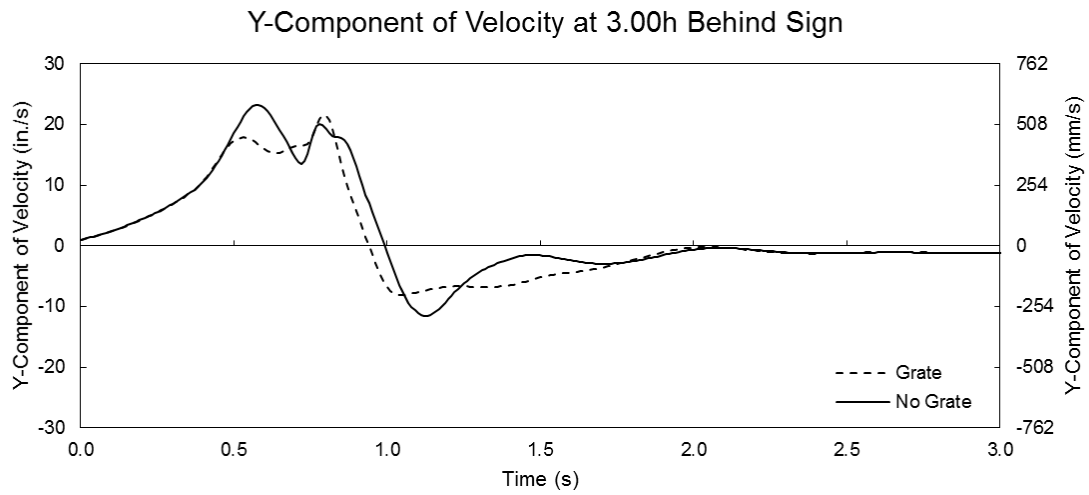

Figure A1.88: Y-component of velocity for the small sign at V=61.2 mph (27.4 m/s) at a distance = 3.0h behind the sign

A1.9: Y-Component of Velocity Behind Small Sign at V=105mph (46.9 m/s)

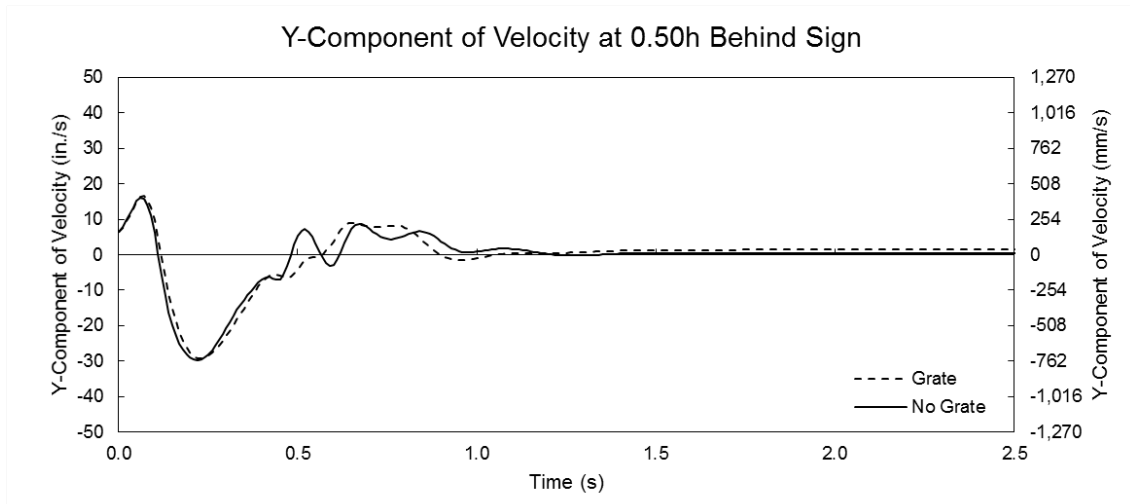

Figure A1.89: Y-component of velocity for the small sign at V=105 mph (46.9 m/s) at a distance = 0.5h behind the sign

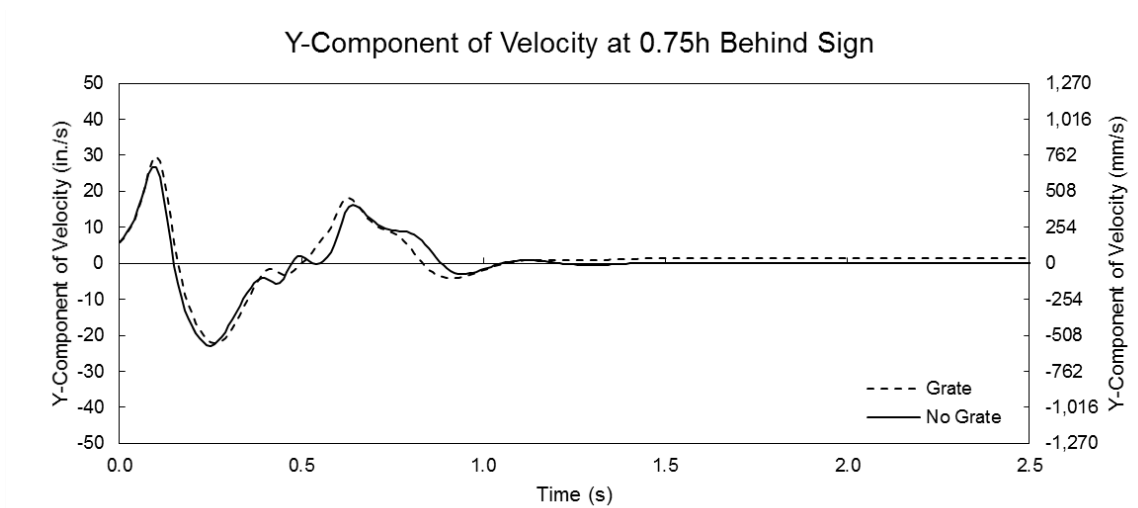

Figure A1.90: Y-component of velocity for the small sign at V=105 mph (46.9 m/s) at a distance = 0.75h behind the sign

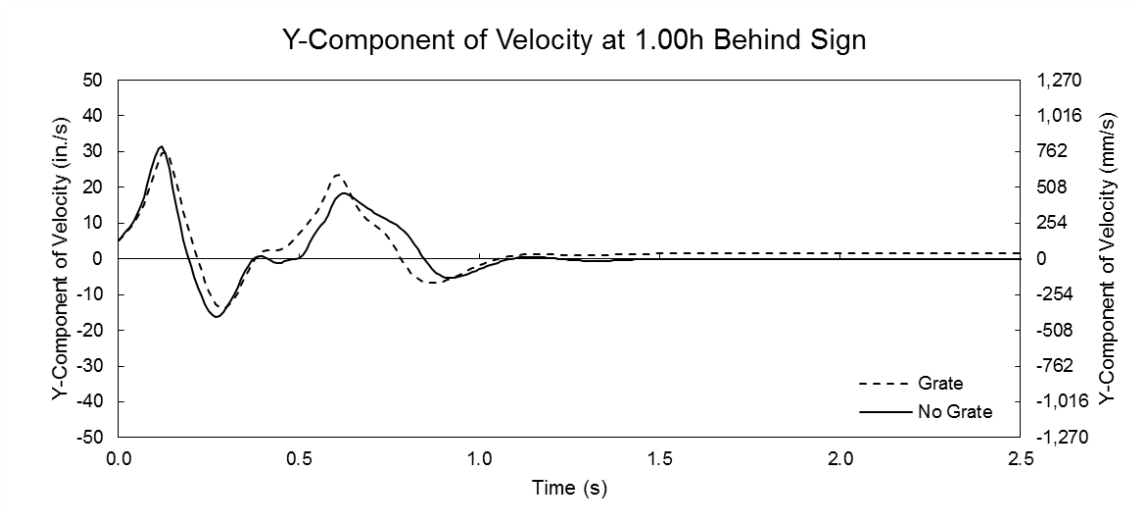

Figure A1.91: Y-component of velocity for the small sign at V=105 mph (46.9 m/s) at a distance = 1.0h behind the sign

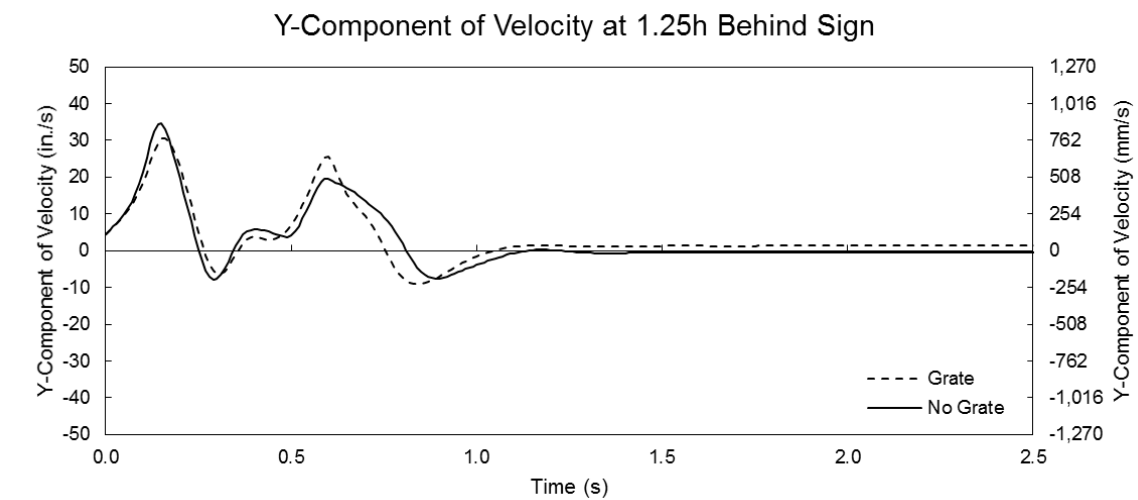

Figure A1.92: Y-component of velocity for the small sign at V=105 mph (46.9 m/s) at a distance = 1.25h behind the sign

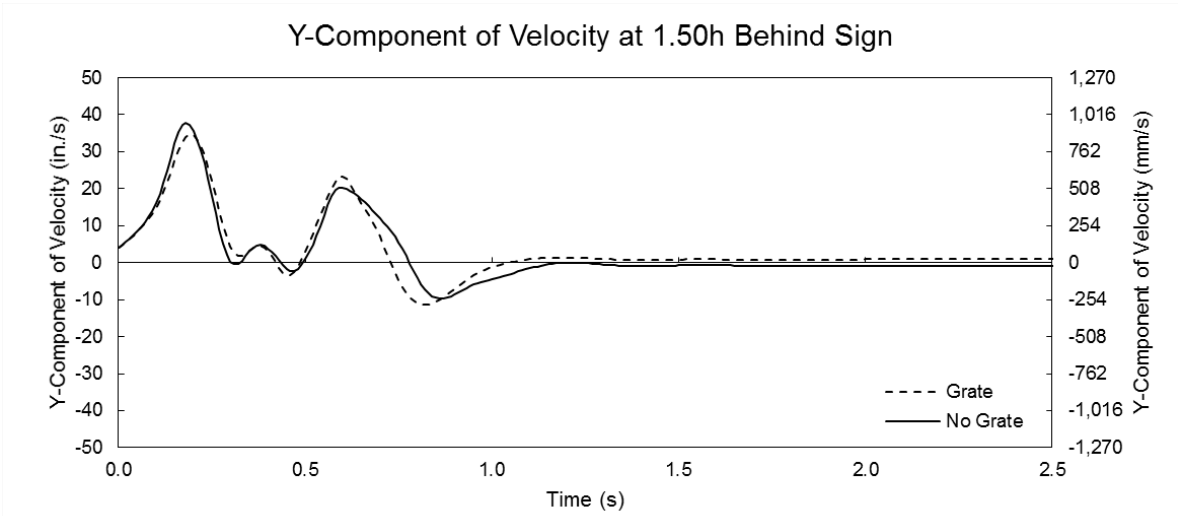

Figure A1.93: Y-component of velocity for the small sign at V=105 mph (46.9 m/s) at a distance = 1.5h behind the sign

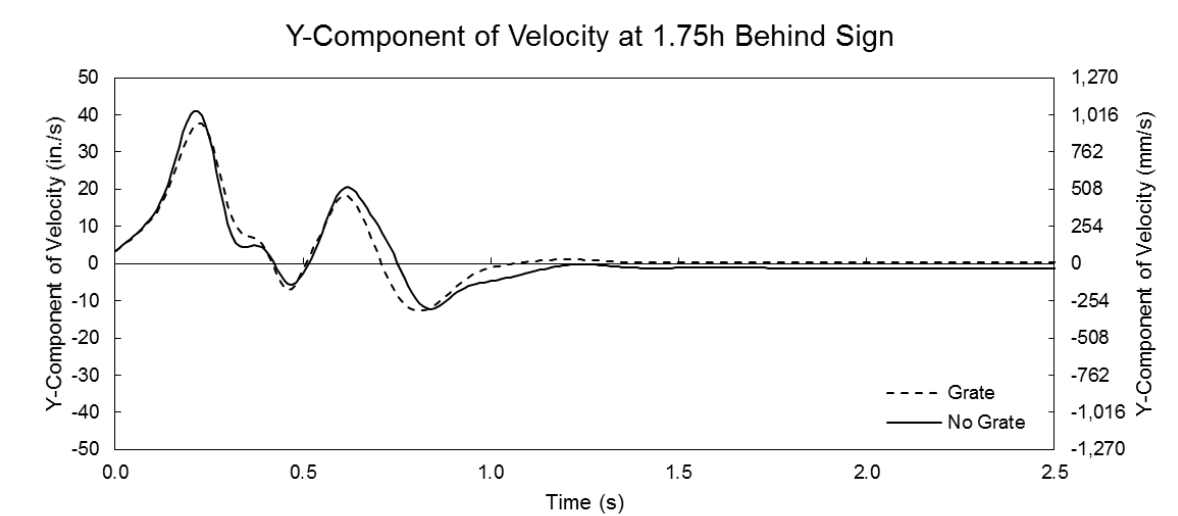

Figure A1.94: Y-component of velocity for the small sign at V=105 mph (46.9 m/s) at a distance = 1.75h behind the sign

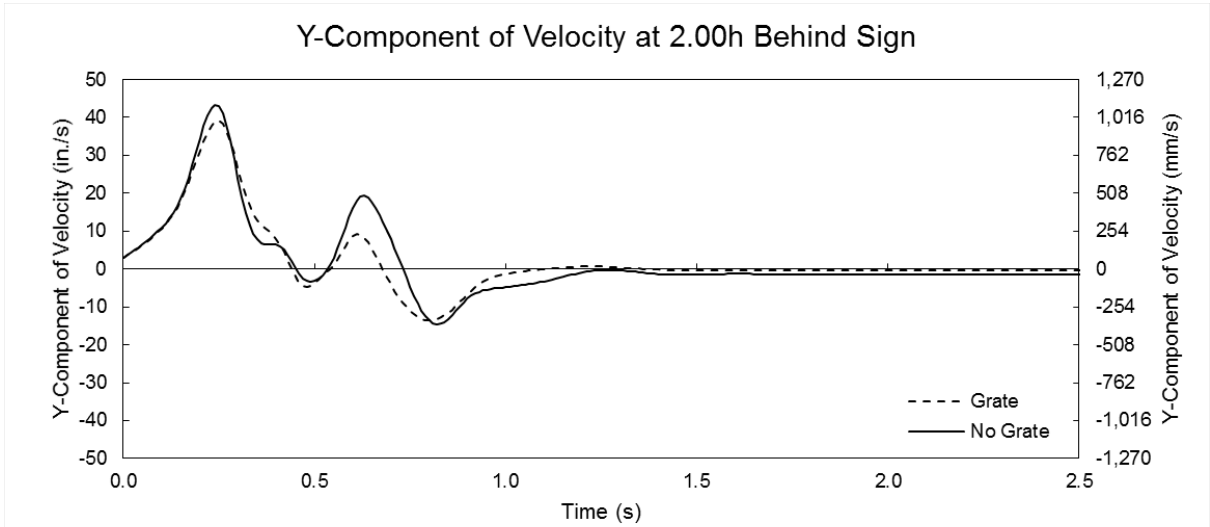

Figure A1.95: Y-component of velocity for the small sign at V=105 mph (46.9 m/s) at a distance = 2.0h behind the sign

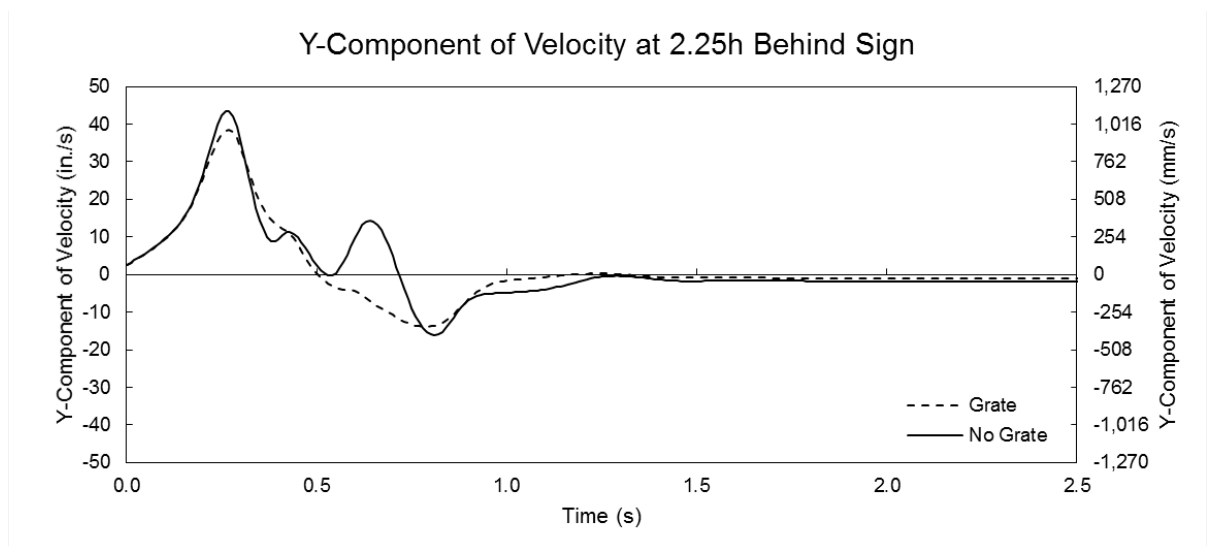

Figure A1.96: Y-component of velocity for the small sign at V=105 mph (46.9 m/s) at a distance = 2.25h behind the sign

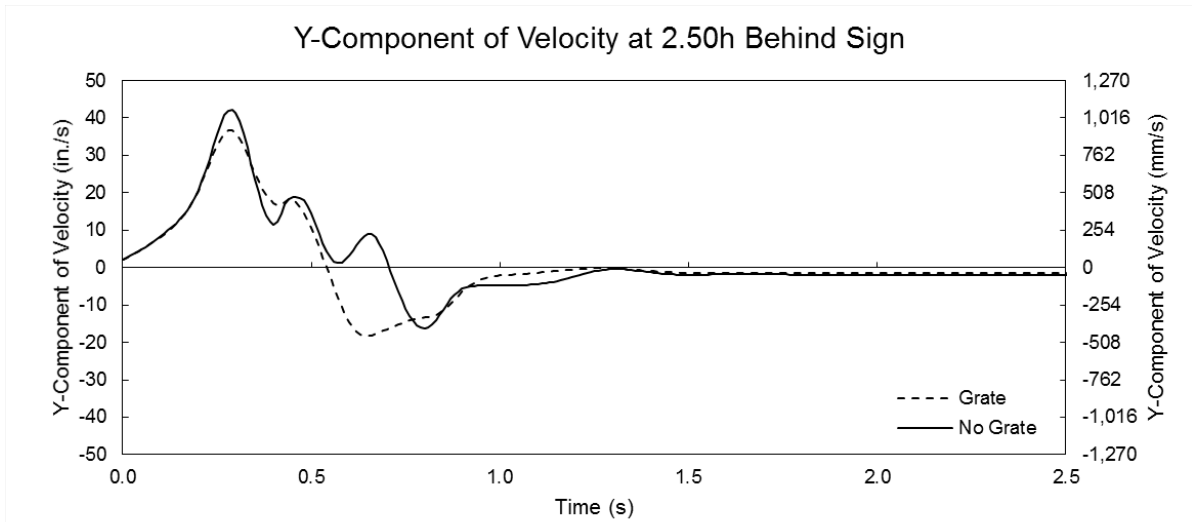

Figure A1.97: Y-component of velocity for the small sign at V=105 mph (46.9 m/s) at a distance = 2.5h behind the sign

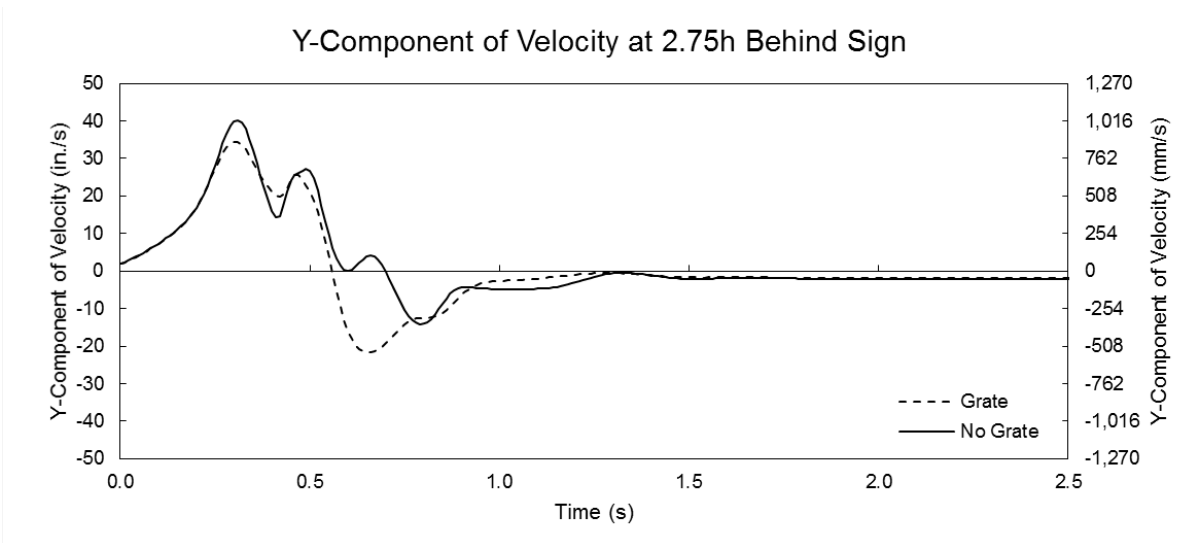

Figure A1.98: Y-component of velocity for the small sign at V=105 mph (46.9 m/s) at a distance = 2.75h behind the sign

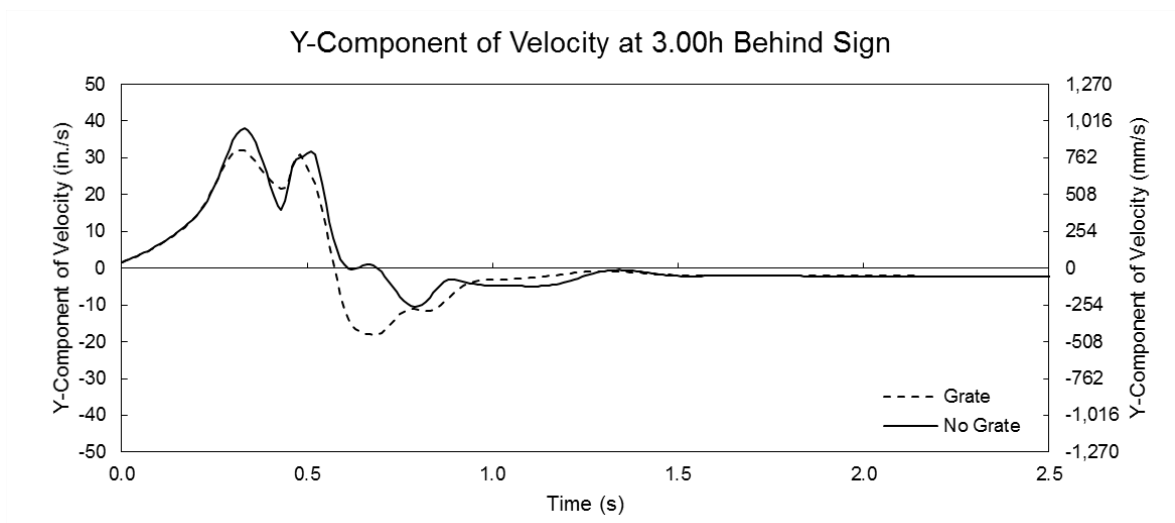
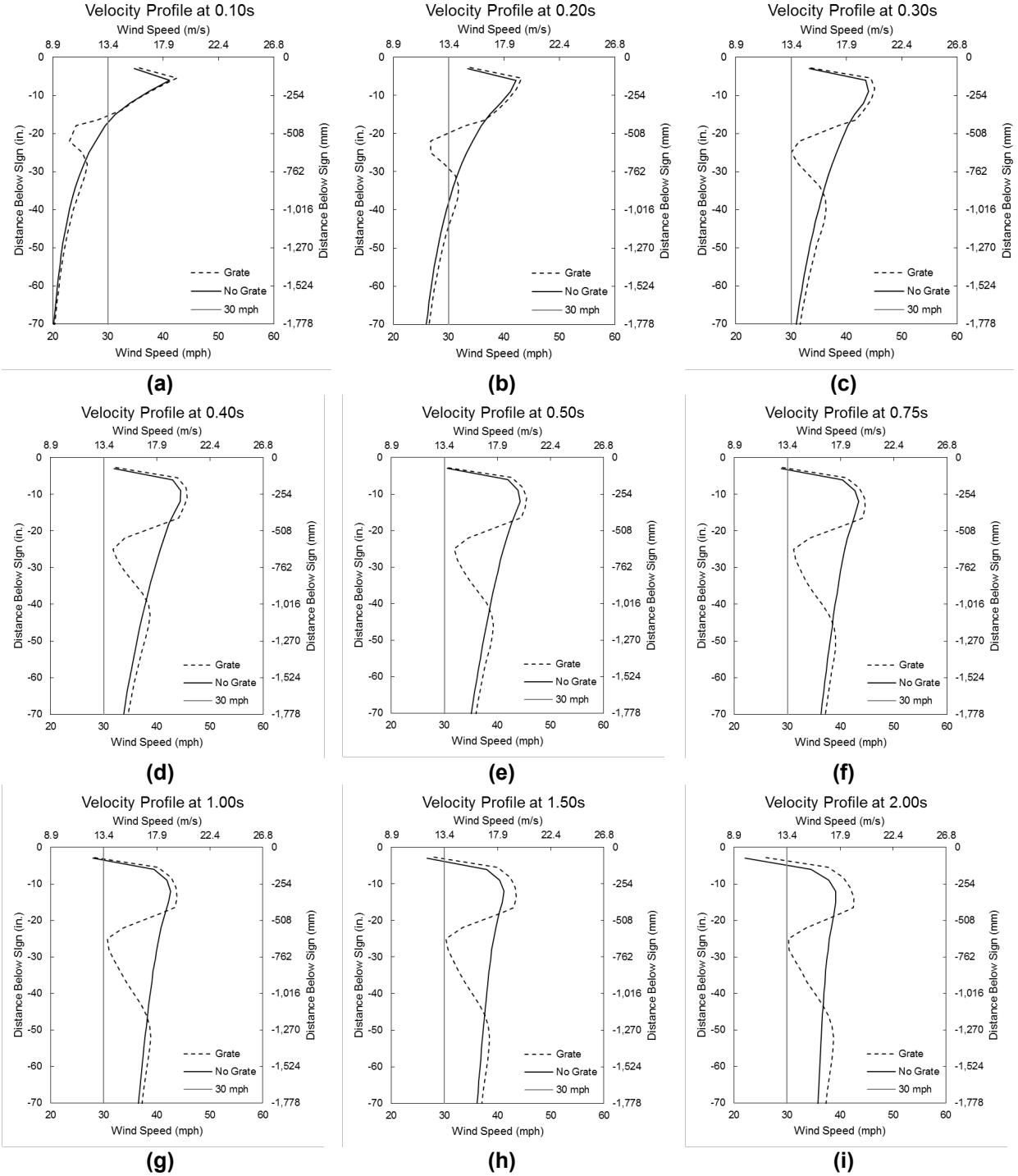

Figure A1.99: Y-component of velocity for the small sign at V=105 mph (46.9 m/s) at a distance = 3.0h behind the sign

Appendix A2

A2.1: Large Sign Velocity Profile at V=30 mph (13.4 m/s)



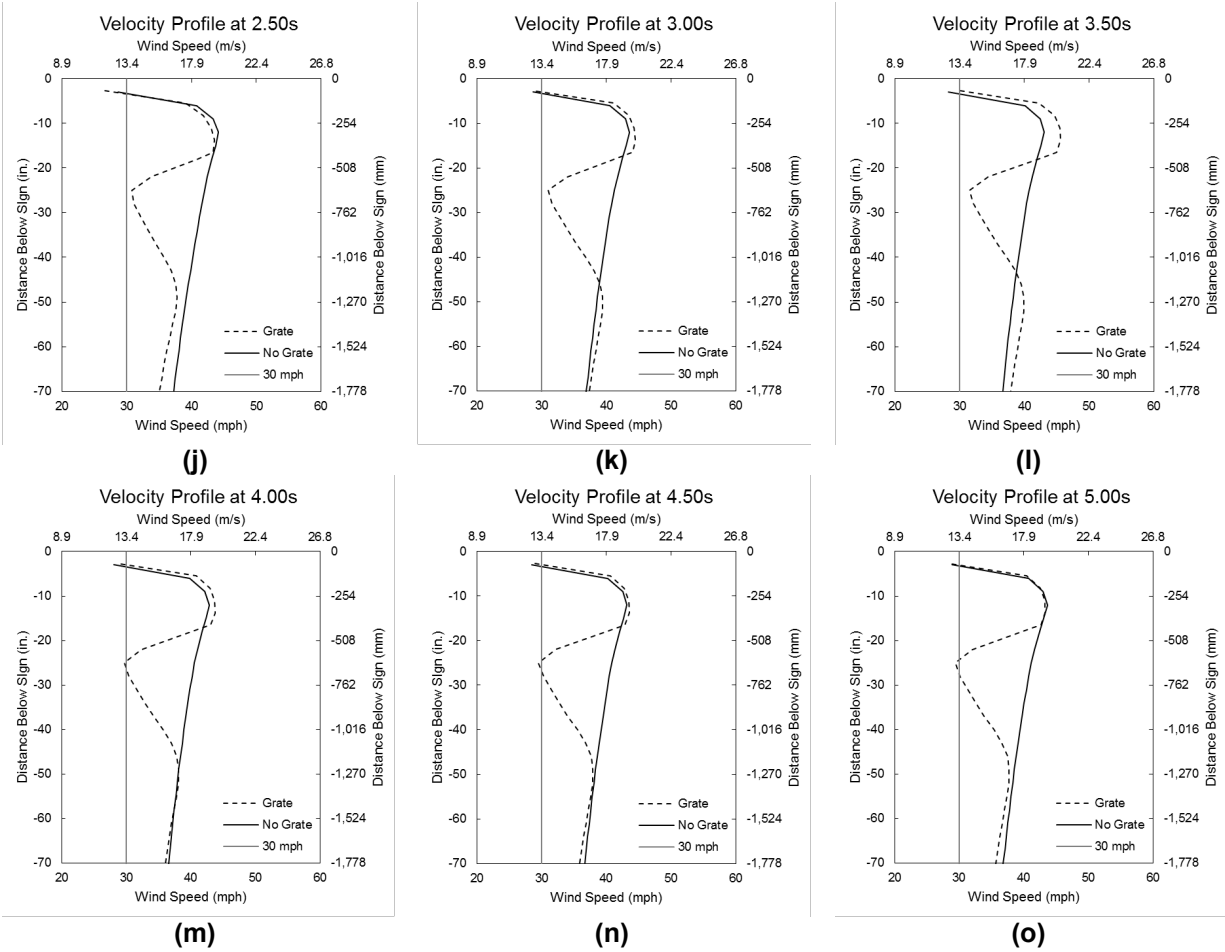
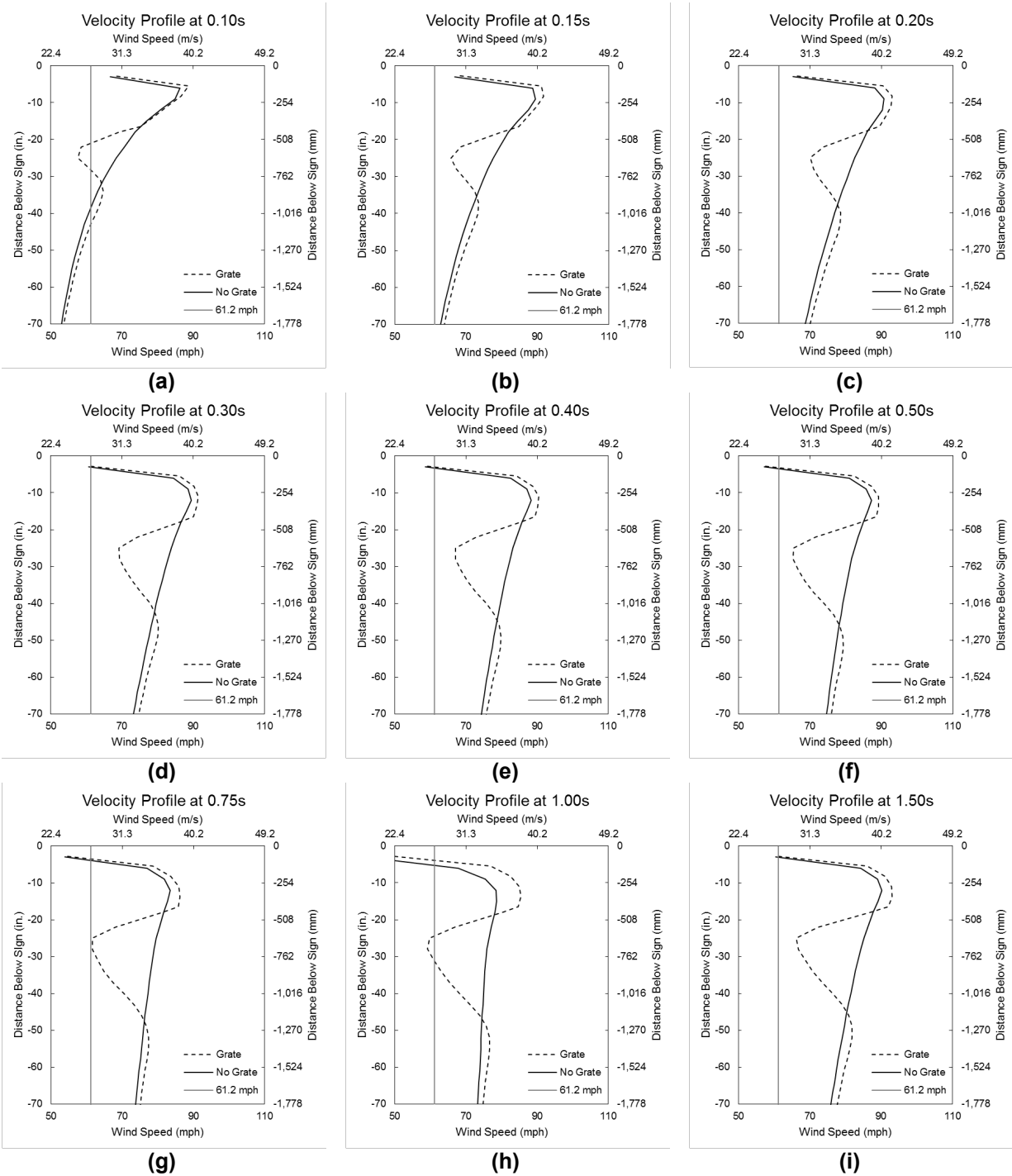

Figure A2.1: Velocity profile below the sign, for the large sign and a wind speed of $V=30$ mph (13.4 m/s)

A2.2: Large Sign Velocity Profile at V=61.2 mph (27.4 m/s)



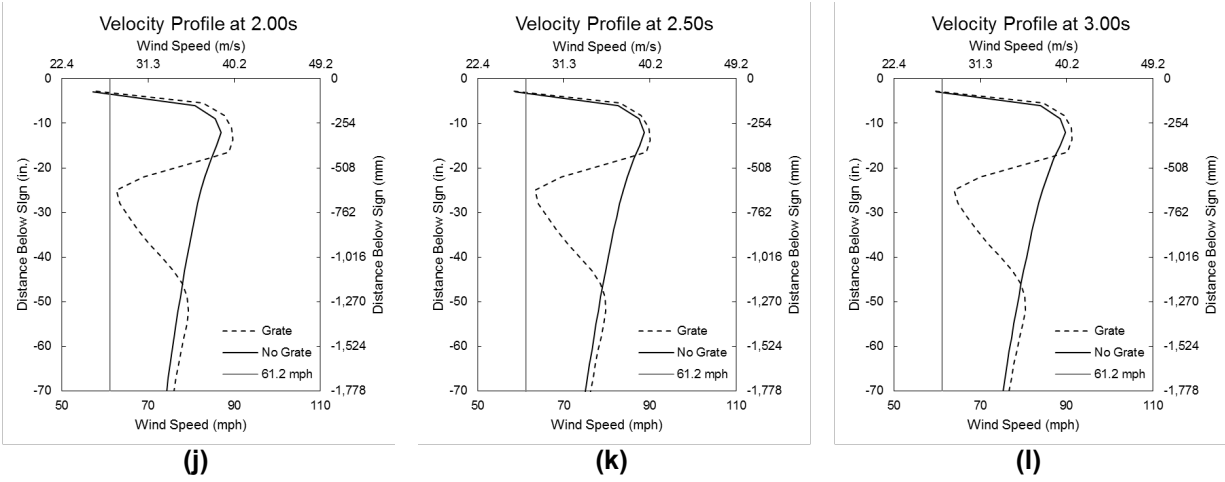
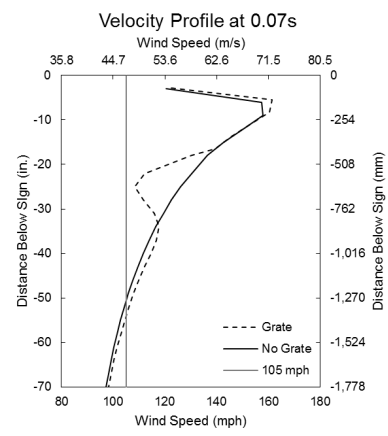
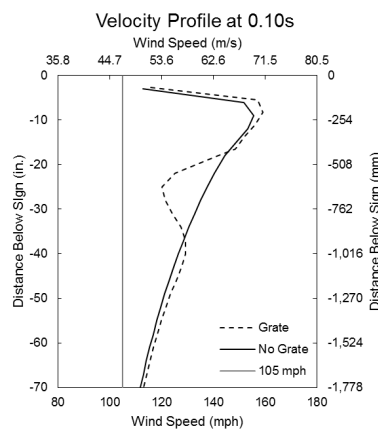

Figure A2.2: Velocity profile below the sign, for the large sign and a wind speed of $V=61.2$ mph (27.4 m/s)

A2.3: Large Sign Velocity Profile at V=105mph (46.9 m/s)



(a)



(b)

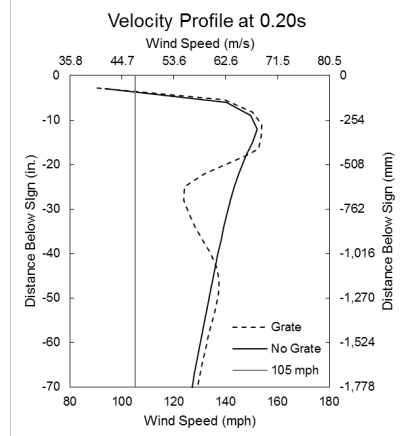

(c)

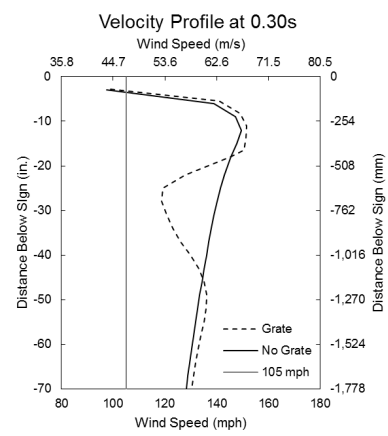

(d)

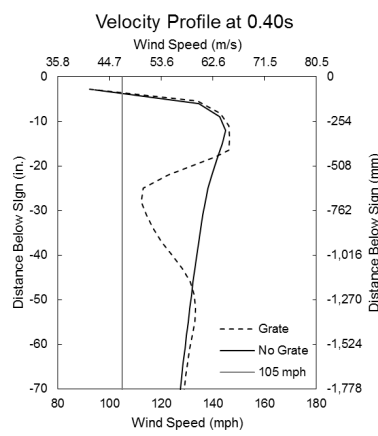

(e)

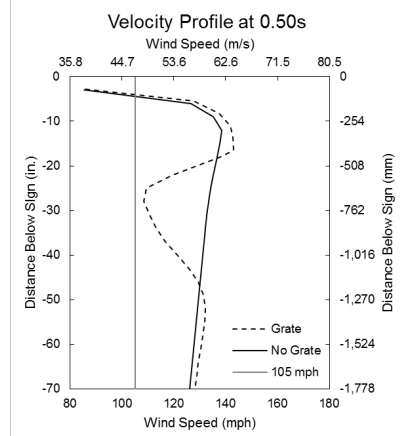

(f)

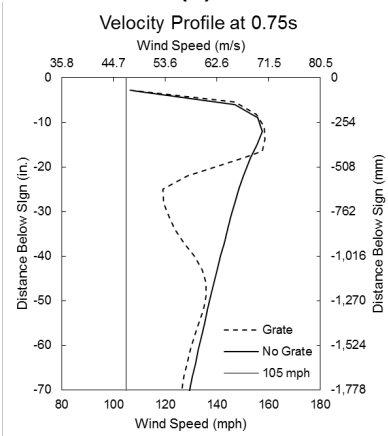

(g)

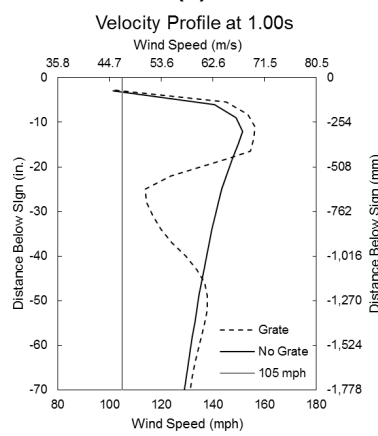

(h)

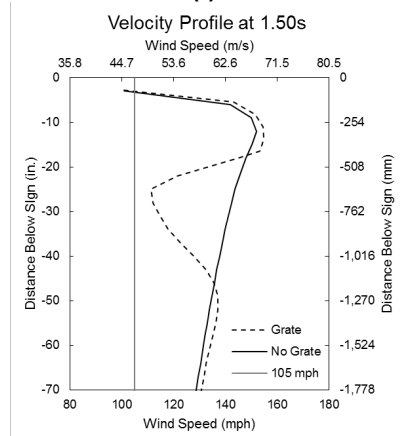

(i)

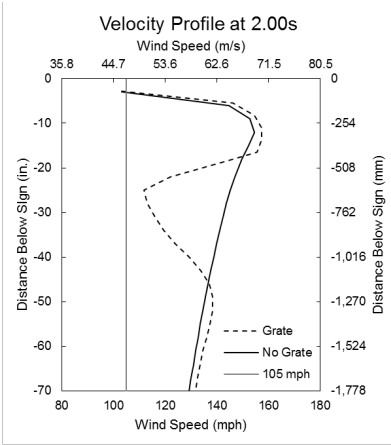

(j)

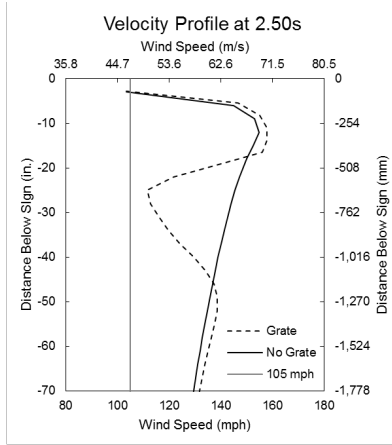

(k)

Figure A2.3: Velocity profile below the sign, for the large sign and a wind speed of V=105 mph (46.9 m/s)

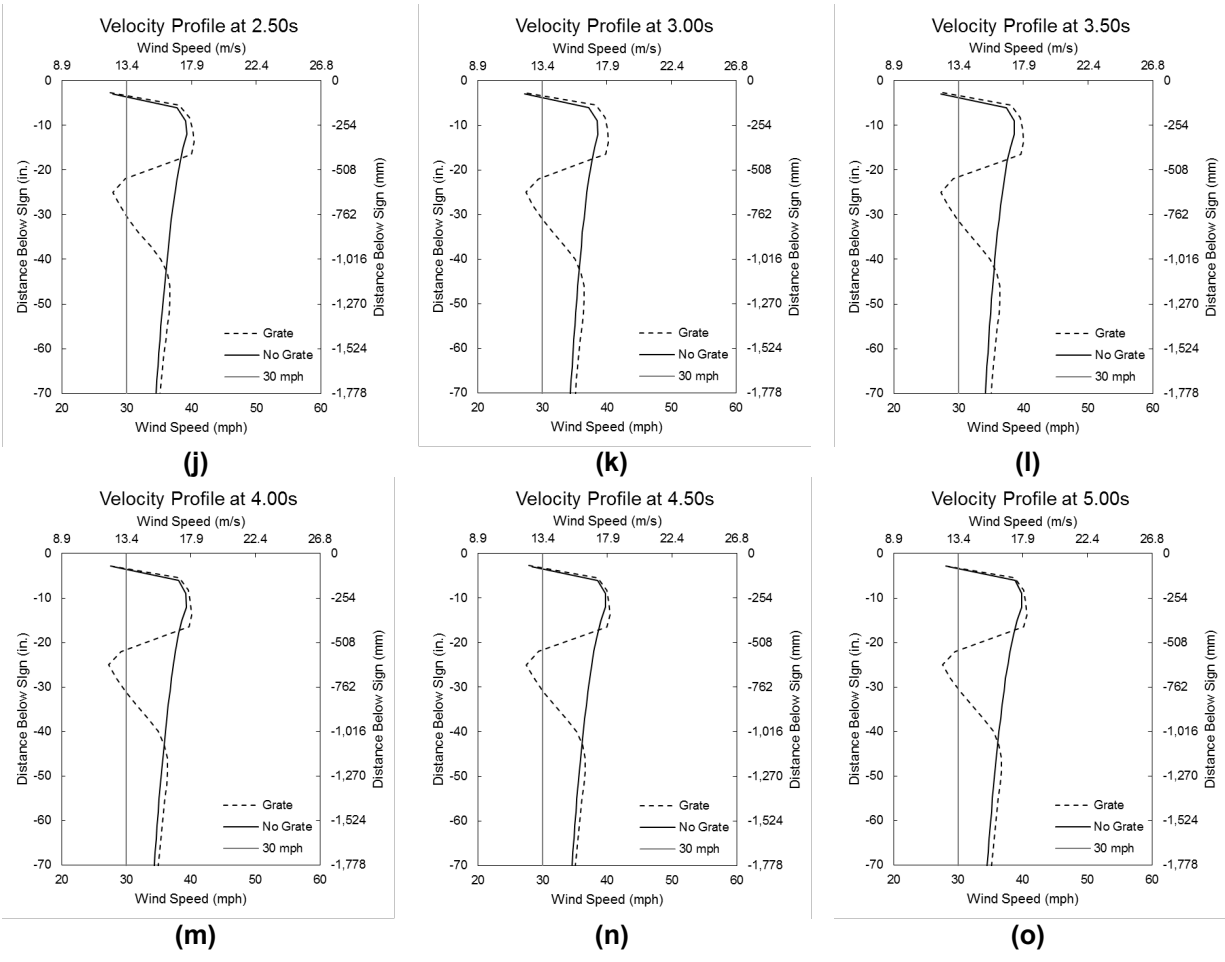
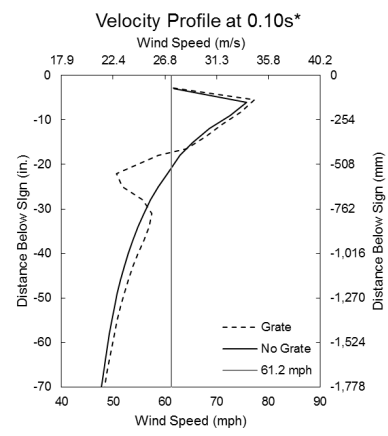
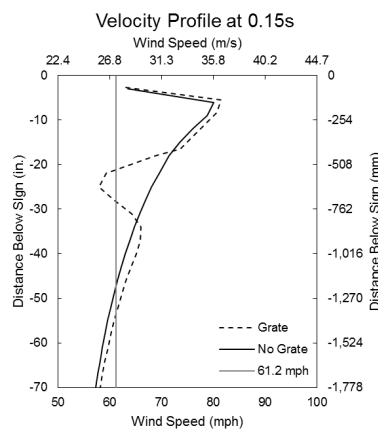

Figure A2.4: Velocity profile below the sign, for the medium sign and a wind speed of $V=30$ mph (13.4 m/s)

A2.5: Medium Sign Velocity Profile at V=61.2 mph (27.4 m/s)



(a)



(b)

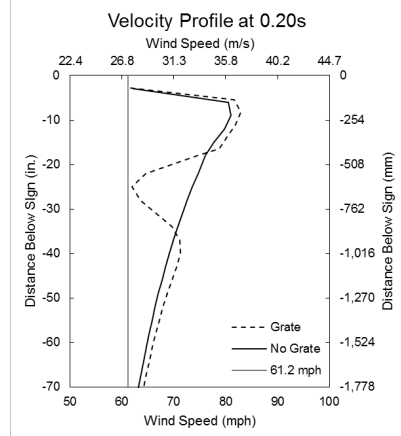

(c)

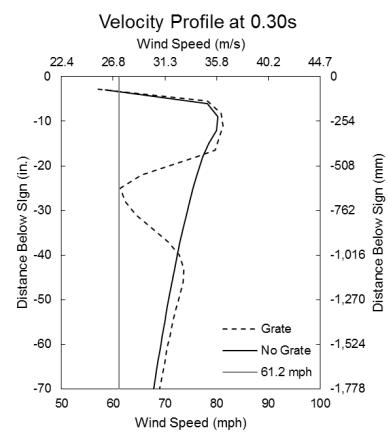

(d)

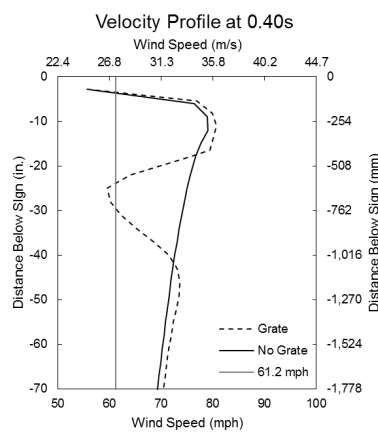

(e)

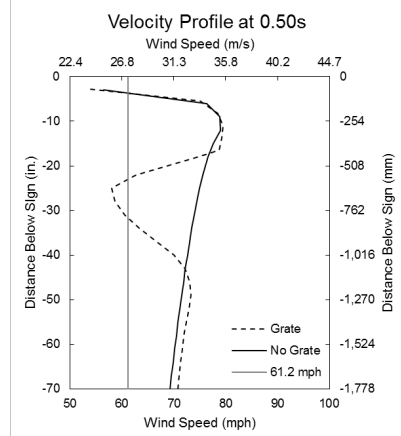

(f)

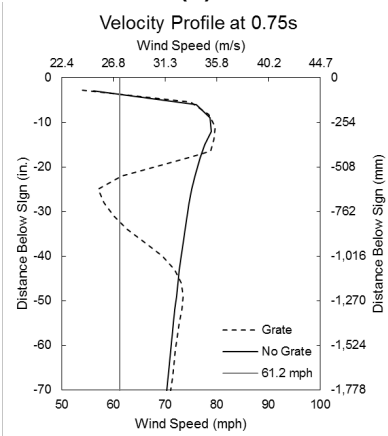

(g)

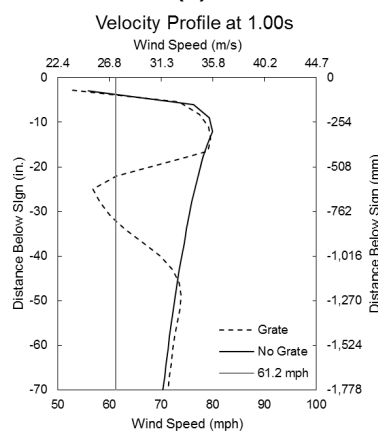

(h)

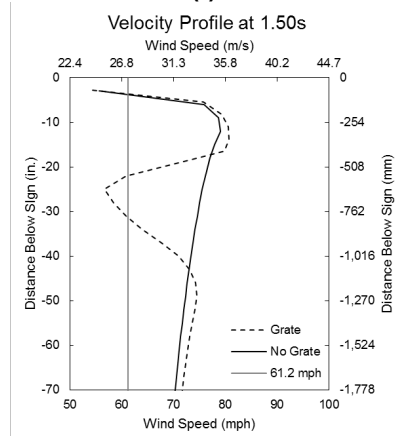

(i)

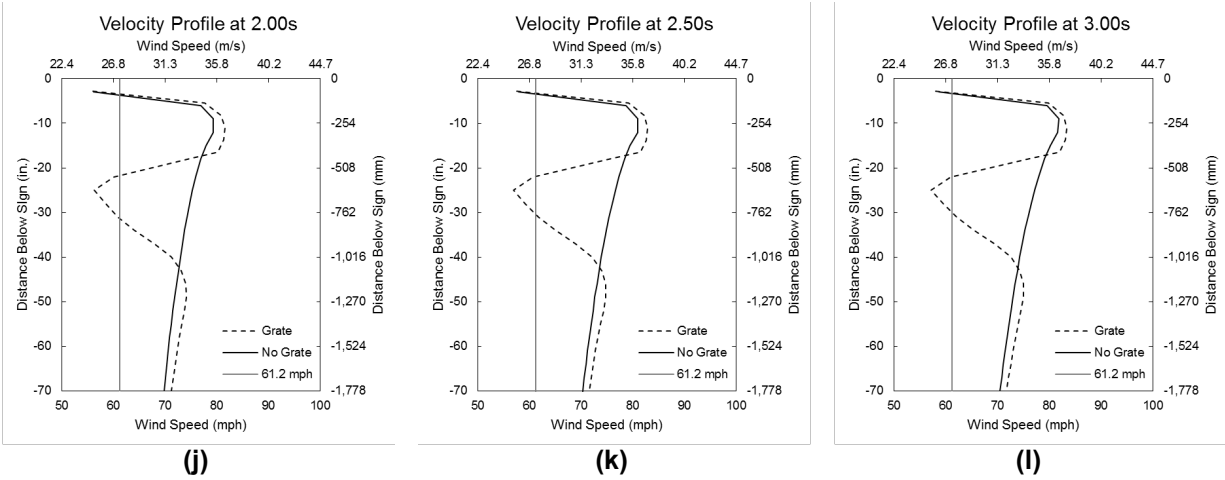
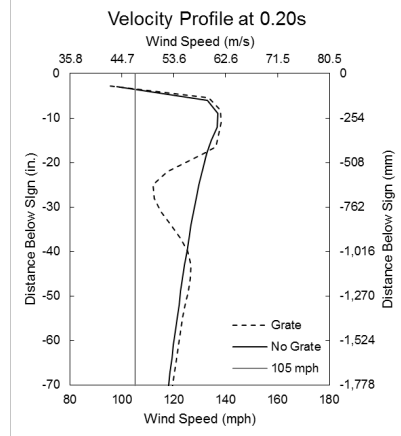
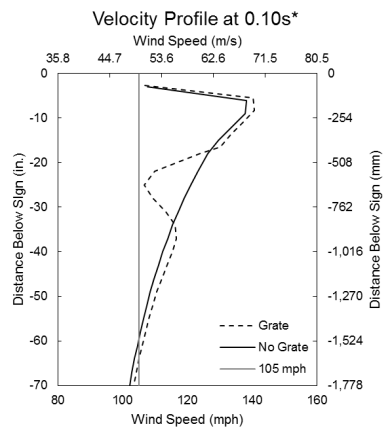
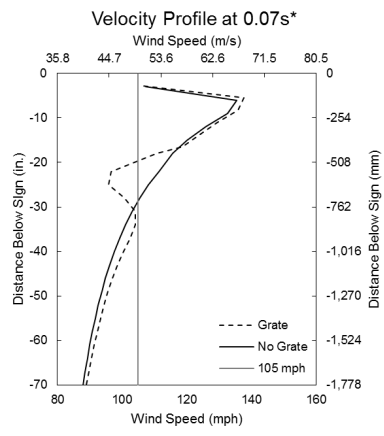
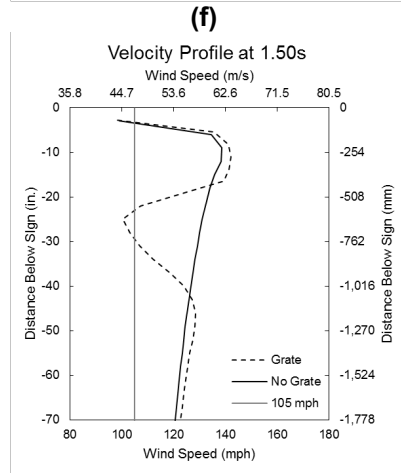
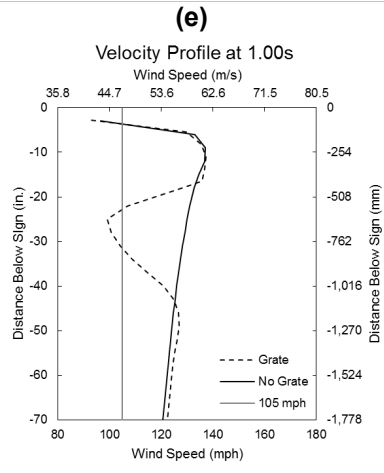
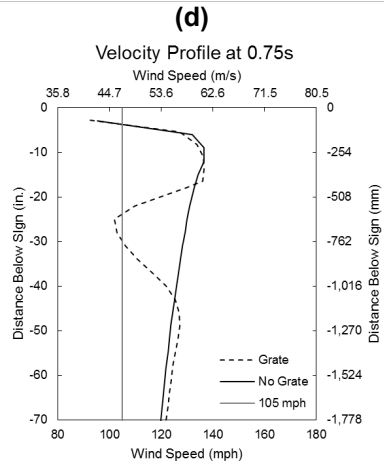
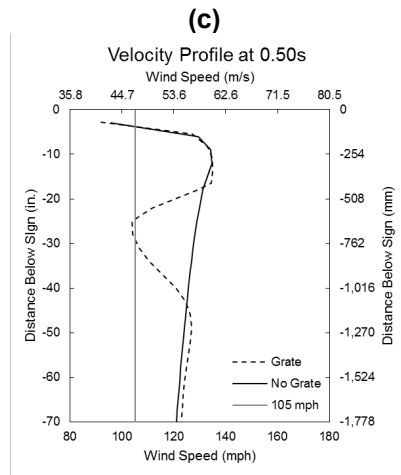
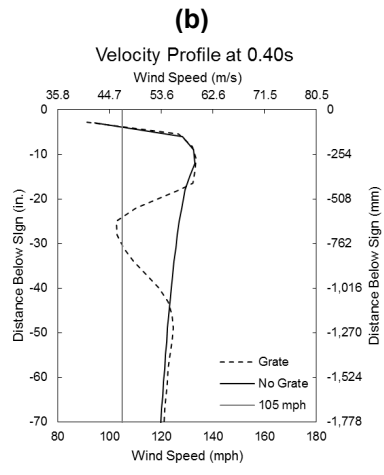
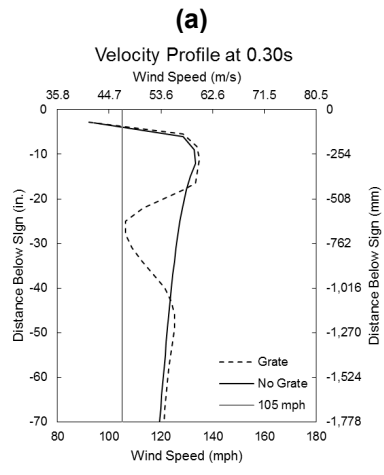

Figure A2.5: Velocity profile below the sign, for the medium sign and a wind speed of $V=61.2$ mph (27.4 m/s)

A2.6: Medium Sign Velocity Profile at V=105mph (46.9 m/s)



*Wind speed scales are different from the rest of the batch.



(g)

(h)

(i)

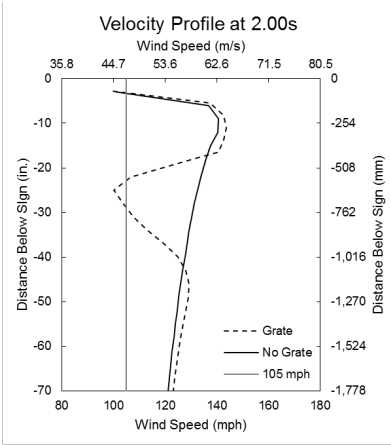

(j)

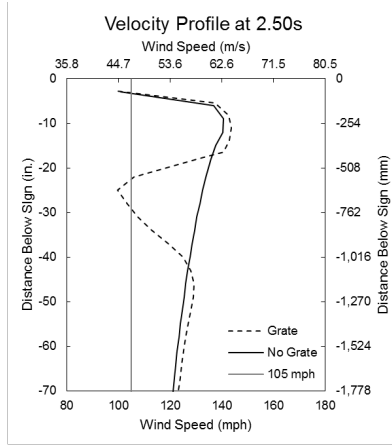

(k)

Figure A2.6: Velocity profile below the sign, for the medium sign and a wind speed of $V=105\text{mph}$ (46.9 m/s)

A2.7: Small Sign Velocity Profile at V=30 mph (13.4 m/s)

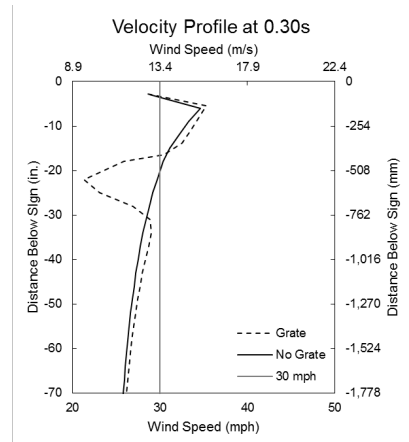
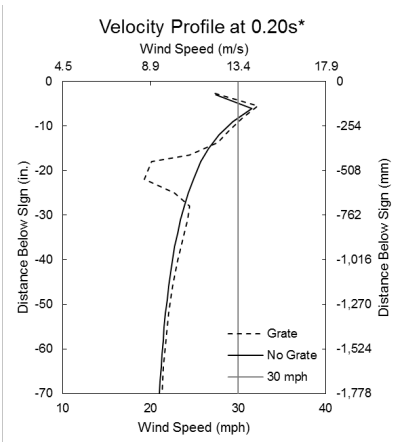
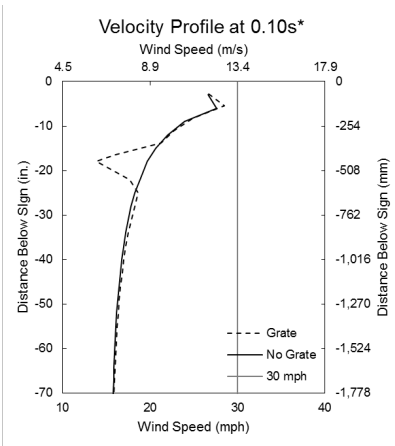

*Wind speed scales are different from the rest of the batch.

(a)

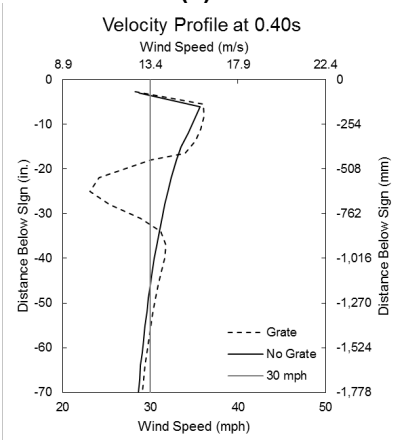

(b)

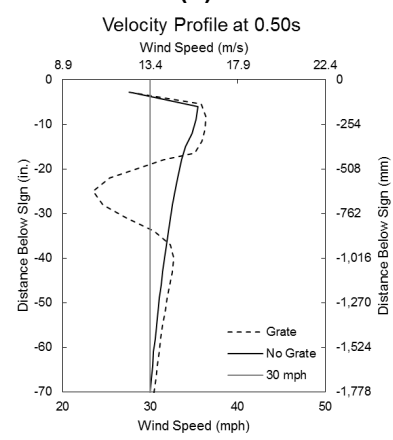

(c)

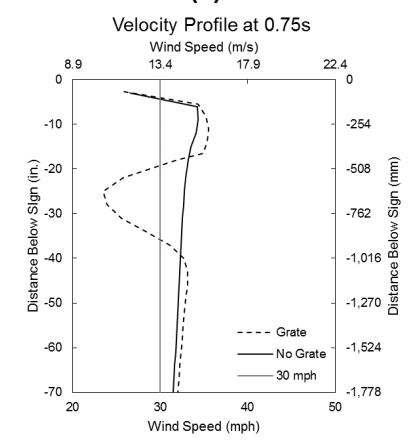

(d)

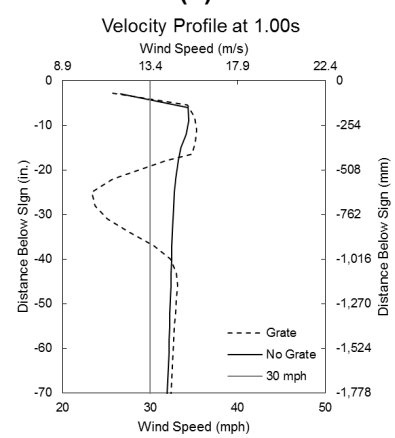

(e)

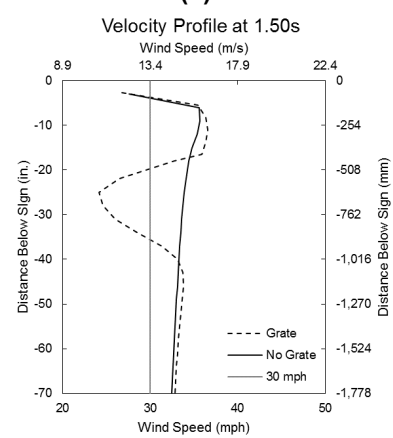

(f)

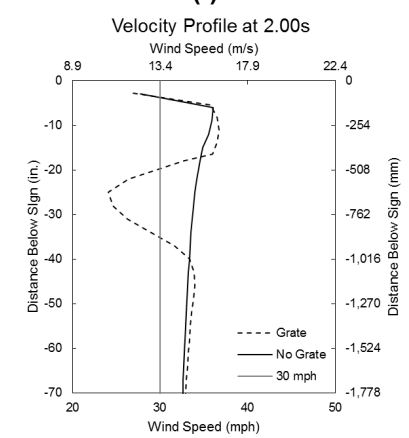

(g)



(h)

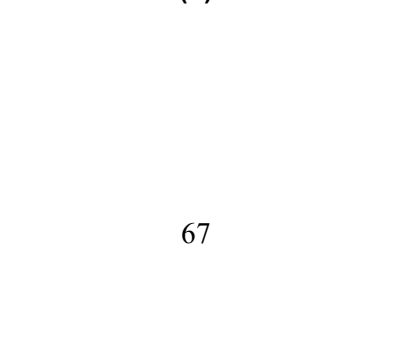

(i)

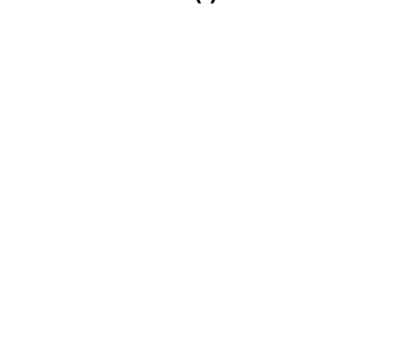

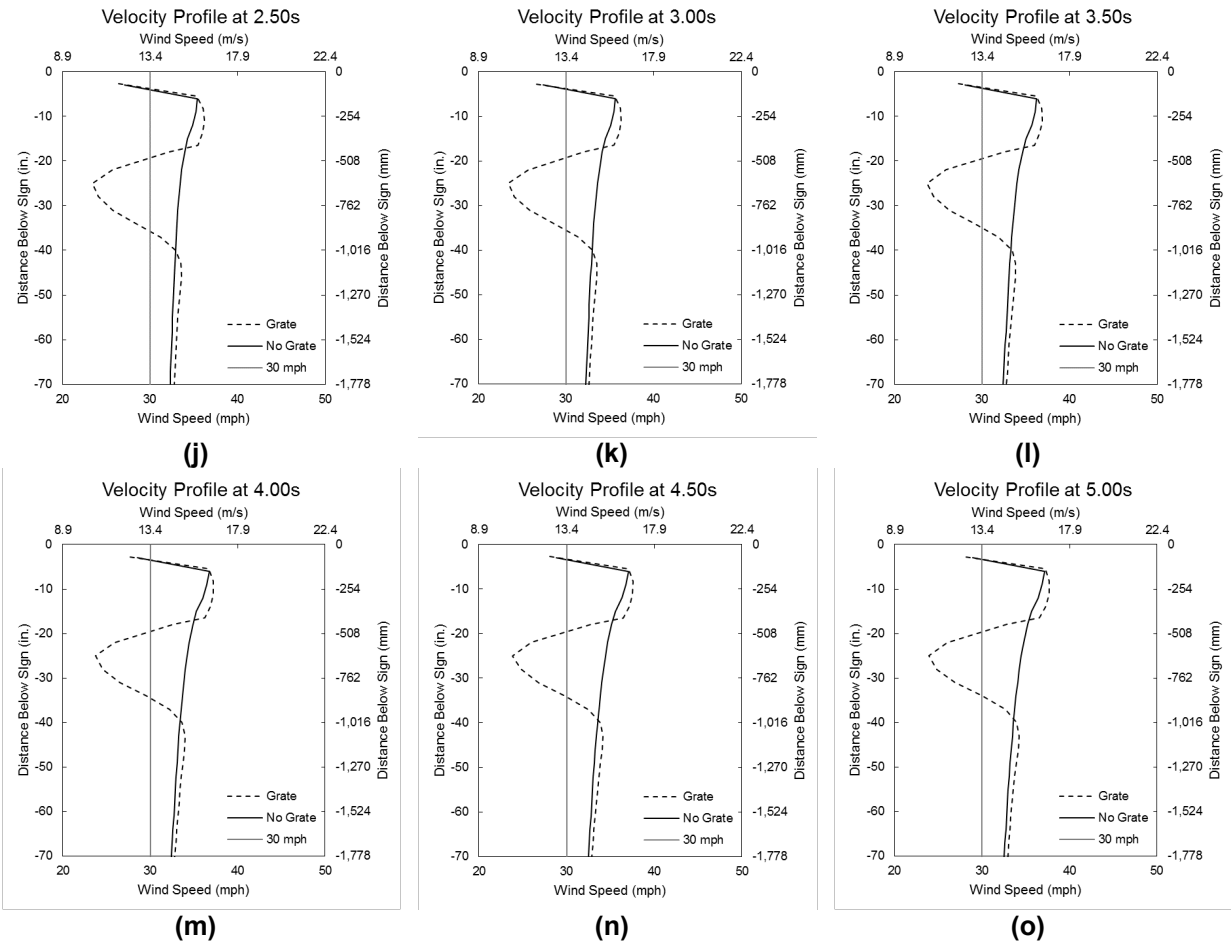
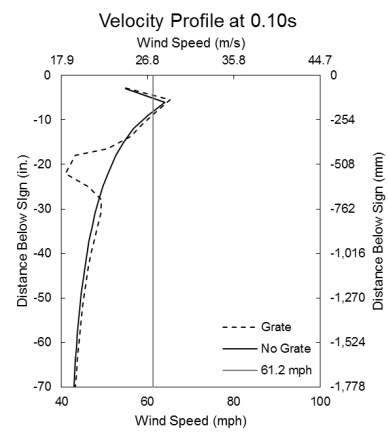
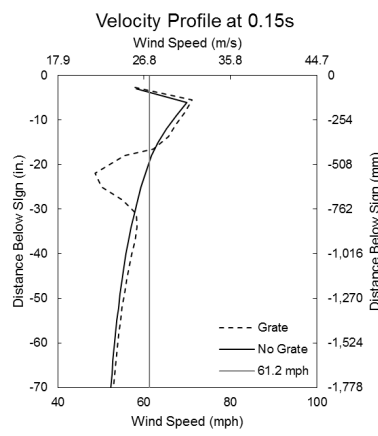

Figure A2.7: Velocity profile below the sign, for the small sign and a wind speed of 30 mph (13.4 m/s)

A2.8: Small Sign Velocity Profile at V=61.2 mph (27.4 m/s)



(a)



(b)

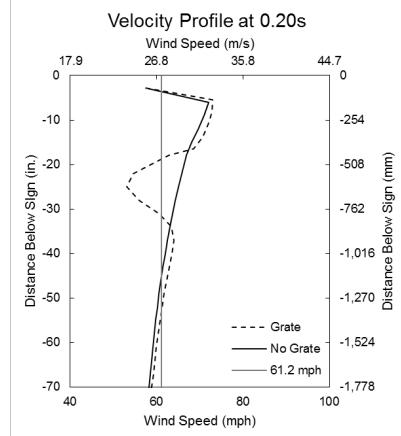

(c)

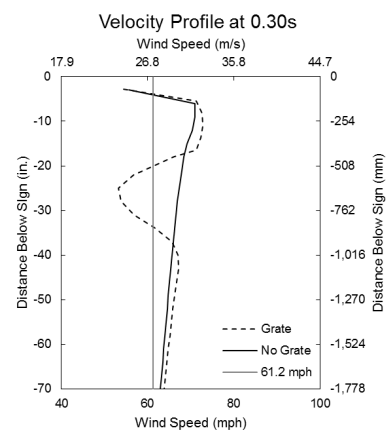

(d)

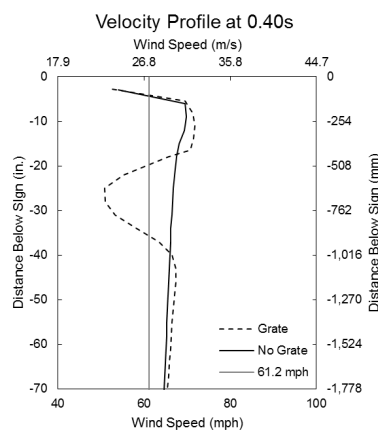

(e)

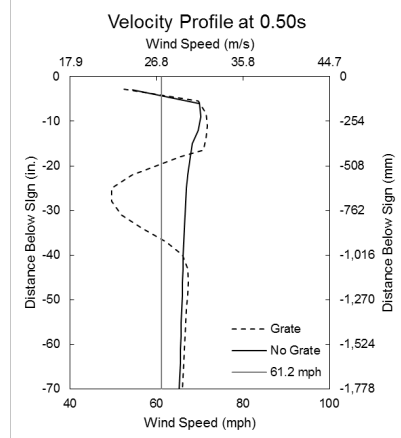

(f)

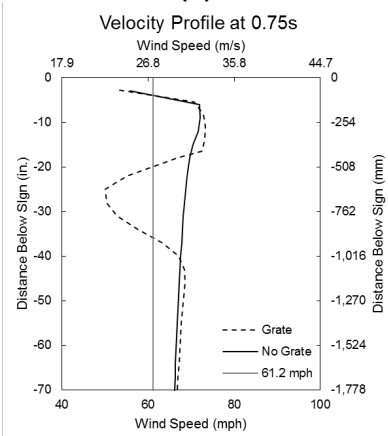

(g)

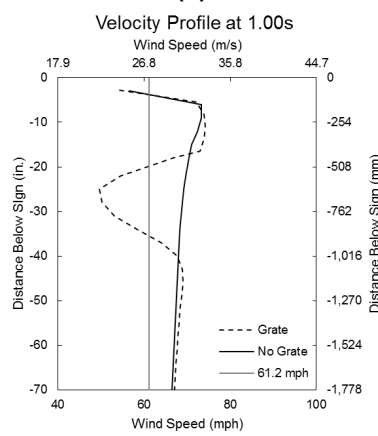

(h)

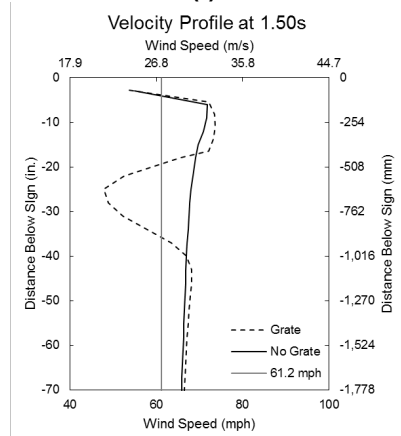

(i)

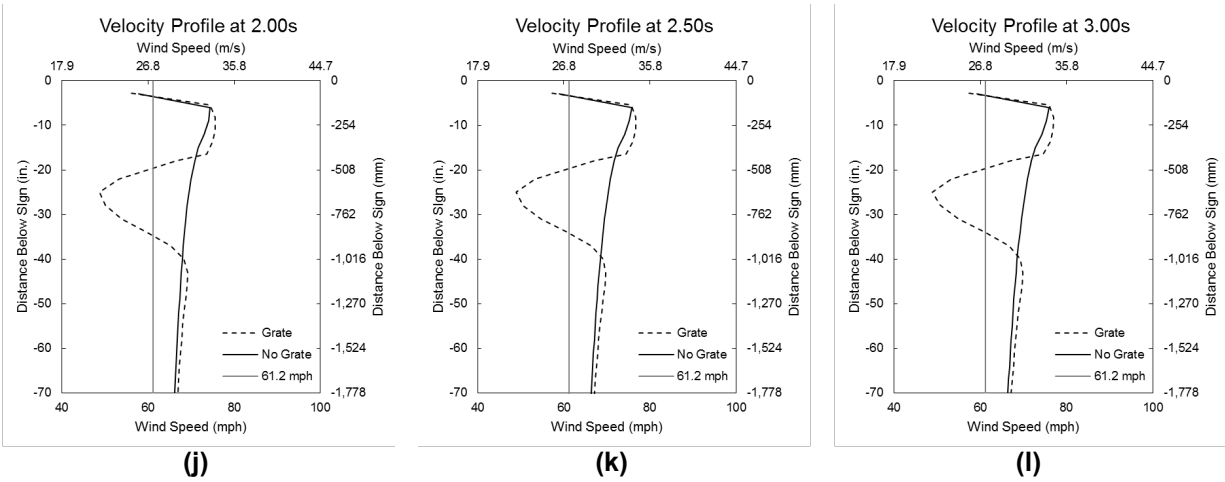
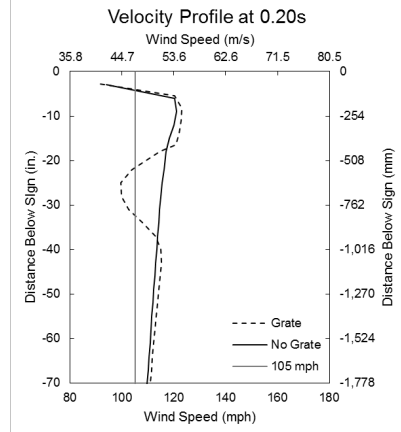
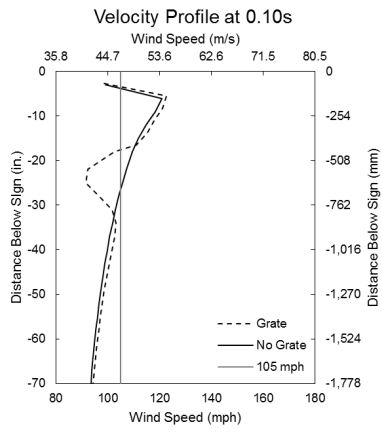
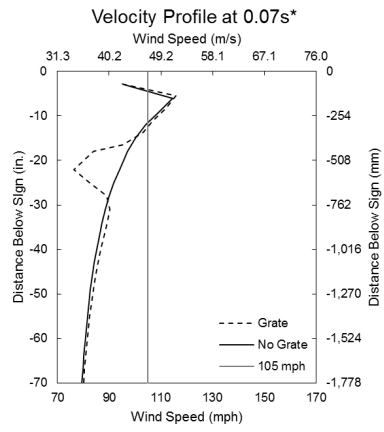

Figure A2.8: Velocity profile below the sign, for the small sign and a wind speed of 61.2 mph (27.4 m/s)

A2.9: Small Sign Velocity Profile at V=105mph (46.9 m/s)



*Wind speed scales are different from the rest of the batch.

(a)

(b)

(c)

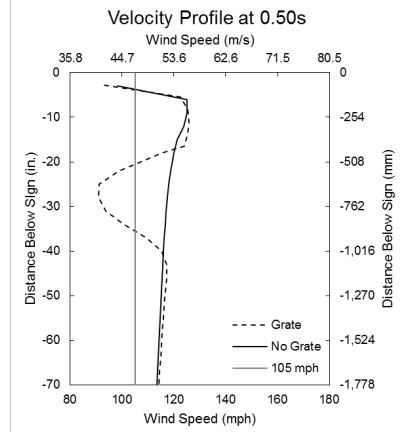
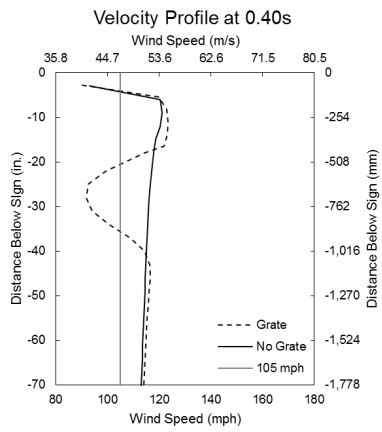
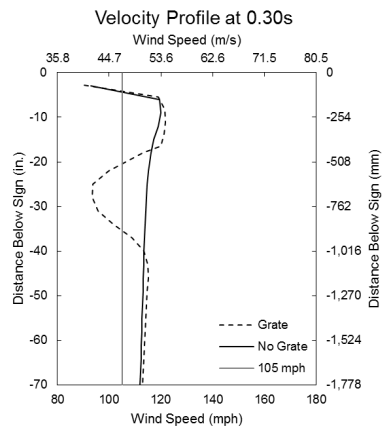

(d)

(e)

(f)

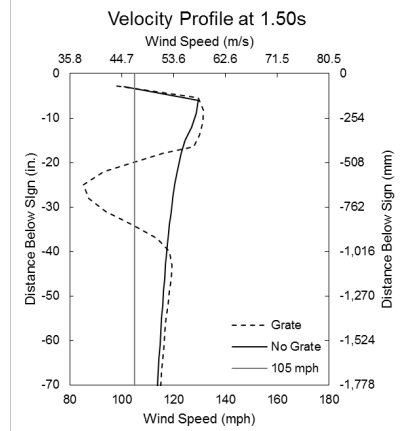
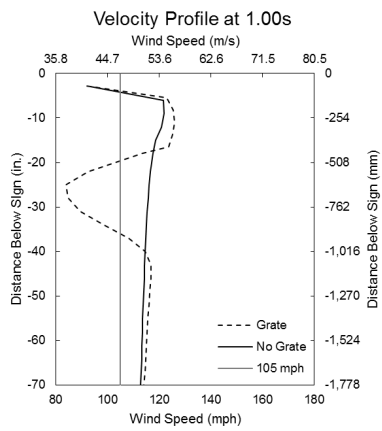
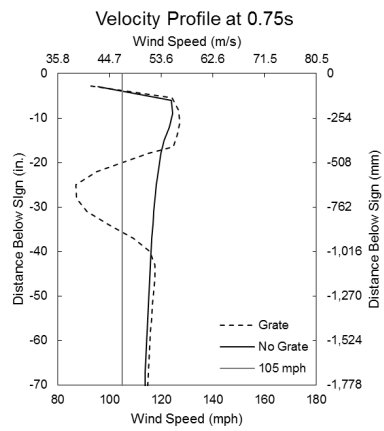

(g)

(h)

(i)

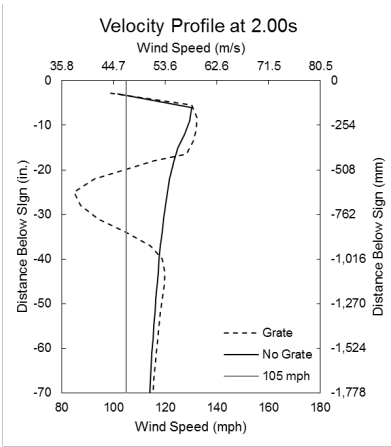

(j)

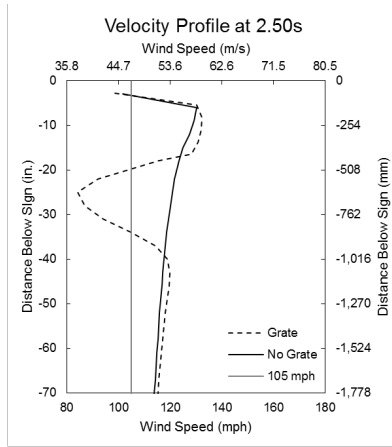

(k)

Figure A2.9: Velocity profile below the sign, for the small sign and a wind speed of $V=105\text{mph}$ (46.9 m/s)

Appendix A3

Table A3.1: Displacements at V=30 mph (13.4 m/s)

Model	ΔUZ				ΔUY			
	w/ Walkway		w/o Walkway		w/ Walkway		w/o Walkway	
	in.	mm	in.	mm	in.	mm	in.	mm
S20x12-L20-P25	5.13	130.38	4.96	125.91	0.13	3.26	0.04	0.90
S20x12-L20-P27	5.47	139.06	5.29	134.33	0.14	3.44	0.04	0.91
S20x12-L20-P29	5.88	149.40	5.64	143.31	0.14	3.65	0.04	1.04
S20x12-L16-P25	3.88	98.67	3.76	95.43	0.10	2.64	0.03	0.82
S20x12-L16-P27	4.15	105.51	4.05	102.90	0.11	2.81	0.03	0.84
S20x12-L16-P29	4.46	113.24	4.31	109.51	0.11	2.91	0.03	0.86
S20x12-L12-P25	2.88	73.23	2.72	69.18	0.07	1.77	0.02	0.52
S20x12-L12-P27	3.12	79.37	2.99	75.96	0.08	2.03	0.03	0.69
S20x12-L12-P29	3.40	86.24	3.23	82.09	0.09	2.41	0.03	0.83
S16x9-L20-P25	3.44	87.29	3.54	89.81	0.05	1.36	0.05	1.21
S16x9-L20-P27	3.65	92.68	3.72	94.52	0.05	1.39	0.05	1.20
S16x9-L20-P29	3.90	98.98	3.95	100.39	0.06	1.46	0.05	1.37
S16x9-L16-P25	2.52	63.95	2.53	64.37	0.04	1.08	0.03	0.83
S16x9-L16-P27	2.70	68.52	2.73	69.23	0.05	1.24	0.04	1.06
S16x9-L16-P29	2.89	73.48	2.91	73.96	0.05	1.38	0.05	1.24
S16x9-L12-P25	1.71	43.31	1.71	43.36	0.03	0.69	0.02	0.54
S16x9-L12-P27	1.87	47.39	1.87	47.57	0.03	0.89	0.03	0.72
S16x9-L12-P29	2.03	51.51	2.04	51.83	0.05	1.17	0.03	0.82
S12x6-L20-P25	2.08	52.88	2.13	54.22	0.04	0.92	0.03	0.67
S12x6-L20-P27	2.23	56.53	2.27	57.60	0.04	1.09	0.03	0.84
S12x6-L20-P29	2.38	60.35	2.42	61.42	0.05	1.24	0.04	0.91
S12x6-L16-P25	1.46	36.97	1.47	37.35	0.03	0.68	0.02	0.56
S12x6-L16-P27	1.58	40.22	1.60	40.75	0.03	0.79	0.02	0.61
S12x6-L16-P29	1.74	44.13	1.75	44.36	0.04	0.91	0.03	0.65
S12x6-L12-P25	0.97	24.54	0.97	24.74	0.02	0.58	0.02	0.42
S12x6-L12-P27	1.07	27.23	1.09	27.68	0.02	0.60	0.02	0.48
S12x6-L12-P29	1.20	30.41	1.19	30.33	0.03	0.66	0.02	0.52

Table A3.2: Top Box-Connection Stresses at V=30 mph (13.4 m/s)

Model	S33				S11			
	w/ Walkway		w/o Walkway		w/ Walkway		w/o Walkway	
	ksi	MPa	ksi	MPa	ksi	MPa	ksi	MPa
S20x12-L20-P25	3.91	26.98	3.89	26.82	0.09	0.65	0.03	0.23
S20x12-L20-P27	3.92	27.04	3.91	26.96	0.07	0.50	0.02	0.17
S20x12-L20-P29	3.91	26.95	3.93	27.11	0.06	0.43	0.02	0.14
S20x12-L16-P25	3.41	23.54	3.34	23.03	0.06	0.43	0.02	0.14
S20x12-L16-P27	3.41	23.53	3.37	23.23	0.05	0.35	0.02	0.11
S20x12-L16-P29	3.40	23.46	3.39	23.38	0.05	0.31	0.01	0.10
S20x12-L12-P25	2.89	19.93	2.83	19.54	0.04	0.26	0.01	0.10
S20x12-L12-P27	2.88	19.82	2.81	19.39	0.04	0.26	0.02	0.11
S20x12-L12-P29	2.88	19.88	2.85	19.64	0.04	0.25	0.01	0.10
S16x9-L20-P25	4.17	28.78	4.19	28.91	0.05	0.37	0.03	0.23
S16x9-L20-P27	4.19	28.87	4.18	28.84	0.04	0.25	0.02	0.16
S16x9-L20-P29	4.17	28.72	4.21	29.05	0.03	0.21	0.02	0.16
S16x9-L16-P25	3.58	24.71	3.60	24.81	0.03	0.23	0.02	0.14
S16x9-L16-P27	3.59	24.74	3.58	24.66	0.03	0.18	0.02	0.12
S16x9-L16-P29	3.57	24.65	3.55	24.48	0.03	0.18	0.02	0.14
S16x9-L12-P25	2.96	20.38	2.96	20.40	0.02	0.15	0.01	0.10
S16x9-L12-P27	2.96	20.42	2.95	20.35	0.02	0.15	0.02	0.11
S16x9-L12-P29	2.96	20.40	2.93	20.21	0.02	0.14	0.02	0.11
S12x6-L20-P25	2.02	13.93	2.02	13.95	0.01	0.08	0.01	0.06
S12x6-L20-P27	2.01	13.86	2.01	13.85	0.01	0.08	0.01	0.06
S12x6-L20-P29	2.00	13.80	1.99	13.73	0.01	0.07	0.01	0.06
S12x6-L16-P25	1.68	11.60	1.71	11.76	0.01	0.06	0.01	0.05
S12x6-L16-P27	1.69	11.67	1.72	11.83	0.01	0.06	0.01	0.05
S12x6-L16-P29	1.70	11.71	1.72	11.84	0.01	0.06	0.01	0.05
S12x6-L12-P25	1.34	9.25	1.37	9.45	0.01	0.05	0.01	0.04
S12x6-L12-P27	1.37	9.42	1.39	9.58	0.01	0.05	0.01	0.04
S12x6-L12-P29	1.38	9.53	1.39	9.60	0.01	0.04	0.01	0.04

Table A3.3: Bottom Box-Connection Stresses at V=30 mph (13.4 m/s)

Model	S33				S11			
	w/ Walkway		w/o Walkway		w/ Walkway		w/o Walkway	
	ksi	MPa	ksi	MPa	ksi	MPa	ksi	MPa
S20x12-L20-P25	5.67	39.11	5.56	38.37	0.16	1.10	0.06	0.40
S20x12-L20-P27	5.70	39.28	5.55	38.26	0.12	0.84	0.04	0.28
S20x12-L20-P29	5.70	39.31	5.52	38.05	0.10	0.71	0.04	0.24
S20x12-L16-P25	4.98	34.37	4.84	33.38	0.11	0.77	0.04	0.25
S20x12-L16-P27	5.02	34.61	4.83	33.33	0.09	0.62	0.03	0.21
S20x12-L16-P29	5.02	34.63	4.81	33.17	0.08	0.55	0.03	0.19
S20x12-L12-P25	4.29	29.60	4.11	28.32	0.07	0.50	0.03	0.17
S20x12-L12-P27	4.30	29.67	4.15	28.63	0.07	0.48	0.03	0.19
S20x12-L12-P29	4.28	29.51	4.10	28.24	0.07	0.49	0.03	0.18
S16x9-L20-P25	5.23	36.04	5.22	35.96	0.09	0.63	0.06	0.40
S16x9-L20-P27	5.24	36.13	5.20	35.87	0.06	0.43	0.04	0.28
S16x9-L20-P29	5.23	36.07	5.18	35.69	0.05	0.36	0.04	0.27
S16x9-L16-P25	4.47	30.79	4.43	30.52	0.06	0.44	0.04	0.27
S16x9-L16-P27	4.48	30.91	4.44	30.61	0.07	0.50	0.05	0.34
S16x9-L16-P29	4.49	30.98	4.45	30.71	0.05	0.34	0.04	0.26
S16x9-L12-P25	3.65	25.17	3.62	24.93	0.04	0.30	0.03	0.20
S16x9-L12-P27	3.68	25.38	3.67	25.29	0.06	0.42	0.04	0.31
S16x9-L12-P29	3.72	25.68	3.71	25.60	0.04	0.29	0.03	0.20
S12x6-L20-P25	2.40	16.58	2.43	16.77	0.02	0.14	0.01	0.10
S12x6-L20-P27	2.41	16.60	2.44	16.81	0.02	0.15	0.02	0.11
S12x6-L20-P29	2.41	16.62	2.45	16.86	0.02	0.14	0.01	0.10
S12x6-L16-P25	2.06	14.18	2.04	14.06	0.02	0.13	0.01	0.10
S12x6-L16-P27	2.05	14.13	2.02	13.93	0.02	0.14	0.02	0.11
S12x6-L16-P29	2.03	13.99	2.05	14.15	0.02	0.12	0.01	0.09
S12x6-L12-P25	1.68	11.60	1.67	11.50	0.02	0.12	0.01	0.09
S12x6-L12-P27	1.68	11.60	1.66	11.41	0.02	0.11	0.01	0.08
S12x6-L12-P29	1.67	11.49	1.68	11.57	0.01	0.09	0.01	0.08

Table A3.4: Pole Stresses at V=30 mph (13.4 m/s)

Model	S21			
	w/ Walkway		w/o Walkway	
	ksi	MPa	ksi	MPa
S20x12-L20-P25	3.42	23.56	3.23	22.27
S20x12-L20-P27	3.71	25.58	3.54	24.41
S20x12-L20-P29	3.96	27.31	3.91	26.94
S20x12-L16-P25	3.34	23.00	3.20	22.08
S20x12-L16-P27	3.46	23.87	3.44	23.73
S20x12-L16-P29	3.85	26.54	3.81	26.30
S20x12-L12-P25	3.35	23.07	3.12	21.52
S20x12-L12-P27	3.62	24.98	3.48	24.02
S20x12-L12-P29	4.04	27.83	3.81	26.26
S16x9-L20-P25	1.96	13.54	2.00	13.78
S16x9-L20-P27	2.15	14.86	2.25	15.49
S16x9-L20-P29	2.39	16.45	2.47	17.05
S16x9-L16-P25	1.93	13.32	1.98	13.64
S16x9-L16-P27	2.16	14.89	2.22	15.33
S16x9-L16-P29	2.36	16.28	2.42	16.65
S16x9-L12-P25	1.89	13.04	1.91	13.17
S16x9-L12-P27	2.08	14.36	2.12	14.60
S16x9-L12-P29	2.32	16.02	2.31	15.91
S12x6-L20-P25	1.38	9.52	1.46	10.04
S12x6-L20-P27	1.56	10.77	1.62	11.17
S12x6-L20-P29	1.71	11.76	1.73	11.92
S12x6-L16-P25	1.35	9.32	1.41	9.70
S12x6-L16-P27	1.52	10.48	1.54	10.65
S12x6-L16-P29	1.67	11.54	1.69	11.66
S12x6-L12-P25	1.30	8.95	1.30	8.95
S12x6-L12-P27	1.41	9.73	1.44	9.90
S12x6-L12-P29	1.55	10.66	1.57	10.84

Table A3.5: Displacements at V=61.2 mph (27.4 m/s)

Model	ΔUZ				ΔUY			
	w/ Walkway		w/o Walkway		w/ Walkway		w/o Walkway	
	in.	mm	in.	mm	in.	mm	in.	mm
S20x12-L20-P25	20.94	531.86	21.00	533.39	0.38	9.64	0.30	7.63
S20x12-L20-P27	22.36	567.91	22.39	568.58	0.42	10.66	0.34	8.72
S20x12-L20-P29	23.91	607.39	23.95	608.23	0.55	13.84	0.44	11.22
S20x12-L16-P25	16.34	414.98	16.44	417.60	0.30	7.70	0.24	6.08
S20x12-L16-P27	17.11	434.49	17.59	446.66	0.33	8.45	0.25	6.47
S20x12-L16-P29	18.26	463.84	18.29	464.63	0.35	8.77	0.27	6.85
S20x12-L12-P25	12.07	306.46	11.99	304.56	0.28	6.99	0.20	5.12
S20x12-L12-P27	13.18	334.75	13.13	333.49	0.26	6.59	0.20	5.09
S20x12-L12-P29	14.33	364.01	14.23	361.33	0.27	6.80	0.22	5.54
S16x9-L20-P25	14.10	358.10	14.39	365.49	0.30	7.58	0.21	5.46
S16x9-L20-P27	14.90	378.52	14.97	380.13	0.31	7.94	0.22	5.48
S16x9-L20-P29	15.77	400.64	15.85	402.50	0.33	8.48	0.22	5.49
S16x9-L16-P25	10.64	270.21	10.66	270.65	0.25	6.23	0.16	4.00
S16x9-L16-P27	11.35	288.17	11.33	287.78	0.25	6.25	0.18	4.63
S16x9-L16-P29	12.06	306.34	12.13	307.99	0.27	6.84	0.19	4.92
S16x9-L12-P25	7.55	191.86	7.46	189.55	0.18	4.67	0.11	2.90
S16x9-L12-P27	8.25	209.52	8.11	205.87	0.20	5.16	0.12	3.00
S16x9-L12-P29	8.91	226.39	8.80	223.51	0.21	5.22	0.13	3.21
S12x6-L20-P25	8.31	211.04	8.49	215.54	0.11	2.72	0.10	2.46
S12x6-L20-P27	8.89	225.90	9.08	230.57	0.10	2.58	0.09	2.37
S12x6-L20-P29	9.54	242.20	9.70	246.36	0.10	2.66	0.09	2.28
S12x6-L16-P25	5.92	150.47	6.06	153.98	0.09	2.40	0.08	1.95
S12x6-L16-P27	6.43	163.37	6.54	166.20	0.10	2.42	0.07	1.88
S12x6-L16-P29	6.93	176.08	7.07	179.54	0.09	2.23	0.08	1.96
S12x6-L12-P25	4.16	105.77	4.30	109.15	0.08	1.99	0.06	1.65
S12x6-L12-P27	4.56	115.80	4.70	119.30	0.08	2.06	0.06	1.61
S12x6-L12-P29	4.98	126.38	5.07	128.68	0.08	2.08	0.07	1.67

Table A3.6: Top Box-Connection Stresses at V=61.2 mph (27.4 m/s)

Model	S33				S11			
	w/ Walkway		w/o Walkway		w/ Walkway		w/o Walkway	
	ksi	MPa	ksi	MPa	ksi	MPa	ksi	MPa
S20x12-L20-P25	16.40	113.05	16.65	114.80	0.29	2.01	0.21	1.46
S20x12-L20-P27	16.39	113.01	16.73	115.33	0.26	1.77	0.19	1.31
S20x12-L20-P29	16.41	113.14	16.81	115.94	0.25	1.70	0.21	1.44
S20x12-L16-P25	14.25	98.24	14.30	98.61	0.21	1.42	0.15	1.06
S20x12-L16-P27	14.22	98.05	14.41	99.39	0.17	1.19	0.15	1.04
S20x12-L16-P29	14.15	97.57	14.52	100.11	0.16	1.10	0.15	1.01
S20x12-L12-P25	12.19	84.05	12.25	84.46	0.15	1.07	0.13	0.88
S20x12-L12-P27	12.13	83.62	12.18	83.96	0.13	0.87	0.12	0.84
S20x12-L12-P29	12.16	83.84	12.18	83.98	0.12	0.81	0.11	0.76
S16x9-L20-P25	17.30	119.31	17.23	118.83	0.25	1.74	0.12	0.81
S16x9-L20-P27	17.29	119.21	17.09	117.87	0.21	1.45	0.09	0.65
S16x9-L20-P29	17.19	118.53	17.09	117.83	0.18	1.23	0.09	0.59
S16x9-L16-P25	15.00	103.45	14.97	103.24	0.18	1.26	0.08	0.57
S16x9-L16-P27	15.00	103.39	14.86	102.46	0.15	1.05	0.07	0.49
S16x9-L16-P29	14.93	102.93	14.73	101.57	0.13	0.91	0.06	0.42
S16x9-L12-P25	12.54	86.48	12.52	86.34	0.13	0.91	0.06	0.40
S16x9-L12-P27	12.53	86.43	12.44	85.80	0.11	0.74	0.05	0.35
S16x9-L12-P29	12.49	86.14	12.31	84.90	0.10	0.70	0.05	0.35
S12x6-L20-P25	8.16	56.23	8.23	56.72	0.04	0.24	0.03	0.18
S12x6-L20-P27	8.13	56.03	8.17	56.34	0.03	0.21	0.02	0.17
S12x6-L20-P29	8.10	55.88	8.11	55.93	0.03	0.17	0.02	0.15
S12x6-L16-P25	6.84	47.16	7.01	48.36	0.03	0.20	0.02	0.16
S12x6-L16-P27	6.88	47.46	7.05	48.58	0.03	0.17	0.02	0.14
S12x6-L16-P29	6.92	47.71	7.04	48.52	0.02	0.16	0.02	0.13
S12x6-L12-P25	5.59	38.55	5.74	39.54	0.02	0.14	0.02	0.11
S12x6-L12-P27	5.64	38.87	5.78	39.88	0.02	0.13	0.01	0.10
S12x6-L12-P29	5.69	39.23	5.77	39.77	0.02	0.12	0.01	0.09

Table A3.7: Bottom Box-Connection Stresses at V=61.2 mph (27.4 m/s)

Model	S33				S11			
	w/ Walkway		w/o Walkway		w/ Walkway		w/o Walkway	
	ksi	MPa	ksi	MPa	ksi	MPa	ksi	MPa
S20x12-L20-P25	23.84	164.35	23.88	164.62	0.48	3.31	0.36	2.45
S20x12-L20-P27	23.92	164.93	23.80	164.13	0.43	2.94	0.32	2.19
S20x12-L20-P29	23.93	164.99	23.67	163.18	0.41	2.86	0.35	2.41
S20x12-L16-P25	20.94	144.35	20.85	143.78	0.36	2.48	0.28	1.92
S20x12-L16-P27	21.05	145.12	20.80	143.44	0.31	2.13	0.27	1.85
S20x12-L16-P29	21.04	145.07	20.69	142.63	0.28	1.91	0.26	1.78
S20x12-L12-P25	18.03	124.30	17.84	123.02	0.28	1.96	0.22	1.52
S20x12-L12-P27	18.13	125.03	17.83	122.97	0.25	1.73	0.21	1.43
S20x12-L12-P29	17.96	123.87	17.75	122.36	0.22	1.55	0.19	1.33
S16x9-L20-P25	21.54	148.52	21.32	147.00	0.42	2.87	0.20	1.39
S16x9-L20-P27	21.56	148.68	21.27	146.63	0.36	2.47	0.16	1.11
S16x9-L20-P29	21.51	148.34	21.17	145.96	0.30	2.05	0.14	1.00
S16x9-L16-P25	18.49	127.50	18.26	125.88	0.34	2.34	0.16	1.11
S16x9-L16-P27	18.54	127.86	18.30	126.20	0.28	1.92	0.13	0.92
S16x9-L16-P29	18.57	128.07	18.37	126.63	0.24	1.64	0.11	0.77
S16x9-L12-P25	15.63	107.74	15.23	105.02	0.25	1.72	0.11	0.79
S16x9-L12-P27	15.48	106.74	15.39	106.08	0.21	1.44	0.10	0.66
S16x9-L12-P29	15.61	107.62	15.51	106.93	0.20	1.38	0.10	0.68
S12x6-L20-P25	9.77	67.34	9.79	67.53	0.07	0.47	0.05	0.37
S12x6-L20-P27	9.73	67.06	9.86	68.01	0.07	0.46	0.05	0.33
S12x6-L20-P29	9.72	67.03	9.89	68.19	0.05	0.36	0.04	0.30
S12x6-L16-P25	8.51	58.71	8.51	58.69	0.06	0.42	0.05	0.32
S12x6-L16-P27	8.47	58.38	8.41	57.97	0.05	0.37	0.04	0.27
S12x6-L16-P29	8.37	57.70	8.36	57.63	0.05	0.33	0.04	0.25
S12x6-L12-P25	7.09	48.88	7.09	48.90	0.05	0.31	0.04	0.26
S12x6-L12-P27	7.05	48.64	7.00	48.24	0.04	0.29	0.03	0.23
S12x6-L12-P29	6.95	47.94	6.91	47.61	0.04	0.24	0.03	0.20

Table A3.8: Pole Stresses at V=61.2 mph (27.4 m/s)

Model	S21			
	w/ Walkway		w/o Walkway	
	ksi	MPa	ksi	MPa
S20x12-L20-P25	14.13	97.43	13.79	95.11
S20x12-L20-P27	15.22	104.91	15.17	104.59
S20x12-L20-P29	16.41	113.14	16.75	115.48
S20x12-L16-P25	13.96	96.26	13.50	93.06
S20x12-L16-P27	14.43	99.46	14.84	102.31
S20x12-L16-P29	16.16	111.42	16.43	113.32
S20x12-L12-P25	14.08	97.08	13.55	93.40
S20x12-L12-P27	14.96	103.13	15.06	103.81
S20x12-L12-P29	16.93	116.72	16.52	113.87
S16x9-L20-P25	8.04	55.41	8.17	56.35
S16x9-L20-P27	8.85	61.04	9.16	63.15
S16x9-L20-P29	9.81	67.62	10.03	69.16
S16x9-L16-P25	7.90	54.49	8.16	56.25
S16x9-L16-P27	8.76	60.40	9.10	62.78
S16x9-L16-P29	9.75	67.24	9.88	68.15
S16x9-L12-P25	8.01	55.25	8.04	55.47
S16x9-L12-P27	8.76	60.39	8.90	61.36
S16x9-L12-P29	9.70	66.90	9.71	66.93
S12x6-L20-P25	5.55	38.27	5.84	40.24
S12x6-L20-P27	6.24	43.00	6.42	44.29
S12x6-L20-P29	6.76	46.61	7.09	48.90
S12x6-L16-P25	5.54	38.22	5.65	38.96
S12x6-L16-P27	6.18	42.58	6.25	43.11
S12x6-L16-P29	6.69	46.12	6.59	45.41
S12x6-L12-P25	5.49	37.83	5.52	38.03
S12x6-L12-P27	5.97	41.15	6.01	41.46
S12x6-L12-P29	6.46	44.52	6.59	45.45

Table A3.9: Displacements at V=105mph (46.9 m/s)

Model	ΔUZ				ΔUY			
	w/ Walkway		w/o Walkway		w/ Walkway		w/o Walkway	
	in.	mm	in.	mm	in.	mm	in.	mm
S20x12-L20-P25	66.38	1686.08	64.51	1638.60	0.92	23.24	1.24	31.51
S20x12-L20-P27	70.87	1800.10	68.72	1745.60	0.94	23.82	1.14	29.08
S20x12-L20-P29	75.66	1921.82	73.27	1861.07	0.90	22.83	1.03	26.27
S20x12-L16-P25	49.78	1264.44	48.31	1227.16	0.82	20.79	1.12	28.47
S20x12-L16-P27	53.62	1362.03	52.04	1321.78	0.78	19.75	1.09	27.57
S20x12-L16-P29	57.76	1467.14	55.95	1421.13	0.79	20.04	1.00	25.46
S20x12-L12-P25	35.01	889.21	34.58	878.43	0.60	15.21	0.80	20.32
S20x12-L12-P27	38.28	972.20	37.76	959.16	0.60	15.29	0.85	21.67
S20x12-L12-P29	41.85	1062.90	40.92	1039.27	0.61	15.37	0.87	22.20
S16x9-L20-P25	42.93	1090.54	42.46	1078.49	0.47	11.83	0.42	10.56
S16x9-L20-P27	45.56	1157.32	45.12	1146.16	0.48	12.23	0.45	11.40
S16x9-L20-P29	47.75	1212.79	47.70	1211.65	0.52	13.17	0.48	12.14
S16x9-L16-P25	31.09	789.59	30.70	779.73	0.44	11.10	0.31	7.75
S16x9-L16-P27	33.31	846.15	32.86	834.56	0.39	9.96	0.27	6.89
S16x9-L16-P29	35.85	910.71	35.13	892.27	0.38	9.70	0.30	7.74
S16x9-L12-P25	21.26	539.89	21.18	537.89	0.31	7.76	0.36	9.11
S16x9-L12-P27	23.29	591.44	22.93	582.43	0.32	8.18	0.31	7.91
S16x9-L12-P29	25.25	641.31	24.85	631.13	0.34	8.62	0.27	6.97
S12x6-L20-P25	23.36	593.40	23.93	607.89	0.21	5.42	0.21	5.35
S12x6-L20-P27	24.87	631.64	25.39	645.02	0.24	6.22	0.22	5.66
S12x6-L20-P29	26.40	670.62	26.75	679.52	0.26	6.69	0.24	5.98
S12x6-L16-P25	17.36	441.01	17.96	456.22	0.19	4.80	0.20	5.16
S12x6-L16-P27	18.68	474.35	19.15	486.38	0.20	5.02	0.18	4.64
S12x6-L16-P29	19.96	506.86	20.67	524.97	0.22	5.51	0.20	4.97
S12x6-L12-P25	12.18	309.27	12.61	320.30	0.15	3.74	0.13	3.33
S12x6-L12-P27	13.37	339.55	13.91	353.20	0.15	3.88	0.14	3.52
S12x6-L12-P29	14.67	372.57	15.07	382.66	0.18	4.49	0.15	3.69

Table A3.10: Top Box-Connection Stresses at V=105mph (46.9 m/s)

Model	S33				S11			
	w/ Walkway		w/o Walkway		w/ Walkway		w/o Walkway	
	ksi	MPa	ksi	MPa	ksi	MPa	ksi	MPa
S20x12-L20-P25	48.76	336.22	48.78	336.35	0.73	5.03	0.57	3.95
S20x12-L20-P27	48.77	336.30	48.93	337.40	0.60	4.16	0.51	3.51
S20x12-L20-P29	48.66	335.53	49.18	339.12	0.51	3.51	0.44	3.06
S20x12-L16-P25	42.33	291.85	42.03	289.80	0.52	3.56	0.53	3.63
S20x12-L16-P27	42.32	291.78	42.15	290.62	0.43	2.95	0.47	3.23
S20x12-L16-P29	42.15	290.60	42.17	290.75	0.39	2.68	0.42	2.87
S20x12-L12-P25	35.59	245.36	35.49	244.71	0.36	2.47	0.42	2.86
S20x12-L12-P27	35.61	245.51	35.26	243.10	0.36	2.48	0.45	3.09
S20x12-L12-P29	35.40	244.10	35.48	244.60	0.32	2.20	0.41	2.84
S16x9-L20-P25	50.20	346.14	50.09	345.36	0.48	3.30	0.35	2.38
S16x9-L20-P27	50.05	345.13	49.73	342.89	0.35	2.39	0.26	1.77
S16x9-L20-P29	49.99	344.70	49.58	341.88	0.30	2.05	0.22	1.48
S16x9-L16-P25	43.44	299.53	43.40	299.24	0.34	2.33	0.22	1.55
S16x9-L16-P27	36.00	248.22	36.00	248.22	0.30	2.10	0.20	1.37
S16x9-L16-P29	43.25	298.23	42.77	294.88	0.23	1.61	0.16	1.09
S16x9-L12-P25	36.29	250.25	36.35	250.67	0.20	1.39	0.16	1.10
S16x9-L12-P27	36.27	250.08	36.13	249.13	0.18	1.22	0.14	0.93
S16x9-L12-P29	36.17	249.36	35.80	246.84	0.16	1.13	0.12	0.81
S12x6-L20-P25	23.36	161.09	23.56	162.46	0.11	0.72	0.08	0.52
S12x6-L20-P27	23.28	160.54	23.43	161.54	0.10	0.66	0.07	0.50
S12x6-L20-P29	23.24	160.24	23.30	160.63	0.09	0.60	0.07	0.52
S12x6-L16-P25	19.57	134.96	20.07	138.35	0.09	0.64	0.07	0.48
S12x6-L16-P27	19.72	135.95	20.20	139.29	0.08	0.58	0.06	0.43
S12x6-L16-P29	19.85	136.89	20.22	139.43	0.08	0.53	0.06	0.39
S12x6-L12-P25	16.20	111.71	16.62	114.63	0.07	0.47	0.04	0.26
S12x6-L12-P27	16.26	112.08	16.60	114.46	0.07	0.45	0.04	0.26
S12x6-L12-P29	16.34	112.65	16.60	114.43	0.06	0.44	0.04	0.27

Table A3.11: Bottom Box-Connection Stresses at V=105mph (46.9 m/s)

Model	S33				S11			
	w/ Walkway		w/o Walkway		w/ Walkway		w/o Walkway	
	Ksi	MPa	ksi	MPa	ksi	MPa	ksi	MPa
S20x12-L20-P25	70.61	486.85	69.99	482.56	1.21	8.32	0.99	6.84
S20x12-L20-P27	70.92	488.96	69.81	481.37	1.03	7.13	0.86	5.96
S20x12-L20-P29	71.03	489.76	69.48	479.05	0.84	5.81	0.73	5.06
S20x12-L16-P25	62.08	428.03	61.22	422.12	0.91	6.26	0.90	6.18
S20x12-L16-P27	62.39	430.17	61.05	420.91	0.77	5.32	0.81	5.59
S20x12-L16-P29	62.38	430.12	61.08	421.13	0.71	4.90	0.71	4.91
S20x12-L12-P25	53.61	369.62	52.48	361.82	0.68	4.67	0.79	5.47
S20x12-L12-P27	53.40	368.19	52.29	360.55	0.66	4.53	0.82	5.64
S20x12-L12-P29	53.20	366.81	52.16	359.63	0.58	3.99	0.76	5.27
S16x9-L20-P25	62.43	430.46	61.73	425.64	0.80	5.50	0.60	4.12
S16x9-L20-P27	62.03	427.73	61.60	424.72	0.64	4.42	0.44	3.02
S16x9-L20-P29	62.45	430.57	61.36	423.11	0.51	3.49	0.38	2.59
S16x9-L16-P25	53.54	369.18	52.84	364.31	0.64	4.44	0.44	3.02
S16x9-L16-P27	36.00	248.23	36.00	248.22	0.79	5.43	0.51	3.53
S16x9-L16-P29	53.78	370.82	53.19	366.74	0.39	2.67	0.29	2.02
S16x9-L12-P25	44.71	308.30	44.11	304.15	0.42	2.87	0.32	2.18
S16x9-L12-P27	44.84	309.14	44.59	307.46	0.35	2.40	0.25	1.76
S16x9-L12-P29	45.23	311.89	44.99	310.21	0.33	2.25	0.22	1.52
S12x6-L20-P25	28.09	193.71	28.03	193.27	0.19	1.29	0.15	1.00
S12x6-L20-P27	27.81	191.75	28.09	193.71	0.19	1.30	0.15	1.02
S12x6-L20-P29	27.74	191.28	28.34	195.43	0.17	1.16	0.14	0.94
S12x6-L16-P25	24.43	168.47	24.49	168.88	0.19	1.28	0.13	0.93
S12x6-L16-P27	24.35	167.87	24.24	167.13	0.17	1.15	0.12	0.82
S12x6-L16-P29	24.12	166.29	23.99	165.44	0.16	1.11	0.12	0.80
S12x6-L12-P25	20.34	140.27	20.44	140.95	0.13	0.87	0.09	0.64
S12x6-L12-P27	20.29	139.88	20.47	141.16	0.11	0.78	0.09	0.60
S12x6-L12-P29	20.06	138.30	19.82	136.64	0.12	0.81	0.09	0.61

Table A3.12: Pole Stresses at V=105mph (46.9 m/s)

Model	S21			
	w/ Walkway		w/o Walkway	
	ksi	MPa	ksi	MPa
S20x12-L20-P25	42.24	291.24	40.47	279.05
S20x12-L20-P27	45.85	316.17	44.47	306.64
S20x12-L20-P29	48.74	336.03	49.12	338.65
S20x12-L16-P25	40.50	279.28	39.14	269.87
S20x12-L16-P27	42.52	293.19	43.40	299.25
S20x12-L16-P29	47.99	330.92	48.18	332.22
S20x12-L12-P25	40.46	278.97	39.20	270.27
S20x12-L12-P27	43.49	299.84	44.32	305.56
S20x12-L12-P29	49.10	338.51	48.56	334.84
S16x9-L20-P25	23.29	160.58	23.68	163.24
S16x9-L20-P27	26.77	184.60	26.60	183.38
S16x9-L20-P29	28.46	196.25	29.18	201.20
S16x9-L16-P25	22.94	158.18	23.63	162.90
S16x9-L16-P27	25.83	178.08	26.35	181.71
S16x9-L16-P29	28.26	194.84	28.93	199.46
S16x9-L12-P25	23.24	160.22	23.27	160.46
S16x9-L12-P27	25.42	175.26	25.69	177.11
S16x9-L12-P29	28.13	193.94	27.98	192.93
S12x6-L20-P25	16.03	110.51	16.91	116.56
S12x6-L20-P27	18.01	124.16	18.59	128.18
S12x6-L20-P29	19.52	134.62	19.85	136.89
S12x6-L16-P25	16.11	111.04	16.94	116.79
S12x6-L16-P27	17.89	123.36	18.96	130.74
S12x6-L16-P29	19.67	135.60	19.35	133.43
S12x6-L12-P25	16.00	110.30	16.43	113.26
S12x6-L12-P27	17.05	117.57	17.29	119.24
S12x6-L12-P29	18.51	127.65	19.96	137.60

Appendix B

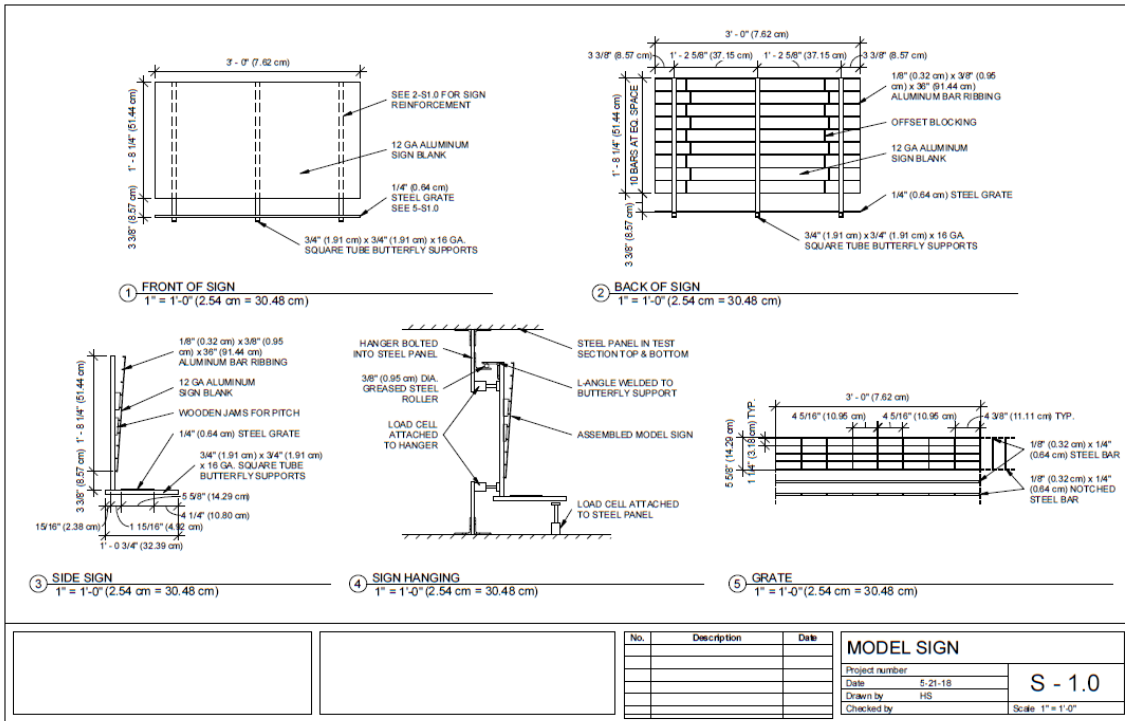

Figure B.1: Schematic of model sign used in wind tunnel testing at the University of Kansas

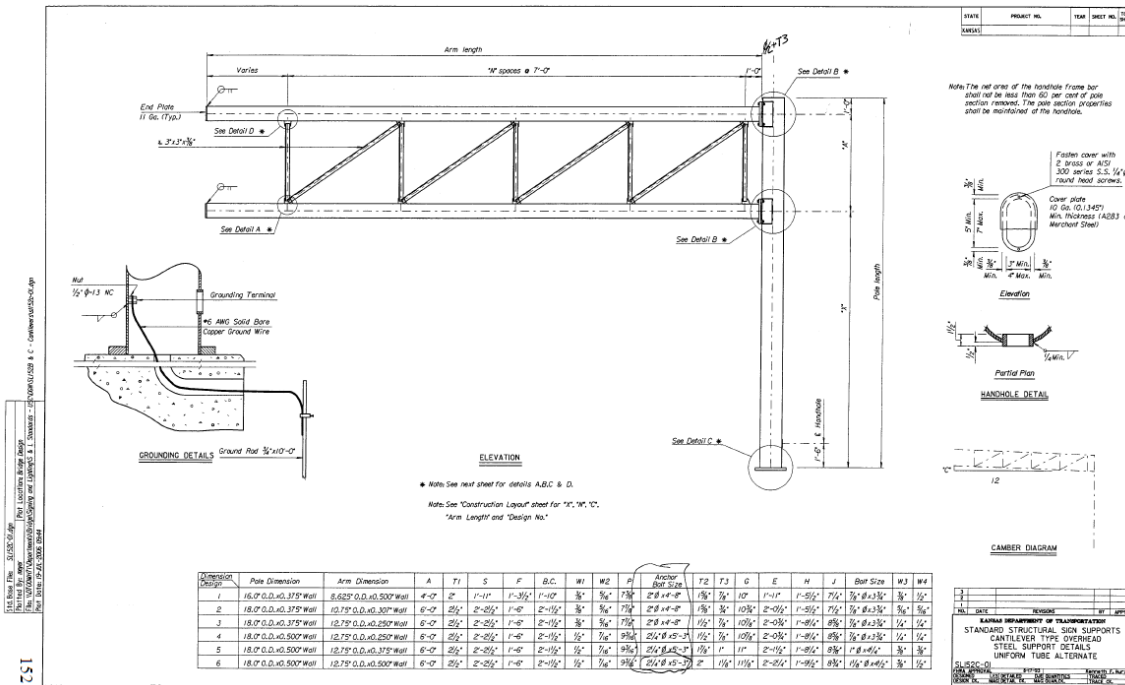

Figure B.2: KDOT standard detail for cantilevered structural sign supports

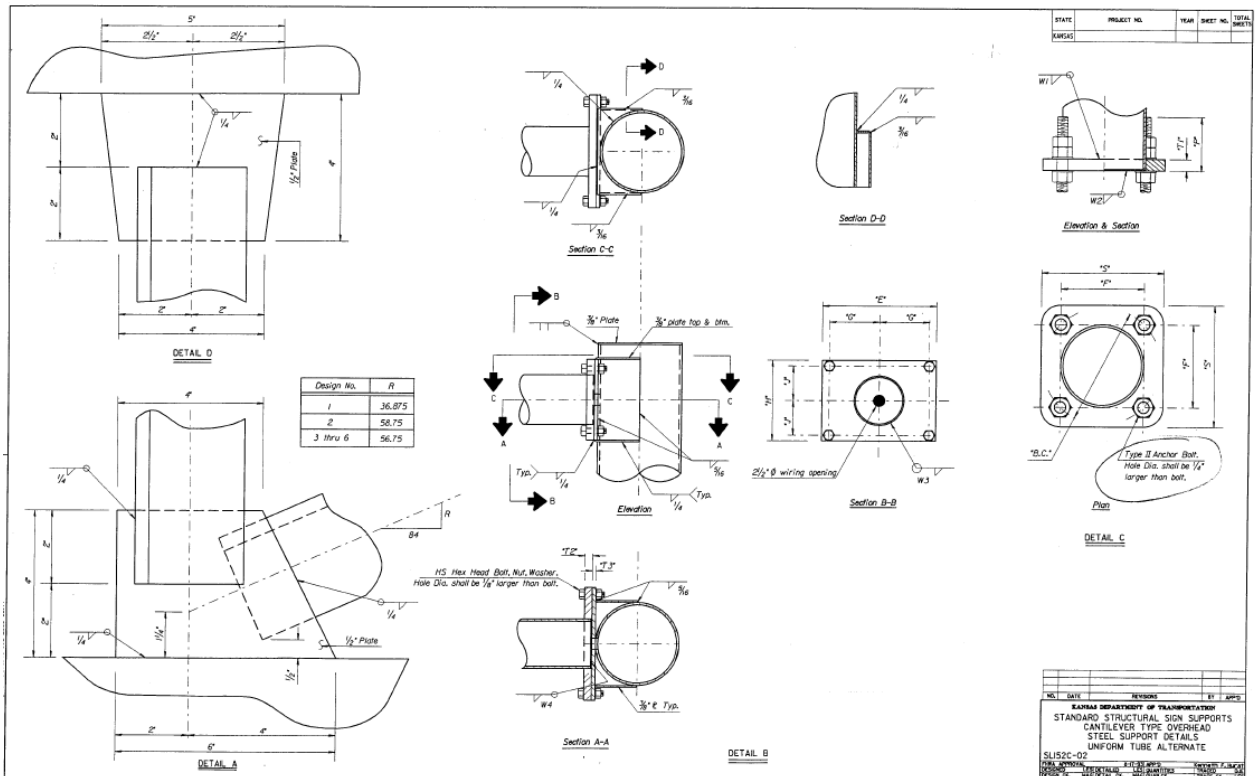

Figure B.3: KDOT standard detail for cantilevered structural sign supports

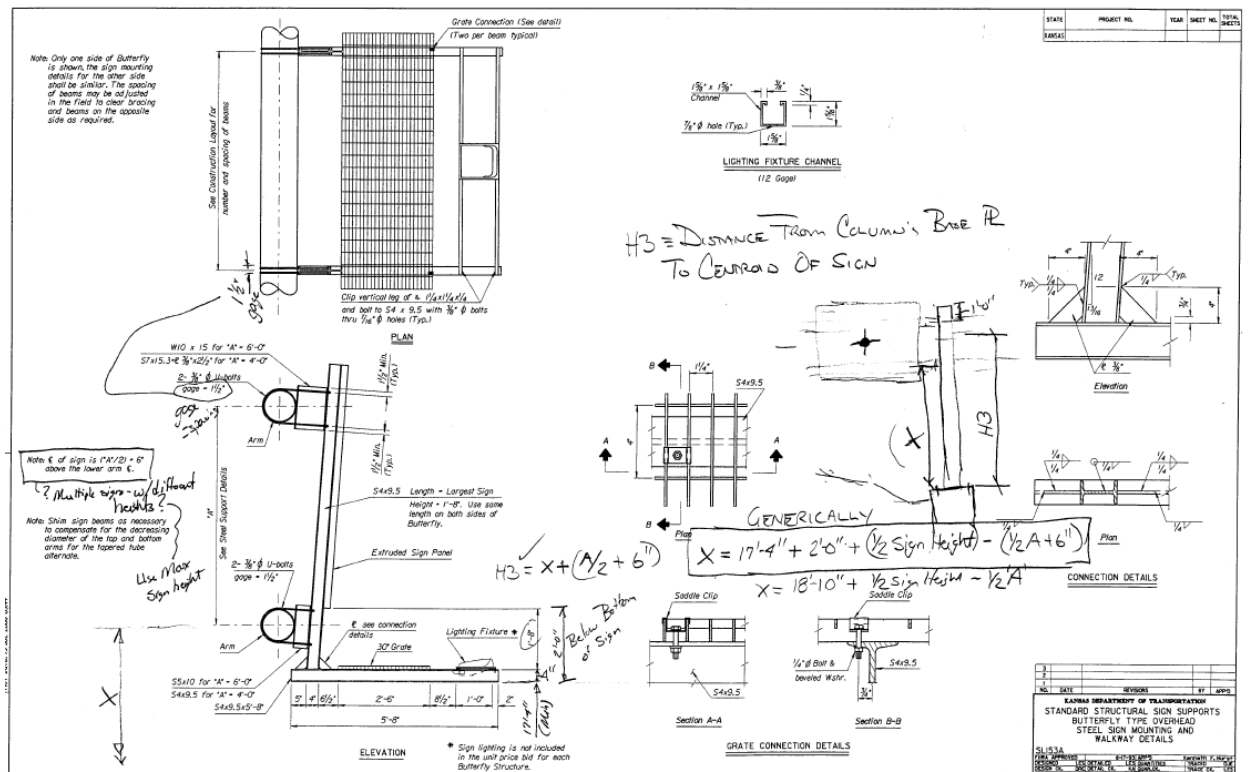

Figure B.4: KDOT standard detail for cantilevered structural sign supports

K-TRAN

KANSAS TRANSPORTATION RESEARCH AND NEW-DEVELOPMENT PROGRAM

