



U.S. Department
of Transportation

**National Highway
Traffic Safety
Administration**



DOT HS 813 096

June 2021

Development of a Representative Seat Assembly for FMVSS No. 213

DISCLAIMER

This publication is distributed by the U.S. Department of Transportation, National Highway Traffic Safety Administration, in the interest of information exchange. The opinions, findings, and conclusions expressed in this publication are those of the authors and not necessarily those of the Department of Transportation or the National Highway Traffic Safety Administration. The United States Government assumes no liability for its content or use thereof. If trade or manufacturers' names or products are mentioned, it is because they are considered essential to the object of the publication and should not be construed as an endorsement. The United States Government does not endorse products or manufacturers.

NOTE: This report is published in the interest of advancing motor vehicle safety research. While the report may provide results from research or tests using specifically identified motor vehicle or motor vehicle equipment models, it is not intended to make conclusions about the safety performance or safety compliance of those motor vehicles or equipment items, and no such conclusions should be drawn.

Suggested APA Format Reference:

Wietholter, K., Loudon, A., & Echemendia, C. (2021, June). *Development of a representative seat assembly for FMVSS No. 213*. (Report No. DOT HS 813 096). National Highway Traffic Safety Administration.

TECHNICAL REPORT DOCUMENTATION PAGE

1. Report No. DOT HS 813 096	2. Government Accession No.	3. Recipient's Catalog No.	
4. Title and Subtitle Development of a Representative Seat Assembly for FMVSS No. 213		5. Report Date June 2021	
		6. Performing Organization Code NHTSA/NSR-130	
7. Authors Kedryn Wietholter; TRC Inc. Allison E. Loudon, Cristina Echemendia; National Highway Traffic Safety Administration		8. Performing Organization Report No.	
		9. Performing Organization Name and Address National Highway Traffic Safety Administration Vehicle Research and Test Center P.O. Box 37 East Liberty, OH 43319	
12. Sponsoring Agency Name and Address National Highway Traffic Safety Administration 1200 New Jersey Avenue SE Washington, D.C. 20590		10. Work Unit No. (TRAIS)	
		11. Contract or Grant No.	
15. Supplementary Notes		13. Type of Report and Period Covered Final Report	
		14. Sponsoring Agency Code NHTSA/NSR-130	
16. Abstract The Federal Motor Vehicle Safety Standard No. 213 sled test was originally based on the configuration and performance parameters of the 1974 Chevrolet Impala production front bench seat. This sled test was upgraded on June 24, 2003, by incorporating advanced child anthropomorphic test devices and associated injury criteria and by modifying some features of the standard seat assembly to make it more representative of rear seats of the vehicle fleet at that time. However, due to limited resources and other agency priorities, the upgrade of the standard seat assembly did not include all the recommended modifications. This report describes the upgrades to the standard seat assembly to be more representative of a current vehicle rear seat environment. The upgrades to the standard seat assembly included seat geometry, seat cushion characteristics, and anchorages locations. In addition, the report details the child restraint system fleet sled testing used to evaluate the upgraded seat assembly, which provided repeatable results in three test configurations. This report is the same as the report with the same title found in Docket NHTSA-2020-0093-0005 dated September 2016, except for minor editorial updates.			
17. Key Words FMVSS 213, sled test, child restraint system		18. Distribution Statement Document is available to the public from the National Technical Information Service, www.ntis.gov .	
19. Security Classif. (of this report) Unclassified	20. Security Classif. (of this page) Unclassified	21. No. of Pages 44	22. Price

Form DOT F 1700.7 (8-72)

Reproduction of completed page authorized

Table of Contents

Executive Summary	1
1. Introduction	3
2. Standard Seat Assembly Upgrade	5
2.1. Seat Geometry	5
2.1.1. Seat Angles	6
2.1.2. Seat Back Height and Seat Pan Length	6
2.1.3. Seat Belt Anchorages	7
2.1.4. Child Restraint Anchorage System	9
2.2. Seat Cushions	11
3. Sled Testing	13
3.1. Test Parameters	13
3.2. V1 Seat Assembly Sled Testing	14
3.2.1. Design Issues	15
3.3. V2 Seat Assembly Sled Testing	17
3.3.1. Design Resolution	18
3.3.2. Injury Response	20
3.3.3. Repeatability Assessment	20
4. Summary	23
Appendix A	A-1
Appendix B	B-1
Appendix C	C-1
Appendix D	D-1

List of Tables

Table 1: Standard Seat Assembly Geometry	7
Table 2: Belt Anchorage Measurements	8
Table 3: Child Restraint Anchorage System Measurements.....	10
Table 4: Upgraded Foam Specifications	11
Table 5: Instrumentation Used in CRABI 12 MO	13
Table 6: Instrumentation Used in HIII 3YO	13
Table 7: Instrumentation Used in HIII 6YO	14
Table 8: Instrumentation Used in HIII 10YO	14
Table 9: Belt Tensioning Targets.....	18
Table 10: RF Infant Repeatability.....	21
Table 11: FF Convertible Repeatability	21
Table 12: BPB Repeatability	22
Table A-1: Durability Evaluation on V1 Bench	A-1
Table A-2: Fleet Testing on V2 Bench	A-4
Table B-1: V2 Fleet Injury Data	B-1

List of Figures

Figure 1: FMVSS No. 213 Standard Seat Assembly-Current Test Buck	3
Figure 2: SGMF Sketch (left), SGMF Positioned in a Vehicle Rear Seat (right).....	5
Figure 3: V2 Anchorage Hardware.....	8
Figure 4: Version 2 Seat Assembly Depicting the FMVSS No. 210 Corridor	9
Figure 5: Seat Cushion Assembly.....	12
Figure 6: V1 Seat Assembly	15
Figure 7: Original Anchorage Shape (above), Deformed Anchorage (below).....	15
Figure 8: HIII 6YO Rollout	16
Figure 9: Seat Back Height With Low Back Booster	17
Figure 10: V2 Seat Assembly	17
Figure 11: V1 Anchorage Bracket (above), V2 Anchorage Bracket (below).....	18
Figure 12: V1 Shoulder Belt Location (left), V2 Shoulder Belt Location (right).....	19
Figure 13: Seat Cushion Assembly With Increased Height.....	19
Figure C-1: Generic Routing Hardware Design	C-1
Figure C-2: Outboard Lap Belt Anchorage Design	C-2

Executive Summary

Manufacturers of child restraint systems sold in the United States must certify that the systems meet performance requirements specified in the Federal Motor Vehicle Safety Standards (FMVSS) No. 213, “Child restraint systems.” FMVSS No. 213 includes a sled test simulating a 48 km/h (30 mph) frontal impact using a test bench based on a 1974 Chevrolet Impala bench seat.¹ This sled test was upgraded on June 24, 2003,² by incorporating advanced child anthropomorphic test devices and associated injury criteria and by modifying some features of the standard seat assembly to make it more representative of rear seats of 2001 model year vehicles. However, due to limited resources and other agency priorities, the upgrade of the standard seat assembly did not include all of the recommended modifications.

The “Moving Ahead for Progress in the 21st Century Act” (MAP-21) directed the National Highway Traffic Safety Administration to initiate a rulemaking to amend the standard seat assembly specifications under FMVSS No. 213 to better simulate a single representative motor vehicle rear seat. Specifically, research was conducted to develop a new standard seat assembly that better represents the current vehicle fleet, including stiffer seat cushions, a more representative seat geometry and updated lap/shoulder belt and child restraint anchorages.

This report describes the upgrades to the standard seat assembly to be more representative of a current vehicle rear seat environment. To compile data on the representative rear seat environment, Alpha Technology Associate, Inc., surveyed vehicles in the fleet. Alpha’s 2012 Vehicle Rear Seat Study³ took measurements of 43 individual rear seating positions in 24 model year 2010 vehicles, including but not limited to: seat back angle, seat back height, seat pan and seat back cushion thickness, seat pan width, and location of seat belt and child restraint anchorages. The vehicle survey was used to guide the design towards a seat assembly that better represents the current vehicle fleet.

The development of the upgraded seat assembly occurred in two parts. An initial design concept, referred to as Version 1, was evaluated with sled testing which identified additional modifications needed to the bench and anchorage locations. The Version 1 design drawing package of the standard seat assembly was released in the NHTSA docket in 2015.⁴ Additional updates to the anchorage locations were released in a schematic to the docket after modifications were completed. The revised design, Version 2, resulted after modifications and additional CRS fleet testing.

Sled testing was used to evaluate the Version 2 seat assembly per the FMVSS No. 213 specifications. To assess CRS performance, testing included the use of Child Restraint/Air Bag Interaction (CRABI) 12-month-old, Hybrid III 3-year-old, Hybrid III 6-year-old, and Hybrid III 10-year-old anthropomorphic test devices. Testing was performed with the Hybrid III 3-year-old in rear-facing configurations with knee joint stops removed to allow hyperextension of the leg at the knee for a more realistic seating position.⁵

¹ 49 CFR 571 213

² 68 FR 37620

³ Aram, M. L., & Rockwell, T. (2012, July). *Vehicle rear seat study*. Docket No. NHTSA-2014-0012, Item No. 0005.

⁴ Child Frontal Impact Sled-Feb 2015, *Drawing Package* (2015, March). Docket No. NHTSA-2013-0055.

⁵ Manary, M., Klinich, K., Orton, N. (2015, March). *Assessment of ATD selection and use for dynamic testing of rear facing restraint systems designed for larger toddlers*” (Report No. UMTRI-2014-12). University of Michigan Transportation Research Institute.

Also published as Manary, M. A., Klinich, K. D., & Orton, N. R. (2018, March). *Assessment of ATD selection and use for testing of rear-facing child restraint systems for larger infants and toddlers* (Report No. DOT HS 812 469). National Highway Traffic Safety Administration. Available at www.nhtsa.gov/sites/nhtsa.dot.gov/files/documents/812469_assess-atd-selection-and-use-testing-rear-facing-child-restraint-systems-larger-infants-and-toddlers.pdf

The sled testing analysis examined ATD injury measures, ATD and child restraint kinematics, and bench durability. An initial repeatability assessment of injury and other performance measures for the CRABI 12-month-old in an infant seat as well as the Hybrid III 6-year-old in a forward-facing convertible child restraint and belt-positioning booster during sled testing was acceptable, as the injury measures or maximums from the tests of all three configurations had less than a 10 percent coefficient of variation.

1. Introduction

The Federal Motor Vehicle Safety Standard (FMVSS) No. 213, Child restraint systems, specifies performance requirements for child restraint systems (CRSs). The performance of a child restraint system is evaluated in dynamic frontal sled tests involving a 30 mph velocity change, which is representative of a severe crash. The FMVSS No. 213 sled test was originally based on the configuration and performance parameters of the 1974 Chevrolet Impala production front bench seat.

This sled test was upgraded on June 24, 2003,⁶ by incorporating advanced child anthropomorphic test devices (ATDs) and associated injury criteria and by modifying some features of the standard seat assembly to make it more representative of rear seats of the vehicle fleet at that time. The changes to the standard seat were based on results of a test program at the U.S. Naval Air Warfare Center Aircraft Division at Naval Air Station Patuxent River, Maryland (NAS Pax River) initiated by NHTSA to assess seat parameters of production seats.⁷ NAS Pax River analyzed the seat geometries of 35 vehicles representing a range of vehicle classes and identified some features of the standard seat assembly that did not reflect vehicle designs at the time.

The 2003 final rule⁸ adopted changes to the seat assembly in the features that presented notable differences between the existing seat assembly and the vehicle fleet including the seat bottom cushion angle, seat back cushion angle, spacing between the anchorages of the lap belts and the seat back rigidity of the seat assembly. An example of the standard seat assembly resulting from the 2003 final rule is shown in Figure 1 and is currently being used in FMVSS No. 213 compliance testing.

Due to limited resources and other agency priorities, the upgrade of the standard seat assembly did not include all of the recommended modifications to the seat assembly including the seat cushion, which was found to be soft and too thick in comparison to seat cushion of rear seats in the vehicle fleet.



Figure 1: FMVSS No. 213 Standard Seat Assembly-Current Test Buck

⁶ 68 FR 37620

⁷ Glass, W. (2002, April). *Technical report on the FMVSS 213 crash pulse and test bench analysis*, Docket No. NHTSA-2002-11707-009.

⁸ The 2003 final rule also updated the sled pulse to provide a wider test corridor; incorporated improved child test ATDs; and expanded the applicability to child restraint systems recommended for use by children weighing up to 65 lb. The 2003 final rule also fulfilled the mandate in the Transportation Recall Enhancement, Accountability and Documentation Act (the TREAD Act).

The MAP-21 Act directed NHTSA to initiate a rulemaking to amend the standard seat assembly specifications under FMVSS No. 213 to better simulate a single representative motor vehicle rear seat. Specifically, research was conducted to develop a new standard seat assembly that better represents the current vehicle fleet, including stiffer seat cushions, a more representative seat geometry and updated lap/shoulder belts and child restraint anchorages.

This report details the seat assembly upgrade to be more representative of a vehicle rear seat environment. Changes to the standard seat assembly included seat geometry, seat cushion characteristics, and anchorage locations. Sled testing was used to evaluate the upgraded seat assembly for durability and ATD injury response. Details of the development of a new, single-piece foam that represents recent model year vehicles can be found in *Evaluation of Seat Foams for the FMVSS No. 213 Test Bench*.⁹

⁹ Wietholter, K., Loudon, A., Sullivan, L., & Burton, R. (2016, June; revised 2021, June). *Evaluation of seat foams for the FMVSS No. 213 test bench* (Report No. DOT HS 813 099). In Docket No. NHTSA-2013-0055. National Highway Traffic Safety Administration.

2. Standard Seat Assembly Upgrade

To compile data on the representative rear seat environment, NHTSA contracted Alpha Technology Associate, Inc. (Alpha) to conduct a survey of current vehicles in the fleet. Alpha's 2012 Vehicle Rear Seat Study¹⁰ took measurements of 43 individual rear seating positions in 24 model year (MY) 2010 vehicles, including: seat back angle, seat back height, seat pan and seat back cushion thickness, seat pan width, and location of seat belt and child restraint anchorages. Alpha also measured the test benches that were used to evaluate CRSs including NHTSA's FMVSS No. 213 bench, as well as the bench from European tests by the Economic Commission for Europe, ECE R.44.

The vehicle survey was used to assess the current rear seat environment and to guide the design towards a seat assembly that better represents the current vehicle fleet. Seat assembly geometry and anchorage locations that were within one standard deviation of the average values were targeted. However, other factors were also considered. The agency assessed the side impact seat assembly (ECE R.44 foam specifications) that was proposed in the January 28, 2014, notice of proposed rulemaking (NPRM) as a starting point to create the proposed bench.¹¹ While selecting seat design parameters, NHTSA also took into consideration complexity of fabrication and variability in test results.

The development of the upgraded seat assembly occurred in two parts. An initial design concept, referred to as Version 1 (V1), was evaluated with sled testing which led to additional modifications. The V1 design of the standard seat assembly was released in drawing package form in 2015.¹² A revised design, Version 2 (V2), resulted after modifications.¹³ Details of the standard seat assembly differences can be found in the subsequent sections of Chapter 2. Discussion of the reasons the modifications were necessary can be found in Chapter 3 unless directly related to the targeted measurements described in Chapter 2.

2.1. Seat Geometry

Alpha's vehicle survey used a seat geometry measuring fixture (SGMF) to consistently measure the seat geometry and anchorage locations. The SGMF consisted of two wood blocks (600 mm x 88 mm x 38 mm) attached by a three-inch wide (76 mm) hinge. To take the rear seat geometry measurements, the SGMF was positioned on the centerline of each rear seat position. Point A in Figure 2, which corresponds to the hinge location of the SGMF, was the reference point for all measurements.

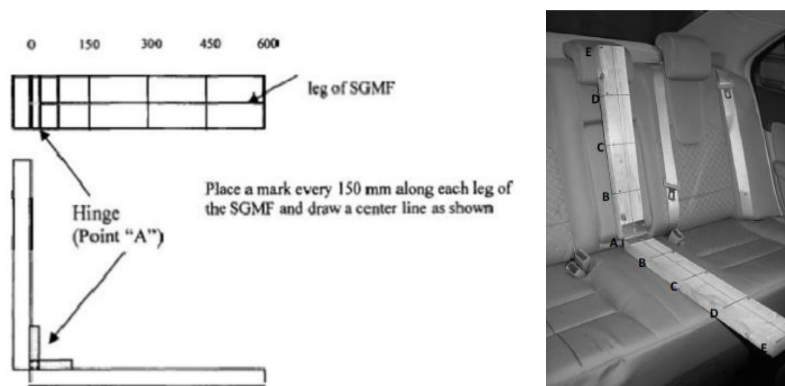

Figure 2: SGMF Sketch (left), SGMF Positioned in a Vehicle Rear Seat (right)

¹⁰ Aram & Rockwell, 2012.

¹¹ The January 28, 2014 (79 FR 4570) NPRM proposed incorporating a new side impact sled test into FMVSS No. 213.

¹² Child Frontal Impact Sled-Feb 2015, Drawing Package, March 2015. Docket No. NHTSA-2013-0055.

¹³ Child Frontal Impact Sled-V2, NHTSA Standard Seat Assembly; FMVSS No. 213, No. NHTSA-213-2016, Drawing Package, November 2016.

2.1.1. Seat Angles

The vehicle survey conducted by Alpha¹⁴ showed that the average seat back angle of the surveyed vehicles was 20 degrees from the vertical with a standard deviation of 4 degrees. The current seat back angle of the FMVSS No. 213 seat assembly is 20 degrees.

For the seat pan angle, the survey showed that the average angle was 13 degrees with a standard deviation of 4 degrees from the horizontal. The current seat pan angle of the FMVSS No. 213 seat assembly is 15 degrees.

The seat back angle of 20 degrees and seat pan angle of 15 degrees were maintained on both V1 and V2 upgraded seat assemblies. Both measurements are representative of the seat back and seat pan angles found in the vehicle fleet. Also, they do not differ from the current FMVSS No. 213 test seat assembly and those of the standard seat assembly for the side impact sled test proposed in the January 28, 2014, NPRM. Table 1 shows a comparison of the seat back and seat pan angles found in the vehicle fleet, V1, V2, and current angles of the test seat assembly.

2.1.2. Seat Back Height and Seat Pan Length

Alpha's vehicle survey showed that the average seat pan length of the surveyed vehicles was 16 inches (406 mm) with a standard deviation of 1.5 inches (38 mm). The current FMVSS No. 213 test seat assembly specifies a seat pan length of 16.3 inches (416 mm).

The survey also showed that the average height of the seat back was 27 inches (688 mm) with a standard deviation of three inches (76 mm) when the head restraint was included and 22.7 inches (578 mm) with a standard deviation of 2.3 inches (60 mm) when the head restraint was not included in the measurement. The current FMVSS No. 213 seat assembly specifies a seat back height of 20.4 inches (517 mm), and it does not have a head restraint.

The V1 and V2 seat assemblies had a seat pan length of 15.7 inches (412 mm) which is within one standard deviation of the average seat pan length in the current vehicle fleet. The V1 seat assembly had a seat back height of 19.8 inches (504 mm) which was not within one standard deviation of the average seat back height. The low seat back height was a result of the proposed side impact seat assembly which is for use with only the smaller 12-month-old and 3-year-old ATDs. Thus, the V2 seat assembly was updated to have a seat back height of 22.5 inches (573 mm), which is within one standard deviation of the average seat back height without a head restraint.

¹⁴ Aram & Rockwell, 2012.

Table 1: Standard Seat Assembly Geometry

		Average	Standard Deviation	Current FMVSS No. 213	ECE R.44	Upgraded FMVSS No. 213 V1	Upgraded FMVSS No. 213 V2
Seat Back Angle [deg]		20	4	20	20	20	20
Seat Pan Angle [deg]		13	4	15	15	15	15
Seat Pan Length [mm]		406	38	416	438	412	412
Seat Back Height [mm]	With Head Restraint	688	76	-	-	-	-
	Without Head Restraint	578	60	517	432	504	573

2.1.3. Seat Belt Anchorages

Various factors were taken into consideration while determining the location of the lap belt and shoulder belt anchorages for the seat assembly. One consideration was the vehicle survey data. The second consideration was the anchorage location requirements in FMVSS No. 210, Seat belt assembly anchorages.¹⁵ The third consideration was the practicability in testing different types and sizes of CRSs and identifying the variability in test results due to interference of the seat belt anchorages with the seat structure.

The average positions along with the standard deviations of the lap and shoulder belt anchorages with respect to Point A of the SGMF measured in the 24 vehicles surveyed are presented in Table 2. Similar measurements of the seat belt anchorage locations from Point A of the SGMF on the current FMVSS No. 213 seat assembly, the V1 and V2 upgraded seat assemblies, and the ECE R.44 seat assembly are presented in Table 2. A negative fore/aft value indicates the anchorage is behind Point A on the SGMF while a negative vertical value indicates the anchorage is below it. Since an increasingly large percentage of vehicles on the nation’s roads have three-point belt systems at all designated seating positions, only a three-point belt configuration was tested on the either the V1 or V2 seat assemblies.

¹⁵ FMVSS No. 210 specifies a location corridor for the lap belt anchorages that is 30 to 75 degrees from the horizontal at the H-point.

Table 2: Belt Anchorage Measurements

		Average	Standard Deviation	Current FMVSS No. 213	ECE R.44	Upgraded FMVSS No. 213 V1	Upgraded FMVSS No. 213 V2
Shoulder Belt Location [mm]	Aft	350	118	350	216	322	393
	Lateral	247	57	385*	302	305	244
	Vertical	581	72	690	500	582	634
Lap Belt Location [mm]	Fore/Aft	-57	61	-	-	-29	-77
	Lateral	211	54	-	-	225	225
	Vertical	-44	82	-	-	-62	-89
Distance Between Lap Belt Anchorages [mm]	Outboard	450	36	427	-	454	449
	Center	356	60	400	-	-	-

*Note: The shoulder belt lateral measurement on the current FMVSS No. 213 standard seat assembly reported in the Vehicle Rear Seat Study¹⁶ is incorrect, it should be 247 mm.

Both the V1 and V2 seat assemblies utilized seven panel seat belt webbing from Seat Belts Plus. The locking, knurled bar anchorage hardware and d-ring were from a deconstructed seat belt system (WSCH201P) from Seat Belts Plus. The V1 anchorage system utilized routing hardware from a deconstructed seat belt system (CH201-BP-bench) from Wesco Performance for the inboard lap belt anchorage. For the V2 seat assembly, generic routing hardware was designed to prevent unnecessary expense. A photo of the anchorage hardware selected for use in the V2 assembly can be found below as Figure 3. Detailed drawings of the generic routing hardware and outboard lap belt anchorage can be found in Appendix C as Figures C1 and C2, respectively.



Figure 3: V2 Anchorage Hardware

The shoulder belt anchorage on the V1 seat assembly was located more rearward and higher than the average location (1 mm out of one standard deviation) from the vehicle survey. For the V2 assembly, it was re-positioned to avoid interaction of the shoulder belt with the seat back cushion and interaction of

¹⁶ Aram & Rockwell, 2012.

large high back boosters with the shoulder belt anchorage hardware during the sled test. The location of the lap belt anchorages on the V2 seat assembly were selected to be more rearward and lower than the average location from the vehicle survey. This was to avoid interaction of the belt and belt hardware with the seat cushion, which could introduce variability in the test results. However, as shown in Table 2, the fore/aft, lateral, and vertical positions of the lap and shoulder belt anchorages relative to Point A for the V2 seat assembly are within one standard deviation of the average values found in the vehicle survey. Additionally, the distance between lap belt anchorages are approximately equal to the average spacing between the anchorages measured in the 24 vehicle survey.

The location of the lap belt anchorages on the V2 seat assembly was also evaluated against the FMVSS No. 210 specified corridor for lap belt anchorage location. Figure 4 shows the side view of the V2 seat assembly, the location of the lap belt anchorages, and the FMVSS No. 210 corridor. This figure shows that the lap belt anchorage locations in the V2 seat assembly are within the FMVSS No. 210 corridor.

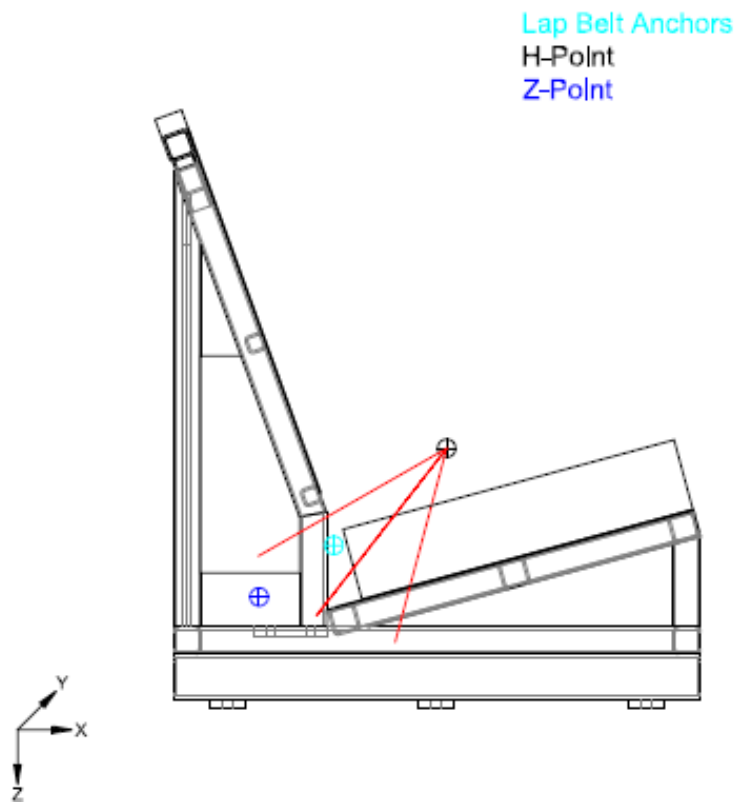

Figure 4: Version 2 Seat Assembly Depicting the FMVSS No. 210 Corridor

2.1.4. Child Restraint Anchorage System

FMVSS No. 225, Child restraint anchorage systems, requires lower anchorages to be 11 inches (280 mm) apart and have specific anchorage geometry. Table 3 shows the location of the lower anchorages and the tether anchorage from Point A of the SGMF in the 24-vehicle survey and the V1 and V2 seat assemblies. A negative vertical value indicates the anchorage is below Point A on the SGMF. The lower anchorages of the V2 seat assembly have an 11-inch (280 mm) lateral spacing as specified in FMVSS No. 225, and the lower anchorage metal bar is 1.45 inches (37 mm) long.

Table 3: Child Restraint Anchorage System Measurements

		Average	Standard Deviation	Upgraded FMVSS No. 213 V1	Upgraded FMVSS No. 213 V2
Lower Anchorages [mm]	Aft	100	21	34	58
	Lateral	137	29	140	140
	Vertical	-12	24	-29	-38
Tether Anchorage (Seat Back Position) [mm]	Aft	280	88	318	330
	Lateral	0	44	0	0
	Vertical	140	281	105	133

The location of the lower anchorages selected for the V2 seat assembly is lower than the average location and one standard deviation in the vehicle survey, by 2 millimeters, as anchorages positioned higher may cause interferences with the seat back cushion, and some CRSs with rigid LATCH may adopt an incorrect installation angle. A lower anchorage location more forward than the average from the vehicle survey was selected to make it easier to install the CRSs on the seat assembly. This should also make it easier to measure the tension in the seat belt and lower anchorage attachments after installing the child restraint. While the proposed lower anchorage location in the aft direction is not within one standard deviation of the average in the current vehicle fleet, the aft location of lower anchorages for the V2 upgraded standard seat is likely to be representative of the average vehicle fleet that would comply with the proposed LATCH usability requirements.¹⁷

Although the tether anchorages can be located in a wide area specified by FMVSS No. 225, the vehicle survey showed that the tethers were mostly centered along the designated seating position (DSP) centerline. Also, tether anchorages are found in two main areas: the seat back at different heights and the package shelf. Based on sales volumes, the number of vehicles with tether anchorages at the package shelf is about the same as those with tether anchorages at the seat back. The tether anchorage location on the seat back, rather than on the package shelf position, was selected as the anchorage position for the seat assembly. It introduces more belt webbing from the tether strap which may result in slightly higher head excursions, making the test more challenging. The location of the tether anchorages in the V2 seat assembly is in the seat back area and is within one standard deviation of the average found in the fleet as shown in Table 3.

¹⁷ A notice of proposed rulemaking to improve the ease of use of child restraint anchorage systems was published on January 23, 2015, Docket No. NHTSA-2014-0123.

2.2. Seat Cushions

After evaluation of the Woodbridge seat cushions described in the technical report *Evaluation of Seat Foams for the FMVSS No. 213 Test Bench*, the cushion was selected for use on the V2 seat assembly.¹⁸ Testing showed that the four-inch (102 mm) thickness cushion foam had stiffness characteristics that are representative of an average vehicle in the fleet. The specifications are given in Table 4.¹⁹

Table 4: Upgraded Foam Specifications

Foam Characteristics	
Density	47 kg/m ³ (2.9 lb/ft ³)
IFD (25% deflection)	237 Newton (N) (53.3 lb)
IFD (50% deflection)	440 Newton (N) (99 lb)
IFD (65% deflection)	724 Newton (N) (162.7 lb)
CFD (50% compression)	6.6 kPa (137.8 lb/ft ²)

For the seat back cushion, a Woodbridge custom seat foam of a two-inch (50.8 mm) thickness was used. Alpha's vehicle survey showed a seat pan length of 16 inches (406 mm) (as discussed in Section 2.1.2) was an average length for the fleet. In order to fit the upgraded design of the bench, a two-inch cushion was used as the seat back.

The current FMVSS No. 213 test procedure indicates use of a seat cushion cover of "elastic-backed automotive vinyl, which is in contact with the child restraint, backed by a thin layer of nylon-impregnated vinyl."²⁰ No other specifications are given for the fabric, so many different products could be used by test labs and potentially effect the cushion response. The upgraded cushion assembly aims to eliminate this problem by including additional specifications other than material.

On the V1 seat assembly, the seat cushion foam was covered by the ECE R.44 cover material. The ECE R.44 cover material is a sun-shade cloth made of poly-acrylate fiber with a specific mass of 290 (g/m²) and a lengthwise and breadthwise breaking strength of 120 kgf and 80 kgf, respectively.

On the V2 seat assembly, a similar cover material was used, which was selected as it was easier to procure. This cover material was a Sunbrella (brand) acrylic awning product with a specific mass of 305 (g/m²), a lengthwise breaking strength of 129 kgf, and a breadthwise breaking strength of 82 kgf.

The cushion assembly procedure was based on ECE R.44 3.1.7, Covering the seat and seat back. The cover was folded over the foam and secured to the standard seat by a metal plate. Three-inch wide preservation tape (Dr. Shrink brand) was used to secure the cover to the plate. Figure 5 demonstrates the cushion assembly for the V2 seat pan cushion. The procedure for folding the fabric to create the cushion can be found in Appendix D.²¹

¹⁸ Wietholter et al., 2016.

¹⁹ Foam standard specifications are given as in test method B1 of ASTM D3574 that measures indentation force deflection (IFD).

²⁰ TP-213-10

²¹ Dimensions and other details regarding the cushion assembly can be found in Child Frontal Impact Sled-V2, NHTSA Standard Seat Assembly; FMVSS No. 213, No. NHTSA-213-2016, Drawing Package, November 2016.

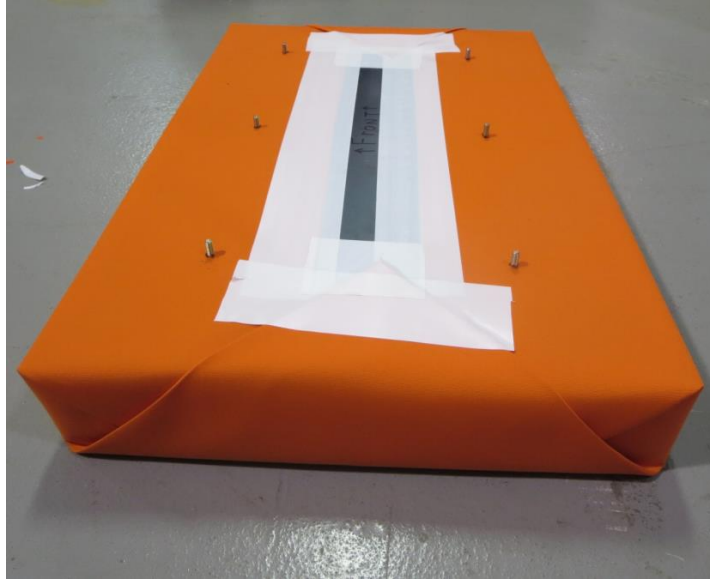

Figure 5: Seat Cushion Assembly

3. Sled Testing

3.1. Test Parameters

Sled testing to evaluate the upgraded standard seat assembly was conducted per the FMVSS No. 213 specifications of 48, +0, -3.2 km/h (30, +0, -2 mph). To assess CRS performance, testing included the use of CRABI 12-month-old (CRABI 12 MO), Hybrid III 3-year-old (HIII 3 YO), Hybrid III 6-year-old (HIII 6 YO), and Hybrid III 10-year-old (HIII 10 YO) ATDs.

The CRABI 12 MO was used in the rear-facing (RF) configuration with infant and convertible CRSs. The list of instrumentation used for the CRABI 12 MO ATD can be found in Table 5.

Table 5: Instrumentation Used in CRABI 12 MO

Location	Measurement	Instrument	Channels
Head	Head C.G. Acceleration	Accelerometers (tri-axial)	3
Neck	Upper Neck Forces & Moments	Channel Load Cell	6
	Lower Neck Forces & Moments	Channel Load Cell	6
Thorax	Chest Acceleration	Accelerometers (tri-axial)	3
Lumbar Spine	Forces & Moments	Channel Load Cell	6
Pelvis	Pelvis Acceleration	Accelerometers (tri-axial)	3
Total			27

The HIII 3YO was tested in both RF and forward-facing (FF) configurations with convertible and combination CRSs. Table 6 contains the list of instrumentation used for the HIII 3YO ATD.

Table 6: Instrumentation Used in HIII 3YO

Location	Measurement	Instrument	Channels
Head	Head C.G. Acceleration	Accelerometers (tri-axial)	3
Neck	Upper Neck Forces & Moments	Channel Load Cell	6
	Lower Neck Forces & Moments	Channel Load Cell	6
Thorax	Chest Acceleration	Accelerometers (tri-axial)	3
	Chest Displacement	Rotary Potentiometer	1
Lumbar Spine	Forces & Moments	Channel Load Cell	6
Pelvis	Pelvis Acceleration	Accelerometers (tri-axial)	3
Total			28

The HIII 6YO was used in the FF configuration with convertible CRSs and belt positioning boosters (BPBs). The instrumentation used to evaluate the HIII 6YO can be found in Table 7.

Table 7: Instrumentation Used in HIII 6YO

Location	Measurement	Instrument	Channels
Head	Head C.G. Acceleration	Accelerometers (tri-axial)	3
Neck	Upper Neck Forces & Moments	Channel Load Cell	6
	Lower Neck Forces & Moments	Channel Load Cell	6
Thorax	Chest Acceleration	Accelerometers (tri-axial)	3
	Chest Displacement	Rotary Potentiometer	1
Lumbar Spine	Forces & Moments	Channel Load Cell	6
Pelvis	Pelvis Acceleration	Accelerometers (tri-axial)	3
Lower Extremities	Left Femur Force	Channel Load Cell	1
	Right Femur Force	Channel Load Cell	1
Total			30

Finally, the HIII 10YO was used in the FF configuration with convertible and combination CRSs as well as BPs. Table 8 lists the instrumentation used in the HIII 10YO ATD.

Table 8: Instrumentation Used in HIII 10YO

Location	Measurement	Instrument	Channels
Head	Head C.G. Acceleration	Accelerometers (tri-axial)	3
Neck	Upper Neck Forces & Moments	Channel Load Cell	6
	Lower Neck Forces & Moments	Channel Load Cell	6
Thorax	Chest Acceleration	Accelerometers (tri-axial)	3
	Chest Displacement	Rotary Potentiometer	1
Pelvis	Pelvis Acceleration	Accelerometers (tri-axial)	3
Lumbar Spine	Forces & Moments	Channel Load Cell	6
Lower Extremities	Left Femur Force	Channel Load Cell	1
	Right Femur Force	Channel Load Cell	1
Total			30

All of the above data was collected. However, analysis was only performed for injury criteria given in the FMVSS No. 213 procedure: head injury criteria (HIC36), 3ms chest acceleration, and occupant excursions. The exception being the computation of HIC for the HIII 10YO; according to FMVSS No. 213, HIC is not a criterion for the HIII 10YO, yet this data was analyzed for consistency.

3.2. V1 Seat Assembly Sled Testing

An initial series of dynamic sled tests (FRUPG1_01-54) were performed at TRC Inc. on an HYGE acceleration sled to evaluate the V1 seat assembly upgrade. Details of the sled testing can be found in Appendix A, Table A1. The testing was conducted to determine the durability of the bench and the effect on ATD response. Figure 6 illustrates the V1 seat assembly.



Figure 6: VI Seat Assembly

A series of tests using the CRABI 12 MO, HIII 3YO, HIII 6YO, and HIII 10YO ATDs in CRSs with restraint types of lower anchorages only, lower anchorages and top tether anchorage, 3-point belt with and without top tether, and 2-point lap belt with and without top tether were performed.

This included 14 tests with the CRABI 12 MO in 11 RF infant seats and 3 RF convertible seats. The HIII 3YO was tested in 13 tests with 4 in RF convertible seats and 9 in FF convertible seats. Twenty-one tests with the HIII 6YO were performed with 15 in FF convertible CRSs and 6 in BPBs. The HIII 10YO was used in 5 tests with one in a FF combination seat and 4 in BPBs.

3.2.1. Design Issues

Throughout the test series many issues were noticed, primarily with the anchorages. During the first sled test, the child restraint lower anchorage bar deformed as seen in Figure 7.

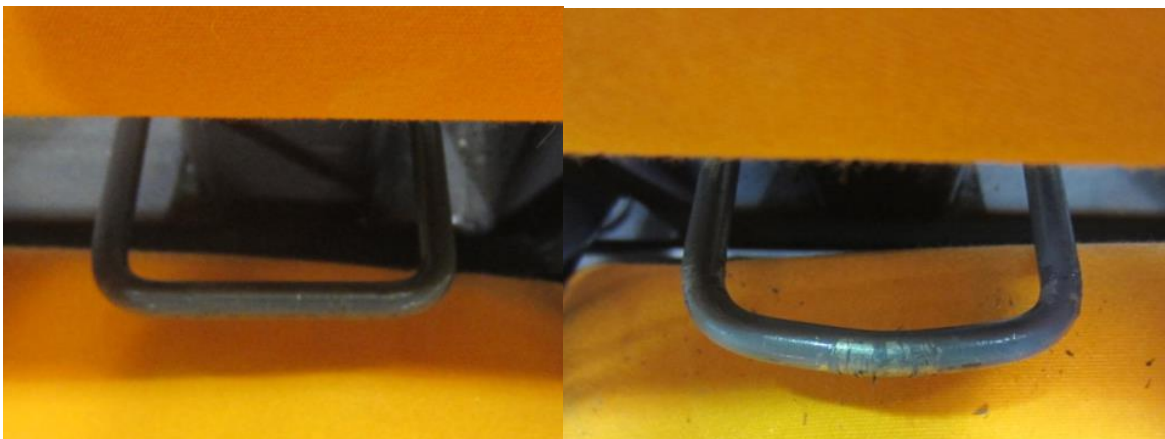

Figure 7: Original Anchorage Shape (above), Deformed Anchorage (below)

Due to the difficulty in replacing the lower anchorages and in assessing the durability, the lower anchorages continued to be used and no additional deformation was observed. The design of the lower anchorage was re-evaluated for durability and ease of replacement after this series. A new anchorage assembly was fabricated to be used in the V2 seat assembly.

It was noted in Chapter 2 that the outboard shoulder belt anchor was placed in a more outboard location. During testing, it could be seen that the ATDs experienced rollout due to the outboard shoulder belt location. Depicted in Figure 8, the HIII 6YO can be seen twisting as well as the shoulder belt coming off of the shoulder. The location of the shoulder belt was updated during modifications to the V2 seat assembly to be representative of the vehicle fleet measurements.



Figure 8: HIII 6YO Rollout

It was also noted that compared to the vehicle fleet measurements, the seat back height of the V1 seat assembly was not within one standard deviation of the average fleet seat back height. The seat back height of the V1 seat assembly also introduced complications when testing low back boosters. As seen in Figure 9, the dummy's head was exposed to the metal seat back at the top of the seat. Data often showed a significant spike in head acceleration after the event due to contact with the seat back. Due to the potential for damage to the ATD, the seat back height, including the foam, was increased in the V2 design.



Figure 9: Seat Back Height With Low Back Booster

3.3. V2 Seat Assembly Sled Testing

A fleet series of dynamic sled tests (FRUPG2_55-94) were performed at TRC Inc. to evaluate the V2 seat assembly. Details of the fleet sled testing can be found in Appendix A, Table A2. The testing was conducted to validate the design changes and evaluate injury response. Figure 10 illustrates the V2 seat assembly.



Figure 10: V2 Seat Assembly

A series of tests using the CRABI 12 MO, HIII 3YO, HIII 6YO, and HIII 10YO ATDs in child seats with configurations of lower anchorages only, lower anchorages and top tether anchorage, and 3-point belt with and without top tether were completed. The ATDs were instrumented as detailed in Tables 6-9. For rear-facing tests with the HIII 3YO, knee joint stops were removed to allow hyperextension of the leg at the knee for a more realistic seating position.²²

The series included 8 tests with the CRABI 12 MO in seven RF infant seats and one RF convertible seat. The HIII 3YO was tested in 7 tests with 4 in RF convertible seats and 3 in FF convertible seats. Eighteen tests with the HIII 6YO were performed with 10 in FF convertibles CRSs and 8 in BPBs. And the HIII 10YO was used in 7 tests with 3 in FF convertible seat, 1 in FF combination seats, and 3 in BPBs.

For all of the configurations tested, the belts were tensioned as given in Table 9 using a three-prong belt tensioning gauge (Borrourghs BT3329S). Occasionally, the lower anchorages were unable to be accessed or accurately measured using the device, so CRS movement of less than one inch was targeted instead. The CRSs were measured with a digital measuring device (FARO arm) to align the ATD and CRS laterally on the seat assembly and to set them similarly on the seat, in the case of repeat tests.

Table 9: Belt Tensioning Targets

Belt Type	Tension (N)
Harness	8.9-13.3
Lower Anchorages	53.4-66.7
Tether Anchorage	44.5-53.4
Belts for CRSs	53.4-66.7
Belts for BPBs	8.9-13.3

3.3.1. **Design Resolution**

The V2 seat assembly incorporated design changes that aimed to resolve the issues seen in the testing with the V1 seat assembly. The anchorage bracket design was updated to be stronger and have a replaceable lower anchorage bar, in case deformation occurs, as seen in Figure 11.



Figure 11: V1 Anchorage Bracket (above), V2 Anchorage Bracket (below)

²² Manary et al., 2015.

The shoulder belt location was updated to be within the Vehicle Rear Seat Study ranges and to properly restrain the ATD. The HIII 6YO in a low back booster, similar to that previously used, was evaluated to verify the occupant seating. Figure 12 shows the difference in location of the shoulder belt between V1 and V2 designs.

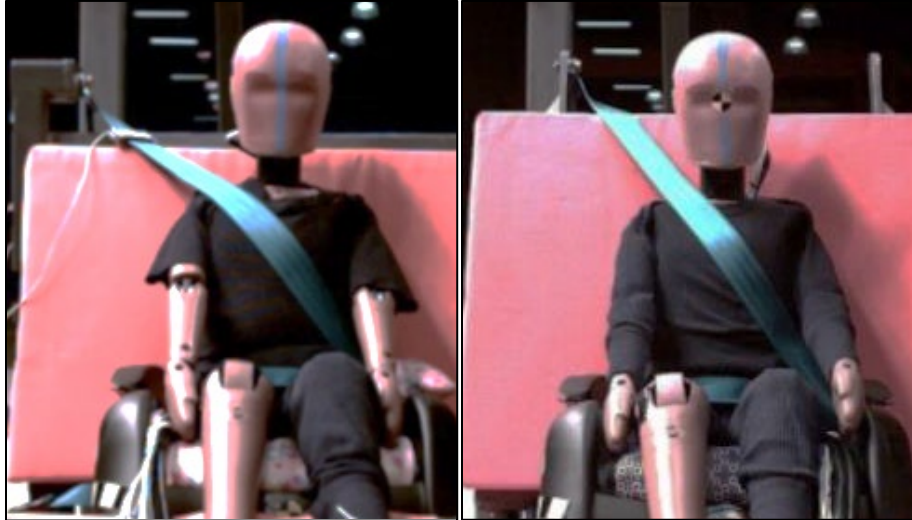

Figure 12: V1 Shoulder Belt Location (left), V2 Shoulder Belt Location (right)

Finally, the seat back frame was increased by 0.87 inch (22 mm) vertically, which allowed the seat back foam height to be increased 2.5 inches (64 mm) from that used on the V1 seat assembly. Since the seat back foam dimensions are limited by the foam manufacturer, this could not be done with a single piece of foam. So, a 2.5-inch section of foam was cut and adhered to the top portion of the V1 seat back foam to achieve the increased height. An example of the seat cushion assembly with the additional height is shown in Figure 13.



Figure 13: Seat Cushion Assembly With Increased Height

These design changes attempted to resolve the issues noted during the testing on the V1 seat assembly. Thus, only the ATD injury responses from the tests using the V2 seat assembly are discussed here.

3.3.2. *Injury Response*

The FMVSS No. 213 injury criteria of HIC36 (1000), 3ms chest acceleration (60 g), maximum seat back angle from vertical for rear-facing orientations (70 degrees), head excursion (720 mm with top tether, 813 mm without top tether), and knee excursions (915 mm) for forward-facing orientations were analyzed and compared to the injury assessment reference values (IARVs) and limits given in parentheses. Excursion values were measured using 2D image analysis software. Results were categorized as exceeded (100 percent or more of the IARV/limit, elevated (less than 100 percent but greater than or equal to 80 percent of the IARV/limit), and less than 80 percent of the IARV/limit.

Results of the fleet testing were as follows.

- 1/40 exceeded the IARV for HIC36
- 1/40 had an elevated HIC36
- 11/40 had an elevated chest acceleration

The two tests that were greater than 80 percent of the HIC36 limit were test numbers FRUPG2_59 and FRUPG2_94 with the HIII 10YO in a FF combination CRS.²³ The 11 tests that reached 80 percent of the chest acceleration IARV were comprised of 3 RF infant seats, 2 RF convertible seats, and 6 BPBs.

Rear-facing CRSs

- 6/12 had an elevated seat back angle

Forward-facing CRSs

- 2/28 exceeded the maximum for head excursion
- 13/28 had elevated head excursions
- 10/28 had elevated knee excursions

All the CRSs that reached 80 percent of the limit for head excursion were FF convertibles.²⁴ Of the 10 tests that reached 80 percent of the limit for knee excursion, 7 were FF convertibles, 2 were FF combination CRSs, and 1 was a BPB.

All the injury responses and maximums can be found in Table B1, Appendix B. Values that exceed the IARV/limit are highlighted in red, elevated values are highlighted in orange, and values that are less than 80 percent are in green. For HIC36 values that are marked with an asterisk, the accelerometer data had to be truncated due to a data spike caused by the head striking the seat back. The truncation only removed rebound, starting at approximately 175 milliseconds.

3.3.3. *Repeatability Assessment*

Repeatability was analyzed on the V2 seat assembly utilizing three CRS configurations that were repeated three times within the series. The coefficient of variation (CV) was used to compare injury response within repeat tests. The percent CV is calculated by dividing the standard deviation by the average and multiplying the CV by 100. The target response for repeatability was a percent CV at or below 10 percent.

²³ It was noted that in both tests the chest clip released.

²⁴ Both tests that exceeded the maximum for head excursion were the same tests as the elevated HIC36 results where it was noted that the chest clip released.

The first set of repeats was with the 12 MO CRABI in a RF infant seat. HIC36, 3ms chest clip, and maximum seat back angle were analyzed and had percentage CVs of 3, 2, and 8 percent, respectively, as seen in Table 10.

Table 10: RF Infant Repeatability

VDB Test No.	VRTC Number	Test Number	Seat Name	Orientation	Installation Method	Dummy	HIC36	Chest Clip (g)	Max Seat Back Angle (°)
V09610	FRUPG2_73	S150731-1	Evenflo Nurture	RF Infant	LA Only	12 MTH CRABI	680	48	56
V09611	FRUPG2_75	S150909-1	Evenflo Nurture	RF Infant	LA Only	12 MTH CRABI	685	50	53
V09612	FRUPG2_77	S150910-1	Evenflo Nurture	RF Infant	LA Only	12 MTH CRABI	721	50	62
St. Dev.							22	1	5
Average							695	49	57
%CV							3	2	8

Repeatability with the HIII 6YO in a FF convertible was also analyzed. HIC36, chest clip, and head and knee excursions had percentage CVs of 4, 2, 2, and 1 percent, respectively, as given in Table 11.

Table 11: FF Convertible Repeatability

VDB Test No.	VRTC Number	Test Number	Seat Name	Orientation	Installation Method	Dummy	HIC36	Chest Clip (g)	Head Excursion (mm)	Knee Excursion (mm)
V09611	FRUPG2_76	S150909-1	Graco Nautilus	FF Convertible	SB3PT	Hybrid III 6YO	570	44	664	725
V09612	FRUPG2_78	S150910-1	Graco Nautilus	FF Convertible	SB3PT	Hybrid III 6YO	535	42	656	721
V09613	FRUPG2_80	S150911-1	Graco Nautilus	FF Convertible	SB3PT	Hybrid III 6YO	535	43	676	740
St. Dev.							21	1	10	10
Average							547	43	665	729
%CV							4	2	2	1

Repeatability with the HIII 6YO in a BPB was also analyzed. The HIC36, chest clip, and head and knee excursions were analyzed and found to be repeatable with percentage CVs of 9, 3, 3, and 1 percent, respectively, as shown in Table 12.

Table 12: BPB Repeatability

VDB Test No.	VRTC Number	Test Number	Seat Name	Orientation	Installation Method	Dummy	HIC36	Chest Clip (g)	Head Excursion (mm)	Knee Excursion (mm)
V09616	FRUPG2_86	S150917-1	Graco Affix NB	BPB	SB3PT	Hybrid III 6YO	479	55	466	589
V09617	FRUPG2_88	S150918-1	Graco Affix NB	BPB	SB3PT	Hybrid III 6YO	573	58	491	599
V09618	FRUPG2_90	S150921-1	Graco Affix NB	BPB	SB3PT	Hybrid III 6YO	535	58	495	598
St. Dev.							48	2	15	6
Average							529	57	484	595
%CV							9	3	3	1

Repeatability for the 12 MO CRABI in a RF infant seat as well as the HIII 6YO in FF Convertible and BPB during sled testing on the V2 seat assembly was deemed acceptable, as the injury measures or maximums from tests with the 3 configurations of CRS all had less than 10 percent CV.

4. Summary

The standard seat assembly for the FMVSS No. 213 sled test was upgraded to be more representative of a vehicle rear seat environment. The upgrades to the standard seat assembly included seat geometry, seat cushion characteristics, and anchorages locations. The FMVSS No. 213 sled test was originally based on the configuration and performance parameters of the 1974 Chevrolet Impala production front bench seat. This sled test was upgraded on June 24, 2003,²⁵ by incorporating advanced child ATDs and associated injury criteria and by modifying some features of the standard seat assembly to make it more representative of rear seats of the vehicle fleet at that time. However, due to limited resources and other agency priorities, the upgrade of the standard seat assembly did not include all of the recommended modifications. Hence, the upgraded V2 seat assembly resolves these concerns and was found to have acceptable repeatability after a limited repeatability assessment.

²⁵ 68 FR 37620

Appendix A

Table A-1: Durability Evaluation on VI Bench

VDB Test No.	Test Date	VRTC Test No.	Position	CRS Model	ATD Type	CRS Orientation And Restraints	Seat Foam #	Test Sled Pulse	Test Velocity (mph)
V08910	S140410-1	FRUPG1_01_02	Left	Chicco KeyFit with Base	CRABI 12MO	RF Infant LA Only	WB Foam 3	FMVSS No. 213 Pulse	30
			Right	Evenflo Titan Elite	HIII 6YO	FF Convertible LA Only	WB Foam 4		
V08911	S140411-1	FRUPG1_03_04	Left	Graco Snugride 22	CRABI 12MO	RF Infant LA Only	WB Foam 3	FMVSS No. 213 Pulse	30
			Not Tested						
V08912	S140411-2	FRUPG1_09_10	Left	Evenflo Discovery	CRABI 12MO	RF Infant LA Only	WB Foam 3	FMVSS No. 213 Pulse	30
			Right	Evenflo Titan Elite	HIII 6YO	FF Convertible LATCH	WB Foam 4		
V08913	S140414-1	FRUPG1_11_12	Left	Baby Trend Flex Loc	CRABI 12MO	RF Infant LA Only	WB Foam 3	FMVSS No. 213 Pulse	30
			Right	Alpha Omega Elite	HIII 6YO	FF Convertible LATCH	WB Foam 4		
V08914	S140414-2	FRUPG1_13_14	Left	Evenflo Tribute	CRABI 12MO	RF Convertible LA Only	WB Foam 3	FMVSS No. 213 Pulse	30
			Right	Graco My Ride 65	HIII 6YO	FF Convertible LATCH	WB Foam 4		
V08915	S140415-1	FRUPG1_05_06	Left	Cybex Aton (no leg)	CRABI 12MO	RF Infant LA Only	WB Foam 3	FMVSS No. 213 Pulse	30
			Right	Britax Marathon	HIII 6YO	FF Convertible 3pt seatbelt	WB Foam 4		
V08916	S140415-2	FRUPG1_07_08	Left	Britax B-Safe	CRABI 12MO	RF Infant LA Only	WB Foam 3	FMVSS No. 213 Pulse	30
			Right	Chicco Nextfit	HIII 6YO	FF Convertible 3pt seatbelt with tether	WB Foam 4		
V08917	S140416-1	FRUPG1_15_16	Left	Graco SnugRide 22	CRABI 12MO	RF Infant 3pt seatbelt	WB Foam 3	FMVSS No. 213 Pulse	30
			Right	Evenflo Titan Elite	HIII 6YO	FF Convertible 3pt seatbelt	WB Foam 4		
V08918	S140417-1	FRUPG1_17_18	Left	Safety 1 st Onboard 35	CRABI 12MO	RF Infant 3pt seatbelt	WB Foam 3		30

VDB Test No.	Test Date	VRTC Test No.	Position	CRS Model	ATD Type	CRS Orientation And Restraints	Seat Foam #	Test Sled Pulse	Test Velocity (mph)
			Right	Graco Nautilus	HIII 6YO	FF Convertible 3pt seatbelt	WB Foam 4	FMVSS No. 213 Pulse	
V08919	S140417-2	FRUPG1_19_20	Left	Evenflo Tribute	CRABI 12MO	RF Convertible 3pt seatbelt	WB Foam 3	FMVSS No. 213 Pulse	30
			Right	Britax Marathon	HIII 6YO	FF Convertible 3pt seatbelt with tether	WB Foam 4		
V08920	S140421-1	FRUPG1_21_22	Left	Evenflo Discovery w/o Base	CRABI 12MO	RF Infant 3pt seatbelt	WB Foam 3	FMVSS No. 213 Pulse	30
			Right	Recaro Performance Ride	HIII 6YO	FF Convertible 3pt seatbelt	WB Foam 4		
V08921	S140422-1	FRUPG1_23_24	Left	Evenflo Discovery	CRABI 12MO	RF Infant 3pt seatbelt	WB Foam 3	FMVSS No. 213 Pulse	30
			Right	Graco Nautilus	HIII 6YO	BPB 3pt seatbelt	WB Foam 4		
V08922	S140423-1	FRUPG1_25_26	Left	Graco Snug Ride 22	CRABI 12MO	RF Infant 2pt seatbelt	WB Foam 3	FMVSS No. 213 Pulse	30
			Right	Graco Turbo Booster	HIII 6YO	BPB 3pt seatbelt	WB Foam 4		
V08923	S140424-1	FRUPG1_27_28	Left	Evenflo Tribute	CRABI 12MO	RF Convertible 2pt seatbelt	WB Foam 3	FMVSS No. 213 Pulse	30
			Right	Evenflo Titan Elite	HIII 6YO	FF Convertible 3pt seatbelt with tether	WB Foam 4		
V08924	S140425-1	FRUPG1_29_30	Left	Evenflo Tribute	HIII 3YO	RF Convertible LA Only	WB Foam 3	FMVSS No. 213 Pulse	30
			Right	Cosco Highrise Booster NB	HIII 6YO	BPB 3pt seatbelt	WB Foam 4		
V08925	S140425-2	FRUPG1_31_32	Left	Britax Marathon	HIII 3YO	RF Convertible LA Only	WB Foam 3	FMVSS No. 213 Pulse	30
			Right	Evenflo Amp High Back	HIII 6YO	BPB 3pt seatbelt	WB Foam 4		
V08926	S140425-3	FRUPG1_33_34	Left	Evenflo Tribute	HIII 3YO	FF Convertible LA Only	WB Foam 3	FMVSS No. 213 Pulse	30
			Right	Harmony Youth NB	HIII 6YO	BPB 3pt seatbelt	WB Foam 4		
V08927	S140428-1	FRUPG1_35_36	Left	Alpha Omega Elite	HIII 3YO	FF Convertible LATCH	WB Foam 3		30

VDB Test No.	Test Date	VRTC Test No.	Position	CRS Model	ATD Type	CRS Orientation And Restraints	Seat Foam #	Test Sled Pulse	Test Velocity (mph)
			Right	Bubble Bum	HIII 6YO	BPB 3pt seatbelt	WB Foam 4	FMVSS No. 213 Pulse	
V08928	S140429-1	FRUPG1 _37_38	Left	Alpha Omega Elite	HIII 3YO	RF Convertible 3pt seatbelt	WB Foam 3	FMVSS No. 213 Pulse	30
			Right	Recaro Performance Ride	HIII 6YO	FF Convertible 3pt seatbelt with tether	WB Foam 4		
V08929	S140429-2	FRUPG1 _39_40	Left	Evenflo Tribute	HIII 3YO	FF Convertible 3pt seatbelt	WB Foam 3	FMVSS No. 213 Pulse	30
			Right	Graco Nautilus	HIII 6YO	FF Convertible 3pt seatbelt with tether	WB Foam 4		
V08930	S140430-1	FRUPG1 _41_42	Left	Alpha Omega Elite	HIII 3YO	FF Convertible 3pt seatbelt	WB Foam 3	FMVSS No. 213 Pulse	30
			Right	Alpha Omega Elite	HIII 6YO	FF Convertible 3pt seatbelt with tether	WB Foam 4		
V08931	S140430-2	FRUPG1 _43_44	Left	Graco MyRide65	HIII 3YO	RF Convertible 3pt seatbelt	WB Foam 3	FMVSS No. 213 Pulse	30
			Right	Graco Nautilus	HIII 6YO	FF Convertible 2pt seatbelt with tether	WB Foam 4		
V08932	S140501-1	FRUPG1 _45_46	Left	Cosco Scenera	HIII 3YO	FF Convertible 3pt seatbelt with tether	WB Foam 2	FMVSS No. 213 Pulse	30
			Right	Britax Frontier 85	HIII 10YO	BPB 3pt seatbelt	WB Foam 4		
V08933	S140505-1	FRUPG1 _47_48	Left	Graco MyRide65	HIII 3YO	FF Convertible 3pt seatbelt with tether	WB Foam 2	FMVSS No. 213 Pulse	30
			Right	Britax Frontier 85	HIII 10YO	FF Combination 3pt seatbelt with tether	WB Foam 4		
V08934	S140506-1	FRUPG1 _49_50	Left	Cosco Scenera	HIII 3YO	FF Convertible LA Only	WB Foam 2	FMVSS No. 213 Pulse	30
			Right	Graco Nautilus	HIII 10YO	BPB 3pt seatbelt	WB Foam 4		
V08935	S140506-2	FRUPG1 _51_52	Left	Cosco Scenera	HIII 3YO	FF Convertible LATCH	WB Foam 2	FMVSS No. 213 Pulse	30
			Right	Alpha Omega Elite	HIII 10YO	BPB 3pt seatbelt	WB Foam 4		
V08936	S140507-1	FRUPG1 _53_54	Left	Check Foonf	HIII 3YO	FF Convertible LATCH	WB Foam 2		30

VDB Test No.	Test Date	VRTC Test No.	Position	CRS Model	ATD Type	CRS Orientation And Restraints	Seat Foam #	Test Sled Pulse	Test Velocity (mph)
			Right	Graco Turbo Booster	HIII 10YO	BPB 3pt seatbelt	WB Foam 4	FMVSS No. 213 Pulse	

Table A-2: Fleet Testing on V2 Bench

VDB Test No.	Test Date	VRTC Test No.	Position	CRS Model	ATD Type	CRS Orientation And Restraints	Seat Foam #	Test Sled Pulse	Test Velocity (mph)
V09601	S150721-1	FRUPG2 _55_56	Left	Britax Frontier Clicktight	HIII 10YO	FF Combination SB3PT&T	WB Foam 4	FMVSS No. 213 Pulse	30
			Right	Graco My Ride 65	HIII 6YO	FF Convertible LATCH	WB Foam 5		
V09602	S150722-1	FRUPG2 _57_58	Left	Graco Nautilus	HIII 10YO	BPB SB3PT	WB Foam 4	FMVSS No. 213 Pulse	30
			Right	Britax Marathon	HIII 6YO	FF Convertible SB3PT	WB Foam 5		
V09603	S150723-1	FRUPG2 _59_60	Left	Diono Radian R120	HIII 10YO	FF Convertible SB3PT	WB Foam 4	FMVSS No. 213 Pulse	30
			Right	Cosco Ambassador NB	HIII 6YO	BPB SB3PT	WB Foam 5		
V09604	S150724-1	FRUPG2 _61_62	Left	Harmony Youth NB	HIII 10YO	BPB SB3PT	WB Foam 4	FMVSS No. 213 Pulse	30
			Right	Recaro Performance Ride	HIII 6YO	FF Convertible SB3PT	WB Foam 5		
V09605	S150727-1	FRUPG2 _63_64	Left	Graco Argos 80	HIII 10YO	FF Convertible SB3PT	WB Foam 4	FMVSS No. 213 Pulse	30
			Right	Chicco Nextfit	HIII 6YO	FF Convertible SB3PT&T	WB Foam 5		
V09606	S150728-1	FRUPG2 _65_66	Left	Chicco Key Fit 30	CRABI 12MO	RF Infant LA Only	WB Foam 4	FMVSS No. 213 Pulse	30
			Right	Britax Marathon	HIII 6YO	FF Convertible LATCH	WB Foam 5		
V09607	S150729-1	FRUPG2 _67_68	Left	Graco SnugRide 30	CRABI 12MO	RF Infant LA Only	WB Foam 4	FMVSS No. 213 Pulse	30
			Right	Evenflo Chase	HIII 6YO	BPB SB3PT	WB Foam 5		

VDB Test No.	Test Date	VRTC Test No.	Position	CRS Model	ATD Type	CRS Orientation And Restraints	Seat Foam #	Test Sled Pulse	Test Velocity (mph)
V09608	S150730-1	FRUPG2_69_70	Left	Britax B-Safe 35	CRABI 12MO	RF Infant LA Only	WB Foam 4	FMVSS No. 213 Pulse	30
			Right	Alpha Omega Elite	HIII 6YO	FF Convertible SB3PT&T	WB Foam 5		
V09609	S150730-2	FRUPG2_71_72	Left	Safety 1 st Onboard 35 Air	CRABI 12MO	RF Infant SB3PT	WB Foam 4	FMVSS No. 213 Pulse	30
			Right	Graco Turbo Booster	HIII 6YO	BPB SB3PT	WB Foam 5		
V09610	S150731-1	FRUPG2_73_74	Left	Evenflo Nurture	CRABI 12MO	RF Infant LA Only	WB Foam 4	FMVSS No. 213 Pulse	30
			Right	Harmony Youth NB	HIII 6YO	BPB SB3PT	WB Foam 5		
V09611	S150909-1	FRUPG2_75_76	Left	Evenflo Nurture	CRABI 12MO	RF Infant LA Only	WB Foam 4	FMVSS No. 213 Pulse	30
			Right	Graco Nautilus	HIII 6YO	FF Convertible SB3PT	WB Foam 5		
V09612	S150910-1	FRUPG2_77_78	Left	Evenflo Nurture	CRABI 12MO	RF Infant LA Only	WB Foam 4	FMVSS No. 213 Pulse	30
			Right	Graco Nautilus	HIII 6YO	FF Convertible SB3PT	WB Foam 5		
V09613	S150911-1	FRUPG2_79_80	Left	Evenflo Nurture	CRABI 12MO	RF Infant SB3PT	WB Foam 4	FMVSS No. 213 Pulse	30
			Right	Graco Nautilus	HIII 6YO	FF Convertible SB3PT	WB Foam 5		
V09614	S150915-1	FRUPG2_81_82	Left	Alpha Omega Elite	HIII 3YO	RF Convertible SB3PT	WB Foam 4	FMVSS No. 213 Pulse	30
			Right	Bubble Bum	HIII 6YO	BPB SB3PT	WB Foam 5		
V09615	S150916-1	FRUPG2_83_84	Left	Graco My Ride 65	HIII 3YO	RF Convertible SB3PT	WB Foam 4	FMVSS No. 213 Pulse	30
			Right	Evenflo Titan	HIII 6YO	FF Convertible LA Only	WB Foam 5		
V09616	S150917-1	FRUPG2_85_86	Left	Chicco Nextfit	HIII 3YO	RF Convertible LA Only	WB Foam 4	FMVSS No. 213 Pulse	30
			Right	Graco Affix NB	HIII 6YO	BPB SB3PT	WB Foam 5		
V09617	S150918-1	FRUPG2_87_88	Left	Evenflo Tribute	HIII 3YO	RF Convertible LA Only	WB Foam 4		30

VDB Test No.	Test Date	VRTC Test No.	Position	CRS Model	ATD Type	CRS Orientation And Restraints	Seat Foam #	Test Sled Pulse	Test Velocity (mph)
			Right	Graco Affix NB	HIII 6YO	BPB SB3PT	WB Foam 5	FMVSS No. 213 Pulse	
V09618	S150921-1	FRUPG2_89_90	Left	Alpha Omega Elite	HIII 3YO	FF Convertible LA Only	WB Foam 4	FMVSS No. 213 Pulse	30
			Right	Graco Affix NB	HIII 6YO	BPB SB3PT	WB Foam 5		
V09619	S150922-1	FRUPG2_91_92	Left	Cosco Scenera NEXT	HIII 3YO	FF Convertible LA Only	WB Foam 4	FMVSS No. 213 Pulse	30
			Right	Evenflo Amp NB	HIII 10YO	BPB SB3PT	WB Foam 5		
V09620	S150923-1	FRUPG2_93_94	Left	Evenflo Tribute	HIII 3YO	FF Convertible LA Only	WB Foam 4	FMVSS No. 213 Pulse	30
			Right	Diono Radian R120	HIII 10YO	FF Convertible SB3PT	WB Foam 5		

Appendix B

Table B-1: V2 Fleet Injury Data

VDB Test No.	Test Number	VRTC Number	Side of Bench	Seat Name	Orientation	Installation Method	Dummy	HIC 36	Chest Clip 3ms (g)	Max Seat Back Angle (°)	Head Excursion (mm)	Knee Excursion (mm)
V09601	S150721-1	FRUPG2_55	Left	Britax Frontier Clicktight	FF Combination	SB3PT&T	HIII 10YO	367.59	38.4		700	831
		FRUPG2_56	Right	Graco My Ride 65	FF Convertible	LATCH	HIII 6YO	462.92	42.3		598	721
V09602	S150722-1	FRUPG2_57	Left	Graco Nautilus	BPB	SB3PT	HIII 10YO	761.44	46.68		574	758
		FRUPG2_58	Right	Britax Marathon	FF Convertible	SB3PT	HIII 6YO	671.45	38.13		725	749
V09603	S150723-1	FRUPG2_59	Left	Diono Radian R120	FF Convertible	SB3PT	HIII 10YO	1004.18	46.99		855	822
		FRUPG2_60	Right	Cosco Ambassador NB	BPB	SB3PT	HIII 6YO	446.85	47.89		477	575
V09604	S150724-1	FRUPG2_61	Left	Harmony Youth NB	BPB	SB3PT	HIII 10YO	417.82 *	47.56		513	679
		FRUPG2_62	Right	Recaro Performance Ride	FF Convertible	SB3PT	HIII 6YO	714.33	45.68		705	754
V09605	S150727-1	FRUPG2_63	Left	Graco Argos 80	FF Convertible	SB3PT	HIII 10YO	580.84	47.17		728	834
		FRUPG2_64	Right	Chicco Nextfit	FF Convertible	SB3PT&T	HIII 6YO	429.91	39.1		639	739
V09606	S150728-1	FRUPG2_65	Left	Chicco Key Fit 30	RF Infant	LA Only	CRABI 12MO	430.92	43.55	51		
		FRUPG2_66	Right	Britax Marathon	FF Convertible	LATCH	HIII 6YO	329.2	33.08		631	723
V09607	S150729-1	FRUPG2_67	Left	Graco SnugRide 30	RF Infant	LA Only	CRABI 12MO	644.77	47.72	66		
		FRUPG2_68	Right	Evenflo Chase	BPB	SB3PT	HIII 6YO	617.01	55.81		579	689
V09608	S150730-1	FRUPG2_69	Left	Britax B-Safe 35	RF Infant	LA Only	CRABI 12MO	598.2	41.6	64		
		FRUPG2_70	Right	Alpha Omega Elite	FF Convertible	SB3PT&T	HIII 6YO	461.08	44.33		654	711
V09609	S150730-2	FRUPG2_71	Left	Safety1st Onboard 35 Air	RF Infant	SB3PT	CRABI 12MO	363.86	41.69	45		
		FRUPG2_72	Right	Graco Turbo Booster	BPB	SB3PT	HIII 6YO	484.65	45.85		568	620
V09610	S150731-1	FRUPG2_73	Left	Evenflo Nurture	RF Infant	LA Only	CRABI 12MO	679.78	48.26	56		
		FRUPG2_74	Right	Harmony Youth NB	BPB	SB3PT	HIII 6YO	399.32	52.8		483	591
V09611	S150909-1	FRUPG2_75	Left	Evenflo Nurture	RF Infant	LA Only	CRABI 12MO	685.43	50.42	53		
		FRUPG2_76	Right	Graco Nautilus	FF Convertible	SB3PT	HIII 6YO	570.4	44.02		664	725
V09612	S150910-1	FRUPG2_77	Left	Evenflo Nurture	RF Infant	LA Only	CRABI 12MO	720.86	49.53	62		

		FRUPG2_78	Right	Graco Nautilus	FF Convertible	SB3PT	HIII 6YO	534.85	42.43		656	721
V09613	S150911-1	FRUPG2_79	Left	Evenflo Tribute	RF Convertible	SB3PT	CRABI 12MO	453.92	44.9	38		
		FRUPG2_80	Right	Graco Nautilus	FF Convertible	SB3PT	HIII 6YO	534.93	43.1		676	740
V09614	S150915-1	FRUPG2_81	Left	Alpha Omega Elite	RF Convertible	SB3PT	HIII 3YO	711.14	43.4	30		
		FRUPG2_82	Right	Bubble Bum	BPB	SB3PT	HIII 6YO	338.85 *	51.23		450	591
V09615	S150916-1	FRUPG2_83	Left	Graco My Ride 65	RF Convertible	SB3PT	HIII 3YO	482.53	49.32	56		
		FRUPG2_84	Right	Evenflo Titan	FF Convertible	LA Only	HIII 6YO	523.51 *	35.98		792	773
V09616	S150917-1	FRUPG2_85	Left	Chicco Nextfit	RF Convertible	LA Only	HIII 3YO	653.82	45.94	56		
		FRUPG2_86	Right	Graco Affix NB	BPB	SB3PT	HIII 6YO	478.51 *	54.8		466	589
V09617	S150918-1	FRUPG2_87	Left	Evenflo Tribute	RF Convertible	LA Only	HIII 3YO	512.23	48.78	49		
		FRUPG2_88	Right	Graco Affix NB	BPB	SB3PT	HIII 6YO	573.09 *	58.14		491	599
V09618	S150921-1	FRUPG2_89	Left	Alpha Omega Elite	FF Convertible	LATCH	HIII 3YO	384.08	47.04		612	652
		FRUPG2_90	Right	Graco Affix NB	BPB	SB3PT	HIII 6YO	534.55 *	58.1		495	598
V09619	S150922-1	FRUPG2_91	Left	Cosco Scenera NEXT	FF Convertible	LA Only	HIII 3YO	585.79	42.65		640	504
		FRUPG2_92	Right	Evenflo Amp NB	BPB	SB3PT	HIII 10YO	540.95 *	44.79		500	652
V09620	S150923-1	FRUPG2_93	Left	Evenflo Tribute	FF Convertible	SB3PT	HIII 3YO	453.22	42.25		603	664
		FRUPG2_94	Right	Diono Radian R120	FF Convertible	SB3PT	HIII 10YO	975.69	44.98		839	791

Appendix C

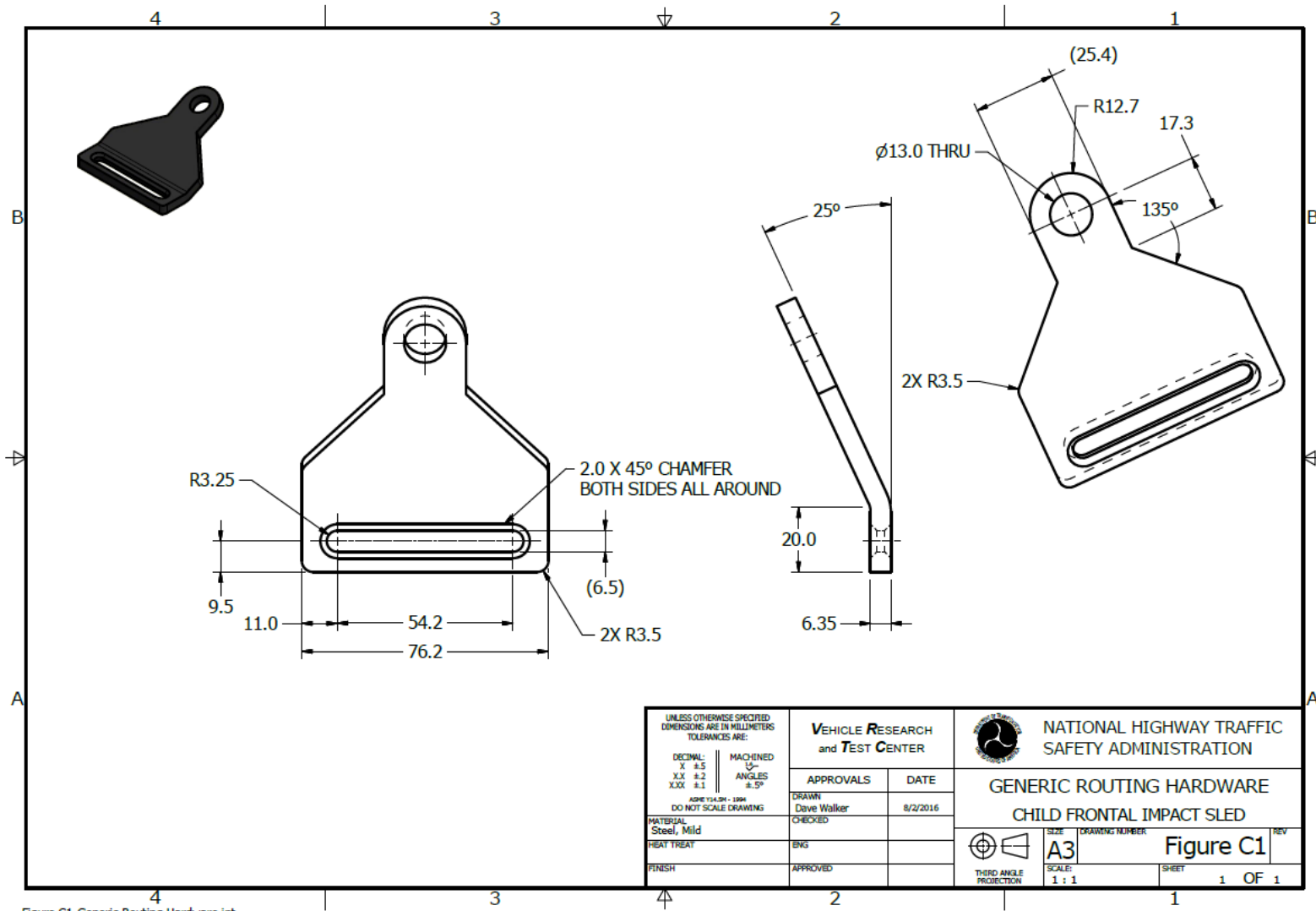

Figure C1-Generic Routing Hardware.ipt

Figure C-1: Generic Routing Hardware Design

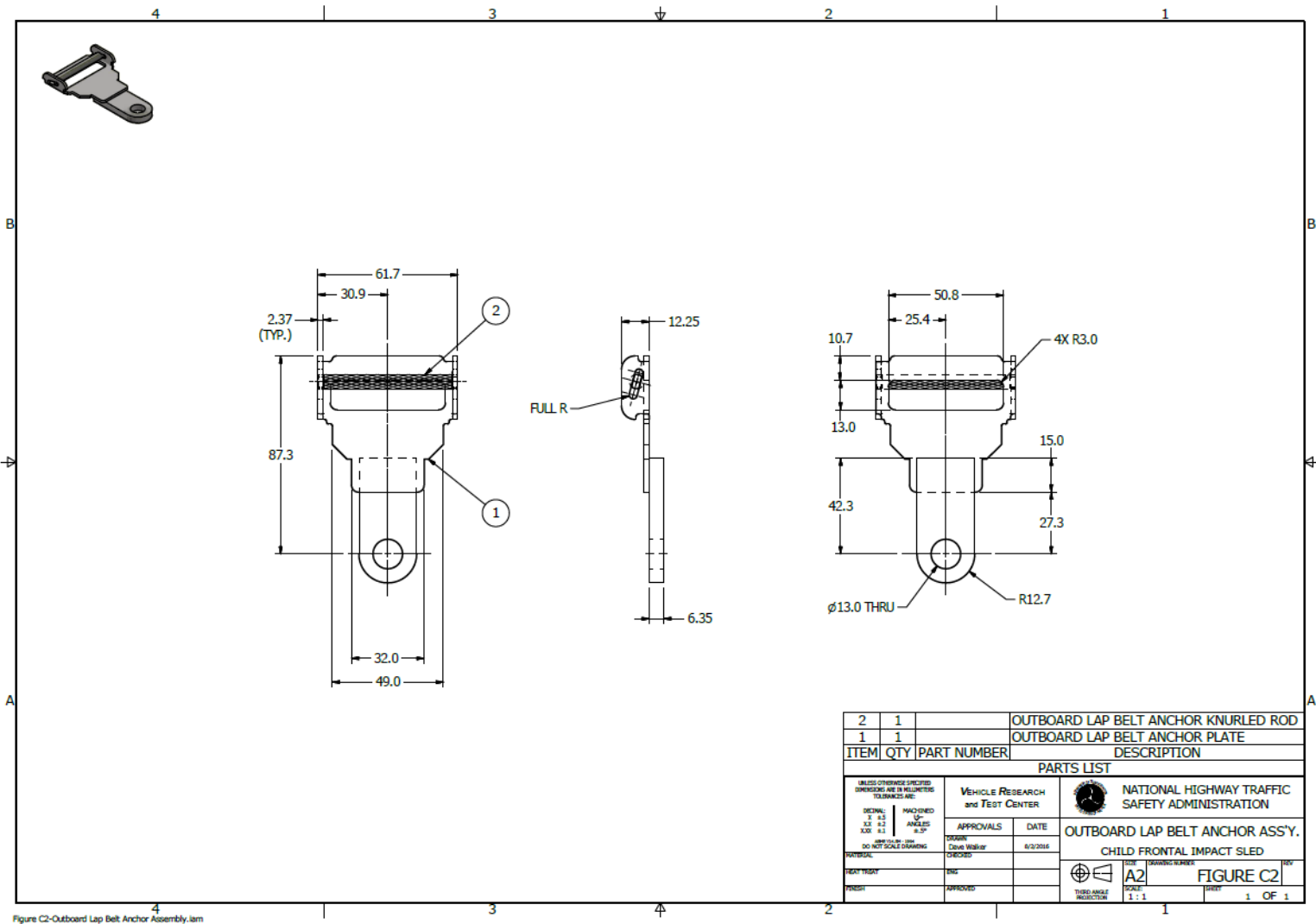

Figure C2-Outboard Lap Belt Anchor Assembly.lam

Figure C-2: Outboard Lap Belt Anchorage Design

Appendix D Procedure for Preparing Cushion Assemblies

Items needed:²⁶

- Aluminum mounting plates
- Sandpaper (50 grit garnet paper)
- Duct tape (3M)
- Preservation tape (Dr. Shrink)
- Fabric (Sunbrella)
 - 4 inch cushion: 48 inches (1219 mm) x 42.5 inch (1080 mm)
 - 2 inch cushion: 42 inches (1067 mm) x 44 inches (1118 mm)
- Foam (Woodbridge)
 - 4 inch cushion: 28 inches (711 mm) x 19 inches (483 mm)
 - 2 inch cushion: 28 inches (711 mm) x 22 inches (559 mm)

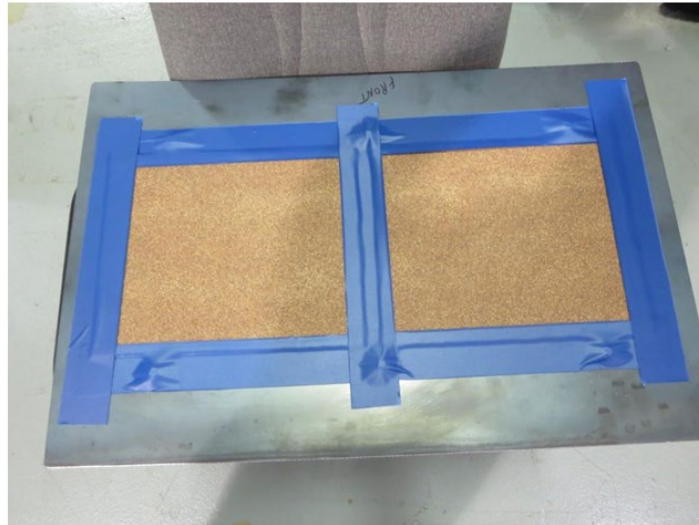

Adhere 50 Garnet Paper to the side of the plate that will be in contact with the foam

²⁶Part details can be found in Child Frontal Impact Sled-V2, NHTSA Standard Seat Assembly; FMVSS No. 213, No. NHTSA-213-2016, Drawing Package, November 2016.

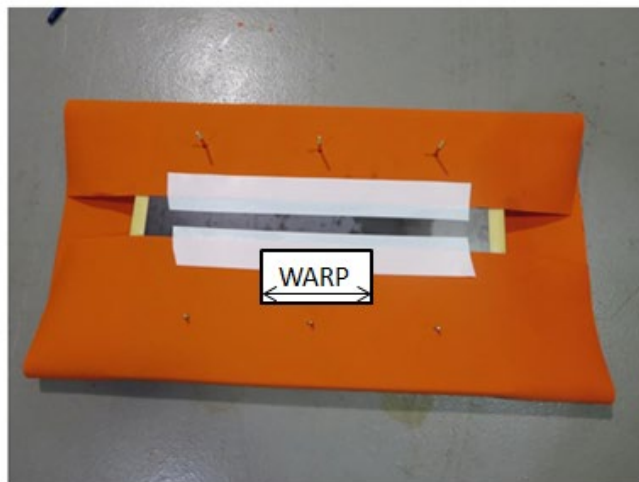

Place plate on foam with 1" on each side and place bolts through holes in fabric; adhere using preservation tape

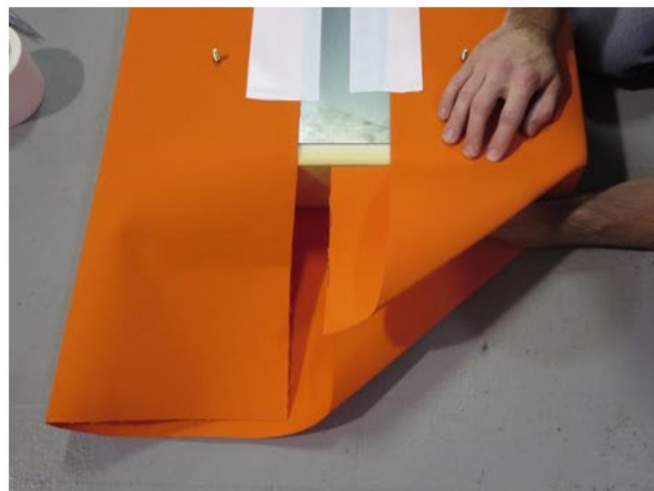
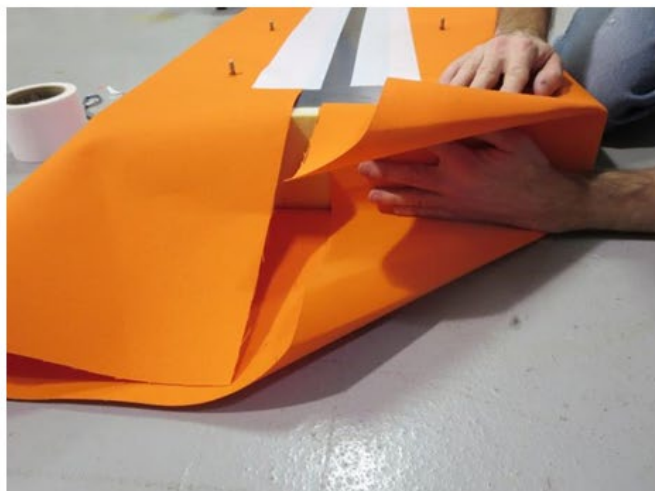

Push fabric into the thickness of the foam

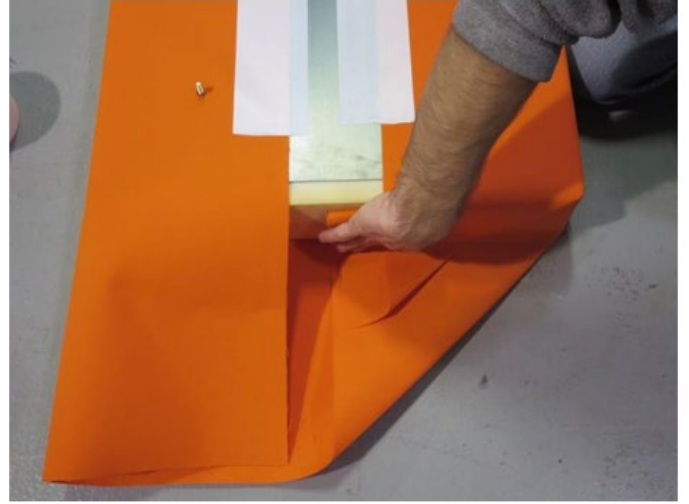
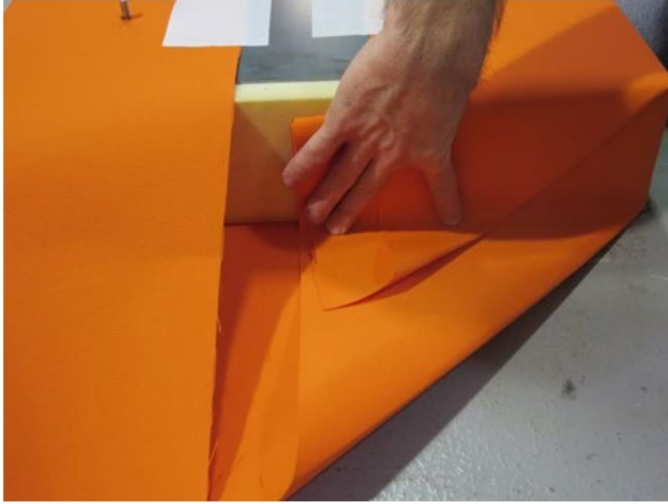

Fold top piece downward

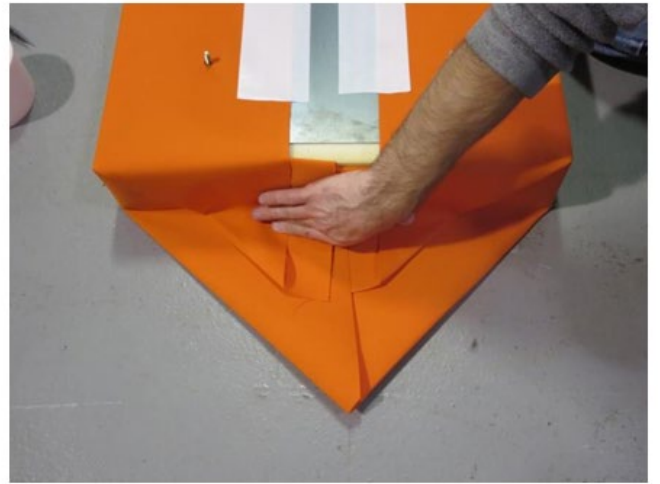
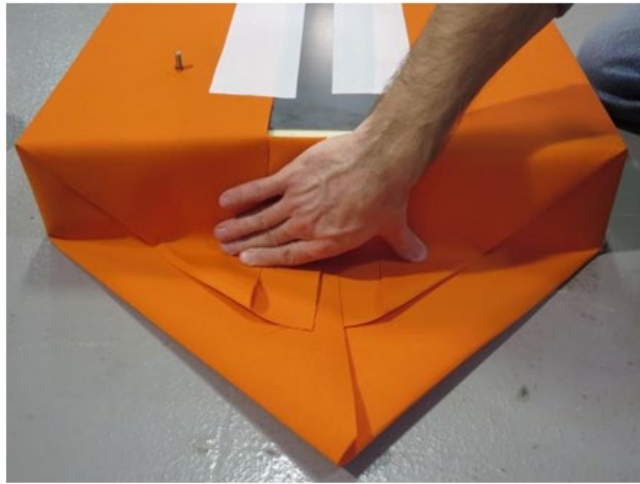

Complete on both sides
Then, pull upward and secure with preservation tape

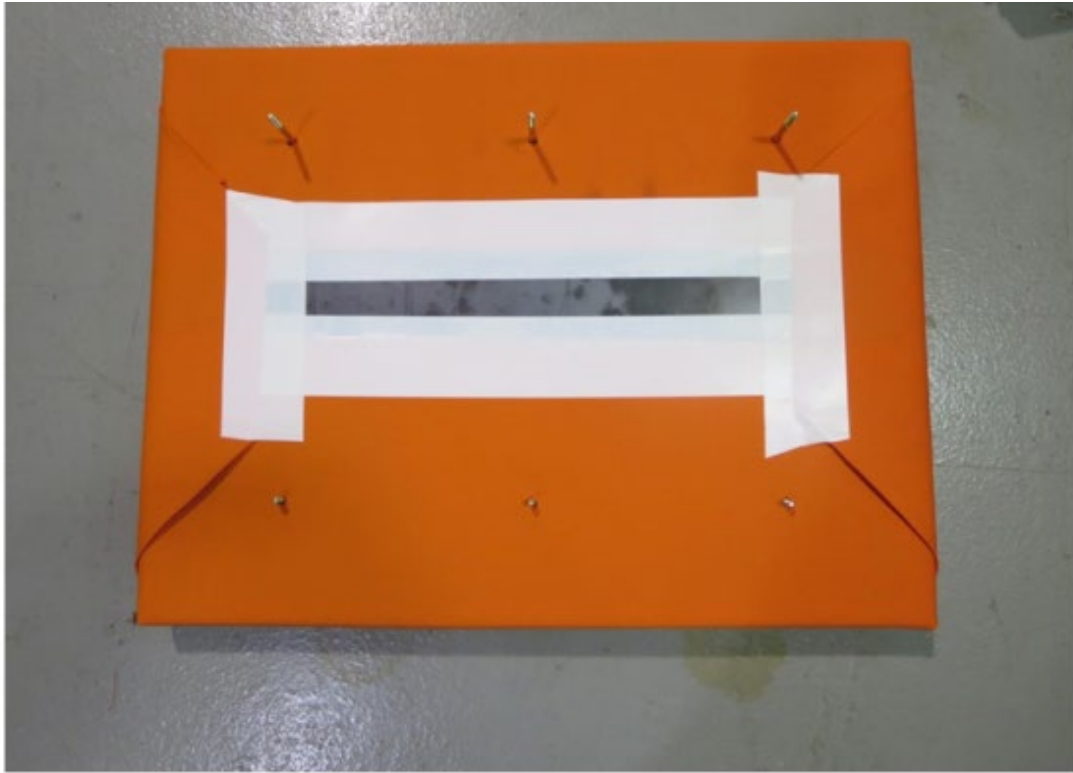

Final Product

DOT HS 813 096
June 2021



U.S. Department
of Transportation
**National Highway
Traffic Safety
Administration**

