

Standard Specifications for Plow Blades with Carbide Inserts

Final Report



research for winter highway maintenance

SRF Consulting Group, Inc.

**Project 1028785/CR17-02
April 2020**

Pooled Fund #TPF-5(353)
www.clearroads.org

Standard Specifications for Plow Blades with Carbide Inserts

Final Report

Clear Roads Project 17-02

Prepared by:



In collaboration with Kirchner and Associates, Inc.

April 2020

SRF No. 10939

Technical Report Documentation Page

1. Report No. CR 17-02	2. Government Accession No	3. Recipient's Catalog No.	
4. Title and Subtitle Standard Specifications for Plow Blades with Carbide Inserts		4. Report Date April 2020	
		5. Performing Organization Code	
7. Authors Erik Minge, Jeremy Sala, Larry Kirchner		8. Performing Organization Report No. 10939	
9. Performing Organization Name & Address SRF Consulting Group, Inc. 1 Carlson Parkway, Suite 150 Minneapolis, MN 55447		10. Purchase Order No.	
		11. Contract or Grant No. 1028785	
12. Sponsoring Agency Name & Address Clear Roads Pooled Fund Minnesota Department of Transportation 395 John Ireland Blvd St. Paul, MN 55155-1899		13. Type of Report & Period Covered Final Report; [Feb. 2018 – Apr. 2020]	
		14. Sponsoring Agency Code	
15. Supplementary Notes Project completed for Clear Roads Pooled Fund program, TPF-5(353). See www.clearroads.org .			
16. Abstract <p>Many agencies use snowplow blades with carbide inserts to remove snow and ice from their roadways. While carbide inserts are effective at extending the service life of plow blades, there is variability in carbide quality and in the specifications used by each agency in their procurement. This project developed a set of standard specifications to improve this procurement process. Project tasks included a literature review and surveys of both winter maintenance agencies and snowplow blade manufacturers. Follow-up interviews and a site visit to a plant that manufactures these blades provided additional insight into the challenges and opportunities in creating a standard specification.</p> <p>The standard specifications developed cover the chemical composition and the metallurgical, mechanical and physical properties of the carbide inserts. In addition to these technical elements, the specifications include a general set of testing and inspection procedures that can be used to accept or reject a lot of carbide inserts. Separate specifications were developed for inserts with a trapezoid shape and bullnose shape. By putting these standard specifications into practice, winter road maintenance agencies can realize better performance in their plow blades and possible cost reductions as manufacturers can streamline their manufacturing and inventory processes to more efficiently prepare blades to a single set of specifications.</p>			
17. Key Words Carbide inserts; snowplow blade inserts; snowplow blade performance; carbide insert specifications; procurement specifications		Distribution Statement No restriction. This document is available to the public through the Clear Roads pooled fund and the Minnesota Department of Transportation.	
19. Security Classification (this report) Unclassified	20. Security Classification (this page) Unclassified	20. No. of pages 57	21. Price -0-

Table of Contents

Executive Summary	1
Literature Review	3
Summary of Past Research	3
Literature Summary	7
Existing Specifications.....	8
Agency Specifications.....	8
NASPO Specifications	8
Industry Input.....	9
Vendor Input.....	9
Vendor Plant Visit	11
Vendor Summary	13
Data Synthesis and Analysis	14
Survey Analysis.....	14
Specification Analysis.....	15
Testing.....	17
Quality Inspections.....	17
Summary.....	18
Standard Specifications and Details.....	19
Testing.....	20
Inspection and Acceptable Quality Level (AQL).....	20
General Procedures	20
Application of Procedures.....	22
Conclusion	24
Appendix A – Standard Specifications for Plow Blades with Carbide Inserts (Trapezoid Shape)	25
Appendix B – Standard Specifications for Plow Blades with Carbide Inserts (Bullnose Shape).....	29

Appendix C – Existing Agency Specifications.....33
Appendix D – Agency Survey.....38
Appendix E – Vendor Survey.....43
Appendix F – Agency Survey Results45

H:\Projects\10000\10939\IT\Task 5 - Final Report and Closeout Webinar\Carbide Insert Final Report.docx

Executive Summary

Many agencies use snowplow blades with carbide inserts to remove snow and ice from their roadways. While carbide inserts are effective at extending the service life of plow blades, there is variability in carbide quality and in the specifications used by each agency in their procurement. Clear Roads initiated this project to develop a set of standard specifications for plow blades with carbide inserts. Standard specifications will help simplify and streamline the procurement process for all agencies with the goal of procuring higher quality blades at lower costs.

The project included:

- A literature review to understand the state of the practice and document prior research on carbide inserts.
- An agency survey to collect existing specifications, explore best practices and understand issues around the use of carbide inserts.
- An industry survey, industry interviews and a plant visit to understand how specifications relate to the manufacturing process and factors that are perceived to affect the quality of carbide inserts.
- A synthesis of the various specifications that are currently in use, including those specifications that are consistent across agencies.
- An analysis by the team's metallurgist to identify key properties of carbide inserts that should be focused on in the development of standard specifications.

Key findings included:

- The literature review finds blades with carbide inserts offer improved plow performance and a positive return on investment.
- Very little prior research exists on the use of standard specifications with the notable exception of Clear Roads Project 07-01, predecessor to this project, which established a set of laboratory procedures and a purchasing process that would limit the risk of poor quality carbide inserts.
- Review of existing specifications from all 36 Clear Roads members revealed a wide variety of specifications, but also some commonality, suggesting standardization values.
- Outreach to the carbide insert industry identified which products are most commonly sold, challenges they currently experience, and limitations on insert size and shape in relation to the manufacturing process. One vendor commented that customers using an uncommon blade or insert type could have lead times of up to six months. A standard specification would allow vendors to have material on hand at potentially reduced costs.
- The team's metallurgist recommends standard specifications focus on carbide composition, insert dimensions and the physical and mechanical properties of the insert itself. Of little value are carbide insert "grade", transverse rupture strength or brazing shear strength.

- Lack of testing and quality level analysis has hampered the end user's ability to verify the quality of blades being procured. Independent testing using a random sampling system and acceptable quality level analysis is needed to ensure quality end products are being obtained.

The final outcome of this study is a set of formal specifications developed for plow blades with carbide inserts. These specifications cover the chemical composition and the metallurgical, mechanical and physical properties of the carbide inserts. In addition to these technical elements, the specifications include a general set of testing and inspection procedures that can be used to accept or reject a lot of carbide inserts. One set of specifications was developed for inserts with a trapezoid shape (Appendix A) and another set of specifications for bullnose shape (Appendix B).

By putting these standard specifications into practice, winter road maintenance agencies can realize better performance in their plow blades and possible cost reductions as manufacturers can streamline their manufacturing and inventory processes to more efficiently prepare blades to a single set of specifications.

Literature Review

The Literature Review identified existing standard specifications and more broadly identified past research of carbide-insert blades. By performing a broad search, the project captured standard industry practices and identified strengths and weakness of various plow types with carbide inserts. In addition, specifications were reviewed from a few select state DOT's and a search of the National Association of State Procurement Officials (NASPO) website identified relevant specifications.

Summary of Past Research

A literature search was conducted to identify common specifications and any relevant past research on the application of plow blades with carbide inserts. The literature search was conducted through online databases such as the Transportation Research Board (TRB), Transportation Research Information Services (TRIS), and the International Transport Research Documentation (ITRD), as well as a general Internet search. Table 1 summarizes the past research that was reviewed. A brief synopsis of each publication follows and online links to these sources are provided later in this section.

Table 1. Relevant Publications

Date of Publication	Author	Research Agency	Publication Name (Literature Source)
1967	Fitzpatrick, J.R.	Ontario Department of Highways	Tungsten Carbide for Snowplow Blades
1993	Nixon, Wilfrid A. Frisbie, Todd R. Chung, Cheng-Hua	Strategic Highway Research Program	Field Testing of New Cutting Edges for Ice Removal from Pavements
12/2003	Maclver, John	Missouri Department of Transportation	Evaluation of Cracking in Pre-Service and In-Service Snow Plow Carbide Wear Surfaces
08/2010	Kruse, Cameron G. Kirchner, Larry A.	Clear Roads	Development of Standardized Test Procedures for Carbide Insert Snowplow Blade Wear
12/2011	Mastel, Andy	North Dakota Department of Transportation	Evaluation of Snow Plow Blade Systems
04/2012	Nixon, Wilfrid A.	Transportation Research Board	Factors for Consideration in Selecting Snowplow Cutting Edges
08/2015	Schneider, William Crow, Mallory Holik, William A	Ohio Department of Transportation	Investigate Plow Blade Optimization
09/2015	Elhouar, Souhail Dragoo, Drew Khodair, Yasser Lee, Yoon-Si	Illinois Department of Transportation	Performance Evaluation of Snow and Ice Plows

Tungsten Carbide for Snowplow Blades

Ontario Department of Highways

Fitzpatrick, J.R.

1967

<http://onlinepubs.trb.org/Onlinepubs/hrr/1967/173/173-005.pdf>

The earliest research found on the effectiveness of carbide inserts in snowplow blades was conducted by the Ontario Department of Highways in the mid-1960s. Two plows were deployed on the same stretch of highway spanning several winters, one with a conventional steel blade and one with an experimental blade with a carbide tip. The original experimental blade had a triangular tip but evolved to a trapezoidal insert as the testing progressed. The testing allowed the agency to project how many steel blades would need to be purchased for every tungsten carbide blade, revealing major material costs savings in the long run.

Field Testing of New Cutting Edges for Ice Removal from Pavements

Strategic Highway Research Program

Nixon, Wilfrid A.; Frisbie, Todd R.; Chung, Cheng-Hua

1993

<http://onlinepubs.trb.org/Onlinepubs/trr/1993/1387/1387-020.pdf>

This project tested three unique plowing systems to determine their effectiveness in scraping ice from a roadway. Using as much of a controlled environment as possible, the three cutting edges tested were: conventional steel blade, a steel blade with carbide insert, and a prototype underbody edge with the carbide mounted flush to the front face exposing it directly to the ice. These blades were tested with other variables such as blade angle and attack angle. The testing determined that the underbody plow had superior performance as compared to the other blades.

Evaluation of Cracking in Pre-Service and In-Service Snow Plow Carbide Wear Surfaces

Missouri Department of Transportation

MacIver, John

2003

<https://library.modot.mo.gov/RDT/reports/Ri01023/RDT03015.pdf>

This project determined defects in plow blades with carbide inserts using non-destructive testing as the products were received. The project also monitored blades that were in-service and investigated optimum blade configurations. The research determined that ultrasonic testing could be used to help ensure quality blades are received from the manufacturer, however the research also revealed that although manufacturing defects are certainly possible, operational and environmental situations have the greatest influence on blade life. It was also suggested a configuration using a front wear plate protected blades and generally exhibited longer service life.

Development of Standardized Test Procedures for Carbide Insert Snowplow Blade Wear

Clear Roads PR 07-01

Kruse, Cameron G.; Kirchner, Larry A.

2010

http://clearroads.org/wp-content/uploads/dlm_uploads/07-01-Carbide-Insert-Blade-Final-Report.pdf

This Clear Roads project established a set of laboratory procedures and a purchasing process that would limit the risk of poor quality carbide inserts in snowplow blades. A three-step testing procedure was developed to determine the acceptability of the inserts. The first step is a visual examination of the face of the inserts identifying the percent of inserts with visible cracks. The second step subjected the inserts to hardness and density testing to determine materials used in the manufacturing process. The third step tested for porosity and grain size, which identified voids and cracks and helped determined the manufacturing quality. The study noted that poor manufacturing processes were more likely to result in inserts with voids and cracks rather than chemical properties of the inserts. This project also recommended specifications for the test procedures mentioned, which have been incorporated into the final specifications of this project.

Evaluation of Snow Plow Blade Systems

North Dakota Department of Transportation

Mastel, Andy

2011

http://www.dot.nd.gov/divisions/materials/research_project/mr201003final.pdf

The North Dakota DOT sought to improve winter maintenance operations by comparing their traditional steel blades with carbide inserts to three other plow systems. Two of the three other systems included a rubber component which are not being looked at as part of this project. The third blade system tested was two stacked steel plow blades with carbide inserts. The study showed that there was no improvement in snow/ice removal or in wear performance with stacked configuration and this configuration was replaced with a single blade mid study.

Factors for Consideration in Selecting Snowplow Cutting Edges

Transportation Research Board

Nixon, Wilfrid A.

2012

<http://onlinepubs.trb.org/onlinepubs/circulars/ec162.pdf> (pg. 502-509)

The author noted that there are many factors for agencies to consider when selecting a snowplow blade and there is no “one size fits all” approach for each agency. This study encouraged agencies to look at variables such pavement condition, pavement type, the presence of raised pavement markers, life cycle costs, and condition of trucks. Another main factor in blade selection is noise and vibration, which can lead to pavement damage and driver fatigue. The author recommends the use of an advanced composite carbide blade if noise and vibrations are issues, but due to the higher front end

costs of specialty blades, each agency, through a life cycle cost analysis, needs to assess whether the product chosen will perform to expectations. Although past research has been conducted on testing to predict performance of blades, there is not a test that considers all the factors. While there are tests to determine factors like hardness and wear resistance, it is difficult to determine performance and longevity of the blade under real plowing conditions. The study identified the factors an agency must consider in making an educated decision on which type of plow blade would make the most sense for each roadway.

Investigate Plow Blade Optimization

Ohio Department of Transportation

Schneider, William; Crow, Mallory; Holik, William A

2015

<http://cdm16007.contentdm.oclc.org/cdm/ref/collection/p267401ccp2/id/12839>

This study compared the standard steel blade with other blade systems including a steel blade with carbide inserts to provide the Ohio DOT options for optimizing winter maintenance operations. Utilizing a combination of field data collection, GPS tracking, video data analysis, and plow blade measurements, a cost-benefit analysis was determined for each of the various blade systems over two winter seasons. The steel blade with carbide insert was determined to have an \$80 cost savings per blade when compared to the standard steel blade in year one. However, during year two, one carbide blade was damaged randomly and had to be replaced. Considering the more expensive replacement cost of a carbide blade, the study did not show a savings in year two. Numerous DOT's were also polled on blade usage, which noted most states at the time of the study were using steel blades with carbide inserts, but many of the evaluations have been focused on the performance of specialty blades, such as the JOMA, to determine potential cost savings. This study showed that these specialty blades do have a greater savings per blade over a two-year period as compared to traditional steel blades and steel blades with carbide inserts.

Performance Evaluation of Snow and Ice Plows

Illinois Department of Transportation

Elhouar, Souhail; Dragoo, Drew; Khodair, Yasser; Lee, Yoon-Si

2015

<https://apps.ict.illinois.edu/projects/getfile.asp?id=3692>

The purpose of this research was to perform a comprehensive study of plow performance using a variety of instrumentation and video monitoring. This project tested a variety of blade types including front mounted and underbody plows using both trapezoidal and dowel-type carbide inserts. Using the data provided by the field testing, the team could determine the stresses acting on the plow and concluded that an underbody scraper in tandem with a front plow was most effective in providing a clean driving lane.

Literature Summary

The review of past research did not find any literature that had compiled standard specifications for carbide inserts in plow blades, further justifying the need for this project. However, a broader literature search did find several studies that explored the performance of various blade configurations. This broader research on the performance of various blade types led to the following key findings:

- Carbide insert blades offer improved plow performance
- Carbide blade inserts offer a positive return on investment
- Standardized test procedures are recommended to ensure a quality carbide insert is being provided by the manufacturer
- Ultrasonic testing could be used to ensure quality blades are received from the manufacturer
- Operational and environmental situations have the greatest influence on blade life
- Tests show front wear plates or blade savers could be used to extend the life of the blade and improve performance
- Many tests have shown specialty blades, such as those encased in rubber, exhibit better performance than steel blades with carbide inserts, however, have higher upfront costs

Existing Specifications

Agency Specifications

Clear Road member agencies were contacted to request their existing specifications on carbide inserts. Specifications were obtained from 34 different agencies, predominantly from Clear Roads states, with a few additional from non-Clear Roads states/agencies. These specifications are compiled into a series of tables for comparison purposes in Appendix C, Tables C-1 to C-4.

In reviewing these specifications, a variety of items were noted. The plow blade type, dimensions, and punch appear to be very comparable across state specifications, similarly with the carbide insert. Some state specifications define the insert type, such as trapezoidal, but the dimensions of the insert can vary. Other specifications included are brazing, testing, certification, and others. The process of developing a standard specification that incorporates the commonalities, minimizes the differences and eliminates the ambiguities is discussed later in the report.

These states/agencies were also surveyed to understand their viewpoint on the use of blades with carbide inserts. They were asked which part of their specifications, if any, do not meet their needs. The survey questions are provided in Appendix D. The actual survey was distributed using the online survey tool Survey Monkey to all Clear Roads agencies, the five other winter maintenance agencies, and others willing to participate. The survey is meant to capture information regarding agency specifications, current procurement practices, and assist in the development of determining Acceptable Quality Levels (AQL) for rejecting/accepting carbide lots. The results of the survey were also used by the project team to determine additional information the project should consider and which vendors should be contacted.

NASPO Specifications

The National Association of State Procurement Officials (NASPO) is a non-profit organization that is dedicated to advancing public procurement. A division of NASPO is ValuePoint, a cooperative purchasing organization that allows states to leverage their spending through a single solicitation to obtain the best value. Currently on the NASPO ValuePoint website is a cooperative contract for Snowplow Cutting Edges.

In reviewing this solicitation, specifications for steel plow blades with carbide inserts from the State of Vermont were found. There are six vendors listed on the website and currently nine Clear Road states have used this cooperative contract.

Industry Input

Vendor Input

The Agency Outreach Survey asked Clear Roads members to identify carbide insert vendors/manufacturers they have worked with in the past. The following six vendors mentioned most frequently are listed below.

- Evolution Edges
- Kennametal
- Kuper
- Valk
- Winter Equipment
- Built Blades

These vendors were then surveyed about their products and their recommendations for procurement specifications. Vendors were asked about which products are sold most commonly and any challenges they face supplying these blades. Additionally, vendors were asked to describe limitations on insert size and shape in relation to the manufacturing process and the way raw materials are supplied and processed. Vendors were given an opportunity to provide feedback on current procurement specifications, input on industry trends, innovative ideas, and any accompanying comments. The vendor survey is provided in Appendix E.

Receiving completed vendor surveys proved difficult. Despite several follow-up efforts, only two surveys were submitted, both from the same vendor, therefore different methods for obtaining vendor input were used. Specific individuals for each vendor, identified by Clear Roads members, were contacted via phone or in person at the Kennametal plant visit to provide their input on developing standard specifications for carbide-insert plow blades. The vendors were asked to discuss products most commonly sold and any challenges faced, thoughts on current specifications and product quality, and industry trends or innovative ideas. Although not every vendor answered the survey questions developed, the project team obtained valuable insight from most of the vendors.

Key findings from the vendor survey:

- Consistent with many DOT specifications, vendors echoed that the trapezoid-shaped carbide insert plow blade is the most sold. However, vendors are starting to see more bullnose-shaped plow blade request for bids. One vendor commented that customers using an uncommon blade or insert type could have lead times of up to six months and they see the value of having a standard specification. If more agencies used a standard specification, it would allow vendors to have material on hand at potentially reduced costs.

- Vendors were also asked describe limitations on insert size and shape in relation to the manufacturing process and the way raw materials are supplied and processed. Carbide inserts come in many different shapes and sizes with the primary limitation being the width of the steel and machined width of the milled slot. The typical steel blade is ¾” x 6” usually in 3-foot or 4-foot segments. Obtaining raw materials with the appropriate grain sizes is very important in the mixing process to ensure uniformity. One vendor commented that most raw materials for tungsten carbide are produced overseas making it difficult to control costs. One way to help control costs is to use recycled carbide; this is discussed later in this section.
- Much of the feedback received from the vendors regarding current procurement specifications was aimed towards quality. The vendors expressed concern that contracts were being awarded to the low bid with no guarantee of quality. DOT specifications include parameters such as Hardness, Density, Porosity, Transverse Rupture Strength, Brazing Shear Strength, etc., but the agencies do not independently test for any of these requirements. Most agencies rely on a certificate of compliance, but they do not have the means to verify that these requirements are met. Awarding contracts at low bid with no means to verify quality could result in premature failures of the blades, leading to costly downtime of plowing operations.
- According to the manufacturers, much of the success of a snowplow blade is attributed to carbide quality and braze technique. Carbide insert composition is key to ensuring that it wears properly and basic ASTM tests such as Density, Hardness, and Porosity can help ensure good quality. Many vendors expressed that a proper braze and precise milling of the slot is just as important as carbide quality. A slot that is fractions of an inch too wide or narrow could result in a weak braze joint. Many DOTs have an insert spacing tolerance specification, but no means to verify once the shipment is received. (Note – subsequent investigation does not support brazing being the point of failure in carbide inserts).
- There are QC processes in place for each manufacturer, but they were not uniform, such as internally testing versus sending random samples of each carbide lot to an independent lab. A suggestion was made to require sending random samples to independent laboratories and providing test results to the agencies as part of the specification. The vendors seemed receptive to the idea, feeling that it would create a more level playing field.

Lastly, the vendors were provided the opportunity to comment on industry trends and innovative technologies in the snowplow blade industry.

- Kuper is developing a “premium” carbide insert blade using 1045 steel and only virgin tungsten carbide. Many states only require 1020 steel and do not specify virgin carbide.
- Winter Equipment sells their blades as systems that come complete with fasteners, wear shoes, and wear components and provide a “wear life guarantee”. They suggested providing

a wear life guarantee makes the manufacturer completely responsible for all blades purchased.

- Kennametal was looking for a means to recycle carbide inserts from snowplow blades. They currently recycle carbide from various milling teeth and provide credit to the customer's future orders, but the shape of a blade might make it difficult to recycle the carbide. A Kennametal supplier recently visited an agency's stockpile of used blades which provided them an appreciation for the amount of unused carbide left in used blades.

Vendor Plant Visit

A member of the consultant team along with two Clear Roads members visited the Kennametal plant in Bedford, PA on January 14, 2019 and the Kennametal laboratory in Latrobe, PA on January 15, 2019 to get insight into the development of standard specifications. This section presents the notes from the tour and discusses potential issues encountered with producing multiple blades to meet differing agency specifications. Other details regarding the production of carbide inserts were explored, such as different carbide insert sizes and shapes. This section also presents new innovations and observed trends in snowplowing that Kennametal is seeing in the industry.

Attendees:

- Jonathan Fleming, PennDOT (Clear Roads member)
- Jeff Pifer, WVDOT (Clear Roads member)
- Cary Ritchey, Kennametal
- Gardi Willis, Kuper
- Patricia Schuster, Kuper
- Roland Kuper, Kuper
- Kelly Condello, Northern Supply
- Adam Condello, Northern Supply
- Jeremy Sala, SRF Consulting Group (consultant team)

Day 1 Kennametal Manufacturing Plant Tour (Bedford, PA)

This tour was comprised of showing the attendees the manufacturing process from raw carbide materials to the finished carbide insert blade. The raw tungsten carbide material comes from Nevada or China. Kennametal produces many different insert shapes and sizes for various equipment from milling teeth to farming equipment. The process starts with machines pressing carbide powder with wax and cobalt into what is called a "green state." It is very brittle at this stage and can be snapped in your hand.

Inserts are then sintered (pressure heated) at different temperatures, first removing the wax, then liquifying the cobalt as binder. This process can take up to one day and results in finished carbide product. The finished inserts are then inspected for dimensions. It did not appear that each production lot of inserts goes through any testing beyond this dimension check. The vendor

representative mentioned they have the means to do lab tests at the facility but could not reference a quality control procedure or manual that they follow for each production lot.

Kennametal has one section in the facility dedicated to snowplow blade production. It was close to the end of shift therefore not much was happening, however, the process was described by the Kennametal representative. The steel blade is cut into typically 3- or 4-foot segments and the slot for the insert is milled. Inserts are then placed into the slot and brazed by hand wand to ensure brazing material gets in between each insert. It was mentioned that brazing techniques are just as important as carbide quality. The steel is then punched with the square bolt hole to the order's specifications. Lastly, the blades are painted and shipped.

One of the issues encountered with producing multiple blades to meet differing agency specifications is that a vendor may not have a particular product on hand at any given time, resulting in long lead times depending on the uniqueness of the specification. It appears that Kennametal only had enough equipment to manufacture to one blade specification at a time. Having a standard blade specification would allow Kennametal to mass produce for multiple agencies at a time, reducing costs and product lead time.

Carbide insert shape and dimensions were discussed. The Kennametal representative said the primary limitation on carbide insert size and shape is the width of the steel and the machined width of the slot. The most common insert shape produced by Kennametal is the 25-degree trapezoid. Agencies that require unique shapes could encounter a lead time to obtain the proper tooling to produce the insert.

Kennametal noted that some agency specifications are of limited value. One specification that many agencies have is brazing shear strength, which is hard to test once the blade assembly is complete. Although Kennametal has the means to do the testing, the finished blade needs to be cross sectioned, essentially destroying the blade. Therefore, the test is rarely done and the validity of including in the project's standard specifications should be reviewed.

The tour also included innovations such as the carbide recycling program. Kennametal receives used equipment such as milling teeth with carbide inserts from contractors. They have a machine that can dislodge the carbide from the steel using heat and air pressure and can recycle the carbide insert. Kennametal can crush the carbide close to its original powder form and recycle it for use in future applications with no loss of quality, allowing them to control cost by not having to rely as much on outside vendors for raw materials.

Kennametal was asked what other products they have developed. They mentioned the I.C.E blade that has cylindrical bullnose inserts protruding beneath the steel. With this configuration they claim the blade is more effective at removing ice and hard-packed snow because it scarifies as it plows. A trend Kennametal is seeing is increased use of bullnose-shaped inserts.

Day 2 Kennametal Laboratory (Latrobe, PA)

The Latrobe facility is Kennametal's world and corporate headquarters. They offer regular tours at this facility, therefore the tour was broader in nature and covered multiple Kennametal products,

ongoing research, and testing capabilities. We discussed the physical and mechanical properties currently on many agency carbide specifications such as hardness, density, and porosity. The laboratory has the capabilities to test for these properties and they seem fairly routine to perform. One specific component of interest is that some agencies require the use of virgin tungsten carbide in their blades. The Kennametal representative said they could verify whether an insert is virgin or recycled, but that they did not know of any other lab with this capability. However, they do not currently offer the service of investigative testing for other products.

Vendor Summary

The information gathered from vendors will assist the project team in writing a standard specification for carbide-inserts. Some of the challenges ahead are determining a practical process to ensure the quality of the carbide inserts and that proper brazing techniques are being used. That many of the vendors have their own quality control processes is a good start, but coming up with a proper independent sampling system, such as Acceptable Quality Limit (AQL), would ensure the products being received by agencies meet specifications. Some of the challenges with incorporating a “wear life guarantee” would be defining the wear life. Road types have differing effects on plow blades and other factors such as operator experience or geographical location make it difficult to define how long a carbide-insert plow blade should last. The key takeaway from the interactions with vendors is that the specifications being developed need to better ensure quality of the products received and not just rely on low bid. This can be accomplished by:

- Introducing an independent test laboratory into the specifications that will provide test results representing the lot received by the ordering agency.
- Developing a random sampling system, such as AQL, that manufacturers must adhere to as they send products to the independent test lab.
- Remove requirements currently on many agency specifications that are irrelevant for ensuring the quality of the carbide-insert plow blade.
- Continue to require certification of compliance for relevant specifications that cannot be tested by the independent test laboratory.

Vendor input is a critical component in writing standard specifications that are accepted by the industry. Witnessing the manufacturing process during the visit to Kennametal’s plant provided valuable insight and the ability view things from a vendor’s perspective. The knowledge gained from the vendors will be incorporated into development of the standard specifications.

Data Synthesis and Analysis

This section combines the knowledge gained from the existing specifications, survey responses and vendor input to identify what to include in the final standard specification. Using the data received, the project team reviewed each specification to determine common elements. These elements were then reviewed by our team's metallurgist to determine if they provide benefit or whether they were unnecessary. The team's metallurgist also identified standard test methods and quality assurance procedures.

Survey Analysis

The agency outreach survey provided valuable insight into current procurement practices and attempts to acquire quality products. The goal for each agency is to obtain a quality product, but the survey revealed concerns with the service life of the blades received. The detailed survey responses are compiled in Appendix F. These findings strengthen the need for proper specifications and the value in verifying they are met by using standardized testing for the products being received.

Survey questions focused on testing of the inserts found the following results for 26 DOT's:

- Four claimed testing was done somewhere in the supply chain
- Eleven claimed that no testing was done
- Two received test results
- Fourteen did not receive test results
- Six said results were available upon request
- Eight said results were not available upon request

In a number of survey questions, responses included "... no in house testing...", "we don't test...", or "no tests used", and a variety of comments which asked the vendor to "certify" that their product met the agency specifications. A number of survey comments indicated a strong suspicion of a "certification" as being nothing more than a verbal claim. This illustrates what can happen when nothing measurable is stated; no test results and reporting are required by the end user; and no consequences are incorporated into the purchasing process. This highlights the value in developing testable specifications and standard test methods.

The survey also identified numerous concerns relating to the performance (service life) and quality of the carbide inserts. The comments were a bit more direct and specific when from the DOT's and a bit more general and vague when from the vendors. Premature carbide fractures and erratic service life were concerns appearing from both DOT's and vendors. Indirect evidence of this appears in many comments about trying new vendors and various products in an attempt to find a desired performance level, which has been missing.

Most all of these concerns about specifications, quality and performance were also encountered in the previous Clear Roads study on carbide inserts (CR 07-01). The survey findings from this project have

identified more details and a better definition of specification items which could be improved upon.

Specification Analysis

A total of 34 different agency specifications were obtained and, as noted earlier, are compiled into a series of tables for comparison purposes in Appendix C, Tables C-1 to C-4. These specifications were reviewed for context on blade performance and quality of the carbide inserts. Most of the procurement specifications collected did not give information which could be tested and/or measured. These are required and are defining characteristics of a specification. Most agencies do not list all components which are required to form a valid specification. This results in an incomplete and inadequate statement of what is needed or required. A few of these specifications did list numerical values but were not appropriate to the product nor the application at hand.

A review of agency specifications also found significant variability not only within the values of each specification, but also in what components are included. For example, while most states had a specification for the steel alloy in the plow blade, very few identified a tungsten carbide content for the inserts in the blade. In the first case, the AISI or ASTM specification listed contains the complete list of alloys and impurities in that particular steel. In the second case, we must have the composition of cobalt, tungsten carbide and all other impurities. If any one of the three alloy components are missing, we do not have a valid specification. An evaluation of specifications follows and was derived from all 34 DOT's participating. Not all DOT's responded to all questions.

Grade and Carbide Insert Composition

Insert "grade" was described by 22 DOT's as "high shock tungsten carbide" or other similar terms, three used a vendor product number and nine gave no response. There is no grade designation for this alloy, therefore the composition must be spelled out completely for the three categories of tungsten carbide, cobalt and all other elements. The range of cobalt content was given by 27 DOT's and 7 did not list any numerical value. In most of the listings the range of cobalt was larger and generally higher than suggested. Only 6 DOT's listed anything for tungsten carbide content and they were generally high or unacceptable. None of the DOT's listed a 1% maximum of all other elements (impurities). The final conclusion in this matter is that the DOT's are working with an attempted alloy specification which is inadequate and open to wide variations in composition and desired properties.

Insert Dimensions

Insert dimensions were given by most DOT's and could be of interest in the machining of the blade and the exposure of the insert beyond the edge of the blade. The width of the insert is quite important since it must be compatible with the width of the milled slot in the blade and give proper clearance for the brazing alloy to be added. In the survey, 21 of the 34 DOT's specified a width of .365/.369" and three listed .355/.360". If a standard 3/8" milling cutter is used to cut the slot, the more desirable insert width could be .360/.365". It would be desirable to also specify the height of the insert to standardize that dimension as well. The interest in this dimension is to determine how far the insert extends beyond the edge of the blade, if at all. In the survey, 17 of the 34 DOT's listed the height as .635/.642" and 6 DOT's listed .750/.760". If the height is standardized at .750/.755", the DOT's

simply need to specify the depth of the slot to determine the extension of the insert beyond the blade edge. The length of the insert has been listed as 1" without variation and is best if left at that dimension. This is also a dimension of the tooling and the insert could not vary by more than +/- .001", which is quite acceptable.

Insert Shape

The shape of the insert could be of significant interest also. Whether it be a trapezoid or "bullnose" may be a somewhat academic issue regarding service life but could make a significant impact upon the cost of the tooling. The trapezoid shape requires a sloped, flat surface on the tooling, which is relatively inexpensive to maintain. The radius on a bullnose insert will likely be worn off in a very short time, once put into service. The bullnose shape requires the radius to be machined and maintained as a concave surface in the tools. This can be quite expensive and also limit the service life of the tools. Ultimately, standard specifications were developed for both trapezoid shape (Appendix A) and bullnose shape (Appendix B).

Insert Physical and Mechanical Properties

Physical and mechanical properties of the carbide inserts are of greatest interest. In simple terms, hardness will indicate the abrasion resistance of the insert and density will indicate the ratio of the two alloys present and possibly porosity within the insert. The specified individual values of hardness and density will indicate additional properties. The combined consideration will give assurance of the nominal 11% cobalt and 88% tungsten carbide composition of these inserts. It is not likely that another alloy could possess both values of hardness and density. The additional benefit is that an expensive chemical analysis need not be performed to verify the composition. Porosity is a mechanical/physical property of great interest also. In these surveys and the previous study (CR 07-01) the most significant problem was short service life with large variations and frequent fracturing of the inserts. Most of these failures were traceable to porosity and this in turn is a direct indicator of the quality and workmanship in fabricating the carbide inserts.

Other Insert Properties

Past and some current specifications call for specified values of transverse rupture strength for inserts and specified values of shear strength for brazing alloys. There is little value in these specifications since these components are not exposed to transverse rupture stresses nor shear stresses. The brazing of the inserts could be of secondary interest but is not considered a part of the scope of this effort. It would be expected to be performed with quality materials, best methods, and by qualified or certified technicians.

Plow Blade Alloy

The material alloy specification for the steel used in plow blades was provided by 32 DOT's. The DOTs use either AISI-1020, AISI-1045 or ASTM A-36. A quick comparison of these shows a small gradual increase in desired mechanical properties along with a small increase in material cost from the first to last material listed. All of these steel alloys are acceptable for plow blade use with negligible performance differences between them.

Plow Blade Dimensions and Hole Patterns

Plow blade assemblies are bolted to the bottom of the curved plow frame. The blade heights were listed about equally at 5" or 6" with a small number listed at 8". Most blade thicknesses were listed at 3/4" or 7/8" with a small number listed at 1/2" or 1". The bolt pattern for attachment to the plow frame also has wide variations. The "gage" dimension (top edge of the blade to the hole center) was listed at 1.5" by 30% of DOT's and 2" by another 30% of DOT's. Twenty four percent of DOT's gave no answer. Bolt spacing horizontally, was listed as 3", 6", 8", 12" or combinations of these dimensions. These variations are likely due to the hole pattern for each manufacturer's plow frame making it challenging to identify a standard specification.

Testing

Product testing is critical to assure good quality and uniform properties of the carbide inserts. Test methods must be contained in widely recognized and accepted standards. These standards assure the ability to duplicate methods, equipment and results regardless of who does the testing and their location. For this product and application, ASTM testing standards are the choice.

Numerical values are assigned to each property of interest, usually in the form of a maximum and minimum value. Some carbide within the shipment is then selected for testing. Note that testing of carbide inserts after they have been brazed into the body of the blade is not recommended. The test results will establish some parts within the limits and some parts testing outside the limits. The ASTM test methods and numerical results must be certified by the party doing the testing. The meaning of "certification" here is to absolutely affirm compliance with the ASTM procedures and of all numerical values obtained. All results must be recorded, maintained and ultimately submitted to the end user with each shipment of parts. Certification must also be made by a licensed/certified individual or by an official who has the responsibility and the authority over the testing and lab operations.

In summary, testing is required by the purchaser or end user to assure that what was needed and specified is what they will get. The testing must also be practical, affordable and appropriate to the application. Testing is discussed in more detail in the next section of the report.

Quality Inspections

After testing has been performed on all properties specified and of interest, there is a need to evaluate the numerical results. Some numerical values will be within stated limits or considered acceptable and others will fall outside of numerical limits or considered unacceptable. This evaluation will ultimately decide on the acceptance or rejection of the shipment of parts. In the best interests of all parties involved, it is best if statistical procedures are used and remove all personal behaviors, attitudes and biases from the decision. This set of procedures is frequently referred to as "Acceptable Quality Level" or AQL. In simple terms, this inspection method works with a probability that no more than a specified percentage of defective parts will be accepted with the shipment. AQL procedures are explained in more detail in the next section.

Summary

A detailed review by the team's metallurgist identified several key properties of carbide insert blades that should be focused on in the development of standard specifications. These include:

- Carbide Insert Composition
- Carbide Insert Dimensions
- Assurance of physical and mechanical properties of the carbide insert

In addition, some existing elements of specifications were found to be of little value to the performance of carbide insert plow blades and do not need to be included in the specifications at all. These include:

- Carbide Insert "Grade"
- Transverse Rupture Strength
- Brazing Shear Strength

The next section provides standard specifications, test methods and a quality inspection procedure for carbide-insert plow blades.

Standard Specifications and Details

This section port presents a set of standard specifications for carbide inserts; including geometry, dimensions, and metallurgical, mechanical and physical properties. These specifications were developed to be “industry wide” and apply to all vendors and agencies. CAD drawings are also provided to illustrate the physical dimensions required for plow blade and insert fabrication. This enables vendors to produce a template or fixtures to improve efficiency and accuracy in the production of their blades. Lastly, detailed procedures are provided for the unbiased acceptance or rejection of carbide inserts to be used in blade assemblies.

From previous studies (Clear Roads project 07-01), it has been established that carbide insert quality and service life are most affected by manufacturing methods. Cracking and premature failure of the carbide inserts can and do limit the service life of the plow blades. Previous tasks in this project have provided details from vendors and agencies which give a definition of items which could be improved upon.

The formal specifications developed for plow blades with carbide inserts are provided in Appendix A and Appendix B. These specifications cover the chemical composition and the metallurgical, mechanical and physical properties of the carbide inserts. In addition to these technical elements, the specifications include a brief general set of testing and inspection procedures that can be used to accept or reject a lot of carbide inserts.

For proper accommodation, the following items should be noted by all agencies:

1. The agency survey found three plow blade alloys are currently in use: AISI 1020, AISI 1045 and ASTM A-36. The type of blade alloy does not noticeably contribute to service life and all three are used through the industry (approximately 55% of agencies use AISI 1020, and 35% of agencies use ASTM A-36). AISI 1020 was selected for this standard specification because it is the most commonly used, but agencies are free to use another alloy of their choice. The standard specification also describes the blades’ thickness and width (example: 3/4" x 6") and as a hot rolled bar. In addition, the blade shall contain a 3/8" slot centered on the blade thickness. While bolt hole pattern has little or no effect on service life and varies across the industry, this standard specification uses a widely accepted AASHTO spacing. Agencies may wish to customize these specifications to accommodate their desired option of material, dimensions, and other information. Appendix A and Appendix B include specifications for plow blades, including CAD drawings that illustrate dimensions.
2. Carbide inserts shall have nominal dimensions of 0.365" thick, 1" long and height of 0.635" (trapezoidal shape) to 0.750" (bullnose shape). Thickness and length are controlled by the tooling and variations are likely to be less than +/- 0.001". The thickness is also determined to provide an adequate gap for brazing alloy. The height is controlled by the tooling adjustments and can be a bit more or less, if needed or desired. Detailed specification and

CAD drawings are provided for two shapes:

- a. Trapezoidal shape (see Appendix A, Figure 2A) with a 1/16” radius bullnose on the insert, which matches the vast majority of the carbide inserts available on the market, but this small bullnose shape does not affect performance and may be omitted.
- b. Bullnose shape (see Appendix B, Figure 2B) with a 3/16” radius bullnose on the insert.

Testing

The specifications provide a full and proper description of what is required of the carbide inserts. Inserts provided by industry will ideally exhibit test values within the given ranges. In reality, some or a few parts may test outside of these ranges. The properties listed in the specifications were selected for a variety of reasons. They are very well known by test labs and test procedures will yield fast, simple and cost-effective results. These properties also relate quite well to other important properties in a cost-efficient manner without additional expensive tests. The testing will be done in a sequential manner. Appendices A and B list specific ASTM test procedures for hardness (ASTM B294-92), density (ASTM 311-08) and porosity (ASTM B276-05e1). These ASTM test methods describe such items as the test equipment to use; preparation of test specimens; the calibration of equipment; testing procedures; recording numerical test results and sometimes calculations which may be necessary. The details of these ASTM testing standards give maximum assurance that the test results will be the same for any lab at any location. Any parts which test outside of the given ranges above, shall be separated from all other sample parts and retained. It is possible for a rejection to be identified after the testing procedures and before inspections.

Inspection and Acceptable Quality Level (AQL)

The tungsten carbide inserts are referred to as “cemented carbides” in the powdered metals industry. They are made of a somewhat unique material and manufactured in a unique set of procedures. Defects are introduced in a different manner than most manufacturing processes. Due to these differences, the inspections will maintain the fundamentals of the Acceptable Quality Level (AQL) procedures, but some procedures will be customized to be appropriate to this product and its applications. AQL gives a numerical value for the maximum percent of defects which may be accepted. It is all based on statistics and probability. If there will be a rejection, it would be most desirable to determine that status as soon as possible and avoid additional procedures and expenses. The later inspections will be a bit more sophisticated and cost more than the early testing. The later procedures are where the most significant or major defects will be identified and confirmed.

General Procedures

A DOT or end user may want to consider purchasing carbide inserts themselves, especially if there are issues of trust, accuracy or bias in testing, inspection, certification or rejection of the lot of parts. A DOT or end user could easily avoid these potential problems and still cost justify this action. In order to be justifiable, the purchase quantity may need to be equal to two or more years of blade

consumption. The DOT would then be required to store a quantity of inserts for an additional year or more. To use this option would give maximum quality control and selection of the independent lab to the end user, which could be an advantage.

Sample Selection

The risks and consequences of failures in this industry are significantly different than in the medical device or aerospace industries. As a result, the AQL levels will be numerically larger than in a more critical industry, which will allow more insert defects to be accepted with the lot of parts. “Lot size” is the quantity of the production run by the manufacturer, or the quantity received by the vendor for assembly into blades. Sample size is determined by the lot size and is the quantity of parts selected for testing and inspection. Recommended lot and sample sizes are listed in Table 2 below.

For the hardness and density testing, a general inspection level 1 (G1), with an AQL of 15 will be used. This results in the smallest sample size to be examined, with a maximum of 15% defects allowed for acceptance. For porosity and fractures, a special inspection level 3 (S3) will be used with an AQL of 10 for porosity (10% defects) and an AQL of 4 used for fractures (4% defects). The term “defects” refers to a test value outside of the numerical range given in the specification. The lab must certify the ASTM test procedures are used. The vendor can then present copies of the certifications to all end users for review before a purchase order is issued or after the blade assemblies are received. The value of a data review is to assure that the parts were justifiably accepted. Certifications shall be made by a licensed or certified individual or by an official who has responsibility and the authority over the testing and lab operations.

Manufacturers may want to perform these tests and inspections in order to gain the assurance of their own quality of manufacturing. Ultimately, they must be prepared to accept rejected lots from vendors or end users which require these quality standards as a part of a contract or as a condition of purchase. Under most conditions, vendors arrange for the sampling and testing through a qualified independent lab. A qualified lab will have the capability and personnel to perform metallurgical and microscopic examinations along with a full understanding of ASTM testing standards.

Testing and Inspections

To begin the testing procedures, a “sample” of parts shall be taken from the “lot” of parts. All sample parts are then tested for hardness. They must be run on the Rockwell Hardness “A” (RHA) scale. They must not be tested on another scale and then converted to the “A” scale by using a conversion chart. Any test result falling outside the given range is considered a “defect” and that part shall be separated from the other samples. If the quantity of defects exceeds the “acceptable” limit, the lot of parts should be rejected. If the quantity of defects is less than the “reject” quantity, the defects shall be separated from the other samples and retained for further testing. After hardness testing, there could be a large group of pieces which test within the hardness range as “okay” and possibly a small group of “hardness defects”.

The density test is performed in a similar fashion. All sample parts are tested for density. Any test result falling outside the given range is considered a “defect” and that part shall be separated from the other samples. If the quantity of density defects exceeds the “acceptable” limit, the lot of parts should

be rejected. If the quantity of density defects is less than the “reject” quantity, the defects shall be separated from the other samples and retained for further testing. After density testing, there could be a large group of pieces which test within the hardness and density ranges as “okay”. Smaller groups will consist of defects of “hardness” (only) or “density” (only) or “hardness and density” defects.

The final inspections will use a smaller quantity of sample of parts, referred to previously as a special inspection level 3, and will determine the amount of porosity and/or the presence of fractures or laminations within the carbide inserts. The samples for this inspection will come from possibly two or more sources which have previously been determined. First, recover defects from the group of “density only” defects. Second, if more samples are needed get them from the group of “density and hardness” defects. Third, if more samples are needed get them from the group of “hardness only” defects. If more samples are needed get them from the group which tested “okay” for hardness and density. The lab will now perform more of a metallurgical exam, by cutting the samples approximately in half, exposing a surface of about 5/8" x 1". This will be followed by a series of “grinding” operations which will expose any porosity, cracks or laminations within the inserts. If the quantity or size of porosity defects exceeds the “acceptable” limit, the lot of parts should be rejected. If the quantity of fracture or lamination defects exceed the “acceptable” limit, the lot should be rejected. If the two types of defects are each less than the “reject” quantity, the lots should be accepted. See the footnotes at the end of this report for a description of porosity defects and defects consisting of cracks or laminations.

Application of Procedures

In the event that the carbide insert manufacturer not only manufactures the inserts, but also performs the assembly operations and sells directly to the DOT, the manufacturer or the lab may select the sample pieces based upon the entire production run. A new sample must be drawn for each production run, with all procedures and certifications repeated for each run. The manufacturer shall then supply copies of the certifications to any DOT or end user receiving assemblies containing these inserts. It is important to select sample parts at random throughout the lot of parts. If the lot of parts are in multiple containers, a proportional number of samples should be drawn from each container. In the event that a vendor purchases the inserts, the sample may be selected by the vendor or the lab based on the purchase quantity. The lab results and certifications then go back to the vendor, and finally copies are supplied to any end user receiving blade assemblies containing parts from that production run. The DOT or end user should make sure they get the copies of the lab results and certifications before placing the purchase order. There is a need to review the numerical tabulations to make sure that acceptance is justified by the lab results. If not, the DOT should reject assemblies containing inserts from a lot of parts which did not meet specifications. This process gives agencies an option to assure quality requirements are met.

Visual inspection for fractures should be done initially with the G1 sample, which is intended to discover surface exposure of cracks or laminations. The later exam (with the porosity exam) will discover additional cracks or laminations which are difficult to find visually and may also be hidden internally and not exposed on the surface. If these defects (from the G1 inspection) exceed the acceptable quantity, the lot of parts should be rejected and there will be no need to proceed to the

porosity examinations. If the defects from this examination are less than the reject quantity, they should be separated from the samples and combined with any defects from later exams for cracks or laminations.

Table 2: Sample Sizes and AQL Chart

Lot Size	Sample Size G1	AQL=15 Ac/Re	Sample Size S3	AQL=10 Ac/Re	AQL=4 Ac/Re
501 to 1200	32	10 / 11	13	3 / 4	1 / 2
1201 to 3200	50	14 / 15	13	3 / 4	1 / 2
3201 to 10000	80	21 / 22	20	5 / 6	2 / 3
10001 to 35000	125	21 / 22	20	5 / 6	2 / 3
35001 to 150000	200	21 / 22	32	7 / 8	3 / 4

GENERAL NOTES:

1. Sample size G1 is used for initial testing which includes hardness and density. Sample size S3 is used for inspections which include porosity, fractures and laminations. See text material above for details.
2. Porosity is specified as “A04, B02 and C04”; where the letters “A, B, or C” indicate the size or type of pore and the numerical portion as “04, 02 and 04 respectively, indicate a “quantity” value. If any one of these numerical values is exceeded, it is considered a “defect”. Unusually large pores are reported separately by their size and quantity. It is possible, as a result, for any one part to possess more than three defects (A + B + C + any unusually large pores). If the quantity of defects exceed the “acceptable” limit, the lot of parts should be rejected.
3. Cracks and laminations may appear in the inspections using G1 (early) or S3 (later) samples. Each crack or lamination is considered a “defect” and shall be added together for both inspections. If the quantity of defects exceed the “acceptable” limit, the lot of parts should be rejected.
4. It is suggested that feedback, recording and subsequent review be undertaken for possible revisions of these AQL values and the accept/reject quantities due to the unique application to the winter road maintenance industry. An attempt has been made to avoid excessive rejections but also to enforce minimum standards which will noticeably improve the service life of inserts and plow blades. These AQL criteria were selected for a maximum acceptance of 15% defects in hardness and density; 10% defects in porosity and 4% defects in cracks and/or fractures.

Conclusion

This project presents detailed information on the use of carbide inserts in plow blades. A thorough understanding of the current state of the practice was captured through a combination of literature review, existing specification review and contact with insert manufacturers and vendors. This background understanding was reviewed by the project team's metallurgist who shed light on the specifications that are of the most interest and what specification values will yield the best outcomes. The need for standardized testing and quality control was identified as critical to ensuring the final products provide the expected performance.

This report presents final standard specifications for carbide insert plow blades with accompanying CAD drawings. The carbide insert is the most critical element to service life of the plow blade. As such, it is critical that carbide inserts meet the specifications presented here. The testing and inspection procedures provided give the DOT assurance that quality requirements are met.

Ultimately, it is the public agency procurement process that will determine what quality of blade is procured. This report seeks to expand understanding and present a set of standard specifications and testing expectations to achieve the best possible outcomes.

Appendix A – Standard Specifications for Plow Blades with Carbide Inserts (Trapezoid Shape)

APPENDIX A
Standard Specifications for Plow Blades with Carbide Inserts (Trapezoid Shape)
Prepared by Clear Roads

1. PLOW BLADE
 - a. Plow blades shall be 3/4" by 6" by 48" and shall be hot rolled AISI 1020 quality steel.
 - b. Lengths other than 48" may be specified in 12" increments.
 - c. Hole punching shall be 11/16" square and countersunk to receive 5/8" bolts.
 - d. Location and spacing of hole punches shall be as shown on the attached Figure 1A.
 - e. Tolerance of bolt hole location shall be 1/32".
 - f. A 3/8" groove for the carbide inserts shall be milled in the center of the blade edge.

2. CARBIDE BLADE INSERTS
 - a. Inserts shall be made of the following materials:
 - i. 87-88% tungsten carbide
 - ii. 11-12% cobalt
 - iii. 1% maximum for all other elements
 - b. Inserts shall be 25-degree trapezoidal with the following nominal dimensions (Figure 2A):
 - i. Length: 1" ± 0.005"
 - ii. Thickness: 0.365" ± 0.005"
 - iii. Height: 0.635" ± 0.005" (measured on long side)
 - iv. Nose radius: 1/16"
 - c. Inserts shall have the following properties:
 - i. Hardness: 88.0-90.5 HRA per ASTM B294-92
 - ii. Density: 14.4-14.5 g/cc per ASTM 311-08
 - iii. Porosity: A04 = 0.06%, B02 = 0.02%, C04 = 0.06% per ASTM B276-05e1
 - d. All surfaces (internal and external) shall be free of cracks and laminations.

3. BRAZING
 - a. Carbide inserts shall be spaced in the milled groove with .010" between the inserts for the entire length of each blade section.
 - b. The inserts shall be brazed on all sides.
 - c. Brazing shall leave no voids or shims.
 - d. Brazes shall use quality materials, best methods and qualified/certified technicians.
 - e. There shall be no gaps or spacing between adjacent inserts after brazing.

4. TESTING PROCEDURES
 - a. The vendor shall perform ASTM testing on a representative sample of each lot of carbide material that is used in the production of carbide inserts. All ASTM carbide test procedures listed above shall be conducted.
 - b. Prior to delivery, the vendor shall provide the Department with all ASTM carbide test results and a statement of Acceptable Quality Level (AQL) inspection data, including acceptance and rejection findings. At its discretion, the Department will review the provided information and either accept or reject the carbide material. Accepted carbide material may move forward in the procurement process. Rejected carbide material shall result in rejection of the full lot of carbide from which the test samples were derived and cancelation of the procurement. If the vendor desires to continue with the procurement they must submit test results and AQL findings from a different lot of carbide material.

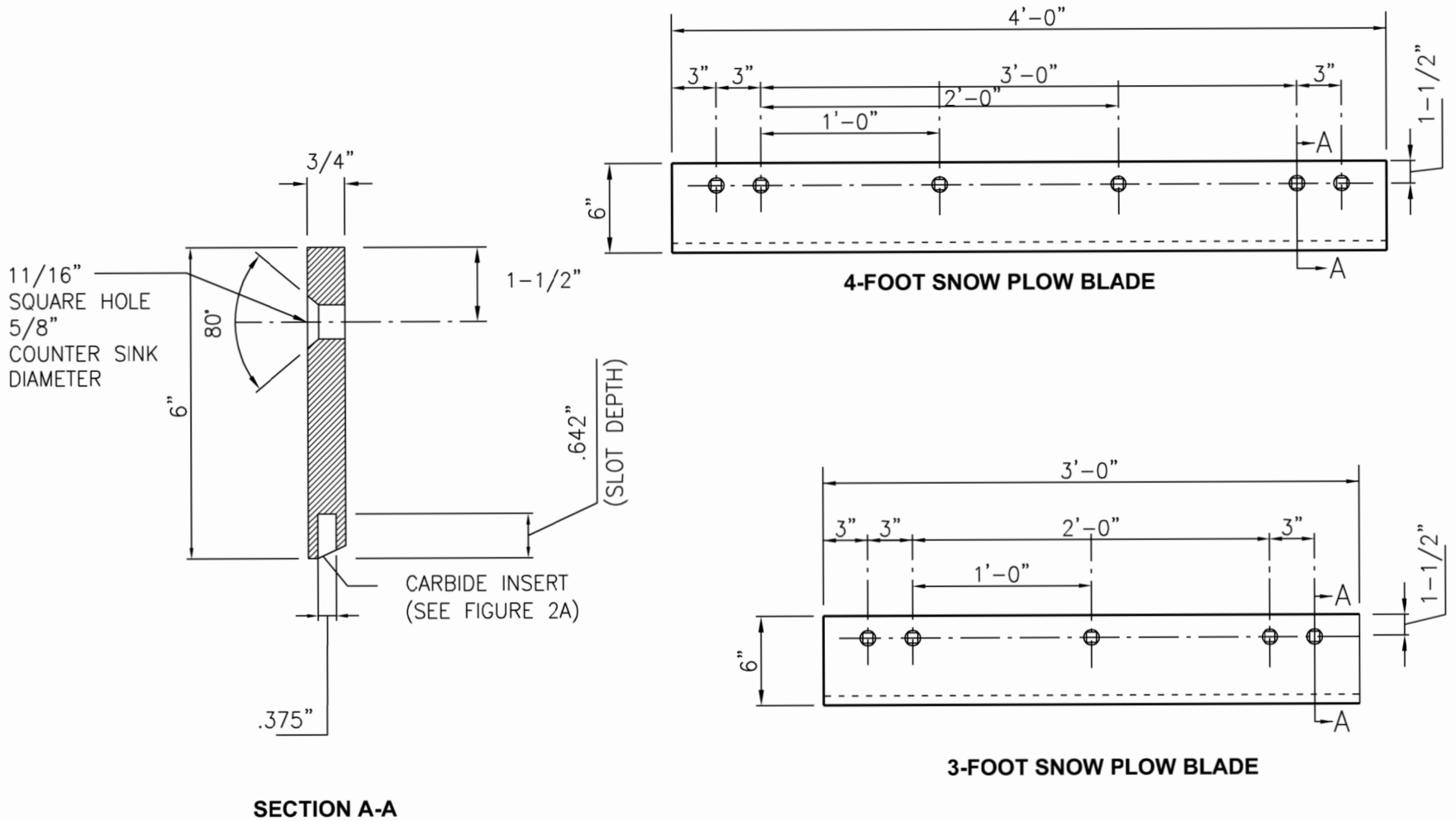

APPENDIX A: SNOW PLOW BLADE DETAIL DRAWING (TRAPEZOID)

Figure 1A

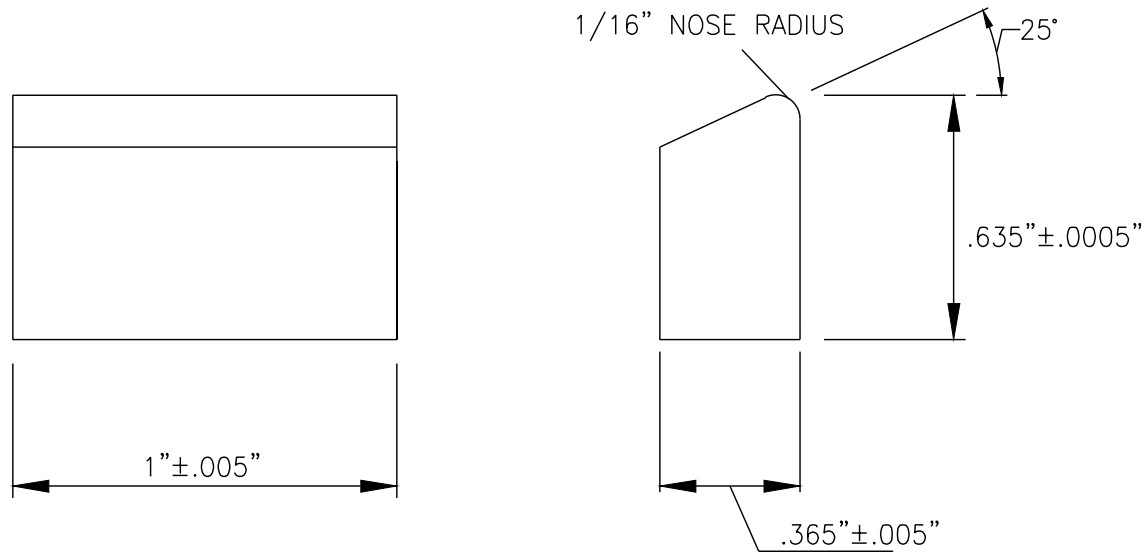

CARBIDE INSERT

Appendix B – Standard Specifications for Plow Blades with Carbide Inserts (Bullnose Shape)

APPENDIX B
Standard Specifications for Plow Blades with Carbide Inserts (Bullnose Shape)
Prepared by Clear Roads

1. PLOW BLADE

- a. Plow blades shall be 3/4" by 6" by 48" and shall be hot rolled AISI 1020 quality steel.
- b. Lengths other than 48" may be specified in 12" increments.
- c. Hole punching shall be 11/16" square and countersunk to receive 5/8" bolts.
- d. Location and spacing of hole punches shall be as shown on the attached Figure 1B.
- e. Tolerance of bolt hole location shall be 1/32".
- f. A 3/8" groove for the carbide inserts shall be milled in the center of the blade edge.

2. CARBIDE BLADE INSERTS

- a. Inserts shall be made of the following materials:
 - i. 87-88% tungsten carbide
 - ii. 11-12% cobalt
 - iii. 1% maximum for all other elements
- b. Inserts shall be bullnose shape with the following nominal dimensions (Figure 2B):
 - i. Length: 1" ± 0.005"
 - ii. Thickness: 0.365" ± 0.005"
 - iii. Height: 0.750" ± 0.005" (total height, including bullnose radius)
 - iv. Nose radius: 3/16"
- c. Inserts shall have the following properties:
 - i. Hardness: 88.0-90.5 HRA per ASTM B294-92
 - ii. Density: 14.4-14.5 g/cc per ASTM 311-08
 - iii. Porosity: A04 = 0.06%, B02 = 0.02%, C04 = 0.06% per ASTM B276-05e1
- d. All surfaces (internal and external) shall be free of cracks and laminations.

3. BRAZING

- a. Carbide inserts shall be spaced in the milled groove with .010" between the inserts for the entire length of each blade section.
- b. The inserts shall be brazed on all sides.
- c. Brazing shall leave no voids or shims.
- d. Brazes shall use quality materials, best methods and qualified/certified technicians.
- e. There shall be no gaps or spacing between adjacent inserts after brazing.

4. TESTING PROCEDURES

- a. The vendor shall perform ASTM testing on a representative sample of each lot of carbide material that is used in the production of carbide inserts. All ASTM carbide test procedures listed above shall be conducted.
- b. Prior to delivery, the vendor shall provide the Department with all ASTM carbide test results and a statement of Acceptable Quality Level (AQL) inspection data, including acceptance and rejection findings. At its discretion, the Department will review the provided information and either accept or reject the carbide material. Accepted carbide material may move forward in the procurement process. Rejected carbide material shall result in rejection of the full lot of carbide from which the test samples were derived and cancelation of the procurement. If the vendor desires to continue with the procurement they must submit test results and AQL findings from a different lot of carbide material.

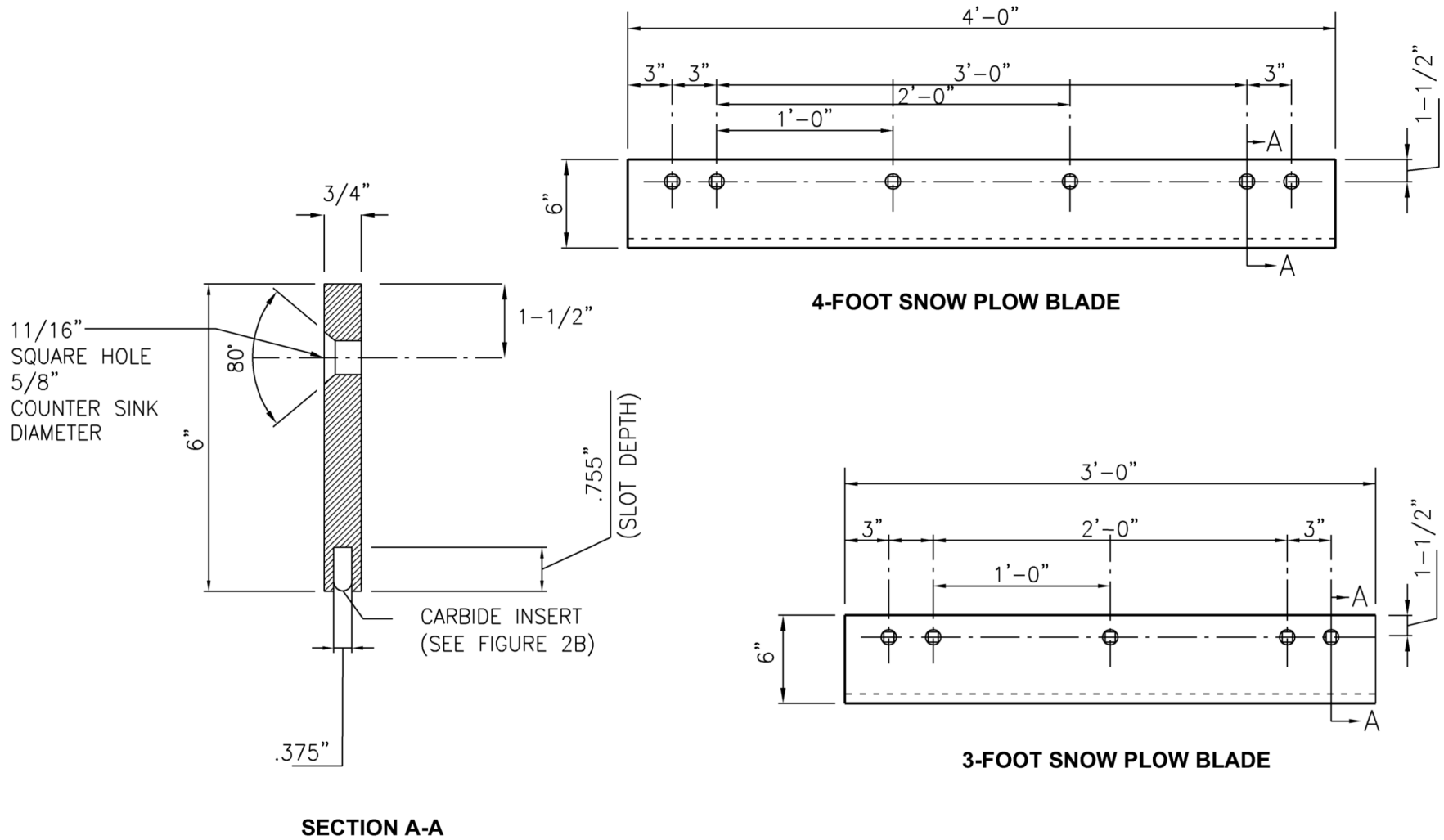

APPENDIX B: SNOW PLOW BLADE DETAIL DRAWING (BULLNOSE)

Figure 1B

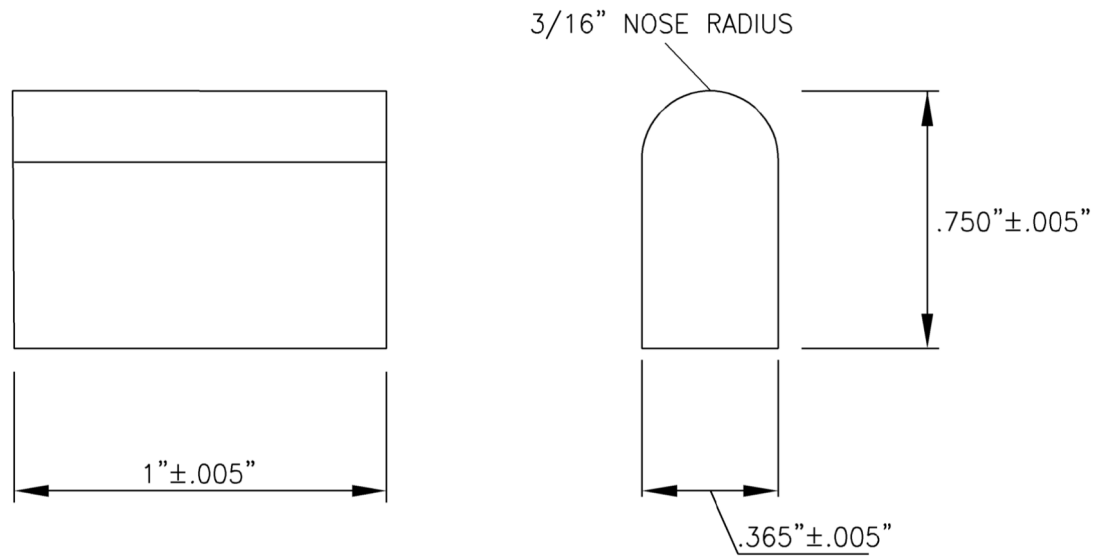

CARBIDE INSERT

Appendix C – Existing Agency Specifications

TABLE C-2

Carbide Plow Blade Specification Comparison Sheet: Iowa to North Dakota

Plow Blade	Iowa	Kansas	Maine	Maryland	Massachusetts	Michigan	Minnesota	Missouri	Montana	North Dakota
Steel Specification	ASTM A36	SAE 1020-1045	SAE 1020	A36	SAE 1021	SAE 1020	SAE 1020-1045	ASTM A 576-90b or ASTM A 575-89	C1020	SAE 1020 or A36
Length (Feet)	3 and 4	3 or 4	3 and 4	?	3 or 4	?	3 or 4	3,4, or 5	3 or 4	?
Height (inches)	6	6	6	?	6	5	5 or 6	5	6 or 8	?
Thickness (inches)	0.75	3/4	0.75	?	3/4		3/4 or 7/8	3/4 or 7/8	3/4	?
Bolt Hole Distance From Top (inches)	1.5	1.5	2	2	1.5		AASHTO	1.5	1.5	?
Bolt Hole Spacing (inches)	?	12	12	3, 3, 12	3 and 12	3 and 12	3 and 12	3 and 12	?	?
Bolt Hole Shape	Square	Square	Square	square	square	Square	Square or Round	square	square	square
Bolt Hole Size (inches)	11/16	11/16	11/16	0.6875	0.6875	11/16	11/16	11/16	11/16	11/16
Bolt Head Countersink Diameter (inches)	?	5/8	5/8	0.625	0.625	5/8	?	5/8	5/8	5/8
Bolt Hole Location Tolerance (inches)	?	?	1/32	0.03125	?	?	1/32	?	?	1/32 horizontal, 1/16 vertical

Carbide Insert										
Grade	?	?	High Shock WC	?	High Stock Virgin WC	Kennametal 3030 or Equal	Kennametal 3030 or Equal	High Shock WC	Kennametal 3030 or Equal	High Shock WC
Segment Length (inches, nominal)	1	1	1	?	?	?	1	1	1	?
Height (inches)	0.642	0.625	0.635	0.625	0.625	0.562	0.625	0.760	0.750	0.750
Height Tolerance (inches)	0.010	0.010	0.005	?	0.005	0.005	?	0.010	0.005	0.010
Width (inches)	0.369	0.375	0.365	0.365	0.365	0.365	0.355	0.365	0.365	0.360
Width Tolerance (inches)	0.005	0.010	?	?	0.010	0.005	?	0.010	0.010	0.004
Cobalt Content (%)	11 to 12.5	10-13	11.5 to 12.5	10.5	10-12	11-13	11-13	10.5-12.5	11-12.5	11-13
Tungsten Carbide Content (%)	N/A	87	87.5 to 88.5	?	?	?	?	?	?	?
All other constituents content (max %)	N/A	?	N/A	?	?	?	?	?	0.0	?
Transverse Rupture Strength (min. PSI)	350,000	?	350,000	350,000	350,000	350,000	?	?	350,000	350,000
Brazing Shear Strength (min. PSI)	30,000	?	30,000	30,000	?	?	30,000	?	30,000	30,000
Insert Spacing Tolerance (inches)	N/A	?	0.010	?	?	?	?	0.01	0.01	?
Shape	Trapezoid	Trapezoid	Trapezoid		Trapezoid	Rectangle	Trapezoid	Rectangle	Trapezoid	Trapezoid
Bottom Angle (degrees)	25	25	25	?	25	0	25 to 30	?	25	25
Nose Radius Minimum (inches)	1/16	1/16	1/16	?	1/16	1/16	1/32 to 1/16	?	1/32	Jan-32

Test Results 95% Min. Confidence										
Surface Cracks, 3X magnification (max %)	N/A	?	N/A	?	?	?	?	?	?	?
Hardness by ASTM B294-92 (HRA)	87.5 to 89.0	87.0	N/A	88.0	87.5	87.5-89	87-88	87-89	87.5-88.5	86.8-89.2
Density by ASTM B311-08 (g/cc)	14.1 to 14.6	14	N/A	14.2	14.1-14.6	14.1-14.6	14.2	14.1-14.6	14.1-14.6	13.9-14.6
Porosity by ASTM B276-05e1	N/A	?	N/A	?	?	A06	?	?	?	A08
	N/A	?	N/A	?	?	B00	?	?	?	B04
	N/A	?	N/A	?	?	C00	?	?	?	C00
Grain Size by ASTM B390-92(2006)	N/A	?	N/A	?	?	?	?	?	?	?
clusters under 200x microscope (%)	N/A	?	N/A	?	?	?	?	?	?	?

TABLE C-3

Carbide Plow Blade Specification Comparison Sheet: New Hampshire to Washington

Plow Blade	New Hampshire	New York	Ohio	Oklahoma	Rhode Island	South Dakota	Texas	Utah	Vermont	Washington
Steel Specification	SAE 1020	SAE 1020	SAE 1020	SAE 1020	A36 or M1020	A36 or SAE1020-1045	A36	A36 or SAE 1020	SAE 1020	A36
Length (Feet)	3 and 4	3 and 4	?	2,3,4,5, or 6	3 or 4	3 or 4	3 or 4	4	3 and 4	2,3,4
Height (inches)	6	6	?	5 or 6	6	6	?	6	6	5 or 6
Thickness (inches)	0.75	0.75	?	3/4 or 7/8	3/4	3/4	?	3/4	0.75	3/4 or 7/8
Bolt Hole Distance From Top (inches)	2	2	?	?	2	2	2	2	2	?
Bolt Hole Spacing (inches)	8	12	?	?	3 and 12	?	12		12	?
Bolt Hole Shape	Square	Square	?	Round	Square	square	square	Square	Square	?
Bolt Hole Size (inches)	11/16	11/16	?	11/16 or 13/16	11/16	11/16	11/16	11/16	11/16	?
Bolt Head Countersink Diameter (inches)	5/8	?	?	5/8 or 3/4	5/8	5/8	5/8	5/8	5/8	?
Bolt Hole Location Tolerance (inches)	1/32	?	?	1/16	1/32	1/16	0.06	.03 horizontal .06 vertical	1/32	?

Carbide Insert										
Grade	High Shock WC		High Shock	High Shock WC	?	High Shock WC	?		High Shock WC	?
Segment Length (inches, nominal)	1	1	1	1	1	1	1	1	1	1
Height (inches)	0.635	0.63	0.625	0.635	0.635	0.635	0.635	0.760	0.635	0.75
Height Tolerance (inches)	0.005	N/A	0.005	0.005	0.005	0.005	0.005	0.010	0.005	?
Width (inches)	0.365	0.360	0.365	0.365	0.365	0.365	0.365	0.360	0.365	0.350
Width Tolerance (inches)	?	N/A	0.010	0.005	0.005	0.01	0.005	0.005	?	?
Cobalt Content (%)	11.5 to 12.5	N/A	10 to 12.5	11-12.5	10 to 12.5	10 to 12.5	11 to 14	11 to 12	11.5 to 12.5	?
Tungsten Carbide Content (%)	87.5 to 88.5	N/A	?	?	?	?	?	?	87.5 to 88.5	?
All other constituents content (max %)	N/A	N/A	?	?	?	?	?	?	N/A	?
Transverse Rupture Strength (min. PSI)	350,000	350,000	350,000	350,000	350,000	350,000	350000 to 450000		350,000	?
Brazing Shear Strength (min. PSI)	30,000	30,000	30,000	30,000	30,000	30,000	?	30,000	30,000	?
Insert Spacing Tolerance (inches)	0.010	N/A	0.010	?	?	0.1	?		0.010	?
Shape	Trapezoid	Trapezoid	Trapezoid	Trapezoid	Trapezoid	Trapezoid	Trapezoid	Rectangular	Trapezoid	Trapezoid
Bottom Angle (degrees)	25	?	25	25	25	25	25		25	?
Nose Radius Minimum (inches)	1/16	1/16	1/16	1/16	1/16	1/16	1/16		1/16	?

Test Results 95% Min. Confidence										
Surface Cracks, 3X magnification (max %)	N/A	N/A	N/A	?	?	?	?	15	N/A	?
Hardness by ASTM B294-92 (HRA)	N/A	88.0	87.8 to 88.6	87.5-89	87.5-89	87.5-89	87.5-89	88-90.5	N/A	88-89
Density by ASTM B311-08 (g/cc)	N/A	N/A	14.1 to 14.6	14.1-14.6	14.1-14.6	14.1-14.6	?	14 to 14.5	N/A	?
Porosity by ASTM B276-05e1	N/A	N/A	N/A	A06	?	A06	A06	A00-A04	N/A	?
	N/A	N/A	N/A	B00	?	B02	B00	B00-B02	N/A	?
	N/A	N/A	N/A	C00	?	C00	C00	C00-C04	N/A	?
Grain Size by ASTM B390-92(2006)	N/A	N/A	N/A	?	?	?	?		N/A	?
clusters under 200x microscope (%)	N/A	N/A	N/A	?	?	?	?	15	N/A	?

TABLE C-4

Carbide Plow Blade Specification Comparison Sheet: West Virginia to Waukesha County

Plow Blade	West Virginia	Wyoming	Dane County	Waukesha County
Steel Specification	?	ASTM A36 or 1020	A36 or 1020	A36 or 1020
Length (Feet)	3 or 4		?	?
Height (inches)	6		?	?
Thickness (inches)	0.5		3/4	?
Bolt Hole Distance From Top (inches)	AASHTO		1.5	1.5
Bolt Hole Spacing (inches)	AASHTO		12	3, 6, or 12
Bolt Hole Shape	AASHTO	Square	square	square
Bolt Hole Size (inches)	AASHTO	11/16	11/16	11/16
Bolt Head Countersink Diameter (inches)	AASHTO	5/8	?	5/8
Bolt Hole Location Tolerance (inches)	?	1/32 horizontal, 1/16 vertical	1/32 horizontal, 1/16 vertical	1/32

Carbide Insert	West Virginia	Wyoming	Dane County	Waukesha County
Grade	WC Cemented	High Shock WC	High Shock WC	High Shock WC
Segment Length (inches, nominal)	?	1	1	?
Height (inches)	?	0.5 + bullnose	0.635	?
Height Tolerance (inches)	?	?	0.005	?
Width (inches)	?	0.365	0.365	?
Width Tolerance (inches)	?	?	0.010	?
Cobalt Content (%)	?	11 to 12.5	11 to 12.5	11+
Tungsten Carbide Content (%)	?	89	?	?
All other constituents content (max %)	?	?	?	?
Transverse Rupture Strength (min. PSI)	?	350,000	350,000	?
Brazing Shear Strength (min. PSI)	?	30,000	30,000	30,000
Insert Spacing Tolerance (inches)	?	?	0.010	?
Shape		Bullnose	Trapezoid	
Bottom Angle (degrees)	?	?	25	
Nose Radius Minimum (inches)	?	?	1/16	

Test Results 95% Min. Confidence	West Virginia	Wyoming	Dane County	Waukesha County
Surface Cracks, 3X magnification (max %)	?	?	?	?
Hardness by ASTM B294-92 (HRA)	88.0	87.5-89	87.5 to 89	?
Density by ASTM B311-08 (g/cc)	?	14.1-14.6	14.1-14.6	?
Porosity by ASTM B276-05e1	?	A06	A06	?
	?	B02	B00	?
	?	C00	C00	?
Grain Size by ASTM B390-92(2006)	?		?	?
clusters under 200x microscope (%)	?		?	?

Appendix D – Agency Survey

Appendix D – Agency Survey

On behalf of Clear Roads, SRF Consulting Group is working on a project to develop Standard Specifications for Plow Blades with Carbide Inserts. Using plow blades with carbide inserts is an effective option many agencies currently use to remove snow and ice from the roadway. However, there is variability in the specifications used by each agency to procure the blades. Clear Roads initiated this project to develop a set of standard specifications for carbide-insert plow blades that will simplify and streamline the procurement process for all agencies.

Your participation is requested in taking a short survey (5-10 minutes) to better understand current uses, opinions, and practices of plow blades with carbide inserts. Comment boxes are provided for each question – to improve our understanding, please provide any insight into why you selected each response.

Q1: Provided the project information above, will you be the main contact for the project?

- YES
- NO

Q2: If answered “No” for the previous question, please provide a main contact for project.

Name:
Title:
Phone:
Email:

Q3. What type(s) of plow(s) do you use? (check all that apply)

- Front
- Wing
- Underbody
- Tow

Q4: Does your agency use steel plow blades with carbide inserts? (This project is looking specifically at steel plow blades with carbide inserts. We will not be developing specifications for blades consisting of rubber, ceramic, neoprene, or other materials.)

- YES
- NO
- NOT SURE

Q5: If answered “No” to Q4, has your agency used steel plow blades with carbide inserts in the past?

- YES
- NO
- NOT SURE
- N/A

Q6: If answered “No” to Q4, please describe the blade type(s) your agency currently uses and/or why steel blades with carbide inserts are not used.

If answered “No” to Q4, the survey is concluded. Thank you for your time.

Q7: What vendor(s) has your Agencies used to order plow blades with carbide inserts?

Q8: The National Association of State Procurement Officials (NASPO) has an open cooperative contract for Snowplow Cutting Edges through its ValuePoint division. Have you ordered snow plow blades with carbide inserts through NASPO?

- YES
- NO
- NOT SURE

Q9: If answered “Yes” to the question above, please describe your experience. If answered “No” to the question above, please explain why you have not used this option.

The following questions are grouped into three categories.

Category A. Application of Findings in Clear Roads 07-01: Development of Standardized Test Procedures for Carbide Insert Snowplow Blade Wear

Q10: This Clear Roads project established a set of laboratory procedures and a purchasing process that would limit the risk of poor quality carbide inserts in snowplow blades. A three-step testing procedure was developed to determine the acceptability of the inserts. Are you familiar with this research and its findings?

- YES
- NO

Q11. CR 07-01 identified four ASTM test specifications to be applied in the process of ordering carbide inserts. They are listed below. Identify any test specifications that your agency uses for ordering carbide inserts? (Select all that apply)

- Hardness
- Density
- Porosity
- Grain Size

Q12. Has someone in your supply line tested parts to these ASTM specifications?

- YES
- NO
- NOT SURE

Q13. Did you receive the results of the lab tests?

- YES
- NO
- NOT SURE

Q14. Are the lab test results available upon your request?

- YES
- NO
- NOT SURE

Q15. Please include comments on other aspects of CR 07-01 project findings that you have used:

Q16. Do you have any questions regarding the CR 07-01 project findings or its use?

Category B. Blades and Inserts

Q17. In most cases do your blades ultimately fail with equal wear of the insert AND blade?

- YES
- NO
- NOT SURE

Q18. What percentage of the carbide inserts are worn before typically changing the blade?

- 100%
- 90%
- 80%
- Less than 80%
- Not sure

Q19. If failure is due to cracks and chips, which is most likely to fail first?

- Blade
- Insert
- Not Sure

Q20. Are the replaced blades with the leftover carbide insert material treated as a hazardous waste in your State?

- YES
- NO
- NOT SURE

Q21. In general, are you satisfied with the product you are currently using?

- YES
- NO
- NOT SURE

Category C. Parties in Supply Chain

There may be four or more parties in supply chain: insert manufacturer, assembler, supplier (could be the same as the assembler), and end user.

Q22. Does your supplier also assemble the carbide inserts into the blade?

- YES
- NO
- NOT SURE

Q23. How frequently do you order steel blades with carbide inserts?

- Each year
- 2 years
- 3 years or more
- Not Sure

Q24. In the past 5-6 years, what quantity of blades with carbide inserts do you typically order per year?

Q25. In the past 5-6 years, what is the largest quantity ordered?

Q26. In your supply chain, do you know who does the blade and carbide insert sampling and testing? Please comment on

who you feel is best qualified to do this testing.

- Assembler
- Supplier
- End User
- Not Sure

Appendix E – Vendor Survey



Appendix E - Vendor Survey

	YES	NO
1. Do you supply steel plow blade assemblies WITH carbide inserts ?	_____	_____
2. Do you braze the inserts into the blade ?	_____	_____
3. Do you purchase the carbide inserts ?	_____	_____
4. Are quality standards and certifications required with the purchase of inserts ?	_____	_____
5. Does the DOT (or end user) select the quality standards ?	_____	_____
6. Are ASTM standards used for the testing and reporting to the DOT's ?	_____	_____
7. Are you familiar with "Acceptable Quality Level" (AQL) inspections ?	_____	_____
8. Do you have actual working experience with AQL's ?	_____	_____
9. Do you know of a metals test lab that certifies their testing and results ?	_____	_____
10. If you purchase the inserts, do you order a quantity for multiple DOT orders ?	_____	_____
11. In the past 4-5 years, what is a typical quantity ordered (per season) ?		
12. Is this usually a "one per year" order ?	_____	_____
13. What is a typical price for a blade assembly of about 3 - 4 ft. long ?		
14. What is your estimate of the cost of the inserts in this type of blade ?		
15. What carbide insert shape is most popular ?		
16. Are there limits on size and shape of inserts related to manufacturing processes ?	_____	_____
17. Do you have specifications, drawings and literature for your plow blades with inserts ?	_____	_____
18. Do you have suggestions to improve procurement specifications ?		
19. What is your best selling type of snow plow blade ?		
20. Do you have comments regarding industry trends, innovative ideas, or other feedback ?		

Appendix F – Agency Survey Results

Attachment F - Agency Survey Results

Q1. Please provide your contact information.		
Answer Choices	Responses	
Name:	100.00%	29
Title:	96.55%	28
Phone	93.10%	27
Email:	100.00%	29
	Answered	29
	Skipped	0

Q2a. What type(s) of plow(s) does your agency use? (Check all that apply)		
Answer Choices	Responses	
Front	96.30%	26
Wing	96.30%	26
Underbody	44.44%	12
Tow	77.78%	21
	Answered	27
	Skipped	2

Q2b. Comments:		
We mainly use wing, underbody, and tow plow blades. We use front in some circumstances.	Melissa Longworth	Michigan
Our fleet consists of trucks with front plows only, front plows with right hand wings, and front plows with double wings (left and right side). At UDOT we mostly use front plows, but there are some trucks that have wings and tow plows.	Joseph A. Bucci, P.E.	Rhode Island
Only have two tow plow	Ryan Ferrin	Utah
	Steve Spoor	Idaho

Q3a. Does your agency currently use steel plow blades with carbide inserts? (This project is looking specifically at steel plow blades with carbide inserts. We will not be developing specifications for blades consisting of rubber, ceramic, neoprene, or other materials.)		
Answer Choices	Responses	
Yes	92.59%	25
No	7.41%	2
Not Sure	0.00%	0
	Answered	27
	Skipped	2

Q3b. Comments:		
We use steel blades with tungsten carbide inserts for our underbody plows.	Melissa Longworth	Michigan
Some but not many. Using mostly high performance plow blades	Larry Gangl	North Dakota
Currently only on Tow Plow and one pilot truck.	Scott Niland	Connecticut
We use Chemung's Standard Carbide mostly, but have also tried out the Ice O' Force, Lake Effect, Joma, Blockbuster, Razor, Polar Flex, Evolution VST, Joma Replacement (TXS), and Patriots which are all considered "high performance" blades.	Ryan Ferrin	Utah
Used on front plows only. Not on wing	Mark Goldstein	Massachusetts
We use or are trying several designs.	Robert Vasek	Minnesota

Q4a. Has your agency used steel plow blades with carbide inserts in the past?		
--	--	--

Attachment F - Agency Survey Results

Answer Choices	Responses	
Yes	50.00%	1
No	50.00%	1
Not Sure	0.00%	0
	Answered	2
	Skipped	27

Q4b. Please describe the blade type(s) your agency currently uses and/or why steel blades with carbide inserts are not used:		
Joma blades	William Davenport	Pennsylvania

Q5a. What vendor(s) has your agency used to order plow blades with carbide inserts?		
Chumung, Kennametal	Brad Maupin	South Dakota
Not Sure	Sandi Sauter	Maryland
Far North Supply providing Kennametal brand & most recently, Alaska Wear Steel providing the Valk Manufacturing brand	Becky Gattung	Alaska
We order all of our blades through MANCON	Scott Lucas	Ohio
Kennametal Inc. and Chemung Supply Corporation	Melissa Longworth	Michigan
VALK Manufacturing Company	Joseph Bucci	Rhode Island
Various	Russell Modrell	California
Atlantic Broom and Built Blades	Scott Noland	Connecticut
Not sure	Larry Gangl	North Dakota
Chemung	Ryan Ferrin	Utah
Valley Blades will be our supplier for the 2018-2019 winter season. Previously we had a contract with Chemung Supply.	Craig Bargfrede	Iowa
kennimetal	Clifford Spoonemore	Wyoming
Kueper, Winter equipment, Built Blades, Chemung iron works, Valk	Bruce Nichols	Vermont
Kenna Metals, Winter, Ironhawk	Jeff Pifer	West Virginia
Kueper, Polar Flex	Mark Goldstein	Massachusetts
???	Tom Renninger	Alaska
First State	Alastair Probert	Delaware
H&L Mesabi (Standard and Kuper), Winter Equipment (Block Buster and Performance Pack), Kris Engineering (JOMA), Bucyrus (Standard), Iron Hawk Industrial (Lake Effect and Ice of Force), Kennametal (Standard)	Robert Vasek	Minnesota
Wlnter Equipment,Kuper	David Gray	New Hampshire
Vaulk, maybe others	Clay Adams	Kansas
Valk (Poor Quality)	Steve Spoor	Idaho

Q5b. Comments:		
MANCON is a parts supplier for equipment.	Scott Lucas	Ohio
We mainly use Kennametal Inc.	Melissa Longworth	Michigan
Built Blade - Test Blade Atlantic Broom - came standard on Viking Tow Plows	Scott Niland	Connecticut
Minnesota has a multi-award contract with various products available. I included the specific products or Manufacturers in parentheses above after the specific vendor.	Robert Vasek	Minnesota

Attachment F - Agency Survey Results

Q6a. The National Association of State Procurement Officials (NASPO) has an open cooperative contract for Snowplow Cutting Edges through its ValuePoint division. Have you ordered snow plow blades with carbide inserts through NASPO?

Answer Choices	Responses	
Yes	19.05%	4
No	76.19%	16
Not Sure	14.29%	3
	Answered	21
	Skipped	5

Q6b. If you answered "Yes" to the question above, please describe your experience. If answered "No" to the question above, please explain why you have not used this option.

No issues, Called and got quote and purchased	Brad Maupin	South Dakota
The NASPO contract is not cost effective for Alaska's diverse shipping challenges. We annually bid firm quantities FOB to the final destination and receive the best possible shipping rate based on quantity/weight. NASPO pricing is based on "as-needed" quantities. This method does not get us the best price.	Becky Gattung	Alaska
This year we noticed a rise in blade cost due to a reported price of steel increase.	Joseph Bucci	Rhode Island
Connecticut purchases off its own contract.	Scott Niland	Connecticut
I have heard of many issues surrounding SciQuest where bids are placed. The idea behind NASPO is nice, but the methodology needs a ton of work to make bidding easier. It doesn't do anyone any good when prospective bidders give up and fail to bid because they can't get SciQuest to work.	Ryan Ferrin	Utah
WYDOT Procurement Services believes that they get better prices bidding the carbide blades on the open market rather than using the NASPO price listing.	Clifford Spoonmoore	Wyoming
We have contracts with these vendors thought our state procurement office	Bruce Nichols	Vermont
"We procure through the MassDOT contract we have with Kueper and Atlantic Broom." is what the buyer said. We will be looking into the NASPO alternative!	Mark Goldstein	Massachusetts
We have not evaluated whether it would offer us the flexibility we are looking for.	Robert Vasek	Minnesota
Idaho was one of the member states on this NASPO contract and has participated in the steel/carbide blade portion by purchasing all of our blades from this contract. We recently started purchasing Winter Equipment Blades from the contract as well. The Valk blades purchased have shown less than desired quality	Steve Spoor	Idaho

Q7a. This Clear Roads project established a set of laboratory procedures and a purchasing process that would limit the risk of poor quality carbide inserts in snowplow blades. A three-step testing procedure was developed to determine the acceptability of the inserts. Are you familiar with this research and its findings?

Answer Choices	Responses	
Yes	35.00%	7
No	65.00%	13

Attachment F - Agency Survey Results

	Answered	20
	Skipped	7

Q7b. Comments:		
I am aware there was a study, but not familiar with the findings.	Melissa Longworth	Michigan
Sorry, I'm familiar but the majority of WYDOT is not aware of this process.	Clifford Spoonemore	Wyoming

Q8a. CR 07-01 identified four ASTM test specifications to be applied in the process of ordering carbide inserts. They are listed below. Identify any test specifications that your agency uses for ordering carbide inserts.		
	Answer Choices	Responses
	Hardness	38.89% 7
	Density	33.33% 6
	Porosity	11.11% 2
	Grain Size	5.56% 1
	Not Sure	61.11% 11
	Answered	18
	Skipped	7

Q8b. Comments:		
Our specifications require compliance to SAE 1020 specs with grade SP341 Macro crystalline type WC, tungsten carbide and a hardness based on the Rockwell "A" scale.	Becky Gattung	Alaska
I am not sure.	Scott Lucas	Ohio
We currently have no in house testing for the ASTM specifications.	Joseph Bucci	Rhode Island
We don't test our plow edges	Larry Gangl	North Dakota
Hardness 88 to 90.5 HRA, Density 14 to 14.5 g/cc, Porosity A00-A04 B00 -B02 C00-C04, Grain Size 10M/10C 15% or less have large voids or void clusters when viewed under a 200 power microscope.	Ryan Ferrin	Utah
None Used	Mark Goldstein	Massachusetts
100% virgin carbide required, 11-13 % cobalt required, Reference to Kennemetal 3030 or approved equal. Mining Grade and High Shock Resistance. We spec the inserts as part of the edges and do not order inserts. We have discussed grain size but do not have the capability to test for that.	Robert Vasek	Minnesota
None of the above	Steve Spoor	Idaho

Q9a. Has someone in your supply chain tested parts to these ASTM specifications?		
	Answer Choices	Responses
	Yes	21.05% 4
	No	57.89% 11
	Not sure	21.05% 4
	Answered	19
	Skipped	7

Q9b. Comments:		
In 2016, we received bids for blades made in China from The Blomfield Co. in Anchorage and requested acceptance testing at Simon Forensic, LLC in Shoreline, WA.	Becky Gattung	Alaska
I am not sure.	Scott Lucas	Ohio

Attachment F - Agency Survey Results

We require the supplier to certify that they meet our specifications. Our carbide is sold as virgin carbide and is tested by the tip manufacturer prior to final assembly at VALK. I was informed they are not tested to ASTM specifications.	Melissa Longworth	Michigan
We have steel inspectors that randomly test for QC/QA	Joseph Bucci	Rhode Island
	Ryan Ferrin	Utah

Q9c. Did you receive the results of the lab tests?		
Answer Choices	Responses	
Yes	11.11%	2
No	77.78%	14
Not Sure	11.11%	2
	Answered	18
	Skipped	8

Q9d. Comments:		
I am not sure.	Scott Lucas	Ohio
We require the supplier to certify that they meet our specifications. It has been a long time since I received a report. No failures of test procedures that I am aware of.	Melissa Longworth	Michigan
	Robert Vasek	Minnesota

Q9e. Are the lab test results available upon your request?		
Answer Choices	Responses	
Yes	33.33%	6
No	44.44%	8
Not Sure	22.22%	4
	Answered	18
	Skipped	8

Q9f. Comments:		
From the bidding vender	Brad Maupin	South Dakota
I am not sure.	Scott Lucas	Ohio
We require the supplier to certify that they meet our specifications. Lab testing has been requested from the manufacturer, we are waiting for the results.	Melissa Longworth	Michigan
	Joseph Bucci	Rhode Island

Q10. Please include comments on other aspects of CR 07-01 project findings that you have used:		
None	Brad Maupin	South Dakota
I don't have any at this time.	Scott Lucas	Ohio
I am unfamiliar with this project.	Joseph Bucci	Rhode Island
None	Russell Modrell	California
na	Clifford Spoonemore	Wyoming
none	Bruce Nichols	Vermont

Q11. Do you have any questions regarding the CR 07-01 project findings or its use?		
No	Brad Maupin	South Dakota
No.	Scott Lucas	Ohio
Is there a list of manufacturers that provide certification of compliance with ASTM test specifications?	Joseph Bucci	Rhode Island
No	Russell Modrell	California
This is the first that I have heard of this study since I just took this job 9 months ago. I will now read into it further.	Ryan Ferrin	Utah
na	Clifford Spoonemore	Wyoming
no	Bruce Nichols	Vermont

Attachment F - Agency Survey Results

Is anyone using porosity and grain size and what test equipment or procedures does it take. concern with "new" requirements is whether any vendor could meet them.	Robert Vasek	Minnesota
--	--------------	-----------

Q12a. In most cases do your blades ultimately fail with equal wear of the insert AND blade?		
Answer Choices	Responses	
Yes	47.37%	9
No	26.32%	5
Not Sure	26.32%	5
	Answered	19
	Skipped	7

Q12b. Comments:		
This is a question for our field personnel	Becky Gattung	Alaska
Wear is dependent on the route maintained, loading, and other local factors. In general they wear equally.	Melissa Longworth	Michigan
Have not had to change blades. Currently 2 years on tow plow blades 1 season on Built Blade	Scott Niland	Connecticut
Blades are failing first. One blade section will fall off and then wear the mold board down to a useless condition, necessitating a \$2,800 repair and more importantly removing the truck from service	Mark Goldstein	Massachusetts
The insert is usually worn down first. The crown of the roads oftentimes causes uneven wearing across the entire blade with the insert being the first to be fully gone	Ryan Ferrin	Utah
blade savers are not used correctly. Not sure if this is bad habits or bad training.	Clifford Spoonemore	Wyoming
Not sure what this question is about. Wear will be different from one end of a plow to another with end sections wearing more or unevenly in urban areas. We do have some insert failure likely due to hitting something.	Robert Vasek	Minnesota

Q13a. What percentage of the carbide inserts are worn before typically changing the blade?		
Answer Choices	Responses	
100%	15.79%	3
90%	47.37%	9
80%	5.26%	1
Less than 80%	10.53%	2
Not sure	21.05%	4
	Answered	19
	Skipped	7

Q13b. Comments:		
This is a question for our field personnel	Becky Gattung	Alaska
Have not had to change blades. Currently 2 years on tow plow blades 1 season on Built Blade	Scott Niland	Connecticut
usually 95-100	Larry Gangl	North Dakota
This depends on the storm that is predicted to come at us. If a short storm the blade is used up. If it is a long storm the blades are changed under dry conditions before the storm arrives.	Clifford Spoonemore	Wyoming

Q14a. If failure is due to cracks and chips, which is most likely to fail first?		
--	--	--

Attachment F - Agency Survey Results

Answer Choices	Responses	
Blade	22.22%	4
Insert	27.78%	5
Not sure	50.00%	9
	Answered	18
	Skipped	7

Q14b. Comments:		
This is a question for our field personnel	Becky Gattung	Alaska
We rarely see cracks, if we do it is usually a total blade loss.	Joseph Bucci	Rhode Island
Pieces will fall out or deform to the point where it doesn't make good contact with the roadway anymore.	Ryan Ferrin	Utah
inserts break and fall out.	Clifford Spoonemoore	Wyoming
The insert will break out due to brazing heating up or impact. Not a big issue with cracks/chips.	Robert Vasek	Minnesota

Q15a. Are the replaced blades with the leftover carbide insert material treated as a hazardous waste in your State?	Answer Choices	Responses	
	Yes	5.26%	1
	No	73.68%	14
	Not Sure	21.05%	4
		Answered	19
		Skipped	7

Q15b. Comments:		
This is a question for our field personnel	Becky Gattung	Alaska
No, we aren't weird about carbide.	Ryan Ferrin	Utah

Q16a. In general, are you satisfied with the product you are currently using?	Answer Choices	Responses	
	Yes	75.00%	15
	No	10.00%	2
	Not Sure	15.00%	3
		Answered	20
		Skipped	7

Q16b. Comments:		
WYDOT does not have a good handle on the life cycle for a carbide blade. It ranges between 40 hours and 80 hours.	Clifford Spoonemoore	Wyoming
We are still trying new and different products every year.	Bruce Nichols	Vermont
We use multiple products and are always looking for better products.	Robert Vasek	Minnesota

Q17a. Does your supplier also assemble the carbide inserts into the blade?	Answer Choices	Responses	
	Yes	65.00%	13
	No	5.00%	1
	Not Sure	25.00%	5
		Answered	19
		Skipped	8

Attachment F - Agency Survey Results

Q17b. Comments:		
This is a question for our field persone	Becky Gattung	Alaska
Carbide comes from China, then installed into the blade at Valk.	Joseph Bucci	Rhode Island

Q18a. How frequently do you order steel blades with carbide inserts?			
	Answer Choices	Responses	
Each year		83.33%	15
2 years		0.00%	0
3 years or more		5.56%	1
Not sure		11.11%	2
	Answered		18
	Skipped		8

Q18b. Comments:		
None	Russell Modrell	California
We order just a small amount compared to what we have in the past. Again, we use mainly HP edges	Larry Gangl	North Dakota
Orders go out around August or September of every year.	Ryan Ferrin	Utah

Q19a. In the past 5-6 years, what quantity of blades with carbide inserts have you typically ordered per year?		
9000 Feet avg	Brad Maupin	South Dakota
Not Sure	Sandi Sauter	Maryland
2014 = 1451 ea., 2015 = 1197ea., 2016 = 692ea., 2017 = 750ea., 2018 = 996ea.	Becky Gattung	Alaska
I am not sure.	Scott Lucas	Ohio
1300	Melissa Longworth	Michigan
We order 1000 to 2000 blades depending on the storm severity of the previous winter.	Joseph Bucci	Rhode Island
Not sure	Russell Modrell	California
1	Scott Niland	Connecticut
Not sure	Larry Gangl	North Dakota
30	Mark Goldstein	Massachusetts
About 100 per year	Ryan Ferrin	Utah
For the past 5-6 years we average about 1200 blades per year.	Craig Bargfrede	Iowa
4000	Clifford Spoonemore	Wyoming
400-1200 sets for 11' PLOWS	Bruce Nichols	Vermont
Not sure	Jeff Pifer	West Virginia
none really. going over to JOMA blades	alastair probert	Delaware
I dont track them	Robert Vasek	Minnesota

Q19b. Comments:		
Past 3 years of data was available	Melissa Longworth	Michigan
we take inventory each off-season prior to ordering blades.	Joseph Bucci	Rhode Island
One trail set (Built Blades) Tow plows are w/ standard blades (Atlantic Broom)	Scott Niland	Connecticut
These are ordered at the individual service districts, not at a statewide level.	Jeff Pifer	West Virginia

Q20a. In the past 5-6 years, what was the largest quantity ordered?		
6540	Brad Maupin	South Dakota
Not Sure	Sandi Sauter	Maryland

Attachment F - Agency Survey Results

1451 ea.	Becky Gattung	Alaska
I am not sure.	Scott Lucas	Ohio
1469	Melissa Longworth	Michigan
2250	Joseph Bucci	Rhode Island
Not sure	Russell Modrell	California
1	Scott Niland	Connecticut
Not sure	Larry Gangl	North Dakota
120	Mark Goldstein	Massachusetts
200	Ryan Ferrin	Utah
For the upcoming 2018-2019 season we have 1600 blades on order.	Craig Bargfrede	Iowa
6000	Clifford Spoonemore	Wyoming
1200	Bruce Nichols	Vermont
Not sure	Jeff Pifer	West Virginia
none really. using up inventory	alastair probert	Delaware
Unkown	Robert Vasek	Minnesota

Q20b. Comments:		
Past 3 years of data was available	Melissa Longworth	Michigan
These are ordered at the individual service districts, not at a statewide level.	Jeff Pifer	West Virginia

Q21a. In your supply chain, do you know who does the blade/carbide insert sampling and testing? Please comment on who you feel is best qualified to do this testing.			
	Answer Choices	Responses	
Assembler		5.56%	1
Supplier		22.22%	4
End User		16.67%	3
Not Sure		55.56%	10
	Answered		18
	Skipped		8

Q21b. Comments:		
I would suggest contacting Doug Burke in our office of Equipment Management for more details on the questions. His number is 614-351-2836 and his email is Doug.Burke@dot.ohio.gov. I wanted to provide some information for the survey. I have not been able to contact him as he has been out of the office a lot.	Scott Lucas	Ohio
Testing by each vendor in the supply chain and the end user would be best.	Joseph Bucci	Rhode Island
Most likely the assembler.	Jeff Pifer	West Virginia



research for winter highway maintenance

Lead state:

Minnesota Department of Transportation

Research Services & Library

395 John Ireland Blvd.

St. Paul, MN 55155