

# JOINT TRANSPORTATION RESEARCH PROGRAM

INDIANA DEPARTMENT OF TRANSPORTATION  
AND PURDUE UNIVERSITY



## Life-Cycle Cost Analysis for Short- and Medium-Span Bridges



**Stefan L. Leiva Maldonado**

**Mark D. Bowman**

## RECOMMENDED CITATION

Leiva Maldonado, S. L., & Bowman, M. D. (2019). *Life-cycle cost analysis for short- and medium-span bridges* (Joint Transportation Research Program Publication No. FHWA/IN/JTRP-2019/09). West Lafayette, IN: Purdue University. <https://doi.org/10.5703/1288284316919>

## AUTHORS

### **Stefan L. Leiva Maldonado**

Graduate Research Assistant  
Lyles School of Civil Engineering  
Purdue University

### **Mark Bowman, PhD**

Professor of Civil Engineering  
Lyles School of Civil Engineering  
Purdue University  
(765) 494-2220  
[bowmanmd@purdue.edu](mailto:bowmanmd@purdue.edu)  
*Coresponding Author*

## ACKNOWLEDGMENTS

Our research team is most grateful to the Study Advisory Committee members who provided outstanding support during this study: Timothy Wells, Jeremy Hunter, Edward Spahr, and Ron McCaslin. Thanks are also extended to Mr. Tariq Saeed, who was a big help with understanding the bridge deterioration modeling, and to Mr. Francisco Pena, who assisted with the corresponding programming in Matlab. Lastly, we extend a special thank you to Edward Spahr, who assisted greatly with the agency cost allocation and provided an outstanding work experience and engineering judgment throughout.

## JOINT TRANSPORTATION RESEARCH PROGRAM

The Joint Transportation Research Program serves as a vehicle for INDOT collaboration with higher education institutions and industry in Indiana to facilitate innovation that results in continuous improvement in the planning, design, construction, operation, management and economic efficiency of the Indiana transportation infrastructure. [https://engineering.purdue.edu/JTRP/index\\_html](https://engineering.purdue.edu/JTRP/index_html)

Published reports of the Joint Transportation Research Program are available at <http://docs.lib.purdue.edu/jtrp/>.

## NOTICE

The contents of this report reflect the views of the authors, who are responsible for the facts and the accuracy of the data presented herein. The contents do not necessarily reflect the official views and policies of the Indiana Department of Transportation or the Federal Highway Administration. The report does not constitute a standard, specification or regulation.

## TECHNICAL REPORT DOCUMENTATION PAGE

<b>1. Report No.</b> FHWA/IN/JTRP-2019/09	<b>2. Government Accession No.</b>	<b>3. Recipient's Catalog No.</b>	
<b>4. Title and Subtitle</b> Life-Cycle Cost Analysis for Short- and Medium-Span Bridges		<b>5. Report Date</b> May 2019	
		<b>6. Performing Organization Code</b>	
<b>7. Author(s)</b> Stefan L. Leiva Maldonado and Mark D. Bowman		<b>8. Performing Organization Report No.</b> FHWA/IN/JTRP-2019/09	
<b>9. Performing Organization Name and Address</b> Joint Transportation Research Program (SPR) Hall for Discovery and Learning Research (DLR), Suite 204 207 S. Martin Jischke Drive West Lafayette, IN 47907		<b>10. Work Unit No.</b>	
		<b>11. Contract or Grant No.</b> SPR-3914	
<b>12. Sponsoring Agency Name and Address</b> Indiana Department of Transportation State Office Building 100 North Senate Avenue Indianapolis, IN 46204		<b>13. Type of Report and Period Covered</b> Final Report	
		<b>14. Sponsoring Agency Code</b>	
<b>15. Supplementary Notes</b> Conducted in cooperation with the U.S. Department of Transportation, Federal Highway Administration.			
<b>16. Abstract</b> Life-cycle cost analysis (LCCA) has been defined as a method to assess the total cost of a project. It is a simple tool to use when a single project has different alternatives that fulfill the original requirements. Different alternatives could differ in initial investment, operational and maintenance costs among other long term costs. The cost involved in building a bridge depends upon many different factors. However, long-term cost need to be considered to estimate the overall cost of the project and determine its LCC. Without watchful consideration of the long-term costs and full life-cycle costing, current investment decisions that look attractive could be resulting in a waste of economic resources in the future. This research is focused on short and medium span bridges (between 30 ft and 130 ft) which represents 57% of the NBI INDIANA bridge inventory. Bridges are categorized in three different groups of span ranges. Different superstructure types are considered for both concrete and steel options. Types considered include: bulb tees, AASHTO prestressed beams, slab bridges, prestressed concrete box beams, steel beams, steel girders, folded plate girders and simply supported steel beams for dead load and continuous for live load (SDCL). A design plan composed of simply supported bridges and continuous spans arrangements was carried out. Analysis for short and medium span bridges in Indiana based on LCCA is presented for different span ranges and span configurations. Results will help designers to consider the most cost-effective bridge solution for new projects, resulting in cost savings for agencies involved.			
<b>17. Key Words</b> deterioration factors, agency costs, discount rate, service life, working actions, life-cycle profiles, life-cycle cost analysis		<b>18. Distribution Statement</b> No restrictions. This document is available through the National Technical Information Service, Springfield, VA 22161.	
<b>19. Security Classif. (of this report)</b> Unclassified	<b>20. Security Classif. (of this page)</b> Unclassified	<b>21. No. of Pages</b> 232 including appendices	<b>22. Price</b>

## EXECUTIVE SUMMARY

### Introduction

Life-cycle cost analysis (LCCA) is a method used to assess the total cost of a project. LCCA is particularly useful when a single project has different alternatives that fulfill the original requirements. Alternatives could differ in initial investment or cost, operational costs, maintenance costs, or other long-term costs. This kind of analysis, when applied to bridge infrastructure projects, is called bridge life-cycle cost analysis (BLCCA). According to NCHRP Report 483 (Hawk, 2002): "Several recent legislative and regulatory requirements recognized the potential benefits of life-cycle cost analysis and call for consideration of such analyses for infrastructure investments, including investments in highway bridge programs." This contemporary tendency has been the main driving force for the research and use of BLCCA throughout the country. The current study focuses on efforts to identify the best approach to incorporate BLCCA in new bridge construction in Indiana.

The cost involved in building a bridge depends upon different factors. The following features can play a role in the initial cost:

- number of substructure elements needed;
- right-of-way and earthwork required to develop the height of the approach due to the depth of the bridge structure type;
- typical deck span and thickness for the superstructure;
- span length and material properties;
- distance for shipping from the precast plant or fabrication shop to the bridge site; and
- familiarity of the contractors with the type of bridge construction.

However, long-term costs must be considered when estimating the overall cost of the project and determining its LCC.

Long-term costs include but are not limited to the following:

- repair or rehabilitation of the bridge deck;
- repair of collision-damaged concrete or steel girders;
- repainting a steel bridge;
- removal of the deck for a pre-stressed bulb-tee without damaging the girder;
- routine maintenance;
- the cost of inspection for fracture-critical steel bridges;
- inspection to identify and repair duct voids in grouted post-tensioned concrete bridges;
- and miscellaneous minor repairs such as spot painting or concrete patching.

Without watchful consideration of the long-term costs and full life-cycle costing, initial investment decisions that look attractive could result in a waste of economic resources. The design decision at the beginning of the project can create less than optimal requirements in future years. According to the American Society

of Civil Engineers and ENO Center of Transportation (2014): "An examination of the full life-cycle costs can help an agency in determining the appropriate investment in an asset given current and future constraints."

### Findings

For this project an initial cost and LCCA comparison was made for simply supported and continuous bridge structures. Different LCC profiles were proposed for different superstructure types. Additionally, cost-effective life-cycle profiles were suggested for the different alternatives.

Three different bridge span ranges were proposed to categorize the cost-effectiveness of multiple superstructure design solutions:

- span range 1 for bridges with maximum spans between 30 ft and 60 ft;
- span range 2 for spans within 60 ft and 90 ft; and
- span range 3 for structures longer than 90 ft and shorter than 130 ft.

Additionally, cost allocation for different agency costs including initial and long-term costs were presented. User costs were avoided since those depend on assumptions of traffic and specific site conditions that are considered an oversimplification for the aim of this report.

In order to compare different alternatives with different service lives, the present worth of the LCC method was suggested. This method computes the net present value of a single LCC that is repeated over time indefinitely based on its service life. Using this method, a LCCA comparison was made for simply supported and continuous bridges. Results showed that for span range 1, slab bridges are the most cost effective solution for spans up to 35 ft. In contrast, a galvanized steel alternative is the optimal solution for spans up to 60 ft (for the case of simply supported beams, cost-effectiveness of the galvanized option goes up to 65 ft). For spans longer than 60 ft, the prestressed bulb tee option is the most cost-effective solution, for both simply supported and continuous beams. However, for simply supported beams, galvanized steel plate girders are also cost-effective for spans between 90 ft and 105 ft.

### Implementation

The LCC profiles developed in this study can be applied to the planning and design of new state and locally owned bridges. As a result, INDOT now has proposed profiles for different superstructure types that correspond to the most effective working action distribution for new bridges. Charts included in this report present the most cost-effective bridge structure solutions for simply supported and continuous bridges of different span ranges. These charts are a suggested tool for designers to use during the early stages of planning for new structures. Their use could result in the most cost-effective structure selection for new bridges and ultimately result in cost savings for bridge owners.

## CONTENTS

1. INTRODUCTION . . . . .	1
1.1 Objective . . . . .	1
1.2 Scope . . . . .	1
2. LITERATURE REVIEW . . . . .	1
2.1 Bridge Superstructure Types . . . . .	1
2.2 Deterioration Curves . . . . .	5
2.3 Bridge Life-Cycle Cost Analysis (BLCCA) . . . . .	7
3. BRIDGE DESIGN PLAN. . . . .	8
3.1 Superstructure Types Selection . . . . .	8
3.2 Span Configuration and Span Ranges Selection . . . . .	9
3.3 Bridge Design . . . . .	10
4. COST ALLOCATION . . . . .	13
4.1 Outliers Identification . . . . .	13
4.2 Design Costs (DC) . . . . .	14
4.3 Construction Costs (CC) . . . . .	14
4.4 Maintenance Costs and Rehabilitation Costs (MC and RC) . . . . .	16
4.5 Salvage Costs (SC) . . . . .	17
4.6 User Costs (UC) . . . . .	17
5. DETERIORATION MODELS FOR INDIANA BRIDGES . . . . .	18
6. LIFE-CYCLE COST PROFILES FOR INDIANA BRIDGES. . . . .	21
7. LIFE-CYCLE COST ANALYSIS FOR INDIANA BRIDGES . . . . .	26
7.1 Interest Rate, Inflation, and Discount Rate . . . . .	26
7.2 Interest Equations and Equivalences . . . . .	27
7.3 Life-Cycle Cost Analysis Comparison. . . . .	27
7.4 Life-Cycle Cost Analysis Example—Simply Supported Beams Configuration: 30-ft Span . . . . .	28
8. SUMMARY AND CONCLUSIONS . . . . .	48
9. FUTURE WORK. . . . .	48
REFERENCES . . . . .	49
APPENDICES	
Appendix A: Case of Study: Prestressed Concrete Bulb Tee Bridge . . . . .	52
Appendix B: Selected Examples of Bridge Designs . . . . .	52
Appendix C: Bridge Drawings . . . . .	52
Appendix D: Life-Cycle Profiles for Indiana Bridges. . . . .	52
Appendix E: Life-Cycle Cost Input for Matlab. . . . .	52

## LIST OF TABLES

Table	Page
<b>Table 2.1</b> General description of bridge elements condition ratings	6
<b>Table 3.1</b> Final design plan for simply supported options	12
<b>Table 3.2</b> Final design plan for 2- and 3-span continuous configurations	12
<b>Table 4.1</b> Inflation rates	13
<b>Table 4.2</b> Summary agency costs—construction costs	15
<b>Table 4.3</b> Summary agency costs—prestressed concrete elements costs	16
<b>Table 4.4</b> Summary agency costs—maintenance and rehabilitation costs	17
<b>Table 5.1</b> Deterioration curves for cast in place concrete slab	19
<b>Table 7.1</b> Initial cost—simply supported beam, span length 30 ft	29
<b>Table 7.2</b> LCC summary simply supported beams—span length 30 ft	41

## LIST OF FIGURES

Figure	Page
<b>Figure 2.1</b> Folded plate bridge system	2
<b>Figure 2.2</b> Precast, pre-tensioned concrete beam sections used for short span bridges in the United States	4
<b>Figure 2.3</b> Typical bulb tee girder	5
<b>Figure 2.4</b> Typical life-cycle condition with repairs and renewals	6
<b>Figure 3.1</b> INDOT database—bridge structural type summary	9
<b>Figure 3.2</b> NBI database—span range summary	10
<b>Figure 3.3</b> INDOT database—bridge span configuration summary	11
<b>Figure 3.4</b> NBI database—span configuration summary	11
<b>Figure 3.5</b> INDOT database—aspect ratio summary	12
<b>Figure 4.1</b> Historical cost data—superstructure concrete pay item	15
<b>Figure 5.1</b> Deterioration curves example for steel bridges	18
<b>Figure 5.2</b> Deck deterioration examples	19
<b>Figure 5.3</b> Deterioration curves example for concrete slab bridges	20
<b>Figure 5.4</b> Deterioration curves example for prestressed concrete beam bridges	20
<b>Figure 5.5</b> Deterioration curves example for prestressed concrete box bridges	21
<b>Figure 6.1</b> Life-cycle profile for slab bridges	23
<b>Figure 6.2</b> Life-cycle profile for prestressed concrete I beams with elastomeric bearings	23
<b>Figure 6.3</b> Life-cycle profile for prestressed concrete box beams with elastomeric bearings	24
<b>Figure 6.4</b> Life-cycle profile for steel structures	24
<b>Figure 6.5</b> Life-cycle profile for steel structures SDCL	25
<b>Figure 6.6</b> Life-cycle profile for prestressed concrete I beams including diaphragms	25
<b>Figure 6.7</b> Life-cycle profile for galvanized steel structures	25
<b>Figure 6.8</b> Life-cycle profile for galvanized steel structures SDCL	26
<b>Figure 7.1</b> Slab bridge life-cycle profiles	30
<b>Figure 7.2</b> Initial and LCCAP cost-effectiveness for simply supported beams—span range 1	42
<b>Figure 7.3</b> Initial and LCCAP cost-effectiveness for simply supported beams—span range 2	43
<b>Figure 7.4</b> Initial and LCCAP cost-effectiveness for simply supported beams—span range 3	44
<b>Figure 7.5</b> Initial and LCCAP cost-effectiveness for continuous beams—span range 1	45
<b>Figure 7.6</b> Initial and LCCAP cost-effectiveness for continuous beams—span range 2	46
<b>Figure 7.7</b> Initial and LCCAP cost-effectiveness for continuous beams—span range 3	47

## 1. INTRODUCTION

The true cost of a bridge structure is the cost to build, inspect and maintain the bridge over the entire lifespan of the bridge. This is often referred to as the “life-cycle” cost, and it is a better measure of the real cost of a bridge, rather than the initial, or first cost. Typically, decisions regarding selection of the superstructure type when a new or replacement bridge is needed are based solely upon the initial construction cost, rather than the life-cycle cost. There are very few data or prior published studies regarding the life-cycle cost of entire bridge structures in Indiana that utilize different materials. A study to evaluate these costs would be useful for efficient and cost-effective future planning.

The life-cycle cost analysis (LCCA) has been defined as a method to assess the total cost of a project. It is a simple tool to use when a single project has different alternatives that fulfill the original requirements. Different alternatives could vary in initial investment, operational and maintenance costs among other long term costs. Without watchful consideration of the long-term costs and full life-cycle costing, current investment decisions that look attractive could be resulting in a waste of economic resources in the future. This research is focused on short to medium span bridges (less than 130 ft) which represents 97% of the NBI INDIANA bridge inventory. Bridges are categorized in three different groups of span ranges. Different superstructure types are considered for both concrete and steel options. Types considered include bulb tees, AASHTO prestressed beams, slab bridges, prestressed concrete box beams, steel beams, steel girders, folded plate girders and simply supported steel beams for dead load and continuous for live load (SDCL). A design plan composed of simply supported bridges and continuous spans arrangements was carried out. Analysis for short and medium span bridges in Indiana based on LCCA is presented for different span ranges and span configurations. Findings will help designers to consider the most cost-effective bridge solution for new projects, resulting in cost savings for agencies involved.

### 1.1 Objective

The purpose of the proposed research is to examine the life-cycle costs associated with steel and concrete bridge structures of comparable types and sizes. The bridge study will be limited to bridges that have an overall length in the range of 30 ft to 130 ft. The study will examine various bridges for a given site condition—such as a particular span length and optimal configuration for the overall bridge length considering structural continuity, etc.—to determine the life-cycle costs of the bridges. The final result of the study will then be a set of guideline recommendations that a designer may use to achieve the greatest long-term cost efficiency.

### 1.2 Scope

A detailed study of the life-cycle cost of Indiana bridge structures is proposed in this study. The scope of the proposed work will include the following: (a) collection of information gathered from previous studies that have been conducted and reported in the open literature; (b) collection of critical features of both new bridges that are being designed and built in Indiana, as well as the features that were common in Indiana bridges; (c) collection of deterioration factors for steel and concrete bridges; (d) analysis of the life-cycle costs for new concrete and steel bridge structures; and (e) production of a summary report to document the study findings and recommendations.

## 2. LITERATURE REVIEW

This section presents a literature review on innovative cost effective solutions for short span bridges. Also, a literature review on deterioration curves is included. In addition, current approaches taken to conduct a bridge life-cycle cost assessment are summarized.

### 2.1 Bridge Superstructure Types

Multiple design solutions have been investigated and used throughout the years with the objective not only of proposing a structural solution for bridges but also to provide a cost-effective option for owners and agencies. These two have been the motivating force of numerous advances in the steel and concrete bridge industries. Structural systems such as reinforced concrete slab bridges, prestressed concrete bulb tees, prestressed concrete box beams, prestressed concrete AASHTO beams, steel beams, steel plate girders and steel box girders have been commonly used across the country. Nonetheless, the options discussed herein correspond to new technologies or, in some cases, recent approaches to standard systems that could provide a great design solution with competitive costs.

#### 2.1.1 Steel Bridges

**Folded plate girder bridge system (FPG).** This design approach utilizes U-type shapes built from, cold-bending flat steel plates into tub sections using a press-brake. According to the Short Span Steel Bridge Alliance (n.d.) a maximum span of 60 ft is able to take advantage of this system. Folds are uniform but thicknesses and dimensions vary depending on project conditions. Concrete is typically cast in the shop to connect the folded plates to the deck as part of a prefabricated section. Two different options have been considered in recent years. One is a folded plate that is closed at the top by the concrete deck which is connected by shear studs placed in top flanges disposed at each side of the beam (see Figure 2.1). In further references this option will be called the folded plate



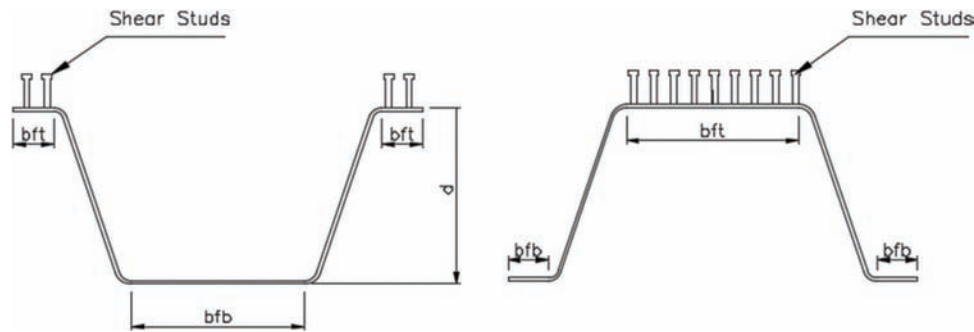

**Figure 2.1** Folded plate bridge system.

bridge system. In contrast, the second option uses the folded plate upside down, which means that the deck will be connected throughout the back of the folded plate by shear studs. This second option implies that the bottom of the bridge is open see Figure 2.1). In further references this option will be called the inverse folded plate bridge system.

Advantages of the press brake system include the following:

- Utilizes standard plate sizes for the folded plates.
- Pre-topped module option could be built for accelerated bridge construction (ABC).
- Module option reduces erection times and costs.
- No cross frames for either local or global stability are needed.
- For the inverse folded plate bridge system, the opening of the tube at the bottom of the element makes the inspection easier.
- Minimum amount of welding is needed, decreasing fabrication costs.

Disadvantages include:

- For the folded plate bridge system, inspection could be difficult due to closed box section.
- The inverse folded plate system is proprietary.
- Transportation can be limited due to weight or width of the prefabricated pieces compared to prestressed concrete box beams.
- Lack of research on seismic behavior of bridges using this design option.

Since late 1970s the idea of prefabricated press-formed steel T-Box girder bridge system has been of special concern of the structural research community. Taly and Gangaro (1979) proposed this system as a feasible option for highway bridges. Topics treated includes design basics, fabrication solutions, feasibility study, erection considerations, bearing types, end joints solutions, curb, parapet and railing types, maintenance aspects and alternative design procedures.

The investigation developed by Barth, Michaelson, and Barker (2015) describes the procedure to develop the FPG bridge system. Methodology of the design proposed, along with experimental validation for the composite girder's flexural capacity are presented. Results show that AASHTO specifications used to compute composite girder's ultimate capacity are conservative. Finally,

a more accurate proposal to compute the flexural capacity is proposed.

Inverse folded bridge system described by Burner (2010) is cold bent out of a single sheet of steel. Six specimens containing closure regions were subjected to both positive and negative moment loading to investigate their behavior and failure modes under ultimate load. Fatigue resistance along with hooked construction joints were studied (in comparison with the headed bars construction joints). Conclusions of the research indicates that this bridge system can withstand the equivalent 75 years of the physical maximum traffic without significant loss of stiffness. Additionally, headed bars and hooked bars for the construction joint provided sufficient strength and ductility for both positive and negative moments, however, hooked joints are preferred due to its low-cost fabrication and ease in detailing and fabrication.

A project that used inverse folded plate girders as an ABC solution was monitored by Civjan, Sit, and Breña (2016). This study was sponsored by the Massachusetts Department of Transportation, and focused on monitoring a single-span integral-abutment bridge. Results indicated that the neutral axis is located above the one assumed from section properties. However, stresses in concrete and steel components are within values expected not only during construction, but also during long term data collection and truck load testing.

A report presented to the Michigan Department of Transportation by Burgueño and Pavlich (2008) had the objective to evaluate through numerical simulations the feasibility of creating an entirely prefabricated composite box girder bridge system and employing such system for highway bridges. Topics such as composite girder/deck joints, vibration characteristics, longitudinal joint of girder/deck units, transversally posttensioned joints and others were studied. Different longitudinal joint connections are reviewed, including grouted shear keys, reinforced shear keys, post tensioned grouted shear keys, welded plate grouted shear key blocks, reinforced grouted moment key blocks and posttensioned grouted moment keys. Cost, structural performance, constructability, design ease and other topics were analyzed for spans under 100 ft. There is not a conclusive selection of joints based on performance or strength. However, it is concluded that according to

the parametric study the performance of all the different joints considered were adequate for spans ranging from 50 ft to 100 ft.

Other researches like the one published by Nakamura (2002) describes a new type of steel and concrete composite bridge with steel U-shape girders. From the economical point of view, lack of welding in comparison with regular I-shape girders is an advantage for this system and therefore very cost-effective. Testing of folded plate girders replicating loads due to construction without using prefabricated beams were carried out at the University of Nebraska (Glaser, 2010). Two different plate girder specimens were tested. To consider proper behavior simulating construction stages, the behavior of the girder alone was evaluated and no concrete slab was cast in any specimen. The objective of the test was to estimate not only the overall behavior but the girder components performance. Load levels to cause failure were included, also modes of failure were reported. Results prove that the folded plate girder provides adequate strength and stability resistance during construction.

**Simply supported span for dead load and continuous for live load (SDCL).** Simple span steel members are utilized at the early construction stages (dead load only), and then modified by adding the required continuity tension and compression details during construction to create a continuous structural system. This structural system eliminates field splices when spans are shorter than transportation limitations. According to the SSSBA normal detailing includes various combinations of anchor bolts, sole plates and often expensive bearing types. The SDCL method is considered as a special construction process rather than an application of special bridge elements.

Advantages of the system:

- Eliminates field splices, which are expensive.
- For live loads the whole structure could be considered as continuous which could reduce structural depths and weight costs.
- Erection procedure is simpler due to the elimination of field splices.
- Reduction of cross frames along the length of the bridge.

Disadvantages of the system:

- Limited span length can be used to avoid field splices due to transportation limitations.

Azizinamini, Yakel, and Farimani (2005), in conjunction with the Nebraska Department of Roads (NDOR) and the University of Nebraska Lincoln, examined a new steel bridge system which considers simply supported beams for dead load and continuous spans for live loads. Two full-scale specimens were constructed and tested in order to determine their structural behavior. Ultimate load tests were conducted to investigate the failure mechanism. As a result, design equations were developed and verified through finite element analysis.

Independent design professionals have been proposing SDCL systems as a cost-effective solution for the bridge industry according to Henkle (2001). For instance, Hoorpah, Zanon, Dabee, and Muhomud (2015) presents the experience with Colville Deverell Bridge located in Mauritius Island. The SDCL system is presented as an economic and fast construction technology for developing countries. Zanon, Ochojski, Hechler, Klimaszewski, and Lorenc (2015) presented an example of the use of an SDCL project as part of a new express road construction in Gdansk, Poland. Some of the points highlighted by this project are mainly focused on the advantage of prefabrication cost and effective procedures for medium span bridges, especially for the span range between 80 ft and 115 ft.

Finally, a cost-benefit analysis was conducted by Azizinamini et al. (2005) for two different structures, a steel box girder superstructure and a steel I-girder superstructure. It is shown that girders are slightly heavier using the SDCL system in comparison with the conventional continuous bridge system. However, the elimination of field splices reduced the total cost of the structural elements by 7% in both cases.

### 2.1.2 Concrete Bridges

A paper summarizing the Japanese state of the art was published by Yamane, Tadros, and Arumugassamy (1994) on short to medium span (16 ft to 130 ft) precast pre-stressed concrete bridges. Topics such as construction techniques, design procedures and overall costs for bridges in Japan and the United States were reviewed. This document presents a summary of basic geometrical considerations for different bridge types including typical span ranges (see Figure 2.2).











**Bulb tee beams.** Bridges using bulb tee beams consist of a horizontal slab supported by beams, which are supported either by abutments at both ends or at interior points for continuous beams. The cross section of the beam is designed to have optimal material and structural resistance, commonly fabricated in "I" shapes (see Figure 2.3). Due to the maximized moment of inertia obtained with the cross section, long spans can be considered for this type of bridge. Industry has standardized heights and general dimensions.

Advantages of this system:

- First initial cost effectiveness.
- Easy construction procedures.
- No fatigue design is needed.

Disadvantages of this system:

- Simply supported beams need to be considered in multiple continuous spans.
- Depending on the environment, corrosion penetration could lead to major structural issues.
- Transportation can be limited due to weight or width of the prefabricated pieces
- Expensive and complicated retrofitting procedures.

Typical section	Width mm (in.)	Depth mm (in.)	Span range m (ft)	Cast-in-place to precast concrete weight ratio
 Solid slab	910 to 2440 (36 to 96)	250 to 460 (10 to 18)	up to 9.1 (up to 30)	0.0 <sup>a</sup>
 Voided slab	910 to 1220 (36 to 48)	380 to 530 (15 to 21)	7.6 to 15.2 (25 to 50)	0.0 <sup>a</sup>
 Multistem	1220 (48)	410 to 530 (16 to 21)	7.6 to 16.8 (25 to 55)	0.0 <sup>a</sup>
 Double stem	1520 to 2440 (60 to 96)	410 to 580 (16 to 23)	6.1 to 18.3 (20 to 60)	0.0 <sup>†</sup>
 Single stem	1220 to 1830 (48 to 72)	610 to 1220 (24 to 48)	12.2 to 24.4 (40 to 80)	0.0 <sup>†</sup>
 Box girder	910 to 1220 (36 to 48)	690 to 1070 (27 to 42)	18.3 to 30.5 (60 to 100)	0.0 <sup>a</sup>
 Deck bulb tee <sup>‡</sup>	1220 to 2130 (48 to 84)	740 to 1040 (29 to 41)	18.3 or more (60 or more)	0.0 <sup>†</sup>
 I-girder <sup>‡</sup>	460 to 660 (18 to 26)	910 to 1370 (36 to 54)	12.2 to 30.5 (40 to 100)	0.6 to 1.2
 AASHTO/PCI bulb tee <sup>‡</sup>	1070 (42)	1370 to 1830 (54 to 72)	24.4 to 42.7 (80 to 140)	0.6 to 1.2
 Local standard I-girder <sup>‡</sup>	610 to 1520 (24 to 60)	710 to 2740 (28 to 108)	up to 50.9 (up to 167)	0.6 to 1.2

**Figure 2.2** Precast, pre-tensioned concrete beam sections used for short span bridges in the United States. (Source: Yamane, et al., 1994.)

- During re-decking processes, girders can be damaged or original structural sections could be diminished.
- Longer waiting times when a retrofit or member replacement is needed.

A precast bulb tee pre-stressed concrete girders system is being used as a bridge rapid construction option. Due to construction procedures, load transfer between adjacent girders is provided by the composite concrete deck. Bardow, Seraderian, and Culmo (1997) discussed the advantages of the approach through the examination of the New England bulb-tee precast girder proposed by New England Precast Concrete

Institute (PCI) committee. Reasons such as limitations in the range of applicability from the previous standardized American Association of State Highway and Transportation Officials (AASHTO) I girders and successful experiences of other states using more efficient precast girder shapes influenced the committee to propose bulb tee girders as an option in bridge design. A summary is provided on the girder depth limitation, as well as shipping and erection issues. Also, reviews of the new standardized sections completed by University of Nebraska and PCI are mentioned. Parallel to this proposal, the bridge portion of the Boston central artery project was designed using the new bulb

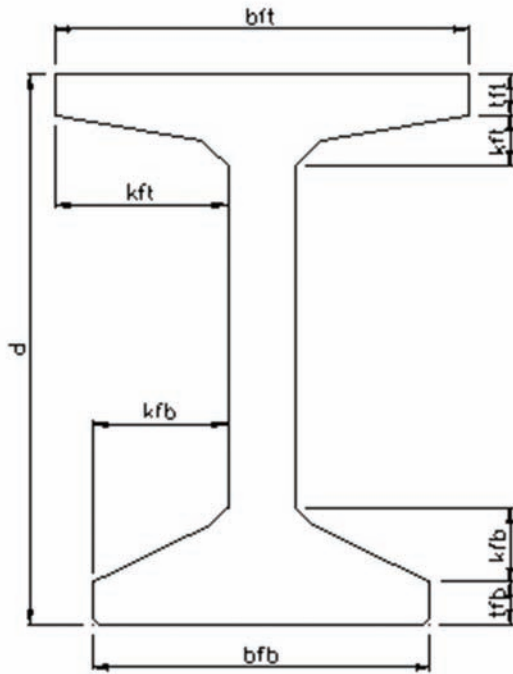

Figure 2.3 Typical bulb tee girder.

tees suggested by the committee. As a result of this cooperation, a standardized bulb tee sections were adopted, and have been used in numerous projects since then.

## 2.2 Deterioration Curves

Deterioration models for bridges were introduced into the life-cycle cost assessment during the 1980s as a result of the rising interest in predicting the future condition of infrastructure assets (Morcoux & Hatami, 2011). Nonetheless, those models have been researched prior to the 1980s for pavement management systems (PMS). Difference between these two approaches focus mainly on the importance of safety, construction materials used and structural functionality. Even knowing the differences between them, the approaches used to deal with the deterioration of infrastructure assets (no matter its origin) are based on the same principles. “By definition, a bridge deterioration model is a link between a measure of bridge condition that assesses the extent and severity of damages, and a vector of explanatory variables that represent the factors affecting bridge deterioration such as age, material properties, applied loads, environmental conditions, etc.” (Morcoux & Lounis, 2007).

Deterioration curves have been understood as a model intended to describe the process and mechanisms by which assets deteriorate and even fail through its service life. Probabilistic and statistical methods are usually used to accomplish this goal, leading to a graphical representation of the deterioration of the structure (see example in Figure 2.4).

There are some key components that must be determined to develop a deterioration model of a structure. The following are the most important:

- The anticipated deterioration rate of the element. Known as the pace at which an asset degrades over time under operating conditions. This must be taken into account from the beginning of the life of the structure.
- The thresholds that define the start and the end of the maintenance stages.
- Actions to take into account at different points and during sequential stages. The jumps in the deterioration curves are intended to extend the service life of the asset or to accomplish the overall life-cycle objective of the structure.

The basic data used to develop a deterioration prediction is based on the condition ratings. Condition ratings reflect the deterioration or damage of the structure but not design deficiencies. To address these scenarios, the National Bridge Inventory (NBI) classifies them as “Structurally Deficient” or “Functionally Obsolete.” Based on field inspections the condition ratings are considered more like snapshots in time rather than prediction of future conditions or behavior of the structure.

As a rule, the NBI regulated the condition ratings as a numerical coding from 0 to 9, in which 9 reflects “Excellent condition” and 0 represents the “Failed condition” —see Table 2.1 For further details, see the official NBI condition ratings document.

Using condition ratings, it is possible to develop a model that predicts the future condition of the structure analyzed. The basic representation of this analysis takes the current condition of the asset and predicts how the condition rating will change in future years if no maintenance is performed. Some of the options found in the literature for the predictive modeling include deterministic analysis and stochastic analysis.

### 2.2.1 Deterministic Analysis

Deterministic analysis models contain no random variables (no probabilities involved) and no degree of randomness. It is dependent on a mathematical formula for the relationship between the factors affecting the bridge deterioration and the measure of the condition of the asset. The output obtained is commonly expressed by deterministic values that represent the average predicted condition. This type of model can be developed using extrapolations, regressions or curve-fitting techniques (Morcoux & Hatami, 2011).

The Nebraska Department of Transportation sponsored a research project to develop specific models for Nebraska’s bridges (Hatami & Morcoux, 2012). This project was focused on the application of both deterministic and stochastic analysis in bridge decks. Some key conclusions were made including the significant impact of the traffic volume (AADT and ADTT) on the deck deterioration. Also, the importance of environmental and climate changes throughout the state were

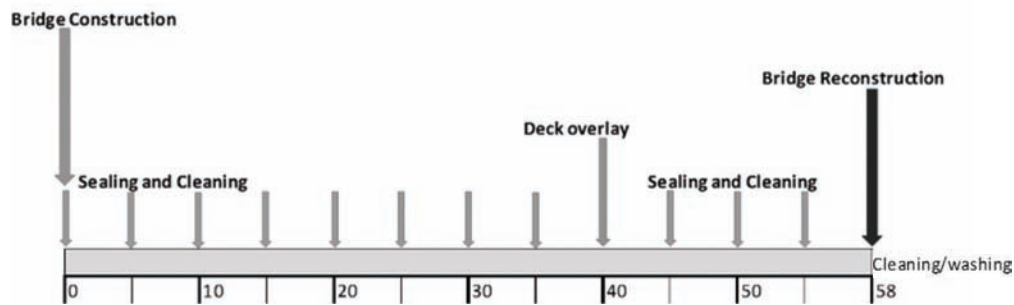
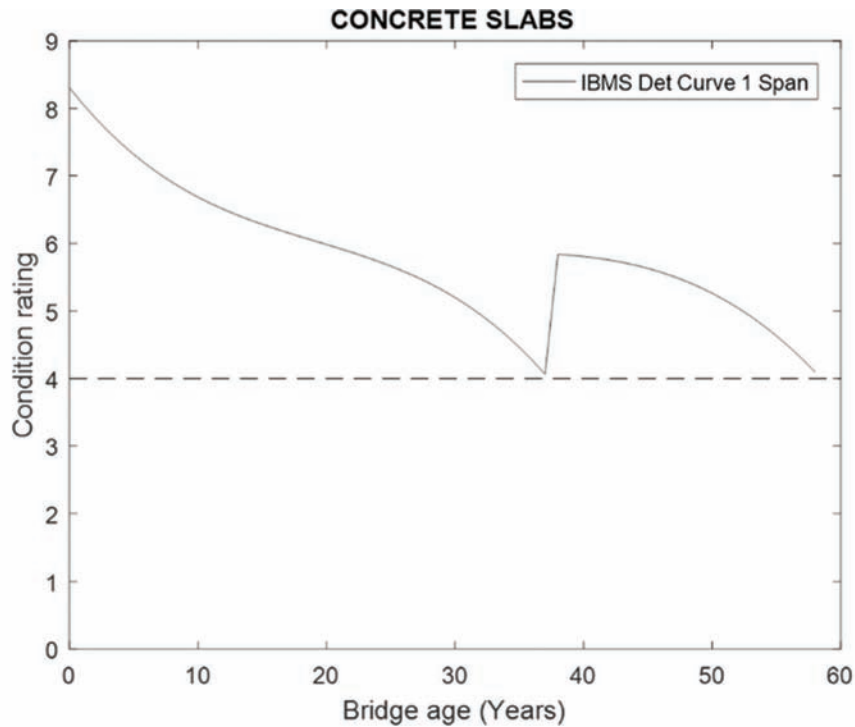

Figure 2.4 Typical life-cycle condition with repairs and renewals.

TABLE 2.1  
General description of bridge elements condition ratings

State	Description
N	Not Applicable
9	Excellent Condition
8	Very Good Condition—No problems noted
7	Good Condition—Some minor problems
6	Satisfactory Condition
5	Fair Condition
4	Poor Condition
3	Serious Condition
2	Critical Condition
1	“Imminent” Failure Condition
0	Failed Condition

addressed. It was found that higher traffic volumes increase the deterioration rate for bridge decks. In addition, in the detailed report on bridge decks, Morcouc and Hatami (2011) also analyzed superstructures and

substructures. Data suggest that prestressed concrete superstructures have similar performance to steel structures up to condition 6 for Nebraska bridges. Below condition 6 no adequate condition data for prestressed concrete superstructure were found.

Indiana sponsored a recent project focused on updating bridge deterioration models through its Department of Transportation (Moomen, Qiao, Agbelie, Labi, & Sinha, 2016). The final report identifies independent variables such as bridge age, features to cross beneath the bridge, ADTT among others. This document presents different deterioration curves divided in different groups depending on the material and design types. Curves for decks, different superstructure types and substructures are summarized. Also, it presents the different significant explanatory variables used for each probabilistic model. Finally, deterministic and probabilistic case examples are presented using the outcome of the curves presented. Findings identified trends in the deterioration rates linked to the independent variables

used. Data show that the road classification influences highway bridge deterioration due to the related ADTT. Higher ADTT values result in higher deterioration rates. In addition, bridges located over waterways tend to deteriorate faster than bridges traversing other features.

### 2.2.2 Stochastic Analysis: Markov Chains

A stochastic model traces the projection of variables that can change randomly with certain probabilities. In this specific case, deterioration progression is set as one or more stochastic variables that capture the uncertainty of the process. Two different approximations could be made in this kind of model: state-based and time-based approximation (Mauch & Madanat, 2001). State-based models predict the probability that an asset will undergo a change in condition-state at a given time. One of the most known examples of this model are the Markov chains and the semi-Markov processes. On the other hand, time-based models predict the probability distribution of the time taken by an asset to change its condition-state. This type of approximation has been used more frequently in pavement deterioration modeling. However, the two modeling approaches can be related. It is possible to use one modeling approach to predict the dependent variable of the other.

A stochastic process can be considered as Markovian if the future behavior depends only on the present condition but not on the past. In other words, if the state is known at any given time, no more information is needed in order to predict the future state of the asset (Sinha, Labi, McCullouch, Bhargava, & Bai, 2009).

The most important step when a Markov chain method is used is the computation of the matrix that contains the transition probabilities, which represents the probability of an element to remain or change from one rating to the other. Transition probabilities can be obtained either from accumulated condition data or by using an expert judgment elicitation procedure (Morcous & Hatami, 2011). Different methods can be used to generate transition probabilities. However, there are two which have been used to solve this problem using the condition data available: regression based optimization and percentage prediction method. The first one solves the non-linear optimization problem minimizing the sum of the absolute differences between the regression curve that best fits the condition data and the predictions using the Markov chains. This method can be greatly influenced by maintenance that are not reported to the database used. This means that any change in the database will have a significant impact in the outcome. The second approach relates the number of transitions from one state to another within a given time span with the number of structures in the original state.

Markovian's biggest disadvantage is the inherent assumption of the future condition as independent of the historical condition of the asset. "The Markov process assumes, in theory, a programmed and fixed inspection interval for bridges occurs, but in practice, bridges can be inspected less or more frequently than

programmed for reasons such as financial limitations and technical challenges. The Markov chain has its merits, such as accounting for the stochastic nature of deterioration, facilitation of the condition characterization of large bridge networks and its computational efficiency and simplicity" (Moomen et al., 2016).

### 2.3 Bridge Life-Cycle Cost Analysis (BLCCA)

Decision making in projects related with infrastructure frequently have constrained budgets. Consequently, decision makers and elected officials often only consider short-term cost (a.k.a. initial cost), rather than the long-term costs. However, failure to consider long-term costs could lead to decisions that are costlier over the service life of the structure.

According to the American Society of Civil Engineers & ENO Center of Transportation (2014) bridge life-cycle cost analysis (BLCCA) is defined as "a data-driven tool that provides a detailed account of the total cost of a project over its expected life." In addition, "BLCCA has been proven to create short-term savings for transportation agencies and infrastructure owners by helping decision-makers identify the most beneficial and cost effective projects and alternatives." Numerous transportation agencies throughout the country have been using BLCCA as a tool for policymakers. BLCCA has several applications, including:

- Calculating the most cost-effective approaches to project implementation.
- Evaluating a design requirement within a specific project, such as material type in bridge construction.
- Comparing overall costs between different types of projects to help prioritize limited funding in an agency-wide program.

Even though BLCCA is presented as a precise tool to allocate budgets, the approximation itself has different limitations that the agency using it must consider. The most notorious constraint is the reliability of the prediction of future costs. Determination of such predictions are subjected to a substantial estimating risk that can radically modify the outcome. A second limitation is based on the time horizons of the analysis. Setting different time horizons can have a dramatic effect on the analysis results. However, the most important issue is attributed to the lack of transparency and full knowledge of how BLCCA works and how it can be implemented. It is important to understand that BLCCA must not be considered as an infallible tool to predict future costs. Nevertheless, it is a helpful instrument to provide better information to decision-makers.

BLCCA is based upon a series of factors that need to be quantified and investigated. First, there is a need to identify alternatives, not only of the structural type or material but also bridge maintenance and improvement that may vary with the locations depending on weather conditions and contractor's experience. Second, agency costs need to be addressed. These are (but not limited to)

maintenance, rehabilitation and replacement costs. “Most routine maintenance activities are performed by an agency’s own workforce. Rehabilitation works consist of minor and major repair activities that may require the assistance of design engineers and contractors for construction. Most rehabilitation work is deck related. A major rehabilitation activity may involve deck replacement. The term “bridge replacement” is, on the other hand, reserved for a complete replacement of the entire bridge structure” (Hawk, 2002).

An accurate estimation and prediction of such prices is a difficult task since they tend to fluctuate. Moreover, those prices are connected with the length and type of bridgework programed in each of the alternatives. Finally, user costs that are the value of time lost by the user due to delays, detours and roadwork. There are other costs such as salvage costs, staffing, tax implications, downtime and so forth, that would be present in the BLCCA depending on the government dispositions.

General models for BLCCA are summarized as the sum of nonrecurring cost and recurring costs. The final cost is the result of adding the construction costs, maintenance costs and rehabilitation costs among others. Those costs must include not only appropriate agency costs but also user costs. Specifically, the model for bridges is presented in equation (2.1) (Hawk, 2002).

$$LCC = DC + CC + MC + RC + UC + SV \quad (\text{Equation 2.1})$$

Where:

LCC = Life-Cycle Cost

DC = Design Cost

CC = Construction Cost

MC = Maintenance Cost

RC = Rehabilitation Cost

UC = User Cost

SV = Salvage Cost

Measurements commonly used for alternative selection are: net present value (NPV), equivalent uniform annual cost (EUAC) and incremental rate of return.

### 2.3.1 Life-Cycle Profiles

Life-cycle profiles were conceived as graphical representation of all the costs involved during the service life of a given structure. Those include not only the major working actions (e.g., reconstruction of an element, overlays, bridge replacement) but also routine working actions characteristic of the bridge life. The combination of different maintenance, preventive or major working actions creates a unique profile that can be considered. Accurate estimation of service lives for all the working actions is a combination of agency experience, research efforts and engineering judgment.

Bridges typically involve three different elements that could have different working actions to consider: deck, superstructure, and substructure. It is true that a combination of all of them results in a complete LCCA. However, this research is only focused on the deck and

the superstructure. Superstructure working actions often involve the full or partial intervention of the deck. Therefore, life-cycle profiles proposed here on are a combination of preventive/maintenance/repair/rehabilitation strategies of both elements.

The following are the crucial factors to consider when a life-cycle profile is proposed: the service life of the structure, working actions considered, life cycle of the treatments proposed, proposed schedule of major working actions and possible extensions of the structure service life due to preventive or corrective procedures.

The service life of the structures considered corresponds to the age at which the deterioration curve used reaches the limiting condition rating. According to Indiana experience, the limiting condition rating that triggers the scheduling of a working actions corresponds to “Poor Condition” (condition rating 4). It is true that this condition does not mean imminent failure or a collapse but it is considered a safe threshold to assure safety standards.

## 3. BRIDGE DESIGN PLAN

### 3.1 Superstructure Types Selection

Information obtained from the National Bridge Inventory (NBI) is used to summarize the most common structures within the state and generate a design plan for the structures to analyze. The NBI database is an open source information that can be found in the National Bridge Inventory webpage and can be used freely.

The Indiana Department of Transportation (INDOT) has been collecting information on highway construction projects since 2011. This information has been organized and compiled in a single database that includes not only the total cost of different projects but also discretizes pay items involved. As it can be seen in Figure 3.1, the INDOT database shows a predominant use of concrete that represents 72% of the bridge contracts built from 2011 to 2015. In contrast, structural steel was used only 28% of the time. This tendency can be seen at a network level also analyzing the NBI database. According to NBI data, approximately 67% of the structures are concrete or prestressed concrete bridges (distributed almost evenly) while 30% are structural steel. This trend may be driven by the first cost effectiveness of concrete in comparison with structural steel.

Designs will cover the most common structures found in Indiana (as shown in Figure 3.1) along with the innovative bridge systems presented in section 2.1 of this document. It should be noted, however, that design options for timber, masonry, aluminum or other materials are not considered. The following are the bridge types used:

- Slab bridges, constant thickness
- Prestressed concrete box beams
- Prestressed concrete AASHTO beams
- Prestressed concrete bulb tees and hybrid bulb tees
- Structural steel folded plate beams

Summary Types			
Type	ID	%	Quantity
<u>Prestressed Concrete Box Beams</u>	1	3.87%	15
<u>Structural Steel Beams</u>	2	17.27%	67
<u>Prestressed Concrete Bulb-Tee Beam</u>	5	27.58%	107
<u>Prestressed Concrete AASHTO Beams</u>	4	17.78%	69
<u>Structural Steel Girder</u>	3	11.08%	43
<u>Reinforced Concrete Slab</u>	6	10.82%	42
<u>Prestressed Concrete Hybrid Bulb-Tee Beam</u>			
<u>Beam</u>	7	11.60%	45
<u>Reinforced Concrete Beam</u>	8	0.26%	1

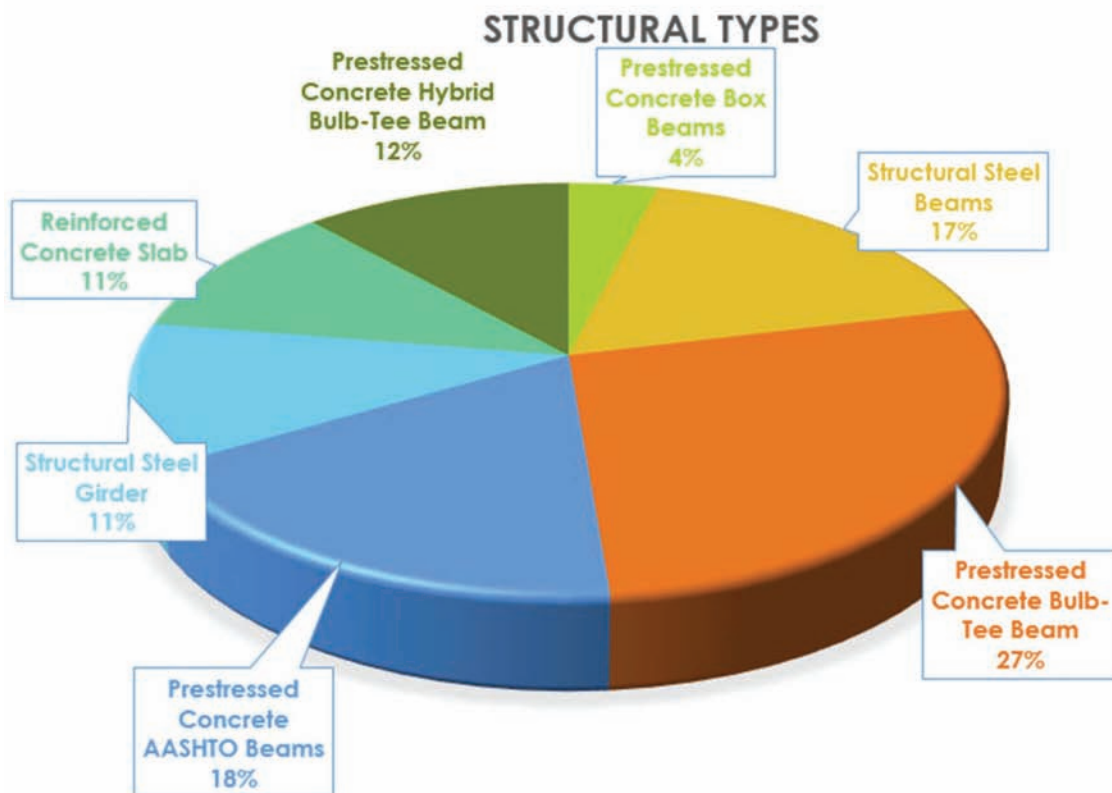

Figure 3.1 INDOT database—bridge structural type summary.

- Structural steel continuous beams
- SDCL beams
- Steel plate girders

### 3.2 Span Configuration and Span Ranges Selection

As shown in Figure 3.2, bridge spans between 30 ft and 130 ft represent 65% of the total Indiana bridge inventory. However, structures with spans shorter than 20 ft (5.8%) are considered “culverts” and are out of the scope of this research. In addition, bridges between 20 ft and 30 ft use predominantly slab and culvert superstructure types (82% of the time). Consequently, bridges between 30 ft and 130 ft were selected as the objective of this study.

To categorize different design options depending on the maximum span length, 3 different span ranges were established. Range 1 includes bridges with spans within 30 ft and 60 ft, range 2 spans between 60 ft and 90 ft, and range 3 span lengths range from 90 ft to 130 ft. Design types were considered depending on their cost-effectiveness potential for each of the span ranges.

Figure 3.3 shows the bridge span distribution within the state in the last six years. It is clear that bridges with four or more spans are less common. Simple-span (28%) and 3-span arrangements (38%) are the most common structure found in Indiana. Nevertheless, the 2-span configuration is also used (16%) widely. Two spans are commonly used for longer bridges in highway crossroads. Moreover, Figure 3.4 shows that according



**TOTAL BRIDGES INVENTORY: 19,145 (NBI DATA 2016)**  
**97% (18,073) of Total INDIANA Inventory are concrete and steel**

Summary Ranges					
Ranges	ID	Span		%	Quantity
		Minimum	Maximum		
0	Culverts	LESS THAN 20 FT		5.8%	1113
1	Range 1	30	60	41.6%	7960
2	Range 2	60	90	17.3%	3315
3	Range 3	90	130	6.1%	1164
4	Range 4	130	200	2.2%	430
N/A	N/A	20	30	27.0%	5163
				100.00%	19145

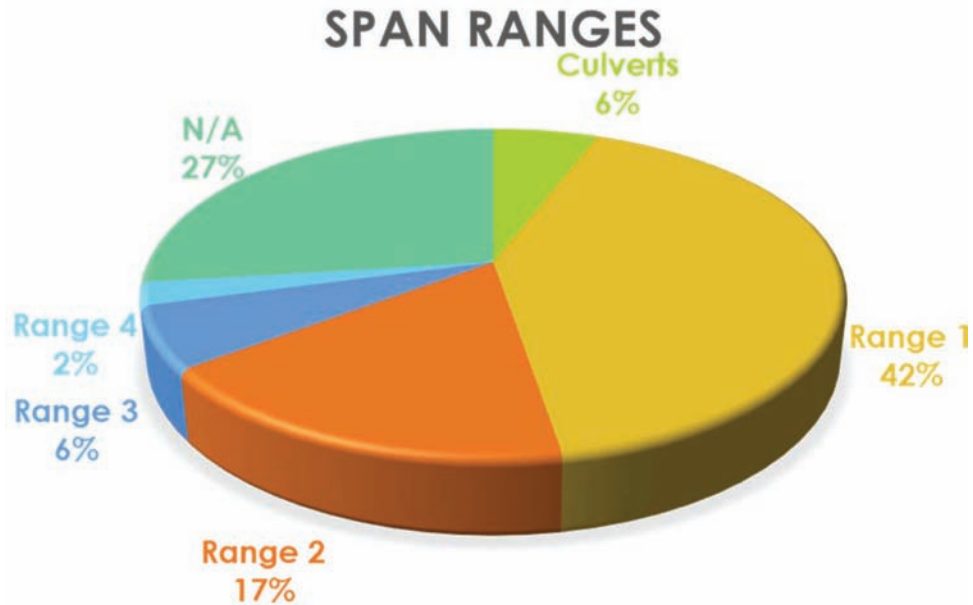

**Figure 3.2** NBI database—span range summary.

to the NBI database, 1- and 3-span configurations comprised 82% of the concrete and steel bridges in Indiana. Conversely, by comparing span length and span ranges, it was found that one and three spans bridges are the most common configurations for span range 1 (94%) and span range 2 (65%), but for span range 3 the most commonly used option is the 2-span arrangement (36%). Using this trend, the design plan utilized simple and 2-span structures for span ranges 1 and 2, and simple and 2-span structures for span range 3.

Figure 3.5 shows the aspect ratio summary result of the INDOT database. As can be seen, the most common ratio between the longest span and the total span of the bridge are 0.50 and 0.35 for 2- and 3-span configurations, respectively. Therefore, two equal spans will be used for the 2-span configuration, while for 3-span configurations the design will use two external spans of 32% of the total length and a central span of 36% of the total span bridge length.

The final design plan includes bridge designs developed for extreme span ranges values and a single intermediate point along the range. Table 3.1 presents a summary of the designs developed for the simply supported configuration. As shown, different superstructure types are considered depending on its potential cost effectiveness for each span length. The same approach was used for the continuous-span configuration design plan shown in Table 3.2. The span length shown in Table 3.2 corresponds to the maximum span length within the multiple spans and not the total length of the bridge.

### 3.3 Bridge Design

#### 3.3.1 General procedure and standard design values

Bridge designs were then developed for the design plan. The seventh edition AASHTO LRFD specifications

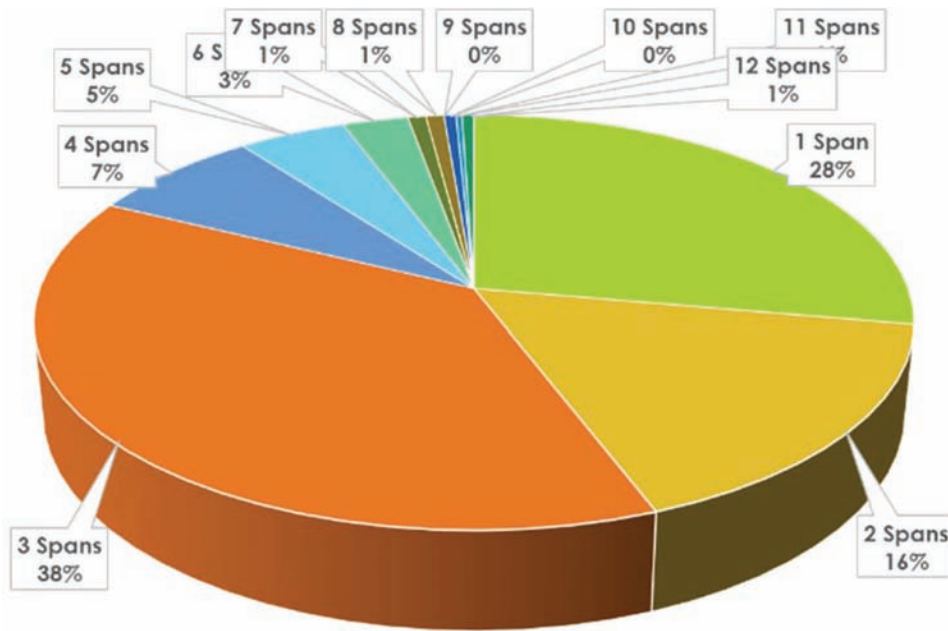

Figure 3.3 INDOT database—bridge span configuration summary.

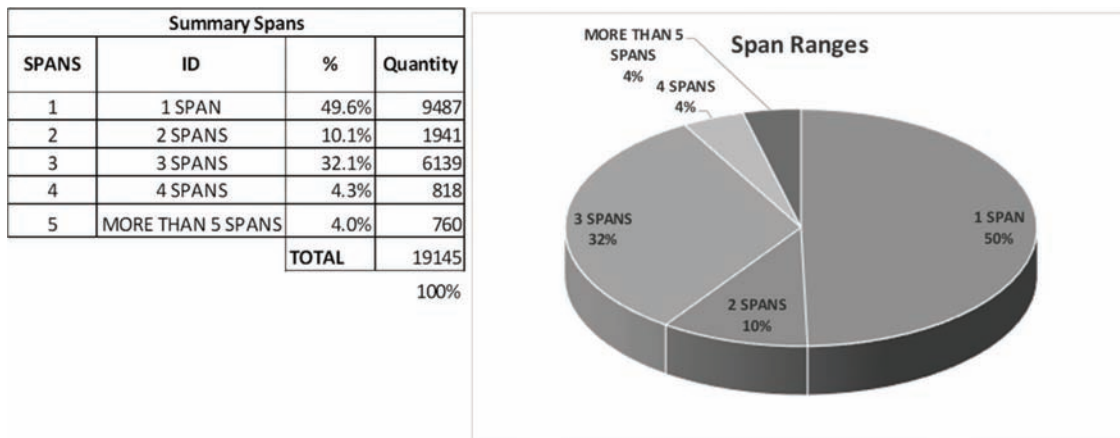

Figure 3.4 NBI database—span configuration summary.

(AASHTO, 2015) and the Indiana Design Manual (INDOT, 2013) were used for the designs. There are some simplifications and assumptions made that need to be addressed. To simplify the design process some aspects are taken as constant for every option considered. These assumptions are as follows:

- Two 12 ft lanes in opposite directions along with 8 ft shoulders on each side of the bridge. Total width of the bridge is 43 ft.
- Concrete bridge railing type FC was used per Indiana Design Manual and Standard Drawing No. E 706-BRSF-01.
- Skew: 0°. INDOT database shows that most of the Indiana bridges have skew values less than 30°, which in practical design terms will not significantly impact the final design.
- Moderate ADTT, i.e., average truck traffic values below 3,500 trucks per day that are representative of the majority of bridges in Indiana.
- Concrete deck of 8 in, minimum longitudinal reinforcement of 5/8 in and maximum rebar spacing of 8 in as the minimum required per the Indiana Design Manual.
- Structural steel ASTM A709 Grade 50. Modulus of Elasticity: 29,000 ksi, Fy: 50 ksi and Fu: 65 ksi.
- Reinforcement steel AASHTO A615 Grade 60. Modulus of Elasticity: 29,000 ksi, Fy: 60 ksi and Fu: 80 ksi.
- Prestressing Strands: Low relaxation strands. Modulus of Elasticity: 28,500 ksi, Fy: 243 ksi and Fu: 270 ksi.
- Slab concrete f'c: 4 ksi, Modulus of Elasticity: 3,834 ksi.
- Concrete prestressed beams f'c: 7 ksi. Modulus of Elasticity: 5,072 ksi. Conditions at transfer may vary.

The research described herein is focused on the superstructure only; the substructure was not designed

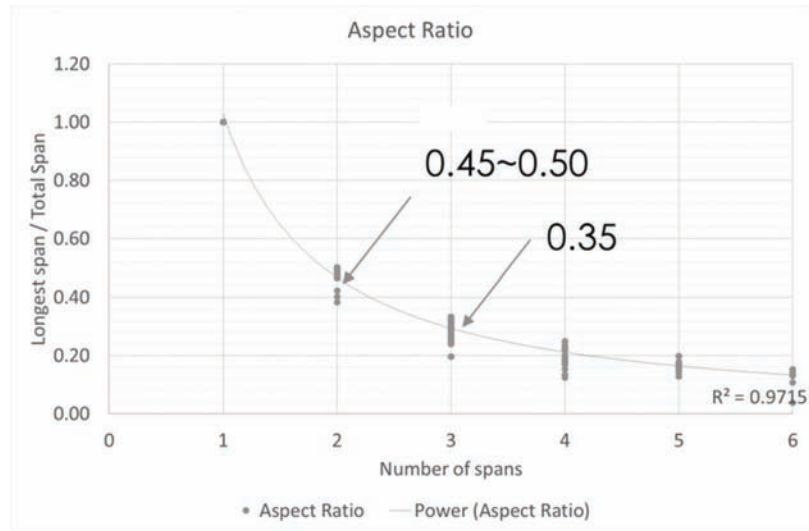

Figure 3.5 INDOT database—aspect ratio summary.

TABLE 3.1  
Final design plan for simply supported options

Superstructure Type	Span Range (SR)						
	SR 1	SR 1	SR 1-2	SR 2	SR 2-3	SR 3	SR 3
	Span						
	30	45	60	75	90	110	130
Slab Bridge	×	×	×				
Steel Beam (5B)	×	×	×	×	×		
Steel Beam (4B)	×	×	×	×	×		
PS Concrete Beam	×	×	×	×	×		
Folded Steel Plate	×	×	×				
PS Concrete Box	×	×	×				
PSC Bulb Tee			×	×	×	×	×
Steel Girders					×	×	×

TABLE 3.2  
Final design plan for 2- and 3-span continuous configurations

Superstructure Type	Span Range (SR)						
	SR 1	SR 1	SR 1-2	SR 2	SR 2-3	SR 3	SR 3
	Span						
	30	45	60	75	90	110	130
Slab Bridge	×	×					
Steel Beam (5B)		×	×				
Steel Beam (4B)		×	×				
PS Concrete Beam		×	×	×	×		
PS Concrete Box	×	×	×				
PSC Bulb Tee			×	×	×	×	×
Steel Girders					×	×	×
SDCL Beam (5B)			×	×	×		
SDCL Beam (4B)			×	×	×		

Note: Red indicates 2-span configuration included.

for any of the bridges considered. Generalization of soil and foundation types throughout Indiana is not within the scope of this research.

Spreadsheets that include applicable sections of the LRFD and the Indiana Design Manual specifications were created for every design option. As an input, live load envelopes were generated using a simple beam element model in SAP2000®. The models were also used to check deflection limits. Limit states checked are service level, strength level, and fatigue and fracture.

Different design examples were considered as a basis for the designs. Examples include those from Wassef, Smith, Clancy, and Smith (2003), FDOT (2003), Hartle et al. (2003), Parsons Brinckerhoff (2011), Chavel and Carnahan (2012), Grubb and Schmidt (2012) and Wisconsin Department of Transportation (2019).

As noted above, detailed bridge designs were developed for each of the options considered in the design plan. This involved the design of 64 bridges in total. To illustrate the design process, an example design is presented in detail for a prestressed bulb tee bridge in Appendix A. Comparable design details were developed for each of the other options in the design plan. Spreadsheets and final design details for a two equal 110-ft span continuous bridge is presented in Appendix B, which includes designs for both prestressed concrete bulb tee and structural steel plate girder sections. Summary information from the designs can be found in the design drawings in Appendix C. The detailed spreadsheet designs for each bridge are available by request.

#### 4. COST ALLOCATION

As noted earlier, the cost allocation model used herein is described in Equation 2.1. Then, the final life-cycle cost for each alternative would be the sum of the agency costs, which includes design costs (DC), construction costs (CC), maintenance costs (MC), rehabilitation costs (RC) salvage costs (SC), and user costs (UC). Unless there is a reason to do otherwise, agency costs are typically assumed to be incurred at the end of the period in which expenditures actually will occur (Hawk, 2002).

The most widely used basis to estimate those costs are the utilization of unit costs and bills of quantities. In the absence of this information, parametric cost estimating models may be used to best-guess estimate (Hawk, 2002). This study is focused on the highway bridge system costs in Indiana. The Indiana Department of Transportation (INDOT) has been collecting information on highway construction projects since 2011. This information has been organized and compiled in a single database that includes not only the total cost of different projects but also discretizes pay items involved. Using this information, it is possible to identify the cost trend of basic pay items such as

concrete, structural steel, structural elements among others.

In order to obtain the current price for each one of the data points from the database, inflation rates need to be used. Inflation rates were calculated using the current consumer price index (CPI) published monthly by the Bureau of Labor Statistics (BLS). Values presented in Table 4.1 correspond to the average value throughout the year. Table 4.1 also presents the cumulative multiplier factor used to compute the net present value.

#### 4.1 Outliers Identification

The definition of an outlier is at best a subjective idea. However, different investigators have been addressing this problem from different perspectives. One of the most accepted definitions of this term is presented by D’Agostino and Stephens (1986): “A discordant observation is one that appears surprising or discrepant to the investigator; a contaminant is one that does not come from the target population; an outlier is either a contaminant or a discordant observation.” Once the outliers are identified there are different paths to treat the database, shown as follows:

- Omit the outliers and treat the reduced sample as a new database.
- Omit the outliers and treat the reduced sample as a censored sample.
- Replace the outliers with the value of the nearest “good” observation (also called Winsorize the outliers).
- Take new observations to replace the outliers.
- Do two different analyses with and without outliers. If results are clearly different the conclusions need to be examined cautiously.

TABLE 4.1  
Inflation rates

Year	Other Resources	
	Inflation Rate (%)	Cumulative
2017	2.10	1.0210
2016	1.30	1.0343
2015	0.12	1.0355
2014	1.62	1.0523
2013	1.47	1.0678
2012	2.07	1.0899
2011	3.16	1.1243
2010	1.60	1.1423
2009	-0.40	1.1377
2008	3.80	1.1810
2007	2.80	1.2140
2006	3.20	1.2529
2005	3.40	1.2955
2004	2.70	1.3304
2003	2.30	1.3610
2002	1.60	1.3828
2001	2.80	1.4215
2000	3.40	1.4699
1999	2.20	1.5022

Due to the source of the database used in this research the outliers will be identified and the reduced sample treated as a new database. There are multiple techniques to identify outliers in a sample, including Pierce's criterion, modified Thompson Tau test and anomaly detection, among others. Nevertheless, the method used for this sample was the implementation of the interquartile range (IQR) and the Tukey's fence approximation. The IQR it is the difference between the first and the third quartile. The first ( $Q_1$ ) and third quartile ( $Q_3$ ) are the values in the database that holds 25% and 75% of the values below it respectively. According to the Tukey's fences method, outliers are values outside of the limits represented by 1.5 times the IQR below  $Q_1$  and above  $Q_3$ . The generalization of the method is presented in Equations 4.1, 4.2, and 4.3.

$$IQR = Q_3 - Q_1 \quad (\text{Equation 4.1})$$

$$Lim_{Bot} = Q_1 - 1.5(IQR) \quad (\text{Equation 4.2})$$

$$Lim_{Top} = Q_3 + 1.5(IQR) \quad (\text{Equation 4.3})$$

Once the database is cleaned from outliers, a standard deviation and mean is computed for all the pay items involved. However, and in order to take into account the economics of size of the projects, a weighted average and standard deviation are chosen to use as an input in the BLCCA. The usage of a weighted average is based on the fact that larger projects would have a more significant impact on the computation of the mean than smaller projects, which could result in costlier unit prices. Weights are calculated based on the quantities for each one of the activities considered. Basic definition of weighted average ( $\bar{x}$ ) and standard deviation ( $\sigma$ ) is presented in Equations 4.4 and 4.5 where  $x_i$  represents a single value in the database and  $w_i$  is the weight associated to that specific value. Weights, as mentioned before, correspond to the ratio between the individual quantity of the data point and the total sum of quantities.

$$\bar{x} = \frac{\sum_{i=1}^n w_i x_i}{\sum_{i=1}^n w_i} \quad (\text{Equation 4.4})$$

$$\sigma = \sqrt{\frac{\sum_{i=1}^n w_i (x_i - \bar{x})^2}{\sum_{i=1}^n w_i}} \quad (\text{Equation 4.5})$$

#### 4.2 Design Costs (DC)

Includes all the engineering and regulatory studies, environmental and other reviews, and consultant contracts prior to the construction or major rehabilitation of an asset. It is a common practice to compute these values as a percentage of the construction cost when no data are available. However, these costs are not considered in the computation of the total LCCA

for two reasons: Firstly, designs are made by the researchers and no cost is involved or considered due to such activities, however, in real projects this cost must be included. Secondly, since this research is not localizing the design structure in any specific location, environmental and other reviews along with consultant contracts are not needed.

#### 4.3 Construction Costs (CC)

Includes all the activities made between the design and the operation of the asset. In a project, it may include bridge elements, ancillary facilities, and approach roads among others. In this study only major superstructure elements are considered. Substructure construction is neglected since this design is outside of the scope of the project. Barriers and other miscellaneous items are neglected also due to that all the alternatives share the same specifications, in other words, they will have the same elements in the same quantities. Pay items considered include: slab concrete, structural concrete elements, reinforcing steel and structural steel. Table 4.2 shows the summary of the construction cost for different superstructure elements. All pay items shown include all the activities needed until the elements are cast or erection of the element on site. No additional costs need to be considered due to erection of superstructure beams or provisional formwork for cast in place elements, since these costs are included in the pay item price.

A further analysis was done for the pay item related to the concrete of the superstructure. As a common practice it is assumed that concrete cost depends on the superstructure type used. As a general standardized exercise, this cost is discretized depending on the superstructure material type. In other words, concrete superstructures are believed to have different concrete prices than steel superstructures. It is true that in past years the tendency was that steel superstructures resulted in costlier cast in place concrete slabs than the concrete superstructures as shown in Figure 4.1. Nonetheless, analyzing the historical data, the differences in prices between those two pay items has been reduced in the recent years. Therefore, concrete for superstructures pay item was taken as the same value independent of the material or superstructure type.

In addition, the unit cost for concrete diaphragms and continuity concrete details for continuous spans needed to be determined. Since there is no discretization of any pay item in the database, it is not possible to determine this cost from historical data directly. However, a different approach was used that involved the average values for superstructure concrete and typical quantities of a continuous bridge.

Computation of the diaphragm cost is presented in Equations 4.6–4.8. The approximation proposed uses a weighted computation of the price since the

TABLE 4.2  
Summary agency costs—construction costs

Item	Unit	INDOT			Weighted (\$)	Std Dev (\$)	Data
		Maximum (\$)	Minimum (\$)	Average (\$)			
Concrete C Superstructure	yd <sup>3</sup>	898.76	354.25	589.04	565.03	109.61	354.00
Concrete Bulb-T Beam	LFT	419.06	188.86	294.98	298.99	54.86	145.00
Concrete Box Beam	SFT	320.99	139.03	241.37	241.51	55.66	132.00
Concrete I-Beam	LFT	346.43	107.53	221.07	219.21	66.93	55.00
Structural Steel	lb	3.00	0.64	1.94	1.72	0.44	63.00
Reinforcing Steel	lb	1.34	0.65	0.96	0.92	0.12	150.00
Epoxy Reinforcing Steel	lb	1.40	0.74	1.05	1.02	0.13	324.00

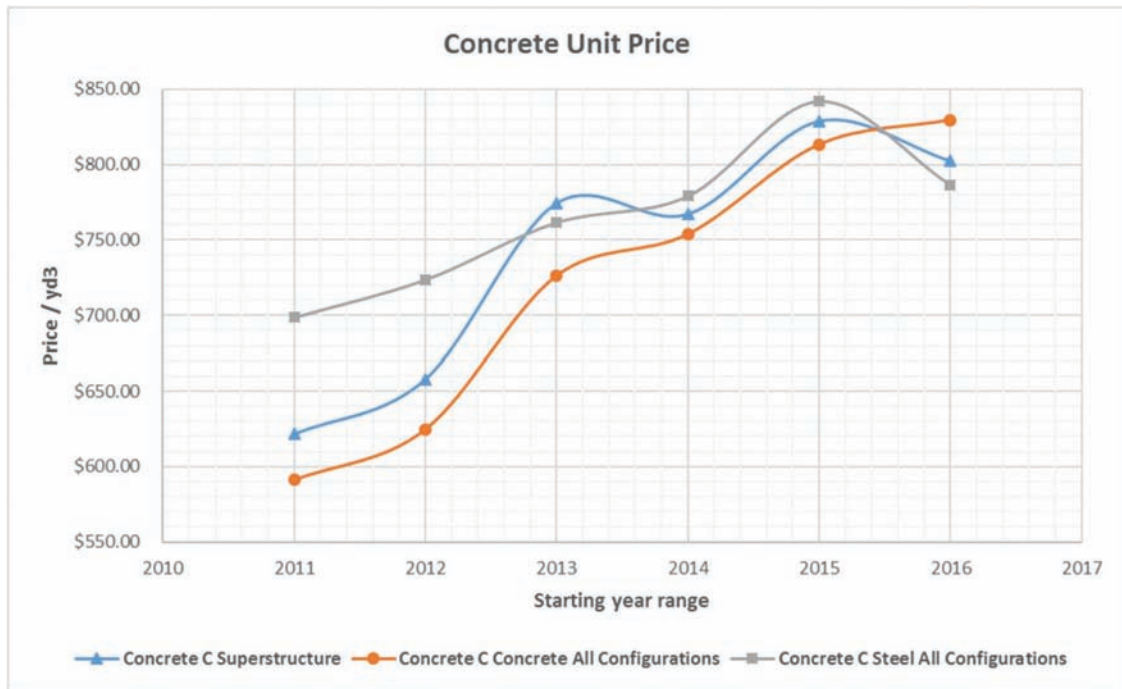

Figure 4.1 Historical cost data—superstructure concrete pay item.

value of the concrete is known for continuous spans (in this case 3-span configuration:  $P_{Total}$ ) and simply supported span (assumed as basically slab concrete:  $P_{Slab}$ ), and also the relative percentage of concrete used for the slab ( $\alpha_{Slab}$ ) and the diaphragms ( $\alpha_{Diaph}$ ) of a typical bridge. To obtain the cost of the material used for continuity above the piers the procedure is as follows ( $P_{Diaph}$ , value shown in Equation 4.9):

$$P_{Total} = \frac{\sum_{i=1}^n w_i x_i}{\sum_{i=1}^n w_i} = \alpha_{Slab} P_{Slab} + \alpha_{Diaph} P_{Diaph} \quad (\text{Equation 4.6})$$

$$\alpha_{Slab} = \frac{\text{Concrete}_{Slab}}{\text{Concrete}_{Total}} = 88\%$$

$$\alpha_{Diaph} = \frac{\text{Concrete}_{Diaph}}{\text{Concrete}_{Total}} = 12\% \quad (\text{Equation 4.7})$$

$$P_{Total} = \$600.59/\text{yd}^3 \quad P_{Slab} = \$579.27/\text{yd}^3 \quad (\text{Equation 4.8})$$

$$P_{Total} = 88\%(\$529.27/\text{yd}^3) + 12\%P_{Diaph} = \$600.59/\text{yd}^3$$

Then, solving for  $P_{Diaph}$ :

$$P_{Diaph} = \$1,123.60/\text{yd}^3 \quad (\text{Equation 4.9})$$

As it can be seen in Table 4.2, unit cost for concrete superstructure elements like beams is given in dollars per linear foot independent of the beam type. This feature implies that the lack of data points of certain beam types (different bulb tees sections for instance) make the unit price for that specific section not accurate. To solve this problem this unit price can be converted to dollars per volume units using the total

area of the beam type. This additional step resulted in a general unit price for all beam types that can be converted into unique unit values for all different sections using again the net area. The same procedure was done for structural prestressed concrete box beams using the superficial area of all sections. A summary of unit cost for different prestressed concrete beam sections can be seen in Table 4.3.

#### 4.4 Maintenance Costs and Rehabilitation Costs (MC and RC)

Includes all the activities needed during the service life of the asset in order to maintain the current condition or improve it above acceptable criteria. These activities also cover all actions to repair or replace elements that threaten safe bridge operation. There are two types of maintenance activities: (a) a regularly scheduled operation such as deck flushing or deck cleaning, and (b) preventive or protective maintenance which are the response of an observed condition. Overlays, painting, patching among others generally are considered as part of the second type. As a general rule of thumb, the better approach to determine this costs and its service lives is by using agency experience in conjunction with historical cost data.

Rehabilitation costs may include full replacement of bridge elements or even the whole superstructure. Additionally, activities such as bridge widening or collision damage repairs are considered rehabilitations for most public agencies. This research is not considering any future contingencies such as change in specifications that involves widening, possible

collisions during the service life of the asset, or repairs due to hazards.

Depending on the superstructure type, different activities could be considered. Concrete superstructures may require crack sealing or patching due to wearing. According to INDOT experience, prestressed superstructures tend to develop more beam end atypical deterioration when construction joints are used. On the other hand, steel superstructures could have fatigue cracking or excessive section loss due to corrosion. Actions needed to address such problems are considered as rehabilitation costs. However, these working actions are only triggered due to the operation of the asset and its prediction on new bridges is a complex task that need historical data and, statistical and probabilistic methodologies. These problems could be avoided to some extent during the design process, considering jointless bridges and adequate fatigue detailing. This research is based on this premises, which is the reason why those types of repairs and retrofitting activities are not considered in any of the cases analyzed. Determination of those costs then are not needed.

As described in more detail in chapter 6, working actions considered for the superstructure often involves deck maintenance and rehabilitation. These costs are obtained from the historical database mentioned earlier in this document. Table 4.4 presents the cost values used for different maintenance and rehabilitation activities done in Indiana.

As shown in the table, activities such as overlays and deck reconstruction involved more pay items that need to be considered in order to obtain the final cost. For instance, overlays as a maintenance activity

TABLE 4.3  
Summary agency costs—prestressed concrete elements costs

Type	Area (in <sup>2</sup> )	Unit Price (\$/ft)	Type	Area (in <sup>2</sup> )	Unit Price (\$/ft)
CB 12 × 36	423	186.25	BT 78 × 60	1102	323.23
CB 17 × 36	471	207.38	BT 84 × 48	1100	322.64
CB 21 × 36	515	226.76	BT 84 × 60	1144	335.55
CB 27 × 36	581	255.82	HBT 36 × 49	878.2	257.59
CB 33 × 36	647	284.88	HBT 36 × 61	932.4	273.48
CB 42 × 36	746	328.47	HBT 42 × 49	926.3	271.70
CB 12 × 48	567	249.65	HBT 42 × 61	980.4	287.56
CB 17 × 48	603	265.50	HBT 48 × 49	974.3	285.77
CB 21 × 48	647	284.88	HBT 48 × 61	1028.4	301.64
CB 27 × 48	713	313.94	HBT 54 × 49	1022.3	299.85
CB 33 × 48	779	343.00	HBT 54 × 61	1076.4	315.72
CB 42 × 48	878	386.59	HBT 60 × 49	1070.3	313.93
BT 54 × 48	883	259.00	HBT 60 × 61	1124.4	329.80
BT 54 × 60	934	273.95	HBT 66 × 49	1118.3	328.01
BT 60 × 48	932	273.37	HBT 66 × 61	1172.4	343.88
BT 60 × 60	976	286.27	HBT 72 × 49	1166.3	342.09
BT 66 × 48	974	285.69	HBT 72 × 61	1220.4	357.96
BT 66 × 60	1018	298.59	IB Type I	276	121.52
BT 72 × 48	1016	298.01	IB Type II	369	162.47
BT 72 × 60	1060	310.91	IB Type III	560	246.57
BT 78 × 48	1058	310.32	IB Type IV	789	347.40

TABLE 4.4  
Summary agency costs—maintenance and rehabilitation costs

Item	Unit	INDOT			Weighted (\$)	Std Dev (\$)	Data
		Maximum (\$)	Minimum (\$)	Average (\$)			
Concrete C Superstructure	yd <sup>3</sup>	898.76	354.25	589.04	565.03	109.61	354.00
Concrete Bulb-T Beam	LFT	419.06	188.86	294.98	298.99	54.86	145.00
Concrete Box Beam	SFT	320.99	139.03	241.37	241.51	55.66	132.00
Concrete I-Beam	LFT	346.43	107.53	221.07	219.21	66.93	55.00
Structural Steel	lb	3.00	0.64	1.94	1.72	0.44	63.00
Reinforcing Steel	lb	1.34	0.65	0.96	0.92	0.12	150.00
Epoxy Reinforcing Steel	lb	1.40	0.74	1.05	1.02	0.13	324.00
Overlay	SFT	56.29	29.27	40.65	39.64	5.92	—
Overlay	SFT	16.05	6.04	10.57	9.95	2.28	226.00
Overlay Remove	SFT	1.90	0.18	1.03	0.94	0.40	121.00
Hydro Demolition	SFT	15.57	1.98	7.13	6.83	2.72	212.00
Overlay Additional	SFT	22.76	21.07	21.92	21.92	0.51	263.00
Deck Patching—Partial Depth	SFT	133.74	5.35	53.41	37.97	56.77	276.00
Deck Patching—Full Depth	SFT	118.09	1.03	47.68	37.23	29.23	328.00
Bearing Elastomeric Assembly	UND	2,275.40	213.99	966.72	930.16	658.17	31.00
Deck Reconstruction	SFT	88.55	25.37	48.67	47.41	15.25	—
Deck Reconstruction	SFT	39.63	14.06	25.72	25.01	5.97	65.00
Present Structure, Remove	SFT	48.92	11.31	22.95	22.40	9.29	63.00
Painting	SFT	5.22	1.39	2.46	2.27	0.91	22.00
Cleaning (Deck)	SFT	Bowman and Moran (2015), Yanev and Richards (2011)			2.17	<i>Orig data from 1999</i>	
Sealing	SFT	Bowman and Moran (2015)			1.27	<i>Orig data from 2013</i>	
Cleaning and Washing Bearing	UND	Morcouc (2013)			222.28	<i>Orig data from 2013</i>	
Jacking Superstructure Elements	UND	Bowman and Moran (2015), INDOT (2012), INDOT personnel			2,552.50	<i>Orig data from 2013</i>	
Spot Painting 15 Years	SFT	Fricker et al. (1999)			2.19	<i>Orig data from 1999</i>	
Bridge Removal	SFT	Morcouc (2013)			11.11	<i>Orig data from 2013</i>	
Recycle Structural Steel	lb	Actual market price			0.08	—	

also involves the removal of the wearing surface, a demolition activity alongside with the overlay material needed, in this case latex modified concrete as explained in chapter 6. Deck reconstruction on the other hand, only involves and additional removal of the present structure. Those additional activities are summarized in Table 4.4.

#### 4.5 Salvage Costs (SC)

Salvage cost is the value of the asset at the end of the useful life. Depending on the material type it can be considered as a cost or as a benefit at the end of the analysis period. Usually, this value for concrete superstructures is measured as costs related to the demolition of the structure and its disposal. In contrast, the salvage value for steel superstructures is taken as a benefit due to the recycle capability of the structural steel. Usually, market prices for structural steel recycling vary between 5 and 10 cents per pound recycled. It is true that concrete demolition material could be used as rip rap material in other parts of a project, however, the percentage used is often low. Despite that, INDOT does not consider salvage value as an agency cost, rather, it is

considered as a contractor's activity and therefore their responsibility.

#### 4.6 User Costs (UC)

These costs are attributable to the functional deficiency of a bridge such as a load posting, clearance restriction, and closure (Hawk, 2002). Then, a proper way to address its estimation is to compute the cost of vehicle operation (VOC) and travel time (TTC) incurred due to detouring or traveling through narrow bridges or assets with poor deck surface conditions. According to Sinha et al. (2009) Indiana resumed user costs due to three different deficiencies: load capacity limitation, vertical clearance limitation, and narrow bridge width. However, as related to the limitation, the final cost will be the sum of VOC and TTC. It is true that, as mentioned before, no contingencies other than regular deterioration of the bridge are considered, however, maintenance or rehabilitation activities may affect user costs mainly due to narrow lane traffic on and under the bridge. Nonetheless, and in order to compute those costs, a deep understanding of the traffic (quantities and type of vehicles), detour



lengths, travel times and travel velocities is needed. As specified earlier in this document, all bridge designs have no specific location along any specific road. In other words, traffic, velocity and detour assumptions are not taken into account. Additionally, such assumptions are considered an oversimplification of the problem and could impact negatively the outcome of the LCC comparison. More information about user costs models can be found in Hawk (2002) and Sinha et al. (2009).

### 5. DETERIORATION MODELS FOR INDIANA BRIDGES

Deterioration curves are critical for development of the BLCCA. Their accurate determination will lead to more precise answers and better recommendations to designers. The use of the NBI database to develop deterioration curves is the most commonly utilized practice. Since this study is focused only on the Indiana bridge system administrated by INDOT, deterioration curves will consider the Indiana NBI database. Accordingly, deterioration curves made for the Indiana state highway system by Moomen et al. (2016), Sinha et al. (2009), and Cha, Liu, Prakash, and Varma (2016) will be used.

In addition to the deterioration path for each material type, a limiting condition rating needs to be chosen in order to establish the lowest allowed

bound of deterioration. This lower bound could vary depending on the budget allocation and availability. According to INDOT experience, the threshold for the state of Indiana is 4. Additionally, analyzing the historical NBI database it is clear that a condition rating of 4 is considered as the lowest deterioration limit before a major rehab or repair action is scheduled. Consequently, for this research a condition rating of 4 is established as the threshold before a major work action is needed.

Deterioration rates vary depending on the database and method used to compute it. Nonetheless, it is clear that deterioration rate is time dependent. Focusing on steel structures only as shown in Figure 5.1, Moomen et al. (2016) predicted that a steel bridge deteriorates to a replacement state in less than 50 years. In contrast, the constant deterioration rate Cha et al. (2016) projected an age close to 90 years, while the deterioration curve used by Sinha et al. (2009) for the Indiana Bridge Management System (IBMS) stated that this life value is in the vicinity of 80 years for the same threshold rating. Further analysis is needed, nonetheless, but steel superstructure deterioration curves used in the IBMS appear to fit better the historical data.

On the other hand, deck behavior appears to agree closely with the curve fitting approach (Table 5.1). Figure 5.2 shows the deterioration behavior of decks using curve fitting (Moomen et al., 2016). Additionally, the constant deterioration rate model and the

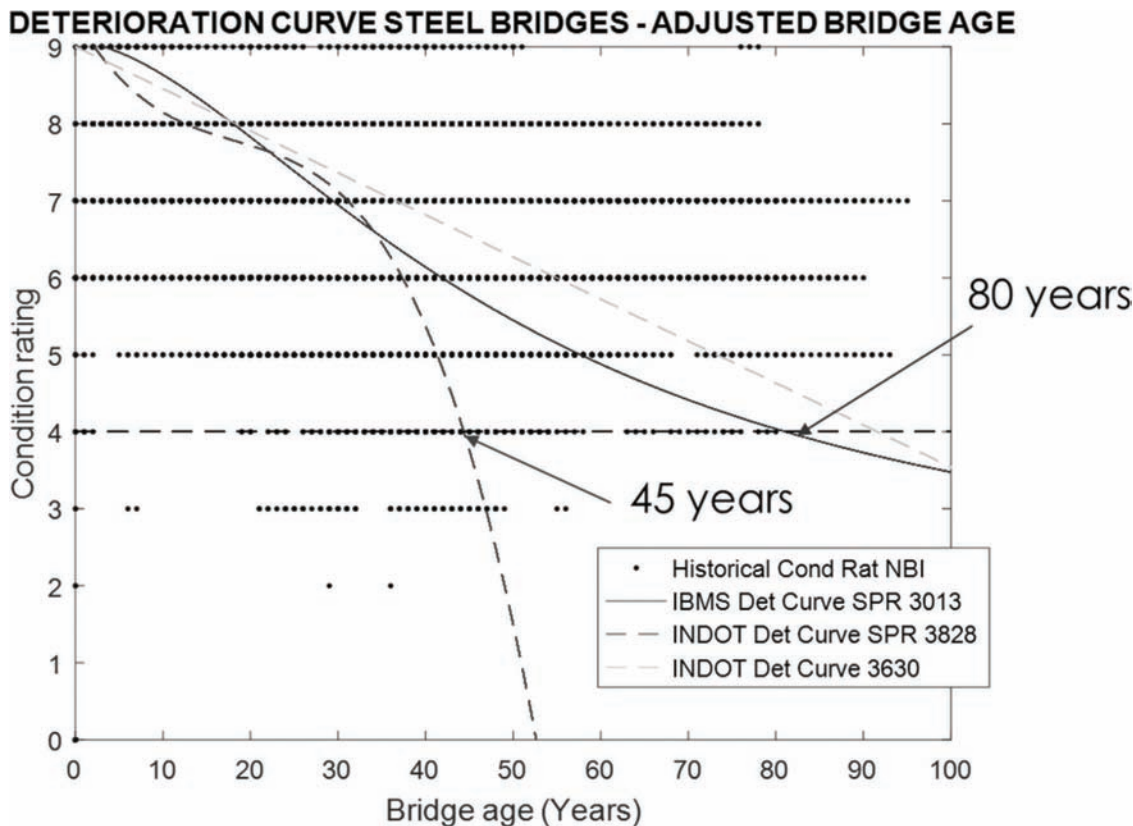

Figure 5.1 Deterioration curves example for steel bridges.

TABLE 5.1  
Deterioration curves for cast-in-place concrete slab

Northern	NHS	$SUPCR = 9.5820 - 0.27195 \cdot AGE + 0.00874 \cdot AGE^2 - 0.0000933 \cdot AGE^3 - 0.1991 \cdot INT - 0.17981 \cdot SERVUNDER - 0.71169 \cdot FRZINDEX$
	Non-NHS	$SUPCR = 8.85183 - 0.22032 \cdot AGE + 0.00598 \cdot AGE^2 - 0.00005627 \cdot AGE^3 - 0.11229 \cdot ADTT$
Central	NHS	$SUPCR = EXP(2.10113 - 0.01135 \cdot AGE - 0.01968 \cdot INT - 0.01845 \cdot SPANNO)$
	Non-NHS	$SUPCR = EXP(2.13095 - 0.01255 \cdot AGE - 0.00027854 \cdot SKEW - 0.01169 \cdot SPANNO - 0.0933 \cdot ADTT)$
Southern	NHS	$SUPCR = 8.1804 - 0.02287 \cdot AGE - 0.00058022 \cdot AGE^2 - 0.06369 \cdot SPANNO - 0.00942 \cdot LENGTH - 0.74059 \cdot FRZINDEX - 0.29919 \cdot ADTT$
	Non-NHS	$SUPCR = 9.00 - 0.09891 \cdot AGE + 0.00108 \cdot AGE^2 - 0.00000876 \cdot AGE^3 - 0.00458 \cdot SKEW - 0.11453 \cdot SPANNO - 1.01643 \cdot FRZINDEX - 0.21873 \cdot ADTT$

Source: Moomen et al. (2016).

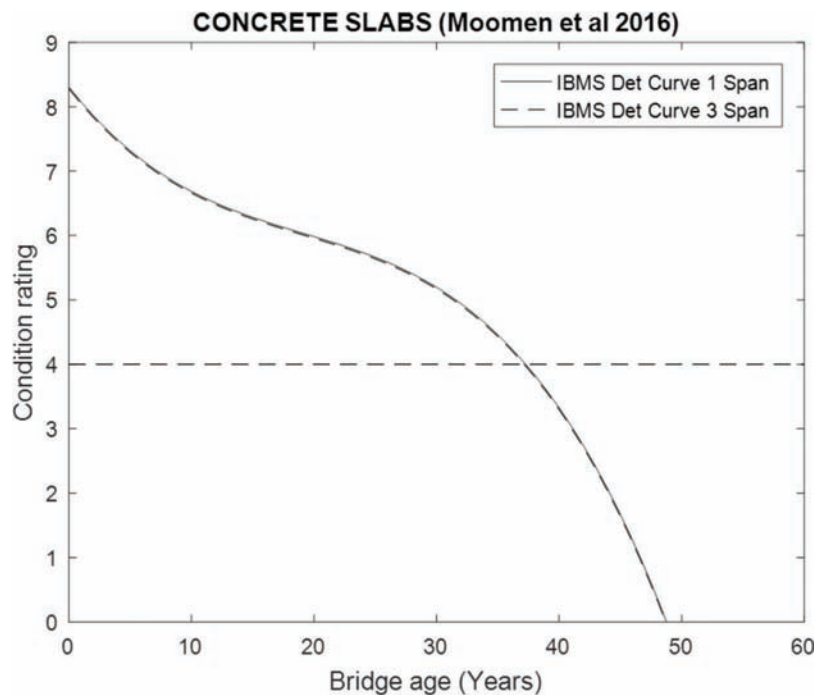

Figure 5.2 Deck deterioration examples.

IBMS deterioration curves both propose different deterioration paths depending on the superstructure material type. In contrast, curves used by Moomen et al. (2016) indicates that superstructure material type is not a factor that affects the deterioration behavior. As shown in the figure, the service life proposed by this approach (service life when a condition rating of 4 is achieved) is close to 37 years. The likelihood of programming a deck replacement at a much greater service life is low according to actual data and INDOT experience, and it is often scheduled between 30 and 40 years. This means the deterministic method can be used reliably.

Deterioration curves for concrete superstructures are presented in Figures 5.3, 5.4, and 5.5. As explained in analyses for decks and steel structures, three different

approaches are considered: Moomen et al. (2016), Sinha et al. (2009), and Cha et al. (2016). Moomen et al. (2016) present different deterioration curves depending on the superstructure structural type. However, threshold rating age for different structural types lies between 55 and 65 years not only for the curve fitting approach but also for the constant deterioration rate method (Cha et al., 2016). In contrast, IBMS deterioration curve reaches a condition rating of 4 at 80 years. INDOT experience indicate that is unlikely to have a concrete superstructure older than 70 years without any rehabilitation or repair. Deterioration models proposed by Moomen et al. (2016), appear to better reflect the common practices in Indiana for concrete superstructures.

Deterioration curves are used to predict maintenance, rehabilitation and reconstruction scheduling for

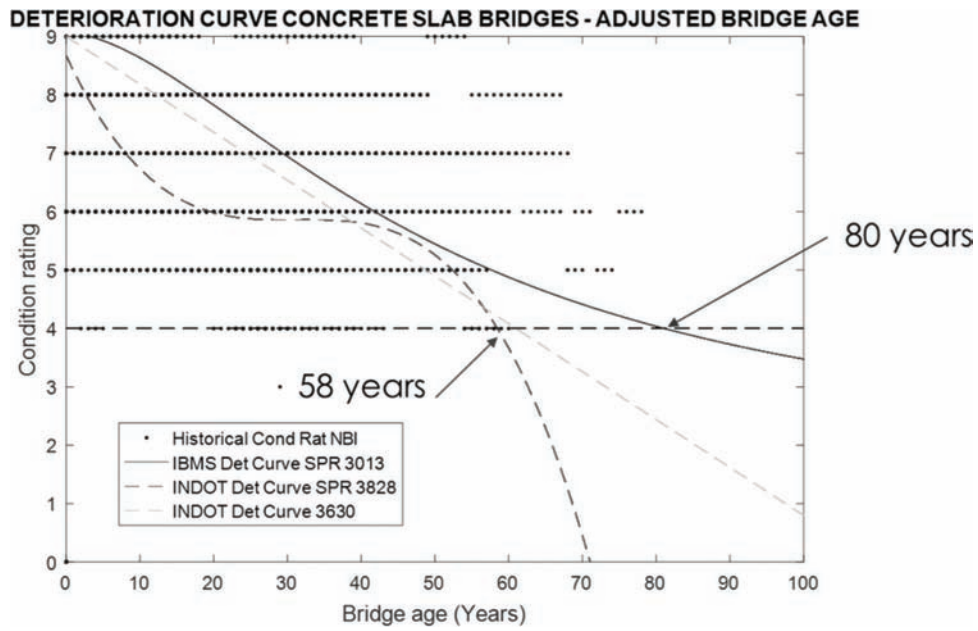

Figure 5.3 Deterioration curves example for concrete slab bridges.

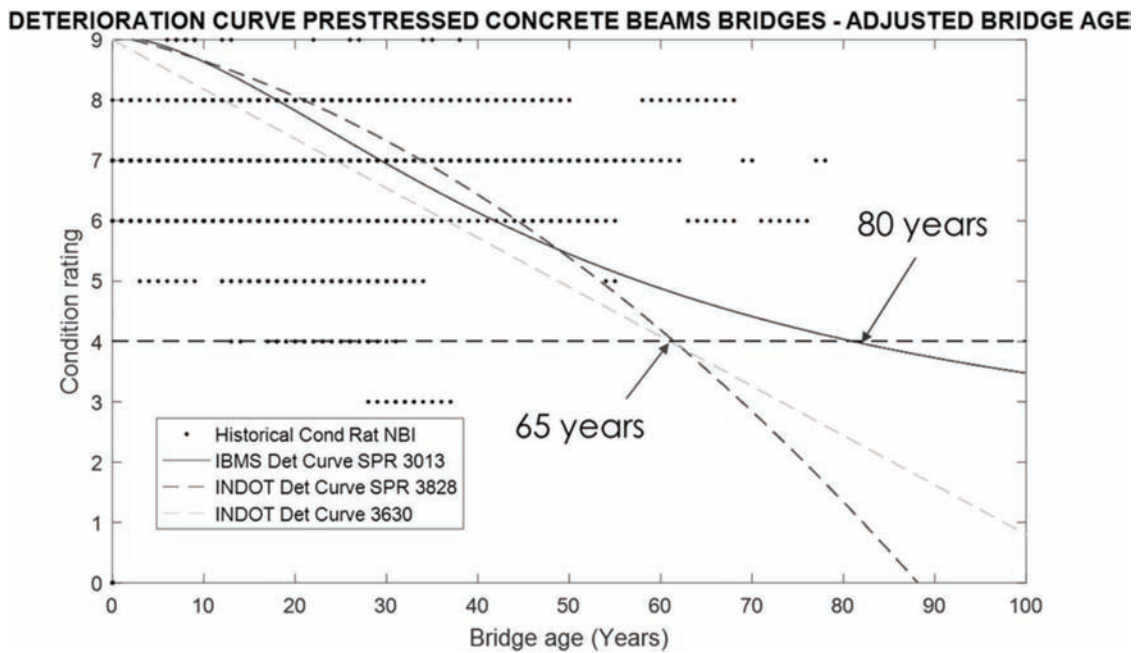

Figure 5.4 Deterioration curves example for prestressed concrete beam bridges.

each of the design options considered. For concrete structures, models proposed by Moomen et al. (2016) were selected. Additionally, the model for steel structures corresponds to curves proposed by Sinha et al. (2009). Once an element reaches the threshold for each

condition, a jump in the condition rating will be assumed and the deterioration afterwards will follow the correspondent curve (see Figure 2.4). Final deterioration profiles will be used to allocate agency and user costs during the BLCCA process.

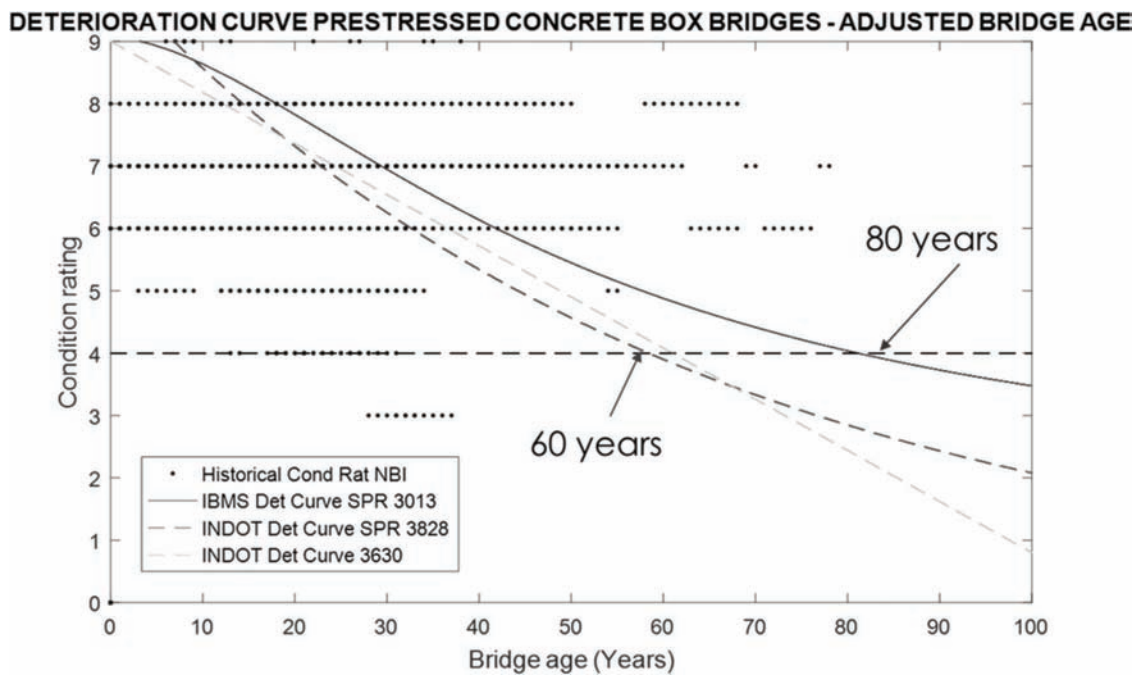

Figure 5.5 Deterioration curves example for prestressed concrete box bridges.

## 6. LIFE-CYCLE COST PROFILES FOR INDIANA BRIDGES

For concrete structures, deterioration models proposed by Moomen et al. (2016) are used. For concrete slabs, the model projected a service life of 58 years. Prestressed structures are divided into two structural types; pre-stressed concrete beams with a service life of 65 years and pre-stressed concrete boxes with a service life of 60 years. In contrast, steel structures service life is projected to be 80 years, according to the model proposed by Sinha et al. (2009). These expected lives limit the life cycle of the structure and are the basis of profiles proposed.

As discussed before, working actions considered in the superstructure often involves deck interventions. For this reason, preventive and maintenance activities for decks must be considered in the life cycle of the superstructure. Working actions recommended include cleaning and washing of the deck surface, deck and crack sealing, deck patching and deck overlays. In addition, joint maintenance needs to be addressed for bridge decks. However, this working action is not considered since all continuous bridges were designed jointless. Further information about costs, maintenance, scheduling and life cycle of different alternatives for joint replacement is discussed in the report by Bowman and Moran (2015).

The research Soltesz (2003) concludes that a decrease of chloride content for decks is only appreciable if it is washed on a daily basis, which is not practical or cost-effective. However, ACI Committee 345 (2016) recommends washing the exposed surfaces on a yearly basis in order to avoid extreme deterioration. Therefore, and following the recommendations made by Bowman and

Moran (2015) to INDOT, washing, and cleaning of the deck surface is considered on a yearly basis schedule.

Deck sealing has been proven to be beneficial to extend decks service life (Frosch, Kreger, Byl, Lyrenmann, & Pollastrini, 2016). However, INDOT regular bridge maintenance current practice only considers it during deck constructions or reconstructions (Bowman & Moran, 2015). Soriano (2002) and Mamaghani et al. (2007) stated that the first sealing process should be done within 3 to 6 months after construction, with justification to consider it at year 0 or simultaneously with deck reconstructions. Regular use of sealants could extend the initial life of a deck up to 40 years according to Zemajtis and Weyers (1996). However, sealants depending on the fabricator, weather conditions, and traffic wearing have different service lives. Sealant service life expectancy varies from 5 to 10 years (based on studies made by Weyers, Prowell, Sprinkel, & Vorster, 1993; Zemajtis & Weyers, 1996; Meggers, 1998; Soriano, 2002; Mamaghani et al., 2007; Wenzlick, 2007; and ACI Committee 345, 2016) and need to be replaced routinely. Both Bowman and Moran (2015), and Frosch et al. (2016) recommended that Indiana bridge decks to be resealed every 5 years for high traffic roads. Consequently, profiles considering deck sealing every 5 years and a deck overlay after 40 years are considered.

Concrete deck patching involves the removal of contaminated concrete down to the level of the reinforcement steel in the affected area, followed by steel cleaning and replacement if necessary, and installation of the final patch with new high-quality concrete or mortar with low permeability (Olek & Liu, 2001). There are some disadvantages using this method that are

related mostly to the incomplete or insufficient removal of concrete in the affected area. In Indiana, some decks have experienced significant corrosion processes after only 7 years from the reparation according to Olek and Liu (2001). This repair action must be performed as early as possible in order to avoid accelerated corrosion problems. Bowman and Moran (2015) proposed a 10-year life cycle for patching repairs for bridge decks areas with no more than 10% of the total deck surface repaired. Additionally, as considered by Weyers et al. (1993) in their proposed life-cycle models, an increase in maintenance cost due to progressive deterioration needs to be considered.

Among the numerous deck protection systems that are available, overlays are considered as one of the most cost-effective options since the early 1980s (Craig, O'Conner, & Ahlskog, 1982). There are different types of overlays: Portland cement overlays, polymer, and epoxy mortars or concretes and polymer impregnated concrete (ACI Committee 224, 2001). As noted by Frosch, Blackman, and Radabaugh (2003) "Portland cement overlays include low-slump dense concrete (LSDC), polymer-modified concrete (also called latex-modified concrete) and fiber-reinforced concrete (FRC). Latex modified concrete overlays are the most common type found in Indiana." Polymer-impregnated concrete overlays will not be discussed in this report as they have not become generally effective, economical, or practical (ACI Committee 224, 2001). Asphaltic concrete overlays are relatively porous and, by themselves, do not provide an effective seal. This porosity entraps salt-laden moisture, which, in the absence of an effective deck sealer, can promote deck deterioration (ACI Committee 345, 2016). The current INDOT policy considers the service life of the deck surface to be between 20 or 25 years, followed by a deck re-placement after 15 to 20 years (Bowman & Moran, 2015). This policy does not include deck maintenance activities. To conclude, latex modified concrete overlays after 25 years of bridge construction followed by deck reconstruction after 20 years is considered. The service life of over-lays after a bridge repair activity will be considered as 20 years as a lower bound.

Maintenance activities on the superstructure vary depending on the material type and in some cases on the structural type chosen. There are some activities that can be considered as common regarding those two characteristics. Bearing maintenance and replacement is one of them. Different bearing types are available such as elastomeric bearings, cotton duck pads, sliding bearing, manufactured high load multi-rotational bearings and mechanical steel bearings among others (Azizinamini, Power, Myers, & Ozyildirim, 2014). However, INDOT generally only uses two types of devices: for concrete members elastomeric pad devices, and for steel structures elastomeric and steel bearings (INDOT, 2014). This research only will consider elastomeric devices as a common bearing type for all structural designs. Preventive maintenance activities such as cleaning, washing, and flushing are commonly used

for elastomeric bearings on a biannual basis (Bowman & Moran, 2015).

The service life of elastomeric devices when they are well maintained, constructed and designed can last as long as the structure (Lee, 1994; Azizinamini et al., 2014). However, in order to achieve a service life of 100-plus-years, more emphasis must be placed on manufacturing quality (Azizinamini et al., 2014). Aria and Akbari (2013) proposed a service life between 30 to 50 years, while Azizinamini et al. (2014) based on surveys across the United States report a service life of between 50 to 75 years. Case scenarios used in the BLCCA includes a bearing replacement after 60 years in conjunction with the appropriate preventive maintenance, and bearing replacement without maintenance every 40 to 55 years.

Additionally, steel structures could be subjected to preventive superstructure washing, spot painting or full beam recoating. However, superstructure washing is not considered in the LCCA profiles. Conversely, spot painting and recoating procedures need to be performed on a regular basis.

Protection against corrosion for steel structures includes painting, metalized coat, galvanization and weathering steel use. Among them, painting is the most common coating system to protect carbon steel bridges due to its relatively low initial cost and simplicity of application (Bowman & Moran, 2015). Fricker, Zayed, and Chang (1999) conducted an extensive evaluation of on steel bridge maintenance practices using different types of painting procedures and coatings. Deterioration curves and LCCA were conducted. LCCA computation showed that the most cost-effective painting system is the three-coat painting system (Zayed, Chang, & Fricker, 2002). The service life of initial painting could vary from 30 to 50 years, however, repainting maintenance may not be as effective, and will generally last between 20 to 30 years as described by Soliman and Frangopol (2015). Internal communication with INDOT personnel indicates that for Indiana steel bridges the initial painting service life is assumed as 35 years and the repainting service life as 20 years.

Spot painting activities involves the treatment of a small damaged region of the painted area. Some researchers have studied the cost-effectiveness of the spot painting in comparison with the repainting alternative. Fricker et al. (1999) proposed that the best re-habilitation scenario is to perform spot repairs every 15 years instead of replacing the coating with a total recoating option currently used by INDOT. Tam and Stierner (1996) performed an LCCA including spot painting, overcoat, and full recoat. They conclude that "spot repair is the most cost-effective method for rehabilitating the corrosion resistance of a steel bridge." Bowman and Moran (2015) proposed a maintenance practice that includes a two coat system (using a primer and a top coat) as part of spot painting that is performed every 10 years in areas not larger than 10% of the exposed area.

The combination of all the working actions described before to an applicable structure leads to a unique life-cycle profile. Different alternatives were considered for each of the superstructure types analyzed, leading to the optimal life-cycle profile for each one of them based on lower present values computed using BLCCA. All the life-cycle profiles considered are presented in Appendix D: Life-cycle Profiles for Indiana Bridges. The most cost effective profile for each superstructure type was chosen and then used to compare cost effectiveness of various superstructure types. Those profiles used are illustrated as follows:

- Slab bridges (see Figure 6.1). Cleaning and washing as a regular annual activity (showed as a shaded area in the figures herein). Crack sealing and cleaning every 5 years since the bridge construction. A deck overlay at 40 years. Finally, a bridge superstructure replacement at the end of its service life (58 years).
- Prestressed concrete I beams with elastomeric bearings (see Figure 6.2). Cleaning and washing of the deck as a regular annual activity. Crack sealing and cleaning of the deck every 5 years since the bridge construction. A full deck replacement at 40 years along with bearing replacements. Finally, a bridge superstructure replacement at the end of its service life (65 years).

- Pre-stressed concrete box beams (see Figure 6.3). Cleaning and washing of the deck as a regular annual activity. Crack sealing and cleaning of the deck every 5 years since the bridge construction. A full deck replacement at 40 years along with bearings replacements. Finally, a bridge superstructure replacement at the end of its service life (60 years).
- Steel superstructures (see Figure 6.4). Cleaning and washing of the deck as a regular annual activity. Crack sealing and cleaning of the deck every 5 years since the bridge construction. One bearings replacement at 40 years. A full deck replacement at 40 years. Spot painting every 10 years on less than 10% of the exposed beam area. Finally, a bridge superstructure replacement at the end of its service life (80 years).

Through discussion with INDOT personnel, it was noted that accelerated deterioration at beams ends is one of the main reasons of why prestressed elements show shorter service lives compared with structural steel elements. One option to avoid this abnormal deterioration is to eliminate beam end joints and cast diaphragms over the piers and use integral end abutments. This alternative will undoubtedly extend the service life of prestressed structures. For the purpose of this study, it is assumed that this activity will extend the service life of these type of superstructures

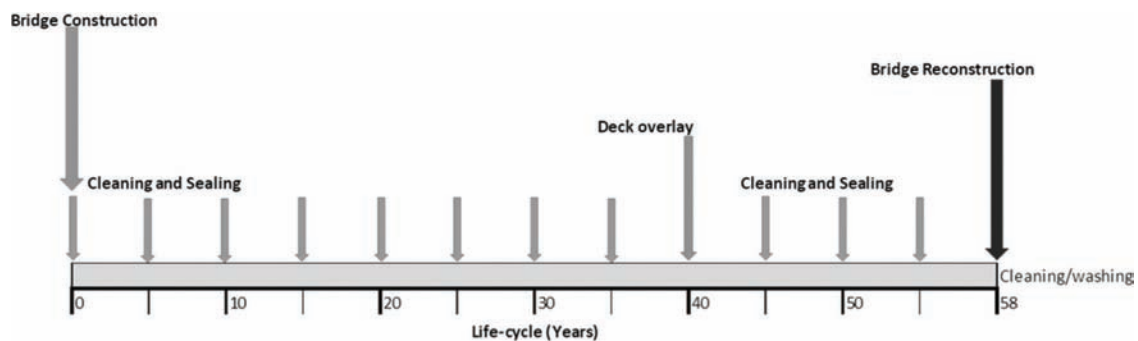

Figure 6.1 Life-cycle profile for slab bridges.

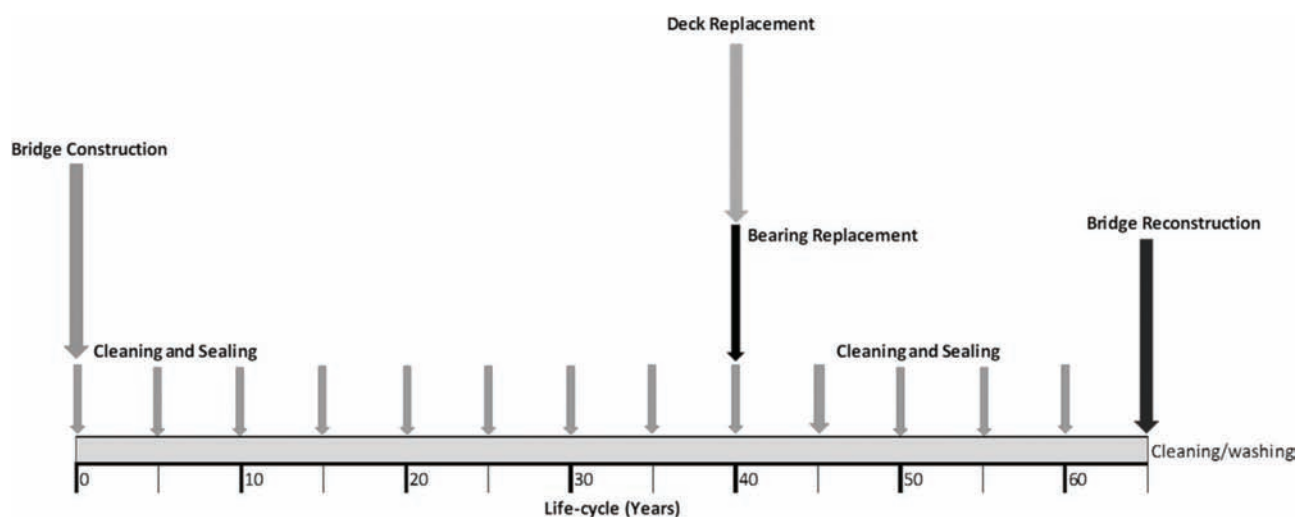

Figure 6.2 Life-cycle profile for prestressed concrete I beams with elastomeric bearings.

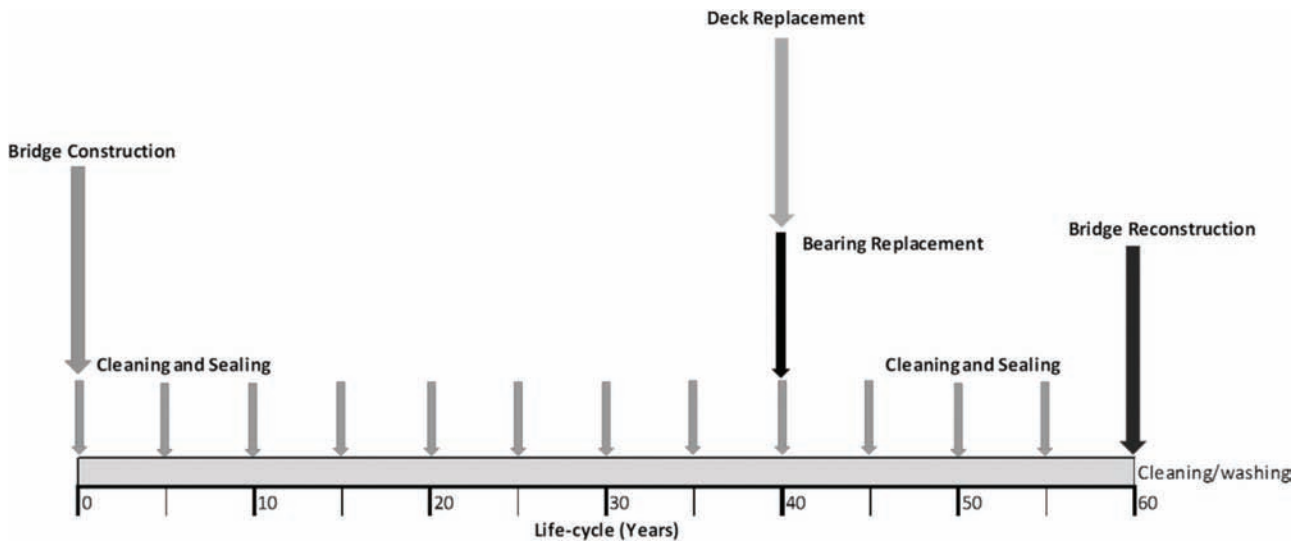

Figure 6.3 Life-cycle profile for prestressed concrete box beams with elastomeric bearings.

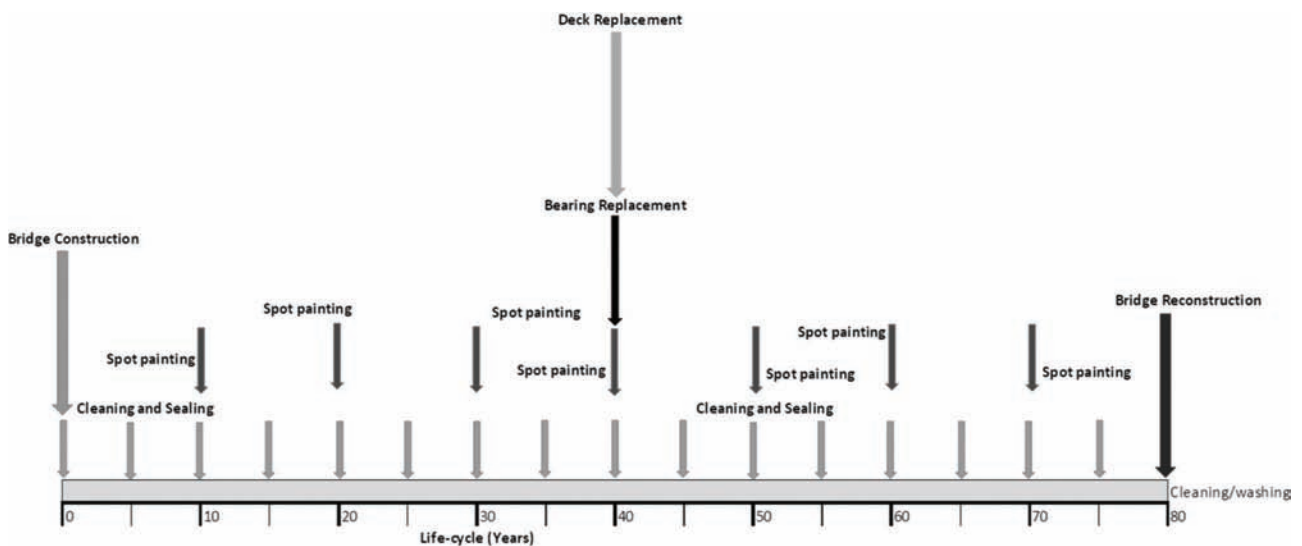

Figure 6.4 Life-cycle profile for steel structures.

up to the same value used for structural steel elements, which is 80 years, and is an extension of 15 years of the service life. Therefore, life-cycle profiles including this improvement are also considered, adding the corresponding diaphragm initial cost to the alternative analyzed. In addition, SDCL system service life is also extended in the same proportion since the system itself is based on the same principle of integral abutments and intermediate pier diaphragms, making its service life 95 years. Consequently, profiles chosen to compare its cost effectiveness are the following:

- Steel superstructures SDCL (see Figure 6.5). Cleaning and washing of the deck as a regular annual activity. Crack sealing and cleaning of the deck every 5 years since the bridge construction. A full deck replacement at 50 years. Spot painting every 10 years less than 10% of

the exposed beam area. Finally, a bridge superstructure replacement at the end of its service life (95 years).

- Prestressed concrete I beams including diaphragms (see Figure 6.6). Cleaning and washing of the deck as a regular annual activity. Crack sealing and cleaning of the deck every 5 years since the bridge construction. A full deck replacement at 40 years. Finally, a bridge superstructure replacement at the end of its service life (80 years).

Finally, section loss due to corrosion for steel superstructures is considered as one of the main reasons for deterioration. Therefore, corrosion protection is important to enhance service lives in these type of superstructures. Different alternatives have been considered including painting, weathering steel, metallization and galvanization. The life-cycle cost profile (LCCP) presented in Figure 6.4 only depicts the painted alternative.

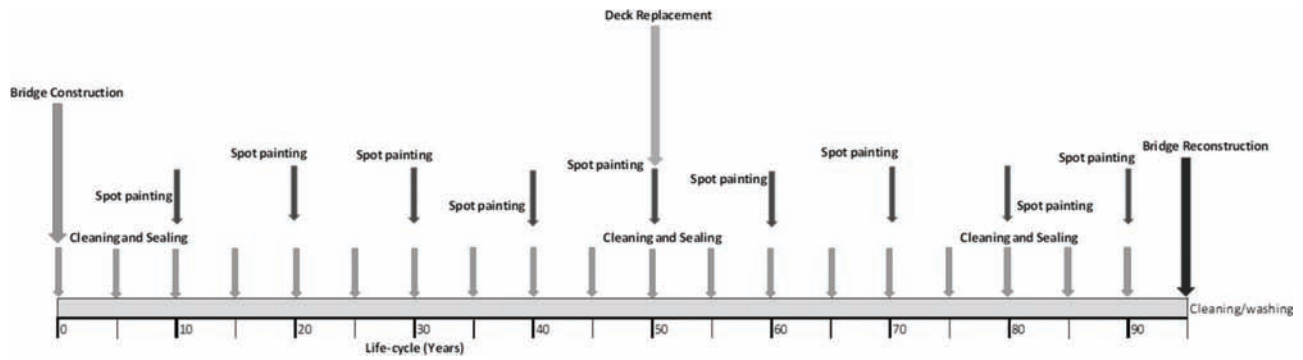

Figure 6.5 Life-cycle profile for steel structures SDCL.

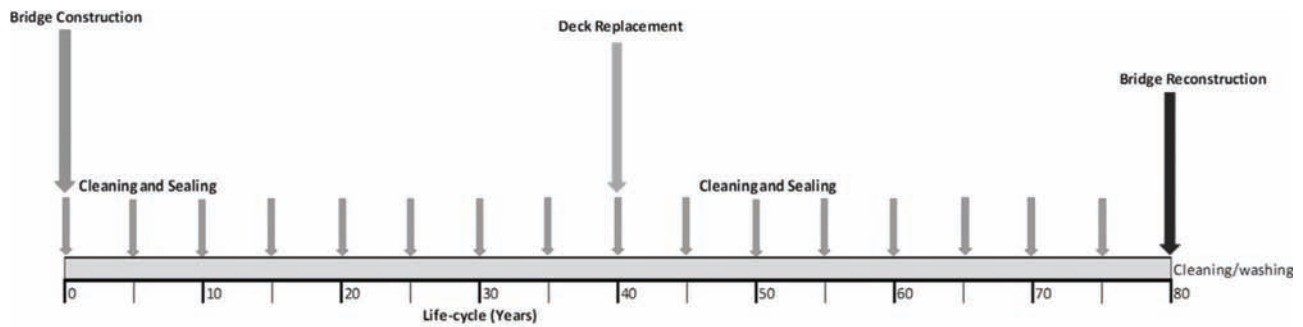

Figure 6.6 Life-cycle profile for prestressed concrete I beams including diaphragms.

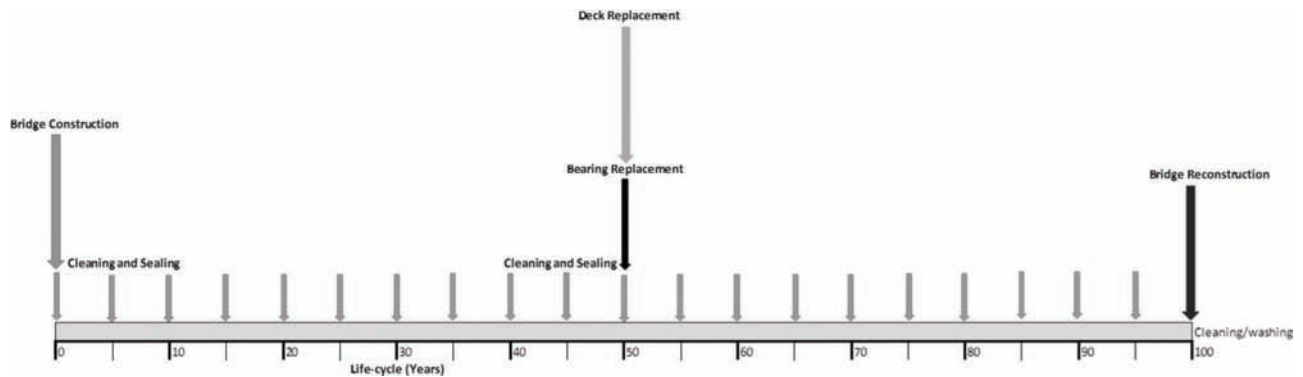

Figure 6.7 Life-cycle profile for galvanized steel structures.

However, the usage of other corrosion protection systems could increase the service life of steel elements significantly. According to the American Galvanizers Association (2015), for suburban environments, a zinc average thickness of 4.0 mils or more could extend the service life of the initial coating up to 100 years or more. This represents an extension of the service life of 20 years compared with the painted elements. Accordingly, equivalent extension in the service life is considered for the SDCL galvanized option with integral end abutments, improving its service life to 115 years. Consequently, profiles chosen to compare its cost effectiveness are the following

- Steel superstructures—galvanized (see Figure 6.7). Cleaning and washing of the deck as a regular annual activity.

Crack sealing and cleaning of the deck every 5 years since the bridge construction. One bearing replacement at 50 years. A full deck replacement also at 50 years. Finally, a bridge superstructure replacement at the end of its service life (100 years).

- Steel superstructures SDCL—Galvanized (see Figure 6.8). Cleaning and washing of the deck as a regular annual activity. Crack sealing and cleaning of the deck every 5 years since the bridge construction. Full deck replacements at 40 and 80 years. Finally, a bridge superstructure replacement at the end of its service life (115 years).

It is important to mention that continuous steel galvanized beam structures with integral end abutments are not considered in this study due to its cost-effectiveness. As it can be seen in Chapter 7 results



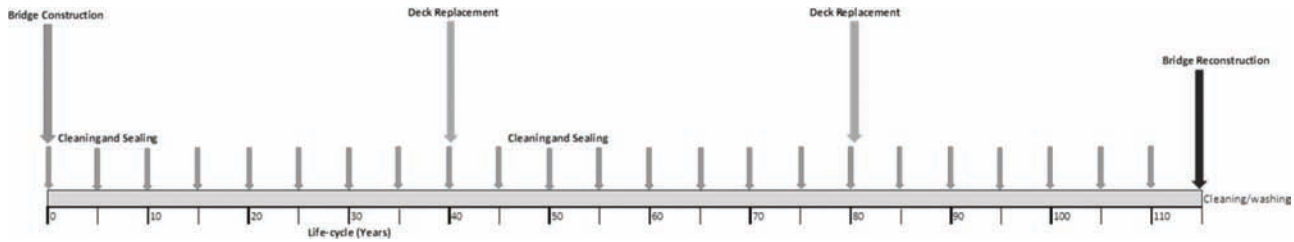

Figure 6.8 Life-cycle profile for galvanized steel structures SDCL.

for the case of SDCL, if galvanized and painted options are compared, the extension in service life due to galvanization involves an additional deck reconstruction, that impact negatively the cost effectiveness of this alternative. Following this trend, it is assumed that the extension in the service life due to the inclusion of integral end abutments for continuous steel galvanized structures will also require an additional deck reconstruction that will impact negatively the final outcome of this alternative.

## 7. LIFE-CYCLE COST ANALYSIS FOR INDIANA BRIDGES

Results of the bridge design, cost allocation, and deterioration curves were used to create the BLCCA for each design option. Those investigations will be the starting point for recommendations made to designers based on BLCCA.

Sinha et al. (2009) developed a Life-Cycle Cost module for the Indiana bridge management system (IBMS) called LCCOST. The outcome of this module is the difference in expected life-cycle costs with or without the decision tree module recommendation (maintenance/rehabilitation/reconstruction). Nevertheless, LCCOST does not compare different alternatives for the same project in terms of life-cycle costs. This study can be understood as a complementary tool for agencies rather than an extension to the modules created for the IBMS.

Life-cycle profiles indicate not only the possible location for each major and routine working actions, but they also indicate the length of the life-cycle itself. Depending on the type of material, structural type and major work actions considered, the length of the life cycle could vary. In order to compare different options using BLCCA, there is a need to establish a comparable service life for all alternatives. If two alternatives with different service lives are to be compared, the least common multiple of the two estimated service lives of the two alternatives must be used according to Grant and Grant-Ireson (1960). However, it is assumed that in the case of highway assets with long service lives like bridges, it is likely to replace the structure in the same place over and over again rather than replace it in different locations each time. This factor implies that the life cycle is recurrent independent of the structure type used.

Consequently, it can be assumed that each alternative will be indefinitely replaced, in other words in perpetuity. Fwa (2006) and Thompson et al. (2012) both describe methods to compute the present worth of life-cycle cost in perpetuity. Equation 7.1 shows Ford's alternative, where  $P_p$  is the present worth of LCCA in perpetuity (LCCAP for further reference),  $P$  is the life-cycle cost of a single service life at the beginning of the SL,  $i$  is the interest rate used and is the service life in years of each option. Using this equation, it is possible to compare different alternatives with different service lives in terms of life-cycle costs.

$$P_p = \frac{P(1+i)^{SL}}{(1+i)^{SL} - 1} \quad (\text{Equation 7.1})$$

It is important to clarify that all analyses and alternative cost considerations are made in constant dollars as is commonly done for economic analysis. Inflation rates will not be considered "on the assumption that all costs and benefits of various alternatives are affected equally by inflation" (Sinha & Labi, 2011). However, if it is considered that the inflation will affect the future costs differently of a given alternative, then such adjustment, need to be made according to the American Association of State Highway Transportation Officials (AASHTO, 1978).

### 7.1 Interest Rate, Inflation, and Discount Rate

A generalized engineering economic principle states that all analyses that are based on the value of money is strictly related to the time during which the value is considered. In other words, a given amount of money does not have the same value in the present than it has in the past or the future due to the combination of the inflation and the opportunity cost that affect the value of money over time. On one hand, *inflation* ( $f$ ) is the increase of prices of goods and services with time and is reflected by a decrease in the purchasing power of a given sum of money at a current period. On the other hand, *opportunity cost* is the income that is foregone at a later time by not investing a given sum of money at a current period, Sinha and Labi (2011).

*Interest* ( $i$ ) is the value that represents the amount by which a given sum of money differs from its future value. In other words, it is the price of borrowing money or the time value of money. Additionally, the

change of interest over a time (*interest rate*) used to compute the present value of a future sum or cash flow is known as *discount rate*. By definition, inflation has to be included when the discount rate needs to be determined. However, and as specified before, it is assumed that inflation will affect all costs the same, which is the reason why inflation is not considered or taken as 0%.

Discount rates differ depending on the economic activity analyzed. For instance, the discount rate used for social analyses is often different than that used for highway asset management. Some economists have suggested that the long-term true cost of the money to be between 4% and 6% (Craig et al., 1982). The value often used for highway bridge management according to the Indiana Department of Transportation is 4% (INDOT, 2013; Bowman & Moran, 2015).

## 7.2 Interest Equations and Equivalences

According to Sinha and Labi (2011), *interest equations* known also as *equivalency equations* are the relationships between amounts of money that occur at different points in time and are used to estimate the worth of a single amount of money or a series of monetary amounts from one time period to another to reflect the time value of money. All relationships involve some of the following five basic factors: *P*, initial amount; *F*, amount of money at a specified future period; *A*, a periodic amount of money; *i*, the interest rate or discount rate for the compounding period; and *N*, a specified number of compounding periods or the analysis period.

### 7.2.1 Single payment compound amount factor (SPACF)

Finding the future compounded amount (*F*) at the end of a specified period given the initial amount (*P*), the analysis period (*N*) and interest rate (*i*), is given by Equation 7.2.

$$F = P \times SPACF, SPACF = (1 + i)^N \quad (\text{Equation 7.2})$$

### 7.2.2 Single payment present worth factor (SPPWF)

Finding the initial amount (*P*) that would yield a given future amount (*F*), at the end of a specified analysis period (*N*) given the interest rate (*i*), is given by Equation 7.3.

$$P = F \times SPPWF, SPPWF = \frac{1}{(1 + i)^N} \quad (\text{Equation 7.3})$$

### 7.2.3 Sinking fund deposit factor (SFDF)

Finding the uniform yearly amount (*A*) that would yield a given future amount (*F*), at the end of an

specified analysis period (*N*) given the interest rate (*i*), is given by Equation 7.4.

$$A = F \times SFDF, SFDF = \frac{i}{(1 + i)^N - 1} \quad (\text{Equation 7.4})$$

### 7.2.4 Uniform series compound amount factor (USCAF)

Finding the future compounded amount (*F*) at the end of a specified period given the annual payments (*A*), the analysis period (*N*) and the interest rate (*i*), is given by Equation 7.5.

$$F = A \times USCAF, USCAF = \frac{(1 + i)^N - 1}{i} \quad (\text{Equation 7.5})$$

### 7.2.5 Uniform series present worth factor (USPWF)

Finding the initial amount (*P*) that is equivalent to a series of uniform annual payments (*A*), given the analysis period (*N*) and the interest rate (*i*), is given by Equation 7.6.

$$P = A \times USPWF, USPWF = \frac{(1 + i)^N - 1}{i(1 + i)^N} \quad (\text{Equation 7.6})$$

### 7.2.6 Capital recovery factor (CRF)

Finding the amount of uniform yearly payments (*A*) that would completely recover an initial amount (*P*), at the end of the analysis period (*N*) given the interest rate (*i*), is given by Equation 7.7.

$$A = P \times CRF, CRF = \frac{i(1 + i)^N}{(1 + i)^N - 1} \quad (\text{Equation 7.7})$$

## 7.3 Life-Cycle Cost Analysis Comparison

There are several criteria used to assess the economic efficiency of a project. Some of them are listed as:

- Present worth of cost (PWC)
- Equivalent uniform annual cost (EUAC)
- Equivalent uniform annual return (EUAR)
- Net present value (NPV)
- Internal rate of return (IRR)
- Benefit-cost ratio (BCR) Procedure proposed

The first two indicators of economic efficiency are applicable when all alternatives have a similar expected level of benefits and cost minimization is the main objective of the analysis. However, the alternatives analyzed in this document do not have the same level of benefits, as demonstrated by the salvage value for each superstructure type. The last two criteria require a solid estimation of the benefits resulting from the implementation of the alternatives analyzed. Therefore, a complete socio-economic analysis is needed. Such an analysis is outside of the scope of this project and

requires a specific location for the alternative chosen. As a consequence, EUAR and NPV are the most common indicators used, however, only NPV is the approach used in this study.

### 7.3.1 Equivalent uniform annual return (EUAR)

The EUAR is the combination of all costs and benefits expected from a project expressed into a single annual value of return over the analysis period. This method is useful when all the alternatives have different level of cost or benefits, or when the analysis periods differ from one option to the other.

### 7.3.2 Net present value (NPV)

The NPV is understood as the difference between the present worth of benefits and the present worth of costs. Basically, this method represents the value of the project at the time of the base year of the analysis period or the year of the decision making. NPV is often considered as the most appropriate of all economic efficiency indicators because it provides a magnitude of net benefits in monetary terms (Sinha & Labi, 2011). Therefore, the alternative with the lowest NPV is considered the most economically efficient. For the case of this study, costs are treated as positive values and benefits as negative values. Consequently, the lowest value of NPV is desired.

## 7.4 Life-Cycle Cost Analysis Example—Simply Supported Beams Configuration: 30-ft Span

This section describes the procedure used for the computation of the LCCA and the indicator of economic efficiency. Information needed is the following: Alternatives considered (as described in section 3.2), bridge designs (see Appendices B and C), service life depending on the superstructure type (per Chapter 5), life-cycle profiles and working action scheduling (see Chapter 6), agency costs (described in Chapter 4) and finally, the LCCA strategy including discount rate and comparison criteria as mentioned earlier in this chapter.

As a general outline, this example is performed using the following procedure. First, computation of the initial cost for all the alternatives is assembled. Then a LCCA of different profiles for one superstructure alternative is conducted to show the procedure used for the selection of the definitive profile. After that, computation of the LCCA for the different superstructure type alternatives is done, followed by the estimation of the LCCAP of each one of them. Finally, a graphical representation of the comparison is shown for all the configuration and span ranges, so that the results can be compared and discussed.

### 7.4.1 Superstructure types—Initial cost estimation

Following the design plan shown in Table 3.1, six different superstructure types are considered for the

simply supported configuration in span range 1, and specifically for a span length of 30 ft. Types considered are the following: slab bridge, structural steel rolled beam bridge (5-beam configuration alternative), structural steel rolled beam bridge (4-beam configuration alternative), prestressed concrete AASHTO beams bridge, structural steel FPG bridge, and prestressed concrete box beam bridge. As mentioned before in this document, barriers and other miscellaneous elements are not considered in the initial cost estimation. Thus, the only costs considered are those for concrete for the superstructure (slab), reinforcing steel, structural steel, and prestressed concrete elements. The costs used are shown in Table 4.2 and Table 4.3. Quantities were obtained from the designs drawings shown in the Appendix C. Critical features for each of the designs alternatives are noted below.

- *Slab bridge*: Total concrete slab thickness of 17.5 in including sacrificial surface. Longitudinal reinforcing steel (parallel to direction of the traffic): #5 @ 8" top and #8 @ 5" bottom. Transverse reinforcing steel (perpendicular to direction of the traffic): #5 @ 8.0" top and bottom.
- *Structural steel rolled beams (5 beams)*: Total concrete slab thickness of 8.0 in including sacrificial surface. Transverse reinforcing steel (perpendicular to direction of the traffic): #7 @ 5.0" top and #5 @ 7.0" bottom. Longitudinal reinforcing steel (parallel to direction of the traffic): #5 @ 7.0" top and bottom. Five (5) W18 × 65 beams separated by 9.5 ft.
- *Structural steel rolled beams (4 beams)*: Total concrete slab thickness of 8.0 in including sacrificial surface. Transverse reinforcing steel (perpendicular to direction of the traffic): #7 @ 4.0" top and #5 @ 5.0" bottom. Longitudinal reinforcing steel (parallel to direction of the traffic): #5 @ 7" top and bottom. Four (4) W18 × 76 beams separated by 12.5 ft.
- *Prestressed concrete AASHTO beams*: Total concrete slab thickness of 8.0 in including sacrificial surface. Transverse reinforcing steel (perpendicular to direction of the traffic): #5 @ 4.0" top and #5 @ 8.0" bottom. Longitudinal reinforcing steel (parallel to direction of the traffic): #5 @ 8.0" top and bottom. Six (6) type I AASHTO beams separated by 7.5 ft.
- *Structural steel FPG (6 beams)*: Total concrete slab thickness of 8.0 in including sacrificial surface. Transverse reinforcing steel (perpendicular to direction of the traffic): #5 @ 5.0" top and #5 @ 8.0" bottom. Longitudinal reinforcing steel (parallel to direction of the traffic): #5 @ 8.0" top and bottom. Six (6) FP60 × 12 × 1/2 beams separated by 7.5 ft.
- *Structural steel FPG (4 beams)*: Total concrete slab thickness of 8.0 in including sacrificial surface. Transverse reinforcing steel (perpendicular to direction of the traffic): #7 @ 4.0" top and #5 @ 5.0" bottom. Longitudinal reinforcing steel (parallel to direction of the traffic): #5 @ 7.00 top and bottom. Four (4) FP72 × 17 × 1/2 beams separated by 12.5 ft.
- *Prestressed concrete box beams*: Total concrete slab thickness of 8.0 in including sacrificial surface. Transverse reinforcing steel (perpendicular to direction of the traffic): #5 @ 5.0" top and #5 @ 7.0" bottom. Longitudinal reinforcing steel (parallel to direction of the

TABLE 7.1  
Initial cost—simply supported beam, span length 30 ft

Type	Width, ft	Total (\$)
Slab Bridge	43	51,438
Steel Beam (5B Painted)	43	59,464
Steel Beam (4B Painted)	43	59,224
Steel Beam (5B Galvanized)	43	62,511
Steel Beam (4B Galvanized)	43	62,234
PS Concrete Beam (Bearings)	43	59,747
PS Concrete Beam (Diaphragm)	43	73,639
Folded S Plate (6B Galvanized)	43	67,921
Folded S Plate (4B Galvanized)	43	62,790
Concrete Box	43	75,404

traffic): #5 @ 8.0" top and bottom. Five (5) box beams CB17 × 48 separated by 9.5 ft.

Based on the descriptions of the design features for each of the alternatives, the construction costs can be obtained. The initial cost for all the alternatives is shown in Table 7.1. Since the construction is considered at year 0, this value does not need to be discounted to a present value. However, if Equation 7.1 is to be used to calculate the LCCA, all costs need to be projected to the end of the service life and then converted to a single present value using the present worth in perpetuity factor. This methodology is used in the Appendix E. Nonetheless, for the example given, present values will be used to compute the single life-cycle cost of the alternative, then this amount is projected to the end of the service life using the SPACF (Equation 7.2), and finally the LCCAP is obtained (Equation 7.1).

#### 7.4.2 Life-cycle profile selection and TLCC estimation

Different maintenance schedules were considered for each superstructure type that resulted in different life-cycle profiles. The minimum TLCC among all the different alternatives per superstructure type is then used for comparison with other superstructure types. Therefore, the lowest value corresponds to the most cost effective option for that specific span length. All the different profiles used can be seen in Appendix D. For this illustrative example, only one superstructure type is detailed (slab bridge). For the remaining types only the most cost-effective profile is shown.

Working actions considered for the slab bridges are described below. Various combinations of all of them are presented in the life-cycle profiles shown in Figure 7.1.

- *Cleaning and washing of the deck:* Only the current INDOT practice is taken into account. The procedure is performed on a yearly basis.
- *Deck overlay:* Two different alternatives were considered: Alternative A involves a first overlay after 25 years of original construction, then 25 years of overlay service life. Due to the limited service life of this type of superstructure, only two overlays are considered. However, INDOT policies indicates that a slab bridge could stand up to three different overlays if needed until

the end of its service life. Alternative B involves a single overlay after 40 years of construction along with a process of sealing and cleaning of the deck surface every 5 years.

- *Sealing and cleaning of the deck surface:* INDOT current policy contemplate the sealing and cleaning of the deck surface only after the construction/reconstruction of the deck, it means it is considered at year 0 exclusively for slab bridges. Alternative practice involves performing this procedure every five years for the service life of the bridge.
- *Deck patching:* Deck patching is considered for 10% of the total deck surface area. This working action is performed every 10 years.
- *Bridge reconstruction:* At the end of the service life (58 years).

Using the profiles shown in Figure 7.1, the interest equivalences proposed in section 7.2, and the agency costs summarized in Table 4.4, it is possible to obtain the present value of all the working actions predicted.

*Current INDOT practice.* This option involves a deck overlay (OC) at 25 and 50 years, plus sealing and cleaning of the deck surface (SCC) at the beginning of the service life, and washing of the deck surface (WC) on a yearly basis, plus the initial cost (IC) and the removal of the bridge cost (BRC). The present value of this alternative can be obtained as follows:

$$TLCC_{Alt\ INDOT} = IC + PV(WC) + SCC + PV(OC) + PV(BRC) \quad (\text{Equation 7.8})$$

$$IC = \$51,438$$

$$PV(WC) = wc \times USPWF(4\%, 58\text{years}) \quad (\text{Equation 7.9})$$

$$PV(WC) = \$2.17/\text{ft}^2(30\text{ft} \times 43\text{ft}) \frac{(1 + 4\%)^{58\text{years}} - 1}{4\%(1 + 4\%)^{58\text{years}}} = \$62,787$$

$$SCC = se \times Area = \$1.27/\text{ft}^2(30\text{ft} \times 43\text{ft}) = \$1,638 \quad (\text{Equation 7.10})$$

$$PV(OC) = o \times SPPWF(4\%, 25) + o \times SPPWF(4\%, 50) \quad (\text{Equation 7.11})$$

$$PV(OC) = \$39.64/\text{ft}^2(30\text{ft} \times 40\text{ft}) \frac{1}{(1 + 4\%)^{25}} + \$39.64/\text{ft}^2(30\text{ft} \times 40\text{ft}) \frac{1}{(1 + 4\%)^{50}}$$

$$PV(OC) = \$24,537$$

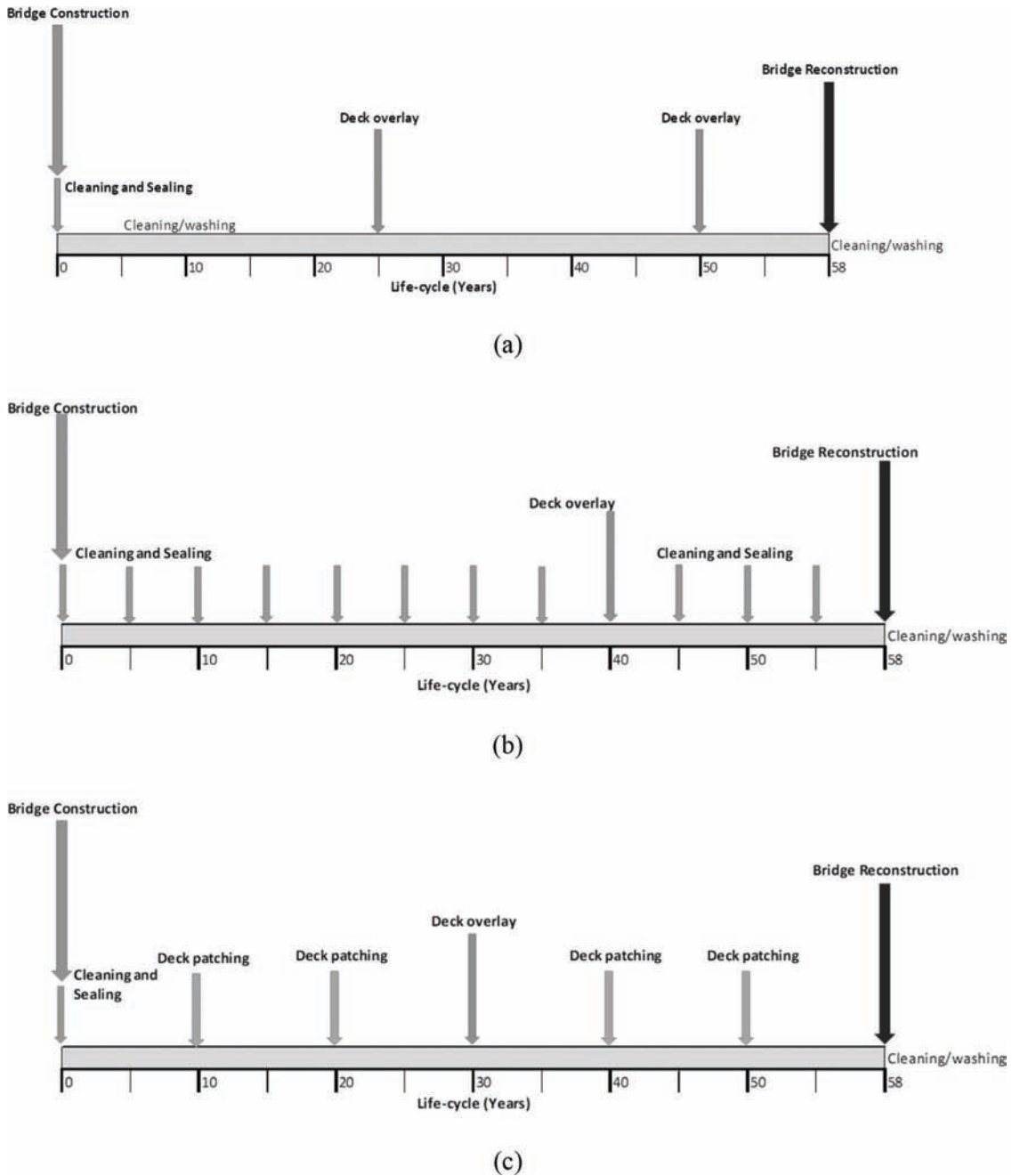

**Figure 7.1** Slab bridge life-cycle profiles. (a) INDOT current practice, (b) Alternative A: initial extended deterioration, and (c) Alternative B: deck patching.

$$\begin{aligned}
 PV(BRC) &= br \times SPPWF(4\%, 58) \\
 &= \$11.11/\text{ft}^2(30\text{ft} \times 43\text{ft}) \frac{1}{(1+4\%)^{58}} \\
 &\quad \text{(Equation 7.12)}
 \end{aligned}$$

$$PV(BRC) = \$1,474$$

$$\begin{aligned}
 TLCC_{Alt\ INDOT} &= \$51,438 + \$62,787 + \$1,638 \\
 &\quad + \$24,537 + \$1,474 = \$141,874
 \end{aligned}$$

**Alternative A: Initial extended deterioration.** This option involves a deck overlay (OC) at 40 years, plus sealing and cleaning of the deck surface (SCC) every 5 years since the bridge construction, and washing of the deck surface (WC) on a yearly basis, plus the initial cost (IC) and the removal of the bridge cost (BRC).

The present value of this alternative can be obtained as follows:

$$TLCC_{AltA} = IC + PV(WC) + PV(SCC) + PV(OC) + PV(BRC) \quad (\text{Equation 7.13})$$

$$IC = \$51,438$$

$$PV(WC) = wc \times USPWF(4\%, 58\text{years}) = \$2.17/\text{ft}^2(30\text{ft} \times 43\text{ft}) \frac{(1+4\%)^{58\text{years}} - 1}{4\%(1+4\%)^{58\text{years}}} \quad (\text{Equation 7.14})$$

$$PV(WC) = \$62,787$$

$$PV(SCC) = \sum_0^N se \times SPPWF(4\%, y_i) - \sum_1^n se \times SPPWF(4\%, y_x) \quad (\text{Equation 7.15})$$

$$\therefore y_i = \begin{Bmatrix} 0 \\ 5 \\ 10 \\ \vdots \\ SL \end{Bmatrix}, y_x = \begin{Bmatrix} 40 \\ SL \end{Bmatrix}$$

$$PV(SCC) = \$1.27/\text{ft}^2(30\text{ft} \times 43\text{ft})$$

$$\left( \frac{1}{(1+4\%)^0} + \frac{1}{(1+4\%)^5} + \frac{1}{(1+4\%)^{10}} + \dots + \frac{1}{(1+4\%)^{58}} \right) - \$1.27/\text{ft}^2(30\text{ft} \times 43\text{ft}) \left( \frac{1}{(1+4\%)^{40}} + \frac{1}{(1+4\%)^{58}} \right) \\ PV(SCC) = \$7,984$$

$$PV(OC) = o \times SPPWF(4\%, 40) \quad (\text{Equation 7.16})$$

$$PV(OC) = \$9,908$$

$$PV(BRC) = br \times SPPWF(4\%, 58) = \$11.11/\text{ft}^2(30\text{ft} \times 43\text{ft}) \frac{1}{(1+4\%)^{58}} \quad (\text{Equation 7.17})$$

$$PV(BRC) = \$1,474$$

$$TLCC_{AltA} = \$51,438 + \$62,787 + \$7,984 + \$9,908 + \$1,474 = \$133,591$$

**Alternative B: Deck patching.** This option involves a deck overlay (OC) at 30 years, plus sealing and cleaning of the deck surface (SCC) at the beginning of the service life, plus full depth patching of the deck (PC) every 10 years since the bridge construction (10% of the deck surface), and washing of the deck surface (WC) on a yearly basis, plus the initial cost (IC) and the removal of the bridge cost (BRC). The present value of this alternative can be obtained as follows:

$$TLCC_{AltB} = IC + PV(WC) + PV(PC) + PV(OC) + PV(SCC) + PV(BRC) \quad (\text{Equation 7.18}) \\ IC = \$51,438$$

$$PV(WC) = wc \times USPWF(4\%, 58\text{years}) = \$2.17/\text{ft}^2(30\text{ft} \times 43\text{ft}) \frac{(1+4\%)^{58\text{years}} - 1}{4\%(1+4\%)^{58\text{years}}} \quad (\text{Equation 7.19})$$

$$PV(WC) = \$62,787$$

$$PV(PC) = \sum_1^N pc \times SPPWF(4\%, y_i) - \sum_1^n pc \times SPPWF(4\%, y_x) \\ \therefore y_i = \begin{Bmatrix} 10 \\ 20 \\ \vdots \\ SL \end{Bmatrix}, y_x = \begin{Bmatrix} 30 \\ SL \end{Bmatrix} \quad (\text{Equation 7.20})$$

$$PV(PC) = \$37.23/\text{ft}^2(30\text{ft} \times 40\text{ft}) \times 10\% \left( \frac{1}{(1+4\%)^{10}} + \frac{1}{(1+4\%)^{20}} + \dots + \frac{1}{(1+4\%)^{58}} \right) - \$37.23/\text{ft}^2(30\text{ft} \times 40\text{ft}) \times 10\% \left( \frac{1}{(1+4\%)^{30}} + \frac{1}{(1+4\%)^{58}} \right)$$

$$PV(PC) = \$6,616$$

$$SCC = se \times Area = \$1.27/\text{ft}^2(30\text{ft} \times 43\text{ft}) = \$1,638 \quad (\text{Equation 7.21})$$

$$PV(OC) = o \times SPPWF(4\%, 30) \quad (\text{Equation 7.22})$$

$$PV(OC) = \$39.64/ft^2(30ft \times 40ft) \frac{1}{(1+4\%)^{30}}$$

$$PV(OC) = \$14,666$$

$$PV(BRC) = br \times SPPWF(4\%, 58)$$

$$= \$11.11/ft^2(30ft \times 43ft) \frac{1}{(1+4\%)^{58}}$$

$$(\text{Equation 7.23})$$

$$PV(BRC) = \$1,474$$

$$TLCC_{AltB} = \$51,438 + \$62,787 + \$14,666 + \$6,616 + 1,638 + \$1,474$$

$$TLCC_{AltB} = \$136,981$$

As it can be seen, no residual value or salvage value was included. Salvage value was only considered for the steel superstructures and it was included as a benefit. To conclude, it is shown that the most cost-effective profile for slab bridges corresponds to Alternative B.

Following the same principles for the remaining superstructure types, the most cost-effective life-cycle profiles were chosen. However, only the calculation of the definitive profiles for each of the superstructure types analyzed are shown below. Refer to Appendix D for all life-cycle profiles considered for all superstructure types.

**Structural steel rolled beam—5-beam configuration. Alternative C: Bearing replacement, spot painting and sealing process.** This option involves a deck reconstruction (DRC) at 40 years, plus sealing and cleaning of the deck surface (SCC) every 5 years since the bridge construction, plus spot painting (SPC) every 10 years since the bridge construction (10% of the structural element surface), bearing replacements (BC) at 40 years, and washing of the deck surface (WC) on a yearly basis, plus the initial cost (IC), the removal of the bridge cost (BRC) and the salvage value represented by the benefit of selling the structural steel for recycling (SRC). In addition, some details are needed regarding the structural steel beam elements. Firstly, the exposed perimeter of the beam is for spot painting 4.94 ft. Secondly, the total weight of the steel elements is 10,506 lb. Finally, a total price for the reinforcement steel of \$12,365 which will be included together with the bridge deck reconstruction cost calculation. The present value of this alternative can be obtained as follows:

$$TLCC_{AltC} = IC + PV(WC) + PV(SCC) + PV(DRC) + PV(BC) + PV(SPC) + PV(BRC) + PV(SRC) \quad (\text{Equation 7.24})$$

$$IC = \$59,464$$

$$PV(WC) = wc \times USPWF(4\%, 80years)$$

$$= \$2.17/ft^2(30ft \times 43ft) \frac{(1+4\%)^{80years} - 1}{4\%(1+4\%)^{80years}}$$

$$(\text{Equation 7.25})$$

$$PV(WC) = \$66,946$$

$$PV(SCC) = \sum_0^N se \times SPPWF(4\%, y_i) - \sum_1^n se$$

$$\times SPPWF(4\%, y_x) \therefore y_i = \begin{cases} 0 \\ 5 \\ 10 \\ \vdots \\ SL \end{cases}, y_x = \{SL\}$$

$$(\text{Equation 7.26})$$

$$PV(SCC) = \$1.27/ft^2(30ft \times 43ft)$$

$$\left( \frac{1}{(1+4\%)^0} + \frac{1}{(1+4\%)^5} + \frac{1}{(1+4\%)^{10}} + \dots + \frac{1}{(1+4\%)^{80}} \right) - \$1.27/ft^2(30ft \times 43ft) \left( \frac{1}{(1+4\%)^{80}} \right)$$

$$PV(SCC) = \$8,801$$

$$PV(DRC) = dr \times SPPWF(4\%, 40) \quad (\text{Equation 7.27})$$

$$PV(DRC) = \left( \$47.41/ft^2(30ft \times 43ft) + \$12,365 \right) \frac{1}{(1+4\%)^{40}}$$

$$PV(DRC) = \$15,314$$

$$PV(BC) = bc \times SPPWF(4\%, 40) \quad (\text{Equation 7.28})$$

$$PV(BC) = \$3,483/unt(5bm \times 2sup) \frac{1}{(1+4\%)^{40}}$$

$$PV(BC) = \$7,254$$

$$PV(SPC) = \sum_0^N spc \times SPPWF(4\%, y_i) - \sum_1^n spc \times SPPWF(4\%, y_x) \quad (\text{Equation 7.29})$$

$$\therefore y_i = \left\{ \begin{array}{c} 10 \\ 20 \\ 30 \\ \vdots \\ SL \end{array} \right\}, y_x = \{SL\}$$

$$PV(SPC) = \$2.19/ft^2(4.94ft \times 30ft \times 5bm \times 10\%) \left( \frac{1}{(1+4\%)^{10}} + \frac{1}{(1+4\%)^{20}} + \dots + \frac{1}{(1+4\%)^{80}} \right) - \$1.27/ft^2(4.94ft \times 30ft \times 5bm \times 10\%) \left( \frac{1}{(1+4\%)^{80}} \right)$$

$$PV(SPC) = \$316$$

$$PV(BRC) = br \times SPPWF(4\%, 80) = \$11.11/ft^2(30ft \times 43ft) \frac{1}{(1+4\%)^{80}} \quad (\text{Equation 7.30})$$

$$PV(BRC) = \$622$$

$$PV(SRC) = sr \times SPPWF(4\%, 80) = \$0.08/Lb(5 \times 10,506lb) \frac{1}{(1+4\%)^{80}} \quad (\text{Equation 7.31})$$

$$PV(SRC) = \$182$$

$$TLCC_{AltC} = \$59,464 + \$66,946 + \$8,801 + \$15,314 + \$7,254 + \$316 + \$622 - \$182$$

$$TLCC_{AltC} = \$158,535$$

**Prestressed concrete AASTHO beams. Alternative A: Modified INDOT routine procedure.** This option involves a deck reconstruction (DRC) at 40 years, plus sealing and cleaning of the deck surface (SCC) every 5 years since the bridge construction, bearing replacements (BC) at 45 years, and washing of the deck surface

(WC) on a yearly basis, plus the initial cost (IC) and the removal of the bridge cost (BRC). Finally, a total price for the reinforcing steel of \$9,086 which will be included together with the bridge deck reconstruction cost calculation. The present value of this alternative can be obtained as follows:

$$TLCC_{AltA} = IC + PV(WC) + PV(SCC) + PV(DRC) + PV(BC) + PV(BRC) \quad (\text{Equation 7.32})$$

$$IC = \$59,747$$

$$PV(WC) = wc \times USPWF(4\%, 65years) = \$2.17/ft^2(30ft \times 43ft) \frac{(1+4\%)^{65years} - 1}{4\%(1+4\%)^{65years}} \quad (\text{Equation 7.33})$$

$$PV(WC) = \$64,515$$

$$PV(SCC) = \sum_0^N se \times SPPWF(4\%, y_i) - \sum_1^n se \times SPPWF(4\%, y_x) \quad (\text{Equation 7.34})$$

$$\therefore y_i = \left\{ \begin{array}{c} 0 \\ 5 \\ 10 \\ \vdots \\ SL \end{array} \right\}, y_x = \{SL\}$$

$$PV(SCC) = \$1.27/ft^2(30ft \times 43ft) \left( \frac{1}{(1+4\%)^0} + \frac{1}{(1+4\%)^5} + \frac{1}{(1+4\%)^{10}} + \dots + \frac{1}{(1+4\%)^{65}} \right) - \$1.27/ft^2(30ft \times 43ft) \left( \frac{1}{(1+4\%)^{65}} \right)$$

$$PV(SCC) = \$8,481$$

$$PV(DRC) = dr \times SPPWF(4\%, 40) \quad (\text{Equation 7.35})$$

$$PV(DRC) = \left( \$47.41/ft^2(30ft \times 43ft) + \$9,086 \right) \frac{1}{(1+4\%)^{40}}$$

$$PV(DRC) = \$14,631$$

$$PV(BC) = bc \times SPPWF(4\%, 40) \quad (\text{Equation 7.36})$$



$$PV(BC) = \$3,483/_{unt}(6bm \times 2sup) \frac{1}{(1+4\%)^{40}}$$

$$PV(BC) = \$8,705$$

$$PV(BRC) = br \times SPPWF(4\%, 65)$$

$$= \$11.11/_{ft^2}(30ft \times 43ft) \frac{1}{(1+4\%)^{65}}$$

(Equation 7.37)

$$PV(BRC) = \$1,120$$

$$TLCC_{AltA} = \$59,747 + \$64,515 + \$8,481 + \$14,631$$

$$+ \$8,705 + \$1,120$$

$$TLCC_{AltA} = \$157,199$$

**Structural steel rolled beam—4-beam configuration. Alternative C: Bearing replacement, spot painting and sealing process.** This option involves a deck reconstruction (DRC) at 40 years, plus sealing and cleaning of the deck surface (SCC) every 5 years since the bridge construction, plus spot painting (SPC) every 10 years since the bridge construction (10% of the structural element surface), bearing replacements (BC) at 40 years, and washing of the deck surface (WC) on a yearly basis, plus the initial cost (IC), the removal of the bridge cost (BRC) and the salvage value represented by the benefit of selling the structural steel for recycling (SRC). In addition, some details are needed regarding the structural steel beam elements. Firstly, the exposed perimeter of the beam is 5.76 ft. Secondly, the total weight of the steel elements is 10,382 lb. Finally, a total price for the reinforcement steel of \$14,222 which will be included together with the bridge deck reconstruction cost calculation. The present value of this alternative can be obtained as follows:

$$TLCC_{AltC} = IC + PV(WC) + PV(SCC) + PV(DRC) + PV(BC) + PV(SPC) + PV(BRC) + PV(SRC)$$

(Equation 7.38)

$$IC = \$59,224$$

$$PV(WC) = wc \times USPWF(4\%, 80years)$$

$$= \$2.17/_{ft^2}(30ft \times 43ft) \frac{(1+4\%)^{80years} - 1}{4\%(1+4\%)^{80years}}$$

(Equation 7.39)

$$PV(WC) = \$66,946$$

$$PV(SCC) = \sum_0^N se \times SPPWF(4\%, y_i) - \sum_1^n se \times SPPWF(4\%, y_x)$$

$$\therefore y_i = \begin{Bmatrix} 0 \\ 5 \\ 10 \\ \vdots \\ SL \end{Bmatrix}, y_x = \{SL\} \quad (\text{Equation 7.40})$$

$$PV(SCC) = \$1.27/_{ft^2}(30ft \times 43ft)$$

$$\left( \frac{1}{(1+4\%)^0} + \frac{1}{(1+4\%)^5} + \frac{1}{(1+4\%)^{10}} + \dots + \frac{1}{(1+4\%)^{80}} \right) - \$1.27/_{ft^2}(30ft \times 43ft) \left( \frac{1}{(1+4\%)^{80}} \right)$$

$$PV(SCC) = \$8,801$$

$$PV(DRC) = dr \times SPPWF(4\%, 40) \quad (\text{Equation 7.41})$$

$$PV(DRC) = \left( \$47.41/_{ft^2}(30ft \times 43ft) + \$14,222 \right) \frac{1}{(1+4\%)^{40}}$$

$$PV(DRC) = \$15,701$$

$$PV(BC) = bc \times SPPWF(4\%, 40) \quad (\text{Equation 7.42})$$

$$PV(BC) = \$3,483/_{unt}(4bm \times 2sup) \frac{1}{(1+4\%)^{40}}$$

$$PV(BC) = \$5,803$$

$$PV(SPC) = \sum_0^N spc \times SPPWF(4\%, y_i) - \sum_1^n spc \times SPPWF(4\%, y_x)$$

$$\therefore y_i = \begin{Bmatrix} 10 \\ 20 \\ 30 \\ \vdots \\ SL \end{Bmatrix}, y_x = \{SL\} \quad (\text{Equation 7.43})$$

$$PV(SPC) = \$2.19/ft^2(5.76ft \times 30ft \times 4bm \times 10\%)$$

$$\left( \frac{1}{(1+4\%)^{10}} + \frac{1}{(1+4\%)^{20}} + \dots + \frac{1}{(1+4\%)^{80}} \right)$$

$$- \$1.27/ft^2(5.16ft \times 30ft \times 4bm \times 10\%) \left( \frac{1}{(1+4\%)^{80}} \right)$$

$$PV(SPC) = \$295$$

$$PV(BRC) = br \times SPPWF(4\%, 80)$$

$$= \$11.11/ft^2(30ft \times 43ft) \frac{1}{(1+4\%)^{80}}$$

(Equation 7.44)

$$PV(BRC) = \$622$$

$$PV(SRC) = sr \times SPPWF(4\%, 80)$$

$$= \$0.08/Lb(4bm \times 10,382lb) \frac{1}{(1+4\%)^{80}}$$

(Equation 7.45)

$$PV(SRC) = \$144$$

$$TLCC_{Alt C} = \$59,224 + \$66,946 + \$8,801 + \$15,701$$

$$+ \$5,803 + \$295 + \$622 - \$144$$

$$TLCC_{Alt C} = \$157,248$$

**Prestressed concrete box beams. Alternative A: Modified INDOT routine procedure.** This option involves a deck reconstruction (DRC) at 40 years, plus sealing and cleaning of the deck surface (SCC) every 5 years since the bridge construction, bearing replacements (BC) at 40 years, washing of the deck surface (WC) on a yearly basis, plus the initial cost (IC) and the removal of the bridge cost (BRC). Finally, a total price for the reinforcement steel of \$8,651 which will be included together with the bridge deck reconstruction cost calculation. The present value of this alternative can be obtained as follows:

$$TLCC_{Alt A} = IC + PV(WC) + PV(SCC) + PV(BC)$$

$$+ PV(DRC) + PV(BRC)$$

(Equation 7.46)

$$IC = \$75,404$$

$$PV(WC) = wc \times USPWF(4\%, 60years)$$

$$= \$2.17/ft^2(30ft \times 43ft) \frac{(1+4\%)^{60years} - 1}{4\%(1+4\%)^{60years}}$$

(Equation 7.47)

$$PV(WC) = \$63,330$$

$$PV(SCC) = \sum_0^N se \times SPPWF(4\%, y_i)$$

$$- \sum_1^n se \times SPPWF(4\%, y_x)$$

$$\therefore y_i = \begin{Bmatrix} 0 \\ 5 \\ 10 \\ \vdots \\ SL \end{Bmatrix}, y_x = \{SL\}$$

(Equation 7.48)

$$PV(SCC) = \$1.27/ft^2(30ft \times 43ft)$$

$$\left( \frac{1}{(1+4\%)^0} + \frac{1}{(1+4\%)^5} + \frac{1}{(1+4\%)^{10}} + \dots + \frac{1}{(1+4\%)^{60}} \right)$$

$$- \$1.27/ft^2(30ft \times 43ft) \left( \frac{1}{(1+4\%)^{60}} \right)$$

$$PV(SCC) = \$8,326$$

$$PV(DRC) = dr \times SPPWF(4\%, 40) \quad \text{(Equation 7.49)}$$

$$PV(DRC) = \left( \$47.41/ft^2(30ft \times 43ft) + \$8,651 \right) \frac{1}{(1+4\%)^{40}}$$

$$PV(DRC) = \$14,541$$

$$PV(BC) = bc \times SPPWF(4\%, 30) \quad \text{(Equation 7.50)}$$

$$PV(BC) = \$3,483/unt(5bm \times 2sup) \frac{1}{(1+4\%)^{40}}$$

$$PV(BC) = \$7,254$$

$$PV(BRC) = br \times SPPWF(4\%, 60)$$

$$= \$11.11/ft^2(30ft \times 43ft) \frac{1}{(1+4\%)^{60}}$$

(Equation 7.51)

$$PV(BRC) = \$1,362$$

$$TLCC_{Alt A} = \$75,404 + \$63,330 + \$8,326 + \$14,541 \\ + \$7,254 + \$1,362$$

$$TLCC_{Alt A} = \$170,217$$

**Structural steel rolled beam—5-beam configuration galvanized. Alternative A: Bearing replacement and sealing process.** This option involves a deck reconstruction (DRC) at 50 years, plus sealing and cleaning of the deck surface (SCC) every 5 years since the bridge construction, bearing replacements (BC) at 50 years, and washing of the deck surface (WC) on a yearly basis, plus the initial cost (IC), the removal of the bridge cost (BRC) and the salvage value represented by the benefit of selling the structural steel for recycling (SRC). Structural steel beam elements with an exposed perimeter of 4.94 ft and a total weight of the steel elements of 10,506 lb. Finally, a total price for the reinforcement steel of \$12,365 which will be included together with the bridge deck reconstruction cost calculation. The present value of this alternative can be obtained as follows:

$$TLCC_{Alt A} = IC + PV(WC) + PV(SCC) + PV(DRC) \\ + PV(BC) + PV(BRC) + PV(SRC) \quad (\text{Equation 7.52})$$

$$IC = \$62,511$$

$$PV(WC) = wc \times USPWF(4\%, 100 \text{ years}) \\ = \$2.17/\text{ft}^2(30\text{ft} \times 43\text{ft}) \frac{(1+4\%)^{100 \text{ years}} - 1}{4\%(1+4\%)^{100 \text{ years}}} \\ (\text{Equation 7.53})$$

$$PV(WC) = \$68,597$$

$$PV(SCC) = \sum_0^N se \times SPPWF(4\%, y_i) \\ - \sum_1^n se \times SPPWF(4\%, y_x) \\ \therefore y_i = \begin{Bmatrix} 0 \\ 5 \\ 10 \\ \vdots \\ SL \end{Bmatrix}, y_x = \{SL\} \quad (\text{Equation 7.54})$$

$$PV(SCC) = \$1.27/\text{ft}^2(30\text{ft} \times 43\text{ft})$$

$$\left( \frac{1}{(1+4\%)^0} + \frac{1}{(1+4\%)^5} + \frac{1}{(1+4\%)^{10}} + \dots + \frac{1}{(1+4\%)^{100}} \right) \\ - \$1.27/\text{ft}^2(30\text{ft} \times 43\text{ft}) \left( \frac{1}{(1+4\%)^{100}} \right)$$

$$PV(SCC) = \$9,018$$

$$PV(DRC) = dr \times SPPWF(4\%, 50) \quad (\text{Equation 7.55})$$

$$PV(DRC) = \left( \$47.41/\text{ft}^2(30\text{ft} \times 43\text{ft}) + \$12,365 \right) \frac{1}{(1+4\%)^{50}}$$

$$PV(DRC) = \$10,346$$

$$PV(BC) = bc \times SPPWF(4\%, 50) \quad (\text{Equation 7.56})$$

$$PV(BC) = \$3,483/\text{unt}(5\text{bm} \times 2\text{sup}) \frac{1}{(1+4\%)^{50}}$$

$$PV(BC) = \$4,901$$

$$PV(BRC) = br \times SPPWF(4\%, 100)$$

$$= \$11.11/\text{ft}^2(30\text{ft} \times 43\text{ft}) \frac{1}{(1+4\%)^{100}}$$

$$(\text{Equation 7.57})$$

$$PV(BRC) = \$284$$

$$PV(SRC) = sr \times SPPWF(4\%, 100)$$

$$= \$0.08/\text{Lb}(5 \times 10,506\text{lb}) \frac{1}{(1+4\%)^{100}}$$

$$(\text{Equation 7.58})$$

$$PV(SRC) = \$83$$

$$TLCC_{Alt A} = \$62,511 + \$68,597 + \$9,018 + \$10,346 \\ + \$4,901 + \$284 - \$83$$

$$TLCC_{Alt A} = \$155,573$$

*Prestressed Concrete AASTHO Beams Diaphragms Included: Alternative A—Modified INDOT procedure.* This option involves a deck reconstruction (DRC) at 40 years, plus sealing and cleaning of the deck surface (SCC) every 5 years since the bridge construction, and washing of the deck surface (WC) on a yearly basis,

plus the initial cost (IC) and the removal of the bridge cost (BRC). Finally, a total price for the reinforcement steel of \$9,086 which will be included together with the bridge deck reconstruction cost calculation. The present value of this alternative can be obtained as follows:

$$TLCC_{Alt A} = IC + PV(WC) + PV(SCC) + PV(DRC) + PV(BRC) \quad (\text{Equation 7.59})$$

$$IC = \$73,639$$

$$PV(WC) = wc \times USPWF(4\%, 80\text{years}) = \$2.17/\text{ft}^2(30\text{ft} \times 43\text{ft}) \frac{(1+4\%)^{80\text{years}} - 1}{4\%(1+4\%)^{80\text{years}}} \quad (\text{Equation 7.60})$$

$$PV(WC) = \$66,946$$

$$PV(SCC) = \sum_0^N se \times SPPWF(4\%, y_i) - \sum_1^n se \times SPPWF(4\%, y_x) \therefore y_i = \begin{Bmatrix} 0 \\ 5 \\ 10 \\ \vdots \\ SL \end{Bmatrix}, y_x = \{SL\} \quad (\text{Equation 7.61})$$

$$PV(SCC) = \$1.27/\text{ft}^2(30\text{ft} \times 43\text{ft}) \left( \frac{1}{(1+4\%)^0} + \frac{1}{(1+4\%)^5} + \frac{1}{(1+4\%)^{10}} + \dots + \frac{1}{(1+4\%)^{80}} \right) - \$1.27/\text{ft}^2(30\text{ft} \times 43\text{ft}) \left( \frac{1}{(1+4\%)^{80}} \right) PV(SCC) = \$8,801$$

$$PV(DRC) = dr \times SPPWF(4\%, 40) \quad (\text{Equation 7.62})$$

$$PV(DRC) = \left( \$47.41/\text{ft}^2(30\text{ft} \times 43\text{ft}) + \$9,086 \right) \frac{1}{(1+4\%)^{40}}$$

$$PV(DRC) = \$14,631$$

$$PV(BRC) = br \times SPPWF(4\%, 80) = \$11.11/\text{ft}^2(30\text{ft} \times 43\text{ft}) \frac{1}{(1+4\%)^{80}} \quad (\text{Equation 7.63})$$

$$PV(BRC) = \$622$$

$$TLCC_{Alt A} = \$73,639 + \$66,946 + \$8,801 + \$14,631 + \$622 = \$164,639$$

**Structural steel rolled beam—4-beam configuration galvanized. Alternative A: Bearing replacement and sealing process.** This option involves a deck reconstruction (DRC) at 50 years, plus sealing and cleaning of the deck surface (SCC) every 5 years since the bridge construction, bearing replacements (BC) at 50 years, and washing of the deck surface (WC) on a yearly basis, plus the initial cost (IC), the removal of the bridge cost (BRC) and the salvage value represented by the benefit of selling the structural steel for recycling (SRC). Structural steel beam elements with an exposed perimeter of 5.76 ft and a total weight of the steel elements of 10,382 lb. Finally, a total price for the reinforcement steel of \$14,222 which will be included together with the bridge deck reconstruction cost calculation. The present value of this alternative can be obtained as follows:

$$TLCC_{Alt A} = IC + PV(WC) + PV(SCC) + PV(DRC) + PV(BC) + PV(BRC) + PV(SRC) \quad (\text{Equation 7.64})$$

$$IC = \$62,234$$

$$PV(WC) = wc \times USPWF(4\%, 100\text{years}) = \$2.17/\text{ft}^2(30\text{ft} \times 43\text{ft}) \frac{(1+4\%)^{100\text{years}} - 1}{4\%(1+4\%)^{100\text{years}}} \quad (\text{Equation 7.65})$$

$$PV(WC) = \$68,597$$

$$PV(SCC) = \sum_0^N se \times SPPWF(4\%, y_i) - \sum_1^n se \times SPPWF(4\%, y_x) \therefore y_i = \begin{Bmatrix} 0 \\ 5 \\ 10 \\ \vdots \\ SL \end{Bmatrix}, y_x = \{SL\} \quad (\text{Equation 7.66})$$

$$PV(SCC) = \$1.27/ft^2(30ft \times 43ft) \left( \frac{1}{(1+4\%)^0} + \frac{1}{(1+4\%)^5} + \frac{1}{(1+4\%)^{10}} + \dots + \frac{1}{(1+4\%)^{100}} \right) - \$1.27/ft^2(30ft \times 43ft) \left( \frac{1}{(1+4\%)^{100}} \right)$$

$$PV(SCC) = \$9,018$$

$$PV(DRC) = dr \times SPPWF(4\%, 50) \quad (\text{Equation 7.67})$$

$$PV(DRC) = \left( \$47.41/ft^2(30ft \times 43ft) + \$14,222 \right) \frac{1}{(1+4\%)^{50}}$$

$$PV(DRC) = \$10,607$$

$$PV(BC) = bc \times SPPWF(4\%, 50) \quad (\text{Equation 7.68})$$

$$PV(BC) = \$3,483/unt(4bm \times 2sup) \frac{1}{(1+4\%)^{50}}$$

$$PV(BC) = \$3,920$$

$$PV(BRC) = br \times SPPWF(4\%, 100)$$

$$= \$11.11/ft^2(30ft \times 43ft) \frac{1}{(1+4\%)^{100}}$$

$$(\text{Equation 7.69})$$

$$PV(BRC) = \$284$$

$$PV(SRC) = sr \times SPPWF(4\%, 100)$$

$$= \$0.08/Lb(4bm \times 10,382lb) \frac{1}{(1+4\%)^{100}}$$

$$(\text{Equation 7.70})$$

$$PV(SRC) = \$66$$

$$TLCC_{Alt A} = \$62,234 + \$68,597 + \$9,018 + \$10,607$$

$$+ \$3,920 + \$284 - \$66$$

$$TLCC_{Alt A} = \$154,594$$

A special discussion is needed for the FPG system since it is a new system included in this study. As discussed in the literature review, there are two different configurations that can be addressed using FPGs, the regular closed section and the inverted option with the bottom open for inspection. The second option is a proprietary product, and its use involves an additional cost that depends on the holder of the patent. These

hidden costs are not available to the public, and consequently it was decided to not include this option in this analysis. However, the closed section is an open technology that can be used without restriction, and therefore it is used as the alternative discussed in this report.

The FPG acts as a steel box section, and such sections are subjected to all the geometric and proportion requirements given by the AASHTO LFRD specification, in particular section 6.11. The requirement given by AASHTO LRFD Section 6.11.2.3 includes the maximum spacing between parallel elements in order to use the distribution factors proposed by the code. This requirement is based on the lateral distribution factors for steel box girders provided by Johnston and Mattock (1967).

Using the section properties available and the AASHTO requirements it is mandatory to use six 6 beams in the cross section of the bridge. The use of this additional beam (compared with the total elements needed for a regular rolled I steel beam) increases the initial cost of this alternative an amount that makes it not cost-effective. Nonetheless, a separate analysis was made using a 4-beam arrangement. A conservative assumption was made regarding the distribution factors (considering the distribution factor as 1.00 for each beam), designing accordingly the beam elements. This change increases the unit weight of each supporting element, however, the final total weight is less than the 6-beam alternative. Both LCCA are included herein, proving that the 6-beam configuration is not cost-effective while the 4-beam alternative is a competitive option. Further research is needed to explore the viability of 4 girders and the applicability of AASHTO 6.11.2.3 for FPG girders.

**Structural steel folded plate beams—6-beam galvanized configuration. Alternative A: Bearing replacement, spot painting and sealing process.** This option involves a deck reconstruction (DRC) at 50 years, plus sealing and cleaning of the deck surface (SCC) every 5 years since the bridge construction, bearing replacements (BC) at 50 years, and washing of the deck surface (WC) on a yearly basis, plus the initial cost (IC), the removal of the bridge cost (BRC) and the salvage value represented by the benefit of selling the structural steel for recycling (SRC). Structural steel beam elements with an exposed perimeter of 3.60 ft and a total weight of the steel elements of 16,020 lb. Finally, a total price for the reinforcement steel of \$8,375 which will be included together with the bridge deck reconstruction cost calculation. The present value of this alternative can be obtained as follows:

$$TLCC_{Alt A} = IC + PV(WC) + PV(SCC) + PV(DRC) + PV(BC) + PV(BRC) + PV(SRC)$$

$$(\text{Equation 7.71})$$

$$IC = \$67,921$$

$$\begin{aligned}
PV(WC) &= wc \times USPWF(4\%, 100\text{years}) \\
&= \$2.17/\text{ft}^2(30\text{ft} \times 43\text{ft}) \frac{(1+4\%)^{100\text{years}} - 1}{4\%(1+4\%)^{100\text{years}}} \\
&\quad \text{(Equation 7.72)}
\end{aligned}$$

$$PV(WC) = \$68,597$$

$$\begin{aligned}
PV(SCC) &= \sum_0^N se \times SPPWF(4\%, y_i) \\
&\quad - \sum_1^n se \times SPPWF(4\%, y_x) \\
\therefore y_i &= \left\{ \begin{array}{c} 0 \\ 5 \\ 10 \\ \vdots \\ SL \end{array} \right\}, y_x = \{SL\} \quad \text{(Equation 7.73)}
\end{aligned}$$

$$PV(SCC) = \$1.27/\text{ft}^2(30\text{ft} \times 43\text{ft})$$

$$\begin{aligned}
&\left( \frac{1}{(1+4\%)^0} + \frac{1}{(1+4\%)^5} + \frac{1}{(1+4\%)^{10}} + \dots \right. \\
&\left. + \frac{1}{(1+4\%)^{100}} \right) - \$1.27/\text{ft}^2(30\text{ft} \times 43\text{ft}) \left( \frac{1}{(1+4\%)^{100}} \right) \\
PV(SCC) &= \$9,018
\end{aligned}$$

$$PV(DRC) = dr \times SPPWF(4\%, 50) \quad \text{(Equation 7.74)}$$

$$PV(DRC) = \left( \$47.41/\text{ft}^2(30\text{ft} \times 43\text{ft}) + \$8,375 \right) \frac{1}{(1+4\%)^{50}}$$

$$PV(DRC) = \$9,784$$

$$PV(BC) = bc \times SPPWF(4\%, 50) \quad \text{(Equation 7.75)}$$

$$PV(BC) = \$3,483/\text{unit}(6\text{bm} \times 2\text{sup}) \frac{1}{(1+4\%)^{50}}$$

$$PV(BC) = \$5,881$$

$$PV(BRC) = br \times SPPWF(4\%, 100)$$

$$= \$11.11/\text{ft}^2(30\text{ft} \times 43\text{ft}) \frac{1}{(1+4\%)^{100}}$$

$$\text{(Equation 7.76)}$$

$$PV(BRC) = \$284$$

$$PV(SRC) = sr \times SPPWF(4\%, 100)$$

$$= \$0.08/\text{Lb}(6\text{bm} \times 16,020\text{lb}) \frac{1}{(1+4\%)^{100}} \quad \text{(Equation 7.77)}$$

$$PV(SRC) = \$152$$

$$\begin{aligned}
TLCC_{Alt A} &= \$67,921 + \$68,597 + \$9,018 + \$9,784 \\
&\quad + \$284 + \$5,881 - \$152
\end{aligned}$$

$$TLCC_{Alt A} = \$161,332$$

**Structural steel folded plate beams—4 beam galvanized configuration. Alternative A: Bearing replacement, spot painting and sealing process.** This option involves a deck reconstruction (DRC) at 50 years, plus sealing and cleaning of the deck surface (SCC) every 5 years since the bridge construction, bearing replacements (BC) at 50 years, and washing of the deck surface (WC) on a yearly basis, plus the initial cost (IC), the removal of the bridge cost (BRC) and the salvage value represented by the benefit of selling the structural steel for recycling (SRC). Structural steel beam elements with an exposed perimeter of 4.17 ft and a total weight of the steel elements of 12,240 lb. Finally, a total price for the reinforcement steel of \$14,222 which will be included together with the bridge deck reconstruction cost calculation. The present value of this alternative can be obtained as follows:

$$\begin{aligned}
TLCC_{Alt A} &= IC + PV(WC) + PV(SCC) + PV(DRC) \\
&\quad + PV(BC) + PV(BRC) + PV(SRC) \\
&\quad \text{(Equation 7.78)}
\end{aligned}$$

$$IC = \$62,790$$

$$PV(WC) = wc \times USPWF(4\%, 100\text{years})$$

$$\begin{aligned}
&= \$2.17/\text{ft}^2(30\text{ft} \times 43\text{ft}) \frac{(1+4\%)^{100\text{years}} - 1}{4\%(1+4\%)^{100\text{years}}} \\
&\quad \text{(Equation 7.79)}
\end{aligned}$$

$$PV(WC) = \$68,597$$

$$PV(SRC) = \$78$$

$$PV(SCC) = \sum_0^N se \times SPPWF(4\%, y_i) - \sum_1^n se \times SPPWF(4\%, y_x)$$

$$\therefore y_i = \left\{ \begin{array}{c} 0 \\ 5 \\ 10 \\ \vdots \\ SL \end{array} \right\}, y_x = \{SL\} \quad (\text{Equation 7.80})$$

$$TLCC_{Alt A} = \$62,790 + \$68,597 + \$9,018 + \$10,607 + \$284 + \$3,920 - \$78$$

$$TLCC_{Alt A} = \$155,139$$

\*\*\*

Initial cost comparison, as well as LCCA, were made for every superstructure type considered. Table 7.2 presents a summary of the life-cycle cost analysis for simply supported bridges with a simple span of 30 ft. The discount rate used for the life-cycle cost in perpetuity (LCCAP) is 4%. It presents the service life, total life-cycle cost (LCCA), LCCAP and the cost-effectiveness-ratio between the initial cost and LCCAP of the different superstructure types ( $ER_{Initial\ Cost}$  and  $ER_{LCCAP}$  respectively). Ratios shown correspond to the ratio between the option analyzed and the lowest price among all the alternatives for a given span length as shown in Equation 7.85.

$$PV(SCC) = \$1.27/ft^2(30ft \times 43ft)$$

$$\left( \frac{1}{(1+4\%)^0} + \frac{1}{(1+4\%)^5} + \frac{1}{(1+4\%)^{10}} + \dots + \frac{1}{(1+4\%)^{100}} \right)$$

$$- \$1.27/ft^2(30ft \times 43ft) \left( \frac{1}{(1+4\%)^{100}} \right)$$

$$PV(SCC) = \$9,018$$

$$ER_{cost} = \frac{C_{alt}}{\min_i(C_{alt\ 1}, C_{alt\ 2}, \dots, C_{alt\ i})} \quad (\text{Equation 7.85})$$

$$PV(DRC) = dr \times SPPWF(4\%, 50) \quad (\text{Equation 7.81})$$

The results for the LCCA shown in Table 7.2 illustrate the evidence of considering all costs for various structural types. The cost-effectiveness ratio for initial cost,  $ER_{Initial\ Cost}$ , clearly shows that slab bridges provide the best alternative, with most other systems costing an additional 15% or more. However, if the cost-effectiveness ratio in perpetuity is examined,  $ER_{LCCAP}$ , the results change notably. In this case (for a 30-ft span) the slab bridge is still the most cost-effective solution, but the cost differential— $ER_{Initial\ Cost}$  versus  $ER_{LCCAP}$ —changes significantly, with other systems becoming more competitive. The 4-beam and 5-beam galvanized rolled beam system have considerably closed the cost gap. Other structural systems have also improved in cost-effectiveness when all long-term costs are considered.

$$PV(DRC) = \left( \$47.41/ft^2(30ft \times 43ft) + \$14,222 \right) \frac{1}{(1+4\%)^{50}}$$

$$PV(DRC) = \$10,607$$

Figures 7.2, 7.3, and 7.4 show the initial cost and LCCAP comparison for simply supported beams for all span ranges. As it can be seen in the figures, in general the inclusion of long term-costs using LCCA reduces the difference between all the alternatives for the same span length. Explicitly, for span range 1, it is shown that the slab bridge is the most cost-effective solution either considering or not considering long-term costs for spans less than 35 ft. However, for spans longer than 35 ft, the inclusion of galvanized steel structures—specifically the 4-beam configuration—is the most cost-effective alternative. In contrast, if only initial costs are considered, painted rolled beams and prestressed concrete AASHTO beams would be the preferable options. Additionally, it is important to mention that the FPG option is among the cost-effective solution for

$$PV(BC) = bc \times SPPWF(4\%, 50) \quad (\text{Equation 7.82})$$

$$PV(BC) = \$3,483/unt(4bm \times 2sup) \frac{1}{(1+4\%)^{50}}$$

$$PV(BC) = \$3,920$$

$$PV(BRC) = br \times SPPWF(4\%, 100)$$

$$= \$11.11/ft^2(30ft \times 43ft) \frac{1}{(1+4\%)^{100}}$$

$$(\text{Equation 7.83})$$

$$PV(BRC) = \$284$$

$$PV(SRC) = sr \times SPPWF(4\%, 100)$$

$$= \$0.08/Lb(4 \times 12,240lb) \frac{1}{(1+4\%)^{100}}$$

$$(\text{Equation 7.84})$$

TABLE 7.2  
LCC summary simply supported beams—span length 30 ft

Type	Service Life	Initial Cost (\$)	ER <sub>Initial Cost</sub>	LCCA (\$)	LCCAP (\$)	ER <sub>LCCAP</sub>
	(years)					
Slab Bridge	58	51,438	1.00	133,591	148,900	1.00
Prestressed Concrete AASHTO Beams—Bearings	65	59,747	1.16	157,199	170,522	1.15
Prestressed Concrete AASHTO Beams— Diaphragms Included	80	73,639	1.43	164,639	172,106	1.16
Prestressed Concrete Box Beams	60	75,404	1.47	170,217	188,097	1.26
Structural Steel Rolled Beams—4-Beam Configuration—Painted	80	59,224	1.15	157,248	164,380	1.10
Structural Steel Rolled Beams—5-Beam Configuration—Painted	80	59,464	1.16	158,535	165,725	1.11
Structural Steel Rolled Beams—4-Beam Configuration—Galvanized	100	62,234	1.21	154,594	157,717	1.06
Structural Steel Rolled Beams—5-Beam Configuration—Galvanized	100	62,511	1.22	155,573	158,715	1.07
Structural Steel Folded Plate System—4-Beam Configuration—Galvanized	100	62,790	1.22	155,139	158,272	1.06
Structural Steel Folded Plate System—6-Beam Configuration—Galvanized	100	67,921	1.32	161,332	164,591	1.11

the second part of the span range; however, it is not the optimal selection.

For span range 2, 4 beam galvanized rolled beams are still cost-effective for spans shorter than 65 ft, while the prestressed concrete bulb tees became the optimal solution for longer spans. If only initial costs are considered, prestressed concrete bulb tees alone would be selected for this span range. This trend is attributed to the lower material and fabrication costs and resistance optimization achieved by the bulb tee system.

Span range 3 results show that including long-term costs suggests multiple cost-effective design solutions for spans up to 105 ft, with two optimal options being prestressed concrete bulb tees and galvanized steel plate girders. Beyond this point, bulb tees are the most cost effective solution. Again, if only first costs are considered, bulb tees would be the optimal solution for the entire span range.

Results for continuous beams are presented in Figures 7.5, 7.6, and 7.7. For span range 1, several different outcomes were obtained considering and not considering long-costs. Slab bridges and galvanized steel continuous beams are the most cost effective solutions for the two halves of the span range, respectively. However, prestressed concrete AASHTO beams are also a competitive option for spans

between 45 and 60 ft. In contrast, span range 2 rejects the premise of the cost-effectiveness of the SDCL system for spans up to 90 ft. Additionally, it is noticeable that prestressed bulb tees and AASHTO beams become more attractive for longer spans. Finally, for span range 3, no variance in the cost-effectiveness of the bulb tee option is noticed between the initial cost comparison and the inclusion of long-term costs, although the cost differential is notably reduced.

It is important to underline the fact that results shown are not a precise measurement of cost-effectiveness. Rather, they are an approximation and the first approach to designers at the moment of bridge planning. This tool could clarify which super-structure options could be cost-effective during the planning process. However, final site conditions and project level cost estimations should represent accurately the best option for construction.

FPG system needs a special discussion. As shown, FPG option could be considered as a cost-effective solution depending on the span length of the structure. Nonetheless, a more accurate cost estimation of construction cost, not only for steel elements but also for prefabricated composite modules, is needed to demonstrate that viability of this system.



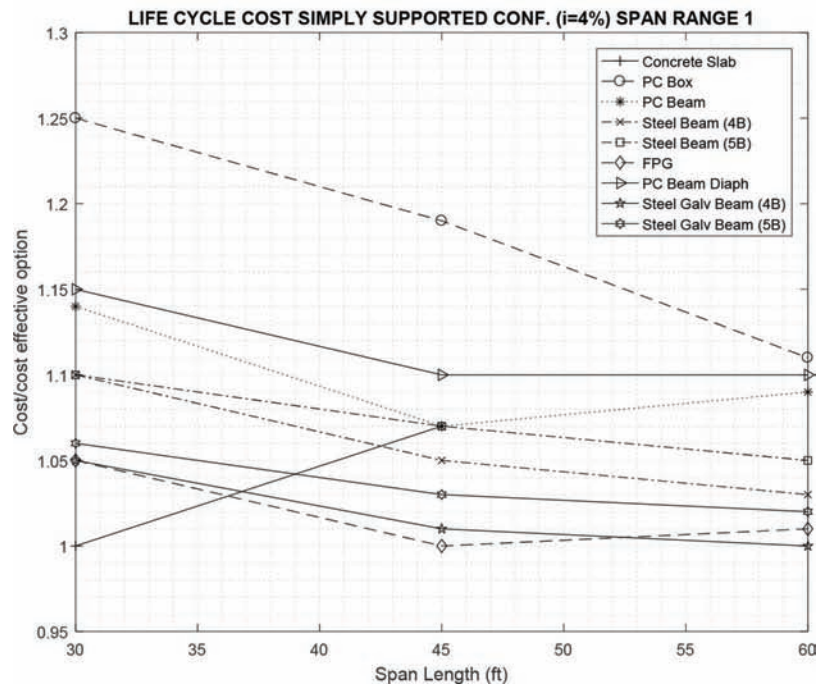
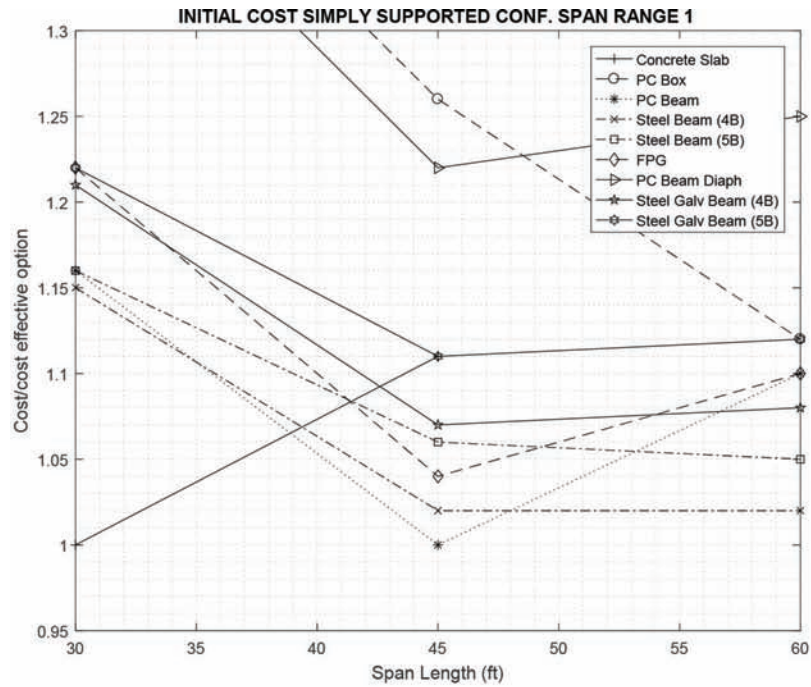

Figure 7.2 Initial and LCCAP cost-effectiveness for simply supported beams—span range 1.

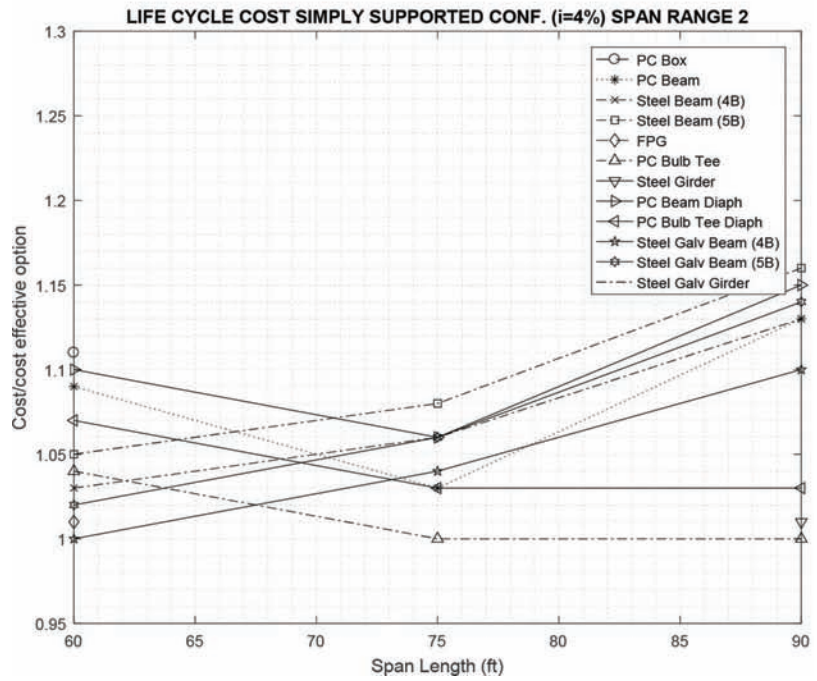
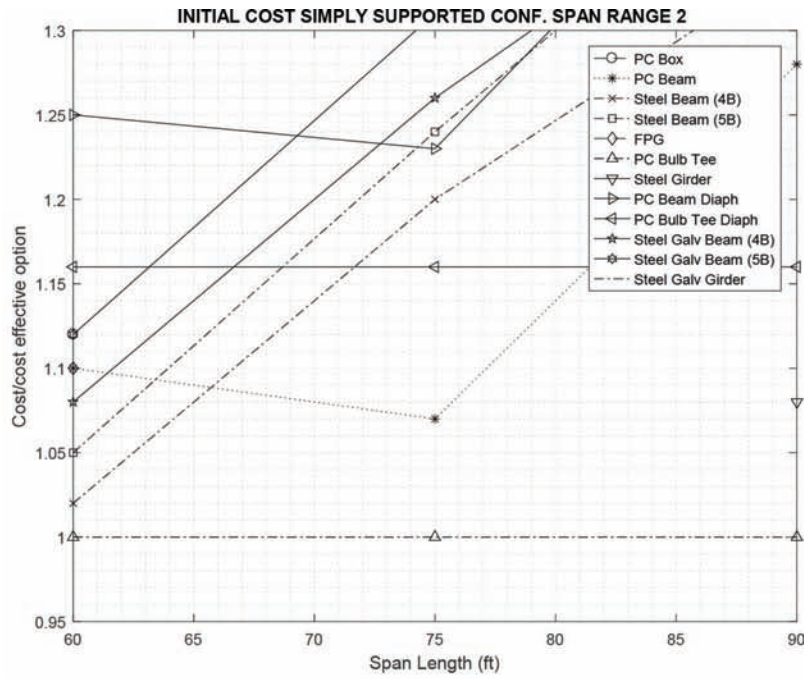

Figure 7.3 Initial and LCCAP cost-effectiveness for simply supported beams—span range 2.

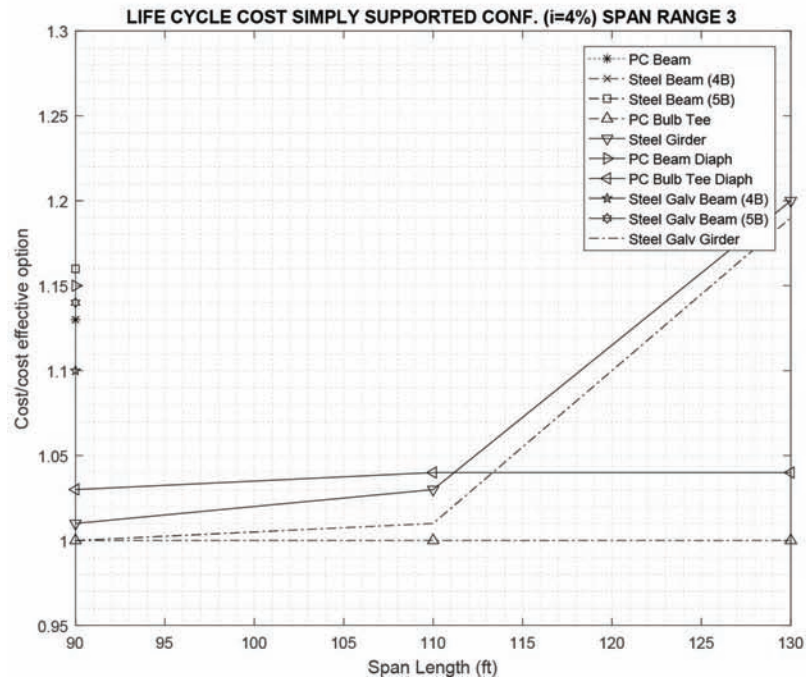
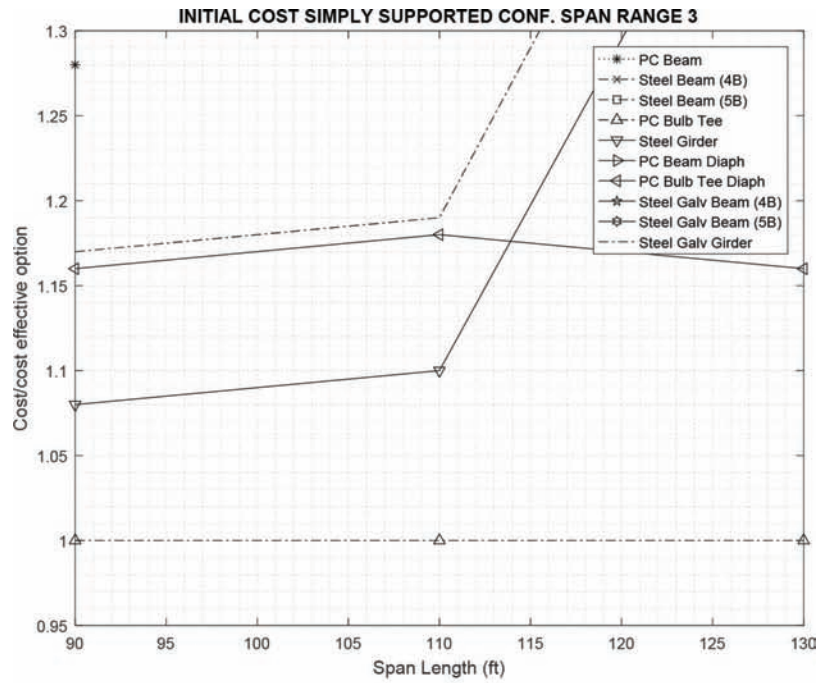

Figure 7.4 Initial and LCCAP cost-effectiveness for simply supported beams—span range 3.

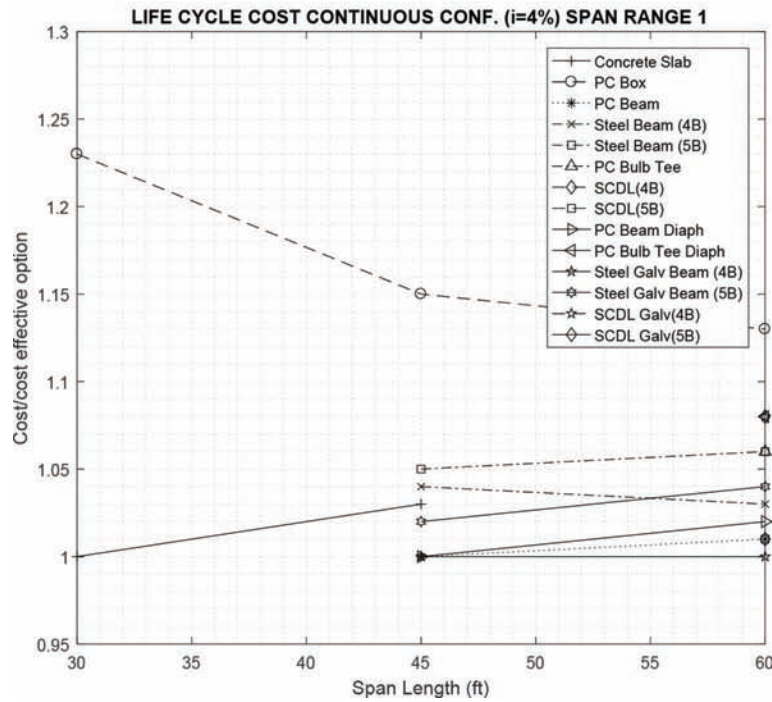
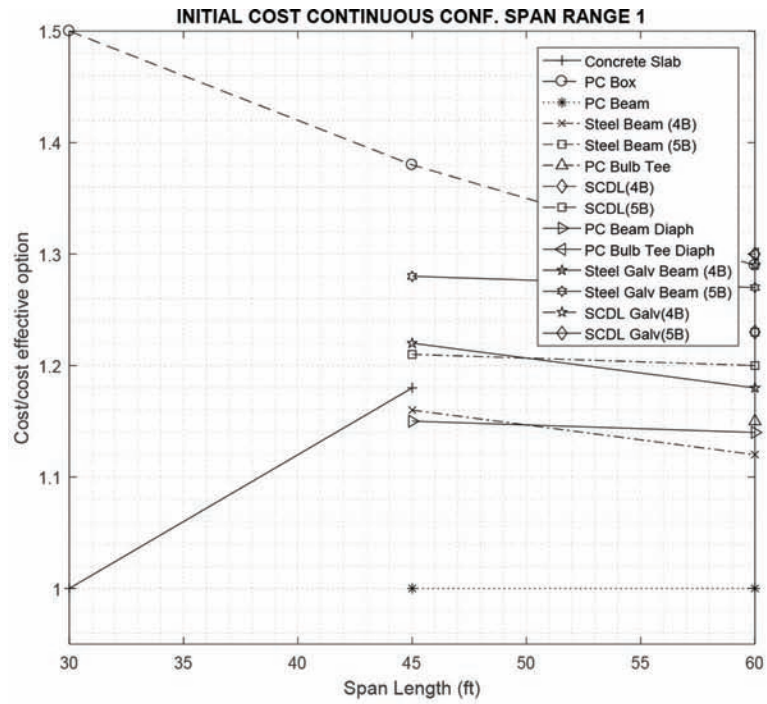

Figure 7.5 Initial and LCCAP cost-effectiveness for simply supported beams—span range 1.

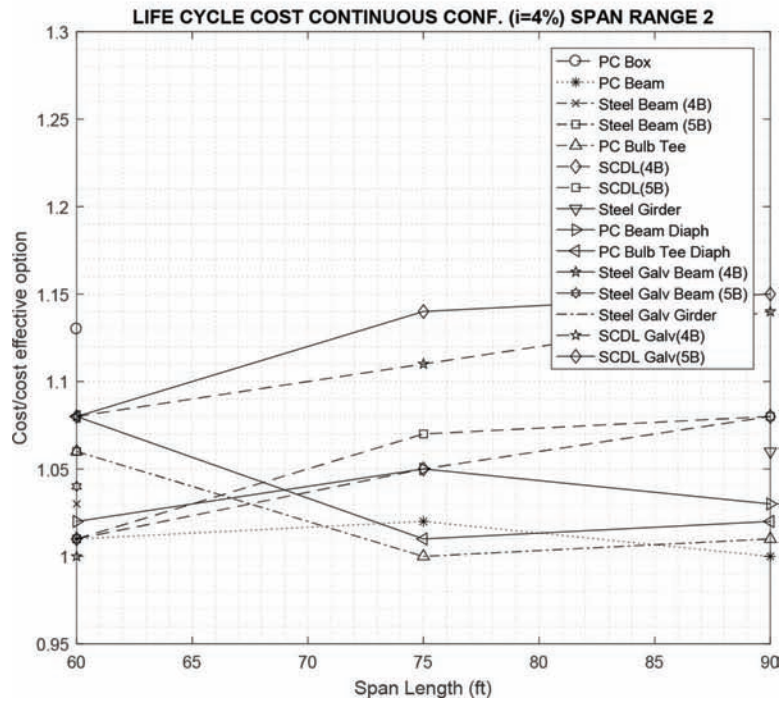
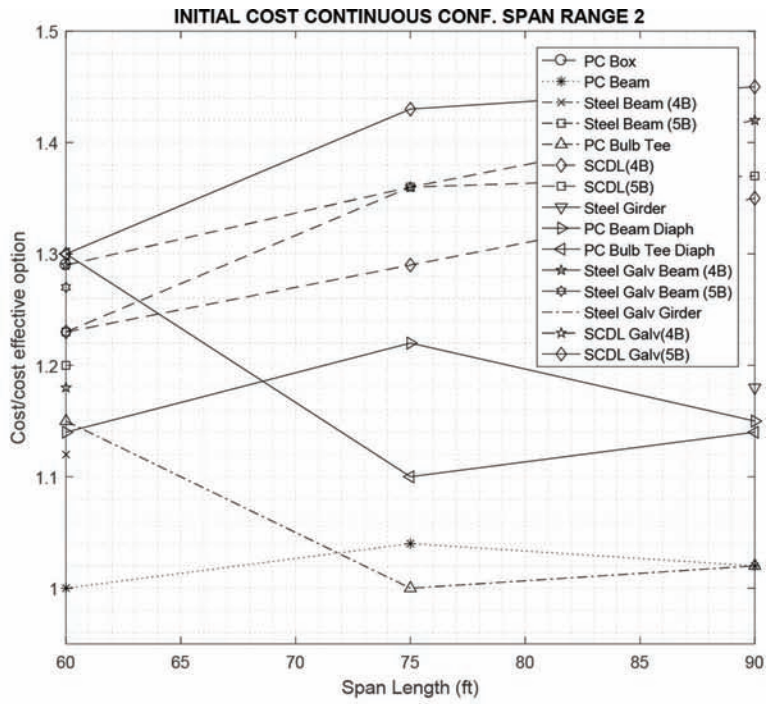

Figure 7.6 Initial and LCCAP cost-effectiveness for continuous beams—span range 2.

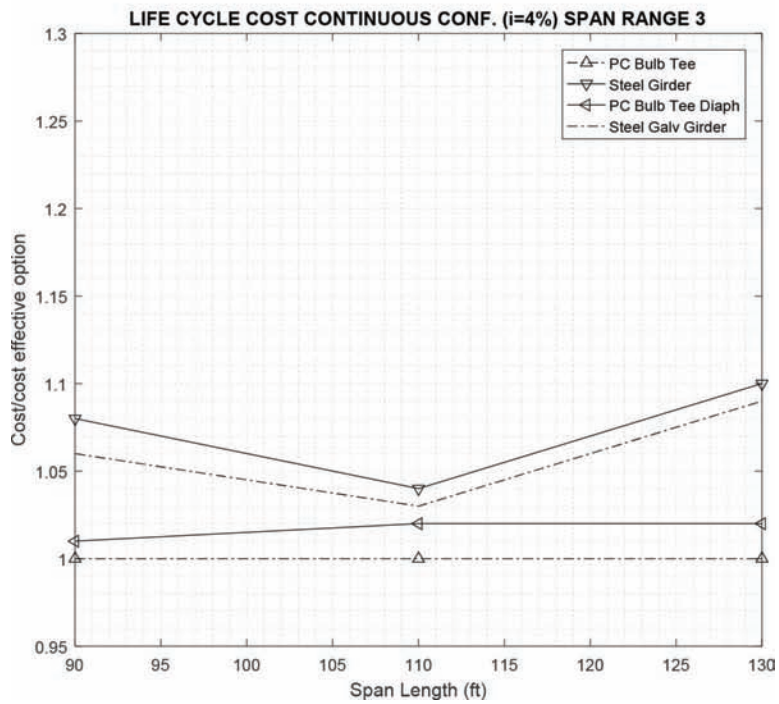
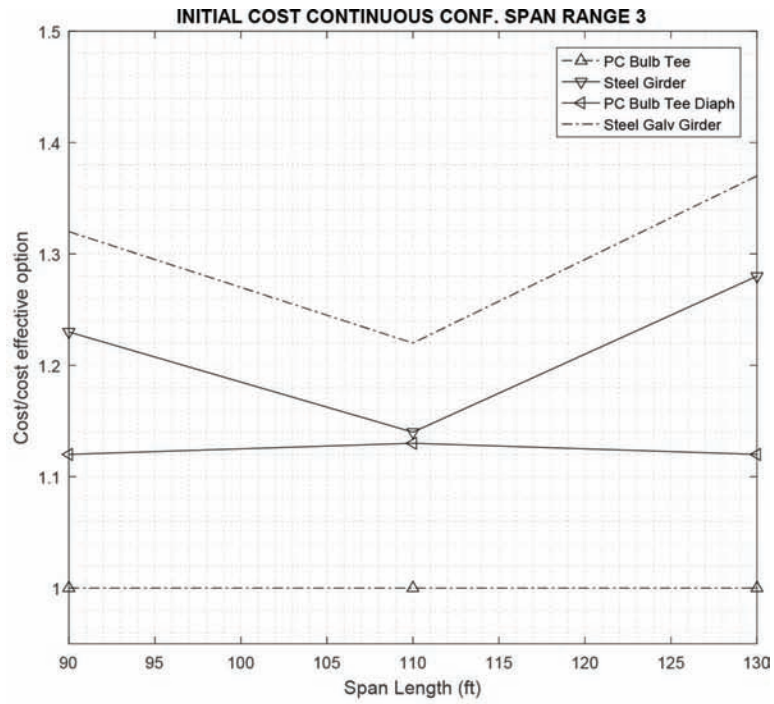

Figure 7.7 Initial and LCCAP cost-effectiveness for continuous beams—span range 3.

## 8. SUMMARY AND CONCLUSIONS

A literature review was presented on innovative cost effective solutions for short to medium span bridges, deterioration curves and current approaches taken to conduct a bridge life-cycle cost assessment. Additionally, information obtained from the National Bridge Inventory (NBI) was used to summarize the most common structures within the state and generate a design plan for the structures to analyze. Designs covered the most common structures found in Indiana along with the innovative bridge systems presented in Section 2.1 of this document. Bridge types used are: slab bridges (constant thickness), prestressed concrete box beams, concrete AASHTO beams, concrete bulb tees, structural steel folded plate beams, rolled steel beams, steel plate girders, and finally, structural steel SDCL beams.

Three different span ranges were established for further study. Range 1 includes bridges with spans between 30 ft and 60 ft. Range 2 for spans between 60 ft and 90 ft. Finally, range 3 for span lengths between 90 ft to 130 ft. Design types were considered depending on their cost-effectiveness potential for each of the span ranges. Spreadsheets that include applicable sections of the LRFD and the Indiana Design Manual specifications were created for every design option. A prestressed concrete bulb tee continuous structure is presented as an example. Additional design information and drawings are presented in Appendices A, B, and C.

Extensive cost allocations for agency costs were presented, including not only initial costs involved but also long-term costs depending on the material and superstructure type considered. No contingencies other than regular deterioration of the bridge were considered, however, maintenance or rehabilitation activities may affect user costs. Nonetheless, and in order to compute those costs, a thorough understanding of the traffic (quantities and type of vehicles), detour lengths, travel times and travel velocities is needed. As specified in this document, all bridge designs have no specific location along any specific road. In other words, traffic, velocity and detour assumptions are not made. Additionally, such assumptions are considered an oversimplification of the problem and could impact negatively the outcome of the LCC comparison.

Deterioration curves for the Indiana state highway system from work conducted by Moomen et al. (2016), Sinha et al. (2009) and Cha et al. (2016) were used to obtain the service lives for each alternative. Additionally, and considering the working actions along with the service life for each alternative, different LCC profiles were proposed and the most cost-effective were used for the LCCA comparison for each superstructure type analyzed. In addition to the regular superstructure options described before, prestressed beam alternatives including integral abutments and intermediate diaphragms, as well as galvanized structural steel beams were considered, including the equivalent extension of the service life of each option. A case study for a 30 ft

simply supported structure is presented to illustrate the LCCA approach used. In order to compare all the alternatives considered, a life cycle present worth in perpetuity method is used.

Initial cost and LCCA comparison for all span ranges of simply supported beams and continuous beams are presented. It was shown that the inclusion of long term-costs using LCCA generally reduces the cost-effectiveness difference between all the alternatives for the same span length. This reduction could be an important factor if specific site conditions are considered during the analysis. If specific site conditions are known, multiple options for each span length must be considered before choosing the best alternative.

Explicitly for simply supported beams, it is shown that for span range 1 that the slab bridge is the most cost-effective solution either considering or not considering long-term costs for spans less than 35 ft. However, for spans longer than 35 ft, the inclusion of galvanized steel structures—specifically the 4-beam configuration—provided the most cost-effective alternative. For span range 2, 4 galvanized rolled steel beams are still cost-effective for spans shorter than 65 ft, while the prestressed concrete bulb tees became the optimal solution for longer spans. Additionally, Span range 3 results show that including long-term costs suggests multiple cost-effective design solutions for spans up to 105 ft, with prestressed concrete bulb tees and galvanized steel plate girders being the two optimal solution. Beyond this point, bulb tees are the most cost effective solution.

For continuous beams, it is shown for span range 1 that slab bridges and galvanized steel continuous beams are again the most cost effective solutions for the lower and upper parts of the span range, respectively. However, prestressed concrete AASHTO beams are also a competitive option for spans between 45 and 60 ft. In contrast, span range 2 rejects the premise of the cost-effectiveness of the SDCL system for spans up to 90 ft. Additionally, it is noticeable that prestressed bulb tees and AASHTO beams become more attractive for longer spans. Finally, for span range 3, no variance in the cost-effectiveness of the bulb tee option is noticed between the initial cost comparison and the inclusion of long-term costs.

## 9. FUTURE WORK

Results shown in this report are specific for bridges in the Indiana highway system. Costs, deterioration models, as well as other economic assumptions may vary depending on the location of the analysis. Moreover, only a deterministic approach of the LCCA applicable to bridges was used for this study. Nonetheless, the inherent probability nature in the computation of all the factors required to obtain the final comparisons should be addressed. Probabilistic approaches to computing construction, maintenance, and preventive costs are needed. Likewise, bridge deterioration is also a variable factor that affects the final out-come. Monte Carlo simulations

that involve all these random variables could be implemented in future research studies. Results of such analyses will reinforce the LCCA presented herein and will enhance the recommendations made to designers during the planning phase of new bridge constructions.

Consideration of different coatings for steel elements such as metalized options and stainless-type weathering steels (including ASTM A1010) and its extension into the service life of the steel superstructure systems should be explored further.

Lastly, the steel FPG system appears to be promising, but were not found to be optimal in cost-effectiveness. But there is a lack of data on the construction costs for these systems. Further research and development of these systems may improve the viability of such systems. Also, further clarity on girder spacing requirements for the FPG box sections should be explored.

## REFERENCES

- AASHTO. (1978). *A manual on user benefit analysis of highway and bus-transit improvements*. Washington, DC: American Association of State Highway Transportation Officials.
- AASHTO. (2015). *AASHTO LRFD bridge design specification* (7th ed.). Washington, DC: American Association of State Highway Transportation Officials.
- ACI Committee 224. (2001). *Control of cracking in concrete structures* (ACI 224R-01). Farmington Hills, MI: American Concrete Institute.
- ACI Committee 345. (2016). *Guide to maintenance of concrete bridge members* (ACI 345.1R-16). Farmington Hills, MI: American Concrete Institute.
- American Galvanizers Association. (2015). *Hot dip galvanizing: Costs less, lasts longer talking points*. Retrieved from [https://galvanizeit.org/uploads/publications/Galvanizing\\_Costs\\_Less\\_Last\\_Longer.pdf](https://galvanizeit.org/uploads/publications/Galvanizing_Costs_Less_Last_Longer.pdf)
- American Society of Civil Engineers & ENO Center of Transportation. (2014). *Maximizing the value of investments using life cycle cost analysis*. Washington, DC: American Society of Civil Engineers. Retrieved from <https://www.enotrans.org/wp-content/uploads/LCCA.pdf>
- Aria, M., & Akbari, R. (2013). Inspection, condition evaluation and replacement of elastomeric bearings in road bridges. *Structure and Infrastructure Engineering: Maintenance, Management, Life-Cycle Design and Performance*, 9(9), 918–934. <https://doi.org/10.1080/15732479.2011.638171>
- Azizinamini, A., Power, E. H., Myers, G. F., & Ozyildirim, H. C. (2014). *Bridges for service life beyond 100 years: Innovative systems, subsystems, and components* (Report No. S2-R19A-RW-1). Washington, DC: Transportation Research Board. <https://doi.org/10.17226/22479>
- Azizinamini, A., Yakel, A., & Farimani, M. (2005). *Development of a steel bridge system—Simple for dead load and continuous for live load; Volume 1: Analysis and recommendations* (NDOR Research Project Number P542). Lincoln, NE: National Bridge Research Organization. Retrieved from <http://govdocs.nebraska.gov/epubs/R6000/B267-2005v1.pdf>
- Bardow, A. K., Seraderian, R. L., & Culmo, M. P. (1997). Design, fabrication and construction of the new england bulb-tee girder. *PCI Journal*, 42(6), 30–40.
- Barth, K. E., Michaelson, G. K., & Barker, M. G. (2015). Development and experimental validation of composite press brake—Formed modular steel tub girders for short-span bridges. *Journal of Bridge Engineering*, 20(11), 04015007-1–04015007-7. [https://doi.org/10.1061/\(ASCE\)BE.1943-5592.0000770](https://doi.org/10.1061/(ASCE)BE.1943-5592.0000770)
- Bowman, M. D., & Moran, L. M. (2015). *Bridge preservation treatments and best practices* (Joint Transportation Research Program Publication No. FHWA/IN/JTRP-2015/22). West Lafayette, IN: Purdue University. <https://doi.org/10.5703/1288284316007>
- Burgueño, R., & Pavlich, B. S. (2008). *Evaluation of prefabricated composite steel box girder systems for rapid bridge construction* (Report No. RC-1507). East Lansing, MI: Michigan Department of Transportation. Retrieved from [https://www.michigan.gov/documents/mdot/MDOT\\_Research\\_Report\\_RC-1507\\_238838\\_7.pdf](https://www.michigan.gov/documents/mdot/MDOT_Research_Report_RC-1507_238838_7.pdf)
- Burner, K. A. (2010). *Experimental investigation of folded plate girders and slab joints used in modular construction* (Master's thesis). Retrieved from <https://digitalcommons.unl.edu/civilengdiss/8/>
- Cha, H., Liu, B., Prakash, A., & Varma, A. H. (2016). *Efficient load rating and quantification of life-cycle damage of indiana bridges due to overweight loads* (Joint Transportation Research Program Publication No. FHWA/IN/JTRP-2016/06). West Lafayette, IN: Purdue University. <https://doi.org/10.5703/1288284316329>
- Chavel, B., & Carnahan, J. (2012). *Steel bridge design handbook design example 4: Three-span continuous straight composite steel tub girder bridge* (Publication No. FHWA-HIF-16-002—Vol. 24). Pittsburgh, PA: Federal Highway Administration. Retrieved from <https://www.fhwa.dot.gov/bridge/steel/pubs/hif16002/designexample05.pdf>
- Civjan, S. A., Sit, M. H., & Breña, S. F. (2016). Field and analytical studies of the first folded-plate girder bridge. *Journal of Bridge Engineering*, 21(11), 04016074-1–04016074-16. [https://doi.org/10.1061/\(ASCE\)BE.1943-5592.0000918](https://doi.org/10.1061/(ASCE)BE.1943-5592.0000918)
- Craig, J., O'Conner, D., & Ahlskog, J. (1982). Economics of bridge deck protection methods. *Materials Performance*, 22(11), 32–34.
- D'Agostino, R. B., & Stephens, M. A. (Eds.). (1986). *Goodness-of-fit techniques: Statistics, textbooks and monographs* (Vol. 68). New York, NY: Marcel Dekker Inc.
- FDOT. (2003). *LRFD design example #1: Prestressed precast concrete beam bridge design*. Tampa, FL: Florida Department of Transportation. Retrieved from [https://fdotwww.blob.core.windows.net/sitefinity/docs/default-source/content/structures/structuresmanual/currentrelease\\_test\\_old/precastbeamexample.pdf](https://fdotwww.blob.core.windows.net/sitefinity/docs/default-source/content/structures/structuresmanual/currentrelease_test_old/precastbeamexample.pdf)
- Fricke, J. D., Zayed, T., & Chang, L. M. (1999). *Steel bridge protection policy: Life cycle cost analysis and maintenance plan* (Joint Transportation Research Program Publication No. FHWA/IN/JTRP-98/21-IV). West Lafayette, IN: Purdue University. <https://doi.org/10.5703/1288284313320>
- Frosch, R. J., Kreger, M. E., Byl, E. A., Lyrenmann, J. P., & Pollastrini, A. S. (2016). *Development of a cost-effective concrete bridge deck preservation program: Volume 2—Final results and recommendations* (Joint Transportation Research Program Publication No. FHWA/IN/JTRP-2016/23). West Lafayette, IN: Purdue University. <https://doi.org/10.5703/1288284316346>
- Frosch, R. J., Blackman, D. T., Radabaugh, R. D. (2003). *Investigation of bridge deck cracking in various bridge superstructure systems* (Joint Research Transportation



- Publication No. FHWA/IN/JTRP-2002/25). West Lafayette, IN: Purdue University. <https://doi.org/10.5703/1288284313257>
- Fwa, T. F. (2006). *The handbook of highway engineering*. Boca Raton, FL: CRC Press.
- Glaser, L. A. (2010). *Constructability testing of folded plate girders* (Master's thesis). Retrieved from [https://digitalcommons.unl.edu/civilengdiss/9/?utm\\_source=digitalcommons.unl.edu%2Fcivilengdiss%2F9&utm\\_medium=PDF&utm\\_campaign=PDFCoverPages](https://digitalcommons.unl.edu/civilengdiss/9/?utm_source=digitalcommons.unl.edu%2Fcivilengdiss%2F9&utm_medium=PDF&utm_campaign=PDFCoverPages)
- Grant, E. L., & Grant-Ireson, W. (1960). *Principles of engineering economy* (4th ed.). New York, NY: Ronald Press.
- Grubb, M. A., & Schmidt, R. E. (2012). *Steel bridge design handbook design example 1: Three-span continuous straight composite steel I-girder bridge* (Report No. FHWA-IF-12-052). Pittsburgh, PA: Federal Highway Administration.
- Hartle, R. A., Wilson, K. E., Amrhein, W., Zang, S. D., Bouscher J., Volle, L. E. (2003). *LRF design example for steel girder superstructure bridge* (Report No. FHWA NHI-04-041). Washington, DC: Federal Highway Administration National Highway Institute.
- Hatami, A., & Morcous, G. (2012). Deterioration models for life-cycle cost analysis of bridge decks in Nebraska. *Transportation Research Record: Journal of the Transportation Research Board*, 2313(1), 3–11. <https://doi.org/10.3141/2313-01>
- Hawk, H. (2002). *Bridge life-cycle cost analysis* (NCHRP Report 483). Washington, DC: Transportation Research Board.
- Henkle, D. (2001). Competitive edge. *Civil Engineering Magazine—ASCE*, 71(7), 64–67.
- Hoorpah, W., Zanon, R., Dabee, V., & Muhomud S. R. (2015). Colville Deverell Bridge, Mauritius Island composite deck with steel main girders and concrete crossbeams: Economic and fast construction technology for developing countries. In N. Yardimci, A. B. Aydoğan, & H. Y. Gür'es (Eds.), *Steel bridges: Innovation & new challenges—Proceedings of the 8th International Symposium on Steel Bridges* (pp. 277–282). Istanbul, Turkey: Turkish Constructional Steelwork Association.
- INDOT. (2013). *Indiana design manual*. Indianapolis, IN: Indiana Department of Transportation. Retrieved from <http://www.in.gov/dot/div/contracts/design/IDM%20Complete%202013.pdf>
- INDOT. (2014). *Bridge construction and deck repair training manual*. Indianapolis, IN: Indiana Department of Transportation.
- Johnston, S. B., & Mattock, A. H. (1967). *Lateral distribution of load in composite box girder bridges* (Highway Research Record, Report No. 167). Retrieved from <https://trid.trb.org/view/105336>
- Lee, D. J. (1994). *Bridge bearings and expansion joints* (2nd ed.). London, NY: E & FN Spon.
- Mamaghani, I., Moretti, C., & Dockter, B. A. (2007). *Application of sealing agents in concrete durability of infrastructure systems*. Bismark, ND: North Dakota Department of Transportation. Retrieved from [http://www.dot.nd.gov/divisions/materials/research\\_project/und0601final.pdf](http://www.dot.nd.gov/divisions/materials/research_project/und0601final.pdf)
- Mauch, M., & Madanat, S. (2001). Semiparametric hazard rate models of reinforced concrete bridge deck deterioration. *Journal of Infrastructure Systems*, 7(6), 49–57. [https://doi.org/10.1061/\(ASCE\)1076-0342\(2001\)7:2\(49\)](https://doi.org/10.1061/(ASCE)1076-0342(2001)7:2(49))
- Megggers, D. A. (1998). *Crack sealing and repair of older serviceable bridges using polymer sealers* (Report No. FHWA-KS-98-4). Topeka, KS: Kansas Department of Transportation. Retrieved from <https://rosap.nrl.bts.gov/view/dot/14163>
- Moomen, M., Qiao, Y., Agbelie, B. R., Labi, S., & Sinha, K. C. (2016). *Bridge deterioration models to support Indiana's bridge management system* (Joint Transportation Research Program Publication No. FHWA/IN/JTRP-2016/03). West Lafayette, IN: Purdue University. <https://doi.org/10.5703/1288284316348>
- Morcous, G. (2013). *Life-cycle assessment of Nebraska Bridges*. Nebraska Department of Transportation Research Reports. <http://digitalcommons.unl.edu/ndor/114>
- Morcous, G., & Hatami, A. (2011). *Developing deterioration models for Nebraska bridges*. Lincoln, NE: Nebraska Transportation Center. Retrieved from <http://digitalcommons.unl.edu/cgi/viewcontent.cgi?article=1030&context=matcreports>
- Morcous, G., & Lounis, Z. (2007). Probabilistic and mechanistic deterioration models for bridge management. In B. Akinci & L. Soibelman (Eds.), *The 2007 ASCE International Workshop on Computing in Civil Engineering* (pp. 364–373). Reston, VA: American Society of Civil Engineers (ASCE). [https://doi.org/doi:10.1061/40937\(261\)45](https://doi.org/doi:10.1061/40937(261)45)
- Nakamura, S. (2002). Bending behavior of composite girders with cold formed steel U section. *Journal of Structural Engineering*, 128(9), 1169–1176. [https://doi.org/10.1061/\(ASCE\)0733-9445\(2002\)128:9\(1169\)](https://doi.org/10.1061/(ASCE)0733-9445(2002)128:9(1169))
- Olek, J., & Liu, R. (2001). *Development and evaluation of cement-based materials for repair of corrosion-damaged reinforced concrete slabs* (Joint Transportation Research Program Publication No. FHWA/IN/JTRP-2000/10). West Lafayette, IN: Purdue University. <https://doi.org/10.5703/1288284313177>
- Parsons Brinckerhoff. (2011). *Example no. 1: Prestressed concrete girder bridge design*. Santa Fe, NM: New Mexico Department of Transportation. Retrieved from [http://dot.state.nm.us/content/dam/nmdot/Infrastructure/LRFD\\_Design\\_Example.pdf](http://dot.state.nm.us/content/dam/nmdot/Infrastructure/LRFD_Design_Example.pdf)
- Short Span Steel Bridge Alliance. (n.d.). Press-brake-formed tub girders [Web page]. Retrieved January 24, 2019, from <https://www.shortspansteelbridges.org/steel-solutions/press-brake-tub-girders>
- Sinha, K. C., & Labi, S. (2011). *Transportation decision making: Principles of project evaluation and programming*. New York, NY: John Wiley and Sons. <https://doi.org/10.1002/9780470168073>
- Sinha, K. C., Labi, S., McCullouch, B. G., Bhargava, A., & Bai, Q. (2009). *Updating and enhancing the Indiana Bridge Management System (IBMS)* (Joint Transportation Research Program Publication No. FHWA/IN/JTRP-2008/30). West Lafayette, IN: Purdue University. <https://doi.org/10.5703/1288284314306>
- Soliman, M., & Frangopol, D. M. (2015). Life-cycle cost evaluation of conventional and corrosion-resistant steel for bridges. *Journal of Bridge Engineering*, 20(1), 06014005-1–06014005-5. [https://doi.org/10.1061/\(ASCE\)BE.1943-5592.0000647](https://doi.org/10.1061/(ASCE)BE.1943-5592.0000647)
- Soltész, S. (2003). *Washing bridges to reduce chloride* (Report No. FHWA-OR-DF-04-05). Salem, OR: Oregon Department of Transportation. Retrieved from <https://www.oregon.gov/ODOT/Programs/ResearchDocuments/WashingBridgeInterim.pdf>
- Soriano, A. (2002). *Alternative sealants for bridge decks* (Report No. SD2001-04-D). Minneapolis, MN: South Dakota Department of Transportation. Retrieved from [http://www.sddot.com/business/research/projects/docs/SD2001\\_04\\_Final\\_Report.pdf](http://www.sddot.com/business/research/projects/docs/SD2001_04_Final_Report.pdf)

- Taly, N., & Gangaro, H. V. S. (1979). Prefabricated preformed steel t-box girder bridge system. *Engineering Journal AISC*, 16(3), 75–83.
- Tam, C. K., & Stiemeier, S. F. (1996). Development of bridge corrosion cost model for coating maintenance. *Journal of Performance of Constructed Facilities*, 10(2), 47–56. [https://doi.org/10.1061/\(ASCE\)0887-3828\(1996\)10:2\(47\)](https://doi.org/10.1061/(ASCE)0887-3828(1996)10:2(47))
- Thompson, P. D., Ford, K. M., Arman, M. H. R., Labi, S., Sinha, K. C., & Shirole, A. M. (2012). *Estimating life expectancies of highway assets; Volume 1: Guidebook* (NCHRP Report 713). Washington, DC: Transportation Research Board. <https://doi.org/10.17226/22782>
- Wassef, W. G., Smith, C., Clancy, C. M., & Smith, M. J. (2003). *Comprehensive design example for prestressed concrete (PSC) girder superstructure bridge with commentary* (Report No. FHWA NHI-04-043). Harrisburg, PA: Modjeski and Masters, Inc. Retrieved from <https://www.fhwa.dot.gov/bridge/lrfd/fhwanhi04043.pdf>
- Wenzlick, J. (2007). *Bridge deck concrete sealers* (Report No. OR07-009). Jefferson City, MO: Missouri Department of Transportation. Retrieved from <https://library.modot.mo.gov/RDT/reports/Ri04051/or07009.pdf>
- Weyers, R. E., Prowell, B. D., Sprinkel, M. M., & Vorster, M. (1993). *Concrete bridge protection, repair, and rehabilitation relative to reinforcement corrosion: A methods application manual* (Report No. SHRP-S-360). Washington, DC: Strategic Highway Research Program. Retrieved from <http://onlinepubs.trb.org/onlinepubs/shrp/SHRP-S-360.pdf>
- Wisconsin Department of Transportation. (2019). Chapter 18—Concrete slab structures. In *WisDOT bridge design manual* (18.5 Design Example). Madison, WI: Wisconsin Department of Transportation. Retrieved from <https://wisconsin.dot.gov/dtsdManuals/strct/manuals/bridge/ch18.pdf>
- Yamane, T., Tadros, M. K., & Arumugassamy, P. (1994). Short to medium span precast prestressed concrete bridges in Japan. *PCI Journal*, 39(2), 74–100.
- Yanev, B., & Richards, G. (2011). Bridge maintenance in New York City: Network- and Project-level interaction. *Transportation Research Record*, 2220(1), 28–37. <https://doi.org/10.3141/2220-04>
- Zanon, R., Ochojski, W., Hechler, O., Klimaszewski, P., & Lorenc, W. (2015). Road bridges with prefabricated composite beams in high-strength steel—realization example. In N. Yardimci, A. A. Berna & G. H. Yener (Eds.), *Steel bridges: Innovation & new challenges 2015—Proceedings of the 8th International Symposium on Steel Bridges* (pp. 283–292). Istanbul, Turkey: Turkish Constructional Steelwork Association (TUCSA).
- Zayed, T. M., Chang, L.-M., & Fricker, J. D. (2002). Life-cycle cost analysis using deterministic and stochastic methods: Conflicting results. *Journal of Performance of Constructed Facilities*, 16(2), 63–74. [https://doi.org/10.1061/\(ASCE\)0887-3828\(2002\)16:2\(63\)](https://doi.org/10.1061/(ASCE)0887-3828(2002)16:2(63))
- Žemajtis, J., & Weyers, R. (1996). Concrete bridge service life extension using sealers in chloride-laden environments. *Transportation Research Record: Journal of the Transportation Research Board*, 1561(1), 1–5. <https://doi.org/10.3141/1561-01>

## APPENDICES

**Appendix A: Case Study: Prestressed Concrete Bulb Tee Bridge**

**Appendix B: Selected Examples of Bridge Designs**

**Appendix C: Bridge Drawings**

**Appendix D: Life-Cycle Profiles for Indiana Bridges**

**Appendix E: Life-Cycle Cost Input for Matlab**

## APPENDIX A. CASE STUDY: PRESTRESSED CONCRETE BULB TEE BRIDGE

### A.1 Bridge description:

A two-span configuration with equal spans of 110 ft each is used for this example. The superstructure is composed of a reinforced concrete deck on simple span prestressed girders made continuous for live load. Girders used were hybrid bulb tees, 66 in deep, 61 in wide top flange and 40 in wide bottom flange (HBT66x61) as presented in the INDOT Design Manual (INDOT, 2013). The selection of girder size and strand configuration is usually based on past experience. The strand configuration was refined using trial and error until final and release stresses fell within the allowable stress limits and the strength resistance is greater than that required by the applied loads. In order to validate the design, not only was the design compared with similar projects extracted from the contractor database, but also a general results check was performed using a specialized bridge software called “LEAP bridge concrete” licensed by Bentley® software developers.

It is important to underline some additional requirements regarding the use of debonded strands if they are needed according to the LRFD Section 5.11.4.3. Firstly, the number of partially debonded strands should not exceed 25 percent of the total number of strands. Secondly, the number of debonded strands in any horizontal row shall not exceed 40 percent of the strands in that row. Thirdly, debonded strands shall be symmetrically distributed about the centerline of the member. Debonded lengths of pairs of strands that are symmetrically positioned about the centerline of the member shall be equal. Finally, exterior strands in each horizontal row shall be fully bonded.

### A.2 Deck slab design:

The approximate method is used (called equivalent strip method). This method is based on the following premises:

- The transverse strip of the slab is assumed to structurally support the truck loads.
- The strip is assumed to be supported on rigid supports at the center of the beams.
- The truck axle loads are moved laterally to produce the moment envelopes. Multiple presence factors and the dynamic load allowance are included. The total moment is divided by the strip distribution width to determine the live load per unit width.
- The reinforcement is designed using conventional principles of reinforced concrete design.

According to AASHTO LRFD Section 4.6.2, the equivalent strip width for cast-in-place decks with stay in place concrete formwork must be taken as follows (equations [A.1] and [A.2]), where  $S$  is the spacing of supporting elements (in this case 9.5 ft, as shown in Figure A.1):

$$+M = 26.0 + 6.6S = 26.0 + 6.6(9.5ft) = 88.7in \quad [A.1]$$

$$-M = 48.0 + 3.0S = 48.0 + 3.0(9.5ft) = 76.5in \quad [A.2]$$

The bridge cross section is presented in Figure A.1. The beam spacing is 9.5 ft, concrete cover is 2 ½” and 1” for the top and bottom layers, respectively. For this design, slab thickness of 8” including the ½” integral wearing surface is assumed, according to the INDOT design manual Section 404-2.0. Additionally, the integral wearing surface does not have to be included in the structural thickness of the composite section. Finally, all reinforcing steel in both, the top and bottom layers shall be epoxy coated for a bridge deck supported on beams. Since the deck is assumed to be rigidly supported at the center line of the supporting elements, the load effects are calculated using equation [A.3] that assumes continuity of the deck:

$$M = \frac{wl^2}{c} \quad [A.3]$$

where  $w$  is the dead load per unit area,  $l$  is the beam spacing and  $c$  is a constant that typically is a value taken between 10 and 12. For this example,  $c$  is considered as 10. Consequently, dead load moments due to self-weight, stay in place forms and a 3-in thick bituminous future wearing surface are calculated as follows:

$$M_{sw} = \frac{0.10 \frac{kip}{ft^2} (9.5ft)^2}{10} = 0.90 \frac{kip-ft}{ft}$$

$$M_{spf} = \frac{0.015 \frac{kip}{ft^2} (9.5ft)^2}{10} = 0.135 \frac{kip-ft}{ft}$$

$$M_{fws} = \frac{0.035 \frac{kip}{ft^2} (9.5ft)^2}{10} = 0.316 \frac{kip-ft}{ft}$$

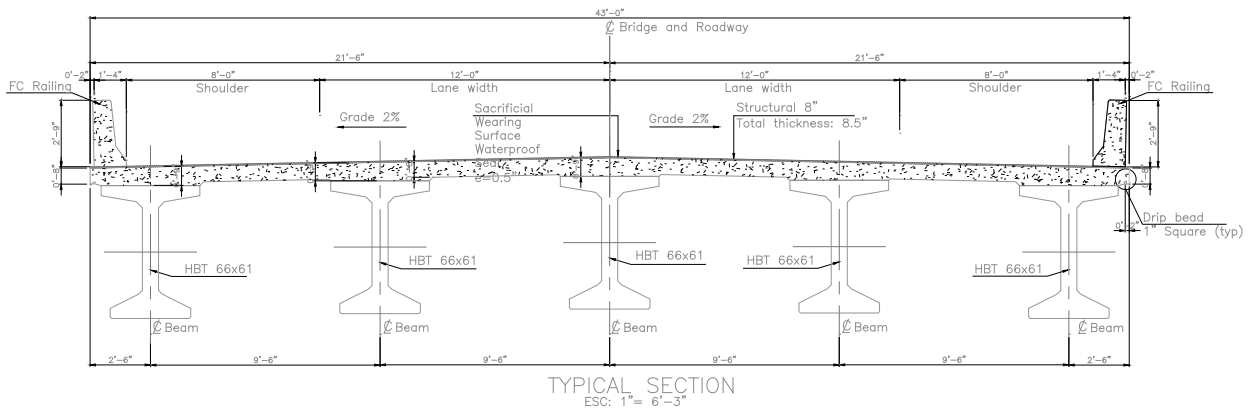

**Figure A.1 General cross section bulb tee superstructure**

Since the premise of the specifications is not maximizing the load effect for deck design using different load factors for different bays within the same cross section, maximum load factor controls the design and minimum load factor could be neglected. According to Table 3.4.1-1 of the LRFD, maximum load

factors for dead load and wearing surface are 1.25 and 1.50, respectively for the strength limit state. Additionally, for negative moment it is important to underline that the design section location should be taken as one third of the flange width from the center line of the support, but not exceeding 15-in (S4.6.2.1.6). For the HBT668x61, one third of the top flange is equal to 20-in, which means that the negative moment design location is at 15-in.

Live load effect on the deck needs to satisfy the following conditions: the minimum distance from center of the wheel to the edge of the parapet is 1 ft, and the minimum distance between the wheel of two adjacent trucks is 4 ft. In addition, a dynamic load allowance of 33% (AASHTO Table 3.6.2.1-1) was considered, as well as a multiple presence factor of 1.00 equivalent to two lanes. The load factor for the strength limit state is 1.75. It is important to remark that fatigue is not required to be checked for concrete slabs in multi-girder systems according to Sections 9.5.3 and 5.5.3.1 of the AASHTO LRFD Specifications. Moment resistance factor for strength limit state ( $\phi_{strength}$ ) is considered as 0.90.

In lieu of the approximate strip method procedure, the LRFD Specification allows the live load effects (positive and negative moments) to be computed using the Table A4.1-1. This table lists the positive and negative moment per unit width of decks with various girder spacings and with various distances from the design section to the centerline of the girders for negative moment. Using as an input the beam separation of 9.5 ft and the negative moment distance location of 15-in, the maximum positive and negative moments are 6.59 kip ft/ft and 4.04kip ft/ft, respectively. Final strength limit state moment are:

$$\begin{aligned}
 M_{Strg} &= DL(M_{sw} + M_{spf}) + DW(M_{fws}) + (LL + IM)M_{LL} & [A.4] \\
 M_{Strg+M} &= 1.25 \left( 0.90 \frac{\text{kip-ft}}{\text{ft}} + 0.135 \frac{\text{kip-ft}}{\text{ft}} \right) + 1.50 \left( 0.316 \frac{\text{kip-ft}}{\text{ft}} \right) \\
 &\quad + 1.75 \left( 6.59 \frac{\text{kip-ft}}{\text{ft}} \right) \\
 M_{Strg+M} &= 13.30 \frac{\text{kip-ft}}{\text{ft}} \\
 M_{Strg-M} &= 1.25 \left( 0.90 \frac{\text{kip-ft}}{\text{ft}} + 0.135 \frac{\text{kip-ft}}{\text{ft}} \right) + 1.50 \left( 0.316 \frac{\text{kip-ft}}{\text{ft}} \right) \\
 &\quad + 1.75 \left( 4.04 \frac{\text{kip-ft}}{\text{ft}} \right) \\
 M_{Strg-M} &= 8.84 \frac{\text{kip-ft}}{\text{ft}}
 \end{aligned}$$

According to Equation S5.7.3.1.1-4 of the LRFD, for rectangular section behavior, the depth of the section in compression,  $c$ , is determined by equation [A.5]:

$$c = \frac{A_s f_y}{0.85 f'_c \beta_1 b} \quad [A.5]$$

It is important to mention that prestressing steel and compression steel are neglected for the compression depth. The factor  $\beta_1$  is taken as 0.85 according to S5.7.2.2 since the deck concrete strength does not exceeds 4ksi. The depth of the compression block,  $a$ , is computed as:

$$a = c \beta_1 \quad [A.6]$$

The nominal flexural resistance,  $M_n$ , neglecting the compression and the prestressing steel is the following (Equation S5.7.3.2.2-1):

$$M_n = A_s f_y \left( d - \frac{a}{2} \right) \quad [A.7]$$

There are two different approaches to compute the required steel of the slab. The first one substitutes  $a$  and  $c$  into the above equation and then obtaining  $A_s$  minimum required supposing that the flexural capacity needs to be as the load demand. The other approach is to select a deck reinforcement amount and check the adequacy of the flexural moment capacity. The second method is used in this example. For this case, the following reinforcement is assumed: Top principal reinforcement of #5@5" equivalent to  $0.74 \text{ in}^2/\text{ft}$ , bottom principal reinforcement of #5@7" equivalent to  $0.53 \text{ in}^2/\text{ft}$ , and transversal reinforcement of #5@8" equivalent to  $0.46 \text{ in}^2/\text{ft}$ . This pattern satisfies the requirement from the INDOT Design Manual, Section 404-2.01 which requires a minimum reinforcement of #5@8" for principal steel and a maximum separation of 8" for all kind of reinforcement. Thus, assuming a design width of 1 ft, for negative moment the flexural strength capacity is:

$$c = \frac{0.74 \text{ in}^2 (60 \text{ ksi})}{0.85 (4 \text{ ksi}) (0.85) (12 \text{ in})} = 1.28 \text{ in}$$

$$a = 1.28 \text{ in} (0.85) = 1.09 \text{ in}$$

$$\phi M_n = 0.9 (0.74 \text{ in}^2) (60 \text{ ksi}) \left( \left( 8.0 \text{ in} - 0.5 \text{ in} - 2.5 \text{ in} - \frac{5''/8}{2} \right) - \frac{1.09 \text{ in}}{2} \right) = 13.80 \text{ kip} - \text{ft}$$

As can be seen, flexural factored resistance,  $\phi M_n$ , is greater than the moment strength limit state demands,  $M_{Strg-M}$ , which means that the design is acceptable. Additionally, a check of minimum reinforcement according to S5.7.3.2 is necessary. Usually, this requirement does not control the design, however, its calculation is presented below for information purposes.

According to the specifications, any section of a noncompression-controlled flexural component, the amount of prestressed and nonprestressed tensile reinforcement shall be adequate to develop a factored flexural resistance,  $M_r$ , at least equal to the lesser of 1.33 times the factored moment and cracking moment of the section,  $M_{cr}$ , computed as follows:

$$M_{cr} = \gamma_3 \left[ (\gamma_1 f_r + \gamma_2 f_{cpe}) S_c - M_{dnc} \left( \frac{S_c}{S_{nc}} - 1 \right) \right] \quad [A.8]$$

However, since there is no prestressing force considered in the deck, the formula is simplified as follows:

$$M_{cr} = \gamma_3 [(\gamma_1 f_r) S_c] \quad [A.9]$$

where,  $f_r$  is the modulus of rupture specified in S5.4.2.6 as 0.24 times the square root of the compression resistance of the concrete,  $S_c$  is the section modulus,  $\gamma_1$  is the flexural cracking variability factor taken as 1.60 as for other structures different than precast segmental structures and,  $\gamma_3$  is the ratio of the specified minimum yield strength to the ultimate tensile strength of the reinforcement, which is 0.67 for A615 grade 60 reinforcement. Thus, the cracking moment is computed as follows, which is less than 1.33 times the factored moment and then less than the factored flexural resistance:

$$M_{cr} = 0.67 \left[ \left( (1.60)(0.24\sqrt{4\text{ksi}}) \right) \frac{12\text{in}(7.5\text{in})^3}{\frac{12}{\frac{7.5\text{in}}{2}}} \right] = 4.82\text{kip} - \text{ft}$$

Moreover, a serviceability check needs to be addressed. This requirement is represented by the maximum rebar separation due to service loading to control cracking in the cross section:

$$s \leq \frac{700\gamma_e}{\beta_s f_{ss}} - 2d_c \quad [\text{A.10}]$$

$$\beta_s = 1 + \frac{d_c}{0.70(h - d_c)} \quad [\text{A.11}]$$

where  $\gamma_e$  is the exposure factor considered as 0.75 for class 2 exposure condition recommended for decks exposed to water,  $f_{ss}$  is the calculated tensile stress in mild steel reinforcement at the service limit state not to exceed  $0.60 f_y$ ,  $d_c$  is the thickness of concrete cover measured from extreme tension fiber to the center of the flexural reinforcement located closest thereto, and  $h$  is the overall thickness. Furthermore,  $f_{ss}$  is computed following the stress distribution presented in Figure A.2.

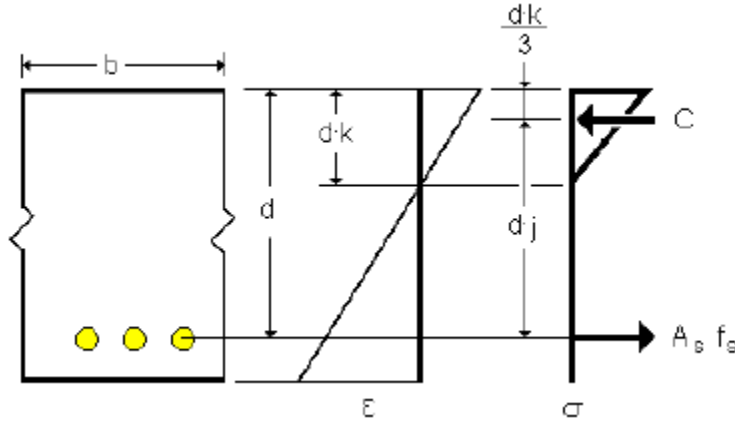

**Figure A.2 Stress distribution of a concrete rectangular section**

Then, the maximum separation is 7.72-in, which is higher than the separation for the negative region reinforcement set as 4 in, the computation is as follows:

$$\rho = \frac{A_s}{db} \quad [\text{A.12}]$$

$$\rho = \frac{0.74\text{in}^2}{\left( 8.0\text{in} - 0.5\text{in} - 2.5\text{in} - \frac{5''}{8} \right) 12\text{in}} = 0.0132$$

$$k = \sqrt{(2\rho n) + (\rho n)^2} - (\rho n) \quad [\text{A.13}]$$

$$k = \sqrt{(2)(0.0132)(8) + ((0.0132)8)^2} - (0.0132)(8) = 0.37$$

$$j = 1 - \frac{(k)}{3} \quad [\text{A.14}]$$



$$j = 1 - \frac{(0.37)}{3} = 0.88$$

$$f_{ss} = \frac{M_s}{A_s j d}$$

[A.15]

$$f_{ss} = \frac{(0.90 + 0.135 + 0.316 + 4.04) \frac{\text{kip} - \text{ft}}{\text{ft}}}{0.74 \text{in}^2 (0.88) \left( 8.0 \text{in} - 0.5 \text{in} - 2.5 \text{in} - \frac{5''/8}{2} \right)} = 21.19 \text{ksi}$$

$$\beta_s = 1 + \frac{\left( 2.5 \text{in} - \frac{5''/8}{2} \right)}{0.70 \left( 7.5 \text{in} - \left( 2.5 \text{in} - \frac{5''/8}{2} \right) \right)} = 1.86$$

$$s \leq \frac{700(0.75)}{(1.86)(21.19 \text{ksi})} - 2 \left( 2.5 \text{in} + \frac{5''/8}{2} \right) = 7.70 \text{in}$$

Finally, shrinkage and temperature reinforcement need to be checked for the principal reinforcing steel. According to Section 5.10.8, the minimum area required is as follows:

$$A_{s_{shr}} \geq \frac{1.30bh}{2(b+h)f_y} \quad [A.16]$$

$$\frac{1.30bh}{2(b+h)f_y} = \frac{1.30(12 \text{in})(7.5 \text{in})}{2(12 \text{in} + 7.5 \text{in})60 \text{ksi}} = 0.05 \text{in}^2$$

This value is less than the area provided and is thereby satisfied.

The same requirements need to be satisfied in the positive moment region. Using the appropriate values, the results are the following:

$$c = \frac{0.53 \text{in}^2 (60 \text{ksi})}{0.85(4 \text{ksi})(0.85)(12 \text{in})} = 0.92 \text{in}$$

$$a = 0.92 \text{in}(0.85) = 0.78 \text{in}$$

$$\phi M_n = 0.9(0.53 \text{in}^2)(60 \text{ksi}) \left( \left( 8.0 \text{in} - 0.5 \text{in} - 1.0 \text{in} - \frac{5''/8}{2} \right) - \frac{0.78 \text{in}}{2} \right) = 13.83 \text{kip} - \text{ft}$$

$$M_{cr} = 0.67 \left[ \left( (1.60)(0.24\sqrt{4 \text{ksi}}) \right) \frac{12 \text{in}(7.5 \text{in})^3}{\frac{12}{7.5 \text{in}} \frac{2}{2}} \right] = 4.82 \text{kip} - \text{ft}$$

$$\rho = \frac{A_s}{db} = \frac{0.53 \text{in}^2}{\left( 8.0 \text{in} - 0.5 \text{in} - 1.0 \text{in} - \frac{5''/8}{2} \right) 12 \text{in}} = 0.0071$$

$$k = \sqrt{(2\rho n) + (\rho n)^2} - (\rho n) = \sqrt{(2(0.0071)8) + ((0.0071)8)^2} - ((0.0071)8) = 0.28$$

$$j = 1 - \frac{(k)}{3} = 1 - \frac{(0.28)}{3} = 0.91$$

$$f_{ss} = \frac{M_s}{A_s j d} = \frac{(0.90 + 0.135 + 0.316 + 6.59) \frac{\text{kip} - \text{ft}}{\text{ft}}}{0.53 \text{in}^2 (0.91) \left( 8.0 \text{in} - 0.5 \text{in} - 1.0 \text{in} - \frac{5''}{2} \right)} = 31.93 \text{ksi}$$

$$\beta_s = 1 + \frac{\left( 1.0 \text{in} - \frac{5''}{2} \right)}{0.70 \left( 7.5 \text{in} - \left( 1.0 \text{in} - \frac{5''}{2} \right) \right)} = 1.27$$

$$s \leq \frac{700(0.75)}{(1.27)(31.93 \text{ksi})} - 2 \left( 1.0 \text{in} + \frac{5''}{2} \right) = 10.32 \text{in}$$

$$A_{s\_shr} \geq \frac{1.30bh}{2(b+h)f_y} = \frac{1.30(12 \text{in})(7.5 \text{in})}{2(12 \text{in} + 7.5 \text{in})60 \text{ksi}} = 0.05 \text{in}^2$$

As it can be seen, the design for the negative moment region is also satisfactory, which means that the assumed reinforcement is adequate for the computed load demands. Shear design does not have to be performed according to AASHTO LRFD 5.14.4, which states that "Slabs and slab bridges designed for moment in conformance with Article 4.6.2.3, "Equivalent Strip Widths for Slab Type Bridges" may be considered satisfactory for shear."

Finally, a transverse distribution reinforcement check is needed, following the recommendations of the LRFD Section 5.14.4.1. Transverse distribution reinforcement shall be placed in the bottoms of all slabs. The amount of the bottom transverse reinforcement may be determined by two-dimensional analysis, or the amount of distribution reinforcement may be taken as the percentage of the main reinforcement required for positive moment taken as:

$$\frac{100}{\sqrt{L}} \leq 50\% \quad [\text{A.17}]$$

$$\frac{100}{\sqrt{9.5 \text{ft}}} = 32\% \leq 50\% \quad [\text{A.18}]$$

Since this is a brief example of an actual design, the overhang is not detailed.

### A.3 Superstructure design:

As mentioned before, selection of the beam section and the strand configuration rely heavily on previous experience and engineering judgment. The section used for this example is a hybrid bulb tee 66-in deep and with a 61-in top flange width. Section properties for both the section only and the composite section are presented in Figures A.3 and A.4, respectively. Strand configuration is presented in Figure A.5.

Loads on the superstructure must be computed. Dead load includes self-weight of the beam, self-weight of the slab (corresponding to an 8-in thick slab), stay in place forms, haunch (corresponding to ½-in thick haunch), interior diaphragms, barrier railings (correspond to the railing type FC) and future wearing

surface. The last two components will be applied to the composite section, while the remaining loads will be applied to the non-composite section. Dead load values used are presented in Table A.1.

In addition to the use of Chapter 4 of the LRFD Specification to compute moment and shear values a 3D model (see Figure A.6) was used to compute moments and shears of the bridge. Appropriate values of dead loads as well as dimensions and span lengths and configuration were used for the modeling. However, a cross section corresponding to the HBT66x61 was not included in the database of the software. Consequently, an approximate equivalent section was used using the general dimensions of the standardized section.

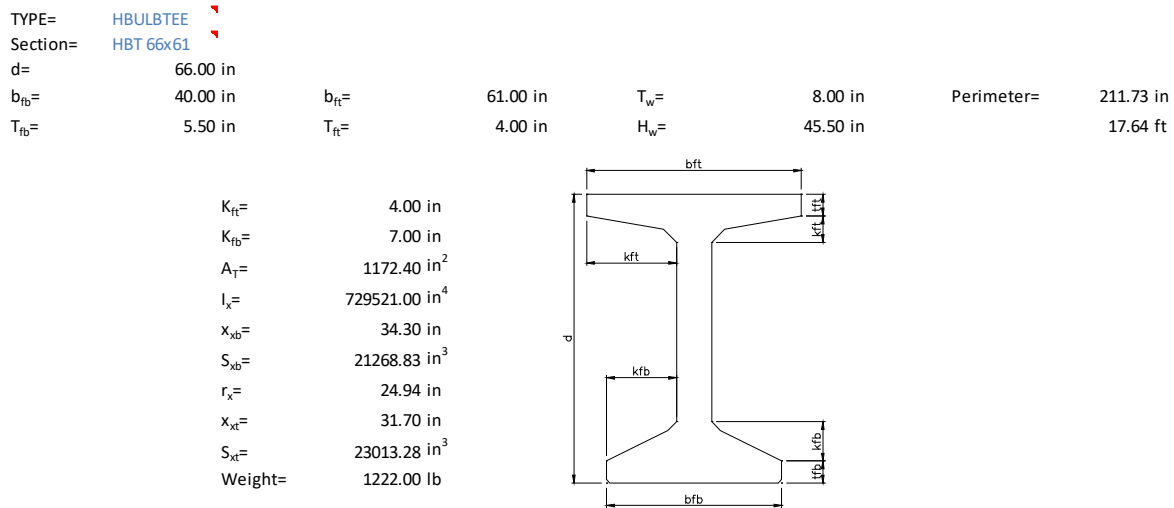

**Figure A.3 Section properties hybrid bulb tee HBT66x61**

Height of Steel Deck Rib (f) 0.00 in  
 Effective Conc Height (f')= 7.50 in  
 Effective Width (be)= 9.50 ft  
 (AASTO 4.6.2.6)

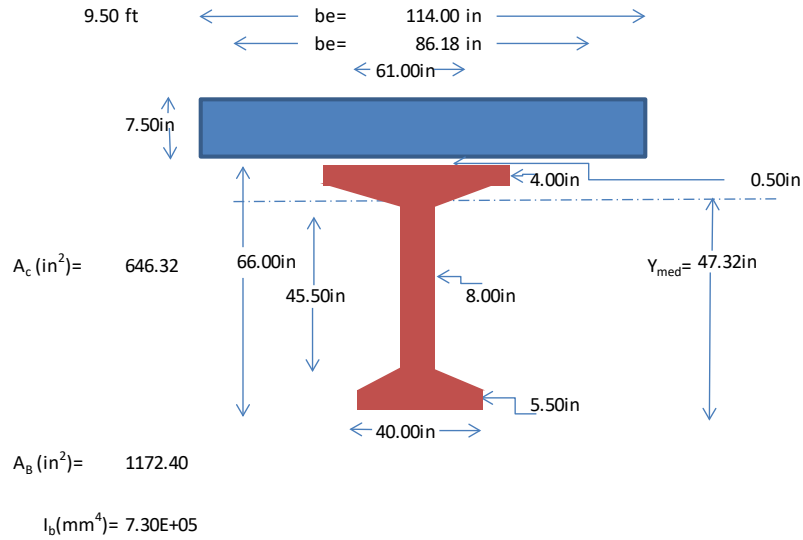

Section	Area (in <sup>2</sup> )	y (in)	A.y (in <sup>3</sup> )	I <sub>xx</sub> (in <sup>4</sup> )	d <sub>y</sub> (in)	A.d <sub>y</sub> <sup>2</sup> (in <sup>4</sup> )
Beam	1172.40	34.30	4.02E+04	7.30E+05	-13.02	1.99E+05
Haunch	23.06	66.25	1.53E+03	4.80E-01	18.93	8.27E+03
Slab	646.32	70.25	4.54E+04	3.03E+03	22.93	3.40E+05

Position	y (in)	S (in <sup>3</sup> )
Top Slab	26.68	6.34E+04
Top Beam	18.68	6.85E+04
Bott Beam	47.32	2.70E+04

$A_T = 1841.78 in^2$   
 $y = 47.32 in$   
 $I_{xx} = 1.28E+06 in^4$

**Figure A.4 Composed section properties HBT66x61 with 8 in deck and 9.5 ft effective width**

**3.2.3 STRANDS CONFIGURATION**

**3.2.3.1 Ends**

Distance from the bottom of the beam to the center of strands

Concrete Cover= 1.75 in

Strands Separation= 2.00 in

Draped Strands? Yes

Draped Length= 20.00 ft

Debonded Strands? No

Strands Diameter=

Type= 1/2 in

Strands Area= Seven Wire Strand (270)

Top Beam to 1st Strand= 0.15 in<sup>2</sup>

5.00 in

Row	Location	Strands	Debonded	Bonded
1	2.00	17.00	0.00	17.00
2	4.00	19.00	0.00	19.00
3	6.00	4.00	0.00	4.00
4	8.00	0.00	0.00	0.00
5	10.00	0.00	0.00	0.00
6	12.00	0.00	0.00	0.00
7	14.00	0.00	0.00	0.00
8	16.00	0.00	0.00	0.00

**Draped Strands**

Row	Location	Bonded
1	47.00	0.00
2	49.00	0.00
3	51.00	0.00
4	53.00	0.00
5	55.00	0.00
6	57.00	0.00
7	59.00	0.00
8	61.00	3.00

**Top Strands**

Row	Debonded	Bonded
1	0.00	0.00
2	0.00	0.00
3	0.00	0.00
4	0.00	0.00
5	0.00	0.00
6	0.00	0.00
7	0.00	0.00
8	0.00	0.00

**3.2.3.2 Mid Span**

Row	Location	Strands
1	2.00	17.00
2	4.00	19.00
3	6.00	7.00
4	8.00	0.00
5	10.00	0.00
6	12.00	0.00
7	14.00	0.00
8	16.00	0.00

**Top Strands**

Row	Location	Strands
1	47.00	0.00
2	49.00	0.00
3	51.00	0.00
4	53.00	0.00
5	55.00	0.00
6	57.00	0.00
7	59.00	0.00
8	61.00	0.00

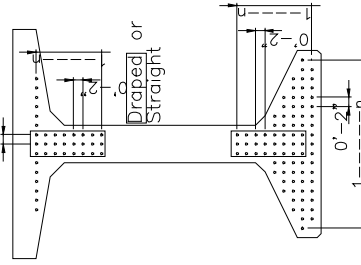

ENDS

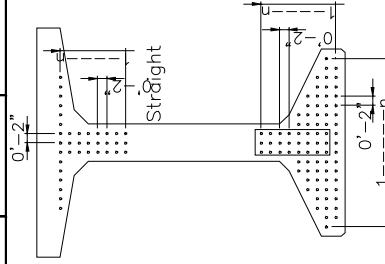

MID SPAN

**Figure A.5 Strand configuration HBT48x49-110 ft span**

**Table A.1 Dead load design example span 110 ft**

<b>Distributed Loads</b>	<b>SPAN 1 and 2</b>
Beam self-weight=	1.015 kip/ft
Concrete Deck=	0.950 kip/ft
Concrete Haunch=	0.026 kip/ft
Stay-in-Place Forms=	0.015 kip/ft
Diaphragms=	0.000 kip/girder
<b>Total DC non Composite=</b>	<b>2.01 kip/ft</b>
Rail Barriers*=	0.12 kip/ft
<b>Total DW non Composite=</b>	<b>2.01 kip/ft</b>
Future Wearing Surface=	0.025 kip/ft <sup>2</sup>
<b>Total DW Composite=</b>	<b>2.01 kip/ft</b>

Following the calculation of the bridge loading, live load needs to be determined. AASHTO-LFRD allows the use of advanced methods to determine the load distribution factors, which are used for the 3D model. Nonetheless, the specification lists equations to compute those factors depending on the superstructure type in Table 4.6.2.2.2b-1. Before the computation of the distribution factors, the longitudinal stiffness parameter,  $K_g$ , is needed where  $A$  is the gross area of the beam,  $n$  is the modulus of elasticity ratio and  $e_g$  is the distance between the center of gravity of the beam and the deck.

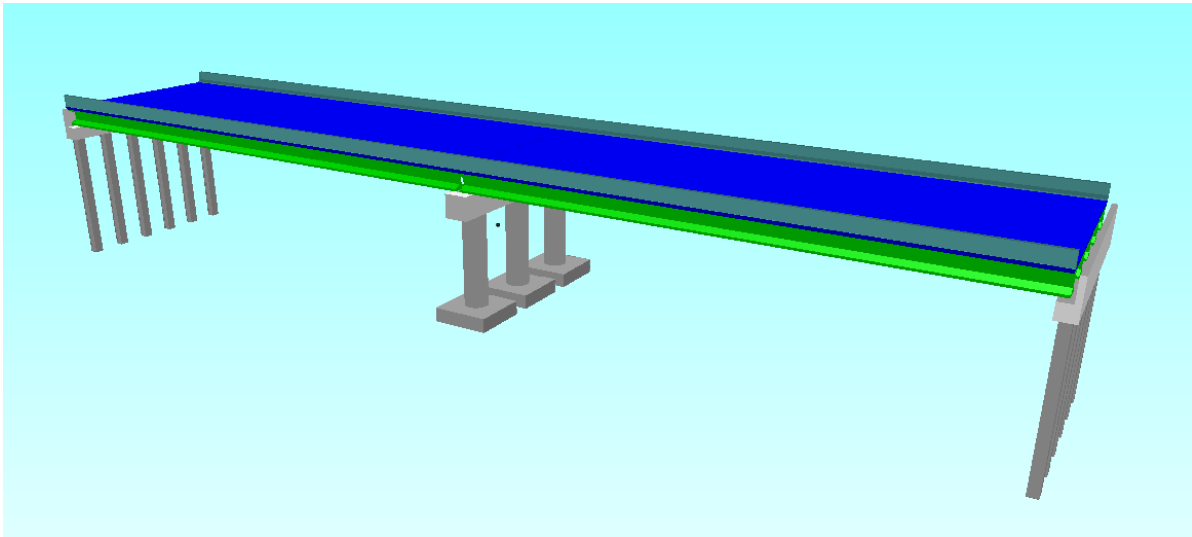

**Figure A.6 3D model created for LEAP bridge concrete.**

$$n = \frac{E_{cb}}{E_{cs}} \quad [A.19]$$

$$n = \frac{5072 \text{ksi}}{3834 \text{ksi}} = 1.3228$$

$$K_g = n \left( I + A e_g^2 \right) \quad [A.20]$$

$$K_g = 1.3228 (729,521 \text{in}^4 + 1,172.40 \text{in}^2 (35.95 \text{in}^2)^2) = 2.97 \times 10^6 \text{in}^4$$

$$r_{Moment} = 1 - c_1 (\tan \theta)^{1.5} = 1.0 \quad [A.21]$$

$$r_{Shear} = 1.0 + 0.20 \left( \frac{12Lt_s^3}{K_g} \right)^{0.3} \tan \theta = 1.0 \quad [A.22]$$

Using the multiple presence factor as 1.00 corresponding to 2 lanes and a skewness of 0°, load distribution factors for multiple and single lanes, for moments and shears, for a typical interior beams are as follows:

- *Load distribution factor for single lane loaded:*

$$mg_{Mp}^{SI} = 0.06 + \left( \frac{S}{14} \right)^{0.4} \left( \frac{S}{L} \right)^{0.3} \left( \frac{K_g}{12Lt_s^3} \right)^{0.1} \quad [A.23]$$

$$mg_{Mp}^{SI} = 0.06 + \left( \frac{9.5ft}{14} \right)^{0.4} \left( \frac{9.5ft}{110} \right)^{0.3} \left( \frac{2.97 \times 10^6 in^4}{12(110)(7.5in)^3} \right)^{0.1} = 0.55$$

$$\begin{aligned} mg_M^{SI} &= r m_{Mp}^{SI} \\ mg_M^{SI} &= 1.0(0.55) = 0.55 \end{aligned} \quad [A.24]$$

- *Load distribution factor for multiple lanes loaded:*

$$mg_{Mp}^{MI} = 0.075 + \left( \frac{S}{9.5} \right)^{0.6} \left( \frac{S}{L} \right)^{0.2} \left( \frac{K_g}{12Lt_s^3} \right)^{0.1} \quad [A.25]$$

$$mg_{Mp}^{MI} = 0.075 + \left( \frac{9.5ft}{9.5} \right)^{0.6} \left( \frac{9.5ft}{110} \right)^{0.2} \left( \frac{2.97 \times 10^6 in^4}{12(110)(7.5in)^3} \right)^{0.1} = 0.80$$

$$\begin{aligned} mg_M^{MI} &= r m_{Mp}^{MI} \\ mg_M^{MI} &= 1.0(0.80) = 0.80 \end{aligned} \quad [A.26]$$

- *Load distribution factor for single lane loaded:*

$$mg_{Vp}^{SI} = 0.36 + \frac{S}{25} \quad [A.27]$$

$$mg_{Vp}^{SI} = 0.36 + \frac{9.5ft}{25} = 0.74$$

$$\begin{aligned} mg_V^{SI} &= r m_{Vp}^{SI} \\ mg_V^{SI} &= 1.0(0.74) = 0.74 \end{aligned} \quad [A.28]$$

- *Load distribution factor for single lane loaded:*

$$mg_{Vp}^{SI} = 0.20 + \frac{S}{12} - \left( \frac{S}{35} \right)^{2.0} \quad [A.29]$$

$$mg_{Vp}^{SI} = 0.20 + \frac{9.5ft}{12} - \left( \frac{9.5ft}{35} \right)^{2.0} = 0.92$$

$$\begin{aligned} mg_V^{SI} &= r m_{Vp}^{SI} \\ mg_V^{SI} &= 1.0(0.92) = 0.92 \end{aligned} \quad [A.30]$$

Load distribution factor for external beams differ from the values presented before and can be computed using the same table from the specifications. Additionally, these values were contrasted with the results obtained from the 3D model. As it can be seen, values from the model agree with the ones computed using the tables from the specifications. In summary, the values of the load distribution factor for interior beams from the model are (see Figures A.7 to A.10):

- *Load distribution factor for single lane loaded: 0.546*
- *Load distribution factor for multiple lanes loaded: 0.78*
- *Load distribution factor for single lane loaded: 0.741*
- *Load distribution factor for single lane loaded: 0.930*

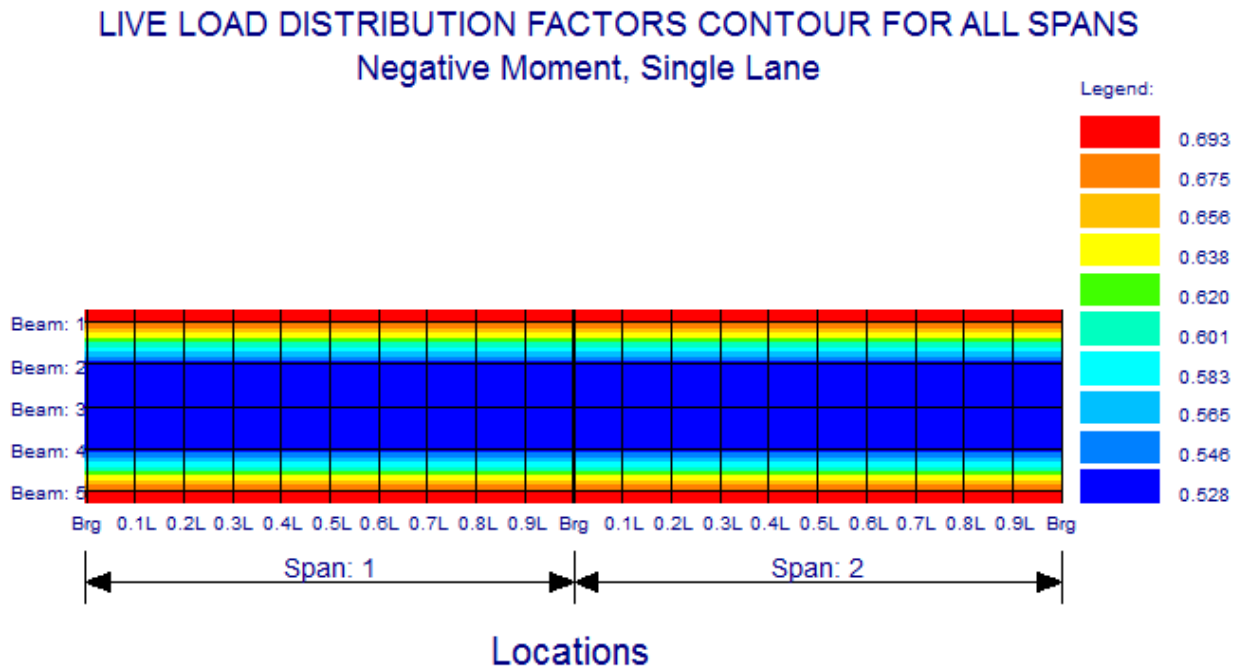

**Figure A.7 Load distribution factors for moments—single lanes loaded 3D model**



LIVE LOAD DISTRIBUTION FACTORS CONTOUR FOR ALL SPANS  
Negative Moment, Multi Lane

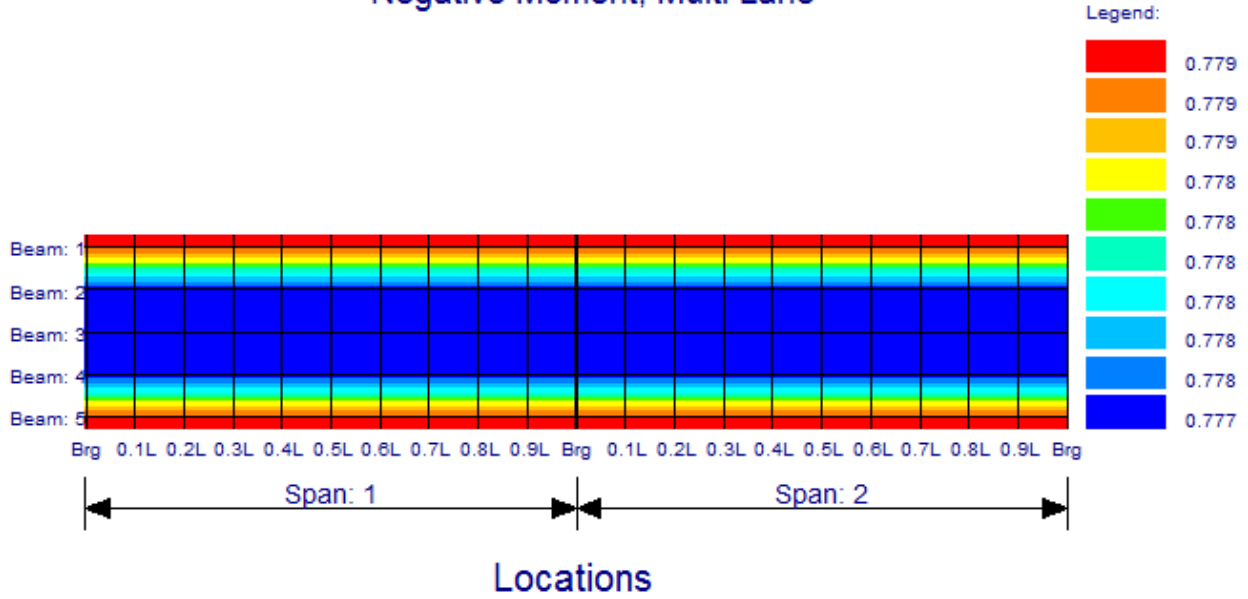

Figure A.8 Load distribution factors for moments—multiple lane loaded 3D model

LIVE LOAD DISTRIBUTION FACTORS CONTOUR FOR ALL SPANS  
Shear, Single Lane

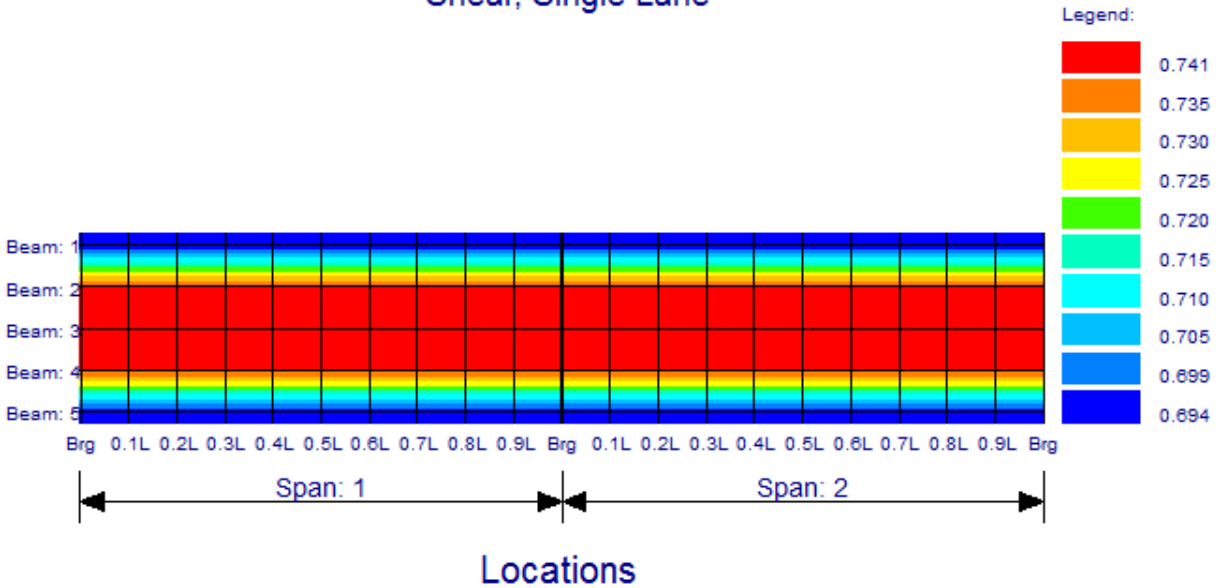
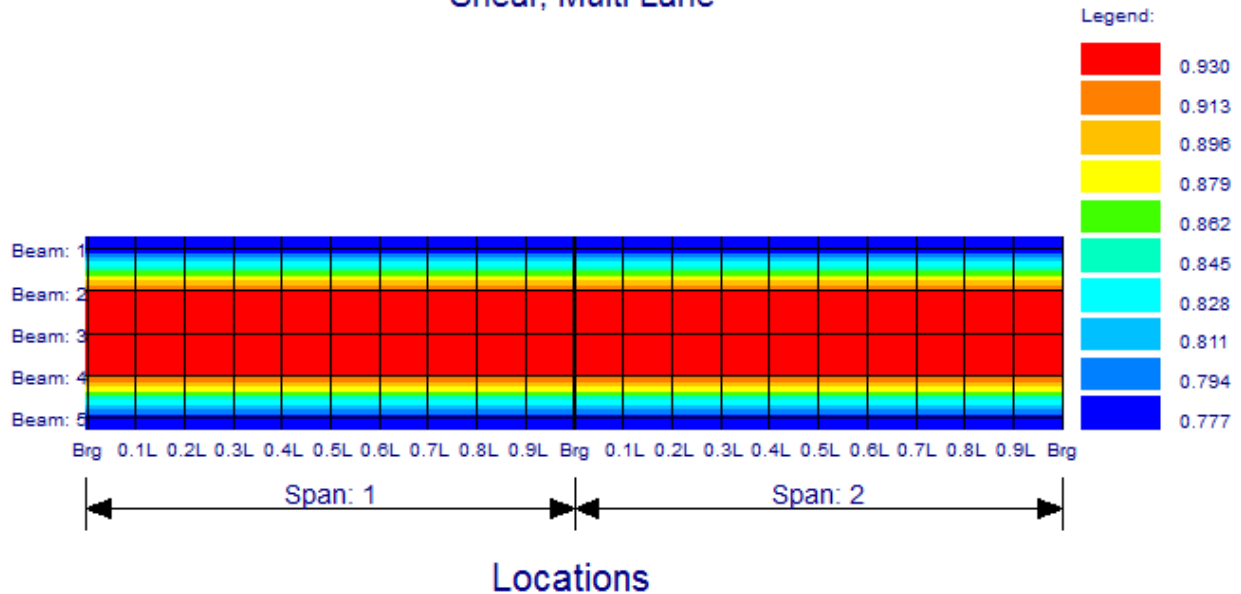

Figure A.9 Load distribution factors for shears—single lane loaded 3D model

## LIVE LOAD DISTRIBUTION FACTORS CONTOUR FOR ALL SPANS Shear, Multi Lane



**Figure A.10 Load distribution factors for shears—multiple lanes loaded 3D model**

Once the load distribution factors were calculated, the live load is needed. This is composed by the following according to the AASHTO LFRD Specifications:

- i. Design Truck (see Figure A.11) or Design Tandem (pair of 25kips axles spaced 4 ft apart)

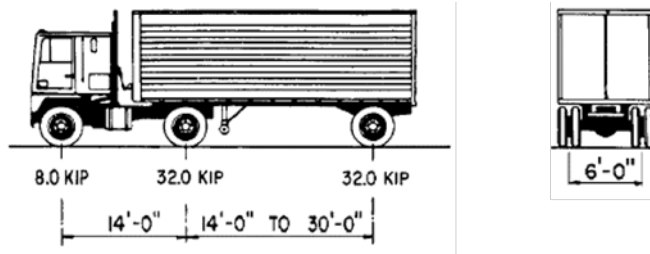

**Figure A.11 Design truck AASHTO LFRD (AASHTO, 2015)**

- ii. Design lane load (The design lane load shall consist of a load of 0.64klf uniformly distributed in the longitudinal direction. Transversely, the design lane load shall be assumed to be uniformly distributed over a 10.0 ft width.)

The extreme force effect shall be taken as the larger of the following:

- i. The effect of the design tandem combined with the effect of the design lane load, or

- ii. The effect of one design truck with the variable axle spacing specified in Article 3.6.1.2.2, combined with the effect of the design lane load, or
- iii. For negative moment between points of contra-flexure under a uniform load on all spans, and reaction at interior piers only, 90 percent of the effect of two design trucks spaced a minimum of 50.0 ft between the lead axle of one truck and the rear axle of the other truck, combined with 90 percent of the effect of the design lane load. The distance between the 32.0kip axles of each truck shall be taken as 14.0 ft.

Dynamic load allowance is taken as 33% for Service and Strength limit states and 15% for fatigue and fracture limit state according to the LFRD table 3.6.2.1-1. Load effects are discretized by type and if it is acting on the composite and non-composite section. Live loads were computed using a simple beam element model in SAP2000® using the section properties described before and the loads summarized in previous sections. Load effect results for dead and live loads are presented from Tables A.2 to A.5.

Load combinations correspond to the ones in Table 3.4.1-1 of the AASHTO LRFD Specifications. Combinations used are Service I and III, Strength I, III and V, and Fatigue and Fracture. Shear and moments resulting from the combinations used are presented in Tables A 6 and A 8. Finally a summary of the design moments and shears is shown in Table A.9. In contrast, the 3D model produced a maximum positive moment of 7,752kip ft, minimum negative moment of -4,080kip ft and maximum shear of 393kips. Compared with the values obtained from the spreadsheet, these values are a maximum of 4% lower only for moment. This may be explained due to the difference in load distribution factors for moments and the automatic computation of the dead self-weight of the elements that differs from the actual values for simplification.

**Table A.2 Non-composite section dead load effects—two spans 110 ft**

<b>SPAN 1</b>												
<b>UNFACTORED SHEARS (Kips)</b>												
<b>LOAD COMPONENT</b>	<b>LOCATION</b>											
	<b>0.0L</b>	<b>0.1L</b>	<b>0.2L</b>	<b>0.3L</b>	<b>0.4L</b>	<b>0.5L</b>	<b>0.6L</b>	<b>0.7L</b>	<b>0.8L</b>	<b>0.9L</b>	<b>1.0L</b>	
<i>Steel Beam self-weight</i>	67.21	53.95	40.69	27.43	14.18	0.92	-12.34	-25.60	-38.86	-52.12	-65.38	
<i>Concrete Deck</i>	52.25	41.94	31.64	21.33	11.02	0.71	-9.59	-19.90	-30.21	-40.52	-50.83	
<i>Concrete Haunch</i>	1.75	1.40	1.06	0.71	0.37	0.02	-0.32	-0.67	-1.01	-1.36	-1.70	
<i>Stay-in-Place Forms</i>	0.83	0.66	0.50	0.34	0.17	0.01	-0.15	-0.31	-0.48	-0.64	-0.80	
<i>Miscellaneous</i>	0.00	0.00	0.00	0.00	0.00	0.00	0.00	0.00	0.00	0.00	0.00	
<b>Total DC</b>	<b>122.03</b>	<b>97.96</b>	<b>73.89</b>	<b>49.81</b>	<b>25.74</b>	<b>1.66</b>	<b>-22.41</b>	<b>-46.48</b>	<b>-70.56</b>	<b>-94.63</b>	<b>-118.70</b>	
<b>Construction Live Load</b>	<b>10.31</b>	<b>8.25</b>	<b>6.18</b>	<b>4.12</b>	<b>2.06</b>	<b>0.00</b>	<b>-2.06</b>	<b>-4.12</b>	<b>-6.18</b>	<b>-8.25</b>	<b>-10.31</b>	
<b>UNFACTORED MOMENTS (Kips-ft)</b>												
<b>LOAD COMPONENT</b>	<b>LOCATION</b>											
	<b>0.0L</b>	<b>0.1L</b>	<b>0.2L</b>	<b>0.3L</b>	<b>0.4L</b>	<b>0.5L</b>	<b>0.6L</b>	<b>0.7L</b>	<b>0.8L</b>	<b>0.9L</b>	<b>1.0L</b>	
<i>Steel Beam self-weight</i>	0.00	647.36	1150.86	1510.50	1726.28	1798.21	1726.28	1510.50	1150.86	647.36	0.00	
<i>Concrete Deck</i>	0.00	503.26	894.69	1174.28	1342.04	1397.95	1342.04	1174.28	894.69	503.26	0.00	
<i>Concrete Haunch</i>	0.00	16.83	29.92	39.27	44.88	46.75	44.88	39.27	29.92	16.83	0.00	
<i>Stay-in-Place Forms</i>	0.00	7.95	14.13	18.54	21.19	22.07	21.19	18.54	14.13	7.95	0.00	
<i>Miscellaneous</i>	0.00	0.00	0.00	0.00	0.00	0.00	0.00	0.00	0.00	0.00	0.00	
<b>Total DC</b>	<b>0.00</b>	<b>1175.40</b>	<b>2089.59</b>	<b>2742.59</b>	<b>3134.39</b>	<b>3264.99</b>	<b>3134.39</b>	<b>2742.59</b>	<b>2089.59</b>	<b>1175.40</b>	<b>0.00</b>	
<b>Construction Live Load</b>	<b>0.00</b>	<b>100.65</b>	<b>178.94</b>	<b>234.86</b>	<b>268.41</b>	<b>279.59</b>	<b>268.41</b>	<b>234.86</b>	<b>178.94</b>	<b>100.65</b>	<b>0.00</b>	

<b>SPAN 2</b>												
<b>UNFACTORED SHEARS (Kips)</b>												
<b>LOAD COMPONENT</b>	<b>LOCATION</b>											
	<b>0.0L</b>	<b>0.1L</b>	<b>0.2L</b>	<b>0.3L</b>	<b>0.4L</b>	<b>0.5L</b>	<b>0.6L</b>	<b>0.7L</b>	<b>0.8L</b>	<b>0.9L</b>	<b>1.0L</b>	
<i>Steel Beam self-weight</i>	66.29	53.03	39.78	26.52	13.26	0.00	-13.26	-26.52	-39.78	-53.03	-66.29	
<i>Concrete Deck</i>	51.54	41.23	30.92	20.62	10.31	0.00	-10.31	-20.62	-30.92	-41.23	-51.54	
<i>Concrete Haunch</i>	1.72	1.38	1.03	0.69	0.34	0.00	-0.34	-0.69	-1.03	-1.38	-1.72	
<i>Stay-in-Place Forms</i>	0.81	0.65	0.49	0.33	0.16	0.00	-0.16	-0.33	-0.49	-0.65	-0.81	
<i>Miscellaneous</i>	0.00	0.00	0.00	0.00	0.00	0.00	0.00	0.00	0.00	0.00	0.00	
<b>Total DC</b>	<b>120.37</b>	<b>96.29</b>	<b>72.22</b>	<b>48.15</b>	<b>24.07</b>	<b>0.00</b>	<b>-24.07</b>	<b>-48.15</b>	<b>-72.22</b>	<b>-96.29</b>	<b>-120.37</b>	
<b>Construction Live Load</b>	<b>10.31</b>	<b>8.36</b>	<b>6.27</b>	<b>4.18</b>	<b>2.09</b>	<b>0.00</b>	<b>-2.09</b>	<b>-4.18</b>	<b>-6.27</b>	<b>-8.36</b>	<b>-10.45</b>	
<b>UNFACTORED MOMENTS (Kips-ft)</b>												
<b>LOAD COMPONENT</b>	<b>LOCATION</b>											
	<b>0.0L</b>	<b>0.1L</b>	<b>0.2L</b>	<b>0.3L</b>	<b>0.4L</b>	<b>0.5L</b>	<b>0.6L</b>	<b>0.7L</b>	<b>0.8L</b>	<b>0.9L</b>	<b>1.0L</b>	
<i>Steel Beam self-weight</i>	0.00	647.36	1150.86	1510.50	1726.28	1798.21	1726.28	1510.50	1150.86	647.36	0.00	
<i>Concrete Deck</i>	0.00	503.26	894.69	1174.28	1342.04	1397.95	1342.04	1174.28	894.69	503.26	0.00	
<i>Concrete Haunch</i>	0.00	16.83	29.92	39.27	44.88	46.75	44.88	39.27	29.92	16.83	0.00	
<i>Stay-in-Place Forms</i>	0.00	7.95	14.13	18.54	21.19	22.07	21.19	18.54	14.13	7.95	0.00	
<i>Miscellaneous</i>	0.00	0.00	0.00	0.00	0.00	0.00	0.00	0.00	0.00	0.00	0.00	
<b>Total DC</b>	<b>0.00</b>	<b>1175.40</b>	<b>2089.59</b>	<b>2742.59</b>	<b>3134.39</b>	<b>3264.99</b>	<b>3134.39</b>	<b>2742.59</b>	<b>2089.59</b>	<b>1175.40</b>	<b>0.00</b>	
<b>Construction Live Load</b>	<b>0.00</b>	<b>100.65</b>	<b>178.94</b>	<b>234.86</b>	<b>268.41</b>	<b>279.59</b>	<b>268.41</b>	<b>234.86</b>	<b>178.94</b>	<b>100.65</b>	<b>0.00</b>	

Table A.3 Composite section load effects—span 1, span 110 ft

SPAN 1												
UNFACTORED SHEARS (Kips)												
LOAD COMPONENT	LOCATION											
	0.0L	0.1L	0.2L	0.3L	0.4L	0.5L	0.6L	0.7L	0.8L	0.9L	1.0L	
DC (Barriers)	-4.98	-3.66	-2.34	-1.02	0.30	1.62	2.94	4.26	5.58	6.90	8.22	
DW (Future Wearing Sur)	-9.13	-6.71	-4.29	-1.87	0.55	2.97	5.39	7.81	10.23	12.65	15.07	
Lane	-26.55	-19.51	-12.47	-5.43	1.61	8.65	15.69	22.73	29.77	36.81	43.85	
Lane Max	-30.88	-23.84	-16.80	-9.76	-2.72	4.32	11.36	18.40	25.44	32.48	39.52	
Lane Min	4.32	4.32	4.32	4.32	4.32	4.32	4.32	4.32	4.32	4.32	4.32	
Truck max	6.56	6.84	10.83	19.01	27.55	35.75	43.51	50.74	57.32	63.15	68.13	
Truck min	-64.44	-55.63	-47.02	-38.71	-30.80	-23.41	-16.64	-10.58	-5.56	-1.97	0.00	
Tandem max	4.70	5.24	11.23	17.25	23.05	28.58	33.75	38.50	42.75	46.43	49.48	
Tandem min	-48.87	-42.67	-36.56	-30.62	-24.91	-19.50	-14.48	-9.90	-5.85	-2.39	0.00	
90% 2 Trucks max	5.98	6.23	9.82	17.49	26.21	35.15	43.68	51.17	57.43	66.17	77.72	
90% 2 Trucks min	-67.01	-54.71	-43.87	-35.05	-27.72	-21.07	-14.98	-9.53	-5.00	-1.77	0.00	
90% Lane	-23.90	-17.56	-11.23	-4.89	1.45	7.78	14.12	20.45	26.79	33.13	39.46	
LL + IM (Positive Moment)	11.97	12.31	17.68	27.18	37.60	51.58	67.53	82.81	97.31	110.89	123.43	
LL - IM (Negative Moment)	-107.32	-89.80	-72.82	-56.21	-40.10	-24.62	-16.35	-8.95	-3.17	1.05	3.57	
LL + IM	107.32	89.80	72.82	56.21	40.10	24.62	16.35	8.95	3.17	1.05	3.57	
UNFACTORED MOMENTS (Kips-ft)												
LOAD COMPONENT	LOCATION											
	0.0L	0.1L	0.2L	0.3L	0.4L	0.5L	0.6L	0.7L	0.8L	0.9L	1.0L	
DC (Barriers)	0.00	47.51	80.50	98.96	102.91	92.34	67.25	27.64	-26.49	-95.15	-178.32	
DW (Future Wearing Sur)	0.00	87.10	147.58	181.44	188.67	169.29	123.29	50.67	-48.57	-174.43	-326.91	
Lane	0.00	253.38	429.32	527.81	548.87	492.49	358.66	147.40	-141.30	-507.44	-951.03	
Lane Max	0.00	300.93	524.42	670.47	739.08	730.24	643.97	480.26	239.11	-79.48	-475.51	
Lane Min	0.00	-47.55	-95.10	-142.65	-190.21	-237.76	-285.31	-332.86	-380.41	-427.96	-475.51	
Truck max	0.27	604.90	1022.17	1268.71	1370.94	1346.25	1210.21	956.41	611.07	218.09	0.14	
Truck min	0.00	-72.10	-144.20	-216.30	-288.41	-360.51	-432.61	-504.71	-576.81	-648.91	-721.01	
Tandem max	0.21	464.39	795.66	999.27	1083.75	1066.57	961.71	777.00	532.08	250.13	0.11	
Tandem min	0.00	-51.64	-103.28	-154.92	-206.56	-258.20	-309.84	-361.48	-413.12	-464.76	-516.40	
90% 2 Trucks max	0.24	592.68	954.35	1160.43	1239.25	1211.63	1094.59	875.28	553.33	196.28	0.12	
90% 2 Trucks min	0.00	-197.20	-394.40	-591.60	-788.80	-986.00	-1183.20	-1380.40	-1577.60	-1774.80	-1972.00	
90% Lane	0.00	-65.73	-131.47	-197.20	-262.93	-328.66	-394.40	-460.13	-525.86	-591.60	-657.33	
Truck max	0.00	228.04	386.38	475.03	493.98	443.24	322.80	132.66	-127.17	-456.70	-855.92	
Truck min	0.00	-197.20	-394.40	-591.60	-788.80	-986.00	-1183.20	-1380.40	-1577.60	-1774.80	-1972.00	
LL + IM (Positive Moment)	0.28	883.66	1505.93	1884.79	2048.32	2015.01	1801.42	1400.72	840.80	202.39	-379.96	
LL - IM (Negative Moment)	0.00	-114.67	-229.33	-344.00	-458.66	-573.33	-688.00	-802.66	-917.33	-1136.10	-2025.39	

Table A.4 Composite section load effects—span 2, span 110 ft

SPAN 2												
UNFACTORED SHEARS (Kips)												
LOAD COMPONENT	LOCATION											
	0.0L	0.1L	0.2L	0.3L	0.4L	0.5L	0.6L	0.7L	0.8L	0.9L	1.0L	
DC (Barriers)	-8.22	-6.90	-5.58	-4.26	-2.94	-1.62	-0.30	1.02	2.34	3.66	4.98	
DW (Future Wearing Sur)	-15.07	-12.65	-10.23	-7.81	-5.39	-2.97	-0.55	1.87	4.29	6.71	9.13	
Lane	-43.85	-36.81	-29.77	-22.73	-15.69	-8.65	-1.61	5.43	12.47	19.51	26.55	
Lane Max	-4.32	-4.32	-4.32	-4.32	-4.32	-4.32	-4.32	-4.32	-4.32	-4.32	-4.32	
Lane Min	-39.52	-32.48	-25.44	-18.40	-11.36	-4.32	2.72	9.76	16.80	23.84	30.88	
Truck max	0.00	1.97	5.56	10.58	16.64	23.41	30.80	38.71	47.02	55.63	64.44	
Truck min	-68.13	-63.15	-57.32	-50.74	-43.51	-35.75	-27.55	-19.01	-10.83	-6.84	-6.56	
Tandem max	0.00	2.39	5.85	9.90	14.48	19.50	24.91	30.62	36.56	42.67	48.87	
Tandem min	-49.48	-46.43	-42.75	-38.50	-33.75	-28.58	-23.05	-17.25	-11.23	-5.24	-4.70	
90% 2 Trucks max	0.00	1.77	5.00	9.53	14.98	21.07	27.72	35.05	43.87	54.71	67.01	
90% 2 Trucks min	-77.72	-66.17	-57.43	-51.17	-43.68	-35.15	-26.21	-17.49	-9.82	-6.23	-5.98	
90% Lane	-39.46	-33.13	-26.79	-20.45	-14.12	-7.78	-1.45	4.89	11.23	17.56	23.90	
LL + IM (Positive Moment)	-3.97	-1.05	3.17	8.95	16.35	24.62	40.10	56.21	72.82	89.80	107.02	
LL - IM (Negative Moment)	-131.12	-111.19	-97.31	-82.81	-67.53	-51.58	-37.60	-27.18	-17.68	-12.31	-11.97	
LL + IM	131.12	111.19	97.31	82.81	67.53	51.58	40.10	56.21	72.82	89.80	107.02	
UNFACTORED MOMENTS (Kips-ft)												
LOAD COMPONENT	LOCATION											
	0.0L	0.1L	0.2L	0.3L	0.4L	0.5L	0.6L	0.7L	0.8L	0.9L	1.0L	
DC (Barriers)	-178.32	-95.15	-26.49	27.64	67.25	92.34	102.91	98.96	80.50	47.51	0.00	
DW (Future Wearing Sur)	-326.91	-174.43	-48.57	50.67	123.29	169.29	188.67	181.44	147.58	87.10	0.00	
Lane	-951.03	-507.44	-141.30	147.40	358.66	492.49	548.87	527.81	429.32	253.38	0.00	
Lane Max	-475.51	-427.96	-380.41	-332.86	-285.31	-237.76	-190.21	-142.65	-95.10	-47.55	0.00	
Lane Min	-475.51	-79.48	239.11	480.26	643.97	730.24	739.08	670.47	524.42	300.93	0.00	
Truck max	0.14	218.09	611.07	956.41	1210.21	1346.25	1370.94	1268.71	1022.17	604.90	0.27	
Truck min	-721.01	-648.91	-576.81	-504.71	-432.61	-360.51	-288.41	-216.30	-144.20	-72.10	0.00	
Tandem max	0.11	250.13	532.08	777.00	961.71	1066.57	1083.75	999.27	795.66	464.39	0.21	
Tandem min	-516.40	-464.76	-413.12	-361.48	-309.84	-258.20	-206.56	-154.92	-103.28	-51.64	0.00	
90% 2 Trucks max	0.12	196.28	553.33	875.28	1094.59	1211.63	1239.25	1160.43	954.35	592.68	0.24	
90% 2 Trucks min	-1261.52	-725.23	-525.86	-460.13	-394.40	-328.66	-262.93	-197.20	-131.47	-65.73	0.00	
90% Lane	-855.92	-456.70	-127.17	132.66	322.80	443.24	493.98	475.03	386.38	228.04	0.00	
LL + IM (Positive Moment)	-379.96	202.39	840.80	1400.72	1801.42	2015.01	2048.32	1884.79	1505.93	883.66	0.28	
LL - IM (Negative Moment)	-2025.39	-1136.10	-917.33	-802.66	-688.00	-573.33	-458.66	-344.00	-229.33	-114.67	0.00	

**Table A.5 Live load effects Fatigue and Fracture—two spans 110 ft**

<b>SPAN 1</b>												
UNFACTORED SHEARS (Kips)												
LOAD COMPONENT	LOCATION											
	0.0L	0.1L	0.2L	0.3L	0.4L	0.5L	0.6L	0.7L	0.8L	0.9L	1.0L	
<i>LL + IM</i>	39.74	34.31	28.99	23.87	19.00	22.05	26.83	31.29	35.35	38.94	42.01	
UNFACTORED MOMENTS (Kips-ft)												
LOAD COMPONENT	LOCATION											
	0.0L	0.1L	0.2L	0.3L	0.4L	0.5L	0.6L	0.7L	0.8L	0.9L	1.0L	
<i>Truck max</i>	0.16	365.75	618.05	767.12	828.93	814.01	731.75	578.29	369.48	131.87	0.08	
<i>Truck min</i>	0.00	-43.60	-87.19	-130.79	-174.38	-217.98	-261.57	-305.17	-348.77	-392.36	-435.96	
<i>LL + IM</i>	0.16	409.35	705.24	897.91	1003.32	1031.99	993.32	883.46	718.25	524.23	436.04	
<b>SPAN 2</b>												
UNFACTORED SHEARS (Kips)												
LOAD COMPONENT	LOCATION											
	0.0L	0.1L	0.2L	0.3L	0.4L	0.5L	0.6L	0.7L	0.8L	0.9L	1.0L	
<i>LL + IM</i>	42.01	38.94	35.35	31.29	26.83	22.05	19.00	23.87	28.99	34.31	39.74	
UNFACTORED MOMENTS (Kips-ft)												
LOAD COMPONENT	LOCATION											
	0.0L	0.1L	0.2L	0.3L	0.4L	0.5L	0.6L	0.7L	0.8L	0.9L	1.0L	
<i>Truck max</i>	0.08	131.87	369.48	578.29	731.75	814.01	828.93	767.12	618.05	365.75	0.16	
<i>Truck min</i>	-435.96	-392.36	-348.77	-305.17	-261.57	-217.98	-174.38	-130.79	-87.19	-43.60	0.00	
<i>LL + IM</i>	436.04	524.23	718.25	883.46	993.32	1031.99	1003.32	897.91	705.24	409.35	0.16	

Table A.6 Service limit state combinations results

<b>SERVICE I</b>												
<b>SPAN 1</b>												
COMBINED LOADS - MOMENTS (Kips-ft)												
LOAD COMBINATION	LOCATION											
	0.0L	0.1L	0.2L	0.3L	0.4L	0.5L	0.6L	0.7L	0.8L	0.9L	1.0L	
Max DL NonComposite	0.00	1175.40	2089.59	2742.59	3134.39	3264.99	3134.39	2742.59	2089.59	1175.40	0.00	
Max DL Composite	0.00	134.61	228.07	280.40	291.59	261.63	190.54	78.31	-75.07	-269.58	-505.23	
Max LL Composite	0.28	883.66	1505.93	1884.79	2048.32	2015.01	1801.42	1400.72	840.80	202.39	-379.96	
Min LL Composite	0.00	-114.67	-229.33	-344.00	-458.66	-573.33	-688.00	-802.66	-917.33	-1136.10	-2025.39	
<b>Service I Max TOTAL</b>	0.28	2193.66	3823.60	4907.78	5474.30	5541.64	5126.35	4221.62	2855.32	1108.21	-885.20	
<b>Service I Min TOTAL</b>	0.00	1195.34	2088.34	2678.99	2967.31	2953.29	2636.94	2018.24	1097.20	-230.28	-2530.62	
<b>SPAN 2</b>												
COMBINED LOADS - MOMENTS (Kips-ft)												
LOAD COMBINATION	LOCATION											
	0.0L	0.1L	0.2L	0.3L	0.4L	0.5L	0.6L	0.7L	0.8L	0.9L	1.0L	
Max DL NonComposite	0.00	1175.40	2089.59	2742.59	3134.39	3264.99	3134.39	2742.59	2089.59	1175.40	0.00	
Max DL Composite	-505.23	-269.58	-75.07	78.31	190.54	261.63	291.59	280.40	228.07	134.61	0.00	
Max LL Composite	-379.96	202.39	840.80	1400.72	1801.42	2015.01	2048.32	1884.79	1505.93	883.66	0.28	
Min LL Composite	-2025.39	-1136.10	-917.33	-802.66	-688.00	-573.33	-458.66	-344.00	-229.33	-114.67	0.00	
<b>Service I Max TOTAL</b>	-885.20	1108.21	2855.32	4221.62	5126.35	5541.64	5474.30	4907.78	3823.60	2193.66	0.28	
<b>Service I Min TOTAL</b>	-2530.62	-230.28	1097.20	2018.24	2636.94	2953.29	2967.31	2678.99	2088.34	1195.34	0.00	
<b>SERVICE III</b>												
<b>SPAN 1</b>												
COMBINED LOADS - MOMENTS (Kips-ft)												
LOAD COMBINATION	LOCATION											
	0.0L	0.1L	0.2L	0.3L	0.4L	0.5L	0.6L	0.7L	0.8L	0.9L	1.0L	
Max DL NonComposite	0.00	1175.40	2089.59	2742.59	3134.39	3264.99	3134.39	2742.59	2089.59	1175.40	0.00	
Max DL Composite	0.00	134.61	228.07	280.40	291.59	261.63	190.54	78.31	-75.07	-269.58	-505.23	
Max LL Composite	0.23	706.93	1204.74	1507.83	1638.66	1612.01	1441.13	1120.57	672.64	161.91	-303.97	
Min LL Composite	0.00	-91.73	-183.47	-275.20	-366.93	-458.66	-550.40	-642.13	-733.86	-908.88	-1620.31	
<b>Service III Max TOTAL</b>	0.23	2016.93	3522.41	4530.82	5064.63	5138.63	4766.06	3941.47	2687.17	1067.73	-809.20	
<b>Service III Min TOTAL</b>	0.00	1218.27	2134.20	2747.79	3059.05	3067.96	2774.53	2178.77	1280.67	-3.06	-2125.54	
<b>SPAN 2</b>												
COMBINED LOADS - MOMENTS (Kips-ft)												
LOAD COMBINATION	LOCATION											
	0.0L	0.1L	0.2L	0.3L	0.4L	0.5L	0.6L	0.7L	0.8L	0.9L	1.0L	
Max DL NonComposite	0.00	1175.40	2089.59	2742.59	3134.39	3264.99	3134.39	2742.59	2089.59	1175.40	0.00	
Max DL Composite	-505.23	-269.58	-75.07	78.31	190.54	261.63	291.59	280.40	228.07	134.61	0.00	
Max LL Composite	-303.97	161.91	672.64	1120.57	1441.13	1612.01	1638.66	1507.83	1204.74	706.93	0.23	
Min LL Composite	-1620.31	-908.88	-733.86	-642.13	-550.40	-458.66	-366.93	-275.20	-183.47	-91.73	0.00	
<b>Service III Max TOTAL</b>	-809.20	1067.73	2687.17	3941.47	4766.06	5138.63	5064.63	4530.82	3522.41	2016.93	0.23	
<b>Service III Min TOTAL</b>	-2125.54	-3.06	1280.67	2178.77	2774.53	3067.96	3059.05	2747.79	2134.20	1218.27	0.00	



Table A.7 Strength limit state combinations results

STRENGTH												
SPAN 1												
COMBINED LOADS - SHEARS (Kips)												
LOAD COMBINATION	LOCATION											
	0.0L	0.1L	0.2L	0.3L	0.4L	0.5L	0.6L	0.7L	0.8L	0.9L	1.0L	
Strength I Max +M	360.26	294.24	229.15	164.71	103.56	98.84	157.95	220.07	280.81	339.95	397.26	
Strength I Min -M	308.05	252.97	198.83	145.34	93.98	95.16	144.49	195.66	245.46	293.66	340.03	
Strength III Max +M	172.46	137.08	101.71	66.34	33.38	8.56	39.78	75.15	110.52	145.89	181.26	
Strength III Min +M	120.24	95.82	71.39	46.96	23.79	4.89	26.32	50.75	75.17	99.60	124.03	
Strength V Max +M	317.34	258.32	200.02	142.23	87.52	78.20	130.94	186.94	241.88	295.59	347.89	
Strength V Min +M	265.12	217.05	169.70	122.85	77.93	74.53	117.48	162.54	206.54	249.30	290.66	
COMBINED LOADS - MOMENTS (Kips-ft)												
LOAD COMBINATION	LOCATION											
	0.0L	0.1L	0.2L	0.3L	0.4L	0.5L	0.6L	0.7L	0.8L	0.9L	1.0L	
Strength I Max +M	0.50	3205.68	5569.36	7122.48	7914.20	7976.87	7339.47	5990.04	3977.41	1442.84	-1378.21	
Strength I Min +M	0.50	2703.63	4684.38	5973.72	6620.77	6657.91	6114.09	4977.39	3296.61	1213.02	-1037.92	
Strength I Max -M	0.00	1458.61	2532.65	3222.10	3526.98	3447.28	2982.99	2134.13	900.69	-899.51	-4257.70	
Strength I Min -M	0.00	956.56	1647.68	2073.34	2233.55	2128.31	1757.62	1121.48	219.89	-1129.33	-3917.41	
Strength III Max +M	0.00	1659.28	2933.98	3824.10	4329.64	4450.60	4186.99	3538.79	2506.02	1088.66	-713.27	
Strength III Min +M	0.00	1157.23	2049.01	2675.33	3036.21	3131.64	2961.62	2526.14	1825.22	858.84	-372.98	
Strength V Max +M	0.38	2852.22	4966.98	6368.56	7094.87	7170.87	6618.90	5429.76	3641.09	1361.89	-1226.22	
Strength V Min +M	0.38	2350.17	4082.01	5219.80	5801.44	5851.91	5393.53	4417.11	2960.29	1132.07	-885.93	
Strength V Max -M	0.00	1504.48	2624.38	3359.70	3710.44	3676.61	3258.19	2455.20	1267.62	-445.07	-3447.55	
Strength V Min -M	0.00	1002.43	1739.41	2210.94	2417.02	2357.64	2032.82	1442.55	586.83	-674.89	-3107.26	

SPAN 2												
COMBINED LOADS - SHEARS (Kips)												
LOAD COMBINATION	LOCATION											
	0.0L	0.1L	0.2L	0.3L	0.4L	0.5L	0.6L	0.7L	0.8L	0.9L	1.0L	
Strength I Max +M	412.80	342.56	282.89	222.15	160.03	96.76	101.48	162.63	227.07	292.16	357.66	
Strength I Min -M	354.98	295.69	246.96	197.16	145.99	93.66	92.48	143.84	197.33	251.48	306.03	
Strength III Max +M	183.34	147.97	112.60	77.23	41.86	6.48	31.30	64.26	99.63	135.00	170.38	
Strength III Min +M	125.53	101.10	76.67	52.25	27.82	3.39	22.30	45.46	69.89	94.32	118.75	
Strength V Max +M	360.35	298.08	243.96	189.02	133.02	76.12	85.44	140.15	197.94	256.24	314.86	
Strength V Min +M	302.54	251.21	208.04	164.04	118.98	73.03	76.44	121.35	168.20	215.55	263.23	
COMBINED LOADS - MOMENTS (Kips-ft)												
LOAD COMBINATION	LOCATION											
	0.0L	0.1L	0.2L	0.3L	0.4L	0.5L	0.6L	0.7L	0.8L	0.9L	1.0L	
Strength I Max +M	-1378.21	1442.84	3977.41	5990.04	7339.47	7976.87	7914.20	7122.48	5569.36	3205.68	0.50	
Strength I Min +M	-1037.92	1213.02	3296.61	4977.39	6114.09	6657.91	6620.77	5973.72	4684.38	2703.63	0.50	
Strength I Max -M	-4257.70	-899.51	900.69	2134.13	2982.99	3447.28	3526.98	3222.10	2532.65	1458.61	0.00	
Strength I Min -M	-3917.41	-1129.33	219.89	1121.48	1757.62	2128.31	2233.55	2073.34	1647.68	956.56	0.00	
Strength III Max +M	-713.27	1088.66	2506.02	3538.79	4186.99	4450.60	4329.64	3824.10	2933.98	1659.28	0.00	
Strength III Min +M	-372.98	858.84	1825.22	2526.14	2961.62	3131.64	3036.21	2675.33	2049.01	1157.23	0.00	
Strength V Max +M	-1226.22	1361.89	3641.09	5429.76	6618.90	7170.87	7094.87	6368.56	4966.98	2852.22	0.38	
Strength V Min +M	-885.93	1132.07	2960.29	4417.11	5393.53	5851.91	5801.44	5219.80	4082.01	2350.17	0.38	
Strength V Max -M	-3447.55	-445.07	1267.62	2455.20	3258.19	3676.61	3710.44	3359.70	2624.38	1504.48	0.00	
Strength V Min -M	-3107.26	-674.89	586.83	1442.55	2032.82	2357.64	2417.02	2210.94	1739.41	1002.43	0.00	

**Table A.8 Fatigue limit state combinations results**

<b>FATIGUE I</b>												
<b>SPAN 1</b>												
<b>COMBINED LOADS - MOMENTS (Kips-ft)</b>												
<b>LOAD COMBINATION</b>	<b>LOCATION</b>											
	<b>0.0L</b>	<b>0.1L</b>	<b>0.2L</b>	<b>0.3L</b>	<b>0.4L</b>	<b>0.5L</b>	<b>0.6L</b>	<b>0.7L</b>	<b>0.8L</b>	<b>0.9L</b>	<b>1.0L</b>	
<i>Fatigue / Max TOTAL</i>	0.24	548.63	927.08	1150.68	1243.40	1221.01	1097.62	867.43	554.22	197.80	0.12	
<i>Fatigue / Min TOTAL</i>	0.00	-65.39	-130.79	-196.18	-261.57	-326.97	-392.36	-457.76	-523.15	-588.54	-653.94	
<b>SPAN 2</b>												
<b>COMBINED LOADS - MOMENTS (Kips-ft)</b>												
<b>LOAD COMBINATION</b>	<b>LOCATION</b>											
	<b>0.0L</b>	<b>0.1L</b>	<b>0.2L</b>	<b>0.3L</b>	<b>0.4L</b>	<b>0.5L</b>	<b>0.6L</b>	<b>0.7L</b>	<b>0.8L</b>	<b>0.9L</b>	<b>1.0L</b>	
<i>Fatigue / Max TOTAL</i>	0.12	197.80	554.22	867.43	1097.62	1221.01	1243.40	1150.68	927.08	548.63	0.24	
<i>Fatigue / Min TOTAL</i>	-653.94	-588.54	-523.15	-457.76	-392.36	-326.97	-261.57	-196.18	-130.79	-65.39	0.00	

**Table A.9 Summary design shear and moments—strength limit state**

<b>SPAN 1</b>			
LOAD COMBINATION	SHEAR (kip)	POSITIVE MOMENT (kip-ft)	NEGATIVE MOMENT (kip-ft)
<b>Strength I</b>	397.26	7976.87	4257.70
<b>Strength III</b>	181.26	4450.60	1226.22
<b>Strength V</b>	347.89	7170.87	3447.55

<b>SPAN 2</b>			
LOAD COMBINATION	SHEAR (kip)	POSITIVE MOMENT (kip-ft)	NEGATIVE MOMENT (kip-ft)
<b>Strength I</b>	412.80	7976.87	4257.70
<b>Strength III</b>	183.34	4450.60	713.27
<b>Strength V</b>	360.35	7170.87	3447.55

Once the design actions are computed, prestress forces in the strands are needed. Loss of prestress (S5.9.5) can be characterized in two different groups, instantaneous losses and time dependent losses. Generally speaking, for pretensioned members total losses,  $\Delta f_{pT}$ , is the sum of losses due to elastic shortening,  $\Delta f_{pES}$ , and the time dependent losses due to shrinkage, creep of concrete and relaxation of the steel,  $\Delta f_{pLT}$ . The loss due to elastic shortening in pretensioned members can be determined using the formula presented in the commentary C5.9.5.2.3a as follows:

$$\Delta f_{pES} = \frac{A_{ps} f_{pbt} (I_g + e_m^2 A_g) - e_m M_g A_g}{A_{ps} (I_g + e_m^2 A_g) + \frac{A_g I_g E_{ci}}{E_{PS}}} \quad [A.31]$$

where:

$$A_{ps} = \text{area of prestressing steel (in}^2\text{)} = 43 \text{strands} \times 0.153 \text{in}^2 = 6.58 \text{in}^2$$

$$A_g = \text{gross area of section (in}^2\text{)} = 1,172.40 \text{in}^2$$

$$E_{ci} = \text{modulus of elasticity of concrete at transfer (ksi)} = 4,696 \text{ksi}$$

$$E_{PS} = \text{modulus of elasticity of prestressing tendons (ksi)} = 28,500 \text{ksi}$$

$$e_m = \text{average prestressing steel eccentricity at midspan (in.)} = 30.77 \text{in}$$

$$f_{pbt} = \text{stress in prestressing steel immediately prior to transfer (ksi)}$$

$$f_{pbt} = 0.75 f_{pu} = 202.5 \text{ksi}$$

$$I_g = \text{moment of inertia of the gross concrete section (in.}^4\text{)} = 729,521 \text{in}^4$$

$$M_g = \text{midspan moment due to member self-weight (kip-in.)} = 1,798.21 \text{kip} - \text{ft}$$

$$\Delta f_{pES} = \frac{(6.58)(202.5)((729,521) + (30.77)^2(1,172.40)) - (30.77)(1,798.21)(1,172.40)}{(6.58)((729,521) + ((30.77)^2)(1,172.40)) + \frac{(974.30)(729,521)(4,696)}{28,500}}$$

$$\Delta f_{pES} = 10.93 \text{ksi}$$

Then the prestressing stress and force at transfer are the following:

$$f_{pt} = f_{pbt} - \Delta f_{pES} \quad [A.32]$$

$$f_{pt} = 202.5 \text{ksi} - 10.93 \text{ksi} = 191.57 \text{ksi} \text{ (5.40\% effective loss)}$$

$$P_t = f_{pt} A_{ps} \quad [A.33]$$

$$P_t = 191.57 \text{ksi} (6.58 \text{in}^2) = 1,260.37 \text{kips}$$

The approximate estimate of time-dependent losses due to creep of concrete, shrinkage of concrete and relaxation of steel is computed according to formula S5.9.5.3-1, where  $f_{pi}$  is prestressing steel stress immediately prior to transfer (ksi),  $H$  is the average annual ambient relative humidity (%) taken as the 70% according to Figure S5.4.2.3.3-1,  $\gamma_h$  is the correction factor for relative humidity of the ambient air  $\gamma_h = 1.7 - 0.01H = 1.0$ ,  $\gamma_{st}$  is the correction factor for specified concrete strength at time of prestress transfer to the concrete member  $5/(1 + f'_{ci}) = 0.71$ , and  $\Delta f_{pR}$  is an estimate of relaxation loss taken as 2.4 ksi for low relaxation strand.

$$\Delta f_{pLT} = 10.0 \frac{f_{pi} A_{ps}}{A_g} \gamma_h \gamma_{st} + 12.0 \gamma_h \gamma_{st} + \Delta f_{pR} = 19.09 \text{ksi} \quad [A.34]$$

Then the final effective prestress stress and force are computed. It is important to remark that according to Table S5.9.3-1 stress limit for tendons after all losses is 80% of the prestressing steel yielding stress, which in this case is  $0.80(243 \text{ksi}) = 194.4 \text{ksi}$ . As it is shown, effective prestress stress for this example is below this limit.

$$f_{pe} = f_{pt} - \Delta f_{pLT} \quad [A.35]$$

$$f_{pe} = 191.57 \text{ksi} - 19.09 \text{ksi} = 172.49 \text{ksi} \text{ (14.82\% effective total loss)}$$

$$P_e = f_{pe} A_{ps} \quad [A.36]$$

$$P_e = 172.49 \text{ksi} (6.58 \text{in}^2) = 1,134 \text{kips}$$

Stress in prestressing strands at nominal flexural resistance is computed as described in S5.7.3.1. Since there are bonded and debonded tendons, the simplified analysis described in 5.7.3.1.3b is used. Variation from bonded strands only is that for debonded tendons the stress is conservatively taken as the effective stress,  $f_{pe}$ , and the total prestressing force must be taken as the sum of product between the bonded ( $A_{psb}$ ) and unbonded ( $A_{psu}$ ) areas and the ultimate stress of the tendons and the effective stress of the tendons, respectively. Additionally, as a result of the reinforcing steel, prestressing steel pattern and section properties, the composite section behavior is to be taken as rectangular since the value of distance between the neutral axis and the compressive face,  $c$ , is less than the slab structural thickness. Then the calculation of the prestressing strands at nominal flexural resistance is:

$$c = \frac{A_{psb} f_{pu} + A_{psu} f_{pe} + A_s f_s - A'_s f'_s}{0.85 f'_c \beta_1 b + k A_{ps} \frac{f_{pu}}{d_p}} = 2.93 \text{in} \quad [A.37]$$

$$k = 2 \left( 1.04 - \frac{f_{py}}{f_{pu}} \right) = 0.28 \quad [A.38]$$

$$f_{PS} = f_{pu} \left( 1 - k \frac{c}{d_p} \right) = 266.86 \text{ksi} \quad [A.39]$$

Prestressing force is assumed to vary linearly from 0.0 at the beam end, to a maximum value at the transfer length. Between transfer length and the development length this variation is parabolic, however, as a simplification, this change is often assumed to be linear. Transfer length is taken as 60 times the diameter of the strand, which in this case is 30 in. Pretension strands shall be bonded beyond the section required to develop  $f_{PS}$  for a development length,  $l_d$ , in inches, where  $l_d$  shall satisfy (S5.11.4.2), factor K is taken as 2.0 since the strand configuration is composed of both bonded and unbonded tendons as recommended in S5.11.4.3:

$$l_d \geq K \left( f_{ps} - \frac{2}{3} f_{pe} \right) d_b \quad [A.40]$$

$$K \left( f_{ps} - \frac{2}{3} f_{pe} \right) d_b = 2.0 \left( 266.86 \text{ksi} - \frac{2}{3} 172.49 \text{ksi} \right) 0.5 \text{in} = 121.50 \text{in}$$

A full profile of prestressing strand forces is needed in order to compute stresses in every point of the girder as presented in Table A.10. Using these, the flexural stresses at transfer, under the Service limit state combinations, and under the Fatigue limit state actions are checked. Examples shown in Appendix B also checked construction stage flexural stresses that are not shown in this example.

Limiting stresses for concrete according to S5.9.4 were utilized, with values before and after losses considered as described in the AASHTO LRFD Specifications. Before losses, limit stresses are the following:

*Compression:*

$$f_{lim-com-bl} = 0.6 f'_{ci} \quad [A.41]$$

$$f_{lim-com-bl} = 0.6(6.0 \text{ksi}) = 3.6 \text{ksi}$$

*Tension:* The stress limit in areas with bonded reinforcement sufficient to resist 120% of the tension force in the cracked concrete computed on the basis of an un-cracked section is

$$f_{lim-ten-bl} = 0.24 \sqrt{f'_{ci}} \quad [A.42]$$

$$f_{lim-ten-bl} = 0.24(\sqrt{6.0 \text{ksi}}) = 0.58 \text{ksi}$$

Limit stresses after losses are computed not only for the prestressed concrete section but also for the reinforced concrete slab. Compression limits are taken from Table S5.9.4.2.1-1 and tension limits from Table S5.9.4.2.2-1. Limit stresses are the following:

*Compression:* Due to the sum of effective prestress and permanent loads

$$f_{lim-com-al-b} = 0.45 f'_{cb} \quad [A.43]$$

$$f_{lim-com-al-b} = 0.45(7.0 \text{ksi}) = 3.15 \text{ksi}$$

$$f_{lim-com-al-cs} = 0.45 f'_{ccs} \quad [A.44]$$

$$f_{lim-com-al-cs} = 0.45(4.0 \text{ksi}) = 1.80 \text{ksi}$$

*Compression:* Due to the sum of effective prestress, permanent loads and transient loads

$$\begin{aligned} f_{lim-com-al-b} &= 0.6\phi_w f'_{cb} & [A.45] \\ f_{lim-com-al-b} &= 0.6(1.0)(7.0ksi) = 3.15ksi \end{aligned}$$

$$\begin{aligned} f_{lim-com-al-cs} &= 0.6\phi_w f'_{ccs} & [A.46] \\ f_{lim-com-al-cs} &= 0.6(1.0)(4.0ksi) = 1.80ksi \end{aligned}$$

*Tension:* For components with bonded prestressing tendons or reinforcement that are subjected to not worse than moderate corrosion conditions.

$$\begin{aligned} f_{lim-ten-al-b} &= 0.19\sqrt{f'_{cb}} & [A.47] \\ f_{lim-ten-al-b} &= 0.19(\sqrt{7.0ksi}) = 0.50ksi \end{aligned}$$

$$\begin{aligned} f_{lim-ten-al-cs} &= 0.19\sqrt{f'_{ccs}} & [A.48] \\ f_{lim-ten-al-cs} &= 0.19(\sqrt{4.0ksi}) = 0.38ksi \end{aligned}$$

Finally, limit stresses for fatigue and fracture limit state also need to be checked. Provisions from Section S5.5.3.1 are considered. Limits are only computed to the prestressed section.

*Compression:* Due to the Fatigue I load combination and one-half the sum of the unfactored effective prestress and permanent loads.

$$\begin{aligned} f_{lim-com-al} &= 0.40f'_{cb} & [A.49] \\ f_{lim-com-al} &= 0.40(7.0ksi) = 2.80ksi \end{aligned}$$

*Tension:* Due to the Fatigue I load combination and one-half the sum of the unfactored effective prestress and permanent loads.

$$\begin{aligned} f_{lim-ten-al} &= 0.095\sqrt{f'_c} & [A.50] \\ f_{lim-ten-al} &= 0.095(\sqrt{7.0ksi}) = 0.25ksi \end{aligned}$$

It is important to note that the sign convention utilized is that, compressive stresses are considered to be negative, and tension stresses as positive. Flexural stresses at transfer are computed as follows:

$$f_{transfer} = -\frac{P_{ps}}{A_g} \pm \frac{P_{ps}e_0}{S_x} \pm \frac{M_g}{S_x} \quad [A.51]$$

Where:

- $P_{ps}$  = Prestressed strand force at transfer
- $A_g$  = Gross area non-composite section
- $e_0$  = Eccentricity of the prestressing force at each point of the beam
- $S_x$  = Section moduli - non-composite - top or bottom of beam accordingly
- $M_g$  = Moment due to girder self-weight only

**Table A.10 Prestressing strand forces—two spans 110 ft**

7.7.1 AT TRANSFER														
SPAN 1														
PRESTRESSING STRAND FORCES (kip)														
Group	Beam Start	LOCATION												
		0.0L	0.1L	0.2L	0.3L	0.4L	0.5L	0.6L	0.7L	0.8L	0.9L	1.0L		
Bonded	0.00	296.94	1484.68	1484.68	1484.68	1484.68	1484.68	1484.68	1484.68	1484.68	1484.68	1484.68	1484.68	0.00
Debonded	0.00	0.00	171.31	171.31	171.31	171.31	171.31	171.31	171.31	171.31	171.31	171.31	171.31	0.00
Total	0.00	296.94	1655.99	1655.99	1655.99	1655.99	1655.99	1655.99	1655.99	1655.99	1655.99	1655.99	1655.99	0.00
Excentricity	14.19	14.25	15.59	16.93	18.27	19.52	19.48	19.48	18.14	16.81	15.47	14.19	14.19	
SPAN 2														
PRESTRESSING STRAND FORCES (kip)														
Group	Beam Start	LOCATION												
		0.0L	0.1L	0.2L	0.3L	0.4L	0.5L	0.6L	0.7L	0.8L	0.9L	1.0L		
Bonded		0.00	1484.68	1484.68	1484.68	1484.68	1484.68	1484.68	1484.68	1484.68	1484.68	1484.68	1484.68	0.00
Debonded		0.00	171.31	171.31	171.31	171.31	171.31	171.31	171.31	171.31	171.31	171.31	171.31	0.00
Total		0.00	1655.99	1655.99	1655.99	1655.99	1655.99	1655.99	1655.99	1655.99	1655.99	1655.99	1655.99	0.00
Excentricity		14.19	15.47	16.81	18.14	19.48	19.52	19.48	18.14	16.81	15.47	14.19	14.19	
7.7.2 AFTER LOSSES														
SPAN 1														
PRESTRESSING STRAND FORCES (kip)														
Group	Beam Start	LOCATION												
		0.0L	0.1L	0.2L	0.3L	0.4L	0.5L	0.6L	0.7L	0.8L	0.9L	1.0L		
Bonded	0.00	258.52	1292.58	1292.58	1292.58	1292.58	1292.58	1292.58	1292.58	1292.58	1292.58	1292.58	1292.58	0.00
Debonded	0.00	0.00	149.14	149.14	149.14	149.14	149.14	149.14	149.14	149.14	149.14	149.14	149.14	0.00
Total	0.00	258.52	1441.72	1441.72	1441.72	1441.72	1441.72	1441.72	1441.72	1441.72	1441.72	1441.72	1441.72	0.00
SPAN 2														
PRESTRESSING STRAND FORCES (kip)														
Group	Beam Start	LOCATION												
		0.0L	0.1L	0.2L	0.3L	0.4L	0.5L	0.6L	0.7L	0.8L	0.9L	1.0L		
Bonded		0.00	1292.58	1292.58	1292.58	1292.58	1292.58	1292.58	1292.58	1292.58	1292.58	1292.58	1292.58	0.00
Debonded		0.00	149.14	149.14	149.14	149.14	149.14	149.14	149.14	149.14	149.14	149.14	149.14	0.00
Total		0.00	1441.72	1441.72	1441.72	1441.72	1441.72	1441.72	1441.72	1441.72	1441.72	1441.72	1441.72	0.00
7.7.3 AT THE NOMINAL FLEXURAL RESISTANCE														
SPAN 1														
PRESTRESSING STRAND FORCES (kip)														
Group	Beam Start	LOCATION												
		0.0L	0.1L	0.2L	0.3L	0.4L	0.5L	0.6L	0.7L	0.8L	0.9L	1.0L		
Bonded	0.00	258.52	2091.26	2091.26	2091.26	2091.26	2091.26	2091.26	2091.26	2091.26	2091.26	2091.26	2091.26	0.00
Debonded	0.00	0.00	103.05	241.30	241.30	241.30	241.30	241.30	241.30	241.30	241.30	241.30	241.30	0.00
Total	0.00	258.52	2194.31	2332.56	2332.56	2332.56	2332.56	2332.56	2332.56	2332.56	2332.56	2332.56	2332.56	0.00
SPAN 2														
PRESTRESSING STRAND FORCES (kip)														
Group	Beam Start	LOCATION												
		0.0L	0.1L	0.2L	0.3L	0.4L	0.5L	0.6L	0.7L	0.8L	0.9L	1.0L		
Bonded		0.00	2091.26	2091.26	2091.26	2091.26	2091.26	2091.26	2091.26	2091.26	2091.26	2091.26	2091.26	0.00
Debonded		0.00	84.31	241.30	241.30	241.30	241.30	241.30	241.30	241.30	241.30	241.30	241.30	0.00
Total		0.00	2175.58	2332.56	2332.56	2332.56	2332.56	2332.56	2332.56	2332.56	2332.56	2332.56	2332.56	0.00

As an example, the computation of stresses at mid-span of span 1 are presented. Summary of stresses at transfer is shown in Table A.11. As can be seen, stresses obtained are below the stress limits noted before.

Top of Beam:

$$f_{transfer} = -\frac{1,260.37kips}{1,172.40in^2} + \frac{1,260.37kips(30.77in)}{20,013in^3} - \frac{1,798kip - ft \left(12 \frac{in}{ft}\right)}{23,013in^3} = -0.33ksi$$

Bottom of Beam:

$$f_{transfer} = -\frac{1,260.37kips}{1,172.40in^2} - \frac{1,260.37kips(30.77in)}{21,268in^3} + \frac{1,798kip - ft \left(12 \frac{in}{ft}\right)}{21,268in^3} = -1.88ksi$$

**Table A.11 Flexural stresses at transfer—two spans 110 ft**

SPAN 1												
STRESSES (ksi)												
Group	LOCATION											
	Beam Start	0.0L	0.1L	0.2L	0.3L	0.4L	0.5L	0.6L	0.7L	0.8L	0.9L	1.0L
Top of Beam	0.00	0.08	0.18	0.01	-0.18	-0.29	-0.33	-0.29	-0.18	0.01	0.17	0.00
Check	OK	OK	OK	OK	OK	OK	OK	OK	OK	OK	OK	OK
Bot of Beam	0.00	-0.54	-2.44	-2.25	-2.05	-1.92	-1.88	-1.92	-2.05	-2.25	-2.42	0.00
Check	OK	OK	OK	OK	OK	OK	OK	OK	OK	OK	OK	OK
SPAN 2												
STRESSES (ksi)												
Group	LOCATION											
		0.0L	0.1L	0.2L	0.3L	0.4L	0.5L	0.6L	0.7L	0.8L	0.9L	1.0L
Top of Beam		0.00	0.17	0.01	-0.18	-0.29	-0.33	-0.29	-0.18	0.01	0.17	0.00
Check		OK	OK	OK	OK	OK	OK	OK	OK	OK	OK	OK
Bot of Beam		0.00	-2.42	-2.25	-2.05	-1.92	-1.88	-1.92	-2.05	-2.25	-2.42	0.00
Check		OK	OK	OK	OK	OK	OK	OK	OK	OK	OK	OK

Stresses of the Service limit state need to address two aspects. Firstly, according to AASTHO 5.14.1.4.6 a cast-in-place composite deck slab shall not be subject to the tensile stress limits for the service limit state after losses. Secondly, at the service limit state after losses, when tensile stresses develop at the top of the girders near interior supports, the tensile stress limits specified in Table 5.9.4.1.2-1 for other than segmentally constructed bridges shall apply. The specified compressive strength of the girder concrete,  $f'_{c'}$ , shall be substituted for  $f'_{ci}$  in the stress limit equations. Flexural stresses under service limit state (after losses) are computed as follows:

$$f_{service} = -\frac{P_e}{A_g} \pm \frac{P_e e_0}{S_x} \pm \frac{M_{DNC}}{S_x} \pm \frac{M_{DC}}{S_{xC}} \pm \frac{M_{LLC}}{S_{xC}} \quad [A.52]$$

Where:

- $P_{ps}$  = Prestressed strand force after losses
- $A_g$  = Gross area non-composite section
- $e_0$  = Eccentricity of the prestressing force at each point of the beam
- $S_x$  = Section moduli - non-composite - top or bottom of beam accordingly
- $M_{DNC}$  = Moment due to Dead Load acting on the non-composite section



- $M_{DC}$  = Moment due to Dead Load acting on the composite section  
 $S_{xc}$  = Section moduli - composite - top or bottom of beam accordingly  
 $M_{LLC}$  = Moment due to Live Load acting on the composite section

Following the same procedure for the stresses at transfer, a calculation example of final stresses at mid-span of span 1 is presented as a guide. Summary of final stresses is shown in Tables A 12 and A 13. Again, stresses obtained are below the stress limits noted beforehand.

*Top of Beam:*

$$f_{service} = -\frac{1,134\text{kips}}{1,172.4\text{in}^2} + \frac{1,134\text{kips}(30.77\text{in})}{23,013\text{in}^3} - \left( \frac{3,264\text{kip} - \text{ft}}{23,013\text{in}^3} - \frac{261\text{kip} - \text{ft}}{68,473\text{in}^3} \right) \left( 12 \frac{\text{in}}{\text{ft}} \right)$$

$$f_{service} = -1.20\text{ksi}$$

*Bottom of Beam:*

$$f_{service} = -\frac{1,134\text{kips}}{1,172.4\text{in}^2} - \frac{1,134\text{kips}(30.77\text{in})}{21,268\text{in}^3} + \left( \frac{3,264\text{kip} - \text{ft}}{21,268\text{in}^3} + \frac{261\text{kip} - \text{ft}}{27,039\text{in}^3} \right) \left( 12 \frac{\text{in}}{\text{ft}} \right)$$

$$f_{service} = -0.65\text{ksi}$$

*Top of Slab:*

$$f_{service} = -\frac{261\text{kip} - \text{ft}}{63,425\text{in}^3} \left( 12 \frac{\text{in}}{\text{ft}} \right) = -0.05\text{ksi}$$

Slabs above multi girder systems do not need a fatigue limit state check (AASHTO LRFD S5.5.3). According to AASHTO LRFD S5.5.3, fatigue limit state stresses need to be checked using half the combined effects of prestressing and permanent loads along with the live load corresponding to Fatigue I load Combination (Truck only). Parameter definition is the same as service limit state.

$$f_{service} = \frac{1}{2} \left( -\frac{P_e}{A_g} \pm \frac{P_e e_0}{S_x} \pm \frac{M_{DNC}}{S_x} \pm \frac{M_{DC}}{S_{xc}} \right) \pm \frac{M_{LLC}}{S_{xc}} \quad [\text{A.53}]$$

Finally, an example calculation of stresses at mid-span of span 1 is presented. Summary of stresses at transfer is shown in Table A.14. Stresses obtained are below the stress limits required.

*Top of Beam maximum:*

$$f_{fatigue} = \frac{1}{2} \left( -\frac{1,134}{1,172.40} + \frac{1,134(30.77)}{23,013} - \left[ \frac{3264}{23,013} + \frac{261}{68,473} \right] \times 12 \right) - \frac{1,221 \times 12}{68,473} = -0.81\text{ksi}$$

*Top of Beam minimum:*

$$f_{fatigue} = \frac{1}{2} \left( -\frac{1,134}{1,172.40} + \frac{1,134(30.77)}{23,013} - \left[ \frac{3264}{23,013} + \frac{261}{68,473} \right] \times 12 \right) + \frac{327 \times 12}{68,473} = -0.54\text{ksi}$$

*Bottom of Beam maximum:*

$$f_{fatigue} = \frac{1}{2} \left( -\frac{1,134}{1,172.40} - \frac{1,134(30.77)}{21,268} + \left[ \frac{3264}{21,268} + \frac{261}{27,039} \right] \times 12 \right) + \frac{1,221 \times 12}{27,039} = 0.22 \text{ksi}$$

Bottom of Beam minimum:

$$f_{fatigue} = \frac{1}{2} \left( -\frac{1,134}{1,172.40} - \frac{1,134(30.77)}{21,268} + \left[ \frac{3264}{21,268} + \frac{261}{27,039} \right] \times 12 \right) - \frac{327 \times 12}{27,039} = -0.47 \text{ksi}$$

**Table A.12 Flexural stresses at service I limit state—two spans 110 ft**

SERVICE I												
SPAN 1												
STRESSES (ksi)												
FINAL STRESS UNDER PRESTRESSING AND PERMANENT LOADS												
Group	LOCATION											
	Beam Start	0.0L	0.1L	0.2L	0.3L	0.4L	0.5L	0.6L	0.7L	0.8L	0.9L	1.0L
Top of Beam	0.00	0.07	-0.17	-0.58	-0.93	-1.14	-1.20	-1.12	-0.89	-0.53	-0.11	0.09
Check	OK	OK	OK	OK	OK	OK	OK	OK	OK	OK	OK	OK
Bot of Beam	0.00	-0.48	-1.80	-1.33	-0.94	-0.71	-0.65	-0.76	-1.03	-1.46	-1.97	-0.22
Check	OK	OK	OK	OK	OK	OK	OK	OK	OK	OK	OK	OK
Top of Slab	0.00	0.00	-0.03	-0.04	-0.05	-0.06	-0.05	-0.04	-0.01	0.01	0.05	0.10
Check	OK	OK	OK	OK	OK	OK	OK	OK	OK	OK	OK	OK
FINAL STRESS UNDER PRESTRESSING, PERMANENT LOADS AND TRANSIENT LOADS												
Group	LOCATION											
	Beam Start	0.0L	0.1L	0.2L	0.3L	0.4L	0.5L	0.6L	0.7L	0.8L	0.9L	1.0L
T of B Max	0.00	0.07	-0.32	-0.84	-1.26	-1.50	-1.55	-1.43	-1.14	-0.67	-0.14	0.16
Check	OK	OK	OK	OK	OK	OK	OK	OK	OK	OK	OK	OK
T of B Min	0.00	0.07	-0.15	-0.54	-0.87	-1.06	-1.10	-1.00	-0.75	-0.37	0.09	0.44
Check	OK	OK	OK	OK	OK	OK	OK	OK	OK	OK	OK	OK
B of B Max	0.00	-0.48	-1.41	-0.66	-0.10	0.20	0.24	0.04	-0.41	-1.09	-1.88	-0.39
Check	OK	OK	OK	OK	OK	OK	OK	OK	OK	OK	OK	OK
B of B Min	0.00	-0.48	-1.85	-1.43	-1.09	-0.92	-0.91	-1.06	-1.38	-1.87	-2.47	-1.12
Check	OK	OK	OK	OK	OK	OK	OK	OK	OK	OK	OK	OK
T of S Max	0.00	0.00	-0.19	-0.33	-0.41	-0.44	-0.43	-0.38	-0.28	-0.14	0.01	0.17
Check	OK	OK	OK	OK	OK	OK	OK	OK	OK	OK	OK	OK
T of S Min	0.00	0.00	0.00	0.00	0.01	0.03	0.06	0.09	0.14	0.19	0.27	0.48
Check	OK	OK	OK	OK	OK	OK	OK	OK	OK	OK	OK	REINF
SPAN 2												
STRESSES (ksi)												
FINAL STRESS UNDER PRESTRESSING AND PERMANENT LOADS												
Group	LOCATION											
	Beam Start	0.0L	0.1L	0.2L	0.3L	0.4L	0.5L	0.6L	0.7L	0.8L	0.9L	1.0L
Top of Beam		0.09	-0.11	-0.53	-0.89	-1.12	-1.20	-1.14	-0.93	-0.58	-0.18	0.00
Check		OK	OK	OK	OK	OK	OK	OK	OK	OK	OK	OK
Bot of Beam		-0.22	-1.97	-1.46	-1.03	-0.76	-0.65	-0.71	-0.94	-1.33	-1.79	0.00
Check		OK	OK	OK	OK	OK	OK	OK	OK	OK	OK	OK
Top of Slab		0.00	-0.03	-0.04	-0.05	-0.06	-0.05	-0.04	-0.01	0.01	0.05	0.10
Check		OK	OK	OK	OK	OK	OK	OK	OK	OK	OK	OK
FINAL STRESS UNDER PRESTRESSING, PERMANENT LOADS AND TRANSIENT LOADS												
Group	LOCATION											
	Beam Start	0.0L	0.1L	0.2L	0.3L	0.4L	0.5L	0.6L	0.7L	0.8L	0.9L	1.0L
T of B Max		0.16	-0.14	-0.67	-1.14	-1.43	-1.55	-1.50	-1.26	-0.84	-0.33	0.00
Check		OK	OK	OK	OK	OK	OK	OK	OK	OK	OK	OK
T of B Min		0.44	0.09	-0.37	-0.75	-1.00	-1.10	-1.06	-0.87	-0.54	-0.16	0.00
Check		OK	OK	OK	OK	OK	OK	OK	OK	OK	OK	OK
B of B Max		-0.39	-1.88	-1.09	-0.41	0.04	0.24	0.20	-0.10	-0.66	-1.40	0.00
Check		OK	OK	OK	OK	OK	OK	OK	OK	OK	OK	OK
B of B Min		-1.12	-2.47	-1.87	-1.38	-1.06	-0.91	-0.92	-1.09	-1.43	-1.84	0.00
Check		OK	OK	OK	OK	OK	OK	OK	OK	OK	OK	OK
T of S Max		0.07	-0.06	-0.20	-0.32	-0.40	-0.43	-0.42	-0.37	-0.27	-0.12	0.10
Check		OK	OK	OK	OK	OK	OK	OK	OK	OK	OK	OK
T of S Min		0.38	0.19	0.13	0.10	0.08	0.06	0.05	0.05	0.06	0.07	0.10
Check		REINF	OK	OK	OK	OK	OK	OK	OK	OK	OK	OK

T of B = Top of Beam; B of B = Bottom of Beam; T of S = Top of Slab.

**Table A.13 Flexural stresses at service III limit state—two spans 110 ft**

SERVICE III												
SPAN 1												
STRESSES (ksi)												
FINAL STRESS UNDER PRESTRESSING AND PERMANENT LOADS												
Group	LOCATION											
	Beam Start	0.0L	0.1L	0.2L	0.3L	0.4L	0.5L	0.6L	0.7L	0.8L	0.9L	1.0L
Top of Beam	0.00	0.07	-0.17	-0.58	-0.93	-1.14	-1.20	-1.12	-0.89	-0.53	-0.11	0.09
Check	OK	OK	OK	OK	OK	OK	OK	OK	OK	OK	OK	OK
Bot of Beam	0.00	-0.48	-1.80	-1.33	-0.94	-0.71	-0.65	-0.76	-1.03	-1.46	-1.97	-0.22
Check	OK	OK	OK	OK	OK	OK	OK	OK	OK	OK	OK	OK
Top of Slab	0.00	0.00	-0.03	-0.04	-0.05	-0.06	-0.05	-0.04	-0.01	0.01	0.05	0.10
Check	OK	OK	OK	OK	OK	OK	OK	OK	OK	OK	OK	OK
FINAL STRESS UNDER PRESTRESSING, PERMANENT LOADS AND TRANSIENT LOADS												
Group	LOCATION											
	Beam Start	0.0L	0.1L	0.2L	0.3L	0.4L	0.5L	0.6L	0.7L	0.8L	0.9L	1.0L
T of B Max	0.00	0.07	-0.29	-0.79	-1.19	-1.42	-1.48	-1.37	-1.09	-0.65	-0.13	0.14
Check	OK	OK	OK	OK	OK	OK	OK	OK	OK	OK	OK	OK
T of B Min	0.00	0.07	-0.15	-0.55	-0.88	-1.07	-1.12	-1.02	-0.78	-0.40	0.05	0.37
Check	OK	OK	OK	OK	OK	OK	OK	OK	OK	OK	OK	OK
B of B Max	0.00	-0.48	-1.49	-0.79	-0.27	0.02	0.06	-0.12	-0.53	-1.17	-1.90	-0.36
Check	OK	OK	OK	OK	OK	OK	OK	OK	OK	OK	OK	OK
B of B Min	0.00	-0.48	-1.84	-1.41	-1.06	-0.87	-0.85	-1.00	-1.31	-1.79	-2.37	-0.94
Check	OK	OK	OK	OK	OK	OK	OK	OK	OK	OK	OK	OK
T of S Max	0.00	0.00	-0.16	-0.27	-0.34	-0.37	-0.35	-0.31	-0.23	-0.11	0.02	0.15
Check	OK	OK	OK	OK	OK	OK	OK	OK	OK	OK	OK	OK
T of S Min	0.00	0.00	-0.01	-0.01	0.00	0.01	0.04	0.07	0.11	0.15	0.22	0.40
Check	OK	OK	OK	OK	OK	OK	OK	OK	OK	OK	OK	REINF
SPAN 2												
STRESSES (ksi)												
FINAL STRESS UNDER PRESTRESSING AND PERMANENT LOADS												
Group	LOCATION											
	Beam Start	0.0L	0.1L	0.2L	0.3L	0.4L	0.5L	0.6L	0.7L	0.8L	0.9L	1.0L
Top of Beam		0.09	-0.11	-0.53	-0.89	-1.12	-1.20	-1.14	-0.93	-0.58	-0.18	0.00
Check		OK	OK	OK	OK	OK	OK	OK	OK	OK	OK	OK
Bot of Beam		-0.22	-1.97	-1.46	-1.03	-0.76	-0.65	-0.71	-0.94	-1.33	-1.79	0.00
Check		OK	OK	OK	OK	OK	OK	OK	OK	OK	OK	OK
Top of Slab		0.00	-0.03	-0.04	-0.05	-0.06	-0.05	-0.04	-0.01	0.01	0.05	0.10
Check		OK	OK	OK	OK	OK	OK	OK	OK	OK	OK	OK
FINAL STRESS UNDER PRESTRESSING, PERMANENT LOADS AND TRANSIENT LOADS												
Group	LOCATION											
	Beam Start	0.0L	0.1L	0.2L	0.3L	0.4L	0.5L	0.6L	0.7L	0.8L	0.9L	1.0L
T of B Max		0.14	-0.13	-0.65	-1.09	-1.37	-1.48	-1.42	-1.19	-0.79	-0.30	0.00
Check		OK	OK	OK	OK	OK	OK	OK	OK	OK	OK	OK
T of B Min		0.37	0.05	-0.40	-0.78	-1.02	-1.12	-1.07	-0.88	-0.55	-0.16	0.00
Check		OK	OK	OK	OK	OK	OK	OK	OK	OK	OK	OK
B of B Max		-0.36	-1.90	-1.17	-0.53	-0.12	0.06	0.02	-0.27	-0.79	-1.48	0.00
Check		OK	OK	OK	OK	OK	OK	OK	OK	OK	OK	OK
B of B Min		-0.94	-2.37	-1.79	-1.31	-1.00	-0.85	-0.87	-1.06	-1.41	-1.83	0.00
Check		OK	OK	OK	OK	OK	OK	OK	OK	OK	OK	OK
T of S Max		0.15	0.02	-0.11	-0.23	-0.31	-0.35	-0.37	-0.34	-0.27	-0.16	0.00
Check		OK	OK	OK	OK	OK	OK	OK	OK	OK	OK	OK
T of S Min		0.40	0.22	0.15	0.11	0.07	0.04	0.01	0.00	-0.01	-0.01	0.00
Check		REINF	OK	OK	OK	OK	OK	OK	OK	OK	OK	OK

T of B = Top of Beam; B of B = Bottom of Beam; T of S = Top of Slab.

An earlier calculation showed how to obtain the value of distance between the neutral axis and the compressive face,  $c$ , which for mid-span is 2.93-in. Multiplying this value by the factor  $\beta_1$  set as 0.85, the depth of the equivalent stress block,  $a$ , can be found and is 2.49-in. As mentioned before, the section is treated as a rectangular section, which means that the web width of a T section,  $b_w$ , has to be taken as  $b$ , in Equation S5.7.3.2.2-1, which is used to calculate the nominal flexural resistance. Additionally, no additional tension reinforcement is considered. The slab reinforcement is used as compression steel and the resistance factor for flexure is taken as 1.00 since the section is tension controlled (further computations can be found in Appendix B). The resulting expression is given as follows:

$$M_n = A_{ps}f_{ps} \left( d_p - \frac{a}{2} \right) - A'_s f'_y \left( d'_s - \frac{a}{2} \right) \quad [A.54]$$

$$\phi M_n = \left[ 6.58 \text{in}^2 (266.86 \text{ksi}) \left( 70.46 \text{in} - \frac{2.49 \text{in}}{2} \right) - 13.19 \text{in}^2 (60 \text{ksi}) \left( 2.81 \text{in} - \frac{2.49 \text{in}}{2} \right) \right] \frac{ft}{12 \text{in}}$$

$$\phi M_n = 10,006 \quad - \quad \geq M_u = 7977 \quad -$$

**Table A.14 Flexural stresses at fatigue and fracture limit state—two spans 110 ft**

FATIGUE I												
SPAN 1												
STRESSES (ksi)												
FINAL STRESS UNDER PRESTRESSING, PERMANENT LOADS AND TRANSIENT LOADS												
Group	LOCATION											
	Beam Start	0.0L	0.1L	0.2L	0.3L	0.4L	0.5L	0.6L	0.7L	0.8L	0.9L	1.0L
T of B Max	0.00	0.04	-0.18	-0.45	-0.67	-0.79	-0.81	-0.75	-0.60	-0.36	-0.09	0.04
Check	OK	OK	OK	OK	OK	OK	OK	OK	OK	OK	OK	OK
T of B Min	0.00	0.04	-0.07	-0.27	-0.43	-0.52	-0.54	-0.49	-0.37	-0.17	0.05	0.16
Check	OK	OK	OK	OK	OK	OK	OK	OK	OK	OK	OK	OK
B of B Max	0.00	-0.24	-0.66	-0.25	0.04	0.20	0.22	0.11	-0.13	-0.49	-0.90	-0.11
Check	OK	OK	OK	OK	OK	OK	OK	OK	OK	OK	OK	OK
B of B Min	0.00	-0.24	-0.93	-0.72	-0.56	-0.47	-0.47	-0.55	-0.72	-0.96	-1.25	-0.40
Check	OK	OK	OK	OK	OK	OK	OK	OK	OK	OK	OK	OK
SPAN 2												
STRESSES (ksi)												
FINAL STRESS UNDER PRESTRESSING, PERMANENT LOADS AND TRANSIENT LOADS												
Group	LOCATION											
		0.0L	0.1L	0.2L	0.3L	0.4L	0.5L	0.6L	0.7L	0.8L	0.9L	1.0L
T of B Max		0.04	-0.09	-0.36	-0.60	-0.75	-0.81	-0.79	-0.67	-0.45	-0.18	0.00
Check		OK	OK	OK	OK	OK	OK	OK	OK	OK	OK	OK
T of B Min		0.16	0.05	-0.17	-0.37	-0.49	-0.54	-0.52	-0.43	-0.27	-0.08	0.00
Check		OK	OK	OK	OK	OK	OK	OK	OK	OK	OK	OK
B of B Max		-0.11	-0.90	-0.49	-0.13	0.11	0.22	0.20	0.04	-0.25	-0.65	0.00
Check		OK	OK	OK	OK	OK	OK	OK	OK	OK	OK	OK
B of B Min		-0.40	-1.25	-0.96	-0.72	-0.55	-0.47	-0.47	-0.56	-0.72	-0.92	0.00
Check		OK	OK	OK	OK	OK	OK	OK	OK	OK	OK	OK

T of B = Top of Beam; B of B = Bottom of Beam.

As shown, the section proposed together with the assumed stand pattern has an adequate flexural capacity to resist the loading on the bridge. Nevertheless, further checks need to be done. Those checks include: minimum reinforcement for flexure, flexural resistance for the negative moment region as well as the minimum reinforcement for those sections, distributing reinforcement in the slab for crack control, longitudinal steel at top of the girder, complete shear design, complete design of the continuity connection in the negative moment zones (positive and negative moment detailing), confinement reinforcement, and the deformation due to live load. All of these calculations and designs are included in the spreadsheets used for the design of this type of structure and can be seen in Appendix B. For further explanations, design examples from FHWA and PCI can be consulted. Finally, and acknowledging that all of these complementary calculations are important for the complete design of the section, the aim of this example was simply to show that the section selected is adequate in terms of limiting stresses and flexural resistance. Further design details and calculations are included in Appendix B.

## **APPENDIX B. SELECTED EXAMPLES OF BRIDGE DESIGNS**

This research is focused on the superstructure only; the substructure was not designed for any of the bridges considered. Generalization of soil and foundation types throughout Indiana is not within the scope of this research.

Spread sheets that include applicable sections of the LRFD and the Indiana Design Manual specifications were created for every design option. As an input, live load envelopes were generated using a simple beam element model in SAP2000®. The models were also used to check deflection limits. Limit states checked are service, strength and, fatigue and fracture. Different design examples were considered as a basis. Examples from the Federal Highway Administration (FHWA) (Wassef et al., 2003) and (Chavel and Carnahan, 2012), different Departments of Transportation (DOT's) (Florida Department of Transportation (2003), Parsons Brinckerhoff (2011), Grubb and Schmidt (2015), Hartle et al. (2003) and Wisconsin Department of Transportation (2019) were used.

Even though different superstructure designs were performed for different span lengths and configurations, all summaries are not detailed in this appendix. A separate document was assembled including each one of the designs used for this research. For further analysis and checks, the Interim Report: "Bridge Designs" submitted to INDOT in September 2018 should be consulted.

This appendix only shows a single design example for a concrete and a structural steel superstructure. In concordance with the example given in Appendix A, a bulb tee two continuous span superstructure with equal spans of 110 ft, is presented. In addition, for the same span length and configuration, a structural steel plate girder superstructure design is presented for comparison. For both superstructure designs, a bridge deck design is presented.

## BRIDGE DECK DESIGN (Reinforced Concrete Section)

### Table of Contents

- 1. MATERIALS PROPERTIES
  - 1.1 CONCRETE
  - 1.3 REINFORCEMENT STEEL
- 2. LIMIT STATE FACTORS (AASHTO 6.5.4.2)
  - 2.1 Concrete
- 3. GEOMETRIC PROPERTIES
  - 3.1 GENERAL
- 4. LOADS
  - 4.1 DEAD LOAD (DC)
  - 4.2 DEAD LOAD WEARING SURFACE (DW)
  - 4.3 LIVE LOAD (LL) - (According to AASHTO 3.6.1.2)
    - 4.3.1 Equivalent Strip Width (AASHTO 4.6.2.2)
- 5. MOMENTS
  - 5.1 DEAD LOAD
  - 5.2 LIVE LOAD
  - 5.3 LOAD COMBINATIONS
  - 5.4 DESIGN SHEAR AND MOMENTS
- 6. DESIGN OF REINFORCED CONCRETE
  - 6.1 MOMENT CAPACITY - NEGATIVE (TOP) (AASHTO 5.7.3.2)
    - 6.1.1 Minimum Flexural Reinforcement (AASHTO 5.7.3.3.2)
    - 6.1.2 Moment Capacity (AASHTO 5.7.3.2)
    - 6.1.3 Serviceability Check - Control of Cracking (AASHTO 5.7.3.4)
    - 6.1.4 Fatigue Limit State Check (AASHTO 5.5.3, 5.7.1, 9.5.3)
    - 6.1.5 Shrinkage and Temperature Reinforcement (Bottom bars) (AASHTO 5.10.8)
  - 6.2 MOMENT CAPACITY - POSITIVE (BOTTOM) (AASHTO 5.7.3.2)
    - 6.2.1 Minimum Flexural Reinforcement (AASHTO 5.7.3.3.2)
    - 6.2.2 Moment Capacity (AASHTO 5.7.3.2)
    - 6.2.3 Serviceability Check - Control of Cracking (AASHTO 5.7.3.4)
    - 6.2.4 Transverse Distribution Reinforcement (Top bars) (AASHTO 5.14.4.1)

## BRIDGE DECK DESIGN (Reinforced Concrete Section)

AASHTO LRFD Bridge Design Specifications U.S. Customary Units, Seventh Edition, 2014

### 1. MATERIALS PROPERTIES

#### 1.1 CONCRETE

$f'_c$ =	4.00 ksi
$E_c$ =	3834 ksi
$\gamma_c$ =	0.150 kip/ft <sup>3</sup>
$n$ =	8.00

#### 1.3 REINFORCEMENT STEEL

AASHTO A615, Grade 60

$F_y$ =	60 ksi
$F_u$ =	80 ksi
$E_s$ =	29000 ksi
$\gamma_s$ =	0.490 kip/ft <sup>3</sup>

AASHTO 3.7.1 The modular ratio,  $n$ , is rounded to the nearest integer number.

### 2. LIMIT STATE FACTORS (AASHTO 6.5.4.2)

#### 2.1 Concrete

$\phi_{Tens}$ Controlled=	0.90	$\phi_{Bearing}$ =	0.70	$\phi_{Moment}$ =	0.90
$\phi_{Shear}$ =	0.90	$\phi_{Comp}$ Control=	0.75		

### 3. GEOMETRIC PROPERTIES

#### 3.1 GENERAL

Slab Thickness ( $e$ )=	8.00 in	Number of Lanes ( $N_L$ )=	3.00
Sacrificial Surface ( $sw$ )=	0.50 in	Skew ( $\theta$ )=	0.00 °
Width ( $W$ )=	44.00 ft	Beams Separation ( $S$ )=	9.50 ft
Number of Beams ( $N$ )=	6.00 beams	$d_s$ =	15.00 in

The distance from the centerline of girder to the design section for negative moment in the deck ( $d_s$ ) should be taken equal to one-third of the flange width from the centerline of the support (AASHTO 4.6.2.1.6), but not to exceed 15 in.

#### 3.3.1 CONCRETE BEAM

TYPE= HBULBTEE

Section= HBT 60x61

$d$ =	60.00 in	$b_{ft}$ =	61.00 in	$T_w$ =	8.00 in
$b_{fb}$ =	40.00 in	$b_{ft}$ =	4.00 in	$H_w$ =	39.50 in
$T_{fb}$ =	5.50 in				

$K_R$ =	4.00 in
$K_{fb}$ =	7.00 in
$A_f$ =	1124.40 in <sup>2</sup>
$I_x$ =	576476.00 in <sup>4</sup>
$x_{cb}$ =	31.30 in
$S_{xb}$ =	18417.76 in <sup>3</sup>
$r_{xb}$ =	22.64 in
$x_{ct}$ =	28.70 in
$S_{xt}$ =	20086.27 in <sup>3</sup>
Weight=	1172.00 lb

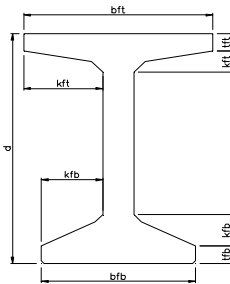

### 4. LOADS

#### 4.1 DEAD LOAD (DC)

Concrete Deck=	0.100 kip/ft <sup>2</sup>
Stay-in-Place Forms=	0.015 kip/ft
<b>Total DC=</b>	<b>0.12 kip/ft<sup>2</sup></b>
Rail Barriers=	0.39 kip/ft/Barrier

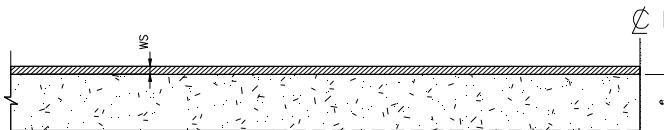

**4.2 DEAD LOAD WEARING SURFACE (DW)**

Future Wearing Surface= 0.035 kip/ft<sup>2</sup> (Common Value used see FHWA examples)

**4.3 LIVE LOAD (LL) - (According to AASHTO 3.6.1.2)**

Live load is composed by the following:

i) Design Truck or design Tandem (pair of 25kips axles spaced 4ft apart)

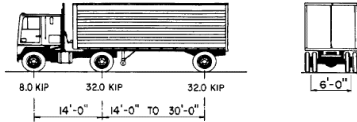

ii) Design lane load (The design lane load shall consist of a load of 0.64 Klf uniformly distributed in the longitudinal direction. Transversely, the design lane load shall be assumed to be uniformly distributed over a 10.0-ft width.)

Using the approximate method of deck analysis (AASHTO 4.6.2), live load effects may be determined by modeling the deck as a beam supported on the girders. One or more axles may be placed side by side on the deck (representing axles from trucks in different traffic lanes) and move them transversely across the deck to maximize the moments (AASHTO 4.6.2.1.6). To determine the live load moment per unit width of the bridge, the calculated total live load moment is divided by a strip width determined using the appropriate equation from Table AASHTO 4.6.2.1.3-1.

The specifications allow the live load moment per unit width of the deck to be determined using AASHTO Table A4.1-1. This table lists the positive and negative moment per unit width of decks with various girder spacing and with various distances from the design section to the centerline of the girders for negative moment. This table is based on the analysis procedure outlined above.

Dyn Load Allowance (IM)= 33% AASHTO Table 3.6.2.1-1

**4.3.1 Equivalent Strip Width (AASHTO 4.6.2.2)**

The equivalent strip width defines the width of the slab that will be impacted by the live load within a design lane. The slab is designed based on the forces developed within this width.

The Cast-in-place option with stay-in-place concrete formwork is used according to the AASHTO Table 4.6.2.1.3-1 - Equivalent Strips

Strip Width Positive Moment (E<sub>PM</sub>)= 88.70 in +M = 26.0 + 6.6S

Strip Width Negative Moment (E<sub>NM</sub>)= 76.50 in -M = 48.0 + 3.0S

**5. MOMENTS**

**5.1 DEAD LOAD**

$$M_l = \frac{w_l S^2}{c} \quad \text{Constant (c)} = 10.00 \text{ Typically taken as 10 or 12}$$

Concrete Deck= 0.903 kip-ft/ft

Future Wearing Surface= 0.316 kip-ft/ft

Stay-in-Place Forms= 0.135 kip-ft/ft

**5.2 LIVE LOAD**

Positive Moment Live Load (M+)= 6.59 kip-ft/ft

Negative Moment Live Load (M-)= 4.04 kip-ft/ft

Dynamic Allowance is Included in the values obtained from AASHTO A4.1-1

**5.3 LOAD COMBINATIONS**

COMBINATION	Type	LOAD CASES										
		DC	DW	LL	IM	BR	WS	WL	FR	TU	TG	IC
Strength I	Max	1.25	1.50	1.75	1.75	1.75	-	-	1.00	1.20	-	-
	Min	0.90	0.65	1.75	1.75	1.75	-	-	1.00	0.50	-	-
Extreme Event II	Max	1.25	1.50	0.50	0.50	0.50	-	-	1.00	-	-	1.00
	Min	0.90	0.65	0.50	0.50	0.50	-	-	1.00	-	-	1.00
Service I	Max	1.00	1.00	1.00	1.00	1.00	0.30	1.00	1.00	1.00	0.50	-
	Min	1.00	1.00	1.00	1.00	1.00	0.30	1.00	1.00	1.20	0.50	-
Service II	Max	1.00	1.00	1.30	1.30	1.30	-	-	1.00	1.00	0.50	-
	Min	1.00	1.00	1.30	1.30	1.30	-	-	1.00	1.20	0.50	-

**5.4 DESIGN SHEAR AND MOMENTS**

SPAN 1		
LOAD COMBINATION	POSITIVE MOMENT (kip-ft)	NEGATIVE MOMENT (kip-ft)
Strength I	13.30	8.84
Extreme Event II	5.07	3.79
Service I	7.94	5.39
Service II	9.92	6.61

**6. DESIGN OF REINFORCED CONCRETE**

**Reinforcement**

**Top**

Rebar Number (#)= 5 /8"

Rebar Spacing (s)= 5.00 in

A<sub>REBAR</sub>= 0.31 in<sup>2</sup>

A<sub>REB TOP</sub>= 0.74 in<sup>2</sup>/ft

**Top Compression Region**

Rebar Number (#)= 0 /8"

Rebar Spacing (s)= 14.00 in

A<sub>REBAR</sub>= 0.00 in<sup>2</sup>

A<sub>REB TOP</sub>= 0.00 in<sup>2</sup>/ft

Cover<sub>TOP</sub>= 2.50 in Measured to edge of top reinforcement

Cover<sub>BOT</sub>= 1.00 in Measured to edge of top reinforcement

**Bottom**

Rebar Number (#)= 5 /8"

Rebar Spacing (s)= 7.00 in

A<sub>REBAR</sub>= 0.31 in<sup>2</sup>

A<sub>REB TOP</sub>= 0.53 in<sup>2</sup>/ft

**Bottom Compression Region**

Rebar Number (#)= 0 /8"

Rebar Spacing (s)= 8.00 in

A<sub>REBAR</sub>= 0.00 in<sup>2</sup>

A<sub>REB TOP</sub>= 0.00 in<sup>2</sup>/ft

**Transversal Reinforcement**

Rebar Number (#)= 5 /8"

Rebar Spacing (s)= 8.00 in

A<sub>REBAR</sub>= 0.31 in<sup>2</sup>

A<sub>REB TOP</sub>= 0.46 in<sup>2</sup>/ft

**6.1 MOMENT CAPACITY - NEGATIVE (TOP) (AASHTO 5.7.3.2)**

Design strip width equal to 1 ft

b= 12.00 in  
h<sub>neg</sub>= 7.50 in

**6.1.1 Minimum Flexural Reinforcement (AASHTO 5.7.3.3.2)**

Factored Flexural Resistance, Mr, must be greater than or equal to the lesser of Mcr (Cracking Moment) or 1.33 Mu (Ultimate Moment)

$$M_{cr} = \gamma_3 \left[ (\gamma_1 f_r + \gamma_2 f_{cpe}) S_c - M_{dnc} \left( \frac{S_c}{S_{nc}} - 1 \right) \right] \quad f_r = 0.24 \sqrt{f'_c} \quad S_c : S_{top} \quad \begin{matrix} \gamma_1 = & 1.60 & \text{Other structures} \\ \gamma_2 = & 1.00 & \text{None Prestressed} \\ \gamma_3 = & 0.67 & \text{AASHTO A615 Grade 60} \end{matrix}$$

Gross Moment of Inertia (I<sub>g</sub>)= 421.88 in<sup>4</sup>  
Modulus of Rupture (f<sub>r</sub>)= 0.48 ksi AASHTO 5.4.2.6  
Distance From Center of Gravity to Extreme tension fiber (y<sub>t</sub>)= 3.75 in  
Section Modulus (S<sub>top</sub>)= 112.50 in<sup>3</sup>  
Section Modulus of noncomposite subjected to tension(S<sub>nc</sub>)= 112.50 in<sup>3</sup>  
Total unfactored dead load acting on noncomposite(M<sub>dnc</sub>)= 1.35 kip-ft  
Compressive Stress due to prestress (f<sub>cpe</sub>)= 0.00 ksi  
Cracking Moment (M<sub>cr, neg</sub>)= 4.82 kip-ft  
Ultimate Moment (M<sub>u, neg</sub>)= 8.84 kip-ft

**Minimum principal reinforcement according to  
INDOT 404-2.01 is # 5 @ 8"**

Factored Flexural Resistance (M<sub>t, neg</sub>)= 4.82 kip-ft

**6.1.2 Moment Capacity (AASHTO 5.7.3.2)**

β<sub>1</sub> shall be taken as 0.85 for concrete strengths not exceeding 4.0 ksi. For concrete strengths exceeding 4.0 ksi β<sub>1</sub> shall be reduced at a rate of 0.05 for each 1.0 ksi of strength in excess of 4.0 ksi, β<sub>1</sub> shall not be taken to be less than 0.65.

β<sub>1, neg</sub>= 0.85 AASHTO 5.7.2.2

Depth of cross section in Compression (c<sub>neg</sub>)= 1.27 in

Depth of equivalent stress block (a<sub>neg</sub>) (AASHTO 5.7.2.2)= 1.08 in

$$c_{neg} = \frac{A_s neg f_y}{0.85 f'_c \beta_{1, neg} b}$$

$$a_{neg} = c_{neg} \beta_{1, neg}$$

c<sub>neg</sub>/d<sub>neg</sub>= 0.17 OK < 0.60, Reinforcement will yield

$$M_{n, neg} = A_s neg f_y \left( d_{neg} - \frac{a_{neg}}{2} \right) \quad \text{AASHTO Eq. 5.7.3.2.2-1}$$

Nominal Flexural Resistance (ϕ<sub>m</sub>M<sub>n, neg</sub>)= 14.08 kip-ft

Ultimate Moment (M<sub>u, neg</sub>)= 8.84 kip-ft OK

Factored Flexural Resistance (M<sub>t, neg</sub>)= 4.82 kip-ft OK

**6.1.3 Serviceability Check - Control of Cracking (AASHTO 5.7.3.4)**

d<sub>c, neg</sub>= 2.81 in

d<sub>neg</sub>= 4.69 in

ρ<sub>neg</sub>= 0.0131

k<sub>neg</sub>= 0.36

j<sub>neg</sub>= 0.88

$$j_{neg} = 1 - \frac{(k_{neg})}{3}$$

$$k_{neg} = \sqrt{(2\rho_{neg} n) + (\rho_{neg} n)^2} - (\rho_{neg} n)$$

$$f_{ss, neg} = \frac{M_{s, neg}}{A_s neg j_{neg} d_{neg}} \quad \beta_1 = 1 + \frac{d_{c, neg}}{0.70(h - d_{c, neg})} \quad s \leq \frac{700\gamma_e}{\beta_1 f_{ss}} - 2d_{c, neg}$$

Service Moment (M<sub>s, neg</sub>)= 6.61 kip-ft

Service Load Bending Stress (f<sub>ss, neg</sub>)= 26.15 ksi

β<sub>1</sub>= 1.86

Exposure Factor (γ<sub>e</sub>)= 0.75 Class 2

Maximum separation of rebars (s<sub>max</sub>)= 5.19 in OK

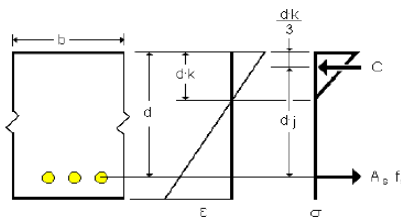

**6.1.4 Fatigue Limit State Check (AASHTO 5.5.3, 5.7.1, 9.5.3)**

*Fatigue need not be investigated for concrete slab in multi girder bridges (AASHTO 9.5.3 and 5.5.3.1)*

**6.1.5 Shrinkage and Temperature Reinforcement (Bottom bars) (AASHTO 5.10.8)**

$$A_{s, shr} \geq \frac{1.30bh}{2(b+h)f_y} \quad 0.11 \leq A_{s, shr} \leq 0.60$$

b= 12.00 in

h<sub>neg</sub>= 7.50 in

A<sub>s, shr</sub>= 0.74 in<sup>2</sup>

A<sub>t, req</sub>= 0.05 in<sup>2</sup>

A<sub>s, req, min</sub>= 0.11 in<sup>2</sup> OK

**6.2 MOMENT CAPACITY - POSITIVE (BOTTOM) (AASHTO 5.7.3.2)**

Design strip width equal to 1 ft

b= 12.00 in

h<sub>pos</sub>= 7.50 in



**6.2.1 Minimum Flexural Reinforcement (AASHTO 5.7.3.3.2)**

Factored Flexural Resistance,  $M_r$ , must be greater than or equal to the lesser of  $M_{cr}$  (Cracking Moment) or  $1.33 M_u$  (Ultimate Moment)

$M_{cr} = \gamma_3 \left[ (\gamma_1 f_r + \gamma_2 f_{cp}) S_c - M_{dnc} \left( \frac{S_c}{S_{nc}} - 1 \right) \right]$	$f_r = 0.24 \sqrt{f'_c}$	$S_c: S_{top}$	$\gamma_1 = 1.60$	Other structures
			$\gamma_2 = 1.00$	None Prestressed
			$\gamma_3 = 0.67$	AASHTO A615 Grade 60
Gross Moment of Inertia ( $I_g$ )=	421.88 in <sup>4</sup>			
Modulus of Rupture ( $f_r$ )=	0.48 ksi	AASHTO 5.4.2.6		
Distance From Center of Gravity to Extreme tension fiber ( $\gamma_1$ )=	3.75 in			
Section Modulus ( $S_{top}$ )=	112.50 in <sup>3</sup>			
Section Modulus of noncomposite subjected to tension ( $S_{nc}$ )=	112.50 in <sup>3</sup>			
Total unfactored dead load acting on noncomposite ( $M_{dnc}$ )=	1.35 kip-ft			
Compressive Stress due to prestress ( $f_{cp}$ )=	0.00 ksi			
Cracking Moment ( $M_{cr, neg}$ )=	4.82 kip-ft			
Ultimate Moment ( $M_{u, neg}$ )=	13.30 kip-ft			
Factored Flexural Resistance ( $M_{t, neg}$ )=	4.82 kip-ft			

**Minimum principal reinforcement according to INDOT 404-2.01 is # 5 @ 8"**

**6.2.2 Moment Capacity (AASHTO 5.7.3.2)**

$\beta_1$  shall be taken as 0.85 for concrete strengths not exceeding 4.0 ksi. For concrete strengths exceeding 4.0 ksi  $\beta_1$  shall be reduced at a rate of 0.05 for each 1.0 ksi of strength in excess of 4.0 ksi,  $\beta_1$  shall not be taken to be less than 0.65.

$\beta_{1, pos} = 0.85$ AASHTO 5.7.2.2	$c_{pos} = \frac{A_s, pos f_y}{0.85 f'_c \beta_1, pos b}$	
Depth of cross section in Compression ( $c_{pos}$ )=	0.91 in	
Depth of equivalent stress block ( $a_{pos}$ ) (AASHTO 5.7.2.2)=	0.77 in	$a_{neg} = c_{pos} \beta_1, pos$
	$c_{pos}/d_{pos} = 0.12$ <b>OK</b>	< 0.60, Reinforcement will yield
$M_{n, pos} = A_s, pos f_y \left( d_{pos} - \frac{a_{pos}}{2} \right)$ AASHTO Eq. 5.7.3.2.2-1		
Nominal Flexural Resistance ( $\phi_f M_{n, pos}$ )=	13.98 kip-ft	
Ultimate Moment ( $M_{u, pos}$ )=	13.30 kip-ft	<b>OK</b>
Factored Flexural Resistance ( $M_{t, pos}$ )=	4.82 kip-ft	<b>OK</b>

**6.2.3 Serviceability Check - Control of Cracking (AASHTO 5.7.3.4)**

$d_{c, pos} = 1.31$ in		
$d_{pos} = 6.19$ in	$j_{pos} = 1 - \frac{(k_{pos})}{3}$	
$\rho_{pos} = 0.0071$		
$k_{pos} = 0.28$	$k_{pos} = \sqrt{(2\rho_{pos} n) + (\rho_{pos} n)^2} - (\rho_{pos} n)$	
$j_{pos} = 0.91$		
$f_{ss, pos} = \frac{M_{s, pos}}{A_s, pos / \rho_{pos} d_{pos}}$	$\beta_1 = 1 + \frac{d_{c, pos}}{0.70(h - d_{c, pos})}$	$s \leq \frac{700 \gamma_e}{\beta_1 f_{ss}} - 2d_{c, neg}$
Service Moment ( $M_{s, pos}$ )=	9.92 kip-ft	
Service Load Bending Stress ( $f_{ss, pos}$ )=	40.42 ksi	
$\beta_1 = 1.30$		
Exposure Factor ( $\gamma_e$ )=	0.75 Class 2	
Maximum separation of rebars ( $s_{max}$ )=	7.34 in	<b>OK</b>

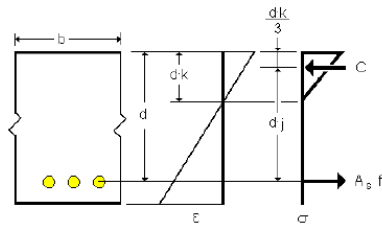

**6.2.4 Transverse Distribution Reinforcement (Top bars) (AASHTO 5.14.4.1)**

Transverse distribution reinforcement shall be placed in the bottoms of all slabs. The amount of the bottom transverse reinforcement may be determined by two-dimensional analysis, or the amount of distribution reinforcement may be taken as the percentage of the main reinforcement required for positive moment taken as:

$\frac{100}{\sqrt{L}} \leq 50\%$	
$100/\sqrt{L} = 32.44$ %	
$A_{s, tid} = 0.46$ in <sup>2</sup>	
$A_{s, req} = 32.44$ %	
$A_{s, req} = 0.24$ in <sup>2</sup>	<b>OK</b>

**6.3 DESIGN FOR SHEAR**

From AASHTO LRFD 5.14.4, "Slabs and slab bridges designed for moment in conformance with Article 4.6.2.3 - "Equivalent Strip Widths for Slab Type Bridges" may be considered satisfactory for shear."

## DESIGN OF INTERIOR BEAM - Continuous (PRESTRESSED BULB TEE BEAM - Composite Section)

### Table of Contents

1. MATERIALS PROPERTIES	
1.1 CONCRETE FOR BEAMS	
1.2 CONCRETE FOR SLAB	
1.3 REINFORCEMENT STEEL	
2. LIMIT STATE FACTORS (AASHTO 6.5.4.2)	
2.1 Steel	
3. GEOMETRIC PROPERTIES	
3.1 GENERAL	
3.2 SPANS 1	
3.2.1 CONCRETE BEAM	
3.2.2 COMPOSITE SECTION	
3.2.3 STRANDS CONFIGURATION	
3.2.4 CONCRETE SLAB	
3.3 SPAN 2	
3.3.1 CONCRETE BEAM	
3.3.2 COMPOSITE SECTION	
3.3.3 STRANDS CONFIGURATION	
3.3.4 CONCRETE SLAB	
4. LOADS	
4.1 CONSTRUCTION STAGE (NON COMPOSITE)	
4.1.1 DEAD LOAD (DC)	
4.1.2 LIVE LOAD (LL)	
4.2 SERVICE STAGE (COMPOSITE)	
4.2.1 DEAD LOAD (DC)	
4.2.2 DEAD LOAD WEARING SURFACE (DW)	
4.2.3 LIVE LOAD (LL) - (According to AASHTO 3.6.1.2)	
4.3 FATIGUE AND FRACTURE (COMPOSITE)	
5. LOAD COMBINATIONS	
6. COMBINED LOAD EFFECTS	
6.1 CONSTRUCTABILITY	
6.1.1 Combined Shear and Moments	
6.2 COMPOSITE SECTION (OPERATION)	
6.2.1 Combined Shear and Moments	
6.2.2 Design Shear and Moments	
7. LOSS OF PRESTRESS (AASHTO 5.9.5)	
7.1 STRESS LIMITS FOR PRESTRESSING TENDONS (AASHTO 5.9.3)	
7.2 STRESS LIMITS IN PRESTRESSED CONCRETE (AASHTO 5.9.4)	
7.2.1 Before Losses	
7.2.2 At Service Limit State After Losses	
7.3 INSTANTANEOUS LOSSES	
7.3.1 Elastic Shortening (5.9.5.2.3)	
7.4 TIME DEPENDANT LOSSES (5.9.5.3)	
7.5 STRESS IN PRESTRESSING STEEL AT NOMINAL FLEXURAL RESISTANCE (5.7.3.1)	
7.6 TRANSFER AND DEVELOPMENT LENGTH	
7.7 PRESTRESSING STRAND FORCES	
7.7.1 AT TRANSFER	
7.7.2 AFTER LOSSES	
7.7.3 AT THE NOMINAL FLEXURAL RESISTANCE	
8. FLEXURE DESIGN	
8.1 FLEXURAL STRESSES AT TRANSFER	
8.2 FLEXURAL STRESSES CONSTRUCTION STAGE	
8.3 FLEXURAL STRESSES UNDER SERVICE LIMIT STATES	
8.4 FLEXURAL STRESSES UNDER FATIGUE LIMIT STATE	
8.5 DESIGN FOR STRENGTH LIMIT STATE (5.7.3.1 and 5.7.3.2)	
8.5.1 POSITIVE MOMENT ZONES	
8.5.2 NEGATIVE MOMENT ZONES (AASHTO 5.7.3.2)	
9. SHEAR DESIGN (AASHTO 5.8)	
9.1 GENERAL REQUIREMENTS (5.8.1)	
9.2 SECTIONAL DESIGN MODEL	
9.3 MINIMUM LONGITUDINAL STEEL (AASHTO 5.8.3.5)	
9.4 HORIZONTAL SHEAR (AASHTO 5.8.4)	
10. CONTINUITY CONNECTION IN THE NEGATIVE MOMENT ZONES	
10.1 NEGATIVE MOMENT CONNECTION (AASHTO 5.7.3.2)	
10.2 POSITIVE MOMENT CONNECTION (AASHTO 5.14.1.4)	
11. PRETENSIONED ANCHORAGE ZONES (AASHTO 5.10.10.1)	
12. CONFINEMENT REINFORCEMENT (AASHTO 5.10.10.2)	
13. DEFORMATIONS	
13.1 CAMBER (AASHTO 5.7.3.6.2)	
13.2 PERMANENT DEFLECTION - According to AASHTO 3.6.1.3.2	

## DESIGN OF INTERIOR BEAM - Continuous (PRESTRESSED BULB TEE BEAM - Composite Section)

AASHTO LRFD Bridge Design Specifications U.S. Customary Units, Seventh Edition, 2014

### 1. MATERIALS PROPERTIES

#### 1.1 CONCRETE FOR BEAMS

$f'_{ci}$ (At transfer)=	6.00 ksi
$f'_c$ =	7.00 ksi
$E_{ci}$ (At transfer)=	4696 ksi
$E_c$ =	5072 ksi
$\chi_c$ =	0.150 kip/ft <sup>3</sup>

#### 1.2 CONCRETE FOR SLAB

$f'_c$ =	4.00 ksi
$E_{CS}$ =	3834 ksi
$E_C/E_{CS}(n)$ =	1.32
$\chi_{cs}$ =	0.150 kip/ft <sup>3</sup>

#### 1.3 REINFORCEMENT STEEL

AASHTO A615, Grade 60

$F_y$ =	60 ksi
$F_u$ =	80 ksi
$E_s$ =	29000 ksi
$\chi_s$ =	0.490 kip/ft <sup>3</sup>

#### 1.4 PRESTRESSING STRAND

Type=	Low Relaxation Strand
$F_{yPS}$ =	243 ksi
$F_{uPS}$ =	270 ksi
$E_{PS}$ =	28500 ksi
$\chi_{sPS}$ =	0.490 kip/ft <sup>3</sup>

#### 1.5 ATMOSPHERIC PARAMETERS

Time of Transfer=	1.00 Day
Average Humidity=	70%

Corrosive Conditions= Moderate

### 2. LIMIT STATE FACTORS (AASHTO 6.5.4.2)

#### 2.1 Steel

$\phi_{Flexure}$ =	1.00	$\phi_{Shear Conn}$ =	0.85
$\phi_{Shear}$ =	1.00	$\phi_{Bolt Tension}$ =	0.80
$\phi_{Compression}$ =	0.90	$\phi_{Bolt Shear}$ =	0.80
$\phi_{Tens Fracture}$ =	0.80	$\phi_{Block Shear}$ =	0.80
$\phi_{Tens Yielding}$ =	0.95	$\phi_{bearing}$ =	1.00
$\phi_{Bolt bearing}$ =	0.80	$\phi_{Welds}$ =	0.80

### 3. GEOMETRIC PROPERTIES

#### 3.1 GENERAL

Slab Thickness (e)=	8.00 in
Sacrificial Surface (sw)=	0.50 in
Haunch (hu)=	0.50 in
Dist Brg to Brg (Lb) Span 1=	108.50 ft
Dist Brg to Brg (Lb) Span 2=	108.50 ft

Overall Length=	220.00 ft
Span 1 Length=	110.00 ft
Span 2 Length=	110.00 ft
Bent Length=	0.50 ft
Dist to bearing End Spans=	0.50 ft

Diaphragm Thickness=	0.00 in
$S_{overhang}$ =	2.50 ft
Beams Separation (S)=	9.50 ft
Number of Beams (N)=	5.00 beams
Unbraced Length ( $L_b$ )=	0.00 ft
Distance to end of beam=	0.50 ft
Dist to bearing Mid span=	1.00 ft

### 3.2 SPANS 1

#### 3.2.1 CONCRETE BEAM

TYPE= HBULBTEE

Section= HBT 66x61

d=	66.00 in
$b_{fb}$ =	40.00 in
$T_{fb}$ =	5.50 in

$b_{ft}$ =	61.00 in	$T_w$ =	8.00 in	Perimeter=	211.73 in
$T_{ft}$ =	4.00 in	$H_w$ =	45.50 in		17.64 ft

$K_{ft}$ =	4.00 in
$K_{fb}$ =	7.00 in
$A_T$ =	1172.40 in <sup>2</sup>
$I_x$ =	729521.00 in <sup>4</sup>
$x_{cb}$ =	34.30 in
$S_{cb}$ =	21268.83 in <sup>3</sup>
$r_x$ =	24.94 in
$x_{ct}$ =	31.70 in
$S_{ct}$ =	23013.28 in <sup>3</sup>
Weight=	1222.00 lb

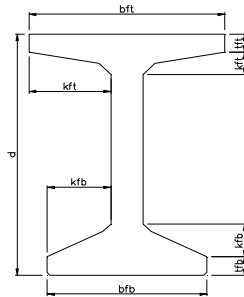

#### 3.2.2 COMPOSITE SECTION

Height of Steel Deck Rib (f)=	0.00 in
Effective Conc Height (f')=	7.50 in
Effective Width (be)=	9.50 ft

(AASHTO 4.6.2.6)

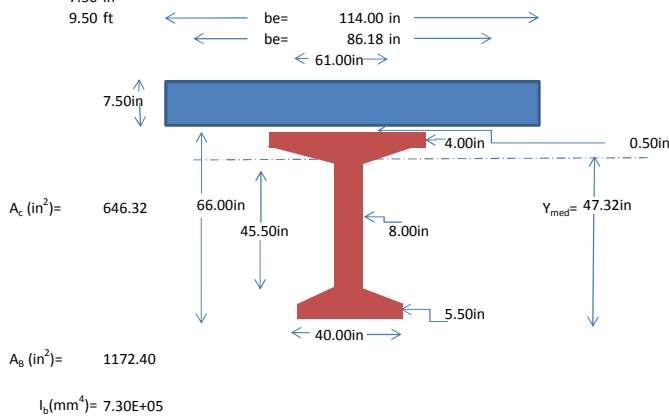

Section	Area (in <sup>2</sup> )	y (in)	A.y (in <sup>3</sup> )	I <sub>xx</sub> (in <sup>4</sup> )	d <sub>y</sub> (in)	A.d <sub>y</sub> <sup>2</sup> (in <sup>4</sup> )
Beam	1172.40	34.30	4.02E+04	7.30E+05	-13.02	1.99E+05
Haunch	23.06	66.25	1.53E+03	4.80E-01	18.93	8.27E+03
Slab	646.32	70.25	4.54E+04	3.03E+03	22.93	3.40E+05

Position	y (in)	S (in <sup>3</sup> )
Top Slab	26.68	6.34E+04
Top Beam	18.68	6.85E+04
Bott Beam	47.32	2.70E+04

A<sub>T</sub>= 1841.78 in<sup>2</sup>  
y= 47.32 in  
I<sub>xx</sub>= 1.28E+06 in<sup>4</sup>

3.2.3 STRANDS CONFIGURATION

3.2.3.1 Ends

Distance from the bottom of the beam to the center of strands

Concrete Cover= 1.75 in  
Strands Separation= 2.00 in  
Draped Strands? Yes  
Draped Length= 20.00 ft  
Debonded Strands? No

Strands Diameter= 1/2 in  
Type= Seven Wire Strand (270)  
Strands Area= 0.15 in<sup>2</sup>  
Top Beam to 1st Strand= 5.00 in

Row	Location	Strands	Debonded	Bonded
1	2.00	17.00	0.00	17.00
2	4.00	19.00	0.00	19.00
3	6.00	4.00	0.00	4.00
4	8.00	0.00	0.00	0.00
5	10.00	0.00	0.00	0.00
6	12.00	0.00	0.00	0.00
7	14.00	0.00	0.00	0.00
8	16.00	0.00	0.00	0.00

Row	Location	Bonded
1	47.00	0.00
2	49.00	0.00
3	51.00	0.00
4	53.00	0.00
5	55.00	0.00
6	57.00	0.00
7	59.00	0.00
8	61.00	3.00

Row	Debonded	Bonded
1	0.00	0.00
2	0.00	0.00
3	0.00	0.00
4	0.00	0.00
5	0.00	0.00
6	0.00	0.00
7	0.00	0.00
8	0.00	0.00

3.2.3.2 Mid Span

Row	Location	Strands
1	2.00	17.00
2	4.00	19.00
3	6.00	7.00
4	8.00	0.00
5	10.00	0.00
6	12.00	0.00
7	14.00	0.00
8	16.00	0.00

Row	Location	Strands
1	47.00	0.00
2	49.00	0.00
3	51.00	0.00
4	53.00	0.00
5	55.00	0.00
6	57.00	0.00
7	59.00	0.00
8	61.00	0.00

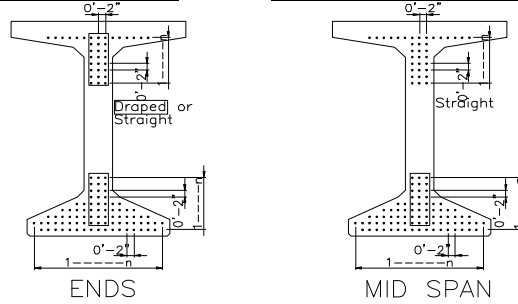

3.2.4 CONCRETE SLAB

Top

Rebar Number (#)= 5 /8"  
Rebar Spacing (s)= 4.00 in  
A<sub>REBAR</sub>= 0.31 in<sup>2</sup>  
A<sub>REB TOP</sub>= 0.92 in<sup>2</sup>/ft

Top Compression Region (Extra Reinf)

Rebar Number (#)= 0 /8"  
Rebar Spacing (s)= 8.00 in  
A<sub>REBAR</sub>= 0.00 in<sup>2</sup>  
A<sub>REB EXTRA TOP</sub>= 0.00 in<sup>2</sup>/ft

Cover<sub>TOP</sub>= 2.50 in

Cover<sub>BOT</sub>= 1.00 in

Bottom

Rebar Number (#)= 5 /8"  
Rebar Spacing (s)= 6.00 in  
A<sub>REBAR</sub>= 0.31 in<sup>2</sup>  
A<sub>REB BOT</sub>= 0.61 in<sup>2</sup>/ft

Bottom Compression Region (Extra Reinf)

Rebar Number (#)= 6 /8"  
Rebar Spacing (s)= 6.00 in  
A<sub>REBAR</sub>= 0.44 in<sup>2</sup>  
A<sub>REB EXTRA BOT</sub>= 0.88 in<sup>2</sup>/ft

Measured to edge of top reinforcement

Measured to edge of Bottom reinforcement

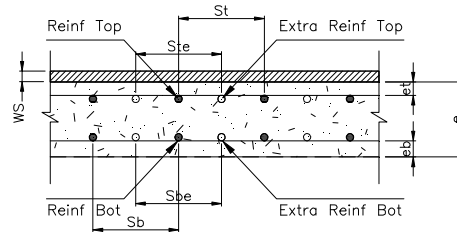

NEGATIVE MOMENT REGION

Total Reinf Top (A<sub>sTop</sub>)= 7.98 in<sup>2</sup>  
Dist From Bot of Beam= 71.19 in  
Equivalent Dist Slab Reinf= 69.11 in

Total Reinf Bot (A<sub>sBot</sub>)= 12.73 in<sup>2</sup>  
Dist From Bot of Beam= 67.81 in

MID SPAN REGION

Total Reinf Top (A<sub>sTop</sub>)= 7.98 in<sup>2</sup>  
Dist From Bot of Beam= 71.19 in  
Equivalent Dist Slab Reinf= 69.85 in

Total Reinf Bot (A<sub>sBot</sub>)= 5.22 in<sup>2</sup>  
Dist From Bot of Beam= 67.81 in

**3.3 SPAN 2**

**3.3.1 CONCRETE BEAM**

TYPE= HBULBTEE

Section= HBT 66x61

d= 66.00 in  
b<sub>fb</sub>= 40.00 in      b<sub>ft</sub>= 61.00 in      T<sub>w</sub>= 8.00 in  
T<sub>fb</sub>= 5.50 in      T<sub>ft</sub>= 4.00 in      H<sub>w</sub>= 45.50 in

K<sub>ft</sub>= 4.00 in  
K<sub>fb</sub>= 7.00 in  
A<sub>T</sub>= 1172.40 in<sup>2</sup>  
I<sub>x</sub>= 729521.00 in<sup>4</sup>  
x<sub>sb</sub>= 34.30 in  
S<sub>xb</sub>= 21268.83 in<sup>3</sup>  
r<sub>xb</sub>= 24.94 in  
x<sub>st</sub>= 31.70 in  
S<sub>xt</sub>= 23013.28 in<sup>3</sup>  
Weight= 1222.00 lb

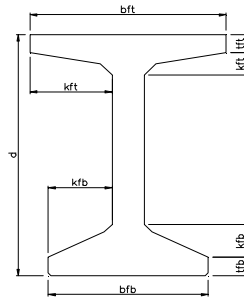

**3.3.2 COMPOSITE SECTION**

Height of Steel Deck Rib (f)= 0.00 in  
Effective Conc Height (f')= 7.50 in  
Effective Width (be)= 9.50 ft  
(AASHTO 4.6.2.6)

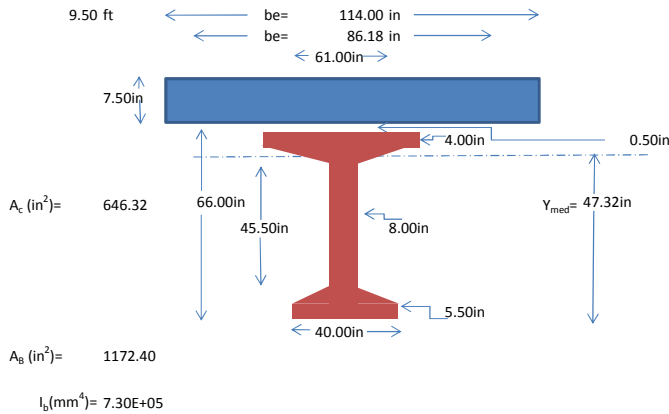

A<sub>c</sub> (in<sup>2</sup>)= 646.32

A<sub>b</sub> (in<sup>2</sup>)= 1172.40

I<sub>y</sub> (mm<sup>4</sup>)= 7.30E+05

Section	Area (in <sup>2</sup> )	y (in)	A.y (in <sup>3</sup> )	I <sub>xx</sub> (in <sup>4</sup> )	d <sub>y</sub> (in)	A.d <sub>y</sub> <sup>2</sup> (in <sup>4</sup> )
Beam	1172.40	34.30	4.02E+04	7.30E+05	-13.02	1.99E+05
Haunch	23.06	66.25	1.53E+03	4.80E-01	18.93	8.27E+03
Slab	646.32	70.25	4.54E+04	3.03E+03	22.93	3.40E+05

Position	y (in)	S (in <sup>3</sup> )
Top Slab	26.68	6.34E+04
Top Beam	18.68	6.85E+04
Bott Beam	47.32	2.70E+04

A<sub>T</sub>= 1841.78 in<sup>2</sup>  
y= 47.32 in  
I<sub>xx</sub>= 1.28E+06 in<sup>4</sup>

**3.3.3 STRANDS CONFIGURATION**

**3.3.3.1 Ends**

Distance from the bottom of the beam to the center of strands

Concrete Cover= 1.75 in      Strands Diameter= 1/2 in  
Strands Separation= 2.00 in      Type= Seven Wire Strand (270)  
Draped Strands? Yes      Strands Area= 0.15 in<sup>2</sup>  
Draped Length= 20.00 ft      Top Beam to 1st Strand= 5.00 in  
Debonded Strands? No

Row	Location	Strands	Debonded	Bonded
1	2.00	17.00	0.00	17.00
2	4.00	19.00	0.00	19.00
3	6.00	4.00	0.00	4.00
4	8.00	0.00	0.00	0.00
5	10.00	0.00	0.00	0.00
6	12.00	0.00	0.00	0.00
7	14.00	0.00	0.00	0.00
8	16.00	0.00	0.00	0.00

**Draped Strands**

Row	Location	Bonded
1	47.00	0.00
2	49.00	0.00
3	51.00	0.00
4	53.00	0.00
5	55.00	0.00
6	57.00	0.00
7	59.00	0.00
8	61.00	3.00

**Top Strands**

Row	Debonded	Bonded
1	0.00	0.00
2	0.00	0.00
3	0.00	0.00
4	0.00	0.00
5	0.00	0.00
6	0.00	0.00
7	0.00	0.00
8	0.00	0.00

3.3.3.2 Mid Span

Row	Location	Strands
1	2.00	17.00
2	4.00	19.00
3	6.00	7.00
4	8.00	0.00
5	10.00	0.00
6	12.00	0.00
7	14.00	0.00
8	16.00	0.00

Top Strands

Row	Location	Strands
1	47.00	0.00
2	49.00	0.00
3	51.00	0.00
4	53.00	0.00
5	55.00	0.00
6	57.00	0.00
7	59.00	0.00
8	61.00	0.00

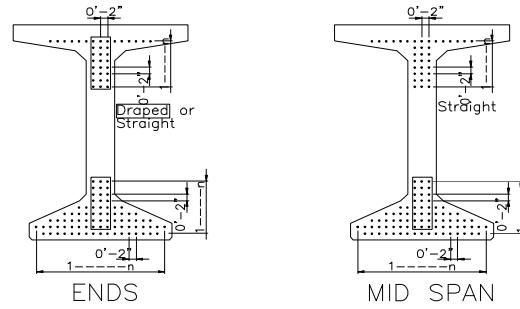

3.3.4 CONCRETE SLAB

Top

Rebar Number (#)= 5 / 8"  
 Rebar Spacing (s)= 4.00 in  
 $A_{REBAR} = 0.31 \text{ in}^2$   
 $A_{REB\ TOP} = 0.92 \text{ in}^2/\text{ft}$

**Top Compression Region (Extra Reinf)**  
 Rebar Number (#)= 0 / 8"  
 Rebar Spacing (s)= 8.00 in  
 $A_{REBAR} = 0.00 \text{ in}^2$   
 $A_{REB\ EXTRA\ TOP} = 0.00 \text{ in}^2/\text{ft}$

Cover<sub>TOP</sub>= 2.50 in Measured to edge of top reinforcement  
 Cover<sub>BOT</sub>= 1.00 in Measured to edge of Bottom reinforcement

Bottom

Rebar Number (#)= 5 / 8"  
 Rebar Spacing (s)= 6.00 in  
 $A_{REBAR} = 0.31 \text{ in}^2$   
 $A_{REB\ BOT} = 0.61 \text{ in}^2/\text{ft}$

**Bottom Compression Region (Extra Reinf)**  
 Rebar Number (#)= 6 / 8"  
 Rebar Spacing (s)= 6.00 in  
 $A_{REBAR} = 0.44 \text{ in}^2$   
 $A_{REB\ EXTRA\ BOT} = 0.88 \text{ in}^2/\text{ft}$

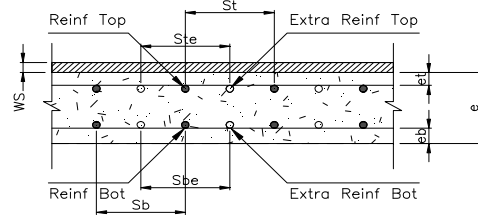

NEGATIVE MOMENT REGION

Total Reinf Top ( $A_{STOP}$ )=	7.98 in <sup>2</sup>	Total Reinf Bot ( $A_{SBOT}$ )=	12.73 in <sup>2</sup>
Dist From Bot of Beam=	71.19 in	Dist From Bot of Beam=	67.81 in
Equivalent Dist Slab Reinf=	69.11 in		

MID SPAN REGION

Total Reinf Top ( $A_{STOP}$ )=	7.98 in <sup>2</sup>	Total Reinf Bot ( $A_{SBOT}$ )=	5.22 in <sup>2</sup>
Dist From Bot of Beam=	71.19 in	Dist From Bot of Beam=	67.81 in
Equivalent Dist Slab Reinf=	69.85 in		

4. LOADS

4.1 CONSTRUCTION STAGE (NON COMPOSITE)

4.1.1 DEAD LOAD (DC)

(Common Value used see Virginia DOT and FHWA examples)

**Distributed Loads**

	SPAN 1
Beam self-weight=	1.222 kip/ft
Concrete Deck=	0.950 kip/ft
Concrete Haunch=	0.032 kip/ft
Stay-in-Place Forms=	0.015 kip/ft
Diaphragms=	0.000 kip/girder
<b>Total DC=</b>	<b>2.22 kip/ft</b>

4.1.2 LIVE LOAD (LL)

Construction Live Load= 0.020 kip/ft<sup>2</sup> (Common Value used see FHWA examples)  
 Distributed Loads  
 Construction Live Load= 0.190 kip/ft

Correspond to a diaphragms located along the length of the beam, it is considered as a punctual load acting on each location.

SPAN 1											
UNFACTORED SHEARS (Kips)											
LOAD COMPONENT	LOCATION										
	0.0L	0.1L	0.2L	0.3L	0.4L	0.5L	0.6L	0.7L	0.8L	0.9L	1.0L
Steel Beam self-weight	67.21	53.95	40.69	27.43	14.18	0.92	-12.34	-25.60	-38.86	-52.12	-65.38
Concrete Deck	52.25	41.94	31.64	21.33	11.02	0.71	-9.59	-19.90	-30.21	-40.52	-50.83
Concrete Haunch	1.75	1.40	1.06	0.71	0.37	0.02	-0.32	-0.67	-1.01	-1.36	-1.70
Stay-in-Place Forms	0.83	0.66	0.50	0.34	0.17	0.01	-0.15	-0.31	-0.48	-0.64	-0.80
Miscellaneous	0.00	0.00	0.00	0.00	0.00	0.00	0.00	0.00	0.00	0.00	0.00
<b>Total DC</b>	<b>122.03</b>	<b>97.96</b>	<b>73.89</b>	<b>49.81</b>	<b>25.74</b>	<b>1.66</b>	<b>-22.41</b>	<b>-46.48</b>	<b>-70.56</b>	<b>-94.63</b>	<b>-118.70</b>
Construction Live Load	10.31	8.25	6.18	4.12	2.06	0.00	-2.06	-4.12	-6.18	-8.25	-10.31
UNFACTORED MOMENTS (Kips-ft)											
LOAD COMPONENT	LOCATION										
	0.0L	0.1L	0.2L	0.3L	0.4L	0.5L	0.6L	0.7L	0.8L	0.9L	1.0L
Steel Beam self-weight	0.00	647.36	1150.86	1510.50	1726.28	1798.21	1726.28	1510.50	1150.86	647.36	0.00
Concrete Deck	0.00	503.26	894.69	1174.28	1342.04	1397.95	1342.04	1174.28	894.69	503.26	0.00
Concrete Haunch	0.00	16.83	29.92	39.27	44.88	46.75	44.88	39.27	29.92	16.83	0.00
Stay-in-Place Forms	0.00	7.95	14.13	18.54	21.19	22.07	21.19	18.54	14.13	7.95	0.00
Miscellaneous	0.00	0.00	0.00	0.00	0.00	0.00	0.00	0.00	0.00	0.00	0.00
<b>Total DC</b>	<b>0.00</b>	<b>1175.40</b>	<b>2089.59</b>	<b>2742.59</b>	<b>3134.39</b>	<b>3264.99</b>	<b>3134.39</b>	<b>2742.59</b>	<b>2089.59</b>	<b>1175.40</b>	<b>0.00</b>
Construction Live Load	0.00	100.65	178.94	234.86	268.41	279.59	268.41	234.86	178.94	100.65	0.00

SPAN 2											
UNFACTORED SHEARS (Kips)											
LOAD COMPONENT	LOCATION										
	0.0L	0.1L	0.2L	0.3L	0.4L	0.5L	0.6L	0.7L	0.8L	0.9L	1.0L
Steel Beam self-weight	66.29	53.03	39.78	26.52	13.26	0.00	-13.26	-26.52	-39.78	-53.03	-66.29
Concrete Deck	51.54	41.23	30.92	20.62	10.31	0.00	-10.31	-20.62	-30.92	-41.23	-51.54
Concrete Haunch	1.72	1.38	1.03	0.69	0.34	0.00	-0.34	-0.69	-1.03	-1.38	-1.72
Stay-in-Place Forms	0.81	0.65	0.49	0.33	0.16	0.00	-0.16	-0.33	-0.49	-0.65	-0.81
Miscellaneous	0.00	0.00	0.00	0.00	0.00	0.00	0.00	0.00	0.00	0.00	0.00
<b>Total DC</b>	<b>120.37</b>	<b>96.29</b>	<b>72.22</b>	<b>48.15</b>	<b>24.07</b>	<b>0.00</b>	<b>-24.07</b>	<b>-48.15</b>	<b>-72.22</b>	<b>-96.29</b>	<b>-120.37</b>
Construction Live Load	10.31	8.36	6.27	4.18	2.09	0.00	-2.09	-4.18	-6.27	-8.36	-10.45
UNFACTORED MOMENTS (Kips-ft)											
LOAD COMPONENT	LOCATION										
	0.0L	0.1L	0.2L	0.3L	0.4L	0.5L	0.6L	0.7L	0.8L	0.9L	1.0L
Steel Beam self-weight	0.00	647.36	1150.86	1510.50	1726.28	1798.21	1726.28	1510.50	1150.86	647.36	0.00
Concrete Deck	0.00	503.26	894.69	1174.28	1342.04	1397.95	1342.04	1174.28	894.69	503.26	0.00
Concrete Haunch	0.00	16.83	29.92	39.27	44.88	46.75	44.88	39.27	29.92	16.83	0.00
Stay-in-Place Forms	0.00	7.95	14.13	18.54	21.19	22.07	21.19	18.54	14.13	7.95	0.00
Miscellaneous	0.00	0.00	0.00	0.00	0.00	0.00	0.00	0.00	0.00	0.00	0.00
<b>Total DC</b>	<b>0.00</b>	<b>1175.40</b>	<b>2089.59</b>	<b>2742.59</b>	<b>3134.39</b>	<b>3264.99</b>	<b>3134.39</b>	<b>2742.59</b>	<b>2089.59</b>	<b>1175.40</b>	<b>0.00</b>
Construction Live Load	0.00	100.65	178.94	234.86	268.41	279.59	268.41	234.86	178.94	100.65	0.00

4.2 SERVICE STAGE (COMPOSITE)

4.2.1 DEAD LOAD (DC)

Rail Barriers= 0.30 kip/ft/Barrier  
 Distributed Loads  
 Rail Barriers\* = 0.12 kip/ft  
 Total DC= 0.12 kip/ft

\*Distributed equally to every beam

4.2.3 LIVE LOAD (LL) - (According to AASHTO 3.6.1.2)

Live load is composed by the following:

i) Design Truck or design Tandem (pair of 25kips axles spaced 4ft apart)

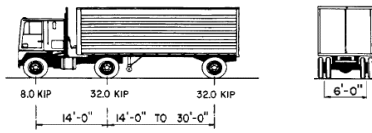

ii) Design lane load (The design lane load shall consist of a load of 0.64 klf uniformly distributed in the longitudinal direction. Transversely, the design lane load shall be assumed to be uniformly distributed over a 10.0-ft width.)

4.2.2 DEAD LOAD WEARING SURFACE (DW)

Future Wearing Surface= 0.025 kip/ft<sup>2</sup> (Common Value used see FHWA examples)  
 Distributed Loads  
 Future Wearing Surface= 0.215 kip/ft (Distribution is made proportionally to the afferent width)  
 Total DW= 0.22 kip/ft

The extreme force effect shall be taken as the larger of the following:

- I) The effect of the design tandem combined with the effect of the design lane load, or
- II) The effect of one design truck with the variable axle spacing specified in Article 3.6.1.2.2, combined with the effect of the design lane load, and
- III) For negative moment between points of contraflexure under a uniform load on all spans, and reaction at interior piers only, 90 percent of the effect of two design trucks spaced a minimum of 50.0 ft between the lead axle of one truck and the rear axle of the other truck, combined with 90 percent of the effect of the design lane load. The distance between the 32.0-kip axles of each truck shall be taken as 14.0 ft

Dyn Load Allowance (IM)= 33% AASHTO Table 3.6.2.1-1  
 Dyn Load Allowance Fatigue (IM)= 15% AASHTO Table 3.6.2.1-1

a) LOAD DISTRIBUTION FACTORS

Multiple Presence Factor= 1.00 2 Lanes  
 Skew= 0°

e<sub>g</sub> (Dist CG Beam and CG deck)  
 K<sub>g</sub> (Longitudinal Stiffness Parameter)

$$K_g = n \left( I + A e_g^2 \right)$$

SPAN	e <sub>g</sub> (in)	K <sub>g</sub> (in <sup>4</sup> )
Span 1	35.95	2.97E+06
Span 2	35.95	2.97E+06

Moment (See AASHTO Table 4.6.2.2.2b-1)

$$r = 1 - c_1 (\tan \theta)^{1.5} \quad m_{g_{Mp}}^{SI} = 0.06 + \left(\frac{S}{14}\right)^{0.4} \left(\frac{S}{L}\right)^{0.3} \left(\frac{K_g}{12L_t S^3}\right)^{0.1} \quad \text{One Lane Loaded} \quad m_{g_M}^{SI} = r m_{g_{Mp}}^{SI}$$

$$c_1 = 0.25 \left(\frac{K_g}{12L_t S^3}\right)^{0.25} \left(\frac{S}{L}\right)^{0.5} \quad m_{g_{Mp}}^{MI} = 0.075 + \left(\frac{S}{9.5}\right)^{0.6} \left(\frac{S}{L}\right)^{0.2} \left(\frac{K_g}{12L_t S^3}\right)^{0.1} \quad \text{Multiple Lane Loaded} \quad m_{g_M}^{MI} = r m_{g_{Mp}}^{MI}$$

SPAN	c <sub>1</sub>	r	m <sub>g<sub>M</sub></sub> <sup>SI</sup>	m <sub>g<sub>M</sub></sub> <sup>MI</sup>	g <sub>M</sub> <sup>SI Fatigue</sup>
SPAN 1	0.00	1.00	0.55	0.80	0.45
SPAN 2	0.00	1.00	0.55	0.80	0.45

Shear (See AASHTO Table 4.6.2.2.3a-1)

$$r = 1.0 + 0.20 \left(\frac{12L_t S^3}{K_g}\right)^{0.3} \tan \theta \quad m_{g_{Vp}}^{SI} = 0.36 + \frac{S}{25} \quad \text{One Lane Loaded} \quad m_{g_V}^{SI} = r m_{g_{Vp}}^{SI}$$

$$m_{g_{Vp}}^{SI} = 0.20 + \frac{S}{12} - \left(\frac{S}{35}\right)^{2.0} \quad \text{Multiple Lane Loaded} \quad m_{g_V}^{SI} = r m_{g_{Vp}}^{SI}$$

SPAN	r	m <sub>g<sub>V</sub></sub> <sup>SI</sup>	m <sub>g<sub>V</sub></sub> <sup>MI</sup>	g <sub>V</sub> <sup>SI Fatigue</sup>
SPAN 1	1.00	0.74	0.92	0.62
SPAN 2	1.00	0.74	0.92	0.62





SPAN 1											
UNFACTORED SHEARS (Kips)											
LOAD COMPONENT	LOCATION										
	0.0L	0.1L	0.2L	0.3L	0.4L	0.5L	0.6L	0.7L	0.8L	0.9L	1.0L
LL + IM	39.74	34.31	28.99	23.87	19.00	22.05	26.83	31.29	35.35	38.94	42.01
UNFACTORED MOMENTS (Kips-ft)											
LOAD COMPONENT	LOCATION										
	0.0L	0.1L	0.2L	0.3L	0.4L	0.5L	0.6L	0.7L	0.8L	0.9L	1.0L
Truck max	0.16	365.75	618.05	767.12	828.93	814.01	731.75	578.29	369.48	131.87	0.08
Truck min	0.00	-43.60	-87.19	-130.79	-174.38	-217.98	-261.57	-305.17	-348.77	-392.36	-435.96
LL + IM	0.16	409.35	705.24	897.91	1003.32	1031.99	993.32	883.46	718.25	524.23	436.04

SPAN 2											
UNFACTORED SHEARS (Kips)											
LOAD COMPONENT	LOCATION										
	0.0L	0.1L	0.2L	0.3L	0.4L	0.5L	0.6L	0.7L	0.8L	0.9L	1.0L
LL + IM	42.01	38.94	35.35	31.29	26.83	22.05	19.00	23.87	28.99	34.31	39.74
UNFACTORED MOMENTS (Kips-ft)											
LOAD COMPONENT	LOCATION										
	0.0L	0.1L	0.2L	0.3L	0.4L	0.5L	0.6L	0.7L	0.8L	0.9L	1.0L
Truck max	0.08	131.87	369.48	578.29	731.75	814.01	828.93	767.12	618.05	365.75	0.16
Truck min	-435.96	-392.36	-348.77	-305.17	-261.57	-217.98	-174.38	-130.79	-87.19	-43.60	0.00
LL + IM	436.04	524.23	718.25	883.46	993.32	1031.99	1003.32	897.91	705.24	409.35	0.16

5. LOAD COMBINATIONS

COMBINATION	Type	LOAD CASES										
		DC	DW	LL	IM	BR	WS	WL	FR	TU	TG	IC
Strength I	Max	1.25	1.50	1.75	1.75	1.75	-	-	1.00	1.20	-	-
	Min	0.90	0.65	1.75	1.75	1.75	-	-	1.00	0.50	-	-
Strength III	Max	1.25	1.50	-	-	-	1.40	-	1.00	1.20	-	-
	Min	0.90	0.65	-	-	-	-	-	1.00	0.50	-	-
Strength IV	Max	1.50	1.50	-	-	-	-	-	-	-	-	-
	Min	0.90	0.90	-	-	-	-	-	-	-	-	-
Strength V	Max	1.25	1.50	1.35	1.35	1.35	0.40	1.00	1.00	1.20	-	-
	Min	0.90	0.65	1.35	1.35	1.35	-	1.00	1.00	0.50	-	-
Extreme Event II	Max	1.25	1.50	0.50	0.50	0.50	-	-	1.00	-	-	1.00
	Min	0.90	0.65	0.50	0.50	0.50	-	-	1.00	-	-	1.00
Service I	Max	1.00	1.00	1.00	1.00	1.00	0.30	1.00	1.00	1.00	0.50	-
	Min	1.00	1.00	1.00	1.00	1.00	-	1.00	1.00	1.20	0.50	-
Service III	Max	1.00	1.00	0.80	0.80	0.80	-	-	1.00	1.00	0.50	-
	Min	1.00	1.00	0.80	0.80	0.80	-	-	1.00	1.20	0.50	-
Fatigue I		-	-	1.50	1.50	1.50	-	-	-	-	-	-
Fatigue II		-	-	0.75	0.75	0.75	-	-	-	-	-	-

6. COMBINED LOAD EFFECTS

6.1 CONSTRUCTABILITY

6.1.1 Combined Shear and Moments

SPAN 1											
COMBINED LOADS - SHEARS (Kips)											
LOAD COMBINATION	LOCATION										
	0.0L	0.1L	0.2L	0.3L	0.4L	0.5L	0.6L	0.7L	0.8L	0.9L	1.0L
Service I Max	132.34	106.20	80.07	53.93	27.80	1.66	-24.47	-50.61	-76.74	-102.88	-129.01
Service III Max	130.28	104.56	78.83	53.11	27.39	1.66	-24.06	-49.78	-75.50	-101.23	-126.95
COMBINED LOADS - MOMENTS (Kips-ft)											
LOAD COMBINATION	LOCATION										
	0.0L	0.1L	0.2L	0.3L	0.4L	0.5L	0.6L	0.7L	0.8L	0.9L	1.0L
Service I Max	0.00	1276.05	2268.53	2977.45	3402.80	3544.58	3402.80	2977.45	2268.53	1276.05	0.00
Service III Max	0.00	1255.92	2232.74	2930.48	3349.12	3488.66	3349.12	2930.48	2232.74	1255.92	0.00

SPAN 2											
COMBINED LOADS - SHEARS (Kips)											
LOAD COMBINATION	LOCATION										
	0.0L	0.1L	0.2L	0.3L	0.4L	0.5L	0.6L	0.7L	0.8L	0.9L	1.0L
Service I Max	130.68	104.65	78.49	52.33	26.16	0.00	-26.16	-52.33	-78.49	-104.65	-130.82
Service III Max	128.61	104.65	78.49	52.33	26.16	0.00	-26.16	-52.33	-78.49	-104.65	-130.82
COMBINED LOADS - MOMENTS (Kips-ft)											
LOAD COMBINATION	LOCATION										
	0.0L	0.1L	0.2L	0.3L	0.4L	0.5L	0.6L	0.7L	0.8L	0.9L	1.0L
Service I Max	0.00	1276.05	2268.53	2977.45	3402.80	3544.58	3402.80	2977.45	2268.53	1276.05	0.00
Service III Max	0.00	1255.92	2232.74	2930.48	3349.12	3488.66	3349.12	2930.48	2232.74	1255.92	0.00

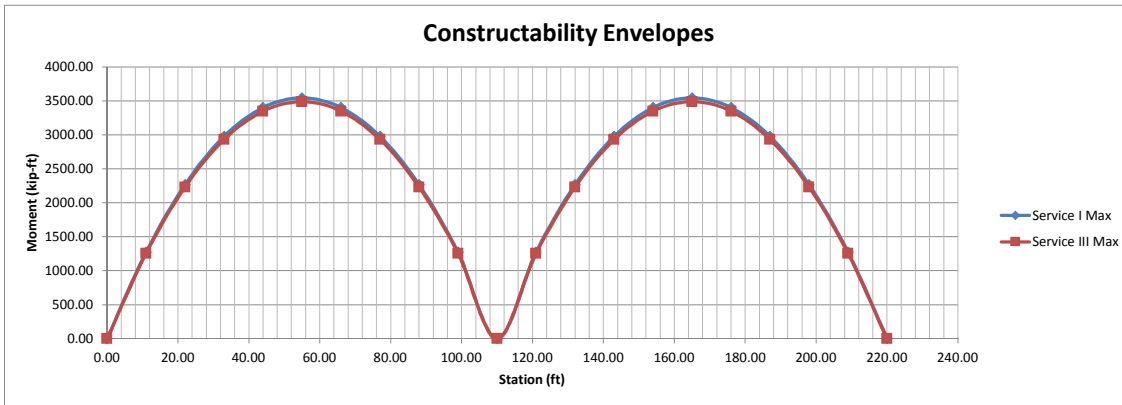

6.2 COMPOSITE SECTION (OPERATION)

6.2.1 Combined Shear and Moments

SERVICE I											
SPAN 1											
COMBINED LOADS - MOMENTS (Kips-ft)											
LOAD COMBINATION	LOCATION										
	0.0L	0.1L	0.2L	0.3L	0.4L	0.5L	0.6L	0.7L	0.8L	0.9L	1.0L
Max DL NonComposite	0.00	1175.40	2089.59	2742.59	3134.39	3264.99	3134.39	2742.59	2089.59	1175.40	0.00
Max DL Composite	0.00	134.61	228.07	280.40	291.59	261.63	190.54	78.31	-75.07	-269.58	-505.23
Max LL Composite	0.28	883.66	1505.93	1884.79	2048.32	2015.01	1801.42	1400.72	840.80	202.39	-379.96
Min LL Composite	0.00	-114.67	-229.33	-344.00	-458.66	-573.33	-688.00	-802.66	-917.33	-1136.10	-2025.39
Service I Max TOTAL	0.28	2193.66	3823.60	4907.78	5474.30	5541.64	5126.35	4221.62	2855.32	1108.21	-885.20
Service I Min TOTAL	0.00	1195.34	2088.34	2678.99	2967.31	2953.29	2636.94	2018.24	1097.20	-230.28	-2530.62
SPAN 2											
COMBINED LOADS - MOMENTS (Kips-ft)											
LOAD COMBINATION	LOCATION										
	0.0L	0.1L	0.2L	0.3L	0.4L	0.5L	0.6L	0.7L	0.8L	0.9L	1.0L
Max DL NonComposite	0.00	1175.40	2089.59	2742.59	3134.39	3264.99	3134.39	2742.59	2089.59	1175.40	0.00
Max DL Composite	-505.23	-269.58	-75.07	78.31	190.54	261.63	291.59	280.40	228.07	134.61	0.00
Max LL Composite	-379.96	202.39	840.80	1400.72	1801.42	2015.01	2048.32	1884.79	1505.93	883.66	0.28
Min LL Composite	-2025.39	-1136.10	-917.33	-802.66	-688.00	-573.33	-458.66	-344.00	-229.33	-114.67	0.00
Service I Max TOTAL	-885.20	1108.21	2855.32	4221.62	5126.35	5541.64	5474.30	4907.78	3823.60	2193.66	0.28
Service I Min TOTAL	-2530.62	-230.28	1097.20	2018.24	2636.94	2953.29	2967.31	2678.99	2088.34	1195.34	0.00
SERVICE III											
SPAN 1											
COMBINED LOADS - MOMENTS (Kips-ft)											
LOAD COMBINATION	LOCATION										
	0.0L	0.1L	0.2L	0.3L	0.4L	0.5L	0.6L	0.7L	0.8L	0.9L	1.0L
Max DL NonComposite	0.00	1175.40	2089.59	2742.59	3134.39	3264.99	3134.39	2742.59	2089.59	1175.40	0.00
Max DL Composite	0.00	134.61	228.07	280.40	291.59	261.63	190.54	78.31	-75.07	-269.58	-505.23
Max LL Composite	0.23	706.93	1204.74	1507.83	1638.66	1612.01	1441.13	1120.57	672.64	161.91	-303.97
Min LL Composite	0.00	-91.73	-183.47	-275.20	-366.93	-458.66	-550.40	-642.13	-733.86	-908.88	-1620.31
Service III Max TOTAL	0.23	2016.93	3522.41	4530.82	5064.63	5138.63	4766.06	3941.47	2687.17	1067.73	-809.20
Service III Min TOTAL	0.00	1218.27	2134.20	2747.79	3059.05	3067.96	2774.53	2178.77	1280.67	-3.06	-2125.54
SPAN 2											
COMBINED LOADS - MOMENTS (Kips-ft)											
LOAD COMBINATION	LOCATION										
	0.0L	0.1L	0.2L	0.3L	0.4L	0.5L	0.6L	0.7L	0.8L	0.9L	1.0L
Max DL NonComposite	0.00	1175.40	2089.59	2742.59	3134.39	3264.99	3134.39	2742.59	2089.59	1175.40	0.00
Max DL Composite	-505.23	-269.58	-75.07	78.31	190.54	261.63	291.59	280.40	228.07	134.61	0.00
Max LL Composite	-303.97	161.91	672.64	1120.57	1441.13	1612.01	1638.66	1507.83	1204.74	706.93	0.23
Min LL Composite	-1620.31	-908.88	-733.86	-642.13	-550.40	-458.66	-366.93	-275.20	-183.47	-91.73	0.00
Service III Max TOTAL	-809.20	1067.73	2687.17	3941.47	4766.06	5138.63	5064.63	4530.82	3522.41	2016.93	0.23
Service III Min TOTAL	-2125.54	-3.06	1280.67	2178.77	2774.53	3067.96	3059.05	2747.79	2134.20	1218.27	0.00
FATIGUE I											
SPAN 1											
COMBINED LOADS - MOMENTS (Kips-ft)											
LOAD COMBINATION	LOCATION										
	0.0L	0.1L	0.2L	0.3L	0.4L	0.5L	0.6L	0.7L	0.8L	0.9L	1.0L
Fatigue I Max TOTAL	0.24	548.63	927.08	1150.68	1243.40	1221.01	1097.62	867.43	554.22	197.80	0.12
Fatigue I Min TOTAL	0.00	-65.39	-130.79	-196.18	-261.57	-326.97	-392.36	-457.76	-523.15	-588.54	-653.94

SPAN 2											
COMBINED LOADS - MOMENTS (Kips-ft)											
LOAD COMBINATION	LOCATION										
	0.0L	0.1L	0.2L	0.3L	0.4L	0.5L	0.6L	0.7L	0.8L	0.9L	1.0L
<i>Strength I Max TOTAL</i>	0.12	197.80	554.22	867.43	1097.62	1221.01	1243.40	1150.68	927.08	548.63	0.24
<i>Strength I Min TOTAL</i>	-653.94	-588.54	-523.15	-457.76	-392.36	-326.97	-261.57	-196.18	-130.79	-65.39	0.00

STRENGTH											
SPAN 1											
COMBINED LOADS - SHEARS (Kips)											
LOAD COMBINATION	LOCATION										
	0.0L	0.1L	0.2L	0.3L	0.4L	0.5L	0.6L	0.7L	0.8L	0.9L	1.0L
<i>Strength I Max +M</i>	360.26	294.24	229.15	164.71	103.56	98.84	157.95	220.07	280.81	339.95	397.26
<i>Strength I Min -M</i>	308.05	252.97	198.83	145.34	93.98	95.16	144.49	195.66	245.46	293.66	340.03
<i>Strength III Max +M</i>	172.46	137.08	101.71	66.34	33.38	8.56	39.78	75.15	110.52	145.89	181.26
<i>Strength III Min +M</i>	120.24	95.82	71.39	46.96	23.79	4.89	26.32	50.75	75.17	99.60	124.03
<i>Strength V Max +M</i>	317.34	258.32	200.02	142.23	87.52	78.20	130.94	186.94	241.88	295.59	347.89
<i>Strength V Min +M</i>	265.12	217.05	169.70	122.85	77.93	74.53	117.48	162.54	206.54	249.30	290.66

COMBINED LOADS - MOMENTS (Kips-ft)											
LOAD COMBINATION	LOCATION										
	0.0L	0.1L	0.2L	0.3L	0.4L	0.5L	0.6L	0.7L	0.8L	0.9L	1.0L
<i>Strength I Max +M</i>	0.50	3205.68	5569.36	7122.48	7914.20	7976.87	7339.47	5990.04	3977.41	1442.84	-1378.21
<i>Strength I Min +M</i>	0.50	2703.63	4684.38	5973.72	6620.77	6657.91	6114.09	4977.39	3296.61	1213.02	-1037.92
<i>Strength I Max -M</i>	0.00	1458.61	2532.65	3222.10	3526.98	3447.28	2982.99	2134.13	900.69	-899.51	-4257.70
<i>Strength I Min -M</i>	0.00	956.56	1647.68	2073.34	2233.55	2128.31	1757.62	1121.48	219.89	-1129.33	-3917.41
<i>Strength III Max +M</i>	0.00	1659.28	2933.98	3824.10	4329.64	4450.60	4186.99	3538.79	2506.02	1088.66	-713.27
<i>Strength III Min +M</i>	0.00	1157.23	2049.01	2675.33	3036.21	3131.64	2961.62	2526.14	2049.01	858.84	-372.98
<i>Strength V Max +M</i>	0.38	2852.22	4966.98	6368.56	7094.87	7170.87	6618.90	5429.76	3641.09	1361.89	-1226.22
<i>Strength V Min +M</i>	0.38	2350.17	4082.01	5219.80	5801.44	5851.91	5393.53	4417.11	2960.29	1132.07	-885.93
<i>Strength V Max -M</i>	0.00	1504.48	2624.38	3359.70	3710.44	3676.61	3258.19	2455.20	1267.62	-445.07	-3447.55
<i>Strength V Min -M</i>	0.00	1002.43	1739.41	2210.94	2417.02	2357.64	2032.82	1442.55	586.83	-674.89	-3107.26

SPAN 2											
COMBINED LOADS - SHEARS (Kips)											
LOAD COMBINATION	LOCATION										
	0.0L	0.1L	0.2L	0.3L	0.4L	0.5L	0.6L	0.7L	0.8L	0.9L	1.0L
<i>Strength I Max +M</i>	412.80	342.56	282.89	222.15	160.03	96.76	101.48	162.63	227.07	292.16	357.66
<i>Strength I Min -M</i>	354.98	295.69	246.96	197.16	145.99	93.66	92.48	143.84	197.33	251.48	306.03
<i>Strength III Max +M</i>	183.34	147.97	112.60	77.23	41.86	6.48	31.30	64.26	99.63	135.00	170.38
<i>Strength III Min +M</i>	125.53	101.10	76.67	52.25	27.82	3.39	22.30	45.46	69.89	94.32	118.75
<i>Strength V Max +M</i>	360.35	298.08	243.96	189.02	133.02	76.12	85.44	140.15	197.94	256.24	314.86
<i>Strength V Min +M</i>	302.54	251.21	208.04	164.04	118.98	73.03	76.44	121.35	168.20	215.55	263.23

COMBINED LOADS - MOMENTS (Kips-ft)											
LOAD COMBINATION	LOCATION										
	0.0L	0.1L	0.2L	0.3L	0.4L	0.5L	0.6L	0.7L	0.8L	0.9L	1.0L
<i>Strength I Max +M</i>	-1378.21	1442.84	3977.41	5990.04	7339.47	7976.87	7914.20	7122.48	5569.36	3205.68	0.50
<i>Strength I Min +M</i>	-1037.92	1213.02	3296.61	4977.39	6114.09	6657.91	6620.77	5973.72	4684.38	2703.63	0.50
<i>Strength I Max -M</i>	-4257.70	-899.51	900.69	2134.13	2982.99	3447.28	3526.98	3222.10	2532.65	1458.61	0.00
<i>Strength I Min -M</i>	-3917.41	-1129.33	219.89	1121.48	1757.62	2128.31	2233.55	2073.34	1647.68	956.56	0.00
<i>Strength III Max +M</i>	-713.27	1088.66	2506.02	3538.79	4186.99	4450.60	4329.64	3824.10	2933.98	1659.28	0.00
<i>Strength III Min +M</i>	-372.98	858.84	1825.22	2526.14	2961.62	3131.64	3036.21	2675.33	2049.01	1157.23	0.00
<i>Strength V Max +M</i>	-1226.22	1361.89	3641.09	5429.76	6618.90	7170.87	7094.87	6368.56	4966.98	2852.22	0.38
<i>Strength V Min +M</i>	-885.93	1132.07	2960.29	4417.11	5393.53	5851.91	5801.44	5219.80	4082.01	2350.17	0.38
<i>Strength V Max -M</i>	-3447.55	-445.07	1267.62	2455.20	3258.19	3676.61	3710.44	3359.70	2624.38	1504.48	0.00
<i>Strength V Min -M</i>	-3107.26	-674.89	586.83	1442.55	2032.82	2357.64	2417.02	2210.94	1739.41	1002.43	0.00

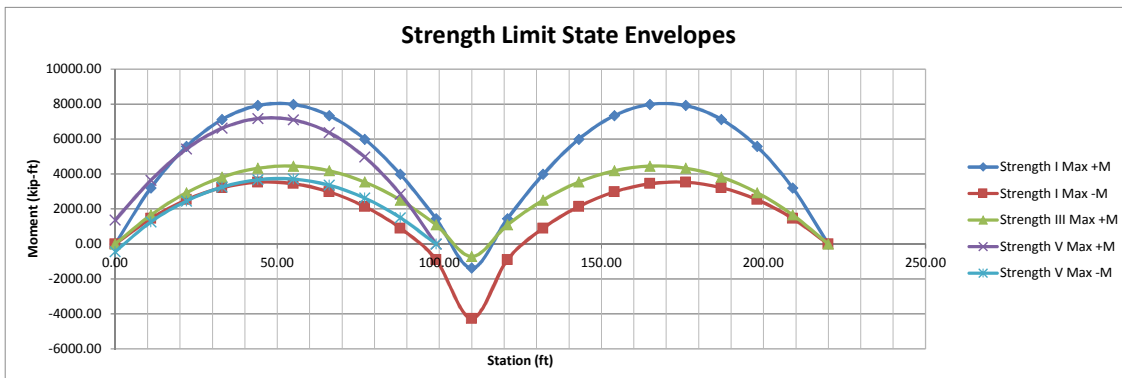

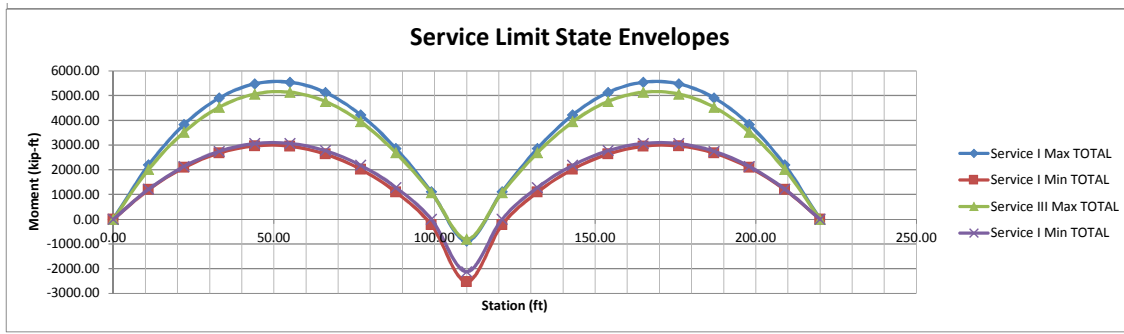

6.2.2 Design Shear and Moments

SPAN 1			
LOAD COMBINATION	SHEAR (kip)	POSITIVE MOMENT (kip-ft)	NEGATIVE MOMENT (kip-ft)
Strength I	397.26	7976.87	4257.70
Strength III	181.26	4450.60	1226.22
Strength V	347.89	7170.87	3447.55

SPAN 2			
LOAD COMBINATION	SHEAR (kip)	POSITIVE MOMENT (kip-ft)	NEGATIVE MOMENT (kip-ft)
Strength I	412.80	7976.87	4257.70
Strength III	183.34	4450.60	713.27
Strength V	360.35	7170.87	3447.55

7. LOSS OF PRESTRESS (AASHTO 5.9.5)

7.1 STRESS LIMITS FOR PRESTRESSING TENDONS (AASHTO 5.9.3)

Immediately After Transfer ( $f_{pbt}$ )= 202.50 ksi  
 Service Limit State after losses ( $f_{pe}$ )= 194.40 ksi

7.2 STRESS LIMITS IN PRESTRESSED CONCRETE (AASHTO 5.9.4)

7.2.1 Before Losses

Compression Stress ( $f_{cb}$ )= 3.60 ksi  
 Tension Stress ( $f_{tb}$ )= 0.59 ksi

7.2.2 At Service Limit State After Losses

Beam

Compression Stress (Prestress + DL) ( $f_{cap}$ )= 3.15 ksi  
 Compression Stress (PreS + DL + LL) ( $f_{cas}$ )= 4.20 ksi  
 Tension Stress ( $f_{ta}$ )= 0.50 ksi  
 Tension Stress close to supports ( $f_{ta}$ )= 0.47 ksi  
 Compression Stress {1/2 Prestress + DL}( $F_{capf}$ )= 2.80 ksi  
 Tension Stress {1/2 Prestress + DL}( $f_{tar}$ )= 0.25 ksi

Slab

Compression Stress (Prestress + DL) ( $f_{cap}$ )= 1.80 ksi  
 Compression Stress (PreS + DL + LL) ( $f_{cas}$ )= 2.40 ksi  
 Tension Stress ( $f_{ta}$ )= 0.38 ksi  
 Only regions close to the supports (AASHTO 5.14.1.4.6)  
 Only for Fatigue limit State (AASHTO 5.5.3)

7.3 INSTANTANEOUS LOSSES

7.3.1 Elastic Shortening (5.9.5.2.3)

$\Delta f_{pES} = \frac{E_{PS}}{E_{ct}} f_{cgp}$   $f_{cgp}$ = the concrete stress at the center of gravity of prestressing tendons due to the prestressing force immediately after transfer and the selfweight of the member at the section of maximum moment (ksi).

Alternatively, the loss due to elastic shortening may be calculated using Eq. C5.9.5.2.3a-1

$$\Delta f_{pES} = \frac{A_{ps} f_{pbt} (I_g + e_m^2 A_g) - e_m M_g A_g}{A_{ps} (I_g + e_m^2 A_g) + \frac{A_g I_g E_{ct}}{E_{PS}}}$$

SPAN 1		SPAN 2	
$A_{ps}$ =	6.58 in <sup>2</sup>	$A_{ps}$ =	6.58 in <sup>2</sup>
$A_g$ =	1172.40 in <sup>2</sup>	$A_g$ =	1172.40 in <sup>2</sup>
$I_g$ =	729521.00 in <sup>4</sup>	$I_g$ =	729521.00 in <sup>4</sup>
<i>Average Prestressing steel eccentricity at midspan</i>			
$e_m$ =	30.77 in	$e_m$ =	30.77 in
<i>Stress in Prestressing steel Immediately prior to transfer (0.75fu)</i>			
$f_{pbt}$ =	202.50 ksi		
<i>Mid-Span Moment due to member self-weight</i>			
$M_g$ =	1798.21 kip-ft	$M_g$ =	1798.21 kip-ft
<i>Elastic Shortening Losses</i>			
$\Delta f_{pES}$ =	10.93 ksi	$\Delta f_{pES}$ =	10.93 ksi
<b>Prestressing Stress at Transfer (<math>f_{pt}</math>)=</b>	191.57 ksi	<b>(<math>f_{pt}</math>)=</b>	191.57 ksi
<b>Effective loss (<math>\Delta f_{pe}</math>)=</b>	5.40%	<b>(<math>\Delta f_{pe}</math>)=</b>	5.40%

**7.4 TIME DEPENDANT LOSSES (5.9.5.3)**

$$\Delta f_{pLT} = 10.0 \frac{f_{pi} A_{ps}}{A_g} \gamma_h \gamma_{st} + 12.0 \gamma_h \gamma_{st} + \Delta f_{pR}$$

Correction Factor for Relative Humidity of the ambient air ( $\psi_h$ )= 1.00  
 $\gamma_h = 1.7 - 0.01H$

correction factor for specified concrete strength at time of prestress transfer to the concrete member ( $\psi_s$ )= 0.71  
 $\gamma_{st} = \frac{5}{1 + f'_{ci}}$

Estimate Relaxation Loss ( $\Delta f_{pR}$ )= 2.40 ksi

		<b>Time Dependent Losses</b>		
$\Delta f_{pL1}$ =	19.09 ksi		$\Delta f_{pL1}$ =	19.09 ksi
<b>Prestressing Stress after losses (<math>f_{pe}</math>)=</b>	172.49 ksi		<b>(<math>f_{pe}</math>)=</b>	172.49 ksi
<b>Effective Total loss (<math>\Delta f_{pt}\%</math>)=</b>	14.82%		<b>(<math>\Delta f_{pt}\%</math>)=</b>	14.82%

**7.5 STRESS IN PRESTRESSING STEEL AT NOMINAL FLEXURAL RESISTANCE (5.7.3.1)**

Section Type= Rectangular Section

**Bonded**

$$f_{ps} = f_{pu} \left(1 - k \frac{c}{d_p}\right) \quad k = 2 \left(1.04 - \frac{f_{py}}{f_{pu}}\right)$$

**T Section Behavior**

$$c = \frac{A_{ps} f_{pu} + A_s f_s - A'_s f'_s - 0.85 f'_c (b - b_w) h_f}{0.85 f'_c \beta_1 b_w + k A_{ps} \frac{f_{pu}}{d_p}}$$

**Rectangular Section Behavior**

$$c = \frac{A_{ps} f_{pu} + A_s f_s - A'_s f'_s}{0.85 f'_c \beta_1 b + k A_{ps} \frac{f_{pu}}{d_p}}$$

Mild Steel ( $A_s$ )= 0.00 in<sup>2</sup>  
 Compression Steel ( $A'_s$ )= 13.19 in<sup>2</sup>

**Span 1**

$l_e$ = N/A ft  
 $k$ = 0.28  
 $\beta_1$ = 0.85  
 $d_p$ = 70.47 in  
 $c$ = 2.93 in  
 $f_{ps}$ = 266.86 ksi  
 $a$ = 2.49 in

Section Type= Rectangular Section

**Debonded**

$$f_{ps} = f_{pe} + 900 \left(\frac{d_p - c}{l_e}\right) \leq f_{py} \quad l_e = \left(\frac{2l_i}{2 + N_s}\right)$$

**T Section Behavior**

$$c = \frac{A_{ps} f_{pu} + A_s f_s - A'_s f'_s - 0.85 f'_c (b - b_w) h_f}{0.85 f'_c \beta_1 b_w}$$

**Rectangular Section Behavior**

$$c = \frac{A_{ps} f_{pu} + A_s f_s - A'_s f'_s}{0.85 f'_c \beta_1 b}$$

Mild Steel ( $A_s$ )= 0.00 in<sup>2</sup>  
 Compression Steel ( $A'_s$ )= 13.19 in<sup>2</sup>

**Span 2**

$l_e$ = N/A ft  
 $k$ = 0.28  
 $\beta_1$ = 0.85  
 $d_p$ = 70.47 in  
 $c$ = 2.93 in  
 $f_{ps}$ = 266.86 ksi  
 $a$ = 2.49 in

**7.6 TRANSFER AND DEVELOPMENT LENGTH**

Transfer length ( $L_t$ )= 30.00 in      Transfer length ( $L_t$ )= 30.00 in

**Development Length**

$$l_d \geq K \left(f_{ps} - \frac{2}{3} f_{pe}\right) d_b$$

Bonded ( $L_{db}$ )= 121.50 in      Bonded ( $L_{db}$ )= 121.50 in  
 Debonded ( $L_{dd}$ )= 151.87 in      Debonded ( $L_{dd}$ )= 151.87 in

**7.7 PRESTRESSING STRAND FORCES**

**7.7.1 AT TRANSFER**

<b>SPAN 1</b>													
<b>PRESTRESSING STRAND FORCES (kip)</b>													
Group	LOCATION												
	Beam Start	0.0L	0.1L	0.2L	0.3L	0.4L	0.5L	0.6L	0.7L	0.8L	0.9L	1.0L	
<b>Bonded</b>	0.00	252.07	1260.37	1260.37	1260.37	1260.37	1260.37	1260.37	1260.37	1260.37	1260.37	1260.37	0.00
<b>Debonded</b>	0.00	0.00	0.00	0.00	0.00	0.00	0.00	0.00	0.00	0.00	0.00	0.00	0.00
<b>Total</b>	0.00	252.07	1260.37	1260.37	1260.37	1260.37	1260.37	1260.37	1260.37	1260.37	1260.37	1260.37	0.00
<b>Eccentricity</b>	26.93	27.02	29.13	30.77	30.77	30.77	30.77	30.77	30.77	30.77	30.77	28.94	26.93

<b>SPAN 2</b>													
<b>PRESTRESSING STRAND FORCES (kip)</b>													
Group	LOCATION												
		0.0L	0.1L	0.2L	0.3L	0.4L	0.5L	0.6L	0.7L	0.8L	0.9L	1.0L	
<b>Bonded</b>		0.00	1260.37	1260.37	1260.37	1260.37	1260.37	1260.37	1260.37	1260.37	1260.37	1260.37	0.00
<b>Debonded</b>		0.00	0.00	0.00	0.00	0.00	0.00	0.00	0.00	0.00	0.00	0.00	0.00
<b>Total</b>		0.00	1260.37	1260.37	1260.37	1260.37	1260.37	1260.37	1260.37	1260.37	1260.37	1260.37	0.00
<b>Eccentricity</b>		26.93	28.94	30.77	30.77	30.77	30.77	30.77	30.77	30.77	30.77	28.94	26.93

7.7.2 AFTER LOSSES

SPAN 1													
PRESTRESSING STRAND FORCES (kip)													
Group	LOCATION												
	Beam Start	0.0L	0.1L	0.2L	0.3L	0.4L	0.5L	0.6L	0.7L	0.8L	0.9L	1.0L	
Bonded	0.00	226.96	1134.79	1134.79	1134.79	1134.79	1134.79	1134.79	1134.79	1134.79	1134.79	1134.79	0.00
Debonded	0.00	0.00	0.00	0.00	0.00	0.00	0.00	0.00	0.00	0.00	0.00	0.00	0.00
Total	0.00	226.96	1134.79	1134.79	1134.79	1134.79	1134.79	1134.79	1134.79	1134.79	1134.79	1134.79	0.00

SPAN 2													
PRESTRESSING STRAND FORCES (kip)													
Group	LOCATION												
	Beam Start	0.0L	0.1L	0.2L	0.3L	0.4L	0.5L	0.6L	0.7L	0.8L	0.9L	1.0L	
Bonded		0.00	1134.79	1134.79	1134.79	1134.79	1134.79	1134.79	1134.79	1134.79	1134.79	1134.79	0.00
Debonded		0.00	0.00	0.00	0.00	0.00	0.00	0.00	0.00	0.00	0.00	0.00	0.00
Total		0.00	1134.79	1134.79	1134.79	1134.79	1134.79	1134.79	1134.79	1134.79	1134.79	1134.79	0.00

7.7.3 AT THE NOMINAL FLEXURAL RESISTANCE

SPAN 1													
PRESTRESSING STRAND FORCES (kip)													
Group	LOCATION												
	Beam Start	0.0L	0.1L	0.2L	0.3L	0.4L	0.5L	0.6L	0.7L	0.8L	0.9L	1.0L	
Bonded	0.00	226.96	1755.67	1755.67	1755.67	1755.67	1755.67	1755.67	1755.67	1755.67	1755.67	1755.67	0.00
Debonded	0.00	0.00	0.00	0.00	0.00	0.00	0.00	0.00	0.00	0.00	0.00	0.00	0.00
Total	0.00	226.96	1755.67	1755.67	1755.67	1755.67	1755.67	1755.67	1755.67	1755.67	1755.67	1755.67	0.00

SPAN 2													
PRESTRESSING STRAND FORCES (kip)													
Group	LOCATION												
	Beam Start	0.0L	0.1L	0.2L	0.3L	0.4L	0.5L	0.6L	0.7L	0.8L	0.9L	1.0L	
Bonded		0.00	1755.67	1755.67	1755.67	1755.67	1755.67	1755.67	1755.67	1755.67	1755.67	1755.67	0.00
Debonded		0.00	0.00	0.00	0.00	0.00	0.00	0.00	0.00	0.00	0.00	0.00	0.00
Total		0.00	1755.67	1755.67	1755.67	1755.67	1755.67	1755.67	1755.67	1755.67	1755.67	1755.67	0.00

8. FLEXURE DESIGN

8.1 FLEXURAL STRESSES AT TRANSFER

$$f_{transfer} = -\frac{P_{ps}}{A_g} \pm \frac{P_{ps}e_0}{S_x} \pm \frac{M_g}{S_x}$$

$P_{ps}$ = Prestressed Force at Transfer  
 $A_g$ = Gross Area - Non Composite -  
 $S_x$ = Section Moduli - Non Composite - Top or Bottom of beam accordingly  
 $M_g$ = Moment due to self weight only  
 $e_0$ = Eccentricity of the prestressing force at each point of the beam

SPAN 1												
STRESSES (ksi)												
Group	LOCATION											
	Beam Start	0.0L	0.1L	0.2L	0.3L	0.4L	0.5L	0.6L	0.7L	0.8L	0.9L	1.0L
Top of Beam	0.00	0.08	0.18	0.01	-0.18	-0.29	-0.33	-0.29	-0.18	0.01	0.17	0.00
Check	OK	OK	OK	OK	OK	OK	OK	OK	OK	OK	OK	OK
Bot of Beam	0.00	-0.54	-2.44	-2.25	-2.05	-1.92	-1.88	-1.92	-2.05	-2.25	-2.42	0.00
Check	OK	OK	OK	OK	OK	OK	OK	OK	OK	OK	OK	OK

SPAN 2												
STRESSES (ksi)												
Group	LOCATION											
	Beam Start	0.0L	0.1L	0.2L	0.3L	0.4L	0.5L	0.6L	0.7L	0.8L	0.9L	1.0L
Top of Beam		0.00	0.17	0.01	-0.18	-0.29	-0.33	-0.29	-0.18	0.01	0.17	0.00
Check		OK	OK	OK	OK	OK	OK	OK	OK	OK	OK	OK
Bot of Beam		0.00	-2.42	-2.25	-2.05	-1.92	-1.88	-1.92	-2.05	-2.25	-2.42	0.00
Check		OK	OK	OK	OK	OK	OK	OK	OK	OK	OK	OK

8.2 FLEXURAL STRESSES CONSTRUCTION STAGE

$$f_{construction} = -\frac{P_{ps}}{A_g} \pm \frac{P_{ps}e_0}{S_x} \pm \frac{M_{CS}}{S_x}$$

$P_{ps}$ = Prestressed Force after Losses  
 $A_g$ = Gross Area - Non Composite -  
 $S_x$ = Section Moduli - Non Composite - Top or Bottom of beam accordingly  
 $M_{CS}$ = Moment due to SERVICE I (Compression) and SERVICE III (Tension) Combinations including Construction Live Load  
 $e_0$ = Eccentricity of the prestressing force at each point of the beam  
 Note: Stress condition without Live load is not considered since it is a constant load during that stage.

SERVICE I												
SPAN 1												
STRESSES (ksi)												
Group	LOCATION											
	Beam Start	0.0L	0.1L	0.2L	0.3L	0.4L	0.5L	0.6L	0.7L	0.8L	0.9L	1.0L
Top of Beam	0.00	0.07	-0.20	-0.63	-1.00	-1.23	-1.30	-1.23	-1.00	-0.63	-0.21	0.00
Check	OK	OK	OK	OK	OK	OK	OK	OK	OK	OK	OK	OK
Bot of Beam	0.00	-0.48	-1.80	-1.33	-0.93	-0.69	-0.61	-0.69	-0.93	-1.33	-1.79	0.00
Check	OK	OK	OK	OK	OK	OK	OK	OK	OK	OK	OK	OK

SPAN 2												
STRESSES (ksi)												
Group	LOCATION											
	0.0L	0.1L	0.2L	0.3L	0.4L	0.5L	0.6L	0.7L	0.8L	0.9L	1.0L	
Top of Beam	0.00	-0.21	-0.63	-1.00	-1.23	-1.30	-1.23	-1.00	-0.63	-0.21	0.00	
Check	OK	OK	OK	OK	OK	OK	OK	OK	OK	OK	OK	
Bot of Beam	0.00	-1.79	-1.33	-0.93	-0.69	-0.61	-0.69	-0.93	-1.33	-1.79	0.00	
Check	OK	OK	OK	OK	OK	OK	OK	OK	OK	OK	OK	

SERVICE III												
SPAN 1												
STRESSES (ksi)												
Group	LOCATION											
	Beam Start	0.0L	0.1L	0.2L	0.3L	0.4L	0.5L	0.6L	0.7L	0.8L	0.9L	1.0L
Top of Beam	0.00	0.07	-0.19	-0.62	-0.98	-1.20	-1.27	-1.20	-0.98	-0.62	-0.20	0.00
Check	OK	OK	OK	OK	OK	OK	OK	OK	OK	OK	OK	OK
Bot of Beam	0.00	-0.48	-1.81	-1.35	-0.96	-0.72	-0.64	-0.72	-0.96	-1.35	-1.80	0.00
Check	OK	OK	OK	OK	OK	OK	OK	OK	OK	OK	OK	OK

SPAN 2												
STRESSES (ksi)												
Group	LOCATION											
	0.0L	0.1L	0.2L	0.3L	0.4L	0.5L	0.6L	0.7L	0.8L	0.9L	1.0L	
Top of Beam	0.00	-0.20	-0.62	-0.98	-1.20	-1.27	-1.20	-0.98	-0.62	-0.20	0.00	
Check	OK	OK	OK	OK	OK	OK	OK	OK	OK	OK	OK	
Bot of Beam	0.00	-1.80	-1.35	-0.96	-0.72	-0.64	-0.72	-0.96	-1.35	-1.80	0.00	
Check	OK	OK	OK	OK	OK	OK	OK	OK	OK	OK	OK	

**8.3 FLEXURAL STRESSES UNDER SERVICE LIMIT STATES**

1. According to AASTHO 5.14.1.4.6 a cast-in-place composite deck slab shall not be subject to the tensile stress limits for the service limit state after losses

$$f_{service} = -\frac{P_{ps}}{A_g} \pm \frac{P_{ps}e_0}{S_x} \pm \frac{M_{DNC}}{S_x} \pm \frac{M_{DC}}{S_{xc}} \pm \frac{M_{LLC}}{S_{xc}}$$

- $P_{ps}$ = Prestressed Force after Losses
- $A_g$ = Gross Area - Non Composite -
- $S_x$ = Section Moduli - Non Composite - Top or Bottom of beam accordingly
- $S_{xc}$ = Section Moduli - Composite - Top or Bottom of beam accordingly
- $M_{DNC}$ = Moment due to Dead Load in the non Composite Section
- $M_{DC}$ = Moment due to Dead Load in the Composite Section
- $M_{LLC}$ = Moment due to Live Load in the Composite Section
- $e_0$ = Eccentricity of the prestressing force at each point of the beam

2. At the service limit state after losses, when tensile stresses develop at the top of the girders near interior supports, the tensile stress limits specified in Table 5.9.4.1.2-1 for other than segmentally constructed bridges shall apply. The specified compressive strength of the girder concrete,  $f'c$ , shall be substituted for  $f'ci$  in the stress limit equations

SERVICE I												
SPAN 1												
STRESSES (ksi)												
FINAL STRESS UNDER PRESTRESSING AND PERMANENT LOADS												
Group	LOCATION											
	Beam Start	0.0L	0.1L	0.2L	0.3L	0.4L	0.5L	0.6L	0.7L	0.8L	0.9L	1.0L
Top of Beam	0.00	0.07	-0.17	-0.58	-0.93	-1.14	-1.20	-1.12	-0.89	-0.53	-0.11	0.09
Check	OK	OK	OK	OK	OK	OK	OK	OK	OK	OK	OK	OK
Bot of Beam	0.00	-0.48	-1.80	-1.33	-0.94	-0.71	-0.65	-0.76	-1.03	-1.46	-1.97	-0.22
Check	OK	OK	OK	OK	OK	OK	OK	OK	OK	OK	OK	OK
Top of Slab	0.00	0.00	-0.03	-0.04	-0.05	-0.06	-0.05	-0.04	-0.01	0.01	0.05	0.10
Check	OK	OK	OK	OK	OK	OK	OK	OK	OK	OK	OK	OK
FINAL STRESS UNDER PRESTRESSING, PERMANENT LOADS AND TRANSIENT LOADS												
Group	LOCATION											
	Beam Start	0.0L	0.1L	0.2L	0.3L	0.4L	0.5L	0.6L	0.7L	0.8L	0.9L	1.0L
T of B Max	0.00	0.07	-0.32	-0.84	-1.26	-1.50	-1.55	-1.43	-1.14	-0.67	-0.14	0.16
Check	OK	OK	OK	OK	OK	OK	OK	OK	OK	OK	OK	OK
T of B Min	0.00	0.07	-0.15	-0.54	-0.87	-1.06	-1.10	-1.00	-0.75	-0.37	0.09	0.44
Check	OK	OK	OK	OK	OK	OK	OK	OK	OK	OK	OK	OK
B of B Max	0.00	-0.48	-1.41	-0.66	-0.10	0.20	0.24	0.04	-0.41	-1.09	-1.88	-0.39
Check	OK	OK	OK	OK	OK	OK	OK	OK	OK	OK	OK	OK
B of B Min	0.00	-0.48	-1.85	-1.43	-1.09	-0.92	-0.91	-1.06	-1.38	-1.87	-2.47	-1.12
Check	OK	OK	OK	OK	OK	OK	OK	OK	OK	OK	OK	OK
T of S Max	0.00	0.00	-0.19	-0.33	-0.41	-0.44	-0.43	-0.38	-0.28	-0.14	0.01	0.17
Check	OK	OK	OK	OK	OK	OK	OK	OK	OK	OK	OK	OK
T of S Min	0.00	0.00	0.00	0.00	0.01	0.03	0.06	0.09	0.14	0.19	0.27	0.48
Check	OK	OK	OK	OK	OK	OK	OK	OK	OK	OK	OK	REINF

SPAN 2												
STRESSES (ksi)												
FINAL STRESS UNDER PRESTRESSING AND PERMANENT LOADS												
Group	LOCATION											
	0.0L	0.1L	0.2L	0.3L	0.4L	0.5L	0.6L	0.7L	0.8L	0.9L	1.0L	
Top of Beam	0.09	-0.11	-0.53	-0.89	-1.12	-1.20	-1.14	-0.93	-0.58	-0.18	0.00	
Check	OK	OK	OK	OK	OK	OK	OK	OK	OK	OK	OK	
Bot of Beam	-0.22	-1.97	-1.46	-1.03	-0.76	-0.65	-0.71	-0.94	-1.33	-1.79	0.00	
Check	OK	OK	OK	OK	OK	OK	OK	OK	OK	OK	OK	
Top of Slab	0.00	-0.03	-0.04	-0.05	-0.06	-0.05	-0.04	-0.01	0.01	0.05	0.10	
Check	OK	OK	OK	OK	OK	OK	OK	OK	OK	OK	OK	
FINAL STRESS UNDER PRESTRESSING, PERMANENT LOADS AND TRANSIENT LOADS												
Group	LOCATION											
	0.0L	0.1L	0.2L	0.3L	0.4L	0.5L	0.6L	0.7L	0.8L	0.9L	1.0L	
T of B Max	0.16	-0.14	-0.67	-1.14	-1.43	-1.55	-1.50	-1.26	-0.84	-0.33	0.00	
Check	OK	OK	OK	OK	OK	OK	OK	OK	OK	OK	OK	
T of B Min	0.44	0.09	-0.37	-0.75	-1.00	-1.10	-1.06	-0.87	-0.54	-0.16	0.00	
Check	OK	OK	OK	OK	OK	OK	OK	OK	OK	OK	OK	
B of B Max	-0.39	-1.88	-1.09	-0.41	0.04	0.24	0.20	-0.10	-0.66	-1.40	0.00	
Check	OK	OK	OK	OK	OK	OK	OK	OK	OK	OK	OK	
B of B Min	-1.12	-2.47	-1.87	-1.38	-1.06	-0.91	-0.92	-1.09	-1.43	-1.84	0.00	
Check	OK	OK	OK	OK	OK	OK	OK	OK	OK	OK	OK	
T of S Max	0.07	-0.06	-0.20	-0.32	-0.40	-0.43	-0.42	-0.37	-0.27	-0.12	0.10	
Check	OK	OK	OK	OK	OK	OK	OK	OK	OK	OK	OK	
T of S Min	0.38	0.19	0.13	0.10	0.08	0.06	0.05	0.05	0.06	0.07	0.10	
Check	REINF	OK	OK	OK	OK	OK	OK	OK	OK	OK	OK	

SERVICE III												
SPAN 1												
STRESSES (ksi)												
FINAL STRESS UNDER PRESTRESSING AND PERMANENT LOADS												
Group	Beam Start	LOCATION										
		0.0L	0.1L	0.2L	0.3L	0.4L	0.5L	0.6L	0.7L	0.8L	0.9L	1.0L
Top of Beam	0.00	0.07	-0.17	-0.58	-0.93	-1.14	-1.20	-1.12	-0.89	-0.53	-0.11	0.09
Check	OK	OK	OK	OK	OK	OK	OK	OK	OK	OK	OK	OK
Bot of Beam	0.00	-0.48	-1.80	-1.33	-0.94	-0.71	-0.65	-0.76	-1.03	-1.46	-1.97	-0.22
Check	OK	OK	OK	OK	OK	OK	OK	OK	OK	OK	OK	OK
Top of Slab	0.00	0.00	-0.03	-0.04	-0.05	-0.06	-0.05	-0.04	-0.01	0.01	0.05	0.10
Check	OK	OK	OK	OK	OK	OK	OK	OK	OK	OK	OK	OK
FINAL STRESS UNDER PRESTRESSING, PERMANENT LOADS AND TRANSIENT LOADS												
Group	Beam Start	LOCATION										
		0.0L	0.1L	0.2L	0.3L	0.4L	0.5L	0.6L	0.7L	0.8L	0.9L	1.0L
T of B Max	0.00	0.07	-0.29	-0.79	-1.19	-1.42	-1.48	-1.37	-1.09	-0.65	-0.13	0.14
Check	OK	OK	OK	OK	OK	OK	OK	OK	OK	OK	OK	OK
T of B Min	0.00	0.07	-0.15	-0.55	-0.88	-1.07	-1.12	-1.02	-0.78	-0.40	0.05	0.37
Check	OK	OK	OK	OK	OK	OK	OK	OK	OK	OK	OK	OK
B of B Max	0.00	-0.48	-1.49	-0.79	-0.27	0.02	0.06	-0.12	-0.53	-1.17	-1.90	-0.36
Check	OK	OK	OK	OK	OK	OK	OK	OK	OK	OK	OK	OK
B of B Min	0.00	-0.48	-1.84	-1.41	-1.06	-0.87	-0.85	-1.00	-1.31	-1.79	-2.37	-0.94
Check	OK	OK	OK	OK	OK	OK	OK	OK	OK	OK	OK	OK
T of S Max	0.00	0.00	-0.16	-0.27	-0.34	-0.37	-0.35	-0.31	-0.23	-0.11	0.02	0.15
Check	OK	OK	OK	OK	OK	OK	OK	OK	OK	OK	OK	OK
T of S Min	0.00	0.00	-0.01	-0.01	0.00	0.01	0.04	0.07	0.11	0.15	0.22	0.40
Check	OK	OK	OK	OK	OK	OK	OK	OK	OK	OK	OK	REINF



SPAN 2												
STRESSES (ksi)												
FINAL STRESS UNDER PRESTRESSING AND PERMANENT LOADS												
Group	LOCATION											
	0.0L	0.1L	0.2L	0.3L	0.4L	0.5L	0.6L	0.7L	0.8L	0.9L	1.0L	
Top of Beam	0.09	-0.11	-0.53	-0.89	-1.12	-1.20	-1.14	-0.93	-0.58	-0.18	0.00	
Check	OK	OK	OK	OK	OK	OK	OK	OK	OK	OK	OK	
Bot of Beam	-0.22	-1.97	-1.46	-1.03	-0.76	-0.65	-0.71	-0.94	-1.33	-1.79	0.00	
Check	OK	OK	OK	OK	OK	OK	OK	OK	OK	OK	OK	
Top of Slab	0.00	-0.03	-0.04	-0.05	-0.06	-0.05	-0.04	-0.01	0.01	0.05	0.10	
Check	OK	OK	OK	OK	OK	OK	OK	OK	OK	OK	OK	
FINAL STRESS UNDER PRESTRESSING, PERMANENT LOADS AND TRANSIENT LOADS												
Group	LOCATION											
	0.0L	0.1L	0.2L	0.3L	0.4L	0.5L	0.6L	0.7L	0.8L	0.9L	1.0L	
T of B Max	0.14	-0.13	-0.65	-1.09	-1.37	-1.48	-1.42	-1.19	-0.79	-0.30	0.00	
Check	OK	OK	OK	OK	OK	OK	OK	OK	OK	OK	OK	
T of B Min	0.37	0.05	-0.40	-0.78	-1.02	-1.12	-1.07	-0.88	-0.55	-0.16	0.00	
Check	OK	OK	OK	OK	OK	OK	OK	OK	OK	OK	OK	
B of B Max	-0.36	-1.90	-1.17	-0.53	-0.12	0.06	0.02	-0.27	-0.79	-1.48	0.00	
Check	OK	OK	OK	OK	OK	OK	OK	OK	OK	OK	OK	
B of B Min	-0.94	-2.37	-1.79	-1.31	-1.00	-0.85	-0.87	-1.06	-1.41	-1.83	0.00	
Check	OK	OK	OK	OK	OK	OK	OK	OK	OK	OK	OK	
T of S Max	0.15	0.02	-0.11	-0.23	-0.31	-0.35	-0.37	-0.34	-0.27	-0.16	0.00	
Check	OK	OK	OK	OK	OK	OK	OK	OK	OK	OK	OK	
T of S Min	0.40	0.22	0.15	0.11	0.07	0.04	0.01	0.00	-0.01	-0.01	0.00	
Check	REINF	OK	OK	OK	OK	OK	OK	OK	OK	OK	OK	

8.4 FLEXURAL STRESSES UNDER FATIGUE LIMIT STATE

Slabs above multi girder systems do not need a fatigue limit state checking (AASHTO 5.5.3)

- $P_{ps}$  = Prestressed Force after Losses  
 $A_g$  = Gross Area - Non Composite -  
 $S_x$  = Section Moduli - Non Composite - Top or Bottom of beam accordingly  
 $S_{xc}$  = Section Moduli - Composite - Top or Bottom of beam accordingly  
 $M_{DNC}$  = Moment due to Dead Load in the non Composite Section  
 $M_{DC}$  = Moment due to Dead Load in the Composite Section  
 $M_{LLC}$  = Moment due to Live Load in the Composite Section  
 $e_0$  = Eccentricity of the prestressing force at each point of the beam

$$f_{service} = \frac{1}{2} \left( -\frac{P_{ps}}{A_g} \pm \frac{P_{ps}e_0}{S_x} \pm \frac{M_{DNC}}{S_x} \pm \frac{M_{DC}}{S_{xc}} \right) \pm \frac{M_{LLC}}{S_{xc}}$$

According to AASHTO 5.5.3 Fatigue limit state stresses need to be checked using half the combined effects of prestressing and permanent loads along with the live load corresponding to Fatigue I load Combination ( Truck only)

FATIGUE I												
SPAN 1												
STRESSES (ksi)												
FINAL STRESS UNDER PRESTRESSING, PERMANENT LOADS AND TRANSIENT LOADS												
Group	Beam Start	LOCATION										
		0.0L	0.1L	0.2L	0.3L	0.4L	0.5L	0.6L	0.7L	0.8L	0.9L	1.0L
T of B Max	0.00	0.04	-0.18	-0.45	-0.67	-0.79	-0.81	-0.75	-0.60	-0.36	-0.09	0.04
Check	OK	OK	OK	OK	OK	OK	OK	OK	OK	OK	OK	OK
T of B Min	0.00	0.04	-0.07	-0.27	-0.43	-0.52	-0.54	-0.49	-0.37	-0.17	0.05	0.16
Check	OK	OK	OK	OK	OK	OK	OK	OK	OK	OK	OK	OK
B of B Max	0.00	-0.24	-0.66	-0.25	0.04	0.20	0.22	0.11	-0.13	-0.49	-0.90	-0.11
Check	OK	OK	OK	OK	OK	OK	OK	OK	OK	OK	OK	OK
B of B Min	0.00	-0.24	-0.93	-0.72	-0.56	-0.47	-0.47	-0.55	-0.72	-0.96	-1.25	-0.40
Check	OK	OK	OK	OK	OK	OK	OK	OK	OK	OK	OK	OK
SPAN 2												
STRESSES (ksi)												
FINAL STRESS UNDER PRESTRESSING, PERMANENT LOADS AND TRANSIENT LOADS												
Group	LOCATION											
	0.0L	0.1L	0.2L	0.3L	0.4L	0.5L	0.6L	0.7L	0.8L	0.9L	1.0L	
T of B Max	0.04	-0.09	-0.36	-0.60	-0.75	-0.81	-0.79	-0.67	-0.45	-0.18	0.00	
Check	OK	OK	OK	OK	OK	OK	OK	OK	OK	OK	OK	
T of B Min	0.16	0.05	-0.17	-0.37	-0.49	-0.54	-0.52	-0.43	-0.27	-0.08	0.00	
Check	OK	OK	OK	OK	OK	OK	OK	OK	OK	OK	OK	
B of B Max	-0.11	-0.90	-0.49	-0.13	0.11	0.22	0.20	0.04	-0.25	-0.65	0.00	
Check	OK	OK	OK	OK	OK	OK	OK	OK	OK	OK	OK	
B of B Min	-0.40	-1.25	-0.96	-0.72	-0.55	-0.47	-0.47	-0.56	-0.72	-0.92	0.00	
Check	OK	OK	OK	OK	OK	OK	OK	OK	OK	OK	OK	

8.5 DESIGN FOR STRENGTH LIMIT STATE (5.7.3.1 and 5.7.3.2)

8.5.1 POSITIVE MOMENT ZONES

8.5.1.1 Nominal Resistance and Flexural Resistance

Section Type Span 1 & 3 = Rectangular Section

Section Type Span 2 = Rectangular Section

Bonded

Debonded

$$f_{ps} = f_{pu} \left( 1 - k \frac{c}{d_p} \right) \quad k = 2 \left( 1.04 - \frac{f_{py}}{f_{pu}} \right)$$

$$f_{ps} = f_{pe} + 900 \left( \frac{d_p - c}{l_e} \right) \leq f_{py} \quad l_e = \left( \frac{2l_i}{2 + N_s} \right)$$

$$c = \frac{A_{ps}f_{pu} + A_s f_s - A'_s f'_s - 0.85 f'_c (b - b_w) h_f}{0.85 f'_c \beta_1 b_w + k A_{ps} \frac{f_{pu}}{d_p}}$$

$$c = \frac{A_{ps}f_{pu} + A_s f_s - A'_s f'_s - 0.85 f'_c (b - b_w) h_f}{0.85 f'_c \beta_1 b_w}$$

**Rectangular Section Behavior**

$$c = \frac{A_{ps}f_{pu} + A_s f_s - A'_s f'_s}{0.85f'_c \beta_1 b + k A_{ps} \frac{f_{pu}}{d_p}}$$

Mild Steel (A <sub>s</sub> )=	0.00 in <sup>2</sup>
Dist to mild Steel (d <sub>s</sub> )=	0.00 in
Compression Steel (A' <sub>s</sub> )=	13.19 in <sup>2</sup>
Dist to comp Steel (d' <sub>s</sub> )=	2.81 in

**Span 1**

l <sub>e</sub> =	N/A	ft
k=	0.28	
β <sub>1</sub> =	0.85	
d <sub>p</sub> =	70.47 in	
c=	2.93 in	
f <sub>ps</sub> =	266.86 ksi	
a=	2.49 in	

$$M_n = A_{ps}f_{ps} \left( d_p - \frac{a}{2} \right) + A_s f_y \left( d_s - \frac{a}{2} \right) - A'_s f'_y \left( d'_s - \frac{a}{2} \right) + 0.85f'_c (b - b_w) \beta_1 h_f \left( \frac{a}{2} - \frac{h_f}{2} \right)$$

M <sub>n</sub> =	10024.04 kip-ft
φ <sub>flexure</sub> =	1.00
φM <sub>n</sub> =	10024.04 kip-ft <span style="border: 1px solid green; padding: 2px;">OK</span>
M <sub>u (+)</sub> =	7976.87 kip-ft

**8.5.1.2 Stress Controlled Sections (AASHTO 5.7.2.1)**

Tension Controlled Strain (ε <sub>t</sub> )=	0.005 in/in
Compression Strain Limit (ε <sub>c</sub> )=	0.003 in/in
Compression Controlled Strain (ε <sub>cs</sub> )=	0.002 in/in
Tension Controlled Limit (c/d) <sub>T</sub> =	0.38
Compression Controlled Limit (c/d) <sub>C</sub> =	0.60
Dist to Extreme Tension Steel (d <sub>t</sub> )=	72.00 in
C/d <sub>t</sub> =	0.04 <span style="border: 1px solid green; padding: 2px;">Tension Controlled</span>

**Rectangular Section Behavior**

$$c = \frac{A_{ps}f_{pu} + A_s f_s - A'_s f'_s}{0.85f'_c \beta_1 b}$$

Mild Steel (A <sub>s</sub> )=	0.00 in <sup>2</sup>
Dist to mild Steel (d <sub>s</sub> )=	0.00 in
Compression Steel (A' <sub>s</sub> )=	13.19 in <sup>2</sup>
Dist to comp Steel (d' <sub>s</sub> )=	2.81 in

**Span 2**

l <sub>e</sub> =	N/A	ft
k=	0.28	
β <sub>1</sub> =	0.85	
d <sub>p</sub> =	70.47 in	
c=	2.93 in	
f <sub>ps</sub> =	266.86 ksi	
a=	2.49 in	

M <sub>n</sub> =	10024.04 kip-ft
φ <sub>flexure</sub> =	1.00
φM <sub>n</sub> =	10024.04 kip-ft <span style="border: 1px solid green; padding: 2px;">OK</span>
M <sub>u (+)</sub> =	7976.87 kip-ft

$$\left( \frac{C}{d_t} \right) \leq \left( \frac{C}{d_t} \right)_T \text{ Tension Controlled}$$

$$\left( \frac{C}{d_t} \right) \geq \left( \frac{C}{d_t} \right)_C \text{ Compression Controlled}$$

$$\left( \frac{C}{d_t} \right)_T \leq \left( \frac{C}{d_t} \right) \leq \left( \frac{C}{d_t} \right)_C \text{ Transition Stress Controlled}$$

Dist to Extreme Tension Steel (d <sub>t</sub> )=	72.00 in
C/d <sub>t</sub> =	0.04 <span style="border: 1px solid green; padding: 2px;">Tension Controlled</span>

**8.5.1.3 Minimum Steel (5.7.3.3 and 5.4.2.6)**

φM <sub>n</sub> ≥ M <sub>m</sub> = min(1.33M <sub>u</sub> , 1.2M <sub>cr</sub> )	M <sub>cr</sub> = γ <sub>3</sub> [ (γ <sub>3</sub> f <sub>r</sub> + γ <sub>3</sub> f <sub>pb</sub> )S <sub>c</sub> - M <sub>DNC</sub> ( $\frac{S_c}{S_{NC}} - 1$ ) ]	f <sub>r</sub> = 0.24√f' <sub>c</sub>	f <sub>pb</sub> = $\frac{P_{ps}}{A_{NC}} + \frac{P_{ps}e_{ps}}{S_{NC}}$
1.33M <sub>u</sub> =	10609.24 kip-ft	1.33M <sub>u</sub> =	10609.24 kip-ft
f <sub>r</sub> =	0.63 ksi	f <sub>r</sub> =	0.63 ksi
f <sub>pb</sub> =	2.61 ksi	f <sub>pb</sub> =	2.61 ksi
M <sub>DNC</sub> =	5713.73 kip-ft	M <sub>DNC</sub> =	5713.73 kip-ft
S <sub>NC</sub> =	21268.83 in <sup>3</sup>	S <sub>NC</sub> =	21268.83 in <sup>3</sup>
S <sub>c</sub> =	27039.36 in <sup>3</sup>	S <sub>c</sub> =	27039.36 in <sup>3</sup>
Y <sub>1</sub> =	1.60	Y <sub>1</sub> =	1.60
Y <sub>2</sub> =	1.10	Y <sub>2</sub> =	1.10
Y <sub>3</sub> =	1.00	Y <sub>3</sub> =	1.00
M <sub>cr</sub> =	7206.66 kip-ft	M <sub>cr</sub> =	7206.66 kip-ft
1.2M <sub>cr</sub> =	8647.99 kip-ft	1.2M <sub>cr</sub> =	8647.99 kip-ft
M <sub>m</sub> =	8647.99 kip-ft <span style="border: 1px solid green; padding: 2px;">OK</span>	M <sub>m</sub> =	8647.99 kip-ft <span style="border: 1px solid green; padding: 2px;">OK</span>

**8.5.2 NEGATIVE MOMENT ZONES (AASHTO 5.7.3.2)**

**8.5.2.1 Nominal Resistance and Flexural Resistance (AASHTO 5.7.3.2.1)**

Section Type Span 1 & 3 = Rectangular Section

**Bonded**

$$f_{ps} = f_{pu} \left( 1 - k \frac{c}{d_p} \right) \quad k = 2 \left( 1.04 - \frac{f_{py}}{f_{pu}} \right)$$

**T Section Behavior**

$$c = \frac{A_{ps}f_{pu} + A_s f_s - A'_s f'_s - 0.85f'_c (b - b_w) h_f}{0.85f'_c \beta_1 b_w + k A_{ps} \frac{f_{pu}}{d_p}}$$

**Rectangular Section Behavior**

$$c = \frac{A_{ps}f_{pu} + A_s f_s - A'_s f'_s}{0.85f'_c \beta_1 b + k A_{ps} \frac{f_{pu}}{d_p}}$$

Section Type Span 2 = Rectangular Section

**Debonded**

$$f_{ps} = f_{pe} + 900 \left( \frac{d_p - c}{l_e} \right) \leq f_{py} \quad l_e = \left( \frac{2l_i}{2 + N_s} \right)$$

**T Section Behavior**

$$c = \frac{A_{ps}f_{pu} + A_s f_s - A'_s f'_s - 0.85f'_c (b - b_w) h_f}{0.85f'_c \beta_1 b_w}$$

**Rectangular Section Behavior**

$$c = \frac{A_{ps}f_{pu} + A_s f_s - A'_s f'_s}{0.85f'_c \beta_1 b}$$

Mild Steel (A <sub>s</sub> )=	0.00 in <sup>2</sup>	Mild Steel (A <sub>s</sub> )=	0.00 in <sup>2</sup>
Dist to mild Steel (d <sub>s</sub> )=	0.00 in	Dist to mild Steel (d <sub>s</sub> )=	0.00 in
Tension Steel (A' <sub>s</sub> )=	20.70 in <sup>2</sup>	Tension Steel (A' <sub>s</sub> )=	20.70 in <sup>2</sup>
Dist to Tension Steel (d' <sub>s</sub> )=	69.11 in	Dist to Tension Steel (d' <sub>s</sub> )=	69.11 in
<b>Span 1</b>		<b>Span 2</b>	
I <sub>e</sub> =	N/A ft	I <sub>e</sub> =	N/A ft
k=	0.28	k=	0.28
β <sub>1</sub> =	0.70	β <sub>1</sub> =	0.70
d <sub>p</sub> =	0.00 in	d <sub>p</sub> =	0.00 in
c=	7.46 in	c=	7.46 in
f <sub>ps</sub> =	270.00 ksi	f <sub>ps</sub> =	270.00 ksi
a=	5.22 in	a=	5.22 in

$$M_n = A_{ps}f_{ps} \left( d_p - \frac{a}{2} \right) + A_s f_y \left( d_s - \frac{a}{2} \right) - A'_s f'_y \left( d'_s - \frac{a}{2} \right) + 0.85 f'_c (b - b_w) \beta_1 h_f \left( \frac{a}{2} - \frac{h_f}{2} \right)$$

M <sub>n</sub> =	6883.96 kip-ft	M <sub>n</sub> =	6883.96 kip-ft
φ <sub>flexure</sub> =	1.00	φ <sub>flexure</sub> =	1.00
φM <sub>n</sub> =	6883.96 kip-ft	φM <sub>n</sub> =	6883.96 kip-ft
M <sub>u</sub> (-)=	4257.70 kip-ft	M <sub>u</sub> (-)=	4257.70 kip-ft

**8.5.2.2 Stress Controlled Sections (AASHTO 5.7.2.1)**

Tension Controlled Strain (ε <sub>ti</sub> )=	0.005 in/in	$\left( \frac{c}{d_t} \right) \leq \left( \frac{c}{d_t} \right)_T$ Tension Controlled	
Compression Strain Limit (ε <sub>c</sub> )=	0.003 in/in	$\left( \frac{c}{d_t} \right) \geq \left( \frac{c}{d_t} \right)_C$ Compression Controlled	
Compression Controlled Strain (ε <sub>ci</sub> )=	0.002 in/in	$\left( \frac{c}{d_t} \right)_T \leq \left( \frac{c}{d_t} \right) \leq \left( \frac{c}{d_t} \right)_C$ Transition Stress Controlled	
Tension Controlled Limit (c/d <sub>t</sub> ) <sub>T</sub> =	0.38	Dist to Extreme Tension Steel (d <sub>t</sub> )=	71.50 in
Compression Controlled Limit (c/d <sub>t</sub> ) <sub>C</sub> =	0.60	Dist to Extreme Tension Steel (d <sub>t</sub> )=	71.50 in
C/d <sub>t</sub> =	0.10	C/d <sub>t</sub> =	0.10

**8.5.2.3 Minimum Steel (AASHTO 5.7.3.3 and 5.4.2.6)**

$\phi M_n \geq M_m = \min(1.33M_u, 1.2M_{cr})$		$M_{cr} = \gamma_3 \left[ (\gamma_3 f_r + \gamma_3 f_{pb}) S_c - M_{DNC} \left( \frac{S_c}{S_{NC}} - 1 \right) \right]$		$f_r = 0.24 \sqrt{f'_c}$	$f_{pb} = \frac{P_{ps}}{A_{NC}} + \frac{P_{ps} e_{ps}}{S_{NC}}$
1.33M <sub>u</sub> =	5662.74 kip-ft	1.33M <sub>u</sub> =	5662.74 kip-ft	f <sub>r</sub> =	0.63 ksi
f <sub>r</sub> =	0.63 ksi	f <sub>r</sub> =	0.63 ksi	f <sub>pb</sub> =	-0.55 ksi
f <sub>pb</sub> =	-0.55 ksi	f <sub>pb</sub> =	-0.55 ksi	M <sub>DNC</sub> =	0.00 kip-ft
M <sub>DNC</sub> =	0.00 kip-ft	M <sub>DNC</sub> =	0.00 kip-ft	S <sub>NC</sub> =	23013.28 in <sup>3</sup>
S <sub>NC</sub> =	23013.28 in <sup>3</sup>	S <sub>NC</sub> =	23013.28 in <sup>3</sup>	S <sub>c</sub> =	68473.36 in <sup>3</sup>
S <sub>c</sub> =	68473.36 in <sup>3</sup>	S <sub>c</sub> =	68473.36 in <sup>3</sup>	Y <sub>1</sub> =	1.60
Y <sub>1</sub> =	1.60	Y <sub>1</sub> =	1.60	Y <sub>2</sub> =	1.10
Y <sub>2</sub> =	1.10	Y <sub>2</sub> =	1.10	Y <sub>3</sub> =	0.67
Y <sub>3</sub> =	0.67	Y <sub>3</sub> =	0.67	M <sub>cr</sub> =	1574.91 kip-ft
M <sub>cr</sub> =	1574.91 kip-ft	M <sub>cr</sub> =	1574.91 kip-ft	1.2M <sub>cr</sub> =	1889.89 kip-ft
1.2M <sub>cr</sub> =	1889.89 kip-ft	1.2M <sub>cr</sub> =	1889.89 kip-ft	M <sub>m</sub> =	1889.89 kip-ft
M <sub>m</sub> =	1889.89 kip-ft	M <sub>m</sub> =	1889.89 kip-ft		

**8.5.2.4 Control of Cracking by Distribution of Reinforcing in the Slab (AASHTO 5.7.3.4)**

$$s \leq \frac{700 y_e}{\beta_2 f_{ss}} - 2d_c \quad \beta_2 = 1 + \frac{d_c}{0.7(h - d_c)}$$

Exposure Factor (y <sub>e</sub> )=	1.00 Class 1 Exposure	Exposure Factor (y <sub>e</sub> )=	1.00 Class 1 Exposure
Thick of Con Cover (d <sub>c</sub> )=	2.81 in	Thick of Con Cover (d <sub>c</sub> )=	2.81 in
Overall Height (h)=	74.00 in	Overall Height (h)=	74.00 in
β <sub>2</sub> =	1.06	β <sub>2</sub> =	1.06
Min Reb Separation (S)=	23.33 in	Min Reb Separation (S)=	23.33 in
Reinf Separation (S <sub>r</sub> )=	4.00 in	Reinf Separation (S <sub>r</sub> )=	4.00 in

**Cracked Section Properties**

**BOTTOM OF BEAM**

$$A\bar{x} = \sum_i A_i \bar{x}_i$$

$$(A_1 + 2A_2 + b_w \bar{x} + A_{ps} + A_s) \bar{x} = A_1 x_1 + 2A_2 x_2 + b_w \frac{\bar{x}^2}{2} + A_{ps} Y_p + A_s Y_s \rightarrow A_1 + 2A_2 + A_{ps} + A_s = B \text{ and } A_1 x_1 + 2A_2 x_2 + A_{ps} Y_p + A_s Y_s = P$$

$$B\bar{x} + b_w \bar{x}^2 = P + b_w \frac{\bar{x}^2}{2} \rightarrow b_w \frac{\bar{x}^2}{2} + B\bar{x} - P = 0$$

$$\bar{x} = \frac{-B \pm \sqrt{B^2 - 4 \frac{b_w}{2} (-P)}}{b_w}$$

$b_w =$	8.00 in
$A_1 =$	176.00 in <sup>2</sup>
$A_2 =$	60.38 in <sup>2</sup>
$x_1 =$	2.75 in
$x_2 =$	7.83 in
$A_{ps} =$	0.00 in <sup>2</sup>
$Y_p =$	0.00 in
$A_s =$	118.36 in <sup>2</sup>
$Y_s =$	69.11 in
$B =$	415.11 in <sup>2</sup>
$P =$	9610.42 in <sup>3</sup>
$\bar{x} =$	19.49 in

$b_w =$	8.00 in
$A_1 =$	176.00 in <sup>2</sup>
$A_2 =$	60.38 in <sup>2</sup>
$x_1 =$	2.75 in
$x_2 =$	7.83 in
$A_{ps} =$	0.00 in <sup>2</sup>
$Y_p =$	0.00 in
$A_s =$	118.36 in <sup>2</sup>
$Y_s =$	69.11 in
$B =$	415.11 in <sup>2</sup>
$P =$	9610.42 in <sup>3</sup>
$\bar{x} =$	19.49 in

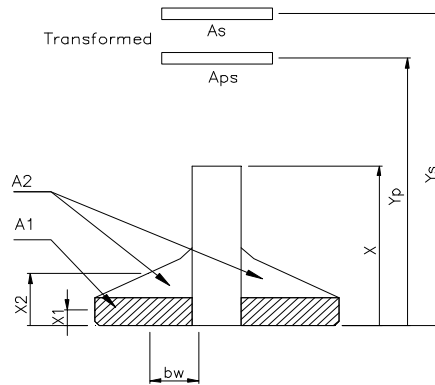

$I_{cr} =$	376494.90 in <sup>4</sup>
$S_{cr} =$	19316.66 in <sup>3</sup>
$M_{serv} =$	-2530.62 kip-ft

$I_{cr} =$	376494.90 in <sup>4</sup>
$S_{cr} =$	19316.66 in <sup>3</sup>
$M_{serv} =$	-2530.62 kip-ft

**Tensile Stress in Mild Steel Reinforcement At Service Limit State**

$f_{ss} =$	<b>22.88 ksi</b>	$f_{ss} =$	<b>22.88 ksi</b>
------------	------------------	------------	------------------

$$A\bar{x} = \sum A_i \bar{x}_i$$

$$(A_1 + 2A_2 + b_w \bar{x} + A_{ps} + A_s + A_{sl})\bar{x} = A_1 x_1 + 2A_2 x_2 + A_{sl} x_3 + b_w \frac{\bar{x}^2}{2} + A_{ps} Y_p + A_s Y_s \rightarrow A_1 + 2A_2 + A_{ps} + A_s + A_{sl} = B \text{ and } A_1 x_1 + 2A_2 x_2 + A_{ps} Y_p + A_s Y_s + A_{sl} x_3 = P$$

$$B\bar{x} + b_w \bar{x}^2 = P + b_w \frac{\bar{x}^2}{2} \rightarrow b_w \frac{\bar{x}^2}{2} + B\bar{x} - P = 0$$

$b_w =$	8.00 in
$A_1 =$	176.00 in <sup>2</sup>
$A_2 =$	60.38 in <sup>2</sup>
$A_3 =$	586.32 in <sup>2</sup>
$x_1 =$	10.25 in
$x_2 =$	15.33 in
$x_3 =$	3.75 in
$A_{ps} =$	37.61 in <sup>2</sup>
$Y_p =$	70.47 in
$A_s =$	0.00 in <sup>2</sup>
$Y_s =$	0.00 in
$B =$	920.68 in <sup>2</sup>
$P =$	8504.72 in <sup>3</sup>
$\bar{x} =$	8.89 in

$$\bar{x} = \frac{-B \pm \sqrt{B^2 - 4 \frac{b_w}{2} (-P)}}{b_w}$$

$b_w =$	8.00 in
$A_1 =$	176.00 in <sup>2</sup>
$A_2 =$	60.38 in <sup>2</sup>
$A_3 =$	586.32 in <sup>2</sup>
$x_1 =$	10.25 in
$x_2 =$	15.33 in
$x_3 =$	3.75 in
$A_{ps} =$	37.61 in <sup>2</sup>
$Y_p =$	70.47 in
$A_s =$	0.00 in <sup>2</sup>
$Y_s =$	0.00 in
$B =$	920.68 in <sup>2</sup>
$P =$	8504.72 in <sup>3</sup>
$\bar{x} =$	8.89 in

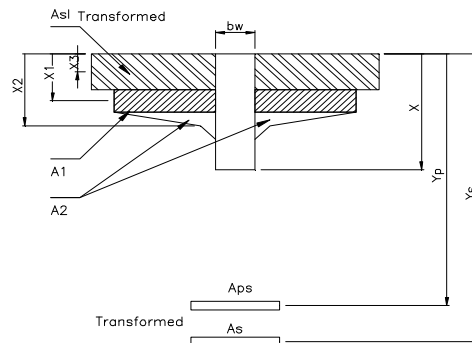

$I_{cr} =$	150191.44 in <sup>4</sup>
$S_{cr} =$	16887.31 in <sup>3</sup>

$I_{cr} =$	150191.44 in <sup>4</sup>
$S_{cr} =$	16887.31 in <sup>3</sup>

**8.5.2.5 Longitudinal Steel at Top of Girder (AASHTO 5.9.4.1.2)**

Bonded reinforcement (reinforcing bars or prestressing steel) sufficient to resist the tensile force in the concrete computed assuming an uncracked section, where reinforcement is proportioned using a stress of 0.5 fy, not to exceed 30 ksi.

Height of the Beam (H)=	66.00 in
Top Stress at Service (ot)=	0.44 ksi
Bot Stress at Service (ob)=	-1.12 ksi
Distance to N.A. (X)=	18.68 in
$\sigma_1 =$	0.35 ksi
$\sigma_2 =$	0.25 ksi
$b_w =$	8.00 in
$T_{ft} =$	4.00 in
$K_{ft} =$	4.00 in
$b_{ft} =$	61.00 in
Tensile Force (T)=	159.85 kip
Steel Allowable Stress(fs)=	30.00 ksi
Steel Required (As)=	5.33 in <sup>2</sup>
Rebar Number (#)=	5 / 8"
$A_{REBAR} =$	0.31 in <sup>2</sup>
#REB Extra TOP=	18.00 Rebars
#REB Extra TOP=	20.00 Rebars

Height of the Beam (H)=	66.00 in
Top Stress at Service (ot)=	0.44 ksi
Bot Stress at Service (ob)=	-1.12 ksi
Distance to N.A. (X)=	18.68 in
$\sigma_1 =$	0.35 ksi
$\sigma_2 =$	0.25 ksi
$b_w =$	8.00 in
$T_{ft} =$	4.00 in
$K_{ft} =$	4.00 in
$b_{ft} =$	66.00 in
Tensile Force (T)=	170.79 kip
Steel Allowable Stress(fs)=	30.00 ksi
Steel Required (As)=	5.69 in <sup>2</sup>
Rebar Number (#)=	5 / 8"
$A_{REBAR} =$	0.31 in <sup>2</sup>
#REB Extra TOP=	19.00 Rebars
#REB Extra TOP=	20.00 Rebars

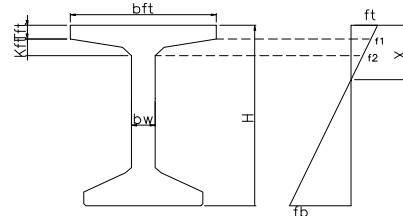

OK

OK

**9. SHEAR DESIGN (AASHTO 5.8)**

**9.1 GENERAL REQUIREMENTS (5.8.1)**

$\phi_v = 0.90$  (See AASHTO 5.5.4.2)

$\phi_f = 0.90$  (See AASHTO 5.5.4.2)

$\phi_c = 0.70$  (See AASHTO 5.5.4.2)

**9.1.1 Minimum Transverse Reinforcement**

Rebar Number (#) = 4 / 8"

$A_{REBAR} = 0.20 \text{ in}^2$

$$s_{min} \geq \frac{A_v f_y}{0.0316 b_v \sqrt{f'_c}}$$

Min Separation ( $s_{min}$ ) = 35.23 in

**9.1.2 Effective Shear Depth**

$$d_v = d_e - \frac{a}{2} \quad d_e = \frac{A_{ps} f_{ps} d_{ps} + A_s f_y d_s}{A_{ps} f_{ps} + A_s f_y}$$

$b_v = 8.00 \text{ in}$

Positive Moment  $d_e = 70.47 \text{ in}$

$d_v = 69.22 \text{ in}$

Negative Moment  $d_e = 69.11 \text{ in}$

$d_v = 66.50 \text{ in}$

Rebar Number (#) = 4 / 8"

$A_{REBAR} = 0.20 \text{ in}^2$

$$s_{min} \geq \frac{A_v f_y}{0.0316 b_v \sqrt{f'_c}}$$

Min Separation ( $s_{min}$ ) = 35.23 in

$b_v = 8.00 \text{ in}$

$d_e = 70.47 \text{ in}$

$d_v = 69.22 \text{ in}$

$d_e = 69.11 \text{ in}$

$d_v = 66.50 \text{ in}$

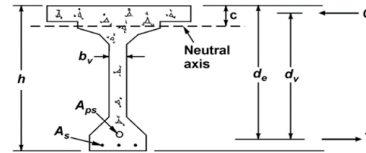

**9.1.2 Shear Stress on Concrete (AASHTO 5.8.2.9)**

$$v_u = \frac{|V_u + \phi_v V_p|}{\phi_v b_v d_v}$$

**9.1.3 Maximum Spacing of Transverse Reinforcement (AASHTO 5.8.2.7)**

if  $v_u < 0.125 f'_c$  then  $s_{max} = 0.8 d_v \leq 24 \text{ in}$

if  $v_u \geq 0.125 f'_c$  then  $s_{max} = 0.4 d_v \leq 12 \text{ in}$

**9.2 SECTIONAL DESIGN MODEL**

The nominal resistance is given by the lesser of:

$$V_n = V_c + V_s + V_p \leq 0.25 f'_c b_v d_v + V_p$$

$$V_c = 0.0316 \beta \sqrt{f'_c} b_v d_v \quad V_s = \frac{A_v f_y d_v (\cot \theta + \cot \alpha) \sin \alpha}{s}$$

$\alpha$  = Inclination of the stirrups

$V_p$  = Component of the Prestressing Force =  $F_{ps} C_y$

$C_y = 0.02$

$\alpha = 90.00^\circ$

$C_y = 0.02$

$\alpha = 90.00^\circ$

$\beta$  = Factor indicating ability of diagonally cracked concrete to transmit tension and shear

$$\beta = \frac{4.8}{(1 + 750 \epsilon_s)}$$

$\theta$  = Angle of inclination of compressive stress

$$\theta = 29 + 3500 \epsilon_s$$

$\epsilon_s$  = Net longitudinal tensile strain in the section at the centroid of the tension reinforcement

$$\epsilon_s = \frac{\left( \frac{|M_u|}{d_v} + 0.5 N_u + |V_u - V_p| - A_{ps} f_{po} \right)}{E_s A_s + E_p A_{ps}}$$

$|M_u|$  should not be taken less than  $|V_u - V_p|$

$A_s$  and  $A_{ps}$  should be reduced in proportion to the development length where is needed

When  $\epsilon_s$  is less than 0, it should be taken as 0 or recalculated using other expression but not taken less than  $-0.4 \times 10^{-3}$

$$f_{po} = 0.7 f_{pu}$$

$$f_{po} = 189.00 \text{ ksi}$$

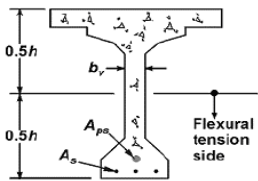

Section

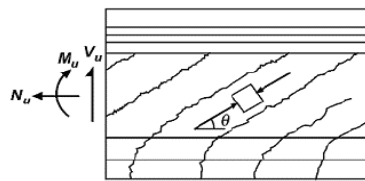

Sectional Forces

Diagonal Cracks

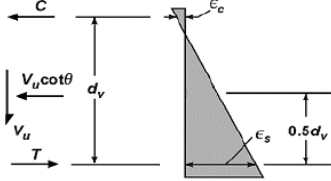

Equivalent Forces

Longitudinal Strains

SPAN 1												
SHEAR RESISTANCE (kip)												
GENERAL PROCEDURE FOR THE SECTIONAL DESIGN MODEL												
Parameter	Units	LOCATION										
		0.05L	0.1L	0.2L	0.3L	0.4L	0.5L	0.6L	0.7L	0.8L	0.9L	0.95L
$V_u$	kip	327.25	294.24	229.15	164.71	103.56	98.84	157.95	220.07	280.81	339.95	368.61
$V_p$	kip	10.89	18.14	18.14	18.14	18.14	18.14	18.14	18.14	18.14	18.14	9.07
$ V_u - V_p $	kip	316.37	276.10	211.01	146.57	85.41	80.69	139.81	201.92	262.66	321.81	359.54
$N_u$	kip	0.00	0.00	0.00	0.00	0.00	0.00	0.00	0.00	0.00	0.00	0.00
$IM_u$	kip-in	19237.08	38468.16	66832.32	85469.76	94970.40	95722.44	88073.64	71880.48	47728.92	17314.08	68018.70
# Strand Tension Side		40.00	40.00	43.00	43.00	43.00	43.00	43.00	43.00	43.00	3.00	3.00
$A_{ps}$	in <sup>2</sup>	3.67	6.12	6.58	6.58	6.58	6.58	6.58	6.58	6.58	0.46	0.23
$\epsilon_s$	in/in	0.00E+00	0.00E+00	0.00E+00	6.37E-04	9.88E-04	1.02E-03	7.79E-04	0.00E+00	0.00E+00	8.08E-04	2.21E-03
$\theta$		29.00	29.00	29.00	31.23	32.46	32.56	31.73	29.00	29.00	31.83	36.72
$\beta$		4.80	4.80	4.80	3.25	2.76	2.72	3.03	4.80	4.80	2.99	1.81
$S_{min\ reinf}$	in	35.23	35.23	35.23	35.23	35.23	35.23	35.23	35.23	35.23	35.23	35.23
$v_u$	ksi	0.64	0.56	0.43	0.30	0.18	0.17	0.28	0.41	0.53	0.68	0.75
$s_{max}$	in	24.00	24.00	24.00	24.00	24.00	24.00	24.00	24.00	24.00	24.00	24.00
$s$	in	11.00	16.00	16.00	24.00	24.00	24.00	24.00	24.00	16.00	8.00	5.00
$V_c$	kip	267.49	183.90	183.90	112.08	106.84	106.43	109.91	122.60	183.90	315.58	420.11
$V_c$	kip	222.23	222.23	222.23	150.40	127.63	126.09	140.26	222.23	222.23	132.97	80.43
$V_n$	kip	500.61	424.27	424.27	280.63	252.62	250.67	268.31	362.98	424.27	466.69	509.62
$\phi V_n$	kip	450.55	381.85	381.85	252.57	227.35	225.60	241.48	326.68	381.85	420.02	458.65
Check		OK	OK	OK	OK	OK	OK	OK	OK	OK	OK	OK
Design: USE		# 4 C/11 in	# 4 C/16 in	# 4 C/16 in	# 4 C/24 in	# 4 C/24 in	# 4 C/24 in	# 4 C/24 in	# 4 C/24 in	# 4 C/16 in	# 4 C/8 in	# 4 C/5 in

SPAN 2												
SHEAR RESISTANCE (kip)												
GENERAL PROCEDURE FOR THE SECTIONAL DESIGN MODEL												
Parameter	Units	LOCATION										
		0.05L	0.1L	0.2L	0.3L	0.4L	0.5L	0.6L	0.7L	0.8L	0.9L	0.95L
$V_u$	kip	377.68	342.56	282.89	222.15	160.03	96.76	101.48	162.63	227.07	292.16	324.91
$V_p$	kip	9.07	18.14	18.14	18.14	18.14	18.14	18.14	18.14	18.14	18.14	9.07
$ V_u - V_p $	kip	368.61	324.42	264.74	204.00	141.89	78.61	83.33	144.49	208.93	274.02	315.84
$N_u$	kip	0.00	0.00	0.00	0.00	0.00	0.00	0.00	0.00	0.00	0.00	0.00
$IM_u$	kip-in	68018.70	17314.08	47728.92	71880.48	88073.64	95722.44	94970.40	85469.76	66832.32	38468.16	19237.08
# Strand Tension Side		3.00	3.00	43.00	43.00	43.00	43.00	43.00	43.00	43.00	40.00	40.00
$A_{ps}$	in <sup>2</sup>	0.23	0.46	6.58	6.58	6.58	6.58	6.58	6.58	6.58	6.12	3.06
$\epsilon_s$	in/in	2.22E-03	8.12E-04	0.00E+00	0.00E+00	7.89E-04	1.01E-03	9.79E-04	6.27E-04	0.00E+00	0.00E+00	1.33E-04
$\theta$		36.77	31.84	29.00	29.00	31.76	32.52	32.43	31.20	29.00	29.00	29.46
$\beta$		1.80	2.98	4.80	4.80	3.02	2.73	2.77	3.26	4.80	4.80	4.37
$S_{min\ reinf}$	in	35.23	35.23	35.23	35.23	35.23	35.23	35.23	35.23	35.23	35.23	35.23
$v_u$	ksi	0.77	0.68	0.53	0.41	0.29	0.16	0.17	0.29	0.42	0.55	0.64
$s_{max}$	in	24.00	24.00	24.00	24.00	24.00	24.00	24.00	24.00	24.00	24.00	24.00
$s$	in	5.00	8.00	16.00	24.00	24.00	24.00	24.00	24.00	16.00	16.00	11.00
$V_c$	kip	419.32	315.39	183.90	122.60	109.77	106.57	106.98	112.23	183.90	183.90	262.45
$V_c$	kip	80.09	132.71	222.23	222.23	139.62	126.61	128.16	151.14	222.23	222.23	202.13
$V_n$	kip	508.48	466.24	424.27	362.98	267.53	251.32	253.28	281.51	424.27	424.27	473.66
$\phi V_n$	kip	457.63	419.62	381.85	326.68	240.78	226.19	227.96	253.36	381.85	381.85	426.29
Check		OK	OK	OK	OK	OK	OK	OK	OK	OK	OK	OK
Design: USE		# 4 C/5 in	# 4 C/8 in	# 4 C/16 in	# 4 C/24 in	# 4 C/24 in	# 4 C/24 in	# 4 C/24 in	# 4 C/24 in	# 4 C/16 in	# 4 C/16 in	# 4 C/11 in

9.3 MINIMUM LONGITUDINAL STEEL (AASHTO 5.8.3.5)

$$T = \frac{M_u}{\phi_f d_v} + 0.5 \frac{N_u}{\phi_c} + \left( \left| \frac{V_u}{\phi_v} - V_p \right| - 0.5 V_c \right) \cot \theta \quad T_n = A_s f_y + A_{ps} f_{ps} \geq T$$

SPAN 1												
MINIMUM LONGITUDINAL STEEL (kip)												
GENERAL PROCEDURE FOR THE SECTIONAL DESIGN MODEL												
Parameter	Units	LOCATION										
		0.05L	0.1L	0.2L	0.3L	0.4L	0.5L	0.6L	0.7L	0.8L	0.9L	0.95L
$V_u / \phi_v$	kip	363.61	326.93	254.62	183.02	115.06	109.82	175.50	244.52	312.01	377.72	409.56
$V_p$	kip	10.89	18.14	18.14	18.14	18.14	18.14	18.14	18.14	18.14	18.14	9.07
$ V_u / \phi_v - V_p $	kip	352.73	308.79	236.47	164.87	96.92	91.67	157.36	226.37	293.86	359.58	400.49
$V_c$	kip	267.49	183.90	183.90	112.08	106.84	106.43	109.91	122.60	183.90	315.58	420.11
$N_u / \phi_c$	kip	0.00	0.00	0.00	0.00	0.00	0.00	0.00	0.00	0.00	0.00	0.00
$IM_u / \phi_f d_v$	kip	308.79	617.47	1072.76	1371.92	1524.42	1536.49	1413.72	1153.79	766.12	289.28	1136.43
$\theta$		29.00	29.00	29.00	31.23	32.46	32.56	31.73	29.00	29.00	31.83	36.72
$T$	kip	703.84	1008.67	1333.49	1551.42	1592.81	1596.73	1579.34	1451.60	1130.39	614.39	1391.72
$f_{ps}$	ksi	991.32	1755.67	1755.67	1755.67	1755.67	1755.67	1755.67	1755.67	1755.67	1755.67	877.84
$T_n$	kip	6066.85	10744.73	11550.58	11550.58	11550.58	11550.58	11550.58	11550.58	11550.58	2048.01	1645.08
Check		OK	OK	OK	OK	OK	OK	OK	OK	OK	OK	OK

0.56

0.50

SPAN 2												
MINIMUM LONGITUDINAL STEEL (kip)												
GENERAL PROCEDURE FOR THE SECTIONAL DESIGN MODEL												
Parameter	Units	LOCATION										
		0.05L	0.1L	0.2L	0.3L	0.4L	0.5L	0.6L	0.7L	0.8L	0.9L	0.95L
$V_u / \phi_v$	kip	419.65	380.62	314.32	246.83	177.81	107.51	112.75	180.71	252.30	324.62	361.01
$V_p$	kip	9.07	18.14	18.14	18.14	18.14	18.14	18.14	18.14	18.14	18.14	9.07
$IV_u / \phi_v - V_p$	kip	410.57	362.48	296.17	228.69	159.67	89.36	94.61	162.56	234.16	306.48	351.94
$V_s$	kip	419.32	315.39	183.90	122.60	109.77	106.57	106.98	112.23	183.90	183.90	262.45
$N_u / \phi_c$	kip	0.00	0.00	0.00	0.00	0.00	0.00	0.00	0.00	0.00	0.00	0.00
$IM_u / \phi_t d_v$	kip	1136.43	289.28	766.12	1153.79	1413.72	1536.49	1524.42	1371.92	1072.76	617.47	308.79
$\theta$		36.77	31.84	29.00	29.00	31.76	32.52	32.43	31.20	29.00	29.00	29.46
$T$	kip	1405.25	619.02	1134.56	1455.77	1582.97	1593.07	1589.15	1547.72	1329.32	1004.50	699.47
$f_{ps}$	ksi	877.84	1755.67	1755.67	1755.67	1755.67	1755.67	1755.67	1755.67	1755.67	1755.67	877.84
$T_n$	kip	1645.08	2048.01	11550.58	11550.58	11550.58	11550.58	11550.58	11550.58	11550.58	10744.73	5372.36
Check		OK	OK	OK	OK	OK	OK	OK	OK	OK	OK	OK

9.4 HORIZONTAL SHEAR (AASHTO 5.8.4)

The Horizontal Shear is caused only by composite Loads

$$\phi V_{ni} \geq V_{ui}$$

$$V_{ni} = cA_{cv} + \mu(A_{vf}f_y + P_c)$$

$$V_{ni} \leq \min(K_2f_cA_{cv}, K_2A_{cv})$$

$$A_{cv} = b_{vi}L_{vi}$$

$$v_{ui} = \frac{V_{ui}}{b_{vi}d_v} \quad V_{ui} = v_{ui}b_{vi}L_{vi} \quad \mu =$$

Cohesion Factor (c)=

Fraction of concrete strength to resist Interface Shear (K1)=

Limiting Interface Shear Resistance (K2)=

0.28 (See AASHTO 5.8.4.3)

0.30 (See AASHTO 5.8.4.3)

1.80 (See AASHTO 5.8.4.3)

1.00 (See AASHTO 5.8.4.3)

SPAN 1												
COMBINED LOADS - SHEARS (Kips)												
LOAD COMBINATION	Units	LOCATION										
		0.0L	0.1L	0.2L	0.3L	0.4L	0.5L	0.6L	0.7L	0.8L	0.9L	1.0L
Strength I Max +M		207.72	171.79	136.80	102.45	71.39	96.76	129.94	161.96	192.61	221.66	248.88
Strength I Min -M		198.22	164.81	132.33	100.51	70.81	93.66	124.32	153.83	181.96	208.49	233.20
Strength III Max +M		19.92	14.64	9.36	4.08	1.20	6.48	11.76	17.04	22.32	27.60	32.88
Strength III Min +M		10.41	7.65	4.89	2.13	0.63	3.39	6.15	8.91	11.67	14.43	17.20
Strength V Max +M		164.80	135.87	107.67	79.96	55.34	76.12	102.93	128.84	153.69	177.31	199.51
Strength V Min +M		155.29	128.89	103.20	78.02	54.77	73.03	97.31	120.71	143.04	164.14	183.82
HORIZONTAL SHEAR DESIGN - SHEARS (Kips)												
Parameter	Units	LOCATION										
		0.0L	0.1L	0.2L	0.3L	0.4L	0.5L	0.6L	0.7L	0.8L	0.9L	1.0L
$V_{u1}$	kip	207.72	171.79	136.80	102.45	71.39	96.76	129.94	161.96	192.61	221.66	248.88
$b_{vi}$	in	61.00	61.00	61.00	61.00	61.00	61.00	61.00	61.00	61.00	61.00	61.00
$L_{vi}$	in	11.00	16.00	16.00	24.00	24.00	24.00	24.00	24.00	16.00	8.00	5.00
$A_{cv}$	in <sup>2</sup>	671.00	976.00	976.00	1464.00	1464.00	1464.00	1464.00	1464.00	976.00	488.00	305.00
$v_{ui}$	ksi	0.05	0.04	0.03	0.02	0.02	0.02	0.03	0.04	0.05	0.05	0.06
$V_{ui}$	kip	33.01	39.71	31.62	35.52	24.75	33.55	45.05	56.15	44.52	26.66	18.71
$P_c$	kip	0.00	0.00	0.00	0.00	0.00	0.00	0.00	0.00	0.00	0.00	0.00
$V_{ni}$	kip	211.44	296.84	296.84	433.48	433.48	433.48	433.48	433.48	296.84	160.20	108.96
$\phi V_{ni}$	kip	190.30	267.16	267.16	390.13	390.13	390.13	390.13	390.13	267.16	144.18	98.07
Check		OK	OK	OK	OK	OK	OK	OK	OK	OK	OK	OK
SPAN 2												
COMBINED LOADS - SHEARS (Kips)												
LOAD COMBINATION	Units	LOCATION										
		0.0L	0.1L	0.2L	0.3L	0.4L	0.5L	0.6L	0.7L	0.8L	0.9L	1.0L
Strength I Max +M		262.34	222.19	192.61	161.96	129.94	96.76	71.39	102.45	136.80	171.79	207.20
Strength I Min -M		246.65	209.02	181.96	153.83	124.32	93.66	70.81	100.51	132.33	164.81	197.70
Strength III Max +M		32.88	27.60	22.32	17.04	11.76	6.48	1.20	4.08	9.36	14.64	19.92
Strength III Min +M		17.20	14.43	11.67	8.91	6.15	3.39	0.63	2.13	4.89	7.65	10.41
Strength V Max +M		209.89	177.71	153.69	128.84	102.93	76.12	55.34	79.96	107.67	135.87	164.39
Strength V Min +M		194.21	164.54	143.04	120.71	97.31	73.03	54.77	78.02	103.20	128.89	154.89
HORIZONTAL SHEAR DESIGN - SHEARS (Kips)												
Parameter	Units	LOCATION										
		0.0L	0.1L	0.2L	0.3L	0.4L	0.5L	0.6L	0.7L	0.8L	0.9L	1.0L
$V_{u1}$	kip	262.34	222.19	192.61	161.96	129.94	96.76	71.39	102.45	136.80	171.79	207.20
$b_{vi}$	in	61.00	61.00	61.00	61.00	61.00	61.00	61.00	61.00	61.00	61.00	61.00
$L_{vi}$	in	5.00	8.00	16.00	24.00	24.00	24.00	24.00	24.00	16.00	16.00	11.00
$A_{cv}$	in <sup>2</sup>	305.00	488.00	976.00	1464.00	1464.00	1464.00	1464.00	1464.00	976.00	976.00	671.00
$v_{ui}$	ksi	0.06	0.05	0.05	0.04	0.03	0.02	0.02	0.02	0.03	0.04	0.05
$V_{ui}$	kip	19.72	26.73	44.52	56.15	45.05	33.55	24.75	35.52	31.62	39.71	32.93
$P_c$	kip	0.00	0.00	0.00	0.00	0.00	0.00	0.00	0.00	0.00	0.00	0.00
$V_{ni}$	kip	108.96	160.20	296.84	433.48	433.48	433.48	433.48	433.48	296.84	296.84	211.44
$\phi V_{ni}$	kip	98.07	144.18	267.16	390.13	390.13	390.13	390.13	390.13	267.16	267.16	190.30
Check		OK	OK	OK	OK	OK	OK	OK	OK	OK	OK	OK

**10. CONTINUITY CONNECTION IN THE NEGATIVE MOMENT ZONES**

**10.1 NEGATIVE MOMENT CONNECTION (AASHTO 5.7.3.2)**

**10.1.1 NOMINAL RESISTANCE AND FLEXURAL RESISTANCE (AASHTO 5.7.3.2.1)**

**Rectangular Section Behavior**

$$c = \frac{A_s f_s - A'_s f'_s}{0.85 f'_c \beta_1 b}$$

Mild Steel ( $A_s$ )=	0.00 in <sup>2</sup>	$\beta_1$ =	0.70
Dist to mild Steel ( $d_s$ )=	0.00 in	c=	2.62 in
Tension Steel ( $A'_s$ )=	20.70 in <sup>2</sup>	a=	1.83 in
Dist to Tension Steel ( $d'_s$ )=	69.11 in	Dist to Extreme Tension Steel ( $d_t$ )=	71.50 in
C/ $d_t$ =	0.04	Tension Controlled Strain ( $\epsilon_{t1}$ )=	0.005 in/in
$M_n = A_s f_y \left(d_s - \frac{a}{2}\right) - A'_s f'_y \left(d'_s - \frac{a}{2}\right)$		Compression Strain Limit ( $\epsilon_c$ )=	0.003 in/in
$M_n$ =	7059.30 kip-ft	Compression Controlled Strain ( $\epsilon_{c1}$ )=	0.002 in/in
$\phi_{flexure}$ =	1.00	Tension Controlled Limit ( $c/d_t$ ) <sub>T</sub> =	0.38
$\phi M_n$ =	7059.30 kip-ft	Compression Controlled Limit ( $c/d_t$ ) <sub>C</sub> =	0.60
$M_u (-)$ =	4257.70 kip-ft		

OK

**10.2. POSITIVE MOMENT CONNECTION (AASHTO 5.14.1.4)**

A minimum girder age of at least 90 days when continuity is established is required (AASHTO 5.14.1.4.4) In order to avoid computation of time dependent effect:

**10.2.1 POSITIVE MOMENT CONNECTION USING PRESTRESSING STRANDS (AASHTO 5.14.1.4.9c)**

Pretensioning strands that are not debonded at the end of the girder may be extended into the continuity diaphragm as positive moment reinforcement. The extended strands shall be anchored into the diaphragm by bending the strands into a 90-degree hook or by providing a development length.

**Service Limit State**

$$f_{psi} = \frac{(\ell_{dsh} - 8)}{0.228} \quad \text{limit state, Cracked section shall be assumed}$$

$$f_r = 0.24 \sqrt{f'_c}$$

$$M_{cr} = f_r S_{bc}$$

$\ell_{dsh}$ =	26.00 in
$f_{psi}$ =	78.95 ksi
$f_r$ =	0.63 ksi

$S_{bc}$ =	16887.31 in <sup>3</sup>
$M_{cr}$ =	893.59 kip-ft
1.2 $M_{cr}$ =	1072.31 kip-ft

$$a = \frac{A_{ps} f_{psi}}{0.85 f'_c b} \quad d = h - h_{ps}$$

$$M_n = A_{ps} f_{psi} \left(d - \frac{a}{2}\right)$$

Number of Strand Rows Used=	2
Distance to Strands (d)=	71.00 in
Number of Strands Used=	20
$A_{ps}$ =	3.06 in <sup>2</sup>
a=	0.36 in
$\phi M_n$ =	1425.76 kip-ft

OK

**Strength Limit State**

$$f_{pul} = \frac{(\ell_{dsh} - 8)}{0.163} \quad f_{pul} = \text{Stress in the strand at the Strength Limit State}$$

$$f_r = 0.24 \sqrt{f'_c}$$

$$M_{cr} = f_r S_{bc}$$

$f_{pul}$ =	
$f_r$ =	
$S_{bc}$ =	27039.36 in <sup>3</sup>
$M_{cr}$ =	1430.79 kip-ft
1.2 $M_{cr}$ =	1716.95 kip-ft

$$a = \frac{A_{ps} f_{psi}}{0.85 f'_c b} \quad d = h - h_{ps}$$

$$M_n = A_{ps} f_{pul} \left(d - \frac{a}{2}\right)$$

Number of Strand Rows Used=	2
Distance to Strands (d)=	71.00 in
Number of Strands Used=	20
$A_{ps}$ =	3.06 in <sup>2</sup>
a=	0.50 in
$\phi M_n$ =	1992.31 kip-ft

OK

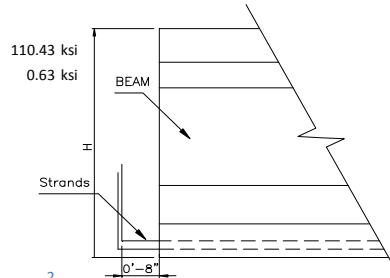

**11. PRETENSIONED ANCHORAGE ZONES (AASHTO 5.10.10.1)**

Reinforcing at the end of the girder to resist splitting forces. The stirrups must resist 4% of  $P_i$

$$P_n = A_s f_s \geq 0.04 P_i \quad \text{The term } f_s \text{ cannot exceed 20 ksi}$$

$$A_s \geq \frac{0.04 P_i}{20} \quad \text{These must be placed over a distance } h/4 \text{ (h=depth of the Girder)}$$

$P_i$ =	1755.67 kip	$P_i$ =	1755.67 kip
$A_s$ =	3.51 in <sup>2</sup>	$A_s$ =	3.51 in <sup>2</sup>
Rebar Number (#)=	5 /8"	Rebar Number (#)=	5 /8"
$A_{REBAR}$ =	0.31 in <sup>2</sup>	$A_{REBAR}$ =	0.31 in <sup>2</sup>
#REB Extra TOP=	5.00 Rebars	#REB Extra TOP=	5.00 Rebars
h/4=	16.50 in	h/4=	16.50 in

**12. CONFINEMENT REINFORCEMENT (AASHTO 5.10.10.2)**

For the distance of 1.5d from the end of the beams other than box beams, reinforcement shall be placed to confine the prestressing steel in the bottom flange. The reinforcement shall not be less than No. 3 deformed bars, with spacing not exceeding 6.0 in. and shaped to enclose the strands.

1.5d=	99.00 in	1.5d=	99.00 in
-------	----------	-------	----------



**13. DEFORMATIONS**

**13.1 CAMBER (AASHTO 5.7.3.6.2)**

Camber includes:

$$\Delta_{ps} = \frac{P_i}{E_{ci}I} \left( \frac{e_c L^2}{8} - \frac{e' a^2}{6} \right)$$

$\Delta_{ps} = 2.45$  in ↑ Spans 1 and 3  
 $\Delta_{ps} = 2.45$  in ↑ Span 2

For simplicity, this values must be check during fabrication.

- Permanent Loads acting in the non composite section such as: Beam Weight, slab and others

$$\Delta_{DL} = \frac{1}{EI} \left( \frac{wLx^3}{12} - \frac{wx^4}{24} - \frac{wL^3x}{24} \right) \quad \Delta_{DL\ Max} = \frac{5wL^4}{384EI}$$

$\Delta_{DL\ max} = 2.06$  in ↓ Spans 1 and 3  
 $\Delta_{DL\ max} = 2.06$  in ↓ Span 2

- Permanent Loads acting in the composite section such as: Barriers and future wearing surface. (Computed with a Structural Analysis Software)

$\Delta_{DL\ Barr\ max} = \#REF!$  in ↓ Spans 1 and 3       $\Delta_{DL\ DW\ max} = \#REF!$  in ↓ Spans 1 and 3  
 $\Delta_{DL\ Barr\ max} = -0.03$  in ↓ Span 2       $\Delta_{DL\ DW\ max} = -0.06$  in ↓ Span 2

**13.2 PERMANENT DELFECTION - According to AASHTO 3.6.1.3.2**

The deflection should be taken as the larger of:

- i) That resulting from the design truck alone, or
- ii) That resulting from 25 percent of the design truck taken together with the design lane load

It is assumed that all design lanes are loaded and that all supporting components are assumed to deflect equally (AASHTO article 2.5.2.6.2)

Live-load deflection is checked using the live-load portion of SERVICE I load combination, including the appropriate dynamic load allowance

$\Delta_{L\ max} \leq \frac{Span}{800}$

Number of Lanes= 2.00 Lanes  
 Load Combination? Service I According to AASHTO 2.5.2.6.2  
 Live Load Factor= 1.00 LL+IM  
 Distribution Factor= 0.40 Trucks  
 (#Lanes/#Beams)

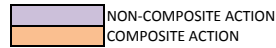

SPAN	Span Length (ft)	$\Delta_{Truck\ MAX}$ (in)	$\Delta_{Lane\ MAX}$ (in)	$\Delta_{LL+IM\ MAX}$ (in)	$\Delta_{L\ MAX}$ (in)	$\Delta_{limit\ (Sp/800)}$ (in)	
SPAN 1	110.00	0.23	0.10	0.23	0.23	1.65	OK
SPAN 2	110.00	0.23	0.10	0.23	0.23	1.65	OK

## BRIDGE DECK DESIGN (Reinforced Concrete Section)

### Table of Contents

- 1. MATERIALS PROPERTIES
  - 1.1 CONCRETE
  - 1.3 REINFORCEMENT STEEL
- 2. LIMIT STATE FACTORS (AASHTO 6.5.4.2)
  - 2.1 Concrete
- 3. GEOMETRIC PROPERTIES
  - 3.1 GENERAL
- 4. LOADS
  - 4.1 DEAD LOAD (DC)
  - 4.2 DEAD LOAD WEARING SURFACE (DW)
  - 4.3 LIVE LOAD (LL) - (According to AASHTO 3.6.1.2)
    - 4.3.1 Equivalent Strip Width (AASHTO 4.6.2.2)
- 5. MOMENTS
  - 5.1 DEAD LOAD
  - 5.2 LIVE LOAD
  - 5.3 LOAD COMBINATIONS
  - 5.4 DESIGN SHEAR AND MOMENTS
- 6. DESIGN OF REINFORCED CONCRETE
  - 6.1 MOMENT CAPACITY - NEGATIVE (TOP) (AASHTO 5.7.3.2)
    - 6.1.1 Minimum Flexural Reinforcement (AASHTO 5.7.3.3.2)
    - 6.1.2 Moment Capacity (AASHTO 5.7.3.2)
    - 6.1.3 Serviceability Check - Control of Cracking (AASHTO 5.7.3.4)
    - 6.1.4 Fatigue Limit State Check (AASHTO 5.5.3, 5.7.1, 9.5.3)
    - 6.1.5 Shrinkage and Temperature Reinforcement (Bottom bars) (AASHTO 5.10.8)
  - 6.2 MOMENT CAPACITY - POSITIVE (BOTTOM) (AASHTO 5.7.3.2)
    - 6.2.1 Minimum Flexural Reinforcement (AASHTO 5.7.3.3.2)
    - 6.2.2 Moment Capacity (AASHTO 5.7.3.2)
    - 6.2.3 Serviceability Check - Control of Cracking (AASHTO 5.7.3.4)
    - 6.2.4 Transverse Distribution Reinforcement (Top bars) (AASHTO 5.14.4.1)

## BRIDGE DECK DESIGN (Reinforced Concrete Section)

AASHTO LRFD Bridge Design Specifications U.S. Customary Units, Seventh Edition, 2014

### 1. MATERIALS PROPERTIES

#### 1.1 CONCRETE

$f'_c$ =	4.00 ksi
$E_c$ =	3834 ksi
$\chi_c$ =	0.150 kip/ft <sup>3</sup>
n=	8.00

#### 1.3 REINFORCEMENT STEEL

AASHTO A615, Grade 60

$F_y$ =	60 ksi
$F_u$ =	80 ksi
$E_s$ =	29000 ksi
$\chi_s$ =	0.490 kip/ft <sup>3</sup>

AASHTO 3.7.1 The modular ratio, n, is rounded to the nearest integer number.

### 2. LIMIT STATE FACTORS (AASHTO 6.5.4.2)

#### 2.1 Concrete

$\Phi_{Tens\ Controlled}$ =	0.90	$\Phi_{Bearing}$ =	0.70	$\Phi_{Moment}$ =	0.90
$\Phi_{Shear}$ =	0.90	$\Phi_{Comp\ Control}$ =	0.75		

### 3. GEOMETRIC PROPERTIES

#### 3.1 GENERAL

Slab Thickness (e)=	8.00 in	Number of Lanes ( $N_L$ )=	3.00
Sacrificial Surface (sw)=	0.50 in	Skew ( $\theta$ )=	0.00 °
Width (W)=	43.00 ft	Beams Separation (S)=	9.50 ft
Number of Beams ( $N_B$ )=	5.00 beams	$d_s$ =	5.33 in

The distance from the centerline of girder to the design section for negative moment in the deck ( $d_x$ ) should be taken equal to one-third of the flange width from the centerline of the support (AASHTO 4.6.2.1.6), but not to exceed 15 in.

#### 3.3.1 CONCRETE BEAM

d=	45.75 in				
$b_{fb}$ =	16.00 in	$b_{ft}$ =	16.00 in	$T_w$ =	0.50 in
$T_{fb}$ =	0.88 in	$T_{ft}$ =	0.88 in	$H_w$ =	44.00 in

Section	Area (in <sup>2</sup> )	y (in)	x (in)	A.y (in <sup>3</sup> )	A.x (in <sup>3</sup> )	$I_{xx}$ (in <sup>4</sup> )	$I_{yy}$ (in <sup>4</sup> )	$d_y$ (in)	$d_x$ (in)	A. $d_y^2$ (in <sup>4</sup> )	A. $d_x^2$ (in <sup>4</sup> )
Top Flange	14.00	0.44	8.00	6.13E+00	1.12E+02	8.93E-01	2.99E+02	0.44	8.00	2.68E+00	8.96E+02
Bot Flange	14.00	45.31	8.00	6.34E+02	1.12E+02	8.93E-01	2.99E+02	45.31	8.00	2.87E+04	8.96E+02
Web	22.00	22.88	8.00	5.03E+02	1.76E+02	3.55E+03	4.58E-01	22.88	8.00	1.15E+04	1.41E+03

$A_T$ =	50.00 in <sup>2</sup>
$I_x$ =	43810.76 in <sup>4</sup>
Weight=	170.14 lb

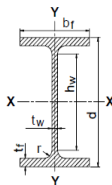

### 4. LOADS

#### 4.1 DEAD LOAD (DC)

Concrete Deck=	0.100 kip/ft <sup>2</sup>
Stay-in-Place Forms=	0.015 kip/ft
<b>Total DC=</b>	<b>0.12 kip/ft<sup>2</sup></b>
Rail Barriers=	0.39 kip/ft/Barrier

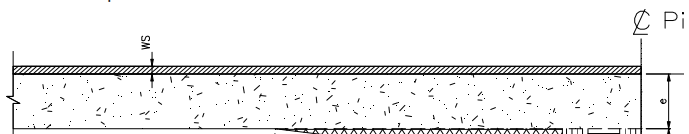

**4.2 DEAD LOAD WEARING SURFACE (DW)**

Future Wearing Surface= 0.035 kip/ft<sup>2</sup> (Common Value used see FHWA examples)

**4.3 LIVE LOAD (LL) - (According to AASHTO 3.6.1.2)**

Live load is composed by the following:

i) Design Truck or design Tandem (pair of 25kips axles spaced 4ft apart)

ii) Design lane load (The design lane load shall consist of a load of 0.64 kif uniformly distributed in the longitudinal direction. Transversely, the design lane load shall be assumed to be uniformly distributed over a 10.0-ft width.)

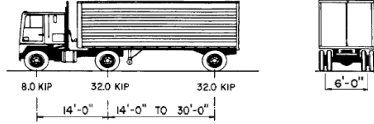

Using the approximate method of deck analysis (AASHTO 4.6.2), live load effects may be determined by modeling the deck as a beam supported on the girders. One or more axles may be placed side by side on the deck (representing axles from trucks in different traffic lanes) and move them transversely across the deck to maximize the moments (AASHTO 4.6.2.1.6). To determine the live load moment per unit width of the bridge, the calculated total live load moment is divided by a strip width determined using the appropriate equation from Table AASHTO 4.6.2.1.3-1.

The specifications allow the live load moment per unit width of the deck to be determined using **AASHTO Table A4.1-1**. This table lists the positive and negative moment per unit width of decks with various girder spacing and with various distances from the design section to the centerline of the girders for negative moment. This table is based on the analysis procedure outlined above.

Dyn Load Allowance (IM)= 33% AASTO Table 3.6.2.1-1

**4.3.1 Equivalent Strip Width (AASHTO 4.6.2.2)**

The equivalent strip width defines the width of the slab that will be impacted by the live load within a design lane. The slab is designed based on the forces developed within this width.

The Cast-in-place option with stay-in-place concrete formwork is used according to the AASHTO Table 4.6.2.1.3-1 - Equivalent Strips

Strip Width Positive Moment (E<sub>PM</sub>)= 88.70 in +M = 26.0 + 6.6S

Strip Width Negative Moment (E<sub>NM</sub>)= 76.50 in -M = 48.0 + 3.0S

**5. MOMENTS**

**5.1 DEAD LOAD**

$$M_f = \frac{w_f S^2}{c} \quad \text{Constant (c)}= 10.00 \text{ Typically taken as 10 or 12}$$

Concrete Deck= 0.903 kip-ft/ft

Future Wearing Surface= 0.316 kip-ft/ft

Stay-in-Place Forms= 0.135 kip-ft/ft

**5.2 LIVE LOAD**

Positive Moment Live Load (M+)= 6.59 kip-ft/ft

Negative Moment Live Load (M-)= 5.70 kip-ft/ft

Dynamic Allowance is Included in the values obtained from AASHTO A4.1-1

**5.3 LOAD COMBINATIONS**

COMBINATION	Type	LOAD CASES										
		DC	DW	LL	IM	BR	WS	WL	FR	TU	TG	IC
Strength I	Max	1.25	1.50	1.75	1.75	1.75	-	-	1.00	1.20	-	-
	Min	0.90	0.65	1.75	1.75	1.75	-	-	1.00	0.50	-	-
Extreme Event II	Max	1.25	1.50	0.50	0.50	0.50	-	-	1.00	-	-	1.00
	Min	0.90	0.65	0.50	0.50	0.50	-	-	1.00	-	-	1.00
Service I	Max	1.00	1.00	1.00	1.00	1.00	0.30	1.00	1.00	1.00	0.50	-
	Min	1.00	1.00	1.00	1.00	1.00	0.30	1.00	1.00	1.20	0.50	-
Service II	Max	1.00	1.00	1.30	1.30	1.30	-	-	1.00	1.00	0.50	-
	Min	1.00	1.00	1.30	1.30	1.30	-	-	1.00	1.20	0.50	-

**5.4 DESIGN SHEAR AND MOMENTS**

SPAN 1		
LOAD COMBINATION	POSITIVE MOMENT (kip-ft)	NEGATIVE MOMENT (kip-ft)
Strength I	13.30	11.75
Extreme Event II	5.07	4.62
Service I	7.94	7.05
Service II	9.92	8.76

**6. DESIGN OF REINFORCED CONCRETE**

**Reinforcement**

**Top**

Rebar Number (#)= 6 /8"

Rebar Spacing (s)= 5.00 in

A<sub>REBAR</sub>= 0.44 in<sup>2</sup>

A<sub>REB TOP</sub>= 1.06 in<sup>2</sup>/ft

**Top Compression Region**

Rebar Number (#)= 0 /8"

Rebar Spacing (s)= 7.00 in

A<sub>REBAR</sub>= 0.00 in<sup>2</sup>

A<sub>REB TOP</sub>= 0.00 in<sup>2</sup>/ft

Cover<sub>TOP</sub>= 2.50 in Measured to edge of top reinforcement

Cover<sub>BOT</sub>= 1.00 in Measured to edge of top reinforcement

**Bottom**

Rebar Number (#)= 5 /8"

Rebar Spacing (s)= 7.00 in

A<sub>REBAR</sub>= 0.31 in<sup>2</sup>

A<sub>REB TOP</sub>= 0.53 in<sup>2</sup>/ft

**Bottom Compression Region**

Rebar Number (#)= 0 /8"

Rebar Spacing (s)= 8.00 in

A<sub>REBAR</sub>= 0.00 in<sup>2</sup>

A<sub>REB TOP</sub>= 0.00 in<sup>2</sup>/ft

**Transversal Reinforcement**

Rebar Number (#)= 5 /8"

Rebar Spacing (s)= 7.00 in

A<sub>REBAR</sub>= 0.31 in<sup>2</sup>

A<sub>REB TOP</sub>= 0.53 in<sup>2</sup>/ft

**6.1 MOMENT CAPACITY - NEGATIVE (TOP) (AASHTO 5.7.3.2)**

Design strip width equal to 1 ft

b= 12.00 in  
h<sub>neg</sub>= 7.50 in

**6.1.1 Minimum Flexural Reinforcement (AASHTO 5.7.3.3.2)**

Factored Flexural Resistance, Mr, must be greater than or equal to the lesser of M<sub>cr</sub> (Cracking Moment) or 1.33 Mu (Ultimate Moment)

$$M_{cr} = \gamma_3 \left[ (\gamma_1 f_r + \gamma_2 f_{cpe}) S_c - M_{dnc} \left( \frac{S_c}{S_{nc}} - 1 \right) \right] \quad f_r = 0.24 \sqrt{f'_c} \quad S_c : S_{top} \quad \begin{matrix} V_1 = 1.60 & \text{Other structures} \\ V_2 = 1.00 & \text{None Prestressed} \\ V_3 = 0.67 & \text{AASHTO A615 Grade 60} \end{matrix}$$

Gross Moment of Inertia (I<sub>g</sub>)= 421.88 in<sup>4</sup>  
Modulus of Rupture (f<sub>r</sub>)= 0.48 ksi AASHTO 5.4.2.6  
Distance From Center of Gravity to Extreme tension fiber (y<sub>t</sub>)= 3.75 in  
Section Modulus (S<sub>top</sub>)= 112.50 in<sup>3</sup>  
Section Modulus of noncomposite subjected to tension (S<sub>nc</sub>)= 112.50 in<sup>3</sup>  
Total unfactored dead load acting on noncomposite (M<sub>dnc</sub>)= 1.35 kip-ft  
Compressive Stress due to prestress (f<sub>cpe</sub>)= 0.00 ksi  
Cracking Moment (M<sub>cr, neg</sub>)= 4.82 kip-ft  
Ultimate Moment (M<sub>u, neg</sub>)= 11.75 kip-ft

**Minimum principal reinforcement according to  
INDOT 404-2.01 is # 5 @ 8"**

Factored Flexural Resistance (M<sub>f, neg</sub>)= 4.82 kip-ft

**6.1.2 Moment Capacity (AASHTO 5.7.3.2)**

β<sub>1</sub> shall be taken as 0.85 for concrete strengths not exceeding 4.0 ksi. For concrete strengths exceeding 4.0 ksi β<sub>1</sub> shall be reduced at a rate of 0.05 for each 1.0 ksi of strength in excess of 4.0 ksi, β<sub>1</sub> shall not be taken to be less than 0.65.

β<sub>1, neg</sub>= 0.85 AASHTO 5.7.2.2

Depth of cross section in Compression (c<sub>neg</sub>)= 1.83 in

Depth of equivalent stress block (a<sub>neg</sub>) (AASHTO 5.7.2.2)= 1.56 in

$$c_{neg} = \frac{A_{s, neg} f_y}{0.85 f'_c \beta_{1, neg} b}$$

$$a_{neg} = c_{neg} \beta_{1, neg}$$

c<sub>neg</sub>/d<sub>neg</sub>= 0.26 OK < 0.60, Reinforcement will yield

$$M_{n, neg} = A_{s, neg} f_y \left( d_{neg} - \frac{a_{neg}}{2} \right) \quad \text{AASHTO Eq. 5.7.3.2.2-1}$$

Nominal Flexural Resistance (ϕ<sub>M</sub> M<sub>n, neg</sub>)= 18.35 kip-ft

Ultimate Moment (M<sub>u, neg</sub>)= 11.75 kip-ft OK

Factored Flexural Resistance (M<sub>f, neg</sub>)= 4.82 kip-ft OK

**6.1.3 Serviceability Check - Control of Cracking (AASHTO 5.7.3.4)**

d<sub>c, neg</sub>= 2.88 in

d<sub>neg</sub>= 4.63 in

ρ<sub>neg</sub>= 0.0191

k<sub>neg</sub>= 0.42

j<sub>neg</sub>= 0.86

$$j_{neg} = 1 - \frac{(k_{neg})}{3}$$

$$k_{neg} = \sqrt{(2\rho_{neg} n) + (\rho_{neg} n)^2} - (\rho_{neg} n)$$

$$f_{ss, neg} = \frac{M_{s, neg}}{A_{s, neg} j_{neg} d_{neg}} \quad \beta_1 = 1 + \frac{d_{c, neg}}{0.70(h - d_{c, neg})} \quad s \leq \frac{700\gamma_e}{\beta_1 f_{ss}} - 2d_{c, neg}$$

Service Moment (M<sub>s, neg</sub>)= 8.76 kip-ft

Service Load Bending Stress (f<sub>ss, neg</sub>)= 24.94 ksi

β<sub>1</sub>= 1.89

Exposure Factor (γ<sub>e</sub>)= 0.75 Class 2

Maximum separation of rebars (s<sub>max</sub>)= 5.40 in OK

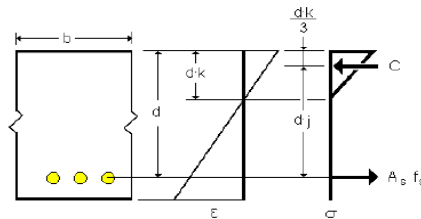

**6.1.4 Fatigue Limit State Check (AASHTO 5.5.3, 5.7.1, 9.5.3)**

*Fatigue need not be investigated for concrete slab in multi girder bridges (AASHTO 9.5.3 and 5.5.3.1)*

**6.1.5 Shrinkage and Temperature Reinforcement (Bottom bars) (AASHTO 5.10.8)**

$$A_{s, shr} \geq \frac{1.30bh}{2(b+h)f_y} \quad 0.11 \leq A_{s, shr} \leq 0.60$$

b= 12.00 in

h<sub>neg</sub>= 7.50 in

A<sub>s, shr</sub>= 1.06 in<sup>2</sup>

A<sub>s, req</sub>= 0.05 in<sup>2</sup>

A<sub>s, req, min</sub>= 0.11 in<sup>2</sup> OK

**6.2 MOMENT CAPACITY - POSITIVE (BOTTOM) (AASHTO 5.7.3.2)**

Design strip width equal to 1 ft

b= 12.00 in

h<sub>pos</sub>= 7.50 in

**6.2.1 Minimum Flexural Reinforcement (AASHTO 5.7.3.3.2)**

Factored Flexural Resistance, Mr, must be greater than or equal to the lesser of Mcr (Cracking Moment) or 1.33 Mu (Ultimate Moment)

$M_{cr} = \gamma_3 \left[ (\gamma_1 f_r + \gamma_2 f_{cpe}) S_c - M_{dnc} \left( \frac{S_c}{S_{nc}} - 1 \right) \right]$	$f_r = 0.24 \sqrt{f'_c}$	$S_c: S_{Top}$	$V_1 = 1.60$	Other structures
			$V_2 = 1.00$	None Prestressed
			$V_3 = 0.67$	AASHTO A615 Grade 60
Gross Moment of Inertia ( $I_g$ )=	421.88 in <sup>4</sup>			
Modulus of Rupture ( $f_r$ )=	0.48 ksi	AASHTO 5.4.2.6		
Distance From Center of Gravity to Extreme tension fiber ( $y_t$ )=	3.75 in			
Section Modulus ( $S_{Top}$ )=	112.50 in <sup>3</sup>			
Section Modulus of noncomposite subjected to tension( $S_{nc}$ )=	112.50 in <sup>3</sup>			
Total unfactored dead load acting on noncomposite( $M_{dnc}$ )=	1.35 kip-ft			
Compressive Stress due to prestress ( $f_{cpe}$ )=	0.00 ksi			
Cracking Moment ( $M_{cr, neg}$ )=	4.82 kip-ft			
Ultimate Moment ( $M_{u, neg}$ )=	13.30 kip-ft			
Factored Flexural Resistance ( $M_{f, neg}$ )=	4.82 kip-ft			

Minimum principal reinforcement according to INDOT 404-2.01 is  
# 5 @ 8"

**6.2.2 Moment Capacity (AASHTO 5.7.3.2)**

$\beta_1$  shall be taken as 0.85 for concrete strengths not exceeding 4.0 ksi. For concrete strengths exceeding 4.0 ksi  $\beta_1$  shall be reduced at a rate of 0.05 for each 1.0 ksi of strength in excess of 4.0 ksi,  $\beta_1$  shall not be taken to be less than 0.65.

$\beta_{1, pos} = 0.85$ AASHTO 5.7.2.2	$c_{pos} = \frac{A_s, pos f_y}{0.85 f'_c \beta_1, pos b}$	
Depth of cross section in Compression ( $c_{pos}$ )=	0.91 in	$a_{neg} = c_{pos} \beta_1, pos$
Depth of equivalent stress block ( $a_{pos}$ ) (AASHTO 5.7.2.2)=	0.77 in	$c_{pos}/d_{pos} = 0.15$ OK < 0.60, Reinforcement will yield
$M_{n, pos} = A_s, pos f_y \left( d_{pos} - \frac{a_{pos}}{2} \right)$ AASHTO Eq. 5.7.3.2.2-1		
Nominal Flexural Resistance ( $\phi_M M_{n, pos}$ )=	13.98 kip-ft	
Ultimate Moment ( $M_{u, pos}$ )=	13.30 kip-ft	OK
Factored Flexural Resistance ( $M_{f, pos}$ )=	4.82 kip-ft	OK

**6.2.3 Serviceability Check - Control of Cracking (AASHTO 5.7.3.4)**

$d_{c, pos} = 1.21$ in	$j_{pos} = 1 - \frac{(k_{pos})}{3}$	
$d_{pos} = 5.98$ in	$k_{pos} = \sqrt{(2\rho_{pos} n) + (\rho_{pos} n)^2} - (\rho_{pos} n)$	
$\rho_{pos} = 0.0073$		
$k_{pos} = 0.29$		
$j_{pos} = 0.90$		
$f_{ss, pos} = \frac{M_{s, pos}}{A_s, pos j_{pos} d_{pos}}$	$\beta_1 = 1 + \frac{d_{c, pos}}{0.70(h - d_{c, pos})}$	$s \leq \frac{700\gamma_e}{\beta_1 f_{ss}} - 2d_{c, neg}$
Service Moment ( $M_{s, pos}$ )=	9.92 kip-ft	
Service Load Bending Stress ( $f_{ss, pos}$ )=	41.89 ksi	
$\beta_1 = 1.27$		
Exposure Factor ( $\gamma_e$ )=	0.75 Class 2	
Maximum separation of rebars ( $s_{max}$ )=	7.42 in	OK

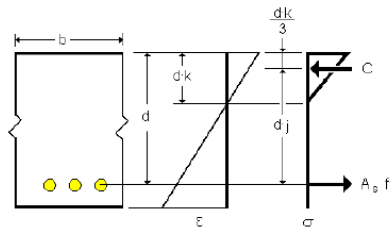

**6.2.4 Transverse Distribution Reinforcement (Top bars) (AASHTO 5.14.4.1)**

Transverse distribution reinforcement shall be placed in the bottoms of all slabs. The amount of the bottom transverse reinforcement may be determined by two-dimensional analysis, or the amount of distribution reinforcement may be taken as the percentage of the main reinforcement required for positive moment taken as:

$\frac{100}{\sqrt{L}} \leq 50\%$	
$100/\sqrt{L} = 32.44$ %	
$A_{s, tr} = 0.53$ in <sup>2</sup>	
$A_{s, req} = 32.44$ %	
$A_{s, req} = 0.34$ in <sup>2</sup>	OK

**6.3 DESIGN FOR SHEAR**

From AASHTO LRFD 5.14.4, "Slabs and slab bridges designed for moment in conformance with Article 4.6.2.3 - "Equivalent Strip Widths for Slab Type Bridges" may be considered satisfactory for shear."

## DESIGN OF INTERIOR BEAM - Continuous (Steel Plate Girder - Composite Section)

### Table of Contents

- 1. MATERIALS PROPERTIES
  - 1.1 STEEL
  - 1.2 CONCRETE
  - 1.3 REINFORCEMENT STEEL
- 2. LIMIT STATE FACTORS (AASHTO 6.5.4.2)
  - 2.1 Steel
  - 2.2 Concrete
- 3. GEOMETRIC PROPERTIES
  - 3.1 GENERAL
  - 3.2 SECTION 1
    - 3.2.1 STEEL BEAM
    - 3.2.2 COMPOSITE SECTION SHORT-TERM EFFECTS (n)
    - 3.2.3 COMPOSITE SECTION LONG-TERM EFFECTS (3n)
  - 3.3 SECTION 2
    - 3.3.1 STEEL BEAM
    - 3.3.2 COMPOSITE SECTION SHORT-TERM EFFECTS (n)
    - 3.3.3 COMPOSITE SECTION LONG-TERM EFFECTS (3n)
    - 3.3.4 COMPOSITE BEAM (REINFORCEMENT ONLY)
  - 3.4 SECTION 3
    - 3.4.1 STEEL BEAM
    - 3.4.2 COMPOSITE SECTION SHORT-TERM EFFECTS (n)
    - 3.4.3 COMPOSITE SECTION LONG-TERM EFFECTS (3n)
    - 3.4.4 COMPOSITE BEAM (REINFORCEMENT ONLY)
- 4. LOADS
  - 4.1 CONSTRUCTION STAGE (NON COMPOSITE)
    - 4.1.1 DEAD LOAD (DC)
    - 4.1.2 LIVE LOAD (LL)
  - 4.2 SERVICE STAGE (COMPOSITE)
    - 4.2.1 DEAD LOAD (DC)
    - 4.2.2 DEAD LOAD WEARING SURFACE (DW)
    - 4.2.3 LIVE LOAD (LL) - (According to AASHTO 3.6.1.2)
  - 4.3 FATIGUE AND FRACTURE (COMPOSITE)
- 5. LOAD COMBINATIONS
- 6. COMBINED LOAD EFFECTS
  - 6.1 CONSTRUCTABILITY
    - 6.1.1 Combined Shear and Moments
    - 6.1.2 Design Shear and Moments
  - 6.2 COMPOSITE SECTION (OPERATION)
    - 6.2.1 Combined Shear and Moments
    - 6.2.2 Design Shear and Moments
- 7. DESIGN OF THE STEEL BEAM
  - 7.1 SECTION PROPORTIONS LIMITS (AASHTO 6.10.2)
  - 7.2 SLENDER LIMITS FOR COMPRESSION ELEMENTS DUE TO FLEXURE
  - 7.3 CONSTRUCTABILITY DESIGN - NON COMPOSITE SECTION - (AASHTO 6.10.3.2)
    - 7.3.1 FLEXURAL NOMINAL RESISTANCE
      - 7.3.1.1 Flange Nominal Yielding (6.10.3.2.1)
      - 7.3.1.2 Flexural Resistance (AASHTO 6.10.3.2.1, 6.10.1.6 and 6.10.8)
      - 7.3.1.3 Web Bend Buckling (AASHTO 6.10.1.9)
      - 7.3.1.4 Summary
    - 7.3.2 SHEAR (AASHTO 6.10.9.1)
  - 7.4 COMPOSITE SECTION DESIGN
    - 7.4.1 POSITIVE MOMENT
      - 7.4.1.1 PLASTIC MOMENT (AASHTO Table D6.1-1)
      - 7.4.1.2 STRENGTH LIMIT STATE (AASHTO 6.10.6)
      - 7.4.1.3 FATIGUE LIMIT STATE (AASHTO 6.5.3 and 6.6)
      - 7.4.1.4 SERVICE LIMIT STATE
        - 7.4.1.4.1 Permanent Deformations (AASHTO 6.10.4.2)
        - 7.4.1.4.2 Web Bend Buckling (AASHTO 6.10.1.9)
    - 7.4.2 NEGATIVE MOMENT
      - 7.4.2.1 PLASTIC MOMENT
      - 7.4.2.2 STRENGTH LIMIT STATE
        - 7.4.2.2.1 Flange Nominal Yielding (6.10.3.2.1)
        - 7.4.2.2.2 Flexural Resistance (AASHTO 6.10.3.2.1, 6.10.1.6 and 6.10.8)
        - 7.4.2.2.3 Web Bend Buckling (AASHTO 6.10.1.9)
        - 7.4.2.2.4 Summary
      - 7.4.2.3 SERVICE LIMIT STATE
        - 7.4.2.3.1 Permanent Deformations (AASHTO 6.10.4.2)
        - 7.4.2.3.2 Web Bend Buckling (AASHTO 6.10.1.9)
    - 7.4.3 SHEAR (AASHTO 6.10.9)
      - 7.4.3.1 Intermediate Stiffeners (AASHTO 6.10.11.1)
      - 7.4.3.2 Bearing Stiffeners (AASHTO 6.10.11.2)
    - 7.4.4 SHEAR CONNECTORS (AASHTO 6.10.10)
      - 7.4.4.1 FATIGUE LIMIT STATE
      - 7.4.4.2 STRENGTH LIMIT STATE
  - 7.5 DEFORMATIONS
    - 7.5.1 CAMBER
    - 7.5.2 PERMANENT DELFECTION - According to AASHTO 3.6.1.3.2

## DESIGN OF INTERIOR BEAM - Continuous (Steel Plate Girder - Composite Section)

AASHTO LRFD Bridge Design Specifications U.S. Customary Units, Seventh Edition, 2014

### 1. MATERIALS PROPERTIES

#### 1.1 STEEL A709 Gr50

$F_y =$	50 ksi
$F_u =$	70 ksi
$E_s =$	29000 ksi
$X_c =$	0.490 kip/ft <sup>3</sup>

#### 1.3 REINFORCEMENT STEEL AASTO A615, Grade 60

$F_y =$	60 ksi
$F_u =$	80 ksi
$E_s =$	29000 ksi
$X_c =$	0.490 kip/ft <sup>3</sup>

#### 1.2 CONCRETE

$f_c =$	4.00 ksi
$E_c =$	3834 ksi
$E_s/E_c (n) =$	7.56
$X_c =$	0.150 kip/ft <sup>3</sup>

### 2. LIMIT STATE FACTORS (AASHTO 6.5.4.2)

#### 2.1 Steel

$\phi_{Flexure} =$	1.00	$\phi_{Shear Conn} =$	0.85
$\phi_{Shear} =$	1.00	$\phi_{Bolt Tension} =$	0.80
$\phi_{Compression} =$	0.90	$\phi_{Bolt Shear} =$	0.80
$\phi_{Tens Fracture} =$	0.80	$\phi_{Block Shear} =$	0.80
$\phi_{Tens Yielding} =$	0.95	$\phi_{bearing} =$	1.00
$\phi_{Bolt bearing} =$	0.80	$\phi_{Welds} =$	0.80

#### 2.2 Concrete

$\phi_{Tens Controlled} =$	0.90	$\phi_{bearing} =$	0.70
$\phi_{Shear} =$	0.90	$\phi_{Comp Control} =$	0.75

### 3. GEOMETRIC PROPERTIES

#### 3.1 GENERAL

Slab Thickness (e)=	8.00 in	Overall Length=	220.00 ft	Overhang=	2.50 ft
Sacrificial Surface (sw)=	0.50 in	Span 1 Length=	110.00 ft	Beams Separation (S)=	9.50 ft
Haunch (hu)=	0.75 in	Span 2 Length=	110.00 ft	Number of Beams (N)=	5.00 beams
				Unbraced Length (L <sub>u</sub> )=	27.50 ft

#### 3.2 SECTION 1

##### 3.2.1 STEEL BEAM

d=	52.00 in	$T_w =$	0.50 in	Perimeter=	147.00 in
$b_{fb} =$	14.00 in	$b_{ft} =$	14.00 in	$H_w =$	50.00 in
$T_{fb} =$	1.00 in	$T_{ft} =$	1.00 in		12.25 ft

Section	Area (mm <sup>2</sup> )	y (mm)	x (mm)	A.y (mm <sup>3</sup> )	A.x (mm <sup>3</sup> )	I <sub>xx</sub> (mm <sup>4</sup> )	I <sub>yy</sub> (mm <sup>4</sup> )	d <sub>y</sub> (mm)	d <sub>x</sub> (mm)	A.d <sub>y</sub> <sup>2</sup> (mm <sup>4</sup> )	A.d <sub>x</sub> <sup>2</sup> (mm <sup>4</sup> )
Top Flange	14.00	0.50	7.00	7.00E+00	9.80E+01	1.17E+00	2.29E+02	-25.50	0.00	9.10E+03	0.00E+00
Bot Flange	14.00	51.50	7.00	7.21E+02	9.80E+01	1.17E+00	2.29E+02	25.50	0.00	9.10E+03	0.00E+00
Web	25.00	26.00	7.00	6.50E+02	1.75E+02	5.21E+03	5.21E-01	0.00	0.00	0.00E+00	0.00E+00

$A_T =$	53.00 in <sup>2</sup>
y=	26.00 in
x=	7.00 in
$I_{xx} =$	2.34E+04 in <sup>4</sup>
$I_{yy} =$	4.58E+02 in <sup>4</sup>
$S_{x,bot} =$	900.68 in <sup>3</sup>
$S_{x,top} =$	900.68 in <sup>3</sup>
$S_y =$	65.41 in <sup>3</sup>
$r_x =$	21.02 in
$r_y =$	2.94 in
$H_0 =$	51.00 in
J=	11.42 in <sup>4</sup>
CW=	2.97E+05 in <sup>6</sup>
Zx=	1046.72 in <sup>3</sup>

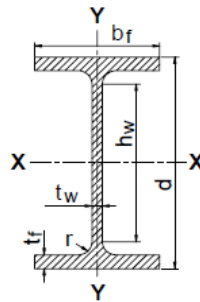

##### 3.2.2 COMPOSITE SECTION SHORT-TERM EFFECTS (n)

Height of Steel Deck Rib (f)=	0.00 in
Effective Conc Height (f')=	7.50 in
Effective Width (be)=	9.50 ft

(AASHTO 4.6.2.6)

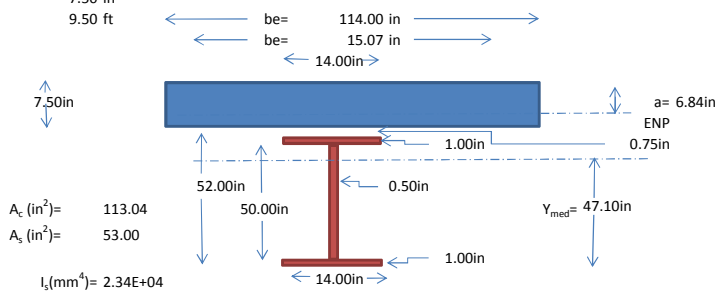

Section	Area (in <sup>2</sup> )	y (in)	A.y (in <sup>3</sup> )	I <sub>xx</sub> (in <sup>4</sup> )	d <sub>y</sub> (in)	A.d <sub>y</sub> <sup>2</sup> (in <sup>4</sup> )
Steel	53.00	26.00	1.38E+03	2.34E+04	-21.10	2.36E+04
Haunch	10.50	52.38	5.50E+02	6.51E-02	5.28	2.92E+02
Concrete	113.04	56.50	6.39E+03	5.30E+02	9.40	9.99E+03

$A_T =$	176.54 in <sup>2</sup>
y=	47.10 in
$I_{xx} =$	5.78E+04 in <sup>4</sup>

3.2.3 COMPOSITE SECTION LONG-TERM EFFECTS (3n)

Height of Steel Deck Rib (f)= 0.00 in  
Effective Conc Height (f')= 7.50 in  
Effective Width (be)= 9.50 ft  
(AASTO 4.6.2.6)

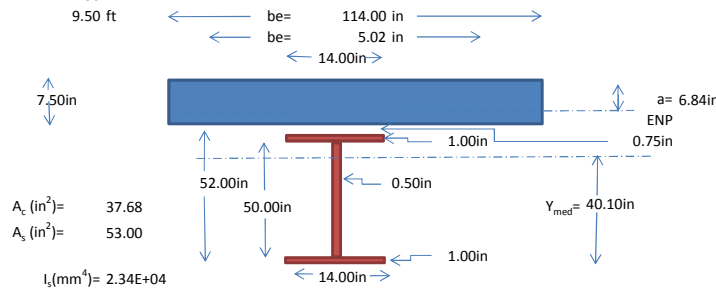

Section	Area (in <sup>2</sup> )	y (in)	A.y (in <sup>3</sup> )	I <sub>xx</sub> (in <sup>4</sup> )	d <sub>y</sub> (in)	A.d <sub>y</sub> <sup>2</sup> (in <sup>4</sup> )
Steel	53.00	26.00	1.38E+03	2.34E+04	-14.10	1.05E+04
Haunch	10.50	52.38	5.50E+02	2.17E-02	12.28	1.58E+03
Concrete	37.68	56.50	2.13E+03	1.77E+02	16.40	1.01E+04

A<sub>T</sub>= 101.18 in<sup>2</sup>  
y= 40.10 in  
I<sub>xx</sub>= 4.58E+04 in<sup>4</sup>

3.2.4 COMPOSITE BEAM (REINFORCEMENT ONLY)

Reinforcement

Top

Rebar Number (#)= 6 /8"  
Rebar Spacing (s)= 5.00 in  
A<sub>REBAR</sub>= 0.44 in<sup>2</sup>  
A<sub>REB TOP</sub>= 1.06 in<sup>2</sup>/ft

Bottom

Rebar Number (#)= 5 /8"  
Rebar Spacing (s)= 7.00 in  
A<sub>REBAR</sub>= 0.31 in<sup>2</sup>  
A<sub>REB TOP</sub>= 0.53 in<sup>2</sup>/ft

Rebar Cover

Top Slab= 2.50 in  
Bot Slab= 1.00 in

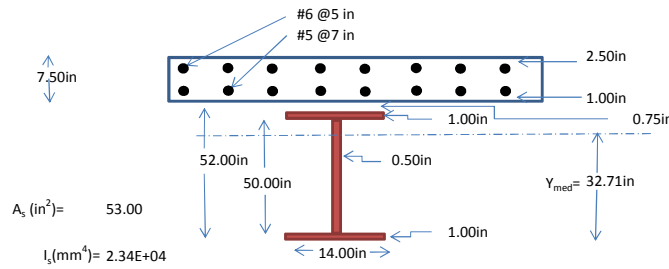

Section	Area (in <sup>2</sup> )	y (in)	A.y (in <sup>3</sup> )	I <sub>xx</sub> (in <sup>4</sup> )	d <sub>y</sub> (in)	A.d <sub>y</sub> <sup>2</sup> (in <sup>4</sup> )
Steel	53.00	26.00	1.38E+03	2.34E+04	-6.71	2.38E+03
Top R. Steel	10.07	57.38	5.78E+02	0.00E+00	24.67	6.13E+03
Bot R. Steel	5.00	54.13	2.70E+02	0.00E+00	21.42	2.29E+03

A<sub>T</sub>= 68.07 in<sup>2</sup>  
y= 32.71 in  
I<sub>xx</sub>= 3.42E+04 in<sup>4</sup>

POSITIVE MOMENT GEOMETRIC PROPERTIES SUMMARY						
SECTION	Y <sub>BOT GIRDER</sub> in	Y <sub>TOP GIRDER</sub> in	Y <sub>TOP SLAB</sub> in	S <sub>BOT GIRDER</sub> in <sup>3</sup>	S <sub>TOP GIRDER</sub> in <sup>3</sup>	S <sub>TOP SLAB</sub> in <sup>3</sup>
Girder Only	26.00	26.00	-	900.68	900.68	-
Composite (n)	47.10	4.90	13.15	1227.74	11796.90	4396.74
Composite (3n)	40.10	11.90	20.15	1143.47	3851.39	2274.86
Negative Moment (Reinf)	32.71	19.29	57.75	1046.35	1773.89	592.61

3.3 SECTION 2

3.3.1 STEEL BEAM

d= 52.75 in  
b<sub>fb</sub>= 14.00 in      b<sub>ft</sub>= 14.00 in      T<sub>w</sub>= 0.50 in      Perimeter= 148.13 in  
T<sub>fb</sub>= 1.38 in      T<sub>ft</sub>= 1.38 in      H<sub>w</sub>= 50.00 in      12.34 ft

Section	Area (mm <sup>2</sup> )	y (mm)	x (mm)	A.y (mm <sup>3</sup> )	A.x (mm <sup>3</sup> )	I <sub>xx</sub> (mm <sup>4</sup> )	I <sub>yy</sub> (mm <sup>4</sup> )	d <sub>y</sub> (mm)	d <sub>x</sub> (mm)	A.d <sub>y</sub> <sup>2</sup> (mm <sup>4</sup> )	A.d <sub>x</sub> <sup>2</sup> (mm <sup>4</sup> )
Top Flange	19.25	0.69	7.00	1.32E+01	1.35E+02	3.03E+00	3.14E+02	-25.69	0.00	1.27E+04	0.00E+00
Bot Flange	19.25	52.06	7.00	1.00E+03	1.35E+02	3.03E+00	3.14E+02	25.69	0.00	1.27E+04	0.00E+00
Web	25.00	26.38	7.00	6.59E+02	1.75E+02	5.21E+03	5.21E-01	0.00	0.00	0.00E+00	0.00E+00



$A_T =$	63.50 in <sup>2</sup>
$y =$	26.38 in
$x =$	7.00 in
$I_{xx} =$	3.06E+04 in <sup>4</sup>
$I_{yy} =$	6.29E+02 in <sup>4</sup>
$S_{xBot} =$	1160.89 in <sup>3</sup>
$S_{xTop} =$	1160.89 in <sup>3</sup>
$S_y =$	89.91 in <sup>3</sup>
$r_x =$	21.96 in
$r_y =$	3.15 in
$H_0 =$	51.38 in
$J =$	26.35 in <sup>4</sup>
$C_w =$	4.15E+05 in <sup>6</sup>
$Z_x =$	1426.71 in <sup>3</sup>

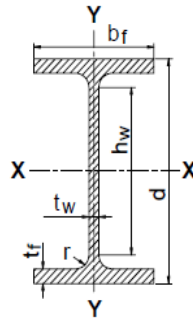

**3.3.2 COMPOSITE SECTION SHORT-TERM EFFECTS (n)**

Height of Steel Deck Rib (f) = 0.00 in  
Effective Conc Height (f') = 7.50 in  
Effective Width (be) = 9.50 ft  
(AASTO 4.6.2.6)

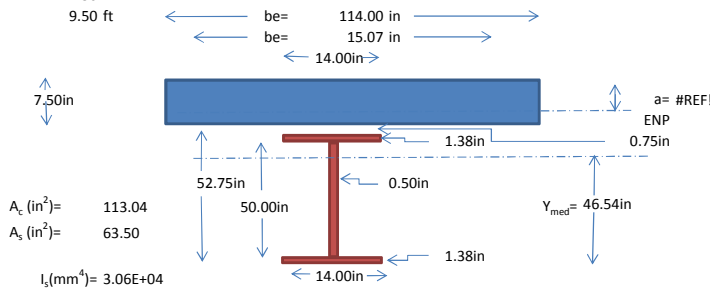

Section	Area (in <sup>2</sup> )	y (in)	A.y (in <sup>3</sup> )	I <sub>xx</sub> (in <sup>4</sup> )	d <sub>y</sub> (in)	A.d <sub>y</sub> <sup>2</sup> (in <sup>4</sup> )
Steel	63.50	26.38	1.67E+03	3.06E+04	-20.72	2.73E+04
Haunch	10.50	53.13	5.58E+02	6.51E-02	6.03	3.81E+02
Concrete	113.04	57.25	6.47E+03	5.30E+02	10.15	1.16E+04

$A_T =$	187.04 in <sup>2</sup>
$y =$	46.54 in
$I_{xx} =$	7.05E+04 in <sup>4</sup>

**3.3.3 COMPOSITE SECTION LONG-TERM EFFECTS (3n)**

Height of Steel Deck Rib (f) = 0.00 in  
Effective Conc Height (f') = 7.50 in  
Effective Width (be) = 9.50 ft  
(AASTO 4.6.2.6)

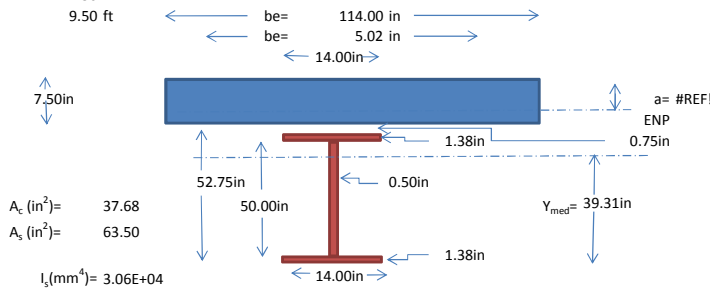

Section	Area (in <sup>2</sup> )	y (in)	A.y (in <sup>3</sup> )	I <sub>xx</sub> (in <sup>4</sup> )	d <sub>y</sub> (in)	A.d <sub>y</sub> <sup>2</sup> (in <sup>4</sup> )
Steel	63.50	26.38	1.67E+03	3.06E+04	-13.72	1.20E+04
Haunch	10.50	53.13	5.58E+02	2.17E-02	13.03	1.78E+03
Concrete	37.68	57.25	2.16E+03	1.77E+02	17.15	1.11E+04

$A_T =$	111.68 in <sup>2</sup>
$y =$	39.31 in
$I_{xx} =$	5.56E+04 in <sup>4</sup>

**3.3.4 COMPOSITE BEAM (REINFORCEMENT ONLY)**

**Reinforcement**

**Top**

Rebar Number (#)= 6 /8"  
Rebar Spacing (s)= 5.00 in  
 $A_{REBAR}$ = 0.44 in<sup>2</sup>  
 $A_{REB TOP}$ = 1.06 in<sup>2</sup>/ft

**Bottom**

Rebar Number (#)= 5 /8"  
Rebar Spacing (s)= 7.00 in  
 $A_{REBAR}$ = 0.31 in<sup>2</sup>  
 $A_{REB TOP}$ = 0.53 in<sup>2</sup>/ft

**Rebar Cover**

Top Slab= 2.50 in  
Bot Slab= 1.00 in

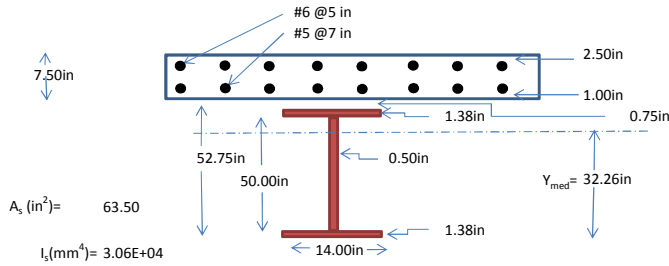

$A_s$  (in<sup>2</sup>)= 63.50  
 $I_x$  (mm<sup>4</sup>)= 3.06E+04

Section	Area (in <sup>2</sup> )	y (in)	A.y (in <sup>3</sup> )	$I_{xx}$ (in <sup>4</sup> )	$d_y$ (in)	$A.d_y^2$ (in <sup>4</sup> )
Steel	63.50	26.38	1.67E+03	3.06E+04	-5.88	2.20E+03
Top R. Steel	10.07	58.13	5.85E+02	0.00E+00	25.87	6.74E+03
Bot R. Steel	5.00	54.88	2.74E+02	0.00E+00	22.62	2.56E+03

$A_T$ = 78.57 in<sup>2</sup>  
y= 32.26 in  
 $I_{xx}$ = 4.21E+04 in<sup>4</sup>

POSITIVE MOMENT GEOMETRIC PROPERTIES SUMMARY						
SECTION	$Y_{BOT GIRDER}$ in	$Y_{TOP GIRDER}$ in	$Y_{TOP SLAB}$ in	$S_{BOT GIRDER}$ in <sup>3</sup>	$S_{TOP GIRDER}$ in <sup>3</sup>	$S_{TOP SLAB}$ in <sup>3</sup>
Girder Only	26.38	26.38	-	1160.89	1160.89	-
Composite (n)	46.54	6.21	14.46	1513.87	11338.50	4870.95
Composite (3n)	39.31	13.44	21.69	1415.02	4137.58	2564.01
Negative Moment (Reinf)	32.26	20.49	58.50	1305.47	2055.01	719.86

**3.4 SECTION 3**

**3.4.1 STEEL BEAM**

d= 55.25 in  
 $b_{fb}$ = 14.00 in       $b_{ft}$ = 14.00 in       $T_w$ = 0.50 in      Perimeter= 151.88 in  
 $T_{fb}$ = 2.63 in       $T_{ft}$ = 2.63 in       $H_w$ = 50.00 in      12.66 ft

Section	Area (mm <sup>2</sup> )	y (mm)	x (mm)	$A.y$ (mm <sup>3</sup> )	$A.x$ (mm <sup>3</sup> )	$I_{xx}$ (mm <sup>4</sup> )	$I_{yy}$ (mm <sup>4</sup> )	$d_y$ (mm)	$d_x$ (mm)	$A.d_y^2$ (mm <sup>4</sup> )	$A.d_x^2$ (mm <sup>4</sup> )
Top Flange	36.75	1.31	7.00	4.82E+01	2.57E+02	2.11E+01	6.00E+02	-26.31	0.00	2.54E+04	0.00E+00
Bot Flange	36.75	53.94	7.00	1.98E+03	2.57E+02	2.11E+01	6.00E+02	26.31	0.00	2.54E+04	0.00E+00
Web	25.00	27.63	7.00	6.91E+02	1.75E+02	5.21E+03	5.21E-01	0.00	0.00	0.00E+00	0.00E+00

$A_T$ = 98.50 in<sup>2</sup>  
y= 27.63 in  
x= 7.00 in  
 $I_{xx}$ = 5.61E+04 in<sup>4</sup>  
 $I_{yy}$ = 1.20E+03 in<sup>4</sup>  
 $S_{xBOT}$ = 2032.15 in<sup>3</sup>  
 $S_{xTOP}$ = 2032.15 in<sup>3</sup>  
 $S_y$ = 171.57 in<sup>3</sup>  
 $r_x$ = 23.87 in  
 $r_y$ = 3.49 in  
 $H_0$ = 52.63 in  
J= 170.90 in<sup>4</sup>  
Cw= 8.31E+05 in<sup>6</sup>  
Zx= 3105.67 in<sup>3</sup>

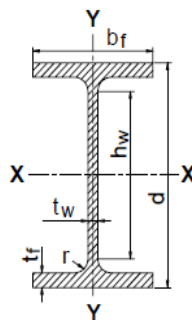

**3.4.2 COMPOSITE SECTION SHORT-TERM EFFECTS (n)**

Height of Steel Deck Rib (f)= 0.00 in  
Effective Conc Height (f')= 7.50 in  
Effective Width (be)= 9.50 ft  
(AASTO 4.6.2.6)

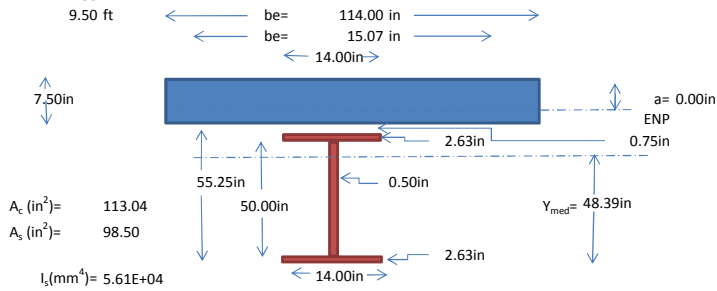

Section	Area (in <sup>2</sup> )	y (in)	A.y (in <sup>3</sup> )	I <sub>xx</sub> (in <sup>4</sup> )	d <sub>y</sub> (in)	A.d <sub>y</sub> <sup>2</sup> (in <sup>4</sup> )
Steel	98.50	27.63	2.72E+03	5.61E+04	-20.76	4.25E+04
Haunch	105.00	55.63	5.84E+03	6.51E-02	7.24	5.50E+03
Concrete	113.04	59.75	6.75E+03	5.30E+02	12.65	1.81E+04

A<sub>T</sub>= 316.54 in<sup>2</sup>  
y= 48.39 in  
I<sub>xx</sub>= 1.23E+05 in<sup>4</sup>

**3.4.3 COMPOSITE SECTION LONG-TERM EFFECTS (3n)**

Height of Steel Deck Rib (f)= 0.00 in  
Effective Conc Height (f')= 7.50 in  
Effective Width (be)= 9.50 ft  
(AASTO 4.6.2.6)

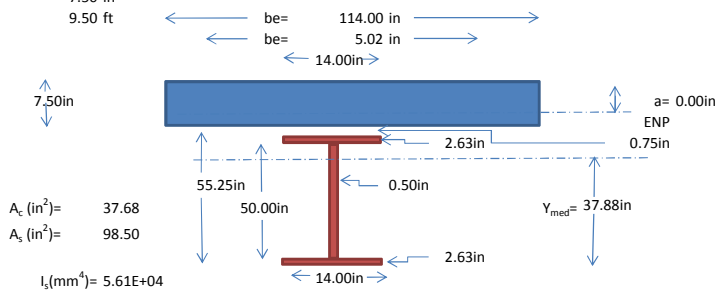

Section	Area (in <sup>2</sup> )	y (in)	A.y (in <sup>3</sup> )	I <sub>xx</sub> (in <sup>4</sup> )	d <sub>y</sub> (in)	A.d <sub>y</sub> <sup>2</sup> (in <sup>4</sup> )
Steel	98.50	27.63	2.72E+03	5.61E+04	-10.26	1.04E+04
Haunch	10.50	55.63	5.84E+02	2.17E-02	17.74	3.31E+03
Concrete	37.68	59.75	2.25E+03	1.77E+02	21.87	1.80E+04

A<sub>T</sub>= 146.68 in<sup>2</sup>  
y= 37.88 in  
I<sub>xx</sub>= 8.80E+04 in<sup>4</sup>

**3.4.4 COMPOSITE BEAM (REINFORCEMENT ONLY)**

**Reinforcement**

**Top**

Rebar Number (#)= 5 / 8"  
Rebar Spacing (s)= 8.00 in  
A<sub>REBAR</sub>= 0.31 in<sup>2</sup>  
A<sub>REB TOP</sub>= 0.46 in<sup>2</sup>/ft

**Bottom**

Rebar Number (#)= 5 / 8"  
Rebar Spacing (s)= 8.00 in  
A<sub>REBAR</sub>= 0.31 in<sup>2</sup>  
A<sub>REB TOP</sub>= 0.46 in<sup>2</sup>/ft

**Rebar Cover**

Top Slab= 2.50 in  
Bot Slab= 1.00 in

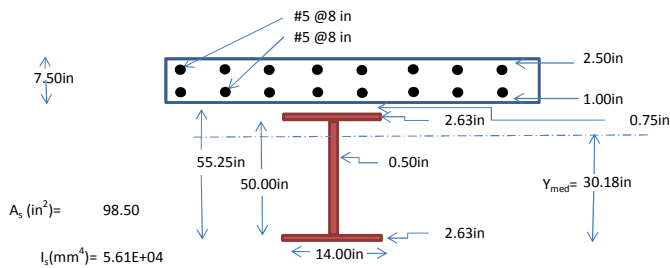

A<sub>s</sub> (in<sup>2</sup>)= 98.50  
I<sub>s</sub> (mm<sup>4</sup>)= 5.61E+04

Section	Area (in <sup>2</sup> )	y (in)	A-y (in <sup>3</sup> )	I <sub>xx</sub> (in <sup>4</sup> )	d <sub>y</sub> (in)	A·d <sub>y</sub> <sup>2</sup> (in <sup>4</sup> )
Steel	98.50	27.63	2.72E+03	5.61E+04	-2.56	6.45E+02
Top R. Steel	4.37	60.69	2.65E+02	0.00E+00	30.50	4.07E+03
Bot R. Steel	4.37	57.31	2.51E+02	0.00E+00	27.13	3.22E+03

A<sub>T</sub>= 107.24 in<sup>2</sup>  
y= 30.18 in  
I<sub>xx</sub>= 6.41E+04 in<sup>4</sup>

POSITIVE MOMENT GEOMETRIC PROPERTIES SUMMARY						
SECTION	Y <sub>BOT GIRDER</sub> in	Y <sub>TOP GIRDER</sub> in	Y <sub>TOP SLAB</sub> in	S <sub>BOT GIRDER</sub> in <sup>3</sup>	S <sub>TOP GIRDER</sub> in <sup>3</sup>	S <sub>TOP SLAB</sub> in <sup>3</sup>
Girder Only	27.63	27.63	-	2032.15	2032.15	-
Composite (n)	48.39	6.86	15.11	2536.27	17876.68	8119.13
Composite (3n)	37.88	17.37	25.62	2323.07	5066.96	3435.20
Negative Moment (Reinf)	30.18	25.07	61.00	2122.66	2555.89	1050.30

4. LOADS

4.1 CONSTRUCTION STAGE (NON COMPOSITE)

4.1.1 DEAD LOAD (DC)

(Common Value used see Virginia DOT and FHWA examples)

Distributed Loads	SECTION 1
Steel Beam self-weight=	0.180 kip/ft
Concrete Deck=	0.950 kip/ft
Concrete Haunch=	0.011 kip/ft
Stay-in-Place Forms=	0.015 kip/ft
Miscellaneous=	0.030 kip/ft
<b>Total DC=</b>	<b>1.19 kip/ft</b>

4.1.2 LIVE LOAD (LL)

Construction Live Load= 0.020 kip/ft<sup>2</sup> (Common Value used see FHWA examples)

Distributed Loads

Construction Live Load= 0.190 kip/ft

SECTION 2	SECTION 3
0.216 kip/ft	0.335 kip/ft

Correspond to Cross-frames, splices detailing elements and other additional miscellaneous components (STANDARD VALUE USED)

SPAN 1											
UNFACTORED SHEARS (Kips)											
LOAD COMPONENT	LOCATION										
	0.0L	0.1L	0.2L	0.3L	0.4L	0.5L	0.6L	0.7L	0.8L	0.9L	1.0L
Steel Beam self-weight	-9.00	-6.60	-4.20	-1.80	0.60	2.99	5.39	7.79	10.19	12.59	29.97
Concrete Deck	-39.21	-28.76	-18.31	-7.86	2.59	13.04	23.49	33.94	44.39	54.84	130.58
Concrete Haunch	-0.33	-0.24	-0.15	-0.07	0.02	0.11	0.20	0.29	0.37	0.46	1.10
Stay-in-Place Forms	-0.62	-0.45	-0.29	-0.12	0.04	0.21	0.37	0.54	0.70	0.87	2.06
Miscellaneous	-1.24	-0.91	-0.58	-0.25	0.08	0.41	0.74	1.07	1.40	1.73	4.12
<b>Total DC</b>	<b>-50.39</b>	<b>-36.96</b>	<b>-23.53</b>	<b>-10.10</b>	<b>3.33</b>	<b>16.76</b>	<b>30.19</b>	<b>43.63</b>	<b>57.06</b>	<b>70.49</b>	<b>167.84</b>
Construction Live Load	-7.84	-5.75	-3.66	-1.57	0.52	2.61	4.70	6.79	8.88	10.97	26.12

UNFACTORED MOMENTS (Kips-ft)											
LOAD COMPONENT	LOCATION										
	0.0L	0.1L	0.2L	0.3L	0.4L	0.5L	0.6L	0.7L	0.8L	0.9L	1.0L
Steel Beam self-weight	0.00	85.78	145.18	178.20	184.85	165.12	119.01	46.52	-52.35	-177.60	-329.22
Concrete Deck	0.00	373.81	632.67	776.57	805.53	719.54	518.60	202.71	-228.13	-773.93	-1434.67
Concrete Haunch	0.00	3.15	5.33	6.54	6.78	6.06	4.37	1.71	-1.92	-6.52	-12.08
Stay-in-Place Forms	0.00	5.90	9.99	12.26	12.72	11.36	8.19	3.20	-3.60	-12.22	-22.65
Miscellaneous	0.00	11.80	19.98	24.52	25.44	22.72	16.38	6.40	-7.20	-24.44	-45.31
<b>Total DC</b>	<b>0.00</b>	<b>480.44</b>	<b>813.14</b>	<b>998.10</b>	<b>1035.32</b>	<b>924.80</b>	<b>666.54</b>	<b>260.53</b>	<b>-293.21</b>	<b>-994.70</b>	<b>-1843.93</b>
Construction Live Load	0.00	74.75	126.51	155.28	161.06	143.85	103.64	40.45	-45.73	-154.90	-287.06

SPAN 2											
UNFACTORED SHEARS (Kips)											
LOAD COMPONENT	LOCATION										
	0.0L	0.1L	0.2L	0.3L	0.4L	0.5L	0.6L	0.7L	0.8L	0.9L	1.0L
Steel Beam self-weight	29.97	-12.59	-10.19	-7.79	-5.39	-2.99	-0.60	1.80	4.20	6.60	9.00
Concrete Deck	130.58	-54.84	-44.39	-33.94	-23.49	-13.04	-2.59	7.86	18.31	28.76	39.21
Concrete Haunch	1.10	-0.46	-0.37	-0.29	-0.20	-0.11	-0.02	0.07	0.15	0.24	0.33
Stay-in-Place Forms	2.06	-0.87	-0.70	-0.54	-0.37	-0.21	-0.04	0.12	0.29	0.45	0.62
Miscellaneous	4.12	-1.73	-1.40	-1.07	-0.74	-0.41	-0.08	0.25	0.58	0.91	1.24
<b>Total DC</b>	<b>167.84</b>	<b>-70.49</b>	<b>-57.06</b>	<b>-43.63</b>	<b>-30.19</b>	<b>-16.76</b>	<b>-3.33</b>	<b>10.10</b>	<b>23.53</b>	<b>36.96</b>	<b>50.39</b>
Construction Live Load	26.12	-10.97	-8.88	-6.79	-4.70	-2.61	-0.52	1.57	3.66	5.75	7.84

UNFACTORED MOMENTS (Kips-ft)											
LOAD COMPONENT	LOCATION										
	0.0L	0.1L	0.2L	0.3L	0.4L	0.5L	0.6L	0.7L	0.8L	0.9L	1.0L
Steel Beam self-weight	-329.22	-177.60	-52.35	46.52	119.01	165.12	184.85	178.20	145.18	85.78	0.00
Concrete Deck	-1434.67	-773.93	-228.13	202.71	518.60	719.54	805.53	776.57	632.67	373.81	0.00
Concrete Haunch	-12.08	-6.52	-1.92	1.71	4.37	6.06	6.78	6.54	5.33	3.15	0.00
Stay-in-Place Forms	-22.65	-12.22	-3.60	3.20	8.19	11.36	12.72	12.26	9.99	5.90	0.00
Miscellaneous	-45.31	-24.44	-7.20	6.40	16.38	22.72	25.44	24.52	19.98	11.80	0.00
<b>Total DC</b>	<b>-1843.93</b>	<b>-994.70</b>	<b>-293.21</b>	<b>260.53</b>	<b>666.54</b>	<b>924.80</b>	<b>1035.32</b>	<b>998.10</b>	<b>813.14</b>	<b>480.44</b>	<b>0.00</b>
Construction Live Load	-287.06	-154.90	-45.73	40.45	103.64	143.85	161.06	155.28	126.51	74.75	0.00

**4.2 SERVICE STAGE (COMPOSITE)**

**4.2.1 DEAD LOAD (DC)**

Rail Barriers= 0.39 kip/ft/Barrier  
**Distributed Loads**  
 Rail Barriers\*= 0.16 kip/ft  
**Total DC= 0.16 kip/ft**

\*Distributed equally to every beam  
**4.2.3 LIVE LOAD (LL) - (According to AASHTO 3.6.1.2)**  
 Live load is composed by the following:

i) Design Truck or design Tandem (pair of 25kips axles spaced 4ft apart)

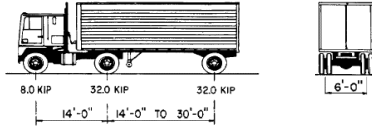

ii) Design lane load (The design lane load shall consist of a load of 0.64 klf uniformly distributed in the longitudinal direction. Transversely, the design lane load shall be assumed to be uniformly distributed over a 10.0-ft width.)

**4.2.2 DEAD LOAD WEARING SURFACE (DW)**

Future Wearing Surface= 0.035 kip/ft<sup>2</sup> (Common Value used see FHWA examples)  
**Distributed Loads**  
 Future Wearing Surface= 0.333 kip/ft Distribution is made proportionally to the afferent width  
**Total DW= 0.33 kip/ft**

The extreme force effect shall be taken as the larger of the following:

- I) The effect of the design tandem combined with the effect of the design lane load, or
- II) The effect of one design truck with the variable axle spacing specified in Article 3.6.1.2.2, combined with the effect of the design lane load, and
- III) For negative moment between points of contraflexure under a uniform load on all spans, and reaction at interior piers only, 90 percent of the effect of two design trucks spaced a minimum of 50.0 ft between the lead axle of one truck and the rear axle of the other truck, combined with 90 percent of the effect of the design lane load. The distance between the 32.0-kip axles of each truck shall be taken as 14.0 ft

Dyn Load Allowance (IM)= 33% AASTO Table 3.6.2.1-1  
 Dyn Load Allowance Fatigue (IM)= 15% AASTO Table 3.6.2.1-1

**a) LOAD DISTRIBUTION FACTORS**

Multiple Presence Factor= 1.00 2 Lanes  
 Skew= 0 °

$e_g$  (Dist CG Beam and CG deck)  
 $K_g$  (Longitudinal Stiffness Parameter)

$$K_g = n \left( I + A e_g^2 \right)$$

SECTION	$e_g$ (in)	$K_g$ (in <sup>4</sup> )
SECTION 1	30.50	5.50E+05
SECTION 2	30.88	6.89E+05
SECTION 3	32.13	1.19E+06

**Moment (See AASHTO Table 4.6.2.2.2b-1)**

$$r = 1 - c_1 (\tan \theta)^{1.5} \quad m_{g_{Mp}}^{SI} = 0.06 + \left(\frac{S}{14}\right)^{0.4} \left(\frac{S}{L}\right)^{0.3} \left(\frac{K_g}{12Lt_s^3}\right)^{0.1} \quad \text{One Lane Loaded} \quad m_{g_M}^{SI} = r m_{Mp}^{SI}$$

$$c_1 = 0.25 \left(\frac{K_g}{12Lt_s^3}\right)^{0.25} \left(\frac{S}{L}\right)^{0.5} \quad m_{g_{Mp}}^{MI} = 0.075 + \left(\frac{S}{9.5}\right)^{0.6} \left(\frac{S}{L}\right)^{0.2} \left(\frac{K_g}{12Lt_s^3}\right)^{0.1} \quad \text{Multiple Lane Loaded} \quad m_{g_M}^{MI} = r m_{Mp}^{MI}$$

SECTION	$c_1$	r	$m_{g_M}^{SI}$		$m_{g_M}^{MI}$		$\bar{g}_M^{SI \text{ Fatigue}}$	
			SPAN 1	SPAN 2	SPAN 1	SPAN 2	SPAN 1	SPAN 2
SECTION 1	0.00	1.00	0.47	0.47	0.69	0.69	0.39	0.39
SECTION 2	0.00	1.00	0.48	0.48	0.70	0.70	0.40	0.40
SECTION 3	0.00	1.00	0.50	0.50	0.74	0.74	0.42	0.42

**Shear (See AASHTO Table 4.6.2.2.3a-1)**

$$m_{g_{Vp}}^{SI} = 0.36 + \frac{S}{25} \quad \text{One Lane Loaded} \quad m_{g_V}^{SI} = r m_{Vp}^{SI}$$

$$r = 1.0 + 0.20 \left(\frac{12Lt_s^3}{K_g}\right)^{0.3} \tan \theta \quad m_{g_{Vp}}^{MI} = 0.20 + \frac{S}{12} - \left(\frac{S}{35}\right)^{2.0} \quad \text{Multiple Lane Loaded} \quad m_{g_V}^{MI} = r m_{Vp}^{MI}$$

SPAN	r	$m_{g_V}^{SI}$	$m_{g_V}^{MI}$	$\bar{g}_V^{SI \text{ Fatigue}}$
SECTION 1	1.00	0.74	0.92	0.62
SECTION 2	1.00	0.74	0.92	0.62
SECTION 3	1.00	0.74	0.92	0.62

SPAN 1											
UNFACTORED SHEARS (Kips)											
LOAD COMPONENT	LOCATION										
	SECTION 1	SECTION 1	SECTION 1	SECTION 1	SECTION 1	SECTION 1	SECTION 2	SECTION 2	SECTION 2	SECTION 2	SECTION 3
	0.0L	0.1L	0.2L	0.3L	0.4L	0.5L	0.6L	0.7L	0.8L	0.9L	1.0L
DC (Barriers)	-6.60	-4.84	-3.08	-1.32	0.44	2.20	3.96	5.72	7.48	9.24	21.99
DW (Future Wearing Sur)	-13.62	-9.99	-6.36	-2.73	0.90	4.53	8.16	11.79	15.42	19.05	45.37
Lane	-26.41	-19.37	-12.33	-5.29	1.75	8.79	15.83	22.87	29.91	36.95	43.99
Lane Max	-30.81	-23.77	-16.73	-9.69	-2.65	4.40	11.44	18.48	25.52	32.56	39.60
Lane Min	4.40	4.40	4.40	4.40	4.40	4.40	4.40	4.40	4.40	4.40	4.40
Truck max	6.66	6.94	10.86	19.07	27.63	35.85	43.62	50.85	57.42	63.22	68.16
Truck min	-64.42	-55.58	-46.94	-38.61	-30.70	-23.31	-16.54	-10.50	-5.50	-1.95	43.99
Tandem max	4.77	5.31	11.27	17.30	23.12	28.65	33.83	38.57	42.81	46.47	49.48
Tandem min	-48.86	-42.65	-36.52	-30.56	-24.84	-19.43	-14.40	-9.83	-5.80	-2.36	68.16
90% 2 Trucks max	6.08	6.32	9.85	17.55	26.31	35.29	43.85	51.36	57.62	66.27	77.81
90% 2 Trucks min	-66.91	-54.61	-43.78	-34.96	-27.63	-20.98	-14.88	-9.45	-4.95	-1.75	49.48
90% Lane	-23.77	-17.43	-11.10	-4.76	1.58	7.91	14.25	20.58	26.92	33.26	79.18
Fatigue Truck max	6.20	6.36	8.65	13.87	20.75	28.95	37.01	44.61	51.64	57.99	63.57
Fatigue Truck min	-57.38	-48.79	-40.47	-32.56	-25.14	-18.33	-12.31	-7.77	-4.46	-1.87	0.00
LL + IM (Positive Moment)	12.17	12.50	17.79	27.32	37.77	51.84	67.79	83.07	97.56	111.11	123.61
LL + IM (Negative Moment)	-107.14	-89.68	-72.67	-56.03	-39.91	-24.42	-16.16	-8.79	-3.04	-1.15	57.74
LL + IM	107.14	89.68	72.67	56.03	39.91	24.42	16.16	8.79	3.04	1.15	123.61

UNFACTORED MOMENTS (Kips-ft)											
LOAD COMPONENT	LOCATION										
	0.0L	0.1L	0.2L	0.3L	0.4L	0.5L	0.6L	0.7L	0.8L	0.9L	1.0L
<b>DC (Barriers)</b>	<b>0.00</b>	<b>62.96</b>	<b>106.55</b>	<b>130.79</b>	<b>135.67</b>	<b>121.19</b>	<b>87.34</b>	<b>34.14</b>	<b>-38.42</b>	<b>-130.35</b>	<b>-241.63</b>
<b>DW (Future Wearing Sur)</b>	<b>0.00</b>	<b>129.83</b>	<b>219.72</b>	<b>269.69</b>	<b>279.73</b>	<b>249.84</b>	<b>180.01</b>	<b>70.26</b>	<b>-79.42</b>	<b>-269.03</b>	<b>-498.58</b>
Lane	0.00	251.79	426.13	523.04	542.51	484.53	349.12	136.26	-154.03	-521.76	-966.94
Lane Max	0.00	300.13	522.83	668.08	735.89	726.27	639.20	474.69	232.75	-86.64	-483.47
Lane Min	0.00	-48.35	-96.69	-145.04	-193.39	-241.73	-290.08	-338.43	-386.77	-435.12	-483.47
Truck max	0.27	604.32	1020.49	1265.66	1366.46	1340.35	1203.04	948.37	603.22	211.90	0.13
Truck min	0.00	-73.31	-146.62	-219.92	-293.23	-366.54	-439.85	-513.15	-586.46	-659.77	-733.08
Tandem max	0.21	464.11	794.70	997.33	1080.65	1062.36	956.57	771.33	526.72	246.26	0.10
Tandem min	0.00	-52.50	-105.01	-157.51	-210.02	-262.52	-315.03	-367.53	-420.03	-472.54	-525.04
90% 2 Trucks max	0.24	591.67	952.48	1157.58	1235.15	1206.32	1088.08	867.66	546.17	190.71	0.12
90% 2 Trucks min	0.00	-66.83	-133.66	-200.50	-267.33	-334.16	-400.99	-467.83	-534.66	-602.69	-670.52
90% Lane	0.00	226.61	383.52	470.74	488.26	436.08	314.21	122.64	-138.63	-469.59	-870.24
Fatigue Truck max	0.27	529.83	884.30	1098.58	1166.13	1136.98	1035.20	813.49	488.32	193.28	0.13
Fatigue Truck min	0.00	-68.20	-136.39	-204.59	-272.78	-340.98	-409.17	-477.37	-545.57	-613.76	-681.96
<b>LL + IM (Positive Moment)</b>	<b>0.24</b>	<b>758.33</b>	<b>1291.55</b>	<b>1615.34</b>	<b>1754.02</b>	<b>1723.56</b>	<b>1538.29</b>	<b>1216.86</b>	<b>725.50</b>	<b>168.85</b>	<b>-355.83</b>
<b>LL + IM (Negative Moment)</b>	<b>0.00</b>	<b>94.61</b>	<b>141.34</b>	<b>140.19</b>	<b>91.17</b>	<b>-5.74</b>	<b>-162.04</b>	<b>-382.88</b>	<b>-654.70</b>	<b>-1021.35</b>	<b>-1896.70</b>

SPAN 2											
UNFACTORED SHEARS (Kips)											
LOAD COMPONENT	LOCATION										
	SECTION 3	SECTION 2	SECTION 2	SECTION 2	SECTION 1	SECTION 1	SECTION 1	SECTION 1	SECTION 1	SECTION 1	SECTION 1
	0.0L	0.1L	0.2L	0.3L	0.4L	0.5L	0.6L	0.7L	0.8L	0.9L	1.0L
<b>DC (Barriers)</b>	<b>21.99</b>	<b>-9.24</b>	<b>-7.48</b>	<b>-5.72</b>	<b>-3.96</b>	<b>-2.20</b>	<b>-0.44</b>	<b>1.32</b>	<b>3.08</b>	<b>4.84</b>	<b>6.60</b>
<b>DW (Future Wearing Sur)</b>	<b>45.37</b>	<b>-19.05</b>	<b>-15.42</b>	<b>-11.79</b>	<b>-8.16</b>	<b>-4.53</b>	<b>-0.90</b>	<b>2.73</b>	<b>6.36</b>	<b>9.99</b>	<b>13.62</b>
Lane	-43.99	-36.95	-29.91	-22.87	-15.83	-8.79	-1.75	5.29	12.33	19.37	26.41
Lane Max	-4.40	-4.40	-4.40	-4.40	-4.40	-4.40	-4.40	-4.40	-4.40	-4.40	-4.40
Lane Min	-39.60	-32.56	-25.52	-18.48	-11.44	-4.40	2.65	9.69	16.73	23.77	30.81
Truck max	0.00	1.95	5.50	10.50	16.54	23.31	30.70	38.61	46.94	55.58	64.42
Truck min	-68.16	-63.22	-57.42	-50.85	-43.62	-35.85	-27.63	-19.07	-10.86	-6.94	-6.66
Tandem max	0.00	2.36	5.80	9.83	14.40	19.43	24.84	30.56	36.52	42.65	48.86
Tandem min	-49.48	-46.47	-42.81	-38.57	-33.83	-28.65	-23.12	-17.30	-11.27	-5.31	-4.77
90% 2 Trucks max	0.00	1.75	4.95	9.45	14.88	20.98	27.63	34.96	43.78	54.61	66.91
90% 2 Trucks min	-77.81	-66.27	-57.62	-51.36	-43.85	-35.29	-26.31	-17.55	-9.85	-6.32	-6.08
90% Lane	79.18	-33.26	-26.92	-20.58	-14.25	-7.91	-1.58	4.76	11.10	17.43	23.77
Fatigue Truck max	0.00	1.87	4.46	7.77	12.31	18.33	25.14	32.56	40.47	48.79	57.38
Fatigue Truck min	-63.57	-57.99	-51.64	-44.61	-37.01	-28.95	-20.75	-13.87	-8.65	-6.36	-6.20
<b>LL + IM (Positive Moment)</b>	<b>-4.03</b>	<b>-1.15</b>	<b>3.04</b>	<b>8.79</b>	<b>16.16</b>	<b>24.42</b>	<b>39.91</b>	<b>56.03</b>	<b>72.67</b>	<b>89.68</b>	<b>106.93</b>
<b>LL + IM (Negative Moment)</b>	<b>-127.71</b>	<b>-111.44</b>	<b>-97.56</b>	<b>-83.07</b>	<b>-67.79</b>	<b>-51.84</b>	<b>-37.77</b>	<b>-27.32</b>	<b>-17.79</b>	<b>-12.50</b>	<b>-12.17</b>
<b>LL + IM</b>	<b>127.71</b>	<b>111.44</b>	<b>97.56</b>	<b>83.07</b>	<b>67.79</b>	<b>51.84</b>	<b>39.91</b>	<b>56.03</b>	<b>72.67</b>	<b>89.68</b>	<b>106.93</b>

UNFACTORED MOMENTS (Kips-ft)											
LOAD COMPONENT	LOCATION										
	0.0L	0.1L	0.2L	0.3L	0.4L	0.5L	0.6L	0.7L	0.8L	0.9L	1.0L
<b>DC (Barriers)</b>	<b>-241.63</b>	<b>-130.35</b>	<b>-38.42</b>	<b>34.14</b>	<b>87.34</b>	<b>121.19</b>	<b>135.67</b>	<b>130.79</b>	<b>106.55</b>	<b>62.96</b>	<b>0.00</b>
<b>DW (Future Wearing Sur)</b>	<b>-498.58</b>	<b>-269.03</b>	<b>-79.42</b>	<b>70.26</b>	<b>180.01</b>	<b>249.84</b>	<b>279.73</b>	<b>269.69</b>	<b>219.72</b>	<b>129.83</b>	<b>0.00</b>
Lane	-966.94	-521.76	-154.03	136.26	349.12	484.53	542.51	523.04	426.13	251.79	0.00
Lane Max	-483.47	-435.12	-386.77	-338.43	-290.08	-241.73	-193.39	-145.04	-96.69	-48.35	0.00
Lane Min	-483.47	-86.64	232.75	474.69	639.20	726.27	735.89	668.08	522.83	300.13	0.00
Truck max	0.13	211.90	603.22	948.37	1203.04	1340.35	1366.46	1265.66	1020.49	604.32	0.27
Truck min	-733.08	-659.77	-586.46	-513.15	-439.85	-366.54	-293.23	-219.92	-146.62	-73.31	0.00
Tandem max	0.10	246.26	526.72	771.33	956.57	1062.36	1080.65	997.33	794.70	464.11	0.21
Tandem min	-525.04	-472.54	-420.03	-367.53	-315.03	-262.52	-210.02	-157.51	-105.01	-52.50	0.00
90% 2 Trucks max	0.12	190.71	546.17	867.66	1088.08	1206.32	1235.15	1157.58	952.48	591.67	0.24
90% 2 Trucks min	-1282.62	-742.49	-534.66	-467.83	-400.99	-334.16	-267.33	-200.50	-133.66	-66.83	0.00
90% Lane	-870.24	-469.59	-138.63	122.64	314.21	436.08	488.26	470.74	383.52	226.61	0.00
Fatigue Truck max	0.13	193.28	488.32	813.49	1035.20	1136.98	1166.13	1098.58	884.30	529.83	0.27
Fatigue Truck min	-681.96	-613.76	-545.57	-477.37	-409.17	-340.98	-272.78	-204.59	-136.39	-68.20	0.00
<b>LL + IM (Positive Moment)</b>	<b>-355.83</b>	<b>168.85</b>	<b>725.50</b>	<b>1216.86</b>	<b>1538.29</b>	<b>1723.56</b>	<b>1754.02</b>	<b>1615.34</b>	<b>1291.55</b>	<b>758.33</b>	<b>0.24</b>
<b>LL + IM (Negative Moment)</b>	<b>-1896.70</b>	<b>-1021.35</b>	<b>-817.84</b>	<b>-715.61</b>	<b>-601.15</b>	<b>-500.96</b>	<b>-400.77</b>	<b>-300.57</b>	<b>-200.38</b>	<b>-100.19</b>	<b>0.00</b>

4.3 FATIGUE AND FRACTURE (COMPOSITE)

SPAN 1											
UNFACTORED SHEARS (Kips)											
LOAD COMPONENT	LOCATION										
	0.0L	0.1L	0.2L	0.3L	0.4L	0.5L	0.6L	0.7L	0.8L	0.9L	1.0L
<b>LL + IM</b>	<b>45.09</b>	<b>39.10</b>	<b>34.84</b>	<b>32.92</b>	<b>32.54</b>	<b>33.53</b>	<b>34.98</b>	<b>37.15</b>	<b>39.79</b>	<b>42.46</b>	<b>45.08</b>

UNFACTORED MOMENTS (Kips-ft)											
LOAD COMPONENT	LOCATION										
	0.0L	0.1L	0.2L	0.3L	0.4L	0.5L	0.6L	0.7L	0.8L	0.9L	1.0L
Truck max	0.12	238.75	398.48	495.03	525.47	512.34	466.48	373.87	224.43	88.83	0.06
Truck min	0.00	-30.73	-61.46	-92.19	-122.92	-153.65	-184.38	-219.40	-250.74	-282.08	-328.89
<b>LL + IM</b>	<b>0.12</b>	<b>269.48</b>	<b>459.94</b>	<b>587.22</b>	<b>648.39</b>	<b>665.99</b>	<b>650.85</b>	<b>593.27</b>	<b>475.17</b>	<b>370.91</b>	<b>328.95</b>

SPAN 2											
UNFACTORED SHEARS (Kips)											
LOAD COMPONENT	LOCATION										
	0.0L	0.1L	0.2L	0.3L	0.4L	0.5L	0.6L	0.7L	0.8L	0.9L	1.0L
<i>LL + IM</i>	45.08	42.46	39.79	37.15	34.98	33.53	32.54	32.92	34.84	39.10	45.09
UNFACTORED MOMENTS (Kips-ft)											
LOAD COMPONENT	LOCATION										
	0.0L	0.1L	0.2L	0.3L	0.4L	0.5L	0.6L	0.7L	0.8L	0.9L	1.0L
<i>Truck max</i>	0.06	88.83	224.43	373.87	466.48	512.34	525.47	495.03	398.48	238.75	0.12
<i>Truck min</i>	-328.89	-282.08	-250.74	-219.40	-184.38	-153.65	-122.92	-92.19	-61.46	-30.73	0.00
<i>LL + IM</i>	328.95	370.91	475.17	593.27	650.85	665.99	648.39	587.22	459.94	269.48	0.12

5. LOAD COMBINATIONS

COMBINATION	Type	LOAD CASES										
		DC	DW	LL	IM	BR	WS	WL	FR	TU	TG	IC
Strength I	Max	1.25	1.50	1.75	1.75	1.75	-	-	1.00	1.20	-	-
	Min	0.90	0.65	-	-	1.75	-	-	1.00	0.50	-	-
Strength III	Max	1.25	1.50	-	-	-	1.40	-	1.00	1.20	-	-
	Min	0.90	0.65	-	-	-	1.40	-	1.00	0.50	-	-
Strength IV	Max	1.50	1.50	-	-	-	-	-	-	-	-	-
	Min	0.90	0.90	-	-	-	-	-	-	-	-	-
Strength V	Max	1.25	1.50	1.35	1.35	1.35	0.40	1.00	1.00	1.20	-	-
	Min	0.90	0.65	1.35	1.35	1.35	-	1.00	1.00	0.50	-	-
Extreme Event II	Max	1.25	1.50	0.50	0.50	0.50	-	-	1.00	-	-	1.00
	Min	0.90	0.65	0.50	0.50	0.50	-	-	1.00	-	-	1.00
Service I	Max	1.00	1.00	1.00	1.00	1.00	0.30	1.00	1.00	1.00	0.50	-
	Min	1.00	1.00	1.00	1.00	1.00	0.30	1.00	1.00	1.20	0.50	-
Service II	Max	1.00	1.00	1.30	1.30	1.30	-	-	1.00	1.00	0.50	-
	Min	1.00	1.00	1.30	1.30	1.30	-	-	1.00	1.20	0.50	-
Fatigue I		-	-	1.50	1.50	1.50	-	-	-	-	-	-
Fatigue II		-	-	0.75	0.75	0.75	-	-	-	-	-	-

6. COMBINED LOAD EFFECTS

6.1 CONSTRUCTABILITY

6.1.1 Combined Shear and Moments

SPAN 1											
COMBINED LOADS - SHEARS (Kips)											
LOAD COMBINATION	LOCATION										
	0.0L	0.1L	0.2L	0.3L	0.4L	0.5L	0.6L	0.7L	0.8L	0.9L	1.0L
<i>Strength I Max</i>	-76.71	-56.26	-35.82	-15.37	5.08	25.52	45.97	66.41	86.86	107.31	255.51
<i>Strength I Min</i>	-59.07	-43.33	-27.58	-11.84	3.91	19.65	35.40	51.15	66.89	82.64	196.76
<i>Service II Max</i>	-60.58	-44.44	-28.29	-12.14	4.01	20.16	36.30	52.45	68.60	84.75	201.79
<i>Service II Min</i>	-60.58	-44.44	-28.29	-12.14	4.01	20.16	36.30	52.45	68.60	84.75	201.79
COMBINED LOADS - MOMENTS (Kips-ft)											
LOAD COMBINATION	LOCATION										
	0.0L	0.1L	0.2L	0.3L	0.4L	0.5L	0.6L	0.7L	0.8L	0.9L	1.0L
<i>Strength I Max</i>	0.00	731.36	1237.82	1519.36	1576.00	1407.73	1014.55	396.46	-446.54	-1514.44	-2807.26
<i>Strength I Min</i>	0.00	563.21	953.22	1170.03	1213.64	1084.05	781.26	305.27	-343.91	-1166.30	-2161.89
<i>Service II Max</i>	0.00	577.62	977.60	1199.96	1244.70	1111.80	801.27	313.12	-352.66	-1196.07	-2217.10
<i>Service II Min</i>	0.00	577.62	977.60	1199.96	1244.70	1111.80	801.27	313.12	-352.66	-1196.07	-2217.10

SPAN 2											
COMBINED LOADS - SHEARS (Kips)											
LOAD COMBINATION	LOCATION										
	0.0L	0.1L	0.2L	0.3L	0.4L	0.5L	0.6L	0.7L	0.8L	0.9L	1.0L
<i>Strength I Max</i>	255.51	-107.31	-86.86	-66.41	-45.97	-25.52	-5.08	15.37	35.82	56.26	76.71
<i>Strength I Min</i>	196.76	-82.64	-66.89	-51.15	-35.40	-19.65	-3.91	11.84	27.58	43.33	59.07
<i>Service II Max</i>	201.79	-84.75	-68.60	-52.45	-36.30	-20.16	-4.01	12.14	28.29	44.44	60.58
<i>Service II Min</i>	201.79	-84.75	-68.60	-52.45	-36.30	-20.16	-4.01	12.14	28.29	44.44	60.58
COMBINED LOADS - MOMENTS (Kips-ft)											
LOAD COMBINATION	LOCATION										
	0.0L	0.1L	0.2L	0.3L	0.4L	0.5L	0.6L	0.7L	0.8L	0.9L	1.0L
<i>Strength I Max</i>	-2807.26	-1514.44	-446.54	396.46	1014.55	1407.73	1576.00	1519.36	1237.82	731.36	0.00
<i>Strength I Min</i>	-2161.89	-1166.30	-343.91	305.27	781.26	1084.05	1213.64	1170.03	953.22	563.21	0.00
<i>Service II Max</i>	-2217.10	-1196.07	-352.66	313.12	801.27	1111.80	1244.70	1199.96	977.60	577.62	0.00
<i>Service II Min</i>	-2217.10	-1196.07	-352.66	313.12	801.27	1111.80	1244.70	1199.96	977.60	577.62	0.00

6.1.2 Design Shear and Moments

SPAN 1												
LOAD COMBINATION	LOCATION											
	0.0L	0.1L	0.2L	0.3L	0.4L	0.5L	0.6L	0.7L	0.8L	0.9L	1.0L	
Strength I	Shear (kips)	76.71	56.26	35.82	15.37	5.08	25.52	45.97	66.41	86.86	107.31	255.51
	+M (kip-ft)	0.00	731.36	1237.82	1519.36	1576.00	1407.73	1014.55	396.46	343.91	1166.30	2161.89
	-M (kip-ft)	0.00	563.21	953.22	1170.03	1213.64	1084.05	781.26	305.27	446.54	1514.44	2807.26
Service II	Shear (kips)	60.58	44.44	28.29	12.14	4.01	20.16	36.30	52.45	68.60	84.75	201.79
	+M (kip-ft)	0.00	577.62	977.60	1199.96	1244.70	1111.80	801.27	313.12	352.66	1196.07	2217.10
	-M (kip-ft)	0.00	577.62	977.60	1199.96	1244.70	1111.80	801.27	313.12	352.66	1196.07	2217.10

		SPAN 2										
LOAD COMBINATION		LOCATION										
		0.0L	0.1L	0.2L	0.3L	0.4L	0.5L	0.6L	0.7L	0.8L	0.9L	1.0L
Strength I	Shear (kips)	255.51	107.31	86.86	66.41	45.97	25.52	5.08	15.37	35.82	56.26	76.71
	+M (kip-ft)	2161.89	1166.30	343.91	396.46	1014.55	1407.73	1576.00	1519.36	1237.82	731.36	0.00
Service II	-M (kip-ft)	2807.26	1514.44	446.54	305.27	781.26	1084.05	1213.64	1170.03	953.22	563.21	0.00
	Shear (kips)	201.79	84.75	68.60	52.45	36.30	20.16	4.01	12.14	28.29	44.44	60.58
Service II	+M (kip-ft)	2217.10	1196.07	352.66	313.12	801.27	1111.80	1244.70	1199.96	977.60	577.62	0.00
	-M (kip-ft)	2217.10	1196.07	352.66	313.12	801.27	1111.80	1244.70	1199.96	977.60	577.62	0.00

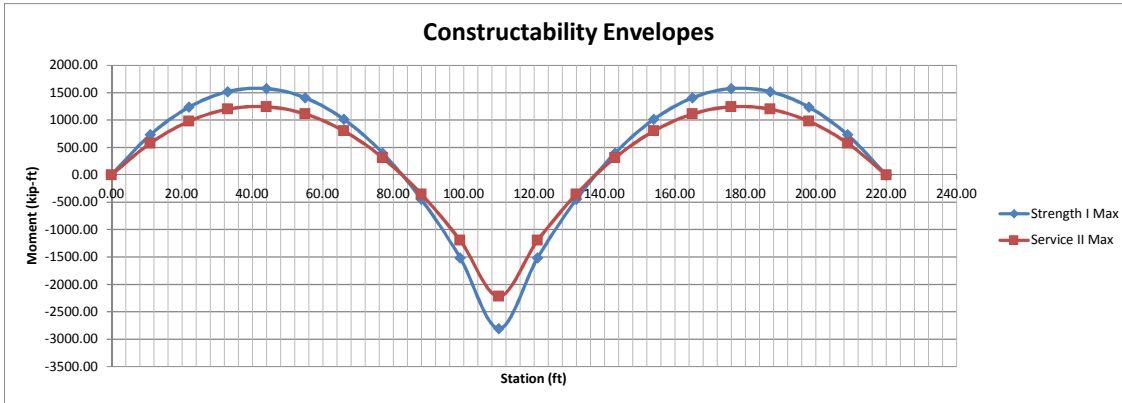

6.2 COMPOSITE SECTION (OPERATION)

6.2.1 Combined Shear and Moments

		SPAN 1										
		COMBINED LOADS - SHEARS (Kips)										
LOAD COMBINATION		LOCATION										
		0.0L	0.1L	0.2L	0.3L	0.4L	0.5L	0.6L	0.7L	0.8L	0.9L	1.0L
Strength I Max +M		279.17	224.17	169.97	116.43	75.91	121.21	173.57	224.75	274.53	322.68	521.65
Strength I Min +M		247.65	201.05	155.25	110.11	73.82	110.72	154.67	197.45	238.83	278.58	416.65
Strength III Max +M		-91.67	-67.24	-42.80	-18.37	6.07	30.50	54.93	79.37	103.80	128.23	305.34
Strength III Min +M		-60.15	-44.12	-28.08	-12.05	3.98	20.01	36.04	52.07	68.10	84.14	200.33
Strength V Max +M		236.31	188.30	140.90	94.01	59.94	100.48	146.45	191.52	235.50	278.24	472.20
Strength V Min +M		204.79	165.18	126.18	87.70	57.86	89.99	127.56	164.22	199.81	234.14	367.20
Extreme Event II Max +M		145.24	112.07	79.13	46.39	26.02	56.42	88.83	120.90	152.58	183.79	367.14
Extreme Event II Min +M		113.72	88.95	64.42	40.07	23.93	45.93	69.94	93.61	116.88	139.69	262.14
Service I Max +M		177.76	141.47	105.64	70.18	44.58	75.33	110.10	144.21	177.51	209.89	358.80
Service I Min +M		177.76	141.47	105.64	70.18	44.58	75.33	110.10	144.21	177.51	209.89	358.80
Service II Max +M		209.90	168.37	127.44	86.99	56.55	90.88	130.44	169.13	206.78	243.22	395.88
Service II Min +M		209.90	168.37	127.44	86.99	56.55	90.88	130.44	169.13	206.78	243.22	395.88
Fatigue II		33.82	29.33	26.13	24.69	24.41	25.15	26.23	27.86	29.84	31.84	33.81

		SPAN 1										
		COMBINED LOADS - MOMENTS (Kips-ft)										
LOAD COMBINATION		LOCATION										
		0.0L	0.1L	0.2L	0.3L	0.4L	0.5L	0.6L	0.7L	0.8L	0.9L	1.0L
Strength I Max +M		0.43	2201.07	3739.43	4642.50	4952.87	4698.46	3904.38	2603.24	735.96	-1514.37	-3977.50
Strength I Min +M		0.43	1900.52	3230.77	4018.15	4305.26	4120.00	3487.51	2440.39	919.54	-891.92	-2823.77
Strength I Max -M		0.00	1039.56	1726.55	2060.99	2042.87	1672.19	928.80	-196.30	-1679.40	-3597.22	-6674.02
Strength I Min -M		0.00	739.01	1217.89	1436.64	1395.26	1093.74	511.93	-359.16	-1495.82	-2974.78	-5520.29
Strength III Max +M		0.00	873.99	1479.21	1815.66	1883.33	1682.24	1212.37	473.73	-533.67	-1809.86	-3354.81
Strength III Min +M		0.00	573.45	970.55	1191.30	1235.72	1103.78	795.50	310.88	-350.09	-1187.41	-2201.07
Strength V Max +M		0.33	1897.73	3222.81	3996.37	4251.26	4009.04	3289.06	2116.50	445.75	-1581.91	-3835.17
Strength V Min +M		0.33	1597.19	2714.15	3372.02	3603.65	3430.58	2872.19	1953.64	629.33	-959.46	-2681.44
Strength V Max -M		0.00	1001.71	1670.02	2004.92	2006.41	1674.49	993.62	-43.15	-1417.52	-3188.68	-5915.35
Strength V Min -M		0.00	701.17	1161.36	1380.56	1358.79	1096.03	576.75	-206.01	-1233.94	-2566.24	-4761.61
Extreme Event II Max +M		0.12	1253.15	2124.99	2623.33	2760.34	2544.02	1981.52	1082.17	-170.92	-1725.43	-3532.72
Extreme Event II Min +M		0.12	952.61	1616.33	1998.98	2112.73	1965.56	1564.65	919.31	12.66	-1102.99	-2378.99
Extreme Event II Max -M		0.00	921.30	1549.88	1885.75	1928.92	1679.37	1131.35	282.30	-861.02	-2320.53	-4303.15
Extreme Event II Min -M		0.00	620.75	1041.22	1261.40	1281.30	1100.91	714.48	119.44	-677.44	-1698.09	-3149.42
Service I Max +M		0.24	1431.56	2430.98	3013.93	3204.74	3019.38	2472.18	1581.80	314.45	-1225.23	-2939.96
Service I Min +M		0.24	1431.56	2430.98	3013.93	3204.74	3019.38	2472.18	1581.80	314.45	-1225.23	-2939.96
Service I Max -M		0.00	767.84	1280.76	1538.78	1541.89	1290.08	771.86	-17.94	-1065.76	-2415.43	-4480.83
Service I Min -M		0.00	796.22	1323.16	1580.84	1569.24	1288.36	723.24	-132.81	-1262.17	-2721.84	-5049.83
Service II Max +M		0.32	1659.05	2818.44	3498.53	3730.95	3536.44	2933.67	1946.86	532.10	-1174.57	-3046.70
Service II Min +M		0.32	1659.05	2818.44	3498.53	3730.95	3536.44	2933.67	1946.86	532.10	-1174.57	-3046.70
Service II Max -M		0.00	796.22	1323.16	1580.84	1569.24	1288.36	723.24	-132.81	-1262.17	-2721.84	-5049.83
Service II Min -M		0.00	796.22	1323.16	1580.84	1569.24	1288.36	723.24	-132.81	-1262.17	-2721.84	-5049.83
Fatigue I		0.18	404.22	689.90	880.83	972.59	998.98	976.28	889.90	712.75	556.37	493.43
Fatigue II		0.09	202.11	344.95	440.42	486.29	499.49	488.14	444.95	356.38	278.18	246.72



SPAN 2											
COMBINED LOADS - SHEARS (Kips)											
LOAD COMBINATION	LOCATION										
	0.0L	0.1L	0.2L	0.3L	0.4L	0.5L	0.6L	0.7L	0.8L	0.9L	1.0L
Strength I Max +M	528.83	323.25	274.53	224.75	173.57	121.21	75.91	116.43	169.97	224.17	278.79
Strength I Min -M	423.83	279.16	238.83	197.45	154.67	110.72	73.82	110.11	155.25	201.05	247.27
Strength III Max +M	305.34	-128.23	-103.80	-79.37	-54.93	-30.50	-6.07	18.37	42.80	67.24	91.67
Strength III Min +M	200.33	-84.14	-68.10	-52.07	-36.04	-20.01	-3.98	12.05	28.08	44.12	60.15
Strength V Max +M	477.75	278.68	235.50	191.52	146.45	100.48	59.94	94.01	140.90	188.30	236.02
Strength V Min +M	372.74	234.58	199.81	164.22	127.56	89.99	57.86	87.70	126.18	165.18	204.50
Extreme Event II Max +M	369.19	183.95	152.58	120.90	88.83	56.42	26.02	46.39	79.13	112.07	145.13
Extreme Event II Min +M	264.19	139.86	116.88	93.61	69.94	45.93	23.93	40.07	64.42	88.95	113.61
Service I Max +M	362.91	210.22	177.51	144.21	110.10	75.33	44.58	70.18	105.64	141.47	177.54
Service I Min +M	362.91	210.22	177.51	144.21	110.10	75.33	44.58	70.18	105.64	141.47	177.54
Service II Max +M	401.22	243.65	206.78	169.13	130.44	90.88	56.55	86.99	127.44	168.37	209.62
Service II Min +M	401.22	243.65	206.78	169.13	130.44	90.88	56.55	86.99	127.44	168.37	209.62
Fatigue II	33.81	31.84	29.84	27.86	26.23	25.15	24.41	24.69	26.13	29.33	33.82

COMBINED LOADS - MOMENTS (Kips-ft)											
LOAD COMBINATION	LOCATION										
	0.0L	0.1L	0.2L	0.3L	0.4L	0.5L	0.6L	0.7L	0.8L	0.9L	1.0L
Strength I Max +M	-3977.50	-1514.37	735.96	2603.24	3904.38	4698.46	4952.87	4642.50	3739.43	2201.07	0.43
Strength I Min +M	-2823.77	-891.92	919.54	2440.39	3487.51	4120.00	4305.26	4018.15	3230.77	1900.52	0.43
Strength I Max -M	-6674.02	-3597.22	-1964.90	-778.59	160.36	805.56	1181.99	1289.65	1128.54	698.66	0.00
Strength I Min -M	-5520.29	-2974.78	-1781.32	-941.45	-256.51	227.11	534.38	665.30	619.88	398.11	0.00
Strength III Max +M	-3354.81	-1809.86	-533.67	473.73	1212.37	1682.24	1883.33	1815.66	1479.21	873.99	0.00
Strength III Min +M	-2201.07	-1187.41	-350.09	310.88	795.50	1103.78	1235.72	1191.30	970.55	573.45	0.00
Strength V Max +M	-3835.17	-1581.91	445.75	2116.50	3289.06	4009.04	4251.26	3996.37	3222.81	1897.73	0.33
Strength V Min +M	-2681.44	-959.46	629.33	1953.64	2872.19	3430.58	3603.65	3372.02	2714.15	1597.19	0.33
Strength V Max -M	-5915.35	-3188.68	-1637.76	-492.34	400.82	1005.95	1342.30	1409.88	1208.69	738.73	0.00
Strength V Min -M	-4761.61	-2566.24	-1454.18	-655.20	-16.05	427.49	694.68	785.53	700.03	438.19	0.00
Extreme Event II Max +M	-3532.72	-1725.43	-170.92	1082.17	1981.52	2544.02	2760.34	2623.33	2124.99	1253.15	0.12
Extreme Event II Min +M	-2378.99	-1102.99	12.66	919.31	1564.65	1965.56	2112.73	1998.98	1616.33	952.61	0.12
Extreme Event II Max -M	-4303.15	-2320.53	-942.60	115.93	911.80	1431.76	1682.95	1665.37	1379.02	823.89	0.00
Extreme Event II Min -M	-3149.42	-1698.09	-759.02	-46.93	494.93	853.30	1035.33	1041.02	870.36	523.35	0.00
Service I Max +M	-2939.96	-1225.23	314.45	1581.80	2472.18	3019.38	3204.74	3013.93	2430.98	1431.56	0.24
Service I Min +M	-2939.96	-1225.23	314.45	1581.80	2472.18	3019.38	3204.74	3013.93	2430.98	1431.56	0.24
Service I Max -M	-4480.83	-2415.43	-1228.90	-350.68	332.75	794.87	1049.95	1098.01	939.04	573.04	0.00
Service I Min -M	-4480.83	-2415.43	-1228.90	-350.68	332.75	794.87	1049.95	1098.01	939.04	573.04	0.00
Service II Max +M	-3046.70	-1174.57	532.10	1946.86	2933.67	3536.44	3730.95	3498.53	2818.44	1659.05	0.32
Service II Min +M	-3046.70	-1174.57	532.10	1946.86	2933.67	3536.44	3730.95	3498.53	2818.44	1659.05	0.32
Service II Max -M	-5049.83	-2721.84	-1474.25	-565.36	152.40	644.58	929.73	1007.84	878.92	542.98	0.00
Service II Min -M	-5049.83	-2721.84	-1474.25	-565.36	152.40	644.58	929.73	1007.84	878.92	542.98	0.00
Fatigue I	493.43	556.37	712.75	889.90	976.28	998.98	972.59	880.83	689.90	404.22	0.18
Fatigue II	246.72	278.18	356.38	444.95	488.14	499.49	486.29	440.42	344.95	202.11	0.09



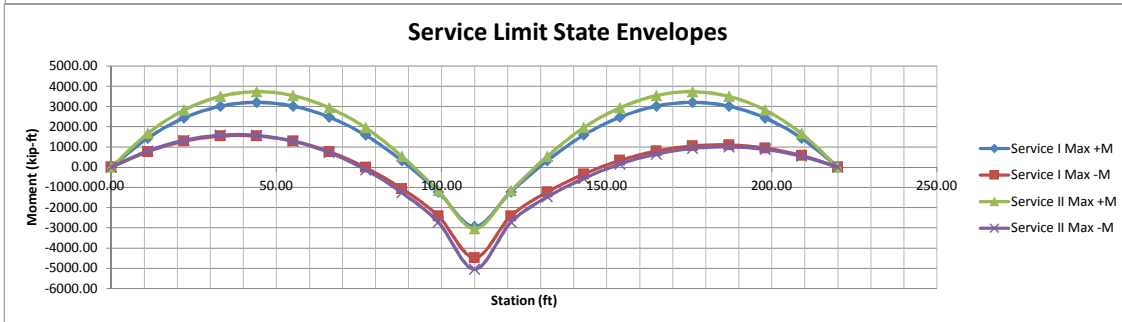
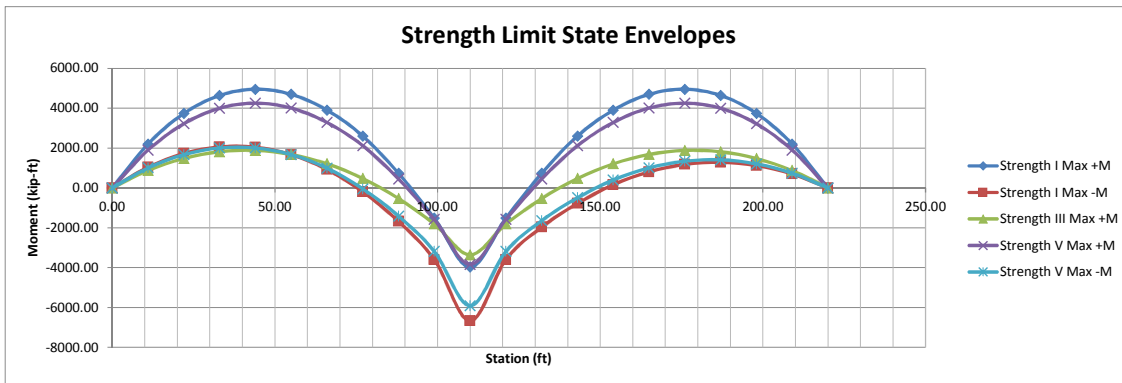

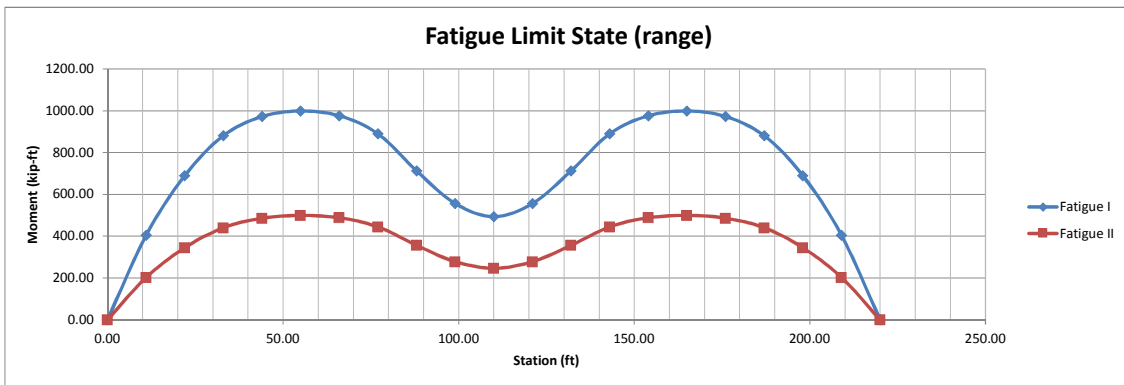
6.2.2 Design Shear and Moments

For FATIGUE Stress Range for Both - Positive and Negative

SPAN 1												
LOAD COMBINATION		LOCATION										
		0.0L	0.1L	0.2L	0.3L	0.4L	0.5L	0.6L	0.7L	0.8L	0.9L	1.0L
Strength I	Shear (kips)	279.17	224.17	169.97	116.43	75.91	121.21	173.57	224.75	274.53	322.68	521.65
	+M (kip-ft)	0.43	2201.07	3739.43	4642.50	4952.87	4698.46	3904.38	2603.24	919.54	891.92	2823.77
	-M (kip-ft)	0.00	739.01	1217.89	1436.64	1395.26	1093.74	511.93	359.16	1679.40	3597.22	6674.02
Strength III	Shear (kips)	91.67	67.24	42.80	18.37	6.07	30.50	54.93	79.37	103.80	128.23	305.34
	+M (kip-ft)	0.00	873.99	1479.21	1815.66	1883.33	1682.24	1212.37	473.73	350.09	1187.41	2201.07
	-M (kip-ft)	0.00	573.45	970.55	1191.30	1235.72	1103.78	795.50	310.88	533.67	1809.86	3354.81
Strength V	Shear (kips)	236.31	188.30	140.90	94.01	59.94	100.48	146.45	191.52	235.50	278.24	472.20
	+M (kip-ft)	0.33	1897.73	3222.81	3996.37	4251.26	4009.04	3289.06	2116.50	629.33	959.46	2681.44
	-M (kip-ft)	0.00	701.17	1161.36	1380.56	1358.79	1096.03	576.75	206.01	1417.52	3188.68	5915.35
Extreme Event II	Shear (kips)	145.24	112.07	79.13	46.39	26.02	56.42	88.83	120.90	152.58	183.79	367.14
	+M (kip-ft)	0.12	1253.15	2124.99	2623.33	2760.34	2544.02	1981.52	1082.17	12.66	1102.99	2378.99
	-M (kip-ft)	0.00	620.75	1041.22	1261.40	1281.30	1100.91	714.48	119.44	861.02	2320.53	4303.15
Service I	Shear (kips)	177.76	141.47	105.64	70.18	44.58	75.33	110.10	144.21	177.51	209.89	358.80
	+M (kip-ft)	0.24	1431.56	2430.98	3013.93	3204.74	3019.38	2472.18	1581.80	314.45	1225.23	2939.96
	-M (kip-ft)	0.00	767.84	1280.76	1538.78	1541.89	1288.36	723.24	132.81	1262.17	2721.84	5049.83
Service II	Shear (kips)	209.90	168.37	127.44	86.99	56.55	90.88	130.44	169.13	206.78	243.22	395.88
	+M (kip-ft)	0.32	1659.05	2818.44	3498.53	3730.95	3536.44	2933.67	1946.86	532.10	1174.57	3046.70
	-M (kip-ft)	0.00	796.22	1323.16	1580.84	1569.24	1288.36	723.24	132.81	1262.17	2721.84	5049.83
Fatigue I	Shear (kips)	-	-	-	-	-	-	-	-	-	-	-
	+M (kip-ft)	0.18	404.22	689.90	880.83	972.59	998.98	976.28	889.90	712.75	556.37	493.43
	-M (kip-ft)	-	-	-	-	-	-	-	-	-	-	-
Fatigue II	Shear (kips)	33.82	29.33	26.13	24.69	24.41	25.15	26.23	27.86	29.84	31.84	33.81
	+M (kip-ft)	0.09	202.11	344.95	440.42	486.29	499.49	488.14	444.95	356.38	278.18	246.72
	-M (kip-ft)	-	-	-	-	-	-	-	-	-	-	-

For FATIGUE Stress Range for Both - Positive and Negative

SPAN 2												
LOAD COMBINATION		LOCATION										
		0.0L	0.1L	0.2L	0.3L	0.4L	0.5L	0.6L	0.7L	0.8L	0.9L	1.0L
Strength I	Shear (kips)	528.83	323.25	274.53	224.75	173.57	121.21	75.91	116.43	169.97	224.17	278.79
	+M (kip-ft)	2823.77	891.92	919.54	2603.24	3904.38	4698.46	4952.87	4642.50	3739.43	2201.07	0.43
	-M (kip-ft)	6674.02	3597.22	1964.90	941.45	256.51	227.11	534.38	665.30	619.88	398.11	0.00
Strength III	Shear (kips)	305.34	128.23	103.80	79.37	54.93	30.50	6.07	18.37	42.80	67.24	91.67
	+M (kip-ft)	2201.07	1187.41	350.09	473.73	1212.37	1682.24	1883.33	1815.66	1479.21	873.99	0.00
	-M (kip-ft)	3354.81	1809.86	533.67	310.88	795.50	1103.78	1235.72	1191.30	970.55	573.45	0.00
Strength V	Shear (kips)	477.75	278.68	235.50	191.52	146.45	100.48	59.94	94.01	140.90	188.30	236.31
	+M (kip-ft)	2681.44	959.46	629.33	2116.50	3289.06	4009.04	4251.26	3996.37	3222.81	1897.73	0.33
	-M (kip-ft)	5915.35	3188.68	1637.76	655.20	16.05	427.49	694.68	785.53	700.03	438.19	0.00
Extreme Event II	Shear (kips)	369.19	183.95	152.58	120.90	88.83	56.42	26.02	46.39	79.13	112.07	145.13
	+M (kip-ft)	2378.99	1102.99	12.66	1082.17	1981.52	2544.02	2760.34	2623.33	2124.99	1253.15	0.12
	-M (kip-ft)	4303.15	2320.53	942.60	46.93	494.93	853.30	1035.33	1041.02	870.36	523.35	0.00
Service I	Shear (kips)	362.91	210.22	177.51	144.21	110.10	75.33	44.58	70.18	105.64	141.47	177.54
	+M (kip-ft)	2939.96	1225.23	314.45	1581.80	2472.18	3019.38	3204.74	3013.93	2430.98	1431.56	0.24
	-M (kip-ft)	4480.83	2415.43	1228.90	350.68	332.75	794.87	1049.95	1098.01	939.04	573.04	0.00
Service II	Shear (kips)	401.22	243.65	206.78	169.13	130.44	90.88	56.55	86.99	127.44	168.37	209.62
	+M (kip-ft)	3046.70	1174.57	532.10	1946.86	2933.67	3536.44	3730.95	3498.53	2818.44	1659.05	0.32
	-M (kip-ft)	5049.83	2721.84	1474.25	565.36	152.40	644.58	929.73	1007.84	878.92	542.98	0.00
Fatigue I	Shear (kips)	-	-	-	-	-	-	-	-	-	-	-
	+M (kip-ft)	493.43	556.37	712.75	889.90	976.28	998.98	972.59	880.83	689.90	404.22	0.18
	-M (kip-ft)	-	-	-	-	-	-	-	-	-	-	-
Fatigue II	Shear (kips)	33.81	31.84	29.84	27.86	26.23	25.15	24.41	24.69	26.13	29.33	33.82
	+M (kip-ft)	246.72	278.18	356.38	444.95	488.14	499.49	486.29	440.42	344.95	202.11	0.09
	-M (kip-ft)	-	-	-	-	-	-	-	-	-	-	-

**7. DESIGN OF THE STEEL BEAM**

**7.1 SECTION PROPORTIONS LIMITS (AASHTO 6.10.2)**

Flanges:

$\frac{b_f}{2t_f} \leq 12.0$	$\frac{b_{fT}}{2t_{fT}} =$	7.00 <b>Top Flange Section 1</b>	OK	$\frac{D}{6} \leq b_f$	$\frac{D}{6} =$	8.67 in	
		5.09 <b>Top Flange Section 2</b>	OK			$b_{f1} =$	14.00 in <b>Top Flange Section 1</b> OK
		2.67 <b>Top Flange Section 3</b>	OK			$b_{f2} =$	14.00 in <b>Top Flange Section 2</b> OK
						$b_{f3} =$	14.00 in <b>Top Flange Section 3</b> OK
	$\frac{b_{fB}}{2t_{fB}} =$	7.00 <b>Bottom Flange Section 1</b>	OK			$b_{b1} =$	14.00 in <b>Bottom Flange Section 1</b> OK
		5.09 <b>Bottom Flange Section 2</b>	OK			$b_{b2} =$	14.00 in <b>Bottom Flange Section 2</b> OK
		2.67 <b>Bottom Flange Section 3</b>	OK			$b_{b3} =$	14.00 in <b>Bottom Flange Section 3</b> OK
$t_f \geq 1.1t_w$	$1.1t_w =$	0.55 in <b>+mom</b>		$0.1 \leq \frac{I_{yc}}{I_{yt}} \leq 10$	$\frac{I_{yc}}{I_{yt}} =$	1.00 <b>Section 1</b>	OK
$t_f \geq 1.1t_w$	$1.1t_w =$	0.55 in <b>-mom</b>			$\frac{I_{yc}}{I_{yt}} =$	1.00 <b>Section 2</b>	OK
$t_f \geq 1.1t_w$	$1.1t_w =$	0.55 in <b>-mom</b>			$\frac{I_{yc}}{I_{yt}} =$	1.00 <b>Section 3</b>	OK
	$T_{f1} =$	1.00 in <b>Top Flange Section 1</b>	OK			$I_{v1} =$	228.67 in <b>Top Flange Section 1</b>
	$T_{f2} =$	1.38 in <b>Top Flange Section 2</b>	OK			$I_{v2} =$	228.67 in <b>Top Flange Section 2</b>
	$T_{f3} =$	2.63 in <b>Top Flange Section 3</b>	OK			$I_{v3} =$	314.42 in <b>Top Flange Section 1</b>
	$T_{b1} =$	1.00 in <b>Bottom Flange Section 1</b>	OK			$I_{v4} =$	314.42 in <b>Top Flange Section 2</b>
	$T_{b2} =$	1.38 in <b>Bottom Flange Section 2</b>	OK			$I_{v5} =$	600.25 in <b>Top Flange Section 3</b>
	$T_{b3} =$	2.63 in <b>Bottom Flange Section 3</b>	OK			$I_{v6} =$	600.25 in <b>Top Flange Section 3</b>

Web:

$\frac{D}{t_w} \leq 150$	$\frac{D}{t_w} =$	104.00 <b>Section 1</b>	OK
		105.50 <b>Section 2</b>	OK
		100.00 <b>Section 3</b>	OK

**7.2 SLENDER LIMITS FOR COMPRESSION ELEMENTS DUE TO FLEXURE**

Flanges:

Limiting slenderness for a compact flange (6.10.8.2.2-4)

$\lambda_{pf} = 0.38 \sqrt{\frac{E}{f_{yc}}} =$	9.15	$\lambda_{fT} = \frac{b_{fT}}{2t_{fT}} =$	7.00 <b>Top Flange Section 1</b>	COMPACT
			5.09 <b>Top Flange Section 2</b>	COMPACT
			2.67 <b>Top Flange Section 3</b>	COMPACT

Limiting slenderness for a non-compact flange (6.10.8.2.2-5)

$\lambda_{rf} = 0.56 \sqrt{\frac{E}{f_{yr}}} =$	16.12	$\lambda_{fB} = \frac{b_{fB}}{2t_{fB}} =$	7.00 <b>Bottom Flange Section 1</b>	COMPACT
			5.09 <b>Bottom Flange Section 2</b>	COMPACT
			2.67 <b>Bottom Flange Section 3</b>	COMPACT

$f_{yr}$  is the lesser of  $0.7F_{yc}$  and  $F_{yw}$  but not less than  $0.5F_{yc}$ , for homogeneous sections,  $f_{yr}$  is taken as  $0.7F_{yc}$

**7.3 CONSTRUCTABILITY DESIGN - NON COMPOSITE SECTION - (AASHTO 6.10.3.2)**

**7.3.1 FLEXURAL NOMINAL RESISTANCE**

Discretely Braced Compression Flange?  YES

**7.3.1.1 Flange Nominal Yielding (6.10.3.2.1)**

$f_{bu} + f_t \leq \phi_f R_h F_{yf}$  **Discretely Braced**  $f_t = 0.00$  ksi

$f_{bu} \leq \phi_f R_h F_{yf}$  **Continuous Braced**  $\phi_f R_h F_{yf} = 50.00$  ksi

**7.3.1.2 Flexural Resistance (AASHTO 6.10.3.2.1, 6.10.1.6 and 6.10.8)**

$f_{bu} + \frac{1}{3} f_t \leq \phi_f F_{nc}$   
 $f_t \leq 0.6F_{yf}$

**Local Buckling Resistance (6.10.8.2.2)**

$F_{nc} = R_b R_h F_{yc}$  if  $\lambda_f \leq \lambda_{pf}$   $F_{cr} =$

$F_{nc} = \left[ 1 - \left( 1 - \frac{F_{yr}}{R_h F_{yc}} \right) \left( \frac{\lambda_f - \lambda_{pf}}{\lambda_{rf} - \lambda_{pf}} \right) \right] R_b R_h F_{yc}$  if  $\lambda_f > \lambda_{pf}$

SECTION	BOTTOM			TOP			CHECK
	$F_{cr}$ (ksi)	$F_{nc}$ (ksi)	$\phi F_{nc}$ (ksi)	$F_{nc}$ (ksi)	$\phi F_{nc}$ (ksi)	$0.6F_{yf}$ (ksi)	
SECTION 1	35.00	50.00	33.08	50.00	33.08	30.00	OK
SECTION 2	35.00	50.00	35.08	50.00	35.08	30.00	OK
SECTION 3	35.00	50.00	35.97	50.00	35.97	30.00	OK

Lateral Torsional Buckling Resistance ( $R_h$  and  $R_b$  are taken as 1.0 according to AASHTO 6.10.1.10)

$C_b = 1.00$

$L_p = 1.0r_t \sqrt{\frac{E}{F_{yc}}}$   $L_r = \pi r_t \sqrt{\frac{E}{F_{yr}}}$   $r_t = \frac{b_{fc}}{\sqrt{12 \left( 1 + \frac{1}{3} \frac{D_c t_w}{b_{fc} t_{fc}} \right)}}$

$F_{nc} = R_b R_h F_{yc}$  if  $L_b \leq L_p$

$F_{nc} = C_b \left[ 1 - \left( 1 - \frac{F_{yr}}{R_h F_{yc}} \right) \left( \frac{L_b - L_p}{L_r - L_p} \right) \right] R_b R_h F_{yc} \leq R_b R_h F_{yc}$  if  $L_p < L_b \leq L_r$

$F_{nc} = F_{cr} \leq R_b R_h F_{yc}$  if  $L_b > L_r$   $F_{cr} = \frac{C_b R_b \pi^2 E}{\left( \frac{L_b}{r_t} \right)^2}$

SECTION	BOTTOM						TOP					
	$L_b$ (ft)	$r_t$ (in)	$L_p$ (ft)	$L_r$ (ft)	$F_{cr}$ (ksi)	$F_{nc}$ (ksi)	$L_b$ (ft)	$r_t$ (in)	$L_p$ (ft)	$L_r$ (ft)	$F_{cr}$ (ksi)	$F_{nc}$ (ksi)
SECTION 1	27.50	3.55	7.12	26.74	33.08	33.08	27.50	3.55	7.12	26.74	33.08	33.08
SECTION 2	27.50	3.66	7.35	27.61	35.29	35.08	27.50	3.66	7.35	27.61	35.29	35.08
SECTION 3	27.50	3.83	7.69	28.86	38.56	35.97	27.50	3.83	7.69	28.86	38.56	35.97

7.3.1.3 Web Bend Buckling (AASHTO 6.10.1.9)

$$f_{bu} \leq \phi_f F_{crw}$$

Longitudinal Stiffeners? NO

$$F_{crw} = \frac{0.9Ek}{\left(\frac{D}{t_w}\right)^2} \quad k = \frac{9}{\left(\frac{D_0}{D}\right)^2}$$

SECTION	Positive			Top	Bottom	Negative		
	k	F <sub>crw</sub> (ksi)	ϕF <sub>crw</sub> (ksi)	S <sub>x</sub> (in <sup>3</sup> )	S <sub>x</sub> (in <sup>3</sup> )	k	F <sub>crw</sub> (ksi)	ϕF <sub>crw</sub> (ksi)
SECTION 1	38.94	50.00	50.00	900.68	900.68	38.94	50.00	50.00
SECTION 2	40.07	50.00	50.00	1160.89	1160.89	40.07	50.00	50.00
SECTION 3	43.96	50.00	50.00	2032.15	2032.15	43.96	50.00	50.00

7.3.1.4 Summary

SPAN 1												
DESCRIPTION		LOCATION										
		SECTION 1	SECTION 1	SECTION 1	SECTION 1	SECTION 1	SECTION 1	SECTION 1	SECTION 2	SECTION 2	SECTION 2	SECTION 3
		0.0L	0.1L	0.2L	0.3L	0.4L	0.5L	0.6L	0.7L	0.8L	0.9L	1.0L
M <sub>u</sub> (kip-ft)	Positive	0.00	731.36	1237.82	1519.36	1576.00	1407.73	1014.55	396.46	352.66	1196.07	2217.10
	Negative	0.00	577.62	977.60	1199.96	1244.70	1111.80	801.27	313.12	446.54	1514.44	2807.26
S <sub>x</sub> (in <sup>3</sup> )	Top	900.68	900.68	900.68	900.68	900.68	900.68	900.68	900.68	1160.89	1160.89	2032.15
	Bottom	900.68	900.68	900.68	900.68	900.68	900.68	900.68	1160.89	1160.89	1160.89	2032.15
f <sub>bu</sub> (ksi)	Top (Pos)	0.00	9.74	16.49	20.24	21.00	18.76	13.52	4.10	3.65	12.36	13.09
	Top (Neg)	0.00	7.70	13.02	15.99	16.58	14.81	10.68	3.24	4.62	15.65	16.58
	Bottom (Pos)	0.00	9.74	16.49	20.24	21.00	18.76	13.52	4.10	3.65	12.36	13.09
	Bottom (Neg)	0.00	7.70	13.02	15.99	16.58	14.81	10.68	3.24	4.62	15.65	16.58
f <sub>t</sub> (ksi)		0.00	0.00	0.00	0.00	0.00	0.00	0.00	0.00	0.00	0.00	0.00
ϕ <sub>R<sub>n</sub></sub> F <sub>y</sub> t (ksi)		50.00	50.00	50.00	50.00	50.00	50.00	50.00	50.00	50.00	50.00	50.00
CHECK		OK	OK	OK	OK	OK	OK	OK	OK	OK	OK	OK
ϕF <sub>nc</sub> (ksi)	Top	33.08	33.08	33.08	33.08	33.08	33.08	33.08	35.08	35.08	35.08	35.97
	Bottom	50.00	50.00	50.00	50.00	50.00	50.00	50.00	50.00	50.00	50.00	50.00
CHECK	Top	OK	OK	OK	OK	OK	OK	OK	OK	OK	OK	OK
	Bottom	OK	OK	OK	OK	OK	OK	OK	OK	OK	OK	OK
ϕF <sub>crw</sub> (ksi)	Top	50.00	50.00	50.00	50.00	50.00	50.00	50.00	50.00	50.00	50.00	50.00
	Bottom	50.00	50.00	50.00	50.00	50.00	50.00	50.00	50.00	50.00	50.00	50.00
CHECK	Top	OK	OK	OK	OK	OK	OK	OK	OK	OK	OK	OK
	Bottom	OK	OK	OK	OK	OK	OK	OK	OK	OK	OK	OK

SPAN 2												
DESCRIPTION		LOCATION										
		SECTION 3	SECTION 2	SECTION 2	SECTION 2	SECTION 1	SECTION 1	SECTION 1	SECTION 1	SECTION 1	SECTION 1	SECTION 1
		0.0L	0.1L	0.2L	0.3L	0.4L	0.5L	0.6L	0.7L	0.8L	0.9L	1.0L
M <sub>u</sub> (kip-ft)	Positive	2217.10	1196.07	352.66	396.46	1014.55	1407.73	1576.00	1519.36	1237.82	731.36	0.00
	Negative	2807.26	1514.44	446.54	313.12	801.27	1111.80	1244.70	1199.96	977.60	577.62	0.00
S <sub>x</sub> (in <sup>3</sup> )	Top	2032.15	1160.89	1160.89	1160.89	900.68	900.68	900.68	900.68	900.68	900.68	900.68
	Bottom	2032.15	1160.89	1160.89	1160.89	900.68	900.68	900.68	900.68	900.68	900.68	900.68
f <sub>bu</sub> (ksi)	Top (Pos)	13.09	12.36	3.65	4.10	13.52	18.76	21.00	20.24	16.49	9.74	0.00
	Top (Neg)	16.58	15.65	4.62	3.24	10.68	14.81	16.58	15.99	13.02	7.70	0.00
	Bottom (Pos)	13.09	12.36	3.65	4.10	13.52	18.76	21.00	20.24	16.49	9.74	0.00
	Bottom (Neg)	16.58	15.65	4.62	3.24	10.68	14.81	16.58	15.99	13.02	7.70	0.00
f <sub>t</sub> (ksi)		0.00	0.00	0.00	0.00	0.00	0.00	0.00	0.00	0.00	0.00	0.00
ϕ <sub>R<sub>n</sub></sub> F <sub>y</sub> t (ksi)		50.00	50.00	50.00	50.00	50.00	50.00	50.00	50.00	50.00	50.00	50.00
CHECK		OK	OK	OK	OK	OK	OK	OK	OK	OK	OK	OK
ϕF <sub>nc</sub> (ksi)	Top	35.97	35.08	35.08	35.08	33.08	33.08	33.08	33.08	33.08	33.08	33.08
	Bottom	50.00	50.00	50.00	50.00	50.00	50.00	50.00	50.00	50.00	50.00	50.00
CHECK	Top	OK	OK	OK	OK	OK	OK	OK	OK	OK	OK	OK
	Bottom	OK	OK	OK	OK	OK	OK	OK	OK	OK	OK	OK
ϕF <sub>crw</sub> (ksi)	Top	50.00	50.00	50.00	50.00	50.00	50.00	50.00	50.00	50.00	50.00	50.00
	Bottom	50.00	50.00	50.00	50.00	50.00	50.00	50.00	50.00	50.00	50.00	50.00
CHECK	Top	OK	OK	OK	OK	OK	OK	OK	OK	OK	OK	OK
	Bottom	OK	OK	OK	OK	OK	OK	OK	OK	OK	OK	OK

7.3.2 SHEAR (AASHTO 6.10.9.1)

Unstiffened webs and exterior panels

$$V_u \leq \phi_v V_n$$

$$V_n = C V_p$$

$$V_p = 0.58 F_{yw} D t_w$$

$$C = 1.0 \text{ if } \frac{D}{t_w} \leq 1.12 \sqrt{\frac{Ek}{F_{yw}}} \quad C = \frac{1.12}{\frac{D}{t_w}} \sqrt{\frac{Ek}{F_{yw}}} \text{ if } 1.12 \sqrt{\frac{Ek}{F_{yw}}} < \frac{D}{t_w} \leq 1.40 \sqrt{\frac{Ek}{F_{yw}}} \quad C = \frac{1.57}{\frac{D}{t_w}} \sqrt{\frac{Ek}{F_{yw}}} \text{ if } \frac{D}{t_w} > 1.40 \sqrt{\frac{Ek}{F_{yw}}}$$

Interior Panels

$$\frac{2Dt_w}{(b_{ft}t_{ft} + b_{fb}t_{fb})_p} = \omega$$

$$V_n = V_p \delta$$

$$\delta = \left[ C + \frac{0.87(1-C)}{\sqrt{1 + \left(\frac{d_0}{D}\right)^2}} \right] \text{ if } \omega \leq 2.5 \quad \delta = \left[ C + \frac{0.87(1-C)}{\sqrt{1 + \left(\frac{d_0}{D}\right)^2 + \frac{d_0}{D}}} \right] \text{ if } \omega > 2.5$$

SECTION	d (in)	D (in)	t <sub>w</sub> (in)	D/t <sub>w</sub> =	V <sub>p</sub> (kip)	b <sub>fb</sub> t <sub>fb</sub> (in <sup>2</sup> )	b <sub>ft</sub> t <sub>ft</sub> (in <sup>2</sup> )
SECTION 1	52.00	50.00	0.50	100.00	725.00	14.00	14.00
SECTION 2	52.75	50.00	0.50	100.00	725.00	19.25	19.25
SECTION 3	55.25	50.00	0.50	100.00	725.00	36.75	36.75

SPAN 1											
DESCRIPTION	LOCATION										
	SECTION 1	SECTION 1	SECTION 1	SECTION 1	SECTION 1	SECTION 1	SECTION 1	SECTION 2	SECTION 2	SECTION 2	SECTION 3
	0.0L	0.1L	0.2L	0.3L	0.4L	0.5L	0.6L	0.7L	0.8L	0.9L	1.0L
Transverse Stiffeners?	NO	NO	NO	NO	NO	NO	NO	NO	NO	NO	NO
Dist btwn Stiffeners (in)	0.00	0.00	0.00	0.00	0.00	0.00	0.00	0.00	0.00	0.00	0.00
Stiffened?	NO	NO	NO	NO	NO	NO	NO	NO	NO	NO	NO
k (in)	5.00	5.00	5.00	5.00	5.00	5.00	5.00	5.00	5.00	5.00	5.00
C	0.85	0.85	0.85	0.85	0.85	0.85	0.85	0.85	0.85	0.85	0.85
$\omega$	0.00	1.79	1.79	1.79	1.79	1.79	1.79	1.30	1.30	1.30	0.68
$\delta$	0.98	0.98	0.98	0.98	0.98	0.98	0.98	0.98	0.98	0.98	0.98
$\phi V_n$ (kip)	612.97	612.97	612.97	612.97	612.97	612.97	612.97	612.97	612.97	612.97	612.97
$V_u$ (kip)	76.71	56.26	35.82	15.37	5.08	25.52	45.97	66.41	86.86	107.31	255.51
CHECK	OK	OK	OK	OK	OK	OK	OK	OK	OK	OK	OK

SPAN 2											
DESCRIPTION	LOCATION										
	SECTION 3	SECTION 2	SECTION 2	SECTION 2	SECTION 1	SECTION 1	SECTION 1	SECTION 1	SECTION 1	SECTION 1	SECTION 1
	0.0L	0.1L	0.2L	0.3L	0.4L	0.5L	0.6L	0.7L	0.8L	0.9L	1.0L
Transverse Stiffeners?	NO	NO	NO	NO	NO	NO	NO	NO	NO	NO	NO
Dist btwn Stiffeners (in)	0.00	0.00	0.00	0.00	0.00	0.00	0.00	0.00	0.00	0.00	0.00
Stiffened?	NO	NO	NO	NO	NO	NO	NO	NO	NO	NO	NO
k (in)	5.00	5.00	5.00	5.00	5.00	5.00	5.00	5.00	5.00	5.00	5.00
C	0.85	0.85	0.85	0.85	0.85	0.85	0.85	0.85	0.85	0.85	0.85
$\omega$	0.00	1.30	1.30	1.30	1.79	1.79	1.79	1.79	1.79	1.79	1.79
$\delta$	0.98	0.98	0.98	0.98	0.98	0.98	0.98	0.98	0.98	0.98	0.98
$\phi V_n$ (kip)	612.97	612.97	612.97	612.97	612.97	612.97	612.97	612.97	612.97	612.97	612.97
$V_u$ (kip)	255.51	107.31	86.86	66.41	45.97	25.52	5.08	15.37	35.82	56.26	76.71
CHECK	OK	OK	OK	OK	OK	OK	OK	OK	OK	OK	OK

7.4 COMPOSITE SECTION DESIGN

7.4.1 POSITIVE MOMENT

7.4.1.1 PLASTIC MOMENT (AASHTO Table D6.1-1)

Section 1

Deck reinforcement is neglected

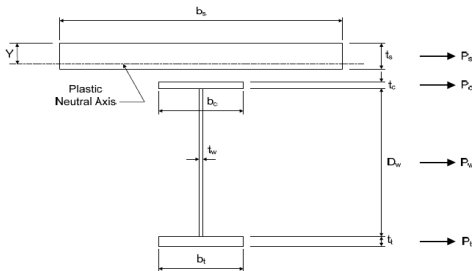

$P_s =$	2907.00 kip	$d_s =$	3.09 in
$P_c =$	700.00 kip	$d_c =$	1.91 in
$P_w =$	1250.00 kip	$d_w =$	27.41 in
$P_t =$	700.00 kip	$d_t =$	52.91 in
$\bar{Y} =$	6.84		
PNA =	6.84 in	PNA IN THE CONCRETE SLAB	
Compression =	2650.00 ksi		
Tension =	2650.00 ksi	OK	

$M_p = 6808.63 \text{ kip-ft}$

Capacity (AASHTO D6.3.2 and 6.10.6.2)  $\frac{E}{F_{yc}} = 3.76 \sqrt{\frac{E}{F_{yc}}} = 90.55$

$\frac{2D_{cp}}{t_w} \leq 3.76 \sqrt{\frac{E}{F_{yc}}}$

(AASHTO D.6.3.2)  $D_{cp} = 0.00 \text{ in}$   $\frac{2D_{cp}}{t_w} = 0.00$  COMPACT

SECTION 2

Deck reinforcement is neglected

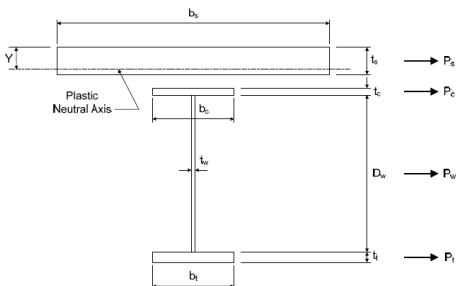

$P_s =$	2907.00 kip	$d_s =$	4.69 in
$P_c =$	962.50 kip	$d_c =$	0.50 in
$P_w =$	1250.00 kip	$d_w =$	26.18 in
$P_t =$	962.50 kip	$d_t =$	51.87 in
$\bar{Y} =$	0.19		
PNA =	8.44 in	PNA IN THE TOP FLANGE	
Compression =	3041.00 ksi		
Tension =	3041.00 ksi	OK	

$M_p = 8066.37 \text{ kip-ft}$

Capacity (AASHTO D6.3.2 and 6.10.6.2)  $\frac{E}{F_{yc}} = 3.76 \sqrt{\frac{E}{F_{yc}}} = 90.55$

$\frac{2D_{cp}}{t_w} \leq 3.76 \sqrt{\frac{E}{F_{yc}}}$

(AASHTO D.6.3.2)  $D_{cp} = 0.00 \text{ in}$   $\frac{2D_{cp}}{t_w} = 0.00$  COMPACT

**SECTION 3**

Deck reinforcement is neglected

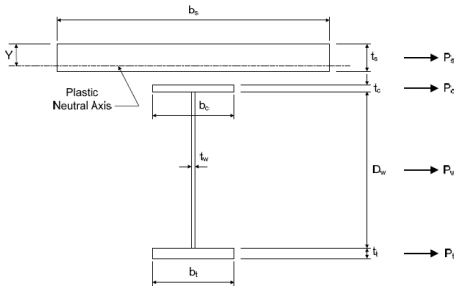

$P_o = 2907.00$  kip       $d_o = 5.94$  in  
 $P_c = 1837.50$  kip       $d_c = 0.13$  in  
 $P_w = 1250.00$  kip       $d_w = 26.18$  in  
 $P_t = 1837.50$  kip       $d_t = 52.50$  in  
 $\bar{Y} = 1.44$   
 PNA = 9.69 in      **PNA IN THE TOP FLANGE**  
**Compression = 3916.00 ksi**  
**Tension = 3916.00 ksi**      **OK**  
 $M_p = 12306.69$  kip-ft  
**Capacity (AASHTO D6.3.2 and 6.10.6.2)**  
 $\frac{2D_{cp}}{t_w} \leq 3.76 \sqrt{\frac{E}{F_{yc}}}$        $3.76 \sqrt{\frac{E}{F_{yc}}} = 90.55$   
 (AASHTO D.6.3.2)  $D_{cp} = 0.00$  in       $\frac{2D_{cp}}{t_w} = 0.00$       **COMPACT**

**7.4.1.2 STRENGTH LIMIT STATE (AASHTO 6.10.6)**

$$F_y = \frac{M_{D1}}{S_{NC}} + \frac{M_{D2}}{S_{LT}} + \frac{M_{AD}}{S_{ST}}$$

$$M_{AD} = S_{ST} \left( F_y - \frac{M_{D1}}{S_{NC}} - \frac{M_{D2}}{S_{LT}} \right)$$

$$M_y = M_{D1} + M_{D2} + M_{AD}$$

$$M_n = M_p \text{ if } D_p \leq 0.1D_t$$

**Ductility Requirement**

$$M_n \leq 1.3R_n M_y \quad D_p \leq 0.42D_t$$

$$M_n = M_p \left[ 1.07 - 0.7 \frac{D_p}{D_t} \right] \text{ if } D_p > 0.1D_t \quad M_u + \frac{1}{3} f_t S_{xt} \leq \phi_f M_n$$

SECTION	BOTTOM GIRDER			TOP GIRDER		
	$S_{NC}$ (in <sup>3</sup> )	$S_{LT}$ (in <sup>3</sup> )	$S_{ST}$ (in <sup>3</sup> )	$S_{NC}$ (in <sup>3</sup> )	$S_{LT}$ (in <sup>3</sup> )	$S_{ST}$ (in <sup>3</sup> )
SECTION 1	900.68	1143.47	1227.74	900.68	3851.39	11796.90
SECTION 2	1160.89	1415.02	1513.87	1160.89	4137.58	11338.50
SECTION 3	2032.15	2323.07	2536.27	2032.15	5066.96	17876.68

SECTION	$D_p$ in	$D_t$ in	$M_p$ kip-ft	Ductility Requirement
SECTION 1	6.84	60.25	6808.63	OK
SECTION 2	8.44	61.00	8066.37	OK
SECTION 3	9.69	63.50	12306.69	OK

SPAN 1											
DESCRIPTION	LOCATION										
	SECTION 1	SECTION 1	SECTION 1	SECTION 1	SECTION 1	SECTION 1	SECTION 1	SECTION 2	SECTION 2	SECTION 2	SECTION 3
	0.0L	0.1L	0.2L	0.3L	0.4L	0.5L	0.6L	0.7L	0.8L	0.9L	1.0L
$M_{D1}$ (kip-ft) Positive	0.00	720.66	1219.71	1497.15	1552.98	1387.20	999.81	390.80	0.00	0.00	0.00
$M_{D2}$ (kip-ft) Positive	0.00	289.18	489.42	600.73	623.10	556.53	401.04	156.60	0.00	0.00	0.00
$M_{AD}$ (kip-ft) Bottom Girder	5115.59	3822.74	2927.47	2429.78	2329.65	2627.11	3322.13	5630.61	6307.78	6307.78	10567.81
$M_{AD}$ (kip-ft) Top Girder	49153.73	38828.89	31679.09	27704.30	26904.55	29279.82	34830.12	42997.66	47243.77	47243.77	74486.15
$M_y$ (kip-ft)	5115.59	4832.58	4636.60	4527.66	4505.73	4570.84	4722.97	6178.02	6307.78	6307.78	10567.81
$M_n$ (kip-ft)	6650.26	6282.36	6027.59	5885.95	5857.45	5942.09	6139.87	7849.64	7849.64	7849.64	11853.37
$M_u$ (kip-ft)	0.43	2201.07	3739.43	4642.50	4952.87	4698.46	3904.38	2603.24	919.54	0.00	0.00
$f_t$ (ksi)	0.00	0.00	0.00	0.00	0.00	0.00	0.00	0.00	0.00	0.00	0.00
$\phi_f M_n$ (kip-ft)	6650.26	6282.36	6027.59	5885.95	5857.45	5942.09	6139.87	7849.64	7849.64	7849.64	11853.37
CHECK	OK	OK	OK	OK	OK	OK	OK	OK	OK	OK	OK
USAGE RATIO	0.01%	35.04%	62.04%	78.87%	84.56%	79.07%	63.59%	33.16%	11.71%	0.00%	0.00%

SPAN 2											
DESCRIPTION	LOCATION										
	SECTION 3	SECTION 2	SECTION 2	SECTION 2	SECTION 1	SECTION 1	SECTION 1	SECTION 1	SECTION 1	SECTION 1	SECTION 1
	0.0L	0.1L	0.2L	0.3L	0.4L	0.5L	0.6L	0.7L	0.8L	0.9L	1.0L
$M_{D1}$ (kip-ft) Positive	0.00	0.00	0.00	390.80	999.81	1387.20	1552.98	1497.15	1219.71	720.66	0.00
$M_{D2}$ (kip-ft) Positive	0.00	0.00	0.00	156.60	401.04	556.53	623.10	600.73	489.42	289.18	0.00
$M_{AD}$ (kip-ft) Bottom Girder	10567.81	6307.78	6307.78	5630.61	3322.13	2627.11	2329.65	2429.78	2927.47	3822.74	5115.59
$M_{AD}$ (kip-ft) Top Girder	74486.15	47243.77	47243.77	42997.66	34830.12	29279.82	26904.55	27704.30	31679.09	38828.89	49153.73
$M_y$ (kip-ft)	10567.81	6307.78	6307.78	6178.02	4722.97	4570.84	4505.73	4527.66	4636.60	4832.58	5115.59
$M_n$ (kip-ft)	11853.37	7849.64	7849.64	7849.64	6139.87	5942.09	5857.45	5885.95	6027.59	6282.36	6650.26
$M_u$ (kip-ft)	0.00	0.00	919.54	2603.24	3904.38	4698.46	4952.87	4642.50	3739.43	2201.07	0.43
$f_t$ (ksi)	0.00	0.00	0.00	0.00	0.00	0.00	0.00	0.00	0.00	0.00	0.00
$\phi_f M_n$ (kip-ft)	11853.37	7849.64	7849.64	7849.64	6139.87	5942.09	5857.45	5885.95	6027.59	6282.36	6650.26
CHECK	OK	OK	OK	OK	OK	OK	OK	OK	OK	OK	OK
USAGE RATIO	0.00%	0.00%	11.71%	33.16%	63.59%	79.07%	84.56%	78.87%	62.04%	35.04%	0.01%

7.4.1.3 FATIGUE LIMIT STATE (AASHTO 6.5.3 and 6.6)

Detail Category C'

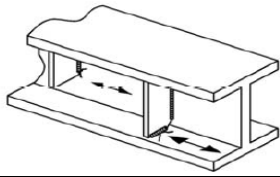

$$\Delta F_n = \left(\frac{A}{N}\right)^{\frac{1}{3}}$$

$$N = 365(75)nADTT_{SL}$$

$$ADTT_{SL} = \rho ADTT$$

A= 4.40E+09 ksi<sup>3</sup>  
N= 2.23E+08 cycles  
n= 1.00  
 $\Delta F_{TH}$ = 12.00 ksi  
 $\Delta F_n$ = 12.00 ksi

AADT= 56300.00 Vehicles per day (17% Trucks)  
ADTT= 9571 Trucks  
 $\rho$ = 0.85 2 Lanes (AASHTO Table 3.6.1.4.2-1)  
ADTT<sub>SL</sub>= 8136 Trucks/lane/day

SPAN 1											
DESCRIPTION	LOCATION										
	SECTION 1	SECTION 1	SECTION 1	SECTION 1	SECTION 1	SECTION 1	SECTION 1	SECTION 2	SECTION 2	SECTION 2	SECTION 3
	0.0L	0.1L	0.2L	0.3L	0.4L	0.5L	0.6L	0.7L	0.8L	0.9L	1.0L
S <sub>g</sub> (in <sup>3</sup> ) Top Girder	1227.74	1227.74	1227.74	1227.74	1227.74	1227.74	1227.74	1513.87	1513.87	1513.87	2536.27
S <sub>g</sub> (in <sup>3</sup> ) Bot Girder	11796.90	11796.90	11796.90	11796.90	11796.90	11796.90	11796.90	11338.50	11338.50	11338.50	17876.68
M <sub>LL-HM</sub> (Stress Range) (kip-ft)	0.18	404.22	689.90	880.83	972.59	998.98	976.28	889.90	712.75	556.37	493.43
f <sub>topG</sub> (ksi) Top Girder	0.00	0.41	0.70	0.90	0.99	1.02	0.99	0.94	0.75	0.59	0.33
f <sub>botG</sub> (ksi) Bot Girder	0.00	3.95	6.74	8.61	9.51	9.76	9.54	7.05	5.65	4.41	2.33
Check	INFINITE LIFE										

SPAN 2											
DESCRIPTION	LOCATION										
	SECTION 3	SECTION 2	SECTION 2	SECTION 2	SECTION 1	SECTION 1	SECTION 1	SECTION 1	SECTION 1	SECTION 1	SECTION 1
	0.0L	0.1L	0.2L	0.3L	0.4L	0.5L	0.6L	0.7L	0.8L	0.9L	1.0L
S <sub>g</sub> (in <sup>3</sup> ) Top Girder	2536.27	1513.87	1513.87	1513.87	1227.74	1227.74	1227.74	1227.74	1227.74	1227.74	1227.74
S <sub>g</sub> (in <sup>3</sup> ) Bot Girder	17876.68	11338.50	11338.50	11338.50	11796.90	11796.90	11796.90	11796.90	11796.90	11796.90	11796.90
M <sub>LL-HM</sub> (Stress Range) (kip-ft)	493.43	556.37	712.75	889.90	976.28	998.98	972.59	880.83	689.90	404.22	0.18
f <sub>topG</sub> (ksi) Top Girder	0.33	0.59	0.75	0.94	0.99	1.02	0.99	0.90	0.70	0.41	0.00
f <sub>botG</sub> (ksi) Bot Girder	2.33	4.41	5.65	7.05	9.54	9.76	9.51	8.61	6.74	3.95	0.00
Check	INFINITE LIFE										

Special Shear Requirements for Webs

Unstiffened webs and exterior panels

$$V_u \leq \phi_v V_n$$

$$V_n = C V_p$$

$$V_p = 0.58 F_{yw} D t_w$$

$$C = 1.0 \text{ if } \frac{D}{t_w} \leq 1.12 \sqrt{\frac{E k}{F_{yw}}}$$

$$C = \frac{1.12}{\frac{D}{t_w}} \sqrt{\frac{E k}{F_{yw}}} \text{ if } 1.12 \sqrt{\frac{E k}{F_{yw}}} < \frac{D}{t_w} \leq 1.40 \sqrt{\frac{E k}{F_{yw}}}$$

$$C = \frac{1.57}{\frac{D}{t_w}} \sqrt{\frac{E k}{F_{yw}}} \text{ if } \frac{D}{t_w} > 1.40 \sqrt{\frac{E k}{F_{yw}}}$$

Interior Panels

$$\frac{2 D t_w}{(b_{ft} t_{ft} + b_{fb} t_{fb})_p} = \omega$$

$$V_n = V_p \delta$$

$$\delta = \left[ C + \frac{0.87(1-C)}{\sqrt{1 + \left(\frac{d_0}{D}\right)^2}} \right] \text{ if } \omega \leq 2.5$$

$$\delta = \left[ C + \frac{0.87(1-C)}{\sqrt{1 + \left(\frac{d_0}{D}\right)^2 + \frac{d_0}{D}}} \right] \text{ if } \omega > 2.5$$

SECTION	d (in)	D (in)	t <sub>w</sub> (in)	D/t <sub>w</sub> =	V <sub>p</sub> (kip)	b <sub>ft</sub> t <sub>ft</sub> (in <sup>2</sup> )	b <sub>fb</sub> t <sub>fb</sub> (in <sup>2</sup> )
SECTION 1	52.00	50.00	0.50	100.00	725.00	14.00	14.00
SECTION 2	52.75	50.00	0.50	100.00	725.00	19.25	19.25
SECTION 3	55.25	50.00	0.50	100.00	725.00	36.75	36.75

SPAN 1											
DESCRIPTION	LOCATION										
	SECTION 1	SECTION 1	SECTION 1	SECTION 1	SECTION 1	SECTION 1	SECTION 1	SECTION 2	SECTION 2	SECTION 2	SECTION 3
	0.0L	0.1L	0.2L	0.3L	0.4L	0.5L	0.6L	0.7L	0.8L	0.9L	1.0L
Transverse Stiffeners?	NO	NO	NO	NO	NO	NO	NO	NO	NO	NO	NO
Dist btwn Stiffeners (in)	0.00	0.00	0.00	0.00	0.00	0.00	0.00	0.00	0.00	0.00	0.00
Stiffened?	NO	NO	NO	NO	NO	NO	NO	NO	NO	NO	NO
k (in)	5.00	5.00	5.00	5.00	5.00	5.00	5.00	5.00	5.00	5.00	5.00
C	0.85	0.85	0.85	0.85	0.85	0.85	0.85	0.85	0.85	0.85	0.85
ω	0.00	1.79	1.79	1.79	1.79	1.79	1.79	1.30	1.30	1.30	0.68
δ	0.98	0.98	0.98	0.98	0.98	0.98	0.98	0.98	0.98	0.98	0.98
φ <sub>v</sub> V <sub>n</sub> (kip)	612.97	612.97	612.97	612.97	612.97	612.97	612.97	612.97	612.97	612.97	612.97
V <sub>u</sub> (kip)	-36.79	-22.46	-6.84	10.54	29.08	48.64	68.55	88.99	109.80	130.62	269.01
CHECK	OK	OK	OK	OK	OK	OK	OK	OK	OK	OK	OK

SPAN 2												
DESCRIPTION	LOCATION											
	SECTION 3	SECTION 2	SECTION 2	SECTION 2	SECTION 1	SECTION 1	SECTION 1	SECTION 1	SECTION 1	SECTION 1	SECTION 1	
	0.0L	0.1L	0.2L	0.3L	0.4L	0.5L	0.6L	0.7L	0.8L	0.9L	1.0L	
Transverse Stiffeners?	NO	NO	NO	NO	NO	NO	NO	NO	NO	NO	NO	NO
Dist btwn Stiffeners (in)	0.00	0.00	0.00	0.00	0.00	0.00	0.00	0.00	0.00	0.00	0.00	0.00
Stiffened?	NO	NO	NO	NO	NO	NO	NO	NO	NO	NO	NO	NO
k (in)	5.00	5.00	5.00	5.00	5.00	5.00	5.00	5.00	5.00	5.00	5.00	5.00
C	0.85	0.85	0.85	0.85	0.85	0.85	0.85	0.85	0.85	0.85	0.85	0.85
ω	0.00	1.30	1.30	1.30	1.79	1.79	1.79	1.79	1.79	1.79	1.79	1.79
δ	0.98	0.98	0.98	0.98	0.98	0.98	0.98	0.98	0.98	0.98	0.98	0.98
Φ <sub>v</sub> V <sub>u</sub> (kip)	612.97	612.97	612.97	612.97	612.97	612.97	612.97	612.97	612.97	612.97	612.97	612.97
V <sub>u</sub> (kip)	269.01	-66.93	-50.12	-33.28	-16.08	1.66	19.74	38.84	59.10	81.12	104.43	
CHECK	OK	OK	OK	OK	OK	OK	OK	OK	OK	OK	OK	OK

7.4.1.4 SERVICE LIMIT STATE

7.4.1.4.1 Permanent Deformations (AASHTO 6.10.4.2)

Top Flange

Bottom Flange

$$f_f \leq 0.95R_h F_{yf}$$

$$f_f + \frac{1}{2}f_t \leq 0.95R_h F_{yf}$$

$$f_f + \frac{1}{2}f_t = f_b$$

$$0.95R_h F_{yf} = 47.50 \text{ ksi}$$

SECTION	BOTTOM GIRDER			TOP GIRDER		
	S <sub>NC</sub> (in <sup>3</sup> )	S <sub>LT</sub> (in <sup>3</sup> )	S <sub>ST</sub> (in <sup>3</sup> )	S <sub>NC</sub> (in <sup>3</sup> )	S <sub>LT</sub> (in <sup>3</sup> )	S <sub>ST</sub> (in <sup>3</sup> )
SECTION 1	900.68	1143.47	1227.74	900.68	3851.39	11796.90
SECTION 2	1160.89	1415.02	1513.87	1160.89	4137.58	11338.50
SECTION 3	2032.15	2323.07	2536.27	2032.15	5066.96	17876.68

7.4.1.4.2 Web Bend Buckling (AASHTO 6.10.1.9)

$$f_{bu} \leq \phi_f F_{crw}$$

Longitudinal Stiffeners?

NO

$$F_{crw} = \frac{0.9Ek}{\left(\frac{D}{t_w}\right)^2} \quad k = \frac{9}{\left(\frac{D_c}{D}\right)^2}$$

$$D_c = \left(\frac{-f_c}{|f_c| + f_t}\right) d - t_{fc}$$

SECTION	Positive							
	d (in)	D (in)	t <sub>w</sub> (in)	t <sub>t</sub> (in)	t <sub>b</sub> (in)	D/t <sub>w</sub> =	PNA (in)	Y <sub>up to bot fl</sub> (in)
SECTION 1	52.00	50.00	0.50	1.00	1.00	100.00	6.84	59.75
SECTION 2	52.75	50.00	0.50	1.38	1.38	100.00	8.44	60.13
SECTION 3	55.25	50.00	0.50	2.63	2.63	100.00	9.69	61.38

SPAN 1												
DESCRIPTION	LOCATION											
	SECTION 1	SECTION 1	SECTION 1	SECTION 1	SECTION 1	SECTION 1	SECTION 1	SECTION 2	SECTION 2	SECTION 2	SECTION 3	
	0.0L	0.1L	0.2L	0.3L	0.4L	0.5L	0.6L	0.7L	0.8L	0.9L	1.0L	
M <sub>u</sub> (kip-ft)	Negative	0.32	1659.05	2818.44	3498.53	3730.95	3536.44	2933.67	1946.86	532.10	0.00	0.00
f <sub>t</sub> (ksi)	top flange	0.00	5.17	8.78	10.90	11.62	11.02	9.14	5.65	1.54	0.00	0.00
CHECK		OK	OK	OK	OK	OK	OK	OK	OK	OK	OK	OK
f <sub>t</sub> (ksi)	Bot flange	0.00	17.41	29.58	36.71	39.15	37.11	30.79	16.51	4.51	0.00	0.00
f <sub>t</sub> (ksi)	Bot flange	0.00	0.00	0.00	0.00	0.00	0.00	0.00	0.00	0.00	0.00	0.00
f <sub>b</sub> (ksi)	Bot flange	0.00	17.41	29.58	36.71	39.15	37.11	30.79	16.51	4.51	0.00	0.00
CHECK		OK	OK	OK	OK	OK	OK	OK	OK	OK	OK	OK
f <sub>c</sub> (ksi)		0.00	9.67	16.40	20.25	21.32	19.68	15.38	7.39	5.89	11.34	12.48
f <sub>t</sub> (ksi)		0.00	18.63	31.64	39.25	41.78	39.46	32.48	16.94	11.96	15.31	16.78
D <sub>c</sub> (in)		0.00	0.00	0.00	0.00	0.00	0.00	0.00	0.00	0.00	0.00	0.00
k		N/A	N/A	N/A	N/A	N/A	N/A	N/A	N/A	N/A	N/A	N/A
F <sub>crw</sub> (ksi)		50.00	50.00	50.00	50.00	50.00	50.00	50.00	50.00	50.00	50.00	50.00
Φ <sub>f</sub> F <sub>crw</sub> (ksi)		50.00	50.00	50.00	50.00	50.00	50.00	50.00	50.00	50.00	50.00	50.00
F <sub>bu</sub> (ksi)		0.00	0.00	0.00	0.00	0.00	0.00	0.00	0.00	0.00	0.00	0.00
CHECK		OK	OK	OK	OK	OK	OK	OK	OK	OK	OK	OK

SPAN 2												
DESCRIPTION	LOCATION											
	SECTION 3	SECTION 2	SECTION 2	SECTION 2	SECTION 1	SECTION 1	SECTION 1	SECTION 1	SECTION 1	SECTION 1	SECTION 1	
	0.0L	0.1L	0.2L	0.3L	0.4L	0.5L	0.6L	0.7L	0.8L	0.9L	1.0L	
M <sub>u</sub> (kip-ft)	Positive	0.00	0.00	532.10	1946.86	2933.67	3536.44	3730.95	3498.53	2818.44	1659.05	0.32
f <sub>t</sub> (ksi)	top flange	0.00	0.00	1.54	5.65	9.14	11.02	11.62	10.90	8.78	5.17	0.00
CHECK		OK	OK	OK	OK	OK	OK	OK	OK	OK	OK	OK
f <sub>t</sub> (ksi)	Bot flange	0.00	0.00	4.51	16.51	30.79	37.11	39.15	36.71	29.58	17.41	0.00
f <sub>t</sub> (ksi)	Bot flange	0.00	0.00	0.00	0.00	0.00	0.00	0.00	0.00	0.00	0.00	0.00
f <sub>b</sub> (ksi)	Bot flange	0.00	0.00	4.51	16.51	30.79	37.11	39.15	36.71	29.58	17.41	0.00
CHECK		OK	OK	OK	OK	OK	OK	OK	OK	OK	OK	OK
f <sub>c</sub> (ksi)		10.95	10.32	3.07	2.74	8.96	12.43	13.96	13.53	11.14	6.78	0.45
f <sub>t</sub> (ksi)		16.78	15.31	11.96	16.94	32.48	39.46	41.78	39.25	31.64	18.63	0.00
D <sub>c</sub> (in)		0.00	0.00	0.00	0.00	0.00	0.00	0.00	0.00	0.00	0.00	0.00
k		N/A	N/A	N/A	N/A	N/A	N/A	N/A	N/A	N/A	N/A	N/A
F <sub>crw</sub> (ksi)		50.00	50.00	50.00	50.00	50.00	50.00	50.00	50.00	50.00	50.00	50.00
Φ <sub>f</sub> F <sub>crw</sub> (ksi)		50.00	50.00	50.00	50.00	50.00	50.00	50.00	50.00	50.00	50.00	50.00
F <sub>bu</sub> (ksi)		0.00	0.00	0.00	0.00	0.00	0.00	0.00	0.00	0.00	0.00	0.00
CHECK		OK	OK	OK	OK	OK	OK	OK	OK	OK	OK	OK



7.4.2 NEGATIVE MOMENT

7.4.2.1 PLASTIC MOMENT

Section 1

Deck is neglected, only reinforcement is taken into account

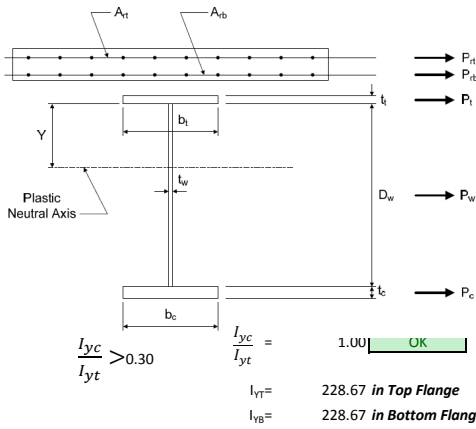

$P_{rt}$ =	604.36 kip	$d_{rt}$ =	24.83 in
$P_{rb}$ =	299.78 kip	$d_{rb}$ =	20.83 in
$P_c$ =	700.00 kip	$d_c$ =	32.42 in
$P_w$ =	1250.00 kip	$d_w$ =	6.92 in
$P_t$ =	700.00 kip	$d_t$ =	18.58 in
$\bar{Y}$ =	6.92		
PNA=	27.33 in		

PNA IN THE WEB

$M_p$ = 6099.14 kip-ft

Compacity

$\frac{2D_{cp}}{t_w} \leq 5.7 \sqrt{\frac{E}{F_{yc}}}$        $5.7 \sqrt{\frac{E}{F_{yc}}} = 137.27$   
 (AASHTO D.6.3.2)  $D_{cp}$ = 43.08 in       $\frac{2D_{cp}}{t_w} = 172.33$  NON-COMPACT

Section 2

Deck is neglected, only reinforcement is taken into account

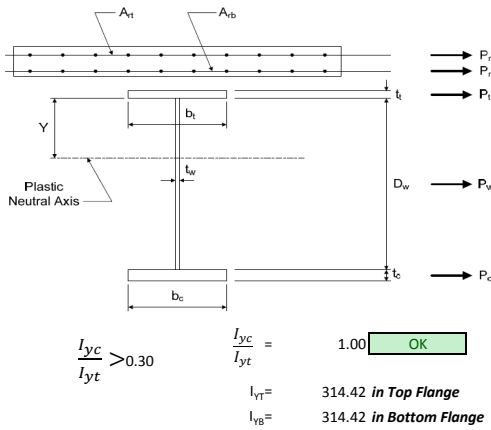

$P_{rt}$ =	604.36 kip	$d_{rt}$ =	24.83 in
$P_{rb}$ =	299.78 kip	$d_{rb}$ =	20.83 in
$P_c$ =	962.50 kip	$d_c$ =	32.98 in
$P_w$ =	1250.00 kip	$d_w$ =	7.30 in
$P_t$ =	962.50 kip	$d_t$ =	18.39 in
$\bar{Y}$ =	7.30		
PNA=	27.33 in		

PNA IN THE WEB

$M_p$ = 7316.11 kip-ft

Compacity

$\frac{2D_{cp}}{t_w} \leq 5.7 \sqrt{\frac{E}{F_{yc}}}$        $5.7 \sqrt{\frac{E}{F_{yc}}} = 137.27$   
 (AASHTO D.6.3.2)  $D_{cp}$ = 45.45 in       $\frac{2D_{cp}}{t_w} = 181.81$  NON-COMPACT

Section 3

Deck is neglected, only reinforcement is taken into account

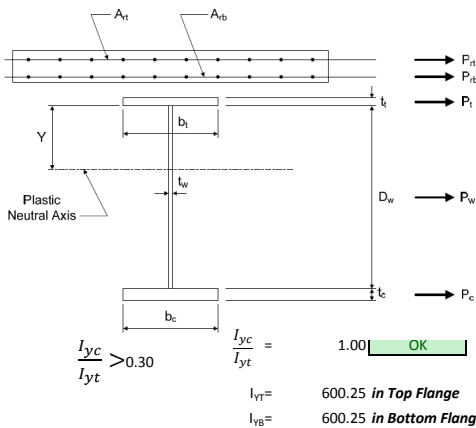

$P_{rt}$ =	262.31 kip	$d_{rt}$ =	13.99 in
$P_{rb}$ =	262.31 kip	$d_{rb}$ =	9.99 in
$P_c$ =	1837.50 kip	$d_c$ =	45.70 in
$P_w$ =	1250.00 kip	$d_w$ =	19.38 in
$P_t$ =	1837.50 kip	$d_t$ =	6.93 in
$\bar{Y}$ =	14.51		
PNA=	16.49 in		

PNA IN THE WEB

$M_p$ = 10113.93 kip-ft

Compacity

$\frac{2D_{cp}}{t_w} \leq 5.7 \sqrt{\frac{E}{F_{yc}}}$        $5.7 \sqrt{\frac{E}{F_{yc}}} = 137.27$   
 (AASHTO D.6.3.2)  $D_{cp}$ = 35.49 in       $\frac{2D_{cp}}{t_w} = 141.97$  NON-COMPACT

7.4.2.2 STRENGTH LIMIT STATE

Discretely Braced Compression Flange? **YES**

7.4.2.2.1 Flange Nominal Yielding (6.10.3.2.1)

$f_{bu} + f_t \leq \phi_f R_h F_{yf}$       Discretely Braced

$f_{bu} \leq \phi_f R_h F_{yf}$       Continuous Braced

$f_t$ =	0.00 ksi
$\phi_f R_h F_{yf}$ =	50.00 ksi

7.4.2.2.2 Flexural Resistance (AASHTO 6.10.3.2.1, 6.10.1.6 and 6.10.8)

$$f_{bu} + \frac{1}{3}f_i \leq \phi_f F_{nc}$$

$$f_i \leq 0.6F_{yf}$$

Local Buckling Resistance (6.10.8.2.2)

$$F_{nc} = R_b R_h F_{yc} \text{ if } \lambda_f \leq \lambda_{pf}$$

$$F_{nc} = \left[ 1 - \left( 1 - \frac{F_{yr}}{R_h F_{yc}} \right) \left( \frac{\lambda_f - \lambda_{pf}}{\lambda_{rf} - \lambda_{pf}} \right) \right] R_b R_h F_{yc} \text{ if } \lambda_f > \lambda_{pf}$$

$$F_{yr} =$$

SECTION	F <sub>yr</sub> (ksi)	BOTTOM		CHECK
		F <sub>nc</sub> (ksi)	0.6F <sub>yr</sub> (ksi)	
SECTION 1	35.00	50.00	30.00	OK
SECTION 2	35.00	50.00	30.00	OK
SECTION 3	35.00	50.00	30.00	OK

Lateral Torsional Buckling Resistance (R<sub>h</sub> and R<sub>b</sub> are taken as 1.0 according to AASHTO 6.10.1.10)

$$C_b = 1.00$$

$$L_b = 27.50 \text{ ft}$$

$$F_{nc} = R_b R_h F_{yc} \text{ if } L_b \leq L_p$$

$$F_{nc} = C_b \left[ 1 - \left( 1 - \frac{F_{yr}}{R_h F_{yc}} \right) \left( \frac{L_b - L_p}{L_r - L_p} \right) \right] R_b R_h F_{yc} \leq R_b R_h F_{yc} \text{ if } L_p < L_b \leq L_r$$

$$L_p = 1.0r_t \sqrt{\frac{E}{F_{yc}}} \quad L_r = \pi r_t \sqrt{\frac{E}{F_{yr}}} \quad r_t = \frac{b_{fc}}{\sqrt{12 \left( 1 + \frac{1}{3} \frac{D_c t_w}{b_{fc} t_{fc}} \right)}}$$

$$F_{nc} = F_{cr} \leq R_b R_h F_{yc} \text{ if } L_b > L_r \quad F_{cr} = \frac{C_b R_b \pi^2 E}{\left( \frac{L_b}{r_t} \right)^2}$$

SECTION	Negative									
	d (in)	D (in)	t <sub>w</sub> (in)	t <sub>n</sub> (in)	t <sub>nb</sub> (in)	b <sub>fl</sub> (in)	b <sub>fb</sub> (in)	D/t <sub>w</sub>	PNA (in)	Y <sub>slab+Tflang</sub> (in)
SECTION 1	52.00	50.00	0.50	1.00	1.00	14.00	14.00	100.00	27.33	9.00
SECTION 2	52.75	50.00	0.50	1.38	1.38	14.00	14.00	100.00	27.33	9.38
SECTION 3	55.25	50.00	0.50	2.63	2.63	14.00	14.00	100.00	16.49	10.63

7.4.2.2.3 Web Bend Buckling (AASHTO 6.10.1.9)

$$f_{bu} \leq \phi_f F_{crw}$$

Longitudinal Stiffeners?

NO

$$F_{crw} = \frac{0.9Ek}{\left( \frac{D_c}{t_w} \right)^2} \quad k = \frac{9}{\left( \frac{D_c}{D} \right)^2}$$

SECTION	BOTTOM GIRDER		TOP GIRDER	
	S <sub>Nc</sub> (in <sup>3</sup> )	S <sub>NegRef</sub> (in <sup>3</sup> )	S <sub>Nc</sub> (in <sup>3</sup> )	S <sub>NegRef</sub> (in <sup>3</sup> )
SECTION 1	900.68	1046.35	900.68	1773.89
SECTION 2	1160.89	1305.47	1160.89	2055.01
SECTION 3	2032.15	2122.66	2032.15	2555.89

$$D_c = \left( \frac{-f_c}{|f_c| + f_t} \right) d - t_{fc}$$

7.4.2.2.4 Summary

SPAN 1												
DESCRIPTION		LOCATION										
		SECTION 1 0.0L	SECTION 1 0.1L	SECTION 1 0.2L	SECTION 1 0.3L	SECTION 1 0.4L	SECTION 1 0.5L	SECTION 1 0.6L	SECTION 2 0.7L	SECTION 2 0.8L	SECTION 2 0.9L	SECTION 3 1.0L
M <sub>u</sub> (kip-ft)	Negative	0.00	0.00	0.00	0.00	0.00	0.00	0.00	359.16	1679.40	3597.22	6674.02
S <sub>x</sub> (in <sup>3</sup> )	Top	1773.89	1773.89	1773.89	1773.89	1773.89	1773.89	1773.89	2055.01	2055.01	2055.01	2555.89
	Bottom	1046.35	1046.35	1046.35	1046.35	1046.35	1046.35	1046.35	1305.47	1305.47	1305.47	2122.66
f <sub>bu</sub> (ksi)	Top (Neg)	0.00	0.00	0.00	0.00	0.00	0.00	0.00	2.10	9.81	21.01	31.33
	Bottom (Neg)	0.00	0.00	0.00	0.00	0.00	0.00	0.00	3.30	15.44	33.07	37.73
f <sub>t</sub> (ksi)		0.00	0.00	0.00	0.00	0.00	0.00	0.00	0.00	0.00	0.00	0.00
ϕ <sub>r</sub> R <sub>h</sub> F <sub>yr</sub> (ksi)		50.00	50.00	50.00	50.00	50.00	50.00	50.00	50.00	50.00	50.00	50.00
CHECK		OK	OK	OK	OK	OK	OK	OK	OK	OK	OK	OK
f <sub>c</sub> (ksi)		0.00	14.82	24.70	29.65	29.67	24.98	21.17	11.64	16.70	37.36	41.37
f <sub>t</sub> (ksi)		0.00	12.68	21.23	25.67	25.99	22.31	17.95	8.87	12.27	29.36	37.13
D <sub>c</sub> (in)		25.93	27.02	26.96	26.87	26.72	26.47	27.14	28.56	29.04	28.16	26.49
L <sub>b</sub> (ft)		27.50	27.50	27.50	27.50	27.50	27.50	27.50	27.50	27.50	27.50	27.50
r <sub>t</sub> (in)		3.53	3.52	3.52	3.52	3.52	3.52	3.51	3.62	3.61	3.62	3.82
L <sub>p</sub> (ft)		7.09	7.06	7.06	7.06	7.06	7.07	7.05	7.26	7.25	7.27	7.66
L <sub>r</sub> (ft)		22.27	22.16	22.17	22.18	22.19	22.22	22.15	22.82	22.78	22.85	24.08
F <sub>cr</sub> (ksi)		32.80	32.48	32.50	32.52	32.57	32.64	32.45	34.42	34.30	34.51	38.32
F <sub>nc</sub> (ksi)		32.80	32.48	32.50	32.52	32.57	32.64	32.45	34.42	34.30	34.51	38.32
ϕ <sub>r</sub> F <sub>nc</sub> (ksi)	Bottom	32.80	32.48	32.50	32.52	32.57	32.64	32.45	34.42	34.30	34.51	38.32
CHECK	Bottom	OK	OK	OK	OK	OK	OK	OK	OK	OK	OK	OK
k		33.48	30.81	30.95	31.16	31.51	32.12	30.55	27.58	26.69	28.37	32.06
F <sub>crw</sub> (ksi)		50.00	50.00	50.00	50.00	50.00	50.00	50.00	50.00	50.00	50.00	50.00
ϕ <sub>r</sub> F <sub>crw</sub> (ksi)	Bottom	50.00	50.00	50.00	50.00	50.00	50.00	50.00	50.00	50.00	50.00	50.00
CHECK	Bottom	OK	OK	OK	OK	OK	OK	OK	OK	OK	OK	OK

SPAN 2												
DESCRIPTION		LOCATION										
		SECTION 3	SECTION 2	SECTION 2	SECTION 2	SECTION 1	SECTION 1	SECTION 1	SECTION 1	SECTION 1	SECTION 1	
		0.0L	0.1L	0.2L	0.3L	0.4L	0.5L	0.6L	0.7L	0.8L	0.9L	1.0L
$M_u$ (kip-ft)	Negative	6674.02	3597.22	1964.90	941.45	256.51	0.00	0.00	0.00	0.00	0.00	0.00
$S_x$ (in <sup>3</sup> )	Top	2555.89	2055.01	2055.01	2055.01	1773.89	1773.89	1773.89	1773.89	1773.89	1773.89	1773.89
	Bottom	2122.66	1305.47	1305.47	1305.47	1046.35	1046.35	1046.35	1046.35	1046.35	1046.35	1046.35
$f_{bu}$ (ksi)	Top (Neg)	31.33	21.01	11.47	5.50	1.74	0.00	0.00	0.00	0.00	0.00	0.00
	Bottom (Neg)	37.73	33.07	18.06	8.65	2.94	0.00	0.00	0.00	0.00	0.00	0.00
$f_t$ (ksi)		0.00	0.00	0.00	0.00	0.00	0.00	0.00	0.00	0.00	0.00	0.00
$\phi R_n F_{yf}$ (ksi)		50.00	50.00	50.00	50.00	50.00	50.00	50.00	50.00	50.00	50.00	50.00
CHECK		OK	OK	OK	OK	OK	OK	OK	OK	OK	OK	OK
$f_c$ (ksi)		41.37	37.36	19.33	16.99	29.98	34.92	35.88	32.87	25.89	14.93	0.00
$f_t$ (ksi)		37.13	29.36	13.94	12.27	23.15	28.18	29.65	27.57	21.93	12.74	0.00
$D_c$ (in)		26.49	28.16	29.27	29.26	28.34	27.78	27.47	27.28	27.15	27.05	26.51
$L_u$ (ft)		27.50	27.50	27.50	27.50	27.50	27.50	27.50	27.50	27.50	27.50	27.50
$r_r$ (in)		3.82	3.62	3.61	3.61	3.49	3.50	3.51	3.51	3.51	3.51	3.52
$L_y$ (ft)		7.66	7.27	7.24	7.25	7.01	7.03	7.04	7.05	7.05	7.05	7.07
$L_r$ (ft)		24.08	22.85	22.76	22.76	22.03	22.09	22.12	22.14	22.15	22.16	22.22
$F_{cr}$ (ksi)		38.32	34.51	34.25	34.25	32.10	32.26	32.35	32.40	32.44	32.47	32.63
$F_{rc}$ (ksi)		38.32	34.51	34.25	34.25	32.10	32.26	32.35	32.40	32.44	32.47	32.63
$\phi F_{cr}$ (ksi)	Bottom	38.32	34.51	34.25	34.25	32.10	32.26	32.35	32.40	32.44	32.47	32.63
CHECK		OK	OK	OK	OK	OK	OK	OK	OK	OK	OK	OK
$k$		32.06	28.37	26.25	26.28	28.01	29.16	29.81	30.23	30.53	30.74	32.01
$F_{crw}$ (ksi)		50.00	50.00	50.00	50.00	50.00	50.00	50.00	50.00	50.00	50.00	50.00
$\phi F_{crw}$ (ksi)	Bottom	50.00	50.00	50.00	50.00	50.00	50.00	50.00	50.00	50.00	50.00	50.00
CHECK		OK	OK	OK	OK	OK	OK	OK	OK	OK	OK	OK

7.4.2.3 SERVICE LIMIT STATE

7.4.2.3.1 Permanent Deformations (AASHTO 6.10.4.2)

Top Flange

Bottom Flange

$$f_f \leq 0.95R_n F_{yf}$$

$$f_f + \frac{1}{2} f_t \leq 0.95R_n F_{yf}$$

$$f_f + \frac{1}{2} f_t = f_b$$

$$0.95R_n F_{yf} = 99.75 \text{ ksi}$$

SECTION	BOTTOM GIRDER		TOP GIRDER	
	$S_{NC}$ (in <sup>3</sup> )	$S_{NegRef}$ (in <sup>3</sup> )	$S_{NC}$ (in <sup>3</sup> )	$S_{NegRef}$ (in <sup>3</sup> )
SECTION 1	900.68	1046.35	900.68	1773.89
SECTION 2	1160.89	1305.47	1160.89	2055.01
SECTION 3	2032.15	2122.66	2032.15	2555.89

7.4.2.3.2 Web Bend Buckling (AASHTO 6.10.1.9)

$$f_{bu} \leq \phi F_{crw}$$

Longitudinal Stiffeners?

NO

$$F_{crw} = \frac{0.9Ek}{\left(\frac{D}{t_w}\right)^2} \quad k = \frac{9}{\left(\frac{D}{D}\right)^2}$$

$$D_c = \left(\frac{-f_c}{|f_c| + f_t}\right) d - t_{fc}$$

SECTION	Positive							PNA (in)	$Y_{slab+TFlang}$ (in)
	d (in)	D (in)	$t_w$ (in)	$t_r$ (in)	$t_b$ (in)	D/ $t_w$			
SECTION 1	52.00	50.00	0.50	1.00	1.00	100.00	27.33	9.00	
SECTION 2	52.75	50.00	0.50	1.38	1.38	100.00	27.33	9.38	
SECTION 3	55.25	50.00	0.50	2.63	2.63	100.00	16.49	10.63	

SPAN 1												
DESCRIPTION		LOCATION										
		SECTION 1	SECTION 1	SECTION 1	SECTION 1	SECTION 1	SECTION 1	SECTION 1	SECTION 2	SECTION 2	SECTION 2	SECTION 3
		0.0L	0.1L	0.2L	0.3L	0.4L	0.5L	0.6L	0.7L	0.8L	0.9L	1.0L
$M_u$ (kip-ft)	Negative	0.00	0.00	0.00	0.00	0.00	0.00	0.00	132.81	1262.17	2721.84	5049.83
$f_t$ (ksi)	top flange	0.00	0.00	0.00	0.00	0.00	0.00	0.00	0.78	7.37	15.89	23.71
CHECK		OK	OK	OK	OK	OK	OK	OK	OK	OK	OK	OK
$f_t$ (ksi)	Bot flange	0.00	0.00	0.00	0.00	0.00	0.00	0.00	1.22	11.60	25.02	28.55
$f_t$ (ksi)	Bot flange	0.00	0.00	0.00	0.00	0.00	0.00	0.00	0.00	0.00	0.00	0.00
$f_b$ (ksi)	Bot flange	0.00	0.00	0.00	0.00	0.00	0.00	0.00	1.22	11.60	25.02	28.55
CHECK		OK	OK	OK	OK	OK	OK	OK	OK	OK	OK	OK
$f_c$ (ksi)		0.00	8.54	14.28	17.24	17.41	14.88	12.11	6.21	8.69	20.37	25.94
$f_t$ (ksi)		0.00	10.02	16.68	19.98	19.92	16.66	14.36	8.23	11.94	26.16	29.01
$D_c$ (in)		24.04	22.92	22.99	23.09	23.25	23.53	22.79	21.31	20.85	21.72	23.46
$k$		42.12	46.33	46.06	45.66	45.02	43.94	46.85	55.14	57.63	53.10	49.94
$F_{crw}$ (ksi)		109.92	120.92	120.22	119.18	117.50	114.70	122.27	143.91	150.41	138.58	130.33
$\phi F_{crw}$ (ksi)		50.00	50.00	50.00	50.00	50.00	50.00	50.00	50.00	50.00	50.00	50.00
$F_{bu}$ (ksi)		0.00	0.00	0.00	0.00	0.00	0.00	0.00	1.22	11.60	25.02	28.55
CHECK		OK	OK	OK	OK	OK	OK	OK	OK	OK	OK	OK

SPAN 2												
DESCRIPTION		LOCATION										
		SECTION 3	SECTION 2	SECTION 2	SECTION 2	SECTION 1	SECTION 1	SECTION 1	SECTION 1	SECTION 1	SECTION 1	
		0.0L	0.1L	0.2L	0.3L	0.4L	0.5L	0.6L	0.7L	0.8L	0.9L	1.0L
$M_u$ (kip-ft)	Negative	5049.83	2721.84	1474.25	565.36	0.00	0.00	0.00	0.00	0.00	0.00	0.00
$f_r$ (ksi)	top flange	23.71	15.89	8.61	3.30	0.00	0.00	0.00	0.00	0.00	0.00	0.00
CHECK		OK	OK	OK	OK	OK	OK	OK	OK	OK	OK	OK
$f_t$ (ksi)	Bot flange	28.55	25.02	13.55	5.20	0.00	0.00	0.00	0.00	0.00	0.00	0.00
$f_b$ (ksi)	Bot flange	0.00	0.00	0.00	0.00	0.00	0.00	0.00	0.00	0.00	0.00	0.00
$f_b$ (ksi)	Bot flange	28.55	25.02	13.55	5.20	0.00	0.00	0.00	0.00	0.00	0.00	0.00
CHECK		OK	OK	OK	OK	OK	OK	OK	OK	OK	OK	OK
$f_c$ (ksi)		25.94	20.37	9.93	8.74	15.98	19.24	20.13	18.65	14.80	8.59	0.00
$f_t$ (ksi)		29.01	26.16	13.89	12.20	20.91	24.05	24.53	22.37	17.56	10.11	0.00
$D_c$ (in)		23.46	21.72	20.61	20.63	21.52	22.11	22.44	22.64	22.78	22.89	23.48
$k$		49.94	53.10	58.93	58.84	52.54	49.77	48.35	47.47	46.88	46.46	44.16
$F_{crw}$ (ksi)		130.33	138.58	153.81	153.57	137.12	129.91	126.18	123.91	122.37	121.26	115.25
$\phi F_{crw}$ (ksi)		50.00	50.00	50.00	50.00	50.00	50.00	50.00	50.00	50.00	50.00	50.00
$F_{bu}$ (ksi)		28.55	25.02	13.55	5.20	0.00	0.00	0.00	0.00	0.00	0.00	0.00
CHECK		OK	OK	OK	OK	OK	OK	OK	OK	OK	OK	OK

7.4.3 SHEAR (AASHTO 6.10.9)

Unstiffened webs and exterior panels

$$V_u \leq \phi_v V_n$$

$$V_n = C V_p$$

$$V_p = 0.58 F_{yw} D t_w$$

$$C = 1.0 \text{ if } \frac{D}{t_w} \leq 1.12 \sqrt{\frac{E k}{F_{yw}}} \quad C = \frac{1.12}{\frac{D}{t_w}} \sqrt{\frac{E k}{F_{yw}}} \text{ if } 1.12 \sqrt{\frac{E k}{F_{yw}}} < \frac{D}{t_w} \leq 1.40 \sqrt{\frac{E k}{F_{yw}}} \quad C = \frac{1.57}{\frac{D}{t_w}} \sqrt{\frac{E k}{F_{yw}}} \text{ if } \frac{D}{t_w} > 1.40 \sqrt{\frac{E k}{F_{yw}}}$$

Interior Panels

$$\frac{2 D t_w}{(b_{f1} t_{f1} + b_{f2} t_{f2})_p} = \omega$$

$$V_n = V_p \delta$$

$$\delta = \left[ C + \frac{0.87(1-C)}{\sqrt{1 + \left(\frac{d_0}{D}\right)^2}} \right] \text{ if } \omega \leq 2.5 \quad \delta = \left[ C + \frac{0.87(1-C)}{\sqrt{1 + \left(\frac{d_0}{D}\right)^2 + \frac{d_0}{D}}} \right] \text{ if } \omega > 2.5$$

SECTION	d (in)	D (in)	$t_w$ (in)	D/ $t_w$ =	$V_p$ (kip)	$b_{fb} t_{fb}$ (in <sup>2</sup> )	$b_{ft} t_{ft}$ (in <sup>2</sup> )
SECTION 1	52.00	50.00	0.50	100.00	725.00	14.00	14.00
SECTION 2	52.75	50.00	0.50	100.00	725.00	19.25	19.25
SECTION 3	55.25	50.00	0.50	100.00	725.00	36.75	36.75

SPAN 1												
DESCRIPTION		LOCATION										
		SECTION 1	SECTION 1	SECTION 1	SECTION 1	SECTION 1	SECTION 1	SECTION 1	SECTION 2	SECTION 2	SECTION 2	SECTION 3
		0.0L	0.1L	0.2L	0.3L	0.4L	0.5L	0.6L	0.7L	0.8L	0.9L	1.0L
Transverse Stiffeners?		NO	NO	NO	NO	NO	NO	NO	NO	NO	NO	NO
Dist btwn Stiffeners (in)		0.00	0.00	0.00	0.00	0.00	0.00	0.00	0.00	0.00	0.00	0.00
Stiffened?		NO	NO	NO	NO	NO	NO	NO	NO	NO	NO	NO
$k$ (in)		5.00	5.00	5.00	5.00	5.00	5.00	5.00	5.00	5.00	5.00	5.00
$C$		0.85	0.85	0.85	0.85	0.85	0.85	0.85	0.85	0.85	0.85	0.85
$\omega$		0.00	1.79	1.79	1.79	1.79	1.79	1.79	1.30	1.30	1.30	0.68
$\delta$		0.98	0.98	0.98	0.98	0.98	0.98	0.98	0.98	0.98	0.98	0.98
$\phi V_n$ (kip)		612.97	612.97	612.97	612.97	612.97	612.97	612.97	612.97	612.97	612.97	612.97
$V_u$ (kip)		279.17	224.17	169.97	116.43	75.91	121.21	173.57	224.75	274.53	322.68	521.65
CHECK		OK	OK	OK	OK	OK	OK	OK	OK	OK	OK	OK

SPAN 2												
DESCRIPTION		LOCATION										
		SECTION 3	SECTION 2	SECTION 2	SECTION 2	SECTION 1	SECTION 1	SECTION 1	SECTION 1	SECTION 1	SECTION 1	SECTION 1
		0.0L	0.1L	0.2L	0.3L	0.4L	0.5L	0.6L	0.7L	0.8L	0.9L	1.0L
Transverse Stiffeners?		NO	NO	NO	NO	NO	NO	NO	NO	NO	NO	NO
Dist btwn Stiffeners (in)		0.00	0.00	0.00	0.00	0.00	0.00	0.00	0.00	0.00	0.00	0.00
Stiffened?		NO	NO	NO	NO	NO	NO	NO	NO	NO	NO	NO
$k$ (in)		5.00	5.00	5.00	5.00	5.00	5.00	5.00	5.00	5.00	5.00	5.00
$C$		0.85	0.85	0.85	0.85	0.85	0.85	0.85	0.85	0.85	0.85	0.85
$\omega$		0.00	1.30	1.30	1.30	1.79	1.79	1.79	1.79	1.79	1.79	1.79
$\delta$		0.98	0.98	0.98	0.98	0.98	0.98	0.98	0.98	0.98	0.98	0.98
$\phi V_n$ (kip)		612.97	612.97	612.97	612.97	612.97	612.97	612.97	612.97	612.97	612.97	612.97
$V_u$ (kip)		528.83	323.25	274.53	224.75	173.57	121.21	75.91	116.43	169.97	224.17	278.79
CHECK		OK	OK	OK	OK	OK	OK	OK	OK	OK	OK	OK

7.4.3.1 Intermediate Stiffeners (AASHTO 6.10.11.1)

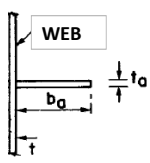

$F_{yst} = 36.00$  ksi  
 $b_a = 6\ 1/2$  in  
 $t_a = 1\ 1/4$  in  
 $I_t = 256.29$  in<sup>4</sup>  
 $I_t \geq I_{t2}$   
 $I_t \geq I_{t1}$

$$J = \frac{2.5}{\left(\frac{d_o}{D}\right)^2} - 2.0 \geq 0.5$$

$$I_{t1} = b t_w^3 J$$

$$F_{crs} = \frac{0.31E}{\left(\frac{b_a}{t_a}\right)^2} \leq F_{ys}$$

$$I_{t2} = \frac{D^4 \rho_t^{1.3}}{40} \left(\frac{F_{yw}}{E}\right)^{1.5}$$

DESCRIPTION	SPAN 1											
	LOCATION											
	SECTION 1 0.0L	SECTION 1 0.1L	SECTION 1 0.2L	SECTION 1 0.3L	SECTION 1 0.4L	SECTION 1 0.5L	SECTION 1 0.6L	SECTION 2 0.7L	SECTION 2 0.8L	SECTION 2 0.9L	SECTION 3 1.0L	
Transverse Stiffeners?	NO	NO	NO	NO	NO	NO	NO	NO	NO	NO	NO	NO
Dst btwn Stiffeners (in) ( $d_o$ )	0.00	0.00	0.00	0.00	0.00	0.00	0.00	0.00	0.00	0.00	0.00	0.00
$b_a \geq 2.0 + \frac{D}{30}$	OK	OK	OK	OK	OK	OK	OK	OK	OK	OK	OK	OK
$16t_a \geq b_a \geq 0.25b_f$	OK	OK	OK	OK	OK	OK	OK	OK	OK	OK	OK	OK
<b>b (in)</b>	0.00	0.00	0.00	0.00	0.00	0.00	0.00	0.00	0.00	0.00	0.00	0.00
<b>J</b>	0.00	0.00	0.00	0.00	0.00	0.00	0.00	0.00	0.00	0.00	0.00	0.00
<b><math>I_{t1}</math> (in<sup>4</sup>)</b>	0.00	0.00	0.00	0.00	0.00	0.00	0.00	0.00	0.00	0.00	0.00	0.00
CHECK	OK	OK	OK	OK	OK	OK	OK	OK	OK	OK	OK	OK
<b><math>F_{crs}</math> (ksi)</b>	36.00	36.00	36.00	36.00	36.00	36.00	36.00	36.00	36.00	36.00	36.00	36.00
<b><math>\rho</math></b>	1.39	1.39	1.39	1.39	1.39	1.39	1.39	1.39	1.39	1.39	1.39	1.39
<b><math>I_{t2}</math> (in<sup>4</sup>)</b>	0.00	0.00	0.00	0.00	0.00	0.00	0.00	0.00	0.00	0.00	0.00	0.00
CHECK	OK	OK	OK	OK	OK	OK	OK	OK	OK	OK	OK	OK

DESCRIPTION	SPAN 2											
	LOCATION											
	SECTION 3 0.0L	SECTION 2 0.1L	SECTION 2 0.2L	SECTION 2 0.3L	SECTION 1 0.4L	SECTION 1 0.5L	SECTION 1 0.6L	SECTION 1 0.7L	SECTION 1 0.8L	SECTION 1 0.9L	SECTION 1 1.0L	
Transverse Stiffeners?	NO	NO	NO	NO	NO	NO	NO	NO	NO	NO	NO	NO
Dst btwn Stiffeners (in) ( $d_o$ )	0.00	0.00	0.00	0.00	0.00	0.00	0.00	0.00	0.00	0.00	0.00	0.00
$b_a \geq 2.0 + \frac{D}{30}$	OK	OK	OK	OK	OK	OK	OK	OK	OK	OK	OK	OK
$16t_a \geq b_a \geq 0.25b_f$	OK	OK	OK	OK	OK	OK	OK	OK	OK	OK	OK	OK
<b>b (in)</b>	0.00	0.00	0.00	0.00	0.00	0.00	0.00	0.00	0.00	0.00	0.00	0.00
<b>J</b>	0.00	0.00	0.00	0.00	0.00	0.00	0.00	0.00	0.00	0.00	0.00	0.00
<b><math>I_{t1}</math> (in<sup>4</sup>)</b>	0.00	0.00	0.00	0.00	0.00	0.00	0.00	0.00	0.00	0.00	0.00	0.00
CHECK	OK	OK	OK	OK	OK	OK	OK	OK	OK	OK	OK	OK
<b><math>F_{crs}</math> (ksi)</b>	36.00	36.00	36.00	36.00	36.00	36.00	36.00	36.00	36.00	36.00	36.00	36.00
<b><math>\rho</math></b>	1.39	1.39	1.39	1.39	1.39	1.39	1.39	1.39	1.39	1.39	1.39	1.39
<b><math>I_{t2}</math> (in<sup>4</sup>)</b>	0.00	0.00	0.00	0.00	0.00	0.00	0.00	0.00	0.00	0.00	0.00	0.00
CHECK	OK	OK	OK	OK	OK	OK	OK	OK	OK	OK	OK	OK

7.4.3.2 Bearing Stiffeners (AASHTO 6.10.11.2)

Supports 1 and 3

Area (A)= 19.25 in<sup>2</sup>  
 $\phi R_n = 693.00$  kip  
 $\frac{b_a}{t_a} \leq 0.48 \sqrt{\frac{E}{f_{ys}}} = 18.16$   
 $\phi R_n \geq \phi R_{sb} = \phi 1.44 p_n F_{ys}$   
 $I_{st} = 256.35$  in<sup>4</sup>  
 $KL/r = 10.28$   
 $\frac{KL}{r_{st}} = \frac{0.75 D_w}{r_{st}}$   
 $\lambda = \left(\frac{KL}{r_{st} \pi}\right)^2 \frac{F_{yst}}{E}$   
 $p_n = 689.19$  kip  
 $\phi P_n = 620.27$  kip

# of Plates= 1.00 Plates

Ra= 279.17 kip  
 $g = 1.00$  in  
 $b_{brg} = 5.50$  in

$b_s/t_s = 5.20$  OK

$r_{st} = 3.65$  in

$\lambda = 0.01$

OK

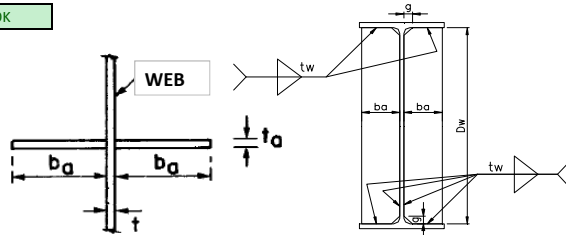

Stiffeners Weld (AASHTO 6.13.3)

Weld Throat= 1/4 in  
 Length of Weld= 48.00 in  
 Effective Weld Throat= 0.177 in  
 Weld Both Sides? YES  
 Both Sides Stiffeners? YES  
 Shear Resistance= 1140.42 kip

$F_{EXX\ WELD} = 70.00$  ksi  
 $\phi_{Welds} = 0.80$

$\phi R_n = 0.60 \phi F_{EXX}$

OK

**Supports 2**

Area (A)=	19.25 in <sup>2</sup>	# of Plates=	1.00 Plates	Ra=	528.83 kip	g=	1.00 in
φRn=	693.00 kip	<input type="text" value="OK"/>		b <sub>brg</sub> =	5.50 in		
$\frac{b_a}{t_a} \leq 0.48 \sqrt{\frac{E}{f_{ys}}}$	= 18.16	b <sub>s</sub> /t <sub>s</sub> =	5.20 <input type="text" value="OK"/>				
I <sub>st</sub> =	256.35 in <sup>4</sup>	r <sub>st</sub> =	3.65 in				
KL/r=	10.28	λ=	0.01				
$\frac{KL}{r_{st}} = \frac{0.75D_w}{r_{st}}$							
Pn=	689.19 kip						
φPn=	620.27 kip	<input type="text" value="OK"/>					

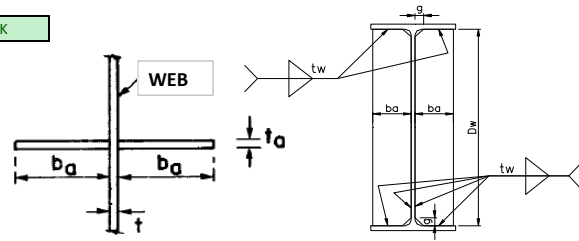

**Stiffeners Weld (AASHTO 6.13.3)**

Weld Throat=	1/4 in	F <sub>EXX WELD</sub> =	70.00 ksi
Length of Weld=	48.00 in	φ <sub>Welds</sub> =	0.80
Effective Weld Throat=	0.177 in		
Weld Both Sides?	YES	φ <sub>Rn</sub> = 0.60φF <sub>EXX</sub>	
Both Sides Stiffeners?	YES		
Shear Resistance=	1140.42 kip	<input type="text" value="OK"/>	

**7.4.4 SHEAR CONNECTORS (AASHTO 6.10.10)**

**7.4.4.1 FATIGUE LIMIT STATE**

# Shear C=	4.00	Penetration	<input type="text" value="OK"/>	Min Penetr	<input type="text" value="OK"/>
φ <sub>SC</sub> =	5/8 in	Length <sub>SC</sub> =	5.00 in		
A <sub>SC</sub> =	0.31 in <sup>2</sup>	L/d=	8.00 <input type="text" value="OK"/>		

$$\rho \leq \frac{nZ_r}{V_{sr}}$$

$$V_{sr} = V_{fat}$$

$$V_{fat} = \frac{V_f Q}{I}$$

Z<sub>r</sub> = αd<sup>2</sup> Fatigue II

Z<sub>r</sub> = 5.5d<sup>2</sup> Fatigue I

SECTION	TOP GIRDER				
	I <sub>NC</sub> (in <sup>4</sup> )	I <sub>LT</sub> (in <sup>4</sup> )	I <sub>ST</sub> (in <sup>4</sup> )	Q <sub>ST</sub> (in <sup>3</sup> )	b <sub>r</sub> (in)
SECTION 1	23417.67	45848.15	57824.53	1062.81	14.00
SECTION 2	30618.53	55620.57	70450.29	1211.09	14.00
SECTION 3	56138.09	88002.72	122718.35	1284.72	14.00

SPAN 1											
DESCRIPTION	LOCATION										
	SECTION 1	SECTION 1	SECTION 1	SECTION 1	SECTION 1	SECTION 1	SECTION 1	SECTION 2	SECTION 2	SECTION 2	SECTION 3
	0.0L	0.1L	0.2L	0.3L	0.4L	0.5L	0.6L	0.7L	0.8L	0.9L	1.0L
V <sub>r</sub> (kip)	67.64	58.66	52.26	49.39	48.82	50.30	52.47	55.72	59.68	63.68	67.62
I <sub>ST</sub> (in <sup>4</sup> )	57824.53	57824.53	57824.53	57824.53	57824.53	57824.53	57824.53	70450.29	70450.29	70450.29	122718.35
Q (in <sup>3</sup> )	1062.81	1062.81	1062.81	1062.81	1062.81	1062.81	1062.81	1211.09	1211.09	1211.09	1284.72
V <sub>sr</sub> (kip/in)	1.24	1.08	0.96	0.91	0.90	0.92	0.96	0.96	1.03	1.09	0.71
α	5.50	5.50	5.50	5.50	5.50	5.50	5.50	5.50	5.50	5.50	5.50
Z <sub>r</sub> (kip)	2.15	2.15	2.15	2.15	2.15	2.15	2.15	2.15	2.15	2.15	2.15
ρ (in)	6.91	7.97	8.95	9.47	9.58	9.30	8.91	8.97	8.38	7.85	12.14
ρ (in) Selected	6.50	7.50	8.50	9.00	9.50	9.00	8.50	8.50	8.00	7.50	12.00
CHECK	<input type="text" value="OK"/>	<input type="text" value="OK"/>	<input type="text" value="OK"/>	<input type="text" value="OK"/>	<input type="text" value="OK"/>	<input type="text" value="OK"/>	<input type="text" value="OK"/>	<input type="text" value="OK"/>	<input type="text" value="OK"/>	<input type="text" value="OK"/>	<input type="text" value="OK"/>
ρ < 24in?	<input type="text" value="OK"/>	<input type="text" value="OK"/>	<input type="text" value="OK"/>	<input type="text" value="OK"/>	<input type="text" value="OK"/>	<input type="text" value="OK"/>	<input type="text" value="OK"/>	<input type="text" value="OK"/>	<input type="text" value="OK"/>	<input type="text" value="OK"/>	<input type="text" value="OK"/>
ρ > 6d?	<input type="text" value="OK"/>	<input type="text" value="OK"/>	<input type="text" value="OK"/>	<input type="text" value="OK"/>	<input type="text" value="OK"/>	<input type="text" value="OK"/>	<input type="text" value="OK"/>	<input type="text" value="OK"/>	<input type="text" value="OK"/>	<input type="text" value="OK"/>	<input type="text" value="OK"/>
Spacing (s) (in)	2.50	2.50	2.50	2.50	2.50	2.50	2.50	2.50	2.50	2.50	2.50
Distance Clear (in)	2.94	2.94	2.94	2.94	2.94	2.94	2.94	2.94	2.94	2.94	2.94
CHECK	<input type="text" value="OK"/>	<input type="text" value="OK"/>	<input type="text" value="OK"/>	<input type="text" value="OK"/>	<input type="text" value="OK"/>	<input type="text" value="OK"/>	<input type="text" value="OK"/>	<input type="text" value="OK"/>	<input type="text" value="OK"/>	<input type="text" value="OK"/>	<input type="text" value="OK"/>

SPAN 2											
DESCRIPTION	LOCATION										
	SECTION 3	SECTION 2	SECTION 2	SECTION 2	SECTION 1	SECTION 1	SECTION 1	SECTION 1	SECTION 1	SECTION 1	SECTION 1
	0.0L	0.1L	0.2L	0.3L	0.4L	0.5L	0.6L	0.7L	0.8L	0.9L	1.0L
V <sub>r</sub> (kip)	67.62	63.68	59.68	55.72	52.47	50.30	48.82	49.39	52.26	58.66	67.64
I <sub>ST</sub> (in <sup>4</sup> )	122718.35	70450.29	70450.29	70450.29	57824.53	57824.53	57824.53	57824.53	57824.53	57824.53	57824.53
Q (in <sup>3</sup> )	1284.72	1211.09	1211.09	1211.09	1062.81	1062.81	1062.81	1062.81	1062.81	1062.81	1062.81
V <sub>sr</sub> (kip/in)	0.71	1.09	1.03	0.96	0.96	0.92	0.90	0.91	0.96	1.08	1.24
α	5.50	5.50	5.50	5.50	5.50	5.50	5.50	5.50	5.50	5.50	5.50
Z <sub>r</sub> (kip)	2.15	2.15	2.15	2.15	2.15	2.15	2.15	2.15	2.15	2.15	2.15
ρ (in)	12.14	7.85	8.38	8.97	8.91	9.30	9.58	9.47	8.95	7.97	6.91
ρ (in) Selected	12.00	7.50	8.00	8.50	8.50	9.00	9.50	9.00	8.50	7.50	6.50
CHECK	<input type="text" value="OK"/>	<input type="text" value="OK"/>	<input type="text" value="OK"/>	<input type="text" value="OK"/>	<input type="text" value="OK"/>	<input type="text" value="OK"/>	<input type="text" value="OK"/>	<input type="text" value="OK"/>	<input type="text" value="OK"/>	<input type="text" value="OK"/>	<input type="text" value="OK"/>
ρ < 24in?	<input type="text" value="OK"/>	<input type="text" value="OK"/>	<input type="text" value="OK"/>	<input type="text" value="OK"/>	<input type="text" value="OK"/>	<input type="text" value="OK"/>	<input type="text" value="OK"/>	<input type="text" value="OK"/>	<input type="text" value="OK"/>	<input type="text" value="OK"/>	<input type="text" value="OK"/>
ρ > 6d?	<input type="text" value="OK"/>	<input type="text" value="OK"/>	<input type="text" value="OK"/>	<input type="text" value="OK"/>	<input type="text" value="OK"/>	<input type="text" value="OK"/>	<input type="text" value="OK"/>	<input type="text" value="OK"/>	<input type="text" value="OK"/>	<input type="text" value="OK"/>	<input type="text" value="OK"/>
Spacing (s) (in)	2.50	2.50	2.50	2.50	2.50	2.50	2.50	2.50	2.50	2.50	2.50
Distance Clear (in)	2.94	2.94	2.94	2.94	2.94	2.94	2.94	2.94	2.94	2.94	2.94
CHECK	<input type="text" value="OK"/>	<input type="text" value="OK"/>	<input type="text" value="OK"/>	<input type="text" value="OK"/>	<input type="text" value="OK"/>	<input type="text" value="OK"/>	<input type="text" value="OK"/>	<input type="text" value="OK"/>	<input type="text" value="OK"/>	<input type="text" value="OK"/>	<input type="text" value="OK"/>

**7.4.4.2 STRENGTH LIMIT STATE**

Composite for negative region?  
Fu= 60.00 ksi  
Qn= 18.41 kip  
φQn= 15.65 kip

YES

$$\phi_{sc} Q_n = 0.5 A_{sc} \sqrt{f'_c E_c} \leq A_{sc} F_u$$

$$P = \sqrt{P_p^2 + F_p^2} = P_p \text{ for straight bridges non - composite in negative region}$$

$$P_T = \sqrt{P_p^2 + F_T^2} = P_T \text{ for straight bridges composite in negative region}$$

$$P_p = \min \left( F_{wy} D t_w + F_{yt} b_{ft} t_{ft} + F_{yc} b_{fc} t_{fc} \right) \quad P_n = \min \left( 0.85 f'_c b_s t_s, 0.45 f'_c b_s t_s \right)$$

**SPAN 1**

Pp= 2650.00 kip  
Pn= 1539.00 kip  
P= 4189.00 kip

Number of Shear Studs required from the point of maximum positive moment and the closest support

$$n = \frac{P}{\phi_{sc} Q_n} = 267.73 \text{ SC} \quad \text{Shear studs provided} = 344.00 \text{ OK}$$

**SPAN 2**

Pp= 2650.00 kip  
Pn= 1539.00 kip  
P= 4189.00 kip

Number of Shear Studs required from the point of maximum positive moment and the closest support

$$n = \frac{P}{\phi_{sc} Q_n} = 267.73 \text{ SC} \quad \text{Shear studs provided} = 320.00 \text{ OK}$$

**7.5 DEFORMATIONS**

NON-COMPOSITE ACTION  
COMPOSITE ACTION

**7.5.1 CAMBER**

SPAN 1											
DEFLECTIONS DEAD LOADS EFFECTS (in)											
LOAD COMPONENT	LOCATION										
	0.0L	0.1L	0.2L	0.3L	0.4L	0.5L	0.6L	0.7L	0.8L	0.9L	1.0L
Steel Beam self-weight	0.00	-0.07	-0.13	-0.17	-0.18	-0.17	-0.14	-0.10	-0.05	-0.02	0.00
Concrete Deck	0.00	-0.31	-0.57	-0.74	-0.80	-0.75	-0.62	-0.43	-0.24	-0.07	0.00
Concrete Haunch	0.00	0.00	0.00	-0.01	-0.01	-0.01	-0.01	0.00	0.00	0.00	0.00
Stay-in-Place Forms	0.00	0.00	-0.01	-0.01	-0.01	-0.01	-0.01	-0.01	0.00	0.00	0.00
Miscellaneous	0.00	-0.01	-0.02	-0.02	-0.03	-0.02	-0.02	-0.01	-0.01	0.00	0.00
DC (Barriers)	0.00	-0.05	-0.10	-0.12	-0.13	-0.13	-0.10	-0.07	-0.04	-0.01	0.00
DW (Future Wearing Sur)	0.00	-0.11	-0.20	-0.26	-0.26	-0.22	-0.22	-0.15	-0.08	-0.03	0.00
TOTAL CAMBER	0.000	0.557	1.021	1.326	1.439	1.355	1.115	0.781	0.424	0.131	0.000

SPAN 2											
DEFLECTIONS DEAD LOADS EFFECTS											
LOAD COMPONENT	LOCATION										
	0.0L	0.1L	0.2L	0.3L	0.4L	0.5L	0.6L	0.7L	0.8L	0.9L	1.0L
Steel Beam self-weight	0.00	-0.02	-0.05	-0.10	-0.14	-0.17	-0.18	-0.17	-0.13	-0.07	0.00
Concrete Deck	0.00	-0.07	-0.24	-0.43	-0.62	-0.75	-0.80	-0.74	-0.57	-0.31	0.00
Concrete Haunch	0.00	0.00	0.00	0.00	-0.01	-0.01	-0.01	-0.01	0.00	0.00	0.00
Stay-in-Place Forms	0.00	0.00	0.00	-0.01	-0.01	-0.01	-0.01	-0.01	-0.01	0.00	0.00
Miscellaneous	0.00	0.00	-0.01	-0.01	-0.02	-0.02	-0.03	-0.02	-0.02	-0.01	0.00
DC (Barriers)	0.00	-0.01	-0.04	-0.07	-0.10	-0.13	-0.13	-0.12	-0.10	-0.05	0.00
DW (Future Wearing Sur)	0.00	-0.03	-0.08	-0.15	-0.22	-0.26	-0.26	-0.20	-0.11	-0.01	0.00
TOTAL CAMBER	0.000	0.131	0.424	0.781	1.115	1.355	1.439	1.326	1.021	0.557	0.000

**7.5.2 PERMANENT DELFECTION - According to AASHTO 3.6.1.3.2**

The deflection should be taken as the larger of:

- i) That resulting from the design truck alone, or
- ii) That resulting from 25 percent of the design truck taken together with the design lane load

It is assumed that all design lanes are loaded and that all supporting components are assumed to deflect equally (AASHTO article 2.5.2.6.2). Live-load deflection is checked using the live-load portion of SERVICE I load combination, including the appropriate dynamic load allowance

Number of Lanes= 2.00 Lanes  
Load Combination? Service I According to AASHTO 2.5.2.6.2  
Live Load Factor= 1.00 LL+IM  
Distribution Factor= 0.40 Trucks  
(#Lanes/#Beams)

$$\Delta_{L \max} \leq \frac{\text{Span}}{800}$$

SPAN	Span Length (ft)	Δ <sub>Truck</sub> MAX (in)	Δ <sub>Lane</sub> MAX (in)	Δ <sub>LL+IM</sub> MAX (in)	Δ <sub>L</sub> MAX (in)	Δ <sub>limit</sub> (Sp/800) (in)	
SPAN 1	110.00	0.80	0.29	0.80	0.80	1.65	OK
SPAN 2	110.00	0.80	0.29	0.80	0.80	1.65	OK

**APPENDIX C. BRIDGE DRAWINGS**



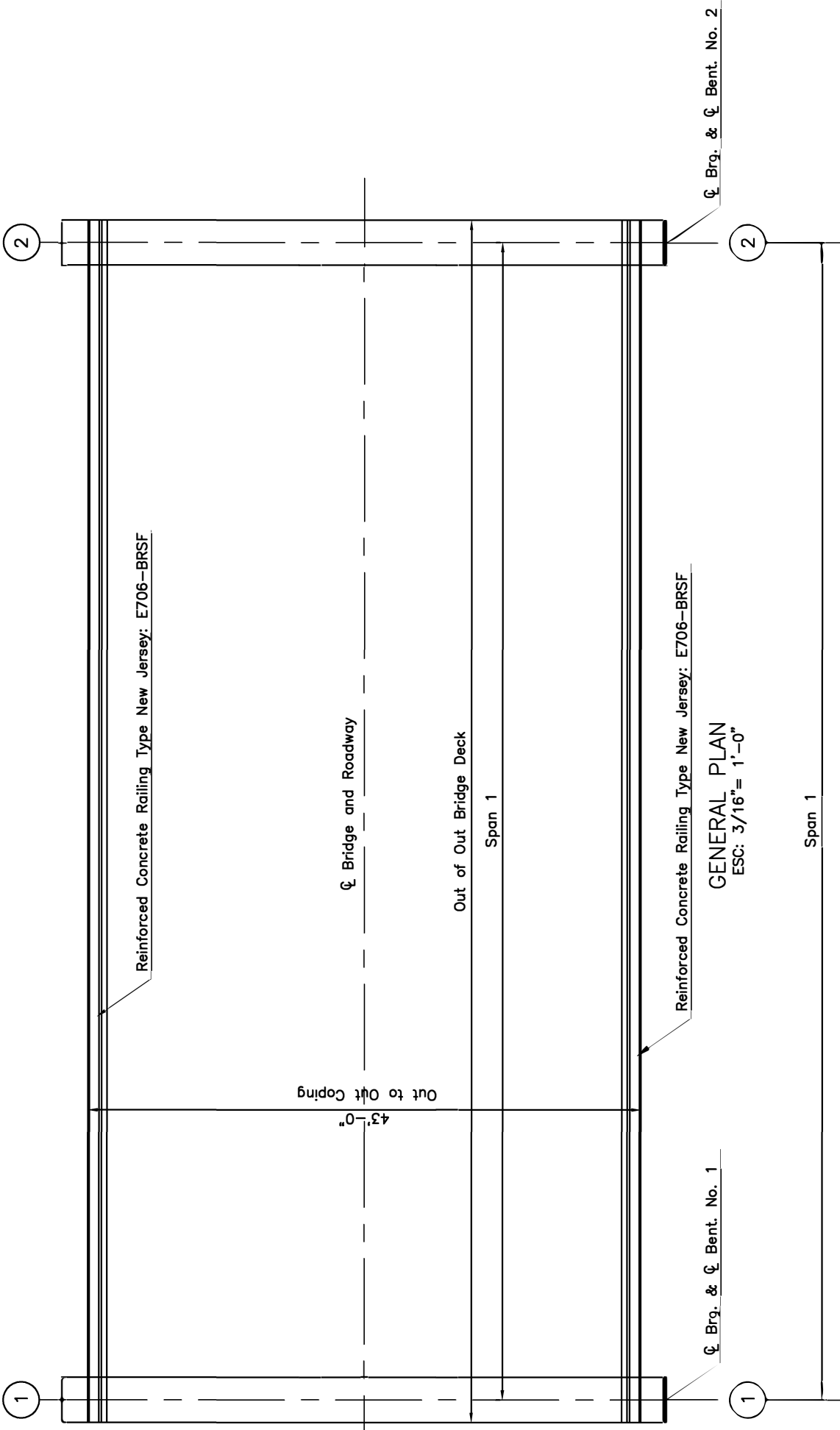

☉ Brg. & ☉ Bent. No. 2

☉ Brg. & ☉ Bent. No. 1

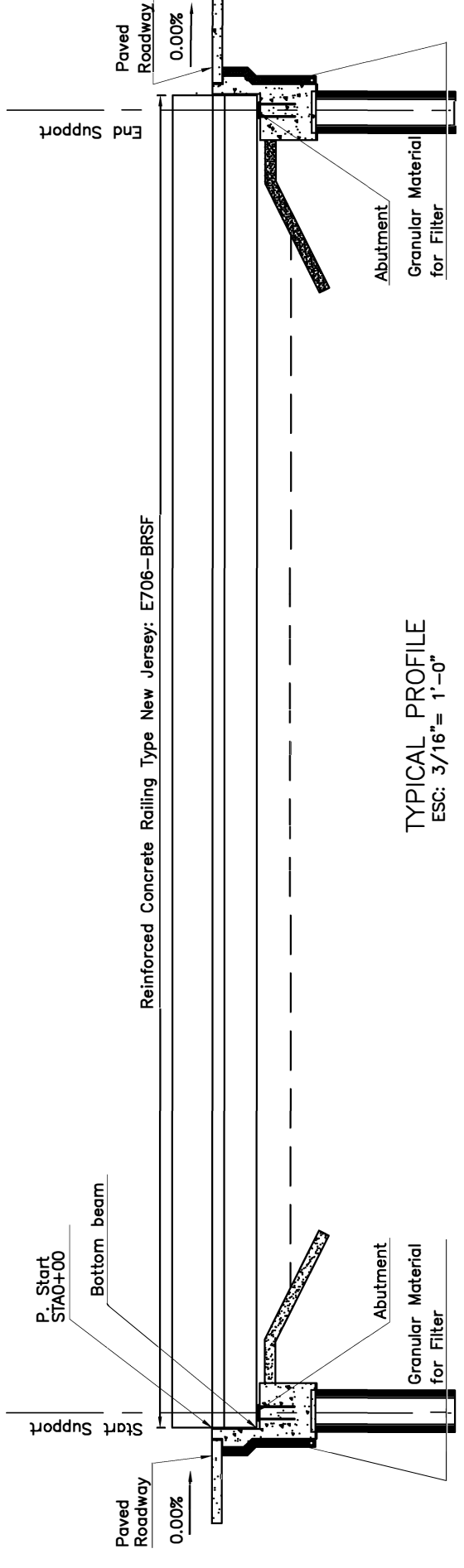

This drawing is part of the SPR 3914 project  
**NOT VALID FOR CONSTRUCTION**

DATE WINTER/2018	REVISION	INDIANA DEPARTMENT OF TRANSPORTATION	SCALE AS NOTED	BRIDGE FILE
Original Version (V.1)		GENERAL PLAN		DESIGNATION
				PAGE
				1 of 12

RECOMMENDED FOR APPROVAL	DESIGNED: SJM	CHECKED: MOB	DESIGNED: CLK	CHECKED: SJM
Stefan Leonardo Lelwa Melibando DESIGN ENGINEER	Winter/2018 DATE			

SIMPLY SUPPORTED BEAMS CONFIGURATION

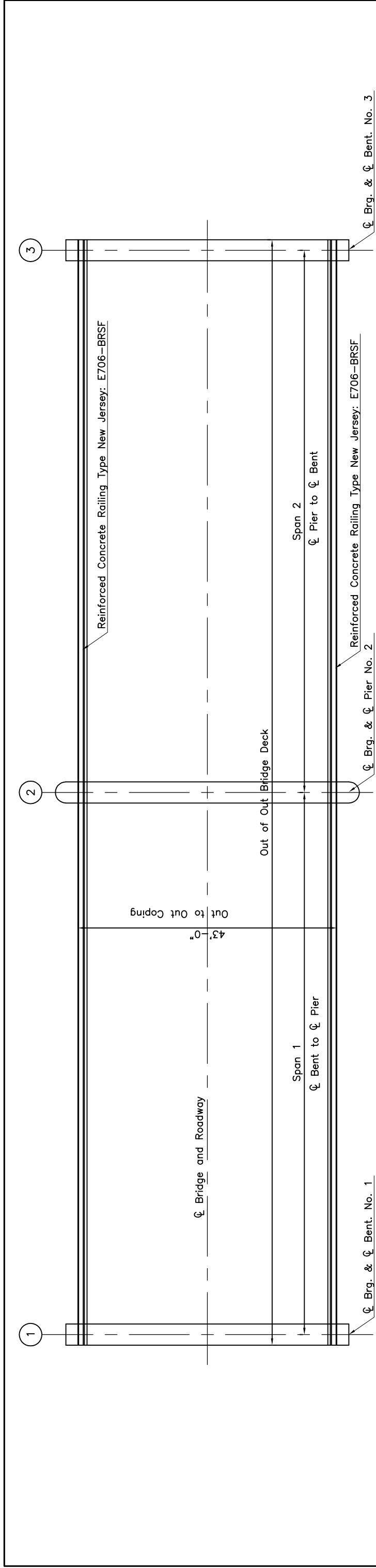

GENERAL PLAN  
ESC: 1/8" = 1'-0"

PLAN

Scale: 1/8" = 1'-0"

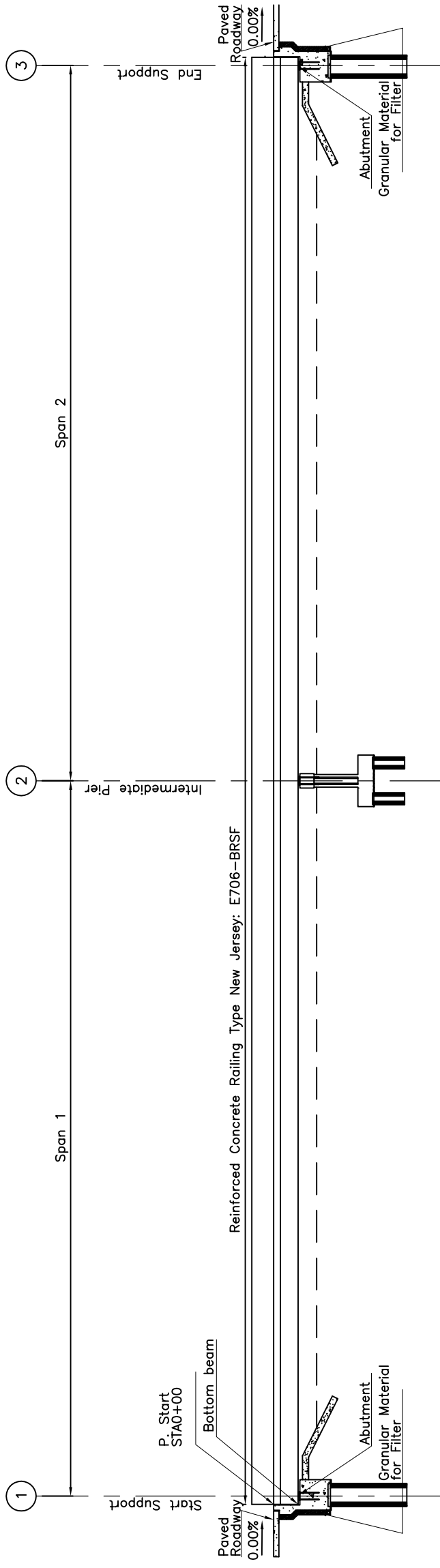

TYPICAL PROFILE  
ESC: 1/8" = 1'-0"

This drawing is part of the SPR 3914 project  
**NOT VALID FOR CONSTRUCTION**

DATE WINTER/2018	REVISION	INDIANA DEPARTMENT OF TRANSPORTATION	SCALE AS NOTED	BRIDGE FILE
Original Version (V1)				DESIGNATION
		GENERAL PLAN		PAGE
			2	of

RECOMMENDED FOR APPROVAL	DESIGN ENGINEER	DATE
Stefan Leonardo Latta Meliborac		Winter/2018
DESIGNED: SJM	DRAWN: CLK	
CHECKED: MDB	CHECKED: SJM	

TWO SPAN CONFIGURATION

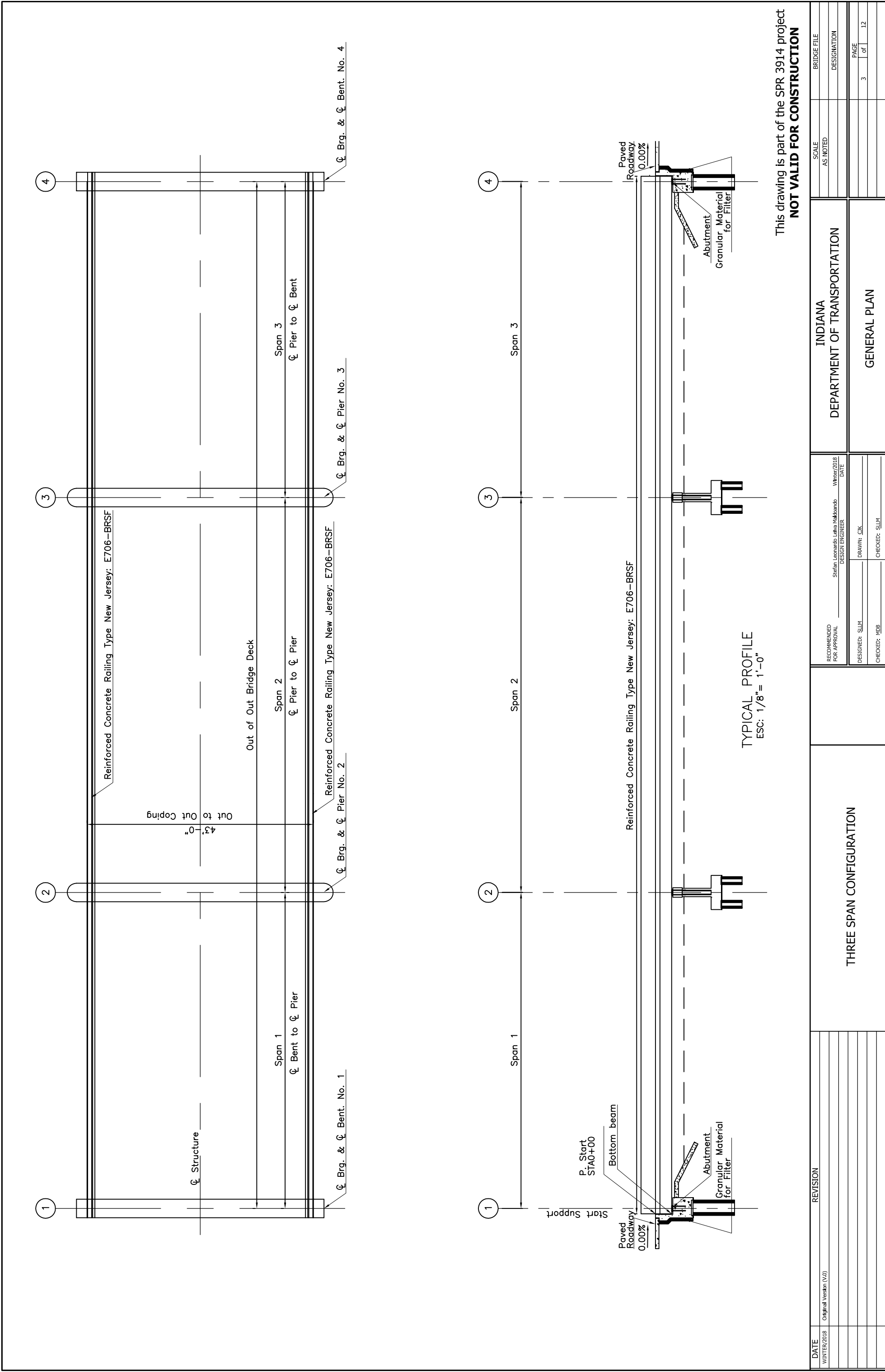

This drawing is part of the SPR 3914 project  
**NOT VALID FOR CONSTRUCTION**

DATE WINTER/2018	REVISION	RECOMMENDED FOR APPROVAL Stefan Leonardo Latta McElroy DESIGN ENGINEER	INDIANA DEPARTMENT OF TRANSPORTATION	SCALE AS NOTED	BRIDGE FILE
Original Version (V1)		Winter/2018 DATE			DESIGNATION
		DRAWN: CLK			PAGE 3 of 12
		CHECKED: SJM			
		CHECKED: MDB	THREE SPAN CONFIGURATION		
			GENERAL PLAN		



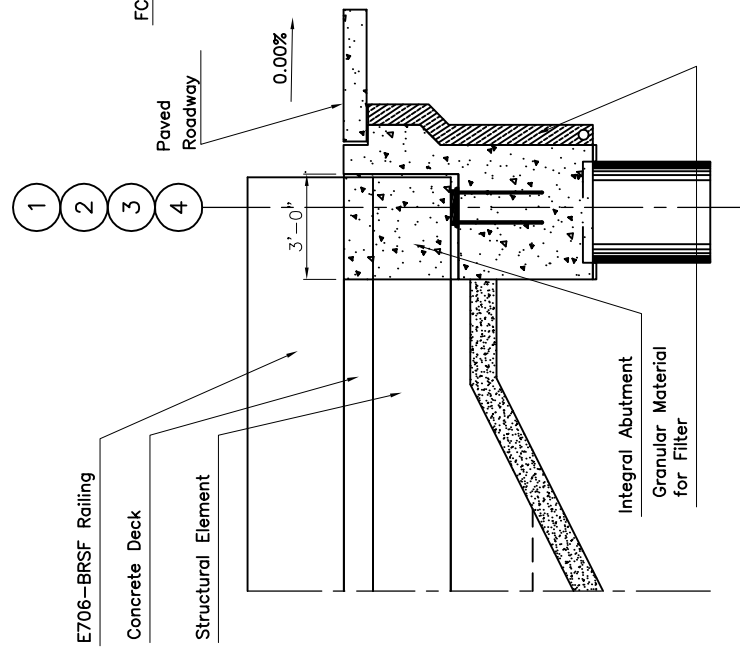

TYPICAL SECTION INTEGRAL ABUTMENT  
ESC: 3/8" = 1'-0"

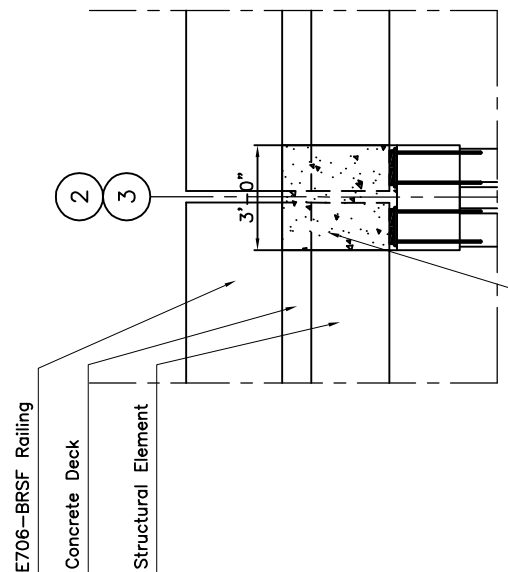

TYPICAL SECTION INTERMEDIATE DIAPHRAGMS  
ESC: 3/8" = 1'-0"

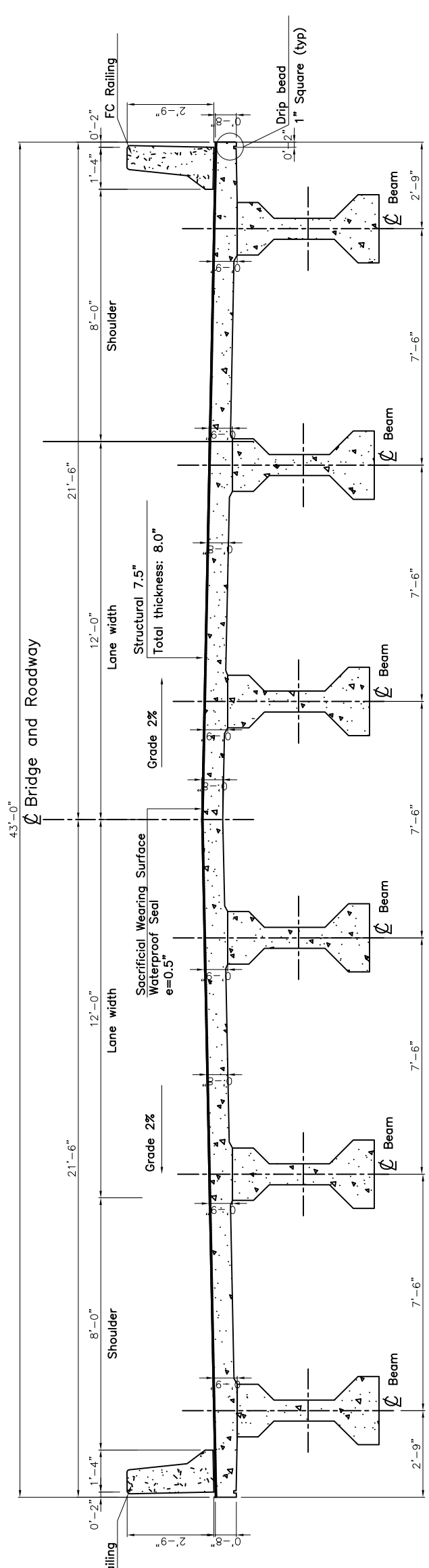

TYPICAL SECTION  
ESC: 1" = 2'-0"

Bridge and Roadway

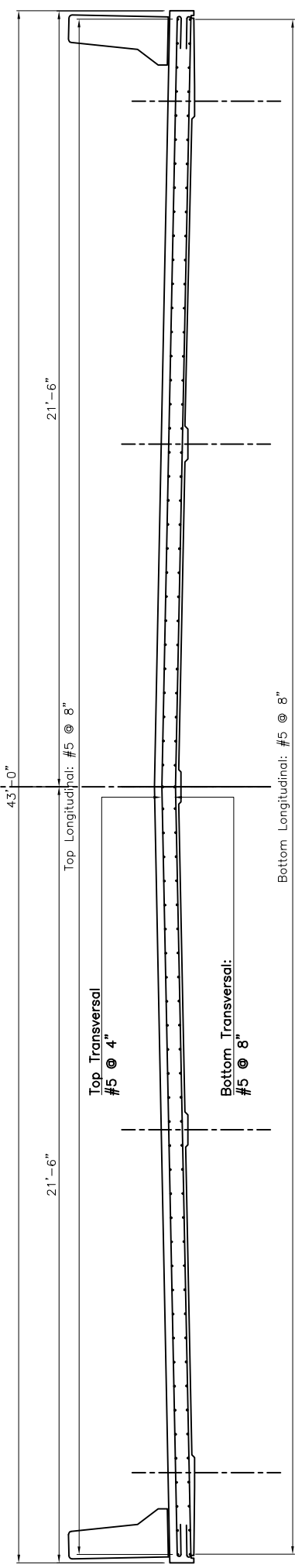

TYPICAL SECTION  
ESC: 1" = 2'-0"

**PRESTRESSED CONCRETE AASHTO I-BEAM SUPERSTRUCTURE DESIGNS**

Girder Type	Number of Spans	Span Length(s) (ft)			No. of Girders
		Span 1	Span 2	Span 3	
A Type I	1	30	-	-	6
A Type II	1	45	-	-	6
A Type III	1	60	-	-	6
A Type III	1	75	-	-	6
A Type IV	1	90	-	-	6
A Type I	3	35	45	35	6
A Type II	3	50	60	50	6
A Type III	3	60	75	60	6
A Type III	3	70	90	70	6

This drawing is part of the SPR 3914 project  
**NOT VALID FOR CONSTRUCTION**

DATE WINTER/2018	REVISION	INDIANA DEPARTMENT OF TRANSPORTATION	SCALE AS NOTED	BRIDGE FILE
Original Version (V.0)				
DESIGNED: SLM	DESIGN ENGINEER Stefan Leonardo Latta McBarbado		DESIGNATION	
CHECKED: MDB	DATE Winter/2018			
	DRAWN: CLK		PAGE	
	CHECKED: SLM		5	of 12
<b>PRESTRESSED CONCRETE AASHTO BEAMS</b>		<b>GENERAL DETAILS</b>		

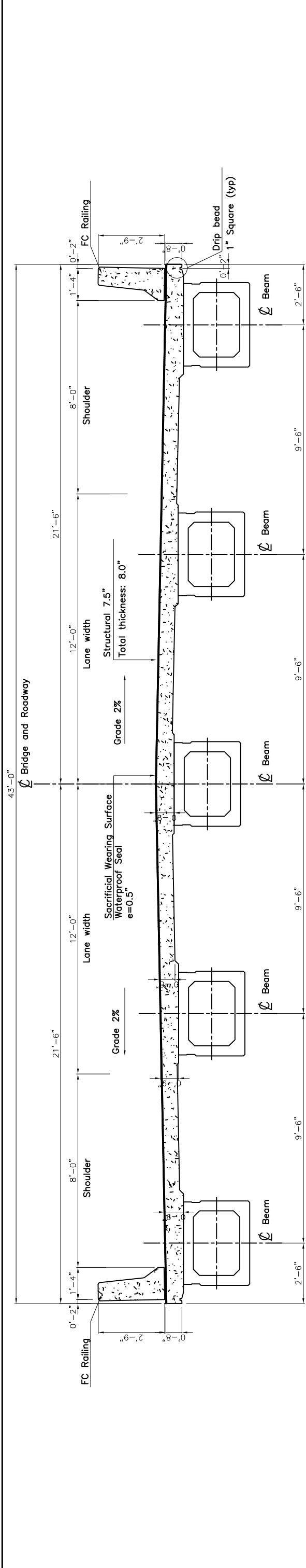

TYPICAL SECTION  
ESC: 1" = 2'-0"

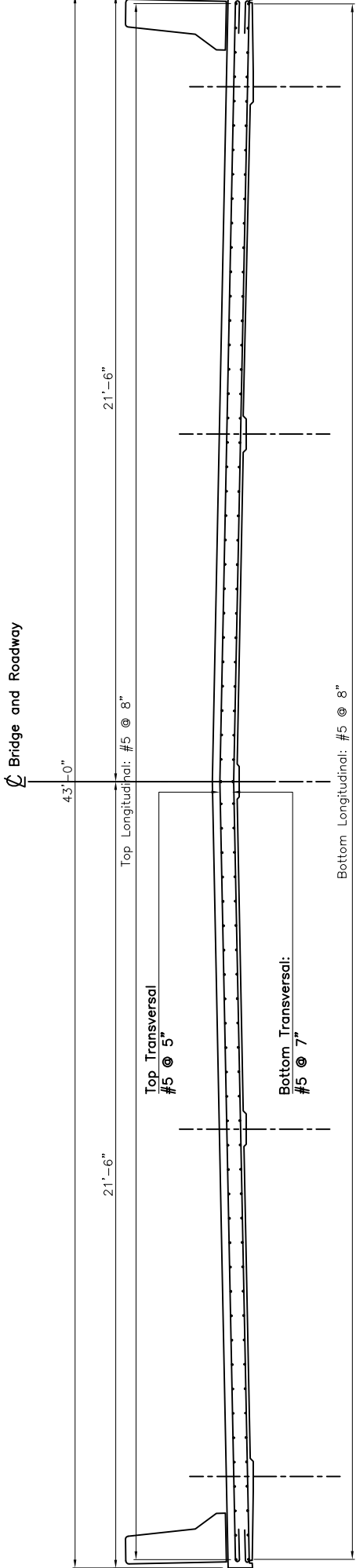

TYPICAL SECTION  
ESC: 1" = 2'-0"

Girder Type	Number of Spans	Span Length(s) (ft)			No. of Girders
		Span 1	Span 2	Span 3	
		CB 17x48	1	30	
CB 27x48	1	45	-	5	
CB 27x48	1	60	-	5	
CB 17x36	3	25	30	25	5
CB 21x48	3	35	45	35	5
CB 27x48	3	50	60	50	5

PRESTRESSED CONCRETE BOX BEAM SUPERSTRUCTURE DESIGNS

This drawing is part of the SPR 3914 project  
**NOT VALID FOR CONSTRUCTION**

DATE	REVISION	INDIANA DEPARTMENT OF TRANSPORTATION	SCALE	BRIDGE FILE
WINTER/2018	Original Version (V.1)		AS NOTED	
		DESIGNED: SLJM	DESIGN ENGINEER	DESIGNATION
		CHECKED: MDB	Stefan Leonardo Lata MelloBarbo	DATE
		DRAWN: CLK	Winter/2018	
		CHECKED: SLJM		PAGE
				6 of 12

PRESTRESSED CONCRETE BOX BEAMS

GENERAL DETAILS

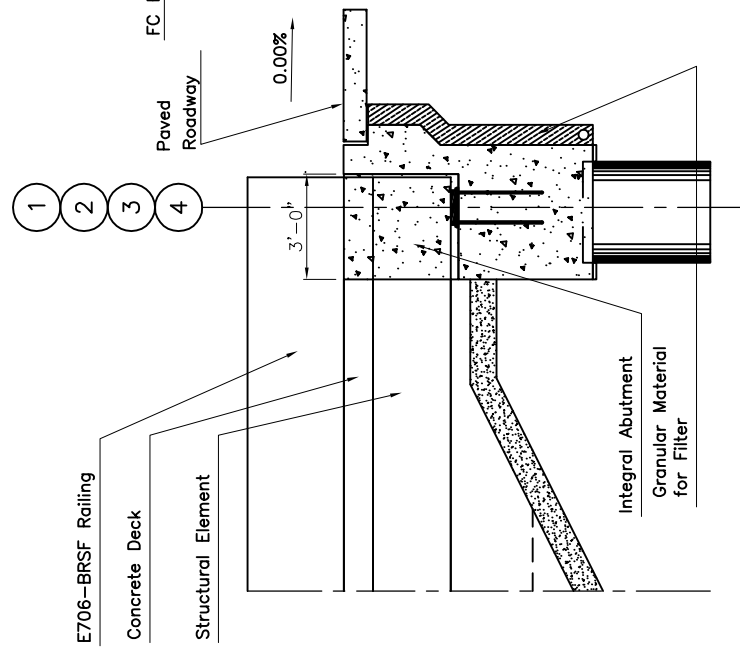

**TYPICAL SECTION  
INTEGRAL ABUTMENT**  
ESC: 3/8" = 1'-0"

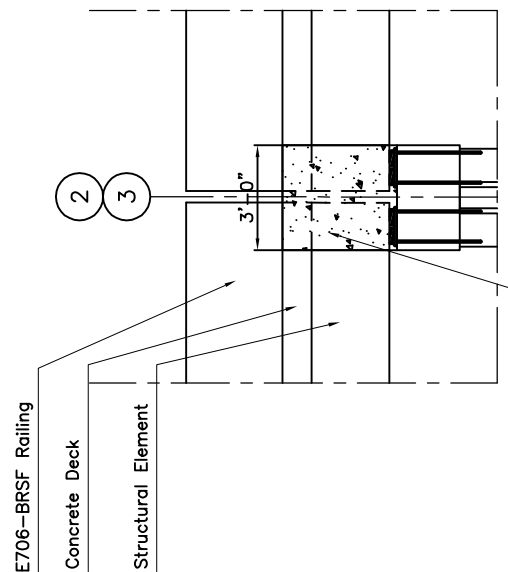

**TYPICAL SECTION  
INTERMEDIATE DIAPHRAGMS**  
ESC: 3/8" = 1'-0"

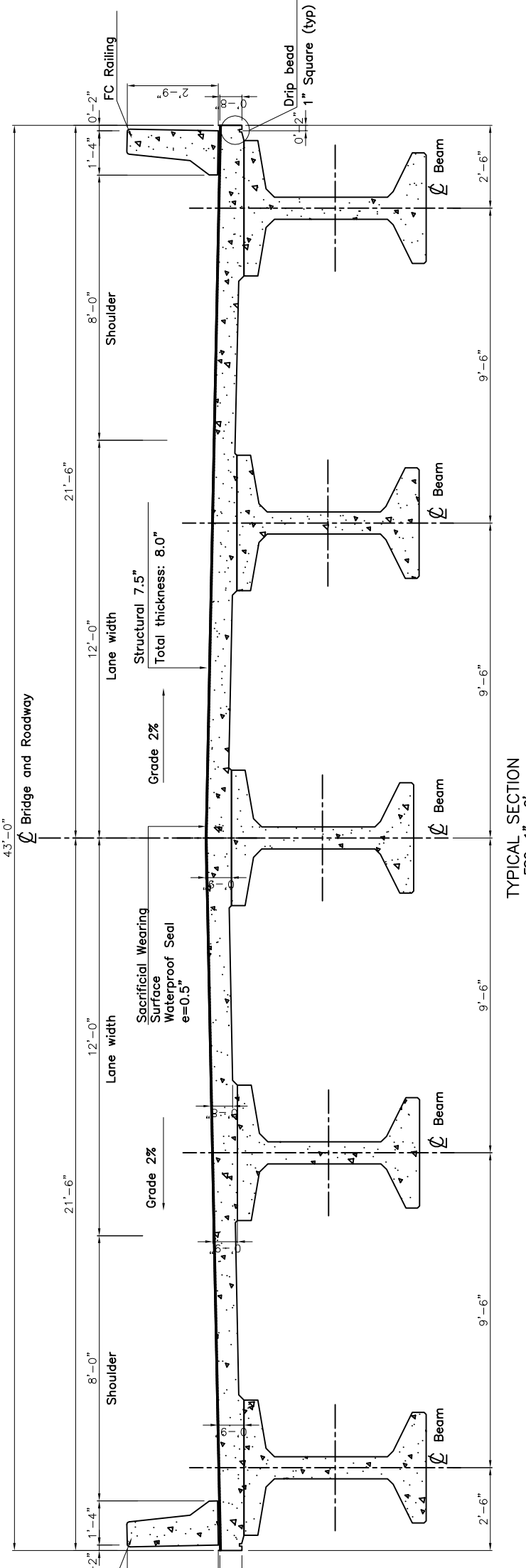

**TYPICAL SECTION  
BRIDGE AND ROADWAY**  
ESC: 1" = 2'-0"

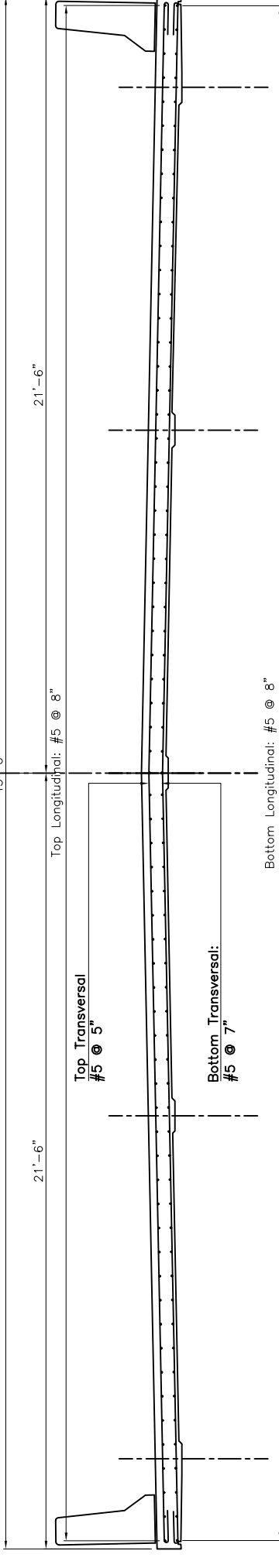

**TYPICAL SECTION  
BRIDGE AND ROADWAY**  
ESC: 1" = 2'-0"

**PRESTRESSED CONCRETE BULB TEE BEAM SUPERSTRUCTURE DESIGNS**

Girder Type	Number of Spans	Span Length(s) (ft)			No. of Girders
		Span 1	Span 2	Span 3	
HBT 36x49	1	60	-	-	5
HBT 42x49	1	75	-	-	5
HBT 48x49	1	90	-	-	5
HBT 60x49	1	110	-	-	5
HBT 72x49	1	130	-	-	5
HBT 48x49	2	90	90	-	5
HBT 66x61	2	110	110	-	5
HBT 72x61	2	130	130	-	5
HBT 36x49	3	50	60	50	5
HBT 36x49	3	60	75	60	5
HBT 48x49	3	70	90	70	5

This drawing is part of the SPR 3914 project  
**NOT VALID FOR CONSTRUCTION**

DATE WINTER/2018	REVISION	RECOMMENDED FOR APPROVAL Stefan Leonardo Latta Melendez DESIGN ENGINEER	INDIANA DEPARTMENT OF TRANSPORTATION	SCALE AS NOTED	BRIDGE FILE
		Winter/2018 DATE			DESIGNATION
		DRAWN: CLK			PAGE
		CHECKED: SLM			7 of 12
		CHECKED: MDB			
<b>PRESTRESSED CONCRETE BULB TEE</b>			<b>GENERAL DETAILS</b>		

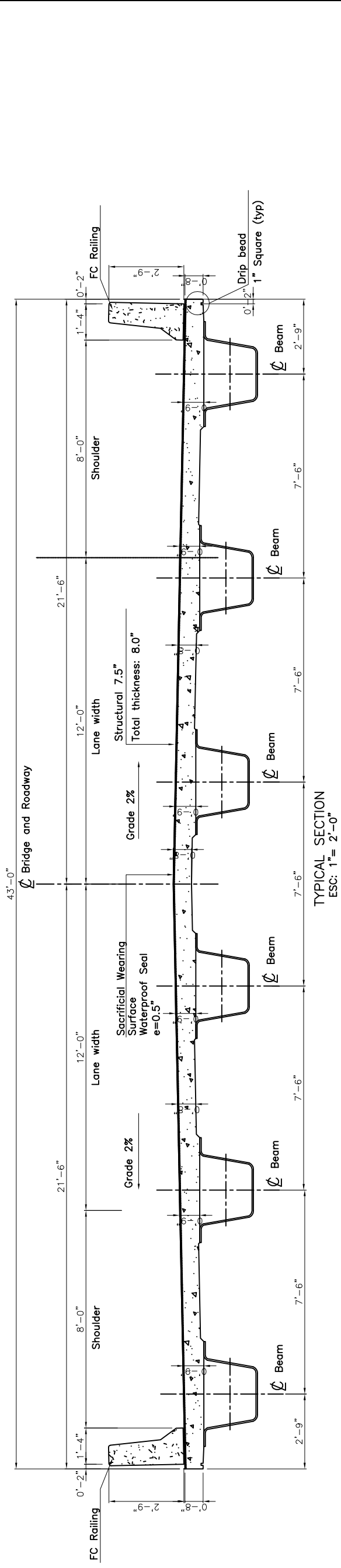

TYPICAL SECTION  
ESC: 1"= 2'-0"

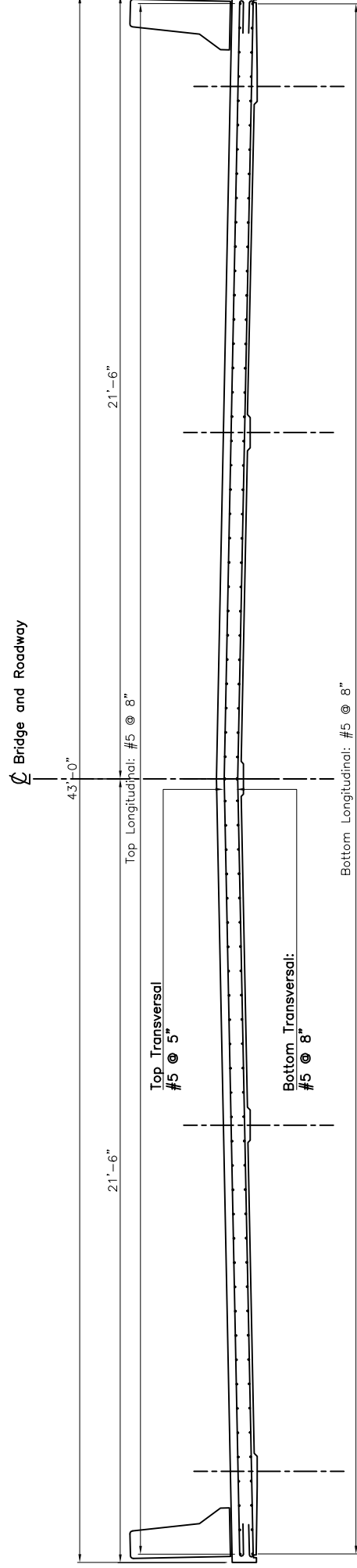

TYPICAL SECTION  
ESC: 1"= 2'-0"

FOLDED STEEL PLATE GIRDER SUPERSTRUCTURE DESIGNS			
Girder Type	Number of Spans	Span Length (ft)	No. of Girders
FP 60x12 $\frac{1}{2}$	1	30	6
FP 84x23 $\frac{3}{8}$	1	45	6
FP 96x26 $\frac{3}{8}$	1	60	6

This drawing is part of the SPR 3914 project  
**NOT VALID FOR CONSTRUCTION**

DATE	REVISION	SCALE	BRIDGE FILE
WINTER/2018	Original Version (V.1)	AS NOTED	
			DESIGNATION
			PAGE
			8 of 12

RECOMMENDED FOR APPROVAL	DESIGNED ENGINEER	DATE
Stefan Leonardo Latta Holmboe	Winter/2018	

DESIGNED: SLJM	DRAWN: CLK
CHECKED: MDB	CHECKED: SLJM

  

INDIANA
DEPARTMENT OF TRANSPORTATION
GENERAL DETAILS

  

STRUCTURAL STEEL FOLDED PLATE GIRDERS (FPG)
6 BEAMS CONFIGURATION



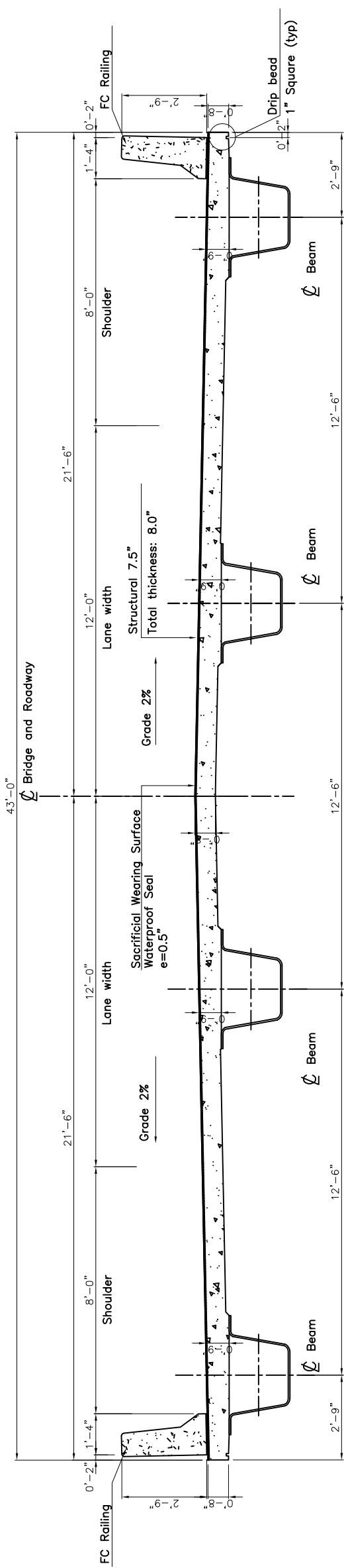

TYPICAL SECTION  
ESC: 1" = 2'-0"

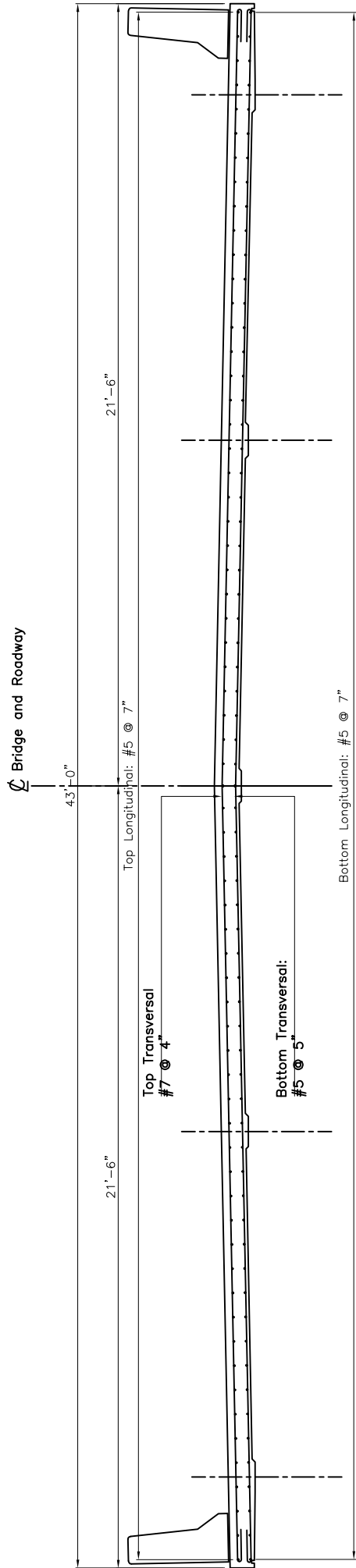

TYPICAL SECTION  
ESC: 1" = 2'-0"

FOLDED STEEL PLATE GIRDER SUPERSTRUCTURE DESIGNS			
Girder Type	Number of Spans	Span Length (ft)	No. of Girders
FP 72x17½	1	30	6
FP 96x26½	1	45	6
FP 120x34½	1	60	6

This drawing is part of the SPR 3914 project  
**NOT VALID FOR CONSTRUCTION**

DATE WINTER/2018	REVISION	RECOMMENDED FOR APPROVAL Stefan Leonardo Latta Meliborido DESIGN ENGINEER	INDIANA DEPARTMENT OF TRANSPORTATION	SCALE AS NOTED	BRIDGE FILE
		Winter/2018 DATE			DESIGNATION
		DRAWN: CLK CHECKED: SLM			PAGE 9 of 12
			GENERAL DETAILS		
			STRUCTURAL STEEL FOLDED PLATE GIRDERS (FPG) 4 BEAMS CONFIGURATION		

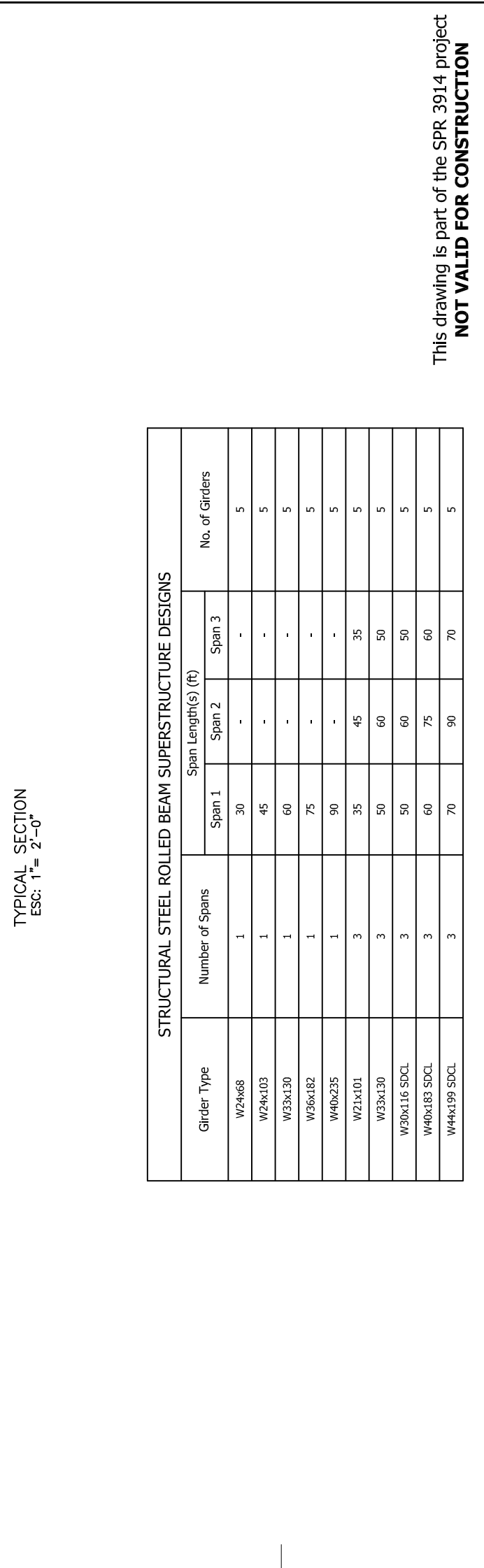
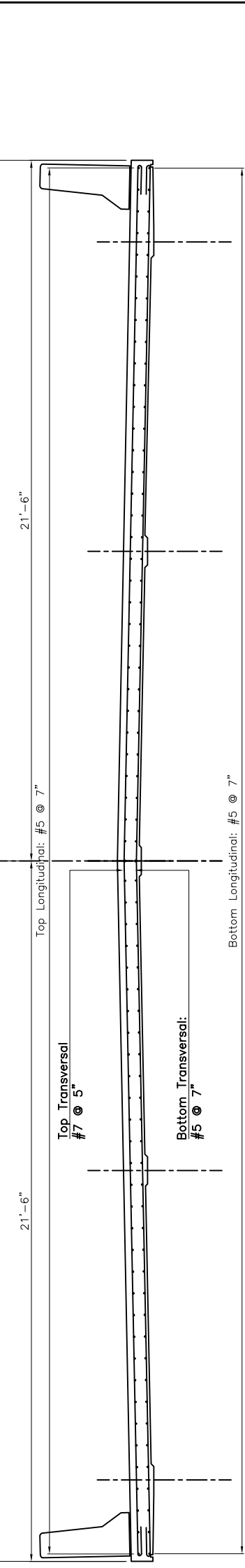
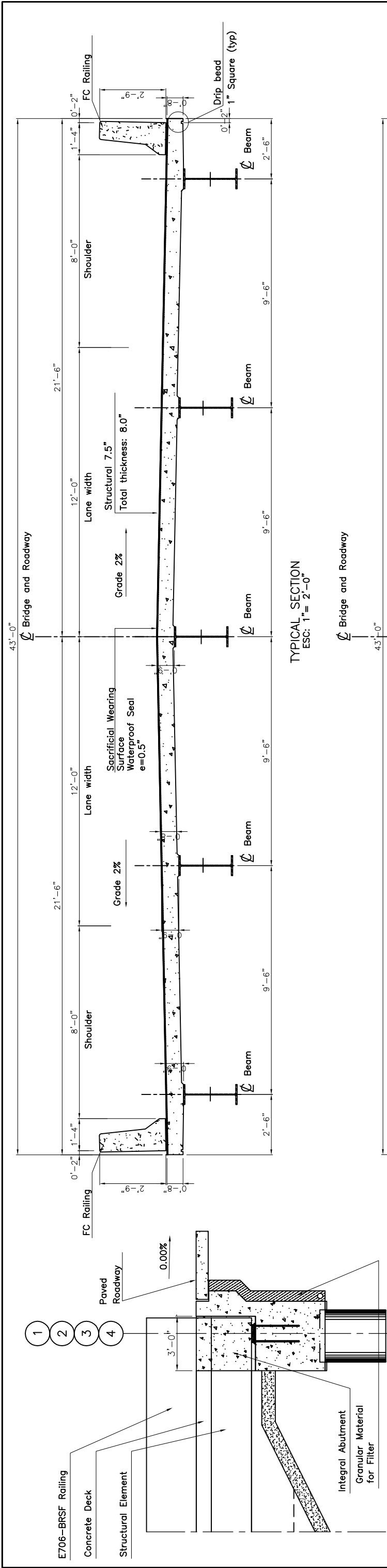

**STRUCTURAL STEEL ROLLED BEAM SUPERSTRUCTURE DESIGNS**

Girder Type	Number of Spans	Span Length(s) (ft)			No. of Girders
		Span 1	Span 2	Span 3	
W24x68	1	30	-	-	5
W24x103	1	45	-	-	5
W33x130	1	60	-	-	5
W36x182	1	75	-	-	5
W40x235	1	90	-	-	5
W21x101	3	35	45	35	5
W33x130	3	50	60	50	5
W30x116 SDCL	3	50	60	50	5
W40x183 SDCL	3	60	75	60	5
W44x199 SDCL	3	70	90	70	5

This drawing is part of the SPR 3914 project  
**NOT VALID FOR CONSTRUCTION**

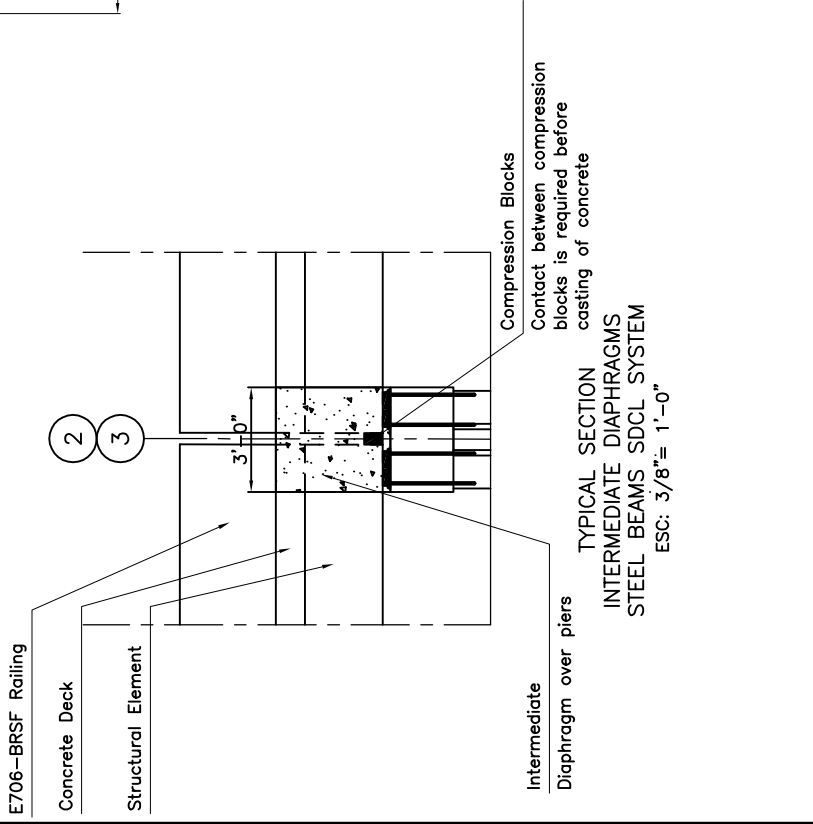
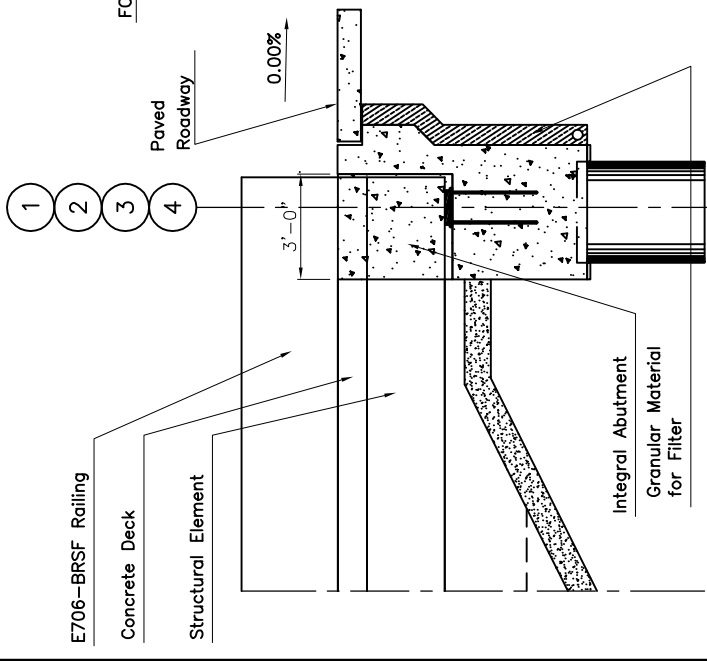

DATE WINTER/2018	REVISION	RECOMMENDED FOR APPROVAL Stefan Leonardo Latta McBarbano DESIGN ENGINEER	INDIANA DEPARTMENT OF TRANSPORTATION
Original Version (V.0)		Winter/2018 DATE	
		DRAWN: CLK	
		CHECKED: SLJM	
			GENERAL DETAILS
			PAGE 10 of 12

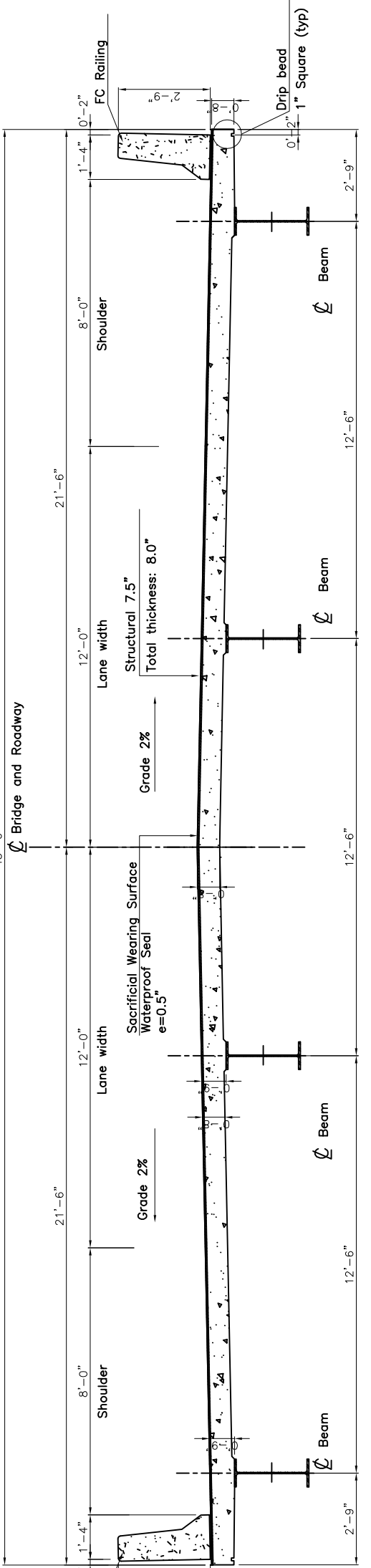

TYPICAL SECTION  
ESC: 1" = 2'-0"

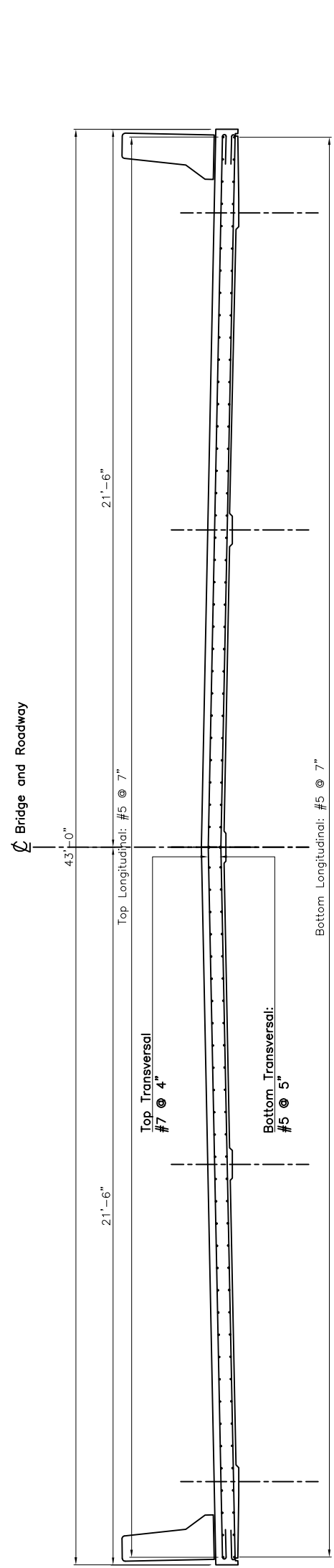

TYPICAL SECTION  
ESC: 1" = 2'-0"

STRUCTURAL STEEL ROLLED BEAM SUPERSTRUCTURE DESIGNS

Girder Type	Number of Spans	Span Length(s) (ft)			No. of Girders
		Span 1	Span 2	Span 3	
W27x84	1	30	-	-	4
W30x116	1	45	-	-	4
W36x150	1	60	-	-	4
W40x211	1	75	-	-	4
W44x262	1	90	-	-	4
W21x111	3	35	45	35	4
W36x135	3	50	60	50	4
W33x130 SDCL	3	50	60	50	4
W40x199 SDCL	3	60	75	60	4
W44x230 SDCL	3	70	90	70	4

This drawing is part of the SPR 3914 project  
**NOT VALID FOR CONSTRUCTION**

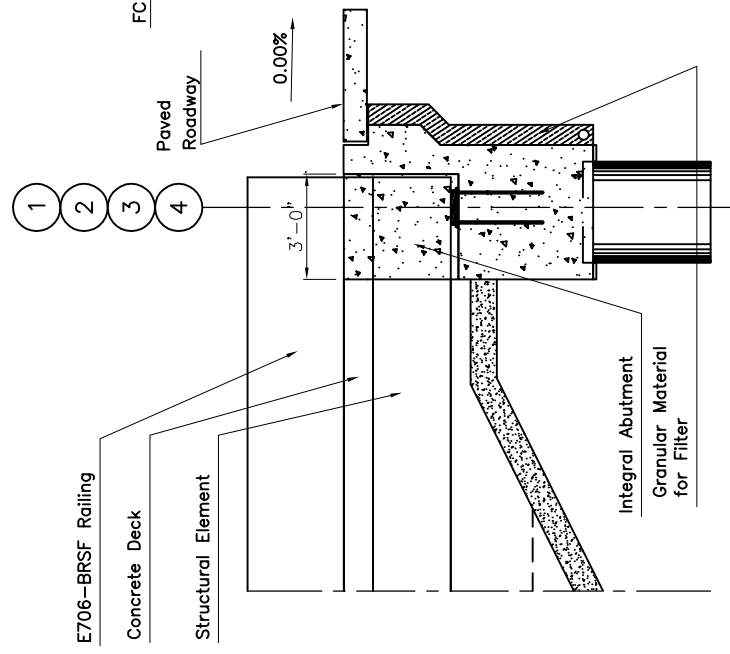

TYPICAL SECTION  
INTEGRAL ABUTMENT  
ESC: 3/8" = 1'-0"

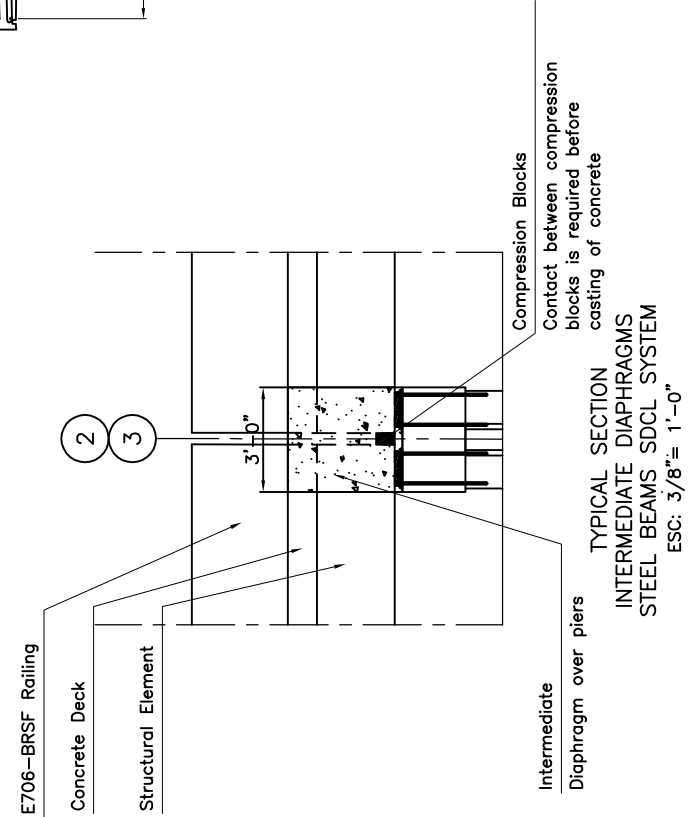

TYPICAL SECTION  
INTERMEDIATE DIAPHRAGMS  
STEEL BEAMS SDCL SYSTEM  
ESC: 3/8" = 1'-0"

DATE WINTER/2018	REVISION	RECOMMENDED FOR APPROVAL Sofien Leonardo Lata Madarand DESIGN ENGINEER	DATE Winter/2018	INDIANA DEPARTMENT OF TRANSPORTATION	SCALE AS NOTED	BRIDGE FILE DESIGNATION
		DESIGNED: SLM	DRAWN: CLK			
		CHECKED: MDB	CHECKED: SLM			
						PAGE 11 of 12
				GENERAL DETAILS		

STRUCTURAL STEEL FOLDED ROLLED BEAMS  
AND SIMPLY SUPPORTED FOR DEAD LOAD AND  
CONTINUOUS FOR LIVE LOAD (SDCL)  
4 BEAMS CONFIGURATION

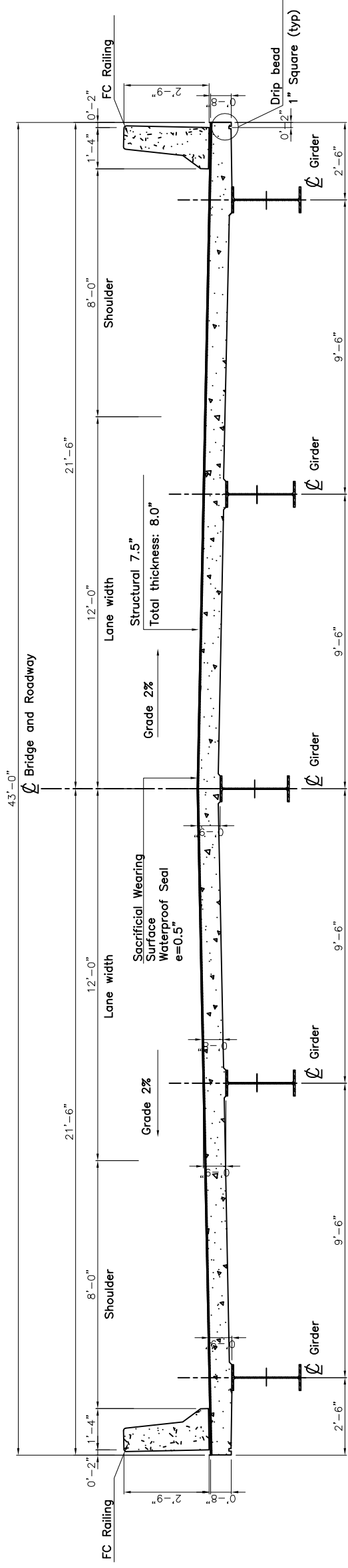

TYPICAL SECTION  
ESC: 1" = 2'-0"

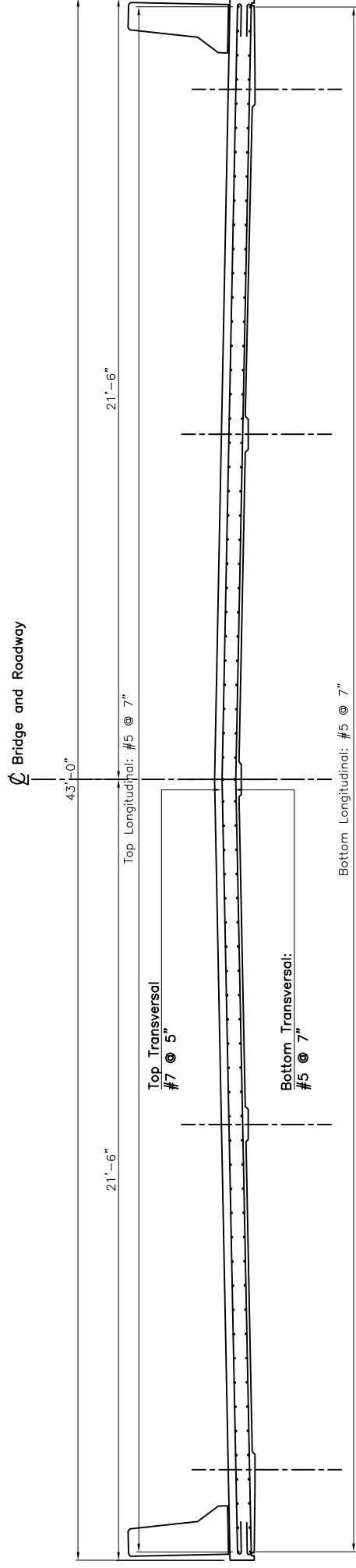

TYPICAL SECTION  
ESC: 1" = 2'-0"

This drawing is part of the SPR 3914 project  
**NOT VALID FOR CONSTRUCTION**

Number of Spans	Span Length(s) (ft)			No. of Girders	Bottom Flange (in)			Top Flange (in)			Web (in)
	Span 1	Span 2	Span 3		Span 1	Span 2	Span 3	Span 1	Span 2	Span 3	
1	90	-	-	5	16 x 3/4 (70%) - 17 x 3/8 (30%)	-	-	16 x 3/4 (70%) - 17 x 3/8 (30%)	-	-	48 x 7/16
1	110	-	-	5	16 x 3/4 (50%) - 21 x 1 (50%)	-	-	16 x 3/4 (50%) - 21 x 1 (50%)	-	-	50 x 7/16
1	130	-	-	5	20 x 1 (50%) - 23 x 1 1/4 (50%)	-	-	20 x 1 (50%) - 23 x 1 1/4 (50%)	-	-	50 x 3/4
2	90	90	-	5	14 x 1 (80%) - 14 x 1 1/2 (20%) - 14 x 2 1/4 (10%)	14 x 1 (80%) - 14 x 1 1/2 (20%) - 14 x 2 1/4 (10%)	-	14 x 1 (80%) - 14 x 1 1/2 (20%) - 14 x 2 1/4 (10%)	14 x 1 (80%) - 14 x 1 1/2 (20%) - 14 x 2 1/4 (10%)	-	46 x 1/2
2	110	110	-	5	14 x 1 (60%) - 14 x 1 1/8 (30%) - 14 x 2 3/8 (10%)	14 x 1 (60%) - 14 x 1 1/8 (30%) - 14 x 2 3/8 (10%)	-	14 x 1 (60%) - 14 x 1 1/8 (30%) - 14 x 2 3/8 (10%)	14 x 1 (60%) - 14 x 1 1/8 (30%) - 14 x 2 3/8 (10%)	-	50 x 1/2
2	130	130	-	5	14x1 (80%) - 14x1 1/2 (30%) - 14x2 1/4 (10%)	14x1 (80%) - 14x1 1/2 (30%) - 14x2 1/4 (10%)	-	14x1 (80%) - 14x1 1/2 (30%) - 14x2 1/4 (10%)	14x1 (80%) - 14x1 1/2 (30%) - 14x2 1/4 (10%)	-	60 x 1/2
3	70	90	70	5	16 x 7/8 (80%) - 16 x 1 1/4 (20%)	16 x 7/8 (80%) - 16 x 1 1/4 (20%)	16 x 7/8 (80%) - 16 x 1 1/4 (20%)	16 x 7/8 (80%) - 16 x 1 1/4 (20%)	16 x 7/8 (80%) - 16 x 1 1/4 (20%)	16 x 7/8 (80%) - 16 x 1 1/4 (20%)	44 x 1/2

DATE		REVISION	
WINTER/2018	Original Version (V.1)		

STRUCTURAL STEEL PLATE GIRDERS		INDIANA	
5 GIRDERS CONFIGURATION		DEPARTMENT OF TRANSPORTATION	
DESIGNED: SJM	DRAWN: CLK	DESIGN ENGINEER: Stefan Leonardo Latta McMorris	DATE: Winter/2018
CHECKED: MDB	CHECKED: SJM		

GENERAL DETAILS		BRIDGE FILE	
PAGE 12	of 12	SCALE AS NOTED	DESIGNATION

## APPENDIX D. LIFE-CYCLE PROFILES FOR INDIANA BRIDGES

This appendix presents the different life-cycle cost profiles considered for each one of the superstructures analyzed in this document. Those presented in Chapter 6 are the most cost-effective LCCP for each of the superstructure types used.

### 1. CONCRETE SLAB

*Service Life:* 58 years Moomen et al (2016)

#### 1.1. INDOT routine procedure

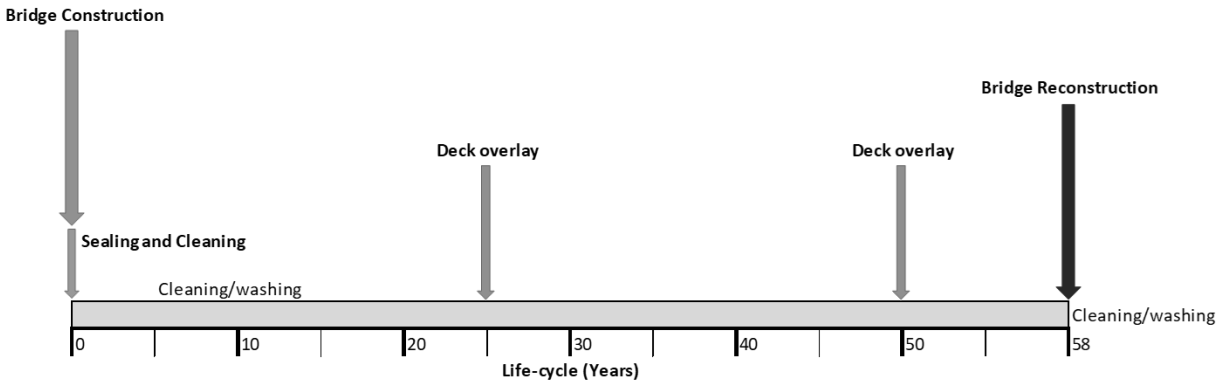

#### 1.2. Alternative A: Modified INDOT routine procedure

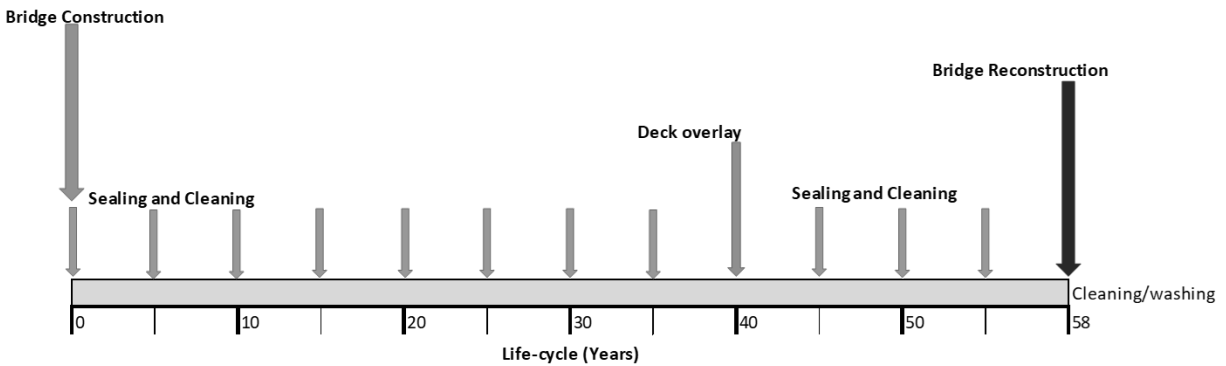

#### 1.3. Alternative B: Alternative INDOT routine procedure

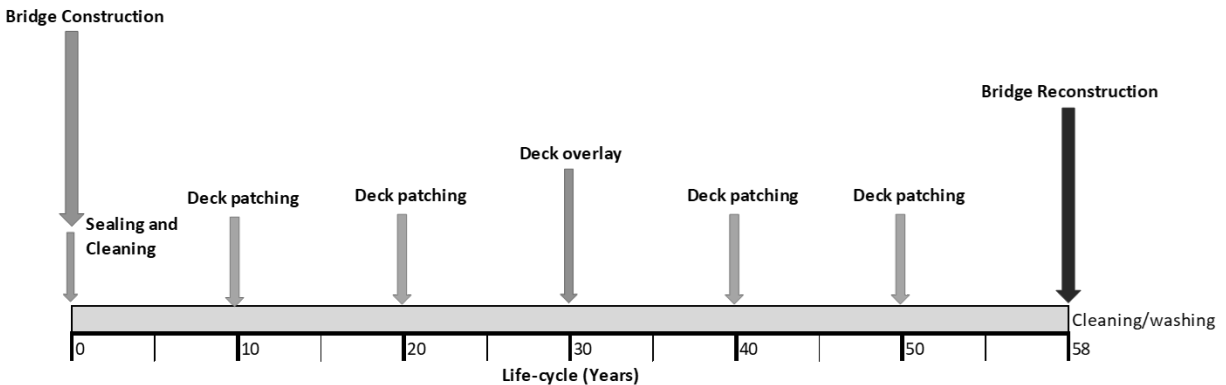

**2. PRESTRESSED CONCRETE BEAM - BEARINGS INCLUDED**

*Service Life:* 65 years Moomen et al (2016)

**2.1. INDOT routine procedure**

2.1

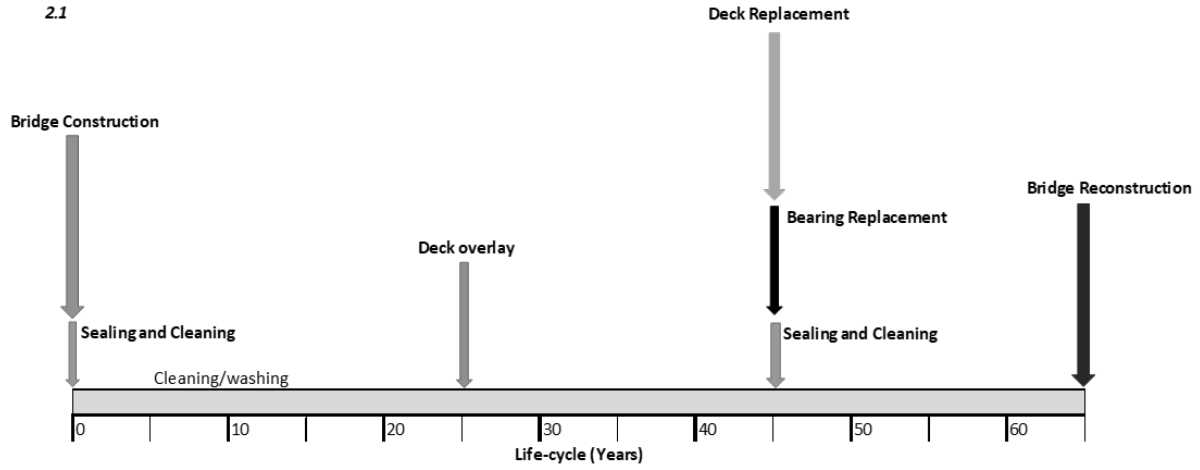

**2.2. Modified INDOT routine procedure**

2.2 Alternative A

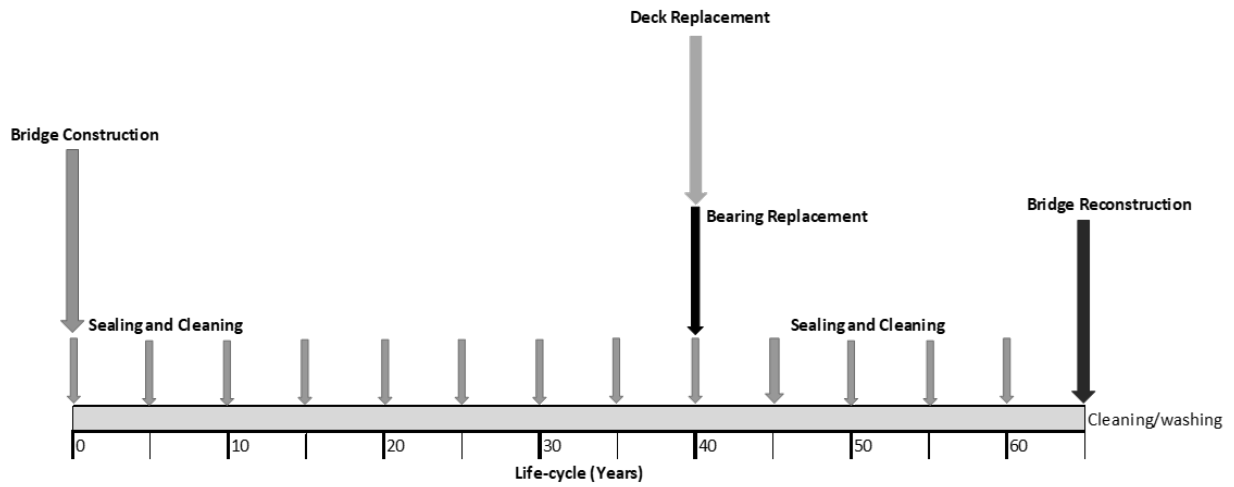

**2.3. Alternative INDOT routine procedure**

2.3 Alternative B

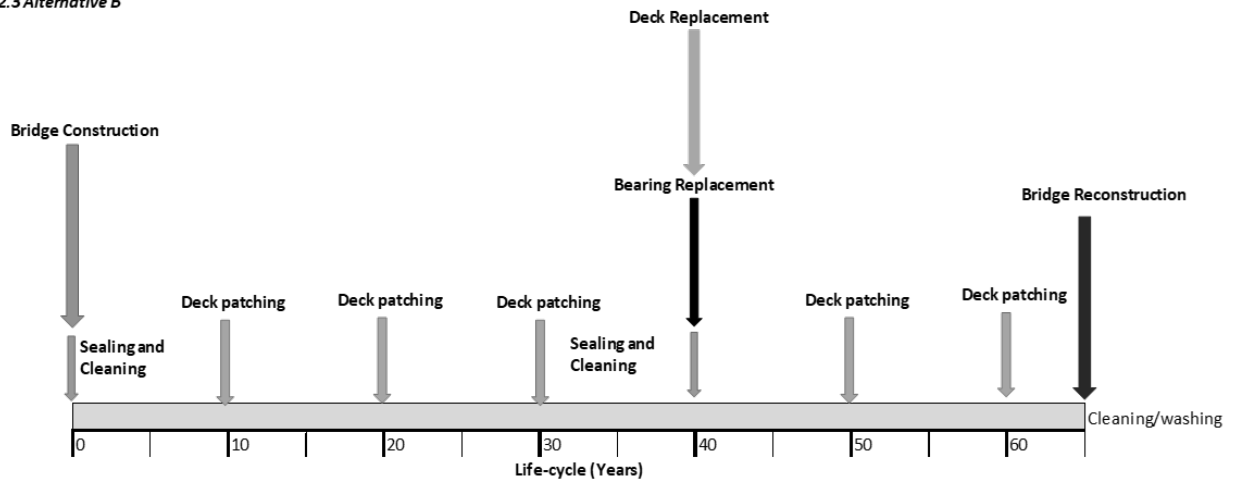

3. PRESTRESSED CONCRETE BOX

Service Life: 60 years Moomen et al (2016)

3.1. INDOT routine procedure

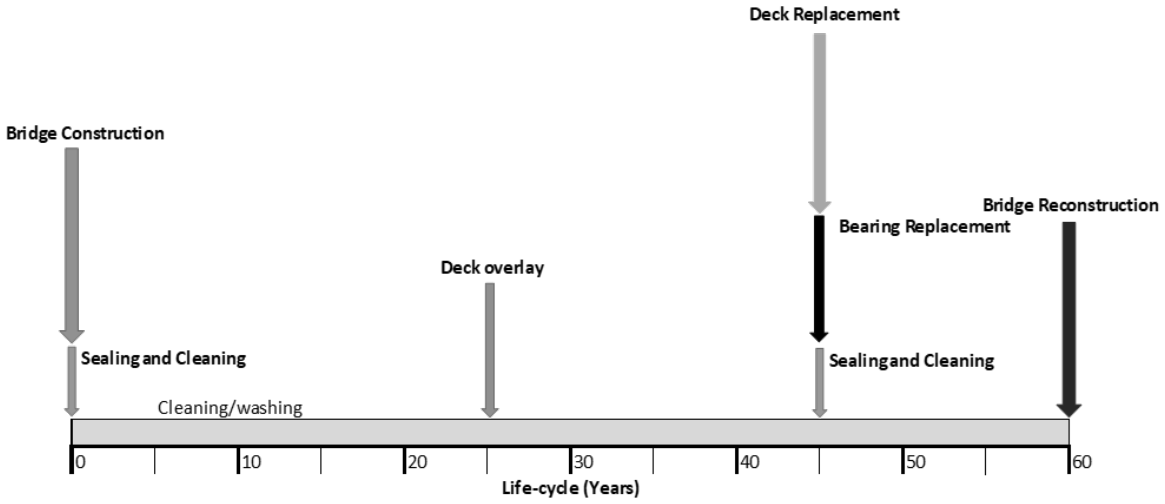

3.2. Modified INDOT routine procedure

3.2.1 Alternative A

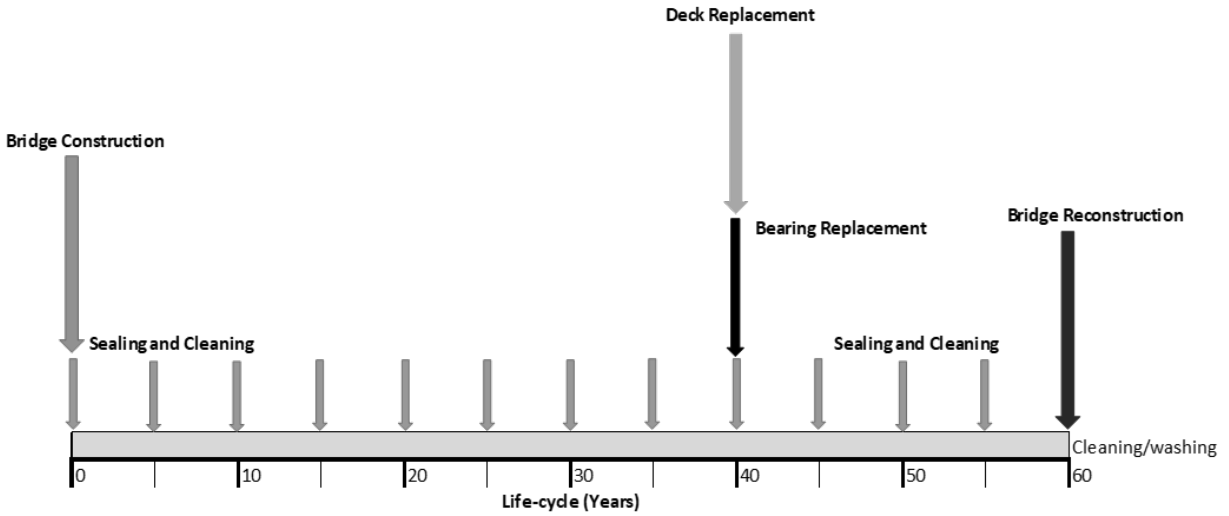

3.3. Alternative INDOT routine procedure

3.3 Alternative B

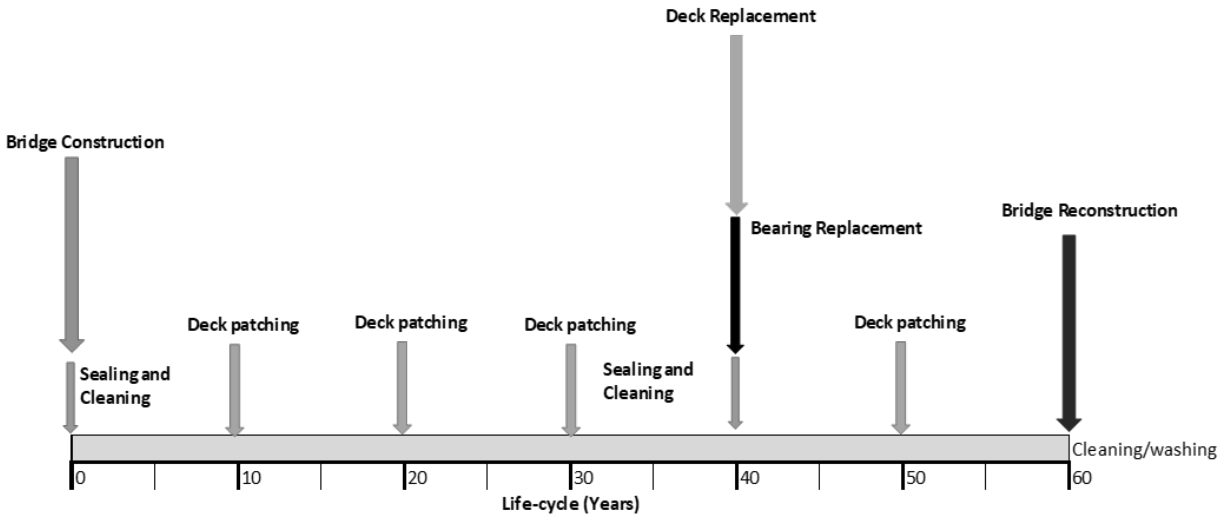

4. STRUCTURAL STEEL ELEMENTS - PAINTED CORROSION PROTECTION

Service Life: 80 years Sinha et al (2009)

4.1. INDOT routine procedure

4.1.1.

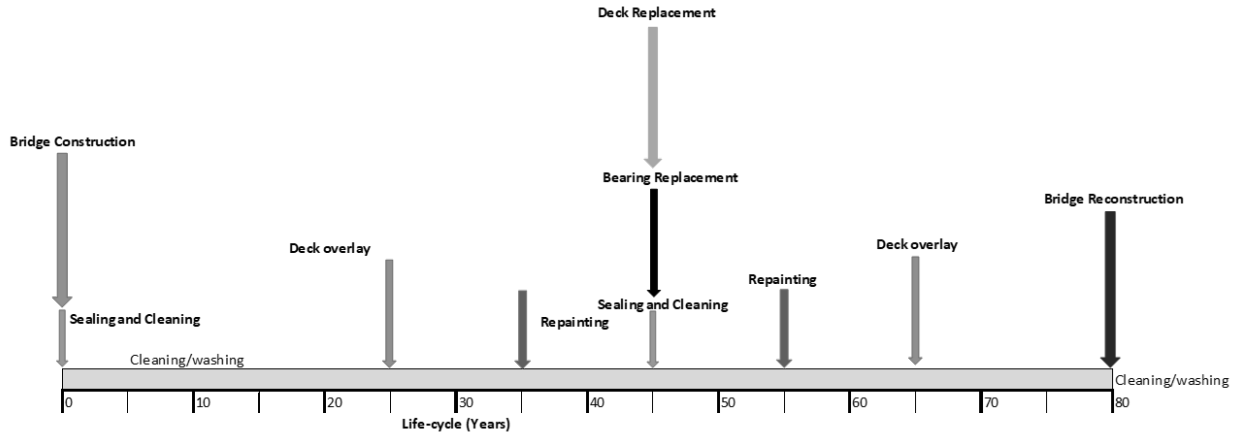

4.1.2 Alternative A

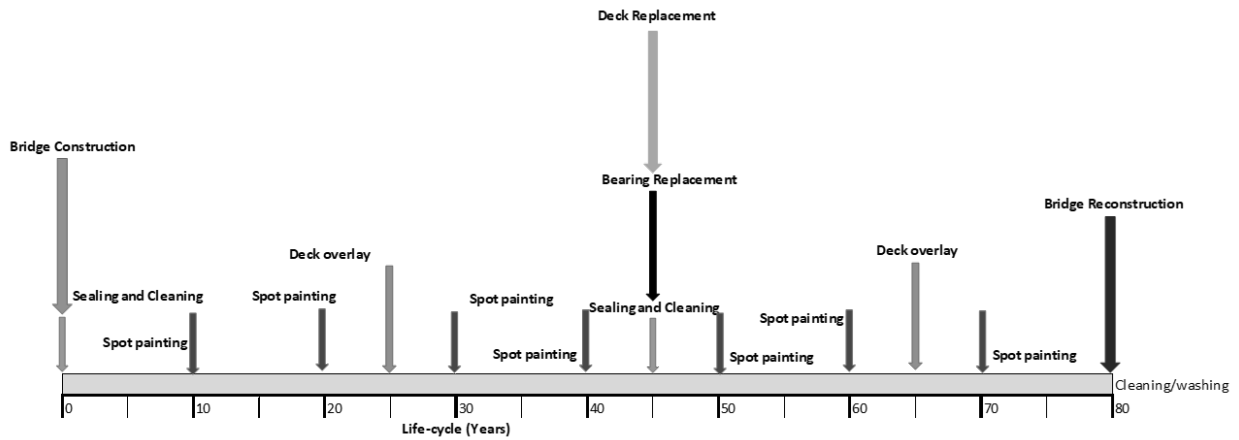

4.2. Modified INDOT routine procedure

4.2.1

4.2.1 Alternative B

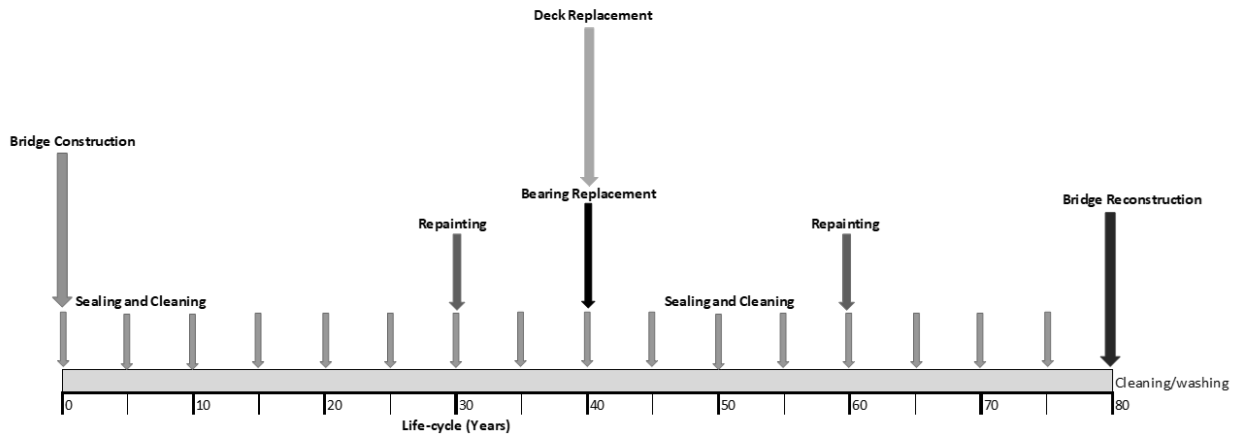



4.2.2 Alternative C

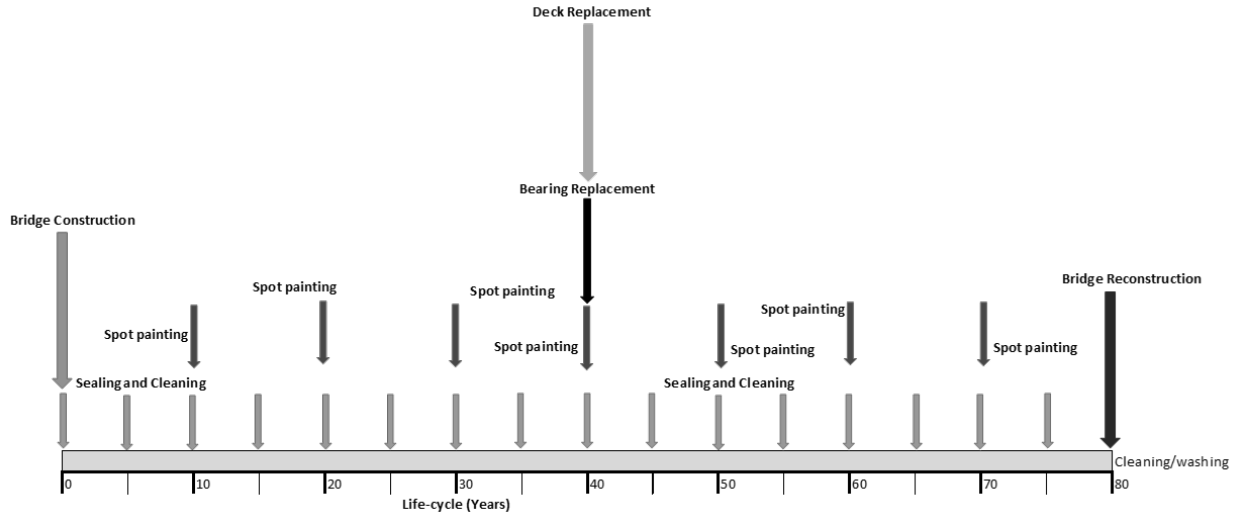

4.3. Alternative INDOT routine procedure

4.3.1

4.3.1 Alternative D

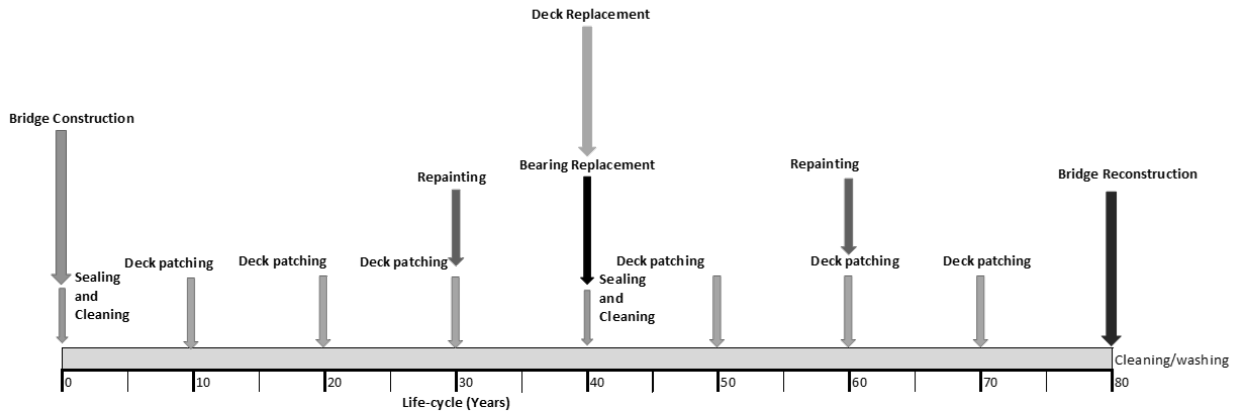

4.3.2 Alternative E

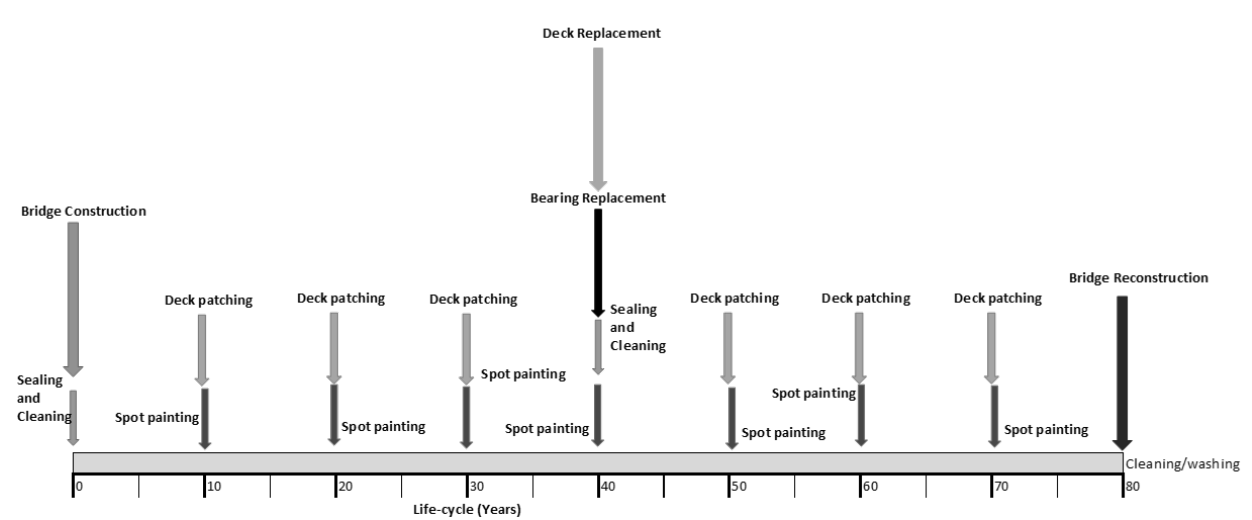

5. SIMPLY SUPPORTED FOR DEAD LOAD CONTINUOUS FOR LIVE LOAD BEAMS (SDCL) - PAINTED CORROSION PROTECTION

Service Life: 95 years Sinha et al (2009)

5.1. INDOT routine procedure

5.1.1.

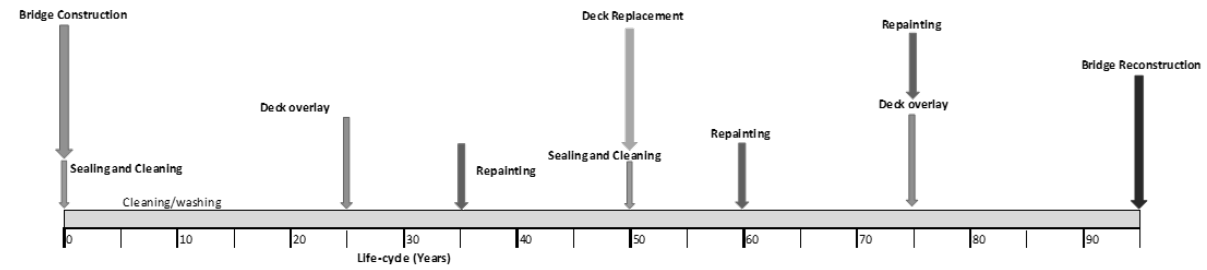

5.1.2 Alternative A

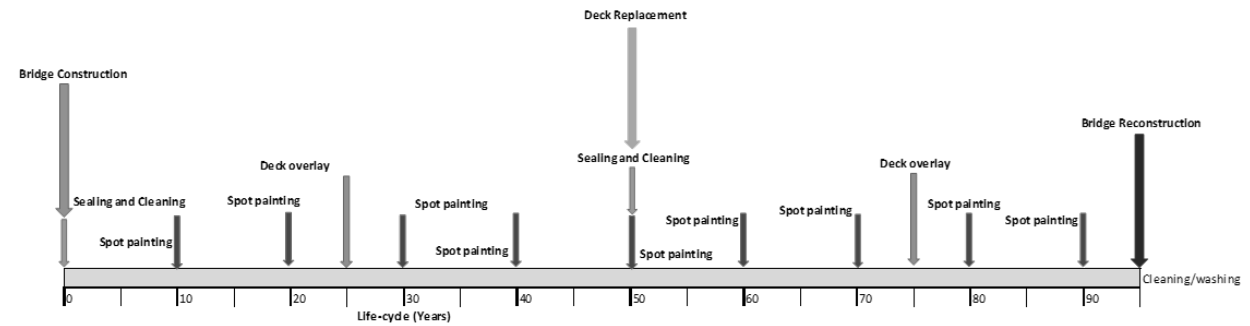

5.2. Modified INDOT routine procedure

5.2.1 Alternative B

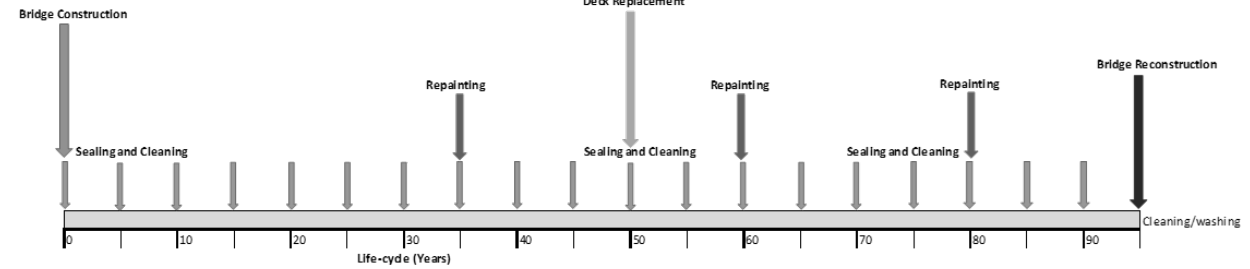

5.2.2 Alternative C

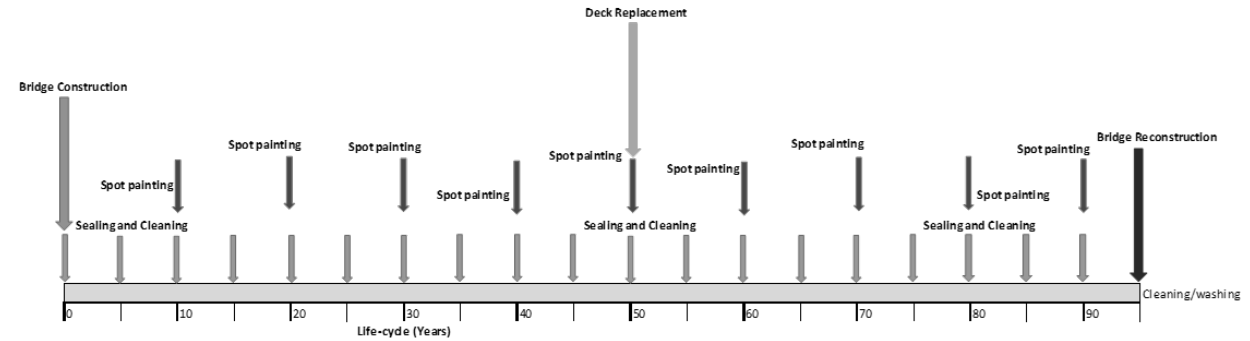

5.3. Alternative INDOT routine procedure

5.3.1 Alternative D

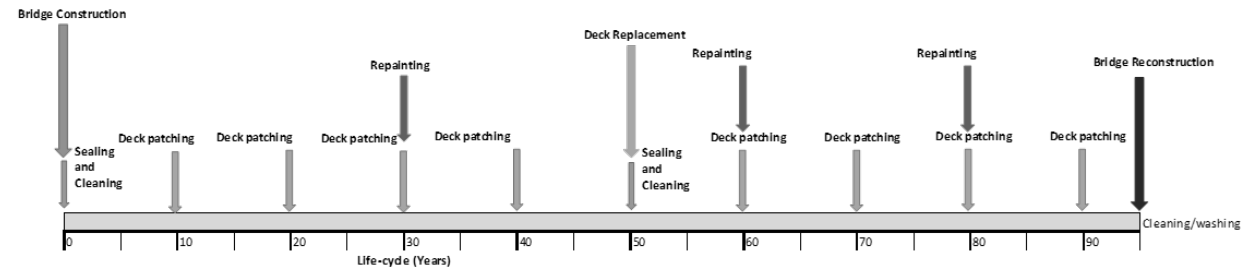

5.3.2 Alternative E

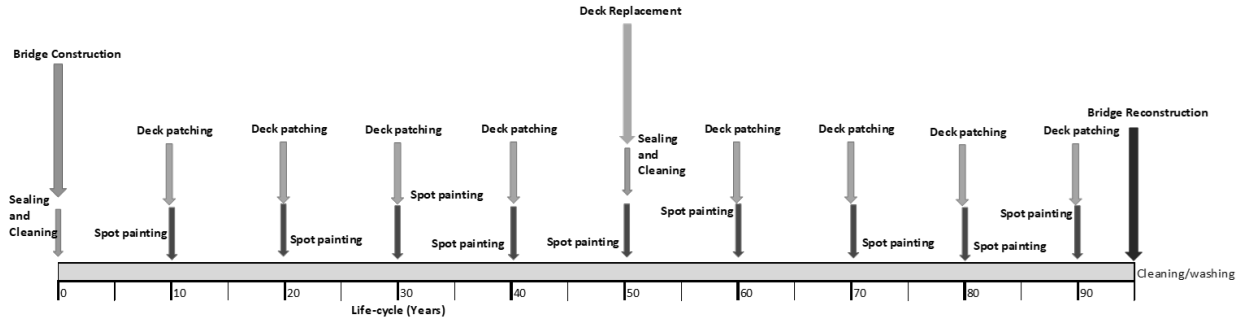

6. PRESTRESSED CONCRETE BEAM - DIAPHRAGMS AND INTEGRAL ABUTMENTS INCLUDED

Service Life: 80 years Moomen et al (2016)

6.1. INDOT routine procedure

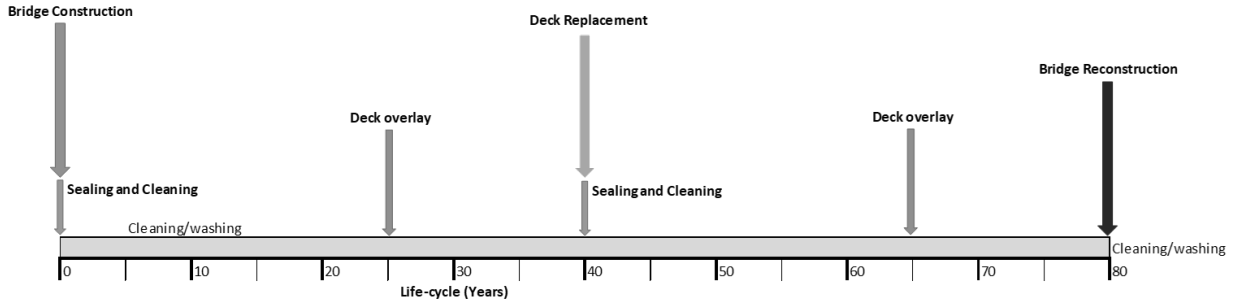

6.2. Alternative A: Modified INDOT routine procedure

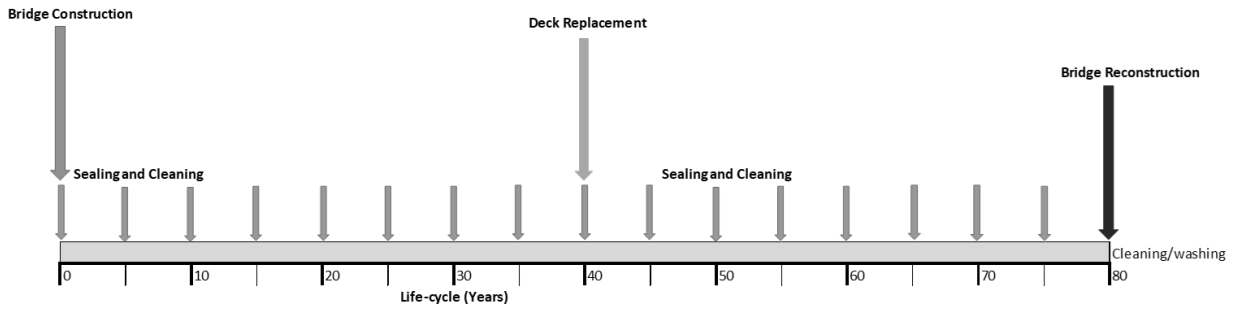

6.3. Alternative B: Alternative INDOT routine procedure

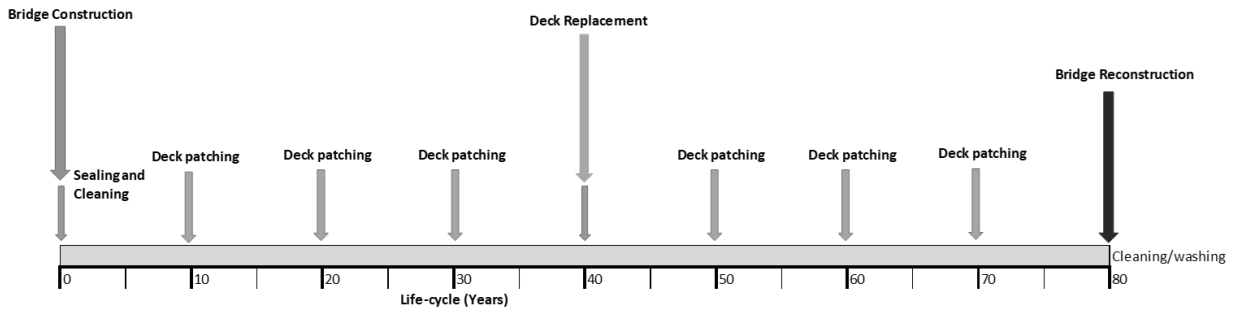

7. STRUCTURAL STEEL ELEMENTS - GALVANIZED CORROSION PROTECTION

Service Life: 115 years

7.1. INDOT routine procedure

7.1.1

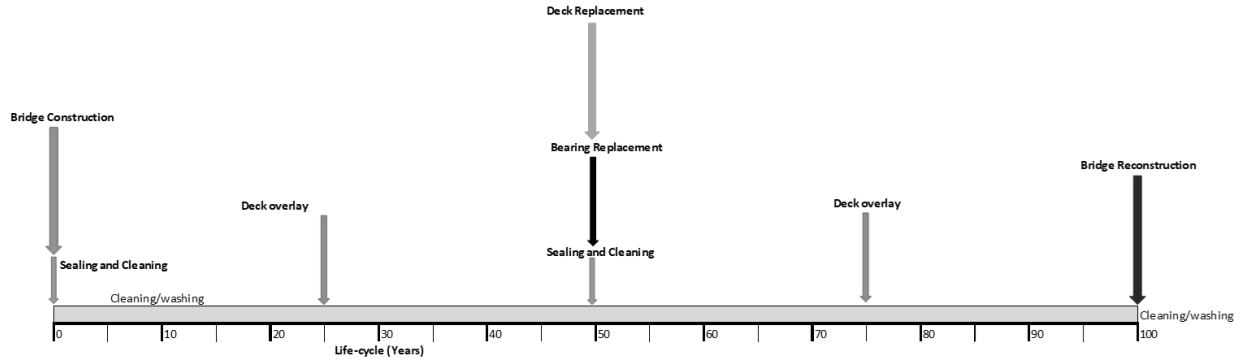

7.2. Modified INDOT routine procedure

7.2.1 Alternative A

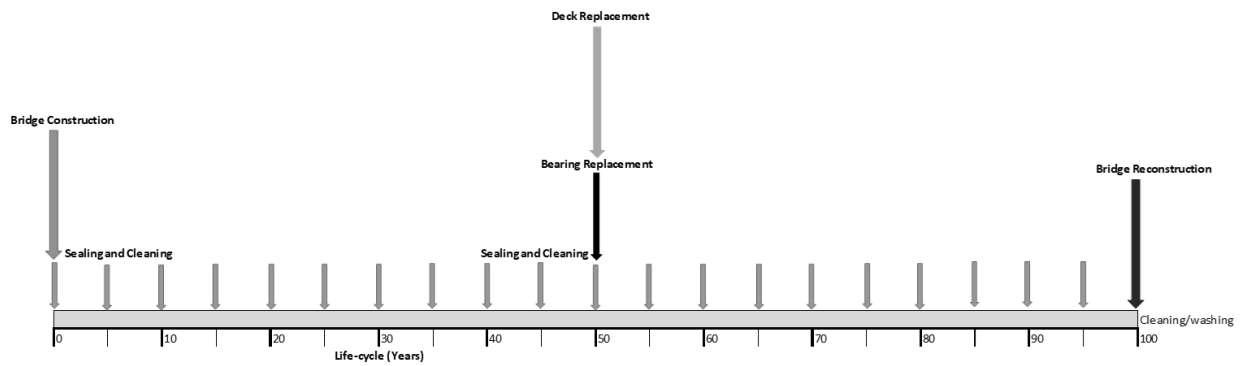

7.3. Alternative INDOT routine procedure

7.3.1 Alternative B

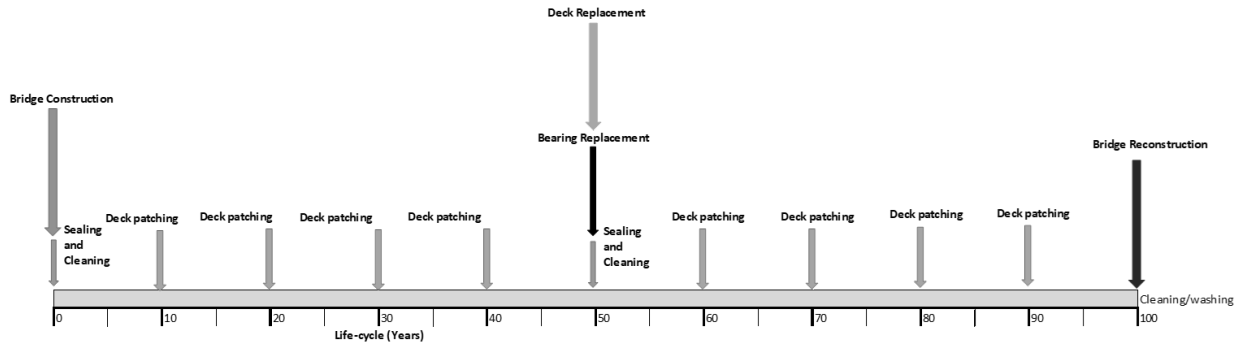

8. SIMPLY SUPPORTED FOR DEAD LOAD CONTINUOUS FOR LIVE LOAD BEAMS (SDCL) - GALVANIZED CORROSION PROTECTION

Service Life: 115 years

8.1. INDOT routine procedure

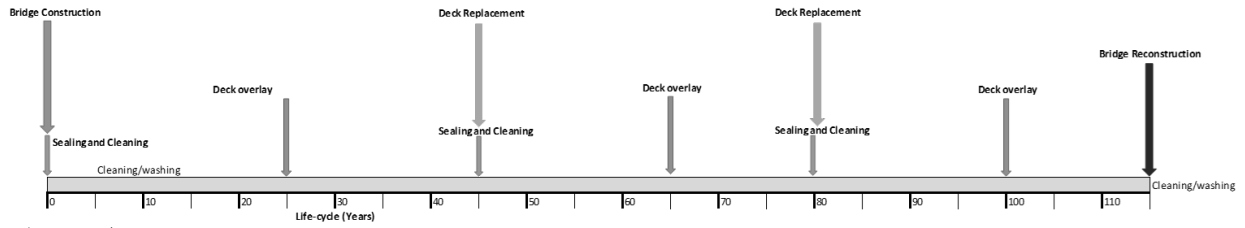

8.2. Alternative A Modified INDOT routine procedure

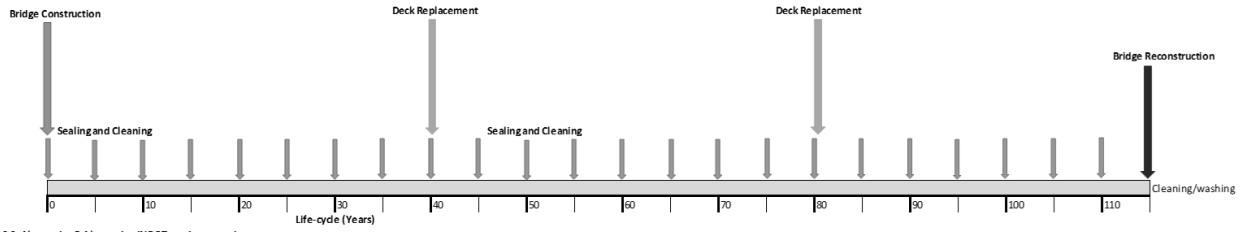

8.3. Alternative B Alternative INDOT routine procedure

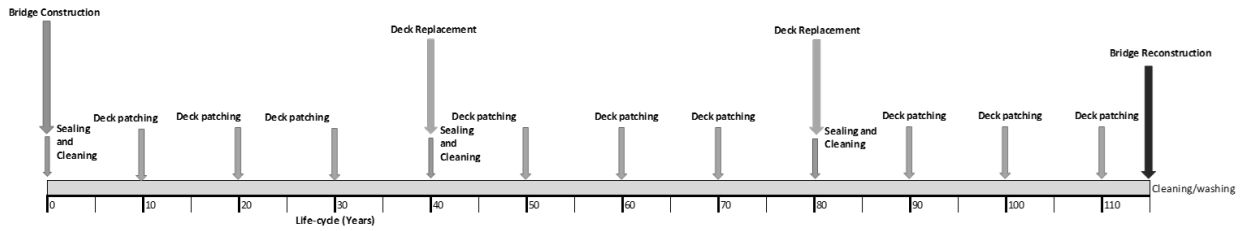

## APPENDIX E. LIFE-CYCLE COST INPUT FOR MATLAB

```
clear all, clc

%           LIFE CYCLE COST ANALYSIS - DETERMINISTIC APPROACH

%GENERAL COMMENTS

%           Description

% 1. CONCRETE SLAB ANALYSIS
% 2. PRESTRESSED CONCRETE BOX BEAMS ANALYSIS
% 3. PRESTRESSED CONCRETE AASHTO BEAMS ANALYSIS
% 4. STEEL BEAM 4 BEAMS ANALYSIS
% 5. STEEL BEAM 5 BEAMS ANALYSIS
% 6. STEEL FOLDED PLATE BEAM ANALYSIS
% 7. PRESTRESSED CONCRETE BULB TEE BEAMS ANALYSIS
% 8. STEEL GIRDER 5 BEAM ANALYSIS
% 9. PRESTRESSED CONCRETE AASHTO BEAMS ANALYSIS (Concrete diaphragms at
supports)
% 10. PRESTRESSED CONCRETE BULB TEE BEAMS ANALYSIS (Concrete diaphragms at
supports)
% 11. STEEL BEAM 4 BEAMS ANALYSIS (Galvanized)
% 12. STEEL BEAM 5 BEAMS ANALYSIS (Galvanized)
% 13. STEEL GIRDER 5 BEAM ANALYSIS (Galvanized)
% 14. SDCL 4 BEAMS ANALYSIS
% 15. SDCL 5 BEAMS ANALYSIS
% 16. SDCL 4 BEAMS ANALYSIS (Galvanized)
% 17. SDCL 5 BEAMS ANALYSIS (Galvanized)
% INTEREST EQUATIONS FOR DISCRETE AND CONTINUOUS COMPOUNDING
% LIFE CYCLE STANDARIZED PROFILES
%%

%General Values

wab=;           % Washing and Clenaning of decks
Ob=;           % Overlay
Seb=;         % Sealing and cleaning cracks
```

```

Dpb=;                % Deck Patching
BDRb=;              % Bridge deck reconstruction
Cwbb=;              % Cleaning and washing of bearings
BRb=;                % Elastomeric bearing replacement + Jacking
superstructure Elements
W=;                  % Width of the bridge
RPb=;                % Bridge repainting
SPb=;                % Bridge spot painting
Brem=;              % Bridge removal
Srec=;              % Structural Steel recycle

%%1 Concrete Slab
SCSpans=[L1 L2 ; P1 P2 ; N1 N2]';                % Main input
matrix [span length ; Initial cost ; Number of Spans]
LCCCSM=zeros(size(SCSpans,1)*3,6);

%%2 Prestressed Concrete Box
SPboxpans=[L1 L2 ; P1 P2 ; Pe1 Pe2 ; R1 R2 ; N1 N2]';                % Main input
matrix [Span ; Initial cost ; Exposed perimeter of beams (ft) ; Cost of
reinforcement of deck ; Number of Spans]
LCCPCBoxM=zeros(size(SPboxpans,1)*6,6);

%%3 Prestressed Concrete AASTHO Beam
SPbeampan=[L1 L2 ; P1 P2 ; Pe1 Pe2 ; R1 R2 ; N1 N2]';                % Main input
matrix [Span ; Initial cost ; Exposed perimeter of beams (ft) ; Cost of
reinforcement of deck ; Number of Spans]
LCCPCBeamM=zeros(size(SPbeampan,1)*3,6);

%%4 Steel Rolled Beam (4 beam configuration)
SSB4Bpans=[L1 L2 ; P1 P2 ; Pe1 Pe2 ; R1 R2 ; S1 S2 ; N1 N2]';                % Main input
matrix [Span ; Initial cost ; Exposed perimeter of beams (ft) ; Cost of
reinforcement of deck; Structural Steel weight ; Number of Spans]
LCCSB4M=zeros(size(SSB4Bpans,1)*12,6);

%%5 Steel Rolled Beam (5 beam configuration)
SSB5Bpans=[L1 L2 ; P1 P2 ; Pe1 Pe2 ; R1 R2 ; S1 S2 ; N1 N2]';                % Main input
matrix [Span ; Initial cost ; Exposed perimeter of beams (ft) ; Cost of
reinforcement of deck; Structural Steel weight ; Number of Spans]
LCCSB5M=zeros(size(SSB5Bpans,1)*12,6);

%%6 Steel Folded Plate

```



```

SSFPMpans=[L1 L2 ; P1 P2 ; Pe1 Pe2 ; R1 R2 ; S1 S2 ; N1 N2]'; % Main input
matrix [Span ; Initial cost ; Exposed perimeter of beams (ft) ; Cost of
reinforcement of deck; Structural Steel weight ; Number of Spans]

LCCSFPM=zeros(size(SSFPMpans,1)*12,6);

%%7 Prestressed Concrete Bulb Tee

SPCBTMpans=[L1 L2 ; P1 P2 ; Pe1 Pe2 ; R1 R2 ; N1 N2]'; % Main input
matrix [Span ; Initial cost ; Exposed perimeter of beams (ft) ; Cost of
reinforcement of deck ; Number of Spans]

LCCPCBTM=zeros(size(SPCBTMpans,1)*3,6);

%%8 Steel Plate Girder (5 Beam Configuration)

SSG5Bpans=[L1 L2 ; P1 P2 ; Pe1 Pe2 ; R1 R2 ; S1 S2 ; N1 N2]'; % Main input
matrix [Span ; Initial cost ; Exposed perimeter of beams (ft) ; Cost of
reinforcement of deck; Structural Steel weight ; Number of Spans]

LCCSSG5M=zeros(size(SSG5Bpans,1)*12,6);

%%9 Prestressed Concrete AASTHO Beam (Concrete diaphragms at supports)

SPbeampanasd=[L1 L2 ; P1 P2 ; Pe1 Pe2 ; R1 R2 ; N1 N2]'; % Main input
matrix [Span ; Initial cost ; Exposed perimeter of beams (ft) ; Cost of
reinforcement of deck ; Number of Spans]

LCCPCBeamMd=zeros(size(SPbeampanasd,1)*3,6);

%%10 Prestressed Concrete Bulb Tee (Concrete diaphragms at supports)

SPCBTMpanasd=[L1 L2 ; P1 P2 ; Pe1 Pe2 ; R1 R2 ; N1 N2]'; % Main input
matrix [Span ; Initial cost ; Exposed perimeter of beams (ft) ; Cost of
reinforcement of deck ; Number of Spans]

LCCPCBTMd=zeros(size(SPCBTMpanasd,1)*3,6);

%%11 Steel Rolled Beam (4 beam configuration Galvanized)

SSB4Bpansg=[L1 L2 ; P1 P2 ; Pe1 Pe2 ; R1 R2 ; S1 S2 ; N1 N2]'; % Main input
matrix [Span ; Initial cost ; Exposed perimeter of beams (ft) ; Cost of
reinforcement of deck; Structural Steel weight ; Number of Spans]

LCCSB4Mg=zeros(size(SSB4Bpansg,1)*3,6);

%%12 Steel Rolled Beam (5 beam configuration Galvanized)

SSB5Bpansg=[L1 L2 ; P1 P2 ; Pe1 Pe2 ; R1 R2 ; S1 S2 ; N1 N2]'; % Main input
matrix [Span ; Initial cost ; Exposed perimeter of beams (ft) ; Cost of
reinforcement of deck; Structural Steel weight ; Number of Spans]

LCCSB5Mg=zeros(size(SSB5Bpansg,1)*3,6);

%%13 Steel Plate Girder (5 Beam Configuration Galvanized)

SSG5Bpansg=[L1 L2 ; P1 P2 ; Pe1 Pe2 ; R1 R2 ; S1 S2 ; N1 N2]'; % Main input
matrix [Span ; Initial cost ; Exposed perimeter of beams (ft) ; Cost of
reinforcement of deck; Structural Steel weight ; Number of Spans]

LCCSSG5Mg=zeros(size(SSG5Bpansg,1)*3,6);

%14. SDCL 4 Beams

```

```
SSDCL4Bpans=[L1 L2 ; P1 P2 ; Pe1 Pe2 ; R1 R2 ; S1 S2 ; N1 N2]'; % Main input
matrix [Span ; Initial cost ; Exposed perimeter of beams (ft) ; Cost of
reinforcement of deck; Structural Steel weight ; Number of Spans]
```

```
LCCSDCL4M=zeros (size (SSDCL4Bpans,1)*6,6);
```

```
%15. SDCL 5 Beams
```

```
SSDCL5Bpans=[L1 L2 ; P1 P2 ; Pe1 Pe2 ; R1 R2 ; S1 S2 ; N1 N2]'; % Main input
matrix [Span ; Initial cost ; Exposed perimeter of beams (ft) ; Cost of
reinforcement of deck; Structural Steel weight ; Number of Spans]
```

```
LCCSDCL5M=zeros (size (SSDCL5Bpans,1)*6,6);
```

```
%16 SDCL 4 Beams (4 beam configuration Galvanized)
```

```
SSDCL4Bpansg=[L1 L2 ; P1 P2 ; Pe1 Pe2 ; R1 R2 ; S1 S2 ; N1 N2]';% Main input
matrix [Span ; Initial cost ; Exposed perimeter of beams (ft) ; Cost of
reinforcement of deck; Structural Steel weight ; Number of Spans]
```

```
LCCSDCL4Mg=zeros (size (SSDCL4Bpansg,1)*3,6);
```

```
%17 SDCL 5 Beams (5 Beam Configuration Galvanized)
```

```
SSDCL5Bpansg=[L1 L2 ; P1 P2 ; Pe1 Pe2 ; R1 R2 ; S1 S2 ; N1 N2]';% Main input
matrix [Span ; Initial cost ; Exposed perimeter of beams (ft) ; Cost of
reinforcement of deck; Structural Steel weight ; Number of Spans]
```

```
LCCSDCL5Mg=zeros (size (SSDCL5Bpansg,1)*3,6);
```

```
inf=i1:0.01:i2;
```

```
%DISCOUNT RATE RANGE
```

```
for z=0:size (inf,2)-1
```

```
in=inf (1,z+1);
```

```
%%
```

```
%1. Concrete Slab Life-cycle cost
```

```
SL=58;
```

```
% Service Life
```

```
LCS=LCCAS (SCSpans,LCCCSM,in,SL,W,wab,Ob,Seb,Dpb,Brem);
```

```
LCCS (:,1)=LCS (:,1);
```

```
LCCS (:,2)=LCS (:,2);
```

```
LCCS (:,3)=LCS (:,3);
```

```
LCCS (:,4)=LCS (:,4);
```

```
LCCS (:,2*z+5)=LCS (:,5);
```

```
LCCS (:,2*z+6)=LCS (:,6);
```

%%

%2. Prestressed Concrete Box Beam Life-cycle cost

SL=60; % Service Life  
NumBeam=5; % Number of Beams

LCB=LCCAPCB (SPboxpans, LCCPCBoxM, in, SL, W, wab, BDRb, Ob, Seb, Dpb, BRb, Cwbb, Brem, NumBeam);

LCCB(:, 1)=LCB(:, 1);

LCCB(:, 2)=LCB(:, 2);

LCCB(:, 3)=LCB(:, 3);

LCCB(:, 4)=LCB(:, 4);

LCCB(:, 2\*z+5)=LCB(:, 5);

LCCB(:, 2\*z+6)=LCB(:, 6);

%%

%3. Prestressed Concrete Beam Life-cycle cost

SL=65; % Service Life  
NumBeam=6; % Number of Beams

LCAB=LCCAPC (SPbeampan, LCCPCBeamM, in, SL, W, wab, BDRb, Ob, Seb, Dpb, BRb, Cwbb, Brem, NumBeam);

LCCAB(:, 1)=LCAB(:, 1);

LCCAB(:, 2)=LCAB(:, 2);

LCCAB(:, 3)=LCAB(:, 3);

LCCAB(:, 4)=LCAB(:, 4);

LCCAB(:, 2\*z+5)=LCAB(:, 5);

LCCAB(:, 2\*z+6)=LCAB(:, 6);

%%

%4. Steel Beam 4 Beams Life-cycle cost

```

SL=80; % Service Life
NumBeam=4; % Number of Beams

LCSS4B=LCCASS (SSB4Bpans, LCCSB4M, in, SL, W, wab, BDRb, Ob, Seb, Dpb, BRb, Cwbb, Brem, Num
Beam, SPb, RPb, Srec);

LCCSS4B(:,1)=LCSS4B(:,1);
LCCSS4B(:,2)=LCSS4B(:,2);
LCCSS4B(:,3)=LCSS4B(:,3);
LCCSS4B(:,4)=LCSS4B(:,4);
LCCSS4B(:,2*z+5)=LCSS4B(:,5);
LCCSS4B(:,2*z+6)=LCSS4B(:,6);

```

```

%%
%5. Steel Beam 5 Beams Life-cycle cost

```

```

SL=80; % Service Life
NumBeam=5; % Number of Beams

LCSS5B=LCCASS (SSB5Bpans, LCCSB5M, in, SL, W, wab, BDRb, Ob, Seb, Dpb, BRb, Cwbb, Brem, Num
Beam, SPb, RPb, Srec);

LCCSS5B(:,1)=LCSS5B(:,1);
LCCSS5B(:,2)=LCSS5B(:,2);
LCCSS5B(:,3)=LCSS5B(:,3);
LCCSS5B(:,4)=LCSS5B(:,4);
LCCSS5B(:,2*z+5)=LCSS5B(:,5);
LCCSS5B(:,2*z+6)=LCSS5B(:,6);

```

```

%%
%6. Steel Folded Plate Beam Life-cycle cost

```

```

SL=80; % Service Life
NumBeam=6; % Number of Beams

```

```
LCSSFP=LCCASS (SSFPMpans, LCCSFPM, in, SL, W, wab, BDRb, Ob, Seb, Dpb, BRb, Cwbb, Brem, Num  
Beam, SPb, RPb, Srec);
```

```
LCCSSFP(:, 1)=LCSSFP(:, 1);
```

```
LCCSSFP(:, 2)=LCSSFP(:, 2);
```

```
LCCSSFP(:, 3)=LCSSFP(:, 3);
```

```
LCCSSFP(:, 4)=LCSSFP(:, 4);
```

```
LCCSSFP(:, 2*z+5)=LCSSFP(:, 5);
```

```
LCCSSFP(:, 2*z+6)=LCSSFP(:, 6);
```

```
%%
```

```
%7. Prestressed Concrete Bulb Tee Beam Life-cycle cost
```

```
SL=65;
```

```
% Service Life
```

```
NumBeam=5;
```

```
% Number of Beams
```

```
LCBT=LCCAPC (SPCBTMpans, LCCPCBTM, in, SL, W, wab, BDRb, Ob, Seb, Dpb, BRb, Cwbb, Brem, Num  
Beam);
```

```
LCCBT(:, 1)=LCBT(:, 1);
```

```
LCCBT(:, 2)=LCBT(:, 2);
```

```
LCCBT(:, 3)=LCBT(:, 3);
```

```
LCCBT(:, 4)=LCBT(:, 4);
```

```
LCCBT(:, 2*z+5)=LCBT(:, 5);
```

```
LCCBT(:, 2*z+6)=LCBT(:, 6);
```

```
%%
```

```
%8. Steel Girder 5 Beams Life-cycle cost
```

```
SL=80;
```

```
% Service Life
```

```
NumBeam=5;
```

```
% Number of Beams
```

```
LCSG5B=LCCASS (SSG5Bpans, LCCSSG5M, in, SL, W, wab, BDRb, Ob, Seb, Dpb, BRb, Cwbb, Brem, Nu  
mBeam, SPb, RPb, Srec);
```

```
LCCSG5B(:, 1)=LCSG5B(:, 1);
```

```
LCCSG5B(:, 2)=LCSG5B(:, 2);
```

```
LCCSG5B(:, 3)=LCSG5B(:, 3);
```

```

LCCSG5B(:,4)=LCSG5B(:,4);
LCCSG5B(:,2*z+5)=LCSG5B(:,5);
LCCSG5B(:,2*z+6)=LCSG5B(:,6);
%%
%9. Prestressed Concrete Beam Life-cycle cost (Concrete Diaphragms at
%supports)

SL=80; % Service Life
NumBeam=6; % Number of Beams

LCABD=LCCAPCD(SPbeampansd,LCCPCBeamMd,in,SL,W,wab,BDRb,Ob,Seb,Dpb,BRb,Cwbb,Brem,NumBeam);
LCCABD(:,1)=LCABD(:,1);
LCCABD(:,2)=LCABD(:,2);
LCCABD(:,3)=LCABD(:,3);
LCCABD(:,4)=LCABD(:,4);
LCCABD(:,2*z+5)=LCABD(:,5);
LCCABD(:,2*z+6)=LCABD(:,6);

%%
%10. Prestressed Concrete Bulb Tee Beam Life-cycle cost (Concrete Diaphragms
at
%supports)

SL=80; % Service Life
NumBeam=5; % Number of Beams

LCBTD=LCCAPCD(SPCBTMpansd,LCCPCBTMd,in,SL,W,wab,BDRb,Ob,Seb,Dpb,BRb,Cwbb,Brem,NumBeam);
LCCBTD(:,1)=LCBTD(:,1);
LCCBTD(:,2)=LCBTD(:,2);
LCCBTD(:,3)=LCBTD(:,3);
LCCBTD(:,4)=LCBTD(:,4);
LCCBTD(:,2*z+5)=LCBTD(:,5);

```

```
LCCBTD(:, 2*z+6)=LCBTD(:, 6);
```

```
%%
```

```
%11. Steel Beam 4 Beams Life-cycle cost (Galvanized)
```

```
SL=100; % Service Life  
NumBeam=4; % Number of Beams
```

```
LCSS4BG=LCCASSG(SSB4Bpansg, LCCSB4Mg, in, SL, W, wab, BDRb, Ob, Seb, Dpb, BRb, Cwbb, Brem  
, NumBeam, SPb, RPb, Srec);
```

```
LCSS4BG(:, 1)=LCSS4BG(:, 1);
```

```
LCSS4BG(:, 2)=LCSS4BG(:, 2);
```

```
LCSS4BG(:, 3)=LCSS4BG(:, 3);
```

```
LCSS4BG(:, 4)=LCSS4BG(:, 4);
```

```
LCSS4BG(:, 2*z+5)=LCSS4BG(:, 5);
```

```
LCSS4BG(:, 2*z+6)=LCSS4BG(:, 6);
```

```
%%
```

```
%12. Steel Beam 5 Beams Life-cycle cost
```

```
SL=100; % Service Life  
NumBeam=5; % Number of Beams
```

```
LCSS5BG=LCCASSG(SSB5Bpansg, LCCSB5Mg, in, SL, W, wab, BDRb, Ob, Seb, Dpb, BRb, Cwbb, Brem  
, NumBeam, SPb, RPb, Srec);
```

```
LCSS5BG(:, 1)=LCSS5BG(:, 1);
```

```
LCSS5BG(:, 2)=LCSS5BG(:, 2);
```

```
LCSS5BG(:, 3)=LCSS5BG(:, 3);
```

```
LCSS5BG(:, 4)=LCSS5BG(:, 4);
```

```
LCSS5BG(:, 2*z+5)=LCSS5BG(:, 5);
```

```
LCSS5BG(:, 2*z+6)=LCSS5BG(:, 6);
```

```
%%
```

```
%13. Steel Girder 5 Beams Life-cycle cost
```

```

SL=100; % Service Life
NumBeam=5; % Number of Beams

LCSG5BG=LCCASSG(SSG5Bpansg,LCCSSG5Mg,in,SL,W,wab,BDRb,Ob,Seb,Dpb,BRb,Cwbb,Brem,NumBeam,SPb,RPb,Srec);

LCCSG5BG(:,1)=LCSG5BG(:,1);
LCCSG5BG(:,2)=LCSG5BG(:,2);
LCCSG5BG(:,3)=LCSG5BG(:,3);
LCCSG5BG(:,4)=LCSG5BG(:,4);
LCCSG5BG(:,2*z+5)=LCSG5BG(:,5);
LCCSG5BG(:,2*z+6)=LCSG5BG(:,6);

```

```

%%
%14. SDCL 4 Beams Life-cycle cost

```

```

SL=80; % Service Life
NumBeam=4; % Number of Beams

LCSSDCL4B=LCCASDCL(SSDCL4Bpans,LCCSDCL4M,in,SL,W,wab,BDRb,Ob,Seb,Dpb,BRb,Cwbb,Brem,NumBeam,SPb,RPb,Srec);

LCCSSDCL4B(:,1)=LCSSDCL4B(:,1);
LCCSSDCL4B(:,2)=LCSSDCL4B(:,2);
LCCSSDCL4B(:,3)=LCSSDCL4B(:,3);
LCCSSDCL4B(:,4)=LCSSDCL4B(:,4);
LCCSSDCL4B(:,2*z+5)=LCSSDCL4B(:,5);
LCCSSDCL4B(:,2*z+6)=LCSSDCL4B(:,6);

```

```

%%
%15. SDCL 5 Beams Life-cycle cost

```

```

SL=80; % Service Life
NumBeam=5; % Number of Beams

```



```
LCSSDCL5B=LCCASDCL (SSDCL5Bpans, LCCSDCL5M, in, SL, W, wab, BDRb, Ob, Seb, Dpb, BRb, Cwbb, Brem, NumBeam, SPb, RPb, Srec) ;
```

```
LCCSSDCL5B (:, 1)=LCSSDCL5B (:, 1) ;
```

```
LCCSSDCL5B (:, 2)=LCSSDCL5B (:, 2) ;
```

```
LCCSSDCL5B (:, 3)=LCSSDCL5B (:, 3) ;
```

```
LCCSSDCL5B (:, 4)=LCSSDCL5B (:, 4) ;
```

```
LCCSSDCL5B (:, 2*z+5)=LCSSDCL5B (:, 5) ;
```

```
LCCSSDCL5B (:, 2*z+6)=LCSSDCL5B (:, 6) ;
```

```
%%
```

```
%16. SDCL 4 Beams Life-cycle cost (Galvanized)
```

```
SL=80;
```

```
% Service Life
```

```
NumBeam=4;
```

```
% Number of Beams
```

```
LCSSDCL4Bg=LCCASDCLG (SSDCL4Bpansg, LCCSDCL4Mg, in, SL, W, wab, BDRb, Ob, Seb, Dpb, BRb, Cwbb, Brem, NumBeam, SPb, RPb, Srec) ;
```

```
LCCSSDCL4Bg (:, 1)=LCSSDCL4Bg (:, 1) ;
```

```
LCCSSDCL4Bg (:, 2)=LCSSDCL4Bg (:, 2) ;
```

```
LCCSSDCL4Bg (:, 3)=LCSSDCL4Bg (:, 3) ;
```

```
LCCSSDCL4Bg (:, 4)=LCSSDCL4Bg (:, 4) ;
```

```
LCCSSDCL4Bg (:, 2*z+5)=LCSSDCL4Bg (:, 5) ;
```

```
LCCSSDCL4Bg (:, 2*z+6)=LCSSDCL4Bg (:, 6) ;
```

```
%%
```

```
%17. SDCL 5 Beams Life-cycle cost (Galvanized)
```

```
SL=80;
```

```
% Service Life
```

```
NumBeam=5;
```

```
% Number of Beams
```

```
LCSSDCL5Bg=LCCASDCLG (SSDCL5Bpansg, LCCSDCL5Mg, in, SL, W, wab, BDRb, Ob, Seb, Dpb, BRb, Cwbb, Brem, NumBeam, SPb, RPb, Srec) ;
```

```
LCCSSDCL5Bg (:, 1)=LCSSDCL5Bg (:, 1) ;
```

```
LCCSSDCL5Bg (:, 2)=LCSSDCL5Bg (:, 2) ;
```

```

LCCSSDCL5Bg(:,3)=LCSSDCL5Bg(:,3);
LCCSSDCL5Bg(:,4)=LCSSDCL5Bg(:,4);
LCCSSDCL5Bg(:,2*z+5)=LCSSDCL5Bg(:,5);
LCCSSDCL5Bg(:,2*z+6)=LCSSDCL5Bg(:,6);

end

%%
%INTEREST EQUATIONS FOR DISCRETE AND CONTINUOUS COMPOUNDING

function F = SPCAF (i,N) %Single payment compound amount
factor. Future value do to a single present cost
    F=(1+i).^N;
end

function P = SPPWF (i,N) %Single payment worth factor.
Present value of a single future cost
    P=1./((1+i).^N);
end

function A = SFDF (i,N) %Sinking fund deposit factor.
Equally distributed payments equivalet to a future cost
    A=i./(((1+i).^N)-1);
end

function F = USCAF (i,N) %Uniform series compound amount
factor. Future value equivalent to a equally distributed payments
    F=(((1+i).^N)-1)./i;
end

function P = USPWF (i,N) %Uniform series present worth
factor. Present value equivalent to a equally distributed payments
    P=(((1+i).^N)-1)/(i.*((1+i).^N));
end

function A = CRF (i,N) %Capital recovery facotr. Equally
distributed payments equivalent to a present cost.
    A=(i.*((1+i).^N))./(((1+i).^N)-1);
end

function C = LCCAP (i,N,P) %Capital recovery facotr. Equally
distributed payments equivalent to a present cost.

```

```

        C=P./((1+i).^N)-1);
end

%%
%LIFE CYCLE STANDARIZED PROFILES

%1. Concrete Slabs
function LCCPCM = LCCAS (Spans,Analysis,in,SL,W,wab,Ob,Seb,Dpb,Brem)
for k=0:size(Spans,1)-1
    L=Spans (k+1,1); % Bridge Length
    BC=Spans (k+1,2); % Length and Initial
bridge construction cost
    BCL=BC*SPCAF(in,SL); % Bridge construction
future cost
    Area=L*W;
    wa=wab*Area; % Washing and
cleaning of deck
    waL=wa*USCAF(in,SL); % Washing and
cleaning of deck future cost annually distributed
    O=Ob*Area; % Overlay
    Se=Seb*Area; % Sealing and
cleaning od cracks
    Dp=Dpb*Area*0.1; % 10% of the deck
area patched
    BRem= Brem*Area; % Bridge removal
value, cost at the end of the Service Life
%%
    %Life-cycle profile 1.1 INDOT Routine procedure
    %Years in which Overlays are done.
AcYO=[25 50]';
AcYOL=zeros(length(AcYO),1);
for i=1:length(AcYO)
    AcYOL (i,1)= O.*SPCAF(in,SL-AcYO(i,1));
end

%Years in which Sealing procedures are done.

```

```

AcYSe=[0]';
AcYSeL=zeros(length(AcYSe),1);
for i=1:length(AcYSe)
    AcYSeL(i,1)= Se.*SPCAF(in,SL-AcYSe(i,1));
end

Analysis(3*k+1,1)=1.1;
Analysis(3*k+1,2)=L;
Analysis(3*k+1,3)=BCL+sum(AcYOL)+sum(AcYSeL)+waL+BRem;
Analysis(3*k+1,4)=SL;
Analysis(3*k+1,5)=in;
Analysis(3*k+1,6)=LCCAP(Analysis(3*k+1,5),Analysis(3*k+1,4),Analysis(3*k+1,3));

%%
    %Life-cycle profile 1.2. Reccommended INDOT routine Procedure
%Years in which Overlays are done.
AcYO=[40]';
AcYOL=zeros(length(AcYO),1);
for i=1:length(AcYO)
    AcYOL(i,1)= 0.*SPCAF(in,SL-AcYO(i,1));
end

%Years in which Sealing procedures are done.
Sefreq=5;
AcYSe=[0];
AcYSeL=zeros(length(AcYSe),1);
for i=0:fix(SL/Sefreq)
    AcYSe(i+1,1)=(Sefreq).*i;
end
for i=1:length(AcYSe)
    AcYSeL(i,1)= Se.*SPCAF(in,SL-AcYSe(i,1));
end

```

```

Analysis(3*k+2,1)=1.2;
Analysis(3*k+2,2)=L;
Analysis(3*k+2,3)=BCL+sum(AcYOL)+sum(AcYSeL)+waL+BRem;
Analysis(3*k+2,4)=SL;
Analysis(3*k+2,5)=in;
Analysis(3*k+2,6)=LCCAP(Analysis(3*k+2,5),Analysis(3*k+2,4),Analysis(3*k+2,3)
);

%%
    %Life-cycle profile 1.3. Alternative INDOT routine Procedure
%Years in which Overlays are done.
AcYO=[30]';
AcYOL=zeros(length(AcYO),1);
for i=1:length(AcYO)
    AcYOL(i,1)=0.*SPCAF(in,SL-AcYO(i,1));
end

%Years in which Deck patching procedures are done.
Dpfreq=10;
AcYDp=[0];
AcYDpL=zeros(length(AcYDp),1);
for i=1:fix(SL/Dpfreq)
    AcYDp(i,1)=(Dpfreq).*i;
end
for i=1:length(AcYDp)
    j=1;
    if AcYDp(i,1)==AcYO(j,1)
        AcYDpL(i,1)=0;
        j=j+1;
    else
        AcYDpL(i,1)=Dp.*SPCAF(in,SL-AcYDp(i,1));
    end
end
end

```

```

Analysis(3*k+3,1)=1.3;
Analysis(3*k+3,2)=L;
Analysis(3*k+3,3)=BCL+sum(AcYOL)+sum(AcYDpL)+waL+BRem;
Analysis(3*k+3,4)=SL;
Analysis(3*k+3,5)=in;
Analysis(3*k+3,6)=LCCAP(Analysis(3*k+3,5),Analysis(3*k+3,4),Analysis(3*k+3,3)
);

```

```
end
```

```
LCCPCM=Analysis;
```

```
end
```

```
%%
```

```

function LCCPCM = LCCAPC
(Spans,Analysis,in,SL,W,wab,BDRb,Ob,Seb,Dpb,BRb,Cwbb,Brem,NumBeam)
for k=0:size(Spans,1)-1
    L=Spans(k+1,1); % Bridge Length
    BC=Spans(k+1,2); % Length and Initial
    bridge construction cost
    BCL=BC*SPCAF(in,SL); % Bridge construction
    future cost
    Area=L*W;
    wa=wab*Area; % Washing and
    cleaning of deck
    waL=wa*USCAF(in,SL); % Washing and
    cleaning of deck future cost annually distributed
    O=Ob*Area; % Overlay
    BDR=BDRb*Area; % Bridge Deck
    Reconstruction cost
    Se=Seb*Area; % Sealing and
    cleaning of cracks
    Dp=Dpb*Area*0.1; % 10% of the deck
    area patched
    BR=BRb*NumBeam*(1+Spans(k+1,5)); % Bearing
    Replacement Cost
    Cwb=Cwbb*NumBeam*(1+Spans(k+1,5)); % Cleaning and
    Washing of Bearings

```

```

    BRem= Brem*Area; % Bridge removal
value, cost at the end of the Service Life
%%
    %Life-cycle profile 2.1 INDOT Routine procedure
%Years in which Overlays are done.
AcYO=[25]';
AcYOL=zeros(length(AcYO),1);
for i=1:length(AcYO)
    AcYOL (i,1)= O.*SPCAF(in,SL-AcYO(i,1));
end
%Years in which Deck Reconstruction is done.
AcYR=[45]';
AcYRL=zeros(length(AcYR),1);
for i=1:length(AcYR)
    AcYRL (i,1)= BDR.*SPCAF(in,SL-AcYR(i,1))+Spans (k+1,4)*SPCAF(in,SL-
AcYR(i,1));
end
%Years in which Sealing procedures are done.
AcYSe=[0 45]';
AcYSeL=zeros(length(AcYSe),1);
for i=1:length(AcYSe)
    AcYSeL (i,1)= Se.*SPCAF(in,SL-AcYSe(i,1));
end
%Years in which bearing replacements are done.
AcYBR=[45]';
AcYBRL=zeros(length(AcYBR),1);
for i=1:length(AcYBR)
    AcYBRL (i,1)= BR.*SPCAF(in,SL-AcYBR(i,1));
end

Analysis(3*k+1,1)=2.11;
Analysis(3*k+1,2)=L;
Analysis(3*k+1,3)=BCL+sum(AcYOL)+sum (AcYSeL)+sum (AcYRL)+sum
(AcYBRL)+waL+BRem;
Analysis(3*k+1,4)=SL;

```

```

Analysis(3*k+1,5)=in;
Analysis(3*k+1,6)=LCCAP(Analysis(3*k+1,5),Analysis(3*k+1,4),Analysis(3*k+1,3)
);

%%
    %Life-cycle profile 2.2. Recommended INDOT routine Procedure
%Years in which Deck Reconstruction is done.
AcYR=[40]';
AcYRL=zeros(length(AcYR),1);
for i=1:length(AcYR)
    AcYRL(i,1)= BDR.*SPCAF(in,SL-AcYR(i,1))+Spans(k+1,4)*SPCAF(in,SL-
AcYR(i,1));
end

%Years in which Deck Sealing procedures are done.
Sefreq=5;
AcYSe=[0];
AcYSeL=zeros(length(AcYSe),1);
for i=0:fix(SL/Sefreq)
    AcYSe(i+1,1)=(Sefreq).*i;
end
for i=1:length(AcYSe)
    AcYSeL(i,1)= Se.*SPCAF(in,SL-AcYSe(i,1));
end

%Years in which bearing replacements are done.
AcYBR=[40]';
AcYBRL=zeros(length(AcYBR),1);
for i=1:length(AcYBR)
    AcYBRL(i,1)= BR.*SPCAF(in,SL-AcYBR(i,1));
end

Analysis(3*k+2,1)=2.21;

```



```

Analysis(3*k+2,2)=L;
Analysis(3*k+2,3)=BCL+sum(AcYRL)+sum (AcYSeL)+waL+sum (AcYBRL)+BRem;
Analysis(3*k+2,4)=SL;
Analysis(3*k+2,5)=in;
Analysis(3*k+2,6)=LCCAP(Analysis(3*k+2,5),Analysis(3*k+2,4),Analysis(3*k+2,3)
);

%%
    %Life-cycle profile 2.3. Alternative INDOT routine Procedure

%Years in which Deck Reconstruction is done.
AcYR=[40]';
AcYRL=zeros(length(AcYR),1);
for i=1:length(AcYR)
    AcYRL(i,1)= BDR.*SPCAF(in,SL-AcYR(i,1))+Spans(k+1,4)*SPCAF(in,SL-
AcYR(i,1));
end

%Years in which Deck patching procedures are done.
Dpfreq=10;
AcYDp=[0];
AcYDpL=zeros(length(AcYDp),1);
for i=1:fix(SL/Dpfreq)
    AcYDp(i,1)=(Dpfreq).*i;
end
for i=1:length(AcYDp)
    j=1;
    if AcYDp(i,1)==AcYR(j,1)
        AcYDpL(i,1)=0;
        j=j+1;
    else
        AcYDpL(i,1)= Dp.*SPCAF(in,SL-AcYDp(i,1));
    end
end
end

```

```

%Years in which bearing replacements are done.
AcYBR=[40]';
AcYBRL=zeros(length(AcYBR),1);
for i=1:length(AcYBR)
    AcYBRL (i,1)= BR.*SPCAF(in,SL-AcYBR(i,1));
end

%Years in which Sealing procedures are done.
AcYSe=[0 40]';
AcYSeL=zeros(length(AcYSe),1);
for i=1:length(AcYSe)
    AcYSeL (i,1)= Se.*SPCAF(in,SL-AcYSe(i,1));
end

Analysis(3*k+3,1)=2.31;
Analysis(3*k+3,2)=L;
Analysis(3*k+3,3)=BCL+sum(AcYRL)+sum(AcYDpL)+sum(AcYSeL)+waL+sum
(AcYBRL)+BRem;
Analysis(3*k+3,4)=SL;
Analysis(3*k+3,5)=in;
Analysis(3*k+3,6)=LCCAP(Analysis(3*k+3,5),Analysis(3*k+3,4),Analysis(3*k+3,3)
);

end
LCCPCM=Analysis;
end

%%
%3. Prestressed Concrete Box beams
function LCCPCM = LCCAPCB
(Spans,Analysis,in,SL,W,wab,BDRb,Ob,Seb,Dpb,BRb,Cwbb,Brem,NumBeam)
for k=0:size(Spans,1)-1
    L=Spans (k+1,1); % Bridge Length

```

```

    BC=Spans (k+1,2); % Length and Initial
bridge construction cost

    BCL=BC*SPCAF(in,SL); % Bridge construction
future cost

    Area=L*W;

    wa=wab*Area; % Washing and
cleaning of deck

    waL=wa*USCAF(in,SL); % Washing and
cleaning of deck future cost annually distributed

    O=Ob*Area; % Overlay

    BDR=BDRb*Area; % Bridge Deck
Reconstruction cost

    Se=Seb*Area; % Sealing and
cleaning od cracks

    Dp=Dpb*Area*0.1; % 10% of the deck
area patched

    BR=BRb*NumBeam*(1+Spans (k+1,5)); %
Bearing Replacement Cost

    Cwb=Cwbb*NumBeam*(1+Spans (k+1,5)); %
Cleaning and Washing of Bearings

    BRem= Brem*Area; % Bridge removal
value, cost at the end of the Service Life

%%

    %Life-cycle profile 3.1 INDOT Routine procedure
%Years in which Overlays are done.
AcYO=[25]';
AcYOL=zeros(length(AcYO),1);
for i=1:length(AcYO)
    AcYOL (i,1)= O.*SPCAF(in,SL-AcYO(i,1));
end

%Years in which Deck Reconstruction is done.
AcYR=[45]';
AcYRL=zeros(length(AcYR),1);
for i=1:length(AcYR)
    AcYRL (i,1)= BDR.*SPCAF(in,SL-AcYR(i,1))+Spans (k+1,4)*SPCAF(in,SL-
AcYR(i,1));
end

%Years in which Sealing procedures are done.

```

```

AcYSe=[0 45]';
AcYSeL=zeros(length(AcYSe),1);
for i=1:length(AcYSe)
    AcYSeL(i,1)= Se.*SPCAF(in,SL-AcYSe(i,1));
end
%Years in which bearing replacements are done.
AcYBR=[45]';
AcYBRL=zeros(length(AcYBR),1);
for i=1:length(AcYBR)
    AcYBRL(i,1)= BR.*SPCAF(in,SL-AcYBR(i,1));
end

Analysis(3*k+1,1)=3.11;
Analysis(3*k+1,2)=L;
Analysis(3*k+1,3)=BCL+sum(AcYOL)+sum(AcYSeL)+sum(AcYRL)+sum
(AcYBRL)+waL+BRem;
Analysis(3*k+1,4)=SL;
Analysis(3*k+1,5)=in;
Analysis(3*k+1,6)=LCCAP(Analysis(3*k+1,5),Analysis(3*k+1,4),Analysis(3*k+1,3)
);

%%
    %Life-cycle profile 3.2. Recommended INDOT routine Procedure
%Years in which Deck Reconstruction is done.
AcYR=[40]';
AcYRL=zeros(length(AcYR),1);
for i=1:length(AcYR)
    AcYRL(i,1)= BDR.*SPCAF(in,SL-AcYR(i,1))+Spans(k+1,4)*SPCAF(in,SL-
AcYR(i,1));
end

%Years in which Deck Sealing procedures are done.
Sefreq=5;
AcYSe=[0];
AcYSeL=zeros(length(AcYSe),1);

```

```

for i=0:fix(SL/Sefreq)
    AcYSe(i+1,1)=(Sefreq).*i;
end
for i=1:length(AcYSe)
    AcYSeL (i,1)= Se.*SPCAF(in,SL-AcYSe(i,1));
end

%Years in which bearing replacements are done.
AcYBR=[40]';
AcYBRL=zeros(length(AcYBR),1);
for i=1:length(AcYBR)
    AcYBRL (i,1)= BR.*SPCAF(in,SL-AcYBR(i,1));
end

Analysis(3*k+2,1)=3.21;
Analysis(3*k+2,2)=L;
Analysis(3*k+2,3)=BCL+sum(AcYRL)+sum (AcYSeL)+waL+sum (AcYBRL)+BRem;
Analysis(3*k+2,4)=SL;
Analysis(3*k+2,5)=in;
Analysis(3*k+2,6)=LCCAP(Analysis(2*k+2,5),Analysis(3*k+2,4),Analysis(3*k+2,3)
);

%%
    %Life-cycle profile 3.3. Alternative INDOT routine Procedure

%Years in which Deck Reconstruction is done.
AcYR=[40]';
AcYRL=zeros(length(AcYR),1);
for i=1:length(AcYR)
    AcYRL (i,1)= BDR.*SPCAF(in,SL-AcYR(i,1))+Spans (k+1,4)*SPCAF(in,SL-
AcYR(i,1));
end

%Years in which Deck patching procedures are done.

```

```

Dpfreq=10;
AcYDp=[0];
AcYDpL=zeros(length(AcYDp),1);
for i=1:fix(SL/Dpfreq)
    AcYDp(i,1)=(Dpfreq).*i;
end
for i=1:length(AcYDp)
    j=1;
    if AcYDp(i,1)==AcYR(j,1)
        AcYDpL(i,1)=0;
        j=j+1;
    else
        AcYDpL(i,1)=Dp.*SPCAF(in,SL-AcYDp(i,1));
    end
end

%Years in which bearing replacements are done.
AcYBR=[40]';
AcYBRL=zeros(length(AcYBR),1);
for i=1:length(AcYBR)
    AcYBRL(i,1)=BR.*SPCAF(in,SL-AcYBR(i,1));
end

%Years in which Sealing procedures are done.
AcYSe=[0 40]';
AcYSeL=zeros(length(AcYSe),1);
for i=1:length(AcYSe)
    AcYSeL(i,1)=Se.*SPCAF(in,SL-AcYSe(i,1));
end

Analysis(3*k+3,1)=3.31;
Analysis(3*k+3,2)=L;
Analysis(3*k+3,3)=BCL+sum(AcYRL)+sum(AcYDpL)+sum(AcYSeL)+waL+sum
(AcYBRL)+BRem;

```

```

Analysis(3*k+3,4)=SL;
Analysis(3*k+3,5)=in;
Analysis(3*k+3,6)=LCCAP(Analysis(3*k+3,5),Analysis(3*k+3,4),Analysis(3*k+3,3)
);

end

LCCPCM=Analysis;

end

%%

%4. Structural Steel Elements

function LCCPCM = LCCASS
(Spans,Analysis,in,SL,W,wab,BDRb,Ob,Seb,Dpb,BRb,Cwbb,Brem,NumBeam,SPb,RPb,Sre
c)

for k=0:size(Spans,1)-1

    L=Spans (k+1,1); % Bridge Length
    BC=Spans (k+1,2); % Length and Initial
bridge construction cost
    BCL=BC*SPCAF(in,SL); % Length and Initial
bridge construction cost
    Area=L*W; % Bridge construction
future cost
    wa=wab*Area; % Washing and
cleaning of deck
    waL=wa*USCAF(in,SL); % Washing and
cleaning of deck future cost annually distributed
    BDR=BDRb*Area; % Bridge Deck
Reconstruction cost
    O=Ob*Area; % Overlay
    Se=Seb*Area; % Sealing and
cleaning od cracks
    Dp=Dpb*Area*0.1; % 10% of the deck
area patched
    RatioP=0.10; %Percentage of
exposed area to spot paint
    SP=SPb*Spans (k+1,3)*Spans (k+1,1)*RatioP*NumBeam; % Spot painting Cost
    RP=RPb*Spans (k+1,3)*Spans (k+1,1)*NumBeam; % Full repainting
Cost

```

```

BR=BRb*NumBeam*(Spans (k+1,6)); %
Bearing Replacement Cost

Cwb=Cwbb*NumBeam*(Spans (k+1,6)); %
Cleaning and Washing of Bearings

BRem= Brem*Area; % Bridge removal
value, cost at the end of the Service Life

SRec= Srec*NumBeam*Spans(k+1,5); % Cost of structural
steel recycle per pound for all beams
%%

%Life-cycle profile 4.1 INDOT Routine procedure
    %Life-cycle profile 4.1.1 Single bearing replacement
%Years in which Overlays are done.
AcYO=[25 65]';
AcYOL=zeros(length(AcYO),1);
for i=1:length(AcYO)
    AcYOL (i,1)= 0.*SPCAF(in,SL-AcYO(i,1));
end

%Years in which Deck Reconstruction is done.
AcYR=[45]';
AcYRL=zeros(length(AcYR),1);
for i=1:length(AcYR)
    AcYRL (i,1)= BDR.*SPCAF(in,SL-AcYR(i,1))+Spans (k+1,4)*SPCAF(in,SL-
AcYR(i,1));
end

%Years in which Sealing procedures are done.
AcYSe=[0 45]';
AcYSeL=zeros(length(AcYSe),1);
for i=1:length(AcYSe)
    AcYSeL (i,1)= Se.*SPCAF(in,SL-AcYSe(i,1));
end

%Years in which bearing replacements are done.
AcYBR=[45]';
AcYBRL=zeros(length(AcYBR),1);
for i=1:length(AcYBR)
    AcYBRL (i,1)= BR.*SPCAF(in,SL-AcYBR(i,1));
end

```



```

%Years in which full repaintings are done.
AcYRP=[35 55]';
AcYRPL=zeros(length(AcYRP),1);
for i=1:length(AcYRP)
    AcYRPL(i,1)=RP.*SPCAF(in,SL-AcYRP(i,1));
end

Analysis(6*k+1,1)=4.111;
Analysis(6*k+1,2)=L;
Analysis(6*k+1,3)=BCL+sum(AcYOL)+sum(AcYSeL)+sum(AcYRL)+sum(AcYBRL)+sum
(AcYRPL)+waL+BRem-SRec;
Analysis(6*k+1,4)=SL;
Analysis(6*k+1,5)=in;
Analysis(6*k+1,6)=LCCAP(Analysis(6*k+1,5),Analysis(6*k+1,4),Analysis(6*k+1,3)
);

%%
    %Life-cycle profile 4.1.2 Spot repainting of beam elements
%Years in which Overlays are done.
AcYO=[25 65]';
AcYOL=zeros(length(AcYO),1);
for i=1:length(AcYO)
    AcYOL(i,1)=0.*SPCAF(in,SL-AcYO(i,1));
end
%Years in which Deck Reconstruction is done.
AcYR=[45]';
AcYRL=zeros(length(AcYR),1);
for i=1:length(AcYR)
    AcYRL(i,1)=BDR.*SPCAF(in,SL-AcYR(i,1))+Spans(k+1,4)*SPCAF(in,SL-
AcYR(i,1));
end
%Years in which Sealing procedures are done.

```

```

AcYSe=[0 45]';
AcYSeL=zeros(length(AcYSe),1);
for i=1:length(AcYSe)
    AcYSeL(i,1)= Se.*SPCAF(in,SL-AcYSe(i,1));
end
%Years in which bearing replacements are done.
AcYBR=[45]';
AcYBRL=zeros(length(AcYBR),1);
for i=1:length(AcYBR)
    AcYBRL(i,1)= BR.*SPCAF(in,SL-AcYBR(i,1));
end

%Years in which spot paintings are done.
SPfreq=10;
AcYSP=[0];
AcYSPL=zeros(length(AcYSP),1);
for i=1:fix(SL/SPfreq)
    AcYSP(i,1)=(SPfreq).*i;
end
for i=1:length(AcYSP)
    if AcYSP(i,1)==SL
        AcYSPL(i,1)=0;
    else
        AcYSPL(i,1)= SP.*SPCAF(in,SL-AcYSP(i,1));
    end
end

Analysis(6*k+2,1)=4.112;
Analysis(6*k+2,2)=L;
Analysis(6*k+2,3)=BCL+sum(AcYOL)+sum(AcYSeL)+sum(AcYRL)+sum(AcYBRL)+sum
(AcYSPL)+waL+BRem-SRec;
Analysis(6*k+2,4)=SL;
Analysis(6*k+2,5)=in;

```

```
Analysis(6*k+2,6)=LCCAP(Analysis(6*k+2,5),Analysis(6*k+2,4),Analysis(6*k+2,3)
);
```

```
%%
```

```
    %Life-cycle profile 4.2. Recommended INDOT routine Procedure
```

```
        %Life-cycle profile 4.2.1 Single bearing replacement
```

```
%Years in which Deck Reconstruction is done.
```

```
AcYR=[40]';
```

```
AcYRL=zeros(length(AcYR),1);
```

```
for i=1:length(AcYR)
```

```
    AcYRL(i,1)= BDR.*SPCAF(in,SL-AcYR(i,1))+Spans(k+1,4)*SPCAF(in,SL-
AcYR(i,1));
```

```
end
```

```
%Years in which Deck Sealing procedures are done.
```

```
Sefreq=5;
```

```
AcYSe=[0];
```

```
AcYSeL=zeros(length(AcYSe),1);
```

```
for i=0:fix(SL/Sefreq)
```

```
    AcYSe(i+1,1)=(Sefreq).*i;
```

```
end
```

```
for i=1:length(AcYSe)
```

```
    AcYSeL(i,1)= Se.*SPCAF(in,SL-AcYSe(i,1));
```

```
end
```

```
%Years in which bearing replacements are done.
```

```
AcYBR=[40]';
```

```
AcYBRL=zeros(length(AcYBR),1);
```

```
for i=1:length(AcYBR)
```

```
    AcYBRL(i,1)= BR.*SPCAF(in,SL-AcYBR(i,1));
```

```
end
```

```
%Years in which full repaintings are done.
```

```
AcYRP=[30 60]';
```

```

AcYRPL=zeros (length (AcYRP) , 1);
for i=1:length (AcYRP)
    AcYRPL (i,1)= RP.*SPCAF (in,SL-AcYRP (i,1));
end

Analysis (6*k+3,1)=4.211;
Analysis (6*k+3,2)=L;
Analysis (6*k+3,3)=BCL+sum (AcYRL)+sum (AcYSeL)+waL+sum (AcYBRL)+sum
(AcYRPL)+BRem-SRec;
Analysis (6*k+3,4)=SL;
Analysis (6*k+3,5)=in;
Analysis (6*k+3,6)=LCCAP (Analysis (6*k+3,5) , Analysis (6*k+3,4) , Analysis (6*k+3,3)
);

%%
                                %Life-cycle profile 4.2.2 Spot repainting of beam elements
%Years in which Deck Reconstruction is done.
AcYR=[40]';
AcYRL=zeros (length (AcYR) , 1);
for i=1:length (AcYR)
    AcYRL (i,1)= BDR.*SPCAF (in,SL-AcYR (i,1))+Spans (k+1,4)*SPCAF (in,SL-
AcYR (i,1));
end

%Years in which Deck Sealing procedures are done.
Sefreq=5;
AcYSe=[0];
AcYSeL=zeros (length (AcYSe) , 1);
for i=0:fix (SL/Sefreq)
    AcYSe (i+1,1)=(Sefreq) .*i;
end
for i=1:length (AcYSe)
    AcYSeL (i,1)= Se.*SPCAF (in,SL-AcYSe (i,1));
end

```

```

%Years in which bearing replacements are done.
AcYBR=[40]';
AcYBRL=zeros(length(AcYBR),1);
for i=1:length(AcYBR)
    AcYBRL (i,1)= BR.*SPCAF(in,SL-AcYBR(i,1));
end

%Years in which spot paintings are done.
SPfreq=10;
AcYSP=[0];
AcYSPL=zeros(length(AcYSP),1);
for i=1:fix(SL/SPfreq)
    AcYSP(i,1)=(SPfreq).*i;
end
for i=1:length(AcYSP)
    if AcYSP(i,1)==SL
        AcYSPL (i,1)=0;
    else
        AcYSPL (i,1)= SP.*SPCAF(in,SL-AcYSP(i,1));
    end
end

Analysis(6*k+4,1)=4.212;
Analysis(6*k+4,2)=L;
Analysis(6*k+4,3)=BCL+sum(AcYRL)+sum (AcYSeL)+waL+sum (AcYBRL)+sum
(AcYSPL)+BRem-SRec;
Analysis(6*k+4,4)=SL;
Analysis(6*k+4,5)=in;
Analysis(6*k+4,6)=LCCAP(Analysis(6*k+4,5),Analysis(6*k+4,4),Analysis(6*k+4,3)
);

%%
%Life-cycle profile 4.3. Alternative INDOT routine Procedure

```

%Life-cycle profile 4.3.1 Single Bearing Replacement

%Years in which Deck Reconstruction is done.

```
AcYR=[40]';
```

```
AcYRL=zeros(length(AcYR),1);
```

```
for i=1:length(AcYR)
```

```
    AcYRL (i,1)= BDR.*SPCAF(in,SL-AcYR(i,1))+Spans (k+1,4)*SPCAF(in,SL-  
AcYR(i,1));
```

```
end
```

%Years in which Deck patching procedures are done.

```
Dpfreq=10;
```

```
AcYDp=[0];
```

```
AcYDpL=zeros(length(AcYDp),1);
```

```
for i=1:fix(SL/Dpfreq)
```

```
    AcYDp(i,1)=(Dpfreq).*i;
```

```
end
```

```
for i=1:length(AcYDp)
```

```
    j=1;
```

```
    if AcYDp(i,1)==AcYR(j,1)
```

```
        AcYDpL (i,1)=0;
```

```
        j=j+1;
```

```
    else
```

```
        AcYDpL (i,1)= Dp.*SPCAF(in,SL-AcYDp(i,1));
```

```
    end
```

```
end
```

%Years in which bearing replacements are done.

```
AcYBR=[40]';
```

```
AcYBRL=zeros(length(AcYBR),1);
```

```
for i=1:length(AcYBR)
```

```
    AcYBRL (i,1)= BR.*SPCAF(in,SL-AcYBR(i,1));
```

```
end
```

%Years in which full repaintings are done.

```

AcYRP=[30 60]';
AcYRPL=zeros(length(AcYRP),1);
for i=1:length(AcYRP)
    AcYRPL(i,1)=RP.*SPCAF(in,SL-AcYRP(i,1));
end

%Years in which Sealing procedures are done.
AcYSe=[0 40]';
AcYSeL=zeros(length(AcYSe),1);
for i=1:length(AcYSe)
    AcYSeL(i,1)=Se.*SPCAF(in,SL-AcYSe(i,1));
end

Analysis(6*k+5,1)=4.311;
Analysis(6*k+5,2)=L;
Analysis(6*k+5,3)=BCL+sum(AcYRL)+sum(AcYDpL)+sum(AcYSeL)+waL+sum
(AcYBRL)+sum(AcYRPL)+BRem-SRec;
Analysis(6*k+5,4)=SL;
Analysis(6*k+5,5)=in;
Analysis(6*k+5,6)=LCCAP(Analysis(6*k+5,5),Analysis(6*k+5,4),Analysis(6*k+5,3)
);

%%
                                %Life-cycle profile 4.3.2 Spot repainting of beam elements
%Years in which Deck Reconstruction is done.
AcYR=[40]';
AcYRL=zeros(length(AcYR),1);
for i=1:length(AcYR)
    AcYRL(i,1)=BDR.*SPCAF(in,SL-AcYR(i,1))+Spans(k+1,4)*SPCAF(in,SL-
AcYR(i,1));
end

%Years in which Deck patching procedures are done.
Dpfreq=10;

```

```

AcYDp=[0];
AcYDpL=zeros(length(AcYDp),1);
for i=1:fix(SL/Dpfreq)
    AcYDp(i,1)=(Dpfreq).*i;
end
for i=1:length(AcYDp)
    j=1;
    if AcYDp(i,1)==AcYR(j,1)
        AcYDpL(i,1)=0;
        j=j+1;
    else
        AcYDpL(i,1)= Dp.*SPCAF(in,SL-AcYDp(i,1));
    end
end

%Years in which bearing replacements are done.
AcYBR=[40]';
AcYBRL=zeros(length(AcYBR),1);
for i=1:length(AcYBR)
    AcYBRL(i,1)= BR.*SPCAF(in,SL-AcYBR(i,1));
end

%Years in which spot paintings are done.
SPfreq=10;
AcYSP=[0];
AcYSPL=zeros(length(AcYSP),1);
for i=1:fix(SL/SPfreq)
    AcYSP(i,1)=(SPfreq).*i;
end
for i=1:length(AcYSP)
    if AcYSP(i,1)==SL
        AcYSPL(i,1)=0;
    else

```



```

        AcYSPL (i,1)= SP.*SPCAF(in,SL-AcYSP(i,1));
    end
end

%Years in which Sealing procedures are done.
AcYSe=[0 40]';
AcYSeL=zeros(length(AcYSe),1);
for i=1:length(AcYSe)
    AcYSeL (i,1)= Se.*SPCAF(in,SL-AcYSe(i,1));
end

Analysis(6*k+6,1)=4.312;
Analysis(6*k+6,2)=L;
Analysis(6*k+6,3)=BCL+sum(AcYRL)+sum (AcYDpL)+sum(AcYSeL)+waL+sum
(AcYBRL)+sum(AcYSPL)+BRem-SRec;
Analysis(6*k+6,4)=SL;
Analysis(6*k+6,5)=in;
Analysis(6*k+6,6)=LCCAP(Analysis(6*k+6,5),Analysis(6*k+6,4),Analysis(6*k+6,3)
);

end
LCCPCM=Analysis;
end

%%
%5. Prestressed Concrete I beams (Diaphragms at supports)
function LCCPCM = LCCAPCD
(Spans,Analysis,in,SL,W,wab,BDRb,Ob,Seb,Dpb,BRb,Cwbb,Brem,NumBeam)
for k=0:size(Spans,1)-1
    L=Spans (k+1,1); % Bridge Length
    BC=Spans (k+1,2); % Length and Initial
bridge construction cost
    BCL=BC*SPCAF(in,SL); % Bridge construction
future cost

```

```

    Area=L*W;

    wa=wab*Area; % Washing and
cleaning of deck

    waL=wa*USCAF(in,SL); % Washing and
cleaning of deck future cost annually distributed

    BDR=BDRb*Area; % Bridge Deck
Reconstruction cost

    O=Ob*Area; % Overlay

    Se=Seb*Area;SeB=Seb*L*Spans (k+1,3); % Sealing and
cleaning od cracks

    Dp=Dpb*Area*0.1; % 10% of the deck
area patched

    BR=BRb*NumBeam*(1+Spans (k+1,5)); %
Bearing Replacement Cost

    Cwb=Cwbb*NumBeam*(1+Spans (k+1,5)); %
Cleaning and Washing of Bearings

    BRem= Brem*Area; % Bridge removal
value, cost at the end of the Service Life

%%

    %Life-cycle profile 6.1 INDOT Routine procedure

%Years in which Overlays are done.
AcYO=[25 65]';
AcYOL=zeros(length(AcYO),1);
for i=1:length(AcYO)
    AcYOL (i,1)= O.*SPCAF(in,SL-AcYO(i,1));
end

%Years in which Deck Reconstruction is done.
AcYR=[40]';
AcYRL=zeros(length(AcYR),1);
for i=1:length(AcYR)
    AcYRL (i,1)= BDR.*SPCAF(in,SL-AcYR(i,1))+Spans (k+1,4)*SPCAF(in,SL-
AcYR(i,1));
end

%Years in which Sealing procedures are done.
AcYSe=[0 40]';
AcYSeL=zeros(length(AcYSe),1);

```

```

for i=1:length(AcYSe)
    AcYSeL (i,1)= Se.*SPCAF(in,SL-AcYSe(i,1));
end
Analysis(3*k+1,1)=6.1;
Analysis(3*k+1,2)=L;
Analysis(3*k+1,3)=BCL+sum(AcYOL)+sum (AcYSeL)+sum (AcYRL)+waL+BRem;
Analysis(3*k+1,4)=SL;
Analysis(3*k+1,5)=in;
Analysis(3*k+1,6)=LCCAP(Analysis(3*k+1,5),Analysis(3*k+1,4),Analysis(3*k+1,3)
);

%%
    %Life-cycle profile 6.2. Reccommended INDOT routine Procedure

%Years in which Deck Reconstruction is done.
AcYR=[40]';
AcYRL=zeros(length(AcYR),1);
for i=1:length(AcYR)
    AcYRL (i,1)= BDR.*SPCAF(in,SL-AcYR(i,1))+Spans (k+1,4)*SPCAF(in,SL-
AcYR(i,1));
end

%Years in which Deck Sealing procedures are done.
Sefreq=5;
AcYSe=[0];
AcYSeL=zeros(length(AcYSe),1);
for i=0:fix(SL/Sefreq)
    AcYSe(i+1,1)=(Sefreq).*i;
end
for i=1:length(AcYSe)
    AcYSeL (i,1)= Se.*SPCAF(in,SL-AcYSe(i,1));
end
Analysis(3*k+2,1)=6.2;
Analysis(3*k+2,2)=L;

```

```

Analysis(3*k+2,3)=BCL+sum(AcYRL)+sum (AcYSeL)+waL+BRem;
Analysis(3*k+2,4)=SL;
Analysis(3*k+2,5)=in;
Analysis(3*k+2,6)=LCCAP(Analysis(3*k+2,5),Analysis(3*k+2,4),Analysis(3*k+2,3)
);

%%
    %Life-cycle profile 6.3. Alternative INDOT routine Procedure

%Years in which Deck Reconstruction is done.
AcYR=[40]';
AcYRL=zeros(length(AcYR),1);
for i=1:length(AcYR)
    AcYRL(i,1)= BDR.*SPCAF(in,SL-AcYR(i,1))+Spans(k+1,4)*SPCAF(in,SL-
AcYR(i,1));
end

%Years in which Deck patching procedures are done.
Dpfreq=10;
AcYDp=[0];
AcYDpL=zeros(length(AcYDp),1);
for i=1:fix(SL/Dpfreq)
    AcYDp(i,1)=(Dpfreq).*i;
end
for i=1:length(AcYDp)
    j=1;
    if AcYDp(i,1)==AcYR(j,1)
        AcYDpL(i,1)=0;
        j=j+1;
    else
        AcYDpL(i,1)= Dp.*SPCAF(in,SL-AcYDp(i,1));
    end
end

%Years in which Sealing procedures are done.

```

```

AcYSe=[0 40]';
AcYSeL=zeros(length(AcYSe),1);
for i=1:length(AcYSe)
    AcYSeL(i,1)=Se.*SPCAF(in,SL-AcYSe(i,1));
end

Analysis(3*k+3,1)=6.3;
Analysis(3*k+3,2)=L;
Analysis(3*k+3,3)=BCL+sum(AcYRL)+sum(AcYDpL)+sum(AcYSeL)+waL+BRem;
Analysis(3*k+3,4)=SL;
Analysis(3*k+3,5)=in;
Analysis(3*k+3,6)=LCCAP(Analysis(3*k+3,5),Analysis(3*k+3,4),Analysis(3*k+3,3));

end

LCCPCM=Analysis;

end

%%
%6. Structural Steel Elements Galvanized

function LCCPCM = LCCASSG
(Spans,Analysis,in,SL,W,wab,BDRb,Ob,Seb,Dpb,BRb,Cwbb,Brem,NumBeam,SPb,RPb,Srec)

for k=0:size(Spans,1)-1
    L=Spans(k+1,1); % Bridge Length
    BC=Spans(k+1,2); % Length and Initial
    bridge construction cost
    BCL=BC*SPCAF(in,SL); % Length and Initial
    bridge construction cost
    Area=L*W; % Bridge construction
    future cost
    wa=wab*Area; % Washing and
    cleaning of deck
    waL=wa*USCAF(in,SL); % Washing and
    cleaning of deck future cost annually distributed
    BDR=BDRb*Area; % Bridge Deck
    Reconstruction cost

```

```

O=Ob*Area; % Overlay
Se=Seb*Area; % Sealing and
cleaning od cracks
Dp=Dpb*Area*0.1; % 10% of the deck
area patched
RatioP=0.10; %Percentage of
exposed area to spot paint
SP=SPb*Spans (k+1, 3) *Spans (k+1, 1) *RatioP*NumBeam; % Spot painting Cost
RP=RPb*Spans (k+1, 3) *Spans (k+1, 1) *NumBeam; % Full repainting
Cost
BR=BRb*NumBeam*( Spans (k+1, 6) ); %
Bearing Replacement Cost
Cwb=Cwbb*NumBeam*( Spans (k+1, 6) ); %
Cleaning and Washing of Bearings
BRem= Brem*Area; % Bridge removal
value, cost at the end of the Service Life
SRec= Srec*NumBeam*Spans (k+1, 5) ; % Cost of structural
steel recycle per pound for all beams
%%
%Life-cycle profile 7.1 INDOT Routine procedure
%Years in which Overlays are done.
AcYO=[25 75]';
AcYOL=zeros (length (AcYO), 1);
for i=1:length (AcYO)
AcYOL (i, 1)= O.*SPCAF (in, SL-AcYO (i, 1));
end
%Years in which Deck Reconstruction is done.
AcYR=[50]';
AcYRL=zeros (length (AcYR), 1);
for i=1:length (AcYR)
AcYRL (i, 1)= BDR.*SPCAF (in, SL-AcYR (i, 1))+Spans (k+1, 4) *SPCAF (in, SL-
AcYR (i, 1));
end
%Years in which Sealing procedures are done.
AcYSe=[0 50]';
AcYSeL=zeros (length (AcYSe), 1);
for i=1:length (AcYSe)

```

```

    AcYSeL (i,1)= Se.*SPCAF(in,SL-AcYSe(i,1));
end
%Years in which bearing replacements are done.
AcYBR=[50]';
AcYBRL=zeros(length(AcYBR),1);
for i=1:length(AcYBR)
    AcYBRL (i,1)= BR.*SPCAF(in,SL-AcYBR(i,1));
end

Analysis(3*k+1,1)=7.1;
Analysis(3*k+1,2)=L;
Analysis(3*k+1,3)=BCL+sum(AcYOL)+sum (AcYSeL)+sum (AcYRL)+sum
(AcYBRL)+waL+BRem-SRec;
Analysis(3*k+1,4)=SL;
Analysis(3*k+1,5)=in;
Analysis(3*k+1,6)=LCCAP(Analysis(3*k+1,5),Analysis(3*k+1,4),Analysis(3*k+1,3)
);

%%
    %Life-cycle profile 7.2. Reccommended INDOT routine Procedure
%Years in which Deck Reconstruction is done.
AcYR=[50]';
AcYRL=zeros(length(AcYR),1);
for i=1:length(AcYR)
    AcYRL (i,1)= BDR.*SPCAF(in,SL-AcYR(i,1))+Spans (k+1,4)*SPCAF(in,SL-
AcYR(i,1));
end

%Years in which Deck Sealing procedures are done.
Sefreq=5;
AcYSe=[0];
AcYSeL=zeros(length(AcYSe),1);
for i=0:fix(SL/Sefreq)
    AcYSe(i+1,1)=(Sefreq).*i;
end

```

```

for i=1:length(AcYSe)
    AcYSeL (i,1)= Se.*SPCAF(in,SL-AcYSe(i,1));
end

%Years in which bearing replacements are done.
AcYBR=[50]';
AcYBRL=zeros(length(AcYBR),1);
for i=1:length(AcYBR)
    AcYBRL (i,1)= BR.*SPCAF(in,SL-AcYBR(i,1));
end

Analysis(3*k+2,1)=7.2;
Analysis(3*k+2,2)=L;
Analysis(3*k+2,3)=BCL+sum(AcYRL)+sum (AcYSeL)+waL+sum (AcYBRL)+BRem-SRec;
Analysis(3*k+2,4)=SL;
Analysis(3*k+2,5)=in;
Analysis(3*k+2,6)=LCCAP(Analysis(3*k+2,5),Analysis(3*k+2,4),Analysis(3*k+2,3)
);

%%
    %Life-cycle profile 7.3. Alternative INDOT routine Procedure
%Years in which Deck Reconstruction is done.
AcYR=[50]';
AcYRL=zeros(length(AcYR),1);
for i=1:length(AcYR)
    AcYRL (i,1)= BDR.*SPCAF(in,SL-AcYR(i,1))+Spans (k+1,4)*SPCAF(in,SL-
AcYR(i,1));
end

%Years in which Deck patching procedures are done.
Dpfreq=10;
AcYDp=[0];
AcYDpL=zeros(length(AcYDp),1);

```



```

for i=1:fix(SL/Dpfreq)
    AcYDp(i,1)=(Dpfreq).*i;
end
for i=1:length(AcYDp)
    j=1;
    if AcYDp(i,1)==AcYR(j,1)
        AcYDpL(i,1)=0;
        j=j+1;
    else
        AcYDpL(i,1)=Dp.*SPCAF(in,SL-AcYDp(i,1));
    end
end

%Years in which bearing replacements are done.
AcYBR=[50]';
AcYBRL=zeros(length(AcYBR),1);
for i=1:length(AcYBR)
    AcYBRL(i,1)=BR.*SPCAF(in,SL-AcYBR(i,1));
end

%Years in which Sealing procedures are done.
AcYSe=[0 50]';
AcYSeL=zeros(length(AcYSe),1);
for i=1:length(AcYSe)
    AcYSeL(i,1)=Se.*SPCAF(in,SL-AcYSe(i,1));
end

Analysis(3*k+3,1)=7.3;
Analysis(3*k+3,2)=L;
Analysis(3*k+3,3)=BCL+sum(AcYRL)+sum(AcYDpL)+sum(AcYSeL)+waL+sum
(AcYBRL)+BRem-SRec;
Analysis(3*k+3,4)=SL;
Analysis(3*k+3,5)=in;

```

```
Analysis(3*k+3,6)=LCCAP(Analysis(3*k+3,5),Analysis(3*k+3,4),Analysis(3*k+3,3)
);
```

```
end
```

```
LCCPCM=Analysis;
```

```
end
```

```
%%
```

```
%7. SDCL Elements
```

```
function LCCPCM = LCCASDCL
```

```
(Spans,Analysis,in,SL,W,wab,BDRb,Ob,Seb,Dpb,BRb,Cwbb,Brem,NumBeam,SPb,RPb,Sre
c)
```

```
for k=0:size(Spans,1)-1
```

```
    L=Spans(k+1,1); % Bridge Length
```

```
    BC=Spans(k+1,2); % Length and Initial
```

```
    bridge construction cost
```

```
    BCL=BC*SPCAF(in,SL); % Length and Initial
```

```
    bridge construction cost
```

```
    Area=L*W; % Bridge construction
```

```
    future cost
```

```
    wa=wab*Area; % Washing and
```

```
    cleaning of deck
```

```
    waL=wa*USCAF(in,SL); % Washing and
```

```
    cleaning of deck future cost annually distributed
```

```
    BDR=BDRb*Area; % Bridge Deck
```

```
    Reconstruction cost
```

```
    O=Ob*Area; % Overlay
```

```
    Se=Seb*Area; % Sealing and
```

```
    cleaning od cracks
```

```
    Dp=Dpb*Area*0.1; % 10% of the deck
```

```
    area patched
```

```
    RatioP=0.10; %Percentage of
```

```
    exposed area to spot paint
```

```
    SP=SPb*Spans(k+1,3)*Spans(k+1,1)*RatioP*NumBeam; % Spot painting Cost
```

```
    RP=RPb*Spans(k+1,3)*Spans(k+1,1)*NumBeam; % Full repainting
```

```
    Cost
```

```
    BR=BRb*NumBeam*(1+Spans(k+1,6)); %
```

```
    Bearing Replacement Cost
```

```

    Cwb=Cwbb*NumBeam*(1+Spans (k+1,6)); %
Cleaning and Washing of Bearings

    BRem= Brem*Area; % Bridge removal
value, cost at the end of the Service Life

    SRec= Srec*NumBeam*Spans(k+1,5); % Cost of structural
steel recycle per pound for all beams

%%

    %Life-cycle profile 5.1 INDOT Routine procedure
    %Life-cycle profile 5.1.1 Full repainting of beam elements
%Years in which Overlays are done.
AcYO=[25 75]';
AcYOL=zeros(length(AcYO),1);
for i=1:length(AcYO)
    AcYOL (i,1)= O.*SPCAF(in,SL-AcYO(i,1));
end
%Years in which Deck Reconstruction is done.
AcYR=[50]';
AcYRL=zeros(length(AcYR),1);
for i=1:length(AcYR)
    AcYRL (i,1)= BDR.*SPCAF(in,SL-AcYR(i,1))+Spans (k+1,4)*SPCAF(in,SL-
AcYR(i,1));
end
%Years in which Sealing procedures are done.
AcYSe=[0 50]';
AcYSeL=zeros(length(AcYSe),1);
for i=1:length(AcYSe)
    AcYSeL (i,1)= Se.*SPCAF(in,SL-AcYSe(i,1));
end

%Years in which full repaintings are done.
AcYRP=[35 60 75]';
AcYRPL=zeros(length(AcYRP),1);
for i=1:length(AcYRP)
    AcYRPL (i,1)= RP.*SPCAF(in,SL-AcYRP(i,1));
end

```

```

Analysis(6*k+1,1)=5.11;
Analysis(6*k+1,2)=L;
Analysis(6*k+1,3)=BCL+sum(AcYOL)+sum (AcYSeL)+sum (AcYRL)+sum
(AcYRPL)+waL+BRem-SRec;
Analysis(6*k+1,4)=SL;
Analysis(6*k+1,5)=in;
Analysis(6*k+1,6)=LCCAP(Analysis(6*k+1,5),Analysis(6*k+1,4),Analysis(6*k+1,3)
);

%%
                %Life-cycle profile 5.1.2 Spot repainting of beam elements
%Years in which Overlays are done.
AcYO=[25 75]';
AcYOL=zeros(length(AcYO),1);
for i=1:length(AcYO)
    AcYOL (i,1)= 0.*SPCAF(in,SL-AcYO(i,1));
end
%Years in which Deck Reconstruction is done.
AcYR=[50]';
AcYRL=zeros(length(AcYR),1);
for i=1:length(AcYR)
    AcYRL (i,1)= BDR.*SPCAF(in,SL-AcYR(i,1))+Spans (k+1,4)*SPCAF(in,SL-
AcYR(i,1));
end
%Years in which Sealing procedures are done.
AcYSe=[0 50]';
AcYSeL=zeros(length(AcYSe),1);
for i=1:length(AcYSe)
    AcYSeL (i,1)= Se.*SPCAF(in,SL-AcYSe(i,1));
end

%Years in which spot paintings are done.
SPfreq=10;
AcYSP=[0];

```

```

AcYSPL=zeros (length (AcYSP) ,1);
for i=1:fix (SL/SPfreq)
    AcYSP (i,1)=(SPfreq) .*i;
end
for i=1:length (AcYSP)
    if AcYSP (i,1)==SL
        AcYSPL (i,1)=0;
    else
        AcYSPL (i,1)= SP.*SPCAF (in,SL-AcYSP (i,1));
    end
end

Analysis (6*k+2,1)=5.12;
Analysis (6*k+2,2)=L;
Analysis (6*k+2,3)=BCL+sum (AcYOL)+sum (AcYSeL)+sum (AcYRL)+sum
(AcYSPL)+waL+BRem-SRec;
Analysis (6*k+2,4)=SL;
Analysis (6*k+2,5)=in;
Analysis (6*k+2,6)=LCCAP (Analysis (6*k+2,5) ,Analysis (6*k+2,4) ,Analysis (6*k+2,3)
);

%%
    %Life-cycle profile 5.2. Recommended INDOT routine Procedure
    %Life-cycle profile 5.2.1 Full repainting of beam elements
%Years in which Deck Reconstruction is done.
AcYR=[50]';
AcYRL=zeros (length (AcYR) ,1);
for i=1:length (AcYR)
    AcYRL (i,1)= BDR.*SPCAF (in,SL-AcYR (i,1))+Spans (k+1,4)*SPCAF (in,SL-
AcYR (i,1));
end

%Years in which Deck Sealing procedures are done.
Sefreq=5;
AcYSe=[0];

```

```

AcYSeL=zeros (length (AcYSe) ,1);
for i=0:fix (SL/Sefreq)
    AcYSe (i+1,1)=(Sefreq) .*i;
end
for i=1:length (AcYSe)
    AcYSeL (i,1)= Se.*SPCAF (in,SL-AcYSe (i,1));
end

%Years in which full repaintings are done.
AcYRP=[35 60 80]';
AcYRPL=zeros (length (AcYRP) ,1);
for i=1:length (AcYRP)
    AcYRPL (i,1)= RP.*SPCAF (in,SL-AcYRP (i,1));
end

Analysis (6*k+3,1)=5.21;
Analysis (6*k+3,2)=L;
Analysis (6*k+3,3)=BCL+sum (AcYRL)+sum (AcYSeL)+waL+sum (AcYRPL)+BRem-SRec;
Analysis (6*k+3,4)=SL;
Analysis (6*k+3,5)=in;
Analysis (6*k+3,6)=LCCAP (Analysis (6*k+3,5) ,Analysis (6*k+3,4) ,Analysis (6*k+3,3)
);

%%
                %Life-cycle profile 5.2.2 Spot repainting of beam elements
%Years in which Deck Reconstruction is done.
AcYR=[50]';
AcYRL=zeros (length (AcYR) ,1);
for i=1:length (AcYR)
    AcYRL (i,1)= BDR.*SPCAF (in,SL-AcYR (i,1))+Spans (k+1,4)*SPCAF (in,SL-
AcYR (i,1));
end

%Years in which Deck Sealing procedures are done.

```

```

Sefreq=5;
AcYSe=[0];
AcYSeL=zeros (length (AcYSe) , 1);
for i=0:fix (SL/Sefreq)
    AcYSe (i+1,1)=(Sefreq) .*i;
end
for i=1:length (AcYSe)
    AcYSeL (i,1)= Se.*SPCAF (in,SL-AcYSe (i,1));
end

%Years in which spot paintings are done.
SPfreq=10;
AcYSP=[0];
AcYSPL=zeros (length (AcYSP) , 1);
for i=1:fix (SL/SPfreq)
    AcYSP (i,1)=(SPfreq) .*i;
end
for i=1:length (AcYSP)
    if AcYSP (i,1)==SL
        AcYSPL (i,1)=0;
    else
        AcYSPL (i,1)= SP.*SPCAF (in,SL-AcYSP (i,1));
    end
end

Analysis (6*k+4,1)=5.22;
Analysis (6*k+4,2)=L;
Analysis (6*k+4,3)=BCL+sum (AcYRL)+sum (AcYSeL)+waL+sum (AcYSPL)+BRem-SRec;
Analysis (6*k+4,4)=SL;
Analysis (6*k+4,5)=in;
Analysis (6*k+4,6)=LCCAP (Analysis (6*k+4,5) , Analysis (6*k+4,4) , Analysis (6*k+4,3)
);

%%

```

```

    %Life-cycle profile 5.3. Alternative INDOT routine Procedure
    %Life-cycle profile 5.3.1 Full repainting of beam elements
    %Years in which Deck Reconstruction is done.
    AcYR=[50]';
    AcYRL=zeros(length(AcYR),1);
    for i=1:length(AcYR)
        AcYRL (i,1)= BDR.*SPCAF(in,SL-AcYR(i,1))+Spans (k+1,4)*SPCAF(in,SL-
        AcYR(i,1));
    end

    %Years in which Deck patching procedures are done.
    Dpfreq=10;
    AcYDp=[0];
    AcYDpL=zeros(length(AcYDp),1);
    for i=1:fix(SL/Dpfreq)
        AcYDp(i,1)=(Dpfreq).*i;
    end
    for i=1:length(AcYDp)
        j=1;
        if AcYDp(i,1)==AcYR(j,1)
            AcYDpL (i,1)=0;
            j=j+1;
        else
            AcYDpL (i,1)= Dp.*SPCAF(in,SL-AcYDp(i,1));
        end
    end
end

    %Years in which full repaintings are done.
    AcYRP=[30 60 80]';
    AcYRPL=zeros(length(AcYRP),1);
    for i=1:length(AcYRP)
        AcYRPL (i,1)= RP.*SPCAF(in,SL-AcYRP(i,1));
    end
end

```



```

%Years in which Sealing procedures are done.
AcYSe=[0 50]';
AcYSeL=zeros(length(AcYSe),1);
for i=1:length(AcYSe)
    AcYSeL(i,1)= Se.*SPCAF(in,SL-AcYSe(i,1));
end

Analysis(6*k+5,1)=5.31;
Analysis(6*k+5,2)=L;
Analysis(6*k+5,3)=BCL+sum(AcYRL)+sum
(AcYDpL)+sum(AcYSeL)+waL+sum(AcYRPL)+BRem-SRec;
Analysis(6*k+5,4)=SL;
Analysis(6*k+5,5)=in;
Analysis(6*k+5,6)=LCCAP(Analysis(6*k+5,5),Analysis(6*k+5,4),Analysis(6*k+5,3)
);

%%
    %Life-cycle profile 5.3.2 Spot repainting of beam elements
%Years in which Deck Reconstruction is done.
AcYR=[50]';
AcYRL=zeros(length(AcYR),1);
for i=1:length(AcYR)
    AcYRL(i,1)= BDR.*SPCAF(in,SL-AcYR(i,1))+Spans(k+1,4)*SPCAF(in,SL-
AcYR(i,1));
end

%Years in which Deck patching procedures are done.
Dpfreq=10;
AcYDp=[0];
AcYDpL=zeros(length(AcYDp),1);
for i=1:fix(SL/Dpfreq)
    AcYDp(i,1)=(Dpfreq).*i;
end
for i=1:length(AcYDp)
    j=1;

```

```

    if AcYDp(i,1)==AcYR(j,1)
        AcYDpL (i,1)=0;
        j=j+1;
    else
        AcYDpL (i,1)= Dp.*SPCAF(in,SL-AcYDp(i,1));
    end
end

```

*%Years in which spot paintings are done.*

```

SPfreq=10;
AcYSP=[0];
AcYSPL=zeros(length(AcYSP),1);
for i=1:fix(SL/SPfreq)
    AcYSP(i,1)=(SPfreq).*i;
end
for i=1:length(AcYSP)
    if AcYSP(i,1)==SL
        AcYSPL (i,1)=0;
    else
        AcYSPL (i,1)= SP.*SPCAF(in,SL-AcYSP(i,1));
    end
end
end

```

*%Years in which Sealing procedures are done.*

```

AcYSe=[0 50]';
AcYSeL=zeros(length(AcYSe),1);
for i=1:length(AcYSe)
    AcYSeL (i,1)= Se.*SPCAF(in,SL-AcYSe(i,1));
end
end

```

```

Analysis(6*k+6,1)=5.32;

```

```

Analysis(6*k+6,2)=L;

```

```

Analysis(6*k+6,3)=BCL+sum(AcYRL)+sum
(AcYDpL)+sum(AcYSeL)+waL+sum(AcYSPL)+BRem-SRec;

```

```

Analysis(6*k+6,4)=SL;
Analysis(6*k+6,5)=in;
Analysis(6*k+6,6)=LCCAP(Analysis(6*k+6,5),Analysis(6*k+6,4),Analysis(6*k+6,3)
);

end

LCCPCM=Analysis;

end

%%

%8. SDCL Elements Galvanized

function LCCPCM = LCCASDCLG
(Spans,Analysis,in,SL,W,wab,BDRb,Ob,Seb,Dpb,BRb,Cwbb,Brem,NumBeam,SPb,RPb,Sre
c)

for k=0:size(Spans,1)-1

    L=Spans(k+1,1); % Bridge Length
    BC=Spans(k+1,2); % Length and Initial
bridge construction cost
    BCL=BC*SPCAF(in,SL); % Length and Initial
bridge construction cost
    Area=L*W; % Bridge construction
future cost
    wa=wab*Area; % Washing and
cleaning of deck
    waL=wa*USCAF(in,SL); % Washing and
cleaning of deck future cost annually distributed
    BDR=BDRb*Area; % Bridge Deck
Reconstruction cost
    O=Ob*Area; % Overlay
    Se=Seb*Area; % Sealing and
cleaning od cracks
    Dp=Dpb*Area*0.1; % 10% of the deck
area patched
    RatioP=0.10; %Percentage of
exposed area to spot paint
    SP=SPb*Spans(k+1,3)*Spans(k+1,1)*RatioP*NumBeam; % Spot painting Cost
    RP=RPb*Spans(k+1,3)*Spans(k+1,1)*NumBeam; % Full repainting
Cost

```

```

BR=BRb*NumBeam*(1+Spans (k+1,6)); %
Bearing Replacement Cost

Cwb=Cwbb*NumBeam*(1+Spans (k+1,6)); %
Cleaning and Washing of Bearings

BRem= Brem*Area; % Bridge removal
value, cost at the end of the Service Life

SRec= Srec*NumBeam*Spans(k+1,5); % Cost of structural
steel recycle per pound for all beams
%%

%Life-cycle profile 8.1 INDOT Routine procedure
%Years in which Overlays are done.
AcYO=[25 65 100]';
AcYOL=zeros(length(AcYO),1);
for i=1:length(AcYO)
    AcYOL (i,1)= 0.*SPCAF(in,SL-AcYO(i,1));
end

%Years in which Deck Reconstruction is done.
AcYR=[45 80]';
AcYRL=zeros(length(AcYR),1);
for i=1:length(AcYR)
    AcYRL (i,1)= BDR.*SPCAF(in,SL-AcYR(i,1))+Spans (k+1,4)*SPCAF(in,SL-
AcYR(i,1));
end

%Years in which Sealing procedures are done.
AcYSe=[0 45 80]';
AcYSeL=zeros(length(AcYSe),1);
for i=1:length(AcYSe)
    AcYSeL (i,1)= Se.*SPCAF(in,SL-AcYSe(i,1));
end

Analysis(3*k+1,1)=8.1;
Analysis(3*k+1,2)=L;
Analysis(3*k+1,3)=BCL+sum(AcYOL)+sum (AcYSeL)+sum (AcYRL)+waL+BRem-SRec;
Analysis(3*k+1,4)=SL;
Analysis(3*k+1,5)=in;

```

```
Analysis(3*k+1,6)=LCCAP(Analysis(3*k+1,5),Analysis(3*k+1,4),Analysis(3*k+1,3)
);
```

```
%%
```

```
    %Life-cycle profile 8.2. Recommended INDOT routine Procedure
```

```
%Years in which Deck Reconstruction is done.
```

```
AcYR=[40 80]';
```

```
AcYRL=zeros(length(AcYR),1);
```

```
for i=1:length(AcYR)
```

```
    AcYRL(i,1)=BDR.*SPCAF(in,SL-AcYR(i,1))+Spans(k+1,4)*SPCAF(in,SL-
AcYR(i,1));
```

```
end
```

```
%Years in which Deck Sealing procedures are done.
```

```
Sefreq=5;
```

```
AcYSe=[0];
```

```
AcYSeL=zeros(length(AcYSe),1);
```

```
for i=0:fix(SL/Sefreq)
```

```
    AcYSe(i+1,1)=(Sefreq).*i;
```

```
end
```

```
for i=1:length(AcYSe)
```

```
    AcYSeL(i,1)=Se.*SPCAF(in,SL-AcYSe(i,1));
```

```
end
```

```
Analysis(3*k+2,1)=8.2;
```

```
Analysis(3*k+2,2)=L;
```

```
Analysis(3*k+2,3)=BCL+sum(AcYRL)+sum(AcYSeL)+waL+BRem-SRec;
```

```
Analysis(3*k+2,4)=SL;
```

```
Analysis(3*k+2,5)=in;
```

```
Analysis(3*k+2,6)=LCCAP(Analysis(3*k+2,5),Analysis(3*k+2,4),Analysis(3*k+2,3)
);
```

```
%%
```

```
    %Life-cycle profile 8.3. Alternative INDOT routine Procedure
```

```

%Years in which Deck Reconstruction is done.
AcYR=[40 80]';
AcYRL=zeros(length(AcYR),1);
for i=1:length(AcYR)
    AcYRL(i,1)= BDR.*SPCAF(in,SL-AcYR(i,1))+Spans(k+1,4)*SPCAF(in,SL-
AcYR(i,1));
end

%Years in which Deck patching procedures are done.
Dpfreq=10;
AcYDp=[0];
AcYDpL=zeros(length(AcYDp),1);
for i=1:fix(SL/Dpfreq)
    AcYDp(i,1)=(Dpfreq).*i;
end
for i=1:length(AcYDp)
    j=1;
    if AcYDp(i,1)==AcYR(j,1)
        AcYDpL(i,1)=0;
        j=j+1;
    else
        AcYDpL(i,1)= Dp.*SPCAF(in,SL-AcYDp(i,1));
    end
end

%Years in which Sealing procedures are done.
AcYSe=[0 40 80]';
AcYSeL=zeros(length(AcYSe),1);
for i=1:length(AcYSe)
    AcYSeL(i,1)= Se.*SPCAF(in,SL-AcYSe(i,1));
end

Analysis(3*k+3,1)=8.3;
Analysis(3*k+3,2)=L;

```

```
Analysis(3*k+3,3)=BCL+sum(AcYRL)+sum (AcYDpL)+sum(AcYSeL)+waL+BRem-SRec;  
Analysis(3*k+3,4)=SL;  
Analysis(3*k+3,5)=in;  
Analysis(3*k+3,6)=LCCAP(Analysis(3*k+3,5),Analysis(3*k+3,4),Analysis(3*k+3,3)  
);  
  
end  
  
LCCPCM=Analysis;  
  
end
```

## About the Joint Transportation Research Program (JTRP)

On March 11, 1937, the Indiana Legislature passed an act which authorized the Indiana State Highway Commission to cooperate with and assist Purdue University in developing the best methods of improving and maintaining the highways of the state and the respective counties thereof. That collaborative effort was called the Joint Highway Research Project (JHRP). In 1997 the collaborative venture was renamed as the Joint Transportation Research Program (JTRP) to reflect the state and national efforts to integrate the management and operation of various transportation modes.

The first studies of JHRP were concerned with Test Road No. 1—evaluation of the weathering characteristics of stabilized materials. After World War II, the JHRP program grew substantially and was regularly producing technical reports. Over 1,600 technical reports are now available, published as part of the JHRP and subsequently JTRP collaborative venture between Purdue University and what is now the Indiana Department of Transportation.

Free online access to all reports is provided through a unique collaboration between JTRP and Purdue Libraries. These are available at: <http://docs.lib.purdue.edu/jtrp>

Further information about JTRP and its current research program is available at: <http://www.purdue.edu/jtrp>

## About This Report

An open access version of this publication is available online. This can be most easily located using the Digital Object Identifier (doi) listed below. Pre-2011 publications that include color illustrations are available online in color but are printed only in grayscale.

The recommended citation for this publication is:

Leiva Maldonado, S. L., & Bowman, M. D. (2019). *Life-cycle cost analysis for short- and medium-span bridges* (Joint Transportation Research Program Publication No. FHWA/IN/JTRP-2019/09). West Lafayette, IN: Purdue University. <https://doi.org/10.5703/1288284316919>