

BEARING PLATE

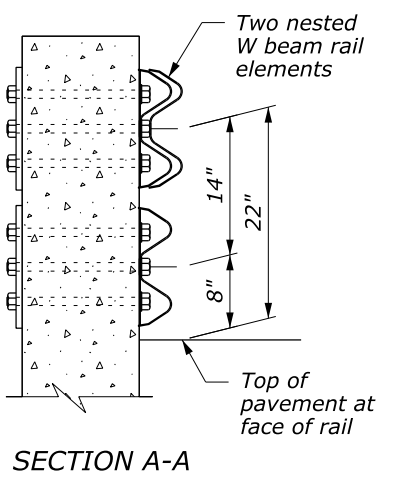

SECTION A-A

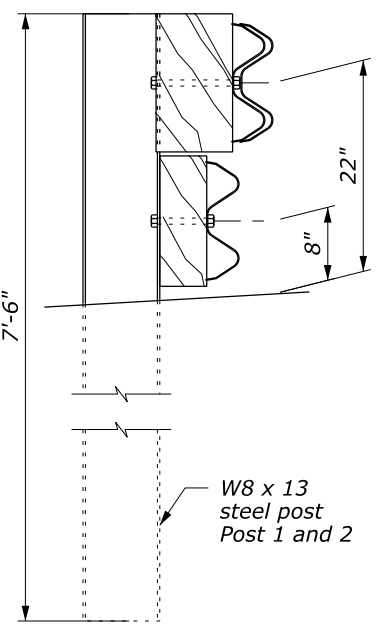

SECTION B-B

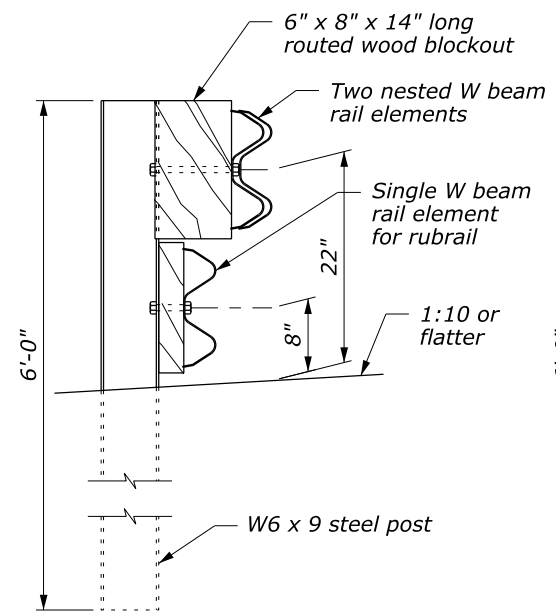

SECTION C-C

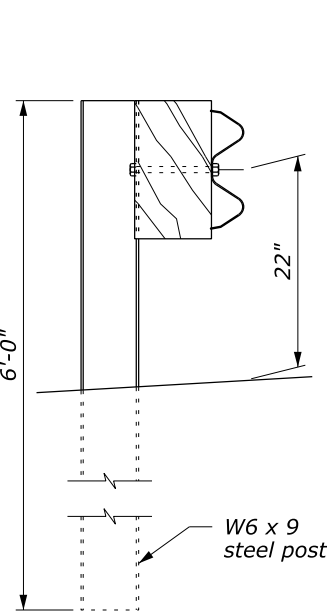

SECTION D-D

NOTE:

1. The rubrail may be shop bent in the last 37 1/2" to facilitate installation.
2. Offset drill wood blocks for rubrail to sit squarely on the post flange posts 1 through 4. Secure blocks to post 1 through 3 with #5 carriage bolts.
3. Posts 1, 2, 3, 4 and 6 require an additional hole to attach lower wood blocks and/or the rubrail.
4. Do not bolt nested W beam or rubrail W beam to posts and blocks on posts 1, 2, 3 and 5. Bolt blocks directly to posts.
5. Reinforced concrete wall or bridge parapet must be capable of developing a 59.6 kip pull out strength.

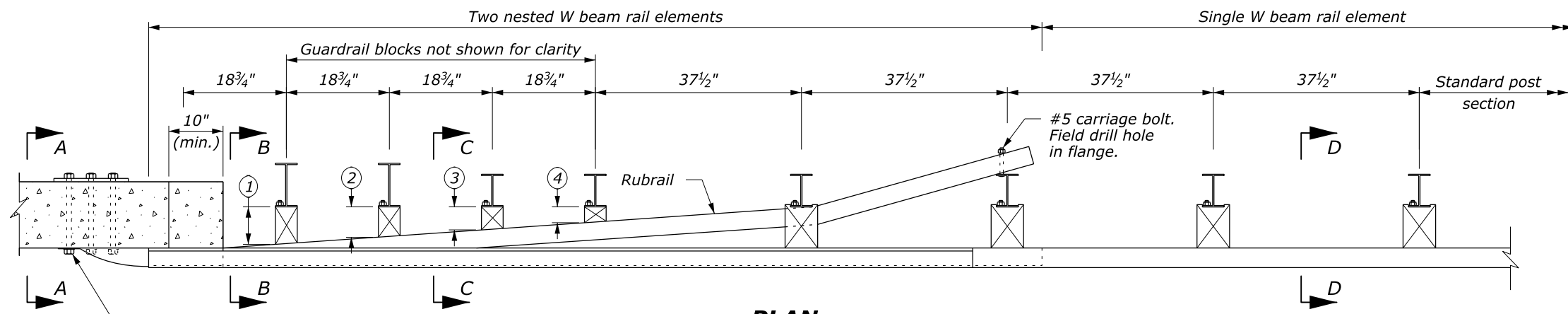

PLAN

| WOOD BLOCKS FOR RUBRAIL | | |
|-------------------------|-------------|-------------|
| POST | THICKNESS 1 | THICKNESS 2 |
| ① | 6 1/2" | 6 1/4" |
| ② | 5 3/8" | 5" |
| ③ | 4" | 3 5/8" |
| ④ | 2 5/8" | 2 7/16" |
| ⑤ | NO BLOCK | NO BLOCK |

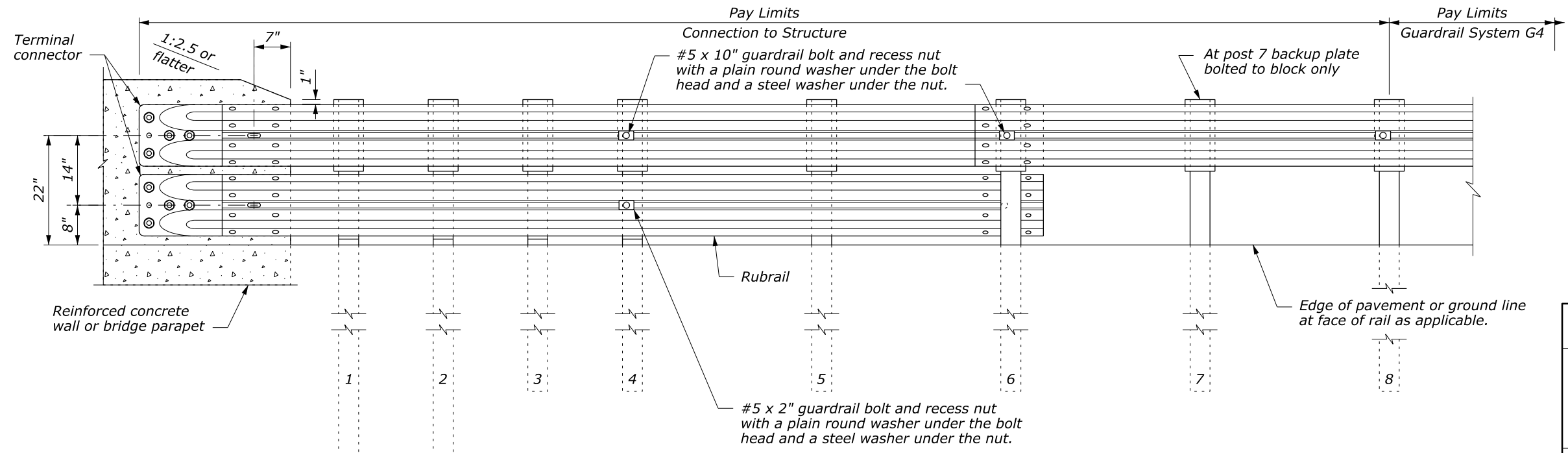

ELEVATION

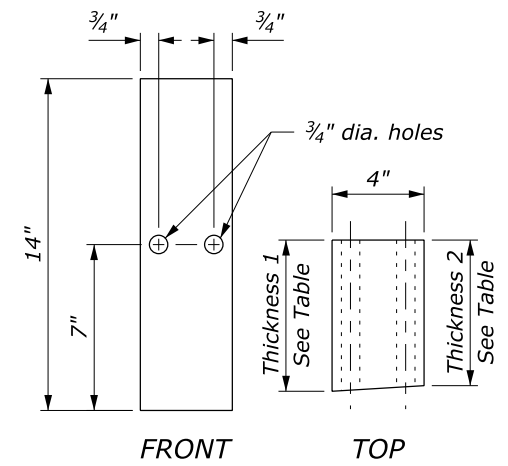

WOOD BLOCK FOR RUBRAIL

U.S. DEPARTMENT OF TRANSPORTATION
FEDERAL HIGHWAY ADMINISTRATION
FEDERAL LANDS HIGHWAY

U.S. CUSTOMARY STANDARD
G4 W-BEAM GUARDRAIL CONNECTION TO VERTICAL FACE STRUCTURE STEEL POSTS

STANDARD APPROVED FOR USE --/--

REVISOR: 9/2013

STANDARD 617-26

NO SCALE