

**ELEVATION
5.715 m GUARDRAIL SPAN**

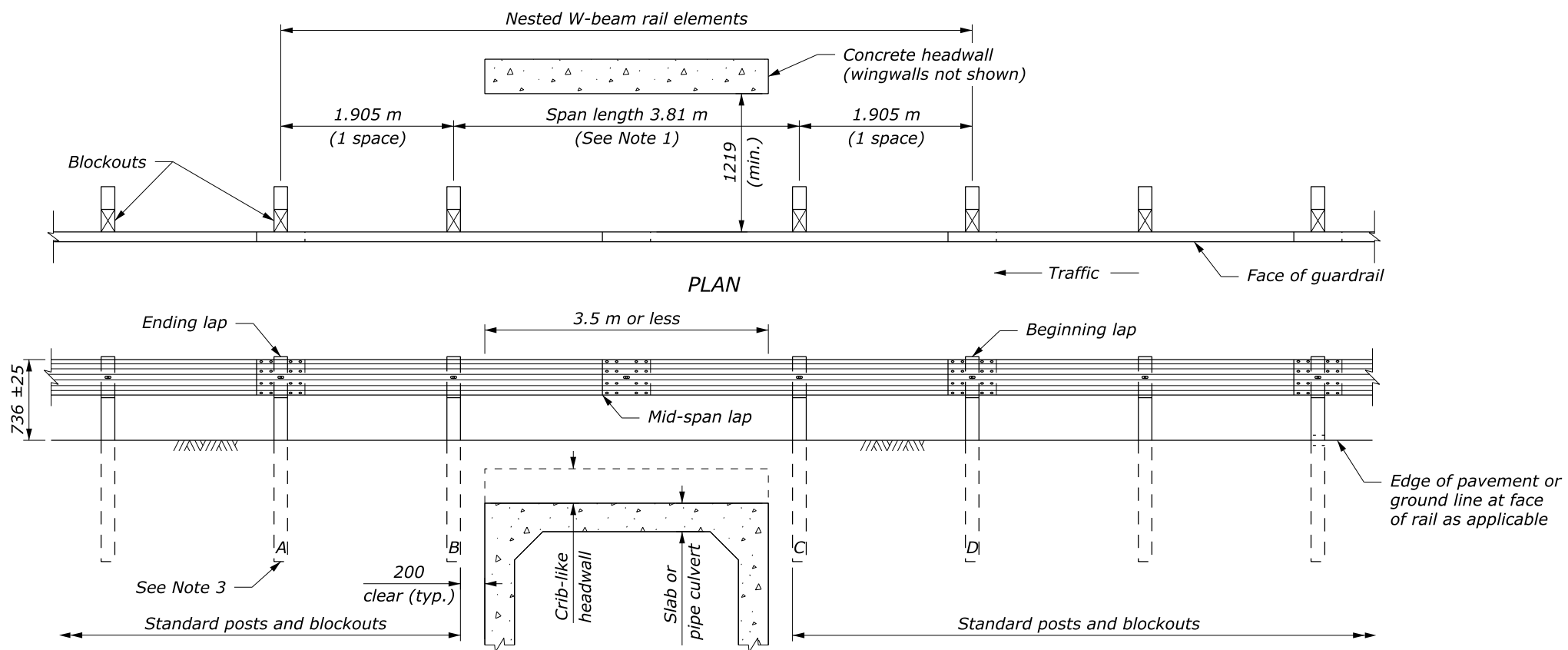

**ELEVATION
3.81 m GUARDRAIL SPAN**

- NOTE:**
- 7.62 m rail lengths may be used to eliminate the intermediate lap without a post. Do not place a lap without a post unless needed due to gap length.
 - Posts 1 thru 5 are CRT posts with two blockouts. All other posts are wood or steel.
 - Posts A thru D are standard wood posts with one blockout. All other posts are wood or steel.
 - See Sheet 2 of 2 for additional details.
 - Dimensions without units are millimeters.

U.S. DEPARTMENT OF TRANSPORTATION FEDERAL HIGHWAY ADMINISTRATION FEDERAL LANDS HIGHWAY	
METRIC STANDARD	
G4 W-BEAM GUARDRAIL LONG SPAN SYSTEM, TL-2	
Sheet 1 of 2	
STANDARD APPROVED FOR USE 3/1996	STANDARD
REVISED: 8/1997 6/2005	M617-24
DRAFT: 9/2014	

NO SCALE

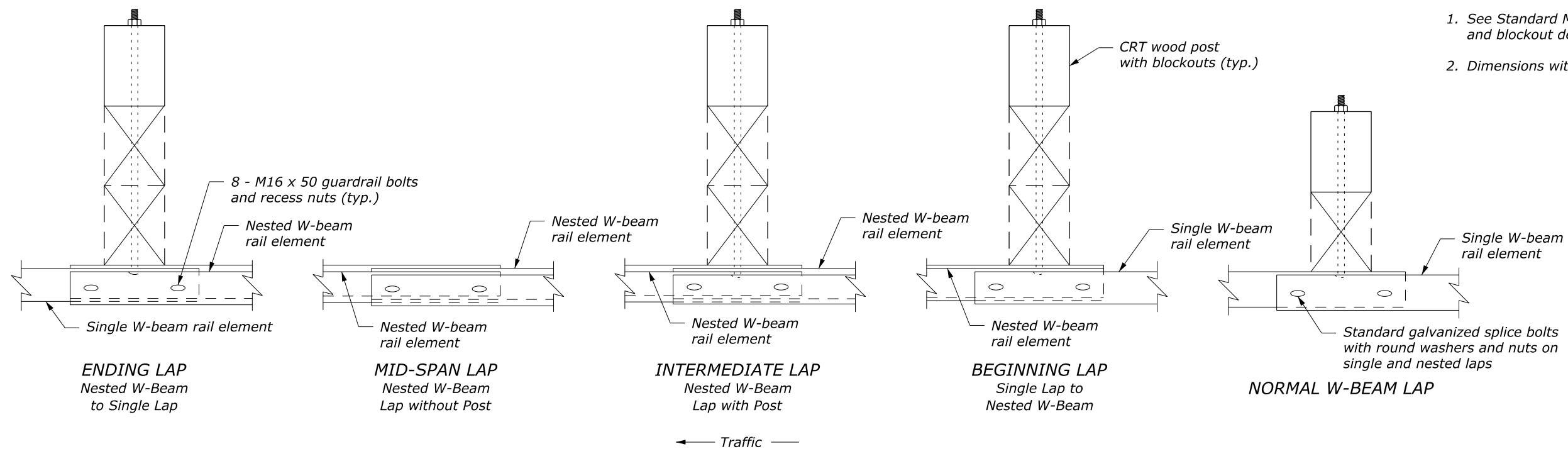

NOTE:

1. See Standard M617-10 for standard wood post and blockout details.
2. Dimensions without units are millimeters.

LAPPING DETAILS

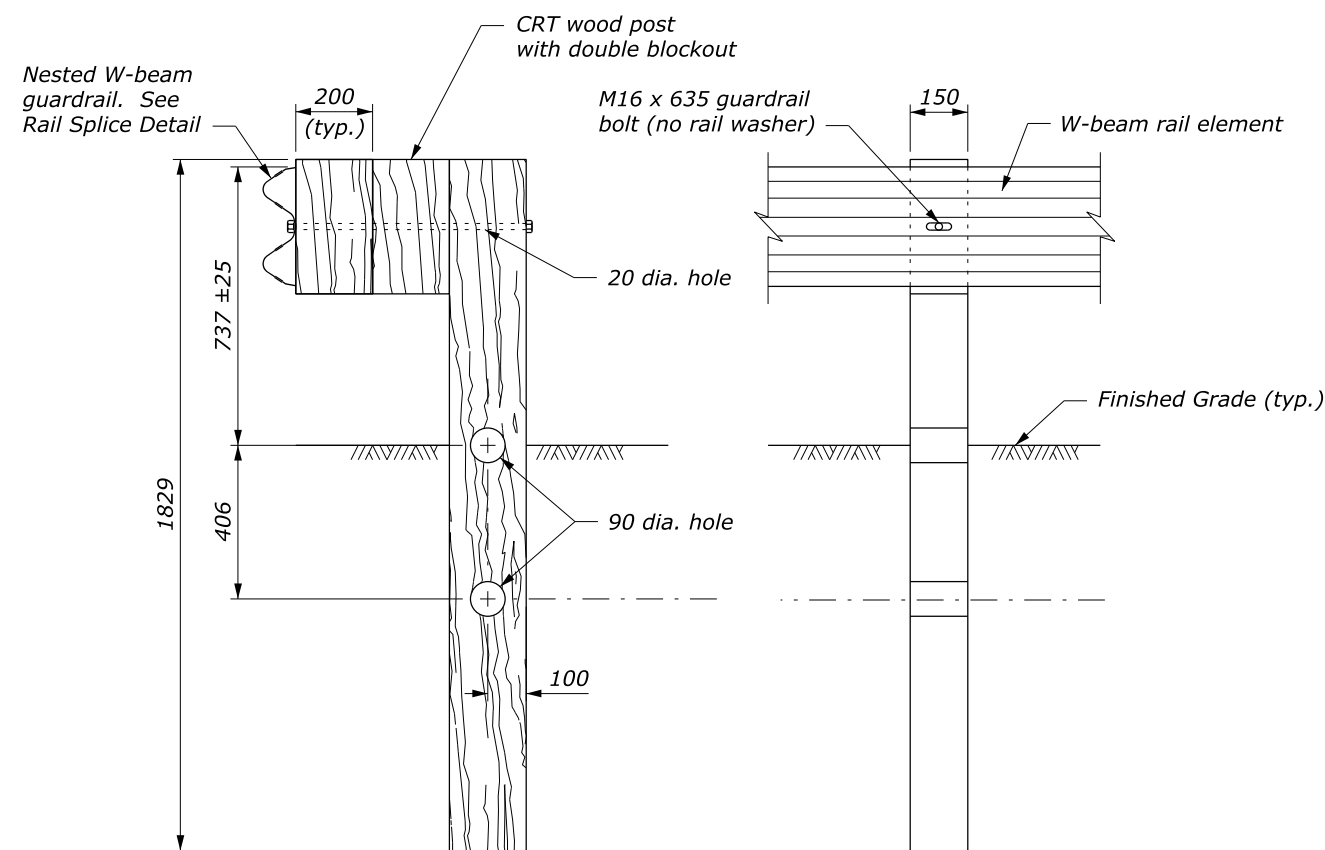

CRT POST DETAIL

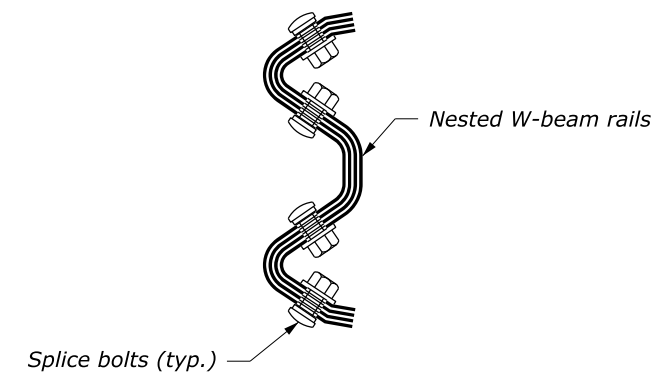

RAIL SPLICE DETAIL AT MID-SPAN LAP

NO SCALE

U.S. DEPARTMENT OF TRANSPORTATION FEDERAL HIGHWAY ADMINISTRATION FEDERAL LANDS HIGHWAY	
METRIC STANDARD	
G4 W-BEAM GUARDRAIL LONG SPAN SYSTEM, TL-2	
Sheet 2 of 2	
STANDARD APPROVED FOR USE 3/1996	STANDARD
REVISED: 8/1997 6/2005 DRAFT: 9/2014	M617-24