



U.S. Department
of Transportation
**Federal Highway
Administration**

PB2009-110465
February 1 2009

Load Rating Guidance and Examples For Bolted and Riveted Gusset Plates In Truss Bridges



by

Firas I. Sheikh Ibrahim, PhD, PE

Table of Contents

I - Load Rating Guidance.....	1
Part – A: Gusset Plate Resistance in Accordance with the Load and Resistance Factor Rating Method (LRFR).....	
1. General:.....	1
2. Resistance of Fasteners	1
3. Resistance of Gusset Plates.....	2
3.1. Gusset Plates in Tension.....	3
3.1.1. Gross Section Yielding Resistance	3
3.1.2. Net Section Fracture Resistance	3
3.1.3. Block Shear Rupture Resistance	5
3.2. Gusset Plates Subject to Shear.....	6
3.3. Gusset Plates in Compression.....	7
3.4. Gusset Plates Under Combined Flexural and Axial Loads.....	9
3.5. Limiting Slenderness Ratio	9
Part – B: Gusset Plate Resistance in Accordance with the Load Factor Rating Method (LFR).....	
1. General.....	10
2. Resistance of Fasteners	10
3. Resistance of Gusset Plates.....	11
3.1. Gusset Plates in Tension.....	11
3.1.1. Effective Gross Section Yielding.....	11
3.1.2. Block Shear Rupture Resistance	13
3.2. Gusset Plates Subject to Shear.....	14
3.3. Gusset Plates in Compression.....	16
3.4. Gusset Plates Under Combined Flexural and Axial Loads.....	17
3.5. Limiting Slenderness Ratio	17
II - Load Rating Examples.....	18
Part – A: Gusset Plate Load Rating Example in Accordance with the Load and Resistance Factor Rating Method (LRFR)	
1. Resistance of Fasteners	18
1.1. Fasteners at End of Members 1 and 5	18
1.1.1. Shear Resistance of Fasteners	18
1.1.2. Plate Bearing Resistance at Fasteners	19
1.2. Fasteners at End of Member 2	19
1.2.1. Shear Resistance of Fasteners	19
1.2.2. Plate Bearing Resistance at Fasteners	19
1.3. Fasteners at End of Member 3	20

1.3.1.	Shear Resistance of Fasteners	20
1.3.2.	Plate Bearing Resistance at Fasteners	20
1.4.	Fasteners at End of Member 4	20
1.4.1.	Shear Resistance of Fasteners	20
1.4.2.	Plate Bearing Resistance at Fasteners	20
2.	Resistance of Gusset Plate	21
2.1.	Gusset Plate in Tension at Members 1 and 5	21
2.1.1.	Gross Section Yielding Resistance	21
2.1.2.	Net Section Fracture Resistance	21
2.1.3.	Block Shear Rupture Resistance	22
2.2.	Gusset Plate in Tension at Member 2	22
2.2.1.	Gross Section Yielding Resistance	22
2.2.2.	Net Section Fracture Resistance	23
2.2.3.	Block Shear Rupture Resistance	24
2.3.	Gusset Plate Subject to Vertical Shear.....	25
2.3.1.	Gross Section Shear Yielding Resistance	25
2.3.2.	Net Section Shear Fracture Resistance	25
2.4.	Gusset Plate Subject to Horizontal Shear	26
2.4.1.	Gross Section Shear Yielding Resistance	26
2.4.2.	Net Section Shear Fracture Resistance	27
2.5.	Gusset Plate in Compression at Member 3	27
2.6.	Gusset Plate in Compression at Member 4	29
3.	Resistance Summary	30
4.	Inventory and Operating Rating Factors	31

Part – B: Gusset Plate Load Rating Example in Accordance with the Load Factor Rating Method (LFR)

1.	Resistance of Fasteners	32
1.1.	Fasteners at End of Members 1 and 5	32
1.1.1.	Shear Resistance of Fasteners	32
1.1.2.	Plate Bearing Resistance at Fasteners	33
1.2.	Fasteners at End of Member 2	33
1.2.1.	Shear Resistance of Fasteners	33
1.2.2.	Plate Bearing Resistance at Fasteners	33
1.3.	Fasteners at End of Member 3	34
1.3.1.	Shear Resistance of Fasteners	34
1.3.2.	Plate Bearing Resistance at Fasteners	34
1.4.	Fasteners at End of Member 4	34
1.4.1.	Shear Resistance of Fasteners	34
1.4.2.	Plate Bearing Resistance at Fasteners	35
2.	Resistance of Gusset Plate	35
2.1.	Gusset Plate in Tension at Members 1 and 5	35
2.1.1.	Gross Section Yielding Resistance	35
2.1.2.	Block Shear Rupture Resistance	36
2.2.	Gusset Plate in Tension at Member 2	37
2.2.1.	Gross Section Yielding Resistance	37

2.2.2.	Block Shear Rupture Resistance	38
2.3.	Gusset Plate Subject to Vertical Shear.....	39
2.3.1.	Gross Section Shear Yielding Resistance	39
2.3.2.	Net Section Shear Fracture Resistance	39
2.4.	Gusset Plate Subject to Horizontal Shear	40
2.4.1.	Gross Section Shear Yielding Resistance	40
2.4.2.	Net Section Shear Fracture Resistance	41
2.5.	Gusset Plate in Compression at Member 3	41
2.6.	Gusset Plate in Compression at Member 4	42
3.	Resistance Summary.....	43
4.	Inventory and Operating Rating Factors.....	44

NTIS DISCLAIMER



This document has been reproduced from the best copy furnished by the sponsoring agency.

Load Rating Guidance and Examples for Bolted and Riveted Gusset Plates in Truss Bridges

By Firas I. Sheikh Ibrahim, PhD, PE

Release Date: February 1, 2009

I - Load Rating Guidance

Part – A: Gusset Plate Resistance in Accordance with the Load and Resistance Factor Rating Method (LRFR)

1. General

Gusset connections of non-load-path-redundant steel truss bridges shall be evaluated during a bridge load rating analysis. Non-load-path-redundant bridges are those with no alternate load paths and whose failure of a main component is expected to result in the collapse of the bridge

The evaluation of gusset connections shall include the evaluation of the connecting plates and fasteners. The resistance of a gusset connection is determined as the smaller resistance of the fasteners or gusset plates.

The following guidance is intended to provide for life safety and thus the resistance of the connection is required to be checked at the strength limit state only. Owners may require that connections be checked at other limit states such as the service limit state to minimize serviceability concerns.

2. Resistance of Fasteners

For concentrically loaded bolted and riveted gusset connections, the axial load in each connected member may be assumed to be distributed equally to all fasteners at the strength limit state.

The bolts in bolted gusset connections shall be evaluated to prevent bolt shear and plate bearing failures at the strength limit state. At the strength limit state, the provisions of AASHTO LRFD Articles 6.13.2.7 and 6.13.2.9 shall apply for determining the resistance of bolts to prevent bolt shear and plate bearing failures.

The rivets in riveted gusset connections shall be evaluated to prevent rivet shear and plate bearing failures at the strength limit state. The plate bearing resistance for riveted connections shall be in accordance with AASHTO LRFD Article 6.13.2.9 for bearing at bolt holes.

The factored shear resistance of one rivet shall be taken as:

$$\phi R = \phi F m A_r \tag{1}$$

where:

ϕF = Factored shear strength of one rivet. The values in Table 1 may be used for ϕF based on the year of construction for unknown rivet types, or on the type of rivets.

Table 1

Year of Construction	ϕF ksi
Constructed prior to 1936 or of unknown origin	18
Constructed after 1936 but of unknown origin	21
ASTM A 502 Grade I	27
ASTM A 502 Grade II	32

m = the number of shear planes

A_r = cross-sectional area of the rivet before driving

The shear resistance of a rivet in connections greater than 50.0 in. in length shall be taken as 0.80 times the value given in Eq. 1. The length of the connection is measured between the extreme fasteners on one side of the connection.

3. Resistance of Gusset Plates

The resistance of a gusset plate shall be determined as the least resistance of the plate in compression, shear, and tension including block shear.

3.1. Gusset Plates in Tension

Gusset plates subjected to axial tension shall be investigated for three conditions:

- Yield on the gross section,
- Fracture on the net section, and
- Block shear rupture

The factored resistance, P_r , for gusset plates in tension shall be taken as the least of the values given by yielding, fracture, or the block shear rupture resistance.

3.1.1. Gross Section Yielding Resistance

$$P_r = \phi_y P_{ny} = \phi_y F_y A_g \quad (2)$$

3.1.2. Net Section Fracture Resistance

$$P_r = \phi_u P_{nu} = \phi_u F_u A_n U \quad (3)$$

where:

- ϕ_y = resistance factor for tension yielding = 0.95
 ϕ_u = resistance factor for tension fracture = 0.80
 P_{ny} = nominal tensile resistance for yielding in gross section
 A_n = net cross-sectional area of the plates as specified in AASHTO LRFD Article 6.8.3.
 A_g = gross cross-sectional area of the plates.
 P_{nu} = nominal tensile resistance for fracture on the net section
 F_y = yield strength of the plates
 F_u = tensile strength of the plates
 U = reduction factor to account for shear lag = 1.0 for gusset plates

For the determination of the gross and net section areas, the effective gross width of the gusset plate in tension may be determined by the Whitmore method. In this method, the effective width is measured across the last row of fasteners in the connection under consideration. The effective width is bound on either side by the closer of the nearest adjacent plate edges or lines constructed starting from the external fasteners within the first row and extending from these fasteners at an angle of 30 degrees with respect to the line of action of the axial force. Figures 1 and 2 provide examples for determining the effective width in tension in accordance with the Whitmore method.

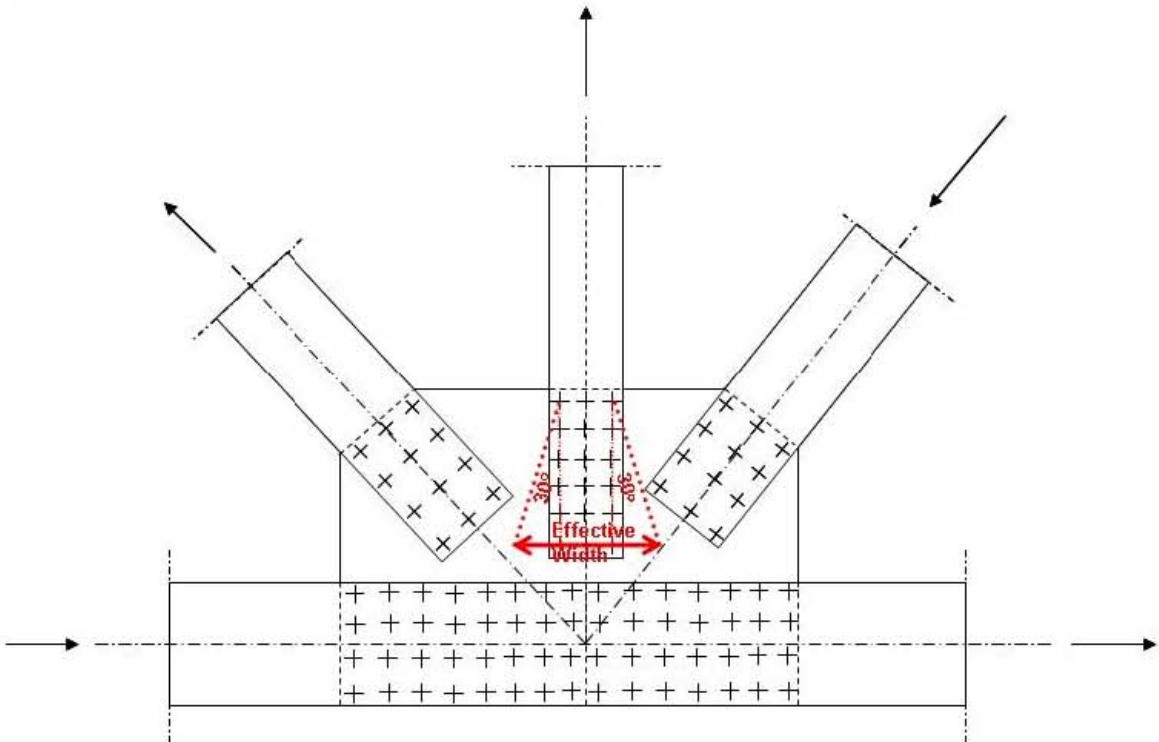

Figure 1 – Example 1 for using the Whitmore method to determine the effective width in tension

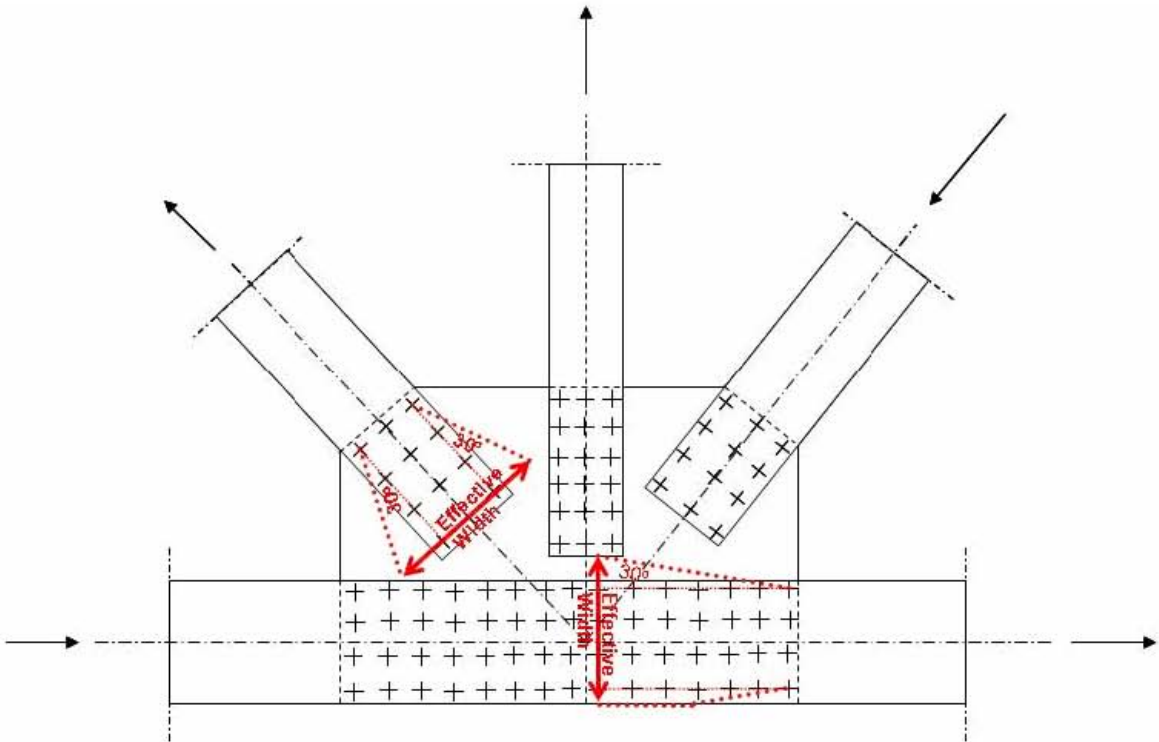

Figure 2 – Example 2 for using the Whitmore method to determine the effective width in tension

3.1.3. Block Shear Rupture Resistance

The resistance to block shear rupture is that resulting from the combined resistance of parallel and perpendicular planes; one in axial tension and the others in shear. The factored resistance of the plate for block shear rupture shall be taken as:

- If $A_{tn} \geq 0.58A_{vn}$, then $P_r = \phi_{bs}(0.58F_yA_{vg} + F_uA_{tn})$ (4)

- Otherwise: $P_r = \phi_{bs}(0.58F_uA_{vn} + F_yA_{tg})$ (5)

Where:

- ϕ_{bs} = resistance factor for block shear = 0.80
- A_{vg} = gross area along the plane resisting shear stress
- A_{tg} = gross area along the plane resisting tension stress
- A_{vn} = net area along the plane resisting shear stress
- A_{tn} = net area along the plane resisting tension stress
- F_y = minimum yield strength of the plate
- F_u = minimum tensile strength of the plate

The analysis of block shear rupture involves the evaluation of several patterns of planes to arrive at the governing pattern. Figure 3 provides some examples of potential block shear rupture planes for gusset plates in tension.

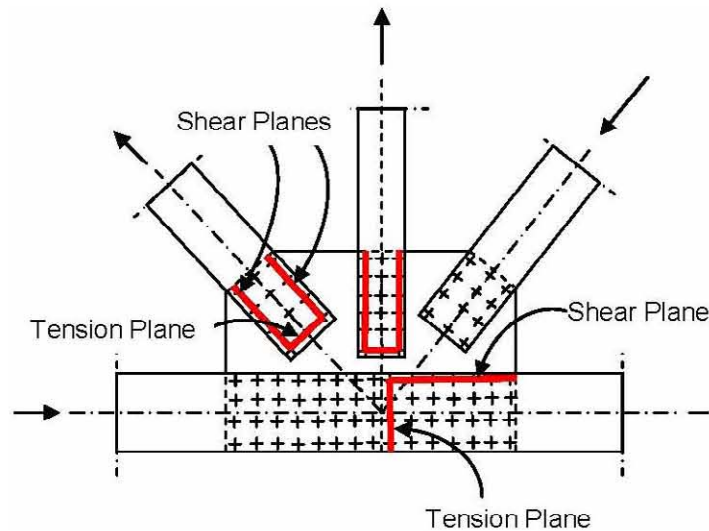

Figure 3 – Examples of potential block shear rupture planes for gusset plates in tension

3.2. Gusset Plates Subject to Shear

The factored shear resistance, V_r , for gusset plates subject to shear shall be taken as the lesser of the shear yield and the shear fracture resistance specified in Equations 6 and 7, respectively:

$$V_r = \phi_{vy} V_n = \phi_{vy} \times 0.58 F_y A_g \times \Omega \quad (6)$$

$$V_r = \phi_{vu} V_n = \phi_{vu} \times 0.58 F_u A_n \quad (7)$$

where:

ϕ_{vy} = resistance factor for shear yielding on the gross section = 0.95

ϕ_{vu} = resistance factor for shear fracture on the net section = 0.80

V_n = nominal resistance in shear

A_g = gross area of the plates resisting shear

A_n = net area of the plates resisting shear

F_y = minimum yield strength of the plates

F_u = minimum tensile strength of the plates

Ω = reduction factor taken as:

- $\Omega = 1.00$ when the gusset plates are of ample stiffness to prevent buckling and develop the plastic shear force of the plates, or
- $\Omega = 0.74$ in the absence of a more rigorous analysis or criterion to assure and quantify the stiffness requirements to develop the plastic shear force of the plates.

The analysis of gusset plates for shear involves the evaluation of several shear sections to arrive at the governing section. Figures 4 and 5 provide examples of shear sections to be evaluated in gusset plates in gross section shear yielding and net section shear fracture.

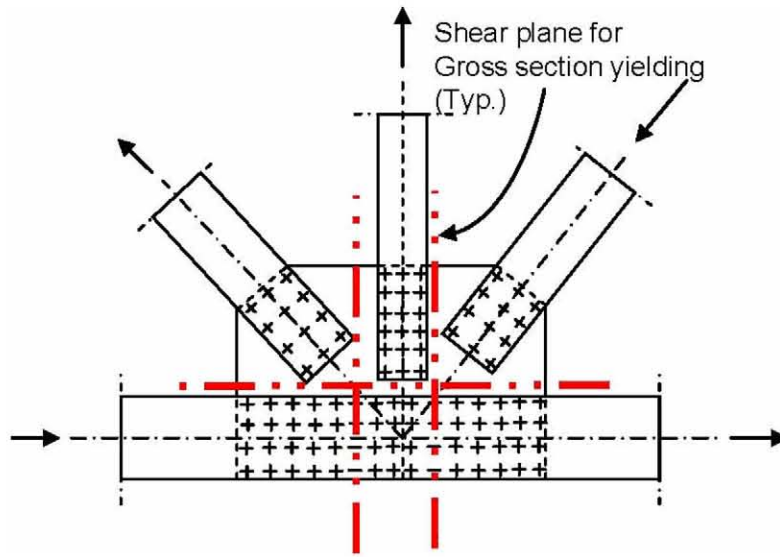

Figure 4 – Examples of gross section shear yielding planes

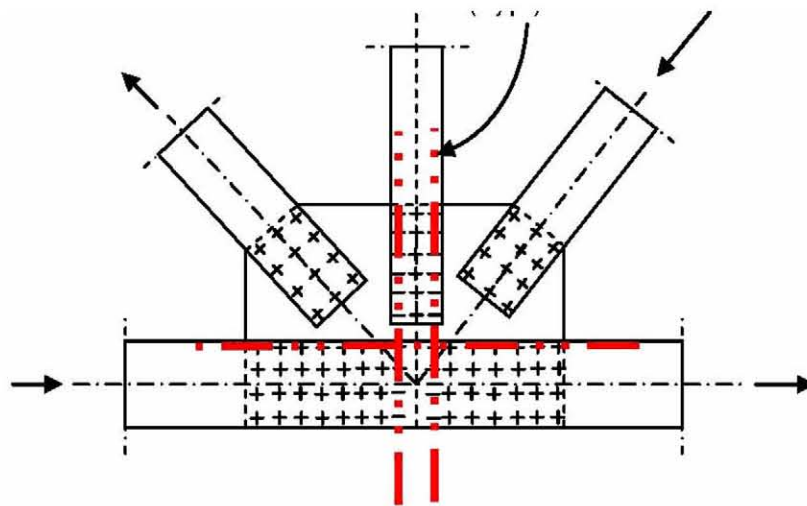

Figure 5 – Examples of net section shear fracture planes

3.3. Gusset Plates in Compression

The proximity of connected members, complex state of stress, and boundary conditions can influence the resistance of gusset plates in compression. Therefore, special care must be exercised to properly assess the buckled shape and compressive resistance of gusset plates in compression.

In the absence of a more rigorous analysis, the resistance of gusset plates in compression may be determined as that of idealized members in compression, in accordance with the provisions of AASHTO LRFD Articles 6.9.2.1 and 6.9.4.

The effective width of the idealized compression member may be determined in accordance with the Whitmore method. The unbraced length, L_c , may be determined as the average of three distances (L_1 , L_2 , L_3) as follows:

where:







L_2 = The distance from the last row of fasteners in the compression member under consideration to the first row of fasteners in the closest adjacent member, measured along the line of action of the compressive axial force.

L_1, L_3 = The distance from each of the ends of the Whitmore width to the first row of fasteners in the closest adjacent member, measured parallel to the line of action of the compressive axial force. When the Whitmore width enters into the adjacent member, the associated distance at that end should be set to zero.

Figure 6 provides an example showing L_1 , L_2 , L_3 , and effective width for a gusset plate in compression.

When lateral sway of gusset plates is possible, the effective length factor, K , for gusset plates may be taken from Table 2 for Cases (d), (e), or (f), depending on the anticipated buckled shape. When lateral sway of gusset plates is not possible, the effective length factor, K , for gusset plates may be taken from Table 2 for Cases (a), (b), or (c), as appropriate.

Table 2 – K Values

	(a)	(b)	(c)	(d)	(e)	(f)
Buckled shape						
Theoretical K value	0.5	0.7	1.0	1.0	2.0	2.0
Design K value	0.65	0.80	1.0	1.2	2.1	2.0

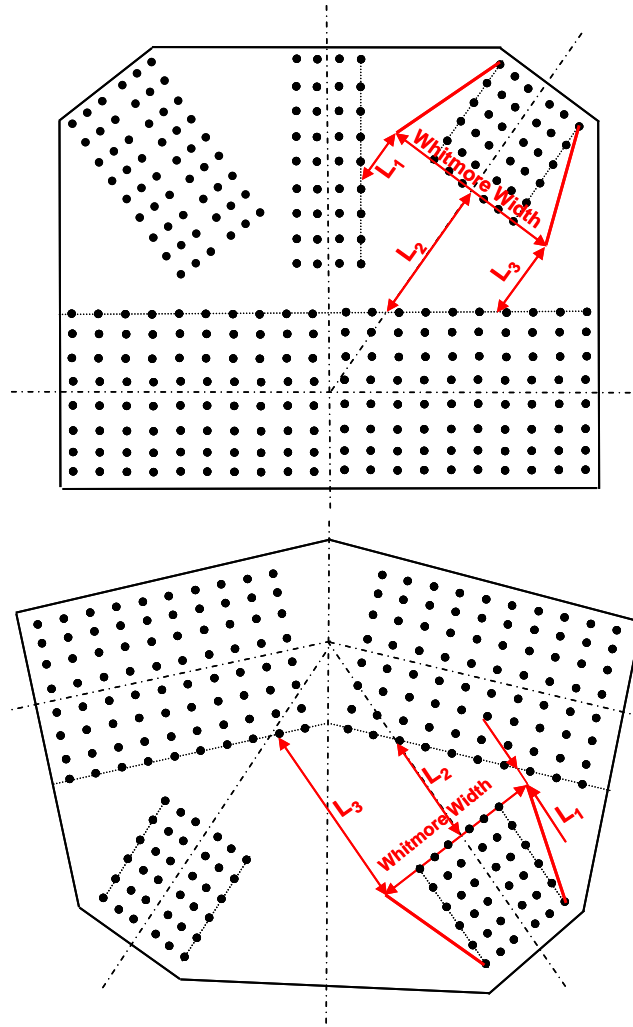

Figure 6 – Examples showing L_1 , L_2 , L_3 , and effective width for a gusset plate in compression.

3.4. Gusset Plates Under Combined Flexural and Axial Loads

Gusset plates behave as deep members. Therefore, the application of flexural theory to the analysis of gusset plates is questionable and not required in this Guidance.

3.5. Limiting Slenderness Ratio

The existing requirement of length-to-thickness ratio (for the design of unsupported edges of gusset plates) not to exceed $2.06 \sqrt{\frac{E}{F_y}}$ is equivalent to the slenderness ratio

requirement of $\frac{l}{r} \leq 200$ for Grade 36 tension members not subject to stress reversal.

Although an appropriate slenderness limit is advisable for the design of new gusset plates, it is not required in this guidance for load rating purposes. However, Owners are advised to evaluate the cause and effect of any excessive out of flatness at the free edges of gusset plates.

Part – B: Gusset Plate Resistance in Accordance with the Load Factor Rating Method (LFR)

1. General

Gusset connections of non-load-path-redundant steel truss bridges shall be evaluated during a bridge load rating analysis. Non-load-path-redundant bridges are those with no alternate load paths and whose failure of a main component is expected to result in the collapse of the bridge.

The evaluation of gusset connections shall include the evaluation of the connecting plates and fasteners. The capacity (referred to as the resistance in this Guidance) of a gusset connection is determined as the smaller resistance of the fasteners or gusset plates.

The following guidance is intended to provide for life safety and thus the resistance of the connection is required to be checked at maximum loads only. The maximum loads are the loadings specified in AASHTO Article 10.47. Owners may require that connections be checked for other loading levels such as overload to minimize serviceability concerns.

2. Resistance of Fasteners

For concentrically loaded bolted and riveted gusset connections, the maximum axial load in each connected member may be assumed to be distributed equally to all fasteners.

At maximum loads, the fasteners in bolted and riveted gusset connections shall be evaluated to prevent fastener shear and plate bearing failures. The provisions of AASHTO Article 10.56.1.3.2 shall apply for determining the resistance of fasteners to prevent fastener shear and plate bearing failures.

For unknown rivet types, the shear resistance of one rivet shall be taken as:

$$\phi R = \phi F m A_r \tag{1}$$

where:

ϕF = shear strength of one rivet. The values in Table 1 may be used for ϕF based on the year of construction:

Table 1

Year of Construction	ϕF ksi
Constructed prior to 1936 or of unknown origin	18
Constructed after 1936 but of unknown origin	21

m = the number of shear planes
 A_r = cross-sectional area of the rivet before driving

The shear resistance of a rivet in connections greater than 50.0 in. in length shall be taken as 0.80 times the value given in Eq. 1. The length of the connection is measured between the extreme fasteners on one side of the connection.

3. Resistance of Gusset Plates

The resistance of a gusset plate shall be determined as the least resistance of the plate in compression, shear, and tension including block shear.

3.1. Gusset Plates in Tension

Gusset plates subjected to axial tension shall be investigated for two conditions:

- Yield on the effective gross section, and
- Block shear rupture

The resistance for gusset plates in tension, R_r , shall be taken as the least of the values given by either yielding on the effective area or the block shear rupture resistance.

3.1.1. Effective Gross Section Yielding

$$R_r = A_e F_y \quad (2)$$

where:

A_e = effective gross cross-sectional area taking into account the possibility of net section fracture.

$$A_e = A_n + \beta A_g \leq A_g \quad (3)$$

A_n = net cross-sectional area of the plates as specified in AASHTO Article 10.16.14.

β = 0.0 for M 270 Grade 100/100W steels, or when holes exceed 1¼ inch in diameter.
= 0.15 for all other steels and when holes are less than or equal to 1¼ inch in diameter.

A_g = gross cross-sectional area of the plates.

F_y = yield strength of the plates, as specified in AASHTO Table 10.2A.

For the determination of the gross and net section areas, the effective gross width of the gusset plate in tension may be determined by the Whitmore method. In this method, the effective width is measured across the last row of fasteners in the connection under consideration. The effective width is bound on either side by the closer of the nearest adjacent plate edges or lines constructed starting from the external fasteners within the first row and extending from these fasteners at an angle of 30 degrees with respect to the line of action of the axial force. Figures 1 and 2 provide examples for determining the effective width in tension in accordance with the Whitmore method.

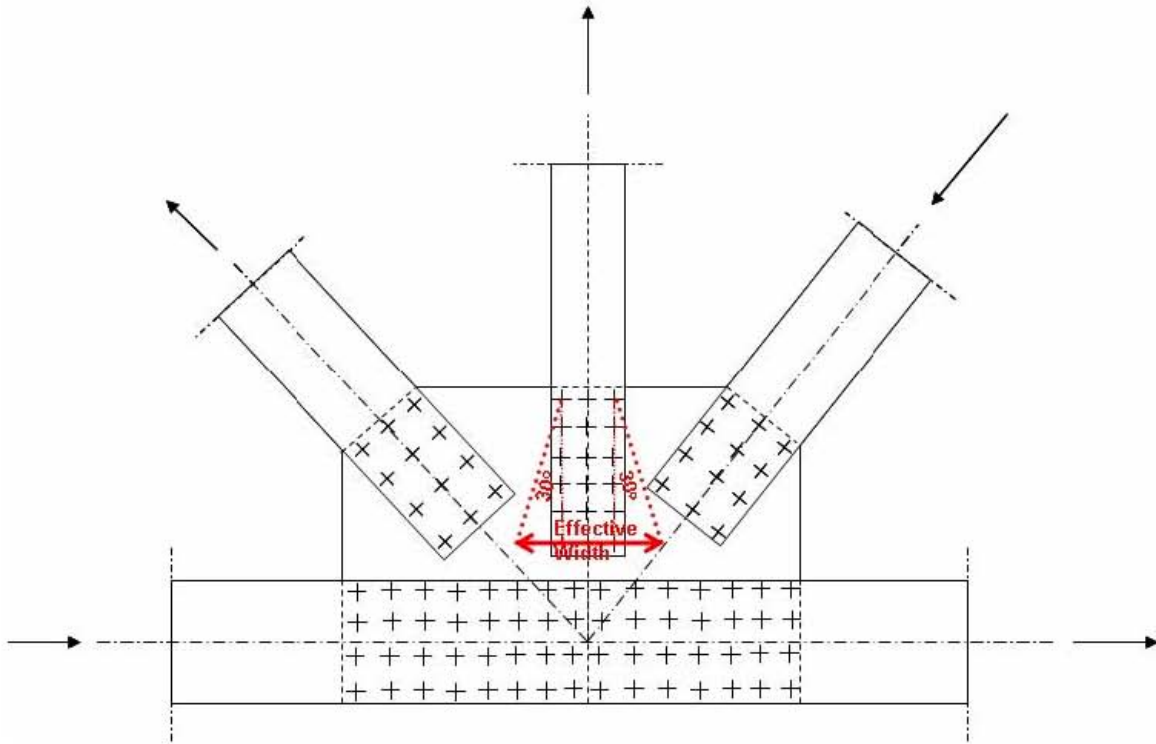

Figure 1 – Example 1 for using the Whitmore method to determine the effective width in tension

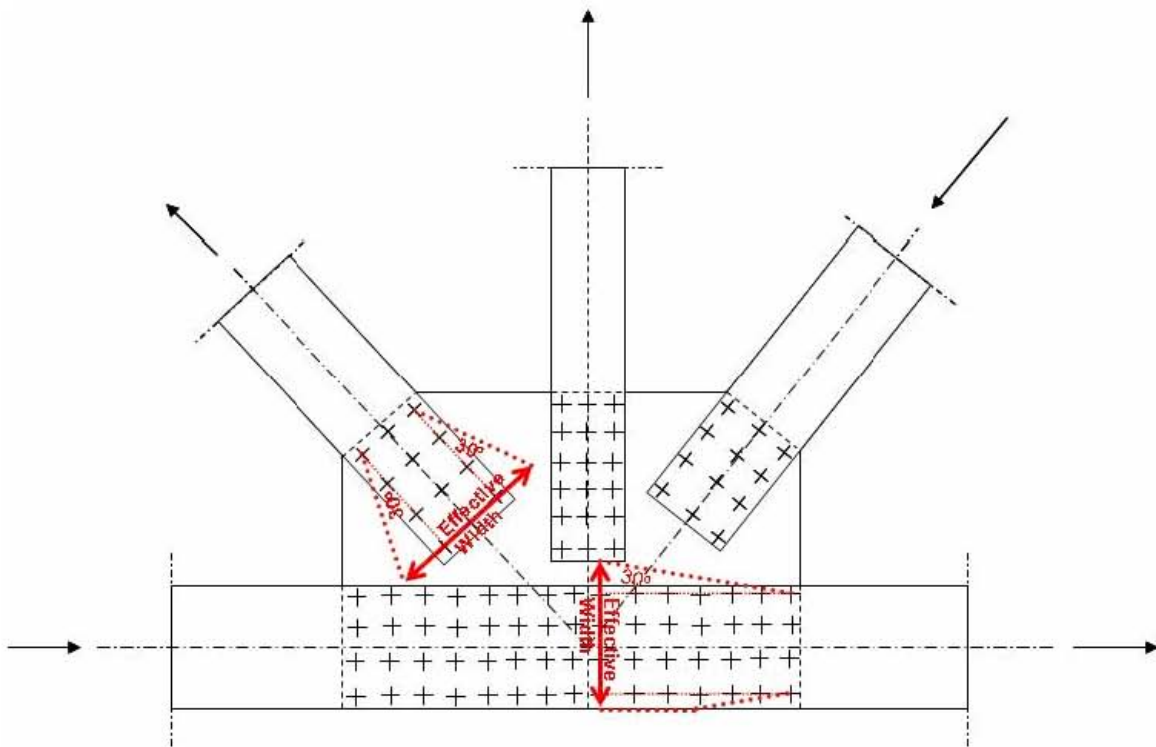

Figure 2 – Example 2 for using the Whitmore method to determine the effective width in tension

3.1.2. Block Shear Rupture Resistance

The resistance to block shear rupture is that resulting from the combined resistance of parallel and perpendicular planes; one in axial tension and the others in shear. The resistance of the plate for block shear rupture shall be taken as:

- If $A_m \geq 0.58A_{vn}$, then $R_r = 0.85(0.58F_y A_{vg} + F_u A_m)$ (4)
- Otherwise: $R_r = 0.85(0.58F_u A_{vn} + F_y A_{tg})$ (5)

Where:

0.85 = resistance factor for block shear. This value is calculated as the LRFD resistance factor for net section tension fracture (0.8) divided by the resistance factor for gross section tension yielding (0.95)

A_{vg} = gross area along the plane resisting shear stress

A_{tg} = gross area along the plane resisting tension stress

A_{vn} = net area along the plane resisting shear stress

A_{tn} = net area along the plane resisting tension stress

F_y = yield strength of the plate, as specified in AASHTO Table 10.2A

F_u = tensile strength of the plate, as specified in AASHTO Table 10.2A

The analysis of block shear rupture involves the evaluation of several patterns of planes to arrive at the governing pattern. Figure 3 provides some examples of potential block shear rupture planes for gusset plates in tension.

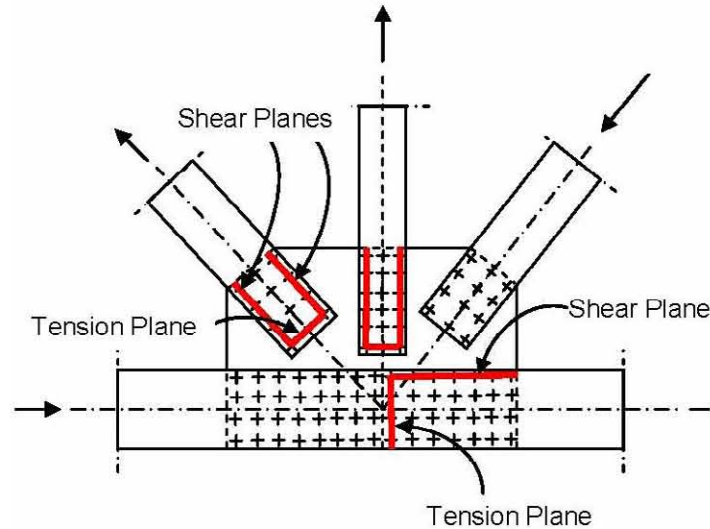

Figure 3 – Examples of potential block shear rupture planes for gusset plates in tension

3.2. Gusset Plates Subject to Shear

The shear resistance, R_r , for gusset plates subject to shear shall be taken as the lesser of the shear yield and the shear fracture resistance specified in Equations 6 and 7, respectively:

$$R_r = 0.58F_y A_g \times \Omega \quad (6)$$

$$R_r = 0.85 \times 0.58F_u A_n \quad (7)$$

where:

0.85 = resistance factor for shear fracture on the net section. This value is calculated as the LRFD resistance factor for net section tension fracture (0.8) divided by the resistance factor for gross section tension yielding (0.95)

A_g = gross area of the plates resisting shear

A_n = net area of the plates resisting shear

F_y = minimum yield strength of the plates

F_u = minimum tensile strength of the plates

Ω = reduction factor taken as:

- $\Omega = 1.00$ when the gusset plates are of ample stiffness to prevent buckling and develop the plastic shear force of the plates, or
- $\Omega = 0.74$ in the absence of a more rigorous analysis or criterion to assure and quantify the stiffness requirements to develop the plastic shear force of the plates.

The analysis of gusset plates for shear involves the evaluation of several shear sections to arrive at the governing section. Figures 4 and 5 provide examples of shear sections to be evaluated in gusset plates in gross section shear yielding and net section shear fracture.

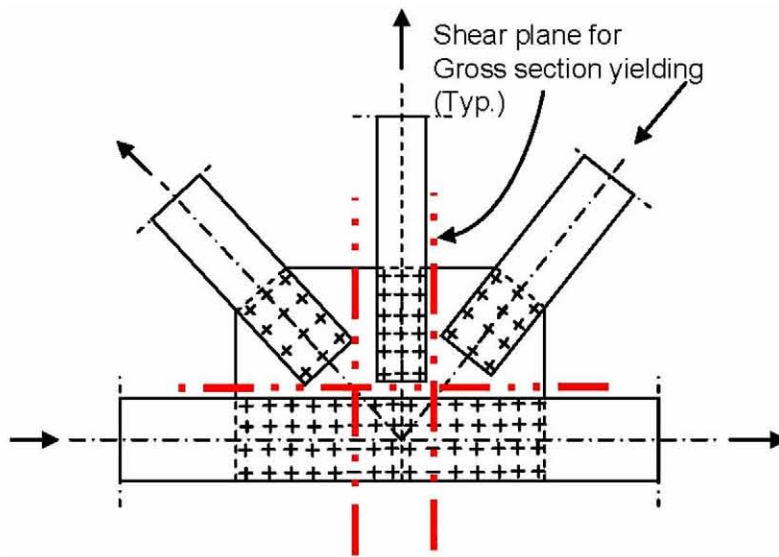

Figure 4 – Examples of gross section shear yielding planes

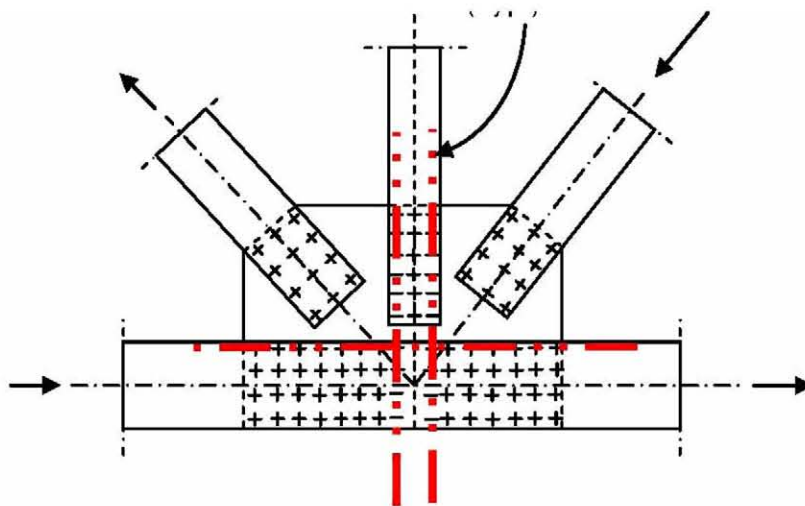

Figure 5 – Examples of net section shear fracture planes

3.3. Gusset Plates in Compression

The proximity of connected members, complex state of stress, and boundary conditions can influence the resistance of gusset plates in compression. Therefore, special care must be exercised to properly assess the buckled shape and compressive resistance of gusset plates in compression.

In the absence of a more rigorous analysis, the resistance of gusset plates in compression may be determined as that of idealized members in compression, in accordance with the provisions of AASHTO Article 10.54.1.1.

The effective width of the idealized compression member may be determined in accordance with the Whitmore method. The unbraced length, L_c , may be determined as the average of three distances (L_1 , L_2 , L_3) as follows:

where:







L_2 = The distance from the last row of fasteners in the compression member under consideration to the first row of fasteners in the closest adjacent member, measured along the line of action of the compressive axial force.

L_1, L_3 = The distance from each of the ends of the Whitmore width to the first row of fasteners in the closest adjacent member, measured parallel to the line of action of the compressive axial force. When the Whitmore width enters into the adjacent member, the associated distance at that end should be set to zero.

Figure 6 provides an example showing L_1 , L_2 , L_3 , and effective width for a gusset plate in compression.

When lateral sway of gusset plates is possible, the effective length factor, K , for gusset plates may be taken from Table 2 for Cases (d), (e), or (f), depending on the anticipated buckled shape. When lateral sway of gusset plates is not possible, the effective length factor, K , for gusset plates may be taken from Table 2 for Cases (a), (b), or (c), as appropriate.

Table 2 – K Values

	(a)	(b)	(c)	(d)	(e)	(f)
Buckled shape						
Theoretical K value	0.5	0.7	1.0	1.0	2.0	2.0
Design K value	0.65	0.80	1.0	1.2	2.1	2.0

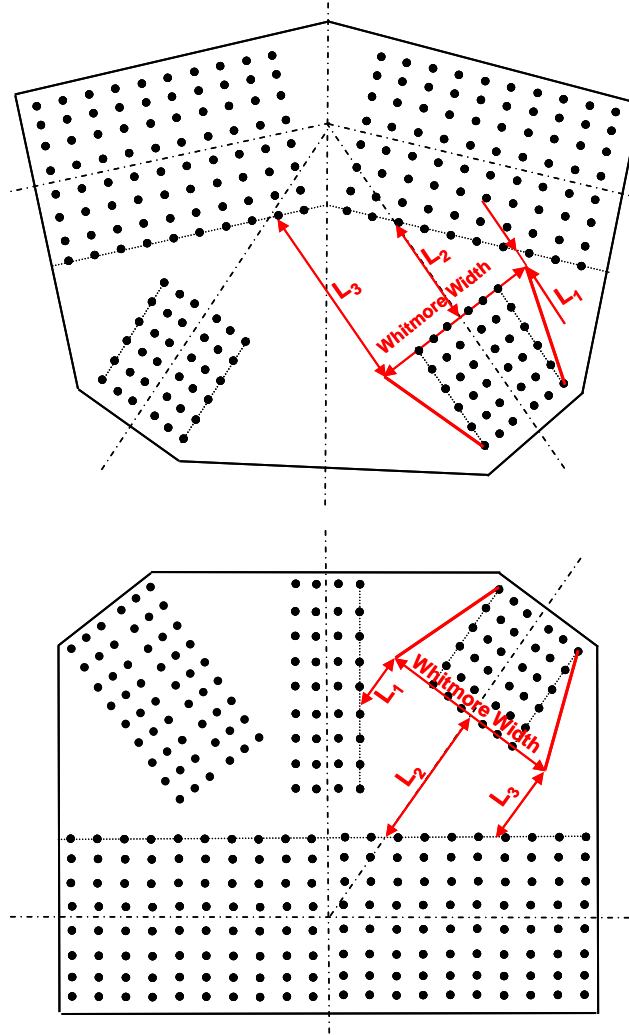

Figure 6 – Examples showing L_1 , L_2 , L_3 , and effective width for a gusset plate in compression.

3.4. Gusset Plates Under Combined Flexural and Axial Loads

Gusset plates behave as deep members. Therefore, the application of flexural theory to the analysis of gusset plates is questionable and not required in this Guidance.

3.5. Limiting Slenderness Ratio

The existing requirement of length-to-thickness ratio (for the design of unsupported edges of gusset plates) not to exceed $11,000/\sqrt{F_y}$ is equivalent to the slenderness ratio

requirement of $\frac{l}{r} \leq 200$ for Grade 36 tension members not subject to stress reversal.

Although an appropriate slenderness limit is advisable for the design of new gusset plates, it is not required in this guidance for load rating purposes. However, Owners are advised to evaluate the cause and effect of any excessive out of flatness at the free edges of gusset plates.

II - Load Rating Examples

Part – A: Gusset Plate Load Rating Example in Accordance with the Load and Resistance Factor Rating Method (LRFR)

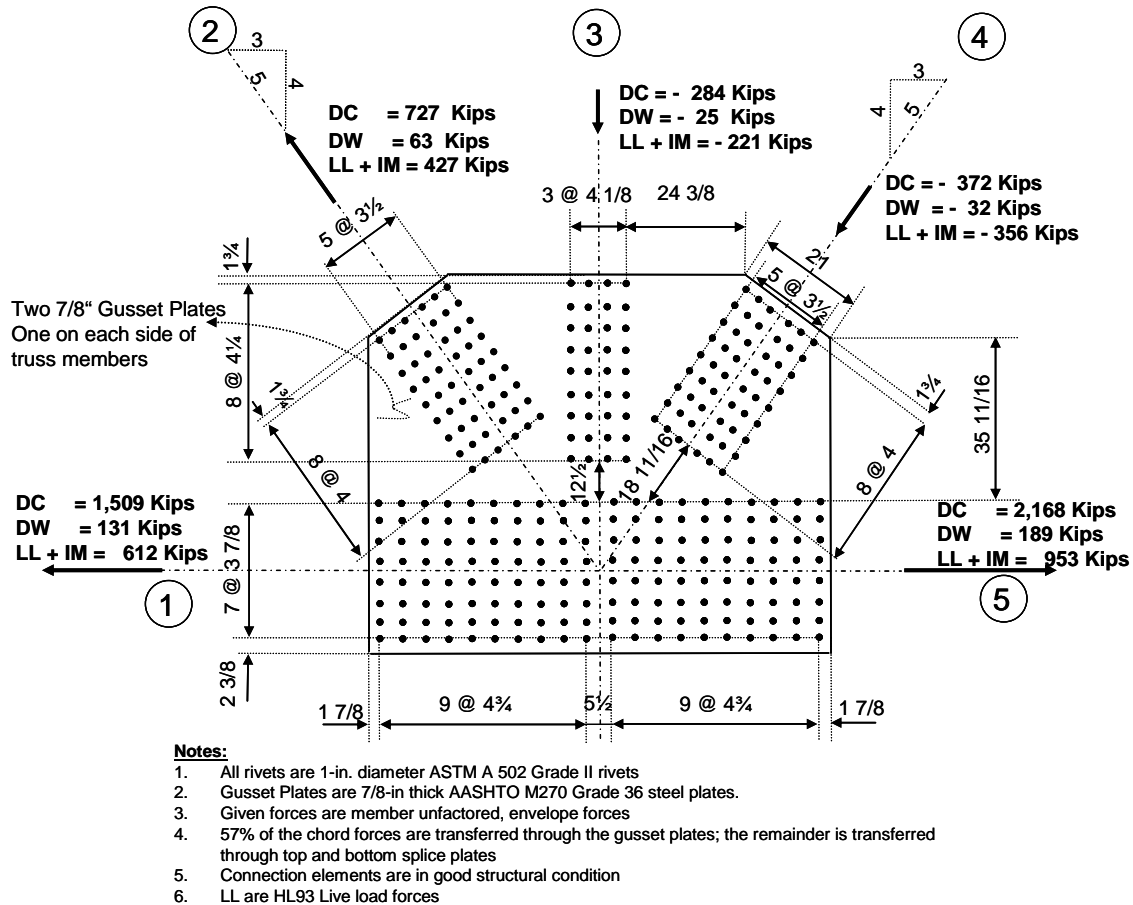

1. Resistance of Fasteners

1.1. Fasteners at End of Members 1 and 5

1.1.1. Shear Resistance of Fasteners

The shear resistance of one rivet is:

$$\phi_s R_n = \phi F A_r = 32 \times \frac{\pi \times 1^2}{4} = 25.13 \text{ kips}$$

1.1.2. Plate Bearing Resistance at Fasteners

$$\text{Clear distance between holes} = 4.75 - \left(1 + \frac{1}{16}\right) = 3.6875 > 2d = 2 \times 1 = 2$$

$$\text{Clear end distance} = 1.875 - \frac{1}{2} \left(1 + \frac{1}{16}\right) = 1.34375 < 2d = 2$$

Since the clear end distance is less than $2.0d$, the bearing resistance of one end rivet is:

$$\phi_{bb} R_n = \phi_{bb} \times 1.2 L_c t F_u$$

$$\phi_{bb} R_n = 0.8 \times 1.2 \times 1.34375 \times 0.875 \times 58 = 65.47 \text{ kips}$$

Therefore, rivet shear controls the resistance of fasteners.

The resistance of all rivets in the connection is:

$$P_r = 25.13 \times 80 = 2,011 \text{ kips}$$

1.2. Fasteners at End of Member 2

1.2.1. Shear Resistance of Fasteners

The shear resistance of one rivet is:

$$\phi_s R_n = \phi F A_r = 32 \times \frac{\pi \times 1^2}{4} = 25.13 \text{ kips}$$

1.2.2. Plate Bearing Resistance at Fasteners

$$\text{Clear distance between holes} = 4 - \left(1 + \frac{1}{16}\right) = 2.9375 > 2d = 2 \times 1 = 2$$

$$\text{Clear end distance} = 1.75 - \frac{\left(1 + \frac{1}{16}\right)}{2} = 1.21875 < 2d = 2$$

Since the clear end distance is less than $2.0d$, the bearing resistance of one end rivet is:

$$\phi_{bb} R_n = \phi_{bb} \times 1.2 L_c t F_u$$

$$\phi_{bb} R_n = 0.8 \times 1.2 \times 1.21875 \times 0.875 \times 58 = 59.4 \text{ kips}$$

Therefore, rivet shear controls the resistance of fasteners.

The resistance of all rivets in the connection is:

$$P_r = 25.13 \times 54 = 1,357 \text{ kips}$$

1.3. Fasteners at End of Member 3

1.3.1. Shear Resistance of Fasteners

The shear resistance of one rivet is:

$$\phi_s R_n = \phi F A_r = 32 \times \frac{\pi \times 1^2}{4} = 25.13 \text{ kips}$$

1.3.2. Plate Bearing Resistance at Fasteners

$$\text{Clear distance between holes} = 4.25 - \left(1 + \frac{1}{16}\right) = 3.1875 > 2d = 2 \times 1 = 2$$

Since the clear distance is larger than $2.0d$, the bearing resistance of one rivet is:

$$\phi_{bb} R_n = \phi_{bb} \times 2.4 d t F_u$$

$$\phi_{bb} R_n = 0.8 \times 2.4 \times 1 \times 0.875 \times 58 = 97.44 \text{ kips}$$

Therefore, rivet shear controls the resistance of fasteners.

The resistance of all rivets in the connection is:

$$P_r = 25.13 \times 36 = 905 \text{ kips}$$

1.4. Fasteners at End of Member 4

1.4.1. Shear Resistance of Fasteners

The shear resistance of one rivet is:

$$\phi_s R_n = \phi F A_r = 32 \times \frac{\pi \times 1^2}{4} = 25.13 \text{ kips}$$

1.4.2. Plate Bearing Resistance at Fasteners

$$\text{Clear distance between holes} = 4 - \left(1 + \frac{1}{16}\right) = 2.9375 > 2d = 2 \times 1 = 2$$

Since the clear distance is larger than $2.0d$, the bearing resistance of one rivet is:

$$\phi_{bb}R_n = \phi_{bb} \times 2.4dtF_u$$

$$\phi_{bb}R_n = 0.8 \times 2.4 \times 1 \times 0.875 \times 58 = 97.44 \text{ kips}$$

Therefore, rivet shear controls the resistance of fasteners.

The resistance of all rivets in the connection is:

$$P_r = 25.13 \times 54 = 1,357 \text{ kips}$$

2. Resistance of Gusset Plate

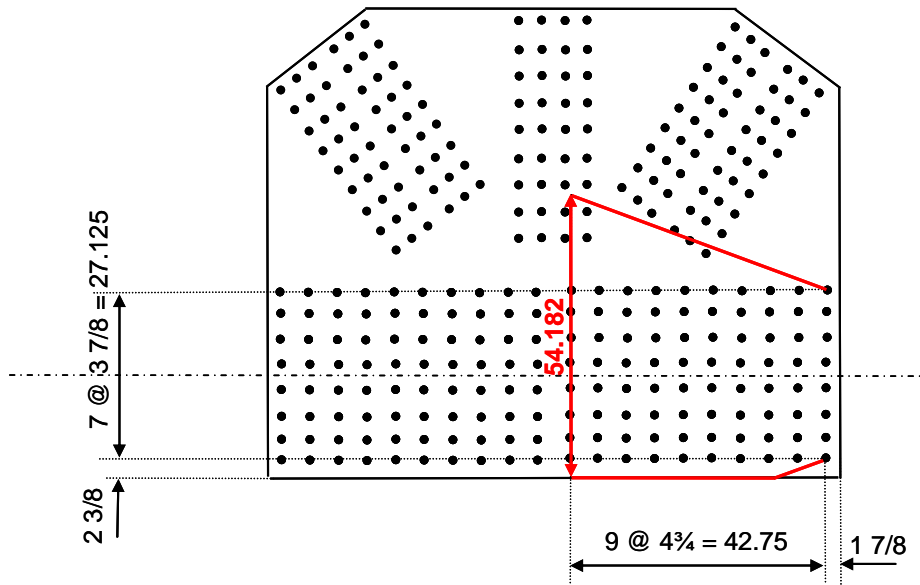

2.1. Gusset Plate in Tension at Members 1 and 5

2.1.1. Gross Section Yielding Resistance

$$P_r = \phi_y P_{ny} = \phi_y F_y A_g$$

$$P_r = 0.95 \times 36 \times \left(\frac{7}{8} \times 54.182 \right) = 1,621 \text{ kips}$$

2.1.2. Net Section Fracture Resistance

$$P_r = \phi_u P_{nu} = \phi_u F_u A_n U$$

$$P_r = 0.80 \times 58 \times \left\{ \frac{7}{8} \times \left[54.182 - 8 \times \left(1 + \frac{1}{8} \right) \right] \right\} \times 1 = 1,834 \text{ kips}$$

2.1.3. Block Shear Rupture Resistance

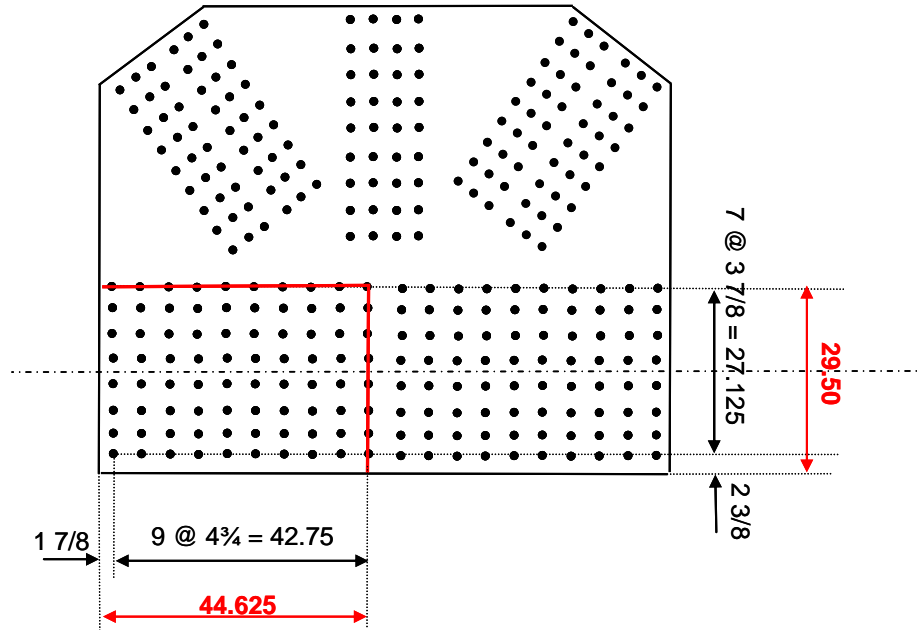

$$A_m = \frac{7}{8} \left[29.50 - 7.5 \left(1 + \frac{1}{8} \right) \right] = 18.43 \text{ in}^2$$

$$A_{vn} = \frac{7}{8} \left[44.625 - 9.5 \left(1 + \frac{1}{8} \right) \right] = 29.70 \text{ in}^2$$

$A_m = 18.43 > 0.58A_{vn} = 0.58 \times 29.70 = 17.22$, therefore:

$$P_r = \phi_{bs} (0.58F_y A_{vn} + F_u A_m)$$

$P_r = 0.80 \left(0.58 \times 36 \times \frac{7}{8} \times 44.625 + 58 \times 18.43 \right) = 1,507 \text{ kips}$ governs the capacity of the gusset plate at member 1 and 5.

2.2. Gusset Plate in Tension at Member 2

2.2.1. Gross Section Yielding Resistance

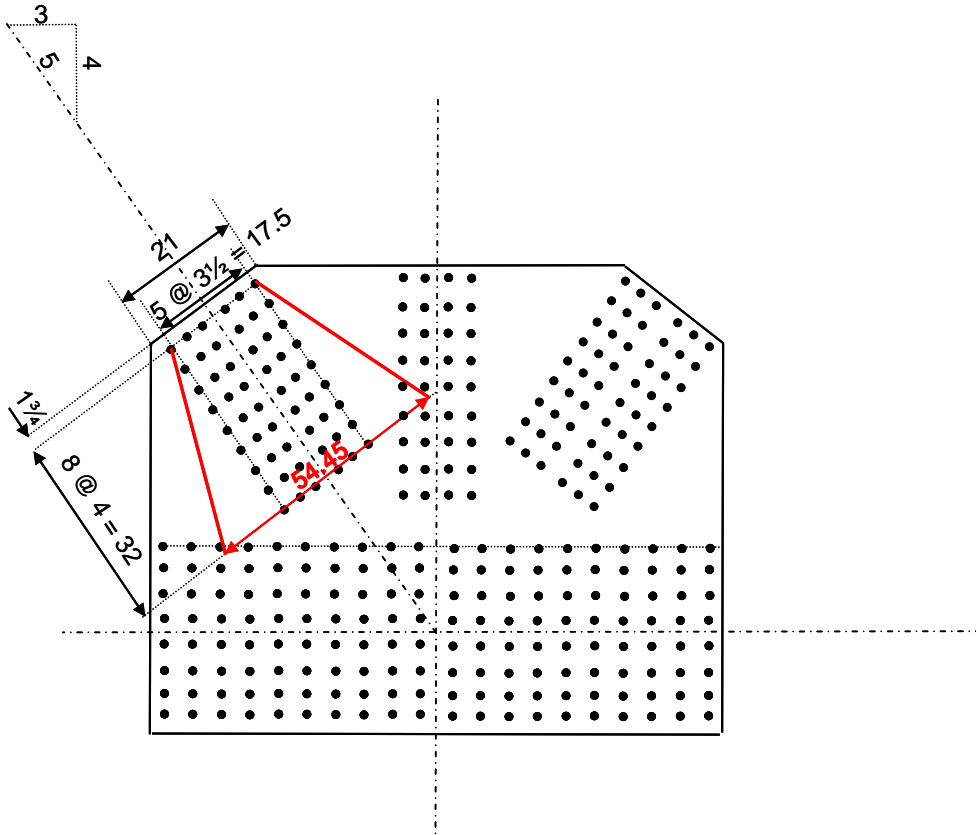

$$P_r = \phi_y P_{ny} = \phi_y F_y A_g$$

$$P_r = 0.95 \times 36 \times \left(\frac{7}{8} \times 54.45 \right) = 1,629 \text{ kips}$$

2.2.2. Net Section Fracture Resistance

$$P_r = \phi_u P_{nu} = \phi_u F_u A_n U$$

$$P_r = 0.80 \times 58 \times \left\{ \frac{7}{8} \times \left[54.45 - 6 \times \left(1 + \frac{1}{8} \right) \right] \right\} \times 1 = 1,937 \text{ kips}$$

2.2.3. Block Shear Rupture Resistance

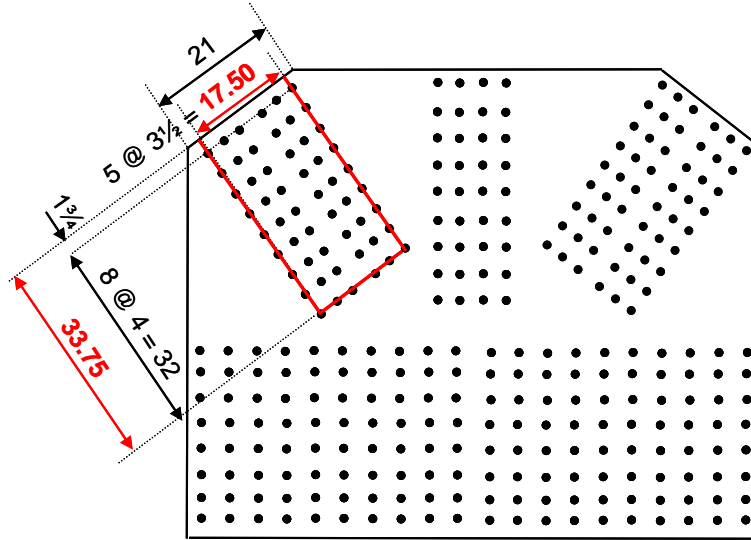

$$A_m = \frac{7}{8} \left[17.50 - 5 \left(1 + \frac{1}{8} \right) \right] = 10.39 \text{ in}^2$$

$$A_{vn} = 2 \times \frac{7}{8} \left[33.75 - 8.5 \left(1 + \frac{1}{8} \right) \right] = 42.33 \text{ in}^2$$

$A_m = 10.39 < 0.58A_{vn} = 0.58 \times 42.33 = 24.55$, therefore:

$$P_r = \phi_{bs} \left(0.58F_u A_{vn} + F_y A_{tg} \right)$$

$$P_r = 0.80 \left(0.58 \times 58 \times 42.33 + 36 \times 17.5 \times \frac{7}{8} \right) = 1,580 \text{ kips} \text{ governs the capacity}$$

of the gusset plate at member 2.

2.3. Gusset Plate Subject to Vertical Shear

2.3.1. Gross Section Shear Yielding Resistance

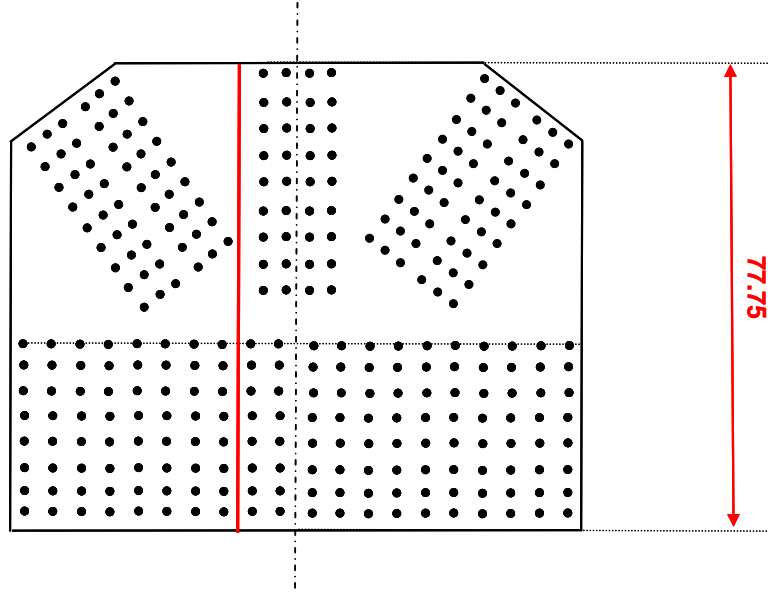

$$V_r = \phi_{vy} V_n = \phi_{vy} \times 0.58 F_y A_g \times \Omega$$

$$V_r = 0.95 \times 0.58 \times 36 \times \left(\frac{7}{8} \times 77.75 \right) \times 0.74 = 999 \text{ kips}$$

2.3.2. Net Section Shear Fracture Resistance

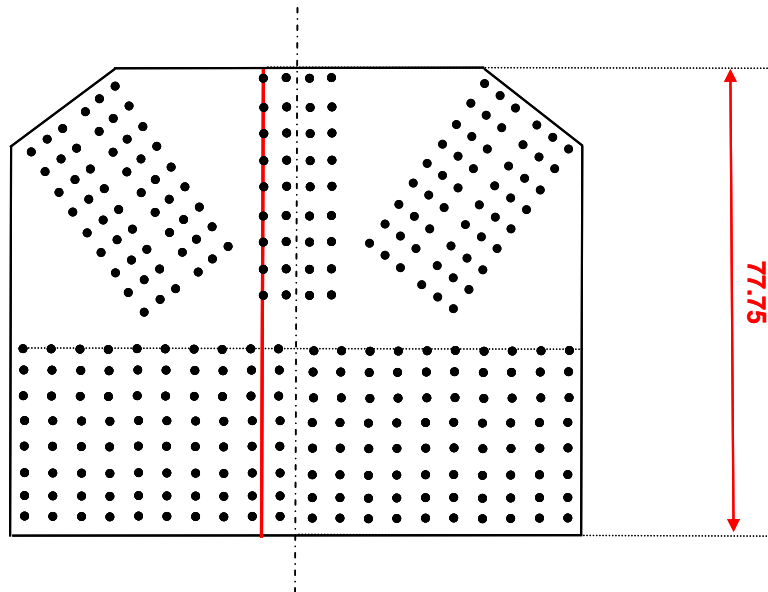

$$V_r = \phi_{vu} V_n = \phi_{vu} \times 0.58 F_u A_n$$

$$V_r = 0.80 \times 0.58 \times 58 \times \left\{ \frac{7}{8} \times \left[77.75 - 9 \times \left(1 + \frac{1}{8} \right) \right] \right\} = 1,592 \text{ kips}$$

2.4. Gusset Plate Subject to Horizontal Shear

2.4.1. Gross Section Shear Yielding Resistance

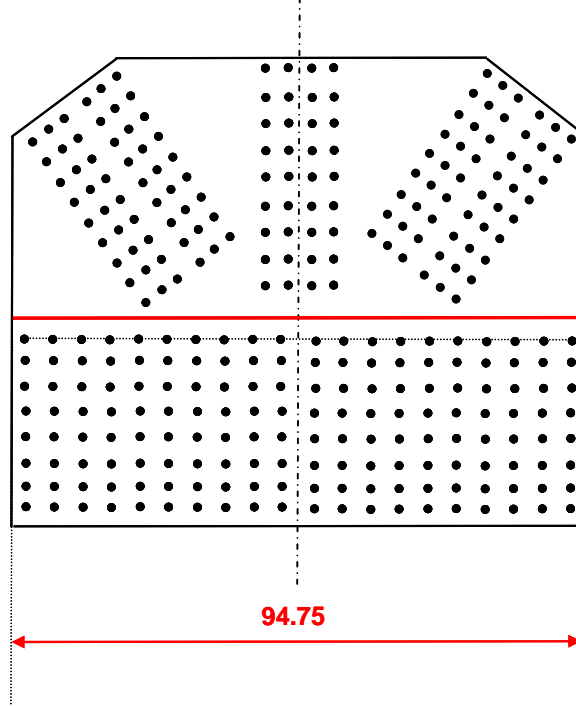

$$V_r = \phi_{vy} V_n = \phi_{vy} \times 0.58 F_y A_g \times \Omega$$

$$V_r = 0.95 \times 0.58 \times 36 \times \left(\frac{7}{8} \times 94.75 \right) \times 0.74 = 1,217 \text{ kips}$$

2.4.2. Net Section Shear Fracture Resistance

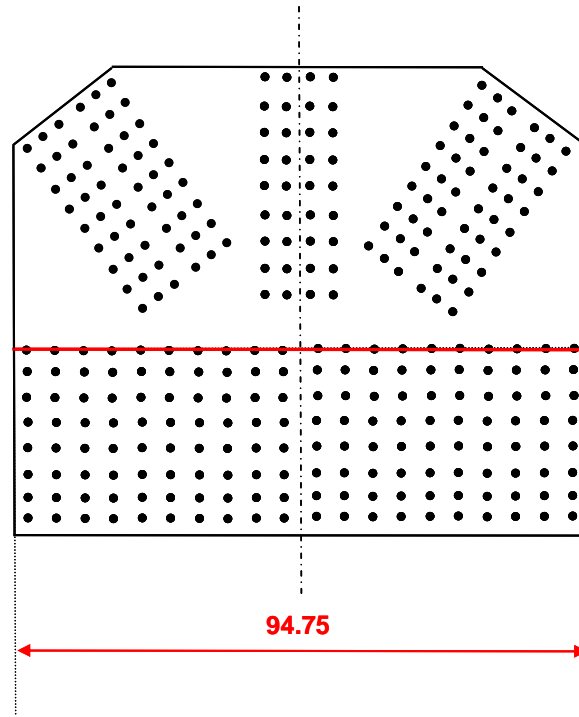

$$V_r = \phi_{vu} V_n = \phi_{vu} \times 0.58 F_u A_n$$

$$V_r = 0.80 \times 0.58 \times 58 \times \left\{ \frac{7}{8} \times \left[94.75 - 20 \times \left(1 + \frac{1}{8} \right) \right] \right\} = 1,701 \text{ kips}$$

2.5. Gusset Plate in Compression at Member 3

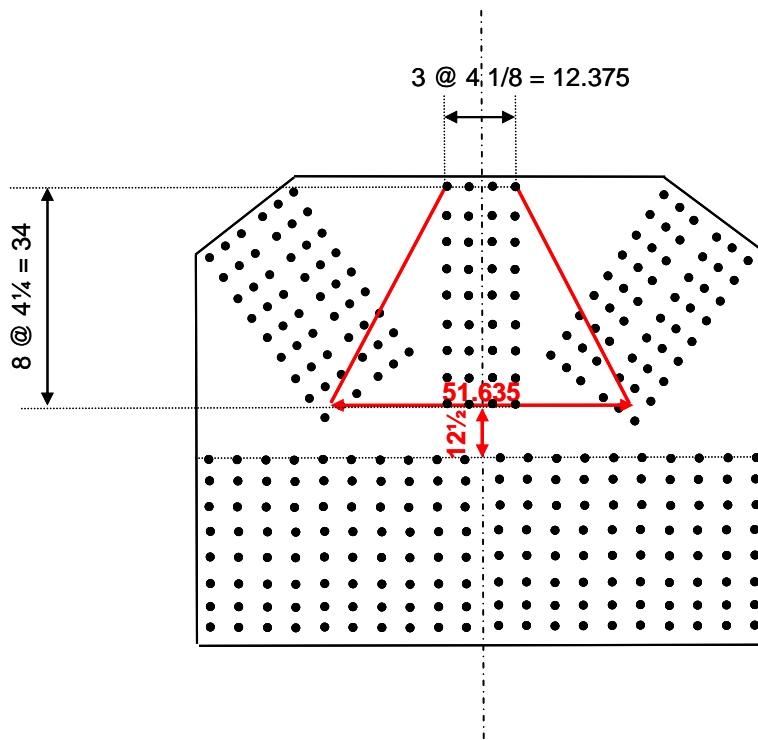

Ignore any lateral constraint to the gusset, and use the K value ($K = 1.2$) for unbraced gusset assuming the following buckled shape (case d):



$$r_s = \frac{I_g}{A_g} = \frac{51.635 \times \left(\frac{7}{8}\right)^3}{12} = \frac{2.883}{45.18} = 0.25$$

$$l = \frac{L_1 + L_2 + L_3}{3} = \frac{12.50 + 12.50 + 12.50}{3} = 12.50$$

$$\lambda = \left(\frac{Kl}{r_s \pi}\right)^2 \frac{F_y}{E} = \left(\frac{1.20 \times 12.50}{0.25 \times \pi}\right)^2 \times \frac{36}{29,000} = 0.4528$$

Since $\lambda = 0.4528 < 2.25$, $P_n = 0.66^\lambda F_y A_g$

$$P_n = 0.66^{0.4528} \times 36 \times \left(51.635 \times \frac{7}{8}\right) = 29.83 \times 45.18 = 1,348$$

$$P_r = \phi_c P_n = 0.90 \times 1,348 = 1,213 \text{ kips}$$

2.6. Gusset Plate in Compression at Member 4

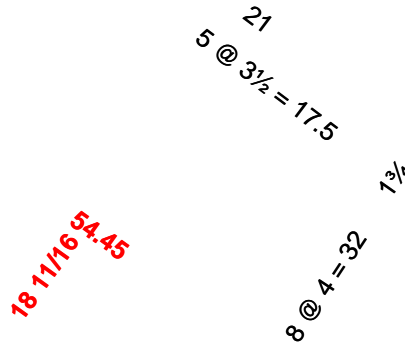

Ignore any lateral constraint to the gusset, and use the K value ($K = 1.2$) for unbraced gusset assuming the following buckled shape (case d):



$$r_s = \frac{I_g}{A_g} = \frac{54.45 \times \left(\frac{7}{8}\right)^3}{54.45 \times \frac{7}{8}} = \frac{3.040}{47.64} = 0.25$$

$$l = \frac{L_1 + L_2 + L_3}{3} = \frac{0 + 18.6875 + 0}{3} = 6.229$$

$$\lambda = \left(\frac{Kl}{r_s \pi}\right)^2 \frac{F_y}{E} = \left(\frac{1.20 \times 6.229}{0.25 \times \pi}\right)^2 \times \frac{36}{29,000} = 0.1124$$

Since $\lambda = 0.1124 < 2.25$, $P_n = 0.66^\lambda F_y A_g$

$$P_n = 0.66^{0.1124} \times 36 \times \left(54.45 \times \frac{7}{8}\right) = 34.36 \times 47.64 = 1,637$$

$$P_r = \phi_c P_n = 0.90 \times 1,637 = 1,473 \text{ kips}$$

3. Resistance Summary

Location	Resistance of Fasteners Kips	Axial Resistance of one Gusset Plate Kips				Controlling Axial Resistance Kips
		Gross Section Yielding in Tension	Net Section Fracture in Tension	Block Shear Rupture	Compression Buckling	
At End of Member	Fastener Shear					
1	2,011	1,621	1,834	1,507	-	1,507
2	1,357	1,629	1,937	1,580	-	1,357
3	905	-	-	-	1,213	905
4	1,357	-	-	-	1,473	1,357
5	2,011	1,621	1,834	1,507	-	1,507

Orientation of Section	Shear Resistance of one Gusset Plate - Kips		Controlling Shear Resistance Kips
	Gross Section Yielding in Shear	Net Section Fracture in Shear	
Vertical	999	1,592	999
Horizontal	1,217	1,701	1,217

4. Inventory and Operating Rating Factors

At End of Member	1.25DC + 1.50DW	(LL+IM)	Controlling Axial Resistance $C = \phi_c \phi_s \phi R_n$ $C = 1 \times 0.9 \times \phi R_n$ Kips	Inventory Rating Factor $\frac{C - 1.25DC - 1.50DW}{1.75(LL + I)}$	Operating Rating Factor $\frac{C - 1.25DC - 1.50DW}{1.35(LL + I)}$
1	$0.57(1.25 \times 1,509 + 1.50 \times 131)/2$ = 594	$0.57 \times 612/2$ = 174	$0.9 \times 1,507$ = 1,356	2.5	3.24
2	$(1.25 \times 727 + 1.50 \times 63)/2$ = 502	$427/2$ = 214	$0.9 \times 1,357$ = 1,221	1.93	2.50
3	$(1.25 \times 284 + 1.50 \times 25)/2$ = 196	$221/2$ = 111	0.9×905 = 815	3.20	4.14
4	$(1.25 \times 372 + 1.50 \times 32)/2$ = 257	$356/2$ = 178	$0.9 \times 1,357$ = 1,221	3.10	4.01
5	$0.57(1.25 \times 2,168 + 1.50 \times 189)/2$ = 853	$0.57 \times 953/2$ = 272	$0.9 \times 1,507$ = 1,356	1.06	1.37

Orientation of Section	1.25DC + 1.50DW	(LL+IM)	Controlling Shear Resistance C Kips	Inventory Rating Factor $\frac{C - 1.25DC - 1.50DW}{1.75(LL + IM)}$	Operating Rating Factor $\frac{C - 1.25DC - 1.50DW}{1.35(LL + IM)}$
Vertical	$(1.25 \times 727 + 1.50 \times 63) \times 4/5/2$ = 401	$(427 \times 4/5)/2$ = 171	$0.9 \times 999 = 899$	1.67	2.16
Horizontal	$[(1.25 \times 727 + 1.50 \times 63) + (1.25 \times 372 + 1.50 \times 32)] \times 3/5/2$ = 455	$[(427 + 356) \times 3/5]/2$ = 235	$0.9 \times 1,217 = 1,095$	1.56	2.02

Therefore, the controlling Inventory Rating Factor for the Gusset Connection is 1.06 for HL-93 loading (block shear rupture at the end of member 5)

Part – B: Gusset Plate Load Rating Example in Accordance with the Load Factor Rating Method (LFR)

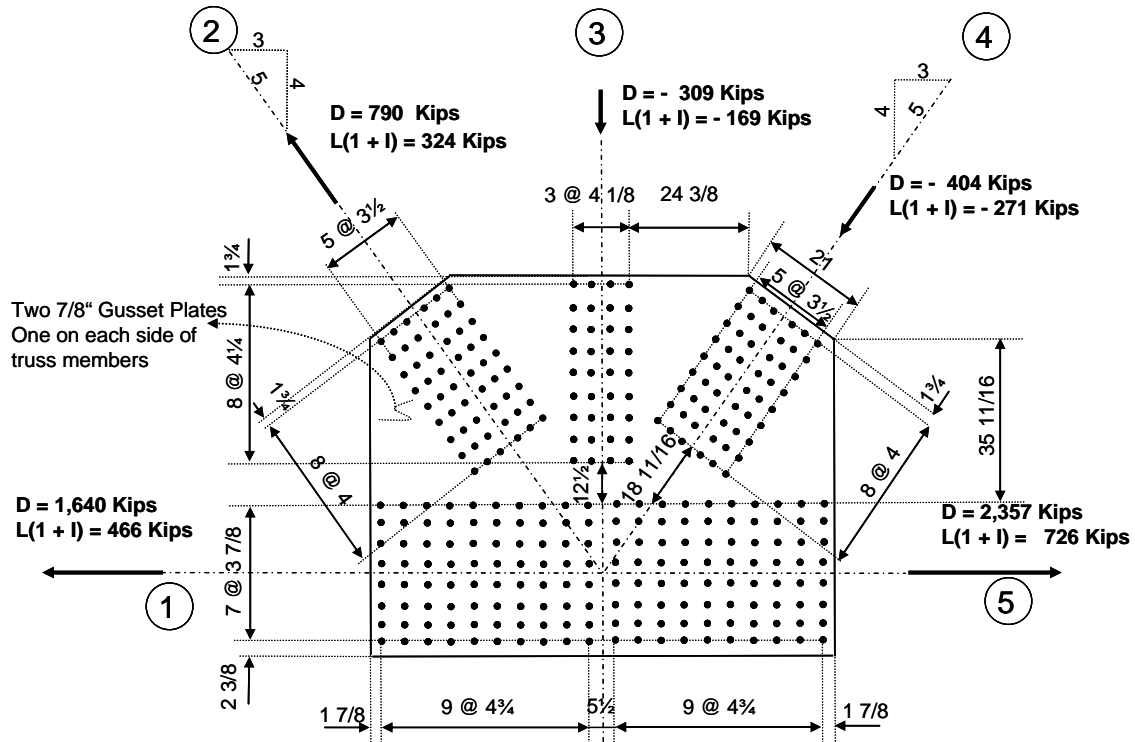

Notes:

1. All rivets are 1-in. diameter ASTM A 502 Grade II rivets
2. Gusset Plates are 7/8-in thick AASHTO M270 Grade 36 steel plates.
3. Given forces are member unfactored, envelope forces
4. 57% of the chord forces are transferred through the gusset plates; the remainder is transferred through top and bottom splice plates
5. Connection elements are in good structural condition
6. L forces are HS20 Live load forces

1. Resistance of Fasteners

1.1. Fasteners at End of Members 1 and 5

1.1.1. Shear Resistance of Fasteners

The shear resistance of one rivet is:

$$\phi R = \phi F A_b = 30 \times \frac{\pi \times 1^2}{4} = 23.56 \text{ kips}$$

1.1.2. Plate Bearing Resistance at Fasteners

$$\text{Clear distance between holes} = L_c = 4.75 - \left(1 + \frac{1}{16}\right) = 3.6875$$

The bearing resistance of an interior rivet is:

$$\phi R = 0.9L_c t F_u \leq 1.8dt F_u$$

$$\phi R = \min \text{ of } \left(\begin{array}{l} 0.9 \times 3.6875 \times 0.875 \times 58 = 168 \\ 1.8 \times 1 \times 0.875 \times 58 = 91.35 \end{array} \right) = 91.35 \text{ kips}$$

$$\text{Clear end distance} = L_c = 1.875 - \frac{1}{2} \left(1 + \frac{1}{16}\right) = 1.34375$$

The bearing resistance of an end rivet is:

$$\phi R = 0.9L_c t F_u \leq 1.8dt F_u$$

$$\phi R = \min \text{ of } \left(\begin{array}{l} 0.9 \times 1.34375 \times 0.875 \times 58 = 61.38 \\ 1.8 \times 1 \times 0.875 \times 58 = 91.35 \end{array} \right) = 61.38 \text{ kips}$$

Therefore, rivet shear controls the resistance of fasteners.

The resistance of all rivets in the connection is:

$$P_r = 23.56 \times 80 = 1,885 \text{ kips}$$

1.2. Fasteners at End of Member 2

1.2.1. Shear Resistance of Fasteners

The shear resistance of one rivet is:

$$\phi R = \phi F A_b = 30 \times \frac{\pi \times 1^2}{4} = 23.56 \text{ kips}$$

1.2.2. Plate Bearing Resistance at Fasteners

$$\text{Clear distance between holes} = L_c = 4 - \left(1 + \frac{1}{16}\right) = 2.9375$$

The bearing resistance of an interior rivet is:

$$\phi R = 0.9L_c t F_u \leq 1.8dt F_u$$

$$\phi R = \min \text{ of } \left(\begin{array}{l} 0.9 \times 2.9375 \times 0.875 \times 58 = 134 \\ 1.8 \times 1 \times 0.875 \times 58 = 91.35 \end{array} \right) = 91.35 \text{ kips}$$

$$\text{Clear end distance} = L_c = 1.75 - \frac{\left(1 + \frac{1}{16}\right)}{2} = 1.21875$$

The bearing resistance of an end rivet is:

$$\phi R = 0.9L_c t F_u \leq 1.8dt F_u$$

$$\phi R = \min \text{ of } \left(\begin{array}{l} 0.9 \times 1.21875 \times 0.875 \times 58 = 55.67 \\ 1.8 \times 1 \times 0.875 \times 58 = 91.35 \end{array} \right) = 55.67 \text{ kips}$$

Therefore, rivet shear controls the resistance of fasteners.

The resistance of all rivets in the connection is:

$$P_r = 23.56 \times 54 = 1,272 \text{ kips}$$

1.3. Fasteners at End of Member 3

1.3.1. Shear Resistance of Fasteners

The shear resistance of one rivet is:

$$\phi R = \phi F A_s = 30 \times \frac{\pi \times 1^2}{4} = 23.56 \text{ kips}$$

1.3.2. Plate Bearing Resistance at Fasteners

$$\text{Clear distance between holes} = L_c = 4.25 - \left(1 + \frac{1}{16}\right) = 3.1875$$

The bearing resistance of one rivet is:

$$\phi R = 0.9L_c t F_u \leq 1.8dt F_u$$

$$\phi R = \min \text{ of } \left(\begin{array}{l} 0.9 \times 3.1875 \times 0.875 \times 58 = 145.59 \\ 1.8 \times 1 \times 0.875 \times 58 = 91.35 \end{array} \right) = 91.35 \text{ kips}$$

Therefore, rivet shear controls the resistance of fasteners.

The resistance of all rivets in the connection is:

$$P_r = 23.56 \times 36 = 848 \text{ kips}$$

1.4. Fasteners at End of Member 4

1.4.1. Shear Resistance of Fasteners

The shear resistance of one rivet is:

$$\phi R = \phi F A_b = 30 \times \frac{\pi \times 1^2}{4} = 23.56 \text{ kips}$$

1.4.2. Plate Bearing Resistance at Fasteners

$$\text{Clear distance between holes} = L_c = 4 - \left(1 + \frac{1}{16}\right) = 2.9375$$

The bearing resistance of one rivet is:

$$\phi R = 0.9 L_c t F_u \leq 1.8 d t F_u$$

$$\phi R = \min \text{ of } \begin{pmatrix} 0.9 \times 2.9375 \times 0.875 \times 58 = 134.17 \\ 1.8 \times 1 \times 0.875 \times 58 = 91.35 \end{pmatrix} = 91.35 \text{ kips}$$

Therefore, rivet shear controls the resistance of fasteners.

The resistance of all rivets in the connection is:

$$P_r = 23.56 \times 54 = 1,272 \text{ kips}$$

2. Resistance of Gusset Plate

2.1. Gusset Plate in Tension at Members 1 and 5

2.1.1. Gross Section Yielding Resistance

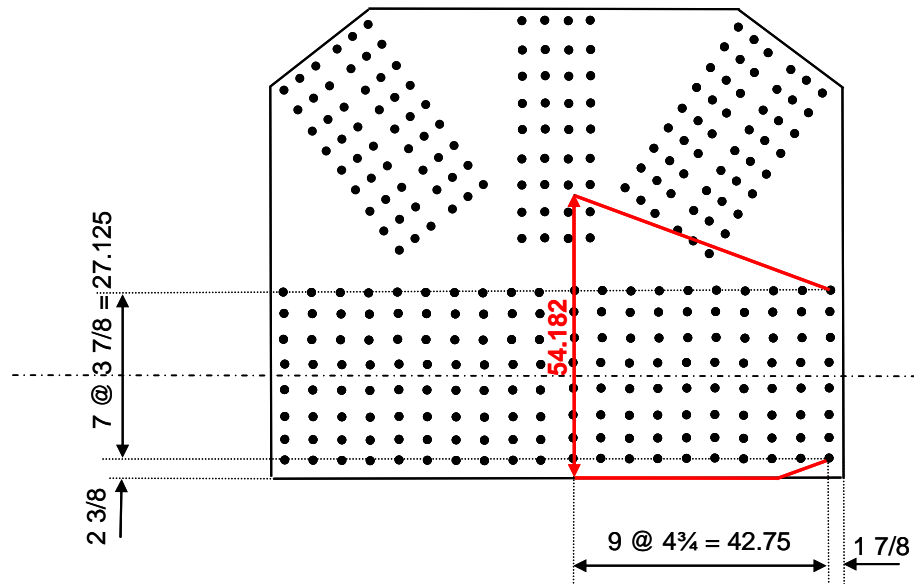

$$A_g = \frac{7}{8} \times 54.182 = 47.41$$

$$A_n = \left\{ \frac{7}{8} \times \left[54.182 - 8 \times \left(1 + \frac{1}{8} \right) \right] \right\} = 39.53$$

$$A_e = A_n + \beta A_g \leq A_g$$

$$A_e = \min \text{ of } \left\{ \begin{array}{l} A_n + \beta A_g = 39.53 + 0.15 \times 47.41 = 46.64 \\ A_g = 47.41 \end{array} \right\} = 46.64$$

$$R_r = A_e F_y$$

$$R_r = 46.64 \times 36 = 1,679 \text{ kips}$$

2.1.2. Block Shear Rupture Resistance

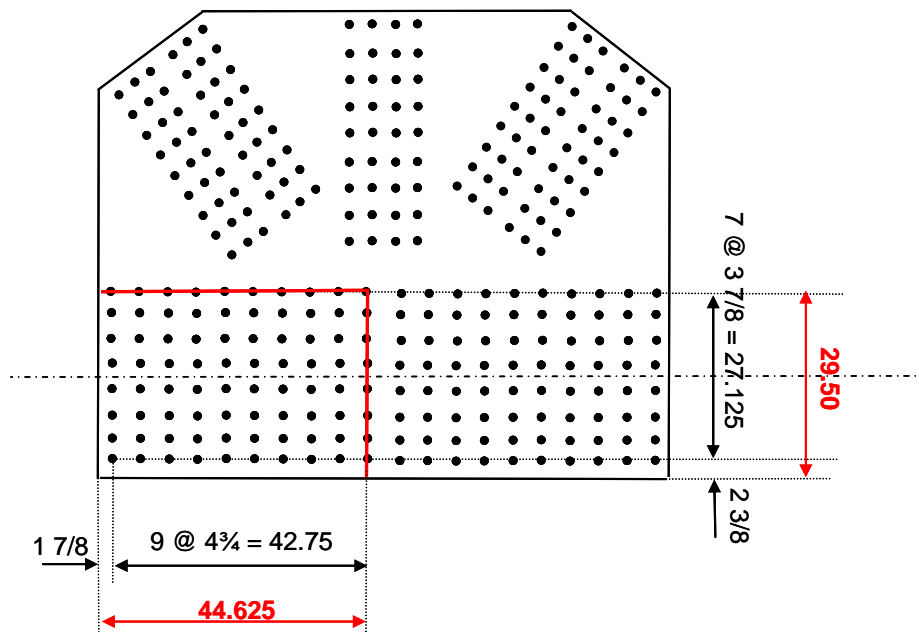

$$A_m = \frac{7}{8} \left[29.50 - 7.5 \left(1 + \frac{1}{8} \right) \right] = 18.43 \text{ in}^2$$

$$A_{vn} = \frac{7}{8} \left[44.625 - 9.5 \left(1 + \frac{1}{8} \right) \right] = 29.70 \text{ in}^2$$

$$A_m = 18.43 > 0.58 A_{vn} = 0.58 \times 29.70 = 17.22, \text{ therefore:}$$

$$R_r = 0.85 (0.58 F_y A_{vg} + F_u A_m)$$

$$P_r = 0.85 \left(0.58 \times 36 \times \frac{7}{8} \times 44.625 + 58 \times 18.43 \right) = 1,602 \text{ kips}$$

Block shear governs the capacity of the gusset plate at member 1 and 5.

2.2. Gusset Plate in Tension at Member 2

2.2.1. Gross Section Yielding Resistance

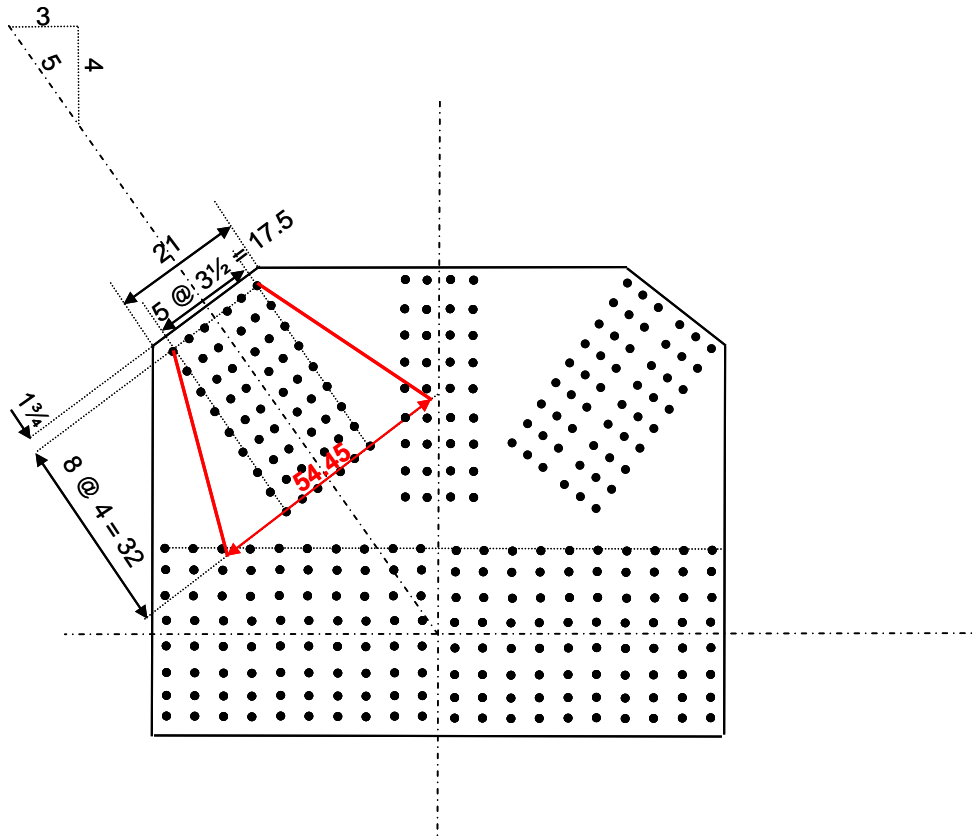

$$A_g = \frac{7}{8} \times 54.45 = 47.64$$

$$A_n = \left\{ \frac{7}{8} \times \left[54.45 - 6 \times \left(1 + \frac{1}{8} \right) \right] \right\} = 41.74$$

$$A_e = A_n + \beta A_g \leq A_g$$

$$A_e = \min \text{ of } \left\{ \begin{array}{l} A_n + \beta A_g = 41.74 + 0.15 \times 47.64 = 48.88 \\ A_g = 47.64 \end{array} \right\} = 47.64$$

$$R_r = A_e F_y$$

$$R_r = 47.64 \times 36 = 1,715 \text{ kips}$$

2.2.2. Block Shear Rupture Resistance

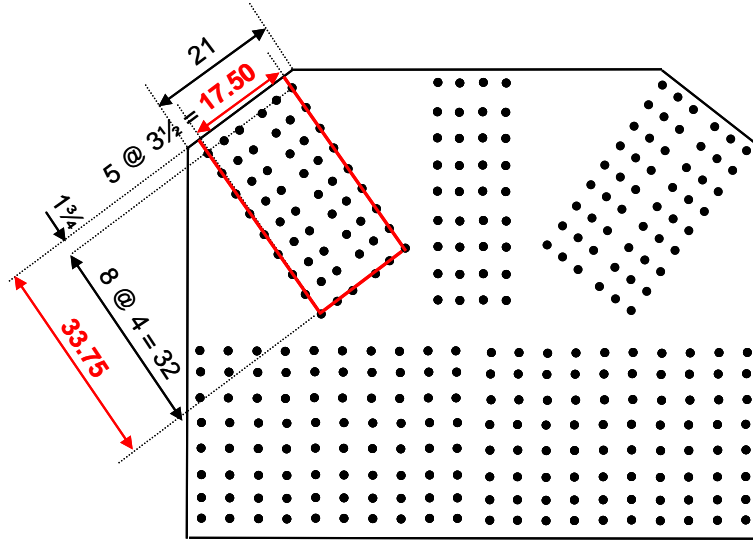

$$A_m = \frac{7}{8} \left[17.50 - 5 \left(1 + \frac{1}{8} \right) \right] = 10.39 \text{ in}^2$$

$$A_{vn} = 2 \times \frac{7}{8} \left[33.75 - 8.5 \left(1 + \frac{1}{8} \right) \right] = 42.33 \text{ in}^2$$

$A_m = 10.39 < 0.58A_{vn} = 0.58 \times 42.33 = 24.55$, therefore:

$$R_r = 0.85 \left(0.58F_u A_{vn} + F_y A_{ig} \right)$$

$$R_r = 0.85 \left(0.58 \times 58 \times 42.33 + 36 \times 17.50 \times \frac{7}{8} \right) = 1,679 \text{ kips} \text{ governs the capacity of the gusset plate at member 2.}$$

2.3. Gusset Plate Subject to Vertical Shear

2.3.1. Gross Section Shear Yielding Resistance

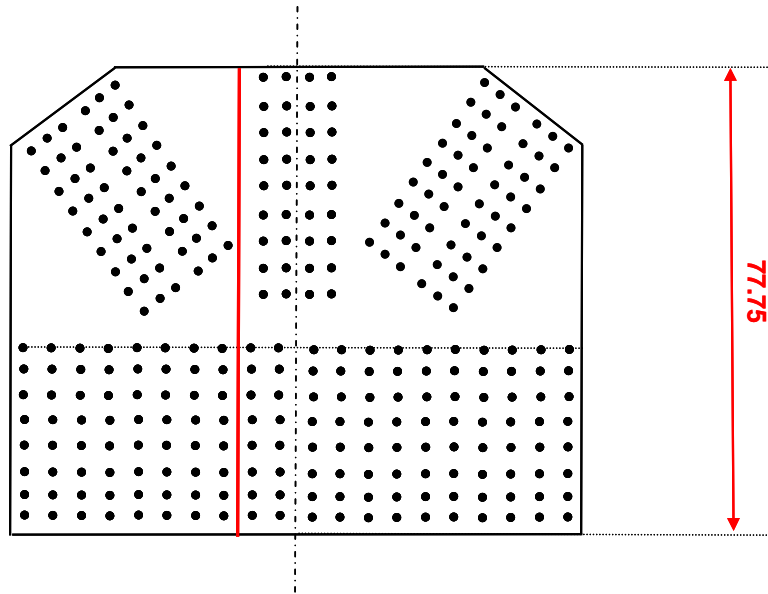

$$V_r = 0.58F_y A_g \times \Omega$$

$$V_r = 0.58 \times 36 \times \left(\frac{7}{8} \times 77.75 \right) \times 0.74 = 1,051 \text{ kips}$$

2.3.2. Net Section Shear Fracture Resistance

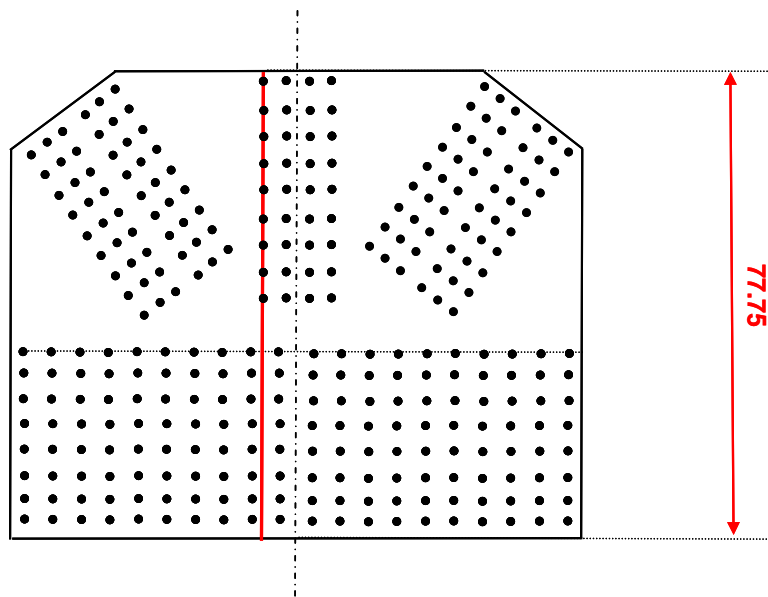

$$V_r = 0.85 \times 0.58 F_u A_n$$

$$V_r = 0.85 \times 0.58 \times 58 \times \left\{ \frac{7}{8} \times \left[77.75 - 9 \times \left(1 + \frac{1}{8} \right) \right] \right\} = 1,692 \text{ kips}$$

2.4. Gusset Plate Subject to Horizontal Shear

2.4.1. Gross Section Shear Yielding Resistance

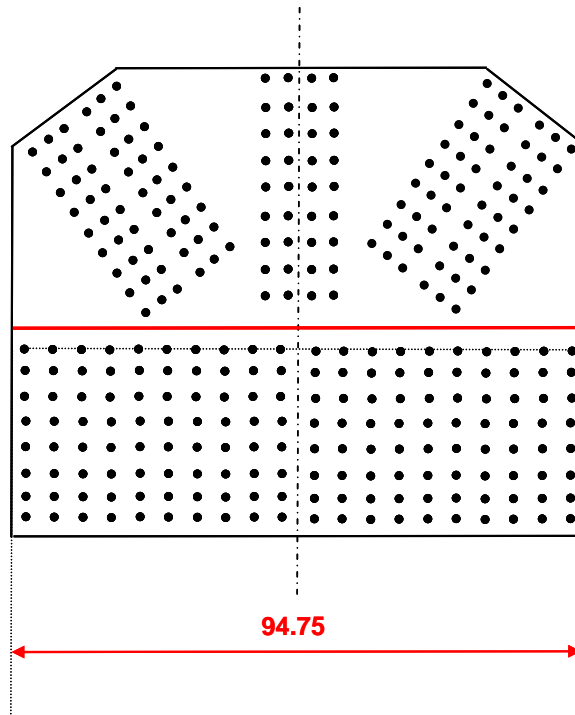

$$V_r = 0.58 F_y A_g \times \Omega$$

$$V_r = 0.58 \times 36 \times \left(\frac{7}{8} \times 94.75 \right) \times 0.74 = 1,281 \text{ kips}$$

2.4.2. Net Section Shear Fracture Resistance

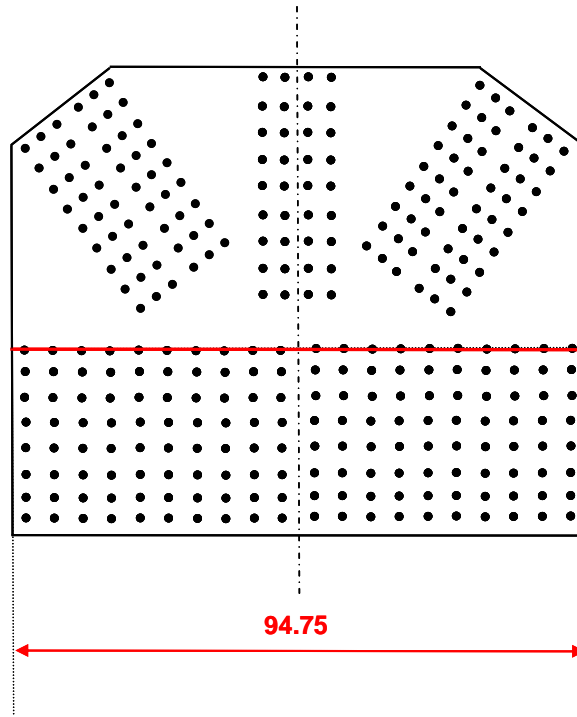

$$V_r = 0.85 \times 0.58 F_u A_n$$

$$V_r = 0.85 \times 0.58 \times 58 \times \left\{ \frac{7}{8} \times \left[94.75 - 20 \times \left(1 + \frac{1}{8} \right) \right] \right\} = 1,808 \text{ kips}$$

2.5. Gusset Plate in Compression at Member 3

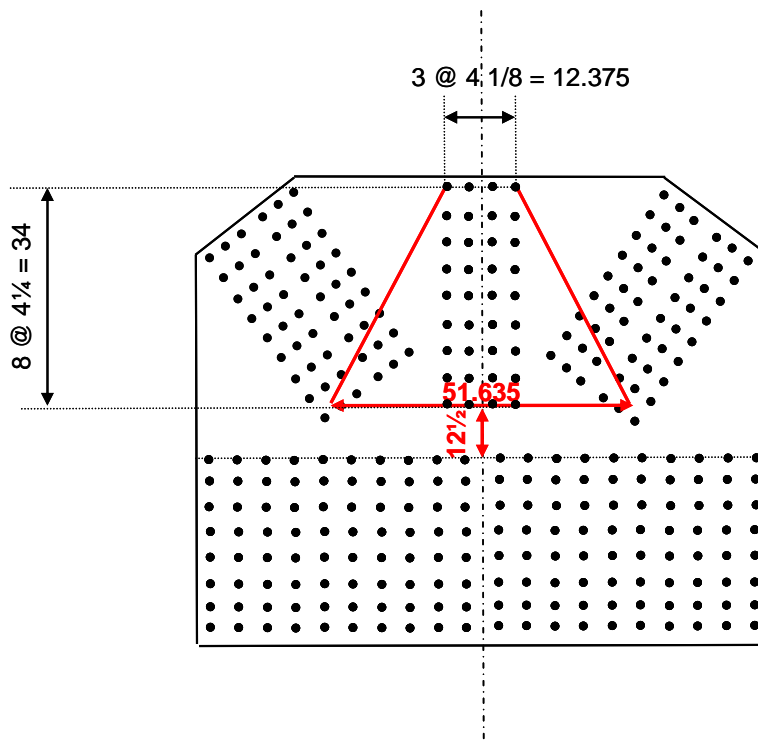

Ignore any lateral constraint to the gusset, and use the K value ($K = 1.2$) for unbraced gusset assuming the following buckled shape (case d):



$$r_s = \frac{I_g}{A_g} = \frac{51.635 \times \left(\frac{7}{8}\right)^3}{12} = \frac{2.883}{45.18} = 0.25$$

$$l = \frac{L_1 + L_2 + L_3}{3} = \frac{12.50 + 12.50 + 12.50}{3} = 12.50$$

$$\frac{KL_c}{r} = \frac{1.20 \times 12.50}{0.25} = 60 < \frac{2\pi^2 E}{F_y} = \frac{2\pi^2 \times 29,000}{36} = 126$$

Therefore:

$$F_{cr} = F_y \left[1 - \frac{F_y}{4\pi^2 E} \left(\frac{KL_c}{r} \right)^2 \right] = 36 \left[1 - \frac{36}{4\pi^2 \times 29,000} \times (60)^2 \right] = 31.92$$

$$P_u = 0.85 A_s F_{cr}$$

$$P_u = 0.85 \times \left(\frac{7}{8} \times 51.635 \right) \times 31.92 = 1,226 \text{ kips}$$

2.6. Gusset Plate in Compression at Member 4

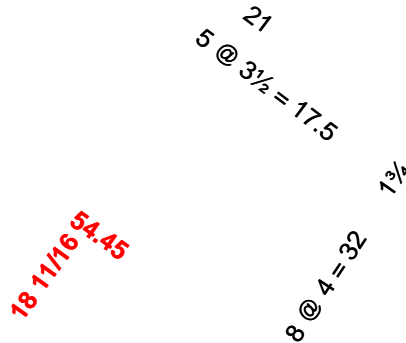

Ignore any lateral constraint to the gusset, and use the K value ($K = 1.2$) for unbraced gusset assuming the following buckled shape (case d):



$$r = \sqrt{\frac{I_g}{A_g}} = \sqrt{\frac{54.45 \times \left(\frac{7}{8}\right)^3}{12}} = \sqrt{\frac{3.040}{47.64}} = 0.25$$

$$L_c = l = \frac{L_1 + L_2 + L_3}{3} = \frac{0 + 18.6875 + 0}{3} = 6.229$$

$$\frac{KL_c}{r} = \frac{1.20 \times 6.229}{0.25} = 29.9 < \sqrt{\frac{2\pi^2 E}{F_y}} = \sqrt{\frac{2\pi^2 \times 29,000}{36}} = 126$$

Therefore:

$$F_{cr} = F_y \left[1 - \frac{F_y}{4\pi^2 E} \left(\frac{KL_c}{r} \right)^2 \right] = 36 \left[1 - \frac{36}{4\pi^2 \times 29,000} \times (29.9)^2 \right] = 34.99$$

$$P_u = 0.85 A_s F_{cr}$$

$$P_u = 0.85 \times \left(\frac{7}{8} \times 54.45 \right) \times 34.99 = 1,417 \text{ kips}$$

3. Resistance Summary

Location	Resistance of Fasteners Kips	Axial Resistance of one Gusset Plate Kips			Controlling Axial Resistance Kips
		Effective Gross Section Yielding in Tension	Block Shear Rupture	Compression Buckling	
At End of Member	Fastener Shear				
1	1,885	1,679	1,602	-	1,602
2	1,272	1,715	1,679	-	1,272
3	848	-	-	1,226	848
4	1,272	-	-	1,417	1,272
5	1,885	1,679	1,602	-	1,602

Orientation of Section	Shear Resistance of one Gusset Plate - Kips		Controlling Shear Resistance Kips
	Gross Section Yielding in Shear	Net Section Fracture in Shear	
Vertical	1,051	1,692	1,051
Horizontal	1,281	1,808	1,281

4. Inventory and Operating Rating Factors

At End of Member	1.3D	L(1+I)	Controlling Axial Resistance* $C = 0.9P_r$ Kips	Inventory Rating Factor $\frac{C - 1.3D}{2.17L(1+I)}$	Operating Rating Factor $\frac{C - 1.3D}{1.3L(1+I)}$
1	$0.57(1.3 \times 1,640) \times 1/2$ = 608	$0.57 \times 466/2$ = 133	$0.9 \times 1,602$ = 1,442	2.89	4.83
2	$(1.3 \times 790) \times 1/2$ = 514	$324/2$ = 162	$0.9 \times 1,272$ = 1,145	1.80	3.00
3	$(1.3 \times 309) \times 1/2$ = 201	$169/2$ = 85	0.9×848 = 763	3.07	5.12
4	$(1.3 \times 404) \times 1/2$ = 263	$271/2$ = 136	$0.9 \times 1,272$ = 1,145	3.00	5.01
5	$0.57(1.3 \times 2,357) \times 1/2$ = 873	$0.57 \times 726/2$ = 207	$0.9 \times 1,602$ = 1,442	1.27	2.11

* Since the failure of gusset plates in non-redundant structures may result in the collapse of the bridge, the capacity is therefore reduced by 10% to increase the margin of safety.

Orientation of Section	1.3D	L(1+I)	Controlling Shear Resistance* $C = 0.9V_r$ Kips	Inventory Rating Factor $\frac{C - 1.3D}{2.17L(1+I)}$	Operating Rating Factor $\frac{C - 1.3D}{1.3L(1+I)}$
Vertical	$(1.3 \times 790) \times 4/5 \times 1/2$ = 411	$0.5 \times 324 \times 4/5$ = 130	$0.9 \times 1,051$ = 946	1.90	3.18
Horizontal	$1.3(790 + 404) \times 3/5 \times 1/2$ = 466	$0.5(324 + 271) \times 3/5$ = 179	$0.9 \times 1,281$ = 1,153	1.77	2.96

* Since the failure of gusset plates in non-redundant structures may result in the collapse of the bridge, the capacity is therefore reduced by 10% to increase the margin of safety.

Therefore, the controlling Inventory Rating Factor for the Gusset Connection is 1.27 for HS20 (block shear rupture at the end of member 5)