



PB2005-108586

**COMPREHENSIVE DESIGN EXAMPLE FOR PRESTRESSED
CONCRETE (PSC) GIRDER SUPERSTRUCTURE BRIDGE
WITH COMMENTARY**
(Task order DTFH61-02-T-63032)

US CUSTOMARY UNITS

Submitted to
THE FEDERAL HIGHWAY ADMINISTRATION

Prepared By
Modjeski and Masters, Inc.

November 2003

1. Report No. FHWA NHI - 04-043	2. Government Accession No. PB2005-108586	3. Recipient's Catalog No.	
4. Title and Subtitle Comprehensive Design Example for Prestressed Concrete (PSC) Girder Superstructure Bridge with Commentary (in US Customary Units)		5. Report Date November 2003	6. Performing Organization Code
7. Author (s) Wagdy G. Wassef, Ph.D., P.E., Christopher Smith, E.I.T. Chad M. Clancy, P.E., Martin J. Smith, P.E.		8. Performing Organization Report No.	
9. Performing Organization Name and Address Modjeski and Masters, Inc. P.O.Box 2345 Harrisburg, Pennsylvania 17105		10. Work Unit No. (TRAIS)	11. Contract or Grant No. DTFH61-02-D-63006
12. Sponsoring Agency Name and Address Federal Highway Administration National Highway Institute (HNHI-10) 4600 N. Fairfax Drive, Suite 800 Arlington, Virginia 22203		13. Type of Report and Period Covered Final Submission August 2002 – November 2003	
15. Supplementary Notes Modjeski and Masters Principle Investigator and Project Manager : Wagdy G. Wassef , Ph.D., P.E. FHWA Contracting Officer's Technical Representative: Thomas K. Saad, P.E. Team Leader, Technical Review Team: Jerry Potter, P.E.		14. Sponsoring Agency Code	
16. Abstract <p>This document consists of a comprehensive design example of a prestressed concrete girder bridge. The superstructure consists of two simple spans made continuous for live loads. The substructure consists of integral end abutments and a multi-column intermediate bent. The document also includes instructional commentary based on the <i>AASHTO-LRFD Bridge Design Specifications</i> (Second Edition, 1998, including interims for 1999 through 2002). The design example and commentary are intended to serve as a guide to aid bridge design engineers with the implementation of the <i>AASHTO-LRFD Bridge Design Specifications</i>. This document is offered in US Customary Units. An accompanying document in Standard International (SI) Units is offered under report No. FHWA NHI-04-044.</p> <p>This document includes detailed flowcharts outlining the design steps for all components of the bridge. The flowcharts are cross-referenced to the relevant specification articles to allow easy navigation of the specifications. Detailed design computations for the following components are included: concrete deck, prestressed concrete I-girders, elastomeric bearing, integral abutments and wing walls, multi-column bent and pile and spread footing foundations.</p> <p>In addition to explaining the design steps of the design example, the comprehensive commentary goes beyond the specifics of the design example to offer guidance on different situations that may be encountered in other bridges.</p>			
17. Key Words Bridge Design, Prestressed Concrete, Load and Resistance Factor Design, LRFD, Concrete Deck, Intermediate Bent, Integral Abutment, Wingwall, Pile Foundation, Spread Footings		18. Distribution Statement This report is available to the public from the National Technical Information Service in Springfield, Virginia 22161 and from the Superintendent of Documents, U.S. Government Printing Office, Washington, D.C. 20402.	
19. Security Classif. (of this report) Unclassified	20. Security Classif. (of this page) Unclassified	21. No. of Pages 388	22. Price

ACKNOWLEDGEMENTS

The authors would like to express appreciation to the review teams from the Illinois Department of Transportation, Minnesota Department of Transportation and Washington State Department of Transportation for providing review and direction on the Technical Review Committee.

The authors would also like to acknowledge the contributions of Dr. John M. Kulicki, President/CEO and Chief Engineer of Modjeski and Masters, Inc., for his guidance throughout the project.

TABLE OF CONTENTS

		<u>Page</u>
1.	INTRODUCTION	1-1
2.	EXAMPLE BRIDGE	2-1
	2.1 Bridge geometry and materials.....	2-1
	2.2 Girder geometry and section properties	2-4
	2.3 Effective flange width	2-10
3.	FLOWCHARTS	3-1
4.	DESIGN OF DECK	4-1
5.	DESIGN OF SUPERSTRUCTURE	
	5.1 Live load distribution factors	5-1
	5.2 Dead load calculations.....	5-10
	5.3 Unfactored and factored load effects.....	5-13
	5.4 Loss of prestress	5-27
	5.5 Stress in prestressing strands.....	5-36
	5.6 Design for flexure	
	5.6.1 Flexural stress at transfer	5-46
	5.6.2 Final flexural stress under Service I limit state	5-49
	5.6.3 Longitudinal steel at top of girder.....	5-61
	5.6.4 Flexural resistance at the strength limit state in positive moment region	5-63
	5.6.5 Continuity correction at intermediate support	5-67
	5.6.6 Fatigue in prestressed steel	5-75
	5.6.7 Camber	5-75
	5.6.8 Optional live load deflection check	5-80
	5.7 Design for shear	5-82
	5.7.1 Critical section for shear near the end support.....	5-84
	5.7.2 Shear analysis for a section in the positive moment region.....	5-85
	5.7.3 Shear analysis for sections in the negative moment region	5-93
	5.7.4 Factored bursting resistance.....	5-101
	5.7.5 Confinement reinforcement	5-102
	5.7.6 Force in the longitudinal reinforcement including the effect of the applied shear	5-104
6.	DESIGN OF BEARINGS	6-1

7. DESIGN OF SUBSTRUCTURE 7-1

 7.1. Design of Integral Abutments 7-1

 7.1.1 Gravity loads 7-6

 7.1.2 Pile cap design 7-11

 7.1.3 Piles 7-12

 7.1.4 Backwall design 7-16

 7.1.5 Wingwall design 7-30

 7.1.6 Design of approach slab 7-34

 7.1.7 Sleeper slab 7-37

 7.2. Design of Intermediate Pier 7-38

 7.2.1 Substructure loads and application 7-38

 7.2.2 Pier cap design 7-51

 7.2.3 Column design 7-66

 7.2.4 Footing design 7-75

Appendix A - Comparisons of Computer Program Results (QConBridge and Opis)

 Section A1- QConBridge Input A1

 Section A2- QConBridge Output A3

 Section A3- Opis Input A10

 Section A4- Opis Output A47

 Section A5- Comparison Between the Hand Calculations and the Two Computer
 Programs A55

 Section A6- Flexural Resistance Sample Calculation from Opis to Compare with
 Hand Calculations A58

Appendix B - General Guidelines for Refined Analysis of Deck Slabs

Appendix C - Example of Creep and Shrinkage Calculations

1. INTRODUCTION

This example is part of a series of design examples sponsored by the Federal Highway Administration. The design specifications used in these examples is the AASHTO LRFD Bridge design Specifications. The intent of these examples is to assist bridge designers in interpreting the specifications, limit differences in interpretation between designers, and to guide the designers through the specifications to allow easier navigation through different provisions. For this example, the Second Edition of the AASHTO-LRFD Specifications with Interims up to and including the 2002 Interim is used.

This design example is intended to provide guidance on the application of the AASHTO-LRFD Bridge Design Specifications when applied to prestressed concrete superstructure bridges supported on intermediate multicolumn bents and integral end abutments. The example and commentary are intended for use by designers who have knowledge of the requirements of AASHTO Standard Specifications for Highway Bridges or the AASHTO-LRFD Bridge Design Specifications and have designed at least one prestressed concrete girder bridge, including the bridge substructure. Designers who have not designed prestressed concrete bridges, but have used either AASHTO Specification to design other types of bridges may be able to follow the design example, however, they will first need to familiarize themselves with the basic concepts of prestressed concrete design.

This design example was not intended to follow the design and detailing practices of any particular agency. Rather, it is intended to follow common practices widely used and to adhere to the requirements of the specifications. It is expected that some users may find differences between the procedures used in the design compared to the procedures followed in the jurisdiction they practice in due to Agency-specific requirements that may deviate from the requirements of the specifications. This difference should not create the assumption that one procedure is superior to the other.

Reference is made to AASHTO-LRFD specifications article numbers throughout the design example. To distinguish between references to articles of the AASHTO-LRFD specifications and references to sections of the design example, the references to specification articles are preceded by the letter “S”. For example, S5.2 refers to Article 5.2 of AASHTO-LRFD specifications while 5.2 refers to Section 5.2 of the design example.

Two different forms of fonts are used throughout the example. Regular font is used for calculations and for text directly related to the example. Italic font is used for text that represents commentary that is general in nature and is used to explain the intent of some specifications provisions, explain a different available method that is not used by the example, provide an overview of general acceptable practices and/or present difference in application between different jurisdictions.

2. EXAMPLE BRIDGE

2.1 Bridge geometry and materials

Bridge superstructure geometry

Superstructure type:	Reinforced concrete deck supported on simple span prestressed girders made continuous for live load.
Spans:	Two spans at 110 ft. each
Width:	55'-4 ½" total 52'-0" gutter line-to-gutter line (Three lanes 12'- 0" wide each, 10 ft. right shoulder and 6 ft. left shoulder. For superstructure design, the location of the driving lanes can be anywhere on the structure. For substructure design, the maximum number of 12 ft. wide lanes, i.e., 4 lanes, is considered)
Railings:	Concrete Type F-Parapets, 1'- 8 ¼" wide at the base
Skew:	20 degrees, valid at each support location
Girder spacing:	9'-8"
Girder type:	AASHTO Type VI Girders, 72 in. deep, 42 in. wide top flange and 28 in. wide bottom flange (AASHTO 28/72 Girders)
Strand arrangement:	Straight strands with some strands debonded near the ends of the girders
Overhang:	3'-6 ¼" from the centerline of the fascia girder to the end of the overhang
Intermediate diaphragms:	For load calculations, one intermediate diaphragm, 10 in. thick, 50 in. deep, is assumed at the middle of each span.

Figures 2-1 and 2-2 show an elevation and cross-section of the superstructure, respectively. Figure 2-3 through 2-6 show the girder dimensions, strand arrangement, support locations and strand debonding locations.

Typically, for a specific jurisdiction, a relatively small number of girder sizes are available to select from. The initial girder size is usually selected based on past experience. Many jurisdictions have a design aid in the form of a table that determines the most likely girder size for each combination of span length and girder spacing. Such tables developed using the HS-25 live loading of the AASHTO Standard Specifications are expected to be applicable to the bridges designed using the AASHTO-LRFD Specifications.

The strand pattern and number of strands was initially determined based on past experience and subsequently refined using a computer design program. This design was refined using trial and error until a pattern produced stresses, at transfer and under service loads, that fell within the permissible stress limits and produced load resistances greater than the applied loads under the strength limit states. For debonded strands, S5.11.4.3 states that the number of partially debonded strands should not exceed 25 percent of the total number of strands. Also, the number of debonded strands in any horizontal row shall not exceed 40 percent of the strands in that row. The selected pattern has 27.2 percent of the total strands debonded. This is slightly higher than the 25 percent stated in the specifications, but is acceptable since the specifications require that this limit “should” be satisfied. Using the word “should” instead of “shall” signifies that the specifications allow some deviation from the limit of 25 percent.

Typically, the most economical strand arrangement calls for the strands to be located as close as possible to the bottom of the girders. However, in some cases, it may not be possible to satisfy all specification requirements while keeping the girder size to a minimum and keeping the strands near the bottom of the beam. This is more pronounced when debonded strands are used due to the limitation on the percentage of debonded strands. In such cases, the designer may consider the following two solutions:

- *Increase the size of the girder to reduce the range of stress, i.e., the difference between the stress at transfer and the stress at final stage.*
- *Increase the number of strands and shift the center of gravity of the strands upward.*

Either solution results in some loss of economy. The designer should consider specific site conditions (e.g., cost of the deeper girder, cost of the additional strands, the available under-clearance and cost of raising the approach roadway to accommodate deeper girders) when determining which solution to adopt.

Bridge substructure geometry

Intermediate pier: Multi-column bent (4 – columns spaced at 14'-1")

Spread footings founded on sandy soil

See Figure 2-7 for the intermediate pier geometry

End abutments: Integral abutments supported on one line of steel H-piles supported on bedrock. U-wingwalls are cantilevered from the fill face of the abutment. The approach slab is supported on the integral abutment at one end and a sleeper slab at the other end.

See Figure 2-8 for the integral abutment geometry

Materials

Concrete strength

Prestressed girders: Initial strength at transfer, $f'_{ci} = 4.8$ ksi
 28-day strength, $f'_c = 6$ ksi
 Deck slab: 4.0 ksi
 Substructure: 3.0 ksi
 Railings: 3.5 ksi

Concrete elastic modulus (calculated using S5.4.2.4)

Girder final elastic modulus, $E_c = 4,696$ ksi
 Girder elastic modulus at transfer, $E_{ci} = 4,200$ ksi
 Deck slab elastic modulus, $E_s = 3,834$ ksi

Reinforcing steel

Yield strength, $f_y = 60$ ksi

Prestressing strands

0.5 inch diameter low relaxation strands Grade 270
 Strand area, $A_{ps} = 0.153$ in²
 Steel yield strength, $f_{py} = 243$ ksi
 Steel ultimate strength, $f_{pu} = 270$ ksi
 Prestressing steel modulus, $E_p = 28,500$ ksi

Other parameters affecting girder analysis

Time of Transfer = 1 day
 Average Humidity = 70%

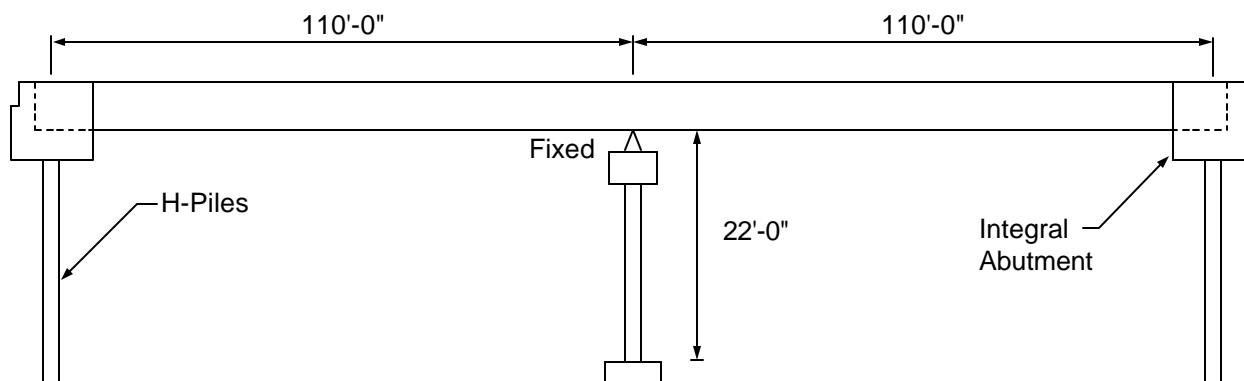

Figure 2-1 – Elevation View of the Example Bridge

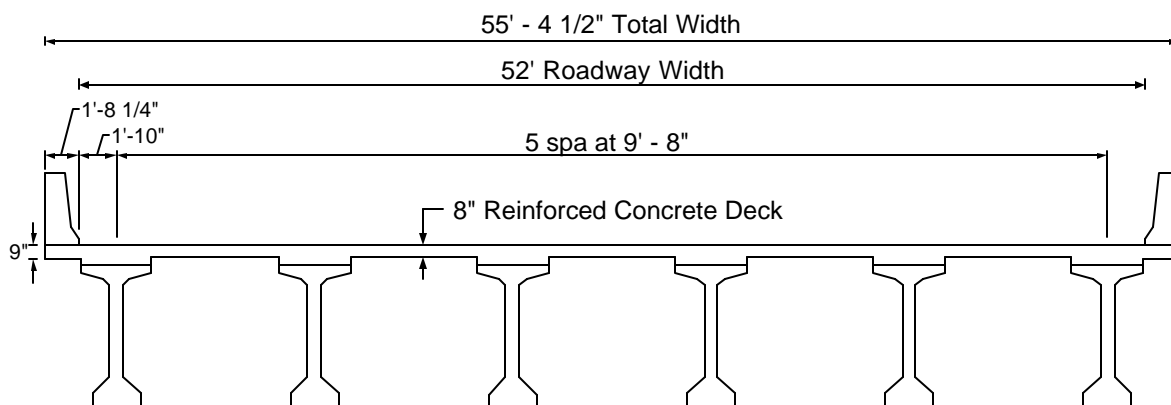

Figure 2-2 – Bridge Cross-Section

2.2 Girder geometry and section properties

Basic beam section properties

Beam length, L	= 110 ft. – 6 in.
Depth	= 72 in.
Thickness of web	= 8 in.
Area, A_g	= 1,085 in ²
Moment of inertia, I_g	= 733,320 in ⁴
N.A. to top, y_t	= 35.62 in.
N.A. to bottom, y_b	= 36.38 in.
Section modulus, S_{TOP}	= 20,588 in ³
Section modulus, S_{BOT}	= 20,157 in ³
CGS from bottom, at 0 ft.	= 5.375 in.
CGS from bottom, at 11 ft.	= 5.158 in.
CGS from bottom, at 54.5 ft.	= 5.0 in.
P/S force eccentricity at 0 ft., $e_{0'}$	= 31.005 in.
P/S force eccentricity at 11 ft., $e_{11'}$	= 31.222 in.
P/S force eccentricity at 54.5 ft., $e_{54.5'}$	= 31.380 in.

Interior beam composite section properties

Effective slab width	= 111 in. (see calculations in Section 2.3)
Deck slab thickness	= 8 in. (includes 1/2 in. integral wearing surface which is not included in the calculation of the composite section properties)

Haunch depth	= 4 in. (maximum value - notice that the haunch depth varies along the beam length and, hence, is ignored in calculating section properties but is considered when determining dead load)
Moment of inertia, I_c	= 1,384,254 in ⁴
N.A. to slab top, y_{sc}	= 27.96 in.
N.A. to beam top, y_{tc}	= 20.46 in.
N.A. to beam bottom, y_{bc}	= 51.54 in.
Section modulus, $S_{TOP\ SLAB}$	= 49,517 in ³
Section modulus, $S_{TOP\ BEAM}$	= 67,672 in ³
Section modulus, $S_{BOT\ BEAM}$	= 26,855 in ³

Exterior beam composite section properties

Effective Slab Width	= 97.75 in. (see calculations in Section 2.3)
Deck slab thickness	= 8 in. (includes ½ in. integral wearing surface which is not included in the calculation of the composite section properties)
Haunch depth	= 4 in. (maximum value - notice that the haunch depth varies along the beam length and, hence, is ignored in calculating section properties but is considered when determining dead load)
Moment of inertia, I_c	= 1,334,042 in ⁴
N.A. to slab top, y_{sc}	= 29.12 in.
N.A. to beam top, y_{tc}	= 21.62 in.
N.A. to beam bottom, y_{bc}	= 50.38 in.
Section modulus, $S_{TOP\ SLAB}$	= 45,809 in ³
Section modulus, $S_{TOP\ BEAM}$	= 61,699 in ³
Section modulus, $S_{BOT\ BEAM}$	= 26,481 in ³

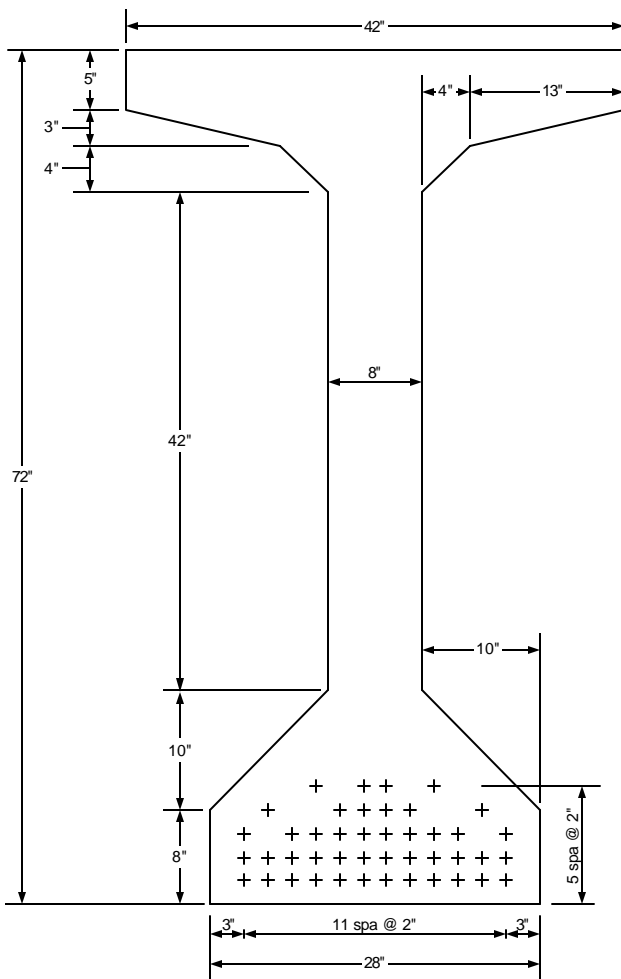

Figure 2-3 – Beam Cross-Section Showing 44 Strands

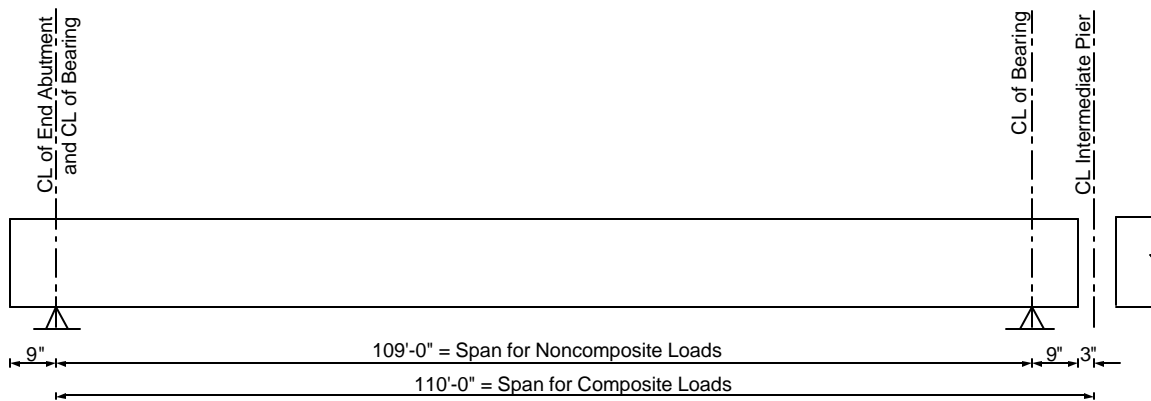

Figure 2-4 – General Beam Elevation

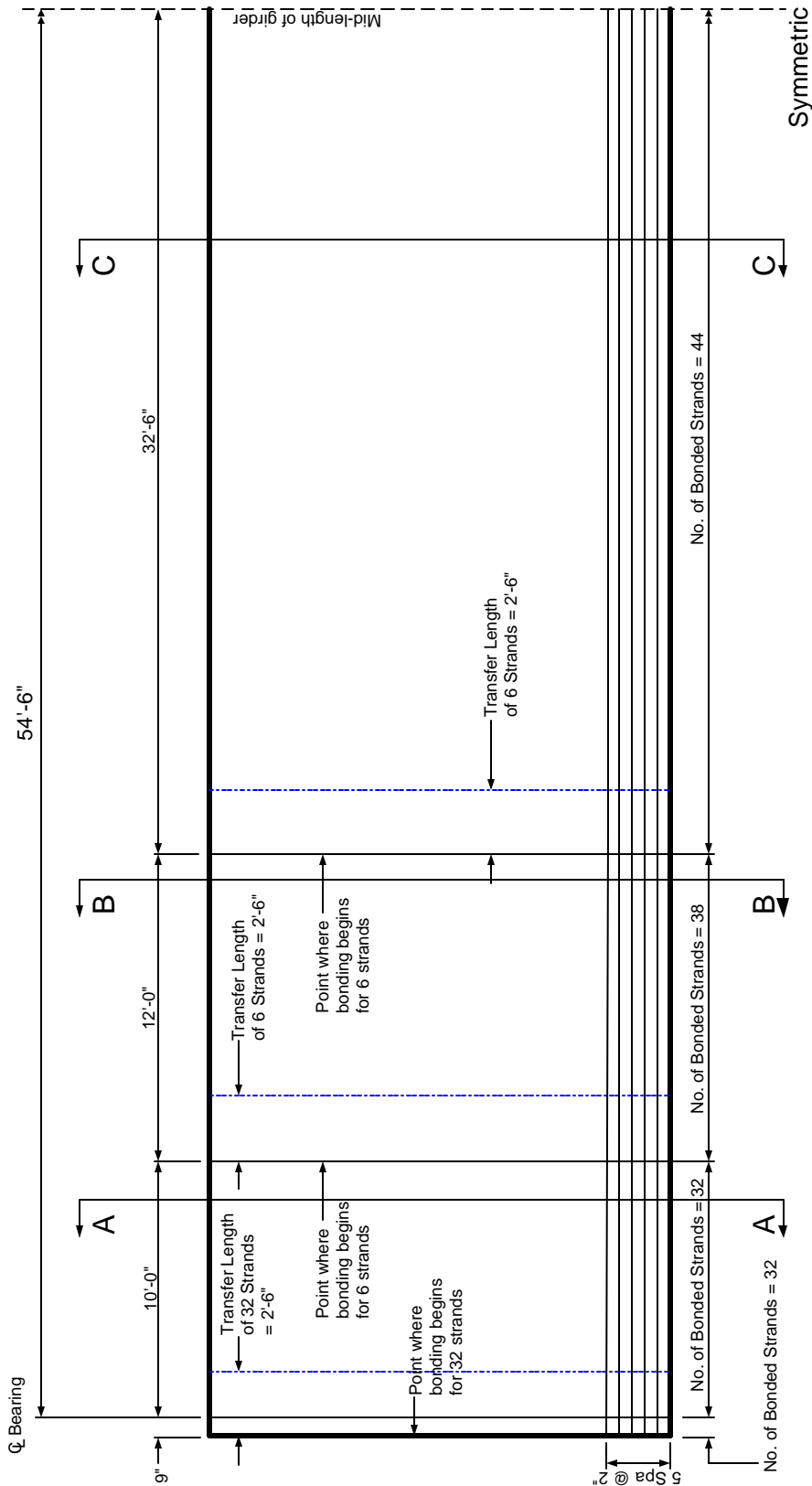
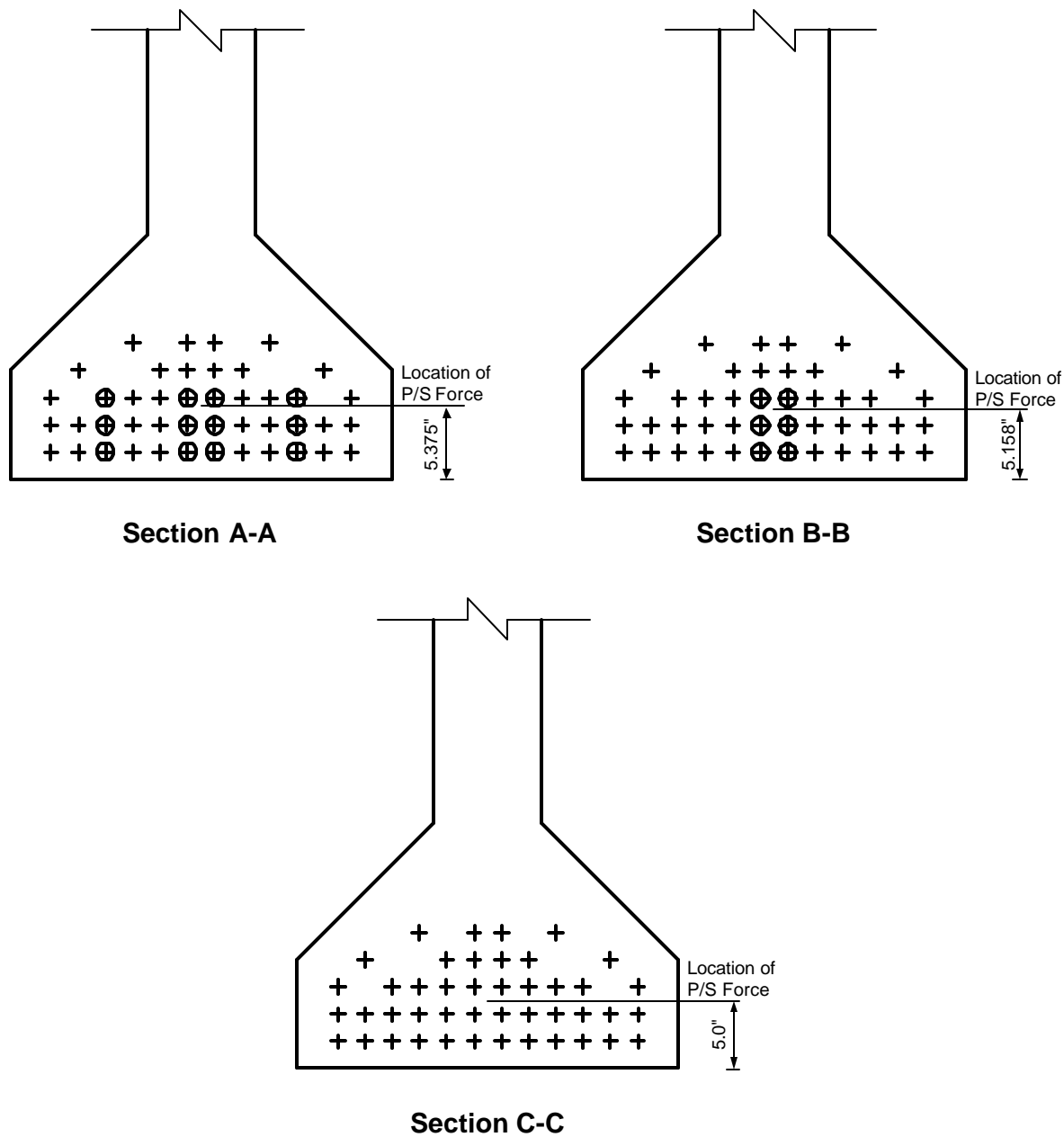

Figure 2-5 – Elevation View of Prestressing Strands



+ - Bonded Strand
 ⊕ - Debonded Strand

For location of Sections A-A, B-B and C-C, see Figure 2-5

Figure 2-6 – Beam at Sections A-A, B-B, and C-C

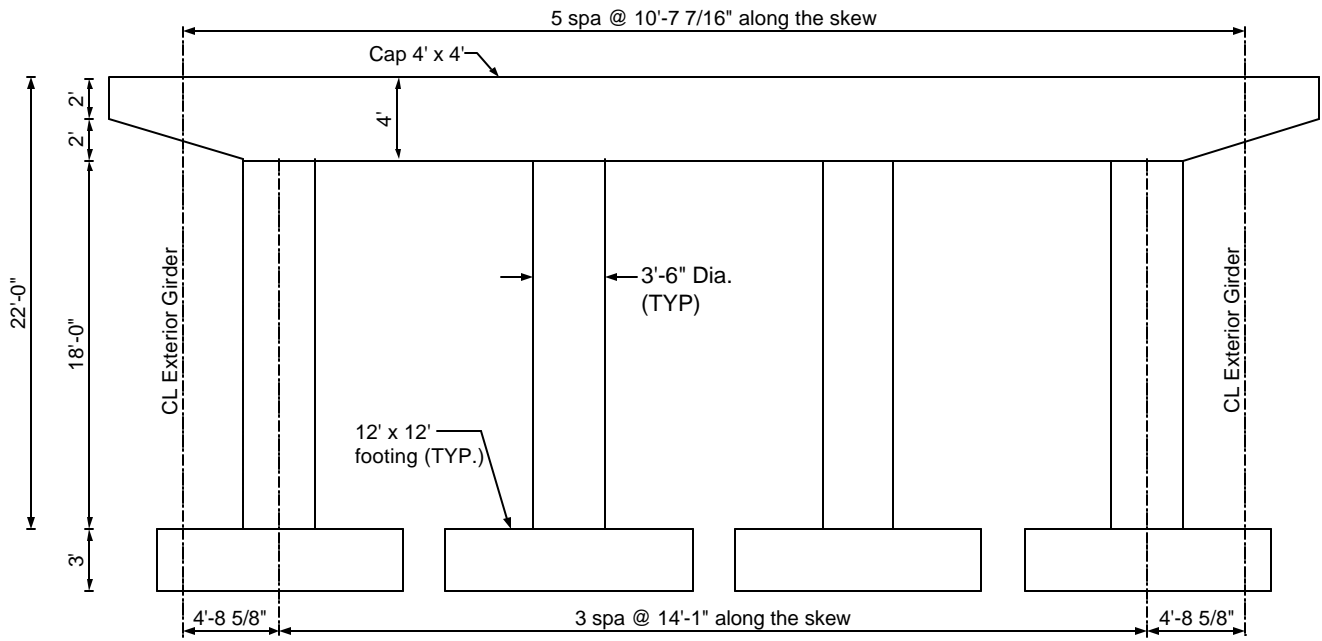

Figure 2-7 – Intermediate Bent

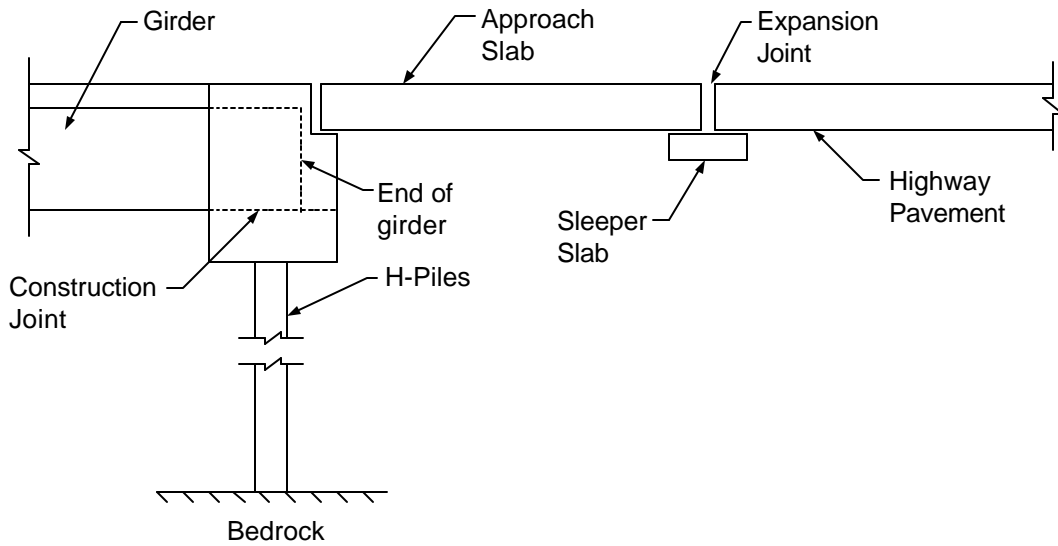

Figure 2-8 – Integral Abutment

2.3 Effective flange width (S4.6.2.6)

Longitudinal stresses in the flanges are distributed across the flange and the composite deck slab by in-plane shear stresses, therefore, the longitudinal stresses are not uniform. The effective flange width is a reduced width over which the longitudinal stresses are assumed to be uniformly distributed and yet result in the same force as the non-uniform stress distribution if integrated over the entire width.

The effective flange width is calculated using the provisions of S4.6.2.6. See the bulleted list at the end of this section for a few S4.6.2.6 requirements. According to S4.6.2.6.1, the effective flange width may be calculated as follows:

For interior girders :

The effective flange width is taken as the least of the following:

- One-quarter of the effective span length $= 0.25(82.5)(12)$
 $= 247.5$ in.
- 12.0 times the average thickness of the slab,
plus the greater of the web thickness $= 12(7.5) + 8 = 104$ in.
or
one-half the width of the top flange of the girder $= 12(7.5) + 0.5(42)$
 $= \underline{111}$ in.
- The average spacing of adjacent beams $= 9$ ft.- 8 in. or 116 in.

The effective flange width for the interior beam is 111 in.

For exterior girders :

The effective flange width is taken as one-half the effective width of the adjacent interior girder plus the least of:

- One-eighth of the effective span length $= 0.125(82.5)(12)$
 $= 123.75$ in.
- 6.0 times the average thickness of the slab,
plus the greater of half the web thickness $= 6.0(7.5) + 0.5(8)$
 $= 49$ in.
or
one-quarter of the width of the top flange
of the basic girder $= 6.0(7.5) + 0.25(42)$
 $= 55.5$ in.

- The width of the overhang = 3 ft.- 6 ¼ in. or 42.25 in.

Therefore, the effective flange width for the exterior girder is:

$$(111/2) + 42.25 = 97.75 \text{ in.}$$

Notice that:

- *The effective span length used in calculating the effective flange width may be taken as the actual span length for simply supported spans or as the distance between points of permanent dead load inflection for continuous spans, as specified in S4.6.2.6.1. For analysis of I-shaped girders, the effective flange width is typically calculated based on the effective span for positive moments and is used along the entire length of the beam.*
- *The slab thickness used in the analysis is the effective slab thickness ignoring any sacrificial layers (i.e., integral wearing surfaces)*
- *S4.5 allows the consideration of continuous barriers when analyzing for service and fatigue limit states. The commentary of S4.6.2.6.1 includes an approximate method of including the effect of the continuous barriers on the section by modifying the width of the overhang. Traditionally, the effect of the continuous barrier on the section is ignored in the design of new bridges and is ignored in this example. This effect may be considered when checking existing bridges with structurally sound continuous barriers.*
- *Simple-span girders made continuous behave as continuous beams for all loads applied after the deck slab hardens. For two-equal span girders, the effective length of each span, measured as the distance from the center of the end support to the inflection point for composite dead loads (load is assumed to be distributed uniformly along the length of the girders), is 0.75 the length of the span.*

3. FLOWCHARTS

Main Design Steps

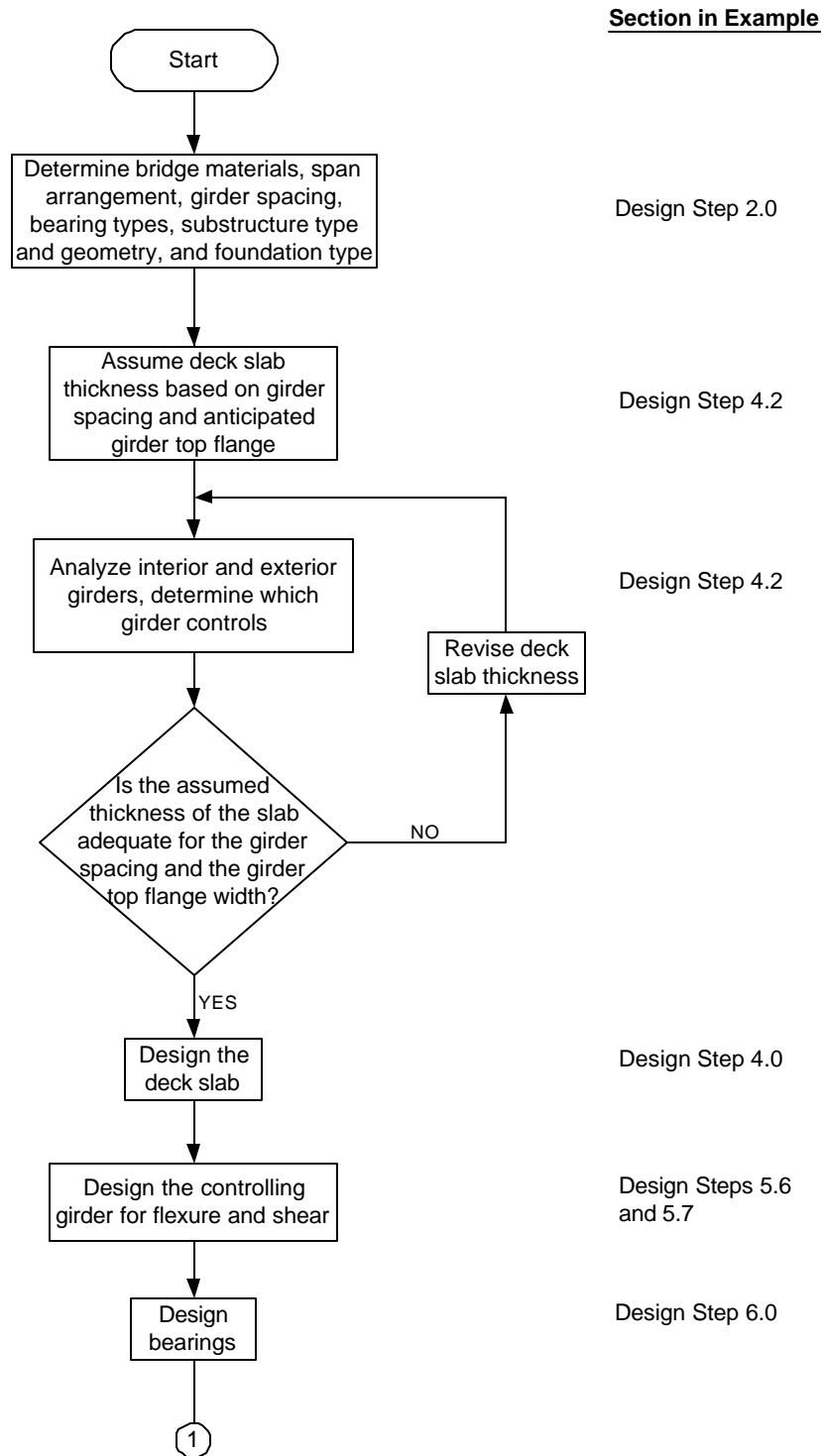

Main Design Steps (cont.)

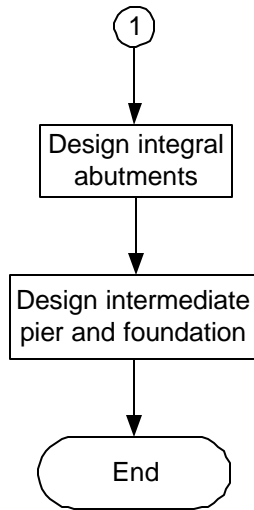

Section in Example

Design Step 7.1

Design Step 7.2

Deck Slab Design

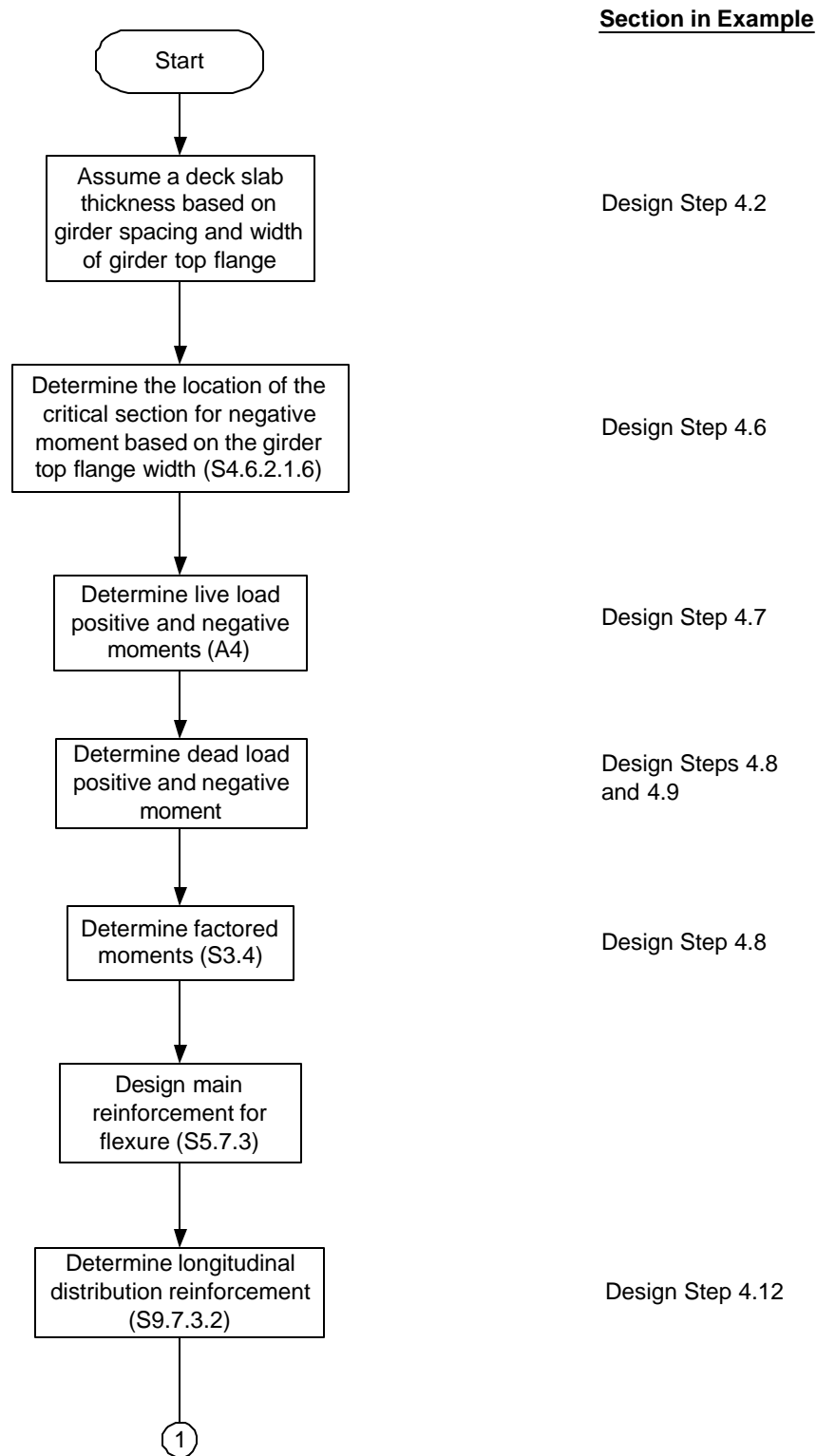

Deck Slab Design (cont.)

Section in Example

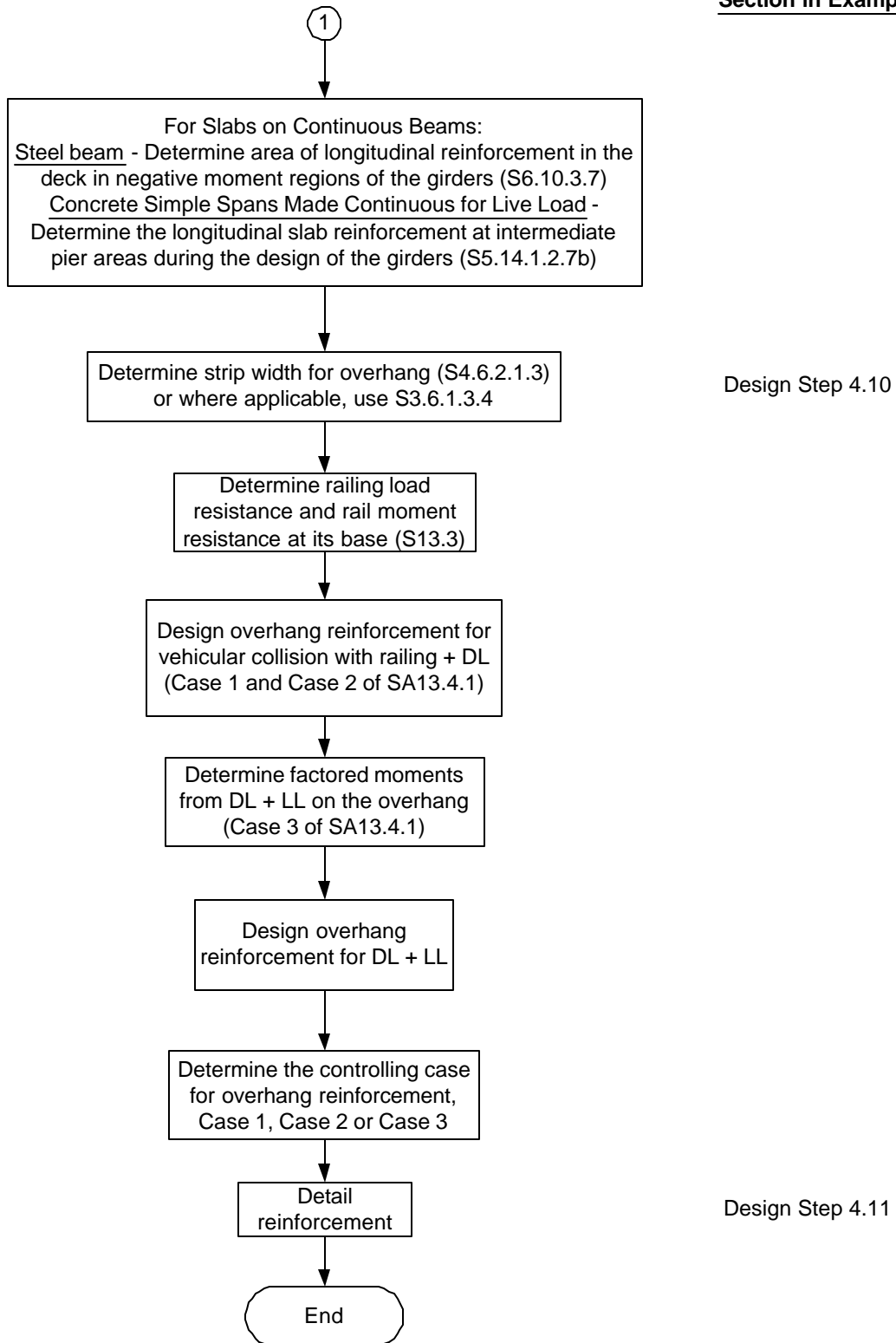

General Superstructure Design

(Notice that only major steps are presented in this flowchart. More detailed flowcharts of the design steps follow this flowchart)

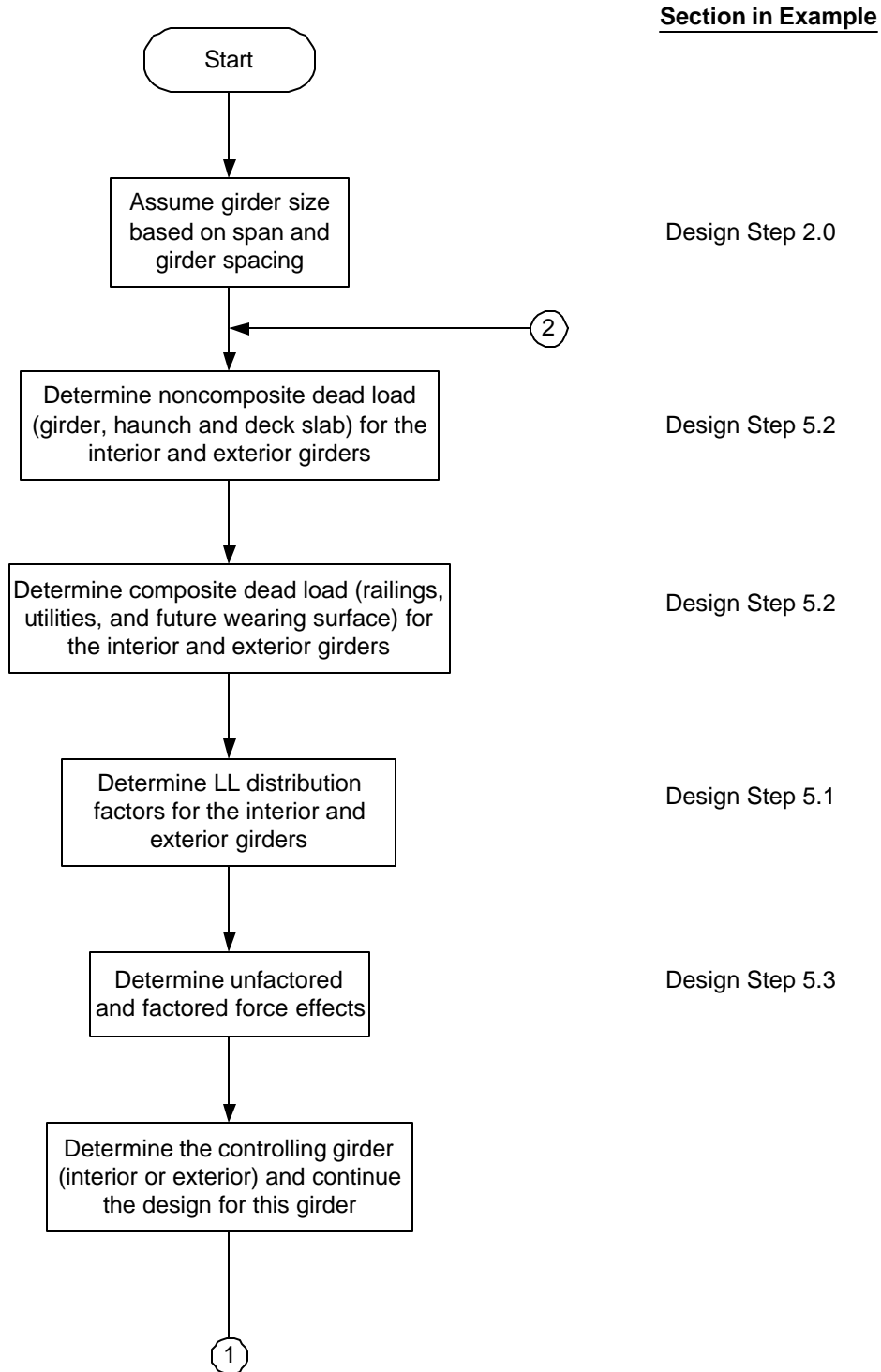

General Superstructure Design (cont.)

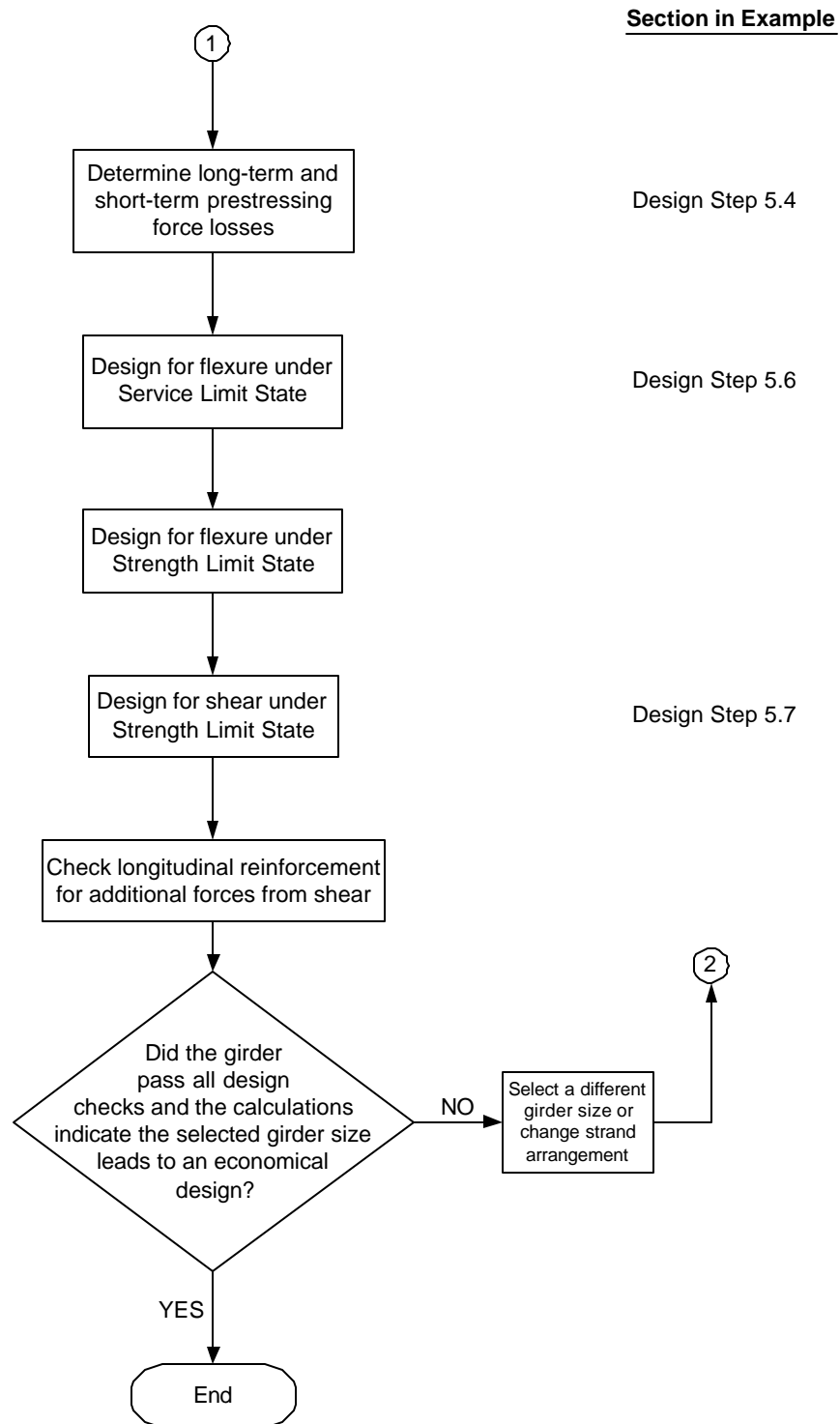

Live Load Distribution Factor Calculations

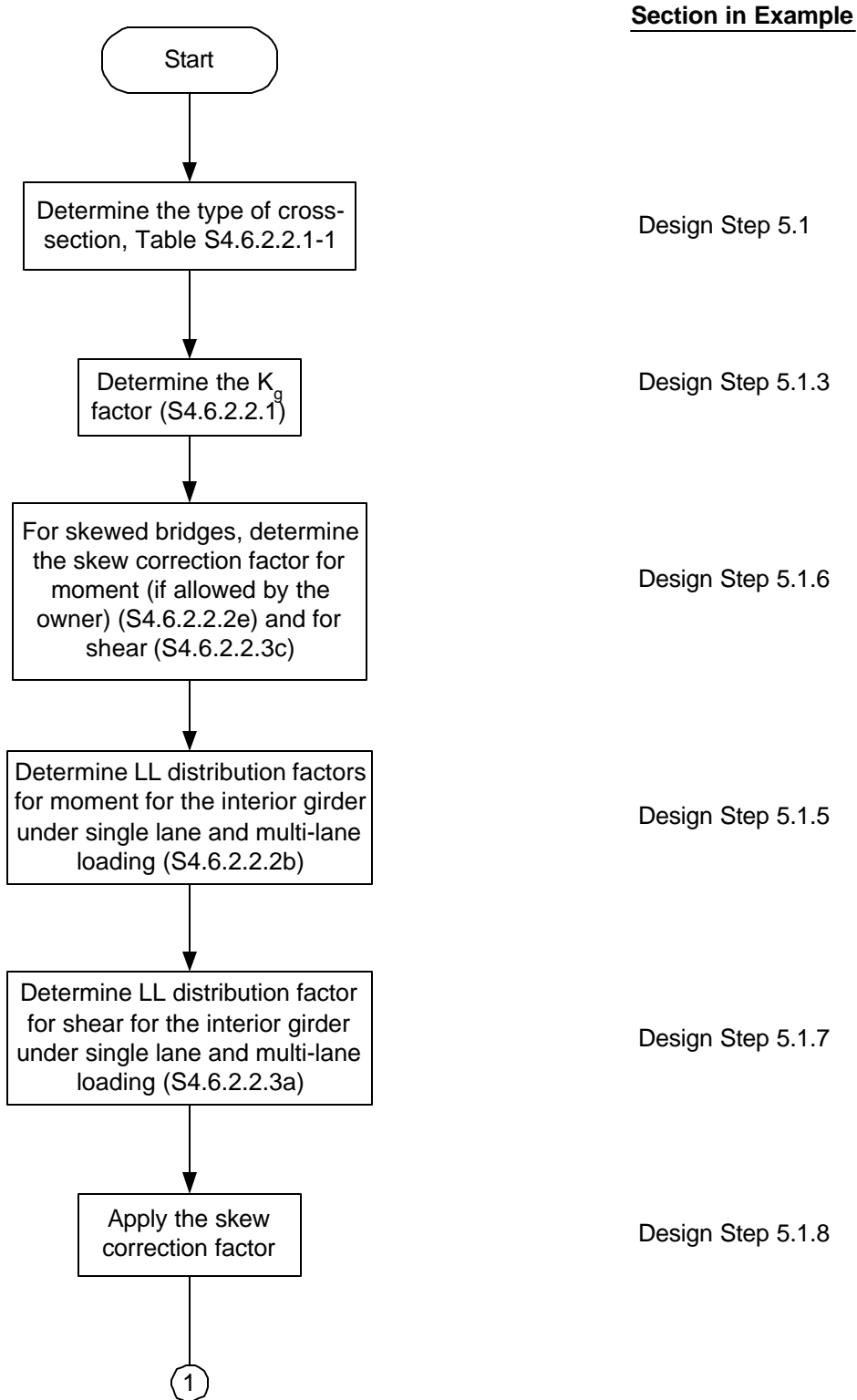

Live Load Distribution Factor Calculations (cont.)

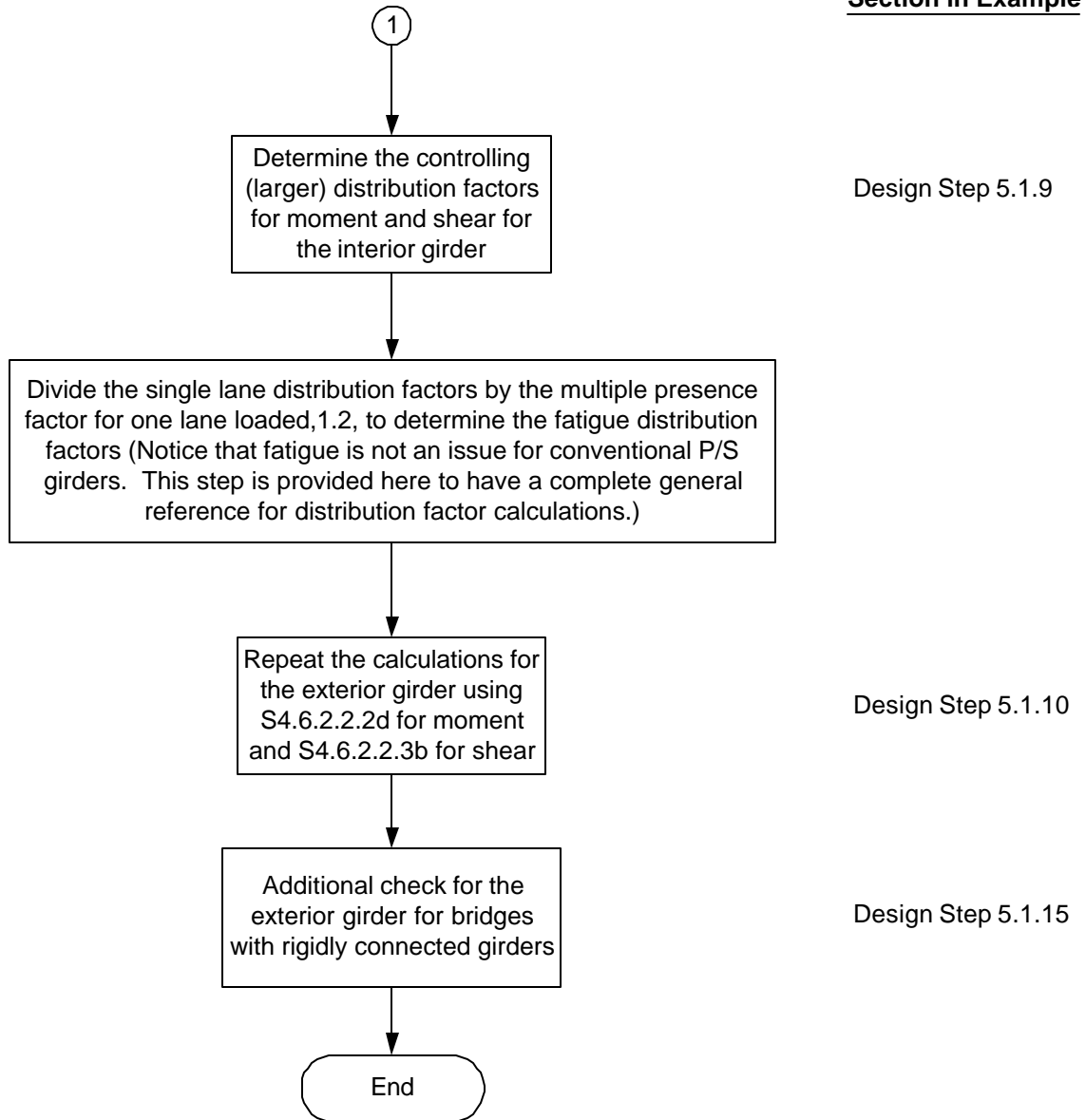

Creep and Shrinkage Calculations

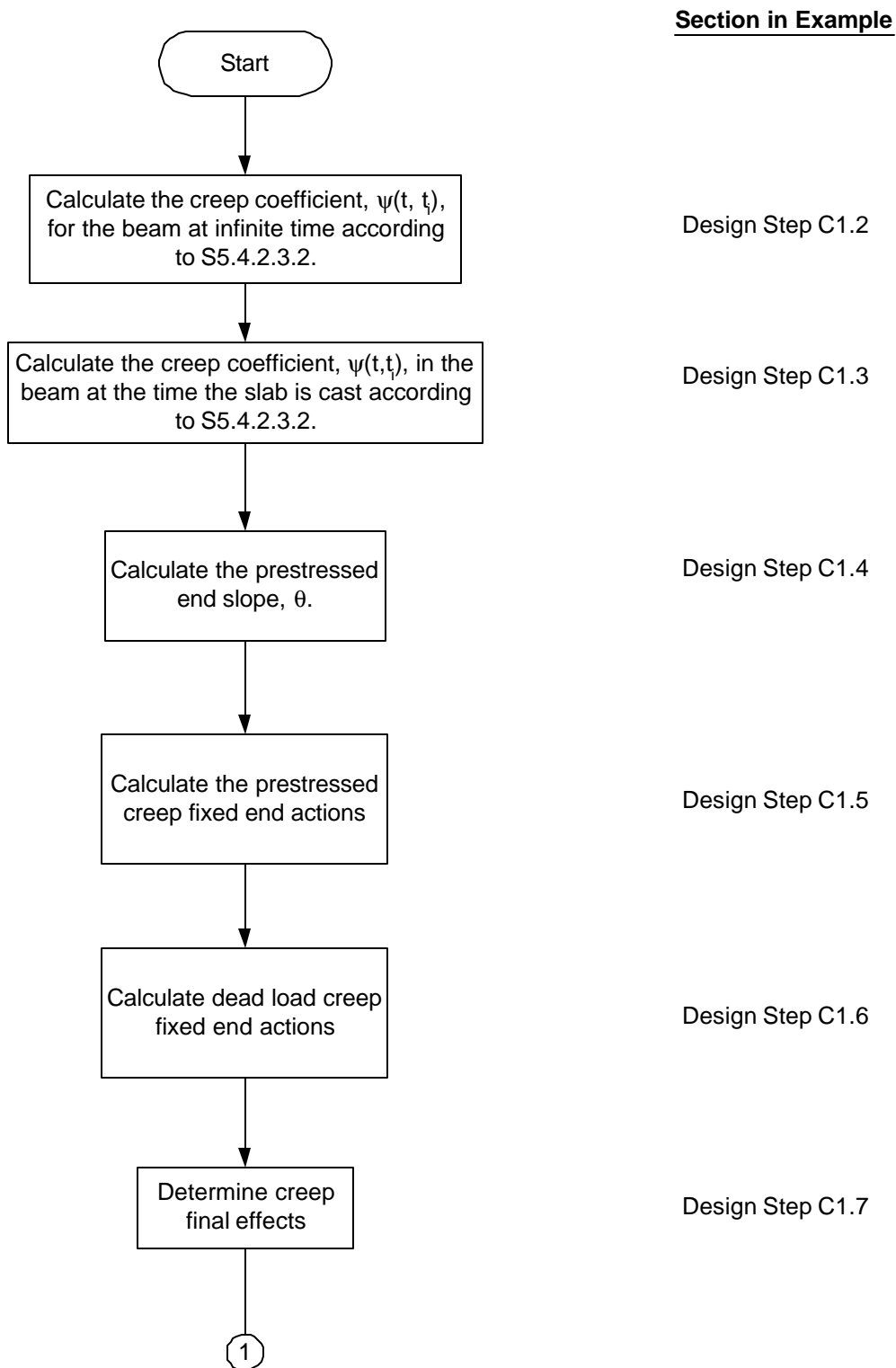

Creep and Shrinkage Calculations (cont.)

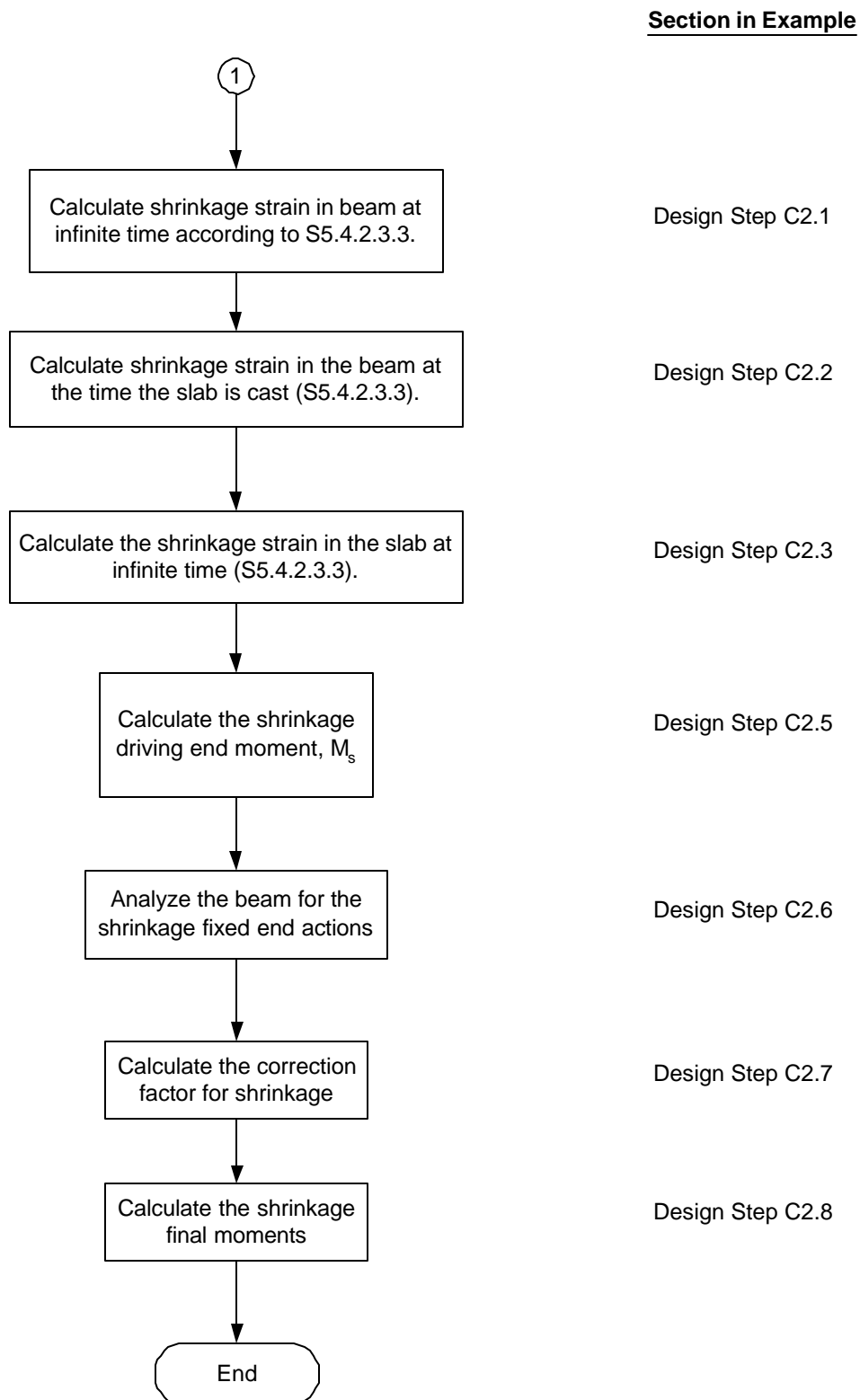

Prestressing Losses Calculations

Section in Example

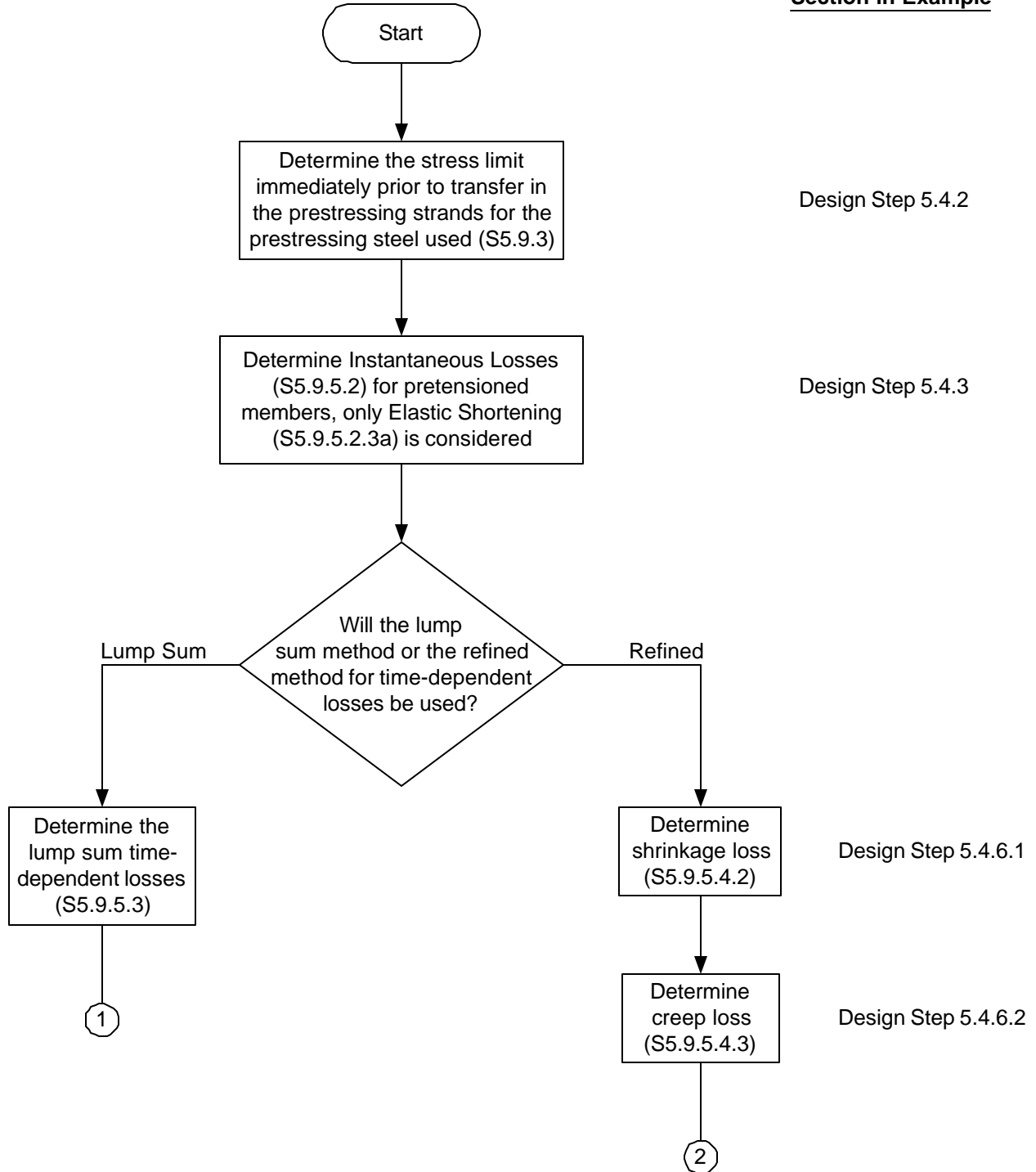

Prestressing Losses Calculations (cont.)

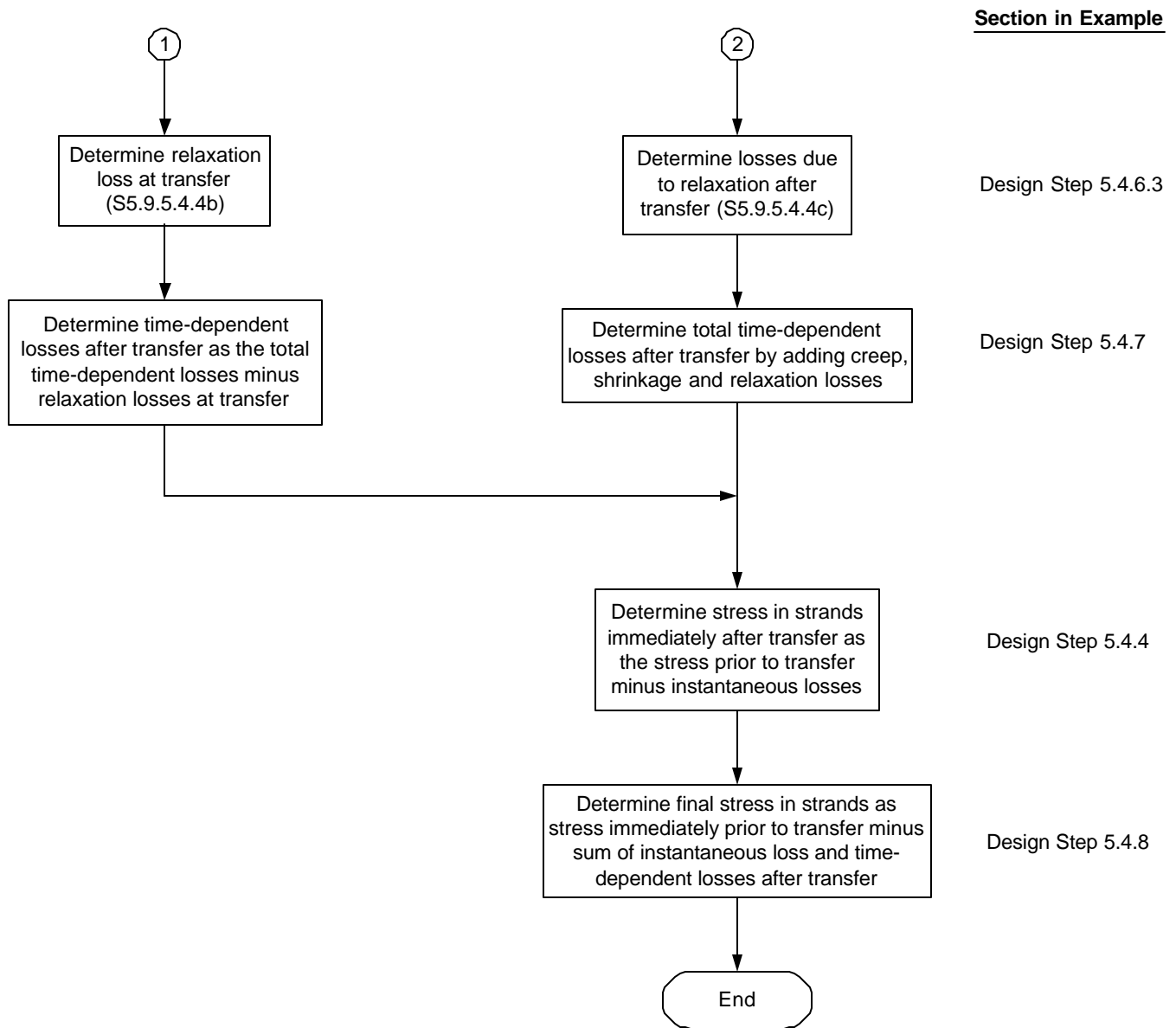

Flexural Design

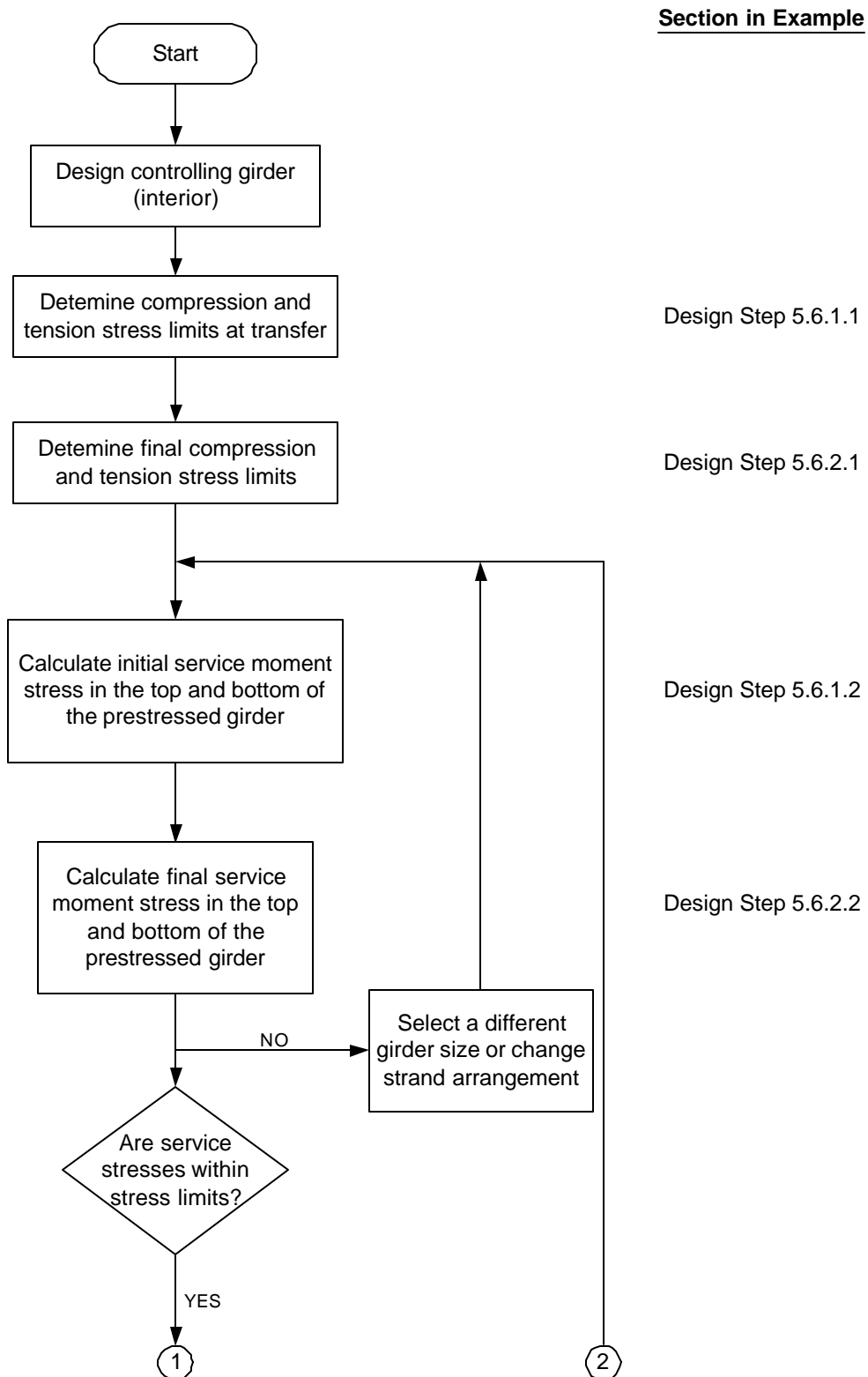

Flexural Design (cont.)

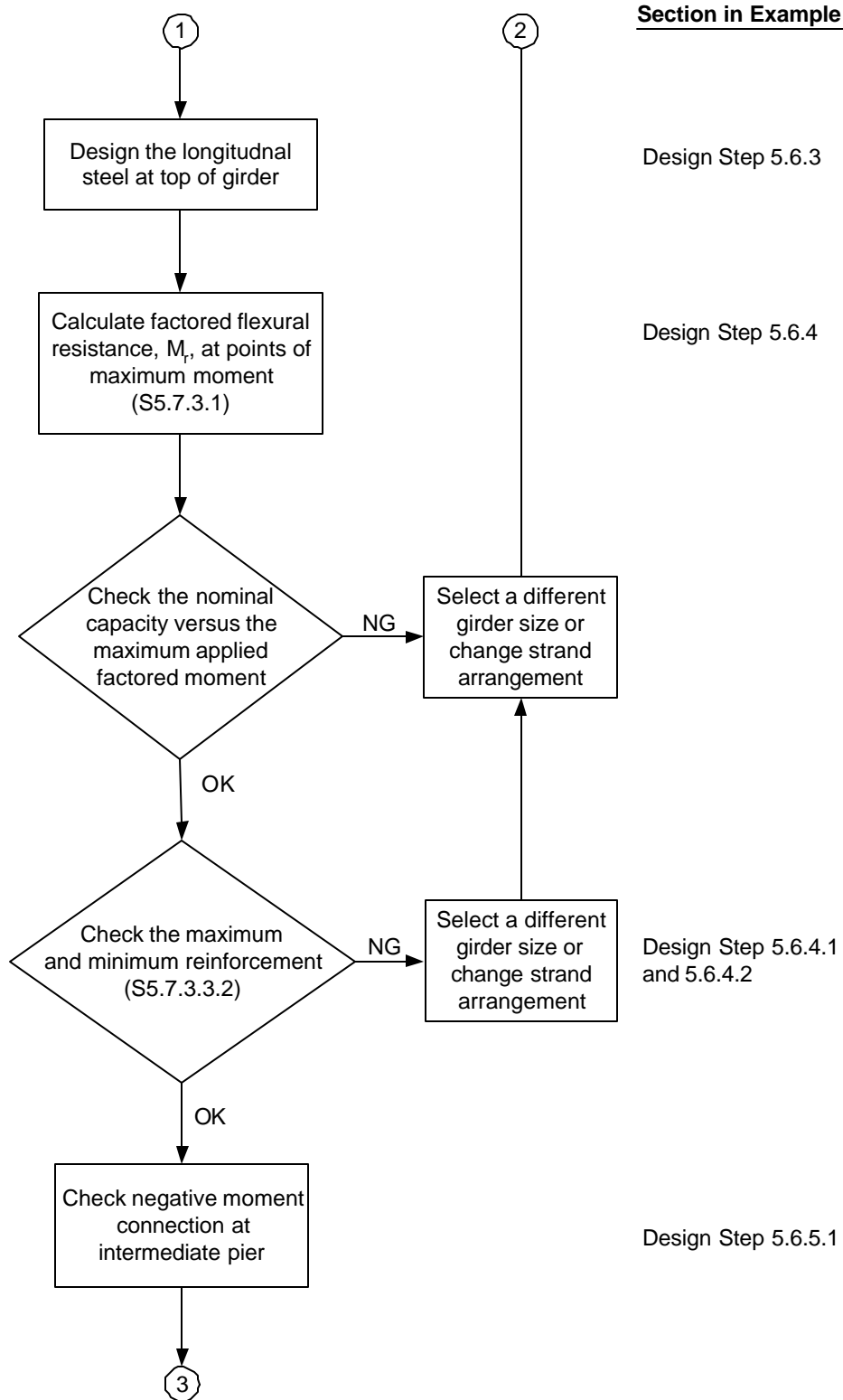

Flexural Design (cont.)

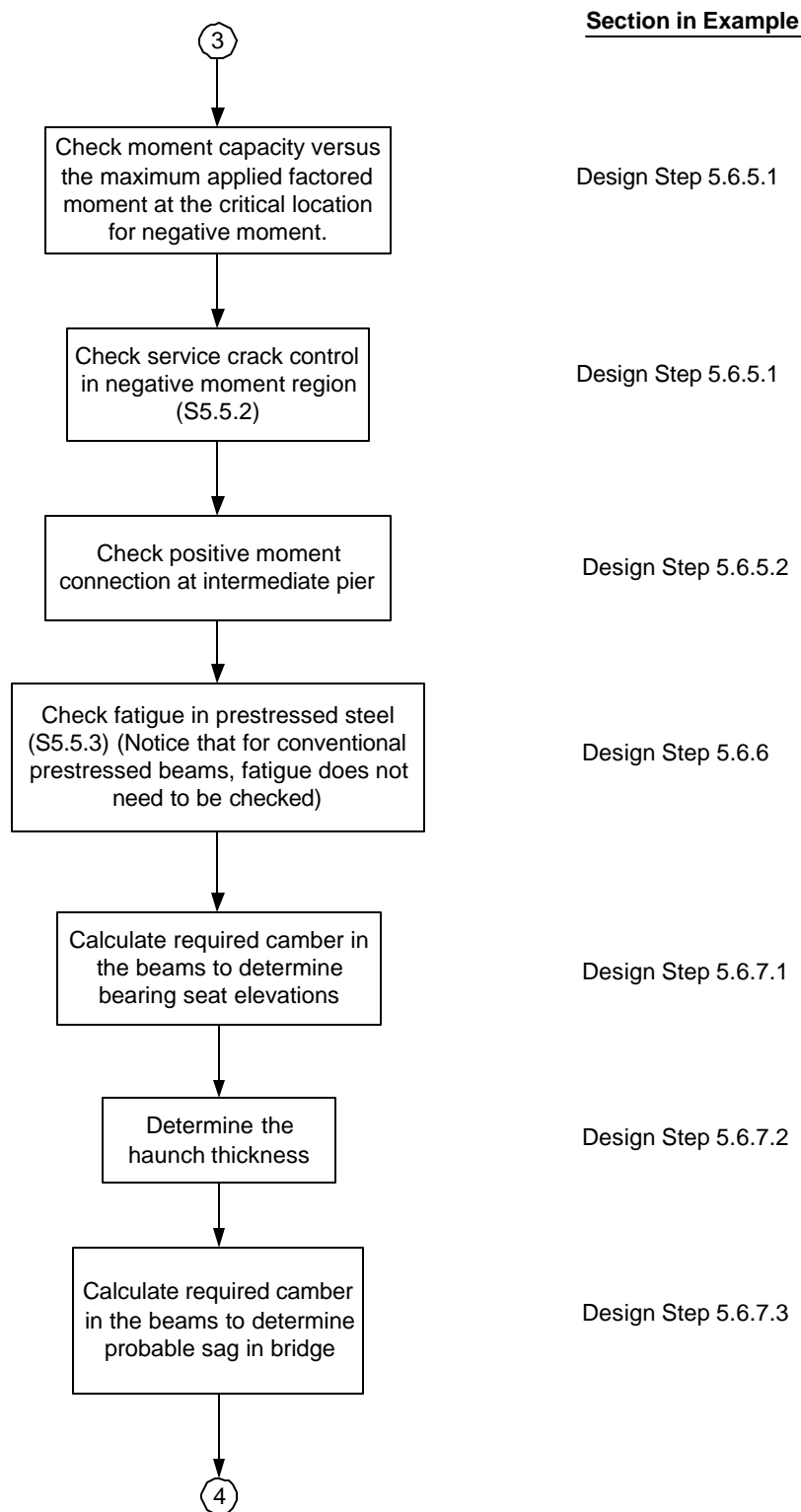

Flexural Design (cont.)

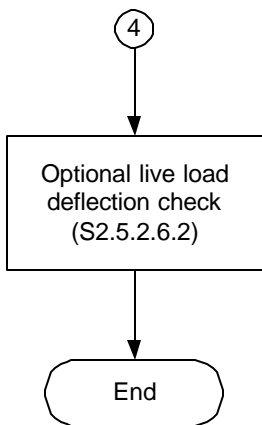

Section in Example

Design Step 5.6.8

Shear Design – Alternative 1, Assumed Angle ?

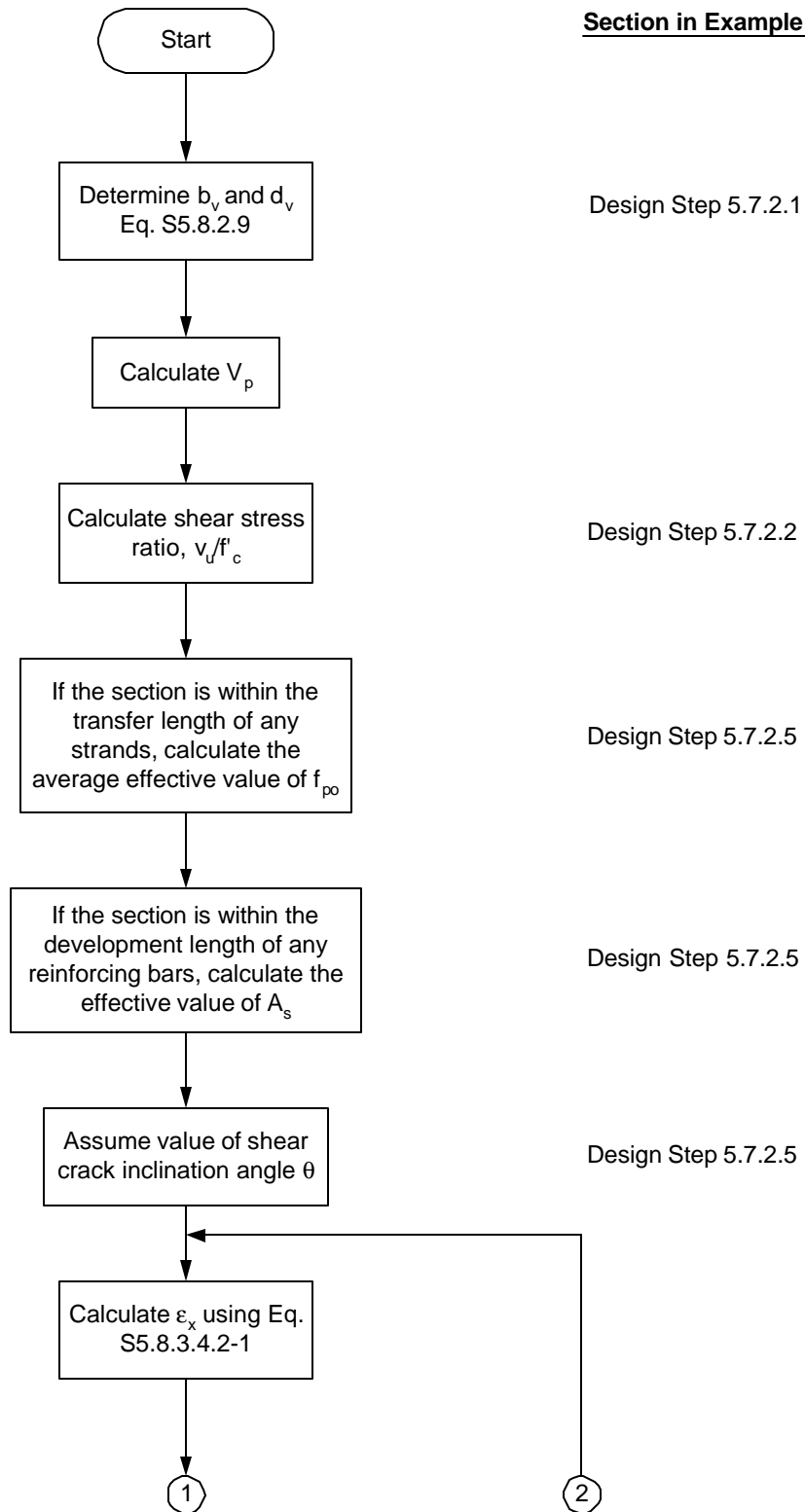

Shear Design – Alternative 1, Assumed Angle ? (cont.)

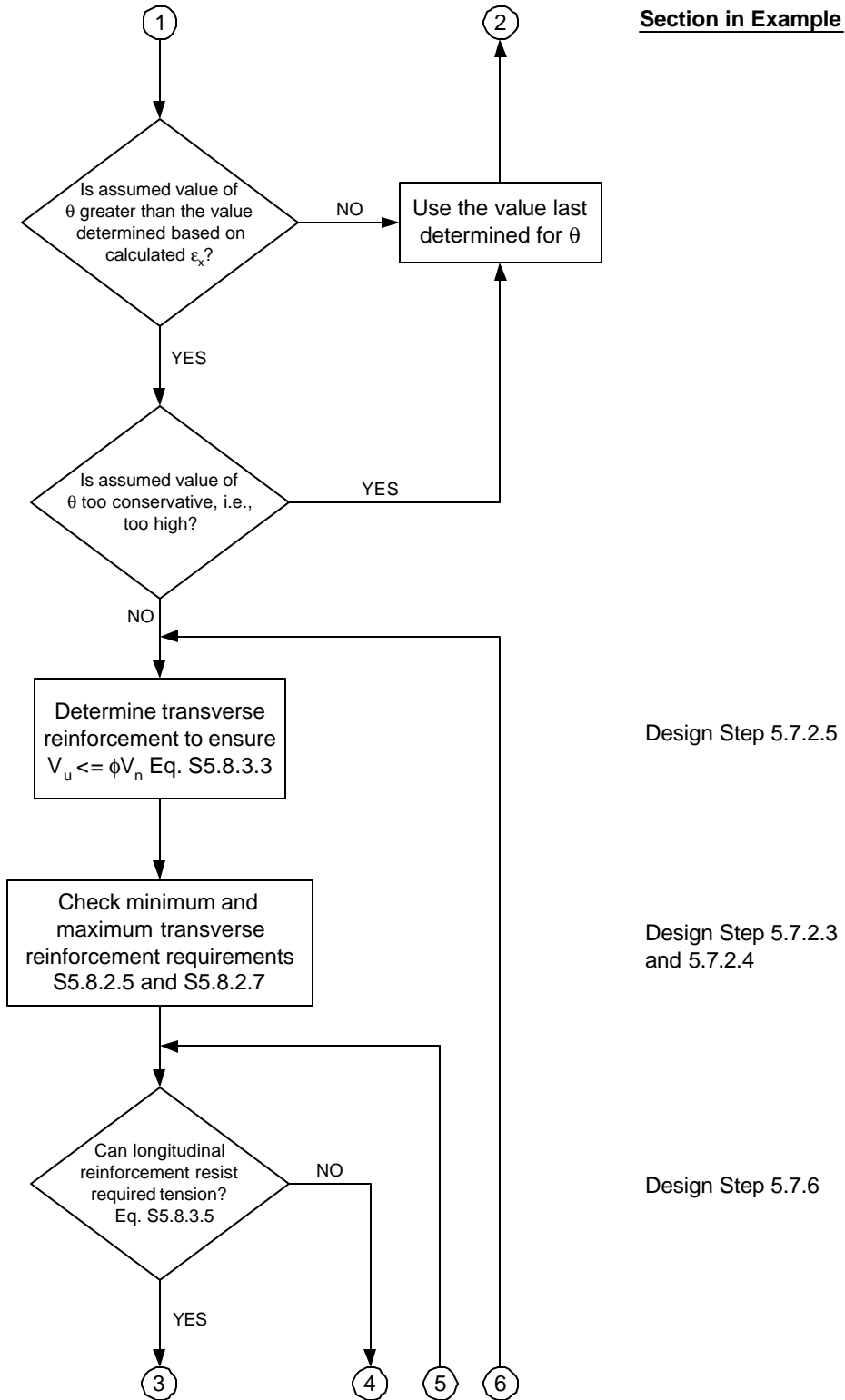

Section in Example

Design Step 5.7.2.5

Design Step 5.7.2.3 and 5.7.2.4

Design Step 5.7.6

Shear Design – Alternative 1, Assumed Angle ? (cont.)

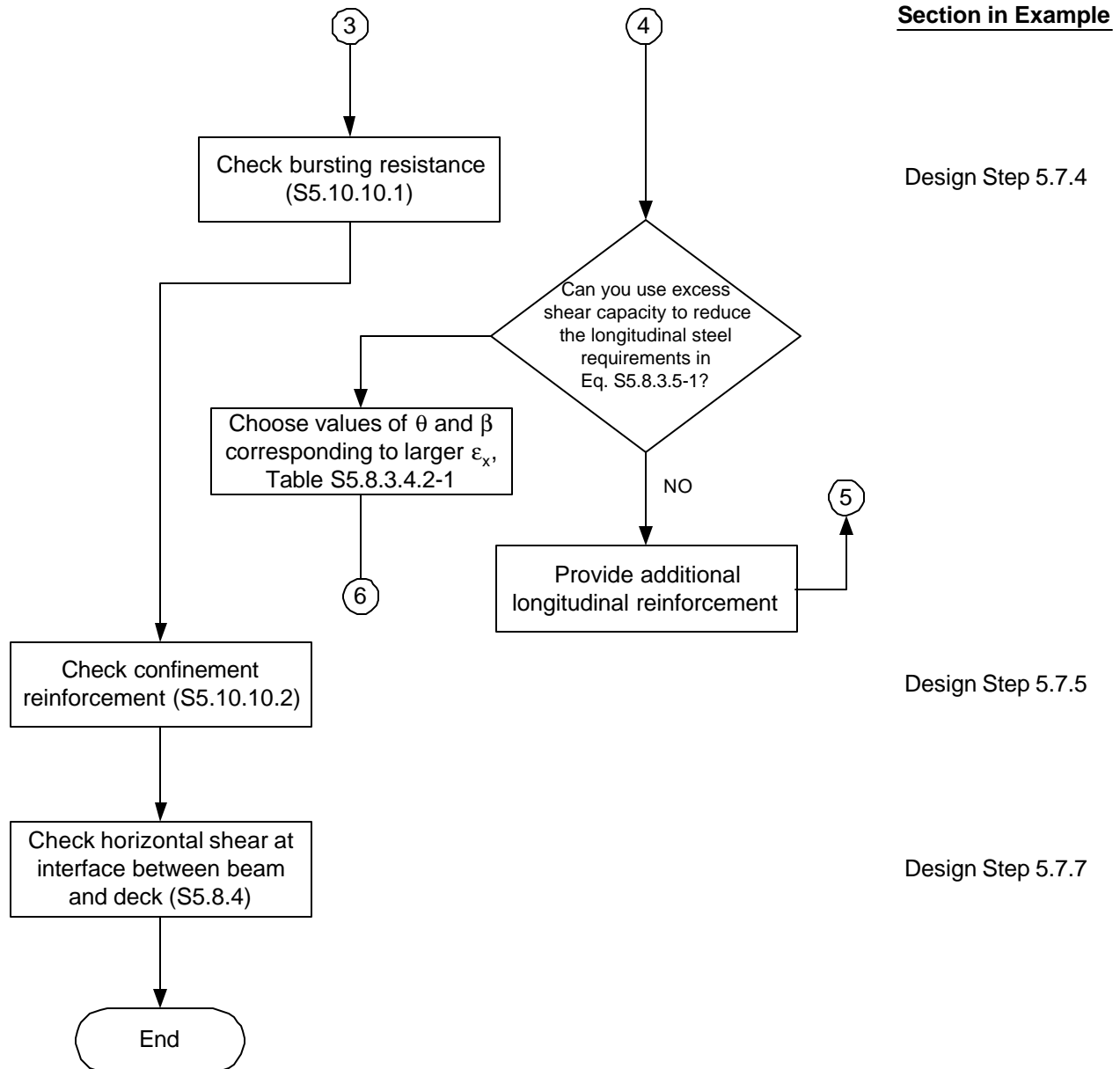

Section in Example

Design Step 5.7.4

Design Step 5.7.5

Design Step 5.7.7

Shear Design – Alternative 2, Assumed Strain ϵ_x

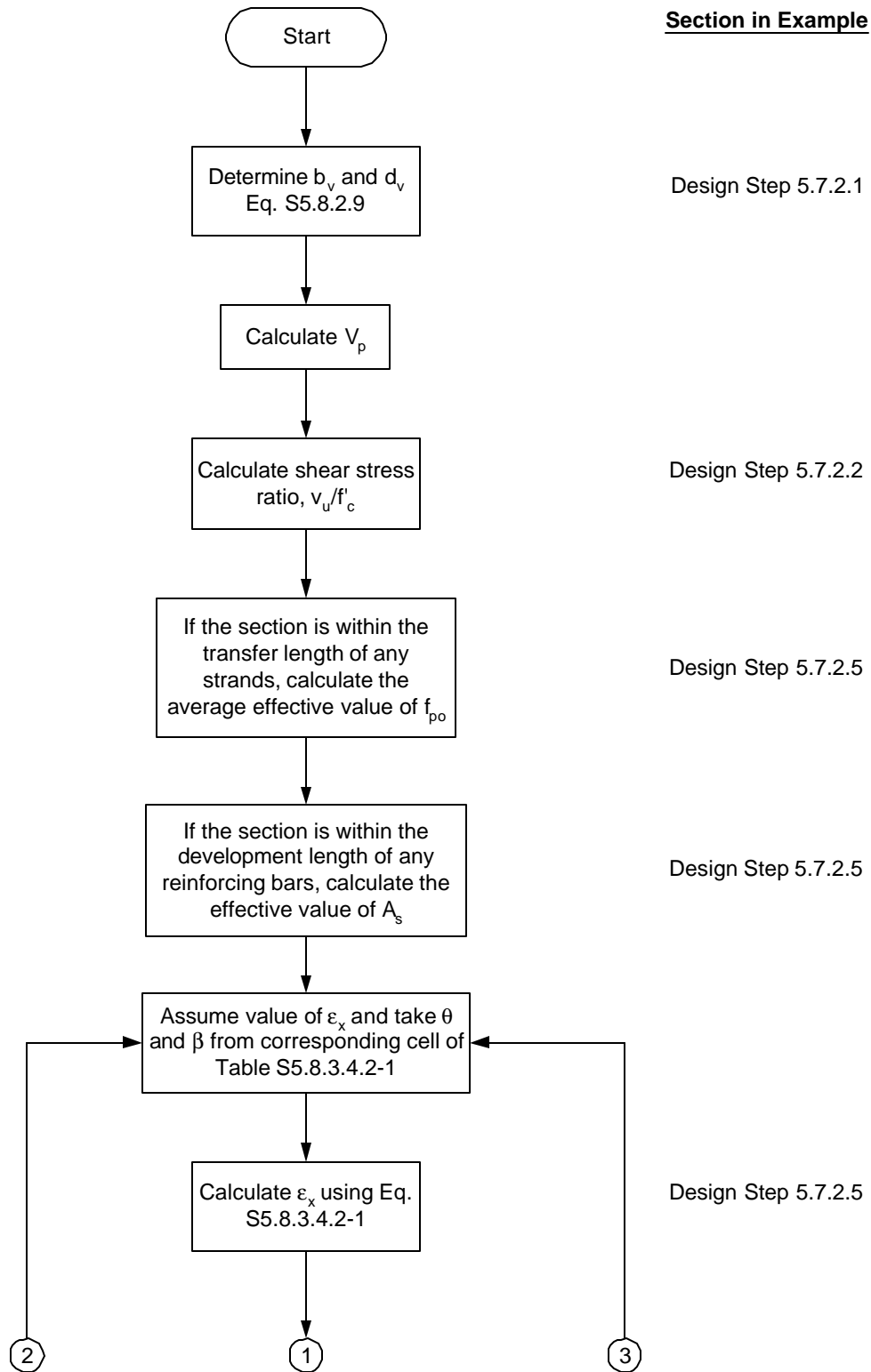

Shear Design – Alternative 2, Assumed Strain ϵ_x (cont.)

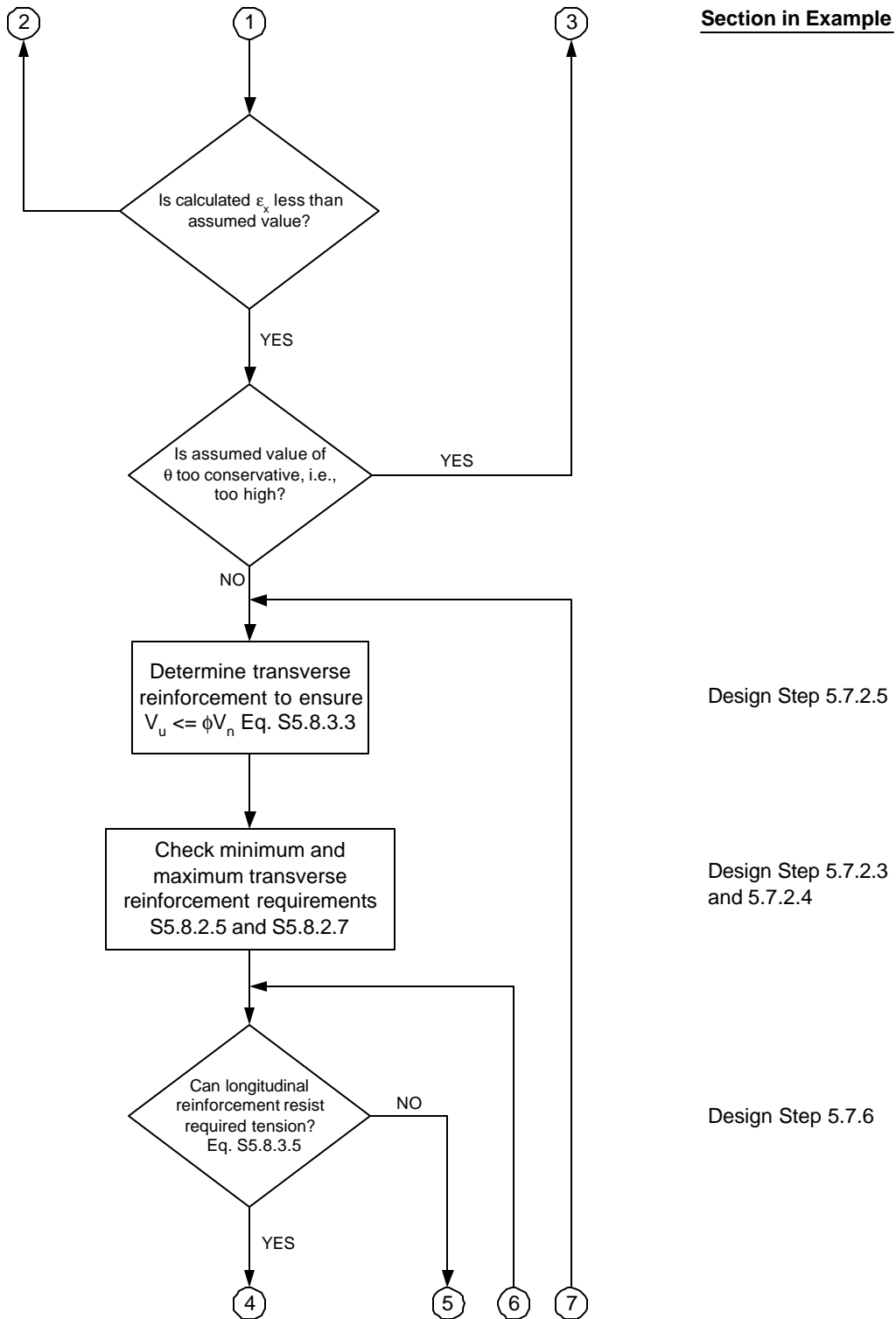

Section in Example

Design Step 5.7.2.5

Design Step 5.7.2.3 and 5.7.2.4

Design Step 5.7.6

Shear Design – Alternative 2, Assumed Strain ϵ_x (cont.)

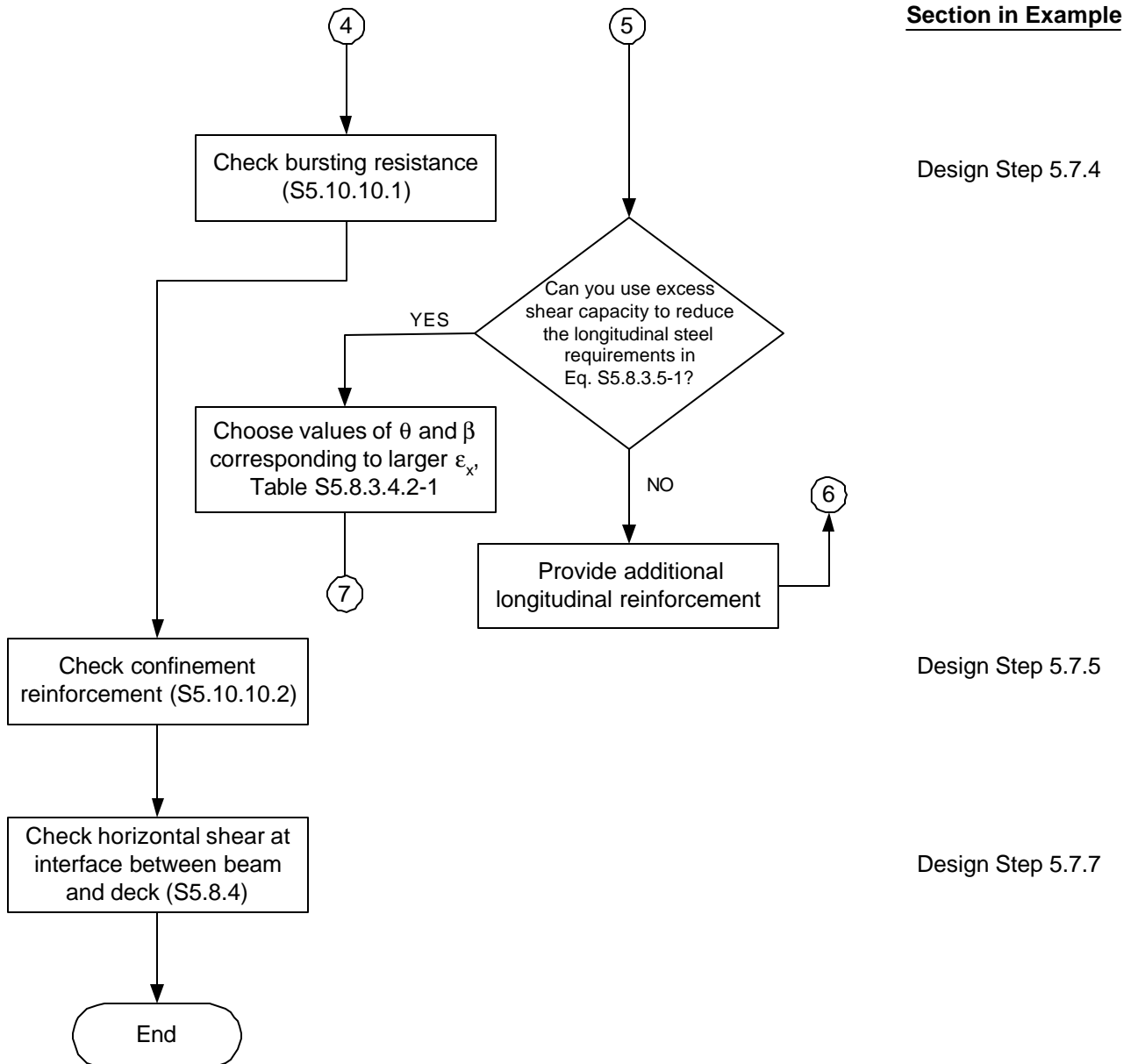

Section in Example

Design Step 5.7.4

Design Step 5.7.5

Design Step 5.7.7

Steel-Reinforced Elastomeric Bearing Design – Method A (Reference Only)

Section in Example

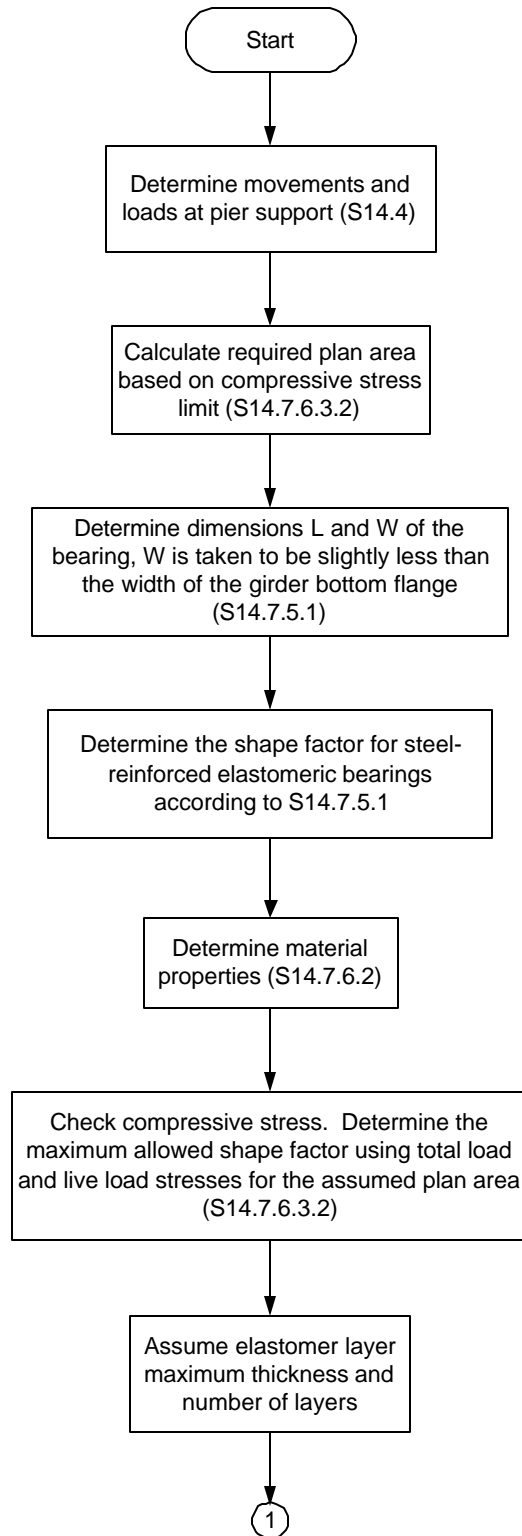

Steel-Reinforced Elastomeric Bearing Design – Method A (Reference Only) (cont.)

Section in Example

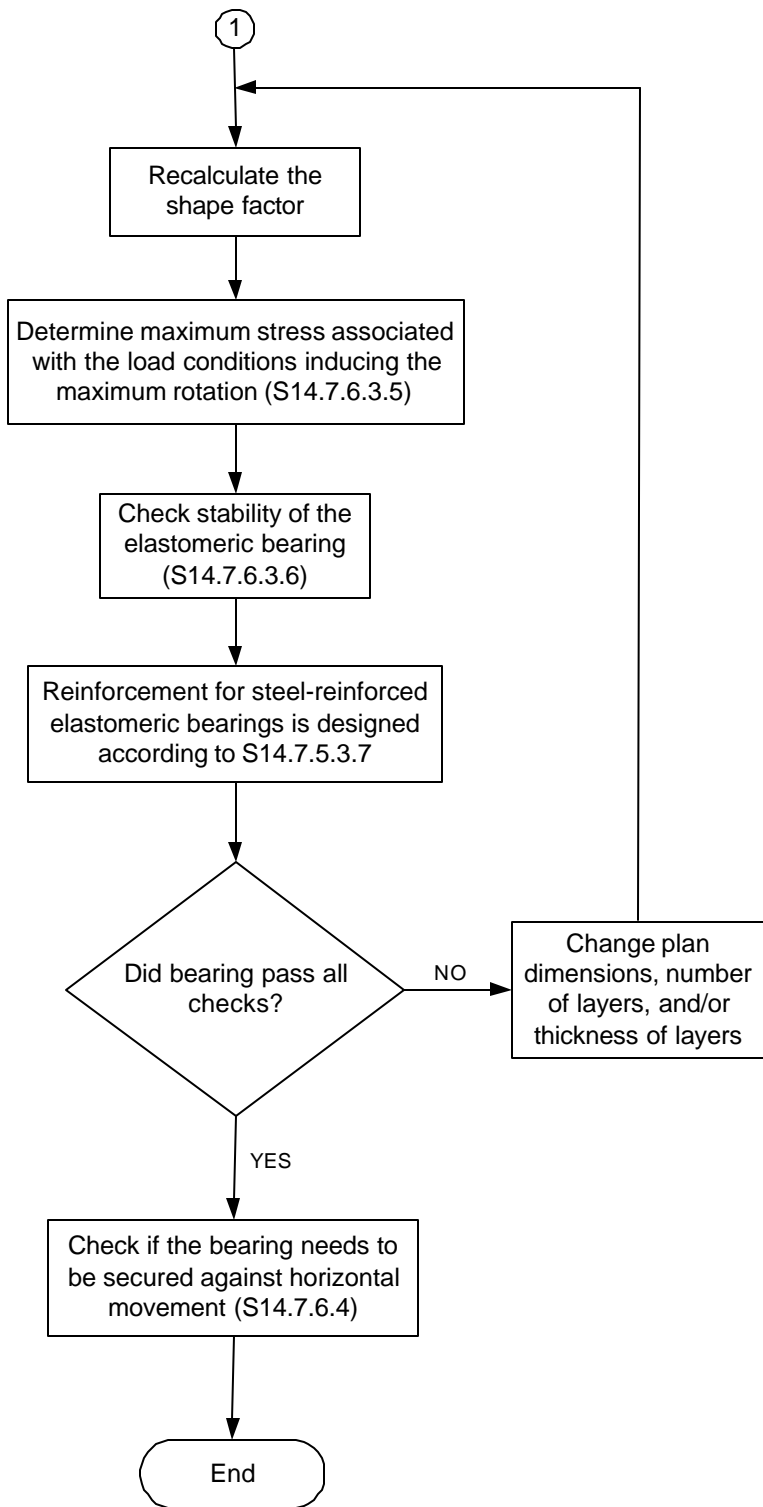

Steel-Reinforced Elastomeric Bearing Design – Method B

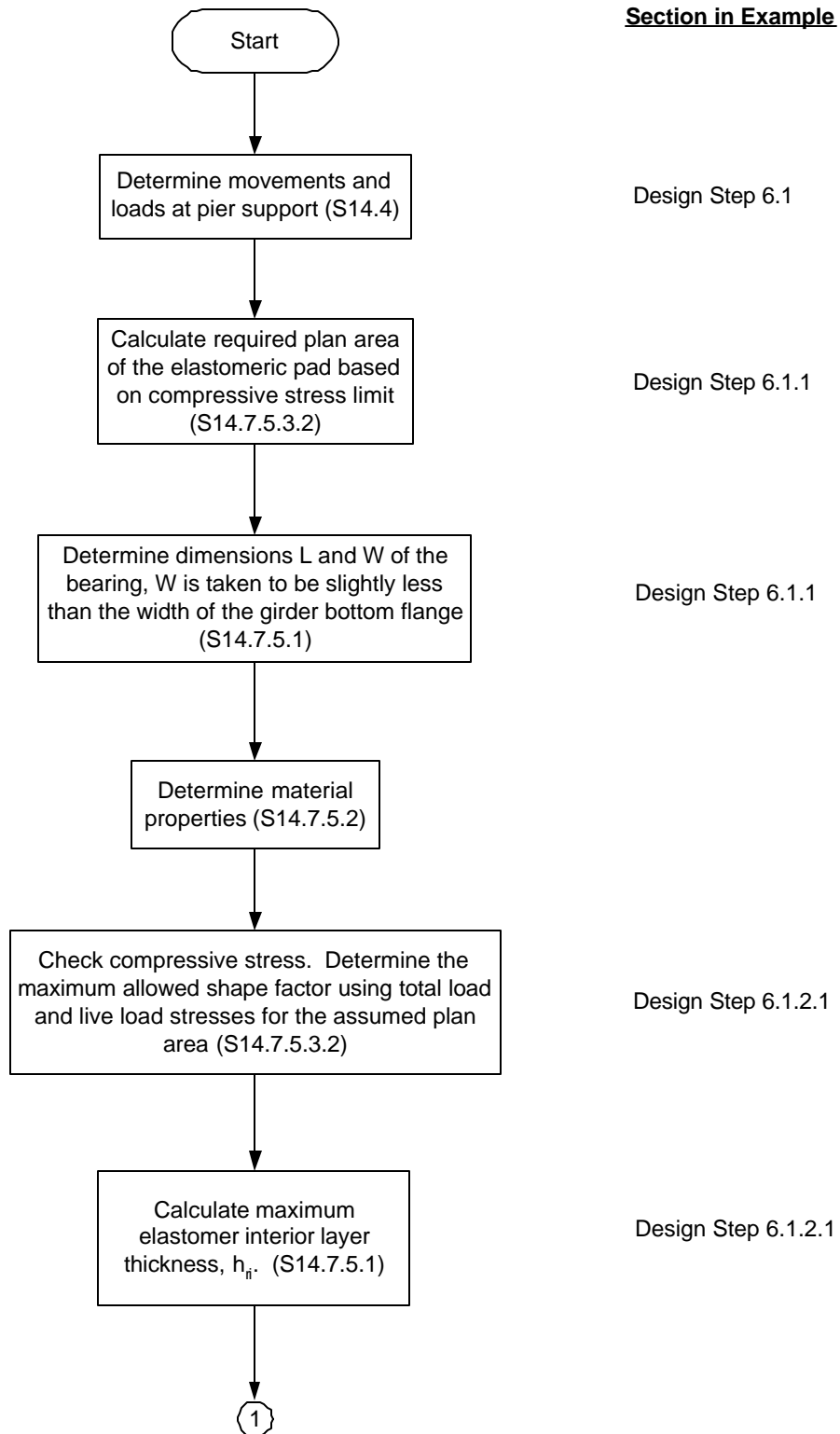

Steel-Reinforced Elastomeric Bearing Design – Method B (cont.)

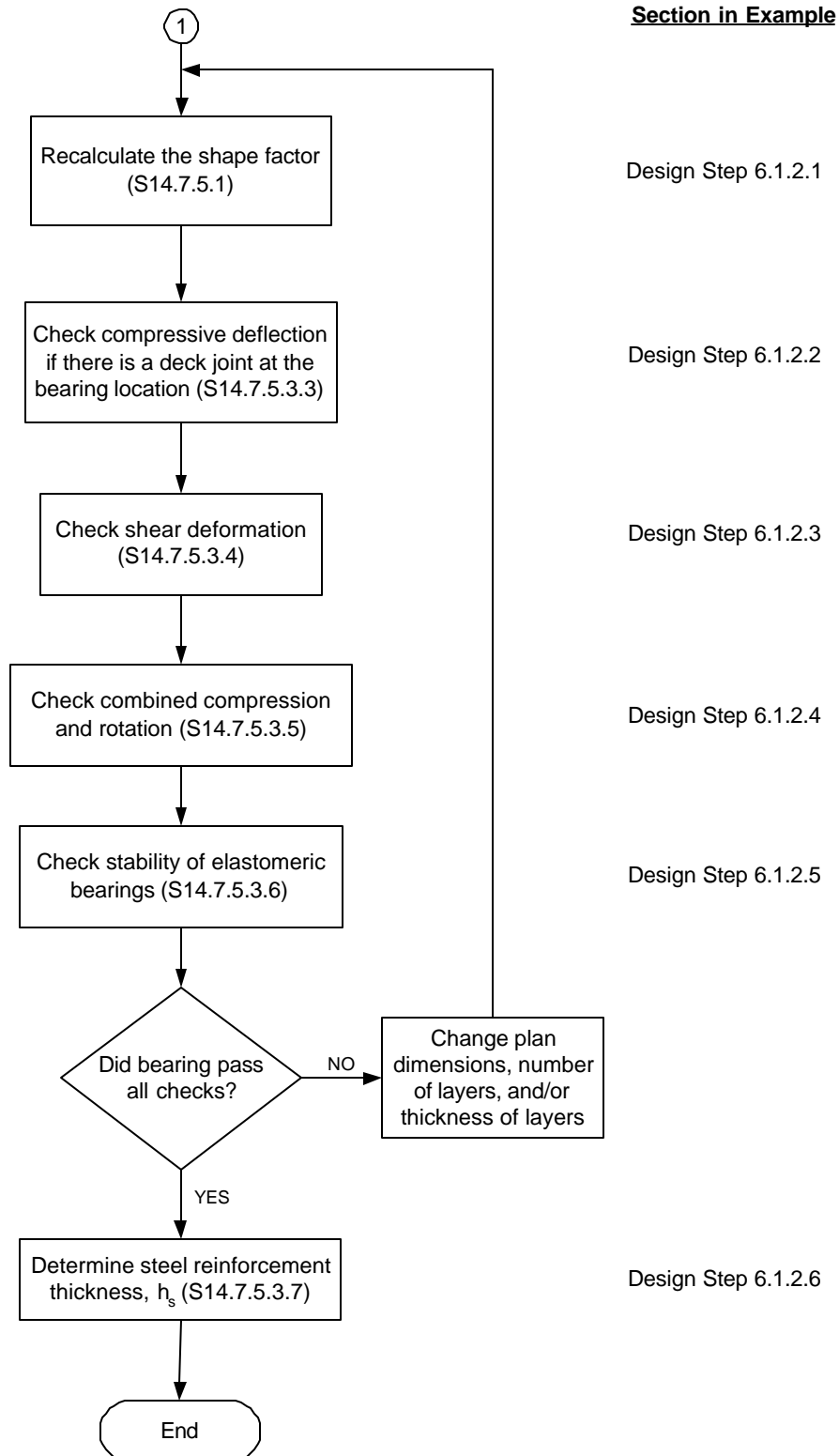

SUBSTRUCTURE

Integral Abutment Design

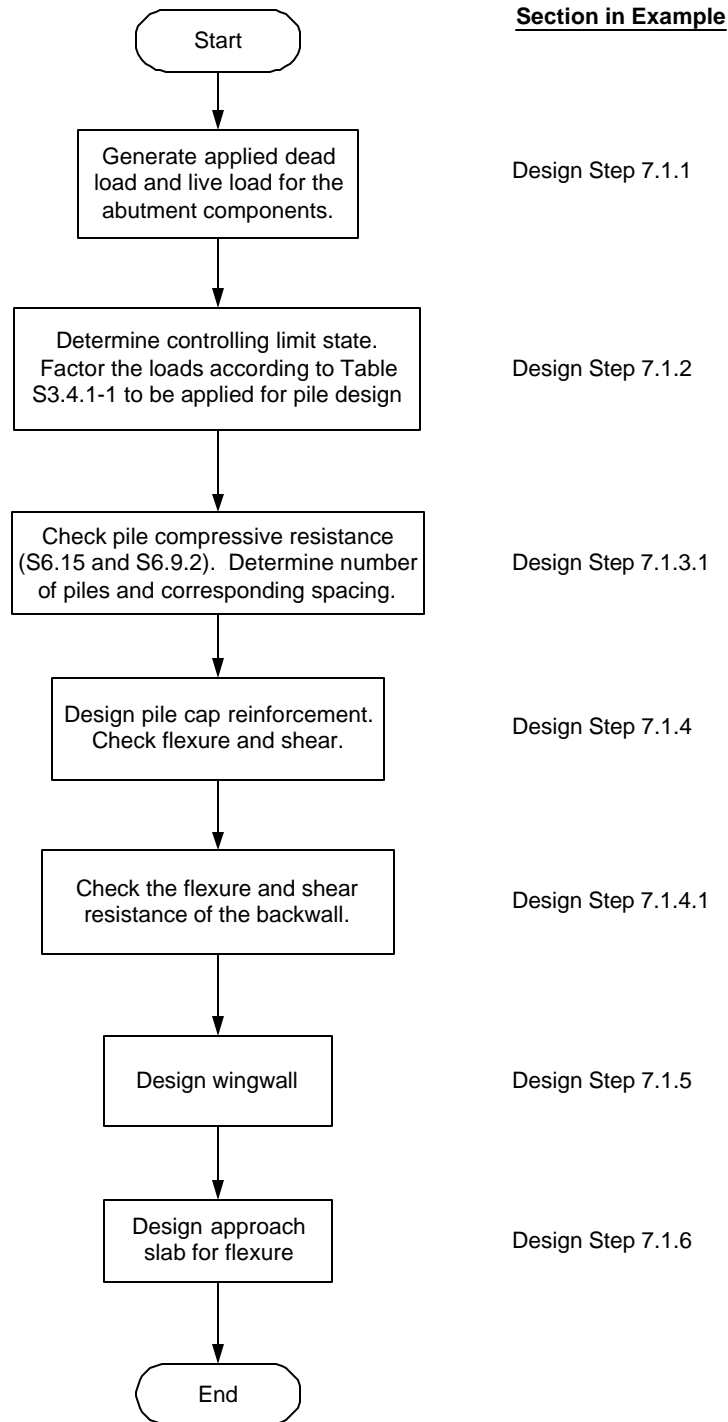

Intermediate Bent Design

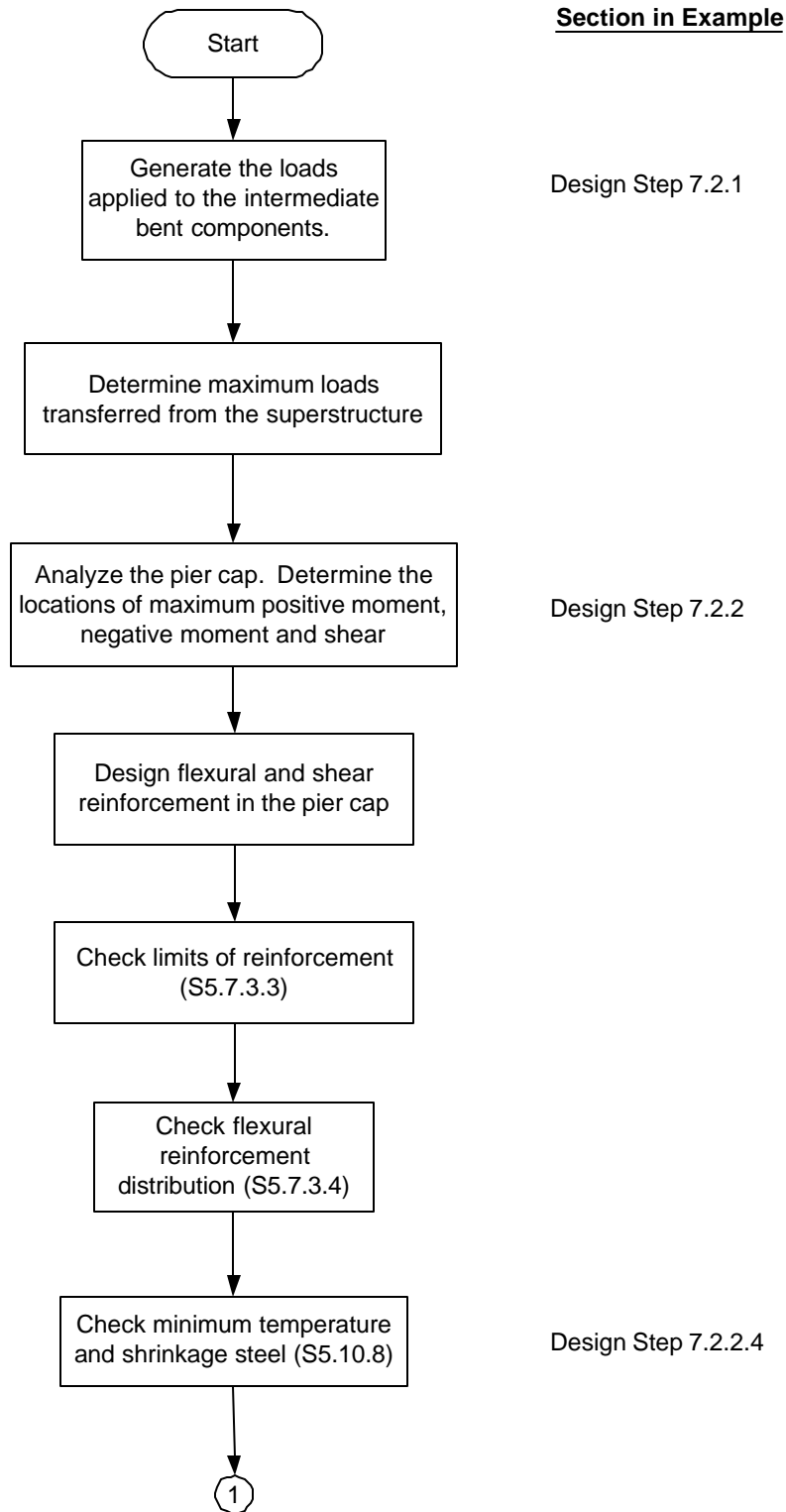

Intermediate Bent Design (cont.)

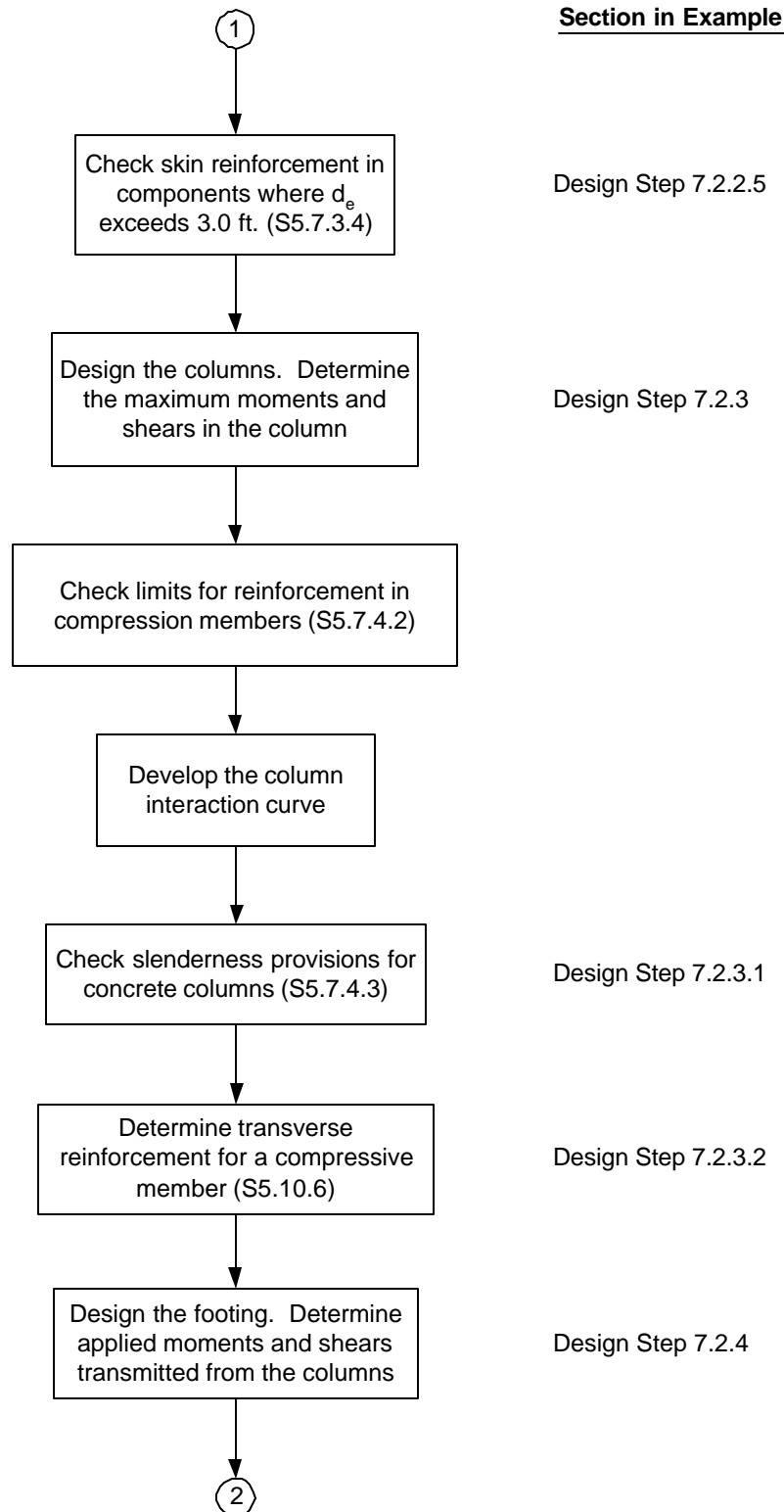

Intermediate Bent Design (cont.)

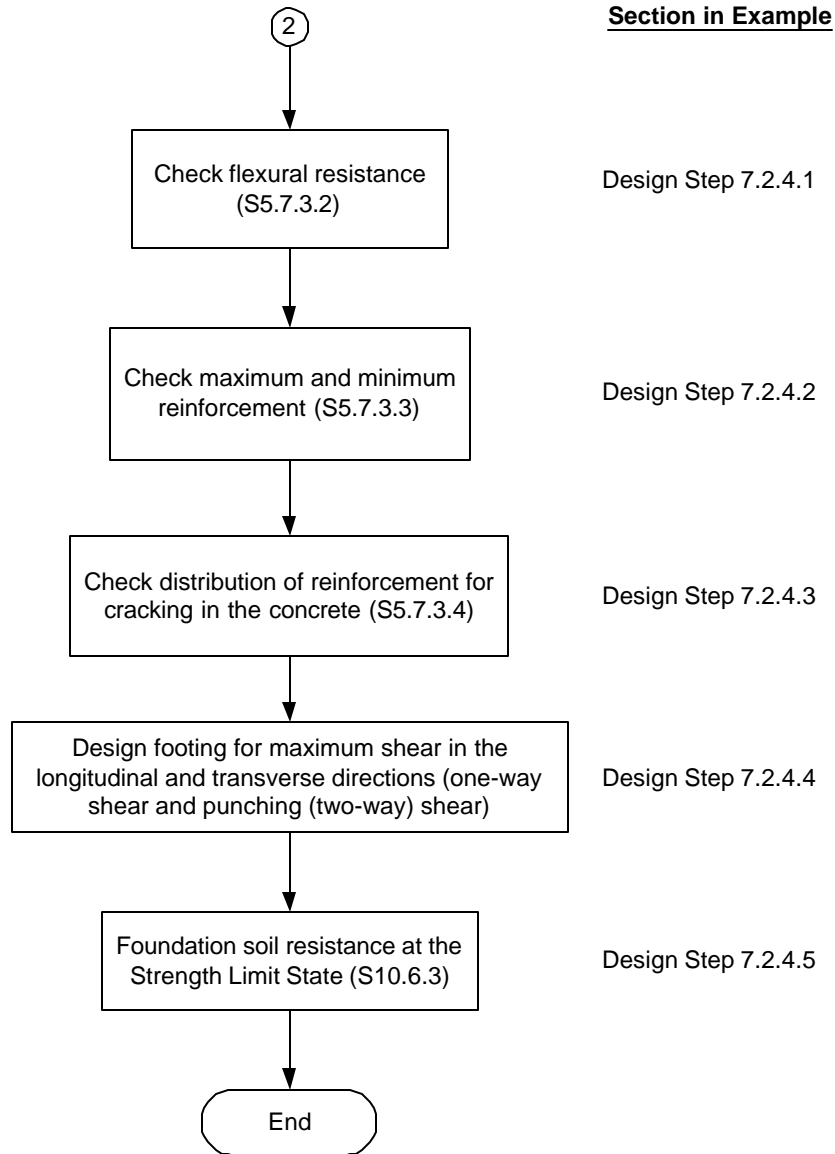

Design Step 4 DECK SLAB DESIGN**Design Step 4.1**

In addition to designing the deck for dead and live loads at the strength limit state, the AASHTO-LRFD specifications require checking the deck for vehicular collision with the railing system at the extreme event limit state. The resistance factor at the extreme event limit state is taken as 1.0. This signifies that, at this level of loading, damage to the structural components is allowed and the goal is to prevent the collapse of any structural components.

The AASHTO-LRFD Specifications include two methods of deck design. The first method is called the approximate method of deck design (S4.6.2.1) and is typically referred to as the equivalent strip method. The second is called the Empirical Design Method (S9.7.2).

The equivalent strip method is based on the following:

- *A transverse strip of the deck is assumed to support the truck axle loads.*
- *The strip is assumed to be supported on rigid supports at the center of the girders. The width of the strip for different load effects is determined using the equations in S4.6.2.1.*
- *The truck axle loads are moved laterally to produce the moment envelopes. Multiple presence factors and the dynamic load allowance are included. The total moment is divided by the strip distribution width to determine the live load per unit width.*
- *The loads transmitted to the bridge deck during vehicular collision with the railing system are determined.*
- *Design factored moments are then determined using the appropriate load factors for different limit states.*
- *The reinforcement is designed to resist the applied loads using conventional principles of reinforced concrete design.*
- *Shear and fatigue of the reinforcement need not be investigated.*

The Empirical Design Method is based on laboratory testing of deck slabs. This testing indicates that the loads on the deck are transmitted to the supporting components mainly through arching action in the deck, not through shears and moments as assumed by traditional design. Certain limitations on the geometry of the deck are listed in S9.7.2. Once these limitations are satisfied, the specifications give reinforcement ratios for both the longitudinal and transverse reinforcement for both layers of deck reinforcement. No other design calculations are required for the interior portions of the deck. The overhang region is then designed for vehicular collision with the railing system and for

dead and live loads acting on the deck. The Empirical Design Method requires less reinforcement in the interior portions of the deck than the Approximate Method.

For this example, the Approximate Method (Strip Width Method) is used.

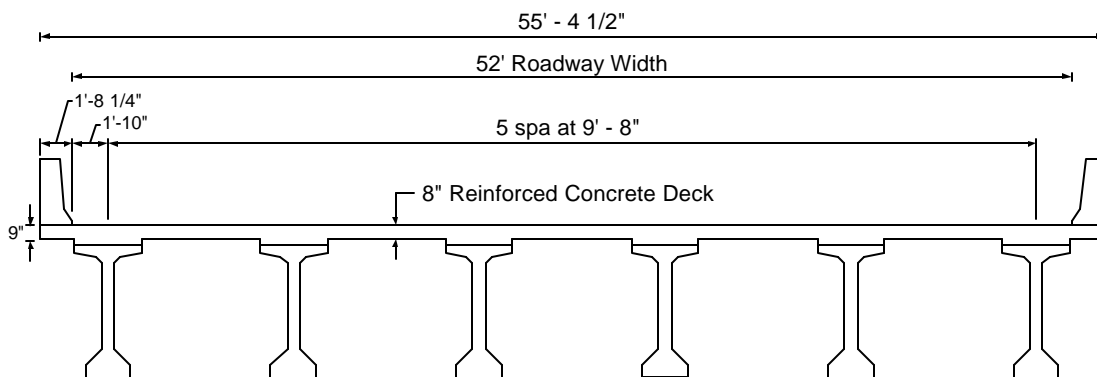

Figure 4-1 – Bridge Cross-Section

Required information:

Girder spacing	= 9 ft.- 8 in.
Top cover	= 2 ½ in. (S5.12.3) (includes ½ in. integral wearing surface)
Bottom cover	= 1 in. (S5.12.3)
Steel yield strength	= 60 ksi
Slab conc. compressive strength	= 4 ksi
Concrete density	= 150 pcf
Future wearing surface density	= 30 psf

Design Step 4.2 DECK THICKNESS

The specifications require that the minimum thickness of a concrete deck, excluding any provisions for grinding, grooving and sacrificial surface, should not be less than 7 in. (S9.7.1.1). Thinner decks are acceptable if approved by the bridge owner. For slabs with depths less than 1/20 of the design span, consideration should be given to prestressing in the direction of that span in order to control cracking.

Most jurisdictions require a minimum deck thickness of 8 in., including the ½ inch integral wearing surface.

In addition to the minimum deck thickness requirements of S9.7.1.1, some jurisdictions check the slab thickness using the provisions of S2.5.2.6.3. The provisions in this article are meant for slab-type bridges and their purpose is to limit deflections under live loads. Applying these provisions to the design of deck slabs rarely controls deck slab design.

For this example, a slab thickness of 8 in., including the ½ inch integral wearing surface, is assumed. The integral wearing surface is considered in the weight calculations. However, for resistance calculations, the integral wearing surface is assumed to not contribute to the section resistance, i.e., the section thickness for resistance calculations is assumed to be 7.5 in.

Design Step 4.3 OVERHANG THICKNESS

For decks supporting concrete parapets, the minimum overhang thickness is 8 in. (S13.7.3.1.2), unless a lesser thickness is proven satisfactory through crash testing of the railing system. Using a deck overhang thickness of approximately ¾" to 1" thicker than the deck thickness has proven to be beneficial in past designs.

For this example, an overhang thickness of 9 in., including the ½ in. sacrificial layer is assumed in the design.

Design Step 4.4 CONCRETE PARAPET

A Type-F concrete parapet is assumed. The dimensions of the parapet are shown in Figure 4-2. The railing crash resistance was determined using the provisions of SA13.3.1. The characteristics of the parapet and its crash resistance are summarized below.

Concrete Parapet General Values and Dimensions:

Mass per unit length	= 650 lb/ft
Width at base	= 1 ft.- 8 ¼ in.
Moment capacity at the base calculated assuming the parapet acts as a vertical cantilever, M_c /length	= 17.83 k-ft/ft
Parapet height, H	= 42 in.
Length of parapet failure mechanism, L_c	= 235.2 in.
Collision load capacity, R_w	= 137.22 k

Notice that each jurisdiction typically uses a limited number of railings. The properties of each parapet may be calculated once and used for all deck slabs. For a complete railing design example, see Lecture 16 of the participant notebook of the National Highway Institute Course No. 13061.

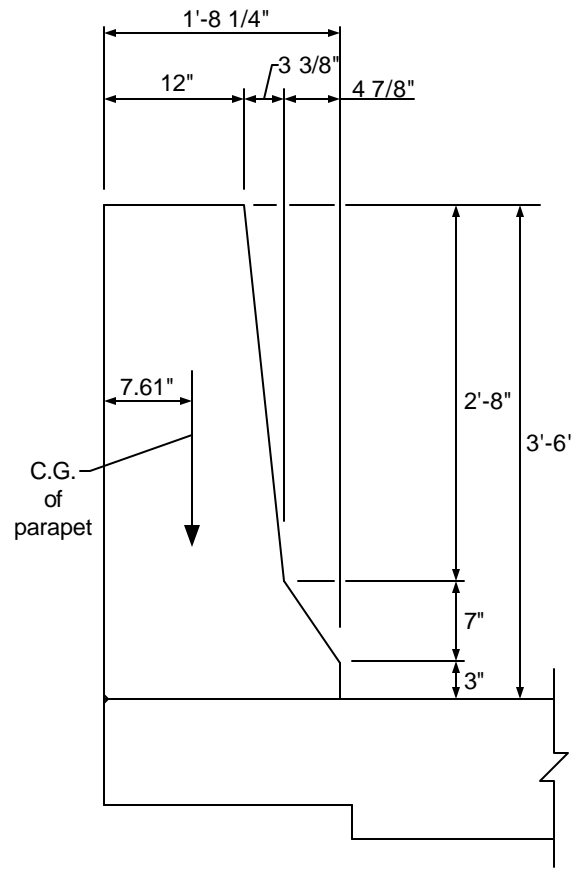

Figure 4-2 – Parapet Cross-Section

The load capacity of this parapet exceeds the minimum required by the Specifications. The deck overhang region is required to be designed to have a resistance larger than the actual resistance of the concrete parapet (SA13.4.2).

Design Step 4.5 EQUIVALENT STRIP METHOD (S4.6.2)

Moments are calculated for a deck transverse strip assuming rigid supports at web centerlines. The reinforcement is the same in all deck bays. The overhang is designed for cases of DL + LL at the strength limit state and for collision with the railing system at the extreme event limit state.

Design Step 4.5.1 Design dead load moments:

Load factors (S3.4.1):

Slab and parapet:

Minimum = 0.9

Maximum = 1.25

Future wearing surface:

Minimum = 0.65

Maximum = 1.5

It is not intended to maximize the load effects by applying the maximum load factors to some bays of the deck and the minimum load factors to others. Therefore, for deck slabs the maximum load factor controls the design and the minimum load factor may be ignored.

Dead loads represent a small fraction of the deck loads. Using a simplified approach to determine the deck dead load effects will result in a negligible difference in the total (DL + LL) load effects. Traditionally, dead load positive and negative moments in the deck, except for the overhang, for a unit width strip of the deck are calculated using the following approach:

$$M = wl^2/c$$

where:

M = dead load positive or negative moment in the deck for a unit width strip (k-ft/ft)

w = dead load per unit area of the deck (ksf)

l = girder spacing (ft.)

c = constant, typically taken as 10 or 12

For this example, the dead load moments due to the self weight and future wearing surface are calculated assuming $c = 10$.

Self weight of the deck = $8(150)/12 = 100$ psf

Unfactored self weight positive or negative moment = $(100/1000)(9.66)^2/10$
= 0.93 k-ft/ft

Future wearing surface = 30 psf

Unfactored FWS positive or negative moment = $(30/1000)(9.66)^2/10$
= 0.28 k-ft/ft

Design Step 4.6

DISTANCE FROM THE CENTER OF THE GIRDER TO THE DESIGN SECTION FOR NEGATIVE MOMENT

For precast I-shaped and T-shaped concrete beams, the distance from the centerline of girder to the design section for negative moment in the deck should be taken equal to one-third of the flange width from the centerline of the support (S4.6.2.1.6), but not to exceed 15 in.

Girder top flange width = 42 in.

One-third of the girder top flange width = 14 in. < 15 in. **OK**

Design Step 4.7 DETERMINING LIVE LOAD EFFECTS

Using the approximate method of deck analysis (S4.6.2), live load effects may be determined by modeling the deck as a beam supported on the girders. One or more axles may be placed side by side on the deck (representing axles from trucks in different traffic lanes) and move them transversely across the deck to maximize the moments (S4.6.2.1.6). To determine the live load moment per unit width of the bridge, the calculated total live load moment is divided by a strip width determined using the appropriate equation from Table S4.6.2.1.3-1. The following conditions have to be satisfied when determining live load effects on the deck:

Minimum distance from center of wheel to the inside face of parapet = 1 ft. (S3.6.1.3)

Minimum distance between the wheels of two adjacent trucks = 4 ft.

Dynamic load allowance = 33% (S3.6.2.1)

Load factor (Strength I) = 1.75 (S3.4.1)

Multiple presence factor (S3.6.1.1.2):

Single lane = 1.20

Two lanes = 1.00

Three lanes = 0.85

(Note: the “three lanes” situation never controls for girder spacings up to 16 ft.)

Trucks were moved laterally to determine extreme moments (S4.6.2.1.6)

Fatigue need not be investigated for concrete slabs in multi-girder bridges (S9.5.3 and S5.5.3.1)

*Resistance factors, ϕ , for moment: 0.9 for strength limit state (S5.5.4.2)
1.0 for extreme event limit state (S1.3.2.1)*

In lieu of this procedure, the specifications allow the live load moment per unit width of the deck to be determined using Table SA4.1-1. This table lists the positive and negative moment per unit width of decks with various girder spacings and with various distances from the design section to the centerline of the girders for negative moment. This table is based on the analysis procedure outlined above and will be used for this example.

Table SA4.1-1 does not include the girder spacing of 9'-8". It does include girder spacings of 9'-6" and 9'-9". Interpolation between the two girder spacings is allowed. However, due to the small difference between the values, the moments corresponding to the girder spacing of 9'-9" are used which gives slightly more conservative answers than interpolating. Furthermore, the table lists results for the design section for negative moment at 12 in. and 18 in. from the center of the girder. For this example, the distance from the design section for negative moment to the centerline of the girders is 14 in. Interpolation for the values listed for 12 in. and 18 in. is allowed. However, the value corresponding to the 12 in. distance may be used without interpolation resulting in a more conservative value. The latter approach is used for this example.

Design Step 4.8

DESIGN FOR POSITIVE MOMENT IN THE DECK

The reinforcement determined in this section is based on the maximum positive moment in the deck. For interior bays of the deck, the maximum positive moment typically takes place at approximately the center of each bay. For the first deck bay, the bay adjacent to the overhang, the location of the maximum design positive moment varies depending on the overhang length and the value and distribution of the dead load. The same reinforcement is typically used for all deck bays.

Factored loads

Live load

From Table SA4.1-1, for the girder spacing of 9'-9" (conservative):
Unfactored live load positive moment per unit width = 6.74 k-ft/ft

Maximum factored positive moment per unit width = $1.75(6.74)$
= 11.80 k-ft/ft

This moment is applicable to all positive moment regions in all bays of the deck (S4.6.2.1.1).

Deck weight

$1.25(0.93) = 1.16$ k-ft/ft

Future wearing surface

$1.5(0.28) = 0.42$ k-ft/ft

Dead load + live load design factored positive moment (Strength I limit state)

$M_{DL+LL} = 11.8 + 1.16 + 0.42$
= 13.38 k-ft/ft

Notice that the total moment is dominated by the live load.

Resistance factor for flexure at the strength limit state, $\phi = 0.90$ (S5.5.4.2.1)

The flexural resistance equations in the AASHTO-LRFD Bridge Design Specifications are applicable to reinforced concrete and prestressed concrete sections. Depending on the provided reinforcement, the terms related to prestressing, tension reinforcing steel and/or compression reinforcing steel, are set to zero. The following text is further explanation on applying these provisions to reinforced concrete sections and the possible simplifications to the equations for this case.

For rectangular section behavior, the depth of the section in compression, c , is determined using Eq. S5.7.3.1.1-4:

$$c = \frac{A_{ps} f_{pu} + A_s f_y - A'_s f'_y}{0.85 f'_c \beta_1 b + k A_{ps} \frac{f_{pu}}{d_p}} \quad (S5.7.3.1.1-4)$$

where:

A_{ps} = area of prestressing steel (in^2)

f_{pu} = specified tensile strength of prestressing steel (ksi)

f_{py} = yield strength of prestressing steel (ksi)

A_s = area of mild steel tension reinforcement (in^2)

A'_s = area of compression reinforcement (in^2)

f_y = yield strength of tension reinforcement (ksi)

f'_y = yield strength of compression reinforcement (ksi)

b = width of rectangular section (in.)

d_p = distance from the extreme compression fiber to the centroid of the prestressing tendons (in.)

c = distance between the neutral axis and the compressive face (in.)

β_1 = stress block factor specified in S5.7.2.2

For reinforced concrete sections (no prestressing) without reinforcement on the compression side of the section, the above equation is reduced to:

$$c = \frac{A_s f_y}{0.85 f'_c b_1 b}$$

The depth of the compression block, *a*, may be calculated as:

$$a = c b_1$$

These equations for “*a*” and “*c*” are identical to those traditionally used in reinforced concrete design. Many text books use the following equation to determine the reinforcement ratio, *r*, and area of reinforcement, *A_s*:

$$k' = M_u / (j b d^2)$$

$$r = 0.85 \left(\frac{f'_c}{f_y} \right) \left[1.0 - \sqrt{1.0 - \frac{2k'}{0.85 f'_c}} \right]$$

$$A_s = r d_e$$

A different method to determine the required area of steel is based on using the above equation for “*a*” and “*c*” with the Eq. S5.7.3.2.2-1 as shown below. The nominal flexural resistance, *M_n*, may be taken as:

$$M_n = A_p f_{ps} (d_p - a/2) + A_s f_y (d_s - a/2) - A_c f'_c (d'_c - a/2) + 0.85 f'_c (b - b_w) b_1 h_f (a/2 - h_f/2) \tag{S5.7.3.2.2-1}$$

where:

f_{ps} = average stress in prestressing steel at nominal bending resistance specified in Eq. S5.7.3.1.1-1 (ksi)

d_s = distance from extreme compression fiber to the centroid of nonprestressed tensile reinforcement (in.)

d'_s = distance from extreme compression fiber to the centroid of compression reinforcement (in.)

b = width of the compression face of the member (in.)

b_w = web width or diameter of a circular section (in.)

h_f = compression flange depth of an I or T member (in.)

For rectangular reinforced concrete sections (no prestressing) without reinforcement on the compression side of the section, the above equation is reduced to:

$$M_n = A_s f_y \left(d_s - \frac{a}{2} \right)$$

From the equations for “c” and “a” above, substituting for:

$$a = c b_1 = \frac{A_s f_y}{0.85 f'_c b} \text{ in the equation for } M_n \text{ above yields:}$$

$$M_n = A_s f_y \left(d_s - \frac{a}{2} \right) = f_y d_s A_s - \left(\frac{f_y^2}{1.7 f'_c b} \right) A_s^2$$

Only A_s is unknown in this equation. By substituting for $b = 12$ in., the required area of reinforcement per unit width can be determined by solving the equation.

Both methods outlined above yield the same answer. The first method is used throughout the following calculations.

For the positive moment section:

$$\begin{aligned} d_e &= \text{effective depth from the compression fiber to the centroid of the tensile force in the tensile reinforcement (in.)} \\ &= \text{total thickness} - \text{bottom cover} - \frac{1}{2} \text{ bar diameter} - \text{integral wearing surface} \\ &= 8 - 1 - \frac{1}{2} (0.625) - 0.5 \\ &= 6.19 \text{ in.} \end{aligned}$$

$$\begin{aligned} k' &= M_u / (\phi b d^2) \\ &= 13.38 / [0.9(1.0)(6.19)^2] \\ &= 0.388 \text{ k/in}^2 \end{aligned}$$

$$\begin{aligned} r &= 0.85 \left(\frac{f'_c}{f_y} \right) \left[1.0 - \sqrt{1.0 - \frac{2k'}{0.85 f'_c}} \right] \\ &= 0.00688 \end{aligned}$$

Therefore,

$$\text{Required } A_s = r d_e = 0.00688(6.19) = 0.0426 \text{ in}^2/\text{in.}$$

$$\text{Required \#5 bar spacing with bar area } 0.31 \text{ in}^2 = 0.31 / 0.0426 = 7.28 \text{ in.}$$

Use #5 bars at 7 in. spacing

Check maximum and minimum reinforcement

Based on past experience, maximum and minimum reinforcement requirements never control the deck slab design. The minimum reinforcement requirements are presented in S5.7.3.3.2. These provisions are identical to those of the AASHTO Standard Specifications. These provisions are illustrated later in this example.

Maximum reinforcement requirements are presented in S5.7.3.3.1. These requirements are different from those of the AASHTO Standard Specifications. Reinforced concrete sections are considered under-reinforced when $c/d_e = 0.42$. Even though these requirements are not expected to control the design, they are illustrated below to familiarize the user with their application.

Check depth of compression block:

$$\begin{aligned} T &= \text{tensile force in the tensile reinforcement (k)} \\ &= 0.31(60) \\ &= 18.6 \text{ k} \end{aligned}$$

$$\begin{aligned} a &= 18.6/[0.85(4)(7)] \\ &= 0.78 \text{ in.} \end{aligned}$$

$$\begin{aligned} \beta_1 &= \text{ratio of the depth of the equivalent uniformly stressed compression} \\ &\quad \text{zone assumed in the strength limit state to the depth of the actual} \\ &\quad \text{compression zone} \\ &= 0.85 \text{ for } f_c = 4 \text{ ksi (S5.7.2.2)} \end{aligned}$$

$$\begin{aligned} c &= 0.78/0.85 \\ &= 0.918 \text{ in.} \end{aligned}$$

Check if the section is over-reinforced

$$\begin{aligned} c/d_e &= 0.918/6.19 \\ &= 0.15 < 0.42 \text{ OK (S5.7.3.3.1)} \end{aligned}$$

Check for cracking under Service I Limit State (S5.7.3.4)

Allowable reinforcement service load stress for crack control using Eq. S5.7.3.4-1:

$$f_{sa} = \frac{Z}{(d_c A)^{1/3}} \leq 0.6f_y = 36 \text{ ksi}$$

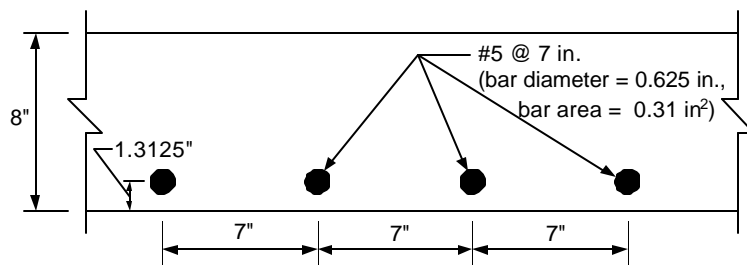

Figure 4-3 - Bottom Transverse Reinforcement

where:

d_c = thickness of concrete cover measured from extreme tension fiber to center of bar located closest thereto (in.)
 $= 1.3125 \text{ in.} < (2 + \frac{1}{2} \text{ bar diameter}) \text{ in.}$ **OK**

A = area of concrete having the same centroid as the principal tensile reinforcement and bounded by the surfaces of the cross-section and a straight line parallel to the neutral axis, divided by the number of bars (in²)
 $= 2(1.3125)(7)$
 $= 18.375 \text{ in}^2$

Z = crack control parameter (k/in)
 $= 130 \text{ k/in.}$ for severe exposure conditions

By substituting for d_c , A and Z :

$f_{sa} = 45 \text{ ksi} > 36 \text{ ksi}$ therefore, use maximum allowable $f_{sa} = 36 \text{ ksi}$

Notice that the crack width parameter, Z , for severe exposure conditions was used to account for the remote possibility of the bottom reinforcement being exposed to deicing salts leaching through the deck. Many jurisdictions use Z for moderate exposure conditions when designing the deck bottom reinforcement except for decks in marine environments. The rationale for doing so is that the bottom reinforcement is not directly exposed to salt application. The difference in interpretation rarely affects the design because the maximum allowable stress for the bottom reinforcement, with a 1 in. clear concrete cover, is typically controlled by the $0.6f_y$ limit and will not change if moderate exposure was assumed.

Stresses under service loads (S5.7.1)

In calculating the transformed compression steel area, the Specifications require the use of two different values for the modular ratio when calculating the service load stresses caused by dead and live loads, $2n$ and n , respectively. For deck design, it is customary to ignore the compression steel in the calculation of service load stresses and, therefore,

this provision is not applicable. For tension steel, the transformed area is calculated using the modular ratio, n.

Modular ratio for 4 ksi concrete, $n = 8$

Assume stresses and strains vary linearly

Dead load service load moment = $0.93 + 0.28 = 1.21$ k-ft/ft

Live load service load moment = 6.74 k-ft/ft

Dead load + live load service load positive moment = 7.95 k-ft/ft

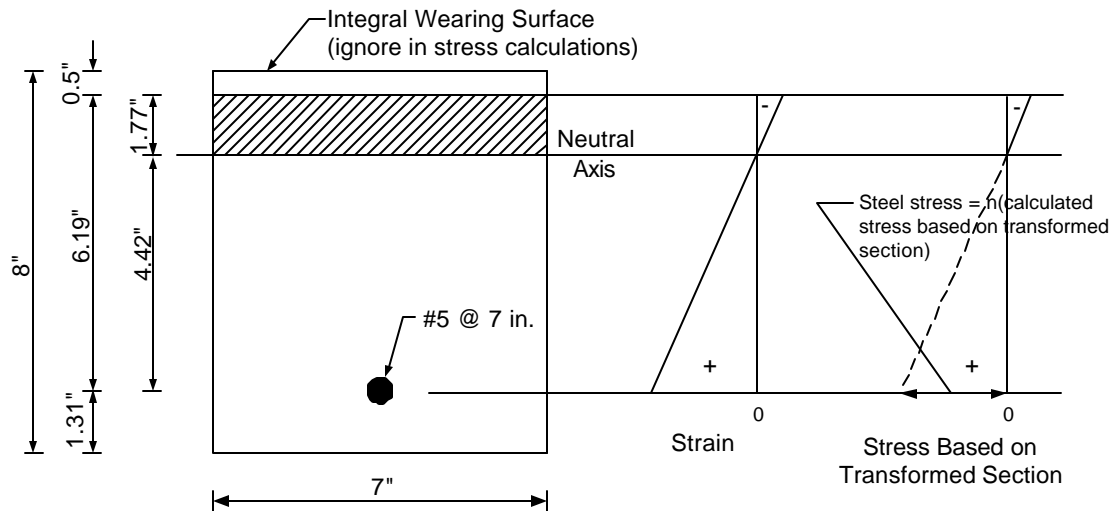

Figure 4-4 - Crack Control for Positive Moment Reinforcement Under Live Loads

The transformed moment of inertia is calculated assuming elastic behavior, i.e. linear stress and strain distribution. In this case, the first moment of area of the transformed steel on the tension side about the neutral axis is assumed equal to that of the concrete in compression. The process of calculating the transformed moment of inertia is illustrated in Figure 4-4 and by the calculations below.

For 4 ksi concrete, the modular ratio, $n = 8$ (S6.10.3.1.1b or by dividing the modulus of elasticity of the steel by that of the concrete and rounding up as required by S5.7.1)

Assume the neutral axis is at a distance “y” from the compression face of the section

Assume the section width equals the reinforcement spacing = 7 in.

The transformed steel area = (steel area)(modular ratio) = $0.31(8) = 2.48$ in²

By equating the first moment of area of the transformed steel to that of the concrete, both about the neutral axis:

$$2.48(6.19 - y) = 7y(y/2)$$

Solving the equation results in $y = 1.77$ in.

$$\begin{aligned} I_{\text{transformed}} &= 2.48(6.19 - 1.77)^2 + 7(1.77)^3/3 \\ &= 61.4 \text{ in}^4 \end{aligned}$$

Stress in the steel, $f_s = (Mc/I)n$, where M is the moment acting on 7 in. width of the deck.

$$\begin{aligned} f_s &= [(7.95(12/12)(7)(4.42)]/61.4]8 \\ &= 32.05 \text{ ksi} \end{aligned}$$

Allowable service load stress = 36 ksi > 32.05 ksi **OK**

Design Step 4.9

DESIGN FOR NEGATIVE MOMENT AT INTERIOR GIRDERS

a. Live load

From Table SA4.1-1, for girder spacing of 9'-9" and the distance from the design section for negative moment to the centerline of the girder equal to 12 in. (see Design Step 4.7 for explanation):

Unfactored live load negative moment per unit width of the deck = 4.21 k-ft/ft

Maximum factored negative moment per unit width at the design section for negative moment = $1.75(4.21) = 7.37$ k-ft/ft

b. Dead load

Factored dead load moments at the design section for negative moment:

Dead weight

$$1.25(0.93) = 1.16 \text{ k-ft/ft}$$

Future wearing surface

$$1.5(0.28) = 0.42 \text{ k-ft/ft}$$

Dead Load + live load design factored negative moment = $1.16 + 0.42 + 7.37$
= 8.95 k-ft/ft

$$d = \text{distance from compression face to centroid of tension reinforcement (in.)}$$

$$= \text{total thickness} - \text{top cover} - \frac{1}{2} \text{ bar diameter}$$

Assume #5 bars; bar diameter = 0.625 in., bar area = 0.31 in²

$$d = 8 - 2 \frac{1}{2} - \frac{1}{2} (0.625)$$

$$= 5.19 \text{ in.}$$

Required area of steel = 0.0339 in²/in.

Required spacing = 0.31/0.0339 = 9.15 in.

Use #5 at 9 in. spacing

As indicated earlier, checking the minimum and maximum reinforcement is not expected to control in deck slabs.

Check for cracking under service limit state (S5.7.3.4)

Allowable service load stresses:

$$f_{sa} = \frac{Z}{(d_c A)^{1/3}} \leq 0.6f_y = 36 \text{ ksi}$$

Concrete cover = 2 1/2 in. – 1/2 in. integral wearing surface = 2 in.

(Note: maximum clear cover to be used in the analysis = 2 in.) (S5.7.3.4)

where:

$$d_c = \text{clear cover} + \frac{1}{2} \text{ bar diameter}$$

$$= 2 + \frac{1}{2} (0.625)$$

$$= 2.31 \text{ in.}$$

$$A = 2(2.31)(9)$$

$$= 41.58 \text{ in}^2$$

$$Z = 130 \text{ k/in. for severe exposure conditions}$$

$$f_{sa} = 28.38 \text{ ksi}$$

As explained earlier, service load stresses are calculated using a modular ratio, $n = 8$.

Dead load service load moment at the design section for negative moment near the middle = -1.21 k-ft/ft.

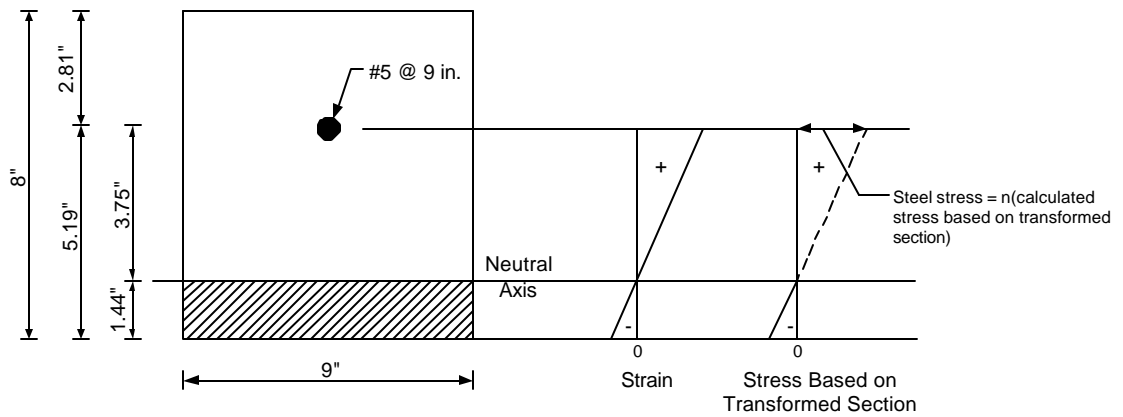

Figure 4-5a - Crack Control for Negative Moment Reinforcement Under Live Loads

Live load service bad moment at the design section in the first interior bay near the first interior girder = -4.21 k-ft/ft.

Transformed section properties may be calculated as done for the positive moment section in Design Step 4.8. Refer to Figure 4-5a for the section dimensions and location of the neutral axis. The calculations are shown below.

Maximum dead load + live load service load moment = 5.42 k-ft/ft

$$n = 8$$

$$I_{\text{transformed}} = 43.83 \text{ in}^4$$

$$\begin{aligned} \text{Total DL + LL service load stresses} &= \left[\frac{5.42(9)(3.75)}{43.83} \right] (8) \\ &= 33.39 \text{ ksi} > f_{sa} = 28.38 \text{ ksi} \quad \mathbf{NG} \end{aligned}$$

To satisfy the crack control provisions, the most economical change is to replace the reinforcement bars by smaller bars at smaller spacing (area of reinforcement per unit width is the same). However, in this particular example, the #5 bar size cannot be reduced as this bar is customarily considered the minimum bar size for deck main reinforcement. Therefore, the bar diameter is kept the same and the spacing is reduced.

Assume reinforcement is #5 at 8 in. spacing (refer to Figure 4-5b).

$$I_{\text{transformed}} = 42.77 \text{ in}^4$$

$$\begin{aligned} \text{Total DL + LL service load stresses} &= \left[\frac{5.42(8)(3.68)}{42.77} \right] (8) \\ &= 29.85 \text{ ksi} \end{aligned}$$

$$f_{sa} = 29.52 \text{ ksi}$$

Applied stress = 29.85 ksi \cong $f_{sa} = 29.52$ ksi

Use main negative moment reinforcement #5 at 8 in. spacing

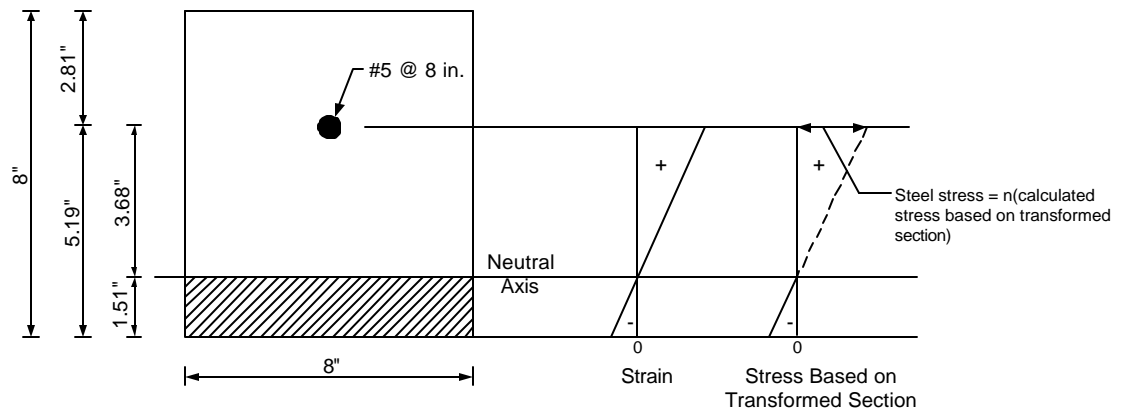

Figure 4-5b - Crack Control for Negative Moment Reinforcement Under Live Loads

Design Step 4.10 DESIGN OF THE OVERHANG

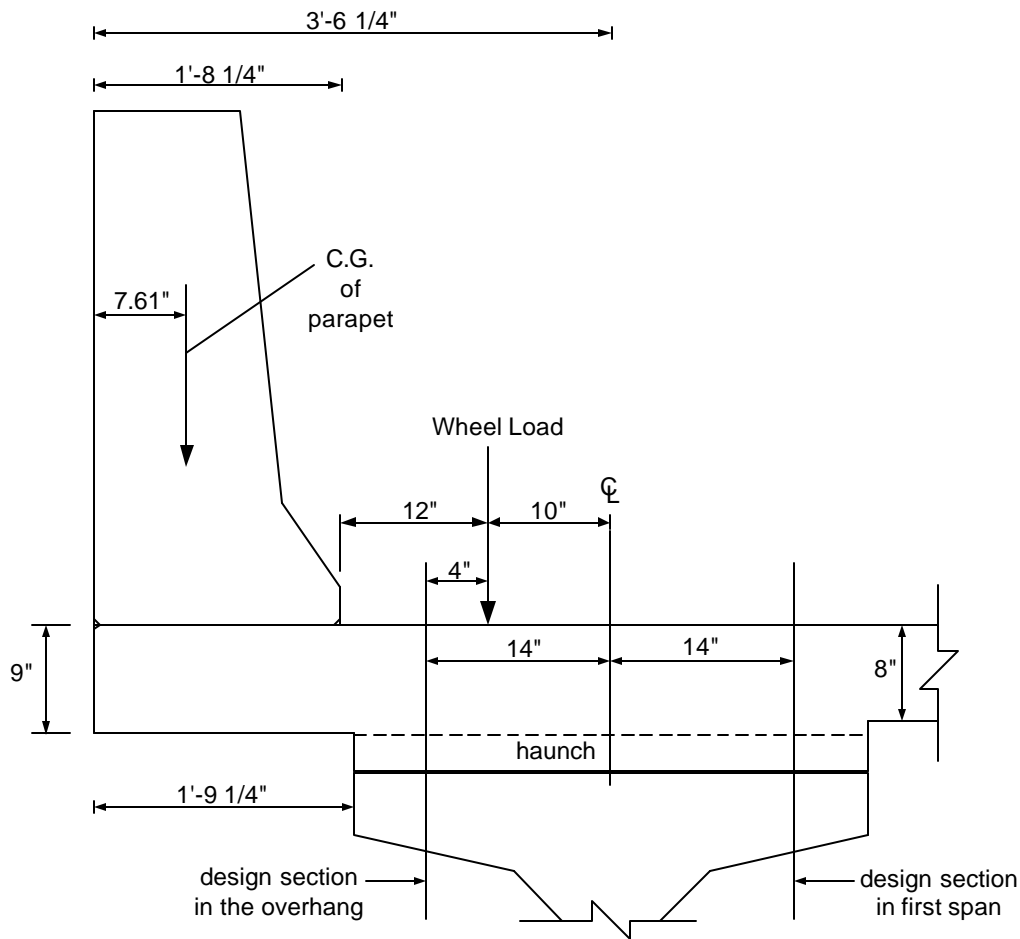

Figure 4-6 - Overhang Region, Dimensions and Truck Loading

Assume that the bottom of the deck in the overhang region is 1 inch lower than the bottom of other bays as shown in Figure 4-6. This results in a total overhang thickness equal to 9 in. This is usually beneficial in resisting the effects of vehicular collision. However, a section in the first bay of the deck, where the thickness is smaller than that of the overhang, must also be checked.

Assumed loads

Self weight of the slab in the overhang area = 112.5 lb/ft² of the deck overhang surface area

Weight of parapet = 650 lb/ft of length of parapet

Future wearing surface = 30 lb/ft² of deck surface area

As required by SA13.4.1, there are three design cases to be checked when designing the deck overhang regions.

Design Case 1: Check overhang for horizontal vehicular collision load (SA13.4.1, Case 1)

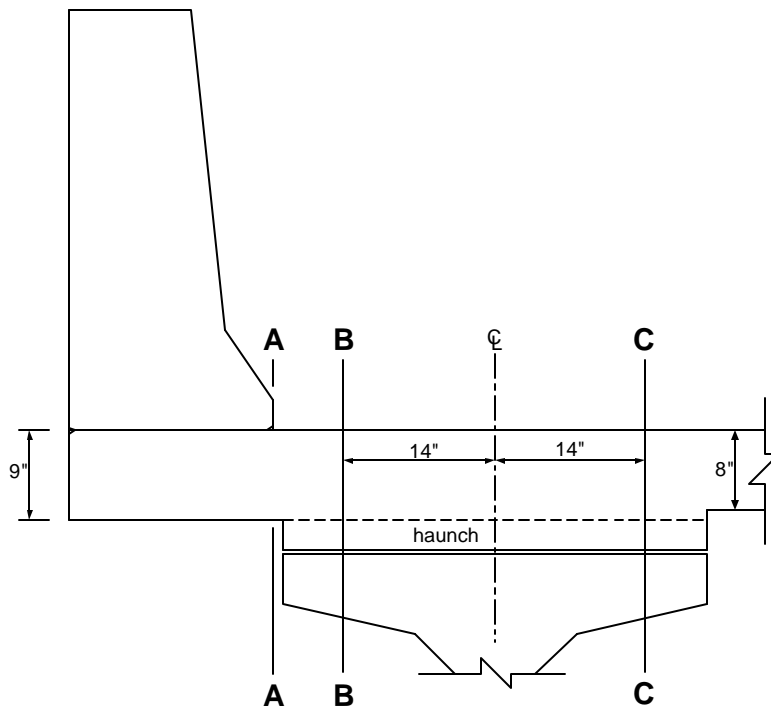

Figure 4-7 - Design Sections in the Overhang Region

The overhang is designed to resist an axial tension force from vehicular collision acting simultaneously with the collision + dead load moment.

The resistance factor, $\mathbf{j} = 1.0$ for extreme event limit state (S1.3.2.1). The Specification requires that load effects in the extreme event limit state be multiplied by $\mathbf{h}_i \cong 1.05$ for bridges deemed important or $\mathbf{h}_i \cong 0.95$ for bridges deemed not important. For this example, a value of $\eta_i = 1.0$ was used.

a. At inside face of parapet (Section A-A in Figure 4-7)
(see Design Step 4.4 for parapet characteristics)

M_c = moment capacity of the base of the parapet given as 17.83 k-ft/ft.

When this moment is transmitted to the deck overhang it subjects the deck to negative moment.

For a complete railing design example that includes sample detailed calculations of railing parameters, see Lecture 16 of the participant notebook of the National Highway Institute Course No. 13061.

$$\begin{aligned} M_{DL, \text{slab}} &= 0.1125(20.25/12)^2/2 \\ &= 0.16 \text{ k-ft/ft} \end{aligned}$$

$$\begin{aligned} M_{DL, \text{parapet}} &= 0.65(20.25 - 7.61)/12 \\ &= 0.68 \text{ k-ft/ft} \end{aligned}$$

$$\text{Design factored moment} = -17.83 - 1.25(0.16 + 0.68) = -18.88 \text{ k-ft/ft}$$

$$\begin{aligned} \text{Design axial tensile force (SA13.4.2)} &= R_w/(L_c + 2H) \\ &= 137.22/[(235.2 + 2(42))/12] \\ &= 5.16 \text{ k/ft} \end{aligned}$$

$$h \text{ slab} = 9 \text{ in.}$$

Assuming #5 reinforcement bars,

$$\begin{aligned} d &= \text{overhang slab thickness} - \text{top cover} - \frac{1}{2} \text{ bar diameter} \\ &= 9 - 2 \frac{1}{2} - \frac{1}{2}(0.625) \\ &= 6.19 \text{ in.} \end{aligned}$$

$$\text{Assume required area of steel} = 0.70 \text{ in}^2/\text{ft} \quad (1)$$

The over-reinforced section check is not expected to control. However, due to the additional reinforcement in the overhang, it is prudent to perform this check using the provisions of S5.7.3.3.1.

Effective depth of the section, $h = 6.19 \text{ in.}$

(Notice that the overhang has 1 inch additional thickness at its bottom)

For a section under moment and axial tension, P , the nominal resistance, M_n , may be calculated as:

$$M_n = T(d - a/2) - P(h/2 - a/2)$$

$$\text{Tension in reinforcement, } T = 0.70(60) = 42.0 \text{ k/ft}$$

$$\text{Compression in concrete, } C = 42.0 - 5.16 = 36.84 \text{ k/ft}$$

$$\begin{aligned}
 a &= C/b\beta_1f'_c \\
 &= 36.84/[12(0.85)(4)] \\
 &= 0.90 \text{ in.}
 \end{aligned}$$

$$\begin{aligned}
 M_n &= 42.0[6.19 - (0.9/2)] - 5.16[(6.19/2) - (0.9/2)] \\
 &= 227.43/12 \\
 &= 18.95 \text{ k-ft/ft}
 \end{aligned}$$

Notice that many designers determine the required reinforcement for sections under moment and axial tension, P , as the sum of two components:

- 1) the reinforcement required assuming the section is subjected to moment
- 2) P/f_y

This approach is acceptable as it results in more conservative results, i.e., more reinforcement.

Resistance factor = 1.0 for extreme event limit state (S1.3.2.1)

$$\begin{aligned}
 M_r &= \phi M_n \\
 &= 1.0(18.95) = 18.95 \text{ k-ft/ft} > M_u = 18.88 \text{ k-ft/ft} \quad \mathbf{OK}
 \end{aligned}$$

$$c/d_e = (0.9/0.85)/(6.19) = 0.17 < 0.42 \quad \text{steel yields before concrete crushing, i.e., the section is not over-reinforced}$$

b. At design section in the overhang (Section B-B in Figure 4-7)

Assume that the minimum haunch thickness is at least equal to the difference between the thickness of the interior regions of the slab and the overhang thickness, i.e., 1 in. This means that when designing the section in the overhang at 14 in. from the center of the girder, the total thickness of the slab at this point can be assumed to be 9 in. For thinner haunches, engineering judgment should be exercised to determine the thickness to be considered at this section.

At the inside face of the parapet, the collision forces are distributed over a distance L_c for the moment and $L_c + 2H$ for axial force. It is reasonable to assume that the distribution length will increase as the distance from the section to the parapet increases. The value of the distribution angle is not specified in the specifications and is determined using engineering judgment. In this example, the distribution length was increased at a 30° angle from the base of the parapet (see Figure 4-8). Some designers assume a distribution angle of 45° , this angle would have also been acceptable.

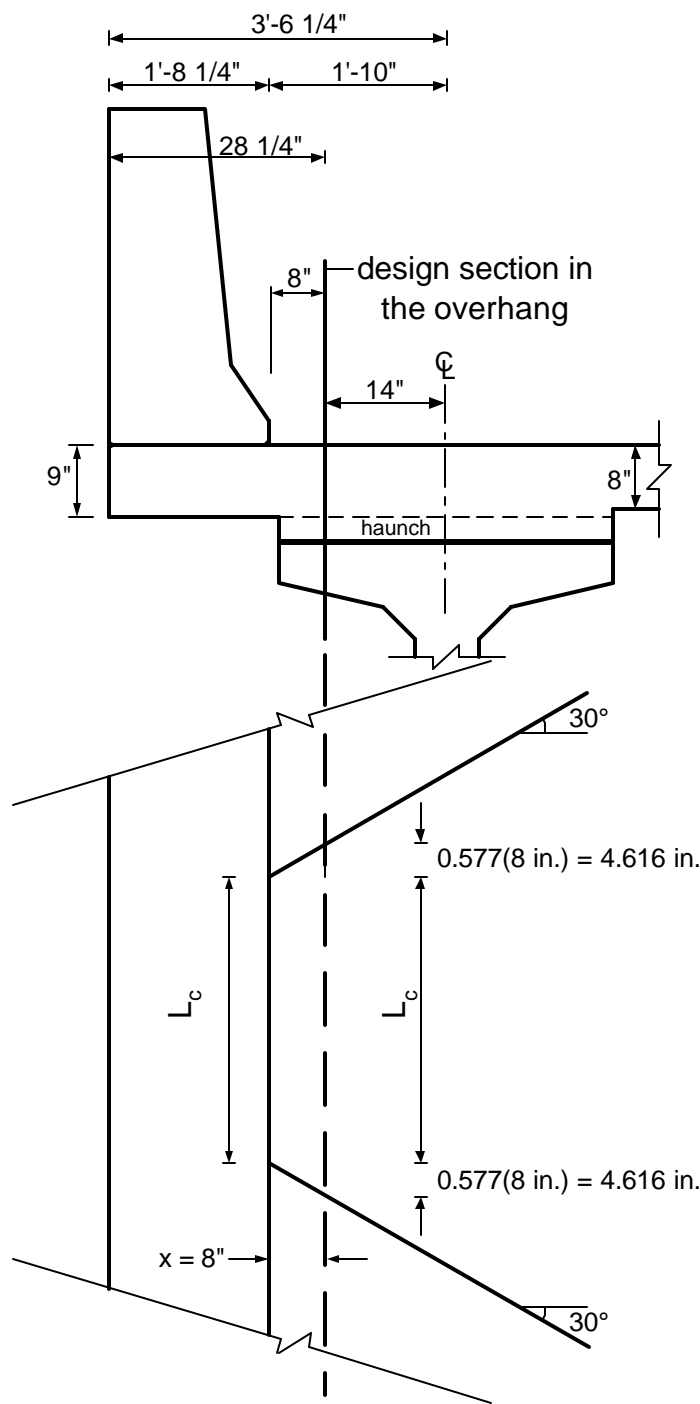

Figure 4-8 - Assumed Distribution of Collision Moment Load in the Overhang

$$\begin{aligned}
 \text{Collision moment at the design section} &= M_c L_c / [L_c + 2(0.577)X] \\
 &= -17.83(235.2) / [235.2 + 2(0.577)(8)] \\
 &= -17.16 \text{ k-ft/ft}
 \end{aligned}$$

Dead load moment at the design section:

$$\begin{aligned} M_{DL, \text{slab}} &= 0.1125(28.25/12)^2/2 \\ &= 0.31 \text{ k-ft/ft} \end{aligned}$$

$$\begin{aligned} M_{DL, \text{parapet}} &= 0.65(28.25 - 7.61)/12 \\ &= 1.12 \text{ k-ft/ft} \end{aligned}$$

$$\begin{aligned} M_{DL, \text{FWS}} &= 0.03(8/12)^2/2 \\ &= 0.007 \text{ k-ft/ft} \end{aligned}$$

$$\text{Factored design } M = -17.16 - 1.25(0.31 + 1.12) - 1.5(0.007) = -18.96 \text{ k-ft/ft}$$

$$\begin{aligned} \text{Design tensile force} &= R_w/[L_c + 2H + 2(0.577)X] \\ &= 137.22/[235.2 + 2(42) + 2(0.577)(8)]/12] \\ &= 5.01 \text{ k/ft} \end{aligned}$$

$$h \text{ slab} = 9 \text{ in.}$$

By inspection, for Section A-A, providing an area of steel = 0.70 in²/ft resulted in a moment resistance of 18.95 k-ft/ft \cong the design moment for Section B-B.

Therefore, the required area of steel for Section B-B = 0.70 in²/ft (2)

c. Check dead load + collision moments at design section in first span (Section C-C in Figure 4-7)

The total collision moment can be treated as an applied moment at the end of a continuous strip. The ratio of the moment M_2/M_1 (see Figure 4-9) can be calculated for the transverse design strip. As an approximation, the ratio M_2/M_1 may be taken equal to 0.4. This approximation is based on the fact that $M_2/M_1 = 0.5$ if the rotation at the first interior girder is restrained. Since this rotation is not restrained, the value of M_2 will be less than $0.5M_1$. Thus, the assumption that $M_2/M_1 = 0.4$ seems to be reasonable. The collision moment per unit width at the section under consideration can then be determined by dividing the total collision moment by the distribution length. The distribution length may be determined using the 30° distribution as illustrated in Figure 4-8 except that the distance "X" will be 36 in. for Section C.

The dead load moments at the design section for negative moment to the inside of the exterior girder may be determined by superimposing two components: (1) the moments in the first deck span due to the dead loads acting on the overhang (see Figure 4-10), and (2) the effect of the dead loads acting on the first span of the deck (see Figure 4-11).

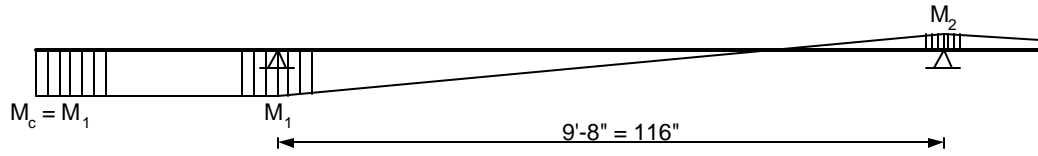

Figure 4-9 – Assumed Distribution of the Collision Moment Across the Width of the Deck

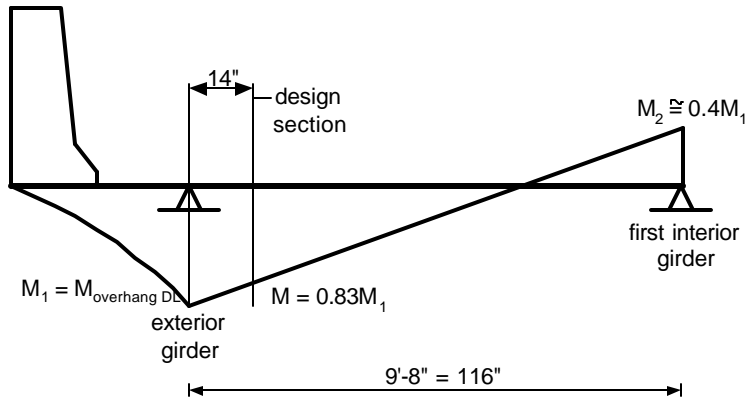

Figure 4-10 - Dead Load Moment at Design Section Due to Dead Loads on the Overhang

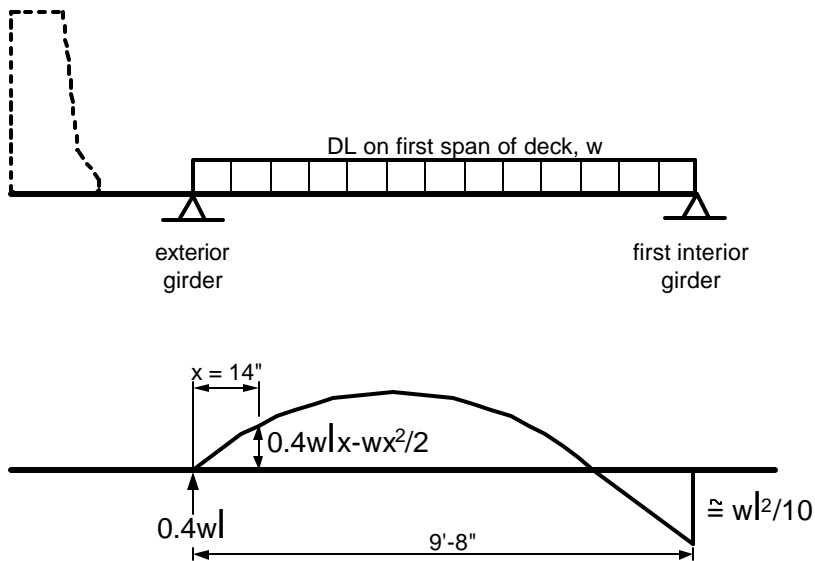

Figure 4-11 - Dead Load Moment at Design Section Due to Dead Loads on the First Deck Span

Collision moment at exterior girder, $M_1 = -17.83$ k-ft/ft

Collision moment at first interior girder, $M_2 = 0.4(17.83) = 7.13$ k-ft/ft

By interpolation for a section in the first interior bay at 14 in. from the exterior girder:

Total collision moment = $-17.83 + 14(17.83 + 7.13)/116 = -14.81$ k-ft/ft

Using the 30° angle distribution, as shown in Figure 4-8:

Design collision moment = $-14.81L_c/[L_c + 2(0.577)(22 + 14)] = -12.59$ k-ft/ft

where $L_c = 235.2$ in.

Dead load moment at the centerline of the exterior girder:

$$\begin{aligned} M_{DL, \text{Slab}} &= -0.1125(42.25/12)^2/2 \\ &= -0.70 \text{ k-ft/ft} \end{aligned}$$

$$\begin{aligned} M_{DL, \text{Parapet}} &= -0.65 (42.25 - 7.61)/12 \\ &= -1.88 \text{ k-ft/ft} \end{aligned}$$

$$\begin{aligned} M_{DL, \text{FWS}} &= -0.03[(42.25 - 20.25)/12]^2/2 \\ &= -0.05 \text{ k-ft/ft} \end{aligned}$$

Factored dead load moment at the centerline of the exterior girder:

$$\begin{aligned} M_{FDL} &= 1.25(-0.70) + 1.25(-1.88) + 1.5(-0.05) \\ &= -3.3 \text{ k-ft/ft} \end{aligned}$$

Based on Figure 4-10

The design factored dead load moment at the design section due to loads on the overhang is:

$$\begin{aligned} M_{FDL,O} &= 0.83(-3.3) \\ &= -2.74 \text{ k-ft/ft} \end{aligned}$$

From Figure 4-11, the dead load design factored moment due to DL on the first deck span is:

$$\begin{aligned} M &= 1.25[0.1125[0.4(9.66)(14/12) - (14/12)^2/2]] + 1.5[0.03[0.4(9.66)(14/12) - (14/12)^2/2]] \\ &= 0.71 \text{ k-ft/ft} \end{aligned}$$

Total design dead load + collision moment:

$$\begin{aligned} M_{DL+C} &= -12.59 - 2.74 + 0.71 \\ &= -14.62 \text{ k-ft/ft} \end{aligned}$$

Resistance factor = 1.0 for extreme event limit state (S1.3.2.1)

Assuming the slab thickness at this section equals 8 in. and the effective depth equals 5.19 in.;

Required area of steel = 0.62 in²/ft (3)

Design Case 2: Vertical collision force (SA13.4.1, Case 2)

For concrete parapets, the case of vertical collision never controls

Design Case 3: Check DL + LL (SA13.4.1, Case 3)

Except for decks supported on widely spaced girders (approximately 12 ft. and 14 ft. girder spacing for girders with narrow flanges and wide flanges, respectively), Case 3 does not control the design of decks supporting concrete parapets. Widely spaced girders allow the use of wider overhangs which in turn may lead to live load moments that may exceed the collision moment and, thus, control the design. The deck of this example is highly unlikely to be controlled by Case 3. However, this case is checked to illustrate the complete design process.

Resistance factor = 0.9 for strength limit state (S5.5.4.2.1).

a. Design section in the overhang (Section B-B in Figure 4-7)

The live load distribution width equations for the overhang (S4.6.2.1.3) are based on assuming that the distance from the design section in the overhang to the face of the parapet exceeds 12 in. such that the concentrated load representing the truck wheel is located closer to the face of the parapet than the design section. As shown in Figure 4-12, the concentrated load representing the wheel load on the overhang is located to the inside of the design section for negative moment in the overhang. This means that the distance "X" in the distribution width equation is negative which was not intended in developing this equation. This situation is becoming common as prestressed girders with wide top flanges are being used more frequently. In addition, Figure 4-6 may be wrongly interpreted as that there is no live load negative moment acting on the overhang. This would be misleading since the wheel load is distributed over the width of the wheels in the axle. Live load moment in these situations is small and is not expected to control design. *For such situations, to determine the live load design moment in the overhang, either of the following two approaches may be used:*

- 1) The design section may be conservatively assumed at the face of the girder web, or
- 2) The wheel load may be distributed over the width of the wheels as shown in Figure 4-12 and the moments are determined at the design section for negative moment. The distribution width may be calculated assuming "X" as the distance from the design section to the edge of the wheel load nearest the face of the parapet.

The latter approach is used in this example. The wheel load is assumed to be distributed over a tire width of 20 in. as specified in S3.6.1.2.5.

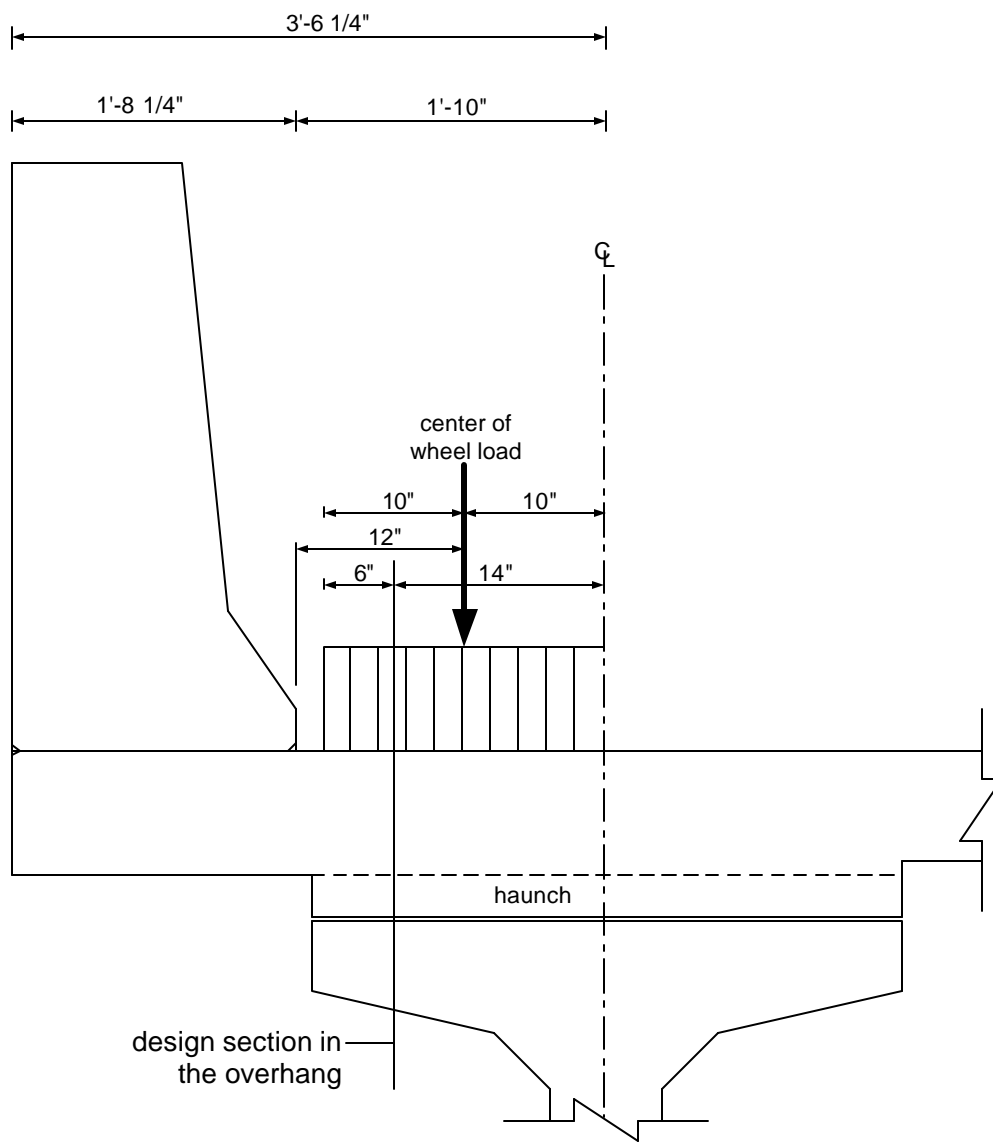

Figure 4-12 – Overhang Live Load - Distributed Load

Using the multiple presence factor for a single truck = 1.2 (S3.6.1.1.2) and dynamic load allowance for truck loading = 1.33 (S3.6.2.1), live load moment may be determined.

$$\begin{aligned} \text{Equivalent strip width for live load} &= 45 + 10(6/12) \\ &= 50 \text{ in. (S4.6.2.1.3)} \end{aligned}$$

Design factored moment:

$$\begin{aligned} M_n &= -1.25(0.1125)[(42.25 - 14)/12]^2/2 \\ &\quad -1.25(0.65)(42.25 - 14 - 7.61)/12 \\ &\quad -1.5(0.03)[(42.25 - 20.25 - 14)/12]^2/2 \\ &\quad -1.75(1.33)(1.2)[16/(20/12)[((6/12)^2/2)/(50/12)]] \\ &= -2.60 \text{ k-ft/ft} \end{aligned}$$

$$d = 6.19 \text{ in.}$$

$$\text{Required area of steel} = 0.09 \text{ in}^2/\text{ft} \quad (4)$$

b. Check dead load + live load moments at design section in first span (Section C-C in Figure 4-7)

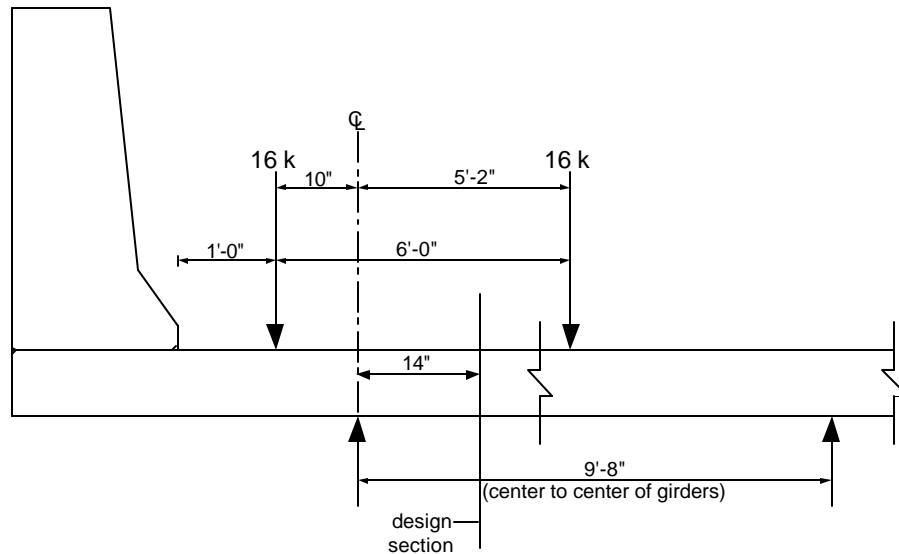

Figure 4-13 – Overhang Live Load

Assume slab thickness at this section = 8 in. (conservative to ignore the haunch)

Based on the earlier calculations for this section under collision + DL, DL factored moment at the section = -2.74 k-ft/ft.

Determining live load at this section may be conducted by modeling the deck as a beam supported on the girders and by moving the design load across the width of the deck to generate the moment envelopes. However, this process implies a degree of accuracy that may not be possible to achieve due to the approximate nature of the distribution width and other assumptions involved, e.g., the girders are not infinitely rigid and the top flange is not a point support. An approximate approach suitable for hand calculations is illustrated in Figure 4-13. In this approximate approach, the first axle of the truck is applied to a simply supported beam that consists of the first span of the deck and the overhang. The negative moment at the design section is then calculated. The multiple presence factor for a single lane (1.2) and dynamic load allowance (33%) are also applied. Based on the dimensions and the critical location of the truck axle shown in Figure 4-13, the unfactored live load moment at the design section for negative moment is 3.03 k-ft.

Live load moment (including the load factor, dynamic load allowance and multiple presence factor) = $3.03(1.75)(1.33)(1.2) = 8.46$ k-ft

Since the live load negative moment is produced by a load on the overhang, use the overhang strip width at the girder centerline.

Equivalent strip width = $45 + 10(10/12) = 53.3$ in. (S4.6.2.1.3)

Design factored moment (DL + LL) = $2.74 + 8.46/(53.3/12)$
= 4.65 k-ft/ft

Required area of steel = 0.19 in²/ft (5)

Design Step 4.11 **DETAILING OF OVERHANG REINFORCEMENT**

From the different design cases of the overhang and the adjacent region of the deck, the required area of steel in the overhang is equal to the largest of (1), (2), (3), (4) and (5) = 0.7 in²/ft

The provided top reinforcement in the slab in regions other than the overhang region is:
#5 at 8 in. = $0.31(12/8) = 0.465$ in²/ft

0.465 in²/ft provided < 0.7 in²/ft required, therefore, additional reinforcement is required in the overhang.

Bundle one #4 bar to each top bar in the overhang region of the deck.

Provided reinforcement = $(0.2 + 0.31)(12/8) = 0.76 \text{ in}^2/\text{ft} > 0.7 \text{ in}^2/\text{ft}$ required **OK**.

Notice that many jurisdictions require a #5 minimum bar size for the top transverse reinforcement. In this case, the #4 bars used in this example would be replaced by #5 bars. Alternatively, to reduce the reinforcement area, a #5 bar may be added between the alternating main bars if the main bar spacing would allow adding bars in between without resulting in congested reinforcement.

Check the depth of the compression block:

$$\begin{aligned} T &= 60(0.76) \\ &= 45.6 \text{ kips} \end{aligned}$$

$$\begin{aligned} a &= 45.6/[0.85(4)(12)] \\ &= 1.12 \text{ in.} \end{aligned}$$

$$\beta_1 = 0.85 \text{ for } f_c = 4 \text{ ksi (S5.7.2.2)}$$

$$\begin{aligned} c &= 1.12/0.85 \\ &= 1.32 \text{ in.} \end{aligned}$$

Among Sections A, B and C of Figure 4-7, Section C has the least slab thickness. Hence, the ratio c/d_e is more critical at this section.

$$d_e \text{ at Section C-C} = 5.19 \text{ in.}$$

$$\text{Maximum } c/d_e = 1.32/5.19 = 0.25 < 0.42 \text{ **OK** (S5.7.3.3.1)}$$

Cracking under service load in the overhang needs to be checked. The reinforcement area in the overhang is 65% larger than the negative moment reinforcement in the interior portions of the deck, yet the applied service moment ($2.74 + 3.03 = 5.77 \text{ k-ft/ft}$) is 6% larger than the service moment at interior portions of the deck (5.42 k-ft/ft from Step 4.9). By inspection, cracking under service load does not control.

Determine the point in the first bay of the deck where the additional bars are no longer needed by determining the point where both (DL + LL) moment and (DL + collision) moments are less than or equal to the moment of resistance of the deck slab without the additional top reinforcement. By inspection, the case of (DL + LL) does not control and only the case of (DL + collision) needs to be checked.

Negative moment resistance of the deck slab reinforced with #5 bars at 8 in. spacing is 10.15 k-ft/ft for strength limit state (resistance factor = 0.9), or 11.27 k-ft/ft for the extreme event limit state (resistance factor = 1.0). By calculating the moments at different points along the deck first span in the same manner they were calculated for Section C-C for (DL + collision), it was determined that the design negative moment is

less than 11.27 k-ft/ft at a point approximately 25 in. from the centerline of the exterior girder.

The theoretical termination point from the centerline of the exterior girder is 25 in.

Extend the additional bars beyond this point for a distance equal to the cut-off length. In addition, check that the provided length measured beyond the design section for moment is larger than the development length (S5.11.1.2.1).

Cut-off length requirement (S5.11.1.2.1)

Checking the three requirements of S5.11.1.2.1, the cut-off length is controlled by 15 times the bar diameter.

$$\text{Cut-off length} = 15(0.625) = 9.375 \text{ in.}$$

$$\begin{aligned} \text{Required length past the centerline of the exterior girder} &= 25 + 9.375 \\ &= 34.375 \text{ in.} \end{aligned}$$

Development length (S5.11.2)

The basic development length, l_{db} , is taken as the larger of:

$$\frac{1.25 A_b f_y}{\sqrt{f'_c}} = \frac{1.25(0.31)(60)}{\sqrt{4}} = 11.625 \text{ in.}$$

OR

$$0.4d_b f_y = 0.4(0.625)(60) = 15 \text{ in.}$$

OR

$$12 \text{ in.}$$

Therefore, the basic development length = 15 in.

Correction factors:

$$\text{Epoxy-coated bars} = 1.2 \text{ (S5.11.2.1.2)}$$

$$\text{Two bundled bars} = 1.0 \text{ (S5.11.2.3)}$$

$$\text{Spacing} > 6 \text{ in.} = 0.8 \text{ (S5.11.2.1.3)}$$

$$\text{Development length} = 15(1.2)(1.0)(0.8) = 14.4 \text{ in.}$$

Required length of the additional bars past the centerline of the exterior girder = 14 + 14.4 = 28.4 in. < 34.375 in. (needed to be satisfy cut off requirements) **OK**

Extend the additional bars in the overhang a minimum of 34.375 in. (say 3 ft.) beyond the centerline of the exterior girder.

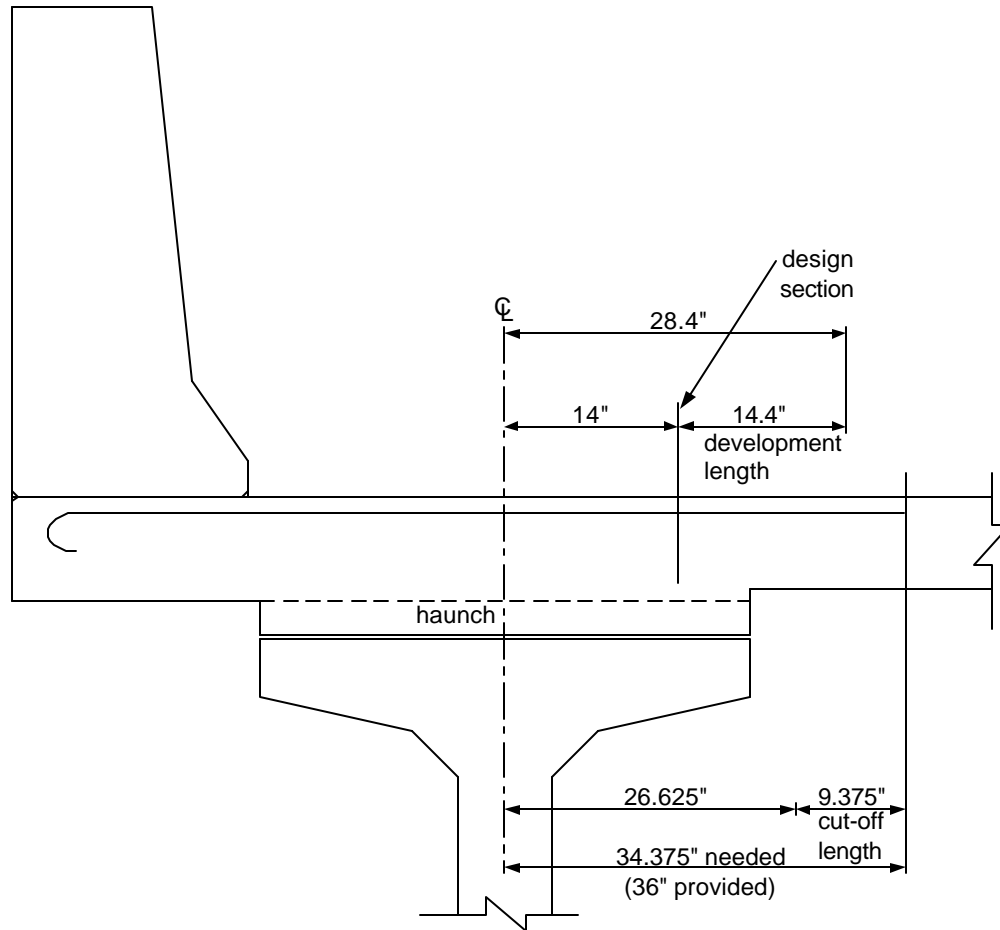

Figure 4-14 - Length of the Overhang Additional Bars

Design Step 4.12 LONGITUDINAL REINFORCEMENT

Bottom distribution reinforcement (S9.7.3.2)

Percentage of longitudinal reinforcement = $\frac{220}{\sqrt{S}} \leq 67\%$

where:

- S = the effective span length taken as equal to the effective length specified in S9.7.2.3 (ft.); the distance between sections for negative moment and sections at the ends of one deck span
- = (116 – 14 – 14)(12)
- = 7.33 ft.

$$\text{Percentage} = \frac{220}{\sqrt{7.33}} = 81\% > 67\%$$

Use 67% of transverse reinforcement

Transverse reinforcement = #5 at 7 in. spacing = 0.53 in²/ft

Required longitudinal reinforcement = 0.67(0.53) = 0.36 in²/ft

Use #5 bars; bar diameter = 0.625 in., bar area = 0.31 in²

Required spacing = 0.31/0.36 = 0.86 ft. (10.375 in.)

Use #5 bars at 10 in. spacing

Top longitudinal reinforcement

There are no specific requirements to determine this reinforcement. Many jurisdictions use #4 bars at 12 in. spacing for the top longitudinal reinforcement.

Design Step 4.13 DECK TOP LONGITUDINAL REINFORCEMENT IN THE GIRDER NEGATIVE MOMENT REGION, I.E., OVER THE INTERMEDIATE SUPPORTS OF THE GIRDERS

For simple span precast girders made continuous for live load: design according to S5.14.1.2.7

(Notice that for continuous steel girders, this reinforcement is designed according to S6.10.3.7.)

The required reinforcement area is determined during girder design. See Section 5.6 for the calculations for this reinforcement.

Provided reinforcement area = 14.65 in²

Use #6 bars at 5.5 in. spacing in the top layer
 #6 bars at 8.5 in. spacing in the bottom layer

Design Step 4.14 CHECK SHRINKAGE AND TEMPERATURE REINFORCEMENT ACCORDING TO S5.10.8

Reinforcement for shrinkage and temperature stresses is provided near surfaces of concrete exposed to daily temperature changes. Shrinkage and temperature reinforcement is added to ensure that the total reinforcement on exposed surfaces is not less than the following:

$$A_s \geq 0.11A_g/f_y \quad (S5.10.8.2-1)$$

where:

$$\begin{aligned} A_g &= \text{gross area of the section (in}^2\text{)} \\ &= 12(7.5) \\ &= 90 \text{ in}^2/\text{ft. width of deck} \end{aligned}$$

$$\begin{aligned} f_y &= \text{specified yield strength of the reinforcing bars (ksi)} \\ &= 60 \text{ ksi} \end{aligned}$$

$$\begin{aligned} A_{s \text{ req}} &= 0.11(90/60) \\ &= 0.165 \text{ in}^2/\text{ft. width of deck} \end{aligned}$$

This area should be divided between the two surfaces, $A_{s \text{ req}}$ per surface = 0.0825 in²/ft. width of deck.

Assuming longitudinal reinforcement is #4 bars at 12 in. spacing:

$$A_{s, \text{ provided}} = 0.2 \text{ in}^2/\text{ft. width of deck} > 0.0825 \text{ in}^2/\text{ft. width of deck required} \quad \mathbf{OK}$$

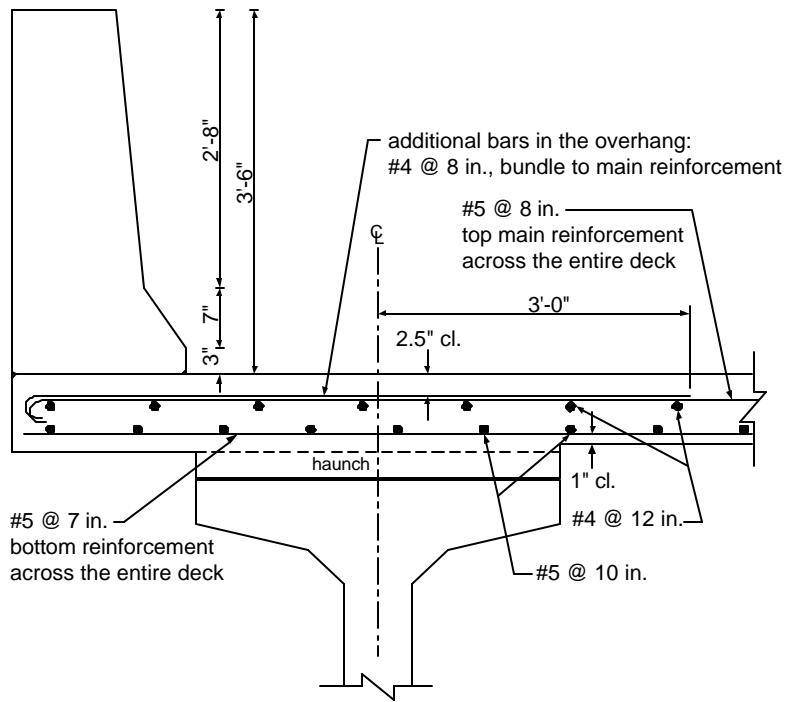

Figure 4-15 - Deck Reinforcement at Midspan of Girders

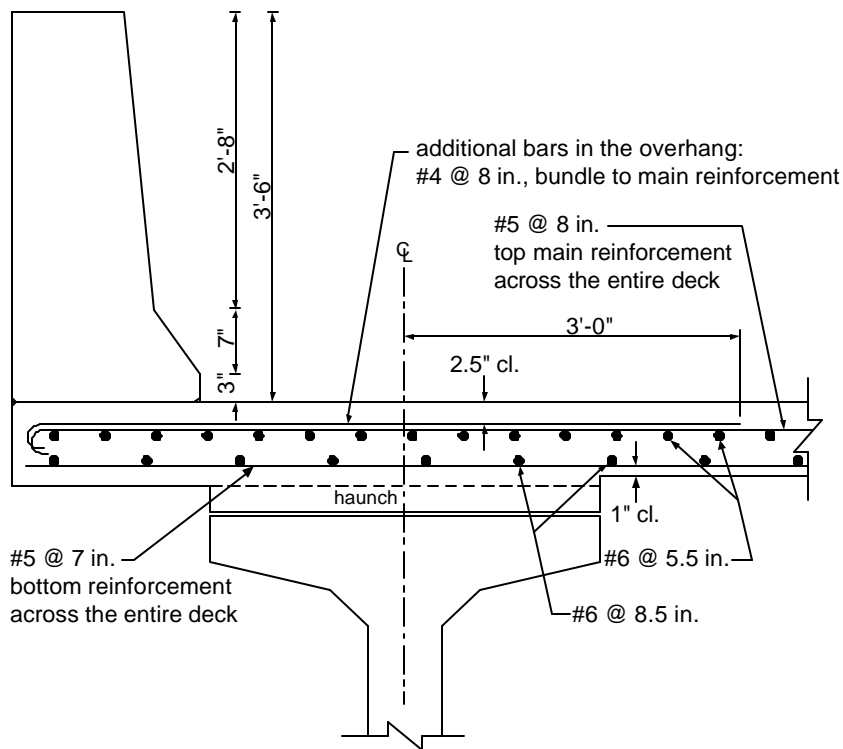

Figure 4-16 - Deck Reinforcement at Intermediate Pier

Design Step
5.1 | **LIVE LOAD DISTRIBUTION FACTORS**
(S4.6.2.2)

The AASHTO-LRFD Specifications allow the use of advanced methods of analysis to determine the live load distribution factors. However, for typical bridges, the specifications list equations to calculate the distribution factors for different types of bridge superstructures. The types of superstructures covered by these equations are described in Table S4.6.2.2.1-1. From this table, bridges with concrete decks supported on precast concrete I or bulb-tee girders are designated as cross-section “K”. Other tables in S4.6.2.2.2 list the distribution factors for interior and exterior girders including cross-section “K”. The distribution factor equations are largely based on work conducted in the NCHRP Project 12-26 and have been verified to give accurate results compared to 3-dimensional bridge analysis and field measurements. The multiple presence factors are already included in the distribution factor equations except when the tables call for the use of the lever rule. In these cases, the computations need to account for the multiple presence factors. Notice that the distribution factor tables include a column with the heading “range of applicability”. The ranges of applicability listed for each equation are based on the range for each parameter used in the study leading to the development of the equation. When the girder spacing exceeds the listed value in the “range of applicability” column, the specifications require the use of the lever rule (S4.6.2.2.1). One or more of the other parameters may be outside the listed range of applicability. In this case, the equation could still remain valid, particularly when the value(s) is(are) only slightly out of the range of applicability. However, if one or more of the parameters greatly exceed the range of applicability, engineering judgment needs to be exercised.

Article S4.6.2.2.d of the specifications states: “In beam-slab bridge cross-sections with diaphragms or cross-frames, the distribution factor for the exterior beam shall not be taken less than that which would be obtained by assuming that the cross-section deflects and rotates as a rigid cross-section”. This provision was added to the specifications because the original study that developed the distribution factor equations did not consider intermediate diaphragms. Application of this provision requires the presence of a sufficient number of intermediate diaphragms whose stiffness is adequate to force the cross section to act as a rigid section. For prestressed girders, different jurisdictions use different types and numbers of intermediate diaphragms. Depending on the number and stiffness of the intermediate diaphragms, the provisions of S4.6.2.2.d may not be applicable. For this example, one deep reinforced concrete diaphragm is located at the midspan of each span. The stiffness of the diaphragm was deemed sufficient to force the cross-section to act as a rigid section, therefore, the provisions of S4.6.2.2.d apply.

Notice that the AASHTO Standard Specifications express the distribution factors as a fraction of wheel lines, whereas the AASHTO-LRFD Specifications express them as a fraction of full lanes.

For this example, the distribution factors listed in S4.6.2.2.2 will be used.

Notice that fatigue in the prestressing steel need not be checked for conventional prestressed girders (S5.5.3) when maximum stress in the concrete at Service III limit state is taken according to Table S5.9.4.2.2-1. This statement is valid for this example. The fatigue distribution factors are calculated in the following sections to provide the user with a complete reference for the application of the LRFD distribution factors.

Required information:

AASHTO Type I-Beam (28/72)	
Noncomposite beam area, A_g	= 1,085 in ²
Noncomposite beam moment of inertia, I_g	= 733,320 in ⁴
Deck slab thickness, t_s	= 8 in.
Span length, L	= 110 ft.
Girder spacing, S	= 9 ft. - 8 in.
Modulus of elasticity of the beam, E_B	= 4,696 ksi (S5.4.2.4)
Modulus of elasticity of the deck, E_D	= 3,834 ksi (S5.4.2.4)
C.G. to top of the basic beam	= 35.62 in.
C.G. to bottom of the basic beam	= 36.38 in.

Design Step 5.1.1 Calculate n , the modular ratio between the beam and the deck.

$$\begin{aligned} n &= E_B/E_D && \text{(S4.6.2.2.1-2)} \\ &= 4,696/3,834 \\ &= 1.225 \end{aligned}$$

Design Step 5.1.2 Calculate e_g , the distance between the center of gravity of the noncomposite beam and the deck. Ignore the thickness of the haunch in determining e_g . It is also possible to ignore the integral wearing surface, i.e., use $t_s = 7.5$ in. However the difference in the distribution factor will be minimal.

$$\begin{aligned} e_g &= NA_{YT} + t_s/2 \\ &= 35.62 + 8/2 \\ &= 39.62 \text{ in.} \end{aligned}$$

Design Step 5.1.3 Calculate K_g , the longitudinal stiffness parameter.

$$\begin{aligned} K_g &= n(I + Ae_g^2) && \text{(S4.6.2.2.1-1)} \\ &= 1.225[733,320 + 1,085(39.62)^2] \\ &= 2,984,704 \text{ in}^4 \end{aligned}$$

Design Step 5.1.4 **Interior girder**

Calculate the moment distribution factor for an interior beam with two or more design lanes loaded using Table S4.6.2.2.2b-1.

$$D_M = 0.075 + (S/9.5)^{0.6} (S/L)^{0.2} (K_g/12.0Lt_s^3)^{0.1}$$

$$= 0.075 + (9.667/9.5)^{0.6} (9.667/110)^{0.2} [2,984,704/[12(110)(8)^3]]^{0.1}$$

$$= 0.796 \text{ lane} \quad (1)$$

Design Step 5.1.5 According to S4.6.2.2.2e, a skew correction factor for moment may be applied for bridge skews greater than 30 degrees. The bridge in this example is skewed 20 degrees, and, therefore, no skew correction factor for moment is allowed.

Calculate the moment distribution factor for an interior beam with one design lane loaded using Table S4.6.2.2.2b-1.

$$D_M = 0.06 + (S/14)^{0.4} (S/L)^{0.3} (K_g/12.0L_t^3)^{0.1}$$

$$= 0.06 + (9.667/14)^{0.4} (9.667/110)^{0.3} [2,984,704/[12(110)(8)^3]]^{0.1}$$

$$= 0.542 \text{ lane} \quad (2)$$

Notice that the distribution factor calculated above for a single lane loaded already includes the 1.2 multiple presence factor for a single lane, therefore, this value may be used for the service and strength limit states. However, multiple presence factors should not be used for the fatigue limit state. Therefore, the multiple presence factor of 1.2 for the single lane is required to be removed from the value calculated above to determine the factor used for the fatigue limit state.

For single-lane loading to be used for fatigue design, remove the multiple presence factor of 1.2.

$$D_M = 0.542/1.2$$

$$= 0.452 \text{ lane} \quad (3)$$

Design Step 5.1.6 **Skew correction factor for shear**

According to S4.6.2.2.3c, a skew correction factor for support shear at the obtuse corner must be applied to the distribution factor of all skewed bridges. The value of the correction factor is calculated using Table S4.6.2.2.3c-1

$$SC = 1.0 + 0.20(12.0L_t^3/K_g)^{0.3} \tan \theta$$

$$= 1.0 + 0.20[[12.0(110)(8)^3]/2,984,704]^{0.3} \tan 20$$

$$= 1.047$$

Design Step 5.1.7 Calculate the shear distribution factor for an interior beam with two or more design lanes loaded using Table S4.6.2.2.3a-1.

$$D_V = 0.2 + (S/12) - (S/35)^2$$

$$= 0.2 + (9.667/12) - (9.667/35)^2$$

$$= 0.929 \text{ lane}$$

Apply the skew correction factor:

$$D_V = 1.047(0.929)$$

$$= 0.973 \text{ lane} \quad (4)$$

Design Step 5.1.8 Calculate the shear distribution factor for an interior beam with one design lane loaded using Table S4.6.2.2.3a-1.

$$D_V = 0.36 + (S/25.0)$$

$$= 0.36 + (9.667/25.0)$$

$$= 0.747 \text{ lane}$$

Apply the skew correction factor:

$$D_V = 1.047(0.747)$$

$$= 0.782 \text{ lane} \quad (5)$$

For single-lane loading to be used for fatigue design, remove the multiple presence factor of 1.2.

$$D_V = 0.782/1.2$$

$$= 0.652 \text{ lane} \quad (6)$$

Design Step 5.1.9 From (1) and (2), the service and strength limit state moment distribution factor for the interior girder is equal to the larger of 0.796 and 0.542 lane. Therefore, the moment distribution factor is 0.796 lane.

From (3):

The fatigue limit state moment distribution factor is 0.452 lane

From (4) and (5), the service and strength limit state shear distribution factor for the interior girder is equal to the larger of 0.973 and 0.782 lane. Therefore, the shear distribution factor is 0.973 lane.

From (6):

The fatigue limit state shear distribution factor is 0.652 lane

Design Step 5.1.10

Exterior girder

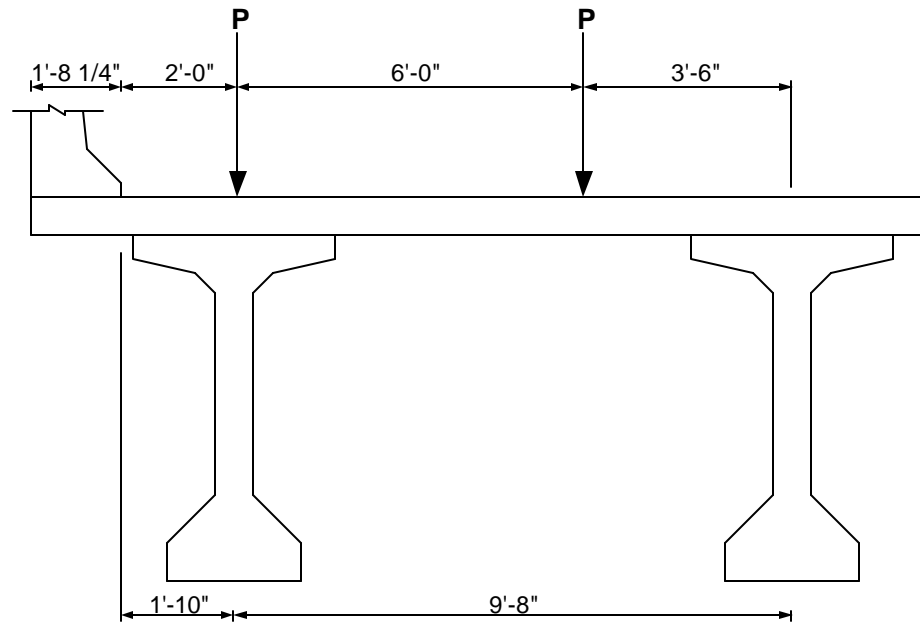

Figure 5.1-1 – Lever Rule

Design Step 5.1.11

Calculate the moment distribution factor for an exterior beam with two or more design lanes using Table S4.6.2.2.2d-1.

$$D_M = eD_{M\text{Interior}}$$

$$e = 0.77 + d_e/9.1$$

where d_e is the distance from the centerline of the exterior girder to the inside face of the curb or barrier.

$$e = 0.77 + 1.83/9.1 = 0.97$$

$$D_M = 0.97(0.796) = 0.772 \text{ lane} \quad (7)$$

Design Step 5.1.12

Calculate the moment distribution factor for an exterior beam with one design lane using the lever rule as per Table S4.6.2.2.2d-1.

$$D_M = [(3.5 + 6) + 3.5]/9.667 = 1.344 \text{ wheels}/2 = 0.672 \text{ lane} \quad (8) \quad (\text{Fatigue})$$

Notice that this value does not include the multiple presence factor, therefore, it is adequate for use with the fatigue limit state. For service and strength limit states, the multiple presence factor for a single lane loaded needs to be included.

$$\begin{aligned} D_M &= 0.672(1.2) \\ &= 0.806 \text{ lane} \end{aligned} \quad (9) \quad (\text{Strength and Service})$$

Design Step 5.1.13 Calculate the shear distribution factor for an exterior beam with two or more design lanes loaded using Table S4.6.2.2.3b-1.

$$D_V = eD_{V_{\text{interior}}}$$

where:

$$\begin{aligned} e &= 0.6 + d_e/10 \\ &= 0.6 + 1.83/10 \\ &= 0.783 \end{aligned}$$

$$\begin{aligned} D_V &= 0.783(0.973) \\ &= 0.762 \text{ lane} \end{aligned} \quad (10)$$

Design Step 5.1.14 Calculate the shear distribution factor for an exterior beam with one design lane loaded using the lever rule as per Table S4.6.2.2.3b-1. This value will be the same as the moment distribution factor with the skew correction factor applied.

$$\begin{aligned} D_V &= 1.047(0.672) \\ &= 0.704 \text{ lane} \end{aligned} \quad (11) \quad (\text{Fatigue})$$

$$\begin{aligned} D_V &= 1.047(0.806) \\ &= 0.845 \text{ lane} \end{aligned} \quad (12) \quad (\text{Strength and Service})$$

Notice that S4.6.2.2.2d includes additional requirements for the calculation of the distribution factors for exterior girders when the girders are connected with relatively stiff cross-frames that force the cross-section to act as a rigid section. As indicated in Design Step 5.1, these provisions are applied to this example; the calculations are shown below.

Design Step 5.1.15 **Additional check for rigidly connected girders (S4.6.2.2.2d)**

The multiple presence factor, m , is applied to the reaction of the exterior beam (Table S3.6.1.1.2-1)

$$\begin{aligned} m_1 &= 1.20 \\ m_2 &= 1.00 \end{aligned}$$

$$m_3 = 0.85$$

$$R = N_L/N_b + X_{\text{ext}}(\Sigma e)/\Sigma x^2 \quad (\text{SC4.6.2.2.2d-1})$$

where:

R = reaction on exterior beam in terms of lanes

N_L = number of loaded lanes under consideration

e = eccentricity of a design truck or a design land load from the center of gravity of the pattern of girders (ft.)

x = horizontal distance from the center of gravity of the pattern of girders to each girder (ft.)

X_{ext} = horizontal distance from the center of gravity of the pattern to the exterior girder (ft.)

See Figure 5.1-1 for dimensions.

One lane loaded (only the leftmost lane applied):

$$\begin{aligned} R &= 1/6 + 24.167(21)/[2(24.167^2 + 14.5^2 + 4.833^2)] \\ &= 0.1667 + 0.310 \\ &= 0.477 \end{aligned} \quad (\text{Fatigue})$$

Add the multiple presence factor of 1.2 for a single lane:

$$\begin{aligned} R &= 1.2(0.477) \\ &= 0.572 \end{aligned} \quad (\text{Strength})$$

Two lanes loaded:

$$\begin{aligned} R &= 2/6 + 24.167(21 + 9)/[2(24.167^2 + 14.5^2 + 4.833^2)] \\ &= 0.333 + 0.443 \\ &= 0.776 \end{aligned}$$

Add the multiple presence factor of 1.0 for two lanes loaded:

$$\begin{aligned} R &= 1.0(0.776) \\ &= 0.776 \end{aligned} \quad (\text{Strength})$$

Three lanes loaded:

$$\begin{aligned}
 R &= 3/6 + 24.167(21 + 9 - 3)/[2(24.167^2 + 14.5^2 + 4.833^2)] \\
 &= 0.5 + 0.399 \\
 &= 0.899
 \end{aligned}$$

Add the multiple presence factor of 0.85 for three or more lanes loaded:

$$\begin{aligned}
 R &= 0.85(0.899) \\
 &= 0.764 \qquad \qquad \qquad \text{(Strength)}
 \end{aligned}$$

These values do not control over the distribution factors summarized in Design Step 5.1.16.

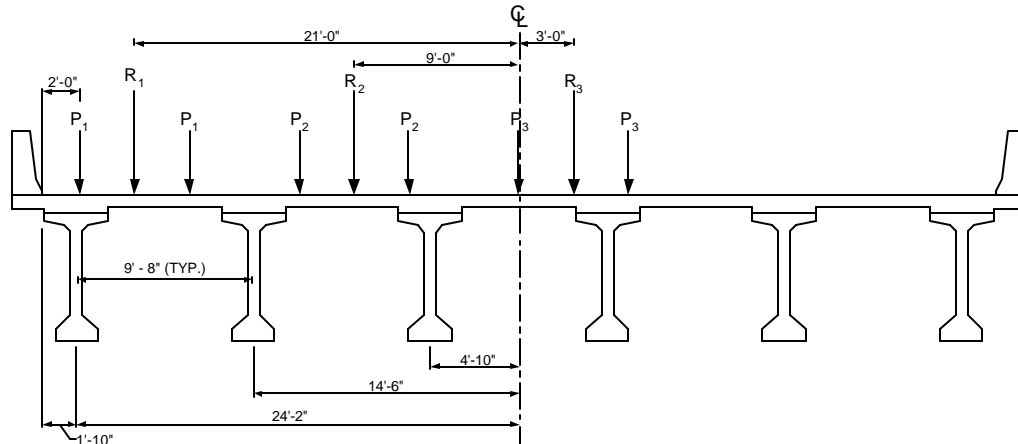

Figure 5.1-2 - General Dimensions

Design Step 5.1.16

From (7) and (9), the service and strength limit state moment distribution factor for the exterior girder is equal to the larger of 0.772 and 0.806 lane. Therefore, the moment distribution factor is 0.806 lane.

From (8):

The fatigue limit state moment distribution factor is 0.672 lane

From (10) and (12), the service and strength limit state shear distribution factor for the exterior girder is equal to the larger of 0.762 and 0.845 lane. Therefore, the shear distribution factor is 0.845 lane.

From (11):

The fatigue limit state shear distribution factor is 0.704 lane

Table 5.1-1 – Summary of Service and Strength Limit State Distribution Factors

	Load Case	Moment interior beams	Moment exterior beams	Shear interior beams	Shear exterior beams
Distribution factors from Tables in S4.6.2.2.2	Multiple lanes loaded	0.796	0.772	0.973	0.762
	Single lane loaded	0.542	0.806	0.782	0.845
Additional check for rigidly connected girders	Multiple lanes loaded	NA	0.776	NA	0.776
	Single lane loaded	NA	0.572	NA	0.572
Design value		0.796	0.806	0.973	0.845

Table 5.1-2 – Summary of Fatigue Limit State Distribution Factors

	Load Case	Moment interior beams	Moment exterior beams	Shear interior beams	Shear exterior beams
Distribution factors from Tables in S4.6.2.2.2	Multiple lanes loaded	NA	NA	NA	NA
	Single lane loaded	0.452	0.672	0.652	0.704
Additional check for rigidly connected girders	Multiple lanes loaded	NA	NA	NA	NA
	Single lane loaded	NA	0.477	NA	0.477
Design value		0.452	0.672	0.652	0.704

Design Step 5.2 DEAD LOAD CALCULATION

Calculate the dead load of the bridge superstructure components for the controlling interior girder. Values for the exterior girder have also been included for reference. The girder, slab, haunch, and exterior diaphragm loads are applied to the noncomposite section; the parapets and future wearing surface are applied to the composite section.

Interior girder

Girder weight

$$DC_{\text{girder (I)}} = A_g(\gamma_{\text{girder}})$$

where:

$$\begin{aligned} A_g &= \text{beam cross-sectional area (in}^2\text{)} \\ &= 1,085 \text{ in}^2 \end{aligned}$$

$$\begin{aligned} \gamma &= \text{unit weight of beam concrete (kcf)} \\ &= 0.150 \text{ kcf} \end{aligned}$$

$$\begin{aligned} DC_{\text{girder (I)}} &= (1,085/144)(0.150) \\ &= 1.13 \text{ k/ft/girder} \end{aligned}$$

Deck slab weight

The total thickness of the slab is used in calculating the weight.

$$\begin{aligned} \text{Girder spacing} &= 9.667 \text{ ft.} \\ \text{Slab thickness} &= 8 \text{ in.} \end{aligned}$$

$$\begin{aligned} DC_{\text{slab (I)}} &= 9.667(8/12)(0.150) \\ &= 0.967 \text{ k/ft/girder} \end{aligned}$$

Exterior girder

Girder weight

$$DC_{\text{girder (E)}} = 1.13 \text{ k/ft/girder}$$

Deck slab weight

$$\begin{aligned} \text{Slab width} &= \text{overhang width} + \frac{1}{2} \text{ girder spacing} \\ &= 3.521 + \frac{1}{2}(9.667) \\ &= 8.35 \text{ ft.} \end{aligned}$$

$$\text{Slab thickness} = 8 \text{ in.}$$

$$\begin{aligned} DC_{\text{slab (E)}} &= 8.35(8/12)(0.150) \\ &= 0.835 \text{ k/ft/girder} \end{aligned}$$

Haunch weight

$$\begin{aligned} \text{Width} &= 42 \text{ in.} \\ \text{Thickness} &= 4 \text{ in.} \end{aligned}$$

$$\begin{aligned} DC_{\text{haunch}} &= [42(4)/144](0.150) \\ &= 0.175 \text{ k/ft/girder} \end{aligned}$$

Notice that the haunch weight in this example is assumed as a uniform load along the full length of the beam. This results in a conservative design as the haunch typically have a variable thickness that decreases toward the middle of the span length. Many jurisdictions calculate the haunch load effects assuming the haunch thickness to vary parabolically along the length of the beam. The location of the minimum thickness varies depending on the grade of the roadway surface at bridge location and the presence of a vertical curve. The use of either approach is acceptable and the difference in load effects is typically negligible. However, when analyzing existing bridges, it may be necessary to use the variable haunch thickness in the analysis to accurately represent the existing situation

Concrete diaphragm weight

A concrete diaphragm is placed at one-half the noncomposite span length.

Location of the diaphragms:

$$\begin{aligned} \text{Span 1} &= 54.5 \text{ ft. from centerline of end bearing} \\ \text{Span 2} &= 55.5 \text{ ft. from centerline of pier} \end{aligned}$$

For this example, arbitrarily assume that the thickness of the diaphragm is 10 in. The diaphragm spans from beam to beam minus the web thickness and has a depth equal to the distance from the top of the beam to the bottom of the web. Therefore, the concentrated load to be applied at the locations above is:

$$\begin{aligned} DC_{\text{diaphragm}} &= 0.15(10/12)[9.667 - (8/12)](72 - 18)/12 \\ &= 5.0625 \text{ k/girder} \end{aligned}$$

The exterior girder only resists half of this loading.

Parapet weight

According to the S4.6.2.2.1, the parapet weight may be distributed equally to all girders in the cross section.

$$\text{Parapet cross-sectional area} = 4.33 \text{ ft}^2$$

$$\begin{aligned} DC_{\text{parapet}} &= 4.33(0.150) = 0.650 \text{ k/ft} \\ &= 0.650/6 \text{ girders} \\ &= 0.108 \text{ k/ft/girder for one parapet} \end{aligned}$$

Therefore, the effect of two parapets yields:

$$DC_{\text{parapet}} = 0.216 \text{ k/ft per girder}$$

Future wearing surface

Interior girder

$$\begin{aligned} \text{Weight/ft}^2 &= 0.030 \text{ k/ft}^2 \\ \text{Width} &= 9.667 \text{ ft.} \end{aligned}$$

$$\begin{aligned} DW_{\text{FWS (I)}} &= 0.030(9.667) \\ &= 0.290 \text{ k/ft/girder} \end{aligned}$$

Exterior Girder

$$\begin{aligned} \text{Weight/ft}^2 &= 0.030 \text{ k/ft}^2 \\ \text{Width} &= \text{slab width} - \text{parapet width} \\ &= 8.35 - 1.6875 \\ &= 6.663 \text{ ft.} \end{aligned}$$

$$\begin{aligned} DW_{\text{FWS (E)}} &= 0.030(6.663) \\ &= 0.200 \text{ k/ft/girder} \end{aligned}$$

Notice that some jurisdictions divide the weight of the future wearing surface equally between all girders (i.e. apply a uniform load of 0.26 k/ft to all girders). Article S4.6.2.2.1 states that permanent loads of and on the deck may be distributed uniformly among the beams. This method would also be acceptable and would minimally change the moments and shears given in the tables in Design Step 5.3.

Design Step 5.3 UNFACTORED AND FACTORED LOAD EFFECTS

Design Step 5.3.1 Summary of loads

The dead load moments and shears were calculated based on the loads shown in Design Step 5.2. The live load moments and shears were calculated using a generic live load analysis computer program. The live load distribution factors from Design Step 5.1 are applied to these values.

Table 5.3-1 - Summary of Unfactored Moments

Interior girder, Span 1 shown, Span 2 mirror image

Location*	Noncomposite					Composite		Live Load + IM	
	Girder		Slab and Haunch	Exterior Diaphragm	Total Noncomp.	Parapet	FWS	Positive HL-93	Negative HL-93
	**	***							
(ft.)	(k-ft)	(k-ft)	(k-ft)	(k-ft)	(k-ft)	(k-ft)	(k-ft)	(k-ft)	(k-ft)
0	47	0	0	0	0	0	0	0	0
1.0	108	61	62	3	125	9	12	92	-11
5.5	368	322	325	14	661	46	62	476	-58
11.0	656	609	615	28	1,252	85	114	886	-116
16.5	909	863	871	42	1,776	118	158	1,230	-174
22.0	1,128	1,082	1,093	56	2,230	144	193	1,509	-233
27.5	1,313	1,267	1,279	70	2,616	164	220	1,724	-291
33.0	1,464	1,417	1,432	84	2,933	177	237	1,882	-349
38.5	1,580	1,534	1,549	98	3,181	183	246	1,994	-407
44.0	1,663	1,616	1,633	111	3,360	183	246	2,047	-465
49.5	1,711	1,664	1,681	125	3,471	177	237	2,045	-523
54.5	1,725	1,679	1,696	138	3,512	165	222	2,015	-576
55.0	1,725	1,678	1,695	137	3,511	164	220	2,010	-581
60.5	1,705	1,658	1,675	123	3,456	144	194	1,927	-640
66.0	1,650	1,604	1,620	109	3,333	118	159	1,794	-698
71.5	1,562	1,515	1,531	95	3,141	86	115	1,613	-756
77.0	1,439	1,392	1,407	81	2,880	46	62	1,388	-814
82.5	1,282	1,236	1,248	67	2,551	1	1	1,124	-872
88.0	1,091	1,044	1,055	53	2,152	-52	-69	825	-1,124
93.5	865	819	827	39	1,686	-110	-148	524	-1,223
99.0	606	560	565	25	1,150	-176	-236	297	-1,371
104.5	312	266	268	11	546	-248	-332	113	-1,663
108.0	110	61	62	3	125	-297	-398	33	-1,921
109.0	47	0	0	0	0	-311	-418	15	-2,006
Span 2 - 0	-	0	0	0	0	-326	-438	0	-2,095

* Distance from the centerline of the end bearing

** Based on the simple span length of 110.5 ft. and supported at the ends of the girders. These values are used to calculate stresses at transfer.

*** Based on the simple span length of 109 ft. and supported at the centerline of bearings. These values are used to calculate the final stresses.

Table 5.3-2 – Summary of Factored Moments

Interior girder, Span 1 shown, Span 2 mirror image

Location*	Strength I (k-ft)	Service I **		Service III **	
		NC (k-ft)	Comp. (k-ft)	NC (k-ft)	Comp. (k-ft)
0	0	0	0	0	0
1.0	346	125	112	125	94
5.5	1,809	661	584	661	488
11.0	3,394	1,252	1,085	1,252	908
16.5	4,756	1,776	1,506	1,776	1,260
22.0	5,897	2,230	1,846	2,230	1,544
27.5	6,821	2,616	2,108	2,616	1,763
33.0	7,536	2,933	2,296	2,933	1,920
38.5	8,063	3,181	2,423	3,181	2,024
44.0	8,381	3,360	2,477	3,360	2,067
49.5	8,494	3,471	2,459	3,471	2,050
54.5	8,456	3,512	2,402	3,512	1,999
55.0	8,440	3,511	2,394	3,511	1,992
60.5	8,163	3,456	2,265	3,456	1,880
66.0	7,690	3,333	2,070	3,333	1,712
71.5	7,027	3,141	1,813	3,141	1,490
77.0	6,181	2,880	1,497	2,880	1,219
82.5	5,158	2,551	1,126	2,551	901
88.0	3,967	2,152	-1,245	2,152	-1,020
93.5	2,664	1,686	-1,481	1,686	-1,237
99.0	-1,535	1,150	-1,783	1,150	-1,509
104.5	-3,035	546	-2,242	546	-1,910
108.0	-4,174	125	-2,616	125	-2,232
109.0	-4,525	0	-2,734	0	-2,333
Span 2 - 0	-4,729	0	-2,858	0	-2,439

Load Factor Combinations

Strength I = 1.25(DC) + 1.5(DW) + 1.75(LL + IM)

Service I = 1.0[DC + DW + (LL + IM)]

Service III = 1.0(DC + DW) + 0.8(LL + IM)

* Distance from the centerline of the end bearing

** For service limit states, moments are applied to the section of the girder, i.e. noncomposite or composite, that resists these moments. Hence, noncomposite and composite moments have to be separated for service load calculations.

Table 5.3-3 - Summary of Unfactored Shear

Interior girder, Span 1 shown, Span 2 mirror image

Location*	Noncomposite				Composite		Live Load + IM	
	Girder	Slab and Haunch	Exterior Diaphragm	Total Noncomp.	Parapet	FWS	Positive HL-93	Negative HL-93
(ft.)	(k)	(k)	(k)	(k)	(k)	(k)	(k)	(k)
0	61.6	62.2	2.5	126.4	8.9	12.0	113.3	-12.9
1.0	60.5	61.1	2.5	124.1	8.7	11.7	111.7	-12.9
5.5	55.4	55.9	2.5	113.9	7.7	10.4	104.3	-13.0
11.0	49.2	49.7	2.5	101.4	6.5	8.8	95.5	-13.4
16.5	43.0	43.4	2.5	88.9	5.4	7.2	86.9	-15.9
22.0	36.7	37.1	2.5	76.4	4.2	5.6	78.7	-20.6
27.5	30.5	30.8	2.5	63.9	3.0	4.0	70.8	-26.0
33.0	24.3	24.6	2.5	51.4	1.8	2.4	63.1	-32.8
38.5	18.1	18.3	2.5	38.9	0.6	0.8	55.9	-39.8
44.0	11.9	12.0	2.5	26.4	-0.6	-0.8	48.9	-46.8
49.5	5.7	5.7	2.5	13.9	-1.8	-2.4	42.4	-54.0
54.5	0	0	-2.5	-2.5	-2.9	-3.8	36.8	-60.5
55.0	-0.6	-0.6	-2.5	-3.7	-3.0	-4.0	36.2	-61.2
60.5	-6.8	-6.9	-2.5	-16.2	-4.2	-5.6	30.4	-68.4
66.0	-13.0	-13.1	-2.5	-28.7	-5.3	-7.2	25.0	-75.7
71.5	-19.2	-19.4	-2.5	-41.2	-6.5	-8.8	20.0	-82.9
77.0	-25.4	-25.7	-2.5	-53.7	-7.7	-10.4	15.4	-90.1
82.5	-31.7	-32.0	-2.5	-66.1	-8.9	-12.0	11.3	-97.3
88.0	-37.9	-38.3	-2.5	-78.6	-10.1	-13.6	8.2	-104.3
93.5	-44.1	-44.5	-2.5	-91.1	-11.3	-15.1	5.5	-111.3
99.0	-50.3	-50.8	-2.5	-103.6	-12.5	-16.7	3.2	-118.0
104.5	-56.5	-57.1	-2.5	-116.1	-13.7	-18.3	1.2	-124.7
108.0	-60.5	-61.1	-2.5	-124.1	-14.4	-19.4	0.4	-128.7
109.0	-61.6	-62.2	-2.5	-126.4	-14.6	-19.6	0.2	-129.9
Span 2 - 0	0	0	0	0	-14.8	-19.9	0	-131.1

* Distance from the centerline of the end bearing

Table 5.3-4 – Summary of Factored Shear
Interior girder, Span 1 shown, Span 2 mirror image

Location*	Strength I	Service I	Service III
(ft.)	(k)	(k)	(k)
0	385.4	260.6	237.9
1.0	379.0	256.2	233.8
5.5	350.0	236.2	215.4
11.0	315.1	212.1	193.0
16.5	280.7	188.3	170.9
22.0	246.8	164.8	149.1
27.5	213.4	141.6	127.5
33.0	180.6	118.7	106.1
38.5	148.3	96.2	85.0
44.0	116.7	74.0	64.2
49.5	85.7	52.1	43.6
54.5	-118.4	-69.7	-57.6
55.0	-121.3	-71.8	-59.6
60.5	-153.5	-94.3	-80.6
66.0	-185.7	-116.9	-101.7
71.5	-217.9	-139.4	-122.8
77.0	-250.0	-161.8	-143.8
82.5	-282.0	-184.3	-164.8
88.0	-313.8	-206.6	-185.7
93.5	-345.4	-228.8	-206.6
99.0	-376.8	-250.9	-227.3
104.5	-407.9	-272.8	-247.8
108.0	-427.4	-286.6	-260.8
109.0	-433.0	-290.5	-264.5
Span 2 - 0	-277.8	-165.8	-139.6

Load Factor Combinations

Strength I = 1.25(DC) + 1.5(DW) + 1.75(LL + IM)

Service I = 1.0[DC + DW + (LL + IM)]

Service III = 1.0(DC + DW) + 0.8(LL + IM)

* Distance from the centerline of the end bearing

Table 5.3-5 - Summary of Unfactored Moments

Exterior girder, Span 1 shown, Span 2 mirror image

Location*	Noncomposite					Composite		Live Load + IM	
	Girder		Slab and Haunch	Exterior Diaphragm	Total Noncomp.	Parapet	FWS	Positive HL-93	Negative HL-93
	**	***							
(ft.)	(k-ft)	(k-ft)	(k-ft)	(k-ft)	(k-ft)	(k-ft)	(k-ft)	(k-ft)	(k-ft)
0	47	0	0	0	0	0	0	0	0
1.0	108	61	55	1	117	9	8	93	-11
5.5	368	322	288	7	616	46	41	482	-59
11.0	656	609	545	14	1,168	85	77	897	-118
16.5	909	863	771	21	1,655	118	106	1,245	-177
22.0	1,128	1,082	967	28	2,076	144	130	1,528	-236
27.5	1,313	1,267	1,132	35	2,434	164	148	1,746	-294
33.0	1,464	1,417	1,267	42	2,726	177	160	1,906	-353
38.5	1,580	1,534	1,371	49	2,954	183	165	2,019	-412
44.0	1,663	1,616	1,445	56	3,117	183	166	2,073	-471
49.5	1,711	1,664	1,488	63	3,215	177	160	2,071	-530
54.5	1,725	1,679	1,501	69	3,248	165	149	2,041	-583
55.0	1,725	1,678	1,501	68	3,247	164	148	2,035	-589
60.5	1,705	1,658	1,482	61	3,202	144	130	1,951	-648
66.0	1,650	1,604	1,434	54	3,092	118	107	1,816	-706
71.5	1,562	1,515	1,355	48	2,917	86	77	1,633	-765
77.0	1,439	1,392	1,245	41	2,678	46	42	1,406	-824
82.5	1,282	1,236	1,105	34	2,374	1	1	1,139	-883
88.0	1,091	1,044	934	27	2,005	-52	-47	836	-1,138
93.5	865	819	732	20	1,571	-110	-100	531	-1,238
99.0	606	560	500	13	1,072	-176	-159	300	-1,389
104.5	312	266	238	6	509	-248	-224	114	-1,683
108.0	110	61	55	1	117	-297	-268	33	-1,945
109.0	47	0	0	0	0	-311	-281	15	-2,031
Span 2 - 0	-	0	0	0	0	-326	-294	0	-2,121

* Distance from the centerline of the end bearing

** Based on the simple span length of 110.5 ft. and supported at the ends of the girders. These values are used to calculate stresses at transfer.

*** Based on the simple span length of 109 ft. and supported at the centerline of bearings. These values are used to calculate the final stresses.

Table 5.3-6 – Summary of Factored Moments

Exterior girder, Span 1 shown, Span 2 mirror image

Location*	Strength I (k-ft)	Service I **		Service III **	
		NC (k-ft)	Comp. (k-ft)	NC (k-ft)	Comp. (k-ft)
0	0	0	0	0	0
1.0	331	117	110	117	91
5.5	1,734	616	570	616	473
11.0	3,251	1,168	1,059	1,168	879
16.5	4,554	1,655	1,469	1,655	1,220
22.0	5,644	2,076	1,801	2,076	1,496
27.5	6,524	2,434	2,057	2,434	1,708
33.0	7,203	2,726	2,242	2,726	1,861
38.5	7,702	2,954	2,368	2,954	1,964
44.0	8,001	3,117	2,422	3,117	2,007
49.5	8,103	3,215	2,407	3,215	1,993
54.5	8,061	3,248	2,355	3,248	1,947
55.0	8,047	3,247	2,347	3,247	1,940
60.5	7,793	3,202	2,226	3,202	1,836
66.0	7,351	3,092	2,041	3,092	1,678
71.5	6,727	2,917	1,796	2,917	1,469
77.0	5,928	2,678	1,494	2,678	1,213
82.5	4,961	2,374	1,140	2,374	912
88.0	3,834	2,005	-1,237	2,005	-1,009
93.5	2,605	1,571	-1,448	1,571	-1,201
99.0	-1,547	1,072	-1,723	1,072	-1,445
104.5	-2,954	509	-2,154	509	-1,818
108.0	-4,031	117	-2,510	117	-2,121
109.0	-4,364	0	-2,623	0	-2,217
Span 2 - 0	-4,560	0	-2,741	0	-2,317

Load Factor Combinations

Strength I = 1.25(DC) + 1.5(DW) + 1.75(LL + IM)

Service I = 1.0[DC + DW + (LL + IM)]

Service III = 1.0(DC + DW) + 0.8(LL + IM)

* Distance from the centerline of the end bearing

** For service limit states, moments are applied to the section of the girder, i.e. noncomposite or composite, that resists these moments. Hence, noncomposite and composite moments have to be separated for service load calculations.

Table 5.3-7 - Summary of Unfactored Shear

Exterior girder, Span 1 shown, Span 2 mirror image

Location*	Noncomposite				Composite		Live Load + IM	
	Girder	Slab and Haunch	Exterior Diaphragm	Total Noncomp.	Parapet	FWS	Positive HL-93	Negative HL-93
(ft.)	(k)	(k)	(k)	(k)	(k)	(k)	(k)	(k)
0	61.6	55.1	1.3	117.9	8.9	8.1	98.4	-11.2
1.0	60.5	54.1	1.3	115.8	8.7	7.9	97.0	-11.2
5.5	55.4	49.5	1.3	106.2	7.7	7.0	90.6	-11.3
11.0	49.2	44.0	1.3	94.4	6.5	5.9	82.9	-11.6
16.5	43.0	38.4	1.3	82.6	5.4	4.8	75.5	-13.8
22.0	36.7	32.8	1.3	70.8	4.2	3.8	68.3	-17.9
27.5	30.5	27.3	1.3	59.1	3.0	2.7	61.4	-22.6
33.0	24.3	21.7	1.3	47.3	1.8	1.6	54.8	-28.5
38.5	18.1	16.2	1.3	35.5	0.6	0.5	48.5	-34.5
44.0	11.9	10.6	1.3	23.7	-0.6	-0.5	42.5	-40.7
49.5	5.7	5.1	1.3	12.0	-1.8	-1.6	36.8	-46.9
54.5	0	0	-1.3	-1.3	-2.9	-2.6	31.9	-52.6
55.0	-0.6	-0.5	-1.3	-2.3	-3.0	-2.7	31.4	-53.1
60.5	-6.8	-6.1	-1.3	-14.1	-4.2	-3.8	26.4	-59.4
66.0	-13.0	-11.6	-1.3	-25.9	-5.3	-4.8	21.7	-65.7
71.5	-19.2	-17.2	-1.3	-37.7	-6.5	-5.9	17.4	-72.0
77.0	-25.4	-22.7	-1.3	-49.4	-7.7	-7.0	13.4	-78.3
82.5	-31.7	-28.3	-1.3	-61.2	-8.9	-8.0	9.8	-84.5
88.0	-37.9	-33.9	-1.3	-73.0	-10.1	-9.1	7.2	-90.6
93.5	-44.1	-39.4	-1.3	-84.8	-11.3	-10.2	4.8	-96.6
99.0	-50.3	-45.0	-1.3	-96.5	-12.5	-11.3	2.8	-102.5
104.5	-56.5	-50.5	-1.3	-108.3	-13.7	-12.3	1.0	-108.3
108.0	-60.5	-54.1	-1.3	-115.8	-14.4	-13.0	0.4	-111.8
109.0	-61.6	-55.1	-1.3	-117.9	-14.6	-13.2	0.2	-112.8
Span 2 - 0	0	0	0	0	-14.8	-13.4	0	-113.8

* Distance from the centerline of the end bearing

Table 5.3-8 – Summary of Factored Shear

Exterior girder, Span 1 shown, Span 2 mirror image

Location*	Strength I	Service I	Service III
(ft.)	(k)	(k)	(k)
0	342.9	233.3	213.7
1.0	337.2	229.4	210.0
5.5	311.3	211.4	193.3
11.0	280.1	189.7	173.2
16.5	249.3	168.3	153.2
22.0	219.0	147.1	133.4
27.5	189.1	126.2	113.9
33.0	159.7	105.5	94.6
38.5	130.9	85.2	75.5
44.0	102.5	65.1	56.6
49.5	74.8	45.4	38.0
54.5	-101.0	-59.3	-48.7
55.0	-103.6	-61.1	-50.5
60.5	-132.4	-81.4	-69.5
66.0	-161.3	-101.8	-88.6
71.5	-190.1	-122.1	-107.7
77.0	-218.8	-142.4	-126.7
82.5	-247.5	-162.6	-145.7
88.0	-276.0	-182.8	-164.7
93.5	-304.4	-202.8	-183.5
99.0	-332.5	-222.8	-202.2
104.5	-360.4	-242.5	-220.9
108.0	-377.9	-255.0	-232.7
109.0	-382.9	-258.6	-236.0
Span 2 - 0	-237.8	-142.1	-119.3

Load Factor CombinationsStrength I = $1.25(\text{DC}) + 1.5(\text{DW}) + 1.75(\text{LL} + \text{IM})$ Service I = $1.0[\text{DC} + \text{DW} + (\text{LL} + \text{IM})]$ Service III = $1.0(\text{DC} + \text{DW}) + 0.8(\text{LL} + \text{IM})$

* Distance from the centerline of the end bearing

Based on the analysis results, the interior girder controls the design. The remaining sections covering the superstructure design are based on the interior girder analysis. The exterior girder calculations would be identical.

Design Step 5.3.2 ANALYSIS OF CREEP AND SHRINKAGE EFFECTS**Design Step 5.3.2.1 Creep effects**

The compressive stress in the beams due to prestressing causes the prestressed beams to creep. For simple span pretensioned beams under dead loads, the highest compression in the beams is typically at the bottom, therefore, creep causes the camber to increase, i.e., causes the upward deflection of the beam to increase. This increased upward deflection of the simple span beam is not accompanied by stresses in the beam since there is no rotational restraint of the beam ends. When simple span beams are made continuous through a connection at the intermediate support, the rotation at the ends of the beam due to creep taking place after the connection is established are restrained by the continuity connection. This results in the development of fixed end moments (FEM) that maintain the ends of the beams as flat. As shown schematically in Figure 5.3-1 for a two-span bridge, the initial deformation is due to creep that takes place before the continuity connection is established. If the beams were left as simple spans, the creep deformations would increase; the deflected shape would appear as shown in part “b” of the figure. However, due to the continuity connection, fixed end moments at the ends of the beam will be required to restrain the end rotations after the continuity connection is established as shown in part “c” of the figure. The beam is analyzed under the effects of the fixed end moments to determine the final creep effects.

Similar effects, albeit in the opposite direction, take place under permanent loads. For ease of application, the effect of the dead load creep and the prestressing creep are analyzed separately. Figures 5.3-2 and 5.3-3 show the creep moment for a two-span bridge with straight strands. Notice that the creep due to prestressing and the creep due to dead load result in restrained moments of opposite sign. The creep from prestressing typically has a larger magnitude than the creep from dead loads.

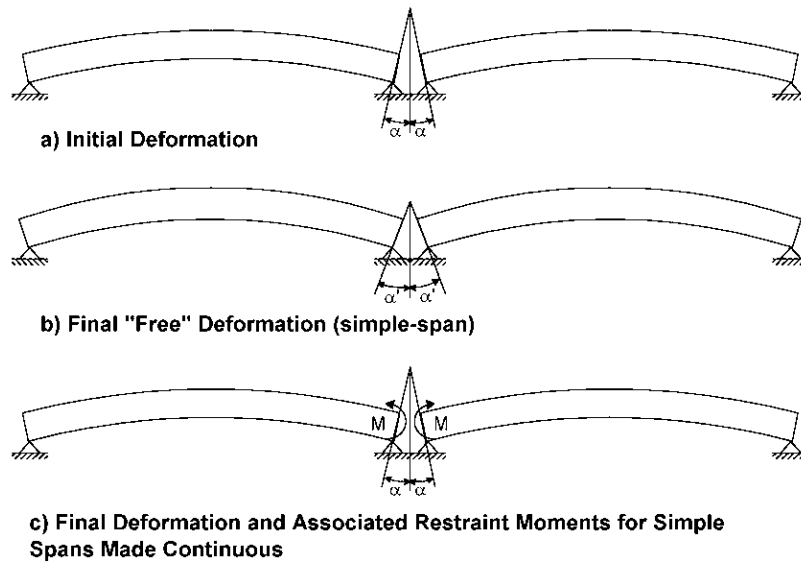

Figure 5.3-1 - Prestressed Creep Deformations and Restraint Moments

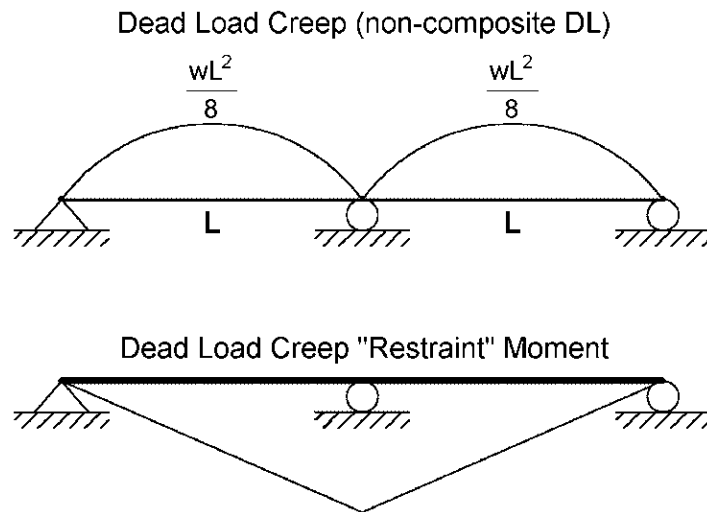

Figure 5.3-2 - Dead Load Creep Moment

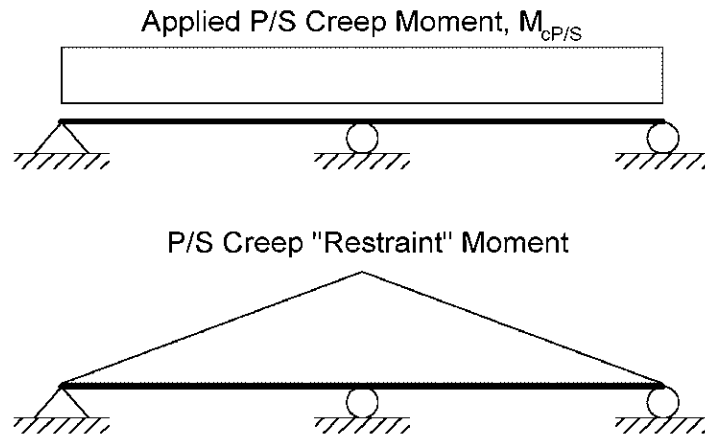

Figure 5.3-3 - Prestressed Creep Moment

Shrinkage effects

The shrinkage of the pretensioned beams is different from the shrinkage of the deck slab. This is due to the difference in the age, concrete strength, and method of curing of the two concretes. Unlike creep, differential shrinkage induces stresses in all prestressed composite beams, including simple spans. The larger shrinkage of the deck causes the composite beams to sag as shown in Figure 5.3-4. The restraint and final moments are also shown schematically in the figure.

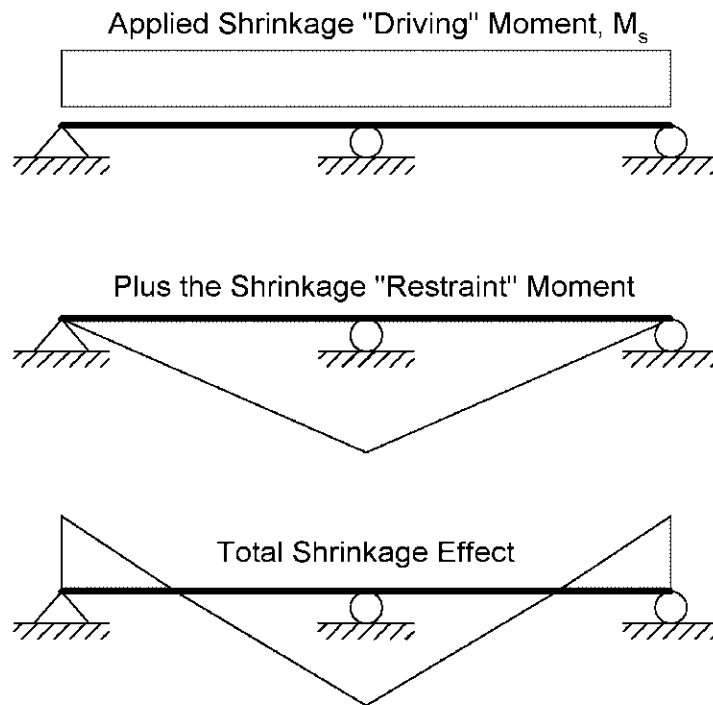
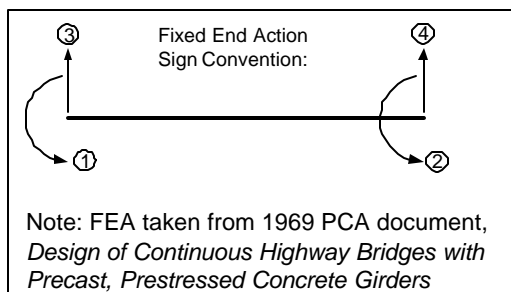

Figure 5.3-4 - Shrinkage Moment

Calculations of creep and shrinkage effects

The effect of creep and shrinkage may be determined using the method outlined in the publication entitled “Design of Continuous Highway Bridges with Precast, Prestressed Concrete Girders” published by the Portland Cement Association (PCA) in August 1969. This method is based on determining the fixed end moments required to restrain the ends of the simple span beam after the continuity connection is established. The continuous beam is then analyzed under the effect of these fixed end moments. For creep effects, the result of this analysis is the final result for creep effects. For shrinkage, the result of this analysis is added to the constant moment from shrinkage to determine the final shrinkage effects. Based on the PCA method, Table 5.3-9 gives the value of the fixed end moments for the continuous girder exterior and interior spans with straight strands as a function of the length and section properties of each span. The fixed end moments for dead load creep and shrinkage are also applicable to beams with draped strands. The PCA publication has formulas that may be used to determine the prestress creep fixed end moments for beams with draped strands.

Table 5.3-9 - Fixed End Actions for Creep and Shrinkage Effects



	DL Creep			P/S Creep			Shrinkage		
	Left End Span	Interior Span	Right End Span	Left End Span	Interior Span	Right End Span	Left End Span	Interior Span	Right End Span
Left Moment (1)	0	2/3(M _D)	M _D	0	2EIθ/L	3EIθ/L	0	M _s	1.5M _s
Right Moment (2)	-M _D	-2/3(M _D)	0	-3EIθ/L	-2EIθ/L	0	-1.5M _s	-M _s	0
Left Shear (3)	-M _D /L	0	M _D /L	-3EIθ/L ²	0	3EIθ/L ²	-3M _s /2L	0	3M _s /2L
Right Shear (4)	M _D /L	0	-M _D /L	3EIθ/L ²	0	-3EIθ/L ²	3M _s /2L	0	-3M _s /2L

Notation for Fixed End Actions:

- M_D = maximum non-composite dead load moment
- L = simple span length
- E_c = modulus of elasticity of beam concrete (final)
- I = moment of inertia of composite section
- θ = end rotation due to eccentric P/S force
- M_s = applied moment due to differential shrinkage between slab and beam

Design Step 5.3.2.3 Effect of beam age at the time of the continuity connection application

The age of the beam at the time of application of the continuity connection has a great effect on the final creep and shrinkage moments. As the age of the beam increases before pouring the deck and establishing the continuity connection, the amount of creep, and the resulting creep load effects, that takes place after the continuity connection is established gets smaller. The opposite happens to the shrinkage effects as a larger amount of beam shrinkage takes place before establishing the continuity connection leading to larger differential shrinkage between the beam and the deck.

Due to practical considerations, the age of the beam at the time the continuity connection is established can not be determined with high certainty at the time of design. In the past, two approaches were followed by bridge owners to overcome this uncertainty:

- 1) Ignore the effects of creep and shrinkage in the design of typical bridges. (The jurisdictions following this approach typically have lower stress limits at service limit states to account for the additional loads from creep and shrinkage.)*
- 2) Account for creep and shrinkage using the extreme cases for beam age at the time of establishing the continuity connection. This approach requires determining the effect of creep and shrinkage for two different cases: a deck poured over a relatively “old” beam and a deck poured over a relatively “young” beam. One state that follows this approach is Pennsylvania. The two ages of the girders assumed in the design are 30 and 450 days. In case the beam age is outside these limits, the effect of creep and shrinkage is reanalyzed prior to construction to ensure that there are no detrimental effects on the structure.*

For this example, creep and shrinkage effects were ignored. However, for reference purposes, calculations for creep and shrinkage are shown in Appendix C.

Design Step 5.4 **LOSS OF PRESTRESS (S5.9.5)**

Design Step 5.4.1 **General**

Loss of prestress can be characterized as that due to instantaneous loss and time-dependent loss. Losses due to anchorage set, friction and elastic shortening are instantaneous. Losses due to creep, shrinkage and relaxation are time-dependent.

For pretensioned members, prestress loss is due to elastic shortening, shrinkage, creep of concrete and relaxation of steel. For members constructed and prestressed in a single stage, relative to the stress immediately before transfer, the loss may be taken as:

$$Df_{pT} = Df_{pES} + Df_{pSR} + Df_{pCR} + Df_{pR2} \quad (S5.9.5.1-1)$$

where:

Df_{pES} = loss due to elastic shortening (ksi)

Df_{pSR} = loss due to shrinkage (ksi)

Df_{pCR} = loss due to creep of concrete (ksi)

Df_{pR2} = loss due to relaxation of steel after transfer (ksi)

Notice that an additional loss occurs during the time between jacking of the strands and transfer. This component is the loss due to the relaxation of steel at transfer, Df_{pR1} .

The stress limit for prestressing strands of pretensioned members given in S5.9.3 is for the stress immediately prior to transfer. To determine the jacking stress, the loss due to relaxation at transfer, Df_{pR1} , needs to be added to the stress limits in S5.9.3. Practices differ from state to state as what strand stress is to be shown on the contract drawings. The Specifications assume that the designer will determine the stress in the strands immediately before transfer. The fabricator is responsible for determining the jacking force by adding the relaxation loss at transfer, jacking losses and seating losses to the Engineer-determined stress immediately prior to transfer. The magnitude of the jacking and seating losses depends on the jacking equipment and anchorage hardware used in the precasting yard. It is recommended that the Engineer conduct preliminary calculations to determine the anticipated jacking stress.

Accurate estimation of the total prestress loss requires recognition that the time-dependent losses resulting from creep and relaxation are interdependent. If required, rigorous calculation of the prestress losses should be made in accordance with a method supported by research data. However, for conventional construction, such a refinement is seldom warranted or even possible at the design stage, since many of the factors are either unknown or beyond the designer's control. Thus, three methods of estimating time-dependent losses are provided in the LRFD Specifications: (1) the approximate

lump sum estimate, (2) a refined estimate, and (3) the background necessary to perform a rigorous time-step analysis.

The Lump Sum Method for calculating the time-dependent losses is presented in S5.9.5.3. The values obtained from this method include the loss due to relaxation at transfer, Df_{pR1} . To determine the time-dependent loss after transfer for pretensioned members, Df_{pR1} needs to be estimated and deducted from the total time-dependent losses calculated using S5.9.5.3. The refined method of calculating time-dependent losses is presented in S5.9.5.4. The method described above is used in this example.

A procedure for estimating the losses for partially prestressed members, which is analogous to that for fully prestressed members, is outlined in SC5.9.5.1.

Design Step 5.4.2 Calculate the initial stress in the tendons immediately prior to transfer (S5.9.3).

$$\begin{aligned} f_{pt} + \Delta f_{pES} &= 0.75f_{pu} \\ &= 0.75(270) \\ &= 202.5 \text{ ksi} \end{aligned}$$

Design Step 5.4.3 Determine the instantaneous losses (S5.9.5.2)

Friction (S5.9.5.2.2)

The only friction loss possible in a pretensioned member is at hold-down devices for draping or harping tendons. The LRFD Specifications specify the consideration of these losses.

For this example, all strands are straight strands and hold-down devices are not used.

Elastic Shortening, Δf_{pES} (S5.9.5.2.3)

The prestress loss due to elastic shortening in pretensioned members is taken as the concrete stress at the centroid of the prestressing steel at transfer, f_{cgp} , multiplied by the ratio of the modulus of elasticities of the prestressing steel and the concrete at transfer. This is presented in Eq. S5.9.5.2.3a-1.

$$Df_{pES} = (E_p/E_{ci})f_{cgp} \quad (S5.9.5.2.3a-1)$$

where:

f_{cgp} = sum of concrete stresses at the center of gravity of prestressing tendons due to the prestressing force at transfer and the self-weight of the member at the sections of maximum moment (ksi)

E_p = modulus of elasticity of the prestressing steel (ksi)

E_{ci} = modulus of elasticity of the concrete at transfer (ksi)

Applying this equation requires estimating the stress in the strands after transfer. Proposed estimates for pretensioned members are given in S5.9.5.2.3a.

Alternatively, the loss due to elastic shortening may be calculated using Eq. C5.9.5.2.3a-1:

$$\Delta f_{pES} = \frac{A_{ps} f_{pbt} (I_g + e_{54.5'}^2 A_g) - e_{54.5'} M_g A_g}{A_{ps} (I_g + e_{54.5'}^2 A_g) + \frac{A_g I_g E_{ci}}{E_p}} \quad (SC5.9.5.2.3a-1)$$

where:

$e_{54.5'}$ = average eccentricity of prestressing steel at midspan (in.)

f_{pbt} = stress in prestressing steel immediately prior to transfer as specified in Table S5.9.3-1; $0.75f_{pu}$ (ksi)

M_g = midspan moment due to member self-weight (k-in)

The alternative approach is used for this example.

$$\Delta f_{pES} = \frac{44(0.153)[0.75(270)][733,320 + 31.38^2(1,085)] - 31.38(20,142)(1,085)}{44(0.153)[733,320 + 31.38^2(1,085)] + \frac{1,085(733,320)(4,200)}{28,500}}$$

$$\Delta f_{pES} = 13.7 \text{ ksi}$$

Design Step 5.4.4 Calculate the prestressing stress at transfer

$$\begin{aligned} f_{pt} &= \text{Stress immediately prior to transfer} - \Delta f_{pES} \\ &= 202.5 - 13.7 \\ &= 188.8 \text{ ksi} \end{aligned}$$

Design Step 5.4.5 Calculate the prestressing force at transfer

$$\begin{aligned} P_t &= N_{\text{strands}}(A_{ps})(f_{pt}) \\ &= 44(0.153)(188.8) \\ &= 1,271 \text{ kips (initial loss} = 6.77\%) \end{aligned}$$

Design Step 5.4.6 Time-dependent losses after transfer, refined method (S5.9.5.4)

Refined estimated time-dependent losses are specified in S5.9.5.4. The refined method can provide a better estimate of total losses than the Lump Sum Method of S5.9.5.3.

Design Step 5.4.6.1 Shrinkage Losses (S5.9.5.4.2)

The expression for prestress loss due to shrinkage is a function of the average annual ambient relative humidity, H , and is given as Equation S5.9.5.4.2-1 for pretensioned members.

$$Df_{pSR} = (17.0 - 0.15H) \text{ (ksi)} \quad \text{(S5.9.5.4.2-1)}$$

where:

H = the average annual ambient relative humidity (%)

The average annual ambient relative humidity may be obtained from local weather statistics or taken from the map of Figure S5.4.2.3.3-1 shown below.

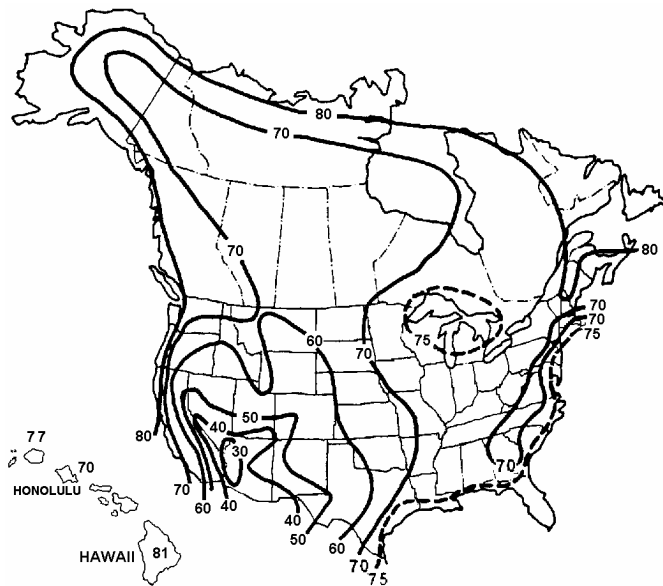

Figure S5.4.2.3.3-1 – Annual Average Ambient Relative Humidity in Percent

Calculate the loss due to shrinkage, Δf_{pSR}

For the Atlanta, Georgia area, where the example bridge is assumed, the average relative humidity may be taken as 70%.

$$\begin{aligned} \Delta f_{pSR} &= 17.0 - 0.15(70) \\ &= 6.5 \text{ ksi} \end{aligned}$$

Design Step 5.4.6.2 Creep losses (S5.9.5.4.3)

The expression for prestress losses due to creep is a function of the concrete stress at the centroid of the prestressing steel at transfer, f_{cgp} , and the change in concrete stress at the

centroid of the prestressing steel due to all permanent loads except those at transfer, Df_{cdp} , and is given by the Eq. S5.9.5.4.3-1.

$$Df_{pCR} = 12.0f_{cgp} - 7.0Df_{cdp} \geq 0 \quad (S5.9.5.4.3-1)$$

where:

f_{cgp} = concrete stress at the center of gravity of the prestressing steel at transfer (ksi)

Df_{cdp} = change in concrete stress at center of gravity of prestressing steel due to permanent loads, except the load acting at the time the prestressing force is applied. Values of Df_{cdp} should be calculated at the same section or at sections for which f_{cgp} is calculated (ksi)

The value of Df_{cdp} includes the effect of the weight of the diaphragm, slab and haunch, parapets, future wearing surface, utilities and any other permanent loads, other than the loads existing at transfer at the section under consideration, applied to the bridge.

Calculate the loss due to creep, Δf_{pCR}

Determine the concrete stress at the center of gravity of prestressing steel at transfer, f_{cgp} .

$$f_{cgp} = \frac{\frac{A_{ps}(0.75f_{pu})}{A_g} \left(1 + \frac{e_{54.5'}^2 A_g}{I_g} \right) - \frac{M_g e_{54.5'}}{I_g}}{1 + \frac{A_{ps}}{A_g} \left(\frac{E_p}{E_{ci}} \right) \left(1 + \frac{e_{54.5'}^2 A_g}{I_g} \right)}$$

$$f_{cgp} = \frac{\frac{44(0.153)(0.75(270))}{1,085} \left(1 + \frac{31.38^2(1,085)}{733,320} \right) - \frac{20,142(31.38)}{733,320}}{1 + \frac{44(0.153)}{1,085} \left(\frac{28,500}{4,200} \right) \left(1 + \frac{31.38^2(1,085)}{733,320} \right)}$$

$$f_{cgp} = [1.256(2.457) - 0.862]/1.103$$

$$= 2.016 \text{ ksi}$$

Notice that the second term in both the numerator and denominator in the above equation for f_{cgp} makes this calculation based on the transformed section properties. Calculating f_{cgp} using the gross concrete section properties of the concrete section is also acceptable, but will result in a higher concrete stress and, consequently, higher calculated losses. Deleting the second term from both the numerator and denominator of the above equation gives the stress based on the gross concrete section properties.

The value of f_{cgp} may also be determined using two other methods:

- 1) Use the same equation above and set the stress in the strands equal to the stress after transfer (188.8 ksi) instead of the stress immediately prior to transfer ($0.75f_{pu} = 202.5$ ksi) and let the value of the denominator be 1.0.
- 2) Since the change in the concrete strain during transfer (strain immediately prior to transfer minus strain immediately after transfer) is equal to the change in strain in the prestressing strands during transfer, the change in concrete stress is equal to the change in prestressing stress during transfer divided by the modular ratio between prestressing steel and concrete at transfer. Noticing that the concrete stress immediately prior to transfer is 0.0 and that the change in prestressing stress during transfer is the loss due to elastic shortening = 13.7 ksi, f_{cgp} can be calculated as:

$$\begin{aligned} f_{cgp} &= 13.7 / (28,500 / 4,200) \\ &= 2.019 \text{ ksi} \cong 2.016 \text{ ksi calculated above (difference due to rounding)} \end{aligned}$$

Determine Δf_{cdp} as defined above.

$$\Delta f_{cdp} = [(M_{dia} + M_{slab})e_{54.5'}] / I_g + [(M_{parapet} + M_{FWS})(N.A._{beambot} - CGS_{ps})] / I_c$$

$$\Delta f_{cdp} = [(138 + 1,696)(12)31.38] / 733,320 + [(165 + 222)(12)(51.54 - 5.0)] / 1,384,254$$

$$\Delta f_{cdp} = 1.10 \text{ ksi}$$

Solving,

$$\begin{aligned} \Delta f_{pCR} &= 12.0(2.016) - 7.0(1.10) \\ &= 16.49 \text{ ksi} \end{aligned}$$

Design Step 5.4.6.3 Relaxation (S5.9.5.4.4)

The total relaxation at any time after transfer is composed of two components: relaxation at transfer and relaxation after transfer.

After Transfer (S5.9.5.4.4c):

Article S5.9.5.4.4c provides equations to estimate relaxation after transfer for pretensioned members with stress-relieved or low relaxation strands.

For pretensioning with stress-relieved strands:

$$Df_{pR2} = 20.0 - 0.4Df_{pES} - 0.2(Df_{pSR} + Df_{pCR}) \text{ (ksi)} \quad (S5.9.5.4.4c-1)$$

where:

Df_{pES} = loss due to elastic shortening (ksi)

Df_{pSR} = loss due to shrinkage (ksi)

Df_{pCR} = loss due to creep of concrete (ksi)

For prestressing steels with low relaxation properties conforming to AASHTO M 203 (ASTM A 416 or E 328) use 30% of Df_{pR2} given by the above equation.

Relaxation losses increase with increasing temperatures. The expressions given for relaxation are appropriate for normal temperature ranges only.

Losses due to relaxation should be based on approved test data. If test data is not available, the loss may be assumed to be 3.0 ksi.

Calculate the loss due to relaxation after transfer, Δf_{pR2}

$$\begin{aligned}\Delta f_{pR2} &= 20.0 - 0.4(13.7) - 0.2(6.5 + 16.49) \\ &= 9.92 \text{ ksi}\end{aligned}$$

For low relaxation strands, multiply Δf_{pR2} by 30%.

$$\begin{aligned}\Delta f_{pR2} &= 0.3(9.92) \\ &= 2.98 \text{ ksi}\end{aligned}$$

Design Step 5.4.7 Calculate total loss after transfer

$$\begin{aligned}\Delta f_{pT} &= \Delta f_{pES} + \Delta f_{pSR} + \Delta f_{pCR} + \Delta f_{pR2} \\ &= 13.7 + 6.5 + 16.49 + 2.98 \\ &= 39.67 \text{ ksi}\end{aligned}$$

Design Step 5.4.8 Calculate the final effective prestress responses

$$\begin{aligned}\text{Max } f_{pe} &= 0.80f_{py} \quad (\text{Table S5.9.3-1 – Stress Limits for Prestressing Tendons at the Service Limit State after all losses}) \\ &= 0.8(243) \\ &= 194.4 \text{ ksi}\end{aligned}$$

Calculate the actual effective prestress stress after all losses

$$\begin{aligned}f_{pe} &= 0.75f_{pu} - \Delta f_{pT} \\ &= 0.75(270) - 39.67 \\ &= 162.83 \text{ ksi} < 194.4 \text{ ksi} \quad \mathbf{OK}\end{aligned}$$

Calculate the actual effective prestress force after all losses

$$\begin{aligned}
 P_e &= N_{\text{strands}}(A_{ps})(f_{pe}) \\
 &= 44(0.153)(162.83) \\
 &= 1,096 \text{ kips (total loss = 19.59\%)}
 \end{aligned}$$

Design Step 5.4.9 Calculate jacking stress, f_{pj}

As indicated earlier, the Fabricator is responsible for calculation of the jacking force. The calculations presented below are for reference purposes.

As shown earlier, the stress in the prestressing strands immediately prior to transfer is 202.5 ksi.

The Jacking Stress, f_{pj} = Stress immediately prior to transfer + Relaxation loss at transfer

Relaxation at transfer (S5.9.5.4.4b) – time-dependent loss

Generally, the initial relaxation loss is now determined by the Fabricator. Where the Engineer is required to make an independent estimate of the initial relaxation loss, or chooses to do so as provided in S5.9.5.1, the provisions of this article may be used as a guide. If project-specific information is not available, the value of f_{pj} may be taken as $0.80f_{pu}$ for the purpose of this calculation. For this example, f_{pj} will be taken as $0.75f_{pu}$.

Article S5.9.5.4.4b provides equations to estimate relaxation at transfer for pretensioned members, initially stressed in excess of 50% of the tendon’s tensile strength, f_{pu} .

For low-relaxation strands:

$$\Delta f_{pR1} = \frac{\log(24.0t)}{40.0} \left[\frac{f_{pj}}{f_{py}} - 0.55 \right] f_{pj} \quad (S5.9.5.4.4b-2)$$

where:

t = time estimated in days from stressing to transfer (days) assumed to be 1 day for this example

f_{pj} = initial stress in the tendon at the end of stressing (ksi) assumed to be 205.0 ksi for this example

f_{py} = specified yield strength of prestressing steel (ksi)

$$\Delta f_{pR1} = \frac{\log(24.0(1))}{40.0} \left[\frac{205.0}{243} - 0.55 \right] 205.0$$

$$\Delta f_{pR1} = 2.08 \text{ ksi}$$

Therefore,
Jacking stress, f_{pj} = 202.5 + 2.08
= 204.58 ksi

Design Step 5.5 | **STRESS IN PRESTRESSING STRANDS**

Design Step 5.5.1 | **Stress in prestressing strands at nominal flexural resistance**

The stress in prestressing steel at nominal flexural resistance may be determined using stress compatibility analysis. In lieu of such analysis a simplified method is presented in S5.7.3.1.1. This method is applicable to rectangular or flanged sections subjected to flexure about one axis where the Whitney stress block stress distribution specified in S5.7.2.2 is used and for which f_{pe} , the effective prestressing steel stress after losses, is not less than $0.5f_{pu}$. The average stress in prestressing steel, f_{ps} , may be taken as:

$$f_{ps} = f_{pu}[1 - k(c/d_p)] \quad (S5.7.3.1.1-1)$$

where:

$$k = 2(1.04 - f_{py}/f_{pu}) \quad (S5.7.3.1.1-2)$$

The value of “k” may be calculated using the above equation based on the type and properties of prestressing steel used or it may be obtained from Table SC5.7.3.1.1-1.

The distance from the neutral axis to the compression face of the member may be determined as follows:

for T-section behavior (Eq. S5.7.3.1.1-3):

$$c = \frac{A_{ps} f_{pu} + A_s f_y - A'_s f'_y - 0.85 \beta_1 f'_c (b - b_w) h_f}{0.85 f'_c \beta_1 b_w + k A_{ps} \frac{f_{pu}}{d_p}}$$

for rectangular section behavior (Eq. S5.7.3.1.1-4):

$$c = \frac{A_{ps} f_{pu} + A_s f_y - A'_s f'_y}{0.85 f'_c \beta_1 b + k A_{ps} \frac{f_{pu}}{d_p}}$$

T-sections where the neutral axis lies in the flange, i.e., “c” is less than the slab thickness, are considered rectangular sections.

From Table SC5.7.3.1.1-1:

$$k = 0.28 \text{ for low relaxation strands}$$

Assuming rectangular section behavior with no compression steel or mild tension reinforcement:

$$c = A_{ps} f_{pu} / [0.85 f'_c \beta_1 b + k A_{ps} (f_{pu}/d_p)]$$

For the midspan section

$$\begin{aligned} \text{Total section depth, } h &= \text{girder depth} + \text{structural slab thickness} \\ &= 72 + 7.5 \\ &= 79.5 \text{ in.} \end{aligned}$$

$$\begin{aligned} d_p &= h - (\text{distance from bottom of beam to location of P/S steel force}) \\ &= 79.5 - 5.0 \\ &= 74.5 \text{ in.} \end{aligned}$$

$$\beta_1 = 0.85 \text{ for 4 ksi slab concrete (S5.7.2.2)}$$

$$\begin{aligned} b &= \text{effective flange width (calculated in Section 2 of this example)} \\ &= 111 \text{ in.} \end{aligned}$$

$$\begin{aligned} c &= 6.73(270)/[0.85(4)(0.85)(111) + 0.28(6.73)(270/74.5)] \\ &= 5.55 \text{ in.} < \text{structural slab thickness} = 7.5 \text{ in.} \end{aligned}$$

The assumption of the section behaving as a rectangular section is correct.

Notice that if “c” from the calculations above was greater than the structural slab thickness (the integral wearing surface is ignored), the calculations for “c” would have to be repeated assuming a T-section behavior following the steps below:

- 1) *Assume the neutral axis lies within the precast girder flange thickness and calculate “c”. For this calculation, the girder flange width and area should be converted to their equivalent in slab concrete by multiplying the girder flange width by the modular ratio between the precast girder concrete and the slab concrete. The web width in the equation for “c” will be substituted for using the effective converted girder flange width. If the calculated value of “c” exceeds the sum of the deck thickness and the precast girder flange thickness, proceed to the next step. Otherwise, use the calculated value of “c”.*
- 2) *Assume the neutral axis is below the flange of the precast girder and calculate “c”. The term “ $0.85 f_c \beta_1 (b - b_w)$ ” in the calculations should be broken into two terms, one refers to the contribution of the deck to the composite section flange and the second refers to the contribution of the precast girder flange to the composite girder flange.*

$$\begin{aligned} f_{ps} &= f_{pu}[1 - k(c/d_p)] && \text{(S5.7.3.1.1-1)} \\ &= 270[1 - 0.28(5.55/74.5)] \\ &= 264.4 \text{ ksi} \end{aligned}$$

Design Step 5.5.2 Transfer and development length

$$\begin{aligned} \text{Transfer Length} &= 60(\text{Strand diameter}) && \text{(S5.11.4.1)} \\ &= 60(0.5 \text{ in.}) \\ &= 30 \text{ in.} \end{aligned}$$

$$\text{Development Length} = l_d \geq \kappa [f_{ps} - (2/3)f_{pe}]d_b \quad \text{(S5.11.4.2-1)}$$

From earlier calculations:

$$\begin{aligned} f_{ps} &= 264.4 \text{ ksi (Design Step 5.4.8)} \\ f_{pe} &= 162.83 \text{ ksi (Design Step 5.5.1)} \end{aligned}$$

From S5.11.4.2, $\kappa = 1.6$ for fully bonded strands

From S5.11.4.3, $\kappa = 2.0$ for partially debonded strands

For fully bonded strands (32 strands):

$$l_d \geq 1.6[264.4 - (2/3)162.83](0.5) = 124.7 \text{ in. (10.39 ft. or } 10^{\prime}\text{-}4 \frac{11}{16}\text{'')}$$

For partially debonded strands (two groups of 6-strands each):

$$l_d \geq 2.0[264.4 - (2/3)162.83](0.5) = 155.8 \text{ in. (12.98 ft. or } 12^{\prime}\text{-}11 \frac{3}{4}\text{'')}$$

Design Step 5.5.3 Variation in stress in prestressing steel along the length of the girders

According to S5.11.4.1, the prestressing force, f_{pe} , may be assumed to vary linearly from 0.0 at the point where bonding commences to a maximum at the transfer length. Between the transfer length and the development length, the strand force may be assumed to increase in a parabolic manner, reaching the tensile strength of the strand at the development length.

To simplify the calculations, many jurisdictions assume that the stress increases linearly between the transfer and the development lengths. This assumption is used in this example.

As shown in Figures 2-5 and 2-6, each beam contains three groups of strands:

Group 1: 32 strands fully bonded, i.e., bonded length starts 9 in. outside the centerline of bearings of the noncomposite beam

Group 2: 6 strands. Bonded length starts 10 ft. from the centerline of bearings of the noncomposite beam, i.e., 10'-9" from the end of the beam

Group 3: 6 strands. Bonded length starts 22 ft. from the centerline of bearings of the noncomposite beam, i.e., 22'-9" from the end of the beam

For each group, the stress in the prestressing strands is assumed to increase linearly from 0.0 at the point where bonding commences to f_{pe} , over the transfer length, i.e., over 30 inches. The stress is also assumed to increase linearly from f_{pe} at the end of the transfer length to f_{ps} at the end of the development length. Table 5.5-1 shows the strand forces at the service limit state (maximum strand stress = f_{pe}) and at the strength limit state (maximum strand stress = f_{ps}) at different sections along the length of the beams. To facilitate the calculations, the forces are calculated for each of the three groups of strands separately and sections at the points where bonding commences, end of transfer length and end of development length for each group are included in the tabulated values. Figure 5.5-1 is a graphical representation of Table 5.5-1.

Table 5.5-1 – Prestressing Strand Forces

Dist. from Grdr End	Dist. from CL of Brg	Initial Prestressing Force at Transfer			
		Group 1	Group 2	Group 3	Total
(ft)	(ft)	(k)	(k)	(k)	(k)
0 [*]	-0.75 [*]	0.0			0.0
0.75	0.00	277.3			277.3
2.50	1.75	924.4			924.4
7.75	7.00	924.4			924.4
10.39	9.64	924.4			924.4
10.75 ^{**}	10.00 ^{**}	924.4	0.0		924.4
11.75	11.00	924.4	69.3		993.7
13.25	12.50	924.4	173.3		1,097.7
17.25	16.50	924.4	173.3		1,097.7
22.75 ^{***}	22.00 ^{***}	924.4	173.3	0.0	1,097.7
23.73	22.98	924.4	173.3	67.9	1,165.6
25.25	24.50	924.4	173.3	173.3	1,271.0
28.25	27.50	924.4	173.3	173.3	1,271.0
33.75	33.00	924.4	173.3	173.3	1,271.0
35.73	34.98	924.4	173.3	173.3	1,271.0
39.25	38.50	924.4	173.3	173.3	1,271.0
44.75	44.00	924.4	173.3	173.3	1,271.0
50.25	49.50	924.4	173.3	173.3	1,271.0
55.25	54.50	924.4	173.3	173.3	1,271.0
55.75	55.00	924.4	173.3	173.3	1,271.0
61.25	60.50	924.4	173.3	173.3	1,271.0
66.75	66.00	924.4	173.3	173.3	1,271.0
72.25	71.50	924.4	173.3	173.3	1,271.0
74.77	74.02	924.4	173.3	173.3	1,271.0
77.75	77.00	924.4	173.3	173.3	1,271.0
83.25	82.50	924.4	173.3	173.3	1,271.0
85.25	84.50	924.4	173.3	173.3	1,271.0
86.77	86.02	924.4	173.3	67.9	1,165.6
87.75 ⁺⁺⁺	87.00 ⁺⁺⁺	924.4	173.3	0.0	1,097.7
88.75	88.00	924.4	173.3		1,097.7
94.25	93.50	924.4	173.3		1,097.7
97.25	96.50	924.4	173.3		1,097.7
99.75 ⁺⁺	99.00 ⁺⁺	924.4	0.0		924.4
100.11	99.36	924.4			924.4
103.25	102.50	924.4			924.4
108.00	107.25	924.4			924.4
109.75	109.00	277.3			277.3
110.5 ⁺	109.75 ⁺	0.0			0.0

*, **, *** - Point where bonding commences for strand Groups 1, 2, and 3, respectively

+, ++, +++ - Point where bonding ends for strand Groups 1, 2, and 3, respectively

Table 5.5-1 (cont.) – Prestressing Strand Forces

Dist. from Grdr End	Dist. from CL of Brg	Prestressing Force After Losses				Force at the Nominal Flexural Resistance			
		Group 1	Group 2	Group 3	Total	Group 1	Group 2	Group 3	Total
(ft)	(ft)	(k)	(k)	(k)	(k)	(k)	(k)	(k)	(k)
0*	-0.75*	0.0			0.0	0.0			0.0
0.75	0.00	239.0			239.0	239.0			239.0
2.50	1.75	797.2			797.2	797.2			797.2
7.75	7.00	797.2			797.2	1,128.1			1,128.1
10.39	9.64	797.2			797.2	1,294.5			1,294.5
10.75**	10.00**	797.2	0.0		797.2	1,294.5	0.0		1,294.5
11.75	11.00	797.2	59.8		857.0	1,294.5	59.8		1,354.3
13.25	12.50	797.2	149.5		946.7	1,294.5	149.5		1,444.0
17.25	16.50	797.2	149.5		946.7	1,294.5	185.1		1,479.6
22.75***	22.00***	797.2	149.5	0.0	946.7	1,294.5	234.0	0.0	1,528.5
23.73	22.98	797.2	149.5	58.6	1,005.3	1,294.5	242.7	58.6	1,595.8
25.25	24.50	797.2	149.5	149.5	1,096.2	1,294.5	242.7	149.5	1,686.7
28.25	27.50	797.2	149.5	149.5	1,096.2	1,294.5	242.7	176.2	1,713.4
33.75	33.00	797.2	149.5	149.5	1,096.2	1,294.5	242.7	225.1	1,762.3
35.73	34.98	797.2	149.5	149.5	1,096.2	1,294.5	242.7	242.7	1,779.9
39.25	38.50	797.2	149.5	149.5	1,096.2	1,294.5	242.7	242.7	1,779.9
44.75	44.00	797.2	149.5	149.5	1,096.2	1,294.5	242.7	242.7	1,779.9
50.25	49.50	797.2	149.5	149.5	1,096.2	1,294.5	242.7	242.7	1,779.9
55.25	54.50	797.2	149.5	149.5	1,096.2	1,294.5	242.7	242.7	1,779.9
55.75	55.00	797.2	149.5	149.5	1,096.2	1,294.5	242.7	242.7	1,779.9
61.25	60.50	797.2	149.5	149.5	1,096.2	1,294.5	242.7	242.7	1,779.9
66.75	66.00	797.2	149.5	149.5	1,096.2	1,294.5	242.7	242.7	1,779.9
72.25	71.50	797.2	149.5	149.5	1,096.2	1,294.5	242.7	242.7	1,779.9
74.77	74.02	797.2	149.5	149.5	1,096.2	1,294.5	242.7	242.7	1,779.9
77.75	77.00	797.2	149.5	149.5	1,096.2	1,294.5	242.7	216.2	1,753.4
83.25	82.50	797.2	149.5	149.5	1,096.2	1,294.5	242.7	167.3	1,704.5
85.25	84.50	797.2	149.5	149.5	1,096.2	1,294.5	242.7	149.5	1,686.7
86.77	86.02	797.2	149.5	58.6	1,005.3	1,294.5	242.7	58.6	1,595.8
87.75+++	87.00+++	797.2	149.5	0.0	946.7	1,294.5	234.0	0.0	1,528.5
88.75	88.00	797.2	149.5		946.7	1,294.5	225.1		1,519.6
94.25	93.50	797.2	149.5		946.7	1,294.5	176.2		1,470.7
97.25	96.50	797.2	149.5		946.7	1,294.5	149.5		1,444.0
99.75++	99.00++	797.2	0.0		797.2	1,294.5	0.0		1,294.5
100.11	99.36	797.2			797.2	1,294.5			1,294.5
103.25	102.50	797.2			797.2	1,096.6			1,096.6
108.00	107.25	797.2			797.2	797.2			797.2
109.75	109.00	239.0			239.0	239.0			239.0
110.5+	109.75+	0.0			0.0	0.0			0.0

*, **, *** - Point where bonding commences for strand Groups 1, 2, and 3, respectively

+, ++, +++ - Point where bonding ends for strand Groups 1, 2, and 3, respectively

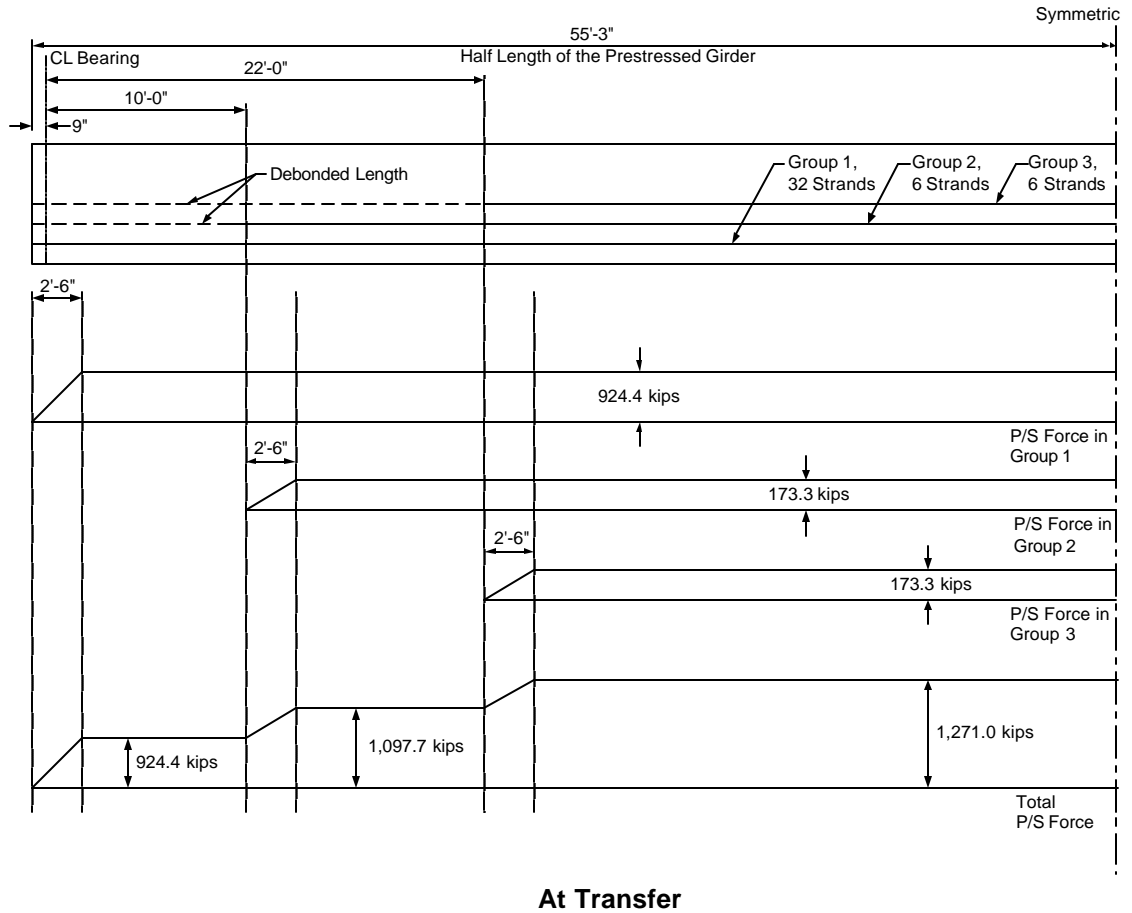
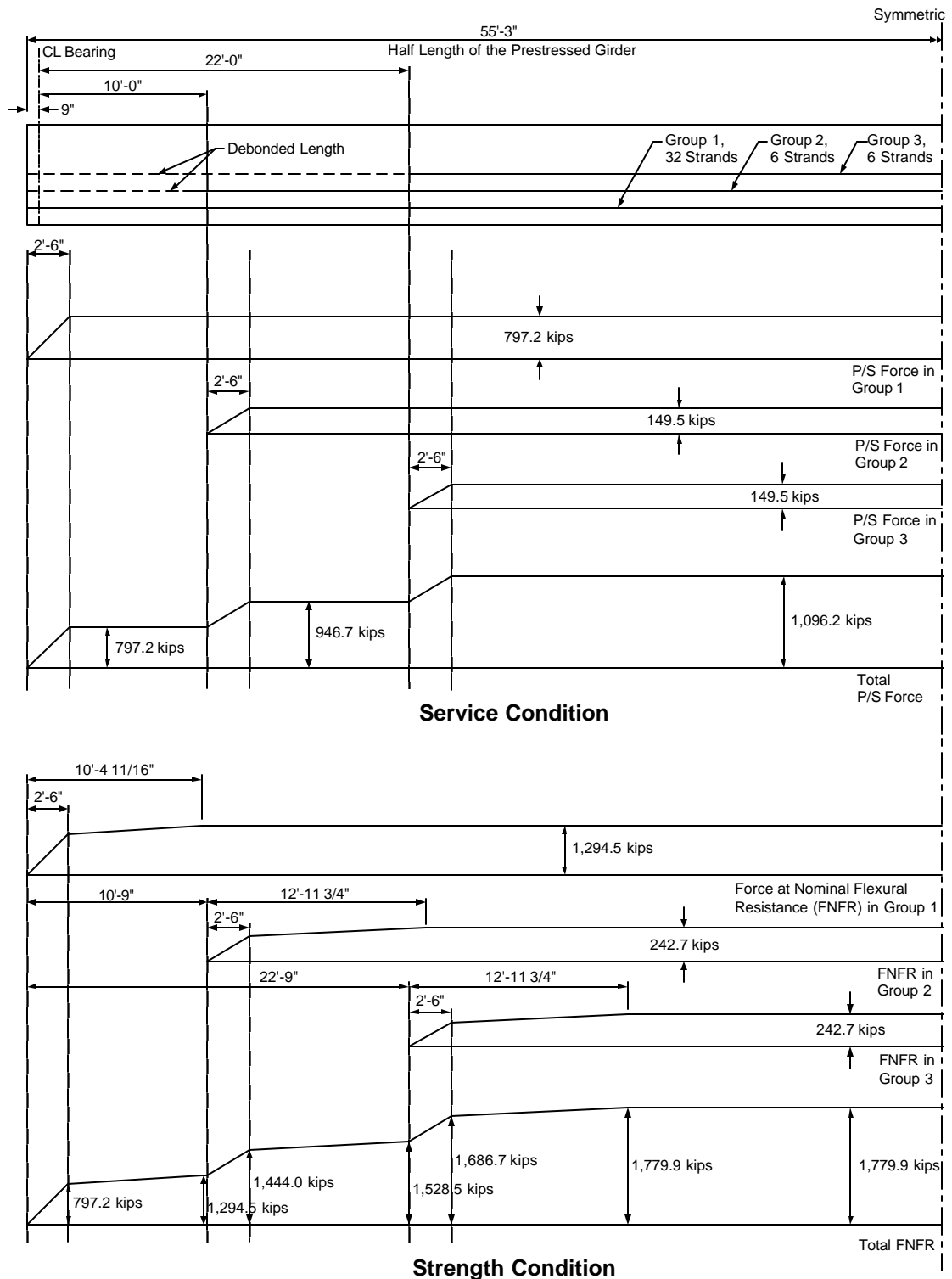

Figure 5.5-1 – Prestressing Strand Forces Shown Graphically



Transfer length = 30 in.
 Development length, fully bonded = 124.7 in.
 Development length, debonded = 155.8 in.

Figure 5.5-1 (cont.) – Prestressing Strand Forces Shown Graphically

Design Step 5.5.4 | **Sample strand stress calculations**
Prestress force at centerline of end bearing after losses under Service or Strength

Only Group 1 strands are bonded at this section. Ignore Group 2 and 3 strands.

Distance from the point bonding commences for Group 1 strands = 0.75 ft < transfer length

$$\begin{aligned} \text{Percent of prestressing force developed in Group 1 strands} &= 0.75/\text{transfer length} \\ &= (0.75/2.5)(100) = 30\% \end{aligned}$$

$$\text{Stress in strands} = 0.3(162.83) = 48.8 \text{ ksi}$$

$$\text{Force in strands at the section} = 32(0.153)(48.8) = 239 \text{ kips}$$

Prestress force at a section 11 ft. from the centerline of end bearing after losses under Service conditions

Only strands in Group 1 and 2 are bonded at this section. Ignore Group 3 strands.

The bonded length of Group 1 strands before this section is greater than the transfer length. Therefore, the full prestressing force exists in Group 1 strands.

$$\text{Force in Group 1 strands} = 32(0.153)(162.83) = 797.2 \text{ kips}$$

Distance from the point bonding commences for Group 2 strands = 1.0 ft. < transfer length

$$\begin{aligned} \text{Percent of prestressing force developed in Group 2 strands} &= 1.0/\text{transfer length} \\ &= (1.0/2.5)(100) = 40\% \end{aligned}$$

$$\text{Stress in Group 2 strands} = 0.4(162.83) = 65.1 \text{ ksi}$$

$$\text{Force in Group 2 strands at the section} = 6(0.153)(65.1) = 59.8 \text{ kips}$$

$$\begin{aligned} \text{Total prestressing force at this section} &= \text{force in Group 1} + \text{force in Group 2} \\ &= 797.2 + 59.8 = 857 \text{ kips} \end{aligned}$$

Strands maximum resistance at nominal flexural capacity at a section 7.0 ft. from the centerline of end bearing

Only Group 1 strands are bonded at this section. Ignore Group 2 and 3 strands.

Distance from the point bonding commences for Group 1 strands, i.e., distance from end of beam = 7.75 ft. (7'- 9")

This distance is greater than the transfer length (2.5 ft.) but less than the development length of the fully bonded strands (10.39 ft.). Therefore, the stress in the strand is assumed to reach f_{pe} , 162.83 ksi, at the transfer length then increases linearly from f_{pe} to f_{ps} , 264.4 ksi, between the transfer length and the development length.

$$\begin{aligned}\text{Stress in Group 1 strands} &= 162.83 + (264.4 - 162.83)[(7.75 - 2.5)/(10.39 - 2.5)] \\ &= 230.41 \text{ ksi}\end{aligned}$$

$$\begin{aligned}\text{Force in Group 1 strands} &= 32(0.153)(230.41) \\ &= 1,128.1 \text{ kips}\end{aligned}$$

Strands maximum resistance at nominal flexural capacity at a section 22 ft. from centerline of end bearing

Only strands in Group 1 and 2 are bonded at this section. Ignore Group 3 strands.

The bonded length of Group 1 strands before this section is greater than the development length for Group 1 (fully bonded) strands. Therefore, the full force exists in Group 1 strands.

$$\text{Force in Group 1 strands} = 32(0.153)(264.4) = 1,294.5 \text{ kips}$$

The bonded length of Group 2 at this section = 22 – 10 = 12 ft.

$$\begin{aligned}\text{Stress in Group 2 strands} &= 162.83 + (264.4 - 162.83)[(12 - 2.5)/(12.98 - 2.5)] \\ &= 254.9 \text{ ksi}\end{aligned}$$

$$\text{Force in Group 2 strands} = 6(0.153)(254.9) = 234.0 \text{ kips}$$

$$\begin{aligned}\text{Total prestressing force at this section} &= \text{force in Group 1} + \text{force in Group 2} \\ &= 1,294.5 + 234.0 \\ &= 1,528.5 \text{ kips}\end{aligned}$$

Design Step 5.6 FLEXURE DESIGN**Design Step 5.6.1 Flexural stress at transfer****Design Step 5.6.1.1 Stress limits at transfer**

Compression stress:

The allowable compression stress limit for pretensioned concrete components is calculated according to S5.9.4.1.1.

$$\begin{aligned}f_{\text{Compression}} &= -0.60(f'_{ci}) \\ &= -0.60(4.8 \text{ ksi}) \\ &= -2.88 \text{ ksi}\end{aligned}$$

Tension stress:

From Table S5.9.4.1.2-1, the stress limit in areas with bonded reinforcement sufficient to resist 120% of the tension force in the cracked concrete computed on the basis of an uncracked section is calculated as:

$$\begin{aligned}f_{\text{Tension}} &= 0.22\sqrt{f'_{ci}} \\ &= 0.22\sqrt{4.8} \\ &= 0.48 \text{ ksi}\end{aligned}$$

Design Step Stress calculations at transfer
5.6.1.2

Table 5.6-1 – Stresses at Top and Bottom of Beam at Transfer

Location (ft.) ⁽¹⁾	Girder self weight moment (k-ft) ⁽²⁾	F _{ps} at transfer (kips) ⁽³⁾	Stress at transfer	
			Top of beam (ksi)	Bottom of beam (ksi)
0	47	277.3	0.135	-0.654
1.75	153	924.4	0.451	-2.183
5.5	368	924.4	0.326	-2.055
11.0	656	993.7	0.209	-2.065
16.5	909	1,097.7	0.123	-2.171
22.0	1,128	1,097.7	-0.005	-2.040
27.5	1,313	1,271.0	-0.009	-2.358
33.0	1,464	1,271.0	-0.097	-2.269
38.5	1,580	1,271.0	-0.155	-2.209
44.0	1,663	1,271.0	-0.203	-2.160
49.5	1,711	1,271.0	-0.231	-2.132
54.5	1,725	1,271.0	-0.240	-2.120
55.0	1,725	1,271.0	-0.240	-2.123
60.5	1,705	1,271.0	-0.228	-2.135
66.0	1,650	1,271.0	-0.196	-2.168
71.5	1,562	1,271.0	-0.144	-2.220
77.0	1,439	1,271.0	-0.083	-2.284
82.5	1,282	1,271.0	0.009	-2.377
88.0	1,091	1,097.7	0.017	-2.063
93.5	865	1,097.7	0.149	-2.197
99.0	606	924.4	0.197	-1.923
104.5	312	924.4	0.358	-2.105
107.25	153	924.4	0.451	-2.200
109.0	47	277.3	0.135	-0.660

Notes:

- 1 - Distance measured from the centerline of the bearing of the simple span girder
 2 - See Section 5.3, based on 110.5 ft. length
 3 - See Section 5.5 for prestressing forces

Sample Calculations for Flexural Stresses at Transfer

Definitions:

- P_t = Initial prestressing force taken from Table 5.5-1 (kips)
 A_g = Gross area of the basic beam (in²)
 e = Distance between the neutral axis of the noncomposite girder and the center of gravity of the prestressing steel (in.)

$$\begin{aligned}
 S_t &= \text{Section moduli, top of noncomposite beam (in}^3\text{)} \\
 S_b &= \text{Section moduli, bottom of noncomposite beam (in}^3\text{)} \\
 M_g &= \text{Moment due to the girder self weight only (k-ft)}
 \end{aligned}$$

See Section 2.2 for section properties.

Sample Calculations at 1 ft. – 9 in. From CL of Bearing (2 ft. – 6 in. From Girder End)

Girder top stress:

$$\begin{aligned}
 f_{top} &= -P_t/A_g + P_t e_0'/S_t - M_g/S_t \\
 &= \frac{-924.4}{1,085} + \frac{924.4(31.005)}{20,588} - \frac{153(12)}{20,588} \\
 &= 0.451 \text{ ksi} < \text{Stress limit for tension (0.48 ksi) } \mathbf{OK}
 \end{aligned}$$

Girder bottom stress:

$$\begin{aligned}
 f_{bottom} &= -P_t/A_g - P_t e_0'/S_b + M_g/S_b \\
 &= \frac{-924.4}{1,085} - \frac{924.4(31.005)}{20,157} + \frac{153(12)}{20,157} \\
 &= -2.183 \text{ ksi} < \text{Stress limit for compression (-2.88 ksi) } \mathbf{OK}
 \end{aligned}$$

Sample Calculations at 11 ft. From the CL of Bearing (11 ft. – 9 in. From Girder End)

Girder top stress:

$$\begin{aligned}
 f_{top} &= -P_t/A_g + P_t e_{11}'/S_t - M_g/S_t \\
 &= \frac{-993.7}{1,085} + \frac{993.7(31.222)}{20,588} - \frac{656(12)}{20,588} \\
 &= 0.209 \text{ ksi} < \text{Stress limit for tension (0.48 ksi) } \mathbf{OK}
 \end{aligned}$$

Girder bottom stress:

$$\begin{aligned}
 f_{bottom} &= -P_t/A_g - P_t e_{11}'/S_b + M_g/S_b \\
 &= \frac{-993.7}{1,085} - \frac{993.7(31.222)}{20,157} + \frac{656(12)}{20,157} \\
 &= -2.064 \text{ ksi} < \text{Stress limit for compression (-2.88 ksi) } \mathbf{OK}
 \end{aligned}$$

Sample Calculations at 54 ft. – 6 in. From the CL of Bearing (55 ft. – 3 in. From Girder End) – Midspan of Noncomposite Beam

Girder top stress:

$$\begin{aligned} f_{\text{top}} &= -P_t/A_g + P_t e_{54.5'} / S_t - M_g / S_t \\ &= \frac{-1,271.0}{1,085} + \frac{1,271.0(31.38)}{20,588} - \frac{1,725(12)}{20,588} \\ &= -0.239 \text{ ksi} < \text{Stress limit for compression (-2.88 ksi)} \quad \mathbf{OK} \end{aligned}$$

Girder bottom stress:

$$\begin{aligned} f_{\text{bottom}} &= -P_t/A_g - P_t e_{54.5'} / S_b + M_g / S_b \\ &= \frac{-1,271.0}{1,085} - \frac{1,271.0(31.38)}{20,157} + \frac{1,725(12)}{20,157} \\ &= -2.123 \text{ ksi} < \text{Stress limit for compression (-2.88 ksi)} \quad \mathbf{OK} \end{aligned}$$

Design Step 5.6.2 Final flexural stress under Service I limit state

Maximum compression is checked under Service I limit state and maximum tension is checked under Service III limit state. The difference between Service I and Service III limit states is that Service I has a load factor of 1.0 for live load while Service III has a load factor of 0.8.

As indicated in Section 5.3, many jurisdictions do not include creep and shrinkage effects in designing a pretensioned girder bridge. The calculations presented herein do not include creep and shrinkage moments. If creep and shrinkage are required by a specific jurisdiction, then their effects should be included. See Section 5.3 and Appendix C for calculations and values of creep and shrinkage effects for the example bridge.

Design Step 5.6.2.1 Stress limits

Compression stress:

From Table S5.9.4.2.1-1, the stress limit due to the sum of the effective prestress, permanent loads, and transient loads and during shipping and handling is taken as $0.6\phi_w f_c$ (where ϕ_w is equal to 1.0 for solid sections).

For prestressed concrete beams ($f_c = 6.0$ ksi)

$$\begin{aligned} f_{\text{Comp, beam1}} &= -0.6(6.0 \text{ ksi}) \\ &= -3.6 \text{ ksi} \end{aligned}$$

For deck slab ($f_c = 4.0$ ksi)

$$\begin{aligned} f_{\text{Comp, slab}} &= -0.6(4.0 \text{ ksi}) \\ &= -2.4 \text{ ksi} \end{aligned}$$

From Table S5.9.4.2.1-1, the stress limit in prestressed concrete at the service limit state after losses for fully prestressed components in bridges other than segmentally constructed due to the sum of effective prestress and permanent loads shall be taken as:

$$\begin{aligned} f_{\text{Comp, beam 2}} &= -0.45(f_c) \\ &= -0.45(6.0) \\ &= -2.7 \text{ ksi} \end{aligned}$$

From Table S5.9.4.2.1-1, the stress limit in prestressed concrete at the service limit state after losses for fully prestressed components in bridges other than segmentally constructed due to live load plus one-half the sum of the effective prestress and permanent loads shall be taken as:

$$\begin{aligned} f_{\text{Comp, beam 3}} &= -0.40(f_c) \\ &= -0.40(6.0) \\ &= -2.4 \text{ ksi} \end{aligned}$$

Tension stress:

From Table S5.9.4.2.2-1, the stress limit in prestressed concrete at the service limit state after losses for fully prestressed components in bridges other than segmentally constructed, which include bonded prestressing tendons and are subjected to not worse than moderate corrosion conditions shall be taken as the following:

$$\begin{aligned} f_{\text{Tensile}} &= 0.19\sqrt{f_c'} \\ &= 0.19\sqrt{6} \\ &= 0.465 \text{ ksi} \end{aligned}$$

Table 5.6-2 – Stresses in the Prestressed Beam

Location	Girder noncomposite moment	F_{ps} after losses	Composite dead load moment	Live load positive moment
(ft.) ⁽¹⁾	(k-ft) ⁽²⁾	(kips) ⁽³⁾	(k-ft) ⁽²⁾	(k-ft) ⁽²⁾
0	0	239.0	0	0
1.75	217	797.2	36	170
5.5	661	797.0	108	476
11.0	1,252	857.0	199	886
16.5	1,776	946.7	276	1,230
22.0	2,230	946.7	337	1,509
27.5	2,616	1,092.1	384	1,724
33.0	2,933	1,092.1	414	1,882
38.5	3,181	1,096.2	429	1,994
44.0	3,360	1,096.2	429	2,047
49.5	3,471	1,096.2	414	2,045
54.5	3,512	1,096.2	387	2,015
55.0	3,511	1,096.2	384	2,010
60.5	3,456	1,096.2	338	1,927
66.0	3,333	1,096.2	277	1,794
71.5	3,141	1,096.2	201	1,613
77.0	2,880	1,096.2	108	1,388
82.5	2,551	1,096.2	2	1,124
88.0	2,152	946.7	-121	825
93.5	1,686	946.7	-258	524
99.0	1,150	797.2	-452	297
104.5	546	797.2	-580	113
107.25	217	797.2	-670	58
109.0	0	239.0	-729	15

Table 5.6-2 – Stresses in the Prestressed Beam (cont.)

Location (ft.) ⁽¹⁾	Final stress under PS & DL		Stress under 1/2 (DL + P/S) + live load (ksi) ⁽⁴⁾	Final stress under all loads		
	Top of beam (ksi) ⁽⁴⁾	Bottom of beam (ksi) ⁽⁴⁾		Top of beam (ksi) ⁽⁴⁾	Bottom of beam (ksi) ⁽⁵⁾	Top of slab (ksi) ⁽⁴⁾
0	0.140	-0.588	0.070	0.140	-0.588	0.000
1.75	0.333	-1.816	0.136	0.303	-1.755	-0.041
5.5	0.061	-1.519	-0.054	-0.023	-1.349	-0.116
11.0	-0.255	-1.283	-0.285	-0.412	-0.966	-0.215
16.5	-0.521	-1.158	-0.479	-0.739	-0.719	-0.298
22.0	-0.796	-0.861	-0.666	-1.064	-0.321	-0.365
27.5	-0.943	-0.969	-0.777	-1.249	-0.353	-0.417
33.0	-1.133	-0.767	-0.900	-1.467	-0.094	-0.454
38.5	-1.270	-0.631	-0.988	-1.623	0.081	-0.479
44.0	-1.374	-0.525	-1.050	-1.737	0.207	-0.490
49.5	-1.436	-0.465	-1.081	-1.799	0.266	-0.487
54.5	-1.455	-0.453	-1.085	-1.812	0.267	-0.475
55.0	-1.454	-0.455	-1.083	-1.810	0.263	-0.474
60.5	-1.414	-0.508	-1.049	-1.756	0.180	-0.448
66.0	-1.331	-0.609	-0.984	-1.649	0.032	-0.410
71.5	-1.206	-0.757	-0.889	-1.492	-0.181	-0.359
77.0	-1.046	-0.945	-0.769	-1.292	-0.449	-0.296
82.5	-0.835	-1.189	-0.617	-1.034	-0.787	-0.223
88.0	-0.670	-1.112	-0.481	-0.816	-0.817	-0.139
93.5	-0.374	-1.450	-0.280	-0.467	-1.263	-0.053
99.0	-0.116	-1.487	-0.111	-0.169	-1.381	0.031
104.5	0.250	-1.910	0.105	0.230	-1.870	0.092
107.25	0.458	-2.146	0.219	0.448	-2.125	0.121
109.0	0.269	-0.918	0.132	0.266	-0.913	0.141

Notes:

- 1 - Distance measured from the centerline of the bearing of the end abutment
- 2 - See Section 5.3 for load effects
- 3 - See Section 5.5 for prestressing forces
- 4 - Service I limit state for compression
- 5 - Service III limit state for tension

Definitions:

- P_t = Final prestressing force taken from Design Step 5.4 (kips)
 S_{tc} = Section moduli, top of the beam of the composite section – gross section (in³)
 S_{bc} = Section moduli, bottom of the beam of the composite section – gross section (in³)
 S_{tsc} = Section moduli, top of slab of the composite beam (in³)

M_{DNC} = Moment due to the girder, slab, haunch and interior diaphragm (k-ft)

M_{DC} = Total composite dead load moment, includes parapets and future wearing surface (k-ft)

M_{LLC} = Live load moment (k-ft)

All tension stresses and allowables use positive sign convention. All compression stresses and allowables use negative sign convention. All loads are factored according to Table 3.4.1-1 in the AASHTO LRFD Specifications for Service I and Service III limit states as applicable.

Design Step 5.6.2.2

Sample Calculations at 11 ft. From the CL of Bearing (11 ft. – 9 in. From Girder End)

Girder top stress after losses under sum of all loads (Service I):

$$\begin{aligned} f_{top} &= -P_t/A_g + P_t e_{11} / S_t - M_{DNC} / S_t - M_{DC} / S_{tc} - M_{LLC} / S_{tc} \\ &= \frac{-857}{1,085} + \frac{857(31.222)}{20,588} - \frac{1,252(12)}{20,588} - \frac{199(12)}{67,672} - \frac{886(12)}{67,672} \\ &= -0.790 + 1.300 - 0.730 - 0.035 - 0.157 \\ &= -0.412 \text{ ksi} < \text{Stress limit for compression under full} \\ &\quad \text{load (-3.6 ksi) } \mathbf{OK} \end{aligned}$$

Girder top stress under prestressing and dead load after losses:

$$\begin{aligned} f_{top} &= -P_t/A_g + P_t e_{11} / S_t - M_{DNC} / S_t - M_{DC} / S_{tc} \\ &= \frac{-857}{1,085} + \frac{857(31.222)}{20,588} - \frac{1,252(12)}{20,588} - \frac{199(12)}{67,672} \\ &= -0.790 + 1.300 - 0.730 - 0.035 \\ &= -0.255 \text{ ksi} < \text{Stress limit for compression under permanent} \\ &\quad \text{load (-2.7 ksi) } \mathbf{OK} \end{aligned}$$

Girder top stress under LL + ½(PS + DL) after losses:

$$\begin{aligned} f_{top} &= -P_t/A_g + P_t e_{11} / S_t - M_{DNC} / S_t - M_{DC} / S_{tc} - M_{LL} / S_{tc} \\ &= \frac{-857}{1,085(2)} + \frac{857(31.222)}{20,588(2)} - \frac{1,252(12)}{20,588(2)} - \frac{199(12)}{67,672(2)} - \frac{886(12)}{67,672} \\ &= -0.395 + 0.650 - 0.365 - 0.018 - 0.157 \end{aligned}$$

$$= -0.285 \text{ ksi} < \text{Stress limit for compression under LL} + \frac{1}{2}(\text{DL} + \text{PS}) \text{ load } (-2.4 \text{ ksi}) \quad \mathbf{OK}$$

Girder bottom stress under all loads (Service III):

$$\begin{aligned} f_{\text{bottom}} &= -P_t/A_g - P_t e_{11}'/S_b + M_{\text{DNC}}/S_b + M_{\text{DC}}/S_{bc} + M_{\text{LLC}}/S_{bc} \\ &= \frac{-857}{1,085} - \frac{857(31.222)}{20,157} + \frac{1,252(12)}{20,157} + \frac{199(12)}{26,855} + \frac{0.8(886)(12)}{26,855} \\ &= -0.790 - 1.327 + 0.745 + 0.089 + 0.317 \\ &= -0.966 \text{ ksi} < \text{Stress limit for compression under full load } (-2.7 \text{ ksi}) \quad \mathbf{OK} \end{aligned}$$

Notice that the gross concrete composite section properties are typically used for the stress calculations due to all load components. However, some jurisdictions use the transformed section properties in calculating the stress due to live load. The transformed section properties are listed in Section 2. In this example, the gross section properties are used for this calculation.

Girder bottom stress under prestressing and dead load after losses:

$$\begin{aligned} f_{\text{bottom}} &= -P_t/A_g - P_t e_{11}'/S_b + M_{\text{DNC}}/S_b + M_{\text{DC}}/S_{bc} \\ &= \frac{-857}{1,085} - \frac{857(31.222)}{20,157} + \frac{1,252(12)}{20,157} + \frac{199(12)}{26,855} \\ &= -0.790 - 1.327 + 0.745 + 0.089 \\ &= -1.283 \text{ ksi} < \text{Stress limit for compression under prestress and permanent loads } (-2.7 \text{ ksi}) \quad \mathbf{OK} \end{aligned}$$

Sample Calculations at 54 ft. – 6 in. From the CL of Bearing (55 ft. – 3 in. From Girder End) – Midspan of Noncomposite Girder

Girder top stress after losses under sum of all loads (Service I):

$$\begin{aligned} f_{\text{top}} &= -P_t/A_g + P_t e_{54.5}'/S_t - M_{\text{DNC}}/S_t - M_{\text{DC}}/S_{tc} - M_{\text{LLC}}/S_{tc} \\ &= \frac{-1,096.2}{1,085} + \frac{1,096.2(31.38)}{20,588} - \frac{3,512(12)}{20,588} - \frac{387(12)}{67,672} - \frac{2,015(12)}{67,672} \\ &= -1.010 + 1.671 - 2.047 - 0.069 - 0.357 \end{aligned}$$

$$= -1.812 \text{ ksi} < \text{Stress limit for compression under full load (-3.6 ksi) OK}$$

Girder top stress after losses under prestress and permanent loads:

$$\begin{aligned} f_{\text{top}} &= -P_t/A_g + P_t e_{54.5'} / S_t - M_{\text{DNC}} / S_t - M_{\text{DC}} / S_{\text{tc}} \\ &= \frac{-1,096.2}{1,085} + \frac{1,096.2(31.38)}{20,588} - \frac{3,512(12)}{20,588} - \frac{387(12)}{67,672} \\ &= -1.010 + 1.671 - 2.047 - 0.069 \\ &= -1.455 \text{ ksi} < \text{Stress limit for compression under prestress and permanent loads (-2.7 ksi) OK} \end{aligned}$$

Girder top stress under LL + ½(PS + DL) after losses:

$$\begin{aligned} f_{\text{top}} &= -P_t/A_g + P_t e_{54.5'} / S_t - M_{\text{DNC}} / S_t - M_{\text{DC}} / S_{\text{tc}} - M_{\text{LL}} / S_{\text{tc}} \\ &= \frac{-1,096.2}{1,085(2)} + \frac{1,096.2(31.38)}{20,588(2)} - \frac{3,512(12)}{20,588(2)} - \frac{387(12)}{67,672(2)} - \frac{2,015(12)}{67,672} \\ &= -0.505 + 0.835 - 1.024 - 0.034 - 0.357 \\ &= -1.085 \text{ ksi} < \text{Stress limit for compression under LL + ½(DL + PS) load (-2.4 ksi) OK} \end{aligned}$$

Girder bottom stress (Service III):

$$\begin{aligned} f_{\text{bottom}} &= -P_t/A_g - P_t e_{54.5'} / S_b + M_{\text{DNC}} / S_b + M_{\text{DC}} / S_{\text{bc}} + M_{\text{LLC}} / S_{\text{bc}} \\ &= \frac{-1,096.2}{1,085} - \frac{1,096.2(31.38)}{20,157} + \frac{3,512(12)}{20,157} + \frac{387(12)}{26,855} + \frac{0.8(2,015)(12)}{26,855} \\ &= -1.010 - 1.707 + 2.091 + 0.173 + 0.720 \\ &= 0.267 \text{ ksi} < \text{Stress limit for tension (0.465 ksi) OK} \end{aligned}$$

Notice that the stresses are calculated without including creep and shrinkage. Jurisdictions that do not include creep and shrinkage typically design the girders for a reduced tensile stress limit or for zero tension at final condition. Including creep and shrinkage would normally result in additional tensile stress at the bottom of the beam at the midspan section.

Girder bottom stress after losses under prestress and dead load:

$$\begin{aligned}
 f_{\text{bottom}} &= -P_t/A_g - P_t e_{54.5'} / S_b + M_{\text{DNC}} / S_b + M_{\text{DC}} / S_{bc} \\
 &= \frac{-1,096.2}{1,085} - \frac{1,096.2(31.38)}{20,157} + \frac{3,512(12)}{20,157} + \frac{387(12)}{26,855} \\
 &= -1.010 - 1.707 + 2.091 + 0.173 \\
 &= -0.453 \text{ ksi} < \text{Stress limit for compression (-2.7 ksi)} \quad \mathbf{OK}
 \end{aligned}$$

Deck slab top stress under full load:

$$\begin{aligned}
 f_{\text{top slab}} &= (-M_{\text{DC}} / S_{\text{tsc}} - M_{\text{LLC}} / S_{\text{tsc}}) / \text{modular ratio between beam and slab} \\
 &= \left(-\frac{387(12)}{49,517} - \frac{1.0(2,015)(12)}{49,517} \right) / \left(\frac{4,696}{3,834} \right) \\
 &= (-0.094 - 0.488) / 1.225 \\
 &= -0.475 \text{ ksi} < \text{Stress limit for compression in slab (-2.4 ksi)} \quad \mathbf{OK}
 \end{aligned}$$

Stresses at service limit state for sections in the negative moment region

Sections in the negative moment region may crack under service limit state loading due to high negative composite dead and live loads. The cracking starts in the deck and as the loads increase the cracks extend downward into the beam. The location of the neutral axis for a section subject to external moments causing compressive stress at the side where the prestressing force is located may be determined using a trial and error approach as follows:

1. Assume the location of the neutral axis.
2. Assume a value for the compressive strain at the extreme compression fiber (bottom of the beam). Calculate the tensile strain in the longitudinal reinforcement of the deck assuming the strain varies linearly along the height of the section and zero strain at the assumed location of the neutral axis.
3. Calculate the corresponding tension in the deck reinforcement based on the assumed strain.
4. Calculate the compressive force in the concrete.
5. Check the equilibrium of the forces on the section (prestressing, tension in deck steel and compression in the concrete). Change the assumed strain at the bottom of beam until the force equilibrium is achieved.
6. After the forces are in equilibrium, check the equilibrium of moments on the section (moment from prestressing, external moment and moment from internal compression and tension).
7. If moment equilibrium is achieved, the assumed location of the neutral axis and

strains are correct. If the moments are not in equilibrium, change the assumed location of the neutral axis and go to Step 2 above.

8. After both force and moment equilibriums are achieved, calculate the maximum stress in the concrete as the product of the maximum concrete strain and the concrete modulus of elasticity.

Notice that when additional compression is introduced into the concrete due to external applied forces, the instantaneous stress in the prestressing steel is decreased by the modular ratio multiplied by the additional compressive stress in the surrounding concrete. The change in the prestressing steel force is typically small and was ignored in the following calculations.

Sample Calculations for a Section in the Negative Moment Region Under Service Limit State, Section at 107 ft. – 3 in. From the CL of End Bearing (108 ft. From Girder End)

From Table 5.3-1,

Location (ft.)	Noncomposite				Composite		Live Load + IM	
	Girder*	Slab and Haunch	Exterior Diaphragm	Total Noncomp.	Parapet	FWS	Positive HL-93	Negative HL-93
(k-ft)	(k-ft)	(k-ft)	(k-ft)	(k-ft)	(k-ft)	(k-ft)	(k-ft)	(k-ft)
104.5	266	268	11	546	-248	-332	113	-1,663
108.0	61	62	3	125	-297	-398	33	-1,921

* Based on the simple span length of 109 ft.

$$\begin{aligned} \text{Maximum negative moment at the section at 104.5 ft} &= 546 - 248 - 332 - 1,663 \\ &= -1,697 \text{ k-ft} \end{aligned}$$

$$\begin{aligned} \text{Maximum negative moment at the section at 108.0 ft} &= 125 - 297 - 398 - 1,921 \\ &= -2,491 \text{ k-ft} \end{aligned}$$

By interpolation, the maximum Service I negative moment at the section under consideration is:

$$\begin{aligned} M_{\text{neg}} &= -2,491 - (-2,491 + 1,697)[(108 - 107.25)/(108 - 104.5)] \\ &= -2,321 \text{ k-ft} \end{aligned}$$

Trial and error approach (see above) was applied to determine the location of the neutral axis. The calculations of the last cycle of the process are shown below.

Referring to Figure 5.6-1:

Assume neutral axis at 32.5 inches from the bottom of beam

Assume maximum concrete compressive strain = 0.00079 in./in.

Tensile strain in deck reinforcement = $0.00079(75.52 - 32.5)/32.5 = 0.001046$ in./in.

Modulus of elasticity of concrete beam = 4,696 ksi (see Section 2)

Concrete stress at bottom of beam = $0.00079(4,696) = 3.71$ ksi

Area of deck longitudinal reinforcement = 14.65 in² (see Section 5.6.5.1 for calculation)

Force in deck steel = $14.65(0.001046)(29,000) = 444.4$ k

Force in prestressing steel = 797.2 k (see Table 5.5-1)

Compressive forces in the concrete:

Considering Figure 5.6-1, by calculating the forces acting on different areas as the volume of the stress blocks for areas A1, A2 and A3 as the volume of a wedge, prism or pyramid, as appropriate, the forces in Table 5.6-3 may be calculated. Recall that the centers of gravity of a wedge, a prism with all rectangular faces, a prism with a triangular vertical face and a pyramid are at one-third, one-half, one-third and one-quarter the height, respectively. The location of the centers of gravity shown in the figure may also be calculated. The moment from internal compressive concrete forces shown in Table 5.6-3 is equal to the force multiplied by the distance from the neutral axis to the location of the force.

Table 5.6-3 – Forces in Concrete Under Service Load in Negative Moment Regions (Section at 107'-3" from the end bearing)

Area designation	Force designation	Area	Stress	Force	Distance from bot. of beam	Distance to N/A	Moment at N/A
		(in ²)	(ksi)	(kips)	(in)	(in)	(k-ft)
A1	P ₁	260	3.71	482.3	10.83	21.67	871.0
A2	P ₂ a	160	2.80	448.0	4.00	28.50	1,064.0
A2	P ₂ b	160	0.91	72.8	2.67	29.83	181.0
A3 *	P ₃ a	100	1.66	166.0	11.33	21.17	292.9
A3 *	P ₃ b	100	1.14	76.0	10.50	22.00	139.3
Total				1,245.1			2,548.2

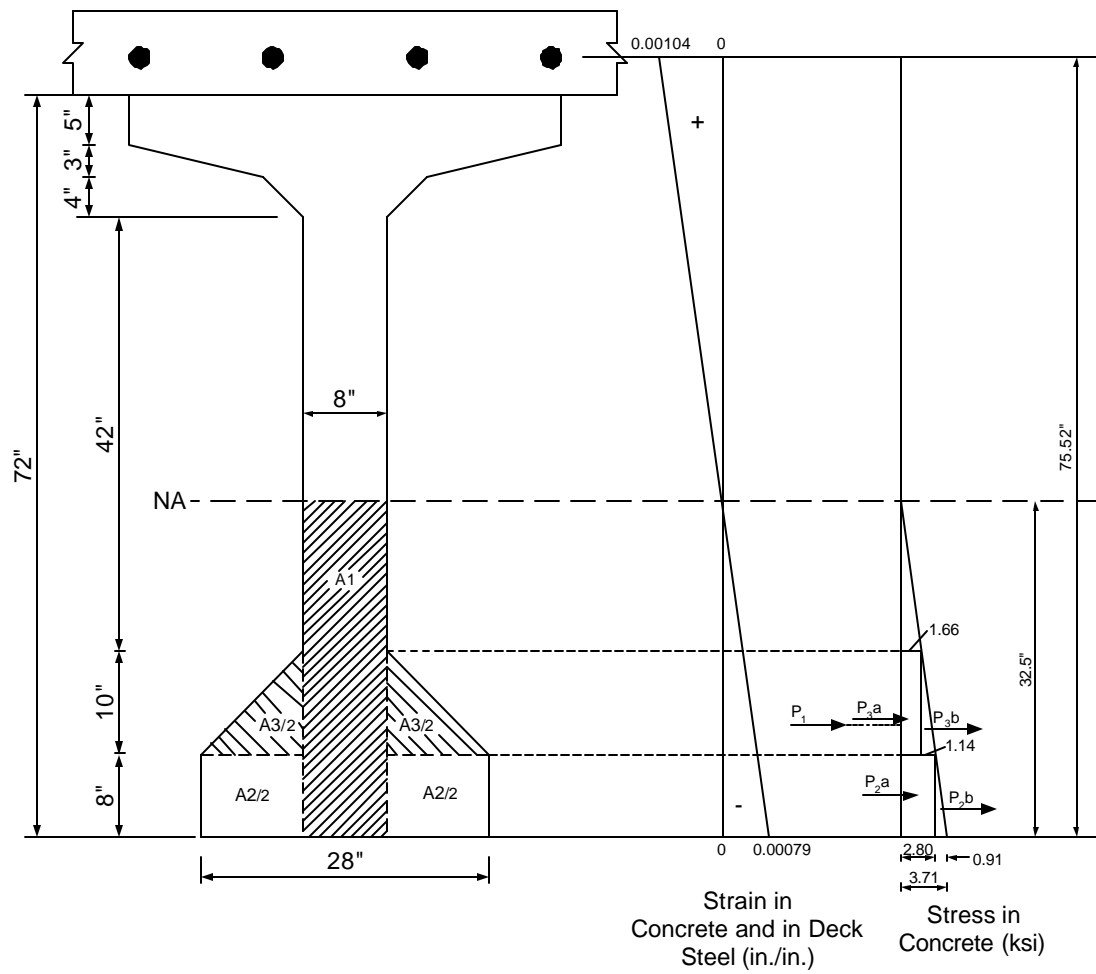
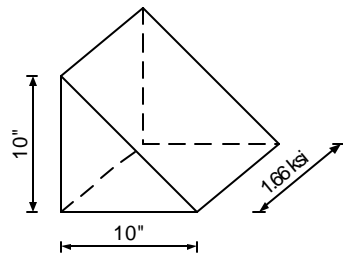
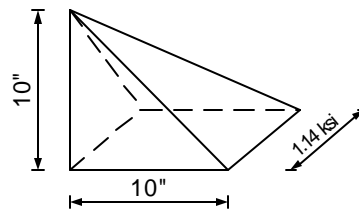

Figure 5.6-1 – Compressive Force in the Concrete



a) Rectangular Stress Distribution



b) Triangular Stress Distribution

*Figure 5.6-1a – Shapes Used in Determining Forces for A3

Sample force calculations for area A3.

Two components of stress act on area A3. The first component is a rectangular stress distribution with an intensity of 1.66 ksi. The second component is a triangular stress distribution with an intensity of 1.14 ksi.

Force due to the rectangular stress distribution:

$$\begin{aligned} F_{\text{rectangular}} &= 2[0.5(10)(10)](1.66) \\ &= 166.0 \text{ k} \end{aligned}$$

The volume used to determine the effect of the triangular stress distribution is calculated using geometry of a pyramid.

$$\begin{aligned} F_{\text{triangular}} &= 2 \text{ triangles}(1/3 \text{ pyramid base})(\text{pyramid height}) \\ &= 2(1/3)(10)(1.14)(10) \\ &= 76.0 \text{ k} \end{aligned}$$

Check force equilibrium:

$$\begin{aligned} \text{Net force on section} &= \text{P/S steel force} + \text{concrete compressive force} + \text{deck steel force} \\ &= 797.2 + (-1,245.1) + 444.4 \\ &= -3.5 \text{ kips} \approx 0 \text{ OK} \end{aligned}$$

Check moment equilibrium:

$$\begin{aligned} \text{Net M on the section} &= \text{external moment} + \text{prestressing force moment} + \text{deck slab force} \\ &\quad \text{moment} + \text{concrete compression moment} \\ &= 2,321 + 797.2(32.5 - 5.375)/12 - 444.4(75.52 - 32.5)/12 - 2,548.2 \\ &= -18.4 \text{ k-ft} \approx 0 \text{ OK} \end{aligned}$$

From Table 5.6-3, the maximum stress in the concrete is 3.71 ksi. The stress limit for compression under all loads (Table S5.9.4.2.1-1) under service condition is $0.6f_c$ (where f_c is the compressive strength of the girder concrete). For this example, the stress limit equals 3.6 ksi.

The calculated stress equals 3.71 ksi or is 3% overstressed. However, as explained above, the stress in the prestressing steel should decrease due to compressive strains in the concrete caused by external loads, i.e., prestressing steel force less than 797.2 k and the actual stress is expected to be lower than the calculated stress, and the above difference (3%) is considered within the acceptable tolerance.

Notice that the above calculations may be repeated for other cases of loading in Table S5.9.4.2.1-1 and the resulting applied stress is compared to the respective stress limit. However, the case of all loads applied typically controls.

Design Step 5.6.3 Longitudinal steel at top of girder

The tensile stress limit at transfer used in this example requires the use of steel at the tension side of the beam to resist at least 120% of the tensile stress in the concrete calculated based on an uncracked section (Table S5.9.4.1.2-1). The sample calculations are shown for the section in Table 5.6-1 with the highest tensile stress at transfer, i.e., the section at 1.75 ft. from the centerline of the end bearing.

By integrating the tensile stress in Figure 5.6-2 over the corresponding area of the beam, the tensile force may be calculated as:

$$\begin{aligned} \text{Tensile force} &= 5(42)(0.451 + 0.268)/2 + 7.33(8.0)(0.268 + 0.0)/2 + 2[4(3)](0.268 + \\ &\quad 0.158)/2 + 2[4(4)/2][0.012 + (0.158 - 0.012)(2/3)] + 2[3(13)/2][0.158 + \\ &\quad (0.268 - 0.158)(2/3)] \\ &= 99.2 \text{ k} \end{aligned}$$

$$\begin{aligned} \text{Required area of steel} &= 1.2(99.2)/f_y \\ &= 119.0/60 \\ &= 1.98 \text{ in}^2 \end{aligned}$$

$$\begin{aligned} \text{Required number of \#5 bars} &= 1.98/0.31 \\ &= 6.39 \text{ bars} \end{aligned}$$

Minimum allowable number of bars = 7 #5 bars

Use 8 #5 bars as shown in Figure 5.6-3

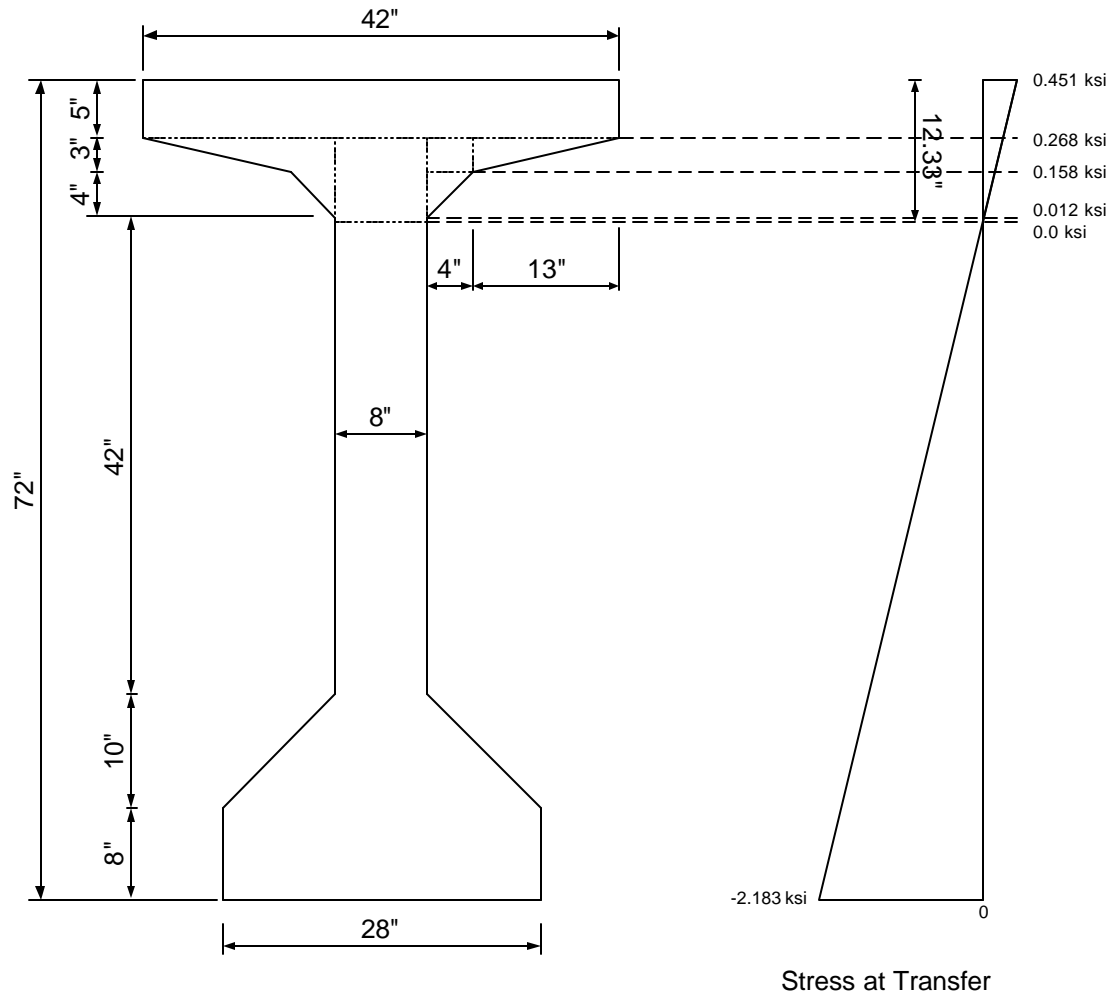

Figure 5.6-2 – Stress at Location of Maximum Tensile Stress at Transfer

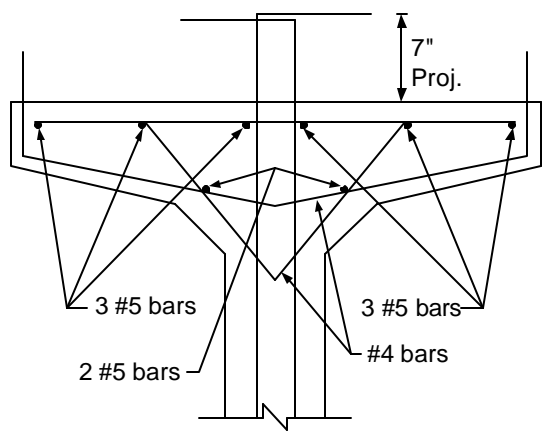

Figure 5.6-3 – Longitudinal Reinforcement of Girder Top Flange

Design Step 5.6.4 Flexural resistance at the strength limit state in positive moment region (S5.7.3.1)
Sample calculations at midspan

c = distance between the neutral axis and the compressive face at the nominal flexural resistance (in.)

c = 5.55 in., which is less than the slab thickness, therefore, the neutral axis is in the slab and section is treated as a rectangular section. (See Design Step 5.5.1 for commentary explaining how to proceed if “ c ” is greater than the deck thickness.)

f_{ps} = stress in the prestressing steel at the nominal flexural resistance (ksi)
 $f_{ps} = 264.4$ ksi

The factored flexural resistance, M_f , shall be taken as ϕM_n , where M_n is determined using Eq. S5.7.3.2.2-1.

Factored flexural resistance in flanged sections (S5.7.3.2.2)

$$M_n = A_{ps}f_{ps}(d_p - a/2) + A_s f_y (d_s - a/2) - A'_s f'_y (d'_s - a/2) + 0.85f'_c(b - b_w)\beta_1 h_f(a/2 - h_f/2) \quad (\text{S5.7.3.2.2-1})$$

The definition of the variables in the above equation and their values for this example are as follows:

$$A_{ps} = \text{area of prestressing steel (in}^2\text{)} \\ = 6.73 \text{ in}^2$$

$$f_{ps} = \text{average stress in prestressing steel at nominal bending resistance specified in Eq. S5.7.3.1.1-1 (ksi)} \\ = 264.4 \text{ ksi}$$

$$d_p = \text{distance from extreme compression fiber to the centroid of prestressing tendons (in.)} \\ = 74.5 \text{ in.}$$

$$A_s = \text{area of nonprestressed tension reinforcement (in}^2\text{)} \\ = 0.0 \text{ in}^2$$

$$f_y = \text{specified yield strength of reinforcing bars (ksi)} \\ = 60 \text{ ksi}$$

$$d_s = \text{distance from extreme compression fiber to the centroid of nonprestressed tensile reinforcement (in.), NA}$$

$$A'_s = \text{area of compression reinforcement (in}^2\text{)} \\ = 0.0 \text{ in}^2$$

$$f_y = \text{specified yield strength of compression reinforcement (ksi), NA}$$

$$d'_s = \text{distance from the extreme compression fiber to the centroid of} \\ \text{compression reinforcement (in.), NA}$$

$$f_c = \text{specified compressive strength of concrete at 28 days, unless another} \\ \text{age is specified (ksi)} \\ = 4.0 \text{ ksi (slab)}$$

$$b = \text{width of the effective compression block of the member (in.)} \\ = \text{width of the effective flange} = 111 \text{ in. (See Design Step 5.5.1 for} \\ \text{commentary for the determination of the effective width, } b, \text{ when the} \\ \text{calculations indicate that the compression block depth is larger than the} \\ \text{flange thickness.)}$$

$$b_w = \text{web width taken equal to the section width “} b \text{” for a rectangular section} \\ \text{(in.), NA}$$

$$\beta_1 = \text{stress block factor specified in S5.7.2.2, NA}$$

$$h_f = \text{compression flange depth of an I or T member (in.), NA}$$

$$a = \beta_1 c; \text{ depth of the equivalent stress block (in.)} \\ = 0.85(5.55) \\ = 4.72 \text{ in.}$$

The second, third and fourth terms in Eq. S5.7.3.2.2-1 are equal to zero for this example.

Substituting,

$$M_n = 6.73(264.4)[74.5 - (4.72/2)] \\ = 128,367/12 \\ = 10,697 \text{ k-ft}$$

Therefore, the factored flexural resistance, M_r , shall be taken as:

$$M_r = \phi M_n \quad (\text{S5.7.3.2.1-1})$$

where:

$$\phi = \text{resistance factor as specified in S5.5.4.2 for flexure in prestressed} \\ \text{concrete} \\ = 1.0$$

$$M_r = 1.0(10,697 \text{ k-ft}) \\ = 10,697 \text{ k-ft}$$

The maximum factored applied moment for Strength I limit state is 8,456 k-ft (see Table 5.3-2)

$$M_r = 10,697 \text{ k-ft} > M_u = 8,456 \text{ k-ft} \quad \mathbf{OK}$$

Design Step Check if section is over-reinforced
5.6.4.1

Limits for reinforcing (S5.7.3.3)

The maximum amount of prestressed and nonprestressed reinforcement must be such that:

$$c/d_e \leq 0.42 \quad (\text{S5.7.3.3.1-1})$$

where:

$$c = 5.55 \text{ in. (see Section 5.5.1)}$$

$$d_e = 74.5 \text{ in. (same as } d_p \text{ since no mild steel is considered)}$$

$$c/d_e = 5.55/74.5 \\ = 0.074 < 0.42 \quad \mathbf{OK}$$

Design Step Check minimum required reinforcement (S5.7.3.3.2)
5.6.4.2

Critical location is at the midspan of the continuous span = 55 ft. from the end bearing.

All strands are fully bonded at this location.

According to S5.7.3.3.2, unless otherwise specified, at any section of a flexural component, the amount of prestressed and nonprestressed tensile reinforcement shall be adequate to develop a factored flexural resistance, M_r , at least equal to the lesser of:

1.2 times the cracking strength determined on the basis of elastic stress distribution and the modulus of rupture, f_r , on the concrete as specified in S5.4.2.6.

OR

1.33 times the factored moment required by the applicable strength load combinations specified in Table 3.4.1-1.

The cracking moment, M_{cr} , is calculated as the total moment acting on the beam when the maximum tensile stress equals the modulus of rupture.

$$f_t = -P_t/A_g - P_t e/S_b + M_{DNC}/S_b + M_{DC}/S_{bc} + M/S_{bc}$$

where:

$$M_{DNC} = \text{factored using Service I limit state, see Table 5.3-1} \\ = 3,511 \text{ k-ft}$$

$$M_{DC} = \text{factored using Service I limit state, see Table 5.3-1} \\ = 384 \text{ k-ft}$$

$$P_t = f_{pf} A_{strand} N_{strands} \\ = 1,096.2 \text{ k (from Table 5.6-2)}$$

$$A_g = 1,085 \text{ in}^2$$

$$e_{54.5'} = 31.38 \text{ in.}$$

$$S_b = 20,157 \text{ in}^3$$

$$S_{bc} = 26,855 \text{ in}^3$$

$$f_t = 0.24 \sqrt{f'_c} \quad (\text{S5.4.2.6}) \\ = 0.24 \sqrt{6} \\ = 0.587 \text{ ksi}$$

$$0.587 = \frac{-1,096.2}{1,085} - \frac{1,096.2(31.38)}{20,157} + \frac{3,511(12)}{20,157} + \frac{384(12)}{26,855} + \frac{M}{26,855}$$

Solving for M, the additional moment required to cause cracking, in this equation:

$$M = 27,983/12 \\ = 2,332 \text{ k-ft}$$

$$M_{cr} = M_{DNC} + M_{DC} + M \\ = 3,511 + 384 + 2,332 \\ = 6,227 \text{ k-ft}$$

$$1.2M_{cr} = 1.2(6,227) \\ = 7,472 \text{ k-ft}$$

The applied factored moment, M_u , taken from Table 5.3-2 is 8,456 k-ft (Strength I)

$$1.33(8,456) = 11,246 \text{ k-ft}$$

M_r has to be greater than the lesser of $1.2M_{cr}$ and $1.33M_u$, i.e., 7,472 k-ft.

M_r also has to be greater than the applied factored load $M_u = 8,456 \text{ k-ft}$ (strength requirement)

$M_r = 10,697 \text{ k-ft}$, therefore, both provisions are **OK**

Design Step 5.6.5 Continuity connection at intermediate support**Design Step 5.6.5.1** Negative moment connection at the Strength limit state

Determine the deck steel at the intermediate pier.

Based on preliminary calculations, the top and bottom longitudinal reinforcement of the deck are assumed to be #6 bars at 5.5 in. spacing and #6 bars at 8.5 in. spacing, respectively (see Figure 5.6-5).

Calculate the total area of steel per unit width of slab:

$$A_s = A_{\text{bar}}/\text{spacing} \text{ (in}^2\text{/in.)}$$

For top row of bars: $A_{s \text{ top}} = 0.44/5.5$
 $= 0.08 \text{ in}^2\text{/in.}$

For bottom row of bars: $A_{s \text{ bot}} = 0.44/8.5$
 $= 0.052 \text{ in}^2\text{/in.}$

Therefore, $A_s = 0.08 + 0.052$
 $= 0.132 \text{ in}^2\text{/in.}$

Calculate the center of gravity of the slab steel from the top of the slab. Calculations are made from the top of the total thickness and include the integral wearing surface in the total thickness of slab. (See Figure 4-16)

Top mat (B1): $CGS_{\text{top}} = \text{Cover}_{\text{top}} + \text{Dia}_{\#5 \text{ main rein.}} + \frac{1}{2} \text{Dia}_{\#6}$
 $= 2.5 + 0.625 + \frac{1}{2} (0.75)$
 $= 3.5 \text{ in.}$

Bot. mat (B2): $CGS_{\text{bot}} = t_{\text{slab}} - \text{Cover}_{\text{bot}} - \text{Dia}_{\#5 \text{ main rein.}} - \frac{1}{2} \text{Dia}_{\#6}$
 $= 8 - 1 - 0.625 - \frac{1}{2} (0.75)$
 $= 6 \text{ in.}$

Center of gravity of the deck longitudinal reinforcement from the top of the deck:

$$CGS = [A_{s \text{ top}}(CGS_{\text{top}}) + A_{s \text{ bot}}(CGS_{\text{bot}})]/A_s$$

$$= [0.08(3.5) + 0.052(6)]/0.132$$

$$= 4.48 \text{ in. from the top of slab (3.98 in. from the top of the structural thickness)}$$

Calculate the depth to the slab steel from the bottom of the beam. The haunch depth is ignored in the following calculations.

$$\begin{aligned}d_s &= \text{girder} + \text{slab} - \text{CGS} \\ &= 72 + 8 - 4.48 \\ &= 75.52 \text{ in.}\end{aligned}$$

The specification is silent about the strength of the concrete in the connection zone. Many jurisdictions use the girder concrete strength for these calculations. This reflects observations made during girder tests in the past. In these tests, the failure always occurred in the girder. This behavior is due to the confinement of the diaphragm concrete in the connection zone provided by the surrounding concrete. This confinement increases the apparent strength of the diaphragm concrete compared to the unconfined strength measured during typical testing of concrete cylinders.

Assume the neutral axis is in the bottom flange (rectangular behavior), therefore,

$$\begin{aligned}f_c &= f_{c, \text{ beam}} = 6.0 \text{ ksi} \\ \beta_1 &= \beta_{1, \text{ beam}} = 0.75 \text{ (corresponds to the 6.0 ksi concrete, S5.7.2.2)} \\ b &= \text{width of section} = \text{width of girder bottom flange} = 28 \text{ in.}\end{aligned}$$

Calculate c ,

$$c = A_s f_y / 0.85 \beta_1 f_c b \quad (\text{S5.7.3.1.1-4, modified})$$

where:

$$\begin{aligned}A_s &= \text{area of reinforcement within the effective flange} \\ &\quad \text{width of 111 in. (in}^2\text{)} \\ &= A_s b_{\text{slab}} \\ &= (0.132)(111) \\ &= 14.65 \text{ in}^2\end{aligned}$$

$$\begin{aligned}f_y &= 60 \text{ ksi} \\ f_c &= 6.0 \text{ ksi} \\ \beta_1 &= 0.75 \\ b &= 28 \text{ in.}\end{aligned}$$

$$c = 14.65(60) / [0.85(0.75)(6.0)(28)]$$

= 8.21 in., which is approximately equal to the thickness of the bottom flange of the beam (8 in.), therefore, the section is checked as a rectangular section. If “ c ” was significantly larger than the thickness of the bottom flange, a reduction in the section width should be considered.

Calculate the nominal flexural resistance according to S5.7.3.2.1 and the provisions for a rectangular section.

$$M_n = A_s f_y (d_s - a/2)$$

where:

$$\begin{aligned} a &= \beta_1 c \\ &= 0.75(8.21) \\ &= 6.16 \text{ in.} \end{aligned}$$

$$d_s = 75.52 \text{ in.}$$

$$\begin{aligned} M_n &= 14.65(60)[75.52 - (6.16/2)]/12 \\ &= 5,306 \text{ k-ft} \end{aligned}$$

The factored flexural resistance, M_r , is

$$M_r = \phi_f M_n \quad (\text{S5.7.3.2.1-1})$$

where:

$$\phi_f = 0.9 \text{ for flexure in reinforced concrete (S5.5.4.2.1)}$$

$$\begin{aligned} M_r &= 0.9(5,306) \\ &= 4,775 \text{ k-ft} \end{aligned}$$

Check moment capacity versus the maximum applied factored moment at the critical location

Critical location is at the centerline of pier.

Strength I limit state controls.

$$|M_u| = 4,729 \text{ k-ft (see Table 5.3-2)} < M_r = 4,775 \text{ k-ft OK}$$

Check service crack control (S5.5.2)

Actions to be considered at the service limit state are cracking, deformations, and concrete stresses, as specified in Articles S5.7.3.4, S5.7.3.6, and S5.9.4, respectively. The cracking stress is taken as the modulus of rupture specified in S5.4.2.6.

Components shall be so proportioned that the tensile stress in the mild steel reinforcement at the service limit state does not exceed f_{sa} , determined as:

$$f_{sa} = Z/(d_c A)^{1/3} \leq 0.6f_y = 0.6(60) = 36 \text{ ksi}$$

where:

Z = crack width parameter (kip/in.)
 = 170 kip/in. (for members in moderate exposure conditions; the example bridge is located in a warm climate (Atlanta) where the use of deicing salts is possible, but not likely)

d_c = depth of concrete measured from extreme tension fiber to center of bar or wire located closest thereto (in.); for calculation purposes, the thickness of clear cover used to compute d_c shall not be taken to be greater than 2.0 in.

= concrete cover + $\frac{1}{2}$ secondary rein.
 = 2.0 + $\frac{1}{2}$ (0.75) = 2.375 in. (see Figure 5.6-4)

A = area of concrete having the same centroid as the principal tensile reinforcement and bounded by the surfaces of the cross-section and a straight line parallel to the neutral axis, divided by the number of bars or wires (in²); for calculation purposes, the thickness of clear concrete cover used to compute “A” shall not be taken to be greater than 2.0 in.

= [2(2.0) + 0.75]5.5/1 bar = 26.125 in²/bar (see Figure 5.6-4)

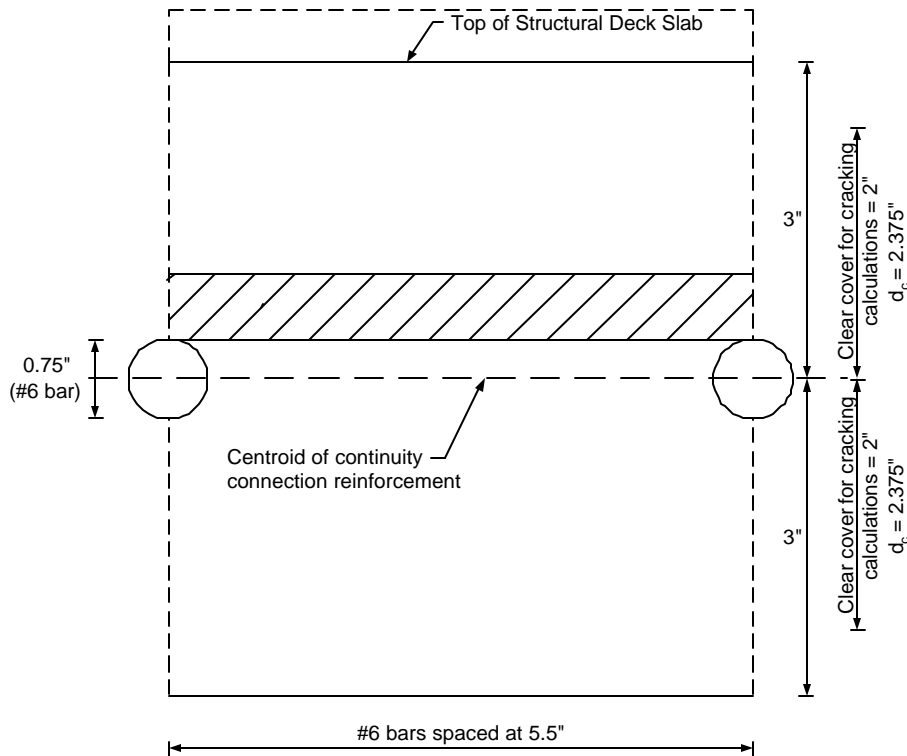

Figure 5.6-4 – Dimensions for Calculation of the Area, A

$$f_{sa} = 170/[2.375(26.125)]^{1/3}$$

$$= 42.94 \text{ ksi} > 0.6f_y = 36 \text{ ksi, therefore, use } f_{sa} = 36 \text{ ksi}$$

Connection moment at Service I limit state is 2,858 k-ft (see Table 5.3-2)

Assuming: Section width is equal to beam bottom flange width = 28 in.

Modular ratio = 6 for 6 ksi concrete

Area of steel = 14.65 in²

At service limit state, the depth of the neutral axis and the transformed moment of inertia under service loads may be calculated using the same procedure used earlier in the example (Section 4). The neutral axis is 18.86 in. from the bottom of the beam.

Maximum service stress in the steel = 33.74 ksi < 36 ksi **OK**

Design Step 5.6.5.2 Positive moment connection

For jurisdictions that consider creep and shrinkage in the design, it is likely that positive moment will develop at intermediate piers under the effect of prestressing, permanent loads and creep and shrinkage. These jurisdictions provide reinforcement at the bottom of the beams at intermediate diaphragms to resist the factored positive moment at these locations.

For jurisdictions that do not consider creep and shrinkage in the design, it is unlikely that live load positive moments at intermediate supports will exceed the negative moments from composite permanent loads at these locations. This suggests that there is no need for the positive moment connection. However, in recognition of the presence of creep and shrinkage effects, most jurisdictions specify some reinforcement to resist positive moments.

Two forms of the connection have been in use:

- 1) Figure 5.6-5 shows one alternative that requires extending some of the prestressing strands at the end of the girder into the intermediate diaphragm. Due to the small space between girders, these strands are bent upwards into the diaphragm to provide adequate anchorage. Only strands that are fully bonded are used for the positive moment connection.*
- 2) The second alternative requires adding mild reinforcement bars as shown in Figure 5.6-6. This alternative may lead to congestion at the end of the beam due to the presence of the prestressing strands at these locations.*

Typical details of the top of the pier cap for expansion and fixed bearings are shown schematically in Figures 5.6-7 and 5.6-8.

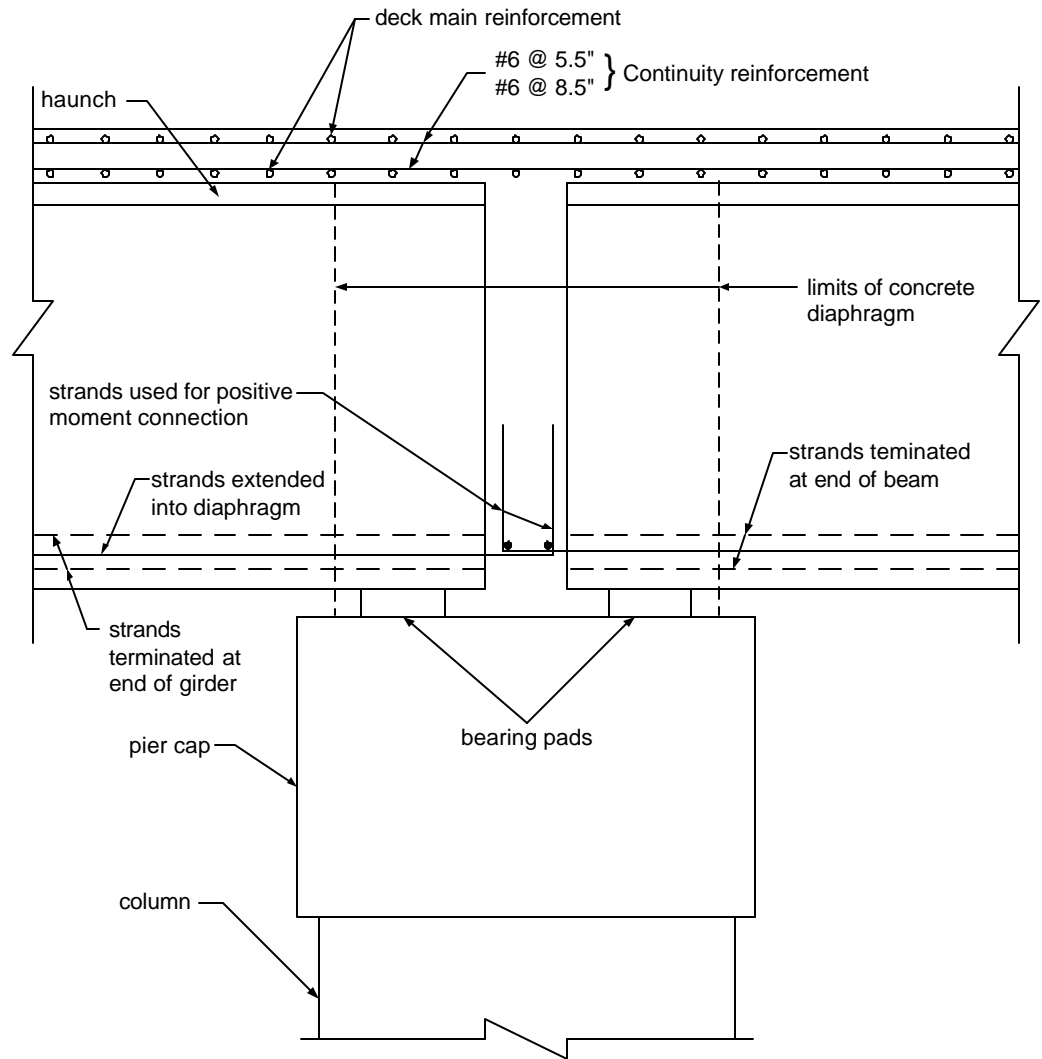

Figure 5.6-5 – Continuity Connection Alternative 1: Strands Used for Positive Moment Connection

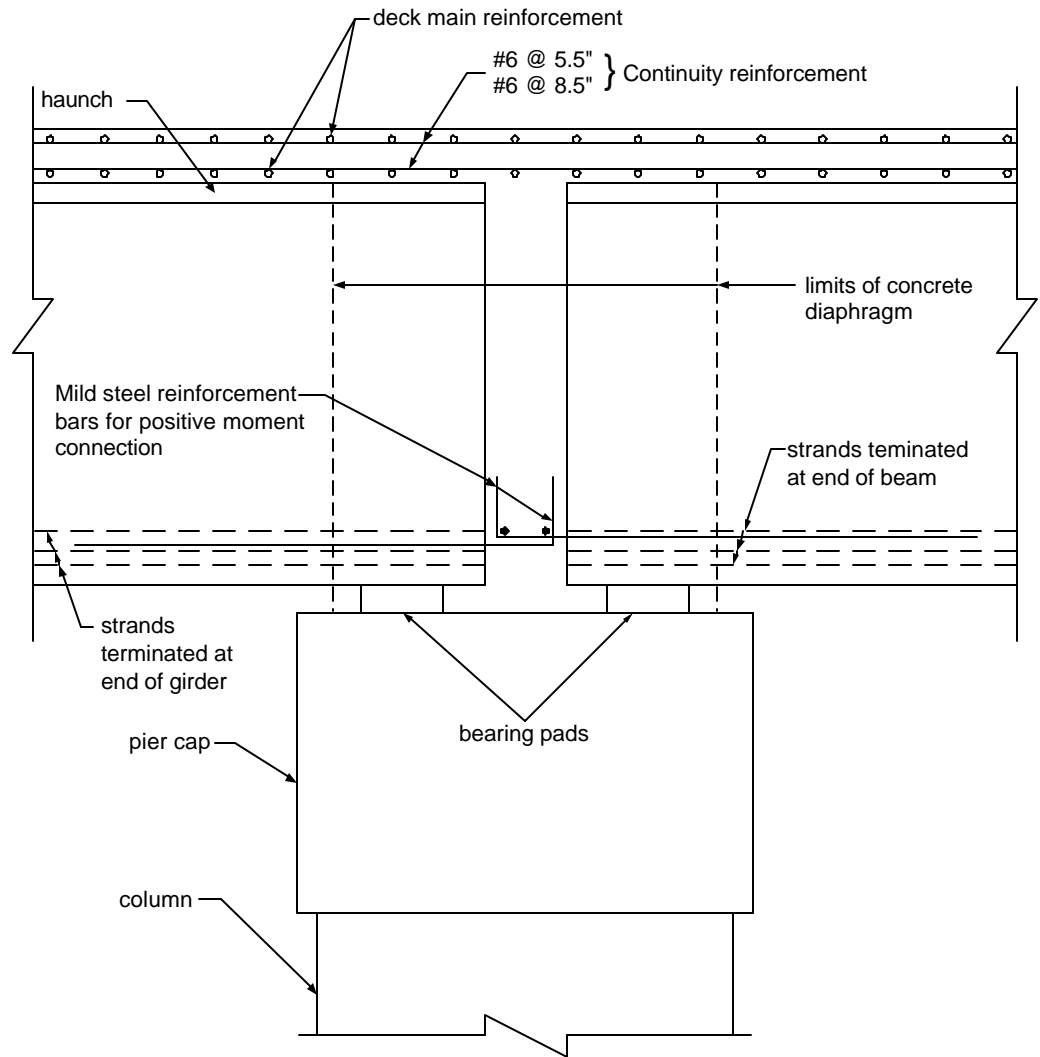

Figure 5.6-6 – Continuity Connection Alternative 2: Reinforcement Bars Used for Positive Moment Connection

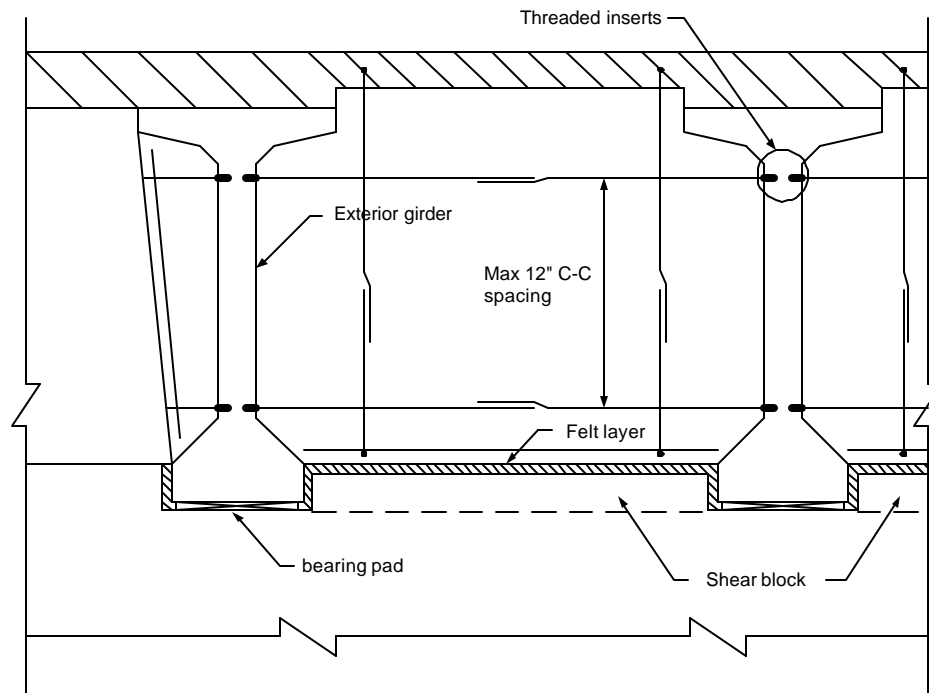

Figure 5.6-7 – Typical Diaphragm at Intermediate Pier (Expansion Bearing)

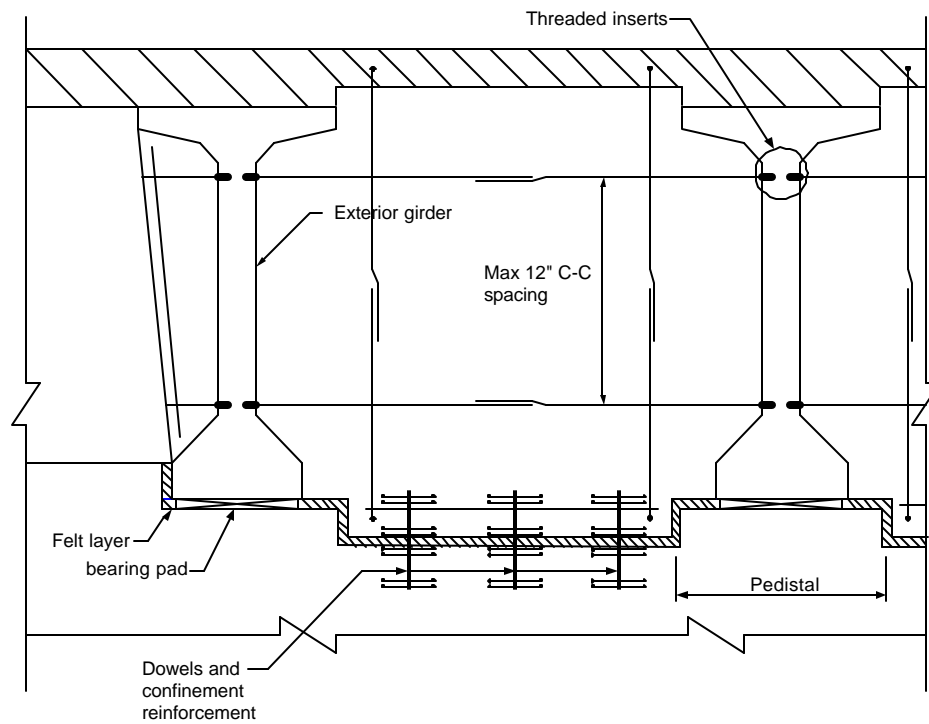

Figure 5.6-8 – Typical Diaphragm at Intermediate Pier (Fixed Bearing)

Design Step 5.6.6 Fatigue in prestressed steel (S5.5.3)

Article S5.5.3 states that fatigue need not be checked when the maximum tensile stress in the concrete under Service III limit state is taken according to the stress limits of Table S5.9.4.2.2-1. The stress limit in this table was used in this example and, therefore, fatigue of the prestressing steel need not be checked.

Design Step 5.6.7 Camber (S5.7.3.6)

The provisions of S2.5.2.6 shall be considered.

Deflection and camber calculations shall consider dead load, live load, prestressing, erection loads, concrete creep and shrinkage, and steel relaxation. For determining deflection and camber, the provisions of Articles S4.5.2.1, S4.5.2.2, and S5.9.5.5 shall apply.

Instantaneous deflections are computed using the modulus of elasticity for concrete as specified in S5.4.2.4 and taking the gross moment of inertia, I_g , as allowed by S5.7.3.6.2.

Deflection values are computed based on prestressing, girder self-weight, slab, formwork, exterior diaphragm weight, and superimposed dead load weight. Camber values are computed based on initial camber, initial camber adjusted for creep, and final camber. Typically, these calculations are conducted using a computer program. Detailed calculations are presented below.

Deflection due to initial prestressing is computed as:

$$\Delta_{P/S} = -(P_t e_s L^2) / (8 E_{ci} I_g) \quad (\text{for straight bonded strands})$$

$$\Delta_{P/S} = -P_t e_s [L^2 - (L_t + 2L_x)^2] / (8 E_{ci} I_g) \quad (\text{for debonded strands})$$

where:

P_t = applied load acting on the section (kips)

e_s = eccentricity of the prestressing force with respect to the centroid of the cross section at the midspan of the beam (in.)

L = span length (ft.)

L_t = transfer length of the strands (in.)

L_x = distance from end of beam to point where bonding commences (in.)

E_{ci} = modulus of elasticity of concrete at transfer (ksi)

I_g = moment of inertia (in⁴)

The negative sign indicates upward deflection.

Computer software is generally used to determine the deflections due to each loading. However, sample calculations are provided for this example.

See Table 5.5-1 for prestressing forces.

Group 1 strands: 32 fully bonded strands
Initial prestressing force = 924.4 k

Distance from bottom of the beam to the neutral axis = 36.38 in.

Distance from the bottom of the beam to the centroid of Group 1 strands = 5.375 in.

Deflection due to Group 1 strands:

$$\begin{aligned}\Delta_{P/S 1} &= -(P_t e_s L^2)/(8E_{ci} I_g) \\ &= -[924.4(36.38 - 5.375)[109(12)]^2]/[8(4,200)(733,320)] \\ &= -1.99 \text{ in. (upward deflection)}\end{aligned}$$

Group 2 strands: 6 strands debonded for 10 ft. from centerline of bearings
Transfer length = 30 in.
Initial prestressing force = 173.3 k

From Figures 2-5 and 2-6, the distance from the bottom of the beam to the centroid of Group 2 is 4.0 in.

Deflection due to Group 2 strands:

$$\begin{aligned}\Delta_{P/S 2} &= -P_t e_s [L^2 - (L_t + 2L_x)^2]/(8E_{ci} I_g) \\ &= -173.3(36.38 - 4.0)[[109(12)]^2 - [30 + 2(10)(12)]^2]/[8(4,200)(733,320)] \\ &= -0.37 \text{ in. (upward deflection)}\end{aligned}$$

Group 3 strands: 6 strands debonded for 22 ft. from centerline of bearings
Transfer length = 30 in.
Initial prestressing force = 173.3 k

From Figures 2-5 and 2-6, the distance from the bottom of the beam to the centroid of Group 3 is 4.0 in.

Deflection due to Group 3 strands:

$$\begin{aligned}\Delta_{P/S 3} &= -P_t e_s [L^2 - (L_t + 2L_x)^2]/(8E_{ci} I_g) \\ &= -173.3(36.38 - 4.0)[[109(12)]^2 - [30 + 2(22)(12)]^2]/[8(4,200)(733,320)] \\ &= -0.32 \text{ in. (upward deflection)}\end{aligned}$$

Total initial deflection due to prestressing:

$$\begin{aligned}\Delta_{P/S Tot} &= -1.99 - 0.37 - 0.32 \\ &= -2.68 \text{ in. (upward deflection)}\end{aligned}$$

Notice that for camber calculations, some jurisdictions assume that some of the prestressing force is lost and only consider a percentage of the value calculated above (e.g. Pennsylvania uses 90% of the above value). In the following calculations the full value is used. The user may revise these values to match any reduction required by the bridge owner's specification.

Using conventional beam theory to determine deflection of simple span beams under uniform load or concentrated loads and using the loads calculated in Section 5.2, using noncomposite and composite girder properties for loads applied before and after the slab is hardened, respectively, the following deflections may be calculated:

$$\begin{aligned}\Delta_{sw} &= \text{deflection due to the girder self-weight} \\ &= 1.16 \text{ in.}\end{aligned}$$

$$\begin{aligned}\Delta_s &= \text{deflection due to the slab, formwork, and exterior diaphragm weight} \\ &= 1.12 \text{ in.}\end{aligned}$$

$$\begin{aligned}\Delta_{SDL} &= \text{deflection due to the superimposed dead load weight} \\ &= 0.104 \text{ in.}\end{aligned}$$

All deflection from dead load is positive (downward).

Design Step 5.6.7.1 Camber to determine bridge seat elevations

Initial camber, C_i :

$$\begin{aligned}C_i &= \Delta_{P/S \text{ Tot}} + \Delta_{sw} \\ &= -2.68 + 1.16 \\ &= -1.52 \text{ in. (upward deflection)}\end{aligned}$$

Initial camber adjusted for creep, C_{iA} :

$$C_{iA} = C_i C_r$$

where:

C_r = constant to account for creep in camber (S5.4.2.3.2)

$$= 3.5k_c k_f \left(1.58 - \frac{H}{120} \right) t_i^{-0.118} \frac{(t - t_i)^{0.6}}{10.0 + (t - t_i)^{0.6}} \quad (\text{S5.4.2.3.2-1})$$

k_c = factor for the effect of the volume-to-surface area ratio of the component as specified in Figure S5.4.2.3.2-1

In order to determine k_c , the volume-to-surface area ratio needs to be calculated. See Figure 2-3 for girder dimensions.

$$\begin{aligned} \text{Beam area} &= 1,085 \text{ in}^2 \\ \text{Beam volume} &= 1,085(12) \\ &= 13,020 \text{ in}^3/\text{ft} \\ \text{Surface area} &= 2,955.38 \text{ in}^2/\text{ft} \\ (V/S)_b &= 13,020/2,955.38 \\ &= 4.406 \text{ in.} \end{aligned}$$

Using Figure S5.4.2.3.2-1 or SC5.4.2.3.2-1, the correction factor, k_c , is taken to be approximately 0.759.

k_f = factor for the effect of concrete strength

$$\begin{aligned} &= \frac{1}{0.67 + \left(\frac{f'_c}{9}\right)} \quad (\text{S5.4.2.3.2-2}) \\ &= \frac{1}{0.67 + \left(\frac{6.0}{9}\right)} = 0.748 \end{aligned}$$

H = relative humidity from Figure S5.4.2.3.3-1
= 70%

t_i = age of concrete when load is initially applied
= 1 day

t = maturity of concrete
= infinite

$$\begin{aligned} C_r &= 3.5(0.759)(0.748)[1.58 - (70/120)](1)^{-0.118} \\ &= 1.98 \end{aligned}$$

Therefore, the initial camber, C_{iA} is:

$$\begin{aligned} C_{iA} &= -1.52(1.98) \\ &= -3.01 \text{ in. (upward deflection)} \end{aligned}$$

Final camber, C_F :

$$\begin{aligned}
 C_F &= C_{iA} + \Delta_s + \Delta_{SDL} \\
 &= -3.01 + 1.12 + 0.104 \\
 &= -1.79 \text{ in. (upward deflection)}
 \end{aligned}$$

This camber is used to determine bridge seat elevation.

Design Step 5.6.7.2 Haunch thickness

The haunch thickness is varied along the length of the girders to provide the required roadway elevation. For this example, the roadway grade is assumed to be 0.0. Therefore, the difference between the maximum haunch thickness at the support and the minimum haunch thickness at the center of the beam should equal the final camber, i.e., 1.79 in. in this example. Minimum haunch thickness is not included in the specifications and is typically specified by the bridge owner. Figure 5.6-9 shows schematically the variation in haunch thickness. Haunch thickness at intermediate points is typically calculated using a computer program.

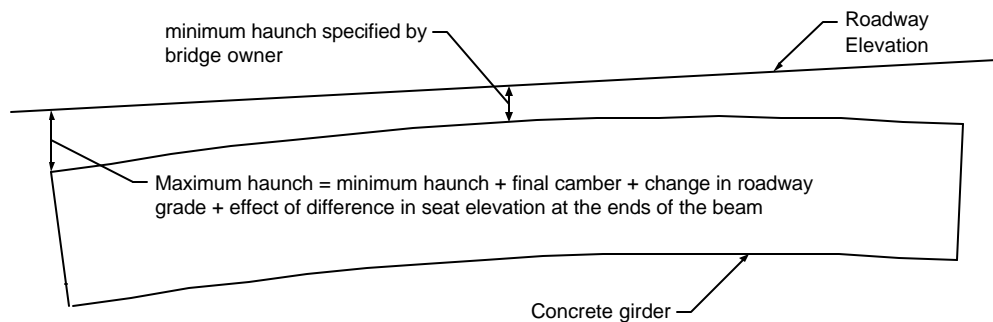

Figure 5.6-9 – Schematic View of Haunch

Design Step 5.6.7.3 Camber to determine probable sag in bridge

To eliminate the possibility of sag in the bridge under permanent loads, some jurisdictions require that the above calculations for C_F be repeated assuming a further reduction in the initial P/S camber. The final C_F value after this reduction should show upward deflection.

Design Step 5.6.8 Optional live load deflection check

Service load deformations may cause deterioration of wearing surfaces and local cracking in concrete slabs and in metal bridges which could impair serviceability and durability, even if self limiting and not a potential source of collapse.

As early as 1905, attempts were made to avoid these effects by limiting the depth-to-span ratios of trusses and girders, and starting in the 1930's, live load deflection limits were prescribed for the same purpose. In a study of deflection limitations of bridges ASCE (1958), an ASCE committee, found numerous shortcomings in these traditional approaches and noted them. For example:

"The limited survey conducted by the Committee revealed no evidence of serious structural damage that could be attributed to excessive deflection. The few examples of damaged stringer connections or cracked concrete floors could probably be corrected more effectively by changes in design than by more restrictive limitations on deflection. On the other hand, both the historical study and the results from the survey indicate clearly that unfavorable psychological reaction to bridge deflection is probably the most frequent and important source of concern regarding the flexibility of bridges. However, those characteristics of bridge vibration which are considered objectionable by pedestrians or passengers in vehicles cannot yet be defined."

Since that time, there has been extensive research on human response to motion, and it is now generally agreed that the primary factor affecting human sensitivity is acceleration as opposed to deflection, velocity, or the rate of change of acceleration for bridge structures, but the problem is a difficult subjective one. Thus, to this point in history there are no simple definitive guidelines for the limits of tolerable static deflection or dynamic motion. Among current specifications, the Ontario Highway Bridge Design Code of 1983 contains the most comprehensive provisions regarding vibrations tolerable to humans.

The deflection criteria in S2.5.2.6.2 is considered optional. The bridge owner may select to invoke this criteria if desired. If an Owner chooses to invoke deflection control, the following principles may apply:

- *when investigating the maximum absolute deflection, all design lanes should be loaded, and all supporting components should be assumed to deflect equally,*
- *for composite design, the design cross-section should include the entire width of the roadway and the structurally continuous portions of the railings, sidewalks and median barriers*
- *when investigating maximum relative displacements, the number and position of loaded lanes should be selected to provide the worst differential effect,*

- *the live load portion of load combination Service I of Table S3.4.1-1 should be used, including the dynamic load allowance, IM*
- *the live load shall be taken from S3.6.1.3.2,*
- *the provisions of S3.6.1.1.2 should apply,*
- *for skewed bridges, a right cross-section may be used; for curved and curved skewed bridges a radial cross-section may be used.*

If the Owner invokes the optional live load deflection criteria, the deflection should be taken as the larger of:

- *That resulting from the design truck alone, or*
- *That resulting from 25 percent of the design truck taken together with the design lane load.*

According to S2.5.2.6.2, the deflection criteria for vehicular live load limits deflection to $L/800$.

$$110(12)/800 = 1.65 \text{ in.}$$

The calculated live load deflection determined by using computer software is 0.324 in.

$$0.324 \text{ in.} < 1.65 \text{ in.} \quad \mathbf{OK}$$

Design Step 5.7 SHEAR DESIGN (S5.8)

Shear design in the AASHTO-LRFD Specifications is based on the modified compression field theory. This method takes into account the effect of the axial force on the shear behavior of the section. The angle of the shear cracking, θ , and the shear constant, β , are both functions of the level of applied shear stress and the axial strain of the section. Figure S5.8.3.4.2-1 (reproduced below) illustrates the shear parameters.

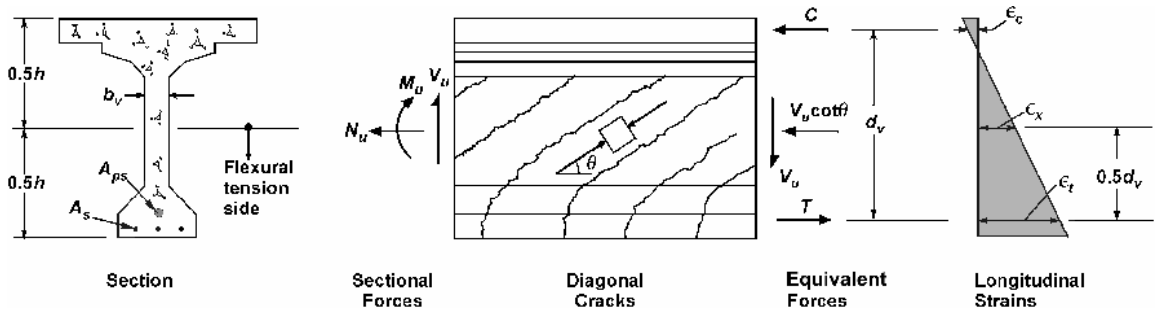

Figure S5.8.3.4.2-1 - Illustration of Shear Parameters for Section Containing at Least the Minimum Amount of Transverse Reinforcement, $V_p = 0$.

The transverse reinforcement (stirrups) along the beam is shown in Figure 5.7-1. Table 5.7-1 lists the variables required to be calculated at several sections along the beam for shear analysis.

A sample calculation for shear at several sections follows the table.

Notice that many equations contain the term V_p , the vertical component of the prestressing force. Since draped strands do not exist in the example beams, the value of V_p is taken as 0.

Table 5.7-1 Shear Analysis at Different Sections

Dist. ⁽¹⁾	A _{ps}	A _s ⁽³⁾	CGS ⁽⁴⁾	d _e ⁽⁵⁾	c (Rectan- gular be- havior) ⁽⁶⁾	c (T-section behavior) ⁽⁷⁾	d _e - b ₁ c/2	0.9d _e	d _v ⁽⁸⁾	V _u ⁽⁹⁾	V _p ^(9,10)	V _H /f _c ⁽¹¹⁾	M _u ^(9,12)	M _u /d _v
(ft.)	(in ²)	(in ²)	(in.)	(in.)	(in.)	(in.)	(in.)	(in.)	(in.)	(kips)	(kips)		(kip-ft)	(kips)
7.00	4.90		5.375	74.13	4.06	#N/A	72.40	66.71	72.40	340.4	0.00	0.1088	2,241	371.4
11.00	5.26		5.279	74.22	4.35	#N/A	72.37	66.80	72.37	315.1	0.00	0.1008	3,393	562.6
16.50	5.81		5.158	74.34	4.80	#N/A	72.30	66.91	72.30	280.7	0.00	0.0899	4,755	789.2
22.00	5.81		5.158	74.34	4.80	#N/A	72.14	66.91	72.14	246.7	0.00	0.0790	5,897	978.7
27.50	6.73		5.000	74.50	5.55	#N/A	72.14	67.05	72.14	213.4	0.00	0.0685	6,821	1,134.6
33.00	6.73		5.000	68.37	5.55	#N/A	72.14	67.05	72.14	180.6	0.00	0.0579	7,535	1,253.3
38.50	6.73		5.000	68.37	5.55	#N/A	72.14	67.05	72.14	148.3	0.00	0.0476	8,063	1,341.2
44.00	6.73		5.000	68.37	5.55	#N/A	72.14	67.05	72.14	116.7	0.00	0.0374	8,381	1,394.1
49.50	6.73		5.000	68.37	5.55	#N/A	72.14	67.05	72.14	85.7	0.00	0.0275	8,494	1,412.9
54.50	6.73		5.000	68.37	5.55	#N/A	72.14	67.05	72.14	118.4	0.00	0.0380	8,456	1,406.5
55.00	6.73		5.000	68.37	5.55	#N/A	72.14	67.05	72.14	121.3	0.00	0.0389	8,440	1,403.9
60.50	6.73		5.000	68.37	5.55	#N/A	72.14	67.05	72.14	153.5	0.00	0.0492	8,163	1,357.8
66.00	6.73		5.000	68.37	5.55	#N/A	72.14	67.05	72.14	185.7	0.00	0.0596	7,690	1,279.1
71.50	6.73		5.000	68.37	5.55	#N/A	72.14	67.05	72.14	217.9	0.00	0.0699	7,027	1,168.8
77.00	6.73		5.000	68.37	5.55	#N/A	72.14	67.05	72.14	250.0	0.00	0.0802	6,180	1,028.0
82.50	6.73		5.000	74.50	5.55	#N/A	72.14	67.05	72.14	282.0	0.00	0.0905	5,158	858.0
88.00	5.81		5.158	74.34	4.80	#N/A	72.30	66.91	72.30	313.8	0.00	0.1005	3,966	658.2
93.50	5.81 ⁽²⁾	14.65	5.158	75.52	8.21	#N/A	72.44	67.97	72.44	345.4	0.00	0.1104	-393	65.1
99.00	4.90 ⁽²⁾	14.65	5.375	75.52	8.21	#N/A	72.44	67.97	72.44	376.8	0.00	0.1204	-1,535	254.3
102.50	4.90 ⁽²⁾	14.65	5.375	75.52	8.21	#N/A	72.44	69.97	72.44	396.6	0.00	0.1267	-2,489	412.3

Dist.	A _s f _{po} (2,13)	q (guess) (14)	0.5(V _u - V _p) cot q	Net Force	e _x ⁽¹⁵⁾	Adjusted e _x ⁽¹⁶⁾	q (comp.) (17)	b ⁽¹⁷⁾	V _c	Max. Stirrup Spcg.	V _s (comp.)	f V _n	f V _n /V _u	T ⁽¹⁸⁾
(ft.)	(kips)		(kips)	(kips)	(strain)	(strain)			(kips)	(in.)	(kips)	(kips)		(kips)
7.00	926.1	22.60	408.9	-145.8	-0.000520	-0.000026	22.60	3.05	136.7	16.0	260.9	307.8	1.051	967
11.00	994.1	22.80	374.8	-56.7	-0.000190	-0.000010	22.80	3.07	137.6	18.0	229.5	317.3	1.049	1,123
16.50	1,098.1	22.33	341.7	32.8	0.000100	0.000100	24.75	2.99	133.9	21.0	179.2	305.6	1.004	1,272
22.00	1,098.1	28.66	225.7	106.3	0.000320	0.000320	28.66	2.74	122.7	20.0	158.7	311.1	1.027	1,335
27.50	1,272.0	26.03	218.4	81.0	0.000210	0.000210	26.03	3.02	134.9	24.0	147.7	329.0	1.192	1,469
33.00	1,272.0	28.55	165.9	147.2	0.000380	0.000380	29.53	2.68	119.7	24.0	127.4	321.2	1.232	1,495
38.50	1,272.0	31.30	122.0	191.2	0.000500	0.000500	31.30	2.54	113.5	24.0	118.7	317.7	1.409	1,515
44.00	1,272.0	31.30	96.0	218.1	0.000570	0.000570	32.10	2.49	111.2	24.0	115.0	316.8	1.744	1,509
49.50	1,272.0	31.30	70.5	211.4	0.000550	0.000550	31.30	2.54	113.5	24.0	118.7	318.1	2.438	1,472
54.50	1,272.0	32.10	94.4	228.9	0.000600	0.000600	32.10	2.49	111.2	24.0	115.0	315.8	1.720	1,525
55.00	1,272.0	32.10	96.7	228.6	0.000600	0.000600	32.10	2.49	111.2	24.0	115.0	315.8	1.678	1,527
60.50	1,272.0	31.30	126.2	212.0	0.000550	0.000550	31.30	2.54	113.5	24.0	118.7	316.2	1.362	1,541
66.00	1,272.0	29.53	163.9	171.0	0.000450	0.000450	30.50	2.59	115.7	24.0	122.5	318.8	1.155	1,526
71.50	1,272.0	27.28	208.5	105.3	0.000270	0.000270	27.85	2.85	127.3	24.0	138.1	238.9	1.097	1,500
77.00	1,272.0	23.83	283.0	39.0	0.000100	0.000100	24.45	3.16	141.2	24.0	158.7	269.9	1.080	1,465
82.50	1,272.0	22.33	343.2	-70.8	-0.000180	-0.000012	22.33	3.29	147.0	21.0	175.6	290.3	1.030	1,407
88.00	1,098.1	22.80	373.2	-66.7	-0.000200	-0.000012	22.80	3.07	137.4	19.0	217.3	319.2	1.017	1,229
93.50	1,098.1 ⁽²⁾	30.20	296.7	361.8	0.000430	0.000430	30.20	2.56	114.8	11.0	271.6	347.8	1.007	#N/A
99.00	926.1 ⁽²⁾	33.65	283.0	537.3	0.000630	0.000630	33.65	2.30	103.2	8.0	326.5	386.7	1.026	#N/A
102.50	926.1 ⁽²⁾	35.17	281.4	693.7	0.000820	0.000820	35.81	2.19	98.2	7.0	344.3	398.3	1.004	#N/A

Notes:

- (1) Distance measured from the centerline of the end support. Calculations for Span 1 are shown. From symmetry, Span 2 is a mirror image of Span 1.
- (2) Prestressing steel is on the compression side of the section in the negative moment region of the girder (intermediate pier region). This prestressing steel is ignored where the area of steel in an equation is defined as the area of steel on the tension side of the section.
- (3) Area of continuity reinforcement, i.e., the longitudinal reinforcement of the deck slab within the effective flange width of the girder in the girder negative moment region.
- (4) Distance from the centroid of the tension steel reinforcement to the extreme tension fiber of the section. In the positive moment region, this is the distance from the centroid of prestressing strands to the bottom of the prestressed beam. In the negative moment region, this is the distance from the centroid of the longitudinal deck slab reinforcement to the top of the structural deck slab (ignore the thickness of the integral wearing surface).
- (5) Effective depth of the section equals the distance from the centroid of the tension steel reinforcement to the extreme compression fiber of the section. In the positive moment region, this is the distance from the centroid of the prestressing strands to the top of the structural deck slab (ignore the thickness of the integral wearing surface). In the negative moment region, this is the distance from the centroid of the longitudinal deck slab reinforcement to the bottom of the prestressed beam. The effective depth is calculated as the total depth of the section (which equals the depth of precast section, 72 in. + structural deck thickness, 7.5 in. = 79.5 in.) minus the quantity defined in note (4) above.
- (6) Distance from the extreme compression fiber to the neutral axis calculated assuming rectangular behavior using Eq. S5.7.3.1.1-4. Prestressing steel, effective width of slab and slab compressive strength are considered in the positive moment region. The slab longitudinal reinforcement, width of the girder bottom (compression) flange and girder concrete strength are considered in the negative moment region.
- (7) Distance from the extreme compression fiber to the neutral axis calculated assuming T-section behavior using Eq. S5.7.3.1.1-3. Only applicable if the rectangular section behavior proves untrue.
- (8) Effective depth for shear calculated using S5.8.2.9.
- (9) Maximum applied factored load effects obtained from the beam load analysis.
- (10) Vertical component of prestressing which is 0.0 for straight strands
- (11) The applied shear stress, v_u , calculated as the applied factored shear force divided by product of multiplying the web width and the effective shear depth.
- (12) Only the controlling case (positive moment or negative moment) is shown.
- (13) In the positive moment region, the parameter f_{po} is taken equal to $0.7f_{pu}$ of the prestressing steel as allowed by S5.8.3.4.2. This value is reduced within the transfer length of the strands to account for the lack of full development.
- (14) Starting (assumed) value of shear crack inclination angle, θ , used to determine the parameter ϵ_x .
- (15) Value of the parameter ϵ_x calculated using Eq. S5.8.3.4.2-1 which assumes that ϵ_x has a positive value.
- (16) Value of the parameter ϵ_x recalculated using Eq. S5.8.3.4.2-3 when the value calculated using Eq. S5.8.3.4.2-1 is a negative value.
- (17) Value of θ and β determined from Table S5.8.3.4.2-1 using the calculated value of ϵ_x and v_u/f'_c . These values are determined using a step function to interpolate between the values in Table S5.8.3.4.2-1.
- (18) Force in longitudinal reinforcement including the effect of the applied shear (S5.8.3.5)

Design Step 5.7.1 Critical section for shear near the end support

According to S5.8.3.2, where the reaction force in the direction of the applied shear introduces compression into the end region of a member, the location of the critical section for shear is taken as the larger of $0.5d_v \cot \theta$ or d_v from the internal face of the

support (d_v and q are measured at the critical section for shear). This requires the designer to estimate the location of the critical section first to be able to determine d_v and q , so a more accurate location of the critical section may be determined.

Based on a preliminary analysis, the critical section near the end support is estimated to be at a distance 7.0 ft. from the centerline of the end bearing. This distance is used for analysis and will be reconfirmed after determining d_v and θ .

Design Step 5.7.2 Shear analysis for a section in the positive moment region
Sample Calculations: Section 7.0 ft. from the centerline of the end bearing

Design Step 5.7.2.1 Determine the effective depth for shear, d_v

d_v = effective shear depth taken as the distance, measured perpendicular to the neutral axis, between the resultants of the tensile and compressive forces due to flexure; it need not be taken to be less than the greater of $0.9d_e$ or $0.72h$ (S5.8.2.9)

h = total depth of beam (in.)
 = depth of the precast beam + structural slab thickness
 = $72 + 7.5 = 79.5$ in. (notice that the depth of the haunch was ignored in this calculation)

d_e = distance from the extreme compression fiber to the center of the prestressing steel at the section (in.). From Figure 2-6,
 = $79.5 - 5.375 = 74.125$ in.

Assuming rectangular section behavior with no compression steel or mild tension reinforcement, the distance from the extreme compression fiber to the neutral axis, c , may be calculated as:

$$c = A_{ps}f_{pu} / [0.85f_c\beta_1b + kA_{ps}(f_{pu}/d_p)] \quad (S5.7.3.1)$$

$$\beta_1 = 0.85 \text{ for 4 ksi slab concrete} \quad (S5.7.2.2)$$

b = effective flange width
 = 111 in. (calculated in Section 2.2)

Area of prestressing steel at the section = $32(0.153) = 4.896 \text{ in}^2$

$$c = 4.896(270) / [0.85(4)(0.85)(111) + 0.28(4.896)(270/74.125)]$$

= 4.06 in. < structural slab thickness = 7.5 in.

The assumption of the section behaving as a rectangular section is correct.

Depth of compression block, $a = \beta_1 c = 0.85(4.06) = 3.45$ in.

Distance between the resultants of the tensile and compressive forces due to flexure:

$$\begin{aligned} &= d_e - a/2 \\ &= 74.125 - 3.45/2 \\ &= 72.4 \text{ in.} \end{aligned} \quad (1)$$

$$\begin{aligned} 0.9d_e &= 0.9(74.125) \\ &= 66.71 \text{ in.} \end{aligned} \quad (2)$$

$$\begin{aligned} 0.72h &= 0.72(79.5) \\ &= 57.24 \text{ in.} \end{aligned} \quad (3)$$

$d_v =$ largest of (1), (2) and (3) = 72.4 in.

Notice that 0.72h is always less than the other two values for all sections of this beam. This value is not shown in Table 5.7-1 for clarity.

Design Step 5.7.2.2

Shear stress on concrete

From Table 5.3-4, the factored shear stress at this section, $V_u = 340.4$ kips

$\phi =$ resistance factor for shear is 0.9 (S5.5.4.2.1)

$b_v =$ width of web = 8 in. (see S5.8.2.9 for the manner in which b_v is determined for sections with post-tensioning ducts and for circular sections)

From Article S5.8.2.9, the shear stress on the concrete is calculated as:

$$\begin{aligned} v_u &= (V_u - \phi V_p) / (\phi b_v d_v) && (S5.8.2.9-1) \\ &= (340.4 - 0) / [0.9(8)(72.4)] \\ &= 0.653 \text{ ksi} \end{aligned}$$

Ratio of applied factored shear stress to concrete compressive strength:

$$v_u / f'_c = 0.653 / 6.0 = 0.1088$$

Design Step 5.7.2.3

Minimum required transverse reinforcement

Limits on maximum factored shear stresses for sections without transverse reinforcement are presented in S5.8.2.4. Traditionally, transverse reinforcement satisfying the minimum transverse reinforcement requirements of S5.8.2.5 is provided along the full length of the beam.

Minimum transverse reinforcement, A_v :

$$A_v \geq 0.0316\sqrt{f'_c} \frac{b_v s}{f_y} \quad (\text{S5.8.2.5-1})$$

f'_c = compressive strength of the web concrete = 6.0 ksi

f_y = yield strength of the transverse reinforcement = 60 ksi

Assume that #4 bars are used for the stirrups. A_v = area of 2 legs of a #4 bar = 0.4 in²
Substitute 0.4 in² to determine “s”, the maximum allowable spacing of #4 bars (2-leg stirrups).

$$0.4 \geq 0.0316(2.449)(8/60)s$$

$$s \leq 38.77 \text{ in.}$$

Design Step 5.7.2.4 Maximum spacing for transverse reinforcement

The maximum spacing of transverse reinforcement is determined in accordance with S5.8.2.7. Depending on the level of applied factored shear stress, v_u , the maximum permitted spacing, s_{max} , is determined as:

- If $v_u < 0.125f'_c$, then:

$$s_{max} = 0.8d_v < 24.0 \text{ in.} \quad (\text{S5.8.2.7-1})$$

- If $v_u \geq 0.125f'_c$, then:

$$s_{max} = 0.4d_v < 12.0 \text{ in.} \quad (\text{S5.8.2.7-2})$$

For the section under consideration, $v_u = 0.1088f'_c$. Therefore, the maximum permitted spacing,

$$\begin{aligned} s_{max} &= 0.8d_v \\ &= 0.8(72.4) \\ &= 57.9 \text{ in.} > 24.0 \text{ in. NG, assume maximum permitted stirrup} \\ &\quad \text{spacing} = 24 \text{ in.} \end{aligned}$$

Design Step 5.7.2.5 Shear strength

The shear strength provided by the concrete, V_c , is calculated using the following equation:

$$V_c = 0.0316\beta\sqrt{f'_c} b_v d_v \quad (\text{S5.8.3.3-3})$$

The values of \mathbf{b} and the shear cracking inclination angle, \mathbf{q} , are determined using the procedure outlined in S5.8.3.4.2. This iterative procedure begins with assuming a value of the parameter \mathbf{e}_x , or the crack inclination angle \mathbf{q} , then calculating a new \mathbf{e}_x value which is subsequently compared to the assumed value.

If the two values match, or the assumed value is slightly greater than the calculated value, no further iterations are required. Otherwise, a new cycle of analysis is conducted using the calculated value.

The calculations shown below are based on assuming a value of the crack inclination angle \mathbf{q} .

The flowcharts in Section 3 include two for shear analysis. The first flowchart is based on assuming the analyses are based on an assumed value of \mathbf{q} and the second flowchart is based on an assumed value of \mathbf{e}_x .

The parameter \mathbf{e}_x is a measure of the strain in the concrete on the tension side of the section. For sections containing at least the minimum transverse reinforcement calculated above, \mathbf{e}_x may be calculated using the following equations:

$$\mathbf{e}_x = \frac{\left(\frac{M_u}{d_v} + 0.5N_u + 0.5(V_u - V_p) \cot \theta - A_{ps}f_{po} \right)}{2(E_s A_s + E_{ps} A_{ps})} \leq 0.002 \quad (S5.8.3.4.2-1)$$

If the value of \mathbf{e}_x from Eqs. S5.8.3.4.2-1 or -2 is negative, the strain shall be taken as:

$$\mathbf{e}_x = \frac{\left(\frac{M_u}{d_v} + 0.5N_u + 0.5(V_u - V_p) \cot \theta - A_{ps}f_{po} \right)}{2(E_c A_c + E_s A_s + E_{ps} A_{ps})} \quad (S5.8.3.4.2-3)$$

For this example, the value of both the applied factored axial load, N_u , and the vertical component of prestressing, V_p , are taken equal to 0.

For the section under consideration:

$$V_u = \text{maximum applied factored shear} = 340.4 \text{ kips}$$

$$M_u = \text{maximum factored moment at the section} = 2,241 \text{ k-ft}$$

Notice that the maximum live load moment and the maximum live load shear at any section are likely to result from two different locations of the load along the length of the bridge. Conducting the shear analysis using the maximum factored shear and the concurrent factored moment is permitted. However, most computer programs list the

maximum values of the moment and the maximum value of the shear without listing the concurrent forces. Therefore, hand calculations and most design computer programs typically conduct shear analysis using the maximum moment value instead of the moment concurrent with the maximum shear. This results in a conservative answer.

According to S5.8.3.4.2, f_{po} is defined as follows:

f_{po} = a parameter taken as the modulus of elasticity of the prestressing tendons multiplied by the locked in difference in strain between the prestressing tendons and the surrounding concrete (ksi). For the usual levels of prestressing, a value of $0.7f_{pu}$ will be appropriate for both pretensioned and posttensioned members.

For pretensioned members, multiplying the modulus of elasticity of the prestressing tendons by the locked in difference in strain between the prestressing tendons and the surrounding concrete yields the stress in the strands when the concrete is poured around them, i.e., the stress in the strands immediately prior to transfer. For pretensioned members, S5.8.3.4.2 allows f_{po} to be taken equal to the jacking stress. This value is typically larger than $0.7f_{pu}$. Therefore, using $0.7f_{pu}$ is more conservative since it results in a larger value of ϵ_x .

For this example, f_{po} is taken as $0.7f_{pu}$

Notice that, as required by Article S5.8.3.4.2, within the transfer length, f_{po} shall be increased linearly from zero at the location where the bond between the strands and concrete commences to its full value at the end of the transfer length.

Assume that $\theta = 23.0$ degrees (this value is based on an earlier cycle of calculations).

$$\begin{aligned} A_{ps} &= \text{area of prestressed steel at the section} \\ &= 32(0.153) \\ &= 4.896 \text{ in}^2 \end{aligned}$$

$$d_v = 72.4 \text{ in. (6.03 ft.)}$$

A_s , E_s , A_{ps} and E_{ps} are the area of mild tension reinforcement (0.0), modulus of elasticity of mild reinforcement (29,000 ksi), area of prestressing steel (4.896 in²) and modulus of elasticity of the prestressing strands (28,500 ksi), respectively.

Substitute these variables in Eq. S5.8.3.4.2-1 and recalculate ϵ_x .

$$\epsilon_x = -0.00055 < 0.0 \text{ NG, therefore, use Eq. S5.8.3.4.2-3}$$

The area of the concrete on the tension side of the beam is taken as the area of concrete on the tension side of the beam within half the total depth of the beam.

$H/2$ = one half of the total composite beam depth = $79.5/2 = 39.75$ in.

From Figure S5.8.3.4.2-1 (reproduced above), the concrete area on the tension side, the lower 39.75 in. of the beam, equals 578 in^2 .

Modulus of elasticity of the beam concrete, $E_c = 33,000w_c^{1.5}\sqrt{f'_c} = 4,696$ ksi

Substitute these variables in Eq. S5.8.3.4.2-3 and recalculate ϵ_x .

$$\epsilon_x = -0.000027$$

At the section under consideration $v_u/f'_c = 0.1088$ (from Design Step 5.7.2.2 above)

Table S5.8.3.4.2-1 is reproduced below. This table is used to determine the value of q and b at different sections.

Notice that:

- *Linear interpolation between the rows of the table is permitted to account for the value of v_u/f'_c at the section*
- *Linear interpolation between the columns of the table is allowed to account for the calculated value of ϵ_x*
- *In lieu of interpolating, using values of q and b from a cell that correspond to the values of v_u/f'_c and ϵ_x greater than the calculated values is permitted. This approach is preferred for hand calculations and will result in a conservative answer.*

Using Table S5.8.3.4.2-1 for the above values of ϵ_x and v_u/f'_c :

Use the row that corresponds to $v_u/f'_c \leq 0.125$ (this value is next greatest to the calculated value of v_u/f'_c)

Use the column corresponding to $\epsilon_x \leq 0.0$ (the value in Table S5.8.3.4.2-1 that is next larger to the assumed value of ϵ_x)

$$\theta = 23.7 \text{ degrees}$$

$$\beta = 2.87$$

Check the assumed value of θ :

For the purpose of calculating ϵ_x , the value of θ was assumed to be 23.0 degrees. This value is close to the value obtained above. Therefore, the assumed value of θ was appropriate and there is no need for another cycle of calculations.

Notice that the assumed and calculated values of q do not need to have the same exact value. A small difference will not drastically affect the outcome of the analysis and, therefore, does not warrant conducting another cycle of calculations. The assumed value may be accepted if it is larger than the calculated value.

Notice that the values in Table 5.7-1 are slightly different (22.60 and 3.05). This is true since the spreadsheet used to determine the table values uses a step function instead of linear interpolation.

Calculate the shear resistance provided by the concrete, V_c .

$$V_c = 0.0316\beta\sqrt{f'_c}b_v d_v \quad (\text{S5.8.3.3-3})$$

$$V_c = 0.0316(2.87)(2.449)(8)(72.4) = 128.6 \text{ k}$$

Calculate the shear resistance provided by the transverse reinforcement (stirrups), V_s .

$$V_s = [A_v f_y d_v (\cot \theta + \cot \alpha) \sin \alpha] / s \quad (\text{S5.8.3.3-4})$$

Assuming the stirrups are placed perpendicular to the beam longitudinal axis at 16 in. spacing and are comprised of #4 bars, each having two legs:

$$\begin{aligned} A_v &= \text{area of shear reinforcement within a distance "s" (in}^2\text{)} \\ &= 2(\text{area of \#4 bar}) \\ &= 2(0.2) \\ &= 0.4 \text{ in}^2 \end{aligned}$$

$$s = 16 \text{ in.}$$

$$\begin{aligned} \alpha &= \text{angle between the stirrups and the longitudinal axis of the beam} \\ &= 90 \text{ degrees} \end{aligned}$$

$$V_s = [0.4(60)(72.4)(\cot 23.0)] / 16 = 255.8 \text{ k}$$

The nominal shear resistance, V_n , is determined as the lesser of:

$$V_n = V_c + V_s + V_p \quad (\text{S5.8.3.3-1})$$

$$V_n = 0.25f'_c b_v d_v + V_p \quad (\text{S5.8.3.3-2})$$

Notice that the purpose of the limit imposed by Eq. S5.8.3.3-2 is intended to eliminate excessive shear cracking.

$$V_p = 0.0 \text{ for straight strands}$$

V_n = lesser of:

$$V_c + V_s + V_p = 128.6 + 255.8 + 0.0 = 384.4 \text{ k}$$

and

$$0.25f'_c b_v d_v + V_p = 0.25(6)(8)(72.4) + 0.0 = 868.8 \text{ k}$$

Therefore, $V_n = 384.4 \text{ k}$

The resistance factor, ϕ , for shear in normal weight concrete is 0.9 (S5.5.4.2.1)

Shear factored resistance, V_r :

$$\begin{aligned} V_r &= \phi V_n && \text{(S5.8.2.1-2)} \\ &= 0.9(384.4) \\ &= 346.0 \text{ k} > \text{maximum applied factored shear, } V_u = 340.4 \text{ k} \quad \text{OK} \end{aligned}$$

Table S5.8.3.4.2-1 – Values of q and b for Sections with Transverse Reinforcement (Reproduced from the AASHTO-LRFD Specifications)

V/f'_c	$\epsilon_x \times 1,000$										
	= -0.20	= -0.10	= -0.05	= 0	= 0.125	= 0.25	= 0.50	= 0.75	= 1.00	= 1.50	= 2.00
= 0.075	22.3	20.4	21.0	21.8	24.3	26.6	30.5	33.7	36.4	40.8	43.9
	6.32	4.75	4.10	3.75	3.24	2.94	2.59	2.38	2.23	1.95	1.67
= 0.100	18.1	20.4	21.4	22.5	24.9	27.1	30.8	34.0	36.7	40.8	43.1
	3.79	3.38	3.24	3.14	2.91	2.75	2.50	2.32	2.18	1.93	1.69
= 0.125	19.9	21.9	22.8	23.7	25.9	27.9	31.4	34.4	37.0	41.0	43.2
	3.18	2.99	2.94	2.87	2.74	2.62	2.42	2.26	2.13	1.90	1.67
= 0.150	21.6	23.3	24.2	25.0	26.9	28.8	32.1	34.9	37.3	40.5	42.8
	2.88	2.79	2.78	2.72	2.60	2.52	2.36	2.21	2.08	1.82	1.61
= 0.175	23.2	24.7	25.5	26.2	28.0	29.7	32.7	35.2	36.8	39.7	42.2
	2.73	2.66	2.65	2.60	2.52	2.44	2.28	2.14	1.96	1.71	1.54
= 0.200	24.7	26.1	26.7	27.4	29.0	30.6	32.8	34.5	36.1	39.2	41.7
	2.63	2.59	2.52	2.51	2.43	2.37	2.14	1.94	1.79	1.61	1.47
= 0.225	26.1	27.3	27.9	28.5	30.0	30.8	32.3	34.0	35.7	38.8	41.4
	2.53	2.45	2.42	2.40	2.34	2.14	1.86	1.73	1.64	1.51	1.39
= 0.250	27.5	28.6	29.1	29.7	30.6	31.3	32.8	34.3	35.8	38.6	41.2
	2.39	2.39	2.33	2.33	2.12	1.93	1.70	1.58	1.50	1.38	1.29

Check the location of the critical section for shear near the end support

According to S5.8.3.2, where the reaction force in the direction of the applied shear introduces compression into the end region of a member, the location of the critical section for shear shall be taken as the larger of $0.5d_v \cot \alpha$ or d_v from the internal face of the support. For existing bridges, the width of the bearing is known and the distance is measured from the internal face of the bearings. For new bridges, the width of the

bearing is typically not known at this point of the design and one of the following two approaches may be used:

- *Estimate the width of the bearing based on past experience.*
- *Measure the distance from the CL of bearing. This approach is slightly more conservative.*

The second approach is used for this example.

For calculation purposes, the critical section for shear was assumed 7.0 ft. from the centerline of the bearing (see Design Step 5.7.1). The distance from the centerline of the support and the critical section for shear may be taken as the larger of $0.5d_v \cot \theta$ and d_v .

$$0.5d_v \cot \theta = 0.5(72.4)(\cot 23.7) = 82.5 \text{ in. (6.875 ft.)}$$

$$d_v = 72.4 \text{ in. (6.03 ft.)}$$

The larger of $0.5d_v \cot \theta$ and d_v is 82.5 in. (6.875 ft.)

The distance assumed in the analysis was 7.0 ft., i.e., approximately 0.125 ft. (0.1% of the span length) further from the support than the calculated distance. Due to the relatively small distance between the assumed critical section location and the calculated section location, repeating the analysis based on the applied forces at the calculated location of the critical section is not warranted. In cases where the distance between the assumed location and the calculated location is large relative to the span length, another cycle of the analysis may be conducted taking into account the applied forces at the calculated location of the critical section.

Design Step 5.7.3 Shear analysis for sections in the negative moment region

The critical section for shear near the intermediate pier may be determined using the same procedure as shown in Design Steps 5.7.1 and 5.7.2 for a section near the end support. Calculations for a section in the negative moment region are illustrated below for the section at 99 ft. from the centerline of the end bearing. This section is not the critical section for shear and is used only for illustrating the design process.

Sample Calculations: Section 99 ft. from the centerline of end bearings

Design Step 5.7.3.1 Difference in shear analysis in the positive and negative moment regions

- 1) *For the pier (negative moment) regions of precast simple span beams made continuous for live load, the prestressing steel near the piers is often in the compression side of the beam. The term A_{ps} in the equations for e_x is defined as the area of prestressing steel on the tension side of the member. Since the*

prestressing steel is on the compression side of the member, this steel is ignored in the analysis. This results in an increase in e_x and, therefore, a decrease in the shear resistance of the section. This approach gives conservative results and is appropriate for hand calculations.

A less conservative approach is to calculate e_x as the average longitudinal strain in the web. This requires the calculation of the strain at the top and bottom of the member at the section under consideration at the strength limit state. This approach is more appropriate for computer programs.

The difference between the two approaches is insignificant in terms of the cost of the beam. The first approach requires more shear reinforcement near the ends of the beam. The spacing of the stirrups in the middle portion of the beam is often controlled by the maximum spacing requirements and, hence, the same stirrup spacing is often required by both approaches.

It is beneficial to use the second approach in the following situations:

- *Heavily loaded girders where the first approach results in congested shear reinforcement*
 - *Analysis of existing structures where the first approach indicates a deficiency in shear resistance.*
- 2) *In calculating the distance from the neutral axis to the extreme compression fiber “c”, the following factors need to be considered:*
- *The compression side is at the bottom of the beam. The concrete strength used to determine “c” is that of the precast girder*
 - *The width of the bottom flange of the beam is substituted for “b”, the width of the member*
 - *The area of the slab longitudinal reinforcement over the intermediate pier represents the reinforcement on the tension side of the member. The area and yield strength of this reinforcement should be determined in advance.*

The first approach is used in this example.

Design Step 5.7.3.2

Determine the effective depth for shear, d_v

$$h = 72 + 7.5 = 79.5 \text{ in. (notice that the depth of the haunch was ignored in this calculation)}$$

The center of gravity of the deck slab longitudinal reinforcement from the top of the structural thickness of the deck = 3.98 in. (see Design Step 5.6.5.1)

$$d_e = 79.5 - 3.98 = 75.52 \text{ in.}$$

The area of longitudinal slab reinforcement within the effective flange width of the beam is 14.65 in^2 (see Design Step 5.6.5.1)

Yield strength of the slab reinforcement = 60 ksi

Assuming rectangular section behavior with no compression or prestressing steel, the distance from the extreme compression fiber to the neutral axis, c , may be calculated as:

$$c = A_s f_y / (0.85 f_c \beta_1 b) \quad (\text{S5.7.3.1.1-4})$$

where:

$$\beta_1 = 0.75 \text{ for 6 ksi beam concrete (S5.7.2.2)}$$

$$b = \text{precast beam bottom (compression) flange width (in.)} \\ = 28 \text{ in.}$$

$$f_c = 6 \text{ ksi}$$

$$c = 14.65(60) / [0.85(6)(0.75)(28)] \\ = 8.21 \text{ in.} \sim \text{thickness of the beam bottom flange (8 in.)}$$

Therefore, the assumption of the section behaving as a rectangular section is considered correct.

Notice that if the value of "c" is significantly larger than the beam bottom flange thickness, a rectangular behavior may be used after adjusting the beam bottom flange width to account for the actual beam area in compression. However, if "c" is not significantly larger than the beam bottom flange thickness, the effect on the results will be minor and the analysis may be continued without adjusting the beam bottom flange width. This reasoning is used in this example.

Depth of compression block, $a = \beta_1 c = 0.75(8.21) = 6.16 \text{ in.}$

Distance between the resultants of the tensile and compressive forces due to flexure:

$$= d_e - a/2 \\ = 75.52 - 6.16/2 \\ = 72.44 \text{ in.} \quad (1)$$

$$0.9d_e = 0.9(75.52) \\ = 67.97 \text{ in.} \quad (2)$$

$$0.72h = 0.72(79.5) \\ = 57.24 \text{ in.} \quad (3)$$

$$d_v = \text{largest of (1), (2) and (3)} = 72.44 \text{ in.}$$

Notice that $0.72h$ is always less than the other two values for all sections of this beam. This value is not shown in Table 5.7-1 for clarity.

Design Step 5.7.3.3 Shear stress on concrete

From Table 5.3-4, the factored shear stress at this section, $V_u = 376.8$ kips

$$\phi = 0.9 \text{ (shear)} \quad (\text{S5.5.4.2.1})$$

$$b_v = \text{width of web} = 8 \text{ in.}$$

From Article S5.8.2.9, the shear stress on the concrete is:

$$v_u = (V_u - \phi V_p) / (\phi b_v d_v)$$

$$v_u = (376.8 - 0) / [0.9(8)(72.44)] = 0.722 \text{ ksi}$$

Ratio of the applied factored shear stress to the concrete compressive strength:

$$v_u / f'_c = 0.722 / 6.0 = 0.1203$$

Design Step 5.7.3.4 Minimum required transverse reinforcement

Maximum allowable spacing for #4 stirrups with two legs per stirrup was calculated in Design Step 5.7.2.2.

$$s \leq 38.77 \text{ in.}$$

Design Step 5.7.3.5 Maximum spacing for transverse reinforcement

The maximum spacing of transverse reinforcement is determined in accordance with S5.8.2.7. Depending on the level of applied factored shear stress, v_u , the maximum permitted spacing, s_{\max} , is determined as:

- If $v_u < 0.125f'_c$, then:

$$s_{\max} = 0.8d_v < 24.0 \text{ in.} \quad (\text{S5.8.2.7-1})$$

- If $v_u \geq 0.125f'_c$, then:

$$s_{\max} = 0.4d_v < 12.0 \text{ in.} \quad (\text{S5.8.2.7-2})$$

For the section under consideration, $v_u = 0.1203f'_c$.

Therefore, the maximum permitted spacing,

$$\begin{aligned} s_{\max} &= 0.8d_v \\ &= 0.8(72.44) \\ &= 57.95 \text{ in.} > 24.0 \text{ in.} \quad \mathbf{NG} \end{aligned}$$

Assume maximum permitted stirrup spacing = 24 in.

Design Step 5.7.3.6 Shear resistance

For sections in the negative moment region of the beam, calculate e_x , using Eq. S5.8.3.4.2-1 and assume there is no prestressing steel.

$$e_x = \frac{\left(\frac{M_u}{d_v} + 0.5N_u + 0.5(V_u - V_p) \cot \theta - A_{ps} f_{po} \right)}{2(E_s A_s + E_p A_{ps})} \quad (S5.8.3.4.2-1)$$

For this example, the value of both the applied factored axial load, N_u , and the vertical component of prestressing, V_p , are taken equal to 0.

$$\begin{aligned} V_u &= \text{maximum applied factored shear from Table 5.3-4} \\ &= 376.8 \text{ kips} \end{aligned}$$

$$\begin{aligned} M_u &= \text{maximum applied factored moment from Table 5.3-2} \\ &= -1,535 \text{ k-ft} \end{aligned}$$

Notice that the term M_u/d_v represents the force in the tension reinforcement due to the applied factored moment. Therefore, M_u/d_v is taken as a positive value regardless of the sign of the moment.

Assume that $\theta = 35$ degrees

$$f_{po} = 0.0 \text{ ksi at this location (prestressing force ignored)}$$

$$\begin{aligned} A_s &= \text{area of longitudinal reinforcement in the deck at this section} \\ &= 14.65 \text{ in}^2 \end{aligned}$$

Notice that the area of deck longitudinal reinforcement used in this calculation is the area of the bars that extend at least one development length beyond the section under consideration. If the section lies within the development length of some bars, these bars may be conservatively ignored or the force in these bars be prorated based on the ratio between the full and available development length. Consideration should also be given to adjusting the location of the center of gravity of the reinforcement to account for the smaller force in the bars that are not fully developed.

$$d_v = 72.44 \text{ in. (6.04 ft.)}$$

$$E_s = 29,000 \text{ ksi}$$

$$E_{ps} = 28,500 \text{ ksi}$$

$$A_{ps} = \text{area of prestressing steel on the } \underline{\text{tension side}} \text{ of the member} \\ = 0.0 \text{ in}^2$$

Substitute these variables in Eq. S5.8.3.4.2-1 to determine ϵ_x :

$$\epsilon_x = [1,535(12)/72.44 + 0.5(376.8 - 0)\cot 35 - 0]/[2(29,000)(14.65) + 0] \\ = 0.00062$$

At the section under consideration $v_u/f'_c = 0.1203$ (from Design Step 5.7.3.3)

Determine the values of θ and β using Table S5.8.3.4.2-1 (reproduced above)

If no interpolation between the values in Table S5.8.3.4.2-1 is desired:

Use the row and column that have the closest headings, but still larger than the calculated values, i.e.:

Use the row that corresponds to $v_u/f'_c \leq 0.125$

Use the column corresponding to $\epsilon_x \leq 0.00075$

$$\theta = 34.4 \text{ degrees}$$

$$\beta = 2.26$$

If interpolation between the values in Table S5.8.3.4.2-1 is desired:

Interpolate between the values in the row with heading values closest to the calculated $v_u/f'_c = 0.1203$, i.e., interpolate between the rows with headings of $v_u/f'_c \leq 0.1$ and ≤ 0.125 . Then, interpolate between the values in the columns with heading values closest to the calculated $\epsilon_x = 0.00062$, i.e., interpolate between the columns with headings of $\epsilon_x \leq 0.0005$ and ≤ 0.00075 . The table below shows the relevant portion of Table S5.8.3.4.2-1 with the original and interpolated values. The shaded cells indicate interpolated values.

Excerpt from Table S5.8.3.4.2-1

v/f_c	$\epsilon_x \times 1,000$		
	= 0.50	0.62	= 0.75
= 0.100	30.8 2.50		34.0 2.32
0.1203	31.29 2.44	32.74 2.36	34.32 2.27
= 0.125	31.4 2.42		34.4 2.26

From the sub-table:

$$\theta = 32.74 \text{ degrees}$$

$$\beta = 2.36$$

Notice that the interpolated values are not significantly different from the ones calculated without interpolation. The analyses below are based on the interpolated values to provide the user with a reference for this process.

Check the assumed value of θ

For the purpose of calculating ϵ_x , the value of θ was assumed to be 35 degrees. This value is close to the calculated value (32.74 degrees) and conducting another cycle of the analysis will not result in a significant difference. However, for the purpose of providing a complete reference, another cycle of calculations is provided below.

Assume that θ is the calculated value of 32.74 degrees

Substituting for the variables in Eq. S5.8.3.4.2-1 for ϵ_x :

$$\epsilon_x = 0.00064$$

Determine the values of θ and β by interpolating the values in Table S5.8.3.4.2-1

$$\theta = 32.98 \text{ degrees (almost equal to the assumed value, OK)}$$

$$\beta = 2.34$$

Notice that the values in Table 5.7-1 are slightly different (33.65 and 2.30). This is true since the spreadsheet used to determine the table values uses a step function instead of linear interpolation.

Calculate the shear resistance provided by concrete, V_c :

$$V_c = 0.0316\beta\sqrt{f'_c}b_vd_v \quad (\text{S5.8.3.3-3})$$

$$V_c = 0.0316(2.34)(2.449)(8)(72.44) = 104.94 \text{ k}$$

Calculate the shear resistance provided by the transverse reinforcement (stirrups), V_s :

$$V_s = [A_v f_y d_v (\cot \theta + \cot \alpha) \sin \alpha] / s \quad (\text{S5.8.3.3-4})$$

Assuming the stirrups are placed perpendicular to the beam longitudinal axis at 7 in. spacing and are comprised of #4 bars, each having two legs:

$$\begin{aligned} A_v &= 2(\text{area of \#4 bar}) \\ &= 2(0.2) \\ &= 0.4 \text{ in}^2 \end{aligned}$$

$$s = 7 \text{ in.}$$

$$a = 90 \text{ degrees}$$

$$V_s = 0.4(60)(72.44)(\cot 32.98)/7 = 382.74 \text{ k}$$

The nominal shear resistance, V_n , is determined as the lesser of:

$$V_n = V_c + V_s + V_p \quad (\text{S5.8.3.3-1})$$

$$V_n = 0.25f'_c b_v d_v + V_p \quad (\text{S5.8.3.3-2})$$

Notice that the purpose of the limit imposed by Eq. S5.8.3.3-2 is intended to eliminate excessive shear cracking.

$$V_p = 0.0 \text{ for straight strands}$$

V_n is taken as the lesser of:

$$V_c + V_s + V_p = 104.94 + 382.74 + 0.0 = 487.68 \text{ k}$$

and

$$0.25f'_c b_v d_v + V_p = 0.25(6)(8)(72.44) + 0.0 = 869.3 \text{ k}$$

Therefore, $V_n = 487.68 \text{ k}$

The resistance factor, ϕ , for shear in normal weight concrete = 0.90 (S5.5.4.2.1)

Factored shear resistance:

$$\begin{aligned} V_r &= \phi V_n \\ &= 0.9(487.68) \\ &= 438.91 \text{ k} > \text{max. applied factored shear, } V_u = 376.8 \text{ k} \quad \mathbf{OK} \end{aligned}$$

Design Step 5.7.4 **Factored bursting resistance (S5.10.10.1)**

The bursting resistance of the pretensioned anchorage zones is calculated according to S5.10.10.1 at the service limit state.

$$P_r = f_s A_s \quad (\text{S5.10.10.1-1})$$

where:

f_s = stress in the steel not exceeding 20 ksi

A_s = total area of vertical reinforcement located within the distance $h/4$ from the end of the beam (in^2)

h = overall depth of the precast member (in.)

The resistance shall not be less than 4% of the prestressing force at transfer.

From Design Step 5.4.4:

$$\begin{aligned} \text{Prestressing force at transfer at end of beam} &= 32(0.153)(188.8) \\ &= 924.4 \text{ kips} \end{aligned}$$

Determine the required area of steel to meet the minimum resistance using $f_s = 20$ ksi (max).

Therefore,

$$\begin{aligned} 0.04(924.4) &= 20(A_s) \\ A_s &= 1.85 \text{ in}^2 \end{aligned}$$

Since one stirrup is 0.4 in^2 (includes 2 legs), determine the number of stirrups required.

$$1.85/0.4 = 4.63 \quad \text{Say 5 stirrups required}$$

These stirrups must fit within $h/4$ distance from the end of the beam.

$$\begin{aligned} h/4 &= 72/4 \\ &= 18 \text{ in.} \end{aligned}$$

Use 5 stirrups at 3 in. spacing as shown in Figure 5.7-1.

**Design Step
5.7.5** **Confinement reinforcement
(S5.10.10.2)**

For the distance of $1.5d$ [$1.5(72/12) = 9$ ft.] from the end of the beam, reinforcement shall be placed to confine the prestressing steel in the bottom flange. The reinforcement is required to be not less than No. 3 deforming bars, with spacing not exceeding 6.0 in. and shaped to enclose the strands. The stirrups required to resist the applied shear and to satisfy the maximum stirrup requirements are listed in Table 5.7-1 for different sections. The maximum required spacings shown in Table 5.7-1 in the end zones of the beam is greater than 6 in. For a beam where all strands are located in the bottom flange, two different approaches may be utilized to provide the required confinement reinforcement:

- 1) Reduce the stirrup spacing in the end zone ($1.5d$) to not greater than 6 in.*
- 2) Place the main vertical bars of the stirrups at the spacing required by vertical shear analysis. Detail the vertical bars in the bottom of the beam to enclose the prestressing and place these bars at a spacing not greater than 6 in. within the end zones. The stirrups and the confinement bars in this approach will not be at the same spacing and pouring of the concrete may be difficult.*

For a beam where some strands are located in the web approach (1) should be used.

For this example, approach (1) was used. This is the basis for the stirrup distribution shown in Figure 5.7-1.

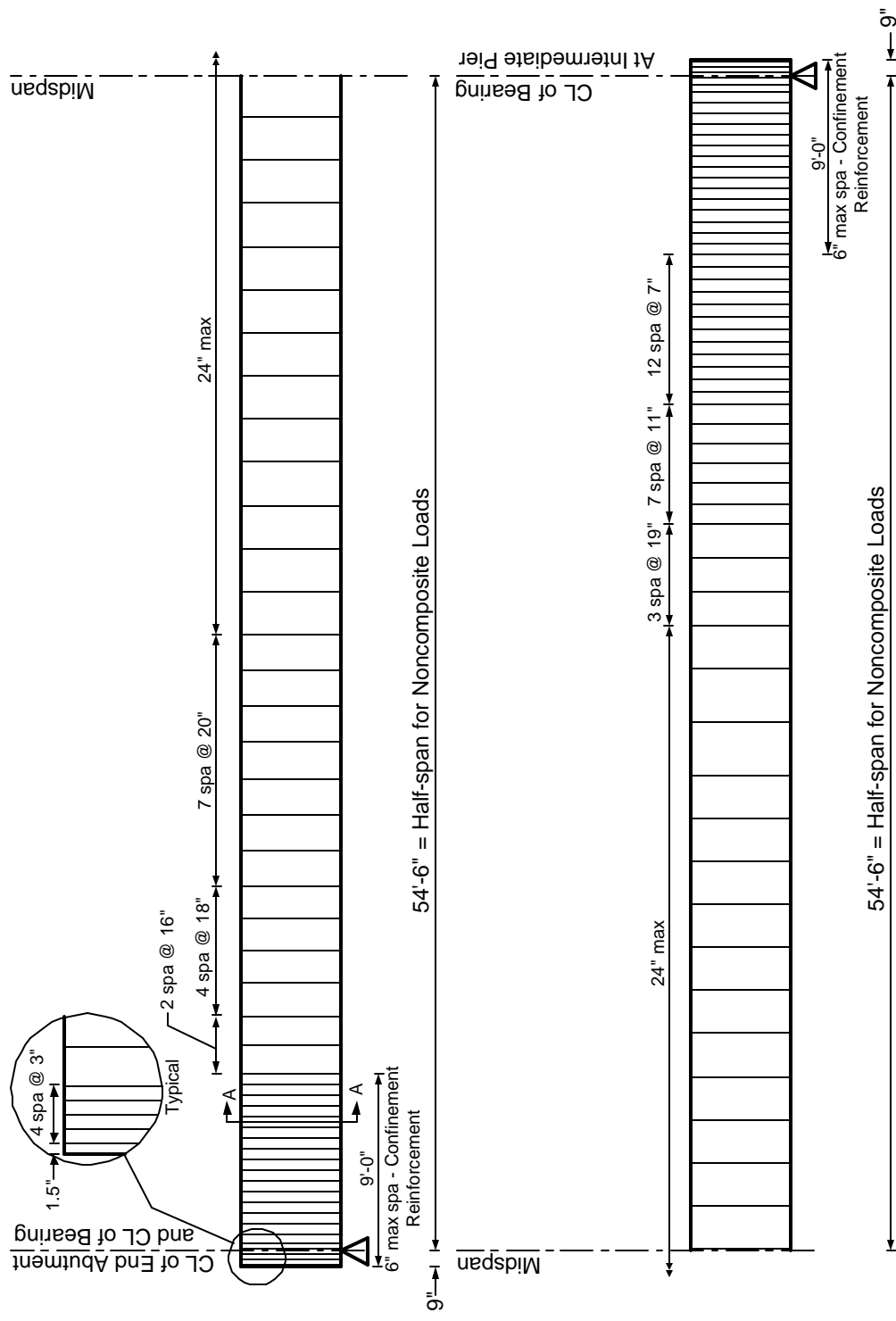

Figure 5.7-1 – Beam Transverse Reinforcement

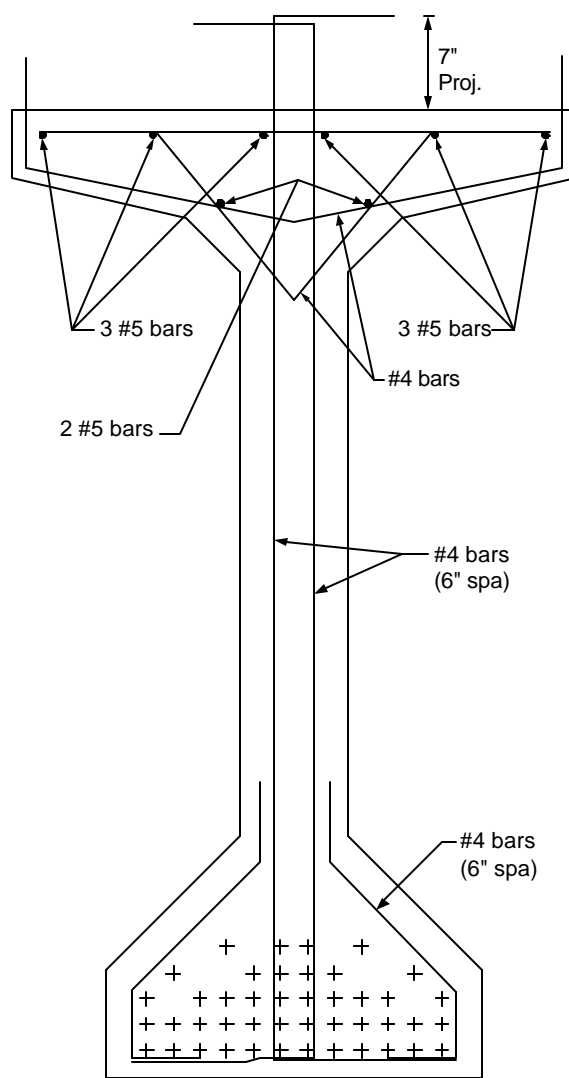

Figure 5.7-2 – Section A-A from Figure 5.7-1, Beam Cross Section Near the Girder Ends

Design Step 5.7.6 Force in the longitudinal reinforcement including the effect of the applied shear (S5.8.3.5)

In addition to the applied moment, M_u , the following force effects contribute to the force in the longitudinal reinforcement:

- *Applied shear forces, V_u*
- *Vertical component of the prestressing force*
- *Applied axial force, N_u*
- *The shear force resisted by the transverse reinforcement, V_s*

To account for the effect of these force effects on the force in the longitudinal reinforcement, S5.8.3.5 requires that the longitudinal reinforcement be proportioned so that at each section, the tensile capacity of the reinforcement on the flexural tension side of the member, taking into account any lack of full development of that reinforcement, is greater than or equal to the force T calculated as:

$$T = \frac{M_u}{d_j} + 0.5 \frac{N_u}{j} + \left(\frac{V_u}{j} - 0.5V_s - V_p \right) \cot q \quad (S5.8.3.5-1)$$

where:

V_s = shear resistance provided by the transverse reinforcement at the section under investigation as given by Eq. S5.8.3.3-4, except V_s needs to be greater than V_u/j (kips)

q = angle of inclination of diagonal compressive stresses used in determining the nominal shear resistance of the section under investigation as determined by S5.8.3.4 (deg)

j = resistance factors taken from S5.5.4.2 as appropriate for moment, shear and axial resistance

This check is required for sections located no less than a distance equal to $0.5d_v \cot \theta$ from the support. The values for the critical section for shear near the end support are substituted for d_v and θ .

$$0.5(72.44) \cot 22.6 = 87.01 \text{ in.} \sim 7.0 \text{ ft.}$$

The check for tension in the longitudinal reinforcement may be performed for sections no closer than 7.0 ft. from the support.

Sample calculation: Section at 7.0 ft. from the centerline of bearing at the end support

Using information from Table 5.7-1

Force in the longitudinal reinforcement at nominal flexural resistance, T

$$\begin{aligned} T &= 2,241(12)/[72.40(1.0)] + 0 + [(340.4/0.9) - 0.5(260.9) - 0] \cot 22.6 \\ &= 966.7 \text{ kips} \end{aligned}$$

From Table 5.5-1, the maximum strand resistance at this section at the nominal moment resistance is 1,128.1 kips > $T = 966.7$ kips **OK**

Design Step 5.7.7 | **Horizontal shear between the beam and slab**
Table 5.7-2 - Interface Shear Calculations

Dist.	d_e	V_u	Max. Stirrup Spcg	Interface reinf., A_{vf}	Horiz. Shear, V_h	Nominal resistance	Factored resistance	resist./ applied load
(ft.)	(in.)	(kips)	(in.)	(in ² /in.)	(k/in.)	(k/in.)	(k/in.)	> 1.0 OK
7.00	74.13	340.40	16.0	0.050	4.59	7.20	6.48	1.41
11.00	74.22	315.10	18.0	0.044	4.25	6.84	6.16	1.45
16.50	74.34	280.66	21.0	0.038	3.78	6.48	5.83	1.54
22.00	74.34	246.74	20.0	0.040	3.32	6.60	5.94	1.79
27.50	74.50	213.36	24.0	0.033	2.86	6.18	5.56	1.94
33.00	74.50	180.55	24.0	0.033	2.42	6.18	5.56	2.30
38.50	74.50	148.33	24.0	0.033	1.99	6.18	5.56	2.79
44.00	74.50	116.71	24.0	0.033	1.57	6.18	5.56	3.55
49.50	74.50	85.74	24.0	0.033	1.15	6.18	5.56	4.83
54.50	74.50	118.40	24.0	0.033	1.59	6.18	5.56	3.50
55.00	74.50	121.32	24.0	0.033	1.63	6.18	5.56	3.42
60.50	74.50	153.49	24.0	0.033	2.06	6.18	5.56	2.70
66.00	74.50	185.68	24.0	0.033	2.49	6.18	5.56	2.23
71.50	74.50	217.85	24.0	0.033	2.92	6.18	5.56	1.90
77.00	74.50	249.96	24.0	0.033	3.36	6.18	5.56	1.66
82.50	74.50	281.95	21.0	0.033	3.78	6.18	5.56	1.47
88.00	74.34	313.79	19.0	0.042	4.22	6.72	6.05	1.43
93.50	75.52	345.42	11.0	0.073	4.57	8.58	7.72	1.69
99.00	75.52	376.79	8.0	0.100	4.99	10.20	9.18	1.84
102.50	75.52	396.58	7.0	0.114	5.25	11.04	9.94	1.89

Sample calculations at 11 ft. from the centerline of bearing on the abutment (11 ft. – 9 in. from girder end)

Horizontal shear forces develop along the interface between the concrete girders and the deck. As an alternative to the classical elastic strength of materials approach, the value of these forces per unit length of the girders at the strength limit state can be taken as:

$$V_h = V_u/d_e \quad (\text{SC5.8.4.1-1})$$

where:

V_h = horizontal shear per unit length of the girder (kips)

V_u = the factored vertical shear (kips)
= 315.1 k (From Table 5.7-2)

$$d_e = \text{distance between the centroid of the steel in the tension side of the beam to the center of the compression blocks in the deck (in.)}$$

$$= 74.22 \text{ in. (see Table 5.7-2)}$$

$$V_h = 315.1/74.22$$

$$= 4.25 \text{ k/in.}$$

Stirrup spacing at this location = 18 in.

Assume that the stirrups extend into the deck. In addition, assume that there is another #4 bar with two legs extending into the deck as shown in Figure 5.7-2.

Area of reinforcement passing through the interface between the deck and the girder, A_{vf}

$$A_{vf} = 4 \text{ #4 bars}$$

$$= 4(0.2)$$

$$= 0.8 \text{ in}^2$$

A_{vf} per unit length of beam = $0.8/18 = 0.044 \text{ in}^2/\text{in.}$ of beam length.

Check if the minimum interface shear reinforcement may be waived (S5.8.4.1)

$$\text{Shear stress on the interface} = V_h/\text{area of the interface}$$

$$= 4.25/42$$

$$= 0.101 \text{ ksi} > 0.1 \text{ ksi, minimum reinforcement requirement may not be waived}$$

Notice that the difference is only 1%. For actual design, this difference would be within acceptable tolerances, therefore, the minimum reinforcement requirement could be waived. For this example, in order to provide a complete reference, the minimum reinforcement requirement will not be waived.

Check the minimum interface shear reinforcement

$$A_{vf} \geq 0.05b_v/f_y \quad (\text{S5.8.4.1-4})$$

$$= 0.05(42)/60$$

$$= 0.035 \text{ in}^2/\text{in. of beam length} < A_s \text{ provided } \mathbf{OK}$$

Shear friction resistance

The interface shear resistance of the interface has two components. The first component is due to the adhesion between the two surfaces. The second component is due to the friction. In calculating friction, the force acting on the interface is taken equal to the compression force on the interface plus the yield strength of the reinforcement passing

through the interface. The nominal shear resistance of the interface plane, V_n , is calculated using S5.8.4.1.

$$V_n = cA_{cv} + \mu(A_{vf}f_y + P_c) \quad (S5.8.4.1-1)$$

where:

V_n = nominal shear friction resistance (kips)

A_{cv} = area of concrete engaged in shear transfer (in^2)

A_{vf} = area of shear reinforcement crossing the shear plane (in^2)

f_y = yield strength of reinforcement (ksi)

c = cohesion factor specified in S5.8.4.2 (ksi)

μ = friction factor specified in S5.8.4.2

P_c = permanent net compressive force normal to the shear plane (kips)

Calculate the nominal shear resistance per unit length of beam.

Assuming the top surface of the beam was clean and intentionally roughened,

$$c = 0.1 \text{ ksi and } \mu = 1.0\lambda \quad (S5.8.4.2)$$

Ignore compression on the interface from loads on the deck: $P_c = 0.0$

$$A_{cv} = 42 \text{ in}^2/\text{in. of beam length}$$

$$A_{vf} = 0.044 \text{ in}^2/\text{in. of beam length}$$

$$f_y = 60 \text{ ksi}$$

Therefore,

$$\begin{aligned} V_n &= 0.1(42) + 1.0[0.044(60) + 0.0] \\ &= 6.84 \text{ k/in. of beam length} \end{aligned}$$

According to S5.8.4.1, the nominal shear resistance, V_n , used in the design must also satisfy:

$$V_n \leq 0.2f_c A_{cv} \quad (S5.8.4.1-2)$$

OR

$$V_n \leq 0.8A_{cv} \quad (S5.8.4.1-3)$$

where:

$$\begin{aligned} f_c &= \text{the strength of the weaker concrete (ksi)} \\ &= 4.0 \text{ ksi for slab concrete} \end{aligned}$$

$$V_n \leq 0.2 f_c A_{cv} = 0.2(4.0)(42) = 33.6 \text{ k/in. of beam length}$$

OR

$$V_n \leq 0.8 A_{cv} = 0.8(42) = 33.6 \text{ k/in. of beam length}$$

Therefore, V_n used for design = 7.02 k/in. of beam length.

$$\begin{aligned} V_r &= \phi V_n \\ &= 0.9(6.84) \\ &= 6.16 \text{ k/in. of beam length} > \text{ applied force, } V_h = 4.25 \text{ k/in. } \mathbf{OK} \end{aligned}$$

Design Step 6.0 STEEL-REINFORCED ELASTOMERIC BEARING DESIGN (S14)**Design requirements (S14.5.3)**Movements during construction

Where practicable, construction staging should be used to delay construction of abutments and piers located in or adjacent to embankments until the embankments have been placed and consolidated. Otherwise, deck joints should be sized to accommodate the probable abutment and pier movements resulting from embankment consolidation after their construction.

Closure pours may be used to minimize the effect of prestress-induced shortening on the width of seals and the size of bearings.

Characteristics (S14.6.2)

The bearing chosen for a particular application has to have appropriate load and movement capabilities. Table S14.6.2-1 may be used as a guide when comparing different bearing systems.

Force effects resulting from restraint of movement at the bearing (S14.6.3)

Restraint forces occur when any part of a movement is prevented. Forces due to direct loads include dead load of the bridge and loads due to traffic, earthquakes, water and wind. The applicable limit states must be considered.

Bearings are typically located in an area which collects large amounts of dirt and moisture and promotes problems of corrosion and deterioration. As a result, bearings should be designed and installed to have the maximum possible protection against the environment and to allow easy access for inspection.

Elastomeric bearing overview

Shore A Durometer hardnesses of 60 ± 5 are common, and they lead to shear modulus values in the range of 80 to 180 psi. The shear stiffness of the bearing is its most important property since it affects the forces transmitted between the superstructure and substructure. Some states use a slightly different common range than stated above. See S14.7.5.2 and S14.7.6.2 for material requirements of neoprene bearing pads.

Elastomer may be used as a plain pad (PEP) or may be reinforced with steel. Steel reinforced elastomeric bearings are composed of layers of elastomer and steel plates bonded together with adhesive.

Elastomers are flexible under shear and uniaxial deformation, but they are very stiff against volume changes. This feature makes the design of a bearing that is stiff in compression but flexible in shear possible. Under uniaxial compression, the flexible elastomer would shorten significantly and, to maintain constant volume, sustain large increases in its plan dimension, but the stiff steel layers of the steel reinforced elastomeric bearings restrain the lateral expansion.

Elastomers stiffen at low temperatures. The low temperature stiffening effect is very sensitive to the elastomer compound, and the increase in shear resistance can be controlled by selection of an elastomer compound which is appropriate for the climatic conditions.

The design of a steel reinforced elastomeric bearing requires an appropriate balance of compressive, shear and rotational stiffnesses. The shape factor, taken as the plan area divided by the area of the perimeter free to bulge, affects the compressive and rotational stiffnesses, but it has no impact on the translational stiffness or deformation capacity.

The bearing must be designed to control the stress in the steel reinforcement and the strain in the elastomer. This is done by controlling the elastomer layer thickness and the shape factor of the bearing. Fatigue, stability, delamination, yield and rupture of the steel reinforcement, stiffness of the elastomer, and geometric constraints must all be satisfied.

Design methods

Two design methods are allowed by the AASHTO-LRFD Specifications. Method A, specified in S14.7.6, is applicable to plain, steel reinforced and fiber glass reinforced elastomeric pads as well as cotton duck pads. Method B, specified in S14.7.5, is applicable to steel reinforced elastomeric bearings. The following sections and the design example below are based on Method B. Flowcharts for the bearing design using both Method A and Method B are included in Section 3.

General elastomer material properties and selection criteria (S14.7.5.2)

Commonly used elastomers have a shear modulus between 0.080 and 0.175 ksi and a nominal hardness between 50 and 60 on the Shore A scale. The shear modulus of the elastomer at 73° F is used as the basis for design. The elastomer may be specified by its shear modulus or hardness. If the elastomer is specified explicitly by its shear modulus, that value is used in design, and other properties are obtained from Table S14.7.5.2-1. If the material is specified by its hardness, the shear modulus is taken as the least favorable value from the range for that hardness given in Table S14.7.5.2-1. Intermediate values may be obtained by interpolation.

Elastomer grade is selected based on the temperature zone of the bridge location and by Table S14.7.5.2-2. The temperature zones are shown in Figure 6-1.

Table S14.7.5.2-2 – Low-Temperature Zones and Minimum Grades of Elastomer

Low-Temperature Zone	A	B	C	D	E
50-year low temperature (°F)	0	-20	-30	-45	< -45
Maximum number of consecutive days when the temperature does not rise above 32°F	3	7	14	NA	NA
Minimum low-temperature elastomer grade	0	2	3	4	5
Minimum low-temperature elastomer grade when special force provisions are incorporated	0	0	2	3	5

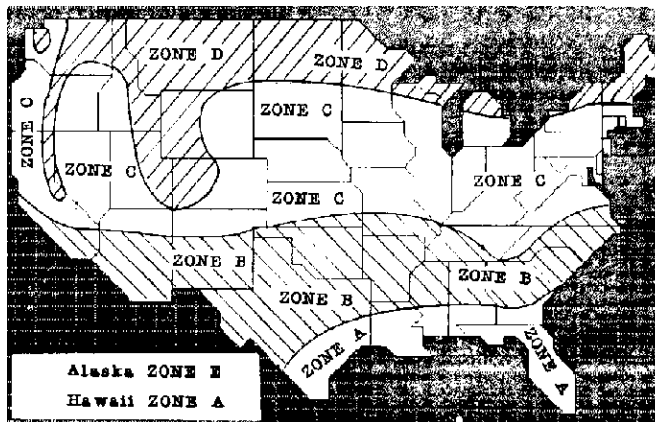

Figure 6-1 – Temperature Zones

According to S14.7.5.2, any of the three design options listed below may be used to specify the elastomer:

- 1) *Specify the elastomer with the minimum low-temperature grade indicated in Table S14.7.5.2-2 and determine the shear force transmitted by the bearing as specified in S14.6.3.1;*
- 2) *Specify the elastomer with the minimum low-temperature grade for use when special force provisions are incorporated in the design but do not provide a low friction sliding surface, in which case the bridge shall be designed to withstand twice the design shear force specified in S14.6.3.1; or*

- 3) *Specify the elastomer with the minimum low-temperature grade for use when special force provisions are incorporated in the design but do not provide a low friction sliding surface, in which case the components of the bridge shall be designed to resist four times the design shear force as specified in S14.6.3.1.*

Design Step 6.1 Design a steel reinforced elastomeric bearing for the interior girders at the intermediate pier

A typical elastomer with hardness 60 Shore A Durometer and a shear modulus of 150 psi is assumed. The 1.75 ksi delamination stress limit of Eq. S14.7.5.3.2-3 requires a total plan area at least equal to the vertical reaction on the bearing divided by 1.75. The bearing reaction at different limit states is equal to the shear at the end of Span 1 as shown in Tables 5.3-3 and -4. These values are shown in Table 6-1 below.

Table 6-1 – Design Forces on Bearings of Interior Girders at the Intermediate Pier

	Max. factored reaction (k)	Max. reaction due to LL (k)
Strength I	433.0	1.75(129.9)
Service I	290.5	129.9

Notice that:

- The loads shown above include the dynamic load allowance. According to the commentary of S14.7.5.3.2, the effect of the dynamic load allowance on the elastomeric bearing reaction may be ignored. The reason for this is that the dynamic load allowance effects are likely to be only a small proportion of the total load and because the stress limits are based on fatigue damage, whose limits are not clearly defined. For this example, the dynamic load allowance (33% of the girder maximum response due to the truck) adds 21.64 and 37.88 kips to the girder factored end shear at the Service I and Strength I limit states, respectively. This is a relatively small force, therefore, the inclusion of the dynamic load allowance effect leads to a slightly more conservative design.*
- The live load reaction per bearing is taken equal to the maximum girder live load end shear. Recognizing that the girder, which is continuous for live load, has two bearings on the intermediate pier, another acceptable procedure is to divide the maximum live load reaction on the pier equally between the two bearings. This will result in lower bearing loads compared to using the girder end shear to design the bearings. This approach was not taken in this example, rather, the girder end shear was applied to the bearing.*

Design Step Determine the minimum bearing area
6.1.1

The bearing at the intermediate pier is fixed and is not subject to shear deformation due to the lack of movements. According to S14.7.5.3.2, the maximum compressive stress limit under service limit state for bearings fixed against shear deformations:

$$\sigma_s \leq 2.00GS \leq 1.75 \text{ ksi} \quad (\text{S14.7.5.3.2-3})$$

$$\sigma_L \leq 1.00GS \quad (\text{S14.7.5.3.2-4})$$

where:

σ_s = service average compressive stress due to the total load (ksi)

σ_L = service average compressive stress due to live load (ksi)

G = shear modulus of elastomer (ksi)

S = shape factor of the thickest layer of the bearing

To satisfy the 1.75 ksi limit, the minimum bearing area, A_{req} , should satisfy:

$$A_{req} > 290.5/1.75 = 166.0 \text{ in}^2$$

The corners of the bottom flanges of the girder are usually chamfered. The bearing should be slightly narrower than the flat part of the flange unless a stiff sole plate is used to insure uniform distribution of the compressive stress and strain over the bearing area. The bearing should be as short along the length of the girder as practical to permit rotation about the transverse axis. This requires the bearing to be as wide as possible which is desirable when stabilizing the girder during erection. For a first estimate, choose a 24 in. width [28 in. wide girder bottom flange – 2(1 in. chamfer + 1 in. edge clearance)] and a 7.5 in. longitudinal dimension to ensure that the maximum compressive stress limit is satisfied (area = 24(7.5) = 180 in² > 166 in² required **OK**). The longitudinal translation is 0 in. for a fixed bearing. Notice that for a bearing subject to translation, i.e., movable bearing, the shear strains due to translation must be less than 0.5 in./in. to prevent rollover and excess fatigue damage. This means that the total elastomer thickness, h_{tt} , must be greater than two times the design translation, Δ_s , where applicable. A preliminary shape factor should be calculated according to S14.7.5.1.

Design Step Steel-reinforced elastomeric bearings – Method B (S14.7.5)
6.1.2

For bridges at locations where the roadway has positive or negative grade, the thickness of the bearing may need to be varied along the length of the girder. This is typically accomplished through the use of a tapered steel top plate. In this example, the bridge is assumed to be at zero grade and, therefore, each elastomer and reinforcement layer has a constant thickness. All internal layers of elastomer shall be of the same thickness. For bearings with more than two elastomer layers, the top and bottom cover layers should be no thicker than 70 percent of the internal layers.

The shape factor of a layer of an elastomeric bearing, S_i , is taken as the plan area of the layer divided by the area of perimeter free to bulge. For rectangular bearings without holes, the shape factor of the layer may be taken as:

$$S_i = LW/[2h_{ri}(L + W)] \quad (S14.7.5.1-1)$$

where:

L = length of a rectangular elastomeric bearing (parallel to the longitudinal bridge axis) (in.)

W = width of the bearing in the transverse direction (in.)

h_{ri} = thickness of i^{th} elastomeric layer in elastomeric bearing (in.)

Determine the thickness of the i^{th} elastomeric layer by rewriting Eq. S14.7.5.1-1 and solving for h_{ri} due to the total load.

$$h_{ri} = LW/[2S_i(L + W)]$$

Design Step 6.1.2.1 Design Requirements (S14.7.5.3)

Compressive stress (S14.7.5.3.2):

In any elastomeric bearing layer, the average compressive stress at the service limit state will satisfy the following provisions.

These provisions limit the shear stress and strain in the elastomer. The relationship between the shear stress and the applied compressive load depends directly on the shape factor, with higher shape factors leading to higher capacities.

First, solve for the shape factor under total load, S_{TL} , by rewriting Eq. S14.7.5.3.2-3 for bearings fixed against shear deformation.

$$S_{TL} \geq \sigma_s/2.00G \quad (S14.7.5.3.2-3)$$

where:

$$\sigma_s = P_{TL}/A_{req}$$

$$P_{TL} = \text{maximum bearing reaction under total load (k)} \\ = 290.5 \text{ k}$$

$$\sigma_s = 290.5/[7.5(24)] \\ = 1.614 \text{ ksi}$$

$$G = 0.150 \text{ ksi}$$

$$S_{TL} \geq 1.614/[2.00(0.150)] \\ \geq 5.38 \quad (1)$$

Solve for the shape factor under live load, S_{LL} , by rewriting Eq. S14.7.5.3.2-4 for bearings fixed against shear deformation.

$$S_{LL} \geq \sigma_L / 1.00G \quad (\text{S14.7.5.3.2-4})$$

where:

$$\sigma_L = P_{LL} / A_{\text{req}}$$

$$P_{LL} = \text{maximum bearing live load reaction (k)} \\ = 129.9 \text{ k}$$

$$\sigma_L = 129.9 / [7.5(24)] \\ = 0.722 \text{ ksi}$$

$$S_{LL} \geq 0.722 / [1.00(0.150)] \\ \geq 4.81 \quad (2)$$

From (1) and (2), the minimum shape factor of any layer is 5.38.

Notice that if holes are present in the elastomeric bearing their effect needs to be accounted for when calculating the shape factor because they reduce the loaded area and increase the area free to bulge. Use Eq. SC14.7.5.1-1 in this case instead of Eq. S14.7.5.1-1.

Using the shape factors of S_{TL} and S_{LL} calculated above, determine the elastomer thickness.

$$h_{ri(TL)} < (LW) / [2(S_{TL})(L + W)] \\ < 7.5(24) / [2(5.38)(7.5 + 24)] \\ < 0.531 \text{ in.}$$

and

$$h_{ri(LL)} < (LW) / [2(S_{LL})(L + W)] \\ < 7.5(24) / [2(4.81)(7.5 + 24)] \\ < 0.594 \text{ in.}$$

Use an interior elastomer layer thickness of $h_i = 0.5$ in.

The shape factor is:

$$S = (LW) / [2(h_i)(L + W)] \\ = 7.5(24) / [2(0.5)(7.5 + 24)] \\ = 5.71$$

Design Step Compressive deflection (S14.7.5.3.3)
6.1.2.2

This provision need only be checked if deck joints are present on the bridge. Since this design example is a jointless bridge, commentary for this provision is provided below, but no design is investigated.

Deflections of elastomeric bearings due to total load and live load alone will be considered separately.

Instantaneous deflection is be taken as:

$$\mathbf{d} = \mathbf{Se}_i h_{ri} \quad (S14.7.5.3.3-1)$$

where:

\mathbf{e}_i = instantaneous compressive strain in i^{th} elastomer layer of a laminated bearing

h_{ri} = thickness of i^{th} elastomeric layer in a laminated bearing (in.)

Values for \mathbf{e}_i are determined from test results or by analysis when considering long-term deflections. The effects of creep of the elastomer are added to the instantaneous deflection. Creep effects should be determined from information relevant to the elastomeric compound used. In the absence of material-specific data, the values given in S14.7.5.2 may be used.

Design Step Shear deformation (S14.7.5.3.4)
6.1.2.3

This provision need only be checked if the bearing is a movable bearing. Since the bearing under consideration is a fixed bearing, this provision does not apply. Commentary on this provision is provided below, but no design checks are performed.

The maximum horizontal movement of the bridge superstructure, \mathbf{D}_o , is taken as the extreme displacement caused by creep, shrinkage, and posttensioning combined with thermal movements.

The maximum shear deformation of the bearing at the service limit state, \mathbf{D}_s , is taken as \mathbf{D}_o , modified to account for the substructure stiffness and construction procedures. If a low friction sliding surface is installed, \mathbf{D}_s need not be taken to be larger than the deformation corresponding to first slip.

The bearing is required to satisfy:

$$h_{rt} \geq 2\mathbf{D}_s \quad (S14.7.5.3.4-1)$$

where:

h_{rt} = total elastomer thickness (sum of the thicknesses of all elastomer layers) (in.)

D_s = maximum shear deformation of the elastomer at the service limit state (in.)

This limit on h_{ri} ensures that rollover at the edges and delamination due to fatigue will not take place. See SC14.7.5.3.4 for more stringent requirements when shear deformations are due to high cycle loading such as braking forces and vibrations.

Design Step 6.1.2.4 Combined compression and rotation (S14.7.5.3.5)

Service limit state applies. Design rotations are taken as the maximum sum of the effects of initial lack of parallelism between the bottom of the girder and the top of the superstructure and subsequent girder end rotation due to imposed loads and movements.

The goal of the following requirements is to prevent uplift of any corner of the bearing under any combination of loading and corresponding rotation.

Rectangular bearings are assumed to satisfy uplift requirements if they satisfy:

$$\sigma_s > 1.0GS(\theta_s/n)(B/h_{ri})^2 \quad (\text{S14.7.5.3.5-1})$$

where:

n = number of interior layers of elastomer, where interior layers are defined as those layers which are bonded on each face. Exterior layers are defined as those layers which are bonded only on one face. When the thickness of the exterior layer of elastomer is more than one-half the thickness of an interior layer, the parameter, n , may be increased by one-half for each such exterior layer.

h_{ri} = 0.5 in.

σ_s = maximum compressive stress in elastomer (ksi)
= 1.614 ksi

B = length of pad if rotation is about its transverse axis or width of pad if rotation is about its longitudinal axis (in.)
= 7.5 in.

θ_s = maximum service rotation due to the total load (rads)
For this example, θ_s will include the rotations due to live load and construction load (assume 0.005 rads) only. As a result of camber under the prestressing force and permanent dead loads, prestressed beams typically have end rotation under permanent dead loads in the opposite direction than that of the live load end rotations. Conservatively assume the end rotations to be zero under the effect of the prestressing and permanent loads.

$$= 0.005944 \text{ rads (from a live load analysis program)}$$

Rewrite Eq. S14.7.5.3.5-1 to determine the number of interior layers of elastomer, n_i , for uplift:

$$\begin{aligned} n_i &> 1.0GS(\theta_s)(B/h_{ri})^2/\sigma_s \\ &> 1.0(0.150)(5.71)(0.005944)(7.5/0.5)^2/1.614 \\ &> 0.710 \end{aligned}$$

To prevent excessive stress on the edges of the elastomer, rectangular bearings fixed against shear deformation must also satisfy:

$$\sigma_s < 2.25GS[1 - 0.167(\theta_s/n)(B/h_{ri})^2] \quad (\text{S14.7.5.3.5-3})$$

Rewrite Eq. S14.7.5.3.5-3 to determine the number of interior layers of elastomer, n_e , required to limit compression along the edges.

$$\begin{aligned} n_e &> -0.167(\theta_s)(B/h_{ri})^2/[\sigma_s/2.25GS - 1] \\ &> -0.167(0.005944)(7.5/0.5)^2/[1.614/[2.25(0.150)(5.71)] - 1] \\ &> 1.37 \end{aligned}$$

Use 2 interior layers 0.5 in. thick each. Use exterior layers 0.25 in. thick each (< 70% of the thickness of the interior layer).

Design Step 6.1.2.5 Stability of elastomeric bearings (S14.7.5.3.6)

Bearings are investigated for instability at the service limit state load combinations specified in Table S3.4.1-1.

Bearings satisfying Eq. S14.7.5.3.6-1 are considered stable, and no further investigation of stability is required.

$$2A \leq B \quad (\text{S14.7.5.3.6-1})$$

for which:

$$A = \frac{1.92 \frac{h_{ri}}{L}}{\sqrt{1 + \frac{2.0L}{W}}} \quad (\text{S14.7.5.3.6-2})$$

$$B = \frac{2.67}{(S + 2.0) \left(1 + \frac{L}{4.0W} \right)} \quad (\text{S14.7.5.3.6-3})$$

where:

$$L = 7.5 \text{ in.}$$

$$W = 24 \text{ in.}$$

$$\begin{aligned} h_{rt} &= \text{total thickness of the elastomer in the bearing (in.)} \\ &= 2(0.25) + 2(0.5) \\ &= 1.5 \text{ in.} \end{aligned}$$

For a rectangular bearing where L is greater than W, stability will be investigated by interchanging L and W in Eqs. S14.7.5.3.6-2 and -3.

$$\begin{aligned} A &= \frac{1.92 \left(\frac{1.5}{7.5} \right)}{\sqrt{1 + \frac{2.0(7.5)}{24}}} \\ &= 0.301 \end{aligned}$$

$$\begin{aligned} B &= \frac{2.67}{(5.71 + 2.0) \left(1 + \frac{7.5}{4.0(24)} \right)} \\ &= 0.321 \end{aligned}$$

Check $2A \leq B$

$$2(0.301) = 0.602 > 0.321, \text{ therefore, the bearing is not stable and Eqs. S14.7.5.3.6-4 and -5 need to be checked.}$$

For bridge decks fixed against translation, the following equation needs to be satisfied to ensure stability.

$$\sigma_s \leq GS/(A - B) \quad (\text{S14.7.5.3.6-5})$$

However, if $A - B \leq 0$, then the bearing is considered stable.

$$\begin{aligned} A - B &= 0.301 - 0.321 \\ &= -0.02 \end{aligned}$$

Therefore, the bearing is stable.

Design Step Reinforcement (S14.7.5.3.7)
6.1.2.6

The reinforcement should sustain the tensile stresses induced by compression on the bearing. With the present load limitations, the minimum steel plate thickness practical for fabrication will usually provide adequate strength.

At the service limit state:

$$h_s \geq 3h_{\max}\sigma_s/F_y \quad (\text{S14.7.5.3.7-1})$$

where:

$$\begin{aligned} h_{\max} &= \text{thickness of thickest elastomeric layer in elastomeric} \\ &\quad \text{bearing (in.)} \\ &= 0.5 \text{ in.} \end{aligned}$$

$$\sigma_s = 1.614 \text{ ksi}$$

$$\begin{aligned} F_y &= \text{yield strength of steel reinforcement (ksi)} \\ &= 36 \text{ ksi} \end{aligned}$$

$$\begin{aligned} h_{s(\text{TL})} &\geq 3(0.5)(1.614)/36 \\ &\geq 0.067 \text{ in.} \end{aligned}$$

At the fatigue limit state:

$$h_s \geq 2.0h_{\max}\sigma_L/\Delta F_{\text{TH}} \quad (\text{S14.7.5.3.7-2})$$

where:

$$h_{\max} = 0.5 \text{ in.}$$

$$\begin{aligned} \sigma_L &= 129.9/[7.5(24)] \\ &= 0.722 \text{ ksi} \end{aligned}$$

$$\begin{aligned} \Delta F_{\text{TH}} &= \text{constant amplitude fatigue threshold for Category A} \\ &\quad \text{as specified in Table S6.6.1.2.5-3 (ksi)} \\ &= 24 \text{ ksi} \end{aligned}$$

$$\begin{aligned} h_{s(\text{LL})} &\geq 2(0.5)(0.722)/24 \\ &\geq 0.030 \text{ in.} \end{aligned}$$

Use $h_s = 0.120$ in. thick steel reinforcement plates; this is an 11 gage shim.

If holes exist in the reinforcement, the minimum thickness is increased by a factor equal to twice the gross width divided by the net width. Holes in the reinforcement cause stress concentrations. Their use should be discouraged. The required increase in steel

thickness accounts for both the material removed and the stress concentrations around the hole.

The total height of the bearing, h_{rt} :

$$\begin{aligned} h_{rt} &= \text{cover layers} + \text{elastomer layers} + \text{shim thicknesses} \\ &= 2(0.25) + 2(0.5) + 3(0.120) \\ &= 1.86 \text{ in.} \end{aligned}$$

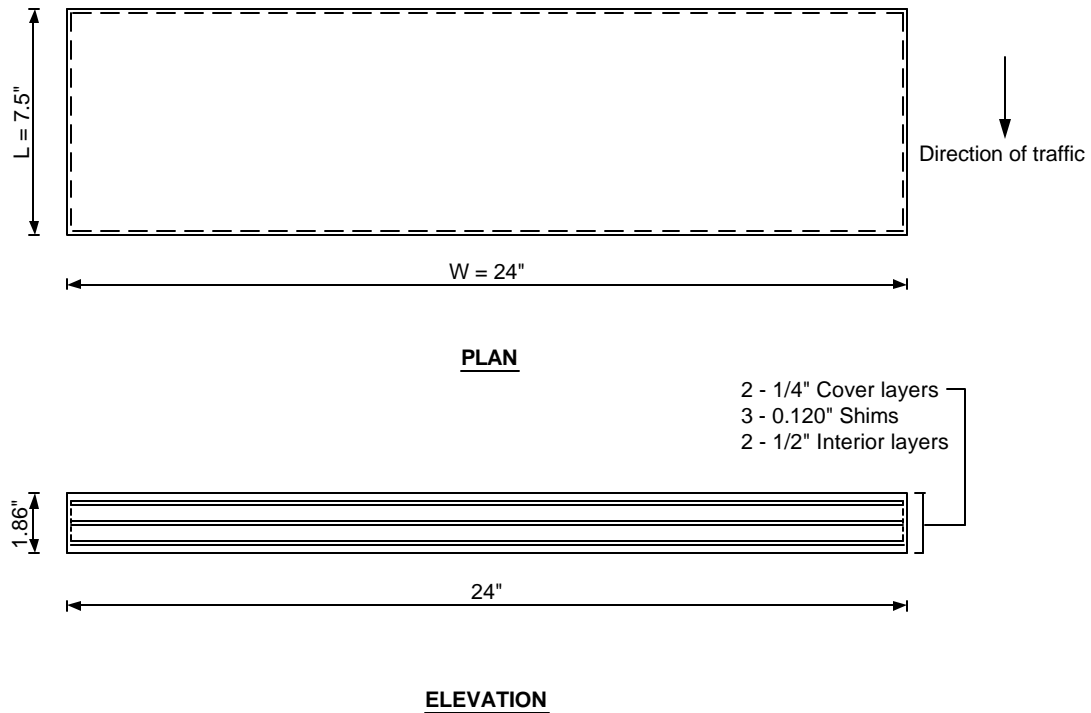

Figure 6-2 – Dimensions of Elastomeric Bearing

Notes:

1. 11 gage steel shim thickness is held constant for all bearings
2. All cover layers and edge covers are to be 1/4-inch thick.
3. Total bearing thickness will include the summation of a masonry plate, a sole plate, and the laminated elastomeric pad thickness.
4. Elastomer in all bearings shall have grade 60 Shore A Durometer hardness.
5. Pad shall be vulcanized to masonry plate and sole plate in the shop
6. Pad thickness shown is uncompressed.

A shear key between the bent cap and the concrete diaphragm will provide the movement restraint in the longitudinal direction. See Figure 6-3.

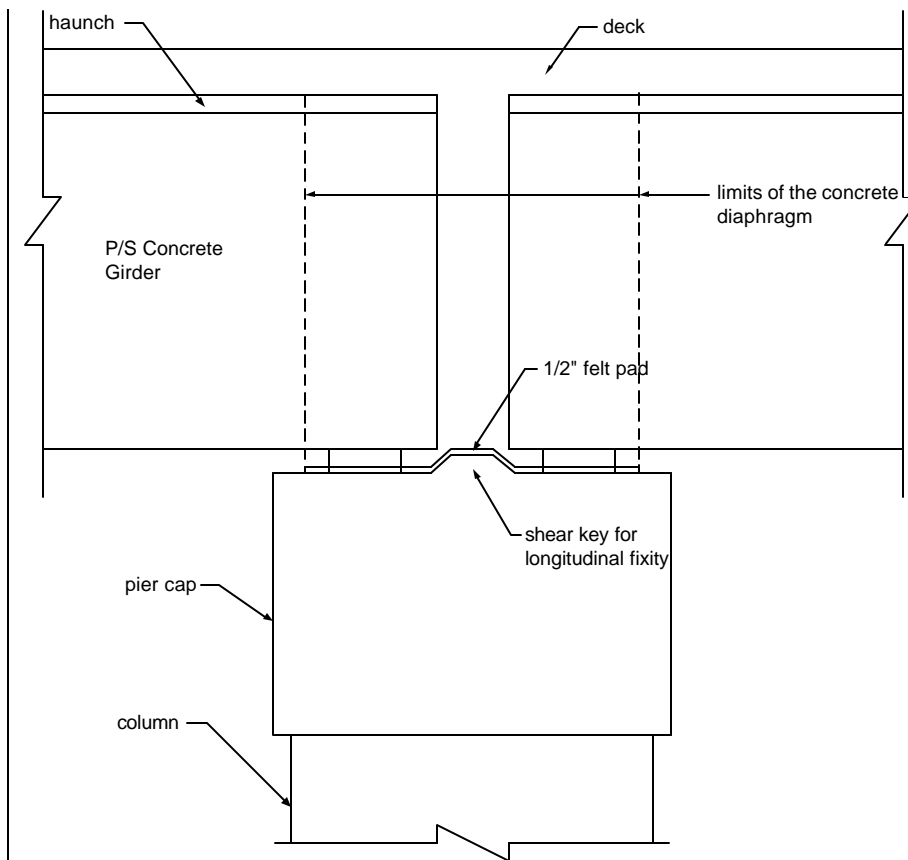

Figure 6-3 – Longitudinal Fixity at Intermediate Bent

Design Step 7.1 | **INTEGRAL ABUTMENT DESIGN****General considerations and common practices**

Integral abutments are used to eliminate expansion joints at the end of a bridge. They often result in “Jointless Bridges” and serve to accomplish the following desirable objectives:

- *Long-term serviceability of the structure*
- *Minimal maintenance requirements*
- *Economical construction*
- *Improved aesthetics and safety considerations*

A jointless bridge concept is defined as any design procedure that attempts to achieve the goals listed above by eliminating as many expansion joints as possible. The ideal jointless bridge, for example, contains no expansion joints in the superstructure, substructure or deck.

Integral abutments are generally founded on one row of piles made of steel or concrete. The use of one row of piles reduces the stiffness of the abutment and allows the abutment to translate parallel to the longitudinal axis of the bridge. This permits the elimination of expansion joints and movable bearings. Because the earth pressure on the two end abutments is resisted by compression in the superstructure, the piles supporting the integral abutments, unlike the piles supporting conventional abutments, do not need to be designed to resist the earth loads on the abutments.

When expansion joints are completely eliminated from a bridge, thermal stresses must be relieved or accounted for in some manner. The integral abutment bridge concept is based on the assumption that due to the flexibility of the piles, thermal stresses are transferred to the substructure by way of a rigid connection, i.e. the uniform temperature change causes the abutment to translate without rotation. The concrete abutment contains sufficient bulk to be considered as a rigid mass. A positive connection to the girders is generally provided by encasing girder ends in the reinforced concrete backwall. This provides for full transfer of forces due to thermal movements and live load rotational displacement experienced by the abutment piles.

Design criteria

Neither the AASHTO-LRFD Specifications nor the AASHTO-Standard Specifications contain detailed design criteria for integral abutments. In the absence of universally-accepted design criteria, many states have developed their own design guidelines. These guidelines have evolved over time and rely heavily on past experience with integral abutments at a specific area. There are currently two distinctive approaches used to design integral abutments:

- *One group of states design the piles of an integral abutment to resist only gravity loads applied to the abutment. No consideration is given to the effect of the horizontal displacement of the abutment on the pile loads and/or pile resistance. This approach is simple and has been used successfully. When the bridge is outside a certain range set by the state, e.g. long bridges, other considerations are taken into account in the design.*
- *The second approach accounts for effects of different loads, in addition to gravity loads, when calculating pile loads. It also takes into account the effect of the horizontal movements on the pile load resistance. One state that has detailed design procedures following this approach is Pennsylvania.*

The following discussion does not follow the practices of a specific state; it provides a general overview of the current state-of-practice.

Bridge length limits

Most states set a limit on the bridge length of jointless bridges beyond which the bridge is not considered a “typical bridge” and more detailed analysis is taken into account. Typically, the bridge length is based on assuming that the total increase of the bridge length under uniform temperature change from the extreme low to the extreme high temperature is 4 inches. This means that the movement at the top of the pile at each end is 2 inches or, when the bridge is constructed at the median temperature, a 1 inch displacement in either direction. This results in a maximum bridge length of 600 ft. for concrete bridges and 400 ft. for steel bridges at locations where the climate is defined as “Moderate” in accordance to S3.12.2.1. The maximum length is shorter for regions defined as having a “cold” climate.

Soil conditions

The above length limits assume that the soil conditions at the bridge location and behind the abutment are such that the abutment may translate with relatively low soil resistance. Therefore, most jurisdictions specify select granular fill for use behind integral abutments. In addition, the fill within a few feet behind the integral abutment is typically lightly compacted using a vibratory plate compactor (jumping jack). When bedrock, stiff soil and/or boulders exist in the top layer of the soil (approximately the top 12 to 15 ft.), it is typically required that oversized holes be drilled to a depth of approximately 15 ft.; the piles are then installed in the oversized holes. Subsequently, the holes are filled with sand. This procedure is intended to allow the piles to translate with minimal resistance.

Skew angle

Earth pressure acts in a direction perpendicular to the abutments. For skewed bridges, the earth pressure forces on the two abutments produce a torque that causes the bridge to twist in plan. Limiting the skew angle reduces this effect. For skewed, continuous bridges, the twisting torque also results in additional forces acting on intermediate bents.

In addition, sharp skews are suspected to have caused cracking in some abutment backwalls due to rotation and thermal movements. This cracking may be reduced or eliminated by limiting the skew. Limiting the skew will also reduce or eliminate design uncertainties, backfill compaction difficulty and the additional design and details that would need to be worked out for the abutment U-wingwalls and approach slab.

Currently, there are no universally accepted limits on the degree of skew for integral abutment bridges.

Horizontal alignment and bridge plan geometry

With relatively few exceptions, integral abutments are typically used for straight bridges. For curved superstructures, the effect of the compression force resulting from the earth pressure on the abutment is a cause for concern. For bridges with variable width, the difference in the length of the abutments results in unbalanced earth pressure forces if the two abutments are to move the same distance. To maintain force equilibrium, it is expected that the shorter abutment will deflect more than the longer one. This difference should be considered when determining the actual expected movement of the two abutments as well as in the design of the piles and the expansion joints at the end of the approach slabs (if used).

Grade

Some jurisdictions impose a limit on the maximum vertical grade between abutments. These limits are intended to reduce the effect of the abutment earth pressure forces on the abutment vertical reactions.

Girder types, maximum depth and placement

Integral abutments have been used for bridges with steel I-beams, concrete I-beams, concrete bulb tees and concrete spread box beams.

Deeper abutments are subjected to larger earth pressure forces and, therefore, less flexible. Girder depth limits have been imposed by some jurisdictions based on past successful practices and are meant to ensure a reasonable level of abutment flexibility. Soil conditions and the length of the bridge should be considered when determining maximum depth limits. A maximum girder depth of 6 ft. has been used in the past. Deeper girders may be allowed when the soil conditions are favorable and the total length of the bridge is relatively short.

Type and orientation of piles

Integral abutments have been constructed using steel H-piles, concrete-filled steel pipe piles and reinforced and prestressed concrete piles. For H-piles, there is no commonly used orientation of the piles. In the past, H-piles have been placed both with their strong

axis parallel to the girder's longitudinal axis and in the perpendicular direction. Both orientations provide satisfactory results.

Consideration of dynamic load allowance in pile design

Traditionally, dynamic load allowance is not considered in foundation design. However, for integral abutment piles, it may be argued that the dynamic load allowance should be considered in the design of the top portion of the pile. The rationale for this requirement is that the piles are almost attached to the superstructure, therefore, the top portions of the piles do no benefit from the damping effect of the soil.

Construction sequence

Typically, the connection between the girders and the integral abutment is made after the deck is poured. The end portion of the deck and the backwall of the abutment are usually poured at the same time. This sequence is intended to allow the dead load rotation of the girder ends to take place without transferring these rotations to the piles.

Two integral abutment construction sequences have been used in the past:

- *One-stage construction:*

In this construction sequence, two piles are placed adjacent to each girder, one pile on each side of the girder. A steel angle is connected to the two piles and the girder is seated on the steel angle. The abutment pier cap (the portion below the bottom of the beam) and the end diaphragm or backwall (the portion encasing the ends of the beams) are poured at the same time. The abutment is typically poured at the time the deck in the end span is poured.

- *Two-stage construction:*

Stage 1:

A pile cap supported on one row of vertical piles is constructed. The piles do not have to line up with the girders. The top of the pile cap reaches the bottom of the bearing pads under the girders. The top of the pile cap is required to be smooth in the area directly under the girders and a strip approximately 4 in. wide around this area. Other areas are typically roughened (i.e. rake finished).

Stage 2:

After pouring the entire deck slab, except for the portions of the deck immediately adjacent to the integral abutment (approximately the end 4 ft. of the deck from the front face of the abutment) the end diaphragm (backwall) encasing the ends of the bridge girders is poured. The end portion of the deck is poured simultaneously with the end diaphragm.

Negative moment connection between the integral abutment and the superstructure

The rigid connection between the superstructure and the integral abutment results in the development of negative moments at this location. Some early integral abutments showed signs of deck cracking parallel to the integral abutments in the end section of the deck due to the lack of proper reinforcement to resist this moment. This cracking was prevented by specifying additional reinforcement connecting the deck to the back (fill) face of the abutment. This reinforcement may be designed to resist the maximum moment that may be transferred from the integral abutment to the superstructure. This moment is taken equal to the sum of the plastic moments of the integral abutment piles. The section depth used to design these bars may be taken equal to the girder depth plus the deck thickness. The length of the bars extending into the deck is typically specified by the bridge owner. This length is based on the length required for the superstructure dead load positive moment to overcome the connection negative moment.

Wingwalls

Typically, U-wingwalls (wingwalls parallel to the longitudinal axis of the bridge) are used in conjunction with integral abutments. A chamfer (typically 1 ft.) is used between the abutment and the wingwalls to minimize concrete shrinkage cracking caused by the abrupt change in thickness at the connection.

Approach slab

Bridges with integral abutments were constructed in the past with and without approach slabs. Typically, bridges without approach slabs are located on secondary roads that have asphalt pavements. Traffic and seasonal movements of the integral abutments cause the fill behind the abutment to shift and to self compact. This often caused settlement of the pavement directly adjacent to the abutment.

Providing a reinforced concrete approach slab tied to the bridge deck moves the expansion joint away from the end of the bridge. In addition, the approach slab bridges cover the area where the fill behind the abutment settles due to traffic compaction and movements of the abutment. It also prevents undermining of the abutments due to drainage at the bridge ends. Typically, approach slabs are cast on polyethylene sheets to minimize the friction under the approach slab when the abutment moves.

The approach slab typically rests on the abutment at one end and on a sleeper slab at the other. The approach slab differs from typical roadway pavement since the soil under the approach slab is more likely to settle unevenly resulting in the approach slab bridging a longer length than expected for roadway pavement. Typically, the soil support under the approach slab is ignored in the design and the approach slab is designed as a one-way slab bridging the length between the integral abutment and the sleeper slab. The required length of the approach slab depends on the total depth of the integral abutment. The sleeper slab should be placed outside the area where the soil is expected to be

affected by the movement of the integral abutment. This distance is a function of the type of fill and the degree of compaction.

Due to the difference in stiffness between the superstructure and the approach slab, the interface between the integral abutment and the approach slab should preferably allow the approach slab to rotate freely at the end connected to the abutment. The reinforcement bars connecting the abutment to the approach slab should be placed such that the rotational restraint provided by these bars is minimized.

A contraction joint is placed at the interface between the approach slab and the integral abutment. The contraction joint at this location provides a controlled crack location rather than allowing a random crack pattern to develop.

Expansion joints

Typically, no expansion joints are provided at the interface between the approach slab and the roadway pavement when the bridge total length is relatively small and the roadway uses flexible pavement. For other cases, an expansion joint is typically used.

Bearing pads

Plain elastomeric bearing pads are placed under all girders when the integral abutment is constructed using the two-stage sequence described above. The bearing pads are intended to act as leveling pads and typically vary from $\frac{1}{2}$ to $\frac{3}{4}$ in. thick. The pad length parallel to the girder's longitudinal axis varies depending on the bridge owner's specifications and the pad length in the perpendicular direction varies depending on the width of the girder bottom flange and the owner's specifications. It is recommended to block the area under the girders that is not in contact with the bearing pads using backer rods. Blocking this area is intended to prevent honeycombing of the surrounding concrete. Honeycombing will take place when the cement paste enters the gap between the bottom of girder and the top of the pile cap in the area under the girders not in contact with the bearing pads.

Design Step 7.1.1 Gravity loads

Interior girder: unfactored loads

(See Table 5.3-3 for girder end shears)

Noncomposite:	
Girder	= 61.6 k
Slab and haunch	= 62.2 k
<u>Exterior diaphragm</u>	<u>= 2.5 k</u>
Total NC	= 126.4 k

Composite:
 Parapets = 8.9 k
 Future wearing surface = 12.0 k

Live load:
 Maximum truck per lane (without impact or distribution factors) = 64.42 k
 Minimum truck per lane (without impact or distribution factors) = -6.68 k
 Maximum lane per lane = 30.81 k
 Minimum lane per lane = -4.39 k

Exterior girder: unfactored loads
 (See Table 5.3-7 for girder end shears)

Noncomposite:
 Girder = 61.6 k
 Slab and haunch = 55.1 k
Exterior diaphragm = 1.3 k
 Total NC = 117.9 k

Composite:
 Parapets = 8.9 k
 Future wearing surface = 8.1 k

Live load:
 Maximum truck per lane (without impact or distribution factors) = 64.42 k
 Minimum truck per lane (without impact or distribution factors) = -6.68 k
 Maximum lane per lane = 30.81 k
 Minimum lane per lane = -4.39 k

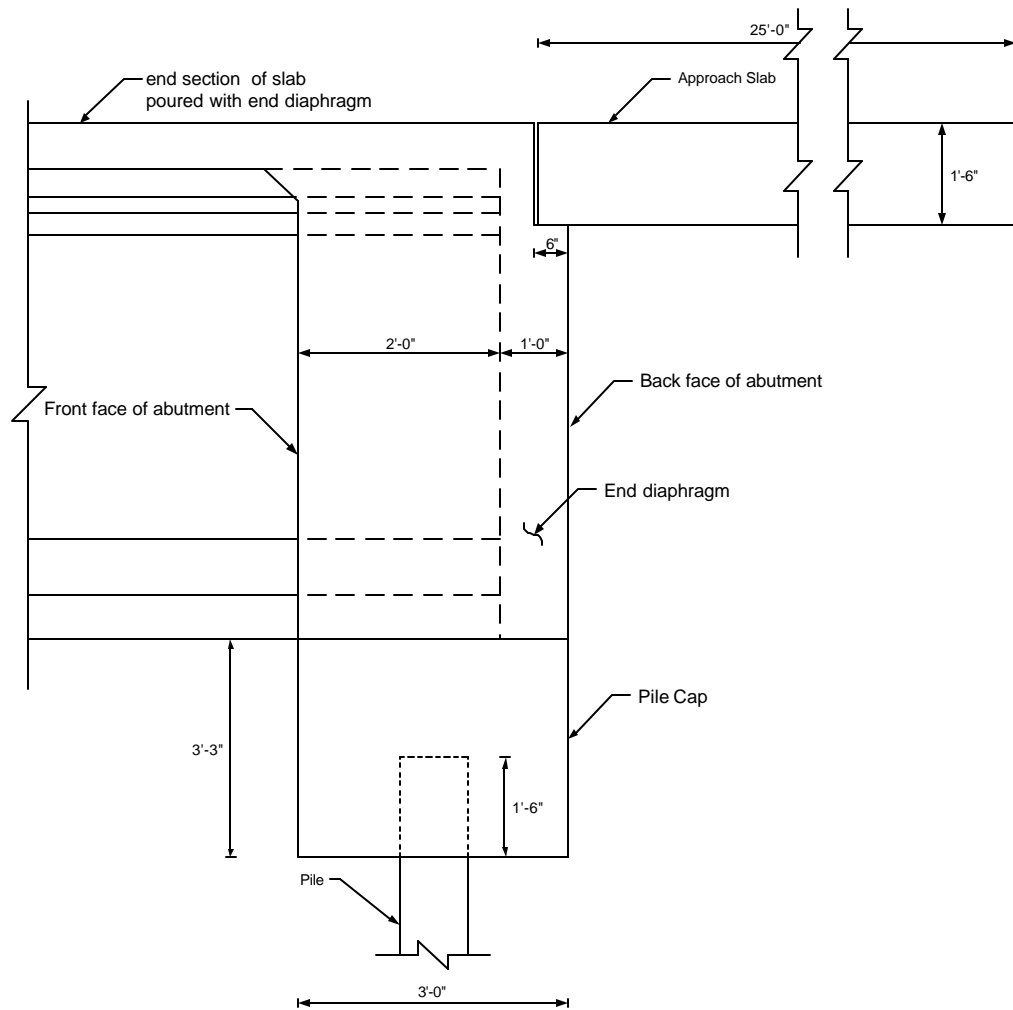

Figure 7.1-1 – General View of an Integral Abutment Showing Dimensions Used for the Example

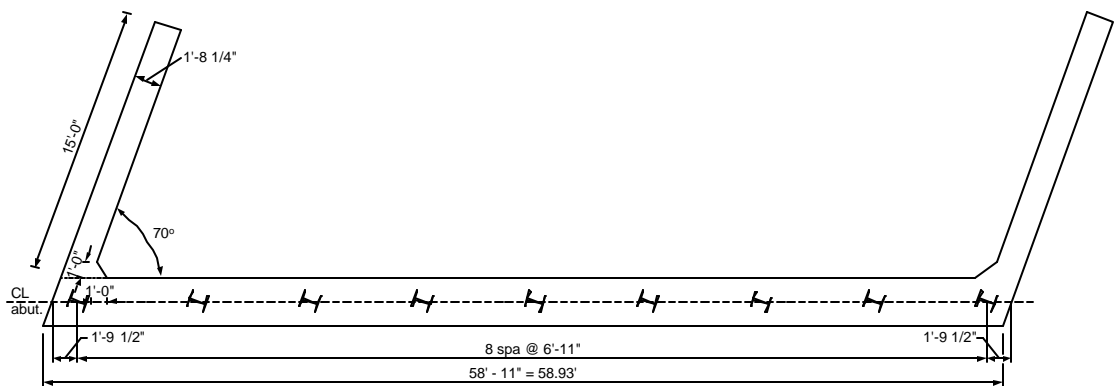

Figure 7.1-2 – Plan View of the Integral Abutment

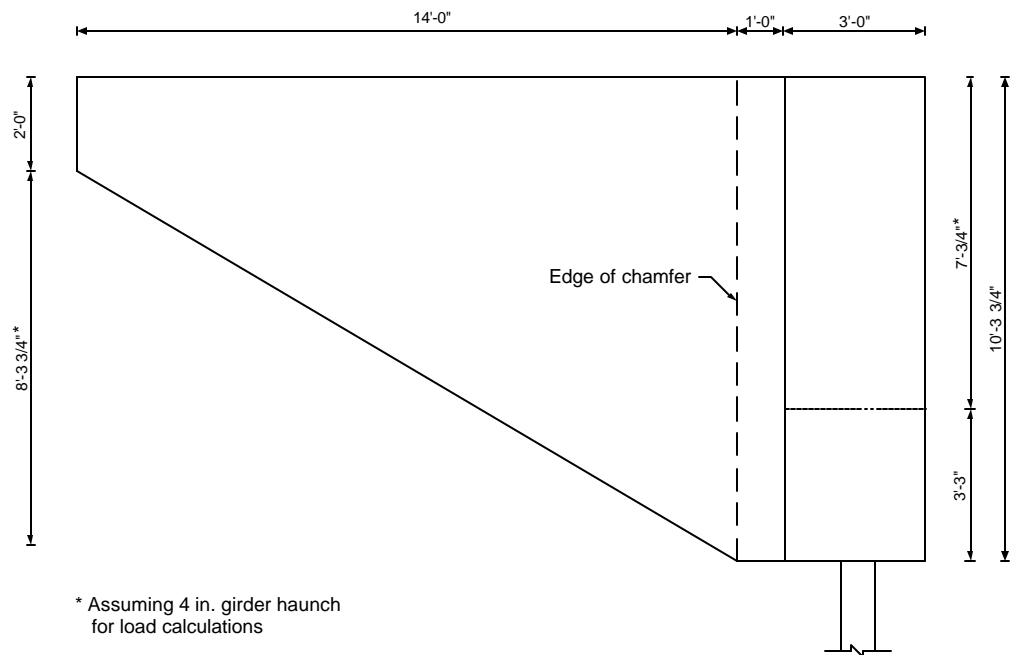

Figure 7.1-3 – Elevation View of Integral Abutment and Tapered Wingwall

In the next section, “w” and “P” denote the load per unit length and the total load, respectively. The subscripts denote the substructure component. Dimensions for each component are given in Figures 7.1-1 through 7.1-3.

Pile cap: unfactored loading

$$\begin{aligned} \text{Pile cap length along the skew} &= 55.354 / \cos 20 \\ &= 58.93 \text{ ft.} \end{aligned}$$

$$\begin{aligned} w_{\text{cap}} &= 3.25(3)(0.150) \\ &= 1.46 \text{ k/ft} \end{aligned}$$

OR

$$\begin{aligned} P_{\text{cap}} &= 1.46(58.93) \\ &= 86.0 \text{ k} \end{aligned}$$

Concrete weight from the end diaphragm (approximate, girder volume not removed): unfactored loading

Assuming bearing pad thickness of ¾ in., girder height of 72 in., haunch thickness of 4 in., and deck thickness of 8 in.:

$$\begin{aligned} w_{\text{end dia}} &= 3[(0.75 + 72 + 4 + 8)/12](0.150) \\ &= 3.18 \text{ k/ft} \end{aligned}$$

OR

$$P_{\text{end dia}} = 3.18(58.93) \\ = 187.4 \text{ k}$$

Wingwall: unfactored load

$$A_{\text{wing}} = (123.75/12)(15) - \frac{1}{2} (14)(99.75/12) \\ = 96.5 \text{ ft}^2$$

$$\text{Wingwall thickness} = \text{parapet thickness at the base} \\ = 20.25 \text{ in. (given in Section 4)}$$

$$\text{Wingwall weight} = 96.5(20.25/12)(0.150) \\ = 24.43 \text{ k}$$

$$\text{Chamfer weight} = (123.75/12)(1.0)(1.0)(0.150)/2 \\ = 0.77 \text{ k}$$

Notice that the chamfer weight is insignificant and is not equal for the two sides of the bridge due to the skew. For simplicity, it was calculated based on a right angle triangle and the same weight is used for both sides.

$$\text{Weight of two wingwalls plus chamfer} = 2(24.43 + 0.77) \\ = 50.4 \text{ k}$$

$$\text{Parapet weight} = 0.65 \text{ k/ft (given in Section 5.2)} \\ \text{Parapet length on wingwall and abutment} = 15 + 3/\sin 70 \\ = 18.19 \text{ ft.}$$

$$P_{\text{parapet}} = 2(0.650)(18.19) \\ = 23.65 \text{ k total weight}$$

Approach slab load acting on the integral abutment: unfactored loading

Approach slab length = 25 ft.

$$\text{Approach slab width between parapets} = 58.93 - 2[(20.25/12)/\sin 70] \\ = 55.34 \text{ ft.}$$

Self weight of the approach slab:

$$W_{\text{approach slab}} = \frac{1}{2} (25)(1.5)(0.150) \\ = 2.81 \text{ k/ft}$$

OR

$$P_{\text{approach slab}} = 2.81(55.34) \\ = 155.5 \text{ k}$$

Future wearing surface acting on the approach slab (assuming 25 psf):

$$\begin{aligned} w_{\text{FWS}} &= \frac{1}{2} (0.025)(25) \\ &= 0.31 \text{ k/ft} \end{aligned}$$

OR

$$\begin{aligned} P_{\text{FWS}} &= 0.31(55.34) \\ &= 17.2 \text{ k} \end{aligned}$$

Live load on the approach slab, reaction on integral abutment:

$$\begin{aligned} P_{\text{lane load}} &= \frac{1}{2} (0.64)(25) && (\text{S3.6.1.2.4}) \\ &= 8.0 \text{ k (one lane)} \end{aligned}$$

Notice that one truck is allowed in each traffic lane and that the truck load is included in the girder reactions. Therefore, no trucks were assumed to exist on the approach slab and only the uniform load was considered.

Design Step 7.1.2 Pile cap design

The girder reactions, interior and exterior, are required for the design of the abutment pile cap. Notice that neither the piles nor the abutment beam are infinitely rigid. Therefore, loads on the piles due to live loads are affected by the location of the live load across the width of the integral abutment. Moving the live load reaction across the integral abutment and trying to maximize the load on a specific pile by changing the number of loaded traffic lanes is not typically done when designing integral abutments. As a simplification, the live load is assumed to exist on all traffic lanes and is distributed equally to all girders in the bridge cross section. The sum of all dead and live loads on the abutment is then distributed equally to all piles supporting the abutment.

The maximum number of traffic lanes allowed on the bridge based on the available width (52 ft. between gutter lines) is:

$$\begin{aligned} N_{\text{lanes}} &= 52 \text{ ft.}/12 \text{ ft. per lane} \\ &= 4.33 \text{ say 4 lanes} \end{aligned}$$

Factored dead load plus live load reactions for one interior girder, Strength I limit state controls (assume the abutment is poured in two stages as discussed earlier):

Maximum reaction Stage I:

$$\begin{aligned} P_{\text{SI(I)}} &= 1.25(\text{girder} + \text{slab} + \text{haunch}) \\ &= 1.25(126.4) \\ &= 158 \text{ k} \end{aligned}$$

Notice that construction loads should be added to the above reaction if construction equipment is allowed on the bridge before pouring the backwall (Stage II).

Maximum reaction for Final Stage:

Including the dynamic load allowance (for design of the pile cap top portion of the piles):

$$\begin{aligned} P_{\text{FNL(I)}} &= 1.25(\text{DC}) + 1.50(\text{DW}) + 1.75(\text{LL} + \text{IM})(N_{\text{lanes}})/N_{\text{girders}} \\ &= 1.25(126.4 + 8.9) + 1.5(12.0) + 1.75[1.33(64.42) + 30.81](4)/6 \\ &= 323 \text{ k} \end{aligned}$$

Without the dynamic load allowance (for design of the lower portion of the piles):

$$P_{\text{FNL(I)}} = 298.3 \text{ k}$$

Factored dead load plus live load reactions for one exterior girder, Strength I limit state controls:

Maximum reaction Stage I:

$$\begin{aligned} P_{\text{SI(E)}} &= 1.25(117.9) \\ &= 147.4 \text{ k} \end{aligned}$$

Notice that construction loads should be added to the above reaction.

Maximum reaction for Final Stage:

Including the dynamic load allowance:

$$\begin{aligned} P_{\text{FNL(E)}} &= 1.25(\text{DC}) + 1.50(\text{DW}) + 1.75(\text{LL} + \text{IM})(N_{\text{lanes}})/N_{\text{girders}} \\ &= 1.25(117.9 + 8.9) + 1.5(8.1) + 1.75[1.33(64.42) + 30.81](4)/6 \\ &= 306.6 \text{ k} \end{aligned}$$

Without the dynamic load allowance:

$$P_{\text{FNL(E)}} = 281.8 \text{ k}$$

Design Step 7.1.3 Piles

Typically, integral abutments may be supported on end bearing piles or friction piles. Reinforced and prestressed concrete piles, concrete-filled steel pipe piles or steel H-piles may be used. Steel H-piles will be used in this example.

Typically, the minimum distance between the piles and the end of the abutment, measured along the skew, is taken as 1'-6" and the maximum distance is usually 2'-6". These distances may vary from one jurisdiction to another. The piles are assumed to be embedded 1'-6" into the abutment. Maximum pile spacing is assumed to be 10 ft. The minimum pile spacing requirements of S10.7.1.5 shall apply.

- From S10.7.1.5, the center-to-center pile spacing shall not be less than the greater of 30.0 in. or 2.5 pile diameters (or widths). The edge distance from the side of any pile to the nearest edge of the footing shall be greater than 9.0 in.
- According to S10.7.1.5, where a reinforced concrete beam is cast-in-place and used as a bent cap supported by piles, the concrete cover at the sides of the piles shall be greater than 6.0 in., plus an allowance for permissible pile misalignment, and the piles shall project at least 6.0 in. into the cap. This provision is specifically for bent caps, therefore, keep 1'-6" pile projection for integral abutment to allow the development of moments in the piles due to movements of the abutment without distressing the surrounding concrete.

From Figure 7.1-2, steel H-piles are shown to be driven with their weak axis perpendicular to the centerline of the beams. As discussed earlier, piles were also successfully driven with their strong axis perpendicular to the centerline of the beams in the past.

According to S10.7.4.1, the structural design of driven concrete, steel, and timber piles must be in accordance with the provisions of Sections S5, S6, and S8 respectively. Articles S5.7.4, S5.13.4, S6.15, S8.4.13, and S8.5.2.2 contain specific provisions for concrete, steel, and wood piles. Design of piles supporting axial load only requires an allowance for unintended eccentricity. For the steel H-piles used in this example, this has been accounted for by the resistance factors in S6.5.4.2 for steel piles.

General pile design

As indicated earlier, piles in this example are designed for gravity loads only.

Generally, the design of the piles is controlled by the minimum capacity as determined for the following cases:

- Case A - Capacity of the pile as a structural member according to the procedures outlined in S6.15. The design for combined moment and axial force will be based on an analysis that takes the effect of the soil into account.
- Case B - Capacity of the pile to transfer load to the ground.
- Case C - Capacity of the ground to support the load.

For piles on competent rock, only Case A needs to be investigated.

Design Step Pile compressive resistance (S6.15 and S6.9.2)
7.1.3.1

The factored resistance of components in compression, P_r , is taken as:

$$P_r = \phi P_n \quad (\text{S6.9.2.1-1})$$

where:

P_n = nominal compressive resistance specified in S6.9.4 and S6.9.5 (kip)

ϕ_c = resistance factor for axial compression, steel only as specified in S6.5.4.2
 = 0.5 for H-piles assuming severe driving conditions

Check the width/thickness requirements per S6.9.4.2. Assume HP12x53 piles.

Slenderness of plates must satisfy:

$$\frac{b}{t} \leq k \sqrt{\frac{E}{F_y}} \quad (\text{S6.9.4.2-1})$$

where:

k = plate buckling coefficient as specified in Table S6.9.4.2-1
 = 0.56 for flanges and projecting legs or plates

b = width of plate equals one-half of flange width as specified in Table S6.9.4.2-1 (in.)
 = 12.045/2
 = 6.02 in.

t = flange thickness (in.)
 = 0.435 in.

$$\frac{b}{t} = 6.02/0.435 \\ = 13.8$$

$$k \sqrt{\frac{E}{F_y}} = 0.56 \sqrt{\frac{29,000}{36}} \\ = 15.9 > 13.8$$

Therefore, use S6.9.4.1 to calculate the compressive resistance.

(Notice that the b/t ratio for the webs of HP sections is always within the limits of Table S6.9.4.2-1 for webs and, therefore, need not be checked.)

For piles fully embedded in soil, the section is considered continuously braced and Eq. S6.9.4.1-1 is reduced to $P_n = F_y A_s$.

$$\begin{aligned} P_n &= 36(15.5) \\ &= 558 \text{ k} \end{aligned}$$

Therefore, the factored resistance of components in compression, P_r , is taken as:

$$\begin{aligned} P_r &= \phi P_n \\ &= 0.5(558) \\ &= 279 \text{ k} \end{aligned}$$

The above capacity applies to the pile at its lower end where damage from driving may have taken place. At the top of the pile, higher resistance factors that do not account for damage may be used. For piles designed for gravity loads only, as in this example, the resistance at the lower end will always control due to the lower resistance factor regardless if the dynamic load allowance is considered in determining the load at the top of the pile or not (notice that the dynamic load allowance is not considered in determining the load at the bottom of the pile).

Design Step 7.1.3.2 Determine the number of piles required

Maximum total girder reactions for Stage I (detailed calculations of girder reactions shown earlier):

$$\begin{aligned} P_{SI(\text{Total})} &= 2(147.4) + 4(158) \\ &= 926.8 \text{ k} \end{aligned}$$

Maximum total girder reaction for final stage not including the dynamic load allowance (detailed calculations of girder reactions shown earlier):

$$\begin{aligned} P_{FNL(\text{Total})} &= 2(281.8) + 4(298.3) \\ &= 1,756.8 \text{ k} \end{aligned}$$

Maximum factored DL + LL on the abutment, Strength I limit state controls:

$$\begin{aligned} P_{\text{Str. I}} &= P_{FNL(\text{Total})} + 1.25(\text{DC}) + 1.50(\text{DW}) + 1.75(\text{LL}_{\text{max}})(N_{\text{lanes}}) \\ &= 1,756.8 + 1.25(86.0 + 187.4 + 50.4 + 23.65 + 155.5) + 1.5(17.2) \\ &\quad + 1.75(8.0)(4) \\ &= 1,756.8 + 710.5 \\ &= 2,467 \text{ k} \end{aligned}$$

where:

“ $P_{FNL(\text{Total})}$ ” is the total factored DL + LL reaction of the bridge girders on the abutment.

“DC” includes the weight of the pile cap, diaphragm, wingwalls, approach slab and parapet on the wingwalls.

“DW” includes the weight of the future wearing surface on the approach slab.

“ LL_{max} ” is the live load reaction from the approach slab transferred to the abutment (per lane)

“ N_{lanes} ” is the maximum number of traffic lanes that fit on the approach slab, 4 lanes.

Therefore, the number of piles required to resist the applied dead and live loads is:

$$\begin{aligned} N_{piles} &= P_{Str.I}/P_r \\ &= 2,467/279 \\ &= 8.84 \text{ piles, say 9 piles} \end{aligned}$$

Design Step 7.1.3.3 Pile spacing

Total length of the pile cap = 58.93 ft.

Assume pile spacing is 6'-11" (6.917 ft.) which provides more than the recommended edge distance of 1'-6" for the piles.

$$\begin{aligned} \text{Pile end distance} &= [58.93 - 8(6.917)]/2 \\ &= 1.80 \text{ ft. (1'-9 1/2")} \end{aligned}$$

Design Step 7.1.4 Backwall design

The thickness of the abutment backwall is taken to be 3 ft.

Design of the pier cap for gravity loads

For an integral abutment constructed in two stages, the abutment is designed to resist gravity loads as follows:

- *Case A - The first stage of the abutment, i.e., the part of the abutment below the bearing pads, is designed to resist the self weight of the abutment, including the diaphragm, plus the reaction of the girders due to the self weight of the girder plus the deck slab and haunch.*
- *Case B - The entire abutment beam, including the diaphragm, is designed under the effect of the full loads on the abutment.*

Instead of analyzing the abutment beam as a continuous beam supported on rigid supports at pile locations, the following simplification is common in conducting these calculations and is used in this example:

- *Calculate moments assuming the abutment beam acting as a simple span between piles and then taking 80% of the simple span moment to account for the continuity. The location of the girder reaction is often assumed at the midspan for moment calculations and near the end for shear calculations. This assumed position of the girders is meant to produce maximum possible load effects. Due to the relatively large dimensions of the pile cap, the required reinforcement is typically light even with this conservative simplification.*

Required information:

Concrete compressive strength, $f'_c = 3$ ksi

Reinforcing steel yield strength, $F_y = 60$ ksi

Pile spacing = 6.917 ft.

CASE A

The maximum factored load due to the girders and slab (from the interior girder):

$$\begin{aligned} P_u &= 1.5(126.4) \\ &= 189.6 \text{ k} \end{aligned}$$

Factored load due to the self weight of the pile cap and diaphragm:

$$\begin{aligned} w_u &= 1.5(1.46 + 3.18) \\ &= 6.96 \text{ k/ft} \end{aligned}$$

Notice that only dead loads exist at this stage. The 1.5 load factor in the above equations is for Strength III limit state, which does not include live loads.

Flexural design for Case A

The maximum positive moment, M_b , assuming a simple span girder, is at midspan between piles. The simple span moments are reduced by 20% to account for continuity:

$$\begin{aligned} M_u &= P_u l/4 + w_u l^2/8 \\ &= 0.8[189.6(6.917)/4 + 6.96(6.917)^2/8] \\ &= 295.6 \text{ k-ft} \end{aligned}$$

Determine the required reinforcing at the bottom of the pile cap.

$$M_r = \phi M_n \quad (\text{S5.7.3.2.1-1})$$

The nominal flexural resistance, M_n , is calculated using Eq. (S5.7.3.2.2-1).

$$M_n = A_s f_y (d_s - a/2) \quad (\text{S5.7.3.2.2-1})$$

where:

$$\begin{aligned} A_s &= \text{area of nonprestressed tension reinforcement (in}^2\text{), notice that} \\ &\quad \text{available room will only allow four bars, two on either side of the} \\ &\quad \text{piles. Use 4 \#8 bars.} \\ &= 4(0.79) \\ &= 3.16 \text{ in}^2 \end{aligned}$$

$$\begin{aligned} f_y &= \text{specified yield strength of reinforcing bars (ksi)} \\ &= 60 \text{ ksi} \end{aligned}$$

$$\begin{aligned} d_s &= \text{distance from the extreme compression fiber to the centroid of the} \\ &\quad \text{nonprestressed tensile reinforcement (in.)} \\ &= \text{depth of pile cap} - \text{bottom cover} - \frac{1}{2} \text{ diameter bar} \\ &= 3.25(12) - 3 - \frac{1}{2}(1.0) \\ &= 35.5 \text{ in.} \end{aligned}$$

$$\begin{aligned} a &= c\beta_1, \text{ depth of the equivalent stress block (in.)} \\ &= A_s f_y / 0.85 f'_c b \quad (\text{S5.7.3.1.1-4}) \\ &= 3.16(60) / [0.85(3)(3.0)(12)] \\ &= 2.07 \text{ in.} \end{aligned}$$

$$\begin{aligned} M_n &= 3.16(60)(35.5 - 2.07/2)/12 \\ &= 544.5 \text{ k-ft} \end{aligned}$$

Therefore,

$$\begin{aligned} M_r &= 0.9(544.5) \\ &= 490 \text{ k-ft} > M_u = 295.6 \text{ k-ft} \quad \mathbf{OK} \end{aligned}$$

Negative moment over the piles is taken equal to the positive moment. Use the same reinforcement at the top of the pile cap as determined for the bottom (4 #8 bars).

By inspection:

- $M_r > 4/3(M_u)$. This means the minimum reinforcement requirements of S5.7.3.3.2 are satisfied.
- The depth of the compression block is small relative to the section effective depth. This means that the maximum reinforcement requirements of S5.7.3.3.1 are satisfied.

Shear design for Case A

The maximum factored shear due to the construction loads assuming the simple span condition and girder reaction at the end of the span:

$$\begin{aligned} V_u &= P_u + w_u l/2 \\ &= 189.6 + 6.96(6.917)/2 \\ &= 213.7 \text{ k} \end{aligned}$$

The factored shear resistance, V_r , is calculated as:

$$V_r = \phi V_n \quad (\text{S5.8.2.1-2})$$

The nominal shear resistance, V_n , is calculated according to S5.8.3.3 and is the lesser of:

$$V_n = V_c + V_s \quad (\text{S5.8.3.3-1})$$

OR

$$V_n = 0.25f'_c b_v d_v \quad (\text{S5.8.3.3-2})$$

where:

$$V_c = 0.0316\beta\sqrt{f'_c} b_v d_v \quad (\text{S5.8.3.3-3})$$

β = factor indicating ability of diagonally cracked concrete to transmit tension as specified in S5.8.3.4
= 2.0

f'_c = specified compressive strength of the concrete (ksi)
= 3.0 ksi

b_v = effective shear width taken as the minimum web width within the depth d_v as determined in S5.8.2.9 (in.)
= 36 in.

d_v = effective shear depth as determined in S5.8.2.9 (in.)

S5.8.2.9 states that d_v is not to be taken less than the greater of $0.9d_e$ or $0.72h$

$$\begin{aligned} d_v &= d_e - a/2 \\ &= 35.5 - (2.07/2) \\ &= 34.47 \text{ in.} \end{aligned}$$

$$\begin{aligned} 0.9d_e &= 0.9(35.5) \\ &= 31.95 \text{ in.} \end{aligned}$$

$$\begin{aligned} 0.72h &= 0.72[3.25(12)] \\ &= 28.08 \text{ in.} \end{aligned}$$

Therefore, d_v should be taken as 34.47 in.

$$\begin{aligned} V_c &= 0.0316(2.0)\sqrt{3}(36)(34.47) \\ &= 135.8 \text{ k} \end{aligned}$$

Assuming shear reinforcement is #5 @ 10 in. spacing perpendicular to the pier cap longitudinal axis.

$$V_s = A_v f_y d_v / s \quad (\text{S5.8.3.3-4})$$

where:

$$\begin{aligned} A_v &= \text{area of shear reinforcement within a distance "s" (in}^2\text{)} \\ &= 2 \text{ legs}(0.31) \\ &= 0.62 \text{ in}^2 \end{aligned}$$

$$\begin{aligned} s &= \text{spacing of stirrups (in.)} \\ &= 10 \text{ in.} \end{aligned}$$

$$\begin{aligned} V_s &= 0.62(60)(34.47)/10 \\ &= 128.2 \text{ k} \end{aligned}$$

The nominal shear resistance, V_n , is taken as the smaller of:

$$\begin{aligned} V_n &= 135.8 + 128.2 \\ &= 264 \text{ k} \end{aligned}$$

OR

$$\begin{aligned} V_n &= 0.25(3)(36)(34.47) \\ &= 930.7 \text{ k} \end{aligned}$$

Therefore, use the shear resistance due to the concrete and transverse steel reinforcement.

$$\begin{aligned} V_r &= \phi V_n \\ &= 0.9(264) \\ &= 237.6 \text{ k} > V_u = 213.7 \text{ k} \quad \mathbf{OK} \end{aligned}$$

CASE B

The maximum factored load due to all applied dead and live loads which include the approach slab, live load on approach slab, etc. The load due to the wingwalls is not included since its load minimally affects the responses at the locations where girder reactions are applied.

Point load:

$$\begin{aligned} P_{\text{Str-1}} &= \text{maximum factored girder reaction calculated earlier} \\ &= 323 \text{ k} \end{aligned}$$

Notice that the 323 k assumes that the live load is distributed equally to all girders. This approximation is acceptable since this load is assumed to be applied at the critical location for moment and shear. Alternately, the maximum reaction from the tables in Section 5.3 may be used.

Distributed load:

$$\begin{aligned} w_{\text{Str-1}} &= 1.25(\text{cap self wt.} + \text{end diaph.} + \text{approach slab}) + 1.5(\text{approach FWS}) + \\ &\quad 1.75(\text{approach slab lane load})(N_{\text{lanes}})/L_{\text{abutment}} \\ &= 1.25(1.46 + 3.18 + 2.81) + 1.5(0.31) + 1.75(8.0)(4)/58.93 \\ &= 10.73 \text{ k/ft} \end{aligned}$$

Flexural design for Case B

The maximum positive moment is calculated assuming the girder reaction is applied at the midspan between piles and taking 80% of the simple span moment.

$$\begin{aligned} M_u &= 0.8[323(6.917)/4 + 10.73(6.917)^2/8] \\ &= 498.2 \text{ k-ft} \end{aligned}$$

Determine the required reinforcing at the bottom of the pile cap.

$$M_r = \phi M_n \quad (\text{S5.7.3.2.1-1})$$

and

$$M_n = A_s f_y (d_s - a/2) \quad (\text{S5.7.3.2.2-1})$$

where:

$$\begin{aligned} A_s &= \text{use 4 \#8 bars} \\ &= 4(0.79) \\ &= 3.16 \text{ in}^2 \end{aligned}$$

$$f_y = 60 \text{ ksi}$$

$$\begin{aligned} d_s &= \text{total depth of int. abut. (no haunch) - bottom cover - } \frac{1}{2} \text{ bar diameter} \\ &= 119.75 - 3 - \frac{1}{2}(1.0) \\ &= 116.25 \text{ in.} \end{aligned}$$

$$\begin{aligned} a &= A_s f_y / 0.85 f'_c b \quad (\text{S5.7.3.1.1-4}) \\ &= 3.16(60) / [0.85(3)(3.0)(12)] \end{aligned}$$

$$= 2.07 \text{ in.}$$

$$\begin{aligned} M_n &= 3.16(60)(116.25 - 2.07/2)/12 \\ &= 1,820 \text{ k-ft} \end{aligned}$$

Therefore,

$$\begin{aligned} M_r &= 0.9(1,820) \\ &= 1,638 \text{ k-ft} > M_u = 498.2 \text{ k-ft} \quad \mathbf{OK} \end{aligned}$$

Negative moment over the piles is taken equal to the positive moment. Use the same reinforcement at the top of the abutment beam as determined for the bottom (4 #8 bars).

By inspection:

- $M_r > 4/3(M_u)$.
- The depth of the compression block is small relative to the section effective depth.

Shear design for Case B

Assume the girder reaction is adjacent to the pile.

The maximum factored shear due to all applied loading:

$$\begin{aligned} V_u &= P_u + w_u l/2 \\ &= 323 + 10.73(6.917)/2 \\ &= 360.1 \text{ k} \end{aligned}$$

The factored shear resistance, V_r , is calculated as:

$$V_r = \phi V_n \quad (\text{S5.8.2.1-2})$$

The nominal shear resistance, V_n , is calculated according to S5.8.3.3 and is the lesser of:

$$V_n = V_c + V_s \quad (\text{S5.8.3.3-1})$$

OR

$$V_n = 0.25f'_c b_v d_v \quad (\text{S5.8.3.3-2})$$

where:

$$V_c = 0.0316\beta\sqrt{f'_c} b_v d_v \quad (\text{S5.8.3.3-3})$$

$$\beta = 2.0$$

$$f_c = 3.0 \text{ ksi}$$

$$b_v = 36 \text{ in.}$$

$$d_v = d_e - a/2$$

$$d_e = 116.25 \text{ in. (calculated earlier)}$$

$$\begin{aligned} d_v &= 116.25 - (2.07/2) \\ &= 115.2 \text{ in.} \end{aligned}$$

$$\begin{aligned} 0.9d_e &= 0.9(116.25) \\ &= 104.6 \text{ in.} \end{aligned}$$

$$\begin{aligned} 0.72h &= 0.72(119.75) \\ &= 86.22 \text{ in.} \end{aligned}$$

Therefore, d_v should be taken as 115.2 in.

The nominal shear resistance, V_n , is taken as the lesser of:

$$\begin{aligned} V_c &= 0.0316(2.0)\sqrt{3}(36)(115.2) \\ &= 454.0 \text{ k} \end{aligned}$$

Notice that V_c is large enough, relative to the applied load, that the contribution of the transverse shear reinforcement, V_s , is not needed.

OR

$$\begin{aligned} V_n &= 0.25(3)(36)(115.2) \\ &= 3,110.4 \text{ k} \end{aligned}$$

Therefore, use the shear resistance due to the concrete, V_c

$$\begin{aligned} V_r &= \phi V_n \\ &= 0.9(454.0) \\ &= 408.6 \text{ k} > V_u = 360.1 \text{ k} \quad \mathbf{OK} \end{aligned}$$

Typical reinforcement details of the abutment beam are shown in Figures 7.1-4 through 7.1-7. Notice that bar shapes vary depending on the presence of girders and/or piles at the section.

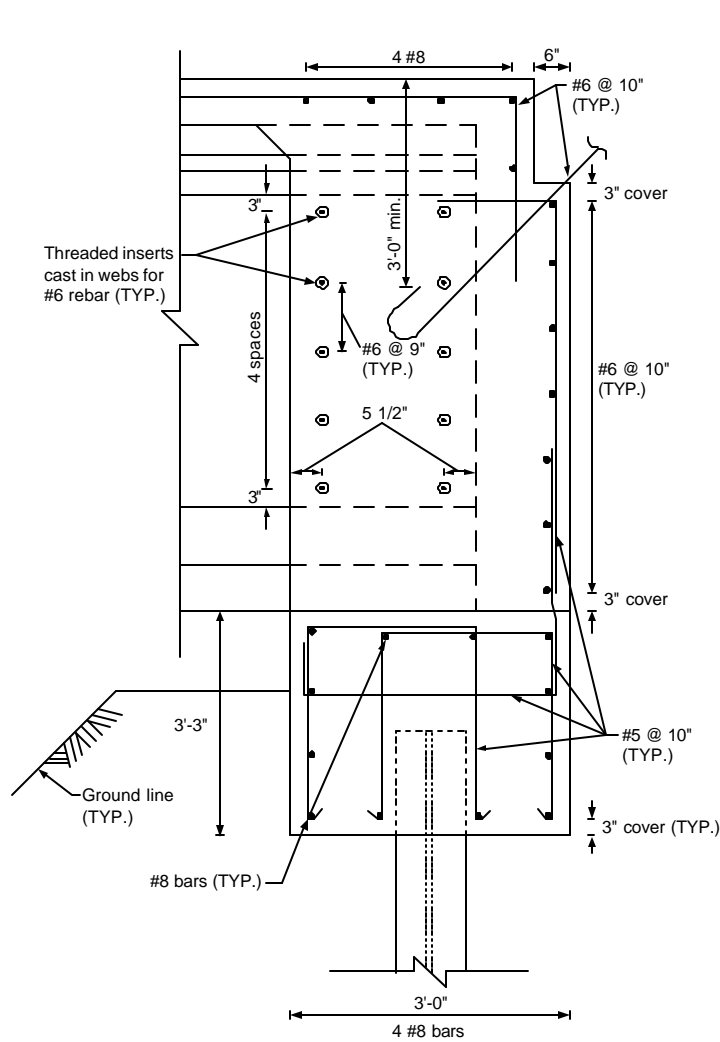

Figure 7.1-4 – Integral Abutment Reinforcement, Girder and Pile Exist at the Same Section

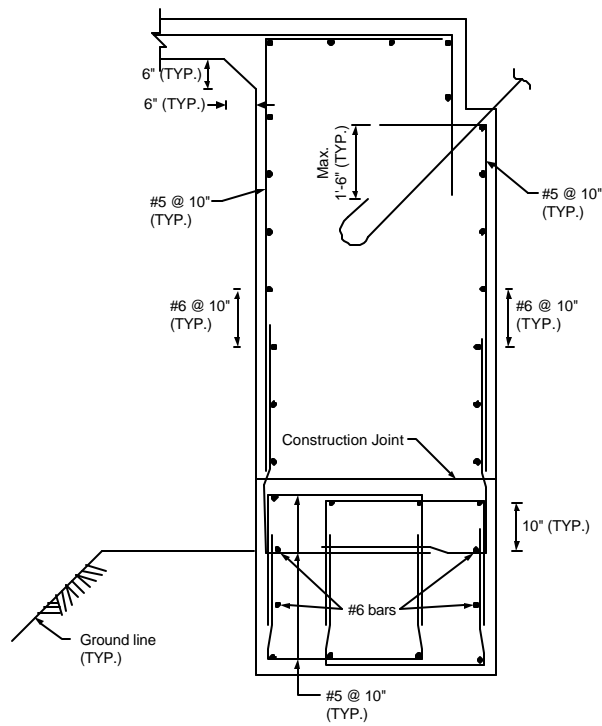

Figure 7.1-5 – Integral Abutment Reinforcement, No Girder and No Pile at the Section

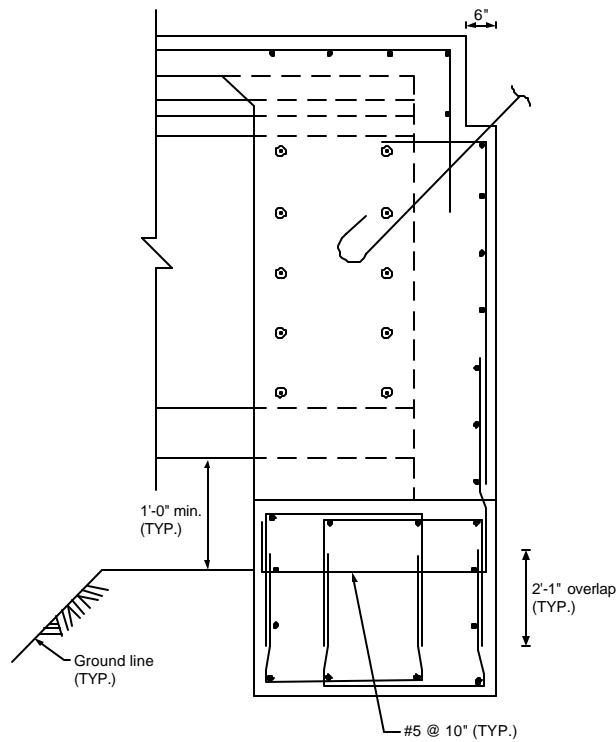

Figure 7.1-6 – Integral Abutment Reinforcement, Girder, No Pile at the Section

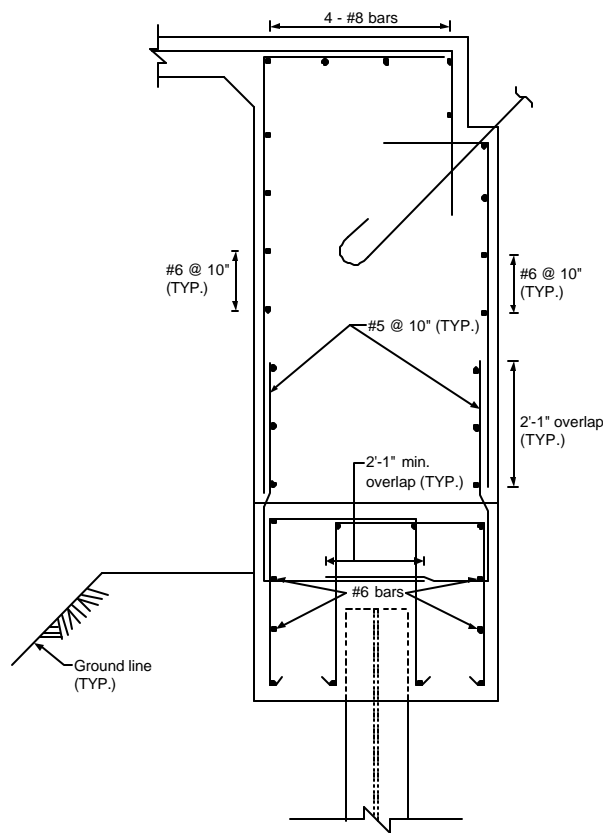

Figure 7.1-7 – Integral Abutment Reinforcement, Pile Without Girder

Design Step
7.1.4.1

Design the backwall as a horizontal beam resisting passive earth pressure

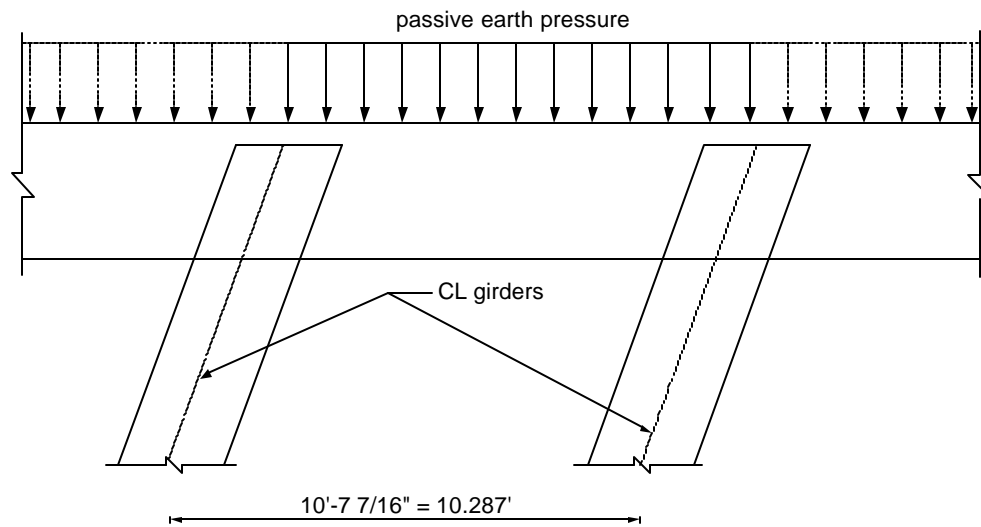

Figure 7.1-8 – Passive Earth Pressure Applied to Backwall

Calculate the adequacy of the backwall to resist passive pressure due to the abutment backfill material.

Passive earth pressure coefficient, $k_p = (1 + \sin \phi)/(1 - \sin \phi)$
 (Notice that k_p may also be obtained from Figure S3.11.5.4-1)

$$w_p = \frac{1}{2} \gamma z^2 k_p \quad (\text{S3.11.5.1-1})$$

where:

w_p = passive earth pressure per unit length of backwall (k/ft)

γ = unit weight of soil bearing on the backwall (kcf)
 = 0.130 kcf

z = height of the backwall from the bottom of the approach slab to the bottom of the pile cap (ft.)
 = slab + haunch + girder depth + bearing pad thickness + pile cap depth – approach slab thickness
 = (8/12) + (4/12) + 6 + (0.75/12) + 3.25 – 1.5
 = 8.81 ft.

ϕ = internal friction of backfill soil assumed to be 30°

$$w_p = \frac{1}{2} (0.130)(8.81)^2 [(1 + \sin 30)/(1 - \sin 30)]$$

$$= 15.1 \text{ k/ft of wall}$$

Notice that developing full passive earth pressure requires relatively large displacement of the structure (0.01 to 0.04 of the height of the structure for cohesionless fill). The expected displacement of the abutment is typically less than that required to develop full passive pressure. However, these calculations are typically not critical since using full passive pressure is not expected to place high demand on the structure or cause congestion of reinforcement.

No load factor for passive earth pressure is specified in the LRFD specifications. Assume the load factor is equal to that of the active earth pressure ($\phi = 1.5$).

$$w_u = \phi_{EH} w_p$$

$$= 1.5(15.1)$$

$$= 22.65 \text{ k/ft of wall}$$

The backwall acts as a continuous horizontal beam supported on the girders, i.e., with spans equal to the girder spacing along the skew.

$$\begin{aligned} M_u &\cong w_u l^2 / 8 \\ &= 22.65(9.667 / \cos 20)^2 / 8 \\ &= 300 \text{ k-ft/ft} \end{aligned}$$

Calculate the nominal flexural resistance, M_n , of the backwall.

$$M_r = \phi M_n \quad (\text{S5.7.3.2.1-1})$$

and

$$M_n = A_s f_y (d_s - a/2) \quad (\text{S5.7.3.2.2-1})$$

where:

$$\begin{aligned} A_s &= \text{area of the longitudinal reinforcement bars at front face (tension} \\ &\quad \text{side) of the abutment (9 \#6 bars)} \\ &= 9(0.44) \\ &= 3.96 \text{ in}^2 \end{aligned}$$

$$f_y = 60 \text{ ksi}$$

$$\begin{aligned} d_s &= \text{width of backwall} - \text{concrete cover} - \text{vertical bar dia.} - \frac{1}{2} \text{ bar dia.} \\ &= 3.0(12) - 3 - 0.625 - \frac{1}{2}(0.75) \\ &= 32.0 \text{ in.} \end{aligned}$$

$$\begin{aligned} a &= A_s f_y / 0.85 f_c b \quad (\text{S5.7.3.1.1-4}) \\ &\quad \text{where "b" is the height of the component} \\ &= 3.96(60) / [0.85(3)(119.75)] \\ &= 0.78 \text{ in.} \end{aligned}$$

$$\begin{aligned} M_n &= 3.96(60)(32.0 - 0.78/2) / 12 \\ &= 626 \text{ k-ft/ft} \end{aligned}$$

Therefore, the factored flexural resistance, where $\phi = 0.9$ for flexure (S5.5.4.2.1), is taken as:

$$\begin{aligned} M_r &= 0.9(626) \\ &= 563 \text{ k-ft/ft} > M_u = 300 \text{ k-ft/ft} \quad \mathbf{OK} \end{aligned}$$

By inspection:

- $M_r > 4/3(M_u)$.
- The depth of the compression block is small relative to the depth.

Check shear for the section of backwall between girders:

$$\begin{aligned} V_u &= P_u l / 2 \\ &= 22.65(9.667 / \sin 20) / 2 \\ &= 116.5 \text{ k/ft} \end{aligned}$$

The factored shear resistance, V_r , is calculated as:

$$V_r = \phi V_n \quad (\text{S5.8.2.1-2})$$

The nominal shear resistance, V_n , is calculated according to S5.8.3.3 and is the lesser of:

$$V_n = V_c + V_s \quad (\text{S5.8.3.3-1})$$

OR

$$V_n = 0.25 f'_c b_v d_v \quad (\text{S5.8.3.3-2})$$

where:

$$V_c = 0.0316 \beta \sqrt{f'_c} b_v d_v \quad (\text{S5.8.3.3-3})$$

$$\begin{aligned} \beta &= 2.0 \\ f'_c &= 3.0 \text{ ksi} \end{aligned}$$

$$\begin{aligned} b_v &= \text{effective horizontal beam width taken as the abutment depth (in.)} \\ &= 119.75 \text{ in.} \end{aligned}$$

$$\begin{aligned} d_v &= d_e - a/2 \\ &= 32.0 - (0.78/2) \\ &= 31.61 \text{ in.} \end{aligned}$$

$$\begin{aligned} 0.9d_e &= 0.9(32.0) \\ &= 28.8 \text{ in.} \end{aligned}$$

$$\begin{aligned} 0.72h &= 0.72(36) \\ &= 25.92 \text{ in.} \end{aligned}$$

Therefore, d_v should be taken as 31.61 in.

Ignore the contribution of the transverse reinforcement to the shear resistance (i.e., $V_s = 0$), V_n is taken as the smaller of:

$$\begin{aligned} V_c &= 0.0316(2.0)\sqrt{3}(119.75)(31.61) \\ &= 414.4 \text{ k/ft} \end{aligned}$$

OR

$$\begin{aligned} V_n &= 0.25(3)(119.75)(31.61) \\ &= 2,839 \text{ k/ft} \end{aligned}$$

Therefore, use the shear resistance due to the concrete, V_c

$$\begin{aligned} V_r &= \phi V_n \\ &= 0.9(414.4) \\ &= 373.0 \text{ k/ft} > V_u = 116.5 \text{ k/ft} \quad \mathbf{OK} \end{aligned}$$

Design Step 7.1.5 Wingwall design

There is no widely accepted method of determining design loads for the wingwalls of integral abutments. The following design procedure will result in a conservative design as it takes into account maximum possible loads.

Two load cases are considered:

Load Case 1:

The wingwall is subjected to passive earth pressure. This case accounts for the possibility of the bridge moving laterally and pushing the wingwall against the fill. It is not likely that the displacement will be sufficient to develop full passive pressure. However, there is no available method to determine the expected pressure with certainty. This load case is considered under strength limit state.

Load Case 2:

The wingwall is subjected to active pressure and collision load on the parapet. Active pressure was considered instead of passive to account for the low probability that a collision load and passive pressure will exist simultaneously. This load case is considered at the extreme event limit state, i.e. $j = 1.0$ (Table S3.4.1-1)

Required information:

Angle of internal friction of fill, ϕ = 30 degrees

Coefficient of active earth pressure, k_a = $(1 - \sin \phi)/(1 + \sin \phi)$
= 0.333

Coefficient of passive earth pressure, k_p = $(1 + \sin \phi)/(1 - \sin \phi)$
= 3

k_a/k_p = 0.333/3
= 0.111

Load Case 1

From Figure 7.1-9 and utilizing properties of a right angle pyramid [volume = 1/3(base area)(height) and the center of gravity (applied at a distance measured from the vertical leg of the right angle pyramid) = 1/4 base length].

Moment at the critical section for moment under passive pressure:

$$M_p = 0.2(14)(0.5)(14/2) + 0.2[14(8.31/2)](14/3) + (1/3)[3.24(8.31)(14/2)](14/4) \\ = 284 \text{ k-ft}$$

Minimum required factored flexural resistance, $M_r = 284 \text{ k-ft}$.

$$M_r = \phi M_n \quad (\text{S5.7.3.2.1-1})$$

where:

$$M_n = \text{nominal resistance (k-ft)} \\ = M_p$$

$$\phi = 0.9 \text{ for flexure at the strength limit state (S5.5.4.2)}$$

$$\text{Min. required } M_n = 284/0.9 \\ = 316 \text{ k-ft}$$

Load Case 2

Moment on the critical section for moment under active pressure:

$$M_a = 0.111(284) \\ = 31.5 \text{ k-ft}$$

Moment from collision load on the parapet:

From SA13.2 for Test Level 5, the crash load on the parapet is equal to 124 kips and is applied over a length of 8 ft.

Maximum collision moment on the critical section:

$$M = 124(14 - 8/2) \\ = 1,240 \text{ k-ft}$$

$$\text{Total moment for Load Case 2, } M_{\text{total}} = 1,240 + 31.5 \\ = 1,271.5 \text{ k-ft}$$

The minimum required factored flexural resistance, $M_r = 1,271.5 \text{ k-ft}$

$$M_r = \phi M_n \quad (\text{S5.7.3.2.1-1})$$

where:

$$\phi = 1.0 \text{ for flexure at the extreme event limit state}$$

$$\begin{aligned} \text{Min. required } M_n &= 1,271.5/1.0 \\ &= 1,271.5 \text{ k-ft} \end{aligned}$$

From the two cases of loading:

$$M_n \text{ required} = 1,271.5 \text{ k-ft}$$

Develop a section that provides the minimum nominal flexural resistance

Required information:

Assuming reinforcement of #8 @ 6 in.

Number of bars within the 10.3125 ft. height of the wing wall = 22 bars

Section thickness = parapet thickness at base
= 20.25 in.

Concrete cover = 3 in.

The nominal flexural resistance, M_n , is taken as:

$$M_n = A_s f_y (d_s - a/2) \quad (\text{S5.7.3.2.2-1})$$

where:

$$\begin{aligned} d_s &= \text{section thickness} - \text{cover} - \frac{1}{2} \text{ bar diameter} \\ &= 20.25 - 3 - \frac{1}{2}(1.0) \\ &= 16.75 \text{ in.} \end{aligned}$$

$$\begin{aligned} A_s &= 22(0.79) \\ &= 17.38 \text{ in}^2 \end{aligned}$$

$$\begin{aligned} a &= A_s f_y / 0.85 f'_c b \quad (\text{S5.7.3.1.1-4}) \\ &= 17.38(60) / [0.85(3)(123.75)] \\ &= 3.30 \text{ in.} \end{aligned}$$

$$\begin{aligned} M_n &= A_s f_y (d_s - a/2) \\ &= 17.38(60)(16.75 - 3.30/2)/12 \\ &= 1,312 \text{ k-ft} > 1,271.5 \text{ k-ft required } \mathbf{OK} \end{aligned}$$

Secondary reinforcement of the wingwall is not by design, it is only meant for shrinkage. Use #6 @ 12 in. spacing as shown in Figure 7.1-10.

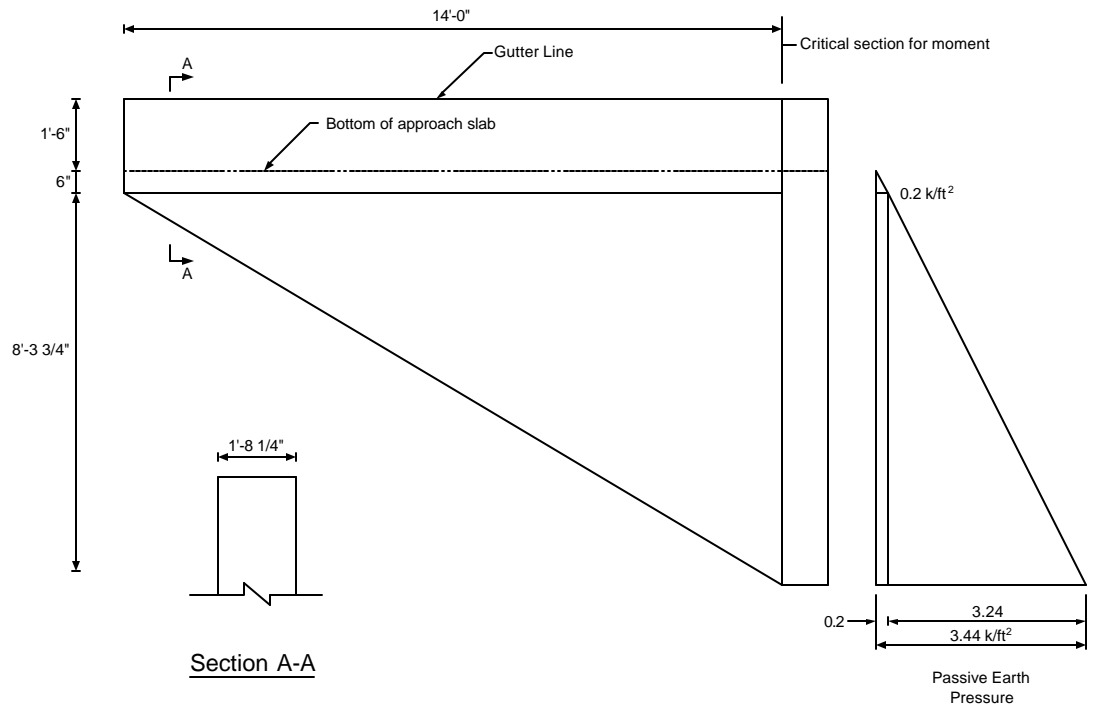

Figure 7.1-9 – Wingwall Dimensions

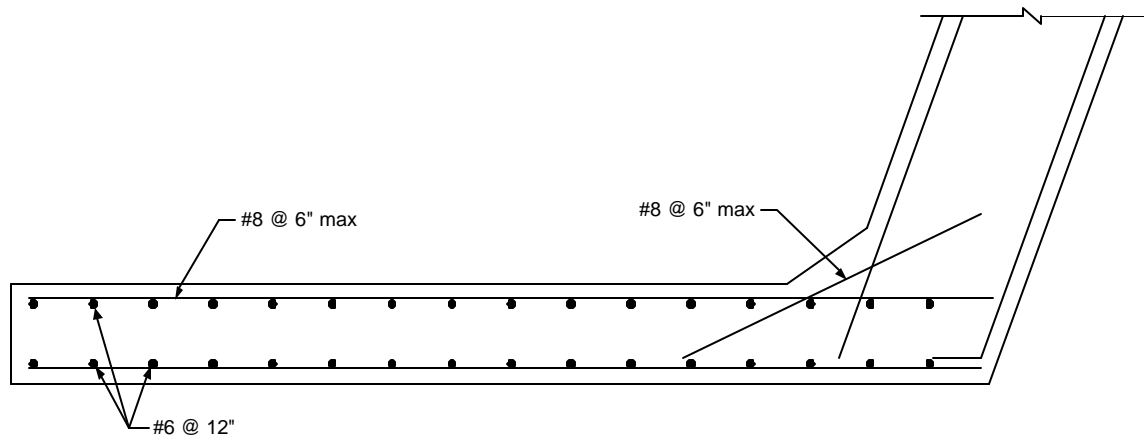

Figure 7.1-10 – Wingwall Reinforcement

Design Step 7.1.6 Design of approach slab

Approach slab loading for a 1 ft. wide strip :

$$\begin{aligned} w_{\text{self}} &= 0.15(1.5) \\ &= 0.225 \text{ k/ft} \end{aligned}$$

$$w_{\text{FWS}} = 0.025 \text{ k/ft}$$

Factored distributed dead loading:

$$\begin{aligned} w_{\text{Str I}} &= 1.25(0.225) + 1.50(0.025) \\ &= 0.32 \text{ k/ft} \end{aligned}$$

Live load distribution width (S4.6.2.3)

The equivalent strip width of longitudinal strips per lane for both shear and moment is calculated according to the provisions of S4.6.2.3.

- For single lane loaded

$$E = 10 + 5\sqrt{L_1 W_1} \quad (\text{S4.6.2.3-1})$$

- For multiple lanes loaded

$$E = 84.0 + 1.44\sqrt{L_1 W_2} \leq \frac{12.0W}{N_L} \quad (\text{S4.6.2.3-2})$$

where:

E = equivalent width (in.)

L_1 = modified span length taken equal to the lesser of the actual span or 60.0 ft. (ft.)

W_1 = modified edge-to-edge width of bridge taken to be equal to the lesser of the actual width or 60.0 ft. for multilane loading, or 30.0 ft. for single-lane loading (ft.)

W = physical edge-to-edge width of bridge (ft.)

N_L = number of design lanes as specified in S3.6.1.1.1

$$\begin{aligned} E_{\text{single}} &= 10 + 5\sqrt{25(30)} \\ &= 146.9 \text{ in.} \end{aligned}$$

$$E_{\text{mult.}} = 84.0 + 1.44\sqrt{25(55.34)}$$

$$= 137.6 \text{ in.}$$

$$\frac{12.0(55.34)}{4} = 166.02 \text{ in.}$$

Therefore, the equivalent strip width is:

$$E = 137.6 \text{ in.}$$

Live load maximum moment:

$$\text{Lane load: max moment} = 0.64(25)^2/8$$

$$= 50 \text{ k-ft}$$

$$\text{Truck load: max moment} = 207.4 \text{ k-ft (from live load analysis output for a 25 ft. simple span)}$$

$$\text{Total LL + IM} = 50 + 1.33(207.4)$$

$$= 325.8 \text{ k-ft}$$

$$\text{Total LL + IM moment per unit width of slab} = 325.8/(137.6/12)$$

$$= 28.4 \text{ k-ft/ft}$$

Maximum factored positive moment per unit width of slab due to dead load plus live load:

$$M_u = wl^2/8 + 1.75(\text{LL + IM moment})$$

$$= 0.32(25)^2/8 + 1.75(28.4)$$

$$= 74.7 \text{ k-ft}$$

The factored flexural resistance, M_r , is taken as:

$$M_r = \phi M_n \quad (\text{S5.7.3.2.1-1})$$

and

$$M_n = A_s f_y (d - a/2) \quad (\text{S5.7.3.2.2-1})$$

where:

$$A_s = \text{use \#9 bars at 9 in. spacing}$$

$$= 1.0(12/9)$$

$$= 1.33 \text{ in}^2 \text{ per one foot of slab}$$

$$f_y = 60 \text{ ksi}$$

$$\begin{aligned} d &= \text{slab depth} - \text{cover (cast against soil)} - \frac{1}{2} \text{ bar diameter} \\ &= 1.5(12) - 3 - \frac{1}{2}(1.128) \\ &= 14.4 \text{ in.} \end{aligned}$$

$$\begin{aligned} a &= A_s f_y / 0.85 f_c b && \text{(S5.7.3.1.1-4)} \\ &= 1.33(60) / [0.85(3)(12)] \\ &= 2.61 \text{ in.} \end{aligned}$$

$$\begin{aligned} M_n &= 1.33(60)(14.4 - 2.61/2)/12 \\ &= 87.1 \text{ k-ft} \end{aligned}$$

Therefore,

$$\begin{aligned} M_r &= 0.9(87.1) \\ &= 78.4 \text{ k-ft} > M_u = 74.7 \text{ k-ft} \quad \mathbf{OK} \end{aligned}$$

Design Step 7.1.6.1 Bottom distribution reinforcement (S9.7.3.2)

For main reinforcement parallel to traffic, the minimum distribution reinforcement is taken as a percentage of the main reinforcement:

$$100/\sqrt{S} \leq 50\%$$

where:

S = the effective span length taken as equal to the effective length specified in S9.7.2.3 (ft.)

Assuming “S” is equal to the approach slab length,

$$100/\sqrt{25} = 20\%$$

$$\begin{aligned} \text{Main reinforcement: \#9 @ 9 in.} &= 1.0(12/9) \\ &= 1.33 \text{ in}^2/\text{ft} \end{aligned}$$

$$\begin{aligned} \text{Required distribution reinforcement} &= 0.2(1.33) \\ &= 0.27 \text{ in}^2/\text{ft} \end{aligned}$$

Use #6 @ 12 in. = 0.44 in²/ft > required reinforcement **OK**

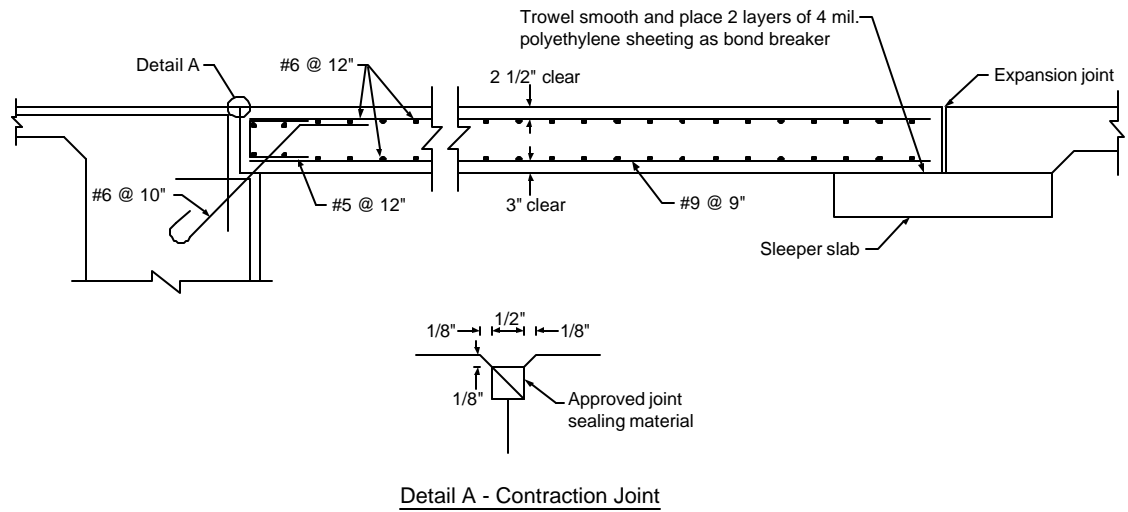
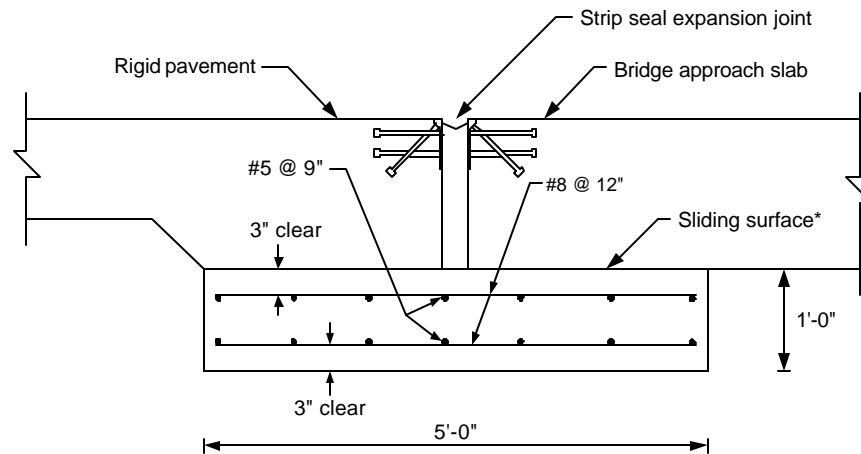

Figure 7.1-11 – Typical Approach Slab Reinforcement Details

Design Step 7.1.7 Sleeper slab

No design provisions are available for sleeper slabs. The reinforcement is typically shown as a standard detail. If desired, moment in the sleeper slab may be determined assuming the wheel load is applied at the midpoint of a length assumed to bridge over settled fill, say a 5 ft. span length.



* Trowel smooth and place 2 layers of 4 mil. polyethylene sheeting as bond breaker

Figure 7.1-12 – Sleeper Slab Details Used by the Pennsylvania Department of Transportation

Design Step 7.2 INTERMEDIATE PIER DESIGN**Design Step 7.2.1** Substructure loads and load application

In the following sections, the word “pier” is used to refer to the intermediate pier or intermediate bent.

Dead load

Notice that the LRFD specifications include a maximum and minimum load factor for dead load. The intent is to apply the maximum or the minimum load factors to all dead loads on the structure. It is not required to apply maximum load factors to some dead loads and minimum load factors simultaneously to other dead loads to obtain the absolute maximum load effects.

Live load transmitted from the superstructure to the substructure

Accurately determining live load effects on intermediate piers always represented an interesting problem. The live load case of loading producing the maximum girder reactions on the substructure varies from one girder to another and, therefore, the case of loading that maximizes live load effects at any section of the substructure also varies from one section to another. The equations used to determine the girder live load distribution produce the maximum possible live load distributed to a girder without consideration to the live load distributed concurrently to the surrounding girders. This is adequate for girder design but is not sufficient for substructure design. Determining the concurrent girder reactions requires a three-dimensional modeling of the structure. For typical structures, this will be cumbersome and the return, in terms of more accurate results, is not justifiable. In the past, different jurisdictions opted to incorporate some simplifications in the application of live loads to the substructure and these procedures, which are independent of the design specifications, are still applicable under the AASHTO-LRFD design specifications. The goal of these simplifications is to allow the substructure to be analyzed as a two-dimensional frame. One common procedure is as follows:

- *Live load reaction on the intermediate pier from one traffic lane is determined. This reaction from the live load uniform load is distributed over a 10 ft. width and the reaction from the truck is applied as two concentrated loads 6 ft. apart. This means that the live load reaction at the pier location from each traffic lane is a line load 10 ft. wide and two concentrated loads 6 ft. apart. The loads are assumed to fit within a 12 ft. wide traffic lane. The reactions from the uniform load and the truck may be moved within the width of the traffic lane, however, neither of the two truck axle loads may be placed closer than 2 ft. from the edge of the traffic lane.*
- *The live load reaction is applied to the deck at the pier location. The load is distributed to the girders assuming the deck acts as a series of simple spans*

supported on the girders. The girder reactions are then applied to the pier. In all cases, the appropriate multiple presence factor is applied.

- *First, one lane is loaded. The reaction from that lane is moved across the width of the bridge. To maximize the loads, the location of the 12 ft. wide traffic lane is assumed to move across the full width of the bridge between gutter lines. Moving the traffic lane location in this manner provides for the possibility of widening the bridge in the future and/or eliminating or narrowing the shoulders to add additional traffic lanes. For each load location, the girder reactions transmitted to the pier are calculated and the pier itself is analyzed.*
- *Second, two traffic lanes are loaded. Each of the two lanes is moved across the width of the bridge to maximize the load effects on the pier. All possible combinations of the traffic lane locations should be included.*
- *The calculations are repeated for three lanes loaded, four lanes loaded and so forth depending on the width of the bridge.*
- *The maximum and minimum load effects, i.e. moment, shear, torsion and axial force, at each section from all load cases are determined as well as the other concurrent load effects, e.g. maximum moment and concurrent shear and axial loads. When a design provision involves the combined effect of more than one load effect, e.g. moment and axial load, the maximum and minimum values of each load effect and the concurrent values of the other load effects are considered as separate load cases. This results in a large number of load cases to be checked. Alternatively, a more conservative procedure that results in a smaller number of load cases may be used. In this procedure, the envelopes of the load effects are determined. For all members except for the columns and footings, the maximum values of all load effects are applied simultaneously. For columns and footings, two cases are checked, the case of maximum axial load and minimum moment and the case of maximum moment and minimum axial load.*

This procedure is best suited for computer programs. For hand calculations, this procedure would be cumbersome. In lieu of this lengthy process, a simplified procedure used satisfactorily in the past may be utilized.

Load combinations

The live load effects are combined with other loads to determine the maximum factored loads for all applicable limit states. For loads other than live, when maximum and minimum load factors are specified, each of these two factored loads should be considered as separate cases of loading. Each section is subsequently designed for the controlling limit state.

Temperature and shrinkage forces

The effects of the change in superstructure length due to temperature changes and, in some cases, due to concrete shrinkage, are typically considered in the design of the substructure.

In addition to the change in superstructure length, the substructure member lengths also change due to temperature change and concrete shrinkage. The policy of including the effects of the substructure length change on the substructure forces varies from one jurisdiction to another. These effects on the pier cap are typically small and may be ignored without measurable effect on the design of the cap. However, the effect of the change in the pier cap length may produce a significant force in the columns of multiple column bents. This force is dependant on:

- *The length and stiffness of the columns: higher forces are developed in short, stiff columns*
- *The distance from the column to the point of equilibrium of the pier (the point that does not move laterally when the pier is subjected to a uniform temperature change): Higher column forces develop as the point of interest moves farther away from the point of equilibrium. The point of equilibrium for a particular pier varies depending on the relative stiffness of the columns. For a symmetric pier, the point of equilibrium lies on the axis of symmetry. The column forces due to the pier cap length changes are higher for the outer columns of multi-column bents. These forces increase with the increase in the width of the bridge.*

Torsion

Another force effect that some computer design programs use in pier design is the torsion in the pier cap. This torsion is applied to the pier cap as a concentrated torque at the girder locations. The magnitude of the torque at each girder location is calculated differently depending on the source of the torque.

- *Torque due to horizontal loads acting on the superstructure parallel to the bridge longitudinal axis: The magnitude is often taken equal to the horizontal load on the bearing under the limit state being considered multiplied by the distance from the point of load application to mid-height of the pier cap, e.g. braking forces are assumed to be applied 6 ft. above the deck surface.*
- *Torque due to noncomposite dead load on simple spans made continuous for live load: Torque at each girder location is taken equal to the difference between the product of the noncomposite dead load reaction and the distance to the mid-width of the cap for the two bearings under the girder line being considered.*

According to SC5.8.2.1, if the factored torsional moment is less than one-quarter of the factored pure torsional cracking moment, it will cause only a very small reduction in

shear capacity or flexural capacity and, hence, can be neglected. For pier caps, the magnitude of the torsional moments is typically small relative to the torsional cracking moments and, therefore, is typically ignored in hand calculations.

For the purpose of this example, a computer program that calculates the maximum and minimum of each load effect and the other concurrent load effects was used. Load effects due to substructure temperature expansion/contraction and concrete shrinkage were not included in the design. The results are listed in Appendix C. Selected values representing the controlling case of loading are used in the sample calculations.

Superstructure dead load

These loads can be obtained from Section 5.2 of the superstructure portion of this design example.

Summary of the unfactored loading applied vertically at each bearing (12 bearings total, 2 per girder line):

Girders (E/I)	= 61.6 k
Deck slab and haunch (E)	= 55.1 k
Deck slab and haunch (I)	= 62.2 k
Intermediate diaphragm (E)	= 1.3 k
Intermediate diaphragm (I)	= 2.5 k
Parapets (E/I)	= 14.8 k
Future wearing surface (E)	= 13.4 k
Future wearing surface (I)	= 19.9 k

(E) – exterior girder

(I) – interior girder

Substructure dead load

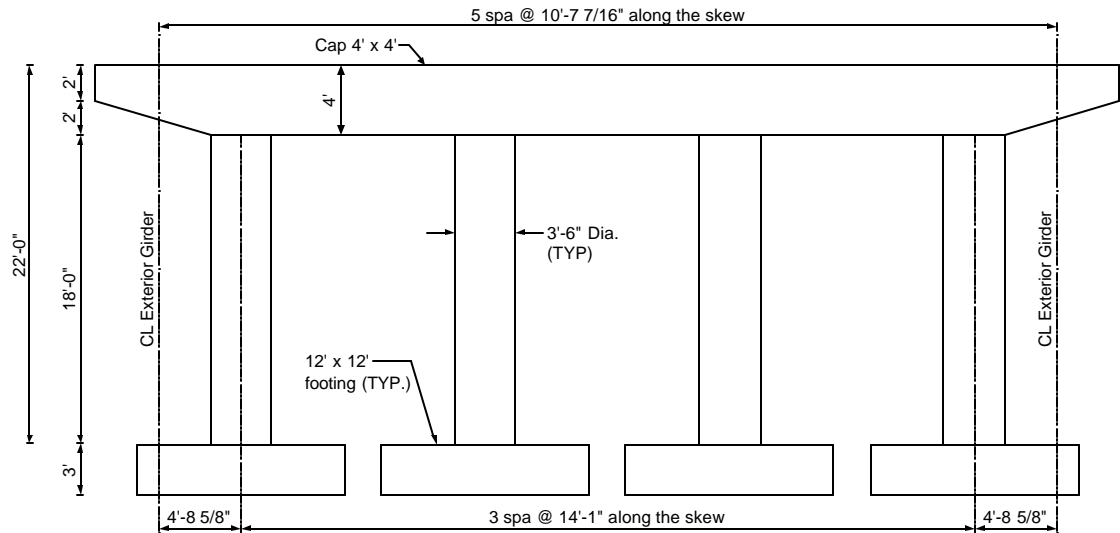

Figure 7.2-1 – General Pier Dimensions

Pier cap unfactored dead load

$$w_{cap} = (\text{cap cross-sectional area})(\text{unit weight of concrete})$$

Varying cross-section at the pier cap ends:

$$w_{cap1} = \text{varies linearly from } 2(2)(0.150) = 0.6 \text{ k/ft} \\ \text{to } 4(4)(0.150) = 2.4 \text{ k/ft}$$

Constant cross-section:

$$w_{cap2} = 4(4)(0.150) \\ = 2.4 \text{ k/ft}$$

OR

$$P_{cap} = 2.4(45.75) + [(2 + 4)/2](0.150)(13.167) \\ = 115.7 \text{ k}$$

Single column unfactored dead load

$$w_{column} = (\text{column cross sectional area})(\text{unit weight of concrete}) \\ = \pi(1.75)^2(0.150) \\ = 1.44 \text{ k/ft}$$

OR

$$P_{column} = 1.44(18) \\ = 25.9 \text{ k}$$

Single footing unfactored dead load

$$\begin{aligned}
 W_{\text{footing}} &= (\text{footing cross sectional area})(\text{unit weight of concrete}) \\
 &= 12(12)(0.150) \\
 &= 21.6 \text{ k/ft}
 \end{aligned}$$

OR

$$\begin{aligned}
 P_{\text{footing}} &= 21.6(3) \\
 &= 64.8 \text{ k}
 \end{aligned}$$

Live load from the superstructure

Use the output from the girder live load analysis to obtain the maximum unfactored live load reactions for the interior and exterior girder lines.

Summary of HL-93 live load reactions, without distribution factors or impact, applied vertically to each bearing (truck pair + lane load case governs for the reaction at the pier, therefore, the 90% reduction factor from S3.6.1.3.1 is applied):

$$\begin{aligned}
 \text{Maximum truck} &= 59.5 \text{ k} \\
 \text{Minimum truck} &= 0.0 \text{ k} \\
 \text{Maximum lane} &= 43.98 \text{ k} \\
 \text{Minimum lane} &= 0.0 \text{ k}
 \end{aligned}$$

Braking force (BR) (S3.6.4)

According to the specifications, the braking force shall be taken as the greater of:

25 percent of the axle weight of the design truck or design tandem

OR

5 percent of the design truck plus lane load or 5 percent of the design tandem plus lane load

The braking force is placed in all design lanes which are considered to be loaded in accordance with S3.6.1.1.1 and which are carrying traffic headed in the same direction. These forces are assumed to act horizontally at a distance of 6 ft. above the roadway surface in either longitudinal direction to cause extreme force effects. Assume the example bridge can be a one-way traffic bridge in the future. The multiple presence factors in S3.6.1.1.2 apply.

$$\begin{aligned}
 BR_1 &= 0.25(32 + 32 + 8)(4 \text{ lanes})(0.65)/1 \text{ fixed support} \\
 &= 46.8 \text{ k}
 \end{aligned}$$

OR

$$\begin{aligned} BR_{2A} &= 0.05[72 + (110 + 110)(0.64)] \\ &= 10.6 \text{ k} \end{aligned}$$

$$\begin{aligned} BR_{2B} &= 0.05[(25 + 25) + 220(0.64)] \\ &= 9.54 \text{ k} \end{aligned}$$

where the subscripts are defined as:

- 1 – use the design truck to maximize the braking force
- 2A – check the design truck + lane
- 2B – check the design tandem + lane

Therefore, the braking force will be taken as 46.8 k (3.9 k per bearing or 7.8 k per girder) applied 6 ft. above the top of the roadway surface.

$$\begin{aligned} \text{Moment arm} &= 6 \text{ ft.} + \text{deck thickness} + \text{haunch} + \text{girder depth} \\ &= 6 + 0.667 + 0.333 + 6 \\ &= 13.0 \text{ ft. above the top of the bent cap} \end{aligned}$$

Apply the moment $2(3.9)(13.0) = 101.4$ k-ft at each girder location.

Wind load on superstructure (S3.8.1.2)

The pressures specified in the specifications are assumed to be caused by a base wind velocity, V_B , of 100 mph.

Wind load is assumed to be uniformly distributed on the area exposed to the wind. The exposed area is the sum of all component surface areas, as seen in elevation, taken perpendicular to the assumed wind direction. This direction is varied to determine the extreme force effects in the structure or in its components. Areas that do not contribute to the extreme force effect under consideration may be neglected in the analysis.

Base design wind velocity varies significantly due to local conditions. For small or low structures, such as this example, wind usually does not govern.

Pressures on windward and leeward sides are to be taken simultaneously in the assumed direction of wind.

The direction of the wind is assumed to be horizontal, unless otherwise specified in S3.8.3. The design wind pressure, in KSF, may be determined as:

$$\begin{aligned} P_D &= P_B(V_{DZ}/V_B)^2 && \text{(S3.8.1.2.1-1)} \\ &= P_B(V_{DZ}^2/10,000) \end{aligned}$$

where:

P_B = base wind pressure specified in Table S3.8.1.2.1-1 (ksf)

Since the bridge component heights are less than 30 ft. above the ground line, V_B is taken to be 100 mph.

Wind load transverse to the superstructure

$$F_{T \text{ Super}} = p_{wT}(H_{\text{wind}})[(L_{\text{back}} + L_{\text{ahead}})/2]$$

where:

$$\begin{aligned} H_{\text{wind}} &= \text{the exposed superstructure height (ft.)} \\ &= \text{girder} + \text{haunch} + \text{deck} + \text{parapet} \\ &= 6 + 0.333 + 0.667 + 3.5 \\ &= 10.5 \text{ ft.} \end{aligned}$$

$$\begin{aligned} p_{wT} &= \text{transverse wind pressure values (ksf)} \\ &= P_B \text{ (use Table S3.8.1.2.2-1)} \end{aligned}$$

$$\begin{aligned} L_{\text{back}} &= \text{span length to the deck joint, or end of bridge, back station from pier (ft.)} \\ &= 110 \text{ ft.} \end{aligned}$$

$$\begin{aligned} L_{\text{ahead}} &= \text{span length to the deck joint, or end of bridge, ahead station from pier (ft.)} \\ &= 110 \text{ ft.} \end{aligned}$$

$$\begin{aligned} F_{T \text{ Super}} &= 0.05(10.5)[(110 + 110)/2] &= 57.8 \text{ k} & \quad (0 \text{ degrees}) \\ &= 0.044(1,155) &= 50.8 \text{ k} & \quad (15 \text{ degrees}) \\ &= 0.041(1,155) &= 47.4 \text{ k} & \quad (30 \text{ degrees}) \\ &= 0.033(1,155) &= 38.1 \text{ k} & \quad (45 \text{ degrees}) \\ &= 0.017(1,155) &= 19.6 \text{ k} & \quad (60 \text{ degrees}) \end{aligned}$$

Wind load along axes of superstructure (longitudinal direction)

The longitudinal wind pressure loading induces forces acting parallel to the longitudinal axis of the bridge.

$$F_{L \text{ Super}} = p_{wL}(H_{\text{wind}})(L_{\text{back}} + L_{\text{ahead}})/n_{\text{fixed piers}}$$

where:

$$H_{\text{wind}} = 10.5 \text{ ft.}$$

$$\begin{aligned} p_{wL} &= \text{Longitudinal wind pressure values (ksf)} \\ &= P_B \text{ (use Table S3.8.1.2.2-1)} \end{aligned}$$

$$L_{\text{back}} = 110 \text{ ft.}$$

$$L_{\text{ahead}} = 110 \text{ ft.}$$

$$\begin{aligned}
 F_{L \text{ Super}} &= 0.0(10.5)[(110 + 110)]/1 &= 0 \text{ k} & (0 \text{ degrees}) \\
 &= 0.006(2,310)/1 &= 13.9 \text{ k} & (15 \text{ degrees}) \\
 &= 0.012(2,310)/1 &= 27.7 \text{ k} & (30 \text{ degrees}) \\
 &= 0.016(2,310)/1 &= 37.0 \text{ k} & (45 \text{ degrees}) \\
 &= 0.019(2,310)/1 &= 43.9 \text{ k} & (60 \text{ degrees})
 \end{aligned}$$

The transverse and longitudinal pressures should be applied simultaneously.

Resultant wind load along axes of pier

The transverse and longitudinal superstructure wind forces, which are aligned relative to the superstructure axis, are resolved into components that are aligned relative to the pier axes.

Load perpendicular to the plane of the pier:

$$F_{L \text{ Pier}} = F_{L \text{ Super}} \cos(\theta_{\text{skew}}) + F_{T \text{ Super}} \sin(\theta_{\text{skew}})$$

At 0 degrees:

$$\begin{aligned}
 F_{L \text{ Pier}} &= 0 \cos 20 + 57.8 \sin 20 \\
 &= 19.8 \text{ k}
 \end{aligned}$$

At 60 degrees:

$$\begin{aligned}
 F_{L \text{ Pier}} &= 43.9 \cos 20 + 19.6 \sin 20 \\
 &= 48.0 \text{ k}
 \end{aligned}$$

Load in the plane of the pier (parallel to the line connecting the columns):

$$F_{T \text{ Pier}} = F_{L \text{ Super}} \sin(\theta_{\text{skew}}) + F_{T \text{ Super}} \cos(\theta_{\text{skew}})$$

At 0 degrees:

$$\begin{aligned}
 F_{T \text{ Pier}} &= 0 \sin 20 + 57.8 \cos 20 \\
 &= 54.3 \text{ k}
 \end{aligned}$$

At 60 degrees:

$$\begin{aligned}
 F_{T \text{ Pier}} &= 43.9 \sin 20 + 19.6 \cos 20 \\
 &= 33.4 \text{ k}
 \end{aligned}$$

The superstructure wind load acts at $10.5/2 = 5.25$ ft. from the top of the pier cap.

The longitudinal and transverse forces applied to each bearing are found by dividing the forces above by the number of girders. If the support bearing line has expansion bearings, the $F_{L \text{ Super}}$ component in the above equations is zero.

Wind load on substructure (S3.8.1.2.3)

The transverse and longitudinal forces to be applied directly to the substructure are calculated from an assumed base wind pressure of 0.040 ksf (S3.8.1.2.3). For wind directions taken skewed to the substructure, this force is resolved into components perpendicular to the end and front elevations of the substructures. The component perpendicular to the end elevation acts on the exposed substructure area as seen in end elevation, and the component perpendicular to the front elevation acts on the exposed areas and is applied simultaneously with the wind loads from the superstructure.

$$W_{\text{wind on sub}} = W_{\text{cap}} + W_{\text{column}}$$

Transverse wind on the pier cap (wind applied perpendicular to the longitudinal axis of the superstructure):

$$\begin{aligned} W_{\text{cap}} &= 0.04(\text{cap width}) \\ &= 0.04(4) \\ &= 0.16 \text{ k/ft of cap height} \end{aligned}$$

Longitudinal wind on the pier cap (wind applied parallel to the longitudinal axis of the superstructure):

$$\begin{aligned} W_{\text{cap}} &= 0.04(\text{cap length along the skew}) \\ &= 0.04(58.93) \\ &= 2.36 \text{ k/ft of cap height} \end{aligned}$$

Transverse wind on the end column, this force is resisted equally by all columns:

$$\begin{aligned} W_{T, \text{column}} &= 0.04(\text{column diameter})/n_{\text{columns}} \\ &= 0.04(3.5)/4 \\ &= 0.035 \text{ k/ft of column height above ground} \end{aligned}$$

Longitudinal wind on the columns, this force is resisted by each of the columns individually:

$$\begin{aligned} W_{L, \text{column}} &= 0.04(\text{column diameter}) \\ &= 0.04(3.5) \\ &= 0.14 \text{ k/ft of column height above ground} \end{aligned}$$

There is no wind on the footings since they are assumed to be below ground level.

Total wind load on substructure:

$$W_{T \text{ wind on sub}} = 0.16 + 0.035 = 0.20 \text{ k/ft}$$

$$W_{L \text{ wind on sub}} = 2.36 + 0.14 = 2.50 \text{ k/ft}$$

Wind on live load (S3.8.1.3)

When vehicles are present, the design wind pressure is applied to both the structure and vehicles. Wind pressure on vehicles is represented by an interruptible, moving force of 0.10 klf acting normal to, and 6.0 ft. above, the roadway and is transmitted to the structure.

When wind on vehicles is not taken as normal to the structure, the components of normal and parallel force applied to the live load may be taken as follows with the skew angle taken as referenced normal to the surface.

Use Table S3.8.1.3-1 to obtain F_W values,

$$F_{T \text{ Super}} = F_{WT}(L_{\text{back}} + L_{\text{ahead}})/2$$

$$\begin{aligned} F_{T \text{ Super}} &= 0.100(110 + 110)/2 = 11 \text{ k} && (0 \text{ degrees}) \\ &= 0.088(110) && = 9.68 \text{ k} && (15 \text{ degrees}) \\ &= 0.082(110) && = 9.02 \text{ k} && (30 \text{ degrees}) \\ &= 0.066(110) && = 7.26 \text{ k} && (45 \text{ degrees}) \\ &= 0.034(110) && = 3.74 \text{ k} && (60 \text{ degrees}) \end{aligned}$$

$$F_{L \text{ Super}} = F_{WL}(L_{\text{back}} + L_{\text{ahead}})/n_{\text{fixed piers}}$$

$$\begin{aligned} F_{L \text{ Super}} &= 0(110 + 110)/1 = 0 \text{ k} && (0 \text{ degrees}) \\ &= 0.012(220) && = 2.64 \text{ k} && (15 \text{ degrees}) \\ &= 0.024(220) && = 5.28 \text{ k} && (30 \text{ degrees}) \\ &= 0.032(220) && = 7.04 \text{ k} && (45 \text{ degrees}) \\ &= 0.038(220) && = 8.36 \text{ k} && (60 \text{ degrees}) \end{aligned}$$

$$F_{WLL} = 11 \text{ k (transverse direction, i.e., perpendicular to longitudinal axis of the superstructure)}$$

Temperature force (S3.12.2)

Due to the symmetry of the bridge superstructure, no force is developed at the intermediate bent due to temperature expansion/shrinkage of the superstructure.

Shrinkage (S3.12.4)

Due to the symmetry of the bridge superstructure, no force is developed at the intermediate bent due to shrinkage of the superstructure.

Load combinations

Figures 7.2-2 and 7.2-3 show the unfactored loads applied to the bent from the superstructure and wind.

Superstructure Dead Loads

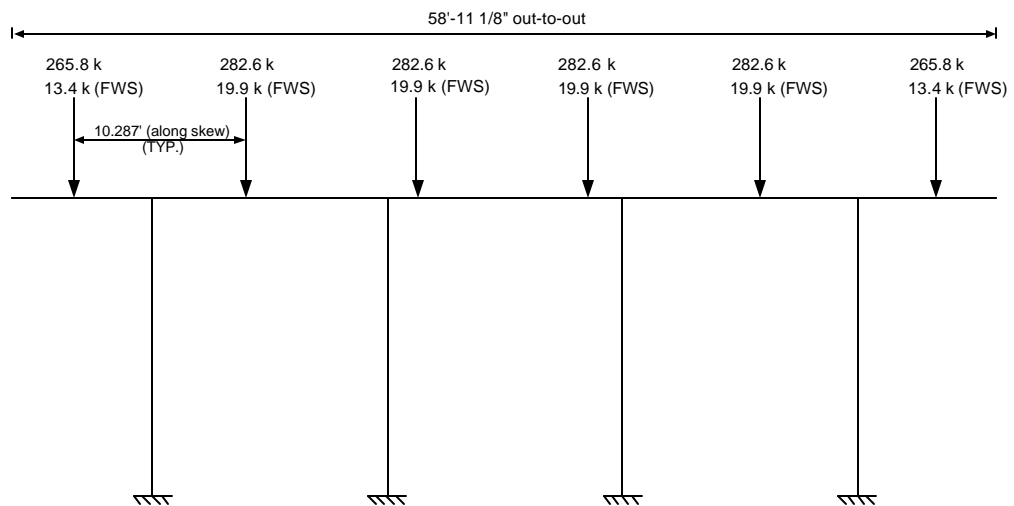

Substructure Dead Loads

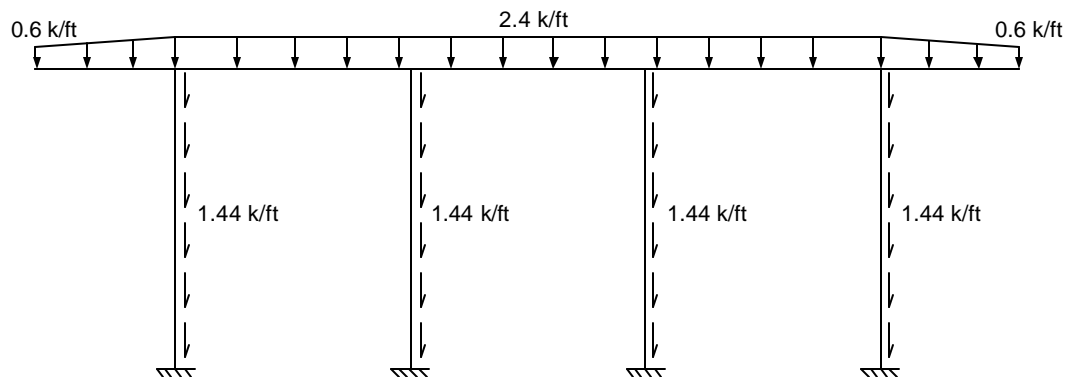
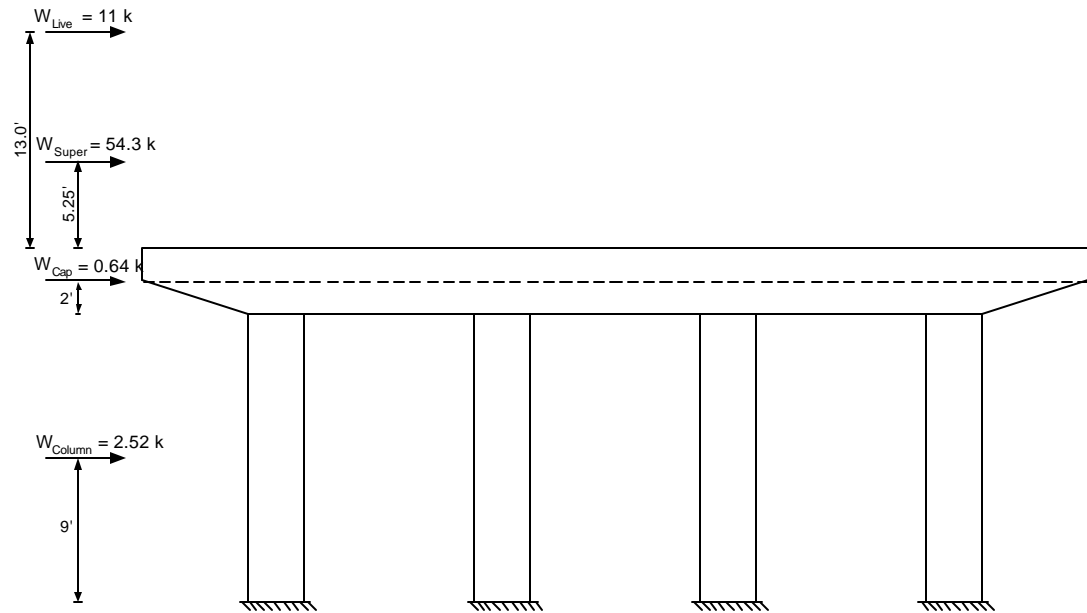

Figure 7.2-2 – Super- and Substructure Applied Dead Loads

Transverse Wind on Structure



Longitudinal Wind on Structure

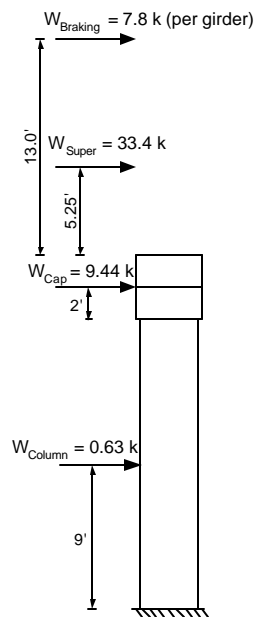

Figure 7.2-3 – Wind and Braking Loads on Super- and Substructure

Design Step
7.2.2 | **Pier cap design**Required information:

General (these values are valid for the entire pier cap):

$$f_c = 3.0 \text{ ksi}$$

$$\beta_1 = 0.85$$

$$f_y = 60 \text{ ksi}$$

Cap width = 4 ft.

Cap depth = 4 ft. (varies at ends)

No. stirrup legs = 6

Stirrup diameter = 0.625 in. (#5 bars)

Stirrup area = 0.31 in² (per leg)

Stirrup spacing = varies along cap length

Side cover = 2 in. (Table S5.12.3-1)

Cap bottom flexural bars:

No. bars in bottom row, positive region = 9 (#8 bars)

Positive region bar diameter = 1.0 in.

Positive region bar area, $A_s = 0.79 \text{ in}^2$

Bottom cover = 2 in. (Table S5.12.3-1)

Cap top flexural bars:

No. bars in top row, negative region = 14 (7 sets of 2 #9 bars bundled horizontally)

Negative region bar diameter = 1.128 in.

Negative region bar area, $A_s = 1.0 \text{ in}^2$

Top cover = 2 in. (Table S5.12.3-1)

From the analysis of the different applicable limit states, the maximum load effects on the cap were obtained. These load effects are listed in Table 7.2-1. The maximum factored positive moment occurs at 44.65 ft. from the cap end under Strength I limit state.

Table 7.2-1 – Strength I Limit State for Critical Locations in the Pier Cap (Maximum Positive Moment, Negative Moment and Shear)

	Location*	Unfactored Responses				Str-I
		DC	DW	LL + IM	BR	
Max Pos M (k-ft)	44.65 ft.	147.5	37.1	437.9	5.2	1,015.5
Max Neg M (k-ft)	6.79 ft.	-878.5	-84.9	-589.0	-1.9	-2,259.4
Max Shear (k)	34.96 ft.	292.9	39.5	210.4	2.8	798.3

* measured from the end of the cap

Notes:

DC: superstructure dead load (girders, slab and haunch, diaphragms, and parapets) plus the substructure dead load (all components)

DW: dead load due to the future wearing surface

LL + IM: live load + impact transferred from the superstructure

BR: braking load transferred from the superstructure

Str-I: load responses factored using Strength I limit state load factors

**Design Step
7.2.2.1**Pier cap flexural resistance (S5.7.3.2)

The factored flexural resistance, M_r , is taken as:

$$M_r = \phi M_n \quad (\text{S5.7.3.2.1-1})$$

where:

$$\begin{aligned} \phi &= \text{flexural resistance factor as specified in S5.5.4.2} \\ &= 0.9 \end{aligned}$$

$$M_n = \text{nominal resistance (k-in)}$$

*For calculation of M_n , use the provisions of S5.7.3.2.3 which state, for rectangular sections subjected to flexure about one axis, where approximate stress distribution specified in S5.7.2.2 is used and where the compression flange depth is **not** less than “c” as determined in accordance with Eq. S5.7.3.1.1-3, the flexural resistance M_n may be determined by using Eq. S5.7.3.1.1-1 through S5.7.3.2.2-1, in which case “ b_w ” is taken as “b”.*

Rectangular section behavior is used to design the pier cap. The compression reinforcement is neglected in the calculation of the flexural resistance.

Design Step Maximum positive moment
7.2.2.2

Applied Strength I moment, $M_u = 1,015.5$ k-ft

Applied Service I moment, $M_s = 653.3$ k-ft (from computer software)

Axial load on the pier cap is small, therefore, the effects of axial load is neglected in this example.

Check positive moment resistance (bottom steel)

Calculate the nominal flexural resistance according to S5.7.3.2.3.

$$M_n = A_s f_y (d_s - a/2) \quad (\text{S5.7.3.2.2-1})$$

Determine d_s , the corresponding effective depth from the extreme fiber to the centroid of the tensile force in the tensile reinforcement.

$$d_s = \text{cap depth} - \text{CSG}_b$$

where:

$$\begin{aligned} \text{CSG}_b &= \text{distance from the centroid of the bottom bars to the bottom of} \\ &\quad \text{the cap (in.)} \\ &= \text{cover} + \text{stirrup diameter} + \frac{1}{2} \text{ bar diameter} \\ &= 2 + 0.625 + \frac{1}{2} (1.0) \\ &= 3.125 \text{ in.} \end{aligned}$$

$$\begin{aligned} d_s &= 4(12) - 3.125 \\ &= 44.875 \text{ in.} \end{aligned}$$

$$\begin{aligned} A_s &= (n_{\text{bars Tension}})(A_s \text{ bar}) \\ &= 9(0.79) \\ &= 7.1 \text{ in}^2 \end{aligned}$$

Determine “a” using Eq. S5.7.3.1.1-4

$$\begin{aligned} a &= A_s f_y / 0.85 f'_c b \quad (\text{S5.7.3.1.1-4}) \\ &= 7.1(60) / [0.85(3)(48)] \\ &= 3.48 \text{ in.} \end{aligned}$$

Calculate the nominal flexural resistance, M_n

$$\begin{aligned} M_n &= A_s f_y (d_s - a/2) \quad (\text{S5.7.3.2.2-1}) \\ &= 7.1(60)[44.875 - (3.48/2)]/12 \\ &= 1,531 \text{ k-ft} \end{aligned}$$

Therefore, the factored flexural resistance, M_r , can be calculated as follows:

$$\begin{aligned} M_r &= 0.9(1,531) \\ &= 1,378 \text{ k-ft} > M_u = 1015.5 \text{ k-ft} \quad \mathbf{OK} \end{aligned}$$

Limits for reinforcement (S5.7.3.3)

Check if the section is over-reinforced.

The maximum amount of nonprestressed reinforcement shall be such that:

$$c/d_e \leq 0.42 \quad (\text{S5.7.3.3.1-1})$$

where:

$$\begin{aligned} c &= a/\beta_1 \\ &= 3.48/0.85 \\ &= 4.1 \text{ in.} \end{aligned}$$

$$\begin{aligned} d_e &= d_s \\ &= 44.875 \text{ in.} \end{aligned}$$

$$\begin{aligned} c/d_e &= 4.1/44.875 \\ &= 0.091 < 0.42 \quad \mathbf{OK} \end{aligned}$$

Check the minimum reinforcement requirements (S5.7.3.3.2)

Unless otherwise specified, at any section of a flexural component, the amount of nonprestressed tensile reinforcement must be adequate to develop a factored flexural resistance, M_r , at least equal to the lesser of:

$$1.2M_{cr} = 1.2f_r S$$

where:

$$\begin{aligned} f_r &= 0.24\sqrt{f'_c} \\ &= 0.24\sqrt{3} \\ &= 0.42 \text{ ksi} \end{aligned} \quad (\text{S5.4.2.6})$$

$$\begin{aligned} S &= bh^2/6 \\ &= 4(12)[4(12)]^2/6 \\ &= 18,432 \text{ in}^3 \end{aligned}$$

$$1.2M_{cr} = 1.2(0.42)(18,432)/12 \\ = 774.1 \text{ k-ft}$$

OR

$$1.33M_u = 1.33(1,015.5) \\ = 1,351 \text{ k-ft}$$

Minimum required section resistance = 774.1 k-ft

Provided section resistance = 1,378 k-ft > 774.1 k-ft **OK**Check the flexural reinforcement distribution (S5.7.3.4)Check allowable stress, f_s

$$f_{s, \text{allow}} = Z/[(d_c A)^{1/3}] \leq 0.6f_y \quad (\text{S5.7.3.4-1})$$

where:

$$Z = \text{crack width parameter (k/in)} \\ = 170 \text{ k/in (moderate exposure conditions are assumed)}$$

$$d_c = \text{distance from the extreme tension fiber to the center of the closest bar (in.)} \\ = \text{clear cover} + \text{stirrup diameter} + \frac{1}{2} \text{ bar diameter}$$

The cover on the bar under investigation cannot exceed 2.0 in., therefore, the stirrup diameter is not taken into account for d_c is:

$$= 2 + \frac{1}{2}(1.0) \\ = 2.5 \text{ in.}$$

$$A = \text{area having the same centroid as the principal tensile reinforcement and bounded by the surfaces of the cross-section and a straight line parallel to the neutral axis, divided by the number of bars (in}^2\text{)} \\ = 2d_c(\text{cap width})/n_{\text{bars}} \\ = 2(2.5)(48)/9 \\ = 26.7 \text{ in}^2$$

$$f_{s, \text{allow}} = Z/[(d_c A)^{1/3}] \\ = 170/[(2.5)(26.7)]^{1/3} \\ = 41.9 \text{ ksi} > 0.6(60) = 36 \text{ ksi} \text{ therefore, } f_{s, \text{allow}} = 36 \text{ ksi}$$

Check service load applied steel stress, $f_{s, \text{actual}}$

For 3.0 ksi concrete, the modular ratio, $n = 9$ (see S6.10.3.1.1b or calculate by dividing the steel modulus of elasticity by the concrete and rounding up as required by S5.7.1)

Assume the stresses and strains vary linearly.

From the load analysis of the bent:

Dead load + live load positive service load moment = 653.3 k-ft

The transformed moment of inertia is calculated assuming elastic behavior, i.e., linear stress and strain distribution. In this case, the first moment of area of the transformed steel on the tension side about the neutral axis is assumed equal to that of the concrete in compression.

Assume the neutral axis at a distance “y” from the compression face of the section.

The section width equals 48 in.

Transformed steel area = (total steel bar area)(modular ratio) = $7.1(9) = 63.9 \text{ in}^2$

By equating the first moment of area of the transformed steel about that of the concrete, both about the neutral axis:

$$63.9(44.875 - y) = 48y(y/2)$$

Solving the equation results in $y = 9.68 \text{ in}$.

$$\begin{aligned} I_{\text{transformed}} &= A_{ts}(d_s - y)^2 + by^3/3 \\ &= 63.9(44.875 - 9.68)^2 + 48(9.68)^3/3 \\ &= 93,665 \text{ in}^4 \end{aligned}$$

Stress in the steel, $f_{s, \text{actual}} = (M_s c/I)n$, where M is the moment action on the section.

$$\begin{aligned} f_{s, \text{actual}} &= [653.3(12)(35.195)/93,665]9 \\ &= 26.5 \text{ ksi} < f_{s, \text{allow}} = 36 \text{ ksi} \quad \mathbf{OK} \end{aligned}$$

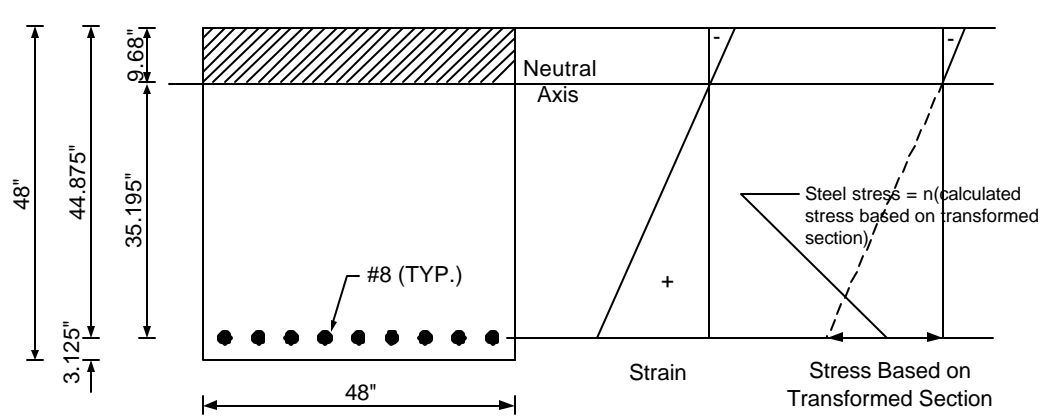

Figure 7.2-4 – Crack Control for Positive Reinforcement Under Service Load

Design Step Maximum negative moment
7.2.2.3

From the bent analysis, the maximum factored negative moment occurs at 6.79 ft. from the cap edge under Strength I limit state:

Applied Strength I moment, $M_u = -2,259.4$ k-ft

Applied Service I moment, $M_s = -1,572.4$ k-ft (from computer analysis)

Check negative moment resistance (top steel)

Calculate M_n using Eq. S5.7.3.2.2-1.

Determine d_s , the corresponding effective depth from the extreme fiber to the centroid of the tensile force in the tensile reinforcement. The compressive reinforcement is neglected in the calculation of the nominal flexural resistance.

$$d_s = \text{cap depth} - CGS_t$$

where:

$$\begin{aligned} CGS_t &= \text{distance from the centroid of the top bars to the top of the cap} \\ &\quad (\text{in.}) \\ &= \text{cover} + \text{stirrup diameter} + \frac{1}{2} \text{ bar diameter} \\ &= 2 + 0.625 + \frac{1}{2} (1.128) \\ &= 3.189 \text{ in.} \end{aligned}$$

$$\begin{aligned} d_s &= 4(12) - 3.189 \\ &= 44.81 \text{ in.} \end{aligned}$$

$$\begin{aligned}
 A_s &= (n_{\text{bars Tension}})(A_s \text{ bar}) \\
 &= 14(1.0) \\
 &= 14.0 \text{ in}^2
 \end{aligned}$$

Determine “a” using Eq. S5.7.3.1.1-4

$$\begin{aligned}
 a &= A_s f_y / 0.85 f_c b && \text{(S5.7.3.1.1-4)} \\
 &= 14.0(60) / [(0.85)(3)(4)(12)] \\
 &= 6.86 \text{ in.}
 \end{aligned}$$

Calculate the nominal flexural resistance, M_n

$$\begin{aligned}
 M_n &= 14.0(60)[44.81 - (6.86/2)]/12 \\
 &= 2,897 \text{ k-ft}
 \end{aligned}$$

Therefore, the factored flexural resistance, M_r :

$$\begin{aligned}
 M_r &= 0.9(2,897) \\
 &= 2,607 \text{ k-ft} > M_u = |-2,259.4| \text{ k-ft} \quad \mathbf{OK}
 \end{aligned}$$

Limits for reinforcement (S5.7.3.3)

Check if the section is over-reinforced.

The maximum amount of nonprestressed reinforcement shall be such that:

$$c/d_e \leq 0.42 \quad \text{(S5.7.3.3.1-1)}$$

where:

$$\begin{aligned}
 c &= a/\beta_1 \\
 &= 6.86/0.85 \\
 &= 8.07 \text{ in.}
 \end{aligned}$$

$$\begin{aligned}
 d_e &= d_s \\
 &= 44.81 \text{ in.}
 \end{aligned}$$

$$\begin{aligned}
 c/d_e &= 8.07/44.81 \\
 &= 0.18 < 0.42 \quad \mathbf{OK}
 \end{aligned}$$

Check minimum reinforcement (S5.7.3.3.2)

Unless otherwise specified, at any section of a flexural component, the amount of nonprestressed tensile reinforcement shall be adequate to develop a factored flexural resistance, M_r , at least equal to the lesser of:

$$1.2M_{cr} = 1.2f_r S$$

where:

$$\begin{aligned} f_r &= 0.24\sqrt{f'_c} && \text{(S5.4.2.6)} \\ &= 0.24\sqrt{3} \\ &= 0.42 \text{ ksi} \end{aligned}$$

$$\begin{aligned} S &= bh^2/6 \\ &= 4(12)[4(12)]^2/6 \\ &= 18,432 \text{ in}^3 \end{aligned}$$

$$\begin{aligned} 1.2M_{cr} &= 1.2(0.42)(18,432)/12 \\ &= 774.1 \text{ k-ft} \end{aligned}$$

OR

$$\begin{aligned} 1.33M_u &= 1.33(-2,259.4) \\ &= |-3,005| \text{ k-ft} \end{aligned}$$

Minimum required section resistance = 774.1 k-ft

Provided section resistance = 2,607 k-ft > 774.1 k-ft **OK**

Check the flexural reinforcement distribution (S5.7.3.4)

Check the allowable stress, f_s

$$f_{s, \text{allow}} = Z/[(d_c A)^{1/3}] \leq 0.6f_y \quad \text{(S5.7.3.4-1)}$$

where:

$$Z = 170 \text{ k/in. (moderate exposure conditions are assumed)}$$

$$\begin{aligned} d_c &= 2 + \frac{1}{2}(1.128) \\ &= 2.56 \text{ in.} \end{aligned}$$

$$\begin{aligned} A &= \text{area having the same centroid as the principal tensile reinforcement} \\ &\quad \text{and bounded by the surfaces of the cross-section and a straight line} \\ &\quad \text{parallel to the neutral axis, divided by the number of bars (in}^2\text{)} \\ &= 2d_c(\text{cap width})/n_{\text{bars}} \\ &= 2(2.56)(48)/14 \\ &= 17.6 \text{ in}^2 \end{aligned}$$

$$\begin{aligned}
 f_{s, \text{allow}} &= Z/[(d_c A)^{1/3}] \\
 &= 170/[2.56(17.6)]^{1/3} \\
 &= 47.8 \text{ ksi} > 0.6(60) = 36 \text{ ksi} \quad \mathbf{OK}, \text{ therefore, use } f_{s, \text{allow}} = 36 \text{ ksi}
 \end{aligned}$$

Check the service load applied steel stress, $f_{s, \text{actual}}$

For 3.0 ksi concrete, the modular ratio, $n = 9$

Assume the stresses and strains vary linearly.

From the load analysis of the bent:

Dead load + live load negative service load moment = -1,572.4 k-ft

The transformed moment of inertia is calculated assuming elastic behavior, i.e., linear stress and strain distribution. In this case, the first moment of area of the transformed steel on the tension side about the neutral axis is assumed equal to that of the concrete in compression.

Assume the neutral axis at a distance “y” from the compression face of the section.

Section width = 48 in.

Transformed steel area = (total steel bar area)(modular ratio) = 14.0(9) = 126 in²

By equating the first moment of area of the transformed steel about that of the concrete, both about the neutral axis:

$$126(44.81 - y) = 48y(y/2)$$

Solving the equation results in $y = 12.9$ in.

$$\begin{aligned}
 I_{\text{transformed}} &= A_{ts}(d_s - y)^2 + by^3/3 \\
 &= 126(44.81 - 12.9)^2 + 48(12.9)^3/3 \\
 &= 162,646 \text{ in}^4
 \end{aligned}$$

Stress in the steel, $f_{s, \text{actual}} = (M_s c/I)n$, where M is the moment action on the section.

$$\begin{aligned}
 f_{s, \text{actual}} &= [|-1,572.4|(12)(31.91)/162,646]9 \\
 &= 33.3 \text{ ksi} < f_{s, \text{allow}} = 36 \text{ ksi} \quad \mathbf{OK}
 \end{aligned}$$

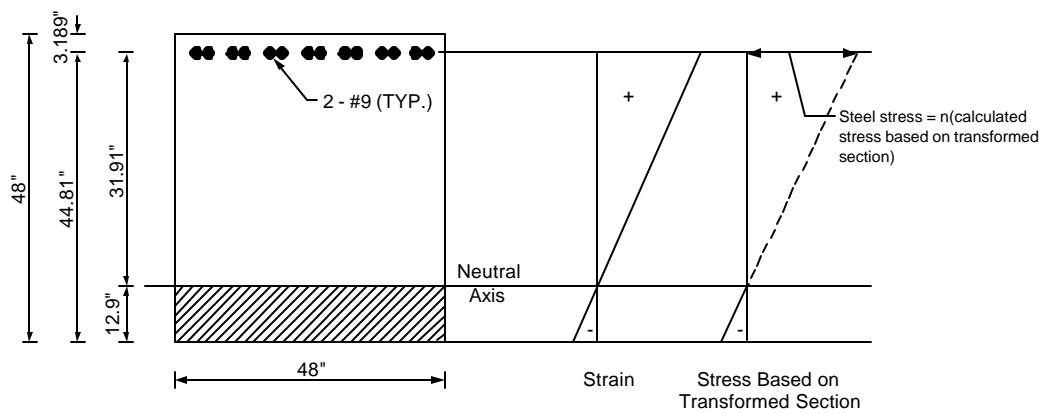

Figure 7.2-5 – Crack Control for Negative Reinforcement Under Service Load

Design Step 7.2.2.4 Check minimum temperature and shrinkage steel (S5.10.8)

Reinforcement for shrinkage and temperature stresses is provided near the surfaces of the concrete exposed to daily temperature changes and in structural mass concrete. Temperature and shrinkage reinforcement is added to ensure that the total reinforcement on exposed surfaces is not less than that specified below.

Using the provisions of S5.10.8.2,

$$A_{s, \min 1} = 0.11 A_g / f_y \quad (\text{S5.10.8.2-1})$$

where:

$$\begin{aligned} A_g &= \text{gross area of section (in}^2\text{)} \\ &= [4(12)]^2 \\ &= 2,304 \text{ in}^2 \end{aligned}$$

$$\begin{aligned} A_{s, \min 1} &= 0.11(2,304)/60 \\ &= 4.2 \text{ in}^2 \end{aligned}$$

This area is to be divided between the two faces, i.e., 2.1 in² per face. Shrinkage and temperature reinforcement must not be spaced farther apart than 3.0 times the component thickness or 18.0 in.

Use 4 #7 bars per face.

$$\begin{aligned} A_{s \text{ provided}} &= 4(0.6) \\ &= 2.4 \text{ in}^2 > 2.1 \text{ in}^2 \quad \mathbf{OK} \end{aligned}$$

Design Step 7.2.2.5 Skin reinforcement (S5.7.3.4)

If the effective depth, d_e , of the reinforced concrete member exceeds 3 ft., longitudinal skin reinforcement is uniformly distributed along both side faces of the component for a distance of $d/2$ nearest the flexural tension reinforcement. The area of skin reinforcement (in^2/ft of height) on each side of the face is required to satisfy:

$$A_{sk} \geq 0.012(d_e - 30) \leq (A_s + A_{ps})/4 \quad (\text{S5.7.3.4-4})$$

where:

$$A_{ps} = \text{area of prestressing (in}^2\text{)}$$

d_e = flexural depth taken as the distance from the compression face of the centroid of the steel, positive moment region (in.)

$$\begin{aligned} A_{sk} &= 0.012(44.875 - 30) \\ &= 0.179 \text{ in}^2/\text{ft} \leq 14.0/4 = 3.5 \text{ in}^2/\text{ft} \end{aligned}$$

Required A_{sk} per face = $0.179(4) = 0.72 \text{ in}^2 < 2.4 \text{ in}^2$ provided **OK**

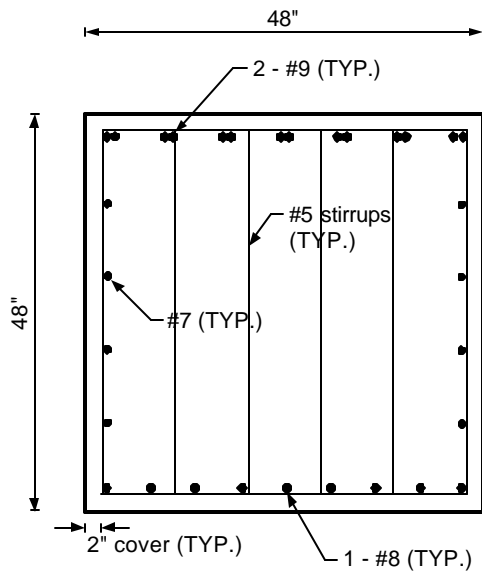

Figure 7.2-6 - Cap Cross-Section

Design Step 7.2.2.6 Maximum shear

From analysis of the bent, the maximum factored shear occurs at 34.96 ft. from the cap end under Strength I limit state:

$$\text{Shear, } V_u = 798.3 \text{ k}$$

Calculate the nominal shear resistance using S5.8.3.3.

The factored shear resistance, V_r

$$V_r = \phi V_n \quad (\text{S5.8.2.1-2})$$

where:

$$\phi = 0.9, \text{ shear resistance factor as specified in S5.5.4.2}$$

$$V_n = \text{nominal shear resistance (k)}$$

The nominal shear resistance, V_n , shall be determined as the lesser of:

$$V_n = V_c + V_s + V_p \quad (\text{S5.8.3.3-1})$$

OR

$$V_n = 0.25f'_c b_v d_v + V_p \quad (\text{S5.8.3.3-2})$$

where:

$$\begin{aligned} V_c &= \text{shear resistance due to concrete (k)} \\ &= 0.0316\beta\sqrt{f'_c} b_v d_v \quad (\text{S5.8.3.3-3}) \end{aligned}$$

where:

$$\begin{aligned} b_v &= \text{effective web width taken as the minimum web width within} \\ &\quad \text{the depth } d_v \text{ as determined in S5.8.2.9 (in.)} \\ &= 48 \text{ in.} \end{aligned}$$

$$\begin{aligned} d_v &= \text{effective shear depth as determined in S5.8.2.9 (in.). It is the} \\ &\quad \text{distance, measured perpendicular to the neutral axis between} \\ &\quad \text{the resultants of the tensile and compressive force due to} \\ &\quad \text{flexure. It need not be taken less than the greater of } 0.9d_e \text{ or} \\ &\quad 0.72h. \\ &= d_e - a/2 \\ &= 44.81 - (6.86/2) \\ &= 41.4 \text{ in.} \end{aligned}$$

$$\begin{aligned} 0.9d_e &= 0.9(44.81) \\ &= 40.3 \text{ in.} \end{aligned}$$

$$\begin{aligned} 0.72h &= 0.72(48) \\ &= 34.56 \text{ in.} \end{aligned}$$

Therefore, use $d_v = 41.4$ in. for V_c calculation.

β = factor indicating ability of diagonally cracked concrete to transmit tension as specified in S5.8.3.4
 = for nonprestressed sections, β may be taken as 2.0

$$V_c = 0.0316(2.0)\sqrt{3}(48)(41.4) \\ = 217.5 \text{ k}$$

$$V_s = \text{shear resistance due to steel (k)} \\ = [A_v f_y d_v (\cot \theta + \cot \alpha) \sin \alpha] / s \quad (\text{S5.8.3.3-4})$$

where:

s = spacing of stirrups (in.)
 = assume 7 in.

θ = angle of inclination of diagonal compressive stresses as determined in S5.8.3.4 (deg)
 = 45 deg for nonprestressed members

α = angle of inclination of transverse reinforcement to longitudinal axis (deg)
 = 90 deg for vertical stirrups

$$A_v = (6 \text{ legs of \#5 bars})(0.31) \\ = 1.86 \text{ in}^2$$

$$V_s = [1.86(60)(41.4)(1/\tan 45)]/7 \\ = 660.0 \text{ k}$$

V_p = component in the direction of the applied shear of the effective prestressing force; positive if resisting the applied shear (k), not applicable in the pier cap
 = 0.0 for nonprestressed members

Therefore, V_n is the lesser of:

$$V_n = 217.5 + 660.0 + 0 \\ = 877.5 \text{ k}$$

OR

$$V_n = 0.25(3)(48)(41.4) + 0 \\ = 1,490.4 \text{ k}$$

Use $V_n = 877.5 \text{ k}$

Therefore,

$$\begin{aligned} V_r &= \phi V_n \\ &= 0.9(877.5) \\ &= 789.8 \text{ k} > V_u = 798.3 \text{ k} \quad \mathbf{OK} \end{aligned}$$

Check the minimum transverse reinforcement (S5.8.2.5)

A minimum amount of transverse reinforcement is required to restrain the growth of diagonal cracking and to increase the ductility of the section. A larger amount of transverse reinforcement is required to control cracking as the concrete strength is increased.

Where transverse reinforcement is required, as specified in S5.8.2.4, the area of steel must satisfy:

$$A_v = 0.0316\sqrt{f'_c}b_v s/f_y \quad (\text{S5.8.2.5-1})$$

where:

b_v = width of web adjusted for the presence of ducts as specified in S5.8.2.9 (in.)

$$\begin{aligned} A_v &= 0.0316\sqrt{3}(48)(7)/60 \\ &= 0.307 \text{ in}^2 < 1.86 \text{ in}^2 \quad \text{provided } \mathbf{OK} \end{aligned}$$

Check the maximum spacing of the transverse reinforcement (S5.8.2.7)

The spacing of the transverse reinforcement must not exceed the maximum permitted spacing, s_{\max} , determined as:

$$\begin{aligned} \text{If } v_u < 0.125f'_c, \text{ then} \\ s_{\max} &= 0.8d_v \leq 24.0 \text{ in.} \quad (\text{S5.8.2.7-1}) \end{aligned}$$

$$\begin{aligned} \text{If } v_u \geq 0.125f'_c, \text{ then:} \\ s_{\max} &= 0.4d_v \leq 12.0 \text{ in.} \quad (\text{S5.8.2.7-2}) \end{aligned}$$

The shear stress on the concrete, v_u , is taken to be:

$$\begin{aligned} v_u &= V_u/(\phi b_v d_v) \quad (\text{S5.8.2.9-1}) \\ &= 798.3/[0.9(48)(41.4)] \\ &= 0.446 \text{ ksi} > 0.125(3) = 0.375 \text{ ksi} \end{aligned}$$

Therefore, use Eq. S5.8.2.7-2

$$s_{\max} = 0.4(41.4) = 16.6 \text{ in. } s_{\max} \text{ cannot exceed 12 in., therefore, use 12 in. as maximum}$$

$$s_{\text{actual}} = 7 \text{ in.} < 12 \text{ in. } \mathbf{OK}$$

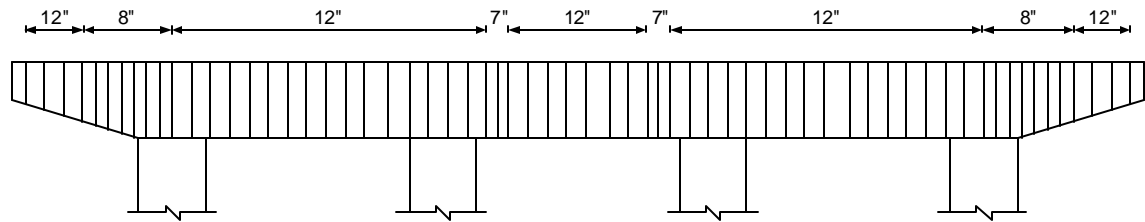

Figure 7.2-7 – Stirrup Distribution in the Bent Cap

Design Step 7.2.3 Column design

Required information:

General:

$$\begin{aligned} f_c &= 3.0 \text{ ksi} \\ E_c &= 3,321 \text{ ksi (S5.4.2.4)} \\ n &= 9 \\ f_y &= 60 \text{ ksi} \end{aligned}$$

Circular Columns:

$$\begin{aligned} \text{Column diameter} &= 3.5 \text{ ft.} \\ \text{Column area, } A_g &= 9.62 \text{ ft}^2 \\ \text{Side cover} &= 2 \text{ in. (Table S5.12.3-1)} \\ \text{Vertical reinforcing bar diameter (\#8)} &= 1.0 \text{ in.} \\ \text{Steel area} &= 0.79 \text{ in}^2 \\ \text{Number of bars} &= 16 \\ \text{Total area of longitudinal reinforcement} &= 12.64 \text{ in}^2 \\ \text{Type of transverse reinforcement} &= \text{ties} \\ \text{Tie spacing} &= 12 \text{ in.} \\ \text{Transverse reinforcement bar diameter (\#3)} &= 0.375 \text{ in. (S5.10.6.3)} \\ \text{Transverse reinforcement area} &= 0.11 \text{ in}^2/\text{bar} \end{aligned}$$

The example bridge is in Seismic Zone 1, therefore, a seismic investigation is not necessary for the column design. Article S5.10.11 provides provisions for seismic design where applicable.

Applied moments and shears

The maximum biaxial responses occur on column 1 at 0.0 ft. from the bottom (top face of footing).

From the load analysis of the bent, the maximum load effects at the critical location were obtained and are listed in Table 7.2-2.

Table 7.2-2 – Maximum Factored Load Effects and the Concurrent Load Effects for Strength Limit States

Load effect maximized	Limit State	M_t (k-ft)	M_l (k-ft)	P_u (k)	M_u (k-ft)
Positive M_t	Strength V	342	352	1,062	491
Negative M_t	Strength V	-129	-216	682	252
Positive M_l	Strength V	174	822	1,070	840
Negative M_l	Strength V	116	-824	1,076	832
Axial Load P	Strength I	90	-316	1,293	329

where:

- M_t : Factored moment about the transverse axis
- M_l : Factored moment about the longitudinal axis
- P_u : Factored axial load

Sample hand calculations are presented for the case of maximum positive M_l from Table 7.2-2.

Maximum shear occurs on column 1 at 0.0 ft. from the bottom (top face of footing)

Factored shears – strength limit state:

$$V_t = 44.8 \text{ k (Str-V)}$$

$$V_l = 26.0 \text{ k (Str-V)}$$

Check limits for reinforcement in compression members (S5.7.4.2)

The maximum area of nonprestressed longitudinal reinforcement for non-composite compression components shall be such that:

$$A_s/A_g \leq 0.08 \quad (\text{S5.7.4.2-1})$$

where:

A_s = area of nonprestressed tension steel (in²)

A_g = gross area of section (in²)

$$12.64/[9.62(144)] = 0.009 < 0.08 \quad \mathbf{OK}$$

The minimum area of nonprestressed longitudinal reinforcement for noncomposite compression components shall be such that:

$$\begin{aligned} A_s f_y / A_g f_c &\geq 0.135 && (\text{S5.7.4.2-3}) \\ &= 12.64(60)/[9.62(144)(3)] \\ &= 0.182 > 0.135 \quad \mathbf{OK} \end{aligned}$$

Therefore, the column satisfies the minimum steel area criteria, do not use a reduced effective section. For oversized columns, the required minimum longitudinal reinforcement may be reduced by assuming the column area is in accordance with S5.7.4.2.

Strength reduction factor, ϕ , to be applied to the nominal axial resistance (S5.5.4.2)

For compression members with flexure, the value of ϕ may be increased linearly from axial (0.75) to the value for flexure (0.9) as the factored axial load resistance, ϕP_n , decreases from $0.10 f_c A_g$ to zero. The resistance factor is incorporated in the interaction diagram of the column shown graphically in Figure 7.2-8 and in tabulated form in Table 7.2-3.

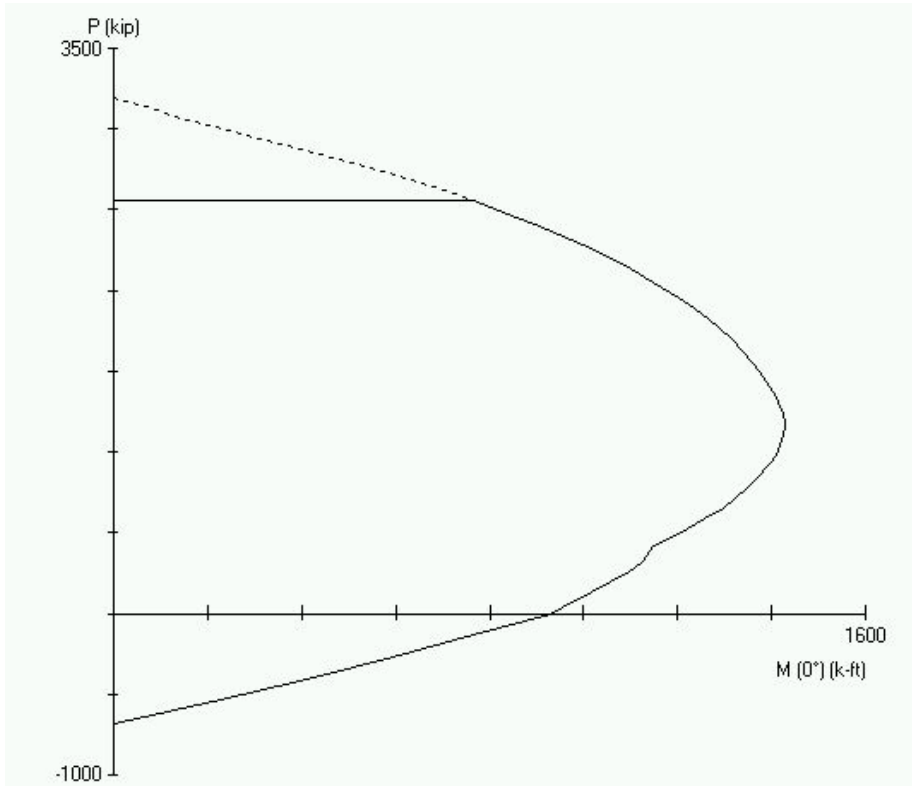

Figure 7.2-8 – Column Interaction Diagram

Table 7.2-3 – Column Interaction Diagram in Tabulated Form

P (k)	M (k-ft)	P (k) (cont.)	M (k-ft) (cont.)
$P_{max} = 2,555$	764	799	1,354
2,396	907	639	1,289
2,236	1,031	479	1,192
2,076	1,135	319	1,124
1,917	1,222	160	1,037
1,757	1,291	0	928
1,597	1,348	-137	766
1,437	1,389	-273	594
1,278	1,419	-410	410
1,118	1,424	-546	212
958	1,404	-683	0

Design Step Slenderness effects
7.2.3.1

The effective length factor, K , is taken from S4.6.2.5. The slenderness moment magnification factors are typically determined in accordance with S4.5.3.2.2. Provisions specific to the slenderness of concrete columns are listed in S5.7.4.3.

Typically, the columns are assumed unbraced in the plane of the bent with the effective length factor, K , taken as 1.2 to account for the high rigidity of the footing and the pier cap. In the direction perpendicular to the bent K may be determined as follows:

- *If the movement of the cap is not restrained in the direction perpendicular to the bent, the column is considered not braced and the column is assumed to behave as a free cantilever. K is taken equal to 2.1 (see Table SC4.6.2.5-1)*
- *If the movement of the cap is restrained in the direction perpendicular to the bent, the column is considered braced in this direction and K is taken equal to 0.8 (see Table SC4.6.2.5-1)*

For the example, the integral abutments provide restraint to the movements of the bent in the longitudinal direction of the bridge (approximately perpendicular to the bent). However, this restraint is usually ignored and the columns are considered unbraced in this direction, i.e. $K = 2.1$.

The slenderness ratio is calculated as Kl_u/r

where:

K = effective length factor taken as 1.2 in the plane of the bent and 2.1 in the direction perpendicular to the bent

l_u = unbraced length calculated in accordance with S5.7.4.3 (ft.)
 = distance from the top of the footing to the bottom of the cap
 = 18 ft.

r = radius of gyration (ft.)
 = $\frac{1}{4}$ the diameter of circular columns
 = 0.875 ft.

For a column to be considered slender, Kl_u/r should exceed 22 for unbraced columns and, for braced columns, should exceed $34 - 12(M_1/M_2)$ where M_1 and M_2 are the smaller and larger end moments, respectively. The term (M_1/M_2) is positive for single curvature flexure (S5.7.4.3)

Slenderness ratio in the plane of the bent

$$\begin{aligned} Kl_u/r &= 1.2(18)/(0.875) \\ &= 24.7 > 22 \text{ therefore, the column is slightly slender} \end{aligned}$$

Slenderness ratio out of the plane of the bent

$$\begin{aligned} Kl_u/r &= 2.1(18)/(0.875) \\ &= 43.2 > 22 \text{ therefore, the column is slender} \end{aligned}$$

With the column slender in both directions, effect of slenderness needs to be considered.

Moment magnification in the bent

Longitudinal direction:

$$M_{cl} = \delta_b M_{2b} + \delta_s M_{2s} \quad (S4.5.3.2.2b-1)$$

where:

$$\delta_b = C_m / [1 - (P_u / \phi P_e)] \geq 1.0 \quad (S4.5.3.2.2b-3)$$

$$\delta_s = 1 / [1 - \Sigma P_u / \phi \Sigma P_e] \quad (S4.5.3.2.2b-4)$$

where:

C_m = parameter of the effect of moment-curvature
= 1.0 for members not braced for sidesway (S4.5.3.2.2b)

P_u = factored axial load for critical case, see Table 7.2-2 (k)
= 1,070 k

P_e = Euler buckling load (k)

ϕ = 0.75, resistance factor for axial compression (S5.5.4.2)

M_{2b} = moment on compression member due to factored gravity loads that result in no appreciable sidesway calculated by conventional first-order elastic frame analysis, always positive (k-ft)

M_{2s} = moment on compression member due to factored lateral or gravity loads that result in sidesway, Δ , greater than $l_u/1500$, calculated by conventional first-order elastic frame analysis, always positive (k-ft)

Calculate P_e ,

$$P_e = \pi^2 EI / (K l_u)^2 \quad (\text{S4.5.3.2.2b-5})$$

where:

EI = column flexural stiffness calculated using the provisions of S5.7.4.3 and is taken as the greater of:

$$EI = [E_c I_g / 5 + E_s I_s] / (1 + \beta_d) \quad (\text{S5.7.4.3-1})$$

AND

$$EI = [E_c I_g / 2.5] / (1 + \beta_d) \quad (\text{S5.7.4.3-2})$$

where:

$$\begin{aligned} E_c &= \text{modulus of elasticity of concrete per S5.4.2.4 (ksi)} \\ &= 33,000 w_c^{1.5} \sqrt{f'_c} = 33,000 (0.150)^{1.5} \sqrt{3} \\ &= 3,321 \text{ ksi} \end{aligned}$$

$$\begin{aligned} I_g &= \text{moment of inertia of gross concrete section about the} \\ &\quad \text{centroidal axis (in}^4\text{)} \\ &= \pi r^4 / 4 = \pi [1.75(12)]^4 / 4 \\ &= 152,745 \text{ in}^4 \end{aligned}$$

$$\begin{aligned} \beta_d &= \text{ratio of the maximum factored permanent load moment to} \\ &\quad \text{the maximum factored total load moment, always positive.} \\ &\quad \text{This can be determined for each separate load case, or for} \\ &\quad \text{simplicity as shown here, it can be taken as the ratio of the} \\ &\quad \text{maximum factored permanent load from all cases to the} \\ &\quad \text{maximum factored total load moment from all cases at the} \\ &\quad \text{point of interest.} \\ &= M_{I \text{ permanent}} / M_{I \text{ total}} \\ &= 118.3 / 822 \\ &= 0.144 \end{aligned}$$

As a simplification, steel reinforcement in the column is ignored in calculating EI , therefore, neglect Eq. S5.7.4.3-1.

$$\begin{aligned} EI &= [3,321(152,745) / 2.5] / (1 + 0.144) \\ &= 1.77 \times 10^8 \text{ k-in}^2 \end{aligned}$$

$$\begin{aligned} K &= \text{effective length factor per Table SC4.6.2.5-1} \\ &= 2.1 \end{aligned}$$

$$\begin{aligned}
 l_u &= \text{unsupported length of the compression member (in.)} \\
 &= 18(12) \\
 &= 216 \text{ in.}
 \end{aligned}$$

$$\begin{aligned}
 P_e &= \pi^2(1.77 \times 10^8)/[2.1(216)]^2 \\
 &= 8,490 \text{ k}
 \end{aligned}$$

Therefore, the moment magnification factors δ_b and δ_s can be calculated.

$$\begin{aligned}
 \delta_b &= 1.0/[1 - (1,070/[0.75(8,490)])] \\
 &= 1.20
 \end{aligned}$$

$$\delta_s = 1/[1 - \Sigma P_u/\phi \Sigma P_e]$$

ΣP_u and ΣP_e are the sum of the applied factored loads and the sum of the buckling loads of all columns in the bent, respectively. For hand calculations, it is not feasible to do calculations involving several columns simultaneously. Therefore, in this example, P_u and P_e of the column being designed are used instead of ΣP_u and ΣP_e .

$$\delta_s = 1.20$$

Therefore, the magnified moment in the longitudinal direction is taken as:

$$\begin{aligned}
 M_{cl} &= \delta_b M_{2b} + \delta_s M_{2s} && \text{(S4.5.3.2.2b-1)} \\
 &= 1.20(M_{2b} + M_{2s}) \\
 &= 1.20(\text{total factored moment, } M_l) \\
 &= 1.20(822) \\
 &= 986.4 \text{ k-ft}
 \end{aligned}$$

Transverse direction:

$$M_{ct} = \delta_b M_{2b} + \delta_s M_{2s} \quad \text{(S4.5.3.2.2b-1)}$$

Calculate P_e ,

$$P_e = \pi^2 EI / (K l_u)^2 \quad \text{(S4.5.3.2.2b-5)}$$

where:

EI = column flexural stiffness calculated using the provisions of S5.7.4.3 and is taken as the greater of:

$$EI = [E_c I_g / 5 + E_s I_s] / (1 + \beta_d) \quad \text{(S5.7.4.3-1)}$$

AND

$$EI = [E_c I_g / 2.5] / (1 + \beta_d) \quad \text{(S5.7.4.3-2)}$$

where:

$$E_c = 3,321 \text{ ksi}$$

$$I_g = 152,745 \text{ in}^4$$

$$\begin{aligned}\beta_d &= M_{t \text{ permanent}}/M_{t \text{ total}} \\ &= 101.7/342 \\ &= 0.30\end{aligned}$$

For simplification, steel reinforcement in the column is ignored in calculating EI, therefore, neglect Eq. S5.7.4.3-1.

$$\begin{aligned}EI &= [3,321(152,745)/2.5]/(1 + 0.30) \\ &= 1.56 \times 10^8 \text{ k-in}^2\end{aligned}$$

$$K = 1.2$$

$$l_u = 216 \text{ in.}$$

$$\begin{aligned}P_e &= \pi^2(1.56 \times 10^8)/[1.2(216)]^2 \\ &= 22,917 \text{ k}\end{aligned}$$

Therefore, the moment magnification factors δ_b and δ_s can be calculated.

$$\begin{aligned}\delta_b &= 1.0/[1 - (1,070/[0.75(23,064)])] \\ &= 1.07\end{aligned}$$

$$\begin{aligned}\delta_s &= 1/[1 - \Sigma P_u/\phi \Sigma P_e] \\ \text{Similar to longitudinal, use } P_u \text{ and } P_e \text{ instead of } \Sigma P_u \text{ and } \Sigma P_e. \\ &= 1.07\end{aligned}$$

Therefore, the magnified moment in the transverse direction is taken as:

$$\begin{aligned}M_{ct} &= 1.07(\text{total factored moment, } M_t) \\ &= 1.07(174) \\ &= 186 \text{ k-ft}\end{aligned}$$

The combined moment M_u is taken as:

$$\begin{aligned}M_u &= \sqrt{M_{cl} + M_{ct}} \\ &= \sqrt{986.4^2 + 186^2} \\ &= 1004 \text{ k-ft}\end{aligned}$$

Factored axial load on the column for the load case being checked = 1,070 k

By inspection, from the column interaction diagram Figure 7.2-8 or Table 7.2-3, the applied factored loads ($M = 1,004 \text{ k-ft}$ and $P = 1,070 \text{ k}$) are within the column resistance.

Design Step
7.2.3.2

Transverse reinforcement for compression members (S5.10.6)

Transverse reinforcement for compression members may consist of either spirals or ties. Ties are used in this example. In tied compression members, all longitudinal bars are enclosed by lateral ties. Since the longitudinal bars are #8, use #3 bars for the ties (S5.10.6.3).

The spacing of ties is limited to the least dimension of the compression member or 12.0 in., therefore, the ties are spaced at 12.0 in. center-to-center.

Ties are located vertically no more than half a tie spacing above the footing and not more than half a tie spacing below the lowest horizontal reinforcement in the cap.

Figure 7.2-9 shows the column cross-section.

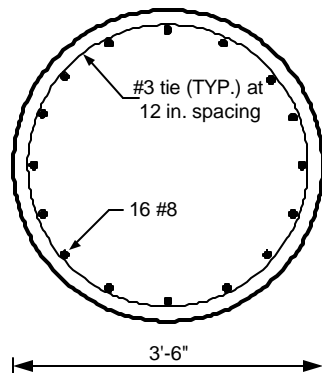

Figure 7.2-9 – Column Cross-Section

Design Step
7.2.4

Footing design

Based on the intermediate bent load analysis, the critical footing is Footing 1 supporting Column 1

Required information:

General:

$$f_c = 3.0 \text{ ksi}$$

$$f_y = 60 \text{ ksi}$$

Side concrete cover = 3 in. (Table S5.12.3-1)

Top concrete cover = 3 in.

Bottom concrete cover = 3 in.

Top bars (T)ransverse or (L)ongitudinal in bottom mat = L

Direction of bottom bars in bottom mat = T

A preliminary analysis of the footing yielded the following information:

Footing depth = 3.0 ft.

Footing width, $W = 12.0$ ft.

Footing length, $L = 12.0$ ft.

Top mat reinforcing bar diameter, #5 bars = 0.625 in.

Top mat reinforcing bar area, #5 bars = 0.31 in^2

Bottom mat reinforcing bar diameter, #9 bars = 1.128 in.

Bottom mat reinforcing bar area, #9 bars = 1.0 in^2

Number of bars = 13 bars in each direction in both the top and bottom mats

Location of critical sections

According to S5.13.3.6.1, the critical section for one-way shear is at a distance d_v , the shear depth calculated in accordance with S5.8.2.9, from the face of the column. For two-way shear, the critical section is at a distance of $d\sqrt{2}$ from the face of the column.

For moment, the critical section is taken at the face of the column in accordance with S5.13.3.4.

For the circular column in this example, the face of the column is assumed to be located at the face of an equivalent square area concentric with the circular column in accordance with S5.13.3.4.

Determine the critical faces along the y-axis for moment

Since the column has a circular cross-section, the column may be transformed into an effective square cross-section for the footing analysis.

Critical face in y-direction = $\frac{1}{2}$ footing width, $W - \frac{1}{2}$ equivalent column width

$$\begin{aligned} \text{Equivalent column width} &= \sqrt{\text{shaft area}} \\ &= \sqrt{9.62} \\ &= 3.10 \text{ ft.} \end{aligned}$$

$$\begin{aligned} \text{Critical face in y-direction} &= \frac{1}{2} \text{ footing width, } W - \frac{1}{2} \text{ equivalent column width} \\ &= \frac{1}{2} (12) - \frac{1}{2} (3.10) \\ &= 4.45 \text{ ft.} \end{aligned}$$

Critical faces in the y-direction = 4.45 ft. and 7.55 ft.

Determine the critical faces along the x-axis for moment

For a square footing with an equivalent square column:

Critical face in the x-direction = Critical face in the y-direction
= 4.45 ft.

Critical faces in the x-direction = 4.45 ft. and 7.55 ft.

See Figure 7.2-10 for a schematic showing the critical sections for moments.

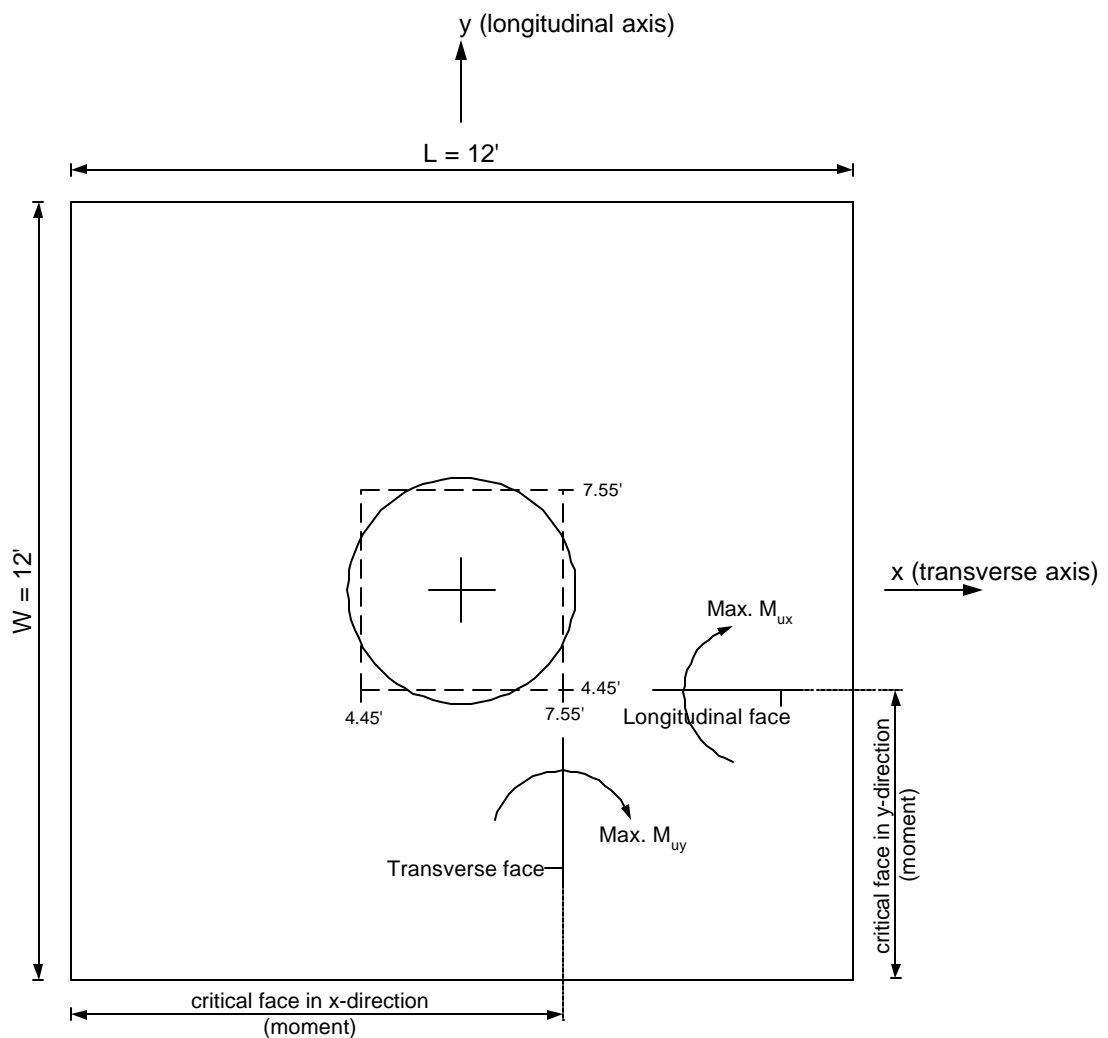

Figure 7.2-10 – Critical Sections for Moment

Design factored loads at the critical section

From the analysis of the intermediate bent computer program, the cases of loading that produced maximum load effects and the other concurrent load effects on the footing are shown in Table 7.2-4.

Table 7.2-4 – Loads on Critical Footing (Footing Supporting Column 1)

Load effect maximized	Limit State	M_t (k-ft)	M_l (k-ft)	P_u (k)
Positive M_t	Strength V	423	377	1,143
Negative M_t	Strength III	-154	-197	628
Positive M_l	Strength V	232	895	1,151
Negative M_l	Strength V	158	-897	1,157
Axial Load P	Strength I	121	-363	1,374

Each row in Table 7.2-4 represents the maximum value of one load effect (max. $+M_t, -M_l$, etc.). The corresponding concurrent load effects are also given. Many engineers design the footing for the above listed cases. However, computer design programs are able to check many more cases of loading to determine the most critical case. For example, a load case that does not produce maximum axial load or maximum moment may still produce the maximum combined effects on the footing. From the output of a footing design program, the critical case for the footing design was found to produce the following factored footing loads under Strength I limit state:

$$\begin{aligned} P_u &= 1,374 \text{ k} \\ M_t &= -121 \text{ k-ft} \\ M_l &= 626 \text{ k-ft} \end{aligned}$$

The critical Service I loads:

$$\begin{aligned} P_u &= 891 \text{ k} \\ M_{t,s} &= 176 \text{ k-ft} \\ M_{l,s} &= 620 \text{ k-ft} \end{aligned}$$

For the sample calculations below, the factored loads listed above for the critical case of loading were used.

Sample calculations for the critical footing under the critical case of loading

If $M/P < L/6$ then the soil under the entire area of the footing is completely in compression and the soil stress may be determined using the conventional stress formula (i.e. $\sigma = P/A \pm Mc/I$).

$$\begin{aligned} M_t/P_u &= 121/1,374 \\ &= 0.088 < 12/6 = 2 \quad \mathbf{OK} \end{aligned}$$

$$\begin{aligned} M_l/P_u &= 626/1,374 \\ &= 0.456 < 2 \quad \mathbf{OK} \end{aligned}$$

Therefore, the soil area under the footing is under compression.

Moment

For M_{ux} (k-ft/ft), where M_{ux} is the maximum factored moment per unit width of the footing due to the combined forces at a longitudinal face, see Figure 7.2-10:

$$\sigma_1, \sigma_2 = P/LW \pm M_l(L/2)/(L^3W/12)$$

where:

σ_1 = stress at beginning of footing in direction considered (see Figure 7.2-10) (ksf)

σ_2 = stress at end of footing in direction considered (ksf)

P = axial load from above (k)

M_l = moment on longitudinal face from above (k-ft)

L = total length of footing (ft.)

W = total width of footing (ft.)

$$\begin{aligned} \sigma_1 &= 1,374/[12(12)] + 626(12/2)/[12^3(12)/12] \\ &= 9.54 + 2.17 \\ &= 11.71 \text{ ksf} \end{aligned}$$

$$\begin{aligned} \sigma_2 &= 9.54 - 2.17 \\ &= 7.37 \text{ ksf} \end{aligned}$$

Interpolate to calculate σ_3 , the stress at critical location for moment (at face of column, 4.45 ft. from the end of the footing along the width.

$$\sigma_3 = 10.10 \text{ ksf}$$

Therefore,

$$M_{ux} = \sigma_3 L_1(L_1/2) + 0.5(\sigma_1 - \sigma_3)(L_1)(2L_1/3)$$

where:

L_1 = distance from the edge of footing to the critical location (ft.)

$$\begin{aligned}
 M_{ux} &= 10.10(4.45)(4.45/2) + 0.5(11.71 - 10.10)(4.45)[2(4.45)/3] \\
 &= 100.0 + 10.63 \\
 &= 110.6 \text{ k-ft/ft}
 \end{aligned}$$

For M_{uy} (k-ft/ft), where M_{uy} is the maximum factored moment per unit length from the combined forces at a transverse face acting at 4.45 ft. from the face of the column (see Figure 7.2-10):

$$\sigma_5, \sigma_6 = P/LW \pm M_t(W/2)/(W^3L/12)$$

where:

M_t = moment on transverse face from above (k-ft)

$$\begin{aligned}
 \sigma_5 &= 1,374/[12(12)] - (-121)(12/2)/[12^3(12)/12] \\
 &= 9.54 - (-0.420) \\
 &= 9.96 \text{ ksf}
 \end{aligned}$$

$$\begin{aligned}
 \sigma_6 &= 9.54 + (-0.420) \\
 &= 9.12 \text{ ksf}
 \end{aligned}$$

Interpolate to calculate σ_7 , the stress at critical location for moment (at face of column, 4.45 ft. from the end of the footing along the length).

$$\sigma_7 = 9.65 \text{ ksf}$$

Therefore,

$$\begin{aligned}
 M_{uy} &= \sigma_7 L_3(L_3/2) + 0.5(\sigma_5 - \sigma_7)(L_3)(2L_3/3) \\
 &= 9.65(4.45)(4.45/2) + 0.5(9.96 - 9.65)(4.45)[2(4.45)/3] \\
 &= 95.54 + 2.05 \\
 &= 97.6 \text{ k-ft/ft}
 \end{aligned}$$

Factored applied design moment, Service I limit state, calculated using the same method as above:

$$\begin{aligned}
 M_{ux,s} &= 75.9 \text{ k-ft/ft} \\
 M_{uy,s} &= 72.0 \text{ k-ft/ft}
 \end{aligned}$$

Where $M_{ux,s}$ is the maximum service moment from combined forces at a longitudinal face at 4.45 ft. along the width and $M_{uy,s}$ is the maximum service moment from combined forces at a transverse face at 7.55 ft. along the length.

Shear

Factored applied design shear.

For V_{ux} (k/ft), where V_{ux} is the shear per unit length at a longitudinal face:

$$V_{ux} = \sigma_4 L_2 + 0.5(\sigma_1 - \sigma_4)L_2$$

where:

L_2 = distance from the edge of footing to a distance d_v from the effective column (ft.)

Based on the preliminary analysis of the footing, d_v is estimated as 30.3 in. Generally, for load calculations, d_v may be assumed equal to the effective depth of the reinforcement minus 1 inch. Small differences between d_v assumed here for load calculations and the final d_v will not result in significant difference in the final results.

The critical face along the y-axis = $4.45 - 30.3/12$
= 1.925 ft. from the edge of the footing

By interpolation between σ_1 and σ_2 , $\sigma_4 = 11.01$ ksf

$$\begin{aligned} V_{ux} &= 11.01(1.925) + 0.5(11.71 - 11.01)(1.925) \\ &= 21.19 + 0.67 \\ &= 21.9 \text{ k/ft} \end{aligned}$$

For V_{uy} (k/ft), where V_{uy} is the shear per unit length at a transverse face:

$$V_{ux} = \sigma_8 L_4 + 0.5(\sigma_5 - \sigma_8)L_4$$

where:

$d_v = 31.4$ in. for this direction (from preliminary design). Alternatively, for load calculations, d_v may be assumed equal to the effective depth of the reinforcement minus 1 inch).

The critical face along the x-axis = $4.45 - 31.4/12$
= 1.833 ft. from the edge of the footing

By interpolation between σ_5 and σ_6 , $\sigma_8 = 9.83$ ksf

$$\begin{aligned} V_{ux} &= 9.83(1.83) + 0.5(9.96 - 9.83)(1.83) \\ &= 17.99 + 0.12 \\ &= 18.1 \text{ k/ft} \end{aligned}$$

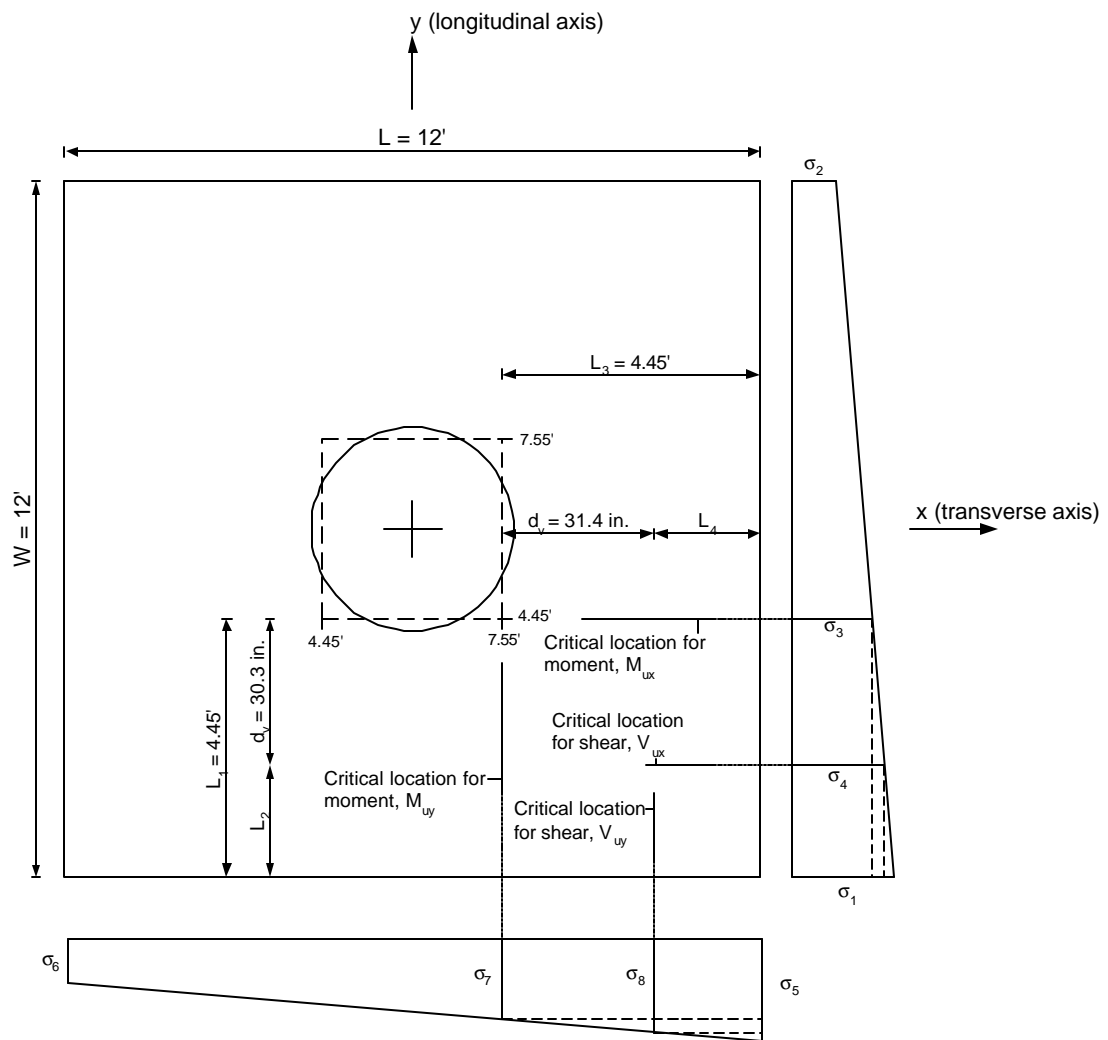

Figure 7.2-11 – Stress at Critical Locations for Moment and Shear

Design Step 7.2.4.1 Flexural resistance (S5.7.3.2)

Check the design moment strength (S5.7.3.2)

Article S5.13.3.5 allows the reinforcement in square footings to be uniformly distributed across the entire width of the footing.

Check the moment resistance for moment at the critical longitudinal face (S5.13.3.4)

The critical section is at the face of the effective square column (4.45 ft. from the edge of the footing along the width). In the case of columns that are not rectangular, the critical section is taken at the side of the concentric rectangle of equivalent area as in this example.

$$M_{rx} = \phi M_{nx} \quad (S5.7.3.2.1-1)$$

where:

$$\phi = 0.9 \quad (S5.5.4.2.1)$$

$$M_{nx} = A_s f_y (d_{sx} - a/2) \quad (S5.7.3.2.2-1)$$

Determine d_{sx} , the distance from the top bars of the bottom reinforcing mat to the compression surface.

$$\begin{aligned} d_{sx} &= \text{footing depth} - \text{bottom cvr} - \text{bottom bar dia.} - \frac{1}{2} \text{ top bar dia. in bottom mat} \\ &= 3(12) - 3 - 1.128 - \frac{1}{2} (1.128) \\ &= 31.3 \text{ in.} \end{aligned}$$

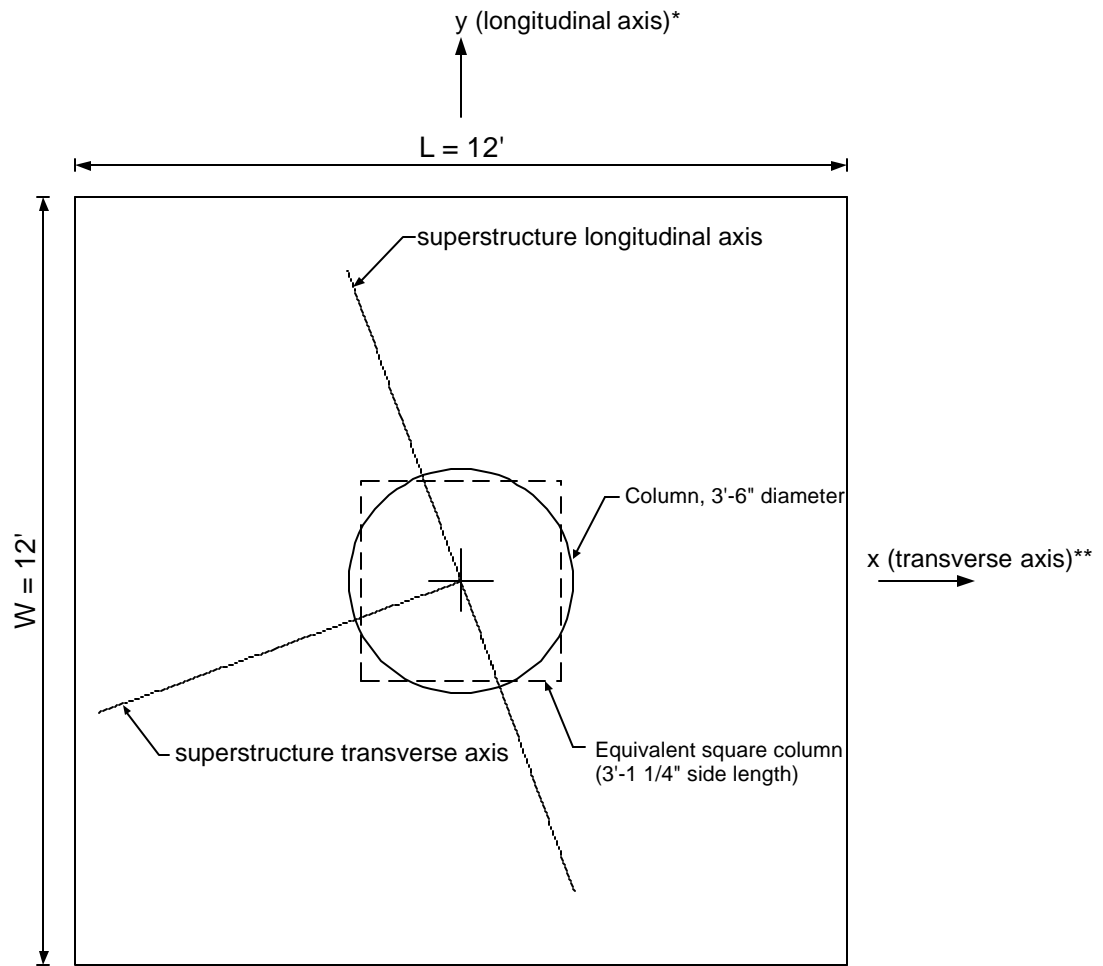

* perpendicular to the bent
 ** in the plane of the bent

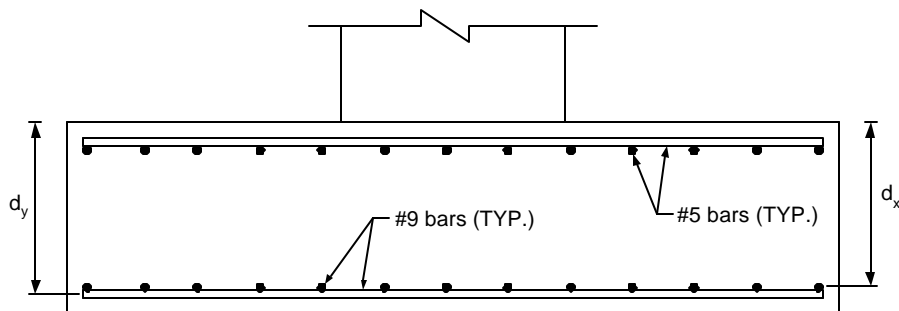

Figure 7.2-12 – Footing Reinforcement Locations

Determine A_s per foot of length. The maximum bar spacing across the width of the footing is assumed to be 12.0 in. in each direction on all faces (S5.10.8.2). Use 13 #9 bars and determine the actual spacing.

$$\begin{aligned}\text{Actual bar spacing} &= [L - 2(\text{side cover}) - \text{bar diameter}] / (n_{\text{bars}} - 1) \\ &= [12 - 2(3)/12 - 1.128/12] / (13 - 1) \\ &= 11.41 \text{ in.}\end{aligned}$$

$$\begin{aligned}A_s &= 1.0(12/11.41) \\ &= 1.05 \text{ in}^2\end{aligned}$$

Determine “a”, the depth of the equivalent stress block.

$$a = A_s f_y / 0.85 f_c b \quad (\text{S5.7.3.1.1-4})$$

for a strip 12 in. wide, $b = 12$ in. and $A_s = 1.05 \text{ in}^2$

$$\begin{aligned}a &= 1.05(60) / [0.85(3)(12)] \\ &= 2.06 \text{ in.}\end{aligned}$$

Calculate ϕM_{nx} , the factored flexural resistance.

$$\begin{aligned}M_{rx} &= \phi M_{nx} \\ &= 0.9[1.05(60)(31.3 - 2.06/2)] / 12 \quad (\text{S5.7.3.2.2-1}) \\ &= 143.0 \text{ k-ft/ft} > \text{applied factored moment, } M_{ux} = 110.6 \text{ k-ft/ft} \quad \mathbf{OK}\end{aligned}$$

Check minimum temperature and shrinkage steel (S5.10.8)

According to S5.10.8.1, reinforcement for shrinkage and temperature stresses shall be provided near surfaces of concrete exposed to daily temperature changes and in structural mass concrete. Footings are not exposed to daily temperature changes and, therefore, are not checked for temperature and shrinkage reinforcement. Nominal reinforcement is provided at the top of the footing to arrest possible cracking during the concrete early age before the footing is covered with fill.

Design Step 7.2.4.2 Limits for reinforcement (S5.7.3.3)

Check maximum reinforcement (S5.7.3.3.1)

$$c/d_e \leq 0.42 \quad (\text{S5.7.3.3.1-1})$$

where:

$$\begin{aligned}c &= a/\beta_1 \\ &= 2.06/0.85 \\ &= 2.42 \text{ in/ft}\end{aligned}$$

$$\begin{aligned}c/d_e &= 2.42/31.3 \\ &= 0.077 < 0.42 \quad \mathbf{OK}\end{aligned}$$

Minimum reinforcement check (S5.7.3.3.2)

Unless otherwise specified, at any section of a flexural component, the amount of nonprestressed tensile reinforcement shall be adequate to develop a factored flexural resistance, M_r , at least equal to the lesser of:

$$1.2M_{cr} = 1.2f_r S$$

where:

$$\begin{aligned} f_r &= 0.24\sqrt{f'_c} && \text{(S5.4.2.6)} \\ &= 0.24\sqrt{3} \\ &= 0.42 \text{ ksi} \end{aligned}$$

For a 1 ft. wide strip, 3 ft. thick,

$$\begin{aligned} S &= bh^2/6 \\ &= [1(12)][3(12)]^2/6 \\ &= 2,592 \text{ in}^3/\text{ft} \end{aligned}$$

$$\begin{aligned} 1.2M_{cr} &= 1.2(0.42)(2,592)/12 \\ &= 108.9 \text{ k-ft/ft} \end{aligned}$$

OR

$$\begin{aligned} 1.33M_{ux} &= 1.33(110.6) \\ &= 147.1 \text{ k-ft/ft} \end{aligned}$$

Therefore, the minimum required section moment resistance = 108.9 k-ft/ft
 Provided moment resistance = 143.0 k-ft/ft > 108.9 k-ft/ft **OK**

Check the moment resistance for moment at the critical transverse face

The critical face is at the equivalent length of the shaft (7.55 ft. from the edge of the footing along the length). In the case of columns that are not rectangular, the critical section is taken at the side of the concentric rectangle of equivalent area.

$$\begin{aligned} M_{ry} &= \phi M_{ny} \\ &= \phi [A_s f_y (d_{sy} - a/2)] && \text{(S5.7.3.2.2-1)} \end{aligned}$$

Determine d_{sy} , the distance from the bottom bars of the bottom reinforcing mat to the compression surface.

$$\begin{aligned} d_{sy} &= \text{footing depth} - \text{cover} - \frac{1}{2} (\text{bottom bar diameter}) \\ &= 3(12) - 3 - \frac{1}{2} (1.128) \\ &= 32.4 \text{ in.} \end{aligned}$$

Determine A_s per foot of length

$$\begin{aligned}\text{Actual bar spacing} &= [W - 2(\text{side cover}) - \text{bar diameter}]/(n_{\text{bars}} - 1) \\ &= [12 - 2(3)/12 - 1.128/12]/(13 - 1) \\ &= 11.41 \text{ in.}\end{aligned}$$

$$\begin{aligned}A_s &= 1.0(12/11.41) \\ &= 1.05 \text{ in}^2\end{aligned}$$

Determine “a”, depth of the equivalent stress block.

$$a = A_s f_y / (0.85 f'_c b)$$

For a strip 12 in. wide, $b = 12$ in. and $A_s = 1.05 \text{ in}^2$

$$\begin{aligned}a &= 1.05(60)/[0.85(3)(12)] \\ &= 2.06 \text{ in.}\end{aligned}$$

Calculate ϕM_{ny} , the factored flexural resistance

$$\begin{aligned}M_{ry} &= \phi M_{ny} \\ &= 0.9[1.05(60)(32.4 - 2.06/2)]/12 \\ &= 148.2 \text{ k-ft/ft} > M_{uy} = 97.6 \text{ k-ft/ft} \quad \mathbf{OK}\end{aligned}$$

Check maximum reinforcement (S5.7.3.3.1)

$$c/d_e \leq 0.42 \quad (\text{S5.7.3.3.1-1})$$

where:

$$\begin{aligned}c &= a/\beta_1 \\ &= 2.06/0.85 \\ &= 2.42 \text{ in.}\end{aligned}$$

$$\begin{aligned}c/d_e &= 2.42/32.4 \\ &= 0.075 < 0.42 \quad \mathbf{OK}\end{aligned}$$

Check minimum reinforcement (S5.7.3.3.2)

Unless otherwise specified, at any section of a flexural component, the amount of nonprestressed tensile reinforcement shall be adequate to develop a factored flexural resistance, M_r , at least equal to the lesser of:

$$1.2M_{cr} = 1.2f_r S$$

where:

$$\begin{aligned} f_r &= 0.24\sqrt{f'_c} && (S5.4.2.6) \\ &= 0.24\sqrt{3} \\ &= 0.42 \text{ ksi} \end{aligned}$$

For a 1 ft. wide strip, 3 ft. thick,

$$\begin{aligned} S &= bh^2/6 \\ &= [1(12)][3(12)]^2/6 \\ &= 2,592 \text{ in}^3 \end{aligned}$$

$$\begin{aligned} 1.2M_{cr} &= 1.2(0.42)(2,592)/12 \\ &= 108.9 \text{ k-ft/ft} \end{aligned}$$

OR

$$\begin{aligned} 1.33M_{uy} &= 1.33(97.6) \\ &= 129.8 \text{ k-ft/ft} \end{aligned}$$

Therefore, the minimum required section moment resistance = 108.9 k-ft/ft
 Provided moment resistance = 148.2 k-ft/ft > 108.9 k-ft/ft **OK**

Design Step 7.2.4.3 Control of cracking by distribution of reinforcement (S5.7.3.4)

Check distribution about footing length, L

$$f_{s, \text{allow}} = Z/(d_c A)^{1/3} \leq 0.60f_y \quad (S5.7.3.4-1)$$

where:

$Z = 170$ k/in. (moderate exposure conditions assumed, no dry/wet cycles and no harmful chemicals in the soil)

Notice that the value of the of the crack control factor, Z , used by different jurisdictions varies based on local conditions and past experience.

$$\begin{aligned} d_c &= \text{bottom cover} + \frac{1}{2} \text{ bar diameter} \\ &= 2 + \frac{1}{2}(1.128) \\ &= 2.56 \text{ in.} \end{aligned}$$

$$\begin{aligned} A &= 2d_c(\text{bar spacing}) \\ &= 2(2.56)(11.41) \\ &= 58.4 \text{ in}^2 \end{aligned}$$

$$\begin{aligned} f_{s, \text{allow}} &= Z/[(d_c A)^{1/3}] \\ &= 170/[2.56(58.4)]^{1/3} \\ &= 32.0 \text{ ksi} < 0.6(60) = 36 \text{ ksi} \text{ therefore, use } f_{s, \text{allow}} = 32.0 \text{ ksi} \end{aligned}$$

Check actual steel stress, $f_{s, \text{actual}}$

For 3.0 ksi concrete, the modular ratio, $n = 9$

Maximum service load moment as shown earlier = 77.3 k-ft

The transformed moment of inertia is calculated assuming elastic behavior, i.e., linear stress and strain distribution. In this case, the first moment of area of the transformed steel on the tension side about the neutral axis is assumed equal to that of the concrete in compression.

Assume the neutral axis at a distance “y” from the compression face of the section.

Section width = bar spacing = 11.41 in.

Transformed steel area = (bar area)(modular ratio) = 1.0(9) = 9.0 in²

By equating the first moment of area of the transformed steel about that of the concrete, both about the neutral axis:

$$9.0(31.3 - y) = 11.41y(y/2)$$

Solving the equation results in $y = 6.28$ in.

$$\begin{aligned} I_{\text{transformed}} &= A_{ts}(d_{sx} - y)^2 + by^3/3 \\ &= 9.0(31.3 - 6.28)^2 + 11.41(6.28)^3/3 \\ &= 6,576 \text{ in}^4 \end{aligned}$$

Stress in the steel, $f_{s, \text{actual}} = (M_s c/I)$, where M_s is the moment acting on the 11.41 in. wide section.

$$\begin{aligned} f_{s, \text{actual}} &= [77.3(11.41)(31.3 - 6.28)/6,576]9 \\ &= 30.2 \text{ ksi} < f_{s, \text{allow}} = 32.0 \text{ ksi} \quad \mathbf{OK} \end{aligned}$$

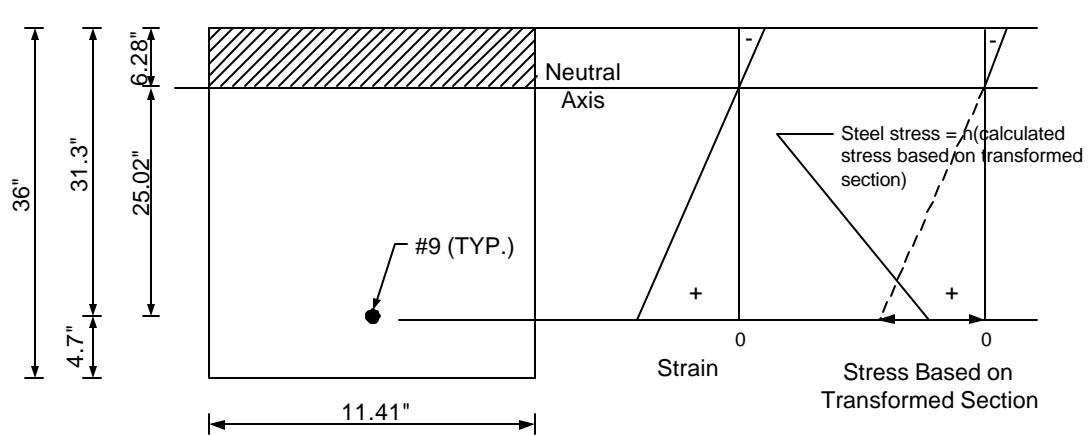

Figure 7.2-13 – Crack Control for Top Bar Reinforcement Under Service Load

Check distribution about footing width, W

This check is conducted similarly to the check shown above for the distribution about the footing length and the reinforcement is found to be adequate.

Design Step 7.2.4.4 Shear analysis

Check design shear strength (S5.8.3.3)

According to S5.13.3.6.1, the most critical of the following conditions shall govern the design for shear:

- *One-way action, with a critical section extending in a plane across the entire width and located at a distance taken as specified in S5.8.3.2.*
- *Two-way action, with a critical section perpendicular to the plane of the slab and located so that its perimeter, b_o , is a minimum but not closer than $0.5d_v$ to the perimeter of the concentrated load or reaction area.*

The subscripts “x” and “y” in the next section refer to the shear at a longitudinal face and shear at a transverse face, respectively.

Determine the location of the critical face along the y-axis

Since the column has a circular cross-section, the column may be transformed into an effective square cross-section for the footing analysis.

As stated previously, the critical section for one-way shear is at a distance d_v , the shear depth calculated in accordance with S5.8.2.9, from the face of the column and for two-way shear at a distance of $d_v/2$ from the face of the column.

Determine the effective shear depth, d_{vx} , for a longitudinal face.

$$\begin{aligned} d_{vx} &= \text{effective shear depth for a longitudinal face per S5.8.2.9 (in.)} \\ &= d_{sx} - a/2 && \text{(S5.8.2.9)} \\ &= 31.3 - 2.06/2 \\ &= 30.3 \text{ in.} \end{aligned}$$

$$\begin{aligned} \text{but not less than:} \\ 0.9d_{sx} &= 0.9(31.3) \\ &= 28.2 \text{ in.} \\ 0.72h &= 0.72(36) \\ &= 25.9 \text{ in.} \end{aligned}$$

Therefore, use $d_{vx} = 30.3$ in.

$$\begin{aligned} \text{The critical face along the y-axis} &= 4.45 - 30.3/12 \\ &= 1.925 \text{ ft. from the edge of the footing} \end{aligned}$$

Determine the location of the critical face along the x-axis

Determine the effective shear depth, d_{vy} , for a transverse face.

$$\begin{aligned} d_{vy} &= \text{effective shear depth for a transverse face per S5.8.2.9 (in.)} \\ &= d_{sy} - a/2 && \text{(S5.8.2.9)} \\ &= 32.4 - 2.06/2 \\ &= 31.4 \text{ in.} \end{aligned}$$

$$\begin{aligned} \text{but not less than:} \\ 0.9d_{sy} &= 0.9(32.4) \\ &= 29.2 \text{ in.} \\ 0.72h &= 0.72(36) \\ &= 25.9 \text{ in.} \end{aligned}$$

Therefore, use $d_{vy} = 31.4$ in.

$$\begin{aligned} \text{The critical face along the x-axis} &= 4.45 - 31.4/12 \\ &= 1.833 \text{ ft. from the edge of the footing} \end{aligned}$$

See Figure 7.2-14 for locations of the critical sections.

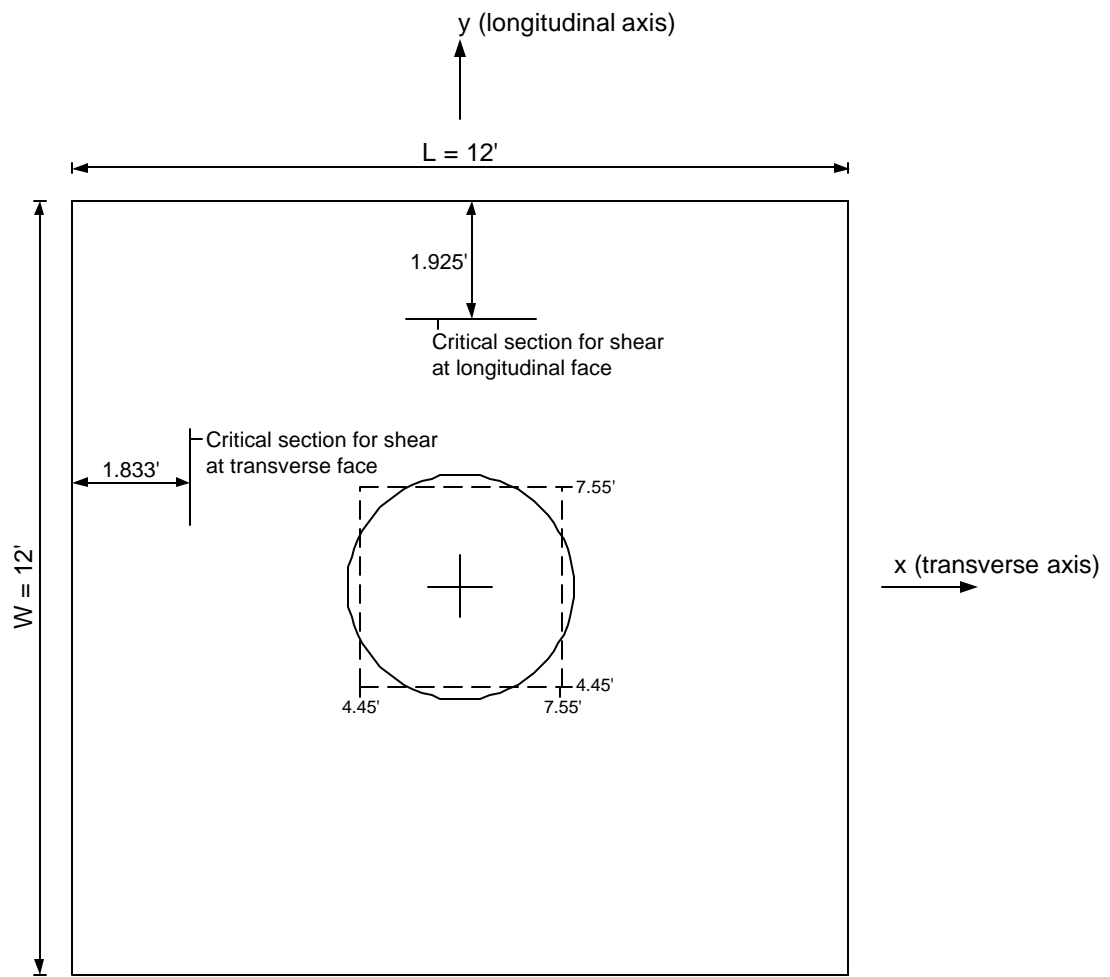

Figure 7.2-14 – Critical Sections for Shear

Determine one-way shear capacity for longitudinal face (S5.8.3.3)

For one-way action, the shear resistance of the footing of slab will satisfy the requirements specified in S5.8.3.

$$V_{rx} = \phi V_{nx} \tag{S5.8.2.1-2}$$

The nominal shear resistance, V_{nx} , is taken as the lesser of:

$$V_{nx} = V_c + V_s + V_p \tag{S5.8.3.3-1}$$

OR

$$V_{nx} = 0.25f'_c b_v d_{vx} + V_p \tag{S5.8.3.3-2}$$

$$V_c = 0.0316\beta\sqrt{f'_c}b_v d_{vx} \quad (\text{S5.8.3.3-3})$$

where:

$$\beta = 2.0$$

$$b_v = 12 \text{ in. (to obtain shear per foot of footing)}$$

$$d_{vx} = \text{effective shear depth for a longitudinal face per S5.8.2.9 (in.)} \\ = 30.3 \text{ in. from above}$$

$$V_p = 0.0 \text{ k}$$

The nominal shear resistance is then taken as the lesser of:

$$V_{nx} = 0.0316(2.0)\sqrt{3}(12)(30.3) \\ = 39.8 \text{ k/ft}$$

AND

$$V_{nx} = 0.25f'_c b_v d_v \\ = 0.25(3)(12)(30.3) \\ = 272.7 \text{ k/ft}$$

Therefore, use $V_{nx} = 39.8 \text{ k/ft}$

$$V_{rx} = \phi V_{nx} \\ = 0.9(39.8) \\ = 35.8 \text{ k/ft} > \text{applied shear, } V_{ux} = 21.9 \text{ k/ft (calculated earlier) } \mathbf{OK}$$

Determine one-way shear capacity for transverse face

$$V_{ry} = \phi V_{ny} \quad (\text{S5.8.2.1-2})$$

The nominal shear resistance, V_{ny} , is taken as the lesser of:

$$V_{ny} = V_c + V_s + V_p \quad (\text{S5.8.3.3-1})$$

OR

$$V_{ny} = 0.25f'_c b_v d_{vy} + V_p \quad (\text{S5.8.3.3-2})$$

$$V_c = 0.0316\beta\sqrt{f'_c}b_v d_{vy} \quad (\text{S5.8.3.3-3})$$

where:

$$\beta = 2.0$$

$$b_v = 12 \text{ in. (to obtain shear per foot of footing)}$$

$$d_{vy} = \text{effective shear depth for a transverse face per S5.8.2.9 (in.)} \\ = 31.4 \text{ in. from above}$$

$$V_p = 0.0 \text{ k}$$

The nominal shear resistance is then taken as the lesser of:

$$V_{cy} = 0.0316(2.0)\sqrt{3}(12)(31.4) \\ = 41.2 \text{ k/ft}$$

AND

$$V_{ny} = 0.25f'_c b_v d_v \\ = 0.25(3)(12)(31.4) \\ = 282.6 \text{ k/ft}$$

Therefore, use $V_{ny} = 41.2 \text{ k/ft}$

$$V_{ry} = \phi V_{ny} \\ = 0.9(41.2) \\ = 37.1 \text{ k/ft} > \text{applied shear, } V_{uy} = 18.1 \text{ k/ft (calculated earlier) OK}$$

Determine two-way (punching) shear capacity at the column (S5.13.3.6.3)

For two-way action for sections without transverse reinforcement, the nominal shear resistance, V_n in kips, of the concrete shall be taken as:

$$V_n = (0.063 + 0.126/\beta_c)\sqrt{f'_c}b_o d_v \leq 0.126\sqrt{f'_c}b_o d_v \quad (\text{S5.13.3.6.3-1})$$

where:

$$\beta_c = \text{ratio of long side to short side of the rectangular through which the} \\ \text{concentrated load or reaction force is transmitted} \\ = (\text{column equivalent length}) / (\text{column equivalent width}) \\ = 3.10/3.10 \\ = 1.0 \text{ (notice, for circular columns this ratio is always 1.0)}$$

$$d_v = \text{average effective shear depth (in.)} \\ = (d_{vx} + d_{vy})/2 \\ = (30.3 + 31.4)/2 \\ = 30.9 \text{ in.}$$

$$b_o = \text{perimeter of the critical section (in.), the critical section is } 0.5d_v \\ \text{from the reaction area (S5.13.3.6.1). Use the circular column cross-} \\ \text{section and cylindrical surface for punching shear.} \\ = 2\pi(42/2 + 30.9/2) \\ = 229 \text{ in.}$$

$$V_n = (0.063 + 0.126/1.0)\sqrt{3}(229)(30.9) \\ = 2,316 \text{ k}$$

The nominal shear resistance, V_n , cannot exceed $0.126\sqrt{f'_c}b_o d_v$

$$V_n = 0.126\sqrt{3}(229)(30.9) \\ = 1,544 \text{ k}$$

Therefore,

$$V_r = 0.9(1,544) \\ = 1,390 \text{ k}$$

The maximum factored vertical force for punching shear calculations equals the maximum factored axial load on the footing minus the factored weight of the footing.

$$P_{2 \text{ way}} = 1,374 - 1.25[12(12)(3)](0.150) \\ = 1,293 \text{ k}$$

The maximum shear force for punching shear calculations for a footing with the entire footing area under compression and the column at the center of the footing:

$$V_{2 \text{ way}} = P_{2 \text{ way}}(1 - \text{area within punching shear perimeter/footing area}) \\ = 1,293[1 - \pi((42/2 + 30.9/2)/12)^2 / 12(12)] \\ = 1,293(1 - 0.201) \\ = 1,033 \text{ k} < V_r = 1,390 \text{ k} \quad \mathbf{OK}$$

For footings with eccentric columns or with tension under some of the footing area, the design force for punching shear is calculated as the applied load, $P_{2 \text{ way}}$, minus the soil load in the area within the perimeter of the punching shear failure.

Design Step 7.2.4.5 Foundation soil bearing resistance at the Strength Limit State (S10.6.3)

Foundation assumptions:

Footings rest on dry cohesionless soil
 Angle of internal friction of the soil (ϕ_f) = 32 degrees
 Depth of the bottom of the footing from the ground surface = 6 ft.
 Soil density = 120 lb/ft³
 Footing plan dimensions are 12 ft. by 12 ft.

Footing effective dimensions

According to S10.6.3.1.1, where loads are eccentric, the effective footing dimensions L' and B' , as specified in S10.6.3.1.5, shall be used instead of the overall dimensions L and B in all equations, tables, and figures pertaining to bearing capacity.

Therefore, for each load case shown in Table 7.2-4, a unique combination of the footing effective dimensions is used. In the following section, the case of maximum axial load on the footing will be used to illustrate the bearing capacity calculations.

The footing effective dimensions are calculated using S10.6.3.1.5 and Figure SC10.6.3.1.5-1 (shown below).

$$B' = B - 2e_B \quad (\text{S10.6.3.1.5-1})$$

where:

e_B = eccentricity parallel to dimension B (ft.)

$$\begin{aligned} B' &= 12 - 2(121/1,374) \\ &= 11.82 \text{ ft.} \end{aligned}$$

$$L' = L - 2e_L \quad (\text{S10.6.3.1.5-2})$$

where:

e_L = eccentricity parallel to dimension L (ft.)

$$\begin{aligned} L' &= 12 - 2(626/1,374) \\ &= 11.09 \text{ ft.} \end{aligned}$$

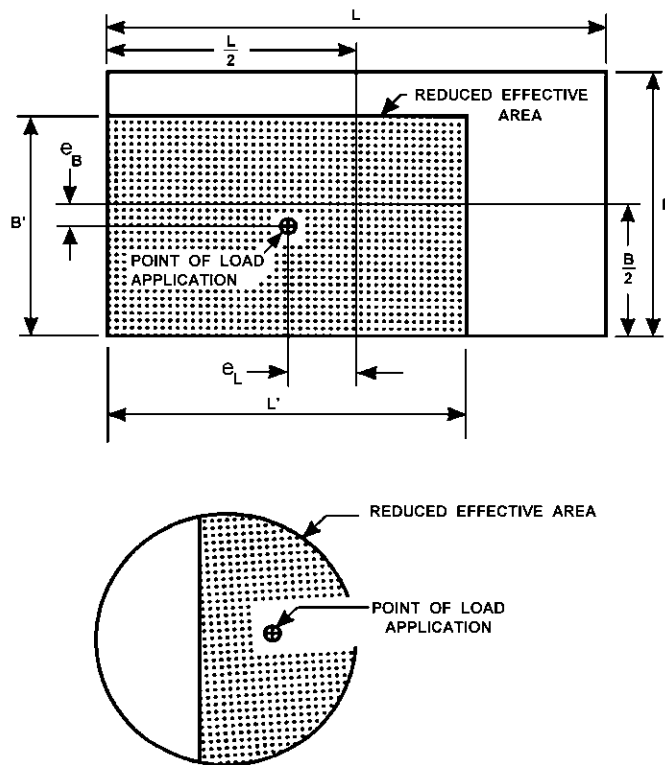

Figure SC10.6.3.1.5-1 – Reduced Footing Dimensions (Reproduced from the Specifications)

According to S10.6.3.1.2c, for cohesionless soil, the nominal bearing resistance of a layer of the soil in TSF may be determined as:

$$q_{ult} = 0.5\gamma B C_{w1} N_{\gamma m} + \gamma C_{w2} D_f N_{qm} \quad (S10.6.3.1.2c-1)$$

where:

D_f = depth of footing from ground level (ft.)
= 6 ft.

γ = total, i.e., moist density of sand or gravel (TCF)
= 120/2,000
= 0.06 TCF

B = footing width (ft.)
= smaller of 11.82 and 11.09 ft.
= 11.09 ft.

C_{w1}, C_{w2} = coefficients as specified in Table S10.6.3.1.2c-1 as a function of D_w (dimensionless)
= for dry soil with a large depth, $C_{w1} = C_{w2} = 1.0$

D_w = depth to water surface taken from the ground surface (ft.)
 = assume a large distance relative to the footing dimensions

$N_{\gamma m}, N_{qm}$ = modified bearing capacity factor (dimensionless)

Substituting in Eq. S10.6.3.1.2c-1:

$$q_{ult} = 0.5(0.06)(11.09)(1.0)N_{\gamma m} + 0.06(1.0)(6)N_{qm}$$

$$= 0.334N_{\gamma m} + 0.36N_{qm}$$

From Eqs. S10.6.3.1.2c-2 and -3

$$N_{\gamma m} = N_{\gamma} S_{\gamma} c_{\gamma} i_{\gamma} \quad (\text{S10.6.3.1.2c-2})$$

$$N_{qm} = N_q S_q c_q i_q d_q \quad (\text{S10.6.3.1.2c-3})$$

where:

N_{γ} = bearing capacity factor as specified in Table S10.6.3.1.2c-2 for footings on relatively level ground

N_q = bearing capacity factor as specified in Table S10.6.3.1.2c-2 for relatively level ground

S_q, S_{γ} = shape factors specified in Tables S10.6.3.1.2c-3 and -4, respectively

c_q, c_{γ} = soil compressibility factors specified in Tables S10.6.3.1.2c-5

i_q, i_{γ} = load inclination factors specified in Tables S10.6.3.1.2c-7 and -8

d_q = depth factor specified in Table S10.6.3.1.2c-9

From Table S10.6.3.1.2c-2: $N_{\gamma} = 30$ for $\phi_f = 32$ degrees

From Table S10.6.3.1.2c-2: $N_q = 23$ for $\phi_f = 32$ degrees

$$L'/B' = 11.82/11.09$$

$$= 1.07$$

Interpolate between $L'/B' = 1$ and 2. However, using values corresponding to $L'/B' = 1.0$ will not lead to significant change because $L'/B' \approx 1.0$.

From Table S10.6.3.1.2c-3: $S_q = 1.62$ for $L'/B' = 1.0$ and $\phi_f = 30$ degrees

From Table S10.6.3.1.2c-4: $S_\gamma = 0.6$ for $L'/B' = 1.0$ and $\phi_f = 30$ degrees

Soil stress at the footing depth before excavation, $q = 0.06(6) = 0.36$ TSF

For Tables S10.6.3.1.2c-5 and -6, either interpolate between $q = 0.25$ and $q = 0.5$ or, as a conservative approach, use the value corresponding to $q = 0.5$. For this example, the value corresponding to $q = 0.5$ TSF is used.

From Table S10.6.3.1.2c-5: $c_q, c_\gamma = 1.0$ for $q = 0.5$ and $\phi_f = 32$ degrees

The maximum factored horizontal load on the bottom of the column from the bent analysis equals 46.0 and 26.0 kips in the transverse and longitudinal directions, respectively. In Table S10.6.3.1.2c-7, it is intended to use the unfactored horizontal and vertical loads. However, due to the small ratio of horizontal to vertical loads, using the factored loads does not affect the results.

Horizontal-to-vertical load ratio:

$$\begin{aligned} H/V &= 44.8/1,374 \\ &= 0.033 \text{ in the transverse direction} \end{aligned}$$

$$\begin{aligned} H/V &= 26.0/1,374 \\ &= 0.019 \text{ in the longitudinal direction} \end{aligned}$$

Table S10.6.3.1.2-7 lists values for i_q, i_γ that correspond to horizontal-to-vertical load ratios of 0.0 and 0.1. Interpolation between the two values is acceptable. A more conservative approach is to use the value corresponding to $H/V = 0.1$.

From Table S10.6.3.1.2c-7: $i_q = 0.85$ for square footing with $H/V = 0.1$

From Table S10.6.3.1.2c-7: $i_\gamma = 0.77$ for square footing with $H/V = 0.1$

Table S10.6.3.1.2c-9 lists values for d_q that correspond to a friction angle, $\phi_f = 32$ degrees and for $D_f/B = 1.0$. For this example, $\phi_f = 30$ degrees and $D_f/B = 6/11.13 = 0.54$

By extrapolation from Table S10.6.3.1.2c-9, use $d_q = 1.05$

Substituting in Eqs. S10.6.3.1.2c-2 and -3:

$$\begin{aligned} N_{vm} &= N_\gamma S_q c_\gamma i_\gamma && \text{(S10.6.3.1.2c-2)} \\ &= 30(0.6)(1.0)(0.77) \\ &= 13.86 \end{aligned}$$

$$\begin{aligned}
 N_{qm} &= N_q S_q c_q i_q d_q && \text{(S10.6.3.1.2c-3)} \\
 &= 23(1.62)(1.0)(0.85)(1.05) \\
 &= 33.3
 \end{aligned}$$

Therefore,

$$\begin{aligned}
 q_{ult} &= 0.333N_{\gamma m} + 0.36N_{qm} \\
 &= 0.333(13.86) + 0.36(33.3) \\
 &= 16.6 \text{ TSF}
 \end{aligned}$$

Resistance factor

From Table S10.5.5-1, several resistance factors are listed for cohesionless soil (sand). The selection of a particular resistance factor depends on the method of soil exploration used to determine the soil properties. Assuming that ϕ was estimated from SPT data, the resistance factor = 0.35

According to S10.6.3.1.1,

$$\begin{aligned}
 q_R &= \phi q_n = \phi q_{ult} \\
 &= 0.35(16.6) \\
 &= 5.81 \text{ TSF}
 \end{aligned}$$

$$\begin{aligned}
 \text{Footing load resistance} &= (q_R)(\text{footing effective area}) \\
 &= 5.81(11.82)(11.09) \\
 &= 762.0 \text{ Tons} \\
 &= 1,524 \text{ k} > 1,374 \text{ k applied } \mathbf{OK}
 \end{aligned}$$

The soil load resistance check may be repeated using the same procedures for other load cases.

APPENDIX A – COMPUTER PROGRAM RESULTS

The results of the hand calculations presented in the example are compared to the results from computer design programs in this appendix. The following programs are included:

QConBridge: This program is a load analysis program developed by Washington State Department of Transportation and is available free of charge from the Department’s web site. For continuous structures, this program considers the structure continuous for all loads. This does not match the conditions for simple-spans made continuous for live loads where the loads applied before the continuity connection is made are actually acting on the simple span structures. This results in differences between the example and QConBridge in the noncomposite dead load effects.

Opis: Opis is a computer program developed by AASHTO as part of the AASHTOWare computer programs suite.

Section A1 – QConBridge Input

Washington State Department of Transportation
 Bridge and Structures Office
 QConBridge Version 1.0

Code: LRFD First Edition 1994

Span Data

Span 1 Length: 110.000 ft

Section Properties

Location (ft)	Ax (in ²)	Iz (in ⁴)	Mod. E (psi)	Unit Wgt (pcf)
0.000	1.764e+03	1.384e+06	4.724e+06	149.999e+00

Live Load Distribution Factors

Location (ft)	Str/Serv gM	Limit States gV	Fatigue Limit gM	State gV
0.000	0.809	0.984	0.458	0.651

Strength Limit State Factors: Ductility 1.00 Redundancy 1.00 Importance 1.00
 Service Limit State Factors: Ductility 1.00 Redundancy 1.00 Importance 1.00

Span 2 Length: 110.000 ft

Section Properties

Location (ft)	Ax (in ²)	Iz (in ⁴)	Mod. E (psi)	Unit Wgt (pcf)
0.000	1.764e+03	1.384e+06	4.724e+06	149.999e+00

Live Load Distribution Factors

Location (ft)	Str/Serv gM	Limit States gV	Fatigue Limit gM	State gV
0.000	0.796	0.973	0.452	0.652

Appendix A

Prestressed Concrete Bridge Design Example

Strength Limit State Factors: Ductility 1.00 Redundancy 1.00 Importance 1.00
Service Limit State Factors: Ductility 1.00 Redundancy 1.00 Importance 1.00

Support Data

Support 1 Roller

Support 2 Pinned

Support 3 Roller

Loading Data

DC Loads

Self Weight Generation Disabled

Traffic Barrier Load Disabled

Span 2 W 2.487e+03 plf from 0.000 ft to 109.999 ft

Span 2 W 0.000e+00 plf from 0.000 ft to 109.999 ft

Span 1 W 2.487e+03 plf from 0.000 ft to 109.999 ft

Span 1 W 0.000e+00 plf from 0.000 ft to 109.999 ft

DW Loads

Utility Load Disabled

Wearing Surface Load 289.999e+00 plf

Live Load Data

Live Load Generation Parameters

Design Tandem : Enabled

Design Truck : 1 rear axle spacing increments

Dual Truck Train : Headway Spacing varies from 49.213 ft to 49.213 ft using 1 increments

Headway Spacing varies from 49.213 ft to 60.000 ft using 1 increments

Dual Tandem Train: Disabled

Fatigue Truck : Enabled

Live Load Impact

Truck Loads 33.000%

Lane Loads 0.000%

Fatigue Truck 15.000%

Pedestrian Live Load 0.000e+00 plf

Load Factors

Strength I DC min 0.900 DC max 1.250 DW min 0.650 DW max 1.500 LL 1.750

Service I DC 1.000 DW 1.000 LL 1.000

Service II DC 1.000 DW 1.000 LL 1.300

Service III DC 1.000 DW 1.000 LL 0.800

Fatigue DC 0.000 DW 0.000 LL 0.750

Section A2 – QConBridge Output

Washington State Department of Transportation
 Bridge and Structures Office
 QConBridge Version 1.0

Analysis Results

DC Dead Load

Span	Point	Shear(lbs)	Moment(ft-lbs)
1	0	102.629e+03	0.000e+00
1	1	75.261e+03	978.405e+03
1	2	47.893e+03	1.655e+06
1	3	20.525e+03	2.032e+06
1	4	-6.841e+03	2.107e+06
1	5	-34.209e+03	1.881e+06
1	6	-61.577e+03	1.354e+06
1	7	-88.945e+03	526.833e+03
1	8	-116.313e+03	-602.095e+03
1	9	-143.681e+03	-2.032e+06
1	10	-171.047e+03	-3.763e+06
2	0	171.049e+03	-3.763e+06
2	1	143.681e+03	-2.032e+06
2	2	116.313e+03	-602.095e+03
2	3	88.945e+03	526.833e+03
2	4	61.577e+03	1.354e+06
2	5	34.209e+03	1.881e+06
2	6	6.841e+03	2.107e+06
2	7	-20.525e+03	2.032e+06
2	8	-47.893e+03	1.655e+06
2	9	-75.261e+03	978.405e+03
2	10	-102.627e+03	0.000e+00

DW Dead Load

Span	Point	Shear(lbs)	Moment(ft-lbs)
1	0	11.962e+03	0.000e+00
1	1	8.772e+03	114.042e+03
1	2	5.582e+03	192.994e+03
1	3	2.392e+03	236.857e+03
1	4	-797.499e+00	245.629e+03
1	5	-3.987e+03	219.312e+03
1	6	-7.177e+03	157.904e+03
1	7	-10.367e+03	61.407e+03
1	8	-13.557e+03	-70.179e+03
1	9	-16.747e+03	-236.857e+03
1	10	-19.937e+03	-438.624e+03
2	0	19.937e+03	-438.624e+03
2	1	16.747e+03	-236.857e+03
2	2	13.557e+03	-70.179e+03
2	3	10.367e+03	61.407e+03
2	4	7.177e+03	157.904e+03
2	5	3.987e+03	219.312e+03
2	6	797.499e+00	245.629e+03
2	7	-2.392e+03	236.857e+03
2	8	-5.582e+03	192.994e+03
2	9	-8.772e+03	114.042e+03
2	10	-11.962e+03	0.000e+00

Live Load Envelopes (Per Lane)

Span	Point	Min Shear (lbs)	Max Shear (lbs)	Min Moment (ft-lbs)	Max Moment (ft-lbs)
1	0	-13.341e+03	117.656e+03	0.000e+00	0.000e+00
1	1	-13.341e+03	102.204e+03	-146.752e+03	1.124e+06
1	2	-13.840e+03	84.016e+03	-293.504e+03	1.914e+06
1	3	-34.021e+03	65.643e+03	-440.256e+03	2.388e+06
1	4	-34.558e+03	51.974e+03	-587.009e+03	2.597e+06
1	5	-63.460e+03	37.680e+03	-733.761e+03	2.550e+06
1	6	-78.483e+03	26.024e+03	-880.513e+03	2.276e+06
1	7	-93.440e+03	16.112e+03	-1.027e+06	1.765e+06
1	8	-101.698e+03	8.468e+03	-1.174e+06	1.053e+06
1	9	-110.990e+03	3.304e+03	-1.469e+06	374.566e+03
1	10	-135.743e+03	0.000e+00	-2.592e+06	0.000e+00
2	0	0.000e+00	132.939e+03	-2.592e+06	0.000e+00
2	1	0.000e+00	125.632e+03	-1.469e+06	374.568e+03
2	2	-3.304e+03	110.990e+03	-1.174e+06	1.053e+06
2	3	-16.112e+03	93.440e+03	-1.027e+06	1.765e+06
2	4	-16.284e+03	80.355e+03	-880.513e+03	2.276e+06
2	5	-37.680e+03	63.460e+03	-733.761e+03	2.550e+06
2	6	-50.919e+03	48.575e+03	-587.008e+03	2.597e+06
2	7	-65.643e+03	34.021e+03	-440.256e+03	2.388e+06
2	8	-67.233e+03	21.193e+03	-293.504e+03	1.914e+06
2	9	-84.016e+03	13.840e+03	-146.752e+03	1.124e+06
2	10	-117.656e+03	13.341e+03	0.000e+00	0.000e+00

Design Tandem + Lane Envelopes (Per Lane)

Span	Point	Min Shear (lbs)	Max Shear (lbs)	Min Moment (ft-lbs)	Max Moment (ft-lbs)
1	0	-10.630e+03	95.017e+03	0.000e+00	0.000e+00
1	1	-10.630e+03	83.324e+03	-116.935e+03	916.565e+03
1	2	-11.579e+03	68.741e+03	-233.871e+03	1.578e+06
1	3	-31.053e+03	53.774e+03	-350.806e+03	1.992e+06
1	4	-31.590e+03	43.263e+03	-467.741e+03	2.170e+06
1	5	-52.774e+03	31.844e+03	-584.677e+03	2.136e+06
1	6	-64.109e+03	22.735e+03	-701.612e+03	1.908e+06
1	7	-75.554e+03	14.885e+03	-818.548e+03	1.497e+06
1	8	-82.265e+03	8.468e+03	-935.483e+03	929.199e+03
1	9	-89.847e+03	3.304e+03	-1.184e+06	374.566e+03
1	10	-108.838e+03	0.000e+00	-1.646e+06	0.000e+00
2	0	0.000e+00	106.420e+03	-1.646e+06	0.000e+00
2	1	0.000e+00	101.408e+03	-1.184e+06	374.568e+03
2	2	-3.304e+03	89.847e+03	-935.483e+03	929.201e+03
2	3	-14.885e+03	75.554e+03	-818.548e+03	1.497e+06
2	4	-15.057e+03	65.981e+03	-701.612e+03	1.908e+06
2	5	-31.844e+03	52.774e+03	-584.677e+03	2.136e+06
2	6	-42.208e+03	41.707e+03	-467.741e+03	2.170e+06
2	7	-53.774e+03	31.053e+03	-350.806e+03	1.992e+06
2	8	-55.364e+03	21.193e+03	-233.870e+03	1.578e+06
2	9	-68.741e+03	11.578e+03	-116.935e+03	916.562e+03
2	10	-95.017e+03	10.630e+03	0.000e+00	0.000e+00

Design Truck + Lane Envelopes (Per Lane)

Span	Point	Min Shear (lbs)	Max Shear (lbs)	Min Moment (ft-lbs)	Max Moment (ft-lbs)
1	0	-13.341e+03	117.656e+03	0.000e+00	0.000e+00
1	1	-13.341e+03	102.204e+03	-146.752e+03	1.124e+06
1	2	-13.840e+03	84.016e+03	-293.504e+03	1.914e+06
1	3	-34.021e+03	65.643e+03	-440.256e+03	2.388e+06
1	4	-34.558e+03	51.974e+03	-587.009e+03	2.597e+06
1	5	-63.460e+03	37.680e+03	-733.761e+03	2.550e+06
1	6	-78.483e+03	26.024e+03	-880.513e+03	2.276e+06
1	7	-93.440e+03	16.112e+03	-1.027e+06	1.765e+06
1	8	-101.698e+03	8.212e+03	-1.174e+06	1.053e+06
1	9	-110.990e+03	2.695e+03	-1.452e+06	329.425e+03
1	10	-135.743e+03	0.000e+00	-1.945e+06	0.000e+00
2	0	0.000e+00	132.939e+03	-1.945e+06	0.000e+00
2	1	0.000e+00	125.632e+03	-1.452e+06	329.427e+03
2	2	-2.695e+03	110.990e+03	-1.174e+06	1.053e+06
2	3	-16.112e+03	93.440e+03	-1.027e+06	1.765e+06
2	4	-16.284e+03	80.355e+03	-880.513e+03	2.276e+06
2	5	-37.680e+03	63.460e+03	-733.761e+03	2.550e+06
2	6	-50.919e+03	48.575e+03	-587.008e+03	2.597e+06
2	7	-65.643e+03	34.021e+03	-440.256e+03	2.388e+06
2	8	-67.233e+03	20.963e+03	-293.504e+03	1.914e+06
2	9	-84.016e+03	13.840e+03	-146.752e+03	1.124e+06
2	10	-117.656e+03	13.341e+03	0.000e+00	0.000e+00

Dual Truck Train + Lane Envelopes (Per Lane)

Span	Point	Min Shear (lbs)	Max Shear (lbs)	Min Moment (ft-lbs)	Max Moment (ft-lbs)
1	0	0.000e+00	0.000e+00	0.000e+00	0.000e+00
1	1	0.000e+00	0.000e+00	0.000e+00	0.000e+00
1	2	0.000e+00	0.000e+00	0.000e+00	0.000e+00
1	3	0.000e+00	0.000e+00	0.000e+00	0.000e+00
1	4	0.000e+00	0.000e+00	0.000e+00	0.000e+00
1	5	0.000e+00	0.000e+00	0.000e+00	0.000e+00
1	6	0.000e+00	0.000e+00	0.000e+00	0.000e+00
1	7	0.000e+00	0.000e+00	0.000e+00	0.000e+00
1	8	0.000e+00	0.000e+00	-1.066e+06	0.000e+00
1	9	0.000e+00	0.000e+00	-1.469e+06	0.000e+00
1	10	0.000e+00	0.000e+00	-2.592e+06	0.000e+00
2	0	0.000e+00	0.000e+00	-2.592e+06	0.000e+00
2	1	0.000e+00	0.000e+00	-1.469e+06	0.000e+00
2	2	0.000e+00	0.000e+00	-1.066e+06	0.000e+00
2	3	0.000e+00	0.000e+00	0.000e+00	0.000e+00
2	4	0.000e+00	0.000e+00	0.000e+00	0.000e+00
2	5	0.000e+00	0.000e+00	0.000e+00	0.000e+00
2	6	0.000e+00	0.000e+00	0.000e+00	0.000e+00
2	7	0.000e+00	0.000e+00	0.000e+00	0.000e+00
2	8	0.000e+00	0.000e+00	0.000e+00	0.000e+00
2	9	0.000e+00	0.000e+00	0.000e+00	0.000e+00
2	10	0.000e+00	0.000e+00	0.000e+00	0.000e+00

Dual Tandem Train + Lane Envelopes (Per Lane)

Span	Point	Min Shear (lbs)	Max Shear (lbs)	Min Moment (ft-lbs)	Max Moment (ft-lbs)
1	0	0.000e+00	0.000e+00	0.000e+00	0.000e+00
1	1	0.000e+00	0.000e+00	0.000e+00	0.000e+00
1	2	0.000e+00	0.000e+00	0.000e+00	0.000e+00
1	3	0.000e+00	0.000e+00	0.000e+00	0.000e+00
1	4	0.000e+00	0.000e+00	0.000e+00	0.000e+00
1	5	0.000e+00	0.000e+00	0.000e+00	0.000e+00
1	6	0.000e+00	0.000e+00	0.000e+00	0.000e+00
1	7	0.000e+00	0.000e+00	0.000e+00	0.000e+00
1	8	0.000e+00	0.000e+00	0.000e+00	0.000e+00
1	9	0.000e+00	0.000e+00	0.000e+00	0.000e+00
1	10	0.000e+00	0.000e+00	0.000e+00	0.000e+00
2	0	0.000e+00	0.000e+00	0.000e+00	0.000e+00
2	1	0.000e+00	0.000e+00	0.000e+00	0.000e+00
2	2	0.000e+00	0.000e+00	0.000e+00	0.000e+00
2	3	0.000e+00	0.000e+00	0.000e+00	0.000e+00
2	4	0.000e+00	0.000e+00	0.000e+00	0.000e+00
2	5	0.000e+00	0.000e+00	0.000e+00	0.000e+00
2	6	0.000e+00	0.000e+00	0.000e+00	0.000e+00
2	7	0.000e+00	0.000e+00	0.000e+00	0.000e+00
2	8	0.000e+00	0.000e+00	0.000e+00	0.000e+00
2	9	0.000e+00	0.000e+00	0.000e+00	0.000e+00
2	10	0.000e+00	0.000e+00	0.000e+00	0.000e+00

Fatigue Truck Envelopes (Per Lane)

Span	Point	Min Shear (lbs)	Max Shear (lbs)	Min Moment (ft-lbs)	Max Moment (ft-lbs)
1	0	-7.232e+03	67.296e+03	0.000e+00	0.000e+00
1	1	-7.232e+03	57.232e+03	-79.555e+03	629.555e+03
1	2	-7.232e+03	47.499e+03	-159.110e+03	1.044e+06
1	3	-15.733e+03	38.223e+03	-238.665e+03	1.304e+06
1	4	-15.733e+03	29.529e+03	-318.220e+03	1.384e+06
1	5	-34.143e+03	21.514e+03	-397.775e+03	1.341e+06
1	6	-43.545e+03	14.396e+03	-477.330e+03	1.229e+06
1	7	-52.395e+03	8.877e+03	-556.885e+03	966.113e+03
1	8	-56.304e+03	5.169e+03	-636.440e+03	581.739e+03
1	9	-60.568e+03	2.146e+03	-715.995e+03	219.754e+03
1	10	-74.413e+03	0.000e+00	-795.550e+03	0.000e+00
2	0	0.000e+00	74.208e+03	-795.550e+03	0.000e+00
2	1	0.000e+00	67.938e+03	-715.995e+03	219.754e+03
2	2	-2.146e+03	60.568e+03	-636.440e+03	581.740e+03
2	3	-8.877e+03	52.395e+03	-556.885e+03	966.113e+03
2	4	-8.877e+03	43.545e+03	-477.330e+03	1.229e+06
2	5	-21.514e+03	34.143e+03	-397.775e+03	1.341e+06
2	6	-29.529e+03	24.315e+03	-318.220e+03	1.384e+06
2	7	-38.223e+03	15.733e+03	-238.665e+03	1.304e+06
2	8	-38.223e+03	10.106e+03	-159.110e+03	1.044e+06
2	9	-47.499e+03	7.232e+03	-79.555e+03	629.555e+03
2	10	-67.296e+03	7.232e+03	0.000e+00	0.000e+00

Strength I Limit State Envelopes

Span	Point	Min Shear (lbs)	Max Shear (lbs)	Min Moment (ft-lbs)	Max Moment (ft-lbs)
1	0	77.169e+03	348.834e+03	0.000e+00	0.000e+00
1	1	50.464e+03	283.231e+03	746.927e+03	2.985e+06
1	2	22.899e+03	212.917e+03	1.200e+06	5.069e+06
1	3	-38.556e+03	142.284e+03	1.359e+06	6.276e+06
1	4	-69.258e+03	82.824e+03	1.225e+06	6.679e+06
1	5	-158.022e+03	31.504e+03	797.123e+03	6.291e+06
1	6	-222.887e+03	-15.272e+03	75.294e+03	5.153e+06
1	7	-287.638e+03	-59.044e+03	-940.286e+03	3.250e+06
1	8	-340.853e+03	-98.911e+03	-2.520e+06	904.573e+03
1	9	-395.850e+03	-134.508e+03	-4.975e+06	-1.452e+06
1	10	-477.465e+03	-166.902e+03	-9.031e+06	-3.671e+06
2	0	243.718e+03	472.639e+03	-9.031e+06	-3.671e+06
2	1	204.723e+03	421.062e+03	-4.975e+06	-1.452e+06
2	2	107.803e+03	356.855e+03	-2.520e+06	904.575e+03
2	3	59.044e+03	287.638e+03	-940.286e+03	3.250e+06
2	4	32.043e+03	226.111e+03	75.294e+03	5.153e+06
2	5	-31.504e+03	158.022e+03	797.124e+03	6.291e+06
2	6	-81.006e+03	93.395e+03	1.225e+06	6.679e+06
2	7	-142.284e+03	38.555e+03	1.359e+06	6.276e+06
2	8	-184.017e+03	-10.238e+03	1.200e+06	5.069e+06
2	9	-251.912e+03	-49.604e+03	746.927e+03	2.985e+06
2	10	-348.831e+03	-77.166e+03	0.000e+00	0.000e+00

Service I Limit State Envelopes

Span	Point	Min Shear (lbs)	Max Shear (lbs)	Min Moment (ft-lbs)	Max Moment (ft-lbs)
1	0	101.464e+03	230.365e+03	0.000e+00	0.000e+00
1	1	70.906e+03	184.603e+03	973.725e+03	2.001e+06
1	2	39.857e+03	136.148e+03	1.611e+06	3.397e+06
1	3	-10.558e+03	87.511e+03	1.912e+06	4.200e+06
1	4	-41.645e+03	43.503e+03	1.878e+06	4.454e+06
1	5	-100.642e+03	-1.119e+03	1.507e+06	4.164e+06
1	6	-145.983e+03	-43.147e+03	800.284e+03	3.354e+06
1	7	-191.259e+03	-83.458e+03	-242.817e+03	2.016e+06
1	8	-229.942e+03	-121.538e+03	-1.622e+06	180.339e+03
1	9	-269.644e+03	-157.177e+03	-3.457e+06	-1.965e+06
1	10	-324.556e+03	-190.984e+03	-6.298e+06	-4.201e+06
2	0	190.987e+03	321.799e+03	-6.298e+06	-4.201e+06
2	1	160.429e+03	284.051e+03	-3.457e+06	-1.965e+06
2	2	126.619e+03	239.086e+03	-1.622e+06	180.340e+03
2	3	83.458e+03	191.258e+03	-242.816e+03	2.016e+06
2	4	52.731e+03	147.825e+03	800.284e+03	3.354e+06
2	5	1.119e+03	100.642e+03	1.507e+06	4.164e+06
2	6	-42.465e+03	55.437e+03	1.878e+06	4.454e+06
2	7	-87.511e+03	10.558e+03	1.912e+06	4.200e+06
2	8	-119.634e+03	-32.622e+03	1.611e+06	3.397e+06
2	9	-166.706e+03	-70.415e+03	973.725e+03	2.001e+06
2	10	-230.363e+03	-101.462e+03	0.000e+00	0.000e+00

Service II Limit State Envelopes

Span	Point	Min Shear (lbs)	Max Shear (lbs)	Min Moment (ft-lbs)	Max Moment (ft-lbs)
1	0	97.526e+03	265.098e+03	0.000e+00	0.000e+00
1	1	66.968e+03	214.774e+03	938.108e+03	2.274e+06
1	2	35.771e+03	160.950e+03	1.540e+06	3.862e+06
1	3	-20.601e+03	106.889e+03	1.805e+06	4.780e+06
1	4	-51.846e+03	58.846e+03	1.735e+06	5.084e+06
1	5	-119.376e+03	10.003e+03	1.329e+06	4.782e+06
1	6	-169.151e+03	-35.465e+03	586.583e+03	3.907e+06
1	7	-218.842e+03	-78.702e+03	-492.134e+03	2.445e+06
1	8	-259.963e+03	-119.038e+03	-1.906e+06	436.123e+03
1	9	-302.409e+03	-156.201e+03	-3.814e+06	-1.874e+06
1	10	-364.627e+03	-190.984e+03	-6.927e+06	-4.201e+06
2	0	190.987e+03	361.042e+03	-6.927e+06	-4.201e+06
2	1	160.429e+03	321.138e+03	-3.814e+06	-1.874e+06
2	2	125.643e+03	271.851e+03	-1.906e+06	436.125e+03
2	3	78.702e+03	218.842e+03	-492.134e+03	2.445e+06
2	4	47.924e+03	171.546e+03	586.583e+03	3.907e+06
2	5	-10.003e+03	119.375e+03	1.329e+06	4.782e+06
2	6	-57.496e+03	69.776e+03	1.735e+06	5.084e+06
2	7	-106.889e+03	20.601e+03	1.805e+06	4.780e+06
2	8	-139.481e+03	-26.366e+03	1.540e+06	3.862e+06
2	9	-191.508e+03	-66.329e+03	938.108e+03	2.274e+06
2	10	-265.095e+03	-97.524e+03	0.000e+00	0.000e+00

Service III Limit State Envelopes

Span	Point	Min Shear (lbs)	Max Shear (lbs)	Min Moment (ft-lbs)	Max Moment (ft-lbs)
1	0	104.090e+03	207.211e+03	0.000e+00	0.000e+00
1	1	73.532e+03	164.489e+03	997.469e+03	1.820e+06
1	2	42.581e+03	119.614e+03	1.658e+06	3.087e+06
1	3	-3.863e+03	74.593e+03	1.983e+06	3.814e+06
1	4	-34.844e+03	33.274e+03	1.973e+06	4.033e+06
1	5	-88.153e+03	-8.535e+03	1.625e+06	3.751e+06
1	6	-130.537e+03	-48.269e+03	942.751e+03	2.986e+06
1	7	-172.869e+03	-86.629e+03	-76.605e+03	1.730e+06
1	8	-209.928e+03	-123.204e+03	-1.432e+06	9.816e+03
1	9	-247.801e+03	-157.827e+03	-3.219e+06	-2.026e+06
1	10	-297.841e+03	-190.984e+03	-5.879e+06	-4.201e+06
2	0	190.987e+03	295.636e+03	-5.879e+06	-4.201e+06
2	1	160.429e+03	259.327e+03	-3.219e+06	-2.026e+06
2	2	127.269e+03	217.243e+03	-1.432e+06	9.817e+03
2	3	86.629e+03	172.869e+03	-76.605e+03	1.730e+06
2	4	55.936e+03	132.011e+03	942.751e+03	2.986e+06
2	5	8.535e+03	88.153e+03	1.625e+06	3.751e+06
2	6	-32.444e+03	45.877e+03	1.973e+06	4.033e+06
2	7	-74.593e+03	3.862e+03	1.983e+06	3.814e+06
2	8	-106.402e+03	-36.793e+03	1.658e+06	3.087e+06
2	9	-150.172e+03	-73.139e+03	997.469e+03	1.820e+06
2	10	-207.208e+03	-104.087e+03	0.000e+00	0.000e+00

Fatigue Limit State Envelopes

Span	Point	Min Shear (lbs)	Max Shear (lbs)	Min Moment (ft-lbs)	Max Moment (ft-lbs)
1	0	-3.531e+03	32.857e+03	0.000e+00	0.000e+00
1	1	-3.531e+03	27.943e+03	-27.327e+03	216.252e+03
1	2	-3.531e+03	23.191e+03	-54.654e+03	358.952e+03
1	3	-7.681e+03	18.662e+03	-81.981e+03	448.201e+03
1	4	-7.681e+03	14.417e+03	-109.308e+03	475.633e+03
1	5	-16.670e+03	10.504e+03	-136.635e+03	460.659e+03
1	6	-21.261e+03	7.029e+03	-163.962e+03	422.252e+03
1	7	-25.582e+03	4.334e+03	-191.290e+03	331.859e+03
1	8	-27.490e+03	2.524e+03	-218.617e+03	199.827e+03
1	9	-29.572e+03	1.047e+03	-245.944e+03	75.485e+03
1	10	-36.332e+03	0.000e+00	-273.271e+03	0.000e+00
2	0	0.000e+00	36.232e+03	-273.271e+03	0.000e+00
2	1	0.000e+00	33.170e+03	-245.944e+03	75.485e+03
2	2	-1.047e+03	29.572e+03	-218.617e+03	199.827e+03
2	3	-4.334e+03	25.582e+03	-191.290e+03	331.859e+03
2	4	-4.334e+03	21.261e+03	-163.962e+03	422.252e+03
2	5	-10.504e+03	16.670e+03	-136.635e+03	460.659e+03
2	6	-14.417e+03	11.872e+03	-109.308e+03	475.633e+03
2	7	-18.662e+03	7.681e+03	-81.981e+03	448.201e+03
2	8	-18.662e+03	4.934e+03	-54.654e+03	358.952e+03
2	9	-23.191e+03	3.531e+03	-27.327e+03	216.252e+03
2	10	-32.857e+03	3.531e+03	0.000e+00	0.000e+00

Section A3 – Opis Input

The computer program Opis is used to analyze the prestressed concrete example problem. This program is part of the AASHTOware software suite. The input data for Opis is provided on the following pages.

```

4-1.1      ANALYSIS                B, 2, REV, S
           1. Analysis Model        : B
           2. Loading Sequence      : 2
           3. Analysis Type         : REV
           4. Element               : S
4-1.2      POINT-OF-INTEREST      T, ON, ON
           1. Point of Interest Control : T
           2. Specification Checks    : ON
           3. Load Factoring/Combination : ON
4-3.1      DIST-CONTROL-GIRDER    2
           1. Girder of Interest     : 2
4-3.2      DIST-CONTROL-DL        TA, UD
           1. Stage 1 Method         : TA
           2. Stage 2 Method         : UD
           3. Stage 3 Method         : UD
3-1.1      COMMENT                BRASS will compute the number of lanes loaded.
4-3.3      DIST-CONTROL-LL        K, , 20.00, 0.200, YES
           1. Cross Section Code     : K
           2. No. Lanes Loaded       :
           3. Skew Angle              : 20.000
           4. Poisson's Ratio        : 0.200
           5. Rigid Method            : YES
4-3.5      DIST-LL-APPLICATION    AP
           1. Dist. Factors           : AP
5-1.1      OUTPUT                 0, ON, OFF, OFF, 1
           1. Action Output Level     : 0
           2. Girder Properties       : ON
           3. Truck Position          : OFF
           4. Rear Axle Spacing       : OFF
           5. Interm. Output Level    : 1
           6. Live Load Settings      : YES
           7. Live Load Combinations : YES
           8. Live Load Details       : NO
           9. Load Combinations       : YES
           10. Load & Resist. Factors : YES
           11. Critical DRs or RFs    : E
           12. Warnings                : YES
           13. Girder Self-Load       : YES
           14. Distributed Dead Loads : YES
5-4.1      OUTPUT-STAGE           ON, ON, ON
           1. Stage 1                 : ON
           2. Stage 2                 : ON
           3. Stage 3                 : ON
5-4.2      OUTPUT-LIMIT-STATE     ST, 1, ON, ON
           1. Limit State              : ST
           2. Limit State Level       : 1
           3. Intermediate Output     : ON
           4. Load Comb. Output       : ON
5-4.2      OUTPUT-LIMIT-STATE     ST, 2, ON, ON
           1. Limit State              : ST
           2. Limit State Level       : 2
           3. Intermediate Output     : ON
           4. Load Comb. Output       : ON
5-4.2      OUTPUT-LIMIT-STATE     ST, 3, ON, ON
           1. Limit State              : ST
           2. Limit State Level       : 3

```



```

        3. Intermediate Output      : ON
        4. Load Comb. Output       : ON
5-4.2  OUTPUT-LIMIT-STATE   ST, 4, ON, ON
        1. Limit State             : ST
        2. Limit State Level       : 4
        3. Intermediate Output     : ON
        4. Load Comb. Output       : ON
5-4.2  OUTPUT-LIMIT-STATE   SE, 1, ON, ON
        1. Limit State             : SE
        2. Limit State Level       : 1
        3. Intermediate Output     : ON
        4. Load Comb. Output       : ON
5-4.2  OUTPUT-LIMIT-STATE   SE, 2, ON, ON
        1. Limit State             : SE
        2. Limit State Level       : 2
        3. Intermediate Output     : ON
        4. Load Comb. Output       : ON
5-4.2  OUTPUT-LIMIT-STATE   SE, 3, ON, ON
        1. Limit State             : SE
        2. Limit State Level       : 3
        3. Intermediate Output     : ON
        4. Load Comb. Output       : ON
5-4.2  OUTPUT-LIMIT-STATE   SE, 4, OFF, OFF
        1. Limit State             : SE
        2. Limit State Level       : 4
        3. Intermediate Output     : OFF
        4. Load Comb. Output       : OFF
5-4.2  OUTPUT-LIMIT-STATE   FA, 1, ON, ON
        1. Limit State             : FA
        2. Limit State Level       : 1
        3. Intermediate Output     : ON
        4. Load Comb. Output       : ON
5-7.1  OUTPUT-PRESTRESS    OFF, OFF, OFF, OFF, OFF
        1. Load Balancing          : OFF
        2. Final Prestress Losses  : OFF
        3. Intermediate Prestress Losses : OFF
        4. Prestress Action Losses : OFF
        5. Ave & Effect Prestress Stress : OFF
5-5.1  OUTPUT-DIST-DL      OFF, ON
        1. Intermediate Output (DL) : OFF
        2. Final Output (DL)       : ON
5-5.2  OUTPUT-DIST-LL      OFF, ON
        1. Intermediate Output (LL) : OFF
        2. Final Output (LL)       : ON
3-1.1  COMMENT             Actual girder spacings are entered on DECK-VSPACING command.
6-1.1  DECK-GEOMETRY       6, 1.000, 8.000, 42.2496, 42.2304, 0.000, DC
        1. Number Girders          : 6
        2. Girder Spacing          : 1.000
        3. Slab Thickness (strength) : 8.000
        4. Left Cantilever         : 42.250
        5. Right Cantilever        : 42.230
        6. Sac. Topping Thickness  : 0.000
        7. Topping Dead Load Type  : DC
6-1.2  DECK-VSPACING       1, 116.0040
        1. Bay Number             : 1
        2. Spacing                 : 116.004
6-1.2  DECK-VSPACING       2, 116.0040
        1. Bay Number             : 2
        2. Spacing                 : 116.004
6-1.2  DECK-VSPACING       3, 116.0040
        1. Bay Number             : 3
        2. Spacing                 : 116.004
6-1.2  DECK-VSPACING       4, 116.0040

```

```

1. Bay Number : 4
2. Spacing : 116.004
6-1.2 DECK-VSPACING 5, 116.0040
1. Bay Number : 5
2. Spacing : 116.004
3-1.1 COMMENT WS Load = 0.1400 kcf X 0.2142 ft = 0.0300 ksf
6-4.1 DECK-MATL-PROPERTIES 0.150, , 0.0300
1. Deck Concrete Density : 0.1500
2. Curb & Median Concrete Density: 0.1500
3. Wearing Surface Weight : 0.0300
3-1.1 COMMENT The line and uniform deck loads are generated with the load
3-1.1 COMMENT group commands because they are assigned to load groups.
6-6.1 DECK-STAGE 1, , 2
1. Slab Stage : 1
2. Curb Stage :
3. Median Stage :
4. Wearing Surface Stage : 2
6-3.3 DECK-TRAVEL-WAY 20.2500, 644.2500
1. Left Edge of Travel Way : 20.250
2. Right Edge of Travel Way : 644.250
3-1.1 COMMENT Cross Section 1
3-1.1 COMMENT Beam Name: AASHTO TYPE VI
8-2.4 CONC-I-SECTION 1, 42.00, 5.00, 8.00, 8.00, 28.00, 8.00
1. Cross Section Number : 1
2. Top Flange Width : 42.000
3. Top Flange Thickness : 5.000
4. Top Web Thickness : 8.000
5. Bottom Web Thickness : 8.000
6. Bottom Flange Width : 28.000
7. Bottom Flange Thickness : 8.000
8-2.7 CONC-FILLETTS 1, 3.000, 0.000, 4.000, 4.000, &
10.000, 0.000, 0.000, 0.000
1. Cross Section Number : 1
2. Top Tapers Height : 3.000
3. Top Tapers Distance : 0.000
4. Top Fillets Height : 4.000
5. Top Fillets Width : 4.000
6. Bottom Tapers Height : 10.000
7. Bottom Tapers Distance : 0.000
8. Bottom Fillets Height : 0.000
9. Bottom Fillets Width : 0.000
10-2.1 COMPOSITE-SLAB 1, 111.0000, 7.5000, 0.0000
1. Cross Section Number : 1
2. Effective Width : 111.000
3. Effective Thickness : 7.500
4. Gap Distance : 0.000
10-2.2 COMPOSITE-REBAR 1, T, 10.000, 4, 4.2500
1. Cross Section Number : 1
2. Row Designation : T
3. Number of Reinforcing Bars : 10.000
4. Bar Size : 4
5. Distance to Bar Center : 4.250
10-2.2 COMPOSITE-REBAR 1, B, 12.000, 5, 1.9375
1. Cross Section Number : 1
2. Row Designation : B
3. Number of Reinforcing Bars : 12.000
4. Bar Size : 5
5. Distance to Bar Center : 1.938
3-1.1 COMMENT Cross Section 2
3-1.1 COMMENT Beam Name: AASHTO TYPE VI
8-2.4 CONC-I-SECTION 2, 42.00, 5.00, 8.00, 8.00, 28.00, 8.00
1. Cross Section Number : 2
2. Top Flange Width : 42.000

```

```

3. Top Flange Thickness      :      5.000
4. Top Web Thickness         :      8.000
5. Bottom Web Thickness     :      8.000
6. Bottom Flange Width      :     28.000
7. Bottom Flange Thickness  :      8.000
8-2.7  CONC-FILLETS        2, 3.000, 0.000, 4.000, 4.000, &
      10.000, 0.000, 0.000, 0.000
      1. Cross Section Number :      2
      2. Top Tapers Height    :      3.000
      3. Top Tapers Distance  :      0.000
      4. Top Fillets Height   :      4.000
      5. Top Fillets Width    :      4.000
      6. Bottom Tapers Height :     10.000
      7. Bottom Tapers Distance :      0.000
      8. Bottom Fillets Height :      0.000
      9. Bottom Fillets Width :      0.000
10-2.1  COMPOSITE-SLAB     2, 111.0000, 7.5000, 0.0000
      1. Cross Section Number :      2
      2. Effective Width      :     111.000
      3. Effective Thickness  :      7.500
      4. Gap Distance         :      0.000
10-2.2  COMPOSITE-REBAR    2, B, 12.000, 6, 2.0000
      1. Cross Section Number :      2
      2. Row Designation      :      B
      3. Number of Reinforcing Bars :     12.000
      4. Bar Size             :      6
      5. Distance to Bar Center :      2.000
10-2.2  COMPOSITE-REBAR    2, B, 21.000, 6, 3.6250
      1. Cross Section Number :      2
      2. Row Designation      :      B
      3. Number of Reinforcing Bars :     21.000
      4. Bar Size             :      6
      5. Distance to Bar Center :      3.625
3-1.1  COMMENT            Cross Section 3
3-1.1  COMMENT            Beam Name: AASHTO TYPE VI
8-2.4  CONC-I-SECTION      3, 42.00, 5.00, 8.00, 8.00, 28.00, 8.00
      1. Cross Section Number :      3
      2. Top Flange Width     :     42.000
      3. Top Flange Thickness :      5.000
      4. Top Web Thickness    :      8.000
      5. Bottom Web Thickness :      8.000
      6. Bottom Flange Width  :     28.000
      7. Bottom Flange Thickness :      8.000
8-2.7  CONC-FILLETS        3, 3.000, 0.000, 4.000, 4.000, &
      10.000, 0.000, 0.000, 0.000
      1. Cross Section Number :      3
      2. Top Tapers Height    :      3.000
      3. Top Tapers Distance  :      0.000
      4. Top Fillets Height   :      4.000
      5. Top Fillets Width    :      4.000
      6. Bottom Tapers Height :     10.000
      7. Bottom Tapers Distance :      0.000
      8. Bottom Fillets Height :      0.000
      9. Bottom Fillets Width :      0.000
8-2.8  CONC-REBAR          3, 1, 5.000, 5, 4.0000
      1. Cross Section Number :      3
      2. Row Number           :      1
      3. Number of Reinforcing Bars :      5.000
      4. Bar Size             :      5
      5. Distance to Bar Center :      4.000
10-2.1  COMPOSITE-SLAB     3, 111.0000, 7.5000, 0.0000
      1. Cross Section Number :      3
      2. Effective Width      :     111.000

```

```

3. Effective Thickness          :      7.500
4. Gap Distance                :      0.000
10-2.2 COMPOSITE-REBAR      3, B, 12.000, 6, 2.0000
1. Cross Section Number       :      3
2. Row Designation            :      B
3. Number of Reinforcing Bars  :     12.000
4. Bar Size                    :      6
5. Distance to Bar Center     :      2.000
10-2.2 COMPOSITE-REBAR      3, B, 21.000, 6, 3.6250
1. Cross Section Number       :      3
2. Row Designation            :      B
3. Number of Reinforcing Bars  :     21.000
4. Bar Size                    :      6
5. Distance to Bar Center     :      3.625
8-1.1 CONC-MATERIALS      0.150, 6.000, 60.00, 60.00, &
6.175, 4695.982, 0.588, , 3.000, YES, 0.000600
1. Density                     :      0.1500
2. f'c                         :      6.000
3. fy                          :     60.000
4. fys                         :     60.000
5. n                           :      6.175
6. Ec                          :     4695.982
7. fr                          :      0.588
8. Z                           :     170.000
9. m                           :      3.000
10. Use Creep                   :      Y
11. Thermal Expansion Coefficient : 0.000600
10-1.1 COMPOSITE-MATERIALS 4.000, 60.000, 7.600, 3.000, 0.480, 130.00
1. f'c                         :      4.000
2. fy                          :     60.000
3. Modular Ratio               :      7.600
4. Creep Factor                 :      3.000
5. fr                          :      0.480
6. Z                           :     130.000
9-1.1 PRESTRESS-MATERIALS 4.800, 6.000, 70.000, 100.000, 4200.214
1. f'ci                        :      4.800
2. Modular Ratio               :      6.000
3. Relative Humidity           :     70.000
4. % V/S                       :    100.000
5. Eci                         :     4200.214
3-1.1 COMMENT                Span 1
11-1.5 SPAN-GENERAL-LENGTH 1, 1320.0000
1. Span Number                  :      1
2. Span Length                  :     1320.000
11-1.6 SPAN-GENERAL-SEGMENT 1, 59.0000, L, 1320.0000, 59.0000
1. Span Number                  :      1
2. Web Depth (Left End)        :      59.000
3. Web Variation Indicator     :      L
4. Range to Segment End       :     1320.000
5. Web Depth (Right End)      :      59.000
11-2.1 SPAN-SECTION         1, 1, 990.0000, 1
1. Span Number                  :      1
2. Cross Section Number (Left) :      1
3. Distance to X-Section Change :     990.000
4. Cross Section Number (Right) :      1
11-2.1 SPAN-SECTION         1, 2, 1188.0000, 2
1. Span Number                  :      1
2. Cross Section Number (Left) :      2
3. Distance to X-Section Change :     1188.000
4. Cross Section Number (Right) :      2
11-2.1 SPAN-SECTION         1, 3, 1320.0000, 3
1. Span Number                  :      1
2. Cross Section Number (Left) :      3

```

```

3. Distance to X-Section Change : 1320.000
4. Cross Section Number (Right) : 3
3-1.1 COMMENT Span 2
11-1.5 SPAN-GENERAL-LENGTH 2, 1320.0000
      1. Span Number : 2
      2. Span Length : 1320.000
11-1.6 SPAN-GENERAL-SEGMENT 2, 59.0000, L, 1320.0000, 59.0000
      1. Span Number : 2
      2. Web Depth (Left End) : 59.000
      3. Web Variation Indicator : L
      4. Range to Segment End : 1320.000
      5. Web Depth (Right End) : 59.000
11-2.1 SPAN-SECTION 2, 3, 132.0000, 3
      1. Span Number : 2
      2. Cross Section Number (Left) : 3
      3. Distance to X-Section Change : 132.000
      4. Cross Section Number (Right) : 3
11-2.1 SPAN-SECTION 2, 2, 330.0000, 2
      1. Span Number : 2
      2. Cross Section Number (Left) : 2
      3. Distance to X-Section Change : 330.000
      4. Cross Section Number (Right) : 2
11-2.1 SPAN-SECTION 2, 1, 1320.0000, 1
      1. Span Number : 2
      2. Cross Section Number (Left) : 1
      3. Distance to X-Section Change : 1320.000
      4. Cross Section Number (Right) : 1
11-4.1 SUPPORT-FIXITY 1, R, R, F
      1. Support Number : 1
      2. Horizontal Restraint : R
      3. Vertical Restraint : R
      4. Rotational Restraint : F
11-4.1 SUPPORT-FIXITY 2, F, R, F
      1. Support Number : 2
      2. Horizontal Restraint : F
      3. Vertical Restraint : R
      4. Rotational Restraint : F
11-4.1 SUPPORT-FIXITY 3, F, R, F
      1. Support Number : 3
      2. Horizontal Restraint : F
      3. Vertical Restraint : R
      4. Rotational Restraint : F
8-4.1 CONC-SHEAR-CONSTANTS 3, 100.000, 1.000
      1. Shear Indicator : 3
      2. % Shear : 100.000
      3. Lightweight Concrete Factor : 1.000
3-1.1 COMMENT Stirrup Schedules
3-1.1 COMMENT Stirrup Group 1: #4 Vert Shear Reinf.
8-4.2 STIRRUP-GROUP 1, 0.4000, 90.000, 200.000
      1. Stirrup Number : 1
      2. Stirrup Area : 0.400
      3. Stirrup Angle : 90.000
      4. % Stir. Area for Horz Shear : 200.000
8-4.3 STIRRUP-SCHEDULE 1, 1, 1.5600, 0.0000, 1.5600
      1. Span Number : 1
      2. Stirrup Number : 1
      3. Stirrup Spacing : 1.560
      4. Start Distance : 0.000
      5. Range : 1.560
3-1.1 COMMENT Stirrup Group 2: #4 Vert Shear Reinf.
8-4.2 STIRRUP-GROUP 2, 0.4000, 90.000, 300.000
      1. Stirrup Number : 2
      2. Stirrup Area : 0.400

```

```

3. StIRRUP Angle : 90.000
4. % Stir. Area for Horz Shear : 300.000
8-4.3 STIRRUP-SCHEDULE 1, 2, 3.0000, 1.5600, 3.0000
1. Span Number : 1
2. StIRRUP Number : 2
3. StIRRUP Spacing : 3.000
4. Start Distance : 1.560
5. Range : 3.000
3-1.1 COMMENT StIRRUP Group 3: #4 Vert Shear Reinf.
8-4.2 STIRRUP-GROUP 3, 0.4000, 90.000, 100.000
1. StIRRUP Number : 3
2. StIRRUP Area : 0.400
3. StIRRUP Angle : 90.000
4. % Stir. Area for Horz Shear : 100.000
8-4.3 STIRRUP-SCHEDULE 1, 3, 5.9400, 4.5600, 5.9400
1. Span Number : 1
2. StIRRUP Number : 3
3. StIRRUP Spacing : 5.940
4. Start Distance : 4.560
5. Range : 5.940
3-1.1 COMMENT StIRRUP Group 4: #4 Vert Shear Reinf.
8-4.2 STIRRUP-GROUP 4, 0.4000, 90.000, 286.667
1. StIRRUP Number : 4
2. StIRRUP Area : 0.400
3. StIRRUP Angle : 90.000
4. % Stir. Area for Horz Shear : 286.667
8-4.3 STIRRUP-SCHEDULE 1, 4, 6.0000, 10.5000, 84.0000
1. Span Number : 1
2. StIRRUP Number : 4
3. StIRRUP Spacing : 6.000
4. Start Distance : 10.500
5. Range : 84.000
3-1.1 COMMENT StIRRUP Group 5: #4 Vert Shear Reinf.
8-4.2 STIRRUP-GROUP 5, 0.4000, 90.000, 233.333
1. StIRRUP Number : 5
2. StIRRUP Area : 0.400
3. StIRRUP Angle : 90.000
4. % Stir. Area for Horz Shear : 233.333
8-4.3 STIRRUP-SCHEDULE 1, 5, 16.0000, 94.5000, 32.0000
1. Span Number : 1
2. StIRRUP Number : 5
3. StIRRUP Spacing : 16.000
4. Start Distance : 94.500
5. Range : 32.000
3-1.1 COMMENT StIRRUP Group 6: #4 Vert Shear Reinf.
8-4.2 STIRRUP-GROUP 6, 0.4000, 90.000, 260.000
1. StIRRUP Number : 6
2. StIRRUP Area : 0.400
3. StIRRUP Angle : 90.000
4. % Stir. Area for Horz Shear : 260.000
8-4.3 STIRRUP-SCHEDULE 1, 6, 18.0000, 126.5000, 72.0000
1. Span Number : 1
2. StIRRUP Number : 6
3. StIRRUP Spacing : 18.000
4. Start Distance : 126.500
5. Range : 72.000
3-1.1 COMMENT StIRRUP Group 7: #4 Vert Shear Reinf.
8-4.2 STIRRUP-GROUP 7, 0.4000, 90.000, 275.000
1. StIRRUP Number : 7
2. StIRRUP Area : 0.400
3. StIRRUP Angle : 90.000
4. % Stir. Area for Horz Shear : 275.000
8-4.3 STIRRUP-SCHEDULE 1, 7, 20.0000, 198.5000, 140.0000

```

```

1. Span Number           : 1
2. Stirrup Number       : 7
3. Stirrup Spacing      : 20.000
4. Start Distance       : 198.500
5. Range                 : 140.000
3-1.1 COMMENT           Stirrup Group 8: #4 Vert Shear Reinf.
8-4.2 STIRRUP-GROUP     8, 0.4000, 90.000, 292.857
    1. Stirrup Number    : 8
    2. Stirrup Area      : 0.400
    3. Stirrup Angle     : 90.000
    4. % Stir. Area for Horz Shear : 292.857
8-4.3 STIRRUP-SCHEDULE  1, 8, 24.0000, 338.5000, 648.0001
    1. Span Number      : 1
    2. Stirrup Number    : 8
    3. Stirrup Spacing  : 24.000
    4. Start Distance   : 338.500
    5. Range            : 648.000
8-4.3 STIRRUP-SCHEDULE  1, 1, 19.0200, 986.5001, 19.0199
    1. Span Number      : 1
    2. Stirrup Number    : 1
    3. Stirrup Spacing  : 19.020
    4. Start Distance   : 986.500
    5. Range            : 19.020
8-4.3 STIRRUP-SCHEDULE  1, 5, 19.0000, 1005.5200, 38.0000
    1. Span Number      : 1
    2. Stirrup Number    : 5
    3. Stirrup Spacing  : 19.000
    4. Start Distance   : 1005.520
    5. Range            : 38.000
8-4.3 STIRRUP-SCHEDULE  1, 7, 11.0000, 1043.5200, 77.0000
    1. Span Number      : 1
    2. Stirrup Number    : 7
    3. Stirrup Spacing  : 11.000
    4. Start Distance   : 1043.520
    5. Range            : 77.000
3-1.1 COMMENT           Stirrup Group 9: #4 Vert Shear Reinf.
8-4.2 STIRRUP-GROUP     9, 0.4000, 90.000, 284.615
    1. Stirrup Number    : 9
    2. Stirrup Area      : 0.400
    3. Stirrup Angle     : 90.000
    4. % Stir. Area for Horz Shear : 284.615
8-4.3 STIRRUP-SCHEDULE  1, 9, 7.0000, 1120.5200, 84.0000
    1. Span Number      : 1
    2. Stirrup Number    : 9
    3. Stirrup Spacing  : 7.000
    4. Start Distance   : 1120.520
    5. Range            : 84.000
8-4.3 STIRRUP-SCHEDULE  1, 1, 6.0400, 1204.5200, 6.0400
    1. Span Number      : 1
    2. Stirrup Number    : 1
    3. Stirrup Spacing  : 6.040
    4. Start Distance   : 1204.520
    5. Range            : 6.040
3-1.1 COMMENT           Stirrup Group 10: #4 Vert Shear Reinf.
8-4.2 STIRRUP-GROUP    10, 0.4000, 90.000, 287.500
    1. Stirrup Number    : 10
    2. Stirrup Area      : 0.400
    3. Stirrup Angle     : 90.000
    4. % Stir. Area for Horz Shear : 287.500
8-4.3 STIRRUP-SCHEDULE  1, 10, 6.0000, 1210.5600, 90.0000
    1. Span Number      : 1
    2. Stirrup Number    : 10
    3. Stirrup Spacing  : 6.000

```

		4. Start Distance	:	1210.560
		5. Range	:	90.000
8-4.3	STIRRUP-SCHEDULE	1, 5, 3.0000, 1300.5600, 6.0000		
		1. Span Number	:	1
		2. Stirrup Number	:	5
		3. Stirrup Spacing	:	3.000
		4. Start Distance	:	1300.560
		5. Range	:	6.000
8-4.3	STIRRUP-SCHEDULE	1, 1, 1.4400, 1306.5600, 1.4400		
		1. Span Number	:	1
		2. Stirrup Number	:	1
		3. Stirrup Spacing	:	1.440
		4. Start Distance	:	1306.560
		5. Range	:	1.440
8-4.3	STIRRUP-SCHEDULE	1, 3, 1.5600, 1308.0000, 1.5600		
		1. Span Number	:	1
		2. Stirrup Number	:	3
		3. Stirrup Spacing	:	1.560
		4. Start Distance	:	1308.000
		5. Range	:	1.560
8-4.3	STIRRUP-SCHEDULE	1, 1, 3.0000, 1309.5600, 3.0000		
		1. Span Number	:	1
		2. Stirrup Number	:	1
		3. Stirrup Spacing	:	3.000
		4. Start Distance	:	1309.560
		5. Range	:	3.000
8-4.3	STIRRUP-SCHEDULE	1, 1, 1.5000, 1312.5600, 1.5000		
		1. Span Number	:	1
		2. Stirrup Number	:	1
		3. Stirrup Spacing	:	1.500
		4. Start Distance	:	1312.560
		5. Range	:	1.500
8-4.3	STIRRUP-SCHEDULE	1, 1, 1.5000, 1314.0600, 5.9400		
		1. Span Number	:	1
		2. Stirrup Number	:	1
		3. Stirrup Spacing	:	1.500
		4. Start Distance	:	1314.060
		5. Range	:	5.940
8-4.3	STIRRUP-SCHEDULE	2, 1, 3.0600, 4.5000, 3.0600		
		1. Span Number	:	2
		2. Stirrup Number	:	1
		3. Stirrup Spacing	:	3.060
		4. Start Distance	:	4.500
		5. Range	:	3.060
8-4.3	STIRRUP-SCHEDULE	2, 2, 3.0000, 7.5600, 3.0000		
		1. Span Number	:	2
		2. Stirrup Number	:	2
		3. Stirrup Spacing	:	3.000
		4. Start Distance	:	7.560
		5. Range	:	3.000
8-4.3	STIRRUP-SCHEDULE	2, 1, 1.4400, 10.5600, 1.4400		
		1. Span Number	:	2
		2. Stirrup Number	:	1
		3. Stirrup Spacing	:	1.440
		4. Start Distance	:	10.560
		5. Range	:	1.440
8-4.3	STIRRUP-SCHEDULE	2, 1, 1.5600, 12.0000, 1.5600		
		1. Span Number	:	2
		2. Stirrup Number	:	1
		3. Stirrup Spacing	:	1.560
		4. Start Distance	:	12.000
		5. Range	:	1.560
8-4.3	STIRRUP-SCHEDULE	2, 2, 3.0000, 13.5600, 3.0000		

```

1. Span Number           : 2
2. Stirrup Number       : 2
3. Stirrup Spacing      : 3.000
4. Start Distance      : 13.560
5. Range                 : 3.000
8-4.3 STIRRUP-SCHEDULE   2, 10, 6.0000, 16.5600, 90.0000
1. Span Number           : 2
2. Stirrup Number       : 10
3. Stirrup Spacing      : 6.000
4. Start Distance      : 16.560
5. Range                 : 90.000
8-4.3 STIRRUP-SCHEDULE   2, 5, 16.0000, 106.5600, 32.0000
1. Span Number           : 2
2. Stirrup Number       : 5
3. Stirrup Spacing      : 16.000
4. Start Distance      : 106.560
5. Range                 : 32.000
8-4.3 STIRRUP-SCHEDULE   2, 1, 18.0400, 138.5600, 18.0400
1. Span Number           : 2
2. Stirrup Number       : 1
3. Stirrup Spacing      : 18.040
4. Start Distance      : 138.560
5. Range                 : 18.040
3-1.1 COMMENT           Stirrup Group 11: #4 Vert Shear Reinf.
8-4.2 STIRRUP-GROUP      11, 0.4000, 90.000, 250.000
1. Stirrup Number       : 11
2. Stirrup Area         : 0.400
3. Stirrup Angle        : 90.000
4. % Stir. Area for Horz Shear : 250.000
8-4.3 STIRRUP-SCHEDULE   2, 11, 18.0000, 156.6000, 54.0000
1. Span Number           : 2
2. Stirrup Number       : 11
3. Stirrup Spacing      : 18.000
4. Start Distance      : 156.600
5. Range                 : 54.000
8-4.3 STIRRUP-SCHEDULE   2, 7, 20.0000, 210.6000, 140.0000
1. Span Number           : 2
2. Stirrup Number       : 7
3. Stirrup Spacing      : 20.000
4. Start Distance      : 210.600
5. Range                 : 140.000
8-4.3 STIRRUP-SCHEDULE   2, 8, 24.0000, 350.6000, 648.0001
1. Span Number           : 2
2. Stirrup Number       : 8
3. Stirrup Spacing      : 24.000
4. Start Distance      : 350.600
5. Range                 : 648.000
8-4.3 STIRRUP-SCHEDULE   2, 11, 19.0000, 998.6001, 56.9999
1. Span Number           : 2
2. Stirrup Number       : 11
3. Stirrup Spacing      : 19.000
4. Start Distance      : 998.600
5. Range                 : 57.000
8-4.3 STIRRUP-SCHEDULE   2, 7, 11.0000, 1055.6000, 77.0000
1. Span Number           : 2
2. Stirrup Number       : 7
3. Stirrup Spacing      : 11.000
4. Start Distance      : 1055.600
5. Range                 : 77.000
8-4.3 STIRRUP-SCHEDULE   2, 9, 7.0000, 1132.6000, 84.0000
1. Span Number           : 2
2. Stirrup Number       : 9
3. Stirrup Spacing      : 7.000

```

```

4. Start Distance          : 1132.600
5. Range                   : 84.000
3-1.1 COMMENT              Stirrup Group 12: #4 Vert Shear Reinf.
8-4.2 STIRRUP-GROUP        12, 0.4000, 90.000, 288.235
    1. Stirrup Number      : 12
    2. Stirrup Area        : 0.400
    3. Stirrup Angle       : 90.000
    4. % Stir. Area for Horz Shear : 288.235
8-4.3 STIRRUP-SCHEDULE     2, 12, 6.0000, 1216.6000, 96.0000
    1. Span Number        : 2
    2. Stirrup Number     : 12
    3. Stirrup Spacing    : 6.000
    4. Start Distance     : 1216.600
    5. Range              : 96.000
8-4.3 STIRRUP-SCHEDULE     2, 5, 3.0000, 1312.6000, 6.0000
    1. Span Number        : 2
    2. Stirrup Number     : 5
    3. Stirrup Spacing    : 3.000
    4. Start Distance     : 1312.600
    5. Range              : 6.000
8-4.3 STIRRUP-SCHEDULE     2, 3, 1.4000, 1318.6000, 1.4000
    1. Span Number        : 2
    2. Stirrup Number     : 3
    3. Stirrup Spacing    : 1.400
    4. Start Distance     : 1318.600
    5. Range              : 1.400
8-4.3 STIRRUP-SCHEDULE     2, 1, 3.0600, 0.0000, 4.5000
    1. Span Number        : 2
    2. Stirrup Number     : 1
    3. Stirrup Spacing    : 3.060
    4. Start Distance     : 0.000
    5. Range              : 4.500
3-1.1 COMMENT              Concrete Stress Limits Schedules
3-1.1 COMMENT              Concrete Stress Limits Group 1: Stress Limit Set #1
9-8.1 CONC-STLIM-GROUP     1, 2.880, 0.480, 2.700, 3.600, 0.465, &
    , 2.880, 0.480, 2.700, 3.600, 0.465, &
    ,
    1. Group Number      : 1
    2. fcb (Girder)      : 2.880
    3. ftb (Girder)      : 0.480
    4. fca (Girder) (DL+PS) : 2.700
    5. fca (Girder) (DL+PS+LL) : 3.600
    6. fta (Girder)      : 0.465
    7. fc (Slab)         :
    8. fcb (Flange)      : 2.880
    9. ftb (Flange)      : 0.480
    10. fca (Flange) (DL+PS) : 2.700
    11. fca (Flange) (DL+PS+LL) : 3.600
    12. fta (Flange)     : 0.465
    13. fca (Girder) (0.5[DL+PS]+LL) :
    14. fca (Flange) (0.5[DL+PS]+LL) :
9-8.2 CONC-STLIM-SCHEDULE  1, 1, 0.0000, 1317.0000
    1. Span Number      : 1
    2. Group Number     : 1
    3. Start Distance   : 0.000
    4. Range            : 1317.000
9-8.2 CONC-STLIM-SCHEDULE  1, 1, 1317.0000, 3.0000
    1. Span Number      : 1
    2. Group Number     : 1
    3. Start Distance   : 1317.000
    4. Range            : 3.000
3-1.1 COMMENT              The width of the top flange will be used as the
3-1.1 COMMENT              default for the shear friction interface width.

```

```

9-7.4    SHEAR-FRICTION-COEFF 0.100, 1.000,
          1. Cohesion Factor      :      0.100
          2. Friction Factor      :      1.000
          3. Interface Width      :
3-1.1    COMMENT              Point of Interest: (100.1591) = Span 1 - 21.0000
3-1.1    COMMENT              The r/h data on the following command are BRASS defaults.
3-1.1    COMMENT              This data is not currently available in Virtis/Opis.
10-3.1   COMPOSITE-FATIGUE    100.1591, 0.300, 0.300
          1. Point of Interest    :    100.1591
          2. r/h (Bottom Rebar)   :      0.300
          3. r/h (Top Rebar)      :      0.300
9-7.3    PRESTRESS-FATIGUE    100.1591, 18.0000
          1. Point of Interest    :    100.1591
          2. Stress Range         :      18.000
5-2.1    OUTPUT-INTERMEDIATE  100.1591, ON, ON
          1. Point of Interest    :    100.1591
          2. Specification Checks :      ON
          3. Load Factoring/Combination :      ON
3-1.1    COMMENT              Point of Interest: (100.6364) = Span 1 - 84.0000
3-1.1    COMMENT              The r/h data on the following command are BRASS defaults.
3-1.1    COMMENT              This data is not currently available in Virtis/Opis.
10-3.1   COMPOSITE-FATIGUE    100.6364, 0.300, 0.300
          1. Point of Interest    :    100.6364
          2. r/h (Bottom Rebar)   :      0.300
          3. r/h (Top Rebar)      :      0.300
9-7.3    PRESTRESS-FATIGUE    100.6364, 18.0000
          1. Point of Interest    :    100.6364
          2. Stress Range         :      18.000
5-2.1    OUTPUT-INTERMEDIATE  100.6364, ON, ON
          1. Point of Interest    :    100.6364
          2. Specification Checks :      ON
          3. Load Factoring/Combination :      ON
3-1.1    COMMENT              DC1
12-1.2   LOAD-DEAD-DESCR      1, DC, 1, DC1
          1. Load Group Number    :      1
          2. Dead Load Type      :      DC
          3. Stage                :      1
          4. Load Group Name      :      DC1
12-1.3   LOAD-DEAD-UNIFORM    1, 1, 0.000, 0.014583, 1320.000, 0.014583
          1. Load Group Number    :      1
          2. Span Number          :      1
          3. Distance to Start of Load :      0.000
          4. Magnitude of Load (Beginning) :      0.015
          5. Distance to End of Load :    1320.000
          6. Magnitude of Load (End) :      0.015
12-1.3   LOAD-DEAD-UNIFORM    1, 2, 0.000, 0.014583, 1320.000, 0.014583
          1. Load Group Number    :      1
          2. Span Number          :      2
          3. Distance to Start of Load :      0.000
          4. Magnitude of Load (Beginning) :      0.015
          5. Distance to End of Load :    1320.000
          6. Magnitude of Load (End) :      0.015
12-1.4   LOAD-DEAD-POINT      1, 1, 0.0000, 5.0630, 654.0000
          1. Load Group Number    :      1
          2. Span Number          :      1
          3. Mag of Point Load (Horizontal):      0.000
          4. Mag of Point Load (Vertical) :      5.063
          5. Distance to Start of Load :      654.000
12-1.4   LOAD-DEAD-POINT      1, 2, 0.0000, 5.0600, 660.0000
          1. Load Group Number    :      1
          2. Span Number          :      2
          3. Mag of Point Load (Horizontal):      0.000
          4. Mag of Point Load (Vertical) :      5.060

```

```

5. Distance to Start of Load      :    660.000
3-1.1 COMMENT                      Parapet: Type F Parapet
6-5.2 DECK-LOAD-LINE              1, 0.0541, 7.6115
    1. Load Group Number          :    1
    2. Line Load                  :    0.054
    3. Load Location              :    7.611
3-1.1 COMMENT                      Parapet: Type F Parapet
6-5.2 DECK-LOAD-LINE              1, 0.0541, 656.8885
    1. Load Group Number          :    1
    2. Line Load                  :    0.054
    3. Load Location              :   656.888
3-1.1 COMMENT                      DC2
12-1.2 LOAD-DEAD-DESCR            2, DC, 2, DC2
    1. Load Group Number          :    2
    2. Dead Load Type            : DC
    3. Stage                      :    2
    4. Load Group Name           : DC2
12-1.3 LOAD-DEAD-UNIFORM          2, 1, 0.000, 0.018000, 1320.000, 0.018000
    1. Load Group Number          :    2
    2. Span Number                :    1
    3. Distance to Start of Load  :    0.000
    4. Magnitude of Load (Beginning) :    0.018
    5. Distance to End of Load    :   1320.000
    6. Magnitude of Load (End)   :    0.018
12-1.3 LOAD-DEAD-UNIFORM          2, 2, 0.000, 0.018000, 1320.000, 0.018000
    1. Load Group Number          :    2
    2. Span Number                :    2
    3. Distance to Start of Load  :    0.000
    4. Magnitude of Load (Beginning) :    0.018
    5. Distance to End of Load    :   1320.000
    6. Magnitude of Load (End)   :    0.018
12-3.2 LOAD-SETL-STAGE            1
    1. Stage                      :    1
12-4.1 LOAD-LIVE-CONTROL          B, N, 0.0000, , , 100.00, 100
    1. Direction Control          : B
    2. Standard Live Loads        : N
    3. Pedestrian Load           :    0.000
    4. Blank Parameter           :
    5. Blank Parameter           :
    6. % of Dynamic Load Allowance :   100.000
    7. Wheel Advance. Denominator :   100.000
12-4.2 LOAD-LIVE-DYNAMIC          D, 33.000, 0.000, 15.000
    1. Design/Rating Procedure   : D
    2. Dyn. Load Allow. (Truck)   :   33.000
    3. Dyn. Load Allow. (Lane)    :    0.000
    4. Dyn. Load Allow. (Fatigue) :   15.000
12-4.3 LOAD-LIVE-DEFINITION      1, DTK_HL-93_~1, DTK, D, 100.0000, 1.0000, CRIT, YES
    1. Live Load Number          :    1
    2. Live Load Code            : DTK_HL-93_~1
    3. Live Load Type            : DTK
    4. Design/Rating Procedure   : D
    5. % of Dynamic Load Allow.  :   100.000
    6. Scale Factor              :    1.000
    7. Lanes Loaded              : CRIT
    8. Notional Load Control     : YES
    9. Dynamic Load Allowance    :
    10. Special Trk/Lane No.     :
    11. Variable Axle Spacing   :
12-4.3 LOAD-LIVE-DEFINITION      2, DTM_HL-93_~2, DTM, D, 100.0000, 1.0000, CRIT, YES
    1. Live Load Number          :    2
    2. Live Load Code            : DTM_HL-93_~2
    3. Live Load Type            : DTM
    4. Design/Rating Procedure   : D

```

```

5. % of Dynamic Load Allow.      : 100.000
6. Scale Factor                   : 1.000
7. Lanes Loaded                   : CRIT
8. Notional Load Control          : YES
9. Dynamic Load Allowance         :
10. Special Trk/Lane No.         :
11. Variable Axle Spacing        :
12-4.3 LOAD-LIVE-DEFINITION 3, TKT_HL-93_~3, TKT, D, 100.0000, 1.0000, CRIT, YES
1. Live Load Number              : 3
2. Live Load Code                 : TKT_HL-93_~3
3. Live Load Type                 : TKT
4. Design/Rating Procedure       : D
5. % of Dynamic Load Allow.      : 100.000
6. Scale Factor                   : 1.000
7. Lanes Loaded                   : CRIT
8. Notional Load Control          : YES
9. Dynamic Load Allowance         :
10. Special Trk/Lane No.         :
11. Variable Axle Spacing        :
12-4.3 LOAD-LIVE-DEFINITION 4, DLN_HL-93_~5, DLN, D, 100.0000, 1.0000, CRIT, YES
1. Live Load Number              : 4
2. Live Load Code                 : DLN_HL-93_~5
3. Live Load Type                 : DLN
4. Design/Rating Procedure       : D
5. % of Dynamic Load Allow.      : 100.000
6. Scale Factor                   : 1.000
7. Lanes Loaded                   : CRIT
8. Notional Load Control          : YES
9. Dynamic Load Allowance         :
10. Special Trk/Lane No.         :
11. Variable Axle Spacing        :
12-4.6 LOAD-LIVE-COMBO 1, 4
1. Live Load Number: Truck       : 1
2. Live Load Number: Lane       : 4
3. Combination Factor: Truck    :
4. Combination Factor: Lane     :
12-4.7 LOAD-LIVE-DEFLECTION 1, , 1.0,
1. Live Load Number: Truck      : 1
2. Live Load Number: Lane      :
3. Combination Factor: Truck    : 1.000
4. Combination Factor: Lane     :
5. Allowable Defl. Denom.      :
6. Absolute Allowable Defl.    :
12-4.7 LOAD-LIVE-DEFLECTION 1, 4, 0.25, 1.0
1. Live Load Number: Truck      : 1
2. Live Load Number: Lane      : 4
3. Combination Factor: Truck    : 0.250
4. Combination Factor: Lane     : 1.000
5. Allowable Defl. Denom.      :
6. Absolute Allowable Defl.    :
12-4.6 LOAD-LIVE-COMBO 2, 4
1. Live Load Number: Truck      : 2
2. Live Load Number: Lane      : 4
3. Combination Factor: Truck    :
4. Combination Factor: Lane     :
12-4.6 LOAD-LIVE-COMBO 3, 4
1. Live Load Number: Truck      : 3
2. Live Load Number: Lane      : 4
3. Combination Factor: Truck    :
4. Combination Factor: Lane     :
9-2.3 PS-BEAM-OVERHANG 1, 9.000, 9.000
1. Span Number                   : 1
2. Beam Overhang (Left)         : 9.000

```

```

3. Beam Overhang (Right) : 9.000
3-1.1 COMMENT Strand Group 1: Prestress Properties #1
3-1.1 COMMENT + Strand Material: Prestressing Strands
9-3.1 STRAND-MATL-PRETEEN 1, 0.153, LR, 270.000, 243.000, 28500.000, &
      0.750, 0.700, 0.700, 30.000, 0.500
      1. Strand Number : 1
      2. Strand Area : 0.153
      3. Strand Type : LR
      4. fpu : 270.000
      5. fpy : 243.000
      6. Ep : 28500.000
      7. Initial Stress Ratio : 0.750
      8. Transfer Stress Ratio : 0.700
      9. T.S.R.: Elastic Shorten : 0.700
      10. Transfer Length : 30.000
      11. Nominal Strand Diameter : 0.500
9-3.1.2 LOSS-AASHTO-PRETEEN 1, 1.00000, 0.00, 20.00, 0.40, 0.20
      1. Strand Number : 1
      2. Transfer Time : 1.000
      3. Blank Parameter :
      4. Relax. Coef: Base : 20.000
      5. Relax. Coef: Elas. Short. : 0.400
      6. Relax. Coef: Shr. & Creep : 0.200
9-6.1 STRAND-GENERAL 1, 1, 1, 8, 1
      1. Span Number : 1
      2. Row Number : 1
      3. Strand Number : 1
      4. Number of Strands : 8
      5. Stage Stressed : 1
9-6.2 STRAND-STRAIGHT 1, 1, 70.000, N
      1. Span Number : 1
      2. Row Number : 1
      3. Distance to Centroid : 70.000
      4. Continuity : N
      5. Identical Rows : 0
      6. Row Spacing : 0.000
9-6.1 STRAND-GENERAL 1, 2, 1, 2, 1
      1. Span Number : 1
      2. Row Number : 2
      3. Strand Number : 1
      4. Number of Strands : 2
      5. Stage Stressed : 1
9-6.2 STRAND-STRAIGHT 1, 2, 70.000, N
      1. Span Number : 1
      2. Row Number : 2
      3. Distance to Centroid : 70.000
      4. Continuity : N
      5. Identical Rows : 0
      6. Row Spacing : 0.000
9-6.7 STRAND-DEBOND 1, 2, 2, 2, 129.000, 129.000
      1. Span Number : 1
      2. Beginning Row Number : 2
      3. Last Row Number : 2
      4. Number of Strands : 2
      5. Debond Length (Left) : 129.000
      6. Debond Length (Right) : 129.000
9-6.1 STRAND-GENERAL 1, 3, 1, 2, 1
      1. Span Number : 1
      2. Row Number : 3
      3. Strand Number : 1
      4. Number of Strands : 2
      5. Stage Stressed : 1
9-6.2 STRAND-STRAIGHT 1, 3, 70.000, N

```

```

1. Span Number           : 1
2. Row Number           : 3
3. Distance to Centroid : 70.000
4. Continuity           : N
5. Identical Rows       : 0
6. Row Spacing          : 0.000
9-6.7 STRAND-DEBOND      1, 3, 3, 2, 273.000, 273.000
1. Span Number           : 1
2. Beginning Row Number : 3
3. Last Row Number      : 3
4. Number of Strands    : 2
5. Debond Length (Left) : 273.000
6. Debond Length (Right): 273.000
9-6.1 STRAND-GENERAL     1, 4, 1, 8, 1
1. Span Number           : 1
2. Row Number           : 4
3. Strand Number        : 1
4. Number of Strands    : 8
5. Stage Stressed       : 1
9-6.2 STRAND-STRAIGHT    1, 4, 68.000, N
1. Span Number           : 1
2. Row Number           : 4
3. Distance to Centroid : 68.000
4. Continuity           : N
5. Identical Rows       : 0
6. Row Spacing          : 0.000
9-6.1 STRAND-GENERAL     1, 5, 1, 2, 1
1. Span Number           : 1
2. Row Number           : 5
3. Strand Number        : 1
4. Number of Strands    : 2
5. Stage Stressed       : 1
9-6.2 STRAND-STRAIGHT    1, 5, 68.000, N
1. Span Number           : 1
2. Row Number           : 5
3. Distance to Centroid : 68.000
4. Continuity           : N
5. Identical Rows       : 0
6. Row Spacing          : 0.000
9-6.7 STRAND-DEBOND      1, 5, 5, 2, 129.000, 129.000
1. Span Number           : 1
2. Beginning Row Number : 5
3. Last Row Number      : 5
4. Number of Strands    : 2
5. Debond Length (Left) : 129.000
6. Debond Length (Right): 129.000
9-6.1 STRAND-GENERAL     1, 6, 1, 2, 1
1. Span Number           : 1
2. Row Number           : 6
3. Strand Number        : 1
4. Number of Strands    : 2
5. Stage Stressed       : 1
9-6.2 STRAND-STRAIGHT    1, 6, 68.000, N
1. Span Number           : 1
2. Row Number           : 6
3. Distance to Centroid : 68.000
4. Continuity           : N
5. Identical Rows       : 0
6. Row Spacing          : 0.000
9-6.7 STRAND-DEBOND      1, 6, 6, 2, 273.000, 273.000
1. Span Number           : 1
2. Beginning Row Number : 6
3. Last Row Number      : 6

```

	4. Number of Strands	:	2
	5. Debond Length (Left)	:	273.000
	6. Debond Length (Right)	:	273.000
9-6.1	STRAND-GENERAL 1, 7, 1, 6, 1		
	1. Span Number	:	1
	2. Row Number	:	7
	3. Strand Number	:	1
	4. Number of Strands	:	6
	5. Stage Stressed	:	1
9-6.2	STRAND-STRAIGHT 1, 7, 66.000, N		
	1. Span Number	:	1
	2. Row Number	:	7
	3. Distance to Centroid	:	66.000
	4. Continuity	:	N
	5. Identical Rows	:	0
	6. Row Spacing	:	0.000
9-6.1	STRAND-GENERAL 1, 8, 1, 2, 1		
	1. Span Number	:	1
	2. Row Number	:	8
	3. Strand Number	:	1
	4. Number of Strands	:	2
	5. Stage Stressed	:	1
9-6.2	STRAND-STRAIGHT 1, 8, 66.000, N		
	1. Span Number	:	1
	2. Row Number	:	8
	3. Distance to Centroid	:	66.000
	4. Continuity	:	N
	5. Identical Rows	:	0
	6. Row Spacing	:	0.000
9-6.7	STRAND-DEBOND 1, 8, 8, 2, 129.000, 129.000		
	1. Span Number	:	1
	2. Beginning Row Number	:	8
	3. Last Row Number	:	8
	4. Number of Strands	:	2
	5. Debond Length (Left)	:	129.000
	6. Debond Length (Right)	:	129.000
9-6.1	STRAND-GENERAL 1, 9, 1, 2, 1		
	1. Span Number	:	1
	2. Row Number	:	9
	3. Strand Number	:	1
	4. Number of Strands	:	2
	5. Stage Stressed	:	1
9-6.2	STRAND-STRAIGHT 1, 9, 66.000, N		
	1. Span Number	:	1
	2. Row Number	:	9
	3. Distance to Centroid	:	66.000
	4. Continuity	:	N
	5. Identical Rows	:	0
	6. Row Spacing	:	0.000
9-6.7	STRAND-DEBOND 1, 9, 9, 2, 273.000, 273.000		
	1. Span Number	:	1
	2. Beginning Row Number	:	9
	3. Last Row Number	:	9
	4. Number of Strands	:	2
	5. Debond Length (Left)	:	273.000
	6. Debond Length (Right)	:	273.000
9-6.1	STRAND-GENERAL 1, 10, 1, 6, 1		
	1. Span Number	:	1
	2. Row Number	:	10
	3. Strand Number	:	1
	4. Number of Strands	:	6
	5. Stage Stressed	:	1
9-6.2	STRAND-STRAIGHT 1, 10, 64.000, N		

```

1. Span Number           : 1
2. Row Number           : 10
3. Distance to Centroid : 64.000
4. Continuity           : N
5. Identical Rows       : 0
6. Row Spacing          : 0.000
9-6.1 STRAND-GENERAL    1, 11, 1, 4, 1
1. Span Number           : 1
2. Row Number           : 11
3. Strand Number        : 1
4. Number of Strands    : 4
5. Stage Stressed       : 1
9-6.2 STRAND-STRAIGHT   1, 11, 62.000, N
1. Span Number           : 1
2. Row Number           : 11
3. Distance to Centroid : 62.000
4. Continuity           : N
5. Identical Rows       : 0
6. Row Spacing          : 0.000
9-2.3 PS-BEAM-OVERHANG  2, 9.000, 9.000
1. Span Number           : 2
2. Beam Overhang (Left) : 9.000
3. Beam Overhang (Right): 9.000
9-6.1 STRAND-GENERAL    2, 1, 1, 8, 1
1. Span Number           : 2
2. Row Number           : 1
3. Strand Number        : 1
4. Number of Strands    : 8
5. Stage Stressed       : 1
9-6.2 STRAND-STRAIGHT   2, 1, 70.000, N
1. Span Number           : 2
2. Row Number           : 1
3. Distance to Centroid : 70.000
4. Continuity           : N
5. Identical Rows       : 0
6. Row Spacing          : 0.000
9-6.1 STRAND-GENERAL    2, 2, 1, 2, 1
1. Span Number           : 2
2. Row Number           : 2
3. Strand Number        : 1
4. Number of Strands    : 2
5. Stage Stressed       : 1
9-6.2 STRAND-STRAIGHT   2, 2, 70.000, N
1. Span Number           : 2
2. Row Number           : 2
3. Distance to Centroid : 70.000
4. Continuity           : N
5. Identical Rows       : 0
6. Row Spacing          : 0.000
9-6.7 STRAND-DEBOND     2, 2, 2, 2, 129.000, 129.000
1. Span Number           : 2
2. Beginning Row Number : 2
3. Last Row Number      : 2
4. Number of Strands    : 2
5. Debond Length (Left) : 129.000
6. Debond Length (Right): 129.000
9-6.1 STRAND-GENERAL    2, 3, 1, 2, 1
1. Span Number           : 2
2. Row Number           : 3
3. Strand Number        : 1
4. Number of Strands    : 2
5. Stage Stressed       : 1
9-6.2 STRAND-STRAIGHT   2, 3, 70.000, N

```

```

1. Span Number           : 2
2. Row Number           : 3
3. Distance to Centroid : 70.000
4. Continuity           : N
5. Identical Rows       : 0
6. Row Spacing          : 0.000
9-6.7 STRAND-DEBOND      2, 3, 3, 2, 273.000, 273.000
1. Span Number           : 2
2. Beginning Row Number : 3
3. Last Row Number      : 3
4. Number of Strands    : 2
5. Debond Length (Left) : 273.000
6. Debond Length (Right): 273.000
9-6.1 STRAND-GENERAL     2, 4, 1, 8, 1
1. Span Number           : 2
2. Row Number           : 4
3. Strand Number        : 1
4. Number of Strands    : 8
5. Stage Stressed       : 1
9-6.2 STRAND-STRAIGHT    2, 4, 68.000, N
1. Span Number           : 2
2. Row Number           : 4
3. Distance to Centroid : 68.000
4. Continuity           : N
5. Identical Rows       : 0
6. Row Spacing          : 0.000
9-6.1 STRAND-GENERAL     2, 5, 1, 2, 1
1. Span Number           : 2
2. Row Number           : 5
3. Strand Number        : 1
4. Number of Strands    : 2
5. Stage Stressed       : 1
9-6.2 STRAND-STRAIGHT    2, 5, 68.000, N
1. Span Number           : 2
2. Row Number           : 5
3. Distance to Centroid : 68.000
4. Continuity           : N
5. Identical Rows       : 0
6. Row Spacing          : 0.000
9-6.7 STRAND-DEBOND      2, 5, 5, 2, 129.000, 129.000
1. Span Number           : 2
2. Beginning Row Number : 5
3. Last Row Number      : 5
4. Number of Strands    : 2
5. Debond Length (Left) : 129.000
6. Debond Length (Right): 129.000
9-6.1 STRAND-GENERAL     2, 6, 1, 2, 1
1. Span Number           : 2
2. Row Number           : 6
3. Strand Number        : 1
4. Number of Strands    : 2
5. Stage Stressed       : 1
9-6.2 STRAND-STRAIGHT    2, 6, 68.000, N
1. Span Number           : 2
2. Row Number           : 6
3. Distance to Centroid : 68.000
4. Continuity           : N
5. Identical Rows       : 0
6. Row Spacing          : 0.000
9-6.7 STRAND-DEBOND      2, 6, 6, 2, 273.000, 273.000
1. Span Number           : 2
2. Beginning Row Number : 6
3. Last Row Number      : 6

```

	4. Number of Strands	:	2
	5. Debond Length (Left)	:	273.000
	6. Debond Length (Right)	:	273.000
9-6.1	STRAND-GENERAL 2, 7, 1, 6, 1		
	1. Span Number	:	2
	2. Row Number	:	7
	3. Strand Number	:	1
	4. Number of Strands	:	6
	5. Stage Stressed	:	1
9-6.2	STRAND-STRAIGHT 2, 7, 66.000, N		
	1. Span Number	:	2
	2. Row Number	:	7
	3. Distance to Centroid	:	66.000
	4. Continuity	:	N
	5. Identical Rows	:	0
	6. Row Spacing	:	0.000
9-6.1	STRAND-GENERAL 2, 8, 1, 2, 1		
	1. Span Number	:	2
	2. Row Number	:	8
	3. Strand Number	:	1
	4. Number of Strands	:	2
	5. Stage Stressed	:	1
9-6.2	STRAND-STRAIGHT 2, 8, 66.000, N		
	1. Span Number	:	2
	2. Row Number	:	8
	3. Distance to Centroid	:	66.000
	4. Continuity	:	N
	5. Identical Rows	:	0
	6. Row Spacing	:	0.000
9-6.7	STRAND-DEBOND 2, 8, 8, 2, 129.000, 129.000		
	1. Span Number	:	2
	2. Beginning Row Number	:	8
	3. Last Row Number	:	8
	4. Number of Strands	:	2
	5. Debond Length (Left)	:	129.000
	6. Debond Length (Right)	:	129.000
9-6.1	STRAND-GENERAL 2, 9, 1, 2, 1		
	1. Span Number	:	2
	2. Row Number	:	9
	3. Strand Number	:	1
	4. Number of Strands	:	2
	5. Stage Stressed	:	1
9-6.2	STRAND-STRAIGHT 2, 9, 66.000, N		
	1. Span Number	:	2
	2. Row Number	:	9
	3. Distance to Centroid	:	66.000
	4. Continuity	:	N
	5. Identical Rows	:	0
	6. Row Spacing	:	0.000
9-6.7	STRAND-DEBOND 2, 9, 9, 2, 273.000, 273.000		
	1. Span Number	:	2
	2. Beginning Row Number	:	9
	3. Last Row Number	:	9
	4. Number of Strands	:	2
	5. Debond Length (Left)	:	273.000
	6. Debond Length (Right)	:	273.000
9-6.1	STRAND-GENERAL 2, 10, 1, 6, 1		
	1. Span Number	:	2
	2. Row Number	:	10
	3. Strand Number	:	1
	4. Number of Strands	:	6
	5. Stage Stressed	:	1
9-6.2	STRAND-STRAIGHT 2, 10, 64.000, N		

```

1. Span Number           : 2
2. Row Number           : 10
3. Distance to Centroid : 64.000
4. Continuity           : N
5. Identical Rows       : 0
6. Row Spacing          : 0.000
9-6.1 STRAND-GENERAL     2, 11, 1, 4, 1
1. Span Number           : 2
2. Row Number           : 11
3. Strand Number        : 1
4. Number of Strands    : 4
5. Stage Stressed       : 1
9-6.2 STRAND-STRAIGHT    2, 11, 62.000, N
1. Span Number           : 2
2. Row Number           : 11
3. Distance to Centroid : 62.000
4. Continuity           : N
5. Identical Rows       : 0
6. Row Spacing          : 0.000
9-2.1 PRESTRESS-CONTINUITY CA
1. Continuity           : CA
9-2.2 PRESTRESS-TIME     21.00, 60.00, 60.00, 75.00, 75.00, , , ,
1. Drying Time          : 21.000
2. Time Continuous      : 60.000
3. Time Composite       : 60.000
4. Service Life         : 75.000
5. Time of Analysis     : 75.000
6. Time Load Group 1    :
7. Time Load Group 2    :
8. Time Load Group 3    :
9. Time Load Group 4    :
3-1.1 COMMENT           User specified to ignore differential deck shrinkage!
9-10.1 PSLOAD-CREEP     NO
1. Perform Creep Adjustments : NO
2. Creep Factor          : 3.500
3. kf                    :
4. kc                    :
5. kh                    :
9-10.2 PSLOAD-CREEP-TIME , , , , ,
1. Time SDL (DC)         :
2. Time SDL (DW)         :
3. Time Temperature      :
4. Time Settlement       :
5. Time Shrinkage       :
3-1.1 COMMENT           The DIST-REACTION commands are generated from the
3-1.1 COMMENT           distribution factor (DF) schedules. The reaction DF is
3-1.1 COMMENT           taken as the average of the DFs from adjacent spans. For
3-1.1 COMMENT           end supports, the DF is taken as the DF from the spans
3-1.1 COMMENT           on which the support is located.
12-5.1 DIST-BEAM-SCHEDULE 1, D, 0.6670, 0.6670, 0.0000, 1320.0000
1. Span Number           : 1
2. Action Code           : D
3. mg(one-lane)         : 0.667
4. mg(mult-lanes)       : 0.667
5. Start Distance       : 0.000
6. Range                 : 1320.000
12-5.1 DIST-BEAM-SCHEDULE 1, M, 0.7960, 0.7960, 0.0000, 1320.0000
1. Span Number           : 1
2. Action Code           : M
3. mg(one-lane)         : 0.796
4. mg(mult-lanes)       : 0.796
5. Start Distance       : 0.000
6. Range                 : 1320.000

```

```

12-5.1  DIST-BEAM-SCHEDULE  1, V, 0.9730, 0.9730, 0.0000, 1320.0000
        1. Span Number      : 1
        2. Action Code      : V
        3. mg(one-lane)     : 0.973
        4. mg(mult-lanes)   : 0.973
        5. Start Distance   : 0.000
        6. Range            : 1320.000
12-5.2  DIST-REACTION      1, 0.9730, 0.7960, 0.6670, 0.9730, 0.7960, 0.6670
        1. Support Number   : 1
        2. g(Shear-1)       : 0.973
        3. g(Moment-1)      : 0.796
        4. g(Deflection-1)  : 0.667
        5. g(Shear-M)       : 0.973
        6. g(Moment-M)      : 0.796
        7. g(Deflection-M)  : 0.667
12-5.1  DIST-BEAM-SCHEDULE  2, D, 0.6670, 0.6670, 0.0000, 1320.0000
        1. Span Number      : 2
        2. Action Code      : D
        3. mg(one-lane)     : 0.667
        4. mg(mult-lanes)   : 0.667
        5. Start Distance   : 0.000
        6. Range            : 1320.000
12-5.1  DIST-BEAM-SCHEDULE  2, M, 0.7960, 0.7960, 0.0000, 1320.0000
        1. Span Number      : 2
        2. Action Code      : M
        3. mg(one-lane)     : 0.796
        4. mg(mult-lanes)   : 0.796
        5. Start Distance   : 0.000
        6. Range            : 1320.000
12-5.1  DIST-BEAM-SCHEDULE  2, V, 0.9730, 0.9730, 0.0000, 1320.0000
        1. Span Number      : 2
        2. Action Code      : V
        3. mg(one-lane)     : 0.973
        4. mg(mult-lanes)   : 0.973
        5. Start Distance   : 0.000
        6. Range            : 1320.000
12-5.2  DIST-REACTION      2, 0.9730, 0.7960, 0.6670, 0.9730, 0.7960, 0.6670
        1. Support Number   : 2
        2. g(Shear-1)       : 0.973
        3. g(Moment-1)      : 0.796
        4. g(Deflection-1)  : 0.667
        5. g(Shear-M)       : 0.973
        6. g(Moment-M)      : 0.796
        7. g(Deflection-M)  : 0.667
12-5.2  DIST-REACTION      3, 0.9730, 0.7960, 0.6670, 0.9730, 0.7960, 0.6670
        1. Support Number   : 3
        2. g(Shear-1)       : 0.973
        3. g(Moment-1)      : 0.796
        4. g(Deflection-1)  : 0.667
        5. g(Shear-M)       : 0.973
        6. g(Moment-M)      : 0.796
        7. g(Deflection-M)  : 0.667
3-1.1   COMMENT           Using system default LRFD load factors.
13-1.1  FACTORS-LOAD-MOD   ST, 1, 1.000, 1.000, 1.000, 1.000, 1.000
        1. Limit State      : ST
        2. Limit State Level : 1
        3. eta D            : 1.000
        4. eta R            : 1.000
        5. eta I            : 1.000
        6. eta (max)        : 1.000
        7. eta (min)        : 1.000
13-1.2  FACTORS-LOAD-DL    ST, 1, 1.250, 0.900, 1.500, 0.650
        1. Limit State      : ST
    
```

```

2. Limit State Level          : 1
3. gamma DC max               : 1.250
4. gamma DC min               : 0.900
5. gamma DW max               : 1.500
6. gamma DW min               : 0.650
13-1.3 FACTORS-LOAD-LL      ST, 1, 1.750, 0.0, 0.0
1. Limit State                : ST
2. Limit State Level          : 1
3. gamma LL (Design)         : 1.750
4. gamma LL (Legal)          : 0.000
5. gamma LL (Permit)         : 0.000
13-1.4 FACTORS-LOAD-TS      ST, 1, 1.200, 1.200, 1.000, 1.000
1. Limit State                : ST
2. Limit State Level          : 1
3. gamma TEMP max            : 1.200
4. gamma TEMP min            : 1.200
5. gamma SETL max            : 1.000
6. gamma SETL min            : 1.000
13-1.5 FACTORS-LOAD-PS      ST, 1, 1.000, 1.000, 1.000, 1.000
1. Limit State                : ST
2. Limit State Level          : 1
3. gamma PS max              : 1.000
4. gamma PS min              : 1.000
5. gamma DS max              : 1.000
6. gamma DS min              : 1.000
13-1.1 FACTORS-LOAD-MOD     ST, 2, 1.000, 1.000, 1.000, 1.000, 1.000
1. Limit State                : ST
2. Limit State Level          : 2
3. eta D                      : 1.000
4. eta R                      : 1.000
5. eta I                      : 1.000
6. eta (max)                  : 1.000
7. eta (min)                  : 1.000
13-1.2 FACTORS-LOAD-DL      ST, 2, 1.250, 0.900, 1.500, 0.650
1. Limit State                : ST
2. Limit State Level          : 2
3. gamma DC max              : 1.250
4. gamma DC min              : 0.900
5. gamma DW max              : 1.500
6. gamma DW min              : 0.650
13-1.3 FACTORS-LOAD-LL      ST, 2, 1.350, 0.0, 0.0
1. Limit State                : ST
2. Limit State Level          : 2
3. gamma LL (Design)         : 1.350
4. gamma LL (Legal)          : 0.000
5. gamma LL (Permit)         : 0.000
13-1.4 FACTORS-LOAD-TS      ST, 2, 1.200, 1.200, 1.000, 1.000
1. Limit State                : ST
2. Limit State Level          : 2
3. gamma TEMP max            : 1.200
4. gamma TEMP min            : 1.200
5. gamma SETL max            : 1.000
6. gamma SETL min            : 1.000
13-1.5 FACTORS-LOAD-PS      ST, 2, 1.000, 1.000, 1.000, 1.000
1. Limit State                : ST
2. Limit State Level          : 2
3. gamma PS max              : 1.000
4. gamma PS min              : 1.000
5. gamma DS max              : 1.000
6. gamma DS min              : 1.000
13-1.1 FACTORS-LOAD-MOD     ST, 3, 1.000, 1.000, 1.000, 1.000, 1.000
1. Limit State                : ST
2. Limit State Level          : 3

```

```

3. eta D : 1.000
4. eta R : 1.000
5. eta I : 1.000
6. eta (max) : 1.000
7. eta (min) : 1.000
13-1.2 FACTORS-LOAD-DL ST, 3, 1.250, 0.900, 1.500, 0.650
1. Limit State : ST
2. Limit State Level : 3
3. gamma DC max : 1.250
4. gamma DC min : 0.900
5. gamma DW max : 1.500
6. gamma DW min : 0.650
13-1.3 FACTORS-LOAD-LL ST, 3, 0.000, 0.0, 0.0
1. Limit State : ST
2. Limit State Level : 3
3. gamma LL (Design) : 0.000
4. gamma LL (Legal) : 0.000
5. gamma LL (Permit) : 0.000
13-1.4 FACTORS-LOAD-TS ST, 3, 1.200, 1.200, 1.000, 1.000
1. Limit State : ST
2. Limit State Level : 3
3. gamma TEMP max : 1.200
4. gamma TEMP min : 1.200
5. gamma SETL max : 1.000
6. gamma SETL min : 1.000
13-1.5 FACTORS-LOAD-PS ST, 3, 1.000, 1.000, 1.000, 1.000
1. Limit State : ST
2. Limit State Level : 3
3. gamma PS max : 1.000
4. gamma PS min : 1.000
5. gamma DS max : 1.000
6. gamma DS min : 1.000
13-1.1 FACTORS-LOAD-MOD ST, 4, 1.000, 1.000, 1.000, 1.000, 1.000
1. Limit State : ST
2. Limit State Level : 4
3. eta D : 1.000
4. eta R : 1.000
5. eta I : 1.000
6. eta (max) : 1.000
7. eta (min) : 1.000
13-1.2 FACTORS-LOAD-DL ST, 4, 1.500, 1.500, 1.500, 0.650
1. Limit State : ST
2. Limit State Level : 4
3. gamma DC max : 1.500
4. gamma DC min : 1.500
5. gamma DW max : 1.500
6. gamma DW min : 0.650
13-1.3 FACTORS-LOAD-LL ST, 4, 0.000, 0.0, 0.0
1. Limit State : ST
2. Limit State Level : 4
3. gamma LL (Design) : 0.000
4. gamma LL (Legal) : 0.000
5. gamma LL (Permit) : 0.000
13-1.4 FACTORS-LOAD-TS ST, 4, 1.200, 1.200, 0.000, 0.000
1. Limit State : ST
2. Limit State Level : 4
3. gamma TEMP max : 1.200
4. gamma TEMP min : 1.200
5. gamma SETL max : 0.000
6. gamma SETL min : 0.000
13-1.5 FACTORS-LOAD-PS ST, 4, 1.000, 1.000, 1.000, 1.000
1. Limit State : ST
2. Limit State Level : 4

```

```

3. gamma PS max           : 1.000
4. gamma PS min           : 1.000
5. gamma DS max           : 1.000
6. gamma DS min           : 1.000
13-1.1 FACTORS-LOAD-MOD    SE, 1, 1.000, 1.000, 1.000, 1.000, 1.000
1. Limit State             : SE
2. Limit State Level       : 1
3. eta D                   : 1.000
4. eta R                   : 1.000
5. eta I                   : 1.000
6. eta (max)               : 1.000
7. eta (min)               : 1.000
13-1.2 FACTORS-LOAD-DL     SE, 1, 1.000, 1.000, 1.000, 1.000
1. Limit State             : SE
2. Limit State Level       : 1
3. gamma DC max           : 1.000
4. gamma DC min           : 1.000
5. gamma DW max           : 1.000
6. gamma DW min           : 1.000
13-1.3 FACTORS-LOAD-LL     SE, 1, 1.000, 0.0, 0.0
1. Limit State             : SE
2. Limit State Level       : 1
3. gamma LL (Design)      : 1.000
4. gamma LL (Legal)       : 0.000
5. gamma LL (Permit)      : 0.000
13-1.4 FACTORS-LOAD-TS     SE, 1, 1.200, 1.200, 1.000, 1.000
1. Limit State             : SE
2. Limit State Level       : 1
3. gamma TEMP max         : 1.200
4. gamma TEMP min         : 1.200
5. gamma SETL max         : 1.000
6. gamma SETL min         : 1.000
13-1.5 FACTORS-LOAD-PS     SE, 1, 1.000, 1.000, 1.000, 1.000
1. Limit State             : SE
2. Limit State Level       : 1
3. gamma PS max           : 1.000
4. gamma PS min           : 1.000
5. gamma DS max           : 1.000
6. gamma DS min           : 1.000
13-1.1 FACTORS-LOAD-MOD    SE, 2, 1.000, 1.000, 1.000, 1.000, 1.000
1. Limit State             : SE
2. Limit State Level       : 2
3. eta D                   : 1.000
4. eta R                   : 1.000
5. eta I                   : 1.000
6. eta (max)               : 1.000
7. eta (min)               : 1.000
13-1.2 FACTORS-LOAD-DL     SE, 2, 1.000, 1.000, 1.000, 1.000
1. Limit State             : SE
2. Limit State Level       : 2
3. gamma DC max           : 1.000
4. gamma DC min           : 1.000
5. gamma DW max           : 1.000
6. gamma DW min           : 1.000
13-1.3 FACTORS-LOAD-LL     SE, 2, 1.300, 0.0, 0.0
1. Limit State             : SE
2. Limit State Level       : 2
3. gamma LL (Design)      : 1.300
4. gamma LL (Legal)       : 0.000
5. gamma LL (Permit)      : 0.000
13-1.4 FACTORS-LOAD-TS     SE, 2, 1.200, 1.200, 0.000, 0.000
1. Limit State             : SE
2. Limit State Level       : 2

```



```

3. gamma TEMP max           : 1.200
4. gamma TEMP min           : 1.200
5. gamma SETL max           : 0.000
6. gamma SETL min           : 0.000
13-1.5 FACTORS-LOAD-PS      SE, 2, 1.000, 1.000, 1.000, 1.000
1. Limit State               : SE
2. Limit State Level         : 2
3. gamma PS max              : 1.000
4. gamma PS min              : 1.000
5. gamma DS max              : 1.000
6. gamma DS min              : 1.000
13-1.1 FACTORS-LOAD-MOD    SE, 3, 1.000, 1.000, 1.000, 1.000, 1.000
1. Limit State               : SE
2. Limit State Level         : 3
3. eta D                     : 1.000
4. eta R                     : 1.000
5. eta I                     : 1.000
6. eta (max)                 : 1.000
7. eta (min)                 : 1.000
13-1.2 FACTORS-LOAD-DL     SE, 3, 1.000, 1.000, 1.000, 1.000
1. Limit State               : SE
2. Limit State Level         : 3
3. gamma DC max              : 1.000
4. gamma DC min              : 1.000
5. gamma DW max              : 1.000
6. gamma DW min              : 1.000
13-1.3 FACTORS-LOAD-LL     SE, 3, 0.800, 0.0, 0.0
1. Limit State               : SE
2. Limit State Level         : 3
3. gamma LL (Design)        : 0.800
4. gamma LL (Legal)         : 0.000
5. gamma LL (Permit)        : 0.000
13-1.4 FACTORS-LOAD-TS     SE, 3, 1.200, 1.200, 1.000, 1.000
1. Limit State               : SE
2. Limit State Level         : 3
3. gamma TEMP max           : 1.200
4. gamma TEMP min           : 1.200
5. gamma SETL max           : 1.000
6. gamma SETL min           : 1.000
13-1.5 FACTORS-LOAD-PS     SE, 3, 1.000, 1.000, 1.000, 1.000
1. Limit State               : SE
2. Limit State Level         : 3
3. gamma PS max              : 1.000
4. gamma PS min              : 1.000
5. gamma DS max              : 1.000
6. gamma DS min              : 1.000
13-1.1 FACTORS-LOAD-MOD    FA, 1, 1.000, 1.000, 1.000, 1.000, 1.000
1. Limit State               : FA
2. Limit State Level         : 1
3. eta D                     : 1.000
4. eta R                     : 1.000
5. eta I                     : 1.000
6. eta (max)                 : 1.000
7. eta (min)                 : 1.000
13-1.2 FACTORS-LOAD-DL     FA, 1, 1.000, 1.000, 1.000, 1.000
1. Limit State               : FA
2. Limit State Level         : 1
3. gamma DC max              : 1.000
4. gamma DC min              : 1.000
5. gamma DW max              : 1.000
6. gamma DW min              : 1.000
13-1.3 FACTORS-LOAD-LL     FA, 1, 0.750, 0.0, 0.0
1. Limit State               : FA

```

```

2. Limit State Level           : 1
3. gamma LL (Design)          : 0.750
4. gamma LL (Legal)           : 0.000
5. gamma LL (Permit)          : 0.000
13-1.4 FACTORS-LOAD-TS        FA, 1, 1.000, 1.000, 1.000, 1.000
1. Limit State                 : FA
2. Limit State Level           : 1
3. gamma TEMP max              : 1.000
4. gamma TEMP min              : 1.000
5. gamma SETL max              : 1.000
6. gamma SETL min              : 1.000
13-1.5 FACTORS-LOAD-PS        FA, 1, 1.000, 1.000, 1.000, 1.000
1. Limit State                 : FA
2. Limit State Level           : 1
3. gamma PS max                : 1.000
4. gamma PS min                : 1.000
5. gamma DS max                : 1.000
6. gamma DS min                : 1.000
13-2.3 FACTORS-RESIST-PS      1.000, 0.900, 0.900, 1.000
1. phi flexure                 : 1.000
2. phi shear                   : 0.900
3. phi flexure (R/C)           : 0.900
4. phi fatigue                 : 1.000

```

End of Input File No. 1

DECK GEOMETRY AND LOAD SUMMARY REPORT

No. Girders: 6

Girder Spacing, in

Bay No.	Spacing
1	116.004
2	116.004
3	116.004
4	116.004
5	116.004

Cantilevers:

Left = 42.250 in
 Right = 42.230 in

Deck Width = 664.500 in

Slab Thickness = 8.000 in

DECK GEOMETRY AND LOAD SUMMARY REPORT (continued)

Travel Way Locations:

Left Edge = 20.250 in
 Right Edge = 644.250 in

Material Weights:

Concrete (deck) = 0.1500 k/ft³
 Concrete (other) = 0.1500 k/ft³
 Wearing Surface = 0.3000E-01 k/ft²

Line Loads:

Line Load, k/ft	Location, in	Load Group
0.649	7.611	1
0.649	656.888	1

GIRDER LOADS SUMMARY REPORT

Units: Loads are in k/ft.

Girder Loads Due to Deck Components:

Component Stage	Slab 1	Soffit 1	Curbs 2	Median 2	Topping 1	Wearing Surface 2
DL Type	DC	DC	DC	DC	DC	DW
Girder No.						
1	0.835	0.000	0.000	0.000	0.000	0.260
2	0.967	0.000	0.000	0.000	0.000	0.260
3	0.967	0.000	0.000	0.000	0.000	0.260
4	0.967	0.000	0.000	0.000	0.000	0.260
5	0.967	0.000	0.000	0.000	0.000	0.260
6	0.835	0.000	0.000	0.000	0.000	0.260

Appendix A

Prestressed Concrete Bridge Design Example

Girder Loads Due to Line and/or Uniform Loads:

Load Group	1	2	3	4
Stage	1	2	N/A	N/A
DL Type	DC	DC	N/A	N/A

Line Loads

Girder No.	1	2	3	4
1	0.649	0.000	0.000	0.000
2	0.000	0.000	0.000	0.000
3	0.000	0.000	0.000	0.000
4	0.000	0.000	0.000	0.000
5	0.000	0.000	0.000	0.000
6	0.649	0.000	0.000	0.000

GIRDER LOADS SUMMARY REPORT (continued)

Units: Loads are in k/ft.

Girder of Interest: 2

Total Loads Due to Superimposed Dead Loads

Stage DL Type	1		2		3	
	DC	DW	DC	DW	DC	DW
Girder No.						
1	0.835	0.000	0.000	0.260	0.000	0.000
=> 2	0.967	0.000	0.000	0.260	0.000	0.000
3	0.967	0.000	0.000	0.260	0.000	0.000
4	0.967	0.000	0.000	0.260	0.000	0.000
5	0.967	0.000	0.000	0.260	0.000	0.000
6	0.835	0.000	0.000	0.260	0.000	0.000

Total Loads Due to Load Groups:

Load Group	1	2	3	4
Girder No.				
1	0.649	0.000	0.000	0.000
=> 2	0.000	0.000	0.000	0.000
3	0.000	0.000	0.000	0.000
4	0.000	0.000	0.000	0.000
5	0.000	0.000	0.000	0.000
6	0.649	0.000	0.000	0.000

Total Loads:

Stage	1	2	3	1 + 2 + 3
Girder No.				
1	1.485	0.260	0.000	1.745
=> 2	0.967	0.260	0.000	1.227
3	0.967	0.260	0.000	1.227
4	0.967	0.260	0.000	1.227
5	0.967	0.260	0.000	1.227
6	1.484	0.260	0.000	1.744

Self-Load Summary:

Span No.	Beginning of Load		End of Load	
	Distance, in	Magnitude, k/in	Distance, in	Magnitude, k/in
1	0.00	0.094184	1320.00	0.094184
2	0.00	0.094184	1320.00	0.094184

Distributed Dead Load Summary:

Load Group No. 1: DC1
 Load Group No. 2: DC2

Load Group No.	Span No.	Beginning of Load		End of Load	
		Distance, in	Magnitude, k/in	Distance, in	Magnitude, k/in
DC1	All		0.08056		0.08056
DW2	All		0.02167		0.02167
1	1	0.00	0.01458	1320.00	0.01458
1	2	0.00	0.01458	1320.00	0.01458
2	1	0.00	0.01800	1320.00	0.01800
2	2	0.00	0.01800	1320.00	0.01800

Note: A span number denoted as "*" indicates the distances reference the left end of the bridge and the load may extend over one or more spans.

Beam Properties: General span segments variation.

Construction Stage: 1

Span No. 1 Span Length = 110.000 (ft) Span Ratio = 1.000 E = 4696.0 (ksi)

Input Dimensions and Cross-Section Geometry: (in)

Span Point	Dist (ft)	Web Depth	Web Width		Flange Thickness		Flange Width	
			top	bot	top	bot	top	bot
1.000	0.000	59.00	8.000	8.000	5.000	8.000	42.00	28.00
1.016	1.750	59.00	8.000	8.000	5.000	8.000	42.00	28.00
1.064	7.000	59.00	8.000	8.000	5.000	8.000	42.00	28.00
1.091	10.000	59.00	8.000	8.000	5.000	8.000	42.00	28.00
1.100	11.000	59.00	8.000	8.000	5.000	8.000	42.00	28.00
1.114	12.500	59.00	8.000	8.000	5.000	8.000	42.00	28.00
1.200	22.000	59.00	8.000	8.000	5.000	8.000	42.00	28.00
1.223	24.500	59.00	8.000	8.000	5.000	8.000	42.00	28.00
1.300	33.000	59.00	8.000	8.000	5.000	8.000	42.00	28.00
1.400	44.000	59.00	8.000	8.000	5.000	8.000	42.00	28.00
1.500	55.000	59.00	8.000	8.000	5.000	8.000	42.00	28.00
1.600	66.000	59.00	8.000	8.000	5.000	8.000	42.00	28.00
1.700	77.000	59.00	8.000	8.000	5.000	8.000	42.00	28.00
1.750	82.500	59.00	8.000	8.000	5.000	8.000	42.00	28.00
1.777	85.500	59.00	8.000	8.000	5.000	8.000	42.00	28.00
1.800	88.000	59.00	8.000	8.000	5.000	8.000	42.00	28.00
1.886	97.500	59.00	8.000	8.000	5.000	8.000	42.00	28.00
1.900	99.000	59.00	8.000	8.000	5.000	8.000	42.00	28.00
1.909	100.000	59.00	8.000	8.000	5.000	8.000	42.00	28.00
1.984	108.250	59.00	8.000	8.000	5.000	8.000	42.00	28.00
2.000	110.000	59.00	8.000	8.000	5.000	8.000	42.00	28.00

Calculated Properties:

Span Point	Dist (ft)	A (in ²)	I (in ⁴)	X-bar (in)
1.000	0.000	1085.0	733320.3	36.38
1.016	1.750	1085.0	733320.3	36.38
1.064	7.000	1085.0	733320.3	36.38
1.091	10.000	1085.0	733320.3	36.38
1.100	11.000	1085.0	733320.3	36.38
1.114	12.500	1085.0	733320.3	36.38
1.200	22.000	1085.0	733320.3	36.38
1.223	24.500	1085.0	733320.3	36.38
1.300	33.000	1085.0	733320.3	36.38
1.400	44.000	1085.0	733320.3	36.38
1.500	55.000	1085.0	733320.3	36.38
1.600	66.000	1085.0	733320.3	36.38
1.700	77.000	1085.0	733320.3	36.38
1.750	82.500	1085.0	733320.3	36.38
1.777	85.500	1085.0	733320.3	36.38
1.800	88.000	1085.0	733320.3	36.38
1.886	97.500	1085.0	733320.3	36.38
1.900	99.000	1085.0	733320.3	36.38
1.909	100.000	1085.0	733320.3	36.38
1.984	108.250	1085.0	733320.3	36.38
2.000	110.000	1085.0	733320.3	36.38

CONCRETE PROPERTIES:

Unit Weight of Girder Concrete: 0.150 kcf

Compressive Strengths (f'c): Prestressed Concrete : 6.000 ksi
 Non-prestressed Concrete : 4.000 ksi
 Prestressed Concrete at Release: 4.800 ksi

Modulus of Elasticity (Ec) : Prestressed Concrete : 4695.982 ksi
 Non-prestressed Concrete : 3644.148 ksi
 Prestressed Concrete at Release: 4200.214 ksi

PRESTRESSING STRAND PROPERTIES:

Strand No.	Strand Type	Strand Area (in ²)	Ultimate Strength (ksi)	Yield Point Stress (ksi)	Modulus of Elasticity (ksi)	Initial Stress (ksi)
1	Low-relaxation - Pretensioned	0.153	270.0	243.0	28500.0	202.5

PRETENSIONED STRANDS

POST-TENSIONED STRANDS

Strand Elastic No. Shortening	Strand Ends	Nominal Diameter (in)	Transfer Length (in)	Bond	Coefficients			End Strand (ksi)	Anchorage Loss (in)	Loss Length Factor
					Wobble (1/in)	Friction (1/rad)	Tensioned			
1	Free	0.5000	30.00	N/A	N/A	N/A	N/A	N/A	N/A	N/A

Notes:

- => Debond, transfer, and/or development lengths are measured from the end of the beam.
- => Search for the report header "Suggested Development Length Commands" for generated commands containing the development lengths computed by BRASS for each prestress row.

Appendix A

Prestressed Concrete Bridge Design Example

This report is only available if a mid-span point of interest is entered in the data file.

SUMMARY OF BEAM OVERHANGS:

Span No.	Beam Overhangs (in)	
	Left End	Right End
1	9.000	9.000
2	9.000	9.000

PRESTRESS LOSS INPUT DATA: AASHTO LRFD 5.9.5

Relative Humidity = 70.00%

Strand No.	Steel Relaxation Loss Coefficients				% of DL Applied Time of Release
	Base	FR	ES	SR & CR	
1	20.0	0.00	0.40	0.20	0.00

STRAND PROPERTIES: (cont.)

Span No.	Row No.	Path Type	Strand Type No.	No. Strands	Stage Strand Tensioned	No. Debonded Strands	Debond Length		Development Length (in)
							Left (in)	Right (in)	
1	1	Straight	1	8	1	N/A	N/A	N/A	82.500
1	2	Straight	1	2	1	2	129.000	129.000	82.500
1	3	Straight	1	2	1	2	273.000	273.000	82.500
1	4	Straight	1	8	1	N/A	N/A	N/A	82.500
1	5	Straight	1	2	1	2	129.000	129.000	82.500
1	6	Straight	1	2	1	2	273.000	273.000	82.500
1	7	Straight	1	6	1	N/A	N/A	N/A	82.500
1	8	Straight	1	2	1	2	129.000	129.000	82.500
1	9	Straight	1	2	1	2	273.000	273.000	82.500
1	10	Straight	1	6	1	N/A	N/A	N/A	82.500
1	11	Straight	1	4	1	N/A	N/A	N/A	82.500
2	1	Straight	1	8	1	N/A	N/A	N/A	82.500
2	2	Straight	1	2	1	2	129.000	129.000	82.500
2	3	Straight	1	2	1	2	273.000	273.000	82.500
2	4	Straight	1	8	1	N/A	N/A	N/A	82.500
2	5	Straight	1	2	1	2	129.000	129.000	82.500
2	6	Straight	1	2	1	2	273.000	273.000	82.500
2	7	Straight	1	6	1	N/A	N/A	N/A	82.500
2	8	Straight	1	2	1	2	129.000	129.000	82.500
2	9	Straight	1	2	1	2	273.000	273.000	82.500
2	10	Straight	1	6	1	N/A	N/A	N/A	82.500
2	11	Straight	1	4	1	N/A	N/A	N/A	82.500

STRAIGHT STRAND DETAILS:

Span No.	Row No.	Distance from Top of Girder to Centroid of Strand (in)	Continuity	
			Not Continuous	Over Either Support
1	1	70.000	Not Continuous	Over Either Support
1	2	70.000	Not Continuous	Over Either Support
1	3	70.000	Not Continuous	Over Either Support
1	4	68.000	Not Continuous	Over Either Support
1	5	68.000	Not Continuous	Over Either Support
1	6	68.000	Not Continuous	Over Either Support
1	7	66.000	Not Continuous	Over Either Support
1	8	66.000	Not Continuous	Over Either Support
1	9	66.000	Not Continuous	Over Either Support
1	10	64.000	Not Continuous	Over Either Support
1	11	62.000	Not Continuous	Over Either Support
2	1	70.000	Not Continuous	Over Either Support

Appendix A

Prestressed Concrete Bridge Design Example

2	2	70.000	Not Continuous Over Either Support
2	3	70.000	Not Continuous Over Either Support
2	4	68.000	Not Continuous Over Either Support
2	5	68.000	Not Continuous Over Either Support
2	6	68.000	Not Continuous Over Either Support
2	7	66.000	Not Continuous Over Either Support
2	8	66.000	Not Continuous Over Either Support
2	9	66.000	Not Continuous Over Either Support
2	10	64.000	Not Continuous Over Either Support
2	11	62.000	Not Continuous Over Either Support

Self-Load Summary:

Span No.	Beginning of Load Distance, in	Beginning of Load Magnitude, k/in	End of Load Distance, in	End of Load Magnitude, k/in
1	0.00	0.094184	1320.00	0.094184
2	0.00	0.094184	1320.00	0.094184

Distributed Dead Load Summary:

Load Group No. 1: DC1

Load Group No. 2: DC2

Load Group No.	Span No.	Beginning of Load Distance, in	Beginning of Load Magnitude, k/in	End of Load Distance, in	End of Load Magnitude, k/in
DC1	All		0.08056		0.08056
DW2	All		0.02167		0.02167
1	1	0.00	0.01458	1320.00	0.01458
1	2	0.00	0.01458	1320.00	0.01458
2	1	0.00	0.01800	1320.00	0.01800
2	2	0.00	0.01800	1320.00	0.01800

Note: A span number denoted as "*" indicates the distances reference the left end of the bridge and the load may extend over one or more spans.

Beam Properties: General span segments variation.

Construction Stage: 2

Span No. 1 Span Length = 110.000 (ft) Span Ratio = 1.000 E = 4696.0 (ksi)

Input Dimensions and Cross-Section Geometry: (in)

Span Point	Dist (ft)	Web Depth	Web Width top	Web Width bot	Flange Thickness top	Flange Thickness bot	Flange Width top	Flange Width bot
1.000	0.000	59.00	8.000	8.000	5.000	8.000	42.00	28.00
1.016	1.750	59.00	8.000	8.000	5.000	8.000	42.00	28.00
1.064	7.000	59.00	8.000	8.000	5.000	8.000	42.00	28.00
1.091	10.000	59.00	8.000	8.000	5.000	8.000	42.00	28.00
1.100	11.000	59.00	8.000	8.000	5.000	8.000	42.00	28.00
1.114	12.500	59.00	8.000	8.000	5.000	8.000	42.00	28.00
1.200	22.000	59.00	8.000	8.000	5.000	8.000	42.00	28.00
1.223	24.500	59.00	8.000	8.000	5.000	8.000	42.00	28.00
1.300	33.000	59.00	8.000	8.000	5.000	8.000	42.00	28.00
1.400	44.000	59.00	8.000	8.000	5.000	8.000	42.00	28.00
1.500	55.000	59.00	8.000	8.000	5.000	8.000	42.00	28.00
1.600	66.000	59.00	8.000	8.000	5.000	8.000	42.00	28.00
1.700	77.000	59.00	8.000	8.000	5.000	8.000	42.00	28.00
1.750	82.500	59.00	8.000	8.000	5.000	8.000	42.00	28.00
1.777	85.500	59.00	8.000	8.000	5.000	8.000	42.00	28.00
1.800	88.000	59.00	8.000	8.000	5.000	8.000	42.00	28.00

Appendix A

Prestressed Concrete Bridge Design Example

1.886	97.500	59.00	8.000	8.000	5.000	8.000	42.00	28.00
1.900	99.000	59.00	8.000	8.000	5.000	8.000	42.00	28.00
1.909	100.000	59.00	8.000	8.000	5.000	8.000	42.00	28.00
1.984	108.250	59.00	8.000	8.000	5.000	8.000	42.00	28.00
2.000	110.000	59.00	8.000	8.000	5.000	8.000	42.00	28.00

Calculated Properties:

Span Point	Dist (ft)	A (in ²)	I (in ⁴)	X-bar (in)
1.000	0.000	1731.0	1363966.1	51.07
1.016	1.750	1731.0	1363966.1	51.07
1.064	7.000	1731.0	1363966.1	51.07
1.091	10.000	1731.0	1363966.1	51.07
1.100	11.000	1731.0	1363966.1	51.07
1.114	12.500	1731.0	1363966.1	51.07
1.200	22.000	1731.0	1363966.1	51.07
1.223	24.500	1731.0	1363966.1	51.07
1.300	33.000	1731.0	1363966.1	51.07
1.400	44.000	1731.0	1363966.1	51.07
1.500	55.000	1731.0	1363966.1	51.07
1.600	66.000	1731.0	1363966.1	51.07
1.700	77.000	1731.0	1363966.1	51.07
1.750	82.500	1731.0	1363966.1	51.07
1.777	85.500	1731.0	1363966.1	51.07
1.800	88.000	1731.0	1363966.1	51.07
1.886	97.500	1731.0	1363966.1	51.07
1.900	99.000	1731.0	1363966.1	51.07
1.909	100.000	1731.0	1363966.1	51.07
1.984	108.250	1731.0	1363966.1	51.07
2.000	110.000	1731.0	1363966.1	51.07

Slab Geometry and Reinforcement: (in, in²)

Span Point	Dist (ft)	Eff. Width	Thickness	Gap	Top Row		Bottom Row	
					Area	Dist	Area	Dist
1.000	0.000	111.00	7.50	0.00	2.00	4.25	3.72	1.94
1.016	1.750	111.00	7.50	0.00	2.00	4.25	3.72	1.94
1.064	7.000	111.00	7.50	0.00	2.00	4.25	3.72	1.94
1.091	10.000	111.00	7.50	0.00	2.00	4.25	3.72	1.94
1.100	11.000	111.00	7.50	0.00	2.00	4.25	3.72	1.94
1.114	12.500	111.00	7.50	0.00	2.00	4.25	3.72	1.94
1.200	22.000	111.00	7.50	0.00	2.00	4.25	3.72	1.94
1.223	24.500	111.00	7.50	0.00	2.00	4.25	3.72	1.94
1.300	33.000	111.00	7.50	0.00	2.00	4.25	3.72	1.94
1.400	44.000	111.00	7.50	0.00	2.00	4.25	3.72	1.94
1.500	55.000	111.00	7.50	0.00	2.00	4.25	3.72	1.94
1.600	66.000	111.00	7.50	0.00	2.00	4.25	3.72	1.94
1.700	77.000	111.00	7.50	0.00	2.00	4.25	3.72	1.94
1.750	82.500	111.00	7.50	0.00	2.00	4.25	3.72	1.94
1.777	85.500	111.00	7.50	0.00	0.00	0.00	14.52	3.03
1.800	88.000	111.00	7.50	0.00	0.00	0.00	14.52	3.03
1.886	97.500	111.00	7.50	0.00	0.00	0.00	14.52	3.03
1.900	99.000	111.00	7.50	0.00	0.00	0.00	14.52	3.03
1.909	100.000	111.00	7.50	0.00	0.00	0.00	14.52	3.03
1.984	108.250	111.00	7.50	0.00	0.00	0.00	14.52	3.03
2.000	110.000	111.00	7.50	0.00	0.00	0.00	14.52	3.03

LIVE LOAD SETTINGS SUMMARY:

No.	Name	Description	Scale Factor	Percent Impact	Fixed Impact	Live Load Type	Rating Procedure
1	DTK_HL-93_~1	Truck: AASHTO LRFD Live Load - US unit s	1.000	100.000	0.33	DTK	Design Load
2	DTM_HL-93_~2	Tandem: AASHTO LRFD Live Load - US unit	1.000	100.000	0.33	DTM	Design Load
3	TKT_HL-93_~3	Truck Train: AASHTO LRFD Live Load - US	1.000	100.000	0.33	TKT	Design Load
4	DLN_HL-93_~5	Lane: AASHTO LRFD Live Load - US unit sy	1.000	100.000	0.00	DLN	Design Load

LIVE LOAD COMBINATIONS SUMMARY:

Comb. Factors			Truck	Lane	Combination	
No.	Name	Description	No.	No.	Truck	Lane
1	DTK_HL-93_~1	DTK_HL-93_~1 + DLN_HL-93_~5	1	4	1.000	1.000
2	DTM_HL-93_~2	DTM_HL-93_~2 + DLN_HL-93_~5	2	4	1.000	1.000
3	TKT_HL-93_~3	TKT_HL-93_~3 + DLN_HL-93_~5	3	4	0.900	0.900

LOAD FACTORS SUMMARY:

Limit State	eta D	eta R	eta I	eta T	
				MAX	MIN
STRENGTH I	1.00	1.00	1.00	1.00	1.00
STRENGTH II	1.00	1.00	1.00	1.00	1.00
STRENGTH III	1.00	1.00	1.00	1.00	1.00
STRENGTH IV	1.00	1.00	1.00	1.00	1.00
SERVICE I	1.00	1.00	1.00	1.00	1.00
SERVICE II	1.00	1.00	1.00	1.00	1.00
SERVICE III	1.00	1.00	1.00	1.00	1.00
FATIGUE	1.00	1.00	1.00	1.00	1.00

Limit State	DC		DW		LL
	MAX	MIN	MAX	MIN	
STRENGTH I	1.25	0.90	1.50	0.65	1.75
STRENGTH II	1.25	0.90	1.50	0.65	1.35
STRENGTH III	1.25	0.90	1.50	0.65	0.00
STRENGTH IV	1.50	1.50	1.50	0.65	0.00
SERVICE I	1.00	1.00	1.00	1.00	1.00
SERVICE II	1.00	1.00	1.00	1.00	1.30
SERVICE III	1.00	1.00	1.00	1.00	0.80
FATIGUE	1.00	1.00	1.00	1.00	0.75

Limit State	TU		SE		PS		DS	
	MAX	MIN	MAX	MIN	MAX	MIN	MAX	MIN
STRENGTH I	1.20	1.20	1.00	1.00	1.00	1.00	1.00	1.00
STRENGTH II	1.20	1.20	1.00	1.00	1.00	1.00	1.00	1.00
STRENGTH III	1.20	1.20	1.00	1.00	1.00	1.00	1.00	1.00
STRENGTH IV	1.20	1.20	0.00	0.00	1.00	1.00	1.00	1.00

```

-----
SERVICE I      1.20  1.20  1.00  1.00  1.00  1.00  1.00  1.00
SERVICE II    1.20  1.20  0.00  0.00  1.00  1.00  1.00  1.00
SERVICE III   1.20  1.20  1.00  1.00  1.00  1.00  1.00  1.00
-----
FATIGUE        1.00  1.00  1.00  1.00  1.00  1.00  1.00  1.00
    
```

RESISTANCE FACTORS SUMMARY:

```

Resistance
  Type      phi
=====
Flexure     1.00
Flx/Tens (R/C) 0.90
Shear       0.90
Fatigue     1.00
    
```

Section A4 – Opis Output

Noncomposite Effects

-Girder

Span	Location (ft.)	%Span	Moment (k-ft)	Shear (k)	Axial (k)	Reaction (k)
1	0	0	0	62.16	0	62.16
1	1.75	1.6	107.06	60.18	0	
1	10.0	9.1	565.12	50.86	0	
1	11.0	10	615.44	49.73	0	
1	12.5	11.4	688.73	48.03	0	
1	22.0	20	1094.06	37.3	0	
1	24.5	22.3	1183.75	34.47	0	
1	33.0	30	1435.93	24.86	0	
1	44.0	40	1641.06	12.43	0	
1	55.0	50	1709.44	0	0	
1	66.0	60	1641.07	-12.43	0	
1	77.0	70	1435.93	-24.86	0	
1	85.5	77.7	1183.76	-34.47	0	
1	88.0	80	1094.07	-37.3	0	
1	97.5	88.6	688.75	-48.03	0	
1	99.0	90	615.45	-49.73	0	
1	100.0	90.9	565.13	-50.86	0	
1	108.25	98.4	107.08	-60.18	0	
1	110.0	100	0	-62.16	0	124.32
2	0	0	0	62.16	0	124.32
2	1.75	1.6	107.08	60.18	0	
2	10.0	9.1	565.14	50.86	0	
2	11.0	10	615.45	49.73	0	
2	12.5	11.4	688.75	48.03	0	
2	22.0	20	1094.07	37.3	0	
2	24.5	22.3	1183.77	34.47	0	
2	33.0	30	1435.94	24.86	0	
2	44.0	40	1641.07	12.43	0	
2	55.0	50	1709.45	0	0	
2	66.0	60	1641.08	-12.43	0	
2	77.0	70	1435.94	-24.86	0	
2	85.5	77.7	1183.77	-34.47	0	
2	88.0	80	1094.07	-37.3	0	
2	97.5	88.6	688.75	-48.03	0	
2	99.0	90	615.45	-49.73	0	
2	100.0	90.9	565.14	-50.86	0	
2	108.25	98.4	107.09	-60.18	0	
2	110.0	100	0	-62.16	0	62.16

-Slab

Span	Location (ft.)	%Span	Moment (k-ft)	Shear (k)	Axial (k)	Reaction (k)
1	0	0	0	53.17	0	53.17
1	1.75	1.6	91.57	51.48	0	
1	10.0	9.1	483.36	43.5	0	
1	11.0	10	526.4	42.53	0	
1	12.5	11.4	589.09	41.08	0	
1	22.0	20	935.78	31.9	0	
1	24.5	22.3	1012.5	29.48	0	
1	33.0	30	1228.19	21.27	0	
1	44.0	40	1403.65	10.63	0	
1	55.0	50	1462.14	0	0	
1	66.0	60	1403.65	-10.63	0	
1	77.0	70	1228.2	-21.27	0	
1	85.5	77.7	1012.51	-29.48	0	
1	88.0	80	935.79	-31.9	0	
1	97.5	88.6	589.1	-41.08	0	
1	99.0	90	526.41	-42.53	0	
1	100.0	90.9	483.38	-43.5	0	
1	108.25	98.4	91.59	-51.48	0	
1	110.0	100	0	-53.17	0	106.34
2	0	0	0	53.17	0	106.34
2	1.75	1.6	91.59	51.48	0	
2	10.0	9.1	483.38	43.5	0	
2	11.0	10	526.41	42.53	0	
2	12.5	11.4	589.11	41.08	0	
2	22.0	20	935.79	31.9	0	
2	24.5	22.3	1012.51	29.48	0	
2	33.0	30	1228.2	21.27	0	
2	44.0	40	1403.66	10.63	0	
2	55.0	50	1462.14	0	0	
2	66.0	60	1403.66	-10.63	0	
2	77.0	70	1228.2	-21.27	0	
2	85.5	77.7	1012.51	-29.48	0	
2	88.0	80	935.79	-31.9	0	
2	97.5	88.6	589.11	-41.08	0	
2	99.0	90	526.41	-42.53	0	
2	100.0	90.9	483.38	-43.5	0	
2	108.25	98.4	91.59	-51.48	0	
2	110.0	100	0	-53.17	0	53.17

-Haunch

Span	Location (ft.)	%Span	Moment (k-ft)	Shear (k)	Axial (k)	Reaction (k)
1	0	0	0	12.18	0	12.18
1	1.75	1.6	21.05	11.87	0	
1	10.0	9.1	113.05	10.43	0	
1	11.0	10	123.39	10.25	0	
1	12.5	11.4	138.57	9.99	0	
1	22.0	20	225.6	8.33	0	
1	24.5	22.3	245.87	7.89	0	
1	33.0	30	306.63	6.4	0	
1	44.0	40	366.49	4.48	0	
1	55.0	50	402.65	-2.51	0	
1	66.0	60	364.47	-4.43	0	
1	77.0	70	305.11	-6.36	0	
1	85.5	77.7	244.75	-7.85	0	
1	88.0	80	224.59	-8.28	0	
1	97.5	88.6	138	-9.95	0	
1	99.0	90	122.89	-10.21	0	
1	100.0	90.9	112.59	-10.38	0	
1	108.25	98.4	20.97	-11.83	0	
1	110.0	100	0	-12.13	0	24.29
2	0	0	0	12.15	0	24.29
2	1.75	1.6	21.01	11.85	0	
2	10.0	9.1	112.8	10.4	0	
2	11.0	10	123.13	10.23	0	
2	12.5	11.4	138.27	9.97	0	
2	22.0	20	225.06	8.3	0	
2	24.5	22.3	245.27	7.87	0	
2	33.0	30	305.82	6.38	0	
2	44.0	40	365.42	4.45	0	
2	55.0	50	403.83	-2.53	0	
2	66.0	60	365.42	-4.45	0	
2	77.0	70	305.83	-6.38	0	
2	85.5	77.7	245.27	-7.87	0	
2	88.0	80	225.06	-8.3	0	
2	97.5	88.6	138.27	-9.97	0	
2	99.0	90	123.13	-10.23	0	
2	100.0	90.9	112.81	-10.4	0	
2	108.25	98.4	21.01	-11.85	0	
2	110.0	100	0	-12.15	0	12.15

-Prestress Loads

Span	Location (ft.)	%Span	Moment (k-ft)	Shear (k)	Axial (k)	Reaction (k)
1	0	0	-683.1	0.02	-264.38	0.02
1	1.75	1.6	-1986.69	0.02	-768.91	
1	10.0	9.1	-2057.51	0.02	-796.33	
1	11.0	10	-2187.89	0.02	-844.25	
1	12.5	11.4	-2374.03	0.02	-912.66	
1	22.0	20	-2449.38	0.02	-941.51	
1	24.5	22.3	-2743.38	0.02	-1048.38	
1	33.0	30	-2796.01	0.02	-1069.07	
1	44.0	40	-2838.12	0.02	-1085.66	
1	55.0	50	-2850.72	0.02	-1090.7	
1	66.0	60	-2830.88	0.02	-1083.03	
1	77.0	70	-2781.69	0.02	-1063.87	
1	85.5	77.7	-2723.58	0.02	-1041.19	
1	88	80	-2430.89	0.02	-934.81	
1	97.5	88.6	-2352.53	0.02	-904.06	
1	99.0	90	-2166.55	0.02	-836.21	
1	100.0	90.9	-2036.39	0.02	-788.69	
1	108.25	98.4	-1963.5	0.02	-759.88	
1	110.0	100	-675.87	0.02	-261.58	-7.24
2	0	0	117.17	-7.22	-261.58	-7.24
2	1.75	1.6	-1183.04	-7.22	-759.88	
2	10.0	9.1	-1315.27	-7.22	-788.7	
2	11.0	10	-1452.63	-7.22	-836.21	
2	12.5	11.4	-1649.4	-7.22	-904.06	
2	22.0	20	-1796.11	-7.22	-934.82	
2	24.5	22.3	-2106.79	-7.22	-1041.2	
2	33.0	30	-2226.04	-7.22	-1063.89	
2	44.0	40	-2354.37	-7.22	-1083.05	
2	55.0	50	-2453.34	-7.22	-1090.73	
2	66.0	60	-2519.72	-7.22	-1085.64	
2	77.0	70	-2556.75	-7.22	-1069.06	
2	85.5	77.7	-2565.26	-7.22	-1048.37	
2	88.0	80	-2289.25	-7.22	-941.5	
2	97.5	88.6	-2284.53	-7.22	-912.66	
2	99.0	90	-2107.85	-7.22	-844.25	
2	100.0	90.9	-1983.8	-7.22	-796.33	
2	108.25	98.4	-1974.16	-7.22	-768.91	
2	110.0	100	-683.1	-7.22	-264.38	7.22

-Initial Prestress Loads

Span	Location (ft.)	%Span	Moment (k-ft)	Shear (k)	Axial (k)	Reaction (k)
1	0	0	-752.99	0	-291.43	0
1	1.75	1.6	-2393.44	0	-926.32	
1	10.0	9.1	-2411.31	0	-933.21	
1	11.0	10	-2585.16	0	-997.43	
1	12.5	11.4	-2840.93	0	-1091.94	
1	22.0	20	-2859.89	0	-1099.17	
1	24.5	22.3	-3275.5	0	-1252.16	
1	33.0	30	-3288.78	0	-1257.36	
1	44.0	40	-3299.59	0	-1261.59	
1	55.0	50	-3303.2	0	-1263	
1	66.0	60	-3299.61	0	-1261.59	
1	77.0	70	-3288.81	0	-1257.36	
1	85.5	77.7	-3275.55	0	-1252.16	
1	88.0	80	-2859.95	0	-1099.17	
1	97.5	88.6	-2841.57	0	-1091.94	
1	99.0	90	-2585.15	0	-997.43	
1	100.0	90.9	-2410.88	0	-933.21	
1	108.25	98.4	-2393.5	0	-926.32	
1	110.0	100	-752.99	0	-291.43	-8.03
2	0	0	130.53	-8.03	-291.43	-8.03
2	1.75	1.6	-1524.02	-8.03	-926.32	
2	10.0	9.1	-1607.67	-8.03	-933.21	
2	11.0	10	-1789.97	-8.03	-997.43	
2	12.5	11.4	-2058.45	-8.03	-1091.94	
2	22.0	20	-2153.13	-8.03	-1099.17	
2	24.5	22.3	-2588.83	-8.03	-1252.16	
2	33.0	30	-2670.37	-8.03	-1257.36	
2	44.0	40	-2769.53	-8.03	-1261.59	
2	55.0	50	-2861.48	-8.03	-1263	
2	66.0	60	-2946.24	-8.03	-1261.59	
2	77.0	70	-3023.79	-8.03	-1257.36	
2	85.5	77.7	-3078.79	-8.03	-1252.16	
2	88.0	80	-2683.26	-8.03	-1099.17	
2	97.5	88.6	-2741.18	-8.03	-1091.94	
2	99.0	90	-2496.8	-8.03	-997.43	
2	100.0	90.9	-2330.56	-8.03	-933.21	
2	108.25	98.4	-2379.45	-8.03	-926.32	
2	110.0	100	-752.99	-8.03	-291.43	8.03

Composite Effects

-Parapets

Span	Location (ft.)	%Span	Moment (k-ft)	Shear (k)	Axial (k)	Reaction (k)
1	0	0	0	8.91	0	8.91
1	1.75	1.6	15.26	8.53	0	
1	10.0	9.1	78.29	6.75	0	
1	11.0	10	84.94	6.53	0	
1	12.5	11.4	94.5	6.21	0	
1	22.0	20	143.74	4.16	0	
1	24.5	22.3	153.46	3.62	0	
1	33.0	30	176.41	1.78	0	
1	44.0	40	182.95	-0.59	0	
1	55.0	50	163.35	-2.97	0	
1	66.0	60	117.61	-5.35	0	
1	77.0	70	45.74	-7.72	0	
1	85.5	77.7	-27.7	-9.56	0	
1	88.0	80	-52.27	-10.1	0	
1	97.5	88.6	-157.95	-12.15	0	
1	99.0	90	-176.42	-12.47	0	
1	100.0	90.9	-189	-12.69	0	
1	108.25	98.4	-301.04	-14.47	0	
1	110.0	100	-326.7	-14.85	0	29.7
2	0	0	-326.7	14.85	0	29.7
2	1.75	1.6	-301.04	14.47	0	
2	10.0	9.1	-189	12.69	0	
2	11.0	10	-176.42	12.47	0	
2	12.5	11.4	-157.95	12.15	0	
2	22.0	20	-52.27	10.1	0	
2	24.5	22.3	-27.7	9.56	0	
2	33.0	30	45.74	7.72	0	
2	44.0	40	117.61	5.35	0	
2	55.0	50	163.35	2.97	0	
2	66.0	60	182.95	0.59	0	
2	77.0	70	176.42	-1.78	0	
2	85.5	77.7	153.47	-3.62	0	
2	88.0	80	143.75	-4.16	0	
2	97.5	88.6	94.5	-6.21	0	
2	99.0	90	84.94	-6.53	0	
2	100.0	90.9	78.3	-6.75	0	
2	108.25	98.4	15.26	-8.53	0	
2	110.0	100	0	-8.91	0	8.91

-Future Wearing Surface

Span	Location (ft.)	%Span	Moment (k-ft)	Shear (k)	Axial (k)	Reaction (k)
1	0	0	0	10.73	0	10.73
1	1.75	1.6	18.37	10.27	0	
1	10.0	9.1	94.24	8.13	0	
1	11.0	10	102.24	7.87	0	
1	12.5	11.4	113.74	7.48	0	
1	22.0	20	173.03	5.01	0	
1	24.5	22.3	184.72	4.36	0	
1	33.0	30	212.35	2.15	0	
1	44.0	40	220.22	-0.71	0	
1	55.0	50	196.62	-3.57	0	
1	66.0	60	141.57	-6.43	0	
1	77.0	70	55.05	-9.29	0	
1	85.5	77.7	-33.35	-11.5	0	
1	88.0	80	-62.92	-12.15	0	
1	97.5	88.6	-190.12	-14.62	0	
1	99.0	90	-212.35	-15.01	0	
1	100.0	90.9	-227.5	-15.27	0	
1	108.25	98.4	-362.36	-17.42	0	
1	110.0	100	-393.25	-17.87	0	35.75
2	0	0	-393.25	17.87	0	35.75
2	1.75	1.6	-362.36	17.42	0	
2	10.0	9.1	-227.5	15.27	0	
2	11.0	10	-212.35	15.01	0	
2	12.5	11.4	-190.12	14.62	0	
2	22.0	20	-62.92	12.15	0	
2	24.5	22.3	-33.34	11.5	0	
2	33.0	30	55.06	9.29	0	
2	44.0	40	141.57	6.43	0	
2	55.0	50	196.63	3.57	0	
2	66.0	60	220.22	0.71	0	
2	77.0	70	212.35	-2.15	0	
2	85.5	77.7	184.73	-4.36	0	
2	88.0	80	173.03	-5.01	0	
2	97.5	88.6	113.75	-7.48	0	
2	99.0	90	102.24	-7.87	0	
2	100.0	90.9	94.25	-8.13	0	
2	108.25	98.4	18.37	-10.27	0	
2	110.0	100	0	-10.73	0	10.73

-Live Load - Axle

Span	Location (ft.)	%Span	Positive Moment (k-ft)	Negative Moment (k-ft)	Positive Shear (k)	Negative Shear (k)	Positive Axial (k)	Negative Axial (k)	Positive Reaction (k)	Negative Reaction (k)
1	0	0	0	0	82.58	-8.68	0	0	82.58	-8.68
1	1.75	1.6	114.9	-12.42	81.25	-8.68	0	0		
1	10.0	9.1	590.15	-71.02	72.04	-8.68	0	0		
1	11.0	10	639.51	-78.12	72.04	-8.68	0	0		
1	12.5	11.4	711.33	-88.78	69.76	-8.68	0	0		
1	22.0	20	1085.74	-156.27	60.77	-13.28	0	0		
1	24.5	22.3	1158.79	-174.02	57.47	-16.36	0	0		
1	33.0	30	1342.86	-234.4	49.91	-23.97	0	0		
1	44.0	40	1454.58	-312.55	39.59	-35.15	0	0		
1	55.0	50	1426.41	-390.69	29.95	-45.9	0	0		
1	66.0	60	1275.16	-468.83	21.14	-56.06	0	0		
1	77.0	70	998.84	-546.97	13.29	-65.51	0	0		
1	85.5	77.7	721.36	-607.35	7.99	-72.45	0	0		
1	88.0	80	630.85	-625.11	6.82	-74.09	0	0		
1	97.5	88.6	267.94	-692.6	2.52	-80.97	0	0		
1	99.0	90	210.54	-703.25	2.25	-81.67	0	0		
1	100.0	90.9	172.66	-710.35	1.99	-82.37	0	0		
1	108.25	98.4	28.13	-768.96	0.32	-86.92	0	0		
1	110.0	100	0	-781.39	0	-88.11	0	0	92.2	0
2	0	0	0	-781.39	88.11	0	0	0	92.2	0
2	1.75	1.6	28.13	-768.95	86.92	-0.32	0	0		
2	10.0	9.1	172.66	-710.34	82.37	-1.99	0	0		
2	11.0	10	210.54	-703.24	81.67	-2.25	0	0		
2	12.5	11.4	267.94	-692.59	80.97	-2.52	0	0		
2	22.0	20	630.85	-625.1	74.09	-6.82	0	0		
2	24.5	22.3	721.36	-607.34	72.45	-7.99	0	0		
2	33.0	30	998.85	-546.96	65.51	-13.29	0	0		
2	44.0	40	1275.17	-468.83	56.06	-21.14	0	0		
2	55.0	50	1426.43	-390.69	45.9	-29.95	0	0		
2	66.0	60	1454.6	-312.55	35.15	-39.59	0	0		
2	77.0	70	1342.88	-234.41	23.97	-49.91	0	0		
2	85.5	77.7	1158.81	-174.03	16.36	-57.47	0	0		
2	88.0	80	1085.76	-156.28	13.28	-60.77	0	0		
2	97.5	88.6	711.36	-88.79	8.68	-69.76	0	0		
2	99.0	90	639.54	-78.14	8.68	-72.04	0	0		
2	100.0	90.9	590.18	-71.03	8.68	-72.04	0	0		
2	108.25	98.4	114.9	-12.43	8.68	-81.25	0	0		
2	110.0	100	0	0	8.68	-82.58	0	0	82.58	-8.68

-Live Load – Truck Pair

Span	Location (ft.)	%Span	Positive Moment (k-ft)	Negative Moment (k-ft)	Positive Shear (k)	Negative Shear (k)	Positive Axial (k)	Negative Axial (k)	Positive Reaction (k)	Negative Reaction (k)
1	0	0	0	0	0	0	0	0	0	0
1	1.75	1.6	0	0	0	0	0	0		
1	10.0	9.1	0	0	0	0	0	0		
1	11.0	10	0	0	0	0	0	0		
1	12.5	11.4	0	0	0	0	0	0		
1	22.0	20	0	0	0	0	0	0		
1	24.5	22.3	0	0	0	0	0	0		
1	33.0	30	0	0	0	0	0	0		
1	44.0	40	0	0	0	0	0	0		
1	55.0	50	0	0	0	0	0	0		
1	66.0	60	0	0	0	0	0	0		
1	77.0	70	0	0	0	0	0	0		
1	85.5	77.7	0	0	0	0	0	0		
1	88.0	80	0	0	0	0	0	0		
1	97.5	88.6	0	0	0	0	0	0		
1	99.0	90	0	0	0	0	0	0		
1	100.0	90.9	0	0	0	0	0	0		
1	108.25	98.4	0	0	0	0	0	0		
1	110.0	100	0	-1561.47	0	0	0	0	153.7	0
2	0	0	0	-1561.47	0	0	0	0	153.7	0
2	1.75	1.6	0	0	0	0	0	0		
2	10.0	9.1	0	0	0	0	0	0		
2	11.0	10	0	0	0	0	0	0		
2	12.5	11.4	0	0	0	0	0	0		
2	22.0	20	0	0	0	0	0	0		
2	24.5	22.3	0	0	0	0	0	0		
2	33.0	30	0	0	0	0	0	0		
2	44.0	40	0	0	0	0	0	0		
2	55.0	50	0	0	0	0	0	0		
2	66.0	60	0	0	0	0	0	0		
2	77.0	70	0	0	0	0	0	0		
2	85.5	77.7	0	0	0	0	0	0		
2	88.0	80	0	0	0	0	0	0		
2	97.5	88.6	0	0	0	0	0	0		
2	99.0	90	0	0	0	0	0	0		
2	100.0	90.9	0	0	0	0	0	0		
2	108.25	98.4	0	0	0	0	0	0		
2	110.0	100	0	0	0	0	0	0	0	0

-Live Load – Lane

Span	Location (ft.)	%Span	Positive Moment (k-ft)	Negative Moment (k-ft)	Positive Shear (k)	Negative Shear (k)	Positive Axial (k)	Negative Axial (k)	Positive Reaction (k)	Negative Reaction (k)
1	0	0	0	0	29.97	-4.28	0	0	29.97	-4.28
1	1.75	1.6	42.04	-6.12	28.95	-4.29	0	0		
1	10.0	9.1	219.67	-35.02	23.82	-4.67	0	0		
1	11.0	10	238.84	-38.52	23.82	-4.67	0	0		
1	12.5	11.4	266.59	-43.77	22.62	-4.85	0	0		
1	22.0	20	416.06	-77.05	18.18	-5.92	0	0		
1	24.5	22.3	447.72	-85.8	16.66	-6.46	0	0		
1	33.0	30	531.63	-115.57	13.39	-8.01	0	0		
1	44.0	40	585.57	-154.1	9.42	-10.92	0	0		
1	55.0	50	577.87	-192.63	6.22	-14.61	0	0		
1	66.0	60	508.52	-231.16	3.77	-19.04	0	0		
1	77.0	70	377.54	-269.68	1.99	-24.15	0	0		
1	85.5	77.7	234.1	-299.45	1.01	-28.68	0	0		
1	88.0	80	184.91	-308.21	0.82	-29.87	0	0		
1	97.5	88.6	50.03	-422.53	0.23	-35.47	0	0		
1	99.0	90	37.65	-453.74	0.19	-36.12	0	0		
1	100.0	90.9	30.54	-476.31	0.15	-36.77	0	0		
1	108.25	98.4	0.85	-710.81	0.01	-41.44	0	0		
1	110.0	100	0	-770.52	0	-42.81	0	0	85.62	0
2	0	0	0	-770.52	42.81	0	0	0	85.62	0
2	1.75	1.6	0.85	-710.81	41.44	-0.01	0	0		
2	10.0	9.1	30.54	-476.31	36.77	-0.15	0	0		
2	11.0	10	37.65	-453.74	36.12	-0.19	0	0		
2	12.5	11.4	50.02	-422.53	35.47	-0.23	0	0		
2	22.0	20	184.91	-308.21	29.87	-0.82	0	0		
2	24.5	22.3	234.1	-299.45	28.68	-1.01	0	0		
2	33.0	30	377.54	-269.68	24.15	-1.99	0	0		
2	44.0	40	508.53	-231.15	19.04	-3.77	0	0		
2	55.0	50	577.87	-192.63	14.61	-6.22	0	0		
2	66.0	60	585.58	-154.1	10.92	-9.42	0	0		
2	77.0	70	531.64	-115.58	8.01	-13.39	0	0		
2	85.5	77.7	447.74	-85.81	6.46	-16.66	0	0		
2	88.0	80	416.07	-77.05	5.92	-18.18	0	0		
2	97.5	88.6	266.6	-43.78	4.85	-22.62	0	0		
2	99.0	90	238.85	-38.52	4.67	-23.82	0	0		
2	100.0	90.9	219.69	-35.02	4.67	-23.82	0	0		
2	108.25	98.4	42.05	-6.13	4.29	-28.95	0	0		
2	110.0	100	0	0	4.28	-29.97	0	0	29.97	-4.28

Section A5 – Comparison Between the Hand Calculations and the Two Computer Programs

Moment Comparison

Method	Location	Girder	Slab, Haunch and Ext. Diaphragm	Parapets	FWS	Positive LL ⁽³⁾	Negative LL ⁽⁴⁾
	(ft.)	(k-ft)	(k-ft)	(k-ft)	(k-ft)	(k-ft)	(k-ft)
Opis	11	615.5 ⁽¹⁾	649.8 ⁽¹⁾	84.9	102.2	878.4	-
QCon		- ⁽⁵⁾	- ⁽⁵⁾	-	114.0	909.3	-
Table 5.3		656.0 ⁽²⁾	643.0 ⁽²⁾	85.0	114.0	886.0	-
Opis	55	1,709.5 ⁽¹⁾	1,864.8 ⁽¹⁾	163.4	196.6	2004.3	-
QCon		-	-	-	219.3	2,063.0	-
Table 5.3		1,725.0 ⁽²⁾	1,832.0 ⁽²⁾	164.0	220.0	2,010.0	-
Opis	~ 110	0	0	-326.7	-393.3	-	-2,098.8
QCon		-	-	-	-438.6	-	-2,096.9
Table 5.3		0	0	-326.0	-438.0	-	-2,095.0

Shear Comparison

Method	Location	Girder	Slab, Haunch and Ext. Diaphragm	Parapets	FWS	Positive LL ⁽³⁾	Negative LL ⁽⁴⁾
	(ft.)	(k)	(k)	(k)	(k)	(k)	(k)
Opis	11	49.7 ⁽¹⁾	52.8 ⁽¹⁾	6.5	7.9	95.9	-14.9
QCon		- ⁽⁵⁾	- ⁽⁵⁾	- ⁽⁵⁾	8.8	99.4	-13.0
Table 5.3		49.2 ⁽²⁾	52.2 ⁽²⁾	6.5	8.8	95.5	-13.4
Opis	55	0 ⁽¹⁾	-2.5 ⁽¹⁾	-3.0	-3.6	36.2	-60.5
QCon		-	-	-	-4.0	36.7	-61.7
Table 5.3		-0.6 ⁽²⁾	-3.1 ⁽²⁾	-3.0	-4.0	36.2	-61.2
Opis	~ 110	0	0	-14.9	-17.9	0	-130.9
QCon		-	-	-	-19.9	0	-132.1
Table 5.3		0	0	-14.8	-19.9	0	-131.1

Notes:

- 1- Calculated based on a 110 ft simple span length and the force effects are calculated at the distance shown in the table measured from the centerline of the abutment neoprene pads.
- 2- Calculated based on a 109 ft simple span length (distance between the centerline of the neoprene pads) and the force effects are calculated at the distance shown in the table measured from the centerline of the abutment neoprene pads.
- 3- Truck + Lane including impact
- 4- 0.90(Truck Pair + Lane including impact) as specified in S3.6.1.3.1
- 5- QConBridge does not apply the noncomposite loads to the simple span girder, the program applies the girder, slab, haunch and diaphragm loads to the continuous girder, therefore, these results are not comparable.

Section A6 – Flexural Resistance Sample Calculation from Opis to Compare with Hand Calculations

The following is sample Opis output for flexure at 55 ft. and 110 ft. from the end bearing. These results may be compared to the hand calculations in Design Step 5.6 for the positive and negative regions.

Positive Bending Region

PERFORMING AASHTO LRFD SPECIFICATION CHECKS - 5.7.3.2 Flexural Resistance

Point of Interest : 105.00 (55.0 ft.)
 Construction Stage: 2

Prestress Summary:

dp = 74.502 in (from top)
 Aps = 6.732 in²
 fps = 264.532 ksi (avg. for all rows)

POSITIVE Flexural Resistance:

** Analyzed as a RECTANGULAR Section **					
Layer	Area, in ²	Stress, ksi	Force, kips	Lever-Arm, in	Moment i, in-k
CS	507.832	-0.85*f'c	-1726.627	3.095	5343.728
RT	2.000	-32.515	-65.029	2.132	138.670
RB	3.720	2.911	10.828	-0.180	1.950
PS11	0.612	264.145	161.657	-64.118	10365.045
PS10	0.918	264.309	242.636	-66.118	16042.478
PS 9	0.306	264.464	80.926	-68.118	5512.478
PS 8	0.306	264.464	80.926	-68.118	5512.478
PS 7	0.918	264.464	242.778	-68.118	16537.434
PS 6	0.306	264.610	80.971	-70.118	5677.476
PS 5	0.306	264.610	80.971	-70.118	5677.476
PS 4	1.224	264.610	323.883	-70.118	22709.904
PS 3	0.306	264.750	81.013	-72.118	5842.487
PS 2	0.306	264.750	81.013	-72.118	5842.487
PS 1	1.224	264.750	324.053	-72.118	23369.949
Sum			-0.002		128574.031

Flexural Resistance Summary:

beta 1 = 0.850	phi f = 1.000
c = 5.382 in	Mn = 128574.031 in-k
a = 4.575 in (from top)	= 10714.503 ft-k
f'c = 4.000 ksi (slab)	phi*Mn = 128574.031 in-k
	[AASHTO LRFD (5.7.3.2.1-1)]
	= 10714.503 ft-k

(COMPARED TO 10,697 ft-k from hand calculations)

Effective Shear Depth: [AASHTO LRFD 5.8.2.7]

Tensile Force = 1791.655 kips
 dv = Mn / Tensile Force = 71.763 in

Tensile Capacity of Reinforcement on Flexural Tension Side: [AASHTO 5.8.3.5]

Rebar = 0.000 kips
 P/S = 1780.827 kips
 T(Cap) = 1780.827 kips

Layer Codes:

=> C_ : C = Concrete, where _ may be:
 S = Slab, TF = Top Flange, W = Web, BF = Bottom Flange,
 ^T = Top fillets and tapers, ^B = Bottom fillets and tapers
=> R_ : R = Reinforcement, where _ is the row number (1-5, B (bottom), T (top))
=> PS_ : PS = Prestress, where _ is the row number

Notes:

=> The flexural resistance is determined based on:
 * Equilibrium
 * Strain compatibility
 * Strain in extreme compressive concrete fiber is 0.003
=> The stress in the mild compression steel includes an adjustment for
 the displaced concrete. $f_s = (e_s * E_s) + (0.85 f'_c \text{ABS}(e_s / e_y))$

Negative Bending Region

PERFORMING AASHTO LRFD SPECIFICATION CHECKS - 5.7.3.2 Flexural Resistance

Point of Interest : 110.00 (110.0 ft.)

Construction Stage: 2

NEGATIVE Flexural Resistance:

** Analyzed as a RECTANGULAR Section **

Layer	Area, in ²	Stress, ksi	Force, kips	Lever-Arm, in	Moment i, in-k
RB	14.520	60.000	871.200	-67.445	58757.660
R1	1.550	-37.650	-58.358	3.590	209.478
CBF	159.381	-0.85*f'c	-812.843	4.743	3855.703
Sum			0.000		62822.840

Flexural Resistance Summary:

beta 1 =	0.750	phi f =	0.900
c =	7.590 in	Mn =	62822.840 in-k
a =	5.692 in (from bottom)	=	5235.237 ft-k
		phi*Mn =	56540.555 in-k
		[AASHTO LRFD (5.7.3.2.1-1)]	
		=	4711.713 ft-k
		(COMPARED TO 4,775 ft-k from hand calculations)	
f'c =	6.000 ksi (flange)		
f'c =	6.000 ksi (stem)		

Effective Shear Depth: [AASHTO LRFD 5.8.2.7]

Tensile Force = 871.200 kips

dv = Mn / Tensile Force = 72.111 in

Tensile Capacity of Reinforcement on Flexural Tension Side: [AASHTO 5.8.3.5]

Rebar = 871.200 kips

T(Cap) = 871.200 kips

Layer Codes:

=> C_ : C = Concrete, where _ may be:

S = Slab, TF = Top Flange, W = Web, BF = Bottom Flange,
 ^T = Top fillets and tapers, ^B = Bottom fillets and tapers

=> R_ : R = Reinforcement, where _ is the row number (1-5, B (bottom), T (top))

=> PS_ : PS = Prestress, where _ is the row number

Notes:

=> The flexural resistance is determined based on:

* Equilibrium

* Strain compatibility

* Strain in extreme compressive concrete fiber is 0.003

=> The stress in the mild compression steel includes an adjustment for the displaced concrete. fs = (es * Es) + (0.85 f'c ABS(es / ey))

Appendix B

GENERAL GUIDELINES FOR REFINED ANALYSIS OF DECK SLABS

Traditionally, deck slabs have been analyzed using approximate methods. The approximate methods are based on calculating moments per unit width of the deck and design the reinforcement to resist these moments. This approach has been used successfully for many decades. However, the approximate methods were generally based on laboratory testing and/or refined analysis of typical decks supported on parallel girders and no skews. In case of deck slabs with unusual geometry, such as sharply skewed decks, the results of the approximate methods may not be accurate. For example, negative moments may develop at the acute corner of a sharply skewed deck. These moments are not accounted for in the approximate methods as they rely on assuming that the deck is behaving as a continuous beam.

In cases of unusual deck geometry, bridge designers may find it beneficial to employ refined methods of analysis. Typically the use of the refined methods of analysis is meant for the design of both of the girders and the deck slab. The design method of analysis most used is the finite element analysis. However, for deck slabs, other methods such as the yield line method and the finite differences method may be used. Following is a general description of the use of the finite elements in analyzing deck slabs.

Finite element modeling of decks

Type of elements

The finite element method is based on dividing a component into a group of small components or “finite elements”. Depending on the type of the element, the number of displacements (translations and rotations) varies at each end or corner of the element varies. The displacements are typically referred to as ‘degrees of freedom’. The basic output of the analysis is the displacements at each node. These displacements are then converted into forces at the nodes. The force output corresponding to a rotational degrees of freedom is in the form of a moment while forces correspond to translational degrees of freedom. Following are the types of elements typically used to model a plate structure and the advantage and disadvantages of each type.

Plate elements: Plate elements are developed assuming that the thickness of the plate component is small relative to the other two dimensions. The plate is modeled by its middle surface. Each element typically has four corners or nodes. Most computer programs have the ability of handling three-node or triangular plate elements, which are typically treated as a special case of the four-node basic element. Following the general plate theory, plate elements are assumed have three allowed displacements at each node; translation perpendicular to the plate and rotations about two perpendicular axes in the plane of the plate. The typical output includes the moments (usually given as moment per unit width of the face of the elements) and the shear in the plate. This form of output is convenient because the moments may be directly used to design the deck.

The main disadvantage of plate elements is that they do not account for the forces in the plane of the plate. This results in ignoring the stiffness of the plate elements in this plane. This precludes them from being used as part of a three-dimensional model to analyze both the deck and the girders.

The deck supports are modeled as rigid supports along the lines of the supporting components, i.e. girders, diaphragms and/or floor beams. Where it is desirable to consider the effect of the flexibility of the supporting components on the deck moments, the model may include these components that are typically modeled as beams. As the plate elements, theoretically, have no in-plane stiffness, the effect of the composite action on the stiffness of the beams should be considered when determining the stiffness of the beam elements.

Shell elements: Shell elements are also developed assuming that the thickness of the component is small relative to the other two dimensions and are also modeled by their middle surface. They differ from plate elements in that they are considered to have six degrees of freedom at each node, three translations and three rotations. Typically the rotation about the axis perpendicular to the surface at a node is eliminated leaving only five degrees of freedom per node. Shell elements may be used to model two dimensional (plate) components or three-dimensional (shell) components. Commercially available computer programs typically allow three-node and four-node elements. The typical output includes the moments (usually given as moment per unit width of the face of the elements) and the shear and axial loads in the element. This form of output is convenient because the moments may be directly used to design the deck.

Due to the inclusion of the translations in the plane of the elements, shell elements may be used as part of a three-dimensional model to analyze both the deck and the girders. When the supporting components are modeled using beam elements, only the stiffness of the noncomposite beams is introduced when defining the stiffness of the beams. The effect of the composite action between the deck and the supporting components is automatically included due to the presence of the in-plane stiffness of the shell elements representing the deck.

Solid elements: Solid elements may be used to model both thin and thick components. The thickness of the component may be divided into several layers or, for thin components such as decks, may be modeled using one layer. The solid elements are developed assuming three translations at each node and the rotations are not considered in the development. The typical output includes the forces in the direction of the three degrees of freedom at the nodes. Most computer programs have the ability to determine the surface stresses of the solid elements. This form of output is not convenient because these forces or stresses need to be converted to moments that may be used to design the deck. Notice that, theoretically, there should be no force perpendicular to the free surface of an element. However, due to rounding off errors, a small force is typically calculated.

Similar to shell elements, due to the inclusion of all translations in the development of the elements, solid elements may be used as part of a three-dimensional model to analyze both the deck and the girders. When the supporting components are modeled using beam elements, only the stiffness of the noncomposite beams is introduced when defining the stiffness of the beams.

Element size and aspect ratio: The accuracy of the results of a finite element model increases as the element size decreases. The required size of elements is smaller at areas where high loads exist such as location of applied concentrated loads and reactions. For a deck slab, the dividing the width between the girders to five or more girders typically yields accurate results. The aspect ratio of the element (length-

to-width ratio for plate and shell elements and longest-to-shortest side length ratio for solid elements) and the corner angles should be kept within the values recommended by the developer of the computer program. Typically an aspect ratio less than 3 and corner angles between 60 and 120 degrees are considered acceptable. In case the developer recommendations are not followed, the inaccurate results are usually limited to the nonconformant elements and the surrounding areas. When many of the elements do not conform to the developer recommendation, it is recommended that a finer model be developed and the results of the two models compared. If the difference is within the acceptable limits for design, the coarser model may be used. If the difference is not acceptable, a third, finer model should be developed and the results are then compared to the previous model. This process should be repeated until the difference between the results of the last two models is within the acceptable limits.

For deck slabs with constant thickness, the results are not very sensitive to element size and aspect ratio.

Load application: Local stress concentrations take place at the locations of concentrated loads applied to a finite element model. For a bridge deck, wheel loads should preferably be applied as uniform load distributed over the tire contact area specified in Article S3.6.1.2.5. To simplify live load application to the deck model, the size of the elements should be selected to eliminate the partial loading of some finite elements, i.e. the tire contact area preferably match the area of one or a group of elements.

APPENDIX C

Calculations of Creep and Shrinkage Effects

See Design Step 5.3 for the basic information about creep and shrinkage effects. Design Step 5.3 also contains the table of fixed end moments used in this appendix.

Design Step C1.1 Analysis of creep effects on the example bridge

Calculations are shown for Span 1 for a deck slab cast 450 days after the beams are made. Span 2 calculations are similar. See the tables at the end of this appendix for the final results for a case of the slab and continuity connection cast 30 days after the beams are cast. All calculations are made following the procedures outlined in the publication entitled "Design of Continuous Highway Bridges with Precast, Prestressed Concrete Girders" published by the Portland Cement Association (PCA) in August 1969.

The distance from the composite neutral axis to the bottom of the beam is 51.54 in. from Section 2. Therefore, the prestressing force eccentricity at midspan is:

$$\begin{aligned} e_c &= NA_{\text{bottom}} - CGS \\ &= 51.54 - 5.0 \\ &= 46.54 \text{ in.} \end{aligned}$$

Design Step C1.2 Calculate the creep coefficient, $\psi_{(t, t_i)}$, for the beam at infinite time according to S5.4.2.3.2.

Calculate the concrete strength factor, k_f

$$\begin{aligned} k_f &= 1/[0.67 + (f'_c/9)] && \text{(S5.4.2.3.2-2)} \\ &= 1/[0.67 + (6.0/9)] \\ &= 0.748 \end{aligned}$$

Calculate the volume to surface area factor, k_c

$$k_c = \left[\frac{\left(\frac{t}{26e^{0.36(V/S)_b} + t} \right)}{\left(\frac{t}{45 + t} \right)} \right] \left[\frac{1.80 + 1.77e^{-0.54(V/S)_b}}{2.587} \right] \quad \text{(SC5.4.2.3.2-1)}$$

where:

t = maturity of concrete
= infinite days

e = natural log base (approx. 2.71828)

$(V/S)_b$ = volume to surface ratio for the beam
 = beam surface area is 2,955.38 in²/ft (see Figure 2-3 for beam dimensions) and the volume is 13,020 in³/ft
 = (13,020/2,955.38)
 = 4.406 in.

$$k_c = [1] \left[\frac{1.80 + 1.77e^{-0.54(4.406)}}{2.587} \right]$$

$$k_c = 0.759$$

The creep coefficient is the ratio between creep strain and the strain due to permanent stress (SC5.4.2.3.2)

Calculate creep coefficient according to Eq. S5.4.2.3.2-1.

$$\psi_{(\infty,1)} = 3.5k_c k_f (1.58 - H/120)t_i^{-0.118} [(t - t_i)^{0.6} / (10.0 + (t - t_i)^{0.6})]$$

where:

$$k_c = 0.759 \text{ (see above)}$$

$$k_f = 0.748 \text{ (see above)}$$

$$H = \text{relative humidity} \\ = 70\%$$

$$t_i = \text{age of concrete when load is initially applied} \\ = 1 \text{ day}$$

$$t = \text{infinite days}$$

$$\psi_{(\infty,1)} = 3.5(0.759)(0.748)(1.58 - 70/120)(1)^{(-0.118)}[1] \\ = 1.98$$

Design Step C1.3

Calculate the creep coefficient, $\psi_{(t,t_i)}$, in the beam at the time the slab is cast according to S5.4.2.3.2.

$$t = 450 \text{ days (maximum time)}$$

Calculate the volume to surface area factor, k_c

$$k_c = \left[\frac{\left(\frac{t}{26e^{0.36(V/S)_b} + t} \right)}{\left(\frac{t}{45 + t} \right)} \right] \left[\frac{1.80 + 1.77e^{-0.54(V/S)_b}}{2.587} \right] \quad (\text{SC5.4.2.3.2-1})$$

where:

$$\begin{aligned} t &= 450 \text{ days} \\ e &= \text{natural log base (approx. 2.71828)} \\ (V/S)_b &= 4.406 \text{ in.} \end{aligned}$$

$$k_c = \left[\frac{\left(\frac{450}{26e^{0.36(4.406)} + 450} \right)}{\left(\frac{450}{45 + 450} \right)} \right] \left[\frac{1.80 + 1.77e^{-0.54(4.406)}}{2.587} \right]$$

$$k_c = 0.651$$

Calculate the creep coefficient, $\psi_{(t,t_i)}$, according to Eq. S5.4.2.3.2-1.

$$\psi_{(450,1)} = 3.5k_c k_f (1.58 - H/120) t_i^{-0.118} [(t - t_i)^{0.6} / [10.0 + (t - t_i)^{0.6}]]$$

where:

$$\begin{aligned} k_c &= 0.651 \text{ (see above)} \\ k_f &= 0.748 \text{ (see above)} \\ H &= 70\% \\ t_i &= 1 \text{ day} \\ t &= 450 \text{ days} \end{aligned}$$

$$\begin{aligned} \psi_{(450,1)} &= 3.5(0.651)(0.748)(1.58 - 70/120)(1)^{(-0.118)} [(450 - 1)^{0.6} / [10 + (450 - 1)^{0.6}]] \\ &= 1.35 \end{aligned}$$

Calculate the restrained creep coefficient in the beam, ϕ , as the creep coefficient for creep that takes place after the continuity connection has been established.

$$\begin{aligned} \phi &= \psi_{\infty} - \psi_{450} \text{ (from PCA publication referenced in Step 5.3.2.2)} \\ &= 1.98 - 1.35 \\ &= 0.63 \end{aligned}$$

Design Step C1.4 Calculate the prestressed end slope, q .

For straight strands (debonding neglected). Calculate the end slope, θ , for a simple beam under constant moment.

$$\text{Moment} = Pe_c$$

$$\theta = Pe_c L_{\text{span}} / 2E_c I_c$$

where:

$$P = \text{initial prestressing force after all losses (kips)} \\ = 1,096 \text{ kips (see Design Step 5.4 for detailed calculations of the prestressing force)}$$

$$e_c = 46.54 \text{ in. (calculated above)}$$

$$L_{\text{span}} = 110.5 \text{ ft. (1,326 in.) (taken equal to the continuous beam span length)}$$

$$E_c = \text{the modulus of elasticity of the beam at final condition (ksi)} \\ = 4,696 \text{ ksi}$$

$$I_c = \text{moment of inertia of composite beam (in}^4\text{)} \\ = 1,384,254 \text{ in}^4$$

$$\theta = [1,096(46.54)(1,326)]/[2(4,696)(1,384,254)] \\ = 0.0052 \text{ rads}$$

Design Step C1.5 Calculate the prestressed creep fixed end action for Span 1

The equation is taken from Table 5.3-9 for prestressed creep FEA, left end span, right moment.

$$FEM_{\text{cr}} = 3E_c I_c \theta / L_{\text{span}} \\ = [3(4,696)(1,384,254)(0.0052)]/1,326 \\ = 76,476/12 \\ = 6,373 \text{ k-ft}$$

End forces due to prestress creep in Span 1:

$$\text{Left reaction} = R1_{\text{PScr}} \\ = -FEM_{\text{cr}}/L_{\text{span}} \\ = -(6,373)/110.5 \\ = -57.7 \text{ k}$$

$$\text{Right reaction} = R2_{\text{PScr}} \\ = -R1_{\text{PScr}} \\ = 57.7 \text{ k}$$

$$\text{Left moment} = M1_{\text{PScr}} \\ = 0.0 \text{ k-ft}$$

$$\text{Right moment} = M2_{\text{PScr}} \\ = FEM_{\text{cr}} \\ = 6,373 \text{ k-ft}$$

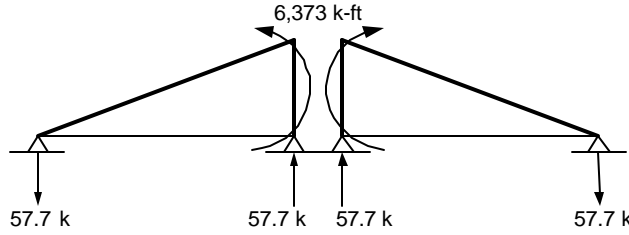

Figure C1 – Prestress Creep Restraint Moment

**Design Step
C1.6**

Calculate dead load creep fixed end actions

Calculate the total dead load moment at the midspan

$$\begin{aligned} \text{Noncomposite DL moment} &= M_{DNC} \\ &= 42,144 \text{ k-in (3,512 k-ft)} \text{ (see Section 5.3)} \end{aligned}$$

$$\begin{aligned} \text{Composite DL moment} &= M_{DC} \\ &= 4,644 \text{ k-in (387 k-ft)} \text{ (see Section 5.3)} \end{aligned}$$

$$\begin{aligned} \text{Total DL moment} &= M_{DL} \\ &= M_{DNC} + M_{DC} \\ &= 42,144 + 4,644 \\ &= 46,788/12 \\ &= 3,899 \text{ k-ft} \end{aligned}$$

End forces due to dead load creep in Span 1:

$$\begin{aligned} \text{Left reaction} &= R1_{DLcr} \\ &= -M_{DL}/L_{span} \\ &= -3,899/110.5 \\ &= -35.3 \text{ k} \end{aligned}$$

$$\begin{aligned} \text{Right reaction} &= R2_{DLcr} \\ &= -R1_{DLcr} \\ &= 35.3 \text{ k} \end{aligned}$$

$$\begin{aligned} \text{Left moment} &= M1_{DLcr} \\ &= 0.0 \text{ k-ft} \end{aligned}$$

$$\begin{aligned} \text{Right moment} &= M2_{DLcr} \\ &= -M_{DL} \\ &= -3,899 \text{ k-ft} \end{aligned}$$

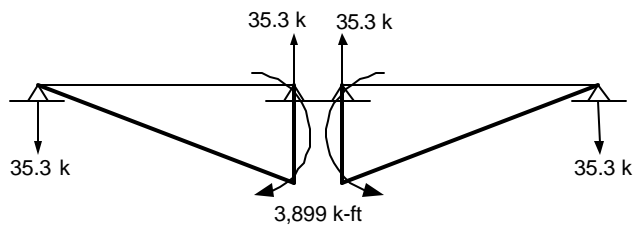

Figure C2 – Dead Load Creep Restraint Moment

Calculate the creep correction factor, C_{cr}

$$\begin{aligned} C_{cr} &= 1 - e^{-\phi} \text{ (from PCA publication referenced in Step 5.3.2.2)} \\ &= 1 - e^{-0.63} \\ &= 0.467 \end{aligned}$$

Calculate the total creep (prestress + dead load) fixed end actions for 450 days.

$$\begin{aligned} \text{Left reaction} &= R1_{cr} \\ &= C_{cr}(R1_{PScr} + R2_{DLcr}) \\ &= 0.467(-57.7 + 35.4) \\ &= -10.41 \text{ k} \end{aligned}$$

$$\begin{aligned} \text{Right reaction} &= R2_{cr} \\ &= -R1_{cr} \\ &= 10.41 \text{ k} \end{aligned}$$

$$\begin{aligned} \text{Left moment} &= M1_{cr} \\ &= 0.0 \text{ k-ft} \end{aligned}$$

$$\begin{aligned} \text{Right moment} &= M2_{cr} \\ &= C_{cr}(M2_{PScr} + M2_{DLcr}) \\ &= 0.467[6,373 + (-3,899)] \\ &= 1,155 \text{ k-ft} \end{aligned}$$

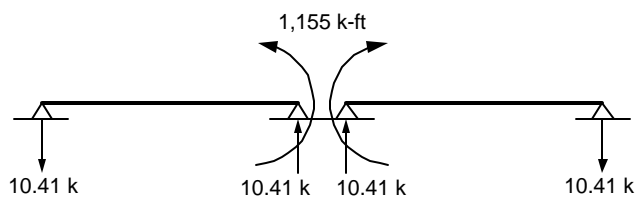

Figure C3 – Total Creep Fixed End Actions

Design Step C1.7 Creep final effects

The fixed end moments shown in Figure C3 are applied to the continuous beam. The beam is analyzed to determine the final creep effects. Due to the symmetry of the two spans of the bridge, the final moments at the middle support are the same as the applied fixed end moments. For a bridge with more than two spans or a bridge with two unequal spans, the magnitude of the final moments would be different from the fixed end moments.

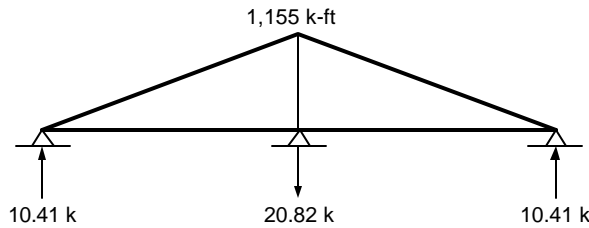

Figure C4 – Creep Final Effects for a Deck and Continuity Connection Cast 450 Days After the Beams were Cast

Design Step C2.1 Analysis of shrinkage effects on the example bridge

Calculate shrinkage strain in beam at infinite time according to S5.4.2.3.3

Calculate the size factor, k_s .

$$k_s = \left[\frac{\left(\frac{t}{26e^{0.36(V/S)_b} + t} \right)}{\left(\frac{t}{45 + t} \right)} \right] \left[\frac{1,064 - 94(V/S)_b}{923} \right] \quad (SC5.4.2.3.3-1)$$

where:

t = drying time
= infinite days

e = natural log base (approx. 2.71828)
 $(V/S)_b = 4.406$ in.

$$k_s = [1] \left[\frac{1,064 - 94(4.406)}{923} \right]$$

$$k_s = 0.704$$

Calculate the humidity factor, k_h

Use Table S5.4.2.3.3-1 to determine k_h for 70% humidity, $k_h = 1.0$.

Assume the beam will be steam cured and devoid of shrinkage-prone aggregates, therefore, the shrinkage strain in the beam at infinite time is calculated as:

$$\epsilon_{sh,b,\infty} = -k_s k_h [t/(55.0 + t)] (0.56 \times 10^{-3}) \quad (S5.4.2.3.3-2)$$

where:

$$k_s = 0.704$$

$$k_h = 1.0 \text{ for 70\% humidity (Table S5.4.2.3.3-1)}$$

$$t = \text{infinite days}$$

$$\begin{aligned} \epsilon_{sh,b,\infty} &= -(0.704)(1.0)[1](0.56 \times 10^{-3}) \\ &= -3.94 \times 10^{-4} \end{aligned}$$

Design Step C2.2

Calculate shrinkage strain in the beam at the time the slab is cast (S5.4.2.3.3)

$$\begin{aligned} t &= \text{time the slab is cast} \\ &= 450 \text{ days (maximum value)} \end{aligned}$$

Calculate the size factor, k_s .

$$k_s = \left[\frac{\left(\frac{t}{26e^{0.36(V/S)_b} + t} \right)}{\left(\frac{t}{45 + t} \right)} \right] \left[\frac{1,064 - 94(V/S)_b}{923} \right] \quad (SC5.4.2.3.3-1)$$

where:

$$t = 450 \text{ days}$$

$$e = \text{natural log base (approx. 2.71828)}$$

$$(V/S)_b = 4.406 \text{ in.}$$

$$k_s = \left[\frac{\left(\frac{450}{26e^{0.36(4.406)} + 450} \right)}{\left(\frac{450}{45 + 450} \right)} \right] \left[\frac{1,064 - 94(4.406)}{923} \right]$$

$$k_s = 0.604$$

Assume the beam will be steam cured and devoid of shrinkage-prone aggregates, therefore, the shrinkage strain in the beam at infinite time is calculated as:

$$\epsilon_{sh,b,450} = -k_s k_h [t/(55.0 + t)] (0.56 \times 10^{-3}) \quad (S5.4.2.3.3-2)$$

where:

$$k_s = 0.604$$

$$k_h = 1.0 \text{ for } 70\% \text{ humidity (Table S5.4.2.3.3-1)}$$

$$t = 450 \text{ days}$$

$$\begin{aligned} \epsilon_{sh,b,450} &= -(0.604)(1.0)[450/(55.0 + 450)](0.56 \times 10^{-3}) \\ &= -3.01 \times 10^{-4} \end{aligned}$$

Design Step C2.3

Calculate the shrinkage strain in the slab at infinite time (S5.4.2.3.3)

Calculate the size factor, k_s

$$k_s = \left[\frac{\left(\frac{t}{26e^{0.36(V/S)_s} + t} \right)}{\left(\frac{t}{45 + t} \right)} \right] \left[\frac{1,064 - 94(V/S)_b}{923} \right] \quad (SC5.4.2.3.3-1)$$

where:

$$t = \text{infinite days}$$

$$e = \text{natural log base (2.71828)}$$

Compute the volume to surface area ratio for the slab.

$$(V/S)_s = (b_{slab})(t_{slab}) / (2b_{slab} - w_{tf})$$

where:

$$b_{slab} = \text{slab width taken equal to girder spacing (in.)}$$

$$t_{slab} = \text{slab structural thickness (in.)}$$

$$w_{tf} = \text{beam top flange width (in.)}$$

$$\begin{aligned} (V/S)_s &= 116(7.5) / [2(116) - 42] \\ &= 4.58 \text{ in.} \end{aligned}$$

$$k_s = [1] \left[\frac{1,064 - 94(4.58)}{923} \right]$$

$$k_s = 0.686$$

The slab will *not* be steam cured, therefore, use

$$\epsilon_{sh,s,\infty} = -k_s k_h [t / (35.0 + t)] (0.51 \times 10^{-3}) \quad (S5.4.2.3.3-1)$$

where:

$$k_s = 0.686$$

$$k_h = 1.0 \text{ for } 70\% \text{ humidity (Table S5.4.2.3.3-1)}$$

$$t = \text{infinite days}$$

$$\begin{aligned} \epsilon_{sh,s,\infty} &= -(0.686)(1.0)[1.0](0.51 \times 10^{-3}) \\ &= -3.50 \times 10^{-4} \end{aligned}$$

Design Step C2.4

Calculate the differential shrinkage strain as the difference between the deck total shrinkage strain and the shrinkage strain of the beam due to shrinkage that takes place after the continuity connection is cast.

$$\begin{aligned} \Delta\epsilon_{sh} &= \epsilon_{sh,s,\infty} - (\epsilon_{sh,b,\infty} - \epsilon_{sh,b,450}) \\ &= -3.50 \times 10^{-4} - [-3.94 \times 10^{-4} - (-3.01 \times 10^{-4})] \\ &= -2.57 \times 10^{-4} \end{aligned}$$

Design Step C2.5

Calculate the shrinkage driving end moment, M_s

$$M_s = \Delta\epsilon_{sh} E_{cs} A_{slab} e' \quad (\text{from PCA publication referenced in Design Step 5.3.2.2})$$

where:

$$\Delta\epsilon_{sh} = \text{differential shrinkage strain}$$

$$E_{cs} = \text{elastic modulus for the deck slab concrete (ksi)}$$

$$A_{slab} = \text{cross-sectional area of the deck slab (in}^2\text{)}$$

$$e' = \text{the distance from the centroid of the slab to the centroid of the composite section (in.)}$$

$$= d_{beam} + t_{slab}/2 - NA_{beam \text{ bottom}}$$

$$= 72 + 7.5/2 - 51.54$$

$$= 24.21 \text{ in.}$$

$$\begin{aligned} M_s &= (-2.57 \times 10^{-4})(3,834)(116)(7.5)(24.21) \\ &= 20,754/12 \\ &= 1,730 \text{ k-ft (see notation in Table 5.3-9 for sign convention)} \end{aligned}$$



Figure C5 – Shrinkage Driving Moment

For beams under constant moment along their full length, the restraint moment may be calculated as shown above for the case of creep due to prestressing force or according to Table 5.3-9.

$$\begin{aligned} \text{Shrinkage fixed end actions} &= -1.5M_s = -1.5(1,730) \\ &= -2,595 \text{ k-ft} \end{aligned}$$

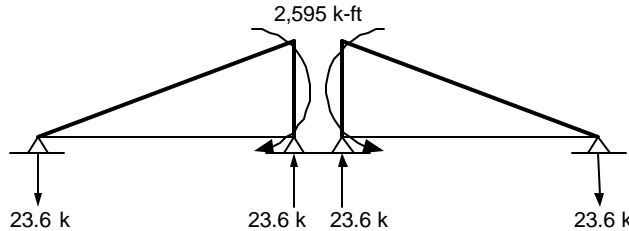

Figure C6 – Shrinkage Fixed End Actions

Design Step C2.6 Analyze the beam for the fixed end actions

Due to symmetry of the spans, the moments under the fixed end moments shown in Figure C6 are the same as the final moments (shown in Fig. C7). For bridges with three or more spans and for bridges with two unequal spans, the continuity moments will be different from the fixed end moments.

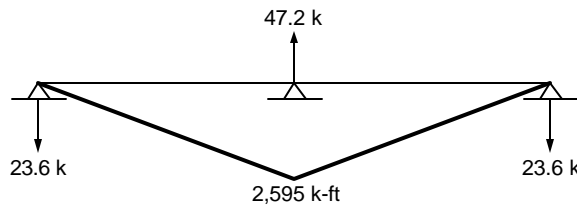

Figure C7 – Shrinkage Continuity Moments

Design Step C2.7 Calculate the correction factor for shrinkage.

$$\begin{aligned} C_{sh} &= (1 - e^{-\phi})/\phi \text{ (from PCA publication referenced in Step 5.3.2.2)} \\ &= [1 - e^{-0.63}]/0.63 \\ &= 0.742 \end{aligned}$$

Design Step C2.8 Calculate the shrinkage final moments by applying the correction factor for shrinkage to the sum of the shrinkage driving moments (Figure C5) and the shrinkage continuity moment (Figure C7) fixed end actions.

End moments, Span 1:

$$\begin{aligned}
 \text{Left end moment} &= M1_{sh} \\
 &= C_{sh}(M_{sh,dr} + \text{shrinkage continuity moment}) \\
 &= 0.742(1,730 + 0) \\
 &= 1,284 \text{ k-ft}
 \end{aligned}$$

$$\begin{aligned}
 \text{Right end moment} &= M2_{sh} \\
 &= C_{sh}(M_{sh,dr} + \text{shrinkage continuity moment}) \\
 &= 0.742(1,730 - 2,595) \\
 &= -642 \text{ k-ft}
 \end{aligned}$$

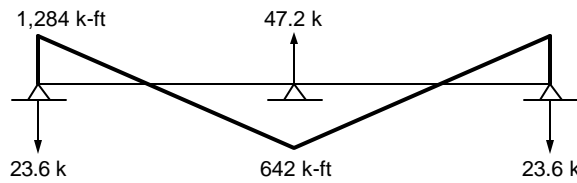

Figure C8 – Final Total Shrinkage Effect

Tables C1 and C2 provide a summary of the final moments for the case of the deck poured 30 days after the beams were cast.

Table C1 - 30 Day Creep Final Moments

Span	M1 (k-ft)	M2 (k-ft)	R1 (k)	R2 (k)
1	0	1,962	-17.7	17.7
2	-1,962	0	17.7	-17.7

Table C2 - 30 Day Shrinkage Final Moments

Span	M1 (k-ft)	M2 (k-ft)	R1 (k)	R2 (k)
1	75.9	-37.9	-2.06	2.06
2	-37.9	75.9	2.06	-2.06

When a limit state calls for inclusion of the creep and shrinkage effects and/or the design procedures approved by the bridge owner calls for their inclusion, the final creep and shrinkage effects should be added to other load effect at all sections. The positive moment connection at the bottom of the beams at the intermediate support is designed to account for the creep and shrinkage effects since these effects are the major source of these moments.

Notice that when combining creep and shrinkage effects, both effects have to be calculated using the same age of beam at the time the continuity connection is established.

DISCLAIMER

- ❖ This document has been reproduced from the best copy furnished by the sponsoring agency. It is being released in the interest of making available as much information as possible.