

U.S. Department of Transportation  
Federal Highway Administration

# Steel Bridge Design Handbook

## Substructure Design

Publication No. FHWA-IF-12-052 - Vol. 16

November 2012



### **Notice**

This document is disseminated under the sponsorship of the U.S. Department of Transportation in the interest of information exchange. The U.S. Government assumes no liability for use of the information contained in this document. This report does not constitute a standard, specification, or regulation.

### **Quality Assurance Statement**

The Federal Highway Administration provides high-quality information to serve Government, industry, and the public in a manner that promotes public understanding. Standards and policies are used to ensure and maximize the quality, objectivity, utility, and integrity of its information. FHWA periodically reviews quality issues and adjusts its programs and processes to ensure continuous quality improvement.

# **Steel Bridge Design Handbook: Substructure Design**

Publication No. FHWA-IF-12-052 - Vol. 16

November 2012



### Technical Report Documentation Page

1. Report No. FHWA-IF-12-052 - Vol. 16	2. Government Accession No.	3. Recipient's Catalog No.	
4. Title and Subtitle Steel Bridge Design Handbook: Substructure Design		5. Report Date November 2012	
		6. Performing Organization Code	
7. Author(s) Domenic Coletti, PE (HDR) and James Sheahan, PE (HDR)		8. Performing Organization Report No.	
9. Performing Organization Name and Address HDR Engineering, Inc. 11 Stanwix Street Suite 800 Pittsburgh, PA 15222		10. Work Unit No.	
		11. Contract or Grant No.	
12. Sponsoring Agency Name and Address Office of Bridge Technology Federal Highway Administration 1200 New Jersey Avenue, SE Washington, D.C. 20590		13. Type of Report and Period Covered Technical Report March 2011 – November 2012	
		14. Sponsoring Agency Code	
15. Supplementary Notes This module was edited in 2012 by HDR Engineering, Inc., to be current with the AASHTO LRFD Bridge Design Specifications, 5 <sup>th</sup> Edition with 2010 Interims.			
16. Abstract While the main focus of the Steel Bridge Design Handbook is the design of steel girder superstructures, the overall design process associated with the design of substructures is equally important. This module provides an overview of many issues associated with substructure and foundation design.  Many factors influence the selection of substructure and foundation materials, types, configurations, positions, and orientations. Often, existing constraints will limit the range of options and intrinsically lead the designer to only one or a few feasible solutions. This module provides designers with an overview of several foundation types including shallow foundations such as spread footings, and deep foundations that utilize piles or drilled shafts. The module also discusses conventional, integral, and semi-integral abutments, and provides considerations for the design and detailing of these substructure components. Several considerations for pier selection are also presented, including multi-column piers, single column piers, pile bents, straddle bents, and integral pier caps. Lastly, this module provides designers with information regarding substructure software availability, seismic design, precast substructures, and superstructure and substructure interaction.			
17. Key Words Substructure, Pile Foundations, Drilled Shaft Foundations, Integral Abutments, Semi-Integral Abutments, Piers		18. Distribution Statement No restrictions. This document is available to the public through the National Technical Information Service, Springfield, VA 22161.	
19. Security Classif. (of this report) Unclassified	20. Security Classif. (of this page) Unclassified	21. No of Pages	22. Price



# Steel Bridge Design Handbook: Substructure Design

## Table of Contents

FOREWARD .....	1
1.0 INTRODUCTION .....	3
2.0 FACTORS INFLUENCING SUBSTRUCTURE TYPE SELECTION .....	4
2.1 Hard Requirements .....	4
2.2 Existing Constraints .....	4
2.3 Other Constraints .....	5
2.4 Tolerable Movements .....	5
3.0 FOUNDATION TYPES .....	7
4.0 SHALLOW FOUNDATIONS (SPREAD FOOTINGS).....	8
4.1 Design Considerations .....	8
4.2 Shallow Foundations (Spread Footings) in Soil .....	8
4.3 Shallow Foundations (Spread Footings) in Rock .....	9
4.4 Detailing Considerations.....	10
4.5 Construction Considerations.....	10
4.6 Scour .....	11
4.7 Deterioration .....	11
5.0 DEEP FOUNDATIONS .....	12
6.0 DEEP FOUNDATIONS – GENERAL DESIGN CONSIDERATIONS .....	13
6.1 Geotechnical Design Considerations .....	13
6.2 Structural Design Considerations .....	14
6.3 Choosing Between Piles and Drilled Shafts .....	15
7.0 DEEP FOUNDATIONS – PILES .....	16
7.1 Pile Types.....	16
7.2 Factors Affecting the Choice of Pile Type .....	18
7.3 Specific Design Considerations for Piles.....	18

7.4	Detailing Considerations for Piles .....	19
7.5	Miscellaneous Considerations for Piles .....	20
8.0	DEEP FOUNDATIONS – DRILLED SHAFTS .....	22
8.1	Factors Affecting Choice of Drilled Shaft Type .....	23
8.2	Specific Design Considerations for Drilled Shafts .....	23
8.3	Detailing Considerations for Drilled Shafts .....	25
8.4	Miscellaneous Considerations for Drilled Shafts .....	26
9.0	ABUTMENTS (END BENTS).....	29
10.0	CONVENTIONAL ABUTMENTS.....	30
10.1	Design Considerations for Conventional Abutments .....	30
10.2	Forces on Conventional Abutments.....	34
10.3	Detailing Considerations for Conventional Abutments .....	35
11.0	INTEGRAL ABUTMENTS .....	38
11.1	Superstructure Design Considerations for Integral Abutment Bridges .....	42
11.2	Forces on Integral Abutments .....	42
11.3	Detailing Considerations for Integral Abutments .....	43
12.0	SEMI-INTEGRAL ABUTMENTS .....	46
12.1	Forces on Semi-Integral Abutments .....	46
12.2	Detailing Considerations for Semi-Integral Abutments .....	46
13.0	PIERS (BENTS) .....	48
13.1	Pier Types .....	48
13.2	Selecting the Right Pier Type .....	51
13.3	General Design Considerations.....	52
13.4	Forces on Piers.....	56
13.5	Multi-column Pier Considerations.....	57
13.6	Single Column Pier Considerations .....	59
13.7	Pile Bent Considerations.....	60
13.8	Straddle Bent Considerations.....	62
13.9	Integral Pier Cap Considerations .....	63
13.10	Integral Pier Cap Considerations .....	64
13.11	Inverted-Tee Pier Cap Considerations .....	66



13.12	Other Pier Types .....	68
14.0	SOFTWARE AVAILABILITY.....	70
15.0	SEISMIC DESIGN .....	71
16.0	PRECAST SUBSTRUCTURES.....	72
17.0	SUPERSTRUCTURE / SUBSTRUCTURE INTERACTION.....	73
18.0	INNOVATIVE SUBSTRUCTURES .....	74
19.0	SUMMARY.....	76
20.0	REFERENCES .....	77

## List of Figures

Figure 1 Spread footing applications: a) spread footing for a stub abutment; b) spread footing for a pier.....	9
Figure 2 Driven pile applications: a) driven piles under a stub abutment; b) driven piles under a pier. ....	16
Figure 3 Driven steel H-piles arranged as the foundation for a conventional abutment. Later, MSE retaining walls will be built in front of these piles, and after that the abutment cap and backwall will be cast. ....	17
Figure 4 Driving of a precast concrete pile.....	17
Figure 5 Example of pile tips.....	20
Figure 6 The effects of scour can be severe. Here a drilled shaft in a multicolumn bent has experienced over 6 feet of permanent (erosion) scour; during a flood event with higher velocity flow, there will be even more temporary (local pier) scour at this pier.....	21
Figure 7 Drilled shaft applications: a) drilled shafts for a conventional stub abutment: b) drilled shafts used for a pier. ....	23
Figure 8 Single round column with an oversized, steel cased, drilled shaft.....	24
Figure 9 Drilled shaft drilling rig. Note the steel casing projecting above ground. ....	27
Figure 10 Conventional abutments of various heights: a) conventional, pile founded, stub abutment; b) conventional, pile-founded, tall abutment. ....	31
Figure 11 Abutment wingwall configurations: a) stub abutment with wingwalls parallel to the abutment cap; b) stub abutment with turned back wingwalls; c) stub abutment with turned forward wingwalls (a.k.a. “ear walls”); d) stub abutment with MSE retaining wall and wingwalls parallel to the abutment cap. ....	32
Figure 12 Conventional stub abutment with MSE retaining wall and wingwalls parallel to the abutment cap. ....	34
Figure 13 Example of integral abutment details, prior to casting the closure pour. Note the reinforcing running through the girder web and the anchor bolts used as girder supports.....	44
Figure 14 Photograph of a completed integral abutment.....	47
Figure 15 Various types of pier caps for multi-column piers: a) prismatic pier cap; b) tapered pier cap; c) pier cap with parabolic haunches.....	49

Figure 16 Various types of pier caps for single column piers: a) prismatic pier cap; b) tapered pier cap; c) pier cap with parabolic haunches. ....	50
Figure 17 Typical multi-column pier with round columns and a prismatic pier cap.....	51
Figure 18 Typical multi-column pier with round columns and a stepped pier cap. ....	51
Figure 19 There can be a wide range of variations on the basic multi-column pier configuration, such as these piers with haunched pier caps and curved columns featuring formliner treatments for a pedestrian bridge. ....	52
Figure 20 Single column hammerhead pier with very tall columns over a deep valley.....	53
Figure 21 Single column hammerhead pier with an inverted T pier cap.....	57
Figure 22 There can be a wide range of variations on the basic single column pier configuration, such as this pier with a haunched pier cap and single, unsymmetrical curved column featuring form liner treatments for a pedestrian bridge.....	60
Figure 23 Pile bent with braced steel H-piles serving as both columns and foundations for the pier. ....	61
Figure 24 Example of a straddle bent carrying a highway bridge over a railroad line. In this case, the pier cap is also fully integral with the curved steel girder superstructure.....	62
Figure 25 Steel plate integral pier cap for a single column pier. ....	63
Figure 26 Post-Tensioned Concrete integral pier cap for a single column pier.....	64
Figure 27 Steel pipe piles, steel pier caps, and steel framing, with a timber mat deck, form the structural system for this temporary work bridge. ....	65
Figure 28 Steel single column hammerhead piers for a dual box girder automated people mover bridge. ....	66
Figure 29 Inverted T pier cap in a multi-column pier.....	67
Figure 30 Dapped girder ends rest on an inverted T pier cap in a single column pier. ....	68
Figure 31 Example of the wide range of variations in pier types. This project featured the widening of an existing bridge which used multi-column piers with web walls. The widened section used single column hammerhead piers. ....	69
Figure 32 Example of a precast pier cap being used on a long viaduct bridge. The columns were cast-in-place with dowels projecting from the top of the columns. The dowels fit into pockets in the precast pier cap. The pier cap initially rested on collars around the tops of the columns. The	

collars were adjustable to facilitate leveling of the pier cap. Once the pier cap was set, grout was injected into the dowel pockets and the gap between the columns and the pier cap. .... 72

Figure 33 Opportunities abound for innovation in substructure design. This unique full height abutment which uses precast double-tees for the stem wall is one example of a creative solution that addressed the specific criteria of a given project. .... 74

## FOREWARD

It took an act of Congress to provide funding for the development of this comprehensive handbook in steel bridge design. This handbook covers a full range of topics and design examples to provide bridge engineers with the information needed to make knowledgeable decisions regarding the selection, design, fabrication, and construction of steel bridges. The handbook is based on the Fifth Edition, including the 2010 Interims, of the AASHTO LRFD Bridge Design Specifications. The hard work of the National Steel Bridge Alliance (NSBA) and prime consultant, HDR Engineering and their sub-consultants in producing this handbook is gratefully acknowledged. This is the culmination of seven years of effort beginning in 2005.

The new *Steel Bridge Design Handbook* is divided into several topics and design examples as follows:

- Bridge Steels and Their Properties
- Bridge Fabrication
- Steel Bridge Shop Drawings
- Structural Behavior
- Selecting the Right Bridge Type
- Stringer Bridges
- Loads and Combinations
- Structural Analysis
- Redundancy
- Limit States
- Design for Constructibility
- Design for Fatigue
- Bracing System Design
- Splice Design
- Bearings
- Substructure Design
- Deck Design
- Load Rating
- Corrosion Protection of Bridges
- Design Example: Three-span Continuous Straight I-Girder Bridge
- Design Example: Two-span Continuous Straight I-Girder Bridge
- Design Example: Two-span Continuous Straight Wide-Flange Beam Bridge
- Design Example: Three-span Continuous Straight Tub-Girder Bridge
- Design Example: Three-span Continuous Curved I-Girder Beam Bridge
- Design Example: Three-span Continuous Curved Tub-Girder Bridge

These topics and design examples are published separately for ease of use, and available for free download at the NSBA and FHWA websites: <http://www.steelbridges.org>, and <http://www.fhwa.dot.gov/bridge>, respectively.

The contributions and constructive review comments during the preparation of the handbook from many engineering professionals are very much appreciated. The readers are encouraged to submit ideas and suggestions for enhancements of future edition of the handbook to Myint Lwin at the following address: Federal Highway Administration, 1200 New Jersey Avenue, S.E., Washington, DC 20590.

A handwritten signature in blue ink that reads "Myint Lwin". The signature is fluid and cursive, with the first name "Myint" and last name "Lwin" clearly distinguishable.

M. Myint Lwin, Director  
Office of Bridge Technology

## **1.0 INTRODUCTION**

The main focus of the Steel Bridge Design Handbook is obviously the design of steel girder superstructures. But equally important in the overall design process is the design of substructures. This module will provide an overview of many issues associated with substructure and foundation design. However, this is only an overview; the reader is directed to the many other excellent references that discuss substructure and foundation design in more detail. The references mentioned at the end of this module constitute a brief list of some of those publications.

## **2.0 FACTORS INFLUENCING SUBSTRUCTURE TYPE SELECTION**

Many factors influence the selection of substructure and foundation materials, types, configurations, positions, and orientations. Often, existing constraints will limit the range of options and intrinsically lead the designer to only one or a few feasible solutions. Some of these constraints are discussed below. Some are obvious and some are subtle; some are routine and some occur only rarely; but all are important and should be considered in each bridge project.

### **2.1 Hard Requirements**

Navigation Clearance Requirements – Design criteria for river, harbor, or other navigable water crossings often include minimum horizontal and vertical clearance requirements for navigation. These determine span lengths and substructure heights, and since higher bridges with longer spans often produce increased substructure loads, these are key factors affecting the choice of substructure type for these bridges. Furthermore, the nature of the marine traffic may directly influence selection of substructure type since vessel impact can be a significant design parameter. The *AASHTO LRFD Bridge Design Specifications, 5<sup>th</sup> Edition* (5) and *AASHTO Guide Specifications for Design for Vessel Impact* (1) offer both general and specific design guidance on this topic.

Environmental Commitments – All modern transportation projects must undergo a rigorous environmental permitting process. As part of this process, commitments are often made to various environmental agencies regarding the location of bridges and the nature of both temporary construction activities and permanent features of the project. These commitments often include very specific discussions regarding the nature of bridges over environmentally sensitive areas. These commitments may include limitations on span lengths, foundation types, substructure types, substructure locations, construction access and methods, etc.

Surface Terrain – An obvious influence on the choice of substructure type is the nature of the existing terrain, both in terms of topography and geology. A bridge across a deep, rocky gorge will need different substructures than a bridge across a wide marshy swamp. Designers should consider geometry (substructure heights, span lengths, etc.), geology (which affects the selection of candidate foundation types and their effect on the overall substructure design), and constructability (physical access to build various substructure types in specific locations).

### **2.2 Existing Constraints**

Existing Structures – Oftentimes, especially in the more urbanized settings of many modern projects, existing structures (both above and below ground) will limit the designer's options for substructure placement and configuration. Designers should obtain the best information available regarding existing structures before laying out substructure locations and discussing foundation and substructure types. Often a combination of existing plans, site visits, aerial survey, ground survey, and subsurface survey is necessary to fully describe these existing conditions. Consider existing roadways, bridges, substructures, foundations, above- and below-ground utilities, buildings, culverts and other drainage structures, and any other possible existing structures. Also,



keep in mind structures that may not be present at the time of design, but which may be built before or during construction of the bridge.

### **2.3 Other Constraints**

**Site Access** – Many factors affect site access, including topography, soil conditions, climate (weather) conditions, waterways, utilities (both above- and below-ground), existing and proposed structures, etc. Site access in turn can affect the selection of foundation types and substructure types. Designers should give careful consideration to the ability of the contractor to deliver materials and operate equipment at a given site.

**Desired Construction Schedule** – On many modern projects with complex construction phasing and tight schedules, the sequence and timing of substructure and foundation construction are key design criteria. Sometimes pile driving equipment physically cannot operate in a given location after a certain point in construction, e.g., due to the large vertical clearance needed for pile-driving. Sometimes waiting several days for cast-in-place concrete to cure prior to the next step in construction is not feasible. Oftentimes drilled shafts require a casing to support the open hole because another nearby structure will be built first and its loading could cause the hole to cave in. For design-build projects, detailed discussions of the proposed construction sequence with the contractor are strongly encouraged. For conventional design-bid-build projects, it may be advisable to consider several possible construction sequences and evaluate the impact of substructure type on constructability issues.

**Local Contractor Expertise** – In many cases, the choices of foundation and substructure types are limited by the expertise and equipment available to local contractors. Sometimes what seems like an inefficient design may in fact be the most economical design if local contractors are equipped, experienced, and efficient at that type of work. Insights into these issues can be obtained by talking with local owner-agencies, local contractors, and other designers who have a history of design in a given locality.

### **2.4 Tolerable Movements**

Excessive movements of bridge foundations, in either vertical or horizontal directions, can lead to a number of problems, including poor ride quality, undesirable appearance, damage to expansion joints, excessive cracking, or other structural integrity or serviceability problems.

Foundation movements, and the resulting structure movements, should be carefully calculated, and, perhaps more importantly, the effects of these movements on the structure must be thoroughly assessed. Tolerable movements should be estimated prior to beginning detailed design. The structural engineer should work with the geotechnical engineer regarding acceptable movements and the resulting implications in terms of both the effects on the structure and the effects on the foundations. NCHRP Report 343 (2) offers a good discussion of the issue of tolerable movements.

Most of the movements discussed above are related to soil displacements caused by applied loads. Conversely, in addition to force-driven loading effects, substructures and foundations are

also affected by deflection-driven loading effects, such as shrinkage, thermal expansion and contraction, etc. This is especially true when integral substructures such as integral pier caps and integral abutments are used.

For example, the use of integral abutments is often limited to superstructure units of certain length – longer lengths would result in excessive thermal movements which cannot be tolerated due to the introduction of overly large passive soil pressures resisting these movements and/or excessive bending moments in pile foundations. In other cases, excessive movements of the tops of tall piers may induce unacceptably large secondary loading effects ( $P-\Delta$  effects) depending on the strength, stiffness, and distance to point-of-fixity of the pier.

### **3.0 FOUNDATION TYPES**

A wide variety of foundation types are available for use on steel girder bridges, as on any bridge. The choice of a preferred foundation type typically is heavily influenced by local subsurface conditions and past success with similar foundation types in the locality. In some cases, the nature of the superstructure will also influence the choice of foundation type, especially when integral substructures are used. Several of the more common foundation types are discussed in this module. Other types are less frequently used, and occasionally innovative foundation types are proposed for special circumstances. Designers are advised to involve qualified geotechnical engineers early in the bridge design process to help select the appropriate foundation type. In addition, designers are encouraged to consult one or more references on foundation design, such as references (2, 7, 8, 35).

## **4.0 SHALLOW FOUNDATIONS (SPREAD FOOTINGS)**

### **4.1 Design Considerations**

As with all foundations, the design of spread footings must consider both geotechnical and structural issues and criteria. The design calculations must address issues related to strength, serviceability, and movements. In addition there are many constructability issues and site-specific issues to be considered. Any of these various issues may control the design and all should be evaluated.

Spread footings offer several advantages in terms of simplicity of construction, particularly when used in proper applications. The decision to use a spread footing, or any foundation for that matter, often comes down to assessing what is the most appropriate foundation choice for the given site conditions and the given structural requirements (applied loads, movements, etc.).

Spread footing design typically includes the following design checks:

**Bearing Capacity** – A check of the applied maximum bearing pressure vs. the allowable bearing pressure.

**Overturning** – This check is particularly important for spread footing abutments which typically must withstand lateral soil pressure on the backwall and for spread footing piers which will have large overturning moments, particularly if the piers are tall.

**Sliding** – This check is particularly important for spread footing abutments which typically must withstand lateral soil pressure on the backwall.

**Settlement** – Particularly for spread footings in soil, the anticipated settlement must be determined and compared to the tolerable settlement for the structure.

**Horizontal Movement and Rotation** – Particularly for spread footings in soil, the anticipated horizontal movements (sliding displacements) and overturning rotations should be determined and compared to tolerable movements for the structure, even if the sliding and overturning calculations show an adequate factor of safety. References (2, 12) discuss spread footings in more detail.

### **4.2 Shallow Foundations (Spread Footings) in Soil**

Spread footings are most often used when competent rock is found at shallow depths, but they can be successfully used for foundations on soil where scour is not a design consideration. Service level bearing capacities for spread footings in soil are generally in the range of 1 to 3 tons per square foot (tsf). This lower range of allowable bearing pressures often limits the use of spread footings in soil to more lightly loaded structures.

A key parameter in spread footing design is the assessment of vertical and horizontal movements. Despite the relatively low applied bearing pressures associated with spread footings in soil, calculated deflections may be the controlling design parameters.

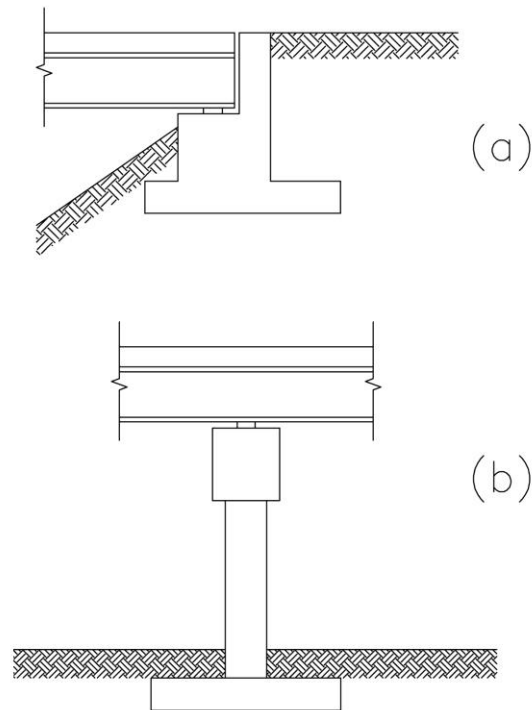

**Figure 1 Spread footing applications: a) spread footing for a stub abutment; b) spread footing for a pier.**

#### **4.3 Shallow Foundations (Spread Footings) in Rock**

As mentioned above, spread footings are most often used when competent rock is found at shallow depths. In these cases, deep foundations are often too difficult and expensive to construct, and a spread footing becomes more economically attractive.

When spread footings are used in rock, some of the concerns and issues associated with spread footings in soil go away, but other issues arise.

Service level bearing capacities for spread footings in rock are generally in the range of 5 to 10 tsf or higher. These higher bearing pressures can potentially allow much more heavily loaded structures to be founded on spread footings.

However, the sizing of a spread footing is dependent on more than just an assessment of bearing capacity. Sliding and overturning checks must also be performed, especially for abutments which have significant lateral loading from soil pressure, but also for piers which can have high overturning moments.

Settlement of spread footings in rock is of less concern than for spread footings in soil, but should still be investigated at least in a cursory manner and compared to tolerable movement allowables.

Construction of spread footings in rock can be expensive if a significant amount of rock excavation is required. In addition, designers should also note that the resulting cut rock surface may not be ideally “smooth and level” and should adjust their detailing accordingly to allow for more generous construction tolerances. Alternatively, lean (unreinforced) concrete is often placed in the bottom of the excavation to provide a more level and uniform bearing surface.

#### **4.4 Detailing Considerations**

In many cases, the need to size a spread footing to reduce bearing pressures, to resist sliding and overturning, and to control deflections will result in a fairly large, stout structure. The reinforcing required to resist the applied loads in structures of these proportions may be quite light. Designers are reminded to keep in mind other reinforcing requirements such as constructability, the need for reinforcing to resist temperature and shrinkage stresses, good seismic detailing practice, etc., which may end up controlling the reinforcing design. For example, larger reinforcing bars may be required simply to ensure that the reinforcing cage can support its own weight prior to concrete placement.

The layout of construction joints should be based on the evaluation of several issues. For example, the volume of concrete in each lift should be limited to control heat of hydration in larger mass concrete pours. Other practical considerations related to hydrostatic pressure of wet concrete, access for consolidation, entrapment of air in stepped concrete structures, etc., may also suggest the need for construction joints. And, once a reasonable construction joint layout has been determined, the reinforcing detailing should be examined to see if adding or moving reinforcing splices would improve constructability.

Keep in mind that many surfaces in spread footings will be cast against soil (or rock) or will be permanently exposed to soil. Concrete cover requirements should be adjusted accordingly. Also remember, as mentioned above, that rock cuts may not be “ideally smooth or level” and that provisions should be made to address this.

#### **4.5 Construction Considerations**

Construction of spread footings in soil may involve fairly easy excavation due to the soft nature of the excavated material. But this same nature may also dictate the need for oversized excavations, generous cut slopes, and/or temporary shoring of the excavation walls. Designers should be aware of the need for an excavation larger than the size of the spread footing and check clearances to adjacent roadways, utilities, foundations, etc. Lack of adequate construction clearances may result in a design that cannot be built.

Conversely, construction of spread footings in rock may involve more difficult excavation operations, possibly necessitating specialty equipment or rock removal techniques. Consultation

with experienced local contractors early in the design is advisable and can alert the designer to key issues which may have significant ramifications on their design.

In addition to providing adequate space for construction activities at the site, consideration should also be given to providing adequate access to the site. Designers should at a minimum investigate the following parameters of access/haul roads:

- Is the haul road wide enough to accommodate the anticipated equipment and trucks?
- Is the grade shallow enough for safe transit of the anticipated equipment and trucks?
- Are the anticipated equipment and trucks able to negotiate any curves in the haul road?
- Do the haul road and its subgrade have sufficient bearing capacity to accommodate the anticipated equipment and trucks?

Again, the value of consultation with experienced local contractors in assessing constructability issues early on in the design process cannot be overstated.

#### **4.6 Scour**

For bridges at stream or river crossings, scour should be investigated in detail. Foundations should extend below the scour line. For the design flood event, foundations should extend deep enough below the scour line to satisfy all strength limit state checks. For the check flood event (typically the 500 year event, sometimes called the “superflood” event) the foundations should extend far enough below the scour line to satisfy stability criteria under extreme event limit states. In some cases, scour prevention methods such as rip rap armoring can be used to reduce the effects of scour, especially at abutments. The assessment of scour potential is a process which involves both the geotechnical engineer and the hydraulics engineer, in addition to the structural designer. Hydraulic Engineering Circular (HEC) 18 (3) and NCHRP Report 516 (36) offer good general and specific discussions of scour.

#### **4.7 Deterioration**

Deterioration of concrete in spread footings can be caused by any of a number of corrosive chemicals which are often found in soils or groundwater. Geotechnical investigations should include evaluations of the presence of these types of chemicals. If they are found to be present, appropriate protective measures should be taken. A wide range of options exists including the use of special materials (or additives to standard materials), protective surface treatments, more frequent inspection and/or maintenance intervals, and the use of conservative design assumptions where future deterioration is anticipated and the strength contribution of part of the structure is discounted.

## **5.0 DEEP FOUNDATIONS**

Deep foundations provide support for substructures in ways that are fundamentally different from spread footings. Deep foundations can be broadly classified as either driven piles or drilled shafts (sometimes also called drilled piers or drilled caissons).

Deep foundations such as piles and drilled shafts are typically long, column-type elements which achieve vertical capacity by means of end bearing in a relatively deep bearing stratum, side friction through part or all of their depth, or a combination of both. Piles and drilled shafts typically achieve lateral capacity by means of embedment rather than sliding friction. Piles and drilled shafts typically achieve overturning capacity by means of either group action, where the overturning moments are resolved into axial force couples distributed among grouped piles or drilled shafts, or on an individual basis acting as flexural elements.



## **6.0 DEEP FOUNDATIONS – GENERAL DESIGN CONSIDERATIONS**

### **6.1 Geotechnical Design Considerations**

Vertical capacity in piles or drilled shafts is typically derived from either end bearing, side friction, or a combination of both; note that the effects of down-drag should also be considered as appropriate. For end bearing piles or drilled shafts, the vertical capacity arises from the bearing of the end of the foundation element on a competent stratum of soil or rock and is thus independent of the length of the pile or drilled shaft. Typically the main design parameters are the bearing capacity of the soil, the axial capacity of the structure element (pile or shaft), and the end bearing area. Note, however, that a minimum length of embedment of the pile or drilled shaft into the ground is also usually required for other reasons, as will be discussed below.

For side friction piles or drilled shafts, the vertical capacity is derived from adhesion or friction between the sides of the pile or drilled shaft and the surrounding soil. The typical design parameters are the length of the pile or drilled shaft in the stratum providing frictional resistance, the perimeter of the pile or drilled shaft cross section, and the frictional capacity of the soil. Typically, the development of the frictional resistance requires some degree of vertical movement of the pile relative to the surrounding soil.

Note that the side friction capacity of closely spaced piles or drilled shafts can be adversely affected by so-called “group effects.” In simple terms, the side friction capacity of an individual foundation element is reduced when the elements are closely spaced; the group of piles or drilled shafts begin to act as a single entity with an overall perimeter measured around the outside of the group due to the overlapping zones of soil movement around each pile which reduce the soil’s strength, rather than as a collection of individual element perimeters. This problem can be easily avoided by keeping to reasonably wide pile or drilled shaft spacing.

Piles and drilled shafts can develop vertical capacity by means of both side friction and end bearing acting simultaneously, depending on the specific subsurface conditions. There are no easy and consistent rules for the calculation of vertical capacity – designs must be addressed on a case-by-case basis by qualified geotechnical engineers using site-specific data.

The determination of the lateral capacity of piles and drilled shafts is a more complex problem than the determination of vertical capacity. Typically the lateral capacity must be calculated by means of a lateral pile analysis, usually facilitated by computer modeling. In determining lateral capacity the key parameters are nearly always related to lateral displacement and overall stability, rather than strength in the strict sense. Usually the limiting parameter in calculating the geotechnical lateral capacity of a pile or drilled shaft is the tolerable movement which the structure can sustain.

A second, but equally important, parameter in evaluating lateral capacity of piles and drilled shafts is the overall stability of the pile as a function of its embedment into the soil. The pile or drilled shaft must have sufficient embedment in the soil to resist global rotation. In other words, the pile or drilled shaft must have sufficient embedment so that the lower end remains fixed against both translation and rotation.

Global overturning moments applied to pile foundations are often resisted as force couples between piles in a group. For example, one common configuration is to found each column in a bent on a group of piles connected to the column by means of a relatively rigid integral footing. In that case the overturning moment is resolved into vertical force couples and the resulting upward and downward forces on individual piles are combined with the pile loads caused by overall vertical load in the column. In this case, the geotechnical capacity of the piles in resisting the overturning moments is simply a function of the axial capacity of the individual piles.

Conversely, in the case of “pile bents” the piles continue uninterrupted above finished ground to the pile cap. In such cases, the piles must directly carry applied moments via bending in the piles.

In either case, the lateral analysis should always consider the horizontal loads on the piles or drilled shafts and evaluate the resulting horizontal movements at the tops of the foundation elements.

## **6.2 Structural Design Considerations**

In addition to evaluating its geotechnical capacity, the pile or drilled shaft itself must be evaluated for its structural capacity. Depending on the nature of the loads and the nature of the structural configuration of the foundation, this might involve evaluating axial capacity, bending capacity, shear capacity, or a combination of all of these. The required structural analyses are typically fairly straightforward and are essentially the same as the corresponding analyses required for columns.

However, the determination of boundary conditions for the structural analysis of deep foundations can sometimes be tricky. The boundary conditions for lateral support and stability are primarily a function of the subgrade modulus of the surrounding soil, but the restraint provided to the top of the foundation element is also important. These boundary conditions can be quantified by means of either a simplified or a more rigorous analysis.

For a simplified analysis, the pile can be modeled as a column fixed at its base, neglecting any other lateral support along its length, and with boundary conditions at the top of the pile based on the structural configuration. The depth of the pile to the assumed fixed base is known as the depth to the “point of fixity.” As mentioned above, piles are typically installed with sufficient embedment into the soil to ensure fixity in the soil. The key question is at what depth that fixity occurs. This can be determined by means of either rules of thumb (for approximate or preliminary analysis) or by means of a more rigorous laterally loaded pile analysis (as described below).

For a more rigorous analysis, the pile is modeled with lateral spring supports where the spring constants are based on the subgrade modulus of the surrounding soil layers. This type of analysis can be done either using specialty soil-structure interaction modeling software or using general finite element analysis software.

Depending on the geotechnical engineer’s recommendation or routine practice of the local owner-agency, the point of fixity is typically assumed to be either at the highest point of moment inflection or the highest point of zero horizontal deflection for a given lateral loading.

In all cases, designers are also encouraged to give careful consideration to the boundary conditions at the top of the piles or drilled shafts. The nature of the substructure and its connection to the foundation, as well as the nature of the superstructure and its connection to the substructure, directly affect the support offered to the foundation elements (for example, a fully integral connection to the superstructure can often add significant support to a substructure/foundation system). There can be a temptation to over-simplify the analysis, which should be avoided. Depending on the nature of the loading, some simplifying assumptions may ultimately prove to be unconservative.

### **6.3 Choosing Between Piles and Drilled Shafts**

There are myriad considerations in choosing between using pile foundations and drilled shaft foundations, including:

**Local Subsurface Conditions:** Piles and drilled shafts each have advantages and disadvantages based on the nature of the subsurface conditions. Often these conditions will clearly suggest one over the other.

**Local Economic Conditions:** Local contractors often have a preference for either piles or drilled shafts based on their experience with one or the other, the availability of laborers with the required specific skills, the availability and cost of specialty equipment, etc.

**Structural Considerations:** Depending on the nature of the loading and the configuration of the rest of the structure, either piles or drilled shafts may be a better choice. For example, individual larger diameter drilled shafts may be more efficient at carrying lateral loads and moments than individual, smaller-size, driven piles.

**Constructability Considerations:** Depending on the nature of the site conditions, equipment access, or the configuration of the rest of the structure, either piles or drilled shafts may be a better choice.

**Environmental Considerations:** Some foundation types and some foundation construction methods are more damaging to the environment than others. Close coordination with environmental permitting specialists may be necessary to evaluate the environmental impacts, and environmental commitments may influence the selection of the preferred foundation type and construction method.

## 7.0 DEEP FOUNDATIONS – PILES

One broad class of deep foundations are driven piles. Driven piles are predominantly characterized by the fact that driving operations represent either a large part or the entirety of the field construction operations. Piles are also typically, but not always, characterized by relatively slender cross-sectional dimensions compared to drilled shafts. References (2, 10) provide detailed discussions of driven pile foundations.

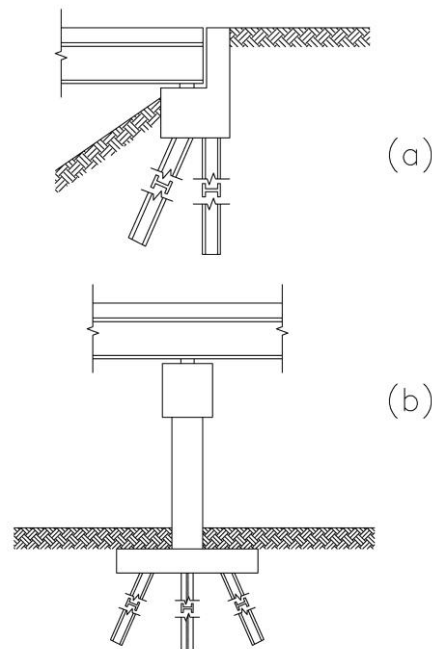

**Figure 2 Driven pile applications: a) driven piles under a stub abutment; b) driven piles under a pier.**

### 7.1 Pile Types

Driven piles can be categorized as either displacement piles, with either a solid section or a closed end, or non-displacement piles which have an open end with a relatively small cross-section. There is a very wide range of driven pile types available to the designer, including:

**Driven Steel H-Piles** – These are typically AISC HP sections, which are open H-shaped rolled steel members. In some cases, “driving plates” (flat plates welded across the cross section at the lower tip of the pile) are provided to increase end bearing area. In other cases, “pile tips” (serrated end fittings) are provided to allow the lower tip of a pile to “bite” into the bearing stratum.

**Driven Steel Pipe Piles** – These are hollow circular steel pipe sections. In some cases, driving plates are provided to increase end bearing area. Pipe piles are sometimes selected over H-piles due to the greater structural capacity of the closed pipe section (e.g., greater bending stiffness, greater buckling capacity, greater moment capacity, etc.).



**Figure 3 Driven steel H-piles arranged as the foundation for a conventional abutment. Later, MSE retaining walls will be built in front of these piles, and after that the abutment cap and backwall will be cast.**

Driven Precast Concrete Piles – These are generally precast concrete square or round cross section shapes. Precast concrete piles are sometimes prestressed to increase their bending capacity.

Auger-Cast Piles – An auger-cast pile is constructed by twisting a continuous flight, hollow-stem auger into the ground. As the auger is removed, concrete is pumped into the open hole. Auger-cast piles have been used extensively in Europe and in the private sector in the US, but have not seen much bridge use in the US. There have been problems with quality, which is very sensitive to construction technique.



**Figure 4 Driving of a precast concrete pile.**

Timber Piles – Timber piles may seem like “obsolete” technology, but they still are viable in certain situations. Due to their relatively low structural capacity, the use of timber piles is usually

limited to lightly loaded structures. But when used in proper applications, timber piles can provide advantages over other pile types. One example of a good timber pile application would be the foundation of a lightly loaded pedestrian bridge in a remote area with easy access to plentiful supplies of high quality treated timber, but where delivery of other materials may be relatively expensive.

Micropiles and Minipiles – These are very small diameter (generally less than 12” diameter), often very long, drilled shafts, which achieve virtually all of their capacity from side friction. Micropiles have been used successfully in Europe. Their use has been encouraged by the FHWA, but they have not yet seen widespread use in the United States. See reference (11) for more information on micropiles.

## **7.2 Factors Affecting the Choice of Pile Type**

The choice of pile type is influenced by many considerations. Some examples are provided below, but designers are reminded that foundation type selection can be a complex process with many competing issues. Some examples are:

Precast concrete piles are more often used in situations where steel pipes would be subject to severe corrosion. However, solid precast concrete piles (or piles with driving plates) may not be suitable in dense soils where driving of solid or closed end piles would be difficult or impossible.

Steel pipe piles and precast concrete piles may be preferred over steel H-piles in situations involving long unbraced pile lengths where the higher buckling and flexural capacity of steel pipe piles and precast concrete piles are desirable.

Steel piles may be preferred over concrete piles when the required pile lengths are long enough that piles must be spliced due to the cost and difficulties associated with splicing concrete piles. Steel piles are relatively easy to splice.

Timber pile use is generally limited to lightly loaded structures, particularly when site access is restricted and when high quality timber is readily available locally.

Steel H-piles are attractive when there is a high end bearing capacity in soil or rock such that only a small cross sectional area is needed in the pile to develop the required end bearing capacity.

Piles with larger cross sections are attractive in cases where side friction is the predominant source of vertical capacity due to their greater perimeter (greater area available for generating side friction resistance).

## **7.3 Specific Design Considerations for Piles**

In addition to the general design considerations for deep foundations listed above, designers are reminded that driven piles are generally relatively slender members. Their structural analysis should consider careful evaluation of their buckling and bending capacity, and need to include

consideration of second-order slenderness effects ( $P-\Delta$  effects), particularly in pile bent applications (which will be discussed in more detail later in this module).

In many bridge foundation applications, piles are used in groups. Designers are cautioned to be aware of pile spacing limitations and overall pile group geometry and to be aware of the potential for such adverse situations as:

- Reduction in lateral and/or vertical capacity due to group effects.
- Possible uplift situations due to overturning moments.
- Possible interferences between adjacent piles when one or more piles are battered.

Care should be taken when using battered (or “brace”) piles. Battered piles can offer a simple solution for providing lateral capacity to pile foundations as long as that lateral capacity is carefully evaluated, the effect of lateral loads in increasing the axial load is considered, and the potential for pile interferences is checked.

Also, designers are advised that there is such a thing as “too many battered piles.” In certain cases, particularly in abutments, where piles may be battered only in one direction to resist lateral soil pressures, battering too many piles may potentially result in a situation where the substructure “walks backward” into the retained fill due to the horizontal component of the battered pile axial loads being greater than the passive resistance of the retained fill on the substructure.

Designers are also advised to be aware of construction tolerances for out-of-plumbness and for top of pile out-of-position. These construction tolerances lead to eccentricities in the application of axial load which should be considered in the design of the pile. Keep in mind that the effects of out-of-plumbness and top of pile out of position can potentially be additive, depending on how the project specifications are written and on the contractor’s ability to control the pile during driving. For example, a pile may be significantly out of position at its lower end while still meeting the out-of-plumbness requirement, and simultaneously the top of the pile may be out of position in the opposite direction while still meeting the out-of-position requirements. In this case, the net effective eccentricity is a combination of both effects.

#### **7.4 Detailing Considerations for Piles**

**Pile Spacing** – As previously mentioned, pile spacing can affect both the axial and lateral geotechnical capacity of piles as well as the load distribution in piles.

**Footing or Pile Cap Embedment** – Piles should be adequately embedded into pile caps or footings. The determination of adequate embedment should consider: a) the capacity to transfer pile axial load via end bearing and side friction in the concrete; b) the capacity to transfer pile bending moments via compression block force couples as described on page 11 of reference (4); and c) the capacity to transfer pile shear forces via bearing between the embedded pile and the surrounding concrete.

Footing Reinforcement – Footing reinforcement should be designed following standard footing design guidelines which can be found in many references, such as (5, 6). Strut and tie modeling is also an excellent method for analysis of footings.

## 7.5 Miscellaneous Considerations for Piles

Construction – Pile construction considerations are myriad. Some considerations include:

- Driving – Depending on the subsurface conditions, pile driving may be difficult or physically impossible. In some cases, predrilling might be a solution; if so, the designer and the geotechnical engineer should discuss appropriate backfilling measures.
- Access – Pile driving equipment is rather large. Sufficient access for the equipment should be investigated. Moreover, sufficient horizontal and especially vertical clearance is required for the equipment to operate properly.
- Subsurface Obstructions – Hitting a boulder or an underground utility can ruin a pile driving contractor’s day; sufficient utility survey and sufficient geotechnical field investigations are usually worth their costs. In extreme cases, such as hitting an underground gas line, the results of unforeseen interferences can be catastrophic.
- Need for Pile Splicing – Long piles will require splices. Depending on the splice requirements, the need for splicing long piles may preclude certain pile types.
- Need for Pile Tips – When driving piles to bearing on rock, it may be advisable or even mandated that pile tips be used to avoid problems with the pile “skipping” or “skidding” on the rock stratum.



**Figure 5 Example of pile tips.**

- Scour – Scour around pile foundations, particularly around groups of piles, can be severe as the pile causes a disruption in flow resulting in severe eddies that significantly increase scour. Scour holes around piles represent a loss of lateral support and a loss of side friction capacity. Both the geotechnical and structural analyses of the piles should include consideration of scour. Scour effects should be quantified by a detailed scour analysis (3).





**Figure 6 The effects of scour can be severe. Here a drilled shaft in a multicolumn bent has experienced over 6 feet of permanent (erosion) scour; during a flood event with higher velocity flow, there will be even more temporary (local pier) scour at this pier.**

Deterioration – As mentioned above for spread footings, deterioration of concrete and steel can be caused by any of a number of corrosive chemicals which are often found in soils or groundwater. Geotechnical investigations should include evaluations of the presence of these types of chemicals. If they are found to be present, appropriate protective measures should be taken. A wide range of options exists, including the use of special materials (or additives to standard materials), protective surface treatments, more frequent inspection and/or maintenance intervals, and the use of conservative design assumptions where future deterioration is anticipated and the contribution of part of the structure is discounted.

Testing – Pile capacity is most often verified by means of simple pile hammer blow count evaluations; as part of routine recordkeeping, the number of blows of known force (known weight of hammer and known drop height) required to achieve a specified movement of the pile is recorded. This is a simple, but effective method. More sophisticated methods are sometimes required by contract specifications, usually as a means of spot-checking pile capacity. One such method is the use of a Pile Driving Analyzer (PDA). The PDA is a dynamic testing device which uses strain gages and acceleration transducers to evaluate bearing capacity, pile integrity, and driving stresses.

## **8.0 DEEP FOUNDATIONS – DRILLED SHAFTS**

Drilled shafts represent a somewhat narrower range of deep foundation types. In all cases, drilled shafts can be characterized by a few common features: a relatively deep, round hole drilled in the ground and backfilled with reinforced concrete. Two good references on drilled shaft construction and design can be found in Report FHWA-IF-99-025 (7) and NCHRP Report 343 (2).

Drilled shafts are sometimes categorized by the source of their vertical capacity as either end bearing drilled shafts, side friction drilled shafts, or a combination of the two.

There are several other features which vary from one drilled shaft application to the next, including:

**Casing** – When shafts are drilled through soils subject to caving, steel casing is often used to keep the hole open until concrete is placed. In some cases the casing is then extracted; in other cases it is left in place.

**Bottom Configuration** – In some instances, the bottom of a drilled shaft is widened to increase the end bearing area. These are called “belled” drilled shafts in reference to the bell shape at the tip of the shaft.

**Rock Sockets** – In some cases where drilled shafts are installed in rock with soil overburden, the shafts are drilled a short depth into rock to obtain reliable end bearing or to achieve lateral fixity. In some cases, the diameter of these rock sockets is slightly less than that of the rest of the drilled shaft.

**Concrete Placement Method** – There are several options for placing concrete in drilled shafts. The choice of which option to use is typically dependent on the conditions in the shaft at time of placement, the presence of casing, and/or the presence of water or slurry in the shaft. Clean, dry shafts can have their concrete dropped, at least up to a specified maximum drop height. If there is ground water in the shaft, concrete is sometimes placed under water using a tremie tube (kept embedded in the wet concrete). In other cases a slurry is used to displace the water and the tremie-placed concrete then displaces the slurry. The use of the slurry-displacement method offers the advantage of avoiding the need for casing since the slurry can be used to prevent cave-in of unstable soils. However, the presence of the slurry prevents the inspection of the bottom of the shaft excavation before concrete placement.

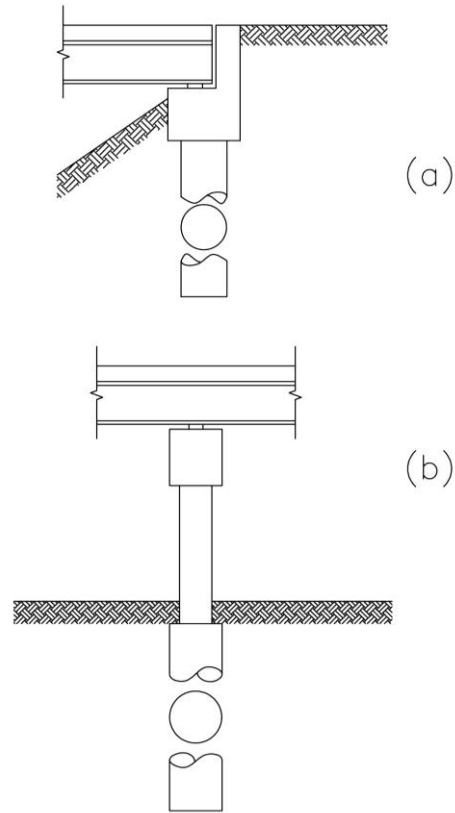

**Figure 7 Drilled shaft applications: a) drilled shafts for a conventional stub abutment: b) drilled shafts used for a pier.**

### **8.1 Factors Affecting Choice of Drilled Shaft Type**

The main factors affecting the choice of features in a drilled shaft are typically the subsurface conditions and constructability issues. The presence of groundwater and/or unstable, caving soils will have a direct impact on whether the shaft must be cased and what type of concrete placement method to use.

The use of belled drilled shafts is not very common anymore, primarily due to the difficulties associated with their construction and with ensuring a clean bottom for end bearing.

The need for rock sockets is typically determined based on the required vertical capacity and lateral fixity and how these can be achieved. If sufficient vertical capacity and lateral fixity can be achieved by means of side friction through soil only, rock sockets may not be required.

### **8.2 Specific Design Considerations for Drilled Shafts**

In addition to the general design considerations for deep foundations listed above, designers are reminded that while drilled shafts are generally relatively stocky members, their structural analysis should consider careful evaluation of their axial and bending capacity, usually by means

of an axial-bending interaction analysis. Drilled shaft structural design is essentially identical to regular reinforced concrete column design and should be approached in that manner.

Depending on the structural configuration, the analysis may need to include consideration of second-order slenderness effects ( $P-\Delta$  effects). In many cases on modern bridges with multicolumn bents, a single drilled shaft is provided for each column with no intermediate pile cap. In those cases, the column is literally an extension of the drilled shaft and, if the column is fairly tall and slender, second-order slenderness effects may become significant. The AASHTO LRFD Bridge Design Specifications, 5<sup>th</sup> Edition (5) and AASHTO Standard Specifications for Highway Bridges (6) recommend that slenderness effects be considered any time that  $KL/r$  exceeds 22, and the specifications require a rigorous analysis of slenderness effects (a  $P-\Delta$  analysis) if  $KL/r$  exceeds 100.

In other applications, drilled shafts may be used in groups. Designers are cautioned to be aware of drilled shaft spacing limitations and overall drilled shaft group geometry and to watch out for the potential for such adverse situations as:

- Reduction in lateral and/or vertical capacity due to group effects.
- Possible uplift situations due to overturning moments.



**Figure 8 Single round column with an oversized, steel cased, drilled shaft.**

Drilled shafts are seldom, if ever, installed in battered configurations to address lateral loading. Instead, lateral load is applied to the plumb drilled shaft and is carried via the bending capacity of the shaft until the load is transferred to the soil through the significant projected lateral bearing area of the shaft. Note that this load transfer mechanism contributes to the previously mentioned design moments in drilled shafts, and these moments must be considered in the structural design of the drilled shaft.

As is the case for all foundation designs, in addition to checking structural and geotechnical capacities, settlement and horizontal movements should be calculated for drilled shafts and compared to tolerable movements.

Be aware that some vertical movement is required to generate end bearing capacity in drilled shafts. One rule of thumb is that vertical movement of about 5% of the shaft diameter is required to generate full end bearing capacity. In some cases, geotechnical engineers will limit the use of the end bearing capacity to as little as 25% of the full end bearing capacity in order to limit the vertical movement of the shaft.

Similarly, a common rule of thumb is that about ½" of vertical movement is required to mobilize side friction capacity.

### **8.3 Detailing Considerations for Drilled Shafts**

**Drilled Shaft Spacing** – As previously mentioned, drilled shaft spacing can affect both the geotechnical capacity of the shafts as well as the load distribution in the shafts.

**Casing** – As mentioned above, casing may be required when drilled shafts are constructed in unstable soils which are subject to caving. Casing may also be required for underwater drilled shaft construction such as in creek and river crossing bridges. The casing is typically advanced as the shaft is drilled, although sometimes in weak soils the casing may be driven into position prior to drilling. The casing is typically large diameter steel pipe, with wall thickness designed to resist soil pressure or hydrostatic pressure and also to resist vertical loading either from installation loads or from loads applied by equipment or platforms which may be mounted on the casing. Casing may be left in place or may be removed, depending on a number of issues, including ease of removal.

**Drilled Shaft Reinforcement, General** – Drilled shafts are typically reinforced in a manner similar to that found in reinforced concrete columns. Vertical reinforcing comprises the primary steel. Spiral reinforcing is often used for confinement, although circular hoops have also been used. The full reinforcing cage is typically assembled and lowered into the shaft as a unit.

**Drilled Shaft Reinforcement, Spacing** – Reinforcement spacing should be carefully evaluated and limited. Concrete placement in drilled shafts is different from that for columns. Consolidation is achieved more by natural flow due to the limited ability to vibrate the concrete. Overly tight reinforcement spacing (either in the vertical reinforcement or the confinement steel) can cause problems with consolidation, problems which are hard to identify due to lack of access. In addition, in deep drilled shafts, reinforcement may need to be spliced; lap splicing may be impractical if the main reinforcement spacing is already tight.

**Detailing for Inspection** – Cross-hole sonic logging (CSL) tubes are often also required and may add to reinforcing congestion problems. At least two CSL tubes are required in a drilled shaft to perform CSL testing; typically four or more are provided. CSL tubes are galvanized steel or PVC pipes, typically 1.5" to 2" in diameter, placed around the perimeter of the reinforcing cage. The CSL process is further explained in the next section.

**Footing or Bent Cap Attachment** – Drilled shafts are cast in place concrete structures, so they do not need embedment into a footing or bent cap per se, but the reinforcement within a drilled shaft is typically projected into the footing or bent cap, usually a full development length. Some

owner-agencies prefer to provide hooks on the projecting reinforcement. Reinforcement projections which provide less than full development of the bars can be used if shown adequate by detailed design calculations, but their use is not encouraged.

Footing Reinforcement – Footing reinforcement should be designed following standard footing design guidelines which can be found in many references, such as AASHTO LRFD Bridge Design Specifications, 5<sup>th</sup> Edition (5) and AASHTO Standard Specifications for Highway Bridges (6).

#### **8.4 Miscellaneous Considerations for Drilled Shafts**

Construction – Drilled shaft construction considerations are myriad. Some considerations include:

- Drilling – Drilling of drilled shafts is generally a large scale construction activity and requires careful planning on the part of the contractor. Designers should be aware of key aspects of drilled shaft construction so as to avoid designs and details that restrict the contractor's options. For example, spoils must be collected and disposed of in an acceptable manner; environmental commitments often limit the options for spoil disposal.
- Access – Drilled shaft drill rigs are not small. Sufficient access for the equipment is required and should be investigated. Moreover, sufficient horizontal and especially vertical clearance is required for the equipment to operate properly. Keep in mind that not only a drill rig is required. Large cranes are often used to lift and place reinforcing cages in the open drilled shafts. Concrete delivery trucks and pumpers are also required to supply and place concrete in the shafts, often using tremie concrete placement methods.
- Subsurface Obstructions – Hitting a boulder or an underground utility can ruin a drilled shaft contractor's day; sufficient utility survey and sufficient geotechnical field investigations are worth their costs. In extreme cases, such as hitting an underground gas line, the results of unforeseen interferences can be catastrophic.



**Figure 9 Drilled shaft drilling rig. Note the steel casing projecting above ground.**

Scour – Scour around drilled shaft foundations, particularly around groups of drilled shafts, can be severe since the drilled shaft causes a disruption in flow resulting in severe eddies that significantly increase scour. Scour holes around drilled shafts represent a loss in lateral support and a loss in side friction capacity. Both the geotechnical and structural analysis of the drilled shafts should include consideration of scour. Scour effects should be quantified by a detailed scour analysis (3).

Deterioration – As mentioned above for spread footings, deterioration of concrete can be caused by any of a number of corrosive chemicals which are periodically found in soils or groundwater. Geotechnical investigations should include evaluations of the presence of these types of chemicals. If they are found to be present, appropriate protective measures should be taken. A wide range of options exists, including the use of special materials (or additives to standard materials), protective surface treatments, more frequent inspection and/or maintenance intervals, and the use of conservative design assumptions where future deterioration is anticipated and the contribution of part of the structure is discounted.

Testing/Inspection, Geotechnical Capacity – Drilled shaft capacity is often not directly verified. Instead reliance is placed on measurements of the shaft diameter, depth, characteristics of the material drilled through, and measurements of the volume of concrete placed and concrete strength. More sophisticated methods are sometimes required by contract specifications, usually as a means of spot-checking drilled shaft capacity. One such method is the use of an Osterberg Load Cell (O-cell). The O-cell is a specially designed hydraulic jack lowered to the base of the shaft hole with the reinforcing cage. After concrete placement and curing, the O-cell is pressurized and causes an upward force on the shaft and a downward force on the foundation material. Side friction and end bearing resistances are measured and compared to the required design values. Reference (9) discusses the O-cell in detail.

Testing/Inspection, Structural Integrity – The integrity of concrete placed in drilled shafts can be verified using cross-hole sonic logging (CSL) testing. For this testing, galvanized steel or PVC pipes are installed around the perimeter of the shaft prior to concrete placement and filled with water. Ultrasonic probes are lowered into the tubes and measurements taken. Voids in the concrete as small as 2.5" can be identified.

Testing/Inspection, Visual – In drilled shafts designed primarily as end bearing foundations the bottom of the shaft hole should be inspected visually. This can sometimes be done by direct visual inspection if the shaft is fairly shallow, dry, and large enough diameter. In other cases, a Shaft Inspection Device (SID) is used; the SID is a remote camera system allowing inspection of the bottom of deep shafts.



## **9.0 ABUTMENTS (END BENTS)**

Abutments (a.k.a. end bents) support the superstructure at the ends of a bridge. Typically abutments must resist not only loads from the superstructure, but also soil pressure loads as they act to retain the approach roadway embankments (note that soil pressures can increase during seismic events).

There are several different basic types of abutments, which can be broadly categorized for discussion purposes as conventional, semi-integral, and integral abutments. Each type will be described in some detail below.

The choice of which of these three abutment types to use is influenced by several parameters, including bridge geometry (e.g., bridge length, skew, etc.), other geometric constraints (e.g., required horizontal clearances, etc.), anticipated loads, future maintenance concerns, and local owner-agency preferences.

## **10.0 CONVENTIONAL ABUTMENTS**

Conventional abutments, sometimes called seat-type abutments, are characterized by these features: a joint separating the bridge deck from the abutment backwall and approach slab/approach pavement, and separation of the superstructure from the abutment by a bearing device of some kind.

These separations simplify the design of conventional abutments and can simplify their construction as well since the superstructure and the substructure are treated independently with a well-defined interface. On the other hand, conventional abutments require the use of expansion joints, which require maintenance and have the potential to jam or to leak, leading to greater potential for deterioration of the girders, bearings, or abutments. In addition, some redundancy and robustness found in integral or semi-integral abutments is not found in conventional abutments.

### **10.1 Design Considerations for Conventional Abutments**

There are numerous issues to consider in the layout and design of conventional abutments. Several are listed below:

**Height** – Conventional abutments can be broadly categorized in terms of height as either stub abutments or tall abutments. In a stub abutment, the depth of the abutment cap is set at a nominal, and usually fairly shallow, depth, typically not much deeper than the cap width, or less. Stub abutment caps depths are often standardized as an owner-agency preference. Stub abutments usually also feature a header slope in front of the abutment cap. The grade of the header slope can be as shallow as 4:1 or shallower or as steep as 1:1 or steeper, depending on owner-agency typical preferences, aesthetic considerations, clearance considerations, and, notably, slope stability considerations, including consideration of the type of slope protection used, if any.

Tall abutments, on the other hand, function as retaining walls as well as supports. Tall abutments are often used when horizontal clearance requirements below the bridge prohibit the use of a header slope, or where superstructure span lengths restrict the location of the abutment.

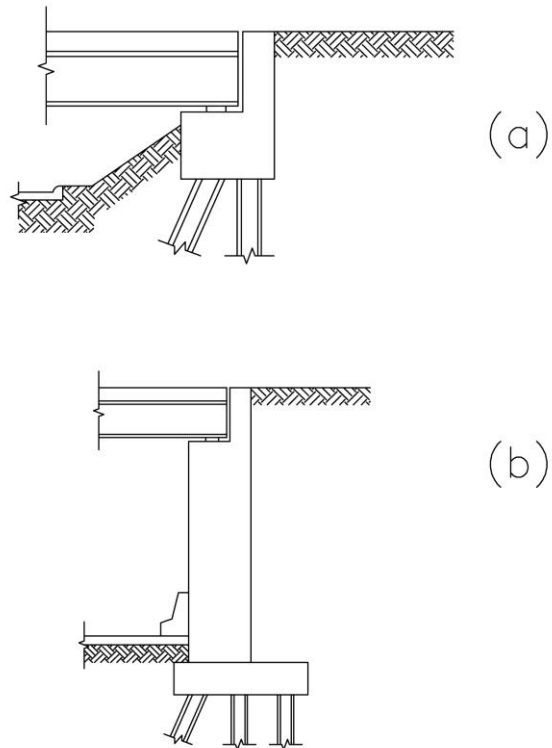
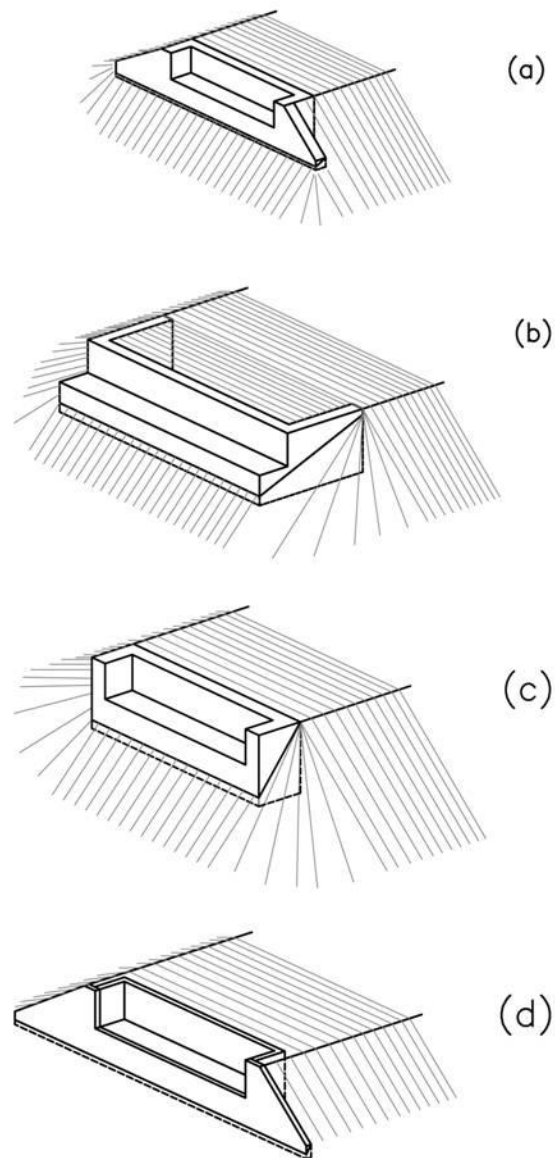

**Figure 10 Conventional abutments of various heights: a) conventional, pile founded, stub abutment; b) conventional, pile-founded, tall abutment.**

Sometimes, a stub abutment is used in conjunction with a separate retaining wall in front of the abutment. This can be done to achieve similar geometric goals as a tall abutment in terms of maintaining horizontal clearances. Any of a number of retaining wall types can be used: Mechanically Stabilized Earth (MSE) walls, soil nail walls, drilled shaft walls, etc. There are a few caveats, however. First of all, careful coordination is required to ensure the abutment foundation elements do not interfere with any of the wall elements, especially when the wall uses straps, tie-backs, soil nails, etc. Also, the wall designer needs to be fully informed of the abutment configuration when designing the wall to make sure that all loads are correctly quantified in the wall analysis. At a minimum the abutment and its backfill represent a surcharge loading on the wall, and depending on the abutment and the wall configurations, additional loads may exist as well.

Width – The width of an abutment cap is controlled by several considerations, including:

- The need to fit bearings and anchor bolts with adequate edge distances.
- The need to fit one or more rows of piles or drilled shafts with sufficient spacing and edge distance.
- The need to meet seismic detailing guidelines related to required seat widths.



**Figure 11 Abutment wingwall configurations: a) stub abutment with wingwalls parallel to the abutment cap; b) stub abutment with turned back wingwalls; c) stub abutment with turned forward wingwalls (a.k.a. “ear walls”); d) stub abutment with MSE retaining wall and wingwalls parallel to the abutment cap.**

Wingwall Configuration – Wingwalls are provided to retain the backfill which would otherwise “spill around” the ends of the abutment backwall and cap. Wingwalls can be oriented in a number of directions including parallel to the cap, angled at some angle (e.g., 30 deg., 45 deg.), turned back (parallel to the roadway, pointed away from the span), or turned forward (parallel to the roadway, pointed toward the span). The preferred orientation and layout of wingwalls is usually determined by owner-agency preference or local practice.

Expansion Joints – Expansion joints should be designed for the anticipated movements of the superstructure relative to the abutment. Care should be taken in calculating these movements to account for all potential sources of movement. Thermal expansion and contraction are typically the primary sources of these movements but other sources may exist, particularly for longer structures or structures subjected to seismic events.

Expansion joints also need to be designed structurally for anticipated vehicle loading, although in many cases this boils down to selecting an appropriate joint from a selection of standard owner-agency or vendor designs based simply on the anticipated traffic.

Many different joint types exist, satisfying a wide range of design criteria. Since joints require maintenance, it is generally advisable to have significant input from the owner-agency regarding selection of the appropriate joint type; in fact, many owner-agencies have very explicit guidelines on this topic.

Backfill – The selection of appropriate backfill for abutments has been the topic of considerable discussion. Typically, the backfill requirements for abutments vary significantly from state-to-state, and sometimes even from county-to-county or city-to-city. Most owner-agencies have standardized details and specifications regarding backfill for abutments. Some require cement-stabilized backfills, others require free-draining granular backfills, sometimes reinforced, with geotextile fabric, and so on. Backfill requirements often also include provisions to facilitate drainage, as will be discussed further below. Designers are advised to consult with the appropriate owner-agency regarding backfill provisions for abutments.

Approach Slabs – The use, design, and detailing of approach slabs varies significantly among different owner-agencies and designers, different regions of the country, and different structure configurations (such as integral vs. non-integral abutments, etc.). Approach slab lengths, design methods, detailing preferences, how to deal with skews, how to connect to the abutment backwall, and even whether or when to provide approach slabs – are all issues for which the answers vary significantly from one owner-agency to the next. Designers are advised to consult with the appropriate owner-agency regarding approach slab guidelines.

Drainage – Drainage issues can be broken into two categories: detailing for drainage of the top surfaces of the abutment, and detailing for drainage of the backfill behind the abutment. For drainage of the top of the abutment, simple common sense rules should be followed to provide positive-draining slopes so that water cannot collect or pond on the top surface of the abutment.

For drainage of the backfill behind the abutment, owner-agencies often have standard drainage details included either with their preferred abutment details or with their preferred backfill details. These may include the use of free-draining granular backfill materials, drainage strip materials placed against the abutment backwall, weep holes in the abutment, underdrain systems, etc.

The following elements of conventional abutments require some degree of design:

Abutment Caps – Caps should be designed for vertical loading as beams spanning between foundation elements. This may be a moot point for abutments on spread footings. The design should include consideration of vertical moment and shear. The design may need to address torsion as well, particularly if the abutment or its backwall are particularly tall, or if there is significant eccentricity between the centerline of application of superstructure reactions (centerline of bearing) and the centerline of the foundations.

Abutment Backwalls – Backwalls are typically designed as cantilever retaining walls carrying lateral soil pressure from the backfill. Some agencies also require application of tractive forces to the top of the backwall.

Abutment Wingwalls – Most designers exercise some discretion in the design of wingwalls due to the complex nature of their support and connection to the rest of the abutment. Designers are encouraged to develop rational design procedures based on careful and realistic consideration of the particular detailing of the wall. Some wingwalls, particularly longer walls, rest on pile or drilled shaft foundations; some use spread footing foundations; some are cantilevered off the abutment cap. Some are square and some are tapered. Most wingwalls will generally behave in a manner that can be adequately captured by a conservative, simplified cantilever beam analyses. In other cases, an analysis based on plate theory may be more appropriate.

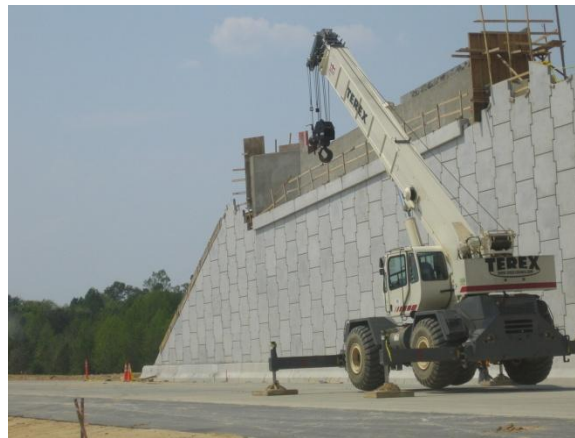

**Figure 12 Conventional stub abutment with MSE retaining wall and wingwalls parallel to the abutment cap.**

Abutment Foundations – The analysis of the abutment cap should include consideration of the foundation system and should probably include calculation of the foundation loads for separate use in the foundation design. Different designers and different owner-agencies have adopted various approaches to the calculation of abutment foundation loads. In some cases, the abutment cap is assumed to act as a rigid body, equally distributing all vertical loads among all piles. In other cases, the abutment cap is assumed to act as a continuous beam on pin supports, with the distribution of load to each pile calculated based on standard beam theory.

## **10.2 Forces on Conventional Abutments**

Conventional abutment design should consider the following forces:

- Abutment cap self weight
- Abutment backwall self weight
- Abutment wingwall self weight
- Miscellaneous dead loads (bearing seats, lateral restraints, etc.)
- Superstructure dead load (including girders, cross frames, deck, barrier rails, medians, overlays, provisions for future overlays, etc.)
- Approach slab dead load
- Superstructure live load
- Approach slab live load
- Lateral soil pressure on the backwall
- Lateral soil pressure on the wingwalls
- Live load surcharge
- Longitudinal forces (in select cases, depending on the nature of the bearings or integral connection provided between the superstructure and the abutment).
- Seismic loads

### **10.3 Detailing Considerations for Conventional Abutments**

Abutments can be complicated to detail. There are many different elements converging in one region in an abutment, requiring care and thoroughness in their layout and detailing.

Approach Slab Connections – Different owner agencies have different details for the connection of approach slabs to abutments. Some prefer full moment connections with a double row of reinforcing. Some prefer a single row of reinforcing and detail the connection as a hinge, sometimes with other provisions such as the use of bond-breaker materials. Some prefer not to provide a positive connection between the abutment and the approach slab. Designers are advised to review their owner-agencies preferences for detailing of this connection and to try to keep their design assumptions consistent with the detailing used.

Expansion Joints – There are so many variations on expansion joints that it is difficult to write a few rules of thumb for detailing abutments at expansion joints. The designer is simply advised to study the provided expansion joint details carefully and to detail the abutment appropriately to adequately accommodate and anchor the expansion joint. Note that many states recommend the

use of blockouts and a second concrete, grout, or elastomeric concrete placement for the expansion joints. Sometimes anchoring reinforcing is provided within this blockout, sometimes it is not.

**Construction Joints** – Construction joints should be judiciously provided in abutments. Usually a construction joint is provided between the abutment cap and the abutment backwall. Sometimes construction joints are provided at the wingwall interface. Construction joints are often also provided in very long (wide) abutments to facilitate placement of concrete in more manageable volumes.

**Bearing Seats** – Various owner-agencies have individual preferences for the detailing of bearing seats. Some like to step the entire width of the abutment cap and to run the seat all the way to the next girder. Other states prefer individual, isolated bearing seats (pedestal seats) of much smaller size, often only large enough to accommodate the bearings and perhaps the anchor bolts.

**Bearings** – Bearing design itself is a complex topic – many good references exist. For the purposes of this discussion it is enough to advise designers to make sure that their bearing seats are detailed to accommodate the proposed bearings. This may require specific sizing of the bearing seats, provisions for inset of the bearings into the bearing seats, adequate seat length for anticipated seismic displacements, etc. Bearing design is discussed in more detail in the module titled *Bearings* of the Steel Bridge Design Handbook.

**Anchor Bolts** – Anchor bolts can prove to be very problematic to deal with during construction if they are not detailed and installed properly (e.g. misalignment of anchor bolts vs. holes/slots in sole plates, etc.). Anchor bolts should be sized to resist all loads applied to them, including horizontal shear loads, e.g., due to seismic load effects, and vertical pullout loads. In addition to sizing the anchor bolt itself for these loads, the concrete within which the anchor bolt is to be installed should also be checked for these loads. The PCI Design Handbook (13) offers procedures for design of embedded anchors. In many cases, owner-agencies have standard details or standard design/detailing requirements for anchor bolts, and designers should seek these out.

Note also that careful anchor bolt positioning is critical to avoiding construction problems. Mislocated anchor bolts, cast in concrete, cause contractors no end of nightmares. If permitted by the owner-agency, designers are encouraged to detail the anchor bolt installation or the bearing to allow for adjustability in the field to facilitate fit-up. Some suggestions include:

- Providing anchor bolt “cans” in the abutment cap – A tube with a closed bottom and a diameter significantly larger than that of the anchor bolt is embedded into the abutment cap during cap concrete placement. Later, when the superstructure is in place, confirming the exact required anchor bolt location, the anchor bolt is grouted in place.
- Using field welded bearing connections – In many cases, the ability to adjust anchor bolt and bearing locations can be improved by allowing the sole plate to be connected to the girder using a field welded connection. In this way the exact position of the bearing relative to both the girder and the anchor bolts can be adjusted in the field.



Reinforcing – Reinforcing in abutments should be detailed following generally accepted detailing practices. Special care should be paid to detailing the connection of the wingwalls to the cap and backwall to avoid reinforcing conflicts and congestion, but to still provide a sound connection.

Pile Embedment – When piles are used as the foundation for an abutment, they are typically embedded at least 9" or more into the cap. In most cases, spiral or hoop reinforcing is provided around the embedded pile as confinement reinforcing, and in some cases a nominal mat of reinforcing is provided directly above the pile. These detailing practices are usually based on owner-agency preferences.

Drilled Shaft Reinforcing Embedment – As mentioned in the drilled shaft discussions earlier in this module, the vertical reinforcing projecting from a drilled shaft into the abutment cap is usually detailed to be fully developed in the cap.

Battered Piles – Depending on the abutment height and the resulting lateral soil pressure on the abutment, it may be necessary to provide battered piles (sometimes called “brace” piles) to resist the applied horizontal forces. Typically, the number of battered piles is selected so that the sum of the horizontal components of the battered pile axial loads balances the net horizontal force due to active soil pressure on the abutment backwall and cap.

Wingwall Piles/Drilled Shafts – Depending on analysis, engineering judgment, or owner-agency policy, wingwalls over a certain length may require their own foundation by means of piles or drilled shafts. The intent of such foundations is to provide both additional vertical support to these long walls and also to provide some measure of horizontal support along the base of the wall. These foundation elements are sometimes detailed directly below the wingwall and sometimes in a “blister” on the side of the wingwall. Usually the preferred scheme is based on owner-agency preference or local practice.

## 11.0 INTEGRAL ABUTMENTS

Integral abutments are a class of abutments in which the superstructure is integrally connected to the abutment and the abutment foundation. Generally the girders are set on an abutment cap and a closure pour is cast which encases the ends of the girders such that the girder ends are embedded several inches or more into the abutment concrete. In some cases, there are other positive connections provided, such as reinforcing running through holes in the girder webs, or anchor studs welded to the girders and embedded in the abutment concrete.

Integral abutments are different from semi-integral abutments (described in more detail later) in that for integral abutments there is no intentional moment relief detail (hinge) anywhere between the superstructure and the abutment foundation. However, much of the guidance provided for integral abutments is applicable for semi-integral abutments as well.

Integral abutments are most typically founded on a single line of vertical steel H-piles, although integral details have occasionally been used with piles, drilled shafts and spread footings. Steel H-piles provide acceptable vertical load capacity and reasonable flexibility for accommodating longitudinal bridge movements without developing excessive restraining forces. In some cases, the piles are installed in predrilled, permanently cased holes filled with loose sand to assure adequate pile flexibility if the natural soils are too stiff to allow sufficient pile flexibility. Foundation systems which are inherently intended to restrict horizontal movement and/or abutment rotation (such as battered pile foundations or multiple rows of piles) are not a good choice for integral abutments.

The variations in terms of configuration and design methodology for integral abutments are myriad and affect mostly the design of the abutment and foundation, not the superstructure per se. The reader is directed to a recent compendium document, the Proceedings of the 2005 FHWA Conference on Integral Abutments and Jointless Bridges (14), which contains numerous papers on integral and semi-integral abutments. Various other recent articles, e.g., (38), exist as well.

There are numerous issues to consider in the layout and design of integral and semi-integral abutments. Several are listed below:

**Height** – Integral and semi-integral abutments can be broadly categorized in terms of height as either stub abutments or tall abutments. Most of the considerations mentioned previously in this module for conventional abutments apply to integral and semi-integral abutments as well. Some owners limit the beam depth that can be used for an integral abutment.

In addition, the wall designer needs to be fully informed of the abutment configuration when designing the wall, in order to make sure that all loads are correctly quantified in the wall analysis. Great care should be taken in designing integral abutments in conjunction with retaining walls to either: a) carefully and rigorously calculate the loading effects on the wall, particularly loading effects caused by integral abutment movements; or b) isolate the piles from the surrounding soil above the bottom of the retaining wall, sometimes accomplished by surrounding the piles with a compressible fill material retained by oversize pipe sleeves around the pile.

- Width – The considerations mentioned previously in this module for conventional abutments apply to integral abutments as well.
- Wingwall Configuration – Many of the considerations mentioned previously in this module for conventional abutments apply to integral and semi-integral abutments as well. Note that for integral and semi-integral bridges, wingwalls typically do not use piles or drilled shafts for support of overly long walls and that they are typically tapered rather than square. Some designers and some owner-agencies have advocated providing an expansion joint between the wingwalls and the abutment cap and backwall, in order to allow for more freedom of rotation in the abutment cap. However, others have reported no problems with fully connected, turned back, cantilever wingwalls with lengths up to 20' and heights up to 10' (4).
- Expansion Joints – Expansion joints for integral and semi-integral bridges are typically provided at the interface between the approach slab and the approach roadway pavement, usually with a sleeper slab to support the far end of the approach slab and approach roadway pavement. Usually only a nominal expansion joint is provided at the interface between the approach slab and the pavement.
- Backfill – Backfill requirements for integral and semi-integral abutments should be evaluated on a case-by-case basis. Many options exist, including options that reduce the unit weight or other properties of the backfill in order to reduce active and passive pressures on the abutment.
- Approach Slabs – Integral and semi-integral abutment bridges should always use an approach slab. The approach slab should be detailed with some type of positive connection to the abutment by means of mild reinforcing. This is recommended to avoid problems associated with opening of the joint between the approach slab and the backwall. Many designers prefer to use a single row of reinforcing bars for this connection so as to create a hinge detail which allows the abutment to rotate more freely without inducing undesirable stresses in the approach slab. Other approach slab design and detailing recommendations mentioned previously in this module for conventional abutments apply for integral and semi-integral abutments as well.
- Drainage – The considerations mentioned above for conventional abutments apply to integral and semi-integral abutments as well.

The following elements of integral and semi-integral abutments require some degree of design:

- Abutment Caps – Caps should be designed for vertical loading as beams spanning between foundation elements, although this may be a moot point for abutments on spread footings. The design should include consideration of vertical shear and moment. Care should be taken to identify exactly which loads act on the effective abutment cap section at various stages of construction. The design may need to address torsion as well, depending on the specific configuration of the structure.

- **Abutment Backwalls** – Unlike backwall design for conventional abutments, backwall design for integral and semi-integral abutments typically models the backwall as a horizontal beam between the girders, carrying lateral soil pressure from the backfill, if the backfill is placed after the deck closure pour is placed around the girders. Alternately, if a partial thickness backwall and the backfill are placed prior to setting the girders and placing the closure pour, that partial thickness backwall is typically designed as a cantilever retaining wall carrying lateral soil pressure from the backfill.
- **Abutment Wingwalls** – Most designers exercise some discretion in the design of wingwalls due to the complex nature of their support and connection to the rest of the abutment. Designers are encouraged to develop rational design procedures based on careful and realistic consideration of the particular detailing of the wall. Some wingwalls, particularly longer walls, include pile or drilled shaft foundations, some use spread footing foundations, and some are cantilevered off the abutment cap. Some are square and some are tapered. Some will behave in a manner adequately captured by some conservative, simplified strip-beam analyses. In other cases, an analysis based on plate theory may be more appropriate.
- **Abutment Foundations** – The analysis of the abutment cap should include consideration of the foundation system and include calculation of the foundation loads for separate use in the foundation design.

Different designers and different owner-agencies have adopted various approaches to the calculation of abutment foundation vertical loads. In some cases, the abutment cap is assumed to act as a rigid body, equally distributing all vertical loads among all piles. In other cases, the abutment cap is assumed to act as a continuous beam on pin supports, with the distribution of load to each pile calculated based on standard beam theory.

Perhaps more important in integral and semi-integral abutment design is the calculation of horizontal forces and moments in the foundation elements. Appropriate design methodologies have been the subject of some debate; designers are encouraged to have open discussions of this issue with their appropriate owner-agency prior to beginning a design.

The range of design methodologies is wide. Some have reported success by simply calculating vertical pile loads, ignoring any horizontal force effects, and keeping the bridge length and other geometry parameters within specified limiting values.

However, a more comprehensive analysis is usually warranted and would consist of careful calculation of superstructure movements and other horizontal force effects on the abutments, combined with a nonlinear soil-structure interaction analysis of the foundation elements. A simplified way to approach this is to separate the foundation analysis from the rest of the structure and consider the foundation elements independently. For the case of pile or drilled shaft foundations, this lateral analysis would be accomplished via a laterally loaded pile analysis, often facilitated by a standardized computer model based on p-y curve analysis of the lateral response of the soil which can be accomplished with programs such as LPILE or COM624. The

geotechnical engineer and the structural engineer would iteratively exchange information until the laterally loaded pile analysis and the structural analysis converge.

A more rigorous approach to a comprehensive analysis might involve the modeling of the soil response directly in the structural analysis model. This step eliminates the tedious iterations of exchanging information manually between the geotechnical and the structural analysis models, but the resulting soil-structure interaction model can become fairly complex.

In either case, designers are encouraged to involve a qualified geotechnical engineer in the determination of the soil response to the various force- and displacement-driven loading conditions. Discussions should include the soil behavior and also the structure behavior since the laterally loaded pile analysis results are heavily dependent on the boundary conditions assumed (e.g., “fixed head condition” vs. “free head condition” vs. other, more refined modeling of moment and translational stiffnesses).

Often a simple 2D model is a sufficiently comprehensive approach to the soil structure interaction analysis. If there is significant skew, a full 3D analysis may be warranted. However, many owner-agencies place limitations on the severity of skew that will be permitted in integral abutment bridges, so this level of modeling complexity is probably not necessary in most cases. Once the analysis method is selected, there are still many issues to be addressed. For example, in many integral abutments founded on steel piles, the calculated longitudinal movements of the bridge will cause sufficiently high internal loads so that the plastic moment capacity of the pile is exceeded. In those cases, the common assumption is to allow a plastic hinge to form, which provides significant moment relief for any movements above those which cause yielding of the piles.

Simultaneously, many designers choose to design the piles so that they satisfy the requirements for bending-axial interaction outlined in the AASHTO LRFD Bridge Design Specifications, 5<sup>th</sup> Edition (5) and AASHTO Standard Specifications for Highway Bridges (6) for steel beam-columns. Some designers have pointed out that allowing a plastic hinge at the pile-abutment interface while simultaneously sizing the pile to prevent even a nominal overstress in terms of bending-axial interaction lower in the pile represents an inconsistent design approach, but to date there have been no known significant in-service problems for piles designed in this fashion. Full resolution of this debate is beyond the scope of the Steel Bridge Design Handbook. Designers are encouraged to consult the most current design guidelines and research papers for the latest positions on this and related issues (e.g., 4, 14).

While much of the above discussion focused on design issues for steel pile foundations for integral and semi-integral abutments, many of the same discussions apply to integral and semi-integral abutments with drilled shaft or spread footing foundations as well. However, these foundation types do not offer the same ductility as steel piles, and so allowing plastic behavior is not advised.

## **11.1 Superstructure Design Considerations for Integral Abutment Bridges**

For many years, the general assumption has often been to ignore any support restraint from the integral abutment when designing the superstructure. However, designers are warned that this may not be conservative in all cases. In the past, it has been considered universally conservative for superstructure design to consider the abutment support as a pinned support. While this is conservative for analysis of the positive moment region of the girders, it is not necessarily conservative at the ends of the girders. At the ends of the girders where they frame into the integral abutments, some degree of negative moment may develop, depending on the relative stiffness of the integral abutment and its foundation. Neglecting this potential for negative moment development may result in undesirable deck cracking or overstress of the girder flanges.

In the case of steel girder bridges with integral abutments, the consequences of these overstresses do not represent life safety issues. If there are overstresses at the ends of the girders, the inherent ductility of the steel girders will allow a hinge to form and the girder will behave as if it were simply supported at that end, as was originally assumed in the superstructure design. The main concerns associated with such overstresses will be related to serviceability.

A suggested redundant design procedure would be to initially design the superstructure assuming simple support conditions at integral abutments – this analysis should be used for the initial sizing of the girders. Then, a second analysis can be performed where the integral abutment and its foundation are included in the overall superstructure analysis to model the frame action at the integral abutments. The results of this second analysis can be used to check the girder design at the integral abutments and to size the deck reinforcing and its continuation into the abutment backwall / cap.

## **11.2 Forces on Integral Abutments**

Integral abutment design should consider the following forces:

- Abutment cap self weight
- Abutment backwall self weight
- Abutment wingwall self weight
- Miscellaneous dead loads (bearing seats, lateral restraints, etc.)
- Superstructure dead load
- Approach slab dead load
- Superstructure live load
- Approach slab live load

- Lateral soil pressure on the backwall (active & passive)
- Lateral soil pressure on the wingwalls
- Longitudinal applied forces (in select cases, depending on the nature of the bearings provided between the superstructure and the abutment).
- Induced forces due to longitudinal movements (most importantly thermal movements)
- Seismic loads

Note that superstructure loads such as dead load and live load can potentially apply moments (or rotations) to the integral abutments, depending on the stiffness of the abutment and the abutment foundation. In the past these effects have been ignored by many designers, based on the assumption that the superstructure is usually significantly stiffer than the integral abutment and its foundation. However, designers are warned that this is not always the case. Thus, some investigation of this issue, at least in a cursory manner, is advisable.

### **11.3 Detailing Considerations for Integral Abutments**

The detailing of the concrete for integral abutments can be much simpler than for conventional abutments, because the shapes are often much simpler. However, great care must be taken when detailing the interface between the abutment, wingwalls and approach slabs to permit adequate movement of the structure while retaining the backfill adequately.

Approach Slab Connections – Different owner agencies have different details for the connection of approach slabs to integral and semi-integral abutments. Most prefer a single row of reinforcing and detail the connection as a hinge, sometimes with other provisions such as the use of bond-breaker materials. Designers are advised to review their owner-agencies' preferences for detailing these connections and to try to keep their design assumptions consistent with the detailing used.

Expansion Joints – For integral and semi-integral abutments, expansion joints are typically provided only away from the abutment, at the interface between the approach slab and the roadway pavement. In most cases, at these locations only a nominally sized expansion joint is provided.

Construction Joints – Construction joints should be judiciously provided in integral and semi-integral abutments. Usually a construction joint is provided between the abutment cap and the abutment backwall. Sometimes construction joints or expansion joints are provided at the wingwall interface. Construction joints are often also provided in very long (wide) abutments to facilitate placement of concrete in more manageable volumes. Depending on the intended construction sequence, a vertical construction joint may be provided between the partial thickness backwall and the closure pour around the girder ends.

Bearing Seats – In integral and semi-integral abutments for steel girder bridges, bearing seats per se are not usually provided.

Bearings – For steel girder bridges with integral abutments, traditional bearings typically are not provided since there is no relative movement or rotation between the girders and the abutment cap. Instead, typically a nominal leveling pad or unreinforced neoprene pad is provided, along with anchor bolts. Alternately, some designers and owner-agencies prefer using “heavy” bolts which function as vertical supports as well as anchor bolts. The bolts must be designed as columns to resist the dead load and live load of the girders, the deck, and the closure pour, but they offer the advantage of allowing vertical adjustment of the ends of the girders via adjustment of the support nuts.

Anchor Bolts – Many traditional design rules and suggestions for anchor bolts do not apply directly in integral and semi-integral abutments. However, many traditional rules related to detailing and providing adjustability for anchor bolts and their connections to the rest of the structure can be adapted for use in integral and semi-integral abutment bridges. See the suggestions listed above for Anchor Bolts in conventional abutment bridges.



**Figure 13 Example of integral abutment details, prior to casting the closure pour. Note the reinforcing running through the girder web and the anchor bolts used as girder supports.**

Reinforcing – Reinforcing in integral and semi-integral abutments should be detailed following generally accepted detailing practices. Special care should be exercised in detailing the connection of the wingwalls to the cap and backwall to avoid reinforcing conflicts and congestion, but to still provide a sound connection. Also of concern is the detailing of the reinforcing connecting the abutment to the deck and, if provided, the reinforcing connecting the abutment to the girders.

Pile Embedment – When piles are used as the foundation for an abutment, they are typically embedded some specified distance into the cap. In most cases, spiral or hoop reinforcing is provided around the embedded pile as confinement reinforcing, and in some cases a nominal mat of reinforcing is provided directly above the pile. These detailing practices are usually based on owner-agency preferences. However, designers are reminded that the connection of a pile to an



abutment cap in an integral end bent bridge is a moment connection and the pile embedment must be designed to accommodate that moment. Reference (4) provides a good design example.

Drilled Shaft Reinforcing Embedment – As mentioned in the drilled shaft discussions earlier in this module, the vertical reinforcing projecting from a drilled shaft into the abutment cap is usually detailed to be fully developed in the cap.

Battered (Brace) Piles – Battered piles are not typically used in integral abutments; however, they may be used in semi-integral abutments.

Wingwall Piles/Drilled Shafts – As mentioned previously, most designers and owner-agencies discourage or disallow the use of founded wingwalls.

## **12.0 SEMI-INTEGRAL ABUTMENTS**

Semi-integral abutments are a class of abutments in which the superstructure is integrally connected to the abutment backwall, but the abutment backwall is isolated from the abutment cap by means of some sort of hinge detail. Semi-integral abutments offer some of the advantages of fully integral abutments such as elimination of expansion joints and a robust end diaphragm detail for the superstructure, while also reducing the moment demand on the piles by providing a reliable hinge detail that allows the piles to behave in a free-head rather than a fixed-head manner (i.e., the top of the pile is free to rotate as well as to translate).

Much of the guidance provided above for integral abutments is applicable for semi-integral abutments as well. Some specific guidance related to semi-integral abutments is provided here, but a full discussion of semi-integral abutments is beyond the scope of this document. The variations in terms of configuration are myriad and affect mostly the design of the abutment itself. The reader is directed to a recent compendium document, the Proceedings of the 2005 FHWA Conference on Integral Abutments and Jointless Bridges (14), which contains numerous papers on integral and semi-integral abutments.

The superstructures for semi-integral bridges are generally supported on bearings as with a conventional structure, thus allowing longitudinal translation. In this case the backwall is separate from the abutment stem, yet the beam ends are encased in the backwall as in an integral abutment bridge. Details are developed to keep the structure backfill from working its way out between the backwall and the abutment stem.

Semi-integral bridge detailing can be used for much longer bridges than integral detailing because the movement capacity is not limited by the pile movement/bending capacity. Additionally, many bridge rehabilitations have converted conventional abutments into semi-integral abutments in order to eliminate the deck joints above the beam ends while retaining most of the existing abutments.

In certain instances, abutments considered to be semi-integral have accomplished semi-integral performance by detailing hinges either between the abutment stem and the backwall or between the abutment stem and the footing to accommodate beam movement through rotation of the abutment.

### **12.1 Forces on Semi-Integral Abutments**

See the discussion of Forces on Integral Abutments.

### **12.2 Detailing Considerations for Semi-Integral Abutments**

See the discussion of Detailing Considerations for Integral Abutments.



**Figure 14 Photograph of a completed integral abutment.**

## 13.0 PIERS (BENTS)

Interior supports for bridges (away from the end supports) go by the title “pier” or “bent.” There is some debate among engineers as to the exact meaning and usage of these terms, and often their definitions depend on local custom and/or owner-agency preference. For the sake of consistency within this module, the term *pier* will be used throughout, and is meant to refer to any structure which supports the superstructure at intermediate points between end supports.

### 13.1 Pier Types

There is a nearly limitless range of pier types. In some ways, it is easier to categorize pier types in terms of various combinations of a few basic pier elements, rather than trying to enumerate all the possible combinations individually. The basic pier elements can be classified as follows:

**Pier Caps** – A more or less horizontal member, on which the superstructure rests. In some cases (such as wall piers), the pier cap and the pier vertical support(s) are in practical terms one and the same. Pier caps can have a square cross section, a rectangular cross section, an “inverted T” cross section, or any of a number of other shapes. Pier caps can be prismatic, tapered, flared, or stepped. Most concrete pier caps to date have been cast-in-place, but precast pier caps have been successfully used and are gaining wider acceptance throughout the US (30).

**Pier Vertical Supports** – Any more or less vertical member which supports the pier cap, and which rests on the pier foundation. In most cases, the pier vertical supports take the form of one or more columns, where columns are vertical members with cross sectional dimensions significantly smaller than the horizontal dimensions of the pier cap. In some cases, the pier vertical support takes the form of a single “wall”, i.e., a member with cross sectional dimensions nearly the same as the horizontal dimensions of the pier cap. Pier vertical supports (whether walls or columns) can take any of a number of cross sectional shapes, including round columns, square columns, rectangular columns, etc. Columns may be prismatic, tapered, stepped, or flared, and may be solid or hollow. Most concrete columns to date have been cast-in-place, but precast columns have been successfully used and are gaining wider acceptance throughout the US.

**Pier Intermediate Struts** – Any more or less horizontal members which serve to brace the pier vertical supports (columns) to increase the column buckling capacity.

**Pier Intermediate Bracing** – Any type of bracing, such as X-bracing, web walls (i.e., concrete shear walls between columns), etc., which serves the purposes of both: a) bracing the columns to increase buckling capacity; and b) providing a more efficient shear load path for carrying horizontal forces through the pier.

Each of the above elements can be fabricated using either steel or concrete (most commonly) or timber or masonry (much less common). In the case of steel, the elements may take the form of rolled sections, built-up open plate sections, built-up closed box sections trusses, lattice-work, or other configurations. In the case of concrete, the elements may be conventionally reinforced, prestressed or post-tensioned, or both. Also in the case of concrete, the elements may be either cast-in-place, or precast.

Some of the more commonly used combinations of these various elements are listed below, but the list should not be considered comprehensive or limiting in any way:

**Reinforced Concrete Multi-column Piers** – Perhaps the most common type of pier, this type consists of a reinforced concrete cap supported by two or more reinforced concrete columns. Generally, the pier cap is only conventionally reinforced, but occasionally post-tensioning is used as well. Generally the column spacing is determined to satisfy a balance between economical design of the pier cap and of the columns, although geometric constraints may control the arrangement in specific cases.

**Reinforced Concrete Single Column Piers** – This type, sometimes called a “hammerhead pier” due to its resemblance to a hammer, consists of a reinforced concrete pier cap “hammer head” supported by a single reinforced concrete column. The use of post-tensioning in a hammerhead pier cap is more common than in a pier cap for a multi-column pier. This pier type is particularly popular for narrow bridges where there is not room for two or more columns as well as for tall piers where a single, much larger column may provide a more efficient means to resist column buckling.

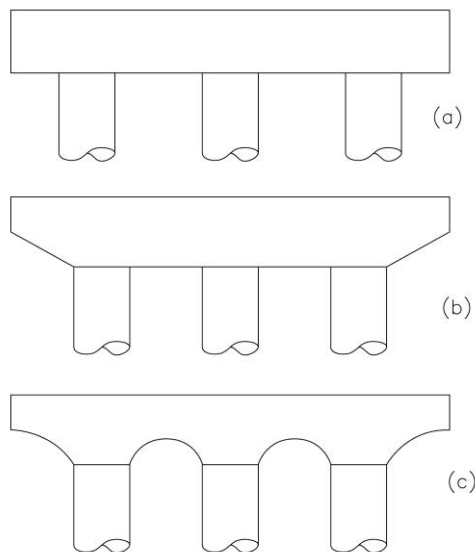

**Figure 15 Various types of pier caps for multi-column piers: a) prismatic pier cap; b) tapered pier cap; c) pier cap with parabolic haunches.**

**Pile Bents** – A pier cap supported on multiple steel or precast concrete piles is sometimes called a “pile bent.” Typically in a pile bent, there is no distinction between the “columns” and the “foundations” – the foundations are just continuations of the piles supporting the cap.

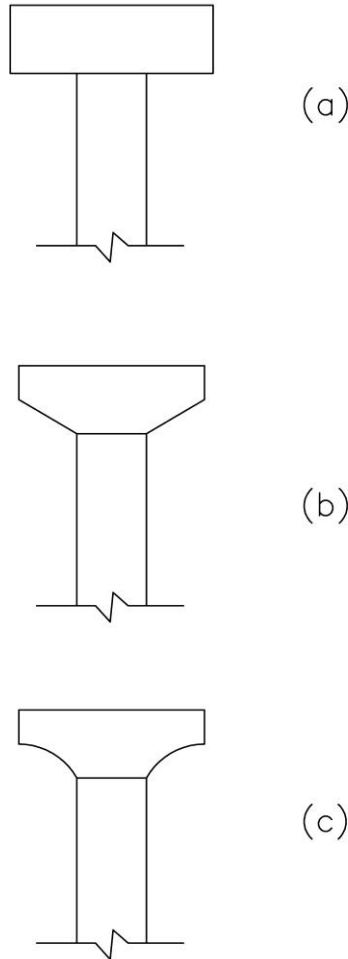

**Figure 16 Various types of pier caps for single column piers: a) prismatic pier cap; b) tapered pier cap; c) pier cap with parabolic haunches.**

**Straddle Bents** – A straddle bent is a multicolumn pier in which an extremely wide column spacing is used to allow for the passage of a roadway directly below the pier, such that the pier is “straddling” the roadway below. Due to the unusually wide column spacing and the resulting long span length of the pier cap, straddle bent pier caps are often specialty structures such as steel box beam caps or post tensioned concrete caps.

**Integral Piers** – It is occasionally desirable to construct pier caps integral with the superstructure. Sometimes this offers advantages in terms of structural efficiency, sometimes it offers aesthetic benefits, and sometimes it helps reduce structure depth and improve vertical clearances. Integral pier caps for steel girder bridges have been constructed both using steel (34) and using concrete (21).

**Steel Piers** – While the majority of piers are constructed from reinforced or prestressed/post-tensioned concrete, there are still situations calling for the use of steel for part or all of a pier. One common opportunity for using steel piers is for temporary bridge structures, such as temporary access bridges on construction sites. In these cases, contractors often prefer using steel

substructures since they are usually light weight and easy to handle, relatively quick to install, and potentially reusable. Other opportunities for using steel elements in piers include long span straddle bent caps and integral pier caps. Other applications of steel piers are perhaps less frequent, but can provide good solutions in the right context. For example, several steel girder bridges have been built with integral slant-leg steel piers or steel delta-piers to solve tough design problems in challenging sites. Another useful option is using concrete-filled steel pipe-piles, which offer many of the advantages of both systems when used in the right applications.



**Figure 17 Typical multi-column pier with round columns and a prismatic pier cap.**



**Figure 18 Typical multi-column pier with round columns and a stepped pier cap.**

### **13.2 Selecting the Right Pier Type**

Selection of pier type is usually heavily influenced by an assessment of the General Design Considerations listed below. However, other factors influence the selection of pier type, including:

Aesthetics – The wide range of pier types available makes piers an attractive candidate for aesthetic manipulation. In many cases, the type and shape of pier caps and columns ends up being dictated by aesthetic considerations such as corridor aesthetic themes or owner-agency or public preferences. Designers are encouraged to embrace rather than fight this trend. Often the

cost of materials is not the driving factor in overall bridge project cost and in many cases aesthetic considerations can be included in a project at little or no additional cost. The key is for the structural engineer to actively participate in the aesthetic design process so that structural considerations are appropriately addressed early on.



**Figure 19** There can be a wide range of variations on the basic multi-column pier configuration, such as these piers with haunched pier caps and curved columns featuring formliner treatments for a pedestrian bridge.

**Local Contractor Preferences** – Local contractor preferences are a key consideration in selecting pier types. In most cases, local contractors are limited in terms of equipment, materials, and experience/expertise to a relatively narrow range of substructure types which they can efficiently and economically build.

**Local Site Conditions** – Subsurface conditions affect foundation type selection which often has a direct impact on the pier type selection. Similarly, local climate conditions (proximity to salt water, regular use of deicing salts, extreme temperature variations, etc.) can have a direct impact on selection of materials for piers.

**Vehicle or Vessel Impact Considerations** – The presence of roadways or railroads in the vicinity of a pier may require the designer to address vehicle impact loads in the pier design; in some cases, owner-agencies have preferences regarding pier type in situations where piers are exposed to higher probability of vehicle impact. The same considerations hold true for piers supporting bridges over navigable waterways, where vessel impact considerations may influence the selection of pier type.

### **13.3 General Design Considerations**

There are many issues to consider in the design of piers. A few select considerations are listed below, but this list should not be viewed as all-inclusive. When designing any pier, designers are advised to carefully consider all possible loading conditions, including displacement-driven as well as force-driven loading effects, structural connection details and how they influence the behavior of the pier, and the influence of foundation response on the behavior of the pier.



Height – The height of the columns supporting a pier obviously has a significant impact on their behavior and design. Height influences not only loads (taller piers generally have higher shear as well as higher moment demands; tall and slender columns can experience second-order moment magnification), but also capacity (buckling capacity is a function of the square of the column heights, moment capacity of some column cross sectional shapes is a function of unbraced length).

Column Proportions – A topic related to pier height is column proportions. Designers are cautioned to pay particular attention to column proportions; excessive slenderness can dramatically reduce axial capacity and can also lead to excessive second-order moment magnification effects (P- $\Delta$  effects).

Guidance in the AASHTO LRFD Bridge Design Specifications, 5<sup>th</sup> Edition (5) and AASHTO Standard Specifications for Highway Bridges (6) requires that moment magnification be considered for any column with  $KL/r$  over 22, at least using the AASHTO approximate moment magnification formulas. The AASHTO LRFD Bridge Design Specifications, 5<sup>th</sup> Edition (5) and AASHTO Standard Specifications for Highway Bridges (6) further require that a rigorous analysis (P- $\Delta$  analysis) be used if  $KL/r$  exceeds 100. Column analysis is discussed further later in this section.

Care should also be taken in determining the appropriate value of K, the effective length factor. Thorough understanding of the underlying assumptions in the development of K factors is key to correct analysis of slender columns. Elastic buckling capacity and second order effects are functions of the square of the effective length; changes to the K factor have significant impact on the design.

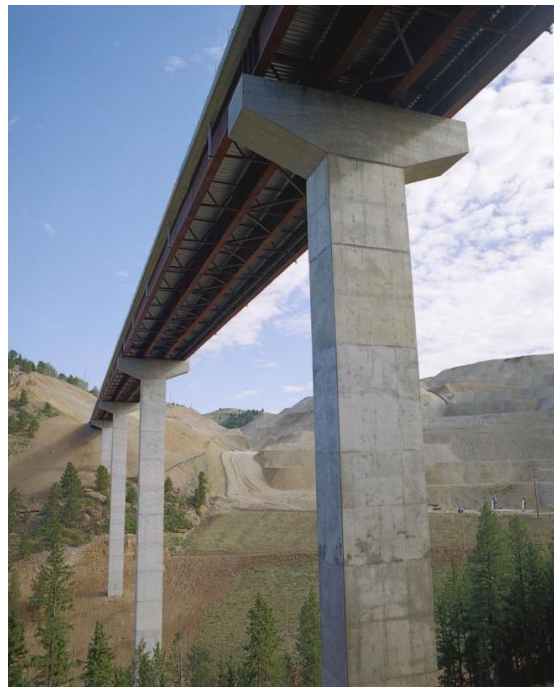

**Figure 20** Single column hammerhead pier with very tall columns over a deep valley.

Keep in mind also that columns should be evaluated about both axes, both in terms of loads and in terms of capacity. In multi-column bents, for example, due to frame action both the column axial capacity and the column moment behavior (shape of the moment diagram) will be significantly different in the transverse and longitudinal directions. For a given pier, these behaviors may be coupled in a skewed bridge.

Designers are reminded that in some cases the clear height of the column from pier cap to ground is not the total height for design. Especially in cases where a single drilled shaft is the foundation for each column, with no intermediate pile footing, or in cases where there are very soft soils with weak lateral capacity, the design height for the column is the distance from the pier cap (generally taken as from the pier cap neutral axis) to the “point of fixity” of the foundation (discussed previously in this module in the section on foundations).

Finally, aesthetics should be a consideration in proportioning columns. A good discussion of general bridge proportioning is provided by Gottemoeller (16).

Solid vs. Hollow Columns – Hollow columns offer some distinct advantages, but generally only in select, fairly rare situations. Hollow columns are best used in very tall piers. Hollow columns offer several advantages, including:

Reduced dead load on foundations.

Potential savings in construction efforts associated with lifting and placing heavy materials on tall piers in difficult terrain.

Reduced stiffness (and resulting reduced internal loads from displacement-driven loading effects).

Hollow columns are often constructed using precast segments, post-tensioned together, which reduces the complexity of field construction work and can simplify construction by reducing heavier lifting and placing operations.

Poston, et al (17) and Taylor, et al (37) offer more discussion of hollow column design.

Column Spacing – Column spacing is ideally set to optimize the design of both the columns and the pier cap, or to satisfy basic aesthetic proportioning guidelines. However, in many projects other issues such as required horizontal clearances to lower roadways, constructability considerations and desire to duplicate details in long, multiple span bridges, need for foundations to clear subsurface conflicts such as existing utilities, etc., override these considerations. Many owner-agencies also have guidelines on preferred maximum column spacing. Overall, designers are advised to keep in mind all of the implications associated with column spacing, since it has a significant impact on pier cap, column, and foundation design.

Column Analysis – As mentioned above, slender columns may require rigorous analysis of second-order moment magnification effects. This is typically accomplished using a second-order

geometrically non-linear analysis, more commonly called a P- $\Delta$  analysis. P- $\Delta$  analysis can be accomplished using a finite element analysis approach using any of a number of commercial FEM programs. Or, for simpler cases (most routine bridges), P- $\Delta$  analysis can be performed using any iterative analysis approach, including via a simple spreadsheet. The analysis need only consider the incremental additional moments due to additional deflection from the previous iteration.

Pier Cap Proportions – Ideally, pier caps should be proportioned to efficiently and economically carry shear and moment effects. Other considerations such as aesthetic requirements or constructability issues may also influence the proportioning of pier caps.

Keep in mind also that there are minimum and maximum thresholds for span to depth ratios for pier caps, just as there are for any beam structures. For example, in extreme cases, excessively shallow pier caps may have deflection or constructability problems. More commonly, pier caps end up quite deep. Pier caps with low span to depth ratios may need to be designed as “deep beams” using strut-and-tie modeling techniques. Much has been recently written about strut-and-tie modeling and many references exist, including a good recent set of practical design examples (33, 39). Deep pier caps may end up requiring significant side face reinforcing to satisfy AASHTO LRFD Bridge Design Specifications, 5<sup>th</sup> Edition (5) requirements.

Tapering or haunching of pier caps is a common practice. There may be a perception that the savings in materials translates directly into a cost savings, but this is seldom true in modern times since the added complexity of tapered or haunched pier caps adds significant labor costs in terms of both shop effort (reinforcing bending) and field effort (cap forming, reinforcing assembly, quality control, etc.). Generally, the main advantages of tapering or haunching of pier caps is aesthetic, with a secondary benefit of reducing loads on pier cap shoring and formwork.

Fixity – A key consideration in layout of a bridge is determination of which piers will be fixed and which will be expansion. This dramatically affects the loading on piers. Fixed piers are generally subject to much higher horizontal (transverse and longitudinal) force effects than expansion piers.

However, the problem is not as simple as just saying “this one is fixed and this one is not.” Even expansion piers carry some degree of horizontal force effects. For example, even if a pier is an “expansion pier” it probably still uses details which provide lateral restraint of the superstructure so that the pier will be subject to transverse load effects. In addition, no bearing is ideally frictionless, and expansion piers with “sliding” bearings (bearings featuring sole plates with low friction PTFE sliding surfaces) are generally designed for the limiting static friction capacity of the bearing.

In addition, in longer, multiple span bridges, designers are encouraged to explore more than one arrangement of fixed vs. expansion piers. A balance can sometimes be found which optimizes the design of all the piers, particularly when the pier heights vary significantly from pier to pier, by judiciously choosing which piers are fixed and which are expansion.

### 13.4 Forces on Piers

Pier design should consider the following forces:

- Pier cap self weight
- Column self weight
- Miscellaneous dead loads (bearing seats, lateral restraints, etc.)
- Superstructure dead load (including girders, cross frames, deck, barrier rails, medians, overlays, provisions for future overlays, etc.)
- Superstructure live load
- Centrifugal force from live load (on curved bridges only)
- Wind on superstructure
- Wind on substructure
- Wind on live load
- Wind overturning
- Longitudinal force from live load (a.k.a. longitudinal braking force)
- Differential earth pressure when constructed in slopes
- Shrinkage
- Thermal expansion/contraction
- Stream flow
- Ice loads
- Seismic loads
- Vessel/vehicle collision loads

For analysis of “routine” bridges, transverse forces on the superstructure (such as wind on superstructure, wind on live load, and centrifugal force, etc.) are assumed to be distributed among the piers and abutments based on a simple tributary span length distribution assumption.



**Figure 21 Single column hammerhead pier with an inverted T pier cap.**

On the other hand, longitudinal forces on the superstructure of a routine bridge (such as wind on superstructure, wind on live load, longitudinal braking force, etc.) are typically distributed among the piers and abutments based on either a simplified or a rigorous relative stiffness analysis. A simplified relative stiffness analysis can be performed by hand and simply models the flexural stiffness of each pier or abutment in the longitudinal direction. The flexibility of both the bearings and the columns over their entire height (down to the point of fixity) are considered. If appropriate, a more rigorous relative stiffness analysis can be performed using either a 2D or 3D computer model.

### **13.5 Multi-column Pier Considerations**

Multi-column piers are perhaps the most common pier type in most routine bridge design. Their design is relatively straightforward and usually requires only a first-order analysis, although sometimes if columns are tall and/or slender, some consideration of second-order moment magnification effects may be required.

In some cases, owner-agencies allow for simplified design of multi-column piers using simple beam analysis programs for determination of the cap bending moment and shear envelopes, and a conservative, simplified analysis of columns. Designers should use good engineering judgment when employing these simplified methods as they are not always appropriate for all bridges.

Detailing of multi-column bents is fairly straightforward as well. Often, owner-agencies have guidelines or standard details they prefer. Local contractor preferences and past local practices should also be considered to achieve maximum economy. Some other specific suggestions include:

Construction Joints – Construction joints should be judiciously provided in multi-column piers. Generally a construction joint is provided between columns and the pier cap and between the

columns and the foundations. Construction joints are often also provided in very long (wide) pier caps to facilitate placement of concrete in more manageable volumes. If staged construction is required, care should be taken in detailing appropriate construction joints and provisions for connection of reinforcing between stages.

**Bearing Seats** – Various owner-agencies have individual preferences for the detailing of bearing seats. Some owners prefer to provide a full width flat step in the pier cap and to run the seat all the way to the next girder. Other states prefer individual, isolated bearing seats (pedestal seats) of much smaller size, often only large enough to accommodate the bearings and perhaps the anchor bolts.

**Bearings** – Bearing design itself is a complex topic which deserves its own discussion – many good references exist (including other modules in the Steel Bridge Design Handbook). For the purposes of this discussion it is enough to advise designers to make sure that their bearing seats are detailed to accommodate the proposed bearings and their anchorage as well as provisions for their replacement and seat width (relevant in seismic zones). This may require specific sizing of the bearing seats, provisions for inset of the bearings into the bearing seats, etc. The module titled *Stringer Bridges* of the Steel Bridge Design Handbook presents a more detailed discussion of bearing design.

**Anchor Bolts** – Anchor bolts can prove to be very problematic to deal with during construction if they and their installation are not detailed carefully. Anchor bolts should be sized to resist all loads applied to them, including horizontal shear loads and vertical pullout loads. In addition to sizing the anchor bolt itself for these loads, the concrete within which the anchor bolt is to be installed should also be checked for these loads. The PCI Design Handbook (13) offers procedures for design of embedded anchors. In many cases, owner-agencies have standard details or standard design/detailing requirements for anchor bolts, and designers should seek these out.

Note also that careful anchor bolt positioning is critical to avoiding construction problems. Mislocated anchor bolts, cast in concrete, cause contractors no end of nightmares. If permitted by the owner-agency, designers are encouraged to detail the anchor bolt installation or the bearing to allow for adjustability in the field to facilitate fit-up. Some suggestions include:

- Providing anchor bolt “cans” in the pier cap – A tube with a closed bottom and a diameter significantly larger than that of the anchor bolt is embedded into the abutment cap during cap concrete placement. Later, when the superstructure is in place, confirming the exact required anchor bolt location, the anchor bolt is grouted in place.
- Using field welded bearing connections. In many cases, the ability to adjust anchor bolt and bearing locations can be improved by allowing the sole plate to be connected to the girder using a field welded connection. In this way the exact position of the bearing relative to the anchor bolts can be set in the field with both the anchor bolts and girder in place.

Reinforcement, General – Reinforcement in piers should be detailed following generally accepted detailing practices, realizing that these practices are typically more stringent in seismic zones. Special care should be paid to detailing the projection of column vertical and confinement reinforcement to avoid reinforcement conflicts and congestion, but to still provide a sound connection. Simple techniques such as interrupting pier cap stirrup patterns at columns and discontinuing some of the pier cap positive moment reinforcement at columns can go a long way to relieving reinforcement conflicts and congestion.

Column Reinforcement Embedment into Pier Cap – The vertical reinforcement projecting from a column into the pier cap is usually detailed to be fully developed in the cap. This can be accomplished by means of straight reinforcement (full development length) or by fully developed hooks. Hooks are shorter (and may fit better in shallower pier caps) but they complicate the construction of the pier cap reinforcement cage.

Column Reinforcement Embedment into Spread or Pile Footings – The vertical reinforcing running from a column into a spread or pile footing should be detailed to be fully developed in the footing. Typically, standard hooks are used to accomplish this. Using hooks, especially if they are detailed to rest on the lower mat of footing reinforcement, facilitates construction by allowing the contractor to rest the column vertical reinforcement on the footing lower reinforcement mat, rather than having to suspend the vertical reinforcement using other methods.

Pile Embedment – When piles are used as the only supports for a pier cap (as in a pile bent), they are typically embedded at least 9" or more into the cap. In many cases, spiral or hoop reinforcing is provided around the embedded pile as confinement reinforcement, and in some cases a nominal mat of reinforcing is provided directly above the pile. These detailing practices are usually based on owner-agency preferences.

Battered Piles – Depending on the severity of the horizontal loads on a pier, it will likely be necessary to provide battered piles (sometimes called brace piles) in the foundation, if the pier is pile-founded, to resist the applied horizontal forces. Typically, the number of battered piles is selected so that the sum of the horizontal components of the pile axial loads balances the net applied horizontal forces.

### **13.6 Single Column Pier Considerations**

As mentioned above, the use of single column piers is especially prevalent for narrow bridges where there is not room for two or more columns as well as for tall piers where a single, much larger column may provide a more efficient means to resist buckling.

The analysis of pier caps for single column piers is relatively straightforward, but there are several key aspects that need to be considered:

Columns in single column piers do not have the benefit of frame action to help brace the columns and reduce internal moments. Also, single column piers are often used on bridges with longer spans and taller pier heights. As a result, columns in single column piers are frequently

candidates for more refined column analysis methods to more accurately assess slenderness effects, as well as more complicated designs (such as hollow columns).

For grade separation bridges, the AASHTO LRFD Bridge Design Specifications, 5<sup>th</sup> Edition (5) require analysis for a vehicle collision force of 400 kips under an Extreme Event limit state if the columns are not barrier protected. The lack of redundancy in single column piers, particularly for narrow bridges with relatively small columns, may require attention from the designer to assure that a vehicle impact will not cause a collapse.

Also, in some cases, the use of post-tensioning is warranted in the pier caps of single column piers to handle the higher loads which may result from heavier, longer-span superstructures and the longer overhangs common in this pier type. Post-tensioning is also sometimes used in the columns of single column piers.



**Figure 22 There can be a wide range of variations on the basic single column pier configuration, such as this pier with a haunched pier cap and single, unsymmetrical curved column featuring form liner treatments for a pedestrian bridge.**

The detailing considerations for single column piers are fundamentally not very different than for multi-column piers in most cases. When hollow columns are used, obviously there are special detailing issues to consider. Due to the unique nature of each hollow column design, detailed discussion of appropriate detailing considerations are beyond the scope of this module, and designers are encouraged to consult appropriate hollow column design references.

### **13.7 Pile Bent Considerations**

As mentioned above, a pier cap supported on multiple steel or precast concrete piles is sometimes called a “pile bent.” Typically in a pile bent, there is no distinction between the “columns” and the “foundations” – the foundations are just continuations of the piles supporting the cap.





**Figure 23 Pile bent with braced steel H-piles serving as both columns and foundations for the pier.**

Pile bents are popular for shorter span structures where high loads and aesthetics are not a concern. Pile bents are particularly appropriate for water and wetland crossings or other long viaduct-type crossings of environmentally-sensitive areas, where extensive excavation for drilled shafts or for pile footings is undesirable. Pile bents can be very economical in these situations due to the extreme simplicity of their construction. Once the piles are driven, the only remaining substructure work is the construction of the pier cap.

One innovative application of pile bents which has become more common in recent years is “top-down construction.” For top-down construction, the structure is built span-by-span; the piles for the next bent are driven by equipment placed on a recently completed span and reaching out to the next bent location. When the piles are driven, the pier cap is placed and cured and then the next span is constructed. Once that span is complete, the pile driving equipment advances to it and reaches out to drive piles in the next bent. In this way, temporary environmental impacts are reduced to practically zero as construction equipment is always located on the completed structure. In most cases, this technique is limited to very short span structures (e.g., in the 50' span range) due to practical limits on the reach of the pile driving equipment, but in those applications this method can be extremely environmentally friendly and economical. This technique has also been used in longer span applications, but generally at much greater cost.

Design of pier caps for pile bents is no different than for multi-column bents and is very straightforward. The analysis of the piles as the primary vertical supports for a pile bent is also fairly straightforward and, in some ways, is simpler than the analysis of columns and foundations for typical multi-column piers. This is due to the fact that there is no difference between the foundations and the columns – they are one in the same. However, this can also lead to complications in the analysis in some cases when pile bents are used in taller pier applications. Since driven piles are typically fairly slender members and since there is no pile footing to provide intermediate bracing, piles in pile bents can quickly become slender column elements requiring careful design including judicious determination of effective length factors (K-factors) and consideration of slender column moment magnification effects. Seismic effects have been investigated in recent publications as well (40, 41).

### 13.8 Straddle Bent Considerations

As mentioned previously, a straddle bent is a multi-column pier in which an extremely wide column spacing is used to allow for the passage of a roadway directly below the pier, such that the pier is “straddling” the roadway below. Due to the unusually wide column spacing and the resulting long span length of the pier cap, straddle bent pier caps are often specialty structures such as steel box beam pier caps or post tensioned concrete pier caps.



**Figure 24 Example of a straddle bent carrying a highway bridge over a railroad line. In this case, the pier cap is also fully integral with the curved steel girder superstructure.**

Straddle bents may also require special design of their supports. In some cases, it may be worthwhile to provide a bearing between a straddle bent pier cap and one of its supporting columns in order to provide relief for shrinkage or thermal expansion/contraction effects.

If a steel box beam is used as the pier cap of a straddle bent, designers are advised that provisions must be made to facilitate future inspection of the interior. A single steel box straddle bent cap is considered a fracture-critical element requiring more frequent inspections, and typically steel box beam straddle bent pier caps include such features as access hatches and minimum internal dimensions which facilitate access. These should be considered early in the design process as they often control the dimensions of the steel box beam section.

Alternately, bent caps may be designed using dual (twin) I-shaped girders for the bent cap, which may address the issue of redundancy and result in a design which is not considered fracture-critical (depending on the owner’s criteria and evaluation of the details).

Constructability is also a serious consideration for straddle bents. Straddle bents are most often used in very congested urban settings where it proves impossible to locate piers and lower roadways separate from each other. In many of those cases, the lower roadway may already be carrying traffic and complex construction staging and traffic control may be required not only for the straddle bent construction but also for the construction of the superstructure which the straddle bent is to support.

### 13.9 Integral Pier Cap Considerations

It is occasionally desirable to construct pier caps integrally with the superstructure. Sometimes this offers advantages in terms of structural efficiency, sometimes it offers aesthetic benefits, and sometimes it helps reduce structure depth and improve vertical clearances. Integral pier caps for steel girder bridges have been constructed using both steel and concrete (21, 34).



**Figure 25 Steel plate integral pier cap for a single column pier.**

Generally each instance of the use of integral pier caps is unique since there are so many project-specific variables affecting the design, including:

The nature of the superstructure loads: an integral pier cap for a curved, continuous plate girder bridge will be subject to completely different loading than an integral pier cap for a straight, tub girder bridge.

The nature of the superstructure type: integral pier caps feature extremely complicated detailing, including a basic choice as to whether to splice the pier cap around continuous girders or to splice the girders around a continuous pier cap. Different superstructure types and sizes will suggest different preferences for integral pier cap detailing.

The nature of the integral pier cap: a post-tensioned concrete integral pier cap will obviously require completely different detailing and shoring during construction than a steel integral pier cap, and each will carry loads in a different way and require different details for connection to the column.

The nature of the column(s); the location, number, size, materials, and configuration of the column or columns of an integral pier cap will suggest different preferences for type and configuration of the integral pier cap.



**Figure 26 Post-Tensioned Concrete integral pier cap for a single column pier.**

As many choices as there may be for integral pier caps, there have been nearly as many solutions previously executed to some degree of success. Designers of integral pier caps are encouraged to keep an open mind regarding possible solutions and also to put careful thought into layout and detailing considerations early in the design process as minor details may end up being controlling design features.

One possible solution which may eliminate many of the complications of integral pier caps is to choose to provide an expansion joint in the superstructure at the integral pier cap location, albeit at the cost of losing the benefits of girder continuity. Making the superstructure discontinuous reduces all superstructure design moments to zero and may allow for the use of dapped girder ends and either an inverted-tee pier cap or possibly even a conventional pier cap which still provides the same vertical clearance benefits as an integral pier cap, but without the complicated design, detailing, and construction associated with an integral pier cap.

### **13.10 Integral Pier Cap Considerations**

While the majority of piers are constructed from reinforced, prestressed or post-tensioned concrete, there are still situations calling for the use of steel for part or all of a pier. One common opportunity for using steel piers is for temporary bridge structures, such as temporary access bridges on construction sites. In these cases, contractors often prefer using steel substructures since they are usually light weight and easy to handle, relatively quick to install, and potentially reusable. Other opportunities for using steel elements in piers include long span straddle bent caps and integral pier caps.



**Figure 27 Steel pipe piles, steel pier caps, and steel framing, with a timber mat deck, form the structural system for this temporary work bridge.**

When using steel piers, care must be taken to carefully design and detail all connections. Due to the reversible nature of many substructure design loads such as wind, longitudinal braking force, thermal expansion/contraction, etc., many connections will have very high stress ranges, while simultaneously the discontinuous nature of many of the connections can potentially lead to unavoidably poor fatigue details with very low allowable stress ranges. Fatigue design can very easily be the controlling limit state in the design of steel substructures in permanent bridges.

Another serious concern when contemplating the use of steel substructures for permanent bridges is geometry control. In a concrete pier, it is fairly easy to adjust column heights, bearing seat elevations, and so on, in the field by making simple field adjustments to reinforcing and formwork. Fabricated steel components are much less forgiving when it comes to misplacements that commonly result from routine construction tolerances. Designers of steel substructures are encouraged to try to include features in their detailing which offer contractors some adjustability to deal with routine construction tolerances (for example, allowing field welding of bearing sole plates to permit adjustment of bearing locations, or allowing the use of shim plates to adjust bearing seats to achieve key elevations).





**Figure 28 Steel single column hammerhead piers for a dual box girder automated people mover bridge.**

### **13.11 Inverted-Tee Pier Cap Considerations**

An inverted-tee pier cap is a pier cap with a cross-section shaped like an upside down capital letter T. Inverted-tee pier caps offer the advantage of very low depth below the bottom surface of superstructure girders. If dapped girder ends are used, the bottom surface of the inverted-tee pier cap can be flush with the bottom surface of the girder. This low profile below the superstructure offers distinct advantages in terms of aesthetics or improvements to vertical clearances below the pier cap.

Most inverted-tee pier caps are made of concrete, sometimes post-tensioned if required to achieve wider column spacings or overhangs.

The design of concrete inverted-tee pier caps is more complicated than the design of regular rectangular concrete pier caps in several important ways. First of all, the design of the pier cap as an inverted-tee concrete section requires some care in the determination of the concrete section bending capacity, particularly in negative moment regions of the cap. If the neutral axis of the inverted-tee in a negative moment region is in the web, the compression block forces must be appropriately adjusted.



**Figure 29 Inverted T pier cap in a multi-column pier.**

Second, the “ledge” or corbel of an inverted-tee pier cap must be carefully designed. This design encompasses both the ledge itself as well as the web of the inverted-tee section. A full discussion of this issue is beyond the scope of this document, but several good references on inverted-tee pier cap design exist (18, 19). Design of the ledge reinforcing may warrant a strut-and-tie analysis. Much has been recently written about strut-and-tie modeling and many references exist, including a good recent set of practical design examples (33, 39).

Finally, column design can be significantly affected by the use of inverted-tee pier caps. Since the centerlines of bearing of two contributing spans are offset very far from the centerline of the cap, any imbalance in the loads applied by either span to the pier cap causes a significant torque on the pier cap. In cases of even moderate span imbalance, this torque may represent a significant overturning moment in the column and the pier foundations, as well as potentially requiring design for torsion of the inverted-tee pier cap itself. Once these overturning effects have been quantified, the column design proceeds as for any other pier column. For the pier cap, torsion design of concrete beams is covered in the ACI Building Code (20). Strut-and-tie modeling may be employed for the torsion design as well.



**Figure 30 Dapped girder ends rest on an inverted T pier cap in a single column pier.**

### **13.12 Other Pier Types**

As has been previously mentioned, this module offers only a brief overview of substructure design. For piers for instance, there is a wide range of variations on the basic common pier types mentioned here. Figure 31 shows just one example of some of the variations designers may need to deal with on a case-by-case basis. When faced with unconventional pier types, designers are encouraged to develop simple, clearly-defined load paths and to keep constructability issues in mind at all times.





**Figure 31** Example of the wide range of variations in pier types. This project featured the widening of an existing bridge which used multi-column piers with web walls. The widened section used single column hammerhead piers.

## **14.0 SOFTWARE AVAILABILITY**

There is a wide range of software available which can do part or all of a substructure design.

Some commercial software packages are capable of performing nearly all of the design of a bridge substructure. These types of programs can build the substructure geometry, build the superstructure geometry, calculate loads on the substructure, perform internal load analysis of the pier caps, columns, and foundations, and then size the various members and perform detailed design. However, in most cases, these programs have some limitations in terms of how complicated a design they can handle in terms of complex geometry, complicated superstructure types, complicated loading, etc. Designers are encouraged to make sure they fully understand the capabilities and, more importantly, the limitations of these “all in one” substructure design programs.

Substructure design can also be performed using a combination of general FEM analysis models and specific design software. Often designers will calculate some or all of the loads on a substructure by hand, input these loads into a simple frame model of the abutment or pier (or into a more complex model if needed), run the model to determine the internal load distribution, and then perform detailed design checks using either commercial software, home-grown spreadsheets or programs, hand calculations, or a combination thereof.

## 15.0 SEISMIC DESIGN

Throughout this module, very little mention has been made of seismic analysis of substructures for steel bridges. This omission was intentional. The complex and highly site-specific nature of seismic analysis makes a detailed discussion of seismic analysis of substructures impossible in the limited scope of this module. Instead designers are advised to consult the following sources for each specific bridge design:

Local Owner-Agency Design Guides and Manuals – In most regions where seismic design is an issue, the local owner-agencies have adopted very specific policies regarding how seismic design of substructures is to be performed. The Caltrans SDC (Seismic Design Criteria) is one such example (42).

AASHTO Specifications – AASHTO LRFD Bridge Design Specifications, 5<sup>th</sup> Edition (5) and AASHTO Guide Specifications for Seismic Isolation Design (23) have very good guidance on seismic design of substructures, which should be reviewed in conjunction with local owner-agency guidelines.

Recent Research Papers – The field of seismic analysis, design, and detailing for bridges is constantly evolving. Designers are encouraged to review the current research for the latest developments and recommendations, in conjunction with AASHTO and local owner-agency guidelines.

Recent Textbooks and Manuals – There are several good manuals and textbooks that cover the basic precepts of seismic design of bridge substructures. The recent NCHRP Report 472 has good, fairly current guidance (22, 43). Several older manuals and guidebooks still have good coverage of basic principles (24, 25, 26, 27, 28).

## 16.0 PRECAST SUBSTRUCTURES

A recent advance in the design and construction of bridge substructures is the use of precast substructure elements. The range of possible applications of precast substructure elements is broad, and some have proposed entire prefabricated bridge systems. However, in practical terms, the most promising applications currently are precast pier caps and precast columns.

The use of precast substructure elements has been proposed as a solution for the challenge of quick construction in congested urban infrastructure projects, where limiting the duration of lane closures and detours is a high priority. In those cases, the use of precast substructure elements versus cast-in-place substructure elements could save days or weeks.

However, to date the most successful applications of precast substructures have been on large, viaduct-type bridges, either over water or land, where the repetition of identical structural elements lends itself to recovery of the initial investment in forms, etc. To date, the most successful application in terms of a substructure element has been the use of precast pier caps, although precast columns have been successfully used as well.

In addition to the economic benefits of precast substructures on large projects, and the time savings in terms of reduced field construction time on urban projects, there are other benefits to precast construction, including improved quality control (due to easier control of workmanship in a controlled fabrication environment of a precast yard versus on site construction) and reduced temporary environmental impacts (due to reduced risk of formwork failures and potential spilling of concrete during casting and reduced material handling in the field).



**Figure 32 Example of a precast pier cap being used on a long viaduct bridge. The columns were cast-in-place with dowels projecting from the top of the columns. The dowels fit into pockets in the precast pier cap. The pier cap initially rested on collars around the tops of the columns. The collars were adjustable to facilitate leveling of the pier cap. Once the pier cap was set, grout was injected into the dowel pockets and the gap between the columns and the pier cap.**

The use of precast substructures has been widely published recently, so several good references exist, including (29, 30, 31, 32).

## 17.0 SUPERSTRUCTURE / SUBSTRUCTURE INTERACTION

Throughout this module the effects of fixity on substructure loads have been mentioned briefly. A few more words on this topic are warranted in a single location to emphasize its importance.

The type of loads, magnitude of loads, and distribution of loads from the superstructure to various substructure elements is directly and significantly affected by the type of connection provided between the superstructure and the substructure. A wide variety of bearing types are available to the designer, and selection of bearing types should be given significant consideration, early in the design process, for this reason. A full discussion of bearings for steel bridges is provided in the module titled *Bearings* of the Steel Bridge Design Handbook.

Designers are cautioned that no bearing acts “ideally” in the real world. “Sliding” bearings still have some nominal static friction force to overcome before they slide. “Flexible” elastomeric bearings still have some nominal shear stiffness and transfer horizontal loads to the substructure even if anchor bolts are not provided. Designers should account for the real-world nature of the behavior of bearings as these “nuisance” loads can represent controlling design loads in some cases such as when tall piers are used.

Designers are also reminded that bearings are typically configured only for downward acting loads, but that not all combinations of superstructure reactions result in a net downward force. The transient nature of live loads, as well as the effects of geometric conditions such as span imbalance, curvature, and skew, can result in uplift on one or all bearings at a given abutment or pier.

In such cases, it may be prudent to provide appropriate tie-downs to prevent uplift. Whether tie-downs are provided or not, designers should account for the actual loads applied to the substructure as well as the potential effects on the superstructure and on the bearings in these cases. When tie-downs are provided, designers are cautioned to design and detail them carefully so that the tie-down does not inadvertently “short circuit” a needed function of the bearing. When confronted with potential uplift and the need for tie-downs, common assumptions regarding simplified behavior and what can be safely neglected should be abandoned in favor of more rigorous and thorough consideration of the behavior of all parts of the structure.

## 18.0 INNOVATIVE SUBSTRUCTURES

Substructures often require unique designs to address site-specific, and bridge-specific, goals and constraints. Innovative solutions are often required. In some cases, creative but reasonable and well thought-out ideas can lead to good solutions.



**Figure 33 Opportunities abound for innovation in substructure design. This unique full height abutment which uses precast double-tees for the stem wall is one example of a creative solution that addressed the specific criteria of a given project.**

For example, Figure 33 shows an innovative abutment system which has been used in the Albuquerque area with some success. It is basically a full height abutment with a modular precast stem. This system has benefits typically expected from precast systems. It has been used in conjunction with a drilled shaft/pile cap system. The pile cap also acts as a leveling pad for the precast double-tee. To resist horizontal loading, the double-tee's connection to the pile cap is post-tensioned. Once the double-tees are in place and backfilled, the abutment cap is then cast on top of the double-tees. Some benefits when compared with MSE wall systems are:

- Decreased construction time.
- Minimized span length by setting the centerline of bearing just beyond the face of barrier.
- Reduced excavation by eliminating the excavation required for strap embedment.

This particular concept is not presented as a panacea, but rather as an example of an innovative, well-reasoned solution which satisfied the specific goals of a given project. Designers are encouraged to explore innovative ideas like this when such opportunities present themselves.

## **19.0 SUMMARY**

In summary, substructure design for steel girder bridges is a broad and varied topic. This single module in the Steel Bridge Design Handbook only scratches the surface of this subject. Designers are encouraged to consult the numerous good references that offer more detail on specific sub-topics.

There are wide ranges of options available to designers for foundations, abutments, and piers. A thorough understanding of the pros and cons of each possible candidate type will lead to better choices. Lessons of past examples, input from other local designers and from local contractors, and preferences of local owner-agencies should not be ignored.

Overly detailed analysis of bridge substructures is not encouraged. Instead, designers are advised to think about the issues involved in their particular design and to choose an appropriately refined level of analysis. Some of the time saved by avoiding excessively detailed structural analysis calculations can probably be better invested by considering such issues as constructability, detailing, appropriate foundation types, and superstructure-substructure interaction issues.

Overall, the old engineering adage still applies particularly well to bridge substructure design: KIS = Keep It Simple. Determine all the loads from the superstructure and from other sources, and find clean, simple, robust load paths to carry those loads.



## 20.0 REFERENCES

1. American Association of State Highway Transportation Officials (AASHTO), Guide Specifications and Commentary for Vessel Collision Design of Highway Bridges, 2nd Edition, 2009.
2. Barker, R.M., Duncan, J.M., Rojiani, K.B., Ooi, P.S.K., Tan, C.K., and Kim, S.G., *Manuals for the Design of Bridge Foundations, NCHRP Report 343*, Transportation Research Board, December 1991.
3. Richardson, E.V., Davis, S.R., *Evaluating Scour at Bridges, 4th Edition, Hydraulic Engineering Circular (HEC) 18*, FHWA Publication No. FHWA NHI 01-001, May 2001.
4. Wasserman, E.P., Walker, J.H., “Integral Abutments for Steel Bridges,” Volume II, Chapter 5, American Iron and Steel Institute (AISI) / National Steel Bridge Alliance (NSBA) Highway Structures Design Handbook, October 1996.
5. American Association of State Highway Transportation Officials (AASHTO), LRFD Bridge Design Specifications, 5th Edition, 2010.
6. American Association of State Highway Transportation Officials (AASHTO), Standard Specifications for Highway Bridges, 17th Edition, 2002.
7. O’Neil, M.W., and Reece, L.C., *Drilled Shafts: Construction Procedures and Design Methods, Report FHWA-IF-99-025*, August, 1999.
8. Federal Highway Administration (FHWA), *Geotechnical Publications, Publication No. FHWA-RD-00-167*, December 2000.
9. Osterberg, J.O., *The Osterberg Cell for Load Testing Drilled Shafts and Driven Piles, Report No. FHWA-SA-94-035*, 1994.
10. Hannigan, P.J., Goble, G.G., Thendean, G., Likins, G.E., and Raushe, F., *Design and Construction of Driven Pile Foundations, Report Nos. FHWA-HI-97-013 and -014*, 1997.
11. Armour, T., and Groneck, P., et al, *Micropile Design and Construction Guidelines and Implementation Manual, Report No. FHWA-SA-97-070*, 1997.
12. Gifford, D.G., Wheeler, J.R., Kraemer, S.R., and McKown, A.F., *Spread Footings for Highway Bridges, Report No. FHWA/RD-86/198*, 1986.
13. Precast/Prestressed Concrete Institute (PCI), PCI Design Handbook, 6th Edition, 2005.
14. Federal Highway Administration (Editors), Proceedings of the 2005 FHWA Conference on Integral Abutments and Jointless Bridges, IAJB 2005, Baltimore, MD, March 16-18, 2005.

15. Reece, L.C., *Behavior of Piles and Pile Groups Under Lateral Load*, Report No. FHWA/RD-85/106, 1985.
16. Goettemoeller, F., *Bridgescape – The Art of Designing Bridges*, 2nd Edition, J. Wiley & Sons, 2004.
17. Poston, R.W., et al, *Design of Slender Non-Prismatic and Hollow Concrete Bridge Piers*, Final Research Report 254F, Center for Transportation Research, University of Texas at Austin, 1983.
18. Mirza, S.A., and Furlong, R.W., “Design of Reinforced and Prestressed Concrete Inverted T Beams for Bridge Structures,” *PCI Journal*, July/August 1985.
19. Texas Department of Transportation, *Bridge Design Manual*, December 2001.
20. American Concrete Institute, *Building Code Requirements for Structural Concrete and Commentary, ACI318-05*, 2005.
21. Wasserman, E.P., “Integral Post-Tensioned Concrete Bent Caps,” *Modern Steel Construction*, July 1997.
22. ATC/MCEER Joint Venture, *Comprehensive Specification for the Seismic Design of Bridges, NCHRP Report 472*, Transportation Research Board, 2002.
23. American Association of State Highway Transportation Officials (AASHTO), *Guide Specifications for Seismic Isolation Design*, 2nd Edition, 1999.
24. Federal Highway Administration (FHWA), *Seismic Design of Bridges, Design Examples No. 1 through 7, Publication Nos. FHWA-SA-97-006 through FHWA-SA-97-012*, October 1997.
25. Buckle, I.G., Mayes, R.L., Button, M.R., *Seismic Design and Retrofit Manual for Highway Bridges, Report No. FHWA-IP-86-6*, July 1986.
26. Buckle, I.G., Friedland, I.M, *Seismic Retrofitting Manual for Highway Bridges, Report No. FHWA-RD-94-052*, May 1995.
27. Federal Highway Administration (FHWA), *Geotechnical Engineering Circular No. 3, Design Guidance: Geotechnical Earthquake Engineering for Highways, Volume I, Design Principles, Report No. FHWA-SA-97-076*, May 1997.
28. Federal Highway Administration (FHWA), *Geotechnical Engineering Circular No. 3, Design Guidance: Geotechnical Earthquake Engineering for Highways, Volume II, Design Examples, Report No. FHWA-SA-97-077*, May 1997.

29. Billington, S., Barnes, R., Breen, J., "Substructures Stack Up," *Civil Engineering Magazine*, American Society of Civil Engineers, April 1999.
30. Matsumoto, E.E., Waggoner, M.C., Sumen, G., Kreger, M.E., Wood, S.L., Breen, J.E., *Development of a Precast Bent Cap System*, Research Report 1748-2, Center for Transportation Research, University of Texas at Austin, January 2001.
31. Freeby, G., Medlock, R., Slagle, S., "Prefabricated Bridge Innovations," *Proceedings of the 2nd New York City Bridge Conference*, October 2003.
32. Freeby, G., Hyzak, M., Medlock, R., Ozuna, K., Vogel, J., Wolf, L., "Design and Construction of Precast Bent Caps at TxDOT," *Proceedings of the Transportation Research Board Annual Meeting*, January 2003.
33. Reineck, K. (Editor), Examples of the Design of Structural Concrete with Strut-and-Tie Models, American Concrete Institute (ACI) Publication SP-208, 2002.
34. Wassef, W., et al, *Integral Steel Box-Beam Pier Caps*, NCHRP Report 527, Transportation Research Board, 2004.
35. Paikowsky, S., et al, *Load and Resistance Factor Design (LRFD) for Deep Foundations*, NCHRP Report 507, Transportation Research Board, 2004.
36. Briaud, J.-L., et al, *Pier and Contraction Scour in Cohesive Soils*, NCHRP Report 516, Transportation Research Board, 2004.
37. Taylor, A. W. Rowell, R. B. Breen, J. E., *Design and Behavior of Thin Walls in Hollow Concrete Bridge Piers and Pylons*, Report CTR 1180-1F, Center for Transportation Research, University of Texas at Austin, 1990.
38. Arockiasamy, M., Narongrit, B., Sivakumar, M., "State-of-the-Art of Integral Abutment Bridges: Design and Practice," *American Society of Civil Engineers (ASCE) Journal of Bridge Engineering*, Vol. 9, No. 5, September/October 2004, pp. 497-506.
39. Mitchell, D., Collins, M., Bhide, S., and Rabbat, B., "AASHTO LRFD Strut-and-Tie Model Design Examples," Portland Cement Association, 2004.
40. Shama, A. A., Mander, J. B., Blabac, B. A., and Chen, S. S., "Seismic Investigation of Steel Pile Bents: I. Evaluation of Performance," *Earthquake Spectra*, Vol. 18, No. 1, Feb. 2002, pp. 121 - 142.
41. Shama, A. A., Mander, J. B., and Chen, S. S., "Seismic Investigation of Steel Pile Bents: II. Retrofit and Vulnerability Analysis," *Earthquake Spectra*, Vol. 18, No. 1, Feb. 2002, pp. 143-160.

42. Caltrans, "Seismic Design Criteria",  
[http://www.dot.ca.gov/hq/esc/earthquake\\_engineering/SDC/SDCPage.html](http://www.dot.ca.gov/hq/esc/earthquake_engineering/SDC/SDCPage.html) (accessed April 2006).
43. MCEER/ATC-49-2, "Recommended LRFD Guidelines for the Seismic Design of Highway Bridges," ATC/MCEER Joint Venture, MCEER Report # MCEER-03-SP09, Multidisciplinary Center for Earthquake Engineering Research, 2003.