

U.S. Department of Transportation
Federal Highway Administration

Steel Bridge Design Handbook

Stringer Bridges: Making the Right Choices

Publication No. FHWA-IF-12-052 - Vol. 6

November 2012



Notice

This document is disseminated under the sponsorship of the U.S. Department of Transportation in the interest of information exchange. The U.S. Government assumes no liability for use of the information contained in this document. This report does not constitute a standard, specification, or regulation.

Quality Assurance Statement

The Federal Highway Administration provides high-quality information to serve Government, industry, and the public in a manner that promotes public understanding. Standards and policies are used to ensure and maximize the quality, objectivity, utility, and integrity of its information. FHWA periodically reviews quality issues and adjusts its programs and processes to ensure continuous quality improvement.

Steel Bridge Design Handbook: Stringer Bridges and Making the Right Choices

Publication No. FHWA-IF-12-052 - Vol. 6

November 2012

Technical Report Documentation Page

1. Report No. FHWA-IF-12-056 - Vol. 6	2. Government Accession No.	3. Recipient's Catalog No.	
4. Title and Subtitle Steel Bridge Design Handbook: Stringer Bridges and Making the Right Choices		5. Report Date November 2012	
		6. Performing Organization Code	
7. Author(s) Ken Wright, PE (HDR)		8. Performing Organization Report No.	
9. Performing Organization Name and Address HDR Engineering, Inc. 11 Stanwix Street Suite 800 Pittsburgh, PA 15222		10. Work Unit No.	
		11. Contract or Grant No.	
12. Sponsoring Agency Name and Address Office of Bridge Technology Federal Highway Administration 1200 New Jersey Avenue, SE Washington, D.C. 20590		13. Type of Report and Period Covered Technical Report March 2011 – November 2012	
		14. Sponsoring Agency Code	
15. Supplementary Notes This module was edited in 2011 by HDR Engineering, Inc., to be current with the AASHTO LRFD Bridge Design Specifications, 5 th Edition with 2010 Interims.			
16. Abstract Once a bridge type is selected, the designer then advances to the detailed design of the bridge. Since the vast majority of steel bridges designed today are steel girders made composite with concrete bridge decks, this module covers many detail issues that are encountered when designing a composite deck girder system. This module addresses the design of welded plate girders. However, many of the principles presented are also applicable to the design of rolled beam bridges.			
17. Key Words Steel Girder Bridge, Span Arrangement, Steel Girder Design, Cross-Frames, Steel Detail Design		18. Distribution Statement No restrictions. This document is available to the public through the National Technical Information Service, Springfield, VA 22161.	
19. Security Classif. (of this report) Unclassified	20. Security Classif. (of this page) Unclassified	21. No of Pages	22. Price

Steel Bridge Design Handbook: Stringer Bridges and Making the Right Choices

Table of Contents

FOREWORD	1
1.0 INTRODUCTION	3
2.0 SPAN ARRANGEMENT SELECTION.....	4
2.1 Assessing Superstructure Cost.....	4
2.2 Assessing Substructure Cost.....	4
2.3 Assessing Access Cost.....	5
2.4 Cost Comparison Summary.....	5
3.0 BASIC FRAMING DEVELOPMENT.....	7
3.1 Girder Economy.....	7
3.2 Redecking	8
4.0 CROSS-FRAME/DIAPHRAGM SELECTION.....	9
4.1 Spacing.....	9
4.2 Orientation	10
4.3 Frame Type Selection	10
5.0 GIRDER DESIGN.....	14
5.1 Selection of Appropriate Analysis Methods.....	14
5.2 Girder Depth Optimization	14
5.3 Girder Plate Transitions	15
5.4 Field Splice Location	18
5.5 Girder Web Design	19
5.6 Material Selection	21
6.0 DETAIL DESIGN ISSUES	23
6.1 Girder Cambers.....	23
6.2 Transverse Stiffeners – Web Stiffeners	24
6.3 Transverse Stiffeners – Connection Plates	24

6.4	Bearing Stiffeners	24
6.5	Longitudinal Stiffeners	25
6.6	Lateral Bracing.....	26
7.0	REFERENCES	28

List of Figures

Figure 1	Graph showing typical bridge cost curves.....	6
Figure 2	Detail sketch of a typical K-frame cross-frame type.....	11
Figure 3	Detail sketch of a typical X-frame cross-frame type.....	11
Figure 4	Photograph of a full-depth plate diaphragm at the end of a span.....	12
Figure 5	Detail sketch of a typical Knocked-Down cross-frame.....	13
Figure 6	Sketches showing the slabbing and stripping process.....	16
Figure 7	Photograph showing a run-off tab	16
Figure 8	Diagram of a mixed steel I-girder	22
Figure 9	Diagram of a hybrid steel I-girder	22
Figure 10	Sketch of a longitudinal and transverse stiffener intersection detail.....	26

List of Tables

Table 1 Weight Saving Factor Per Inch of Plate Width for ASTM A709-Gr 50 Non-Fracture Critical Flanges Requiring Zone 1 CVN Testing	18
--	----

FOREWORD

It took an act of Congress to provide funding for the development of this comprehensive handbook in steel bridge design. This handbook covers a full range of topics and design examples to provide bridge engineers with the information needed to make knowledgeable decisions regarding the selection, design, fabrication, and construction of steel bridges. The handbook is based on the Fifth Edition, including the 2010 Interims, of the AASHTO LRFD Bridge Design Specifications. The hard work of the National Steel Bridge Alliance (NSBA) and prime consultant, HDR Engineering and their sub-consultants in producing this handbook is gratefully acknowledged. This is the culmination of seven years of effort beginning in 2005.

The new *Steel Bridge Design Handbook* is divided into several topics and design examples as follows:

- Bridge Steels and Their Properties
- Bridge Fabrication
- Steel Bridge Shop Drawings
- Structural Behavior
- Selecting the Right Bridge Type
- Stringer Bridges
- Loads and Combinations
- Structural Analysis
- Redundancy
- Limit States
- Design for Constructibility
- Design for Fatigue
- Bracing System Design
- Splice Design
- Bearings
- Substructure Design
- Deck Design
- Load Rating
- Corrosion Protection of Bridges
- Design Example: Three-span Continuous Straight I-Girder Bridge
- Design Example: Two-span Continuous Straight I-Girder Bridge
- Design Example: Two-span Continuous Straight Wide-Flange Beam Bridge
- Design Example: Three-span Continuous Straight Tub-Girder Bridge
- Design Example: Three-span Continuous Curved I-Girder Beam Bridge
- Design Example: Three-span Continuous Curved Tub-Girder Bridge

These topics and design examples are published separately for ease of use, and available for free download at the NSBA and FHWA websites: <http://www.steelbridges.org>, and <http://www.fhwa.dot.gov/bridge>, respectively.

The contributions and constructive review comments during the preparation of the handbook from many engineering professionals are very much appreciated. The readers are encouraged to submit ideas and suggestions for enhancements of future edition of the handbook to Myint Lwin at the following address: Federal Highway Administration, 1200 New Jersey Avenue, S.E., Washington, DC 20590.

A handwritten signature in blue ink that reads "Myint Lwin". The signature is fluid and cursive, with the first name "Myint" and last name "Lwin" clearly distinguishable.

M. Myint Lwin, Director
Office of Bridge Technology

1.0 INTRODUCTION

Once a bridge type is selected, the designer then advances to the detailed design of the bridge. Since the vast majority of steel bridges designed today are steel girders made composite with concrete bridge decks, this module will cover many detail issues that are encountered when designing a composite deck girder system. This module addresses the design of welded plate girders. However, many of the principles presented are also applicable to the design of rolled beam bridges.

2.0 SPAN ARRANGEMENT SELECTION

When designing a plate girder bridge, the first and most important aspect of the design is to choose the proper span arrangement. This is accomplished effectively only by considering the cost of the entire bridge, including both the superstructure and substructure costs.

2.1 Assessing Superstructure Cost

Prior to 1970, the predominant approach to bridge span arrangement was to design structures consisting of a series of simple spans with small movement capacity expansion joints at each pier. These bridges were generally designed with non-composite bridge decks. As welded girders made composite with the concrete deck have become the industry standard, multi-span continuous bridges have become the preferred configuration. Continuous spans reduce the structure depth and minimize the number of expansion joints and bearings in the structure. Using fewer joints reduces future maintenance costs associated with both bearings and joints that will ultimately leak.

Layouts should be developed for various span arrangements, and preliminary girder designs developed for these arrangements. For multi-span continuous bridges, a balanced span arrangement with end span lengths approximately 80 percent of the interior span lengths provides the most economical girder design. Equal span arrangements are also relatively economical. However, physical constraints may preclude development of such ideal span arrangements. In such instances, it is desirable to keep the span lengths as uniform as possible for both economic and aesthetic reasons. Avoiding end spans longer than the adjacent interior spans or extremely short interior spans relative to the adjacent spans will provide an efficient and cost-effective girder section. Where integral abutments are used with the abutment as a counterweight, end spans shorter than 0.6 times the adjacent interior span can be economically feasible.

A few words about appearance are also in order regarding the choice of span arrangements. It is possible to select span arrangements that are attractive and yet cost-effective. As a general rule, an odd number of spans provides a more desirable appearance than does an even number of spans. When crossing a valley, using longer spans in the deeper part of the valley and decreasing the span lengths as the height of the bridge decreases provides a pleasing appearance. For the approaches to a long span structure, it is visually desirable to use equal span approaches adjacent to the long-span structure or to progressively increase the approach span lengths from the abutments toward the long-span structure. It is visually unsatisfying to have a short balanced end span adjacent to a long-span structure.

2.2 Assessing Substructure Cost

In order to determine the optimum span arrangement for a bridge, it is important to assess the total bridge cost, being careful not to confine the comparison of span arrangements to superstructure cost only. Once a span arrangement is determined and the framing geometry developed, preliminary pier costs can be estimated reasonably quickly. The pier locations and out-to-out girder spacing will allow the designer to select an appropriate pier configuration. Once

the pier configuration is determined, basic dimensions can be estimated, quantities computed and costs estimated for each pier with minimal effort.

The designer should assess the foundation conditions when assessing the pier costs. If poor foundation conditions are anticipated, the designer should attempt to capture the additional costs associated with those conditions. It is not imperative that the pier costs be exact, but the general order of magnitude of cost should be close to the actual costs. Foundations in waterways can incur added costs for cofferdams, dewatering and barge mounted equipment. When building new spans over or near railroad tracks, railroad requirements regarding crash barriers and railroad protective insurance should be considered when assessing design costs.

2.3 Assessing Access Cost

For a majority of bridges, particularly grade separation structures, access costs for construction will not be significantly different regardless of the span arrangement chosen. However, there are certain constraints that may increase the cost of construction access. Among these constraints are large streams, rivers or lakes; poor soils that cannot support construction loads without remedial work; and deep valleys that result in very high structures. In such cases, the cost of construction access can vary significantly dependent upon the span arrangement selected. If the designer does not assess access issues, the true bridge cost will not be captured and the comparisons between span arrangements will be invalid.

2.4 Cost Comparison Summary

Once the three main components of the bridge cost are computed, cost summaries can be developed for all components for each of the span arrangements studied. These costs can be represented by a group of curves that, when superimposed upon each other, demonstrate graphically which span arrangement results in the lowest total cost. The span arrangement with the lowest total cost should provide the most cost-effective bridge. An example of typical cost curves is shown in Figure 1.

For most agencies, the initial construction cost often drives the structure choice. While life cycle cost is generally not considered directly when selecting a preferred alternative, it may enter into the comparison between alternatives on a qualitative level. Aesthetics, durability, maintenance, expected useful service life and ability to widen the structure are among the considerations that may become deciding factors in making a recommendation for two span arrangements with similar construction costs.

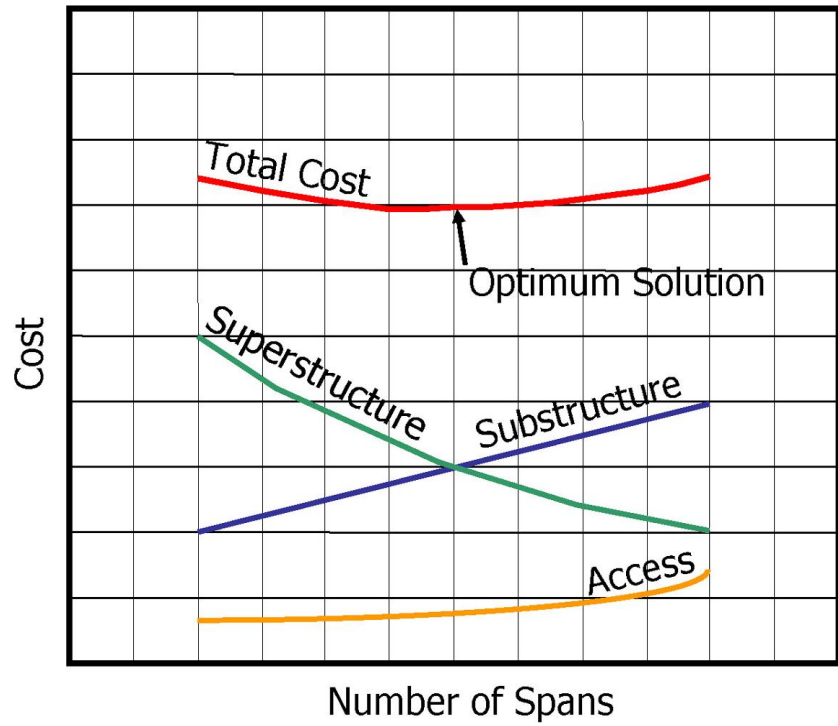

Figure 1 Graph showing typical bridge cost curves

3.0 BASIC FRAMING DEVELOPMENT

Development of a well-conceived framing plan is an important first step in designing an economical bridge. Designers should consider costs from design through fabrication and construction when developing the framing plan in order to minimize the total cost of the bridge. Many factors enter into the development of an appropriate framing plan, not the least of which are owner preferences. Many owners are willing to consider wider girder spacings in an effort to maximize economy. Others still strive to maintain relatively narrow girder spacings, often in the range of 8 to 9 feet. This type of spacing was necessary years ago when the concrete bridge decks were formed using removable forms. However, with the development and acceptance of permanent metal deck forms, larger spacings are feasible and may be economical.

When establishing the girder spacing, it is important to balance the moments in the girders with the appropriate deck overhang width beyond the fascia girder. If the overhang width is too large, the exterior girders will carry significantly higher forces than the interior girders due to the cantilever effect of the deck beyond the fascia. A small deck overhang results in lower forces in the exterior girders than in the interior girders. Refined analyses have shown that the forces in the exterior and interior girders will be reasonably balanced when the deck overhang is around 30% to 32% of the girder spacing. This allows similar sections to be used for the interior and exterior girders, thereby allowing greater fabrication economy due to repetition.

3.1 Girder Economy

As a general rule when considering both the decking and stringers, plate girder spacings in the 11 to 14 feet range provide the most economical superstructure design. The main reason is that the web steel in the plate girders is not efficient in bending but rather in shear. However, the significant variations in shear result in inefficient, or “wasted”, material in the webs. It is not economical to vary the web thickness often enough to truly optimize the design for shear. Thus, fewer lines generally lead to less total steel weight in the bridge and reduce the number of members to be fabricated and erected. Rolled beam bridges often prove to be more economical with somewhat closer spacing than is ideal for plate girders.

When developing a framing plan, it is important to consider fabrication and erection of the girders. From the fabricator’s perspective, the use of fewer girders translates to less welding per pound of fabricated steel. There are also fewer cross-frames/diaphragms to fabricate, and since the cross-frames are among the most labor-intensive fabrication details in a typical girder bridge, a reduction in the number of cross-frames may translate to a significant overall savings in fabrication cost. For the erector, fewer girders mean fewer pieces to erect, fewer field splices to be bolted and fewer cross-frames to install. The reduction in the number of pieces to be installed may result in a shorter erection schedule, which will minimize crane rental time and associated labor costs. Lifting heavier pieces, however, may require larger cranes which could reduce the savings anticipated from erecting fewer pieces.

3.2 Redecking

In many cases, owners now require designers to develop framing options that will permit a phased partial-width deck replacement to occur safely while maintaining traffic on the structure. Depending upon the bridge width, designing to accommodate a staged redecking may require an additional girder than would be optimal. However, the life-cycle cost savings provided by the staged redecking may outweigh the cost of the additional girder in the initial design.

4.0 CROSS-FRAME/DIAPHRAGM SELECTION

Historically, intermediate cross-frames have been assumed to provide intermediate bracing for the girders during erection, particularly for the top flanges in the positive moment regions. The live load distribution factors contained in the *AASHTO LRFD Bridge Design Specifications, 5th Edition*, (referred to herein as the AASHTO LRFD (5th Edition, 2010)) (1), were based on the assumption that live load distribution between the girders occurs through the deck stiffness rather than through frame action provided by the intermediate cross-frames. Cross-frames have not been assumed to distribute live load except for curved girder bridges.

Top flanges of composite girders in positive moment regions are braced by the cross-frames prior to hardening of the concrete decks. Intermediate cross-frames for continuous composite girder bridges also provide bracing against lateral buckling of the compression flange in the negative moment regions both during erection and after the deck is placed. Additionally, intermediate crossframes provide bracing for lateral wind loads on deep girders.

On skewed composite girder bridges, the cross-frames are assumed not to carry live load if the live load distribution is based on the factors found in the AASHTO LRFD (5th Edition, 2010). If a grid or refined analysis is used that models the stiffness of the cross-frames in the analysis, then the intermediate cross-frames should be designed for the loads computed from the analysis results.

For curved girder bridges, the intermediate cross-frames play a significant role in the live load distribution and need to be designed and detailed as main load carrying members.

As with the intermediate cross-frames, the end cross-frames at abutments and those at the piers provide bracing during erection of composite steel girders. However, all support cross-frames are required to distribute lateral loads from the superstructure to the substructure. These loads include wind, centrifugal, seismic and thermal forces for some curved girder bridges. In addition, end support cross-frames generally are designed to carry direct wheel loads since they are supporting expansion joints in the deck.

4.1 Spacing

Historically, the AASHTO Allowable Stress Design (ASD) and Load Factor Design (LFD) specifications have limited the longitudinal cross-frame spacing to a maximum of 25 feet. Over the years, bridges have performed well under this limitation. The AASHTO LRFD (5th Edition, 2010) does not specify a limit on the cross-frame spacing; it instead requires the designer to design the girders for the unbraced length corresponding to the cross-frame spacing. However, the intent of the code writers was not to encourage overly large spacings, but rather to permit designers to exceed the traditional 25 feet maximum spacing requirement so that extra frames are not added into the framing plan solely to meet an arbitrary spacing limit.

Since cross-frames serve as main load carrying members for curved girder bridges, the spacing is generally reduced from what is common for straight girders to limit the lateral bending stresses in the girder flanges due to curvature. As the girder radius decreases, a corresponding decrease in the cross-frame spacing is required in order to limit the lateral flange bending stresses to

acceptable levels. The cross-frame spacing for curved girder bridges is directly related to the horizontal radius of curvature.

4.2 Orientation

Intermediate cross-frames for tangent and curved bridges should be oriented so that they are perpendicular to the girder webs. This orientation simplifies fabrication and maximizes the efficiency of the cross-frame.

For skewed structures the orientation is a function of the skew angle. If the skew is less than 20 degrees (as defined by AASHTO LRFD (5th Edition, 2010)) the cross-frames should be oriented parallel to the support skew. This simplifies the detailing since the cross-frames all attach at the same distance into the span for each girder, which minimizes differential deflection between the ends of the cross-frames.

For skews greater than 20 degrees, AASHTO LRFD (5th Edition, 2010) requires that cross-frames be placed normal to the girder webs. The main reason for this is that the welded connection between the cross-frame connection plates and the girder webs becomes difficult if the skew is greater than 20 degrees. However, turning the cross-frames normal to the girder webs results in relatively large differential deflections between the each end of the cross-frames and may require special guidance to the fabricator and erector.

4.3 Frame Type Selection

Some basic types of cross-frames common in girder bridges are K-frames (see Figure 2), X-frames (see Figure 3) and Z-frames. The K-frame and X-frame may include a top lateral strut in addition to their respective diagonal members.

Occasionally plate diaphragms (see Figure 4) have been used, but they make bridge inspections difficult by blocking off access for inspectors. Access can be obtained by adding manholes through the plate diaphragm webs, but the additional fabrication associated with the manholes adds cost to the plate diaphragms. There have also been instances where the high stiffness of the plate diaphragms has resulted in distortion-induced cracking near the top of the connection plates. Plate diaphragm use is generally limited to shallow rolled beams or plate girders where cross-frames are ineffective in transferring forces between girders or in situations where the girder spacing is so close that the geometry of a frame becomes unworkable. Sometimes plate diaphragms are used at support locations to facilitate future jacking of the girders to permit inspection and maintenance of the bearings.

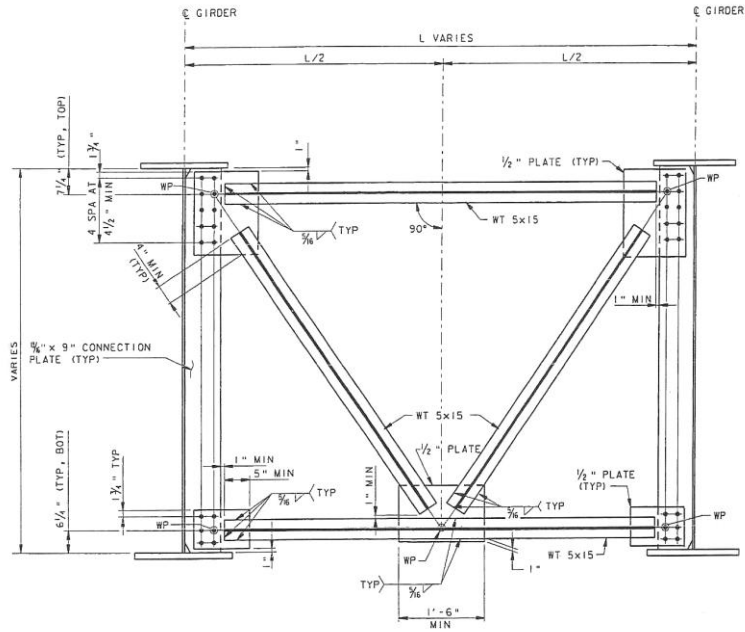

Figure 2 Detail sketch of a typical K-frame cross-frame type

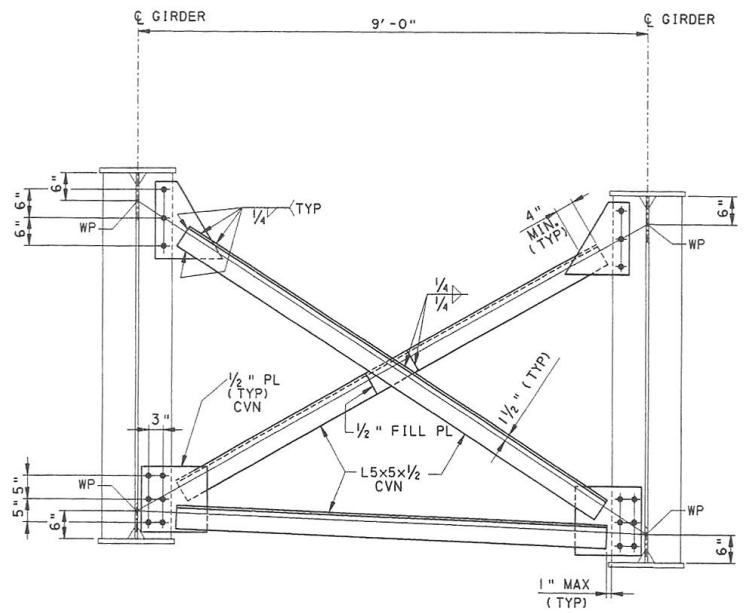

Figure 3 Detail sketch of a typical X-frame cross-frame type



Figure 4 Photograph of a full-depth plate diaphragm at the end of a span

For aspect ratios (girder spacing to girder depth) less than 1, X-frames generally result in an efficient design. For aspect ratios greater than 1.5, K-frames are generally more efficient than X-frames because the diagonals can remain inclined at or near a 45 degree angle. For aspect ratios between 1 and 1.5, the selection of the basic cross-frame configuration may be driven by client preferences.

The other key choice that must be made regarding cross-frames is whether to use assemblies that are pre-fabricated in the shop (usually welded), or to use “knocked down” frames that are sent to the field in pieces and erected one member at a time (see Figure 5). Jigs can be set up in the shop to allow repetition and speed in the fabrication of cross-frame assemblies. Once in the field, shop assemblies reduce the number of pieces that must be lifted with cranes and bolted. Knocked down frames require extra fabrication time in the shop because matching the bolt holes between the cross-frame members and the connection plates is not as readily automated as the welding operation required for shop assembled frames. The transportation costs for knocked down frames may be lower since the smaller, lighter pieces are easier to handle. However, the erection costs may increase since more pieces must be erected and connected.

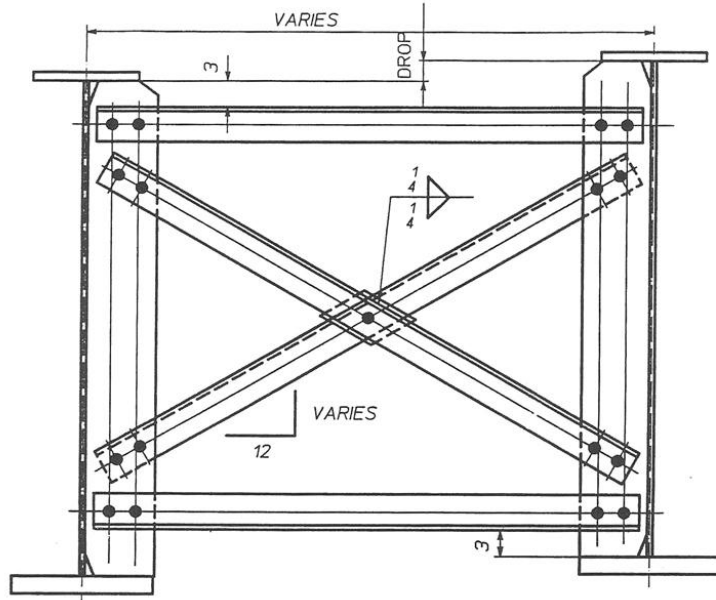

Figure 5 Detail sketch of a typical Knocked-Down cross-frame

5.0 GIRDER DESIGN

5.1 Selection of Appropriate Analysis Methods

Given the current level of advancement in computer software for girder analysis, as well as the availability of powerful software tools to the structural engineer, a discussion of analysis methods is in order.

Line girder analysis is still an appropriate analysis method for many bridges, particularly tangent and skew girder bridges. Line girder methods analyze bridge girders as individual beams. Section properties are incorporated into the model to reflect composite action between the beam and the deck. Live load distribution to adjacent girders through the deck is taken from the tables found in the AASHTO LRFD (5th Edition, 2010).

Grid analysis methods consider the entire framing system in the model. The framing system is generally modeled as a series of beam elements. The deck stiffness is usually approximated in the model through the use of composite girder section properties. Dead loads are generally distributed to the girders based on tributary areas. Load sharing between the girders occurs through the beam elements representing the cross-frames.

Three dimensional finite element analysis is the most refined of the common methods used and models all framing, including the girders, the discrete cross-frame members and the concrete deck in three dimensions. Finite element analysis provides a more accurate distribution of loads through the structure based on the actual stiffness of the various superstructure components but is more labor intensive than the other methods. There is generally a material savings realized through the use of finite element analyses because optimized load distributions occur when the total structural system is analyzed accurately. This improved load distribution allows the designer to place the steel where it is required, rather than using conservative approximations that are inherent in the other methods of analysis. 3D finite element analysis methods can be valuable in analyzing the construction phasing for curved and skewed bridges.

A more comprehensive discussion of the various types of analysis can be found in the Steel Bridge Design Handbook module titled Structural Analysis.

5.2 Girder Depth Optimization

Once a span arrangement has been selected, the girder web depth should be optimized. Historic data or utilizing a depth to span ratio of 1/25 (applied to the distance between points of contraflexure for continuous spans) can be used to estimate a starting web depth. The use of computer software will allow for the efficient refinement of this depth by completing preliminary girder designs at various increments of depth. The total girder weights computed for each depth can then be compared to determine the optimum web depth.

Optimizing the depth to minimize the weight is the most common goal for designers but may not reflect the most cost effective option. However, when comparisons are made between girders that have similar details (number of transverse stiffeners, flange and web transitions, etc.), the

lowest weight girder has historically provided the most cost-effective solution. This is true only if the girder details are well conceived and the designer is attentive to industry input on cost-effective details.

In some cases, the girder depth will be determined in order to optimize the appearance of the bridge. In most cases, more slender bridges are more attractive. Thus, shallower girders tend to be more appealing than deeper girders for the same span arrangement.

Variable depth girders are sometimes used to achieve a desired appearance, typically taking the form of haunched girders with deeper webs over the interior piers than near the center of the spans. The increased web depth in the negative moment regions does not significantly change the overall weight of the girder, because as the web depth increases, the required flange area decreases accordingly. Haunched girders have been fabricated using webs with a straight taper from the field splice at the inflection point to the interior, and with web tapers defined by a parabolic form. The straight taper is less appealing, but the fabrication cost of a parabolic haunch is somewhat higher since there is more scrap from the web plates and because the blocking is more difficult with the curved web geometry. When using variable depth webs, it is usually desirable for the interior pier sections to be at least 1.75 times as deep as the positive moment regions in order to provide a striking appearance. When this depth exceeds about 12 feet, however, shipping and fabrication requirements may dictate a less extreme haunch depth differential.

Haunched girders have also been used in the past to permit economical girder designs for long-span girders. When 50 ksi steel was the primary high-strength steel used in plate girders, haunched girders were almost a necessity for spans in excess of 400 feet. With the development of HPS 70W steel, experience has shown that girder spans can be lengthened to approximately 500 feet before haunched girders become economically superior.

Occasionally, the choice of girder depth will be controlled by depth limitations on the project. Steel girders can accommodate wide ranges of girder depth. As the girder depth decreases the overall girder weight will tend to increase because the flanges become less efficient in resisting moment. Very often, when the design is controlled by a limitation on the web depth, rather than strength, deflection will control the design. While a design controlled by depth is generally not efficient in terms of the girder strength, accommodating a deeper girder may have other cost ramifications on the overall project that are more severe than the penalty in girder weight. For example, an increase in girder depth may cause increased approach roadway quantities and right-of-way takings that will more than offset any girder cost savings.

5.3 Girder Plate Transitions

Once a girder depth is selected, a key factor in developing an economical design is to determine the appropriate number of flange transitions for the design. There are several rules of thumb that are helpful in settling on a girder design with acceptable proportions.

For a tangent structure, it is preferable to set the framing such that all girders in the cross section use an identical design. If this can be accomplished, the girder flange widths should remain

constant within field sections of the girder. This will permit the fabricator to slab and strip the flanges, as illustrated in Figure 6.

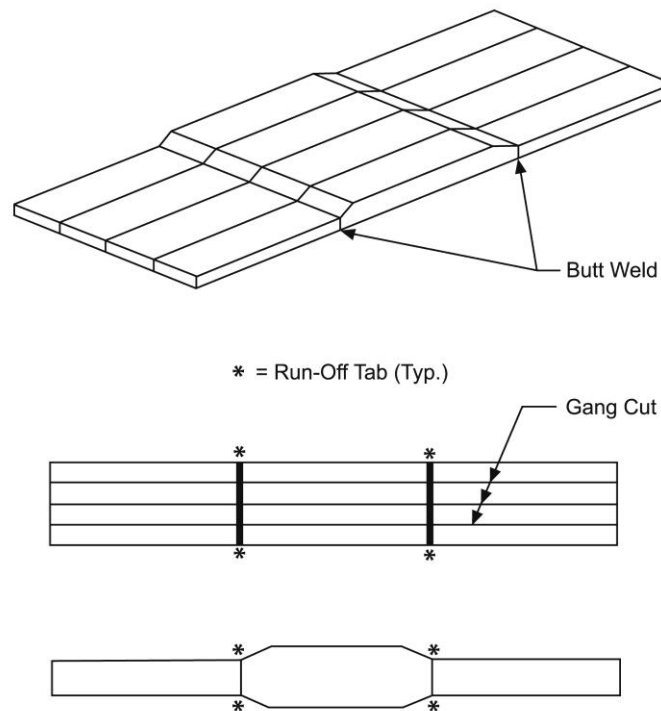

Figure 6 Sketches showing the slabbing and stripping process

Slabbing and stripping entails welding wide plates together and then cutting the flanges to the desired width from the wide plates. This process reduces fabrication costs by minimizing the number of run-off tabs (see Figure 7) that the fabricator needs to use and optimizing setup and handling time.

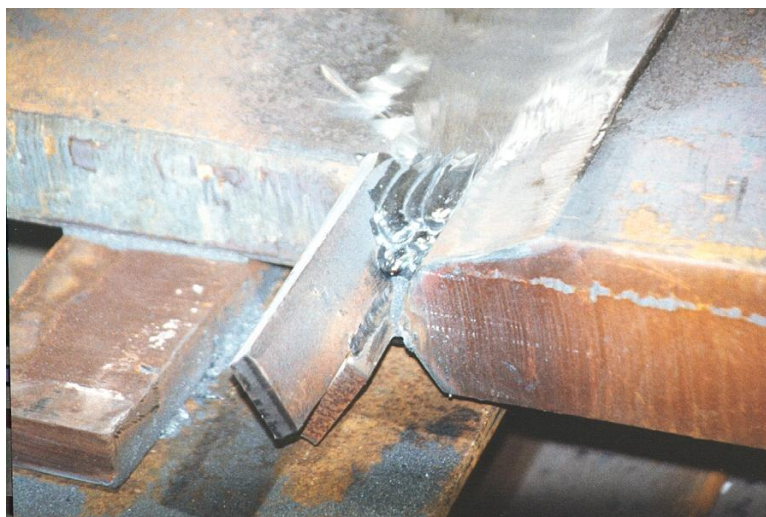

Figure 7 Photograph showing a run-off tab

Handling of the girders during fabrication and erection is an essential constructability issue and must be considered during design. The NSBA has suggested that the minimum flange width be greater than $L/85$, where L is the length of the girder field section. While this is a good rule of thumb, increasing the flange width beyond this minimum limit is often desirable, either to improve the lateral stability during fabrication and erection or to avoid flanges that are excessively thick.

Another rule of thumb is to limit flange transitions such that the smaller flange at a welded transition is no less than 50% of the area of the larger flange. This accomplishes two things. First, the bending stress gradient in the girder web due to the change in section properties does not become overly steep when this criterion is met. It has also been demonstrated in past designs that, if the flange transition results in greater than a 50% reduction in flange area, either the transition is not in the optimum location or an additional transition may prove to be economical.

One important design parameter in providing the appropriate number of welded flange transitions is to ensure that the fabrication cost associated with the butt welds does not exceed the material cost savings resulting from the flange transition. Each fabricator has their own parameters for determining the economy of welded flange transitions, which are considered proprietary information. However, there are two general approaches to determining the economy of welded transitions that have garnered some level of acceptance within the design community.

The first method (2) was developed in the 1970s and has served well over the years in avoiding excessive numbers of welded flange transitions, and uses equations based on flange areas and the yield strength of the steel. The equations are as follows:

For 36 ksi steel:

$$\text{Wt. Savings} \geq 300 + 25(\text{Area of smaller flange (in.}^2))$$

For 50 ksi steel:

$$\text{Wt. Savings} \geq 0.85(\text{Wt. Savings for 36 ksi})$$

For 100 ksi steel:

$$\text{Wt. Savings} \geq 0.65(\text{Wt. Savings for 36 ksi})$$

This approach has typically yielded transitions that have been economical and not subject to redesign. However, these equations were developed in an era when material was a larger percentage of the fabrication cost than was the labor cost. In recent years, this trend has changed to the point that the labor costs during fabrication are a much larger percentage of the total cost, and thus developing a different method for determining the economy of butt-welded transitions was needed. As a result of these changes, the AASHTO/NSBA Steel Bridge Collaboration (3) has developed a method for determining the economy of butt welded flange transitions that places a higher premium on the labor costs associated with fabrication than the earlier equations

do. Table 1 illustrates the suggested criteria for assessment of the economy of welded flange transitions.

It is prudent to consider both methods when assessing economy of welded plate transitions and leaning towards one or the other dependent upon the current market conditions. When factors exist that drive the steel material costs up, such as shortages of available steel scrap that were seen beginning in late 2002 and extending through 2004, the first method may provide a more accurate barometer of the economy of welded flange transitions. When plate costs are not being driven artificially high by market forces, the newer AASHTO/NSBA approach is more appropriate.

Table 1 Weight Saving Factor Per Inch of Plate Width for ASTM A709-Gr 50 Non-Fracture Critical Flanges Requiring Zone 1 CVN Testing

Multiply weight savings/inch x flange width (length of butt weld)							
Thinner Plate at Splice (inches)	Thicker Plate at Splice (inches)						
	1.0	1.5	2.0	2.5	3.0	3.5	4.0
1.0	70	70	70				
1.5		80	80	80	80		
2.0			90	90	90	70	70
2.5				100	100	80	80
3.0					110	90	90
3.5						110	110
4.0							130

Table Notes:

- Source: compiled from various fabricators, November 2001
- Weight factors for non-fracture critical Zone 2 material are the same as for Zone 1, as shown, except that in the shaded areas the factors should be reduced by 20%.
- For compression flanges where CVN testing is not required, the factors should be increased by about 10%, except the bottom two rows should increase by about 30%.
- For fracture critical material, the factors should be reduced by values between 10% and 25% depending upon the thickness.
- Materials other than A709 Gr. 50 will have values that will vary from those shown in the table.
- For intermediate thicknesses, interpolate between closest values.

Where equal plate thicknesses are joined, table values indicate welded splice cost in terms of steel weight. Steel cost per pound is based on unfabricated steel plate, not the bid price of fabricated, delivered steel.

5.4 Field Splice Location

In general, it is desirable to locate bolted field splices at the dead load inflection points of multiple-span continuous plate girders. This approach allows the size of the splices to be

minimized since the sections are generally small and the applied loads low near the inflection points. The inflection point areas are usually subjected to high live load stress ranges, but experience has shown that the stress ranges typically fall within the AASHTO LRFD (5th Edition, 2010) capacities for bolted splices.

For shorter span structures (with end spans less than 90 feet) it may be feasible to eliminate certain field splices, which can result in significant cost savings during erection. First, it may eliminate the need to use pier brackets or hold cranes over the interior supports during erection. Secondly, the labor to bolt the field splices is reduced, thereby lowering labor costs.

As span lengths increase, the need for pier brackets, falsework towers and/or hold cranes becomes more likely to insure erection of the girders without unacceptable overstresses. For spans longer than 100 feet, splices at the inflection points usually provide the optimum solution.

Shipping lengths may dictate the location and number of bolted field splices. Shipping lengths that are limited to approximately 120 feet will generally meet all fabrication and shipping requirements. Shipping pieces exceeding this length may limit the number of fabricators able to complete the work, may require expensive hauling permits and be restricted on the time and route for shipment. However, shipping pieces of approximately 160 feet have been fabricated and shipped. Depending upon the span arrangement, it may be advisable to place field splices at locations other than the dead load inflection points in order to meet fabrication and shipping requirements. Steel tub girders may require additional field splices due to heavier and wider members and to meet sweep restrictions for curved structures.

5.5 Girder Web Design

Once a web depth has been chosen, the approach to shear design must be determined. Transverse stiffeners can be provided to increase the shear capacity of the girder webs past the shear buckling capacity. This is accomplished by tension field action, which idealizes the stiffeners as vertical members of a “truss” with the diagonals comprised of tension fields, or the portion of the web that extends from the top of one stiffener to the bottom of the adjacent one. The tension field occurs as the girder web buckles along this line, and thus tension field action allows the designer to account for a portion of the post-buckling strength of the web when computing the shear capacity.

There are three basic options for shear design of the girder webs. A fully stiffened design entails designing the girder webs to be as thin as possible to meet the D/t limitations for girders without longitudinal stiffeners. The necessary shear capacity is achieved by providing enough transverse stiffeners to meet the shear demand due to dead and live loading. A minimum practical transverse stiffener spacing of 24 inches provides the upper limit to the shear capacity for a given web thickness and depth. Should that capacity not meet the demand, the web thickness is increased until the resistance exceeds the demand.

A partially stiffened design entails using a web 1/16 to 1/8 inch thicker than would be used for a fully stiffened design. This type of design will generally require transverse stiffeners in the first one or two bays between diaphragms at each end of each span.

An unstiffened design entails using a web thickness such that the shear buckling resistance of the web is equal to or greater than the factored shear demand. An unstiffened design would require only bearing stiffeners at the supports and diaphragm connection plates.

While the material costs do increase when unstiffened webs are used, there may be little change in the total fabrication cost of the fabricated girder. The amount of welding for the flange-to-web welds does not increase since minimum welds are generally adequate, thus limiting the increase in cost for the extra web material to the basic material cost of the steel. There may be a corresponding decrease in the size of the girder flanges when the thicker webs are used due to the increased web stiffness, and this decrease in flange material helps to offset the increased web material cost. Elimination of transverse stiffeners reduces labor costs associated with fabrication, fit-up and welding of the stiffener plates.

Other benefits associated with unstiffened webs are becoming increasingly important. If the girder is a painted design, minimizing the number of transverse stiffeners provides both a first cost benefit as well as a life cycle cost benefit by reducing the surface area requiring painting. The cost of bridge inspections may also be reduced since there are fewer details that require close inspection.

A fully stiffened design will provide the lightest possible web design, but will also have the highest unit fabrication cost of the three options. An unstiffened design will result in the heaviest design of the three options, but should have the lowest unit fabrication cost of the three. The partially stiffened option provides a trade-off between unit fabrication cost and material cost. Throughout the late 1980s and the 1990s, the predominant opinion throughout the fabrication industry was that partially stiffened girder webs provided the optimum solution. However, the percentage of total girder cost related to fabrication labor cost has increased relative to the percentage of cost associated with material. Consideration should be given to the use of unstiffened girder webs. However, partially stiffened webs, especially for spans that only require one or possibly two stiffeners per panel near the interior supports, should still prove to be cost effective.

When comparing the cost of additional stiffeners to the cost of the extra web material associated with an increase in thickness, the stiffener unit material cost should be assumed to be approximately 4 to 5 times the base material cost of the web to account for the additional fabrication required to weld the stiffeners to the girder.

Transverse stiffeners are important in minimizing the overall weight of the girders because they allow the web thickness to be minimized. However, there is a distinct cost associated with transverse stiffeners. There is a relatively large amount of welding associated with transverse stiffeners for the weight of steel involved, and the process is not as easily automated in the shop as are flange-to-web welds. Therefore, the increased stiffener cost must be balanced against the material savings associated with a reduction in web material.

The use of longitudinally stiffened girder webs becomes a consideration for web depths above 120 inches. For girder depths less than 120 inches, it has generally proven more economical to

increase the web thickness rather than to include longitudinal web stiffeners. Longitudinal stiffeners are generally placed at approximately $D/5$ from the compression flange. This forces a buckling node in the web at the longitudinal stiffener location, allowing the compression depth of the web to be decreased accordingly when computing a required thickness. The web thickness can generally be reduced proportionally to this reduction, significantly reducing the amount of web material used. The AASHTO LRFD (5th Edition, 2010) now provides a method by which to compute the optimum vertical location of the longitudinal stiffener as a function of D_c . Since D_c varies along the length of the girder as the sections vary, the engineer must make an informed judgment as to the vertical location of the longitudinal stiffener.

There has been vigorous debate within the fabrication industry and the design community as to whether longitudinally stiffened girder webs should ever be used. While the savings in web material can be significant, there are many undesirable details associated with longitudinal stiffeners that both increase the fabrication cost and result in less than desirable fatigue details. Thus, all aspects of design and fabrication should be considered before making the choice to use a longitudinally stiffened design.

5.6 Material Selection

Material selection is a critical aspect of economical girder design. Attention to using the best details is wasted if the proper materials are not chosen as the basis for the design.

The first, and most important, aspect of material selection is whether the steel will ultimately be painted or unpainted. For most cases, the preferred option for overall economy is to use an unpainted design. Unpainted designs have lower initial and life cycle costs since the steel does not require painting. Unpainted designs do not require future painting and are more environmentally friendly since any field painting or sandblasting of an existing paint system risks environmental impacts. However, there are locations where painted designs perform better over time, such as overpass bridges with limited vertical clearance over roadways on which de-icing salts are used, or in areas where the relative humidity is very high for a large percentage of the year. FHWA Technical Advisory T5140.22, "Uncoated Weathering Steel in Structures," defines the appropriate uses and limitations on the use of unpainted weathering steel designs. In some cases the use of weathering steel may be restricted for aesthetic reasons.

The next issue to be resolved is the choice of appropriate steels for the bridge. The most common bridge steels currently used are Grade 50, Grade 50W and HPS 70W. These steels are covered by either the ASTM A709 or the AASHTO M270 Specifications. If the ASTM designation is used, incorporation of the supplemental requirements regarding fracture toughness should be specified as necessary in the contract plans.

One facet of the decision regarding material selection rests on using an appropriate combination of materials within the girder. The most common design for plate girders with spans less than 200 feet long has been to use a homogeneous material grade throughout the girder. Currently, the most common steels used in bridge girders are Grades 50 and 50W. Homogeneous designs in spans shorter than 200 feet have proven to be reasonably cost-effective over time.

As the span lengths increase, the use of mixed steel designs may prove to be economical. A mixed steel design uses homogeneous material grades within each field piece, but may vary the material strength between field pieces. The most common type of mixed design would use a lower strength material (such as Grade 50) in the positive moment field pieces and higher strength material (such as Grade 70) in the negative moment regions, as shown in Figure 8.

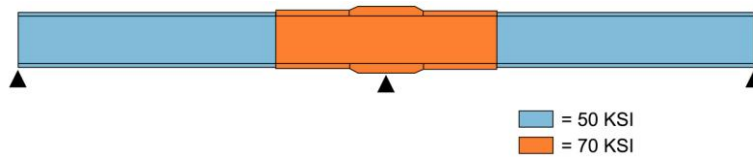

Figure 8 Diagram of a mixed steel I-girder

The use of hybrid designs (see Figure 9), or designs that mix steel grades within design sections, has gained favor within the design community as HPS 70W steel has become more available and accepted. HPS 70W was developed in the 1990s through a joint effort of the US Navy, the FHWA, AISI and NSBA. It exhibits higher yield strength (70 ksi) than other commonly-used bridge steels and has fracture toughness far superior to those achieved with non-HPS steels. The material cost differential of HPS 70W steel has varied in the early 2000s and the average differential has hovered around 15 cents per pound above the cost of Grade 50W. The improved fracture toughness of HPS 70W material can significantly reduce concerns about sudden fracture of highly stressed fracture critical members in highway bridges.

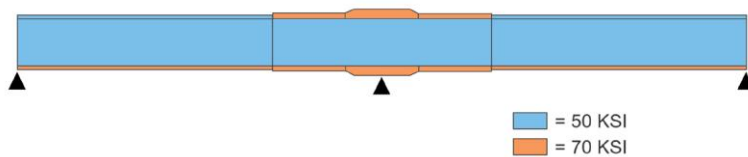

Figure 9 Diagram of a hybrid steel I-girder

As the benefits of HPS became evident, studies were performed by various entities to identify ways in which HPS 70W steel could be efficiently incorporated into bridge designs. One area of study focused on determining what span lengths and girder configurations lent themselves to the efficient use of HPS70W steel. A study funded by the FHWA was performed by HDR Engineering and researchers at the University of Nebraska at Lincoln (4, 5, and 6). Girder designs were prepared for homogeneous, mixed steel and various hybrid configurations at several span lengths to determine optimum ways to incorporate HPS 70W steel into plate girder designs. These studies found that using hybrid girder designs allowed the economical incorporation of HPS 70W steel into bridge girders. The optimum hybrid section used HPS 70W material in all the bottom flanges and in the top flanges in the negative moment regions of the girders. All girder webs and positive moment region top flange plates will use Grade 50 steel. If the design of the bottom flange plate in positive moment regions is governed by fatigue in lieu of strength, the use of HPS 70 material may not be cost effective. In general, the hybrid HPS girders can usually be optimized at a shallower depth than can Grade 50 girders. This more slender appearance is generally considered to provide favorable aesthetics.

6.0 DETAIL DESIGN ISSUES

6.1 Girder Cambers

Girder cambers are generally considered to be a by-product of the design. The girder sections are sized to meet the strength and service demands. These demands are dependent upon the span lengths, girder spacing, design live loading and the analysis method used. The cambers are then determined based on the deflections of the non-composite and long-term composite sections to determine the dead load cambers. The plans should also show the camber for the geometry of the roadway profile. This geometric camber assures that once the deck and barriers are placed, the profile of the top of the girder web will follow the deck geometry.

As refined methods of analysis become more common and higher material strengths are used, bridge girders may be more flexible than in the past. Since cross frames will tend to equalize deflections, keeping the same design for the exterior and interior girders will eliminate problems in predicting behavior under slab pours. It is increasingly important for the designer to pay close attention to cambers for both interior and exterior girders. Designing the interior and exterior girders with different inertias and dead load deflections can result in significant differences in camber between the girders.

Another condition the designer needs to be aware of is the relative deflection across the width of a curved structure. For curved girder bridges, a separate set of cambers should be shown in the design plans for each girder in the cross section. The cambers may vary significantly between adjacent girders due to the differing girder lengths and the overturning effects that occur in curved girder structures. Thus, the outside girder cambers are generally the largest magnitude on the bridge, with the cambers decreasing toward the inside of the curve.

Cambers also need to be considered carefully for skewed bridges. In Accordance with AASHTO, cross-frames are placed parallel to the supports for skews up to 20 degrees as discussed previously. For skews up to this limit, the connection plates can be welded to the girder webs without requiring costly fabrication measures. When the cross-frames are skewed parallel to the supports, there is minimal additional differential camber between girders along the cross-frame lines, and thus no special treatment is required.

For skews in excess of 20 degrees, AASHTO LRFD (5th Edition, 2010) requires that cross-frames be turned normal to the girder webs. This results in significant differential cambers between girders along the various cross-frame lines. The amount of differential camber, which is attributed to the effect of the bridge skew, the design camber plus allowable fabrication variances can be on the order of 2 or 3 inches on highly skewed bridges in the cross-frame lines closest to the support locations. The effect of this differential camber on the cross-frame designs needs to be considered by the designer (3).

Steel bridges, including straight and skewed bridges, should be detailed so they are plumb in the final condition. For steel girder bridges this means that the girder webs should be plumb after deck and barrier placement. This is accomplished by detailing the cross-frames to the final position. The girders are then installed to fit the cross-frames, requiring that for skewed bridges

they be “rolled” during fit-up so that they are out of plumb under steel dead loads. The design intent again needs to be spelled out clearly on the plans so that the fabricator and erector are aware of the intent when bidding and constructing the project.

6.2 Transverse Stiffeners – Web Stiffeners

Transverse stiffeners are typically welded to the girder web and the compression flange while a tight fit (a gap of up to $1/16$ inch between the stiffener and flange) is recommended for the tension flange, although some states may require welding to the flange. Stiffeners do not need to be in bearing with the tension flange. A 1 inch wide cope is typically provided at the top and bottom of the stiffener so the stiffener clears the flange-to-web welds. AASHTO LRFD (5th Edition, 2010) requires that the distance between the ends of the web-to-stiffener welds and the closest edge of the web-to-flange welds be greater than $4t_w$ but not exceed $6t_w$.

For transverse stiffeners in the stress reversal areas of continuous girders (surrounding the point of dead load contraflexure), a tight fit is suggested at both flanges since either flange may be in tension under varying live load conditions.

6.3 Transverse Stiffeners – Connection Plates

Connection plates for cross-frames/diaphragms are required by the AASHTO LRFD (5th Edition, 2010) to be rigidly attached to both the top and bottom girder flanges. Welded connections to the flanges are preferred from the standpoint of economical fabrication and should be designed to resist the lateral forces transmitted through the cross-frame connection. This creates a Category C fatigue detail at a flange subject to tension or stress reversal. Some agencies require that a Category B bolted detail be used to attach the connection plates to the girder flange, even though the detail is costly to fabricate. Another option at these locations is to increase the flange size to reduce the calculated stress range. In the case of bridges with low to moderate truck traffic, it is unusual to have the Category C details at the bottom tension flange control the design. For shorter span lengths, Category C fatigue details will generally govern the design in the positive moment regions.

It is preferable to detail transverse stiffeners in even inch widths (i.e., 6 or 7 inches, not 6.5 inches). This allows the fabricator to use bar stock for the stiffener plates. Bar stock can typically be obtained at a lower unit cost than plate steel, and the cost of cutting plate to the desired width adds cost into the stiffeners.

6.4 Bearing Stiffeners

Bearing stiffeners are required for all plate girders and for rolled beams where the reaction exceeds 75 percent of the shear capacity of the beam. The AASHTO LRFD (5th Edition, 2010) requires that the bearing stiffener extend as close as practical to the edge of the girder flange. Bearing stiffeners are required on both sides of the beam or girder web.

There are two basic design criteria for bearing stiffeners. First, the bearing stress between the stiffener and the bottom flange must not exceed the bearing capacity of steel on steel. This check

is performed based on the area of the bearing stiffeners only, accounting for the width removed by the chamfer at the base of the stiffener. The girder web is not assumed to contribute to the bearing capacity of the stiffener.

The second check is a compression check of the column consisting of the bearing stiffeners and a tributary length of the web equivalent to 18 times the web thickness.

In certain cases, it is advisable to include additional bearing stiffeners to assure that a relatively uniform bearing pressure is maintained on the bearings. This is of particular concern when large movements occur at a bearing or when the plan dimensions of the bearing become very large. In such cases, additional stiffeners should be provided adjacent to the main bearing stiffener to assure uniform bearing pressure at all positions of the girders relative to the bearing. The additional stiffeners do not need to extend for the full depth of the web.

6.5 Longitudinal Stiffeners

As noted previously, longitudinal stiffeners generally do not become economical until the web depth exceeds 120 inches or more.

Longitudinal stiffeners require careful detailing in order to avoid fatigue problems. Section 6.6.1.2.1 of the AASHTO LRFD (5th Edition, 2010) states that, “In regions where the unfactored permanent loads produce compression, fatigue shall be considered only if the compressive stress is less than twice the maximum tensile live load stress...” As long longitudinal attachments, the stiffener ends subjected to a net applied tensile stress result in stress risers that can be critical to fatigue performance of the girder. Longitudinal stiffener terminations in these areas should be detailed to provide at least a Category C detail by transitioning the fillet welded connection to the web from a fillet weld to a complete joint penetration weld near the end of the stiffener. The end of the stiffener should then be ground to a radius of 6 inches or greater to achieve a Category C detail at the end of the stiffener.

Where possible, longitudinal stiffeners should be one-sided and should be placed on the opposite side of the girder web from the transverse stiffeners. However, cross-frame connection plates will, out of necessity, intersect with the longitudinal stiffeners on all interior girders. Interruption of the longitudinal stiffeners would result in Category E fatigue details in zones of applied tensile stress. The longitudinal stiffeners, therefore, should run continuous for their full length and the cross-frame connection plates should be interrupted at the longitudinal stiffener as shown in Figure 10. Care should also be given to any butt welds connecting stiffener sections.

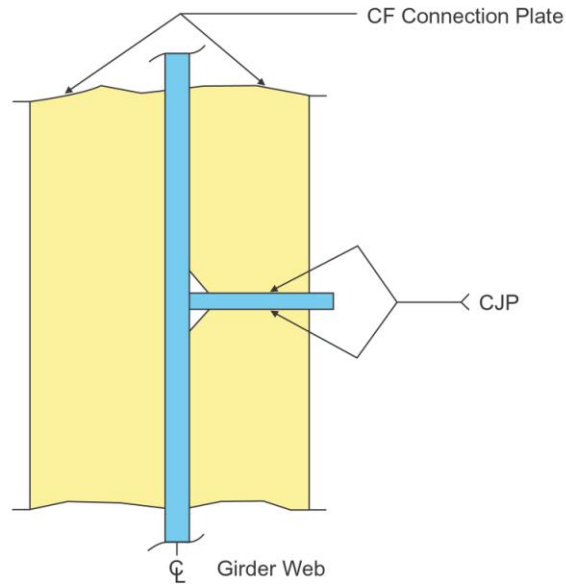

Figure 10 Sketch of a longitudinal and transverse stiffener intersection detail

6.6 Lateral Bracing

Lateral bracing can fulfill an important role in the design and erection of a plate girder bridge, but it also adds cost. The primary purpose of lateral bracing for plate girder bridges is to stiffen the bridge laterally in order to limit lateral deflections. Lateral bracing should be avoided whenever possible, but there are certain situations where its use may be advantageous, such as providing stability for cantilevered sections in erection of long spans.

Lateral bracing checks required by AASHTO LRFD (5th Edition, 2010) generally provide a check of the bridge in its final constructed condition to assure that lateral stresses in the bottom girder flanges are not overstressed due to lateral loads in combination with primary bending stresses. History has shown that a properly proportioned girder will rarely require lateral bracing in the final condition.

Lateral bracing may be considered as a tool to assure proper erection of the bridge and to stiffen the bridge against excessive lateral movement prior to deck placement. As a general rule, spans less than 200 feet will not require lateral bracing for successful erection of the girders. Spans over 200 feet and all curved spans should be checked for lateral stability during erection and prior to deck placement.

When lateral bracing is indicated, it does not necessarily need to be provided for the full length of the bridge. Very often, providing bracing for a few cross-frame bays on either side of the interior piers will stiffen the structure adequately to permit safe erection and deck placement. The stability of the girders prior to completion of the framing erection is primarily the responsibility of the contractor. However, the designer should assess the site conditions and provide for lateral bracing to facilitate the erection if engineering judgment warrants this. Conditions that would lead to the designer requiring lateral bracing would include very long spans (over 300 feet) or very high structures on which high winds are a significant concern.

It is advisable that the lateral bracing not be included in the structural analysis of the girders. When included into a refined analysis, the live load plus dead load forces carried by the lateral bracing members can exceed those due to wind load. Since many agencies do not want the primary load-carrying capacity of their bridges to be dependent upon the integrity of the lateral bracing, lateral bracing should be designed to carry wind loads only. End connections should then be detailed with oversized holes designed to carry the wind loads only. Slip should be permitted to occur under loads larger than the wind load to assure that the lateral bracing does not participate in the load-carrying capacity of the girders.

Lateral bracing attached to the girder bottom flange will participate in carrying both dead and live load stresses. Lateral bracing can also be placed at the top flange in order to minimize its participation in carrying superimposed dead load and live load stresses. However, if top lateral bracing is used, details should be developed so that the bracing will not interfere with the form support angles that are typically used for the installation of stay-in-place metal deck forms.

7.0 REFERENCES

1. AASHTO, (2010). AASHTO LRFD Bridge Design Specifications; 5th Edition, AASHTO, Washington D.C.
2. United States Steel (USS), *Fabrication – Its Relation to Design, Shop Practices, Delivery, and Costs*, Pittsburgh, PA, 1981.
3. AASHTO/NSBA Steel Bridge Collaboration, *AASHTO Publication GDC-2, Guidelines for Design for Constructibility*, Chicago, IL, 2003.
4. Horton, R., Power, E., Van Ooyen, K. & Azizinamini, A., *High Performance Steel Cost Comparison Study*, Conference Proceedings, Steel Bridge Design and Construction for the New Millennium with emphasis on High Performance Steel, Nov. 30-Dec. 1, 2000.
5. Horton, R., Power, E., Van Ooyen, K., Azizinamini, A. & Krupicka, G., *High Performance Steel Cost Comparison Study – Phase II*, Conference Proceedings, 2002 FHWA Steel Bridge Conference For The Western United States, Dec. 12-Dec. 13, 2002.
6. Horton, R., Power, E., Azizinamini, A. & Krupicka, G., *High Performance Steel Cost Comparison Study – Box Girder*, Conference Proceedings, 2004 FHWA Steel Bridge Conference, San Antonio, Texas, Dec. 2004.