

**FINAL REPORT
FEBRUARY 2002**

REPORT NO. 01-27

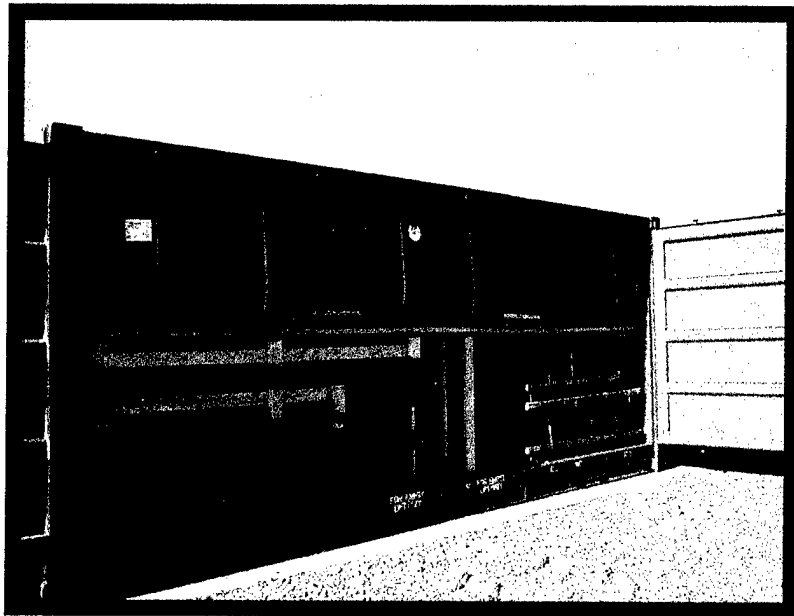

**2,000- POUND GUIDED BOMB UNITS,
GBU-31(V) 1/B, COMPLETE ROUND
TP-94-01,
“TRANSPORTABILITY TESTING PROCEDURES”**

Prepared for:

Program Management Office
USAF Afloat Prepositioned Fleet
Ogden Air Logistics Center
00-ALC/WMR
6043 Elm Lane
Bldg 1246, Rm 9
Hill AFB, UT 84056

Distribution Unlimited:



**VALIDATION ENGINEERING DIVISION
MCALESTER, OKLAHOMA 74501-9053**

20020604 079

AVAILABILITY NOTICE

A copy of this report will be furnished each attendee on automatic distribution. Additional copies or authority for reprinting may be obtained by written request from:

Director
U.S. Army Defense Ammunition Center
ATTN: SOSAC-DEV
1 C Tree Road, Bldg. 35
McAlester, OK 74501-9053

Reports may also be downloaded or viewed in PDF format from our web site at:

<http://www/dac.army.mil/DEV/TestReports>

DISTRIBUTION INSTRUCTIONS

Destroy this report when no longer needed. Do not return.

Citation of trade names in this report does not constitute an official endorsement.

The information contained herein will not be used for advertising purposes.

ABSTRACT

The U.S. Army Defense Ammunition Center (DAC), Validation Engineering Division, (SOSAC-DEV), was tasked by the Program Management Office USAF Afloat Prepositioned Fleet to conduct transportability testing on the 2,000-pound guided bomb units GBU-31(V) 1/B, in a side-opening container in accordance with the procedures specified in AMC Drawing 19-48-8722. The load was tested in accordance with TP-94-01, "Transportability Testing Procedures." Based on our review and testing, the loading and bracing procedures specified in AMC Drawing 19-48-8722, as tested 17-18 October 2001, are adequate for the transport of ammunition.

The JDAM container, as currently designed, does efficiently interface with intermodal transport. The deficiencies in the JDAM container design are:

a. The container does not have sufficient structural strength to enable one JDAM container to be stacked directly on top of another JDAM container. This requires additional wood dunnage to support the upper JDAM container when transporting JDAM containers two-high in an intermodal container.

b. The JDAM container does not have sufficient strength, or a flat and smooth surface area, on the ends to allow for loading of one JDAM against another. Therefore, wood dunnage must be used to separate rows of JDAM containers.

Prepared by:

Reviewed by:

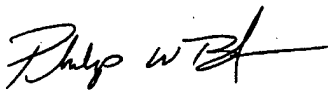

PHILIP W. BARICKMAN
Lead Validation Engineer

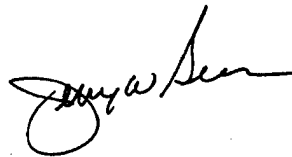

JERRY W. BEAVER
Chief, Validation Engineering Division

U.S. ARMY DEFENSE AMMUNITION CENTER

VALIDATION ENGINEERING DIVISION
MCALESTER, OK 74501-9053

REPORT NO. 01-27

2000-Pound Guided Bomb Units,
GBU-31(V) 1/B, Complete Round
TP-94-01, "Transportability Testing Procedures"

TABLE OF CONTENTS

PART	PAGE NO.
1. INTRODUCTION	1-1
A. BACKGROUND.....	1-1
B. AUTHORITY.....	1-1
C. OBJECTIVE	1-1
D. CONCLUSION	1-1
2. ATTENDEES.....	2-1
3. TEST EQUIPMENT.....	3-1
4. TEST PROCEDURES	4-1
A. RAIL TEST	4-1
B. ON/OFF ROAD TEST	4-2
1. HAZARD COURSE	4-2
2. ROAD TRIP	4-3
3. PANIC STOPS.....	4-4
4. WASHBOARD COURSE	4-4
C. OCEAN-GOING VESSEL TEST (STS).....	4-4
5. TEST RESULTS	5-1
A. RAIL TEST	5-1
B. ON/OFF ROAD TEST	5-4
1. HAZARD COURSE.....	5-4
2. ROAD TRIP.....	5-6
3. PANIC STOPS.....	5-6
4. WASHBOARD COURSE.....	5-6
C. OCEAN-GOING VESSEL TEST (STS).....	5-6
6. DRAWINGS.....	6-1

PART 1 – INTRODUCTION

A. BACKGROUND. The U.S. Army Defense Ammunition Center (DAC), Validation Engineering Division (SOSAC-DEV), was tasked by the Program Management Office USAF Afloat Prepositioned Fleet to conduct transportability testing on the 2,000-pound guided bomb units, GBU-31(V) 1/B, using the loading procedures specified in AMC Drawing 19-48-8722. The 2,000-pound guided bomb units, GBU-31(V) 1/B container load was tested in accordance with TP-94-01, "Transportability Testing Procedures."

B. AUTHORITY. This test was conducted IAW mission responsibilities delegated by the U.S. Army Operations Support Command (OSC), Rock Island, IL. Reference is made to the following:

1. AR 740-1, 15 June 2001, Storage and Supply Activity Operation.
2. IOC-R, 10-23, Mission and Major Functions of USADAC, 7 January 1998.

C. OBJECTIVE. The objective of the testing was to validate the loading and bracing procedures specified in AMC Drawing 19-48-8722, Loading and Bracing in Side Opening ISO Containers of 2,000-Pound Guided Bomb Units GBU-31 (V) 1/B, Complete Round.

D. CONCLUSION. Based on our review and testing, the loading and bracing procedures specified in AMC Drawing 19-48-8722, as tested 17-18 October 2001, are adequate for the transport of ammunition. Deficiencies in the JDAM container design are detailed in the Abstract.

PART 2 - ATTENDEES

ATTENDEE

MAILING ADDRESS

Philip Barickman
General Engineer
DSN 956-8992
(918) 420-8992

Director
U.S. Army Defense Ammunition Center
ATTN: SOSAC-DEV
1 C Tree Road, Bldg. 35
McAlester, OK 74501-9053

Patrick Dougherty
Industrial Engineer
DSN 956-8225
(918) 420-8225

Director
U.S. Army Defense Ammunition Center
ATTN: SOSAC-DET
1 C Tree Road, Bldg. 35
McAlester, OK 74501-9053

PART 3 - TEST EQUIPMENT

1. 2,000-Pound Guided Bomb Units GBU-31(V), 1/B Complete Round

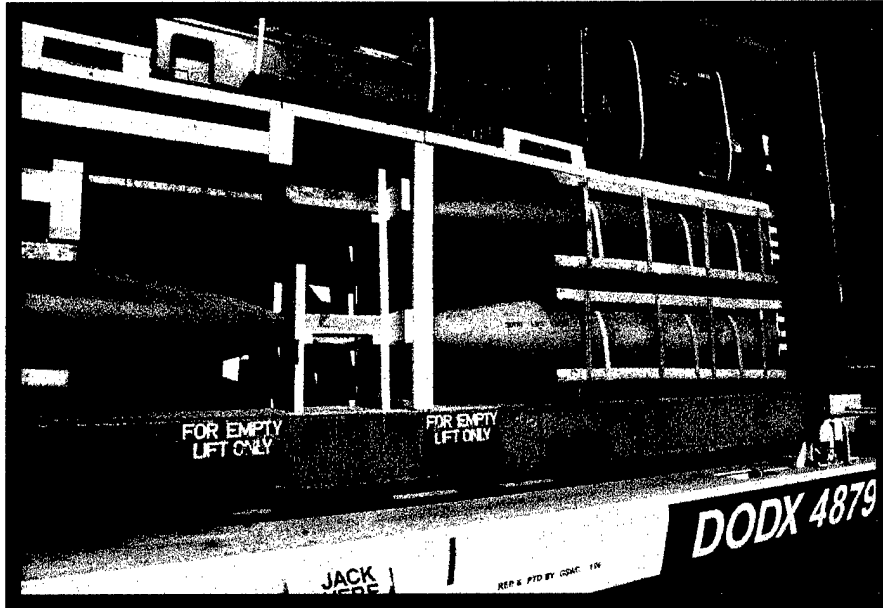

Photo1. Specimen load in intermodal side-opening container on a railroad flatcar.

2. Intermodal Side-Opening Container

Date of Manufacture: 06/89

Manufactured by Containertech, Hamburg, Germany

ID # USAF 002 2053

Maximum Gross Weight: 52,910 pounds

Tare Weight: 6,050 pounds

3. Truck, Tractor

5-Ton, 6 X 6

Model #: XM818 wo/w

ID #: 05E-37770-0124-12331

Weight: 19,260 pounds

PART 4 - TEST PROCEDURES

The test procedures outlined in this section were extracted from TP-94-01, "Transportability Testing Procedures," July 1994, for validating tactical vehicles and outloading procedures used for shipping munitions by tactical or commercial truck, railcar, and ocean-going vessel.

The rail impact test was conducted with the intermodal container with payload secured directly to the railcar. Inert (non-explosive) items were used to build the load. The test load with MK79 bomb pallets and CNU 589/E fin container was prepared using the blocking and bracing procedures proposed for use with munitions (see Part 6 for procedures). The weight and physical characteristics (weights, physical dimensions, center of gravity, etc.) of the test loads were identical to live (explosive) ammunition.

A. RAIL TEST. RAIL IMPACT TEST METHOD. The test load or vehicle will be secured to a flatcar. The equipment needed to perform the test will include the specimen (hammer) car, four empty railroad cars connected together to serve as the anvil, and a railroad locomotive. The anvil cars will be positioned on a level section of track with air and hand brakes set and with draft gears compressed. The locomotive unit will push the specimen car toward the anvil at a predetermined speed, then disconnect from the specimen car approximately 50 yards away from the anvil cars allowing the specimen car to roll freely along the track until it strikes the anvil. This will constitute an impact. Impacting will be accomplished at speeds of 4, 6, and 8.1 mph in one direction and at a speed of 8.1 mph in the reverse direction. The speeds will have a tolerance of plus .5 mph and minus zero mph. The impact speeds will be determined by using an electronic counter to measure the time for the specimen car to traverse an 11-foot distance immediately prior to contact with the anvil cars (see Figure 1).

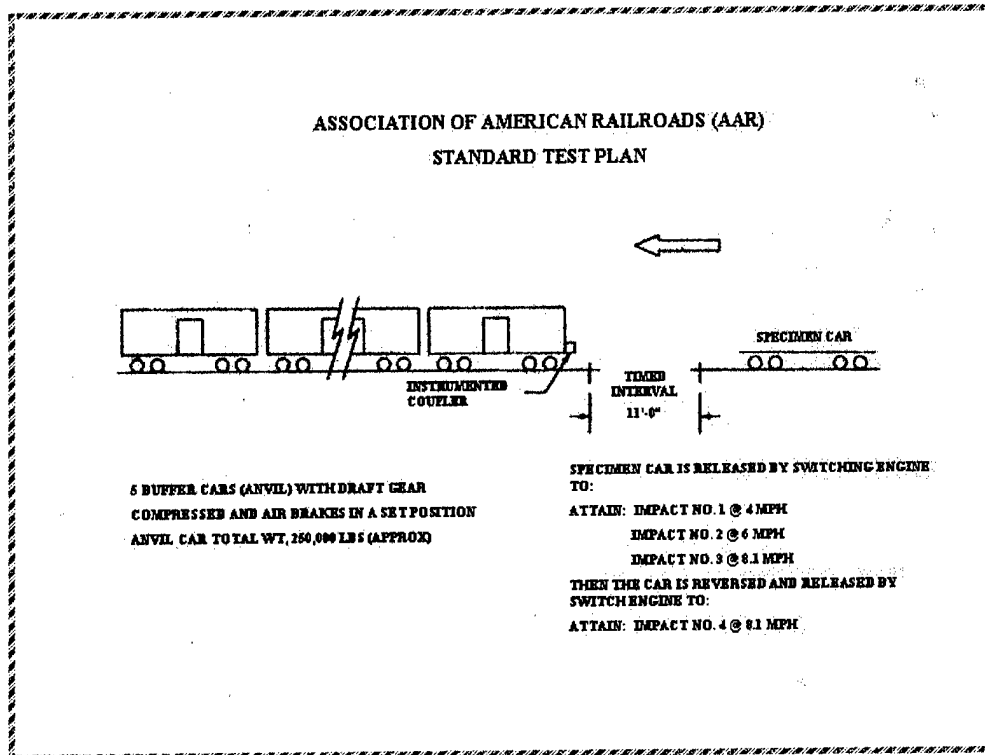

Figure 1. Rail Impact Sketch

B. ON/OFF ROAD TESTS.

1. **HAZARD COURSE.** The test load or vehicle will be transported over the 200-foot-long segment of concrete-paved road consisting of two series of railroad ties projecting 6 inches above the level of the road surface. The hazard course will be traversed two times (see Figure 2).

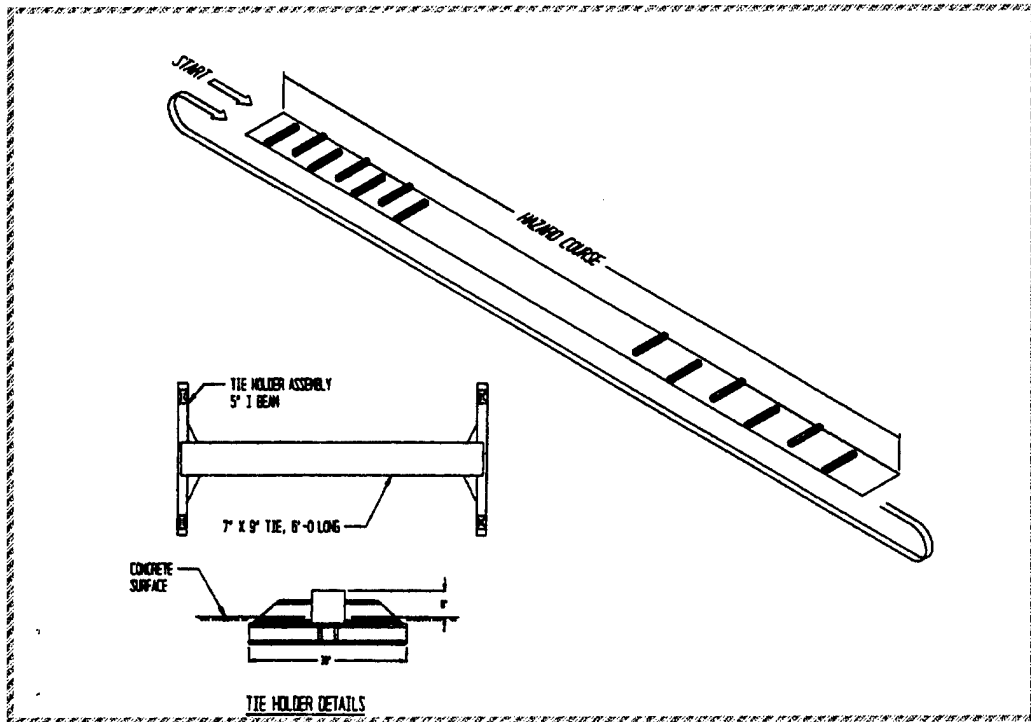

Figure 2. Hazard Course Sketch

- a. The first series of ties are spaced on 10-foot centers and alternately positioned on opposite sides of the road centerline for a distance of 50 feet.
- b. Following the first series of ties, a paved roadway of 75 feet separates the first and second series of railroad ties.
- c. The second series of ties are spaced on 8-foot centers and alternately positioned on opposite sides of the road centerline for a distance of 50 feet.
- d. The test load is driven across the hazard course at speeds that will produce the most violent vertical and side-to-side rolling reaction obtainable in traversing the hazard course (approximately 5 mph).

2. ROAD TRIP. The test load or vehicle will be transported for a distance of 30 miles over a combination of roads surfaced with gravel, concrete, and asphalt. The test route will include curves, corners, railroad crossings and stops and starts. The test load or vehicle will travel at the maximum speed for the particular road being traversed, except as limited by legal restrictions.

3. **PANIC STOPS.** During the road trip, the test load or vehicle will be subjected to three (3) full airbrake stops while traveling in the forward direction and one in the reverse direction while traveling down a 7-degree grade. The first three stops are at 5, 10, and 15 mph while the stop in the reverse direction is approximately 5 mph. This testing will not be required if the Rail Impact Test is performed.

4. **WASHBOARD COURSE.** The test load or vehicle will be driven over the washboard course at a speed that produces the most violent response in the vertical load direction.

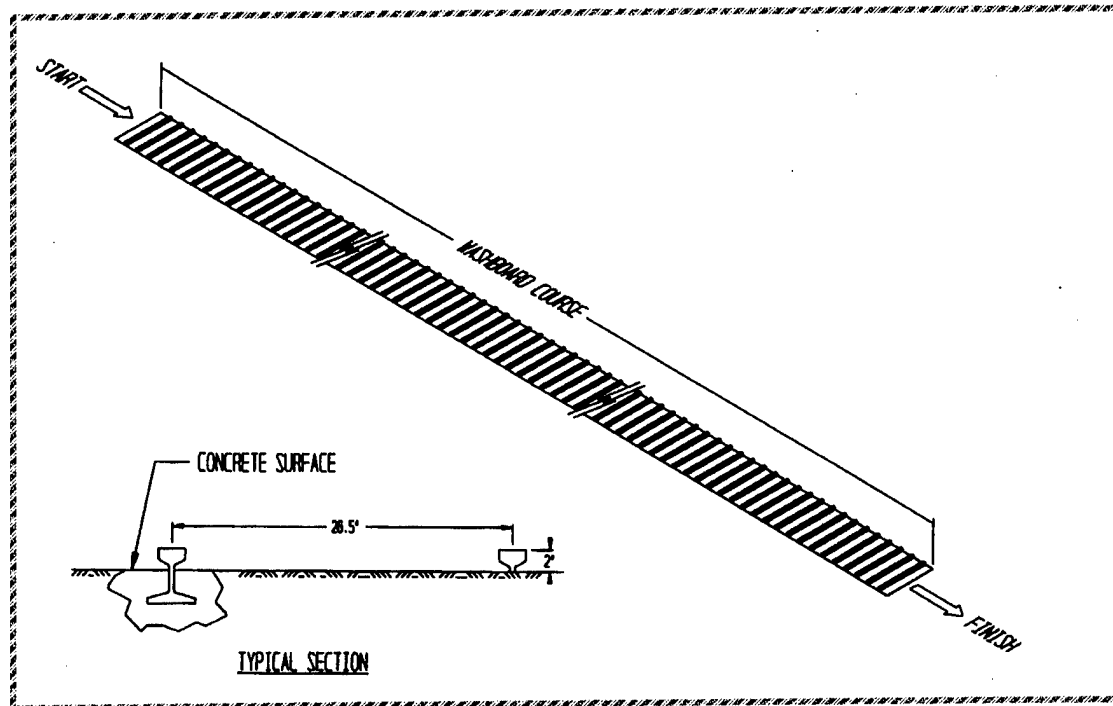

Figure 3. Washboard Course Sketch

C. OCEAN-GOING VESSEL TEST. SHIPBOARD TRANSPORTATION

SIMULATOR (STS) TEST METHOD. The test load will be secured inside an ISO container and will be positioned onto the STS and securely locked in place using the cam locks at each corner. Oscillation of the STS will be started and rotate to an angle of 30 degrees plus or minus 2 degrees, either side of center

and at a frequency of 2 cycles-per-minute (30 seconds plus or minus 2 seconds total roll period). This frequency shall be observed for apparent defects that could cause a safety hazard. The frequency of oscillation will then be increased to 4 cycles-per-minute (15 seconds plus or minus 1 second per roll period) and the apparatus operated a period of two (2) hours. An inspection of the load will then be conducted. If the inspection does not indicate an impending failure, the frequency of oscillation will be further increased to 5 cycles-per-minute (12 seconds plus or minus 1 second-cycle time), and the apparatus operated for four (4) hours. The operation does not necessarily have to be continuous, however, no change or adjustments to the load or load restraints shall be permitted at any time during the test. After once being set in place, the test load (specimen) shall not be removed from the apparatus until the test has been completed or is terminated.

PART 5 - TEST RESULTS

Payload: 2,000-Pound Guided Bomb Units GBU-31(V) 1/B,
Complete Round
Gross Weight: 36,225 pounds
Testing Date: 17-18 October 2001

A. RAIL TEST.



Photo 2. Side-opening container w/GBU-31(V) 1/B on a railroad flatcar.

Description	Weight
Flatcar Number: DODX 48797	62,700 lbs.
Intermodal Container with 2,000 # GBU-31(V) 1/B	36,225 lbs.
M1 Flatrack with MLRS Pods	28,265 lbs.
Intermodal container with Cordstrap Restraint	40,850 lbs.
Total Specimen Wt.	
Buffer Car (four cars)	250,000 lbs.

Figure 4:

Remarks: Figure 4 lists the test components and weights of the items used during rail impact tests. The intermodal container with the test load was secured to the container-on-flatcar (COFC). The M1 flatrack and intermodal container with Cordstrap were used as ballast.

Impact Number	Velocity (mph)
1	4.1
2	6.2
3	8.4
4	8.4

Figure 5:

Remarks:

1. Figure 5 lists the average speeds of the specimen car immediately prior to impact with the anvil. Impact # 4 is the reverse impact.
2. Center portion of the load moved in the direction of impact 0.25 inches during Impact # 2.
3. Center portion of the load moved in the direction of impact 0.25 inches during Impact # 3.
4. No damage to the blocking or bracing occurred during testing.

B. ON/OFF ROAD TEST.

1. HAZARD COURSE.



Photo 3. Side-opening container w/GBU-31(V), 1/B during Hazard Course testing.

Pass No.	Elapsed Time	Velocity (mph)
1	24 Seconds	6.1
2	25 Seconds	5.8
3	24 Seconds	6.1
4	25 Seconds	6.3

Figure 6:

Remarks:

1. Figure 6 lists the average speeds of the test load through the Hazard Course.
2. Load moved 0.5 inches. The load returned to the original starting point prior to the beginning of the rail impact testing.
3. No damage to the blocking or bracing occurred during testing.
4. Passes # 3 and 4 occurred after the Road Trip.

2. **ROAD TRIP:** No excessive movement of the load or damage to the blocking or bracing.

3. **PANIC STOPS:** Testing was not required since the 2000-Pound Guided Bomb Units GBU-31(V) 1/B, Complete Round was rail impact tested.

4. **WASHBOARD COURSE:** No excessive movement of the load or damage to the blocking or bracing.



Photo 4. Side-opening container w/ GBU-31(V), 1/B during Washboard Course testing.

**C. OCEAN-GOING VESSEL TEST. SHIPBOARD TRANSPORTATION
SIMULATOR (STS) TEST METHOD.**



Photo 5. Side-opening container w/GBU-31(V), 1/B during STS testing.

Remarks:

1. The intermodal container with the test load was removed from the trailer and positioned on the STS tester.
2. No excessive movement of the load or damage to the blocking or bracing.
3. Final examination following testing revealed chafing on the intermodal container and the JDAM container due to contact during testing. Note "O" in AMC Drawing 19-48-8722 allows, as an option, the use of anti-chafing material that may prevent the chafing damage.

PART 6 – DRAWINGS

The following drawing represents the load configuration that was subjected to the test criteria. The drawing can be accessed at:

<http://www.dac.army.mil/DET/dapam/toc.html>

APPROVED BY
BUREAU OF EXPLOSIVES

Jan 4/01

DATE 11/4/01



LOADING AND BRACING* IN SIDE OPENING ISO CONTAINERS OF 2,000 POUND GUIDED BOMB UNITS GBU-31(V) 1/B, COMPLETE ROUND

INDEX

ITEM	PAGE(S)
TYPICAL LOADING PROCEDURES (12 COMPLETE ROUNDS) - - - - -	2
GENERAL NOTES AND MATERIAL SPECIFICATIONS - - - - -	3
PALLET UNIT AND CONTAINER DETAILS - - - - -	4
DETAILS (12 COMPLETE ROUNDS) - - - - -	5-7
TYPICAL LOADING PROCEDURES (8 COMPLETE ROUNDS) - - - - -	8
DETAILS (8 COMPLETE ROUNDS) - - - - -	9-12

* LOADING AND BRACING SPECIFICATIONS SET FORTH WITHIN THIS DRAWING ARE APPLICABLE TO LOADS THAT ARE TO BE SHIPPED BY TRAILER/CONTAINER-ON-FLATCAR (T/COFC) RAIL CARRIER SERVICE. THESE SPECIFICATIONS MAY ALSO BE USED FOR LOADS THAT ARE TO BE MOVED BY MOTOR OR WATER CARRIERS.

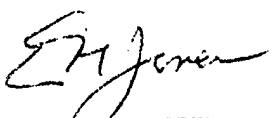
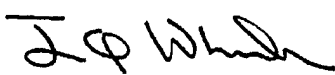
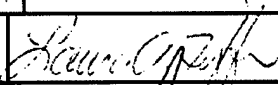
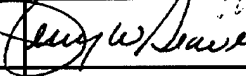
U.S. ARMY MATERIEL COMMAND DRAWING

APPROVED, U.S. ARMY OPERATIONS SUPPORT COMMAND 	ENGINEER	BASIC		DO NOT SCALE			
		REV.		WEBSITE: HTTP://WWW.DAC.ARMY.MIL			
	TECHNICIAN	BASIC	PATRICK DOUGHERTY	APRIL 2001			
		REV.					
	DRAFTSMAN	BASIC					
		REV.					
APPROVED BY ORDER OF COMMANDING GENERAL, U.S. ARMY MATERIEL COMMAND 	TRANSPORTATION ENGINEERING DIVISION			CLASS	DIVISION	DRAWING	FILE
	VALIDATION ENGINEERING DIVISION			19	48	8722	SP15M16
	ENGINEERING DIRECTORATE						
U.S. ARMY DEFENSE AMMUNITION CENTER							

PROJECT SP 421-01

INDICATES CNU-589/E WITH TWO GUIDANCE SETS. NOTE: TWO CNU CONTAINERS SHOWN IN PHANTOM LINES FOR CLARITY.

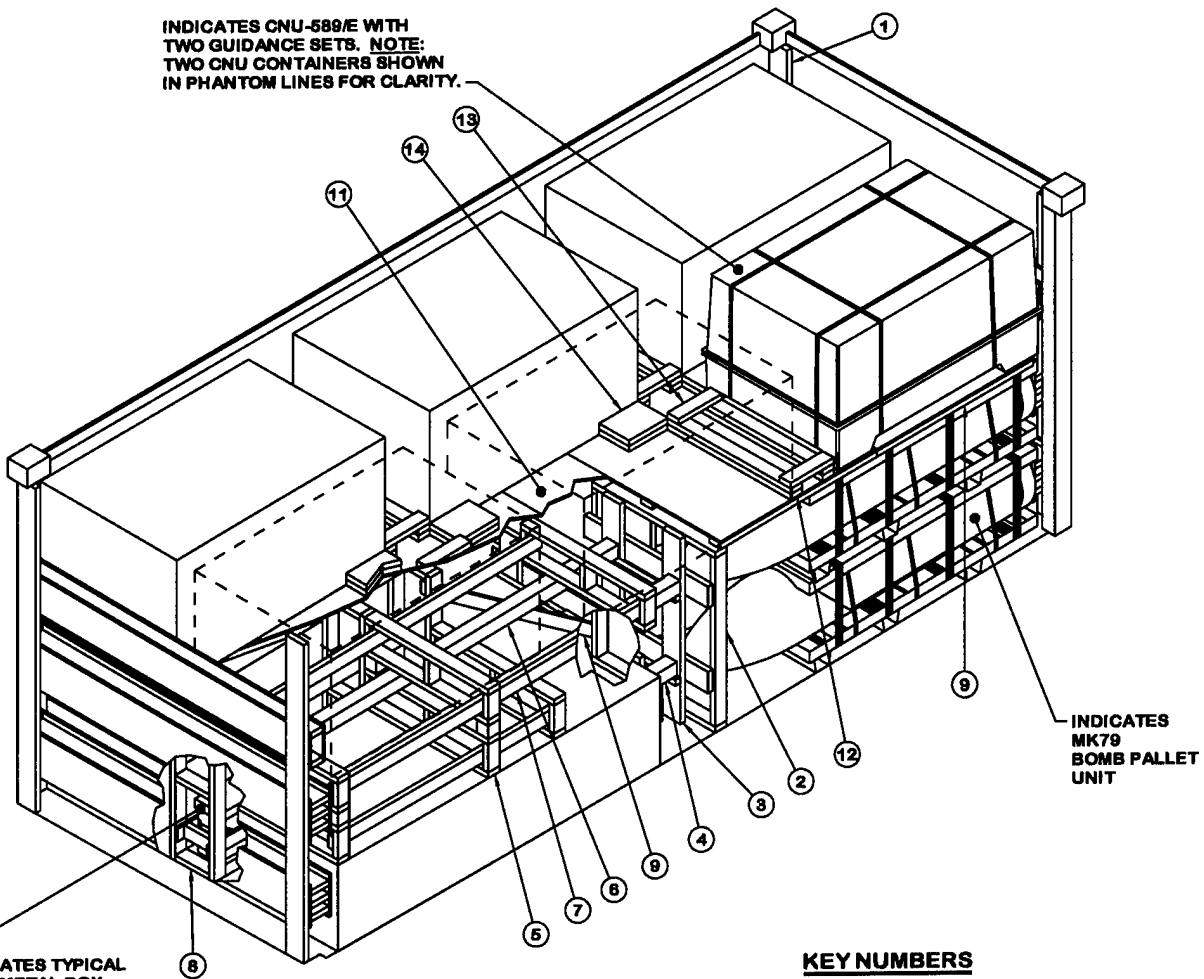

INDICATES TYPICAL M548 METAL BOX OR TYPICAL FIBERBOARD BOX

ISOMETRIC VIEW

KEY NUMBERS

- ① END BLOCKING ASSEMBLY A (2 REQD). SEE DETAIL ON PAGE 5.
- ② DECKING SUPPORT ASSEMBLY A (2 REQD). SEE DETAIL ON PAGE 6. POSITION AT THE FRONT END OF TWO HIGH STACK OF MK79 BOMB PALLET UNITS AS SHOWN.
- ③ CENTER GATE A (2 REQD). SEE DETAIL ON PAGE 6.
- ④ STRUT A, 4" X 4" BY CUT TO FIT (REF: 12-1/2") (4 REQD). POSITION BETWEEN THE CENTER GATES. TOENAIL TO THE CENTER GATES W/2-12d NAILS AT EACH END. SEE THE "BEVEL CUT" DETAIL ON PAGE 7.
- ⑤ STRUT SUPPORT ASSEMBLY (2 REQD). SEE DETAIL ON PAGE 6. POSITION ASSEMBLY ON TOP OF ONE HIGH STACK OF MK79 BOMB PALLET UNITS AGAINST THE END BLOCKING ASSEMBLY. TOENAIL TO THE END BLOCKING ASSEMBLY W/4-12d NAILS.
- ⑥ STRUT B, 4" X 4" BY CUT TO FIT (REF: 9'-8") (4 REQD). POSITION BETWEEN THE CENTER GATE AND THE END BLOCKING ASSEMBLY. TOENAIL TO THE CENTER GATE, STRUT SUPPORT ASSEMBLY AND THE END BLOCKING ASSEMBLY W/2-12d NAILS AT EACH LOCATION. SEE THE "BEVEL CUT" DETAIL ON PAGE 7.
- ⑦ DECKING SUPPORT ASSEMBLY B (2 REQD). SEE DETAIL ON PAGE 7. POSITION ON TOP OF STRUT "B". THE SUPPORT ASSEMBLY WILL BE POSITIONED AGAINST THE END BLOCKING ASSEMBLY AS SHOWN. TOENAIL TO THE STRUTS AND THE END BLOCKING ASSEMBLY W/2-12d NAILS AT EACH LOCATION.
- ⑧ CRIB FILL A (2 REQD). SEE DETAIL ON PAGE 7. POSITION AGAINST THE END BLOCKING ASSEMBLY. TOENAIL TO THE END BLOCKING ASSEMBLY AND THE STRUT SUPPORT ASSEMBLY W/2-12d NAILS AT EACH LOCATION AS APPLICABLE.
- ⑨ BRACE, 2" X 4" BY CUT TO FIT (REF: 43-1/2") (2 REQD). POSITION DIAGONALLY BETWEEN CRIB FILL "A" ASSEMBLY AND DECKING SUPPORT ASSEMBLY "A". NAIL W/2-10d NAILS AT EACH END.

(KEY NUMBERS CONTINUED)

- ⑩ DECKING ASSEMBLY A (4 REQD). SEE DETAIL ON PAGE 7. POSITION ON TOP OF MK79 BOMB PALLET UNITS AND DECKING SUPPORT ASSEMBLIES. NAIL THROUGH THE DECKING STRINGERS INTO THE DECKING SUPPORT ASSEMBLIES W/1-12d NAIL AT EACH LOCATION AND NAIL TO THE CRIB FILL ASSEMBLIES W/2-12d NAILS AS APPLICABLE.
- ⑪ DECKING ASSEMBLY B (1 REQD). SEE DETAIL ON PAGE 7. POSITION ON TOP OF DECKING SUPPORT ASSEMBLIES BETWEEN DECKING ASSEMBLIES "A". NAIL THROUGH THE DECKING STRINGERS INTO THE DECKING SUPPORT ASSEMBLIES W/1-12d NAIL AT EACH LOCATION.
- ⑫ STOP PIECE, 2" X 4" X 40" (DOUBLED) (8 REQD). POSITION AGAINST THE BASE OF THE CNU-589/E CONTAINERS AS SHOWN. NAIL THE FIRST PIECE THROUGH DECKING ASSEMBLY INTO THE STRINGERS W/2-12 NAILS AT EACH LOCATION. LAMINATE THE SECOND BOARD TO THE FIRST W/4-10d NAILS. NOTE: THE CNU-589/E CONTAINERS MUST BE POSITIONED AGAINST THE END BLOCKING ASSEMBLIES AT EACH END OF THE CONTAINER. THE TWO CNU CONTAINERS IN THE MIDDLE OF THE LOAD MUST BE CENTERED. THE CONTAINERS MAY BE PRE-POSITIONED FOR LOCATING STOP PIECES AND THEN REMOVED FOR EASE OF NAILING.
- ⑬ TIE PIECE, 2" X 4" BY CUT TO FIT (REF: 17-1/2") (8 REQD). POSITION LONGITUDINALLY ON TOP OF THE STOP PIECES AND NAIL W/2-10d NAILS AT EACH END.
- ⑭ SPACER PIECE, 2" X 12" X 12" (DOUBLED) (8 REQD). POSITION THE FIRST BOARD AGAINST THE FOOT OF THE CNU-589/E CONTAINER AND NAIL THROUGH DECKING ASSEMBLY INTO THE STRINGER W/3-12d NAILS. LAMINATE THE SECOND BOARD TO THE FIRST W/3-10d NAILS.

(CONTINUED AT LEFT)

(GENERAL NOTES CONTINUED)

GENERAL NOTES

J. CONVERSION TO METRIC EQUIVALENTS: DIMENSIONS WITHIN THIS DOCUMENT ARE EXPRESSED IN INCHES AND WEIGHTS ARE EXPRESSED IN POUNDS. WHEN NECESSARY, THE METRIC EQUIVALENTS MAY BE COMPUTED ON THE BASIS OF ONE INCH EQUALS 25.4MM AND ONE POUND EQUALS 0.454 KG.

K. MAXIMUM LOAD WEIGHT CRITERIA:

THE MAXIMUM LOAD WEIGHTS ARE CONTROLLED BY EQUIPMENT CAPABILITY FACTORS. ALTHOUGH THE HEAVIEST MAXIMUM LOADS ARE DELINEATED IN THE LOAD VIEWS, PROVISIONS ARE INCLUDED WITHIN THIS DRAWING SO THAT THE BASIC LOADS CAN BE ADJUSTED TO SATISFY A LESSER QUANTITY OF LADING UNITS. DEPENDING ON TRANSPORTATION ROUTING, IT MAY BE NECESSARY TO REDUCE THE LOAD WEIGHT TO SATISFY "WEIGHT LAWS" OF CERTAIN STATES. ALSO, IT MAY BE NECESSARY TO REDUCE THE LOAD WEIGHT TO SATISFY OTHER WEIGHT RESTRICTIONS IMPOSED ON THE INTERMODAL CONTAINER SYSTEM.

L. REQUIREMENTS CITED WITHIN THE ASSOCIATION OF AMERICAN RAILROADS (AAR) IN TERMODAL LOADING GUIDE APPLY WHEN THE SHIPMENT MOVES BY TRAILER/CONTAINER-ON-FLATCAR (T/COFC). SPECIAL T/COFC NOTES FOLLOW:

1. A LOADED CONTAINER MUST BE ON A CHASSIS EQUIPPED WITH TWO BOGIE ASSEMBLIES WHEN BEING MOVED IN TOFC SERVICE.
2. THE LOAD LIMIT OF A T/COFC RAILCAR MUST NOT BE EXCEEDED, NOR WILL A CAR BE LOADED SO THAT THE TRUCK UNDER ONE END OF THE CAR CARRIES MORE THAN ONE-HALF OF THE LOAD LIMIT FOR THAT CAR.

M. DURING INTRASTATE AND/OR INTERSTATE MOVES BY MOTOR CARRIER, A PROPER CHASSIS OR MODIFIED FLATBED TRAILER MUST BE USED TO PRECLUDE VIOLATION OF ONE OR MORE "WEIGHT LAWS" APPLICABLE TO THE STATE OR STATES INVOLVED.

N. WHETHER A CONTAINER IS FULL OR IS LOADED WITH A REDUCED QUANTITY OF LADING UNITS, THE LENGTHWISE CENTER OF GRAVITY OF THE LOAD MUST BE WITHIN 12", IN EITHER DIRECTION, OF THE MID-POINT OF THE CONTAINER.

O. ANTI-CHAFING MATERIAL, CONSISTING OF NEUTRAL BARRIER MATERIAL, PLYWOOD, OR HARDBOARD, MAY BE INSTALLED AT POINTS OF CONTACT BETWEEN THE LADING AND THE SIDE OPENING CONTAINER TO PREVENT CHAFING DAMAGE TO CONTAINER PAINT AND MARKINGS.

A. THIS DOCUMENT HAS BEEN PREPARED AND ISSUED IN ACCORDANCE WITH AR 740-1 AND AUGMENTS TM 743-200-1 (CHAPTER 5).

B. THE OUTLOADING PROCEDURES SPECIFIED IN THIS DRAWING ARE APPLICABLE TO LOADS OF 2,000 LB GBU-31(V) 1/B BOMBS AND ASSOCIATED COMPONENTS IN A SIDE OPENING CONTAINER. SUBSEQUENT REFERENCE TO CONTAINER HEREIN MEANS THE CONTAINERS WITH THE GBU-31(V) 1/B COMPONENTS. SEE PAGE 4 FOR DETAILS OF THE COMPONENTS. A FULL LOAD OF 12 COMPLETE ROUNDS IS SHOWN ON PAGE 2. A REDUCED CAPACITY LOAD OF EIGHT COMPLETE ROUNDS IS SHOWN ON PAGE 8. CAUTION: REGARDLESS OF THE QUANTITY OF UNITS TO BE SHIPPED, THE "MAXIMUM GROSS WEIGHT" OF THE SIDE OPENING ISO CONTAINER MUST NOT BE EXCEEDED.

C. THE LOAD AS SHOWN IS BASED ON A 6,050 POUND 20' LONG BY 8' WIDE BY 8'-8" HIGH SIDE OPENING ISO CONTAINER WITH INSIDE DIMENSIONS OF 19'-4" LONG BY 89" WIDE BY 88" HIGH AND A MAXIMUM GROSS WEIGHT OF 52,910 POUNDS. THE LOAD IS DESIGNED FOR TRAILER/CONTAINER-ON-FLATCAR (T/COFC) MOVEMENT, HOWEVER, THE LOAD AS DESIGNED CAN ALSO BE SHIPPED BY MOTOR OR WATER CARRIERS. NOTICE: OTHER CONTAINERS OF THE SAME DESIGN CONFIGURATION CAN ALSO BE USED.

D. WHEN LOADING THE UNITS, THEY ARE TO BE POSITIONED SO AS TO ACHIEVE A TIGHT LOAD (TIGHT AGAINST THE DUNNAGE ASSEMBLIES). THE UNBLOCKED SPACE ACROSS THE WIDTH OF A LOAD BAY IS NOT TO EXCEED 1-1/2". EXCESSIVE SLACK CAN BE ELIMINATED FROM A LOAD BY LAMINATING ADDITIONAL PIECES OF APPROPRIATE THICKNESS TO THE CRIB FILL ASSEMBLIES. NAIL EACH ADDITIONAL PIECE TO THE VERTICAL OR HORIZONTAL PIECE AS APPLICABLE WITH APPROPRIATELY SIZED NAIL EVERY 12". ADDITIONALLY, THE THICKNESS AND QUANTITY OF THE DUNNAGE LUMBER USED MAY BE ADJUSTED AS REQUIRED TO FACILITATE VARIANCE IN THE SIZE OF THE CONTAINER.

E. DUNNAGE LUMBER SPECIFIED IS OF NOMINAL SIZE. FOR EXAMPLE, 1" X 6" MATERIAL IS ACTUALLY 3/4" THICK BY 5-1/2" WIDE AND 2" X 6" MATERIAL IS ACTUALLY 1-1/2" THICK BY 5-1/2" WIDE.

F. A STAGGERED NAILING PATTERN WILL BE USED WHENEVER POSSIBLE WHEN NAILS ARE DRIVEN INTO JOINTS OF DUNNAGE ASSEMBLIES OR WHEN LAMINATING DUNNAGE. ADDITIONALLY, THE NAILING PATTERN FOR AN UPPER PIECE OF LAMINATED DUNNAGE WILL BE ADJUSTED AS REQUIRED SO THAT A NAIL FOR THAT PIECE WILL NOT BE DRIVEN THROUGH ONTO OR RIGHT BESIDE A NAIL IN A LOWER PIECE.

G. IN SOME CONTAINERS THERE IS A SLOT AT THE CORNERS OF THE ENDWALLS. PIECES OF DUNNAGE MATERIAL MUST BE LAMINATED TO THE BUFFER PIECES ON THE END BLOCKING ASSEMBLIES TO PROVIDE A FLAT SURFACE FOR THE BUFFER PIECES. A PIECE OF 2" X 4", 2" X 3" OR A SPECIAL WIDTH PIECE CUT-TO-FIT CAN BE USED. THIS FILL PIECE WILL BE NAILED WITH ONE APPROPRIATELY SIZED NAIL EVERY 12". NOTE THAT SOME CONTAINERS ARE EQUIPPED WITH "TIE-BARS" IN THE CORNER SLOT, WHICH PRECLUDE THE USE OF A FULL HEIGHT FILL PIECE. WHEN "TIE-BARS" ARE PRESENT, THE FILL PIECE MUST BE INSTALLED IN SEGMENTS DESIGNED TO FIT BETWEEN THE "TIE-BARS" VERTICALLY. THE FILL PIECE(S) IS NOT REQUIRED WHEN THE CORNER PORTIONS OF THE CONTAINER ENDWALLS ARE SMOOTH AND FLAT. DO NOT ALLOW ANY DUNNAGE ASSEMBLY TO CONTACT THE CONTAINER ENDWALLS, ONLY THE CORNER POSTS OF THE CONTAINER SHOULD BE USED FOR LONGITUDINAL BLOCKING.

H. CAUTION: DO NOT NAIL DUNNAGE MATERIAL TO THE CONTAINER WALLS OR FLOOR. ALL NAILING WILL BE WITHIN THE DUNNAGE. PORTIONS OF THE CONTAINER DEPICTED WITHIN THIS DRAWING, SUCH AS THE SIDE DOORS, HAVE NOT BEEN SHOWN IN THE LOAD VIEW FOR CLARITY PURPOSES.

LOAD AS SHOWN

ITEM	QUANTITY	WEIGHT (APPROX)
MK79 BOMB PALLET UNIT WITH F275	6	25,728 LBS
CNU-589/E CONTAINER WITH EA69	6	2,718 LBS
M548 CAN WITH G119	2	78 LBS
M548 CAN WITH BY30	6	180 LBS
▲ FW26 BOX	2	(52 LBS)
▲ G008 BOX	2	(72 LBS)
DUNNAGE		1,501 LBS
CONTAINER		6,050 LBS
TOTAL WEIGHT		36,255 LBS (APPROX)

(CONTINUED AT LEFT)

MATERIAL SPECIFICATIONS

- LUMBER - - - - - : SEE TM 743-200-1 (DUNNAGE LUMBER) AND VOLUNTARY PRODUCT STANDARD PS 20.
- NAILS - - - - - : ASTM F1667; COMMON STEEL NAIL (NLCMS OR NLCMMS).
- PLYWOOD - - - - - : COMMERCIAL ITEM DESCRIPTION A-A-55057, INDUSTRIAL PLYWOOD, INTERIOR WITH EXTERIOR GLUE, GRADE C-D. IF SPECIFIED GRADE IS NOT AVAILABLE, A BETTER INTERIOR OR AN EXTERIOR GRADE MAY BE SUBSTITUTED.
- ANTI-CHAFING MATERIAL - - - - - : MIL-B-121 (OR EQUAL); NEUTRAL BARRIER MATERIAL.
- HARDBOARD - - - - - : ANSI/AHA A135.4, CLASS 1.

BILL OF MATERIAL		
LUMBER	LINEAR FEET	BOARD FEET
1" X 4"	47	16
2" X 2"	17	6
2" X 4"	466	311
2" X 6"	166	166
2" X 12"	12	24
4" X 4"	45	59
NAILS	NO. REQD	POUNDS
6d (2")	430	2-3/4
10d (3")	502	7-3/4
12d (3-1/4")	82	1-1/2
PLYWOOD, 1/2"	152.52 SQ FT REQD	209.72 LBS
PLYWOOD, 3/4"	55.59 SQ FT REQD	114.56 LBS

▲ NOTE: WHEN BY30 IS USED, FW26 AND G008 WILL BE OMITTED. WHEN FW26 AND G008 IS USED, BY30 WILL BE OMITTED. WEIGHT IN "LOAD AS SHOWN" INDICATES USE OF BY30 WITH FW26 AND G008 OMITTED.

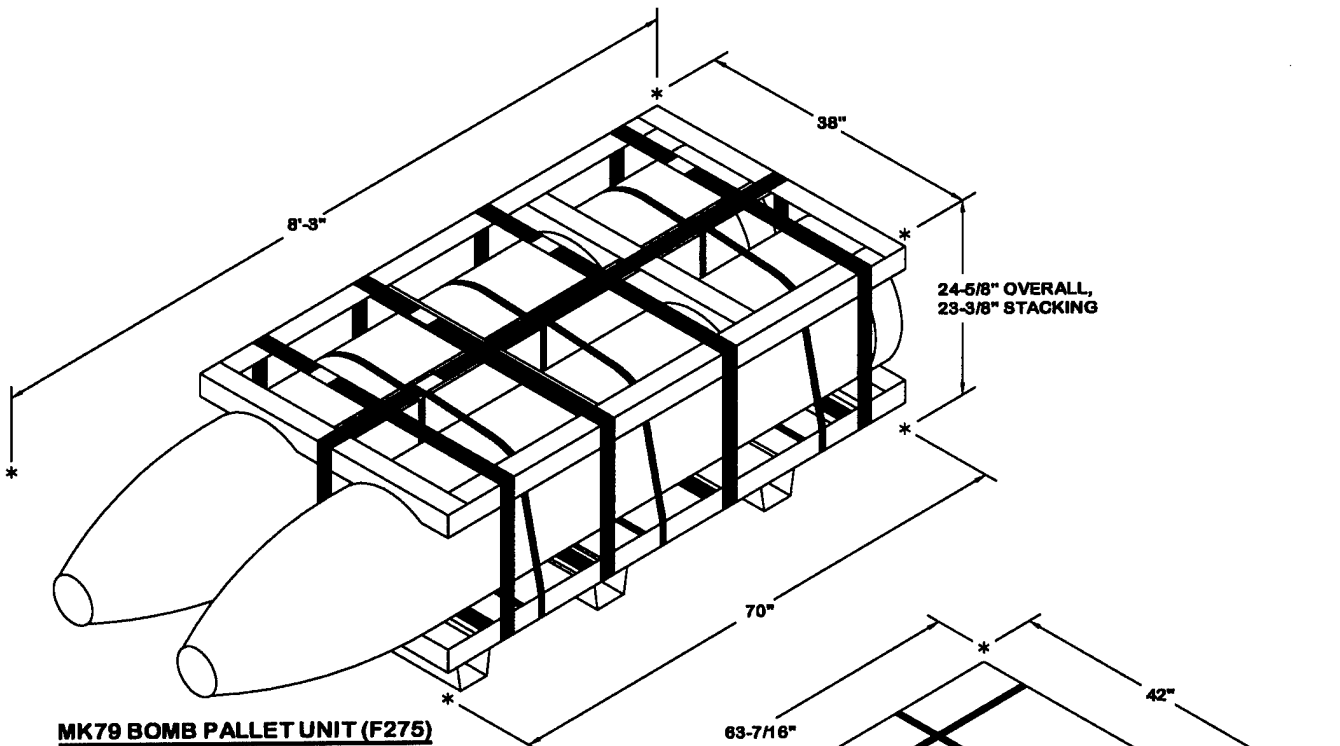

MK79 BOMB PALLET UNIT (F275)

BOMB - - - - - 2 EACH @ 1920 LBS (APPROX)
 CUBE - - - - - 53.6 CU. FT. (APPROX)
 GROSS WEIGHT - - - - - 4,124 LBS (APPROX)

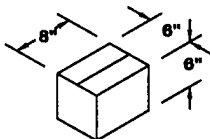

▲ SUPPORT CUP (FW26) IN FIBERBOARD BOX

GROSS WEIGHT - - - - - 26 LBS (APPROX)
 CUBE - - - - - 0.17 CUBIC FEET (APPROX)

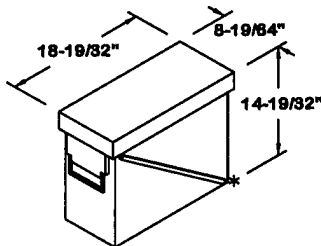

▲ PROXIMITY SENSOR (BY30) IN M548 METAL BOX

GROSS WEIGHT - - - - - 30 LBS (APPROX)
 CUBE - - - - - 1.3 CUBIC FEET (APPROX)

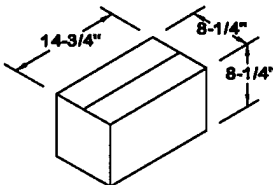

▲ NOSE PLUG (G008) IN FIBERBOARD BOX

GROSS WEIGHT - - - - - 36 LBS (APPROX)
 CUBE - - - - - 0.58 CUBIC FEET (APPROX)

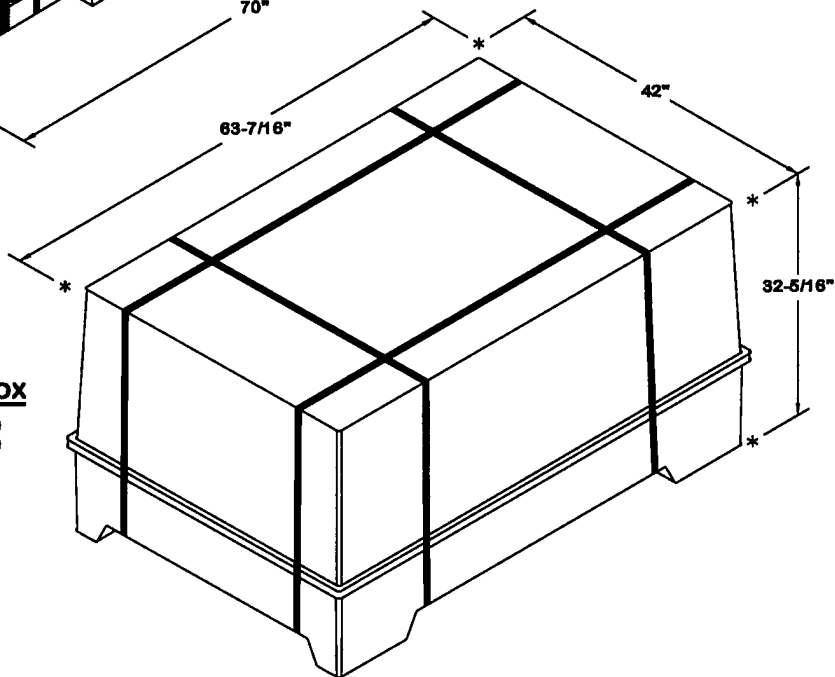

JDAM (EA69) IN CNU-589/E CONTAINER

CNU-589/E CONTAINER WITH 2 EACH GUIDANCE SETS
 GROSS WEIGHT - - - - - 453 LBS (APPROX)
 CUBE - - - - - 50.7 CUBIC FEET (APPROX)

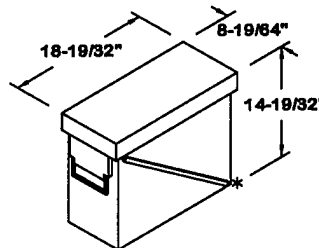

FUZE SET (G119) IN M548 METAL BOX

GROSS WEIGHT - - - - - 39 LBS (APPROX)
 CUBE - - - - - 1.3 CUBIC FEET (APPROX)

▲ NOTE: WHEN BY30 IS USED, FW26 AND G008 WILL BE OMITTED. WHEN FW26 AND G008 IS USED, BY30 WILL BE OMITTED.

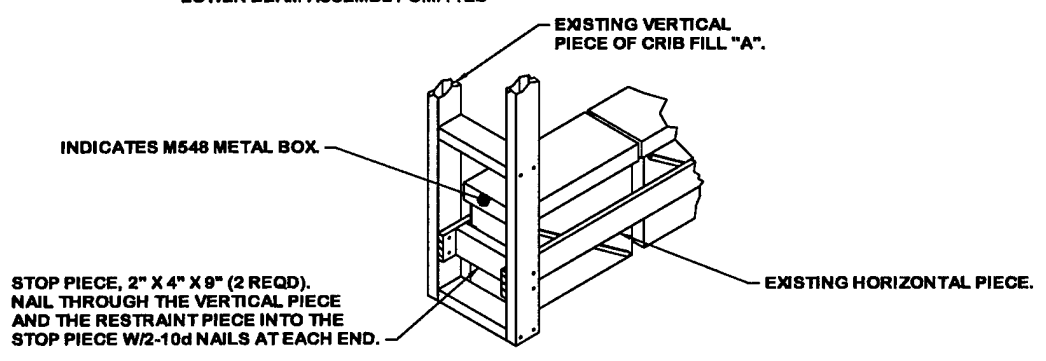
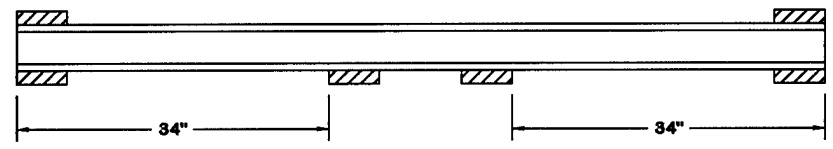
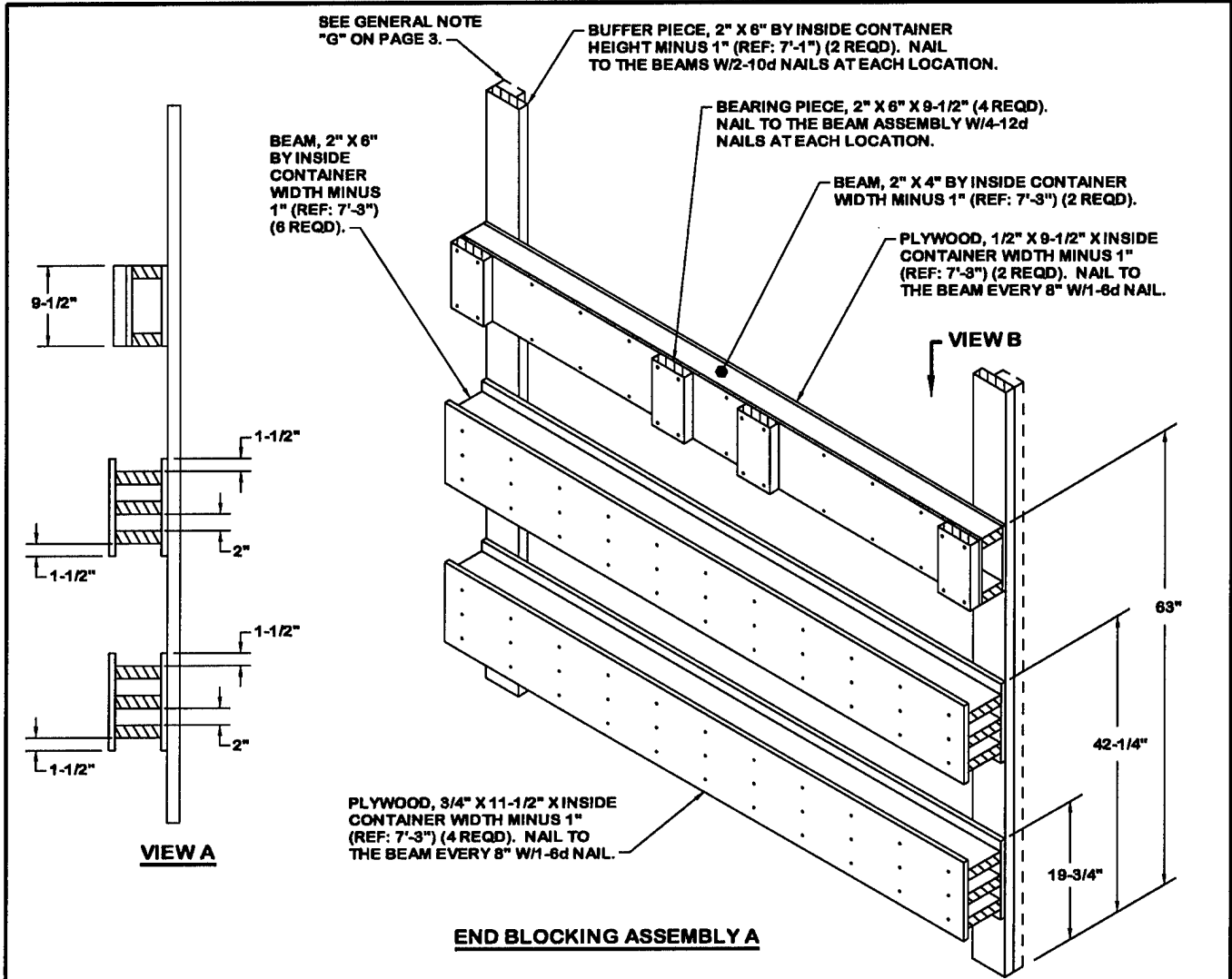

MISCELLANEOUS BOXES MAY ALSO BE PLACED IN THE VOID AREA OF THE STRUT SUPPORT ASSEMBLIES AS SHOWN ON PAGE 6 OR ON TOP OF THE DECKING ASSEMBLIES BETWEEN THE CNU-589/E CONTAINERS. SECURE THE BOXES Laterally AND LONGITUDinally.

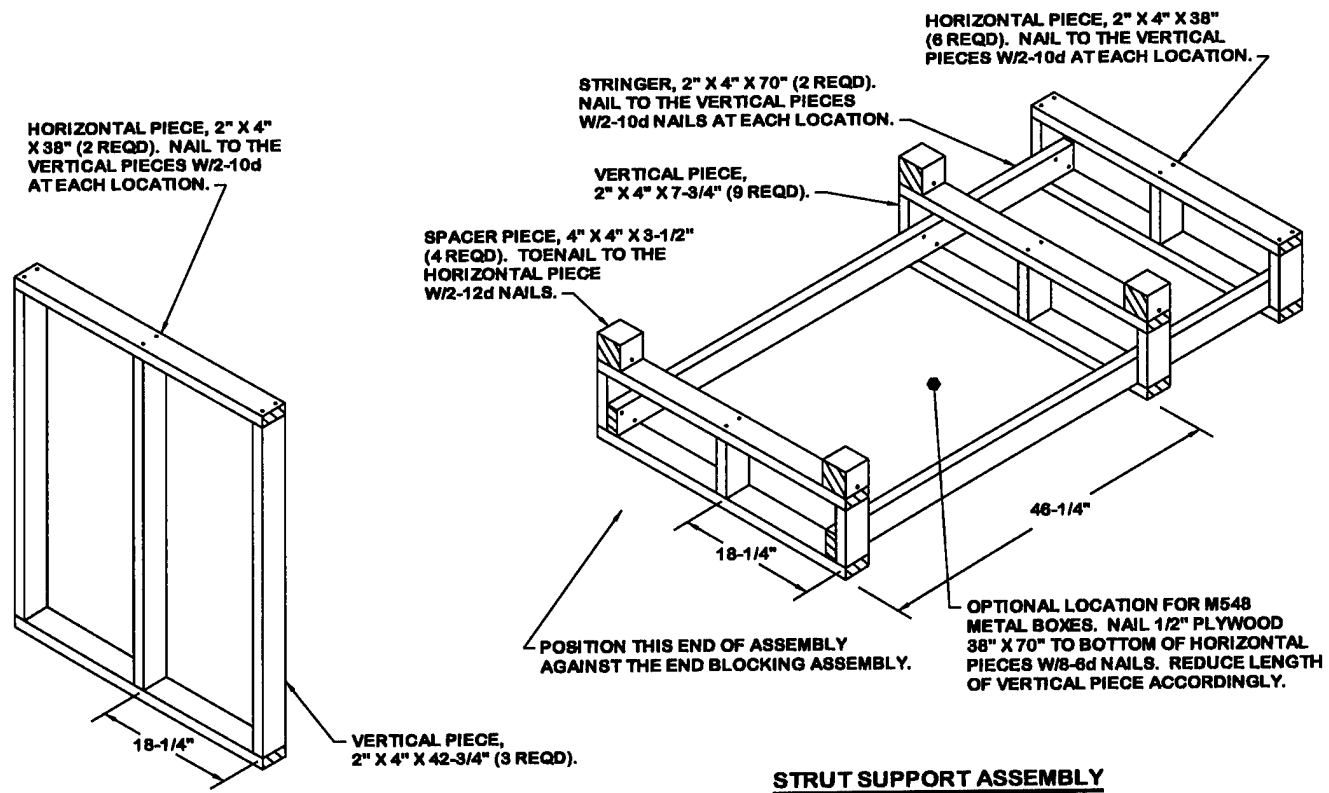

STRUT SUPPORT ASSEMBLY

DECKING SUPPORT ASSEMBLY A

NOTE: THE DECKING SUPPORT ASSEMBLY "A" MUST BE POSITIONED PRIOR TO INSTALLING THE CENTER GATE.

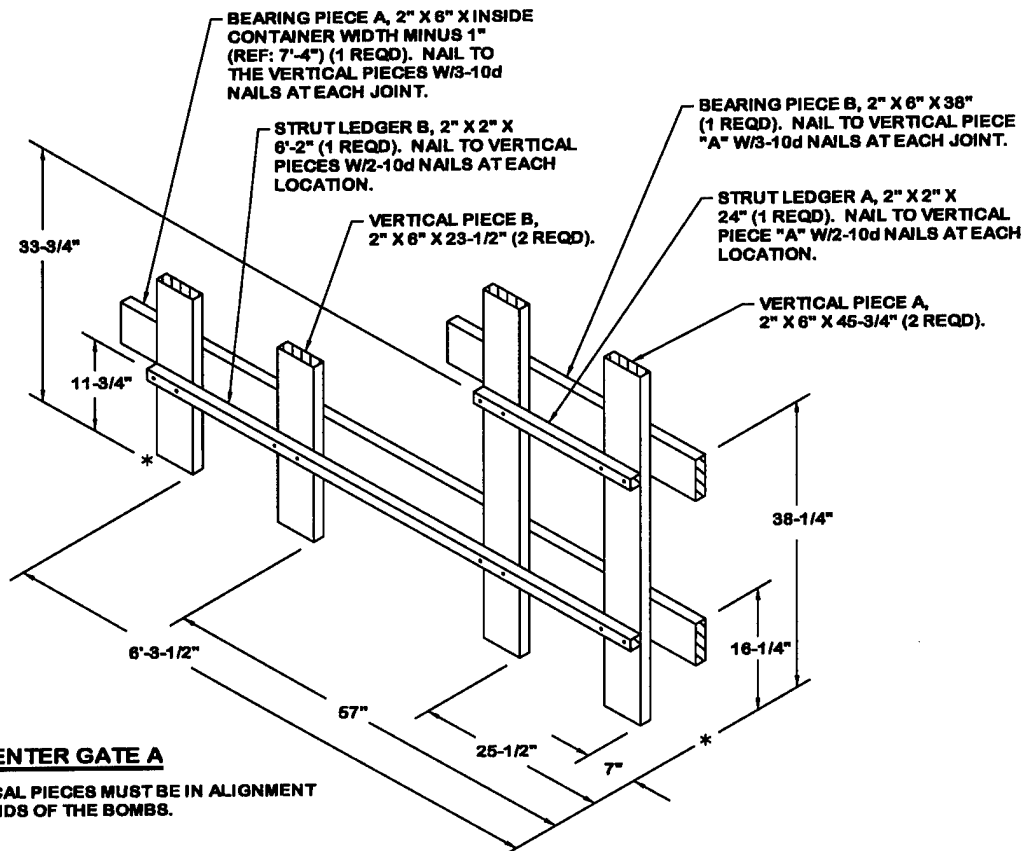

CENTER GATE A

NOTE: THE VERTICAL PIECES MUST BE IN ALIGNMENT WITH THE NOSE ENDS OF THE BOMBS.

STRINGER 2" X 4" X 8'-1-3/4" (2 REQD).
NAIL TO THE VERTICAL PIECES
W/2-10d NAILS AT EACH LOCATION.

POSITION THIS END OF
ASSEMBLY AGAINST THE
END BLOCKING ASSEMBLY.

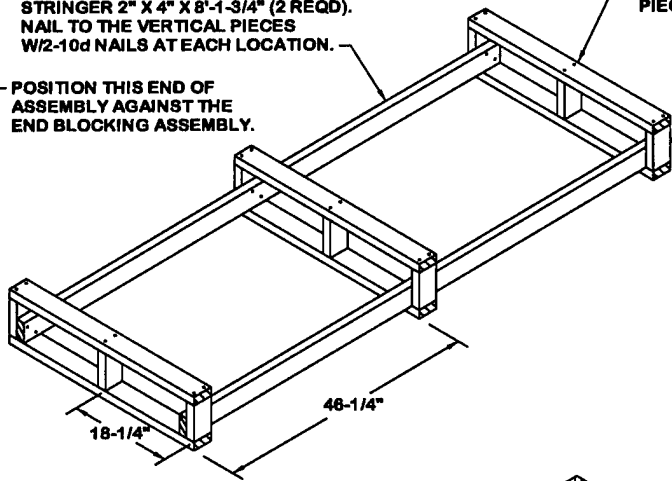

HORIZONTAL PIECE, 2" X 4" X 38"
(6 REQD). NAIL TO THE VERTICAL
PIECES W/2-10d AT EACH LOCATION.

VERTICAL PIECE, 2" X 4"
BY LENGTH AS REQUIRED
(REF: 5-3/4") (9 REQD).

VERTICAL PIECE, 2" X 4" X
45-3/4" (6 REQD). NAIL TO THE
SPACER PIECES W/2-10d
NAILS AT EACH LOCATION.

SPACER PIECE, 2" X 4"
BY LENGTH AS REQUIRED
(REF: 10") (9 REQD).

DECKING SUPPORT ASSEMBLY B

NOTE: TOP OF THE DECKING SUPPORT ASSEMBLY "B" MUST BE
FLUSH WITH THE TOP FRAME OF THE TWO HIGH STACK OF
MK79 BOMB PALLET UNITS AS SHOWN ON THE LOAD ON PAGE 2.

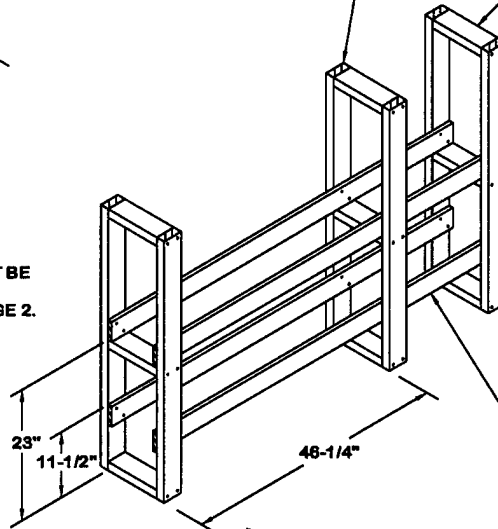

HORIZONTAL PIECE, 1" X 4"
X 70" (4 REQD). NAIL TO THE
VERTICAL PIECES W/2-6d
NAILS AT EACH LOCATION.

CRIB FILL A

POSITION THIS END OF ASSEMBLY
AGAINST THE END BLOCKING ASSEMBLY.

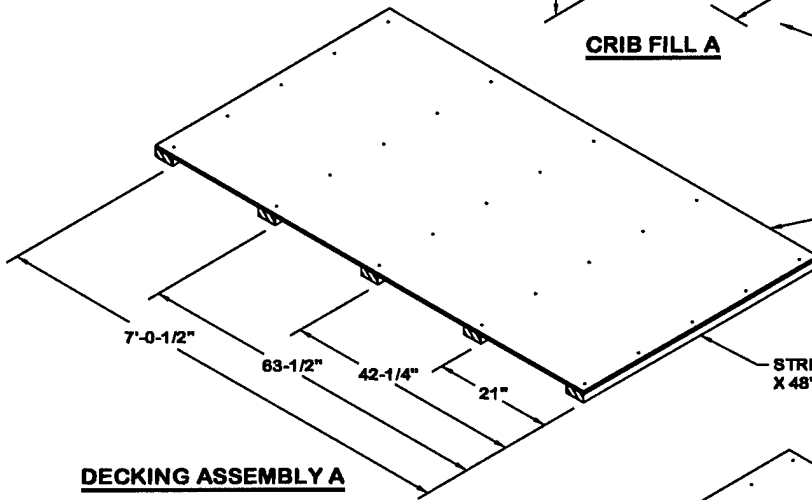

PLYWOOD, 1/2" THICK X 48" BY
CONTAINER WIDTH MINUS 1"
(REF: 7'-4") (1 REQD). NAIL
THROUGH PLYWOOD INTO
STRINGERS W/1-6d NAIL EVERY 8".

STRINGER, 2" X 4"
X 48" (5 REQD).

DECKING ASSEMBLY A

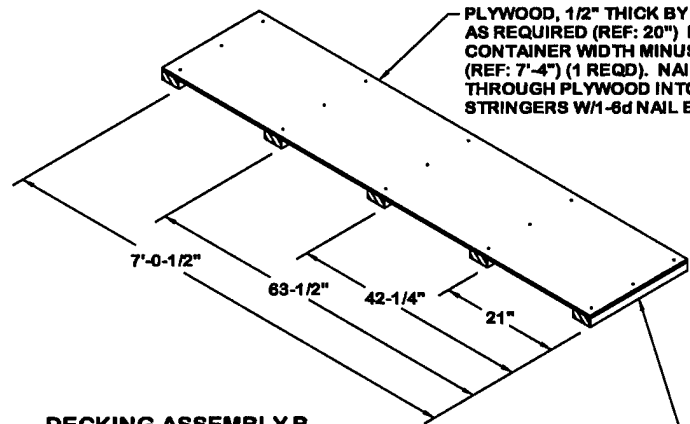

PLYWOOD, 1/2" THICK BY WIDTH
AS REQUIRED (REF: 20") BY
CONTAINER WIDTH MINUS 1"
(REF: 7'-4") (1 REQD). NAIL
THROUGH PLYWOOD INTO
STRINGERS W/1-6d NAIL EVERY 8".

STRINGER, 2" X 4" BY LENGTH
AS REQUIRED (REF: 20") (5 REQD).

DECKING ASSEMBLY B

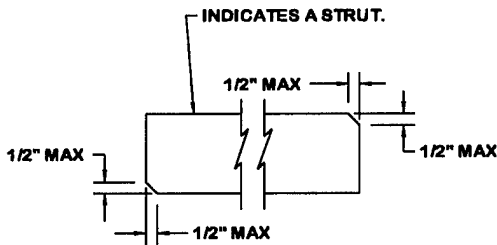

BEVEL-CUT

IF DESIRED, EACH END OF A STRUT MAY BE
BEVEL-CUT AS SHOWN ABOVE TO FACILITATE
THE ACHIEVEMENT OF A TIGHT CENTER-GATE-
TO-CENTER-GATE FIT.

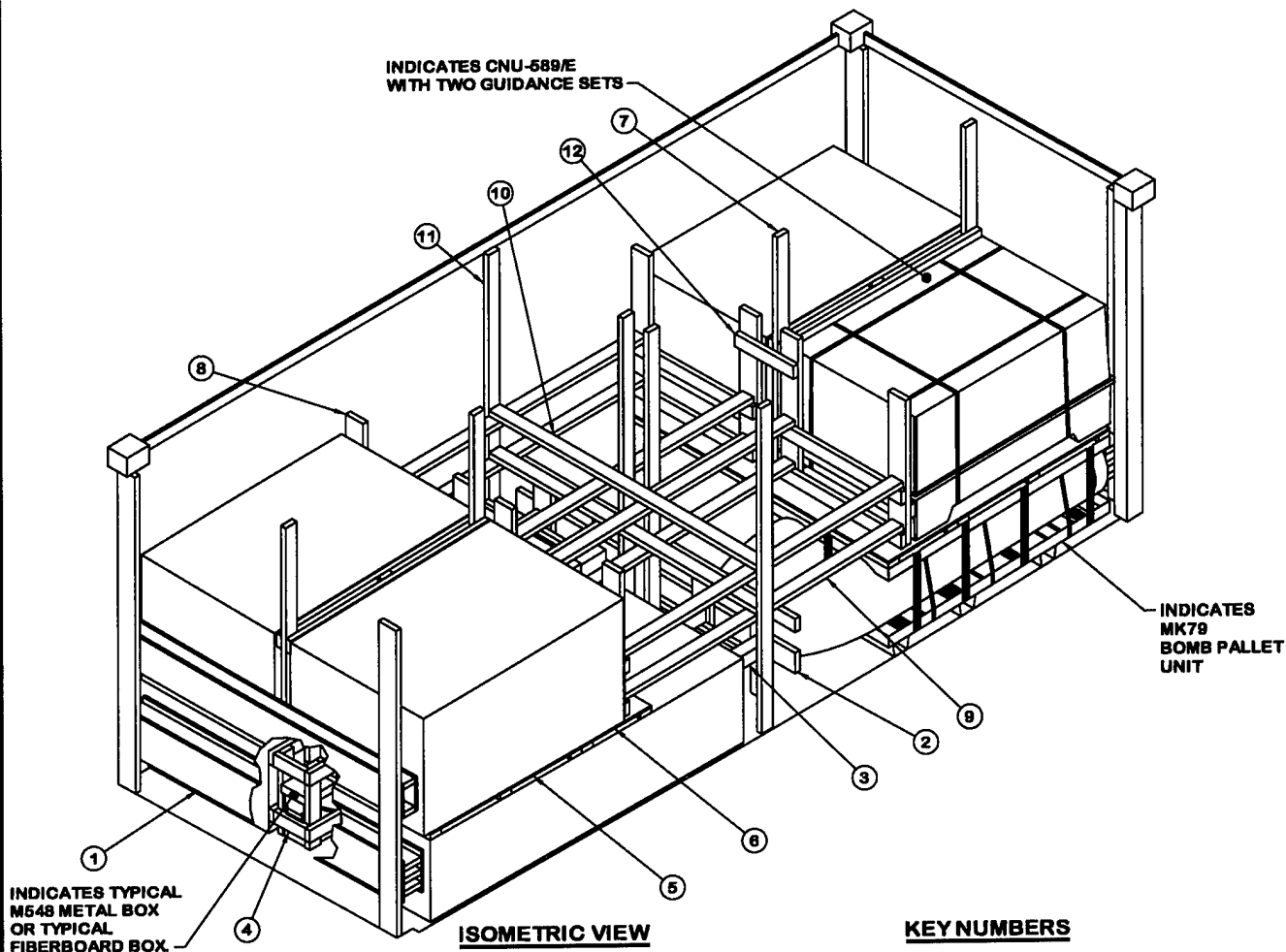

ISOMETRIC VIEW

KEY NUMBERS

INDICATES TYPICAL M548 METAL BOX OR TYPICAL FIBERBOARD BOX

INDICATES MK79 BOMB PALLET UNIT

LOAD AS SHOWN

- ① END BLOCKING ASSEMBLY B (2 REQD). SEE DETAIL ON PAGE 9.
- ② CENTER GATE B (2 REQD). SEE DETAIL ON PAGE 10.
- ③ STRUT, 4" X 4" BY CUT TO FIT (REF: 12-3/4") (4 REQD). POSITION BETWEEN THE CENTER GATES. TOENAIL TO THE CENTER GATES W/2-12d NAILS AT EACH END. SEE THE "BEVEL CUT" DETAIL ON PAGE 7.
- ④ CRIB FILL B (2 REQD). SEE DETAIL ON PAGE 10. POSITION BETWEEN MK79 BOMB PALLET UNITS
- ⑤ DECKING ASSEMBLY C (2 REQD). SEE DETAIL ON PAGE 11. POSITION ON TOP OF MK79 BOMB PALLET UNITS.
- ⑥ DECKING ASSEMBLY D (2 REQD). SEE DETAIL ON PAGE 11. POSITION ON TOP OF MK79 BOMB PALLET UNITS.
- ⑦ CRIB FILL C (2 REQD). SEE DETAIL ON PAGE 12. POSITION BETWEEN THE CNU-589/E CONTAINERS.
- ⑧ CENTER GATE C (4 REQD). SEE DETAIL ON PAGE 12. POSITION AGAINST CNU-589/E CONTAINER WITH THE RESTRAINT PIECE POSITIONED UNDER THE FLARED LIFTING EDGE OF THE CONTAINER.
- ⑨ STRUT, 2" X 4" BY CUT TO FIT (REF: 7'-6") (8 REQD). NAIL TO THE LEDGER BOARD AT EACH END W/2-10d NAILS.
- ⑩ HORIZONTAL SUPPORT, 2" X 4" BY INSIDE CONTAINER WIDTH MINUS 1" (REF: 7'-4") (2 REQD). POSITION ON TOP OF STRUTS AS SHOWN. NAIL TO STRUTS W/2-10d NAILS AT EACH LOCATION.
- ⑪ VERTICAL SUPPORT, 2" X 4" BY INSIDE CONTAINER HEIGHT MINUS 1" (REF: 7'-3") (4 REQD). POSITION AGAINST THE STRUTS AS SHOWN AND NAIL TO THE STRUTS W/2-10d NAILS AT EACH LOCATION.
- ⑫ RESTRAINT PIECE, 2" X 4" BY CUT TO FIT (REF: 18-1/2") (2 REQD). POSITION AS SHOWN AND NAIL TO CENTER GATE "C" VERTICAL PIECES W/2-10d NAILS AT EACH END.

ITEM	QUANTITY	WEIGHT (APPROX)
MK79 BOMB PALLET UNIT WITH F275	4	16,496 LBS
CNU-589/E CONTAINER WITH EA69	4	1,812 LBS
M548 CAN WITH GL19	2	78 LBS
M548 CAN WITH BY30	4	120 LBS
▲ FW26 BOX	1	(26 LBS)
▲ G008 BOX	1	(36 LBS)
DUNNAGE		1,136 LBS
CONTAINER		6,050 LBS

TOTAL WEIGHT - - - - - 25,692 LBS (APPROX)

BILL OF MATERIAL		
LUMBER	LINEAR FEET	BOARD FEET
1" X 4"	14	5
2" X 2"	7	3
2" X 4"	465	310
2" X 6"	136	136
4" X 4"	5	6
NAILS	NO. REQD	POUNDS
6d (2")	346	2-1/4
10d (3")	428	6-3/4
12d (3-1/4")	16	1/4
PLYWOOD, 1/2"	108.52 SQ FT REQD	149.22 LBS
PLYWOOD, 3/4"	27.80 SQ FT REQD	57.34 LBS

8 COMPLETE ROUND LOAD

▲ NOTE: WHEN BY30 IS USED, FW26 AND G008 WILL BE OMITTED. WHEN FW26 AND G008 IS USED, BY30 WILL BE OMITTED. WEIGHT IN "LOAD AS SHOWN" INDICATES USE OF BY30 WITH FW26 AND G008 OMITTED.

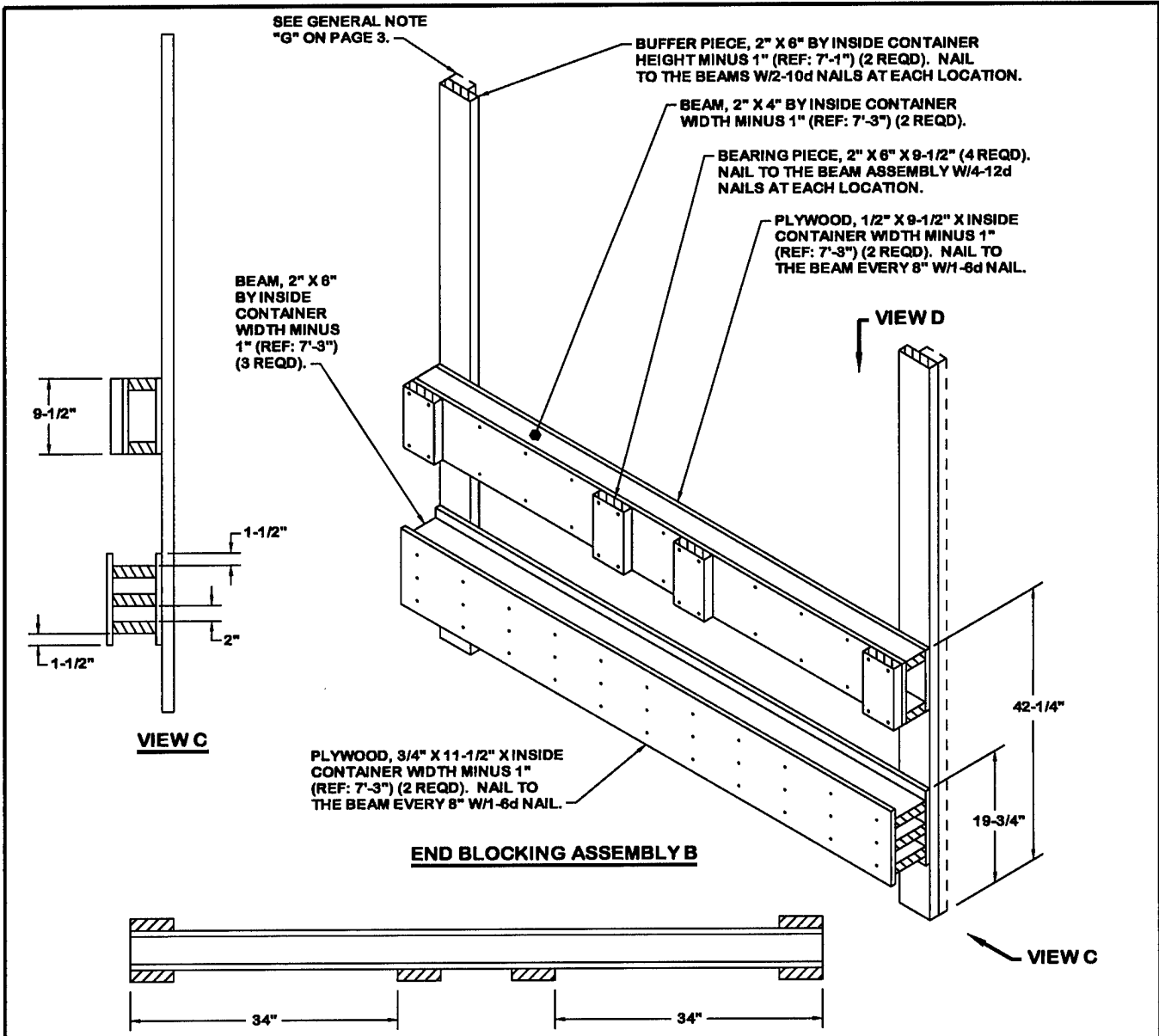

LOWER BEAM ASSEMBLY OMITTED

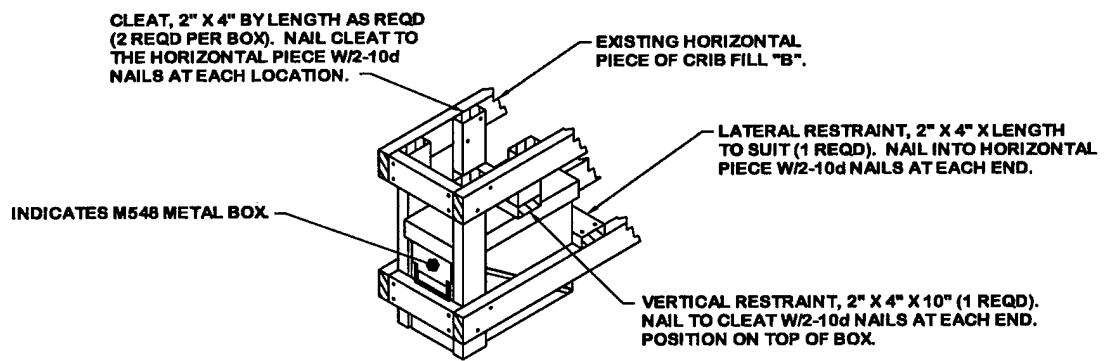

MISCELLANEOUS BOXES MAY ALSO BE PLACED IN THE VOID AREA BETWEEN THE LOAD BEARING PIECES (STRUTS) OF THE CENTER GATE ASSEMBLIES. ADJUSTMENTS TO THE ABOVE DETAIL MAY BE MADE SO AS TO PROVIDE FOR SIMILAR SECUREMENT TO THE CENTER GATE ASSEMBLIES.

BEARING PIECE, 2" X 6" X INSIDE CONTAINER WIDTH MINUS 1" (REF: 7'-4") (1 REQD). NAIL TO THE VERTICAL PIECES W/3-10d NAILS AT EACH JOINT.

VERTICAL PIECE, 2" X 6" X 25-3/8" (4 REQD).

SUPPORT PIECE, 2" X 4" X INSIDE CONTAINER WIDTH MINUS 1" (REF: 7'-4") (1 REQD). NAIL TO THE VERTICAL PIECES W/2-10d NAILS AT EACH JOINT.

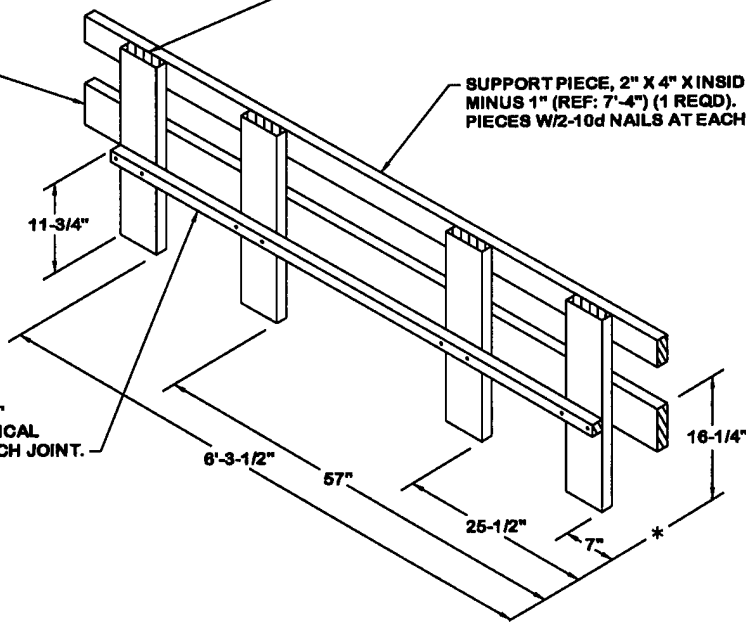

STRUT LEDGER, 2" X 2" X 6'-2" (1 REQD). NAIL TO THE VERTICAL PIECES W/2-10d NAILS AT EACH JOINT.

CENTER GATE B

NOTE: THE VERTICAL PIECES MUST BE IN ALIGNMENT WITH THE NOSE ENDS OF THE BOMBS.

HORIZONTAL PIECE, 2" X 4" X 8'-0" (4 REQD). NAIL TO THE VERTICAL PIECES W/2-10d NAILS AT EACH JOINT.

VERTICAL PIECE, 2" X 4" X 23" (6 REQD).

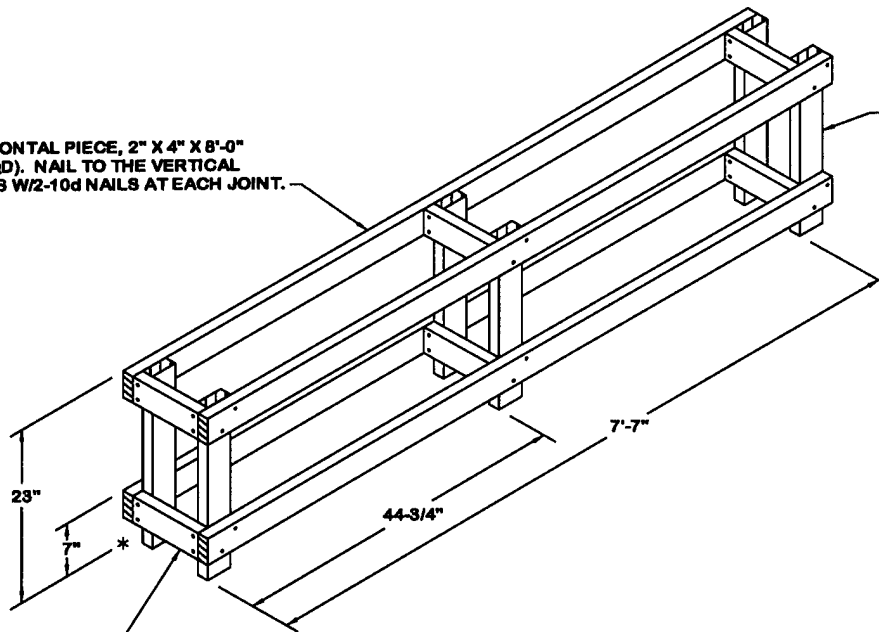

SPACER PIECE, 2" X 4" BY LENGTH TO SUIT (REF: 10") (6 REQD). NAIL TO THE VERTICAL PIECES W/2-10d NAILS AT EACH JOINT.

CRIB FILL B

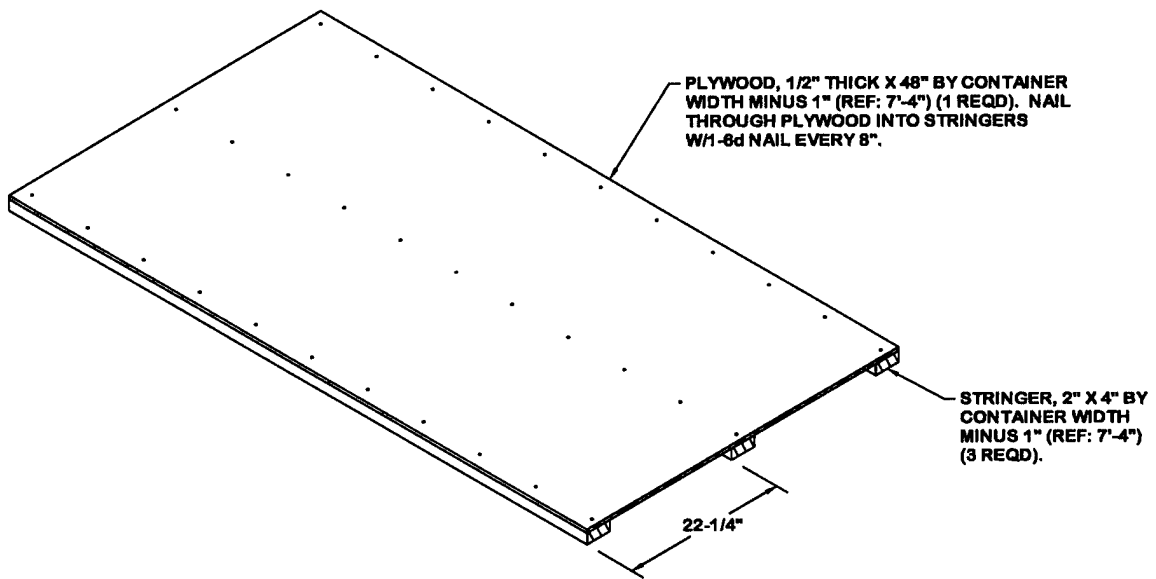

DECKING ASSEMBLY C

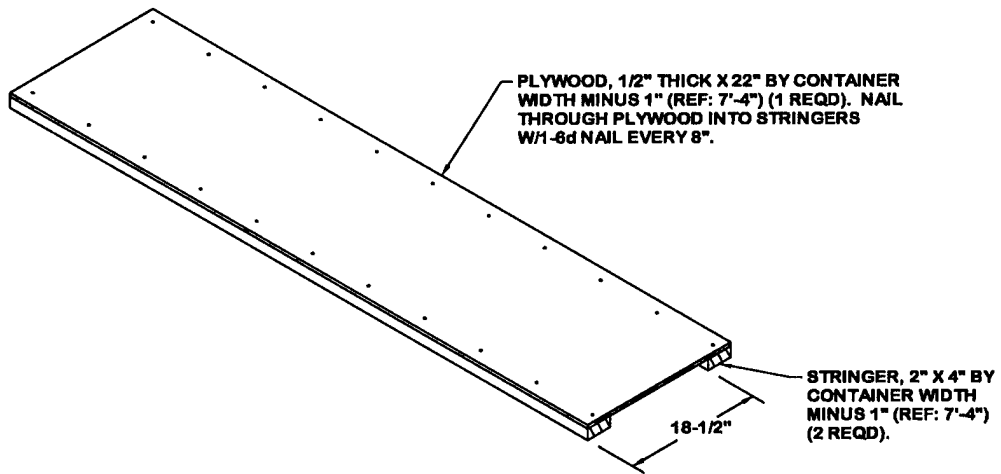

DECKING ASSEMBLY D

