

**FINAL REPORT**  
**SEPTEMBER 1999**

**REPORT NO. 99-11**

**750 POUND M117 BOMB**  
**TRANSPORTABILITY**  
**TESTS**

Prepared for:  
Commander  
U.S. Army Pacific  
ATTN: APLG  
Fort Shafter, HI 96858-5100

Distribution Unlimited



**VALIDATION ENGINEERING DIVISION**  
**MCALESTER, OKLAHOMA 74501**



**U.S. ARMY**  
**DEFENSE**  
**AMMUNITION**  
**CENTER**

**AVAILABILITY NOTICE**

A copy of this report will be furnished each attendee on automatic distribution. Additional copies or authority for reprinting may be obtained by written request from Director, U.S. Army Defense Ammunition Center, ATTN: SIOAC-DEV, McAlester, OK 74501.

**DISTRIBUTION INSTRUCTIONS**

Destroy this report when no longer needed. Do not return.

----

Citation of trade names in this report does not constitute an official endorsement.

----

The information contained herein will not be used for advertising purposes.

# REPORT DOCUMENTATION PAGE

Form Approved  
OMB No. 0704-0188

| <b>1a. REPORT SECURITY CLASSIFICATION</b><br><p style="text-align: center; font-weight: bold;">UNCLASSIFIED</p>  |   | <b>1b. RESTRICTIVE MARKINGS</b>  |   |  |           |  |  |  |  |  |  |  |  |  |  |  |
|--|---|--|---|--|-----------|--|--|--|--|--|--|--|--|--|--|--|
| <b>2a. SECURITY CLASSIFICATION AUTHORITY</b>   |   | <b>3. DISTRIBUTION / AVAILABILITY OF REPORT</b><br><br><p style="text-align: center; font-weight: bold;">UNLIMITED</p>   |   |  |           |  |  |  |  |  |  |  |  |  |  |  |
| <b>2b. DECLASSIFICATION / DOWNGRADING SCHEDULE</b>   |   |  |   |  |           |  |  |  |  |  |  |  |  |  |  |  |
| <b>4. PERFORMING ORGANIZATION REPORT NUMBER(S)</b><br><br><p style="text-align: center; font-weight: bold;">99-11</p>  |   | <b>5. MONITORING ORGANIZATION REPORT NUMBER(S)</b>   |   |  |           |  |  |  |  |  |  |  |  |  |  |  |
| <b>6a. NAME OF PERFORMING ORGANIZATION</b><br>U.S. Army Defense Ammunition Center  | <b>6b. OFFICE SYMBOL (if applicable)</b><br><p style="text-align: center; font-weight: bold;">SIOAC-DEV</p> | <b>7a. NAME OF MONITORING ORGANIZATION</b>   |   |  |           |  |  |  |  |  |  |  |  |  |  |  |
| <b>6c. ADDRESS (City, State, and ZIP Code)</b><br>ATTN: SIOAC-DEV<br>McAlester, OK 74501   |   | <b>7b. ADDRESS (City, State, ZIP Code)</b>   |   |  |           |  |  |  |  |  |  |  |  |  |  |  |
| <b>8a. NAME OF FUNDING / SPONSORING ORGANIZATION</b>   | <b>8b. OFFICE SYMBOL (if applicable)</b>  | <b>9. PROCUREMENT INSTRUMENT IDENTIFICATION NUMBER</b>   |   |  |           |  |  |  |  |  |  |  |  |  |  |  |
| <b>8c. ADDRESS (City, State, ZIP Code)</b><br>U.S. Army Pacific<br>ATTN: APLG<br>FORT SHAFTER, HI 96858-5100   |   | <b>10. SOURCE OF FUNDING NUMBERS</b><br>PROGRAM ELEMENT NO.  | PROJECT NO.<br><br><p style="text-align: center; font-weight: bold;">99-11</p>  | TASK NO.                                   |           |  |  |  |  |  |  |  |  |  |  |  |
| <b>11. TITLE (Include Security Classification)</b><br><br><p style="text-align: center; font-weight: bold;">750 Pound M117 Bomb Transportability Tests</p>   |   | WORK UNIT ACCESSION NO.  |   |  |           |  |  |  |  |  |  |  |  |  |  |  |
| <b>12. PERSONAL AUTHOR(S)</b><br>WILLIAM R. MEYER  |   |  |   |  |           |  |  |  |  |  |  |  |  |  |  |  |
| <b>13a. TYPE OF REPORT</b><br><br><p style="text-align: center; font-weight: bold;">FINAL</p>  | <b>13b. TIME COVERED</b><br>FROM <del>Aug 99</del> TO <del>Sept 99</del>                                    | <b>14. DATE OF REPORT (Year, Month, Day)</b><br><br><p style="text-align: center; font-weight: bold;">1999 September</p> | <b>15. PAGE COUNT</b>   |  |           |  |  |  |  |  |  |  |  |  |  |  |
| <b>16. SUPPLEMENTARY NOTATION</b>  |   |  |   |  |           |  |  |  |  |  |  |  |  |  |  |  |
| <b>17. COSATI CODES</b> <table border="1" style="width: 100%; border-collapse: collapse; margin-top: 5px;"> <thead> <tr> <th style="width: 33%;">FIELD</th> <th style="width: 33%;">GROUP</th> <th style="width: 33%;">SUB-GROUP</th> </tr> </thead> <tbody> <tr><td> </td><td> </td><td> </td></tr> <tr><td> </td><td> </td><td> </td></tr> <tr><td> </td><td> </td><td> </td></tr> </tbody> </table>   |   |  | FIELD   | GROUP                                      | SUB-GROUP |  |  |  |  |  |  |  |  |  | <b>18. SUBJECT TERMS (Continue on reverse if necessary and identify by block number)</b> |  |
| FIELD  | GROUP   | SUB-GROUP  |   |  |           |  |  |  |  |  |  |  |  |  |  |  |
|  |   |  |   |  |           |  |  |  |  |  |  |  |  |  |  |  |
|  |   |  |   |  |           |  |  |  |  |  |  |  |  |  |  |  |
|  |   |  |   |  |           |  |  |  |  |  |  |  |  |  |  |  |
| <b>19. ABSTRACT (Continue on reverse if necessary and identify by block number)</b><br><br><p style="font-weight: bold;">The US Army Defense Ammunition Center (DAC) Validation Engineering Division (SIOAC-DEV) was tasked by the US Army Pacific, Fort Shafter, HI to conduct transportability tests on modified 750 pound bombs. The M117 bombs were modified to include a cylindrical groove 0.20 inches deep around the mid-section of the bomb to assist in the demilitarization of this item. Due to time restraints, the most severe tests were conducted. Ref: Rail Impact Tests at 4, 6, 8, and reverse 8 mph, as well as edgewise-rotational drop tests. As tested, the modified 750 pounds passed both tests with no permanent deformation noted. It's very unlikely that this modification will have any adverse effect on the munitions during the transportation cycle.</p> |   |  |   |  |           |  |  |  |  |  |  |  |  |  |  |  |
| <b>20. DISTRIBUTION / AVAILABILITY OF ABSTRACT</b><br><input checked="" type="checkbox"/> UNCLASSIFIED/UNLIMITED <input type="checkbox"/> SAME AS RPT. <input type="checkbox"/> DTIC USERS   |   |  | <b>21. ABSTRACT SECURITY CLASSIFICATION</b><br><br><p style="text-align: center; font-weight: bold;">UNCLASSIFIED</p> |  |           |  |  |  |  |  |  |  |  |  |  |  |
| <b>22a. NAME OF RESPONSIBLE INDIVIDUAL</b><br><br>WILLIAM R. MEYER   |   |  | <b>22b. TELEPHONE (Include Area Code)</b><br><br>DSN 956-8090   | <b>22c. OFFICE SYMBOL</b><br><br>SIOAC-DEV |           |  |  |  |  |  |  |  |  |  |  |  |

U.S. ARMY DEFENSE AMMUNITION CENTER  
VALIDATION ENGINEERING DIVISION  
MCALESTER, OKLAHOMA 74501

REPORT NO. 99-11

SEPTEMBER 1999

TABLE OF CONTENTS

| PART                     | PART |
|--------------------------|------|
| 1. INTRODUCTION .....    | 1    |
| A. BACKGROUND .....      | 1    |
| B. AUTHORITY .....       | 1    |
| C. OBJECTIVE .....       | 1    |
| D. CONCLUSION .....      | 1    |
| E. RECOMMENDATIONS.....  | 1    |
| 2. ATTENDEES .....       | 2    |
| 3. TEST PROCEDURES ..... | 3    |
| 4. TEST RESULTS .....    | 4    |
| 5. PHOTOGRAPHS .....     | 5    |

## PART 1

### INTRODUCTION

**A. BACKGROUND:** The U.S. Army Defense Ammunition Center (DAC) Validation Engineering Division (SIOAC-DEV) was tasked by the U.S. Army Pacific, Fort Shafter, HI to conduct transportability tests on modified 750 pound bombs. The M117 bombs were modified to include a cylindrical groove 0.20 inches deep around the mid-section of the bomb. This modification will be done on 27,250 bombs at Anderson AB, Guam prior to shipment to Louisiana Army Ammunition Plant (LAAP) in Minden, Louisiana for final demilitarization operations. Demilex a tenant activity on LAAP will perform the final recycling process.

**B. AUTHORITY.** This test was conducted IAW mission responsibilities delegated by the U.S. Army Industrial Operations Command (IOC), Rock Island, IL 61299-6000. Reference is made to Change 4, 4 October 1974, to AR 740-1, 23 April 1971, Storage and Supply operations; AMCCOMR 10-17, 31 August 1991, Mission and Major Functions of USADAC.

**C. OBJECTIVE.** The objective for conducting transportability tests on modified 750 pound bombs is to determine if modifications done to the M117 bombs would have any adverse effect on the munitions during the transportation cycle. The tests conducted will determine if the bombs fail (separate) after severe shock is imparted into the bomb bodies following drop and impact tests.

**D. CONCLUSION:** The modified 750 pound bombs passed all tests conducted with no permanent deformation noted. It's very unlikely that transportation of the modified M117 bombs will be adversely effected by the 0.20 inch cylindrical groove placed around the bomb body prior to shipment. It should be pointed out that due to the uneven surface of the bomb body, the groove

**E. RECOMMENDATIONS:** It is recommended that prior to shipment of the modified 750 pound bombs, the dunnage used at the end of the rail cars be modified (strengthened) to avoid damage noted during rail impact tests.

**PART 2**

**ATTENDEES**

**30 August 1999**

William R. Meyer  
General Engineer  
DSN 956-8090  
918-420-8090

Director  
Defense Ammunition Center  
ATTN: SIOAC-DEV  
McAlester, Ok 74501

William R. Frerichs  
Chief, Transportation Engineering Divison  
DSN 965-8071  
918-420-8071

Director  
Defense Ammunition Center  
ATTN: SIOAC-DET  
McAlester, OK 74501

Daryl Sieczkowski  
Electronics Technician  
DSN 956-8988  
918-420-8988

Director  
Defense Ammunition Center  
ATTN: SIOAC-DEV  
McAlester, OK 74501

# **RAIL IMPACT TEST**



**TRANSPORTABILITY TESTING PROCEDURES  
RAIL IMPACT TEST**

**1. SCOPE.**

**2. DEFINITIONS.**

2.1. Test load (specimen). The inert munitions outloaded IAW prescribed procedures in/on the appropriate transport mode.

2.2. Outloading Procedure. The procedure for loading, blocking and bracing, and restraining the load. (Outloading procedures are prepared/designed by the U.S. Army Defense Ammunition Center (USADAC), Transportation Engineering Division (SIOAC-DEV).

**3. REQUIREMENTS.**

3.1 Tests.

3.1.1. Test Load (Specimen). The test load is prepared using the same blocking and bracing methods specified in the outloading procedures proposed for use with the munitions. The railcar used in the test shall be inspected to assure its adequacy for munitions transport. Items used to build the load configuration shall be identical to the live (explosive) ammunition provided for in the outloading procedure; i.e., weights, physical dimensions, center of gravity, materials, etc. The ammunition packages used shall duplicate that of the live ammunition. Certification of packaging/unitization will have already been accomplished by U.S. Army Armament Research, Development and Engineering Center (ARDEC), U.S. Army Test and Evaluation Command (TECOM), or USADAC, as appropriate.

3.1.2. Test Procedures. Test load (Specimen) shall be subjected to a series of tests as described in the test methods detailed in paragraph 4.

3.1.3. Data Collection. Test load (specimen) shall be instrumented as determined by the test engineer, or as requested by the test sponsor, to determine stress movement forces, velocities, and accelerations. Data collected should be suitable for use in investigating causes for failure and as criteria for design when developing new procedures. At the discretion of the test engineer, or as requested by test sponsor, blocking and bracing and other dunnage members subject to failure may be instrumented at critical points with strain gages, load cells, and displacement gages.

3.1.4. Failure Criteria. At the conclusion of the tests, or at any time deemed necessary by the test engineer, the load shall be examined. Excessive shifting of contents, loosening or breaking of load restraints or blocking and bracing, deformation of tiedown fittings, or any visible damage to the items in the load or their packaging, or any other discernible damage which could render the item being shipped unsuitable/unsafe for its intended use, shall constitute failure. Normally, testing will be stopped when it becomes apparent that the load will fail; however, the test may be continued until complete failure if test engineer determines usable data will be developed and safety of personnel and equipment integrity will not be violated.

3.1.5. Report. Following the test, a report shall be prepared which shall include the following:

- a. A statement that the test was performed IAW this procedure, or if not, a description of deviations from the procedure.
- b. A drawing of the load (specimen) outloading procedure including, as appropriate, unit load, item and packaging dimensions and weights. If other than inert ammunition items are used to build the load, they should be listed and variation from actual munition noted.

c. The results of the test with the final condition of load described in detail. If test was stopped prior to completion IAW this procedure, damages to the load shall be described in detail.

d. A statement that the outloading procedure, or tactical vehicle, has been tested and found satisfactory for use in shipping live munitions, or that procedure was tested and found unsatisfactory. Causes for rejecting shall be detailed.

e. The report should include information, acquired through observation, to improve the outloading procedure being tested.

f. Photographic coverage (including still photos and/or TV tapes) will be provided during the test and will be used as a part of the report documentation to verify procedure certification and/or illustrate failure/damage.

#### 4. **TEST METHODS.**

4.1. Test Method No. 1 - Rail Impact Test. The test load or vehicle should be positioned in/on a railcar. For containers, the loaded container shall be positioned on a container chassis and securely locked in place using the twist locks at each corner. The container chassis shall be secured to a railcar. Equipment needed to perform the test includes the specimen (hammer) car, five empty railroad cars connected together to serve as the anvil, and a railroad locomotive. These anvil cars are positioned on a level section of track with air and hand brakes set and with the draft gears compressed. The locomotive unit pulls the specimen car several hundred yards away from the anvil cars, then pushes the specimen car toward the anvil at a predetermined speed, then disconnects from the specimen car approximately 50 yards away from the anvil cars, which allows the specimen car to roll freely along the track until it strikes the anvil. This constitutes an impact. Impacting is accomplished at speeds of 4, 6, and 8.1 mph in one direction and at a speed of 8.1 mph speed in the opposite direction. The 4 and 6 mph impact speeds are

approximate; the 8.1 mph speed is a minimum. Impact speeds are to be determined by using an electronic counter to measure the time required for the specimen car to traverse an 11-foot distance immediately prior to contact with the anvil cars (see figure 1).

**ASSOCIATION OF AMERICAN RAILROADS (AAR)  
STANDARD TEST PLAN**

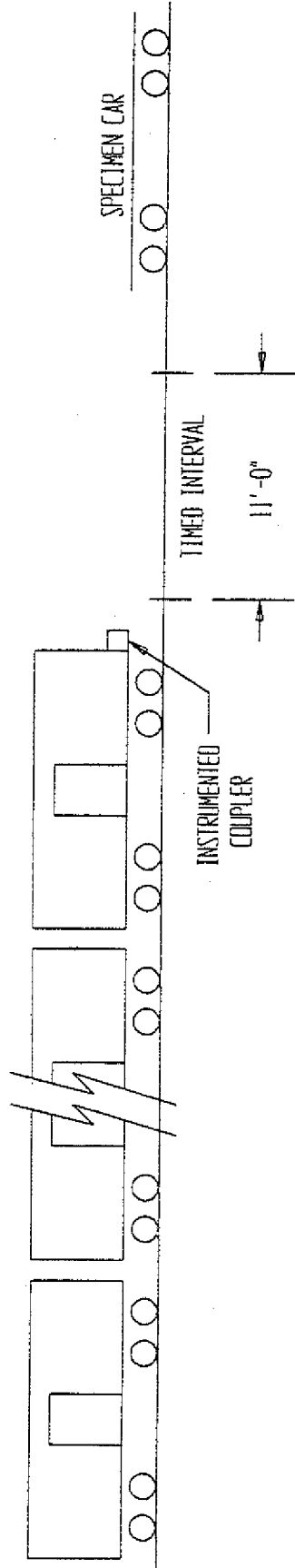

5 BUFFER CARS (ANVIL) WITH DRAFT GEAR  
COMPRESSED AND AIR BRAKES IN A SET  
POSITION

ANVIL CAR TOTAL WT 250,000 LBS (APPROX)

SPECIMEN CAR  
IS RELEASED BY  
SWITCH ENGINE TO

ATTAIN: IMPACT NO. 1 @ 4 MPH

IMPACT NO. 2 @ 6 MPH

IMPACT NO. 3 @ 8.1 MPH

THEN THE CAR IS REVERSED AND

RELEASED BY SWITCH ENGINE TO

ATTAIN: IMPACT NO 4. @ 8.1 MPH

FIGURE 1

**EDGEWISE - DROP  
(ROTATION) TEST**

**FEDERAL TEST METHOD  
5008**

## **EDGEWISE-DROP (ROTATIONAL) TEST**

### **1. SCOPE**

1.1. The following procedure is applicable for determining the ability of large shipping containers to resist the impacts of being dropped on their edges and for determining the ability of the packaging and packing methods to provide protection to the contents when the pack is dropped on its edges.

### **2. DEFINITIONS**

2.1. For the purpose of this test, a large shipping container may be a box, case, crate, or other container constructed of wood, metal, or other material, or any combination of these for which the free fall drop test is not considered practical or adequate. Large containers shall be considered those having:

(a) gross weight over 150 pounds,

(b) length of any edge over 60 inches, or

(c) gross weight under 150 pounds and the container is equipped with skids.

2.2. The level of packing to be provided for any item or contents is dependent upon the handling and shipping conditions which the container or pack may be expected to encounter. For the purpose of this standard the levels of packing shall be defined as:

2.2.1. Level A is the degree of preservation or packing required for protection of materiel against the most severe conditions known or anticipated to be encountered during shipment, handling, and storage. Preservation and packing designated Level A will be designed to protect

materiel against direct exposure to extremes of climate, terrain, operational and transportation environments without protection other than that provided by the pack. The conditions to be considered include, but are not limited to:

(a) Multiple handling during transportation and intransit storage from point of origin to ultimate user.

(b) Shock, vibration and static loading during shipment.

(c) Loading on shipdeck, transfer at sea, helicopter delivery and offshore or over-the-beach discharge, to ultimate user.

(d) Environmental exposure during shipment or during intransit operations where port and warehouse facilities are limited or non-existent.

(e) Extended open storage in all climatic zones.

(f) Static loads imposed by stacking.

2.2.2. Level B is the degree of preservation of packing required for protection of materiel under known favorable conditions during shipment, handling and storage. Preservation and packing designated Level B will be designed to protect materiel against physical damage and deterioration during favorable conditions of shipment, handling and storage. The conditions to be considered include but are no limited to:

(a) Multiple handling during transportation and intransit storage.

Shock, vibration and static loading of shipment worldwide by truck, rail, aircraft, or ocean transport.



(c) Favorable warehouse environment for extended periods.

(d) Environmental exposure during shipment and intransit transfers, excluding deck loading and offshore cargo discharge.

(e) Stacking and supporting superimposed loads during shipment and extended storage.

### **3. APPARATUS**

3.1. In conducting the edgewise-drop test, the container may be handled with any convenient equipment, such as a forklift truck, a hoist, or a block and tackle. A smooth, level, concrete surface (or similarly unyielding surface) shall be used in performing the edgewise-drop test.

### **4. SPECIMEN**

4.1. One container and its contents shall constitute a single specimen. The container shall be loaded for the test with the interior packing and the actual contents for which it was designed. If use of the actual contents is not practical, a dummy load shall be substituted to simulate such contents in weight, rigidity, shape, and center of gravity position in the container and appropriately instrumented to record shock forces or deflections during the test. Contents or dummy load, shall be blocked, braced, and cushioned in place as for shipment.

### **5. CONDITIONING OF SPECIMEN**

5.1. All tests shall be conducted at room temperature 70 degrees +/- 20 degrees F.

### **6. PROCEDURE**

6.1. The specimen shall be placed on its bottom with one end of the base of the container supported on a sill nominally 6 inches high. The height of the sill shall be increased if necessary to insure that there will be no support for the base between the ends of the container when dropping takes place, but should not be high enough to cause the container to slide on the supports when the drop end is raised for the drop. The unsupported end of the container shall then be raised and allowed to fall freely to the concrete surface of similarly unyielding surface from a prescribed height (see figure 1). Unless otherwise specified, the height of drop for Levels A and B protection shall conform to Table I. The maximum heights shall not exceed 36 inches for Level A and 27 inches for Level B protection.

Unless otherwise specified, a total of four drops constitute a complete test. If the size of the container and the location of the center of gravity are such that the drop cannot be made from the prescribed height, the height of the sill shall be increased. Rectangular containers shall be dropped once on each edge of the container base.

Cylindrical containers shall be dropped on the top and bottom rims at diagonally opposite quadrants. The quadrant pairs shall be separated by approximately 90 degrees. If a total of more than four rim drops is specified, the additional drops shall be on sections not previously dropped upon.

If the test specimen contains materials which are affected by temperature, the test shall be conducted while the container is stabilized at the extremes of temperature. Unless otherwise specified, half the total number of drops shall be made at -20 degrees +/- 5 degrees F and half shall be made at 140 degrees +/- 5 degrees F.

## **7. REPORT**

7.1. Following the test a report shall be written which shall include the following:

7.1.1. A statement that the test was conducted in compliance with this procedure, or a description of the deviation from this procedure. Report all options selected and "otherwise specified" details that were followed as permitted in 2.1, 5.1, and 6.1.

7.1.2. Container dimensions, container structural details, type of materials used, spacing, size and type of fasteners, methods of closing and strapping, and the net and gross weights.

7.1.3. A description of the contents of the container including blocking, bracing, cushioning, or isolation system.

7.1.4. The results of the test, describing the final condition of both container and contents.

7.1.5. When the test is conducted to determine satisfactory performance of a container or pack, the report shall include a statement that the container or pack either attained or did not attain the specified performance. If not specified elsewhere, it is suggested that the following be cause for rejection:

(a) Functional or physical damage to the contents.

(b) Functional damage to the container.

(c) Shock forces on the contents (or dummy load) which exceeds the established fragility of the contents.

(d) Failure of a vapor or waterproof container to prevent vapor transmission or water leakage within specified limits.

(e) Structural damage to the container which may result in damage to the contents during subsequent shipping, handling, or storage. Substantial spillage, exposure, or shifting of the

contents are examples of such damage. Minor damage such as dents, paint chipping, or the crushing of wood members which do not impair the function of the container are not causes for rejection.

7.1.6. The report should include information, acquired through observation, to improve container or methods of packing.

## **8. NOTES**

8.1. This test is meant to simulate the impacts of accidentally dropping a container on its edges. It is intended that the edgewise-drop test shall be used only on containers that are susceptible to accidental edgewise drops. The edgewise-drop test was designed specifically for large and/or heavy shipping containers that are likely to be handled mechanically rather than manually. Details are given with the qualification, "unless otherwise specified," in paragraphs regarding:

Definition of large containers (2.1.).

Conditioning of specimens (5.1.).

Number and height of drops (6.1.).

8.2. When the edgewise-drop test is performed to evaluate the protection provided for the contents, the rigidity of a dummy load should closely approximate that of the actual contents for which the container was designed.

Table I. Height of rotational drops for containers of various sizes and weights 1/

| Gross weight<br>(within range limits) | Dimensions of any edge,<br>Height or width<br>(within range limits) |        | Height of drops<br>on edges |                   |
|---------------------------------------|---|--------|-----------------------------|-------------------|
|                                       | Pounds  | Inches | Level A<br>Inches           | Level B<br>Inches |
| 150 - 250                             | 60 - 66   |        | 36                          | 27                |
| 250 - 400                             | 66 - 72   |        | 32                          | 24                |
| 400 - 600                             | 72 - 80   |        | 28                          | 21                |
| 600 - 1000                            | 80 - 95   |        | 24                          | 18                |
| 1000 - 1500                           | 95 - 114  |        | 20                          | 16                |
| 1500 - 2000                           | 114 - 144   |        | 17                          | 14                |
| 2000 - 3000                           | Above 145 - No limit  |        | 15                          | 12                |
| Above - 3000                          |   |        | 12                          | 9                 |

1/ Use the lowest drop height indicated by either gross weight or dimension. For example, a container having a gross weight of 440 lbs. and a maximum edge dimension of 95-5/8" shall be dropped 20 for Level A tests, or 16 inches for Level B test.

METHOD 5003.1  
March 13, 1980

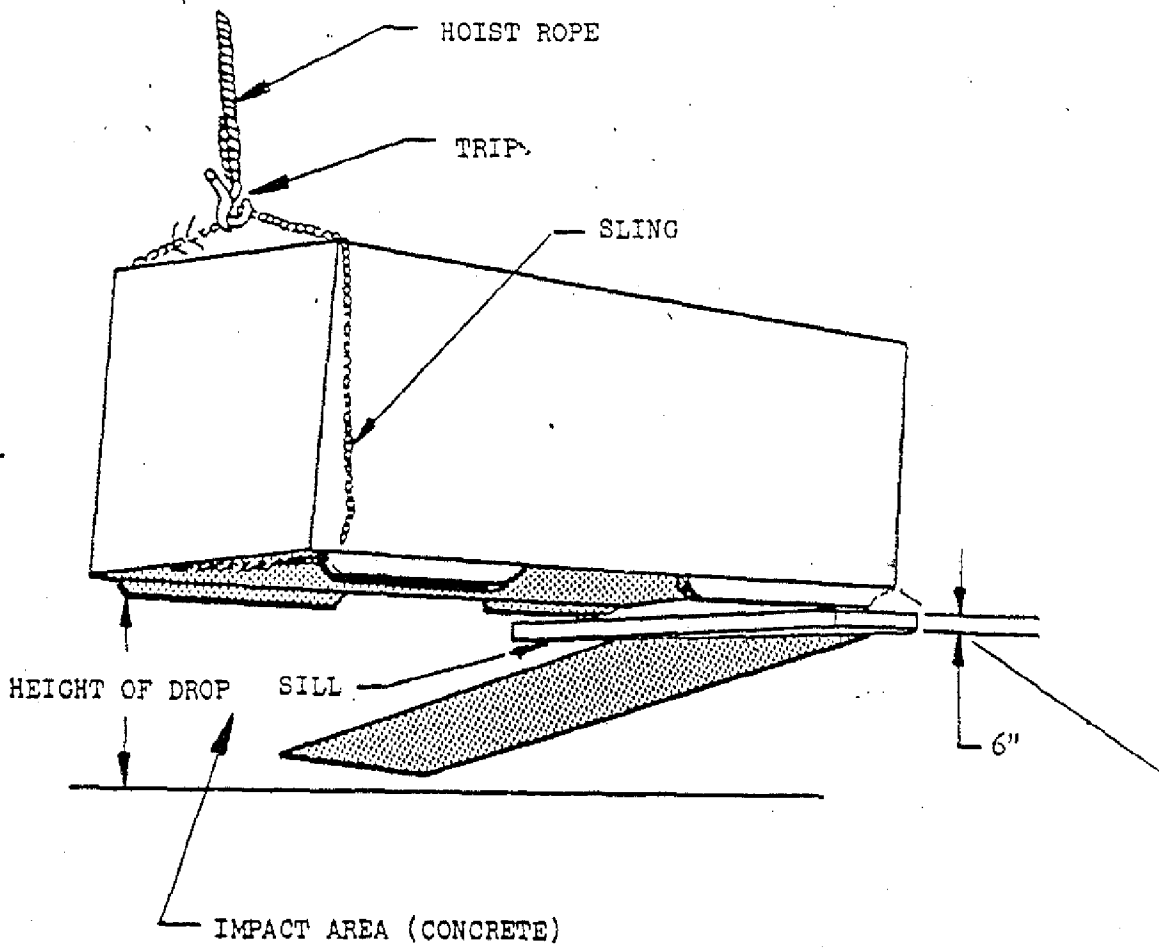

Figure 1. Edgewise drop (Rotational)

## PART 4

### TEST RESULTS

Rail impact tests were conducted on four 750 pound bombs with cylindrical cuts (0.20 inch deep) around the mid-section of each bomb. Ref: two bombs at each end of the boxcar. Additional 750 pound bombs were used to fill out a complete row of this munitions. Rail impacts were conducted at 4, 6, 8, and reverse 8 mph. Following the rail impact tests, the dunnage (blocking and bracing) at each end of the rail car showed severe damage, with no damage sustained to the bombs. See Section 5 for a visual representation of the damage sustained to the blocking and bracing following rail impacts. It is highly recommended that prior to shipment of the M117 munitions, the blocking and bracing be strengthened to avoid potential damage to the bombs.

Edgewise-Rotational Drop Tests: Following the rail impact tests, edgewise-rotational drop tests were conducted per Federal Test Method 5008 (level B requirements). During the four drops per pallet (two bombs per pallet) no significant changes were noted in the bomb(s) physical condition, with no permanent deformation noted.

Prior to and following each series of tests, three measurements of the groove width were taken at approximately 120 degrees intervals around the circumference of the bomb. These measurements were taken to determine if compression or expansion of the groove was taking place. The attached data indicates that there was no clear cut expansion or contraction of the groove following testing. As can be noted from the data, there were deviations in the measurements, with a range of -0.13 to +0.21 millimeters. This variation is more than likely due to the accuracy of the measurement equipment and the location at which the measurement was taken and not movement in the bomb body.

# 750lb Bomb TEST RESULTS

August 3rd 1999

All dimensions in millimeters

## RAIL

## DROP

Before Impact **BOMB A**

| Bomb   | A1   | A2   | A3   |
|--------|------|------|------|
| Top    | 6.18 | 6.02 | 6.02 |
| Bottom | 5.19 | 5.37 | 5.25 |

After Impact

| Bomb   | A1   | A2   | A3   |
|--------|------|------|------|
| Top    | 6.12 | 6.00 | 5.99 |
| Bottom | 5.18 | 5.36 | 5.12 |

Deviation in Dimensions (+/-)

| Bomb   | A1     | A2     | A3     |
|--------|--------|--------|--------|
| Top    | - 0.06 | - 0.02 | - 0.03 |
| Bottom | - 0.01 | - 0.01 | - 0.13 |

Before drop **BOMB A**

| Bomb   | A1   | A2   | A3   |
|--------|------|------|------|
| Top    | 6.12 | 6.00 | 5.99 |
| Bottom | 5.18 | 5.36 | 5.12 |

After drop

| Bomb   | A1   | A2   | A3   |
|--------|------|------|------|
| Top    | 6.21 | 6.00 | 5.94 |
| Bottom | 5.39 | 5.53 | 5.33 |

Deviation in Dimensions (+/-)

| Bomb   | A1     | A2     | A3     |
|--------|--------|--------|--------|
| Top    | + 0.09 | 0.00   | - 0.05 |
| Bottom | + 0.21 | + 0.17 | + 0.21 |

Before Impact **BOMB B**

| Bomb   | B1   | B2   | B3   |
|--------|------|------|------|
| Top    | 6.79 | 6.67 | 6.73 |
| Bottom | 5.79 | 6.15 | 5.93 |

After Impact

| Bomb   | B1   | B2   | B3   |
|--------|------|------|------|
| Top    | 6.61 | 6.60 | 6.66 |
| Bottom | 5.92 | 6.14 | 5.82 |

Deviation in Dimensions (+/-)

| Bomb   | B1     | B2     | B3     |
|--------|--------|--------|--------|
| Top    | - 0.18 | - 0.07 | - 0.07 |
| Bottom | + 0.13 | - 0.01 | - 0.11 |

Before drop **BOMB B**

| Bomb   | B1   | B2   | B3   |
|--------|------|------|------|
| Top    | 6.61 | 6.60 | 6.66 |
| Bottom | 5.92 | 6.14 | 5.82 |

After drop

| Bomb   | B1   | B2   | B3   |
|--------|------|------|------|
| Top    | 6.68 | 6.69 | 6.68 |
| Bottom | 5.94 | 6.08 | 5.98 |

Deviation in Dimensions (+/-)

| Bomb   | B1     | B2     | B3     |
|--------|--------|--------|--------|
| Top    | + 0.07 | + 0.09 | + 0.02 |
| Bottom | + 0.02 | - 0.06 | + 0.16 |



# RAIL

# DROP

All dimensions in millimeters

All dimensions in millimeters

Before Impact **BOMB C**

Before drop **BOMB C**

| Bomb   | C1   | C2   | C3   |
|--------|------|------|------|
| Top    | 6.10 | 5.97 | 6.16 |
| Bottom | 5.35 | 5.37 | 5.44 |

| Bomb   | C1   | C2   | C3   |
|--------|------|------|------|
| Top    | 6.09 | 5.98 | 6.13 |
| Bottom | 5.33 | 5.43 | 5.48 |

After Impact

After drop

| Bomb   | C1   | C2   | C3   |
|--------|------|------|------|
| Top    | 6.09 | 5.98 | 6.13 |
| Bottom | 5.33 | 5.43 | 5.48 |

| Bomb   | C1   | C2   | C3   |
|--------|------|------|------|
| Top    | 6.05 | 6.02 | 6.12 |
| Bottom | 5.35 | 5.47 | 5.45 |

Deviation in Dimensions (+/-)

Deviation in Dimensions (+/-)

| Bomb   | C1     | C2     | C3     |
|--------|--------|--------|--------|
| Top    | - 0.01 | + 0.01 | - 0.03 |
| Bottom | - 0.02 | + 0.06 | + 0.04 |

| Bomb   | C1     | C2     | C3     |
|--------|--------|--------|--------|
| Top    | - 0.04 | + 0.04 | - 0.01 |
| Bottom | + 0.02 | + 0.04 | - 0.03 |

Before Impact **BOMB D**

Before drop **BOMB D**

| Bomb   | D1   | D2   | D3   |
|--------|------|------|------|
| Top    | 5.94 | 6.06 | 6.34 |
| Bottom | 5.23 | 5.63 | 5.44 |

| Bomb   | D1   | D2   | D3   |
|--------|------|------|------|
| Top    | 6.01 | 6.09 | 6.40 |
| Bottom | 5.23 | 5.68 | 5.40 |

After Impact

After drop

| Bomb   | D1   | D2   | D3   |
|--------|------|------|------|
| Top    | 6.01 | 6.09 | 6.40 |
| Bottom | 5.23 | 5.68 | 5.40 |

| Bomb   | D1   | D2   | D3   |
|--------|------|------|------|
| Top    | 6.06 | 6.11 | 6.38 |
| Bottom | 5.36 | 5.73 | 5.44 |

Deviation in Dimensions (+/-)

Deviation in Dimensions (+/-)

| Bomb   | D1     | D2     | D3     |
|--------|--------|--------|--------|
| Top    | + 0.07 | + 0.03 | + 0.06 |
| Bottom | 0.00   | + 0.05 | - 0.04 |

| Bomb   | D1     | D2     | D3     |
|--------|--------|--------|--------|
| Top    | + 0.05 | + 0.02 | - 0.02 |
| Bottom | + 0.13 | + 0.05 | + 0.04 |

**PART 5**

**PHOTOGRAPHS**

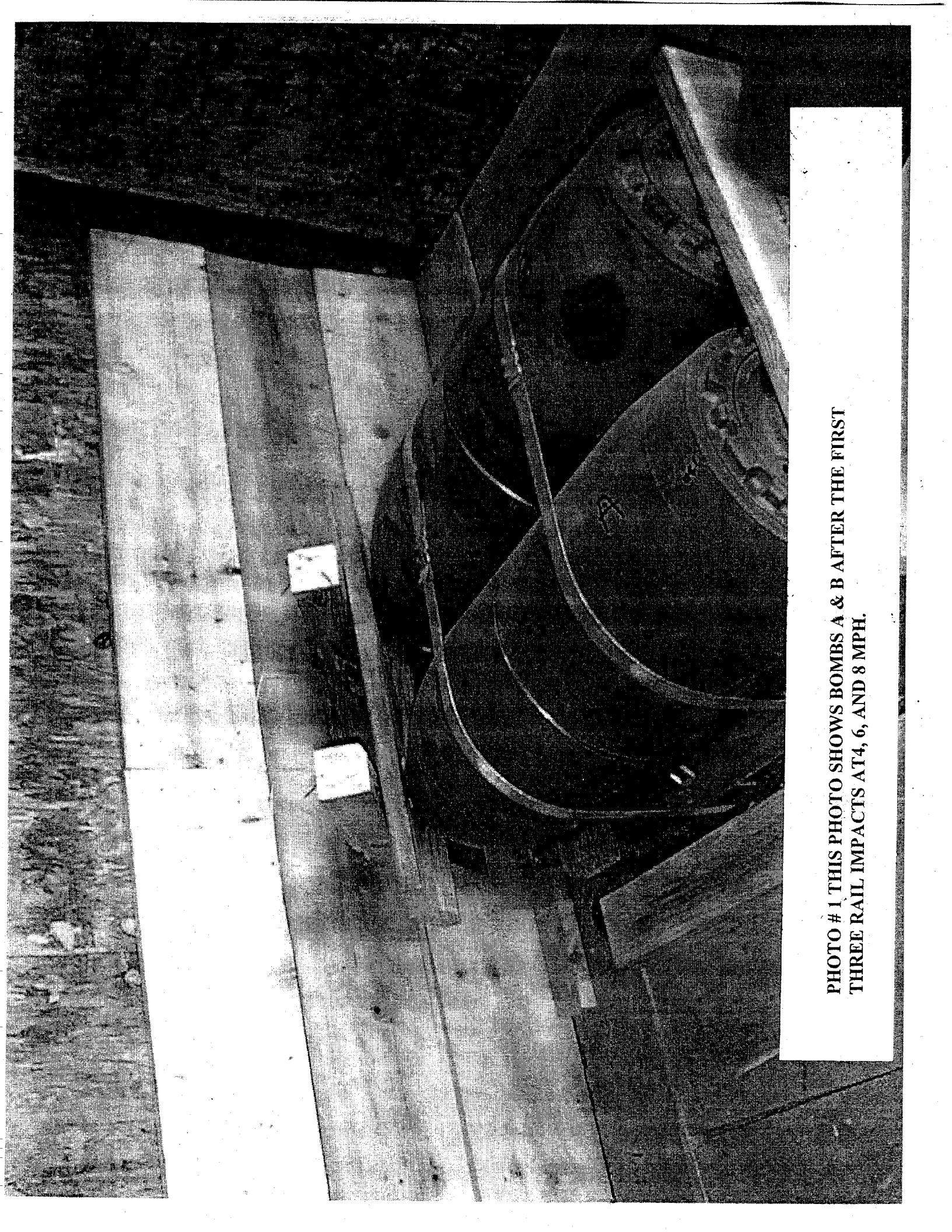
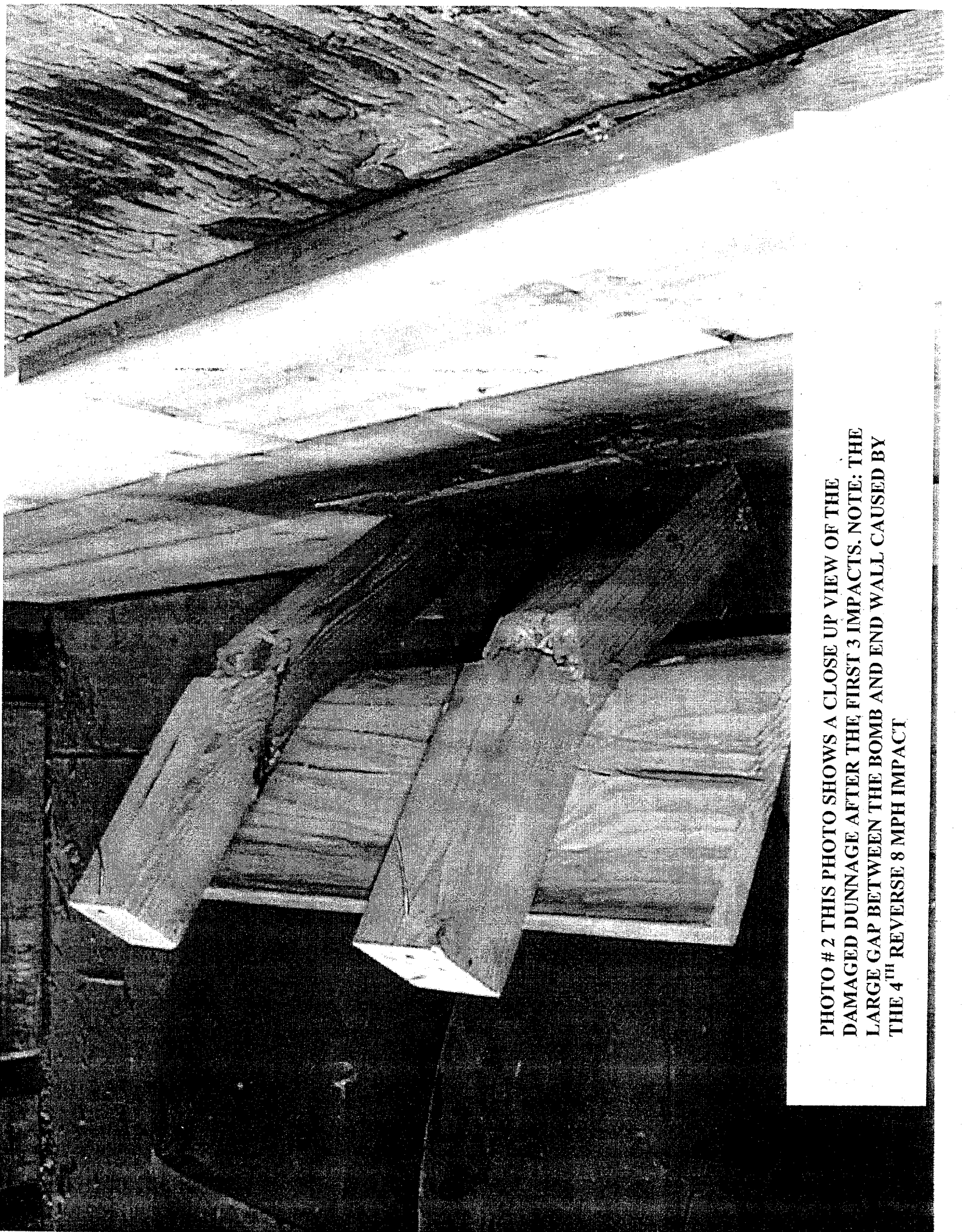

PHOTO # 1 THIS PHOTO SHOWS BOMBS A & B AFTER THE FIRST  
THREE RAIL IMPACTS AT 4, 6, AND 8 MPH.



**PHOTO # 2 THIS PHOTO SHOWS A CLOSE UP VIEW OF THE DAMAGED DUNNAGE AFTER THE FIRST 3 IMPACTS. NOTE: THE LARGE GAP BETWEEN THE BOMB AND END WALL CAUSED BY THE 4<sup>TH</sup> REVERSE 8 MPH IMPACT**



**PHOTO # 3 THIS PHOTO SHOWS BOMBS C & D AFTER THE 4<sup>TH</sup> AND  
FINAL IMPACT AT 8 MPH.**

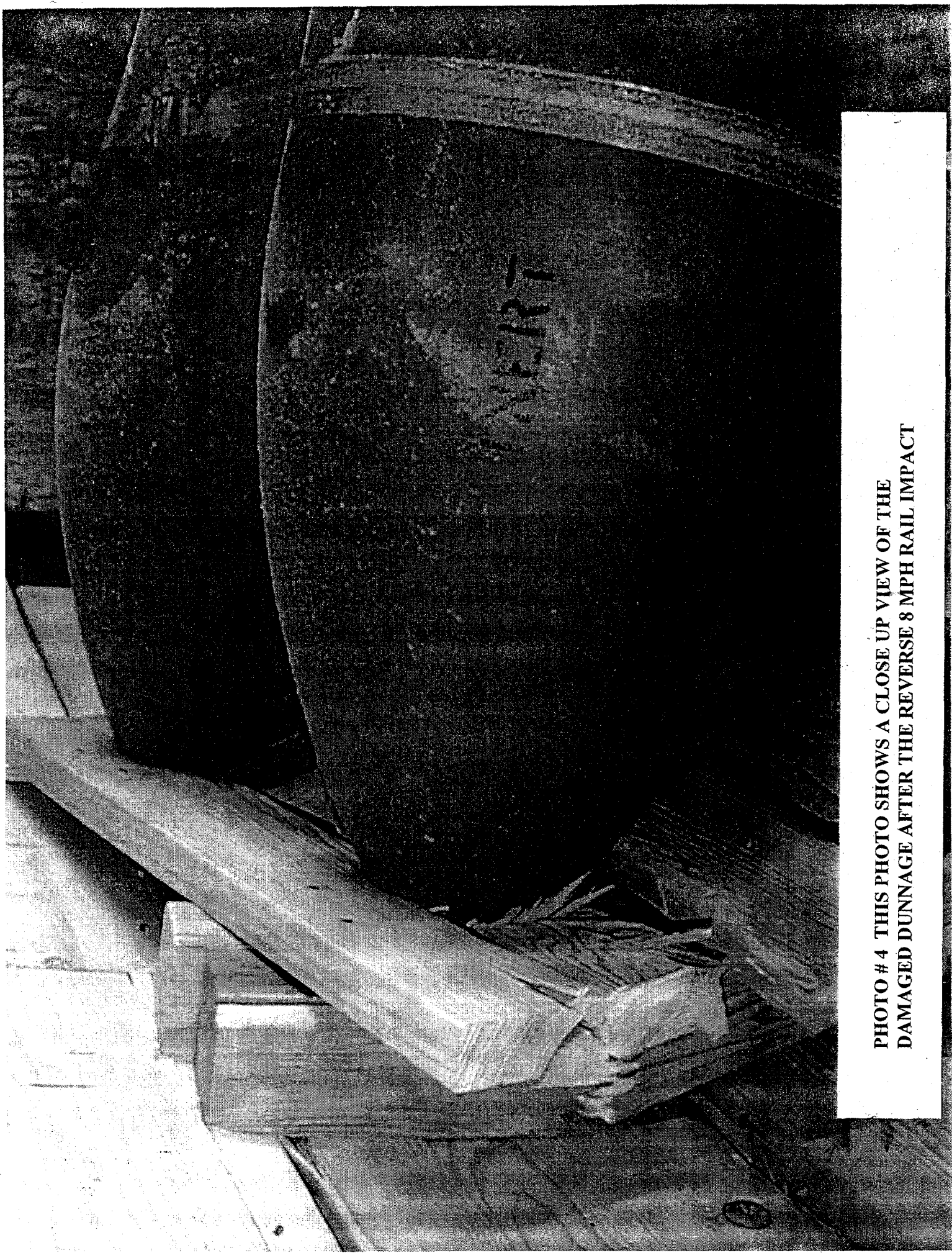

**PHOTO # 4 THIS PHOTO SHOWS A CLOSE UP VIEW OF THE DAMAGED DUNNAGE AFTER THE REVERSE 8 MPH RAIL IMPACT**