

INTERSTATE COMMERCE COMMISSION

WASHINGTON

REPORT OF THE DIRECTOR

BUREAU OF SAFETY

ACCIDENT ON THE

PERE MARQUETTE RAILWAY

BEECH, MICH.

DECEMBER 17, 1937.

INVESTIGATION NO. 2236

SUMMARY

Inv-2236

Railroad:	Pere Marquette
Date:	December 17, 1937.
Location:	Beech, Mich.
Kind of accident:	Derailement
Train involved:	Passenger
Train number:	103
Engine number:	707
Consist:	5 cars
Speed:	45-52 m.p.h.
Track:	Tangent. 0.8 percent ascending grade.
Time:	9:36 a.m.
Weather:	Cloudy
Casualties:	34 injured
Cause:	Spreading of the track

January 21, 1938.

To the Commission:

On December 17, 1937, there was a derailment of a passenger train on the Pere Marquette Railway near Beech, Mich., which resulted in the injury of 30 passengers, 5 employees off duty and 1 employee on duty.

Location and method of operation

This accident occurred on that part of Subdivision No. 1 of the Detroit-Grand Rapids Division which extends between Detroit and Plymouth, Mich., a distance of 24.64 miles. In the vicinity of the point of accident this is a double-track line over which trains are operated by timetable, train orders, and an automatic block-signal system, supplemented by automatic train-stop devices of the intermittent-inductive type.

The point of derailment is located on the westward main track 2,450 feet west of the station at Beech. Approaching this point from the east the track is tangent for more than 2 miles, followed by a $0^{\circ} 20'$ curve to the left 464 feet in length and then a tangent which extends, 1,714 feet to the point of accident and a considerable distance beyond. The grade is slightly undulating and is 0.03 percent ascending for west-bound trains at the point of derailment.

For a distance of 1,716 feet westward, beginning at a point 1,719 feet west of Beech station, the track is laid on a concrete slab roadbed. Of this stretch, 1,326 feet on the east end was laid in 1926 while the balance was laid in 1929. The derailment occurred on the older stretch of this roadbed; the track structure consists of steel-reinforced concrete slabs 39 feet long, 10 feet wide and 21 inches thick. The steel reinforcement consists of a structural frame made up of two longitudinal trusses placed vertically in the plane of the two rails and secured by $\frac{3}{4}$ -inch tie-rods spaced at intervals of 6 feet along the top chord of the truss, and steel-bar cross-frames spaced 12 feet apart. At intervals of 27 inches $\frac{1}{2}$ by 2-inch steel stirrups are bolted to the top chord; these stirrups are designed to provide means for bolting rail-clips to each side of the rail for the purpose of securing the rail to the roadbed. These rail-clips are 2 by $3\frac{1}{4}$ by $\frac{3}{4}$ inches and the bottom face of each is chamfered along the edge in such manner as to fit the rail base. The track bolts used to secure the rail-clips to the stirrups are $2\frac{1}{2}$ by $\frac{5}{8}$ inches. In order to provide insulation for the rails, a fibre plate $\frac{1}{8}$ inch thick by $5\frac{1}{4}$ inches wide is placed beneath the base of the rail

o	Detroit, Mich.
	7.06 mi.
o	Rougemere
	9.08 mi.
o	Beech
X	Point of accident
	8.50 mi.
o	Plymouth, Mich.

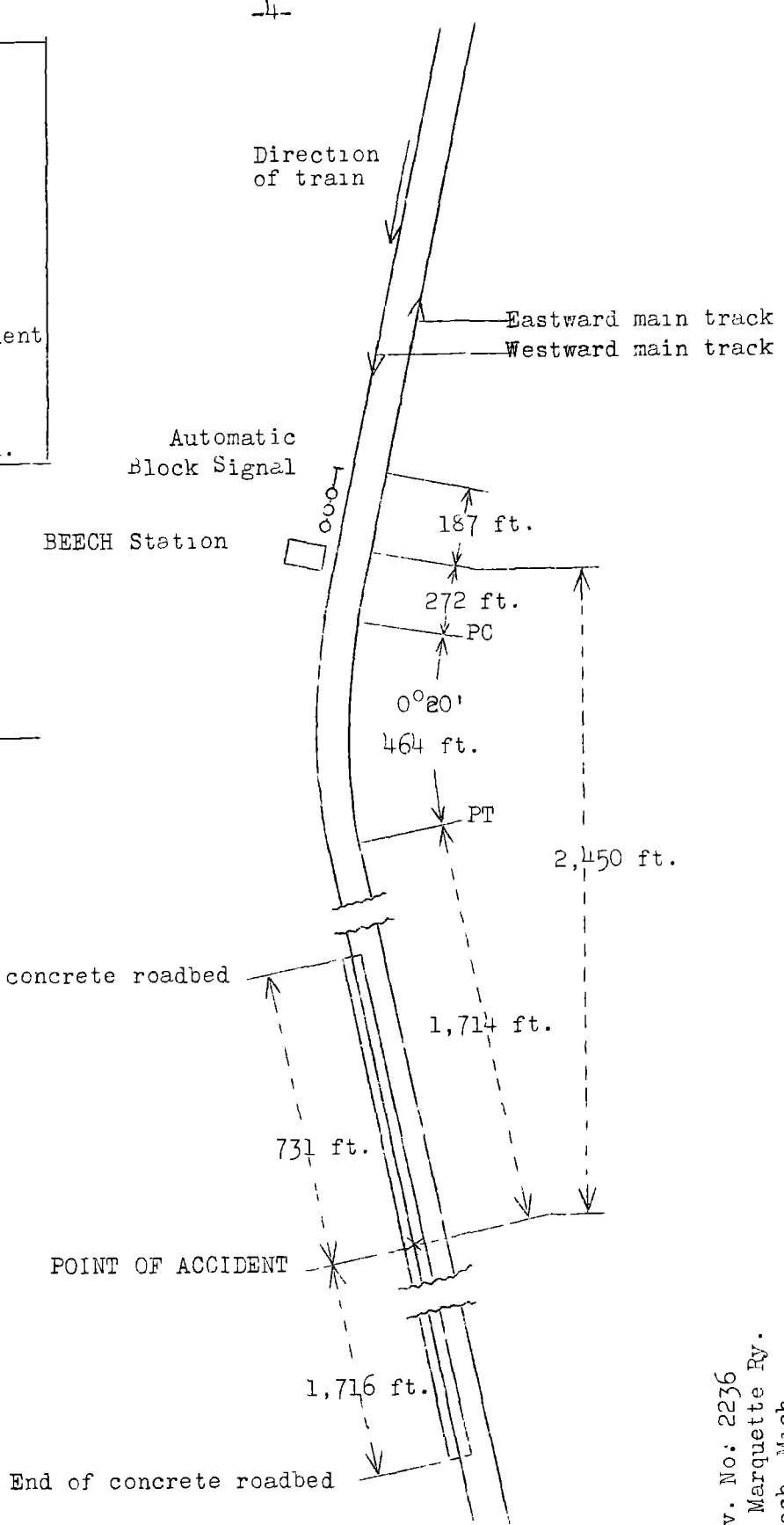
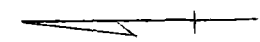

Inv. No: 2236
 Pere Marquette Ry.
 Beech, Mich.
 Dec. 17, 1937

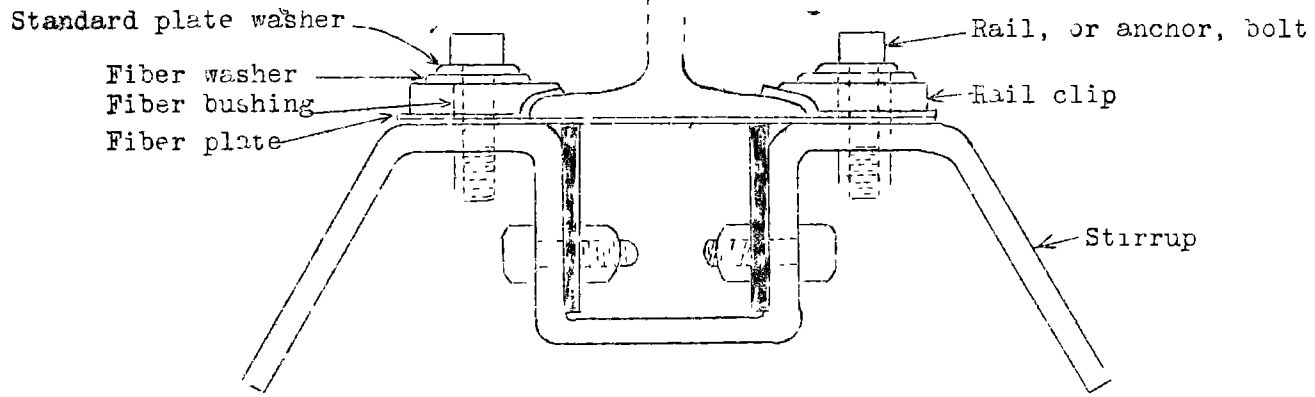

Detail of rail fastenings

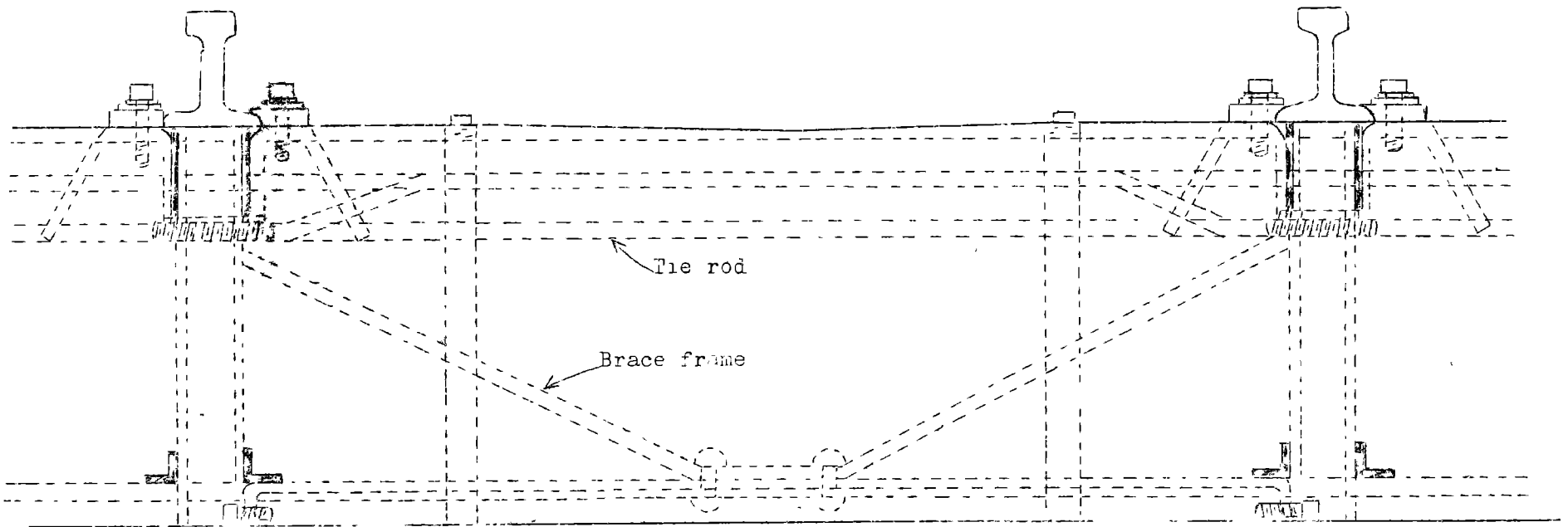

for its entire length; fibre plates 1/8-inch thick are placed under each rail-clip and the bolt-hole in the stirrup is bushed with fibre.

This entire stretch of concrete slab roadbed is laid on a fill varying from 3 feet to 6 feet in height. The track is laid with 90-pound butt-welded continuous rail.

A 3-position, approach-lighted, automatic block-signal, governing west-bound trains, is located 2,637 feet east of the point of derailment. The maximum authorized speed for passenger trains is 60 miles per hour.

The weather was cloudy at the time of the accident which occurred about 9:36 a.m.

Description

No. 103, a west-bound passenger train, consisted of one express car, one baggage car, one mail car, one combination coach and baggage car, and one coach, in the order named, all of all-steel construction except the express car which was of steel underframe construction, with steel and wood superstructure, hauled by engine 707, of the 4-6-2 type, and was in charge of Conductor Wheaton and Engineman Houston. This train left Detroit, its initial station, at 9:05 a.m., according to the train sheet, 15 minutes late, passed Rougemere, 11.44 miles east of the point of accident, at 9:24 a.m., still 15 minutes late, and was derailed while traveling at a speed estimated at between 45 and 52 miles per hour.

The engine was not derailed; it stopped 1,105 feet west of the point of derailment. The tender and first and second cars were derailed to the right but remained coupled and stopped upright and nearly in line with the track. The remaining three cars were derailed to the north and stopped on their right sides parallel to the track. The employee on duty who was injured was the brakeman.

Summary of evidence

Engineman Houston, of No. 103, stated that a terminal test of the air brakes was made at Detroit and all brakes were found to be operative. In making a running test at that point, and in making two slow-downs en route the brakes functioned satisfactorily. At Beech the automatic block-signal was displaying a clear indication. Approaching the section of concrete roadbed at a speed of about 50 miles per hour, he did not notice anything wrong with the track. His first intimation of the derailment was a jerk

which caused him to look to the rear where he saw the cars being derailed; he then made an emergency application of the brakes. During the trip the riding qualities of the engine were good.

Fireman Tomford, of No. 103, estimated the speed at the time of derailment as between 48 and 52 miles per hour.

Conductor Wheaton, of No. 103, stated that the speed of the train at the time of derailment was not over 50 miles per hour, and the train was riding smoothly up to that time. After the accident he examined the track to the rear of the train and found no marks to indicate that any part of the equipment was dragging prior to the derailment.

Members of the crew of passenger train No. 3, the last train to pass over the section of concrete roadbed prior to the derailment, stated that their train passed that point about 25 minutes ahead of No. 103, traveling at a speed of 50 or 55 miles per hour, and at that time there was no apparent defect in the track.

Section Foreman Savale, in charge of the section on which the accident occurred, stated that he has assisted in the maintenance of the section of concrete roadbed since 1929. He patrols this section of track every day but had not yet made his daily inspection at the time the derailment occurred. He was following No. 103 on a motor-car and witnessed the derailment from a point some distance to the rear of that train. As he came up to the derailed train he did not see any marks made by dragging equipment. He stated it is necessary to renew clip retaining bolts nearly every day, sometimes as many as 8 or 10 at a time, and breakage occurs more often in the winter than in the summer; most of the breakage occurs in the old section of concrete. When these bolts break they snap off and sometimes the clips are found in the ditch. In October, 1937, he made a complete check-up of the concrete roadbed and put the track in the best possible condition. At that time the gauge was about $\frac{1}{8}$ inch wide; no check of the gauge has been made since that time. On December 14 he renewed about 10 bolts, some on each side of the track, and some close to the point of derailment. On the 15th he tested the bolts and found them all tight; on the 16th he rode over this section of track and did not notice any indication of wide gauge. Whenever bolts are renewed the gauge is corrected if necessary, but on this section of track the gauge is always about $\frac{1}{8}$ inch wider than that of track laid on ties. He has had more trouble this year than in previous years on this stretch of track; and thinks that all of the bolts are becoming weaker due to getting rusty.

Track Supervisor Meier stated that the principal trouble experienced with the track on the old section of concrete roadbed was due to breakage of the track anchor bolts at or beneath

the surface of the concrete. This trouble started as soon as the section of track was placed in operation. There has been no trouble due to heaving of the roadbed but occasionally a variation of cross-levels, not exceeding 1/16-inch, develops due to wear of the insulating material under the rail or the swelling of this material due to saturation. A rigid inspection is maintained, the section foreman having instructions to patrol the section daily. It was his opinion that the derailment was due to failure of the rail fastenings which permitted the rail to move out sufficiently for the wheels to drop inside of the rails. He was unable to state definitely how many anchor bolts were broken monthly but estimated the number at from 8 to 15. He thought, too, that the accumulation of snow and ice on the inside of the rails might have tended to move the rails out of place. After the accident he found that all of the fastenings on the north side of the north rail westward from the point of derailment were broken or out of place.

Division Engineer Morrison stated that the concrete slab roadbed was completed and placed in operation in December, 1926. The rail was laid perpendicular on a horizontal base; no canting of the rail was allowed. The movement of engines and trains over any track has a natural tendency to force the rails apart and slightly roll the ball outward. This fact and the small tolerance in the rail fastenings when taken up under traffic permitted the gauge to widen uniformly to 4 feet 9 inches. No difficulty has been experienced in maintaining this as normal gauge on the concrete roadbed. No trouble has been experienced in the maintenance of the concrete; there has been no settlement or movement of the slab, nor has there been any deterioration in the concrete. Because of the extreme range of temperature in this locality there was contraction and expansion of the rails and the movement of the rail caused thereby wore the insulation fibre and moved the clips out of normal position. In the winter when the joints were open, battering of the ends of the rails resulted. No hazard was created by this condition because a close inspection was maintained and wear was taken up and replacements made as soon as breakage or wear was detected. This situation continued until the fall of 1933 when the rails on the west half of the 1926 installation were butt-welded to form a continuous rail. This proved successful in controlling contraction and expansion and in 1935 the rails in the balance of the 1926 installation were also butt-welded. As a result, rail movement due to change in temperature has been almost entirely eliminated on that section of the roadbed. When first constructed, a five-ply layer of Fibrock was placed under the rail as insulation. During the

first winter of operation numerous failures in the operation of the block signals required replacement of the Fiberock with standard insulation fibre. This fibre is 1/8 inch thick and has proved satisfactory for insulating purposes. The rail clips and anchor bolts are insulated with the same material. He was of the opinion that the wide gauge east of the point of derailment developed under train No. 103 or the train immediately preceding it, and thought that a factor of considerable importance among the possible causes of derailment was the icy condition caused by the rain and sleet storm of December 14th. While it was evident that spreading of the rails was the immediate cause of derailment, the manner in which the north rail was bent around the last bolt that remained in place indicates that some abnormal stress was applied, but just what this stress might have been he was unable to state. However, inasmuch as the inspection and maintenance at the present time is the same as that which has been practiced for the last 11 years without derailment occurring, he concluded that this accident was occasioned by the application of some unknown powerful force, as above suggested, or by swelling of the insulating materials due to having become saturated and then frozen. The resultant swelling raised the rail clips, permitting the rail to move outward and establish a track gauge 1 inch wide. He stated that during the year 1937 up to the date of derailment 410 anchor bolts were replaced on the concrete roadbed; the number replaced monthly ranged from zero in September to 150 in February. Most of these bolts were damaged during the renewal of insulation. After the derailment the track for over 500 feet east of the point of derailment was gauged and the gauge ranged from 4 feet 9 inches to 4 feet 10 $\frac{1}{2}$ inches; on the same stretch the track levels varied from 1/8 inch high to 3/8 inch low. West of the point of derailment 261 rail fastenings were broken off on the north side of the north rail and 9 on the south side.

Car Foreman Gilles stated that after the accident he made an inspection of the cars involved in the derailment and found all wheels to be in good condition, and no parts of the trucks dragging.

Master Mechanic Kuhn stated that he supervised an inspection of the locomotive involved in the derailment after it had completed the trip during which the accident occurred and found nothing about the engine that would have caused any trouble.

Observations of the Commission's Inspectors

The track was covered with about 2 inches of ice. The rail clips and the anchor bolts had been cut off along the north rail and that rail, for a distance of 1,031 feet west of the point of

derailment, had been moved outward. The rail was broken at a point 325 feet west of the point of initial derailment. Inspection of the equipment involved in the accident disclosed nothing broken or dragging that might have contributed to the derailment.

Discussion

The evidence indicates that no defect existed in the equipment of No. 103 that would have caused the derailment; there was no indication that anything had been dragging. There were indications, however, that wide gauge resulting from spreading of the track had developed. Four feet 9 inches is the normal gauge on this concrete roadbed. After the accident the gauge of the track east of the point of derailment ranged from 4 feet 9 inches to 4 feet 10 $\frac{1}{2}$ inches; west of the point of derailment the rail was pushed away from its fastenings and 261 fastenings on the north side of the north rail were broken off. The evidence disclosed that since the concrete roadbed was placed in service breakage of track anchor bolts has been frequent and a daily patrol has been found necessary to insure safe maintenance. In the 16 days in December prior to the date of the accident, 15 bolts were replaced and about 10 of these replacements were made on December 14th. The insulation used under the rail and under the rail clips in this installation is subject to swelling when water-soaked, and the division engineer advanced the theory that due to a rain which fell 2 days prior to the accident saturation took place and the freezing temperature which followed the rain caused swelling of the insulation sufficient to raise the clips and permit the base of the rail to move outward under the pressure of the weight of a train. The division engineer also stated that the manner in which the rail was bent around the last anchor bolt which remained in place suggested that a powerful blow of some kind delivered near that point had initiated the outward movement of that rail, but nothing to substantiate this theory was found. Two days before the accident the anchor bolts were inspected and none was found to be loose; this was the last inspection made of the track on the concrete roadbed prior to the accident except observations made while moving over it on a motor car.

Conclusion

This derailment was caused by spreading of the track, apparently due to failure of rail fastenings used on track of special construction.

Respectfully submitted,

W. J. PATTERSON,

Director.