

**FLIGHT SIMULATOR EVALUATION OF  
BASELINE CREW PERFORMANCE  
WITH THREE DATA LINK INTERFACES**

ALBERT J REHMANN

September 1995

DOT/FAA/CT-TN95/19

This document is available to the public  
through the National Technical Information  
Service, Springfield, Virginia 22161

1. Report No. DOT/FAA/CT-TN95/19		2. Government Accession No.		3. Recipient's Catalog No.	
4. Title and Subtitle Flight Simulator Evaluation of Baseline Crew Performance With Three Data Link Interfaces				5. Report Date September 1995	
				6. Performing Organization Code	
7. Author(s) Albert J. Rehmann; R.N.H.W. van Gent, H.G.M Bohnen and P.G.A.M. Jorna, NLR				8. Performing Organization Report No. DOT/FAA/CT-TN95/19	
9. Performing Organization Name and Address National Aerospace Laboratory NLR P. O. Box 90502 Amsterdam, The Netherlands				10. Work Unit No. (TRAIS)	
				11. Contract or Grant No. MOC /AIA/CA-52-2-2	
12. Sponsoring Agency Name and Address U.S. Department of Transportation Federal Aviation Administration Technical Center Atlantic City International Airport, NJ 08405				13. Type of Report and Period Covered Technical Note	
				14. Sponsoring Agency Code	
15. Supplementary Notes					
16. Abstract  <p>This study was conducted the National Laboratory for Research of the Netherlands under cooperative sponsorship by the Federal Aviation Administration (FAA), and the Ministry of Transport of the Netherlands. The purpose of the study was the evaluation and measure of fundamental level of effort associated with the use of Data Link as a communications medium.</p> <p>Three Data Link interface designs were evaluated which combined effects of location, operability, size, and level of integration with the cockpit. The scenario was an oceanic flight of 2 hours duration, from a point over the North Atlantic, across the British Isles to a landing at Sciphol Airport, Amersterdam. Experimental conditions included routine flight and diversions in the flight due to oceanic storms and turbulence, enroute traffic conflicts, and airport runway closings. Data measures included subjective assessments of display usefulness, workload, and overall acceptability of Data Link compared to voice and objective measures of level of effort, and errors.</p> <p>Overall, Data Link was rated acceptable in certain flight regimes, and unacceptable in others. Where excessive key entries were required, the Data Link function was rated lower than voice, and where automation alleviated the need for excessive keying, Data Link was rated about the same as voice.</p>					
17. Key Words Data Link          Human Factors International Research Flight Test				18. Distribution Statement This document is available to the public through the National Technical Information Service, Springfield, VA 22161	
19. Security Classif.(of this report) Unclassified		20. Security Classif.(of this page) Unclassified		21. No. of Pages 53	22. Price

## ACKNOWLEDGEMENTS

The execution of a human factors experiment depends, for an important part, on the way the subject pilots perform their task. For their enthusiastic cooperation in the simulation program, the participating pilots are gratefully acknowledged by the authors. Thanks are also due to the airlines for providing the subject crews.

The authors would also like to thank Captain L. van Maris (KLM), Captain H. Benedictus (KLM) and Mr. C. Rupert (KLM) for their advice and constructive critiques during the pretest evaluation phase.

The KLM chief pilot's office 747-400, and the crew, Captain K. Steeman and Mr. W. Auer are gratefully acknowledged for the possibility of a flight to New York and back in the cockpit of a 747-400, thus providing the authors with indispensable experiences for the scenarios.

A special thanks is necessary for the effort, critique and fatherly help of Mr. G. Lamers who proved to be right in so many aspects and also for the effort of Mr. P. Peteri in assisting with the coordination of the subject crews.

Last, but by no means least, the authors are very grateful to the National Aerospace Laboratory (NLR) Air Traffic Simulation and Flight Simulator departments for their incredible effort in preparing the simulation facilities for this experiment. Their flexibility towards the ever changing requirements were the key to the successful execution.



## TABLE OF CONTENTS

		Page
EXECUTIVE SUMMARY		vii
1.	INTRODUCTION	1
1.1	Data Link Overview	1
1.2	FAA Test Plans	2
2.	SCOPE OF THE INVESTIGATION	2
2.1	Test Objectives	2
2.2	Research Strategy	3
3.	EXPERIMENTAL METHODS	3
3.1	Subject Crews	3
3.2	Simulation Facilities	4
3.3	Test Plan	6
3.4	Communication Devices and Procedures	8
3.5	Crew Procedures	13
3.6	Experimental Procedures	13
3.7	Data Collection and Analyses	14
4.	RESULTS	15
4.1	Communication Effectiveness	15
4.2	Head-Front Time	30
4.3	Situational Awareness	34
4.4	Workload	35
4.5	Flight Performance	36
5.	DISCUSSION	39
5.1	Communication Effectiveness	39
5.2	Head-Front Time	40
5.3	Situational Awareness	40
5.4	Workload	41
5.5	Flight Performance	41
6.	CONCLUSION AND RECOMMENDATIONS	42
6.1	Conclusion	42
6.2	Recommendations	42
7.	REFERENCES	43
8.	LIST OF ABBREVIATIONS AND ACRONYMS	45

LIST OF ILLUSTRATIONS

Figure		Page
1	Functional Diagram of the Simulation Facilities	4
2	The RFS Cockpit Configuration	5
3	Basic Flight Plan Used in All Scenarios	6
4	IDU Layout	8
5	CDU Layout	9
6	MFD Layout	10
7	Data Link Menu Structure	10
8	Uplink and Downlink Time-Lines	16
9	Uplink-Accept Times	16
10	Uplink-Accept Times Except Those Containing Meteo Information	17
11	Uplink-Accept Times Without Meteo or Free Text Uplinks	18
12	Uplink-Accept Reaction Times	18
13	Data Link and R/T Reaction Times Without Meteo or Free Text	19
14	Data Link and R/T Reaction Times Without Meteo or Free Text and Filtered Values	19
15	Task Completion Times	20
16	Crew Preference Regarding Readability of Data Link Interfaces	21
17	Crew Preference Regarding Ease of X Check of Data Link Interfaces	21
18	Downlink Compilation Times Averaged for All Types of Messages	22
19	Downlink Compilation Times Averaged for All Downlinks Without Position Reports	22
20	Downlink Compilation Times Averaged for All Downlinks Without Position Reports or Free Text	23
21	Downlink Compilation Times Averaged for All Downlinks Excluding Position Reports, Free Text and Values	24
22	Average Single Character Input Time (Free Text)	24
23	Average Menu Selection Time	25
24	Crew Preference Regarding Ease of Use of Data Link Interfaces	25
25	Crew Preference Regarding Reachability of Data Link Interfaces	26

LIST OF ILLUSTRATIONS (CONTINUED)

FIGURE		PAGE
26	Average Perceived Difficulty in Operating a Data Link Interface Under Various Turbulent Conditions	26
27	Average Number of Uplink Instruction Breaches Per Crew	27
28	Total Number of Radio Frequencies Missed	28
29	Error Ratios for Alpha, Digit and Errors Sent Per Phase and Interface	29
30	Definition of Head-Front Areas and Epochs as Used in the Analyses	30
31	PF and PNF Head-Front Times Per Phase for Each Interface	31
32	Average Head-Front Time for PF After Uplinks or Radio Messages	31
33	Average Head-Front Time for PNF After Uplinks or Radio Messages	32
34	Average Head-Front Time for PF Before Downlinks	33
35	Average Head-Front Time for PNF Before Downlinks	33
36	Average Number of Traffic R/T Generated	34
37	Number of Data Link Requests of Information	34
38	Average Subjective Workload (BSMI) Score of the PF	35
39	Average Subjective Workload (BSMI) Score of the PNF	35
40	Average Data Link, FMS and MCP Entries for IDU Condition	36
41	Average Data Link, FMS and MCP Entries for CDU Condition	36
42	Average Data Link, FMS and MCP Entries for MFD Condition	37
43	Average FMS and MCP Entries for the R/T Condition	37
44	Acceptance of Communication Device by Crew Members	38
45	Conditions Mentioned for Accepting or Rejecting Data Link	38





## EXECUTIVE SUMMARY

A baseline experiment into the effect of likely Data Link-interfaces on crew performance factors as communication effectiveness, head-front time, situational awareness, workload, and flight performance was carried out in the National Aerospace Laboratory (NLR) research flight simulator. Eighteen crews from both European and US airlines participated, each by "flying" four flights of approximately 2 hours duration. Flights started over the Atlantic Ocean, west of Ireland, continued over two London Flight Information Regions and were completed with a landing at Amsterdam Schiphol Airport. Each flight used one out of four different communication devices:

1. An Interactive Display Unit (IDU) located in the aft pedestal location serving as a dedicated Data Link interface.
2. A Control and Display Unit (CDU) serving both as interface for Data Link as well as input device for the Flight Management System (FMS). Two units were available, one at the left and one at the right hand side of the throttle box.
3. A centrally located Multi Function Display (MFD) fitted with a touch screen and allowing scratchpad entries by the CDU keyboard.
4. Standard Radio Telephony (R/T) using the audio and radio control panels.

The scenario included special "events" that provoked the crews to initiate communications and interact with the interfaces. Events were weather changes, air traffic control (ATC) requests, conflicting traffic, minor aircraft problems, and turbulence. Order of occurrence of events was balanced as much as possible as well as the order of the flights and communication devices to be used. Physical performance measures were used to evaluate crew performance objectively. In addition, questionnaires were used to assess pilot opinions. All Data Link devices used the same page layout as much as possible. The page layout was designed in such a way to be compatible with present "page-based" FMSs.

Results show no significant differences between the four communication devices with respect to reaction times to uplinks or R/T directives. However, a significant difference between the Data Link interfaces with respect to downlink creation time was detected.

The best overall Data Link device was the CDU, despite its combined use as an input device for the FMS and the more superior display properties of the MFD.

Pilots reported a suboptimal usability of a touch screen in flight; negative effects were particularly evident for the IDU that also used a touchscreen for scratchpad entries. During uplinks head-front times were generally less for the pilot not flying, but also for the pilot flying. Head-front times were significantly longer in the R/T case. Noticeable was the fact that uplinks had an effect on the scanning behaviour of the crew member not responsible for the communication task. Furthermore, the amount of free text requests for information, otherwise available through "party line," indicate that the Data Link implementation used could degrade situational awareness. None of the Data Link devices were found to be acceptable for ATC applications during high workload situations such as a descent. Options for alternative solutions are discussed.

## 1. INTRODUCTION.

### 1.1 DATA LINK OVERVIEW.

Present day Radio Telephony (R/T) comes with a number of well documented problems (Hawkins, 1987; Lee and Lozito, 1986), such as poor Signal-to-Noise Ratio (SNR), congested frequencies and long, speedy messages overloading the short-term memory capability of pilots. Data Link could solve many of these problems. Having the messages on a display allows the pilot to check the message and would relieve the short-term memory load. The SNR of such a message would be high. Present Data Link systems are not broadcast but transmitted selectively to the concerned aircraft only, solving the problem of frequency congestion. Next to "communication," Data Links can be used to transfer general information relevant for flight efficiency and if capacity allows, complex clearances issued by air traffic control (ATC) could be downloaded directly (with pilot consent) after receiving the digital communication. These areas of application can be denoted as communication, data transfer, and flight integration. Also, ground systems can benefit by receiving aircraft state vectors, etc.

Some other examples of Data Link applications are:

- a. Provision of weather and other flight information in a user friendly way, due to availability in digital form.
- b. Workload can be shifted from typing to system management by designing the uplinked instructions to be downloadable into the Flight Management System (FMS) (again, because of its digital form), thus relieving the pilot of that duty.
- c. The constant availability of a communication line, which in the case of R/T in a congested area is often not the case.

However, there are also potential concerns:

- a. Longer communication times. Obviously it will take longer to create (type) messages than to just speak them.
- b. Transmission times using Mode S or Satcomm will increase compared to R/T.
- c. Lack of "party line" (the ability to hear the conversations of other aircraft with each other and the ground). This is expected to decrease the "situational awareness." Thanks to the "party line," pilots are said to have a better understanding of who is around them and what is happening. They can also anticipate better the situation ahead of them by listening to the requests of, and instructions to, others. Head-front time (the time the pilot is looking at primary instruments or outside) is expected to decrease by reading Data Link displays and entering data.
- d. Possible loss of crew coordination. R/T is heard (and checked) by both pilots, while Data Link messages, unless double interfaces are provided, will only be read by one pilot, possibly introducing errors.
- e. Automatic downloading in the FMS could induce complacency by "push first-think later" strategies.

Some consequences of Data Link implementation have already been investigated. Kerns (1991) has made a review of Data Link studies. Both controller-oriented and pilot-oriented studies were considered. Treated in the review were:

1. Mental workload.
2. Operational acceptability.
3. Time-based performance measures.
4. Transaction counts.

The main results are mentioned below. The review suggests that the combination of voice and Data Link communication outperforms each medium used by itself. R/T is fast and flexible, whereas Data Link is precise and concise. Use of Data Link for routine ATC messages, including tactical messages, appears to be acceptable in areas where workload is low (above 10,000 feet on approach and above 2000 feet on climb out). If Data Link is to be used procedures should be adapted. Crew response times are about 10 seconds with Data Link and tend to be shorter and less variable during high workload phases.

One of the studies in the Kerns' review (Groce & Boucek, 1987) used a control and display unit (CDU) implementation of Data Link and applied a time line analysis. This report examined the tasking impact of the pilot and copilot with Data Link in relation to voice. They used several simulation scenarios and produced estimates of internal vision, left hand, right hand, cognitive auditive, and verbal tasking of both pilots. They concluded that Data Link may be acceptable during periods of low crew activity; however, during high workload phases the visual channels would be overloaded.

In another study (Lozito, Mc Gann & Corker, 1993) a Data Link interface, based on the two Engine Indication and Crew Alerting System (EICAS) screens, was tested using a generic "glass cockpit" simulator. Of primary interest were communication timing data, errors, clarifications and procedures used. Results show that acknowledgment of ATC messages took longer using Data Link than while using R/T. Acknowledgment using Data Link took an average of 21.4 seconds and using R/T it took an average of 7.9 seconds.

Results, however, showed more errors during Air/Ground communication in the R/T condition than in the Data Link condition. Finally, more ATC contact was initiated in the R/T condition than in the Data Link condition.

## 1.2 FEDERAL AVIATION ADMINISTRATION (FAA) TEST PLANS.

The FAA is in the process of conducting active research to develop minimum standards for integration of Data Link communications into transport category aircraft. The current phase of this program is aimed at acquiring operational experience in various aircraft using existing or likely interfaces for Data Link. Included in the scope of this research are procedural, operational, and human performance issues related to electronic communication in all types of flight regimes and conditions. Of particular interest, however, are operations in the oceanic control areas where the potential exists for immediate gains in fuel and time savings per flight. The FAA, therefore, perceives a requirement to intensify the oceanic standards activities.

In Europe, similar requirements exist for more efficient oceanic operations coupled with a strong European commitment to ATC improvements.

European and American programs are sufficiently similar to warrant a cooperative research program. To this end, the FAA Technical Center, the Rijksluchtvaartdienst (RLD) and the Nationaal Lucht- en Ruimtevaartlaboratorium (NLR) of the Netherlands have initiated a cooperative work plan.

## 2. SCOPE OF THE INVESTIGATION.

### 2.1 TEST OBJECTIVES.

The goal of the experiments was to gain operational experience and to acquire baseline data using existing displays as potential Data Link interfaces for ATC communication. This operational experience applied to oceanic control operations and European en route and terminal area operations. Objective data were to be collected consisting of statistical data of pilot involvement time and errors with Data Link, as compared to a voice-only reference. Inferential data of crew coordination and situational awareness, and subjective evaluations of display formats and workload were also to be collected.

### 2.2 RESEARCH STRATEGY.

The research program comprises three phases. In phase one, the communication aspects and data transfer only will be evaluated.

Services to be implemented are ATC directives, transfer of communication, and meteo information. In phase two, flight deck integration issues will be addressed. Automatic FMS dataloading by Data Link will be integrated with flight control functions via the aircraft mode control panel allowing auto climb, auto tune, etc. In phase three, advanced concepts of distributed information presentation, and alternative Data Link formats (e.g., integrated graphics) will be examined. This report documents the results of the first phase.

Three testable likely means of Data Link communication interfaces were selected:

- a. Data Link on the Interactive Display Unit (IDU).
- b. Data Link on the Control and Display Unit (CDU).
- c. Data Link on the lower central Multi Function Display (MFD).

They were compared to a R/T reference condition. The following factors characterize the three Data Link interfaces:

- a. Display location: The displays were either located in the front of the cockpit (lower central MFD), in the forward pedestal area (CDU), or more to the rear of the cockpit (IDU).
- b. Display function sharing: During the experiment both the IDU and MFD served one function, while the CDU displays were used for both Data Link and operating the FMS.
- c. Data Link operability: The use of touch screen and hardware buttons was varied between the three Data Link interfaces. The IDU had a touch screen only; the CDU only hardware buttons; and the MFD combined touch screen functions with the hardware buttons of the CDU for scratchpad operations.
- d. Display size: The size of displays differed between the three interfaces, influencing the number of pages needed for the menu structure.

The IDU, typical of Aircraft Communications Addressing and Reporting System (ACARS)/SITA installations and FMS CDU were likely means of Data Link communications in the near future. The MFD with touch overlay was less likely as a commercial interface but did represent an optimal display, because of its relative large size and its central location viewable for both pilots. Data collected using the MFD would provide valuable trend information in the comparison of R/T, with CDU and IDU performance.

Scenarios were chosen as realistically as possible and were kept relatively uneventful to allow pilots to direct their attention to the communication task. Because of this, pilots were relatively free in their choice of action making the use of an experiment manager mandatory. This system, based on a workstation, could generate consistent experimental events as scenarios dictated but also as a reaction to pilot actions.

### 3. EXPERIMENTAL METHODS.

#### 3.1 SUBJECT CREWS.

Eighteen crews from US (n= 6) and European (n= 12) airlines or aerospace organizations participated in the experiment. All crews were type-rated for wide-body, glass-cockpit aircraft equipped with a FMS. Each crew had at least one pilot with prior Data Link experience in the form of the ACARS. The 36 subject pilots had an average age of 47.9 years (S.D. 7.6). The average flight experience for the Pilots Flying (PF) was 9443 hours, with a minimum of 4100 hours and a maximum of 30,000 hours+. The average flight experience for the Pilot Not Flying (PNF) was 8630 hours with a minimum of 1300 hours and a maximum of 23,000 hours.

#### 3.2 SIMULATION FACILITIES.

The simulation equipment consisted of a combination of a flight simulator and an ATC simulator (see figure 1).

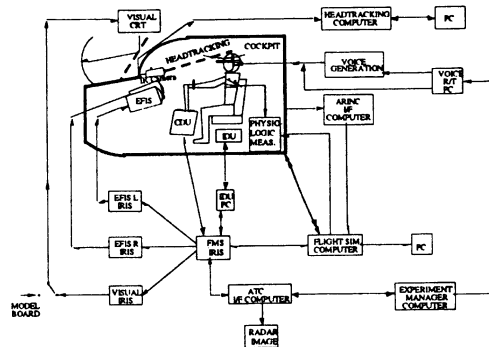

FIGURE 1. FUNCTIONAL DIAGRAM OF THE SIMULATION FACILITIES

All the subsystems were linked together and ran realtime. The facilities will now be described in detail.

##### 3.2.1 Research Flight Simulator.

The experiment was carried out in a generic 4° of freedom moving base flight simulator (the so-called Research Flight Simulator (RFS)). The dynamic aircraft model used was that of a Boeing 747. The functionality of the FMS of the Boeing 747-400 served as an example for the simulator's FMS that was specially developed because no source codes were obtainable from commercially available FMSs. Outside view was generated using both a model board, computer generated imagery, or a mixture of both. The images were projected through a collimated lens system providing a Field Of View (FOV) of 48 by 28 degrees. During the landing phase, the highly detailed model-board (scale 1:2000) imagery was used (terrain: 24.5 by 9.6 km), while during cruise phases outside traffic and/or weather was visualized using the computer-generated imagery. Realistic atmospheric environment conditions could be created such as a cumulo nimbus, turbulence, and traffic to ensure realistic headout times and crew performance. The RFS cockpit was also fitted with:

- a. Six color Cathode Ray Tubes (CRT's):
1. A Primary Flight Display (PFD) for the PF.
  2. A PFD for the PNF.
  3. A Navigation Display (ND) for the PF.
  4. A ND for the PNF.
  5. An EICAS.
  6. A MFD available for Data Link functions.

- b. Two CDUs for FMS and Data Link.
- c. An IDU used for Data Link operations.
- d. Audio and radio communication panels for R/T operations.
- e. All other functions needed to fly the aircraft, such as functional navigation equipment, including very high frequency (VHF) omnidirectional range (VOR)/distance measuring equipment (DME) beacons, Instrument Landing System (ILS) aids, and latitude/longitude navigation, were available by means of standard avionics (see figure 2).
- f. NLR head-tracking systems to register crew head positions and a physiological data acquisition and storage system to investigate mental workload parameters (head-tracking will be described in detail in paragraph 3.6, the latter in a related report).

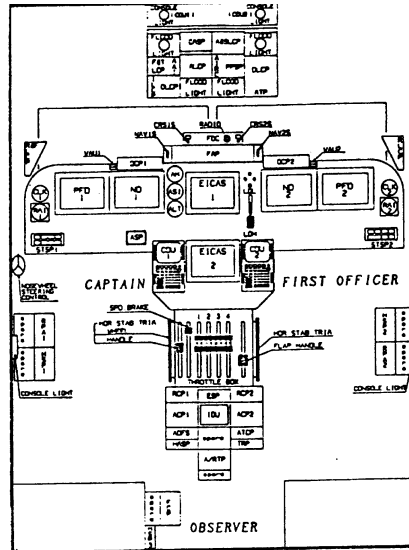

FIGURE 2. THE RFS COCKPIT CONFIGURATION

### 3.2.2 Experiment Manager.

An experiment-manager workstation in combination with the NLR ATC Research Simulator (NARSIM) was situated at a different location. The function of the experiment-manager was to generate experimental events in a consistent way, in order that the events themselves could be seen as experimental conditions. Events were positioned on a computer-generated map resembling figure 3. The position of the simulator was also displayed and triggered the events when passing them. Events could also be triggered by hand. Various communication provoking events such as Data Link and R/T communication were used together with traffic related events such as visible aircraft or background R/T. Other events could also be introduced to provoke actions of crews such as thunderstorms en route or aircraft system problems. R/T (ATC and party-line) messages were digitized and replayed under computer control to guarantee consistency of events as much as possible. Sound edit software was used to make the computer-generated messages sound as natural as possible, by using filters and adding VHF noise.

### 3.3 TEST PLAN.

#### 3.3.1 Flight Profile.

The simulations included Oceanic, European area, and terminal control operations. At the start of all flights, the RFS was located in the middle of the Atlantic Ocean (55N20W) with destination Schiphol (i.e., Amsterdam Airport). All flights used the same basic flight plan (see figure 3).

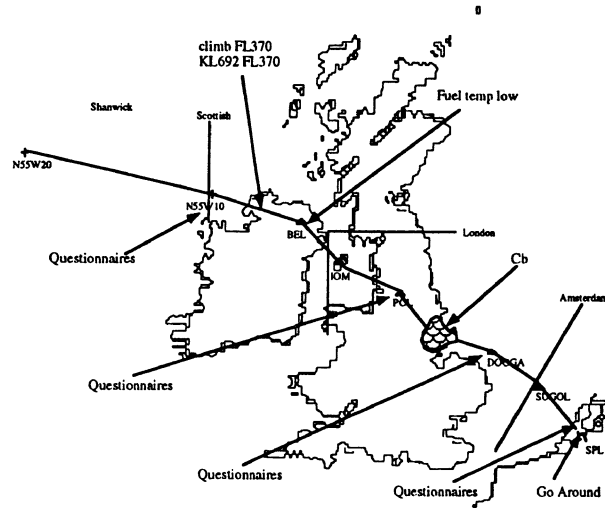

FIGURE 3. BASIC FLIGHT PLAN USED IN ALL SCENARIOS

All flights passed four Flight Information Regions (FIR):

a. Oceanic: During the Oceanic region, the flight was at an altitude of FL330 and an airspeed of Mach 0.84. In the case of R/T little or no radio communication was present in the oceanic environment because of high frequency (HF) characteristics and the use of SelCall. Oceanic tracks were used. In the case of Data Link, Automatic Dependent Surveillance (ADS) made less stringent flight paths possible allowing aircraft to fly ideal tracks, traffic permitting.

b. Scottish: All flights entered the Scottish FIR and were directed towards London FIR in a direct way in case of little traffic or according to the flight plan when more traffic was present. When a step climb was asked for the request was granted in the scenarios with little traffic and denied when much traffic was present.

c. London: All flights entered the London FIR and were directed to the Amsterdam FIR in such a way that the FIR boundary was crossed in the neighborhood of FL200.

d. Amsterdam: Flights entering Amsterdam FIR were directed to Amsterdam Approach and handed over below FL100. Amsterdam Approach would direct flights to the ILS runway 19R. Speed and heading directives were given in scenarios with much traffic. Once established on glidepath flights were handed over to Schiphol Tower.

### 3.3.2 Experimental Design and Flight Scenarios.

Each crew used a different communication device during each of the four different flight scenarios (see 3.4.2 for complete descriptions). The sequence in which the devices were used by each crew and the combination with the flight scenarios was balanced as much as possible. Crew performance was assessed in terms of:

- a. Communication efficiency, defined by speed and error frequency as well as subjective preference.
- b. Head-front time, defined by the amount of time pilots are looking at their primary flight instruments or outside and measured by a head-tracking system.
- c. Situational awareness, defined in this experiment by the situational awareness provided by "party line" information normally available with R/T.
- d. Workload, defined as the (mental) effort needed to perform the tasks.
- e. Flight Performance, in terms of flight-related actions and measures other than used for the communication task.

To prevent anticipatory crew behavior, expected when flying four times the same flight plan (once with every communication device), the amount of surrounding traffic was varied and different experimental events were used in each flight to provoke communication. During half of the flights little traffic was present (permissive flights). During the other two flights more traffic was present (nonpermissive flights). In common, the scenarios were kept relatively uneventful because pilots were expected to neglect communication functions when confronted with high workload situations.

Communication Related Events: To generate communication normal ATC procedures were used together with "special" events. Three uplink services were employed: (a) the transfer of communication, (b) ATC directives, and (c) meteo information:

a. Transfer of communication: ATC coordinated radio frequency changes to/from en route sectors, arrival sectors and approach sectors. The uplinked information consisted of the new controlling authority, e.g. sector designation or center name, and the new radio frequency. The Data Link would transfer automatically to the new sector. The crew had to set the new radio frequency manually and had to respond to the transfer of communication by means of an "accept" followed by a flight report.

b. ATC directives: using the basic flight plan, ATC would direct the aircraft by transmitting among other things standard route directives, altitude, and speed assignments. The crew had to respond by an "accept" or a "reject."

c. Meteo Information: Terminal Area Forecast (TAF), Significant Meteorological Conditions (SIGMET) and Air Traffic Information Services (ATIS) messages were provided at request. The crew had to accept these uplinks.

Next to the former normal events, events had been added to provoke downlinks. A step climb at 10W shown on the FMS was added in all scenarios. Twice during each flight, turbulence was generated up to moderate levels to generate altitude and/or speed changes. This was also done to investigate the interface operability under turbulence conditions. Apart from the events mentioned above (generated each flight), during two of the four flights, special events were added. These were: a Cumulo Nimbus shown directly on their flight path, forcing them to take another route, and a low fuel temperature problem, presented on the upper EICAS display, forcing them to fly lower and/or faster.

Traffic Related Events: During all R/T flights normal background traffic was simulated. In the Oceanic environment, where background ATC communication is normally not heard due to SelCall, plane to plane talk was added. During two flights special events were added to test traffic awareness. The first event was that during the Oceanic flight a plane (KL692) would position itself directly above the RFS. At the Transfer of Communication (TOC), the RFS would be allowed to make their step climb. In the R/T case, they would have heard just beforehand that the KL692 had received a similar step climb freeing the airspace above them. In the Data Link condition, it would appear that they were erroneously cleared to a higher level. The second event was that during final approach the crew would hear (in the R/T case) that the aircraft in front of them had a burst tire and could not vacate the runway, thus queuing them for a go-around. In case of Data Link, the crew was not cued (during this experiment Data Link was used for all communication). In combination with the flights containing the "special" communication provoking events this resulted in four flight scenarios.

## 3.4 COMMUNICATION DEVICES AND PROCEDURES.

### 3.4.1 Description of Data Link Communication Devices.

Interactive Display Unit (IDU): The IDU (3.8 \* 4.1") was located at the rear of the pedestal. It had a light-sensitive touchscreen. The touchscreen was activated at the release of the selected field. Only one Data Link page was shown at the same time. If a pilot wanted to make an entry, he/she had to select a line, after which a keyboard was shown. The data would appear in the scratchpad. If the entry was executed (i.e., activating the accompanying field), the previous page, with the commands entered on the specified line was shown. Because of the relatively small size of the interface, more pages were needed compared to the CDU and MFD applications (see figure 4).



FLIGHT REQUEST

<ALT>	<AT>
FL340	N52W004
<SPD>	<OF S><DIS>
.840	L/ 12NM
<HDG>	
090	

SENT AT  
1045 Z

<UPL><LOG><ATC><SEND>

FIGURE 4. IDU LAYOUT

Control and Display Unit (CDU): CDU's (3.5 \* 4.1") were located on the left and right side of the forward pedestal. Both CDU's had a hardware keyboard. Except for Data Link, the CDU's could be used for FMS operations. Only one page was shown at the same time. Similar to the operation of the FMS, data entered were first displayed in the scratchpad. After the selection of a line select key, data were copied to that field of the display, completing the message. The CDU display suffered a slight parallax problem in relation to the line select keys due to its location with respect to the pilots view point (as is the case in real aircraft)(see figure 5).

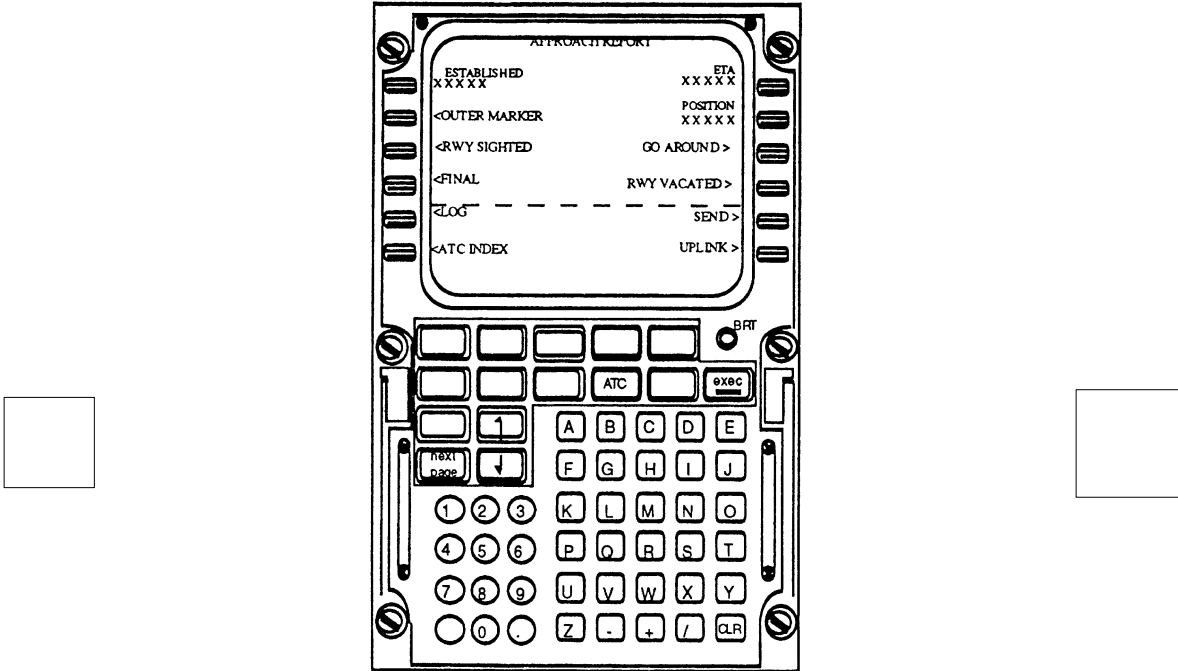
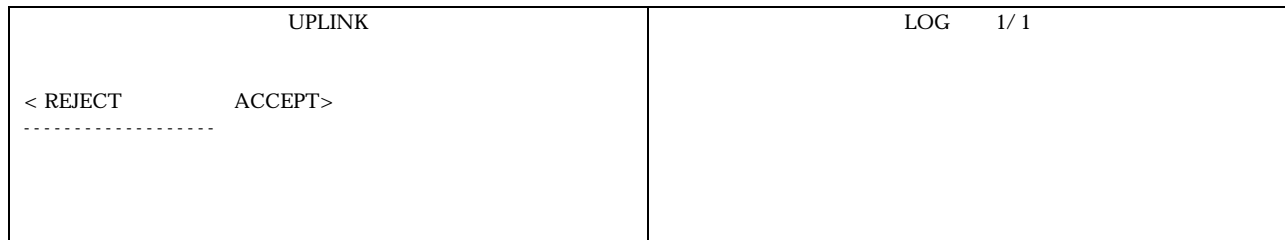

FIGURE 5. CDU LAYOUT

Lower Central MFD (MFD): The lower central MFD (5.5 \* 7.6") was located on the forward pedestal. Two Data Link pages were shown at the same time. Data could be copied in the scratchpad from the left or the right CDU. Operation of the MFD was done in combination with the CDU keyboard. The MFD had a touch-sensitive touchscreen, which was used for menu selections, whereas the CDU keyboard, consisting of hardware buttons, was used for scratchpad operations. The touchscreen was activated at the release of the selected field. There was a slight parallax problem with the MFD as well (see figure 6).



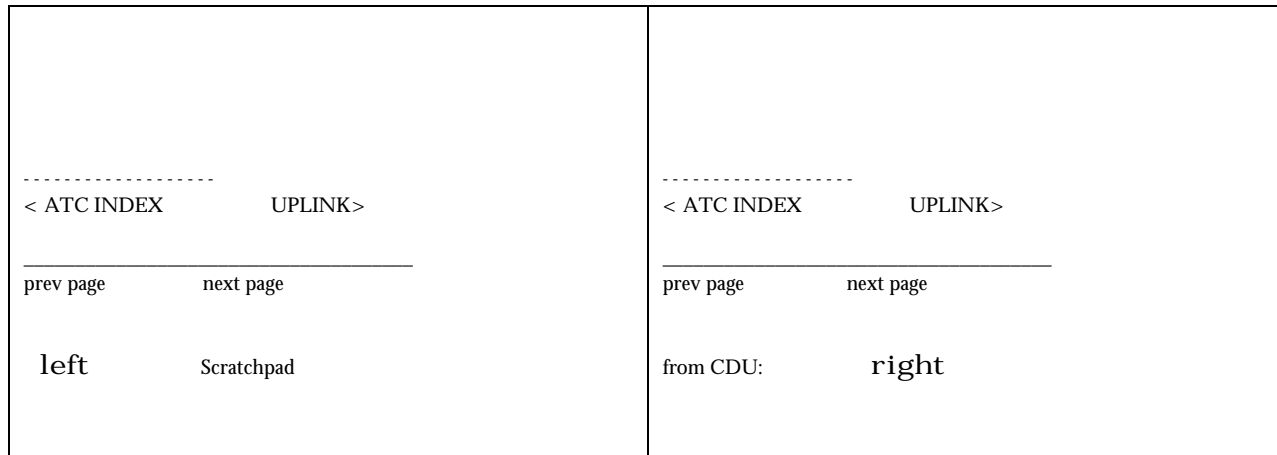

FIGURE 6. MFD LAYOUT

3.4.2 Data Link Functions.

In general, more than one Data Link page was required to accomplish communication operations. Thus, a layered menu-structure was used to guide pilots to the different pages and functions (see figure 7). The general page layout resembled the FMS page layout to minimize training requirements. The first page was always the ATC index page. By means of that page, other pages could be selected. Hoekstra and Ruijgrok (1994) describe the page layout in more detail.

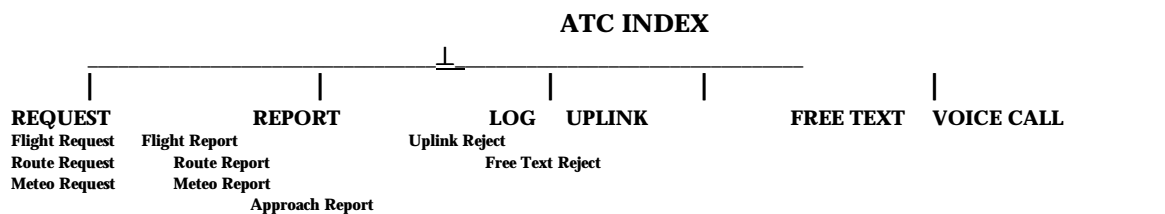

FIGURE 7. DATA LINK MENU STRUCTURE

The Data Link ATC index page and Data Link functions contain the following:

3.4.2.1 ATC INDEX Page:

On all Data Link devices, the ATC INDEX page was the top page. On the CDU Data Link pages were accessed by pressing the ATC menu button. Pages were divided in an upper and a lower part. The contents of the upper part depended

on the specific page. The contents of the lower part was almost the same for every page and contained the ATC INDEX, UPLINK, and LOG and SEND functions. The contents depended on the level of the page. There was a three-level page structure (see figure 7).

The UPLINK page could be chosen on each level and the ATC INDEX on the second and third level. The functions SEND and LOG could only be chosen on the third level, with exception of the FREE TEXT page. The UPLINK page was an exception to all these rules: on the second level, the ATC INDEX and LOG page could be chosen. On the third level of the UPLINK page, the ATC INDEX, UPLINK, SEND, and FREE TEXT functions could be chosen.

The four basic Data Link functions were:

- a. Uplink: On this page all the uplinked messages from ATC were shown. The crew could reject or accept the uplink. In case of rejection, they could select a preprogrammed reason, but they could also add free text to explain the rejection.
- b. Log: The crew could read back together with a timestamp all the messages sent and uplinked during the flight. Complete messages were not directly shown, but if a message was selected, a next page showed the complete message. If the log page was selected, the last log page with the most recent messages was always shown.
- c. Request: The crew could make a request for ATC. This could be: (a) a flight request to change one or more flight plan parameters, (b) a route request to change route waypoints, and (c) a meteo request when the crew wanted to have meteo reports for a selected location. The flight requests "further descent" and "further climb" could be made by selecting that line. A route request page contained a to ... (waypoint), next ... (waypoint) and last... (waypoint), at a certain altitude and with a certain time. The meteo request page contained a SIGMET, ATIS, TAF or aviation routine weather report (METAR) request for specific positions.
- d. Report: The crew could report information to ATC. This could be: (a) the actual aircraft position (FLIGHT REPORT), (b) the intended route (POSITION REPORT), (c) meteo data encountered, and (d) during the approach phase of a flight preprogrammed messages (APPROACH REPORT). A position report was used above the ocean with 4D information. A flight report was used for transfer of communication and consisted of 3D information. A meteo report could be used when abnormal weather conditions were met. At request of ATC, an approach report was used (e.g., "report outer marker!").

Some of the reports were automatically filled: on the CDU and MFD interface, the flight report and position report were automatically updated with the information coming from the FMS. The IDU interface was connected to the Digital Air Data Computer (DADC) and not to the FMS and therefore did not receive 4D information, so the position report had to be filled out by hand.

Once messages were created they had to be downlinked by using the function:

Send: When a message was created or selected, the message was sent to the selected ATC center by the selection of this function.

Next to these functions, two other functions were available:

- a. Free Text: The crew could create their own message by this option. To make an entry on the IDU interface FREE TEXT had to be pushed and a keyboard would be shown on the touchscreen.
- b. Voice Call: The crew could inform ATC that voice communication was preferred.

Indicators used on the Data Link pages were:

- a. Sent At: Indication of the time, the message had been sent to ATC.
- b. Void Time: This was the remaining time before a simulated time-out error would occur.
- c. ATC Ctr: Showed the present ATC center.
- d. ATC Freq: Showed the R/T frequency of the present ATC center.

The latter two indications were automatically generated by Data Link.

### 3.4.3 Communication Procedures.

R/T communication procedures were kept as realistic as possible. Data Link communication procedures were chosen to comply with normal R/T ATC procedures. Data Link frequencies were adjusted automatically. The changing of the radio frequencies was done manually. The radio was only checked for proper operation at the transfer from oceanic to radar control.

Data Link transmission delay times depended on the position of the aircraft. These times were:

- a. Oceanic Region: Data Link was going via satellite and delay time could be up to 30 seconds depending on communication availability on the satellite.

b. En Route and Radar Coverage: Data Link was handled by ground-based radar sites (Mode S) and the delay time was up to 6 seconds depending on the sweep of the radar.

c. Approach: Data Link was going via a VHF/FM station subcarriers and delay time was near 0 seconds.

Uplink, Accept and Reject:

During the experiment different ATC uplinks could be given, similar to now-a-days R/T messages. When an uplink message was issued and the PNF had read the message, the crew could accept or reject the message. The period in which a message had to be accepted or rejected depended on the type of uplink and associated priority. That period was called the "void time" and was displayed between the words ACCEPT and REJECT on the UPLINK page. The countdown of the void time period started when the uplink message was received. There were three types of uplinks:

a. Information messages like meteo reports: these messages had void times of 30 minutes. In this case, actually no void time was displayed on the uplink page of the IDU device.

b. Normal messages like "change heading," "direct to" or "cleared to land": these messages had a void time of 2 minutes.

c. Urgent messages like a "go around" with a void time of 30 seconds. The void time indication blinked in these situations.

Downlinks:

Downlinks were made by following the menu structure of figure 7 up to the moment data entry was required such as the specific flight level. At that moment either a scratchpad entry (CDU, MFD) was required or in the case of the IDU alpha numeric pages were activated and data had to be entered.

Crew Alerting:

There were two ways of alerting the crew with incoming messages:

a. Normal Data Link Message: An announcement "UPLINK PENDING" was displayed in white on the upper EICAS and a SelCall type of sound was presented. The word UPLINK on the screen of the actually used interface was highlighted (on the CDU interface this would only be seen if ATC was selected). The message on the upper EICAS and the highlight of the word UPLINK would only disappear when the message was accepted (or rejected) and cleared.

b. Urgent Data Link Message: An amber caution light in the primary field of view of both pilots was activated. The words UPLINK PENDING on the upper EICAS started flashing in amber and the audio warning was presented as a repetitive tone. To stop the audio warning and the flashing of the amber caution light, the amber caution light had to be reset. The message on the upper EICAS and the flashing of the word UPLINK would only disappear when the message was accepted and cleared.

### 3.5 CREW PROCEDURES.

The PNF was instructed to operate the communication devices. When a message was pending, the crew was asked to first accept (or reject) the message and then complete the task required by ATC. If the crew would first start completing the task, then this would be counted as a "procedure breach." This was not briefed to the pilots. The purpose was to find out whether the above mentioned procedure was naturally acceptable. The PF was instructed to fly the aircraft. Above all, crews were instructed to behave operationally normal. There was one exception to normal operations; company calls were replaced by issuing questionnaires. At times where crews normally would make company calls, questionnaires were handed out by the in-flight observer to be filled in.

### 3.6 EXPERIMENTAL PROCEDURES.

Crews were tested on 2 days. On the first morning each crew received a detailed briefing about the experimental procedures and the use of the Data Link devices. Subsequently, the PF was given a check ride in the flight simulator and the PNF was given practice with the use of the menu structure on a stand-alone Data Link device. After the initial practice sessions, three training flights of about 40 minutes each were flown by both pilots and an instructor, each with a different Data Link interface. The training flights covered all basic actions necessary for performing the experimental flights.

Data were collected during four experimental simulator flights lasting approximately 2 hours each. The first one was flown during the first day and the remaining three flights during the second day. An in-flight observer accompanied the crews during all flights. The in-flight observer noted any impressions of crew behavior and remarks during the flight to enhance data interpretation. The notes also included anything unusual that occurred during the flight. The in-flight observer also served to answer any pilots' questions and to hand out in-flight questionnaires. Before each flight, experimental procedures were briefed again by the in-flight observer.

Head-away times were recorded by means of infrared based optical head-tracking. Both pilots wore a headset attached to a baseball cap to ensure that the systems would remain at a fixed position. A white ball with an infrared light source was attached on a headset. An Infra Red Light Emitting Diode (LED) was attached on top of the white ball, thus creating a pointing device. The ball was viewed by a camera and by means of image processing an area of regard was calculated for each pilot.

Heart-rate and respiratory-rate were measured by means of standard physiological registration methods.

### 3.7 DATA COLLECTION AND ANALYSES.

Data were collected on five separate systems, together with the collection of questionnaires and the in-flight observer's notes. These systems were linked together and running in realtime. The five systems were:

- a. Main simulation computer.
- b. Silicon Graphics IRIS workstation.
- c. HP workstation serving as an experimental manager.
- d. Head tracking system.
- e. Physiological digital data recorder.

To assess the communication effectiveness and device operability the following data were logged:

- a. Voice activity on VHF and HF.
- b. Number of and contents of uplink and downlink messages.
- c. Radio frequency settings.
- d. The time needed to react to an uplink (i.e., the time needed to read the message and accept or reject it), combined with the type of message.
- e. Time needed to compose a message, combined with the type of message.
- f. Number of mistakes made (i.e., using clear (CLR), delete (DEL) or backspace (< < -)).

To assess head-front time, the area of regard of both pilots was measured with the aid of the optical head-tracking system and correlated with the phase of flight and communication events.

To assess situational awareness, the level of knowledge about surrounding traffic was analyzed using questionnaires and indirectly by the reactions of the pilots to traffic-related events in the scenarios. In addition, the number of Data Link requests concerning information, acquired normally by partyline, was tallied. R/T condition served as a basis for comparisons.

To assess workload, heart, and respiratory-rate data of both pilots were collected together with subjective workload questionnaires. The analysis of heart and respiratory rate will be dealt with in another report.

To assess flight performance, the following variables were measured:

- a. Amount of fuel.
- b. Flight time.
- c. Mode Control Panel (CP) entries.
- d. FMS entries.

Several questionnaires had to be filled in by both pilots:

- a. A preprogram questionnaire concerning: (1) biographic data, (2) flight experience issues, and (c) expectations concerning Data Link.
- b. Scale for the length and the quality of sleep on both days.
- c. After each experimental flight: a questionnaire concerning: (1) operability and communication issues, and (2) general opinion concerning Data Link or R/T.
- d. After the last experimental flight: a final questionnaire to assess general Data Link/R/T issues and final opinions.
- e. During and after each experimental flight: a traffic awareness questionnaire for each of the following flight phases: (1) from the start of flight to 10W, (2) from 10W to Pol Hill, (3) from Pol Hill to Dogga, and (4) from Dogga to landing. The final one for the 7000-foot Air Ground Level (AGL). Notes made during flight could be used, communication with the other crew member was allowed, and also looking outside the cockpit. This questionnaire was only given to the PNF.
- f. Workload rating scales: to rate workload for the flight phases mentioned above. This scale consisted of a vertical line with at the bottom "costing no effort" and almost at the top "highly effortful." The first question of this questionnaire concerns the workload of all the tasks that were necessary to bring the aircraft to a particular point. The second question concerns the workload of communication with ATC.

### 4. RESULTS.

The results will be presented in the following order:

- a. Communication Effectiveness
  - Uplinks
  - Downlinks
  - Errors and instruction breaches
- b. Head-Front Times
  - Per phase
  - After uplinks
  - Before downlinks
- c. Situational Awareness Data
  - Special events
  - Questionnaires
  - Data Link request of partyline information
- d. Workload (subjective data only)
- e. Flight Performance
  - Fuel and flight time
  - Device entries.

Means and statistics for tests of significance are given for each result. An analysis of variance (ANOVA) probability (p) value of 0.05 was chosen as the cutoff for statistical significance.

#### 4.1 COMMUNICATION EFFECTIVENESS.

The different periods identified as being typical of the timeline for uplinks and downlinks are shown in figure 8. The measure used to analyze uplinks is the period starting at "uplink pending" and ending at "accept" and for downlinks, the downlink compilation time measured from the selection of a downlink page to the moment the message is sent.

##### 4.1.1 Uplinks.

The uplink-accept reaction times generated during the experiment are shown in figure 9 for all uplinks. All uplinks include all categories of messages. The contribution of each category to the speed of responding will be assessed. The dataset includes uplinks containing information such as meteo. The average reaction time across all flight phases using the IDU was 14.6 seconds, using the CDU 12.2 seconds and using the MFD 10.8 seconds. No significant statistical effect of interface was found. Mean reaction time in the oceanic phase was 16.0 seconds, in the cruise phase (radar coverage) 11.0 seconds, and during the descent phase 10.5 seconds. The effect of phase of flight was statistically significant,  $F(2, 22) = 21.597$ ,  $p < 0.05$ .

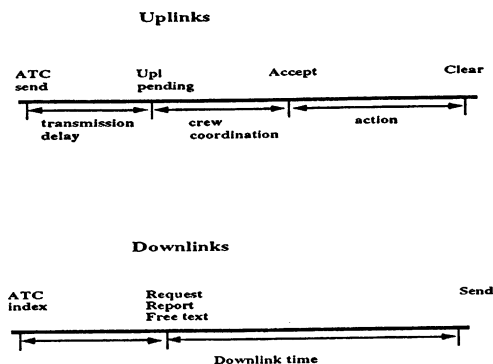

FIGURE 8. UPLINK AND DOWNLINK TIME-LINES



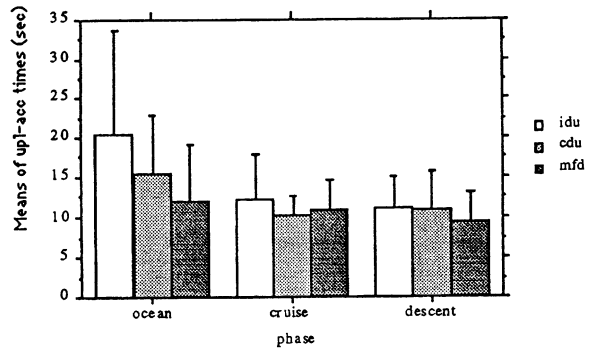

FIGURE 9. UPLINK-ACCEPT TIMES

The uplink-accept times for a dataset without meteo uplinks are shown in figure 10. It was argued that meteo information would increase the uplink-accept reaction times. The average reaction time across all flight phases using the IDU was now 11.6 seconds, using the CDU 10.9 seconds, and using the MFD 10.9 seconds. No significant statistical effect of interface was found. Mean reaction time in the oceanic phase was 13.3 seconds, in the cruise phase (radar coverage) 10.5 seconds, and during the descent phase 9.6 seconds. The effect of phase of flight was statistically significant,  $F(2, 22) = 15.784$ ,  $p < 0.05$ .

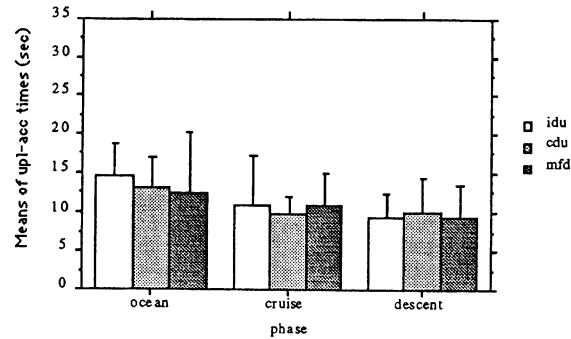

FIGURE 10. UPLINK-ACCEPT TIMES EXCEPT THOSE CONTAINING METEO INFORMATION

The uplink-accept times for uplinks disregarding meteo or free text uplinks are shown in figure 11. It was argued that free text uplinks also contain information that could increase the uplink-accept reaction times. The average reaction time across all flight phases using the IDU was 10.0 seconds, using the CDU 9.2 seconds, and using the MFD 8.5 seconds. No significant statistical effect of interface was found. Mean reaction time in the oceanic phase was 9.6 seconds, in the cruise phase (radar coverage) 8.5 seconds, and during the descent phase 9.6 seconds. No significant statistical effect was found of phase of flight either.

The uplink-accept times for uplinks without meteo or free text uplinks and also disregarding extreme values are shown in figure 12. All reaction times above the sum of the average and three times the standard deviation (SD) have been left out. It was argued that during high workload phases crews would not keep to the procedure of accepting uplinks first and keying them in later, thus increasing uplink-accept reaction times. The average reaction time across all flight phases using the IDU was 8.9 seconds, using the CDU 8.7 seconds, and using the MFD 8.2 seconds. No significant statistical effect of interface was found. Mean reaction time in the oceanic phase was 9.5 seconds, in the cruise phase (radar coverage) 7.8 seconds, and during the descent phase 8.6 seconds. No significant statistical effect was found of phase of flight either.

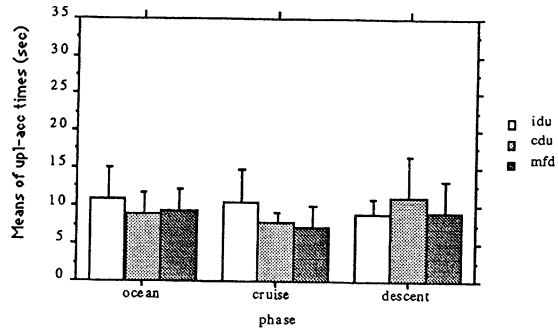

FIGURE 11. UPLINK-ACCEPT TIMES WITHOUT METEO OR FREE TEXT UPLINKS

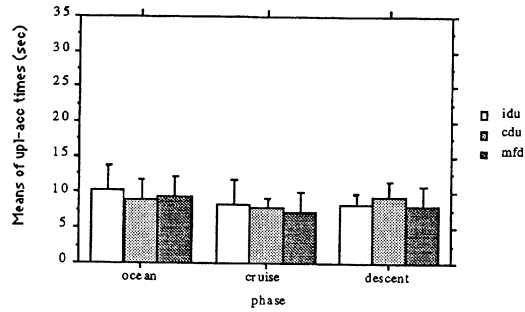

FIGURE 12. UPLINK ACCEPT REACTION TIMES

4.1.1.1. Uplink versus R/T.

The uplink-accept reaction times of uplinks without meteo or free text uplinks (as the measured R/T did not contain those information items) combined with the R/T reaction times are shown in figure 13. The average reaction time (ignoring missing values of the different phases) using the IDU was 8.3 seconds, using the CDU 8.2 seconds, using the MFD 8.8 seconds, and using R/T the reaction time was 7.2 seconds. No significant statistical effect of communication device was found.

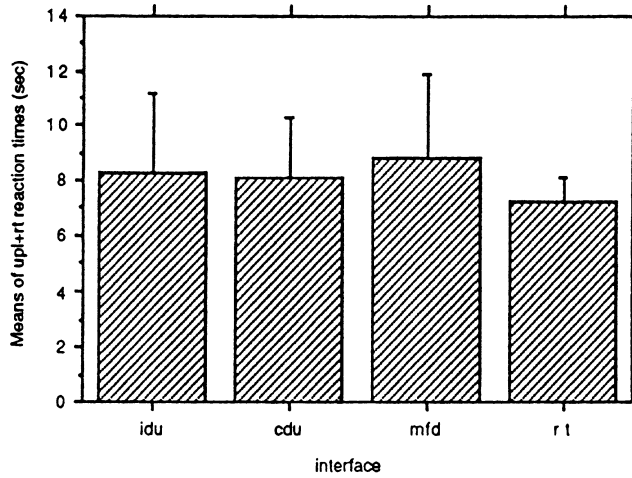

FIGURE 13. DATA LINK AND R/T REACTION TIMES WITHOUT METEO OR FREE TEXT

The uplink-accept reaction times of uplinks without meteo or free text uplinks reaction times are shown in figure 14 combined with R/T and now also disregarding the extreme values. All uplink-reaction times and R/T reaction times above the sum of the average and three times the SD have been left out. The average reaction time (ignoring missing values of the different phases) using the IDU was 7.6 seconds, using the CDU 7.9 seconds, using the MFD 7.5 seconds, and using R/T the reaction time was 6.8 seconds. No significant statistical effect was found of the communication device.

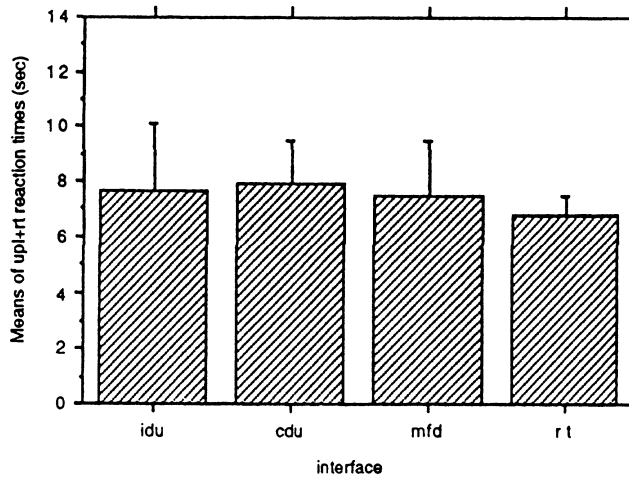

FIGURE 14. DATA LINK AND R/T REACTION TIMES WITHOUT METEO OR FREE TEXT AND FILTERED VALUES

The task completion times for radio tuning upon receiving the uplink are shown in figure 15. The task consisted of tuning the radio on a new frequency after being instructed by ATC. Time was measured beginning the moment the uplink

was pending and ending the moment the radio was set. The average reaction time using the IDU was 17.3 seconds, using the CDU 15.7 seconds, using the MFD 15.4 seconds, and using R/T the reaction time was 11.8 seconds. The effect of communication device was statistically significant,  $F(3, 24) = 3.947, p < 0.05$ .

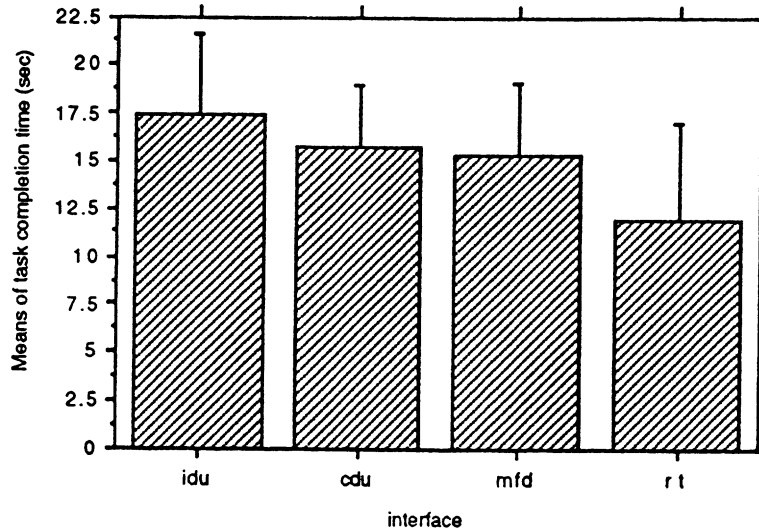

FIGURE 15. TASK COMPLETION TIMES

No sufficient data of altitude, heading or speed changes were available, due to the relatively uneventful character of the scenarios. Speed and altitude assignments were given most of the times at request of the crews (step climbs, altitude, and speed changes because of turbulence) or were given while descending so precise timing of reaction times were not possible (crews were tuning the MCP all the time). Heading assignments were not given in each scenario so no sufficient data for a within subject design remained.

#### 4.1.1.2 Subjective Appreciations.

The results of the questionnaires regarding uplink handling are shown in figures 16 and 17. The percentage of pilots preferring a Data Link interface regarding readability of the device is shown in figure 16. When asked which interface was preferred with regards to readability 58 percent preferred the MFD, 42 percent the CDU, and nobody the IDU.

The percentage of pilots preferring a Data Link interface regarding ease of cross-checking is shown in figure 17. When asked which interface was preferred with regards to ease of X-check 71 percent preferred the MFD, 29 percent the CDU, and nobody the IDU.

#### 4.1.2 Downlinks.

The downlink compilation times for all message types generated during the experiment are shown in figure 18, including downlinks such as manual position reports (IDU). The average compilation time across all flight phases using the IDU was 75.2 seconds, using the CDU 22.7 seconds, and using the MFD 35.6 seconds. The effect of interface was statistically significant,  $F(2, 22) = 13.167, p < 0.05$ . Mean compilation time in the oceanic phase was 71.6 seconds, in the cruise phase (radar coverage) 34.7 seconds, and during the descent phase 27.1 seconds. The effect of flight phase was statistically significant,  $F(2, 22) = 8.694, p < 0.05$ .

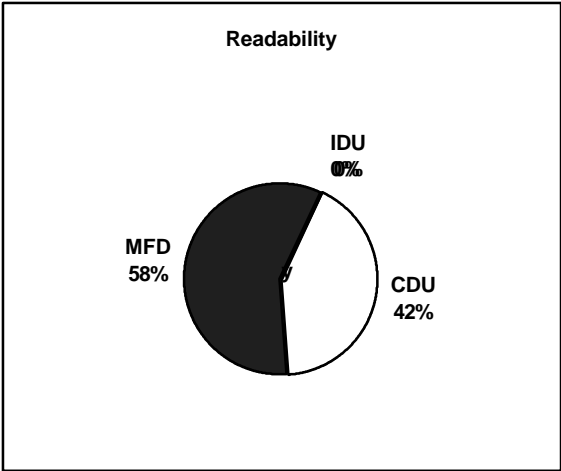

FIGURE 16. CREW PREFERENCE REGARDING READABILITY OF DATA LINK INTERFACES

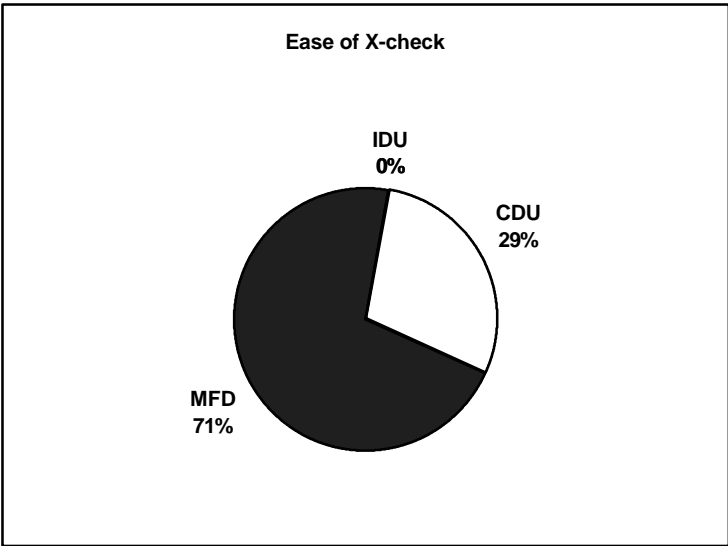

FIGURE 17. CREW PREFERENCE REGARDING EASE OF X-CHECK OF DATA LINK INTERFACES

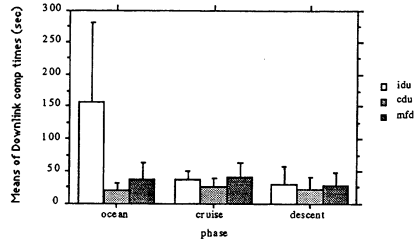

FIGURE 18. DOWNLINK COMPILATION TIMES AVERAGED FOR ALL TYPES OF MESSAGES

The downlink compilation times for all downlinks, but disregarding downlinks containing position reports are shown in figure 19. The average compilation time of this message set across all flight phases using the IDU was 33.5 seconds, using the CDU 24.4 seconds, and using the MFD 37.9 seconds. The effect of interface was statistically significant,  $F(2, 20)=6.113, p < 0.05$ . Mean compilation time in the oceanic phase was 31.8 seconds, in the cruise phase (radar coverage) 36.1 seconds, and during the descent phase 27.9 seconds. The effect of flight phase was not statistically significant.

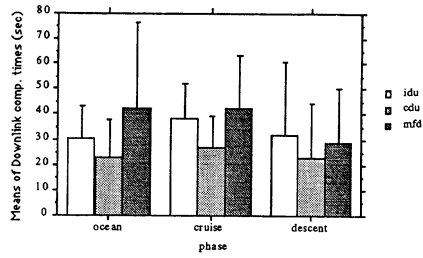

FIGURE 19. DOWNLINK COMPILATION TIMES AVERAGED FOR ALL DOWNLINKS WITHOUT POSITION REPORTS

The downlink compilation times for all downlinks, but disregarding downlinks containing position reports and downlinks containing free text, are shown in figure 20. The average compilation time across flight phases using the IDU was 27.6 seconds, using the CDU 18.3 seconds, and using the MFD 33.9 seconds. The effect of interface was statistically significant,  $F(2, 16) = 9.832$ ,  $p < 0.05$ . Mean compilation time in the oceanic phase was 22.3 seconds, in the cruise phase (radar coverage) 28.0 seconds, and during the descent phase 29.6 seconds. The effect of flight phase was not statistically significant.

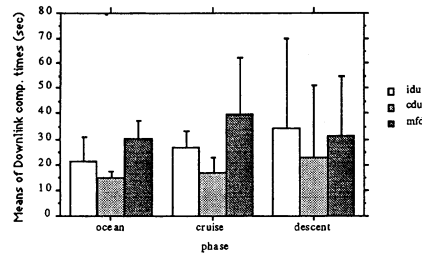

FIGURE 20. DOWNLINK COMPILATION TIMES AVERAGED FOR ALL DOWNLINKS WITHOUT POSITION REPORTS OR FREE TEXT

The downlink compilation times for all downlinks disregarding downlinks containing position reports, and downlinks containing free text, and also disregarding extreme values are shown in figure 21. All downlink times above the sum of the average plus three times the SD have been left out. The average compilation time across flight phases using the IDU was 20.8 seconds, using the CDU 15.0 seconds, and using the MFD 23.0 seconds. The effect of interface was statistically significant,  $F(2, 16) = 8.927$ ,  $p < 0.05$ . Mean compilation time in the oceanic phase was 21.5 seconds, in the cruise phase (radar coverage) 21.8 seconds, and during the descent phase 15.5 seconds. The effect of flight phases was statistically significant,  $F(2, 16) = 7.595$ ,  $p < 0.05$ .

#### 4.1.1.3 Keying Performance.

Because the three Data Link devices used three different character entry and menu selection systems, average times were analyzed. For single character entries ("A,B,C, 1, 2, 3"), both the CDU and the MFD used the scratchpad and keyboard of the CDU's, whereas the IDU used a touchscreen keyboard which was selected when appropriate. For menu selection, both the IDU and the MFD used touchscreen entries (selected upon release of the field!), whereas the CDU used the line select keys located next to the display. Average time per single character (free text) input is shown in figure 22 for each interface. The average input time using the IDU was 2.9 seconds, using the CDU 1.3 seconds, and using the MFD 1.4 seconds. The effect of interface was statistically significant,  $F(2, 12) = 6.383$ ,  $p < 0.05$ .

Average time per menu selection is shown in figure 23 for each interface. The average menu selection time using the IDU was 2.6 seconds, using the CDU 1.7 seconds, and using the MFD 2.2 seconds. The effect of interface was statistically significant,  $F(2, 26) = 22.333$ ,  $p < 0.05$ .

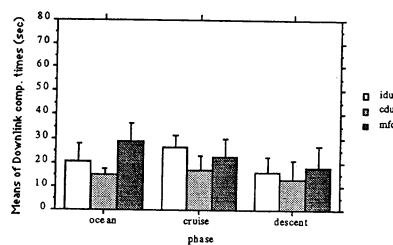



FIGURE 21. DOWNLINK COMPILATION TIMES AVERAGED FOR ALL DOWNLINKS EXCLUDING POSITION REPORTS, FREE TEXT AND VALUES

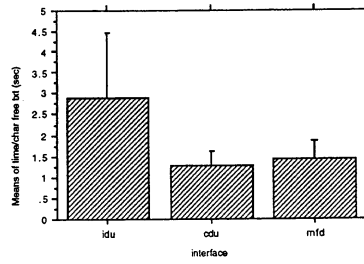

FIGURE 22. AVERAGE SINGLE CHARACTER INPUT TIME (FREE TEXT)

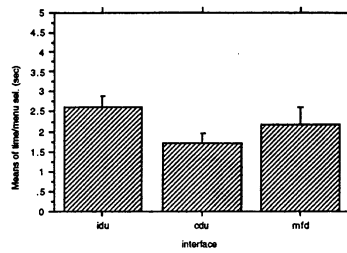

FIGURE 23. AVERAGE MENU SELECTION TIME

#### 4.1.1.4 Subjective Appreciation.

The results of the questionnaires regarding aspects related to downlink handling are shown in figures 24 and 25. The percentage of pilots preferring a Data Link interface regarding ease of use of the device is shown in figure 24. When asked which interface was preferred with regards to ease of use 68 percent preferred the CDU, 26 percent the MFD, and 6 percent the IDU.

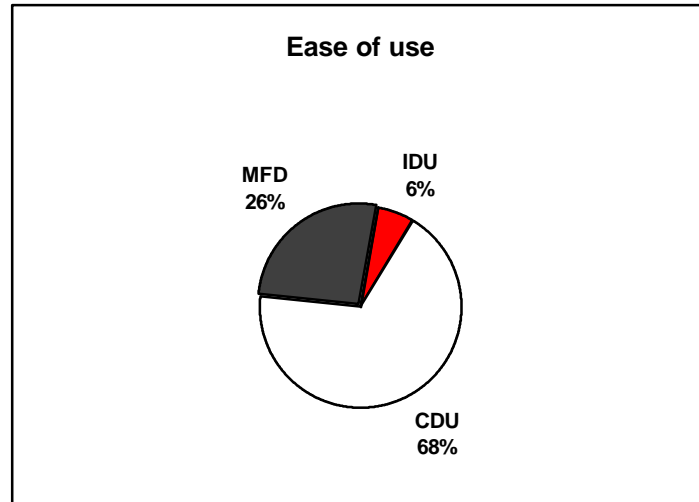

FIGURE 24. CREW PREFERENCE REGARDING EASE OF USE OF DATA LINK INTERFACES

The percentage of pilots preferring a Data Link interface regarding reachability of the device is shown in figure 25. When asked which interface was preferred with regards to reachability 80 percent preferred the CDU, 20 percent the MFD, and nobody the IDU.

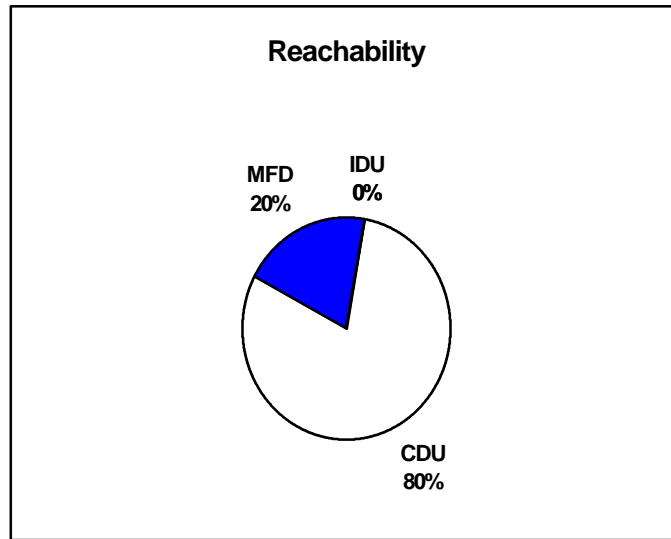

FIGURE 25. CREW PREFERENCE REGARDING REACHABILITY OF DATA LINK INTERFACES

The average perceived difficulty of each Data Link interface regarding the operability of the device during different levels of turbulence is shown in figure 26. These difficulty levels were subjective measures. No difficulty would score the value zero (0) whereas maximum difficulty (meaning not operable) would score four (4). The average operability difficulty using the IDU was 1.02, using the CDU 0.26, and using the MFD 0.91. The effect of interface was statistically significant,  $F(2, 52)=7.588, p< 0.05$ . The average operability difficulty with no turbulence was 0.11, with light turbulence 0.5, and with moderate turbulence 1.56. The effect of level of turbulence was statistically significant,  $F(2, 52)=47.240, p< 0.05$ .

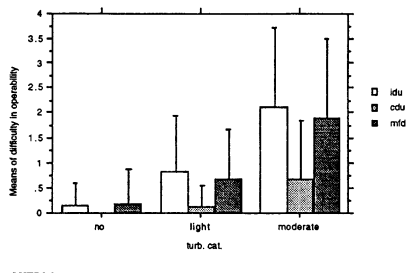

FIGURE 26. AVERAGE PERCEIVED DIFFICULTY IN OPERATING A DATA LINK INTERFACE UNDER VARIOUS TURBULENCE CONDITIONS

### 4.1.3 Errors and Instruction Breaches.

#### 4.1.3.1 Uplinks.

The average number of uplink instruction breaches per crew as function of Data Link interfaces are shown in figure 27. The average number of instruction breaches per crew using the IDU was 1.1 per flight, using the CDU 1.4 per flight, and using the MFD 2.3 per flight. The effect of interface was statistically significant,  $F(2, 26)=5.922$ ,  $p<0.05$ . The average number of instruction breaches per crew in the oceanic phase was 0.5, during cruise (radar coverage) 0.9, and during the descent 3.4. The effect of phase of flight was statistically significant,  $F(2, 26)=71.011$ ,  $p<0.05$ .

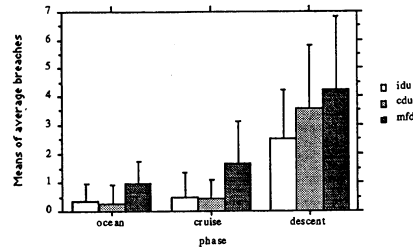

FIGURE 27. AVERAGE NUMBER OF UPLINK INSTRUCTION BREACHES PER CREW

The total number of radio frequencies not set during the experiment for the Data Link interfaces are shown in figure 28. No statistical analysis have been done due to the small total number. There is a clear trend to miss more frequencies during the descent phase. The MFD seems to be the most prone to this type of error.

#### 4.1.3.2 Downlink Errors.

The downlink alpha (text) and digit (numbers) compilation errors together with the errors sent as a ratio of total messages sent are shown in figure 29 for (a) all downlinks, (b) all downlinks not containing position reports, and (c) all downlinks not containing position reports and free text items.

#### 4.1.3.3 All Downlinks.

The average alpha error ratio using the IDU was 0.105, using the CDU 0.036, and using the MFD 0.092 when looking at all downlinks. The effect of interface was statistically significant,  $F(2, 26)=3.428$ ,  $p<0.05$ . The average alpha error ratio in the oceanic phase was 0.052, in the cruise phase 0.124, and in the descent phase 0.056 when looking at all downlinks. The effect of phase of flight was statistically not significant.

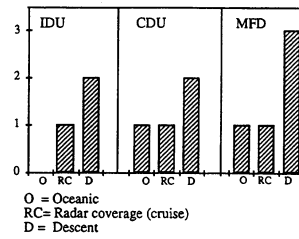

FIGURE 28. TOTAL NUMBER OF RADIO FREQUENCIES MISSED

The average digit error ratio using the IDU was 0.129, using the CDU 0.003, and using the MFD 0.029 when looking at all downlinks. The effect of interface was statistically significant,  $F(2, 26) = 13.012$ ,  $p < 0.05$ . The average digit error ratio in the oceanic phase was 0.114, in the cruise phase 0.039, and in the descent phase 0.008 when looking at all downlinks. The effect of phase of flight was statistically significant,  $F(2, 26) = 10.132$ ,  $p < 0.05$ .

The average error ratio sent using the IDU was 0.007, using the CDU 0.000, and using the MFD 0.007 when looking at all downlinks. The effect of interface was statistically not significant. The average error ratio sent in the oceanic phase was 0.003, in the cruise phase 0.011, and in the descent phase 0.000 when looking at all downlinks. The effect of phase of flight was statistically not significant.

#### 4.1.3.4 Without Position Reports

The average alpha error ratio using the IDU was 0.122, using the CDU 0.038, and using the MFD 0.109 when looking at all downlinks without position reports. The effect of interface was statistically significant,  $F(2, 26) = 3.495$ ,  $p < 0.05$ . The average alpha error ratio in the oceanic phase was 0.090, in the cruise phase 0.124, and in the descent phase 0.056 when looking at all downlinks without position reports. The effect of phase of flight was statistically not significant. The average digit error ratio using the IDU was 0.039, using the CDU 0.003, and using the MFD 0.035 when looking at all downlinks without position reports. The effect of interface was statistically not significant. The average digit error ratio in the oceanic phase was 0.031, in the cruise phase 0.039, and in the descent phase 0.008 when looking at all downlinks without position reports. The effect of phase of flight was statistically not significant.

The average error ratio sent using the IDU was 0.007, using the CDU 0.000, and using the MFD 0.007 when looking at all downlinks without position reports. The effect of interface was statistically not significant. The average error ratio sent in the oceanic phase was 0.003, in the cruise phase 0.011, and in the descent phase 0.000 when looking at all downlinks without position reports. The effect of phase of flight was statistically not significant.

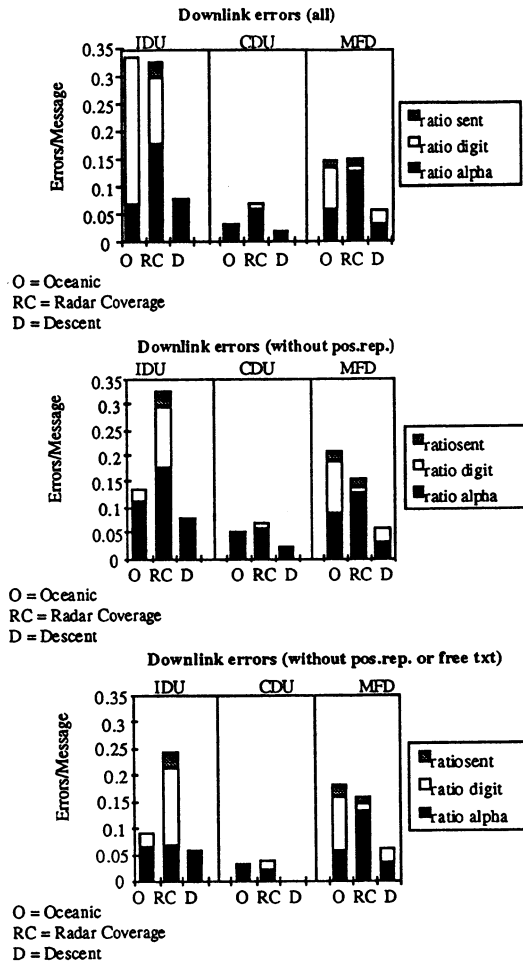

FIGURE 29. ERROR RATIOS FOR ALPHA, DIGIT, AND ERRORS SENT PER PHASE AND INTERFACE

#### 4.1.3.5 Without Position Reports and Free Text.

The average alpha error ratio using the IDU was 0.044, using the CDU 0.008, and using the MFD 0.089 when looking at all downlinks without position reports or free text. The effect of interface was statistically significant,  $F(2, 26) = 4.168, p < 0.05$ . The average alpha error ratio in the oceanic phase was 0.037, in the cruise phase 0.064, and in the descent phase 0.040 when looking at all downlinks without position reports or free text. The effect of phase of flight was statistically not significant.

The average digit error ratio using the IDU was 0.046, using the CDU 0.003, and using the MFD 0.038 when looking at all downlinks without position reports or free text. The effect of interface was statistically not significant. The average digit error ratio in the oceanic phase was 0.033, in the cruise phase 0.048, and in the descent phase 0.008 when looking at all downlinks without position reports or free text. The effect of phase of flight was statistically not significant.

The average error ratio sent using the IDU was 0.015, using the CDU 0.000, and using the MFD 0.010 when looking at all downlinks without position reports or free text. The effect of interface was statistically not significant. The average error ratio sent in the oceanic phase was 0.004, in the cruise phase 0.021, and in the descent phase 0.000 when looking at all downlinks without position reports or free text. The effect of phase of flight was statistically not significant.

#### 4.2 HEAD-FRONT TIME.

The area defined as being head-front, for both pilots as well as the definitions of the different epochs, used in the following graphs and data-analyses are shown in figure 30.

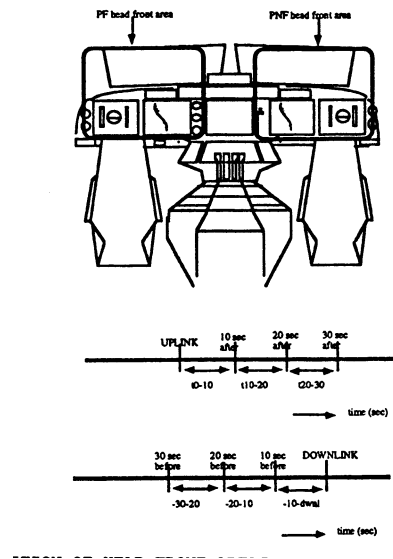

FIGURE 30. DEFINITION OF HEAD-FRONT AREAS AND EPOCHS AS USED IN THE ANALYSES

The average times, the pilot flying and pilot not flying are head-front during the different phases of flight are shown in figure 31 for each communication device. As expected the PF is more head-front than the PNF and head-front time increases when in the descent phase. This graph describes the overall head-tracking times during the entire flight. The next graphs relate to differences between interfaces in relation to communication events.

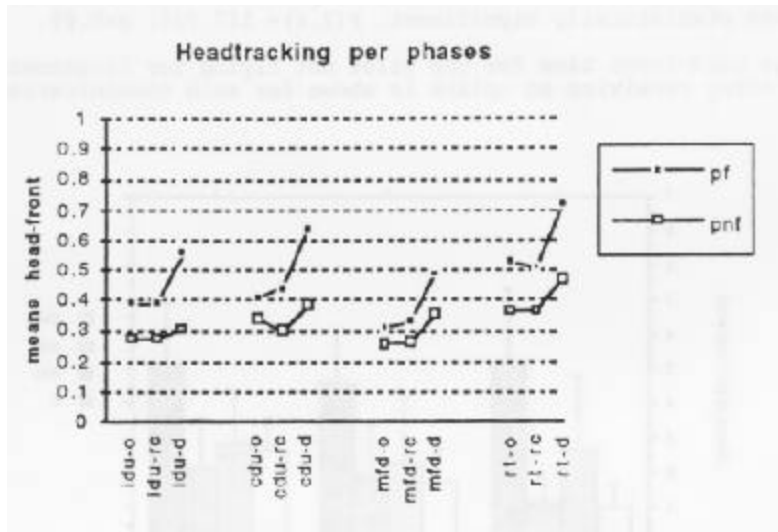

FIGURE 31. PF AND PNF HEAD-FRONT TIME PER PHASE FOR EACH INTERFACE

#### 4.2.1 Uplinks.

The average time the pilot flying is head-front, for 10-second time intervals after receiving an uplink is shown for each communication device in figure 32, starting at the uplink (or radio message) and ending 30 seconds later.

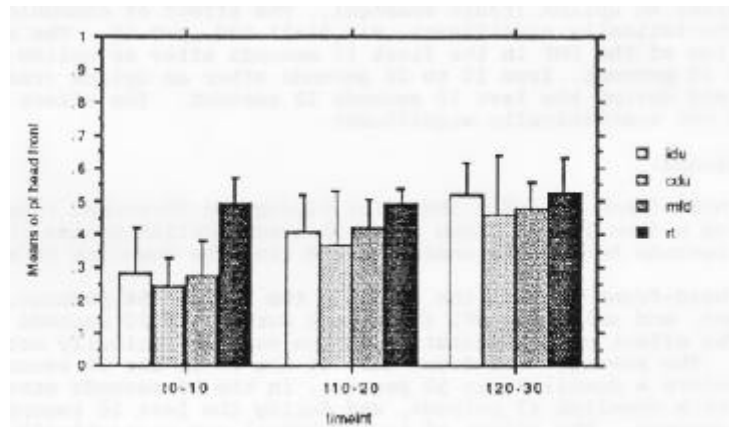

FIGURE 32. AVERAGE HEAD-FRONT TIME FOR PF AFTER UPLINKS OR RADIO MESSAGES



The average head-front time of the PF using the IDU was 40 percent, using the CDU 35 percent, using the MFD 39 percent, and using R/T 50 percent during the 30 seconds after an uplink (radio message). The effect of communication device was statistically significant,  $F(3,9)=5.421$ ,  $p < 0.05$ . The average head-front time of the PF in the first 10 seconds after an uplink (radio message) was 32 percent, from 10 to 20 seconds after an uplink (radio message) 42 percent, and during the last 10 seconds 50 percent. The effect of time-interval was statistically significant,  $F(2,6)=117.228$ ,  $p < 0.05$ .

The average head-front time for the pilot not flying for 10-second time intervals after receiving an uplink is shown for each communication device in figure 33.

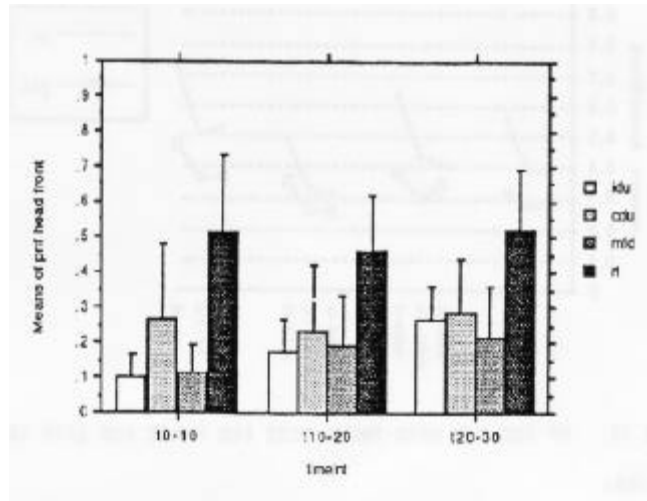

FIGURE 33. AVERAGE HEAD-FRONT TIME FOR PNF AFTER UPLINKS OR RADIO MESSAGE

The average head-front time of the PNF using the IDU was 18 percent, using the CDU 26 percent, using the MFD 17 percent, and using R/T 50 percent during the 30 seconds after an uplink (radio message). The effect of communication device was statistically significant,  $F(3,9)=11.130$ ,  $p < 0.05$ . The average head-front time of the PNF in the first 10 seconds after an uplink (radio message) was 25 percent, from 10 to 20 seconds after an uplink (radio message) 26 percent, and during the last 10 seconds 32 percent. The effect of time-interval was not statistically significant.

#### 4.2.2. Downlinks.

The average head-front time for the pilot flying for 10-second time intervals before sending a downlink is shown for each communication device in figure 34, starting 30 seconds before and ending at the time the downlink is sent.

The average head-front time of the PF using the IDU was 54 percent, using the CDU 44 percent, and using the MFD 45 percent during the 30 seconds before a downlink. The effect of communication device was statistically not significant. The average head-front time of the PF in the 10 seconds starting 30 seconds before a downlink was 50 percent, in the 10 seconds starting 20 seconds before a downlink 47 percent, and during the last 10 seconds before a downlink 46 percent. The effect of time-interval was statistically not significant.

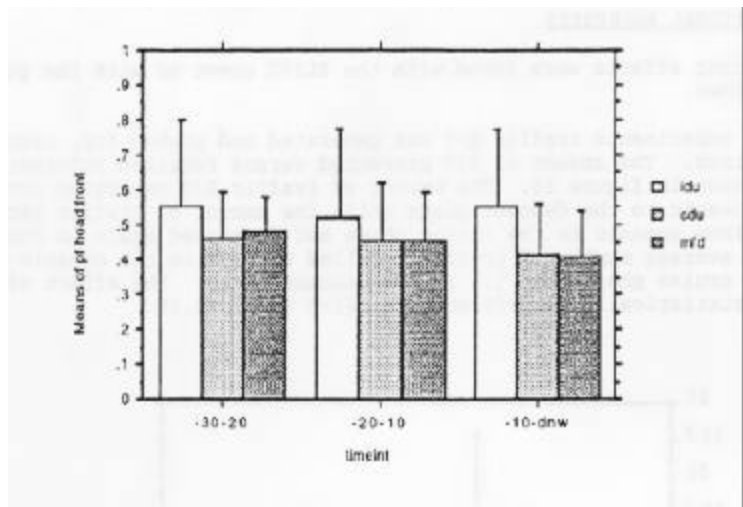

FIGURE 34. AVERAGE HEAD-FRONT TIME FOR PF BEFORE DOWNLINKS

The average head-front time for the pilot not flying for 10 second time intervals before sending a downlink is shown for each communication device in figure 35.

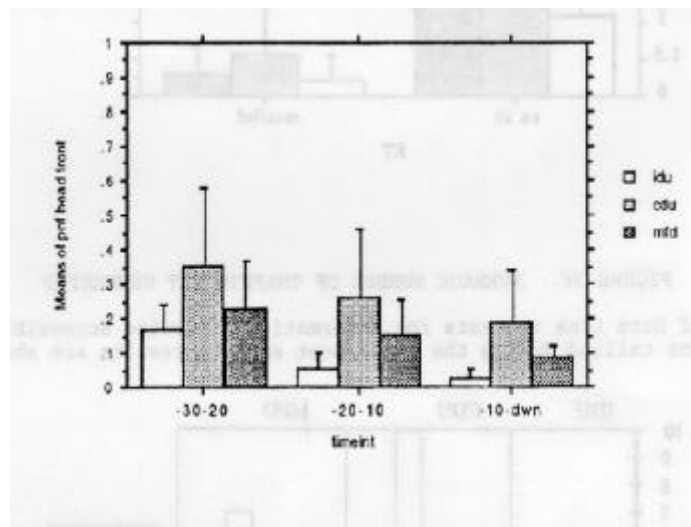

FIGURE 35. AVERAGE HEAD-FRONT TIME FOR PNF BEFORE DOWNLINKS

The average head-front time of the PNF using the IDU was 8 percent, using the CDU 27 percent, and using the MFD 16 percent during the 30 seconds before a downlink. The effect of communication device was statistically significant,  $F(2,10)=6.948$ ,  $p < 0.05$ . The average head-front time of the PNF in the 10 seconds starting 30 seconds before a downlink was 25 percent, in the 10 seconds starting 20 seconds before a downlink 16 percent, and during the last 10 seconds before a downlink 10 percent. The effect of time-interval was statistically significant  $F(2,10)=14.904$ ,  $p < 0.05$ .

4.3 SITUATIONAL AWARENESS.

No significant effects were found with the KL692 event or with the go-around reaction times.

During the experiments traffic R/T was generated and probed for, using questionnaires. The amount of R/T presented versus recalled information by crews is shown in figure 36. The amount of traffic R/T generated increased from the oceanic to the descent phase while the amount of traffic recalled increased from oceanic to the cruise phase but decreased again in the descent phase. The average number of traffic recalled was 1.1 in the oceanic phase, 2.7 in the cruise phase, and 1.5 in the descent phase. The effect of flight phase was statistically significant  $F(2,26)=3.545, p < 0.05$ .

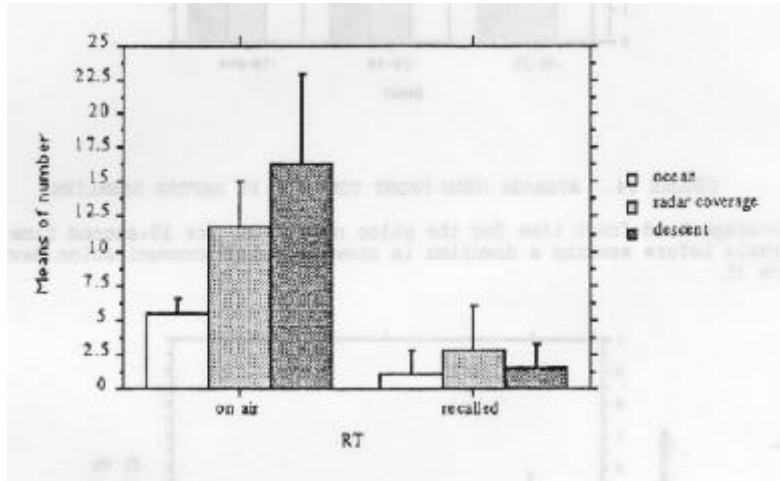

FIGURE 36. AVERAGE NUMBER OF TRAFFIC R/T GENERATED

The number of Data Link requests for information otherwise accessible through party line was tallied during the experiment and the results are shown in figure 37.

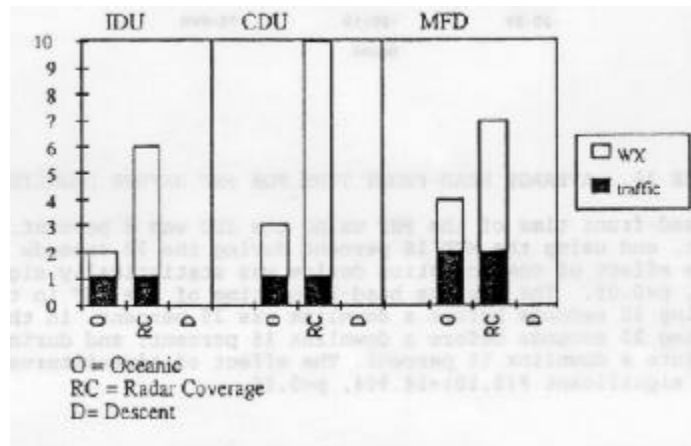

FIGURE 37. NUMBER OF DATA LINK REQUESTS OF INFORMATION

#### 4.4 WORKLOAD

The average subjective workload for the pilot flying for all flying tasks is shown in figure 38 for each interface and for each phase of flight. Pilots could rate their workload on a linear scale from 0-150.

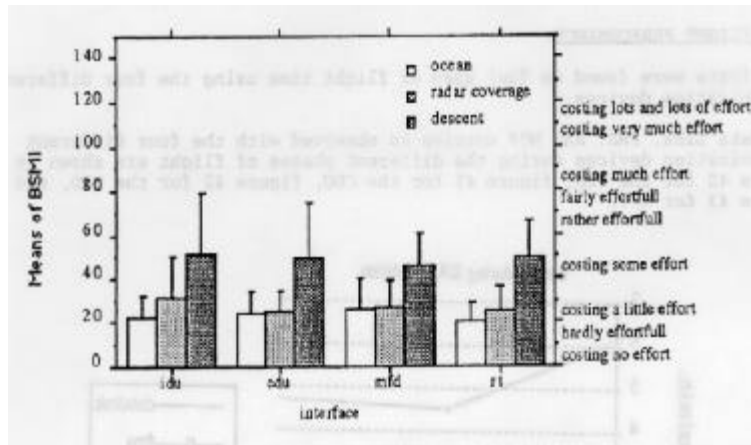

FIGURE 38. AVERAGE SUBJECTIVE WORKLOAD (BSMI) SCORE OF THE PF

The average BSMI-score of the PF using the IDU was 35.0, using the CDU 33.0, using the MFD 32.9, and using R/T 31.6 during the experiment. The effect of communication device was statistically not significant. The average BSMI-score of the PF during the oceanic phase was 23.1, during the cruise phase 27.4, and during the descent phase 48.9. The effect of flight phase was statistically significant  $F(2,22) = 51.159$ ,  $p < 0.05$ .

The average subjective workload for the pilot not flying for the communication task is shown in figure 39 for each interface and for each phase of flight.

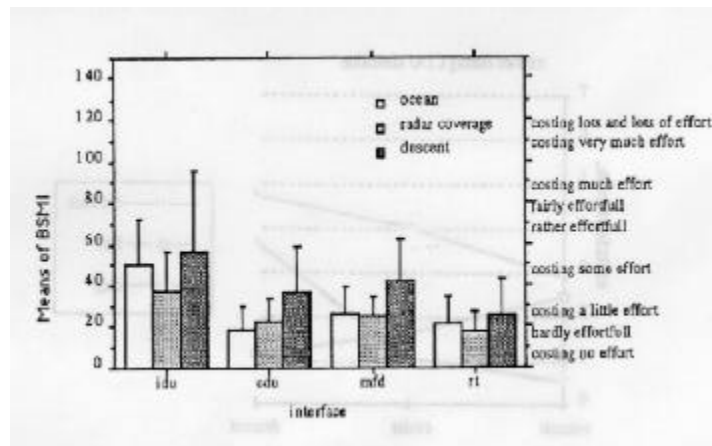

FIGURE 39. AVERAGE SUBJECTIVE WORKLOAD (BSMI) SCORE OF THE PNF

The average BSMI-score of the PNF using the IDU was 48.0, using the CDU 25.6, using the MFD 31.0, and using R/T 21.2 during the experiment. The effect of communication device was statistically significant,  $F(3,27)=9.511$ ,  $p< 0.05$ . The average BSMI-score of the PNF during the oceanic phase was 29.0, during the cruise phase 25.3, and during the descent phase 40.0. The effect of flight phase was statistically significant  $F(2,18)=11.786$ ,  $p< 0.05$ .

#### 4.5 FLIGHT PERFORMANCE.

No effects were found on fuel used or flight time using the four different communication devices.

The Data Link, FMS, and MCP entries as observed with the four different communication devices during the different phases of flight are shown in figure 40 for the IDU, figure 41 for the CDU, figure 42 for the MFD, and figure 43 for R/T.

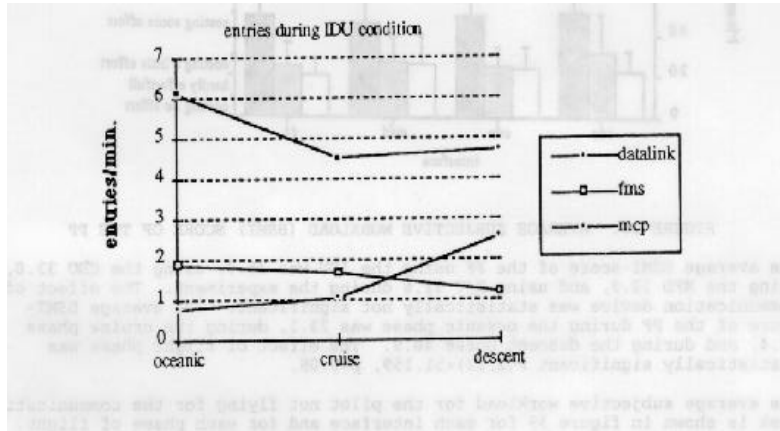

FIGURE 40. AVERAGE DATA LINK, FMS AND MCP ENTRIES FOR IDU CONDITION

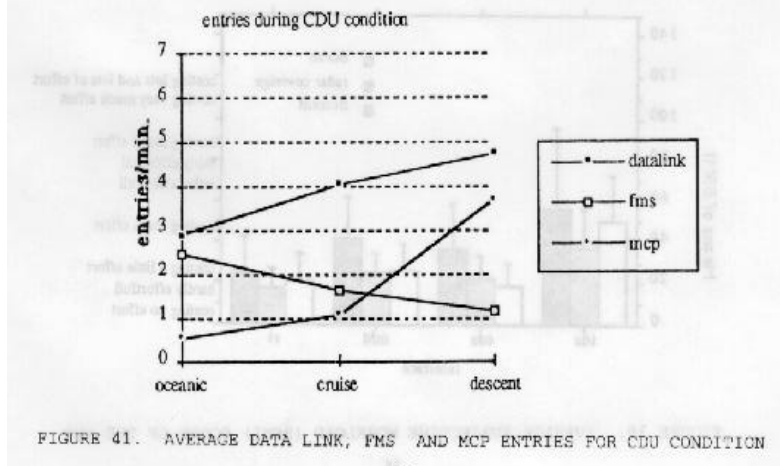

FIGURE 41. AVERAGE DATA LINK, FMS AND MCP ENTRIES FOR CDU CONDITION

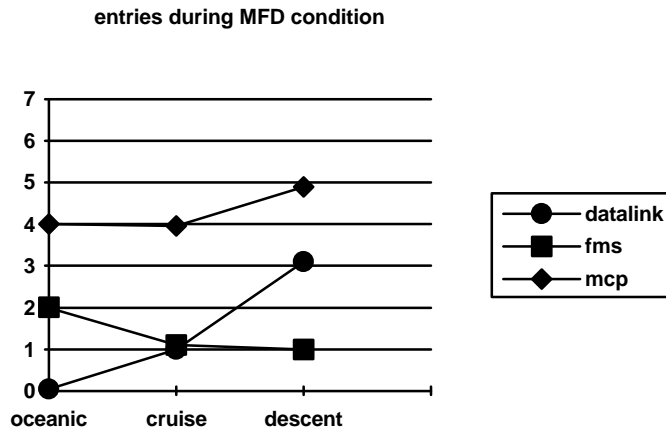

FIGURE 42. AVERAGE DATA LINK, FMS AND MCP ENTRIES FOR MFD CONDITION

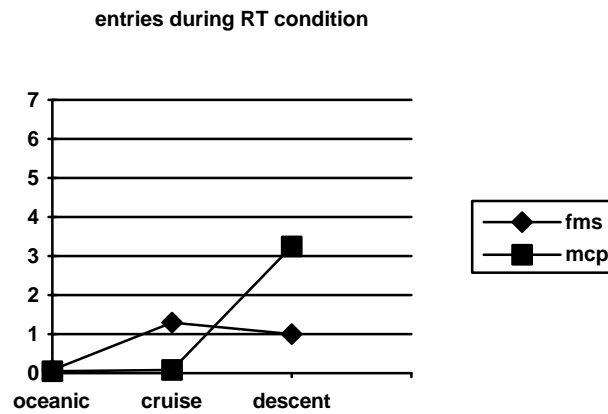

FIGURE 43. AVERAGE FMS AND MCP ENTRIES FOR R/T CONDITION

#### 4.5.1. Pilot Acceptance.

After each experimental flight crewmembers could indicate whether the respective communication device would be acceptable in its present form (as used in the experiment). The result of these questionnaires are shown in figure 44 and 45. The IDU was thought to be acceptable by 18 percent of the crewmembers, the CDU by 56 percent, the MFD by 37 percent, and R/T was thought to be acceptable by 63 percent.

Following the previous question some open space was left on the questionnaires for any spontaneous remarks. During analysis the consistency of those remarks was striking. Acceptance of Data Link (in general) was conditional and the condition most frequently mentioned was phase of flight. Spontaneously, 75

percent of the crew members would add the condition of oceanic flight for accepting Data Link as communication means. Cruise was mentioned by 39 percent of the crew members as condition for accepting Data Link, but 81 percent of the crew members mentioned the descent phase as being a condition in which Data Link was not acceptable. No crew members would mention the condition of oceanic or cruise for rejecting Data Link or the descent for accepting Data Link.

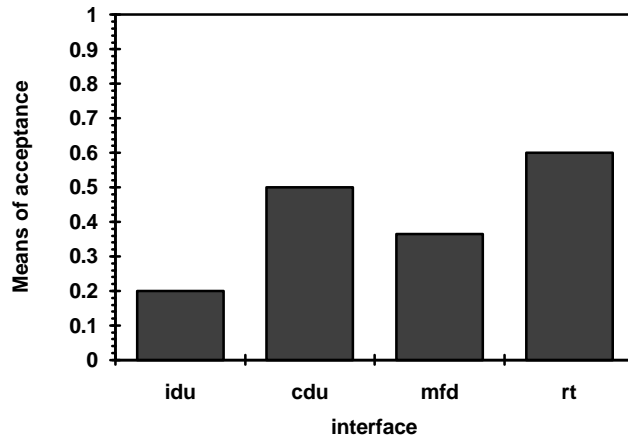

FIGURE 44. ACCEPTANCE OF COMMUNICATION DEVICE BY CREW MEMBERS

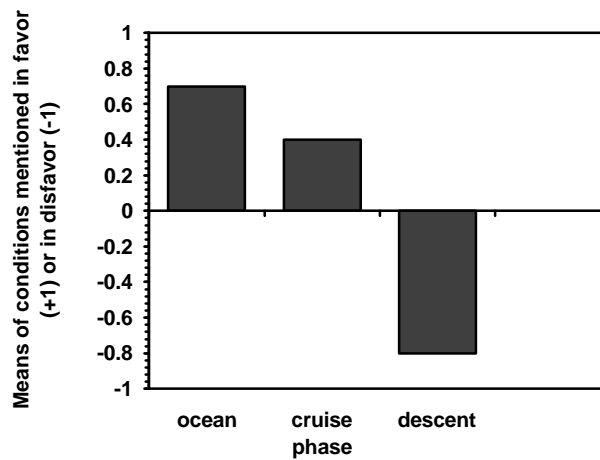

FIGURE 45. CONDITIONS MENTIONED FOR ACCEPTING OR REJECTING DATA LINK

## 5. DISCUSSION.

### 5.1 COMMUNICATION EFFECTIVENESS.

Before the results can be discussed one must keep in mind that this experiment was conducted with crews who were very experienced with the use of R/T and that even though they were trained in the use of the Data Link devices, their experience with Data Link was not in comparison with their experience with R/T. It should also be noted that of the three devices used, the CDU was the most common to all crews and that this could have played a role in the eventual outcome of it being overall the best interface. However, one can immediately add that this will also be the case in reality and that in general airlines will want to keep training requirements to a minimum.

#### 5.1.1. Uplinks.

Uplink-accept times show no effect of interface and only an effect of phase of flight when uplinks contain extensive information such as meteo or free text (figures 9-12). Information items such as meteo or free text are particularly asked for during cruise and oceanic phases. When comparing the Data Link devices to R/T (figures 13-14) again no effect is found on reaction times for the most essential messages implying that the communication devices do not differ in relation to such uplinks. The subjective data (figures 16-17) however do show a large difference between Data Link interfaces regarding aspects related to uplink handling. Both regarding readability and ease of X-check the MFD scores best and the CDU second whereas the IDU is extremely disliked. The fact that no effect is found in reaction times can be attributed to crews being able to compensate for each interface deficiency with regards to reaction time. Task completion times for frequency assignments (figure 15) were analyzed and showed a small but significant effect in favor of the R/T interface implying that even though reaction times to ATC directives were equal, task completion was faster in the R/T case. A possible explanation could be that the aural modality allows the PNF to start operating systems earlier. Another explanation could be that party-line information was used so that frequencies and frequency changes were known in advance.

#### 5.1.2 Downlinks.

Downlink compilation times reveal significant effects of phase of flight for both all downlinks (figure 18) as well as the downlinks without position reports, free text, and extreme values (figure 21). The difference with the full set of downlinks points to the time required by manually keying position reports using the IDU in the oceanic region. The difference with the reduced set can be explained by assuming that crews will tend to spend less time with communication interfaces during the descent phase. Why this effect is not present in the other two graphs (figures 19-20) will be discussed later in this paragraph.

An effect of interface is present in all downlink compilation graphs. This implies that interface optimization will primarily improve message compilation times.

Surprising are the relative bad results of the MFD. One could assume that the location of the MFD is better than that of the IDU, and that using the CDU keyboard for scratchpad entries is also an improvement to the touchscreen of the IDU. Yet, MFD downlink compilation times are not significantly different from the IDU times. Interesting is also the fact that when filtering the data for extreme values (figure 21), the IDU and the MFD benefit more than the CDU. This is very likely due to the multi-function character of the CDU. Both the IDU and the MFD allow the pilot to leave the page "as is" without interrupting other functions, whereas the CDU is also needed for the FMS. The nonfunction sharing devices provide ample message preparation time long before sending it. The fact that the MFD has two pages allows even more easy message preparation, possibly explaining the relative large compilation times. This interpretation could also explain the lack of phase effect in the nonfiltered graphs. More message preparation is used to compensate for time pressure such as during the descent.

The subjective data (figures 24-25) on aspects typically related to downlink compilation show that the MFD is clearly favored above the IDU and even above the CDU making the explanation above more plausible.

The single key input data (figures 22-23) suggest a negative effect of touch screen devices both for character entries and menu selections. Literature confirms that touch screens will result in slower data entry (Salvendy, 1987). The suboptimal effect of touch screens is accentuated by the turbulence operability questionnaires (figure 26) which clearly show the relative difficulty of operating on touch screens during motion conditions.

#### 5.1.3 Instruction Breaches and Errors.

Crews were instructed to accept a message first and key the desired changes later. The number of breaches (figure 27) to that rule seem to depend on two things: first, the available time and second, the quality of the interface. The large effect of time pressure in the descent phase clearly supports the first while the fact that the MFD (having two pages next to each other, allowing messages to be left while still being capable of downlinks) has more procedure breaches than the other two supports the second rule. For this reason, the term "procedure breach" could be better replaced by "adaptive interface management." During the experiment the radios had to be tuned by hand. A number of times wrong frequencies would be selected without crews correcting the error (figure 28). This can be explained by the fact that an all Data Link scenario was used, which kept the cockpit silent during the Data Link conditions allowing crews to select a wrong frequency while not noticing it. This suggests auto-tuning should be used or some check mechanism should be incorporated. Interesting is the fact that this error occurred more often in the descent phase indicating that time pressure will intensify the effect.

The downlink error results (figure 29) point to the superior keying attributes of the CDU. One would expect errors to be made with the IDU because of it using a touch screen for scratchpad entries (alpha and digit). Surprising however is the fact that the MFD still produces a larger amount of errors than the CDU although they both use the same keyboard for alpha and digit entries. Pilots could even use the display of the CDU to produce their entries effectively creating an identical interface. Only one explanation could be thought of to give this result, that is the



distance between the most relevant display (MFD) and the keyboard. Having two displays one would be tempted to look at the definitive one especially when a selection of different input scratchpads has to be made.

## 5.2 HEAD-FRONT TIME.

The head-tracking data per phase (figure 31) show that head-front time will decrease in relation to R/T not only for the PNF but also for the PF. That is, if Data Link will be implemented in the present form. This effect can also be observed after uplinks and before downlinks (figures 32-35), except in the case of the PF before a downlink. Apparently the PF has a keen interest in the contents of an uplink. He will be informed about the downlink to be sent and has no need to turn his head away in that case. The little head-away time of the PNF after an uplink with a CDU (figure 33), illustrates that uplinks can be read quite easily without extended head movement. During downlinks head-front time is considerably less for the PNF using the MFD than while using the CDU (figure 35), supporting the above mentioned interpretation of when having two displays one would look at the definitive one (in the case of the MFD leading to smaller head-front times).

## 5.3 SITUATIONAL AWARENESS.

The KL692 event showed no significant effect, meaning that crews asked for a step climb even though they could see traffic right above them. Crews reported that they trusted ATC fully to guarantee aircraft separation. Above European airspace they would not be so alert on traffic separation by means of party-line as they would be in less equipped environments.

The go-around times did not show a significant effect either, which can be partially explained by the limited number of data-points (all crews only made one go-around), but also by the fact that in the R/T case having an altitude of 1000 feet when the go-around was initiated and knowing that nothing was wrong with the aircraft or the immediate surroundings they could react leisurely. The graph "Traffic R/T generated vs. recalled" (figure 36) shows that in general many traffic R/T events are not memorized and also that increasing the total generated number will not increase the number recalled. This could be explained in numerous ways: the memory is limited, interest in traffic R/T is limited or interest in traffic R/T is specific. That the memory is limited is unlikely because crews were allowed to note down everything generated on R/T and use the notes while filling in the questionnaires. That the interest in traffic R/T is limited is in contradiction with many reports and with the comments of many crews stating concern about the loss of party-line. It is, therefore, very likely that the interest in traffic R/T is specific, namely crews are primarily interested in R/T items operationally of direct concern to them, such as weather, intentions, and clearances of aircraft in their immediate vicinity. This is supported by the number of Data Link downlink requests asking information about weather (during turbulence events) and about traffic intentions (when they were visible) (figure 37). During the descent phase no downlinks requests were made, which is not surprising because of the expected timepressure. This correlates well with the subjective workload graphs showing an increase of workload in the descent phase.

## 5.4 WORKLOAD.

Scenarios during the experiment were relatively quiet with regards to traffic and ATC instructions leading perhaps to workload levels lower than can be expected at busy airports. The workload graphs show a maximum perceived average workload for the PF regarding all flying tasks in the vicinity of "costing some effort" during the descent phases (figure 38). No effect of interface was found. The maximum workload levels found with the PNF regarding the communication task were in the vicinity of "rather effortful" (figure 39). A significant effect was found with interface in disfavor of the IDU. Again an increase in workload is found in the descent phase but also during the oceanic phase when using the IDU (due to the nonautomatic position report). In case of the IDU, all phases show a perceived workload higher than that in the descent phase of the R/T condition. The descent phases with the other two Data Link interfaces also show a larger workload than the descent phase of R/T. In fact, the perceived workload in the oceanic phase using the CDU is the lowest. Compared to present day levels one can state that using the IDU will increase workload of the PNF in all phases of flight to levels above that of a normal R/T descent and that with the other two interfaces only the descent phase will produce workload levels above that of a normal R/T descent.

## 5.5 FLIGHT PERFORMANCE.

No effects were found with fuel left or with flight time implying that no immediate economic benefits were found using Data Link. Looking at the number of entries/minutes in each condition, the number of entries needed for the operation of Data Link is striking (figures 40-43). When realizing that presently crews state that FMS operations alone are burdening them too much with keyboard entries, during high-workload phases of flight, and that they feel that this is decremental to their ability to manage the flight (Wiener 1989). One could argue that minimizing keyboard entries for Data Link, especially during high workload phases of flight, should be a top priority when designing Data Link devices and procedures.

## 6. CONCLUSION AND RECOMMENDATIONS.

### 6.1 CONCLUSION.

When asked which of the interfaces would be acceptable as a communication device, crews responded favorably to radio telephony (R/T) and the Control and Display Unit (CDU) (> 50 percent) and disfavorably to the Integrated Display Unit (IDU) and the Multi Function Display (MFD) (< 50 percent) (figure 44). At the same time, crews would mention spontaneously that Data Link would be acceptable in oceanic and cruise phases, whereas Data Link would not be acceptable in descent phases (figure 45). The other results support the conclusion that in its present form only the CDU is acceptable as a communication device in low workload phases of flight such as oceanic and cruise.

### 6.2 RECOMMENDATIONS.

To increase acceptability of Data Link one should consider:

a. Minimizing downlink time and effort by:

1. Minimizing key entries by means of optimal interface and menu design. This could be achieved by proper use of automation and Flight Management System (FMS) information. Downlink pages could be automatically reconfigured for the flight phase of the aircraft minimizing the number of pages needed.

2. Minimizing reports and requests. Reports could be automated almost fully by means of an FMS connection, thus relieving the pilot of key entries. The number of requests could be diminished through adaptation of present procedures. Air traffic control (ATC) could give more long term "precanned" instructions. This could possibly reduce the number of requests because crews would have more knowledge of ATC plans.

3. Using radio telephony (R/T) for all nonroutine communication. Using R/T only for non-routine communication such as unexpected weather reports and unexpected (evasive) maneuvers would not only reduce the number of downlinks, but would also enhance the situational awareness of crews through party line. An environment where R/T would only be used for nonroutine communication would act as a filter to present day R/T communication, where important R/T calls can be suppressed by a large number of routine R/T calls.

b. Preferably not using touch screens for text input. This experiment clearly showed the suboptimal properties of touchscreens in flight and if possible they should be avoided for text input.

c. Inform the pilot flying of uplinks independently of the Pilot Not Flying (PNF). This could be done by using speech synthesis or by means of an extra display in the forward field of view of the pilot.

d. Use autotuning of radio. The number of tuning mistakes support the concept of autotuning of radio frequencies.

e. Using Traffic Alert and Collision Avoidance System (TCAS). In addition, with the above mentioned usage for R/T for nonstandard communication and the enlargement of the information sent to the aircraft, TCAS could help improving Situation Awareness to a better level than today with party line.

## 7. REFERENCES.

1. Proceedings of the 6th International Symposium on Aviation Psychology, panel Discussion; Data-Link and Human Performance: What is the Net Effect? Waller, M.C. (NASA Langley Research Center), Hansman, R.J., and Hahn, E., and Midkiff, A. (MIT Aeronautical Systems Laboratory), Reynolds, M.C. (Midwest Systems Research), Sauls, L. (Air Line Pilot Association), Capt. Regan, G.R. (Allied Pilots Association), Gomer, F.E. (Honeywell, Inc.) and Lozito, S. (San Jose State University). Proceedings of the 6th International Symposium on Aviation Psychology. April 29-May 2, 1991.
2. Research Agenda for Data-Link: Proposed for Inclusion in the ATC/Flight Deck Integration Section of the National Plan for Aviation Human Factors. Air Transport Association, October, 1991.
3. Aeronautical Radio, Inc.; MARK 2: ARINC Communications Addressing and Reporting System. ARINC Characteristic 724, December 7, 1979.
4. Brown, T.L.; Bensel, B. (CTA, Inc.); Rehmann, A., (FAA); A Line Pilot's Perspective on Data-Link Services in Domestic and Oceanic Air Space Traffic Control.
5. Campbell, R.D.; Bagshaw, M. Human Performance and Limitations in Aviation. BSP Professional Books, 1991.
6. Chappell, S.; Lozito, S. (NASA), NASA Ames' Data-Link Pilot Performance Program. NASA Ames Research Center, 1991.
7. Corker, K.; Lozito, S.; McGann, A. (NASA), Air/Ground Compatibility Experiment. NASA Ames Research Center. Draft 2, June 1992.
8. Corwin, W.H. (Honeywell, Inc.), Data-Link Integration in Commercial Transport Operations. Proceedings of the 6th International Symposium on Aviation Psychology. April 29-May 2, 1991.
9. Groce, J.L.; Boucek, G.P., Jr. (Boeing Commercial Airplane Co.), Air Transport Crew Tasking in an ATC Data-Link Environment. SAE Paper 871764; Proceedings of the 6th Aerospace Behavioral Engineering Technology Conference. Long Beach, CA, October 5-8, 1987.
10. Hoekstra, J.M.; Ruigrok, R.C.J. (NLR), Man Machine Interfaces used for the Flight Simulator Evaluation of Data Link for ATC Communication. NLR CR 942890 L. Amsterdam, 1994.
11. Huisman, H. (NLR), The Use and Operation of the Airborne Meteorological Data-Link Application Process within AAI. NLR CR 92141L. Amsterdam, 1992.
12. Kerns, K. (The MITRE Corporation), Data-Link Communication Between Controllers and Pilots: A Review and Synthesis of the Simulation Literature. The International Journal of Aviation Psychology, 1(3), 181-204, 1991.
13. Klass, P.J., Digital Network Could Improve Aircraft Links to Operations ATC. Aviation Week and Space Technology, November 20, 1989, pages 121-123.
14. Knox, C.E.; Scanlon, C.H. (Langley Research Center), Flight Tests with a Data Link used for Air Traffic Control Information Exchange. NASA Technical Paper 3135. Langley Research Center, Hampton, VA, 1991.
15. Lee, A.T. (NASA Ames Research Center); Lozito, S. (San Jose State University), Air-Ground Information Transfer in the National Airspace System. Proceedings of the 5th International Symposium on Aviation Psychology, Ohio State University, Department of Aviation, Columbus, OH, April 17-20, 1989.
16. Lee, A.T. (NASA Ames Research Center), Human Factors and Information Transfer. SAE Paper 892607, 1989.
17. Lozito, S. (San Jose State University); McGann, A. (Sterling Software); Corker, K. (NASA Ames Research Center), Data Link Air Traffic Control and Flight Deck Environments: Experiment in Flight Crew Performance. NASA Ames Research Center, 1993.
18. Mattox, A.S., Jr. (Allied Pilots Association), Pilot-Controller Communication - A Line Pilot's Perspective. SAE Paper 902354, 1990.
19. Morrow, D.G. (Stanford University); Lee, A.; Rodvold, M. (Decision Systems), Analysis of Routine Pilot-Controller Communication. SAE Paper 902352, 1990.
20. Mulder, H.F., Ergonomie: Een Mensvriendelijke Technologie. Technische Hogeschool Twente, Werkgroep ergonomie.
21. Pomykacz, M.A. (CTA, Inc.), Report of Study on Airlines' Anticipated Near Future Cockpit and Display Capabilities and Plans for Data-Link Communication. US Department of Transportation, Federal Aviation Administration, Technical Center. Report No.: DOT/FAA/CT-TN91/7, February 1991.
22. Pozesky, M.T. (FAA), The Future Air Traffic Management System for the United States. Based on Concepts and Description of the Future Air Traffic Management System for the United States by the FAA, Office of System Development. Flying Safety, September 1991, page 4-6.

23. Ragland, M.A. (The MITRE Corporation), Application of Ground/Air Data Link to General Aviation Operations. Proceedings of the 7th Digital Avionics Systems Conference. Fort Worth, TX, October 13-16, 1986.
24. Rehmann, A.J., et al. (FAA), Terminal Data Link Operational Evaluation Test Plan - Airborne Perspective. US Department of Transportation, Federal Aviation Administration Technical Center. Draft, September 1992.
25. Reynolds, M.C.; Neumeier, M.E. (Midwest Systems Research, Inc.), Mode S Data Link Pilot-System Interface: A Blessing in de Skies or a Beast of Burden? Proceedings of the 6th International Symposium on Aviation Psychology. April 29-May 2, 1991.
26. Riley, V. (Honeywell), Human Factors Issues Associated with Data Link: Application of an Analytic Process to Identify System Level Issues and Requirement Areas. Honeywell, Inc., Systems and Research Center, Minneapolis, MN. April 1991.
27. Salvendy, G. (Ed) Handbook of Human Factors. New York, John Wiley and Sons. 1987.
28. Schwartz, D. (Flight Safety International), Training for Situational Awareness. Proceedings of the 5th International Symposium on Aviation Psychology. Ohio State University, Department of Aviation. Columbus, OH, April 17-20, 1989.
29. Uckermann, R.; Radke, H. (DFVLR), Evaluation of an Airborne Terminal for a Digital Data Link in Aviation. DFVLR-FB 83-05. Braunschweig, 1983.
30. Waller, M.C. (Langley Research Center), Flight Deck Benefits of Integrated Data Link Communication. NASA Technical Paper 3219. Langley Research Center, Hampton, VA, 1992.
31. Wiener, E.L. (Ames Research Center), Human Factors of Advanced Technology (Glass Cockpit) Transport Aircraft. NASA Contractor Report 177528. Ames Research Center, Moffet Field, CA, 1989.

## 8. LIST OF ABBREVIATIONS AND ACRONYMS.

ACARS	ARINC Communications Addressing and Reporting System
ACP	Audio Control Panel
ADS	Automatic Dependent Surveillance
AGL	Above Ground Level
ALT	Altitude
ANOVA	Analysis of Variance
ASRS	Aviation Safety Reporting System
ATA	Actual Time of Arrival
ATC	Air Traffic Control
ATIS	Air Traffic Information Service
ATM	Air Traffic Management
BSMI	Beoordelings Schaal Mentale Inspanning (Assessment Scale Mental Workload)
CDU	Control and Display Unit
CRT	Cathode Ray Tube
CTR	Center
DADC	Digital Air Data Computer
D/L	Data Link
DEST	Destination
DME	Distance Measuring Equipment
EFIS	Electronic Flight Instrument System
EICAS	Engine Indication and Crew Alerting System
ETA	Estimated Time of Arrival
FAA	Federal Aviation Administration
FIR	Flight Information Region
FMS	Flight Management System
FOV	Field of View
FREQ	Frequency
HDG	Heading
HF	High Frequency
IDU	Integrated Display Unit
ILS	Instrument Landing System
LED	Light Emitting Diode
MCP	Mode Control Panel
METAR	Aviation routine weather report
MFD	Multi Function Display

NLR	Nationaal Lucht- en Ruimtevaartlaboratorium (National Aerospace Laboratory)
NARSIM	Nlr Atc Research SIMulator
ND	Navigation Display
OAT	Outside Air Temperature
PF	Pilot Flying
PNF	Pilot Not Flying
PFD	Primary Flight D
PIREP	Pilot REPorts
POS	Position
RCP	Radio Control Panel
RFS	Research Flight Simulator
R/T	Radio Telephony
RLD	RijksLuchtvaartDienst
RWY	Runway
SAT	Static Air Temperature
SD	Standard Deviation
SIGMET	SIGNificant METeorological Conditions
SNR	Signal-to-Noise Radio
SPD	Speed
SSR(/S)	Secondary Surveillance Radar (Mode S)
TAF	Terminal Area Forecast
TCAS	Traffic Alert and Collision Avoidance System
TOC	Transfer Of Communication
VHF	Very High Frequency
VOR	VHF Omnidirectional Range
WX	Weather