

1. REPORT NUMBER CA18-3085	2. GOVERNMENT ASSOCIATION NUMBER	3. RECIPIENT'S CATALOG NUMBER
4. TITLE AND SUBTITLE Continued Evaluation of the TowPlow Trailer System		5. REPORT DATE January 23, 2018
7. AUTHOR Duane Bennett and Ty A. Lasky		6. PERFORMING ORGANIZATION CODE AHMCT Research Center, UC Davis
9. PERFORMING ORGANIZATION NAME AND ADDRESS AHMCT Research Center UCD Dept. of Mechanical & Aerospace Engineering Davis, California 95616-5294		8. PERFORMING ORGANIZATION REPORT NO. UCD-ARR-18-01-12-01
12. SPONSORING AGENCY AND ADDRESS California Department of Transportation P.O. Box 942873, MS #83 Sacramento, CA 94273-0001		10. WORK UNIT NUMBER
15. SUPPLEMENTARY NOTES		11. CONTRACT OR GRANT NUMBER 65A0560, Task 3085
16. ABSTRACT The Caltrans Division of Maintenance is conducting a trial evaluation of the Viking-Cives TowPlow trailer to determine if this equipment could potentially improve the level of service and reduce the cost of their winter snow fighting operations. This report documents the configuration modifications and the deployment activities necessary to deploy this equipment for Caltrans' highway operational testing. Two TowPlow units were purchased, adapted to operate within Caltrans guidelines, and deployed to the Kingvale Highway Maintenance Station (HMS) for winter operation trials. This TowPlow evaluation report focuses on the years 2016 and 2017. This report conducts a detailed analysis based on all available information of both the benefits and limitations of utilizing TowPlow units in Caltrans winter operations.		13. TYPE OF REPORT AND PERIOD COVERED Final Report October 2016 – January 2018
17. KEY WORDS Roadway snow removal, TowPlow, Snowplowing trailer, TowPlow evaluation	14. SPONSORING AGENCY CODE Caltrans	
18. DISTRIBUTION STATEMENT No restrictions. This document is available to the public through the National Technical Information Service, Springfield, Virginia 22161.	19. SECURITY CLASSIFICATION (of this report) Unclassified	20. NUMBER OF PAGES 82
		21. COST OF REPORT CHARGED

DISCLAIMER

The research reported herein was performed by the Advanced Highway Maintenance and Construction Technology (AHMCT) Research Center, within the Department of Mechanical and Aerospace Engineering at the University of California – Davis, for the Division of Research, Innovation and System Information (DRISI) at the California Department of Transportation. AHMCT and DRISI work collaboratively to complete valuable research for the California Department of Transportation.

The contents of this report reflect the views of the author(s) who is (are) responsible for the facts and the accuracy of the data presented herein. The contents do not necessarily reflect the official views or policies of the STATE OF CALIFORNIA or the FEDERAL HIGHWAY ADMINISTRATION. This report does not constitute a standard, specification, or regulation. This report does not constitute an endorsement by the Department of any products or services described herein.

The contents of this report do not necessarily reflect the official views or policies of the University of California. This report does not constitute an endorsement by the University of California of any products or services described herein.

For individuals with sensory disabilities, this document is available in alternate formats. For information, call (916) 654-8899, TTY 711, or write to California Department of Transportation, Division of Research, Innovation and System Information, MS-83, P.O. Box 942873, Sacramento, CA 94273-0001.



Advanced Highway Maintenance and Construction Technology Research Center

Department of Mechanical and Aerospace Engineering
University of California at Davis

Continued Evaluation of the TowPlow Trailer System

Duane Bennett &
Ty A. Lasky: Principal Investigator

Report Number: CA18-3085
AHMCT Research Report: UCD-ARR-18-01-12-01
Final Report of Contract: 65A0560, Task 3085

January 23, 2018

California Department of Transportation

Division of Research, Innovation and System Information

ABSTRACT

The Caltrans Division of Maintenance is conducting a trial evaluation of the Viking-Cives TowPlow trailer to determine if this equipment could potentially improve the level of service and reduce the cost of their winter snow fighting operations. This report documents the configuration modifications and the deployment activities necessary to deploy this equipment for Caltrans' highway operational testing. Two TowPlow units were purchased, adapted to operate within Caltrans guidelines, and deployed to the Kingvale Highway Maintenance Station (HMS) for winter operation trials. This TowPlow evaluation report focuses on the years 2016 and 2017. This report conducts a detailed analysis based on all available information of both the benefits and limitations of utilizing TowPlow units in Caltrans winter operations.

TABLE OF CONTENTS

Abstract	ii
Table of Contents	iii
List of Figures	v
List of Tables	vi
List of Acronyms and Abbreviations	vii
Acknowledgments	ix
Executive Summary	10
Chapter 1: Introduction	12
<i>Problem</i>	12
<i>Background</i>	12
<i>Objectives</i>	13
<i>Scope</i>	13
<i>Caltrans DoE TowPlow Modifications</i>	14
Chapter 2: Observation of TowPlow Use and Test Participation	19
Winter 2016-2017 Season	19
<i>TowPlow Evaluation Implementation Factors</i>	19
<i>TowPlow Deployment Telemetry</i>	20
<i>Caltrans TowPlow Field Observations</i>	21
<i>Caltrans TowPlow Operator Feedback and Equipment Observations</i>	24
Chapter 3: TowPlow Engineering Evaluation	27
<i>Caltrans-Specific TowPlow Performance Considerations</i>	27
<i>Weight of Caltrans Highway Traction Sand</i>	31
<i>Caltrans Wing Plow vs. TowPlow Comparisons</i>	31
<i>Analysis of TowPlow Applications in Caltrans Snow Fighting Operations</i>	35
<i>TowPlow Cost Benefit Analysis</i>	39
Chapter 4: Conclusions and Future Research	44
<i>Future work:</i>	45
References	46
Appendix A: DoE TowPlow2 Weight Analysis	47

<i>Vehicle Legal Weight Limits</i>	47
<i>TowPlow2 Weights as Received</i>	47
<i>Making Vehicle Weight Legal – Option 1</i>	48
<i>Making Vehicle Weight Legal - Option 2</i>	49
<i>Making Vehicle Weight Legal - Option-3</i>	49
Appendix B: TowPlow2 Option-3 Weight Certificate	51
Appendix C: TowPlow2 Option-3 DoE Deficiency Memorandum	52
Appendix D: TowPlow2 Option-3 DoE Weight Measurements	71
Appendix E: DoE Rebuild of TowPlow2 Option-3	73
Appendix F: TP2-DoE Manufacturer Contact	74
Appendix G: TP2-DoE Operator Survey	75
Appendix H: Three-Lane Sections of SnowPlowing Routes	78
Appendix I: DOE TowPlow1 Modifications	80

LIST OF FIGURES

Figure 1: Nevada DOT TowPlow in Reno, NV _____	13
Figure 2: Caltrans TowPlow1 Snowplowing on I-80 _____	15
Figure 3: TowPlow2 – Option-3 Sander Configuration _____	16
Figure 4: TowPlow2 Option-3 Loading and Axle Weights _____	17
Figure 5: Phases of TowPlow1&2 Configurations _____	18
Figure 6: TowPlow1 and 2 Trailers in Kingvale HMS during Snow Event Winter 2016-2017 _____	23
Figure 8: TP1 Trailer Tire Cable Chains _____	30
Figure 9: TP2 Certified Clean Idle Certification _____	30
Figure 10: Caltrans 10-Yard Wing Plow with 18-Foot Snow Clearing Path _____	32
Figure 11: TowPlow with 22-Foot Snow Clearing Path _____	33
Figure 12: Head Plow Width Comparison _____	33
Figure 13: TowPlow Clearing Two Traffic Lanes _____	36
Figure 14: Most Efficient Configuration for Clearing Two Traffic Lanes _____	36
Figure 15: Most Efficient Three-Lane TowPlow Clearing Configuration _____	38
Figure 16: Clearing Three Lanes with Conventional Equipment _____	38
Figure 17: Additional Sander Truck Trailing TP2-DoE on I-80 _____	45

LIST OF TABLES

Table 1: Three-Lane Snowplowing Highway Sections	41
Table 2: TowPlow Cost Savings Per Loop	43

LIST OF ACRONYMS AND ABBREVIATIONS

Acronym	Definition
ABS	Anti-lock Braking System
AHMCT	Advanced Highway Maintenance and Construction Technology Research Center
AVL	Automatic Vehicle Location
Caltrans	California Department of Transportation
CARB	California Air Resources Board
cu-yd	Cubic Yard
lb/cu-yd	Pounds per Cubic Yard
DoE	Caltrans Headquarters Division of Equipment
DOT	Department of Transportation
DRISI	Caltrans Division of Research, Innovation and System Information
EPA	Environmental Protection Agency
gal	Gallon
GPRS	General Packet Radio Service
GPS	Global Positioning System
GSM	Global System for Mobile communication
hp	Horsepower
hr	Hour
HMS	Highway Maintenance Station
I-5	Interstate 5
I-80	Interstate 80
IMMS	Integrated Maintenance Management System
MAZEPP	Maintenance Zone Enhanced Enforcement Program

Acronym	Definition
NDOT	Nevada Department of Transportation
TAG	Caltrans Technical Advisory Group
TP1	First TowPlow Trailer Original Mfg. Configuration
TP1-DoE	Caltrans DoE Modified First TowPlow Trailer
TP2	Second TowPlow Original Mfg. Turnkey Configuration
TP2-Opt3	Option-3 Modified TowPlow2 Configuration
TP2-DoE	Caltrans DoE Modified TowPlow2 Configuration
Wi-Fi	Wireless Fidelity
yd	Yard

ACKNOWLEDGMENTS

The authors thank the California Department of Transportation (Caltrans) for their support, in particular, Jeremy Johnson and Larry Orcutt with the Division of Equipment, David Frame with the Division of Maintenance, and Justin Unck and Larry Baumeister with the Division of Research, Innovation and System Information. The authors also thank Dave Wood and David McIntire at the Kingvale Highway Maintenance Station. The authors acknowledge the dedicated efforts of the AHMCT team who have made this work possible.

EXECUTIVE SUMMARY

The California Department of Transportation (Caltrans) Division of Maintenance is conducting a trial evaluation of the Viking-Cives TowPlow trailer to determine if this equipment could improve the level of service and reduce cost of their winter snow fighting operations. This report documents the configuration modifications and the deployment activities necessary to deploy this equipment in Caltrans for field crew operational testing on the highway. Two TowPlow units were purchased, modified to operate within Caltrans guidelines, and deployed to the Kingvale Highway Maintenance Station (HMS) for winter operation trials.

This TowPlow evaluation report focuses on the years 2016 and 2017. This research period generally coincides with the adaptation of the second TowPlow (TP2) unit. The TP2 unit was purchased as a turnkey system consisting of a sander configuration TowPlow trailer paired to a high horsepower prime mover truck. The Caltrans Technical Advisory Group (TAG) guiding the TowPlow research program mandated that, to be acceptable for Caltrans deployment, the TP2 needed to be reconfigured to ensure that the axle loading would be within Caltrans' recommended limit. On receipt of TP2, Caltrans DoE conducted an equipment quality inspection and took weight measurements, concluding that the fully-laden axle weight of the turnkey TP2 configuration would exceed legal load limits for highway duty, axle manufacturer's rating, and tire manufacturer's rating for maximum loading. DoE and the TAG engineered and approved modifications to mitigate the weight issue, and the Viking-Cives subsidiary agreed to and made these modifications to the TP2, yielding the TP2-Opt3 configuration. These modifications succeeded in bringing the fully-laden axle weights to within legal limits when weighed conventionally on a flat service as measured by AHMCT and independently by DoE. However, further testing by DoE to simulate operational conditions indicated that the Viking-Cives modified TP2-Opt3 configuration had individual axle and wheel/tire loadings that exceed the manufacturers' design parameters (see Appendix C). DOE indicated that this is entirely due to a lack of suspension on the trailer which enables load sharing from side to side and front to back, and that this is an inherent design flaw of the trailer having the axles bolted directly to the frame. Subsequently, Caltrans DoE converted the TP2 trailer into a brine configuration in order to completely mitigate their axle loading concerns. The DoE reconfigured TowPlow, referred to as TP2-DoE, was deployed to the Kingvale HMS together with the TowPlow1, which previously had been similarly configured by Caltrans DoE and henceforth designated as TP1-DoE, for operation during the 2016-2017 winter season.

The amount of information available during this study was limited for two reasons. First, early in the season, the data collection units were not functioning properly. Second, the TowPlows were not used during every storm. TP2 was first delivered to the Kingvale HMS on approximately December 22, 2016. Based on all available information, this report conducts a detailed analysis of both the benefits and limitations of utilizing TowPlow units in Caltrans winter operations.

A detailed, formal cost benefit analysis could not be performed, since data collection of the TowPlow performance under normal Caltrans operating conditions was non-existent. Several other state DOTs have successfully integrated TowPlow equipment into their winter highway maintenance programs. The publicized TowPlow cost savings and

level of service benefits are mainly established on the basis of comparing snowplow trucks that nominally clear a single lane to TowPlow truck-trailer combinations that nominally clear two lanes (see e.g. pg. 57 of [1]). The obvious conclusion is that the TowPlow saves the cost of operating an additional snowplow truck and driver. This narrow methodology fails to take into consideration operations using snowplow trucks with multiple plows, as is the case with Caltrans, which operates a large fleet of wing plow trucks.

This report analyzes a TowPlow vs. Caltrans wing plow clearing path comparison, the result being that the TowPlow only nominally clears up to an additional one quarter of a lane path. An analysis of Caltrans snowplowing pack configurations for multiple-lane highways is also presented, evaluating the most efficient application of Caltrans snowplowing equipment to clear two- and three-lane highways. The results show that the additional path clearing capability of the TowPlow only becomes useful on three-lane per direction highways. Furthermore, since the Caltrans TowPlow units lack a sanding capability, this will require the inclusion of an additional trailing sanding truck in operations. Therefore, the deployment of TowPlow equipment seemingly increases snowplowing echelon vehicle count and cost for prevailing Caltrans snow fighting operations based on Caltrans maintenance personnel interviews.

CHAPTER 1: INTRODUCTION

Problem

The clearing of snow and ice from California's roadways is an essential task that costs the state approximately \$25 million annually, of which about \$20 million is spent on the Sierra Nevada mountains section of the Interstate 80 (I-80) corridor. The operations on multi-lane roadways typically involve numerous snowplows in an echelon configuration to allow clearing of the entire road width. Alternatively, a smaller number of snowplows will be required to make multiple passes over a section of roadway to ensure that it is fully cleared of snow. The California Department of Transportation (DOT) (Caltrans) would like to research and implement more effective ways for clearing snow and ice from highways while at the same time increasing the safety of Caltrans workers and the traveling public.

Background

The TowPlow is a snowplow trailer that extends the snow clearing reach of standard snowplow trucks. Sold exclusively by Viking-Cives, Inc., the TowPlow consists of a steerable tandem axle trailer with a 26-foot long snowplow moldboard mounted along one side. The TowPlow is designed to be hydraulically steered out to a maximum of 30 degrees and clear an adjacent full traffic lane. The term "prime mover truck" in this report refers to a truck specifically configured to operate and control a TowPlow trailer. When used in combination with a 12-foot-wide truck head plow, a TowPlow system can clear two nominal traffic lanes in a single pass. In operation, the required TowPlow moldboard plow force needed to overcome the snow load is generated solely by the tandem axle lateral steering force. Therefore, it is essential to maximize TowPlow tire traction to achieve effective snow clearing capabilities.

The Advanced Highway Maintenance and Construction Technology (AHMCT) Research Center at the University of California, Davis was tasked to purchase and deploy two TowPlow trailer units for evaluation purposes beginning in 2012. The original scope of the Caltrans DRISI TowPlow research project focused solely on the procurement and evaluation of the two TowPlow trailers based on the assumption that existing snowplow trucks in their fleet could be paired in a straightforward way with TowPlow trailers and put into service. To test this assumption, AHMCT adopted an iterative development approach and procured one TowPlow trailer based on Caltrans Technical Advisory Group (TAG) specifications, with the intent of augmenting the specifications of the second unit with information gained from the initial research. The first TowPlow purchased, referred to hereafter as TP1, was to be configured with a brine surface treatment system and married to an existing, slightly modified Caltrans fleet snowplow truck. Caltrans deployed the TP1 system early in 2013 for winter operation testing.

TowPlow trailers are not self-contained systems. Their function is more analogous to equipment attachments. Consequently, major modifications to the TP1 system were necessary to enable it to function connected to a Caltrans fleet standard configuration snowplow truck. The primary obstacle that needed to be overcome was the incompatibility

of the two fundamentally different hydraulic systems. Several methods of adapting the TowPlow to a Caltrans fleet snowplow truck proved to be ineffective. As a result, the Caltrans TAG expanded the scope of the TowPlow research project to include the specification and procurement of a complete turnkey sander system for the second TowPlow similar to successful systems in use by other state DOTs. The term “turnkey” in this report refers to the purchase of customized equipment from a manufacturer which is fully functional when delivered for Caltrans Maintenance use without any further alterations required to either the TowPlow trailer or the prime mover truck. The second TowPlow, configured as a turnkey system, was procured at the end of 2015 and is hereafter referred to as TP2. A detailed evaluation report describing the procurement, development, and deployment of TP1 and the specification and procurement of TP2 is available from Caltrans DRISI [2].

Objectives

This research continues a prior research task [2] where two TowPlow trailers and a 550 hp truck were purchased in order to evaluate their performance in Caltrans snow removal operations. The evaluation was not completed under the prior task due to mild winters and modifications that were needed for both TowPlows and the 550 hp truck to meet loading requirements for use on California’s highways. The objective of the current research was to complete the evaluation on the TowPlow and 550 hp truck combination (collectively referred to as TowPlow2 or TP2) and continue documentation of research not included in the previous report, which used an information cutoff date of June 30, 2015.



Figure 1: Nevada DOT TowPlow in Reno, NV

Scope

The scope of this research evaluation report ranges from an engineering analysis of the various TowPlow development configurations to the overall, general benefits of this technology as viewed from a Caltrans-specific application perspective. The scope also includes observation and tracking of both TowPlow trial units when deployed in Caltrans winter highway operations.

The research methodology included:

- Observation of TowPlow use and test participation
- TowPlow engineering evaluation, including cost benefit analysis
- Documentation and Project Management

The key deliverables of the project include:

- Field performance data and operator surveys for the TowPlow systems
- Identification of best practices, operational recommendations, and cost benefit analysis

The methodology was executed, and deliverables were provided as per the proposal. The amount of information available during this study was limited for two reasons. First, early in the season, the data collection units were not functioning properly. Second, the TowPlows were not used during every storm. TP2 was first delivered to the Kingvale Highway Maintenance Station (HMS) on approximately December 22, 2016. Based on all available information, this report conducts a detailed analysis of both the benefits and limitations of utilizing TowPlow units in Caltrans winter operations.

Caltrans DoE TowPlow Modifications

TowPlow1 Configurations

Throughout the 2013-2014 winter season, the efforts to adapt the TP1 trailer to operate connected to a standard Caltrans fleet snowplow truck (C#7008211) and hydraulic system ultimately failed [2]. The hydraulic system incompatibility issues could not be fully mitigated; therefore, neither the TowPlow moldboard nor brine systems could be effectively controlled during highway operations. In response, the Caltrans Division of Equipment (DoE) decided to modify the Caltrans prime mover truck's hydraulic system to be fully compatible with the TowPlow and made some trailer modifications as well. The TP1 trailer was transferred to the Caltrans fleet in June 2014 in order for DoE to make the necessary modifications, as documented in Appendix I. Caltrans DoE modified the prime mover truck and the TP1 double-tank brine trailer (C#7010259). This configuration will henceforth be referred to as TP1-DoE. The TP1-DoE unit was placed into service in the winter of 2014-2015 and operated out of the Truckee HMS in Caltrans District 3 for service on I-80. The following year, the front brine tank was removed from the trailer and mounted on the prime mover truck dump body by Caltrans DoE in an effort to reduce trailer axle weights.



Figure 2: Caltrans TowPlow1 Snowplowing on I-80

TowPlow2 Configurations

For the second TowPlow purchase, the Caltrans TowPlow TAG specified that a complete turnkey system be purchased, including a prime mover truck married to a TowPlow trailer with fully-integrated operational controls. The unit purchased was to be similar to units already deployed by other state DOTs and was modeled on the Nevada DOT TowPlow units. The Caltrans TAG also specified that the second TowPlow unit was to be configured as a universal sander/brine version, providing Caltrans Maintenance with maximum flexibility in determining their best practices during highway trials. Consequently, the second TowPlow unit was configured with a trailer-mounted 725-gal brine tank to support both pre-wet and direct brine application on the highway. This configuration also included a slip-in sander insert for the truck dump body and fully-integrated controls that would both plow snow and spread sand with pre-wet for two full lanes. The main difference between the typical versions in use by other DOTs and the Caltrans version was that Caltrans specified a 550-horsepower (hp) motor for the prime mover truck which was the most powerful engine available for purchase. Engine cooling capability was the limiting factor preventing the chassis manufacturer from providing the full engine capability of 600 hp.



Figure 3: TowPlow2 – Option-3 Sander Configuration

The turnkey second TowPlow unit was delivered to AHMCT in December 2014. Equipment operational verification of TP2 began in January 2015, and soon thereafter Caltrans DoE conducted an equipment quality inspection and took weight measurements. Their conclusion was that the fully-laden axle weight of the turnkey TP2 configuration would exceed legal load limits for highway duty.¹ DoE engineered modifications to mitigate the overweight issue, along with other adaptations to make it acceptable for Caltrans deployment. The TAG approved the third of three potential reconfiguration options presented by DoE engineers (see Appendix A), referred to hereafter as Option-3, to bring turnkey TP2 axle weights within legal limits. Caltrans then required the manufacturer to make these changes. The Option-3 modification required the sander insert be removed from the truck dump body, the sander hopper on the TowPlow trailer be moved forward, and the trailer-mounted brine tank be removed. These modifications were completed by a subsidiary of Viking-Cives, and hereafter the resulting Option-3 modified TP2 unit will be referred to as TP2-Opt3 (Figure 3 and Figure 4).

The TP2-Opt3 modifications succeeded in bringing the fully-laden axle weights to within legal limits when weighed conventionally on a flat service as measured by AHMCT (see Appendix B). These weights are based on a certified weight certificate of TP2-Opt3 with the trailer hopper filled flush with 2,600 lb/cu-yd of asphalt grindings. Testing was performed to verify that the weight for a given volume of asphalt grindings was essentially equivalent to that of the same volume of wet saturated sand. The decision was made to fill the hopper flush with material in order to support an accurate assessment of material volume, but it is noted that it is possible to load the hopper with additional material beyond the flush level, which would increase the axle weight. Caltrans DoE also internally verified

¹ [Weight Limitation \(http://www.dot.ca.gov/trafficops/trucks/weight.html\)](http://www.dot.ca.gov/trafficops/trucks/weight.html)

that the TP2-Opt3 reconfiguration fully-laden was within legal axle weight limits when weighed conventionally on a flat surface (see Appendix D-(a)).

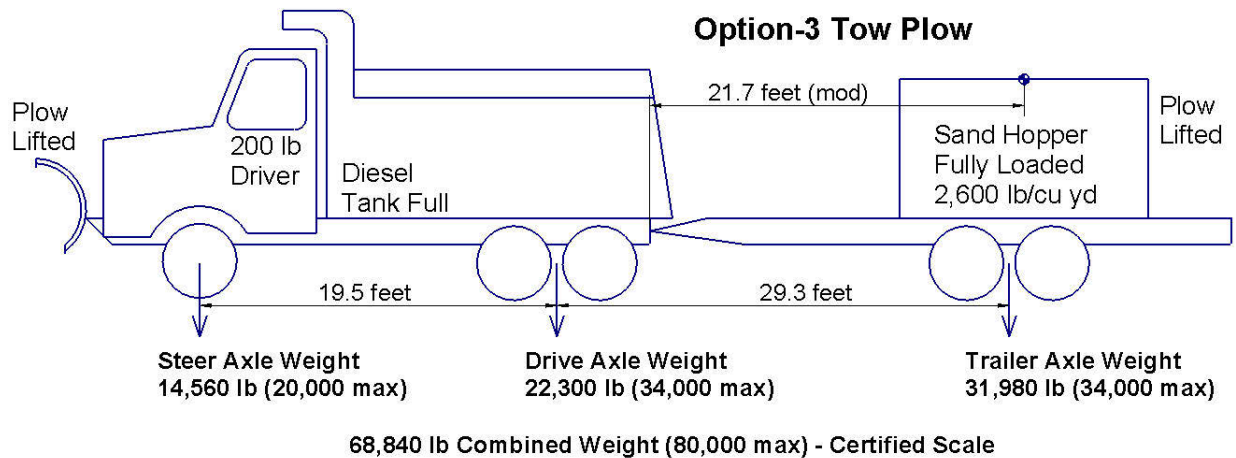
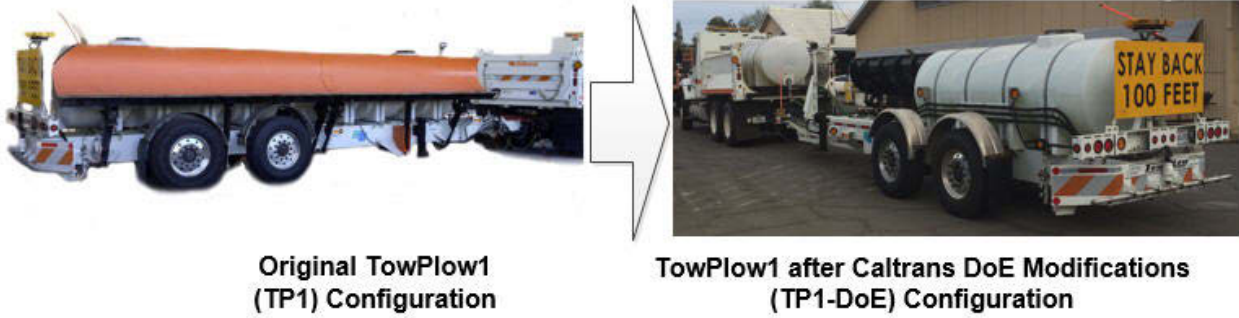

Figure 4: TowPlow2 Option-3 Loading and Axle Weights

However, further testing by DoE to simulate operational conditions indicated that the Viking-Cives modified TP2-Opt3 configuration could have individual axle loadings that exceed the manufacturer’s design parameters (see Appendix C). DOE indicated that 2,600 lb/cu-yd is a dry sand weight. Wet sand is around 3,000 lb/cu-yd. While fresh kiln-dried sand out of a sand house can be 2,600 lb/cu-yd, its use is not guaranteed and the lack of a tarp system over the sander means that moisture accumulates in the hopper during storms. When DoE tilted the TP2-Opt3 trailer tongue up several inches with the moldboard lifted, the weight on one of the trailer axles exceeded the Meritor FL-943 axle’s design parameter maximum of 18,000 lb (see Appendix D-(b)). This rapid shift of weight to one axle and unloading of the other axle is made possible by the fixed axle design used on the TowPlow trailer. On this basis, Caltrans DoE subsequently rejected the TP2-Opt3 configuration (see Appendix C). AHMCT transmitted Caltrans’ concerns to the manufacturer on the acceptability of the TowPlow for legal operation (see Appendix F). After several follow-up contacts, Viking-Cives has failed to address or respond to the issue. Consequently, Caltrans DoE decided to take possession of the TowPlow2 prime mover truck (C#7011279) and TowPlow trailer (C#701126) to configure it in the same manner as the TP1-DoE with a single 1,000-gal brine tank mounted aft of the trailer axles (see Appendix E). The resulting configuration, referred to as TP2-DoE and placed into service in December 2016, was configured for snowplowing and direct brine application only.

The various TowPlow configurations are shown in Figure 5. This figure should be helpful given the number and diversity of TP1 and TP2 configurations, as well as the varied names. Note that the original TP1 configuration included two brine tanks on the trailer. The tops of these two tanks can be seen above the TowPlow blade near the front and rear of the trailer.

First TowPlow Trailer Configurations



**Original TowPlow1
(TP1) Configuration**

**TowPlow1 after Caltrans DoE Modifications
(TP1-DoE) Configuration**

Second TowPlow System Configurations



**TowPlow2
Original Turn-Key
(TP2) Configuration**

**TowPlow2 after Mfg.
Option-3 Modification
(TP2-Opt3) Configuration**

**TowPlow2 after Caltrans
DoE Modifications
(TP2-DoE) Configuration**

Figure 5: Phases of TowPlow1&2 Configurations

CHAPTER 2: OBSERVATION OF TOWFLOW USE AND TEST PARTICIPATION WINTER 2016-2017 SEASON

One of the primary tasks for this research was observation of TowFlow use and test participation. In this task, AHMCT personnel would travel to TowFlow use locations and participate in the implementation of appropriate test procedures from Task 2 of the earlier project. Testing was anticipated in Caltrans' District 3. Additionally, existing snowplowing operations would be observed and Preco data would be collected. AHMCT worked with the Division of Equipment to get Preco units installed. Specifically, speed of snowplowing operations, snowplow routes, and frequency of snowplowing operations on the same sections represented candidate comparison data. AHMCT staff would summarize the Preco data and user-based information collected. If requested, AHMCT would also train Caltrans operators. AHMCT would also survey Caltrans personnel. Survey questions would be substantially the same as those posed during the previous research.

The amount of information available during this study was limited for two reasons. First, early in the season, the data collection units were not functioning properly. Second, the TowFlows were not used during every storm. TP2 was first delivered to the Kingvale HMS on approximately December 22, 2016.

TowFlow Evaluation Implementation Factors

The objective of the TowFlow research and evaluation project was to first facilitate Caltrans Maintenance's gaining access to appropriate TowFlow equipment and then conduct a detailed evaluation of the performance and efficiency of TowFlow equipment in routine Caltrans snow clearing operations.

This section of the report focuses on the TowFlow evaluation effort, which was best accomplished by directly observing and collecting data while Caltrans incorporated the use of the TowFlow in their conventional Caltrans winter operations. Caltrans Maintenance is often conservative in how they utilize new, innovative equipment or how they integrate equipment within standard Caltrans operations. This is especially the case for the snow clearing operations which involve a multitude of variables and procedures that are fluid and pragmatic in nature. In slow times, equipment like the TowFlow can be experimented with freely, but during times of major storm incidents, Caltrans performs in a very intentional and efficient manner in order to meet their responsibilities. Therefore, a strong measure of TowFlow effectiveness is: during storms do Caltrans crews seek to deploy the TowFlow to be more effective? As such, it would be indicative that the TowFlow is effective if Caltrans crews choose to deploy the TowFlow on their own due to its benefits, rather than as part of their participation in a research study. How the crews rely on equipment goes a long way in confirming the equipment's effectiveness. Therefore, if it is observed that the deployment of the TowFlow is avoided during major storm incidents in favor of other equipment that work crews feel is more productive or less

prone to difficulties and problems, it is unlikely that the TowPlow equipment will receive needed support regardless of any published positive cost benefit analyses from other DOTs.

The scope of this research was for AHMCT personnel to travel to locations where both TowPlow units were deployed and participate in the implementation of appropriate test procedures. This testing was to occur in Caltrans District 3 at the Kingvale HMS where existing snowplowing operations were to be observed and PreCise data collected when available. Specifically, speed of snowplowing operations, snowplow routes, and frequency of snowplowing operations on the same sections provide comparison data.

Earlier periods of TowPlow research and trials unfortunately coincided with three consecutive years of drought. For the first three TowPlow winter study seasons, at least one of the various versions of TowPlow units had been deployed and operational in the Caltrans Kingvale area. In normal years, the Kingvale area of operation consistently records the highest highway snowfall accumulation totals in the state, but during the first three seasons, the area lacked the needed highway snowfall accumulations to verify the TowPlow's capabilities. In addition, the need to reconfigure the TowPlow impacted the ability to provide a detailed field-based evaluation, as discussed in the previous report [2]. This lack of adequate snowfall delayed progress in conducting a thorough evaluation of the TowPlow capabilities in ordinary Caltrans snowplowing operations. The lack of adequate snowfall in which to use the TowPlow consequently precluded any meaningful TowPlow performance data from being collected during the previous winter test seasons.

The winter of 2016-2017 proved to be an above average snowfall year. TP1-DoE had remained at the Kingvale HMS since the 2015-2016 winter season. DoE also deployed TP2-DoE system to the Kingvale HMS sometime in late December 2016. The objective was to replace TP1-DoE, which was expected to be moved and redeployed in Caltrans District 2. Due to scheduling issues, the TP2-DoE unit was deployed fully operational at the Kingvale HMS without verifying that the data logging equipment mounted in the both prime mover truck cabs was functioning.

TowPlow Deployment Telemetry

Automatic Vehicle Location (AVL) is a means of using Global Positioning System (GPS) data to track fleet vehicles in real-time. An AVL device records the geographic location, vehicle speed, and activity inputs, and then transmits the information over a cellular network to a service provider that makes the information available on a website. Both TowPlow prime mover trucks are fitted with FORCE America PreCise AVL devices.² TowPlow1 has a PreCise IX-101 telemetry device installed in the cab of prime mover truck Caltrans fleet number 7008211. The IX-101 is a rugged, reliable asset management device that combines a GPS receiver and a Global System for Mobile communication/General Packet Radio Service (GSM/GPRS) cellular radio. GSM is a common architecture used for mobile cellular communication, and GPRS is an extension of GSM that enables higher transmission rates. The AVL device gathers information about where a vehicle has been and when it was there, including position (latitude/longitude), speed, heading, time, and engine hours (ignition on time). The AVL device also monitors

² [PreCise Mobile Resource Management \(http://www.precisemrm.com/\)](http://www.precisemrm.com/)

two discrete inputs and tracks when and where they change, stores data when there is no network coverage, and wirelessly downloads data using the GSM/GPRS network. One of the discrete inputs was used to monitor whether the TowPlow blade was steered out, and the other input was used to monitor when the TowPlow blade was lowered to the ground.

TowPlow2 has a PreCise IX-403-H AVL-GPS system installed in the cab of the prime mover truck with Caltrans fleet number 7011279. The system reports the vehicle position, direction, speed, TowPlow trailer steering in/out, and TowPlow moldboard up/down. The IX-403-H series GPS device can utilize GSM cellular communication, Wireless Fidelity (Wi-Fi) communication, or a combination of the two. The IX-403 can monitor up to six digital or analog inputs. The TowPlow2 has two configured digital inputs: trailer plow up/down and trailer axle steer in/out.

Caltrans TowPlow Field Observations

Sometime in December 2016, TP2-DoE was deployed to the Kingvale HMS to replace TP1-DoE for operational testing in the winter of 2016-2017. The TP1-DoE unit was planned to be transferred to District 2 Redding for winter operations that same winter. Interviews with Caltrans Maintenance at the Kingvale HMS indicated that Caltrans District 2 would bring a similar snowplow truck to Kingvale and take the TP1-DoE unit back to Redding. The exchange never occurred during the 2016-2017 winter season, and consequently the TP1-DoE trailer was unused throughout the winter in the Kingvale HMS lot. The TP1-DoE snowplow truck was disconnected, a tailgate spreader was mounted, and the truck was utilized extensively throughout the winter of 2016-2017 as a snowplow/sander. Therefore, the TP2-DoE was the only TowPlow unit formally deployed by the Kingvale HMS during the 2016-2017 winter season.

Since the PreCise units deployed on both TowPlow units are connected directly to the prime mover trucks, their position data will be recorded whether or not the TowPlow trailers are connected. Only when the TowPlow trailers are connected do the moldboard up/down and trailer steer in/out inputs trigger and register in the recorded dataset. Therefore, PreCise location data alone does not indicate use of the TowPlow. Only by examining the change of state of the inputs can the TowPlow trailer be verified as connected to the prime mover truck. Furthermore, to determine if the TowPlow is being used in a highway operation, a logical examination of both the speed and input data is required. During a TowPlow snowplowing operation, the data should indicate a minimum vehicle speed of approximately 20 mph and the logical succession of moldboard down and trailer steer out data. A simple check of the TowPlow PreCise data indicated that the TP1-DoE was reporting position information but no discrete input data, while the TP2-Opt3 PreCise unit was not reporting any data at all.

Based on these data reporting issues for the two systems, on February 1, 2017, AHMCT researchers traveled to the Kingvale HMS to mitigate the issue in order to bring both TowPlow PreCise units back on-line. The PreCise unit in TP1-DoE was outdated and no longer supported by the service provider. The vendor provided a replacement unit which AHMCT switched-out in the truck cab. The updated PreCise unit initialized normally and began reporting location correctly. The PreCise input triggering could not be positively verified, because the TowPlow1 trailer was not connected to the prime mover truck at the time of the visit. The TP2-DoE PreCise unit appeared to be operating

correctly, so AHMCT contacted the PreCise technical support over the phone to troubleshoot the problem. All available actions were taken, but ultimately the reporting issue could not be resolved on-site. The following day, though, while conducting a quick on-line check, the TP2-DoE location data was being collected and it was assumed that the problem had been with the service provider's internal software and that the vendor was able to resolve it remotely. Since the PreCise unit was not operational during AHMCT's site visit to Kingvale, the TP2-DoE inputs were not positively verified.

Plans for a follow-up visit to the Kingvale HMS to verify the TP2-DoE precise inputs were pending on March 17, 2017. At that time, AHMCT received information that Caltrans Maintenance in Kingvale had operated the TP2-DoE at least once on January, 20 2017 to plow snow on Interstate 80. A video of the operation was recorded by the Kingvale staff. An examination of the collected data during the recorded operation indicated the moldboard up/down input appeared to be incorrectly labeled on the dataset. This assumption is based on the expected logical order of operations and vehicle speed data. A simple vendor website change could resolve this problem, but Caltrans DRISI requested AHMCT make another visit to directly verify the configurations.

On March 24, 2017, AHMCT researchers returned to the Kingvale HMS, where both TowPlow systems were to be connected to their respective prime mover trucks and operated to facilitate the direct verification that both TP1-DoE and TP2-DoE PreCise unit inputs were triggering and reporting correctly. Examination of TP1-DoE indicated that the steer in/out labels were reversed. AHMCT researchers were able to login to the Internet at the Kingvale HMS and switch the input labels on the PreCise website. But in the process of verification of the changes, it was discovered that the TP1-DoE moldboard up/down input was not changing state regardless of whether the moldboard was raised or lowered. The limit switch wiring on TP1-DoE needed troubleshooting by DoE to enable this input. The TowPlow2-DoE had been disconnected and parked in the shed overnight. When Caltrans personnel went to move the TowPlow2 prime mover truck from the shed to reconnect the TowPlow, a CAN bus error showed on the in-cab control screen and none of the truck's hydraulic systems were operational. Since the head plow was down, the prime mover truck could not be moved or reconnected until the failure was repaired. Therefore, the TowPlow2-DoE inputs could not be verified on that trip.

A short time later, the Caltrans Maintenance dedicated TowPlow operator contacted Viking-Cives who were able to troubleshoot the CAN bus problem over the phone and send a replacement connector. The operator replaced the connector and the snowplow truck operation was restored. On April 7, 2016, AHMCT researchers visited Kingvale HMS to directly verify the TowPlow2-DoE PreCise inputs. The TowPlow2-DoE was connected and operational and the researchers were able to directly associate the equipment actions with the PreCise inputs and verify that on-line data collection was operating properly.



Figure 6: TowPlow1 and 2 Trailers in Kingvale HMS during Snow Event Winter 2016-2017

Caltrans TowPlow Operator Feedback and Equipment Observations

At the end of the 2016-2017 winter operations season, AHMCT researchers prepared a questionnaire (see Appendix G) designed to obtain important input from Caltrans Maintenance workers with direct experience not only with winter operations in general, but specifically with operating the TowPlow in highway snow clearing operations. The TowPlow questionnaire was delivered to the Kingvale HMS on April 13, 2017. Additionally, AHMCT staff did gain a substantial amount of information by interacting with the Caltrans dedicated operators at the Kingvale HMS during the several visits AHMCT made to mitigate the TowPlow PreCise issues. The operator and associated support personnel described experimenting with the TP2-DoE in highway trials and evaluated the effectiveness of the TowPlow units in Caltrans operations. The following comments and appraisals are interpretations collected from a series of conversations with the Caltrans TowPlow crew and support staff. The comments are summarized and logically grouped together by topic.

Prime mover truck power: Crew feedback indicated that both the 475 hp TP1-DoE and the 550 hp TP2-DoE prime mover trucks possessed sufficient power to operate on grades matching the 35 mph maximum speed of ordinary Caltrans snowplowing pack operations on the highway. It remains unclear if either vehicle was ever fully loaded with brine during these observations. Operator feedback indicated that engine pyrometer temperature becomes a critical factor in limiting climbing speed once an adequate level of horsepower is furnished. The pyrometer measures engine exhaust turbo temperature, which, if allowed to exceed the normal range, can cause immediate and serious damage to the engine's exhaust turbo system. Truck drivers are trained to moderate pyrometer temperature by selecting lower gears and reducing engine acceleration, both of which actively reduce truck climbing speed.

The adverse relationship between tire traction ballast weight and vehicle climbing weight is another issue which cannot be solved by simply increasing engine horsepower. An excess of engine horsepower combined with insufficient tire traction leads to tire spin, which can quickly destroy tire cable chains. Increasing ballast weight to improve traction equally adds to the overall weight of the vehicle, requiring more traction to climb grades. The goal is finding the optimum balance between these two factors, but increased engine horsepower will not necessarily promote prime mover truck climbing speed on slippery pavements.

Laser pointer: The TP2 unit was purchased with a laser pointer guidance option in order to determine if this technology would prove beneficial to the Caltrans TowPlow operator's awareness of the TowPlow moldboard presence. The laser unit is mounted above the truck cab and projects a green laser spot on the road/snow surface ahead of the truck indicating to the driver where the outermost reach of the TowPlow moldboard should pass. The Caltrans TowPlow operator did not use the laser pointer. Instead the operator relied on a fender mirror to gauge the distance the TowPlow blade was deployed.

Visibility: The Caltrans TowPlow operator did not place any value on the use of the rear view camera system. Instead, the operator favored a low-tech fender spot mirror as the best method of seeing the TowPlow moldboard when deployed. The lighting of the TowPlow moldboard was reported to be effective, and no further improvements were suggested.

Stability: The TowPlow operator reported that the TP2-DoE trailer hops at snowplowing speed on the highway and suggested this may be induced by TowPlow axle steer angle misalignment. It was also suggested that additional ballast weight on the trailer may mitigate the hop issue, but it is not apparent that this theory was ever verified with the TowPlow trailer in highway testing.

Surface treatment: The TowPlow does not have sanding capability, so one additional sander snowplow truck is required on the highway to follow the TowPlow. This negates any efficiency gained from the TowPlow. The several Caltrans operators asked all agreed that sand is spread on almost every snowplow run.

Traffic safety: The steered-out TowPlow requires a trailing snowplow truck to prevent vehicles from driving into the gap created by the steered-out TowPlow. There is risk of collision when the operator needs to steer the TowPlow back in.

Reliability: Modern, sophisticated vehicle electronics and computer systems utilized on late-model trucks and equipment are not rugged enough for Caltrans snow fighting operations in the Sierras. Caltrans operators favor simpler systems utilizing a minimum of technology.

Convenience: Connecting the TowPlow to the prime mover truck is an arduous task involving the disconnection and reconnection of eight different hydraulic hoses and control cables. The TowPlow must be disconnected each and every time sand ballast is to be removed from the truck dump body. The DoE configuration with the brine ballast tank mounted in the truck bed was not mentioned.

Fender clearance: The Kingvale crew removed the TP2-DoE trailer fenders while tire cable-chains were installed. The Viking-Cives removable fender bracket was a popular feature.

Fleet reduction: The additional vehicles and complications required for a TowPlow to operate in a Caltrans standard snowplow echelon far outweigh the minor benefits gained through use of the TowPlow.

Dedicated operator: The operation of the TowPlow requires special training and an experienced equipment operator. Caltrans snow fighting operations maintain a small, year-round experienced staff. During the winter storm season, crews are brought in from permanent intermittent (PI) positions and maintenance crews on

loan from other stations to operate the winter fleet. Therefore, having a team of dedicated TowPlow trained operators readily available is challenging.

CHAPTER 3: TOWFLOW ENGINEERING EVALUATION

Caltrans-Specific TowPlow Performance Considerations

Due to the unique geography, climate conditions, and legal requirements found in California, Caltrans has developed distinct snow fighting equipment and operations that are in many respects very different from those in other states that have successfully introduced TowPlow equipment into their winter fleets. These differences are discussed here.

Climate Zones

In California, which is generally warm and near sea level, snow accumulation of any significance mostly occurs on mountain passes at elevations above 2,000 feet.³ Some light snow accumulation does occur at lower elevations in the northeastern part of the state, but the highways in these areas are comprised almost entirely of two-lane rural highways with lesser snow road classifications. Caltrans' greatest costs are associated with Class A highways, which require the snow to be removed continuously during a snow storm to keep the road open for traffic.⁴ Since the fundamental benefit of utilizing a TowPlow is the capability of clearing two traffic lanes per pass, deployment on highways at least two lanes per direction would be necessary to realize any potential TowPlow productivity benefit. Therefore, based solely on the criteria of the number of Class A traffic lanes above 2,000 feet elevation, the Caltrans TowPlow deployment would be appropriate for use in:

- District 3 on an approximately 75-mile highway section of I-80 – Donner Pass with maximum elevation of 7,057 feet
- A combined distance of nearly 65 miles in District 2 on Interstate 5 (I-5) – Black Butte Pass with maximum elevation of 3,912 feet and Siskiyou Summit with maximum elevation of 4,310 feet
- A 15-mile section in District 8 on Interstate I-5 – El Cajon Pass with maximum elevation of 4,190 feet
- Around 40 miles in District 7 on I-5 – Tejon Pass, a.k.a. The Grapevine with maximum elevation of 4,144 feet
- About 50 miles in District 11 on Interstate 8 – Crestwood Summit with maximum elevation of 4,181 feet

³ Snow & Ice Control Operations, California Department of Transportation Maintenance Program, Pg2, 1999

⁴ Caltrans Maintenance Manual, Chapter R Snow/Ice Control, 2014

Added together, these represent 245 centerline miles out of over 4,000 centerline miles of Caltrans snow routes with elevations above 2,000 feet, which is approximately 6% of centerline miles. Furthermore, of these interstate highway passes listed, only the High Sierra section of I-80 and the northern I-5 sections experience consistent highway snow accumulations throughout the winter months (Figure 7).

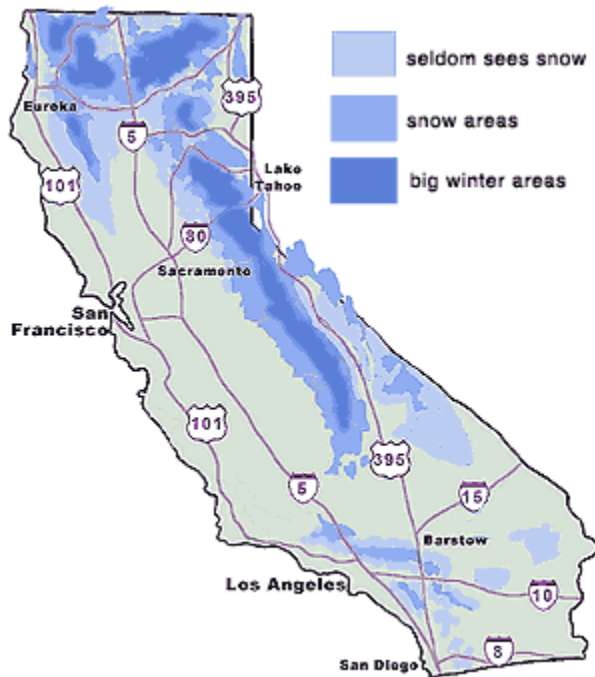

Figure 7. California Average Snowfall Map

Prime Mover Truck Power Enhancement

All of the identified potential Caltrans TowPlow deployment sites are generally mountainous passes that contain section(s) with grades as steep as 6%. Therefore, it is critical that the TowPlow prime mover truck has sufficient engine power to pull a fully-loaded TowPlow trailer up 6% grades while snowplowing at speeds approaching 35 mph. Based on initial trials in the Sierra Nevada mountains running the prime mover truck with tire traction cables, it is apparent that an engine power in the low to mid-500 hp range will be required for a sander-configured TowPlow, while the lighter brine-configured TowPlow requires less engine power, likely in the mid-400 hp range. The standard Caltrans fleet snowplow truck horsepower specification prior to 2014 called for a minimum 325 hp engine. Therefore, Caltrans may be required to purchase special trucks with enhanced horsepower engines to be paired with TowPlow equipment, although DOE has recently changed their horsepower specification.

Traction is a key issue relative to truck power. The first of two common methods for maximizing tire traction on frozen pavements is to attach tire traction devices (chains, etc.), effectively increasing the friction coefficient and the tire normal force. Viking-Cives had never attempted to utilize tire chains on the TowPlow and recommends against their use. Instead, Viking-Cives has focused on the second method, maximizing tire normal force by increasing the weight of the TowPlow trailer. The TowPlow is manufactured with

an exceedingly heavy frame, far beyond what is necessary to handle structural stiffness and loading of the trailer. Each TowPlow is required to be fitted with some type of traction-improving surface treatment system, if only to increase trailer weight to provide enough traction for proper operation of the TowPlow. The standard choices of TowPlow-mounted traction-improving surface treatment systems are brine, sand spreader, or both.

Traffic Safety

Caltrans equipment safe operational policies limit deployment of the TowPlow into the highway traffic lane adjacent to the prime mover truck in controlled maintenance work zones on highways open to traffic. This restricts TowPlow deployment to either: (a) when chain control restrictions are in effect, or (b) in a moving lane closure with Maintenance Zone Enhanced Enforcement Program (MAZEED) assistance. Since most Caltrans snow clearing operations on open highways are generally conducted when chain controls are in effect, this limitation is not necessarily restrictive. Caltrans will often apply brine on the highway before a snowstorm event in an effort to disrupt the bond between surface ice and the pavement, and after a storm to soften surface ice to aid the effort of clearing down to bare pavement. When utilizing the TowPlow to apply this brine, Caltrans will apply the post-storm brine during the final clearing pass at reduced speed while lifting chain control restrictions. The pre-storm application of brine with the Caltrans TowPlow would take place either at full traffic speed in one lane without a moving lane closure, or in two lanes requiring a highway lane moving closure with MAZEED assistance, thereby allowing a slightly reduced operating speed without creating a significant traffic flow obstruction.

Diminishing loads

A standard TowPlow sander configuration system as designed by Viking-Cives may frequently exceed federal interstate truck axle weight limits when fully loaded. Many states legislate exceptions to axle weight restrictions that exempt DOT snow clearing equipment to operate on state roadways or operate under the principle of diminishing loads, which exempts applicable highway maintenance vehicles from legal axle weight limits. California state law exempts snowplows from size, weight, and load provisions, except for those requiring a permit for overweight loads.⁵ In practice, Caltrans operates all snowplow and sanding equipment within legal limits. Therefore, the TowPlow system is operated within legal axle weight restrictions. The principle of diminishing loads generally applies to a highway maintenance vehicle ostensibly operating in a highway work zone with the purpose of applying or spreading its load on the highway. The diminishing loads principle does not pertain to vehicles transporting materials or traveling between locations on the highway.

Chain Restrictions

Since in California motorists are only likely to encounter significant amounts of snow while driving on highways over high mountain passes, the average California vehicle and driver are not typically prepared for the winter season or for driving on snow-covered

⁵ California Department of Motor Vehicles, Vehicle Code §35001, 2016

highways. Of the four TowPlow-applicable mountain passes, snowstorms on the three southern highway passes are so infrequent that Caltrans typically closes these highways when driving conditions become unsafe or until bare pavement can be established. When operating on closed highways, the speed of the TowPlow and traffic conflict concerns are minimal. Highway passes over the Sierra Nevada and Siskiyou mountains have sufficiently frequent snowstorms that Caltrans attempts to keep these highways open even with snow on the highway. Motorists traveling over these passes are therefore required by California law⁶ to carry tire chains and Caltrans compels their use as necessary based on road conditions. These chain control restrictions also apply to the Caltrans snow fighting fleet, therefore the TowPlow must be fitted with tire chains on the Anti-lock Braking System (ABS)-equipped axle, which is the rear axle of the TowPlow trailer.⁷ When Caltrans chain controls are in place, the speed limit is reduced to a safe speed based on weather and road conditions, typically between 25-35 mph. The TowPlow must be capable of traveling near the posted reduced speed limit on these steep grades when it is loaded and plowing snow. Traveling much slower than the speed limit emboldens following traffic to risk unsafe passing. Figure 8 shows an example of Caltrans style heavy-duty tire cable chains installed on TowPlow1.



Figure 8: TP1 Trailer Tire Cable Chains

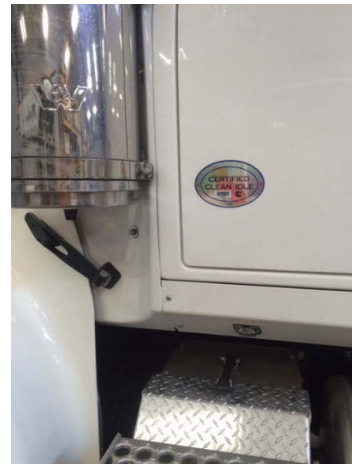

Figure 9: TP2 Certified Clean Idle Certification

Emissions

California has enacted some of the most encompassing and stringent vehicle emission regulations in the country. Caltrans, as a state agency, is under particular scrutiny to follow all of the US Environmental Protection Agency (EPA) and California Air Resources Board (CARB) emission standards for heavy-duty diesel engines, including exhaust gas limits, smoke opacity, and idling emissions countermeasures. The TowPlow prime mover truck must comply with all mandated CARB on-road heavy-duty diesel vehicle regulations. Effective 2008, CARB requires heavy-duty diesel engines operated

⁶ California Department of Motor Vehicles, Vehicle Code §27459

⁷ [Winter Driving Tips - Chain Controls \(http://www.dot.ca.gov/cttravel/chain-controls.html\)](http://www.dot.ca.gov/cttravel/chain-controls.html)

in California to have added controls or auxiliary equipment to reduce emissions during idling. The regulation requires manufacturers of California-certified 2008 and newer model-year diesel engines to incorporate a system that automatically shuts down the engine after five minutes of continuous idling or to certify the engine to a nitrogen oxide (NOx) idling emission standard of 30 or less grams per hour. If the diesel engine meets this NOx limit, it can idle indefinitely. Diesel engines or auxiliary equipment which comply with this regulation are required to display a holographic certification label prominently mounted on the vehicle. The TowPlow2 prime mover truck was procured with the necessary clean idle certification (Figure 9).

Driver Visibility

Caltrans snowplow truck operators routinely encounter people and vehicles along the edges of the plowed right of way. More often than not, this is related to tire chain issues. The vehicle drivers often lack snow driving experience or winter highway maintenance awareness since they live in warm climates and rarely drive on snow-covered highways. Consequently, the TowPlow operator must be able to view the reach of their snowplow when passing these unpredictable people and stationary vehicles to avoid hitting them. Since the TowPlow moldboard is trailing 50 feet behind and in the driver's blind spot, the operator faces challenges in providing a safe passing distance.

Weight of Caltrans Highway Traction Sand

The sand/salt mixture used for the Caltrans DoE weight measurement (Appendix D) was a sand/salt mixture in use by Caltrans Maintenance taken directly from Caltrans storehouses in the Sierra Nevada mountains on I-80. The sand/salt mixture appeared wet and weighed approximately 2,600 lb/cu-yd based on its weight measured in a 5-gallon bucket. To see if this particular sample was fully saturated with moisture, a 5-gallon bucket of the sand was fully saturated and drained. The measured weight of the fully saturated sand/salt mixture sample remained unchanged at approximately 2,600 lb/cu-yd, indicating that the TP2 axle weight data taken by DoE were taken at or near the maximum weight of fully-saturated sand/salt material. The DoE weight measurement data of the TP2-Opt3 used a 3,000 lb/cu-yd value for saturated sand (see Appendix D-(c)). It is assumed the 3,000 lb/cu-yd value is used to account for material density variability based on source and possibly includes a factor of safety. Some discrepancy may also be the result of using a small sample (5-gallon bucket) and weight scale to extrapolate the per cubic yard density. DOE indicates that ice builds up inside the sand/salt mixture of their standard v-body hopper. Moisture in the sand freezes during snow events, adding to the weight of the mixture. To be representative of observed research findings, the measured sand/salt mixture value of 2,600 lb/cu-yd will be used in calculations in this report.

Caltrans Wing Plow vs. TowPlow Comparisons

Wing Plow Truck Clearing Width

Wing plow trucks have been a mainstay of the Caltrans snow fighting fleet for many years. The most common wing plow configuration Caltrans utilizes consists of a 10-yard 325 hp snowplow truck with a wing plow attached to one side of the truck chassis mid-

frame. The front (head) plows are generally bi-directional moldboards with 11 feet of cutting blade. The head plow mounting on the front of the truck enables the moldboard to hydraulically pivot up to a 26-degree attack angle, effectively clearing a 10-foot path. The wing plow attachments Caltrans generally installs on its trucks of this size are moldboards with 12 feet of cutting blade. When fully deployed to a maximum angle of 34 degrees, these wing plows can effectively clear an additional 9-foot path. There is typically a minimum of a 1-foot overlap to ensure the trailing wing plow behind picks up the windrow coming off the head plow. As a result, the maximum clearing path of a standard Caltrans 10-yard wing plow truck is approximately 18 feet, or roughly one-and-a-half traffic lanes (Figure 10). Caltrans operators interviewed verify that the wing plows are typically operated at these maximum angles during snow clearing operations on I-80.



Figure 10: Caltrans 10-Yard Wing Plow with 18-Foot Snow Clearing Path

TowPlow Combined Clearing Path

The TowPlow system, when deployed, clears a 22-foot path, which is less than two nominal highway lanes (Figure 11). Viking-Cives assumes a 12-foot-wide head plow is being used when advertising that the TowPlow can clear two full lanes (nominally 24 feet). However, a Caltrans standard head plow clears 10 feet, which accounts for why the Caltrans TowPlow units clear less than the advertised two lane-widths (Figure 11). A calculation based solely on the lengths and angles of the cutting edges suggests a wider TowPlow clearing path is possible, but the trailer tongue is designed to angle when deployed to bring the leading edge of the TowPlow moldboard in closer to the truck. This creates an overlap between the head plow and the TowPlow moldboard, reducing the clearing path width. This overlap is, however, necessary to ensure that the snow windrow coming off the head plow is fully picked up by the TowPlow moldboard trailing approximately 30 feet behind.



Figure 11: TowPlow with 22-Foot Snow Clearing Path

Snow Clearing Width Comparison

The principal selling point of the TowPlow is the mantra that a conventional snowplow truck clears one traffic lane-width of snow, so adding a TowPlow trailer enables the same snowplow truck to clear two traffic lanes per pass. As a result, significant savings can be achieved by saving the operating costs of a snowplow truck and driver. This basic assumption might hold true for some DOTs, but this is not realistically the case for Caltrans. Since Caltrans operates a fleet of wing plow trucks which nominally clear a path of one-and-a-half lanes, and the Caltrans TowPlow systems can clear a path that is still nominally less than two lanes, the cost benefit of the TowPlow is greatly diminished. In an objective comparison of these two systems utilizing the same Caltrans standard head plow, the TowPlow system clears a path just 2-3 feet wider than a conventional Caltrans 12-foot wing plow truck at maximum extension. In operation though, considering the notoriously heavy, wet snow conditions in the Sierras, a shallower plow attack angle may clear snow more efficiently, so that the wing plow would need to be brought in a few feet. Therefore, for the purposes of this report, the TowPlow will be considered to provide an additional one quarter of a lane-width of clearing capability vs. a standard Caltrans 10-yd wing plow truck.



**Less Than Two Lanes Clearing
with Caltrans 10-ft Head Plow**



Two Lanes of Clearing with 12-ft Head Plow

Figure 12: Head Plow Width Comparison

Truck Power Comparison

As presented in the previous section, the TowPlow unit is believed to clear an additional one quarter of a lane-width vs. a wing plow truck. However, this benefit comes at a cost of an additional 8 tons of combined vehicle weight (empty weight). Therefore, based on vehicle weight alone, the TowPlow prime mover truck requires more power to provide equivalent snowplowing performance than the comparably much lighter wing plow unit. On flat highways the power increase is relatively small, but for Caltrans the added unit weight is especially problematic. In California, heavy snowfall occurs mostly on the high mountain passes where Caltrans highway snow clearing operations are commonly conducted on grades as steep as 6%. Caltrans snowplows typically operate on these steep interstate highways at a maximum speed of approximately 25 to 30 mph. Caltrans institutes chain control restrictions when conditions warranted as well as during in-lane interstate snowplowing operations, in part to reduce traffic speeds to their safe snowplowing speed and to minimize traffic obstructions, thereby minimizing traffic back-ups.⁸ Based on operational trials with the two current Caltrans-configured TowPlow units operating in the Donner Summit area on I-80, empirically a fully-laden TowPlow prime mover truck needs at least an additional 150 hp beyond the Caltrans standard 325 hp snowplow truck engine to operate at 25-30 mph when going up these steep grades.

Traction Comparison

Both the wing plow truck and the TowPlow prime mover truck are based on a 10-yard dump body truck. Therefore both systems have the same number of drive wheels, drive wheel cable chains, and traction. For any given road surface condition, there is an optimum normal force (ballast weight) over a truck's drive tandem axle to achieve maximum traction. Since road surface conditions are in a state of flux, ballast weight must ideally be adaptable. For this reason, snowplow trucks are commonly configured with dump bodies so that sand can be easily added or dumped to carry the desired ballast weight to boost traction. There is little difference between the ballast weight being dump body sand in the wing plow case or a combination of tongue weight and dump body sand in the TowPlow case. Either way, the maximum drive traction of the truck's tandem axle set will be roughly the same.

Since the TowPlow prime mover truck is operating with upwards of over 8 tons of additional inertial load (rolling weight), its dynamic characteristics will be very different from the lighter wing plow truck when operating on the highway. The increase in inertial momentum influences both cornering and braking, but the extra wheels and brakes on the TowPlow help mitigate these forces, so only modest degradations should be expected. There is a significant effect, however, when accelerating up a grade, especially against a snow load. The TowPlow trailer does not contribute to drive power in any way, so instead a portion of the traction force is drawn away and used just to overcome the additional inertial loading. Maximum traction force under these circumstances is a zero-sum game (i.e. a trade-off between propulsive and steering traction), so the lighter wing

⁸ [Caltrans chain requirements \(http://www.dot.ca.gov/hq/roadinfo/ChainRequire.pdf\)](http://www.dot.ca.gov/hq/roadinfo/ChainRequire.pdf)

plow truck will innately have a more efficient traction characteristic, which directly translates to better snowplowing performance as compared to a TowPlow, especially up grades. Adding additional TowPlow prime mover truck engine horsepower to account for the degradation useable traction force only breaks traction, spinning the drive wheels, further reducing traction, and damaging cable chains. Adding additional ballast weight to the TowPlow prime mover truck may improve traction but it also further increases the inertial load, which produces a diminishing return. The most efficient snowplow truck design for optimum traction is a fairly light vehicle overall, with a large variable ballast capability directly over the tandem drive wheels as with the Caltrans wing plow.

Analysis of TowPlow Applications in Caltrans Snow Fighting Operations

Snowplow trucks cannot safely leave windrows of snow on the right of way where they can present issues to passing traffic. Consequently, Caltrans systematically groups snowplow trucks together in packs or echelons, particularly on multiple-lane highways. A pack operation is a procession of closely trailing snowplow trucks spaced laterally such that snow windrow left by the proceeding snowplow is picked up and cleared by the trailing snowplow truck. In this way, snow can progressively be cleared all the way across the entire width of the roadway to the shoulder in a single pass, as required. The number of vehicles comprising a snowplowing pack is directly proportional to the maximum number of travel lanes to be cleared. Frequently, an additional snowplow truck will be included to the pack to split from the pack to clear the windrows left across the on and off-ramps as the pack passes. Caltrans snowplowing operations typically clear all the snow to the right shoulder where there is space for a snow bank. Caltrans will occasionally snowplow to the left on separated highways with very wide medians, if there is space for a snow bank in the median. Caltrans even has a few left-sided wing plows in their fleet, but the practice of snowplowing to the left remains a novelty in pack snowplowing.

One method of determining the benefits of the TowPlow is to examine pack schemes which are the most efficient for the width of the highway. The following pack efficiency analysis will focus on right-side snowplowing, but changing to a left-side plow on the leading truck will have little effect on the presented conclusions. Caltrans' common case of clearing divided highways with nominal 12-foot wide lane and a 2-foot wide shoulder will be the basis of this analysis. Caltrans strives to snowplow at least a minimum of an additional 2 feet beyond the lane edge (fog line) to establish a clear and safe roadway.

Efficient Snowplowing Pack Configurations – Clearing One Lane-Width

Single-direction highways are only divided by a center-line, so the minimum clearing path would be calculated by adding a nominal 12-foot wide lane to a 2-foot wide shoulder which combines for a 14-foot clearing width. Consequently, operating the TowPlow on a single lane highway is completely inefficient and entirely unneeded since a standard Caltrans wing plow can easily clear the entire path in one pass.

Efficient Snowplowing Pack Configurations – Clearing Two Lane-Widths

For the two lane-width analysis, the two 2-foot shoulder overlaps that are added are common for both divided and undivided highways to a nominal 24 feet of lane-width for an overall clearing width of 28 feet. Consequently, a TowPlow trailer and prime mover truck configuration clears approximately 6 feet less than the desired 28 feet, and therefore a second snowplow would be necessary (Figure 13). The most efficient configuration to achieve full coverage with the minimum of resources would be a Caltrans 10-yard wing plow and a Caltrans 10-yard snowplow truck with a Caltrans standard 11-foot-wide head plow only (Figure 14).

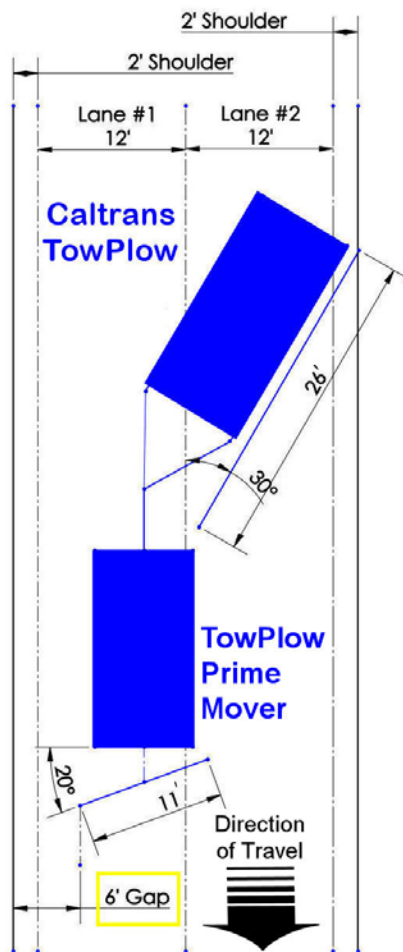

Figure 13: TowPlow Clearing Two Traffic Lanes

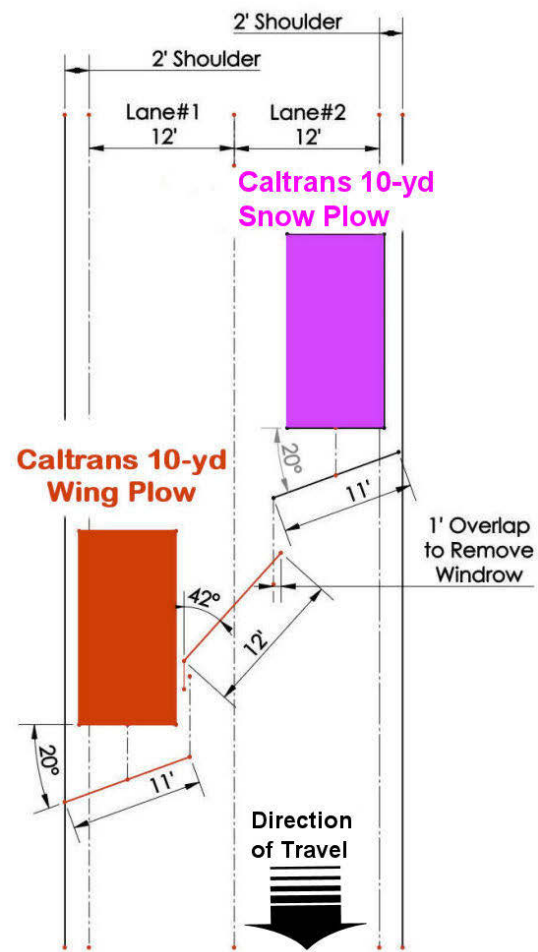

Figure 14: Most Efficient Configuration for Clearing Two Traffic Lanes

Efficient Snowplowing Pack Configurations – Clearing Three Lane-Widths

Consequently, the most efficient configuration for the Caltrans TowPlow would be a three-lane highway, working in combination with a Caltrans 10-yard wing plow truck. The overall clearing width of three-lane highway is 40 feet, consisting of three 12-foot lanes added to two 2-foot shoulders. Deploying the TowPlow in combination with a standard wing plow truck can effectively clear the full 40 feet, including a windrow overlap (Figure 15). For Caltrans to clear the three lane-widths using conventional equipment, the minimum amount of vehicles needed would consist of an echelon of two wing plows and one head plow truck (Figure 16). Therefore, a TowPlow theoretically and geometrically only has the prospect of reducing the number of vehicles in a snowplowing echelon for the three-lane clearing path case. Of the highways that Caltrans typically focuses their clearing operations on, most are one- and two-lane mountain pass highways. Caltrans clears a small inventory of three-lane highways, but these sections generally are fragmented directional (uphill) truck climbing lanes or auxiliary breakout areas, not continuous stretches of highway.

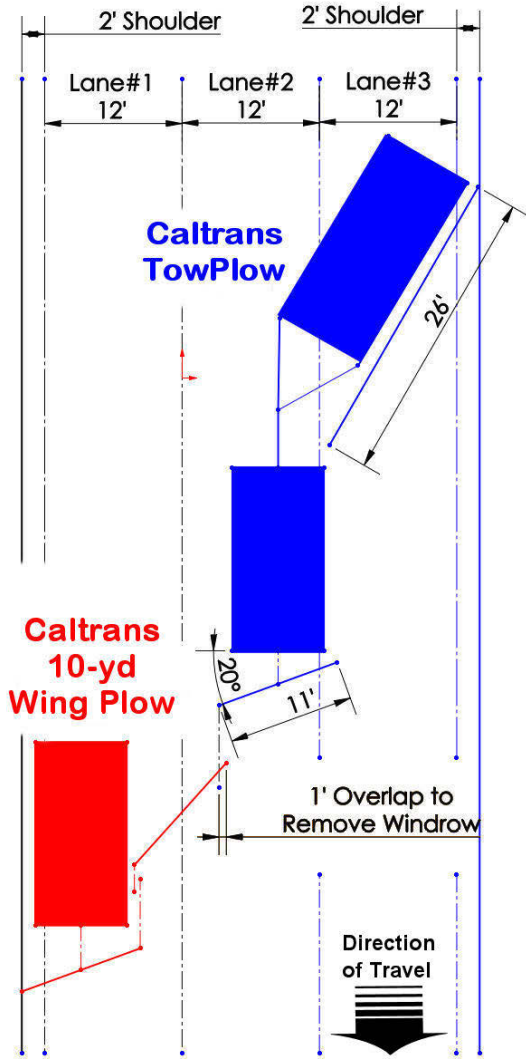

Figure 15: Most Efficient Three-Lane TowPlow Clearing Configuration

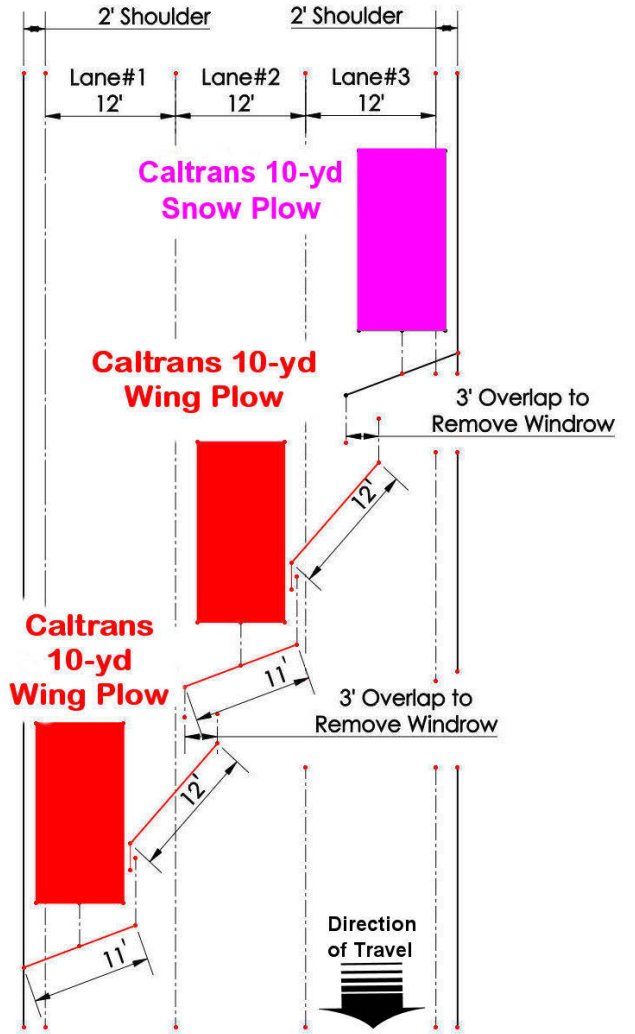

Figure 16: Clearing Three Lanes with Conventional Equipment

Efficient Snowplowing Pack Configurations – Clearing Highway Ramps

Caltrans highway snow clearing echelon operations must also include a scheme to clear traffic ramps. As the snowplowing echelon passes a section of road, all the snow collected across the entire clearing path is deposited harmlessly in a snow windrow off to the side of the highway. However, when crossing traffic ramps, the snow windrow becomes a snow berm across the ramp, blocking the ramp in times of heavy snow accumulation. Caltrans adds an additional snowplowing truck to trail behind the snowplowing operation and clear the ramps as the echelon continues along. If an extra snowplow truck is not available, then the echelon stops and one of the snowplow trucks clears the berm before rejoining the echelon and continuing along the highway. It doesn't seem likely that the TowPlow operation would have any influence on the methods or procedures that Caltrans utilizes to maintain open traffic ramps on the highway.

TowPlow Cost Benefit Analysis

An examination of the costs and benefits of operating TowPlow systems in Caltrans winter operations is a valuable factor in determining the overall effectiveness of this equipment. This cost benefit analysis would preferably be based on actual TowPlow equipment usage data while the systems were in service with Caltrans winter maintenance operations. This would produce the most accurate result. Unfortunately, the two TowPlows systems did not see sufficient use to support this approach to a cost benefit analysis. In the absence of this option, a conceptual cost benefit analysis is presented here to approximate potential benefits to Caltrans utilizing TowPlow equipment. There are implicit attributes that can be evaluated to assist in assessing the expected positive or negative benefits of the TowPlow to Caltrans Maintenance operations. Since the Caltrans TowPlow development process is not complete, this analysis is based on the assumption that certain operational issues revealed during deployment trials could be mitigated in future TowPlow units. Therefore, for this analysis, these issues will be assumed to be resolved.

Operational Assumptions

Viking-Cives promoted the TowPlow as reducing snowplowing costs by enabling a single driver and snowplow truck to nominally clear two lanes per pass and thereby deliver a potential cost savings of one driver and one snowplow truck. This advertised benefit may hold true for other state DOTs, but not for Caltrans, which operates an extensive fleet of wing plow trucks that nominally clear one-and-a-half lanes per pass. As such for Caltrans, the potential for TowPlow cost savings is less than for some other states. The previous section presented an analysis of optimum equipment echelon configurations for lane clearing. For two-lane highways, an echelon of one snowplow truck and one wing plow truck is the most efficient means to clear the full roadway (see Figure 14). A TowPlow alone cannot clear the full roadway (see Figure 13). For three-lane highways, a combination of a TowPlow together with a wing plow truck is the most efficient echelon configuration (see Figure 15). For this three-lane case, the TowPlow does save Caltrans

one snowplow truck and one driver compared to only utilizing conventional snowplow trucks and wing plow trucks (see Figure 16). Therefore, a potential benefit is achievable if deploying the TowPlow on three-lane highways. The TowPlow appears to be an unwarranted expense on exclusively two-lane highways.

Caltrans operates snowplows in echelons which must clear the entire width of the roadway in circular routes. On highway routes that contain a combination of two- and three-lane sections, the echelon configuration must have the clearing capacity equal to the widest sections regardless of how short the three-lane sections are along the route.

Suitable Caltrans Three-Lane Highway Sections

The following is a list of criteria necessary for plowing routes to be suitable for efficient TowPlow deployment:

- 1) Contains three-lane highway sections (The efficient TowPlow echelon configuration)
- 2) Highway elevation of at least approximately 3,000 feet (For sufficient snow accumulation)
- 3) Subject to chain restrictions (To allow TowPlow to deploy without MAZEED)

Three Caltrans HMSs meet the criteria for efficient TowPlow deployment:

- 1) Caltrans District 3 Kingvale HMS operating on I-80
- 2) Caltrans District 3 Whitmore HMS operating on I-80
- 3) Caltrans District 2 Yreka HMS operating on I-5

These areas are predominantly two-lane, mountainous highways with sections containing grades as steep as 6%. Steep highway sections are often widened to three lanes to accommodate slow moving heavy trucks in climbing sections. In addition, chain installation areas along the highway are widened to three lanes and are included in this analysis. In both of these cases the highway widens from two to three lanes and then returns back to two lanes. Table 1 shows a breakdown of the distances of two- and three-lane sections of snowplowing routes appropriate for TowPlow deployment (see Appendix H for details).

Table 1: Three-Lane Snowplowing Highway Sections

Route	Loop Distance	2-Lane	3-Lane
Kingvale East	20 miles	7.6 miles	12.4 miles
Kingvale West	20 miles	19 miles	1.0 mile
Whitmore East	26 miles	13.5 miles	12.5 miles
Truckee East	32 miles	27.4 miles	4.6 miles
Truckee West	14 miles	11.5 miles	2.5 miles
Yreka North	40 miles	37.5 miles	2.5 miles
Yreka South	40 miles	23.6 miles	16.4 miles
Totals	192 miles	140 miles	52 miles

Additional Considerations and Assumptions

Based on Caltrans field trials of the TowPlow operating in the Donner area of I-80, the following operational issues should be incorporated when forming the basis of the cost benefit model.

- Some form of sanding capability must be included when the TowPlow is clearing the highway. Since the TowPlow is available configured as a sander, it will be assumed here that Caltrans could mitigate the axle overweight issue when configuring future TowPlow systems for use in California. Therefore, the current practice of adding an additional sander truck behind the TowPlow is not included in this analysis.
- Caltrans adds a vehicle to trail the TowPlow to insure motorists do not pull up in the space next to the deployed TowPlow trailer. Here, it is assumed that there is another way of keeping motorists back without needing a barrier vehicle, and the cost of an additional vehicle is not included in this analysis.
- Equipment needed to clear highway ramps is variable, and often dictated by the availability of resources. Adding the TowPlow does not affect the decision of ramp-clearing operations in any significant way, and thus this issue is ignored in this analysis.
- Caltrans snowplow blades are generally removable, which enables their fleet of trucks to be utilized year round. This dual use also applies to wheel loaders and graders, but the TowPlow is a winter-specific piece of equipment. Since Caltrans keeps a few snowplow vehicles available year round in case of off-season unexpected storms, it will be assumed here that the TowPlow could be justifiably included in this category, and it is therefore not considered a negative cost asset outside of the winter months.

- Only the eastern portion of I-80 and the most northern portion of I-5 are considered suitable for potential TowPlow application for two major reasons:
 - 1) Other major highways with only occasional snowfall do not institute chain controls. Instead, the highway is closed until safe driving conditions, including but not limited to, bare pavement can be established. It would be far less likely to expect the TowPlow to show a positive cost benefit when expected to only be utilized occasionally.
 - 2) As described in this report in detail, the TowPlow is less efficient than a wing plow when utilized in echelons on two-lane highways.
- Patrolling is defined here as circling a route on the highway looking for snow and ice accumulation. Patrolling with the TowPlow is inefficient, considering the significant additional weight being towed with no benefit. Caltrans cannot deploy the TowPlow unless in a chain control zone or a moving lane closure. Typically, the TowPlow has been disconnected and only the prime mover truck utilized for patrolling operations. Therefore, this analysis focuses on snow-clearing operations only.
- Most modern computerized engines are designed to accommodate a wide range of horsepower outputs depending on the computer control settings. Therefore, this analysis assumes the additional engine horsepower required to tow and operate a TowPlow up steep grades represents a minor cost increase.
- Caltrans typically applies brine before a snowstorm to weaken the bond between ice and the pavement and after the storm to aid the effort of removing road ice and expose bare pavement. The capability of the TowPlow to brine two lanes while deployed is only available to Caltrans while chain controls are in place or during a moving closure operation. This limits the use of the TowPlow's two-lane brine utility to post-storm use. The TowPlow cannot realistically be used pre-storm to brine two lanes, and it typically lacks sufficient power loaded to spray brine in a single lane at normal highway speeds (55 mph) up steep grades without creating a traffic back-up hazard. Therefore, this analysis will not consider the brine function of the TowPlow to be a benefit, and this function is not included.

Equipment Costs

A 10-yd truck configured with a head plow and assorted snowplowing accessories forms the basis for both the wing plow and TowPlow systems at approximately similar costs. Caltrans 10-yd wing plow trucks typically have a sander insert or body which is similar in cost to the sander option for the TowPlow. The TowPlow sander can be configured to sand two lanes and the wing plow sander can sand one-and-a-half lanes. Therefore, the additional cost of a TowPlow can be determined by comparing to the cost of the plow wing installed on the 10-yd snowplow truck (\$15,000) to the bare cost of a TowPlow trailer (\$90,000) which is approximately \$70,000. The additional equipment and seasonal usage costs are factored into the TowPlow hourly operating cost for this analysis.

Caltrans Maintenance Operational Costs

The cost for Caltrans to operate a 10-yd wing plow truck has not been verified. Caltrans Maintenance crews charge the operational hours in the Caltrans Integrated Maintenance Management System (IMMS) to R-10,000, but the actual cost value is not known for this analysis. The dollar value for both the wing plow truck and the TowPlow system would be required to make the cost benefit analysis comparison. Based on costs on contract plowing operations for similar equipment, the loaded cost of a wing plow will be assumed to be \$140 an hour not including sand, the loaded cost of a TowPlow will be assumed to be \$170 an hour, and the loaded cost of a 10-yd snowplow truck will be assumed to be \$120 an hour for this analysis.

TowPlow Cost Benefit Calculation

The TowPlow cost benefit can be calculated for snowplowing routes on combination two- and three-lane highways based on the previously described assumptions and conditions. Without a TowPlow, a Caltrans snowplow echelon on these sections at a minimum would require two wing plow trucks and one snowplow truck at a total cost of \$400 per hour. With the TowPlow, the Caltrans echelon would at a minimum be comprised of one TowPlow system and one wing plow truck at a total cost of \$310 per hour. This represents a base TowPlow cost savings of \$90 per hour of echelon operation on three-lane routes. The cost savings for each of the snowplowing loops are presented in Table 2 based on an average 25 mph highway plowing speed.

Table 2: TowPlow Cost Savings Per Loop

Route	Loop Distance	Loop Time	Loop Cost with TowPlow	Loop Cost without TowPlow	TowPlow Echelon Loop Cost Savings
Kingvale East	20 miles	0.8 hr	\$248	\$320	\$72
Kingvale West	20 miles	0.8 hr	\$248 /hr	\$320 /hr	\$72
Whitmore East	26 miles	1 hr	\$310 /hr	\$400 /hr	\$90
Truckee East	32 miles	1.3 hr	\$403 /hr	\$520 /hr	\$117
Truckee West	14 miles	0.6 hr	\$186 /hr	\$240 /hr	\$54
Yreka North	40 miles	1.6 hr	\$496 /hr	\$640 /hr	\$144
Yreka South	40 miles	1.6 hr	\$496 /hr	\$640 /hr	\$144

CHAPTER 4: CONCLUSIONS AND FUTURE RESEARCH

The TowPlow evaluation suffered due to issues with the data loggers not functioning properly. While the units were repaired at the earliest opportunity, a significant portion of the winter season passed without detailed data logging. Because of this, it is difficult to draw conclusions regarding the usage and effectiveness of the TowPlow units in that period.

The apparently unfavorable results of the Caltrans TowPlow trial deployment effort can be attributed to a number of factors that seem unique to California snowplowing conditions and operations. First and foremost is the cost saving claim that a TowPlow clears two traffic lanes while a standard snowplow truck clears one lane, therefore meaning that the TowPlow delivers cost savings roughly equivalent to the operating expense of one snowplow truck. Previous detailed studies by others have been primarily based on this assumption to justify the purchase of TowPlow units.⁹ In the case of Caltrans winter operations, wing plow trucks, which clear a path just a few feet narrower than the TowPlow, are common and the additional snowplow width gained with the TowPlow is not always tactically useful.

Another major factor is the application of traction abrasives (sand) while snowplowing. Most Caltrans snowplowing operations involve the spreading of sand. However, since Caltrans moved away from utilizing a sander-configured TowPlow due to axle weight concerns, an additional sander truck would need to follow the TowPlow to apply sand. One benefit of this configuration is the trailing sander truck can prevent motorists from getting next to the steered-out TowPlow trailer (Figure 17). However, this increases the overall operating costs of the TowPlow by adding an additional sander truck to the snowplowing echelon. The additional ancillary costs and issues combined with minimal benefits explain the lukewarm reception by Caltrans staff during the TowPlow trial. Achieving maximum value from TowPlow deployment in Caltrans' winter operations, at a minimum, requires finding a solution to reintegrate sanding capability back into the TowPlow and keeping vehicles from trying to pass the TowPlow when it is deployed.

⁹ Evaluation of the Performance of AVL and TowPlow for Winter Maintenance Operations in Wisconsin, TRB Paper # 12-3052, K. Santiago-Chaparro, M.S., University of Wisconsin- Madison DOT report, 2012



Figure 17: Additional Sander Truck Trailing TP2-DoE on I-80

Future work:

The consensus among Caltrans snowplow operators with knowledge of the TowPlow operational trials seems to be that Caltrans should turn away from the TowPlow and instead develop a “Super Wing Plow” truck that could plow two traffic lanes far more efficiently than a TowPlow and with improved visibility. Ideally the additional half-lane snowplow width would be added on the side of the truck opposite the wing plow to counterbalance the spinning moment force caused by the wing plow. Conceptually, a telescoping head plow, which extends laterally in operation, would provide such a solution. A minimal increase in truck engine horsepower may also be needed.

REFERENCES

1. I. Schneider, H. William, C. Miller, M. Crow, and W.A. Holik, "Evaluation of the Viking-Cives TowPlow for Winter Maintenance," Ohio Department of Transportation, Office of Statewide Planning & Research Rept. # 134704, 2014.
2. D. Bennett, G. Burkett, J. Kang, and S. Velinsky, "Evaluation of the TowPlow for Caltrans Operations," AHMCT Research Center Rept. # UCD-ARR-15-09-30-01, 2015.

APPENDIX A: DOE TOWPLOW2 WEIGHT ANALYSIS

The following is the Caltrans Division of Equipment turnkey TowPlow2 weight analysis presented by Jeremy Johnson, DoE Equipment Engineer, to the Caltrans TowPlow TAG on January 19, 2015. Note that this analysis uses the Caltrans DoE saturated sand weight of 3,000 lb/cu-yd. In addition to the weight analysis calculations, the three options to mitigate the overloading are included. All work in this appendix was by Caltrans DoE and is presented here for reference.

TOWPLOW 2 CONFIGURATION ANALYSIS

Vehicle Legal Weight Limits

CA Legal weights of TowPlow 2: Chassis GVWR 52,500 lb, GCWR 80,000 lb, TowPlow GVWR 34,000 lb Chassis front axle 20,000 lb, Chassis rear tandems 34,000 lb, TowPlow axles 34,000 lb

Weight of cu-yd of sand used 3,000 lb. **Axle weights and loadings are estimates pending measurement.**

TowPlow2 Weights as Received

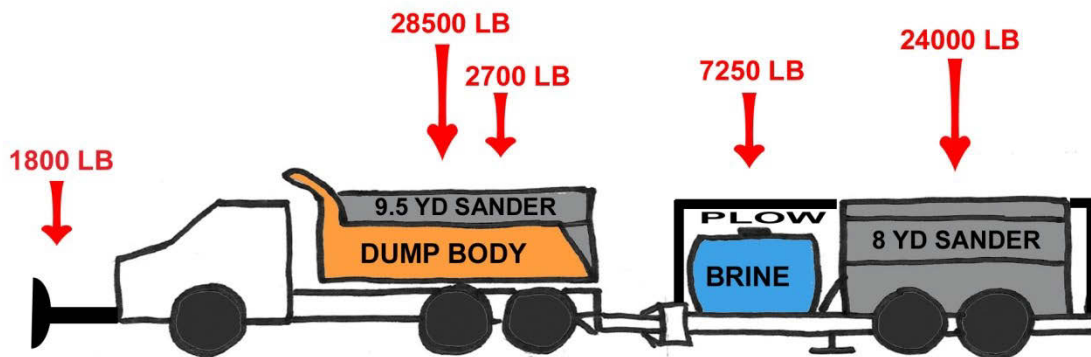

As received by AHMCT TowPlow 2 weights are as follows:

Chassis only:

Front axle = 13,500 lb, Rear tandems = 17,960 lb, Fuel = 643 lb, driver = 300 lb

Total Chassis Tare = **32,403 lb [34,203 lb with plow]**, Trailer tare = **18,820 lb**

Total Package Tare = **51,223 lb [53,023 lb with plow]** Chassis axle Loading
(weight slip with trailer attached):

Front: 12,740 lb, Rear Tandem: 22,640 lb.

Rear Axle Overloading

22,640 lb + 2700 lb brine + 28,500 lb sand *(80%) + 3,625 lb more tongue weight = **51,765 lb**

51,765 lb - 34,000 lb (CA legal) = **17,765 lb over CA Legal**

51,765 lb - 46,000 lb (mfg rating) = **5,765 lb over MFG Rating**

Total Package payload available after tare:

(80,000 lb GCWR-53,023 lb Total Tare) = **26,977 lb**

Total of Payloads:

28,500 lb sand+2,700 lb brine+7,250 lb brine+24,000 lb sand = **64,250 lb**

64,250 lb payload totals - 26,977 lb available payload = **37,273 lb over GCWR**

As shipped TowPlow 2 CANNOT be used in its current configuration with full payloads.

Making Vehicle Weight Legal – Option 1

The first option involves:

- Removing the Slip-in Sander from truck chassis
- De-rating the payloads on the trailer

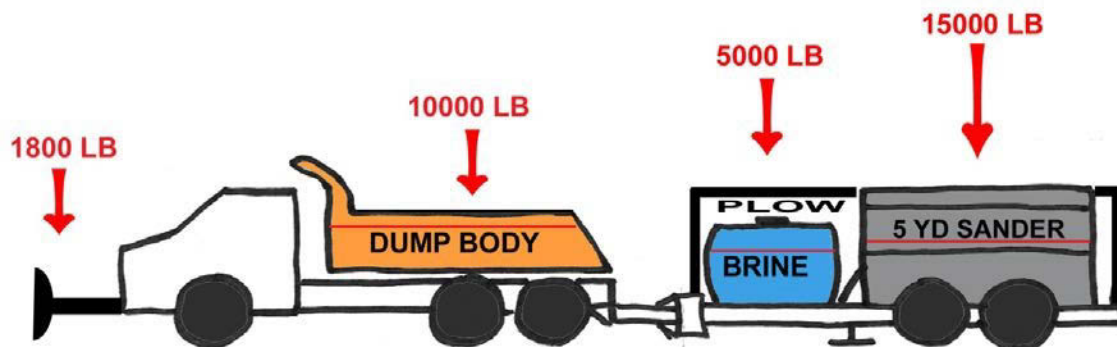

WEIGHTS: 18,820 lb TRAILER TARE+ 5, 000 lb BRINE + 15,000 lb SAND =**38,820 lb TRAILER WEIGHT**. However between 10-15% tongue load will be distributed to the truck making the trailer legal (3,882 lb-5,823 lb) .

Tare 34,203 lb -3000 lb slip-in sander + 10,000 lb payload + 38,820 lb = **80,023 lb**
Gross Combined

Making Vehicle Weight Legal - Option 2

The second option involves:

- Removing the Slip-in Sander from the truck chassis
- Removing the Trailer-mounted Sander
- Adding a 1,000-gal brine tank (or replacing both tanks with 1,000-gal tanks)

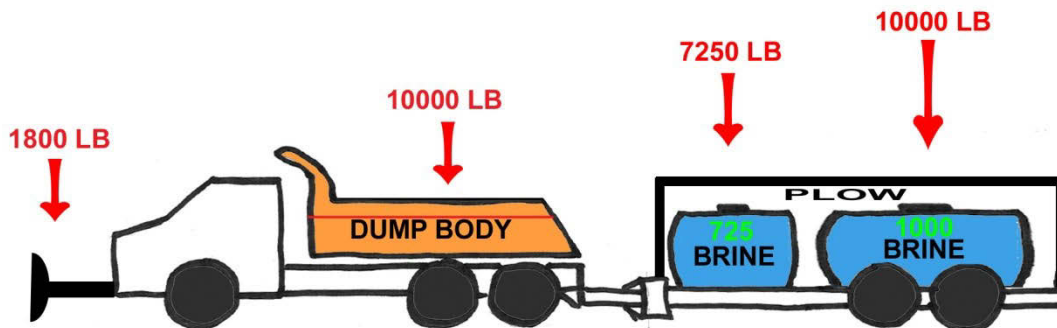

WEIGHTS: 18,820 lb TRAILER TARE+ 7,250 lb BRINE + 10,000 lb SAND =**36,070 lb TRAILER WEIGHT**. However between 10-15% tongue load will be distributed to the truck making the trailer legal (3,607 lb - 5,410 lb).

Tare 34,203 lb - 3,000 lb slip-in sander + 10,000 lb payload + 36,070 lb = **77,273 lb**
Gross Combined

Making Vehicle Weight Legal - Option-3

The third option (Maximum Sand) includes:

- Removing the Slip-in Sander from the truck chassis
- Removing the Brine tank from the TowPlow chassis
- Moving the 8-yd Trailer Sander forward to get more tongue load

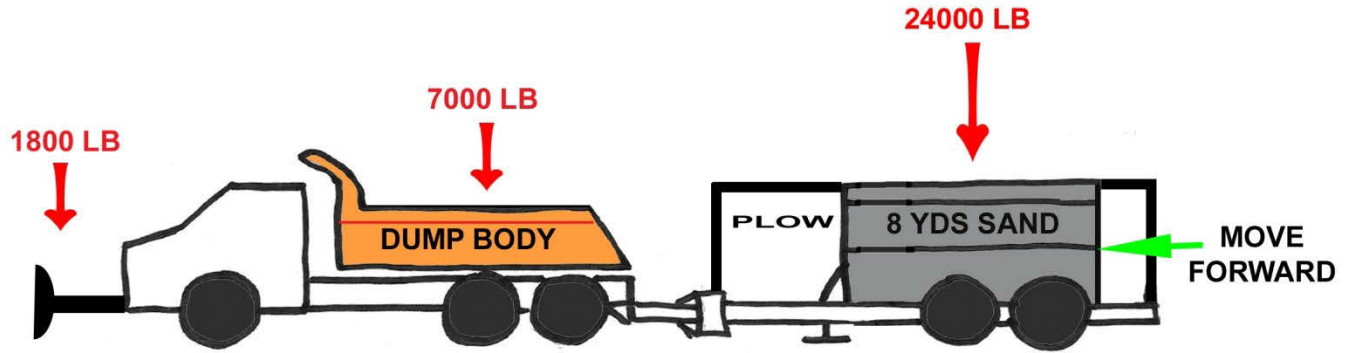

WEIGHTS: 18,820 lb TRAILER TARE+ 24,000 lb sand weight =**42,820 lb TRAILER WEIGHT.**
 For the trailer to be legal, 20% of the trailer weight would have to be transferred to the tongue (8,564 lb).

Chassis tare 34,203 lb - 3,000 lb slip-in sander - 1,000 lb brine system + 7,000 lb payload + 42,820 lb =**80,023 lb Gross Combined**

APPENDIX B: TOWFLOW2 OPTION-3 WEIGHT CERTIFICATE

The following is a certified weight certificate attained by AHMCT measuring axle group weights of the Option-3 TowPlow2 fully loaded. The 7.8 cu-yd maximum capacity sand hopper on the TowPlow trailer was filled and leveled with 2,600 lb/cu-yd asphalt tailings for this measurement.

74070250
TICKET NUMBER



**CERTIFIED
AUTOMATED
TRUCK
SCALE**

CAT SCALE COMPANY
P.O. BOX 630
WALCOTT, IA 52773
(563) 284-6263
www.catscale.com

THE CAT SCALE GUARANTEE

The CAT Scale Company guarantees that our scales will give an accurate weight. What makes us different from other scale companies is that we back up our guarantee with cash.®

"WEIGH WHAT WE SAY OR WE PAY" ®

If you get an overweight fine from the state **AFTER** one of our CAT Scales showed a legal weight, we will immediately check our scale and we will:

- (1) Reimburse you for the cost of the overweight fine if our scale is wrong, **OR**
- (2) A representative of CAT Scale Company will appear in court **WITH** the driver as an expert witness if we believe our scale was correct.

IF YOU SHOULD GET AN OVERWEIGHT FINE, YOU SHOULD DO THE FOLLOWING TO GET THE PROBLEM RESOLVED:

- 1) Post bond and request a court date.
- 2) Call CAT Scale Company direct 24 hours a day at 1-877-CAT-SCALE, ext. 7 (Toll Free) or visit www.catscaleguarantee.com for instructions.
- 3) **IMMEDIATELY** send a copy of the citation, CAT Scale Ticket, your name, company, address, and phone number to CAT Scale Company Attn: Guarantee Department.

The four weights shown below are separate weights. The **TOTAL WEIGHT** was weighed on a full length platform scale. **AXLE WEIGHTS CAN NOT BE CERTIFIED** and are **NOT LEGAL FOR TRADE**, however, **CAT SCALE COMPANY GUARANTEES THESE WEIGHTS TO BE CORRECT.**

DATE:	7-16-2015	STEER AXLE	14560	1b
		DRIVE AXLE	22300	1b
		TRAILER AXLE	31980	1b
		TOTAL AXLE	68840	1b

**CAT SCALE
COLLECTOR
CARD
INSIDE!**

1011 SCALE 642
74070250 LOCATION: RAMOS OIL COMPANY INC.
1900 NORTH 1ST STREET
DIXON CA

WARNING !

THIS FORM IS NOT A CALIFORNIA WEIGHMASTER CERTIFICATE AND IS NOT LEGAL FOR TRADE IN THE STATE OF CALIFORNIA.

FREIGHT ALL KINDS

COMMODITY OR ARTICLE WEIGHED _____

COMPANY UC DAVIS TRACTOR # 3-1864 TRAILER # N/A

WEIGH NUMBER 0250 FEE \$10.50 WEIGHER SIGNATURE Deanna Baker FULL WEIGH TICKET # (IF REWEIGH) _____

DEANNA BAKER

CUSTOMER COPY

© CAT Scale® CA 3051 0514

*Truck & opt 3
Tow plow
Loaded*

APPENDIX C: TOWFLOW2 OPTION-3 DOE DEFICIENCY MEMORANDUM

Caltrans DoE inspectors conducted a quality control inspection of the TowPlow 2 after it was modified by the Viking-Cives subsidiary to meet the Caltrans DoE Option-3 design change. The following Caltrans DoE memorandum of this inspection lists three major discrepancies as described by DoE, and a fourth item lists a series of DoE quality inspection deficiencies. This memo was created by Caltrans DoE and is presented here for reference.

Memorandum

*Serious drought.
Help save water!*

To: Joseph Horton
Supervising Transportation Engineer
Office of Safety and Innovation

Date: August 5, 2015

From: Kris Teague 
Supervising Equipment Engineer
Division of Equipment

Subject: **Division of Equipment Review and Concerns regarding Tow Plow 2**

This memorandum is regarding Tow Plow 2 consisting of 2014 Western Star 4900SF plow truck, VIN# 5KKHAEBG7FPGM8167, and Viking-Cives Tow-plow, VIN # 1V9PP3427EM180133. The Division of Equipment (DOE) performed a comprehensive inspection and axle loading analysis on the unit per the request of the Division of Research, Innovation and System Information (DRISI) and found three major deficiencies. These items include health and safety concerns as well as legal concerns, which could arise from exceeding the manufacturers load ratings in specific circumstances. The issues are as follows:

1. Dump Body Safety leg

In order to deploy the mechanical safety leg (secondary support), for the dump body on the Western Star chassis, the operator needs to raise the bed, leave the control station, and enter into the crush zone of the bed to manually deploy the safety leg. This creates an unnecessary, unsafe condition in which the operator can be pinned or crushed beneath the weight of the body. A means to deploy or stow the safety leg from outside the crush zone is required for safe operation.

Note: Caltrans installs a pull-chain to deploy safety legs from the edge of the body to minimize this hazard. The pull chain is not a legal requirement; however, it is a standard on Caltrans bodies requiring a safety leg.



Safety leg catch

*"Provide a safe, sustainable, integrated and efficient transportation system
to enhance California's economy and livability"*

2. 7.8yd³ As-Modified Hopper Mounting

As shipped from Viking Cives, Morley, MO, the 7.8 yd³ Sand Hopper was mechanically fastened to the frame with six mounts per side and six full width cross members supporting the weight of the hopper and payload.

As modified by the Viking Cives dealer in Utah, only the front two mounts are supported with a cross member. The remainder of the body has been secured using flat-bar acting as an unsupported bridge (green arrow in photo) between the existing crossmembers and body mounts for the remaining four mounts on each side. The flat-bar provides no load handling ability, so additional flat-bar, placed on-edge (blue arrow in photo), has been welded to the body and placed in contact with the cross members on each side of the sill. The flat-bar on edge provides minimal contact area supporting the load on the cross member which results in stress concentrations on the crossmember at each flat-bar. A stress concentration of this nature would be expected to produce a groove being worn into the crossmember along the area of contact of the flat-bar edge, possible deformation of the sander body sill around the flat-bar and possibly the flat-bar splaying in or out under the load. The methods used to mount the body are not representative of standard industry practice for body mounting and do not match the design intent of the OEM mounting system. Furthermore, the trailer certification label and tare weight do not appear updated with an Altered Vehicle Certification label reflecting the work performed at the Utah dealer.



*"Provide a safe, sustainable, integrated and efficient transportation system
to enhance California's economy and livability"*

3. Axle overloading issue

CALTRANS performed an axle-loading analysis using scales on the Viking-Cives Tow Plow. Each axle is rated for a maximum load of 18,000lbs and is directly mounted to the trailer frame, without suspension. This creates a see-saw condition where axle loads are readily transferred from one axle to another depending on the angle of the trailer frame with respect to the road. It was found that a 2" movement of the hitch, either up or down, with 7.8 yd³ of sand weighing 3000lb/yd³, would result in one axle of the Tow Plow trailer exceeding the Meritor FL-943's maximum rating of 18,000lbs per axle by over 2000lbs. The tires and rims have similar design limits and will also be subjected to overloading conditions. In addition to the truck hitch height changing due to variations in the load on the truck, typical roadways have many conditions that can cause the trailer frame to pitch such as entering/exiting driveways, undulations in the highway, on/off ramps, overpasses, and uneven roads. The road crown can also result in a shift of load from left to right with a potential for a wheel/tire overload condition. This results in the Viking Cives Tow-Plow axle, rim, and tire manufacturers load ratings being constantly subjected to overload conditions when in operation. Exceeding manufacturer load limits represents both a safety and legal issue.

4. Inspection Report 2

Inspection Report 2, attached, contains 32 items deemed as deficiencies by the Vehicle Quality Assurance group at Caltrans. These are items that do not meet Caltrans Quality Standards, are of poor workmanship, are missing parts, or are in general need of repair. DOE also recommends that these items be addressed before the units are put into service. It is also noted that the truck with front plow and tow plow will require an over-length permit as the California length limit is 65' and the unit measures 67'6".

DOE understands that Caltrans has a continued interest in testing and operating the tow plow. We look forward to our continued partnership with DRISI and providing additional explanations and evaluations as needed to support a successful resolve of the identified items in the tow plow system from Viking-Cives.

Attachment(s)

- (1) State of California, Department of Transportation-Division of Equipment Inspection Report #2

c: Larry Orcutt, Chief, Division of Equipment



INSPECTION REPORT # 2

SUPPLIER The University of California, Davis		MANUFACTURER Viking-Cives Midwest, Inc.	
PO NUMBER UCD37284	PE NUMBER	MAINTENANCE CLASS - SPEC NUMBER - -	
DESCRIPTION 2014 Western Star 4900SF with Viking-Cives Tow-plow			
PURPOSE OF INSPECTION In-Process Review		LOCATION OF INSPECTION META	
EQUIPMENT INSPECTED BY Shane Whitmore, Tom Keshihian & Randy Taylor			DATE 07/23/2015
INSPECTION REPORT RECEIVED BY Duane Bennett, Larry Baumeister			DATE 07/24/2015

A Pre-Delivery Acceptance Review and Quality Control Inspection was performed on a 2014 Western Star 4900SF, VIN # 5KKHAEBG7FPGM8167 and a Viking-Cives Tow-plow, VIN # 1V9PP3427EM180133. The following items were either found to be either non-compliant with the provided Specification, applicable laws and policies, Caltrans Quality Standards or in need of further resolution.

1. Specification UT 15 ACS, Page 2 of 4, first paragraph, requires hydraulic lines to street side rear rub rail for salt spreader with bulkhead mount, 1" return line, ¾" conveyor line and ½" spinner line, all lines routed through rear bulkhead with 90 degree swivel fittings. Fittings are not 90 degree causing hydraulic hoses to hang out the side of the truck bed to an overall bed width of 108 inches.
2. Specification UT 15 ACS, Page 2 of 4, third paragraph, requires Viking 12R 41" high moldboard painted Orange will be mounted with a UDOT UQH style front plow mount will be bolted on. Pin height will be approximately 15". A 4 x 10 double acting lift cylinder and lift arm will be removable for summer use. The plow is painted black. The pin height is 20 ½" and the double acting lift cylinder is 4 x 11 inches.
 - a) Note: Push plow blades not drilled per Caltrans specifications.
3. Specification UT 15 ACS, Page 2 of 4, sixth paragraph, requires body will be mounted with 20" of overhang and approximately 17" of cab clearance. The body has only 17" of overhang and cab clearance is 13 ½".

INSPECTION REPORT # 2

4. Specification TP260129, Page 3 of 4, first paragraph, requires a 725 gallon poly tank with bands. No poly tank installed.
5. The California Air Resources Board Heavy Duty Vehicle Idling Emission Reduction Program requires 2008 and newer model year heavy-duty diesel engines to be equipped with a non-programmable engine shutdown system that automatically shuts down the engine after five minutes of idling or optionally meet a stringent oxides of nitrogen idling emission. Truck engine did not shut down after five minutes.
6. Tow plow front left wheel hub seal leaking oil. All tow plow wheel hubs overfilled.
7. Trailer air brake quick disconnects are installed by industry standard not Caltrans standard.
8. Specification requires Carbide blades for push and tow plow. Could not confirm blade content.
9. Tow plow fenders do not have enough clearance to install snow chains. Left side fenders are easily removable with pins. Right side fenders are bolted in place and are not easily removable.

INSPECTION REPORT # 2



10. Left tow-plow fenders have sharp edges where the fenders were cut and rear fender mounting bolt not flush with fender.
11. Hydraulic leak on or near screen housing near hydraulic reservoir.
12. Tow Plow safety chains D rings have only one pass on welds.
Caltrans Quality Standard requires three pass welds.
13. Battery hot connections not protected.

INSPECTION REPORT # 2

14. Tow Plow spreader mounting bolt holes are flame cut. Caltrans Workmanship Quality Standard requires holes to be punched or drilled. Flame cutting will not be acceptable.

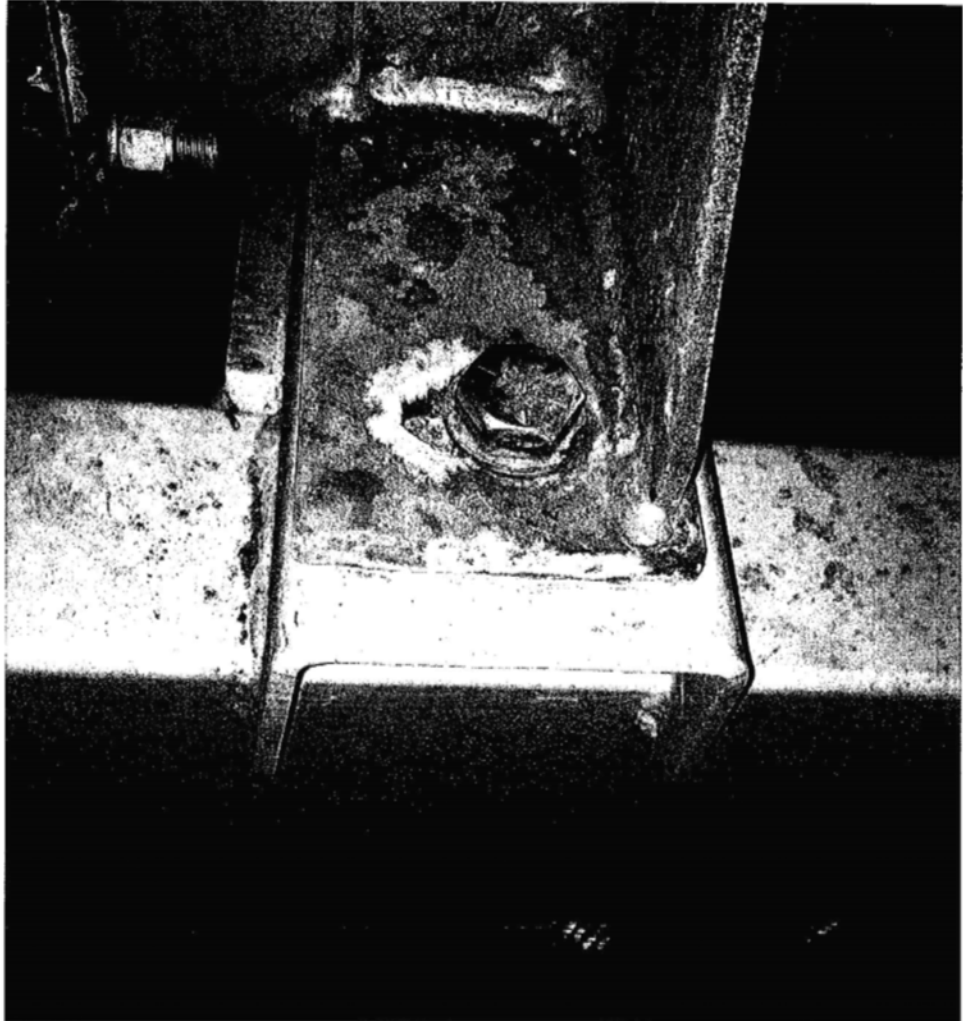

15. Truck rear cross-member welded with one pass inside only. Caltrans Welding Quality Standard requires three pass minimum, vertical uphill only, one pass on inside corner.
16. Bolt through lower frame flange on push plow frame missing.
17. The truck Force America 6100 hydraulic control system cover needs a handle to facilitate removal and top rear retaining strap broken.

INSPECTION REPORT # 2

18. The Force America 6100 hydraulic control system is leaking fluid inside the control box.



19. Left fender spot mirror blocked by left air filter housing.
20. Specification UT 15 ACS, Page 1 of 4, third paragraph, requires a UDOT style ½" buck-plate with a Premier 2300 air hitch mounted at approximately 28". The truck is not equipped with an air hitch.
21. Trailer ABS light not visible from inside the cab.
22. Hydraulic hoses on truck plow secured with tie-wraps not permanent hose clamps.
23. Bolt for trailer proximity switch can't be tightened because washer won't go flush. Washer needs to be trimmed.
24. Blue trailer coiled air supply hose rubs on chain support.
25. Hydraulic reservoir fluid level gage is difficult to see and is exposed to tire debris.

INSPECTION REPORT # 2

26. Airlines are rubbing under truck bed above cross member.



27. No back-up alarm.

28. There is only one bed up safety support.

29. There is no pull chain for bed up safety support release mechanism.

30. Tow plow rear side reflectors are installed at a 45 degree angle.

31. Tow plow tongue pivot pins retainer bolts do not have two threads protruding beyond the lock nuts.

INSPECTION REPORT # 2

32. Ladder on material spreader on tow plow 12 inches higher than grates. Ladder will be in the way of the loader bucket during loading of material.



33. Spreader body on trailer not aligned with, and secured to, tow plow frame cross member supports. Temporary strapping and support blocks have been installed. Some support blocks are not welded in place. Bare metal. No paint or primer.
34. Adjustable tension bolts for material spreader chain belt missing jam nuts.

INSPECTION REPORT # 2

35. Water hoses cover conspicuity tape on left side of tow plow.
36. Upper row of conspicuity tape installed at 103". Must be installed below 60".
37. Tow plow rear conspicuity tape not completely across trailer bumper.
38. Tow plow "stay back" sign supports have unpainted spots, some with rust.
39. Mounting bracket for rear strobe light have unpainted spots, some with rust.
40. Main electrical cable for all rear trailer lights not supported every 8 inches.
41. Bolt missing from material spreader chain belt adjustable tension safety cover.
42. Water hose under tow plow stainless steel control box kinked.

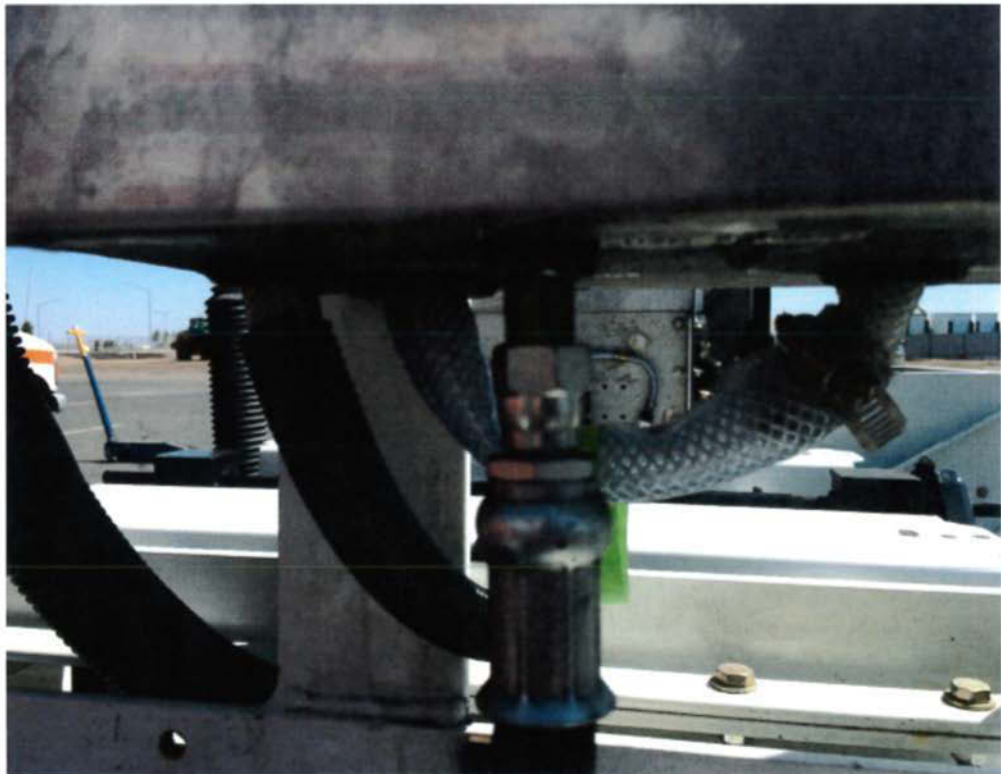

INSPECTION REPORT # 2

43. Hoses are rubbing near trailer swing cylinder.

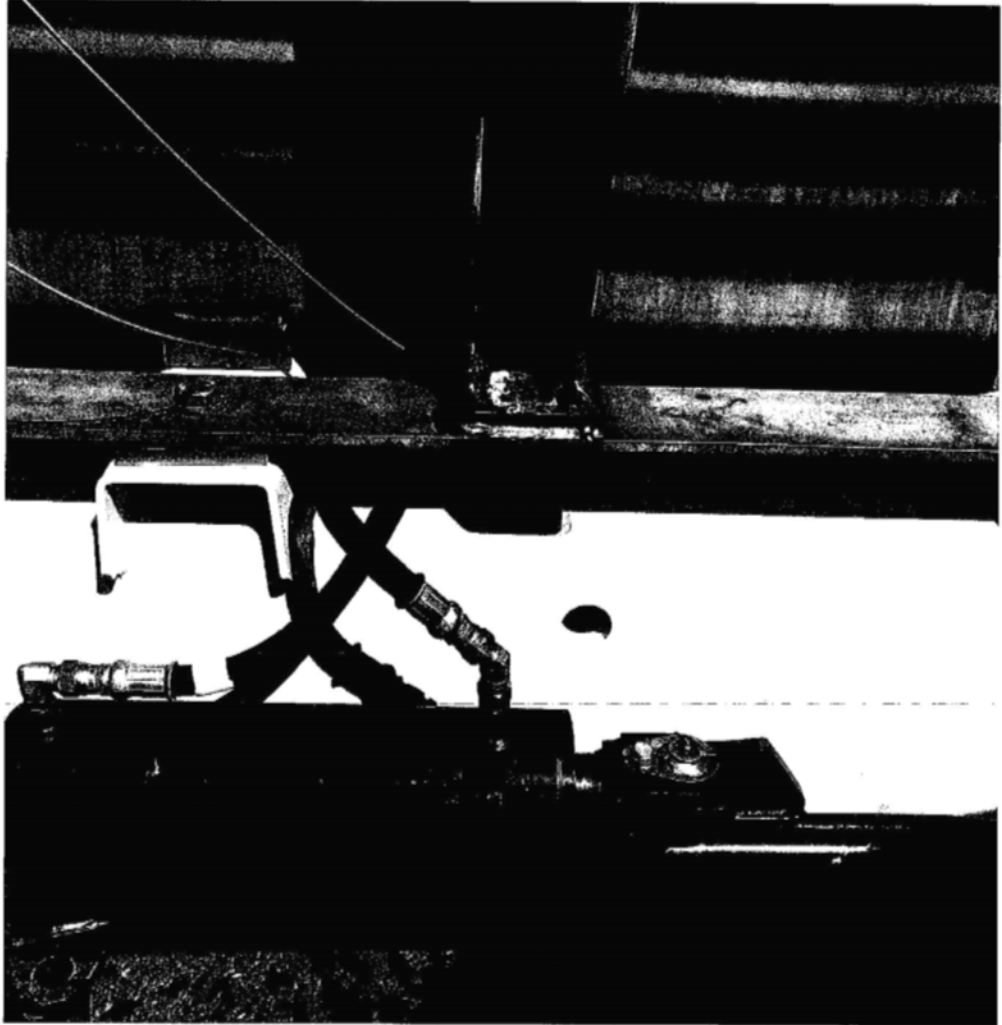

INSPECTION REPORT # 2

- 44. Tow plow steering cylinder hydraulic hose rubbing on sander mounting plate.
- 45. Tow plow steering cylinder hose radius to tight.



INSPECTION REPORT # 2

46. Numerous hydraulic, air hoses and electrical wires are rubbing and chaffing.



INSPECTION REPORT # 2

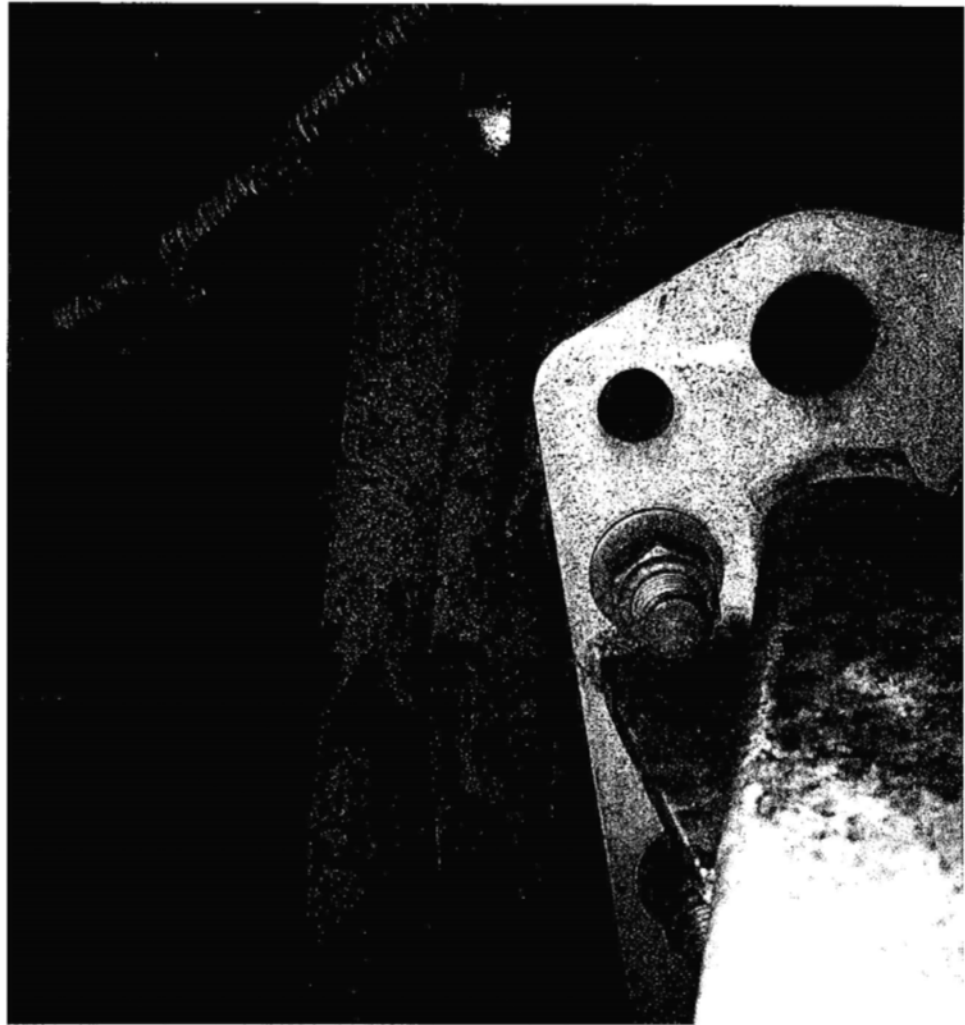

INSPECTION REPORT # 2



INSPECTION REPORT # 2



INSPECTION REPORT # 2



APPENDIX D: TOWFLOW2 OPTION-3 DOE WEIGHT MEASUREMENTS

The following are weight measurements made by Caltrans DoE of the TowPlow2 after the DoE designed Option-3 modifications were made by the Viking-Cives subsidiary. All work in this appendix is by Caltrans DoE and is presented here for reference.

TOW PLOW 2 AXLE WEIGHT TESTING META 7/23/15

FUEL= 1/2 TANK ~ 62.5 GAL SCALE1=DRIVER, SCALE 2= PASS
 TIRE PRESSURE= 120 TRUCK, 125-130 PSI TOW PLOW

TONGUE CONDITION	TRUCK LOAD	TRAILER LOAD	FRONT AXLE TP2			REAR AXLE TP2			TP2 WEIGHT	FRONT TANDEM TRUCK			REAR TANDEM TRUCK			REAR TRUCK
			SCALE 1	SCALE 2	TOTAL	SCALE 1	SCALE 2	TOTAL		SCALE 1	SCALE 2	TOTAL	SCALE 1	SCALE 2	TOTAL	
AS REC'D FROM AHMCT- VERY TOP HOLES LEVEL WHEN EMPTY	NO PAYLOAD	NO PAYLOAD	3660	4580	8240	3100	4000	7100	15340	4720	4720	9440	4920	4120	9040	18480
AS REC'D FROM AHMCT- VERY TOP HOLES LEVEL WHEN EMPTY	NO PAYLOAD	1 SCOOP	4260	5080	9340	3720	4680	8400	17740	4780	4820	9600	4980	4240	9220	18820
AS REC'D FROM AHMCT- VERY TOP HOLES LEVEL WHEN EMPTY	NO PAYLOAD	2 SCOOPS	5140	5580	10720	4560	5160	9720	20440	4160	5020	9180	5140	4460	9600	18780
AS REC'D FROM AHMCT- VERY TOP HOLES LEVEL WHEN EMPTY	NO PAYLOAD	4 SCOOPS	6840	7040	13880	5680	6120	11800	25680	5220	5320	10540	5420	4760	10180	20720
AS REC'D FROM AHMCT- VERY TOP HOLES LEVEL WHEN EMPTY	NO PAYLOAD	FULL	7640	8440	16080	6560	7440	14000	30080	5580	5620	11200	5800	5240	11040	22240
AS REC'D FROM AHMCT- VERY TOP HOLES LEVEL WHEN EMPTY	2 SCOOPS	6-SCOOPS FULL	7820	8680	16500	6420	7200	13620	30120	7040	6700	13740	7300	6300	13600	27340
AS REC'D FROM AHMCT, TONGUE DELOYED	2 SCOOPS	FULL	8980	6800	15780	8100	6260	14360	30140							
AS REC'D, TONGUE DELOYED, PLOW DOWN	2 SCOOPS	FULL	8940	5680	14620	7940	5140	13080	27700							
MOVED DOWN ONE SET OF HOLES (2") FROM REC'D	2 SCOOPS	FULL	5500	6680	12180	8440	8760	17200	29380	7200	6620	13820	7340	6220	13560	27380
MOVED DOWN TWO SETS OF HOLES (4") FROM REC'D	2 SCOOPS	FULL	4220	5340	9560	9420	9780	19200	28760	7520	6740	14260	7620	6540	14160	28420
AS REC'D TOP HOLES- TRAILER ON SCALES TRUCK ON GROUND	2 SCOOPS	FULL	9360	10340	19700	5120	5880	11000	30700							
TRAILER ONLY FULL PAYLOAD WEIGHT	XXXXXXXX	FULL	2800	5300	8100	7120	8520	15640	23740	7020	4620	11640				

TOW PLOW EMPTY TARE 18440

SAND WEIGHT TOTAL TOW PLOW 16940



SAND WEIGHT PER YARD AS TESTED 2420 LOOSE SAND VERY DRY

7 YD³ USED DUE TO LOADING ISSUES FROM LADDER, MAX CAP = 7.8YD³

ADDITIONAL WET SAND PAYLOAD TO TOW PLOW @ 3000LBS/YD 6460

TRUCK TARE CONNECTED NO PAYLOAD FRONT= 15480 REAR=18800 TRAILER= 14380

TRUCK TARE FRONT=16300 REAR=13900

 =TRAILER JACKS
 =OVERLOADED

APPENDIX E: DOE REBUILD OF TOWFLOW2 OPTION-3

Using the “Division of Equipment Review and Concerns regarding Tow Plow 2” memo located in Appendix C as a guide. Caltrans DoE internally modified the Option-3 configuration TowPlow2 trailer from a sander to a single brine tank system. The following is the scope of work performed by DoE to make this modification. All work in this appendix is by Caltrans DoE and is presented here for reference.

TOW PLOW 2 SCOPE OF WORK

Meeting attendees: Jeremy Johnson, Dave McIntire, Jim Simpson, Justin Unck, Jason Mcmillan, Kris Teague, Virgil Realin, Dave Dodge, Efrain Figueroa, Dave Frame, Tim Shaw, Dale Greep.

Truck

- Needs Striping
- Lighting
 - Add Go light
 - Add Roof mount rotator
 - Truck already has front and rear flashers
 - Lower plow lights 6"
- Add Roadwatch
- Replace 8" spot mirror with 10" heated spot, reposition arms inboard
- Check Plow for plow blade and bolt compatibility
- Fix plow main pin bushing, add plow eyebrow
- Remove dump bed drivers side quick couplers
- Cut Cab guard off of body, Add CT std Cab guard (if time allows)

Trailer

- Remove hopper body
- Add brine tank
- Modify lift jacks
 - Currently 5.25" clearance
- Remove Sander hydraulics
- Build brackets for brine hoses
- Lighting
 - Work lights
 - Remove rear forward facing
 - Add 2 front pole mount, glass lens incandescent pointing toward plow
 - Warning lighting
 - Currently 3 rotators on trailer—check for title 13
 - Compare output with LL2 on back of TP1, maybe add LL2 to rear
- Check wheel alignment geometry
- Check steering
- Add Air foil or Heating element to rear sign to keep ice from forming

APPENDIX F: TP2-DOE MANUFACTURER CONTACT

AHMCT transmitted to the manufacturer Caltrans' concerns on the acceptability of the TowPlow for legal operation. Viking-Cives, after follow-up contacts, did not provide a response to these concerns. The correspondence from AHMCT is provided below for reference. Attached to the email were two documents, both contained in these appendices:

- Appendix C: "Division of Equipment Review and Concerns regarding Tow Plow 2" (which includes Inspection Report #2)
- Appendix D: "TowPlow2 Option-3 DoE Weight Measurements"

From Steve V.  ↩ Reply ↩ Reply All → Forward 🗑 Junk 🗑 Delete

Subject **UC-Davis TowPlow System** 8/14/2015 9:07 AM

To Kevin Newson 

Kevin Newson
Viking-Cives Midwest
Via email:

Dear Kevin

I am the faculty principal investigator of our research work concerning the TowPlow. You have previously been in contact with my colleague, Duane Bennett. As you are aware, the California State Department of Transportation (Caltrans) is our contractor and research partner concerning the implementation of the TowPlow in California's snow removal operations. As our machine must be deployed on California roads for testing, it must meet all of Caltrans' requirements and standards for road-going equipment. As such, our TowPlow system has again been inspected by Caltrans' Division of Equipment (DOE) representatives. The purpose of this letter is to share the issues identified by Caltrans and open a dialogue between Caltrans and Viking-Cives so the inspection findings can be addressed thus allowing for the continued evaluation of the TowPlow. There are 3 primary concerns as described in the attached memo of August 5, 2015 and a number of additional identified deficiencies. Please note that several of these additional deficiencies may have already been addressed.

We would like to start by having a teleconference between my university staff, our Caltrans research project directors, and you in the near future. The initial goal is to discuss DOE's concerns. As such, it would be great if you could review the attached document. I suggest that you then contact our Caltrans project manager, Justin Unck, who will serve as the point of contact for any discussions with Caltrans and he can coordinate any teleconferences as this matter moves forward. He can be contacted at _____ and (916)654-9853.

Thanks for your attention to this matter. We look forward to speedy resolution so that the research work and use of the TowPlow use can move forward.

Sincerely,

--
Prof. Steven A. Velinsky
Dept. of Mechanical & Aerospace Engineering
University of California - Davis
One Shields Avenue
Davis, CA 95616-5294

APPENDIX G: TP2-DOE OPERATOR SURVEY

AHMCT delivered this survey to Caltrans TowPlow operators and associated personnel at the Kingvale HMS on April 27, 2017. Responses were to be returned via email. None have been received.

TowPlow2 Deployment Questionnaire

*Query Caltrans maintenance personnel in the Kingvale and Truckee yards
The TowPlow2 trailer (7011126) was originally purchased as a universal sander and brine unit and was later reconfigured by Caltrans DOE to be a brine-only unit similar to TowPlow1. The TowPlow2 prime mover truck (7011279) has been upgraded with increased engine power and controls.*

1. Does the TowPlow2 prime mover truck have sufficient power to plow with the TowPlow up 6% grades loaded with appropriate ballast?
 - Yes
 - No
 - No opinion

2. Are the controls on the TowPlow2 unit effective and easy to understand?
 - Yes
 - No
 - No opinion

3. Do you think training was adequate to operate the TowPlow2 unit?
 - Yes
 - No
 - No opinion

4. Do you believe the additional auxiliary lighting incorporated on TowPlow2 is sufficient to enable the operator to view the TowPlow moldboard during night plowing operations?
 - Yes
 - No
 - No opinion

5. Does the TowPlow2 forward-projected laser pointer improve the operator's sense of how far the moldboard is extended? See image.

- Yes
- No
- No opinion



6. How does the TowPlow2 as configured handle as a trailer on the highway at operational speed?

- Stable
- Unstable
- No opinion

7. Overall, how do the hazards of operating the TowPlow2 on highways compare with those of conventional plow trucks?

- Less
- More
- Similar
- No opinion

8. How would you rate the effectiveness of the TowPlow2 to remove snow from the highway compared to conventional plow trucks?

- Better
- Less
- Similar
- No opinion

9. Is the Caltrans DOE modified brine system on the TowPlow2 useful and does it function as needed?

- Yes
- No
- No opinion

10. Do you think incorporating a TowPlow2 as configured has potential to improve the level of service in highway snow fighting operations?

- Yes
- No
- No opinion

11. Do you think the TowPlow2 as configured has potential to reduce the pack operational costs during a snow event?

- Yes
- No
- No opinion

12. How often is sand spread on the road during snow plowing operations?

- Frequently
- Half of the time
- Rarely

13. How often is brine sprayed on the road during snow plowing operations?

- Frequently
- Half of the time
- Rarely

14. Should the system log material application rates and location?

- Important
- Do not want
- No opinion

15. Do you have any suggestions which would improve the effectiveness and cost benefit of operating TowPlow units in Caltrans snow fighting operations?

1. _____
2. _____
3. _____
4. _____

APPENDIX H: THREE-LANE SECTIONS OF SNOWPLOWING ROUTES

The cost benefit analysis is based on the following snowplowing routes and lists the two- and three-lane per direction sections of highway which meet the previously listed qualification assumptions.

District 3 Kingvale East Route:

Interstate 80 - Kingvale HMS to Donner Lake Interchange (20-mile loop)

20-mile loop containing 12.4 miles of 3-lane highway

3-Lane Westbound: Donner Pass Rd. to Boreal = 8 mi

3-Lane Eastbound: Soda Springs to Donner Pass rest area = 3.4 mi

District 3 Kingvale West Route:

Interstate 80 - Kingvale HMS to Hwy 20 (20-mile loop)

20-mile loop containing 1 mile of 3-lane highway

3-Lane Eastbound: Kingvale chain area = 1 mi

District 3 Whitmore East Route:

Interstate 80 - Whitmore HMS to Hwy 20 (26-mile loop)

26-mile loop containing 12.5 miles of 3-lane highway

Westbound: Whitmore chain area = 0.5 miles

Eastbound: Drum Forebay chain area = 1 miles
Lang Rd. to Yuba Gap = 5 miles
Drum Forebay to Nyack = 6 miles

District 3 Truckee East Route:

Interstate 80 – SR 89 to Donner Lake Interchange (32-mile loop)

32-mile loop containing 4.6 miles of 3-lane highway

Westbound: Hirschdale chain area = 0.5 miles
Boca Canyon to Overland Trail = 2.5 miles

Eastbound: Hirschdale to Truckee River Canyon = 1.6 miles

District 3 Truckee West Route:

Interstate 80 – SR 89 to Donner Lake Interchange (14-mile loop)

14-mile loop containing 2.5 miles of 3-lane highway

Westbound: Central Truckee to Northwoods Rd. = 2 miles

Eastbound: Truckee to SR 89 = 0.5 miles

District 2 Yreka North Route:

Interstate 5 – Yreka HMS to Oregon state line (40-mile loop)

40-mile loop containing 2.5 miles of 3-lane highway

Northbound: Lemos Rd. to Hilt = 2.5 miles

District 2 Yreka South Route:

Interstate 5 – Weed to Dunsmuir (40-mile loop)

40-mile loop containing 16.4 miles of 3-lane highway

Northbound: Siskyou Ave. to South Mt Shasta Blvd. = 6 miles

North Mt. Shasta Blvd. to Black Butte Summit = 2.5 miles

Southbound: Hwy 97 Weed to Vista Rd. = 2.4 miles

Summit Dr. to Abrams Lake Rd. = 2.0 miles

Dunsmuir Weight Station to Siskyou Ave. = 3.5 miles

APPENDIX I: DOE TOWFLOW1 MODIFICATIONS

TowPlow 1 Modifications

Initial transfer to Caltrans:

Trailer:

- Removed Hydraulics blocks and hoses installed by AHMCT
- Removed wiring and panel installed by AHMCT
- Installed rear LED flashing amber LL2
- Installed LED side facing flashing amber lights
- Installed proximity sensors for GPS system on trailer
- Painted travel locks bright red
- Installed trucklite halogen 100watt flood on pole at front of trailer
- Installed metal fenders and raised for cable/chain clearance

Truck:

- Installed Sauer Danfoss Load sensing stack valve bank
- Removed gear pump and installed load sensing piston pump
- Fabricated and installed larger hydraulic tank/toolbox combo
- Replumbed truck hydraulics
 - Converted to return filter
 - Installed suction strainer
 - Installed shuttle valve for load sense
 - Installed larger suction line
 - Converted to ISO32 oil spec for pump
 - Added flush face quick couplers at rear of truck to hook up trailer functions
- Installed in cab controls for Brine pump (variable rheostat control) and valves

- Installed “auto retract” mushroom switch to auto stow the trailer
- Installed Tow plow joystick controls in center console
- Installed Preco 2 channel GPS monitoring system for towplow and truck
- Installed Go-Light movable spot light

2015 modifications

Trailer:

- Converted the front hitch to adjustable height pintle hitch to address axle loading
- Removed forward brine tank
- Added plumbing and swivel for nurse tank
- Converted fenders to be removable
- Fabricated trailer jack cross member and raised trailer jacks ~ 12”

Truck:

- Converted removed brine tank to slip in for truck
 - Fabricated skid, lock system and plumbing