



U.S. Department  
of Transportation



PB2001-100783



# Evaluation of the Metropolitan Atlanta Rapid Transit Authority Intelligent Transportation System



REPRODUCED BY: **NTIS**  
U.S. Department of Commerce  
National Technical Information Service  
Springfield, Virginia 22161

**Federal Transit Administration  
Office of Mobility Innovation  
Service Innovation Division**

**Volpe National Transportation Systems Center  
Office of System and Economic Assessment  
Service Assessment Division**



REPORT DOCUMENTATION PAGE			Form Approved OMB No. 0704-0188	
Public reporting burden for this collection of information is estimated to average 1 hour per response, including the time for reviewing instructions, searching existing data sources, gathering and maintaining the data needed, and completing and reviewing the collection of information. Send comments regarding this burden estimate or any other aspect of this collection of information, including suggestions for reducing this burden, to Washington Headquarters Services, Directorate for Information Operations and Reports, 1215 Jefferson Davis Highway, Suite 1204, Arlington, VA 22202-4302, and to the Office of Management and Budget, Paperwork Reduction Project (0704-0188), Washington, DC 20503.				
1. AGENCY USE ONLY (Leave blank)		2. REPORT DATE  July 2000		3. REPORT TYPE AND DATES COVERED  Final Report December 1995 - February 2000
4. TITLE AND SUBTITLE Evaluation of the Metropolitan Atlanta Rapid Transit Authority Intelligent Transportation System			5. FUNDING NUMBERS  TT50/U0196	
6. AUTHOR(S) Patricia Monahan <sup>1</sup> , Carol Schweiger <sup>1</sup> , and Tom Buffkin <sup>2</sup>				
7. PERFORMING ORGANIZATION NAME(S) AND ADDRESS(ES) U.S. Department of Transportation Research and Special Programs Administration John A. Volpe National Transportation Systems Center Cambridge, MA 02142			8. PERFORMING ORGANIZATION REPORT NUMBER	
9. SPONSORING/MONITORING AGENCY NAME(S) AND ADDRESS(ES) U.S. Department of Transportation Federal Transit Administration, TRI-10 Office of Mobility Innovation 400 Seventh Street, SW Washington, DC 20590			10. SPONSORING/MONITORING AGENCY REPORT NUMBER  FTA-MA-26-7007-2000-3	
11. SUPPLEMENTARY NOTES <sup>1</sup> Multisystems, Inc., <sup>2</sup> Formerly of Cambridge Systematics, Inc.				
12a. DISTRIBUTION/AVAILABILITY STATEMENT This document is available to the public through the National Technical Information Service, Springfield, VA 22161			12b. DISTRIBUTION CODE	
13. ABSTRACT (Maximum 200 words)  This report documents the implementation and operation of the Metropolitan Atlanta Rapid Transit Authority's Advanced Public Transportation System (ITS MARTA '96) as part of a showcase of Intelligent Transportation Systems technologies deployed for the 1996 Summer Olympic Games.  The short time frame between funding for the project and the opening date of the Olympics imposed severe time constraints on the development and implementation of the components of MARTA's ITS system. The result was that all of the desired capabilities were not in place during the Games. Consequently, the evaluation period was extended to allow for implementation of the ITS elements and their operation for at least one year. However, since only about a third of MARTA's fleet was equipped with automatic vehicle location, and small numbers of automatic passenger counters, in-vehicle annunciators, in-vehicle signs, wayside passenger information devices, and passenger information kiosks were deployed, the impacts of the ITS technologies was severely limited. Therefore, the evaluation relied heavily on perceptions of users rather than on formal before and after measurements. As a result much of the analysis is qualitative in nature. Lessons learned from ITS MARTA '96 are also presented.				
14. SUBJECT TERMS Intelligent Transportation Systems (ITS), Advanced Public Transportation Systems (APTS), Automated Vehicle Location, Computer-Aided Dispatching, Trip Itinerary Planning, Geographic Information System, Automatic Passenger Counters, In-vehicle Annunciators, In-vehicle Signs, Wayside Passenger Information Devices, and Kiosks			15. NUMBER OF PAGES	
			16. PRICE CODE	
17. SECURITY CLASSIFICATION OF REPORT Unclassified	18. SECURITY CLASSIFICATION OF THIS PAGE Unclassified	19. SECURITY CLASSIFICATION OF ABSTRACT Unclassified	20. LIMITATION OF ABSTRACT	



## TABLE OF CONTENTS

<u>Section</u>	<u>Page</u>
1. Project Background .....	1-1
1.1 Introduction .....	1-1
1.2 Transit Services .....	1-2
1.3 Local Issues and External Influences .....	1-3
1.4 Description of Project Components .....	1-3
1.5 Project Schedule .....	1-4
1.5.1 MARTA ITS Activities Prior to the 1996 Summer Olympic Games .....	1-4
1.5.2 MARTA ITS Activities Following the Olympics .....	1-6
2. Evaluation Overview .....	2-1
2.1 Project Objectives .....	2-1
2.2 Evaluation Approach .....	2-5
3. Base Geographic Information System .....	3-1
3.1 Description and Relation to Other ITS Components .....	3-1
3.2 Implementation Issues .....	3-2
3.3 Measures of Effectiveness .....	3-3
3.3.1 User Acceptance .....	3-3
3.4 Achievement of Objectives .....	3-4
3.4.1 System Productivity and Job Satisfaction .....	3-4
4. Trip Itinerary Planning System: PARIS® .....	4-1
4.1 Description .....	4-1
4.2 Relation to Other ITS Components .....	4-3
4.3 Implementation Objectives .....	4-3
4.4 Implementation Issues .....	4-4
4.5 Measures of Effectiveness .....	4-4
4.5.1 User Acceptance .....	4-4
4.5.2 Effectiveness .....	4-12
4.5.3 Financial Impact .....	4-13
4.6 Achievement of Objectives .....	4-13

## TABLE OF CONTENTS (cont.)

<u>Section</u>	<u>Page</u>
4.6.1 Enhanced Customer Information .....	4-13
4.6.2 Improved System Efficiency .....	4-13
4.6.3 Needs of Persons with Disabilities .....	4-13
5. Georgia Department of Transportation Advanced Transportation Management System .....	5-1
5.1 Description .....	5-1
5.2 Relation to Other ITS Components .....	5-2
5.3 Implementation Issues .....	5-2
5.4 Achievement of Objectives .....	5-2
5.4.1 Quality of On-Street Service .....	5-2
5.4.2 System Productivity .....	5-3
5.4.3 Communication Between Jurisdictions .....	5-3
6. Computer-Aided Dispatch/Automatic Vehicle Location System .....	6-1
6.1 Description .....	6-1
6.2 Relation to Other ITS Components .....	6-3
6.3 Implementation Issues .....	6-5
6.4 Measures of Effectiveness .....	6-5
6.4.1 User Acceptance .....	6-6
6.4.2 Effectiveness .....	6-13
6.4.3 Financial Impact .....	6-15
6.5 Achievement of Objectives .....	6-15
6.5.1 Quality of On-Street Service .....	6-15
6.5.2 System Productivity and Job Satisfaction .....	6-16
7. In-Vehicle Annunciators and Electronic Signs .....	7-1
7.1 Description .....	7-1
7.2 Relation to Other ITS Components .....	7-2
7.3 Implementation Issues .....	7-2
7.4 Measures of Effectiveness .....	7-3
7.4.1 User Acceptance .....	7-3
7.4.2 Effectiveness .....	7-4

## TABLE OF CONTENTS (cont.)

<b><u>Section</u></b>	<b><u>Page</u></b>
7.4.3 Financial Impact.....	7-5
7.5 Achievement of Objectives.....	7-5
7.5.1 Customer Information.....	7-5
7.5.2 Communication with Persons with Disabilities.....	7-6
8. Automatic Passenger Counter System.....	8-1
8.1 Description.....	8-1
8.2 Relation to Other ITS Components.....	8-1
8.3 Implementation Issues.....	8-1
8.4 Measures of Effectiveness.....	8-2
8.4.1 User Acceptance.....	8-2
8.4.2 Effectiveness.....	8-5
8.4.3 Financial Impact.....	8-5
8.5 Achievement of Objectives.....	8-6
8.5.1 System Productivity.....	8-6
9. Wayside Passenger Information Devices.....	9-1
9.1 Description.....	9-1
9.2 Relation to Other ITS Components.....	9-3
9.3 Measures of Effectiveness.....	9-3
9.3.1 Availability.....	9-3
9.3.2 Financial Impact.....	9-3
9.4 Achievement of Objectives.....	9-3
10. Passenger Information Kiosks.....	10-1
10.1 Description.....	10-1
10.2 Relation to Other ITS Components.....	10-1
10.3 Achievement of Objectives.....	10-1
11. Smart Card Fare Payment System.....	11-1

## TABLE OF CONTENTS (cont.)

<u>Section</u>	<u>Page</u>
11.1 Description .....	11-1
11.2 Relation to Other ITS Components.....	11-1
11.3 Implementation Issues.....	11-1
11.4 Measures of Effectiveness.....	11-2
11.4.1 User Acceptance.....	11-2
11.4.2 Functional Characteristics.....	11-3
11.4.3 Effectiveness .....	11-3
11.4.4 Financial Impact.....	11-3
11.5 Achievement of Objectives .....	11-4
11.5.1 Quality of On-Street Service .....	11-4
11.5.2 Financial Impacts .....	11-5
12. ITS System Costs .....	12-1
13. Summary and Conclusions.....	13-1
13.1 Summary of ITS Technology Status and Benefits to Date .....	13-1
13.1.1 Base Geographic Information System (GIS) .....	13-1
13.1.2 Trip Itinerary Planning System (PARIS®) .....	13-1
13.1.3 Link to Georgia Department of Transportation's (GDOT's) Transportation Management Center (TMC) .....	13-1
13.1.4 Computer-Aided Dispatch/Automatic Vehicle Location (CAD/AVL) System .....	13-2
13.1.5 In-Vehicle Annunciators and Electronic Signs .....	13-2
13.1.6 Automatic Passenger Counter (APC) System.....	13-3
13.1.7 Wayside Passenger Information Devices (PIDs) .....	13-3
13.1.8 Passenger Information Kiosks.....	13-3
13.2 Conclusions .....	13-4
14. Lessons Learned.....	14-1
14.1 Introduction .....	14-1
14.2 Lessons Noted by MARTA Staff.....	14-1
14.3 Additional Observations by Evaluation Team .....	14-3
Appendix A. Glossary of Terms .....	A-1
Appendix B. Site Visit Interview Schedules and Topics .....	B-1



## LIST OF FIGURES

<u>Figure</u>	<u>Page</u>
1. Relationships Among ITS MARTA Components .....	1-5
2. MARTA BCC .....	3-2
3. Transit Control Head.....	6-2
4. CAD/AVL Components.....	6-2
5. MARTA CAD/AVL Workstation.....	6-4
6. CAD/AVL Display.....	6-5
7. False Early Depiction .....	6-8
8. In-Vehicle LED Signs .....	7-1
9. PID Monitor .....	9-1
10. PID LED Sign .....	9-2
11. VISA CASH card Usage.....	11-3

## LIST OF TABLES

<u>Table</u>	<u>Page</u>
1. Status of ITS MARTA '96 as of March 20, 1996.....	1-6
2. MARTA ITS '96 Elements and Federal Objectives .....	2-3
3. Disposition of Voice Response Unit Calls Selected Dates, 1997 and 1999 .....	4-11
4. Initial Costs of MARTA ITS Components for TMS and TRW.....	12-1

**PROTECTED UNDER INTERNATIONAL COPYRIGHT  
ALL RIGHTS RESERVED  
NATIONAL TECHNICAL INFORMATION SERVICE  
U.S. DEPARTMENT OF COMMERCE**

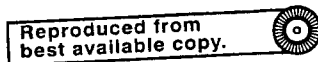

## ABBREVIATIONS AND ACRONYMS

ADA	Americans with Disabilities Act
APC	Automatic Passenger Counter
APTS	Advanced Public Transportation System
ATIS	Advanced Traveler Information System
ATMS	Advanced Transportation Management System
AVL	Automatic Vehicle Location
BCC	Bus Communication Center
CAD	Computer-Aided Dispatch
CEO	Chief Executive Officer
CIO	Customer Information Operator
CNG	Compressed Natural Gas
FHWA	Federal Highway Administration
FTA	Federal Transit Administration
GDOT	Georgia Department of Transportation
GIS	Geographic Information Systems
GPS	Global Positioning System
HERO	Highway Emergency Response Operator
IT	Information Technology
ITS	Intelligent Transportation Systems
IVLU	Intelligent Vehicle Logic Unit
LED	Light Emitting Diode
MARTA	Metropolitan Atlanta Rapid Transit Authority
MOE	Measure of Effectiveness
PA	Public Address
PARIS®	<u>P</u> assenger <u>R</u> outing and <u>I</u> nformation <u>S</u> ystem
PCMCIA	Personal Computer Memory Card International Association
PID	Passenger Information Device
PM/RIS	Performance Management/Ridership Information System
PRTT	Priority Request to Talk
RDBMS	Relational Database Management System
RSA	Route Schedule Adherence
RTT	Request to Talk
SAE	Society of Automotive Engineers
TCH	Transit Control Head
TCRP	Transit Cooperative Research Program
TIC	Transit Information Center
TIPS	Trip Itinerary Planning System
TIS	Traveler Information Showcase
TMC	Transportation Management Center
TMS	Transportation Management Solutions
VNTSC	Volpe National Transportation Systems Center
VRU	Voice Response Unit

# Executive Summary

## Introduction

The Metropolitan Atlanta Rapid Transit Authority (MARTA) implemented components of an Advanced Public Transportation System (APTS) as part of a showcase of current Intelligent Transportation Systems (ITS) technologies deployed for the 1996 Summer Olympic Games. However, due to the funding limitation and the very short time frame for development and implementation, only a portion of the MARTA fleet could be equipped with APTS technologies and most of the technologies were only partially functioning during the Games.

Following the conclusion of the Olympic Games, MARTA completed the implementation of its APTS, made refinements to the system, and began to employ the various technologies in its daily, post-Olympics operations. Consequently, the evaluation, sponsored by the Federal Transit Administration (FTA) and directed the Volpe National Transportation Center, was extended to the time when the APTS technologies were functioning successfully.

This report summarizes the findings from MARTA's experiences with the implementation of new technologies, and offers guidance to other organizations that are contemplating or planning for the adoption of similar technologies. Unfortunately, the impact of the APTS technologies was severely restricted because of the limited number of the various technologies deployed.

## Transit Service

MARTA provides bus and heavy rail service in Atlanta and surrounding Fulton County, as well as in neighboring DeKalb County. The Authority operates 160 bus routes over roughly 1,500 route miles with a fleet of more than 700 vehicles. The rail system is 39 miles in length and serves 38 stations (2 of which will open in 2000) with a total of 240 rail cars.

The service requirements for the period of the Summer Olympics created a unique situation, one in which MARTA carried more than 25 million passengers in the seventeen day period from July 19<sup>th</sup> through August 4<sup>th</sup> – an average of nearly 1.5 million riders per day, as compared to roughly 219,000 per day normally. MARTA used more than 1,500 additional buses supplied by other public and private transportation providers during this period.

## Project Components

MARTA's APTS system, known locally as "ITS MARTA '96," was composed of the following elements:

- Base Geographic Information System (GIS)
- Trip Itinerary Planning System (TIPS, also referred to by its brand name, PARIS®)
- Integration with the GDOT Advanced Transportation Management System (ATMS)
- Computer-Aided Dispatch/Automatic Vehicle Location (CAD/AVL) System installed in 240 buses (out of 700 buses)
- Wayside Passenger Information Devices (PIDs)
- In-Vehicle Annunciators and Electronic Signs, installed in 100 of the 240 buses equipped with AVL
- Automatic Passenger Counters (APCs), installed on 15 of the 100 buses equipped with stop annunciators

### **Project Schedule**

The schedule for the MARTA ITS project called for all elements to be fully operational prior to the beginning of the Olympic Games on July 19, 1996. The ITS components that were installed and in use at the time of the Olympics included: PARIS®, 15 APCs, about 150 buses outfitted with AVL, a few PIDs, the VISA Cash Card fare payment system, and traveler information kiosks. No on-board signs or annunciators were operational during the Olympics, and although PARIS® was used to respond to some customer inquiries, it was not used to generate trip itineraries at that time.

- The status of MARTA's ITS components as of March 1999 was as follows:
- PARIS® – operational.
- AVL-equipped buses – 240 with new Intelligent Vehicle Logic Units (IVLUs) installed.
- APCs – 74 installed
- PIDs – 13 installed, 7 consistently operational
- In-Vehicle signs and annunciators – 95 installed on buses, 52 operational

By this time, the VISA Cash Card demonstration had been terminated due to a lack of merchant participation and interest on the part of potential users. MARTA had disabled the VISA Cash Card system, and the three participating banks were no longer issuing the cards.

### **Project Objectives**

In addition to the APTS Program's objectives, MARTA's objectives for this project were:

- Enrich customer information and improve operations for the 1996 Olympic Games,
- Handle many customer inquiries by computer, leaving operators free to help with difficult requests and customers with special needs,
- Provide more visible and accessible information to the customer through the GDOT ATMS, (e.g., the GDOT kiosks) and direct telephone lines in rail stations,
- Improve the exchange of transportation information between MARTA, GDOT, the City of Atlanta and the five surrounding counties, and
- Test equipment that will provide MARTA dispatchers with an automatic and accurate account of all bus locations, provide MARTA with improved planning information, and allow MARTA to give real-time information to customers.

### **Geographic Information system**

The ability to display, query, and analyze information geographically on this GIS platform was used by other components of MARTA's ITS system, such as PARIS® and the CAD/AVL system.

#### *Findings*

- The MARTA planners described the GIS as a valuable tool, and anticipated using the information it provides in conjunction with schedule adherence data and passenger counts to enable more effective planning of MARTA services.
- The GIS handled data from such varied external sources as the bus stop inventory, the landmarks database, and the CAD/AVL system without difficulty.
- The biggest implementation issue related to the GIS system was gathering latitude, longitude and attribute data for each of the 10,000 bus stops served by MARTA.
- Some Customer Information Operators (CIOs) complained about the slow speed with which maps are displayed or redrawn on their screens.

### **Trip Itinerary Planning System**

MARTA's Customer Information Operators use PARIS® (Passenger Routing and Information System) to provide customers with various types of service information and trip itineraries. The Customer Information Center receives an average of several thousand telephone calls per day over 35 trunk phone lines.

PARIS® uses an automated Voice Response Unit (VRU) to maximize the productivity of CIOs. The VRU is used on the "front end" of a customer inquiry by presenting the caller with a prerecorded menu of selections. General information about fares and pass sales locations, hours of operation, how to ride the subway and buses, and other MARTA telephone numbers can be obtained from the automated system.

### *Findings*

- The integration of PARIS® with the GIS worked well.
- PARIS® has greatly enhanced the quality, timeliness and availability of customer information and allows the CIOs to spend more time talking with customers and addressing their needs than retrieving the information they request.
- Customers liked the ability to obtain walking directions, walking time, accurate schedule times, and driving instructions (to MARTA stations, for example).
- On the dates for which data was available, 15% to 17% of callers received all requested information from the VRU.
- PARIS® is not necessarily faster than the manual system, but rather it provides more consistent and reliable information to callers.
- The VRU initially installed became outdated. When the manufacturer went out of business, the equipment was no longer maintained and supported, and parts became unavailable.
- Biweekly uploads of schedule data are slow and problematic. MARTA is considering the purchase of a customer information software product from the scheduling software vendor, to achieve system integration.
- CIOs reported that the VRU was unavailable regularly and needed to be rebooted by telephone maintenance staff.
- Senior citizens in particular seem to have difficulty using the VRU.

### **Advanced Transportation Management System**

The Georgia Department of Transportation (GDOT) created a network of over 300 video surveillance cameras and radar units that monitor traffic flow and speed on the major roadways throughout the Atlanta metropolitan area.

The dispatchers at MARTA's BCC have access to the ATMS surveillance cameras, both to view the conditions that the cameras are recording, and to change the cameras' positions to view areas that are of interest to MARTA's operations.

The reciprocal side of this arrangement is that the TMC receives information from MARTA's Bus Communication Center (BCC) personnel who have access to the CAD/AVL system.

### *Findings*

- MARTA dispatchers indicated satisfaction with the ability to obtain information about traffic conditions around the metropolitan road network. The information is

helpful to them in dealing with bus operations that are affected by general traffic conditions.

## **Computer-Aided Dispatch/Automatic Vehicle Location System**

The CAD/AVL system allows the BCC to receive and display accurate vehicle locations for AVL-equipped vehicles. In addition, the CAD/AVL system provides essential bus location information to two other components of the MARTA ITS system: the on-board electronic signs and annunciators, and the wayside passenger information devices.

### *Findings*

- MARTA's test of CAD/AVL equipment that provides dispatchers with an automatic and accurate account of all bus locations and provides planners with improved information has been a success, as evidenced by MARTA's current plan to expand the CAD/AVL system to its entire bus fleet.
- Drivers see the recording abilities of the CAD/AVL system as an important enhancement.
- Street supervisors like the ability to pinpoint the exact location of buses.
- The planning staff indicated that they like the playback feature of the CAD/AVL system.
- In the event of an emergency, knowing the exact location of a bus and having the covert microphone are distinct advantages to dispatchers and emergency response personnel.
- The bus operators find it helpful to see an indication that they are running late displayed on the TCH.
- Operators can send canned messages back to the BCC, reducing the amount of voice traffic.
- Customers can now be provided with stop announcements on-board some vehicles and schedule adherence information in some stations and at a few bus stops.
- Data from MARTA's AVL system is not presently being used to adjust on-street operations. To do so would require more BCC personnel.
- Significantly more time is required to maintain an AVL-equipped bus than a regular bus because of the added electronic components and their complexity. One extra maintenance staff person is dedicated to each garage.
- One of the problems with the CAD/AVL system is the amount of effort that is involved in coordinating the real-time data that it produces with the scheduling data that is produced by the scheduling software.

- Some garage supervisors and bus operators thought the system was sometimes slow in processing their requests to the BCC or in providing information to the drivers.
- AVL information is used only to a limited degree by planning staff to make adjustments to routes and/or schedules mainly because only 240 out of 700 buses are equipped with AVL.
- MARTA's Communications and Faregates department estimates it cost approximately \$27,000 per bus to fully equip it with all ITS MARTA '96 features.

### **In-Vehicle Annunciators and Electronic Signs**

ITS MARTA '96 included a combination of light emitting diode (LED) signs and audio annunciators on-board buses to make passengers aware of upcoming stops, landmarks, and major intersections.

Annunciator/sign systems were installed on about 95 AVL-equipped buses. Each bus was outfitted with two signs. Announcements are triggered by latitude/longitude information from the intelligent vehicle logic unit (IVLU).

#### *Findings*

- Bus operators preferred the automated stop and intersection announcements to making announcements themselves over the vehicle's PA system.
- The announcements identify the connections with other routes that can be made at each stop, which passengers find useful.
- In-Vehicle signs and annunciators provide access to information about upcoming stops and other locations to passengers with hearing and/or visual impairments.
- MARTA currently pays a flat rate of \$500 for each annunciator unit that requires repairs by the manufacturer. Other variable costs include the four new staff positions for maintaining the database of bus stops, timepoints, announcement points, and landmarks, and one staff position for updating announcements and preparing master PCMCIA cards.
- Supervisors noted that annunciators do not always announce stops when they are supposed to. This may be due to occasional errors in the stop/announcement data stored on the vehicle's PCMCIA card, or if the bus detours 400-500 feet away from the stop.
- Announcing stops requires extensive data about stops and other items, which is time-consuming to collect and keep current. MARTA staff feels that an update will be needed once every year or two in order to maintain the accuracy of the database.



## **Automatic Passenger Counter System**

The APC units installed by MARTA on some of its AVL-equipped buses count the number of passengers boarding and exiting at each stop and tag this information by location (from the AVL system) and time of day.

MARTA originally installed 15 APCs on buses equipped with AVL, but later purchased and installed 60 additional units. Forty more APCs will be added as part of the purchase of smaller buses currently in process.

APC buses are assigned to routes as required to collect the data needed by the service monitoring group to comply with the National Transit Database reporting requirements, or as requested by the planning and scheduling departments to support analysis of a particular route's performance.

### *Findings*

- The transfer of APC data via radio to the AVL server used about 64% of the data communications channel capacity. Alternative methods of transferring data are now being analyzed.
- MARTA staff feel that the APC data is about 80 to 85% accurate, and that the data available from the APCs is much better than the information that was previously available. MARTA planning staff noted that there is a learning curve associated with recognizing accurate versus inaccurate APC data.
- Maintenance department managers reported that the APC units are currently the greatest ITS equipment maintenance problem.
- The number of traffic checker positions has been reduced from a high of 19 to the current 9 positions.
- One analyst position has been added since the APCs went into operation.
- MARTA planning staff use APC data to see if there is potential for eliminating a route segment. APC data are also used to evaluate the need to move or add a bus shelter.
- MARTA staff reported that having ridership data available in an electronic format is a huge benefit in terms of staff time. The quantity and timeliness of available data are also viewed as significant advantages.
- Use of APCs to collect ridership information provides MARTA with improved data for service planning. More routes can be checked more quickly and more frequently using the APCs than by traffic checkers. While the current process for manipulating the APC data can be cumbersome, a permanent solution is being developed by MARTA's ITS Project Team.

- APC data was used to evaluate the performance of individual routes in MARTA's Comprehensive Bus Study. The first schedule changes recommended in the study, which were implemented in December 1998, resulted in net operating cost savings of approximately \$1.5 million.

### **Wayside Passenger Information Devices**

ITS MARTA '96 involved the installation of monitors or LED signs in bus bays at selected stations and at a few bus stops. The PIDs have the capability to display schedule and expected departure times of the buses.

#### *Findings*

- As of March 1999, only 7 of the 15 PIDs were consistently operational. Problems had been experienced with the others due to their locations, the difficulty of reaching them to perform maintenance, or their power supplies. For these reasons, the impact they have had on the riding public is very small.
- Identifiable variable costs associated with the PIDS consist of a monthly operating expense, primarily the cost of power and phone lines, of about \$108 per PID.

### **Passenger Information Kiosks**

Fiber optic links were established between MARTA's ITS system and Georgia's statewide network of electronic information kiosks. Thirty-nine of the kiosks are located in MARTA rail stations. In addition to MARTA information, the kiosks provide access to traffic information from the GDOT ATMS as well as weather reports, airline schedules, and other information of interest to visitors.

#### *Findings*

- The MARTA bus and rail information provided to travelers through the GDOT electronic kiosks was not as extensive as originally envisioned. The trip itinerary planning function of PARIS® was not used by the MARTA Customer Information Center during the Olympics, due to the time constraints imposed on the PARIS® implementation.
- Following the Olympics, the software in the GDOT kiosks was rewritten to provide bus and rail information and limited itinerary planning (for example, from an origin to a major landmark, or between landmarks) by means of access to MARTA's Internet site.

### **Smart Card Fare Payment System**

In 1995, Visa International, in cooperation with three local Atlanta banks, initiated a VISA CASH smart card pilot program. In conjunction with the Olympic Games, this

program was developed to test a stored-value contact smart card in a multiple-use setting (e.g., transit, food, gasoline and other merchants). Two faregates at each entrance to MARTA's 36 rail stations were retrofitted to accept the VISA CASH card, at no expense to MARTA. Cards could be purchased from card vending machines in MARTA rail stations and at almost 500 other locations at the time of the Olympics, making it very convenient to purchase and use.

While the MARTA pilot officially ended in December 1996, MARTA continued to accept the VISA CASH cards through 1997. However, currently, the banks are not issuing the cards, merchants are not accepting the cards, and MARTA has removed the card accepting devices.

### *Findings*

- A survey revealed that: 84% of those who used the card said they were satisfied or very satisfied with it; 28% of card users said that a major benefit was avoiding the need to carry cash; and 24% said that a major benefit was avoiding the need to count out change.
- Between May and December 1996, the card accepting devices were 99.66% reliable.
- It took 1.75 seconds to process the VISA CASH card.
- The major negative comment of cardholders was the lack of merchants that accepted the cards.
- The one significant problem during the initial implementation of the pilot program was that customers were inserting coins and tokens in the slots intended for the CASH cards. This problem was solved by modifying the slots and posting additional signage describing how to use the VISA CASH card in these faregates.
- The amount of revenue collected from the CASH cards at MARTA was only 0.02% in Fiscal Year 1996 and 0.27% in Fiscal Year 1997. Reasons for low utilization include: the card supported no fare discount program; the smallest denominated card that could be purchased in a MARTA rail station was \$20; and card expiration was within a short time after purchase.
- Although VISA absorbed much of the costs of the pilot program, MARTA casts included: a transaction fee to the bank for each smart card transaction (this fee was negotiated to approximately 2%); a bank account fee; communication lines between faregates and station telephone rooms; and removing and replacing failed card accepting devices.
- Despite the low utilization, this program prompted MARTA to consider a full-scale smart card fare payment system for the future.

## **ITS System Costs**

MARTA staff estimates that the total cost of developing and implementing its ITS system, from initial efforts in 1996 until July 1998 (the end of Phase I of the project), amounted to approximately \$20 million.

## **Lessons Learned**

- MARTA's experience indicates the importance of adequate time for careful planning and development of ITS systems and for deployment of those systems in an transit operating environment.
- Complete installation of ITS technologies would be of more practical use than partial implementation at a transit system.
- Daily users should be involved at the outset of the ITS development/deployment process.
- New technologies may require the addition of personnel, or enhanced capabilities, to the transit agency's staff.
- One of the biggest problems encountered with the introduction of these technologies is the person/equipment interface.
- Organizational change is a significant challenge presented by the adoption of advanced technologies.
- The commitment of the agency's management at the highest level is critical.
- Implementation of ITS technologies takes time, and is an ongoing process.
- Benefits of implementing ITS technologies may not be realized immediately.
- Technological issues include compatibility and integration of ITS hardware and software components with each other and with existing agency systems. Integration of major components is a key factor in the success of an ITS installation.
- ITS applications do not always reduce the amount of time needed to perform functions, but they usually provide more and better information for decision-making.

# Section 1

## Project Background

### 1.1 Introduction

The Metropolitan Atlanta Rapid Transit Authority (MARTA) implemented components of an Advanced Public Transportation System (APTS) as part of a showcase of current Intelligent Transportation Systems (ITS) technologies deployed for the 1996 Summer Olympic Games. Following the conclusion of the Olympic Games, MARTA completed the implementation of its APTS, made refinements to the system, and began to employ the various technologies in its daily, post-Olympics operations.

The Federal Transit Administration (FTA) requested that the Volpe National Transportation Systems Center (VNTSC) evaluate the MARTA ITS project within the framework of the national APTS program. The FTA was interested in learning how well the APTS technologies worked and whether they improved transit service and facilitated the travel of residents and the large number of Olympic visitors during the period of the Games. However, due to the funding limitation and the very short time frame for development and implementation, only a portion of the MARTA fleet could be equipped with APTS technologies and most of the technologies were only partially functioning during the Games. Consequently, the evaluation period was extended to the time when the APTS technologies were functioning successfully. It must be noted that none of the borrowed buses that were used to take spectators to the event venues were equipped with APTS technologies.

The VNTSC selected Multisystems, Inc., to perform the evaluation. Multisystems developed an evaluation plan that was consistent with the *Advanced Public Transportation Systems: Evaluation Guidelines*, produced by VNTSC for FTA.<sup>1</sup> To collect the data identified in the evaluation plan, Multisystems staff made several site visits to Atlanta and conducted numerous interviews with key managers and staff of MARTA and its ITS contractors between 1996 and 1999. This report summarizes the findings from those site visits regarding MARTA's experiences with the implementation of new technologies, and offers guidance to other organizations that are contemplating or planning for the adoption of similar technologies, based on the MARTA experience. Unfortunately, the impact of the APTS technologies was severely restricted because of the limited number of the various technologies deployed. Consequently, the evaluation became much more qualitative than quantitative and focused on discussing how well the various technologies worked rather than their impact on travel in the region.

This report is organized as follows. The remainder of this section briefly describes the characteristics of MARTA's service and several key factors that influenced the implementation of ITS technologies by the Authority, as well as the elements of MARTA's ITS system. Section 2 summarizes national and local objectives for the ITS

---

<sup>1</sup> Robert F. Casey and John Collura, U.S. Department of Transportation Research and Special Programs Administration, January 1994.

implementation and describes the approach taken to evaluating the project. Sections 3 through 11 describe each ITS component in more detail, and compare the results of the implementation of each component to the national and local objectives identified in the project evaluation plan. Section 12 discusses the financial aspects of MARTA's ITS system. Section 13 presents a brief summary of the status and benefits to date of each of the ITS technologies used by MARTA. Section 14 contains general conclusions and describes the lessons learned from the MARTA's ITS project experience. A glossary of terms is provided in Appendix A. Appendix B contains schedules of the interviews conducted with MARTA staff, and questions used during those interviews.

## **1.2 Transit Service**

MARTA provides bus and heavy rail service in Atlanta and surrounding Fulton County, as well as in neighboring DeKalb County. A total population of 1,316,700 resides in this service area, which encompasses 805 square miles. The Authority operates 160 bus routes over roughly 1,500 route miles with a fleet of more than 700 vehicles. The rail system is 39 miles in length and serves 38 stations (2 of which will open in 2000) with a total of 240 rail cars.

Fixed route service is available between 5:00 AM and approximately 1:30 AM on weekdays, and between approximately 5:30 AM and 12:30 AM on weekends and holidays. The rail service operates on 8-minute headways during the day on weekdays (four minutes between Lindbergh and Airport Stations), 10-minute headways in the evening and on Saturdays, and 15 minutes on Sundays. Bus headways vary considerably: 8 to 35 minutes during peak hours, 15 to 70 minutes during the midday, and 12 to 100 minutes in the evening. Weekend headways range from 17 to 80 minutes.

In addition to fixed route service, MARTA operates American with Disabilities Act (ADA) complementary paratransit service for riders who are unable to use a fixed route bus due to a disability. Curb-to-curb service is provided within  $\frac{3}{4}$  of a mile of bus routes and rail stations, using a fleet of approximately 100 vehicles equipped with wheelchair lifts. Service for seniors is provided through MARTA's E-bus program. Special routes are established upon request to serve locations where 25 or more seniors gather (such as apartment complexes or senior centers) with lift-equipped buses.

MARTA offers a variety of fare options to its bus riders. A single fare is \$1.50, payable in cash or with a single token (transfers are free). Tokens sold in rolls of 10 and 20 cost \$15 and \$25, respectively. Weekly "Transcards" are available for \$12; a monthly Transcard costs \$45. Student, weekend, and visitor passes are also available. A monthly parking permit for parking at the Lindbergh and Lenox stations is \$15. The single-ride fare for reduced fare riders (seniors, persons with disabilities) is \$.75. The one-way fare on the paratransit system is \$3.00. The one-way E-bus fare (not subject to half-fare discounts), is \$1.50 per person.

In 1997, MARTA operated approximately 31 million vehicle-miles of bus service and 28 million vehicle-miles of rail service. Ridership in 1997 totaled 79 million one-way passenger trips on MARTA's bus routes, and 91 million on the rail system.

### **1.3 Local Issues and External Influences**

Certain local issues and external influences had an effect on both the results and the evaluation of the MARTA ITS '96 project. The most important issue affecting both the project itself and the evaluation was the Summer Olympics, both the logistics of providing service during the Games and the need to interface with other Olympics-related technological transportation initiatives.

The service requirements for this period created a unique situation, one in which MARTA carried more than 25 million passengers in the seventeen day period from July 19<sup>th</sup> through August 4<sup>th</sup> – an average of nearly 1.5 million riders per day, as compared to roughly 219,000 per day normally. Besides the greater number of visitors concentrated in a few areas, certain sections of downtown Atlanta were closed to auto traffic, while some roads had restricted access. MARTA used more than 1,500 additional buses supplied by other public and private transportation providers during this period. Moreover, many MARTA planning and administrative staff persons were pressed into on-street or other operationally oriented service, so that no staff members were available to assist in any data collection or other evaluation activity during the Olympics.

Thus, the MARTA staff leading the ITS project felt that (1) the Olympics would not represent a realistic test of the ITS technologies being implemented, and (2) it would be very difficult to conduct any type of evaluation activities during the Olympics.

The other issues raised by the Olympics were that (1) MARTA's ITS project was intended to interface with another local ITS element, the Georgia Department of Transportation (GDOT) Advanced Transportation Management System (ATMS) project;<sup>2</sup> and (2) several other transportation-related technology initiatives were being implemented at the same time as the ITS projects. First, GDOT's Traveler Information Showcase (TIS), which made transportation information available to the public through a system of kiosks, included a MARTA component. In addition, MARTA was involved in other projects of its own, including the acquisition of compressed natural gas (CNG) buses and a joint automated fare payment pilot project with VISA International and three banks (NationsBank, First Union, and Wachovia). In the latter effort, VISA installed "smart card" readers in MARTA's rail stations, so that riders were able to use VISA's new prepaid "cash card" (stored value) for fare payment. (As the card was used to ride transit – or to make a purchase from a participating vendor – the amount spent was deducted from the card.) The simultaneous implementation of all of these projects complicated the evaluation of the MARTA ITS '96 project, in that it was difficult in some cases to isolate the costs and benefits of the elements of the ITS project from the other technological improvements.

### **1.4 Description of Project Components**

MARTA's original APTS, known locally as "ITS MARTA '96", was composed of a number of elements, grouped into two "systems":

---

<sup>2</sup> This project is being evaluated separately by the Federal Highway Administration (FHWA).

## **Base System**

- Base Geographic Information System (GIS), showing bus stop locations, roadways, and over 2,500 local landmarks
- Trip Itinerary Planning System (TIPS, also referred to by its brand name, PARIS®), to enable MARTA customer information operators to produce detailed travel itinerary plans for riders electronically
- Integration with the GDOT ATMS, involving the provision of transit information through various devices

## **Real-time Information System**

- Computer-Aided Dispatch/Automatic Vehicle Location (CAD/AVL) System installed in 240 buses (out of 700 buses)
- Wayside Passenger Information Devices (PIDs), to provide schedule and real-time status information at 13 bus bays or stops
- In-Vehicle Annunciators and Electronic Signs, installed in 100 of the 240 buses equipped with AVL
- Automatic Passenger Counters (APCs), installed on 15 of the 100 buses equipped with stop annunciators

A diagram illustrating the relationships between the components of MARTA's ITS project is shown in Figure 1.

The prime contractor (i.e., systems integrator) for the Base System was TRW. Transportation Management Solutions (TMS) was the prime contractor for the Real-time Information System. TRW and TMS were responsible for implementation and coordination of the two systems, as each company had several subcontractors providing individual project components. ITS MARTA '96 was administered by MARTA, although, as indicated above, it was integrated with the ATMS being developed for GDOT. Parsons Brinckerhoff/Tudor assisted MARTA in managing the ITS project.

## **1.5 Project Schedule**

MARTA has been involved with the deployment of ITS technologies for several years, beginning with the 1996 Summer Olympic Games. Activities undertaken by MARTA between 1996 and 1999 are described in the following sections.

### **1.5.1 MARTA ITS Activities Prior to the 1996 Summer Olympic Games**

The schedule for the MARTA ITS project called for all elements to be fully operational prior to the beginning of the Olympic Games on July 19, 1996. Table 1 shows the status of the installation of some of the elements of ITS MARTA '96 as of March 20, 1996.



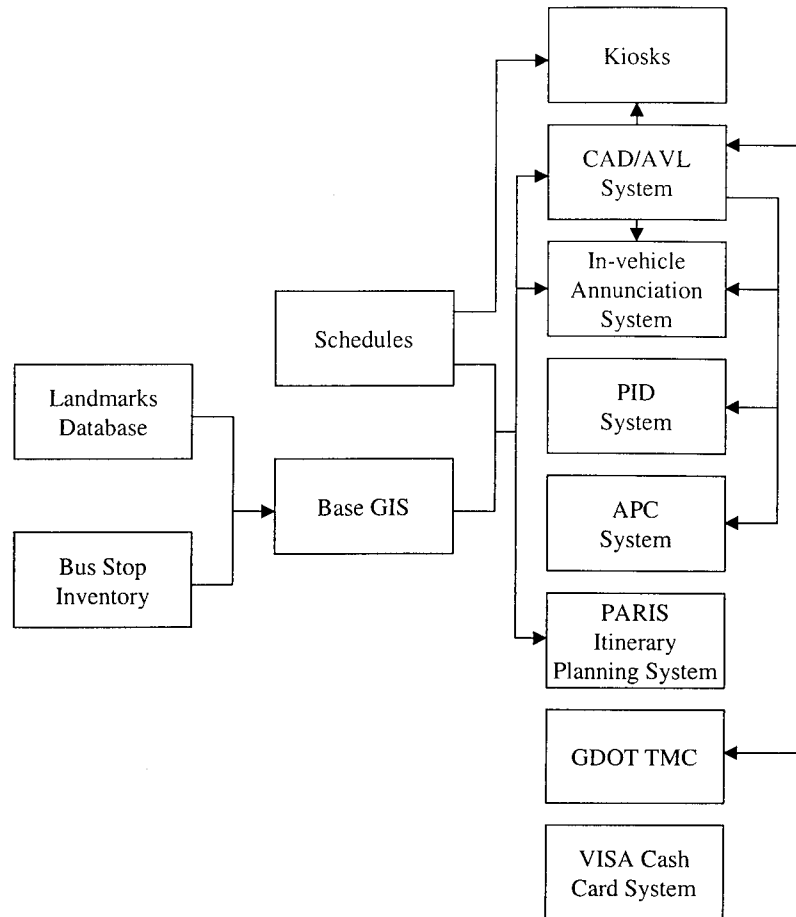

**Figure 1. Relationships Among ITS MARTA Components**

The implementation of the VISA CASH card as a fare payment alternative on MARTA's rail system was not officially part of the ITS MARTA '96 project (the pilot was totally funded by VISA). However, this test of advanced electronic fare payment technology was included in the Evaluation Plan for the MARTA ITS System.

ITS components that were installed and in use at the time of the Olympics included the following:

- PARIS®
- 15 APCs
- About 150 buses outfitted with AVL
- PIDs
- VISA CASH card fare payment pilot test
- Traveler information kiosks

No on-board signs or annunciators were operational during the Olympics, and although PARIS® was used to respond to some customer inquiries, it was not used to generate itineraries at that time.

**Table 1. Status of ITS MARTA '96 as of March 20, 1996**

ELEMENT	STATUS AS OF MARCH 20, 1996
CAD/AVL Implementation	79 MARTA buses outfitted and being tracked by software 53 additional MARTA buses to be outfitted 118 new CNG buses (to be delivered at end of May 1996) to be outfitted
APC System	5 MARTA buses to be equipped 15 new buses to be equipped
In-Vehicle Annunciators and Electronic Signs	21 MARTA buses to be equipped beginning in April 1996 79 new buses to be equipped
Wayside Passenger Information Signs	15 monitors on order
PARIS®	In operation for some routes
VISA CASH Card	Installation in progress in rail stations Completion of installation expected by mid-April 1996 System testing expected in April and May

**1.5.2 MARTA ITS Activities Following the Olympics**

Between the conclusion of the Olympics and the evaluation contractor's site visit in December 1997, MARTA continued with the installation, testing, and enhancement of its ITS system. These activities included the following:

- An additional 60 APCs were acquired, and 44 installed (for a total of 59 installed as of this date).
- AVL equipment was installed on a total of 240 buses.
- Activities with regard to the PARIS® Trip Itinerary Planning System included debugging, identifying data accuracy problems, and enhancing the functionality and reporting capability of the system.
- Efforts were also made to debug and identify and correct data accuracy problems with the AVL system.
- On-board signs and annunciators were still under development.
- The VISA CASH card fare payment pilot program was extended for 1 year beyond the original completion date of September 30, 1996.

During this period, the position of ITS Project Manager within MARTA was held by several different individuals. However, TRW and TMS were still involved in assisting MARTA with the ITS project management.

By the time of the evaluation contractor's last site visit in March 1999, MARTA had reorganized the management of its ITS systems. An ITS Steering Committee was established to make recommendations to the MARTA Chief Executive Officer (CEO) Team about the development of ITS capabilities within the organization. Steering Committee members include representatives of MARTA's Information Technology, Marketing, Facilities Maintenance, Operations and Customer Development departments.

The contracts between MARTA and its ITS vendors, TRW and TMS, expired in September 1998. MARTA then brought in a new ITS project team to focus on stabilization of the ITS systems and Y2K compliance in the short term, and to provide systems support in the future.

As a result of this reorganization, the MARTA ITS Project Manager became responsible for functional aspects of the systems and dealings with the MARTA user community, while the ITS Technical Project Manager became responsible for technical aspects and coordination with vendors. Both positions report directly to MARTA's Vice President for Information Technology.

In order to stabilize MARTA's ITS systems, the new ITS Project Team installed two larger servers with an updated operating system. At the time of the last site visit, ITS databases were being moved onto them. An additional server was installed to store a data warehouse that is now providing ITS information and reports to MARTA staff through an Intranet browser.

Installation of the new operating system ensured Y2K compliance. However, the ITS applications required various modifications in order to function with the new operating system. Y2K compliance with regard to equipment used in some of the ITS systems, such as radios and global positioning system (GPS) receivers in the AVL-equipped buses, was another issue that the ITS Project Team was engaged in addressing.

The ITS Project Team was also providing a single point of contact with outside vendors who are responsible for supporting the various ITS applications.

The status of MARTA's ITS components as of March 1999 was as follows:

- PARIS® – operational. Modifications had been made to address problems identified during the December 1997 visit.
- AVL-equipped buses – 240 (no change); new Intelligent Vehicle Logic Units (IVLUs) had been installed.
- APCs – 74 installed
- PIDs – 13 installed, and 7 consistently operational; 2 spares
- In-Vehicle signs and annunciators – 95 installed on buses and 52 operational

By this time, the VISA CASH card demonstration had been terminated due to a lack of merchant participation and interest on the part of potential users. MARTA had disabled the card-accepting devices on the rail station fare gates, and the three participating banks were no longer issuing the cards.

## Section 2 Evaluation Overview

### 2.1 Project Objectives

This evaluation was performed within the context of the goals and objectives of the FTA's national APTS program. This evaluation also considered the more specific goals and objectives developed by MARTA for the operational test.

The APTS Program objectives, and sub-objectives, are listed below. Because this project incorporates multiple elements, it relates to many of these objectives. Those objectives which are most directly applicable to this project are in bold, while other applicable objectives are in italics.

#### *Objective #1: Enhance quality of on-street service to customers*

- Increase the quality, timeliness and availability of customer information
- Increase the convenience of fare payments within and between modes
- Improve safety and security
- Reduce passenger travel times
- Enhance opportunities for customer feedback

#### *Objective #2: Improve system productivity and job satisfaction*

- Reduce transit system costs
- Improve schedule adherence and incident response
- Improve the usefulness of data for service planning and scheduling
- Enhance the response to vehicle and facility failures
- Provide integrated information management systems and develop improved management practices
- Reduce worker stress and increase job satisfaction

#### *Objective #3: Enhance the contribution of public transportation systems to overall community goals*

- Facilitate the ability to provide discounted fares to special user groups (e.g., individuals with disabilities or employees eligible for tax-free employer subsidies)
- Improve communication with users having disabilities (e.g., visual or hearing impairments)
- Enhance the mobility of users with ambulatory disabilities

- Increase the extent, scope and effectiveness of transportation demand management programs
- Increase the utilization of high occupancy vehicles, with an emphasis on reducing the use of single occupant vehicles
- Assist in achieving regional air quality goals and mandates established in the Clean Air Act Amendments and the Intermodal Surface Transportation Efficiency Act.

*Objective #4: Expand the knowledge base of professionals concerned with APTS innovations*

- Conduct thorough evaluations of operational tests
- Develop an effective information dissemination process
- Showcase successful APTS innovations in model operational tests
- Assist with system design and integration

In MARTA's Project Justification for MARTA ITS '96, MARTA described some objectives for this project. These are:

- Enrich customer information and improve operations for the 1996 Olympic Games
- Handle many customer inquiries by computer, leaving operators free to help with difficult requests and customers with special needs
- Provide more visible and accessible information to the customer through the GDOT ATMS, (e.g., the GDOT kiosks) and direct telephone lines in rail stations
- Improve the exchange of transportation information between MARTA, GDOT, the City of Atlanta and the five surrounding counties
- Test equipment that will provide MARTA dispatchers with an automatic and accurate account of all bus locations, provide MARTA with improved planning information, and allow MARTA to give real-time information to customers.

Table 2 identifies the relationship between the specific elements of MARTA ITS '96 and the most relevant federal sub-objectives.

**Table 2. MARTA ITS '96 Elements and Federal Objectives**

<b>MARTA ITS '96 Elements</b>	<b>Federal Objectives and Sub-objectives</b>
Base GIS	<p><i>Improve system productivity and job satisfaction:</i></p> <ul style="list-style-type: none"> <li>• Improve schedule adherence and incident response</li> <li>• Improve the usefulness of data for service planning and scheduling</li> <li>• Provide integrated information management systems and develop improved management practices</li> <li>• Reduce worker stress and increase job satisfaction</li> </ul>
PARIS®	<p><i>Enhance quality of on-street service to customers:</i></p> <ul style="list-style-type: none"> <li>• Increase the quality, timeliness and availability of customer information</li> <li>• Improve safety and security</li> <li>• Reduce passenger travel times</li> </ul> <p><i>Improve system productivity and job satisfaction:</i></p> <ul style="list-style-type: none"> <li>• Provide integrated information management systems and develop improved management practices</li> <li>• Reduce worker stress and increase job satisfaction</li> </ul> <p><i>Enhance the contribution of public transportation systems to overall community goals:</i></p> <ul style="list-style-type: none"> <li>• Improve communication with users having disabilities</li> </ul> <p>Increase the utilization of high occupancy vehicles, with an emphasis on reducing the use of single occupant vehicles</p>

**Table 2. MARTA ITS '96 Elements and Federal Objectives (cont.)**

<b>MARTA ITS '96 Elements</b>	<b>Federal Objectives and Sub-objectives</b>
Integration with the GDOT ATMS	<p><i>Enhance quality of on-street service to customers:</i></p> <ul style="list-style-type: none"> <li>• Increase the quality, timeliness and availability of customer information</li> <li>• Improve safety and security</li> <li>• Reduce passenger travel times</li> </ul> <p><i>Improve system productivity and job satisfaction:</i></p> <ul style="list-style-type: none"> <li>• Improve schedule adherence and incident response</li> <li>• Improve the usefulness of data for service planning and scheduling</li> <li>• Provide integrated information management systems and develop improved management practices</li> <li>• Enhance the response to vehicle and facility failures</li> </ul> <p><i>Enhance the contribution of public transportation systems to overall community goals:</i></p> <ul style="list-style-type: none"> <li>• Improve communication with users having disabilities (e.g., visual or hearing impairments)</li> <li>• Increase the utilization of high occupancy vehicles, with an emphasis on reducing the use of single occupant vehicles</li> </ul>
CAD/AVL System	<p><i>Enhance quality of on-street service to customers:</i></p> <ul style="list-style-type: none"> <li>• Improve safety and security</li> </ul> <p><i>Improve system productivity and job satisfaction:</i></p> <ul style="list-style-type: none"> <li>• Improve schedule adherence and incident response</li> <li>• Improve the usefulness of data for service planning and scheduling</li> <li>• Enhance the response to vehicle and facility failures</li> <li>• Provide integrated information management systems and develop improved management practices</li> <li>• Reduce worker stress and increase job satisfaction</li> </ul>
In-Vehicle Annunciators & Electronic Signs	<p><i>Enhance quality of on-street service to customers:</i></p> <ul style="list-style-type: none"> <li>• Increase the quality, timeliness and availability of customer information</li> <li>• Improve safety and security</li> </ul> <p><i>Enhance the contribution of public transportation systems to overall community goals:</i></p> <ul style="list-style-type: none"> <li>• Improve communication with users having disabilities</li> </ul>



**Table 2. MARTA ITS '96 Elements and Federal Objectives (cont.)**

MARTA ITS '96 Elements	Federal Objectives and Sub-objectives
APCs	<p><i>Improve system productivity and job satisfaction:</i></p> <ul style="list-style-type: none"> <li>• Improve the usefulness of data for service planning and scheduling</li> <li>• Provide integrated information management systems and develop improved management practices</li> </ul>
Wayside Passenger Information Signs	<p><i>Enhance quality of on-street service to customers:</i></p> <ul style="list-style-type: none"> <li>• Increase the quality, timeliness and availability of customer information</li> <li>• Improve safety and security</li> </ul>

## 2.2 Evaluation Approach

As mentioned above, Multisystems developed a plan for evaluating the MARTA ITS project in accordance with guidelines issued by VNTSC for the evaluation of ITS systems in the context of the national APTS program.

The plan contained a series of test plans, each addressing a specific system or technology, using the evaluation categories outlined in the VNTSC guidelines. Each test plan identified specific Measures of Effectiveness (MOEs), and described how the data required to evaluate the MOEs were to be collected and analyzed.

The multiple elements included in the MARTA ITS '96 project, as well as the broad range of national objectives relating to this project, called for a comprehensive evaluation. However, the resources available for the evaluation were limited, no local evaluation was planned, and there were tight budgetary constraints. The general evaluation approach was, therefore, to concentrate on measures where the data (1) had been already collected by MARTA or the contractors, (2) could be collected by interviewing MARTA personnel and a limited number of other specific individuals in the Atlanta area (e.g., GDOT and/or contractor personnel), or (3) could be obtained by direct observation by the evaluators. Moreover, the evaluation was focused on examining how elements of the project relate to the most relevant Federal and local objectives.

In addition, while the functioning of the MARTA ITS '96 systems during the Olympics was of interest to the FTA, the demands of operating during the Olympics prevented MARTA from being able to assist with the evaluation during this period. Furthermore, the demands on MARTA and the lack of reasonably priced hotel space made it impossible for the national evaluators to observe the functioning of the system during the Olympics. Therefore, virtually the only data available during the Games was ridership, which, not surprisingly, rose substantially. However, since most of the APTS technologies were not fully operational, the fact that little data was available during this period was practically inconsequential to the evaluation. As previously mentioned, all

the elements of the MARTA ITS '96 were operational after the Olympics, so evaluation activities continued after the Olympics concluded.

As of December 1997, several of the major ITS components, including PARIS® and the CAD/AVL system, were still undergoing testing and modification, and others had not yet been installed. As a result, the evaluation period was extended to allow MARTA to complete the process of installing and testing components and develop experience with the use of the ITS systems.

The evaluation team made site visits to Atlanta in March 1996, December 1997, and March 1999. During these visits, the evaluators were briefed on the status of MARTA's ITS deployment, and conducted numerous interviews with MARTA staff.

This evaluation relies on the perceptions of MARTA, GDOT and contractor personnel, rather than formal before and after tests, to (1) identify the functional characteristics (such as adherence to specifications, accuracy, reliability, ease of use, response time, and the ability to handle external data), and (2) measure the effectiveness of the ITS technologies being evaluated. As a result, much of the analysis presented herein is qualitative, rather than quantitative, in nature. The primary objective of the evaluation is to provide information about the lessons learned by MARTA that will be helpful to other organizations that may be considering or planning for the implementation of ITS technologies.

Each section of this report deals with a specific component of MARTA's ITS system. Most sections are organized in a similar fashion, presenting information that describes the component and its place in the ITS system, implementation issues associated with the component that may be of interest to other organizations, and the findings of the evaluation team with regard to the measures used to judge how well the component achieves national and local objectives.

The sections that deal with the wayside passenger information devices and the traveler information kiosks installed by GDOT are somewhat different. At the time that this report was prepared, little data about the PIDs that had been installed was readily available. Consequently, the section of the evaluation concerned with these devices is briefer than those dealing with other ITS components, and describes, rather than evaluates, MARTA's experience with them. While GDOT's traveler information kiosks were not developed or purchased by MARTA as part of ITS MARTA '96, a brief description of the kiosks is included because of their role in assisting travelers during the Olympics and their interaction with MARTA's ITS system.

## Section 3

### Base Geographic Information System

#### 3.1 Description and Relation to Other ITS Components

The Base Geographic Information System (GIS) used by MARTA's ITS system is a software tool that provides both data management and automated mapping capabilities. The GIS links information about the location and characteristics of MARTA's bus routes and rail network (including stops and stations) and major landmarks to a base map of the metropolitan Atlanta area. The ability to display, query, and analyze information geographically on this GIS platform is used by other components of MARTA's ITS system, such as the automated itinerary planning system (known as PARIS®) described in Section 4 and the computer-aided dispatch/automatic vehicle location system discussed in Section 6.

The locations of 2,500 schools, cultural centers, parks, apartment complexes, restaurants, and transportation centers, and a detailed inventory of 10,000 bus stops that includes location and a description of accessibility characteristics and other attributes, comprise the data that is an integral part of the GIS. This information is combined with the GIS base map and bus and rail schedule data generated by MARTA's automated fixed route scheduling system in a relational database management system (RDBMS) so that it can be transferred to PARIS® and the CAD/AVL system.

PARIS® uses the latitude and longitude of origins and destinations from the GIS to calculate itinerary solutions. The mapping capability of the GIS, together with information in the bus stop inventory, allows MARTA's Customer Information Operators (CIOs) to view itineraries on electronic map displays, and to print copies of the maps for customers.

The CAD/AVL system uses latitudes and longitudes to track CAD/AVL-equipped buses and compare the real-time locations to the scheduled locations. Bus dispatchers in MARTA's Bus Communication Center (BCC) are able to view map displays of actual bus locations with the mapping capability of the GIS. (See Figure 2 for a photo of the BCC.)

MARTA planners and schedulers have a need for GIS during the development of route schedules and patterns, but use ArcInfo, rather than the ITS Base GIS, for this purpose. A GIS Specialist in the Planning department requests necessary data (APC data by location, for example) and enters it into ArcInfo for use by the planning staff. Since the two systems now share the same, updated base map, the use of different GIS software within the organization does not pose any technical problems.



**Figure 2. MARTA BCC**

### **3.2 Implementation Issues**

The biggest implementation issue related to the GIS system was gathering latitude and longitude and attribute data for each of the 10,000 bus stops served by MARTA. This effort was significant, requiring temporary employees (college students) to visit every stop long enough to get a GPS reading of the latitude and longitude and to describe its physical characteristics. To complicate matters, many of these readings turned out to be inaccurate because the students were not familiar with the MARTA bus routes or the readings were taken at the wrong location. An added complication was the fact that each bus stop in each direction along a route needed to be identified in order for the bus stop inventory to be accurate enough for PARIS® to provide customers with walking directions to and from destinations.

The second issue related to the Base GIS component is that MARTA found it necessary to obtain an updated base map of the Atlanta region in order to ensure that all bus stops and other points could be located accurately on the GIS maps used by dispatchers and customer information staff.

### **3.3 Measures of Effectiveness**

User acceptance was used in this evaluation to judge how well the Base GIS achieves the objectives established by the national APTS program and MARTA.

#### ***3.3.1 User Acceptance***

Staff members of several MARTA departments utilize the Base GIS system because it is a major component of the ITS systems that they use to perform their daily job duties. All of the MARTA staff members in the BCC who utilize the CAD/AVL system and the Customer Information Center staff who use PARIS® make use of GIS data and the mapping features of the Base GIS. Other staff members who contribute to the maintenance of the Base GIS, but who devote only part of their time to this task, include planning staff, traffic checkers who verify the accuracy of bus stop information, and the staff member who maintains the bus stop inventory. The CIOs will also help maintain the GIS database by notifying the GIS Developer of any inaccuracies or new information that needs to be added to the database. The opinions of the Base GIS held by such staff members were obtained throughout the interviews conducted by the evaluation team, and are summarized below.

Further, according to MARTA's ITS Action Plan developed by the Authority's new ITS Project Team, there will be one GIS Developer to maintain and integrate the GIS system with other ITS and Authority-wide applications.

#### ***Accuracy of Data***

At the time of the evaluation team's site visit in December 1997, MARTA's CIOs indicated that they generally found the maps to be accurate, but they noted the inaccuracy of some of the landmark and bus stop inventory location information (e.g., some landmarks were not included and the locations of some bus stops were inaccurate). Planning staff reported that the base map supporting the GIS was becoming outdated, due to the rapid growth of the Atlanta metropolitan region. Bus stops in new subdivisions on streets without names, for example, could not be entered into the GIS. The purchase of an updated base map, which had taken place by the team's visit in March 1999, addressed these concerns. During the March 1999 visit, MARTA staff indicated that they rely on the GIS maps for information without reservations.

#### ***Ease of Use***

The CIOs are generally satisfied with the ease of using the Base GIS. However, some of them took issue with the speed at which maps are displayed or redrawn on their screens. This seemed too slow, and they felt that at times customers wait too long for answers to their questions. Several tests of the itinerary planning function in PARIS® by the evaluation team confirmed that maps showing routes were very slow to appear on the screen.

One project that is making the Base GIS and other ITS improvements easier for all MARTA employees to use is the new data warehouse concept that MARTA's ITS Project Team is developing. The data warehouse will serve as a central repository for

data that MARTA employees will be able to access using an Intranet browser. The Base GIS will serve as the geographic database on this central server.

### ***Ability to Handle Data from External Sources***

No issues were identified with the Base GIS' ability to handle data from external sources. It seems to utilize data from such varied external sources as the bus stop inventory, the landmarks database, and the CAD/AVL system without difficulty.

### ***Users' Perceptions of Benefits and Impacts***

The users of the Base GIS did not identify benefits specifically related to it, mainly because this system is a background component of other ITS technologies. Therefore, MARTA staff that utilize the capabilities of the Base GIS may not be aware that they are doing so. For example, the CIOs see it as an integral part of the PARIS® software package.

The MARTA planners described the Base GIS as a valuable tool, and anticipated using the information it provides in conjunction with schedule adherence data and passenger counts to do more effective planning of MARTA services. They also felt that having one GIS package would help improve data consistency among different departments within MARTA.

## **3.4 Achievement of Objectives**

One of the established objectives (system productivity and job satisfaction) applies to the Base GIS component of ITS MARTA '96.

### ***3.4.1 System Productivity and Job Satisfaction***

Because the Base GIS is a component of several ITS technologies that enable MARTA to track vehicle locations and schedule adherence, respond more quickly to incidents, and generate more useful information for planning and management purposes (through the AVL system), and to provide customer information (through PARIS®), the Base GIS contributes to the achievement of the objectives mentioned above. Interviews with MARTA staff who make use of the AVL and PARIS® systems (detailed in later sections of this report) indicated that these ITS technologies make their jobs easier. To the extent that the Base GIS is a part of these technologies, it can also be said to have a positive impact on job satisfaction.

## Section 4

### Trip Itinerary Planning System: PARIS®

#### 4.1 Description

An important component of MARTA's ITS system is an automated itinerary planning and information system called PARIS® (Passenger Routing and Information System). The staff of MARTA's Customer Information Center -- Customer Information Operators, or CIOs -- use PARIS® to provide customers with various types of service information and trip itineraries. The Customer Information Center receives an average of several thousand telephone calls per day over 35 trunk phone lines.

PARIS® uses an automated Voice Response Unit (VRU) to maximize the productivity of CIOs. The VRU is used on the "front end" of a customer inquiry by presenting the caller with a prerecorded menu of selections. General information about fares and pass sales locations, hours of operation, how to ride the subway and buses, and other MARTA telephone numbers can be obtained from the automated system. Information is available in English, French, Spanish, German, and Japanese. A caller transfers to an operator only when he/she requests an itinerary plan or selects the "Schedule and Route Information" option on the initial menu.

The PARIS® system contains a number of different "panels", or screens that are used by the CIOs to locate information requested by customers. PARIS® panels that are used to respond to customer inquiries include the following:

#### *Inquiry Panels*

- Itinerary (four panels)
- Fares
- Pass Agencies (two panels)
- Route Description (two panels)
- Stop Information (two panels)
- Route Information (two panels)
- Alternate Route Information (two panels)
- Schedule Information (three panels)
- Literature Request
- Special Events (two panels)

#### *System Text Panels*

- General Information (three panels)
- Driving Instructions (four panels)

The Route Information, Schedule Information, and Itinerary panels are used most frequently by the CIOs to respond to customer inquiries.

Other groups of panels enable MARTA personnel to maintain the PARIS® system and the data pertaining to MARTA's services and facilities.

In order to receive an itinerary, the customer must specify an origin and a destination. The CIO then enters customer preferences such as:

- Departure and/or arrival time
- Mode of travel (bus only, rail only, or combination. Since the MARTA bus system is designed to provide feeder service to the rail system, nearly all trips involve both modes)
- Accessibility (access for persons with disabilities or elderly riders)
- Safety concerns (lighted facilities if traveling at night)
- Minimal wait time

PARIS® uses the customer's preferences and optimization factors selected by MARTA (such as maximum distance from a stop to an origin or destination, minimum time between a customer's preferred arrival/departure time and alighting/boarding, maximum number of transfers) in combination with the schedule database and bus stop inventory to identify several itinerary choices.

PARIS® allows the CIOs to enter origins and destinations as a street address, intersection, or a landmark. Based on the inputs provided by the customer, PARIS® processes several possible itinerary solutions. The CIO selects the preferred solution based on a short discussion with the customer. The CIO then has the choice of conveying the information directly to the caller, sending the information to the VRU to automatically relay the itinerary to the customer over the phone line (in the customer's chosen language), or faxing a text version. The VRU "back end" assistance and faxing option allow the operator to take another call immediately, resulting in improved efficiency.

PARIS® also includes dedicated telephone lines from rail stations into the Customer Information Center, so that passengers at a station can pick up the telephone receiver in order to be connected with a CIO.

PARIS® implementation began in June 1995. The system first went into operation around June 1996, just before the Olympics. During the Olympics, the system was used to provide route and schedule information to callers, but *automated* itinerary planning was not available (CIOs continued to develop itineraries manually).

At the time of the evaluation team's site visit in December 1997, management of the MARTA Customer Information Center felt that PARIS® was not yet a mature system, even though it had been in place for over a year. Most of the necessary corrections to



data had been made, and testing of other aspects of the system was about 50% complete. Between the evaluation team's site visit in December 1997 and its last visit in March 1999, efforts undertaken by MARTA and its PARIS® contractor to develop and refine the system included the following:

- Identifying and correcting bugs in the system
- Identifying and correcting remaining data inaccuracies
- Working to develop the reporting capabilities of call distributor equipment, in order to obtain performance statistics for management purposes
- Identifying desirable changes in the functionality of the system
- Installing new servers
- Configuring links between servers for more stability
- Improving the process for transferring schedule data (which is updated biweekly) from MARTA's scheduling software to PARIS®
- Transitioning from contractor to MARTA personnel for data maintenance

#### **4.2 Relation to Other ITS Components**

The PARIS® system relies on several other ITS and non-ITS inputs. The Base GIS is the foundation of the system. The bus stop inventory and landmarks database are added as "layers" to the GIS, and combined with the bus and train schedules produced by MARTA's automated scheduling system for use by PARIS®.<sup>3</sup>

#### **4.3 Implementation Objectives**

The management of MARTA's Customer Information Center indicated that their primary objectives for the implementation of an automated customer information system were to:

- Improve the consistency of information provided to customers
- Provide more information and a higher level of customer service by relieving CIOs of the need to develop itineraries manually
- Reduce CIO training time
- Facilitate the planning of itineraries for persons with disabilities
- Increase MARTA's ridership by offering more ways of obtaining information to customers

Managers stressed that they were not seeking a reduction in the time needed to respond to a customer's request. MARTA's standard, which is required of all CIOs after the completion of 90 days of training, is the processing of 250-300 calls per shift, at an average time per call of 1.5 minutes or less. Seasoned operators answer most calls in less than 60 seconds.

---

<sup>3</sup> An interface between MARTA's automated scheduling system and PARIS® was developed so that bus and train schedules can be uploaded to PARIS®, but the two systems are not completely integrated.

## 4.4 Implementation Issues

A number of issues related to the introduction of PARIS® were identified by staff of MARTA's Customer Information Center.

- There were initial problems with the accuracy of data regarding bus stops, landmarks and other items, due to the time pressure of the Olympics, the magnitude of the data collection effort and other factors.
- The VRU initially installed became outdated. When the manufacturer went out of business, the equipment was no longer maintained and supported, and parts became unavailable.
- Biweekly uploads of schedule data are slow and problematic because PARIS® and MARTA's automated scheduling system are not integrated. MARTA is considering the purchase of a customer information software product (as well as a paratransit scheduling system) from the scheduling software vendor, to achieve system integration.
- Reports of performance statistics and other management information are still being developed. As of March 1999, there was no connection between PARIS® workstations and MARTA's call distributor equipment. Call distributor reports provide information about number and length of calls, but cannot provide data about what information was requested or given to customers. PARIS® does not provide this information either.

## 4.5 Measures of Effectiveness

This evaluation considered the following measures of effectiveness for the PARIS® system: user acceptance, effectiveness, and financial impact.

### 4.5.1 User Acceptance

The CIOs are the primary users of PARIS®. There are 18 full-time and 6 part-time CIOs. There are 12-14 operators on duty at a time. Shifts are staggered throughout the day, and start every 30 minutes. The staff is unionized. The Customer Information Center is in operation from 6AM to 12AM, Monday through Friday, and from 8AM to 10PM on weekends and holidays.<sup>4</sup> In addition to the CIOs, the staff of the Customer Information Center includes a manager, two supervisors, and a customer assistant, who conducts training for the CIOs.

All of the CIOs employed by MARTA in December 1997, and all those working in March 1999 except for one part-time CIO, had been part of the Customer Information Center staff prior to the implementation of PARIS®. They were knowledgeable about the MARTA bus and rail system and were used to answering customer inquiries with the aid of route maps, schedules, and a street atlas.

---

<sup>4</sup> At the time of the evaluation team's site visit in December 1997, the call center closed at 10PM on weekdays and 4PM on weekends. Hours were later extended.

The evaluation team interviewed Customer Information Center managers, supervisors and CIOs to obtain their views of PARIS®. One manager, two supervisors and three CIOs were interviewed in December 1997. The manager and one supervisor were interviewed again in March 1999, in addition to two other CIOs. Their thoughts are summarized below.

### *Accuracy of Information*

The start date of the Summer Olympics imposed severe time constraints on the PARIS® implementation. The amount of data that needed to be collected and entered in order for PARIS® to function was immense, including, among other things:

- Schedule information for MARTA's two rail lines and 160 bus routes, including numerous variations (i.e., patterns) for many of these routes
- Locations and attributes of 10,000 bus stops
- Locations of 2,500 landmarks

Moreover, the Atlanta metropolitan area, which is rapidly expanding, is complex. Streets with duplicate names, streets without address numbers, and new, sometimes unnamed, streets in quickly growing areas all exist. In addition, the base map used in MARTA's ITS system, which had been acquired through GDOT, did not include street names. Street names for PARIS® had to be entered manually. Not only were the street names entered not always correct, but the names typed into PARIS® panels by CIOs (to enter a customer's origin or destination, for example) had to match the spelling and punctuation of the original entry *exactly* in order for PARIS® to recognize the street.

As a result of these factors, many data inaccuracies existed when PARIS® first went into use. The users of PARIS® interviewed in December 1997, therefore, had initial reservations about the accuracy of the information it provided. Several of the more senior CIOs were able to see immediately if PARIS® delivered faulty itineraries or other types of incorrect information. These CIOs had enough experience and knowledge of the MARTA system to know how almost any trip should be made, and what the fare should be. Moreover, at the time that PARIS® was implemented, all CIOs were trained to cross-reference the information provided by PARIS® with route maps, schedules, and a street atlas.

Other problems included the way in which the system handled "buddy transfers" (on routes with a layover point in the middle, PARIS® would instruct the rider to get off of the bus, even though MARTA policy does not require this ) and other end of the line scheduling issues.

However, by the time of the evaluation team's site visit in March 1999, many data errors and system bugs had been identified and corrected. An updated version of the base map, including street names, had been purchased (although not yet installed). Customer Information Center staff interviewed at that time felt much more confident about the accuracy of the answers provided by PARIS®, although several mentioned that they still checked answers against a street atlas and schedule books.

The CIOs interviewed were asked to indicate the accuracy of different types of information provided by PARIS®. The following bullets summarize their responses by type of information:

- Schedules: very accurate to excellent, especially since the information can be updated every day. The system is now more accurate than the printed schedules used to provide information prior to the installation of PARIS®
- Routes: described as accurate or excellent
- Fares: described as accurate, good, or excellent
- Accessibility: good because it shows which bus runs will be lift-equipped, but it was pointed out that the information is not always 100% accurate
- Location of bus stops: described as good or very accurate
- Trip itineraries: described as accurate but slow

### *Ease of Use*

The CIOs interviewed indicated that PARIS® is a relatively easy system to use once an operator has been trained on it. They also indicated that it was helpful if the operator already had some exposure to computers. In fact, some operators had not had very much exposure to computers, and had to be taught fundamentals such as mouse use and log on/off procedures. However, most of the CIOs adapted quickly to the use of PARIS®.

When compared to the manual system, (i.e., looking up bus schedules and maps in large three-ringed binders), PARIS® is not necessarily faster, in the opinion of the CIOs. One CIO said that it is quicker to use the manual system when providing information about a schedule at a specific bus stop, and it takes about the same amount of time to come up with an itinerary manually as it does using PARIS®. One supervisor reported that calls can be handled more quickly using PARIS®, but not drastically so. However, both the call center managers and some of the CIOs pointed out that PARIS® was not intended to make the CIOs faster at handling calls, but rather to provide more consistent and reliable information to callers, and to expedite calls using the VRU and faxing features.

Several CIOs commented on the number of PARIS® panels, or screens, they must access to answer all of the inquiries a customer may make. They believe they would be able to answer more calls if information could be viewed in fewer panels. Another common remark was that the process of using the PARIS® map function to view a location or an itinerary increases the time it takes to handle a call, due to the slow speed at which the map is drawn on the screen. Other desirable changes that were mentioned by CIOs included (1) the ability to view the schedules for all routes serving a particular location at once, rather than individually; (2) automatic notice of major bus or rail delays and detours to the CIOs through PARIS®, as opposed to updates and announcements on paper; and (3) describing driving instructions in terms of right and left turns instead of turns to the north, south, east or west.

Since virtually all of the CIOs were already familiar with MARTA's bus and rail systems prior to the installation of PARIS®, Customer Information Center managers felt unable to evaluate how easy it would be for a new CIO to use the system.

### ***Reliability***

Generally the Customer Information Center staff feel that the system is reliable, but pointed out that they had not had much experience with such systems, and were not sure how to assess reliability.

In December 1997, managers and CIOs reported that the VRU was unavailable regularly and needed to be rebooted by telephone maintenance staff. In March 1999 this was still happening. However, Customer Information Center managers do not feel that it is a major problem for the CIOs to answer calls that would normally be transferred to the VRU, because most calls are for routine information, which can be handled quickly. The unavailability of the VRU has more of an impact on customers, because there are fewer phone lines into the CIO area, and if they are answering more calls, the chances of a customer encountering a busy signal increase. While some canned information messages are available to callers waiting in the CIO queue, customers are not able to access specific types of information while in that queue.

In December 1997, staff indicated that PARIS® itself was available and functioning most of the time, but tended to be slower to respond during peak times, or when the mapping function was being used. Times when the system was not available were reported as infrequent and/or brief. At such times, the contractor that oversaw the implementation of the system was called upon to correct the problems.

In March 1999, problems were still being experienced with the VRU (see the following discussion of maintainability). At this time, however, there was some disagreement among Customer Information Center staff as to the frequency of PARIS® system failures. Management felt that various elements of the system (the VRU, the PARIS® server, or the work stations) were unavailable as often as two to three times per week, forcing the CIOs to revert to using printed materials to respond to customer inquiries. However, supervisors and CIOs using PARIS® on a daily basis estimated that system slowdowns or failures occurred between once a week and once every other week. The CIOs were not particularly bothered by the frequency or duration of periods when the system was unavailable.

The main reasons for the varying staff opinions appear to be related to differences in perception (based upon extent of use of the system), and to reactions to the departure of the PARIS® contractor (at the conclusion of its contract) and the transition to the new ITS Project Team for stabilization and maintenance of the PARIS® system.

It was also mentioned that PARIS® slowdowns can occur when too many panels are open on a workstation, or when a CIO begins a new inquiry before the current inquiry has been completed, or has not logged off the system properly.

A major issue that was raised at this time involved the biweekly uploads of schedule data to PARIS® from MARTA's automated scheduling system. It was reported that this upload can take up to three days to complete, because of the lack of integration between PARIS® and the scheduling system. During uploads, PARIS® slows down and may crash, and lost call rates increase. However, Customer Information Center staff reported that since the new ITS Project Team had been in place, the upload process was improving. Uploads were occurring during the day, rather than at night, the Customer Information Center was notified in advance of potential slowdowns, system crashes were no longer occurring, and uploads of the updated schedule information were successful.

### ***Maintainability***

One IT staff person has been assigned to maintaining PARIS®. Any additional maintenance tasks are carried out by Customer Information Center managers. Maintenance tasks include:

- Regular back-ups
- Regular uploads of new schedules, bus stops, and/or landmarks
- Troubleshooting application problems

The maintainability of the VRU was raised during the evaluation team's March 1999 visit. It was reported that the installed equipment is outdated and of insufficient size to handle the volume of calls it needs to process. In addition, the hardware manufacturer has gone out of business and no longer provides equipment maintenance or support. Further, replacement parts are no longer available. No plans for addressing these problems were discussed.

### ***Ability to Handle Data from External Sources***

A critical element of the PARIS® system is the ability to handle data from external sources. PARIS® relies on data from the Base GIS system, the schedule database, and other electronic data sources. The managers of the Customer Information Center indicated varying degrees of satisfaction with the system's ability to link with, and process the data from, these disparate sources.

The integration of PARIS® with the GIS database (which includes the bus stop inventory and the landmarks database) worked well. PARIS® was designed to read these inputs seamlessly, and changes from these inputs are easily integrated into PARIS®.

As mentioned above (and in Section 3.2), the lack of integration between PARIS® and the automated system used to prepare bus schedules requires uploading the data generated from the scheduling system (through the schedule database) to an RDBMS and then to PARIS® every two weeks, when minor changes are made to the schedules. Although the negative impacts of this upload process on PARIS® have been lessened due to the actions of the ITS Project Team, system slowdowns still occur. In order to correct this situation, MARTA is considering the purchase of customer information software from the scheduling system vendor, so that the two systems would be completely integrated.

Customer Information Center managers feel that moving to a Windows-based customer information system operating on a personal computer (PC) for each CIO would provide the CIOs with a more comfortable, flexible, user-friendly computing environment.

### ***Changes in Job Requirements and Performance***

As of March 1999, all of the CIOs were using PARIS® to respond to almost every customer request. The only times they may not use the system is when they know the requested information from memory.

PARIS® has not changed the amount of time required to answer calls. Most of the CIOs indicated that this has remained about the same. However, some feel that their responses are quicker than the computer's in some cases. One CIO, who said she regularly handles 300 calls during an eight hour shift, suggested that if she were to rely solely on the system, she would answer less than 250 calls.

One part-time CIO has been added to the staff of the Customer Information Center since the PARIS® system was installed. However, this addition was necessary to provide coverage for the extended hours of operation that began in early 1999, and was unrelated to the use of PARIS®.

Since the CIOs are not answering all calls (the VRU system handles the frequently asked questions that are easy for an automated system to respond to), they are spending time on the calls that require more attention.

PARIS® has changed the way some CIOs approach itinerary planning calls. They now have to proceed in a methodic manner required by the way PARIS® asks for information. Previously, a CIO might have a short conversation with a caller about his/her origin and destination, and then proceed to develop an itinerary. Now, CIOs ask for specific information in a specific order, so that inputs to PARIS® can be made as required. Although this may not have changed the itinerary solution that is communicated to the customer, it has changed the way CIOs arrive at the solution.

The CIOs also have less individual responsibility for updating their sources of information. Prior to PARIS®, each CIO would get printed copies and changes to schedules, maps, or general MARTA information. It was the CIOs' responsibility to make sure these materials were current and available as they answered calls. Now they no longer worry about updating information because it is done electronically.

### ***Training***

PARIS® is expected to reduce the amount of time required to train new CIOs. In the past, new operators required four or more weeks of training. In the future, Customer Information Center managers expect that training will only take 2 weeks: 1 week to learn PARIS®, and 1 week in the field learning the bus and train routes. No operators have been trained on this schedule to date because all of the current staff members were working in the Customer Information Center prior to PARIS® implementation.

The initial PARIS® training that these CIOs received was somewhat lacking, according to the CIOs. Training took place over two weeks, and as many as nine people shared one terminal. The system was not completely ready to be used when the training took place. Many of the CIOs indicated that the real training began when they started using the system during actual phone calls. In addition, one of the Customer Information Center supervisors developed a tutorial for use by the CIOs. Several of the more inquisitive CIOs started familiarizing themselves with the system during slow periods, and they have become the in-house experts on its use. Other CIOs rely on them for help.

### *Effect on Customers*

Customer Information Center managers feel PARIS® has substantially improved the availability and consistency of information that is provided to customers.

The CIOs reported that customers generally are appreciative of the improvements that PARIS® offers, although often the customers are not aware of the changes in the operation of the Customer Information Center. Features that have received positive comments from customers include the ability to obtain walking directions, walking time, accurate schedule times, and driving instructions (to MARTA stations, for example).

As mentioned above, PARIS® is used in conjunction with an automated VRU, which offers a menu of routine information options to callers who do not need or wish to speak with a CIO (i.e., “front end” assistance from the VRU). Another feature of PARIS® enables the CIO to activate the VRU at the conclusion of a call to relay the information (e.g. a trip itinerary) requested to the caller automatically (i.e., “back end” assistance). The number of callers choosing to obtain front end and back end information from the VRU on several separate days during the evaluation team’s visits to MARTA is described below.

Table 3 was prepared using information generated by PARIS® for several dates in 1997 and one date in 1999. As Table 3 indicates, most calls are transferred from the VRU, and connected either to a CIO or to another MARTA phone number.<sup>5</sup> On the dates for which data was available, between 365 and 930 callers per day, or 15% to 17%, used only the VRU for information.<sup>6</sup> These are calls that CIOs would have handled prior to the deployment of the PARIS® and VRU system. The quick provision of information to customers with routine requests, through the VRU, and the increased time that CIOs have to spend handling calls from other customers, represent important benefits of the system to MARTA’s customers.

---

<sup>5</sup> All calls to MARTA’s customer information number are answered by the VRU. Callers may select to hear recorded information in several categories, to be transferred to a CIO, or to be transferred to other MARTA numbers. These other numbers include MARTA’s Job Line, paratransit service information, and the complaints/commendations line. At the time that this evaluation report was prepared, enhancements to PARIS reports to show the specific number of calls transferred to CIOs and to other numbers had not yet been developed.

<sup>6</sup> Customer Information Center managers estimated that the VRU was handling between 1,000 and 1,500 calls per day at this time.



The number of calls that the CIOs transfer either to the VRU or the faxing feature at the conclusion of the call is relatively low, as indicated in Table 3. The CIOs interviewed indicated that some callers specifically ask not to be connected to the VRU. Senior citizens in particular seem to have difficulty using the VRU system. Complaints are sometimes registered by callers who identify themselves as elderly and who feel that they have to navigate through too many menus of options in order to talk to a person. In addition, digitized messages cannot be repeated, and it is not possible to return to an operator if one is calling from a rotary phone. Thus, the Customer Information Center is not realizing the full benefit offered by the back end VRU option (in terms of freeing CIOs to answer calls from other customers) because customers often prefer not to use this option.

**Table 3. Disposition of Voice Response Unit Calls Selected Dates, 1997 and 1999**

	Monday 3/17/97	Thursday 11/6/97	Sunday 12/7/97	Monday 3/22/99
Number of Calls on Front End	5006	4595	2228	5424
Number of Calls on Back End	0	35	7	32
Number of Calls Transferred	4265	3885	1863	4493
Number of Calls Handled by VRU	741	710	365	931
Calls Transferred as % of Front End Calls	85.2%	84.5%	83.6%	85.5%
Calls Handled by VRU as % of Total Calls	14.8%	15.5%	16.4%	17.2%
Back End Calls as % of Transferred Calls	0	.9%	.4%	.7%

Customer Information Center managers reported that, although they have not done a quantitative analysis, there has been a decrease in the number of complaints received since the implementation of PARIS®. Most of MARTA's customer information complaints prior to PARIS® concerned the accuracy and consistency of the information provided. Customers continue to lodge complaints about the amount of time spent on hold and encountering busy signals, however. When CIOs began to utilize PARIS® to respond to inquiries, complaints of this nature dropped and compliments increased.

***Users' Perceptions of Benefits and Impacts***

When PARIS® was first introduced at MARTA, reactions on the part of the CIOs interviewed by the evaluation team were mixed. CIOs who had previous experience with an automated customer information system were positive, while those who were familiar only with manual methods of responding to inquiries were apprehensive. However, by the time of the evaluation team's visit in December 1997, all Customer Information Center staff who were interviewed expressed positive opinions about PARIS®, and preferred using it to manual methods.

Generally, the CIOs and their managers are pleased with the new capabilities of the PARIS® system, and think that it improves their ability to do their jobs. They admit that there are some shortcomings to the system, such as the complicated menus and the amount of effort required to keep the databases current. Nevertheless, they see PARIS® as a valuable tool that provides access to more and better information.

Managers pointed out that one of the advantages of the system is that more time is devoted to customer service, and less to searching for information. Information that is provided to customers is now more comprehensive, and is consistent among the CIOs. PARIS® is also expected to have a positive impact on the amount of time that new CIOs will have to spend in training before they can become productive members of the staff. The processing of calls through the VRU, which frees CIOs from responding to the more routine inquiries, is seen by managers as a distinct benefit in terms of efficiency.

The CIOs also indicated that there is some new information available to them that allows them to answer more customer inquiries. For example, driving instructions to rail stations are now available. These instructions even include the number of parking spaces available at the station.

A few of the CIOs suggested that the trip planning component of PARIS® might not be necessary. They reported that only about 10% of the callers request itinerary planning assistance. (Callers are mostly interested in schedules and general information. There are also many inquiries to find out what MARTA service passes by a particular address or landmark.)

#### ***4.5.2 Effectiveness***

MARTA's Customer Information Center staff utilize PARIS® to respond to nearly every request for information from customers. Other measures of the effectiveness of the PARIS® system include changes in both response time to customer inquiries and data availability.

##### ***Changes in Response Time***

The CIO managers indicated that they have not seen any changes in the response time to caller requests. They reported that CIOs each handle between 230 and 250 calls per shift, about the same number as were handled prior to implementation of PARIS®. However, at the time of the last site visit in March 1999, the VRU was handling between 1,000 and 1,500 additional calls per day, according to Customer Information Center managers. These results are consistent with the expectation that response times would not necessarily decrease due to PARIS®, but that the CIOs would be able to provide more accurate and consistent information, and that more customers could be served as a result of handling as many routine inquiries as possible through the VRU.

### *Changes in Data Availability*

It is difficult to quantify the change in the amount of data available as a result of the PARIS® implementation, but it is clear that the CIOs consider their resources increased because of the system. Several of the CIOs mentioned new types of information that are now available to them such as walking and driving directions to stops and stations, and the ease with which they can now retrieve information that was once cumbersome to access.

#### **4.5.3 Financial Impact**

The costs associated with the entire ITS MARTA '96 project, including PARIS®, are discussed in Section 12. Identifiable variable costs associated with this system are presented below.

#### **Variable Costs**

MARTA is currently purchasing monthly support for both PARIS® and the VRU from vendors. Monthly maintenance charges for PARIS® are approximately \$2,500. Support for the VRU and call distributor equipment costs roughly \$700 per month.

### **4.6 Achievement of Objectives**

Elements of the national and local APTS objectives relevant to MARTA's PARIS® implementation include enhanced customer information, improved system efficiency, and addressing the needs of persons with disabilities.

#### **4.6.1 Enhanced Customer Information**

PARIS® has greatly enhanced the quality, timeliness and availability of customer information. Customer Information Center staff now have timely access to a greater amount of information about routes, schedules, fares, and major destinations. Since the same information is provided to all CIOs, customers receive more consistent responses to their requests.

#### **4.6.2 Improved System Efficiency**

PARIS® has improved system efficiency. It allows the CIOs to spend more time talking with customers and addressing their needs than retrieving the information they request. In many cases, the VRU now handles routine inquiries. In addition, PARIS® offers the CIOs more options for delivering information to customers -- verbally, through the VRU, and by fax.

#### **4.6.3 Needs of Persons with Disabilities**

Accurate and consistent accessibility information is readily available to persons with disabilities because of the PARIS® system. PARIS® enables CIOs to respond to questions about the accessibility of MARTA's bus and rail vehicles, stops and stations, and to develop itineraries that involve only accessible vehicles and facilities.



## Section 5

# Georgia Department of Transportation Advanced Transportation Management System

### 5.1 Description

The Georgia Department of Transportation (GDOT) created a network of over 300 video surveillance cameras and radar units that monitor traffic flow and speed on the major roadways throughout the Atlanta metropolitan area. This network is part of an Advanced Transportation Management System (ATMS). The GDOT Transportation Management Center (TMC) houses the ATMS. Staff of the TMC are able to view traffic speed, coded by color, on a GIS map, and then access camera shots of problem areas for a closer look. GDOT's Highway Emergency Response Operators (HEROs) provide additional surveillance capabilities by patrolling assigned routes at designated times. Helicopter surveillance is used to monitor major incidents that occur outside of the range of the cameras. The ATMS generates a response plan suitable for each incident that occurs, including a list of actions to be taken and relevant phone numbers.

The goals of the ATMS are to (1) minimize response time to highway incidents by GDOT, highway maintenance staff, public safety personnel, hazardous materials teams, and towing service; and (2) enable GDOT to develop response plans to traffic congestion in the area and communicate information about traffic conditions to the public. The TMC is linked to similar Transportation Control Centers in five counties (Clayton, Cobb, DeKalb, Fulton, and Gwinnett) and the Cities of Atlanta and Savannah, and to MARTA's BCC.

The dispatchers at MARTA's BCC have access to the ATMS surveillance cameras, both to view the conditions that the cameras are recording, and to change the cameras' positions to view areas that are of interest to MARTA's operations. The ATMS provides the dispatchers with visual information about the traffic conditions on the roads that MARTA buses travel, displayed on a bank of video monitors in the BCC. MARTA staff has some control over which camera's output is displayed on the BCC screens (up to four can be displayed at once), unless one of the operators at the GDOT control center overrides that selection.

The reciprocal side of this arrangement is that the TMC receives information from MARTA BCC personnel who have access to the CAD/AVL system. This information can alert the traffic monitors to any slow-downs or unusual traffic conditions that the buses may be experiencing, or to accidents involving MARTA vehicles. For example, bus breakdowns along Route 75 and 85, or in other places where traffic would be affected, occur about ten times per day.

Since the dispatchers in the BCC do not typically have time to log onto the GDOT system and activate transmission from the cameras, the Radio Communications supervisor performs this function and passes information along to the dispatchers. The dispatchers interviewed indicated satisfaction with the ability to obtain information about traffic

conditions around the metropolitan road network. The information is helpful to them in dealing with bus operations that are affected by general traffic conditions. The BCC staff raised no issues of concern with regard to the accuracy of data, reliability of information, or timeliness of information from the ATMS.

No additional MARTA staff members are required for exchanging information with the TMC. The number of staff using ATMS information is the same as the number of dispatchers working in the BCC at any given time. Frequency of use of this data and changes in procedures, activities or incident response as a result of the ATMS information are hard to measure, and no anecdotal evidence was provided of such changes.

## **5.2 Relation to Other ITS Components**

Access to the visual information provided by the ATMS is through an entirely separate communications network from the one used at MARTA for the CAD/AVL system. The ATMS does not interface with any of the components of MARTA's ITS network.

## **5.3 Implementation Issues**

Some technical difficulties were experienced with the initial connection between GDOT's TMC and MARTA's BCC. A stand-alone server was to have been provided on MARTA's end, to address GDOT concerns with system security. Since other applications were resident on MARTA's server, several months in 1997 passed without a link between the two control centers. This issue was resolved by early 1998, and the information flow between the TMC and the BCC resumed. Another problem involved the failure of the fiber optic link between the two locations. As a result, MARTA will be assuming responsibility for the maintenance of the fiber optics.

## **5.4 Achievement of Objectives**

Two of the established objectives apply to the integration of MARTA's ITS system with the GDOT ATMS. They include improvements in the quality of on-street service, system productivity, and the exchange of information between jurisdictions.

### **5.4.1 Quality of On-Street Service**

MARTA's access to traffic information from GDOT is likely to contribute to improved safety, security and travel times for MARTA's customers when BCC staff uses that information to route buses around problem areas or to implement other operational strategies.

The impact of the link between MARTA and GDOT on passenger information is less direct. Travelers have access to traffic information from the TMC from a number of sources:

- Changeable Message Signs
- Electronic kiosks
- GDOT's Internet site
- Cable television
- Cellular phone information service

When MARTA supplies information to the TMC about incidents or conditions that affect its buses, that information may be passed on to the public through these sources.

Likewise, information that MARTA obtains from the TMC about conditions that are affecting bus service may be provided to MARTA's Customer Information Center staff so that they are able to respond to customer inquiries with the most current information. However, no examples of this type of occurrence were described to the evaluation team.

#### ***5.4.2 System Productivity***

Information obtained from GDOT's TMC regarding traffic congestion, accidents, and other incidents is likely to aid MARTA's dispatchers and other operational personnel in making decisions that improve the schedule adherence of MARTA buses in the affected areas. On the basis of this information, MARTA personnel are also able to respond more quickly to bus operators who may be in need of assistance due to congestion, accidents, or incidents. Information supplied to GDOT by MARTA about accidents or incidents involving MARTA vehicles also helps GDOT to contact and deploy response teams in a timely manner. These benefits contribute to improved management practices at both MARTA's BCC and GDOT's TMC.

Since the information that is exchanged between the two agencies involves real-time occurrences, the impact of the exchange on MARTA's service planning and scheduling activities is minimal.

#### ***5.4.3 Communication Between Jurisdictions***

As a result of the joint efforts of MARTA and GDOT, information is being exchanged between MARTA's BCC and GDOT's TMC. Other jurisdictions, such as the City of Atlanta and the five surrounding counties, have access to the same transit and highway information.





## Section 6

# Computer-Aided Dispatch/Automatic Vehicle Location System

### 6.1 Description

As part of the ITS MARTA '96 project, MARTA installed a Computer-Aided Dispatch/Automatic Vehicle Location (CAD/AVL) system<sup>7</sup> to track the real-time location of a portion of the buses in its fleet and enhance communications between bus drivers and dispatchers.

The CAD/AVL system allows the BCC to receive and display accurate vehicle locations for AVL-equipped vehicles. The main objectives of the CAD/AVL system are to:

- Calculate schedule adherence so that dispatchers and/or street supervisors can determine strategies to restore service, if necessary
- Determine route adherence so that dispatchers and/or street supervisors can monitor buses that are running off route and determine strategies to make necessary corrections
- Identify the exact location of a vehicle that is sending out a silent emergency alarm, so that the appropriate incident response team can be dispatched to its location
- Provide the bus operator with a visual text message indicating on time, ahead, or behind status
- Provide bus operators with a more efficient means of communicating with the BCC using canned, digital messages sent via the data channel rather than voice channel
- Provide other ITS systems with accurate location information about AVL-equipped buses

The CAD/AVL system consists of the main server and five workstations at the BCC and 240 buses equipped with global positioning system (GPS)-based AVL systems. AVL buses are used in all three MARTA operating divisions, but the majority are based at Perry Garage. In addition to the GPS receivers, the buses are equipped with an intelligent vehicle logic unit (IVLU), a modified Motorola Spectra radio, and a transit control head (TCH) for the display of information to the bus driver (see Figure 3). Transmission of AVL data back to the BCC takes place on a dedicated radio channel. Voice communications are conducted on separate radio channels. Figure 4 shows the relationship between various CAD/AVL components.

---

<sup>7</sup> Prior to the Olympics, all MARTA buses were equipped with Motorola CAD TDS 4500 radios. When AVL equipment was added to some of the buses, components of this existing communications system, such as voice channels and voice hardware, were retained. Motorola no longer manufactures this particular model of radio, and, did not have a replacement that could interface with the new AVL components at the time of the MARTA AVL installation.

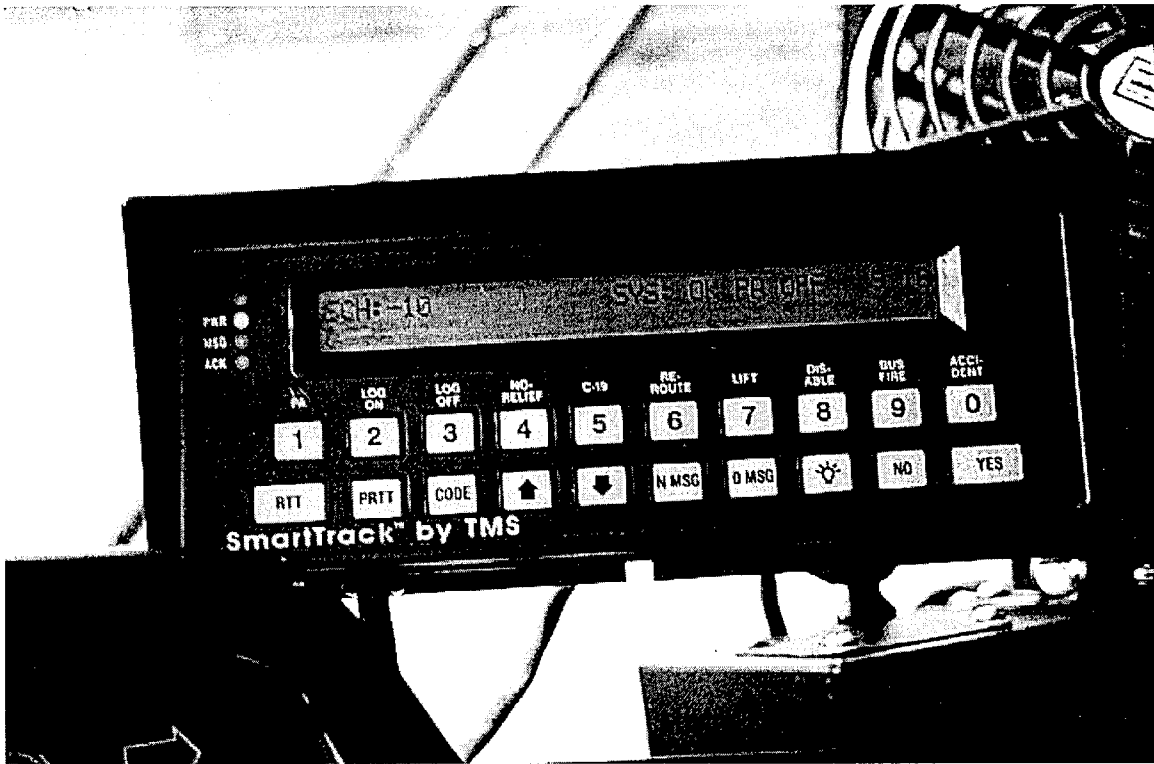

Figure 3. Transit Control Head

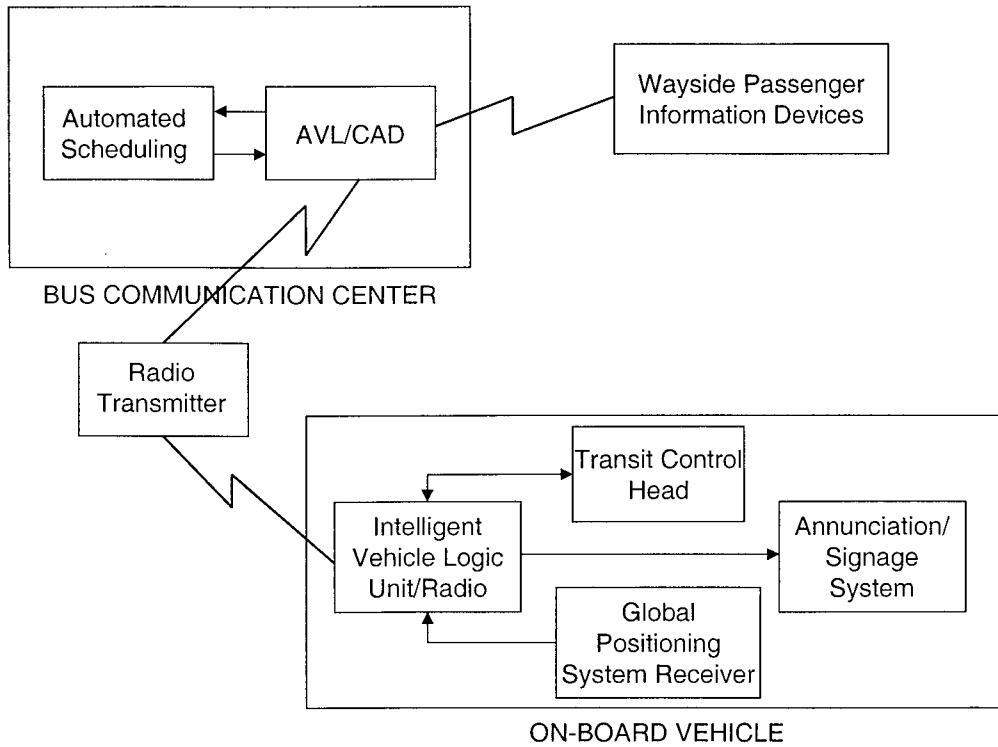

Figure 4. CAD/AVL Components

The CAD/AVL system identifies the location of vehicles and plots the location on a computerized map on the five workstations at the MARTA BCC. (A workstation is shown in Figure 5.) Each bus uses a GPS receiver to identify its location which is calculated using data from at least three GPS satellites. The location data are accurate to within 50 feet. The transmission of the vehicle's latitude and longitude takes place over the on-board radio's data channel, and occurs every two minutes. The workstations in the BCC display a detailed street map, with the location of buses represented by colored icons and associated bus and route numbers (see Figure 6). Different colors indicate that the bus is running on time, ahead of schedule, behind schedule, or that an alarm has been activated on the vehicle. Each time new location information about an AVL-equipped bus is received by the system, the icon moves to the new location. The CAD/AVL system can also provide the dispatchers with schedule and route adherence information, as well as mechanical equipment alarms. This allows analysis of on-time performance, running times, and other service indicators.

An important feature of the CAD/AVL system is the ability to track a bus that is transmitting an emergency alarm. Dispatchers at the BCC are able to view the precise location of the bus, and can activate a hidden microphone on the distressed bus to listen to what is happening on-board. Passengers are not aware that the microphone has been activated, but the operator is notified by means of a subtle signal on the TCH. When an emergency alarm is activated, the location of the bus is also updated more frequently (once every minute). With the information about the location of the bus and what is happening on-board, the dispatcher can deploy the appropriate emergency response team.

The CAD/AVL system also tracks all communications between the drivers and the dispatchers. For example, the system records the time, date, and location of a bus when the driver presses the request to talk (RTT) selection. Other selections that drivers can make include the priority request to talk (PRTT), which can be used to indicate that the bus driver needs assistance immediately, and a silent alarm for those occasions when the driver does not want those on-board to know that he or she has activated an alarm.

Another feature of the CAD/AVL system is used to record the graphic displays of bus movements for storage on compact disk. By replaying the displays of actual service on a particular route or for a particular bus, operations and planning personnel are able to analyze instances of schedule or route deviation.

## **6.2 Relation to Other ITS Components**

In addition to providing vehicle location information to the dispatchers in the BCC, the CAD/AVL system provides essential bus location information to two other components of the MARTA ITS system: the on-board electronic signs and annunciators, and the wayside passenger information devices located at selected bus stops.

The GIS component of MARTA's ITS base system is used to provide the map on which the CAD/AVL system displays bus locations in relation to routes and streets.



**Figure 5. MARTA CAD/AVL Workstation**

Another important interface with other components is with the scheduling software. The CAD/AVL system requires schedule data in specific formats. However, MARTA currently creates its schedules using Trapeze software. These two software packages have slightly different formats for reporting times, dates, and locations. Therefore, considerable manipulation must take place in order to convert flat files from one software package for use by the other. This process involves exporting Trapeze schedule files to a flat file format, manipulating the files using a Sybase database, and exporting the results from Sybase to the format that is required by the CAD/AVL system. This process takes place every 2 weeks, when minor schedule adjustments are uploaded. This process is manually operated and takes about 5 days to complete.

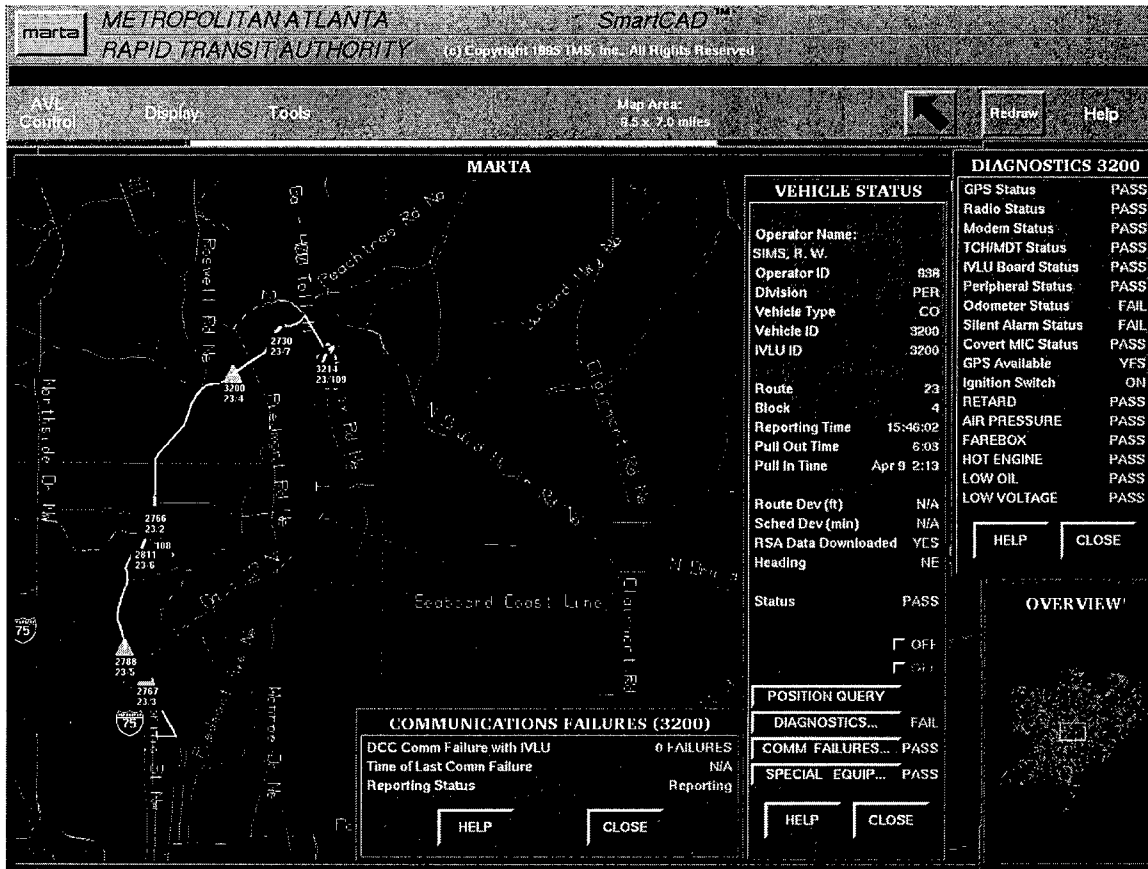

Figure 6. CAD/AVL Display

### 6.3 Implementation Issues

MARTA staff identified several issues to be considered when implementing an AVL system:

- One member of the maintenance staff pointed out that at some point technology may not be worthwhile because of the cost of maintenance. The operating agency must address where resources will come from to support the new ITS technology.
- AVL equipment and the Motorola CAD 4500 systems are not integrated. The subsequent need for two different keyboards is inconvenient for dispatchers, who deal with both AVL-equipped and non-AVL-equipped buses.
- Only a portion of MARTA's bus fleet is equipped with AVL, which lessens the usefulness of route and schedule adherence data for planners and schedulers, dispatchers, and the riding public.

### 6.4 Measures of Effectiveness

There are three main categories of measures that are addressed in this CAD/AVL evaluation: user acceptance, effectiveness, and financial impact.

### **6.4.1 User Acceptance**

Users of the CAD/AVL system include bus operators, dispatchers, and BCC managers. The number of staff using the CAD/AVL system provides perspective on the magnitude of system use at MARTA. MARTA's BCC staff includes eight full-time and eight part-time dispatchers. All of these employees have access to the CAD/AVL system. An additional four employees in other areas have access. Thus, a total of about 20 people have access to the AVL system, 4 to 5 at one time.

One new BCC center staff person was assigned to monitoring and operating the CAD/AVL system. This person's duties included monitoring the ATMS interface with GDOT (described in Section 5) and making sure the system functions properly. All dispatchers use the system as a part of their normal activities.

Users' perceptions were ascertained by interviewing three BCC managers, two dispatchers, four street supervisors, and four bus operators, asking questions such as:

- How accurate is the information provided by the CAD/AVL system?
- How easy is the CAD/AVL system to use?
- How easy is the CAD/AVL information to understand and use?
- How reliable is the CAD/AVL system and the information it produces?
- How much effort goes into maintaining the CAD/AVL system?
- How well does the CAD/AVL system interface with other ITS systems?
- How have your job requirements and activities changed since the installation of the CAD/AVL system?
- What impacts has the CAD/AVL system had on passengers?

The following sections address these and related questions to assess the level of user acceptance of the CAD/AVL system.

#### ***Accuracy of Data***

No comprehensive manual verification of the accuracy has been done on the MARTA CAD/AVL system. Such tests were not the primary focus of this evaluation, as they have been performed as part of earlier ITS project evaluations in other locations.

During the evaluation team's site visit in December 1997, the street supervisors and bus operators who were interviewed reported that the system did not always track schedule adherence accurately. At the time, the supervisors felt that using the running board and a watch was a more reliable method of tracking schedule adherence for operators than relying on CAD/AVL data.

Supervisors and operators both reported that at times there may be disagreement between an operator and a supervisor about an operator's schedule adherence. This occurs during

the window of time before the CAD/AVL system makes operators aware of deviations from schedule adherence. For example, the AVL system does not notify dispatchers and bus operators that a bus is running behind schedule until it is 2.5 minutes late. The street supervisors, on the other hand, may be using a watch and a timetable to judge schedule adherence, and may identify a problem before a bus is 2.5 minutes late. Such disagreements may also be due to differences in the time kept by the CAD/AVL system and the supervisor's watch.

A major problem with the accuracy of the CAD/AVL system that existed initially was referred to by MARTA staff as the "false early" issue. This problem occurred because a single timepoint was used by the CAD/AVL system to identify bus loading areas and long stations that in reality had different arrival and departure spots. The following example, diagrammed in Figure 7, illustrates the false early problem.

The CAD/AVL system expects a particular bus to be departing Point A at 3:00 (see Figure 7). The bus passes within 50 feet of Point A (represented in the figure by the dashed circle around Point A) at 2:45 as it enters the station (Position B). Since the AVL reading cannot determine directionality, the CAD/AVL interprets this reading to mean that the bus is leaving (Position C) the station at 2:45, especially if only the scheduled departure time is programmed into the schedule.

This resulted in an incorrect report that the bus had left the station early. The CAD/AVL vendor was made aware of this problem, and has since corrected the system to recognize both arrival and departure timepoints at some locations.

As of March 1999, the users of the CAD/AVL system interviewed as part of this evaluation – dispatchers, BCC managers, bus operators, and street supervisors – believed that the system provides accurate location and schedule adherence information. "False early" reports no longer occur.

CAD/AVL data is being used to measure on-time performance, even though planning department staff indicated that bus operations staff have been slow to accept the accuracy of this information. Prior to the implementation of the CAD/AVL system, traffic checkers collected on-time performance data manually, on an extra trip that was added to the random sampling of trips and counts at intermodal centers that were performed for National Transit Database reporting. Whereas traffic checkers were able to collect between 500 and 1,000 timepoint samples per month, the CAD/AVL system provides between 300,000 and 400,000 samples, which provide a more accurate picture of on-time performance. During parallel data collection efforts conducted over the period of one month, no difference was found between manual and AVL on-time performance information. Even though those samples are concentrated in one quadrant of MARTA's service area, a much greater amount of data is available now as a result of CAD/AVL technology.

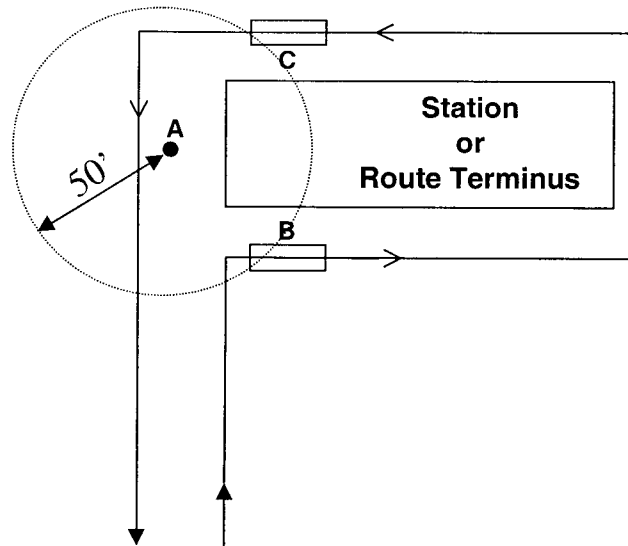

**Figure 7. False Early Depiction**

### *Ease of Use*

The bus operators and supervisors who were interviewed generally had positive things to say about the ease of use of the CAD/AVL system. However, several operators described difficulties with the logging on and off process. When an operator is logging off, he/she is supposed to wait until the log off is complete before turning off the engine. One of the issues raised was that it sometimes takes time to complete the log off process.

If the operator from the previous shift or day does not log off properly, the new driver has to log the previous operator off before logging on. This slows down the log on process considerably. Some operators observed that the log on process can be slower in the morning when the bus has not been warmed up.

The dispatchers made very few comments about the ease of use of the CAD/AVL system. They generally indicated that they were satisfied with what it could do for them, and that it seemed easy to use.

### *Reliability*

The users' perceptions of the reliability of the CAD/AVL system depended heavily on their understanding (or lack thereof) of how the system works and how they are expected to use it. Some bus operators, dispatchers, and street supervisors did not think the system was reliable. But this perception was in part due to unrealistic expectations of the system, or not knowing how to recognize and troubleshoot problems on the spot. For example, many of the problems they perceived to be shortcomings in the reliability of the system were actually log on problems. The following paragraphs describe situations that users mentioned as problems in the reliability of the CAD/AVL system.



One of the issues of reliability that the garage supervisors and the bus operators pointed out is the issue of faulty information due to log on problems. These users reported often getting error messages that wouldn't let them log on (either because the previous operator had not logged off properly or because multiple operators cannot be logging on at the same time), or there was an error in entering the badge number or route/block number. This can lead to other problems, because if a bus leaves the lot when it is not logged on, the silent alarm will sound, and the lot supervisor may think the bus has been stolen.

Another problem involves the integration of the CAD/AVL system with other on-board systems. When a bus operator logs on, not all of the systems on the bus start up at the same time, so the operator gets a system failure message. These are false failures, because eventually all the systems do come on-line. MARTA documented this problem, and demonstrated it to the vendor. The vendor has attempted to fix this problem.

The supervisors suggested that a high percentage of the problems occur because operators do not know how to log on properly. However, another log on problem occurs when the system on-board a particular bus goes into "radio fallback" mode. When this happens, the TCH shuts down and the operator is unable to use it. The operator's only option then is to communicate with the BCC via the voice channel.

The garage supervisors and the bus operators claimed that they were told that the CAD/AVL would solve many problems. However, their expectations have not been met. For example, bus operators thought they would just push the silent alarm and they would get immediate assistance. This is not necessarily the case. The dispatchers and street supervisors still have a set of standard operating procedures that they must run through in order to verify that the alarm is a true alarm (not an accidental activation of the alarm). They listen to what is happening on the bus using the covert microphone to determine the severity of the situation and determine the most appropriate action. The CAD/AVL does provide the dispatchers and supervisors with much more accurate location information about a bus in a silent alarm situation, but the bus operator may not get an immediate resolution to the incident.

Some of the garage supervisors and the bus operators also indicated that they thought the system was sometimes slow in processing their requests to the BCC or in providing information to the drivers. This again may be an issue of unrealistic expectations, or it may be an issue of radio bandwidth capacity being reached, which would slow down the communication between the vehicle and the BCC.

The BCC dispatchers observed that the "No Status" message is frequently displayed on the dispatchers' screens for routes on which AVL-equipped buses are in service. This can occur when communications between the vehicle and the BCC are intermittent.

### *Usefulness*

The users of the CAD/AVL system think that it is a useful system.. During their interviews with the evaluation team, operators, BCC dispatchers, garage supervisors, and

planning department staff commented on the usefulness of the communications aspect of the CAD/AVL system and of the data that the CAD/AVL system provides.

### **Communications**

Some operators reported that the response time to requests to the BCC is a little slower than expected, but take about the same amount of time as the voice radio system.

Drivers also see the recording abilities of the CAD/AVL system as an important enhancement. Because the CAD/AVL system records requests, the kind of request, and the time of requests, the information it provides can be used to monitor communications and improve efficiencies.

Prior to the installation of AVL equipment, the only available mode of communication between operator and dispatcher was voice. Now, the exchange of text messages is possible. With the AVL system, the operator hears a low audible tone and has to look at the TCH in order to see text messages that have been sent by the BCC. The operators do not always do this, especially if they are pre-occupied with other tasks, or if there is a lot of noise on the bus. This can reduce the effectiveness of the system. Some operators feel, however, that the messages provided on the TCH are helpful.

### **Data**

The street supervisors indicated that they see the AVL system as a tool to assist them with their jobs, not to be relied on solely. They still feel that their job requires knowledge of the routes and schedules they are monitoring. Although the street supervisors do not receive information from the AVL system directly (they are notified by dispatch personnel), one benefit that they see is using AVL information to discover drivers who are cutting their routes short. They also like the ability to pinpoint the exact location of buses. For example, when a disabled bus must be taken out of service and replaced with another vehicle, AVL information is used to direct MARTA personnel to the disabled bus.

The planning staff indicated that they like the playback feature of the CAD/AVL system because it provides them with actual observations of events for which they would otherwise only have anecdotal evidence. However, since only a portion of the fleet is equipped with the AVL system, planning department staff have not made great use of AVL on-time performance data.

Conversely, the service monitoring staff indicated that they think the CAD/AVL system provides more and better information, particularly about on-time performance.

### ***Maintainability***

As far as the maintenance of the CAD/AVL system is concerned, the electronics maintenance supervisor indicated that significantly more time is required to maintain an AVL-equipped bus than a regular bus because of the added electronic components and their complexity. At MARTA, one staff person is dedicated to each garage for the maintenance of communications and other equipment on both AVL and non-AVL buses.

At the time of the March 1999 site visit, maintenance department staff reported that TCHs are not a major maintenance problem. IVLU problems have been minimal. When repairs are needed, the entire unit has to be sent back to the manufacturer, at a cost of about \$300 – \$400 per unit.

In the view of BCC staff and managers, the lack of sufficient maintenance staff has an effect on the performance of the CAD/AVL system. For example, when radios are not functioning properly, CAD/AVL data is not transmitted back to the BCC. When an indication of low voltage for the alternator or generator occurs, an incorrect reading of AVL location data for that particular bus can be given.

### ***Ability to Handle Data from External Sources***

One of the problems with the CAD/AVL system is the amount of effort that is involved in coordinating the real-time data that it produces with the scheduling data that is produced by the scheduling software (different vendor, different program and format, etc.). The schedulers make slight adjustments to any number of bus routes as frequently as every two weeks. However, it can take up to several days to make the transfer of the scheduling software's output to a relational database management system (RDBMS) which is then transferred to the CAD/AVL system. This process involves some manual adjustments because there is no integration between the scheduling software and the CAD/AVL system. This laborious process reduces the efficiency of using the CAD/AVL system since updates to the schedule are not automatically entered into the CAD/AVL system. However, over time MARTA expects that they will refine and streamline this process, and reduce the need for manual adjustments.

### ***Effect on Bus Operations***

An AVL system could be expected to result in changes in communications and the delivery of service on the street. MARTA's experience in each of these areas after the installation of AVL equipment is described below.

#### **Communications**

The CAD/AVL system has changed the way dispatchers and operators communicate with each other. With the Motorola radio system previously used on the buses that are now equipped with AVL (and still used on the remainder of the fleet), the radio system handset would ring if the control center wanted to talk to an operator. When an operator wanted to talk he/she would just pick up the handset and begin talking. Now, operators driving the AVL-equipped buses push the request to talk (RTT) or the priority request to talk (PRTT) when s/he wants to speak to dispatch.

#### **On-street Operations**

Knowing the location of each bus that is in service enables operations staff to identify service problems, such as buses "bunching" at stops because of a vehicle that is running behind schedule. With this information, they can make the adjustments needed to restore

service to normal. Data from MARTA's AVL system is not presently being used to affect on-street operations in this way.

The reasons for this relate to staffing levels and the division of responsibilities among operations staff. As noted by BCC managers, monitoring AVL data in order to make real-time evaluations of service would require more BCC personnel. In addition, both BCC staff and street supervisors indicated that street or point supervisors normally handle service issues like bunching. Dispatchers handle too many routes to focus on any one route in that level of detail, and usually handle that type of situation only under special circumstances. Supervisors, unless notified by dispatch personnel, are not aware of AVL data regarding bus locations and schedule adherence, and are therefore able to correct only those on-street situations that they observe. Several of the supervisors interviewed noted that having access to a console displaying AVL information in their vehicles, rather than having to get that type of information from BCC personnel, would be extremely useful.

### ***Effect on Customers***

The benefits of an AVL system to customers come from the schedule adherence information that is displayed on the wayside passenger information devices and changes to routes and schedules which are made possible because of the data collected by the AVL equipment. Because only a portion of the MARTA fleet is AVL-equipped, and because AVL data is not yet being used to make real-time operational adjustments or to alter routes and schedules, the impact of the system on MARTA's customers is somewhat limited.

### ***Training***

Generally, the bus operators and garage supervisors who were interviewed thought the CAD/AVL training they received was helpful. The classroom training was about two hours long. The training sessions covered the log on procedure and use of the TCH. The supervisors noted that the training sessions were used as an opportunity to "sell" the new CAD/AVL system, by explaining its advantages, and trying to get acceptance and cooperation from the bus operators.

### ***Users' Perception of Benefits and Impacts***

Most personnel felt that one of the major benefits of the CAD/AVL system was the ability to enhance the personal security of operators and passengers. Although no one could cite specific circumstances in which the CAD/AVL system was able to pinpoint a vehicle carrying an operator or passengers in distress, all of the MARTA personnel recognize the ability of the AVL system to perform such a function. Supervisors indicated that when the entire bus fleet is AVL-equipped, this functionality of the CAD/AVL system will become more apparent.

Although bus operators have some complaints about the CAD/AVL system, they see the advantages of such a system. The bus operators' comments included that it is helpful to see an indication of their schedule adherence status displayed on the TCH. Also, the

ability to record messages from the BCC and read them at a more convenient time is seen as a convenience. Other comments included that it is helpful to have the BCC know the location of specific buses.

Supervisors and the dispatchers also see the advantages of the system. One of the benefits of the AVL-equipped buses is that operators can send canned messages back to the BCC, which is intended to reduce the amount of voice traffic.

Dispatchers, supervisors and operators feel that it is useful for dispatch and operations personnel to know exactly where each bus is located. Supervisors noted that, while they are able to guess where a vehicle is by checking a routing book, having AVL information available provides a quicker and more accurate location. Some operators interviewed feel more secure knowing that supervisory personnel are aware of their location, in the event that they need assistance. (Other operators, however, feel that the AVL data does not improve emergency response time enough.) Dispatchers also like having the mapping capability that is part of the AVL system available to them, as it can aid them in providing directions to all operators, not only those who are driving AVL buses.

Dispatchers and operators feel that knowing whether a bus is on schedule or not is helpful. At present, however, schedule adherence data from the CAD/AVL system is not being used to make real-time adjustments to service.

AVL is not currently being used to make schedule changes, either, since only a portion of MARTA's bus fleet is equipped. However, planning staff does have access to actual observations of events or occurrences, through the AVL playback feature, for which they would otherwise have only anecdotal evidence.

#### **6.4.2 Effectiveness**

Effectiveness is defined by examining changes in data availability; changes in procedures or activities; changes in emergency/incident response time; and changes in on-time performance due to the implementation of the CAD/AVL system.

##### ***Changes in Data Availability***

As a result of the implementation of the CAD/AVL system, dispatchers, supervisors, and bus operators have access to both location and schedule adherence data for a portion of the fleet. Service monitoring staff have access to on-time performance data for these buses in an automated format for the first time. Schedule adherence data, both statistical and graphical, is also available to planning staff, although at present, the information is of limited use. Customers can now be provided with stop announcements on-board some vehicles and schedule adherence information in some stations and at a few bus stops.

##### ***Changes in Procedures or Activities***

The presence of AVL equipment in buses and the BCC has resulted in changes to the way dispatchers, supervisors, bus operators, and planners and schedulers perform their jobs.

Most of the changes in procedures and activities, as described below, are relatively minor.

### **Dispatchers**

The BCC manager acknowledged that although the CAD/AVL system has the potential to dramatically change the way the dispatchers do their jobs, they are only slowly beginning to take full advantage of the system. This new technology requires new ways of approaching and carrying out tasks that many of the dispatchers have been doing for years. The manager indicated that one of the advantages of the CAD/AVL system is that what is in the veteran dispatchers' heads can now be made available to all dispatchers.

### **Bus Operators**

The CAD/AVL system has required operators and supervisors to change their procedures to a certain degree. Logging onto the CAD/AVL system correctly, and identifying the correct route and block number, are important new procedures. Communications between operators and the BCC have also required the use of new procedures.

### **Planners and Schedulers**

For the service schedulers in the planning department, the CAD/AVL system allows them to fine-tune schedules based on recorded observations of actual service. However, it should be noted that the schedulers indicated that they do not plan to change scheduling procedures based on issues that have arisen from the use of the CAD/AVL system. For example, eliminating situations that have proven to be problematic for the CAD/AVL system (such as the use of two timepoints in long stations) could require new scheduling procedures. Rather than revise scheduling policies and procedures, MARTA has identified these as issues to be addressed by the CAD/AVL system vendor.

### ***Changes in Emergency/Incident Response Time***

Dispatch personnel reported that the response to a silent alarm sent by the operator of an AVL bus actually takes a few seconds longer than the response to an alarm from a non-AVL bus. The alarm from an AVL-equipped bus must be cleared from the system before the dispatcher is able to communicate with the operator. Some operators are aware of the delay and will press the alarm button a second time, which lengthens the delay. Clearing the silent alarm on (non-AVL) buses equipped with the unmodified Motorola systems is immediate. Dispatch staff also pointed out that most alarms are set off accidentally – only about 1-2% of the alarms are real emergencies.

In the event of an emergency, knowing the exact location of a bus and having the ability to utilize the covert microphone to monitor events occurring on-board the vehicle are distinct advantages to dispatchers and emergency response personnel. No such incidents were reported by the MARTA staff interviewed in the course of this evaluation, however.

### ***Changes in On-time Performance***

The measurement of changes in the on-time performance of MARTA's bus service due to the implementation of an AVL system was not done as part of this evaluation. AVL information is not being used by MARTA's operations staff to make changes to on-street

service, and is used only to a limited degree by planning staff to make adjustments to routes and/or schedules to improve performance. The main reason that data is not being used in these ways seems to be the fact that only 240 out of 700 buses are equipped with AVL.

### **6.4.3 Financial Impact**

The costs associated with the entire ITS MARTA '96 project, including the CAD/AVL system, are discussed in Section 12. Identifiable fixed and variable costs of CAD/AVL components are presented below.

#### ***Fixed Costs***

According to the staff of MARTA Communications and Faregates department, it costs approximately \$27,000 per bus to fully equip it with all of the AVL features within MARTA's ITS program. This cost assumes making modifications to the existing radio system.

#### ***Variable Costs***

In interviews with the evaluation team, staff of MARTA's Communications and Faregates department indicated that their maintenance budget has not been severely affected by repairs of ITS equipment. In terms of the CAD/AVL system, problems with the IVLU units have been minimal, with typical repair costs of \$300-400 per unit. These units are sent back to the vendor for repair when necessary.

Another variable cost of the CAD/AVL system is monthly support from the software vendor. Monthly maintenance charges are roughly \$2,300. MARTA plans to transition from monthly to annual maintenance agreements with its ITS vendors in the near future.

The long range plan is to equip the entire MARTA bus fleet (around 700 buses) with AVL technology. When this happens, MARTA anticipates that additional dispatchers will be needed to monitor the CAD/AVL workstations. Additional staff will also be necessary in order to perform real-time analysis.

## **6.5 Achievement of Objectives**

Two of the established objectives apply to the CAD/AVL system. These are to enhance the quality of on-street service, and to improve system productivity and job satisfaction.

### **6.5.1 Quality of On-Street Service**

The CAD/AVL system has only partially met the objectives of enhancing the quality of on-street service to customers by, among other things, improving the quality, timeliness and availability of customer information, and improving safety and security. The real-time location information that the system provides has allowed MARTA to provide customers with improvements in the quality, timeliness and availability of information to a limited degree. MARTA's AVL system enhances the information that is available to customers by generating real-time location and schedule adherence data that is used by

the Customer Information Center, the wayside passengers information devices at selected rail stations and bus stops, and the on-board stop annunciators and electronic signs. However, because only one-third of the fleet is AVL-equipped and because the number of PIDs and on-board devices are limited, the impact on MARTA's customers is also limited.

Mostly what the CAD/AVL system has done is set the groundwork for MARTA to expand and refine its passenger information system. As MARTA develops the capacity to integrate the CAD/AVL technology with other electronic systems throughout the Authority (e.g., scheduling software), and is able to expand the number of routes and stops where real-time information is provided, customers will begin to see how these investments in technology are benefiting them.

In terms of passenger security, information generated by the AVL system is helpful. In the event of a service delay, passengers are notified via the PIDs about the anticipated departure time of a bus from the stop or station. They can then determine whether they feel secure enough at that location to wait for the bus, or whether they should make other arrangements. Again, because there are so few consistently operational PIDs and not all routes use AVL-equipped buses all of the time, this benefit is limited.

Improvements in bus operator safety and security are harder to assess. Fortunately, the types of extreme safety and security incidents where the AVL-provided location information could demonstrate its usefulness have been rare. As MARTA expands the number of AVL-equipped buses and as such incidents do occur, the MARTA staff and their passengers will see the value of this aspect of the CAD/AVL system.

### **6.5.2 System Productivity and Job Satisfaction**

The objective of improving system productivity and job satisfaction by:

- Improving schedule adherence and incident response;
- Improving the usefulness of data for service planning and scheduling;
- Enhancing the response to vehicle and facility failures;
- Providing integrated information management systems and develop improved management practices; and
- Reducing worker stress and increase job satisfaction

has been met to varying degrees. Overall, MARTA's AVL implementation appears to have had a limited impact on improved system productivity and job satisfaction based on users' perceptions of the system, and the limited data available. The following describes the extent to which each of the sub-objectives have been met.

- There was limited pre-implementation data available on schedule adherence, and therefore it is not possible to determine empirically that schedule adherence has improved.



- As mentioned above in the discussion of safety and security improvements, there have not been enough incidents requiring the information provided by the CAD/AVL system to determine whether or not there have been improvements in incident response. This lack of observations also affects the ability to make any determination of whether or not response to vehicle and facility failures has been enhanced.
- MARTA's planning staff feels that the information produced by the CAD/AVL system would be useful to them if it were available for a greater percentage of (or the entire) bus fleet .
- The CAD/AVL system has provided some improvements in integrated information management systems, and through its efforts to develop a central data warehouse, MARTA's ITS group is advancing this objective further. This data warehouse will inevitably lead to improved data management practices.
- There are no indications that the CAD/AVL system has reduced worker stress, but the bus operators, dispatchers, and supervisors expressed greater job satisfaction to the degree that the CAD/AVL system provides new information for doing their jobs.
- MARTA's test of CAD/AVL equipment that provides dispatchers with an automatic and accurate account of all bus locations and provide planners with improved information has been a success, as evidenced by MARTA's current plan to expand the CAD/AVL system to its entire bus fleet.



## Section 7 In-Vehicle Annunciators and Electronic Signs

### 7.1 Description

ITS MARTA '96 included a combination of light emitting diode (LED) signs (see Figure 8) and audio annunciators on-board buses to make passengers aware of upcoming stops, landmarks, and major intersections.



Figure 8. In-Vehicle LED Signs

Annunciator/sign systems were installed on about 95 AVL-equipped buses based at MARTA's Perry Garage. Each bus is outfitted with two signs. The annunciator replaces the existing public address (PA) amplifier on each vehicle, but existing speakers are used.

Announcements are triggered by latitude/longitude information from the intelligent vehicle logic unit that is activated when the vehicle operator logs in with the correct route and block numbers.<sup>8</sup> A Society of Automotive Engineers (SAE) J1708 network provides the interface between the IVLU, the annunciator and the signs. Route Schedule

---

<sup>8</sup> A block is defined in the *Transit Capacity and Quality of Service Manual* prepared for the Transit Cooperative Research Program by Kittelson & Associates, Inc. (Project A-15, TCRP Web Document 6, January 1999) as "the daily operating schedule of a transit unit (vehicle or train) between pull-out and pull-in, including scheduled and deadhead service. A block may consist of a number of runs."

Adherence (RSA) data contains Announcement Points which identify the latitudes and longitudes of announcements. Announcement Points have a threshold of 500 feet; when the IVLU determines that the bus is within that distance of the Announcement Point, it sends a message to the annunciator that identifies the latitude and longitude of the announcement. The annunciator uses that latitude and longitude to select the correct announcement and text message from the look-up table stored on a 20-megabyte Personal Computer Memory Card International Association (PCMCIA) card.

The bus operator and dispatch staff have the ability to override both announcements and the text messages displayed on the signs by activating the PA system on the Transit Control Head (TCH) or sending an SAE J1587 message to the annunciator.

Audio messages and sign text updated remotely by means of a master PCMCIA card, which is generated on a PC-based Central Recording System.

Fifty-two of the annunciators have been operational since February 1999.

## **7.2 Relation to Other ITS Components**

Signs and annunciators rely on the bus stop and schedule databases, and bus location data captured by the AVL system, to identify the appropriate stop, landmark, or intersection at the proper time.

## **7.3 Implementation Issues**

Discussions with MARTA staff identified several issues connected to the implementation of in-vehicle electronic signs and annunciators that may be informative for others considering the use of these technologies.

Announcing stops requires extensive data about stops and other items, which is time-consuming to collect and keep current. In the MARTA system, for example, the location and attributes of timepoints, 2,500 landmarks, and over 10,000 stops needed to be collected, checked, and in some cases, re-collected. The provision of more extensive and improved information to customers therefore involves a tradeoff in terms of staff time and expense.

MARTA's original bus stop database was not completely accurate. The students used for the initial collection of bus stop data, using GPS equipment and laptop computers, incorrectly placed announcement points and employed practices such as taking videos or written descriptions of stops in the field, which were later transcribed by someone else who had not actually seen the bus stop. Students also were not familiar with the requirements of the ADA and the terminology used to describe stops. As a result, MARTA staff feels that this function should not be outsourced, but rather performed by experienced individuals who have knowledge of the transit system.

## **7.4 Measures of Effectiveness**

The categories of measures that are used in this evaluation to judge how well the electronic signs and annunciators that MARTA installed on a portion of its bus fleet achieve established objectives include user acceptance, effectiveness and financial impacts.

### ***7.4.1 User Acceptance***

The users interviewed about the in-vehicle signs and annunciators included bus operators, street supervisors, and managers from the BCC and maintenance departments.

At the time of the evaluation team's site visit in December 1997, neither of the two bus operators interviewed about ITS technologies had had any experience with the signs/annunciators, but the two street supervisors interviewed were able to provide some information. During the next visit in March 1999, both bus operators interviewed had driven buses equipped with the signs/annunciators, and were able to share their opinions.

### ***Accuracy of Data***

Operators and supervisors gave examples of incorrect announcements, such as "North Avenue" instead of "Northpoint Mall", or incorrect timing of announcements (up to two blocks beyond the actual stop, for instance). Operators pointed out that most announcements were correct, and that problems were being rectified. (Announcements are checked by means of a van outfitted with AVL and annunciator equipment.) Supervisors noted that Point Supervisors at stations are notified when an annunciator has a problem, and the operator is instructed to override the annunciator with PA announcements.

### ***Reliability***

Supervisors noted that annunciators do not always announce stops when they are supposed to. This may be due to occasional errors in the stop/announcement data stored on the vehicle's PCMCIA card, or to the fact that announcements are not triggered if the bus detours by 400-500 feet away from the stop..

### ***Maintainability***

The maintenance requirements associated with in-vehicle signs and annunciators include not only the equipment, but also the bus stop database that, together with the schedule database, underlies the audible and text messages.

### **Equipment Maintenance**

MARTA's Radio Maintenance Department is responsible for managing the maintenance of many of the components of the ITS system, including the in-vehicle annunciators and signs. Since the contract under which the equipment was purchased does not call for the vendor to supply documentation or tools (so that MARTA staff could perform necessary maintenance), annunciators in need of repair are sent back to the manufacturer (Digital Recorders). The manufacturer sends them to another entity for the actual repair.

Currently, MARTA is charged a flat rate of \$500 for each unit that is returned. Radio Maintenance Department staff are not always satisfied with the quality of the repair work. At the time of the second site visit (March 1999), eight to ten annunciator units were in need of repair.

### **Data Maintenance**

In the fall of 1997, MARTA staff began to correct inaccuracies in the original bus stop inventory that was collected by Georgia Tech students. The data collection process took almost a year to complete (using two-person crews and two vehicles). In addition to the correction of stop locations and attributes, there was about a 10% change in ADA-related bus stop data. Based on this experience, MARTA staff feels that an update will be needed once every year or two in order to maintain the accuracy of the database.

### ***Changes in Job Requirements and Performance***

Bus operators preferred the automated stop and intersection announcements to making announcements themselves over the vehicle's PA system, or to notifying individual passengers that the stop they need is approaching.

### ***Effect on Customers***

Bus operators were very positive about the usefulness of the stop announcements and text messages to riders, particularly on routes that serve destinations such as hospitals or carry regular riders with vision impairments (Routes 23 and 85, for example). The announcements identify the connections with other routes that can be made at each stop, which passengers find useful.

### ***Users' Perceptions of Benefits and Impacts***

All users of the in-vehicle signs and annunciators feel they are beneficial to MARTA's riders. Bus operators also feel that automating the identification of stops for passengers through the use of this equipment is a benefit to them.

### **7.4.2 Effectiveness**

The effectiveness of the in-vehicle signs and annunciators can be determined primarily in terms of the changes in the procedures followed by operators and other MARTA staff as a result of their use.

### ***Changes in Procedures or Activities***

The in-vehicle signs and annunciators have added one task and removed one task from the job duties of bus operators. Operators must now log in with their correct route and block numbers to activate the system and trigger the signs and announcements but they no longer need to announce approaching stops for passengers over the PA system or notify passengers that the stop they need is approaching.

### ***Changes in Information Available to Customers***

As a result of the in-vehicle signs and annunciators, regular and consistent information about stops, major intersections, landmarks, and connecting bus routes is now automatically available to *all* passengers, including those with disabilities, on the routes on which the equipped buses are used. Passengers no longer need to request this information from the bus operator.

#### ***7.4.3 Financial Impact***

The costs associated with the entire ITS MARTA '96 project, including the in-vehicle electronic signs and annunciators, are discussed in Section 12. Identifiable variable costs and savings associated with the signs and annunciators are presented below.

##### ***Variable Costs***

Several types of variable costs have been identified. As mentioned earlier, MARTA currently pays a flat rate of \$500 for each annunciator unit that requires repairs by the manufacturer. Other variable costs include the four new staff positions that are responsible for maintaining the database of bus stops, timepoints, announcement points, and landmarks that is needed for the stop announcements (one staff person handles bus stops and timepoints; another, landmarks and announcement points; and two staff persons perform the necessary field work), and the one staff position that includes responsibility for updating announcements and preparing master PCMCIA cards.

##### ***Savings***

The in-vehicle signs and annunciators eliminate the need for bus operators to alert riders to upcoming stops, but do not generate any time savings for bus operators that can result in cost savings. The need for staff time to be devoted to maintaining the data used by the signs and annunciators and to keeping announcements correct, as well as the cost of necessary equipment repairs, may actually result in a net expenditure of resources.

### **7.5 Achievement of Objectives**

As shown in Table 2 (Section 2.2), the objectives of increasing the quality, timeliness and availability of customer information and communicating with persons with disabilities are applicable to in-vehicle electronic signs and annunciators.

#### ***7.5.1 Customer Information***

The electronic signs and annunciators installed by MARTA in over 50 buses make real-time information on approaching stops, landmarks, and major intersections available to the riders who are on them. For the most part, this information is timely and accurate; inaccuracies are identified and corrected within a reasonable timeframe. Prior to the use of this equipment, customers who asked were provided with this information by bus operators, but now information is available to all passengers in a consistent manner.

### **7.5.2 *Communication with Persons with Disabilities***

Another objective is to enhance the contribution of public transportation systems to overall community goals by, among other things, improving communication with users having disabilities. In-Vehicle signs and annunciators meet this objective by providing access to information about upcoming stops and other locations to passengers with hearing and/or visual impairments as well as to passengers without disabilities.



## Section 8

# Automatic Passenger Counter System

### 8.1 Description

The Automatic Passenger Counter (APC) units installed by MARTA on some of its AVL-equipped buses count the number of passengers boarding and exiting at each stop and tag this information by location and time of day. An infra-red beam system counts people when they interrupt the beam projected across a boarding and alighting area.

APC buses are assigned to routes as required to collect the data needed by the service monitoring group<sup>9</sup> to comply with the National Transit Database (formerly Section 15) reporting requirements, or as requested by the planning and scheduling departments to support analysis of a particular route's performance.

MARTA originally installed 15 APCs on buses equipped with AVL, but later purchased and installed 60 additional units. Seventy-four buses are equipped with APCs; about fifty to sixty of these are in service on any given day. Forty more APCs will be added as part of the purchase of smaller buses (i.e., 25 or 35 foot) currently in process, so that routes that use the smaller vehicles can be checked automatically.

The system was originally intended to operate by sending APC data via radio communications from each bus to the AVL server when that bus collected 2K of data. This would provide real-time data about passenger boardings and alightings for MARTA's planning and operations staff. With the number of APC buses typically in operation, this data transfer used about 64% of the data communications channel capacity. Alternative methods of transferring data are now being analyzed, including a daily download during the polling of the electronic fareboxes and transferring data from each bus periodically, using a diskette.

Four APC analysts work with the APC data. The lead APC Analyst builds block, trip, segment and stop files from the raw data. The lead analyst evaluates the accuracy of the APC data and cleans it, if necessary, before turning it over to the other analysts.

### 8.2 Relation to Other ITS Components

The passenger counts made by the APCs are correlated with the bus location data captured by the AVL system to identify the exact point at which ridership was counted.

### 8.3 Implementation Issues

MARTA staff had the following comments about the implementation of the APC system:

---

<sup>9</sup> Planning, Research and Analysis (including Service Monitoring), APC Processor, and Operations and Scheduling are all offices within MARTA's Department of Planning. The Department of Planning is part of the Division of Customer Development.

- The implementation of APCs and other ITS technologies has created the need for a paradigm shift from manual to automated procedures, and from a reactive approach to one of planning in advance.
- Users should be involved in the process of designing and implementing an APC system from the beginning.
- MARTA planning staff noted that there is a learning curve associated with using data collected by APCs– it takes time and experience to recognize accurate vs. inaccurate information.
- MARTA has not reduced the number of traffic checker positions since the implementation of the APC system, and it is not clear whether such a reduction in staff will happen in the future. MARTA planning staff feels that APC technology (and AVL technology) should not *replace* manual data collection methods, but that the two should be used to complement and validate each other.

Apart from the difficulties encountered with the transmission of data from the APCs, MARTA staff found that detailed passenger information is useful for planning purposes, but it is neither necessary nor very useful to obtain that information on a real-time basis.

## **8.4 Measures of Effectiveness**

The categories of measures that are used in this evaluation to judge how well the Automatic Passenger Counters achieve established objectives include user acceptance, effectiveness, and financial impacts

### **8.4.1 User Acceptance**

As long as an APC unit is installed and working properly, it takes no effort on the part of staff to use the equipment. “Using” the APC system means extracting and working with the data collected. In order to learn about MARTA’s experience with the use of APC data, the evaluation team interviewed four members of the research and analysis and service monitoring groups and three members of the planning department.

#### ***Accuracy of Data***

While the raw data captured by the APCs usually needs to be cleaned before it is analyzed, the Authority is comfortable with the quality of the data, and has made changes to bus routes and schedules on the basis of the information.

Ride checks and point checks performed by MARTA’s traffic checkers, together with the experience and knowledge of MARTA staff, are used to validate the APC data. Both types of data are used for service planning, since they both have their limitations. Overall trip and route segment level information is consistent between the APCs and the checkers, but stop by stop information sometimes varies. For example, when the bus is more than 500 feet away from a stop, the APC assigns data to the closest stop, which may not be the same stop to which a checker assigns that data. At intermodal terminals, where passengers can board and exit the vehicle repeatedly, the APC counts a passenger each

time someone crosses between its beams. A checker may record fewer passengers because he/she sees and records individuals.

APC data accuracy problems may also be due to difficulties with the data transfer to the optical drive that is used for long-term storage, (an integration issue) or vibration and loose connections.

A Comprehensive Bus Study, which relied exclusively on APC data to evaluate the efficiency and effectiveness of individual routes, was recently conducted by MARTA staff. The Comprehensive Bus Study is continuing, in order to measure the effects of the changes made as a result of the original study. The staff involved feel that the APC data is about 80 to 85% accurate, and that the data available from the APCs is much better than any information that was previously available.

### ***Ease of Use***

Planning department staff noted that extracting APC data for analysis is currently a cumbersome process. A trip file is typically too large to work with on MARTA's network, so staff must select specific data that they are interested in analyzing and move it to local computers. The planning staff working on the Comprehensive Bus Study then uses SPSS to analyze the data, and prepares a report that other planning department staff can work with using Excel spreadsheet software for other types of analysis.

At the time of the evaluation team's site visit in March 1999, the ITS Project Team was at work on the implementation of a data warehouse and development of an Intranet site that will provide access to ITS data for MARTA staff. The data warehouse and the Intranet site will eliminate the difficulties associated with using the APC data. In the meantime, a work-around solution for easier report generation is being developed by MARTA staff.

### ***Reliability***

Planning department staff estimates that about 60 APC buses are usually in operation. Some of those may be undergoing maintenance for reasons unrelated to the APC, with the result that about 40 buses are usually providing good quality APC data.

### ***Maintainability***

Maintenance department managers reported that the APC units are currently the greatest ITS equipment maintenance problem, although little repair work on the units has been done because the vendor is still working on several issues. Problems include the accuracy of passenger data and the transmission of data from the APC buses. An evaluation of the APC data transmission process, using nine APC units, was begun in February 1999.

### ***Changes in Job Requirements and Performance***

When MARTA relied exclusively on manual ride checks, all analysis was done on a case-by-case basis, using a calculator or information that had been transferred to a

spreadsheet. The service monitoring group prepared some summary statistics, such as passengers per hour. Files were stored on paper or microfiche.

With the electronic data collection capabilities offered by the APCs, service monitoring staff no longer needs to tally data manually. The planning and scheduling groups have access to more data on a more frequent basis.

No change in the number of traffic checkers has been made due to the installation of the APCs – the number of traffic checker positions has been reduced from a high of nineteen to the current nine as positions have gone unfilled and been eliminated due to budget constraints. One analyst position has been added since the APCs went into operation.

APCs, rather than one traffic checker, are now used to perform the National Transit Database sampling of trips (three trips are selected randomly every other day), freeing the checker to do other work.

### ***Effect on Planning and Scheduling***

MARTA Planning office staff uses statistics such as maximum load point, passengers per hour, passengers per trip, and passengers per mile (calculated with APC data,) to evaluate route and schedule changes for the schedule “mark-up” conducted two to three times a year. Adjustments are usually made to either peak or fringe service (e.g., early morning or late night service), since service is the most expensive to provide during those periods. Ridership is displayed graphically on routes with the help of the Planning Department GIS or an off-the-shelf trip planner. Viewing ridership in this way allows the Planning staff to see if there is potential for eliminating a route segment, even if the data is not totally accurate. More detailed information can then be obtained elsewhere. APC data is also used to evaluate the need to move or add a bus shelter. In addition, Scheduling office staff occasionally requests reports of APC data from the Planning office.

Since data can be collected much more quickly by the APCs and routes can be checked more frequently, the amount of data available to MARTA’s planners and schedulers has more than doubled. It is now possible to collect three observations of each trip on a route, a level of sampling that was not possible using manual data collection.

Information is also available in a more timely way. Four APC buses can check one route composed of four blocks in one day. It would take all nine traffic checkers more than a day to check the same route.

### ***Users’ Perceptions of Benefits and Impacts***

MARTA staff reported that having ridership data available in an electronic format is a huge benefit in terms of staff time. The quantity and timeliness of available data are also viewed as significant advantages of using an APC system.

### **8.4.2 Effectiveness**

The effectiveness of the APC system can be measured by the data that is now available as a result of the APCs and the changes in the way that staff performs their job duties that have resulted from the use of this technology.

#### ***Frequency of Use***

The APCs provide MARTA's planners and service monitoring staff with substantial amounts of data, which they use on an ongoing basis to evaluate the performance of the bus system. Planning staff are able to request that APC buses be assigned to particular routes at any time, and to obtain data that they need for their analysis. Service monitoring staff uses the APC system to collect the sample of data needed for MARTA's National Transit Database reporting; collection of this data occurs every other day.

#### ***Changes in Data Availability***

As noted above, the amount of data available to planners and schedulers has increased dramatically as a result of the installation of the APC system. Data is also available in a more timely fashion.

#### ***Changes in Procedures or Activities***

Changes in the requirements of various jobs as a result of MARTA's APCs are described above.

### **8.4.3 Financial Impact**

The costs associated with the entire ITS MARTA '96 project, including the APCs, are discussed in Section 12. Identifiable variable costs and savings related the APC equipment are presented below.

#### ***Variable Costs***

While it was noted by MARTA staff that they had encountered problems with the accuracy and transmission of APC data, little maintenance work on these units had been performed. As a result, no information about the variable costs of this equipment was available.

#### ***Savings***

As mentioned earlier, APC data was used to evaluate the performance of individual routes in MARTA's Comprehensive Bus Study. The first schedule changes recommended in the study, which were implemented in December 1998, resulted in net operating cost savings of approximately \$1.5 million. As the efficiency of the routes and schedules increases, the savings from future schedule changes are not likely to be as high.

## **8.5 Achievement of Objectives**

The objective of increasing system productivity by improving the usefulness of data for service planning and scheduling is applicable to the APC system.

### **8.5.1 System Productivity**

Use of APCs to collect ridership information has helped MARTA to meet the objective of improving data for service planning. Staff of MARTA's planning and scheduling groups now have much more ridership data more readily available to them than before the APC system was implemented. More routes can be checked more quickly and more frequently using the APCs than they can be checked by traffic checkers. Staff feels comfortable with the accuracy of the data collected by the APCs, although cleaning the data does require some staff time. While the current process for manipulating the APC data can be cumbersome, a permanent solution is being developed by MARTA's ITS Project Team.

## Section 9

### Wayside Passenger Information Signs

#### 9.1 Description

ITS MARTA '96 involved the installation of Passenger Information Devices in bus bays at selected stations and at bus stops as one of several means of supplying riders with travel information. These devices display schedule information for routes on which AVL-equipped buses are used on monitors (in stations, as shown in Figure 9) or LED signs (at stops and in Buckhead Station, as shown in Figure 10). The PIDs have the capability to display not only schedule information, but the expected departure time of the bus based on current location data from the AVL system, so that passengers are aware if a bus is running behind schedule.



Figure 9. PID Monitor



**Figure 10. PID LED Sign**

Fifteen units were purchased as part of the ITS MARTA '96 project. Thirteen devices (eight monitors and five LED signs) were installed at the Arts Center, Ashby, Buckhead, Dunwoody, Hamilton E. Holmes, Lenox, Lindbergh (two monitors), and West End Stations, and at bus stops at Peachtree and Pharr Road (two signs), and Piedmont and Tower Place (two signs). Two units are used as spares.

Video monitors are 27-inch displays while LED signs are approximately 60 inches across by 12 inches high. While both types of devices were designed to operate under the weather conditions typically found in Atlanta, the monitors are equipped with both heating and cooling systems. They are bolted or hung overhead in the rail stations. The LED signs are mounted on the inside of bus shelters. Both types of PID require access to power and a phone line.

The PID computers query the schedule portion of the AVL database to obtain updated information about the location of AVL-equipped buses. Buses scheduled to arrive at the PID's location are shown on the monitors or LED signs to be "On-time" (less than 2 minutes late), "Delayed 2 to 5 Minutes," or "Delayed 5 to 10 Minutes." The PIDs display a message of "No Status" for buses on routes that serve that location but are not equipped



with AVL. "No Status" is also shown for buses with which communications are intermittent. Staff is able to override the status message that is displayed for any particular bus; the MARTA staff person who is responsible for updating announcements for the in-vehicle annunciators and signs is also responsible for turning on and monitoring the PIDs.

## **9.2 Relation to Other ITS Components**

Information from the AVL system on-board a bus about its location and schedule adherence is sent to the BCC for additional processing. Information about the real-time departure of the bus from the stop or station is then sent to the PIDs from the BCC.

## **9.3 Measures of Effectiveness**

Measures of the effectiveness of the PIDs are their availability to provide passenger information, and their financial impact.

### **9.3.1 Availability**

As of March 1999, about seven of the PIDs were consistently operational. Problems had been experienced with others due to their locations, the difficulty of reaching them to perform maintenance, and their power supplies. PIDs are installed in some shelters that MARTA does not own, and therefore has no control over the power supply to the PIDs.

### **9.3.2 Financial Impact**

The costs associated with the entire ITS MARTA '96 project are discussed in Section 12. Identifiable variable costs associated with the PIDS consist of a monthly operating expense, primarily the cost of power and phone lines, of about \$108 per PID.

## **9.4 Achievement of Objectives**

In general, wayside passenger information signs such as the MARTA PIDs help to enhance the quality of on-street service to customers, in terms of improved information about services and enhanced security. As a result of knowing when each bus on a particular route is expected to depart from the stop or station, riders can decide if waiting for the bus is convenient and if they feel secure enough at that location to wait, or whether they should make other travel plans.

In the context of MARTA's ITS project, the PIDs that are installed in rail stations and at bus stops provide useful information to customers. However, because of the following, the impact they have on the riding public is very small:

- Only seven of the PIDs function consistently
- Problems with power supply

- Difficulty in performing maintenance on the devices as they are mounted (several PIDs cannot be reached without special equipment because they are installed high above the ground)
- PIDs only display information about AVL-equipped buses serving those stations or stops

## **Section 10**

### **Passenger Information Kiosks**

#### **10.1 Description**

As one of many efforts to assist the large number of visitors expected in Atlanta during the Summer Olympics, fiber optic links were established between MARTA's ITS system and Georgia's statewide network of electronic information kiosks. These "Travelink" kiosks comprise one component of the online information system for the state of Georgia managed by the GeorgiaNet Authority. Thirty-nine of the kiosks are located in MARTA rail stations. In addition to MARTA information, the kiosks provide access to traffic information from the GDOT Advanced Transportation Management System as well as weather reports, airline schedules, and other information of interest to visitors.

The goal was to provide the public with access not only to general MARTA information and bus and rail schedule information, but also to real-time schedule adherence information (for routes utilizing AVL-equipped buses) and individualized trip itineraries. The ability to request trip itineraries was to have been accomplished by means of connections between the kiosks and MARTA's PARIS®. However, due to the extremely tight time constraints imposed by the start of the Olympics, only the general MARTA information, bus/rail schedules and real-time bus departure times were available through the kiosks.

Following the Olympics, the software in the GDOT kiosks had been rewritten to provide bus and rail information and limited itinerary planning (for example, from an origin to a major landmark, or between landmarks) by means of access to MARTA's Internet site.

#### **10.2 Relation to Other ITS Components**

The GDOT kiosks obtained bus and rail schedule information from MARTA's schedule database, and schedule adherence information from the AVL system.

#### **10.3 Achievement of Objectives**

MARTA bus and rail information was provided to travelers through the GDOT electronic kiosks, both during and after the Olympics, but not to the extent that was originally envisioned. The trip itinerary planning function of PARIS® was not used by the MARTA Customer Information Center during the Olympics, due to the time constraints imposed on the PARIS® implementation, and was therefore not available to travelers through the kiosks.



## Section 11

### Smart Card Fare Payment System

#### 11.1 Description

Beginning in 1995, Visa International, in cooperation with three local Atlanta banks (First Union, NationsBank and Wachovia), initiated a smart card pilot program at MARTA. This program, in conjunction with the 1996 Olympic Games, was developed to test a stored-value contact<sup>10</sup> smart card in a multiple-use setting (e.g., transit, food, gasoline and other merchants). Two faregates at each entrance to MARTA's 36 rail stations, for a total of 132 read-write units (called card-accepting devices), were retrofitted to accept the VISA CASH card, at no expense to MARTA<sup>11</sup>. VISA CASH cards were accepted in these faregates beginning in May 1996.

VISA CASH cards could be purchased in denominations of \$10, \$20, \$50 and \$100 from MARTA<sup>12</sup>, the three banks and merchants. Cards could be purchased from card vending machines in MARTA rail stations and other high-traffic areas, from bank branches and by telephone from NationsBank.

While the MARTA pilot officially ended in December 1996, MARTA continued to accept the VISA CASH cards through 1997. However, currently, the banks are not issuing the cards, merchants are not accepting the cards, and MARTA has disabled the card-accepting devices on the faregates.

#### 11.2 Relation to Other ITS Components

The VISA CASH card pilot program at MARTA was not officially part of the Federally-funded ITS MARTA '96. The pilot program had no relationship to any of the other ITS components evaluated in this report.

#### 11.3 Implementation Issues

There were several problems during the initial implementation of the pilot program. First, customers were inserting coins and tokens in the slots intended for the CASH cards. This problem was solved by modifying the slots and posting additional signage describing how to use the VISA CASH card in these faregates. The modification consisted of installing a "restrictor" to the card slot, which made it virtually impossible to insert tokens, nickels and quarters. Dimes and pennies could still be inserted in the slot, but that was not a significant problem because dimes are used infrequently and pennies are not accepted for fare payment.

---

<sup>10</sup> Contact cards require physical contact between the card and the read-write unit, which involves inserting the card into a slot.

<sup>11</sup> The cost of retrofitting the faregates was covered by VISA. MARTA estimated these costs at \$1 million.

<sup>12</sup> In MARTA rail stations, the smallest denomination available for purchase was \$20.

Second, there was a problem when cards were purchased in card vending machines using credit cards. It was possible for someone using a stolen credit card to purchase a CASH card. Shortly after the Olympics were over, the credit card purchase option was removed from the card vending machines.

## **11.4 Measures of Effectiveness**

The categories of measures that are used in this evaluation to assess the success of the VISA CASH card pilot program include: user acceptance; functional characteristics; effectiveness; and financial impact.

### **11.4.1 User Acceptance**

Since the VISA CASH card pilot program involved MARTA in addition to other merchants, and was not initiated by MARTA, it is difficult to draw conclusions about user acceptance that relate specifically to MARTA. In fact, the amount of revenue collected from the CASH cards at MARTA was 0.02% in Fiscal Year 1996 and 0.27% in Fiscal Year 1997.

The usage of CASH cards at MARTA accounted for 25% of all CASH card transactions during the Olympics. The number of transactions in MARTA faregates in 1996 and 1997 is shown in Figure 11. As shown in Figure 11, usage peaked during the Olympics and trailed off significantly afterwards. The peak week of usage was the first week in August 1996 which had almost 18,000 transactions.

MARTA's assessment of the pilot program resulted in several conclusions related to user acceptance<sup>13</sup>:

- The VISA CASH card was targeted at occasional MARTA riders, and supports no fare discount program. The likelihood of the occasional MARTA rider using such a card can be increased if the card can be used for non-transit purposes (such as during the Olympics).
- The smallest denominated card that could be purchased in a MARTA rail station was \$20. Perhaps lower value cards, such as \$5 and \$10, would have increased the usage of the cards, particularly by lower income and infrequent riders.
- Card expiration was within a short time after purchase. If expiration dates were extended, more people may have been encouraged to purchase and use the cards.
- Offering both disposable and reloadable cards would appeal to various types of customers. Disposable cards would be appropriate for tourists and low-income customers, while reloadable cards could be used by frequent MARTA customers and/or those customers who have a relationship with a local bank.

---

<sup>13</sup> Degas A. Wright and Edward E. Gilcrease, "The MARTA Smart Card Pilot Program," paper presented to 1996 APTA Fare Collection Workshop, Houston, Texas, November 13, 1996; and Daniel Fleishman, Carol Schweiger, David Lott and George Pierlott, *Multipurpose Transit Payment Media*, Transit Cooperative Research Program Report 32, Transportation Research Board, National Academy Press, Washington, DC, 1998.

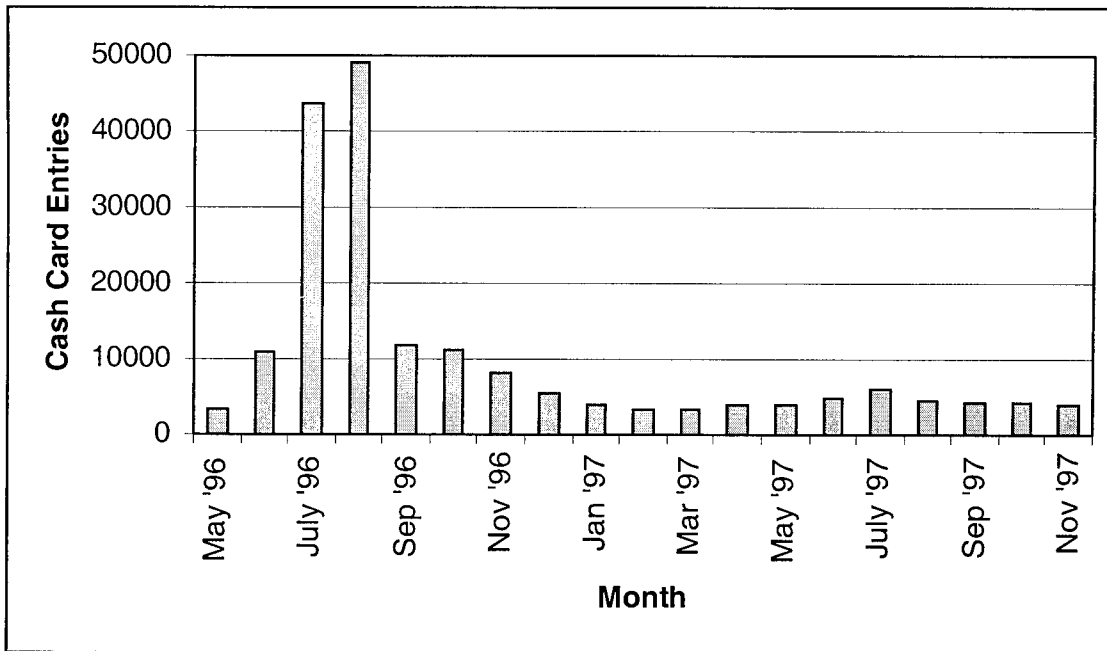

**Figure 11. VISA CASH Card Usage**

**11.4.2 Functional Characteristics**

The VISA CASH card could be processed in 1.75 seconds. This transaction time includes reading the value of the card, displaying the value to the customer, deducting the fare from the card, sending a signal to the faregate to release it, and displaying the remaining card value, and releasing the card to the customer. A transaction that involved an expired card could take 2 to 5 seconds to be processed.

The card-accepting devices were highly reliable. Between May and December 1996, they were 99.66% reliable.

**11.4.3 Effectiveness**

Changes in ridership and throughput due to the implementation of the VISA CASH card pilot program were not measured.

**11.4.4 Financial Impact**

Although VISA absorbed much of the costs of the pilot program, MARTA paid for the following:

- Transaction fee to the bank for each smart card transaction (this fee was negotiated to approximately 2%)
- Bank account fee (a flat monthly account maintenance fee)
- Transfer fee (approximately \$0.12 per transfer of funds from First Union to MARTA's bank)

- Some telecommunications costs (for communication lines between faregates and station telephone rooms)
- Some equipment maintenance costs (to remove and replace failed card accepting devices)

Specific costs in some of these categories were not recorded by MARTA. None of these costs were available to the evaluation team.

If MARTA considered installing their own smart card fare payment system, their goal would be to ensure that the transaction fee plus bank fees would be less than the cost of token fare sales, which at the time was 6.6% of token fare sales. Further, their long-term goal is to implement a smart card system that would significantly decrease the amount of cash and tokens used for fare payment. In 1996, cash and tokens accounted for 61.1% of all fares; in 1997, it was 58.4%. (The difference between 1996 and 1997 cash and token sales, a reduction in 2.7%, was due to increased sales of their farecards, called Transcards.)

## **11.5 Achievement of Objectives**

Although not officially part of the ITS MARTA '96 program, one of the national APTS objectives is relevant to the smart card pilot: enhance the quality of on-street service to customers.

Further, MARTA's objective to test electronic fare payment technology was directly related to the smart card pilot.

### **11.5.1 Quality of On-Street Service**

The results of the smart card pilot indicate that the convenience of fare payment was increased for rail travel. VISA CASH cards were available for purchase in many locations, and accepted by almost 500 merchants<sup>14</sup> (with a total of 4,200 card accepting terminals) at the time of the Olympics, making it very convenient to purchase and use the smart card in several locations.

Since the smart card could not be used in MARTA's bus system, convenience of fare payment between modes was not increased.

Safety and security issues regarding card purchase and use were not examined as part of the pilot program. One implementation problem – purchasing VISA CASH cards with stolen credit cards – could be considered a security problem. However, this problem was resolved after the Olympics concluded by removing credit cards as an option for VISA CASH card purchase.

---

<sup>14</sup> Excluding the 1,000 pay telephones retrofitted to accept the VISA CASH card



Information regarding the opportunities for customer feedback related to the smart card pilot program involved proprietary surveys conducted by VISA to determine the market success of the pilot. Generally, the survey results showed that:

- 70% of Atlanta residents were aware of the card
- 21% of Atlanta residents said they would probably or definitely buy or use the card
- 84% of those who used the card said they were satisfied or very satisfied with the card
- 28% of the card users said that a major benefit was avoiding the need to carry cash
- 24% of the card users said that a major benefit was avoiding the need to count out change

The major comment made by cardholders was the lack of merchants that accepted the cards. While there were almost 500 merchants accepting the card during the Olympics, this number trailed off considerably after the Olympics concluded. Further, merchants were located all around the Atlanta area, not concentrated around MARTA rail stations.

### **11.5.2 Financial Impacts**

The smart card pilot program did not significantly reduce transit system costs, since it accounted for a very small amount of revenue in 1996 and 1997, and required expenditures by MARTA (mentioned in Section 11.4.4). However, this program prompted MARTA to consider a full-scale smart card fare payment system for the future.



## Section 12 ITS System Costs

MARTA staff estimates that the total cost of developing and implementing its ITS system, from initial efforts in 1996 until July 1998 (the end of Phase I of the project), amounted to approximately \$20 million. This amount includes:

- Contracts with two private contractors to develop and implement the various ITS technologies described in preceding sections of this report – one firm was responsible for the elements of the base system; the other focused on the real-time information system
- An additional contract with a third firm to assist the Authority with ITS project management
- Renovations and power supply work in MARTA facilities that were needed to support the implementation of the various technologies
- Purchase of spare ITS equipment
- Staff time for meetings, training, database construction, and project management
- Overhead expenses related to the ITS deployment

The value of the three contracts, including both the initial contract amount and subsequent change orders, was as follows: Base System, \$8.5 million; Real-time Information System, \$8.5 million; project management and oversight, \$1 million. Approximately \$2 million was spent by MARTA on staff time, overhead, facility and power supply upgrades, and the purchase of spare ITS equipment.

Initial costs (before change orders) of Phase I for TMS and TRW only are shown in Table 4.

**Table 4. Initial Costs of MARTA ITS Components for TMS and TRW**

ITS Component	Description	Cost
CAD/AVL	In-Vehicle equipment	\$2,313,904
	Radio system	209,484
	AVL capabilities	72,383
	Schedule database	31,260
	Transit information center (TIC) equipment	1,392,452
	TIC floor layout review	7,268
	Loading the IVLU with software and firmware	65,896
	Capacity study	1,503
	Performance management/ ridership information system (PM/RIS)	318,117
	PM/RIS backup	28,546

**Table 4. Initial Costs of MARTA ITS Components for TMS and TRW (cont.)**

ITS Component	Description	Cost
	Motorola 5-year equipment maintenance	114,676
	Hewlett-Packard 5-year equipment maintenance	205,566
	Trimble 5-year equipment maintenance	262,831
	CAD/AVL 5-year equipment maintenance	444,373
	SYBASE 5-year equipment maintenance	23,898
	DCC 5-year equipment maintenance	55,547
	5-year software escrow fees	83,640
APC	APC equipment	445,386
	5-year equipment maintenance	39,646
Annunciators	Voice annunciators	927,714
	5-year equipment maintenance	75,107
	Signs 5-year equipment maintenance	42,729
PIDs	Wayside PIDs	340,212
	PID 5-year equipment maintenance	56,165
	Wayside sign 5-year equipment maintenance	51,993
ATMS	Interface with ATMS	124,342
	Probes to ATMS	32,921
	Integration of ITS to GDOT's ATMS	1,061,970
GIS	GIS	1,446,007
	Schedule database/bus stop inventory	848,877
PARIS®	PARIS®	2,443,550
Overall	Control data transfers	12,050
	On-site technical support	155,453
	Training and documentation	109,153
	Warranty and acceptance	215,066
	Project scheduling	98,953
	Project management	1,920,451
	Spares	209,363
	Additional TRW personnel	362,544
	TRW training, documentation and maintenance	311,337
TRW Contribution	-310,000	
<b>TOTAL</b>		<b>\$16,652,333</b>

## **Section 13**

### **Summary and Conclusions**

#### **13.1 Summary of ITS Technology Status and Benefits to Date**

The following sections summarize the status of MARTA's ITS technologies as of spring 1999, and the benefits being realized by the Authority at that time as a result of these ITS components.

##### ***13.1.1 Base Geographic Information System***

An updated base map, which is a component of the Base GIS used by the AVL and PARIS® systems, has been acquired to improve the accuracy of the maps displayed to users of those systems.

As a component of the AVL and PARIS® technologies, which enable MARTA to track vehicle locations and schedule adherence, respond more quickly to incidents, generate more useful information for planning and management purposes, and provide customer information, the Base GIS contributes to the achievement of these objectives. To the extent that the Base GIS is a part of these technologies, which have been identified by MARTA staff who use them as tools that make their jobs easier, it can also be said to have a positive impact on job satisfaction.

##### ***13.1.2 Trip Itinerary Planning System (PARIS®)***

PARIS® is fully operational. Data inaccuracies have been identified and corrected. Some modifications have been made to correct system bugs, change itinerary selection criteria, and add functions.

All Customer Information Center staff who were interviewed expressed positive opinions about PARIS®, and prefer using it to manual methods of responding to customer inquiries. The length of time needed for CIOs to respond to inquiries has not decreased as a result of the implementation of this technology (MARTA was not attempting to decrease average call length), but more calls are handled because customers have the option of obtaining routine information from the automated Voice Response Unit (VRU). The quality and consistency of information that MARTA provides to the public have also been improved by the implementation of the automated customer information system.

##### ***13.1.3 Link to Georgia Department of Transportation's (GDOT's) Transportation Management Center (TMC)***

The dispatchers at MARTA's BCC have access to the 300 video surveillance cameras monitored at the TMC, both to view the conditions that the cameras are recording, and to change the cameras' positions to view areas that are of interest to MARTA's operations. The TMC provides the dispatchers with visual information about the traffic conditions on the roads that MARTA buses travel, displayed on a bank of video monitors in the BCC. In addition, the TMC receives information from MARTA's CAD/AVL system which can

alert the traffic monitors to any slow-downs or unusual traffic conditions that the buses may be experiencing, or to accidents involving MARTA vehicles.

MARTA's access to traffic information from GDOT is likely to contribute to improved safety, security and travel times for MARTA's customers when BCC staff uses that information to route buses around problem areas or to implement other operational strategies. This information is also likely to aid MARTA's dispatchers and other operational personnel in making decisions that improve the adherence of MARTA buses in the affected areas to their schedules. Since the information that is exchanged between the two agencies involves real-time occurrences, the impact of the exchange on MARTA's service planning and scheduling activities is minimal.

#### **13.1.4 Computer-Aided Dispatch/Automatic Vehicle Location System**

CAD/AVL equipment has been installed on 240 buses, about one-third of MARTA's fleet. MARTA staff are now comfortable with the accuracy of vehicle location and schedule adherence data generated by the system.

Schedule adherence data is being used to evaluate the on-time performance of bus routes, but is not being used to guide planning decisions or real-time adjustments to the delivery of service. Bus location data is used to help dispatchers and street supervisors provide routine and emergency assistance to bus operators. Schedule adherence data is also sent to wayside passenger information devices. However, because only a portion of the fleet is equipped with AVL components and because the number of PIDs and on-board devices are limited, the impact on MARTA's customers is also limited.

Overall, MARTA's AVL implementation does appear to have improved system productivity and job satisfaction based on the user perceptions of the system, and the limited data available. MARTA's test of CAD/AVL equipment to provide dispatchers and planners with improved information has been a success, as evidenced by MARTA's current plan to expand the CAD/AVL system to its entire bus fleet.

#### **13.1.5 In-Vehicle Annunciators and Electronic Signs**

Ninety-five units each consisting of a stop annunciator and two electronic signs have been installed in AVL-equipped buses. Fifty-two units are currently operational.

As a result of the in-vehicle signs and annunciators, regular and consistent information about stops, major intersections, landmarks, and connecting bus routes is now automatically available to *all* passengers, including those with disabilities, on the routes on which the equipped buses are used. Passengers no longer need to request this information from the bus operator.

The in-vehicle signs and annunciators eliminate the need for bus operators to alert riders to upcoming stops. Bus operators feel that automating this function through the use of this equipment is a benefit to them.

### **13.1.6 Automatic Passenger Counter System**

Seventy-four APC units have been installed in AVL-equipped buses. Because data can be collected much more quickly by the APCs, routes can be checked more frequently. Thus, the amount of data available to MARTA's planners and schedulers has more than doubled. Information is also available in a more timely way.

MARTA staff reported that having ridership data available in an electronic format is a huge benefit in terms of staff time. The quantity and timeliness of available data are also viewed as significant advantages of using an APC system.

Data collected by the APCs is being used to prepare MARTA's National Transit Database reports. The information is also used to evaluate the performance of individual routes. A Comprehensive Bus Study, which relied heavily on APC data, recommended service changes that resulted in operational savings of \$1.5 million for the Authority.

### **13.1.7 Wayside Passenger Information Devices**

Television-style monitors and LED signs provide passenger information at bus bays in rail stations and at major bus stops. Of the thirteen PIDs originally installed, about seven are consistently operational. Failures have been due primarily to problems with the power supply at the bus shelters or bus bays where the signs are installed and to difficulty in reaching the signs to perform maintenance, because they are installed high above the ground. Anticipated real-time departures of AVL-equipped buses from the stop or station are posted on the PIDs. This information could improve the convenience of bus travel for riders, and contribute to increased passenger security. However, due to the low number of PIDs installed and operational, and the fact that only a portion of MARTA's bus fleet is AVL-equipped, the current impact of these devices on MARTA's customers is minimal.

### **13.1.8 Passenger Information Kiosks**

Fiber optic links were established between MARTA's ITS system and Georgia's statewide network of electronic information kiosks. Thirty-nine of the kiosks are located in MARTA rail stations. In addition to MARTA information, the kiosks provide access to traffic information from the GDOT Advanced Transportation Management System as well as weather reports, airline schedules, and other information of interest to visitors.

The original software used to operate the kiosks has been rewritten to connect users with MARTA's Internet site for access to bus and rail schedules and limited itinerary planning.

While MARTA bus and rail information was not provided to travelers through the kiosks to the extent originally planned, the kiosks are making helpful information available to the public.

## **13.2 Conclusions**

Not all of the components of MARTA's ITS system are currently having a significant impact on aspects of bus operations. The APC system and the PARIS®/VRU customer information system are having a positive effect. Data collected by APCs is being used to prepare MARTA's National Transit Database reports and to make adjustments in bus routes and schedules that have resulted in operational savings for the Authority. The availability of automated customer information through PARIS® and the VRU has resulted in improved operations in the Customer Information Center and better, more consistent information for MARTA's customers. Although results were not measured as part of this evaluation, GDOT's traveler information kiosks are providing access to useful information about MARTA service to the public.

The AVL system is being used to measure on-time performance, but is not yet being used to guide real-time adjustments to bus operations or as the basis for service planning decisions. In-Vehicle annunciators and electronic signs help the Authority to comply with its ADA requirements and benefit MARTA's riders, but since less than 100 units have been installed and only about one-half of these are in operation, the benefits of this technology are limited. Likewise, wayside passenger information devices provide useful information about the scheduled departure of buses from stops and stations, but with only a handful of operational PIDs providing information and only on AVL-equipped buses serving the stops where they are located, their impact on riders is small. MARTA's link to GDOT's Traffic Management Center is providing useful information to MARTA's operations personnel, but the impact of this information to date does not appear to be significant.



## Section 14

### Lessons Learned

#### 14.1 Introduction

The primary objective of this evaluation is to offer guidance to other organizations that are contemplating or planning for the adoption of ITS technologies similar to those implemented by MARTA as part of its ITS MARTA '96 project. The preceding sections have described the components of MARTA's ITS system and provided information about how those technologies are being used, users' perceptions about the benefits of those technologies, and the specific implementation issues that arose as those technologies were deployed. This section summarizes some of the key lessons about the implementation of ITS technologies.

#### 14.2 Lessons Noted by MARTA Staff

Throughout the interviews that were conducted for this evaluation, one topic was continually raised regardless of the ITS technology that was being discussed. This common theme was the uniqueness of the circumstances in which MARTA developed and implemented its ITS system. This contains a valuable lesson for future ITS implementations.

The opening date of the 1996 Summer Olympics imposed severe time constraints on the development and implementation of the components of MARTA's ITS system. The result was that all the desired capabilities were not in place by that date, and users did not have the chance to be as involved in the development and implementation of the ITS technologies as they would have been under more normal circumstances.

MARTA's experience indicates the importance of adequate time for careful planning and development of ITS systems that can address the needs of those who will use them on a regular basis (whether transit agency staff or customers or both), and for deployment of those systems in an transit operating environment.

Other advice offered by MARTA staff includes the following:

- ***Complete installations of ITS technologies would be of more practical use than partial implementations of multiple capabilities at one transit system.*** For instance, an entire bus fleet outfitted with ITS would be more useful to a transit agency than ITS on only a portion of the fleet, and wayside passenger information capability that applies to only those buses. The phased implementation of ITS technologies will affect the results achieved. A CAD/AVL system, for example, may not produce any significant benefits to the transit agency until the entire fleet is equipped.

- ***Working with other ITS stakeholders is important, to ensure that ITS systems are compatible with other transit-related ITS activities that are implemented elsewhere in the region.*** In MARTA's case, GDOT was a key partner in the deployment of some ITS technologies (the link to GDOT's TMC and the traveler information kiosks). Important stakeholders to involve in future projects include the Atlanta Regional Commission and neighboring counties.
- ***Daily users should be involved at the outset of the ITS development/deployment process.*** A dedicated core team representing each user group should oversee ITS projects from beginning to end. MARTA has successfully used this approach to develop and implement other complex systems in the past.
- ***Implementation of ITS technologies involves a paradigm shift for an agency, from manual to automated procedures, and from a reactive to a pro-active approach that emphasizes advanced planning.*** ITS technologies such as AVL and APC systems generate greater and more detailed data than a transit agency can collect manually. Such information can be used to make both real-time and planned improvements in service delivery. There is a learning curve associated with using the data that is collected by these systems. Moreover, additional staff may be required in order to use these new sources of data to their greatest potential.
- ***New technologies may require the addition of personnel, or enhanced capabilities, to the transit agency's maintenance staff in order to ensure that the technologies function correctly and produce the results expected by the agency.*** In MARTA's case, the lack of sufficient maintenance staff to address problems with related equipment (bus radios or electrical systems, for example) in a timely manner has had an impact on the operation of the CAD/AVL system.
- ***Responsibility for coordination among ITS vendors and overall project management should remain within the agency, and not be outsourced.*** By taking this approach, the agency will be able to ensure the greatest degree of control and consultation with users. However, this approach assumes that the agency has the appropriate dedicated resources to conduct the project management tasks and coordinate the vendors.
- ***The biggest problem encountered with the introduction of these technologies is the person/equipment interface.*** Advanced technologies may be designed and installed to function correctly, but may not if users are not fully aware of or do not use proper procedures. For example, if bus operators do not activate the CAD/AVL system correctly, or if customer information staff do not log on/off or request information from the itinerary planning system correctly, the performance of these systems will be affected.
- ***Organizational change is the greatest challenge presented by the adoption of advanced technologies.*** Many of the technological challenges faced by MARTA are not as significant as the organizational challenges. As other ITS projects across the U.S. have suggested, the organizational challenges should be addressed very early in an ITS project (e.g., in the initial consideration or planning phase).

- ***The commitment of the agency's management at the highest levels and the development of a process for evaluating needs and approaches are critical.*** MARTA's C EO Team is committed to the continuation and further development of ITS projects within the Authority (the expansion of the CAD/AVL system to the entire bus fleet and the paratransit vehicle fleet, for example) and to joint efforts in the ITS arena with other entities in the Atlanta region. The Authority's ITS Steering Committee is enabling the agency to take a systematic approach to the planning of future ITS efforts.

### 14.3 Additional Observations by Evaluation Team

- ***Implementation of ITS technologies takes time, and is an ongoing process.*** At MARTA, the introduction of some of the ITS technologies originally scheduled to be in place for the opening of the 1996 Summer Olympics was not completed until a year or two later. In addition, technological advancements continue to be made by the ITS industry, so that MARTA is now beginning to plan for the installation of newer versions of some of its ITS components, such as the PIDs and the CAD/AVL system.
- ***Benefits of implementing ITS technologies will not be realized immediately.*** As mentioned above, the introduction of advanced technologies requires changes to the attitudes and approaches of agency staff to the use of more automated procedures and the availability of richer data. Until those changes occur, some of the benefits made possible by ITS systems, such as real-time improvements to service delivery as a result of CAD/AVL data, may not be achieved. Moreover, implementation of ITS capabilities on only part of a fleet (CAD/AVL or stop annunciators and signs) or transit system (PIDs) may generate limited benefits. Maximum results will not be achieved until all phases of a systemwide installation have been completed.
- ***Knowledge of transit planning/management/operations and technical issues related to ITS are both needed.*** MARTA has found that experienced transit personnel as well as experts in computer hardware and software have been invaluable as its ITS project has progressed. For example, staff with detailed knowledge of MARTA's bus system have had the primary responsibility for ensuring the accuracy of the bus stop inventory used by many of the ITS systems. Technical experts have increased the stability of the entire ITS system, addressed Y2K compliance issues, made ITS data available to users within the Authority and planned for future support. With information from experienced staff about the operational aspects of providing transit service, technical experts are also able to communicate the needs of the agency's ITS users to outside vendors using the technical language of the ITS industry.
- ***Knowledge of the transit system is needed for the development of key databases like a detailed bus stop inventory.*** The bus stop inventory is utilized by several components of MARTA's ITS system – PARIS®, the CAD/AVL system, and the stop annunciators and signs. The accuracy of this database is critical. MARTA found that hiring college students to collect the initial bus stop

information was a flawed approach. This may not be a good function to outsource.

- ***Technological issues include compatibility and integration of ITS hardware and software components with each other and with existing agency systems. Integration of major components is a key factor in the success of an ITS implementation involving different systems.*** If components are interfaced but not fully integrated (for example, a fixed route scheduling system and a customer information system, AVL equipment and existing radios), implementation and ongoing use of the ITS technology will be more complicated.
- ***Organizational issues can require as much attention as technical issues.*** Incorporating responsibility for ITS systems into an existing organizational structure may be difficult. Functions that need to be assigned include communicating with ITS users; compiling, analyzing and distributing data; and performing or overseeing maintenance of system hardware and software. A lack of continuity in project management staff over the course of the ITS implementation can increase the complexity not only of the implementation process but also of the transition of ongoing ITS responsibilities to other parts of the organization.
- ***ITS applications do not always reduce the amount of time needed to perform functions, but they usually provide more and better information for decision-making.*** For example, PARIS® has not enabled MARTA's CIOs to handle more calls from customers, but has made a greater amount of information, and more consistent information, available.
- ***Contractors' working relationships can affect the smoothness of ITS implementation.*** Competition for work both within and outside of the ITS contracts within the agency may be a factor that affects communication and willingness to share information between contractors.
- ***Interest in and enthusiasm for ITS technologies within the organization is a necessity.*** Top level commitment to adequately develop staff so that ITS hardware and software is adequately maintained and information generated by the new technologies is used to benefit the agency, is needed.

## Appendix A Glossary of Terms

<b>APC</b>	<b>Automatic Passenger Counter</b> - An automated means for collecting data on passenger boardings and alightings by time and location.
<b>APTS</b>	<b>Advanced Public Transportation System</b> - Advanced technology system that improves public transportation operations, management, planning, communications and other aspects of public transportation service.
<b>ATIS</b>	<b>Advanced Traveler Information System</b> - Advanced technology system that collects, processes and/or disseminates information about the surface transportation system. ATIS can provide information pre-trip and en-route through a variety of media, including telephones, personal computers, the Internet, variable message signs, in-vehicle devices, kiosks, monitors, etc.
<b>ATMS</b>	<b>Advanced Transportation Management System</b> - ATMS employs advanced technologies to provide transportation information and/or to manage and control transportation networks.
<b>AVL</b>	<b>Automatic Vehicle Location</b> - Computer-based vehicle tracking based on location technology, such as the global positioning system
<b>CAD</b>	<b>Computer-Aided Dispatch</b> - Computer-assisted dispatch capability that is usually connected to an AVL capability.
<b>GIS</b>	<b>Geographic Information Systems</b> - A system of computer hardware, software and procedures designed to support the capture, management, manipulation, analysis, modularity and display of spatially-referenced data.
<b>GPS</b>	<b>Global Positioning System</b> - Technology using signals transmitted from a network of satellites in orbit.
<b>ITS</b>	<b>Intelligent Transportation Systems</b> - Advanced technologies applied to various aspects of transportation to enhance mobility, energy efficiency, and environmental protection.
<b>IVLU</b>	<b>Intelligent Vehicle Logic Unit</b> - A device that is connected to a vehicle's radio to provide the interface between other in-vehicle devices, such as a mobile data terminal and a global positioning system receiver.
<b>TCRP</b>	<b>Transit Cooperative Research Program</b> - A program administered through the Transportation Research Board which provides continuing applied research on transit issues. The program is sponsored by the Federal Transit Administration.
<b>TMC</b>	<b>Transportation Management Center</b> - Employs advanced technologies to provide transportation information and/or to manage and control transportation networks.



## **Appendix B**

### **Site Visit Interview Schedules and Topics**

#### **Proposed Interview Schedule, MARTA ITS Evaluation**

#### **December 8-10, 1997**

##### **Monday, December 8**

*Location and approximate time of day:* MARTA Headquarters, following any introduction/overview by MARTA staff; 3:00 p.m. until 5:00 p.m. or until close of business

*MARTA staff:* IT staff knowledgeable about maintenance requirements and histories of the following systems (hardware and software components):

- ◆ TIPS
- ◆ In-vehicle annunciators and electronic signs
- ◆ Wayside signs and station monitors
- ◆ AVL
- ◆ Base GIS
- ◆ Data interchange between MARTA and GDOT
- ◆ Smart card fare collection

##### **Tuesday, December 9**

*Location and approximate time of day:* MARTA Headquarters, start of business until close of business, with Transit Information Center and Customer Information Center staff interviewed between approximately 10:00 a.m. and 3:00 p.m. (or between the morning and afternoon peak periods), and GIS users interviewed before 10:00 a.m. and after 3:00 p.m.

*MARTA staff:*

- ◆ Representative(s) of GIS users from Operations, Planning or other department(s); approximately 15-20 minutes with each.
- ◆ 3-5 staff members from the Transit Information Center who are familiar with AVL; in-vehicle signs and annunciators and wayside signs, if TIC personnel are involved with programming this equipment; and the data interchange between MARTA and GDOT. 20-30 minutes will be needed with each.
- ◆ Customer Information Center manager: one hour.

- ◆ 4-6 Customer Information Agents who are familiar with TIPS; agents who also have experience with the prior manual method of responding to inquiries would be especially helpful. 20-30 minutes will be required with each for interviews, plus about one hour's time with one agent to assist with test itinerary requests.

### **Wednesday, December 10**

*Location and approximate time of day:* One of two garages out of which buses equipped with AVL and annunciators/signs operate; several hours will be needed, preferably after the morning peak period.

*MARTA staff:* (1) 4-6 bus operators who have used buses equipped with in-vehicle annunciators and electronic signs (these operators will also be familiar with the AVL technology). About 15-20 minutes will be needed with each operator. (2) Several supervisors who cover the routes on which the ITS-equipped buses operate. About 15-20 minutes will be needed with each supervisor; these interviews could be conducted while waiting for operators to become available.

*Location and approximate time of day:* GDOT headquarters, 1-2 hours in the afternoon. (This meeting could also be scheduled for the morning of Thursday, December 11.)

*Staff:* GDOT staff involved in any data interchanges with MARTA.



## 1. TIPS/PARIS

### Approximate amount of time required:

- TRW - 1 hour
- Mary Jack Jones - ½ hour
- TRW and/or MARTA staff familiar with PARIS costs - ½ hour
- CIOs - ½ hour each with 2 CIOs

Data: List of functional modifications made to PARIS since our visit; list of weights and penalties used by PARIS to rank itineraries.

Source: Jim Young or contractor (TRW)

Data: The number and type of staff involved in implementing and maintaining TIPS/PARIS (e.g., schedules, bus stops, landmarks and other information).

Source: The contractor (TRW) or the MARTA staff in charge of maintaining PARIS

Data: The number of times different menu items are accessed in TIPS/PARIS

Source: The contractor (TRW) or the MARTA staff in charge of PARIS. Possibly, reports generated by the system itself will contain this information.

Data: The number of calls handled by Customer Information Officers (CIOs), their average length, and the number of lost calls, both before and after the implementation of PARIS. This will come from Automatic Call Distributor (ACD) data and reports, if those are now available to MARTA staff.

Source: Mary Jack Jones, Manager, Schedule Information

Data: Fixed costs of TIPS/PARIS.

Source: MARTA and/or TRW staff, to review and update cost information given to us by TRW during our site visit

Data: Variable costs of TIPS/PARIS, especially costs related to training, updating information in the system, and maintenance (if data is available).

Source: MARTA and/or TRW staff

Data: CIO impressions of the accuracy and ease of use of the base maps in TIPS/PARIS.

Source: Customer Information Officers

Data: The nature and frequency of system failures over time.

Source: Contractor (TRW)

Data: Frequency of scheduled and unscheduled maintenance.

Source: Contractor (TRW)

## 2. AVL

### Approximate amount of time required:

- Bus operators - ½ hour each with 2 operators familiar with AVL system
- Control center dispatchers - 1 hour
- Supervisors - ½ hour with 2 supervisors familiar with AVL system
- Control center or planning department staff responsible for monitoring on-time performance - ½ hour
- New programmer responsible for AVL/APC data in RPMIS - ½ hour
- David Patterson - ½ hour
- MARTA or TRW staff familiar with AVL costs - ½ hour
- E.T. Kelly - ¼ hour

Data: Perceptions of staff on the timeliness of the data collected and generated from the AVL system.

Source: Bus operators, supervisors, and control center dispatchers

Data: Changes in data availability, dispatcher interfaces, and scheduling procedures due to the implementation of the AVL system.

Source: Control center dispatchers

Data: Perceptions of reliability, accuracy and ease of use of AVL data.

Source: Control center dispatchers, bus operators

Data: Changes in emergency/incident response time and response procedures (qualitative discussion).

Source: Control center dispatchers

Data: Data or information to describe changes in on-time performance.

Source: TIC staff or others who monitor on-time performance (e.g. planners). MARTA's new in-house programmer responsible for facilitating use of AVL/APC data in the Ridership Performance Management System (RPMIS).

Data: Information that can be used to identify problems and describe the reasons for them; for example, "false early", "fallback mode" and logon problems.

Source: Appropriate MARTA staff

Data: Nature and frequency of AVL equipment failures over time.

Source: David Patterson

Data: Frequency and duration of scheduled and unscheduled maintenance.

Source: David Patterson

Data: List and explanation of all canned messages that can be sent from TIC to AVL bus; list and explanation of all canned messages that can be sent

from AVL bus to TIC; number of “requests to talk” before and after AVL system was installed.

Source: E.T. Kelly

Data: Series of AM and PM lot check sheets which record problems with buses and their equipment.

Source: Perry Garage supervisors

Data: Fixed costs of AVL.

Source: MARTA and/or TRW staff, to review and update cost information given to us by TRW during our site visit

Data: Variable costs of AVL, especially costs related to training, updating information in the system, and maintenance (if data is available).

Source: MARTA and/or TRW staff

Data: Data on savings related to the AVL implementation (if available).

Source: Appropriate MARTA staff

Data: Any anecdotal stories or descriptions of how the AVL system has helped make a job better, easier, more efficient.

Source: Anyone who uses the system or comes in contact with it

### **3. GIS**

#### **Approximate amount of time required:**

- Milow Bowes and Bill Bullock - ½ hour
- Planning department staff - ½ hour
- MARTA staff familiar with interface between GIS and schedule database - ¼ hour
- TRW or MARTA staff familiar with GIS costs - ¼ hour

Data: Who uses the GIS system (PARIS, AVL, planners) and what’s gone into getting it up and running and available to the different users (including negotiations with Navtech for an updated base map)? Who and how many people are involved in maintaining the GIS system and keeping it updated? Information about issues related to the interface between the GIS and other systems (such as the Planning department GIS and the schedule database).

Sources: Are likely to include Milow Bowes and Bill Bullock (bus stops); Planning department staff; Scheduling department staff, if different from Milow Bowes and Bill Bullock, and MARTA staff member who is familiar with the interface with the schedule database. Meetings with these groups will be separate.

Data: Fixed costs of base GIS.  
Source: MARTA and/or TRW staff, to review and update cost information given to us by TRW during our site visit

Data: Variable costs of base GIS (if data is available).  
Source: MARTA and/or TRW staff

#### **4. Automatic Passenger Counters**

##### **Approximate amount of time required:**

- Planning and/or scheduling department staff and ride check manager - ½ hour
- David Patterson - ¼ hour
- MARTA or TMS staff familiar with costs of APCs - ¼ hour

Data: Information on what technology is actually used to count passengers.  
Source: Bill Bullock, Division of Transportation Planning and Scheduling

Data: Perception of APC data accuracy, reliability, utility, effect on planning and scheduling, ease of use and job requirements.  
Source: Planning, Scheduling department staff

Data: Information (maybe the report) on the study of bus routes that relied on APC data.  
Source: Someone in the Planning department; perhaps Bill Bullock.

Data: Nature and frequency of failures over time.  
Source: David Patterson

Data: Frequency and duration of scheduled and unscheduled maintenance over time.  
Source: David Patterson

Data: Fixed costs of APCs.  
Source: MARTA and/or TMS staff, to review and update cost information given to us by TMS during our site visit

Data: Variable costs of APCs (if data is available).  
Source: MARTA and/or TMS staff

Data: Savings related to the APC implementation; have the number of ride checkers been reduced, or is more data being collected than before the installation of APCs? Is there still a role for human ride checkers?  
Source: Ride check manager?

## 5. Wayside Passenger Information Signs

### Approximate amount of time required:

Staff who could discuss the accuracy etc. of the PIDs and customer reaction to them - ¼ hour

David Patterson - ¼ hour

MARTA or TMS staff familiar with cost of PIDs - ¼ hour

Data: Observation of type and accuracy of information provided on PIDs

Source: Spot checks of operational PIDs

Data: Staff's perception of accuracy, timeliness, utility of information provided on the PIDs

Source: Bus operators; supervisors; staff at stations; CIOs at Five Point information booth, if PIDs are installed there; others?

Data: Perceptions of the effects of the signs on customers

Source: Station personnel, bus operators, CIO's (if applicable); observations

Data: Number of staff members involved in operation and maintenance of PIDs

Source: Contractor (TMS) or MARTA staff

Data: Nature and frequency of failures over time

Source: David Patterson

Data: Frequency and duration of scheduled and unscheduled maintenance over time

Source: David Patterson.

Data: Fixed costs of PIDs

Source: MARTA and/or TMS staff, to review and update cost information given to us by TMS during our site visit

Data: Variable costs of PIDs, particularly costs of operations and maintenance (if data is available)

Source: MARTA and/or TMS staff

Data: Savings related to PID implementation

Source: Appropriate MARTA staff

## 6. GDOT ATMS

### Approximate amount of time required:

E.T. Kelly and dispatchers - ½ hour

MARTA or TRW staff familiar with costs of ATMS interface - ¼ hour

Data: Information about data that is transferred between MARTA and GDOT, ease of exchange, accuracy and reliability of data, staff involved, frequency of exchanges, changes in schedule adherence and/or incident response time as a result. Description of earlier problems with transfer of information from MARTA to GDOT

Source: E.T. Kelly, possibly control center dispatchers

Data: Fixed costs of ATMS interface

Source: MARTA and/or TRW staff, to review and update cost information given to us by TRW during our site visit

Data: Variable costs of ATMS interface (if data is available)

Source: MARTA and/or TRW staff

## **Control Center**

### **Schedule Monitor (Emmitt Kelly)**

- ◆ AVL, including base GIS map
- ◆ In-vehicle electronic signs and annunciators
- ◆ Wayside signs and station monitors
  
- \* Basic description of system, number and type of components, locations; description of current procedures involving the system
  
- \* How many dispatchers are there? Are they unionized?
  
- \* How many total buses operate out of the two garages that the ITS-equipped buses operate from?
  
- \* How many buses is each dispatcher responsible for?
  
- \* How many dispatchers are on duty at different times of the day?

Who uses the technology?

What is it used for?

How often is it used?

How reliable is the system hardware? Software?

Are there times when it is unavailable? How often do they occur? How long do they last?

How accurate is the data used, generated or displayed by the system?

How timely is the data?

How useful is it?

Who else uses data generated by the system? What do they use it for?

How easy is the technology to use?

What effect has the system had on operating procedures?

What effect has the system had on the requirements of your job?

Do you feel it has enhanced your ability to do your job? In what way?

Do you feel it has hindered your ability to do your job? In what way?

Has the system had an effect on procedures used to respond to incidents, or on response time?

Has the system had an effect on schedule adherence?

Has the system had an effect on on-street operations?

Has the system had an effect on communications with operators?

Are there functions that the system performs well? What are they?

What functions do not work so well?

What do you like best about the system?

What would you change?

How easy was it to learn how to use the system?

What type and amount of training did you receive?

Did you feel that training was enough to make you feel comfortable with the system?

What do you feel are the benefits to the system?

Do you see things that you'd like to be able to do with the system that are not being done now? What are they? What prevents them from being done now?

When you first heard that MARTA was planning to install this technology, what was your reaction?

Have your perceptions about the system changed since it has been implemented? In what way?

**Additional questions for dispatchers (exclude starred questions above)**

How long have you worked in the Transit Information Center?

**Data exchange with GDOT (if control center staff are involved in this)**

What data elements are exchanged?



How many staff are involved?

How often is data exchanged?

For what purpose(s) is data exchanged?

Is the exchange of data logged automatically?

How easy is the data exchange process?

How long does it take?

How accurate is the exchanged data? How timely? How useful?

How reliable is the data exchange mechanism or process?

## **GIS Users**

### **Staff from Operations, Planning, other departments**

What do you use the GIS for?

How often do you use it?

How easy is it to use?

How easy was it to learn how to use the system?

What amount and type of training did you receive?

Did you feel that this training was sufficient to make you feel comfortable with the system?

How accurate is the base GIS map?

What other data is used by the GIS (bus stop locations, bus routes, accessibility information, bus schedules, etc.)?

How often do MARTA bus and rail schedules change?

How frequent are route changes?

Does the GIS usually contain current route, stop, schedule data?

How is the data maintained or updated?

How often is the data updated?

How easy is the update process? How time-consuming?

Can the system accept data from external sources (another GIS, or previously compiled computer files of bus stop locations or schedule information, for instance)?

Are there times when the system is unavailable? How often do they occur? How long do they last?

Are there functions that the system performs well? What are they?

What functions are not performed so well?

Do you see potential future uses for the system? What are they?

Who else uses the GIS? What do they use it for?

Who uses information generated by the GIS? What do they use it for?

How accurate is the information generated by the system?

How timely?

How useful?

How have procedures, capabilities or functions in your department changed because of the availability of the GIS?

Do you feel the GIS has enhanced your ability to do your job? In what way?

Do you feel it has hindered your ability to do your job? In what way?

What benefits do you see to the GIS?

When you first heard that MARTA was planning to install this technology, what was your reaction?

Have your perceptions about the system changed since it has been implemented? In what way?

## **MARTA Customer Information Center**

Mary Jack Jones  
Edward Traylor  
Gina Johnson  
Mark Fawley, TRW

In operation 7 days a week: M-F 6a - 10p  
weekends, holidays, 8a - 4p

18 full-time, 5 part-time Customer Information Operators (Officers?)  
2 supervisors  
1 Customer Assistant - does training  
2 Customer Information Representatives at Five Points Station information booth, using  
TIPS

## Information Technology Staff

**Personnel responsible for maintenance of each of the following technologies (either performing maintenance or dealing with maintenance contractor):**

- ◆ TIPS
- ◆ In-vehicle annunciators and electronic signs
- ◆ Wayside signs and station monitors
- ◆ AVL
- ◆ Base GIS
- ◆ Data exchange between MARTA and GDOT's ATMS (TMC)
- ◆ Smart card fare collection

Basic description of system, number and type of components, locations (ITS Program Manager may be better able to answer this)

Estimate of purchase price of system, any other available cost information (ITS Program Manager may be better able to answer this)

Maintenance records documenting instances of unavailability and cause, maintenance activity performed and amount of time spent

Have there been any modifications to the components or the functionality of the system that were not included in the original specifications? What were they?

Who maintains the components of the technology, both hardware and software?

How often is scheduled maintenance performed?

What does scheduled maintenance include?

How often are repairs needed because of system failure performed? (perhaps from maintenance records)

How easy are the components to maintain (availability of replacement parts, timeliness of repairs, how easy is it to identify particular problems, disruption to operations, etc.)

Are there recurring problems that cause failures? What are they? What maintenance response do these problems require?

How reliable are the components?

How often is hardware, software unavailable to the users? (from maintenance records)

Have these technologies caused any changes in the requirements of your job? What are they? Have any caused any changes in your ability to do your job? What are they?

When you first heard that MARTA was planning to install this technology, what was your reaction?

Have your perceptions about the system changed since it has been implemented? In what way?

### **Specific questions pertaining to each technology**

#### **TIPS**

What is the response time of the system at specific load levels (i.e., number of users)?

#### **In-vehicle signs and annunciators, wayside signs and station monitors**

How would you describe the quality of the audio component of the annunciators? How legible are the visual displays?

#### **GIS**

What is the ability of the system to accept data from an external source (such as another GIS system, for example)? How easy is this process?

How was the original bus stop location data that was collected using hand-held GPS devices entered into the GIS? How easy was that process?

#### **Interface with GDOT (if IT staff are involved in this)**

What data elements are exchanged?

How many staff are involved?

How often is data exchanged?

For what purpose(s) is data exchanged?

Is the exchange of data logged automatically?

How easy is the data exchange process?

How long does it take?

How accurate is the exchanged data? How timely? How useful?

How reliable is the data exchange mechanism or process?