

Best Practices for Commercial Vehicle Monitoring Facilities Design

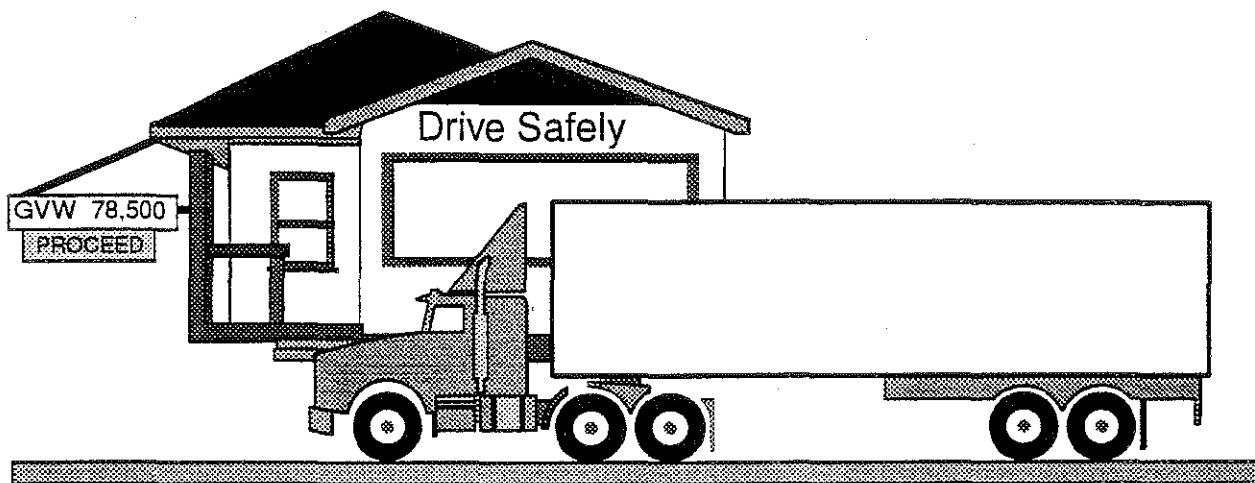

U. S. Department
of Transportation

**Federal Highway
Administration**

Office of Motor Carriers

September 1995
Publication No. FHWA-SA-96-001

Notice

This document is disseminated under the sponsorship of the Department of Transportation in the interest of information exchange. The United States Government assumes no liability for its content or use thereof.

The contents of this report reflect the views of the authors, who are responsible for the facts and accuracy of the data presented herein. The contents do not necessarily reflect the official policy of the Department of Transportation.

This report does not constitute a standard, specification, or regulation.

The United States Government does not endorse products or manufacturers. Trademarks or manufacturers' names appear herein only because they are considered essential to the object of this document.

Best Practices for Commercial Vehicle Monitoring Facilities Design

Prepared By

Kentucky Transportation Center
College of Engineering
University of Kentucky
Lexington, KY 40506

and

JHK & Associates, Inc.
Emeryville, CA 94608

Prepared For

U.S. Department of Transportation
Federal Highway Administration
Office of Motor Carriers
Washington, DC 20590

September 1995

1. Report No. FHWA-SA-96-001		2. Government Accession No.		3. Recipient's Catalog No.	
4. Title and Subtitle Best Practices for Commercial Vehicle Monitoring Facilities Design				5. Report Date September 1995	
				6. Performing Organization Code	
				8. Performing Organization Report No.	
7. Author(s) N. Stamatiadis, R. C. Graves, and J. Schmidt				10. Work Unit No. (TRAIS)	
9. Performing Organization Name and Address KENTUCKY TRANSPORTATION CENTER COLLEGE OF ENGINEERING UNIVERSITY OF KENTUCKY				11. Contract or Grant No. DTFH71-94-AP126-KY-17	
				13. Type of Report and Period Covered Final	
				14. Sponsoring Agency Code	
12. Sponsoring Agency Name and Address Kentucky Transportation Cabinet State Office Building					
15. Supplementary Notes Prepared in cooperation with the U.S. Department of Transportation, Federal Highway Administration					
16. Abstract The great technological advances that were made over the last decade in monitoring traffic and the increased emphasis on highway safety for truck traffic have prompted a need to determine more effective ways to monitor and inspect truck traffic. Commercial Vehicle Monitoring (CVM) facilities provide the highway community with the means of supervising truck traffic. However, in an era with limited funds and space for roadway expansion, some consideration must be given to the types of facilities needed and the most efficient way to spend the available funds. Hence, a research study was initiated to determine the successful practices for designing a new CVM facility or retrofitting or upgrading an existing facility; the findings are presented here. A questionnaire was distributed to all 50 states to identify the state of the nation with respect to the newly constructed and lately upgraded CVM facilities. This report focuses on the presentation of issues that need to be considered and addressed when designing or upgrading a CVM facility and provides a checklist of critical factors, considerations for facility components, and typical facility layouts.					
17. Key Words Weigh Stations Commercial Vehicles Intelligent Transportation Systems			18. Distribution Statement Unlimited with approval of Federal Highway Administration Administration Transportation Cabinet		
19. Security Classif. (of this report) Unclassified		20. Security Classif. (of this page) Unclassified		21. No. of Pages 151	22. Price

SI* (MODERN METRIC) CONVERSION FACTORS

APPROXIMATE CONVERSIONS TO SI UNITS

APPROXIMATE CONVERSIONS FROM SI UNITS

Symbol	When You Know	Multiply By	To Find	Symbol
LENGTH				
in	inches	25.4	millimeters	mm
ft	feet	0.305	meters	m
yd	yards	0.914	meters	m
mi	miles	1.61	kilometers	km
AREA				
in ²	square inches	645.2	square millimeters	mm ²
ft ²	square feet	0.093	square meters	m ²
yd ²	square yards	0.836	square meters	m ²
ac	acres	0.405	hectares	ha
mi ²	square miles	2.59	square kilometers	km ²
VOLUME				
fl oz	fluid ounces	29.57	milliliters	mL
gal	gallons	3.785	liters	L
ft ³	cubic feet	0.028	cubic meters	m ³
yd ³	cubic yards	0.765	cubic meters	m ³
MASS				
oz	ounces	28.35	grams	g
lb	pounds	0.454	kilograms	kg
T	short tons (2000 lb)	0.907	megagrams (or "metric ton")	Mg (or "t")
TEMPERATURE (exact)				
°F	Fahrenheit temperature	5(F-32)/9 or (F-32)/1.8	Celsius temperature	°C
ILLUMINATION				
fc	foot-candles	10.76	lux	lx
fl	foot-Lamberts	3.426	candela/m ²	cd/m ²
FORCE and PRESSURE or STRESS				
lbf	poundforce	4.45	newtons	N
lbf/in ²	poundforce per square inch	6.89	kilopascals	kPa

Symbol	When You Know	Multiply By	To Find	Symbol
LENGTH				
mm	millimeters	0.039	inches	in
m	meters	3.28	feet	ft
m	meters	1.09	yards	yd
km	kilometers	0.621	miles	mi
AREA				
mm ²	square millimeters	0.0016	square inches	in ²
m ²	square meters	10.764	square feet	ft ²
m ²	square meters	1.195	square yards	yd ²
ha	hectares	2.47	acres	ac
km ²	square kilometers	0.386	square miles	mi ²
VOLUME				
mL	milliliters	0.034	fluid ounces	fl oz
L	liters	0.264	gallons	gal
m ³	cubic meters	35.71	cubic feet	ft ³
m ³	cubic meters	1.307	cubic yards	yd ³
MASS				
g	grams	0.035	ounces	oz
kg	kilograms	2.202	pounds	lb
Mg (or "t")	megagrams (or "metric ton")	1.103	short tons (2000 lb)	T
TEMPERATURE (exact)				
°C	Celsius temperature	1.8C + 32	Fahrenheit temperature	°F
ILLUMINATION				
lx	lux	0.0929	foot-candles	fc
cd/m ²	candela/m ²	0.2919	foot-Lamberts	fl
FORCE and PRESSURE or STRESS				
N	newtons	0.225	poundforce	lbf
kPa	kilopascals	0.145	poundforce per square inch	lbf/in ²

* SI is the symbol for the International System of Units. Appropriate rounding should be made to comply with Section 4 of ASTM E380.

These metric equivalents for distance, dimension, and weight quantities give more detailed information for commercial vehicle size and weight programs. For more information refer to 59FR51060, Thursday, October 6, 1994.

Weight	Distance and dimension
1 pound = 0.4536 kilograms	1 mile = 1.609 kilometers
1 Metric ton = 2,205 pounds	1 foot = 0.3048 meters
1 Metric ton = 1,000 kilograms	1 inch = 25.4 millimeters

Quantity	Metric equivalent
1 lb	0.4536 kg
1,000 lbs	450 kg
20,000 lbs	9,070 kg
34,000 lbs	15,420 kg
80,000 lbs	36,290 kg

TABLE OF CONTENTS

	Page
EXECUTIVE SUMMARY	xi
1. INTRODUCTION	1
1.1. Problem Statement	1
1.2. Purpose of the Report	2
1.3. Report Organization	2
2. CHANGING ENVIRONMENT FOR COMMERCIAL VEHICLE OPERATIONS/FACILITY DESIGN	3
2.1. Forces Affecting Motor Carrier Operation	3
2.2. A Vision for Advanced Commercial Vehicle Monitoring Facilities	4
3. EXISTING CONDITIONS	7
3.1. Literature Review	7
3.1.1. General Aspects	7
3.1.2. New Technologies	8
3.2. Overview of Current Truck Inspection and Monitoring Practice	12
3.2.1. Legislative History	12
3.2.2. Commercial Vehicle Roadside Enforcement Functions	13
3.2.3. Weight Enforcement Activity	14
3.2.4. Driver and Vehicle Safety Enforcement Activities	17
3.2.5. Commercial Vehicle Enforcement Strategies	19
3.2.6. Infrastructure Damage Related to Overweight Trucks	21
3.3. Status of Commercial Vehicle Monitoring Facilities	23
4. CASE STUDIES	31
4.1. Overview of Enforcement Program	31
4.1.1. Colorado	31
4.1.2. New Mexico	33
4.1.3. Oregon	34
4.1.4. Utah	36
4.1.5. Virginia	38
4.2. Overview of Most Current Facility	39
4.2.1. Colorado--Trinidad	39
4.2.2. New Mexico--Gallup	41
4.2.3. Oregon--Woodburn	44
4.2.4. Utah--St. George	46
4.2.5. Virginia--Stephens City	49
5. FINDINGS	53
5.1. Procedural Considerations	53
5.1.1. Program Objectives	53

5.1.2. Commercial Vehicle Facility Design and Development Process	55
5.1.3. Commercial Vehicle Facility Components	61
5.1.4. Critical Factors in Designing a CVM Facility	70
5.2. Current Experience	72
5.2.1. Building Considerations	72
5.2.2. Facility Layout Considerations	73
5.2.3. Operational Considerations	75
5.2.4. General Comments	76
5.3. Schematic Layouts	76
5.3.1. Layout Type A	78
5.3.2. Layout Type B	80
5.3.3. Layout Type C	82
5.3.4. Layout Type D	84
5.3.5. Additional Layouts	86
APPENDIX A. COMMERCIAL VEHICLE MONITORING FACILITY LAYOUT FOR CASE STUDIES	87
APPENDIX B. REMAINING CASE STUDIES	97
APPENDIX C. ANALYSIS PROCEDURES FOR QUEUE AND DELAY AT WEIGH FACILITIES	115
APPENDIX D. STATE CONTACTS	129
APPENDIX E. LIST OF ACRONYMS	137

LIST OF TABLES

Table 1. Truck weight enforcement budget and statistics by state, 1992	16
Table 2. MCSAP safety inspection overview, 1987-1992	18
Table 3. Research outcome	53
Table 4. Steps for design process	56
Table 5. Sample matrix of goals and functions	58
Table 6. Sample matrix of functions and solutions	59
Table 7. Checklist for development and design process for a facility	71
Table 8. Matrix of facility functions and required facility components	72
Table 9. Definition of diagram components	77

LIST OF FIGURES

Figure 1. Number of permanent facilities by state	15
Figure 2. Number of mobile enforcement units by state	15
Figure 3. Percent citations and percent portable weighings by state	17
Figure 4. Summary of truck weight violations on California highways	20
Figure 5. Pavement damage costs associated with overweight trucks	22
Figure 6. Survey form	25
Figure 7. States recently upgraded/retrofitted or constructed new facilities	26
Figure 8. States planning to upgrade/retrofit or construct new facilities	26
Figure 9. Summary of features in new facilities	27
Figure 10. Summary of types of upgrades and retrofits	27
Figure 11. Summary of purpose for upgrade or retrofit	28
Figure 12. Summary of types of monitoring facilities	28
Figure 13. Signal display	40
Figure 14. Building layout	41
Figure 15. Changeable message display	45
Figure 16. Building layout	46
Figure 17. Changeable message display	47
Figure 18. Building layout	49
Figure 19. Building layout	51
Figure 20. Schematic process of problem-solving approach	55
Figure 21. Schematic process of CVM facility development and design	56
Figure 22. Example of flow chart for vehicle process	59
Figure 23. Schematic layout of a facility	60
Figure 24. Layout types	77
Figure 25. Layout Type A--Mainline sorting with additional on-ramp sorting	79
Figure 26. Layout Type B--Mainline sorting only	81
Figure 27. Layout Type C--On-ramp sorting only	83
Figure 28. Layout Type D--No sorting	85
Figure 29. Alternative layout for Type A	86

LIST OF TABLES IN APPENDICES

Table C.1. Mean arrival rate to static scale and bypass route, Dumphries, SB, Va.	118
Table C.2. Goodness-of-fit for traffic arrival headway distribution	119
Table C.3. Processing time for weight and size enforcement	119
Table C.4. Capacity of static scales	119
Table C.5. Goodness-of-fit for truck processing time distribution	120
Table C.6. Suggested sorting threshold factor	121
Table C.7. Frequency of mainline backup	124
Table C.8. Evaluation of alternatives	125
Table C.9. Required length of ramp	125

LIST OF FIGURES IN APPENDICES

Figure A-1. Colorado--Trinidad	89
Figure A-2. New Mexico--Gallup	90
Figure A-3. Oregon--Woodburn	91
Figure A-4. Utah--St. George	92
Figure A-5. Virginia--Stephens City	93
Figure A-6. Idaho--East Boise	94
Figure A-7. Kentucky--Kenton	95
Figure B-1. Changeable message display	110
Figure B-2. Westbound building layout	111
Figure B-3. Changeable message display	112
Figure B-4. Building layout	113
Figure C-1. Bypassing probability vs sorting threshold factor	122
Figure C-2. Pull-in probability vs vehicle weight	122
Figure C-3. Average delay at Vancouver POE	127
Figure C-4. Average queue length at Vancouver POE	127

EXECUTIVE SUMMARY

The great technological advances that were made over the last decade in monitoring traffic and the increased emphasis on highway safety for truck traffic have prompted a need to determine more effective ways to monitor and inspect truck traffic. Commercial Vehicle Monitoring (CVM) facilities provide the highway community with the means of supervising truck traffic. However, in an era with limited funds and space for roadway expansion, some consideration must be given to the types of facilities needed and the most efficient way to spend the available funds. Hence, a research study was initiated to determine successful practices of designing a new CVM facility or retrofitting or upgrading an existing facility; the findings are presented here. This report focuses on presenting the issues that need to be considered and addressed when designing or upgrading a CVM facility and provides a checklist of critical factors, considerations for facility components, and typical facility layouts.

A questionnaire was distributed to all 50 states to identify the state of the nation with respect to the newly constructed and lately upgraded CVM facilities. A large number of states (21) indicated that they had constructed a new facility within the past 2 years, while 32 states had upgraded some facilities within the past 3 years. Moreover, a number of states are planning to either construct a facility (19) or upgrade existing ones (29) within the next 3 years. Most of the upgrades have focused on items that will increase the level of enforcement and upgrade existing equipment, while the construction of new facilities has incorporated a number of new technologies.

Ten states were selected for site visits for additional study of their newly constructed, upgraded, or retrofitted facilities. The site visits demonstrated that each state has a different philosophy with respect to the funds that it is willing to invest in such facilities and that these differences are indeed reflected in the facility design. Furthermore, the groups involved in the design and development process of each facility play an important role in the facility layout and amenities and frequently reveal the presence or absence of a team concept during these processes.

The first step in the design and development of a CVM facility is the development of objectives and goals of the commercial vehicle operations (CVO) program and its components. The use of a systems approach for identifying the needs and objectives of the CVO program can provide a holistic solution to the "problem" of determining the purpose and functions of the program. The next step is the evaluation of the existing facilities and technologies to determine if they meet the objectives of the CVO program. Then solutions can be considered for achieving the program goals. Solutions may include constructing a new facility, upgrading existing facilities by retrofitting them with modern equipment, and changing the process for completing activities.

After the purpose and functions of a CVO program have been identified and the existing facilities evaluated, the process required, that is, construction of a new facility or upgrade of an existing one, must be determined. This determination is guided primarily by the availability of state monies,

the general philosophy of the responsible agencies, and the condition and location of existing facilities.

The general process can be divided into three categories: pre-design, design, and construction. During the first stage of the pre-design, a number of steps need to be taken to establish the basis for design:

- *Identification of design "partners"*
- *Development of an enforcement plan and goals*
- *Development of facility functions*
- *Identification of solutions to facility functions*
- *Development of the facility flow*
- *Conceptual layouts of the facility*
- *Sizing of facility components*
- *Addressing future expansion of the facility*
- *Establishment of a procurement and construction process*

A major step is the development of facility functions and identification of the equipment to be used for completing this step. The minimum functions that must be developed are discussed in the following paragraphs in the order in which they would be encountered by a commercial vehicle approaching the facility.

▶ *Vehicle sorting*

This function allows for determining which commercial vehicles are to be called into the facility for additional checking and inspection.

▶ *Ramp system and Internal roads*

Entering, moving within, and exiting the facility occur via entrance and exit ramps and internal roads. For most roads and turns, the turning radii should be longer than recommended by the

American Association of State Highway Transportation Officials (AASHTO), since inexperienced drivers may have problems in maneuvering.

▶ *Vehicle weighing*

Two main alternatives are available for weighing--static scales and weigh-in-motion (WIM) devices.

▶ *Vehicle inspection*

Two types of inspection bays are possible: open pit and flat bay. Some cover for inspection areas is desirable.

▶ *Credential inspection*

This activity is traditionally conducted in the main personnel building. However, modern technologies will allow automated credential checks and building design should consider this possibility.

▶ *Vehicle parking*

Commercial vehicles failing to comply with weight and size limits, having safety problems, being impounded, or being placed out-of-service require an area where they can park. The size of this area as well as a parking area for personnel and visitors should be addressed in designing the facility.

A critical factor checklist is included in the report findings to allow authorities to determine most of the issues that need to be addressed when designing or upgrading a CVM facility. A matrix that correlates the various functions performed in the facility with the required equipment and components of the facility is also provided. Finally, a set of typical layouts of CVM facilities is presented and categorized by the type of sorting that is applied.

1. INTRODUCTION

There are over 600 commercial vehicle inspection stations (weigh stations and ports of entry) in the United States. Federal statutes mandate that states perform vehicle weight checks and vehicle/driver safety inspections; these activities are usually carried out at fixed inspection enforcement sites. Nearly 160 million trucks and about 1 million vehicle/driver safety inspections are conducted each year at these sites.

Many of the nation's fixed enforcement stations were constructed 20 or 30 years ago. Growth in truck traffic often significantly exceeds projected design volumes for these stations. When truck arrivals exceed station operating capacities, queues and delays develop. Eventually, backup may require closing the station to avoid safety risks.

Passage of the 1991 Intermodal Surface Transportation Efficiency Act (ISTEA) introduced a new paradigm and a changing vision for state enforcement interactions with commercial vehicle operators. The ISTEA legislation established a national Intelligent Transportation System (ITS) program to confront safety issues, congestion, productivity concerns, adverse air quality, and other ills of the nation's transportation system infrastructure. Included in this framework are functions and elements that focus directly focused on commercial vehicle operations.

ISTEA and ITS have focused much attention on productivity, safety, and administrative efficiency for commercial vehicle functions. Electronic clearance, streamlined administrative services, safety screening and

clearance, and other applications have been developed and are being demonstrated in field operational tests. Leading states have measured highly beneficial results from applying advanced technology to commercial vehicle enforcement processes.

1.1. PROBLEM STATEMENT

Electronic clearance at enforcement stations is a major element of ITS initiatives for commercial vehicle operation. Relatively few existing stations in the nation are presently designed, equipped, or operated with efficient electronic clearance or safety inspection screening capabilities. Further, many state and consultant designers of inspection facilities are not well versed in ITS/CVO operational concepts and technologies, nor is there widespread knowledge of commercial vehicle functions and processes that take place at these inspection sites. This situation yields facility designs that compromise operational efficiency and productivity for both state agencies and motor carriers. These issues must be addressed to obtain more productive and efficient state and commercial vehicle operations.

ITS commercial vehicle operations are moving beyond research and operational tests to pilot installations and full deployment. Many of the nation's fixed enforcement sites will be modernized; some new stations will be constructed. Western states participating in the HELP, Inc. consortium and members of the ADVANTAGE I-75 partnership in the Southeast and upper Great Lakes area already are deploying these advanced concepts and ITS designs for roadside enforcement. The I-95 Coalition and other

groups are planning related initiatives. Thus, development and dissemination of information and guidelines to support design activities become increasingly important to foster informed decisions and successful deployments.

1.2. PURPOSE OF THE REPORT

This document examines state-of-the-art practices in design and operation strategies for commercial vehicle inspection stations. Its purpose is to provide the design community with guidelines for designing commercial vehicle monitoring facilities that incorporate best practices and use advanced technology elements from the ITS tool kit repertoire. However, this report does not provide specific dimensional values for designing these facilities, since facility geometrics are generally site specific. AASHTO's "A Policy on Geometric Design of Highways and Streets 1994"¹ should be the basis for geometric design decisions. This report focuses on the presentation of issues that need to be considered and

1. American Association of State Highway and Transportation Officials, "A Policy on Geometric Design of Highways and Streets 1994," Washington, D.C. 1995.

addressed when designing commercial vehicle monitoring facilities. The goal is to provide a tool to assist state administrations in developing efficient and productive motor carrier operations in their state.

1.3. REPORT ORGANIZATION

The report is organized into five sections. Following this introduction, Section 2 describes the changing environment for motor carrier inspection operations. Section 3 summarizes North American inspection activity levels and practices. Section 4 of the report presents results of site visits to several states where state-of-the-art technologies are currently being utilized. Section 5 reviews a literature search regarding inspection facility design practices and related enforcement processes.

Case studies of 10 state/province organizations were conducted to examine best practices and design features of state-of-the-art facilities. Five of the 10 case studies are presented in Section 4, while the remaining are given in Appendix B. The results and key findings of the research are summarized and presented along with design considerations and schematic layouts in Section 5.

2. CHANGING ENVIRONMENT FOR COMMERCIAL VEHICLE OPERATIONS/FACILITY DESIGN

2.1. FORCES AFFECTING MOTOR CARRIER OPERATION

Freight transportation in the United States accounted for approximately 6 percent of the GNP in 1992.² Freight transportation, and trucking in particular, is a vital service to all segments of the national economy; it affects the overall cost of doing business and influences production and distribution reliability. It also directly impacts the competitive position of the United States vis-a-vis other nations and regions. The ISTEA legislation recognizes freight transportation's significance by explicit reference.

Powerful forces are at work that strongly influence the highway freight sector. Business and commerce have undergone remarkable globalization, increasing the importance of logistics and transportation services. Globalization is accompanied by widespread organizational restructuring, cost reduction, downsizing, and integrating transportation service providers within the production system.

Motor carrier deregulation has sharpened the competitive edge within the trucking industry. Intense competition in that industry drives carriers to differentiate themselves in customer service quality, to search out higher levels of efficiency, to eliminate empty miles wherever possible, and

to deploy technology where it can improve productivity or shave cost margins.

State and federal governmental agencies face increasingly challenging economic realities in meeting transportation needs. Amid fierce competition for available funds, service demands that frequently outstrip facilities and resources, and higher traffic volumes, there is strong pressure to streamline operations to improve efficiency and productivity.

ITS applications for commercial vehicles are aimed at improving the timeliness, efficiency, and quality of freight operations. ITS goals in the commercial vehicle arena are to improve safety, increase productivity of state agencies and commercial fleet operators, and streamline administrative processes for credentials, licenses, permits, and tax collection apparatus. Much of the attention in ITS/CVO initiatives to date has focused on two main areas--"transparent borders" to allow legal and compliant commercial vehicles to travel unimpeded across state borders (much as cars now do) and "one-stop shopping" to facilitate obtaining necessary licenses, permits, and related regulatory credentials from a single source. As ITS user service concepts were refined, the above elements have been restructured under "electronic clearance" and "administrative services" headings. Other user services have been defined for automated roadside safety inspections, on-board safety monitoring, hazardous materials incident response, and fleet management.

2. Eno Foundation, Transportation in America, 1994.

2.2. A VISION FOR ADVANCED COMMERCIAL VEHICLE MONITORING FACILITIES

A vision of commercial vehicle monitoring (CVM) facilities of the future is useful to illustrate the key concepts and principles that should guide facility planning and design.

Two fundamental features distinguish the future scenario from prevailing current design practice and operating strategies:

- Electronic vehicle identification will be used to clear vehicles through a facility and perform the necessary compliance verifications at the roadside without unnecessary delay to legal and safe vehicles
- A data exchange system and network will be available to support Electronic Data Interchange (EDI). These transactions make key decision support information available to inspection personnel at roadside sites on a timely basis.

Additional operational elements of the future inspection scenario are summarized below. This framework is based on the Commercial Vehicle Information System Network architecture under development by the John Hopkins University Applied Physics Laboratory.³

- Regulatory compliance will be executed via electronic verification without unnecessary delay to legal and safe vehicles

- Resources are focused on high-risk safety elements
- Information to support electronic verification and safety compliance is available to inspection sites via electronic data exchange systems
- Carrier, vehicle, and driver identification is provided by electronic, vehicle to roadside communication readers and transponders using a common protocol across North America
- A commercial vehicle information exchange system facilitates information exchange among states, carriers, office and roadside activity sites, shippers, insurance companies, and other commercial vehicle stakeholders
- Carriers may selectively choose from a wide variety of technologies and systems to support equipment location, routing and dispatch, equipment monitoring, electronic logs, fleet management, and mileage reporting
- Carriers who elect to implement driver fatigue alertness systems and related on-board safety sensing technology may be granted incentive waivers of reporting requirements
- Roadside inspection strategies and resources will be distributed between mobile units and fixed sites
- Fixed inspection sites will be equipped as smart stations
- Some inspection locations will be "virtual" sites--sites that will not affect normal

³ John Hopkins University Applied Physics Laboratory, "Preliminary Draft: Operational Concept for a Commercial Vehicle Information System Network," February 1995.

mainline traffic operations in performing compliance verification. These sites may be manned or unmanned.

The distinguishing characteristics of future smart inspection stations will be the use of information technology to satisfy roadside data needs in a timely manner, coupled with advanced technology to facilitate efficient identification and verification processes. These technological elements collectively will enable electronic identification of carriers, vehicles, and drivers; automated size and weight compliance; safety screening and selectivity of high risk operators; and automated credentials compliance validation.

Getting from the status quo (that is, the present) to the future scenario will be an evolutionary, multistep process. Many of the features and capabilities outlined above are possible today, albeit only in rudimentary form in some cases. The most significant shortcoming of present commercial vehicle operations at roadside truck monitoring facilities is the absence of electronic data exchange and the absence of modern information technology. As a result, rather than electronic verification and automated truck clearance processing with a minimal vehicle delay, inspection activities rely heavily on manual procedures and visual checks.

3. EXISTING CONDITIONS

3.1. LITERATURE REVIEW

3.1.1. General Aspects

One major component of a CVM program is the measure of the effectiveness of enforcement. National Cooperative Highway Research Program (NCHRP) Research Project 20-34,⁴ "Developing Measures of Effectiveness for Truck Weight Enforcement Effectiveness," looks into this area on a nationwide basis.

To quantify program effectiveness, there must be some a measurement scale in place to show the benefits of compliance with size and weight laws, the amount of pavement or bridge damage due to overweight vehicles, fines collected as a result of violations, and reduction of accidents.

In the past, most measures of effectiveness were based on comparisons between the number of vehicles weighed and the number of overloads detected. Also, evaluations have been made comparing the operating cost of the program with the amounts of fines collected. In many cases, such analyses do not take into account the increased damage that is being done to pavement and bridge structures.

The general objectives of NCHRP Project 20-34 are as follows:

- To develop and validate truck weight enforcement measures of effectiveness

4. NCHRP Project 20-34, "Developing Measures of Effectiveness for Truck Weight Enforcement Effectiveness," Interim Report, Transportation Research Corporation, Haymarket, VA, July 1994

(that is, indicate what is accomplished as the result of enforcement activities)

- To document findings in a user guide format to explain appropriate data collection methods, how to apply these methods, and how to interpret the results.

To achieve these objectives, this project evaluated the various methodologies that have been used across the country to monitor effectiveness. Numerous studies have been conducted regarding the pavement damage that can be associated with overweight trucks. Many of these studies quantified this damage in terms of increased rehabilitation or maintenance costs. However, some differences in opinion were observed. This study has conducted an extensive literature review to help determine the most appropriate methods for evaluation of enforcement program effectiveness.

Numerous technical advances have been made in recent years that are enhancing the movement of goods nationwide. These advances have in some instances required governing agencies to alter the traditional way in which they have enforced the size and weight laws. These technological advances have allowed for increased capacity of existing facilities and for the construction of new facilities that are able to keep pace with the emerging technologies.

Many states have developed in-house guidelines for the design and operation of CVM facilities. However, many of these states do not have a formal document that outlines the guidelines or procedures for these facilities. Many facilities have been constructed based on past experience and information gained from other states.

There has been little documented research that outlines the planning and design parameters for CVM facilities. A study was done by the Geometric Design Branch, Highway Design Division, Office of Engineering, Federal Highway Administration (FHWA)⁵ in the early 1980's. The objective of the study was to obtain available technical information on truck weigh and safety inspection stations from FHWA regional and division offices. These comments covered a wide range of areas. Specific information was given regarding various design procedures that have been utilized in various states. These comments were categorized as follows: Design Guides, Design Volumes, Geometric Design, and Safety Inspection Program. The Geometric Design section was further broken down into the following subsections: Alignment, Ramps, Scale Approach, Scale House, Internal Circulation, Inspection Area, Office Requirements, Inspection Pits and Sheds, Parking and Storage Areas, Signing, and Lighting. In each of these areas, comments were included from each of the responding states. However, there were no summarized conclusions or recommendations. The section that dealt with Design Guides stated that most states did not have formal design guidelines for commercial vehicle monitoring stations. Most designs were based on the past experience of state personnel. This practice appears to continue today.

5. Geometric Design Branch, Highway Design Division, Office of Engineering, Federal Highway Administration, "Truck Weigh and Safety Inspection Stations--A Compilation of Comments on Current Practices," Washington, D.C., 1980.

3.1.2. New Technologies

Most of the technological advances in recent years have been in the area of Automated Vehicle Identification (AVI). This technology allows vehicles that have been pre-cleared to bypass the stations and proceed along the highway without stopping. Two major projects have been under way to evaluate this technology. The Heavy Vehicle License Plate Program (HELP)/Crescent⁶ project is a multi-state, multinational research effort in the western states to design and test an integrated system for monitoring commercial vehicles. This system uses AVI, Automatic Vehicle Classification (AVC), and WIM technology to expedite the processing of commercial vehicles at weigh stations. The initial test phase was known as the Crescent Project. This project included approximately 40 equipped sites from British Columbia southward along I-5 through California and then eastward along I-10 to Texas, branching onto I-20. Data gathered from the WIM, AVI, and AVC systems are processed by a central computer and then used by the various agencies for credential checking, weight enforcement, and planning information and by the motor carrier industry for fleet management purposes. HELP's current goal is to implement a system in which vehicles with legal weight and credentials can drive through the entire network without having to stop at a weigh station or a Port of Entry (POE). The operation of the Crescent system and other technical activities of HELP have been turned over to a new private organization known as HELP, Inc.

6. "Intelligent Vehicle Highway Systems Project," Federal Highway Administration, Washington, D.C., March 1994.

Another project that is evaluating the use of advanced vehicle and highway technologies is Advantage I-75, which is a partnership of public and private interests along the I-75 corridor. The goal of this partnership is to reduce congestion, increase efficiency, and enhance the safety of motorists and other users of I-75 (and its connections into Canada) through advanced vehicle and highway technologies. The focus of this project has been on implementation and processes that may result in technological advancements being assimilated into the operational setting.

The project currently being conducted by the Advantage I-75 Partnership is called the Mainline Automated Clearance System (MACS). The objective of MACS is to allow transponder-equipped and properly documented trucks to travel any segment of I-75 (and Highway 401 in Canada) with no more than a single stop at an inspection station.

The MACS system is based on AVI technology to electronically identify and process a truck while it travels along the freeway. The AVI subsystem consists of truck-mounted transponders installed in the cab of the vehicle and is capable of two-way communication with the roadside readers. The credential and weight information of the vehicle is maintained in the system's host computer and is transferred to each of the participating facilities along the corridor.

In 1994 four weigh stations (all in Kentucky) were equipped with the system and operated as an "alpha test." Approximately 240 trucks, representing seven companies, participated in the alpha test, which was completed in December 1994. The system is

now being installed at additional sites throughout the corridor, with the objective of having all 30 sites operational by October 1995. The Operational Test will begin at that time and will run for two years, ending in October 1997.

FHWA Demonstration Project No. 111, "Advanced Motor Carrier Operations and Safety Technologies,"⁷ is currently under development and is expected to be available in the summer of 1996. The purpose of the project is to demonstrate the use of CVO technologies to improve motor carrier safety and productivity. An expandable trailer will be equipped with displays of the latest technologies and will present them in a mobile exhibit. Workshops on the use of these technologies will also be offered to appropriate audiences. The enforcement community and the trucking industry are the primary target audiences for this demonstration project. The draft project work plan has four objectives:

- Demonstrate new and emerging Intelligent Transportation System/Commercial Vehicle Operations (ITS/CVO) technologies and FHWA--Office of Motor Carriers (OMC), Commercial Vehicle Safety Alliance (CVSA), and Motor Carrier Safety Assistance Program (MCSAP) technologies and programs, showing their impact on motor carrier safety and productivity

- Provide information about state and

7. Draft Work Plan Demonstration Project No. 111, "Advanced Motor Carrier Operations and Safety Technologies," Federal Highway Administration Office of Technology Applications Demonstration Projects Program, Washington, D.C., January 1995.

federal regulations pertaining to highway safety and productivity

- Provide a mechanism for education and consensus building among CVO stakeholders
- Educate the general public on the importance of motor carriers and their role in society.

This project will be looking at a wide variety of equipment and technologies that are currently utilized or will be utilized in the motor carrier industry. Some of the technologies being incorporated are Automated Vehicle/Driver Safety Inspection Systems, Automated Vehicle Weight and Credential Verification systems, Communication Links and Data Collection Systems, Automated Vehicle Identification, Classification, Toll Collection, Port-of-Entry Pre-clearance Systems, Crash Avoidance Systems, Hazardous Materials Incident Response Systems, and Fleet Management Systems. Demonstrations of these technologies are scheduled to begin in 1996 and continue into 1998.

A major component of a modern automated CVM facility is the WIM system. Numerous research projects have been conducted to evaluate the various aspects of WIM systems and their accuracy. One of the projects that is currently under way is NCHRP Study 3-39(2), "On-Site Evaluation and Calibration Procedures for Weigh-In-Motion systems."⁸ This project is looking at two methods for evaluating/calibrating WIM systems: using

either a combination of test trucks and vehicle simulation models or traffic stream trucks equipped with AVI systems. The vehicle simulation technique involves modeling the axle load variation of in-motion axles using a vehicle simulation model and taking into account this variation in calibrating/evaluating WIM systems. This provides a link between the dynamic behavior of a vehicle and its effects on measured WIM weights. The second method is based on using AVI-equipped vehicles within the traffic stream to calibrate the WIM system. Since these vehicles have been statically weighed, their weights can be correlated with WIM weights at several locations by monitoring them as they pass over the WIM scale. A literature survey has been conducted during phase one of this project focusing on the various aspects of utilization of WIM devices and what errors may be associated with their use. In addition, pilot studies of the two different calibration alternatives have been conducted. The data analysis of these alternatives is ongoing.

A second study that has been conducted is the "Interstate 95 Multi-State Traffic Monitoring Evaluations Project."⁹ This project is a cooperative agreement among Delaware, Maryland, Pennsylvania, and New Jersey, along with the FHWA to evaluate the performance of a number of low-cost, in-pavement traffic monitoring systems. The project's objective is to conduct a statistical

8. Papagiannakis, A.T., et al., "WIM System Evaluation/Calibration; Progress of NCHRP Study 3-39(2)," 74th Annual Transportation Research Board Annual Meeting, Washington, D.C., January 1995.

9. Faghri, A., Ramesh, R., B., and Glaubitz, M., "Statistical Accuracy Analysis for the I-95 Multi-State Traffic Monitoring Evaluation Project," Preprint, 74th Annual Transportation Research Board Annual Meeting, Washington, D.C., January 1995.

analysis of low-cost, flush-mounted in-pavement traffic monitoring devices/systems in an on-line road laboratory concept. This project evaluated several different WIM systems in various configurations to determine their capability to supply various types of traffic data to support state and federal program initiatives. This evaluation may assist WIM users in determining which type of system would best fit the conditions in their jurisdictions.

The calibration of WIM systems can be critical in the function of a facility since it is the primary means for sorting vehicles for bypassing the facility. Several states indicated that they have no formal procedures to monitor or check the accuracy of these systems. Rather, it is done by the station operator by comparing WIM weights and the corresponding static weights manually on an individual basis.

A second major component of modern facilities that monitor or sort vehicles on the mainline of the highway is AVI technology. Most such technologies involve radio frequency (RF) transmitters or electronic tags (transponders) mounted on the commercial vehicle. The transponders communicate with antennas and readers located on the side of the road, in the pavement, or overhead. Other technologies allow the visual identification of a vehicle and its license plates or Vehicle Identification Number (VIN) by computerized image technology. This technology allows the license plate number of a vehicle to be scanned by a video camera and then the number digitized for processing in a computer database system. Similar technologies can be used to read other

identification numbers that may be on the vehicle.

Oregon is currently in the process of evaluating such a technology to read the Oregon Public Utilities Commission license plate,¹⁰ which is required for all trucks in the state. This plate is used to monitor the Oregon weight-distance tax. This study involves actual field trials for the identification of the license plate number for further processing by the system computer. This technology was installed at the Woodburn POE and was field tested for three months. An outline of this technology is presented in a paper entitled "Development of Vision Technology for Automatic Vehicle Identification (AVI),"¹⁰ presented at the 74th Annual Meeting of the Transportation Research Board. Phase 1 of the study demonstrated the feasibility of using video camera technology for processing license plate numbers. This paper outlines some of the problems and changes required in the systems that will allow its complete implementation. Oregon is currently working on the implementation of this technology at two other stations so it can be used on a full-time basis. The advantage of this technology is that it provides a means to identify a vehicle without requiring the use of a transponder. However, some standardization is required, such as the use of a standardized "license plate" (plate, VIN, or other number) as an essential component of such a system.

10. Krukar, M., and Evert, K., "Development of Vision Technology for Automatic Vehicle Identification (AVI)," Preprint, 74th Annual Transportation Research Board Annual Meeting, Washington, D.C., January 1995.

The applications of the new technology play a major role in the development and implementation of then national Intelligent Transportation System (ITS) program.¹¹

The goals and objectives of the national ITS program have evolved as the program has been developed. The goals are to:

- Improve the safety of the nation's surface transportation system
- Increase the operational efficiency and capacity of the surface transportation system
- Reduce energy and environmental costs associated with traffic congestion
- Enhance present and future productivity,
- Enhance the personal mobility and the convenience and comfort of the surface transportation system
- Create an environment in which the development and deployment of ITS can flourish.

The national ITS program is organized into five general areas that collectively aim at improving all facets of highway and public transportation:

- Research and development
- Operational tests
- National ITS architecture
- Standards and guidelines
- Supporting ITS deployment

11. Euler, G., W., and Robertson, H., D., "National ITS Program Plan," Volume I, ITS America, Washington, D.C., March 1995.

3.2. OVERVIEW OF CURRENT TRUCK INSPECTION AND MONITORING PRACTICE

3.2.1. Legislative History

Federal truck weight limits were first introduced by Congress in 1956 for the newly authorized Interstate Highway System. State higher weight limits that existed before July 1956 were grandfathered in the law. In 1975 maximum allowable axle, tandem, and gross weight limits were raised, and the so-called "bridge formula" was stipulated as the basis for determination of the allowable gross vehicle weight as a function of axle loads and spacings.

These early federal legislative provisions for vehicle weight set maximum (upper) limits on allowable weight; however, the law did not require that states conform to the maximum limits, and many states continued to define weight limits below the federal allowable values. The state practice created an uneven base that inhibited consistency and efficient carrier operation. This condition was rectified with the 1982 Surface Transportation Assistance Act, which required that all states adopt the maximum weight allowances for vehicles operating on the Interstate System.

Federal safety regulations pertaining to operators and equipment were incorporated into the Motor Carrier Act of 1935, which remained the essential authority for safety regulation of interstate carriers for over four decades. Extensive hazardous materials transport regulations were adopted following passage of the 1975 Hazardous Materials Transportation Act. The frequency of motor carrier safety legislation increased noticeably

in the 1980's. Indeed, motor carrier safety statutes were enacted regularly at two-year intervals throughout the decade. These initiatives reflect a broad and continuing public concern about commercial motor vehicle safety issues.

The Motor Carrier Safety Assistance Program (MCSAP) was authorized in 1982, and the Motor Carrier Safety Act of 1984 pre-empted state requirements for interstate carriers, which are inconsistent with federal regulations.

The Commercial Motor Vehicle Safety Act of 1986 mandated that all inter- and intra-state drivers of vehicles with a gross vehicle weight rating of 11,794 Kg (26,001 pounds) or more, designed to transport more than 15 passengers including the driver, or of any size transporting hazardous materials that are required to be placarded, must possess a commercial driver's license prior to April 1, 1992.

Additional requirements for interstate drivers of commercial vehicles with a gross vehicle weight rating of 4,536 Kg (10,001 pounds) or more are found in Part 391 of the Federal Motor Carrier Safety Regulations, including medical certification requirements.

Further regulations pertaining to safe transport of hazardous materials were established in 1990. The 1991 ISTEA legislation expanded MCSAP and directed FHWA to promulgate regulations that assure consistency and compatibility of state safety regulations with federal motor carrier (and driver) safety regulations.

3.2.2. Commercial Vehicle Roadside Enforcement Functions

Roadside commercial vehicle enforcement is carried out by state and federal government agencies to facilitate four goals:

- Promote commercial vehicle safety to benefit all motorists
- Protect the roadway infrastructure from damage due to overweight trucks
- Facilitate compliance with and collection of commercial vehicle taxes
- Encourage equitable competition without unfair advantage of noncompliant operators over compliant and legal operators.

To accomplish these goals, states execute various roadside commercial vehicle enforcement functions. Generally, these enforcement functions may be classified as credentials verification, vehicle size and weight enforcement, and driver/vehicle safety assurance.

- *Credentials verification* encompasses an examination of operating authority, including insurance coverage, vehicle registration, fuel use tax, weight distance tax if applicable, and special freight requirements such as hazardous materials transport permits, agricultural permits, and perhaps customs import clearance or duty. *Size and weight* enforcement entails checks to verify conformity of vehicle height, width, and length dimensions, Axle, tandem, gross weight, and bridge formula compliance is also checked.

- *Safety Assurance* targets verification of safe vehicle mechanical condition, driver qualifications, licensing, and duty hours of service.

3.2.3. Weight Enforcement Activity

Figures 1 and 2 show the number of fixed commercial vehicle monitoring sites and the number of mobile enforcement teams operated by each state. In aggregate, there are over 600 fixed weight stations in the United States.

Identifiable differences in commercial vehicle regulatory and enforcement management are apparent among different states and regions of the country. POE for commercial vehicles at state borders and fixed weigh station enforcement are common in western states; eastern states typically have fewer fixed weigh stations and rely more on mobile enforcement strategies. A few states have no fixed enforcement stations.

Truck weight enforcement in the United States is conducted predominantly at weigh stations or other fixed enforcement facilities. In 1993, 97.73 percent of all trucks weighed were weighed at a fixed facility. The remainder were weighed on portable or semiportable scales by some type of mobile enforcement operation.

The number of trucks inspected and weighed has increased steadily over the last several years. Total weighings have increased by roughly 10 million over the past five years. The use of weigh-in-motion scale technology has also grown significantly in recent years.

Table 1 summarizes truck weight activity statistics by state. The table shows the annual budget for truck weighing, the number of personnel assigned to weight enforcement, the number of trucks weighed by type of scale, and the number of citations issued for size and weight violations.

In aggregate, states spent over \$250 million on truck size and weight enforcement, and weighed in excess of 160,000,000 trucks in 1992. Some 159,858,600 (99.6 percent) of all trucks weighed were within the legal load limits. Weight or size violations were issued to only 684,812 operators (0.4 percent of all trucks weighed).

The logical interpretation of the FHWA annual statistical report to Congress is that overweight trucks in the United States are an insignificant issue. The presented evidence suggests that over 99 percent of all trucks checked are of legal weight and are compliant. One must ask if the statistics are truly representative of truck weights on the national highway network. This point is discussed more fully in Section 3.2.5.

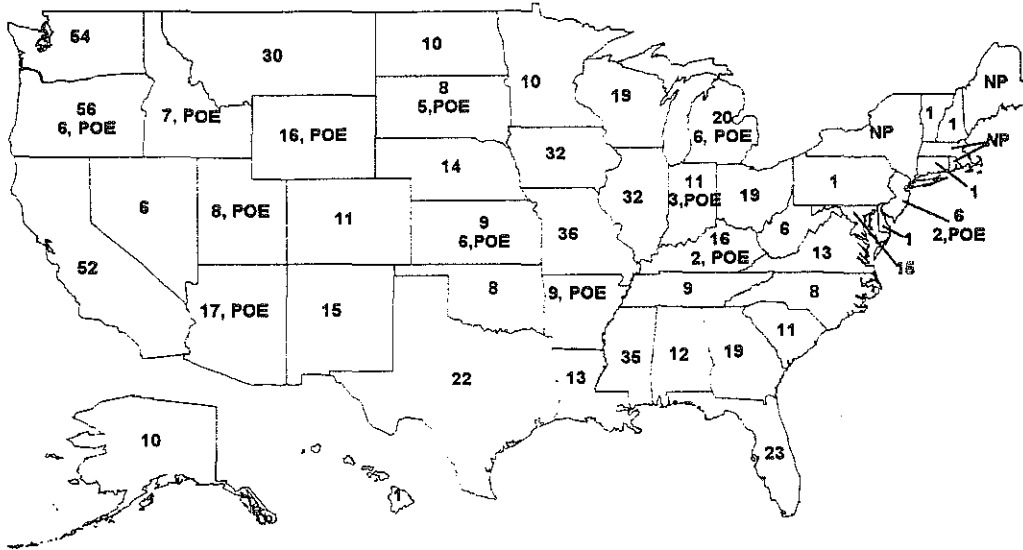

Figure 1. Number of permanent facilities in each state

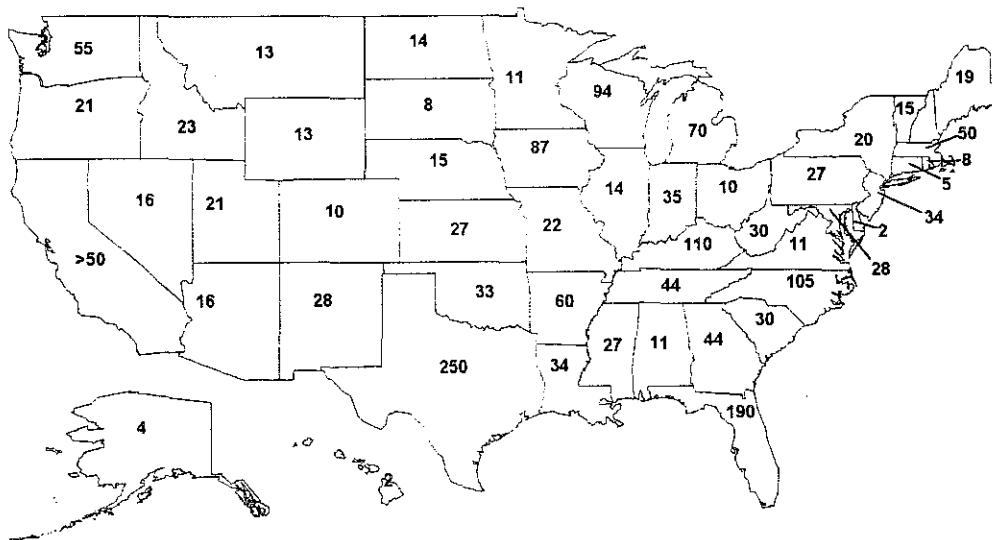

Figure 2. Number of mobile enforcement units in each state

Table 1. Truck weight enforcement budget and statistics by state, 1992

State	Budget (\$mil)	Number of Officers	Trucks Weighed	Citations Issued	Fixed Scales	Portable Scales	WIM Scales
Alabama	1.5	34	98,708	3,416	0	96	13
Alaska	1.3	32	133,201	406	20	62	5
Arizona	5.2	188	3,360,411	2,680	20	38	0
Arkansas	11.2	278	6,610,059	5,769	14	158	4
California	41.3	525	11,853,436	78,532	53	528	10
Colorado	4.7	132	3,652,435	11,011	20	0	0
Connecticut	2.3	29	176,202	3,882	4	27	6
Delaware	0.3	10	230,440	233	1	4	1
District of Columbia	0.3	4	1,515	390	2	12	0
Florida	10.0	144	4,138,420	38,992	22	266	0
Georgia	10.7	274	17,313,934	126,916	18	525	18
Hawaii	0.3	27	128,388	753	1	0	1
Idaho	3.8	102	1,214,988	4,470	26	72	0
Illinois	5.0	75	7,469,788	10,293	32	26	12
Indiana	2.5	191	2,404,901	9,498	16	290	2
Iowa	6.6	89	722,059	8,795	33	340	12
Kansas	5.0	113	1,087,052	6,683	12	101	30
Kentucky	9.9	287	11,683,488	6,687	18	540	15
Louisiana	5.4	159	7,990,137	29,547	23	250	0
Maine	not available	35	93,300	2,736	14	197	7
Maryland	9.5	181	2,248,869	14,402	14	206	6
Massachusetts	1.6	25	5,595,467	5,668	0	124	4
Michigan	4.1	199	3,838,437	4,053	19	158	4
Minnesota	3.8	138	1,791,148	3,650	10	175	6
Mississippi	5.6	180	7,761,870	5,867	39	108	68
Missouri	6.1	185	3,441,388	10,868	38	20	10
Montana	3.8	95	960,507	3,090	32	60	0
Nebraska	3.0	78	1,888,603	15,437	14	147	0
Nevada	0.7	56	104,866	1,175	2	68	1
New Hampshire	0.6	22	26,400	1,922	2	71	0
New Jersey	4.1	53	306,573	6,220	6	101	0
New Mexico	2.7	178	4,242,007	3,771	19	30	5
New York	3.3	94	204,557	12,845	0	386	0
North Carolina	9.5	208	8,312,016	50,923	10	570	0
North Dakota	9.7	190	680,853	2,309	10	168	0
Ohio	2.2	40	6,524,595	15,544	19	202	2
Oklahoma	1.5	27	64,037	2,001	15	174	0
Oregon	4.1	123	3,444,028	22,274	62	76	0
Pennsylvania	not available	64	401,905	3,106	16	396	3
Rhode Island	0.3	8	12,670	344	0	5	1
South Carolina	3.8	41	1,412,315	17,603	11	292	2
South Dakota	1.9	65	508,319	3,007	15	24	0
Tennessee	3.0	51	8,168,095	17,118	8	232	0
Texas	8.7	263	145,658	13,386	19	237	0
Utah	3.7	101	2,625,901	7,277	8	138	2
Vermont	0.3	14	6,923	676	2	15	8
Virginia	8.4	204	10,138,703	57,789	14	206	2
Washington	11.0	150	2,188,925	9,725	56	352	0
West Virginia	1.7	55	812,730	5,309	3	120	1
Wisconsin	4.3	42	1,131,040	14,367	20	96	0
Wyoming	0.9	54	1,179,919	1,397	30	80	3
TOTAL	251.2	5,912	160,532,186	684,812	862	8,569	264

Figure 3 shows the relationship between the percent of citations issued and the percent of portable weighings for each state. The left scale represents the percent of all weighings in each state that were performed with portable scales. The right scale represents the percent of all weighings for which citations were issued. A pattern becomes evident on closer examination of weight violations versus percent of weighings performed by portable and semiportable scales. Violation percentages are directly correlated with the percentage of weighings that are done on portable or semiportable scales. The first quintile set of states with the highest percentage portable weighings (over 55 percent portable) shows a 6 percent overweight violation rate; in contrast, the

fourth and fifth quintile state groupings with 1 to 3 percent portable weighings exhibit under 0.5 percent violation rates.

3.2.4. Driver and Vehicle Safety Enforcement Activities

The fundamental objective of driver and vehicle safety monitoring is to reduce the number of commercial vehicle accidents due to vehicle safety defects, driver operation, or unqualified drivers. Driver and vehicle safety assurance monitoring--like weight and size enforcement--is a critical enforcement function carried out at most truck monitoring facilities. Also, like weight and size enforcement, safety enforcement is strongly guided by federal mandates.

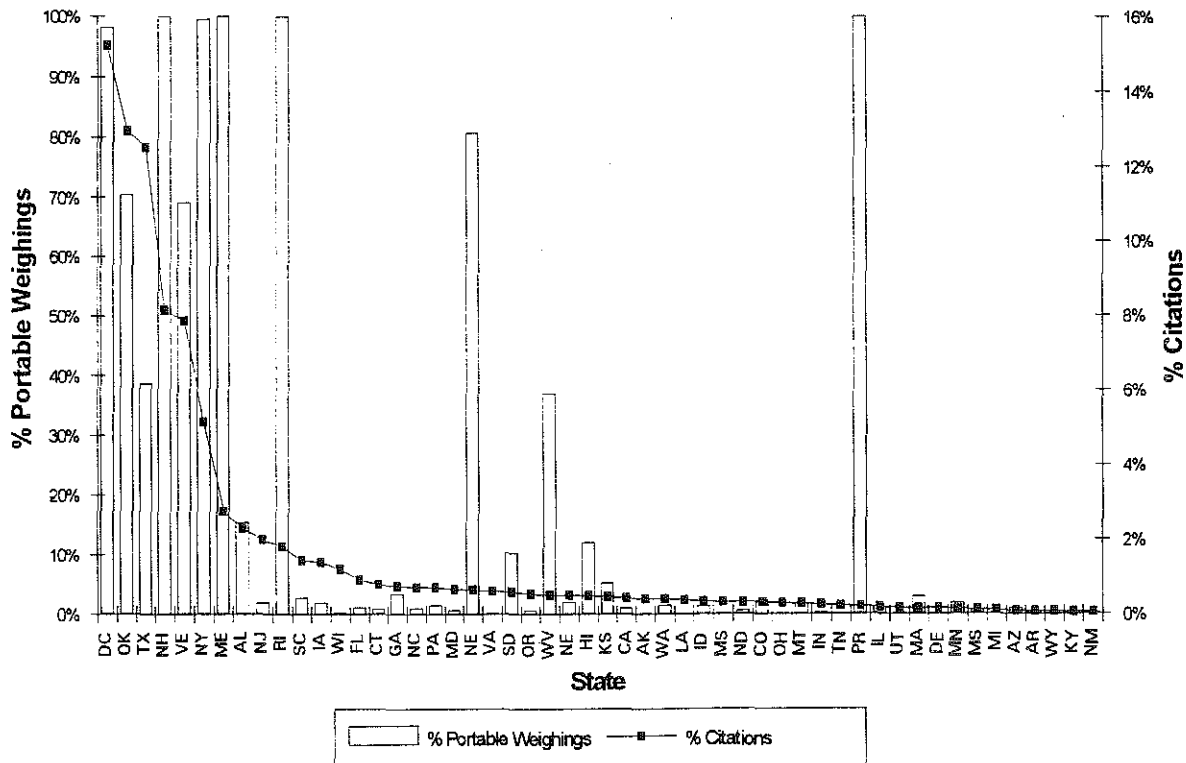

Figure 3. Percent citations and percent portable weighings by state

The majority of vehicle/driver safety inspections are conducted at fixed-scale monitoring facilities. Motor carrier safety inspections are also performed on toll roads at plazas, rest areas, or along the roadside. States that operate few or no fixed weigh stations use rest areas or other temporary sites to perform truck safety checks.

Roadside safety enforcement is carried out by sampling trucks from the traffic stream for safety reviews. Selection of specific vehicles is commonly done by visual screening, and these vehicles are brought in with "probable cause" for closer examination.

Table 2 summarizes commercial vehicle safety inspection statistics for 1987 through 1992.¹² In that five-year period, total MCSAP inspections increased over 60 percent, from just over 1 million inspections in 1987 to 1.66 million inspections in 1992. MCSAP funding authorization by 1992 under Title IV of ISTEA was authorized at \$65 million; state matching requirements would suggest that on the order of \$80 million to \$100 million was expended in 1992 for commercial vehicle safety enforcement activity nationally.

12. "Annual Report on Program Quality and Effectiveness, FY 1992," Federal Highway Administration, Office of Motor Carriers Field Operations, June 1993.

Table 2. MCSAP safety inspection overview, 1987-1992

Year	Hazarduous Materials Inspections	Non Hazardous Materials Inspections	Total Inspections
1987	96,960	890,361	1,003,794
1988	117,354	1,110,041	1,254,076
1989	112,860	1,165,751	1,302,453
1990	137,150	1,430,735	1,601,230
1991	145,703	1,401,781	1,574,188
1992	143,013	1,490,954	1,655,668

A program called Roadcheck has been conducted annually in recent years to provide a large-scale, coordinated, international safety check of commercial vehicles. All 50 states and 12 Canadian provinces participated in the 1992 Roadcheck in mid-May and completed over 47,000 inspections. Twenty-six percent of the vehicles inspected and 4 percent of the drivers checked were placed out of service; these results were a slight improvement over similar figures for the 1991 Roadcheck. Overall, these statistics indicate that a significant proportion of the commercial vehicles operating on the nation's highway network have serious defects that warrant their cessation of operation until repairs or adjustments are made.

3.2.5. Commercial Vehicle Enforcement Strategies

Table 1 and Figure 3 (presented earlier) indicate that a very small percentage of trucks weighed at fixed commercial vehicle monitoring facilities receive citations for overweight loads. Only 0.4 percent of all trucks weighed at fixed sites were issued citations; over 99 percent of weighed trucks were cleared. These results from fixed enforcement sites imply that overweight loads are a minor problem. Are these findings representative of conditions elsewhere on the highway network? The findings from mobile enforcement suggest that conditions on other highway segments may be significantly different from the reported results from truck weighing at fixed enforcement sites.

Data from the state of California were used to compare overweight trucks observed at fixed enforcement sites versus sites where no

enforcement was present. California has a large number of mainline weigh-in-motion installations for planning data acquisition; no enforcement is associated with these sites, so they provide good comparisons with state enforcement sites. California's fixed weigh stations and POE's exhibited an overweight citation rate of 0.76 percent in 1993. In contrast, Figure 4 shows the estimated overweight distributions for two bending plate WIM sites on interstate highways where no enforcement is present. All violations on I-5 near Lodi--an inter-regional corridor location--total over 5 percent; for a more remote, rural site on I-40 near Newberry, total violations exceed 10 percent. The evidence quite strongly indicates a different weight compliance pattern from that reported at fixed enforcement sites.

A widening body of data from Strategic Highway Research Program (SHRP) and other WIM sites around the nation is indicating that the actual rate of violation by overweight trucking operations is considerably higher than is shown by the statistics generated by the fixed facilities. While fixed facilities indicate that less than 1 percent of trucks are operating illegally, WIM data provide values ranging from 5 to 10 percent or higher. This disparity suggests that a re-alignment of strategies from fixed sites to mobile enforcement may warrant closer attention.

Mobile enforcement activities, by definition, yield higher citation rates because they are often directed at suspected violators instead of at all trucks in a traffic stream. Separate statistics for the fixed and mobile citation rate are difficult to obtain. In Colorado, one of a few states providing such statistics, the

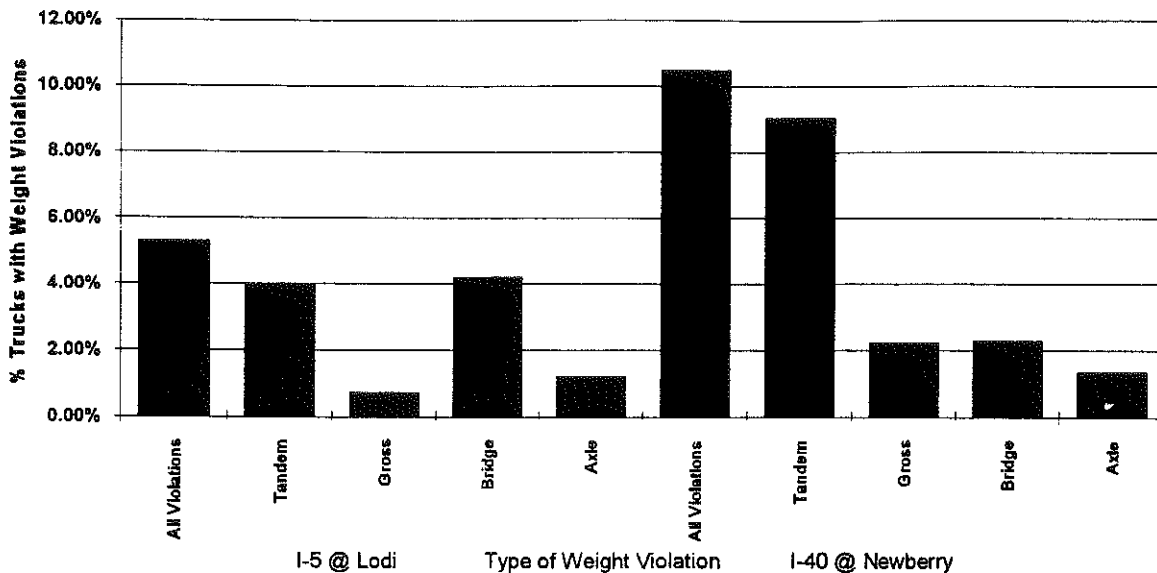

Figure 4. Summary of truck weight violations on California highways

fixed citation rate was 0.15 percent, and the mobile rate was 5.6 percent. A partial explanation for the mobile rate being 37 times greater than the fixed rate is the greater selectivity that mobile enforcement details can employ in seeking violators.

While most states emphasize fixed enforcement strategies, there are several that emphasize mobile enforcement. When the individual states were ranked by citation rate as a percentage of total weighings, it turned out that the 0.4 percent national rate noted earlier represented the mean of values ranging from over 15 percent in the District of Columbia to less than 0.1 percent in New Mexico (Figure 3). Was there a correlation between citation rate and enforcement method? The percentage of total weighings conducted by mobile enforcement ranged from over 30 percent for many of the states having citation rates of 2 to 15 percent, to less than 5 percent for the majority of states with citation rates below 2 percent. From these data, it could be concluded that the

actual violation rate may be understated by the enforcement statistics. Some of the statistics that are obtained from mobile enforcement could be biased toward higher violation rates since in some instances mobile enforcement targets suspected violators. However, these data suggest what may be occurring in areas where permanent enforcement is not present. To better quantify the actual violation rates for a complete highway system, truly random mobile enforcement must be conducted and the violation rates analyzed.

Oregon operates POE stations on a continuous, 24-hour, seven-day-week basis. In addition, other fixed scale sites are operated on a random shift basis. The violation rate observed at the POE's is 1.2 percent, while the rate at the randomly operated other fixed scales is 2.4 percent. When an experiment was conducted to determine the violation rate during the first 30 minutes of operation of random shifts at these fixed scale sites, 4.0 percent of all

trucks weighed were found to have violations.

The state of Mississippi has experimented with various mobile enforcement strategies in order to develop a more effective allocation of limited enforcement resources. Fifteen continuously operating WIM (Strategic Highway Research Program--SHRP) sensors on noninterstate routes revealed that a significant overweight problem was not being addressed by the fixed enforcement facilities on the interstate routes. State patrol officers identified the main violators as logging and agricultural product trucks. Recent state legislation has allowed an increase of gross vehicle weight (GVW) from 80,000 pounds to 84,000 pounds for agricultural product trucks. The WIM data were evaluated carefully to avoid overstating the violation rate in view of this legislation.

Mississippi mobilizes 26 two-person mobile units, called teams, for motor-carrier enforcement throughout the state. A typical deployment includes two or three teams. One team sets up on a major route with a set of axle weighers. Other teams, as needed, set up on alternate routes with wheel weighers to intercept bypassing trucks. A typical enforcement detail lasts eight hours.

The first enforcement strategy operated at regular intervals during standard business hours. Enforcement officials began each enforcement detail by checking and calibrating each piezo WIM system within the influence area of their enforcement activity. Data gathered from the WIM sensors showed that noncompliance rates were largely unaffected by this strategy. Truckers would avoid the enforcement teams once they were aware of them and then

would return immediately because they knew another enforcement would not occur for two or three weeks.

The next enforcement strategy involved setting up enforcement details away from WIM sites, so that the background levels would not be directly affected by enforcement. For political reasons, one of the goals of this style of enforcement was to minimize the number of citations issued, while still maximizing compliance. Typical background violation rates were running at a minimum of 13 percent. The new strategy involved setting up enforcement details at random times. Initially, violation rates would quickly bounce back to background levels following enforcement, so additional details would be executed in quick succession and at differing times. Generally, after four or five details, truckers would perceive that the enforcement risk was too great, and background violation levels would fall to about 3 percent in the region near the enforcement activity. This level tended to gradually rise to about 8 percent after about three weeks. A preliminary conclusion, not yet substantiated in detail, was that this type of enforcement activity could result in a reduction of background violation rates from over 13 percent to 8 percent and that levels as low as 3 percent occurred following intense activity.

The "decay curve" of violators over time during an enforcement detail will be available once this strategy has been implemented for a sufficient time to validate the data.

3.2.6. Infrastructure Damage Related to Overweight Trucks

One of the main arguments for expenditures

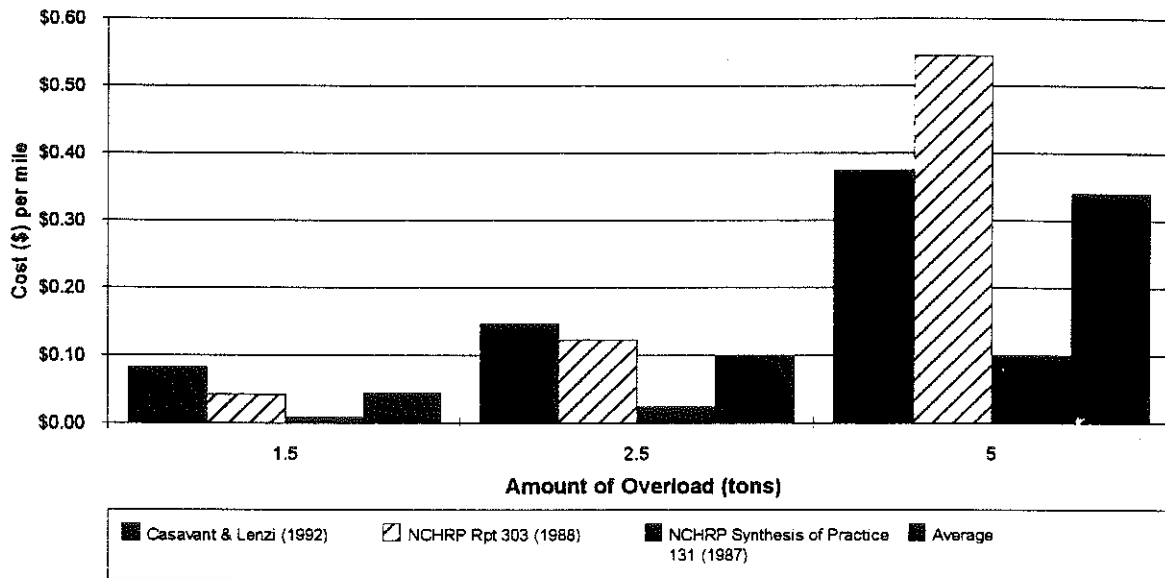

Figure 5. Pavement damage costs associated with overweight trucks

for truck weight enforcement is to prevent excessive pavement and structure damage caused by overweight trucks. Yet few states were found that were able to quantitatively relate weight enforcement efforts to infrastructure benefits. Figure 5 is a compilation of costs of pavement damage from overweight trucks as estimated from various research sources. While these figures are relatively crude, nonetheless they are useful benchmarks to help managers gauge the value of enforcement expenditures and results.

Considerable research has shown an exponential relationship between the weight of a particular axle load and the detrimental effects that axle has on pavement life. Most of our current enforcement effort is concentrated on fixed enforcement facilities, located on interstate and principal highways

that are constructed with superior pavement structural sections. A study by the Brookings Institution¹³ indicates that the marginal maintenance cost (per equivalent single axle load) is 15 times higher on rural major collector routes than on rural interstate routes. This ratio suggests that a 15 percent change in the interstate highway violation rate is equivalent in terms of pavement damage cost to a 1 percent change in violation rates on collector routes. The effect of heavy trucks on secondary and collector roads suggests a need for greater monitoring and enforcement of these routes. When the combined economic benefit of enforcement strategies and pavement costs is considered, there is a compelling case for increased enforcement on these routes. The

13. *Road Work: A New Highway Pricing and Investment Policy*, Small, Winston and Evans, Brookings Institution, 1989.

enforcement strategy best suited for these routes is mobile, since their lower volumes do not justify the expense of building more fixed facilities.

A recent study¹⁴ developed a mathematical correlation between enforcement intensity and overweight violation rates. This correlation was developed in the form of an equation that was tested against several data sets from both fixed and mobile enforcement efforts. The equation was refined until it passed various statistical tests to validate its use. It is important to note that the equation predicts the *maximum* violation rate for each intensity of enforcement. The equation is:

$$f(z) = Ae^{-0.10z}$$

where

$f(z)$ = violation rate (%), which is the number of trucks observed to operate illegally above the stipulated weight limit as a percent of all trucks inspected

A = maximum expected violation rate when enforcement is "zero" (depends on enforcement method), estimated from historical data. From the data used in developing the models, this value ranges between 6 for permanent weigh scales operated 24 hours per day year round to 15 for patrol inspection teams

z = inspection rate (number of trucks inspected as a percentage of all truck traffic for fixed facilities or number of trucks inspected per hour for mobile enforcement patrols)

Fepke and Clayton¹⁴ made a strong argument for looking at random and reduced operations of fixed facilities as a method of reducing enforcement costs without compromising compliance rates. For example, their approach indicates that a one-third reduction in inspection rate results in far less than a one-third increase in violation rates. Therefore, strategies that reallocate resources and personnel toward more random and effective enforcement would seem to merit increased attention.

3.3. STATUS OF COMMERCIAL VEHICLE MONITORING FACILITIES

During phase 1 of this study, a survey of current practices for CVM across the country was conducted. A questionnaire was sent to each of the 50 states, requesting an evaluation of their ongoing activities relating to the construction of new facilities and upgrading/retrofitting of existing ones. A copy of the survey is shown in Figure 6. Responses were received from all 50 states. A list of the persons responding to the survey is given in Appendix D.

Of the 50 responses, 22 indicated the state had constructed a new facility within the last two years. Thirty-four states indicated they had been involved in upgrading or retrofitting their existing facilities within the last three years. Figure 7 is a map that indicates the states that have done retrofitting/upgrading, new construction or both in recent years. Twenty-one of the states indicated they planned to construct a new facility within the next three years, while 32 indicated they were planning to upgrade or retrofit existing stations. Fourteen states were planning to both construct new

14. Fepke and Clayton, "Quantitative Assessment of Effect of Enforcement Intensity on Violations Rates of Vehicle Weight and Dimension Regulations," 1993.

facilities and upgrade/retrofit existing facilities. A map indicating which states are conducting these activities is given in Figure 8. Twenty-five of the 32 states that are planning to upgrade/retrofit have already conducted these activities in the last three years. Thirteen of the 21 states that were planning to construct new facilities have constructed other facilities within the last two years.

All 22 states indicated they were performing weight, size, and safety enforcement at each of these stations. Nineteen were performing license, tax, and other credential inspection, while seven states indicated they were actually issuing credentials. The features included in the new construction are shown in Figure 9. This figure also shows that only 19 states have constructed new facilities with static scale platforms. This indicates that three states constructed a facility with only WIM scales. In addition, three other states have static scale platforms and no WIM devices. Thus, the remaining 16 states utilize both WIM and static scales at their new locations.

Virginia indicated it had installed a remote document reader to allow viewing of documents from within the scale building. This is necessary since Virginia operates several of its two-directional facilities from one side of the highway. The two stations are connected by a tunnel beneath the highway, which the drivers use to bring their credentials to the scale building.

Three states indicated that they had incorporated mainline vehicle clearance into their new station design.

The survey distinguished between upgrading of existing equipment and facilities and retrofitting or adding new equipment and facilities. The results from this portion of the survey are provided in Figure 10. The responses for each of the items are separated into upgrading and retrofitting. It may be seen from this figure that the majority of the upgrading and retrofitting involved weighing of the vehicles and computerized access to information.

The purpose of each of the upgrades or retrofits has been categorized into seven different areas, as shown in Figure 11. The majority of these upgrades fell into the areas of increasing the level of enforcement and upgrading existing equipment.

Four states indicated they had installed some type of mainline clearance in a new station or had retrofitted an existing station. Several of these states are also involved in one of the corridor projects at various locations across the country (HELP, Inc., Advantage I-75, etc.). Ten states responded that they had upgraded or retrofitted stations for Intelligent Vehicle Highway System (IVHS) technology; however, some of these states are clearing the vehicles in ramp at the station and not on the mainline highway.

The types of facilities each state uses were divided into four categories: Permanent Weigh Stations, POE's, Permanent Safety Inspection Facilities (not connected to weighing areas), and Mobile Enforcement Units. However, the term POE has different meanings in various states. No information was gathered regarding the types of functions that were performed at the various states reporting POE's.

COMMERCIAL VEHICLE MONITORING FACILITIES SURVEY

1. Has your state within the past 2 years constructed a new Commercial Vehicle Monitoring Facility?
 Yes No

If yes:

- 1a. Is the facility currently in operation? Yes No
- 1b. What are the functions performed in the facility? (check all that apply)
- | | |
|--|---|
| <input type="checkbox"/> Weight and Size Enforcement | <input type="checkbox"/> Safety Enforcement |
| <input type="checkbox"/> License, Tax, and Credential Inspection | <input type="checkbox"/> Credential Issue |
| <input type="checkbox"/> Other _____ | |
- 1c. What features were incorporated in the design of the facility?
- | | |
|---|---|
| <input type="checkbox"/> Modern Static Scale Platforms | <input type="checkbox"/> Weigh-in-Motion Devices |
| <input type="checkbox"/> Online Access to Computerized Information | <input type="checkbox"/> Inspection Area |
| <input type="checkbox"/> Video Cameras for Traffic Monitoring | <input type="checkbox"/> Changeable Message Signs |
| <input type="checkbox"/> Height-Width-Length Detection Technologies | <input type="checkbox"/> Mainline Vehicle Clearance |
| <input type="checkbox"/> Other _____ | |

2. Has your state within the past 3 years upgraded or retrofitted an existing Commercial Vehicle Monitoring Facility with any of the following:

Upgrade (Existing)	Retrofit (Add)	Device	Upgrade (Existing)	Retrofit (Add)	Device
_____	_____	Modern Scale Platforms	_____	_____	Video Traffic Monitoring
_____	_____	WIM Devices	_____	_____	Changeable Message Signs
_____	_____	Online Access to Computerized Information	_____	_____	Height-Width-Length Detection Technologies
_____	_____	Inspection Area	_____	_____	Mainline Vehicle Clearance
_____	_____	Other _____			

If you checked any of the above:

- 2a. What was the main purpose for the upgrade or retrofit?
- | | |
|--|---|
| <input type="checkbox"/> Upgrade Equipment | <input type="checkbox"/> Increase Level of Enforcement |
| <input type="checkbox"/> New Customs Station | <input type="checkbox"/> Change in the Facility Functions |
| <input type="checkbox"/> Traffic Monitoring | <input type="checkbox"/> IVHS Application |
| <input type="checkbox"/> Increase Capacity | <input type="checkbox"/> Other _____ |

3. Are you planning to construct a new facility or upgrade or retrofit any existing facilities within the next 3 years?
 CONSTRUCT: Yes No UPGRADE/RETROFIT: Yes No

4. Please indicate the number of each type of enforcement facility your state currently uses:
- | | |
|--------------------------------|---|
| _____ Permanent Weigh Stations | _____ Permanent Safety Inspection Facilities
(not connected to weighing areas) |
| _____ Port of Entries | _____ Mobile Enforcement Units |

5. List any questions which you feel should be addressed in Phase 2 of this study. _____

6. If selected, would you be willing to participate in Phase 2 of this study, an interview regarding your current enforcement activities?
 Yes No

7. Name, address and telephone of respondent: _____

8. Would you like to receive the results of this study? Yes No

Figure 6. Survey form

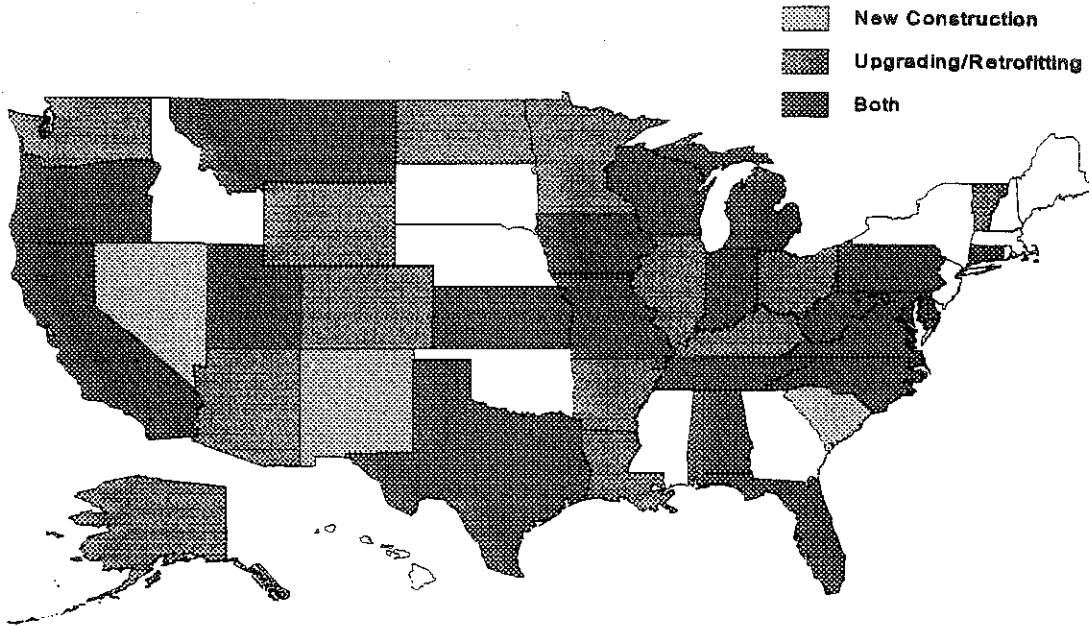

Figure 7. States that recently upgraded/retrofitted or constructed new facilities

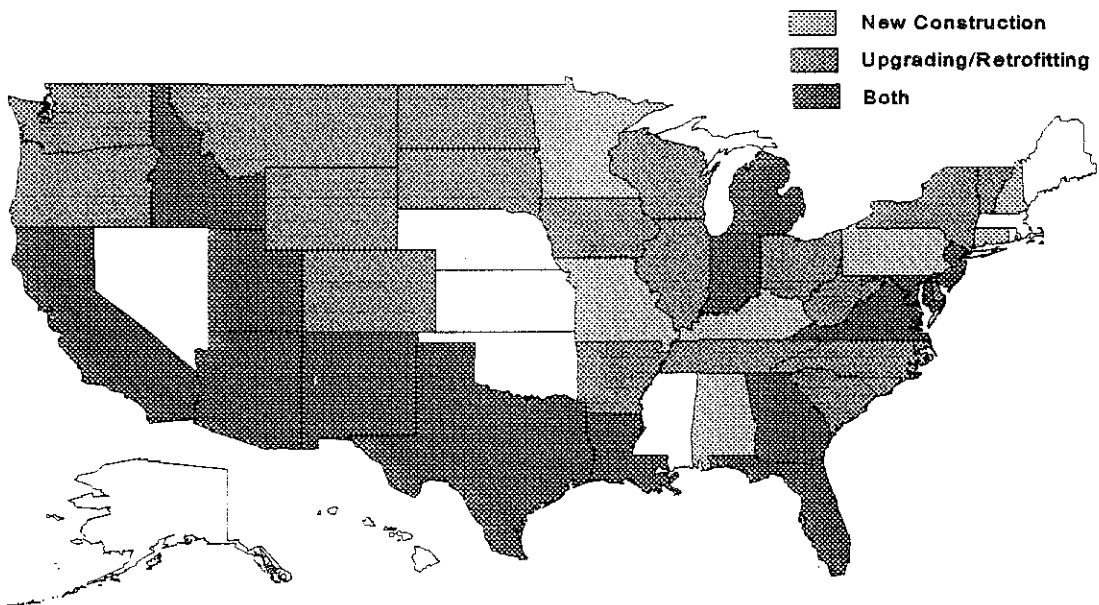

Figure 8. States planning to upgrade/retrofit or construct new facilities

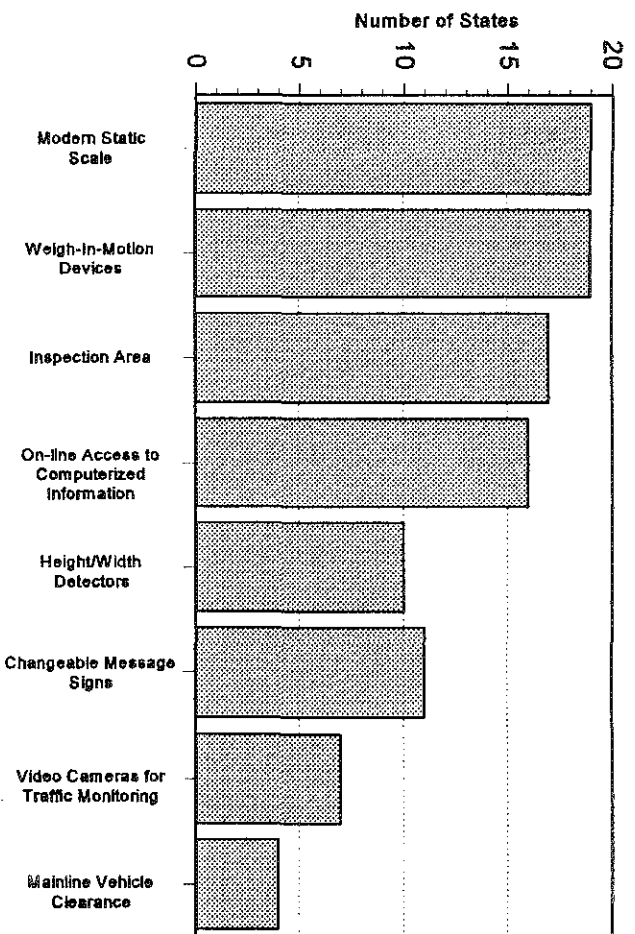

Figure 9. Summary of features in new facilities

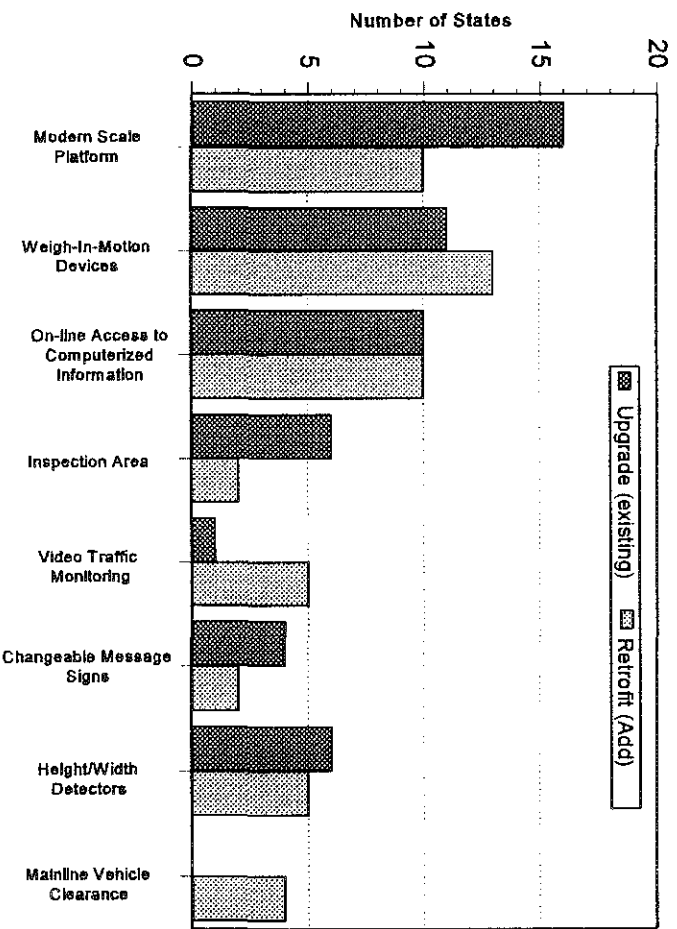

Figure 10. Summary of types of upgrades and retrofits

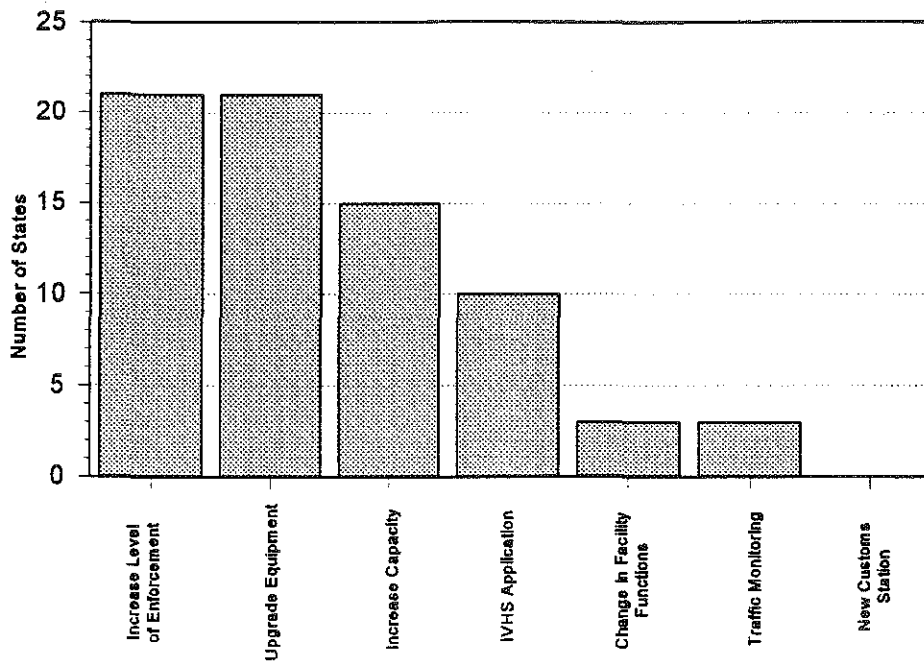

Figure 11. Summary of purposes for upgrade or retrofit

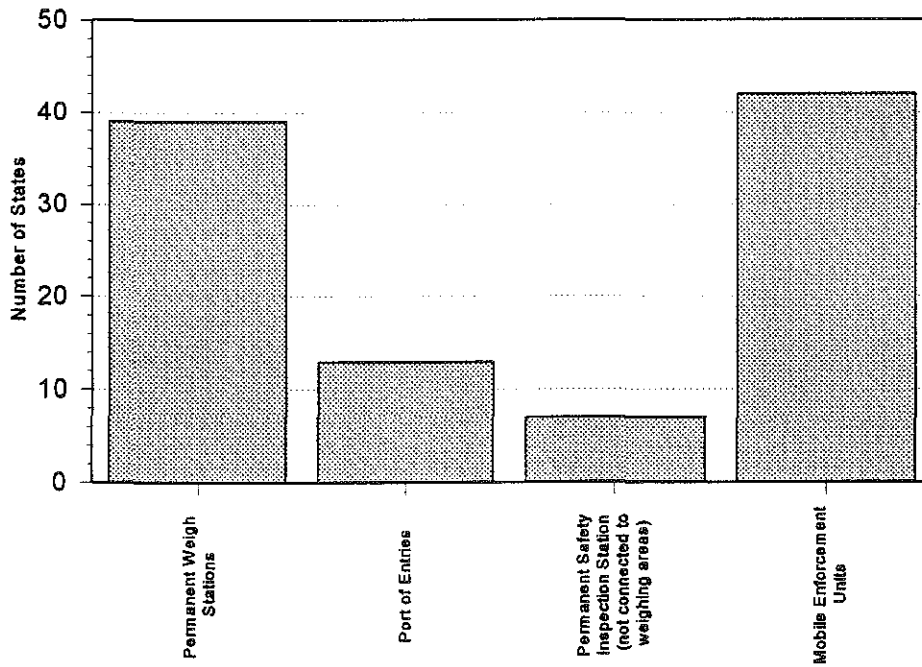

Figure 12. Summary of types of monitoring facilities

Several states responded to question 5 of the survey. Which asked states to voice their concerns about any phase of commercial vehicle enforcement.

Below are quotes obtained from the returned surveys:

“What set of circumstances would justify construction, upgrade or retrofit, an increase in commercial Average Daily Traffic (ADT), lack of monitoring by another site, truck accident statistics, overload statistics?”

“What about large RV’s, driver’s license requirements, especially in combination vehicles?”

“If a new station is constructed or existing facilities upgraded/retrofitted, was a statewide strategic action plan completed prior to the start of the project?”

“Should standards be established regarding certified monitoring facilities, i.e. safety, phones, toilet facilities, lighting, signs, etc.?”

“Quality and reliability of new and upgraded equipment at scale facilities. Types of maintenance programs to avoid costly repairs due to neglect.”

“Number of vehicles weighed and inspected in the state by permanent and mobile enforcement units.”

“Is the equipment satisfactory; is the service satisfactory; why?”

“Selection of a common transponder and related equipment. Standardization of a data base to facilitate exchange of information among states.”

“Minimum and maximum amount of fines by dollars and weight.”

The results of this survey indicate there is quite a lot of activity regarding the modernization of commercial vehicle monitoring facilities across the country. However, it appears that much of this activity is related to utilizing existing technologies and procedures. This report will provide a means to transfer ideas and technology alternatives that some states may utilize in their future activities.

4. CASE STUDIES

Using the answers from the first survey, nine states and a Canadian province were selected for additional study. These states were selected from among those that had just completed a new facility, had retrofitted or upgraded an existing facility, or were planning a new facility. In addition, states that were deemed to be leaders in the research and implementation of technologies in CVM facilities were also considered. Finally, geographic distribution throughout the nation was also a criterion. The states selected for site visits were California, Colorado, Idaho, Kentucky, New Mexico, Oregon, Pennsylvania, Utah, and Virginia; the province of Ontario was also selected. Most of these states have completed new facilities or retrofitted existing facilities and are planning additional facilities.

A second questionnaire was mailed prior to the site visits and formed the basis of discussions. The enforcement program for each of the states visited was first identified. The policies and views of each state with respect to the level and type of enforcement were addressed, since such policies are crucial to the development of the enforcement program and types of facilities to be constructed or remodeled. These findings are reported in the first part of this section. An overview of the most current facility (constructed or upgraded) is presented in the next part of the section. The operational characteristics of each facility visited are documented, as well as the philosophy behind the construction and upgrade of each facility. The site visits have demonstrated that each state has a different philosophy with respect to the funds it is willing to invest in such facilities, and such differences are indeed reflected in the

facility design. Furthermore, the groups involved in the design and development processes for each facility play an important role in the facility layout and amenities and frequently reveal the presence or absence of a team concept during these processes.

This section presents the findings of five of the nine states and the Canadian province visited to allow an understanding of these differences while maintaining the brevity of the report. However, the descriptions of the remaining four states are presented in Appendix B.

4.1. OVERVIEW OF ENFORCEMENT PROGRAM

4.1.1. Colorado

The state of Colorado has 11 fixed ports and 10 mobile units supervised by the POE Division, Department of Revenue. The POE has 143 employees and an annual operating budget of approximately \$5.8 million.

Most of the fixed facilities are old; some were constructed approximately 30 years ago. A typical fixed facility consists of two buildings and is staffed with a supervisor, an assistant supervisor, and 10 or 11 officers. Of the 11 facilities, 9 have a 24-hour operation, while the remaining 2 facilities operate for 16 hours per day for five days per week. These facilities weighed a total of 4,083,620 vehicles during the 1993-1994 fiscal year for an average of 1,017 vehicles per day. The typical functions performed at these facilities include enforcement of size and weight limits, inspection of drivers' licenses and vehicle registrations, and examination of vehicles for safety problems and compliance with regulations for hazardous material transport. Each facility

is equipped with a computer from which information on each vehicle passing through can be retrieved. The information retrieval is based on the last eight characters of the VIN, required to be displayed on the side of the power unit. A major problem with the current system is the absence of any real time communication among the facilities for exchanging these data. The collected, and thus updated, data are downloaded every 24-36 hours in Denver and then become available to all facilities. However, the lack of integration requires each vehicle to stop at all facilities along its way, resulting in complaints from the drivers. Safety inspections at these facilities are performed randomly and usually are done with the use of creepers and visual inspection under the vehicle.

Each port has a mobile unit that does periodic inspections at other locations than the fixed port. Each unit is assigned to a specific geographic area, consists of two officers, and is required to work a minimum of eight hours per day and five days per week including weekends and night shifts. The mobile units weighed 84,871 vehicles during the 1993-1994 fiscal year for an average of 32.64 vehicles per 8-hour work day. The locations for inspection are usually selected based on prior experience and knowledge of "problem locations." Moreover, information provided by police patrols, sheriffs, highway departments, and private citizens is utilized in determining potential problem areas. A typical mobile unit is equipped with a van, semiportable scales, police radio, and cellular phones. The mobile units are not currently automated, but automation is being considered. Functions performed by these units are similar to those performed at fixed facilities--weight enforcement, vehicle

safety inspection, and driver and vehicle credential checking.

The future of the commercial vehicle facilities in Colorado is currently being developed and evaluated by a Re-engineering Team. This team consists of representatives from a number of agencies that have an interest in the operations of commercial vehicles. Membership in the team includes representatives from POE, Title and Registration, Information Systems, Mobile Enforcement, Fuel Tax, and DOT. This team has developed a mission statement, has sought input by brainstorming, has consulted with industry, has analyzed motor carrier functions, and has developed three alternatives that are currently being evaluated. However, the main thrust of the team is to develop a plan for administrative services and to improve the integration and exchange of information rather than to develop a facility layout that will enhance the enforcement functions or facilitate the operation of the facility.

Two main points that reflect the philosophy of the POE division are the shift from an enforcement-only approach to a "customer"-oriented operation and the use of low-cost methods to upgrade and retrofit all existing fixed facilities and not to build any new facilities. The first point is reflected in the division's re-engineering team and its mandate to develop this plan. The second point is mainly guided by economics, since it is believed that it is more feasible to spend small amounts to improve all facilities than to spend the equivalent amount to build a new facility. The re-engineering team estimates that a total of approximately \$6-7 million will be needed over the next few years to upgrade all fixed facilities. It also believes that any attempt to

request a lump sum of \$6 million to build a new fixed facility will most likely be voted down by the legislative body of the state.

Joint operations with states that share their borders with Colorado are considered to be an additional area where significant cost benefits can be realized. Current commercial vehicle operations already include a joint facility in operation with New Mexico and a new one planned with Wyoming, and future plans include work with the remaining border states. Such cooperation allows building new or improving existing facilities with lower costs, since the costs are more likely shared by both states by placing a facility on each side of the border and the benefits are realized by both states by increasing the enforcement levels without increasing their personnel.

The future vision of the commercial vehicle facilities is to increase the current levels of technology and to implement a mainline clearance process. The use of AVI and WIM equipment is seriously considered as the means that will allow instant credential checking, travel without stopping, and reduced delays at commercial vehicle facilities. Ability to transfer data among the facilities is a very desirable feature that will assist in these goals. Moreover, cooperation among the various agencies involved in the commercial vehicle operations is an essential component of the successful model and future vision.

4.1.2. New Mexico

The state of New Mexico operates 13 POE's and 44 mobile units under the Motor Transportation Division of the Taxation and Revenue Department. They have a total of

91 employees and an annual operating budget of approximately \$6.9 million. The organization is divided into two branches--the operations branch, which operates the POE's and does some mobile enforcement, and the enforcement branch, which has full police powers, does mobile enforcement, and issues citations for safety, weight, and size violations.

Most of the fixed facilities are more than 15 years old. The ports are owned by the General Services Department and the State Highway and Transportation Department. Maintenance is the responsibility of the Motor Transportation Division. Eight of these facilities operate 24 hours per day, seven days a week, while the remaining facilities operate variable hours depending on the day of the week. These facilities weighed a total of 4,078,965 vehicles in 1994. Functions conducted at the POE consist of collection of special fuel taxes, weight distance taxes, special fuel permit fees, oversize permit fees, economic regulatory permit fees, verification and validation of driver and vehicle credentials, and administration of size and weight laws and regulations. Ten ports are equipped with computer systems that allow permit processing at the port; the installation of these systems at three more POE's is under way. The information from these computer systems is currently downloaded to the central office on a daily basis. Increasing the frequency of information transfer is under way and will allow better utilization of the data. Field enforcement teams have been formed in each of the enforcement districts. These teams are designed to accomplish the objectives of the department at off-road locations. Field enforcement teams provide a cohesive, fully trained, mobile service unit that can function as a

temporary POE. These teams weighed a total of 7,920 vehicles during fiscal year 1994, utilize both portable wheel weighers and portable axle scales, and are deployed on a random basis in each district to ensure maximum effectiveness. They provide this coverage through varied shift schedules and through saturation and strike efforts. Field saturation efforts are generally scheduled for 72-hour periods. These operations consist of multiple activities and multiple locations being simultaneously patrolled, thus providing maximum enforcement coverage in a defined area. Strikes are localized operations usually confined to a roadside area.

4.1.3. Oregon

The state of Oregon has 6 ports on the interstate system, 49 permanent scales, and 22 mobile enforcement platform scales on other routes supervised by the Oregon DOT, a Motor Carrier Operation, and 13 field offices that operate the portable scales. The personnel consist of 120 employees and the annual operating budget is approximately \$7 million.

Most of the fixed facilities are old; some were constructed approximately 10 years ago. All six POE facilities are located on interstate routes and have a scale for each direction, while the other fixed scales are on other routes and have scales used by one or both directions of traffic. A typical fixed facility along an interstate route consists of one building and is staffed with 10 or 13 officers. The fixed scale facilities on the other routes are staffed periodically, when random enforcement is conducted. The 6 POE facilities have a 24-hour operation, while the other facilities operate for approximately 32 hours per week. These

facilities weighed a total of 2,600,048 vehicles during the 1993-1994 fiscal year. The typical functions performed at these facilities include enforcement of size and weight limits, inspection of drivers' credentials and conditions, vehicle registrations, and examination of vehicles for safety problems and compliance with regulations for hazardous material transport. Two of the POE facilities (Woodburn and Cascade Locks) are equipped with a medium-speed WIM and one (Umatilla) with a high-speed WIM. Special license plates provided by the Public Utility Commission (PUC) are required for all trucks traveling through Oregon, and the number of these plates is recorded and stored, accompanied by the weight and type of the vehicle. AVI transponders, WIM devices, and video cameras are used to sort vehicles through the facilities. For the computerized facilities, weight data are automatically stored by the WIM equipment, while other enforcement activities are conducted with the use of other computer systems. For all facilities these data are compiled and summarized monthly, quarterly, and annually. A major problem with the current system is the absence of any real-time computerized communication among the facilities for exchanging data; this lack of integration requires each vehicle to stop at most facilities along its way. Safety inspections at these facilities are performed visually by port officers and usually are done with the use of creepers and physical inspection. Two facilities (Woodburn and Umatilla) have inspection bays where inspectors can walk under the vehicles.

The state is divided into 13 field offices and each is required to schedule approximately 20 percent of the enforcement hours in

portable scale operations. Platform scales without a scale house are also used in mobile enforcement utilizing a specially designed van equipped with computer equipment that allows a plug-in operation of the scale. Each officer is trained to operate a portable scale and usually works a typical 40-hour week (eight hours per day and five days per week). However, sometimes weekends, holidays, and night shifts are part of the work schedule to increase levels of enforcement. The mobile units weighed 26,599 vehicles during the 1993-1994 fiscal year. The locations for inspection are usually selected based on prior experience and knowledge of locations where the likelihood of violations is high and traffic volumes are large. Moreover, information provided and requests made by highway departments and private citizens are also utilized in determining potential problem areas. Functions performed by these units include weight and length enforcement, driver and vehicle credential checking, and vehicle safety inspections.

The future of the commercial vehicle facilities in the state of Oregon will include upgrading most of the fixed facilities with electronic equipment (WIM and AVI) and improving of communication and computer connections among facilities. More and more working functions are being automated and new technologies are being considered for use in automating these processes. A major concept of the Motor Carrier Operation (present in most discussions with its executives) is a commitment to use electronic technologies in all POE facilities as well as in those weigh facilities to be upgraded. Such improvements and implementation of advanced technologies will improve productivity, both for enforcement officials and motor carriers.

A key element in the future operations of CVO in Oregon is the development of a vision statement for the future of CVO that reflects the commitment of the DOT to have "legal commercial vehicles operate with the same ease as passenger vehicles." To implement this vision, Oregon DOT is committed to "develop and deploy advanced technology to improve the efficiency of commercial vehicle operations, to increase the performance of the highway system, and to protect the public investment in that system." Additional elements in this process include a focus on developing a better and more efficient working relationship with the trucking industry as well as among the various components of enforcement and government agencies. To achieve the latter, annual meetings are held that include industry and government representatives. In addition, local agencies are allowed and encouraged to use the POE facilities as training areas for all personnel.

Participation in the HELP/Crescent program and implementation of the Oregon IVHS/CVO strategic plan over the next five years demonstrates the commitment to implement new technologies. The future vision of the commercial vehicle facilities is to increase the current levels of technology used and to implement a mainline clearance process. The use of WIM and AVI is seriously considered as the means that will allow instant credential checking, traveling without stopping, and a reduction of delays at commercial vehicle facilities. Ability to transfer data among the facilities and associated government agencies is a very desirable feature that will assist in these goals. Moreover, cooperation among the various agencies involved in the commercial vehicle operations is an essential component of the successful model and future vision.

4.1.4. Utah

The state of Utah has eight fixed ports supervised by the POE Section, Division of Motor Carriers, DOT, and four portable scale areas serving as the basis for mobile units supervised by the Utah Highway Patrol (UHP). The POE has 77 employees and an annual operating budget of approximately \$3 million, while the UHP has 30 officers working on commercial vehicle enforcement and an annual operating budget of approximately \$1 million.

Most of the fixed facilities are old; some were constructed approximately 15 years ago. Four facilities are located on interstate routes and have a scale for each direction, while the remaining four facilities are on two-lane highways and have one scale used by both directions of traffic. A typical fixed facility along an interstate route usually consists of one building and is staffed with 10 or 12 officers. One interstate facility has three safety inspection officers, also. The facilities along two-lane highways have three officers. The four facilities along the interstate routes have a 24-hour operation, while the other four facilities operate during normal working hours, that is eight hours per day for five days per week, plus random additional shifts, such as swings and midnights. These facilities weighed a total of 3,442,543 vehicles during the 1993-1994 fiscal year.

The typical functions performed at these facilities include enforcement of size and weight limits, inspection of drivers' credentials and conditions, vehicle registrations, and examination of vehicles for safety problems and compliance with regulations for hazardous material transport. Two of the interstate facilities (Perry and St.

George) are equipped with a computer system in which information for each vehicle passing through the facility can be stored (WIM and AVI data). The monitors of these systems allow automated viewing of weight, length, and axle spacings and provide compliance with bridge formula weight. Height is checked automatically, also. The other facilities use markings on curbs and height poles to determine the length and height of vehicles and compute bridge formula compliance by hand. For the computerized facilities, weight data are automatically stored by the WIM equipment, while other enforcement activities are conducted with the use of other computer systems. At the non-computerized facilities, data from the enforcement activities are stored manually. For all facilities, these data are compiled weekly and summarized monthly, quarterly, and annually.

A major problem with the current system is the absence of real-time computerized communication among the facilities for exchanging data; this lack of integration requires each vehicle to stop at most facilities along its way. Safety inspections at these facilities are performed visually by port officers and usually are done with the use of creepers. One facility (St. George) has inspection bays where inspectors can walk under the vehicles.

The state is divided into four geographical areas, each with five or six mobile units staffed by the UHP. Each unit consists of an officer who has a typical 40-hour week (eight hours per day and five days per week). However, sometimes weekends, holidays, and night shifts are part of the work schedule to increase levels of enforcement. The mobile units weighed 2,040 vehicles during the 1993-1994 fiscal

year. The locations for inspection are usually selected based on prior experience and knowledge that they have a high likelihood of violations. Moreover, information provided and requests made by highway departments and private citizens are also utilized in determining potential problem areas. A typical mobile unit is equipped with a UHP vehicle, portable scales, a police radio, and cellular phones. The mobile units are not automated and all record keeping is done manually. In addition to the portable scales, three of the four areas have semiportable platform scales that are assigned by the supervising sergeant for additional weight enforcement inspections. Functions performed by these units include weight and length enforcement, driver and vehicle credential checking, and vehicle safety inspections.

The future of the commercial vehicle facilities in the state of Utah will include upgrading the eight fixed facilities with electronic equipment (WIM and AVI) and improving communication and computer connections among facilities. More and more working functions are being automated, and a new port facility will be constructed within two to three years to replace an existing small port on an interstate highway. One-stop shopping for motor carrier clients is still a viable, near-term objective. Regional permit systems for interstate carriers with nondivisible loads is now in place and will expand to include 10 western states. A major concept of POE (present in most discussions with POE executives) is commitment to use electronic technologies in the new facility (along I-80) as well as in those to be upgraded. All of these improvements and technologies will improve productivity, for both enforcement officials and the motor carrier industry.

Two items that reflect the philosophy of the POE Division are the development of a vision statement for the future of POE and the development of a "business-like" environment for the facilities. The vision statement reflects the commitment of the POE to "protecting and preserving Utah's highway infrastructure while enhancing safety for the motor carrier industry and the motoring public." The second point is reflected in the way facility officers treat drivers and perform their duties. Use of uniformed officers creates a "business-like" environment and gains respect by the drivers of the vehicles. All drivers are treated like "partners" in the motor carrier industry.

Joint operations with states that share borders with Utah are considered an additional area where significant cost benefits can be realized. Current commercial vehicle operations already have a joint facility in operation with Arizona and a new one planned with Wyoming, and future plans include work with the remaining border states. Such cooperation allows building new or improving existing facilities with lower construction costs. Since the costs are more likely shared by both states by placing a facility either on each side of the border or both facilities within one state, operating cost savings are realized by both states and enforcement levels are enhanced without increasing personnel.

The future vision of the commercial vehicle facilities is to increase the current levels of technology used and to implement a mainline, barrier-free clearance process. The use of AVI and WIM equipment is seriously considered as the means that will allow instant credential checking, traveling without stopping, and reduction of delays at

commercial vehicle facilities. Ability to transfer data among the facilities and associated government agencies is a very desirable feature that will assist in these goals. Moreover, cooperation among the various agencies involved in CVO is an essential component of the successful model and future vision.

4.1.5. Virginia

The Virginia DOT operates thirteen 2-way permanent weigh facilities and 10 mobile weigh teams throughout the state.

Virginia's weigh program is divided into three geographical regions. Each region is staffed by employees that operate fixed scales, portable scales, and WIM systems. Special details are also organized and used in all parts of the state. Portable weigh crews are operational on a full-time basis and work on a rotating five days per week schedule. The total annual budget for the 1995 fiscal year is \$9,969,800.

The permanent scale facilities are equipped to detect axle, tandem, bridge formula, and gross weight violations. The violations are cited based on static scale weights. There are five permanent scales located on the interstate that are operational 24 hours per day, seven days per week, and two interstate scales, that are operational 24 hours per day, five days per week. Also, there are five permanent scales on primary routes that are operational three shifts per day, five days per week, and one permanent scale that is operated on a random schedule.

The portable scale operations are scheduled throughout the state on a regular basis and on interstate, primary, and secondary highways, including bypass routes. Operations are carried out on a 40-hour

rotating schedule by 11 mobile teams with eight portable scales per crew. Schedules are developed to target areas where overweight vehicles are known to exist, areas of citizen concern, and special operations. These teams are utilized to provide an effective enforcement program to deter bypassing of permanent scales and to conduct special operations.

Virginia also utilizes a portable WIM system to collect statistical data for planning purposes. This unit is also assigned eight portable scales for enforcement. This crew works with portable scale teams as a violator screening unit.

Due to heavy bypass traffic, Virginia is constructing two new weighing turn-out sites that will provide additional locations for enforcement.

Virginia has developed a Biennium Business Plan, which is utilized to guide the enforcement operations into the future. This plan consists of a mission statement, specific goals, and measurable objectives. The plan will provide Virginia with a program that is responsive not only to the needs of its citizens but to industry as well. The mission statement indicates that the state should "Promote the preservation of Virginia's highway system and the continued safety of its users by providing an effective and proactive truck weigh program."

The goals of the Virginia enforcement program are:

- Manage and direct the Truck Weight Program to obtain the best utilization of available resources
- Promote an atmosphere that encourages

a highly trained and well motivated work force

- Promote cooperation with DOT, as well as with other agencies and localities, to ensure a consistent and unified weight program that complies with FHWA requirements
- Identify, research, and implement advanced technologies that will improve the consistency and effectiveness of the Truck Weight Program as well as improve data collection capabilities
- Provide a maintenance program that efficiently assures the accuracy and reliability of the weighing equipment as well as the integrity of the weighing program
- Identify new facility needs and evaluate current facilities to effectively address traffic, personnel, and space requirements

The Virginia enforcement program is very involved in employee development and training. It has implemented, or is in the process of implementing, several programs to provide training and feedback to the employees, which will enable them to better perform their job duties.

The department has also assisted 10 counties and local municipalities in the development of weighing programs. These programs are operated independently of the department but rely on it for scale certification and various vehicle size and weight interpretations. The department is encouraging this type of development and will continue to assist local government agencies in weight enforcement activities.

4.2. Overview of Most Current Facilities

4.2.1. Colorado--Trinidad

The facility selected for a site visit in the state of Colorado was the Trinidad site because it is the most recently upgraded facility. The facility is 12 miles from the New Mexico - Colorado border on northbound I-25 and operates only for the northbound traffic. It operates 24 hours per day and has a staff of six officers and a supervisor. Each shift is eight hours with one officer working most of the shift with some short overlaps. During the 1993-1994 fiscal year, it weighed a total of 148,072 vehicles, and the current average daily volume is estimated at approximately 500 vehicles.

The current layout of the facility is shown in Figure A-1, Appendix A. The facility has been retrofitted with WIM and AVI equipment that allows mainline sorting and provides vehicles equipped with AVI to bypass the facility. Vehicles are signaled to enter the facility when they do not have AVI, when inspection of their records is needed, or when their records need to be updated even though they are equipped with AVI. Currently, almost every truck that passes the facility is called for inspection, since very few commercial vehicles are equipped with AVI. Vehicles called to enter the facility proceed to the static scales, where they are weighed. At the same time, the officer enters the vehicle identifier (the last eight characters of the VIN) and retrieves the vehicle data. In the event that the data need to be updated, the driver is called into the facility building with his/her dossier and the required data are entered into the data base. Additional duties of the officers include measurement of the length

of the vehicle, the issuing of citations, the collection of cash fees, and hazardous materials inspection. At the completion of the data entry and any vehicle inspection, the vehicle is cleared to leave the facility.

The mainline sorting is done with the use of a high-speed WIM device and the search for an AVI. Commercial vehicles not equipped with AVI will trigger an electronic board to display a message, "TRUCK MUST EXIT TO WEIGH STATION," followed by a changeable message asking the "TRUCK (to) EXIT TO WEIGH STATION." The AVI-equipped vehicles will result in blank boards to indicate that they are allowed to bypass the facility. Vehicles requested to enter the facility are monitored with loop detectors on the exit ramp, and thus the possibility of bypassing the facility is reduced.

The axle weights from the static scale are displayed to the driver while his/her vehicle is being weighed. This eliminates questioning by the driver regarding the reasons that he/she was stopped as well as reducing possible conflicts between the driver and the officer. It is believed that this display is a very good method for informing the driver and a positive way to assist the job of the enforcement officers. Moreover, such a display can be utilized when the facility is closed, assuming that this is feasible, and can assist the driver in determining the weight of the vehicle.

Communication between the officer and the driver is performed with a combination of a two-color traffic signal and a changeable message display, as well as with a two-way communication speaker. The traffic signal has a red light to indicate stop and a yellow light to indicate proceed with caution. The

message display directs the driver to either "PARK AND COME IN" for credential inspection, to "PARK" for vehicle inspection, or to "PROCEED" to leave the facility. The layout of the signal display (pole mounted) is shown in Figure 13 (the number 23,000 shown in Figure 13 indicates the axle weight displayed). The signal has a two-head display enabling drivers of long vehicles to know how to proceed on the static scale by viewing it in their rear view mirrors when they cannot face the signal. The only problem with the operation of this system was its proximity to the location of the scale; a longer distance to allow vehicles to stop would be desirable.

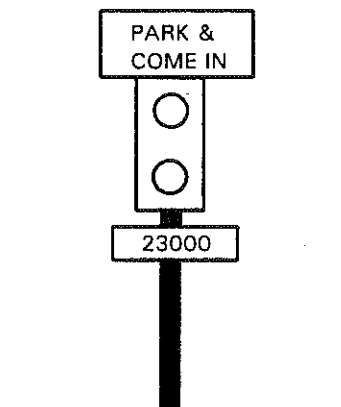

Figure 13. Signal display

The ability of the officers to issue citations and permits is enhanced through automation. The time required to write citations can be used more effectively for other activities and thus can increase the productivity of the officers. Automation has also helped officers to produce more detailed reports and enable them to monitor a larger number of variables that can improve the operation of the facility. However, the fact that the vehicle identifier has to be entered manually into the computer system increases the level of effort

and workload of the officers, and it is possible that this activity may affect their productivity if the volume of traffic increases. Moreover, the current variety of forms and credentials issued by each state makes their inspection a very time-consuming process and requires significant time and attention by the officers. The standardization of these forms is a desirable goal for officers and commercial vehicle drivers as well, since they express similar frustrations when called for inspection. A nationwide uniform set of credentials would also speed the inspection process.

The lack of communication among the various facilities and absence of data sharing in real time are major issues that need to be resolved. The lack of data sharing with other facilities can cause mainline cleared commercial vehicles at Trinidad to be called into the other facilities farther north along their way. This does not allow the realization of the intended benefits nor the creation of a positive image for the mainline sorting and clearance. Moreover, the ability to access other data bases, such as traffic violation and safety inspection records, is an additional issue that needs to be addressed.

The physical layout of the facility allows only a small number of commercial vehicles to park for credential inspection. It is believed that a redesign of the facility may be needed to permit a better flow-through process. Moreover, the current layout may hinder the use of the safety inspection area, since the allocated area may be blocked by parked commercial vehicles. The interior design of the building allows for two workstations and provides adequate space for driver traffic. A high desk separates the officers from the drivers, and driver and officer amenities are provided. The building

has windows on all sides that permit a wide field of view, but the west side of the building needs sun-glare protection. The layout of the building is shown in Figure 14.

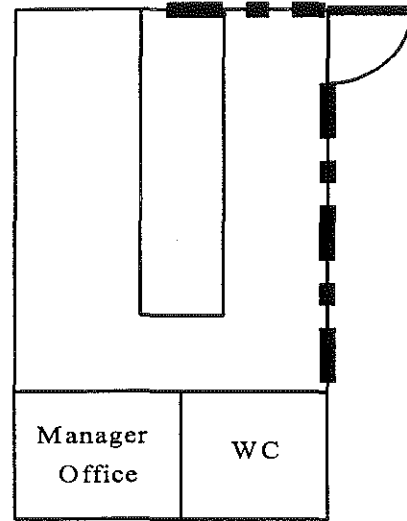

Figure 14. Building layout

4.2.2. New Mexico--Gallup

New Mexico is in the process of building two new ports of entry. To achieve this goal, the Lordsburg/Anthony Port of Entry Quality Improvement Planning Team was formed and was assigned the task of evaluating construction and operation of the Gallup POE (Figure A-2, Appendix A) during planning of the new Lordsburg POE and the Anthony outbound POE. The primary purpose of the team was to develop recommendations relating to POE design elements, operations, and maintenance practices. The interagency team consists of representatives from the Taxation and Revenue Department, Motor Transportation Division, the New Mexico State Highway and Transportation Department, the FHWA, Office of Motor Carriers, HELP Inc., the

Alliance for Transportation Research, Wilson & Company, the New Mexico Motor Carriers' Association Inc, and Sandia National Laboratories.

Currently, there is one automated POE at Gallup and one under construction at Anthony (inbound). Operations occurring at the majority of the POE's consist of primary nonautomated processes; however, they do utilize the computer system to process receipts and cash reconciliations. The Gallup POE was the first facility in the state to be equipped with new automation technology. The design was for the facility to be equipped with AVI, WIM, four-segment static scales, variable message signs, and a computer system to assist port personnel in conducting the port operation.

New Mexico is a weight-distance tax state that requires verification of the tax credentials of a carrier as it passes through the facility. This requires the POE agent to look at the carrier's tax credentials to verify that they are current and to enter the tax ID number into the computer system.

The design allows AVI-equipped motor carriers to drive through the facility without stopping. All vehicles enter the facility through one traffic lane equipped with AVI and WIM. After being screened by AVI and WIM, traffic is sorted onto one of three ramps. One ramp directs AVI-equipped traffic, which had been cleared by the AVI and WIM, back onto the interstate. The second ramp is used to check credentials of vehicles that have been cleared based on their WIM weight. The third ramp is used to check carriers for both weight and credentials. The station was equipped with credential inspection booths on two ramps to allow for verification of tax credentials.

These booths were designed to allow video viewing of the drivers' credentials from within the main port control room. The port was designed to be completely automated and controlled from within the port control room.

A few problems have prevented the Gallup facility from reaching its potential as a fully automated facility. These problems have included the difficulties in integration of the various electronic components and in the manual operation of the facility. These problems led to formation of the interagency design team for the new facilities at Lordsburg and Anthony.

Based on the information available on current technology and experience gained from the Gallup facility, the design team developed several design recommendations for construction of the Lordsburg and Anthony POE's.

The first recommendation is that the port be equipped with ITS technology that allows for compliant vehicles to bypass the facility. This allows port activities to focus on noncompliant vehicles. The specific use of ITS will be the installation of mainline sorting of vehicles equipped with AVI technology to allow them to bypass the facility. In addition, low-speed WIM's will be utilized on the off ramp to further sort vehicles by weight. After crossing the WIM, the vehicles will be sorted onto one of two remaining ramps equipped with credential booths for verification of New Mexico tax credentials. One of the remaining ramps will be equipped with a static scale for weight verification.

The team recommended that the building be designed to accommodate five

administrative offices, a small lobby, separate restroom facilities for both drivers and visitors, a break room, a supply room, a communications and computer room, and a two-workstation front desk area. The front desk area would be equipped with security glass. In addition, an interview room was to be provided.

For the inspection area, the team recommended an open area with a roof and one wall connected to the main POE building. This was done to reduce the cost of heating and ventilating an enclosed area. The area would also have a ventilated mechanical roof. It would consist of two inspection pits of proper length, with pit covers, pit receptacles, and stairs. The team also recommended communication links to the inspection area such as intercom, radio, phone, etc. A concrete-paved section would also be provided adjacent to the inspection building to conduct additional inspections as needed. A separate area adjacent to the existing parking area for out-of-service vehicles and mechanical repairs would also be provided. Finally, computer terminals and links that will provide portable or fixed technology to be added as needed or as it becomes available would be provided. This will permit further expansion of the facility to keep pace with technology.

The systems that will be contained in the proposed POE's are separated into two sections, one for the mainline and the second for systems contained within the port. The mainline systems will consist of mainline WIM and AVI, an in-cab notifier, typical signs (bilingual), compliance sensors for AVC and AVI, and a freeze-frame camera with a storage system. The in-port systems will consist of entrance ramp WIM and AVI, traffic control loops, variable

message signs and typical signs (bilingual), one four-segment electronic static scale, two credential booths equipped with audio and camera systems for security and credential check, a height detector, and traffic control signals.

The team also recommended that providing fiberoptic communication links in lieu of standard copper cable increases lightning protection. The communication links required for the above systems must incorporate uninterrupted power systems and fiberoptic connections.

The credential booths are recommended to be equipped with interior and exterior lighting, a computer monitor, and an external camera for remote credential verification as well as an internal camera for security. Also required are communication links and systems such as intercom, radio, and phone. Bullet-resistant glass and safety barriers around the booth would be incorporated. The booth adjacent to the static scale would be elevated to the drivers' level. The booth on the adjacent ramp could be located at ground level since its use will be minimal.

The team also emphasized that communications and technology must be compatible with other New Mexico ports and compliment surrounding state's technology.

The team recommended that the operation procedures of the POE be documented in an operational manual. Upon completion of construction, the contractor should be required to provide a deliverable which includes an integrated maintenance, operations, and training plan. This plan should also include a 6-12 month on site

operational/training maintenance phase to make sure the systems are operating as required in the contract and that the staff is adequately trained in the operations and maintenance of these systems. The team also recommended that a maintenance contract and/or an in-house maintenance person in charge of maintaining and updating port systems be established.

4.2.3. Oregon--Woodburn

The facility selected for a site visit in the state of Oregon was the Woodburn site because it is the highest volume facility. The facility is 50 miles from the Washington-Oregon border on southbound I-5 and operates only for the southbound traffic. It operates 24 hours every day and has a staff of 29 employees, including 15 weightmasters and 14 PUC employees. Each shift is an eight-hour shift with two officers for most of the shifts (6 a.m. to midnight). During the 1993-1994 fiscal year, it weighed a total of 382,931 vehicles; the current average daily volume is estimated at 4,000 vehicles.

The current layout of the facility is shown in Figure A-3, Appendix A. The facility has WIM and AVI equipment that allows on-ramp sorting and permits vehicles with AVI to travel through the facility. All nonempty vehicles are required to enter the facility and are screened as they enter the ramp by an AVI reader. Legal-size and -weight vehicles with AVI are directed to proceed to the bypass lane, while all others (except those with weights close to empty vehicles) are directed to the static scales, where they are weighed. Due to high traffic volume and low use of AVI transponders, two ramps with static scales are available. Vehicles can select either ramp and officers can close

either one with the use of a two-color overhead signal. As the vehicle proceeds over the static scale, the officer enters the PUC license plate and retrieves the vehicle data. In the event that the license or permits need to be updated, the driver is called into the facility building with his/her documents. Additional duties of the officers include measurement of the length of the vehicle, the issuing of citations, and hazardous materials inspection. At the completion of the data entry and any vehicle inspection, the vehicle is cleared to leave the facility.

The on-ramp sorting is done with the use of a medium-speed WIM device and the search for AVI. Commercial vehicles not equipped with AVI or weighing over the threshold limits of the WIM device will trigger an electronic board to display a green arrow pointing to the lane with an overhead sign that asks the vehicle to "REPORT TO SCALE." All other vehicles will be guided, with a similar arrow under a sign, to "RETURN TO FREEWAY." Vehicles requested to enter the facility are monitored with the use of loop detectors on the exit ramp, and thus the possibility of bypassing the facility is reduced.

The axle weights from the multidraft static scale are displayed to the driver while his/her vehicle is being weighed. This eliminates the questioning by the driver regarding the reasons he/she was stopped as well as reducing possible conflicts and arguing between the driver and the officer. It is believed that this display is a very good method for informing the driver and a positive way to assist the job of the officers. Moreover, such a display can be utilized when the facility is closed and can assist the driver in determining the weight of the vehicle.

Communication between the officer and the driver is performed with the use of a combination of a two-color traffic signal and a changeable message display as well as with a two-way communication speaker. The traffic signal has a red light to indicate stop and a green light to indicate proceed. The message display directs the driver to either "STOP" for weighing the vehicle, to "BACK UP" to adjust the position of the vehicle over the scale, to "MOVE AHEAD NEXT AXLE" to continue the weighing process, to "PARK--BRING IN PAPERS" for credential inspection, to "REPORT FOR INSPECTION" for safety vehicle inspection, or "PROCEED TO FREEWAY" to leave the facility. The layout of the signal display (pole mounted) is shown in Figure 15 (the number 23,000 shown in Figure 15 indicates the axle weight displayed). The only problem for the operation of this system was the manual operation of the signal.

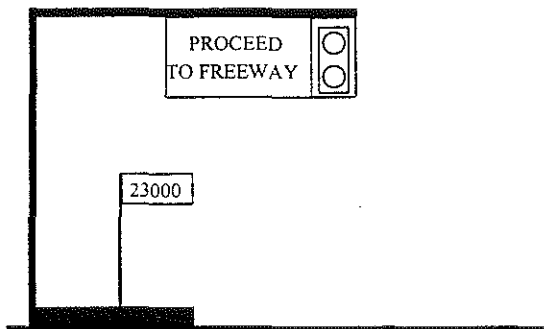

Figure 15. Changeable message display

The ability of the officers to issue citations and permits is enhanced through automation. The time required to write citations can be used more effectively for other activities and thus can increase the productivity of the officers. Automation also allows officers to produce more

detailed reports and to monitor a larger number of variables that can improve the operation of the facility. However, the fact that the vehicle identifier has to be entered manually into the computer system increases the level of effort and workload of the officers. It is possible that this activity may affect the productivity of the officers if the volume of traffic increases. The use of video camera technologies to read and store the PUC license plate is currently being evaluated, and future implementation of this technology will improve the efficiency of the officers and will allow them to work on other activities. This technology is currently being installed at Umatilla and was tested at Woodburn.

The lack of communication among the various facilities and absence of data sharing in real time are major issues that need to be resolved. The lack of data sharing with other facilities can cause on-ramp cleared commercial vehicles at Woodburn to be called into other facilities along their way. This does not allow the realization of the intended benefits nor for the creation of a positive image for on-ramp or mainline sorting and clearance. Moreover, the ability to access other data bases, such as traffic violation and safety inspection records, is an additional issue that needs to be addressed.

The facility has two bays used by safety inspectors for completing safety inspections. Both bays are covered in a building to protect inspectors and vehicles from weather elements. One bay is an open pit and allows the inspector to walk under the vehicle, while the other bay is used for inspections under the vehicle with the use of creepers. Safety inspections are generally random and are made at a rate of approximately eight per day or 1,400 per year. Inspectors work

eight-hour shifts for five days a week. The safety inspection building has classrooms and is used as a training facility for safety inspectors throughout the state. The facility is also used by other agencies, such as state and local police, to conduct independent safety inspections.

The layout of the facility allows a large number of commercial vehicles to park for credentials inspection. In addition to parking for vehicles while in the building, parking is provided for out-of-service vehicles. Vehicles that require service to correct safety violations can stay in the parking lot, have the repairs performed on site, have the safety inspector verify the completion of repairs, and then proceed with their trip. Visual observation of the entire parking lot is performed through the side windows of the building.

The location and design of the building allows a very good view of the entire facility, the bypass ramp, and the scales. The interior design of the building provides two rooms for the officers controlling the changeable message and checking the WIM and static scale; a high stand-up counter with a work space for trucker credential inspections; adequate space for driver traffic; and a room for PUC employees. The building provides driver amenities and a crew lounge. There is also a separate office for the safety inspectors and rooms for utilities, janitorial equipment, computers and communication equipment, and storage. The building has windows all around that allow for a wide field of view, and all windows have pull-down screens to block sunglare. The layout of the building is shown in Figure 16.

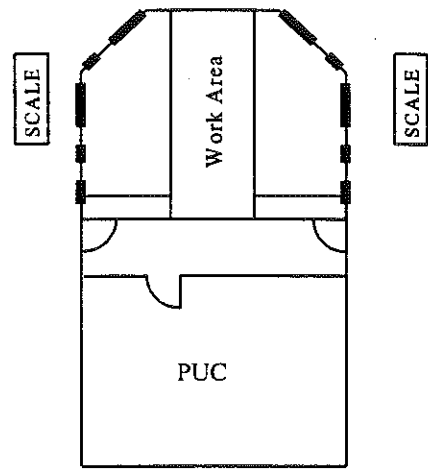

Figure 16. Building layout

4.2.4. Utah--St. George

The facility selected for a site visit in the state of Utah was the St. George port of entry because it is the newest one. The facility is located 2 miles from the Arizona-Utah border on I-15 and operates on both sides of the interstate. The northbound site is mainly staffed by Utah POE personnel, while the southbound site is mainly staffed by Arizona POE officers. Both sites operate 24 hours every day, and each has a staff of 14 officers including a supervisor. The northbound site has three safety inspectors assigned, also. Each shift is eight hours with four to five officers on the busy shifts. During the 1993-1994 fiscal year, 789,283 vehicles were weighed and the current average daily volume is estimated at 2,200 vehicles.

The current layout of the facility is shown in Figure A-4, Appendix A. The facility was completed in 1992 and is considered state-

of-the-art in utilization of modern technologies. All vehicles are required to enter the facility due to Arizona's weight-distance tax system. Vehicles exit the freeway and enter a ramp passing in front of a freeze-frame video camera. While the vehicle image is frozen on the screen, an officer checks the carrier against a carrier list to determine if the vehicle needs to be called in for credential inspection. At the same time, it is weighed by a WIM device and, if transponder equipped, is read by the AVI. If the vehicle is recognized as one that does not require to purchase a trip permit for the Arizona tax system or has an AVI and does not need to stop, it is signaled to continue in the bypass lane; otherwise it is signaled to cross the static scales. This message is shown to the driver with an electronic display of an arrow pointing to the left for the bypass or to the right for the scales. Vehicles called to proceed over the static scales are weighed while moving at slow speeds. If the vehicle is within the legal weight limit and is not required to purchase or show an Arizona permit, it is signaled to continue onto the freeway unless it is asked to enter for safety inspection. If a vehicle is overweight or it is required to have credentials inspected by the officers, it is signaled to proceed to the parking area and the driver enters the building.

Additional duties of the officers include automatic measurement of the size of the vehicle, the issuing of citations and warnings, the collection of cash bail and fees, the checking of hazardous material documentation, and inspection of driver and vehicle credentials and log books.

Currently, the in-ramp sorting ability of the facility is not fully effective due to low market penetration of AVI and to the Arizona weight-distance tax requirements.

However, as Arizona moves to eliminate the weight-distance tax, increased use of this ability is expected. The utilization of the in-ramp sorting and bypass will also be increased with the expansion of AVI in the future.

Communication between the officers and the driver is performed with a programmable variable message display. The message display directs the driver to "GO TO PERMIT PARKING SEE PORT PERSONNEL" for credential inspection, to "GO TO PERMIT PARKING" for vehicle inspection, to "GO TO INSPECTION BAY NO. 1" for safety inspection, or to "PROCEED TO INTERSTATE" to leave the facility. The layout of the changeable message display (overhead sign) is shown in Figure 17 (the number 23,000 shown in Figure 17 indicates the axle weight displayed).

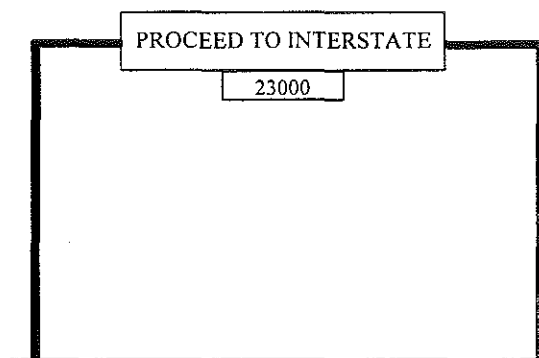

Figure 17. Changeable message display

The axle weights from the static scale are displayed to the driver on the same board with the changeable message signs while his/her vehicle is being weighed. This eliminates questioning by the driver

regarding the reasons that he/she was stopped as well as reducing possible conflicts between the driver and officer. It is believed that this display is a very good method for informing the driver and a positive way to assist the job of the enforcement officers.

The ability of the officers to issue citations and permits and complete reports is enhanced through automation. The time required to do these tasks manually can be used more effectively for other activities, and thus can increase the productivity of officers. Automation has also helped officers to produce more detailed reports and to monitor a larger number of variables that can improve operation of the facility.

The lack of communication among the various facilities and absence of data sharing in real time are major issues that require attention for future integration. The lack of data sharing with other facilities can cause commercial vehicles cleared at St. George to be called into the other facilities farther north along their way. This does not allow the realization of the intended truck free-flow benefits nor the creation of a positive image for in-ramp sorting and clearance. Moreover, the ability to access other data bases, such as traffic violation and safety inspection records, is an additional issue that needs to be addressed.

The facility has two bays used by safety inspectors for completing inspections. Both bays are covered to protect inspectors and vehicles from weather elements. One bay is an open pit with a retractable cover and allows the inspector to walk under the vehicle. The other bay is used for inspections under the vehicle with the use of creepers, and the visual examination of the

vehicles is assisted by the use of lights embedded in the pavement. Safety inspections are generally random and are done at a rate of approximately eight per day, or 1,400 per year. Inspectors work 10-hour shifts for five days a week. Even though the present design is considered adequate, inspectors expressed the desire for longer pits to allow longer combination vehicles (LCVs) to be examined without further moving of the vehicle. Violations are entered into a computer data base, and citations are issued through a software-driven, automated process.

The physical layout of the facility allows a large number of commercial vehicles to park for credentials inspection. In addition to parking for vehicles while in the building, parking is provided for out-of-service vehicles and for vehicles with hazardous material-related violations. There is also a and a collection pit for leakers. Vehicles that require service to correct safety violations can stay in the parking lot, have the repairs performed on site, have the safety inspector verify the completion of the repairs, and then proceed with their trip. Visual observation of the entire parking lot is performed through the side windows of the building and with remote-controlled TV cameras.

The location and design of the building allow a very good view of the entire facility, the bypass ramp, and the scales. The interior design provides a desk for the officer controlling the changeable message and checking the WIM and static scale, a high stand-up counter with five work spaces for trucker credential inspections, and adequate space for driver traffic. Additional areas in the building are driver amenities, a foyer area, an exercise room, lockers and

showers for the officers, a crew lounge/training room, and supervisors' offices. There is also a separate office for the safety inspectors and rooms for utilities, batteries for the uninterruptible power system (UPS), janitorial equipment, computers and communication equipment, and storage. A diesel generator, located near the building, will start automatically if commercial power fails and supply electrical power for all port operations. The building has windows all around that allow a wide field of view and all windows have pull-down screens to block sun glare. The layout of the building is shown in Figure 18.

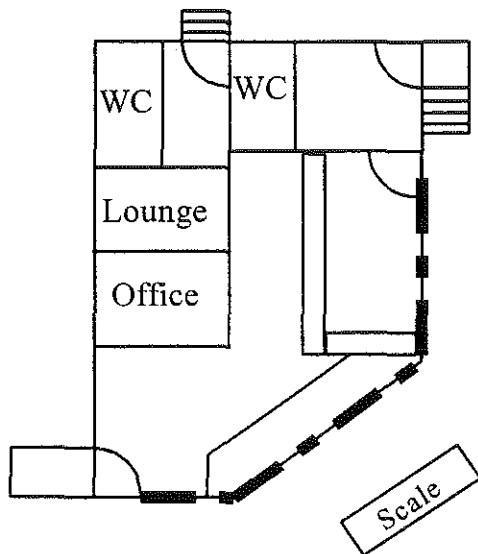

Figure 18. Building layout

4.2.5. Virginia--Stephens City

The Stephens City facility is located approximately 15 miles from the Virginia - West Virginia border on I-81 and operates on both the northbound and southbound sides of the highway. The facility became fully operational in 1994. Both directions of

the station are supervised from a single building located at the southbound facility. A tunnel under the interstate provides access to both sides. The facility operates 24 hours per day seven days per week.

The layout of the facility is shown in Figure A-5, Appendix A. The facility utilizes single-load-cell WIM systems to sort vehicles on the ramp and then direct them to bypass or proceed to the static scale. Changeable directional arrows direct the vehicles through the facility. At present, approximately 75 percent of the vehicles traveling through the station are bypassed after being screened by the WIM system. Once a vehicle reaches the single-draft static scale, it is directed by both a stoplight and a two-way communication intercom system. The stoplight directs the driver to stop on the scale and then to proceed after the weight is verified. In the event of a weight violation, the station operator informs the driver and instructs him/her to pull around, adjust the load if possible, and then proceed back to the scale to be weighed again. Average violation rates are approximately 1.7 percent prior to shifting of the load and 0.7 percent after the load has been shifted. Due to high traffic volume through the facility, the weight from the static scale is not displayed to the driver.

The station also includes an inspection pit to facilitate conducting safety inspections located at the rear of the facility. The pit is not in an enclosed building, and unauthorized access is controlled by means of gates at either end of the pit. A hazardous material containment area is also included in the new station. This area consists of a recessed parking area for hazardous loads to pull into, along with a slump area to catch the hazardous runoff. At present, this area is

not operational due to concerns regarding the handling of the runoff.

The facility was constructed using a single prime contractor, with appropriate supporting subcontractors for the special electronics and other portions of the facility. An engineering consultant was also utilized during design and construction to provide construction inspection. Virginia personnel indicated that this was very important in the successful completion of the project.

The Stephens City station is located between bypass routes that are very close to the interstate. One of the adjacent routes is a two-lane highway, where a standard static scale weigh facility is located. This facility weighs vehicles traveling in both directions and is accessible from the interstate station through an access road. The facility is operated by one person, who does not have the authority to issue citations. If a citation must be issued, an enforcement officer from the interstate station is dispatched.

To monitor the other bypass route, which is a four-lane highway, a WIM system has been installed. This system consists of bending plate WIM devices placed across all four lanes of the highway. Each direction is a self-contained station and can be monitored separately. These systems offer several methods to monitor the vehicle weights. They may be connected directly to a laptop computer or via a computer modem. The use of a modem allows remote monitoring of these systems to determine if overweight violations are occurring. In addition, these systems may be monitored by a system of warning lights, which are displayed on the front of the control cabinet. Using these lights, a mobile enforcement officer may monitor vehicles as they pass

over the system. If a violation is detected, he/she may pull the vehicle over, escort it to the static scale, and issue the citation. Virginia law allows the officer to escort a suspected violator to a static scale for weight verification.

The system was purchased on a competitive bid basis, which included the bending plate systems and all associated hardware, along with three computers, two of which were laptop. The system has been very successful thus far.

The station building is a two-story structure with the control room located on the second floor (Figure 19). This provides an unobstructed view of the operation on both sides of the highway. The station supervisor's office is also located on the second floor. The first floor of the building contains a conference room, additional office space for the enforcement officers, restroom facilities for both drivers and employees, a drivers' receiving area where drivers are issued citations, and an area where the citations are processed and other credentials may be checked. The area utilized for processing the citations is separated from the drivers' receiving area by security glass and locked doors.

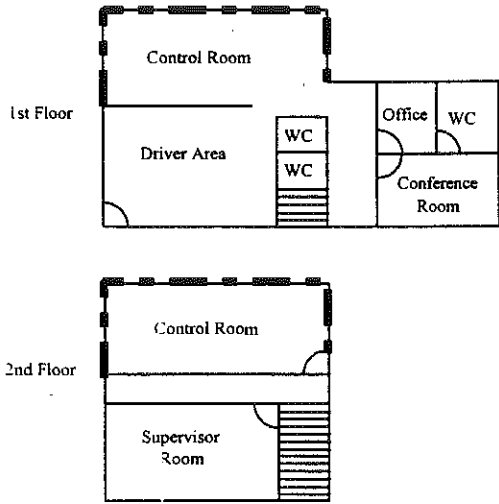

Figure 19. Building layout

To facilitate the verification of credentials for drivers in the northbound direction, a document reader is being installed to allow personnel to view the drivers' credentials remotely. This technology has been used at other locations in Virginia and has worked very well. The system consists of a camera located in a small enclosure. The driver places the appropriate credentials on the viewing area to be verified by the facility personnel. This eliminates the need for some drivers to come through the tunnel to have credentials verified.

5. FINDINGS

5.1. PROCEDURAL CONSIDERATIONS

Several issues were identified in the preceding sections that lead to a set of key points that a state agency should consider while in the process of reviewing its existing CVO program. Such a process would include construction of new facilities or the retrofitting and upgrading of existing facilities. Moreover, no states have specific guidelines for developing or designing a CVM facility. This section of the report presents such guidelines. The first part of this section is the development of objectives and goals for the program. Then, the various steps required for CVM facility design and development are discussed, followed by a description of the components to be included in a CVM facility. The critical factors to be encountered in these processes are also summarized. The last section of this chapter presents general layouts of facilities that can be used as a guideline and a starting point for developing and designing a facility.

It is also useful to restate that this section will not provide specific geometric guidelines for designing or upgrading a CVM facility. Each site visit enforced the notion that facility geometrics are very site specific. Moreover, the arrangement of facility components is generally confined by the flow through the facility and the available area of the site. Furthermore, building layouts are generally governed by the specific functions performed at the CVM facility. Therefore, this document focuses on the presentation of issues that need to be considered when designing or upgrading a CVM facility and attempts to include all possible points that need to be examined. Thus, a minimal number of dimensional

guidelines are presented, since they will be limited in usefulness due to site specific considerations for each facility.

The findings of this analysis can be used as a tool in the development and design of a CVM facility and can provide general guidance during this process. These findings, shown in Table 3, are presented in the following sections.

Table 3. Research outcome

- | |
|---|
| <ul style="list-style-type: none">▶ Facility Development and Design Process▶ Facility Components and Considerations▶ List of Critical Factors--Checklist▶ Function by Purpose and Component Matrix▶ Typical Layouts of Facilities |
|---|

5.1.1. Program Objectives

A very important element in the entire process is the approach selected to identify the needs of the CVO program and its components. Traditionally, two methods are employed for problem solving. The first method identifies current technologies and attempts to implement them in potential areas without addressing the entire problem. This method generally focuses on how the problem may be solved rather than the specific problem. Obviously, such a method does not allow a systematic definition of the problem nor yield the proper solution. Applications of solutions to problem areas will provide localized answers and will run the risk of providing partial solutions by addressing a symptom rather than the problem. Moreover, solutions applied to selected problem areas may not be compatible with other work areas.

The second approach focuses on the general problem first and then attempts to identify solutions and technologies that will solve the problem. Such an approach allows a better understanding of the entire problem and develops a number of possible solutions for all areas. The development of this process lays the common ground for all solutions and provides all working components with a common goal. Interactions among the different approaches are examined, and thus better solutions may be achieved. This approach also allows a ranking of the solutions by developing a priority list and estimating their benefits and costs. Therefore, using the second approach, problems can be properly defined and solved in a more systematic manner.

Identifying the problem first and then searching for solutions is the desired approach to be taken when one decides the future of CVO. The "problem" in this case consists of determining the purpose and functions of CVO. It is very important to determine from the outset the reasons for implementing such a program, the objectives of the program, and how these objectives can be quantified so the results of the actions taken can be evaluated. A CVO program is usually established to provide some means of enforcing compliance with legal weight and height limits, inspecting vehicles to identify safety defects, ensuring proper revenue collection, collecting planning data for future roadway expansion, and so forth. Therefore, identification of the reasons and purpose for the implementation of a CVO program is of utmost importance, and it is the sole component in the entire process that will guide the way and determine the types of solutions to be sought. The purpose of the CVO program can be described in a mission statement outlining these objectives

and goals. Determination of the purpose will also guide the identification of the functions to be performed. For example, when accurate and equitable revenue collection is a purpose, the function of inspecting and recording credentials or commercial vehicle identifiers becomes a primary planning concern. The measures of effectiveness for the functions should also be determined and identified in this phase as well. For the example, such a measure could be the percent of commercial vehicles that had credentials inspected and the number of violations that were observed.

The various agencies involved in the definition and implementation of a CVO may have different views and objectives for the purpose and functions of the program as well as being affected by its implementation. Since the definition of the "problem" (purpose and functions of the CVO program) is the first step in identifying its solution, it is imperative to involve all these agencies at this stage to provide a basis for all solutions to be sought commonly by all involved parties. This way, all concerns and voices can be heard and a unified definition can be reached that will allow a better and more complete solution than if each agency attempted to define the "problem" by itself. Moreover, all agencies will have a common goal and will attempt to reach that goal together. Depending on the structure of each state, agency participation should include state highway and planning, enforcement, revenue, motor vehicle, state economic development, and any other agency affected by the CVO program.

The next step involves the evaluation of the existing facilities and technologies to determine if they meet the purpose and functions of the CVO program. Determining

what is available to achieve these functions permits the identification of needs and deficiencies of the system. Then solutions can be identified and examined to facilitate achievement of the CVO program goals. Such solutions may include building a new

facility, upgrading existing facilities by retrofitting them with modern equipment, changing the process by which activities are completed, and so forth. This process is schematically shown in Figure 20.

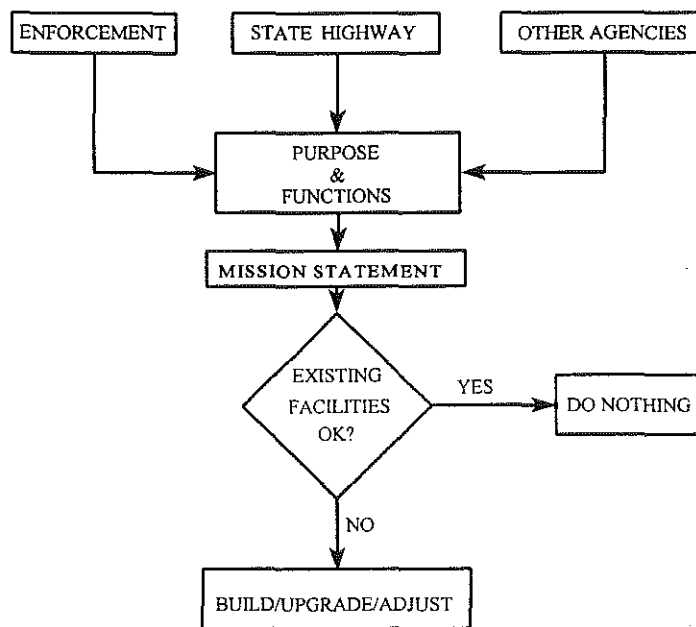

Figure 20. Schematic process of problem-solving approach

5.1.2. Commercial Vehicle Facility Design and Development Process

Having identified the major purpose and functions of a CVO program as well as evaluating the existing facilities, the next step is determination of what will be required to meet the needs, that is, whether a new facility is to be built or an existing one upgraded. This decision is guided primarily by the available monies of the state, the general philosophy of the responsible agencies, and the condition and location of existing facilities. The site visits completed in a number of states indicated that these

items play an important role in the final decision. Moreover, the decision also depends upon the physical characteristics and limitations of the site. For example, even if the policy of the state dictates retrofitting a facility with modern equipment, installation may not be possible due to space limitations of the existing site. In both cases, a similar process should be followed for completion of the improvement of the existing system, either by building a new facility or upgrading an existing facility.

The general process can be broken into three categories: pre-design, design, and

construction. The general flow of these processes is shown in Figure 21.

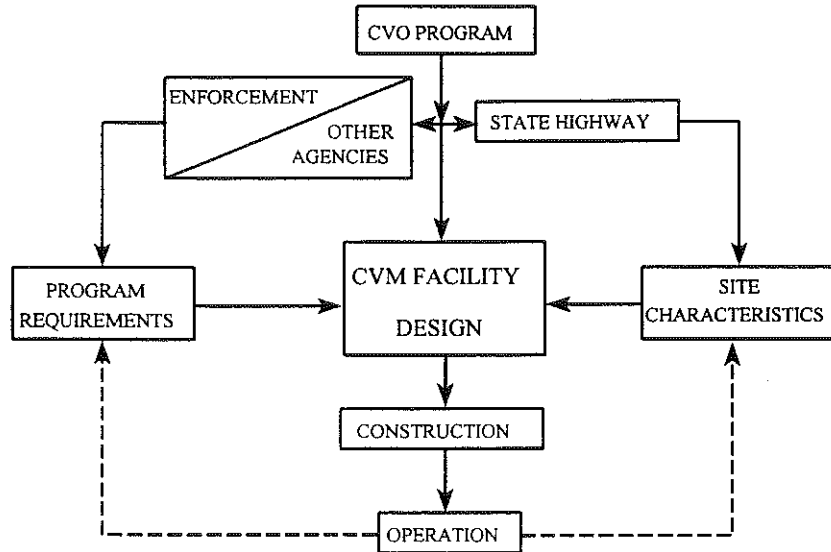

Figure 21. Schematic process of CVM facility development and design

During the first stage of the pre-design a number of steps need to be taken to establish

the basis for design (Table 4).

Table 4. Steps for design process

- | |
|---|
| <ul style="list-style-type: none"> ▶ Identification of Design "Partners" ▶ Development of Enforcement Plan and Goals ▶ Development of Facility Functions ▶ Identification of Solutions to Facility Functions ▶ Development of Facility Flow ▶ Conceptual Layouts of Facility ▶ Sizing Facility Components ▶ Address Future Expansion ▶ Establishment of Procurement and Construction Processes |
|---|

Brief discussions and considerations for these steps include the following:

- *Identification of design "partners"*
As in the development of the purpose and function of the CVO program, the

agencies that will be involved in the development and design stages of the facility need first to be identified. Agencies that may be involved at this point include state highway and planning, vehicle enforcement, facility operators, revenue and taxation, and state economic development office. Clearly, this list is not exhaustive and should be adjusted appropriately for each state to reflect all agencies that may have an impact on design, operation, and use of the facility. For example, border states may need to incorporate customs officials in the list of agencies when the facility is located near a border. In addition to determining all points of view and accommodating all interested parties from the beginning, the inclusion of all affected agencies may increase the available funding levels by pulling all potential funding sources together. Use of the facility by other agencies as a training ground is an additional benefit that can be achieved from the identification of all "partners" from the outset of the process.

- *Development of enforcement plan and goals*

A scaled-down version of the statewide objectives of the CVO program should be identified and stated for the specific facility. These objectives will then allow the determination of the goals that need to be achieved with this facility and determine the way in which such goals could be realized. These objectives will also guide the level of effort to be expended to achieve them and the types of activities performed by the enforcement officers.

- *Development of facility functions*

This is probably the single most important aspect of the pre-design phase, since based on these decisions the various components of the facility will be determined. These functions should also be developed keeping in mind the enforcement goals set forth in the previous step as well as ability to accommodate future expansion and technologies. Therefore, a matrix should be structured to correlate goals and various components to be included in the facility. This matrix should clearly define facility components and will allow the grouping of similar functions into compatible areas. An example of such a matrix is shown in Table 5. It should be noted here that this is a hypothetical example and such matrices should be customized to the CVO program goals of each state.

Table 5. Sample matrix of goals and functions

Goals		Functions
Enforce and Check	Driver compliance	Check license, medical card, log book, documentation
	Vehicle weight & size	Weigh, measure length and height, check for permits
	Vehicle safety	Perform safety inspection
Collect and Disseminate Data	Driver compliance	Record driver violations
	Vehicle weight & size	Record weights and vehicle type and size
	Vehicle safety	Record safety violations
Provide Administrative Services	Driver compliance	Issue citations
	Vehicle weight & size	Sell permits, issue citations
	Vehicle safety	Issue citations, impound vehicle
	Personnel	Training, regional headquarters
Collect Revenue	Vehicles	Check tax credentials, collect fees
Facilitate	Personnel	Provide office amenities
	Drivers	Provide vehicle parking, driver amenities

● *Identification of solutions to facility functions*

This step involves the definition of possible solutions for completing the functions to be performed at the facility. Potential technologies required to accomplish the functions should be identified and evaluated. The advantages and disadvantages of each technological application should be enumerated and the rationale for selecting a specific technology for a function should be stated. Obviously, the cost of the solution will play a role in the determination of the final choice, but it should not be the sole criterion for such a selection. Another matrix can be

constructed here that will assist in the development of the list with possible solutions (Table 6). For retrofitting a facility, the existing components should also be included in this matrix and considered and evaluated at the same time. A more efficient utilization of the existing facility may be achieved by including the available equipment. In addition to these technological considerations, land availability, terrain topography, and site limitations should be considered when these solutions are sought.

Table 6. Sample matrix of functions and solutions

Function	How?	Advantages	Disadvantages
Weigh vehicle	WIM Static scale Portable scale	No vehicle stop Accuracy Not fixed	Accuracy Vehicle delay Accuracy, weight
Measure vehicle	Automatic devices Manual inspections	Automated process Visual inspection	No visual inspection Increased personnel
Inspect credentials	AVI Manual inspections	No vehicle stop Driver compliance	No check for driver compliance Vehicle delays

● *Development of facility flow*

This step will determine the vehicle flow through the facility and the steps required for the completion of this process. The flow must start as the vehicle approaches the facility and be completed after it leaves the facility. All

possible options and their corresponding actions should be identified. This process will guide the design of the facility and the physical relationships among the various components. Such a process can be depicted in a flow chart (shown in Figure 22).

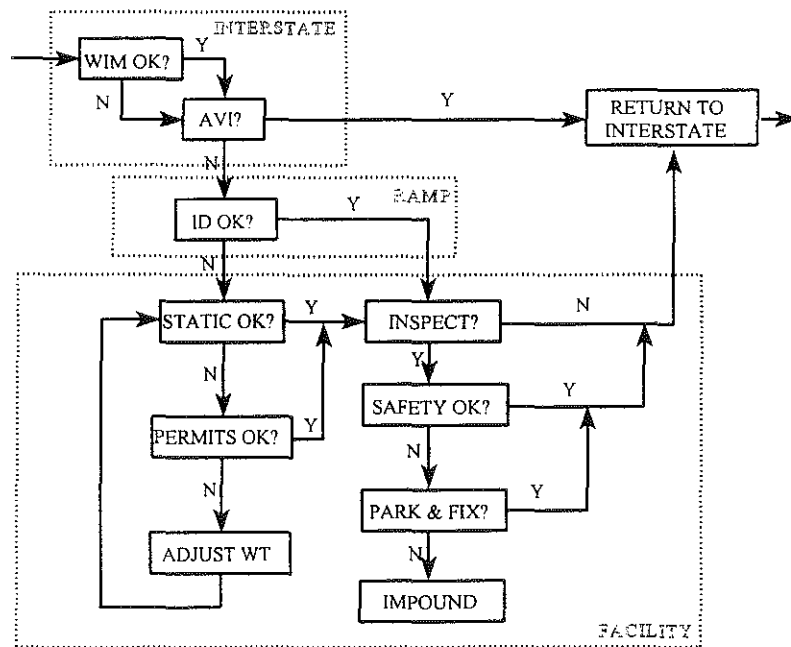

Figure 22. Example of flow chart for vehicle process

- *Conceptual layouts of facility*

After determination of the flow through the facility and identification of the equipment to be used for achieving the functions set forth, the next step involves a preliminary layout of the facility. In this step, the location of the various components can be identified and their placement in the general area of the facility can be identified. The general areas where the functions are to be performed include the location for sorting, the freeway off ramp, the bypass ramp, the weighing facility (static scale), the inspection area, the parking and impounding areas, the freeway on ramp, and the building. There is an order to these components, and they should permit the appropriate interactions

among the components as they were determined in the previous step. It should also be noted that additional areas may be required for specific facilities or functions (diesel fuel testing, agricultural inspections, and interagency personnel training) and that the list developed here attempts to define most of the common areas used in such facilities. For retrofitting an existing facility, the buildings, ramps, scales, and other components of the facility should be considered in this stage. The way these components will interact with the new systems should be clearly identified in order to utilize the existing layout to its maximum potential. An example of such a layout is shown in Figure 23.

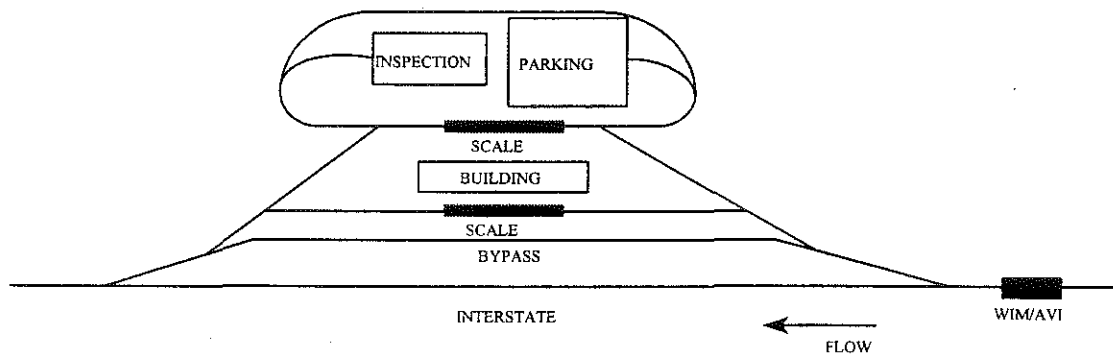

Figure 23. Schematic layout of a facility

- *Sizing facility components*

In this step, the size of each component should be estimated: the length of the ramps required to allow a smooth transition in and out of the facility, the length of bypass lane, the size of the building, the size of the parking area, and the number of inspection bays. The size of most of these items depends on the

current and expected traffic volumes. It is essential to obtain accurate estimates of the expected flows, since both oversizing and undersizing the facility will cause problems. Moreover, the number of vehicles expected to pass through each component of the facility should be determined to allow an estimation of the required number of

units to serve the vehicles. For example, if a large number of vehicles is expected to enter the facility to be weighed, it may be more efficient to have two static scales and thus reduce delay. Another important component in this step is estimation of the processing time for each component of the system. Based on these estimates, the number of servers (units) for each component can be estimated in order to minimize delays to commercial vehicles as well as to ensure adequate personnel coverage. An example of steps required for sizing a facility as well as some guidelines with respect to sizing the facility components are presented in Appendix C.

- *Address future expansion*

The next step in this process involves an examination of what steps should be taken to upgrade the facility in the future to address possible increases in traffic. Moreover, such steps should be at least considered if not incorporated into the current design to allow a smoother future expansion of the facility.

- ◆ *Establishment of procurement and construction processes*

The final step of this process includes the determination of the methods to be used for the procurement and award of the contract for the completion of the facility. Even though each state has different procedures for selecting contractors and awarding construction and equipment contracts, a number of issues, common for all states, should be considered:

- ▶ Single contractor
- ▶ Subcontractors
- ▶ Awarding the contract by sole source, lowest bid or performance-base

- ▶ Equipment contracts
- ▶ Schedule of events, and
- ▶ Types of inspection.

5.1.3. Commercial Vehicle Facility Components

One of the steps described in the previous section is development of the facility functions and the equipment to be used for completing these activities. This section presents a brief overview of the available technologies for achieving these functions and provides a list of issues that should be considered during this phase. These components are shown here in the chronological sequence that a commercial vehicle would follow in approaching the facility.

- *Vehicle sorting*

This function allows a determination of what commercial vehicles are to be called into the facility for additional checking and inspection. This activity may be performed either on the freeway (mainline sorting) or on the freeway exit ramp (ramp sorting). Mainline sorting allows no delays to vehicles in compliance with the existing regulations and provides a means for realization of technologies that allow bypassing of the facility. The disadvantage of this system is the difficulty of visually inspecting vehicles for safety- or driver-related violations. Ramp sorting requires all vehicles to enter the station and thus creates delays even to vehicles in compliance. The ability to visually inspect all vehicles is enhanced in this scenario.

Two categories of vehicle sorting can be identified depending on the type of check

to be performed. When sorting is done based solely on weights and no credential inspection is required, then a WIM device is all that would be required. On the other hand, when both credential and weight checks are required, then a combination of a WIM device and some type of reader of the vehicle's identification are used. In addition to the WIM and vehicle identification equipment, sometimes a vehicle classifier is also used. The classifier allows checking compliance with the weight and axle spacing combination of the vehicle and provides continuous monitoring of the vehicle's location. The vehicle identification readers may be either a computerized device, such as an AVI detector or reader, or a visual device, such as a video camera or license plate reader. Each system has its advantages and disadvantages as well as different costs. The major problem with AVI detectors at this point is the low usage of these devices and concerns of the industry. These concerns include privacy of proprietary information on weight, market share, and routes of their company as well as fears of overregulation by the government. Moreover, the issue of developing an AVI standard that will be readable by a number of detectors and systems throughout the United States is another problem that should be resolved prior to extended use of these devices. The visual devices allow monitoring and the ability to identify a large number of vehicles using identifiers already in place, such as license plates or VIN. Such devices are not used widely because they are in experimental stages (license plate readers) or require

additional personnel (video cameras). In any event, it is apparent that some standardization of the vehicle identifier is needed nationwide. This may be achieved by either a common transponder or common vehicle license plate or identification number.

Another area of concern is the communication of the intended message to the driver. In-ramp sorting allows a clearer display of messages and may eliminate communication problems with the use of either arrow displays directing the driver to the desired lane or changeable message signs providing instructions to the driver.

Communication for mainline sorting may be achieved with the use of changeable message signs that will be turned on when a vehicle is requested to enter the facility; otherwise, they will remain blank. This system may prevent clear communication when spacing of commercial vehicles is very tight and more than one driver may see the message and enter the facility unnecessarily. A special effort should be made when designing this system to guarantee that only the intended driver will see the message. An additional method for communication, used in combination with AVI, is an in-cab device (display of similar messages or warning sounds). The use of this device may divert the driver's attention from the driving task or overload him/her, creating a safety hazard.

To achieve vehicle sorting, a necessary component is the ability to perform one of the following: display all data collected and identified to facility personnel so they may determine if

bypass is permitted; or automate the process and allow computers to decide if bypass is permitted. The facility attendants should be able to check the approaching vehicle for compliance with all required checks, such as vehicle weight, size, safety, and be able to determine whether to allow it to bypass the facility or to call it in. The ability of the facility personnel to access additional data bases relating to these items is very important, not only for vehicle sorting but for all additional components of the process.

- *Ramp system and internal roads*

Entering and exiting the facility are accomplished via ramps. The design of these components is similar to design of any ramps for freeway use, and the only specific requirement is possibly length to accommodate long queues. Guidelines for the length of ramps are provided in Appendix C. It should be kept in mind that the design vehicle here is a commercial vehicle that has different characteristics from passenger cars or other vehicles in the freeway mix. The ability to make quick maneuvers is limited for these vehicles, and they usually require longer distances for acceleration and deceleration. Therefore, the length of the entrance ramp should provide adequate distance for deceleration when the ramp leads to a static scale. Moreover, the acceleration lane should be sufficiently long to provide adequate space for a heavy vehicle to reach freeway speeds and to merge safely with the freeway traffic. Ramp location and grade are very important in achieving a smooth transition in and out of the facility. Entrance ramps uphill or exit ramps

downhill should be avoided to eliminate additional problems.

Internal circulation in the facility is accomplished by the use of a loop-around road, which can facilitate re-entry to specific components (scales or inspection bays) without the vehicle having to back up in the main area of the facility to enter the freeway again. For most of these roads and turns, the turning radii to be used should be longer than recommended by AASHTO.

- *Vehicle weighing*

This activity is completed with scales that can weigh commercial vehicles. Two main alternatives are available--static scales and WIM devices. Static scales require the vehicle to stop to be weighed. They are used either as a single unit, requiring the vehicle to pause with one axle or a combination of axles on it at a time, or as a combination of units, allowing the entire vehicle to be weighed at one time.

Communication between the driver and facility personnel is accomplished either with a changeable message sign, which can provide messages guiding the driver through the scales, or a traffic signal, usually with two colors--red (stop) and yellow (proceed slowly).

Communications are also aided with the use of a speaker system, one-way or two-way, to guide the driver. WIM devices allow for weighing a commercial vehicle while it is in motion and those used as scales within the facility are traditionally low speed devices. Static scales provide higher accuracy than WIM devices but they increase the time a vehicle spends in the facility, since they require stopping.

Delays are usually longer if a single platform static scale is used requiring vehicles to stop for every axle.

Weighing devices should be placed in locations that allow for sufficient time for communication with the driver. Information must be given to the driver either to bypass or enter the facility or to proceed to the static scale area if an in-ramp sorting process is utilized. Moreover, when directional signals or changeable message signs are used, the spacing should be such that confusion between trucks following closely behind one another would be eliminated.

There are two types of WIM devices utilized in enforcement activities--single-load cell and bending plate. Each system has advantages and disadvantages with regard to installation, operation, and maintenance. There have been several projects across the country which have evaluated the various types of WIM systems and how they may be used in enforcement activities. In the installation and operations of WIM systems, two of the most significant areas of concern are the roughness of the roadway approaches which effects the vehicle dynamics, and the initial and ongoing calibration of the system.

In selecting the location of a WIM device (mainline or on ramp), several factors must be considered. The grade of the approach and exit areas of the scale should be as level as possible or have grades such that the vehicles would not be braking or accelerating as they crossed the scale. In addition, the cross slope or superelevation of the roadway is important since this could cause

disproportionate loading between each side of the vehicle. A site should be selected which minimizes these two effects, thus increasing the effectiveness of the WIM system. In situations where WIM systems are being added to existing roadways or ramps, installation of approaches for the system may be required to insure a smooth surface as the vehicle crosses the WIM. In most instances, these approaches would be constructed with Portland cement concrete which will eliminate problems associated with rutting and other types of roughness distress observed in asphaltic concrete pavements. The actual installation of the WIM is also critical to its function. It should be installed such that there is a smooth transition as the vehicle tires pass across the surface. If the WIM is above or below the grade of the approach, this could increase the dynamic effects of the vehicle passing across the system and may produce more variability in the measured weights.

The proper calibration of a WIM system is vitally important to insure accurate determination of vehicle weights. The calibration of the system should consist of an initial calibration in addition to an ongoing calibration program. There are several studies currently underway which are evaluating the various calibration procedures which are utilized for WIM systems. Some WIM systems may have a tendency to drift out of calibration, therefore, it is very important to monitor the system output on a systematic basis. Since most enforcement WIM systems are located in close proximity to a static scale, an ongoing calibration procedure would be easily implemented. Monitoring of the system may be

achieved by observing the trends which may occur in the measured values of both gross weight and steering axle weights. These trends may then be compared to the actual trends observed in the static weight over the same time period.

Threshold levels of WIM systems may be set to only sort out vehicles which are empty or very lightly loaded. In this scenario, the accuracy requirements of the systems may not be quite as important. However, if the threshold level is approaching the legal weight limits, the calibration of the system becomes much more critical, since a scale which is out of calibration could conceivably bypass vehicles which are in violation. The setting of the threshold levels for sorting is an administrative decision which may be based on the functions which are performed at a given facility. In addition, facilities which have higher truck volumes may choose to increase the threshold level to lighten the traffic load which must cross the static scale.

A good practice when vehicles are weighed is to display the measured axle and gross weight to the driver. Such a practice shows professionalism, builds good relationships with the drivers by showing them what the vehicles weigh, eliminates questioning by drivers about the reasons they were stopped, and reduces possible conflicts and arguing between drivers and facility personnel. These displays are a positive method to assist the job of facility personnel. Moreover, displays may remain on even when the facility is closed and provide drivers with a means for determining the

weight of their vehicles. Having these displays connected to an automated system for printing weights of vehicles allows for office automation and also assists the job of facility personnel.

The weighing area has been traditionally located close to the building where the facility personnel are housed. A large windowed area allows for a visual check of a passing vehicle and permits facility personnel to conduct a quick visual inspection of the vehicle and visually identify possible safety problems. The proximity of the scales to the building also allows for facility personnel to ensure that the vehicle has stopped properly on the scale and the weights are measured accurately. Furthermore, types of axles and axle combinations can be viewed with such a design and allow for an accurate calculation of individual axle weights, if needed.

- *Vehicle inspecting*

The area required to complete this activity consists of inspection bays, which have two basic designs--open pit and flat bay. Open pit designs allow for safety inspectors to walk under the vehicle and perform the inspection by visually checking the undercarriage at eye level. Flat bay designs usually have a pavement marking that delineates the area and the inspection is performed by crawling under the vehicle with the help of a creeper. To assist the safety officer in the inspection, recessed lights should be installed in the flat bay. Open pit designs are considered as more convenient for the inspectors, since they can perform the safety inspection at eye level and without crawling. These designs provide inspectors with a closer

look at the various parts of the undercarriage of the vehicle and allow for safety inspections for low clearance vehicles. On the other hand, flat bay designs are cheaper, but they require the officer to crawl or roll with a creeper under the vehicle and require frequent maintenance of the lighting. The type of inspection area is also a function of the level and amount of safety inspections to be performed. Both designs should be sufficiently long to allow for the longest vehicle combination to be inspected without having to move while in the inspection area. Some consideration should be given to cover open pits, since it may well be a hazard for unsuspecting drivers. A parking area should be provided for vehicles that require repairs and are classified as out-of-service until repairs are completed. This will ensure that safety problems are corrected and that vehicles could be considered safe to travel.

To protect both safety inspectors and drivers from weather as well as allow inspections in any type of weather, some cover should be provided for inspection areas. The inspection bays may be either completely enclosed or simply have a roof. Proper ventilation of vehicle exhaust fumes is of high significance for any cover design but more important for enclosed areas. Enclosed bays require proper lighting and some consideration should be given to temperature control of the building for the comfort of the safety inspectors.

Some office automation is desired for preparing citations and storing safety inspection data for future use. This automation will allow inspectors to

develop a uniform nationwide citation system and provide on-site access to data bases for reviewing the safety history of a commercial vehicle. This way, vehicles having safety problems may be identified and targeted for more frequent inspections. Current technologies that utilize pen-based data entry are tested and may aid office automation.

New technologies are developed that will automate safety inspections both at fixed and mobile locations and should also be considered. Such a system is the Automated Roadside Safety Inspection (ARSI) service which will provide automated inspection capabilities. This service will check safety requirements more quickly and accurately during a safety inspection performed at a fixed or mobile inspection site. These capabilities will include the more rapid and accurate inspection of vehicle systems such as brake performance. This service will also include a communications link for updated inspection data, such as out-of-service information, to complement the nationwide availability of CVO information. These new capabilities will enable safety inspectors to check more vehicles and thus increase safety compliance.

Several states are beginning projects to test and evaluate innovative devices for vehicle safety performance testing under the MCSAP. The technologies being tested include flat plate devices and rolling dynamometers that measure brake performance, some of which also include ways to check steering and vehicle suspension systems performance without

having to manually inspect the vehicle. In addition, Sandia National Laboratories is identifying other technologies that can be used to enhance roadside inspections. These devices measure system performance rather than relying on manual measurements of individual components. Future generations of these devices might be mounted onboard the vehicle or in the roadway to measure performance at mainline speeds. An additional area of concern is the driver's condition and performance. In addition to being able to review the operator's driving history and violations, technologies will emerge to assess the driver's current performance and alertness. Future generations of these devices might be mounted onboard the vehicle.

Future technologies can also allow for electronic clearance of vehicles by initially providing to the enforcement officials the historical safety data on the carrier and the current safety inspection status of the vehicle and driver. This way, the officers can decide if a vehicle should be allowed to bypass or be called into the facility. Once the decision is made, the safety technologies under ARSI would be applied to reduce the inspection time. As these technologies continue to develop, the use of onboard devices is envisioned to be incorporated to further reduce the required total inspection time.

- *Credential inspection*

This activity is traditionally completed in the main building of the facility that houses personnel. However, modern technologies allow for automated credential checks with the use of an AVI,

as described in the vehicle sorting section. This section generally focuses on issues dealing with the main building of the facility. This building is the area where the displays and controls of the facility are located as well as the area where driver and vehicle credentials can be inspected. Typical design of such buildings include a large room where all displays are located with areas for the facility personnel to supervise and control the equipment and additional areas used by personnel. The location of the building varies with the ramp design and the various functions performed, as well as with the available space in the area of the facility. For example, at facilities having dual static scale ramps the building should be located between the ramps, while at facilities having one scale ramp, the building could be located at either side.

A number of items should be considered during design and placement of the building. First, the control room should have adequate windows that will allow facility personnel to have a good view of approaching traffic. Placing the main side of the building toward approaching traffic allows facility personnel to supervise approach ramps as well as to be alert for unauthorized vehicles that bypass the facility. A good viewing point of the static scales is also recommended and this may be achieved by having windows in the sides of the building parallel to the flow of traffic over the scales. Furthermore, visual supervision of the entire facility is a desired feature and should be achieved either with additional window areas that will provide unobstructed view of the parking area and exit ramp to the

freeway or with the use of surveillance cameras. The control room should have an elevation that will allow facility personnel to visually inspect vehicles and maintain eye level contact with the drivers.

Adequate space is needed to house all control equipment and provide an efficient and ergonomically sufficient work area for facility personnel. Computer equipment that will allow for driver and vehicle compliance checking should be located in a way that will allow personnel to enter any required data while maintaining visual contact with the approach ramps. Additional space may be required to provide adequate circulation of personnel and allow freedom of movement. Space requirements should be developed based upon the usual number of employees in the facility at any time.

Facility personnel are separated from drivers who enter the building by a high counter or teller-type windows. The counter should be wide to allow for drivers to present their papers and permits and provide some working space for facility personnel. If fees are collected, permits are sold, and citations are issued, additional space may be required to accommodate these activities. Cash registers, electronic printers, and writing desks should be considered in determining the size of the counter.

Some standard amenities for facility personnel should be included to provide a reasonable working environment. Heating, cooling, running water, rest room facilities with showers, meeting and training rooms, lockers, and a

lounge area are some of the amenities that will improve the quality of job conditions. Moreover, it may be necessary to provide separate heating and cooling controls for various portions of the building due to locations relative to the movement of the sun. The fresh air intake for the building should be located far away from areas where vehicles may be parked and idling, such as parking areas and inspection bays. A separate office space for the facility supervisor may also be considered as part of the design.

Driver amenities are also a component of the building design that should be considered. Rest rooms, telephones, snack and soda vending machines, and information displays are elements of good public relations policies. Depending upon the amount of personnel and driver interaction, additional areas may be needed. Such areas may include a room for conducting driver interviews, checking impaired drivers or detaining impaired drivers.

Placement of the building in relation to the sun movement is also critical. Sun glare may obstruct viewing of the approaching traffic or may hinder supervision of scales and other areas within the facility. In the event that the building cannot be placed away from the path of the sun, additional measures that will block sun glare should be considered. These measures include sun screens, overhanging canopies, and polarized windows. To reduce glare from headlights at night, slanted windows should be used.

Safety of the building is another area of

concern that should be addressed. Bullet-proof windows, adequate lighting at night, and surveillance cameras are some items that can enhance and improve the safety of the building and the facility personnel.

Communication devices within the building are also an integral part of the building design. Public address systems, police radios, electronic mail, telephones, facsimiles, and intercoms are equipment that will allow communication among facility personnel as well as with other agencies outside of the facility. Real time access to various data bases, such as drivers' licenses, vehicle registration, and safety records, is essential for a continuous flow of information and updating of available sources. Links to other facilities and to central offices for a continuous, two-way exchange of data is desired in order to be current.

Office automation is another area that should be examined when building design is considered. The ability of facility personnel to issue citations for weight and safety violations and permits, enhanced through automation, allows them to increase their productivity by using the time required to write citations more effectively for other activities. Automation can also help to produce more detailed reports and allow monitoring of a larger number of variables that can improve the operation of the facility. An area of concern is the existing variety of forms and credentials issued by each state, a fact that makes credential inspection a very time-consuming process requiring significant attention by the facility personnel. The standardization of these forms is a

desirable goal for facility personnel and commercial vehicle drivers as well.

- *Vehicle parking*

Commercial vehicles failing to comply with weight and size limits, having safety-related problems, being impounded, or being placed out-of-service require an area where they can park. Parking areas can be divided into two major sections depending upon the time the vehicle will park. Short-term parking is utilized by drivers of vehicles required to use the building for credential inspection, purchasing permits, paying fees, adjusting axle spacing to conform to weight limits or simply conducting personal business. Long-term parking is utilized by drivers of vehicles that need repairs, have been placed out-of-service or are being impounded. Sections of the long-term parking area can be dedicated to vehicles with hazardous material problems and may provide a secure area to confine impounded vehicles.

If space permits, parking should allow for vehicles to pull in and out without a backing maneuver and thus eliminate interference with other vehicles and reduce accident hazards. This parking layout also minimizes congestion and avoids impeding of the facility operations by not creating waiting queues due to backing maneuvers. A flow-through design provides a safer environment for safety inspectors to complete a walk-around vehicle inspection in those cases where inspection areas are not provided. Angle parking requires a narrower overall area and allows for easier transition in and out of the parking area. Furthermore, the parking area should be located away

from the static scales and provide access either to the circulation road leading to the scales for vehicles that need to adjust their load and be weighed again, or to the exit ramp.

The size of the parking area is a major parameter that needs to be estimated in the design process of the facility. The number of parking spaces provided is closely related to the level of interaction between the drivers and the facility personnel. Having drivers spend a long time in the facility building for credential inspection will increase the number of required spaces. On the other hand, requiring only overweight or oversized vehicles to park will reduce the number of required parking spots. Drawing from past experiences based on similar facilities, the number of parking spots required can be estimated. An alternative method to estimate the required number of spaces is the use of queuing theory-based models that can be deterministic or stochastic in nature. To use such models, the required data include estimates on the average daily traffic, the average time that a driver will spend in the building, the number of personnel dedicated to interact with the drivers, the average number of vehicles to be checked, and the average number of vehicles that use the facility as a rest area.

Finally, another parking area to be considered is that for the facility personnel and visitors. This parking usually is placed adjacent to the building and provides storage for the enforcement vehicles and personal vehicles of the personnel. Design standards used for regular parking facilities, such as rest

areas, may be used here. Pavement markings and signs should clearly indicate this area as parking for automobiles and should direct commercial vehicles away from this area. Easy exit of enforcement vehicles should also be considered to allow for those times when a commercial vehicle is pursued.

5.1.4. Critical Factors in Designing a CVM Facility

A number of critical factors during the development and design process have been identified throughout this section. To provide the various agencies with a more organized and systematic tool, all issues discussed in the preceding sections are presented here in the form of a checklist (Table 7). Each item is identified and the basic content of the question is addressed. It should be noted here that this checklist provides for a quick reference to all items discussed previously. This list should not serve as the only tool for the development of the facility.

Table 7. Checklist for development and design process for a facility

	ITEM	CONTENT
Pre-design	Facility functions	Who will use the facility?
	Flow through the facility	How is a vehicle processed though?
	Available equipment to achieve functions	What is out there that can do the job?
	Selection of equipment to be used	Which is the "best"? How is the "best" selected?
	Future integration of equipment	Can it be used in the future? Proposed expansion?
	Maintenance and serviceability of equipment	Can it be maintained easily? Reliability?
	Environmental impact	Will there be a hazardous material area?
Design	Existing and future traffic volumes	What are the current and future design volumes?
	Size of various components of the facility	How large should it be?
	Schematic layouts of facility	How do components fit in the designated area?
	Building size and location	Where should it be placed? How big should it be?
	Amenities for facility personnel	What type of facilities should be provided?
	Amenities for commercial vehicle drivers	Should such facilities be available?
	Communication devices	How will data be transferred and accessed?
Construction	Supervision by appropriate personnel	Who supervises each component of the facility?
	Frequency of site visits	How often is the site to be visited?
	Enforcement of design specifications	Are specifications met?
	Conformance to Manual on Uniform Traffic Control Devices standards	Are signs and signals according to standards?
	Subcontractor structure	Who is responsible for the subcontractors?
	Procurement procedures	How are equipment and contractors selected?

A matrix that correlates and identifies the possible functions of a CVM facility is also presented here (Table 8). This matrix indicates the types of equipment that may be used to satisfy these functions. It should

again be pointed out that this matrix should not be considered as the only tool in selection of available equipment, since newer technologies may be developed in the meantime.

Table 8. Matrix of facility functions and required facility components

FUNCTION	PURPOSE				
	Revenue Collection	Safety	Size/Weight Compliance	Planning	Training
Vehicle Credential Inspection	Building/ID ¹			ID ¹	
Credential Issue	Building		Building		
Vehicle Weight	Scales ²		Scales ²	Scales ²	Scales
Vehicle/Driver Inspection		Inspection Pit			Inspection Pit
Vehicle Size	Size detectors	Size detectors	Size detectors		
Vehicle Detention		Parking	Parking		Parking
Data Collection	Building/ID ¹		Scales ²	Scales ²	Computers
Data Transfer	Building/ID ¹	Building			
Driver Credential Inspection	Building	Building			

Notes: 1. ID may be a license plate, part of VIN or an AVI
 2. Scales may be dynamic (WIM) or static

5.2. CURRENT EXPERIENCE

This section draws upon the experience of the other states and presents a list with recommended practices as well as practices that should be avoided. Most of these comments are anecdotal statements obtained during the site visits. These statements are grouped in four major groups: building design, facility layout, operational considerations, and general comments.

5.2.1. Building Considerations

- What are the activities to be performed in the building? Are fees and fines collected, permits sold, and citations issued? Do you check credentials? Which ones--drivers' licenses, vehicle

registration, tax documents? Will the facility be used as a command center to direct trucks delivering supplies during a disaster? All of these factors should guide your building layout and size.

- Should the building be a secure facility with bank teller-type windows between personnel and drivers? Should exterior glass and building be bullet-proof?
- It is essential to consider the orientation of the building with respect to the roadway and sun. Personnel should be able to clearly see the entire area and especially the approach ramps where the view of incoming traffic should be unobstructed. Make sure that you can follow the paths of trucks instructed to park and adjust their loads and that you

have not provided them with the opportunity to escape without your noticing it.

- Elevation of the control room should allow for the officers to be at eye level with drivers.
- Backup power and UPS power supply are desired so you are not forced to shut down the facility.
- Fresh air intake for the building should be away from areas which will have concentrations of exhaust fumes. Do not put air intakes downstream of predominant wind patterns. That is the same as having it next to the exhaust!
- Need to provide video surveillance of unmanned areas or areas which cannot be seen from the control room. Enhances safety and provides the opportunity for surveillance of out-of-service vehicles.
- Do you need separate rest room facilities for employees and drivers?
- What types of office space are required? Do you need a separate office for the supervisor? Is this an area supervisor's office for field operations?
- Adequate conduit should be provided for future expansions, both inside the building and under the ramps and parking areas.
- May want to consider zoned heating and cooling since some areas of the building will be facing the setting or rising sun and may be quite a bit warmer than other areas.

- Plan for extra storage space; there are always more products to store than anticipated.
- Sufficient communications should be provided throughout the building and the facility--telephones, intercoms, public address systems and radios.
- The layout and design of the building depends a great deal on the amount of customer interaction which occurs. Moreover, this will also dictate the necessary furnishings of the building.
- During the design and construction of the building, someone who is familiar with building construction should be involved. This will help alleviate problems which may arise from someone inexperienced with building construction omitting items which they are not familiar with.
- During the planning, design, and construction of the building, the speciality electronics contractor and the users should be involved since they best know how the facility will be used and operated.
- The opinions and input of the facility personnel are a must in the development and design process. These are the people who will run the facility and they should feel happy with what they will get.

5.2.2. Facility Layout Considerations

- Geometry of roadway should be considered to ensure adequate site distance. Also downgrades and upgrades should be avoided on the

- ramps where WIM's are located if possible.
- Ramp lengths should meet standard geometric design standards and provide adequate storage of vehicles being processed.
 - Some places still use scales on two-lane, two-way roads by having a single site to weigh both-way traffic. These are small facilities but need careful attention to design.
 - Facility parking areas should be designed based on the functions performed at the station. A large parking area may be required if there is a lot of driver-station personnel interaction (checking of tax credentials, issuing permits, etc.). Smaller areas may be appropriate if few trucks are required to stop (for example, only weight and safety enforcement). Facility parking areas used for parking out-of-service vehicles should be designed to accommodate the Vehicle Video Identification System.
 - If a hazardous material containment area is desired, careful consideration must be made about its location, since some means of containment and disposal of leaky materials is required. In addition, environmental impact studies may be required to ensure compliance with EPA standards. If cities or towns are nearby, develop a contract to ensure that the pit does not become a catchall for situations that should have been handled locally. Moreover, plan for the arrival and departure of emergency response vehicles.
 - The building should be protected from incoming trucks by jersey barriers. A facility escape door on the opposite end of the building from which a vehicle is approaching should also be considered.
 - Plan a building to be used as a training facility or to provide meeting rooms for seminars and conferences.
 - Accessibility of utilities must also be considered. In some instances, waste disposal may be a problem. The availability of good quality communication links should also be considered.
 - Special right-of-way restrictions must also be evaluated when the actual layout of the station is designed. In some areas, the acquisition of additional right-of-way may be more difficult.
 - If on-ramp sorting of vehicles is to be performed, good lane delineation and clear directional signing should be included. In some facilities, the presence of duplicate changeable directional signs have caused some confusion for the incoming trucks. In a number of facilities, barrels or flexible lane markers have been added between the bypass and static scale lane to ensure vehicles remain in the proper lanes.
 - The location of the static scale with relation to the building should allow for viewing of the axle locations in relation to the scale platform (at least 8 meters from the building) when individual axle weights are required.
 - All signs and signals should follow the Uniform Manual of Traffic Control

Devices guidelines. Special attention should be given to code requirements for enforceable signs.

- Adequate conduit and utilities should be placed beneath the ramps and parking areas to provide the ability to upgrade the facility as new technology becomes available.
- A display of the vehicle weights that can be viewed by drivers is also helpful. This allows them to see the actual weights as the operator sees them. It is a good public relations tool that can be used to our advantage (reduce driver frustration and arguing.) However, volumes need to be considered, since for high-volume locations this may cause serious backup problems.

5.2.3. Operational Considerations

- If the facility is to be an integrated, computer-operated facility, procedures should be available to operate each of the individual components separately. This would allow the station to continue operation if one of the systems goes down.
- The control area should be comfortable for the operator. Some states have indicated that the equipment control console (computer keyboard and screen) be moveable to allow for customization by the operator. Other states have suggested mounting the terminal or console into the worktable. By mounting the equipment in the worktable, no customization is allowed and may cause some user problems.
- There should be manual overrides of the

control equipment within the station to allow the operator to control traffic flow if problems arise. This feature is especially useful when traffic is backed up on the incoming ramp. Manual operation of the static scale is another desired feature for overcoming computer problems and allowing uninterrupted operation of the facility.

- In stations where WIM devices are used for sorting, there is a need for a routine ongoing calibration of the equipment. This can be achieved with the use of the static scales as the calibrator.
- New technologies implemented in recently constructed or upgraded facilities require training of the operation personnel. This training can be part of the specifications that the vendor or contractor has to fulfill. On-site training is desired to insure proper operation of the installed equipment.
- Provisions should also be made for the continued maintenance of the equipment, either using a maintenance contract with the vendor or having the vendor train in-house personnel to do the maintenance. Delays in obtaining help and repairs from various vendors can greatly decrease the effectiveness of the facility and limit its performance potential.
- Convincing facility personnel of the importance of the facility and the new technologies is an essential component for successful operation of the facility. They need to be included in the design and development process.

5.2.4. General Comments

- In the construction of a new facility or the upgrading of existing facilities, performance-based specifications should be utilized. In addition, some type of mechanism should be employed to ensure the installed equipment meets these expectations. This may include some type of operational testing for a specified period of time to ensure all components are working properly.
- All functions to be performed in the stations should be outlined in the very beginning of the planning process. Each function should be analyzed to ensure that all required equipment and space is included in the design. A facility operation matrix should be developed to include all functions of the station and the responsible agency or person for each of the functions. These responsible persons should ensure that everything needed to perform their function is addressed.
- The ideal location for a facility is level terrain and includes the use of entrance and exit ramps with no slopes that will affect the performance of the trucks.
- Talk to other states' personnel and try to understand what lessons they learned by their experiences and what new technologies they are implementing or testing.
- Work with each user group and interested vendors to develop a design that will satisfy your CVO program. At the same time, ensure acceptability of

the users and the "best" possible equipment for each component.

- Build the facility with the future in mind! Not only address future volume needs and future road expansions but consider what will happen to equipment and how it will change.
- Assess data collection needs while you are developing your equipment specifications.
- Use Portland cement concrete and not asphalt on all roadway and parking components.
- Develop partnerships with border states to increase benefits and reduce costs. Bilateral agreements and facilities can cut down the cost and increase enforcement levels.
- Do not "fast-track" it! Every detail counts.

5.3. SCHEMATIC LAYOUTS

A set of schematic drawings that outlines concept designs for CVM facilities utilizing current technologies is presented in this section. It should be noted that these layouts are not accurate plans with dimensions, but they simply provide a general layout of the facility to ensure adequate completion of functions and easy flow-through process of commercial vehicles. Moreover, additional considerations should be given to vehicle configurations and especially to extra long, extra high, and special permit loads. The definition of the components for each diagram are shown in Table 9.

Table 9. Definition of diagram components

ITEM	DESCRIPTION AND DEFINITION
DS	Directional Sign: Indicates whether to enter or bypass the facility
VIR	Vehicle Identification Reader: Allows for identifying a vehicle with a transponder (AVI) reader, optical reader (license plate) or visual observation (VIN video camera)
WIM	Weigh-In-Motion: Slow or high speed weighing device
AVIC	Automatic Vehicle Identification Compliance
CMS	Changeable Message Sign: Guides driver through facility with a series of messages
SS	Static Scale: Rollover or stopover type
MB	Main Building: Control room, driver-personnel amenities, personnel parking
P	Parking
OSP	Out-of-Service Parking area
HAZ	Hazardous waste area
IA	Inspection Area: Open pit or flat bay designs

Based upon the sorting mechanism, four basic layouts are identified. These layouts

are summarized in Figure 24 and described in the following sections.

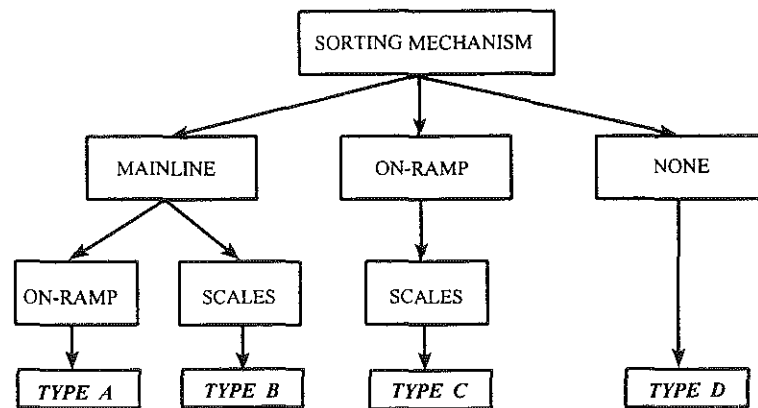

Figure 24. Layout types

5.3.1. Layout Type A

The Type A layout is shown in Figure 25. This layout allows for mainline sorting of vehicles using a VIR, additional sorting on ramp, bypass of regular-weight vehicles, communications with the use of CMS, static scales, inspection area, parking and detention area, and hazardous material parking area.

A vehicle approaching the facility would pass over the mainline WIM, have its credentials checked by the system computer, and then be signaled to continue along the mainline or to enter the facility. The signal can be transmitted either with the use of in-cab displays or with a CMS that will advise only non-compliant vehicles to enter the facility. If the VIR used is based on a vehicle transponder reader and in-cab communication, then the CMS can be eliminated.

Once inside the station, a second WIM may be utilized to sort all vehicles entering the facility by weight. Vehicles having weights

greater than the system threshold level are directed to the static scale using either a changeable message sign or changeable arrow signal. Vehicles having no weight problems are directed to travel through the facility on the bypass lane and return to the highway. A second CMS located over the bypass lane allows for bringing vehicles in the lane in for safety inspection. Vehicles directed to the static scale are weighed and then directed by a CMS to either return to the highway or pull around and come into the building. The same CMS also provides the ability to direct these vehicles to the safety inspection area.

Short-term parking for commercial vehicles is provided adjacent to the main building. A portion of the short-term parking area may also be used by vehicles which have been put out of service for safety violations. An area for hazardous material containment is also provided. The specific sizes of each of these elements may be determined based on the functions which are performed in the facility and the volume of trucks which are to be processed.

Figure 25. Layout Type A--Mainline sorting with additional on-ramp sorting

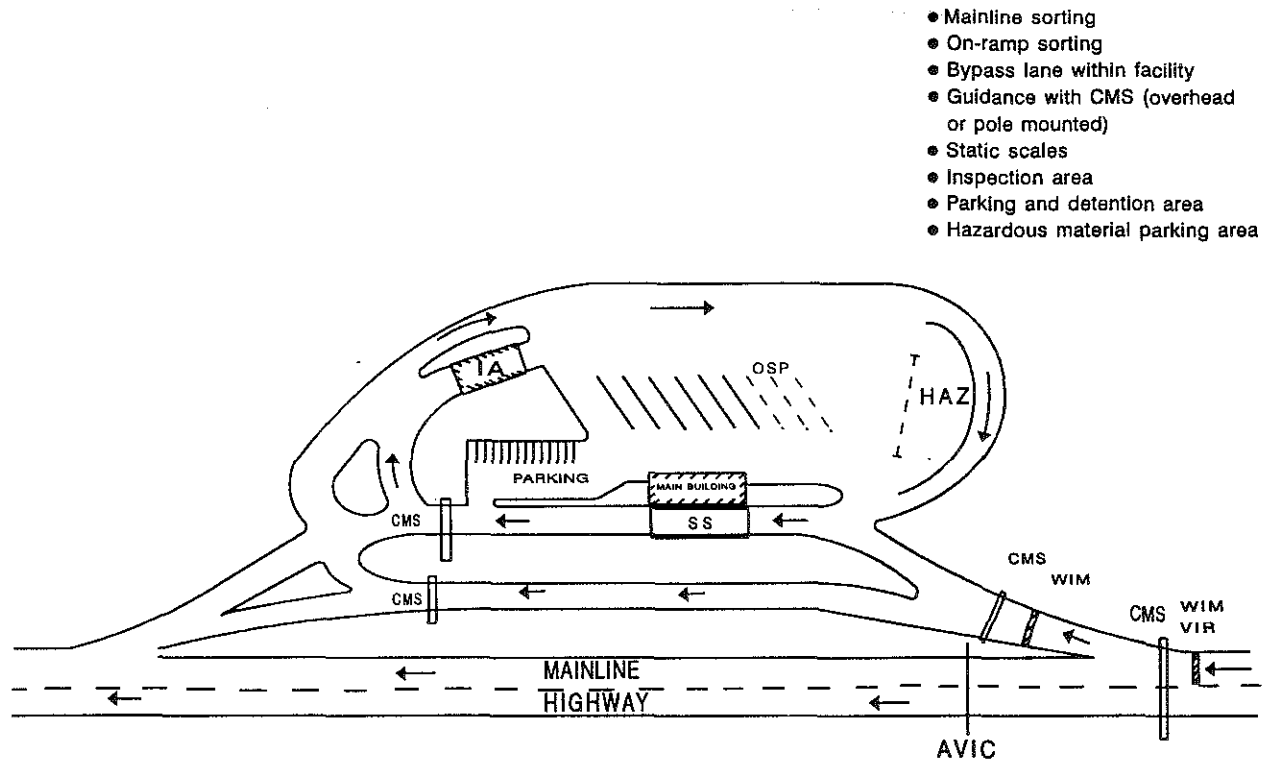

NOTE: SCHEMATIC LAYOUT, NOT TO SCALE

5.3.2. Layout Type B

The Type B layout is shown in Figure 26. This layout allows for mainline sorting of vehicles using a Vehicle Identification Reader (VIR), communications with the use of CMS, static scales, inspection area, parking and detention area, and hazardous material parking area.

A vehicle approaching the facility would pass over the mainline WIM, have its credentials checked by the system computer, and then be signaled to continue along the mainline or to enter the facility. The signal can be transmitted either with the use of in-cab displays or with a CMS that will advise only non-compliant vehicles to enter the facility. As in a Type A layout, the CMS can be eliminated if the VIR used is based on a vehicle transponder reader and in-cab communication.

Once inside the station, the vehicle is routed over a static scale and, using a changeable message sign or changeable arrow signal, is then directed to either return to the highway or pull around and come into the building. The same CMS also provides the ability to direct these vehicles to the safety inspection area.

Similarly to layout of Type A, short-term parking for commercial vehicles is provided adjacent to the main building. A portion of the short-term parking area may also be used by vehicles which have been put out of service for safety violations. An area for hazardous material containment is also provided. The specific sizes of each of these elements may be determined based on the functions which are performed in the facility and the volume of trucks which are to be processed.

- Mainline sorting
- Guidance with CMS (overhead or pole mounted)
- Static scales
- Inspection area
- Parking and detention area
- Hazardous material parking area

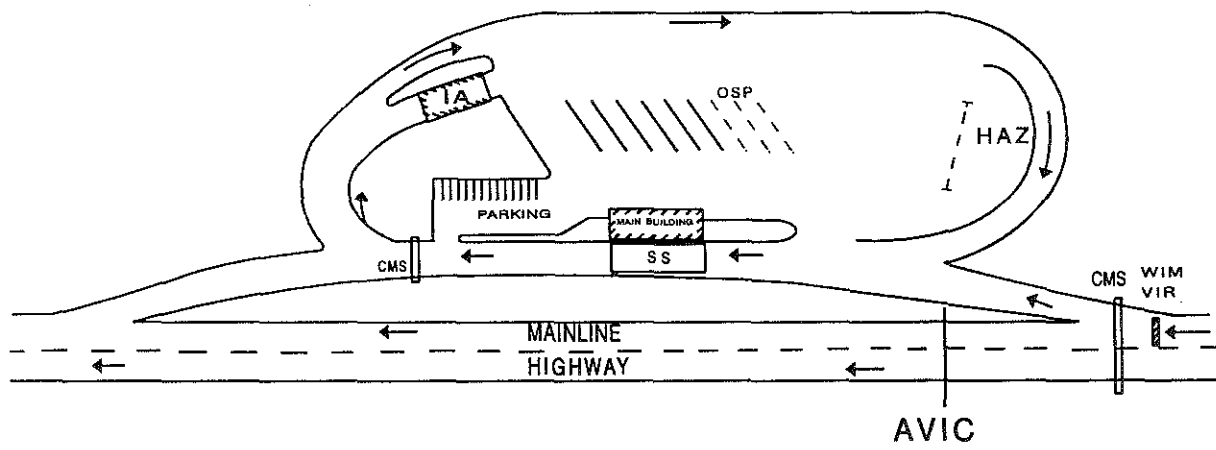

NOTE: SCHEMATIC LAYOUT, NOT TO SCALE

Figure 26. Layout Type B--Mainline sorting only

5.3.3. Layout Type C

The Type C layout is shown in Figure 27. This layout requires all vehicles to enter the facility, allows only for on-ramp sorting of vehicles using a WIM device, bypass of regular-weight vehicles, communications with the use of CMS, static scales, inspection area, parking and detention area, and hazardous material parking area.

All approaching vehicles would enter the facility and pass over a WIM device that will sort them by weight. Vehicles having weights greater than the system threshold level are directed to the static scale using either a changeable message sign or changeable arrow signal. Vehicles having no weight problems are directed to travel through the facility on the bypass lane and return to the highway. A second CMS

located over the bypass lane allows for bringing vehicles on this lane in for safety inspection. Vehicles directed to the static scale are weighed and then directed by a CMS to either return to the highway or pull around and come into the building. The same CMS also provides the ability to direct these vehicles to the safety inspection area.

The parking layout is similar to that of Types A and B. Thus, short-term parking for commercial vehicles is provided adjacent to the main building. A portion of the short-term parking area may also be used by vehicles which have been put out of service for safety violations. An area for hazardous material containment is also provided. The specific sizes of each of these elements may be determined based on the functions which are performed in the facility and the volume of trucks which are to be processed.

- On-ramp sorting
- Bypass lane within facility
- Guidance with CMS (overhead or pole mounted)
- Static scales
- Inspection area
- Parking and detention area
- Hazardous material parking area

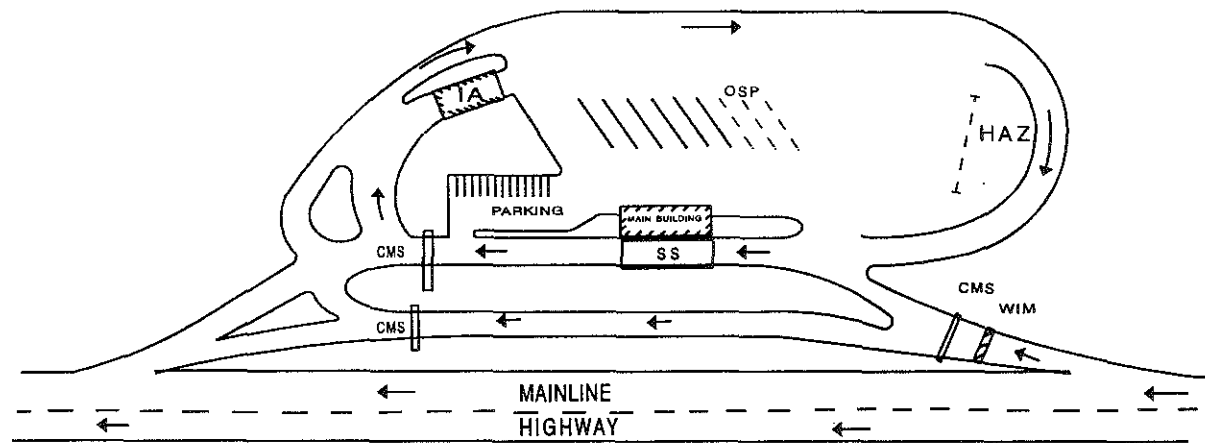

NOTE: SCHEMATIC LAYOUT, NOT TO SCALE

Figure 27. Layout Type C--On-ramp sorting only

5.3.4. Layout Type D

The Type D layout is shown in Figure 28. This layout requires all vehicles to enter the facility and pass over static scales and it does not utilize any of the sorting mechanisms. It also provides an inspection area, parking and detention area, and hazardous material parking area.

Even though this facility does not utilize any of the future technologies available for vehicle sorting, it was deemed necessary to include it among the layouts, since it is possible that in some cases (low volume areas) such a design may be required. Once inside the station, the vehicle is routed over

a static scale and, using a changeable message sign or changeable arrow signal, is then directed to either return to the highway or pull around and come into the building.

The parking layout is similar to that of the other types. Thus, short-term parking for commercial vehicles is provided adjacent to the main building. A portion of the short-term parking area may also be used by vehicles which have been put out of service for safety violations. An area for hazardous material containment is also provided. The specific sizes of each of these elements may be determined based on the functions which are performed in the facility and the volume of trucks which are to be processed.

- Static scales
- Inspection area
- Parking and detention area
- Hazardous material parking area

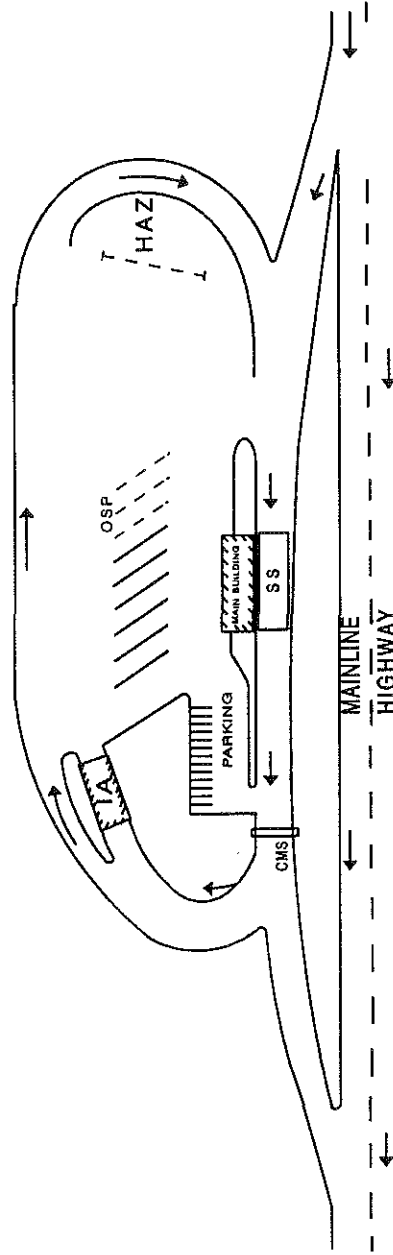

NOTE: SCHEMATIC LAYOUT, NOT TO SCALE

Figure 28. Layout Type D--No sorting

5.3.5. Additional Layouts

A different arrangement for Types A and B is shown in Figure 29. This layout allows for placement of the static scale closer to the freeway by moving the bypass lane behind the main building. Such a layout may be useful in cases where both sides of the traffic flow are supervised from one building, since it will provide a clear view of the opposite site without being obstructed by the bypassing vehicles. The layout in Figure 29 is that of Type A, while the elimination of the WIM and VIR from the mainline will

produce the layout of Type B. The parking layout is similar to that of the other types--a short-term parking area and an area for hazardous material containment are also provided.

Finally, a layout with two static scale ramps can also be utilized, if high traffic volumes exist. However, with the increased use of VIR and other modern technologies that will allow a higher use of mainline or on ramp sorting, the need for two static scales should be small.

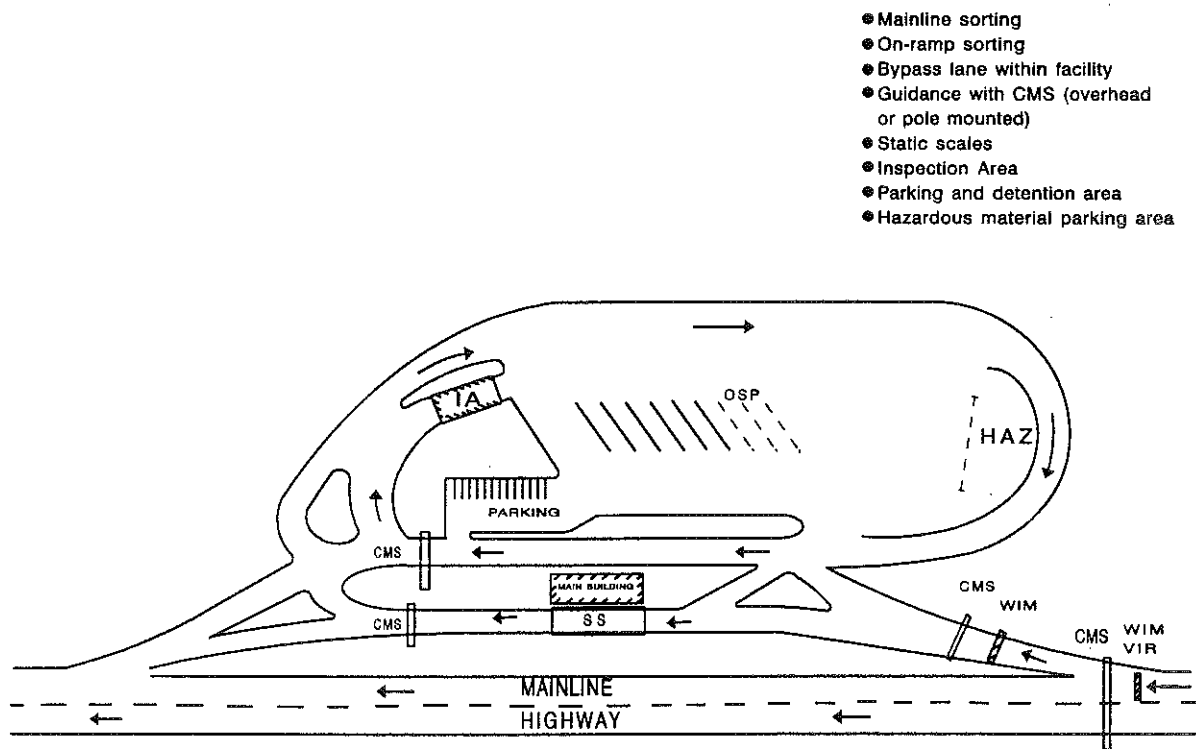

- Mainline sorting
- On-ramp sorting
- Bypass lane within facility
- Guidance with CMS (overhead or pole mounted)
- Static scales
- Inspection Area
- Parking and detention area
- Hazardous material parking area

NOTE: SCHEMATIC LAYOUT, NOT TO SCALE

Figure 29. Alternative layout for Type A

APPENDIX A

COMMERCIAL VEHICLE MONITORING FACILITY LAYOUT FOR CASE STUDIES

- Mainline Sorting
- Static scales
- Inspection area

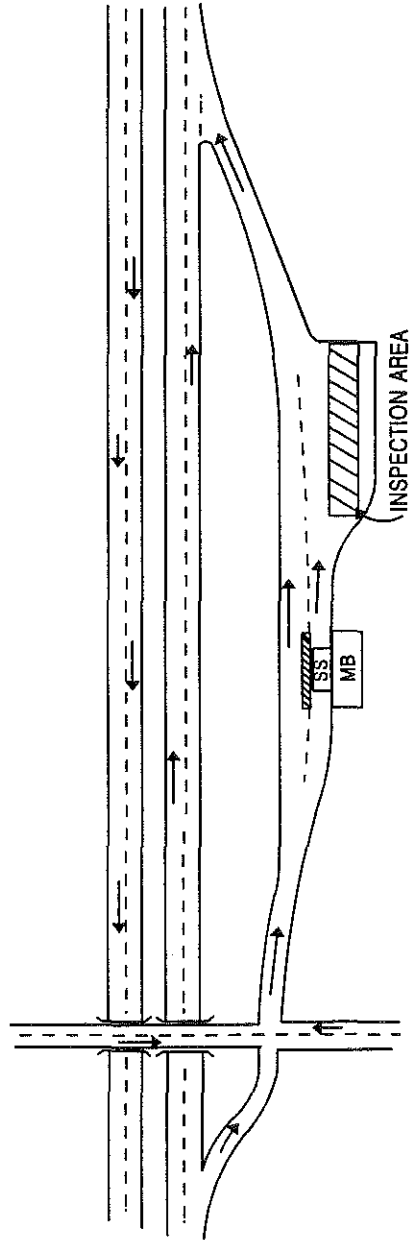

NOTE: SCHEMATIC LAYOUT, NOT TO SCALE

Figure A-1. Colorado--Trinidad

- On-ramp sorting
- Bypass lane within facility
- Guidance with CMS
- Static scales
- Inspection area
- Parking and detention area

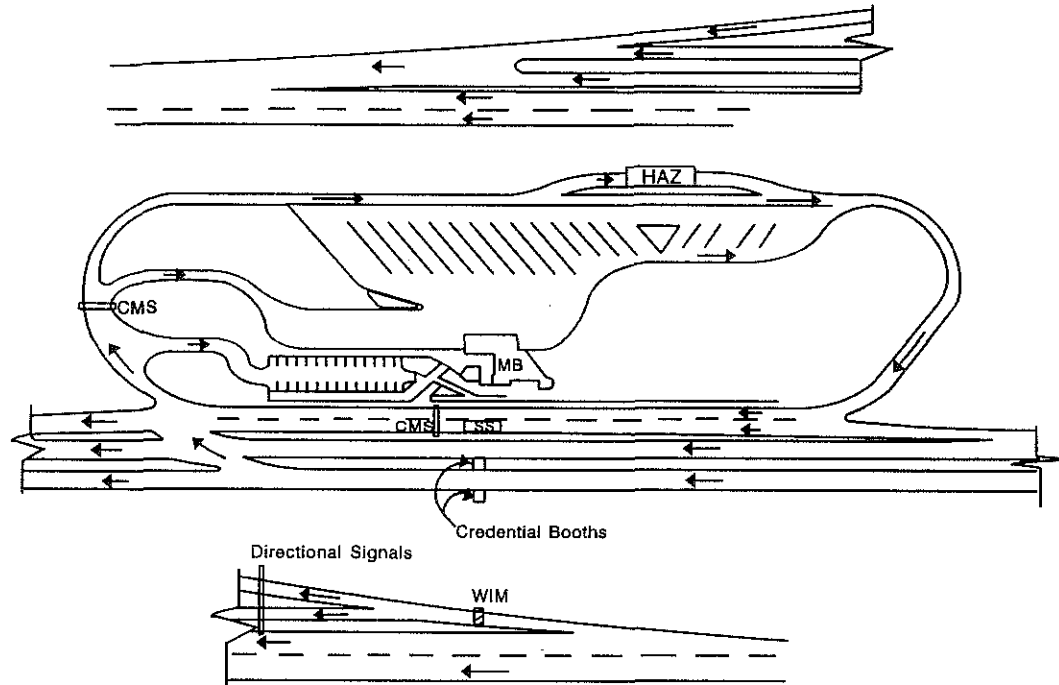

NOTE: SCHEMATIC LAYOUT, NOT TO SCALE

Figure A-2. New Mexico--Gallup

- On-ramp sorting
- Bypass lane within facility
- Static scales
- Inspection area
- Parking and detention area

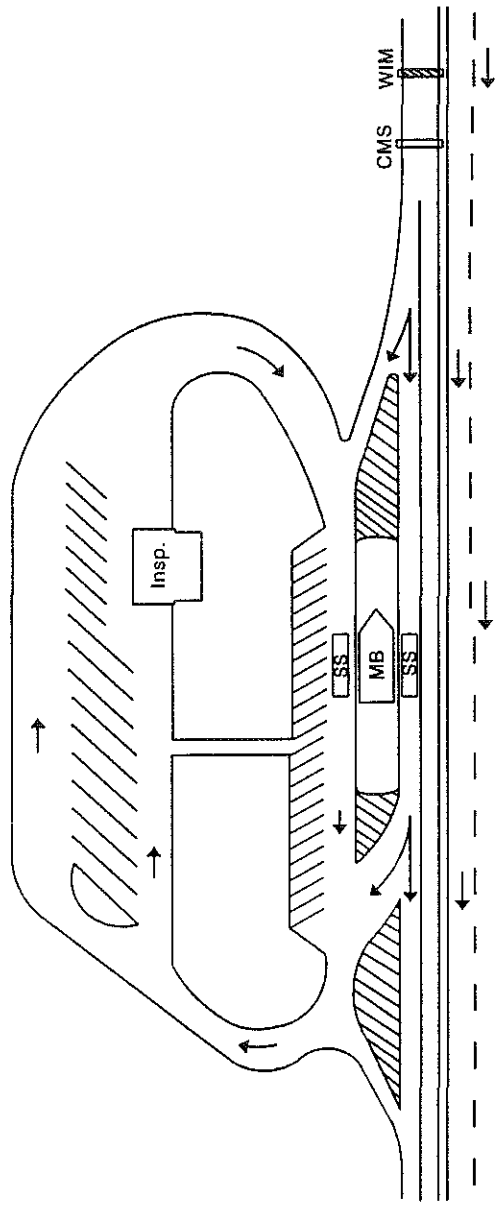

NOTE: SCHEMATIC LAYOUT, NOT TO SCALE

Figure A-3. Oregon--Woodburn

- On-ramp sorting
- Bypass lane within facility
- Static scales
- Inspection area
- Parking and detention area
- Hazardous material parking area
- Freeze-Frame Video Camera

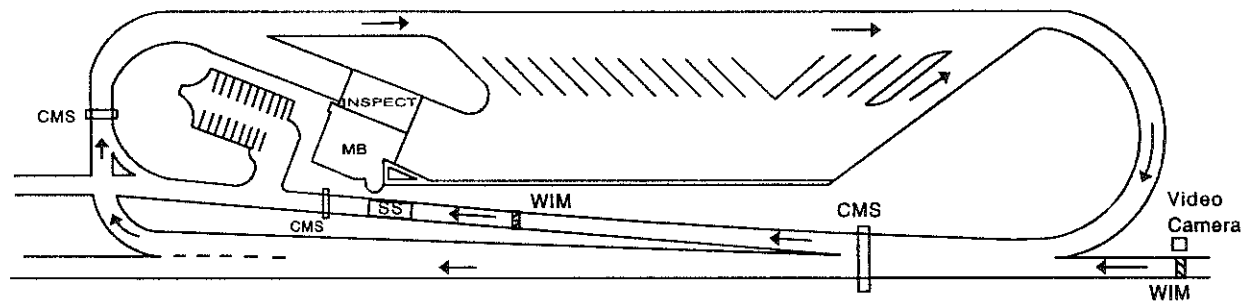

NOTE: SCHEMATIC LAYOUT, NOT TO SCALE

Figure A-4. Utah--St. George

- On-ramp sorting
- Bypass lane within facility
- Static Scales
- Inspection area
- Hazardous material parking area
- Parking and detention area

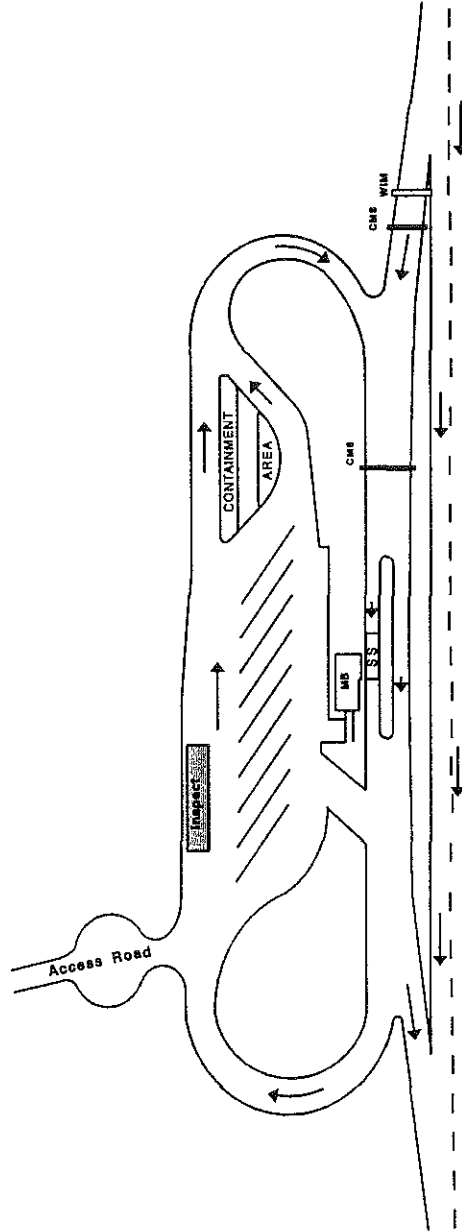

NOTE: SCHEMATIC LAYOUT, NOT TO SCALE

Figure A-5. Virginia--Stephens City

- On-ramp sorting
- Bypass lane within facility
- Static scales
- Inspection area
- Parking and detention area

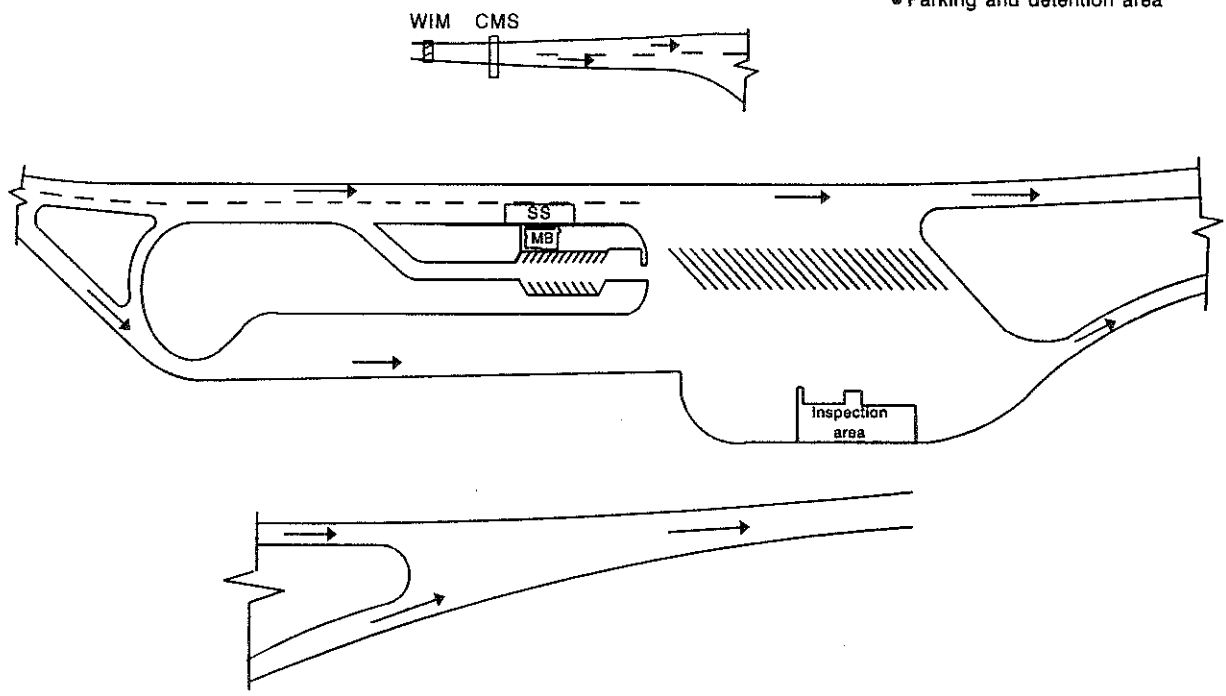

NOTE: SCHEMATIC LAYOUT, NOT TO SCALE

Figure A-6. Idaho--East Boise

- On-ramp sorting
- Bypass lane within facility
- Static scales
- Inspection area
- Parking and detention area
- Mainline Sorting For Advantage I-75

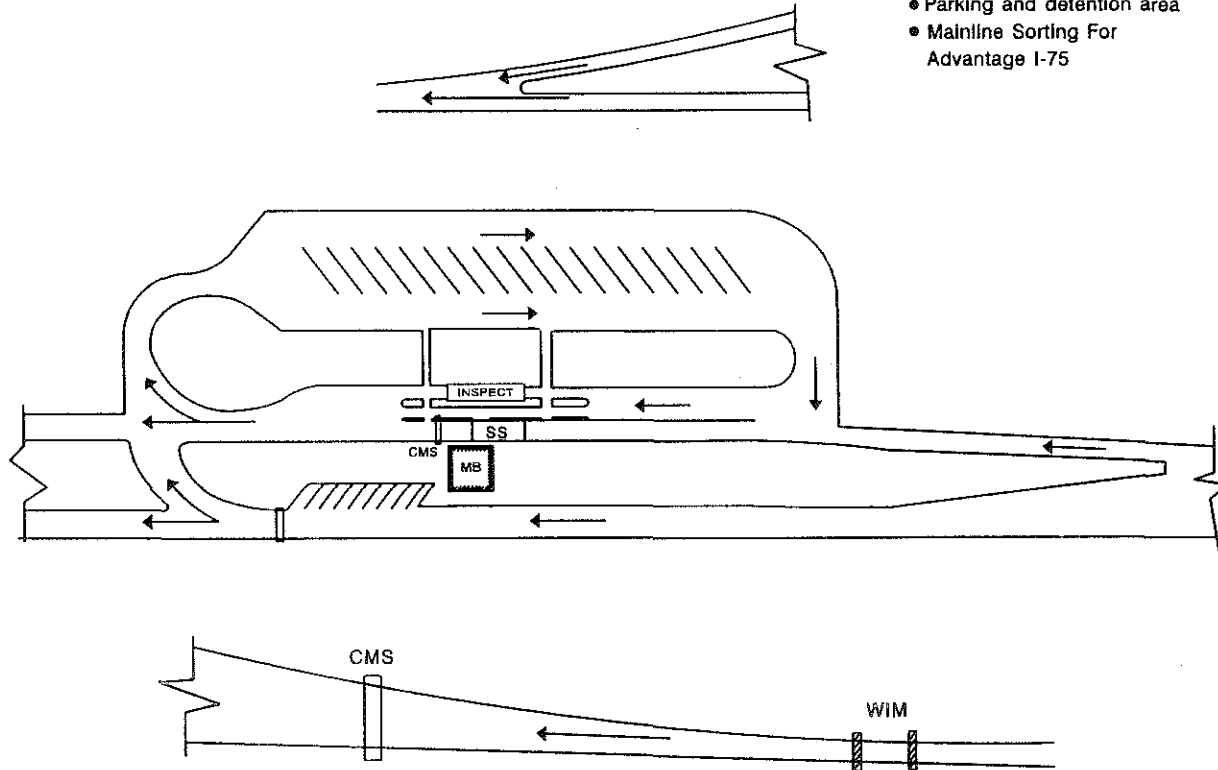

NOTE: SCHEMATIC LAYOUT, NOT TO SCALE

Figure A-7. Kentucky--Kenton

APPENDIX B
REMAINING CASE STUDIES

B.1. OVERVIEW OF ENFORCEMENT PROGRAM

B.1.1. California

The state of California has 52 fixed facilities and 124 mobile enforcement units, operated by the California Highway Patrol (CHP) and owned and maintained by the California Department of Transportation (Caltrans.) CHP has approximately 556 employees funded through the Commercial Vehicle Inspection and Enforcement program, with an annual operating budget for fiscal 1994/1995 of \$45.44 million. Caltrans provides an annual budget of \$800,000 for facility maintenance and \$1.5 million for minor facility improvements.

The fixed facilities weighed a total of 11,301,807 vehicles during 1994 for an average of 30,963 vehicles per day. The 52 fixed facilities intercept trucks in 37 locations, since dual facilities (one for each direction of travel) are operated in 15 locations. These facilities range from inspection facilities on interstate highways which operate around the clock to seasonally operated platform scales on rural non-freeway routes. Random schedules of operation are not used due to the hardship to staff of variable scheduling. The typical functions performed at the fixed facilities include enforcement of weight and dimension limits, compliance verification of vehicle registration and driver qualifications, and examination of vehicles for safety problems.

CHP's facilities are mainly located in the interior of the state at strategic locations having high volumes of truck traffic and a minimum of available bypass routes. Several facilities are also located near

adjacent state borders to intercept truck traffic entering California. The California Department of Food and Agriculture (DFA) operates 16 agricultural inspection stations at the state border that intercept all vehicles entering California. These facilities do not weigh trucks and are not co-located with CHP inspection facilities. DFA does operate separate facilities co-located at certain CHP facilities leaving California produce areas, where produce is inspected for quality control. Also, two CHP facilities are co-located with Immigration and Naturalization Service (INS) Border Patrol checkpoint facilities on Interstates 5 and 15 in northern San Diego County.

Most fixed facilities have direct computer terminal access to at least two data bases. The Management Information System of Terminal Evaluation Records (MISTER) data base contains all California commercial vehicles over 26,000 pounds, plus out-of-state hazardous material haulers. Enrollment is required through the vehicle registration process. Data are no more than two years out of date because BITS (BI-annual Terminal Inspection) data are included. Terminal access is provided for vehicle and carrier history on citations, violations, inspections, accidents, and out-of-service. This data base is available to CHP and other law enforcement officials, the truck industry, insurance carriers, and the general public. The California Law Enforcement Telecommunications System (CLETS) can be accessed directly by terminal and provides commercial driver's license and registration information, but not insurance information. For non-domestic, non-hazardous materials trucks, the MCSAP "SafetyNet" data base can be used, but cannot be directly accessed through terminals.

Although the CHP officers at fixed facilities have access to these data bases, the officers usually rely on their experience with the various carriers when screening trucks for credentials checks and safety inspections. A separate Department of Motor Vehicles (DMV) data base contains driver's license and vehicle registration data. The Board of Equalization's (BOE) data base contains motor carrier tax information. A pilot program, called the CHP Interagency Clerks Program, was conducted in 1992 to test the benefit of stationing DMV and BOE staff in truck enforcement facilities to check commercial vehicles against each agency's credentials requirements. The study concluded that the revenue benefit from increased compliance could exceed the cost of additional staff. Some staff remain stationed at Desert Hills and Dunsmuir Grade. Institutional barriers have prevented further advancement in this area. The six future Ports of Entry, including both Mexican border ports now under construction, will be designed to accommodate DMV and BOE staff.

Four stations have ramp screening WIM systems, which improved efficiency significantly when they were operating, but unfortunately, they have been unreliable. Some of the problems were software-related while the axle sensors have been sensitive to temperature changes and have required frequent replacement. Five stations have mainline WIM/AVI bypass systems as part of the HELP, Inc. program. Moreover, mainline WIM bypass systems are installed, being under construction or planned at 25 facilities with an estimated cost ranging from \$216,000 to \$264,000 per site. The static scales at fixed facilities have digital readouts which must be monitored continuously by officers. Some have a

buzzer to call attention to a certain weight threshold. The CHP is hoping to reduce the labor intensity of static scale weighing by implementing further automation.

Caltrans manages the design and construction of new facilities and major upgrades to existing facilities. Due to funding uncertainties, the construction schedule for Caltrans' major new and upgraded facilities is uncertain. Caltrans also manages an ongoing program of minor improvement projects. Projects having costs below \$300,000 are defined as typical projects, and include building expansions, ADA building upgrades, scale replacements, safety inspection area upgrades, and technological retrofits. The annual budget for minor projects has been on the order of 1.5 million dollars, but funding problems have forced a temporary 50 percent funding cutback. These funds are normally split evenly between CHP initiated improvements and Caltrans' initiated upgrades. During the next four years, minor projects estimated to cost approximately 3 million dollars will be undertaken at 25 facilities.

Portable scale equipment is deployed on a statewide basis with 124 full-time CHP Mobile Road Enforcement (MRE) units. These units have been assigned to patrol roadways that could be used for bypassing fixed-scale locations. MRE officers utilize specially equipped and marked vehicles, allowing them to conduct many of the same inspection functions as at the fixed facilities. MRE units utilize radio dispatch access to obtain carrier credentials data and computer systems that provide remote access are gradually being implemented. Portable scales can be placed on the road surface or in pits at 59 "mini-sites" around the state to weigh trucks. Mini-site operations are labor

intensive, requiring three or four officers. MRE teams weighed 46,294 vehicles during 1994 over approximately 197,500 personnel hours for an average of 1.88 vehicles per typical 8-hour work day. MRE personnel also conduct random truck inspections by stopping all trucks at various locations around the state, including rest areas and truck brake check areas.

CHP commanders also coordinate with local allied agencies to reduce bypassing of fixed facilities. Local allied agencies having trained commercial personnel equipped with portable scales also enforce size and weight laws and aid in the apprehension of drivers bypassing fixed weighing facilities. The CHP is moving away from predictably scheduled solitary territorial patrols toward more "strike forces" where officers from multiple beats are teamed to concentrate on a specific detail during more varied hours. MRE deployments will be shifted from the eight divisions to the fixed facilities in concert with the fixed facility command upgrades. This new command structure will make it easier to orchestrate strike forces. The CHP also conducts the BITS program, performing bi-annual inspections at the carrier's terminal using vans which are "an office on wheels." The inspector examines vehicles, drivers' logs, maintenance logs, etc., and fills out forms manually, part of which are then entered in the MISTER data base. CHP plans to automate the inspection data processing system to make all of the inspection data available.

CHP has an umbrella agreement with neighboring states which allows for the pursuit and apprehension of violators in the adjacent state and other related enforcement matters. However, there is no cooperative

agreement for the design, staffing, and operations of truck enforcement facilities between California and other states. Caltrans has studied the existing joint agreement between Utah and Arizona (for the jointly operated St. George port-of-entry) as a guide for development of a sample agreement. Caltrans and CHP have explored the "superport" concept with their Arizona counterparts, but have not yet been able to reach agreement due to the differing missions of the two states' enforcement efforts and limited funding sources. California does not perceive sufficient benefit from inspecting trucks leaving the state, since the primary focus of California's inspection is on safety. Arizona's Port of Entry system emphasizes collection of revenues from trip permits, motor carrier taxes, and fuel tax surcharges.

Caltrans has deployed approximately 40 active automatic high speed WIM stations throughout California. These stations collect vehicle classification and WIM data continuously. These data are stored in a roadside controller which is periodically (often daily) polled by the data center in Sacramento for retrieval and analysis. Three of the interstate sites gather data for one direction only, with the remaining 37 sites gathering data for both directions of travel. Approximately 13 additional sites have been constructed and decommissioned since Caltrans began deployment of WIM in the late 1980's. Another four sites were under construction or testing (as of November 1, 1994). Over 20 additional sites are under design or have been identified for future design.

B.1.2. Idaho

The state of Idaho has 8 fixed ports and 10 mobile units supervised by the Idaho Transportation Department. The POE Division has 103 employees and an annual operating budget of approximately \$4.2 million. Additionally, Idaho and Montana have a joint facility located on I-90 near the border.

Most of the fixed facilities are old; some were constructed approximately 20 years ago. A typical fixed facility usually consists of two buildings and is staffed with a supervisor, a technical specialist, and six or eight officers. Six of the eight facilities are located along interstate routes and the other two facilities are located on primary highways. The six interstate facilities operate at a minimum of 16 hours per day and some of them operate for 24 hours, depending on the available personnel and the existing commercial vehicle flow patterns. These facilities weighed a total of 1,660,014 vehicles during the 1993-94 fiscal year. The typical functions performed at these facilities include enforcement of size and weight limits, inspection of drivers' licenses and vehicle registrations, and examination of vehicles for safety problems and compliance with regulations for hazardous material transport. Each facility is equipped with a mainframe computer link where information for each vehicle passing through the station can be retrieved relative to a number of taxation items. The information retrieval system is accessible from all facilities. Safety inspections at these facilities are performed randomly by MCSAP personnel under the direction of the Idaho State Police and usually are done with the use of creepers and visual inspection under the vehicle.

In addition to these eight facilities, the state of Idaho has 10 roving teams that perform additional inspections and three "satellite facilities." Each unit covers a specific geographic area, consists of two officers, and usually works on a 40-hour week, that is 10 hours per day and 4 days per week. The "satellite" facilities, equipped with a static scale, are not permanently staffed and are ready for use, having the required equipment and facilities in the existing building. These facilities are available to the roving teams and are used regularly. The mobile units weighed 17,041 vehicles during the 1993-94 fiscal year. The locations for inspection are usually selected based on prior experience and knowledge of "problem locations" or bypass routes. Moreover, information provided by police patrols, sheriffs, highway departments, and private citizens is also utilized in determining potential problem areas. A typical mobile unit is equipped with a van or a pickup, portable scales, police radio, and cellular phones. The mobile units are equipped with a laptop computer and they can access the same software the fixed facilities use with respect to taxation records. Functions performed by these units are similar to those performed at fixed facilities--weight enforcement, vehicle safety inspection, and driver and vehicle credential checking.

The future of the commercial vehicle facilities in the state of Idaho consists of upgrading all existing facilities with electronic equipment (WIM) that will allow for mainline or ramp sorting and improvement of communication systems among facilities. A major concept of POE, present in most discussions with POE executives, is commitment to use electronic technologies in as many as possible of the

existing facilities to be upgraded as well as to fully automate the facility along I-84, currently under construction.

Two items that reflect the philosophy of the POE program are the goal of achieving high customer satisfaction and the use of low-cost methods to upgrade and retrofit all existing fixed facilities. The first point is reflected in the mission statement in which the POE Division promises to "provide quality assistance and information."

Moreover, among the goals set forth by the POE Division are reduction in time required to process a commercial vehicle and increase of public awareness of the POE functions and programs. The second point is mainly guided by economics, since it is believed that it is more feasible to spend small amounts to improve all facilities than to spend the equivalent amount to build a new facility. An estimate provided by POE officials indicates that, with a total cost of approximately \$4.5 million, all existing fixed facilities can be upgraded to at least allow for a mainline or ramp WIM sorting.

Joint operations with states that share the borders with Idaho are also an area to which the POE program is turning for increased levels of enforcement as well as for significant cost benefits. The state of Idaho is currently operating a joint facility with Montana and future plans include work with other border states. Idaho has no current plans to expand joint POE operations with other states.

The future vision of the commercial vehicle facilities is to increase the current levels of technology used and implement a mainline clearance process. The realization of mainline sorting is seriously considered as the means that will allow for reduced

processing time and delays of commercial vehicles through the facilities. Ability to exchange and transfer data among the facilities is a very desirable feature that will assist with the achievement of goals set forth by the POE program. Public awareness is another area the POE program is targeting for improvement. Moreover, cooperation among the various agencies involved in the commercial vehicle operations is an essential component of the successful model and future vision.

B.1.3. Kentucky

Kentucky has 16 fixed facilities supervised by the Division of Motor Vehicle Enforcement (MVE), Department of Vehicle Regulation. The MVE has 287 employees and an annual operating budget of approximately \$8.5 million.

Most of the fixed facilities are old; some were constructed approximately 30 years ago. A typical fixed facility usually consists of a building and is staffed with a supervisor, an assistant supervisor, and 8 or 10 officers. Most of the facilities have a 24-hour operation for 6 days per week, a policy that was required due to staffing shortages. These facilities weighed a total of 13,048,029 vehicles during the 1993-94 fiscal year. The typical functions performed at these facilities include enforcement of size and weight limits, inspection of drivers' licenses and vehicle registrations, and examination of vehicles for safety problems and compliance with regulations for hazardous material transport. Each facility is equipped with a computer where information for each vehicle passing through can be stored. The information recording is based on the Kentucky Unit (KYU) number, required to be displayed on the side of the

power unit. Safety inspections at these facilities are performed randomly and usually are done with the use of creepers and visual inspection under the vehicle. Each facility has one or more officers per shift assigned to patrol potential bypass routes to stop and inspect commercial vehicles which appear to avoid the facility.

The future of the commercial vehicle facilities in the state of Kentucky consists of upgrading all existing facilities with electronic equipment (WIM) that will allow for mainline or ramp sorting and improvement of communication systems among facilities. A major concept of the Division of MVE is commitment to use electronic technologies in as many as possible of the existing facilities to be upgraded as well to fully automate the facility along I-75, currently under construction.

B.1.4. Pennsylvania

Weight enforcement in Pennsylvania is provided by the cooperative efforts of the DOT and the Pennsylvania State Police. The two agencies created teams with dedicated staff to provide surveillance throughout Pennsylvania. Three of the 29 teams provide exclusive surveillance on the interstate. The 26 "county" teams provide surveillance on interstate, primary and secondary highways. Pennsylvania operates one permanent weigh station on Interstate 80 (eastbound) and in addition, operates 22 semi-permanent weigh stations. A total of 482,764 vehicles were weighed in fiscal year 1994; of these 306,124 vehicles were weighed on a platform scale while 176,640 were weighed on portable scales. The average violation rate for the total weight enforcement program was one percent.

The permanent weigh station is operated 7.5 hours per day, 37.5 hours per week. The 7.5-hour daily shifts are scheduled on an irregular basis and may occur on any 5 days in a 7 day week. One weekend shift is operated per month. The mobile teams operate on a similar schedule of random operation. The mobile teams are assigned to 1 of 26 geographical surveillance areas of the state. These teams circulate throughout their region on an irregular schedule to ensure complete coverage of the area. The two mobile interstate teams have been divided into two regions (east and west). Each team is responsible for one-half of the interstate highways in the state. At the present time, the western team has been disbanded to fill vacancies on the county mobile teams.

The personnel involved in weight enforcement are divided among two agencies, the Pennsylvania State Police and the DOT, Motor Carrier Enforcement Unit. State Police has 32 permanently assigned troopers plus 32 designated alternate troopers who are involved in weight enforcement activities. The DOT has a total of 69 personnel. This includes both the administration at the central office and the field personnel which are positioned throughout the state. The two interstate teams are staffed with 3 Motor Carrier Enforcement Officers and 1 Pennsylvania State Police trooper. The remaining interstate team operates the permanent weigh station and is staffed with 2 Motor Carrier Enforcement Officers and 2 Pennsylvania State Police troopers. The 26 county teams are staffed with 2 Motor Carrier Enforcement Officers and 1 trooper.

Each county mobile enforcement team is equipped with six sets of portable scales. In

some situations where truck traffic volumes warrant their use, portable WIM screening scales are utilized. However, the use of this equipment does require additional manpower. Some of the mobile teams have platform scales which are available to them and they are used to provide greater levels of screening. They are generally used for short duration checks to promote maximum efficiency through the element of surprise. Each interstate team also has six sets of portable scales along with WIM screening scales which are available at the semi-permanent weighing facilities. The semi-permanent weigh stations utilize rest and picnic/parking areas on the interstate highway system. These scales are utilized where sufficient room and stable pavement are present to accommodate truck traffic. In-pavement WIM systems, along with the associated traffic loops and directional signs, are installed at these locations. Both visual and audible alarms signal the terminal operator in the event of a potential violator and the vehicle is then directed for reweigh using portable wheel scales. These permanent screening WIM's are operated by laptop computers installed in enforcement vans. The interstate teams and four county teams are also equipped with personnel computers. Expansion of the personnel computer availability to 10 additional county teams which have instrumented rest areas in their areas is planned in the near future. In addition to weight enforcement, other agencies, such as the Revenue Department, Public Utilities Commission, and State Police, utilize the signs and pull-in areas of the semi-permanent locations to do other credential checks and verifications. Pennsylvania plans to retrofit four rest/parking areas with the appropriate hardware to allow them to be utilized as semi-permanent weigh stations.

The operations of the county mobile teams are supplemented with donated and rented public/private owned permanent platform scales, which are available on an "as-needed" basis. Pennsylvania plans to make additional public/private platform scales available to the mobile teams to provide them with a means to increase their effectiveness.

In addition to the weight enforcement activities, enforcement teams devote 15 percent of their time to participating in the Federal MCSAP. Both systematic and probable cause inspections are conducted in conjunction with regular enforcement efforts.

The permanent weigh station consists of a hydraulic load cell WIM scale for sorting the vehicles on the ramp, based on appropriate state and Federal weight laws. The vehicles may then be directed to a static scale for enforcement weighing. The system also includes an over-height detection system which alerts the station operator to the violation, permitting further inspection of appropriate credentials or issuance of citations.

The locations for the various semi-permanent scales and the permanent weigh stations were selected in areas where bypassing the facility would be lengthy, time consuming, and otherwise economically not feasible. Mobile team surveillance of bypass routes is used to monitor vehicles attempting to circumvent the permanent weigh station. The selection of the leased public/private permanent platform scales was based on making bypassing difficult. Additional mobile teams or municipal police are used to monitor possible bypass routes of these

facilities. Pennsylvania is also encouraging municipal police departments to take a more active role in motor carrier enforcement activities. The Pennsylvania DOT will provide the appropriate training necessary for certification of weight enforcement to State Police, other municipal police agencies, and DOT personnel.

Pennsylvania is also involved in education of the commercial vehicle community. Weight and safety compliance seminars and demonstrations are made available to truck owners and operators to explain the laws and regulations which apply to commercial vehicle operation. The Pennsylvania DOT also publishes and distributes an informational booklet entitled "The Trucker's Handbook." This publication interprets the laws governing commercial vehicle operation and was developed to translate the legal language of the Vehicle Code into lay terms. The state also publishes a truckers' map which includes Surface Transportation Assistance Act (STAA) routes, vehicle size and weight limitations, safety requirements, and other relevant information to the trucking community.

B.2. OVERVIEW OF MOST CURRENT FACILITY

B.2.1. California

Four sites were selected for evaluation as California's most current facility. The Santa Nella site was selected because it is the most recently upgraded facility. Three additional sites, currently under construction, were also evaluated in this section because they represent major facilities incorporating new features.

B.2.1.1. Santa Nella

The Santa Nella facilities are located on Interstate 5 near the Stanislaus/Merced County Line in the central portion of the state. These inspection facilities intercept northbound and southbound truck traffic traveling between Los Angeles and Northern California. The commercial vehicle volume is approximately 3,300 vehicles per day in each direction.

Santa Nella's facilities have been retrofitted with WIM and AVI equipment that allows for mainline sorting and permits vehicles equipped with AVI transponders to bypass the facility. This system was installed as part of the HELP, Inc. project. Carriers pay a fee to purchase the AVI transponders needed to participate in the project. A joint agreement for the sharing of data between Caltrans, CHP, and DMV was required to make this project feasible.

The Santa Nella mainline bypass system includes a WIM sensor and AVI unit located approximately one mile upstream of the inspection facility entrance ramp. The WIM sensor verifies compliance with weight regulations. The roadside AVI unit identifies each truck equipped with an AVI transponder and sends a signal to the weigh station, where the data base is checked for registration in the program. Trucks positively identified in the data base receive an audio and visual signal from the roadside AVI unit to a dash-mounted unit in the vehicle if they are eligible to bypass the station. Vehicles must enter the facility if they do not have AVI. Vehicles equipped with AVI may be required to enter the facility if inspection of their records is needed or their records need to be updated. Nearly all trucks must currently enter the

station since very few commercial vehicles are equipped with AVI.

B.2.1.2. Chowchilla

The Chowchilla truck inspection facility is currently under construction along northbound State Route 99, near the Madera/Merced County Line, and will replace the Livingston platform scale. The new facility will intercept 4,500 trucks daily and has a base construction contract amount of approximately \$4.33 million.

The Chowchilla facility will feature a ramp screening WIM system. Trucks receiving clearance from this WIM sensor will be signaled by a green arrow over the bypass lane. If WIM clearance is not granted, a green arrow over the static scale lane will be lit. The WIM load cells will be located approximately 580 meters (1,900 feet) downstream from the freeway ramp gore, and 110 meters (360 feet) upstream from the gore for the bypass lane.

Although no mainline WIM bypass system will be constructed initially, the location of the site is favorable for a future installation.

The facility will include three changeable message signs. The first sign will be placed along the mainline freeway before the exit ramp. Downstream of the static scale, the second sign will face trucks exiting via the bypass lane and the third sign will face vehicles directed to the truck holding area and inspection bays. The first sign will be used to indicate the open or closed status of the facility. The second and third signs will be used to direct trucks either to return to the freeway or proceed to the inspection bays.

In California, new fixed enforcement facilities are constructed with one bypass lane and one or two static scale lanes. Facilities processing the highest truck volumes have two scale lanes. The Chowchilla facility will be constructed with one scale lane and sufficient width for future expansion to two lanes. The raceway configuration was fixed by minimum geometric standards and was not a critical element in the capacity of the facility. Generally, the maximum storage capacity needed to park out-of-service and other vehicles will be available inside the raceway area.

The critical issues and success factors incorporated in this facility design were to:

- Minimize vehicle delay: provide for high volume of truck traffic and provide adequate screening and bypassing systems to keep traffic moving.
- Provide for storage of vehicles: adequate queuing area to prevent backing up onto mainline and adequate parking area for out-of-service vehicles.
- Automate monitoring systems: Relieve officers from constant monitoring of traffic for violations. Have officers signaled when a violation occurs.

The key principles and policies which guided the design of the Chowchilla facility include the Caltrans Project Procedures Manual, Highway Design Manual, and various environmental and safety policy manuals. The Project Procedures Manual guided project development through the Project Study Report (PSR) phase, Project Report (PR) phase, and finally, the Plans, Specifications, and Cost Estimate (PS&E) phase. Factors considered in the design include: site selection, building layout,

roadway geometrics, vehicle processing/station operation, procurement method for advanced technologies, and provisions for station maintenance and future expansion.

System requirements were established using previous experience. No outside consultants or architects were used in the process. Caltrans statewide commercial vehicle operations staff and local district staff participated in the design review process. CHP headquarters and division staff, including some who would later operate the facility, participated in the design and development review process. However, the planning and design process did not include participation from representatives of the trucking industry. Compliance with the Americans with Disabilities Act was accomplished through a design review by the Office of the State Architect.

Performance based technical specifications for specialized equipment were developed by designers following communication with various equipment vendors. Caltrans has tried to avoid procurement of sole-source/proprietary systems due to difficult experience with operating, maintaining and expanding such systems. In some cases, the sole-source has gone out of business. Currently, mainline AVI systems have utilized sole-source procurement. The technical specification written for inspection bay doors is open ended, but only one manufacturer makes doors that comply with the specification, resulting in "de-facto" sole-source procurement. Performance-based technical specifications have also been used to procure computer hardware, and application-specific software/control systems. As with other specialized equipment procurement, Caltrans has

experienced difficulty with companies going out of business. Caltrans is considering providing the software and special controllers, while specifying the remainder of these systems.

Specialized equipment and services for the Chowchilla facility, such as the WIM bypass, traffic control, and changeable message sign systems, were provided through the construction contract. Caltrans designers were responsible for the system integration. System acceptance was executed through the standard review process with performance-based technical specifications. The contractor has been obligated to a one-year warranty period before Caltrans takes over system maintenance responsibility.

B.2.1.3. Otay Mesa and Calexico

Construction began in January of 1995 on the two new Mexican border truck inspection facilities at Calexico and Otay Mesa, and both facilities are expected to be completed in December, 1995. These facilities will be co-located with new Federal border crossing facilities operated by the INS and U.S. Customs. The facilities are unique because they are constructed to accept trucks at slower than freeway speeds as they leave the INS facility. Both facilities will include mainline WIM bypass technology, but with shorter bypass routes due to the slower speeds involved. These border stations will operate coincidentally with Federal operations at the Port-of-Entry.

The design of adjacent state and Federal facilities required considerable cooperation and coordination to complete. The location of the state's facilities was limited by the Federal site selection process. Caltrans and

CHP officials would have preferred to have a greater role in the site selection process. The location of both sites requires truck traffic to travel through city streets between each inspection facility and connecting state route.

B.2.2. Idaho--East Boise

The facility selected for a site visit in the state of Idaho was the East Boise site because it is the most recently completed facility. The facility is located approximately 20 miles east of Boise on I-84 and operates on both sides of the traffic. Both sides operate 24 hours every day and have a staff of 13 officers and a supervisor. Each shift is 10 hours with 4 officers split as 1 and 3 on each side depending upon the volume of traffic. During 1994, it weighed a total of 439,000 vehicles and the current average daily volume is estimated at approximately 3,500 vehicles.

The current layout of the facility is shown in Figure A-6, Appendix A. The facility was completed in 1992 and utilizes several modern technologies. All vehicles approaching the facility are weighed by a WIM device, are checked by a height detection device and, if so equipped, have their transponder read allowing for mainline sorting and bypassing ability. Thus, if the vehicle is recognized as one not required to enter the facility for any reason (overweight, oversized, or credential inspection) it then proceeds along the freeway. Vehicles signaled to enter the facility exit the freeway and pass in front of a freeze-frame video camera. If vehicles do not need to stop, they are signaled to continue on the bypass lane; otherwise they are signaled to enter the scales. This message is shown to the driver with the use of a combined signal (red-

green) and an arrow display pointing either to the bypass lane or to the scales lane. Vehicles called to proceed toward the scales are stopped and weighed on a fixed scale. If the vehicle has a legal weight and size and is not required to purchase any permits, it is signaled to continue onto the freeway unless it is asked to enter for a safety inspection. If a vehicle is overweight or it is required to have its credentials inspected by the officers, it is signaled to proceed to the parking area and enter the building. Additional duties of the officers include measurement of the length of the vehicle, issuing citations, collection of cash fees, and hazardous material inspection. At the same time, the officer may enter the vehicle license plate to determine a variety of data related to the vehicle, the driver, and the carrier and decide whether to request a credential or safety inspection. At the completion of the data entry and any vehicle inspection, the vehicle is cleared to leave the facility.

The mainline sorting is done with the use of a high speed WIM device and the search for an AVI. Commercial vehicles not equipped with an AVI will trigger a series of three fixed message signs indicating that "TRUCK MUST EXIT TO WEIGH STATION." The AVI-equipped vehicles which clear the size/weight/credential screening process will have blank boards to indicate that they are allowed to bypass the facility. Vehicles requested to enter the facility are monitored with the use of loop detectors on the exit ramp and thus, the possibility of bypassing the facility is reduced.

Communication between the officers and the driver is performed with the use of a combination of a two-color traffic signal and a set of message displays illuminated to

provide the intended message. The traffic signal has a red light to indicate "STOP" and a green light to indicate "PROCEED." The message display directs the driver to "BACK UP" to adjust the vehicle to be weighed, to park for vehicle inspection by displaying "PLEASE PARK" or to "BRING PAPERS" for credential inspection. The layout of the signal display (overhead mounted) is shown in Figure B.1 (the number 23,000 shown in Figure B.1 indicates the axle weight displayed).

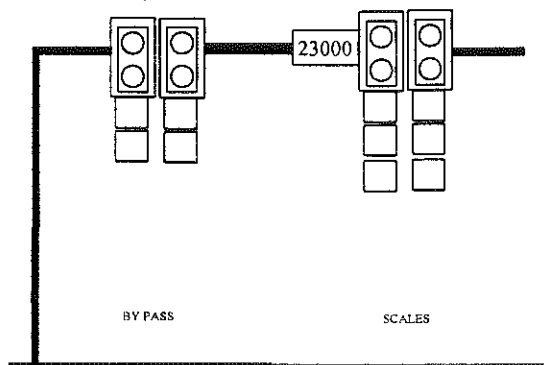

Figure B.1. Changeable message display

The axle weights from the static scale are displayed to the driver on the same board with the changeable message signs while his/her vehicle is being weighed. This eliminates questioning by the driver regarding the reasons that he/she was stopped as well as reduces possible conflicts and arguing between the driver and the officer. It is believed that this display is a very good method for informing the driver and a positive way to assist the job of the enforcement officers.

The officers can enter information relative

to the driver, the vehicle, and the carrier using software available to all facilities. Automation has also helped officers to produce more detailed reports and be able to monitor a larger number of variables that can improve the operation of the facility. However, the fact that the vehicle license plate has to be entered manually into the computer system increases the level of effort and work load of the officers and it is possible that this activity may affect the productivity of the officers if the volume of traffic increases.

The data entered in the computer are available on real-time to all facilities as well as to the POE Main Office. Thus, the ability of data sharing with other facilities can improve the efficiency of mainline clearance and allow for realization of the intended benefits by avoiding to call the same commercial vehicle into other facilities along its way. Moreover, such a practice creates a positive image for the advantages of mainline sorting and clearance. The ability to access other data bases, such as traffic violation and safety inspection records, is an additional positive aspect of this system.

The physical layout of the facility allows for an adequate number of commercial vehicles to park for credential inspection. In addition to the parking for vehicles while in the building, additional parking is provided for impound vehicles and for vehicles having hazardous material-related violations. Visual supervision of the entire parking lot is performed through the side windows of the building.

The location and design of the building allows for a very good view of the entire facility, the bypass ramp, and the scales and

the control room is elevated to enhance visual inspection of the driver and the vehicle. Each side of the facility has a different building design but both buildings are considered efficient in their layout. The interior design of the building provides a desk for the officer controlling the changeable message and checking the WIM and static scale, a high desk with work spaces for credential inspections, and adequate space for driver traffic. The building provides driver amenities, a lounge area for the officers, and a supervisor's office. The building is surrounded by windows that allow for a wide field of view and all windows have pull-down screens to block the sun glare. The layout of the building is shown in Figure B.2.

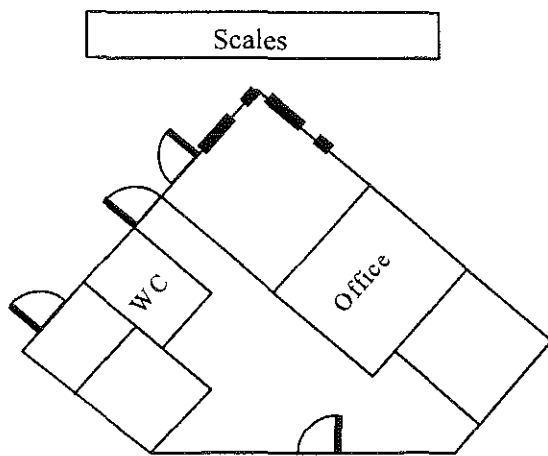

Figure B.2. Westbound building layout

B.2.3. Kentucky--Kenton

The facility selected for a site visit in Kentucky was the Kenton county site because it is the most recently constructed facility. The facility is located 40 km (25 miles) from the Ohio-Kentucky border on southbound I-75 and operates only for the southbound traffic. The facility operates 24 hours for 5 days per week and has a staff of 7 officers including a supervisor and a safety inspector. Each shift is eight hours with three officers per shift. During the 1993-1994 fiscal year, it weighed a total of 963,178 vehicles and the current average daily volume is estimated at approximately 4,300 vehicles.

The current layout of the facility is shown in Figure A-7, Appendix A. The facility was completed in 1992 and is considered state-of-the-art in utilization of modern technologies for the state of Kentucky. The facility has WIM and AVI equipment on the freeway approaching the facility that allows for mainline sorting and provides vehicles equipped with AVI to bypass the facility. All vehicles not equipped with an AVI are required to enter the facility due to the Kentucky weigh-distance tax system. Currently, almost every truck that passes by the facility is required to enter, since very few commercial vehicles are equipped with an AVI. Vehicles exiting the freeway and entering the facility are weighed by a WIM device and have their height measured at the same time. If the vehicle is weighed within the legal limits, it is signaled to continue on the bypass lane; otherwise it is signaled to enter the scales. This message is shown to the vehicle with the use of an overhead electronic display pointing to the bypass lane ("TO I-75") or to the scales lane ("TO SCALES"). As the vehicle proceeds to

either lane and approaches the building, an officer records the Kentucky Unit (KYU) number for taxation purposes. Vehicles called to proceed towards the scales are weighed on a static scale. Vehicles on the bypass lane continue onto the freeway unless they are asked to enter the safety inspection area. When a vehicle is overweight or it is required to have its credentials inspected by the officers, it is signaled to proceed to the parking area and enter the building. Additional duties of the officers include issuing citations, performing safety inspections, and hazardous material inspection.

The mainline sorting ability of the facility is not fully utilized due to low market penetration of AVI. However, the on-ramp sorting facility is fully utilized and allows for a speedier process of commercial vehicles through the facility. The utilization of the mainline sorting and bypass will be increased with the expansion of AVI in the future.

Communication between the officers and the driver is performed with the use of a changeable message display. The message display directs the driver with the assistance of an arrow pointing to "PARK" for vehicle inspection, to "INSPECT" for safety inspection or to proceed "TO I-75" to leave the facility. The layout of the changeable message display (overhead sign) is shown in Figure B.3.

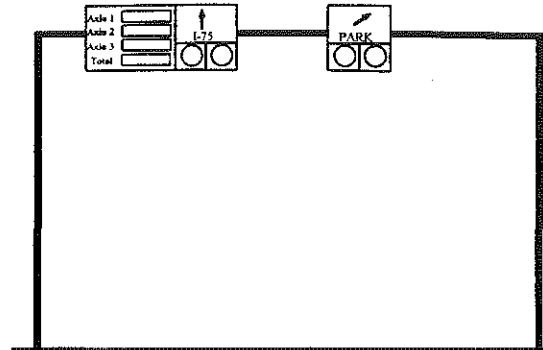

Figure B.3. Changeable message display

The axle weights from the static scale are displayed to the driver on the same board with the changeable message signs while his/her vehicle is being weighed. This eliminates questioning by the driver regarding the reasons that he/she was stopped as well as reduces possible conflicts and arguing between the driver and the officer. It is believed that this display is a very good method for informing the driver and a positive way to assist the job of the enforcement officers.

The facility has a covered area for safety inspections performed by the officers. The bay has an open pit design, allowing for the inspector to walk under the vehicle during the inspection. Safety inspections are generally random and at a rate of approximately 1,400 per year.

The physical layout of the facility allows for a large number of commercial vehicles to park for credential inspection. In the same area, out-of-service vehicles and vehicles with hazardous material-related violations can park. Vehicles that require service for correcting safety violations can stay in the parking lot and have the repairs performed

on site. Visual supervision of the front area of the facility is performed through the front windows of the building and the back of the facility is supervised by a video camera.

The location and design of the building allows for a very good view of the front area of the facility, the bypass ramp, and the scales. The interior design of the building provides a desk for the officer controlling the changeable message signs and checking the WIM and static scale, a high desk with work spaces for credential inspections, and adequate space for driver traffic. The building provides driver amenities, a lounge area for the officers, and a supervisor's office. The building is surrounded by windows that allow for a wide field of view and all windows are slanted to block the glare from lights at night. The layout of the building is shown in Figure B.4.

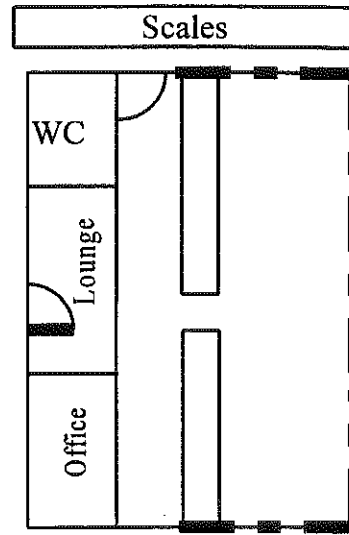

Figure B.4. Building layout

APPENDIX C

ANALYSIS PROCEDURES FOR QUEUE AND DELAY AT WEIGH FACILITIES

C.1. INTRODUCTION ¹

A major concern associated with weigh facility operations is delays and queues of vehicles. Implementation of a new technology, an improvement plan or a new facility usually requires an evaluation of its effectiveness. Common questions in this process are: Can delay and queue be reduced by using a new technology? Does a proposed new facility or improvement plan have the problem of mainline back up? Providing answers to these questions will definitely increase the effectiveness of the proposed action, will provide a better solution to the existing problems, and avoid future problems.

The estimation of queue and delay at weigh facilities involves the following steps:

1. Identify traffic operational features of weigh stations in terms of truck arrival distribution, peak arrival volume, enforcement processing time distribution, mean enforcement processing rate, and number of static scales;
2. Assess the sorting residue rate of truck population with the use of WIM system;
3. Apply queuing models to estimate queue and waiting time in the facility; and
4. Estimate average transit time and delay.

This paper presents the methodology for each step using real life weigh facilities as examples to illustrate the problem solving process.

1. The text presented here is provided by Ms. Ying Weng and is a portion of her M.S. Thesis "Operational Effects of Weigh-in-Motion Systems in Weight Enforcement," Virginia Polytechnic Institute, 1995.

C.2. TRAFFIC OPERATIONAL FEATURES

C.2.1. Data Collection and Evaluation Methods

One of the approaches for determining traffic arrival distributions is by defining the distribution of arrival headways. The selection of reference points for timing each arrival influence the quality of the data. To enable the data to be less interrupted by the queuing vehicles, and to be closer to the true traffic arrival pattern, the reference point should be located as far upstream of the scale house as possible. For weigh facilities without a bypass lane, the entrance gore of the facility is suggested for the reference point. For those having a bypass lane, the suggested point is the split gore where the bypass lane and static scale lane diverge. This is the farthest location upstream at which the sorting direction of each arrival vehicle becomes known. When the queue is longer than the split gore, which often happens in heavy traffic locations, the arrival time is when the vehicles join the end of the queue.

The observed data can be sorted into two categories: arrivals to static scale lane, and arrivals to the bypass lane. The difference in the recorded time for two succeeding arrivals on each of the lanes is considered to be the headway.

Processing time for weight enforcement is measured from the moment a vehicle starts to pass the stop sign at the scale house till the time at which its rear end gets off the static scale. Two ways were utilized to do the manual counts:

1. When the approaching traffic columns are light, the time when a truck's front end reaches the stop sign, and when its rear end cleared the scale is recorded. The difference of these two time measurements is the processing time for the vehicle;

2. When the approaching traffic is very heavy, such as bumper-to-bumper, the moment when the truck ahead clears the scale is considered to be the moment that the succeeding truck starts to get onto the scale. In such a situation, only the time when each truck clears the scale is recorded.

The Chi-square test is used to test the goodness-of-fit of the observed data to a theoretical distribution.

C.2.2. Results from Field Site Studies

C.2.2.1. Distribution of Traffic Arrival Headway

Field data collection was conducted at the southbound Dumfries weigh station on I-95 on March 15, 1994. The station has an on-ramp sorting ability and a bypass lane. A conventional cassette recorder was used to orally

record each vehicle arrival, which enabled one individual to collect the traffic counts even during heavy traffic situations. The relevant time of each arrival was measured by replaying the cassette later.

Because of the resemblance, the observed arrival headway was tested against an exponential distribution, expressed as:

$$P(h \geq t) = e^{-\frac{t}{T}} \quad (1)$$

Where P: probability that headway is equal or larger than time t; h: headway; t: time; T: mean headway; and e: natural base.

Based on the data collected from 10:00 am to 4:00 pm, 118 vehicles per hour were directed to the static scale, and 186 vehicles per hour were sorted to the bypass route. The investigation results are summarized in Table C.1.

Table C.1. Mean arrival rate to static scale and bypass route, Dumfries, SB, Va.
Observation period: 10:00 am - 4:00 pm, March 15, 1994

Headway (sec.)	Static Scale (All Times Approximately)					Bypass
	10:00 am to 10:30 am	10:40 am to 11:40 am	12:40 pm to 2:10 pm	2:30 pm to 4:00 pm	All 10:00 am - 4:00 pm	
Mean	33 sec.	30 sec.	31 sec.	30 sec.	31 sec.	19 sec.
Std. Dev.	40 sec.	35 sec.	29 sec.	35 sec.	34 sec.	19 sec.
Minimum	3 sec.	1 sec.	1 sec.	1 sec.	1 sec.	1 sec.
Maximum	211 sec.	231 sec.	153 sec.	245 sec.	245 sec.	88 sec.
Size	53 veh.	120 veh.	184 veh.	190 veh.	547 veh.	234 veh.
Mean veh/hr	108	120	117	120	118	186

The results of the Chi-square test are summarized in Table C.2. In both cases -- arrival to the static scale and to the bypass route

-- the observed data fit the exponential distribution at the 0.01 confidence level.

Table C.2. Goodness-of-fit for traffic arrival headway distribution

Arrival Volume	χ^2	df	$\chi^2_{Critical}$	Result	Sample
118 veh/hr-static scale	65.29	56	$\chi^2_{(0.01, 56)} = 83.51$	Accept	547 veh
186 veh/hr-bypass lane	45.46	30	$\chi^2_{(0.01, 30)} = 50.89$	Accept	237 veh

C.2.2.2. Capacity of Static Scale and Processing Time

Data collection for the processing time was conducted in four weigh facilities. They are the northbound and southbound Dumfries weigh stations of Virginia on I-95, eastbound Hyattstown weigh station of Maryland on I-270, and northbound Vancouver POE of Washington on I-5. All facilities have a bypass lane and a static scale lane, with the exception of the Vancouver POE which has two static scales.

The results of average processing time at each site are summarized in Table C.3. The capacity of each static scale is estimated by the formula $C=3600/T_p$, where T_p is the mean processing time for each vehicle. The processing capacity of each facility is summarized in Table C.4. Since a pair of static scales is employed in Vancouver POE, the total capacity is the summation of the two scales.

Table C.3. Processing time for weight and size enforcement

Weigh Station	Average (sec/veh)	Standard Deviation (sec/veh)	Min-Max Value (sec/veh)	Sample (veh)
Dumfries, VA, NB	23.5	8	7-67	493
Dumfries, VA, SB	28.7	11	10-116	734
Hyattstown, MD	20.7	17	5-125	162
Vancouver, WA	2	10	4-80	397

Table C.4. Capacity of static scales

Locations	Capacity (from data)	Capacity (round)	Sample Size
Dumfries, VA, NB	153 veh/hr	150 veh/hr	493 veh
Dumfries, VA, SB	125 veh/hr	130 veh/hr	734 veh
Hyattstown, MD	174 veh/hr	170 veh/hr	162 veh
Vancouver, WA	$167 \times 2 = 334$ veh/hr	330 veh/hr	397 veh

C.2.2.3. Processing Time Distribution

Because of the resemblance in shapes, the observed data of processing time was tested against Erlang distributions, which are expressed as:

$$P(T_p \geq t) = \sum_{i=0}^{K-1} \left(\frac{kt}{T}\right)^i \frac{e^{-\frac{kt}{T}}}{i!} \quad (2)$$

Where P: probability that processing time is equal or larger than time t; T_p : processing time for each operation; K: parameter of Erlang family, determines the shape of the distribution;

T: mean processing time; and e: natural base.

The parameter of Erlang distribution, K is estimated by (2):

$$K \approx \frac{T^2}{S^2} \quad (3)$$

Where T: the mean processing time and S^2 : variance of the observed intervals

Table C.5 shows the results of goodness-of-fit test. Basically, processing time distribution belongs to Erlang distributions.

Table C.5. Goodness-of-fit for truck processing time distribution

Location	Distribution	χ^2	df	$\chi^2_{critical}$	Result	Sample
Dumfries VA, NB	Erlang 10	38.33	28	$\chi^2_{(0.01, 28)} = 48.28$	Accept	493
Dumfries VA, SB	Erlang 8	132.69	41	$\chi^2_{(0.01, 41)} = 64.95$	Reject	734
Hyattstown MD	Erlang 2	38.54	21	$\chi^2_{(0.01, 21)} = 38.93$	Accept	162
Vancouver MA	Erlang 6	42.49	30	$\chi^2_{(0.01, 30)} = 50.89$	Accept	397

C.2.3. Sorting Residue Rate of Truck Population

With WIM for vehicle sorting, arrival vehicles are sorted into two bypass routes and static scale lanes. The proportion that is sorted to the static scale is called the residue rate. It influences the operational effects of WIM. The residue rate is determined by truck weight distribution, WIM accuracy, and the setting of sorting threshold.

The truck weight distribution data is available for some locations of States in FHWA Truck Weight Software(TWS). It is presented as number of trucks in each breakdown weight range. The proportion of vehicles that are directed to the scale house due to suspect

overweight in any weight category, such as single axle, and tandem axle is estimated by the method below:

$$R_{ss} = \sum_{k=1}^{k=n} (V_k \times P_k(\text{static scale})) \quad (4)$$

Where R_{ss} : proportion of trucks directed to the scale house; n: number of weight ranges; k: any one of the weight ranges; V_k : percentage of vehicles falling into weight range K; and $P_k(\text{static scale})$: probability that vehicles in weight range K are sensed to be overweight.

The measurement of $P_k(\text{static scale})$ is expressed as percentage lighter or heavier than the sorting

threshold. It is commonly agreed that the distribution of WIM error is a normal distribution. A sorting threshold factor is usually applied to the WIM system to adjust the weight limit when the sorting is taking place. When the WIM system is ideally calibrated, the mean measurement of a vehicle's weight generated by WIM is the vehicle's true weight plus the sorting threshold factor.

Using a normal distribution curve, the area to the left of the sorting threshold is the probability the vehicle is sensed as lighter than the sorting threshold, and thus the probability of bypassing; while the area to the right is the probability the vehicle is sensed as overweight, and thus the probability of being directed to the scale house.

With the sorting threshold as a reference point, the bypassing probability of a vehicle is expressed as

$$P(\text{bypass}) = P(x \leq \text{sorting threshold}) = P(x \leq 0)$$

and the probability of being directed to the static scale is

$$P(\text{static scale}) = 1 - P(\text{bypass}) = P(x > 0)$$

$P(x > 0)$ can be estimated by z-tables in many statistics books after calculating the z value by

the equation below. It can also be estimated by using MS-Excel.

$$Z = \frac{x - \mu}{\sigma} \tag{5}$$

Where x : 0 at sorting limit; σ : standard deviation of error of WIM; $\mu = \pm\alpha\% + \beta\%$: mean measurement of WIM for a true static weight; $\alpha\%$: the true static weight, stated as percentage difference from the sorting threshold; and $\beta\%$: the sorting threshold factor.

Figure C.1 shows the influence of sorting threshold factor on the bypass probability of an overweight vehicle. To achieve the same level of weight enforcement, a larger sorting threshold factor should be applied to a less accurate WIM system, and a smaller sorting threshold factor should be applied to a more accurate WIM. If the sorting threshold is zero, the bypass probability of overweight vehicles is 50 percent no matter how accurate the WIM system is. Table C.6 illustrates the value of sorting threshold factors for different accuracy of WIM so as to prevent a certain percentage of overweight vehicles from erroneously bypassing.

Table C.6. Suggested sorting threshold factor

Bypass Probability	Pull-in Probability	Type of WIM Systems (σ , standard deviation)		
		Type I ($\sigma=5\%$)	Type II ($\sigma=8\%$)	Type III ($\sigma=3\%$)
2%	98%	$\beta=10\%$	$\beta=17\%$	$\beta=6\%$
5%	95%	$\beta=8\%$	$\beta=13\%$	$\beta=5\%$
10%	90%	$\beta=7\%$	$\beta=11\%$	$\beta=4\%$
16%	84%	$\beta=5\%$	$\beta=8\%$	$\beta=3\%$
50%	50%	$\beta=0$	$\beta=0$	$\beta=0\%$

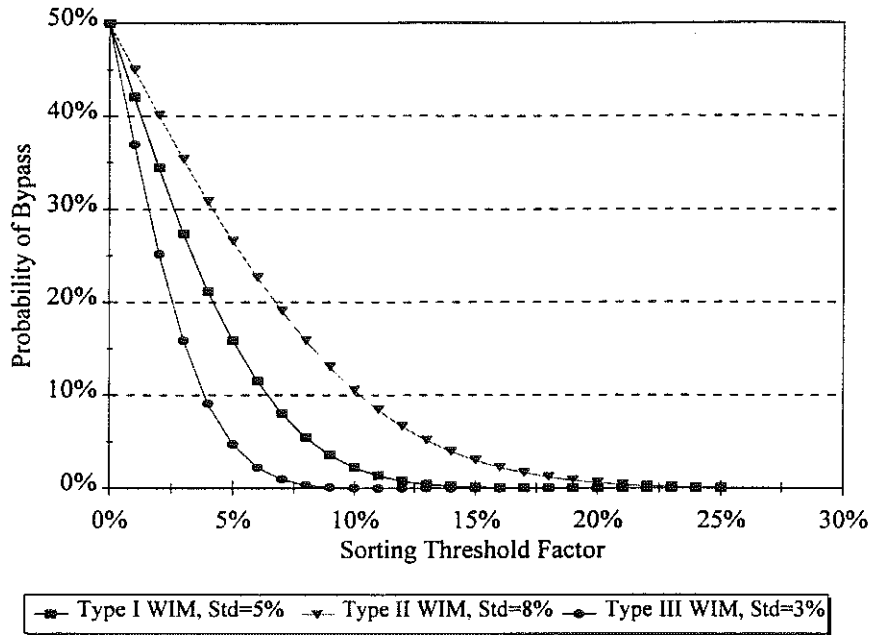

Figure C.1. Bypassing probability vs sorting threshold factor

The probability of pulling-in vehicles at different weight ranges is demonstrated in Figure C.2. Obviously, a heavy vehicle has

higher probability to be directed to the static scale than a lighter one.

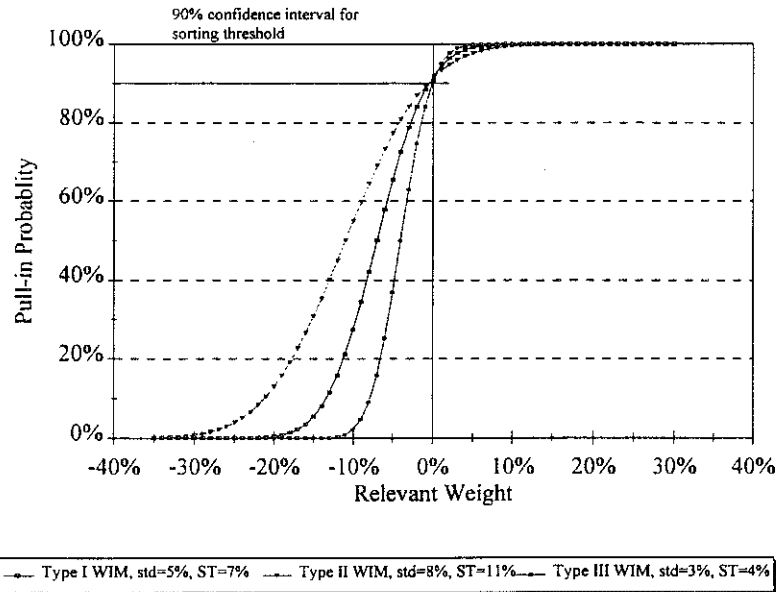

Figure C.2. Pull-in probability vs vehicle weight

C.2.4. Queue and Waiting Time Estimation

C.2.4.1. Queuing Models

Waiting time in a weigh facility is defined as the time duration that a vehicle waits to be serviced in the queue plus the time it is processed. One approach to estimate queue and delay is queuing theory. Queuing models are available in many textbooks. In weigh facility, the service principle is basically "first come, first service". So the selection of queuing models depends on the following attributes of a weigh facility: 1. the number of service channels; 2. the distribution pattern of processing time; and 3. the distribution pattern of arrival vehicles.

Based on field site studies of five weigh stations, four scenarios are usually seen with the features of weigh facilities:

1. one static scale, Exponential arrival headway, Exponential processing time;
2. one static scale, Exponential arrival headway, Erlang processing time;
3. two static scale, Exponential arrival headway, Exponential processing time; and
4. two static scale, Exponential arrival headway, Erlang processing time.

The queuing models for each of these scenarios are presented below, where v is the arrival rate, and c is the processing rate.

◆ *Scenario 1: One static scale, Exponential arrival headway, and Exponential processing time.*

1. The probability of no vehicles in the facility (the facility is being idle)

$$P_0 = 1 - \frac{v}{c} \quad (6)$$

2. The probability of n vehicles in the facility

$$P_n = \left(\frac{v}{c}\right)^n P_0 \quad (7)$$

3. Average number of vehicles in the facility (including the one being serviced)

$$L_f = \frac{v}{(c - v)} \quad (8)$$

4. Average number of vehicles waiting in the queue (not including the one being serviced)

$$L_q = \frac{v^2}{c(c - v)} = L_f \frac{v}{c} \quad (9)$$

5. Average waiting time in the facility (including the time being serviced)

$$W_f = \frac{1}{(v - c)} = \frac{L_f}{v} \quad (10)$$

6. Average waiting time in the queue (not including the time being serviced)

$$W_q = \frac{v}{c(c - v)} = \frac{L_q}{v} \quad (11)$$

◆ *Scenario 2: One static scale, Exponential arrival headway, and Erlang processing time.*

1. Average waiting time in the facility

$$W_q = \frac{2K - \frac{v}{c}(K - 1)}{2Kc(1 - \frac{v}{c})} \quad (12)$$

Where K is the parameter of Erlang family.

2. Average number of vehicles in the facility

$$L_f = W_f v \quad (13)$$

◆ *Scenario 3: Two static scale, Exponential arrival headway, and Exponential processing time.*

1. Probability of no vehicles in the facility

$$P_0 = \frac{1}{1 + \frac{v}{c} + \frac{1}{2} \left(\frac{v}{c}\right)^2 \left(\frac{2c}{2c-v}\right)} \quad (14)$$

$$W_q = \frac{L_q}{v} \quad (19)$$

2. Probability of n vehicles in the facility

$$P_n = \left(\frac{v}{c}\right)^n P_0 \quad \text{for } n = 1 \quad (15)$$

$$P_n = \frac{1}{2 \times 2^{n-2}} \left(\frac{v}{c}\right)^n P_0 \quad \text{for } n \quad (16)$$

3. Average number of vehicles in the queue (not including the one being serviced)

$$L_q = \frac{v c \left(\frac{v}{c}\right)^2}{(2c - v)^2} \times P_0 \quad (17)$$

4. Average number of vehicles in the facility (including the one being serviced)

$$L_f = L_q + \frac{v}{c} \quad (18)$$

5. Average waiting time in the queue (not including the time being serviced)

6. Average waiting time in the facility (including the time being serviced)

$$W_f = W_q + \frac{1}{c} \quad (20)$$

Queuing models for Scenario 4 are not available in literature. One guess is that the calculation process must be very complicated. So, in the case of Scenario 4, queue and delay are suggested to be estimated by using the models in Scenario 3.

C.2.4.2. Applications of Queuing Models

◆ Evaluation of the Probability of Mainline Backup

By using queuing models, we can estimate how often queuing vehicles in a weigh facility would be backed up to the mainline. The four weigh facilities were evaluated (Table C.7). The residue rate at the static scales is assumed to be 35 percent of the arrival vehicles when WIM is employed.

Table C.7. Frequency of mainline backup

Locations	Entrance Ramp (m)	Max. Queue (veh) L_{max}	Static Scales	Capacity (veh/hr/scale)	Volume at Scales (veh/hr)	$P(n > L_{max})$
NB Dumfries	343	11	1	150	300 x 35%	1%
SB Dumfries	343	11	1	130	300 x 35%	8%
EB Hyattstown	267	9	1	170	120	3%
NB Vancouver	244	8	2	165	300	44%
NB Vancouver	244	8	2	165	300 x 35%	0%

The acceptable system will operate at a probability of mainline backup $P(n > L_{max}) \leq 5\%$. From the facilities tested, Southbound Dumfries

and Northbound Vancouver present problems, while the other facilities operate within acceptable levels. If a WIM system is added to

the existing Northbound Vancouver facility, the mainline backup situation can completely disappear.

◆ *Evaluation of Alternatives*

The Vancouver POE has a mainline backup of

44 percent. As a solution, two improvement alternatives are examined here: 1. Extend the existing entrance ramp by 274 meter (900 ft) in length, and 2. Add a WIM to the existing ramp, and change one of the existing static scale lanes to a bypass route. The mainline backup situation is compared in Table C.8.

Table C.8. Evaluation of alternatives

Alternatives	Entrance Ramp (m)	Queue (veh)	Static Scales	Capacity (veh/hr/scale)	Volume at Scales (veh/hr)	P(n>n _{max})
274 m Extension	518	17	2	165	300	19%
Add WIM on Ramp	244	8	1	165	300 x 35%	0%

The results show that even with a 274 meter extension, the mainline backup situation is still above the acceptable level. However, a backup-free situation would be the result if a WIM is employed and one of the existing static scale lanes is changed into a bypass route.

◆ *Estimation of Required Length of Ramp*

If a ramp extension plan is favored, how long should it be? In the case of proposing a new facility, the length of the ramp could be calculated from Table C.9. Table C.9 shows the

analysis results for two real projects: 1. the extension plan with Vancouver port-of-entry, and 2. the proposed enforcement facility at the I-95/I-495 interchange in Maryland. Traffic flow analysis on I-95/I-495 interchange indicated that the maximum hourly truck arrival rate is 900 veh/hr if all the eastbound traffic is subject to enforcement at the same time. The calculation is based on the assumption that the headway of two trucks in queue is 100 ft, and the residue rate at I-95/I-495 is 30 percent if WIMs are employed.

Table C.9. Required length of ramp

Proposed Project	Volume at Scales (veh/hr)	Static Scales	Capacity (veh/hr/scale)	Ramp Length (m)	P(n>L _{max})
Ramp Extension, Vancouver POE	300	2	165	30 vehx30.5 m/veh = 915 m	5%
New Facility at I-95/I-495, MD	900 x 30%	2	165	15 vehx30.5 m/veh = 457 m	4%

For Vancouver POE, the satisfied length of ramp is 915 meters, requiring a 671 meters extension to enable the backup rate of queuing vehicles to

be limited within 5 percent. Compared with the implementation of WIM, no physical changes are necessary with the existing layout.

However, the 671 meters extension alternative is more costly. For the I-95/I-495 weigh facility project, the required length for queuing vehicles is 457 meters if the facility is equipped with two static scales, plus a WIM system.

◆ *Comparison of Transit Time and Delay*

Transit time for a vehicle through a weigh facility is measured from the moment when the vehicle starts to decelerate until it regains mainline speed. For a vehicle passing through the static scale, transit time is composed of moving time and waiting time. For a vehicle taking the bypass route, only moving time is involved. Moving time is associated with the smooth driving process, including acceleration, deceleration, and constant driving process. Waiting time is the time a vehicle waits in the queue plus the time it is processed. So, transit time is expressed as:

For a vehicle traversing a static scale:

$$T_{static} = t_1 + W_f + t_2 \quad (21)$$

For a vehicle traveling via the bypass route:

$$T_{bypass} = t_1 + t_2 + t_3 \quad (22)$$

Where t_1 : deceleration time; t_2 : acceleration time; t_3 : driving time at constant speed; and W_f : waiting time in the facility.

Delay is defined as the time difference for a vehicle passing the same segment of a facility via mainline and via facility. With the use of WIM, delay is experienced in three levels: delay for a vehicle passing through the static scale, delay for vehicles taking the bypass route, and the average delay of truck population.

For a vehicle via static scale

$$D_{Static} = T_{static} - T_{mainline} \quad (23)$$

For a vehicle via bypass route

$$D_{bypass} = T_{bypass} - T_{mainline} \quad (24)$$

For truck population

$$D_{all} = \frac{D_{static} \times A + D_{bypass} \times B}{V_{all}} \quad (25)$$

Where: $T_{mainline}$: transit time via the mainline; A: number of vehicles directed to the static scales; B: number of vehicles directed to the bypass route; and V_{all} : total truck volume at a site.

With Vancouver POE as a testing ground, the average delay experienced in these three different levels is plotted in Figure C.3. At the truck population level, the average delay is approximately two minutes if all the arrival traffic is pulled to the static scales. However if 65 percent of the traffic is sorted to the bypass route in the facility, the average delay per vehicle is 23 seconds. If the same proportion of traffic is sorted to the mainline, the average delay per vehicle is 14 seconds. The maximum difference of delay reduction with the use of high speed WIM and medium speed WIM is only 10 seconds at the truck population level. The calculation is based on the following assumptions:

Truck volume:	300 veh/hr
Per scale capacity:	165 veh/hr
Highway speed:	88 km/hr
Ramp speed:	56 km/hr
Deceleration rate:	1.2 m/sec ²
Acceleration rate:	0.6 m/sec ²

The average queue is compared with different residue rates in Figure C.4. The average length of queue drops significantly from 11 vehicles to 1 vehicle if only 35 percent of the arrival traffic is directed to the static scales.

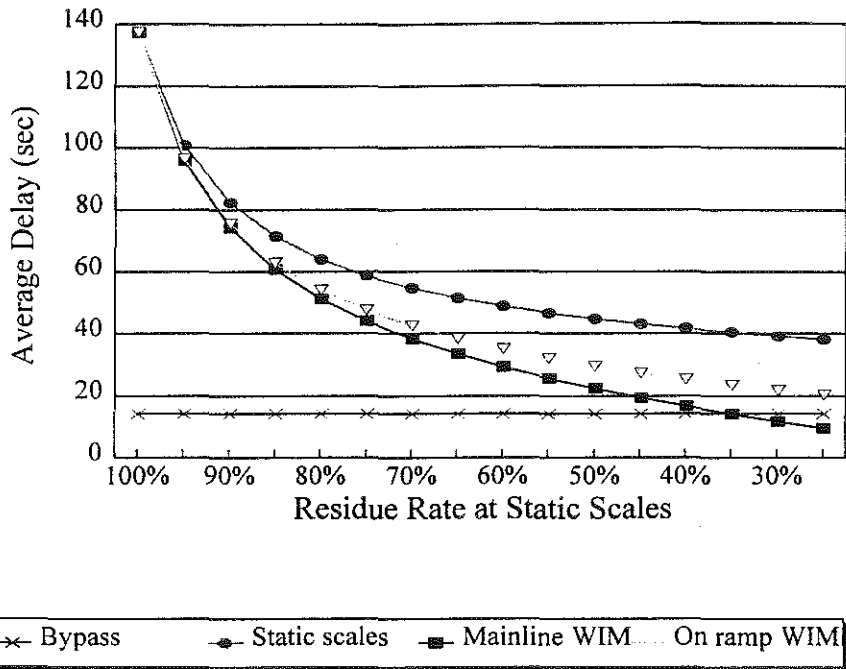

Figure C.3. Average delay at Vancouver POE

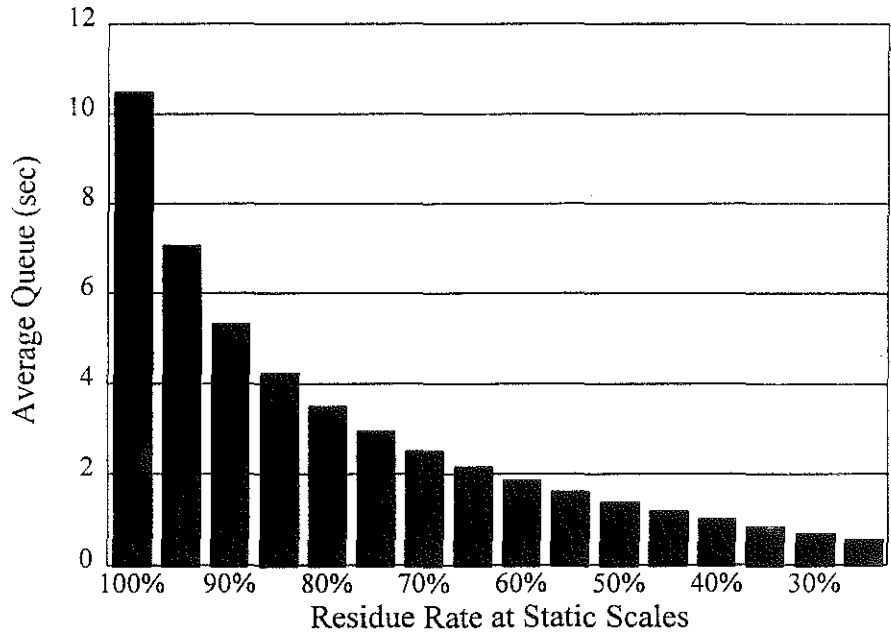

Figure C.4. Average queue length at Vancouver POE

C.3. SUMMARY

Queuing theory is a powerful tool for the evaluation of weigh facilities, especially in situations where no field data is able to be collected. The key parameters to be determined for this analytical process are:

- Vehicle arrival distribution;
- Peak hour truck volume;
- Enforcement processing time distribution;

- Mean processing rate;
- Number of static scale lanes.

To ensure that the estimation results are more reliable, it is suggested to study the residue rate at the static scales carefully when the WIM system is employed. Truck weight distributions, WIM accuracy, and the setting of sorting threshold influence greatly the residue rate of each site.

APPENDIX D
STATE CONTACTS

These contacts are the persons responding to the initial survey conducted in January 1995. This information was accurate at that time, however, it is subject to change.

Alabama

John Lorentson
Permit Engineer
1490 Coliseum Blvd.
Montgomery, AL 36130
Phone: 205-242-6474
Fax: 205-832-9084

California

John Vanberkel
Chief Office of Permits and Truck Studies
California Department of Transportation
1120 "N" Street, Room 4109
Sacramento, CA 95814
Phone: 916-654-5548
Fax: 916-654-4828

Alaska

Aves Thompson
Division of Measurements Standards
Department of Commerce & Economic
Development
12050 Industry Way
Anchorage, AK 99515
Phone: 907-345-7750
Fax: 907-345-6835

Colorado

Phillip A. Vasquez, Chief
Colorado Department of Revenue
Port of Entry Division
Denver, CO 80204
Phone: 303-572-5690
Fax: 303-572-5764

Arizona

Stephen V. Abney
Arizona Department of Transportation
1225 N. 25th Ave.
Phoenix, AZ 85001
Phone: 602-255-7181
Fax: 602-407-3048

Connecticut

Robert L. Cumpstone
Connecticut Department of Transportation
P.O. Box 317546
Newington, CT 06131-7546
Phone: 203-594-2874
Fax: 203-665-8334

Arkansas

Captain George Coffman
Arkansas Highway Police
Arkansas State Highway & Transportation
Department
P.O. Box 2779
Little Rock, AR 72203
Phone: 501-569-2421
Fax: 501-568-4921

Delaware

Bruce E. Littleton
Delaware DOT
P.O. Box 778
Dover, DE 19904
Phone: 302-739-4301
Fax: 302-739-4329

Florida

Major William Mickler
Florida DOT
1815 Thomasville Rd.
Tallahassee, FL 32301
Phone: 904-488-7920
Fax: 904-922-6798

Georgia

Jack Williams
276 Memorial Dr. S W
Atlanta, GA 30303
Phone: 404-656-7572
Fax: 404-656-9717

Hawaii

Alexander K Kaonohi, Jr.
Motor Vehicle Safety Office
Department of Transportation
1505 Dillingham Blvd.
Honolulu, HA 96817
Phone: 808-832-5827
Fax: 808-832-5830

Idaho

Alan Frew
P.O.E. Manager
Idaho Transportation Department
Box 7129
Boise, ID 83707-1129
Phone: 208-334-8694
Fax: 208-334-8690

Illinois

Richard Telford
Illinois DOT
2300 South Dirksen Parkway, Room 009
Springfield, IL 62764
Phone: 217-782-2984
Fax: 217-782-1927

Indiana

Martin Kipp MCI/Adm
Indiana State Police
100 N. Senate Ave, Room 340
Indianapolis, IN 46204-2249
Phone: 317-232-5436
Fax: 317-232-5204

Iowa

Lieutenant Krohn
Iowa DOT, Motor Vehicle Enforcement
P.O. Box 10382
Des Moines, IA 50306-0382
Phone: 515-237-3264
Fax: 515-237-3387

Kansas

Sergeant N.P. Mckee
Kansas Highway Patrol
Motor Vehicle/Motor Carrier Enforcement
700 Jackson Suite 500
Topeka, KS 66603
Phone: 913-296-7903
Fax: 913-296-7908

Kentucky

Major David Herald
Motor Vehicle Enforcement
1231 Wilkerson Blvd.
Frankfort, KY 40621
Phone: 502-564-4603
Fax: 502-564-2227

Louisiana

Major Marshall Linton
Louisiana Department of Transportation and
Development, Box 94042
Baton Rouge, LA 70804
Phone: 504-377-7100
Fax: 504-377-7108

Maine

Lieutenant Harlan Pierson
Maine State Police
242 State Street
Augusta, ME 04333
Phone: 207-287-1057
Fax: 207-287-6248

Maryland

Larry Swartzlander
State Office of Traffic & Safety
Motor Carrier Division
7491 Connelley Dr.
Hanover, MD 21076
Phone: 410-582-5732
Fax:

Massachusetts

Sgt. Paul D. Sullivan
Massachusetts State Police
906 Elm Street
Concord, MA
Phone: 617-727-6599
Fax: 617-727-1808

Michigan

Insp. Brenda Parks
300 N. Clippert
Lansing, MI 48913
Phone: 517-336-6483
Fax: 517-332-4820

Minnesota

Lt. M. Tuckner
Minnesota State Patrol
100 Stockyard Rd.
St. Paul, MN 55101-2156
Phone: 612-282-6875
Fax: 612-282-6873

Mississippi

Tommy Dorsey
Deputy Director
Office of Enforcement
Mississippi Department of Transportation
P.O. Box 1850
Jackson, MS 39215-1850
Phone: 601-359-7001
Fax: 601-359-7050

Missouri

Gary Steinmetz
Missouri State Highway Patrol
P.O. Box 568
Jefferson City, MO 65102
Phone: 315-526-6128
Fax: 315-526-4637

Montana

Dave Galt
Montana Department of Transportation
Motor Carrier Services Division
P.O. Box 4639
Helena, MT 59620
Phone: 406-444-6130
Fax: 406-444-7670

Nebraska

Lieutenant Ron Krolikowski
Nebraska State Patrol
3980 NW 38th St.
Lincoln, NE 68524
Phone: 402-471-0105
Fax: 402-471-3295

Nevada

Michael W. Lawson
1263 S. Stewart St.
Carson City, NV 89712
Phone: 702-687-3443
Fax: 702-687-4846

New York

Sergeant Eric C. Adair
New York State Police
Traffic Services
Albany, NY 12226
Phone: 518-457-3258
Fax: 518-457-9620

New Mexico

James Chavez
Deputy Director
Motor Transportation Division
P.O. Box 1028
Sante Fe, NM 87504
Phone: 505-827-0320
Fax: 505-827-0324

New Hampshire

Major Thomas Walsh
Division of Enforcement
Department of Safety
10 Hazen Dr.
Concord, NH 03305
Phone: 603-271-3347
Fax: 603-271-3903

New Jersey

Lieutenant Joe Ballas
Traffic Bureau
New Jersey State Police
P.O. Box 7068
West Trenton, NJ 80628-0068
Phone: 609-882-2000
Fax: 609-883-0237

North Dakota

Sergeant Ken Halldorson
Highway Patrol
Judicial Wing State Capitol
Bismarck, ND 58505
Phone: 701-328-2455
Fax: 701-328-3000

North Carolina

David Richards
Division of Motor Vehicles
1100 Newbern Ave
Raleigh, NC 27697
Phone: 919-733-2403
Fax: 919-733-0564

Ohio

Lt. J. A. May
Ohio State Patrol
660 East Main
Columbus, OH 43205
Phone: 614-466-2306
Fax: 614-752-3040

Oklahoma

Lieutenant Floyd Allen
OHP Troop S
32 NE 23rd
Oklahoma City, OK 73105
Phone: 405-521-6105
Fax: 405-521-6227

Oregon

Ken Evert
1905 S. Lana Ave. N.E.
Salem, OR 97314
Phone: 503-945-7938
Fax: 503-945-7951

Pennsylvania

Frederick Juba
Motor Carrier Enforcement Division
Rm 1014, Transportation & Safety Bldg.
Harrisburg, PA 17120
Phone: 717-787-4033
Fax: 717-787-9890

Rhode Island

John DiTomaso
Rhode Island Dept. of Transportation
286 Main St.
Pawtucket, RI 02860
Phone: 401-277-2970
Fax: 401-728-0855

South Dakota

Captain Myron Rau
South Dakota Highway Patrol
500 East Capitol Street
Pierre, SD 57501-5070
Phone: 605-773-3195
Fax: 605-773-6046

South Carolina

Curtis Thomas
South Carolina
State Transportation Police
220 Executive Center Drive
Winthrop Bldg. Suite 200
Columbia, SC 29210
Phone: 803-896-7839
Fax: 803-896-7881

Tennessee

Henry Davidson
Commercial Vehicle Enforcement
1150 Foster Ave.
Nashville, TN 37249
Phone: 615-251-5195
Fax: 615-251-5242

Texas

Gary Trietsch, P.E.
125 E. 11th St.
Austin, TX 78701
Phone: 512-416-3200
Fax: 512-416-3214

Utah

Glen Goodrich
Motor Carrier Office
Utah Department of Transportation
Salt Lake City, UT 84119
Phone: 801-965-4156
Fax: 801-965-4338

Vermont

Ron Macie
Motor Vehicle Enforcement
120 State Street
Montpelier, VT 05603-001
Phone: 802-828-2067
Fax: 802-828-2092

Virginia

Ken Jennings
VDOT
1221 E. Broad Street
Richmond, VA 23219
Phone: 804-786-5081
Fax: 804-692-0810

Washington

Ralph Dewitt
P.O. Box 4-2614
Olympia, WA 98504-2614
Phone: 206-664-9497
Fax:

West Virginia

Jeff Davis
West Virginia Department of Highways
710 Central Ave.
Charleston, WV 25305
Phone: 304-558-3545
Fax: 304-558-2080

Wisconsin

Lieutenant Steve Gasper
Wisconsin State Patrol
P.O. Box 7912
Madison, WI 53702-7912
Phone: 608-266-0264
Fax:

Wyoming

Captain Steve Gerard
Wyoming State Patrol
P.O. Box 1708
Cheyenne, WY 82002-1708
Phone: 307-777-4317
Fax: 307-777-4282

APPENDIX E
LIST OF ACRONYMS AND ABBREVIATIONS

AASHTO	American Association of State Highway Transportation Officials
ADA	American Disabilities Act
ARSI	Automated Roadside Safety Inspection
AVC	Automatic Vehicle Classification
AVI	Automatic Vehicle Identification
BOE	Board of Equalization
CALTRANS	California Department of Transportation
CHP	California Highway Patrol
CLETS	California Law Enforcement Telecommunication System
CMS	Changeable Message Sign
CVM	Commercial Vehicle Monitoring
CVO	Commercial Vehicle Operations
CVSA	Commercial Vehicle Safety Alliance
DFA	Department of Food and Agriculture
DMV	Department of Motor Vehicles
DOT	Department of Transportation
EDI	Electronic Data Interchange
FHWA	Federal Highway Administration
FY	Fiscal Year
GNP	Gross National Product
GVW	Gross Vehicle Weight
HELP	Heavy Vehicle Electronic License Plate
INS	Immigration and Naturalization Service
ISTEA	Intermodal Surface Transportation Efficiency Act
ITS	Intelligent Transportation System
ITS/CVO	Intelligent Transportation System -- Commercial Vehicle Operations
IVHS	Intelligent Vehicle Highway System
MACS	Mainline Automated Clearance System
MISTER	Management Information System of Terminal Evaluation Records
MCSAP	Motor Carrier Safety Assistance Program
MOE	Measures of Effectiveness
NCHRP	National Cooperative Highway Research Program
MRE	Mobile Road Enforcement
OMC	Office of Motor Carriers
POE	Port of Entry
RF	Radio Frequency
SHRP	Strategic Highway Research Program
STAA	Surface Transportation Assistance Act
UHP	Utah Highway Patrol
UPS	Uninterruptible Power Supply
VIN	Vehicle Identification Number
VIR	Vehicle Identification Reader
WIM	Weigh-In-Motion

