

U.S. Coast Guard Research and Development Center
1082 Shennecossett Road, Groton, CT 06340-6096

Report No. CG-D-24-98

**Fire Safety Analysis of the
180' WLB Seagoing Buoy Tender**

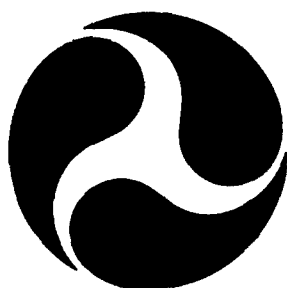

**FINAL REPORT
OCTOBER 1998**

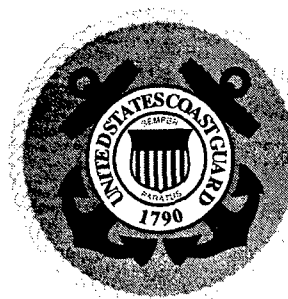

This document is available to the U.S. public through the
National Technical Information Service, Springfield, VA 22161

Prepared for:

U.S. Department of Transportation
United States Coast Guard
Systems (G-S)
Washington, DC 20593-0001

19981113 046

DTIC QUALITY INSPECTED 4

NOTICE

This document is disseminated under the sponsorship of the Department of Transportation in the interest of information exchange. The United States Government assumes no liability for its contents or use thereof.

The United States Government does not endorse products or manufacturers. Trade or manufacturers' names appear herein solely because they are considered essential to the object of this report.

The contents of this report reflect the views of the Coast Guard Research and Development Center. This report does not constitute a standard, specification, or regulation.



Marc B. Mandler, Ph.D.
Technical Director
United States Coast Guard
Research & Development Center
1082 Shennecossett Road
Groton, CT 06340-6096



1. Report No. CG-D-24-98		2. Government Accession No.		3. Recipient's Catalog No.	
4. Title and Subtitle Fire Safety Analysis of the 180' WLB Seagoing Buoy Tender				5. Report Date October 1998	
				6. Performing Organization Code Project No. 3309.88	
7. Author(s) Chester M. Sprague, P.E., Derek White, P.E., and Brian Dolph				8. Performing Organization Report No. R&DC 18/97	
9. Performing Organization Name and Address Worcester Polytechnic Institute 100 Institute Road Worcester, MA 01609 U.S. Coast Guard Research and Development Center 1082 Shennecossett Road Groton, CT 06340-6096 Hughes Associates, Inc. 3610 Commerce Drive Suite 817 Baltimore, MD 21227-1652				10. Work Unit No. (TRAIS)	
				11. Contract or Grant No. DTCG39-96-F-E00073	
				13. Type of Report and Period Covered Final Report, June 1996 to July 1997	
12. Sponsoring Agency Name and Address U.S. Department of Transportation United States Coast Guard Systems (G-S) Washington, DC 20593-0001				14. Sponsoring Agency Code Commandant (G-SEN) U.S. Coast Guard Headquarters Washington, DC 20593-0001	
15. Supplementary Notes The Coast Guard technical point of contact and COTR is Brian Dolph (860-441-2817) of the U.S. Coast Guard Research and Development Center. The Project Officer is LT Joyce Aivalotis (G-SEN-1), Coast Guard Headquarters.					
16. Abstract <p>This report documents the results of a comprehensive fire safety analysis of the 180' WLB Seagoing Buoy Tender. The Ship Fire Safety Engineering Methodology (SFSEM) and associated Ship Applied Fire Engineering (SAFE v 2.2), were utilized as an analytical tool to perform the analysis. The SFSEM is a probabilistic based fire risk analysis methodology. SAFE implements the SFSEM and evaluates the probability of spaces and barriers limiting a fire.</p> <p>Visits to the CGC HORNBEAM were made to collect input data. Baseline fire safety analysis results show that with all passive and active fire protection features in effect, the cutter exceeds the established fire safety objectives by a very substantial margin both in port and at sea. With just passive fire protection in effect (without considering automated or manual fire protection), the 180' WLB exceeds its fire safety objectives in every compartment. The passive fire protection in this cutter may be enhanced due to effective use of compartmentation to segregate engineering spaces and due to the fact that many of the bulkheads are constructed of insulated steel.</p> <p>The most probable rooms of origin for fires that may spread to involve multiple compartments are the Motor Room, Auxiliary Machinery Space #3, Linen Locker and Cleaning Gear Locker. A careful analysis of the results from the various output options in SAFE provided in this report may be effectively used to develop realistic fire scenarios to assist the crew in planning firefighting training drills.</p>					
17. Key Words fire protection cutter fire safety ship fire engineering methodology buoy tender				18. Distribution Statement This document is available to the U.S. public through the National Technical Information Service, Springfield, VA 22161.	
19. Security Classif. (of this report) UNCLASSIFIED		20. SECURITY CLASSIF. (of this page) UNCLASSIFIED		21. No. of Pages	22. Price

METRIC CONVERSION FACTORS

Approximate Conversions to Metric Measures

Symbol	When You Know	Multiply By	To Find	Symbol
LENGTH				
in	inches	* 2.5	centimeters	cm
ft	feet	30	centimeters	cm
yd	yards	0.9	meters	m
mi	miles	1.6	kilometers	km
AREA				
in ²	square inches	6.5	square centimeters	cm ²
ft ²	square feet	0.09	square meters	m ²
yd ²	square yards	0.8	square meters	m ²
mi ²	square miles	2.6	square kilometers	km ²
	acres	0.4	hectares	ha
MASS (WEIGHT)				
oz	ounces	28	grams	g
lb	pounds	0.45	kilograms	kg
	short tons (2000 lb)	0.9	tonnes	t
VOLUME				
tsp	teaspoons	5	milliliters	ml
tbsp	tablespoons	15	milliliters	ml
fl oz	fluid ounces	30	milliliters	ml
c	cups	0.24	liters	l
pt	pints	0.47	liters	l
qt	quarts	0.95	liters	l
gal	gallons	3.8	liters	l
ft ³	cubic feet	0.03	cubic meters	m ³
yd ³	cubic yards	0.76	cubic meters	m ³
TEMPERATURE (EXACT)				
°F	Fahrenheit temperature	5/9 (after subtracting 32)	Celsius temperature	°C

*1 in = 2.54 (exactly).

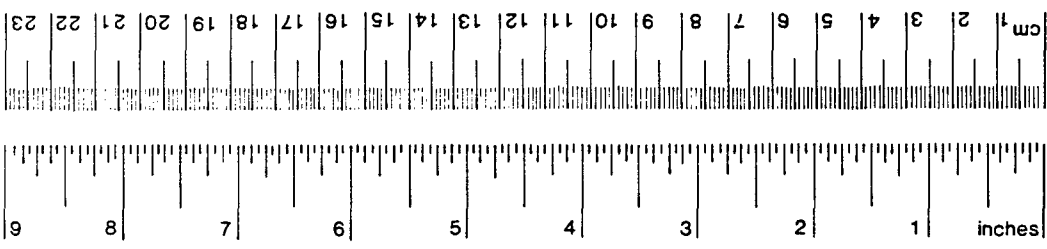
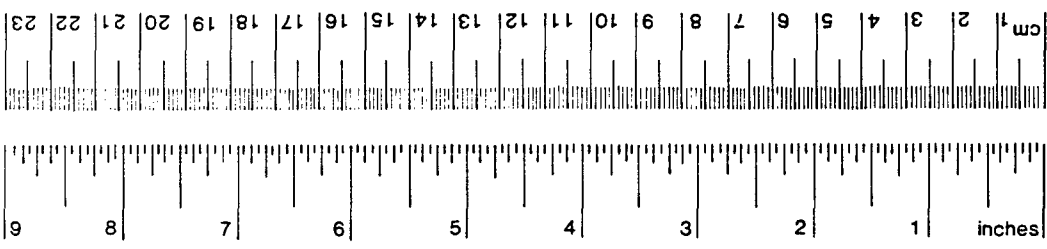

Approximate Conversions from Metric Measures

Symbol	When You Know	Multiply By	To Find	Symbol
LENGTH				
mm	millimeters	0.04	inches	in
cm	centimeters	0.4	inches	in
m	meters	3.3	feet	ft
m	meters	1.1	yards	yd
km	kilometers	0.6	miles	mi
AREA				
cm ²	square centimeters	0.16	square inches	in ²
m ²	square meters	1.2	square yards	yd ²
km ²	square kilometers	0.4	square miles	mi ²
ha	hectares (10,000 m ²)	2.5	acres	
MASS (WEIGHT)				
g	grams	0.035	ounces	oz
kg	kilograms	2.2	pounds	lb
t	tonnes (1000 kg)	1.1	short tons	
VOLUME				
ml	milliliters	0.03	fluid ounces	fl oz
l	liters	0.125	cups	c
l	liters	2.1	pints	pt
l	liters	1.06	quarts	qt
l	liters	0.26	gallons	gal
m ³	cubic meters	35	cubic feet	ft ³
m ³	cubic meters	1.3	cubic yards	yd ³
TEMPERATURE (EXACT)				
°C	Celsius temperature	9/5 (then add 32)	Fahrenheit temperature	°F

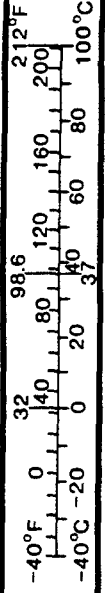

TABLE OF CONTENTS

LIST OF ABBREVIATIONS AND TERMS.....	viii
EXECUTIVE SUMMARY.....	xviii
1. INTRODUCTION	1-1
1.1. BACKGROUND	1-1
1.2. SCOPE	1-2
1.3. OBJECTIVES.....	1-2
1.4. TECHNICAL APPROACH.....	1-3
1.5. FIRE SAFETY ANALYSIS PROCEDURE.....	1-3
1.5.1. FIRE SAFETY AUDIT	1-4
1.5.1.1. Prevention.....	1-4
1.5.1.2. Detection	1-4
1.5.1.3. Containment	1-5
1.5.1.4. Extinguishment.....	1-5
1.5.1.5. Post-Extinguishment.....	1-5
1.5.2. DETAILED FIRE SAFETY ANALYSIS.....	1-5
1.5.2.1. Load Database with Ship's Geometry.....	1-6
1.5.2.2. Conduct Ship Visit.....	1-6
1.5.2.3. Load SAFE Input Values	1-6
1.5.2.4. Calculate FRI Times And Post-FRI Heat Release Rates.....	1-6
1.5.2.5. Run Probabilistic Model.....	1-7
1.5.2.6. Analyze Baseline Results	1-7
1.5.2.7. Analyze Alternatives.....	1-8
1.5.2.8. Conduct Cost-Benefit Analysis.....	1-8
1.5.2.9. Document Results	1-8
1.6. ORGANIZATION OF REPORT	1-8
2. HISTORICAL RECORDS OF FIRE	2-1
2.1. FREQUENCY OF ESTABLISHED BURNING.....	2-1
2.2. HISTORICAL RECORDS OF FIRES ON COAST GUARD CUTTERS	2-3
3. FIRE SAFETY ANALYSIS OF THE 180' WLB.....	3-1
3.1. FIRE SAFETY AUDIT.....	3-1
3.1.1. PREVENTION.....	3-1
3.1.2. DETECTION	3-2
3.1.3. CONTAINMENT.....	3-3
3.1.4. EXTINGUISHMENT	3-3
3.1.5. POST-EXTINGUISHMENT	3-4
3.2. SAFE INPUT DATA.....	3-4
3.2.1. FACTUAL INPUT DATA.....	3-5

3.2.1.1. Ship's Geometry	3-5
3.2.1.2. Automated and Manual Fire Protection Systems.....	3-5
3.2.1.3. Fire Detection System	3-5
3.2.1.4. Ventilation.....	3-6
3.2.1.5. Fuel Loads	3-6
3.2.2. SUBJECTIVE INPUT DATA.....	3-6
3.2.2.1. Probabilities of Flame Termination	3-6
3.2.2.2. Fire Safety Objectives.....	3-7
3.2.2.3. Percent Time Monitored.....	3-10
3.2.2.4. Fire Growth Models.....	3-10
3.3. BASELINE FIRE SAFETY ANALYSIS RESULTS	3-11
3.3.1. LOAD DATABASE WITH SHIP'S GEOMETRY.....	3-11
3.3.2. CONDUCT SHIP VISIT.....	3-11
3.3.3. LOAD SAFE INPUT VALUES	3-11
3.3.4. CALCULATE FRI TIMES AND POST-FRI HEAT RELEASE RATES.....	3-11
3.3.5. RUN PROBABILISTIC MODEL	3-11
3.3.6. ANALYZE BASELINE RESULTS	3-12
3.3.6.1. Individual Target Option.....	3-13
3.3.6.2. Barrier Option.....	3-19
3.3.6.3. Path Option.....	3-19
3.3.7. ANALYZE FIRE PROTECTION ALTERNATIVES.....	3-27
3.3.8. CONDUCT COST-BENEFIT ANALYSIS	3-27
3.3.9. DOCUMENT RESULTS.....	3-27
4. ANALYSIS OF ALTERNATIVES.....	4-1
4.1. BULKHEAD INSULATION	4-1
4.2. COMPARISON OF FIRE SAFETY ANALYSIS RESULTS.....	4-4
5. CONCLUSIONS AND RECOMMENDATIONS.....	5-1
5.1. FIRE SAFETY AUDIT.....	5-1
5.2. BASELINE FIRE SAFETY ANALYSIS.....	5-2
5.3. ANALYSIS OF ALTERNATIVES.....	5-2
5.3.1. BULKHEAD INSULATION	5-2
5.3.2. COMPARISON OF FIRE SAFETY ANALYSIS RESULTS.....	5-3

REFERENCES

APPENDICES

- A. Compartmentation of the 180' WLB (Major Ren)**
- B. SAFE Input Data for the 180' WLB Baseline Fire Safety Analysis**
- C. 180' WLB Baseline Fire Safety Analysis Results**
- D. Analysis of Alternatives Results**
- E. Methodology for Assigning Probabilities of Flame Termination**
- F. Network Diagrams for Flame Movement Analysis on Ships**
- G. Fire Growth Factors in the Analysis of Ship Fire Safety**

LIST OF FIGURES

Figure 3.1 Envelope of L-Curves from Motor Room (4-126-0-E).....	3-21
Figure 3.2 Envelope of L-Curves from Auxiliary Machinery Space #3 (1-112-0-Q).....	3-22
Figure 3.3 Envelope of L-Curves from Linen Locker (1-157-2-Q).....	3-23
Figure 3.4 Envelope of L-Curves from Cleaning Gear Locker (1-161-2-Q).....	3-24
Figure 4.1 Comparison of Baseline Fire Safety Levels.....	4-8
Figure 4.2 Comparison of Baseline Fire Safety Levels.....	4-10

LIST OF TABLES

Table 2.1 Fire Frequency Data.....	2-2
Table 3.1 180' WLB Relative Loss Factors, Scenarios 1, 2, & 3, Baseline Results.....	3-16
Table 3.2 180' WLB Relative Loss Factors, Scenarios 1, 4, 7, & 10, Baseline Results.....	3-17
Table 3.3 180' WLB Relative Loss Factors, Scenarios 3, 6, 9, & 12, Baseline Results.....	3-18
Table 4.1 180' WLB Relative Loss Factors, Analysis of Alternatives, Bulkhead Insulation Study.....	4-3
Table 4.2 Seagoing Buoy Tender Characteristics.....	4-4
Table 4.3 180' WLB and 225' JUNIPER, Relative Loss Factors, Scenarios 1, 2, & 3, Baseline Results.....	4-7
Table 4.4 180' WLB and 225' JUNIPER, Relative Loss Factors, Scenarios 1, 4, 7, & 10, Baseline Results.....	4-9

LIST OF ABBREVIATIONS AND TERMS

- A Curve** - The resulting curve when A values for increasing areas of a compartment are plotted on a graph with probability of flame limitation on the ordinate axis (logarithmic scale) with the origin at the top left and the deck area of the compartment on the abscissa axis (linear scale). See "A Value".
- A Value (%)** - The probability that an automated fixed fire protection system installed in a compartment will successfully extinguish the fire before FRI occurs given that the fire did not self-terminate and was not extinguished by manual firefighting efforts. Each compartment is assigned three A-values: the probability of flame limitation given EB in the room of origin, the probability of flame limitation given EB has occurred in the room as a result of a thermal (T-bar) failure of a barrier, and the probability of flame limitation given EB has occurred in the room as a result of a durability (D-bar) failure of a barrier. In SAFE, these values are abbreviated OA, TA and DA respectively
- Active Fire Protection** - Fire protection features designed to limit flame movement by automatic detection, automatic/automated fire extinguishing systems, and manual suppression systems or equipment. Examples of active fire protection features are: automatic sprinkler systems, fire extinguishers, and trained firefighting teams. See "Passive Fire Protection".
- AFFF** - Aqueous Film Forming Foam. A firefighting agent particularly effective against class B fires.
- Alpha (kilowatts per second squared)** - The fire growth coefficient in the pre-FRI heat release rate algorithm. Values for alpha are established for each fire growth model as documented in the SAFE User Manual, Version 2.2. See "Fire Growth Model" and "Pre-FRI Heat Release Rate".
- Alternative Data Set** - Data sets identified as "Alternative" have had the SAFE baseline input values adjusted, as necessary, to reflect the impact of the proposed alterations or modifications which affect the ships' firesafety system. See "Baseline Data Set".
- ASTM E119 Test Rating (hours and minutes)** - A rating in hours and minutes specifying time to failure of a material in the standard fire test conducted in accordance with the requirements of ASTM E-119 standardized test.
- AutoCAD** - Commercially available Computer Aided Design (CAD) software used to display the plan views of a ship's compartmentation on each deck level.
- Barrier** - Any vertical or horizontal surface which tends to impede, slow, or stop the spread of heat, flames, and combustion products from one space to another. In a ship, barriers may be bulkheads (joiner, watertight, or structural), decks or overheads. See "Zero-Strength Barrier".
- Baseline Data Set** - Data sets identified as "Baseline" utilize input values to the SAFE program based on the physical condition of the ship found during the ship visit and are not influenced by any modifications or alterations which may be proposed as a result of an analysis. See "Alternative Data Set".

- Blackout** - The cessation of visible flaming (not to be mistaken for extinguishment which is the cessation of combustion).
- Bulkhead** - The equivalent in a ship to a wall in a building. Bulkheads can be structural or joiner, insulated or bare. They may be constructed of aluminum, steel, or composite such as marinite or nomex. Together with overheads, they serve to segment the ship into various compartments.
- CBO (minutes)** - Compartment Burnout - The point in the fire growth curve where complete consumption of all fuel due to pyrolysis occurs.
- Ceiling Point** - The point in growth of a compartment fire when the flames first touch or involve the ceiling.
- Cellulosics** - One of two classifications of fuel on board ship. Cellulosics are characterized as ash-producing; examples are wood, paper, and textile products. See "Fuel Load" and "Petro-Chemicals".
- Class A Fire** - A fire involving cellulosic type products (wood, cotton, paper, etc.) that produce ash as a combustion product. Water is the primary firefighting agent and extinguishes the fire by cooling the fuel below the ignition point. See "Class B Fire" and "Class C Fire".
- Class B Fire** - A fire involving flammable liquids (fuel oil, lube oil, gasoline, etc.) that burn vigorously without producing ash. AFFF is the primary firefighting agent and extinguishes the fire by smothering the fire with a thick layer of foam that floats on the surface of the fuel. See "Class A Fire" and "Class C Fire".
- Class C Fire** - A fire involving energized electrical equipment. Class C fires frequently involve class A or B fires as well. Electrical fires are usually extinguished when the electrical power to the affected equipment is secured, however the associated class A or class B fire may continue to burn. CO₂ is the primary firefighting agent and extinguishes the fire by smothering the fire without damaging electrical or electronic components. See "Class A Fire" and "Class B Fire".
- CO₂** - Carbon Dioxide. A firefighting agent particularly effective against class C fires.
- Combustion** - Rapid oxidation in which a fuel pyrolyzes or turns into a vapor and mixes with oxygen at an extremely rapid rate accompanied by the release of intense heat and light, visible as flames. See "Fire" and "Pyrolysis".
- Compartment** - An enclosed space in a ship usually identified with a unique identifying number consisting of deck, forward frame, relation to centerline, and a letter designating the function or type of compartment. See "Plan ID".
- Condition of Readiness** - One of three material conditions of readiness set by the Commanding Officer of a military ship. All accesses such as doors, hatches and scuttles, and other fittings having damage control value, are labeled X, Y, or Z. In condition "XRAY" all YOKE and ZEBRA accesses and fittings are open and those labeled XRAY are closed; in condition "YOKE" all ZEBRA accesses and fittings are open while those labeled XRAY and YOKE are closed; in condition "ZEBRA", all accesses and fittings are closed.

Configuration - The type of fire protection under consideration in a given fire scenario for a SAFE computer model run. Options include Passive only (I), Passive and Automatic Detection/Fixed Fire extinguishing (I and A), Passive and Manual suppression (I and M), or all three (I, A, and M)

CPB - 87' Coastal Patrol Boat, USCG.

CUI - Compartment Use Indicator - An abbreviated designation for a compartment selected from a list provided in SAFE used to define the type or function of the compartment and establish default values for various fire parameters.

Cum-L (%) - The accumulated probability that a fire will be limited (thus points on an "L-curve") in this or some previous compartment in a particular fire path. "1 - Cum L", therefore, is the probability that the fire will spread.

D-Adjust (%) - A user-specified parameter that can range from 0 to -99% to modify the D-bar values for a barrier. Usually used to account for deterioration of the barrier. An open door is not considered a derating of the barrier. See "D-bar".

Data Set - A data set describes those characteristics of a ship which affect its performance as a firesafety system. It includes information describing particular aspects of a compartment such as geometry, construction, fuel type and load, automatic detection and monitoring systems, ventilation and fire protection systems. See "Alternative Data Set" and "Baseline Data Set".

D-bar (%) - The probability of a durability failure of a barrier which would permit significant transfer of heat into the adjacent compartment.

Deck - The equivalent in a ship to a floor in a building. Decks can be continuous or stepped, insulated or bare. They can be constructed of aluminum, steel, or composite such as nomex. They can be covered with tile, carpet, or a poured floor covering such as terrazzo on one side and sheathing, insulation or both on the other. Together with overheads and bulkheads they serve to segment the ship into various compartments.

Destroyed Barrier - When a barrier is "destroyed" in a model run, heat from the burning compartment is transferred to the adjacent compartment if that room is not at full room involvement. The amount of heat transferred is a function of the barrier material and is referred to as residual heat transfer. See "Residual Heat Transfer".

Door - An opening through a bulkhead providing access to a compartment. If a door is open it is equivalent to a durability failure of the associated bulkhead.

Dur IAM (%) - The probability of terminating a fire originating in a compartment due to a durability barrier failure. The probability is calculated from a combination of the I, A, and M curves for that room. If the room is a room of origin, Dur IAM is not applicable.

EB - Established Burning - The point in the fire growth curve between ignition and FRI when the fire starts to grow exponentially with respect to time. In SAFE, it is assumed that this exponential growth varies with the 2nd power of time. EB is usually considered equivalent to a flame 10 inches high. EB also signifies the demarcation between fire prevention and the beginning of the ship's response to the fire.

EEBD - Emergency Escape Breathing Device. This self contained device provides 15 minutes of oxygen to an individual for the purpose of escaping from a fire.

Enclosure Point - The point in the fire growth curve where the fire starts to become influenced by a barrier.

Engineering Judgment - The assessment of risk in a probabilistic model utilizing subjective probabilities. In the SFSEM, engineering judgment is synonymous with an analyst's degree of belief. In this context an analyst is a domain knowledgeable individual whose judgment is augmented by all available data including results of deterministic computer models.

Extinguishment - The cessation of combustion (not to be confused with blackout which is the cessation of visible flaming.)

Failed Barrier - When a barrier has "failed" in a SAFE computer model run, EB is assumed in the adjacent compartment, if that room is not already burning. The failure mode is thermal (T-bar) if the barrier's $T\text{-bar} > D\text{-bar}$; conversely if $D\text{-bar} \geq T\text{-bar}$, the failure mode is D-bar.

FAL - Frequency of Acceptable Loss. The frequency with which a compartment can sustain a given Magnitude of Acceptable Loss (MAL). The FAL and MAL together establish the firesafety objectives (FSOs) for a given compartment. See "MAL" and "FSO".

FFS - Fire Free State. The status of a compartment relative to fire before ignition has occurred.

Fire - Combustion. Usually destructive and undesirable in a ship. See "Combustion" and "Pyrolysis".

Fire Growth Model - One of 16 models of fire growth defined in SAFE that may be selected by the user to describe the characteristics of the fuel load in a compartment. The fire growth model determines the fire growth coefficient, alpha, and the maximum heat release rate, Q_{max} . See "Alpha" and " Q_{max} ".

Fire Path - The sequential spread of fire from the compartment of origin through a failed barrier into an adjacent compartment, then through another barrier into another space and so on until the fire is limited. Multiple fire paths occur when failure of more than one barrier in a compartment permits the fire to spread into multiple compartments.

Firesafety System - A term used to address the overall performance of a ship as it relates to fire safety. It considers the ship as a whole and accounts for such things as compartment geometry, construction, fuel type and load, automatic detection and monitoring systems, ventilation and fire protection systems.

Flashover - A phenomena characteristic of compartment fires denoted by the rapid and sudden propagation of flame through the unburned gases and vapors collected at the top of the enclosure. Flashover is invariably accompanied by full room involvement (FRI). FRI conditions are untenable for humans without self-contained breathing devices.

FLLR - Flammable Liquid Line Rupture. A scenario used in SAFE to model a class B spray fire. The key user defined variables include the amount of fuel due to the rupture that is added to the compartment's fuel load, the room of origin and its associated FRI time and I value.

Frequency of EB (losses per compartment year) - A frequency based on historic fire casualty data compiled from data provided by the U.S. Naval Safety Center and the Coast Guard's MISREP mishap reporting system.

FRI - Full Room Involvement - The point in the fire growth curve when the temperature in a compartment has increased 500C above ambient. FRI conditions include surface burning of all combustibles and survival for unprotected personnel is not possible.

FRI Time (minutes) - The elapsed time from EB to FRI calculated in SAFE using the Peatross/Beyler algorithm. See "FRI".

FSAC - Fire Safety Analysis of Cutters. Project sponsored by the U.S. Coast Guard to analyze firesafety on cutters 180' and greater in length.

FSOs - Fire Safety Objectives - Performance standard, ideally established by cognizant authorities, for a compartment accounting for mission protection, property protection and life safety. The SFSEM is designed to analyze, quantify and compare the ship's performance as a firesafety system to achieve the established FSOs on a compartment basis. The FAL and MAL together establish the FSOs for a given compartment. See "FAL" and "MAL".

Fuel-Controlled Burning - When sufficient ventilation is available, fuel controlled burning will occur. The fire is limited by the fuel surface and fuel quantity available for combustion. See "Ventilation-Controlled Burning".

Fuel Load (BTU's/sq ft) - The total heat energy available for release from combustible materials in a compartment. In SAFE, fuel loads are expressed as fuel load density, where the total fuel load in a compartment is divided by the compartment area. Fuel loads are entered in SAFE for: cellulose, plastics, and petroleum-based flammable liquids. Cellulose and plastics are entered in lbs/sq ft while flammable liquids are entered as gallons. The heat energy content of cellulose is approximately 8000 BTU's/lb; plastics and flammable liquids are approximately 16000 Btu's/lb (flammable liquids are assumed to weigh 8 lbs/gallon).

FY - Fiscal Year (For example, FY96 is Oct. 1, 1995 to Sept. 30, 1996).

Halon - Halogenated Hydrocarbon. A firefighting agent particularly effective against all classes of fires, but presently banned from further production in accordance with the Montreal Protocol due to its atmospheric ozone-depleting characteristics.

Hatch - An opening through a deck providing access to a compartment. If a hatch greater than or equal to 400 square inches is open, it is equivalent to a durability failure of the associated barrier.

Heat Energy Impact (HEI) (kBTU's/sq ft) - The thermal heat flux to which the barrier is subjected during a fire. See "Pre-FRI Heat Release Rate" and "Post-FRI Heat Release Rate".

I-Curve - The resulting curve when I values for a compartment fire reaching the enclosure point, the ceiling point, and the room point are plotted on a graph with probability of flame

limitation on the ordinate axis (logarithmic scale), with the origin at the top left, and the area of fire involvement on the abscissa axis (linear scale). See "I-Value"

Ignition - Point in the fire growth curve that denotes the beginning of pyrolysis of combustible fuel.

Ign Mode - Ignition Mode. In SAFE one of three ways a compartment can reach EB: orig (as room of origin), therm (due to a thermal (T-bar) failure), or dur (due to a durability (D-bar) failure).

Intermediate Barrier Value (IBV) - The probability that the barrier will be successful in limiting the spread of fire. In SAFE, IBV is calculated as $IBV = P(FPC) * P(BF)$, where $P(FPC)$ is the probability of failure in limiting the fire in the previous compartment (1-Cum L in the previous compartment) and $P(BF)$ is the probability of this barrier failing to limit the fire ($1 - (T\text{-bar} + D\text{-bar})$).

I Value (%) - The probability that the fire will self-extinguish at some point between EB and FRI given that the fire was not extinguished by automated systems or by manual firefighting efforts. Each compartment is assigned three I-values: the probability of flame limitation given EB in the room of origin, the probability of flame limitation given EB has occurred in the room as a result of a thermal (T-bar) failure of a barrier, and the probability of flame limitation given EB has occurred in the room as a result of a durability (D-bar) failure of a barrier. In SAFE, these values are abbreviated OI, TI and DI respectively.

L-Curve - A graph which plots the cumulative probability of limiting the flame on the Y axis against time or some other suitable parameter on the X axis such as the number of rooms in a fire path or the deck area of a particular compartment. Convention calls for plotting 0 as the probability of limiting the flame at the top of the Y axis and 100% as the probability of limiting the flame on the X axis. See "cum-L"

L-Value (%) - The probability that a fire will be limited in a given compartment calculated from the I, A, and M values for that compartment.

MAL - Magnitude of Acceptable Loss - The severity of damage that can be tolerated in a compartment. FAL and MAL together establish the FSOs for a given compartment. See "FAL" and "FSOs".

Material ID - A three-character identifier to describe one of a compartment's barriers selected from the catalog of available barrier materials.

M-Curve - The resulting curve when M-values for increasing areas of a compartment are plotted on a graph with probability of flame limitation on the ordinate axis (logarithmic scale) with the origin at the top left and the deck area of the compartment on the abscissa axis (linear scale). See "M-Value".

M Value (%) - The probability that manual firefighting efforts will successfully extinguish the fire before FRI occurs given that the fire did not self-terminate and was not extinguished by automated fire protection systems. Each compartment is assigned three M-values: the probability of flame limitation given EB in the room of origin, the probability of flame limitation given EB has occurred in the room as a result of a thermal (T-bar) failure of a barrier, and the probability of flame limitation given EB has occurred in the room as a

result of a durability (D-bar) failure of a barrier. In SAFE, these values are abbreviated OM, TM and DM respectively

NFTI - Naval Firefighting Thermal Imager. A hand-held device used to locate the source of flames in a compartment by sensing the infrared thermal emissions in the space.

Non-Standard Scenario - Similar in all respects to a Standard Scenario except that it considers reduced levels of available fire protection systems.

NSTM - Naval Ship's Technical Manual. A set of regulations and guidelines issued by the U.S. Navy and frequently cited in U.S. Coast Guard regulations.

OBA - Oxygen Breathing Apparatus. A self contained device that supplies oxygen to facilitate firefighting in untenable atmospheres.

One-Shot Halon System - A total flooding system with the capability to completely flood the protected space one time with the required concentration level of Halon 1301.

Overhead - The equivalent in a ship to a ceiling in a building. Overheads can be continuous or stepped, insulated or bare. They can be constructed from steel, aluminum, or a composite material such as nomex or celotex. They can be covered with sheathing, insulation, or both on one side and covered with carpet, tile or a poured floor such as terrazzo on the other. Together with bulkheads, they serve to segment the ship into various compartments.

P-250 - A portable gasoline-powered pump used for firefighting and dewatering.

Passive Fire Protection - Fire protection features designed to limit flame movement by their presence alone. Barriers are the best example of passive fire protection, intumescent coatings, fire doors, fuel load distribution, and insulation of hot surfaces are other examples. See "Active Fire Protection".

Peatross/Beyler Algorithm - The algorithm used in SAFE, version 2.2, to calculate FRI-time for compartment fires. Primary variables include heat release rate, heat loss through the boundaries and the incoming air. See "FRI-Time".

Percent Monitored At Sea (%) - An estimate of the percentage of time around the clock while a ship is underway that a compartment is monitored to detect the presence of smoke and flames. Both personnel and fire/smoke/heat detectors can monitor a compartment.

Percent Monitored In Port (%) - An estimate of the percentage of time around the clock while a ship is in port that a compartment is monitored to detect the presence of smoke and flames. Both personnel and fire/smoke/heat detectors can monitor a compartment.

Petro-Chemicals - One of two classifications of fuel on ships. Petroleum-based chemical products are characterized by having twice the heat energy per pound than cellulose type of fuel. Examples of petro-chemicals include: flammable liquids and polymeric materials. See "Fuel Load and Cellulosics".

PKP - Potassium Bicarbonate. A dry chemical firefighting agent frequently used in portable fire extinguishers. The only authorized dry chemical portable fire extinguisher permitted on board Coast Guard Cutters.

Plan ID - A unique identifier for compartments as used in the Booklet of General Plans and other ship's drawings. The four fields that make up the identifier are: deck number, forward frame number, relationship to the centerline (1 for starboard, 2 for port, 0 for centerline), and compartment use indicator. Examples are 3-66-0-E, and 01-40-2-L.

Post-FRI Heat Release Rate (kW) - The rate that heat is released from the burning fuel in a compartment during the fully developed fire realm and calculated in accordance with the following expression: $Q = 1500 * A * H^5$. In SAFE, the ventilation factor, $A * H^5$, takes into account the height and area of all ventilation openings. Open doors, hatches, windows, etc. are assumed to be ventilation openings. The numerical coefficient, 1500, assumes stoichiometric burning conditions.

Pre-FRI Heat Release Rate (kW) - The rate that heat is released from the burning fuel in a compartment during the fire growth realm and calculated according to: $Q = \text{Alpha} * t^2$. The heat energy produced is used as a key variable in the Peatross/Beyler algorithm for calculating compartment fire temperatures; when the temperature exceeds ambient by 500 degrees Celsius, full room involvement (FRI) is assumed to exist in the compartment.

Pyrolysis - The conversion of solid fuel into flammable vapor through the application of heat.

Qmax - The maximum heat release rate value applied on a compartment-by-compartment basis. Qmax is the upper limit for Q in the Peatross/Beyler algorithm and is a function of the fire growth model. See "Fire Growth Model".

Radiation Point - The transition point between smoldering combustion and the point where a fire grows proportionally to the square of time. This point (beginning of exponential fire growth) is also referred to as Established Burning (EB) since this is the point where radiational feedback to the fuel bed becomes the predominant mode of heat transfer.

Relative Frequency of Acceptable Loss|Fire Free State - Relative Frequency of Acceptable Loss of a compartment given Fire Free State, calculated in SAFE by summing the probabilities of a target compartment or set failing to meet its FSOs over all fire paths, from all possible rooms of origin, multiplied by the frequency of EB in each room of origin.

Residual Heat Transfer (%) - The percentage of remaining thermal energy transferred from a burning compartment to an adjacent compartment due to a D-bar failure of the bulkhead. This transfer does not occur if the adjacent compartment is at full room involvement. This parameter is a function of the barrier material and can be found in the catalog of available barrier materials. Also referred to as the "Percent Heat Release".

RLF - Relative Loss Factor - RLFs are calculated in SAFE as a means of assessing whether a target compartment or set meets FSOs. A Relative Loss Factor > 1 indicates that a target compartment has failed to meet its FSOs. This factor is determined by multiplying the target's Relative Frequency of Acceptable Loss given Fire Free State of the target in failures/year (calculated during a given run of SAFE) by the assigned frequency of acceptable loss in years. A target is considered lost if its level of fire involvement in a given path exceeds the level specified by its MAL rating.

Room of Origin - The compartment in a fire path where EB first occurs.

Room Point - The point in the growth of a compartment fire where flames fully involve the compartment. See "Full Room Involvement".

SAFE - Ship Applied Fire Engineering - The computerized implementation of the SFSEM. SAFE is actually an integrated series of computer programs utilizing AutoCAD and the INFORMIX relational database management system

Scenario - A situation defined by the user before executing a SAFE probabilistic model run. Such parameters as run time, ship location, material condition of readiness and firefighting configuration are specified.

SCFP - Small Cutter Fire Protection. Project sponsored by the U.S. Coast Guard to analyze firesafety on cutters less than 180' in length.

SFSEM - The Ship Fire Safety Engineering Methodology. A probabilistic-based risk analysis methodology used to analyze all aspects of the ship's performance in response to a fire compared to pre-established FSOs.

Shell Plating - The ship's hull consisting of the underwater body and the freeboard Main Deck and below. The ship's superstructure is above the Main Deck. Shell plating can be steel or aluminum.

SHIPALT - Ship Alteration. A document that describes an authorized change to the configuration, compartmentation, or other major alteration to a ship. The purpose of SHIPALTS is to standardize the configuration of all ships in a class.

Ship Location - A ship is either "at sea" or "in port" for the purpose of setting up a model run in SAFE.

SLEP - Service Life Extension Program. A major overhaul that includes renewal and repair of the ship's hull, machinery, and equipment.

SOLAS - Safety of Life at Sea. An international convention, prompted by the Titanic disaster (amended several times since), that establishes international regulations for building ships to ensure passenger safety.

Standard Scenario - Scenarios that describe a ship's location and material condition of readiness with passive automated and manual fire protection capabilities in effect. Since this describes a ship under normal operating conditions, these scenarios are referred to as standard scenarios. See "Non-Standard Scenario"

Stepped Deck - That portion of a deck which is not in the same horizontal plane as the majority of the deck.

Stoichiometric - A term that describes ideal burning which assumes there is sufficient oxygen to ensure 100% combustion of available fuel. Stoichiometric burning produces the hottest fire temperatures, therefore sufficient ventilation to produce stoichiometric conditions is assumed in the SFSEM where fire protection systems should be designed for worst case conditions.

Superstructure - The ship's structure above the Main Deck. The superstructure can be steel or aluminum.

T-Adjust (%) - A value that can range from 0 to -99% that is applied to the T-bar value of a specified barrier to account for cracks or other flaws that would reduce its ability to resist a thermal or hot spot failure. An open door or window is not considered a derating of the barrier.

Target - A compartment or set of compartments which are analyzed in a probabilistic model run for the frequency and magnitude of fire loss due to fires started in every possible room of origin. A target set of compartments may be selected because they contain components necessary to perform a ship's mission. In this manner the likelihood of mission failure can be ascertained.

T-bar (%) - The probability of a thermal failure of a barrier which would permit a small, hot spot ignition in the adjacent compartment.

Therm IAM (%) - The probability of terminating a fire originating in a compartment due to a thermal barrier failure. The probability is calculated from a combination of the I, A, and M curves for that room. If the room is a room of origin, Therm IAM is not applicable.

Two-Shot Halon System - A total flooding system with the capability to completely flood the protected space two times with the required concentration level of Halon 1301. This system is designed such that each shot of Halon is released from a different location in the vessel.

USCGC - United States Coast Guard Cutter

Vent Area (sq in) - The sum of all the ventilation openings in a compartment, excluding doors and hatches but including ventilation grates in a door. Used to calculate the post-FRI heat release rate. See "Post-FRI Heat Release Rate".

Vent Height (in) - The average of the vertical height of all vent openings in a compartment. The height of the compartment itself is used for horizontal vents.

Ventilation Controlled Burning - When insufficient ventilation is available, ventilation controlled burning occurs. The fire is limited by the air supply available for combustion. See "Fuel Controlled Burning".

Ventilation Factor - A factor, $A \cdot H^{0.5}$, that describes the primary variables in the post-FRI heat release rate calculation in SAFE. These variables are the area and height of the ventilation opening(s) in a compartment. In compartments with multiple vents, areas are summed and heights are averaged.

WLB (R) - Seagoing Buoy Tender. The "R" indicates that this is a replacement for an existing class of buoy tender.

WLM (R) - Coastal Buoy Tender. The "R" indicates that this is a replacement for an existing class of buoy tender.

XRAY, YOKE and ZEBRA - Material Conditions of Readiness. Successively increasing levels of watertight integrity for controlling damage. At each level, additional access closures, valves and fittings are required to be closed to limit fire and flooding.

Zero-Strength Barrier - An imaginary boundary used to model extremely long passageways and multiple deck compartments. The barrier is presumed to have no thermal resistance.

EXECUTIVE SUMMARY

This report documents the results of a comprehensive fire safety analysis of the 180' WLB Seagoing Buoy Tender class as part of the Fire Safety Analysis of Cutters project. The Coast Guard selected the CGC HORNBEAM (WLB 394), Cape May, NJ, as representative of the class to be analyzed. Prior to this project, a fire safety analysis was also conducted of the CGC JUNIPER, the first vessel in the 225' WLB (R) class.

The Ship Fire Safety Engineering Methodology (SFSEM) and Ship Applied Fire Engineering (SAFE v2.2) computer program were utilized as an analytical tool to perform the analysis. The SFSEM is a probabilistic based fire risk analysis methodology, which provides an integrated framework for analyzing fires on ships in comparison to established Fire Safety Objectives (FSO). The SFSEM accounts for all relevant aspects of fire safety including the growth and spread of fire, the effectiveness of passive design features such as barriers, and active fire protection features such as fixed and portable fire extinguishing systems, as well as manual fire suppression.

SAFE implements the SFSEM and evaluates the probability of spaces and barriers limiting a fire. The evaluation is conducted on a compartment-by-compartment basis. SAFE calculates the probable paths of fire spread for a user-specified time duration. SFSEM/SAFE has been successfully used in the past to analyze the fire safety design of existing, as well as, proposed ships.

SAFE input data were based on information collected during a ship visit to the CGC HORNBEAM during the period 26-27 August 1996 and a previous ship visit to the HORNBEAM on October 5, 1995. In addition to collecting information necessary to develop the input data to run SAFE, a fire safety audit was conducted during the ship visits. The fire detection system consists of spot type ionization smoke detectors located in the berthing areas only and is not tied to a central alarm panel. Additionally, Auxiliary Machinery Space #3 may be accessed via ladders from the Generator Room and the Motor Room. Although there is a hatch at the top of the ladder from the Motor Room, only a smoke curtain exists at the top of the ladder in the Generator Room. A steel joiner door installed at the top of the ladder to the Generator Room would serve to help contain fires originating in the Generator Room or the Auxiliary Machinery Space #3 to the room of origin.

Baseline fire safety analysis results in previously analyzed cutters indicate that fire protection levels in most compartments, with passive, automated, and manual fire protection features in effect, generally meet fire safety objectives. Results of the baseline fire safety analysis of the 180' WLB are consistent with these results and are in agreement with historical records for fires in U.S. Coast Guard cutters. With just passive fire protection in effect (without considering automated or manual fire protection), the 180' WLB exceeds its fire safety objectives in every compartment. The passive fire protection in this cutter is remarkably good due to the effective use of compartmentation to segregate engineering spaces and due to the fact that most of the bulkheads in this cutter are steel. The cutter's automated and manual fire protection features minimally increase the margin of safety provided by the excellent passive protection throughout this cutter.

By exercising the various output options available in SAFE, insight into probable rooms of fire origin and the sequence of compartments that are likely to be involved in fire paths from these rooms may be obtained. Results indicate that the most probable rooms of origin for fires that may spread to involve multiple compartments are the Motor Room, Auxiliary Machinery Space #3, Linen Locker and Cleaning Gear Locker. A careful analysis of the results from the various output options in SAFE documented in this report may be effectively used to develop realistic fire scenarios to assist the crew in planning firefighting training drills.

Two issues were studied in the analysis-of-alternatives phase of this project. First, the effect of bulkhead insulation on fire safety was studied. Second, the results of the fire safety analysis of the JUNIPER class Seagoing Buoy Tender were compared to the results of the fire safety analysis of HORNBEAM. The following are the major conclusions from this phase of the project:

- The effect of insulating only watertight bulkheads is negligible on fire safety.
- Insulation added to steel bulkheads has a relatively small beneficial effect on fire safety in HORNBEAM.
- The relatively good baseline results are attributed in part to the fact that most of the bulkheads in the HORNBEAM are steel.
- With passive and active fire protection in effect, all compartments exceed fire safety objectives by a substantial margin in JUNIPER and by a very substantial margin in HORNBEAM.
- Whereas automated and manual fire protection have a negligible effect on fire safety levels of HORNBEAM, they make a very significant contribution in JUNIPER.
- Passive fire protection in JUNIPER must be augmented by automated fire protection systems for all compartments to exceed FSOs. In HORNBEAM all compartments exceed FSOs by a very substantial margin with just passive fire protection in effect.
- HORNBEAM lacks the sophisticated fire detection system and the automated fire protection systems installed in JUNIPER, however the excellent, passive fire protection inherent in HORNBEAM's design and compartmentation overcomes the lack of these systems.

The appendices in this report include the AutoCAD drawings and comprehensive tables of input data used to populate the baseline data set in SAFE. The detailed spreadsheets for calculating the probabilities of flame termination are provided as supporting data. Target, barrier, and path output options from the SAFE analysis are also documented. The input and output data from the bulkhead insulation study conducted in conjunction with the analysis-of-alternatives phase are provided. Finally, the Methodology for Assigning Probabilities of Flame Termination is documented, along with supporting information concerning fire growth factors and network diagrams used to perform the calculations in the flame movement module in SAFE.

BLANK

1. INTRODUCTION

1.1. BACKGROUND

The U.S. Coast Guard operates a large fleet of buoy tenders to maintain an extensive system of floating and fixed aids to navigation in the navigable waters of the United States including harbors, rivers, and coastal regions. The fleet includes 180' WLB Seagoing Buoy Tenders, 157' and 133' WLM Coastal Buoy Tenders, and a variety of construction and river tenders that operate on the "western" rivers such as the Mississippi, Missouri, and Ohio Rivers as well as selected bays and harbors such as the Chesapeake Bay. The fleet is geographically dispersed over the Atlantic and Pacific seaboard, Alaska, Hawaii, the Gulf of Mexico and the Great Lakes.

The Coast Guard has awarded two contracts to Marinette Marine Shipyard, Marinette, WI, to design and build a replacement class of buoy tenders for the aging 180' WLB Seagoing Buoy Tender and the 157' WLM Coastal Buoy Tender. "WLB (R)" is the designation for the replacement Seagoing Buoy Tender. "WLM (R)" is the designation for the replacement Coastal Buoy Tender. Marinette has built and delivered the CGC JUNIPER as the first WLB (R) and the CGC IDA LEWIS as the first WLM (R). The JUNIPER class buoy tender is 225' long and the IDA LEWIS class buoy tender is 175' long. The process of replacing all of the existing buoy tenders will take several years as the new cutters are built and delivered.

A fire safety analysis was conducted of the IDA LEWIS as part of the Small Cutter Fire Protection (SCFP) project. [1] A fire safety analysis was also conducted of the JUNIPER for the Independent Operational Test and Evaluation Staff. [2] The results of these analyses clearly demonstrated the utility of analyzing the fire safety design early in the construction of the lead cutter in a new class of ships. The Coast Guard initiated a fire safety analysis of the existing 180' WLB class of cutters as part of the Fire Safety Analysis of Cutters (FSAC) project. Results of this analysis is documented in this report.

The Coast Guard initiated the SCFP project to thoroughly analyze the fire safety of ten classes of small cutters (less than 180' in length) and produce a tailored fire protection doctrine for each small cutter. The scope of the SCFP project included the 82' Point Class Patrol Boat, 110' Surface Effect Ship, 110' Island Class Patrol Boat, 65' Harbor Tugboat, and several classes of buoy tenders (including the 175' WLM (R) class) in the Coast Guard fleet. The FSAC project was initiated by the Coast Guard to thoroughly analyze the fire safety of large cutters. The scope of the FSAC project includes cutters 180' and greater, such as the 180' Seagoing Buoy Tender, 210', and 270' Medium Endurance Cutters.

The technical approach in the SCFP and FSAC projects specifies the use of the Ship Fire Safety Engineering Method (SFSEM) as the analytical tool to evaluate shipboard fire safety. The SFSEM is a probabilistic-based risk analysis methodology which provides an integrated framework to account for all relevant aspects of shipboard fire protection. The Theoretical Basis of the SFSEM provides a comprehensive discussion of the SFSEM. [3] The SFSEM is designed to evaluate the ship's performance compared to pre-established fire safety objectives (FSO). The methodology quantifies the contribution of passive and active fire protection systems, thus it provides a means for analyzing and comparing hypothetical design alternatives to improve the

overall fire protection on the cutter as necessary. SAFE, version 2.2, is a series of integrated computer programs which automate the numerous calculations required. In addition, various output options are available in SAFE that permit a detailed analysis of compartment and barrier performance. Appropriate documentation is available in the SAFE User Manual, version 2.2. [4]

As noted in the final report for the SCFP project, the following features of the SFSEM have been clearly demonstrated: [5]

- utility to analyze existing ships, as well as proposed designs
- ability to identify problem compartments which fail to meet fire safety objectives
- capability to analyze the effectiveness of hypothetical design alternatives

Therefore, the SFSEM was again specified as the analytical tool to evaluate the fire safety of the 180' WLB Seagoing Buoy Tender in the FSAC project.

1.2. SCOPE

The scope of this project is limited to analyzing the fire safety of the 180' WLB Seagoing Buoy Tender class. There are approximately three subclasses in the WLB class. Most of the cutters in this class have completed either a Major Renovation, Minor Renovation, or Service Life Extension Program (SLEP). The primary difference in these various programs concerns the scope of repairs, overhaul, and renewals of the ship's hull, machinery and equipment. The installed and portable fire protection systems and equipment are considered similar in all three sub-classes. However, there are some differences in the compartmentation of the three sub-classes. The differences between sub-classes are not considered substantial enough to make a significant difference in the outcome of the fire safety analysis. The CGC HORNBEAM (WLB-394) has completed a Major Renovation and was selected by the Coast Guard as representative of the 180' WLB class, thus this ship was used as the basis for this study.

A complete fire safety analysis would optimally include a detailed study of flame movement, smoke movement, people movement, and an analysis of the structural ability of the vessel to withstand fire. Since the SFSEM was specified for use as the analytical tool to evaluate fire safety, a quantitative analysis of flame movement is feasible, however the smoke movement, people movement, and structural analysis modules have not yet been developed and integrated into the methodology. Therefore, to the extent possible, qualitative analyses of these additional aspects of fire safety have been provided in this study.

1.3. OBJECTIVES

The primary objective established for this project is to thoroughly evaluate the fire safety design of the 180' WLB. In this context, "fire safety design" includes the compartmentation, outfitting and construction materials, fire detection and suppression systems, fixed and portable firefighting equipment, and any other aspect of the proposed design that pertains to fire safety. This analysis was based on information collected during ship visits to the CGC HORNBEAM in October 1995 and August 1996. The 180' WLB was studied in its normal operating configuration, in port and at sea, with a full complement of outfit and crew. It is assumed that the ship is intact, and not subject to fires resulting from enemy action or arson. The "at sea" fire scenarios assume that the full crew complement of 54 persons are on board, awake, and alert.

The "in port" fire scenarios are assumed to occur at night when the normal 8-person duty section is on board. In addition, a minimum number of other personnel may also be on board at night in port.

1.4. TECHNICAL APPROACH

This project was organized into five sequential phases:

1. Conduct a ship visit of the CGC HORNBEAM, Cape May, NJ.
2. Document factual input data and develop subjective input data.
3. Perform baseline fire safety analysis using the SFSEM/SAFE.
4. Analyze alternatives using the SFSEM/SAFE.
5. Prepare final report.

The first phase included a preliminary, one-day ship visit on October 5, 1995 and a more thorough two-day ship visit on August 26-27, 1996. During these two visits various documentation was collected such as the ship's compartment check-off lists, casualty control manual, and machinery space firefighting doctrine. This documentation provides valuable information concerning the location of installed and portable fire protection equipment, damage control classifications of closures such as doors and windows, and manual firefighting procedures in port and at sea. This phase also included modeling the compartmentation in AutoCAD as a necessary prerequisite for using the SFSEM and its related computer programs, SAFE, which implement the Method. The second phase involved developing subjective input data such as probabilities of flame termination and documenting the factual input data such as fuel loads and ventilation details. After all input data was entered into SAFE, a thorough review of the baseline fire safety levels of the 180' WLB using the SFSEM/SAFE was performed in phase three. All available output options were used to thoroughly evaluate compartment and barrier performance. The individual target option provided relative loss factors which are a relative comparison of compartment loss compared to the fire safety objectives established for each compartment. The barrier option helped to identify the most probable rooms of origin which cause multiple room fire paths. The path option provided the data which identifies the most probable fire paths from selected rooms of origin. Phase four included analyzing alternatives such as the effect of bulkhead insulation in a fire safety analysis using the SFSEM/SAFE. In addition, a comparison of fire safety analysis results between the 180' WLB and 225' JUNIPER class Buoy Tender was performed in phase four. Finally, the results of the entire study were documented in the final technical report compiled in phase five.

1.5. FIRE SAFETY ANALYSIS PROCEDURE

The fire safety analysis of the 180' WLB was conducted in two major steps:

- Fire Safety Audit. The five phases in the life cycle of a fire were examined during the fire safety audit. These phases include prevention, detection, containment, extinguishment and post-extinguishment. Information and documentation were also collected to identify and determine the input data needed to run SAFE.

- Detailed Fire Safety Analysis using SFSEM/SAFE. The SFSEM/SAFE was used to perform a detailed fire safety analysis of existing "baseline" fire protection levels.

The following sections will address the various aspects of these two steps which are used to analyze fire safety on the 180' WLB.

1.5.1. FIRE SAFETY AUDIT

Information required to conduct the fire safety audit is collected during the ship visit. If a ship visit is not feasible, this information is obtained from ship's drawings and other written documentation that may be available. The fire safety audit is conducted to identify existing passive and active fire protection features and procedures, determine fuel loads and any unusual fire hazards, and to evaluate the accessibility of compartments for firefighting and egress routes for personnel. When possible, a fire drill is observed to assess the characteristic time it takes to set ZEBRA and to enable the analyst to assess manual firefighting effectiveness. The cutter's Machinery Space Firefighting Doctrine, Casualty Control Manual, Compartment Check-off Lists, Repair Locker Inventory and other critical information regarding the cutter's firefighting procedures are collected and reviewed if they are available. The results of this review are organized according to the phases in the life cycle of a fire commencing with prevention, and proceeding through detection, containment, extinguishment, and post-extinguishment. The objectives of these five phases are briefly discussed in the following sections.

1.5.1.1. Prevention

The four basic principles of fire prevention which should be observed routinely to reduce the incidence of shipboard fires are:

1. Frequent inspections
2. Proper stowage of combustibles (housekeeping)
3. Training and education
4. Enforcement of fire prevention policies and practices such as good housekeeping

The fire prevention phase also includes first aid or the initial attempts to extinguish a fire after ignition occurs but before the fire grows substantially beyond the point described as established burning (EB). The 180' WLB was examined for adherence to the four principles described above and to identify procedures and equipment the ship routinely uses for first aid.

1.5.1.2. Detection

There are two ways a fire can be detected on board ship - by a crew member or by an installed monitoring device. Coast Guard cutters are typically equipped with heat and/or smoke detectors in berthing areas, engineering spaces, offices, storerooms and other areas where early warning of fires is deemed beneficial. In some Coast Guard cutters, these detectors are wired to a central alarm panel installed on the Bridge and a slave panel installed on the quarterdeck and sometimes in the Engineering Control Center. If the cutter has a large number of compartments, several compartments are usually tied together into a common zone on the alarm panel. The disadvantage to this method is that further investigation is required to determine which compartment in the zone contains the actual fire. On some other cutters, the detectors are not

wired to a central alarm panel; typically these are battery powered and sound an alarm only in the space where the fire is detected. The design of the detection system, the type and sensitivity of the detectors installed, the location of detectors, and the reliability of the system are some of the factors considered in determining the probability of detection; thus the details concerning the installed detection system are carefully studied during the fire safety analysis.

1.5.1.3. Containment

It is desirable to contain the fire within the room of origin to minimize the damage throughout the vessel. Containment of a fire can be accomplished through passive and/or active means. Passive measures include adequacy of compartmentation, use of non-combustible construction materials, and control of quantity, type and distribution of fuel loads. Active measures include setting condition ZEBRA, and securing ventilation, fuel and electrical power in the affected spaces. All bulkheads and decks which serve as barriers to contain a fire are studied to determine their adequacy for this purpose. The location of isolation valves, remote shutdowns, and fire dampers are also determined and considered in the fire safety analysis.

1.5.1.4. Extinguishment

Extinguishment requires appropriate firefighting equipment in strategic locations, adequate protective equipment and clothing for firefighters, and personnel adequately trained to operate the equipment and work as a team. Firefighting equipment includes both manually operated and automatic/automated systems. Protective equipment and clothing include emergency escape breathing devices, oxygen breathing apparatuses (OBA), firefighting ensembles, flash gear, etc., and hand held detection devices such as a firefinder or the naval firefighting thermal imager (NFTI). The location, type, size, and number of firefighting equipment is studied to determine its adequacy for the typical hazards noted during the ship visit.

1.5.1.5. Post-Extinguishment

Post-extinguishment activities include desmoking, reinstating a safe and healthy atmosphere in affected compartments, and restoring ship's vital systems such as weapons systems, navigation, propulsion, and electrical generating equipment. Thus red devil blowers, atmospheric testing gear, casualty power cables, and so forth are examined to determine if the crew has adequate equipment to rapidly restore vital systems following a fire incident.

1.5.2. DETAILED FIRE SAFETY ANALYSIS

A nine step procedure for conducting a detailed fire safety analysis using the SFSEM/SAFE has been developed and refined over the course of conducting previous similar analyses. Prior to conducting the analysis, it is necessary to convert the ship's general arrangement drawings to an AutoCAD rendition. Once the ship has been modeled in AutoCAD, the following procedure is used to perform a detailed fire safety analysis:

1. Load Database with Ship's Geometry
2. Conduct Ship Visit
3. Load SAFE Input Values

4. Calculate FRI Times and Post-FRI Heat Release Rates
5. Run Probabilistic Model
6. Analyze Baseline Results
7. Analyze Alternatives
8. Conduct Cost-Benefit Analysis
9. Document Results

These steps are discussed briefly in the following sections.

1.5.2.1. Load Database with Ship's Geometry

The simple, yet accurate, representation of the ship's geometry created in AutoCAD is utilized by the connectivity generator in SAFE to produce a listing of all compartments on the ship. Also produced is a listing of each compartment's barriers and individual connections to other compartments or to the weather. Once these lists have been verified for accuracy, they are loaded into SAFE's database and ship visit forms are produced.

1.5.2.2. Conduct Ship Visit

The SFSEM/SAFE requires an extensive amount of data to facilitate an analysis of the cutter's fire safety. Preprinted ship visit forms ensure the information concerning fuel loads, compartmentation, ventilation, fire safety objectives (FSOs) and other required data is collected in an efficient manner. This information is also used by the engineer/analyst to temper the engineering judgment required to develop the probabilistic values entered into SAFE. The quality of the fire safety analysis is directly proportional to the quality and completeness of the information collected either during the ship visit or from written documentation, drawings, and other information sources.

1.5.2.3. Load SAFE Input Values

This step includes refining the ship's geometry with any new information gathered during the ship visit, determining all required fire parameters, performing the data entry of the information on the ship visit forms and verifying the accuracy of the entered data. The values now in the database comprise the "baseline data set" for the ship. This baseline data set permits discrimination from data associated with hypothetical alternatives that may be analyzed later in the analysis.

1.5.2.4. Calculate FRI Times And Post-FRI Heat Release Rates

Flashover is the sudden propagation of flames through the unburned gases and vapors collected at the top of the compartment. Flashover invariably leads to full room involvement (FRI) conditions where the majority of combustible surfaces are burning and conditions for life are untenable without self-contained breathing devices and thermal protective clothing. FRI time, or the elapsed time from EB to Full Room Involvement (FRI), is a very important parameter in fire growth. After all input values have been assigned, FRI times and post-FRI heat release rates are calculated for each compartment. FRI times may be reviewed and adjusted, or input values used to calculate FRI may be adjusted and FRI recalculated. FRI times are calculated in SAFE in

accordance with the Peatross/Beyler algorithm. [6] Basically, this algorithm calculates the time in minutes for the temperature in a compartment to rise 500 degrees Celsius above ambient.

The variables in the post-FRI heat release rate calculation are included in the ventilation factor: $A \cdot H^{0.5}$. This factor takes into account the height and area of a single vertical ventilation opening which is providing natural (unforced) ventilation. The coefficient for this variable is based on the worst-case assumption of stoichiometric combustion. Some ship compartments are served by multiple vents and frequently use forced ventilation through horizontal vents; thus, determining vent opening height becomes problematic. The Theoretical Basis of the SFSEM provides an explanation how SAFE deals with multiple and horizontal vent openings. [3]

1.5.2.5. Run Probabilistic Model

Once the database has been loaded with all required input, the probabilistic model is run on the baseline data set to establish the baseline fire safety levels of the ship. Several parameters have to be specified in order to run the model. These parameters are specified in "scenarios" and include: material condition of readiness (XRAY or YOKE), ship location (in port or at sea), firefighting configuration (passive (I), automated (A), and/or manual (M)), simulation run time (in minutes), and barrier failure criteria (best case or worst case). The Theoretical Basis of the SFSEM and SAFE User Manual, version 2.2, provide detailed explanations for these parameters and scenarios. [3, 4]

1.5.2.6. Analyze Baseline Results

The objective of the detailed fire safety analysis is to quantify the level of fire safety associated with the existing ship. To facilitate discussion, this result is referred to as the "baseline". Baseline Data Sets reflect input values to the SAFE program which are based on the physical condition of the ship and not influenced by any modifications or alterations which may be proposed as a result of this analysis.

The baseline analysis is designed to identify compartments which fail to meet FSOs (or significantly exceed their FSOs) so that attention can be focused on these compartments. Ideally, multiple hypothetical alternatives can be identified and studied to improve the fire safety to minimally acceptable levels where appropriate. A cost-benefit analysis may then be conducted to form the basis for recommendations.

The results of using the individual target option with the standard scenarios on the baseline data set are carefully examined to determine how well the ship performs as a fire safety system in response to a fire. This is accomplished by examining relative loss factors (RLF) for "target" compartments. RLFs greater than 1.0 indicate the target compartment failed to meet the FSOs established for that compartment and an improvement in fire protection is needed. A target compartment with a RLF equal to 1.0 indicates the compartment exactly meets its FSOs. A target with a RLF less than 1.0 indicates the compartment exceeds its FSOs and a reduction in fire protection may be acceptable.

Note that the results from the individual target option focus on the target compartments which do not meet their FSOs, they do not provide any insight as to the primary sources of the fires that ultimately caused the loss of the targets. Determining the source, or cause for each failed compartment may involve running the probabilistic model with different output options such

as the barrier or path options. For example, the detailed reports from the target option, barrier option, and path option may yield information that many of the fire paths that ultimately involve the target compartment actually originate in another compartment. Thus improving the fire protection in the appropriate room of origin may improve the results in the target compartment as well as the room of origin.

1.5.2.7. Analyze Alternatives

To determine ways to improve the fire safety of compartments which fail to meet FSOs, or less typically, to determine ways to reduce fire safety in over-protected compartments, hypothetical alternatives may be efficiently analyzed using the SFSEM/SAFE. An alternative data set modifies the parameters of the baseline data set such that it represents the conditions that would be in effect if that alternative reflected actual conditions on the cutter.

This step usually involves analyzing alternatives to identify improvements in compartments which fail to achieve FSOs. In those cases where the baseline fire safety levels exceed FSOs by a substantial margin in all compartments for all scenarios, no improvements would be necessary. In these cases this step can still serve a useful purpose. For example, certain features of the existing fire safety design may be hypothetically removed so that the effect on fire safety can be demonstrated and perhaps justify a recommendation to eliminate "over-protection". Other "alternatives" that may be studied include certain fire safety features that would achieve the sponsor's objectives. For example, the sponsor may want to study the effect of one parameter on fire safety or an equivalent firefighting agent, even though acceptable FSOs are being achieved.

1.5.2.8. Conduct Cost-Benefit Analysis

If multiple alternatives are identified, a cost-benefit analysis may be conducted to recommend the most cost effective alternative. Moreover, a weight-benefit or volume-benefit analysis may be substituted for the cost-benefit analysis depending on the sponsor's objectives. In either event, the "benefit" is quantified by the improvement in the RLFs. The "cost" should take into account the direct and indirect costs of implementing the change. Weight, volume, and price are examples of direct costs while inconvenience to the crew, effects on the environment, or impact on other missions are examples of indirect costs.

1.5.2.9. Document Results

The final report documents the results of the baseline analysis and consideration of all alternatives. Reports from SAFE that were generated are included as appendices to provide supporting data. Graphic reports from SAFE (including color-graphics) may significantly enhance the report. For example SAFE can generate deck plans which portray compartments which fail to meet FSOs in red, while compartments colored yellow, green or blue are progressively "safer".

1.6. ORGANIZATION OF REPORT

Section 2 of this report discusses historical fire records that pertain to U. S. Coast Guard cutters of similar length and complexity to a 180' WLB class buoy tender as well as the process used to establish the frequency of EB in various types of compartments. The results of the fire safety audit and the baseline fire safety analysis of the 180' WLB are discussed in section 3. Results from the various output options identified certain compartments which are more likely to

be rooms of origin than other compartments in the ship. Consequently a discussion is included in section 3 concerning probable fire paths from these rooms of origin. Section 4 discusses the analysis of alternatives phase of the project. In this section the effect of bulkhead insulation is studied. In addition, the results of the fire safety analyses of the 180' WLB are compared to the results of the fire safety analysis of the 225' JUNIPER class buoy tender. Section 5 provides the conclusions and recommendations that were developed as a result of the fire safety analysis accomplished in this project. Appendix A includes plan views of all decks in the 180' WLB Seagoing Buoy Tender (Major Ren). Appendix B is the documentation of all input data that comprises the baseline data set. Appendix C contains the detailed baseline fire safety analysis results generated by running the individual target option as well as the barrier and path options on selected rooms of origin. Appendix D contains the SAFE input data and the target option output results from the analysis of alternatives phase of the project. Appendix E contains the methodology used to establish the probabilities of flame termination. Appendix F provides a detailed explanation of the network diagrams associated with the SFSEM which are used for calculating probabilities of flame termination. Appendix G describes the various fire growth factors that the engineer's takes into account while assigning probabilities to the subfactors in network diagrams for flame movement analysis.

2. HISTORICAL RECORDS OF FIRE

2.1. FREQUENCY OF ESTABLISHED BURNING

Fire safety analyses of Coast Guard Cutters to date have utilized historical records to establish the frequency of established burning (EB) since adequate data from the U.S. Naval Safety Center and U.S. Coast Guard Headquarters is available for each type of compartment aboard a cutter. Military ships, including Coast Guard Cutters, are required to report all fires that result in damage or personal injury. This provides the opportunity to utilize historical records to determine the frequency of EB.

Historical reports of fires on all classes of Coast Guard Cutters were obtained from the Commandant (G-KSE-4), U.S. Coast Guard, for the period FY87-FY91. This data was combined with data received from the U.S. Naval Safety Center on 21 classes of large naval vessels during the period 1975 through 1986 to refine the reported fire frequencies. For the purposes of the SFSEM, similar compartments were grouped by compartment use indicator (CUI). CUI categories were adapted from the standard nomenclature used by the Coast Guard and Navy to identify compartment usage. Some CUIs were further subdivided in order to permit a more accurate assignment of reported fire frequency. Based on experience, it is estimated that approximately half of all fires which reach EB do little or no damage to the vessel and result in no injuries to personnel; thus they may go unreported. As a result, the "reported frequency of EB" based on historical data is doubled and called "adjusted fire frequency" to account for unreported fires. The number of fires reported and adjusted fire frequency values from the combined Navy and Coast Guard data is shown in Table 2.1 grouped according to CUI.

Note that the Main Propulsion Mechanical (EM) and Emergency Auxiliary Generator Rooms (QE) exhibit adjusted fire frequencies which are orders of magnitude greater than other compartments. This fact has a substantial impact on the results of a fire safety analysis using the SFSEM.

Table 2.1 Fire Frequency Data

Type of Compartment	Compartment Use Indicator (CUI)	Number of Fires Reported	Adjusted Fire Frequency (1) (Fires per Compt Year)
Cargo Hold	AA	0 (2)	0.0001 (3)
Gear Locker	AG	19	0.0010
Refrigerated Storage	AR	3	0.0009
Storeroom	AS	34	0.0009
Ship Control Area	C	4	0.0012
Main Propulsion Electrical (4)	EE	7	0.0031
Main Propulsion Mechanical	EM	148	0.0272
Fuel Oil, Lube Oil Tank	F	0 (2)	0.0001 (3)
JP-5 Fuel Tank	J	0 (2)	0.0001 (3)
Hazardous Material Storage	K	4	0.0013
Berthing Space	L1, L2, L5	20	0.0008
Wardroom, Mess, Lounge Space	LL	7	0.0008
Medical, Dental Space (4)	LM	0	0.0001
Passageway, Staircase, Vestibule	LP	3	0.0001
Sanitary Space	LW	4	0.0002
Explosives Storage	M	1	0.0001
Auxiliary Machine Space (4)	QA	89	0.0029
Emergency Aux. Generator Room (4)	QE	23	0.0204
Fan Room	QF	7	0.0004
Galley Pantry, Scullery	QG	13	0.0026
Helicopter Hangar	QH	3	0.0036
Laundry	QL	5	0.0031
Office Space (4)	QO	5	0.0004
Shops, Labs	QS	15	0.0018
Trunk, Hoist, Dumbwaiter	TH	0 (2)	0.0001
Stack, Uptake	TU	5	0.0013
Void, Cofferdam	V	1	0.0001 (3)
Water, Peak, Ballast Tank	W	1 (2)	0.0004

NOTES:

1. Taken as twice the reported fire frequency
2. Based on 1986 - 1991 USCG data only. (All other numbers of fires based on both USN and USCG data.)
3. Default value used in cases where no fires have been reported, or when calculated adjusted frequency is below 0.00005
4. New compartment types added since analysis of first three small cutters in the SCFP project

2.2. HISTORICAL RECORDS OF FIRES ON COAST GUARD CUTTERS

The Coast Guard MISREP database was researched for historical records of reported fires by all Coast Guard Cutters during the period FY87 through FY91. Commandant (G-KSE-4) data included reports of 29 fires and 2 explosions over the five year period on cutters that represent 95% of the Coast Guard fleet. Three of the 31 fires/explosions (10%) occurred in 378' High Endurance Cutters; 13 fires/explosions (42%) occurred in 210' and 270' Medium Endurance Cutters, 180' Seagoing Buoy Tenders, and 140' Icebreaking Tugboats; the remaining 15 (48%) occurred in small cutters ranging from 65' Harbor Tugboats to 110' Island Class Patrol Boats, and Construction Tenders.

The data provided by the Commandant (G-KSE-4) was also analyzed to obtain information such as the frequency that arson is a problem, the frequency of fires that spread to other compartments from the room of origin, the class of fires that most frequently occur, the type of compartment where high dollar loss fires occur, etc. This analysis revealed the following:

- The breakdown of the 29 fires show that 18 were class A, 4 were class B, 5 were class C and there were 2 unknown class fires.
- Most reported fires were relatively minor. Only 7 fires resulted in damage exceeding \$1,000. There were no deaths, 6 minor injuries, and 25 fires with no injuries.
- Arson was not considered a factor in any reported fire.
- Most reported fires were quickly extinguished by the crew (90% within five minutes). Only three reported fires took longer than five minutes to extinguish. 93% of all reported fires were contained within the room of origin.
- Additional mishap data provided by Commandant (G-KSE-4) shows that the majority of high dollar loss fires originate in Engine Rooms.
- 42% of the fires occurred in port, 29% underway, 23% during a Yard period, and 6% unknown. Note the period of time a vessel was undergoing FRAM, SLEP or MMA was excluded.

3. FIRE SAFETY ANALYSIS OF THE 180' WLB

The objective of this project is to evaluate the fire safety of the 180' WLB Seagoing Buoy Tender class. The basic technical approach includes an analysis of the cutter's fire protection compared to its fire safety objectives using the Ship Fire Safety Engineering Method (SFSEM) as the computer-based analytical tool. This section of the report will discuss the results of the fire safety audit and the detailed fire safety analyses of the 180' WLB using the SFSEM.

The following sections of this report will address the specific fire safety analysis results organized as follows:

- Fire Safety Audit. A fire safety audit is performed in conjunction with the ship visits to the CGC HORNBEAM and a review of their drawings and pertinent documentation available to the analysis team.
- SAFE Input Data. The sources for the factual and subjective input data needed to run SAFE are documented in this section.
- Baseline Fire Safety Analysis. The SFSEM/SAFE is used to perform the fire safety analysis based on the baseline data set populated with data determined from the ship visits, ship's drawings, compartment check-off lists, HORNBEAM's Casualty Control Manual and Machinery Space Firefighting Doctrine.

3.1. FIRE SAFETY AUDIT

The fire safety audit of the 180' WLB is based on a review of the following documentation and other information relevant to the fire safety design of the cutter:

- 180' WLB (Major Renovation) Drawings, provided by the U.S. Coast Guard (see Appendix A to this report)
- CGC HORNBEAM INSTRUCTION M9555.1B dated 22 March 1995, Machinery Space Firefighting Doctrine for Class Bravo Fires [7]
- CGC HORNBEAM Compartment Check-Off Lists
- Report of the CGC HORNBEAM Ship Visit on October 5, 1995 dated October 14, 1995 [8]
- Report of the CGC HORNBEAM Ship Visit on August 26-27, 1996 dated September 3, 1996 [9]

The results of the fire safety audit are presented in the following sections organized according to the life cycle stages of a fire incident that starts with prevention and evolves through detection, containment, extinguishment, and post-extinguishment.

3.1.1. PREVENTION

The following conditions were noted that directly affect this cutter's ability to successfully prevent a fire:

- HORNBEAM is approximately 50 years old, however it is evident that the crew displays pride in their ship and they maintain the vessel in a remarkably clean and neat condition. For

example, no buildup of grease or oil was noted in the bilges or on the machinery in the engineering spaces. Good housekeeping practices are a major factor in preventing unwanted ignitions.

- Other than the fuel stowed for portable pumps, on-board stowage of flammable liquids is limited to the Paint Locker, 1-FP-0-K, which is equipped with a thermal rate-of-rise detector and associated automated CO₂ total flooding fire extinguishing system.
- Smoking is not permitted anywhere inside the ship.
- The type, location, and quantity of portable fire extinguishers installed is shown in Table B.5 in Appendix B. The types of extinguishers installed and their location are considered appropriate to deal with the anticipated fire threat.

The compartmentation was reviewed to determine if adequate means of egress exist for crew members to escape from a fire and to assess the ability of the crew to access each compartment for the purpose of firefighting. The existing compartmentation appears to be adequate to permit egress from all normally occupied spaces. There is adequate access for firefighting to all compartments where a significant fire is likely to occur.

3.1.2. DETECTION

As shown in Table B.4 in Appendix B, only berthing areas and staterooms are equipped with "stick-up", battery-powered, ionization type smoke detectors installed on the overhead. In addition there is a heat detector installed in the Paint Locker. There are no smoke, flame or heat detectors installed in any other space including engineering spaces, storerooms, offices, shops, Galley, etc. None of the existing detectors is wired to a central alarm system. The input values for the percent time monitored for each compartment are based on the estimated time around the clock a compartment is monitored by persons in the crew or by an automatic detector. The normal value of 95% for percent time monitored in compartments protected by automatic detectors was lowered to 90% to reflect the fact that the detectors on HORNBEAM are not wired to a central alarm panel. In addition, they are also less reliable because batteries in detectors must be systematically checked and replaced if low on a regular basis. Crew notification of the fire is one of several factors used in the calculation of the probabilities of automated and manual flame termination. The presence of automatic detectors increases the probability that the crew will be notified of a fire. Table B.4 in Appendix B lists the location, quantity, and type of detectors installed in each compartment; in addition the percent time monitored established for each compartment is shown as well as the estimated minutes to detection. This estimate is actually a calculated output from SAFE as described in Chapter V, sections H.1 and H.2, of the SAFE User Manual [4] which takes into account the time to set ZEBRA throughout the ship and the percent time monitored for each compartment.

The "old" compartment numbering system is used throughout the HORNBEAM. For example the Paint Locker is designated A-101-A, as opposed to 1-FP-0-K in the "new" numbering system. One advantage of the new numbering system is instant identification of the forward frame number of the compartment. This enables the compartment to be located rapidly - even for crew members unfamiliar with the ship. SAFE, requires identification of the compartments using the new numbering system, therefore appropriate compartment numbers

were generated using the new numbering system. Consideration should be given to switching all references to compartment numbers in the ship to the new numbering system.

3.1.3. CONTAINMENT

A very effective means for containing the fire to the room of origin is the inherent ability of non-combustible compartment boundaries to resist the spread of fire and smoke. Open doors quickly compromise the ability of compartmentation to contain fire or smoke. Therefore it is assumed that open joiner doors as well as watertight doors and hatches labeled XRAY, YOKE, and ZEBRA are closed in a timely manner when condition ZEBRA is set in response to a fire. In addition, securing ventilation is an extremely important factor in containing fire and smoke. The ship's Machinery Space Firefighting Doctrine describes the ship's procedures for controlling ventilation to limit the spread of smoke. The damage control classification of doors and hatches was noted during the ship visit and is documented in the ship's compartment check-off lists. The classifications (shown in Appendix B, Table B.2) are considered in accordance with NSTM 079. [10].

As shown in Appendix A, the compartmentation on HORNBEAM is especially conducive to preventing the spread of smoke and flame especially from the engineering spaces on the Hold Deck and Second Deck. For example, The Bow Thruster Room has Fresh Water Tanks aft and the Forepeak Tank forward; the Generator Room has Diesel Oil Tanks aft and two passageways, Fruits & Vegetables and the MAA Locker forward; and the Main Motor Room has Diesel Oil Tanks forward and a Fresh Water Tank aft. This effective use of compartmentation undoubtedly serves to prevent the spread of flames fore and aft from engineering spaces which historically have been a primary source of fires that spread to involve multiple rooms.

The Auxiliary Machinery Space #3 is located above and between the Motor Room and Generator Room and contains the emergency diesel generator. This space is accessed by open steel ladders from the Motor Room and the Generator Room. A smoke curtain is installed at the top of the ladder in the Generator Room and a large watertight hatch labeled XRAY is installed at the top of the ladder in the Motor Room. Consideration should be given to replacing the smoke curtain with a steel joiner door at the top of the ladder to the Generator Room. This would serve to help contain fires originating in the Generator Room or the Auxiliary Machinery Space #3 to the room of origin.

3.1.4. EXTINGUISHMENT

The following firefighting systems and equipment are installed in the 180' WLB:

- The firemain system is supplied by two electric fire pumps. The fire main and fire stations are designed such that any part of the 180' WLB can be reached from at least two fire stations with a single 50' length of fire hose. Some fire stations are equipped with AFFF in-line eductors and sufficient quantities of AFFF concentrate such that a continuous flow of AFFF can be provided in the major engineering spaces with a class B fire threat and/or provide for reentry.
- Two P-250 portable fire pumps are available for firefighting and dewatering.
- The Generator Room is equipped with a 50ft portable AFFF hose reel system.

- A fixed CO₂ total flooding system is installed in the Paint Locker.
- An aqueous potassium carbonate firefighting system is installed to extinguish grease fires in the Galley.
- The magazines are protected by a sea water sprinkling system. Only small arms and 50 cal ammunition is stored in the magazines since the 3" gun has been permanently removed.
- Portable CO₂ and PKP fire extinguishers are installed throughout the cutter.

The above list indicates that this cutter is equipped with adequate quantities and appropriate types of automated and manual fire extinguishment equipment for responding to fire emergencies in most of the spaces on the vessel. In comparison to other Coast Guard cutter classes previously analyzed however, there is a notable lack of automated fire extinguishing systems in this ship. As shown in Table B.5 in Appendix B, the Bow Thruster Room is presently equipped with three CO₂ portable fire extinguishers. Due to the class B fire threat in this space, substituting one PKP portable fire extinguisher for one of the CO₂ portable fire extinguishers should be considered. In addition, consideration should be given to installing one PKP portable fire extinguisher in the Steering Gear Space as well.

3.1.5. POST-EXTINGUISHMENT

The HORNBEAM is equipped with adequate means to desmoke compartments and test the atmosphere in affected compartments for the presence of oxygen and toxic gases. In addition, the ship is equipped with adequate tools, supplies, and repair parts to efficiently restore vital ship's systems following a fire incident.

3.2. SAFE INPUT DATA

The baseline analysis is founded on information collected and observed during the ship visit. This section of the report presents a discussion concerning the input data needed to run SAFE.

There are two general types of input data required for SAFE, factual and subjective. Factual data includes:

- type, location, and condition of bulkhead and deck materials
- compartment deck area and height
- type, location, and quantity of automated and manual fire protection equipment
- type, location, and quantity of smoke, flame and heat detectors
- size and orientation of ventilation duct openings (exhaust and supply) and other ventilation openings
- estimates of cellulose, plastics, and flammable liquid fuel loads

Subjective data is established based on engineering judgment, default values, and comparisons to similar parameters on other ships. This data includes:

- probabilities of flame termination

- fire safety objectives
- percent time monitored for each compartment
- applicable fire growth models

The following sections provide additional information concerning input data collected or determined for the 180' WLB fire safety analysis categorized into factual and subjective input data.

3.2.1. FACTUAL INPUT DATA

Factual data is observed during the ship visit, determined from drawings and official documentation, or it is based on default values, rules of thumb and certain assumptions. Factual data also includes estimated data. For example it would be possible to exactly determine a compartment's fuel load by weighing each combustible. Since this is impractical, fuel loads are estimated based on engineering judgment and using rules of thumb determined from experience gained in numerous ship visits. The following sections describe the factual (and estimated) input data. Subjective input data which is based on engineering judgment is then discussed.

3.2.1.1. Ship's Geometry

The ship's drawings were converted into a three-dimension rendition using AutoCAD, Release 13. Each compartment shown on the Booklet of General Plans for a Major Ren cutter provided by the Coast Guard was assigned a Compartment Use Indicator (CUI). Most of the default values established in SAFE are based on CUI. Since some of the input data for the 180' WLB relies on default values, CUI assignments are particularly important. Type and location of bulkhead and deck materials are based on observations during the ship visits and are documented in Appendix B, Table B.2. [8, 9] Compartment height and deck area are determined from the AutoCAD drawings and shown in Appendix B, Table B.1.1.

3.2.1.2. Automated and Manual Fire Protection Systems

The location, type, and quantity of installed and portable fire protection systems were obtained from the ship visits and the Machinery Space Firefighting Doctrine. [7, 8, 9] This information is recorded in Appendix B, Table B.5. The Paint Locker is protected with a fixed CO₂ total flooding system. The Galley stove is protected by an aqueous potassium carbonate system. Portable CO₂ and PKP fire extinguishers are located throughout the cutter. Finally firemain stations are installed throughout the cutter; some stations include AFFF reentry capability.

3.2.1.3. Fire Detection System

The location, type, and quantity of installed fire detectors were observed during the ship visits. [8, 9] The type and quantity of all installed fire and smoke detectors are shown in Appendix B, Table B.4, including the calculated time to detection.

3.2.1.4. Ventilation

The size and orientation of both ventilation duct and other openings in each compartment were observed during the ship visits. [8, 9] The ventilation input data including area and average height of all ventilation openings in each compartment for the baseline analysis of the 180' WLB are documented in Appendix B, Table B.1.2.

3.2.1.5. Fuel Loads

Estimates of cellulose, plastics, and flammable liquid fuel loads, documented in Appendix B, Table B.7 were based on fuel loads observed in each compartment during the ship visits. [8, 9]

3.2.2. SUBJECTIVE INPUT DATA

Engineering judgment expresses an experienced and knowledgeable person's degree of belief. The SFSEM is a probabilistic-based fire risk analysis methodology. Engineering judgment is therefore appropriate for:

- determining the likelihood that a fire will be terminated in a given compartment
- assigning firesafety objectives
- establishing other important parameters needed to run SAFE as discussed in the following sections

3.2.2.1. Probabilities of Flame Termination

Probabilities of flame termination are documented in Appendix B, Tables B.6.1 and B.6.2 for in port and at sea scenarios respectively. SAFE default values were used extensively, especially for the probabilities of flame termination in compartments entered as a result of a thermal or massive failure of a barrier. Probabilities of passive, automated, and manual means of flame termination for each compartment given EB in that compartment were determined in accordance with the methodology documented in Appendix E. These probabilities were calculated using network diagrams as described in Appendix F. Probabilities were assigned to each of the subfactors at the lowest level of detail for I, A, and M values as described in Appendix G, Fire Growth Factors, and in the Theoretical Basis of the SFSEM. [3] For example, the following illustrates how the "A-Value" of 0.71 was determined as the probability of flame termination by automated means in the Paint Locker protected by an installed CO₂ flooding system:

Probability of Notification (An)

$$A_n = d_{an} * n_{an} * s_{an} = 0.95 * 0.99 * 0.99 = 0.93 \text{ where:}$$

d_{an} = probability of detection

n_{an} = notification of Pilot House

s_{an} = sound the alarm

Probability of Preparation (Ap)

$$A_p = f_{ap} * v_{ap} * p_{ap} = 1.00 * 1.00 * 1.00 = 1.00 \text{ where:}$$

fap = securing the fuel supply to internal combustion engines in the space

vap = securing the ventilation fans in the space

pap = securing the electrical power in the space

Probability of Agent Application (Ap)

$$Aa = saa * aaa * daa = 0.99 * 0.95 * 0.90 = 0.85 \text{ where}$$

saa = automated system is properly aligned for operation

aaa = agent discharges from the nozzle(s)

daa = agent discharges on the fire

Probability of Fire Extinguishment (Ae)

$$Ae = qae * cae * bae = 1.00 * 1.00 * 0.90 = 0.90 \text{ where}$$

qae = quantity of agent is adequate

cae = concentration of agent is adequate

bae = blackout occurs

Probability of Flame Termination by Automated Means (A)

$$A = An * Ap * Aa * Ae = 0.93 * 1.00 * 0.85 * 0.90 = 0.71$$

3.2.2.2. Fire Safety Objectives

In order to analyze the performance of a ship as a fire safety system, there must be acceptable performance standards or criteria established by cognizant authorities. These criteria are referred to as Fire Safety Objectives (FSOs). The development of FSOs should take into consideration life safety, property protection and mission impairment. Ideally, FSOs are established by owners or cognizant authorities who have been delegated responsibility for the management of ship operations and who are knowledgeable of fire protection engineering principles. In the Coast Guard, cognizant authorities are the appropriate program and support managers in Coast Guard Headquarters. In the absence of such input, FSOs were established by the engineer/analyst using the process described in this section. **Approval of this report implies concurrence with the FSOs established herein.**

FSOs are designed to establish the performance standard for a fire safety system taking into account all aspects of fire including flame movement, smoke movement, people movement (egress for the occupants), and the ability of the structure to withstand the fire's assault. In the SFSEM, smoke movement, people movement, and structural analysis modules are not yet fully developed, therefore the FSOs are presently established considering flame movement only.

FSOs were established for the 180' WLB for each compartment utilizing the so-called traditional approach. It is the approach used over the past ten years in the fire safety analysis of fourteen classes of Coast Guard Cutters. A number of limitations and drawbacks have been identified with the traditional approach, and there has been some discussion concerning the practicality and validity of establishing FSOs on a compartment basis. [11, 12] Even with these

minor concerns, the traditional approach has merit and is considered a valid approach. The following paragraphs describe the traditional approach in more detail.

FSOs are established for each compartment in the cutter that may be analyzed by SAFE. Currently, magazines, flammable liquid tanks, and helicopter hangars are not analyzed due to the inability of SAFE to deal with explosion hazards. All other compartments are rated for both Magnitude of Acceptable Loss (MAL) and Frequency of Acceptable Loss (FAL). The MAL is established by assigning a rating to each of the following four factors for each compartment and then weighting these factors to determine an overall rating for the compartment:

- Life Safety (LS)
- Property Protection (PP)
- Primary Mission (PM)
- Secondary Mission (SM)

The weighting factors are different for each module in the SFSEM. For example, in the flame movement module, damage from flames affects the primary mission of the ship more than it causes life safety concerns. Whereas considering the effects of smoke, life safety will be the primary concern compared to property damage. Thus the weighting factors for the four factors are adjusted for each module in the SFSEM. The weighting factors used to assign a MAL rating to each compartment in the 180' WLB considering flame movement only are shown in the following expression:

$$\text{MAL} = 0.1 * \text{LS} + 0.3 * \text{PP} + 0.4 * \text{PM} + 0.2 * \text{SM}$$

The MAL rating for each factor (LS, PP, PM, & SM) is permitted to be one of the following four integer values:

- Established Burning (EB) is not acceptable..... 1
- EB is acceptable but Full Room Involvement (FRI) is not..... 2
- FRI is acceptable but Compartment Burnout (CBO) is not..... 3
- CBO is acceptable..... 4

A MAL rating is assigned to each factor for each compartment, then the overall MAL rating is calculated according to the algebraic expression shown above and the truncated MAL rating is assigned to the compartment. For example, if the results of the calculation is 3.37, a MAL of 3 is assigned.

The ratings are assigned for each factor using engineering judgment and considering the effect flame movement has on each factor. Compartments whose total loss (CBO) would not significantly affect the ship's primary or secondary mission are typically assigned a rating of 4 for factors PM and SM. For example, most sanitary spaces, gear lockers, passageways, voids, water tanks, ladders, cofferdams, and certain storerooms, if totally lost, would not prevent the ship from performing its primary or secondary mission. Note, a compartment may contain a significant fuel

load and contribute materially to the spread of a fire, but if its loss does not significantly affect the ship's mission, it receives a rating of 4. At the other extreme, flammable materials storage lockers, paint lockers, and other compartments containing extremely flammable materials representing a significant fire hazard are normally assigned a rating of 1 for the factors PM and SM.

The balance of the compartments are normally assigned a rating of 2 or 3 for the factors PM and SM. In general, if the compartment contains equipment vital to the ship's primary or secondary mission, and if its loss would likely result in the ship aborting its patrol and returning to homeport for repairs, it would be assigned a 2. On the other hand, if the compartment's loss would degrade, but not prevent, the ship's ability to perform its mission, it would receive a 3 rating. Examples of compartments typically rated 2 for the factors PM or SM are the Engine Room, Bridge, and Galley. Berthing Areas, Ship's Offices and Labs/Workshops are typically assigned a 3 rating for the factors PM and SM. Note, if a compartment would normally be assigned a MAL of 4 for PM and SM factors, but it contains wiring that serves vital systems or equipment in other spaces, the MAL rating for the PM and SM factors are assigned to match the rating assigned to those spaces which contain the vital systems or equipment.

The cost to replace a compartment's contents (machinery and outfit) is the primary consideration for assigning a rating to the property protection (PP) factor. Obviously, Engineering Spaces such as the Engine Room, Emergency Generator Room, Auxiliary Machinery Rooms contain very expensive machinery not only from an acquisition point of view but the costs involved for the labor to install and align the equipment is significant as well. Thus these spaces are typically assigned a rating of 2 for the PP factor. A rating of 1 is assigned to spaces such as paint lockers and flammable materials storage lockers for the property protection factor due to the additional property damage that would undoubtedly occur in other adjacent spaces. A rating of 4 is assigned for the PP factor to those spaces whose total loss would be considered minimal (compared to other spaces). Finally, a rating of 3 is assigned for the PP factor to those compartments whose cost is not minimal but is considered far less than major engineering spaces. Examples of spaces assigned a 3 rating for the PP factor include the Galley, Scullery and spaces with some minor machinery such as sewage machinery spaces and potable water equipment rooms.

Ratings for the life safety (LS) factor take into account the likelihood that personnel will be injured by the fire (not by the smoke or toxic gases). This probability is affected by the likelihood that the space will be occupied, the accessibility of the space, the quantity of personnel likely to be in the space, and the likelihood that the occupants will be sleeping. Thus spaces such as the Paint Locker where personnel would be in danger even if EB occurs are assigned a rating of 1 for the LS factor. If EB can occur but personnel are not likely to be in serious danger unless FRI occurs receive a rating of 2 for the LS factor. If FRI can be tolerated but the entire compartment would have to be lost before personnel are in danger of being injured, a rating of 3 would be appropriate for the LS factor. Finally, if a compartment can be totally lost and still not endanger personnel, a rating of 4 can be assigned to the LS factor. After a rating has been assigned to all four factors the overall MAL rating for the compartment is calculated. This value is then used in the calculation for the Frequency of Acceptable Loss (FAL) as described in the next paragraph.

The FAL is related to the MAL. For example, it may be considered acceptable to lose a compartment with a MAL = 4 once a year but compartments with a MAL = 1 may be lost only once in a ship's lifetime (30 years). Based on MAL and FAL ratings established by engineering judgment for similar compartments in several classes of cutters, a correlation between MAL and FAL was determined by fitting a curve to the data points. The following algebraic relationship expresses this correlation and is used to establish the FAL based on the non-truncated MAL rating for each compartment:

$$FAL = 32.25 - (1.766 * MAL) - (0.214 * MAL^2) - (0.222 * MAL^3)$$

The FSOs established for the 180' WLB using the traditional approach described above are tabulated in Appendix B in Table B.3.

3.2.2.3. Percent Time Monitored

The time to detect a fire is a function of the percent time a compartment is monitored. There are two possible ways a compartment can be monitored: by the ship's crew or by an installed smoke, heat, or flame detector. In compartments monitored by an installed detector that is wired to a central alarm panel, 95% is normally assigned (99% in the event of multiple detectors) as the percent time the compartment is monitored both in port and at sea. This value reflects the reliability expected with this type of detection system. Since the detectors in HORNBEAM are not wired to a central alarm panel and are battery operated/powered, the percent time monitored was lowered to 90% for those few compartments which have detectors. In other compartments, not protected by detectors, engineering judgment was utilized to estimate the percentage of time around the clock a particular compartment is expected to be monitored (visited) by a crew member. The percentage of time each compartment is monitored in port and at sea is documented in Appendix B, Table B.4.

3.2.2.4. Fire Growth Models

There are 16 fire growth models in SAFE that describe the nature and distribution of fuel packages. The model selected pre-determines two extremely important fire growth parameters: alpha and Qmax. Alpha is the fire growth coefficient in the heat release rate formula in the pre-FRI fire growth regime. Qmax describes the maximum heat release rate that is permitted regardless of the fuel load. These parameters in the fire growth models were based on empirical data collected in full scale tests. These tests were conducted in warehouses, basements, and other non-shipboard scenarios. Consequently many of the available fire growth models are a poor match to shipboard conditions, however, their application in SAFE are considered to give conservative results. Fire growth models were assigned based on observations during the ship visits of the fuel loads in each compartment. [8, 9] Fire growth models selected for the 180' WLB are documented in Appendix B, Table B.8.

3.3. BASELINE FIRE SAFETY ANALYSIS RESULTS

The SFSEM was used to conduct the baseline analysis of the 180' WLB following the nine step fire safety analysis procedure used in previous analyses of other cutters. The following sections discuss each of these steps in sequence.

3.3.1. LOAD DATABASE WITH SHIP'S GEOMETRY

The compartmentation shown in the 180' WLB Major Ren drawings provided by the Coast Guard was modeled in AutoCAD. The drawings thus produced in AutoCAD for each deck level are shown in Appendix A. Information concerning the deck area and compartment height is tabulated in Appendix B, Table B.1.1.

3.3.2. CONDUCT SHIP VISIT

The ship visits on the HORNBEAM were conducted during a one day visit on October 5, 1995 and during a two-day visit on August 26-27, 1996. Results from these visits were documented for use in the preparation of SAFE input data. [8, 9]

3.3.3. LOAD SAFE INPUT VALUES

SAFE input values that were used in the baseline analysis are documented in Appendix B. This data was based on the best available information collected from all sources including the ship visits, drawings, and written documentation. [8, 9]

3.3.4. CALCULATE FRI TIMES AND POST-FRI HEAT RELEASE RATES

The Post-FRI heat release rates (Q) and FRI times are calculated in SAFE. These fire parameters are tabulated for each compartment in Appendix B, Table B.8. The algorithms for these calculations are described in the Theoretical Basis of the SFSEM [3].

FRI time is a critically important fire parameter because it determines the length of time between EB and the development of sufficiently high compartment temperatures that full room involvement conditions are expected. When FRI is achieved, conditions in the compartment are assumed to be incapable of supporting life and the heat energy of the burning fuel is assumed to begin impacting the barriers. Therefore, if FRI is infinite (or greater than 60 minutes for practical purposes) the fire will be limited to the compartment. On the other hand if FRI is very short (for example, two or three minutes) there may be little chance that the fire party can respond quickly enough to extinguish the fire in the compartment unless there is little fuel load. In this event, the available fuel may be consumed quickly and the fire may be easily extinguished by the fire party. The ability to achieve FRI is dependent on ventilation. Stoichiometric burning conditions are assumed to exist in each compartment. In an actual ship many compartments may be rendered relatively air-tight, thus this is a conservative assumption. A review of the calculated FRI times tabulated in Appendix B, Table B.8 show expected results for all compartments.

3.3.5. RUN PROBABILISTIC MODEL

The individual target option was specified as an output option for running the probabilistic model in the fire safety analyses of previous cutters as well as the 180' WLB. This option permits

a rapid comparison of each compartment as a target compartment compared to pre-established fire safety objectives for fires that may originate in any compartment. In other words it provides a means to identify "victims" of fires which may start in any compartment (including the target) and ultimately involve the target compartment. Results of the baseline fire safety analysis with the individual target option run on the baseline data set is documented in Appendix C, Individual Target Option - Summary Level Report and discussed in section 3.3.6.1 of this report. These results do not however, provide a great deal of insight into the primary source compartments for fires that ultimately result in the loss of target compartments. Furthermore, a careful review of results achieved in previous analyses revealed that the target compartments with the highest RLFs (most frequently lost compared to FSOs) were not the engineering spaces which have the highest frequency of EB. This result seemed counter-intuitive and prompted a thorough review of the algorithm associated with this output option in SAFE.

The review of the individual target option revealed that the algorithm requires independent fire paths to accurately accumulate results for the calculation of RLFs. The methodology, however, models the real world which, in general, does not produce independent fire paths. Thus, the algorithm calculates imprecise, albeit conservative, RLFs. Results are more accurate for engineering spaces and less accurate for other spaces causing them to have higher-than-actual RLFs (less fire safe). Since these results do not lend any insight into the primary sources of fires, the probabilistic model was also run specifying the barrier output option to obtain information relative to sources of fires. Results of the baseline fire safety analysis with the barrier option run on the baseline data set is documented in Appendix C, Barrier Option - Summary Level Report. These results indicate that the barriers in the Motor Room (4-126-0-E), Auxiliary Machinery Space #3 (1-112-0-Q), Linen Locker (1-157-2-Q), and Cleaning Gear Locker (1-161-2-Q) are more likely to fail and are more likely to fail earlier than barriers in other compartments, therefore these compartments are considered the most likely sources of fires that may spread to involve multiple compartments in the 180' WLB. These results are discussed in more detail in section 3.3.6.2 of this report.

A review of the individual target option results provides insight into the performance of target compartments and a review of the barrier option provides insight into the sources of fires. By identifying probable fire paths (for one or two compartments beyond the room of origin) from likely rooms of origin, the crew can enhance their ability to develop realistic fire drill scenarios for training purposes. Accordingly, the results of the barrier option was used to help select probable rooms of origin and the path option in SAFE was run with these compartments selected as the rooms of origin. Results of the baseline fire safety analysis with the path option run on the baseline data set is documented in Appendix C, Path Option - Summary Level Report, and Path Option - Detail Level Report and discussed in section 3.3.6.3 of this report.

3.3.6. ANALYZE BASELINE RESULTS

The complete baseline results for the 180' WLB are documented in Appendix C in the form of summary level and detail level reports specifying the following output options in SAFE:

- Individual Target Option - Summary Level Report (all 12 standard and non standard scenarios)
- Barrier Option - Summary Level Report (YOKE, At Sea, I, A, & M scenario)

- Path Option - Summary Level Report (YOKE, At Sea, I scenario for the following rooms of origin: Motor Room, Auxiliary Machinery Space #3, Linen Locker and Cleaning Gear Locker)
- Path Option - Detail Level Report (YOKE, At Sea, I scenario for the following rooms of origin: Motor Room, Auxiliary Machinery Space #3, Linen Locker and Cleaning Gear Locker)

The following summarizes some of the basic assumptions made in SAFE and by the analyst that affect the results of the fire safety analysis:

- FRI times are based on a rise of ambient temperatures in the compartment of 500 degrees Celsius.
- Rate of heat release in the pre-FRI fire growth regime is based on an “alpha-T- squared” fire growth curve.
- Rate of heat release in the post-FRI fire growth regime is calculated according to the following formula: $1500 * A * H^{0.5}$ (stoichiometric combustion conditions).
- The Ingberg conversion is used for the determination of heat energy impact on the barriers. Moreover this heat energy is assumed to impact the barriers only after FRI is achieved.
- Fire paths are assumed to be independent in the individual target option. Since actual fire paths are dependent, the results predict target compartments are not as safe as they actually are.
- In a fire, ventilation fans are usually secured. Significantly less air can flow through the ductwork than the natural vent opening assumed in the calculations.
- Based on the reliability of the detection system, it is assumed that fire will be detected with 90% certainty in compartments protected by a single detector.
- An unimpaired, fully trained 54-person crew is assumed to be on board underway. A fully manned and trained 8-person in port duty section is on board in port with all persons in the repair party fully qualified for their roles.

The net effect of these assumptions on the results is considered conservative. In other words it is believed that the fire safety of this ship is actually better (safer) than results indicate.

3.3.6.1. Individual Target Option

An excerpt from the individual target option results are shown in Tables 3.1, 3.2, and 3.3 and list all compartments with RLFs greater than or equal to 0.02 and a MAL of 1, 2, or 3 in scenario 1. These three tables summarize the most interesting results of the baseline analysis. The RLFs shown in Table 3.1 for the two in port scenarios (XRAY and YOKE) are very similar. This indicates that there are relatively few doors, scuttles and hatches labeled YOKE. A review of the access classifications in Appendix B, Table B.2 reveals that there are only four doors classified YOKE (no hatches or scuttles). Thus little difference between the two in port scenarios is to be expected.

A small portion of the differences in the two YOKE scenarios, in port and at sea (scenarios 2 and 3), shown in Table 3.1 may be attributed to the difference in the percent (time) monitored for each compartment in port and at sea as documented in Appendix B, Table B.4. In general, it is more likely that a crew member will discover a fire earlier at sea than in port due to the higher manning levels at sea. Therefore, lower RLFs (safer ship) are expected for at sea scenarios than in port scenarios. The fact that there is very little difference between the two YOKE scenarios shown in Table 3.1 is attributed to the fact that the relative contribution of automated (A) and manual (M) suppression is very small, therefore the results are largely attributable to passive (I) protection only. Since there is virtually no difference in passive protection at sea and in port, very little difference is expected in results between the two YOKE scenarios.

A review of the baseline fire safety analysis results clearly show that with passive (I), automated (A), and manual (M) fire protection in effect, all compartments in the 180' WLB exceed FSOs by a very substantial margin, in port and at sea. This means that no improvements are necessarily required to bring the 180' WLB up to minimally acceptable fire safety levels.

Table 3.2 compares varying levels of fire protection for the in port, XRAY scenario. As expected, the RLFs increase with decreasing levels of fire protection. The results also show that the rank ordering of compartments from most dangerous (highest RLF) to safest (lowest RLF) is approximately the same among the four scenarios. As shown in Table 3.2, all compartments exceed FSOs with I & A in effect, with I & M in effect, and with just I in effect. Therefore it is clear that neither automated or manual fire extinguishment are required to augment passive fire protection in order for the 180' WLB to meet fire safety objectives in port. A comparison of results between I only and I & M clearly shows the minimal contribution of manual firefighting efforts to the overall fire safety of the ship. Similarly there is no significant improvement between I only and I & A in RLFs for all target compartments. This result is attributed to the fact that only two compartments (other than magazines which are not analyzed) are protected by an automated system, the Galley and the Paint Locker. The very slight increase between I & A and I, A, & M again is due to the very slight improvement added by manual firefighting efforts. In summary, the 180' WLB exceeds fire safety objectives in port for all compartments, without considering the contribution of automated and manual firefighting.

Table 3.3 compares varying levels of fire protection for the at sea, YOKE scenario. As expected, the RLFs increase with decreasing levels of fire protection. The results also show that the rank ordering of compartments from most dangerous (highest RLF) to safest (lowest RLF) is approximately the same as for in port conditions. The reason for this is the fact that probabilities of passive (I) and automated (A) means of limiting the flames are the same in port and at sea. As shown in Table 3.3, all compartments exceed FSOs with I & A in effect, with I & M in effect, and with just I in effect. Therefore it is clear that neither automated or manual fire extinguishment are required to augment passive fire protection in order for the 180' WLB to meet fire safety objectives at sea. A comparison of results between I only and I & M shows a very small contribution of manual firefighting efforts to the overall fire safety of the ship. Similarly, there is only a slight improvement between I only and I & A in RLFs for all compartments due to the lack of automated systems installed in the ship. The increase between I & A and I, A, & M again is due to the significant contribution by manual firefighting efforts. In summary, the 180' WLB

exceeds fire safety objectives at sea for all compartments, without considering the contribution of automated and manual firefighting.

Table 3.1
RELATIVE LOSS FACTORS

Plan ID	Compartment Name	CUJ	MAL	FAL	Run 10-58 Scenario 1 Xray, In Port	Run 10-62 Scenario 2 Yoke, In Port	Run 9-52 Scenario 3 Yoke, At Sea
3-9-0-E	BOW THRUSTER ROOM	EM	2	26	0.21	0.21	0.21
01-102-0-E	VENT & UPTAKE SPACE	TU	2	23	0.20	0.20	0.19
1-112-0-Q	AUXILIARY MACHINERY SPACE #3	QA	2	26	0.15	0.15	0.15
4-126-0-E	MAIN MOTOR ROOM	EE	2	26	0.13	0.13	0.13
01-110-0-Q	FAN & EQUIPMENT ROOM	QF	3	18	0.11	0.11	0.11
4-92-0A-E	FIDLEY	QA	2	24	0.10	0.10	0.10
2-126-2-Q	A.C. EQUIPMENT	QA	2	22	0.09	0.09	0.08
4-92-0-E	GENERATOR ROOM	EE	2	26	0.08	0.08	0.08
2-126-1-Q	MACHINE SHOP	QS	2	22	0.08	0.08	0.07
1-157-0-E	STEERING GEAR SPACE	QA	2	26	0.05	0.05	0.05
1-93-1-L	CPO MESS & REC	LL	2	24	0.04	0.04	0.04
1-FP-0-K	PAINT LOCKER	K	1	30	0.04	0.04	0.04
1-110-1-Q	SHIPS OFFICE	QO	2	24	0.04	0.04	0.03
1-92-0-Q	SCULLERY	QG	2	20	0.04	0.04	0.03
3-56-0-Q	SEWAGE SPACE	QA	2	24	0.03	0.00	0.00
1-68-2-Q	HYDRAULIC PUMP ROOM	QA	2	26	0.03	0.03	0.03
3-68-1-A	GENERAL STORES	AS	2	21	0.03	0.01	0.01
1-157-2-Q	LINEN LOCKER	AG	3	12	0.03	0.03	0.03
2-147-0-Q	ENGINEERS STOREROOM	AS	2	25	0.03	0.03	0.02
01-74-1-Q	CODE ROOM	C	2	26	0.02	0.02	0.02
02-81-0-C	CHART ROOM	C	2	26	0.02	0.02	0.02

Compartments listed have
MAL of 1-3 and RLF > .02 in Scenario 1

All Scenarios include I, A, and M

Table 3.2
RELATIVE LOSS FACTORS

Plan ID	Compartment Name	CUI	MAL	FAL	Run 10-58 Scenario 1 I, A & M	Run 10-59 Scenario 4 I & A	Run 10-60 Scenario 7 I & M	Run 10-61 Scenario 10 I Only
3-9-0-E	BOW THRUSTER ROOM	EM	2	26	0.21	0.22	0.21	0.22
01-102-0-E	VENT & UPTAKE SPACE	TU	2	23	0.20	0.22	0.20	0.22
1-112-0-Q	AUXILIARY MACHINERY SPACE #3	QA	2	26	0.15	0.17	0.15	0.17
4-126-0-E	MAIN MOTOR ROOM	EE	2	26	0.13	0.15	0.13	0.15
01-110-0-Q	FAN & EQUIPMENT ROOM	QF	3	18	0.11	0.12	0.11	0.12
4-92-0A-E	FIDLEY	QA	2	24	0.10	0.11	0.10	0.11
2-126-2-Q	A.C. EQUIPMENT	QA	2	22	0.09	0.10	0.09	0.10
4-92-0-E	GENERATOR ROOM	EE	2	26	0.08	0.09	0.08	0.09
2-126-1-Q	MACHINE SHOP	QS	2	22	0.08	0.10	0.08	0.10
1-157-0-E	STEERING GEAR SPACE	QA	2	26	0.05	0.05	0.05	0.05
1-93-1-L	CPO MESS & REC	LL	2	24	0.04	0.06	0.04	0.06
1-FP-0-K	PAINT LOCKER	K	1	30	0.04	0.04	0.04	0.04
1-110-1-Q	SHIPS OFFICE	QO	2	24	0.04	0.07	0.04	0.07
1-92-0-Q	SCULLERY	QG	2	20	0.04	0.05	0.04	0.05
3-56-0-Q	SEWAGE SPACE	QA	2	24	0.03	0.04	0.03	0.04
1-68-2-Q	HYDRAULIC PUMP ROOM	QA	2	26	0.03	0.03	0.03	0.04
3-68-1-A	GENERAL STORES	AS	2	21	0.03	0.04	0.03	0.04
1-157-2-Q	LINEN LOCKER	AG	3	12	0.03	0.03	0.03	0.03
2-147-0-Q	ENGINEERS STOREROOM	AS	2	25	0.03	0.03	0.03	0.03
01-74-1-Q	CODE ROOM	C	2	26	0.02	0.03	0.04	0.04
02-81-0-C	CHART ROOM	C	2	26	0.02	0.03	0.02	0.03

Compartments listed have
MAL of 1-3 and RLF > .02 in Scenario 1

All Scenarios are XRAY, In Port

Table 3.3
RELATIVE LOSS FACTORS

Plan ID	Compartment Name	CUI	MAL	FAL	Run 9-52 Scenario 3 I, A & M	Run 9-53 Scenario 6 I & A	Run 9-54 Scenario 9 I & M	Run 9-55 Scenario 12 I Only
3-9-0-E	BOW THRUSTER ROOM	EM	2	26	0.21	0.22	0.21	0.22
01-102-0-E	VENT & UPTAKE SPACE	TU	2	23	0.19	0.22	0.19	0.22
1-112-0-Q	AUXILIARY MACHINERY SPACE #3	QA	2	26	0.15	0.17	0.15	0.17
4-126-0-E	MAIN MOTOR ROOM	EE	2	26	0.13	0.15	0.13	0.15
01-110-0-Q	FAN & EQUIPMENT ROOM	QF	3	18	0.11	0.12	0.11	0.12
4-92-0A-E	FIDLEY	QA	2	24	0.10	0.11	0.10	0.11
2-126-2-Q	A.C. EQUIPMENT	QA	2	22	0.08	0.10	0.08	0.10
4-92-0-E	GENERATOR ROOM	EE	2	26	0.08	0.09	0.08	0.09
2-126-1-Q	MACHINE SHOP	QS	2	22	0.07	0.10	0.07	0.10
1-157-0-E	STEERING GEAR SPACE	QA	2	26	0.05	0.05	0.05	0.05
1-FP-0-K	PAINT LOCKER	K	1	30	0.04	0.04	0.04	0.04
1-93-1-L	CPO MESS & REC	LL	2	24	0.04	0.06	0.04	0.06
1-110-1-Q	SHIPS OFFICE	QO	2	24	0.03	0.07	0.03	0.07
1-92-0-Q	SCULLERY	QG	2	20	0.03	0.05	0.03	0.05
1-68-2-Q	HYDRAULIC PUMP ROOM	QA	2	26	0.03	0.03	0.03	0.03
1-157-2-Q	LINEN LOCKER	AG	3	12	0.03	0.03	0.03	0.03
2-147-0-Q	ENGINEERS STOREROOM	AS	2	25	0.02	0.03	0.02	0.03
01-74-1-Q	CODE ROOM	C	2	26	0.02	0.03	0.04	0.04
02-81-0-C	CHART ROOM	C	2	26	0.02	0.03	0.02	0.03
3-68-1-A	GENERAL STORES	AS	2	21	0.01	0.01	0.01	0.01
3-56-0-Q	SEWAGE SPACE	QA	2	24	0.00	0.00	0.00	0.00

Compartments listed have
MAL of 1-3 and RLF > .02 in Scenario 1

All Scenarios are YOKE, At Sea

3.3.6.2. Barrier Option

The barrier option in SAFE provides the following details for all barriers in all rooms of origin which failed in the specified model run (e.g. YOKE, At Sea, I, A, & M in effect):

- Room of origin plan ID (the listing is sorted first on the rooms of origin)
- The FRI time for each room of origin
- Room of origin's probability of loss given EB (secondary sort)
- Relative frequency of loss given fire free state in the room of origin
- Adjacent compartment's plan ID
- Time in minutes that the barrier fails from the start of the model run
- Probability of loss given EB in the adjacent compartment
- Relative frequency of loss given fire free state in the adjacent compartment
- Whether the barrier had an open access or was a zero strength barrier

A review of the barrier option results in Appendix C show that the Motor Room (4-126-0-E), Auxiliary Machinery Space #3 (1-112-0-Q), Linen Locker (1-157-2-Q) and Cleaning Gear Locker (1-161-2-Q) are probable rooms of origin leading to EB in adjacent compartments in the 180' WLB. This result is attributed to a combination of the following factors: relatively high frequencies of EB in these compartments, the relatively short FRI times in these spaces, relatively high fuel loads, and the larger numbers of adjacent spaces which yield more fire paths.

A review of the barrier option results provides insight into probable rooms of origin that may contribute to fires that could eventually involve multiple compartments. These results coupled with the path option results provide useful information on the adjacent rooms in potential fire paths and help the crew to formulate realistic fire drill scenarios. The next section discusses the path option results from the baseline analysis of the 180' WLB.

3.3.6.3. Path Option

The path option in SAFE provides the following details for all fire paths from a user-specified room of origin in a user-specified scenario (e.g. YOKE, At Sea, I in effect):

- The time established burning will occur in each room in the fire path
- The FRI time for each room in the fire path
- The time to compartment burnout for each room in the fire path
- The cumulative probability of limiting the fire in the room of origin and in each succeeding room in the fire path
- The cumulative probability of limiting the fire for each barrier that fails allowing the fire to enter the next room
- The mode of failure for each barrier (T-bar or D-bar)

The information provided in the path option provides the necessary information to construct a graphical representation of all possible cumulative L-Curves from any specified room of origin. The barrier option, detailed reports from the target option, and engineering judgment were used to select the Motor Room (4-126-0-E), Auxiliary Machinery Space #3 (1-112-0-Q), Linen Locker (1-157-2-Q), and Cleaning Gear Locker (1-161-2-Q) as highly probable rooms of origin in the 180' WLB. The path option was specified and summary level and detail level reports were generated for these compartments. The YOKE, At Sea, I in effect scenario was selected because there is virtually no difference between I, I&A, I&M and I,A, &M results and the at sea scenario is more useful for crew firefighting training. Results from the path option were used to construct L-Curves, shown in Figures 3.1 through 3.4, that provide the following useful information:

- The L-Curve for the fire path with the least cumulative probability of limiting the fire (the highest probability of fire spread).
- The L-Curve for the fire path with the highest cumulative probability of limiting the fire (the least probability of fire spread).
- The expected time established burning will occur in each room in the fire path.
- The cumulative probability of limiting the fire for each room and barrier in the fire paths shown.

By plotting the L-Curve for the highest and the least cumulative probability of limiting the fire, an "envelope" of L-Curves is shown that brackets all the L-Curves for the room of origin which may include dozens of additional fire paths. The following discussion presents observations from an analysis of the path option results illustrated by the L-Curves shown in Figures 3.1 through 3.4

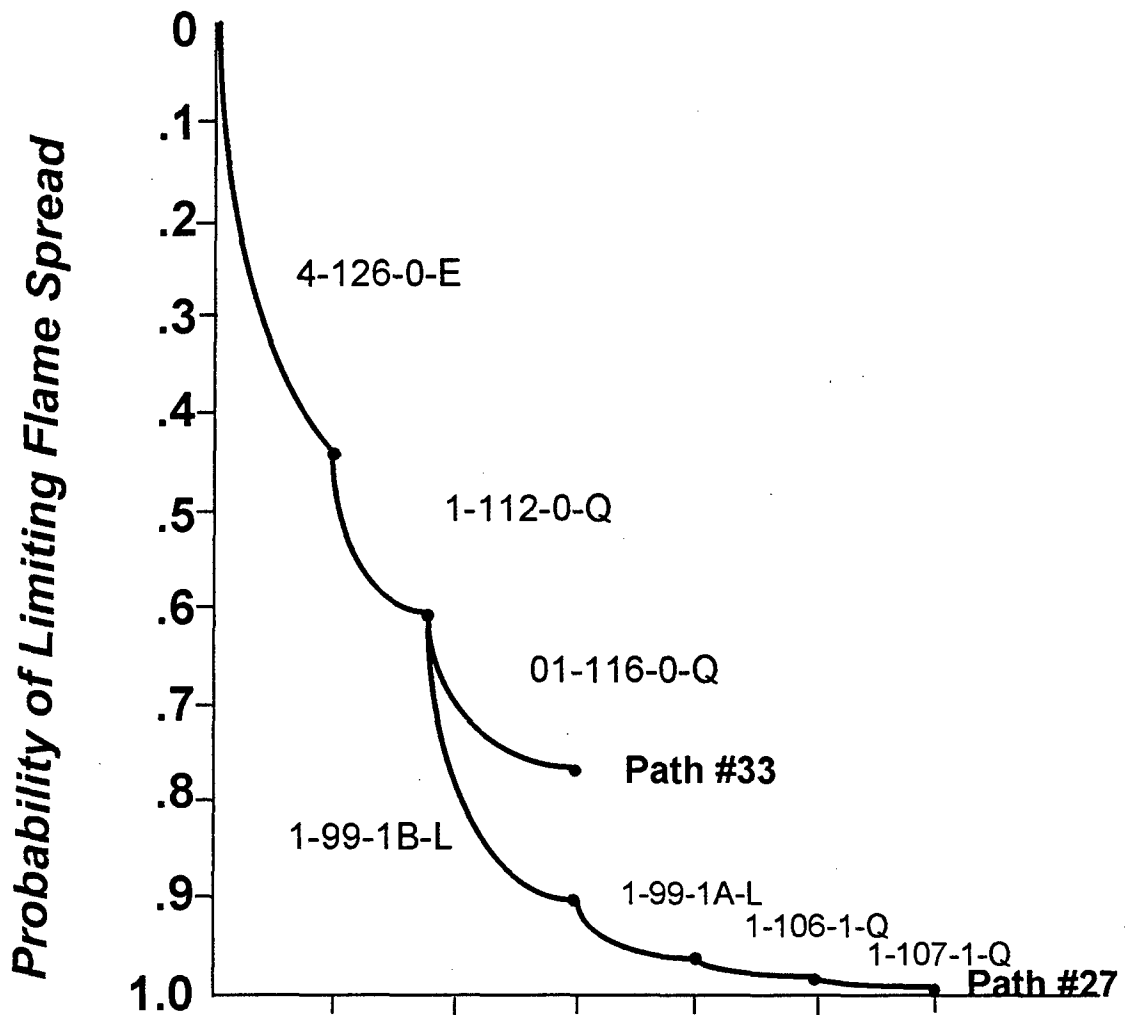

Time to EB (minutes)

Path #33 0 2 5

Path #27 0 2 2 8 47 47

Figure 3.1
Envelope of L-Curves from Motor Room (4-126-0-E)

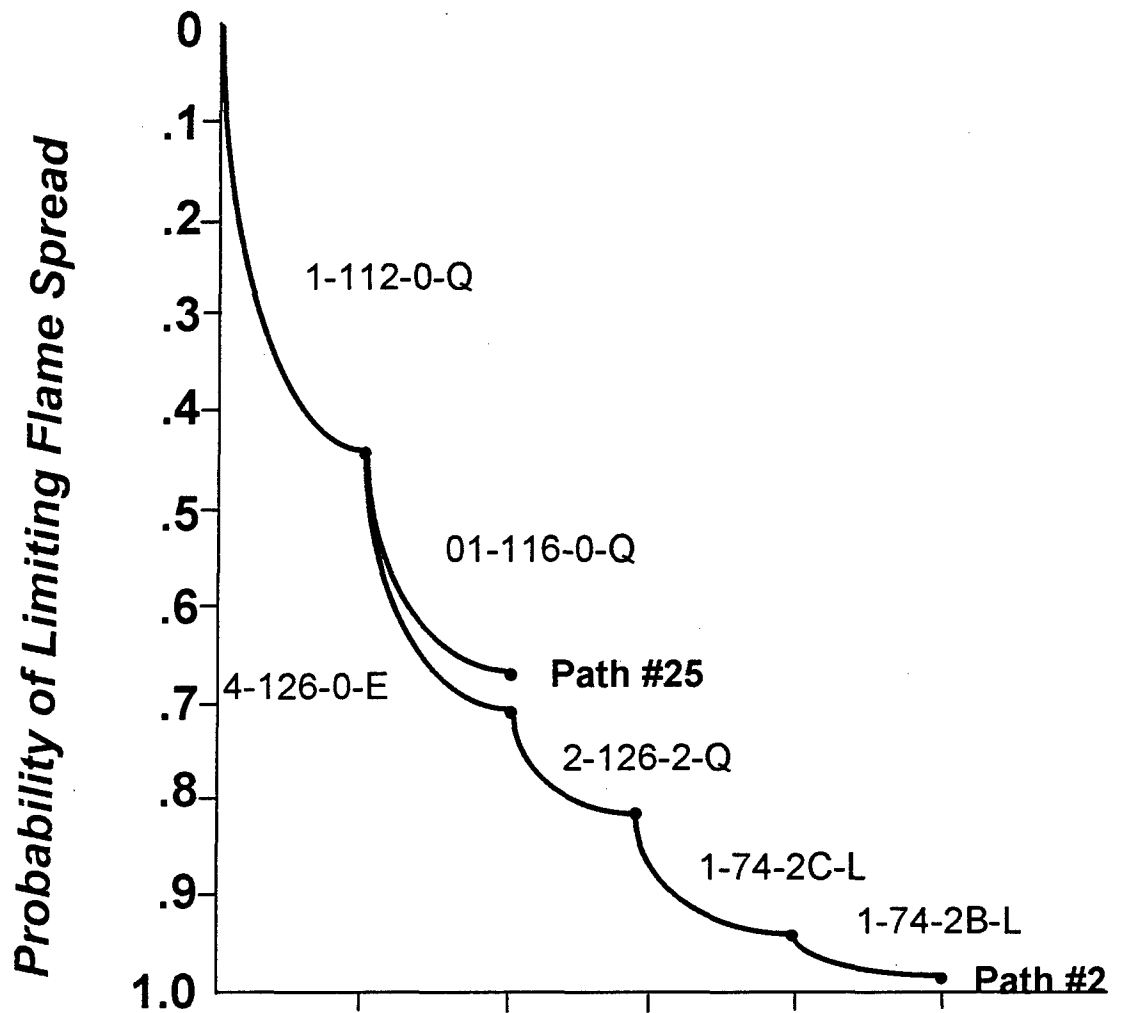

Time to EB (minutes)

Path #25 0 3

Path #2 0 9 11 3 6

Figure 3.2

Envelope of L-Curves from Auxiliary Machinery Space #3 (1-112-0-Q)

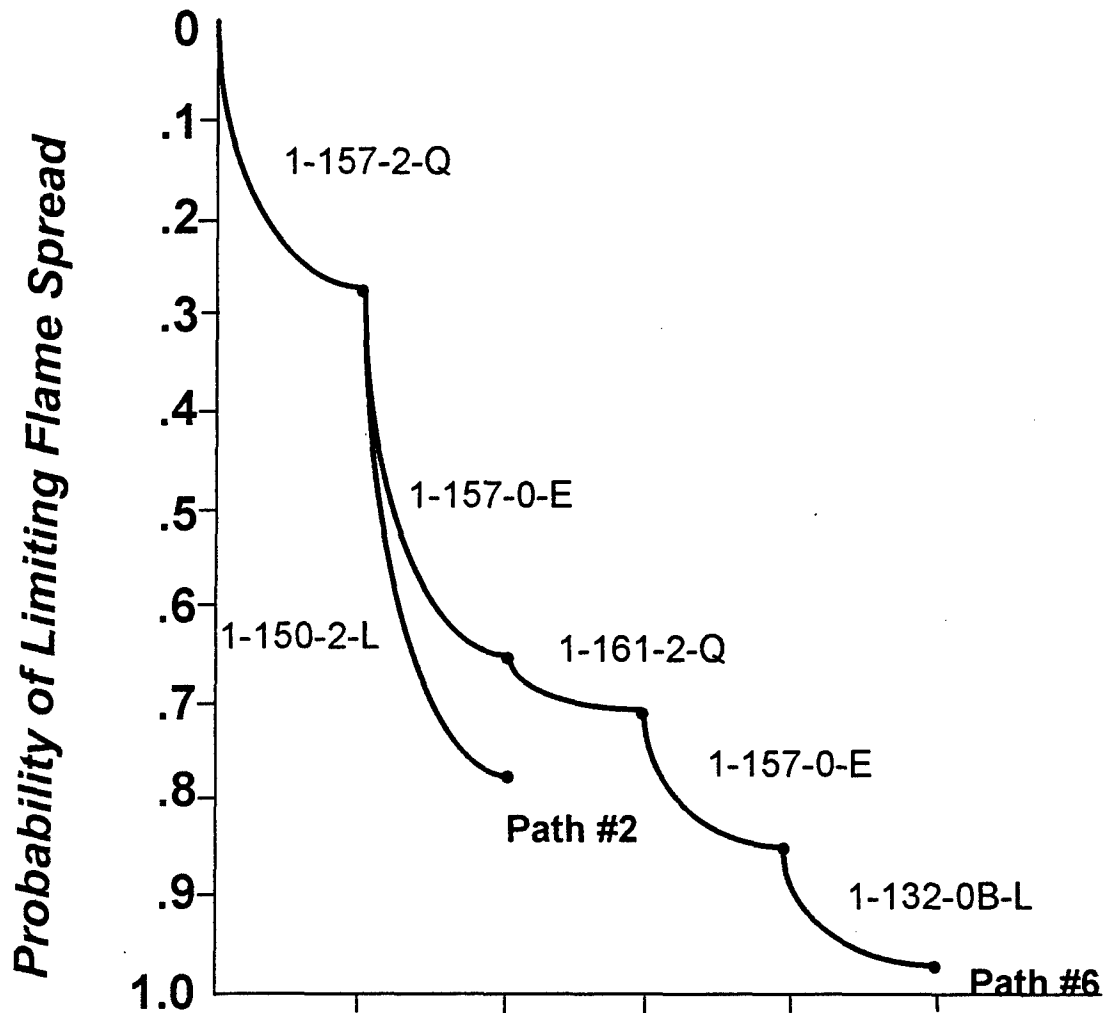

Time to EB (minutes)

Path #6 0 1 1 1 4

Path #2 0 1

Figure 3.3
Envelope of L-Curves from Linen Locker (1-157-2-Q)

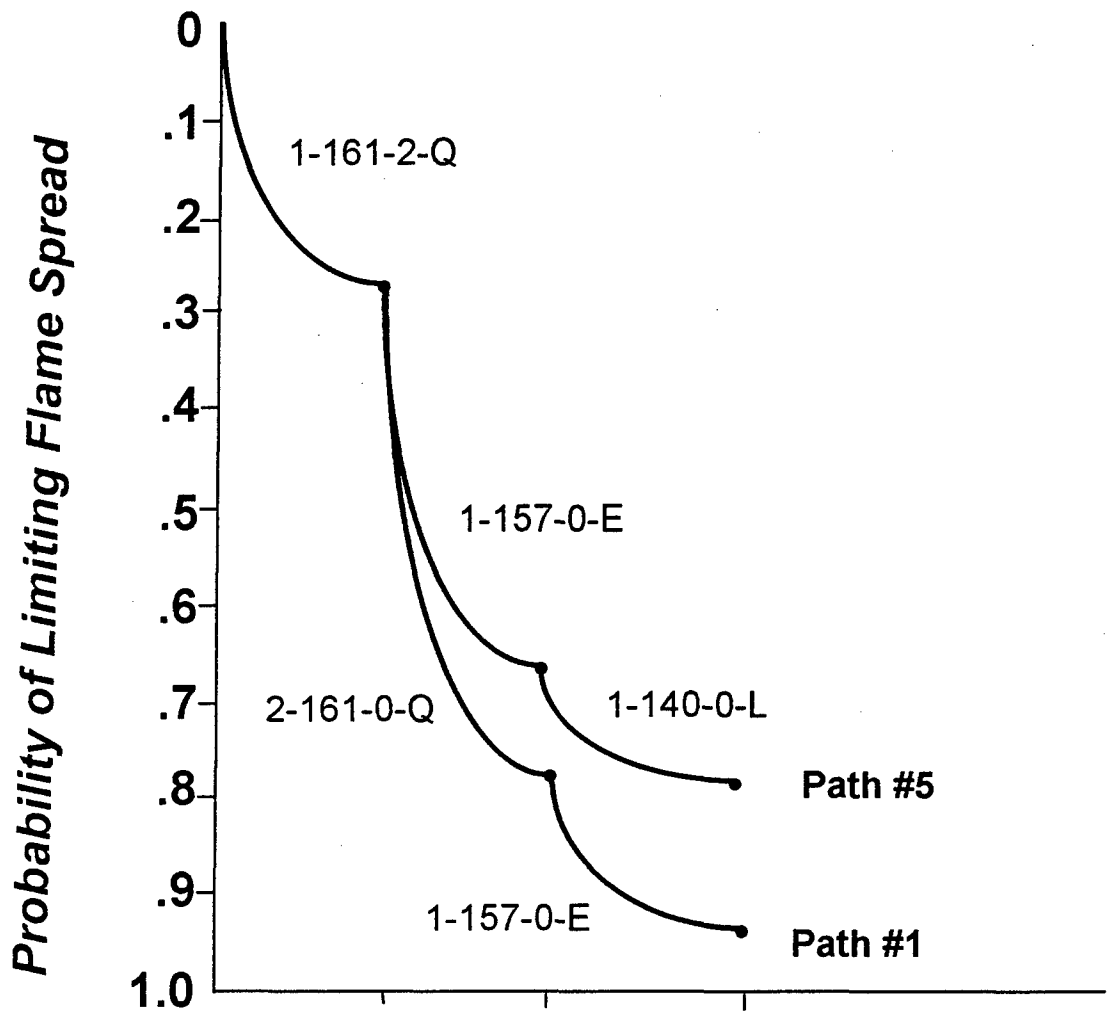

Time to EB (minutes)

Path #5 0 2 5

Path #1 0 15 2

Figure 3.4
Envelope of L-Curves from CG Locker (1-161-2-Q)

Each plot shows the cumulative probability of limiting the fire on the ordinate axis and the sequential rooms in the fire path on the abscissa axis. Note the simulation run time was set to 60 minutes for all scenarios. In general, cumulative probabilities of limiting the flame improve with longer run times. The room of origin is always shown as the first room in the path. Thus the probability of limiting the fire in the room of origin is the first data point plotted along the curve starting from zero at the top left of the graph. The next point on the L-Curve plots shown is the cumulative probability of limiting the flame in the next room in the fire path. If there was a vertical segment shown between rooms it would represent the strength of the barrier between the two compartments. In the L-Curve plots shown in figures 3.1, 3.2, 3.3, and 3.4 the intermediate barrier value happens to be zero (or so near zero, that it can't be distinguished on the plot). There are three possible reasons for a barrier to exhibit zero strength:

- The barrier is a zero-strength barrier. Zero-strength barriers are frequently used to break up long passageways and multiple level compartments. They are also useful to separate one large compartment into two or more compartments to realistically model the different fuel loads and fire threats that may exist within the one large compartment.
- Due to relatively short FRI times and high heat release rates in the compartment, the barrier experiences a D-bar or T-bar failure within the first minute of the compartment reaching FRI. SAFE analyzes the T-bar/D-bar curves once every minute. An open door or large hatch is automatically a D-bar failure as is a zero-strength barrier. The Theoretical Basis of the SFSEM describes T-bar and D-bar failure modes for barriers [3].
- The fire spreads into two or more rooms simultaneously (or within one minute) through a common barrier. This is frequently the case when time to EB is identical for the spaces involved.

The L-Curves shown in Figure 3.1 represent the fire paths with the highest and lowest cumulative probability of loss from fires originating in the Motor Room (4-126-0-E). Path #33 represents the most dangerous fire path insofar as it represents the path with the least cumulative probability of limiting the flame after 60 minutes. The times to EB are also shown to provide a sense of how much time a firefighting crew would have to respond. Path #33 shows there is a probability that EB will occur in two minutes in the Auxiliary Machinery Space #3 (1-112-0-Q). Since the Motor Room has a FRI time of two minutes (Table B.8, Appendix B), this means that EB will occur in the Auxiliary Machinery Space #3 four minutes from the time EB occurs in the Motor Room. However there is a 44% probability that the fire will be limited to the Motor Room in the first place. Or stated another way, there is a 44% probability that FRI will not be achieved in the Motor Room. Path #27 shows the fire path with the highest probability of limiting the flame after 60 minutes. This fire path shows the fire spreading from the Motor Room, through the Auxiliary Machinery Space #3 to the Passageway (1-99-1-L), and finally to the Movie Locker (1-106-1-Q) and Morale Locker (1-107-1-Q). Note the details of all other fire paths originating in the Motor Room are shown in Appendix C. The firefighting crew may construct other training scenarios based on this data.

Figure 3.2 shows the envelope of L-Curves with the Auxiliary Machinery Space #3 (1-112-0-Q) selected as the room of origin. Path #25 begins in the Auxiliary Machinery Space #3 and spreads upward to the Clip Shack (01-116-0-Q) where there is a 67% probability of limiting the flame after 60 minutes. Even though this path represents the path with the least cumulative

probability of loss, it may be worthwhile to consider other paths for training purposes. For example, Path #2, which represents the path with the highest cumulative probability of limiting the flame begins in the Auxiliary Machinery Space #3 and spreads to the Motor Room (4-126-0-E), then to the A.C. Equipment Room (2-126-2-Q), and finally upward to Passageway 1-74-2-L. The probability of limiting the fire somewhere along this path after 60 minutes is 99%. Note the fire paths from the Motor Room when it is entered from an adjacent compartment are not necessarily the same paths as those generated when the Motor Room is the room of origin.

Figure 3.3 shows the envelope of L-Curves with the Linen Locker (1-157-2-Q) selected as the room of origin. Path #2 starts in the Linen Locker (1-157-2-Q) and spreads forward to the Officers Head (1-12-3-Q) where it ends with a cumulative probability of limiting the flame of 78%. Path #6 starts in the Linen Locker (1-157-2-Q) and spreads to the Steering Gear Space (1-157-0-E), then to the Cleaning Gear Locker (1-161-2-Q), then back into the Steering Gear Space (1-157-0-E) and finally ends in the Passageway (1-132-0-L) with a cumulative probability of limiting the flame of 98%. Considering the times to EB, it is apparent that path #6, even though it has the higher cumulative probability of limiting the flame, represents a more serious concern than Path #2 because Path #6 involves more compartments with very short times to EB. The FRI time in the Linen Locker is 1 minute (see Table B.8, Appendix B), and the time to EB in the second adjacent rooms is 1 minute on Paths #2 and #6. Therefore as shown in Figure 3.3, should a fire start in the Linen Locker, the firefighting party would have only two minutes to arrive on scene and prevent the fire from spreading either into the Officer's Head or the Steering Gear Space. However there is a 28% probability that the fire would be limited to the Linen Locker (not subject to spreading to any other adjacent space). Thus, it can be seen that L-Curve plots provide valuable insight for developing realistic firefighting training scenarios, however engineering judgment must be used to interpret the data.

Figure 3.4 shows the envelope of L-Curves with the Cleaning Gear Locker (1-161-2-Q) selected as the room of origin. Path #5 starts in the Cleaning Gear Locker (1-161-2-Q) and spreads to the Steering Gear Space (1-157-0-E), and then to the Wardroom (1-140-0-L) where it ends with a cumulative probability of limiting the flame of 78%. Path #1 starts in the Cleaning Gear Locker (1-161-2-Q) and spreads down to the Lazarette (2-161-0-Q) and then up to the Steering Gear Space (1-157-0-E), with a cumulative probability of limiting the flame of 94%. Path #5 represents the most dangerous path in two different ways. First the cumulative probability of limiting the flame is less in Path #5 than in Path #1 and second, the time to EB in the second adjacent room is much less in Path #5 than in Path #1. This means that the firefighting party has only four minutes in Path #5 to arrive on scene and prevent the fire from growing to FRI in the Steering Gear Space (1-157-0-E). Four minutes is calculated as follows: two minutes for 1-161-2-Q to reach FRI and an additional two minutes for 1-157-0-E to reach EB. The firefighting party would have 17 minutes to prevent fire from spreading beyond the Lazarette (2-161-0-E) in Path #1.

Figures 3.1 through 3.4 are based on data contained in Appendix C. These figures clearly demonstrate the insight that can be gained from plotting L-Curves and for planning realistic fire drill scenarios.

3.3.7. ANALYZE FIRE PROTECTION ALTERNATIVES

Since all compartments in the 180' WLB exceed their FSOs, it is not necessary to consider alternatives to improve the fire safety in any compartment. However, since the 225' JUNIPER class buoy tender is designed to replace the 180' WLB class of buoy tender, it is desirable to study and compare the results of the fire safety analyses conducted on both classes of ships. In addition, since the results from the baseline fire safety analysis clearly show that passive protection is primarily responsible for these results, it is desirable to study the effect of bulkhead insulation. This will provide some insight into the factors that affect passive protection. The effect bulkhead insulation has on the fire safety analysis results may be studied by simply "changing" barrier materials in the baseline data set. Section 4.0 of this report provides a detailed discussion of the comparison of results between the JUNIPER and 180' WLB classes of buoy tender as well as the results of the barrier insulation study.

3.3.8. CONDUCT COST-BENEFIT ANALYSIS

The goal of the fire safety analysis is to maximize the benefit (improvement in fire safety), while minimizing the costs (dollars and other intangible factors) of the changes. A cost-benefit analysis is thus considered an important part of alternative design evaluation. Within the constraints of time and allowable funds, as many alternatives as possible are studied to permit a useful cost-benefit analysis. Since no improvements are required to bring the ship up to minimally acceptable standards, a cost-benefit analysis of alternatives is not applicable for the 180' WLB.

3.3.9. DOCUMENT RESULTS

This report contains comprehensive results and provides the basis of assumptions and estimates when complete or factual information was not available. The appendices present the input data and detailed output results from SAFE. Additional insight may be gained by referring to the other technical reports and documents referenced throughout this report.

4. ANALYSIS OF ALTERNATIVES

The analysis of alternatives phase usually involves consideration of hypothetical improvements in compartments which fail to meet their fire safety objectives. Less frequently, this phase is used to study ways to reduce or eliminate over-protection in compartments which exceed their fire safety objectives. Even if no changes to the existing fire safety systems are considered necessary, this phase may be used to analyze specific firefighting agents or techniques, fire protection systems, or any feature of the ship's design that affects fire safety. By changing the appropriate data in the baseline data set, any hypothetical change can be studied by comparing outputs from the target, barrier and/or path options available in SAFE.

As noted in section 3.0 of this report, all compartments in the 180' WLB exceed their fire safety objectives by a very substantial margin, therefore no changes to the existing fire safety systems are required to bring the ship up to minimally acceptable fire safety standards. While these results are in general agreement with previous fire safety analyses of other Coast Guard cutter classes, they are actually somewhat better (i.e. lower RLFs or "safer" results) than most other cutters. Since target option results with passive (I only) fire protection in effect are similar to results with passive and active (I&A, I&M, and I, A. &M) fire protection in effect, the contribution from active fire protection is minimal, thus the relatively good fire safety levels are primarily attributed to passive fire protection alone. The passive fire protection in the 180' WLB Seagoing Buoy Tender may be performing better compared to newer cutters due to the following:

- Bulkheads are primarily steel or insulated steel. Relatively few nomex or combustibile wall linings are installed in the ship.
- The effective use of compartmentation to segregate engineering spaces with voids, water tanks, fuel tanks, and spaces with sparse fuel loads serve to prevent the spread of flames fore and aft from engineering spaces which historically have been a primary source of multiple room fires.
- Ventilation is relatively poor on this ship. While this may not enhance living conditions, it has a beneficial effect on limiting fire growth.
- Fuel loads are considered relatively low, in addition the type and distribution of fuel packages is associated with slow fire growth.

Since barriers are a key factor in passive fire protection, it is desirable to study the effect insulation has on steel bulkheads. The next subsection discusses the results of this barrier insulation study.

The 180' WLB Seagoing Buoy Tender class is being replaced by the 225' JUNIPER class Buoy Tender. A fire safety analysis was previously conducted on the JUNIPER, therefore there is an opportunity to compare and contrast the results of that analysis with the results from this study. [2] The last subsection in this section of the report provides this comparison.

4.1. BULKHEAD INSULATION

As noted in Table B.2 in Appendix B most of the existing bulkheads in the 180' WLB are bare steel or insulated steel. Watertight bulkheads serve two major purposes in a ship: (1) they serve as fire zone bulkheads and (2) they serve to prevent progressive flooding. Since watertight bulkheads play an

important role as fire zone bulkheads, it was decided that they would be a focus of this investigation. First, all watertight bulkheads are changed to "insulated" and all other bulkheads are changed to "uninsulated". Secondly, all bulkheads are changed to uninsulated. These results are then compared to the baseline or existing conditions where some bulkheads are insulated and others are not. Appendix D documents the results of this study. Part 1 in Appendix D provides the results of insulating watertight (i.e. fire zone) bulkheads only and Part 2 provides the results with all bulkheads uninsulated. Each of these parts includes an associated Barrier Table that was used as SAFE input data and the target option output results for all twelve standard and non-standard scenarios.

Table 4.1 includes the target option output results for the YOKE, At Sea, I, A, & M scenario for the two barrier alternatives compared to the baseline. Since active fire protection (A & M) provides only minimal contribution in this ship, results from other scenarios (e.g. I only, I & A, and I & M) are very similar to I, A, & M scenario. Complete results are documented in Appendix D. The following conclusions are based on results shown in Table 4.1:

- The results of insulating watertight bulkheads only are exactly the same as all bulkheads uninsulated when results are rounded to two decimal places. Therefore, insulating only watertight bulkheads has a negligible effect.
- RLFs are generally slightly higher (less fire safe) with little or no bulkhead insulation compared to the baseline where relatively more bulkheads are insulated. Therefore, bulkhead insulation has a small beneficial effect on fire safety.
- A review of attachment B.1.1 in Appendix B shows that bare steel bulkheads have excellent durability strength. In other words, relatively high heat energy impact is required to cause a D-bar failure. Bare steel on the other hand is an excellent conductor of heat, therefore bare steel has relatively low resistance to a T-bar failure. If the steel is insulated, the material has excellent resistance to both T-bar and D-bar failures. The relatively good baseline results are attributed in part to the fact that many of the bulkheads in the HORNBEAM are insulated steel.

Table 4.1
RELATIVE LOSS FACTORS

Plan ID	Compartment Name	CUI	MAL	FAL	Run 9-52	Run 11-70	Run 12-74
					Baseline	WT BHDS Insulated	All BHDS Uninsulated
3-9-0-E	BOW THRUSTER ROOM	EM	2	26	0.21	0.21	0.21
01-102-0-E	VENT & UPTAKE SPACE	TU	2	23	0.19	0.11	0.11
1-112-0-Q	AUXILIARY MACHINERY SPACE #3	QA	2	26	0.15	0.19	0.19
4-126-0-E	MAIN MOTOR ROOM	EE	2	26	0.13	0.14	0.14
01-110-0-Q	FAN & EQUIPMENT ROOM	QF	3	18	0.11	0.18	0.18
4-92-0A-E	FIDLEY	QA	2	24	0.10	0.12	0.12
2-126-2-Q	A.C. EQUIPMENT	QA	2	22	0.08	0.09	0.09
4-92-0-E	GENERATOR ROOM	EE	2	26	0.08	0.13	0.13
2-126-1-Q	MACHINE SHOP	QS	2	22	0.07	0.07	0.07
1-157-0-E	STEERING GEAR SPACE	QA	2	26	0.05	0.05	0.05
1-93-1-L	CPO MESS & REC	LL	2	24	0.04	0.00	0.00
1-FP-0-K	PAINT LOCKER	K	1	30	0.04	0.04	0.04
1-110-1-Q	SHIPS OFFICE	QO	2	24	0.03	0.06	0.06
1-92-0-Q	SCULLERY	QG	2	20	0.03	0.04	0.04
3-56-0-Q	SEWAGE SPACE	QA	2	24	0.00	0.00	0.00
1-68-2-Q	HYDRAULIC PUMP ROOM	QA	2	26	0.03	0.03	0.03
3-68-1-A	GENERAL STORES	AS	2	21	0.01	0.00	0.00
1-157-2-Q	LINEN LOCKER	AG	3	12	0.03	0.03	0.03
2-147-0-Q	ENGINEERS STOREROOM	AS	2	25	0.02	0.02	0.02
01-74-1-Q	CODE ROOM	C	2	26	0.02	0.03	0.03
02-81-0-C	CHART ROOM	C	2	26	0.02	0.02	0.02

Compartments listed have
MAL of 1-3 and RLF>.02 in Scenario 1

All Scenarios include Yoke; At Sea; I, A, M

4.2. COMPARISON OF FIRE SAFETY ANALYSIS RESULTS

The fire safety analyses of JUNIPER and HORNEAM were conducted by the same engineering team using the same computer-based analytical tools (SFSEM and SAFE). Moreover the JUNIPER class is designed to replace the HORNBEAM class of seagoing buoy tenders, therefore their Coast Guard missions are comparable. However, in addition to its primary mission involving aids to navigation, JUNIPER has been designed and equipped with advanced technological capabilities to deal with oil spills and other marine environmental response duties. The JUNIPER has also been designed to accomplish its missions while operating in higher sea states with fewer crew members compared to HORNBEAM. The fire safety analyses takes into account crew size and the fire protection equipment installed on the two vessels. This section of the report will focus on comparing and contrasting the two ships and the results of the fire safety analyses.

The principal characteristics of the HORNBEAM are shown in Table 4.2 compared to the JUNIPER class Seagoing Buoy Tender:

Table 4.2 Seagoing Buoy Tender Characteristics

Characteristic	HORNBEAM	JUNIPER
Age	>50 years	<2 years
Length	180 ft	225 ft
Max Speed	12-14 knots	17+ knots
Max Range	13,500 - 31,000 miles	6,000 miles
Major Missions	AtoN, Law Enforcement, Ice Ops, Search & Rescue	AtoN, Search & Rescue, Marine Environmental Protection, Law Enforcement, Ice Ops
Crew Size	7 officers, 45 enlisted	6 officers, 34 enlisted
Propulsion	Single Fixed Pitch Propeller, Bow Tunnel Thruster	Single Controllable Pitch Propeller, Bow and Stern Tunnel Thrusters

JUNIPER is equipped with advanced technological and navigational capabilities. For example, the Integrated Ship Control System includes the following special features: Electronic Charting Display and Information System (ECDIS) which enables JUNIPER to fix her position within 5 meters of an exact position; the Dynamic Positioning System (DPS) operates the controllable pitch propeller, bow and stern thrusters to automatically maintain station. These systems permit navigating the ship and working aids to navigation with a minimal number of crew members on the Bridge. The Machinery Plant Control system is designed to monitor vital equipment temperatures and pressures and automatically record hourly readings, thus only a single watchstander is needed in the Engine Room. JUNIPER is also the first Coast Guard vessel to be equipped with an on board Spilled Oil Recovery System (SORS) for enhanced capabilities in

Marine Environmental Response. The Coast Guard uses advanced technology in JUNIPER to effectively and efficiently accomplish it's missions with fewer crew members than HORNBEAM.

A review of the input data that was used to perform the baseline fire safety analysis on both ships reveals the following:

- Not counting Voids and Tanks, there are 98 compartments in HORNBEAM and 140 compartments in JUNIPER.
- Bulkheads and decks in HORNBEAM are primarily steel with some nomex in Staterooms and Heads. Nomex bulkheads are used in most of the JUNIPER's habitability spaces, steel is used elsewhere. Neither ship has aluminum structural materials.
- Fire Safety Objectives and probabilities of flame termination were established for similar compartments in both ships in a consistent manner using the same methodology.
- In the HORNBEAM, battery-powered smoke detectors are installed only in berthing areas and a heat detector is installed in the Paint Locker. A sophisticated fire detection system is installed in JUNIPER with detectors installed in virtually all compartments wired to a central alarm panel.
- In the JUNIPER, automated fire protection systems are installed in most of the engineering spaces whereas HORNBEAM has no automated fire protection systems in any engineering space. Both ships have similar equipment for manual firefighting (portable fire extinguishers, hose lines, etc.) and similar automated fire protection systems in the Paint Locker and Galley.
- There are fewer and smaller ventilation openings providing less fresh and recirculated air in the HORNBEAM compared to the JUNIPER.
- Average fuel load densities are lower in HORNBEAM for all types of compartments (categorized by CUI) compared to JUNIPER.

One of the objectives of the fire safety analysis of the JUNIPER [2] was to examine the relative fire safety of this ship which is larger and more complex than HORNBEAM but has fewer crew members. The key conclusion: JUNIPER, equipped with a comprehensive and sophisticated fire detection system and multiple automated fire protection systems protecting virtually all engineering spaces, exhibits adequate fire safety - as long as the installed systems are reliable and well-maintained. In contrast, HORNBEAM lacks the fire detection system and the automated fire protection systems, however the excellent passive fire protection inherent in her design and compartmentation overcomes the lack of these systems.

The final report of the fire safety analysis of the 225' JUNIPER class Seagoing Buoy Tender was published in December 1996. [2] Tables 4.3 and 4.4 compare baseline fire safety analysis results for both ships. Table 4.3 lists the target option output results in terms of relative loss factors (RLF) for the three standard scenarios with passive, automated, and manual fire protection in effect. Table 4.4 focuses on the XRAY, In Port scenario with various levels of fire protection in effect. Information displayed in Tables 4.3 and 4.4 has been plotted in the bar graphs shown in Figures 4.1 and 4.2. The following discussion is based on a review of the results shown in these two tables and figures.

As shown in Table 4.3 and Figure 4.1, all compartments exceed fire safety objectives by a substantial margin with passive and active fire protection in effect in both ships. In general, there are higher fire safety levels in HORNBEAM (lower RLFs). There are also slightly more differences in the results of the various scenarios in JUNIPER. There does not appear to be any strong correlation between the two ships concerning which compartments have the highest RLFs. For example of the top twelve compartments (with the highest RLFs), only three spaces are considered in common: the Vent & Uptake Space on HORNBEAM is considered similar to the Stack on JUNIPER; the Auxiliary Machinery Space #3 in HORNBEAM and the Emergency Generator Room in JUNIPER both contain the emergency diesel generator; and the Main Motor Room in HORNBEAM is considered equivalent to the Main Machinery Room in JUNIPER. Considering how different the compartmentation is between the two ships, this lack of similarity is not surprising.

Table 4.4 and Figure 4.2 considers the XRAY, In Port scenario with varying levels of fire protection in effect; again the same top twelve compartments (with the highest RLFs) are shown. The differences in scenarios 4, 7, and 10 are quite dramatic. Whereas the effect of automated and manual fire protection is negligible in HORNBEAM, they make a very significant contribution in JUNIPER. The most significant difference is seen in the comparison of results with passive protection only in effect. In JUNIPER, eight compartments fail to meet FSOs, some by a significant amount, whereas the highest RLF in HORNBEAM is 0.22. Several compartments in JUNIPER fail to meet FSOs with passive and manual fire protection in effect. Therefore, passive fire protection in JUNIPER must be augmented by automated fire protection systems for all compartments to exceed FSOs.

The relatively high baseline fire safety in HORNBEAM is attributed to its passive fire protection. The compartmentation and construction materials used to build the vessel are primary contributors to passive fire protection. The margin of safety provided by the passive fire protection in HORNBEAM has been easy to maintain over the years since compartmentation and construction materials have not been significantly altered during the service life of the vessel. On the other hand, the JUNIPER relies heavily on sophisticated fire detection and automated fire protection systems to maintain its relatively high baseline fire safety. Due to a natural tendency for the reliability and maintainability of sophisticated and complex equipment to deteriorate over time, significant potential exists for reduction of fire safety levels below acceptable limits during the service life of JUNIPER.

Table 4.3
RELATIVE LOSS FACTORS

Plan ID	Compartment Name	CUI	MAL	FAL	Scenario 1 Xray, In Port	Scenario 2 Yoke, In Port	Scenario 3 Yoke, At Sea
	HORNBEAM						
3-9-0-E	BOW THRUSTER ROOM	EM	2	26	0.21	0.21	0.21
01-102-0-E	VENT & UPTAKE SPACE	TU	2	23	0.20	0.20	0.19
1-112-0-Q	AUXILIARY MACHINERY SPACE #3	QA	2	26	0.15	0.15	0.15
4-126-0-E	MAIN MOTOR ROOM	EE	2	26	0.13	0.13	0.13
01-110-0-Q	FAN & EQUIPMENT ROOM	QF	3	18	0.11	0.11	0.11
4-92-0A-E	FIDLEY	QA	2	24	0.10	0.10	0.10
2-126-2-Q	A.C. EQUIPMENT	QA	2	22	0.09	0.09	0.08
4-92-0-E	GENERATOR ROOM	EE	2	26	0.08	0.08	0.08
2-126-1-Q	MACHINE SHOP	QS	2	22	0.08	0.08	0.07
1-157-0-E	STEERING GEAR SPACE	QA	2	26	0.05	0.05	0.05
1-93-1-L	CPO MESS & REC	LL	2	24	0.04	0.04	0.04
1-FP-0-K	PAINT LOCKER	K	1	30	0.04	0.04	0.04
	JUNIPER						
1-66-0-L	CREW MESS	LL	2	24	0.44	0.40	0.32
01-68-0-Q	SHIPS OFFICE	QO	2	22	0.42	0.37	0.28
03-76-0-Q	STACK	TU	2	21	0.37	0.31	0.25
01-68-1-L	MEDICAL TREATMENT ROOM	LM	2	22	0.32	0.28	0.21
1-66-1-Q	GALLEY ANNEX	QG	2	26	0.22	0.21	0.16
02-66-0-C	RADIO ROOM	C	2	26	0.22	0.17	0.12
01-78-3-E	EMERGENCY GENERATOR ROOM	QE	2	24	0.21	0.19	0.17
1-76-0-Q	MAIN MACHINERY ROOM UPTAKE	TU	3	16	0.21	0.18	0.16
4-66-0-E	MAIN MACHINERY ROOM	EM	2	26	0.20	0.17	0.16
1-71-2-Q	ENG LOG OFFICE & DC CENTRAL	QO	2	22	0.19	0.18	0.15
2-89-1-C	ENGINEERING CONTROL CENTER	C	2	24	0.17	0.14	0.13
2-57-4-E	WATER SUPPLY EQUIPMENT ROOM	QA	2	22	0.16	0.13	0.12

Compartments listed have
MAL of 1-3 and the largest RLFs in Scenario 1

All Scenarios include I, A, and M

Figure 4.1 Comparison of Baseline Fire Safety Levels

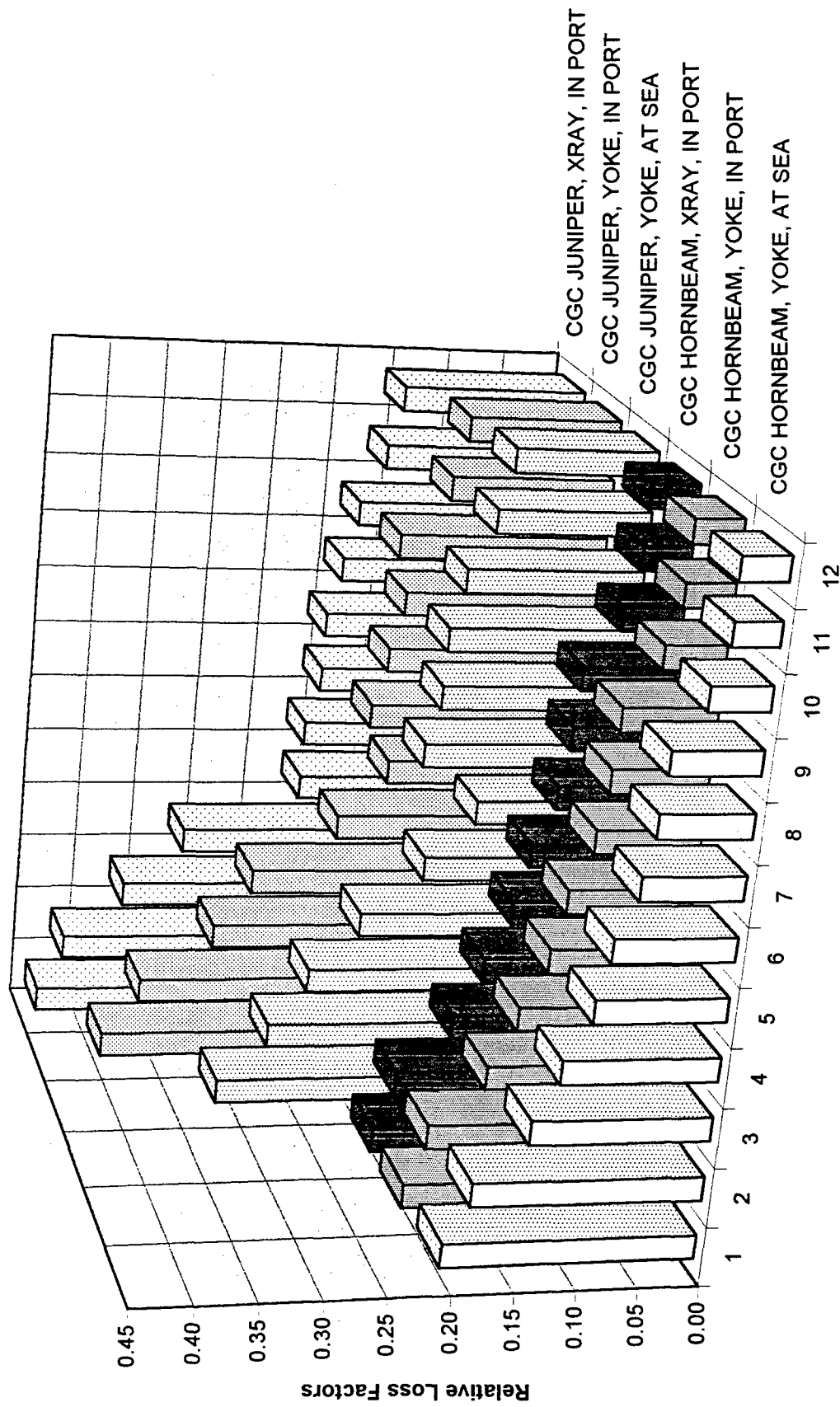

Table 4-4
RELATIVE LOSS FACTORS

180' WLB and 225' JUNIPER class Seagoing Buoy Tenders

Plan ID	Compartment Name	CUI	MAL	FAL	Scenario 1 I, A & M	Scenario 4 I & A	Scenario 7 I & M	Scenario 10 I Only
	HORNBEAM							
3-9-0-E	BOW THRUSTER ROOM	EM	2	26	0.21	0.22	0.21	0.22
01-102-0-E	VENT & UPTAKE SPACE	TU	2	23	0.20	0.22	0.20	0.22
1-112-0-Q	AUXILIARY MACHINERY SPACE #3	QA	2	26	0.15	0.17	0.15	0.17
4-126-0-E	MAIN MOTOR ROOM	EE	2	26	0.13	0.15	0.13	0.15
01-110-0-Q	FAN & EQUIPMENT ROOM	QF	3	18	0.11	0.12	0.11	0.12
4-92-0A-E	FIDLEY	QA	2	24	0.10	0.11	0.10	0.11
2-126-2-Q	A.C. EQUIPMENT	QA	2	22	0.09	0.10	0.09	0.10
4-92-0-E	GENERATOR ROOM	EE	2	26	0.08	0.09	0.08	0.09
2-126-1-Q	MACHINE SHOP	QS	2	22	0.08	0.10	0.08	0.10
1-157-0-E	STEERING GEAR SPACE	QA	2	26	0.05	0.05	0.05	0.05
1-93-1-L	CPO MESS & REC	LL	2	24	0.04	0.06	0.04	0.06
1-FP-0-K	PAINT LOCKER	K	1	30	0.04	0.04	0.04	0.04
	JUNIPER							
1-66-0-L	CREW MESS	LL	2	24	0.44	0.87	1.70	3.30
01-68-0-Q	SHIPS OFFICE	QO	2	22	0.42	0.96	1.44	3.15
03-76-0-Q	STACK	TU	2	21	0.37	0.54	0.99	1.40
01-68-1-L	MEDICAL TREATMENT ROOM	LM	2	22	0.32	0.81	1.22	3.03
1-66-1-Q	GALLEY ANNEX	QG	2	26	0.22	0.45	0.88	1.74
02-66-0-C	RADIO ROOM	C	2	26	0.22	0.64	0.62	2.05
01-78-3-E	EMERGENCY GENERATOR ROOM	QE	2	24	0.21	0.30	1.13	2.02
1-76-0-Q	MAIN MACHINERY ROOM UPTAKE	TU	3	16	0.21	0.27	0.60	0.74
4-66-0-E	MAIN MACHINERY ROOM	EM	2	26	0.20	0.24	0.77	0.93
1-71-2-Q	ENG LOG OFFICE & DC CENTRAL	QO	2	22	0.19	0.35	0.80	1.34
2-89-1-C	ENGINEERING CONTROL CENTER	C	2	24	0.17	0.24	0.67	0.94
2-57-4-E	WATER SUPPLY EQUIPMENT ROOM	QA	2	22	0.16	0.21	0.50	0.68

Compartments listed have
MAL of 1-3 and the largest RLFs in Scenario 1

All Scenarios are XRAY, In Port

Figure 4.2 Comparison of Baseline Fire Safety Levels

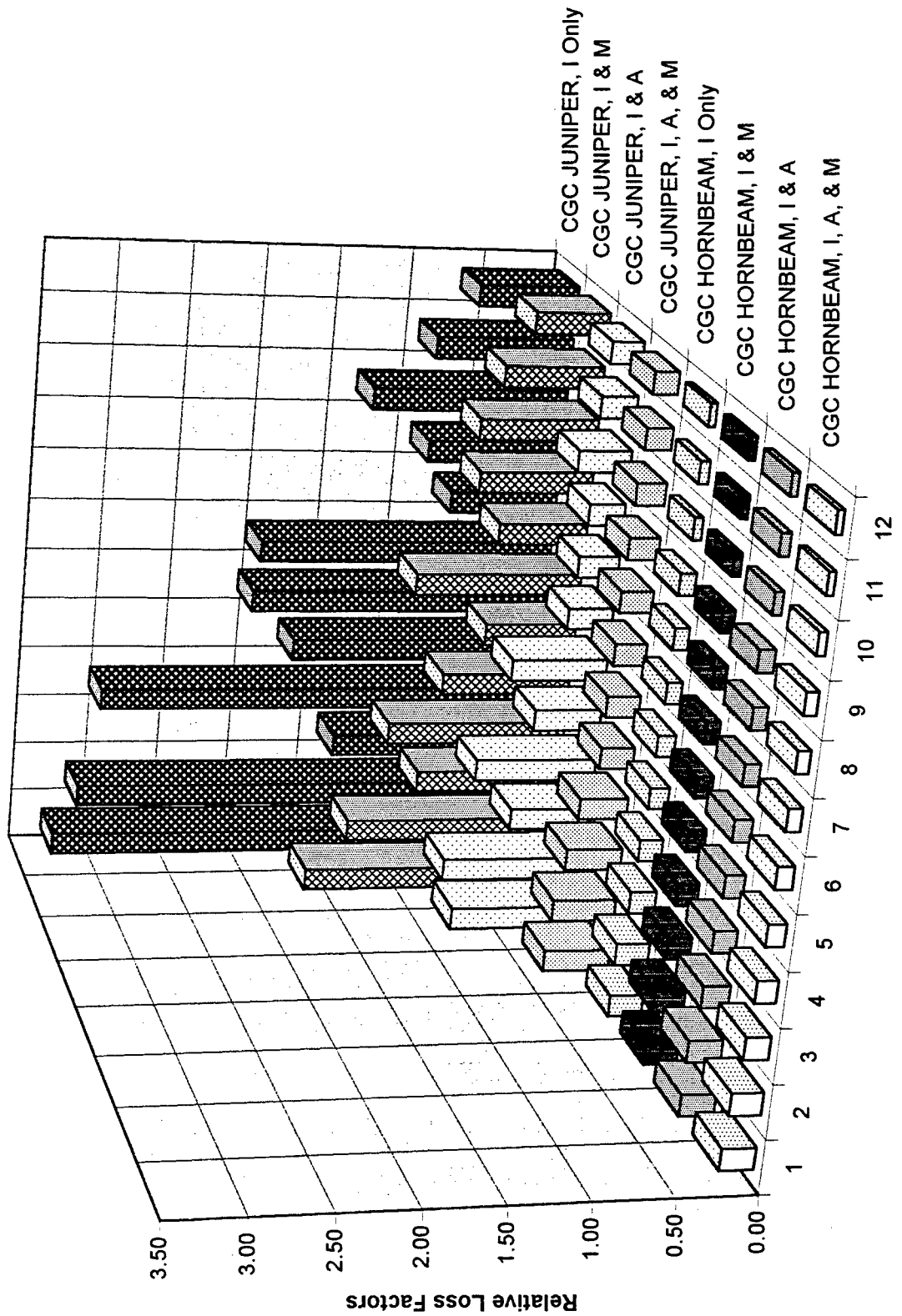

5. CONCLUSIONS AND RECOMMENDATIONS

The primary objective in this project is to analyze the fire safety of the 180' WLB. As the fourteenth cutter to be analyzed using the Ship Fire Safety Engineering Methodology (SFSEM) in the past six years, fire safety analysis results for the 180' WLB may be compared to the results of the ten previously analyzed cutters in the Small Cutter Fire Protection Project, the USCGC VINDICATOR (WMEC 3), 87' Coastal Patrol Boat (CPB), and the WLB (R) Seagoing Buoy Tender. [1, 2, 5, 13, 14] Baseline results in previously analyzed cutters indicate that fire protection levels in most compartments, with passive, automated, and manual fire protection features in effect, generally meet Fire Safety Objectives (FSO). Results of the baseline fire safety analysis of the 180' WLB are consistent with the results discussed in the SCFP, VINDICATOR, CPB and WLB (R) final reports and are in agreement with historical records for fires in U.S. Coast Guard cutters.

The following sections describe the major conclusions and recommendations of the fire safety audit and the baseline fire safety analysis discussed in section 3.0 as well as the analysis of alternatives discussed in section 4.0.

5.1. FIRE SAFETY AUDIT

The following conclusions and recommendations are made in conjunction with the fire safety audit:

- Only berthing areas and staterooms are equipped with "stick-up", battery-powered, ionization type smoke detectors. In addition there is a heat detector installed in the Paint Locker. There are no smoke, flame or heat detectors installed in any other space including engineering spaces, storerooms, offices, shops, Galley, etc. None of the existing detectors are wired to a central alarm system. Automatic detectors installed in virtually every compartment which are wired to a fully addressable central alarm panel increases the probability that the crew will be notified of a fire while it is still small enough to extinguish with a portable fire extinguisher. Moreover, detectors wired to a central alarm panel eliminate any concerns with respect to battery maintenance/performance.
- The "old" compartment numbering system is used in the HORNBEAM. For example the Paint Locker is designated A-101-A, opposed to 1-FP-0-K in the "new" numbering system. One advantage of the new numbering system is instant identification of the forward frame number of the compartment. This enables locating the compartment rapidly - even for crew members unfamiliar with the ship. Consideration should be given to switching all references to compartment numbers in the ship to the new numbering system.
- The compartmentation of a Major Ren 180' WLB is especially conducive to preventing the spread of smoke and flame especially from the engineering spaces on the Hold Deck and Second Deck. For example, the Bow Thruster Room has Fresh Water Tanks aft and the Forepeak Tank forward; the Generator Room has Diesel Oil Tanks aft and two passageways, Fruits & Vegetables and the MAA Locker forward; and the Motor Room has Diesel Oil Tanks forward and a Fresh Water Tank aft. This effective use of compartmentation to segregate engineering spaces undoubtedly serves to prevent the spread of flames fore and aft from compartments which historically have been a primary source of fires that spread to involve multiple rooms.

- The Auxiliary Machinery Space #3 is located above and between the Motor Room and Generator Room. This space is accessed by open steel ladders from the Motor Room and the Generator Room. A smoke curtain is installed at the top of the ladder in the Generator Room while a watertight hatch is installed at the top of the ladder in the Motor Room. Consideration should be given to isolating the Auxiliary Machinery Space #3 by installing a steel joiner door at the top of the ladder to the Generator Room. This would serve to help contain fires originating in the Generator Room or the Auxiliary Machinery Space #3 to the room of origin.
- The 180' WLB is equipped with adequate quantities and appropriate types of automated and manual fire extinguishment equipment for responding to fire emergencies in most of the spaces on the vessel. The Bow Thruster Room is presently equipped with three CO₂ portable fire extinguishers. Due to the class B fire threat in this space, substituting one PKP portable fire extinguisher for one of the CO₂ portable fire extinguishers should be considered. In addition, consideration should be given to installing one PKP portable fire extinguisher in the Steering Gear Space as well.

5.2. BASELINE FIRE SAFETY ANALYSIS

Based on a comprehensive fire safety analysis, all compartments in the 180' WLB exceed FSOs by a very substantial margin with passive, automated, and manual fire protection features in effect both in port and at sea. Without considering the contribution provided by manual firefighting efforts or automated systems, the 180' WLB exceeds FSOs in every compartment (just passive fire protection in effect). Automated and manual fire protection only slightly increases the margin of safety for this cutter at sea and in port.

Based on historical records of reported fires for 95% of the Coast Guard fleet over a 60 month period, relatively high fire safety levels are expected in U.S. Coast Guard Seagoing Buoy Tenders.

Based on a thorough baseline fire safety analysis using the target option as well as the barrier and path options in SAFE, the following additional conclusions and recommendations are offered:

- The most probable rooms of origin for fires that may spread to **involve multiple rooms** are the Motor Room (4-126-0-E), Auxiliary Machinery Space #3 (1-112-0-Q), Linen Locker (1-157-Q), and Cleaning Gear Locker (1-161-2-Q).
- A careful analysis of the results from the various output options in SAFE provided in this report may be effectively used to develop realistic fire scenarios to assist the crew in planning firefighting training.

5.3. ANALYSIS OF ALTERNATIVES

Two issues were studied in the analysis of alternatives phase of this project. First the effect of bulkhead insulation on fire safety was studied. Second, the results of the fire safety analysis of the JUNIPER class Seagoing Buoy Tender was compared to the results of the fire safety analysis of HORNBEAM.

5.3.1. BULKHEAD INSULATION

The following conclusions relative to bulkhead insulation are based on results shown in Table 4.1:

- The effect of insulating only watertight bulkheads is negligible.
- Insulation added to steel bulkheads has a relatively small beneficial effect on fire safety in HORNBEAM.
- The relatively good baseline results are attributed in part to the fact that many of the bulkheads in the HORNBEAM are steel.

5.3.2. COMPARISON OF FIRE SAFETY ANALYSIS RESULTS

The following major conclusions are made in conjunction with the comparison of the fire safety levels in cutters HORNBEAM and JUNIPER:

- With passive and active fire protection in effect, all compartments exceed fire safety objectives by a substantial margin in JUNIPER and by a very substantial margin in HORNBEAM.
- In general, there are higher fire safety levels in HORNBEAM (lower RLFs) than JUNIPER.
- There are slightly more differences in the results of the three standard scenarios in JUNIPER.
- There does not appear to be any strong correlation between the two ships concerning which compartments have the highest RLFs
- Whereas the effect of automated and manual fire protection is negligible in HORNBEAM, they make a very significant contribution in JUNIPER
- Passive fire protection in JUNIPER must be augmented by automated fire protection systems for all compartments to exceed FSOs. In HORNBEAM all compartments exceed FSOs by a very substantial margin with just passive fire protection in effect.
- HORNBEAM lacks the sophisticated fire detection system and the automated fire protection systems installed in JUNIPER, however the excellent passive fire protection inherent in HORNBEAM's design and compartmentation overcomes the lack of these systems.

REFERENCES

1. Sprague, Chester M.; Holmstedt, Herbert A.; Romberg, Betty; and Dolph, Brian, "Fire Safety Analysis of the 175' WLM(R) Coastal Buoy Tender", Report No. CG-D-08-97, Final Report, November 1996.
2. Sprague, Chester M.; White, Derek; and Dolph, Brian, "Fire Safety Analysis of the 225' WLB(R) Seagoing Buoy Tender", Report No. CG-D-01-97, Final Report, December 1996.
3. Sprague, Chester M. and Dolph, Brian, "Theoretical Basis of the Ship Fire Safety Engineering Methodology", Report No. CG-D-30-96, Final Report, September 1996.
4. Clouthier, Elizabeth; Rich, Doris; and Romberg, Betty, "Ship Applied Fire Engineering (SAFE) User Manual, Version 2.2, A Computer Model for the Implementation of The Ship Fire Safety Engineering Methodology (SFSEM)", Report No. CG-D-10-96, Final Report, March 1996.
5. Sprague, Chester M.; Romberg, Betty; and Dolph, Brian, "Small Cutter Fire Protection Project" Report No. CG-D-26-96, Final Report, June 1996.
6. Peatross, Michelle; Beyler, Craig; and Back, Gerry, "Validation of Full Room Involvement Time Correlation Applicable to Steel Ship Compartments", Hughes Associates, Inc, Report No. 1117-001-1993, 1993.
7. USCGC HORNBEAM INSTRUCTION M9555.1B, "Machinery Space Firefighting Doctrine for Class Bravo Fires", 22 March 1995.
8. Report of Ship Visit to CGC HORNBEAM on October 5, 1995, Letter to Brian Dolph dated October 14, 1995.
9. Report of Ship Visit to CGC HORNBEAM on August 26-27, 1996, Letter to Brian Dolph dated September 3, 1996.
10. Naval Ships' Technical Manual, NAVSEA 0901-LP-079-0010, Chapter 079, "Damage Control, Stability and Buoyancy", Author/Sponsor: Naval Sea Systems Command, 15 August 1976.
11. Bahadori, Hamid, "A Quantitative Procedure for Fire Risk Assessment of U.S. Coast Guard Vessels", Master's Thesis, submitted to Worcester Polytechnic Institute, October 1987.
12. Bahadori, Hamid; Beyler, Craig; Richards, Robert; and Romberg, Betty, "Using the Ship Fire Safety Engineering Methodology with Mission Oriented Objectives", Draft Paper, Center for Firesafety Studies, Worcester Polytechnic Institute, June 1991.
13. Sprague, Chester M.; Holmstedt, Herbert A.; Romberg, Betty; and Dolph, Brian, "Fire Safety Analysis of the USCGC VINDICATOR (WMEC 3)", Technical Report, Pending Approval for Publication in the NTIS, June 1995.
14. Sprague, Chester M.; White, Derek; and Dolph, Brian, "Fire Safety Analysis of the 87' Coastal Patrol Boat (CPB)", Technical Report, Pending Approval for Publication in the NTIS, June 1997.

Appendix A
Compartmentation of the 180' WLB (Major Ren)

This appendix includes the plan views of all decks in the 180' WLB (Major Ren) class of Seagoing Buoy Tender. The plan views include the access fittings for each compartment such as doors, scuttles, hatches, and operable windows. The compartmentation shown represents how the ship was modeled in AutoCAD for the fire safety analysis.

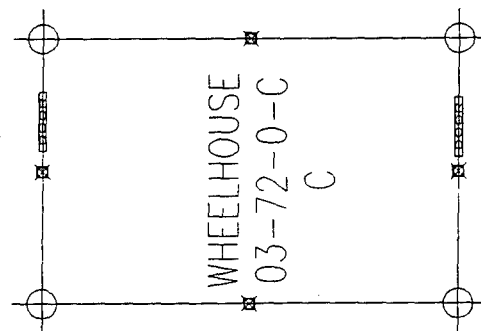
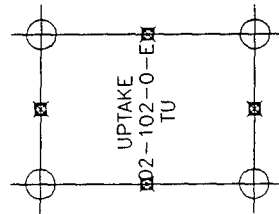
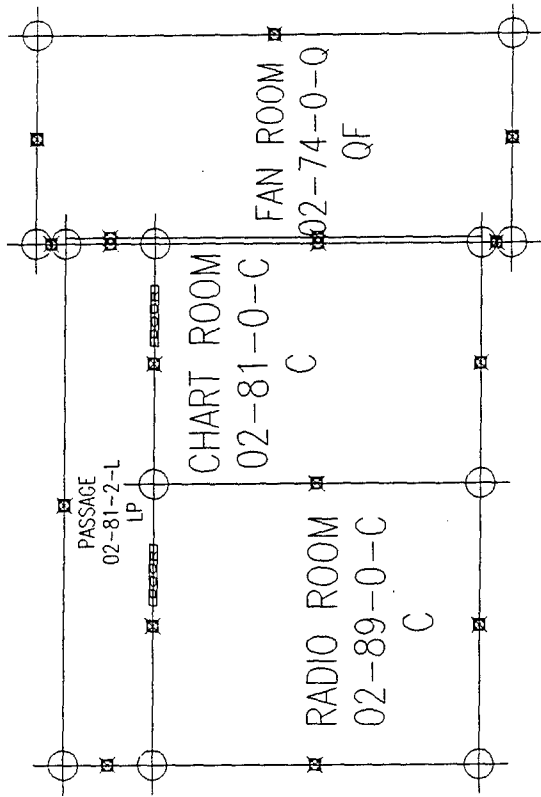

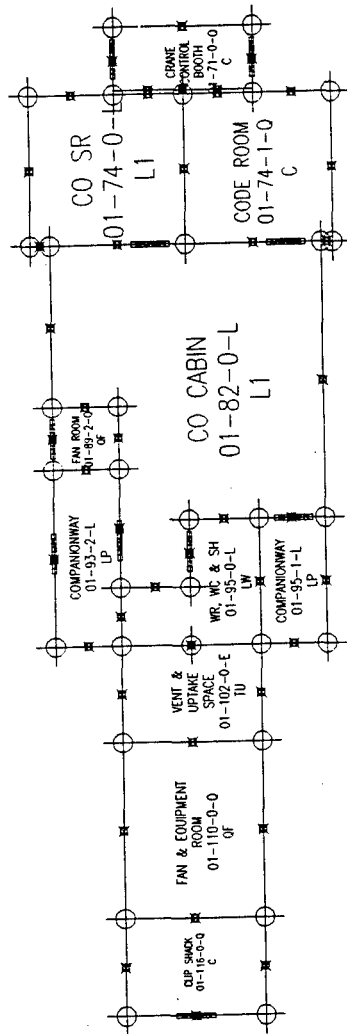

UPPER AND FORECASTLE DECK

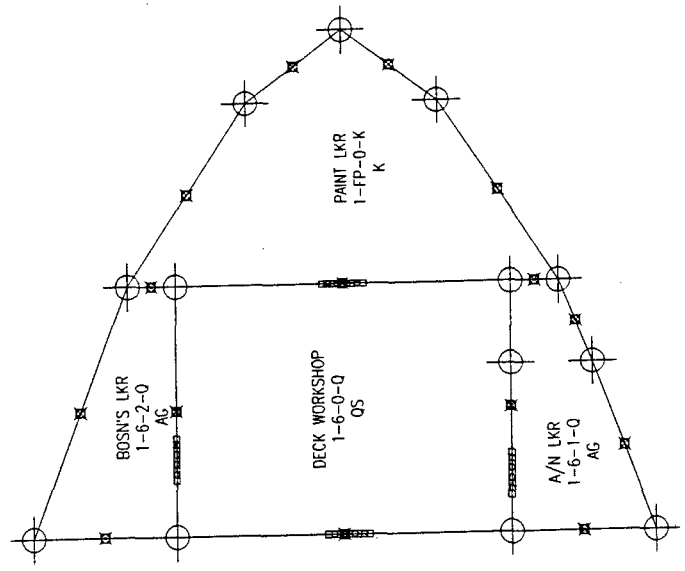
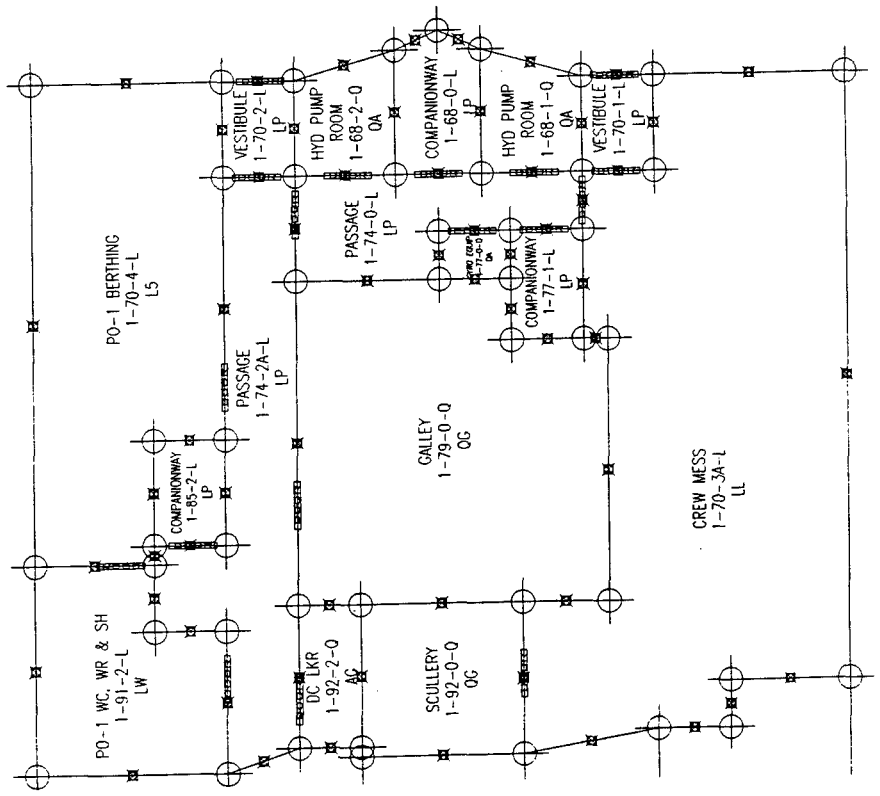

MAIN DECK

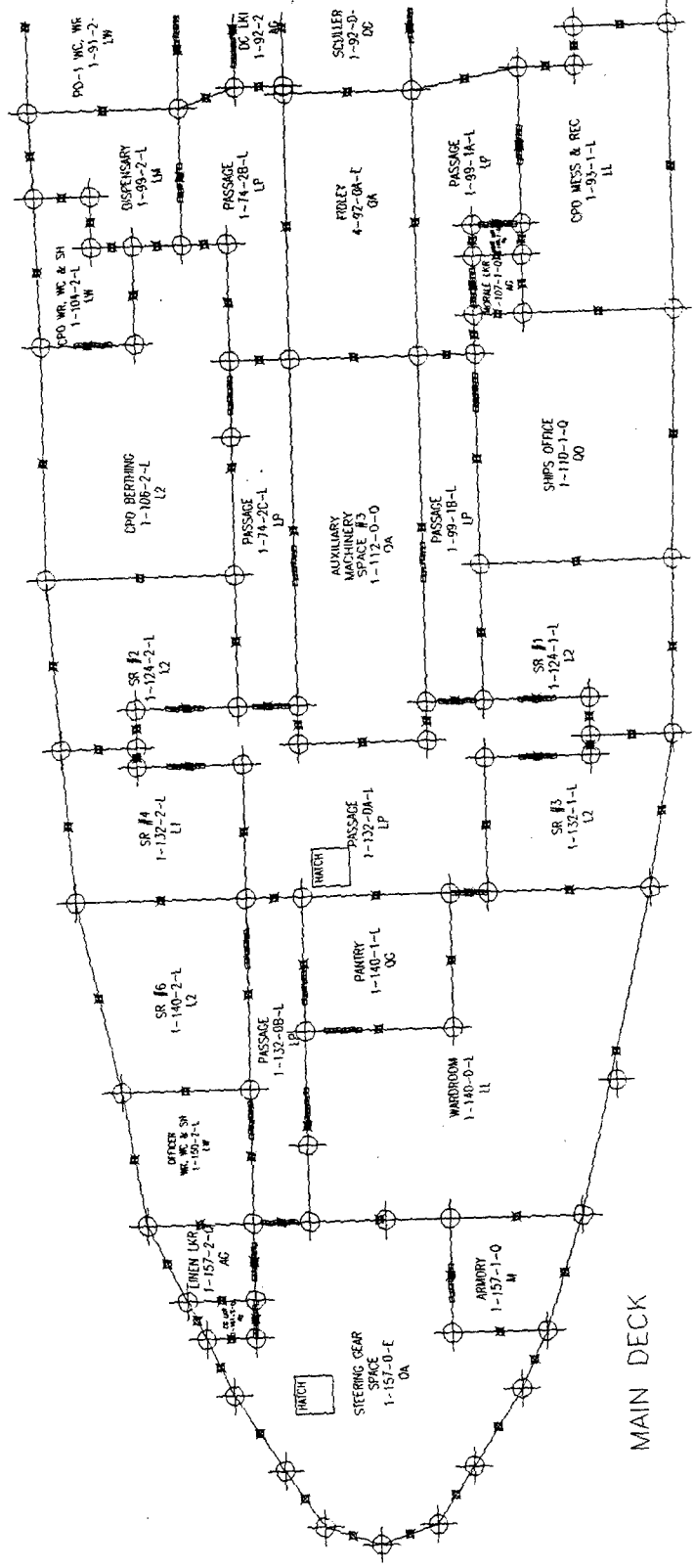

MAIN DECK

2ND DECK

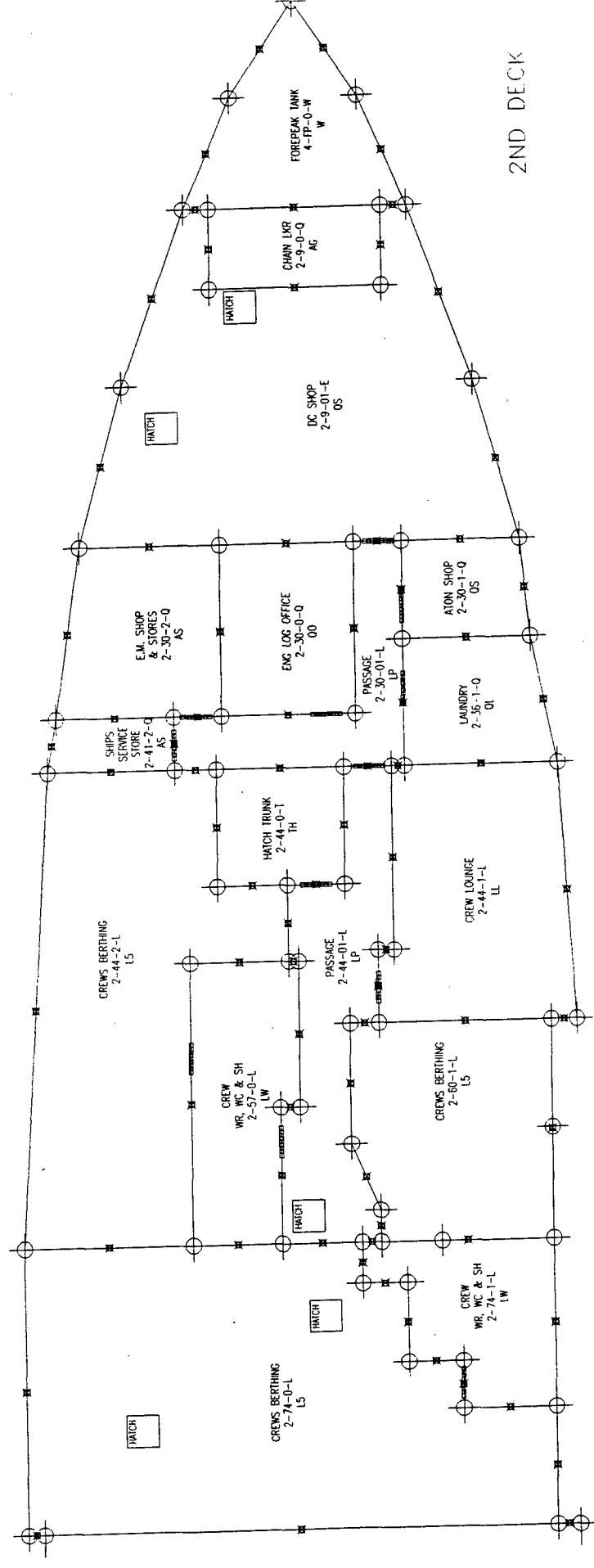

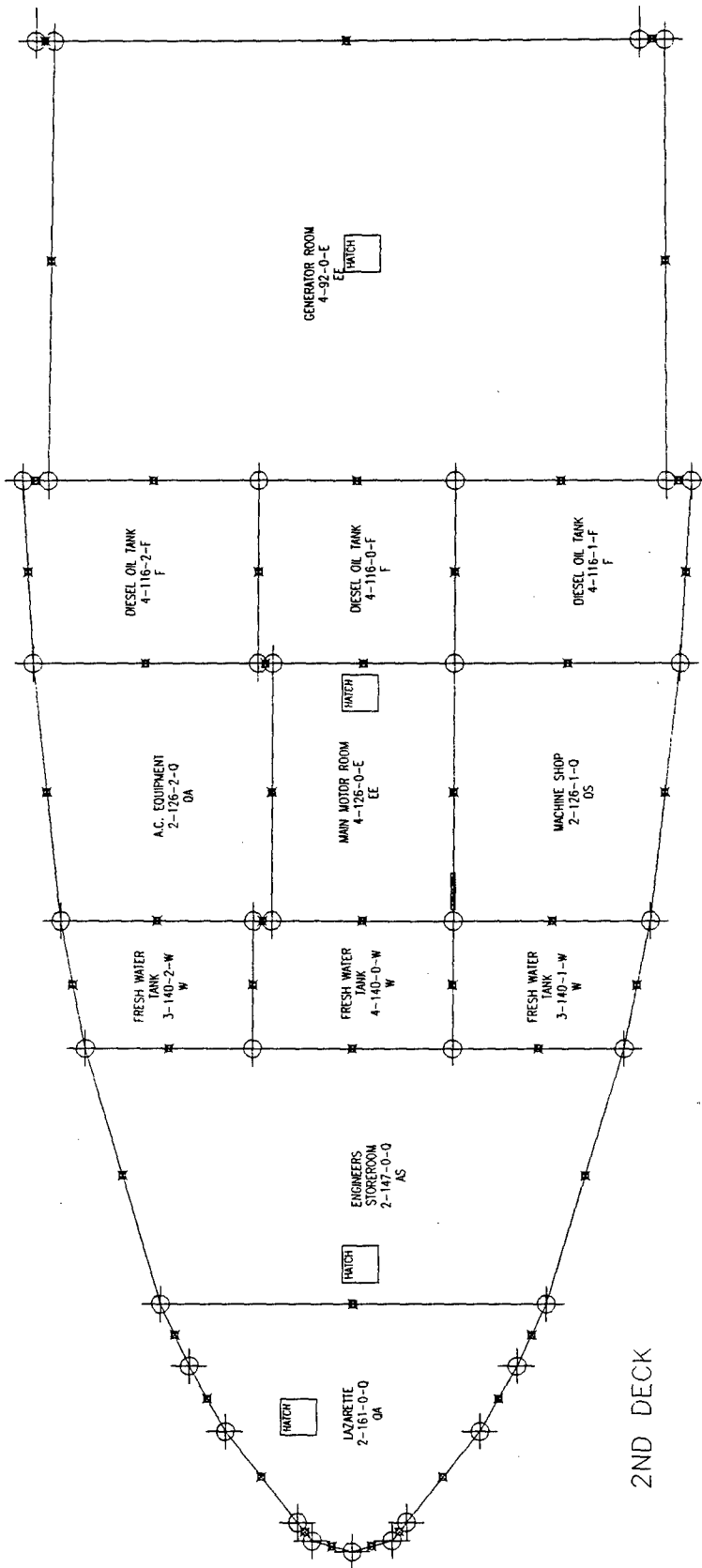

2ND DECK

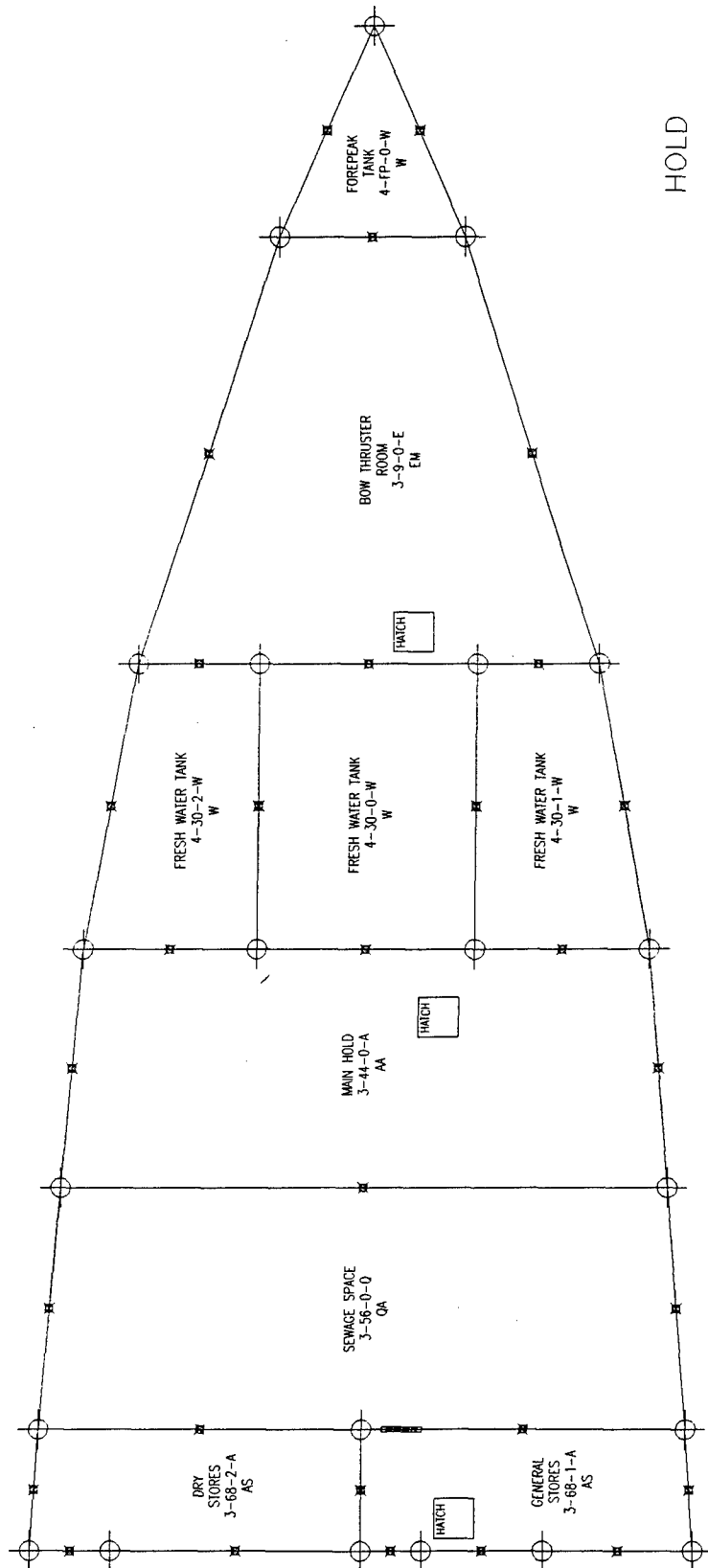

HOLD

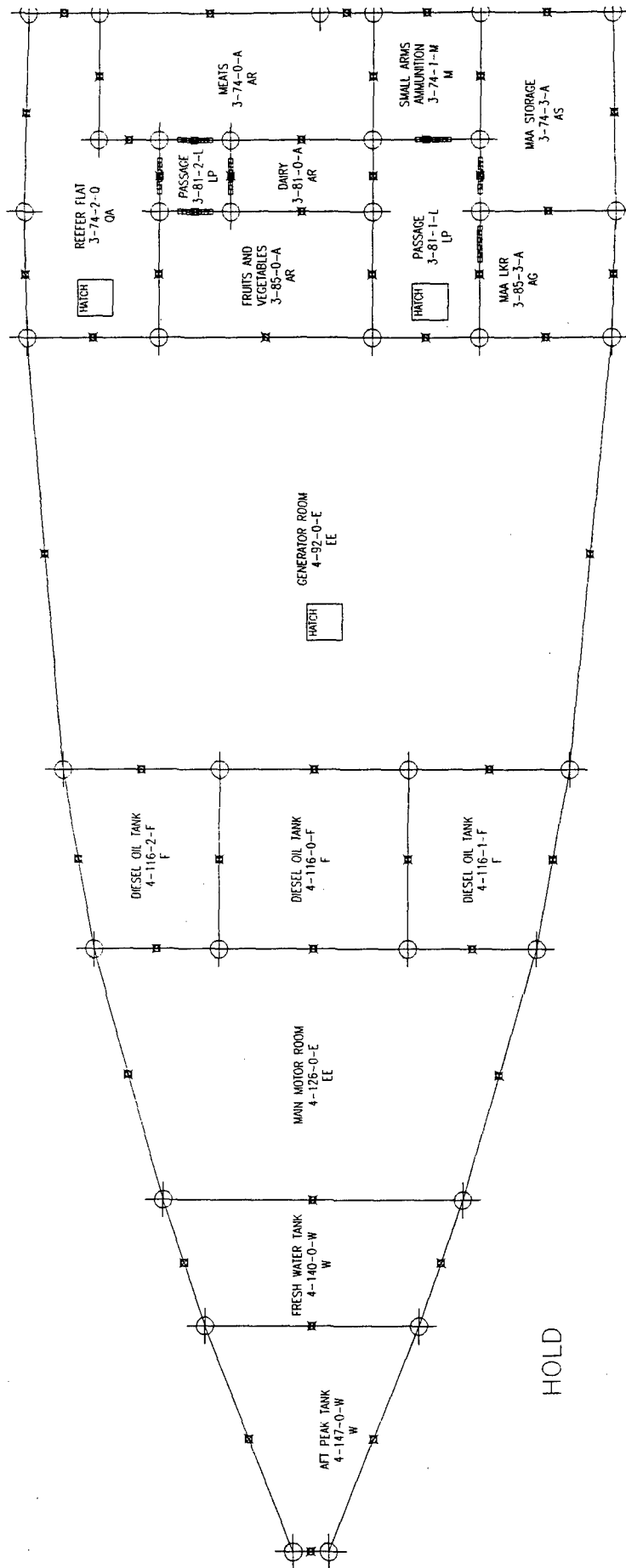

Appendix B
SAFE Input Data for the 180' WLB Baseline Fire Safety Analysis

The various input data required to perform the baseline fire safety analysis on the 180' WLB using SAFE, version 2.2, are documented in this appendix. The following is an index of the tables and attachments contained in this appendix:

B.1	Geometry	
	B.1.1 Compartment Height and Deck Area	B-2
	B.1.2 Ventilation Openings: Area and Average Height	B-5
B.2	Construction Materials	
	B.2.1 SAFE Provided Barrier Materials (attachment)	B-10
	B.2 Barrier Data	B-11
B.3	Fire Safety Objectives (MAL, FAL, and Frequency of EB)	
	B.3 Fire Safety Objectives	B-38
B.4	Fire Detection (% Time Monitored and Time to Detection)	
	B.4 Fire Detection	B-41
B.5	Automated and Manual Fire Protection Systems	
	B.5 Automated and Manual Fire Protection Systems	B-44
B.6	Probability of Flame Termination	
	B.6.1 Probability of Flame Termination: Passive and Automated Measures	B-47
	B.6.1.1 I-Value Calculations	B-50
	B.6.1.2 A-Value Calculations	B-52
	B.6.2 Probability of Flame Termination: Manual Measures (In Port)	B-53
	B.6.2.1 M-Values In Port	B-56
	B.6.2 Probability of Flame Termination: Manual Measures (At Sea)	B-59
	B.6.2.1 M-Values At Sea	B-62
B.7	Fuel Loads (Cellulosics, Plastics, and Flammable Liquids)	
	B.7 Fuel Loads	B-65
B.8	Fire Growth Models, Heat Release Rates, and FRI Times	
	B.8 Fire Growth Models, Heat Release Rates, and FRI Times	B-68

Table B.1.1 Compartment Height and Deck Area

Plan ID	Compartment Name	Height (ft)	Area (sq ft)
CUI=AA	(Cargo Hold)		
3-44-0-A	MAIN HOLD	10.5	348
CUI=AG	(Gear Locker)		
3-85-3-A	MAA LKR	10.5	52.5
2-9-0-Q	CHAIN LKR	8	54
1-6-1-Q	A/N LKR	8	42.1
1-6-2-Q	BOSN'S LKR	8	41.6
1-92-2-Q	DC LKR	8	15.6
1-106-1-Q	MOVIE LKR	8	4.2
1-107-1-Q	MORALE LKR	8	7.8
1-157-2-Q	LINEN LKR	8	18.4
1-161-2-Q	CG LKR	8	6.2
CUI=AR	(Refrigerated Storage)		
3-74-0-A	MEATS	10.5	107.8
3-81-0-A	DAIRY	10.5	32
3-85-0-A	FRUITS AND VEGETABLES	10.5	84
CUI=AS	(Storeroom)		
3-68-1-A	GENERAL STORES	10.5	97.2
3-68-2-A	DRY STORES	10.5	97.2
3-74-3-A	MAA STORAGE	10.5	82.5
2-30-2-Q	E.M. SHOP & STORES	8	101.8
2-41-2-Q	SHIPS SERVICE STORE	8	26.2
2-147-0-Q	ENGINEERS STOREROOM	8	355.6
CUI=C	(Ship Control/Communications)		
01-71-0-Q	CRANE CONTROL BOOTH	7	24.5
01-74-1-Q	CODE ROOM	7	57.8
01-116-0-Q	CLIP SHACK	7	36
02-81-0-C	CHART ROOM	8	88
02-89-0-C	RADIO ROOM	8	103.4
03-72-0-C	WHEELHOUSE	8	126
CUI=EE	(Main Propulsion - Electrical)		
4-92-0-E	GENERATOR ROOM	18.5	811.2
4-126-0-E	MAIN MOTOR ROOM	18.5	291.2
CUI=EM	(Main Propulsion - Mechanical)		
3-9-0-E	BOW THRUSTER ROOM	10.5	336
CUI=K	(Hazardous Material Storage)		
1-FP-0-K	PAINT LKR	8	110.8
CUI=L1	(Senior Officer's Cabin)		
1-132-1-L	SR #3	8	68.8
1-132-2-L	SR #4	8	68.8
01-74-0-L	CO SR	7	60.8
01-82-0-L	CO CABIN	7	188.5
CUI=L2	(Officer/CPO Quarters)		
1-106-2-L	CPO BERTHING	8	147
1-124-1-L	SR #1	8	79.7
1-124-2-L	SR #2	8	74.6
1-140-2-L	SR #6	8	79
CUI=L5	(Crews Berthing)		
2-44-2-L	CREWS BERTHING	8	334.1

Table B.1.1 Compartment Height and Deck Area

Plan ID	Compartment Name	Height (ft)	Area (sq ft)
2-60-1-L	CREWS BERTHING	8	166.5
2-74-0-L	CREWS BERTHING	8	503
1-70-4-L	PO-1 BERTHING	8	146
CUI=LL	(Wardroom/Mess/Lounge Areas)		
2-44-1-L	CREW LOUNGE	8	181.2
1-70-3A-L	CREW MESS	8	285.2
1-93-1-L	CPO MESS & REC	8	110.8
1-140-0-L	WARDROOM	8	224.2
CUI=LM	(Medical/Dental Spaces)		
1-99-2-L	DISPENSARY	8	47.2
CUI=LP	(Passageway/Staircase/Vestibule)		
3-81-1-L	PASSAGE	10.5	66
3-81-2-L	PASSAGE	10.5	16
2-30-01-L	PASSAGE	8	80.8
2-44-01-L	PASSAGE	8	135.1
1-68-0-L	COMPANIONWAY	8	20.2
1-70-1-L	VESTIBULE	8	12
1-70-2-L	VESTIBULE	8	12
1-74-0-L	PASSAGE	8	40.8
1-74-2A-L	PASSAGE	8	84.3
1-74-2B-L	PASSAGE	8	62.5
1-74-2C-L	PASSAGE	8	57.6
1-77-1-L	COMPANIONWAY	8	13.8
1-85-2-L	COMPANIONWAY	8	13.2
1-99-1A-L	PASSAGE	8	61.8
1-99-1B-L	PASSAGE	8	54
1-132-0A-L	PASSAGE	8	148
1-132-0B-L	PASSAGE	8	51
01-93-2-L	COMPANIONWAY	7	30.6
01-95-1-L	COMPANIONWAY	7	21.8
02-81-2-L	PASSAGE	8	52.2
CUI=LW	(Sanitary Spaces)		
2-57-0-L	CREW WR, WC & SH	8	110.7
2-74-1-L	CREW WR, WC & SH	8	94.6
1-91-2-L	PO-1 WC, WR & SH	8	62
1-104-2-L	CPO WR, WC & SH	8	33
1-150-2-L	OFFICER WR, WC & SH	8	43.4
01-95-0-L	WR, WC & SH	7	33.8
CUI=QA	(Aux Machinery Spaces)		
3-56-0-Q	SEWAGE SPACE	10.5	372
3-74-2-Q	REEFER FLAT	10.5	111.2
2-126-2-Q	A.C. EQUIPMENT	8	173.6
2-161-0-Q	LAZARETTE	8	180.8
1-68-1-Q	HYD PUMP ROOM	8	19.3
1-68-2-Q	HYD PUMP ROOM	8	19.3
1-77-0-Q	GYRO EQUIP	8	6
4-92-0A-E	FIDLEY	8	92.5
1-112-0-Q	AUXILIARY MACHINERY SPACE #3	8	136
1-157-0-E	STEERING GEAR SPACE	8	189.6

Table B.1.1 Compartment Height and Deck Area

Plan ID	Compartment Name	Height (ft)	Area (sq ft)
CUI=QF	(Fan Room)		
01-89-2-Q	FAN ROOM	7	10.9
01-110-0-Q	FAN & EQUIPMENT ROOM	7	64.8
02-74-0-Q	FAN ROOM	4	112
CUI=QG	(Galley/Pantry/Scullery)		
1-79-0-Q	GALLEY	8	166.4
1-92-0-Q	SCULLERY	8	43.5
1-140-1-Q	PANTRY	8	54.6
CUI=QL	(Laundry)		
2-36-1-Q	LAUNDRY	8	70.4
CUI=QO	(Office Spaces)		
2-30-0-Q	ENG LOG OFFICE	8	89
1-110-1-Q	SHIPS OFFICE	8	135.2
CUI=QS	(Shops)		
2-9-0-E	DC SHOP	8	392
2-30-1-Q	ATON SHOP	8	46.2
2-126-1-Q	MACHINE SHOP	8	162.4
1-6-0-Q	DECK WORKSHOP	8	145.6
CUI=TH	(Trunks/Hoists/Dumbwaiters)		
2-44-0-T	HATCH TRUNK	8	59.2
CUI=TU	(Stacks/Engine Uptakes)		
01-102-0-E	VENT & UPTAKE SPACE	7	36
02-102-0-E	UPTAKE	16	36
CUI=W	(Water Tank (empty))		
4-FP-0-W	FOREPEAK TANK	18.5	101
4-30-0-W	FRESH WATER TANK	10.5	151.2
4-30-1-W	FRESH WATER TANK	10.5	102.2
4-30-2-W	FRESH WATER TANK	10.5	102.2
4-140-0-W	FRESH WATER TANK	18.5	100.8
4-147-0-W	AFT PEAK TANK	10.5	88.2
3-140-1-W	FRESH WATER TANK	8	70.7
3-140-2-W	FRESH WATER TANK	8	69.3

Table B.1.2 Ventilation Openings: Area and Average Height

Plan ID	Compartment Name	#		Area	Height	Total Area	Avg.Height
		Vents	H/V	(In2)	(In.)	(In2)	(In.)
CUI=AA	(Cargo Hold)						
3-44-0-A	MAIN HOLD					49	7
		1	V	49	7		
CUI=AG	(Gear Locker)						
3-85-3-A	MAA LKR					8	2
		1	V	8	2		
2-9-0-Q	CHAIN LKR					250	20
1-6-1-Q	A/N LKR					250	20
1-6-2-Q	BOSN'S LKR					250	20
1-92-2-Q	DC LKR					250	20
1-106-1-Q	MOVIE LKR					250	20
1-107-1-Q	MORALE LKR					250	20
1-157-2-Q	LINEN LKR					25	96
		1	H	25	96		
1-161-2-Q	CG LKR					250	20
CUI=AR	(Refrigerated Storage)						
3-74-0-A	MEATS					0	0
3-81-0-A	DAIRY					0	0
3-85-0-A	FRUITS AND VEGETABLES					0	0
CUI=AS	(Storeroom)						
3-68-1-A	GENERAL STORES					32	2
		2	V	8	2		
		1	V	16	4		
3-68-2-A	DRY STORES					32	2
		2	V	8	2		
		1	V	16	4		
3-74-3-A	MAA STORAGE					18	3
		2	V	9	3		
2-30-2-Q	E.M. SHOP & STORES					12	3
		1	V	12	3		
2-41-2-Q	SHIPS SERVICE STORE					30	5
		1	V	30	5		
2-147-0-Q	ENGINEERS STOREROOM					30	5
		1	V	30	5		
CUI=C	(Ship Control/Communications)						
01-71-0-Q	CRANE CONTROL BOOTH					250	20
01-74-1-Q	CODE ROOM					226	8
		1	V	9	3		
		1	V	121	11		
		1	V	96	12		
01-116-0-	CLIP SHACK					98	7
		2	V	49	7		
02-81-0-C	CHART ROOM					212	9
		1	V	16	4		
		1	V	196	14		
02-89-0-C	RADIO ROOM					8	4
		1	V	8	4		
03-72-0-C	WHEELHOUSE					1176	14
		6	V	196	14		

Table B.1.2 Ventilation Openings: Area and Average Height

Plan ID	Compartment Name	#		Area (In2)	Height (In.)	Total Area (In2)	Avg.Height (In.)
		Vents	H/V				
CUI=EE	(Main Propulsion - Electrical)						
4-92-0-E	GENERATOR ROOM					441	108
4-126-0-E	MAIN MOTOR ROOM					60	5
		2	V	30	5		
CUI=EM	(Main Propulsion - Mechanical)						
3-9-0-E	BOW THRUSTER ROOM					7216	33
		2	V	80	8		
		1	V	7056	84		
CUI=K	(Hazardous Material Storage)						
1-FP-0-K	PAINT LKR					32	4
		2	V	16	4		
CUI=L1	(Senior Officer's Cabin)						
1-132-1-L	SR #3					130	7
		1	V	9	3		
		1	V	121	11		
1-132-2-L	SR #4					121	11
		1	V	121	11		
01-74-0-L	CO SR					301	9
		1	V	196	14		
		1	V	9	3		
		1	V	96	12		
01-82-0-L	CO CABIN					876	13
		3	V	196	14		
		3	V	96	12		
CUI=L2	(Officer/CPO Quarters)						
1-106-2-L	CPO BERTHING					121	11
		1	V	121	11		
1-124-1-L	SR #1					130	7
		1	V	9	3		
		1	V	121	11		
1-124-2-L	SR #2					121	11
		1	V	121	11		
1-140-2-L	SR #6					130	53
		1	V	121	11		
		1	H	9	96		
CUI=L5	(Crews Berthing)						
2-44-2-L	CREWS BERTHING					16	4
		1	V	16	4		
2-60-1-L	CREWS BERTHING					400	10
2-74-0-L	CREWS BERTHING					228	6
		2	V	9	3		
		2	V	45	5		
		1	V	16	4		
		2	V	52	13		
1-70-4-L	PO-1 BERTHING					77	54
		1	H	25	96		
		1	V	52	13		
CUI=LL	(Wardroom/Mess/Lounge Areas)						
2-44-1-L	CREW LOUNGE					129	5

Table B.1.2 Ventilation Openings: Area and Average Height

Plan ID	Compartment Name	#		Area (In2)	Height (In.)	Total Area (In2)	Avg.Height (In.)
		Vents	H/V				
		1	V	32	4		
		1	V	25	5		
		1	V	72	8		
1-70-3A-L	CREW MESS					676	8
		2	V	25	5		
		5	V	121	11		
		1	V	21	3		
1-93-1-L	CPO MESS & REC					339	31
		1	H	25	96		
		1	V	72	9		
		2	V	121	11		
1-140-0-L	WARDROOM					36	6
		1	V	36	6		
CUI=LM	(Medical/Dental Spaces)						
1-99-2-L	DISPENSARY					40	8
		1	V	40	8		
CUI=LP	(Passageway/Staircase/Vestibule)						
3-81-1-L	PASSAGE					200	10
3-81-2-L	PASSAGE					200	10
2-30-01-L	PASSAGE					200	10
2-44-01-L	PASSAGE					200	10
1-68-0-L	COMPANIONWAY					200	10
1-70-1-L	VESTIBULE					200	10
1-70-2-L	VESTIBULE					200	10
1-74-0-L	PASSAGE					200	10
1-74-2A-L	PASSAGE					0	0
1-74-2B-L	PASSAGE					200	10
1-74-2C-L	PASSAGE					0	0
1-77-1-L	COMPANIONWAY					200	10
1-85-2-L	COMPANIONWAY					200	10
1-99-1A-L	PASSAGE					200	10
1-99-1B-L	PASSAGE					200	10
1-132-0A-	PASSAGE					200	10
1-132-0B-	PASSAGE					72	96
		1	H	72	96		
01-93-2-L	COMPANIONWAY					200	10
01-95-1-L	COMPANIONWAY					200	10
02-81-2-L	PASSAGE					196	14
		1	V	196	14		
CUI=LW	(Sanitary Spaces)						
2-57-0-L	CREW WR, WC & SH					283	9
		2	V	77	7		
		1	V	24	4		
		1	V	105	21		
2-74-1-L	CREW WR, WC & SH					96	12
		1	V	96	12		
1-91-2-L	PO-1 WC, WR & SH					25	96
		1	H	25	96		
1-104-2-L	CPO WR, WC & SH					72	8

Table B.1.2 Ventilation Openings: Area and Average Height

Plan ID	Compartment Name	#		Area (In ²)	Height (In.)	Total Area (In ²)	Avg.Height (In.)
		Vents	H/V				
		1	V	72	8		
1-150-2-L	OFFICER WR, WC & SH					122	67
		1	V	72	9		
		2	H	25	96		
01-95-0-L	WR, WC & SH					96	12
		1	V	96	12		
CUI=QA	(Aux Machinery Spaces)						
3-56-0-Q	SEWAGE SPACE					48	4
		1	V	16	4		
		1	V	32	4		
3-74-2-Q	REEFER FLAT					16	2
		2	V	8	2		
2-126-2-Q	A.C. EQUIPMENT					150	50
2-161-0-Q	LAZARETTE					74	6
		1	V	25	5		
		1	V	49	7		
1-68-1-Q	HYD PUMP ROOM					150	50
1-68-2-Q	HYD PUMP ROOM					150	50
1-77-0-Q	GYRO EQUIP					150	50
4-92-0A-E	FIDLEY					106	96
		2	H	49	96		
		1	H	8	96		
1-112-0-Q	AUXILIARY MACHINERY SPACE					150	50
1-157-0-E	STEERING GEAR SPACE					41	4
		1	V	16	4		
		1	V	25	5		
CUI=QF	(Fan Room)						
01-89-2-Q	FAN ROOM					2000	50
01-110-0-	FAN & EQUIPMENT ROOM					2000	50
02-74-0-Q	FAN ROOM					2000	50
CUI=QG	(Galley/Pantry/Scullery)						
1-79-0-Q	GALLEY					37	3
		1	V	16	4		
		1	V	21	3		
1-92-0-Q	SCULLERY					53	66
		1	V	12	6		
		1	H	25	96		
		1	H	16	96		
1-140-1-Q	PANTRY					16	4
		1	V	16	4		
CUI=QL	(Laundry)						
2-36-1-Q	LAUNDRY					49	7
		1	V	49	7		
CUI=QO	(Office Spaces)						
2-30-0-Q	ENG LOG OFFICE					121	11
		1	V	121	11		
1-110-1-Q	SHIPS OFFICE					251	8
		2	V	121	11		
		1	V	9	3		

Table B.1.2 Ventilation Openings: Area and Average Height

Plan ID	Compartment Name	#		Area (In2)	Height (In.)	Total Area (In2)	Avg.Height (In.)
		Vents	H/V				
CUI=QS	(Shops)						
2-9-0-E	DC SHOP					81	9
		1	V	81	9		
2-30-1-Q	ATON SHOP					8	2
		1	V	8	2		
2-126-1-Q	MACHINE SHOP					250	75
1-6-0-Q	DECK WORKSHOP					148	8
		1	V	108	12		
		1	V	40	5		
CUI=TH	(Trunks/Hoists/Dumbwaiters)						
2-44-0-T	HATCH TRUNK					10	1
CUI=TU	(Stacks/Engine Uptakes)						
01-102-0-	VENT & UPTAKE SPACE					1000	25
02-102-0-	UPTAKE					8	4
		1	V	8	4		
CUI=W	(Water Tank (empty))						
4-FP-0-W	FOREPEAK TANK					0	0
4-30-0-W	FRESH WATER TANK					0	0
4-30-1-W	FRESH WATER TANK					0	0
4-30-2-W	FRESH WATER TANK					0	0
4-140-0-W	FRESH WATER TANK					0	0
4-147-0-W	AFT PEAK TANK					0	0
3-140-1-W	FRESH WATER TANK					0	0
3-140-2-W	FRESH WATER TANK					0	0

Attachment B.2.1
SAFE PROVIDED BARRIER MATERIALS
 (English Units)

ID	Description	Structural or Non	Thickness inches	Density lb/ft ³	Spec Ht in/lb. ft.	Therm. Cond. BTU/in. ft. ° F	Rt Rel X	Ibar			Obar				
								X-1 kBTU/min. ft ²	X-2 kBTU/min. ft ²	X-3 kBTU/min. ft ²	X-1 kBTU/min. ft ²	X-2 kBTU/min. ft ²	X-3 kBTU/min. ft ²		
000	Zero-strength (includes screening and grating)	N	0.000	0	0.000	96.29	100	0	0	0	0	0	0	0	0
A21	1/4" Aluminum with thermal insulation	S	2.000	162	0.048	0.05	5	3	6	10	3	6	10	3	6
A2U	1/4" Aluminum	S	0.250	166	0.230	1.22	15	0	2	4	4	4	6	4	6
C5U	5/8" Celotex (overhead: below crawl space layer)	N	0.625	1	0.167	0.00	25	1	3	4	1	3	4	1	3
F2U	1/4" Fiberglass Toilet/Shower Enclosure	N	0.250	86	0.229	0.00	35	2	5	7	25	35	40	25	35
WPI	Komex honeycomb core - plastic laminate & insulation	N	2.000	3	0.289	0.00	30	2	8	10	9	18	22	9	18
WPU	Komex honeycomb core - plastic laminate facing	N	0.625	3	0.289	0.00	30	2	6	14	3	12	20	3	12
W5U	Komex honeycomb core - stainless steel facing	N	0.625	3	0.289	0.00	25	8	20	30	55	80	105	55	80
P7P	7/8" Plywood - plastic laminate facing, both sides	N	0.875	34	0.290	0.00	15	6	12	21	10	20	27	10	20
S21	1/4" Steel with thermal insulation	S	2.000	487	0.024	0.01	5	5	15	16	75	100	120	75	100
S2U	1/4" Steel	S	0.250	490	0.119	0.44	5	1	4	10	60	80	100	60	80
S31	3/8" Steel with thermal insulation	S	2.000	487	0.024	0.01	5	6	18	20	60	110	130	60	110
S3U	3/8" Steel	S	0.375	490	0.119	0.44	5	1	4	10	65	85	105	65	85
S41	1/2" Steel with thermal insulation	S	2.000	487	0.024	0.01	5	6	18	20	60	110	130	60	110
S4U	1/2" Steel	S	0.500	490	0.119	0.44	5	2	5	12	70	90	110	70	90
S5U	5/8" Steel	S	0.625	490	0.119	0.44	5	2	5	12	75	95	115	75	95

Table B.2 Barrier Data

Barrier Materials			Compartment Name	Area	Therm	Durab	Door/	Readiness
<1>	<2>	<3>		ft2	adj	adj	Hatch	
			4-FP-0-W	FOREPEAK TANK	(CUI	= W)		
B05	S3I	B05	3-9-0-E	BOW THRUSTER ROOM	96.6	0	0	
S2U	S3I	S2U	2-9-0-Q	CHAIN LKR	86.4	0	0	
S2U	S3I	S2U	2-9-0-E	DC SHOP	12.8	0	0	
S2U	S3I	S2U	2-9-0-E	DC SHOP	12.8	0	0	
B05	S3U		(none)	(weather bulkhead)	119.4	0	0	
B05	S3U		(none)	(weather bulkhead)	119.4	0	0	
S3U	S3U		(none)	(weather bulkhead)	57.7	0	0	
S3U	S3U		(none)	(weather bulkhead)	60.9	0	0	
S3U	S3U		(none)	(weather bulkhead)	60.9	0	0	
S3U	S3U		(none)	(weather bulkhead)	57.7	0	0	
S2U			1-FP-0-K	PAINT LKR	58.4	0	0	
S2U			1-6-0-Q	DECK WORKSHOP	42.7	0	0	
			3-9-0-E	BOW THRUSTER ROOM	(CUI	= EM)		
B05	S3I	B05	4-FP-0-W	FOREPEAK TANK	96.6	0	0	
B05	S3I	B05	4-30-0-W	FRESH WATER TANK	113.4	0	0	
B05	S3I	B05	4-30-1-W	FRESH WATER TANK	63	0	0	
B05	S3I	B05	4-30-2-W	FRESH WATER TANK	63	0	0	
B05	S3U		(none)	(weather bulkhead)	231.8	0	0	
B05	S3U		(none)	(weather bulkhead)	231.8	0	0	
S2U			2-9-0-E	DC SHOP	284	0	0	HL X
S2U			2-9-0-Q	CHAIN LKR	52	0	0	
			4-30-0-W	FRESH WATER TANK	(CUI	= W)		
B05	S3I	B05	3-9-0-E	BOW THRUSTER ROOM	113.4	0	0	
B05		B05	4-30-1-W	FRESH WATER TANK	147	0	0	
B05		B05	4-30-2-W	FRESH WATER TANK	147	0	0	
B05	S3I	B05	3-44-0-A	MAIN HOLD	113.4	0	0	
S2U			2-30-0-Q	ENG LOG OFFICE	89	0	0	
D05			2-30-01-L	PASSAGE	57.9	0	0	
S2U			2-30-2-Q	E.M. SHOP & STORES	4.2	0	0	
			4-30-1-W	FRESH WATER TANK	(CUI	= W)		
B05	S3I	B05	3-9-0-E	BOW THRUSTER ROOM	63	0	0	
B05		B05	4-30-0-W	FRESH WATER TANK	147	0	0	
B05	S3I	B05	3-44-0-A	MAIN HOLD	90.3	0	0	
B05	S3U		(none)	(weather bulkhead)	149.5	0	0	
D05			2-30-01-L	PASSAGE	14	0	0	
S2U			2-30-1-Q	ATON SHOP	33.3	0	0	
D05			2-36-1-Q	LAUNDRY	54.9	0	0	
			4-30-2-W	FRESH WATER TANK	(CUI	= W)		
B05	S3I	B05	3-9-0-E	BOW THRUSTER ROOM	63	0	0	
B05		B05	4-30-0-W	FRESH WATER TANK	147	0	0	
B05	S3I	B05	3-44-0-A	MAIN HOLD	90.3	0	0	
B05	S3U		(none)	(weather bulkhead)	149.5	0	0	
S2U			2-30-01-L	PASSAGE	8.8	0	0	
S2U			2-30-2-Q	E.M. SHOP & STORES	74	0	0	

Table B.2 Barrier Data

Barrier Materials			Compartment Name	Area	Therm	Durab	Door/	Readiness
<1>	<2>	<3>		ft2	adj	adj	Hatch	
S2U			2-41-2-Q	SHIPS SERVICE STORE	19.3	0	0	
			3-44-0-A	MAIN HOLD	(CUI	= AA)		
B05	S3I	B05	4-30-0-W	FRESH WATER TANK	113.4	0	0	
B05	S3I	B05	4-30-1-W	FRESH WATER TANK	90.3	0	0	
B05	S3I	B05	4-30-2-W	FRESH WATER TANK	90.3	0	0	
B05	S3I	B05	3-56-0-Q	SEWAGE SPACE	315	0	0	
B05	S3U		(none)	(weather bulkhead)	126.4	0	0	
B05	S3U		(none)	(weather bulkhead)	126.4	0	0	
S2I			2-44-0-T	HATCH TRUNK	59.2	0	0	HO O
S2I			2-44-01-L	PASSAGE	52.2	0	0	
S2I			2-44-1-L	CREW LOUNGE	107.2	0	0	
D05			2-44-2-L	CREWS BERTHING	129.4	0	0	
			3-56-0-Q	SEWAGE SPACE	(CUI	= QA)		
B05	S3I	B05	3-44-0-A	MAIN HOLD	315	0	0	
B05	S3I	B05	3-68-1-A	GENERAL STORES	168	0	0	DWT Y
B05	S3I	B05	3-68-2-A	DRY STORES	168	0	0	
B05	S3U		(none)	(weather bulkhead)	126.4	0	0	
B05	S3U		(none)	(weather bulkhead)	126.4	0	0	
S2I			2-44-01-L	PASSAGE	49.2	0	0	
S2I			2-44-1-L	CREW LOUNGE	44.4	0	0	
D05			2-44-2-L	CREWS BERTHING	100.8	0	0	
D05			2-57-0-L	CREW WR, WC & SH	77.1	0	0	HS X
S2I			2-60-1-L	CREWS BERTHING	98.3	0	0	
			3-68-1-A	GENERAL STORES	(CUI	= AS)		
B05	S3I	B05	3-56-0-Q	SEWAGE SPACE	168	0	0	DWT Y
0		0	3-68-2-A	DRY STORES	63	0	0	
B05	S3I	B05	3-74-0-A	MEATS	31.5	0	0	
B05	S3I	B05	3-74-1-M	SMALL ARMS AMMUNITIO	63	0	0	
B05	S3I	B05	3-74-3-A	MAA STORAGE	77.7	0	0	
S2I	S3U		(none)	(weather bulkhead)	63.1	0	0	
S2I			2-44-01-L	PASSAGE	24.2	0	0	HS X
S2I			2-60-1-L	CREWS BERTHING	68.2	0	0	
			3-68-2-A	DRY STORES	(CUI	= AS)		
B05	S3I	B05	3-56-0-Q	SEWAGE SPACE	168	0	0	
0		0	3-68-1-A	GENERAL STORES	63	0	0	
B05	S3I	B05	3-74-0-A	MEATS	130.2	0	0	
B05	S3I	B05	3-74-2-Q	REEFER FLAT	42	0	0	
S2I	S3U		(none)	(weather bulkhead)	63.1	0	0	
S2I			2-44-01-L	PASSAGE	9.6	0	0	
D05			2-44-2-L	CREWS BERTHING	54	0	0	
D05			2-57-0-L	CREW WR, WC & SH	33.6	0	0	
			3-74-0-A	MEATS	(CUI	= AR)		
B05	S3I	B05	3-68-1-A	GENERAL STORES	31.5	0	0	
B05	S3I	B05	3-68-2-A	DRY STORES	130.2	0	0	

Table B.2 Barrier Data

Barrier Materials			Compartment Name	Area	Therm	Durab	Door/	Readiness
<1>	<2>	<3>		ft2	adj	adj	Hatch	
B05		S2I	3-74-2-Q	REEFER FLAT	73.5	0	0	
B05		S2I	3-74-2-Q	REEFER FLAT	35.7	0	0	
B05		B05	3-74-1-M	SMALL ARMS AMMUNITIO	73.5	0	0	
B05		B06	3-81-0-A	DAIRY	84	0	0	
B05		B05	3-81-2-L	PASSAGE	42	0	0	DJ NC
D05			2-74-0-L	CREWS BERTHING	107.8	0	0	
			3-74-2-Q	REEFER FLAT	(CUI = QA)			
B05	S3I	B05	3-68-2-A	DRY STORES	42	0	0	
S2I		B05	3-74-0-A	MEATS	73.5	0	0	
S2I		B05	3-74-0-A	MEATS	35.7	0	0	
S2I		B05	3-81-2-L	PASSAGE	42	0	0	DJ NC
S2I		S2I	3-85-0-A	FRUITS AND VEGETABLE	73.5	0	0	
B05	S3I	B05	4-92-0-E	GENERATOR ROOM	77.7	0	0	
S2I	S3U		(none)	(weather bulkhead)	115.5	0	0	
S2I	S3U		(none)	(weather bulkhead)	73.5	0	0	
D05			2-74-0-L	CREWS BERTHING	111.2	0	0	HL X
			3-74-3-A	MAA STORAGE	(CUI = AS)			
B05	S3I	B05	3-68-1-A	GENERAL STORES	77.7	0	0	
B05		B05	3-74-1-M	SMALL ARMS AMMUNITIO	73.5	0	0	
B05		B05	3-81-1-L	PASSAGE	42	0	0	DWT X
B05		B05	3-85-3-A	MAA LKR	79.8	0	0	
S2I	S3U		(none)	(weather bulkhead)	115.5	0	0	
D05			2-74-0-L	CREWS BERTHING	4.4	0	0	
D05			2-74-1-L	CREW WR, WC & SH	66	0	0	
			3-81-0-A	DAIRY	(CUI = AR)			
B06		B05	3-74-0-A	MEATS	84	0	0	
B06		B05	3-81-1-L	PASSAGE	42	0	0	
B06		B05	3-81-2-L	PASSAGE	42	0	0	DJ NC
B06		B06	3-85-0-A	FRUITS AND VEGETABLE	84	0	0	
D05			2-74-0-L	CREWS BERTHING	32	0	0	
			3-81-1-L	PASSAGE	(CUI = LP)			
B05		B05	3-74-1-M	SMALL ARMS AMMUNITIO	63	0	0	DWT X
B05		B05	3-74-3-A	MAA STORAGE	42	0	0	DWT X
B05		B06	3-81-0-A	DAIRY	42	0	0	
B05		B06	3-85-0-A	FRUITS AND VEGETABLE	73.5	0	0	
B05		B05	3-85-3-A	MAA LKR	73.5	0	0	DWT X
B05	S3I	B05	4-92-0-E	GENERATOR ROOM	63	0	0	
D05			2-74-0-L	CREWS BERTHING	64.3	0	0	HS X
			3-81-2-L	PASSAGE	(CUI = LP)			
B05		B05	3-74-0-A	MEATS	42	0	0	DJ NC
B05		S2I	3-74-2-Q	REEFER FLAT	42	0	0	DJ NC
B05		B06	3-81-0-A	DAIRY	42	0	0	DJ NC
B05		B06	3-85-0-A	FRUITS AND VEGETABLE	42	0	0	DJ NC
D05			2-74-0-L	CREWS BERTHING	16	0	0	

Table B.2 Barrier Data

Barrier Materials			Compartment Name	Area	Therm	Durab	Door/	Readiness
<1>	<2>	<3>		ft2	adj	adj	Hatch	
			3-85-0-A	FRUITS AND VEGETABLES	(CUI = AR)			
S2I		S2I	3-74-2-Q	REEFER FLAT	73.5	0	0	
B06		B06	3-81-0-A	DAIRY	84	0	0	
B06		B05	3-81-1-L	PASSAGE	73.5	0	0	
B06		B05	3-81-2-L	PASSAGE	42	0	0	DJ NC
B05	S3I	B05	4-92-0-E	GENERATOR ROOM	126	0	0	
D05			2-74-0-L	CREWS BERTHING	84	0	0	
			3-85-3-A	MAA LKR	(CUI = AG)			
B05		B05	3-74-3-A	MAA STORAGE	79.8	0	0	
B05		B05	3-81-1-L	PASSAGE	73.5	0	0	DWT X
B05	S3I	B05	4-92-0-E	GENERATOR ROOM	77.7	0	0	
S2I	S3U		(none)	(weather bulkhead)	73.5	0	0	
D05			2-74-0-L	CREWS BERTHING	44.8	0	0	
			4-92-0-E	GENERATOR ROOM	(CUI = EE)			
B05	S3I	B05	3-74-2-Q	REEFER FLAT	77.7	0	0	
B05	S3I	B05	3-81-1-L	PASSAGE	63	0	0	
B05	S3I	B05	3-85-0-A	FRUITS AND VEGETABLE	126	0	0	
B05	S3I	B05	3-85-3-A	MAA LKR	77.7	0	0	
S3U	S3I	S3U	4-116-0-F	DIESEL OIL TANK	111.3	0	0	
B05	S3I	B05	4-116-0-F	DIESEL OIL TANK	86.4	0	0	
B05	S3I	B05	4-116-1-F	DIESEL OIL TANK	94.5	0	0	
B05	S3I	B05	4-116-1-F	DIESEL OIL TANK	92.8	0	0	
S3U	S3I	S3U	4-116-2-F	DIESEL OIL TANK	92.4	0	0	
B05	S3I	B05	4-116-2-F	DIESEL OIL TANK	92.8	0	0	
S2I	S3I	S2U	2-74-0-L	CREWS BERTHING	257.6	0	0	
S3U	S3U		(none)	(weather bulkhead)	253.1	0	0	
S3U	S3U		(none)	(weather bulkhead)	253.1	0	0	
S2U	S3U		(none)	(weather bulkhead)	192	0	0	
S2U	S3U		(none)	(weather bulkhead)	192	0	0	
B05	S3U		(none)	(weather bulkhead)	11.2	0	0	
S2I			4-92-0A-E	FIDLEY	92.5	-90	-90	HL X
D05			1-70-3A-L	CREW MESS	65.6	0	0	
S2I			1-74-2A-L	PASSAGE	22.5	0	0	
S2I			1-74-2B-L	PASSAGE	62.5	0	0	
S2I			1-74-2C-L	PASSAGE	12.8	0	0	
D05			1-91-2-L	PO-1 WC, WR & SH	51.8	0	0	
D05			1-92-0-Q	SCULLERY	43.5	0	0	
S2I			1-92-2-Q	DC LKR	15.6	0	0	
S2I			1-93-1-L	CPO MESS & REC	109.2	0	0	
S2I			1-99-1A-L	PASSAGE	61.8	0	0	
S2I			1-99-1B-L	PASSAGE	12	0	0	
D05			1-99-2-L	DISPENSARY	47.1	0	0	
D05			1-104-2-L	CPO WR, WC & SH	33	0	0	
S2I			1-106-1-Q	MOVIE LKR	4.2	0	0	
S2I			1-106-2-L	CPO BERTHING	75	0	0	
S2I			1-107-1-Q	MORALE LKR	7.8	0	0	

Table B.2 Barrier Data

Barrier Materials			Compartment Name	Area	Therm	Durab	Door/	Readiness
<1>	<2>	<3>		ft2	adj	adj	Hatch	
S2I			1-110-1-Q	SHIPS OFFICE	63	0	0	
S2I			1-112-0-Q	AUXILIARY MACHINERY	27.2	-15	-15	
S3I			(none)	(weather overhead)	4.1	0	0	
			4-126-0-E	MAIN MOTOR ROOM	(CUI	= EE)		
S3U	S3I	S3U	4-116-0-F	DIESEL OIL TANK	111.3	0	0	
B05	S3I	B05	4-116-0-F	DIESEL OIL TANK	80	0	0	
S3U	S3I	S3U	4-116-1-F	DIESEL OIL TANK	75.6	0	0	
S3U	S3I	S3U	4-116-2-F	DIESEL OIL TANK	73.5	0	0	
S3U	S3I	S3U	4-140-0-W	FRESH WATER TANK	176.4	0	0	
B05	S3I	B05	4-140-0-W	FRESH WATER TANK	80	0	0	
0		0	2-126-1-Q	MACHINE SHOP	112	0	0	DJ NC
0		0	2-126-2-Q	A.C. EQUIPMENT	112	0	0	
S3I	S3U		(none)	(weather bulkhead)	152.9	0	0	
S3I	S3U		(none)	(weather bulkhead)	152.9	0	0	
S2U			2-126-1-Q	MACHINE SHOP	70	0	0	
S2U			2-126-2-Q	A.C. EQUIPMENT	81.2	0	0	
S2U			1-74-2C-L	PASSAGE	4.8	0	0	
S2U			1-99-1B-L	PASSAGE	8	0	0	
S2U			1-112-0-Q	AUXILIARY MACHINERY	40.8	-15	-15	HL X
S2U			1-132-0A-L	PASSAGE	86.4	0	0	HS X
			4-140-0-W	FRESH WATER TANK	(CUI	= W)		
S3U	S3I	S3U	4-126-0-E	MAIN MOTOR ROOM	176.4	0	0	
B05	S3I	B05	4-126-0-E	MAIN MOTOR ROOM	80	0	0	
S3U	S3I	S3U	4-147-0-W	AFT PEAK TANK	126	0	0	
B05	S3I	B05	2-126-2-Q	A.C. EQUIPMENT	8	0	0	
B05		B05	3-140-1-W	FRESH WATER TANK	56	0	0	
B05		B05	3-140-2-W	FRESH WATER TANK	56	0	0	
B05		B05	2-147-0-Q	ENGINEERS STOREROOM	88	0	0	
S3U	S3U		(none)	(weather bulkhead)	77.7	0	0	
S3U	S3U		(none)	(weather bulkhead)	77.7	0	0	
S2U			3-140-1-W	FRESH WATER TANK	12.6	0	0	
S2U			3-140-2-W	FRESH WATER TANK	11.2	0	0	
D05			1-132-0B-L	PASSAGE	15.4	0	0	
S2U			1-140-0-L	WARDROOM	7	0	0	
D05			1-140-1-Q	PANTRY	54.6	0	0	
			4-147-0-W	AFT PEAK TANK	(CUI	= W)		
S3U	S3I	S3U	4-140-0-W	FRESH WATER TANK	126	0	0	
S3U	S3U		(none)	(weather bulkhead)	21	0	0	
S3U	S3U		(none)	(weather bulkhead)	142.3	0	0	
S3U	S3U		(none)	(weather bulkhead)	142.3	0	0	
S2U			2-147-0-Q	ENGINEERS STOREROOM	88.2	0	0	
			2-9-0-Q	CHAIN LKR	(CUI	= AG)		
S2U	S3I	S2U	4-FP-0-W	FOREPEAK TANK	86.4	0	0	
S2U		S2U	2-9-0-E	DC SHOP	40	0	0	
S2U		S2U	2-9-0-E	DC SHOP	86.4	0	0	

Table B.2 Barrier Data

Barrier Materials			Compartment Name	Area	Therm	Durab	Door/	Readiness
<1>	<2>	<3>		ft2	adj	adj	Hatch	
S2U		S2U	2-9-0-E	DC SHOP	40	0	0	
S2U			3-9-0-E	BOW THRUSTER ROOM	52	0	0	
S2U			1-6-0-Q	DECK WORKSHOP	54	0	0	HS X
			2-9-0-E	DC SHOP	(CUI = QS)			
S2U	S3I	S2U	4-FP-0-W	FOREPEAK TANK	12.8	0	0	
S2U	S3I	S2U	4-FP-0-W	FOREPEAK TANK	12.8	0	0	
S2U		S2U	2-9-0-Q	CHAIN LKR	40	0	0	
S2U		S2U	2-9-0-Q	CHAIN LKR	86.4	0	0	
S2U		S2U	2-9-0-Q	CHAIN LKR	40	0	0	
S2U	S3I	S2I	2-30-0-Q	ENG LOG OFFICE	67.2	0	0	
S2U	S3I	S2I	2-30-01-L	PASSAGE	24	0	0	DWT Y
S2U	S3I	S2I	2-30-1-Q	ATON SHOP	59.2	0	0	
S2U	S3I	S2I	2-30-2-Q	E.M. SHOP & STORES	70.4	0	0	
S3U	S3U		(none)	(weather bulkhead)	83.1	0	0	
S3U	S3U		(none)	(weather bulkhead)	93.6	0	0	
S3U	S3U		(none)	(weather bulkhead)	93.6	0	0	
S3U	S3U		(none)	(weather bulkhead)	83.1	0	0	
S2U			3-9-0-E	BOW THRUSTER ROOM	284	0	0	HL X
S2U			1-6-0-Q	DECK WORKSHOP	44	0	0	HS X
S2U			1-6-1-Q	A/N LKR	8.9	0	0	
S2U			1-6-2-Q	BOSN'S LKR	8.9	0	0	
S3I			(none)	(weather overhead)	330.2	0	0	HS X
			2-30-0-Q	ENG LOG OFFICE	(CUI = QO)			
S2I	S3I	S2U	2-9-0-E	DC SHOP	67.2	0	0	
B06		B05	2-30-01-L	PASSAGE	67.2	0	0	DJ NC
B06		B05	2-30-01-L	PASSAGE	84.8	0	0	
B06		B05	2-30-2-Q	E.M. SHOP & STORES	84.8	0	0	
S2U			4-30-0-W	FRESH WATER TANK	89	0	0	
S3I			(none)	(weather overhead)	89	0	0	
			2-30-01-L	PASSAGE	(CUI = LP)			
S2I	S3I	S2U	2-9-0-E	DC SHOP	24	0	0	DWT Y
B05		B06	2-30-0-Q	ENG LOG OFFICE	67.2	0	0	DJ NC
B05		B06	2-30-0-Q	ENG LOG OFFICE	84.8	0	0	
B05		S2I	2-30-1-Q	ATON SHOP	48	0	0	DJ NC
B05		B05	2-30-2-Q	E.M. SHOP & STORES	24	0	0	DJ NC
B05		B06	2-36-1-Q	LAUNDRY	64	0	0	DJ NC
B05		B05	2-41-2-Q	SHIPS SERVICE STORE	27.2	0	0	DJ NC
B05	S3I	B05	2-44-0-T	HATCH TRUNK	64	0	0	
B05	S3I	B05	2-44-01-L	PASSAGE	24	0	0	DWT Y
B05	S3I	B05	2-44-1-L	CREW LOUNGE	6.4	0	0	
B05	S3I	B05	2-44-2-L	CREWS BERTHING	20.8	0	0	
D05			4-30-0-W	FRESH WATER TANK	57.9	0	0	
D05			4-30-1-W	FRESH WATER TANK	14	0	0	
S2U			4-30-2-W	FRESH WATER TANK	8.8	0	0	
S3I			(none)	(weather overhead)	80.8	0	0	

Table B.2 Barrier Data

Barrier Materials			Compartment Name	Area	Therm	Durab	Door/	Readiness
<1>	<2>	<3>		ft2	adj	adj	Hatch	
			2-30-1-Q	ATON SHOP	(CUI = QS)			
S2I	S3I	S2U	2-9-0-E	DC SHOP	59.2	0	0	
S2I		B05	2-30-01-L	PASSAGE	48	0	0	DJ NC
S2I		B05	2-36-1-Q	LAUNDRY	64	0	0	
S2I	S3U		(none)	(weather bulkhead)	48.2	0	0	
S2U			4-30-1-W	FRESH WATER TANK	33.3	0	0	
S3I			(none)	(weather overhead)	46.2	0	0	
			2-30-2-Q	E.M. SHOP & STORES	(CUI = AS)			
S2I	S3I	S2U	2-9-0-E	DC SHOP	70.4	0	0	
B05		B06	2-30-0-Q	ENG LOG OFFICE	84.8	0	0	
B05		B05	2-30-01-L	PASSAGE	24	0	0	DJ NC
B05		B05	2-41-2-Q	SHIPS SERVICE STORE	59.2	0	0	
S2I	S3U		(none)	(weather bulkhead)	85.8	0	0	
S2U			4-30-0-W	FRESH WATER TANK	4.2	0	0	
S2U			4-30-2-W	FRESH WATER TANK	74	0	0	
S3I			(none)	(weather overhead)	101.8	0	0	
			2-36-1-Q	LAUNDRY	(CUI = QL)			
B06		B05	2-30-01-L	PASSAGE	64	0	0	DJ NC
B05		S2I	2-30-1-Q	ATON SHOP	64	0	0	
S2I	S3I	S2U	2-44-1-L	CREW LOUNGE	76.8	0	0	
S2I	S3U		(none)	(weather bulkhead)	65.3	0	0	
D05			4-30-1-W	FRESH WATER TANK	54.9	0	0	
S3I			(none)	(weather overhead)	70.4	0	0	
			2-41-2-Q	SHIPS SERVICE STORE	(CUI = AS)			
B05		B05	2-30-01-L	PASSAGE	27.2	0	0	DJ NC
B05		B05	2-30-2-Q	E.M. SHOP & STORES	59.2	0	0	
B05	S3I	B05	2-44-2-L	CREWS BERTHING	64	0	0	
S2I	S3U		(none)	(weather bulkhead)	27.6	0	0	
S2U			4-30-2-W	FRESH WATER TANK	19.3	0	0	
S3I			(none)	(weather overhead)	26.2	0	0	
			2-44-0-T	HATCH TRUNK	(CUI = TH)			
B05	S3I	B05	2-30-01-L	PASSAGE	64	0	0	
B05		B05	2-44-01-L	PASSAGE	28.8	0	0	DWT Y
S2I		S2U	2-44-01-L	PASSAGE	59.2	0	0	
S2I		S2U	2-44-2-L	CREWS BERTHING	59.2	0	0	
S2U		S2I	2-44-2-L	CREWS BERTHING	35.2	0	0	
S2I			3-44-0-A	MAIN HOLD	59.2	0	0	HO O
S3I			(none)	(weather overhead)	59.2	0	0	HS X
			2-44-01-L	PASSAGE	(CUI = LP)			
B05	S3I	B05	2-30-01-L	PASSAGE	24	0	0	DWT Y
B05		B05	2-44-0-T	HATCH TRUNK	28.8	0	0	DWT Y
S2U		S2I	2-44-0-T	HATCH TRUNK	59.2	0	0	
B05		B05	2-44-1-L	CREW LOUNGE	36.8	0	0	DJ NC
B05		B05	2-44-1-L	CREW LOUNGE	8	0	0	

Table B.2 Barrier Data

Barrier Materials			Compartment Name	Area	Therm	Durab	Door/	Readiness
<1>	<2>	<3>		ft2	adj	adj	Hatch	
B05		B05	2-44-1-L	CREW LOUNGE	92.8	0	0	
0		0	2-44-2-L	CREWS BERTHING	38.4	0	0	
B06		B05	2-57-0-L	CREW WR, WC & SH	4.8	0	0	
B06		B05	2-57-0-L	CREW WR, WC & SH	73.6	0	0	
B06		B05	2-57-0-L	CREW WR, WC & SH	9.6	0	0	
B06		B05	2-57-0-L	CREW WR, WC & SH	68.8	0	0	DJ NC
0		0	2-60-1-L	CREWS BERTHING	16	0	0	
0		0	2-60-1-L	CREWS BERTHING	36.6	0	0	
0		0	2-60-1-L	CREWS BERTHING	60.8	0	0	
0		0	2-60-1-L	CREWS BERTHING	14.4	0	0	
S2I	S3I	S2U	2-74-0-L	CREWS BERTHING	40	0	0	
B05	S3I	B05	2-74-1-L	CREW WR, WC & SH	9.6	0	0	
S2I			3-44-0-A	MAIN HOLD	52.2	0	0	
S2I			3-56-0-Q	SEWAGE SPACE	49.2	0	0	
S2I			3-68-1-A	GENERAL STORES	24.2	0	0	HS X
S2I			3-68-2-A	DRY STORES	9.6	0	0	
S2I			1-68-0-L	COMPANIONWAY	19.1	0	0	HS X
S2I			1-68-1-Q	HYD PUMP ROOM	12	0	0	
S3I			(none)	(weather overhead)	104	0	0	
			2-44-1-L	CREW LOUNGE	(CUI = LL)			
B05	S3I	B05	2-30-01-L	PASSAGE	6.4	0	0	
S2U	S3I	S2I	2-36-1-Q	LAUNDRY	76.8	0	0	
B05		B05	2-44-01-L	PASSAGE	36.8	0	0	DJ NC
B05		B05	2-44-01-L	PASSAGE	8	0	0	
B05		B05	2-44-01-L	PASSAGE	92.8	0	0	
B05		B05	2-60-1-L	CREWS BERTHING	86.4	0	0	
S2I	S3U		(none)	(weather bulkhead)	129.9	0	0	
S2I	S3U		(none)	(weather bulkhead)	12.8	0	0	
S2I			3-44-0-A	MAIN HOLD	107.2	0	0	
S2I			3-56-0-Q	SEWAGE SPACE	44.4	0	0	
S3I			(none)	(weather overhead)	181.2	0	0	
			2-44-2-L	CREWS BERTHING	(CUI = L5)			
B05	S3I	B05	2-30-01-L	PASSAGE	20.8	0	0	
B05	S3I	B05	2-41-2-Q	SHIPS SERVICE STORE	64	0	0	
S2U		S2I	2-44-0-T	HATCH TRUNK	59.2	0	0	
S2I		S2U	2-44-0-T	HATCH TRUNK	35.2	0	0	
0		0	2-44-01-L	PASSAGE	38.4	0	0	
S2I		S2U	2-57-0-L	CREW WR, WC & SH	142.4	0	0	DJ NC
S2I		S2U	2-57-0-L	CREW WR, WC & SH	49.6	0	0	
S2I	S3I	S2U	2-74-0-L	CREWS BERTHING	84.8	0	0	
S2I	S3U		(none)	(weather bulkhead)	240.4	0	0	
D05			3-44-0-A	MAIN HOLD	129.4	0	0	
D05			3-56-0-Q	SEWAGE SPACE	100.8	0	0	
D05			3-68-2-A	DRY STORES	54	0	0	
S2I			1-70-2-L	VESTIBULE	7.2	0	0	
S2I			1-70-4-L	PO-1 BERTHING	32	0	0	
S3I			(none)	(weather overhead)	294.9	0	0	

Table B.2 Barrier Data

Barrier Materials			Compartment Name	Area	Therm	Durab	Door/	Readiness
<1>	<2>	<3>		ft2	adj	adj	Hatch	
			2-57-0-L	CREW WR, WC & SH	(CUI = LW)			
B05		B06	2-44-01-L	PASSAGE	4.8	0	0	
B05		B06	2-44-01-L	PASSAGE	73.6	0	0	
B05		B06	2-44-01-L	PASSAGE	9.6	0	0	
B05		B06	2-44-01-L	PASSAGE	68.8	0	0	DJ NC
S2U		S2I	2-44-2-L	CREWS BERTHING	142.4	0	0	DJ NC
S2U		S2I	2-44-2-L	CREWS BERTHING	49.6	0	0	
B05	S3I	B05	2-74-0-L	CREWS BERTHING	44.8	0	0	
D05			3-56-0-Q	SEWAGE SPACE	77.1	0	0	HS X
D05			3-68-2-A	DRY STORES	33.6	0	0	
S2I			1-68-2-Q	HYD PUMP ROOM	19.3	0	0	
S2I			1-70-2-L	VESTIBULE	4.8	0	0	
S3I			(none)	(weather overhead)	85.6	0	0	
			2-60-1-L	CREWS BERTHING	(CUI = L5)			
0		0	2-44-01-L	PASSAGE	16	0	0	
0		0	2-44-01-L	PASSAGE	36.6	0	0	
0		0	2-44-01-L	PASSAGE	60.8	0	0	
0		0	2-44-01-L	PASSAGE	14.4	0	0	
B05		B05	2-44-1-L	CREW LOUNGE	86.4	0	0	
B05	S3I	B05	2-74-1-L	CREW WR, WC & SH	86.4	0	0	
S2I	S3U		(none)	(weather bulkhead)	110.4	0	0	
S2I			3-56-0-Q	SEWAGE SPACE	98.3	0	0	
S2I			3-68-1-A	GENERAL STORES	68.2	0	0	
S2I			1-68-1-Q	HYD PUMP ROOM	7.3	0	0	
S2I			1-70-1-L	VESTIBULE	12	0	0	
D05			1-70-3A-L	CREW MESS	25.6	0	0	
S3I			(none)	(weather overhead)	121.6	0	0	
			2-74-0-L	CREWS BERTHING	(CUI = L5)			
S2U	S3I	S2I	4-92-0-E	GENERATOR ROOM	257.6	0	0	
S2U	S3I	S2I	2-44-01-L	PASSAGE	40	0	0	
S2U	S3I	S2I	2-44-2-L	CREWS BERTHING	84.8	0	0	
B05	S3I	B05	2-57-0-L	CREW WR, WC & SH	44.8	0	0	
S2I		S2U	2-74-1-L	CREW WR, WC & SH	46.4	0	0	
S2I		S2U	2-74-1-L	CREW WR, WC & SH	24	0	0	DJ NC
S2I		S2U	2-74-1-L	CREW WR, WC & SH	27.2	0	0	
S2I		S2U	2-74-1-L	CREW WR, WC & SH	40	0	0	
S2I		S2U	2-74-1-L	CREW WR, WC & SH	22.4	0	0	
S2I		S2U	2-74-1-L	CREW WR, WC & SH	20.8	0	0	
S2I	S3U		(none)	(weather bulkhead)	59.2	0	0	
S2I	S3U		(none)	(weather bulkhead)	144	0	0	
S2I	S3U		(none)	(weather bulkhead)	8	0	0	
D05			3-74-0-A	MEATS	107.8	0	0	
D05			3-74-2-Q	REEFER FLAT	111.2	0	0	HL X
S2I			3-74-1-M	SMALL ARMS AMMUNITIO	15.1	0	0	
D05			3-74-3-A	MAA STORAGE	4.4	0	0	
D05			3-81-0-A	DAIRY	32	0	0	

Table B.2 Barrier Data

Barrier Materials			Compartment Name	Area	Therm	Durab	Door/	Readiness
<1>	<2>	<3>		ft2	adj	adj	Hatch	
D05			3-81-1-L	PASSAGE	64.3	0	0	HS X
D05			3-81-2-L	PASSAGE	16	0	0	
D05			3-85-0-A	FRUITS AND VEGETABLE	84	0	0	
D05			3-85-3-A	MAA LKR	44.8	0	0	
D05			1-70-3A-L	CREW MESS	70.8	0	0	
S2I			1-70-4-L	PO-1 BERTHING	114	0	0	
S2I			1-74-0-L	PASSAGE	34.6	0	0	
S2I			1-74-2A-L	PASSAGE	61.8	0	0	
S2I			1-77-0-Q	GYRO EQUIP	6	0	0	
S2I			1-77-1-L	COMPANIONWAY	13.3	0	0	HS X
D05			1-79-0-Q	GALLEY	165.9	0	0	
S2I			1-85-2-L	COMPANIONWAY	13.2	0	0	HS X
D05			1-91-2-L	PO-1 WC, WR & SH	9	0	0	
S3I			(none)	(weather overhead)	14.4	0	0	
			2-74-1-L	CREW WR, WC & SH	(CUI = LW)			
B05	S3I	B05	2-44-01-L	PASSAGE	9.6	0	0	
B05	S3I	B05	2-60-1-L	CREWS BERTHING	86.4	0	0	
S2U		S2I	2-74-0-L	CREWS BERTHING	46.4	0	0	
S2U		S2I	2-74-0-L	CREWS BERTHING	24	0	0	DJ NC
S2U		S2I	2-74-0-L	CREWS BERTHING	27.2	0	0	
S2U		S2I	2-74-0-L	CREWS BERTHING	40	0	0	
S2U		S2I	2-74-0-L	CREWS BERTHING	22.4	0	0	
S2U		S2I	2-74-0-L	CREWS BERTHING	20.8	0	0	
B05	S3U		(none)	(weather bulkhead)	84.8	0	0	
D05			3-74-1-M	SMALL ARMS AMMUNITIO	26.9	0	0	
D05			3-74-3-A	MAA STORAGE	66	0	0	
D05			1-70-3A-L	CREW MESS	87.4	0	0	
S2I			1-74-0-L	PASSAGE	6.2	0	0	
			2-126-1-Q	MACHINE SHOP	(CUI = QS)			
B05	S3I	B05	4-116-1-F	DIESEL OIL TANK	99.2	0	0	
0		0	4-126-0-E	MAIN MOTOR ROOM	112	0	0	DJ NC
B05	S3I	B05	3-140-1-W	FRESH WATER TANK	86.4	0	0	
S2I	S3U		(none)	(weather bulkhead)	112.7	0	0	
S2U			4-126-0-E	MAIN MOTOR ROOM	70	0	0	
S2I			1-99-1B-L	PASSAGE	4	0	0	
S2I			1-124-1-L	SR #1	49.2	0	0	
S2I			1-132-0A-L	PASSAGE	26.8	0	0	
S2I			1-132-1-L	SR #3	68.8	0	0	
S3I			(none)	(weather overhead)	13.6	0	0	
			2-126-2-Q	A.C. EQUIPMENT	(CUI = QA)			
B05	S3I	B05	4-116-0-F	DIESEL OIL TANK	6.4	0	0	
B05	S3I	B05	4-116-2-F	DIESEL OIL TANK	99.2	0	0	
0		0	4-126-0-E	MAIN MOTOR ROOM	112	0	0	
B05	S3I	B05	4-140-0-W	FRESH WATER TANK	8	0	0	
B05	S3I	B05	3-140-2-W	FRESH WATER TANK	84.8	0	0	
S2I	S3U		(none)	(weather bulkhead)	112.7	0	0	

Table B.2 Barrier Data

Barrier Materials			Compartment Name	Area	Therm	Durab	Door/	Readiness
<1>	<2>	<3>		ft2	adj	adj	Hatch	
S2U			4-126-0-E MAIN MOTOR ROOM	81.2	0	0		
S2I			1-74-2C-L PASSAGE	8	0	0		
S2I			1-124-2-L SR #2	46.8	0	0		
S2I			1-132-0A-L PASSAGE	34.8	0	0		
S2I			1-132-2-L SR #4	68.8	0	0		
S3I			(none) (weather overhead)	15.2	0	0		
			3-140-1-W FRESH WATER TANK	(CUI = W)				
B05		B05	4-140-0-W FRESH WATER TANK	56	0	0		
B05	S3I	B05	2-126-1-Q MACHINE SHOP	86.4	0	0		
B05		B05	2-147-0-Q ENGINEERS STOREROOM	75.2	0	0		
B05	S3U		(none) (weather bulkhead)	57.1	0	0		
S2U			4-140-0-W FRESH WATER TANK	12.6	0	0		
S2U			1-140-0-L WARDROOM	61.4	0	0		
S3I			(none) (weather overhead)	9.3	0	0		
			3-140-2-W FRESH WATER TANK	(CUI = W)				
B05		B05	4-140-0-W FRESH WATER TANK	56	0	0		
B05	S3I	B05	2-126-2-Q A.C. EQUIPMENT	84.8	0	0		
B05		B05	2-147-0-Q ENGINEERS STOREROOM	73.6	0	0		
B05	S3U		(none) (weather bulkhead)	57.1	0	0		
S2U			4-140-0-W FRESH WATER TANK	11.2	0	0		
D05			1-132-0B-L PASSAGE	5.6	0	0		
S2U			1-140-2-L SR #6	57.6	0	0		
S3I			(none) (weather overhead)	6.1	0	0		
			2-147-0-Q ENGINEERS STOREROOM	(CUI = AS)				
B05		B05	4-140-0-W FRESH WATER TANK	88	0	0		
B05		B05	3-140-1-W FRESH WATER TANK	75.2	0	0		
B05		B05	3-140-2-W FRESH WATER TANK	73.6	0	0		
B05	S3I	B05	2-161-0-Q LAZARETTE	169.6	0	0		
B05	S3U		(none) (weather bulkhead)	116.9	0	0		
B05	S3U		(none) (weather bulkhead)	116.9	0	0		
S2U			4-147-0-W AFT PEAK TANK	88.2	0	0		
D05			1-132-0B-L PASSAGE	30	0	0		
S2U			1-140-0-L WARDROOM	155.8	0	0		
S2U			1-140-2-L SR #6	21.4	0	0		
D05			1-150-2-L OFFICER WR, WC & SH	43.2	0	0		
S2U			1-157-0-E STEERING GEAR SPACE	41.6	0	0	HS	X
S2U			1-157-1-Q ARMORY	25.3	0	0		
S2U			1-157-2-Q LINEN LKR	18.3	0	0		
S3I			(none) (weather overhead)	20	0	0		
			2-161-0-Q LAZARETTE	(CUI = QA)				
B05	S3I	B05	2-147-0-Q ENGINEERS STOREROOM	169.6	0	0		
B05	S3U		(none) (weather bulkhead)	18.2	0	0		
B05	S3U		(none) (weather bulkhead)	10.2	0	0		
B05	S3U		(none) (weather bulkhead)	51.2	0	0		
B05	S3U		(none) (weather bulkhead)	33	0	0		

Table B.2 Barrier Data

Barrier Materials			Compartment Name	Area	Therm	Durab	Door/	Readiness
<1>	<2>	<3>		ft2	adj	adj	Hatch	
B05	S3U		(none)	(weather bulkhead)	30.1	0	0	
B05	S3U		(none)	(weather bulkhead)	30.1	0	0	
B05	S3U		(none)	(weather bulkhead)	33	0	0	
B05	S3U		(none)	(weather bulkhead)	51.2	0	0	
B05	S3U		(none)	(weather bulkhead)	10.2	0	0	
B05	S3U		(none)	(weather bulkhead)	18.2	0	0	
S2U			1-157-0-E	STEERING GEAR SPACE	148	0	0	HS X
S2U			1-157-1-Q	ARMORY	10.7	0	0	
S2U			1-161-2-Q	CG LKR	6.2	0	0	
S3I			(none)	(weather overhead)	15.9	0	0	
			1-FP-0-K	PAINT LKR	(CUI = K)			
B05		B05	1-6-0-Q	DECK WORKSHOP	112	0	0	DJ NC
B05		B05	1-6-1-Q	A/N LKR	16	0	0	
B05		B05	1-6-2-Q	BOSN'S LKR	16	0	0	
B05	S2U		(none)	(weather bulkhead)	72.8	0	0	
B05	S2U		(none)	(weather bulkhead)	40	0	0	
B05	S2U		(none)	(weather bulkhead)	40	0	0	
B05	S2U		(none)	(weather bulkhead)	72.8	0	0	
S2U			4-FP-0-W	FOREPEAK TANK	58.4	0	0	
S2U			(none)	(weather overhead)	110.8	0	0	
			1-6-0-Q	DECK WORKSHOP	(CUI = QS)			
B05		B05	1-FP-0-K	PAINT LKR	112	0	0	DJ NC
B05		B05	1-6-1-Q	A/N LKR	83.2	0	0	DJ NC
B05		B05	1-6-2-Q	BOSN'S LKR	83.2	0	0	DJ NC
B05	S2U		(none)	(weather bulkhead)	112	0	0	DJ NC
S2U			4-FP-0-W	FOREPEAK TANK	42.7	0	0	
S2U			2-9-0-Q	CHAIN LKR	54	0	0	HS X
S2U			2-9-0-E	DC SHOP	44	0	0	HS X
S2I			(none)	(weather overhead)	145.6	0	0	
			1-6-1-Q	A/N LKR	(CUI = AG)			
B05		B05	1-FP-0-K	PAINT LKR	16	0	0	
B05		B05	1-6-0-Q	DECK WORKSHOP	83.2	0	0	DJ NC
B05	S2U		(none)	(weather bulkhead)	48	0	0	
B05	S2U		(none)	(weather bulkhead)	59.7	0	0	
B05	S2U		(none)	(weather bulkhead)	29.4	0	0	
S2U			2-9-0-E	DC SHOP	8.9	0	0	
S2U			(none)	(weather overhead)	42.1	0	0	
			1-6-2-Q	BOSN'S LKR	(CUI = AG)			
B05		B05	1-FP-0-K	PAINT LKR	16	0	0	
B05		B05	1-6-0-Q	DECK WORKSHOP	83.2	0	0	DJ NC
B05	S2U		(none)	(weather bulkhead)	48	0	0	
B05	S2U		(none)	(weather bulkhead)	89.1	0	0	
S2U			2-9-0-E	DC SHOP	8.9	0	0	
S2U			(none)	(weather overhead)	41.6	0	0	

Table B.2 Barrier Data

Barrier Materials			Compartment Name	Area	Therm	Durab	Door/	Readiness
<1>	<2>	<3>		ft2	adj	adj	Hatch	
			1-68-0-L	COMPANIONWAY	(CUI	= LP)		
B05		B05	1-68-1-Q	HYD PUMP ROOM	41.6	0	0	
B05		B05	1-68-2-Q	HYD PUMP ROOM	41.6	0	0	
B05		B05	1-74-0-L	PASSAGE	28.8	0	0	DJ NC
B05	S2U		(none)	(weather bulkhead)	15.8	0	0	
B05	S2U		(none)	(weather bulkhead)	15.8	0	0	
S2I			2-44-01-L	PASSAGE	19.1	0	0	HS X
S2I			01-71-0-Q	CRANE CONTROL BOOTH	12.2	0	0	
S2I			(none)	(weather overhead)	7.9	0	0	
			1-68-1-Q	HYD PUMP ROOM	(CUI	= QA)		
B05		B05	1-68-0-L	COMPANIONWAY	41.6	0	0	
B05		B05	1-70-1-L	VESTIBULE	32	0	0	
B05		B05	1-74-0-L	PASSAGE	33.6	0	0	DJ NC
B05	S2U		(none)	(weather bulkhead)	34.9	0	0	
S2I			2-44-01-L	PASSAGE	12	0	0	
S2I			2-60-1-L	CREWS BERTHING	7.3	0	0	
S2I			01-71-0-Q	CRANE CONTROL BOOTH	6.1	0	0	
S2I			(none)	(weather overhead)	13.2	0	0	
			1-68-2-Q	HYD PUMP ROOM	(CUI	= QA)		
B05		B05	1-68-0-L	COMPANIONWAY	41.6	0	0	
B05		B05	1-70-2-L	VESTIBULE	32	0	0	
B05		B05	1-74-0-L	PASSAGE	33.6	0	0	DJ NC
B05	S2U		(none)	(weather bulkhead)	34.9	0	0	
S2I			2-57-0-L	CREW WR, WC & SH	19.3	0	0	
S2I			01-71-0-Q	CRANE CONTROL BOOTH	6.1	0	0	
S2I			(none)	(weather overhead)	13.2	0	0	
			1-70-1-L	VESTIBULE	(CUI	= LP)		
B05		B05	1-68-1-Q	HYD PUMP ROOM	32	0	0	
S2U		S2I	1-70-3A-L	CREW MESS	24	0	0	DJ NO
S2U		S2I	1-70-3A-L	CREW MESS	32	0	0	
B05	S2U		(none)	(weather bulkhead)	24	0	0	DWT X
S2I			2-60-1-L	CREWS BERTHING	12	0	0	
S2I			(none)	(weather overhead)	12	0	0	
			1-70-2-L	VESTIBULE	(CUI	= LP)		
B05		B05	1-68-2-Q	HYD PUMP ROOM	32	0	0	
S2U		S2I	1-70-4-L	PO-1 BERTHING	32	0	0	
B05		B05	1-74-2A-L	PASSAGE	24	0	0	DJ NO
B05	S2U		(none)	(weather bulkhead)	24	0	0	DWT X
S2I			2-44-2-L	CREWS BERTHING	7.2	0	0	
S2I			2-57-0-L	CREW WR, WC & SH	4.8	0	0	
S2I			(none)	(weather overhead)	12	0	0	
			1-70-3A-L	CREW MESS	(CUI	= LL)		
S2I		S2U	1-70-1-L	VESTIBULE	24	0	0	DJ NO
S2I		S2U	1-70-1-L	VESTIBULE	32	0	0	

Table B.2 Barrier Data

Barrier Materials			Compartment Name	Area	Therm	Durab	Door/	Readiness	
<1>	<2>	<3>		ft2	adj	adj	Hatch		
B05		B05	1-74-0-L	PASSAGE	19.2	0	0	DJ	NO
B05		B05	1-77-1-L	COMPANIONWAY	36.8	0	0		
B05		B05	1-79-0-Q	GALLEY	8	-5	-5		
B05		B05	1-79-0-Q	GALLEY	88	-5	-5		
B05		B05	1-79-0-Q	GALLEY	28.8	-5	-5		
B05		B05	1-92-0-Q	SCULLERY	51.2	0	0	DJ	NO
B05		B05	1-93-1-L	CPO MESS & REC	24	0	0		
B05		B05	1-93-1-L	CPO MESS & REC	16	0	0		
B05		B05	1-93-1-L	CPO MESS & REC	40	0	0		
0		0	1-99-1A-L	PASSAGE	45.5	0	0		
B06	S2U		(none)	(weather bulkhead)	203.2	0	0		
B06	S2U		(none)	(weather bulkhead)	64	0	0		
D05			4-92-0-E	GENERATOR ROOM	65.6	0	0		
D05			2-60-1-L	CREWS BERTHING	25.6	0	0		
D05			2-74-0-L	CREWS BERTHING	70.8	0	0		
D05			2-74-1-L	CREW WR, WC & SH	87.4	0	0		
S2I			01-74-1-Q	CODE ROOM	11.6	0	0		
S2I			01-82-0-L	CO CABIN	13	0	0		
S2I			01-95-1-L	COMPANIONWAY	8.4	0	0		
S2I			(none)	(weather overhead)	251.8	0	0		
			1-70-4-L	PO-1 BERTHING	(CUI = L5)				
S2I		S2U	1-70-2-L	VESTIBULE	32	0	0		
S2I		S2U	1-74-2A-L	PASSAGE	6.4	-25	-25		
S2I		S2U	1-74-2A-L	PASSAGE	88	-25	-25	DJ	NC
S2I		S2U	1-85-2-L	COMPANIONWAY	35.2	0	0		
S2I		S2U	1-85-2-L	COMPANIONWAY	24	0	0		
S2I		NSU	1-91-2-L	PO-1 WC, WR & SH	40	0	0	DJ	NC
S2I	S2U		(none)	(weather bulkhead)	64	0	0		
S2I	S2U		(none)	(weather bulkhead)	161.6	0	0		
S2I			2-44-2-L	CREWS BERTHING	32	0	0		
S2I			2-74-0-L	CREWS BERTHING	114	0	0		
S2I			(none)	(weather overhead)	146	0	0		
			1-74-0-L	PASSAGE	(CUI = LP)				
B05		B05	1-68-0-L	COMPANIONWAY	28.8	0	0	DJ	NC
B05		B05	1-68-1-Q	HYD PUMP ROOM	33.6	0	0	DJ	NC
B05		B05	1-68-2-Q	HYD PUMP ROOM	33.6	0	0	DJ	NC
B05		B05	1-70-3A-L	CREW MESS	19.2	0	0	DJ	NO
B05		B05	1-74-2A-L	PASSAGE	35.2	0	0	DJ	NO
B05		B05	1-77-0-Q	GYRO EQUIP	16	0	0		
B05		B05	1-77-0-Q	GYRO EQUIP	24	0	0	DJ	NC
B05		B05	1-77-1-L	COMPANIONWAY	24	0	0	DJ	NC
B05		B05	1-79-0-Q	GALLEY	48	0	0		
S2I			2-74-0-L	CREWS BERTHING	34.6	0	0		
S2I			2-74-1-L	CREW WR, WC & SH	6.2	0	0		
S2I			01-74-0-L	CO SR	26.4	0	0		
S2I			01-74-1-Q	CODE ROOM	14.4	0	0		

Table B.2 Barrier Data

Barrier Materials			Compartment Name	Area	Therm	Durab	Door/	Readiness
<1>	<2>	<3>		ft2	adj	adj	Hatch	
		1-74-2A-L	PASSAGE	(CUI	= LP)			
B05		B05 1-70-2-L	VESTIBULE	24	0	0	DJ	NO
S2U		S2I 1-70-4-L	PO-1 BERTHING	6.4	-25	-25		
S2U		S2I 1-70-4-L	PO-1 BERTHING	88	-25	-25	DJ	NC
B05		B05 1-74-0-L	PASSAGE	35.2	0	0	DJ	NO
0		0 1-74-2B-L	PASSAGE	25.3	0	0		
B05		B05 1-79-0-Q	GALLEY	108.8	0	0	DJ	NO
B05		B05 1-85-2-L	COMPANIONWAY	35.2	0	0		
B05		B05 1-85-2-L	COMPANIONWAY	24	0	0	DJ	NC
B05		NSU 1-91-2-L	PO-1 WC, WR & SH	22.4	0	0		
B05		NSU 1-91-2-L	PO-1 WC, WR & SH	24	0	0		
B05		NSU 1-91-2-L	PO-1 WC, WR & SH	48	0	0	DJ	NC
B05		B05 1-92-2-Q	DC LKR	48	0	0	DJ	NC
S2I		4-92-0-E	GENERATOR ROOM	22.5	0	0		
S2I		2-74-0-L	CREWS BERTHING	61.8	0	0		
S2I		01-74-0-L	CO SR	15.2	0	0		
S2I		01-82-0-L	CO CABIN	8.2	0	0		
S2I		01-89-2-Q	FAN ROOM	3.2	0	0		
S2I		01-93-2-L	COMPANIONWAY	5.2	0	0		
S2I		(none)	(weather overhead)	52.5	0	0		
		1-74-2B-L	PASSAGE	(CUI	= LP)			
0		0 1-74-2A-L	PASSAGE	25.3	0	0		
0		0 1-74-2C-L	PASSAGE	25.6	0	0		
B05		B05 1-92-2-Q	DC LKR	20.8	0	0		
S2U		S2I 4-92-0A-E	FIDLEY	108.8	0	0		
B05		NSU 1-99-2-L	DISPENSARY	56	-25	-25	DJ	NC
B05		B05 1-106-2-L	CPO BERTHING	19.2	-25	-25		
B05		B05 1-106-2-L	CPO BERTHING	48	-25	-25		
S2I		4-92-0-E	GENERATOR ROOM	62.5	0	0		
S2I		01-93-2-L	COMPANIONWAY	13.4	0	0	HO	O
S2I		(none)	(weather overhead)	46.3	0	0		
		1-74-2C-L	PASSAGE	(CUI	= LP)			
0		0 1-74-2B-L	PASSAGE	25.6	0	0		
B05		B05 1-106-2-L	CPO BERTHING	89.6	-25	-25	DJ	NC
B05		B05 1-112-0-Q	AUXILIARY MACHINERY	144	0	0	DJ	NC
B05		B05 1-124-2-L	SR #2	54.4	0	0		
B05		B05 1-132-0A-L	PASSAGE	25.6	0	0	DJ	NO
S2I		4-92-0-E	GENERATOR ROOM	12.8	0	0		
S2I		4-116-0-F	DIESEL OIL TANK	20	0	0		
S2I		4-116-2-F	DIESEL OIL TANK	12	0	0		
S2U		4-126-0-E	MAIN MOTOR ROOM	4.8	0	0		
S2I		2-126-2-Q	A.C. EQUIPMENT	8	0	0		
S2I		(none)	(weather overhead)	55.8	0	0		
		1-77-0-Q	GYRO EQUIP	(CUI	= QA)			
B05		B05 1-74-0-L	PASSAGE	16	0	0		
B05		B05 1-74-0-L	PASSAGE	24	0	0	DJ	NC

Table B.2 Barrier Data

Barrier Materials			Compartment Name	Area	Therm	Durab	Door/	Readiness
<1>	<2>	<3>		ft2	adj	adj	Hatch	
B05		B05	1-77-1-L	COMPANIONWAY	16	0	0	
B05		B05	1-79-0-Q	GALLEY	24	0	0	
S2I			2-74-0-L	CREWS BERTHING	6	0	0	
S2I			01-74-1-Q	CODE ROOM	6	0	0	
			1-77-1-L	COMPANIONWAY	(CUI = LP)			
B05		B05	1-70-3A-L	CREW MESS	36.8	0	0	
B05		B05	1-74-0-L	PASSAGE	24	0	0	DJ NC
B05		B05	1-77-0-Q	GYRO EQUIP	16	0	0	
B05		B05	1-79-0-Q	GALLEY	20.8	0	0	
B05		B05	1-79-0-Q	GALLEY	24	0	0	
S2I			2-74-0-L	CREWS BERTHING	13.3	0	0	HS X
S2I			01-74-1-Q	CODE ROOM	13.8	0	0	
			1-79-0-Q	GALLEY	(CUI = QG)			
B05		B05	1-70-3A-L	CREW MESS	8	-5	-5	
B05		B05	1-70-3A-L	CREW MESS	88	-5	-5	
B05		B05	1-70-3A-L	CREW MESS	28.8	-5	-5	
B05		B05	1-74-0-L	PASSAGE	48	0	0	
B05		B05	1-74-2A-L	PASSAGE	108.8	0	0	DJ NO
B05		B05	1-77-0-Q	GYRO EQUIP	24	0	0	
B05		B05	1-77-1-L	COMPANIONWAY	20.8	0	0	
B05		B05	1-77-1-L	COMPANIONWAY	24	0	0	
B05		B05	1-92-0-Q	SCULLERY	54.4	0	0	
B05		B05	1-92-2-Q	DC LKR	20.8	0	0	
D05			2-74-0-L	CREWS BERTHING	165.9	0	0	
S2U			01-74-0-L	CO SR	19.2	0	0	
S2U			01-74-1-Q	CODE ROOM	12	0	0	
S2U			01-82-0-L	CO CABIN	129.9	0	0	
S2U			01-89-2-Q	FAN ROOM	5.3	0	0	
			1-85-2-L	COMPANIONWAY	(CUI = LP)			
S2U		S2I	1-70-4-L	PO-1 BERTHING	35.2	0	0	
S2U		S2I	1-70-4-L	PO-1 BERTHING	24	0	0	
B05		B05	1-74-2A-L	PASSAGE	35.2	0	0	
B05		B05	1-74-2A-L	PASSAGE	24	0	0	DJ NC
S2I			2-74-0-L	CREWS BERTHING	13.2	0	0	HS X
S2I			(none)	(weather overhead)	13.2	0	0	
			1-91-2-L	PO-1 WC, WR & SH	(CUI = LW)			
NSU		S2I	1-70-4-L	PO-1 BERTHING	40	0	0	DJ NC
NSU		B05	1-74-2A-L	PASSAGE	22.4	0	0	
NSU		B05	1-74-2A-L	PASSAGE	24	0	0	
NSU		B05	1-74-2A-L	PASSAGE	48	0	0	DJ NC
NSU		NSU	1-99-2-L	DISPENSARY	64	0	0	
NSU	S2U		(none)	(weather bulkhead)	70.4	0	0	
D05			4-92-0-E	GENERATOR ROOM	51.8	0	0	
D05			2-74-0-L	CREWS BERTHING	9	0	0	
S2I			(none)	(weather overhead)	62	0	0	

Table B.2 Barrier Data

Barrier Materials			Compartment Name	Area	Therm	Durab	Door/	Readiness
<1>	<2>	<3>		ft2	adj	adj	Hatch	
			1-92-0-Q	SCULLERY	(CUI = QG)			
B05		B05	1-70-3A-L	CREW MESS	51.2	0	0	DJ NO
B05		B05	1-79-0-Q	GALLEY	54.4	0	0	
B05		B05	1-92-2-Q	DC LKR	48	0	0	
S2U		S2I	4-92-0A-E	FIDLEY	54.4	0	0	
D05			4-92-0-E	GENERATOR ROOM	43.5	0	0	
S2U			01-82-0-L	CO CABIN	34	0	0	
S2U			01-95-0-L	WR, WC & SH	9.5	0	0	
			1-92-2-Q	DC LKR	(CUI = AG)			
B05		B05	1-74-2A-L	PASSAGE	48	0	0	DJ NC
B05		B05	1-74-2B-L	PASSAGE	20.8	0	0	
B05		B05	1-79-0-Q	GALLEY	20.8	0	0	
B05		B05	1-92-0-Q	SCULLERY	48	0	0	
S2I			4-92-0-E	GENERATOR ROOM	15.6	0	0	
S2I			01-89-2-Q	FAN ROOM	2.4	0	0	
S2I			01-93-2-L	COMPANIONWAY	12	0	0	
			1-93-1-L	CPO MESS & REC	(CUI = LL)			
B05		B05	1-70-3A-L	CREW MESS	24	0	0	
B05		B05	1-70-3A-L	CREW MESS	16	0	0	
B05		B05	1-70-3A-L	CREW MESS	40	0	0	
B05		B05	1-99-1A-L	PASSAGE	64	0	0	DJ NC
B05		B05	1-106-1-Q	MOVIE LKR	12.8	0	0	
B05		B05	1-107-1-Q	MORALE LKR	24	0	0	
B05		B05	1-110-1-Q	SHIPS OFFICE	64	-5	-5	
B06	S2U		(none)	(weather bulkhead)	116.8	0	0	
S2I			4-92-0-E	GENERATOR ROOM	109.2	0	0	
S2I			(none)	(weather overhead)	110.8	0	0	
			4-92-0A-E	FIDLEY	(CUI = QA)			
S2I		S2U	1-74-2B-L	PASSAGE	108.8	0	0	
S2I		S2U	1-92-0-Q	SCULLERY	54.4	0	0	
S2I		S2U	1-99-1A-L	PASSAGE	108.8	0	0	
S2I		S2U	1-112-0-Q	AUXILIARY MACHINERY	54.4	0	0	DO O
S2I			4-92-0-E	GENERATOR ROOM	92.5	-90	-90	HL X
S2I			01-82-0-L	CO CABIN	2	0	0	
S2I			01-95-0-L	WR, WC & SH	22.4	0	0	
S2I			01-102-0-E	VENT & UPTAKE SPACE	34	0	0	
S2I			01-110-0-Q	FAN & EQUIPMENT ROOM	34	0	0	
			1-99-1A-L	PASSAGE	(CUI = LP)			
0		0	1-70-3A-L	CREW MESS	45.5	0	0	
B05		B05	1-93-1-L	CPO MESS & REC	64	0	0	DJ NC
S2U		S2I	4-92-0A-E	FIDLEY	108.8	0	0	
0		0	1-99-1B-L	PASSAGE	24	0	0	
B05		B05	1-106-1-Q	MOVIE LKR	12.8	0	0	
B05		B05	1-106-1-Q	MOVIE LKR	20.8	0	0	DJ NC

Table B.2 Barrier Data

Barrier Materials			Compartment Name	Area	Therm	Durab	Door/	Readiness	
<1>	<2>	<3>		ft2	adj	adj	Hatch		
B05		B05	1-107-1-Q	MORALE LKR	24	0	0	DJ	NC
B05		B05	1-110-1-Q	SHIPS OFFICE	16	-5	-5		
S2I			4-92-0-E	GENERATOR ROOM	61.8	0	0		
S2I			01-95-1-L	COMPANIONWAY	13.4	0	0	HO	O
S2I			(none)	(weather overhead)	45.7	0	0		
			1-99-1B-L	PASSAGE	(CUI	= LP)			
0		0	1-99-1A-L	PASSAGE	24	0	0		
B05		B05	1-110-1-Q	SHIPS OFFICE	88	-5	-5	DJ	NC
B05		B05	1-112-0-Q	AUXILIARY MACHINERY	144	0	0	DJ	NC
B05		B05	1-124-1-L	SR #1	56	-5	-5		
B05		B05	1-132-0A-L	PASSAGE	24	0	0	DJ	NO
S2I			4-92-0-E	GENERATOR ROOM	12	0	0		
S2I			4-116-0-F	DIESEL OIL TANK	20	0	0		
S2I			4-116-1-F	DIESEL OIL TANK	10	0	0		
S2U			4-126-0-E	MAIN MOTOR ROOM	8	0	0		
S2I			2-126-1-Q	MACHINE SHOP	4	0	0		
S2I			(none)	(weather overhead)	52.2	0	0		
			1-99-2-L	DISPENSARY	(CUI	= LM)			
NSU		B05	1-74-2B-L	PASSAGE	56	-25	-25	DJ	NC
NSU		NSU	1-91-2-L	PO-1 WC, WR & SH	64	0	0		
NSU		NSU	1-104-2-L	CPO WR, WC & SH	24	0	0		
NSU		NSU	1-104-2-L	CPO WR, WC & SH	20.8	0	0		
NSU		NSU	1-104-2-L	CPO WR, WC & SH	17.6	0	0		
NSU		B05	1-106-2-L	CPO BERTHING	20.8	0	0		
NSU	S2U		(none)	(weather bulkhead)	35.2	0	0		
D05			4-92-0-E	GENERATOR ROOM	47.1	0	0		
S2I			(none)	(weather overhead)	47.2	0	0		
			1-104-2-L	CPO WR, WC & SH	(CUI	= LW)			
NSU		NSU	1-99-2-L	DISPENSARY	24	0	0		
NSU		NSU	1-99-2-L	DISPENSARY	20.8	0	0		
NSU		NSU	1-99-2-L	DISPENSARY	17.6	0	0		
NSU		B05	1-106-2-L	CPO BERTHING	40	0	0	DJ	NC
NSU		B05	1-106-2-L	CPO BERTHING	40	0	0		
NSU	S2U		(none)	(weather bulkhead)	60.8	0	0		
D05			4-92-0-E	GENERATOR ROOM	33	0	0		
S2I			(none)	(weather overhead)	33	0	0		
			1-106-1-Q	MOVIE LKR	(CUI	= AG)			
B05		B05	1-93-1-L	CPO MESS & REC	12.8	0	0		
B05		B05	1-99-1A-L	PASSAGE	12.8	0	0		
B05		B05	1-99-1A-L	PASSAGE	20.8	0	0	DJ	NC
B05		B05	1-107-1-Q	MORALE LKR	20.8	0	0		
S2I			4-92-0-E	GENERATOR ROOM	4.2	0	0		
S2I			(none)	(weather overhead)	4.2	0	0		
			1-106-2-L	CPO BERTHING	(CUI	= L2)			

Table B.2 Barrier Data

Barrier Materials			Compartment Name	Area	Therm	Durab	Door/	Readiness
<1>	<2>	<3>		ft2	adj	adj	Hatch	
B05		B05	1-74-2B-L	PASSAGE	19.2	-25	-25	
B05		B05	1-74-2B-L	PASSAGE	48	-25	-25	
B05		B05	1-74-2C-L	PASSAGE	89.6	-25	-25	DJ NC
B05		NSU	1-99-2-L	DISPENSARY	20.8	0	0	
B05		NSU	1-104-2-L	CPO WR, WC & SH	40	0	0	DJ NC
B05		NSU	1-104-2-L	CPO WR, WC & SH	40	0	0	
B05		B05	1-124-2-L	SR #2	80	0	0	
S2I	S2U		(none)	(weather bulkhead)	97.6	0	0	
S2I			4-92-0-E	GENERATOR ROOM	75	0	0	
S2I			4-116-2-F	DIESEL OIL TANK	72	0	0	
S2I			(none)	(weather overhead)	147	0	0	
			1-107-1-Q	MORALE LKR	(CUI = AG)			
B05		B05	1-93-1-L	CPO MESS & REC	24	0	0	
B05		B05	1-99-1A-L	PASSAGE	24	0	0	DJ NC
B05		B05	1-106-1-Q	MOVIE LKR	20.8	0	0	
B05		B05	1-110-1-Q	SHIPS OFFICE	20.8	-5	-5	
S2I			4-92-0-E	GENERATOR ROOM	7.8	0	0	
S2I			(none)	(weather overhead)	7.8	0	0	
			1-110-1-Q	SHIPS OFFICE	(CUI = QO)			
B05		B05	1-93-1-L	CPO MESS & REC	64	-5	-5	
B05		B05	1-99-1A-L	PASSAGE	16	-5	-5	
B05		B05	1-99-1B-L	PASSAGE	88	-5	-5	DJ NC
B05		B05	1-107-1-Q	MORALE LKR	20.8	-5	-5	
B05		B05	1-124-1-L	SR #1	81.6	-5	-5	
B06	S2U		(none)	(weather bulkhead)	104.1	0	0	
S2I			4-92-0-E	GENERATOR ROOM	63	0	0	
S2I			4-116-1-F	DIESEL OIL TANK	72.2	0	0	
S2I			(none)	(weather overhead)	135.2	0	0	
			1-112-0-Q	AUXILIARY MACHINERY SPACE #	(CUI = QA)			
B05		B05	1-74-2C-L	PASSAGE	144	0	0	DJ NC
S2U	S2I		4-92-0A-E	FIDLEY	54.4	0	0	DO O
B05		B05	1-99-1B-L	PASSAGE	144	0	0	DJ NC
B05		B05	1-132-0A-L	PASSAGE	16	0	0	
B05		B05	1-132-0A-L	PASSAGE	54.4	0	0	
B05		B05	1-132-0A-L	PASSAGE	16	0	0	
S2I			4-92-0-E	GENERATOR ROOM	27.2	-15	-15	
S2I			4-116-0-F	DIESEL OIL TANK	68	-15	-15	
S2U			4-126-0-E	MAIN MOTOR ROOM	40.8	-15	-15	HL X
S2U			01-110-0-Q	FAN & EQUIPMENT ROOM	27.2	0	0	
S2U			01-116-0-Q	CLIP SHACK	34	0	0	
S2I			(none)	(weather overhead)	74.8	0	0	
			1-124-1-L	SR #1	(CUI = L2)			
B05		B05	1-99-1B-L	PASSAGE	56	-5	-5	
B05		B05	1-110-1-Q	SHIPS OFFICE	81.6	-5	-5	
B05		B05	1-132-0A-L	PASSAGE	44.8	0	0	DJ NC

Table B.2 Barrier Data

Barrier Materials			Compartment Name	Area	Therm	Durab	Door/	Readiness
<1>	<2>	<3>		ft2	adj	adj	Hatch	
B05		B05	1-132-0A-L	PASSAGE	16	0	0	
B05		B05	1-132-1-L	SR #3	35.2	-10	-10	
B06	S2U		(none)	(weather bulkhead)	72	0	0	
S2I			4-116-1-F	DIESEL OIL TANK	30.5	0	0	
S2I			2-126-1-Q	MACHINE SHOP	49.2	0	0	
S2I			(none)	(weather overhead)	79.7	0	0	
			1-124-2-L	SR #2	(CUI	= L2)		
B05		B05	1-74-2C-L	PASSAGE	54.4	0	0	
B05		B05	1-106-2-L	CPO BERTHING	80	0	0	
B05		B05	1-132-0A-L	PASSAGE	16	0	0	
B05		B05	1-132-0A-L	PASSAGE	43.2	0	0	DJ NC
B05		B05	1-132-2-L	SR #4	32	0	0	
B06	S2U		(none)	(weather bulkhead)	70.6	0	0	
S2I			4-116-2-F	DIESEL OIL TANK	27.7	0	0	
S2I			2-126-2-Q	A.C. EQUIPMENT	46.8	0	0	
S2I			(none)	(weather overhead)	74.6	0	0	
			1-132-0A-L	PASSAGE	(CUI	= LP)		
B05		B05	1-74-2C-L	PASSAGE	25.6	0	0	DJ NO
B05		B05	1-99-1B-L	PASSAGE	24	0	0	DJ NO
B05		B05	1-112-0-Q	AUXILIARY MACHINERY	16	0	0	
B05		B05	1-112-0-Q	AUXILIARY MACHINERY	54.4	0	0	
B05		B05	1-112-0-Q	AUXILIARY MACHINERY	16	0	0	
B05		B05	1-124-1-L	SR #1	44.8	0	0	DJ NC
B05		B05	1-124-1-L	SR #1	16	0	0	
B05		B05	1-124-2-L	SR #2	16	0	0	
B05		B05	1-124-2-L	SR #2	43.2	0	0	DJ NC
0		0	1-132-0B-L	PASSAGE	24	0	0	
B05		B05	1-132-1-L	SR #3	56	0	0	
B05		B05	1-132-1-L	SR #3	44.8	0	0	DJ NC
B05		B05	1-132-1-L	SR #3	8	0	0	
B05		B05	1-132-2-L	SR #4	8	0	0	
B05		B05	1-132-2-L	SR #4	44.8	0	0	DJ NC
B05		B05	1-132-2-L	SR #4	56	0	0	
B05		B05	1-140-0-L	WARDROOM	16	0	0	DJ NC
B05		B05	1-140-1-Q	PANTRY	62.4	0	0	
S2U			4-126-0-E	MAIN MOTOR ROOM	86.4	0	0	HS X
S2I			2-126-1-Q	MACHINE SHOP	26.8	0	0	
S2I			2-126-2-Q	A.C. EQUIPMENT	34.8	0	0	
S2I			(none)	(weather overhead)	148	0	0	HL X
			1-132-0B-L	PASSAGE	(CUI	= LP)		
0		0	1-132-0A-L	PASSAGE	24	0	0	
B05		B05	1-140-0-L	WARDROOM	80	0	0	DJ NC
B05		B05	1-140-1-Q	PANTRY	56	0	0	DJ NC
B05		B05	1-140-2-L	SR #6	80	0	0	DJ NC
B05		B05	1-150-2-L	OFFICER WR, WC & SH	56	0	0	DJ NC
B05		B05	1-157-0-E	STEERING GEAR SPACE	24	0	0	DJ NC

Table B.2 Barrier Data

Barrier Materials			Compartment Name	Area	Therm	Durab	Door/	Readiness
<1>	<2>	<3>		ft2	adj	adj	Hatch	
D05			4-140-0-W FRESH WATER TANK	15.4	0	0		
D05			3-140-2-W FRESH WATER TANK	5.6	0	0		
D05			2-147-0-Q ENGINEERS STOREROOM	30	0	0		
S2I			(none) (weather overhead)	51	0	0		
			1-132-1-L SR #3	(CUI = L1)				
B05		B05	1-124-1-L SR #1	35.2	-10	-10		
B05		B05	1-132-0A-L PASSAGE	56	0	0		
B05		B05	1-132-0A-L PASSAGE	44.8	0	0	DJ	NC
B05		B05	1-132-0A-L PASSAGE	8	0	0		
B05		B05	1-140-0-L WARDROOM	68.8	0	0		
B06	S2U		(none) (weather bulkhead)	65	0	0		
S2I			2-126-1-Q MACHINE SHOP	68.8	0	0		
S2I			(none) (weather overhead)	68.8	0	0		
			1-132-2-L SR #4	(CUI = L1)				
B05		B05	1-124-2-L SR #2	32	0	0		
B05		B05	1-132-0A-L PASSAGE	8	0	0		
B05		B05	1-132-0A-L PASSAGE	44.8	0	0	DJ	NC
B05		B05	1-132-0A-L PASSAGE	56	0	0		
B05		B05	1-140-2-L SR #6	72	0	0		
B06	S2U		(none) (weather bulkhead)	64.2	0	0		
S2I			2-126-2-Q A.C. EQUIPMENT	68.8	0	0		
S2I			(none) (weather overhead)	68.8	0	0		
			1-140-0-L WARDROOM	(CUI = LL)				
B05		B05	1-132-0A-L PASSAGE	16	0	0	DJ	NC
B05		B05	1-132-0B-L PASSAGE	80	0	0	DJ	NC
B05		B05	1-132-1-L SR #3	68.8	0	0		
B05		B05	1-140-1-Q PANTRY	56	0	0		
B05		B05	1-140-1-Q PANTRY	62.4	0	0	DJ	NO
B05		B05	1-157-0-E STEERING GEAR SPACE	59.2	0	0		
B05		B05	1-157-1-Q ARMORY	56	0	0		
B06	S2U		(none) (weather bulkhead)	139.7	0	0		
S2U			4-140-0-W FRESH WATER TANK	7	0	0		
S2U			3-140-1-W FRESH WATER TANK	61.4	0	0		
S2U			2-147-0-Q ENGINEERS STOREROOM	155.8	0	0		
S2I			(none) (weather overhead)	224.2	0	0		
			1-140-1-Q PANTRY	(CUI = QG)				
B05		B05	1-132-0A-L PASSAGE	62.4	0	0		
B05		B05	1-132-0B-L PASSAGE	56	0	0	DJ	NC
B05		B05	1-140-0-L WARDROOM	56	0	0		
B05		B05	1-140-0-L WARDROOM	62.4	0	0	DJ	NO
D05			4-140-0-W FRESH WATER TANK	54.6	0	0		
S2I			(none) (weather overhead)	54.6	0	0		
			1-140-2-L SR #6	(CUI = L2)				
B05		B05	1-132-0B-L PASSAGE	80	0	0	DJ	NC

Table B.2 Barrier Data

Barrier Materials			Compartment Name	Area	Therm	Durab	Door/	Readiness
<1>	<2>	<3>		ft2	adj	adj	Hatch	
B05		B05	1-132-2-L	SR #4	72	0	0	
B05		B05	1-150-2-L	OFFICER WR, WC & SH	54.4	0	0	
B06	S2U		(none)	(weather bulkhead)	81.9	0	0	
S2U			3-140-2-W	FRESH WATER TANK	57.6	0	0	
S2U			2-147-0-Q	ENGINEERS STOREROOM	21.4	0	0	
S2I			(none)	(weather overhead)	79	0	0	
			1-150-2-L	OFFICER WR, WC & SH	(CUI = LW)			
B05		B05	1-132-0B-L	PASSAGE	56	0	0	DJ NC
B05		B05	1-140-2-L	SR #6	54.4	0	0	
B05		B05	1-157-2-Q	LINEN LKR	44.8	0	0	
B06	S2U		(none)	(weather bulkhead)	56.8	0	0	
D05			2-147-0-Q	ENGINEERS STOREROOM	43.2	0	0	
S2I			(none)	(weather overhead)	43.4	0	0	
			1-157-0-E	STEERING GEAR SPACE	(CUI = QA)			
B05		B05	1-132-0B-L	PASSAGE	24	0	0	DJ NC
B05		B05	1-140-0-L	WARDROOM	59.2	0	0	
B05		B05	1-157-1-Q	ARMORY	48	-15	-15	DJ NC
B05		B05	1-157-1-Q	ARMORY	40	0	0	
B05		B05	1-157-2-Q	LINEN LKR	32	0	0	DO O
B05		B05	1-161-2-Q	CG LKR	16	0	0	DO O
B05		B05	1-161-2-Q	CG LKR	20.8	0	0	
B06	S2U		(none)	(weather bulkhead)	25.3	0	0	
B06	S2U		(none)	(weather bulkhead)	28.8	0	0	
B06	S2U		(none)	(weather bulkhead)	38.2	0	0	
B06	S2U		(none)	(weather bulkhead)	26.5	0	0	
B06	S2U		(none)	(weather bulkhead)	26.5	0	0	
B06	S2U		(none)	(weather bulkhead)	38.2	0	0	
B06	S2U		(none)	(weather bulkhead)	28.8	0	0	
B06	S2U		(none)	(weather bulkhead)	25.3	0	0	
S2U			2-147-0-Q	ENGINEERS STOREROOM	41.6	0	0	HS X
S2U			2-161-0-Q	LAZARETTE	148	0	0	HS X
S2I			(none)	(weather overhead)	189.6	0	0	HS X
			1-157-2-Q	LINEN LKR	(CUI = AG)			
B05		B05	1-150-2-L	OFFICER WR, WC & SH	44.8	0	0	
B05		B05	1-157-0-E	STEERING GEAR SPACE	32	0	0	DO O
B05		B05	1-161-2-Q	CG LKR	28.8	0	0	
B06	S2U		(none)	(weather bulkhead)	35.8	0	0	
S2U			2-147-0-Q	ENGINEERS STOREROOM	18.3	0	0	
S2I			(none)	(weather overhead)	18.4	0	0	
			1-161-2-Q	CG LKR	(CUI = AG)			
B05		B05	1-157-0-E	STEERING GEAR SPACE	16	0	0	DO O
B05		B05	1-157-0-E	STEERING GEAR SPACE	20.8	0	0	
B05		B05	1-157-2-Q	LINEN LKR	28.8	0	0	
B06	S2U		(none)	(weather bulkhead)	17.9	0	0	
S2U			2-161-0-Q	LAZARETTE	6.2	0	0	

Table B.2 Barrier Data

Barrier Materials			Compartment Name	Area	Therm	Durab	Door/	Readiness
<1>	<2>	<3>		ft2	adj	adj	Hatch	
S2I			(none)	(weather overhead)	6.2	0	0	
			01-71-0-Q	CRANE CONTROL BOOTH	(CUI = C)			
B05		B05	01-74-0-L	CO SR	10.8	0	0	
B05		B05	01-74-1-Q	CODE ROOM	10.8	0	0	
B05		B05	02-74-0-Q	FAN ROOM	28.8	0	0	
S2I	S2U		(none)	(weather bulkhead)	23.8	0	0	DJ NC
S2I	S2U		(none)	(weather bulkhead)	50.4	0	0	
S2I	S2U		(none)	(weather bulkhead)	23.8	0	0	DJ NC
S2I			1-68-0-L	COMPANIONWAY	12.2	0	0	
S2I			1-68-1-Q	HYD PUMP ROOM	6.1	0	0	
S2I			1-68-2-Q	HYD PUMP ROOM	6.1	0	0	
S2I			(none)	(weather overhead)	24.5	0	0	
			01-74-0-L	CO SR	(CUI = L1)			
B05		B05	01-71-0-Q	CRANE CONTROL BOOTH	10.8	0	0	
B05		B05	01-74-1-Q	CODE ROOM	53.2	0	0	
B05		B05	01-82-0-L	CO CABIN	49	0	0	DJ NC
S2I	S2U		(none)	(weather bulkhead)	53.2	0	0	
S2I	S2U		(none)	(weather bulkhead)	7	0	0	
S2I	S2U		(none)	(weather bulkhead)	30.8	0	0	
S2I	S2U		(none)	(weather bulkhead)	14.4	0	0	
S2I			1-74-0-L	PASSAGE	26.4	0	0	
S2I			1-74-2A-L	PASSAGE	15.2	0	0	
S2U			1-79-0-Q	GALLEY	19.2	0	0	
S2I			02-74-0-Q	FAN ROOM	56	0	0	
D05			02-81-0-C	CHART ROOM	2.4	0	0	
			01-74-1-Q	CODE ROOM	(CUI = C)			
B05		B05	01-71-0-Q	CRANE CONTROL BOOTH	10.8	0	0	
B05		B05	01-74-0-L	CO SR	53.2	0	0	
B05		B05	01-82-0-L	CO CABIN	49	0	0	DJ NC
S2I	S2U		(none)	(weather bulkhead)	53.2	0	0	
S2I	S2U		(none)	(weather bulkhead)	4.2	0	0	
S2I	S2U		(none)	(weather bulkhead)	28	0	0	
S2I	S2U		(none)	(weather bulkhead)	14.4	0	0	
S2I			1-70-3A-L	CREW MESS	11.6	0	0	
S2I			1-74-0-L	PASSAGE	14.4	0	0	
S2I			1-77-0-Q	GYRO EQUIP	6	0	0	
S2I			1-77-1-L	COMPANIONWAY	13.8	0	0	
S2U			1-79-0-Q	GALLEY	12	0	0	
S2I			02-74-0-Q	FAN ROOM	53.2	0	0	
D05			02-81-0-C	CHART ROOM	4.2	0	0	
			01-82-0-L	CO CABIN	(CUI = L1)			
B05		B05	01-74-0-L	CO SR	49	0	0	DJ NC
B05		B05	01-74-1-Q	CODE ROOM	49	0	0	DJ NC
B05		B05	01-89-2-Q	FAN ROOM	23.8	0	0	
B05		B05	01-89-2-Q	FAN ROOM	22.4	0	0	

Table B.2 Barrier Data

Barrier Materials			Compartment Name	Area	Therm	Durab	Door/	Readiness	
<1>	<2>	<3>		ft2	adj	adj	Hatch		
B05		B05	01-93-2-L	COMPANIONWAY	42	0	0	DJ	NC
B05		A2I	01-95-0-L	WR, WC & SH	25.2	0	0		
B05		A2I	01-95-0-L	WR, WC & SH	23.8	0	0	DJ	NC
B05		A2I	01-95-0-L	WR, WC & SH	25.2	0	0		
B05		B05	01-95-1-L	COMPANIONWAY	23.8	0	0	DJ	NC
S2I	S2U		(none)	(weather bulkhead)	98	0	0		
S2I	S2U		(none)	(weather bulkhead)	57.4	0	0		
S2I			1-70-3A-L	CREW MESS	13	0	0		
S2I			1-74-2A-L	PASSAGE	8.2	0	0		
S2U			1-79-0-Q	GALLEY	129.9	0	0		
S2U			1-92-0-Q	SCULLERY	34	0	0		
S2I			4-92-0A-E	FIDLEY	2	0	0		
D05			02-81-0-C	CHART ROOM	81.4	0	0		
S2I			02-81-2-L	PASSAGE	24.6	0	0		
D05			02-89-0-C	RADIO ROOM	80.4	0	0		
S2I			(none)	(weather overhead)	2.2	0	0		
			01-89-2-Q	FAN ROOM	(CUI = QF)				
B05		B05	01-82-0-L	CO CABIN	23.8	0	0		
B05		B05	01-82-0-L	CO CABIN	22.4	0	0		
B05		B05	01-93-2-L	COMPANIONWAY	23.8	0	0		
B05	S2U		(none)	(weather bulkhead)	22.4	0	0	DJ	NC
S2I			1-74-2A-L	PASSAGE	3.2	0	0		
S2U			1-79-0-Q	GALLEY	5.3	0	0		
S2I			1-92-2-Q	DC LKR	2.4	0	0		
S2U			02-81-2-L	PASSAGE	9.6	0	0		
			01-93-2-L	COMPANIONWAY	(CUI = LP)				
B05		B05	01-82-0-L	CO CABIN	42	0	0	DJ	NC
B05		B05	01-89-2-Q	FAN ROOM	23.8	0	0		
B05		A2I	01-95-0-L	WR, WC & SH	21	0	0		
S2I	S2U		(none)	(weather bulkhead)	23.8	0	0		
S2I	S2U		(none)	(weather bulkhead)	63	0	0	DJ	NC
S2I			1-74-2A-L	PASSAGE	5.2	0	0		
S2I			1-74-2B-L	PASSAGE	13.4	0	0	HO	O
S2I			1-92-2-Q	DC LKR	12	0	0		
S2I			02-81-2-L	PASSAGE	16.2	0	0		
D05			02-89-0-C	RADIO ROOM	2.2	0	0		
S2I			(none)	(weather overhead)	12.2	0	0		
			01-95-0-L	WR, WC & SH	(CUI = LW)				
A2I		B05	01-82-0-L	CO CABIN	25.2	0	0		
A2I		B05	01-82-0-L	CO CABIN	23.8	0	0	DJ	NC
A2I		B05	01-82-0-L	CO CABIN	25.2	0	0		
A2I		B05	01-93-2-L	COMPANIONWAY	21	0	0		
A2I		B05	01-95-1-L	COMPANIONWAY	44.8	0	0		
A2I		B05	01-102-0-E	VENT & UPTAKE SPACE	50.4	0	0		
S2U			1-92-0-Q	SCULLERY	9.5	0	0		
S2I			4-92-0A-E	FIDLEY	22.4	0	0		
D05			02-89-0-C	RADIO ROOM	10.1	0	0		

Table B.2 Barrier Data

Barrier Materials			Compartment Name	Area	Therm	Durab	Door/	Readiness
<1>	<2>	<3>		ft2	adj	adj	Hatch	
S2I			(none)	(weather overhead)	23.8	0	0	
			01-95-1-L	COMPANIONWAY	(CUI = LP)			
B05		B05	01-82-0-L	CO CABIN	23.8	0	0	DJ NC
B05		A2I	01-95-0-L	WR, WC & SH	44.8	0	0	
S2I	S2U		(none)	(weather bulkhead)	23.8	0	0	
S2I	S2U		(none)	(weather bulkhead)	44.8	0	0	
S2I			1-70-3A-L	CREW MESS	8.4	0	0	
S2I			1-99-1A-L	PASSAGE	13.4	0	0	HO O
D05			02-89-0-C	RADIO ROOM	9.5	0	0	
S2I			(none)	(weather overhead)	12.2	0	0	
			01-102-0-E	VENT & UPTAKE SPACE	(CUI = TU)			
B05		A2I	01-95-0-L	WR, WC & SH	50.4	0	0	
B05		B05	01-110-0-Q	FAN & EQUIPMENT ROOM	50.4	0	0	
B05	S2U		(none)	(weather bulkhead)	35	0	0	
B05	S2U		(none)	(weather bulkhead)	35	0	0	
S2I			4-92-0A-E	FIDLEY	34	0	0	
S2I			02-102-0-E	UPTAKE	36	0	0	
			01-110-0-Q	FAN & EQUIPMENT ROOM	(CUI = QF)			
B05		B05	01-102-0-E	VENT & UPTAKE SPACE	50.4	0	0	
B05		B05	01-116-0-Q	CLIP SHACK	50.4	0	0	
B05	S2U		(none)	(weather bulkhead)	63	0	0	
B05	S2U		(none)	(weather bulkhead)	63	0	0	
S2I			4-92-0A-E	FIDLEY	34	0	0	
S2U			1-112-0-Q	AUXILIARY MACHINERY	27.2	0	0	
S2I			(none)	(weather overhead)	64.8	0	0	
			01-116-0-Q	CLIP SHACK	(CUI = C)			
B05		B05	01-110-0-Q	FAN & EQUIPMENT ROOM	50.4	0	0	
B05	S2U		(none)	(weather bulkhead)	50.4	0	0	DWT X
B05	S2U		(none)	(weather bulkhead)	35	0	0	
B05	S2U		(none)	(weather bulkhead)	35	0	0	
S2U			1-112-0-Q	AUXILIARY MACHINERY	34	0	0	
S2I			(none)	(weather overhead)	36	0	0	
			02-74-0-Q	FAN ROOM	(CUI = QF)			
B05		B05	01-71-0-Q	CRANE CONTROL BOOTH	28.8	0	0	
S2U		S2I	02-81-0-C	CHART ROOM	44	0	0	
B05		B05	02-81-2-L	PASSAGE	12	0	0	
B05	S2U		(none)	(weather bulkhead)	28	0	0	
B05	S2U		(none)	(weather bulkhead)	0	0	0	
B05	S2U		(none)	(weather bulkhead)	28	0	0	
B05	S2U		(none)	(weather bulkhead)	4	0	0	
B05	S2U		(none)	(weather bulkhead)	4	0	0	
S2I			01-74-0-L	CO SR	56	0	0	
S2I			01-74-1-Q	CODE ROOM	53.2	0	0	
D05			03-72-0-C	WHEELHOUSE	98	0	0	

Table B.2 Barrier Data

Barrier Materials			Compartment Name	Area	Therm	Durab	Door/	Readiness
<1>	<2>	<3>		ft2	adj	adj	Hatch	
S2I		(none)	(weather overhead)	14	0	0		
		02-81-0-C	CHART ROOM	(CUI	= C)			
S2I	S2U	02-74-0-Q	FAN ROOM	44	0	0		
B05	B05	02-81-2-L	PASSAGE	64	0	0	DJ	NC
B05	B06	02-89-0-C	RADIO ROOM	88	0	0		
B05	B05	03-72-0-C	WHEELHOUSE	44	0	0		
B06	S2U	(none)	(weather bulkhead)	64	0	0		
D05		01-74-0-L	CO SR	2.4	0	0		
D05		01-74-1-Q	CODE ROOM	4.2	0	0		
D05		01-82-0-L	CO CABIN	81.4	0	0		
S2I		(none)	(weather overhead)	88	0	0		
		02-81-2-L	PASSAGE	(CUI	= LP)			
B05	B05	02-74-0-Q	FAN ROOM	12	0	0		
B05	B05	02-81-0-C	CHART ROOM	64	0	0	DJ	NC
B05	B06	02-89-0-C	RADIO ROOM	75.2	0	0	DJ	NC
B05	B05	03-72-0-C	WHEELHOUSE	12	0	0		
B05	S2U	(none)	(weather bulkhead)	24	0	0		
B05	S2U	(none)	(weather bulkhead)	139.2	0	0		
S2I		01-82-0-L	CO CABIN	24.6	0	0		
S2U		01-89-2-Q	FAN ROOM	9.6	0	0		
S2I		01-93-2-L	COMPANIONWAY	16.2	0	0		
S2I		(none)	(weather overhead)	52.2	0	0		
		02-89-0-C	RADIO ROOM	(CUI	= C)			
B06	B05	02-81-0-C	CHART ROOM	88	0	0		
B06	B05	02-81-2-L	PASSAGE	75.2	0	0	DJ	NC
B06	S2U	(none)	(weather bulkhead)	88	0	0		
B06	S2U	(none)	(weather bulkhead)	75.2	0	0		
D05		01-82-0-L	CO CABIN	80.4	0	0		
D05		01-93-2-L	COMPANIONWAY	2.2	0	0		
D05		01-95-0-L	WR, WC & SH	10.1	0	0		
D05		01-95-1-L	COMPANIONWAY	9.5	0	0		
S2I		(none)	(weather overhead)	103.4	0	0		
		02-102-0-E	UPTAKE	(CUI	= TU)			
B05	S2U	(none)	(weather bulkhead)	115.2	0	0		
B05	S2U	(none)	(weather bulkhead)	80	0	0		
B05	S2U	(none)	(weather bulkhead)	115.2	0	0		
B05	S2U	(none)	(weather bulkhead)	80	0	0		
S2I		01-102-0-E	VENT & UPTAKE SPACE	36	0	0		
S2I		(none)	(weather overhead)	36	0	0		
		03-72-0-C	WHEELHOUSE	(CUI	= C)			
B05	B05	02-81-0-C	CHART ROOM	44	0	0		
B05	B05	02-81-2-L	PASSAGE	12	0	0		
S2I	S2U	(none)	(weather bulkhead)	56	0	0		
S2I	S2U	(none)	(weather bulkhead)	72	0	0	DJ	NC

Table B.2 Barrier Data

Barrier Materials			Compartment Name	Area	Therm	Durab	Door/	Readiness
<1>	<2>	<3>		ft2	adj	adj	Hatch	
S2I	S2U		(none)	(weather bulkhead)	112	0	0	
S2I	S2U		(none)	(weather bulkhead)	72	0	0	DJ NC
D05			02-74-0-Q	FAN ROOM	98	0	0	
S2I			(none)	(weather overhead)	126	0	0	

Table B.3 Fire Safety Objectives

Plan ID	Compartment Name	MAL Rating	FAL (Years)	FREQ EB
CUI=AA	(Cargo Hold)			
3-44-0-A	MAIN HOLD	2	24	0.0001
CUI=AG	(Gear Locker)			
3-85-3-A	MAA LKR	3	12	0.001
2-9-0-Q	CHAIN LKR	4	8	0.001
1-6-1-Q	A/N LKR	2	22	0.001
1-6-2-Q	BOSN'S LKR	2	22	0.001
1-92-2-Q	DC LKR	3	15	0.001
1-106-1-Q	MOVIE LKR	4	8	0.001
1-107-1-Q	MORALE LKR	4	8	0.001
1-157-2-Q	LINEN LKR	3	12	0.001
1-161-2-Q	CG LKR	4	8	0.001
CUI=AR	(Refrigerated Storage)			
3-74-0-A	MEATS	2	23	0.0009
3-81-0-A	DAIRY	2	23	0.0009
3-85-0-A	FRUITS AND VEGETABLES	2	23	0.0009
CUI=AS	(Storeroom)			
3-68-1-A	GENERAL STORES	2	21	0.0009
3-68-2-A	DRY STORES	2	22	0.0009
3-74-3-A	MAA STORAGE	2	21	0.0009
2-30-2-Q	E.M. SHOP & STORES	2	25	0.0009
2-41-2-Q	SHIPS SERVICE STORE	3	18	0.0009
2-147-0-Q	ENGINEERS STOREROOM	2	25	0.0009
CUI=C	(Ship Control/Communications)			
01-71-0-Q	CRANE CONTROL BOOTH	2	22	0.0012
01-74-1-Q	CODE ROOM	2	26	0.0012
01-116-0-Q	CLIP SHACK	4	8	0.0012
02-81-0-C	CHART ROOM	2	26	0.0012
02-89-0-C	RADIO ROOM	2	26	0.0012
03-72-0-C	WHEELHOUSE	2	26	0.0012
CUI=EE	(Main Propulsion - Electrical)			
4-92-0-E	GENERATOR ROOM	2	26	0.0031
4-126-0-E	MAIN MOTOR ROOM	2	26	0.0031
CUI=EM	(Main Propulsion - Mechanical)			
3-9-0-E	BOW THRUSTER ROOM	2	26	0.0272
CUI=K	(Hazardous Material Storage)			
1-FP-0-K	PAINT LKR	1	30	0.0013
CUI=L1	(Senior Officer's Cabin)			
1-132-1-L	SR #3	3	14	0.0008
1-132-2-L	SR #4	3	14	0.0008
01-74-0-L	CO SR	3	14	0.0008
01-82-0-L	CO CABIN	3	14	0.0008
CUI=L2	(Officer/CPO Quarters)			
1-106-2-L	CPO BERTHING	3	14	0.0008
1-124-1-L	SR #1	3	14	0.0008
1-124-2-L	SR #2	3	14	0.0008
1-140-2-L	SR #6	3	14	0.0008
CUI=L5	(Crews Berthing)			
2-44-2-L	CREWS BERTHING	3	14	0.0008

Table B.3 Fire Safety Objectives

Plan ID	Compartment Name	MAL Rating	FAL (Years)	FREQ EB
2-60-1-L	CREWS BERTHING	3	14	0.0008
2-74-0-L	CREWS BERTHING	3	14	0.0008
1-70-4-L	PO-1 BERTHING	3	14	0.0008
CUI=LL	(Wardroom/Mess/Lounge Areas)			
2-44-1-L	CREW LOUNGE	3	14	0.0008
1-70-3A-L	CREW MESS	2	24	0.0008
1-93-1-L	CPO MESS & REC	2	24	0.0008
1-140-0-L	WARDROOM	2	24	0.0008
CUI=LM	(Medical/Dental Spaces)			
1-99-2-L	DISPENSARY	2	26	0.0001
CUI=LP	(Passageway/Staircase/Vestibule)			
3-81-1-L	PASSAGE	3	17	0.0001
3-81-2-L	PASSAGE	3	17	0.0001
2-30-01-L	PASSAGE	3	17	0.0001
2-44-01-L	PASSAGE	3	17	0.0001
1-68-0-L	COMPANIONWAY	3	17	0.0001
1-70-1-L	VESTIBULE	3	17	0.0001
1-70-2-L	VESTIBULE	3	17	0.0001
1-74-0-L	PASSAGE	3	17	0.0001
1-74-2A-L	PASSAGE	3	17	0.0001
1-74-2B-L	PASSAGE	3	17	0.0001
1-74-2C-L	PASSAGE	3	17	0.0001
1-77-1-L	COMPANIONWAY	3	17	0.0001
1-85-2-L	COMPANIONWAY	3	17	0.0001
1-99-1A-L	PASSAGE	3	17	0.0001
1-99-1B-L	PASSAGE	3	17	0.0001
1-132-0A-L	PASSAGE	3	17	0.0001
1-132-0B-L	PASSAGE	3	17	0.0001
01-93-2-L	COMPANIONWAY	3	17	0.0001
01-95-1-L	COMPANIONWAY	3	17	0.0001
02-81-2-L	PASSAGE	3	17	0.0001
CUI=LW	(Sanitary Spaces)			
2-57-0-L	CREW WR, WC & SH	4	8	0.0002
2-74-1-L	CREW WR, WC & SH	4	8	0.0002
1-91-2-L	PO-1 WC, WR & SH	4	8	0.0002
1-104-2-L	CPO WR, WC & SH	4	8	0.0002
1-150-2-L	OFFICER WR, WC & SH	4	8	0.0002
01-95-0-L	WR, WC & SH	4	8	0.0002
CUI=QA	(Aux Machinery Spaces)			
3-56-0-Q	SEWAGE SPACE	2	24	0.0029
3-74-2-Q	REEFER FLAT	3	17	0.0029
2-126-2-Q	A.C. EQUIPMENT	2	22	0.0029
2-161-0-Q	LAZARETTE	2	24	0.0029
1-68-1-Q	HYD PUMP ROOM	2	26	0.0029
1-68-2-Q	HYD PUMP ROOM	2	26	0.0029
1-77-0-Q	GYRO EQUIP	2	26	0.0029
4-92-0A-E	FIDLEY	2	24	0.0029
1-112-0-Q	AUXILIARY MACHINERY SPACE #3	2	26	0.0029
1-157-0-E	STEERING GEAR SPACE	2	26	0.0029

Table B.3 Fire Safety Objectives

Plan ID	Compartment Name	MAL Rating	FAL (Years)	FREQ EB
CUI=QF	(Fan Room)			
01-89-2-Q	FAN ROOM	3	18	0.0004
01-110-0-Q	FAN & EQUIPMENT ROOM	3	18	0.0004
02-74-0-Q	FAN ROOM	3	18	0.0004
CUI=QG	(Galley/Pantry/Scullery)			
1-79-0-Q	GALLEY	2	26	0.0026
1-92-0-Q	SCULLERY	2	20	0.0026
1-140-1-Q	PANTRY	2	26	0.0026
CUI=QL	(Laundry)			
2-36-1-Q	LAUNDRY	3	19	0.0004
CUI=QO	(Office Spaces)			
2-30-0-Q	ENG LOG OFFICE	2	25	0.0004
1-110-1-Q	SHIPS OFFICE	2	24	0.0004
CUI=QS	(Shops)			
2-9-0-E	DC SHOP	3	19	0.0018
2-30-1-Q	ATON SHOP	2	24	0.0018
2-126-1-Q	MACHINE SHOP	2	22	0.0018
1-6-0-Q	DECK WORKSHOP	2	25	0.0018
CUI=TH	(Trunks/Hoists/Dumbwaiters)			
2-44-0-T	HATCH TRUNK	4	8	0.0001
CUI=TU	(Stacks/Engine Uptakes)			
01-102-0-E	VENT & UPTAKE SPACE	2	23	0.0013
02-102-0-E	UPTAKE	3	16	0.0013
CUI=W	(Water Tank (empty))			
4-FP-0-W	FOREPEAK TANK	4	8	0.0004
4-30-0-W	FRESH WATER TANK	4	8	0.0004
4-30-1-W	FRESH WATER TANK	4	8	0.0004
4-30-2-W	FRESH WATER TANK	4	8	0.0004
4-140-0-W	FRESH WATER TANK	4	8	0.0004
4-147-0-W	AFT PEAK TANK	4	8	0.0004
3-140-1-W	FRESH WATER TANK	4	8	0.0004
3-140-2-W	FRESH WATER TANK	4	8	0.0004

Table B.4 Fire Detection

Plan ID	Compartment Name	Detection System		% Time Monitored		Est. Minutes to Detect.	
		Quantity	Type	at Sea	in Port	at Sea	in Port
CUI=AA	(Cargo Hold)						
3-44-0-A	MAIN HOLD	None		60	50	4	6
CUI=AG	(Gear Locker)						
3-85-3-A	MAA LKR	None		50	40	6	8
2-9-0-Q	CHAIN LKR	None		50	40	6	8
1-6-1-Q	A/N LKR	None		50	40	6	8
1-6-2-Q	BOSN'S LKR	None		50	40	6	8
1-92-2-Q	DC LKR	None		60	40	4	8
1-106-1-Q	MOVIE LKR	None		50	40	6	8
1-107-1-Q	MORALE LKR	None		50	40	6	8
1-157-2-Q	LINEN LKR	None		50	40	6	8
1-161-2-Q	CG LKR	None		50	40	6	8
CUI=AR	(Refrigerated Storage)						
3-74-0-A	MEATS	None		50	40	6	8
3-81-0-A	DAIRY	None		50	40	6	8
3-85-0-A	FRUITS AND VEGETABLES	None		50	40	6	8
CUI=AS	(Storeroom)						
3-68-1-A	GENERAL STORES	None		60	50	4	6
3-68-2-A	DRY STORES	None		50	40	6	8
3-74-3-A	MAA STORAGE	None		60	50	4	6
2-30-2-Q	E.M. SHOP & STORES	None		60	50	4	6
2-41-2-Q	SHIPS SERVICE STORE	None		60	50	4	6
2-147-0-Q	ENGINEERS STOREROOM	None		60	50	4	6
CUI=C	(Ship Control/Communications)						
01-71-0-Q	CRANE CONTROL BOOTH	None		50	30	6	10
01-74-1-Q	CODE ROOM	None		70	50	2	6
01-116-0-Q	CLIP SHACK	None		50	40	6	8
02-81-0-C	CHART ROOM	None		70	50	2	6
02-89-0-C	RADIO ROOM	None		80	60	1	4
03-72-0-C	WHEELHOUSE	None		80	60	1	4
CUI=EE	(Main Propulsion - Electrical)						
4-92-0-E	GENERATOR ROOM	None		80	60	1	4
4-126-0-E	MAIN MOTOR ROOM	None		80	60	1	4
CUI=EM	(Main Propulsion - Mechanical)						
3-9-0-E	BOW THRUSTER ROOM	None		80	50	1	6
CUI=K	(Hazardous Material Storage)						
1-FP-0-K	PAINT LKR	1	TMP	95	95	1	1
CUI=L1	(Senior Officer's Cabin)						
1-132-1-L	SR #3	1	SMO	90	90	1	1
1-132-2-L	SR #4	1	SMO	90	90	1	1
01-74-0-L	CO SR	1	SMO	90	90	1	1
01-82-0-L	CO CABIN	1	SMO	90	90	1	1
CUI=L2	(Officer/CPO Quarters)						
1-106-2-L	CPO BERTHING	1	SMO	90	90	1	1
1-124-1-L	SR #1	1	SMO	90	90	1	1
1-124-2-L	SR #2	1	SMO	90	90	1	1
1-140-2-L	SR #6	1	SMO	90	90	1	1
CUI=L5	(Crews Berthing)						
2-44-2-L	CREWS BERTHING	2	SMO	90	90	1	1

Table B.4 Fire Detection

Plan ID	Compartment Name	Detection System		% Time Monitored		Est. Minutes to Detect.	
		Quantity	Type	at Sea	in Port	at Sea	in Port
2-60-1-L	CREWS BERTHING	1	SMO	90	90	1	1
2-74-0-L	CREWS BERTHING	1	SMO	90	90	1	1
1-70-4-L	PO-1 BERTHING	1	SMO	90	90	1	1
CUI=LL	(Wardroom/Mess/Lounge Areas)						
2-44-1-L	CREW LOUNGE	None		70	50	2	6
1-70-3A-L	CREW MESS	None		70	60	2	4
1-93-1-L	CPO MESS & REC	None		70	60	2	4
1-140-0-L	WARDROOM	None		70	60	2	4
CUI=LM	(Medical/Dental Spaces)						
1-99-2-L	DISPENSARY	1	SMO	90	90	1	1
CUI=LP	(Passageway/Staircase/Vestibule)						
3-81-1-L	PASSAGE	None		50	40	6	8
3-81-2-L	PASSAGE	None		50	40	6	8
2-30-01-L	PASSAGE	None		55	45	5	7
2-44-01-L	PASSAGE	None		55	45	5	7
1-68-0-L	COMPANIONWAY	None		60	50	4	6
1-70-1-L	VESTIBULE	None		60	50	4	6
1-70-2-L	VESTIBULE	None		60	50	4	6
1-74-0-L	PASSAGE	None		60	50	4	6
1-74-2A-L	PASSAGE	None		60	50	4	6
1-74-2B-L	PASSAGE	None		60	50	4	6
1-74-2C-L	PASSAGE	None		60	50	4	6
1-77-1-L	COMPANIONWAY	None		60	50	4	6
1-85-2-L	COMPANIONWAY	None		60	50	4	6
1-99-1A-L	PASSAGE	None		60	50	4	6
1-99-1B-L	PASSAGE	None		60	50	4	6
1-132-0A-L	PASSAGE	None		60	50	4	6
1-132-0B-L	PASSAGE	None		60	50	4	6
01-93-2-L	COMPANIONWAY	None		55	45	5	7
01-95-1-L	COMPANIONWAY	None		55	45	5	7
02-81-2-L	PASSAGE	None		55	45	5	7
CUI=LW	(Sanitary Spaces)						
2-57-0-L	CREW WR, WC & SH	None		60	50	4	6
2-74-1-L	CREW WR, WC & SH	None		60	50	4	6
1-91-2-L	PO-1 WC, WR & SH	None		55	45	5	7
1-104-2-L	CPO WR, WC & SH	None		55	45	5	7
1-150-2-L	OFFICER WR, WC & SH	None		55	45	5	7
01-95-0-L	WR, WC & SH	None		55	45	5	7
CUI=QA	(Aux Machinery Spaces)						
3-56-0-Q	SEWAGE SPACE	None		55	35	5	9
3-74-2-Q	REEFER FLAT	None		60	40	4	8
2-126-2-Q	A.C. EQUIPMENT	None		60	40	4	8
2-161-0-Q	LAZARETTE	None		55	35	5	9
1-68-1-Q	HYD PUMP ROOM	None		60	40	4	8
1-68-2-Q	HYD PUMP ROOM	None		60	40	4	8
1-77-0-Q	GYRO EQUIP	None		60	40	4	8
4-92-0A-E	FIDLEY	None		80	60	1	4
1-112-0-Q	AUXILIARY MACHINERY SPACE #	None		60	40	4	8
1-157-0-E	STEERING GEAR SPACE	None		60	40	4	8

Table B.4 Fire Detection

Plan ID	Compartment Name	Detection System		% Time Monitored		Est. Minutes to Detect.	
		Quantity	Type	at Sea	in Port	at Sea	in Port
CUI=QF	(Fan Room)						
01-89-2-Q	FAN ROOM	None		50	40	6	8
01-110-0-Q	FAN & EQUIPMENT ROOM	None		50	40	6	8
02-74-0-Q	FAN ROOM	None		50	40	6	8
CUI=QG	(Galley/Pantry/Scullery)						
1-79-0-Q	GALLEY	None		70	60	2	4
1-92-0-Q	SCULLERY	None		70	60	2	4
1-140-1-Q	PANTRY	None		70	60	2	4
CUI=QL	(Laundry)						
2-36-1-Q	LAUNDRY	None		60	50	4	6
CUI=QO	(Office Spaces)						
2-30-0-Q	ENG LOG OFFICE	None		70	60	2	4
1-110-1-Q	SHIPS OFFICE	None		70	60	2	4
CUI=QS	(Shops)						
2-9-0-E	DC SHOP	None		70	60	2	4
2-30-1-Q	ATON SHOP	None		70	60	2	4
2-126-1-Q	MACHINE SHOP	None		70	60	2	4
1-6-0-Q	DECK WORKSHOP	None		70	60	2	4
CUI=TH	(Trunks/Hoists/Dumbwaiters)						
2-44-0-T	HATCH TRUNK	None		50	30	6	10
CUI=TU	(Stacks/Engine Uptakes)						
01-102-0-E	VENT & UPTAKE SPACE	None		80	60	1	4
02-102-0-E	UPTAKE	None		80	60	1	4
CUI=W	(Water Tank (empty))						
4-FP-0-W	FOREPEAK TANK	None		0	0	16	16
4-30-0-W	FRESH WATER TANK	None		0	0	16	16
4-30-1-W	FRESH WATER TANK	None		0	0	16	16
4-30-2-W	FRESH WATER TANK	None		0	0	16	16
4-140-0-W	FRESH WATER TANK	None		0	0	16	16
4-147-0-W	AFT PEAK TANK	None		0	0	16	16
3-140-1-W	FRESH WATER TANK	None		0	0	16	16
3-140-2-W	FRESH WATER TANK	None		0	0	16	16

Table B.5 Automated and Manual Fire Protection Systems

Plan ID	Compartment Name	Fixed (Installed)	Systems	Manual Portable	Firefighting Extinguishers	Equipment Hose/	3 % AFFF
CUI=AA	(Cargo Hold)						
3-44-0-A	MAIN HOLD	None	None	None	None	None	
CUI=AG	(Gear Locker)						
3-85-3-A	MAA LKR	None		None		None	
2-9-0-Q	CHAIN LKR	None		None		None	
1-6-1-Q	A/N LKR	None		None		None	
1-6-2-Q	BOSN'S LKR	None		None		None	
1-92-2-Q	DC LKR	None		None		None	
1-106-1-Q	MOVIE LKR	None		None		None	
1-107-1-Q	MORALE LKR	None		None		None	
1-157-2-Q	LINEN LKR	None		None		None	
1-161-2-Q	CG LKR	None		None		None	
CUI=AR	(Refrigerated Storage)						
3-74-0-A	MEATS	None		None		None	
3-81-0-A	DAIRY	None		None		None	
3-85-0-A	FRUITS AND VEGETABLES	None		None		None	
CUI=AS	(Storeroom)						
3-68-1-A	GENERAL STORES	None		None		None	
3-68-2-A	DRY STORES	None		None		None	
3-74-3-A	MAA STORAGE	None		None		None	
2-30-2-Q	E.M. SHOP & STORES	None		None		None	
2-41-2-Q	SHIPS SERVICE STORE	None		None		None	
2-147-0-Q	ENGINEERS STOREROOM	None			1 CO2	None	
CUI=C	(Ship Control/Communications)						
01-71-0-Q	CRANE CONTROL BOOTH	None		None		None	
01-74-1-Q	CODE ROOM	None			1 CO2	None	
01-116-0-Q	CLIP SHACK	None		None		None	
02-81-0-C	CHART ROOM	None			1 CO2	None	
02-89-0-C	RADIO ROOM	None			1 CO2	None	
03-72-0-C	WHEELHOUSE	None			1 CO2	None	
CUI=EE	(Main Propulsion - Electrical)						
4-92-0-E	GENERATOR ROOM	None			5 CO2	None	
		None			3 PKP	None	
		None		None			1 A3F
4-126-0-E	MAIN MOTOR ROOM	None			1 CO2	None	
CUI=EM	(Main Propulsion - Mechanical)						
3-9-0-E	BOW THRUSTER ROOM	None			3 CO2	None	
CUI=K	(Hazardous Material Storage)						
1-FP-0-K	PAINT LKR		1 CO2	None		None	
CUI=L1	(Senior Officer's Cabin)						
1-132-1-L	SR #3	None		None		None	
1-132-2-L	SR #4	None		None		None	
01-74-0-L	CO SR	None		None		None	
01-82-0-L	CO CABIN	None		None		None	
CUI=L2	(Officer/CPO Quarters)						
1-106-2-L	CPO BERTHING	None		None		None	
1-124-1-L	SR #1	None		None		None	
1-124-2-L	SR #2	None		None		None	
1-140-2-L	SR #6	None		None		None	

Table B.5 Automated and Manual Fire Protection Systems

Plan ID	Compartment Name	Fixed (Installed)	Systems	Manual Portable	Firefighting Extinguishers	Equipment Hose/	
CUI=L5	(Crews Berthing)						3 % AFFF
2-44-2-L	CREWS BERTHING	None		1	PKP	None	
2-60-1-L	CREWS BERTHING	None		2	PKP	None	
2-74-0-L	CREWS BERTHING	None		1	PKP	None	
		None		None			1 A3F
1-70-4-L	PO-1 BERTHING	None		None		None	
CUI=LL	(Wardroom/Mess/Lounge Areas)						
2-44-1-L	CREW LOUNGE	None		None		None	
1-70-3A-L	CREW MESS	None		1	CO2	None	
1-93-1-L	CPO MESS & REC	None		None		None	
1-140-0-L	WARDROOM	None		None		None	
CUI=LM	(Medical/Dental Spaces)						
1-99-2-L	DISPENSARY	None		None		None	
CUI=LP	(Passageway/Staircase/Vestibule)						
3-81-1-L	PASSAGE	None		1	CO2	None	
3-81-2-L	PASSAGE	None		None		None	
2-30-01-L	PASSAGE	None		1	CO2	None	
		None		None			1 A3F
2-44-01-L	PASSAGE	None		None			1 A3F
1-68-0-L	COMPANIONWAY	None		None		None	
1-70-1-L	VESTIBULE	None		None		None	
1-70-2-L	VESTIBULE	None		None		None	
1-74-0-L	PASSAGE	None		None		None	
1-74-2A-L	PASSAGE	None		1	CO2	None	
		None		None			1 A3F
1-74-2B-L	PASSAGE	None		1	CO2	None	
		None		None			1 A3F
1-74-2C-L	PASSAGE	None		1	CO2	None	
1-77-1-L	COMPANIONWAY	None		None		None	
1-85-2-L	COMPANIONWAY	None		None		None	
1-99-1A-L	PASSAGE	None		None		None	
1-99-1B-L	PASSAGE	None		1	CO2	None	
		None		1	PKP	None	
1-132-0A-L	PASSAGE	None		None			1 A3F
1-132-0B-L	PASSAGE	None		None		None	
01-93-2-L	COMPANIONWAY	None		None		None	
01-95-1-L	COMPANIONWAY	None		None		None	
02-81-2-L	PASSAGE	None		1	CO2	None	
CUI=LW	(Sanitary Spaces)						
2-57-0-L	CREW WR, WC & SH	None		None		None	
2-74-1-L	CREW WR, WC & SH	None		None		None	
1-91-2-L	PO-1 WC, WR & SH	None		None		None	
1-104-2-L	CPO WR, WC & SH	None		None		None	
1-150-2-L	OFFICER WR, WC & SH	None		None		None	
01-95-0-L	WR, WC & SH	None		None		None	
CUI=QA	(Aux Machinery Spaces)						
3-56-0-Q	SEWAGE SPACE	None		None		None	
3-74-2-Q	REEFER FLAT	None		None		None	
2-126-2-Q	A.C. EQUIPMENT	None		None		None	

Table B.5 Automated and Manual Fire Protection Systems

Plan ID	Compartment Name	Fixed	Systems	Manual	Firefighting	Equipment	3 % AFFF
		(Installed)		Portable		Extinguishers	
2-161-0-Q	LAZARETTE	None		None		None	
1-68-1-Q	HYD PUMP ROOM	None		None		None	
1-68-2-Q	HYD PUMP ROOM	None		None		None	
1-77-0-Q	GYRO EQUIP	None		None		None	
4-92-0A-E	FIDLEY	None		None		None	
1-112-0-Q	AUXILIARY MACHINERY SPACE #3	None			1 CO2	None	
1-157-0-E	STEERING GEAR SPACE	None			1 CO2	None	
CUI=QF	(Fan Room)						
01-89-2-Q	FAN ROOM	None		None		None	
01-110-0-Q	FAN & EQUIPMENT ROOM	None		None		None	
02-74-0-Q	FAN ROOM	None		None		None	
CUI=QG	(Galley/Pantry/Scullery)						
1-79-0-Q	GALLEY		1 APC	None		None	
		None			1 PKP	None	
1-92-0-Q	SCULLERY	None		None		None	
1-140-1-Q	PANTRY	None			1 CO2	None	
CUI=QL	(Laundry)						
2-36-1-Q	LAUNDRY	None		None		None	
CUI=QO	(Office Spaces)						
2-30-0-Q	ENG LOG OFFICE	None		None		None	
1-110-1-Q	SHIPS OFFICE	None		None		None	
CUI=QS	(Shops)						
2-9-0-E	DC SHOP	None			3 PKP	None	
2-30-1-Q	ATON SHOP	None		None		None	
2-126-1-Q	MACHINE SHOP	None		None		None	
1-6-0-Q	DECK WORKSHOP	None			1 CO2	None	
CUI=TH	(Trunks/Hoists/Dumbwaiters)						
2-44-0-T	HATCH TRUNK	None		None		None	
CUI=TU	(Stacks/Engine Uptakes)						
01-102-0-E	VENT & UPTAKE SPACE	None		None		None	
02-102-0-E	UPTAKE	None		None		None	
CUI=W	(Water Tank (empty))						
4-FP-0-W	FOREPEAK TANK	None		None		None	
4-30-0-W	FRESH WATER TANK	None		None		None	
4-30-1-W	FRESH WATER TANK	None		None		None	
4-30-2-W	FRESH WATER TANK	None		None		None	
4-140-0-W	FRESH WATER TANK	None		None		None	
4-147-0-W	AFT PEAK TANK	None		None		None	
3-140-1-W	FRESH WATER TANK	None		None		None	
3-140-2-W	FRESH WATER TANK	None		None		None	

Table B.6.1 Probability of Flame Termination: Passive and Automated Measures

Plan ID	Compartment Name	I Values			A Values		
		EB	TBAR	DBAR	EB	TBAR	DBAR
CUI=AA	(Cargo Hold) Frequency of EB=0.0001						
3-44-0-A	MAIN HOLD	64	80	48	0	0	0
CUI=AG	(Gear Locker) Frequency of EB=0.0010						
3-85-3-A	MAA LKR	27	35	16	0	0	0
2-9-0-Q	CHAIN LKR	99	100	60	0	0	0
1-6-1-Q	A/N LKR	27	35	16	0	0	0
1-6-2-Q	BOSN'S LKR	27	35	16	0	0	0
1-92-2-Q	DC LKR	27	35	16	0	0	0
1-106-1-Q	MOVIE LKR	27	35	16	0	0	0
1-107-1-Q	MORALE LKR	29	36	17	0	0	0
1-157-2-Q	LINEN LKR	27	35	16	0	0	0
1-161-2-Q	CG LKR	27	35	16	0	0	0
CUI=AR	(Refrigerated Storage) Frequency of EB=0.0009						
3-74-0-A	MEATS	61	73	48	0	0	0
3-81-0-A	DAIRY	61	73	48	0	0	0
3-85-0-A	FRUITS AND VEGETABLES	61	73	48	0	0	0
CUI=AS	(Storeroom) Frequency of EB=0.0009						
3-68-1-A	GENERAL STORES	39	42	23	0	0	0
3-68-2-A	DRY STORES	39	42	23	0	0	0
3-74-3-A	MAA STORAGE	39	42	23	0	0	0
2-30-2-Q	E.M. SHOP & STORES	39	42	23	0	0	0
2-41-2-Q	SHIPS SERVICE STORE	39	42	23	0	0	0
2-147-0-Q	ENGINEERS STOREROOM	39	42	23	0	0	0
CUI=C	(Ship Control/Communications) Frequency of EB=0.0012						
01-71-0-Q	CRANE CONTROL BOOTH	66	73	40	0	0	0
01-74-1-Q	CODE ROOM	39	42	23	0	0	0
01-116-0-Q	CLIP SHACK	58	63	34	0	0	0
02-81-0-C	CHART ROOM	39	42	23	0	0	0
02-89-0-C	RADIO ROOM	43	47	25	0	0	0
03-72-0-C	WHEELHOUSE	43	47	25	0	0	0
CUI=EE	(Main Propulsion - Electrical) Frequency of EB=0.0031						
4-92-0-E	GENERATOR ROOM	43	48	26	0	0	0
4-126-0-E	MAIN MOTOR ROOM	43	48	26	0	0	0
CUI=EM	(Main Propulsion - Mechanical) Frequency of EB=0.0272						
3-9-0-E	BOW THRUSTER ROOM	69	75	41	0	0	0
CUI=K	(Hazardous Material Storage) Frequency of EB=0.0013						
1-FP-0-K	PAINT LKR	25	25	12	71	71	35
CUI=L1	(Senior Officer's Cabin) Frequency of EB=0.0008						
1-132-1-L	SR #3	43	52	22	0	0	0
1-132-2-L	SR #4	50	60	25	0	0	0
01-74-0-L	CO SR	43	52	22	0	0	0
01-82-0-L	CO CABIN	35	42	17	0	0	0
CUI=L2	(Officer/CPO Quarters) Frequency of EB=0.0008						
1-106-2-L	CPO BERTHING	50	55	30	0	0	0
1-124-1-L	SR #1	50	55	30	0	0	0
1-124-2-L	SR #2	50	55	30	0	0	0
1-140-2-L	SR #6	50	55	30	0	0	0
CUI=L5	(Crews Berthing) Frequency of EB=0.0008						
2-44-2-L	CREWS BERTHING	55	56	33	0	0	0

Table B.6.1 Probability of Flame Termination: Passive and Automated Measures

Plan ID	Compartment Name	I Values			A Values		
		EB	TBAR	DBAR	EB	TBAR	DBAR
2-60-1-L	CREWS BERTHING	55	56	33	0	0	0
2-74-0-L	CREWS BERTHING	55	56	33	0	0	0
1-70-4-L	PO-1 BERTHING	55	56	33	0	0	0
CUI=LL	(Wardroom/Mess/Lounge Areas) Frequency of EB=0.0008						
2-44-1-L	CREW LOUNGE	55	61	33	0	0	0
1-70-3A-L	CREW MESS	35	39	21	0	0	0
1-93-1-L	CPO MESS & REC	35	39	21	0	0	0
1-140-0-L	WARDROOM	35	39	21	0	0	0
CUI=LM	(Medical/Dental Spaces) Frequency of EB=0.0004						
1-99-2-L	DISPENSARY	35	38	21	0	0	0
CUI=LP	(Passageway/Staircase/Vestibule) Frequency of EB=0.0001						
3-81-1-L	PASSAGE	84	84	75	0	0	0
3-81-2-L	PASSAGE	84	84	75	0	0	0
2-30-01-L	PASSAGE	84	84	75	0	0	0
2-44-01-L	PASSAGE	84	84	75	0	0	0
1-68-0-L	COMPANIONWAY	87	87	78	0	0	0
1-70-1-L	VESTIBULE	77	77	69	0	0	0
1-70-2-L	VESTIBULE	77	77	69	0	0	0
1-74-0-L	PASSAGE	84	84	75	0	0	0
1-74-2A-L	PASSAGE	84	84	75	0	0	0
1-74-2B-L	PASSAGE	84	84	75	0	0	0
1-74-2C-L	PASSAGE	84	84	75	0	0	0
1-77-1-L	COMPANIONWAY	87	87	78	0	0	0
1-85-2-L	COMPANIONWAY	87	87	78	0	0	0
1-99-1A-L	PASSAGE	84	84	75	0	0	0
1-99-1B-L	PASSAGE	84	84	75	0	0	0
1-132-0A-L	PASSAGE	84	84	75	0	0	0
1-132-0B-L	PASSAGE	84	84	75	0	0	0
01-93-2-L	COMPANIONWAY	87	87	78	0	0	0
01-95-1-L	COMPANIONWAY	87	87	78	0	0	0
02-81-2-L	PASSAGE	84	84	75	0	0	0
CUI=LW	(Sanitary Spaces) Frequency of EB=0.0002						
2-57-0-L	CREW WR, WC & SH	88	88	70	0	0	0
2-74-1-L	CREW WR, WC & SH	88	88	70	0	0	0
1-91-2-L	PO-1 WC, WR & SH	88	88	70	0	0	0
1-104-2-L	CPO WR, WC & SH	88	88	70	0	0	0
1-150-2-L	OFFICER WR, WC & SH	88	88	70	0	0	0
01-95-0-L	WR, WC & SH	88	88	70	0	0	0
CUI=QA	(Aux Machinery Spaces) Frequency of EB=0.0029						
3-56-0-Q	SEWAGE SPACE	50	50	35	0	0	0
3-74-2-Q	REEFER FLAT	84	84	75	0	0	0
2-126-2-Q	A.C. EQUIPMENT	50	50	35	0	0	0
2-161-0-Q	LAZARETTE	69	69	48	0	0	0
1-68-1-Q	HYD PUMP ROOM	58	58	40	0	0	0
1-68-2-Q	HYD PUMP ROOM	58	58	40	0	0	0
1-77-0-Q	GYRO EQUIP	66	66	46	0	0	0
4-92-0A-E	FIDLEY	43	44	30	0	0	0
1-112-0-Q	AUXILIARY MACHINERY SPACE #3	43	44	30	0	0	0
1-157-0-E	STEERING GEAR SPACE	73	73	51	0	0	0

Table B.6.1 Probability of Flame Termination: Passive and Automated Measures

Plan ID	Compartment Name	I Values			A Values		
		EB	TBAR	DBAR	EB	TBAR	DBAR
CUI=QF	(Fan Room) Frequency of EB=0.0004						
01-89-2-Q	FAN ROOM	66	52	39	0	0	0
01-110-0-Q	FAN & EQUIPMENT ROOM	66	52	39	0	0	0
02-74-0-Q	FAN ROOM	66	52	39	0	0	0
CUI=QG	(Galley/Pantry/Scullery) Frequency of EB=0.0026						
1-79-0-Q	GALLEY	61	61	36	85	85	42
1-92-0-Q	SCULLERY	61	61	36	0	0	0
1-140-1-Q	PANTRY	61	61	36	0	0	0
CUI=QL	(Laundry) Frequency of EB=0.0031						
2-36-1-Q	LAUNDRY	32	40	24	0	0	0
CUI=QO	(Office Spaces) Frequency of EB=0.0004						
2-30-0-Q	ENG LOG OFFICE	43	48	26	0	0	0
1-110-1-Q	SHIPS OFFICE	35	43	21	0	0	0
CUI=QS	(Shops) Frequency of EB=0.0018						
2-9-0-E	DC SHOP	43	48	26	0	0	0
2-30-1-Q	ATON SHOP	35	43	21	0	0	0
2-126-1-Q	MACHINE SHOP	43	48	26	0	0	0
1-6-0-Q	DECK WORKSHOP	43	48	26	0	0	0
CUI=TH	(Trunks/Hoists/Dumbwaiters) Frequency of EB=0.0001						
2-44-0-T	HATCH TRUNK	96	100	58	0	0	0
CUI=TU	(Stacks/Engine Uptakes) Frequency of EB=0.0013						
01-102-0-E	VENT & UPTAKE SPACE	35	39	21	0	0	0
02-102-0-E	UPTAKE	35	39	21	0	0	0
CUI=W	(Water Tank (empty)) Frequency of EB=0.0004						
4-FP-0-W	FOREPEAK TANK	100	100	100	0	0	0
4-30-0-W	FRESH WATER TANK	100	100	100	0	0	0
4-30-1-W	FRESH WATER TANK	100	100	100	0	0	0
4-30-2-W	FRESH WATER TANK	100	100	100	0	0	0
4-140-0-W	FRESH WATER TANK	100	100	100	0	0	0
4-147-0-W	AFT PEAK TANK	100	100	100	0	0	0
3-140-1-W	FRESH WATER TANK	100	100	100	0	0	0
3-140-2-W	FRESH WATER TANK	100	100	100	0	0	0

Table B.6.1.1 I-Value Calculations

CUI	Plan ID	Comp	lebar	lcbar	lrbar	lbar	I EB
AA	3-44-0-A	MAIN HOLD	0.60	0.75	0.80	0.36	0.64
AG	1-6-1-Q	A/N LKR	0.90	0.90	0.90	0.73	0.27
AG	1-6-2-Q	BOSN'S LKR	0.90	0.90	0.90	0.73	0.27
AG	1-161-2-Q	CG LKR	0.90	0.90	0.90	0.73	0.27
AG	1-92-2-Q	CG LKR	0.90	0.90	0.90	0.73	0.27
AG	2-9-0-Q	CHAIN LKR	0.20	0.20	0.20	0.01	0.99
AG	1-157-2-Q	LINEN LKR	0.90	0.90	0.90	0.73	0.27
AG	3-85-3-A	MAA LKR	0.90	0.90	0.90	0.73	0.27
AG	1-107-1-Q	MORALE LKR	0.80	0.90	0.99	0.71	0.29
AG	1-106-1-Q	MOVIE LKR	0.90	0.90	0.90	0.73	0.27
AR	3-81-0-A	DAIRY	0.70	0.80	0.70	0.39	0.61
AR	3-85-0-A	FRUITS AND VEGETABLES	0.70	0.80	0.70	0.39	0.61
AR	3-74-0-A	MEATS	0.70	0.80	0.70	0.39	0.61
AS	3-68-2-A	DRY STORES	0.80	0.90	0.85	0.61	0.39
AS	2-30-2-Q	E.M. SHOP & STORES	0.80	0.85	0.90	0.61	0.39
AS	2-147-0-Q	ENGINEERS STOREROOM	0.80	0.85	0.90	0.61	0.39
AS	3-68-1-A	GENERAL STORES	0.80	0.90	0.85	0.61	0.39
AS	3-74-3-A	MAA STORAGE	0.80	0.90	0.85	0.61	0.39
AS	2-41-2-Q	SHIPS SERVICE STORE	0.80	0.85	0.90	0.61	0.39
C	02-81-0-C	CHART ROOM	0.90	0.85	0.80	0.61	0.39
C	01-116-0-Q	CLIP SHACK	0.80	0.75	0.70	0.42	0.58
C	01-74-1-Q	CODE ROOM	0.85	0.90	0.80	0.61	0.39
C	01-71-0-Q	CRANE CONTROL BOOTH	0.60	0.70	0.80	0.34	0.66
C	02-89-0-C	RADIO ROOM	0.75	0.85	0.90	0.57	0.43
C	03-72-0-0	WHEELHOUSE	0.75	0.85	0.90	0.57	0.43
EE	4-92-0-E	GENERATOR ROOM	0.70	0.85	0.95	0.57	0.43
EE	4-126-0-E	MAIN MOTOR ROOM	0.70	0.85	0.95	0.57	0.43
EM	3-9-0-E	BOW THRUSTER ROOM	0.60	0.70	0.75	0.32	0.69
K	1-FP-0-K	PAINT LKR	0.80	0.95	0.99	0.75	0.25
L1	01-82-0-L	CO CABIN	0.85	0.85	0.90	0.65	0.35
L1	01-74-0-L	CO SR	0.70	0.85	0.95	0.57	0.43
L1	1-132-2-L	SR #3	0.70	0.85	0.95	0.57	0.43
L2	1-106-2-L	CPO BERTHING	0.70	0.80	0.90	0.50	0.50
L2	1-124-2-L	SR #1	0.70	0.80	0.90	0.50	0.50
L2	1-124-1-L	SR #2	0.70	0.80	0.90	0.50	0.50
L2	1-132-1-L	SR #4	0.70	0.80	0.90	0.50	0.50
L2	1-140-2-L	SR #5	0.70	0.80	0.90	0.50	0.50
L5	2-44-2-L	CREWS BERTHING	0.70	0.80	0.80	0.45	0.55
L5	2-60-1-L	CREWS BERTHING	0.70	0.80	0.80	0.45	0.55
L5	2-74-0-L	CREWS BERTHING	0.70	0.80	0.80	0.45	0.55
L5	2-44-1-L	ENG. BERTHING	0.70	0.80	0.80	0.45	0.55
L5	1-70-4-L	PO-1 BERTHING	0.70	0.80	0.80	0.45	0.55
LL	1-93-1-L	CPO MESS & REC	0.80	0.85	0.95	0.65	0.35
LL	1-70-3A-L	CREW MESS	0.80	0.85	0.95	0.65	0.35
LL	1-140-0-L	WARDROOM	0.80	0.85	0.95	0.65	0.35
LM	1-99-2-L	DISPENSARY	0.85	0.85	0.90	0.65	0.35
LP	01-93-2-L	COMPANIONWAY	0.60	0.55	0.40	0.13	0.87
LP	01-95-1-L	COMPANIONWAY	0.60	0.55	0.40	0.13	0.87
LP	1-68-0-L	COMPANIONWAY	0.60	0.55	0.40	0.13	0.87
LP	1-77-1-L	COMPANIONWAY	0.60	0.55	0.40	0.13	0.87

Table B.6.1.1 I-Value Calculations

CUI	Plan ID	Comp	lebar	lcbar	lrbar	lbar	l EB
LP	1-85-2-L	COMPANIONWAY	0.60	0.55	0.40	0.13	0.87
LP	02-81-2-L	PASSAGE	0.50	0.55	0.60	0.17	0.84
LP	1-132-0A-L	PASSAGE	0.50	0.55	0.60	0.17	0.84
LP	1-132-0B-L	PASSAGE	0.50	0.55	0.60	0.17	0.84
LP	1-74-0-L	PASSAGE	0.50	0.55	0.60	0.17	0.84
LP	1-74-2A-L	PASSAGE	0.50	0.55	0.60	0.17	0.84
LP	1-74-2B-L	PASSAGE	0.50	0.55	0.60	0.17	0.84
LP	1-74-2C-L	PASSAGE	0.50	0.55	0.60	0.17	0.84
LP	1-99-1A-L	PASSAGE	0.50	0.55	0.60	0.17	0.84
LP	1-99-1B-L	PASSAGE	0.50	0.55	0.60	0.17	0.84
LP	2-30-01-L	PASSAGE	0.50	0.55	0.60	0.17	0.84
LP	2-44-01-L	PASSAGE	0.50	0.55	0.60	0.17	0.84
LP	3-74-01-L	PASSAGE	0.50	0.55	0.60	0.17	0.84
LP	3-81-1-L	PASSAGE	0.50	0.55	0.60	0.17	0.84
LP	3-81-2-L	PASSAGE	0.50	0.55	0.60	0.17	0.84
LP	1-70-1-L	VESTIBULE	0.60	0.60	0.65	0.23	0.77
LP	1-70-2-L	VESTIBULE	0.60	0.60	0.65	0.23	0.77
LW	1-104-2-L	CPO WR, WC & SH	0.45	0.50	0.55	0.12	0.88
LW	2-57-0-L	CREW WR, WC & SH	0.45	0.50	0.55	0.12	0.88
LW	2-74-1-L	CREW WR, WC & SH	0.45	0.50	0.55	0.12	0.88
LW	1-150-2-L	OFFICER SHOWER	0.45	0.50	0.55	0.12	0.88
LW	1-91-2-L	PO-1 WC, WR & SH	0.45	0.50	0.55	0.12	0.88
LW	01-95-0-L	WR, WC & SH	0.45	0.50	0.55	0.12	0.88
QA	2-126-2-Q	A.C. EQUIPMENT	0.70	0.80	0.90	0.50	0.50
QA	1-112-0-Q	AMS #3	0.70	0.90	0.90	0.57	0.43
QA	4-92-0A-E	FIDLEY	0.70	0.85	0.95	0.57	0.43
QA	1-77-0-Q	GYRO EQUIP	0.65	0.70	0.75	0.34	0.66
QA	1-68-1-Q	HYD PUMP ROOM	0.70	0.75	0.80	0.42	0.58
QA	1-68-2-Q	HYD PUMP ROOM	0.70	0.75	0.80	0.42	0.58
QA	2-161-0-Q	LAZARETTE	0.60	0.70	0.75	0.32	0.69
QA	3-56-0-Q	SEWAGE SPACE	0.70	0.80	0.90	0.50	0.50
QA	1-157-0-E	STEERING GEAR SPACE	0.60	0.65	0.70	0.27	0.73
QF	01-110-0-Q	FAN & EQUIPMENT ROOM	0.65	0.70	0.75	0.34	0.66
QF	01-89-2-Q	FAN ROOM	0.65	0.70	0.75	0.34	0.66
QF	02-74-0-Q	FAN ROOM	0.65	0.70	0.75	0.34	0.66
QG	1-79-0-Q	GALLEY	0.70	0.75	0.75	0.39	0.61
QG	1-140-1-L	PANTRY	0.70	0.75	0.75	0.39	0.61
QG	1-92-0-Q	SCULLERY	0.70	0.75	0.75	0.39	0.61
QL	2-36-1-Q	LAUNDRY	0.80	0.90	0.95	0.68	0.32
QO	2-30-1-Q	ENG LOG OFFICE	0.80	0.85	0.95	0.65	0.35
QO	1-110-1-Q	SHIPS OFFICE	0.80	0.85	0.95	0.65	0.35
QS	2-30-0-Q	A.N. SHOP	0.70	0.85	0.95	0.57	0.43
QS	2-9-01-E	DC SHOP	0.70	0.85	0.95	0.57	0.43
QS	1-6-0-Q	DECK WORKSHOP	0.70	0.85	0.95	0.57	0.43
QS	2-126-1-Q	MACHINE SHOP	0.70	0.85	0.95	0.57	0.43
TH	2-44-0-T	HATCH TRUNK	0.30	0.40	0.30	0.04	0.96
TU	01-102-0-E	VENT & UPTAKE SPACE	0.85	0.80	0.95	0.65	0.35

Table B.6.1.2 A-Value Calculations

Plan ID	CUI	Compartment Name	dan	nan	san	An	fap	vap	pap	Ap	saa	aaa	daa	Aa	qae	cae	bae	Ae	A EB
1-FP-0-K	K	PAINT LOCKER	0.95	0.99	0.99	0.99	1.00	1.00	1.00	1.00	0.99	0.95	0.90	0.99	1.00	1.00	0.90	0.99	0.77
1-79-0-Q	QG	GALLEY	0.99	0.99	0.99	0.97	1.00	0.95	0.95	0.99	1.00	0.99	0.99	0.99	1.00	1.00	0.99	0.99	0.85
Shaded columns are calculated according to the following formulas:																			
An=dan*nan*san where dan=detection of fire, nan=notification of Bridge, and san=sound the alarm																			
Ap=fap*vap*cap where fap=secure the fuel supply, vap=secure the ventilation, and cap=secure the electrical power																			
Aa=saa*aaa*daa where saa=alignment of automated system, aaa=agent discharges from nozzle, and daa=agent discharges on the fire																			
Ae=qae*cae*bae where qae=quantity of agent is adequate, cae=concentration of agent is adequate, and bae=blackout occurs																			
A EB=An*Ap*Aa*Ae where An=Notification, Ap=Preparation, Aa=Agent Application, and Ae=Fire Extinguishment																			
Installed Automated Systems:																			
Fixed CO2 Total Flooding System in the Paint Locker and an Aqueous Potassium Carbonate System in the Galley																			
Notes:																			
The Galley is occupied 30% of the time, however, it is assumed that if a grease fire occurs on the Galley stove, it is assumed that a crew member is present in the Galley.																			
The probability of the Galley's automated system successfully extinguishing the fire is based on grease fires on the stove only.																			

Table B.6.2 Probability of Flame Termination: Manual Measures (In Port)

Plan ID	Compartment Name	M Values		
		EB	TBAR	DBAR
CUI=AA	(Cargo Hold) Frequency of EB=0.0001			
3-44-0-A	MAIN HOLD	10	18	7
CUI=AG	(Gear Locker) Frequency of EB=0.0010			
3-85-3-A	MAA LKR	16	19	9
2-9-0-Q	CHAIN LKR	23	27	13
1-6-1-Q	A/N LKR	7	8	4
1-6-2-Q	BOSN'S LKR	7	8	4
1-92-2-Q	DC LKR	2	2	1
1-106-1-Q	MOVIE LKR	2	2	1
1-107-1-Q	MORALE LKR	2	2	1
1-157-2-Q	LINEN LKR	2	2	1
1-161-2-Q	CG LKR	7	8	4
CUI=AR	(Refrigerated Storage) Frequency of EB=0.0009			
3-74-0-A	MEATS	17	20	13
3-81-0-A	DAIRY	17	20	13
3-85-0-A	FRUITS AND VEGETABLES	17	20	13
CUI=AS	(Storeroom) Frequency of EB=0.0009			
3-68-1-A	GENERAL STORES	20	40	20
3-68-2-A	DRY STORES	14	28	14
3-74-3-A	MAA STORAGE	10	20	10
2-30-2-Q	E.M. SHOP & STORES	20	40	20
2-41-2-Q	SHIPS SERVICE STORE	9	18	9
2-147-0-Q	ENGINEERS STOREROOM	10	20	10
CUI=C	(Ship Control/Communications) Frequency of EB=0.0012			
01-71-0-Q	CRANE CONTROL BOOTH	14	15	8
01-74-1-Q	CODE ROOM	8	8	4
01-116-0-Q	CLIP SHACK	12	13	7
02-81-0-C	CHART ROOM	18	19	10
02-89-0-C	RADIO ROOM	12	13	7
03-72-0-C	WHEELHOUSE	27	29	16
CUI=EE	(Main Propulsion - Electrical) Frequency of EB=0.0031			
4-92-0-E	GENERATOR ROOM	5	6	3
4-126-0-E	MAIN MOTOR ROOM	4	5	2
CUI=EM	(Main Propulsion - Mechanical) Frequency of EB=0.0272			
3-9-0-E	BOW THRUSTER ROOM	4	5	2
CUI=K	(Hazardous Material Storage) Frequency of EB=0.0013			
1-FP-0-K	PAINT LKR	10	10	5
CUI=L1	(Senior Officer's Cabin) Frequency of EB=0.0008			
1-132-1-L	SR #3	45	58	27
1-132-2-L	SR #4	45	58	27
01-74-0-L	CO SR	13	16	7
01-82-0-L	CO CABIN	45	58	27
CUI=L2	(Officer/CPO Quarters) Frequency of EB=0.0008			
1-106-2-L	CPO BERTHING	45	72	31
1-124-1-L	SR #1	45	72	31
1-124-2-L	SR #2	45	72	31
1-140-2-L	SR #6	45	72	31
CUI=L5	(Crews Berthing) Frequency of EB=0.0008			
2-44-2-L	CREWS BERTHING	47	94	42

Table B.6.2 Probability of Flame Termination: Manual Measures (In Port)

Plan ID	Compartment Name	M Values		
		EB	TBAR	DBAR
2-60-1-L	CREWS BERTHING	47	94	42
2-74-0-L	CREWS BERTHING	47	94	42
1-70-4-L	PO-1 BERTHING	50	100	45
CUI=LL	(Wardroom/Mess/Lounge Areas) Frequency of EB=0.0008			
2-44-1-L	CREW LOUNGE	23	28	13
1-70-3A-L	CREW MESS	30	37	18
1-93-1-L	CPO MESS & REC	30	37	18
1-140-0-L	WARDROOM	30	37	18
CUI=LM	(Medical/Dental Spaces) Frequency of EB=0.0004			
1-99-2-L	DISPENSARY	28	35	16
CUI=LP	(Passageway/Staircase/Vestibule) Frequency of EB=0.0001			
3-81-1-L	PASSAGE	23	25	20
3-81-2-L	PASSAGE	23	25	20
2-30-01-L	PASSAGE	26	28	23
2-44-01-L	PASSAGE	26	28	23
1-68-0-L	COMPANIONWAY	29	31	26
1-70-1-L	VESTIBULE	29	31	26
1-70-2-L	VESTIBULE	29	31	26
1-74-0-L	PASSAGE	29	31	26
1-74-2A-L	PASSAGE	29	31	26
1-74-2B-L	PASSAGE	29	31	26
1-74-2C-L	PASSAGE	29	31	26
1-77-1-L	COMPANIONWAY	29	31	26
1-85-2-L	COMPANIONWAY	29	31	26
1-99-1A-L	PASSAGE	29	31	26
1-99-1B-L	PASSAGE	29	31	26
1-132-0A-L	PASSAGE	29	31	26
1-132-0B-L	PASSAGE	29	31	26
01-93-2-L	COMPANIONWAY	26	28	23
01-95-1-L	COMPANIONWAY	26	28	23
02-81-2-L	PASSAGE	26	28	23
CUI=LW	(Sanitary Spaces) Frequency of EB=0.0002			
2-57-0-L	CREW WR, WC & SH	29	31	26
2-74-1-L	CREW WR, WC & SH	29	31	26
1-91-2-L	PO-1 WC, WR & SH	26	28	23
1-104-2-L	CPO WR, WC & SH	26	28	23
1-150-2-L	OFFICER WR, WC & SH	26	28	23
01-95-0-L	WR, WC & SH	26	28	23
CUI=QA	(Aux Machinery Spaces) Frequency of EB=0.0029			
3-56-0-Q	SEWAGE SPACE	6	6	4
3-74-2-Q	REEFER FLAT	16	17	12
2-126-2-Q	A.C. EQUIPMENT	5	5	3
2-161-0-Q	LAZARETTE	4	4	3
1-68-1-Q	HYD PUMP ROOM	11	12	8
1-68-2-Q	HYD PUMP ROOM	11	12	8
1-77-0-Q	GYRO EQUIP	14	15	10
4-92-0A-E	FIDLEY	5	5	3
1-112-0-Q	AUXILIARY MACHINERY SPACE #3	5	5	3
1-157-0-E	STEERING GEAR SPACE	3	3	2

Table B.6.2 Probability of Flame Termination: Manual Measures (In Port)

Plan ID	Compartment Name	M Values		
		EB	TBAR	DBAR
CUI=QF	(Fan Room) Frequency of EB=0.0004			
01-89-2-Q	FAN ROOM	4	10	3
01-110-0-Q	FAN & EQUIPMENT ROOM	1	2	0
02-74-0-Q	FAN ROOM	4	10	3
CUI=QG	(Galley/Pantry/Scullery) Frequency of EB=0.0026			
1-79-0-Q	GALLEY	6	8	4
1-92-0-Q	SCULLERY	33	46	26
1-140-1-Q	PANTRY	20	28	16
CUI=QL	(Laundry) Frequency of EB=0.0031			
2-36-1-Q	LAUNDRY	9	13	5
CUI=QO	(Office Spaces) Frequency of EB=0.0004			
2-30-0-Q	ENG LOG OFFICE	19	23	11
1-110-1-Q	SHIPS OFFICE	19	23	11
CUI=QS	(Shops) Frequency of EB=0.0018			
2-9-0-E	DC SHOP	28	33	16
2-30-1-Q	ATON SHOP	28	33	16
2-126-1-Q	MACHINE SHOP	28	33	16
1-6-0-Q	DECK WORKSHOP	28	33	16
CUI=TH	(Trunks/Hoists/Dumbwaiters) Frequency of EB=0.0001			
2-44-0-T	HATCH TRUNK	15	18	9
CUI=TU	(Stacks/Engine Uptakes) Frequency of EB=0.0013			
01-102-0-E	VENT & UPTAKE SPACE	2	2	1
02-102-0-E	UPTAKE	5	6	3
CUI=W	(Water Tank (empty)) Frequency of EB=0.0004			
4-FP-0-W	FOREPEAK TANK	95	95	95
4-30-0-W	FRESH WATER TANK	95	95	95
4-30-1-W	FRESH WATER TANK	95	95	95
4-30-2-W	FRESH WATER TANK	95	95	95
4-140-0-W	FRESH WATER TANK	95	95	95
4-147-0-W	AFT PEAK TANK	95	95	95
3-140-1-W	FRESH WATER TANK	95	95	95
3-140-2-W	FRESH WATER TANK	95	95	95

Table B.6.2.1 M-Values In Port

CUI	Plan ID	Comp	FRI	Class	Size	dmm	nmn	smn	Mtr	fmp	vmp	pmp	mp	sma	ama	dma	Ma	gme	cmc	lme	Me	MJEB
AA	3-44-0-A	MAIN HOLD	3	A	M	0.5	0.8	0.95	0.38	1	0.9	0.9	0.81	0.5	1	0.8	0.4	1	1	0.8	0.8	0.1
AG	1-6-1-Q	A/N LKR	2	A	S	0.4	0.8	0.95	0.3	1	0.9	0.9	0.81	0.3	1	0.3	1	1	0.95	0.95	0.07	
AG	1-6-2-Q	BOSN'S LKR	2	A	S	0.4	0.8	0.95	0.3	1	0.9	0.9	0.81	0.3	1	0.3	1	1	0.95	0.95	0.07	
AG	1-161-2-Q	CG LKR	2	A	S	0.4	0.8	0.95	0.3	1	0.9	0.9	0.81	0.3	1	0.3	1	1	0.95	0.95	0.07	
AG	1-92-2-Q	CG LKR	1	A	S	0.4	0.8	0.95	0.3	1	0.9	0.9	0.81	0.1	1	0.1	1	1	0.95	0.95	0.02	
AG	2-9-0-Q	CHAIN LKR	∞	A	S	0.4	0.8	0.95	0.3	1	0.9	0.9	0.81	1	1	1	1	1	0.95	0.95	0.23	
AG	1-157-2-Q	LINEN LKR	1	A	S	0.4	0.8	0.95	0.3	1	0.9	0.9	0.81	0.1	1	0.1	1	1	0.95	0.95	0.02	
AG	3-85-3-A	MAA LKR	4	A	S	0.4	0.8	0.95	0.3	1	0.9	0.9	0.81	0.7	1	0.7	1	1	0.95	0.95	0.16	
AG	1-107-1-Q	MORALE LKR	1	A	S	0.4	0.8	0.95	0.3	1	0.9	0.9	0.81	0.1	0.9	0.9	1	1	0.95	0.95	0.02	
AG	1-106-1-Q	MOVIE LKR	1	A	S	0.4	0.8	0.95	0.3	1	0.9	0.9	0.81	0.1	0.9	0.9	1	1	0.95	0.95	0.02	
AR	3-81-0-A	DAIRY	∞	A	S	0.4	0.8	0.95	0.3	1	0.9	0.9	0.81	1	0.8	0.9	0.72	1	1	0.95	0.95	0.17
AR	3-85-0-A	FRUITS AND VEGETABLES	∞	A	S	0.4	0.8	0.95	0.3	1	0.9	0.9	0.81	1	0.8	0.9	0.72	1	1	0.95	0.95	0.17
AR	3-74-0-A	MEATS	∞	A	S	0.4	0.8	0.95	0.3	1	0.9	0.9	0.81	1	0.8	0.9	0.72	1	1	0.95	0.95	0.17
AS	3-68-2-A	DRY STORES	∞	A	M	0.4	0.8	0.95	0.3	1	0.9	0.9	0.81	1	0.8	0.9	0.72	1	1	0.95	0.95	0.14
AS	2-30-2-Q	E.M. SHOP & STORES	25	A	M	0.5	0.8	0.95	0.38	1	0.9	0.9	0.81	1	0.9	0.9	0.81	1	1	0.8	0.8	0.2
AS	2-147-0-Q	ENGINEERS STOREROOM	3	A	M	0.5	0.8	0.95	0.38	1	0.9	0.9	0.81	0.5	0.9	0.9	0.41	1	1	0.8	0.8	0.1
AS	3-68-1-A	GENERAL STORES	29	A	M	0.5	0.8	0.95	0.38	1	0.9	0.9	0.81	1	0.9	0.9	0.81	1	1	0.8	0.8	0.2
AS	3-74-3-A	MAA STORAGE	3	A	M	0.5	0.8	0.95	0.38	1	0.9	0.9	0.81	0.5	0.9	0.9	0.41	1	1	0.8	0.8	0.1
AS	2-41-2-Q	SHIPS SERVICE STORE	3	A	M	0.5	0.8	0.95	0.38	1	0.9	0.9	0.81	0.5	0.8	0.9	0.41	1	1	0.8	0.8	0.1
C	02-81-0-C	CHART ROOM	5	A	L	0.5	0.8	0.95	0.38	1	0.9	0.9	0.81	0.9	1	1	0.9	1	1	0.8	0.8	0.09
C	01-116-0-Q	CLIP SHACK	3	A	S	0.4	0.8	0.95	0.3	1	0.9	0.9	0.81	0.5	1	1	0.9	1	1	0.65	0.65	0.18
C	01-74-1-Q	CODE ROOM	4	C	L	0.5	0.8	0.95	0.38	1	0.9	0.8	0.72	0.7	0.8	1	0.5	1	1	0.95	0.95	0.12
C	01-71-0-Q	CRANE CONTROL BOOTH	∞	C	S	0.3	0.8	0.95	0.23	1	0.9	0.9	0.81	1	1	1	1	1	0.9	0.9	0.08	
C	02-89-0-C	RADIO ROOM	6	C	L	0.6	0.8	0.95	0.46	1	0.9	0.8	0.72	0.95	0.8	0.9	0.88	0.9	0.9	0.65	0.53	0.08
C	03-72-0-0	WHEELHOUSE	6	C	M	0.6	1	1	0.6	1	0.9	0.8	0.72	0.95	1	1	0.95	0.9	0.9	0.65	0.53	0.12
EE	4-92-0-E	GENERATOR ROOM	3	C	L	0.6	0.8	0.95	0.46	0.8	0.8	0.8	0.53	0.5	1	0.8	0.4	0.9	0.9	0.65	0.53	0.05
EE	4-126-0-E	MAIN MOTOR ROOM	2	C	L	0.6	0.8	0.95	0.46	1	0.8	0.8	0.64	0.3	1	0.8	0.24	0.9	0.9	0.65	0.53	0.04
EM	3-9-0-E	BOW THRUSTER ROOM	2	B	M	0.5	0.8	0.95	0.38	0.7	0.9	0.9	0.57	0.3	1	0.85	0.26	0.95	0.95	0.8	0.72	0.04
K	1-FP-0-K	PAINT LKR	2	B	L	0.9	0.9	0.95	0.77	1	0.8	0.9	0.72	0.3	1	1	0.3	0.95	0.95	0.65	0.59	0.1
L1	01-82-0-L	CO CABIN	∞	A	M	0.9	0.9	0.95	0.77	1	0.9	0.9	0.81	1	0.9	1	0.9	1	1	0.8	0.8	0.45
L1	01-74-0-L	CO SR	∞	A	M	0.3	0.8	0.95	0.23	1	0.9	0.9	0.81	1	0.9	1	0.9	1	1	0.8	0.8	0.45
L1	1-132-2-L	SR #3	∞	A	M	0.9	0.9	0.95	0.77	1	0.9	0.9	0.81	1	0.9	1	0.9	1	1	0.8	0.8	0.45
L2	1-106-2-L	CPO BERTHING	22	A	M	0.9	0.9	0.95	0.77	1	0.9	0.9	0.81	1	0.9	1	0.9	1	1	0.8	0.8	0.45
L2	1-124-2-L	SR #1	∞	A	M	0.9	0.9	0.95	0.77	1	0.9	0.9	0.81	1	0.9	1	0.9	1	1	0.8	0.8	0.45
L2	1-124-1-L	SR #2	∞	A	M	0.9	0.9	0.95	0.77	1	0.9	0.9	0.81	1	0.9	1	0.9	1	1	0.8	0.8	0.45
L1	1-132-1-L	SR #4	∞	A	M	0.9	0.9	0.95	0.77	1	0.9	0.9	0.81	1	0.9	1	0.9	1	1	0.8	0.8	0.45
L2	1-140-2-L	SR #5	∞	A	M	0.9	0.9	0.95	0.77	1	0.9	0.9	0.81	1	0.9	1	0.9	1	1	0.8	0.8	0.45
L5	2-44-2-L	CREWS BERTHING	∞	A	M	0.9	0.9	0.95	0.77	1	0.9	0.9	0.81	1	0.9	1	0.95	0.95	1	0.8	0.8	0.45
L5	2-60-1-L	CREWS BERTHING	13	A	M	0.9	0.9	0.95	0.77	1	0.9	0.9	0.81	1	1	0.95	0.95	1	1	0.8	0.8	0.47
L5	2-74-0-L	CREWS BERTHING	∞	A	M	0.9	0.9	0.95	0.77	1	0.9	0.9	0.81	1	1	0.95	0.95	1	1	0.8	0.8	0.47
LL	2-44-1-L	CREWS BERTHING	∞	A	M	0.5	0.8	0.95	0.38	1	0.9	0.9	0.81	1	1	0.95	0.95	1	1	0.8	0.8	0.23
L5	1-70-4-L	PO-1 BERTHING	20	A	M	0.9	0.9	0.95	0.77	1	0.9	0.9	0.81	1	1	1	1	1	1	0.8	0.8	0.5
LL	1-93-1-L	CPO MESS & REC	16	A	M	0.6	0.8	0.95	0.46	1	0.9	0.9	0.81	1	1	1	1	1	1	0.8	0.8	0.3
LL	1-70-3A-L	CREW MESS	∞	A	M	0.6	0.8	0.95	0.46	1	0.9	0.9	0.81	1	1	1	1	1	1	0.8	0.8	0.3

Table B.6.2.1 M-Values In Port

CUI	Plan ID	Comp	FRI	Class	Size	dmn	nmn	smn	Min	fmp	vmp	pmp	mp	sma	ama	dma	Ma	qme	cme	bme	Me	MEB
LL	1-140-0-L	WARDROOM		A	M	0.6	0.8	0.95	0.46	1	0.9	0.9	0.81	1	1	1	1	1	1	0.8	0.8	0.3
LM	1-99-2-L	DISPENSARY	18	A	M	0.5	0.9	0.95	0.43	1	0.9	0.9	0.81	1	1	1	1	1	1	0.8	0.8	0.28
LP	01-93-2-L	COMPANIONWAY		A	S	0.45	0.8	0.95	0.34	1	0.9	0.9	0.81	1	1	1	1	1	1	0.95	0.95	0.26
LP	01-95-1-L	COMPANIONWAY		A	S	0.45	0.8	0.95	0.34	1	0.9	0.9	0.81	1	1	1	1	1	1	0.95	0.95	0.26
LP	1-68-0-L	COMPANIONWAY		A	S	0.5	0.8	0.95	0.38	1	0.9	0.9	0.81	1	1	1	1	1	1	0.95	0.95	0.29
LP	1-77-1-L	COMPANIONWAY		A	S	0.5	0.8	0.95	0.38	1	0.9	0.9	0.81	1	1	1	1	1	1	0.95	0.95	0.29
LP	1-85-2-L	COMPANIONWAY		A	S	0.5	0.8	0.95	0.38	1	0.9	0.9	0.81	1	1	1	1	1	1	0.95	0.95	0.29
LP	02-81-2-L	PASSAGE		A	S	0.5	0.8	0.95	0.38	1	0.9	0.9	0.81	1	1	1	1	1	1	0.95	0.95	0.29
LP	1-132-0A-L	PASSAGE		A	S	0.5	0.8	0.95	0.38	1	0.9	0.9	0.81	1	1	1	1	1	1	0.95	0.95	0.29
LP	1-132-0B-L	PASSAGE		A	S	0.5	0.8	0.95	0.38	1	0.9	0.9	0.81	1	1	1	1	1	1	0.95	0.95	0.29
LP	1-74-0-L	PASSAGE		A	S	0.5	0.8	0.95	0.38	1	0.9	0.9	0.81	1	1	1	1	1	1	0.95	0.95	0.29
LP	1-74-2A-L	PASSAGE		A	S	0.5	0.8	0.95	0.38	1	0.9	0.9	0.81	1	1	1	1	1	1	0.95	0.95	0.29
LP	1-74-2B-L	PASSAGE		A	S	0.5	0.8	0.95	0.38	1	0.9	0.9	0.81	1	1	1	1	1	1	0.95	0.95	0.29
LP	1-74-2C-L	PASSAGE		A	S	0.5	0.8	0.95	0.38	1	0.9	0.9	0.81	1	1	1	1	1	1	0.95	0.95	0.29
LP	1-99-1A-L	PASSAGE		A	S	0.5	0.8	0.95	0.38	1	0.9	0.9	0.81	1	1	1	1	1	1	0.95	0.95	0.29
LP	1-99-1B-L	PASSAGE		A	S	0.5	0.8	0.95	0.38	1	0.9	0.9	0.81	1	1	1	1	1	1	0.95	0.95	0.29
LP	2-30-01-L	PASSAGE		A	S	0.45	0.8	0.95	0.34	1	0.9	0.9	0.81	1	1	1	1	1	1	0.95	0.95	0.26
LP	2-44-01-L	PASSAGE		A	S	0.45	0.8	0.95	0.34	1	0.9	0.9	0.81	1	1	1	1	1	1	0.95	0.95	0.26
QA	3-74-2-Q	REEFER FLATS		B	M	0.4	0.8	0.95	0.3	1	0.9	0.9	0.81	1	1	0.9	0.9	0.95	0.95	0.8	0.72	0.16
LP	3-81-1-L	PASSAGE		A	S	0.4	0.8	0.95	0.3	1	0.9	0.9	0.81	1	1	1	1	1	1	0.95	0.95	0.23
LP	3-81-2-L	PASSAGE		A	S	0.4	0.8	0.95	0.3	1	0.9	0.9	0.81	1	1	1	1	1	1	0.95	0.95	0.23
LP	1-70-1-L	VESTIBULE		A	S	0.5	0.8	0.95	0.38	1	0.9	0.9	0.81	1	1	1	1	1	1	0.95	0.95	0.29
LP	1-70-2-L	VESTIBULE		A	S	0.5	0.8	0.95	0.38	1	0.9	0.9	0.81	1	1	1	1	1	1	0.95	0.95	0.29
LW	1-104-2-L	CPO WR, WC & SH		A	S	0.45	0.8	0.95	0.34	1	0.9	0.9	0.81	1	1	1	1	1	1	0.95	0.95	0.26
LW	2-57-0-L	CREW WR, WC & SH		A	S	0.5	0.8	0.95	0.38	1	0.9	0.9	0.81	1	1	1	1	1	1	0.95	0.95	0.29
LW	2-74-1-L	CREW WR, WC & SH		A	S	0.5	0.8	0.95	0.38	1	0.9	0.9	0.81	1	1	1	1	1	1	0.95	0.95	0.29
LW	1-150-2-L	OFFICER SHOWER		A	S	0.45	0.8	0.95	0.34	1	0.9	0.9	0.81	1	1	1	1	1	1	0.95	0.95	0.26
LW	1-91-2-L	PO-1 WC, WR & SH		A	S	0.45	0.8	0.95	0.34	1	0.9	0.9	0.81	1	1	1	1	1	1	0.95	0.95	0.26
LW	01-95-0-L	WR, WC & SH		A	S	0.45	0.8	0.95	0.34	1	0.9	0.9	0.81	1	1	1	1	1	1	0.95	0.95	0.26
QA	2-126-2-Q	A.C. EQUIPMENT		C	M	0.4	0.8	0.95	0.3	1	0.9	0.9	0.81	0.3	1	1	0.3	0.9	0.9	0.8	0.65	0.05
QA	1-112-0-Q	AMS #3		C	M	0.4	0.8	0.95	0.3	1	0.9	0.9	0.81	0.3	1	1	0.3	0.9	0.9	0.8	0.65	0.05
QA	4-92-0A-E	FIDLEY		B	L	0.6	0.8	0.95	0.46	1	0.9	0.9	0.81	0.3	1	0.8	0.24	0.95	0.95	0.65	0.59	0.05
QA	1-77-0-Q	GYRO EQUIP		C	M	0.4	0.8	0.95	0.3	1	0.9	0.9	0.81	1	1	0.9	0.9	0.9	0.9	0.8	0.65	0.04
QA	1-68-1-Q	HYD PUMP ROOM		B	M	0.4	0.8	0.95	0.3	0.7	0.9	0.9	0.81	1	1	0.9	0.9	0.95	0.95	0.8	0.72	0.11
QA	1-68-2-Q	HYD PUMP ROOM		B	M	0.4	0.8	0.95	0.3	0.7	0.9	0.9	0.81	1	1	0.9	0.9	0.95	0.95	0.8	0.72	0.11
QA	2-161-0-Q	LAZARETTE		A	M	0.35	0.8	0.95	0.27	1	0.9	0.9	0.81	0.95	1	0.9	0.86	0.95	0.95	0.8	0.72	0.11
QA	3-56-0-Q	SEWAGE SPACE		C	M	0.35	0.8	0.95	0.27	1	0.9	0.9	0.81	0.3	1	0.85	0.26	1	1	0.8	0.8	0.04
QA	1-157-0-E	STEERING GEAR SPACE		B	M	0.4	0.8	0.95	0.3	0.7	0.9	0.95	0.54	0.3	1	0.85	0.26	0.95	0.95	0.8	0.72	0.03
QF	01-110-0-Q	FAN & EQUIPMENT ROOM		C	M	0.4	0.8	0.95	0.3	1	0.9	0.95	0.77	0.3	1	0.95	0.43	0.9	0.9	0.8	0.65	0.06
QF	01-89-2-Q	FAN ROOM		C	M	0.4	0.8	0.95	0.3	1	0.9	0.95	0.77	0.3	1	0.95	0.29	0.9	0.9	0.8	0.65	0.04
QF	02-74-0-Q	FAN ROOM		C	M	0.4	0.8	0.95	0.3	1	0.9	0.95	0.77	0.3	1	0.95	0.29	0.9	0.9	0.8	0.65	0.04
QG	1-79-0-Q	GALLEY		B	L	0.6	0.8	0.95	0.46	1	0.9	0.95	0.77	0.3	0.9	1	0.27	0.95	0.95	0.65	0.59	0.06
QG	1-140-1-Q	PANTRY		C	M	0.6	0.8	0.95	0.46	1	0.9	0.85	0.77	0.9	1	0.9	0.9	0.9	0.9	0.8	0.65	0.02
QG	1-92-0-Q	SCULLERY		A	S	0.6	0.8	0.95	0.46	1	0.9	0.85	0.77	1	1	1	1	1	1	0.95	0.95	0.33

Table B.6.2.1 M-Values In Port

CUI	Plan ID	Comp	FRI	Class	Size	dmn	hmn	smn	Min	fmp	vmp	pmp	mp	sma	ama	dma	Ma	qme	cme	bme	Me	MIEB
QL	2-36-1-Q	LAUNDRY	3	A	L	0.5	0.8	0.95	0.38	1	0.9	0.85	0.77	0.5	1	1	0.5	1	1	0.65	0.65	0.99
QO	2-30-0-Q	ENG LOG OFFICE	5	A	L	0.6	0.8	0.95	0.48	1	0.9	0.85	0.77	0.9	0.95	1	0.88	1	1	0.65	0.65	0.99
QO	1-110-1-Q	SHIPS OFFICE	5	A	L	0.6	0.8	0.95	0.46	1	0.9	0.85	0.77	0.9	0.95	1	0.86	1	1	0.65	0.65	0.99
QS	2-30-1-Q	A.N. SHOP	∞	A	M	0.6	0.8	0.95	0.46	1	0.9	0.85	0.77	1	1	1	1	1	1	0.8	0.8	0.28
QS	2-9-0-E	DC SHOP	∞	A	M	0.6	0.8	0.95	0.46	1	0.9	0.85	0.77	1	1	1	1	1	1	0.8	0.8	0.28
QS	1-6-0-Q	DECK WORKSHOP	∞	A	M	0.6	0.8	0.95	0.46	1	0.9	0.85	0.77	1	1	1	1	1	1	0.8	0.8	0.28
QS	2-126-1-Q	MACHINE SHOP	31	A	M	0.6	0.8	0.95	0.46	1	0.9	0.85	0.77	1	1	1	1	1	1	0.8	0.8	0.28
TH	2-44-0-T	HATCH TRUNK	∞	A	S	0.3	0.8	0.95	0.23	1	0.9	0.9	0.81	1	1	0.85	0.85	1	1	0.95	0.95	0.15
TU	01-102-0-E	VENT & UPTAKE SPACE	1	B	L	0.6	0.8	0.95	0.46	1	0.8	0.9	0.72	0.1	1	0.8	0.8	0.95	0.95	0.65	0.65	0.02
TU	02-102-0-E	VENT & UPTAKE SPACE	2	B	L	0.6	0.8	0.95	0.46	1	0.8	0.9	0.72	0.3	1	0.8	0.8	0.95	0.95	0.65	0.65	0.03

Table B.6.3 Probability of Flame Termination: Manual Measures (At Sea)

Plan ID	Compartment Name	M Values		
		EB	TBAR	DBAR
CUI=AA	(Cargo Hold) Frequency of EB=0.0001			
3-44-0-A	MAIN HOLD	12	21	9
CUI=AG	(Gear Locker) Frequency of EB=0.0010			
3-85-3-A	MAA LKR	20	24	12
2-9-0-Q	CHAIN LKR	29	34	17
1-6-1-Q	A/N LKR	9	10	5
1-6-2-Q	BOSN'S LKR	9	10	5
1-92-2-Q	DC LKR	3	3	1
1-106-1-Q	MOVIE LKR	3	3	1
1-107-1-Q	MORALE LKR	3	3	1
1-157-2-Q	LINEN LKR	3	3	1
1-161-2-Q	CG LKR	9	10	5
CUI=AR	(Refrigerated Storage) Frequency of EB=0.0009			
3-74-0-A	MEATS	21	25	16
3-81-0-A	DAIRY	21	25	16
3-85-0-A	FRUITS AND VEGETABLES	21	25	16
CUI=AS	(Storeroom) Frequency of EB=0.0009			
3-68-1-A	GENERAL STORES	24	48	24
3-68-2-A	DRY STORES	18	36	18
3-74-3-A	MAA STORAGE	12	24	14
2-30-2-Q	E.M. SHOP & STORES	24	48	24
2-41-2-Q	SHIPS SERVICE STORE	11	22	11
2-147-0-Q	ENGINEERS STOREROOM	12	24	12
CUI=C	(Ship Control/Communications) Frequency of EB=0.0012			
01-71-0-Q	CRANE CONTROL BOOTH	24	26	14
01-74-1-Q	CODE ROOM	11	12	6
01-116-0-Q	CLIP SHACK	15	16	9
02-81-0-C	CHART ROOM	25	27	15
02-89-0-C	RADIO ROOM	16	17	9
03-72-0-C	WHEELHOUSE	35	38	21
CUI=EE	(Main Propulsion - Electrical) Frequency of EB=0.0031			
4-92-0-E	GENERATOR ROOM	7	8	4
4-126-0-E	MAIN MOTOR ROOM	5	6	3
CUI=EM	(Main Propulsion - Mechanical) Frequency of EB=0.0272			
3-9-0-E	BOW THRUSTER ROOM	6	7	3
CUI=K	(Hazardous Material Storage) Frequency of EB=0.0013			
1-FP-0-K	PAINT LKR	10	10	5
CUI=L1	(Senior Officer's Cabin) Frequency of EB=0.0008			
1-132-1-L	SR #3	45	58	27
1-132-2-L	SR #4	45	58	27
01-74-0-L	CO SR	22	28	13
01-82-0-L	CO CABIN	45	58	27
CUI=L2	(Officer/CPO Quarters) Frequency of EB=0.0008			
1-106-2-L	CPO BERTHING	45	72	31
1-124-1-L	SR #1	45	72	31
1-124-2-L	SR #2	45	72	31
1-140-2-L	SR #6	45	72	31
CUI=L5	(Crews Berthing) Frequency of EB=0.0008			
2-44-2-L	CREWS BERTHING	47	94	42

Table B.6.3 Probability of Flame Termination: Manual Measures (At Sea)

Plan ID	Compartment Name	M Values		
		EB	TBAR	DBAR
2-60-1-L	CREWS BERTHING	47	94	42
2-74-0-L	CREWS BERTHING	47	94	42
1-70-4-L	PO-1 BERTHING	50	100	45
CUI=LL	(Wardroom/Mess/Lounge Areas) Frequency of EB=0.0008			
2-44-1-L	CREW LOUNGE	33	41	19
1-70-3A-L	CREW MESS	34	42	20
1-93-1-L	CPO MESS & REC	34	42	20
1-140-0-L	WARDROOM	34	42	20
CUI=LM	(Medical/Dental Spaces) Frequency of EB=0.0004			
1-99-2-L	DISPENSARY	33	41	19
CUI=LP	(Passageway/Staircase/Vestibule) Frequency of EB=0.0001			
3-81-1-L	PASSAGE	29	31	26
3-81-2-L	PASSAGE	29	31	26
2-30-01-L	PASSAGE	32	35	28
2-44-01-L	PASSAGE	32	35	28
1-68-0-L	COMPANIONWAY	35	38	31
1-70-1-L	VESTIBULE	35	38	31
1-70-2-L	VESTIBULE	35	38	31
1-74-0-L	PASSAGE	35	38	31
1-74-2A-L	PASSAGE	35	38	31
1-74-2B-L	PASSAGE	35	38	31
1-74-2C-L	PASSAGE	35	38	31
1-77-1-L	COMPANIONWAY	35	38	31
1-85-2-L	COMPANIONWAY	35	38	31
1-99-1A-L	PASSAGE	35	38	31
1-99-1B-L	PASSAGE	35	38	31
1-132-0A-L	PASSAGE	35	38	31
1-132-0B-L	PASSAGE	35	38	31
01-93-2-L	COMPANIONWAY	32	35	28
01-95-1-L	COMPANIONWAY	32	35	28
02-81-2-L	PASSAGE	32	35	28
CUI=LW	(Sanitary Spaces) Frequency of EB=0.0002			
2-57-0-L	CREW WR, WC & SH	35	38	31
2-74-1-L	CREW WR, WC & SH	35	38	31
1-91-2-L	PO-1 WC, WR & SH	32	35	28
1-104-2-L	CPO WR, WC & SH	32	35	28
1-150-2-L	OFFICER WR, WC & SH	32	35	28
01-95-0-L	WR, WC & SH	32	35	28
CUI=QA	(Aux Machinery Spaces) Frequency of EB=0.0029			
3-56-0-Q	SEWAGE SPACE	9	9	6
3-74-2-Q	REEFER FLAT	24	26	18
2-126-2-Q	A.C. EQUIPMENT	7	7	5
2-161-0-Q	LAZARETTE	7	7	5
1-68-1-Q	HYD PUMP ROOM	17	18	12
1-68-2-Q	HYD PUMP ROOM	16	17	12
1-77-0-Q	GYRO EQUIP	22	24	16
4-92-0A-E	FIDLEY	7	7	5
1-112-0-Q	AUXILIARY MACHINERY SPACE #3	7	7	5
1-157-0-E	STEERING GEAR SPACE	4	4	3

Table B.6.3 Probability of Flame Termination: Manual Measures (At Sea)

Plan ID	Compartment Name	M Values		
		EB	TBAR	DBAR
CUI=QF	(Fan Room) Frequency of EB=0.0004			
01-89-2-Q	FAN ROOM	5	12	3
01-110-0-Q	FAN & EQUIPMENT ROOM	2	5	1
02-74-0-Q	FAN ROOM	5	12	3
CUI=QG	(Galley/Pantry/Scullery) Frequency of EB=0.0026			
1-79-0-Q	GALLEY	6	8	4
1-92-0-Q	SCULLERY	39	54	31
1-140-1-Q	PANTRY	24	33	19
CUI=QL	(Laundry) Frequency of EB=0.0031			
2-36-1-Q	LAUNDRY	11	16	6
CUI=QO	(Office Spaces) Frequency of EB=0.0004			
2-30-0-Q	ENG LOG OFFICE	24	30	14
1-110-1-Q	SHIPS OFFICE	24	30	14
CUI=QS	(Shops) Frequency of EB=0.0018			
2-9-0-E	DC SHOP	33	39	19
2-30-1-Q	ATON SHOP	33	39	19
2-126-1-Q	MACHINE SHOP	33	39	19
1-6-0-Q	DECK WORKSHOP	33	39	19
CUI=TH	(Trunks/Hoists/Dumbwaiters) Frequency of EB=0.0001			
2-44-0-T	HATCH TRUNK	25	30	15
CUI=TU	(Stacks/Engine Uptakes) Frequency of EB=0.0013			
01-102-0-E	VENT & UPTAKE SPACE	2	2	1
02-102-0-E	UPTAKE	6	7	3
CUI=W	(Water Tank (empty)) Frequency of EB=0.0004			
4-FP-0-W	FOREPEAK TANK	95	95	95
4-30-0-W	FRESH WATER TANK	95	95	95
4-30-1-W	FRESH WATER TANK	95	95	95
4-30-2-W	FRESH WATER TANK	95	95	95
4-140-0-W	FRESH WATER TANK	95	95	95
4-147-0-W	AFT PEAK TANK	95	95	95
3-140-1-W	FRESH WATER TANK	95	95	95
3-140-2-W	FRESH WATER TANK	95	95	95

Table B.6.3.1 M-Values At Sea

CUI	Plan ID	Comp	FRI	Class	Size	dmn	nmn	smn	Mtr	fmp	vmp	pmp	mp	sma	ama	dma	Ma	qme	cme	brme	Me	MJEB
AA	3-44-0-A	MAIN HOLD	3	A	M	0.6	0.8	0.95	0.46	1	0.9	0.9	0.81	0.5	1	0.8	0.4	1	1	0.8	0.8	0.12
AG	1-6-1-Q	A/N LKR	2	A	S	0.5	0.8	0.95	0.38	1	0.9	0.9	0.81	0.3	1	1	0.3	1	1	0.95	0.95	0.09
AG	1-6-2-Q	BOSN'S LKR	2	A	S	0.5	0.8	0.95	0.38	1	0.9	0.9	0.81	0.3	1	1	0.3	1	1	0.95	0.95	0.09
AG	1-161-2-Q	CG LKR	2	A	S	0.5	0.8	0.95	0.38	1	0.9	0.9	0.81	0.3	1	1	0.3	1	1	0.95	0.95	0.09
AG	1-92-2-Q	CG LKR	1	A	S	0.5	0.8	0.95	0.38	1	0.9	0.9	0.81	0.1	1	1	0.1	1	1	0.95	0.95	0.03
AG	2-9-0-Q	CHAIN LKR	∞	A	S	0.5	0.8	0.95	0.38	1	0.9	0.9	0.81	1	1	1	1	1	1	0.95	0.95	0.28
AG	1-157-2-Q	LINEN LKR	1	A	S	0.5	0.8	0.95	0.38	1	0.9	0.9	0.81	0.1	1	1	0.1	1	1	0.95	0.95	0.03
AG	3-85-3-A	MAA LKR	4	A	S	0.5	0.8	0.95	0.38	1	0.9	0.9	0.81	0.7	1	1	0.7	1	1	0.95	0.95	0.2
AG	1-107-1-Q	MORALE LKR	1	A	S	0.5	0.8	0.95	0.38	1	0.9	0.9	0.81	0.1	0.9	1	0.09	1	1	0.95	0.95	0.03
AG	1-106-1-Q	MOVIE LKR	1	A	S	0.5	0.8	0.95	0.38	1	0.9	0.9	0.81	0.1	0.9	1	0.09	1	1	0.95	0.95	0.03
AR	3-81-0-A	DAIRY	∞	A	S	0.5	0.8	0.95	0.38	1	0.9	0.9	0.81	1	0.8	0.9	0.72	1	1	0.95	0.95	0.21
AR	3-85-0-A	FRUITS AND VEGETABLES	∞	A	S	0.5	0.8	0.95	0.38	1	0.9	0.9	0.81	1	0.8	0.9	0.72	1	1	0.95	0.95	0.21
AR	3-74-0-A	MEATS	∞	A	S	0.5	0.8	0.95	0.38	1	0.9	0.9	0.81	1	0.8	0.9	0.72	1	1	0.95	0.95	0.21
AS	3-68-2-A	DRY STORES	∞	A	M	0.5	0.8	0.95	0.38	1	0.9	0.9	0.81	1	0.8	0.9	0.72	1	1	0.8	0.8	0.18
AS	2-30-2-Q	E.M. SHOP & STORES	25	A	M	0.6	0.8	0.95	0.46	1	0.9	0.9	0.81	1	0.9	0.9	0.81	1	1	0.8	0.8	0.24
AS	2-147-0-Q	ENGINEERS STOREROOM	3	A	M	0.6	0.8	0.95	0.46	1	0.9	0.9	0.81	0.5	0.9	0.9	0.41	1	1	0.8	0.8	0.12
AS	3-68-1-A	GENERAL STORES	29	A	M	0.6	0.8	0.95	0.46	1	0.9	0.9	0.81	1	0.9	0.9	0.81	1	1	0.8	0.8	0.24
AS	3-74-3-A	MAA STORAGE	3	A	M	0.6	0.8	0.95	0.46	1	0.9	0.9	0.81	1	1	1	1	1	1	0.9	0.9	0.24
AS	2-41-2-Q	SHIPS SERVICE STORE	3	A	M	0.6	0.8	0.95	0.46	1	0.9	0.9	0.81	0.5	0.9	0.9	0.41	1	1	0.8	0.8	0.12
C	02-81-0-C	CHART ROOM	5	A	L	0.7	0.8	0.95	0.53	1	0.9	0.9	0.81	0.9	1	1	0.9	1	1	0.8	0.8	0.11
C	01-116-0-Q	CLIP SHACK	3	A	S	0.5	0.8	0.95	0.38	1	0.9	0.9	0.81	0.5	1	1	0.5	1	1	0.95	0.95	0.25
C	01-74-1-Q	CODE ROOM	4	C	L	0.7	0.8	0.95	0.53	1	0.9	0.9	0.81	0.7	0.8	1	0.56	1	1	0.95	0.95	0.15
C	01-71-0-Q	CRANE CONTROL BOOTH	∞	C	S	0.5	0.8	0.95	0.38	1	0.9	0.9	0.81	1	1	1	1	1	1	0.9	0.9	0.24
C	02-89-0-C	RADIO ROOM	6	C	L	0.8	0.8	0.95	0.61	1	0.9	0.9	0.81	0.95	0.8	0.9	0.68	0.9	0.9	0.95	0.77	0.24
C	03-72-0-0	WHEELHOUSE	6	C	M	0.8	1	1	0.8	1	0.9	0.9	0.81	0.95	1	1	0.95	0.9	0.9	0.95	0.77	0.24
EE	4-92-0-E	GENERATOR ROOM	3	C	L	0.8	0.8	0.95	0.61	0.8	0.8	0.8	0.51	0.5	1	1	0.8	0.4	0.9	0.9	0.8	0.65
EE	4-126-0-E	MAIN MOTOR ROOM	2	C	L	0.8	0.8	0.95	0.61	1	0.8	0.8	0.64	0.3	1	0.8	0.24	0.9	0.9	0.95	0.53	0.07
EM	3-9-0-E	BOW THRUSTER ROOM	2	B	M	0.8	0.8	0.95	0.61	0.7	0.9	0.9	0.57	0.3	1	0.85	0.26	0.95	0.95	0.8	0.72	0.06
K	1-FP-0-K	PAINT LKR	2	B	L	0.9	0.9	0.95	0.77	1	0.8	0.9	0.72	0.3	1	1	0.3	0.95	0.95	0.65	0.59	0.1
L1	01-82-0-L	CO CABIN	∞	A	M	0.9	0.9	0.95	0.77	1	0.9	0.9	0.81	1	0.9	1	0.9	1	1	0.8	0.8	0.45
L1	01-74-0-L	CO SR	∞	A	M	0.5	0.8	0.95	0.38	1	0.9	0.9	0.81	1	0.9	1	0.9	1	1	0.8	0.8	0.45
L1	1-132-2-L	SR #3	∞	A	M	0.9	0.9	0.95	0.77	1	0.9	0.9	0.81	1	0.9	1	0.9	1	1	0.8	0.8	0.45
L2	1-106-2-L	CPO BERTHING	22	A	M	0.9	0.9	0.95	0.77	1	0.9	0.9	0.81	1	0.9	1	0.9	1	1	0.8	0.8	0.45
L2	1-124-2-L	SR #1	∞	A	M	0.9	0.9	0.95	0.77	1	0.9	0.9	0.81	1	0.9	1	0.9	1	1	0.8	0.8	0.45
L2	1-124-1-L	SR #2	∞	A	M	0.9	0.9	0.95	0.77	1	0.9	0.9	0.81	1	0.9	1	0.9	1	1	0.8	0.8	0.45
L1	1-132-1-L	SR #4	∞	A	M	0.9	0.9	0.95	0.77	1	0.9	0.9	0.81	1	0.9	1	0.9	1	1	0.8	0.8	0.45
L2	1-140-2-L	SR #5	∞	A	M	0.9	0.9	0.95	0.77	1	0.9	0.9	0.81	1	0.9	1	0.9	1	1	0.8	0.8	0.45
L5	2-44-2-L	CREWS BERTHING	∞	A	M	0.9	0.9	0.95	0.77	1	0.9	0.9	0.81	1	1	1	0.95	0.95	1	0.8	0.8	0.45
L5	2-60-1-L	CREWS BERTHING	13	A	M	0.9	0.9	0.95	0.77	1	0.9	0.9	0.81	1	1	1	0.95	0.95	1	0.8	0.8	0.47
L5	2-74-0-L	CREWS BERTHING	∞	A	M	0.9	0.9	0.95	0.77	1	0.9	0.9	0.81	1	1	1	0.95	0.95	1	0.8	0.8	0.47
LL	2-44-1-L	CREWS BERTHING	∞	A	M	0.7	0.8	0.95	0.53	1	0.9	0.9	0.81	1	1	1	0.95	0.95	1	0.8	0.8	0.33
L5	1-70-4-L	PO-1 BERTHING	20	A	M	0.9	0.9	0.95	0.77	1	0.9	0.9	0.81	1	1	1	1	1	1	0.8	0.8	0.5
LL	1-93-1-L	CPO MESS & REC	16	A	M	0.7	0.8	0.95	0.53	1	0.9	0.9	0.81	1	1	1	1	1	1	0.8	0.8	0.34
LL	1-70-3A-L	CREW MESS	∞	A	M	0.7	0.8	0.95	0.53	1	0.9	0.9	0.81	1	1	1	1	1	1	0.8	0.8	0.34

Table B.6.3.1 M-Values At Sea

CUI	Plan ID	Comp	FRI	Class	Size dmm	Inmm	smn	Mp	fmp	vmp	pmp	Mp	sma	ama	dma	Ma	qme	cme	bme	Mc	MJEB	
LL	1-140-0-L	WARDROOM	∞	A	M	0.7	0.8	0.95	0.53	1	0.9	0.9	0.81	1	1	1	1	1	1	0.8	0.8	0.34
LM	1-99-2-L	DISPENSARY	18	A	M	0.6	0.9	0.95	0.51	1	0.9	0.9	0.81	1	1	1	1	1	1	0.8	0.8	0.33
LP	01-93-2-L	COMPANIONWAY	∞	A	S	0.55	0.8	0.95	0.42	1	0.9	0.9	0.81	1	1	1	1	1	1	0.95	0.95	0.32
LP	01-95-1-L	COMPANIONWAY	∞	A	S	0.55	0.8	0.95	0.42	1	0.9	0.9	0.81	1	1	1	1	1	1	0.95	0.95	0.32
LP	1-68-0-L	COMPANIONWAY	∞	A	S	0.6	0.8	0.95	0.46	1	0.9	0.9	0.81	1	1	1	1	1	1	0.95	0.95	0.35
LP	1-77-1-L	COMPANIONWAY	∞	A	S	0.6	0.8	0.95	0.46	1	0.9	0.9	0.81	1	1	1	1	1	1	0.95	0.95	0.35
LP	1-86-2-L	COMPANIONWAY	∞	A	S	0.6	0.8	0.95	0.46	1	0.9	0.9	0.81	1	1	1	1	1	1	0.95	0.95	0.35
LP	02-81-2-L	PASSAGE	∞	A	S	0.55	0.8	0.95	0.42	1	0.9	0.9	0.81	1	1	1	1	1	1	0.95	0.95	0.32
LP	1-132-0A-L	PASSAGE	∞	A	S	0.6	0.8	0.95	0.46	1	0.9	0.9	0.81	1	1	1	1	1	1	0.95	0.95	0.35
LP	1-132-0B-L	PASSAGE	∞	A	S	0.6	0.8	0.95	0.46	1	0.9	0.9	0.81	1	1	1	1	1	1	0.95	0.95	0.35
LP	1-74-0-L	PASSAGE	∞	A	S	0.6	0.8	0.95	0.46	1	0.9	0.9	0.81	1	1	1	1	1	1	0.95	0.95	0.35
LP	1-74-2A-L	PASSAGE	∞	A	S	0.6	0.8	0.95	0.46	1	0.9	0.9	0.81	1	1	1	1	1	1	0.95	0.95	0.35
LP	1-74-2B-L	PASSAGE	∞	A	S	0.6	0.8	0.95	0.46	1	0.9	0.9	0.81	1	1	1	1	1	1	0.95	0.95	0.35
LP	1-74-2C-L	PASSAGE	∞	A	S	0.6	0.8	0.95	0.46	1	0.9	0.9	0.81	1	1	1	1	1	1	0.95	0.95	0.35
LP	1-99-1A-L	PASSAGE	∞	A	S	0.6	0.8	0.95	0.46	1	0.9	0.9	0.81	1	1	1	1	1	1	0.95	0.95	0.35
LP	1-99-1B-L	PASSAGE	∞	A	S	0.6	0.8	0.95	0.46	1	0.9	0.9	0.81	1	1	1	1	1	1	0.95	0.95	0.35
LP	2-30-01-L	PASSAGE	∞	A	S	0.55	0.8	0.95	0.42	1	0.9	0.9	0.81	1	1	1	1	1	1	0.95	0.95	0.32
LP	2-44-01-L	PASSAGE	∞	A	S	0.55	0.8	0.95	0.42	1	0.9	0.9	0.81	1	1	1	1	1	1	0.95	0.95	0.32
QA	3-74-2-Q	REEFER FLATS	∞	B	M	0.6	0.8	0.95	0.46	1	0.9	0.9	0.81	1	1	0.9	0.9	0.95	0.8	0.72	0.24	
LP	3-81-1-L	PASSAGE	∞	A	S	0.5	0.8	0.95	0.38	1	0.9	0.9	0.81	1	1	1	1	1	1	0.95	0.95	0.29
LP	3-81-2-L	PASSAGE	∞	A	S	0.5	0.8	0.95	0.38	1	0.9	0.9	0.81	1	1	1	1	1	1	0.95	0.95	0.29
LP	1-70-1-L	VESTIBULE	∞	A	S	0.6	0.8	0.95	0.46	1	0.9	0.9	0.81	1	1	1	1	1	1	0.95	0.95	0.35
LP	1-70-2-L	VESTIBULE	∞	A	S	0.6	0.8	0.95	0.46	1	0.9	0.9	0.81	1	1	1	1	1	1	0.95	0.95	0.35
LW	1-104-2-L	CPO WR, WC & SH	∞	A	S	0.55	0.8	0.95	0.42	1	0.9	0.9	0.81	1	1	1	1	1	1	0.95	0.95	0.32
LW	2-57-0-L	CREW WR, WC & SH	∞	A	S	0.6	0.8	0.95	0.46	1	0.9	0.9	0.81	1	1	1	1	1	1	0.95	0.95	0.35
LW	2-74-1-L	CREW WR, WC & SH	∞	A	S	0.6	0.8	0.95	0.46	1	0.9	0.9	0.81	1	1	1	1	1	1	0.95	0.95	0.35
LW	1-150-2-L	OFFICER SHOWER	∞	A	S	0.6	0.8	0.95	0.46	1	0.9	0.9	0.81	1	1	1	1	1	1	0.95	0.95	0.35
LW	1-91-2-L	PO-1 WC, WR & SH	∞	A	S	0.55	0.8	0.95	0.42	1	0.9	0.9	0.81	1	1	1	1	1	1	0.95	0.95	0.32
LW	01-95-0-L	WR, WC & SH	∞	A	S	0.55	0.8	0.95	0.42	1	0.9	0.9	0.81	1	1	1	1	1	1	0.95	0.95	0.32
QA	2-126-2-Q	A.C. EQUIPMENT	2	C	M	0.6	0.8	0.95	0.46	1	0.9	0.9	0.81	0.3	1	1	0.3	0.9	0.9	0.8	0.65	0.07
QA	1-112-0-Q	AMS #3	2	C	M	0.6	0.8	0.95	0.46	1	0.9	0.9	0.81	0.3	1	1	0.3	0.9	0.9	0.8	0.65	0.07
QA	4-92-0A-E	FIDLEY	2	B	L	0.8	0.8	0.95	0.61	1	0.9	0.9	0.81	0.3	1	0.8	0.24	0.95	0.65	0.59	0.07	
QA	1-77-0-Q	GYRO EQUIP	∞	C	M	0.6	0.8	0.95	0.46	1	0.9	0.9	0.81	1	1	0.9	0.9	0.9	0.9	0.8	0.65	0.22
QA	1-68-1-Q	HYD PUMP ROOM	∞	B	M	0.6	0.8	0.95	0.46	0.7	0.9	0.9	0.57	1	1	0.9	0.9	0.95	0.8	0.72	0.17	
QA	1-68-2-Q	HYD PUMP ROOM	6	B	M	0.6	0.8	0.95	0.46	0.7	0.9	0.9	0.57	1	1	0.9	0.96	0.95	0.8	0.72	0.16	
QA	2-161-0-Q	LAZARETTE	2	A	M	0.55	0.8	0.95	0.42	1	0.9	0.9	0.81	0.95	1	0.9	0.26	1	1	0.8	0.8	0.07
QA	3-56-0-Q	SEWAGE SPACE	3	C	M	0.55	0.8	0.95	0.42	1	0.9	0.85	0.77	0.5	1	0.85	0.43	0.9	0.9	0.8	0.65	0.09
QA	1-157-0-E	STEERING GEAR SPACE	2	B	M	0.6	0.8	0.95	0.46	0.7	0.9	0.85	0.54	0.3	1	0.85	0.26	0.95	0.95	0.8	0.72	0.04
QF	01-110-0-Q	FAN & EQUIPMENT ROOM	1	C	M	0.5	0.8	0.95	0.38	1	0.9	0.85	0.77	0.1	1	0.95	0.1	0.9	0.9	0.8	0.65	0.02
QF	01-89-2-Q	FAN ROOM	2	C	M	0.5	0.8	0.95	0.38	1	0.9	0.85	0.77	0.3	1	0.95	0.29	0.9	0.9	0.8	0.65	0.05
QF	02-74-0-Q	FAN ROOM	2	C	M	0.5	0.8	0.95	0.38	1	0.9	0.85	0.77	0.3	1	0.95	0.29	0.9	0.9	0.8	0.65	0.05
QG	1-79-0-Q	GALLEY	2	B	L	0.7	0.8	0.95	0.53	1	0.9	0.85	0.77	0.3	0.9	1	0.27	0.95	0.95	0.65	0.59	0.06
QG	1-140-1-Q	PANTRY	5	C	M	0.7	0.8	0.95	0.53	1	0.9	0.85	0.77	0.9	1	0.9	0.9	0.9	0.8	0.65	0.24	
QG	1-92-0-Q	SCULLERY	∞	A	S	0.7	0.8	0.95	0.53	1	0.9	0.85	0.77	1	1	1	1	1	1	0.95	0.95	0.39

Table B.6.3.1 M-Values At Sea

CUI	Plan ID	Comp	FRI	Class	Size	dimn	nmm	smn	Mh	fmp	vmp	pmp	mp	sma	ama	dma	Ma	qme	cmc	bme	Me	MIEB
QL	2-36-1-Q	LAUNDRY	3	A	L	0.6	0.8	0.95	0.46	1	0.9	0.85	0.77	0.5	1	1	0.5	1	1	0.65	0.65	0.11
QO	2-30-0-Q	ENG LOG OFFICE	5	A	L	0.7	0.8	0.95	0.53	1	0.9	0.85	0.77	0.9	1	1	0.9	1	1	0.65	0.65	0.24
QO	1-110-1-Q	SHIPS OFFICE	5	A	L	0.7	0.8	0.95	0.53	1	0.9	0.85	0.77	0.9	1	1	0.9	1	1	0.65	0.65	0.24
QS	2-30-1-Q	A.N. SHOP	∞	A	M	0.7	0.8	0.95	0.53	1	0.9	0.85	0.77	1	1	1	1	1	1	0.8	0.8	0.33
QS	2-9-0-E	DC SHOP	∞	A	M	0.7	0.8	0.95	0.53	1	0.9	0.85	0.77	1	1	1	1	1	1	0.8	0.8	0.33
QS	1-6-0-Q	DECK WORKSHOP	∞	A	M	0.7	0.8	0.95	0.53	1	0.9	0.85	0.77	1	1	1	1	1	1	0.8	0.8	0.33
QS	2-126-1-Q	MACHINE SHOP	31	A	M	0.7	0.8	0.95	0.53	1	0.9	0.85	0.77	1	1	1	1	1	1	0.8	0.8	0.33
TH	2-44-0-T	HATCH TRUNK	∞	A	S	0.5	0.8	0.95	0.38	1	0.9	0.9	0.81	1	1	0.85	0.85	1	1	0.95	0.95	0.25
TU	01-102-0-E	VENT & UPTAKE SPACE	1	B	L	0.8	0.8	0.95	0.61	1	0.8	0.9	0.72	0.1	1	0.8	0.08	0.95	0.95	0.65	0.59	0.02
TU	02-102-0-E	VENT & UPTAKE SPACE	2	B	L	0.8	0.8	0.95	0.51	1	0.8	0.9	0.72	0.3	1	0.8	0.24	0.95	0.95	0.65	0.59	0.06

Table B.7 Fuel Loads

Plan ID	Compartment Name	Cell (psf)	Plas (psf)	Fim Liq (Gals.)	Total (kBTUs/sf)	Growth Model	Stack Ht. %	% Deck Occupied
CUI=AA	(Cargo Hold)							
3-44-0-A	MAIN HOLD	2	1	0	32	12	NA	60
CUI=AG	(Gear Locker)							
3-85-3-A	MAA LKR	10	1.5	1	106.4	4	NA	90
2-9-0-Q	CHAIN LKR	0.1	0.1	0	2.4	16	NA	20
1-6-1-Q	A/N LKR	10	2	0	112	12	NA	90
1-6-2-Q	BOSN'S LKR	0.5	1	0	20	12	NA	90
1-92-2-Q	DC LKR	3	2	0	56	12	NA	50
1-106-1-Q	MOVIE LKR	0.1	0.5	0	8.8	3	90	90
1-107-1-Q	MORALE LKR	0.5	0.1	0	5.6	3	90	90
1-157-2-Q	LINEN LKR	1	0.5	0	16	12	NA	90
1-161-2-Q	CG LKR	1.5	0.5	0	20	12	NA	50
CUI=AR	(Refrigerated Storage)							
3-74-0-A	MEATS	0.1	0.1	0	2.4	16	NA	75
3-81-0-A	DAIRY	0.5	0.5	0	12	16	NA	75
3-85-0-A	FRUITS AND VEGETABLES	0.1	0.2	0	4	16	NA	75
CUI=AS	(Storeroom)							
3-68-1-A	GENERAL STORES	0.2	0.2	0	4.8	5	NA	80
3-68-2-A	DRY STORES	0.5	0.1	0	5.6	5	NA	90
3-74-3-A	MAA STORAGE	5	2	0	72	12	NA	80
2-30-2-Q	E.M. SHOP & STORES	1.5	1.5	0	36	5	NA	80
2-41-2-Q	SHIPS SERVICE STORE	3	1	0	40	2	75	75
2-147-0-Q	ENGINEERS STOREROOM	5	3	0	88	5	NA	80
CUI=C	(Ship Control/Communications)							
01-71-0-Q	CRANE CONTROL BOOTH	0.1	0.2	0	4	7	NA	50
01-74-1-Q	CODE ROOM	5	1	1	58.2	7	NA	60
01-116-0-Q	CLIP SHACK	0.5	1	0	20	7	NA	75
02-81-0-C	CHART ROOM	1	2	0	40	7	NA	50
02-89-0-C	RADIO ROOM	1	2	0	40	7	NA	75
03-72-0-C	WHEELHOUSE	0.5	2	0	36	7	NA	50
CUI=EE	(Main Propulsion - Electrical)							
4-92-0-E	GENERATOR ROOM	0.4	0.6	4	13.4	13	NA	75
4-126-0-E	MAIN MOTOR ROOM	0.5	1	0	20	13	NA	75
CUI=EM	(Main Propulsion - Mechanical)							
3-9-0-E	BOW THRUSTER ROOM	0.1	1	1	17.2	12	NA	75
CUI=K	(Hazardous Material Storage)							
1-FP-0-K	PAINT LKR	0.5	0.2	35	47.6	3	0	80
CUI=L1	(Senior Officer's Cabin)							
1-132-1-L	SR #3	4	1	0	48	10	NA	60
1-132-2-L	SR #4	3	1	0	40	10	NA	70
01-74-0-L	CO SR	4	1.5	0	56	10	NA	60
01-82-0-L	CO CABIN	4	2	0	64	9	NA	60
CUI=L2	(Officer/CPO Quarters)							
1-106-2-L	CPO BERTHING	2	2	0	48	10	NA	70
1-124-1-L	SR #1	4	1	0	48	10	NA	70
1-124-2-L	SR #2	3	1	0	40	10	NA	70
1-140-2-L	SR #6	3	1	0	40	10	NA	70
CUI=L5	(Crews Berthing)							
2-44-2-L	CREWS BERTHING	3	1	0	40	10	NA	80

Table B.7 Fuel Loads

Plan ID	Compartment Name	Cell	Plas	Fim Liq	Total	Growth	Stack Ht.	% Deck
		(psf)	(psf)	(Gals.)	(kBTUs/sf)	Model	%	Occupied
2-60-1-L	CREWS BERTHING	3	1	0	40	10	NA	80
2-74-0-L	CREWS BERTHING	2	1	0	32	10	NA	80
1-70-4-L	PO-1 BERTHING	2	2	0	48	10	NA	80
CUI=LL	(Wardroom/Mess/Lounge Areas)							
2-44-1-L	CREW LOUNGE	0.5	0.5	0	12	9	NA	80
1-70-3A-L	CREW MESS	2	1	0	32	9	NA	60
1-93-1-L	CPO MESS & REC	3	2	0	56	9	NA	70
1-140-0-L	WARDROOM	2	2	0	48	9	NA	50
CUI=LM	(Medical/Dental Spaces)							
1-99-2-L	DISPENSARY	2	2	0	48	9	NA	80
CUI=LP	(Passageway/Staircase/Vestibule)							
3-81-1-L	PASSAGE	0.5	1	0	20	15	NA	20
3-81-2-L	PASSAGE	0.5	1	0	20	15	NA	20
2-30-01-L	PASSAGE	0.1	0.2	0	4	15	NA	20
2-44-01-L	PASSAGE	0.5	1	0	20	15	NA	20
1-68-0-L	COMPANIONWAY	0.2	0.1	0	3.2	14	NA	20
1-70-1-L	VESTIBULE	0.2	0.1	0	3.2	15	NA	20
1-70-2-L	VESTIBULE	0.2	0.1	0	3.2	15	NA	20
1-74-0-L	PASSAGE	0.5	1	0	20	15	NA	20
1-74-2A-L	PASSAGE	0.5	1	0	20	15	NA	20
1-74-2B-L	PASSAGE	0.5	1	0	20	15	NA	20
1-74-2C-L	PASSAGE	0.5	1	0	20	15	NA	20
1-77-1-L	COMPANIONWAY	0.2	0.1	0	3.2	14	NA	20
1-85-2-L	COMPANIONWAY	0.2	0.1	0	3.2	14	NA	20
1-99-1A-L	PASSAGE	0.5	1	0	20	15	NA	20
1-99-1B-L	PASSAGE	0.5	1	0	20	15	NA	20
1-132-0A-L	PASSAGE	0.2	0.3	0	6.4	15	NA	20
1-132-0B-L	PASSAGE	0	0.3	0	4.8	15	NA	20
01-93-2-L	COMPANIONWAY	0.2	0.1	0	3.2	14	NA	20
01-95-1-L	COMPANIONWAY	0.2	0.1	0	3.2	14	NA	20
02-81-2-L	PASSAGE	0.5	1	0	20	15	NA	20
CUI=LW	(Sanitary Spaces)							
2-57-0-L	CREW WR, WC & SH	0.2	0.1	0	3.2	16	NA	20
2-74-1-L	CREW WR, WC & SH	0.2	0.6	0	11.2	16	NA	20
1-91-2-L	PO-1 WC, WR & SH	0.2	0.1	0	3.2	16	NA	20
1-104-2-L	CPO WR, WC & SH	0.2	0.1	0	3.2	16	NA	20
1-150-2-L	OFFICER WR, WC & SH	0.1	0.1	0	2.4	16	NA	20
01-95-0-L	WR, WC & SH	0.2	0.1	0	3.2	16	NA	20
CUI=QA	(Aux Machinery Spaces)							
3-56-0-Q	SEWAGE SPACE	0.1	0.5	0	8.8	12	NA	50
3-74-2-Q	REEFER FLAT	1	0.2	0	11.2	15	NA	20
2-126-2-Q	A.C. EQUIPMENT	2	1.6	5	45.3	13	NA	75
2-161-0-Q	LAZARETTE	100	0	0	800	13	NA	50
1-68-1-Q	HYD PUMP ROOM	0.1	0.1	0	2.4	12	NA	75
1-68-2-Q	HYD PUMP ROOM	0.1	0.1	1	9	12	NA	75
1-77-0-Q	GYRO EQUIP	0.1	0.1	0	2.4	7	NA	75
4-92-0A-E	FIDLEY	0.4	0.6	4	18.3	13	NA	50
1-112-0-Q	AUXILIARY MACHINERY SPACE #3	0.2	0.2	0	4.8	13	NA	75
1-157-0-E	STEERING GEAR SPACE	0.5	0.3	3	10.8	12	NA	50

Table B.7 Fuel Loads

Plan ID	Compartment Name	Cell (psf)	Plas (psf)	Fln Liq (Gals.)	Total (kBTUs/sf)	Growth Model	Stack Ht. %	% Deck Occupied
CUI=QF	(Fan Room)							
01-89-2-Q	FAN ROOM	0.1	0.1	0	2.4	13	NA	50
01-110-0-Q	FAN & EQUIPMENT ROOM	0.2	0.2	0	4.8	13	NA	50
02-74-0-Q	FAN ROOM	0.1	0.3	0	5.6	13	NA	50
CUI=QG	(Galley/Pantry/Scullery)							
1-79-0-Q	GALLEY	0.2	0.1	0	3.2	13	NA	40
1-92-0-Q	SCULLERY	0.1	0.5	0	8.8	16	NA	40
1-140-1-Q	PANTRY	0.1	0.1	0	2.4	13	NA	40
CUI=QL	(Laundry)							
2-36-1-Q	LAUNDRY	1	0.2	0	11.2	12	NA	50
CUI=QO	(Office Spaces)							
2-30-0-Q	ENG LOG OFFICE	1	0.5	0	16	7	NA	50
1-110-1-Q	SHIPS OFFICE	5	2	0	72	7	NA	70
CUI=QS	(Shops)							
2-9-0-E	DC SHOP	1	1	0	24	5	NA	50
2-30-1-Q	ATON SHOP	1.5	0.1	0	13.6	8	NA	70
2-126-1-Q	MACHINE SHOP	0.5	0.5	2	13.6	5	NA	50
1-6-0-Q	DECK WORKSHOP	1	2	0	40	5	NA	50
CUI=TH	(Trunks/Hoists/Dumbwaiters)							
2-44-0-T	HATCH TRUNK	2	1	0	32	16	NA	10
CUI=TU	(Stacks/Engine Uptakes)							
01-102-0-E	VENT & UPTAKE SPACE	2	0.9	0	30.4	13	NA	30
02-102-0-E	UPTAKE	2	1	0	32	13	NA	30
CUI=W	(Water Tank (empty))							
4-FP-0-W	FOREPEAK TANK	0	0	0	0	16	NA	0
4-30-0-W	FRESH WATER TANK	0	0	0	0	16	NA	0
4-30-1-W	FRESH WATER TANK	0	0	0	0	16	NA	0
4-30-2-W	FRESH WATER TANK	0	0	0	0	16	NA	0
4-140-0-W	FRESH WATER TANK	0	0	0	0	16	NA	0
4-147-0-W	AFT PEAK TANK	0	0	0	0	16	NA	0
3-140-1-W	FRESH WATER TANK	0	0	0	0	16	NA	0
3-140-2-W	FRESH WATER TANK	0	0	0	0	16	NA	0

Table B.8 Fire Growth Models, Rates, and FRI Times

Plan ID	Compartment Name	Growth	Alpha	Maximum Q	FRI	Time	(Min.)	Post-	FRI Q	(kW)
		Model	kW/sec ²	kW	XRAY	YOKE	ZEBRA	XRAY	YOKE	ZEBRA
CUI=AA	(Cargo Hold)									
3-44-0-A	MAIN HOLD	12	0.1	14115	3	3	3	2235	2235	2235
CUI=AG	(Gear Locker)									
3-85-3-A	MAA LKR	4	0.01	1745	4	4	4	2	2	
2-9-0-Q	CHAIN LKR	16	0.001	2	999	999	999	2	2	
1-6-1-Q	A/N LKR	12	0.1	8961	2	2	2	172	172	172
1-6-2-Q	BOSN'S LKR	12	0.1	1582	2	2	2	172	172	172
1-92-2-Q	DC LKR	12	0.1	923	1	1	1	172	172	172
1-106-1-Q	MOVIE LKR	3	0.2	303	1	1	1	172	172	172
1-107-1-Q	MORALE LKR	3	0.2	461	1	1	1	172	172	172
1-157-2-Q	LINEN LKR	12	0.1	560	1	1	1	560	560	560
1-161-2-Q	CG LKR	12	0.1	131	2	2	2	131	131	131
CUI=AR	(Refrigerated Storage)									
3-74-0-A	MEATS	16	0.001	12	999	999	999	0	0	
3-81-0-A	DAIRY	16	0.001	18	999	999	999	0	0	
3-85-0-A	FRUITS AND VEGETABLES	16	0.001	16	999	999	999	0	0	
CUI=AS	(Storeroom)									
3-68-1-A	GENERAL STORES	5	0.4	272	21	22	22	272	272	272
3-68-2-A	DRY STORES	5	0.4	306	999	999	999	306	306	306
3-74-3-A	MAA STORAGE	12	0.1	10039	2	2	2	5	5	
2-30-2-Q	E.M. SHOP & STORES	5	0.4	285	25	25	25	3	3	
2-41-2-Q	SHIPS SERVICE STORE	2	0.01	2317	3	3	3	10	10	10
2-147-0-Q	ENGINEERS STOREROOM	5	0.1	1707	3	3	3	10	10	10
CUI=C	(Ship Control/Communications)									
01-71-0-Q	CRANE CONTROL BOOTH	7	0.01	80	999	999	999	80	80	80
01-74-1-Q	CODE ROOM	7	0.01	3216	4	4	4	99	99	99
01-116-0-Q	CLIP SHACK	7	0.01	878	3	3	3	40	40	40
02-81-0-C	CHART ROOM	7	0.01	2860	5	5	5	98	98	98
02-89-0-C	RADIO ROOM	7	0.01	5041	6	6	6	2	2	
03-72-0-C	WHEELHOUSE	7	0.01	3686	6	6	6	679	679	679
CUI=EE	(Main Propulsion - Electrical)									
4-92-0-E	GENERATOR ROOM	13	0.2	79795	3	3	3	707	707	707
4-126-0-E	MAIN MOTOR ROOM	13	0.2	43680	2	2	2	43680	43680	43680
CUI=EM	(Main Propulsion - Mechanical)									
3-9-0-E	BOW THRUSTER ROOM	12	0.1	9045	3	3	3	6393	6393	6393
CUI=K	(Hazardous Material Storage)									
1-FP-0-K	PAINT LKR	3	0.2	10832	2	2	2	10	10	10
CUI=L1	(Senior Officer's Cabin)									
1-132-1-L	SR #3	10	0.1	155	999	999	999	53	53	53
1-132-2-L	SR #4	10	0.1	181	999	999	999	62	62	62
01-74-0-L	CO SR	10	0.1	137	999	999	999	137	137	137
01-82-0-L	CO CABIN	9	0.3	566	999	999	999	487	487	487
CUI=L2	(Officer/CPO Quarters)									
1-106-2-L	CPO BERTHING	10	0.1	386	22	22	22	62	62	62
1-124-1-L	SR #1	10	0.1	209	999	999	999	53	53	53
1-124-2-L	SR #2	10	0.1	196	999	999	999	62	62	62
1-140-2-L	SR #6	10	0.1	207	999	999	999	146	146	146
CUI=L5	(Crews Berthing)									
2-44-2-L	CREWS BERTHING	10	0.1	1002	999	999	999	1002	1002	1002
2-60-1-L	CREWS BERTHING	10	0.1	499	13	13	13	499	499	499

Table B.8 Fire Growth Models, Rates, and FRI Times

Plan ID	Compartment Name	Growth	Alpha	Maximum Q	FRI	Time	(Min.)	Post-	FRI Q	(kW)
		Model	kW/sec ²	kW	XRAY	YOKE	ZEBRA	XRAY	YOKE	ZEBRA
2-74-0-L	CREWS BERTHING	10	0.01	1167	999	999	999	86	86	86
1-70-4-L	PO-1 BERTHING	10	0.1	438	20	20	20	87	87	87
CUI=LL	(Wardroom/Mess/Lounge Areas)									
2-44-1-L	CREW LOUNGE	9	0.2	326	999	999	999	44	44	44
1-70-3A-L	CREW MESS	9	0.2	385	999	999	999	385	385	385
1-93-1-L	CPO MESS & REC	9	0.3	388	16	16	16	291	291	291
1-140-0-L	WARDROOM	9	0.3	560	999	999	999	560	560	14
CUI=LM	(Medical/Dental Spaces)									
1-99-2-L	DISPENSARY	9	0.3	189	13	13	13	17	17	17
CUI=LP	(Passageway/Staircase/Vestibule)									
3-81-1-L	PASSAGE	15	0.01	66	999	999	999	66	66	66
3-81-2-L	PASSAGE	15	0.01	16	999	999	999	16	16	16
2-30-01-L	PASSAGE	15	0.01	16	999	999	999	16	16	16
2-44-01-L	PASSAGE	15	0.01	135	999	999	999	135	135	135
1-68-0-L	COMPANIONWAY	14	0.01	5	999	999	999	5	5	5
1-70-1-L	VESTIBULE	15	0.01	2	999	999	999	2	2	2
1-70-2-L	VESTIBULE	15	0.01	2	999	999	999	2	2	2
1-74-0-L	PASSAGE	15	0.01	41	999	999	999	41	41	41
1-74-2A-L	PASSAGE	15	0.01	84	999	999	999	84	84	84
1-74-2B-L	PASSAGE	15	0.01	62	999	999	999	62	62	62
1-74-2C-L	PASSAGE	15	0.01	58	999	999	999	58	58	58
1-77-1-L	COMPANIONWAY	14	0.01	3	999	999	999	3	3	3
1-85-2-L	COMPANIONWAY	14	0.01	3	999	999	999	3	3	3
1-99-1A-L	PASSAGE	15	0.01	62	999	999	999	62	62	62
1-99-1B-L	PASSAGE	15	0.01	54	999	999	999	54	54	54
1-132-0A-L	PASSAGE	15	0.01	47	999	999	999	47	47	47
1-132-0B-L	PASSAGE	15	0.01	12	999	999	999	12	12	12
01-93-2-L	COMPANIONWAY	14	0.01	7	999	999	999	7	7	7
01-95-1-L	COMPANIONWAY	14	0.01	5	999	999	999	5	5	5
02-81-2-L	PASSAGE	15	0.01	52	999	999	999	52	52	52
CUI=LW	(Sanitary Spaces)									
2-57-0-L	CREW WR, WC & SH	16	0.001	4	999	999	999	4	4	4
2-74-1-L	CREW WR, WC & SH	16	0.001	13	999	999	999	13	13	13
1-91-2-L	PO-1 WC, WR & SH	16	0.001	2	999	999	999	2	2	2
1-104-2-L	CPO WR, WC & SH	16	0.001	1	999	999	999	1	1	1
1-150-2-L	OFFICER WR, WC & SH	16	0.001	1	999	999	999	1	1	1
01-95-0-L	WR, WC & SH	16	0.001	1	999	999	999	1	1	1
CUI=QA	(Aux Machinery Spaces)									
3-56-0-Q	SEWAGE SPACE	12	0.1	3458	3	3	3	1620	15	15
3-74-2-Q	REEFER FLAT	15	0.01	62	999	999	999	3	3	3
2-126-2-Q	A.C. EQUIPMENT	13	0.2	56563	2	2	2	21450	21450	21450
2-161-0-Q	LAZARETTE	13	0.2	723040	2	2	2	28	28	28
1-68-1-Q	HYD PUMP ROOM	12	0.1	73	999	999	999	73	73	73
1-68-2-Q	HYD PUMP ROOM	12	0.1	175	6	6	6	164	164	164
1-77-0-Q	GYRO EQUIP	7	0.01	18	999	999	999	18	18	18
4-92-0A-E	FIDLEY	13	0.2	7199	2	2	2	3519	3519	3519
1-112-0-Q	AUXILIARY MACHINERY SPACE #3	13	0.2	4896	2	2	2	3072	3072	3072
1-157-0-E	STEERING GEAR SPACE	12	0.1	1965	2	2	2	1965	1965	1965
CUI=QF	(Fan Room)									
01-89-2-Q	FAN ROOM	13	0.2	131	2	2	2	131	131	131

Table B.8 Fire Growth Models, Rates, and FRI Times

Plan ID	Compartment Name	Growth	Alpha	Maximum Q	FRI	Time	(Min.)	Post-	FRI Q	(kW)
		Model	kW/sec ²	kW	XRAY	YOKE	ZEBRA	XRAY	YOKE	ZEBRA
01-110-0-Q	FAN & EQUIPMENT ROOM	13	0.2	1555	1	1	1	1555	1555	1555
02-74-0-Q	FAN ROOM	13	0.2	3136	2	2	2	2181	2181	2181
CUI=QG	(Galley/Pantry/Scullery)									
1-79-0-Q	GALLEY	13	0.2	2130	2	2	2	2130	2130	10
1-92-0-Q	SCULLERY	16	0.001	10	999	999	999	10	10	10
1-140-1-Q	PANTRY	13	0.2	524	5	5	5	524	524	5
CUI=QL	(Laundry)									
2-36-1-Q	LAUNDRY	12	0.1	833	3	3	3	20	20	20
CUI=QO	(Office Spaces)									
2-30-0-Q	ENG LOG OFFICE	7	0.01	1158	5	5	5	62	62	62
1-110-1-Q	SHIPS OFFICE	7	0.01	11073	5	5	5	109	109	109
CUI=QS	(Shops)									
2-9-0-E	DC SHOP	5	0.4	686	999	999	999	686	37	37
2-30-1-Q	ATON SHOP	8	0.3	97	999	999	999	2	2	2
2-126-1-Q	MACHINE SHOP	5	0.4	284	25	25	25	284	284	284
1-6-0-Q	DECK WORKSHOP	5	0.4	255	999	999	999	65	65	65
CUI=TH	(Trunks/Hoists/Dumbwaiters)									
2-44-0-T	HATCH TRUNK	16	0.001	12	999	999	999	12	12	12
CUI=TU	(Stacks/Engine Uptakes)									
01-102-0-E	VENT & UPTAKE SPACE	13	0.2	3283	1	1	1	771	771	771
02-102-0-E	UPTAKE	13	0.2	3456	2	2	2	2	2	2
CUI=W	(Water Tank (empty))									
4-FP-0-W	FOREPEAK TANK	16	0.001	0	999	999	999	0	0	0
4-30-0-W	FRESH WATER TANK	16	0.001	0	999	999	999	0	0	0
4-30-1-W	FRESH WATER TANK	16	0.001	0	999	999	999	0	0	0
4-30-2-W	FRESH WATER TANK	16	0.001	0	999	999	999	0	0	0
4-140-0-W	FRESH WATER TANK	16	0.001	0	999	999	999	0	0	0
4-147-0-W	AFT PEAK TANK	16	0.001	0	999	999	999	0	0	0
3-140-1-W	FRESH WATER TANK	16	0.001	0	999	999	999	0	0	0
3-140-2-W	FRESH WATER TANK	16	0.001	0	999	999	999	0	0	0

Appendix C
180' WLB Baseline Fire Safety Analysis Results

The various reports produced in the performance of the baseline fire safety analysis on the 180' WLB using the target, barrier, and path output options in SAFE, version 2.2, are documented in this appendix. The following table correlates the results from SAFE computer run numbers with page numbers in this appendix:

SAFE Run Number	SAFE Output Option	Scenario	Page Number
10-58	Individual Target Option	XRAY, In Port, I, A, & M	C-2
10-59	Individual Target Option	XRAY, In Port, I, & A	C-3
10-60	Individual Target Option	XRAY, In Port, I, & M	C-4
10-61	Individual Target Option	XRAY, In Port, I	C-5
10-62	Individual Target Option	YOKE, In Port, I, A & M	C-6
10-63	Individual Target Option	YOKE, In Port, I, & A	C-7
10-64	Individual Target Option	YOKE, In Port, I, & M	C-8
10-65	Individual Target Option	YOKE, In Port, I	C-9
9-52	Individual Target Option	YOKE, At Sea, I, A & M	C-10
9-53	Individual Target Option	YOKE, At Sea, I, & A	C-11
9-54	Individual Target Option	YOKE, At Sea, I, & M	C-12
9-55	Individual Target Option	YOKE, At Sea, I	C-13
9-56	Barrier Option	YOKE, At Sea, I, A & M	C-14
9-66	Path Option - Summary Report Room of Origin: 4-126-0-E	YOKE, At Sea, I	C-21
9-66	Path Option - Detail Report Room of Origin: 4-126-0-E	YOKE, At Sea, I	C-23
9-67	Path Option - Summary Report Room of Origin: 1-112-0-Q	YOKE, At Sea, I	C-48
9-67	Path Option - Detail Report Room of Origin: 1-112-0-Q	YOKE, At Sea, I	C-50
9-68	Path Option - Summary Report Room of Origin: 1-157-2-Q	YOKE, At Sea, I	C-68
9-68	Path Option - Detail Report Room of Origin: 1-157-2-Q	YOKE, At Sea, I	C-69
9-69	Path Option - Summary Report Room of Origin: 1-161-2-Q	YOKE, At Sea, I	C-73
9-69	Path Option - Detail Report Room of Origin: 1-161-2-Q	YOKE, At Sea, I	C-74

INDIVIDUAL TARGET OPTION - SUMMARY LEVEL REPORT

RELATIVE LOSS FACTORS OF INDIVIDUAL TARGETS

READINESS CONDITION . XRAY
CONFIGURATION Passive, Automatic, and Manual
CASE. Worst
ASSUMED LOCATION. . . in Port
RUN TIME. 60 minutes
COMMENTS.
Baseline, In Port M Values

Targets listed include all compartments in model run with Magnitude of Acceptable Loss 1-3 and Relative Loss Factor (RLF) > 0.0000.

TARGET COMPART.	Magnitude/Frequency -of Acceptable Loss-		Rel Freq of Loss FFS	Relative Loss Factor (RLF)
3-9-0-E	2	26 years	0.0081	0.2105
01-102-0-E	2	23 years	0.0085	0.1956
1-112-0-Q	2	26 years	0.0058	0.1520
4-126-0-E	2	26 years	0.0051	0.1314
01-110-0-Q	3	18 years	0.0062	0.1120
4-92-0A-E	2	24 years	0.0043	0.1030
2-126-2-Q	2	22 years	0.0039	0.0866
4-92-0-E	2	26 years	0.0031	0.0801
2-126-1-Q	2	22 years	0.0035	0.0779
1-157-0-E	2	26 years	0.0020	0.0507
1-93-1-L	2	24 years	0.0017	0.0406
1-FP-0-K	1	30 years	0.0013	0.0402
1-110-1-Q	2	24 years	0.0016	0.0393
1-92-0-Q	2	20 years	0.0018	0.0362
3-56-0-Q	2	24 years	0.0014	0.0331
1-68-2-Q	2	26 years	0.0011	0.0285
3-68-1-A	2	21 years	0.0013	0.0269
1-157-2-Q	3	12 years	0.0022	0.0259
2-147-0-Q	2	25 years	0.0010	0.0251
01-74-1-Q	2	26 years	0.0009	0.0230
02-81-0-C	2	26 years	0.0008	0.0217
03-72-0-C	2	26 years	0.0007	0.0189
2-161-0-Q	2	24 years	0.0008	0.0188
3-68-2-A	2	22 years	0.0008	0.0186
1-70-3A-L	2	24 years	0.0007	0.0169
1-6-2-Q	2	22 years	0.0007	0.0147
1-6-1-Q	2	22 years	0.0007	0.0147
01-89-2-Q	3	18 years	0.0007	0.0117
1-79-0-Q	2	26 years	0.0004	0.0103
3-44-0-A	2	24 years	0.0003	0.0061
02-74-0-Q	3	18 years	0.0001	0.0024
3-74-3-A	2	21 years	0.0000	0.0012

INDIVIDUAL TARGET OPTION - SUMMARY LEVEL REPORT

RELATIVE LOSS FACTORS OF INDIVIDUAL TARGETS

READINESS CONDITION . XRAY
CONFIGURATION Passive and Automatic
CASE. Worst
ASSUMED LOCATION. . . in Port
RUN TIME. 60 minutes
COMMENTS.
Baseline, In Port M Values

Targets listed include all compartments in model run with Magnitude of Acceptable Loss 1-3 and Relative Loss Factor (RLF) > 0.0000.

TARGET COMPART.	Magnitude/Frequency -of Acceptable Loss-	Rel Freq of Loss FFS	Relative Loss Factor (RLF)
3-9-0-E	2 26 years	0.0084	0.2192
01-102-0-E	2 23 years	0.0094	0.2169
1-112-0-Q	2 26 years	0.0065	0.1682
4-126-0-E	2 26 years	0.0057	0.1475
01-110-0-Q	3 18 years	0.0068	0.1230
4-92-0A-E	2 24 years	0.0048	0.1144
2-126-1-Q	2 22 years	0.0047	0.1024
2-126-2-Q	2 22 years	0.0044	0.0977
4-92-0-E	2 26 years	0.0035	0.0915
1-110-1-Q	2 24 years	0.0028	0.0679
1-93-1-L	2 24 years	0.0025	0.0612
1-157-0-E	2 26 years	0.0021	0.0549
1-92-0-Q	2 20 years	0.0027	0.0547
1-FP-0-K	1 30 years	0.0014	0.0432
1-70-3A-L	2 24 years	0.0017	0.0413
3-56-0-Q	2 24 years	0.0015	0.0352
3-68-1-A	2 21 years	0.0017	0.0350
2-147-0-Q	2 25 years	0.0013	0.0330
1-68-2-Q	2 26 years	0.0013	0.0326
02-81-0-C	2 26 years	0.0011	0.0293
3-68-2-A	2 22 years	0.0013	0.0282
03-72-0-C	2 26 years	0.0011	0.0279
1-157-2-Q	3 12 years	0.0023	0.0273
01-74-1-Q	2 26 years	0.0010	0.0256
2-161-0-Q	2 24 years	0.0009	0.0211
1-6-2-Q	2 22 years	0.0007	0.0158
1-6-1-Q	2 22 years	0.0007	0.0158
01-89-2-Q	3 18 years	0.0008	0.0143
1-79-0-Q	2 26 years	0.0004	0.0109
3-44-0-A	2 24 years	0.0003	0.0078
02-74-0-Q	3 18 years	0.0001	0.0024
3-74-3-A	2 21 years	0.0000	0.0019

INDIVIDUAL TARGET OPTION - SUMMARY LEVEL REPORT

RELATIVE LOSS FACTORS OF INDIVIDUAL TARGETS

READINESS CONDITION . XRAY
 CONFIGURATION Passive and Manual
 CASE. Worst
 ASSUMED LOCATION. . . in Port
 RUN TIME. 60 minutes
 COMMENTS.
 Baseline, In Port M Values

Targets listed include all compartments in model run with Magnitude of Acceptable Loss 1-3 and Relative Loss Factor (RLF) > 0.0000.

TARGET COMPART.	Magnitude/Frequency -of Acceptable Loss-	Rel Freq of Loss FFS	Relative Loss Factor (RLF)
3-9-0-E	2 26 years	0.0081	0.2105
01-102-0-E	2 23 years	0.0085	0.1956
1-112-0-Q	2 26 years	0.0058	0.1520
4-126-0-E	2 26 years	0.0051	0.1314
01-110-0-Q	3 18 years	0.0062	0.1120
4-92-0A-E	2 24 years	0.0043	0.1030
2-126-2-Q	2 22 years	0.0039	0.0866
4-92-0-E	2 26 years	0.0031	0.0801
2-126-1-Q	2 22 years	0.0035	0.0779
1-157-0-E	2 26 years	0.0020	0.0507
1-93-1-L	2 24 years	0.0017	0.0406
1-FP-0-K	1 30 years	0.0013	0.0402
1-110-1-Q	2 24 years	0.0016	0.0393
01-74-1-Q	2 26 years	0.0015	0.0378
1-79-0-Q	2 26 years	0.0014	0.0369
1-92-0-Q	2 20 years	0.0018	0.0362
3-56-0-Q	2 24 years	0.0014	0.0331
1-68-2-Q	2 26 years	0.0012	0.0302
01-89-2-Q	3 18 years	0.0016	0.0288
3-68-1-A	2 21 years	0.0013	0.0269
1-157-2-Q	3 12 years	0.0022	0.0259
2-147-0-Q	2 25 years	0.0010	0.0251
02-81-0-C	2 26 years	0.0008	0.0217
03-72-0-C	2 26 years	0.0007	0.0189
2-161-0-Q	2 24 years	0.0008	0.0188
3-68-2-A	2 22 years	0.0008	0.0186
1-70-3A-L	2 24 years	0.0007	0.0169
1-6-2-Q	2 22 years	0.0007	0.0147
1-6-1-Q	2 22 years	0.0007	0.0147
3-44-0-A	2 24 years	0.0003	0.0061
02-74-0-Q	3 18 years	0.0001	0.0024
3-74-3-A	2 21 years	0.0000	0.0012

INDIVIDUAL TARGET OPTION - SUMMARY LEVEL REPORT

RELATIVE LOSS FACTORS OF INDIVIDUAL TARGETS

READINESS CONDITION . XRAY
CONFIGURATION Passive
CASE. Worst
ASSUMED LOCATION. . . in Port
RUN TIME. 60 minutes
COMMENTS.
Baseline, In Port M Values

Targets listed include all compartments in model run with Magnitude of Acceptable Loss 1-3 and Relative Loss Factor (RLF) > 0.0000.

TARGET COMPART.	Magnitude/Frequency -of Acceptable Loss-	Rel Freq of Loss FFS	Relative Loss Factor (RLF)
3-9-0-E	2 26 years	0.0084	0.2192
01-102-0-E	2 23 years	0.0094	0.2169
1-112-0-Q	2 26 years	0.0065	0.1682
4-126-0-E	2 26 years	0.0057	0.1475
01-110-0-Q	3 18 years	0.0068	0.1230
4-92-0A-E	2 24 years	0.0048	0.1144
2-126-1-Q	2 22 years	0.0047	0.1024
2-126-2-Q	2 22 years	0.0044	0.0977
4-92-0-E	2 26 years	0.0035	0.0915
1-110-1-Q	2 24 years	0.0028	0.0679
1-93-1-L	2 24 years	0.0025	0.0612
1-157-0-E	2 26 years	0.0021	0.0549
1-92-0-Q	2 20 years	0.0027	0.0547
1-FP-0-K	1 30 years	0.0014	0.0432
01-74-1-Q	2 26 years	0.0017	0.0430
1-79-0-Q	2 26 years	0.0016	0.0425
1-70-3A-L	2 24 years	0.0017	0.0413
1-68-2-Q	2 26 years	0.0014	0.0364
3-56-0-Q	2 24 years	0.0015	0.0352
01-89-2-Q	3 18 years	0.0020	0.0352
3-68-1-A	2 21 years	0.0017	0.0350
2-147-0-Q	2 25 years	0.0013	0.0330
02-81-0-C	2 26 years	0.0011	0.0293
3-68-2-A	2 22 years	0.0013	0.0282
03-72-0-C	2 26 years	0.0011	0.0279
1-157-2-Q	3 12 years	0.0023	0.0273
2-161-0-Q	2 24 years	0.0009	0.0211
1-6-2-Q	2 22 years	0.0007	0.0158
1-6-1-Q	2 22 years	0.0007	0.0158
3-44-0-A	2 24 years	0.0003	0.0078
02-74-0-Q	3 18 years	0.0001	0.0024
3-74-3-A	2 21 years	0.0000	0.0019

INDIVIDUAL TARGET OPTION - SUMMARY LEVEL REPORT

RELATIVE LOSS FACTORS OF INDIVIDUAL TARGETS

READINESS CONDITION . YOKE
 CONFIGURATION Passive, Automatic, and Manual
 CASE. Worst
 ASSUMED LOCATION. . . in Port
 RUN TIME. 60 minutes
 COMMENTS.
 Baseline, In Port M Values

Targets listed include all compartments in model run with Magnitude of Acceptable Loss 1-3 and Relative Loss Factor (RLF) > 0.0000.

TARGET COMPART.	Magnitude/Frequency -of Acceptable Loss-	Rel Freq of Loss FFS	Relative Loss Factor (RLF)
3-9-0-E	2	26 years	0.0081
01-102-0-E	2	23 years	0.0085
1-112-0-Q	2	26 years	0.0058
4-126-0-E	2	26 years	0.0051
01-110-0-Q	3	18 years	0.0062
4-92-0A-E	2	24 years	0.0043
2-126-2-Q	2	22 years	0.0039
4-92-0-E	2	26 years	0.0031
2-126-1-Q	2	22 years	0.0035
1-157-0-E	2	26 years	0.0020
1-93-1-L	2	24 years	0.0017
1-FP-0-K	1	30 years	0.0013
1-110-1-Q	2	24 years	0.0016
1-92-0-Q	2	20 years	0.0018
1-68-2-Q	2	26 years	0.0011
1-157-2-Q	3	12 years	0.0022
2-147-0-Q	2	25 years	0.0010
01-74-1-Q	2	26 years	0.0009
02-81-0-C	2	26 years	0.0008
03-72-0-C	2	26 years	0.0007
2-161-0-Q	2	24 years	0.0008
1-70-3A-L	2	24 years	0.0007
1-6-2-Q	2	22 years	0.0007
1-6-1-Q	2	22 years	0.0007
01-89-2-Q	3	18 years	0.0007
1-79-0-Q	2	26 years	0.0004
3-68-1-A	2	21 years	0.0004
3-68-2-A	2	22 years	0.0003
02-74-0-Q	3	18 years	0.0001
3-44-0-A	2	24 years	0.0000
3-56-0-Q	2	24 years	0.0000

INDIVIDUAL TARGET OPTION - SUMMARY LEVEL REPORT

RELATIVE LOSS FACTORS OF INDIVIDUAL TARGETS

READINESS CONDITION . YOKE
CONFIGURATION Passive and Automatic
CASE. Worst
ASSUMED LOCATION. . . in Port
RUN TIME. 60 minutes
COMMENTS.
Baseline, In Port M Values

Targets listed include all compartments in model run with Magnitude of Acceptable Loss 1-3 and Relative Loss Factor (RLF) > 0.0000.

TARGET COMPART.	Magnitude/Frequency -of Acceptable Loss-	Rel Freq of Loss FFS	Relative Loss Factor (RLF)
3-9-0-E	2 26 years	0.0084	0.2192
01-102-0-E	2 23 years	0.0094	0.2169
1-112-0-Q	2 26 years	0.0065	0.1682
4-126-0-E	2 26 years	0.0057	0.1475
01-110-0-Q	3 18 years	0.0068	0.1230
4-92-0A-E	2 24 years	0.0048	0.1144
2-126-1-Q	2 22 years	0.0047	0.1024
2-126-2-Q	2 22 years	0.0044	0.0977
4-92-0-E	2 26 years	0.0035	0.0915
1-110-1-Q	2 24 years	0.0028	0.0679
1-93-1-L	2 24 years	0.0025	0.0612
1-157-0-E	2 26 years	0.0021	0.0549
1-92-0-Q	2 20 years	0.0027	0.0547
1-FP-0-K	1 30 years	0.0014	0.0432
1-70-3A-L	2 24 years	0.0017	0.0413
2-147-0-Q	2 25 years	0.0013	0.0330
1-68-2-Q	2 26 years	0.0013	0.0326
02-81-0-C	2 26 years	0.0011	0.0293
03-72-0-C	2 26 years	0.0011	0.0279
1-157-2-Q	3 12 years	0.0023	0.0273
01-74-1-Q	2 26 years	0.0010	0.0256
2-161-0-Q	2 24 years	0.0009	0.0211
1-6-2-Q	2 22 years	0.0007	0.0158
1-6-1-Q	2 22 years	0.0007	0.0158
01-89-2-Q	3 18 years	0.0008	0.0143
3-68-1-A	2 21 years	0.0005	0.0115
1-79-0-Q	2 26 years	0.0004	0.0109
3-68-2-A	2 22 years	0.0004	0.0093
02-74-0-Q	3 18 years	0.0001	0.0024
3-44-0-A	2 24 years	0.0000	0.0009
3-56-0-Q	2 24 years	0.0000	0.0004

INDIVIDUAL TARGET OPTION - SUMMARY LEVEL REPORT

RELATIVE LOSS FACTORS OF INDIVIDUAL TARGETS

READINESS CONDITION . YOKE
CONFIGURATION Passive and Manual
CASE. Worst
ASSUMED LOCATION. . . in Port
RUN TIME. 60 minutes
COMMENTS.
Baseline, In Port M Values

Targets listed include all compartments in model run with Magnitude of Acceptable Loss 1-3 and Relative Loss Factor (RLF) > 0.0000.

TARGET COMPART.	Magnitude/Frequency -of Acceptable Loss-	Rel Freq of Loss FFS	Relative Loss Factor (RLF)
3-9-0-E	2 26 years	0.0081	0.2105
01-102-0-E	2 23 years	0.0085	0.1956
1-112-0-Q	2 26 years	0.0058	0.1520
4-126-0-E	2 26 years	0.0051	0.1314
01-110-0-Q	3 18 years	0.0062	0.1120
4-92-0A-E	2 24 years	0.0043	0.1030
2-126-2-Q	2 22 years	0.0039	0.0866
4-92-0-E	2 26 years	0.0031	0.0801
2-126-1-Q	2 22 years	0.0035	0.0779
1-157-0-E	2 26 years	0.0020	0.0507
1-93-1-L	2 24 years	0.0017	0.0406
1-FP-0-K	1 30 years	0.0013	0.0402
1-110-1-Q	2 24 years	0.0016	0.0393
01-74-1-Q	2 26 years	0.0015	0.0378
1-79-0-Q	2 26 years	0.0014	0.0369
1-92-0-Q	2 20 years	0.0018	0.0362
1-68-2-Q	2 26 years	0.0012	0.0302
01-89-2-Q	3 18 years	0.0016	0.0288
1-157-2-Q	3 12 years	0.0022	0.0259
2-147-0-Q	2 25 years	0.0010	0.0251
02-81-0-C	2 26 years	0.0008	0.0217
03-72-0-C	2 26 years	0.0007	0.0189
2-161-0-Q	2 24 years	0.0008	0.0188
1-70-3A-L	2 24 years	0.0007	0.0169
1-6-2-Q	2 22 years	0.0007	0.0147
1-6-1-Q	2 22 years	0.0007	0.0147
3-68-1-A	2 21 years	0.0004	0.0092
3-68-2-A	2 22 years	0.0003	0.0064
02-74-0-Q	3 18 years	0.0001	0.0024
3-44-0-A	2 24 years	0.0000	0.0008
3-56-0-Q	2 24 years	0.0000	0.0004

INDIVIDUAL TARGET OPTION - SUMMARY LEVEL REPORT

RELATIVE LOSS FACTORS OF INDIVIDUAL TARGETS

READINESS CONDITION . YOKE
CONFIGURATION Passive
CASE. Worst
ASSUMED LOCATION. . . in Port
RUN TIME. 60 minutes
COMMENTS.
Baseline, In Port M Values

Targets listed include all compartments in model run with Magnitude of Acceptable Loss 1-3 and Relative Loss Factor (RLF) > 0.0000.

TARGET COMPART.	Magnitude/Frequency -of Acceptable Loss-	Rel Freq of Loss FFS	Relative Loss Factor (RLF)
3-9-0-E	2	26 years	0.0084
01-102-0-E	2	23 years	0.0094
1-112-0-Q	2	26 years	0.0065
4-126-0-E	2	26 years	0.0057
01-110-0-Q	3	18 years	0.0068
4-92-0A-E	2	24 years	0.0048
2-126-1-Q	2	22 years	0.0047
2-126-2-Q	2	22 years	0.0044
4-92-0-E	2	26 years	0.0035
1-110-1-Q	2	24 years	0.0028
1-93-1-L	2	24 years	0.0025
1-157-0-E	2	26 years	0.0021
1-92-0-Q	2	20 years	0.0027
1-FP-0-K	1	30 years	0.0014
01-74-1-Q	2	26 years	0.0017
1-79-0-Q	2	26 years	0.0016
1-70-3A-L	2	24 years	0.0017
1-68-2-Q	2	26 years	0.0014
01-89-2-Q	3	18 years	0.0020
2-147-0-Q	2	25 years	0.0013
02-81-0-C	2	26 years	0.0011
03-72-0-C	2	26 years	0.0011
1-157-2-Q	3	12 years	0.0023
2-161-0-Q	2	24 years	0.0009
1-6-2-Q	2	22 years	0.0007
1-6-1-Q	2	22 years	0.0007
3-68-1-A	2	21 years	0.0005
3-68-2-A	2	22 years	0.0004
02-74-0-Q	3	18 years	0.0001
3-44-0-A	2	24 years	0.0000
3-56-0-Q	2	24 years	0.0000

INDIVIDUAL TARGET OPTION - SUMMARY LEVEL REPORT

RELATIVE LOSS FACTORS OF INDIVIDUAL TARGETS

READINESS CONDITION . YOKE
 CONFIGURATION Passive, Automatic, and Manual
 CASE. Worst
 ASSUMED LOCATION. . . at SEA
 RUN TIME. 60 minutes
 COMMENTS.
 Baseline, At Sea M Values

Targets listed include all compartments in model run with Magnitude of Acceptable Loss 1-3 and Relative Loss Factor (RLF) > 0.0000.

TARGET COMPART.	Magnitude/Frequency -of Acceptable Loss-	Rel Freq of Loss FFS	Relative Loss Factor (RLF)
3-9-0-E	2 26 years	0.0079	0.2061
01-102-0-E	2 23 years	0.0081	0.1873
1-112-0-Q	2 26 years	0.0056	0.1460
4-126-0-E	2 26 years	0.0049	0.1269
01-110-0-Q	3 18 years	0.0059	0.1068
4-92-0A-E	2 24 years	0.0041	0.0985
2-126-2-Q	2 22 years	0.0038	0.0828
4-92-0-E	2 26 years	0.0029	0.0758
2-126-1-Q	2 22 years	0.0033	0.0728
1-157-0-E	2 26 years	0.0019	0.0494
1-FP-0-K	1 30 years	0.0013	0.0393
1-93-1-L	2 24 years	0.0016	0.0381
1-110-1-Q	2 24 years	0.0014	0.0338
1-92-0-Q	2 20 years	0.0016	0.0324
1-68-2-Q	2 26 years	0.0010	0.0266
1-157-2-Q	3 12 years	0.0021	0.0255
2-147-0-Q	2 25 years	0.0009	0.0234
01-74-1-Q	2 26 years	0.0009	0.0221
02-81-0-C	2 26 years	0.0007	0.0192
2-161-0-Q	2 24 years	0.0007	0.0178
03-72-0-C	2 26 years	0.0006	0.0163
1-6-2-Q	2 22 years	0.0007	0.0144
1-6-1-Q	2 22 years	0.0007	0.0144
1-70-3A-L	2 24 years	0.0006	0.0138
01-89-2-Q	3 18 years	0.0006	0.0113
1-79-0-Q	2 26 years	0.0004	0.0102
3-68-1-A	2 21 years	0.0004	0.0088
3-68-2-A	2 22 years	0.0003	0.0058
02-74-0-Q	3 18 years	0.0001	0.0023
3-44-0-A	2 24 years	0.0000	0.0008
3-56-0-Q	2 24 years	0.0000	0.0003

INDIVIDUAL TARGET OPTION - SUMMARY LEVEL REPORT

RELATIVE LOSS FACTORS OF INDIVIDUAL TARGETS

READINESS CONDITION . YOKE
CONFIGURATION Passive and Automatic
CASE. Worst
ASSUMED LOCATION. . . at SEA
RUN TIME. 60 minutes
COMMENTS.
Baseline, At Sea M Values

Targets listed include all compartments in model run with Magnitude of Acceptable Loss 1-3 and Relative Loss Factor (RLF) > 0.0000.

TARGET COMPART.	Magnitude/Frequency -of Acceptable Loss-	Rel Freq of Loss FFS	Relative Loss Factor (RLF)
3-9-0-E	2 26 years	0.0084	0.2192
01-102-0-E	2 23 years	0.0094	0.2169
1-112-0-Q	2 26 years	0.0065	0.1682
4-126-0-E	2 26 years	0.0057	0.1475
01-110-0-Q	3 18 years	0.0068	0.1230
4-92-0A-E	2 24 years	0.0048	0.1144
2-126-1-Q	2 22 years	0.0047	0.1024
2-126-2-Q	2 22 years	0.0044	0.0977
4-92-0-E	2 26 years	0.0035	0.0915
1-110-1-Q	2 24 years	0.0028	0.0679
1-93-1-L	2 24 years	0.0025	0.0612
1-157-0-E	2 26 years	0.0021	0.0549
1-92-0-Q	2 20 years	0.0027	0.0547
1-FP-0-K	1 30 years	0.0014	0.0432
1-70-3A-L	2 24 years	0.0017	0.0413
2-147-0-Q	2 25 years	0.0013	0.0330
1-68-2-Q	2 26 years	0.0012	0.0317
02-81-0-C	2 26 years	0.0011	0.0293
03-72-0-C	2 26 years	0.0011	0.0279
1-157-2-Q	3 12 years	0.0023	0.0273
01-74-1-Q	2 26 years	0.0010	0.0254
2-161-0-Q	2 24 years	0.0009	0.0211
1-6-2-Q	2 22 years	0.0007	0.0158
1-6-1-Q	2 22 years	0.0007	0.0158
01-89-2-Q	3 18 years	0.0008	0.0143
3-68-1-A	2 21 years	0.0005	0.0115
1-79-0-Q	2 26 years	0.0004	0.0109
3-68-2-A	2 22 years	0.0004	0.0093
02-74-0-Q	3 18 years	0.0001	0.0024
3-44-0-A	2 24 years	0.0000	0.0009
3-56-0-Q	2 24 years	0.0000	0.0004

INDIVIDUAL TARGET OPTION - SUMMARY LEVEL REPORT

RELATIVE LOSS FACTORS OF INDIVIDUAL TARGETS

READINESS CONDITION . YOKE
CONFIGURATION Passive and Manual
CASE. Worst
ASSUMED LOCATION. . . at SEA
RUN TIME. 60 minutes
COMMENTS.
Baseline, At Sea M Values

Targets listed include all compartments in model run with Magnitude of Acceptable Loss 1-3 and Relative Loss Factor (RLF) > 0.0000.

TARGET COMPART.	Magnitude/Frequency -of Acceptable Loss-	Rel Freq of Loss FFS	Relative Loss Factor (RLF)
3-9-0-E	2 26 years	0.0079	0.2061
01-102-0-E	2 23 years	0.0081	0.1873
1-112-0-Q	2 26 years	0.0056	0.1460
4-126-0-E	2 26 years	0.0049	0.1269
01-110-0-Q	3 18 years	0.0059	0.1068
4-92-0A-E	2 24 years	0.0041	0.0985
2-126-2-Q	2 22 years	0.0038	0.0828
4-92-0-E	2 26 years	0.0029	0.0758
2-126-1-Q	2 22 years	0.0033	0.0728
1-157-0-E	2 26 years	0.0019	0.0494
1-FP-0-K	1 30 years	0.0013	0.0393
1-93-1-L	2 24 years	0.0016	0.0381
1-79-0-Q	2 26 years	0.0014	0.0359
01-74-1-Q	2 26 years	0.0014	0.0353
1-110-1-Q	2 24 years	0.0014	0.0338
1-92-0-Q	2 20 years	0.0016	0.0324
01-89-2-Q	3 18 years	0.0016	0.0280
1-68-2-Q	2 26 years	0.0010	0.0266
1-157-2-Q	3 12 years	0.0021	0.0255
2-147-0-Q	2 25 years	0.0009	0.0234
02-81-0-C	2 26 years	0.0007	0.0192
2-161-0-Q	2 24 years	0.0007	0.0178
03-72-0-C	2 26 years	0.0006	0.0163
1-6-2-Q	2 22 years	0.0007	0.0144
1-6-1-Q	2 22 years	0.0007	0.0144
1-70-3A-L	2 24 years	0.0006	0.0138
3-68-1-A	2 21 years	0.0004	0.0088
3-68-2-A	2 22 years	0.0003	0.0058
02-74-0-Q	3 18 years	0.0001	0.0023
3-44-0-A	2 24 years	0.0000	0.0008
3-56-0-Q	2 24 years	0.0000	0.0003

INDIVIDUAL TARGET OPTION - SUMMARY LEVEL REPORT

RELATIVE LOSS FACTORS OF INDIVIDUAL TARGETS

READINESS CONDITION . YOKE
CONFIGURATION Passive
CASE. Worst
ASSUMED LOCATION. . . at SEA
RUN TIME. 60 minutes
COMMENTS.
Baseline, At Sea M Values

Targets listed include all compartments in model run with Magnitude of Acceptable Loss 1-3 and Relative Loss Factor (RLF) > 0.0000.

TARGET COMPART.	Magnitude/Frequency -of Acceptable Loss-	Rel Freq of Loss FFS	Relative Loss Factor (RLF)
3-9-0-E	2 26 years	0.0084	0.2192
01-102-0-E	2 23 years	0.0094	0.2169
1-112-0-Q	2 26 years	0.0065	0.1682
4-126-0-E	2 26 years	0.0057	0.1475
01-110-0-Q	3 18 years	0.0068	0.1230
4-92-0A-E	2 24 years	0.0048	0.1144
2-126-1-Q	2 22 years	0.0047	0.1024
2-126-2-Q	2 22 years	0.0044	0.0977
4-92-0-E	2 26 years	0.0035	0.0915
1-110-1-Q	2 24 years	0.0028	0.0679
1-93-1-L	2 24 years	0.0025	0.0612
1-157-0-E	2 26 years	0.0021	0.0549
1-92-0-Q	2 20 years	0.0027	0.0547
1-FP-0-K	1 30 years	0.0014	0.0432
1-79-0-Q	2 26 years	0.0016	0.0425
1-70-3A-L	2 24 years	0.0017	0.0413
01-74-1-Q	2 26 years	0.0016	0.0413
01-89-2-Q	3 18 years	0.0020	0.0352
2-147-0-Q	2 25 years	0.0013	0.0330
1-68-2-Q	2 26 years	0.0012	0.0317
02-81-0-C	2 26 years	0.0011	0.0293
03-72-0-C	2 26 years	0.0011	0.0279
1-157-2-Q	3 12 years	0.0023	0.0273
2-161-0-Q	2 24 years	0.0009	0.0211
1-6-2-Q	2 22 years	0.0007	0.0158
1-6-1-Q	2 22 years	0.0007	0.0158
3-68-1-A	2 21 years	0.0005	0.0115
3-68-2-A	2 22 years	0.0004	0.0093
02-74-0-Q	3 18 years	0.0001	0.0024
3-44-0-A	2 24 years	0.0000	0.0009
3-56-0-Q	2 24 years	0.0000	0.0004

-
-
-
-
-

HORNBEAM
 06/19/97
 MODEL RUN 9-56

ROOM OF ORIGIN BARRIER OPTION - SUMMARY LEVEL REPORT

LISTING OF ROOM OF ORIGIN BARRIER FAILURES
 ORDERED BY ROOM OF ORIGIN AND SECONDARILY BY
 PROBABILITY OF LOSS|EB AT TIME OF BARRIER FAILURE

READINESS CONDITION . YOKE
 CONFIGURATION Passive, Automatic, and Manual
 CASE. Worst
 ASSUMED LOCATION. . . at SEA
 RUN TIME. 60 minutes
 COMMENTS.
 Baseline, At Sea M Values

-----Room of Origin-----				-----Barrier to Adjacent Room-----								
Plan ID	FRI Time	P(Loss) EB	RFL FFS (x 1000)	Adj. Room Plan ID	Fail Time	P(Loss) EB	RFL FFS (x 1000)	Opening/ Zero-Str				
3-9-0-E	3	0.29	7.93	2-9-0-Q	4	0.06	1.54					
				ext. blkhd.	4	0.06	1.54					
				ext. blkhd.	4	0.06	1.54					
				4-30-2-W	10	0.03	0.88					
				4-30-1-W	10	0.03	0.88					
				4-30-0-W	10	0.03	0.88					
				4-FP-0-W	10	0.03	0.88					
				2-9-0-E	17	0.03	0.82					
				2-44-0-T	3	0.32	0.03	Opening				
				ext. blkhd.	7	0.04	0.00					
3-44-0-A	3	0.32	0.03	ext. blkhd.	7	0.04	0.00					
				2-44-1-L	22	0.04	0.00					
				2-44-01-L	22	0.04	0.00					
				3-56-0-Q	25	0.03	0.00					
				4-30-2-W	25	0.03	0.00					
				4-30-1-W	25	0.03	0.00					
				4-30-0-W	25	0.03	0.00					
				3-68-2-A	22	0.46	0.42	Zero-Str				
				4-92-0-E	3	0.52	1.61	ext. blkhd.	35	0.06	0.17	
				ext. blkhd.	35	0.06	0.17					
4-126-0-E	2	0.53	1.65	ext. blkhd.	35	0.06	0.17					
				1-112-0-Q	2	0.53	1.65					
				2-126-2-Q	2	0.53	1.65	Zero-Str				
				2-126-1-Q	2	0.53	1.65	Zero-Str				
				1-132-0A-L	2	0.47	1.45					
				1-99-1B-L	2	0.47	1.45					
				1-74-2C-L	2	0.47	1.45					

				2-126-2-Q	2	0.47		1.45	
				2-126-1-Q	2	0.47		1.45	
				4-140-0-W	2	0.06		0.17	
				not analyzed	2	0.06		0.17	
				4-140-0-W	2	0.06		0.17	
				not analyzed	2	0.06		0.17	
				not analyzed	2	0.06		0.17	
				not analyzed	2	0.06		0.17	
				ext. blkhd.	2	0.06		0.17	
				ext. blkhd.	2	0.06		0.17	
2-60-1-L	13	0.23	0.19	2-44-01-L	13	0.23	0.19	Zero-Str	
				2-44-01-L	13	0.23	0.19	Zero-Str	

-----Room of Origin-----				-----Barrier to Adjacent Room-----				
Plan ID	FRI Time	P(Loss) EB	RFL FFS (x 1000)	Adj. Room Plan ID	Fail Time	P(Loss) EB	RFL FFS (x 1000)	Opening/ Zero-Str
				2-44-01-L	13	0.23	0.19	Zero-Str
				2-44-01-L	13	0.23	0.19	Zero-Str
				2-44-1-L	22	0.03	0.02	
				1-70-1-L	54	0.03	0.02	
				1-68-1-Q	54	0.03	0.02	
				ext. blkhd.	54	0.03	0.02	
2-126-1-Q	25	0.38	0.68	4-126-0-E	25	0.38	0.68	Zero-Str
2-126-2-Q	2	0.47	1.35	4-126-0-E	2	0.47	1.35	Zero-Str
				4-140-0-W	3	0.16	0.45	
				3-140-2-W	3	0.16	0.45	
				not analyzed	3	0.16	0.45	
				not analyzed	3	0.16	0.45	
				ext. ovrhd.	3	0.16	0.45	
				1-132-2-L	2	0.05	0.14	
				1-132-0A-L	2	0.05	0.14	
				1-124-2-L	2	0.05	0.14	
				1-74-2C-L	2	0.05	0.14	
				ext. blkhd.	2	0.05	0.14	
1-6-1-Q	2	0.66	0.66	1-6-0-Q	8	0.07	0.07	
				1-FP-0-K	8	0.07	0.07	
				ext. blkhd.	8	0.07	0.07	
				ext. blkhd.	8	0.07	0.07	
				ext. blkhd.	8	0.07	0.07	
				ext. ovrhd.	8	0.07	0.07	
1-6-2-Q	2	0.66	0.66	1-6-0-Q	8	0.07	0.07	
				1-FP-0-K	8	0.07	0.07	
				ext. blkhd.	8	0.07	0.07	
				ext. blkhd.	8	0.07	0.07	
				ext. ovrhd.	8	0.07	0.07	
1-68-2-Q	6	0.35	1.02	1-74-0-L	9	0.05	0.16	
				1-70-2-L	9	0.05	0.16	
				1-68-0-L	9	0.05	0.16	
				ext. blkhd.	9	0.05	0.16	
1-79-0-Q	2	0.05	0.14	1-74-2A-L	2	0.05	0.14	Opening
				1-92-2-Q	7	0.01	0.03	
				1-92-0-Q	7	0.01	0.03	
				01-89-2-Q	7	0.01	0.03	
				01-82-0-L	7	0.01	0.03	
				01-74-1-Q	7	0.01	0.03	
				01-74-0-L	7	0.01	0.03	
				1-77-1-L	7	0.01	0.03	
				1-77-1-L	7	0.01	0.03	
				1-77-0-Q	7	0.01	0.03	
				1-74-0-L	7	0.01	0.03	
				1-70-3A-L	3	0.00	0.02	
				1-70-3A-L	3	0.00	0.02	
				1-70-3A-L	3	0.00	0.02	
1-92-2-Q	1	0.70	0.70	1-92-0-Q	3	0.10	0.10	
				1-79-0-Q	3	0.10	0.10	
				1-74-2B-L	3	0.10	0.10	
				1-74-2A-L	3	0.10	0.10	
				01-93-2-L	12	0.09	0.09	

1-93-1-L	16	0.42	0.34	01-89-2-Q	12	0.09	0.09
				1-110-1-Q	25	0.05	0.04
				1-107-1-Q	26	0.05	0.04

-----Room of Origin-----				-----Barrier to Adjacent Room-----				
Plan ID	FRI Time	P(Loss) EB	RFL FFS (x 1000)	Adj. Room Plan ID	Fail Time	P(Loss) EB	RFL FFS (x 1000)	Opening/ Zero-Str
				1-106-1-Q	26	0.05	0.04	
				1-99-1A-L	26	0.05	0.04	
				1-70-3A-L	26	0.05	0.04	
				1-70-3A-L	26	0.05	0.04	
				1-70-3A-L	26	0.05	0.04	
4-92-0A-E	2	0.52	1.51	1-112-0-Q	2	0.52	1.51	Opening
				4-92-0-E	2	0.52	1.51	
				1-99-1A-L	5	0.10	0.28	
				01-110-0-Q	5	0.10	0.28	
				01-102-0-E	5	0.10	0.28	
				01-95-0-L	5	0.10	0.28	
				01-82-0-L	5	0.10	0.28	
				1-92-0-Q	5	0.10	0.28	
				1-74-2B-L	5	0.10	0.28	
1-106-1-Q	1	0.70	0.56	1-107-1-Q	1	0.16	0.13	
				1-99-1A-L	1	0.16	0.13	
				1-99-1A-L	1	0.16	0.13	
				1-93-1-L	1	0.16	0.13	
				ext. ovrhd.	41	0.07	0.06	
1-106-2-L	22	0.28	0.22	1-74-2C-L	53	0.04	0.03	
				1-74-2B-L	53	0.04	0.03	
				1-74-2B-L	53	0.04	0.03	
1-107-1-Q	1	0.69	0.55	1-110-1-Q	2	0.20	0.16	
				1-106-1-Q	2	0.17	0.14	
				1-99-1A-L	2	0.17	0.14	
				1-93-1-L	2	0.17	0.14	
				ext. ovrhd.	55	0.09	0.07	
1-110-1-Q	5	0.49	0.19	1-124-1-L	35	0.05	0.02	
				1-107-1-Q	35	0.05	0.02	
				1-99-1B-L	35	0.05	0.02	
				1-99-1A-L	35	0.05	0.02	
				1-93-1-L	35	0.05	0.02	
1-112-0-Q	2	0.52	1.51	4-92-0A-E	2	0.52	1.51	Opening
				1-132-0A-L	3	0.14	0.40	
				1-132-0A-L	3	0.14	0.40	
				1-132-0A-L	3	0.14	0.40	
				01-116-0-Q	3	0.14	0.40	
				01-110-0-Q	3	0.14	0.40	
				1-99-1B-L	3	0.14	0.40	
				1-74-2C-L	3	0.14	0.40	
				ext. ovrhd.	7	0.07	0.20	
				4-126-0-E	9	0.05	0.16	
				not analyzed	38	0.05	0.15	
1-157-0-E	2	0.26	0.75	1-161-2-Q	2	0.26	0.75	Opening
				1-157-2-Q	2	0.26	0.75	Opening
				not analyzed	3	0.03	0.10	
				not analyzed	4	0.03	0.10	
				1-140-0-L	4	0.03	0.10	
				1-132-0B-L	4	0.03	0.10	
				ext. blkhd.	13	0.03	0.08	

ext. blkhd.	13	0.03	0.08
ext. blkhd.	13	0.03	0.08
ext. blkhd.	13	0.03	0.08
ext. blkhd.	13	0.03	0.08
ext. blkhd.	13	0.03	0.08

-----Room of Origin-----				-----Barrier to Adjacent Room-----				
Plan ID	FRI Time	P(Loss) EB	RFL FFS (x 1000)	Adj. Room Plan ID	Fail Time	P(Loss) EB	RFL FFS (x 1000)	Opening/ Zero-Str
				ext. blkhd.	13	0.03	0.08	
				ext. blkhd.	13	0.03	0.08	
				ext. ovrhd.	13	0.03	0.08	
1-157-2-Q	1	0.70	0.70	1-157-0-E	1	0.70	0.70	Opening
				ext. blkhd.	5	0.13	0.13	
				ext. ovrhd.	5	0.13	0.13	
				1-161-2-Q	1	0.09	0.09	
				1-150-2-L	1	0.09	0.09	
				2-147-0-Q	10	0.09	0.09	
1-161-2-Q	2	0.66	0.66	1-157-0-E	2	0.66	0.66	Opening
				1-157-2-Q	3	0.15	0.15	
				1-157-0-E	3	0.15	0.15	
				2-161-0-Q	15	0.07	0.07	
				ext. blkhd.	7	0.07	0.07	
				ext. ovrhd.	7	0.07	0.07	
01-74-1-Q	4	0.54	0.65	01-82-0-L	20	0.06	0.07	
				01-74-0-L	20	0.06	0.07	
				01-71-0-Q	20	0.06	0.07	
01-102-0-E	1	0.63	0.82	01-110-0-Q	2	0.15	0.20	
				ext. blkhd.	2	0.15	0.20	
				ext. blkhd.	2	0.15	0.20	
				02-102-0-E	6	0.07	0.09	
				01-95-0-L	3	0.07	0.09	
01-110-0-Q	1	0.33	0.13	01-116-0-Q	2	0.10	0.04	
				01-102-0-E	2	0.10	0.04	
				ext. blkhd.	2	0.10	0.04	
				ext. blkhd.	2	0.10	0.04	
				ext. ovrhd.	27	0.05	0.02	
				1-112-0-Q	33	0.04	0.01	
01-116-0-Q	3	0.36	0.43	01-110-0-Q	28	0.04	0.05	
				ext. blkhd.	28	0.04	0.05	
				ext. blkhd.	28	0.04	0.05	
				ext. blkhd.	28	0.04	0.05	
02-74-0-Q	2	0.32	0.13	01-71-0-Q	3	0.07	0.03	
				ext. blkhd.	3	0.07	0.03	
				ext. blkhd.	3	0.07	0.03	
				02-81-2-L	3	0.07	0.03	
				ext. blkhd.	3	0.07	0.03	
				ext. blkhd.	3	0.07	0.03	
				ext. blkhd.	3	0.07	0.03	
02-81-0-C	5	0.46	0.55	03-72-0-C	30	0.05	0.06	
				02-81-2-L	30	0.05	0.06	
03-72-0-C	6	0.37	0.44	02-81-2-L	11	0.05	0.06	
				02-81-0-C	11	0.05	0.06	
				ext. blkhd.	28	0.04	0.05	
				ext. blkhd.	28	0.04	0.05	
				ext. blkhd.	28	0.04	0.05	
				ext. blkhd.	28	0.04	0.05	
				ext. ovrhd.	28	0.04	0.05	

HORNBEAM

06/24/97

MODEL RUN 9-66

PATH OPTION - SUMMARY LEVEL REPORT

LISTING OF ALL PATHS FROM 4-126-0-E

READINESS CONDITION . YOKE
CONFIGURATION Passive
CASE. Worst
ASSUMED LOCATION. . . at SEA
RUN TIME. 60 minutes
COMMENTS.
Baseline, At Sea M Values

```
*****  
PATHS FROM 4-126-0-E  
CUM L
```

1.	2-126-1-Q	1-99-1B-L			0.9786
2.	2-126-2-Q	1-74-2C-L	1-106-2-L		0.9721
3.	2-126-2-Q	1-74-2C-L	1-124-2-L		0.9640
4.	2-126-2-Q	1-74-2C-L	1-74-2B-L	1-92-2-Q	0.9852
5.	2-126-2-Q	1-124-2-L	1-132-0A-L		0.9752
6.	2-126-2-Q	1-132-0A-L	1-132-2-L		0.9772
7.	2-126-2-Q	1-132-0A-L	1-74-2C-L		0.9893
8.	2-126-2-Q	1-132-0A-L	1-99-1B-L		0.9894
9.	2-126-2-Q	1-132-0A-L	1-132-0B-L		0.9773
10.	2-126-2-Q	1-132-2-L	1-140-2-L		0.9785
11.	2-126-2-Q	1-132-2-L	1-124-2-L		0.9003
12.	1-74-2C-L	1-106-2-L			0.9570
13.	1-74-2C-L	1-124-2-L			0.9446
14.	1-74-2C-L	1-74-2B-L	1-92-2-Q		0.9773
15.	1-74-2C-L	1-74-2B-L	1-106-2-L		0.9896
16.	1-99-1B-L	1-110-1-Q			0.9502
17.	1-99-1B-L	1-124-1-L			0.9809
18.	1-99-1B-L	1-99-1A-L	1-106-1-Q	1-107-1-Q	0.9854
19.	1-99-1B-L	1-99-1A-L	1-107-1-Q		0.9776
20.	1-99-1B-L	1-99-1A-L	1-110-1-Q		0.9879
21.	1-99-1B-L	1-99-1A-L	1-70-3A-L		0.9724
22.	1-112-0-Q	1-74-2C-L	1-106-2-L		0.9699
23.	1-112-0-Q	1-74-2C-L	1-124-2-L		0.9612
24.	1-112-0-Q	1-74-2C-L	1-74-2B-L	1-92-2-Q	0.9841
25.	1-112-0-Q	1-99-1B-L	1-110-1-Q		0.9651
26.	1-112-0-Q	1-99-1B-L	1-124-1-L		0.9867
27.	1-112-0-Q	1-99-1B-L	1-99-1A-L	1-106-1-Q	
	1-107-1-Q				0.9898
28.	1-112-0-Q	1-99-1B-L	1-99-1A-L	1-107-1-Q	0.9843
29.	1-112-0-Q	1-99-1B-L	1-99-1A-L	1-70-3A-L	0.9806
30.	1-112-0-Q	01-110-0-Q	01-102-0-E	02-102-0-E	0.8848
31.	1-112-0-Q	01-110-0-Q	01-102-0-E	01-95-0-L	0.9683
32.	1-112-0-Q	01-110-0-Q	01-116-0-Q		0.8422
33.	1-112-0-Q	01-116-0-Q			0.7797
34.	1-112-0-Q	1-132-0A-L	1-132-2-L		0.9754
35.	1-112-0-Q	1-132-0A-L	1-74-2C-L		0.9885

36.	1-112-0-Q	1-132-0A-L	1-99-1B-L		0.9886
37.	1-112-0-Q	1-132-0A-L	1-132-0B-L		0.9755
38.	1-112-0-Q	4-92-0A-E	1-74-2B-L	1-92-2-Q	0.9554
39.	1-112-0-Q	4-92-0A-E	1-74-2B-L	1-92-2-Q	
	1-92-0-Q				0.9826
40.	1-112-0-Q	4-92-0A-E	1-74-2B-L	1-92-2-Q	
	1-79-0-Q				0.9826
41.	1-112-0-Q	4-92-0A-E	1-74-2B-L	1-106-2-L	0.9796
42.	1-112-0-Q	4-92-0A-E	1-74-2B-L	1-74-2A-L	0.9829
43.	1-112-0-Q	4-92-0A-E	1-74-2B-L	01-93-2-L	0.9849
44.	1-112-0-Q	4-92-0A-E	1-92-0-Q	01-82-0-L	0.9856
	PATHS FROM 4-126-0-E				CUM L
45.	1-112-0-Q	4-92-0A-E	01-82-0-L		0.7722
46.	1-112-0-Q	4-92-0A-E	01-95-0-L		0.9177
47.	1-112-0-Q	4-92-0A-E	01-102-0-E	02-102-0-E	0.8678
48.	1-112-0-Q	4-92-0A-E	01-102-0-E	01-95-0-L	0.9636
49.	1-112-0-Q	4-92-0A-E	1-99-1A-L	1-93-1-L	0.9878
50.	1-112-0-Q	4-92-0A-E	1-99-1A-L	1-106-1-Q	
	1-93-1-L				0.9848
51.	1-112-0-Q	4-92-0A-E	1-99-1A-L	1-106-1-Q	
	1-107-1-Q				0.9715
52.	1-112-0-Q	4-92-0A-E	1-99-1A-L	1-107-1-Q	
	1-110-1-Q				0.9862
53.	1-112-0-Q	4-92-0A-E	1-99-1A-L	1-110-1-Q	0.9763
54.	1-112-0-Q	4-92-0A-E	1-99-1A-L	1-70-3A-L	0.9458
55.	1-112-0-Q	4-92-0A-E	1-99-1A-L	1-70-3A-L	
	1-93-1-L				0.9874
56.	1-112-0-Q	4-92-0A-E	1-99-1A-L	1-70-3A-L	
	1-79-0-Q				0.9880
57.	1-112-0-Q	4-92-0A-E	1-99-1A-L	01-95-1-L	0.9849
58.	1-112-0-Q	4-92-0A-E	01-110-0-Q	01-102-0-E	
	02-102-0-E				0.9193
59.	1-112-0-Q	4-92-0A-E	01-110-0-Q	01-102-0-E	
	01-95-0-L				0.9778
60.	1-112-0-Q	4-92-0A-E	01-110-0-Q	01-116-0-Q	0.8895
61.	1-112-0-Q	4-92-0A-E	4-92-0-E	1-92-2-Q	0.8738
62.	1-112-0-Q	4-92-0A-E	4-92-0-E	1-106-1-Q	0.8680
63.	1-112-0-Q	4-92-0A-E	4-92-0-E	1-107-1-Q	0.8700
64.	1-112-0-Q	4-92-0A-E	4-92-0-E	1-112-0-Q	0.8579
65.	1-132-0A-L	1-132-2-L			0.9648
66.	1-132-0A-L	1-74-2C-L			0.9836
67.	1-132-0A-L	1-99-1B-L			0.9836
68.	1-132-0A-L	1-132-0B-L			0.9650

HORNBEAM

06/24/97

MODEL RUN 9-66

PATH OPTION - DETAIL LEVEL REPORT

INFORMATION ON ALL PATHS FROM 4-126-0-E

READINESS CONDITION . YOKE
 CONFIGURATION Passive
 CASE. Worst
 ASSUMED LOCATION. . . at SEA
 RUN TIME. 60 minutes
 COMMENTS.
 Baseline, At Sea M Values

Path no. 1 Path Length 3

Compt ID	Cum L	Ign Mode	EB Time	Compt Fuel	Therm IAM	Dur IAM	FRI Time	CBO
4-126-0-E	0.4400	orig	0	0.0	N/A	N/A	2	3
2-126-1-Q	0.5856	dur	2	20.6	0.480	0.260	3	
1-99-1B-L	0.9786	dur	2	26.1	0.840	0.750	15	

Connecting Barrier	HEI	Tbar	Dbar	IBV	Time Destroyed	Failure Type
4-126-0-E/2-126-1-Q	N/A	0.00	1.00	0.0000	2	dur
2-126-1-Q/1-99-1B-L	11.5	0.32	0.00	0.2806		therm

Path no. 2 Path Length 4

Compt ID	Cum L	Ign Mode	EB Time	Compt Fuel	Therm IAM	Dur IAM	FRI Time	CBO
4-126-0-E	0.4400	orig	0	0.0	N/A	N/A	2	3
2-126-2-Q	0.6360	dur	2	0.0	0.500	0.350	3	7
1-74-2C-L	0.9090	dur	2	27.6	0.840	0.750	15	
1-106-2-L	0.9721	therm	28	44.5	0.550	0.300	50	

Connecting Barrier	HEI	Tbar	Dbar	IBV	Time Destroyed	Failure Type
4-126-0-E/2-126-2-Q	N/A	0.00	1.00	0.0000	2	dur
2-126-2-Q/1-74-2C-L	N/A	0.00	1.00	0.0000	14	dur
1-74-2C-L/1-106-2-L	3.8	0.68	0.00	0.0289		therm

Path no. 3 Path Length 4

Compt ID	Cum L	Ign Mode	EB Time	Compt Fuel	Therm IAM	Dur IAM	FRI Time	CBO
4-126-0-E	0.4400	orig	0	0.0	N/A	N/A	2	3
2-126-2-Q	0.6360	dur	2	0.0	0.500	0.350	3	7
1-74-2C-L	0.9090	dur	2	27.6	0.840	0.750	15	
1-124-2-L	0.9640	dur	3	29.8	0.550	0.300	21	

Connecting Barrier	HEI	Tbar	Dbar	IBV	Time Destroyed	Failure Type
4-126-0-E/2-126-2-Q	N/A	0.00	1.00	0.0000	2	dur
2-126-2-Q/1-74-2C-L	N/A	0.00	1.00	0.0000	14	dur
1-74-2C-L/1-124-2-L	8.7	0.88	0.00	0.0109		therm

Path no. 4 Path Length 5

Compt ID	Cum L	Ign Mode	EB Time	Compt Fuel	Therm IAM	Dur IAM	FRI Time	CBO
4-126-0-E	0.4400	orig	0	0.0	N/A	N/A	2	3
2-126-2-Q	0.6360	dur	2	0.0	0.500	0.350	3	7
1-74-2C-L	0.9090	dur	2	27.6	0.840	0.750	15	
1-74-2B-L	0.9773	dur	8	12.1	0.840	0.750	19	
1-92-2-Q	0.9852	therm	47	46.5	0.350	0.160	48	

Connecting Barrier	HEI	Tbar	Dbar	IBV	Time Destroyed	Failure Type
4-126-0-E/2-126-2-Q	N/A	0.00	1.00	0.0000	2	dur
2-126-2-Q/1-74-2C-L	N/A	0.00	1.00	0.0000	14	dur
1-74-2C-L/1-74-2B-L	0.2	0.00	1.00	0.0000	15	dur
1-74-2B-L/1-92-2-Q	18.8	1.00	0.00	0.0000		therm

Path no. 5 Path Length 4

Compt ID	Cum L	Ign Mode	EB Time	Compt Fuel	Therm IAM	Dur IAM	FRI Time	CBO
4-126-0-E	0.4400	orig	0	0.0	N/A	N/A	2	3
2-126-2-Q	0.6360	dur	2	0.0	0.500	0.350	3	7
1-124-2-L	0.7452	dur	3	29.8	0.550	0.300	21	
1-132-0A-L	0.9752	dur	2	10.0	0.840	0.750	15	

Connecting Barrier	HEI	Tbar	Dbar	IBV	Time Destroyed	Failure Type
4-126-0-E/2-126-2-Q	N/A	0.00	1.00	0.0000	2	dur
2-126-2-Q/1-124-2-L	N/A	0.00	1.00	0.0000	14	dur
1-124-2-L/1-132-0A-L	5.3	0.61	0.00	0.1000		therm

Path no. 6 Path Length 4

Compt ID	Cum L	Ign Mode	EB Time	Compt Fuel	Therm IAM	Dur IAM	FRI Time	CBO
4-126-0-E	0.4400	orig	0	0.0	N/A	N/A	2	3
2-126-2-Q	0.6360	dur	2	0.0	0.500	0.350	3	7
1-132-0A-L	0.9090	dur	2	10.0	0.840	0.750	15	
1-132-2-L	0.9772	dur	3	28.2	0.600	0.250	21	

Connecting Barrier	HEI	Tbar	Dbar	IBV	Time Destroyed	Failure Type
4-126-0-E/2-126-2-Q	N/A	0.00	1.00	0.0000	2	dur
2-126-2-Q/1-132-0A-L	N/A	0.00	1.00	0.0000	14	dur
1-132-0A-L/1-132-2-L	5.6	0.63	0.00	0.0339		therm

Path no. 7 Path Length 4

Compt ID	Cum L	Ign Mode	EB Time	Compt Fuel	Therm IAM	Dur IAM	FRI Time	CBO
4-126-0-E	0.4400	orig	0	0.0	N/A	N/A	2	3
2-126-2-Q	0.6360	dur	2	0.0	0.500	0.350	3	7
1-132-0A-L	0.9090	dur	2	10.0	0.840	0.750	15	
1-74-2C-L	0.9893	dur	2	27.6	0.840	0.750	15	

Connecting Barrier	HEI	Tbar	Dbar	IBV	Time Destroyed	Failure Type
4-126-0-E/2-126-2-Q	N/A	0.00	1.00	0.0000	2	dur
2-126-2-Q/1-132-0A-L	N/A	0.00	1.00	0.0000	14	dur
1-132-0A-L/1-74-2C-L	6.9	0.73	0.00	0.0243		therm

Path no. 8 Path Length 4

Compt ID	Cum L	Ign Mode	EB Time	Compt Fuel	Therm IAM	Dur IAM	FRI Time	CBO
4-126-0-E	0.4400	orig	0	0.0	N/A	N/A	2	3
2-126-2-Q	0.6360	dur	2	0.0	0.500	0.350	3	7
1-132-0A-L	0.9090	dur	2	10.0	0.840	0.750	15	
1-99-1B-L	0.9894	dur	2	26.1	0.840	0.750	15	

Connecting Barrier	HEI	Tbar	Dbar	IBV	Time Destroyed	Failure Type
4-126-0-E/2-126-2-Q	N/A	0.00	1.00	0.0000	2	dur
2-126-2-Q/1-132-0A-L	N/A	0.00	1.00	0.0000	14	dur
1-132-0A-L/1-99-1B-L	6.8	0.73	0.00	0.0246		therm

 Path no. 9 Path Length 4

Compt ID	Cum L	Ign Mode	EB Time	Compt Fuel	Therm IAM	Dur IAM	FRI Time	CBO
4-126-0-E	0.4400	orig	0	0.0	N/A	N/A	2	3
2-126-2-Q	0.6360	dur	2	0.0	0.500	0.350	3	7
1-132-0A-L	0.9090	dur	2	10.0	0.840	0.750	15	
1-132-0B-L	0.9773	dur	15	3.0	0.840	0.750	19	

Connecting Barrier	HEI	Tbar	Dbar	IBV	Time Destroyed	Failure Type
4-126-0-E/2-126-2-Q	N/A	0.00	1.00	0.0000	2	dur
2-126-2-Q/1-132-0A-L	N/A	0.00	1.00	0.0000	14	dur
1-132-0A-L/1-132-0B-L	0.0	0.00	1.00	0.0000	15	dur

 Path no. 10 Path Length 4

Compt ID	Cum L	Ign Mode	EB Time	Compt Fuel	Therm IAM	Dur IAM	FRI Time	CBO
4-126-0-E	0.4400	orig	0	0.0	N/A	N/A	2	3
2-126-2-Q	0.6360	dur	2	0.0	0.500	0.350	3	7
1-132-2-L	0.7270	dur	3	28.2	0.600	0.250	21	
1-140-2-L	0.9785	therm	52	25.2	0.550	0.300		

Connecting Barrier	HEI	Tbar	Dbar	IBV	Time Destroyed	Failure Type
4-126-0-E/2-126-2-Q	N/A	0.00	1.00	0.0000	2	dur
2-126-2-Q/1-132-2-L	N/A	0.00	1.00	0.0000	14	dur
1-132-2-L/1-140-2-L	2.1	0.18	0.00	0.2252		therm

 Path no. 11 Path Length 4

Compt ID	Cum L	Ign Mode	EB Time	Compt Fuel	Therm IAM	Dur IAM	FRI Time	CBO
4-126-0-E	0.4400	orig	0	0.0	N/A	N/A	2	3
2-126-2-Q	0.6360	dur	2	0.0	0.500	0.350	3	7
1-132-2-L	0.7270	dur	3	28.2	0.600	0.250	21	
1-124-2-L	0.9003	dur	3	29.8	0.550	0.300	21	

Connecting Barrier	HEI	Tbar	Dbar	IBV	Time Destroyed	Failure Type
4-126-0-E/2-126-2-Q	N/A	0.00	1.00	0.0000	2	dur
2-126-2-Q/1-132-2-L	N/A	0.00	1.00	0.0000	14	dur
1-132-2-L/1-124-2-L	7.8	0.81	0.00	0.0515		therm

Path no. 12 Path Length 3

Compt ID	Cum L	Ign Mode	EB Time	Compt Fuel	Therm IAM	Dur IAM	FRI Time	CBO
4-126-0-E	0.4400	orig	0	0.0	N/A	N/A	2	3
1-74-2C-L	0.8600	dur	2	27.6	0.840	0.750	15	
1-106-2-L	0.9570	therm	28	44.5	0.550	0.300	50	

Connecting Barrier	HEI	Tbar	Dbar	IBV	Time Destroyed	Failure Type
4-126-0-E/1-74-2C-L	N/A	0.00	1.00	0.0000	9	dur
1-74-2C-L/1-106-2-L	3.8	0.68	0.00	0.0445		therm

Path no. 13 Path Length 3

Compt ID	Cum L	Ign Mode	EB Time	Compt Fuel	Therm IAM	Dur IAM	FRI Time	CBO
4-126-0-E	0.4400	orig	0	0.0	N/A	N/A	2	3
1-74-2C-L	0.8600	dur	2	27.6	0.840	0.750	15	
1-124-2-L	0.9446	dur	3	29.8	0.550	0.300	21	

Connecting Barrier	HEI	Tbar	Dbar	IBV	Time Destroyed	Failure Type
4-126-0-E/1-74-2C-L	N/A	0.00	1.00	0.0000	9	dur
1-74-2C-L/1-124-2-L	8.7	0.88	0.00	0.0168		therm

Path no. 14 Path Length 4

Compt ID	Cum L	Ign Mode	EB Time	Compt Fuel	Therm IAM	Dur IAM	FRI Time	CBO
4-126-0-E	0.4400	orig	0	0.0	N/A	N/A	2	3
1-74-2C-L	0.8600	dur	2	27.6	0.840	0.750	15	
1-74-2B-L	0.9650	dur	8	12.1	0.840	0.750	19	
1-92-2-Q	0.9773	therm	47	46.5	0.350	0.160	48	

Connecting Barrier	HEI	Tbar	Dbar	IBV	Time Destroyed	Failure Type
4-126-0-E/1-74-2C-L	N/A	0.00	1.00	0.0000	9	dur
1-74-2C-L/1-74-2B-L	0.2	0.00	1.00	0.0000	15	dur
1-74-2B-L/1-92-2-Q	18.8	1.00	0.00	0.0000		therm

Path no. 15 Path Length 4

Compt ID	Cum L	Ign Mode	EB Time	Compt Fuel	Therm IAM	Dur IAM	FRI Time	CBO
4-126-0-E	0.4400	orig	0	0.0	N/A	N/A	2	3
1-74-2C-L	0.8600	dur	2	27.6	0.840	0.750	15	
1-74-2B-L	0.9650	dur	8	12.1	0.840	0.750	19	
1-106-2-L	0.9896	therm	28	44.5	0.550	0.300	50	

Connecting Barrier	HEI	Tbar	Dbar	IBV	Time Destroyed	Failure Type
4-126-0-E/1-74-2C-L	N/A	0.00	1.00	0.0000	9	dur
1-74-2C-L/1-74-2B-L	0.2	0.00	1.00	0.0000	15	dur
1-74-2B-L/1-106-2-L	3.5	0.66	0.00	0.0119		therm

 Path no. 16 Path Length 3

Compt ID	Cum L	Ign Mode	EB Time	Compt Fuel	Therm IAM	Dur IAM	FRI Time	CBO
4-126-0-E	0.4400	orig	0	0.0	N/A	N/A	2	3
1-99-1B-L	0.8600	dur	2	26.1	0.840	0.750	15	
1-110-1-Q	0.9502	therm	39	70.4	0.430	0.210	44	

Connecting Barrier	HEI	Tbar	Dbar	IBV	Time Destroyed	Failure Type
4-126-0-E/1-99-1B-L	N/A	0.00	1.00	0.0000	9	dur
1-99-1B-L/1-110-1-Q	5.1	0.62	0.00	0.0526		therm

 Path no. 17 Path Length 3

Compt ID	Cum L	Ign Mode	EB Time	Compt Fuel	Therm IAM	Dur IAM	FRI Time	CBO
4-126-0-E	0.4400	orig	0	0.0	N/A	N/A	2	3
1-99-1B-L	0.8600	dur	2	26.1	0.840	0.750	15	
1-124-1-L	0.9809	therm	39	33.2	0.550	0.300		

Connecting Barrier	HEI	Tbar	Dbar	IBV	Time Destroyed	Failure Type
4-126-0-E/1-99-1B-L	N/A	0.00	1.00	0.0000	9	dur
1-99-1B-L/1-124-1-L	2.6	0.30	0.00	0.0976		therm

 Path no. 18 Path Length 5

Compt ID	Cum L	Ign Mode	EB Time	Compt Fuel	Therm IAM	Dur IAM	FRI Time	CBO
4-126-0-E	0.4400	orig	0	0.0	N/A	N/A	2	3

1-99-1B-L	0.8600	dur	2	26.1	0.840	0.750	15	
1-99-1A-L	0.9650	dur	8	11.9	0.840	0.750	19	
1-106-1-Q	0.9773	therm	47	0.0	0.350	0.160	48	49
1-107-1-Q	0.9854	therm	47	0.0	0.360	0.170	48	49

Connecting Barrier	HEI	Tbar	Dbar	IBV	Time Destroyed	Failure Type
4-126-0-E/1-99-1B-L	N/A	0.00	1.00	0.0000	9	dur
1-99-1B-L/1-99-1A-L	0.2	0.00	1.00	0.0000	15	dur
1-99-1A-L/1-106-1-Q	35.4	1.00	0.00	0.0000		therm
1-106-1-Q/1-107-1-Q	12.1	1.00	0.00	0.0000		therm

 Path no. 19 Path Length 4

Compt ID	Cum L	Ign Mode	EB Time	Compt Fuel	Therm IAM	Dur IAM	FRI Time	CBO
4-126-0-E	0.4400	orig	0	0.0	N/A	N/A	2	3
1-99-1B-L	0.8600	dur	2	26.1	0.840	0.750	15	
1-99-1A-L	0.9650	dur	8	11.9	0.840	0.750	19	
1-107-1-Q	0.9776	therm	47	0.0	0.360	0.170	48	49

Connecting Barrier	HEI	Tbar	Dbar	IBV	Time Destroyed	Failure Type
4-126-0-E/1-99-1B-L	N/A	0.00	1.00	0.0000	9	dur
1-99-1B-L/1-99-1A-L	0.2	0.00	1.00	0.0000	15	dur
1-99-1A-L/1-107-1-Q	20.1	1.00	0.00	0.0000		therm

 Path no. 20 Path Length 4

Compt ID	Cum L	Ign Mode	EB Time	Compt Fuel	Therm IAM	Dur IAM	FRI Time	CBO
4-126-0-E	0.4400	orig	0	0.0	N/A	N/A	2	3
1-99-1B-L	0.8600	dur	2	26.1	0.840	0.750	15	
1-99-1A-L	0.9650	dur	8	11.9	0.840	0.750	19	
1-110-1-Q	0.9879	therm	39	70.4	0.430	0.210	44	

Connecting Barrier	HEI	Tbar	Dbar	IBV	Time Destroyed	Failure Type
4-126-0-E/1-99-1B-L	N/A	0.00	1.00	0.0000	9	dur
1-99-1B-L/1-99-1A-L	0.2	0.00	1.00	0.0000	15	dur
1-99-1A-L/1-110-1-Q	4.9	0.61	0.00	0.0138		therm

 Path no. 21 Path Length 4

Compt ID	Cum L	Ign Mode	EB Time	Compt Fuel	Therm IAM	Dur IAM	FRI Time	CBO
----------	-------	----------	---------	------------	-----------	---------	----------	-----

4-126-0-E	0.4400	orig	0	0.0	N/A	N/A	2	3
1-99-1B-L	0.8600	dur	2	26.1	0.840	0.750	15	
1-99-1A-L	0.9650	dur	8	11.9	0.840	0.750	19	
1-70-3A-L	0.9724	dur	19	21.5	0.390	0.210	23	

Connecting Barrier	HEI	Tbar	Dbar	IBV	Time Destroyed	Failure Type
4-126-0-E/1-99-1B-L	N/A	0.00	1.00	0.0000	9	dur
1-99-1B-L/1-99-1A-L	0.2	0.00	1.00	0.0000	15	dur
1-99-1A-L/1-70-3A-L	0.2	0.00	1.00	0.0000	19	dur

 Path no. 22 Path Length 4

Compt ID	Cum L	Ign Mode	EB Time	Compt Fuel	Therm IAM	Dur IAM	FRI Time	CBO
4-126-0-E	0.4400	orig	0	0.0	N/A	N/A	2	3
1-112-0-Q	0.6080	therm	2	0.0	0.440	0.300	4	5
1-74-2C-L	0.9020	dur	2	27.6	0.840	0.750	15	
1-106-2-L	0.9699	therm	28	44.5	0.550	0.300	50	

Connecting Barrier	HEI	Tbar	Dbar	IBV	Time Destroyed	Failure Type
4-126-0-E/1-112-0-Q	N/A	0.00	1.00	0.0000	7	dur
1-112-0-Q/1-74-2C-L	N/A	0.00	1.00	0.0000	33	dur
1-74-2C-L/1-106-2-L	3.8	0.68	0.00	0.0311		therm

 Path no. 23 Path Length 4

Compt ID	Cum L	Ign Mode	EB Time	Compt Fuel	Therm IAM	Dur IAM	FRI Time	CBO
4-126-0-E	0.4400	orig	0	0.0	N/A	N/A	2	3
1-112-0-Q	0.6080	therm	2	0.0	0.440	0.300	4	5
1-74-2C-L	0.9020	dur	2	27.6	0.840	0.750	15	
1-124-2-L	0.9612	dur	3	29.8	0.550	0.300	21	

Connecting Barrier	HEI	Tbar	Dbar	IBV	Time Destroyed	Failure Type
4-126-0-E/1-112-0-Q	N/A	0.00	1.00	0.0000	7	dur
1-112-0-Q/1-74-2C-L	N/A	0.00	1.00	0.0000	33	dur
1-74-2C-L/1-124-2-L	8.7	0.88	0.00	0.0118		therm

 Path no. 24 Path Length 5

Compt ID	Cum L	Ign Mode	EB Time	Compt Fuel	Therm IAM	Dur IAM	FRI Time	CBO
----------	-------	----------	---------	------------	-----------	---------	----------	-----

4-126-0-E	0.4400	orig	0	0.0	N/A	N/A	2	3
1-112-0-Q	0.6080	therm	2	0.0	0.440	0.300	4	5
1-74-2C-L	0.9020	dur	2	27.6	0.840	0.750	15	
1-74-2B-L	0.9755	dur	8	12.1	0.840	0.750	19	
1-92-2-Q	0.9841	therm	47	46.5	0.350	0.160	48	

Connecting Barrier	HEI	Tbar	Dbar	IBV	Time Destroyed	Failure Type
4-126-0-E/1-112-0-Q	N/A	0.00	1.00	0.0000	7	dur
1-112-0-Q/1-74-2C-L	N/A	0.00	1.00	0.0000	33	dur
1-74-2C-L/1-74-2B-L	0.2	0.00	1.00	0.0000	15	dur
1-74-2B-L/1-92-2-Q	18.8	1.00	0.00	0.0000		therm

 Path no. 25 Path Length 4

Compt ID	Cum L	Ign Mode	EB Time	Compt Fuel	Therm IAM	Dur IAM	FRI Time	CBO
4-126-0-E	0.4400	orig	0	0.0	N/A	N/A	2	3
1-112-0-Q	0.6080	therm	2	0.0	0.440	0.300	4	5
1-99-1B-L	0.9020	dur	2	26.1	0.840	0.750	15	
1-110-1-Q	0.9651	therm	39	70.4	0.430	0.210	44	

Connecting Barrier	HEI	Tbar	Dbar	IBV	Time Destroyed	Failure Type
4-126-0-E/1-112-0-Q	N/A	0.00	1.00	0.0000	7	dur
1-112-0-Q/1-99-1B-L	N/A	0.00	1.00	0.0000	33	dur
1-99-1B-L/1-110-1-Q	5.1	0.62	0.00	0.0368		therm

 Path no. 26 Path Length 4

Compt ID	Cum L	Ign Mode	EB Time	Compt Fuel	Therm IAM	Dur IAM	FRI Time	CBO
4-126-0-E	0.4400	orig	0	0.0	N/A	N/A	2	3
1-112-0-Q	0.6080	therm	2	0.0	0.440	0.300	4	5
1-99-1B-L	0.9020	dur	2	26.1	0.840	0.750	15	
1-124-1-L	0.9867	therm	39	33.2	0.550	0.300		

Connecting Barrier	HEI	Tbar	Dbar	IBV	Time Destroyed	Failure Type
4-126-0-E/1-112-0-Q	N/A	0.00	1.00	0.0000	7	dur
1-112-0-Q/1-99-1B-L	N/A	0.00	1.00	0.0000	33	dur
1-99-1B-L/1-124-1-L	2.6	0.30	0.00	0.0683		therm

 Path no. 27 Path Length 6

Compt ID	Cum L	Ign Mode	EB Time	Compt Fuel	Therm IAM	Dur IAM	FRI Time	CBO
4-126-0-E	0.4400	orig	0	0.0	N/A	N/A	2	3
1-112-0-Q	0.6080	therm	2	0.0	0.440	0.300	4	5
1-99-1B-L	0.9020	dur	2	26.1	0.840	0.750	15	
1-99-1A-L	0.9755	dur	8	11.9	0.840	0.750	19	
1-106-1-Q	0.9841	therm	47	0.0	0.350	0.160	48	49
1-107-1-Q	0.9898	therm	47	0.0	0.360	0.170	48	49

Connecting Barrier	HEI	Tbar	Dbar	IBV	Time Destroyed	Failure Type
4-126-0-E/1-112-0-Q	N/A	0.00	1.00	0.0000	7	dur
1-112-0-Q/1-99-1B-L	N/A	0.00	1.00	0.0000	33	dur
1-99-1B-L/1-99-1A-L	0.2	0.00	1.00	0.0000	15	dur
1-99-1A-L/1-106-1-Q	35.4	1.00	0.00	0.0000		therm
1-106-1-Q/1-107-1-Q	12.1	1.00	0.00	0.0000		therm

 Path no. 28 Path Length 5

Compt ID	Cum L	Ign Mode	EB Time	Compt Fuel	Therm IAM	Dur IAM	FRI Time	CBO
4-126-0-E	0.4400	orig	0	0.0	N/A	N/A	2	3
1-112-0-Q	0.6080	therm	2	0.0	0.440	0.300	4	5
1-99-1B-L	0.9020	dur	2	26.1	0.840	0.750	15	
1-99-1A-L	0.9755	dur	8	11.9	0.840	0.750	19	
1-107-1-Q	0.9843	therm	47	0.0	0.360	0.170	48	49

Connecting Barrier	HEI	Tbar	Dbar	IBV	Time Destroyed	Failure Type
4-126-0-E/1-112-0-Q	N/A	0.00	1.00	0.0000	7	dur
1-112-0-Q/1-99-1B-L	N/A	0.00	1.00	0.0000	33	dur
1-99-1B-L/1-99-1A-L	0.2	0.00	1.00	0.0000	15	dur
1-99-1A-L/1-107-1-Q	20.1	1.00	0.00	0.0000		therm

 Path no. 29 Path Length 5

Compt ID	Cum L	Ign Mode	EB Time	Compt Fuel	Therm IAM	Dur IAM	FRI Time	CBO
4-126-0-E	0.4400	orig	0	0.0	N/A	N/A	2	3
1-112-0-Q	0.6080	therm	2	0.0	0.440	0.300	4	5
1-99-1B-L	0.9020	dur	2	26.1	0.840	0.750	15	
1-99-1A-L	0.9755	dur	8	11.9	0.840	0.750	19	
1-70-3A-L	0.9806	dur	19	21.5	0.390	0.210	23	

Connecting Barrier	HEI	Tbar	Dbar	IBV	Time Destroyed	Failure Type

4-126-0-E/1-112-0-Q	N/A	0.00	1.00	0.0000	7	dur
1-112-0-Q/1-99-1B-L	N/A	0.00	1.00	0.0000	33	dur
1-99-1B-L/1-99-1A-L	0.2	0.00	1.00	0.0000	15	dur
1-99-1A-L/1-70-3A-L	0.2	0.00	1.00	0.0000	19	dur

 Path no. 30 Path Length 5

Compt ID	Cum L	Ign Mode	EB Time	Compt Fuel	Therm IAM	Dur IAM	FRI Time	CBO
4-126-0-E	0.4400	orig	0	0.0	N/A	N/A	2	3
1-112-0-Q	0.6080	therm	2	0.0	0.440	0.300	4	5
01-110-0-Q	0.7609	therm	5	0.0	0.520	0.390	6	9
01-102-0-E	0.8111	therm	7	0.0	0.390	0.210	8	30
02-102-0-E	0.8848	therm	13	26.2	0.390	0.210	15	

Connecting Barrier	HEI	Tbar	Dbar	IBV	Time Destroyed	Failure Type
4-126-0-E/1-112-0-Q	N/A	0.00	1.00	0.0000	7	dur
1-112-0-Q/01-110-0-Q	N/A	0.00	1.00	0.0000	27	dur
01-110-0-Q/01-102-0-E	N/A	0.00	1.00	0.0000	28	dur
01-102-0-E/02-102-0-E	N/A	1.00	0.00	0.0000		therm

 Path no. 31 Path Length 5

Compt ID	Cum L	Ign Mode	EB Time	Compt Fuel	Therm IAM	Dur IAM	FRI Time	CBO
4-126-0-E	0.4400	orig	0	0.0	N/A	N/A	2	3
1-112-0-Q	0.6080	therm	2	0.0	0.440	0.300	4	5
01-110-0-Q	0.7609	therm	5	0.0	0.520	0.390	6	9
01-102-0-E	0.8111	therm	7	0.0	0.390	0.210	8	30
01-95-0-L	0.9683	dur	8	7.4	0.880	0.700	55	

Connecting Barrier	HEI	Tbar	Dbar	IBV	Time Destroyed	Failure Type
4-126-0-E/1-112-0-Q	N/A	0.00	1.00	0.0000	7	dur
1-112-0-Q/01-110-0-Q	N/A	0.00	1.00	0.0000	27	dur
01-110-0-Q/01-102-0-E	N/A	0.00	1.00	0.0000	28	dur
01-102-0-E/01-95-0-L	N/A	0.73	0.27	0.0000	57	therm

 Path no. 32 Path Length 4

Compt ID	Cum L	Ign Mode	EB Time	Compt Fuel	Therm IAM	Dur IAM	FRI Time	CBO
4-126-0-E	0.4400	orig	0	0.0	N/A	N/A	2	3
1-112-0-Q	0.6080	therm	2	0.0	0.440	0.300	4	5
01-110-0-Q	0.7609	therm	5	0.0	0.520	0.390	6	9
01-116-0-Q	0.8422	therm	5	15.9	0.630	0.340	8	

Connecting Barrier	HEI	Tbar	Dbar	IBV	Time Destroyed	Failure Type
4-126-0-E/1-112-0-Q	N/A	0.00	1.00	0.0000	7	dur
1-112-0-Q/01-110-0-Q	N/A	0.00	1.00	0.0000	27	dur
01-110-0-Q/01-116-0-Q	N/A	0.00	1.00	0.0000	37	dur

 Path no. 33 Path Length 3

Compt ID	Cum L	Ign Mode	EB Time	Compt Fuel	Therm IAM	Dur IAM	FRI Time	CBO
4-126-0-E	0.4400	orig	0	0.0	N/A	N/A	2	3
1-112-0-Q	0.6080	therm	2	0.0	0.440	0.300	4	5
01-116-0-Q	0.7797	therm	5	15.9	0.630	0.340	8	

Connecting Barrier	HEI	Tbar	Dbar	IBV	Time Destroyed	Failure Type
4-126-0-E/1-112-0-Q	N/A	0.00	1.00	0.0000	7	dur
1-112-0-Q/01-116-0-Q	N/A	0.34	0.66	0.0000	46	dur

 Path no. 34 Path Length 4

Compt ID	Cum L	Ign Mode	EB Time	Compt Fuel	Therm IAM	Dur IAM	FRI Time	CBO
4-126-0-E	0.4400	orig	0	0.0	N/A	N/A	2	3
1-112-0-Q	0.6080	therm	2	0.0	0.440	0.300	4	5
1-132-0A-L	0.9020	dur	2	10.0	0.840	0.750	15	
1-132-2-L	0.9754	dur	3	28.2	0.600	0.250	21	

Connecting Barrier	HEI	Tbar	Dbar	IBV	Time Destroyed	Failure Type
4-126-0-E/1-112-0-Q	N/A	0.00	1.00	0.0000	7	dur
1-112-0-Q/1-132-0A-L	N/A	0.00	1.00	0.0000	34	dur
1-132-0A-L/1-132-2-L	5.6	0.63	0.00	0.0365		therm

 Path no. 35 Path Length 4

Compt ID	Cum L	Ign Mode	EB Time	Compt Fuel	Therm IAM	Dur IAM	FRI Time	CBO
4-126-0-E	0.4400	orig	0	0.0	N/A	N/A	2	3
1-112-0-Q	0.6080	therm	2	0.0	0.440	0.300	4	5
1-132-0A-L	0.9020	dur	2	10.0	0.840	0.750	15	
1-74-2C-L	0.9885	dur	2	27.6	0.840	0.750	15	

Connecting Barrier	HEI	Tbar	Dbar	IBV	Time Destroyed	Failure Type
4-126-0-E/1-112-0-Q	N/A	0.00	1.00	0.0000	7	dur
1-112-0-Q/1-132-0A-L	N/A	0.00	1.00	0.0000	34	dur
1-132-0A-L/1-74-2C-L	6.9	0.73	0.00	0.0262		therm

 Path no. 36 Path Length 4

Compt ID	Cum L	Ign Mode	EB Time	Compt Fuel	Therm IAM	Dur IAM	FRI Time	CBO
4-126-0-E	0.4400	orig	0	0.0	N/A	N/A	2	3
1-112-0-Q	0.6080	therm	2	0.0	0.440	0.300	4	5
1-132-0A-L	0.9020	dur	2	10.0	0.840	0.750	15	
1-99-1B-L	0.9886	dur	2	26.1	0.840	0.750	15	

Connecting Barrier	HEI	Tbar	Dbar	IBV	Time Destroyed	Failure Type
4-126-0-E/1-112-0-Q	N/A	0.00	1.00	0.0000	7	dur
1-112-0-Q/1-132-0A-L	N/A	0.00	1.00	0.0000	34	dur
1-132-0A-L/1-99-1B-L	6.8	0.73	0.00	0.0264		therm

 Path no. 37 Path Length 4

Compt ID	Cum L	Ign Mode	EB Time	Compt Fuel	Therm IAM	Dur IAM	FRI Time	CBO
4-126-0-E	0.4400	orig	0	0.0	N/A	N/A	2	3
1-112-0-Q	0.6080	therm	2	0.0	0.440	0.300	4	5
1-132-0A-L	0.9020	dur	2	10.0	0.840	0.750	15	
1-132-0B-L	0.9755	dur	15	3.0	0.840	0.750	19	

Connecting Barrier	HEI	Tbar	Dbar	IBV	Time Destroyed	Failure Type
4-126-0-E/1-112-0-Q	N/A	0.00	1.00	0.0000	7	dur
1-112-0-Q/1-132-0A-L	N/A	0.00	1.00	0.0000	34	dur
1-132-0A-L/1-132-0B-L	0.0	0.00	1.00	0.0000	15	dur

 Path no. 38 Path Length 5

Compt ID	Cum L	Ign Mode	EB Time	Compt Fuel	Therm IAM	Dur IAM	FRI Time	CBO
4-126-0-E	0.4400	orig	0	0.0	N/A	N/A	2	3
1-112-0-Q	0.6080	therm	2	0.0	0.440	0.300	4	5
4-92-0A-E	0.7256	dur	4	0.0	0.440	0.300	5	9
1-74-2B-L	0.9314	dur	8	12.1	0.840	0.750	19	
1-92-2-Q	0.9554	therm	47	46.5	0.350	0.160	48	

Connecting Barrier	HEI	Tbar	Dbar	IBV	Time Destroyed	Failure Type
4-126-0-E/1-112-0-Q	N/A	0.00	1.00	0.0000	7	dur
1-112-0-Q/4-92-0A-E	N/A	0.00	1.00	0.0000	4	dur
4-92-0A-E/1-74-2B-L	N/A	0.00	1.00	0.0000	30	dur
1-74-2B-L/1-92-2-Q	18.8	1.00	0.00	0.0000		therm

 Path no. 39 Path Length 6

Compt ID	Cum L	Ign Mode	EB Time	Compt Fuel	Therm IAM	Dur IAM	FRI Time	CBO
4-126-0-E	0.4400	orig	0	0.0	N/A	N/A	2	3
1-112-0-Q	0.6080	therm	2	0.0	0.440	0.300	4	5
4-92-0A-E	0.7256	dur	4	0.0	0.440	0.300	5	9
1-74-2B-L	0.9314	dur	8	12.1	0.840	0.750	19	
1-92-2-Q	0.9554	therm	47	46.5	0.350	0.160	48	
1-92-0-Q	0.9826	dur	8	10.4	0.610	0.360	55	

Connecting Barrier	HEI	Tbar	Dbar	IBV	Time Destroyed	Failure Type
4-126-0-E/1-112-0-Q	N/A	0.00	1.00	0.0000	7	dur
1-112-0-Q/4-92-0A-E	N/A	0.00	1.00	0.0000	4	dur
4-92-0A-E/1-74-2B-L	N/A	0.00	1.00	0.0000	30	dur
1-74-2B-L/1-92-2-Q	18.8	1.00	0.00	0.0000		therm
1-92-2-Q/1-92-0-Q	12.1	1.00	0.00	0.0000		therm

 Path no. 40 Path Length 6

Compt ID	Cum L	Ign Mode	EB Time	Compt Fuel	Therm IAM	Dur IAM	FRI Time	CBO
4-126-0-E	0.4400	orig	0	0.0	N/A	N/A	2	3
1-112-0-Q	0.6080	therm	2	0.0	0.440	0.300	4	5
4-92-0A-E	0.7256	dur	4	0.0	0.440	0.300	5	9
1-74-2B-L	0.9314	dur	8	12.1	0.840	0.750	19	
1-92-2-Q	0.9554	therm	47	46.5	0.350	0.160	48	
1-79-0-Q	0.9826	therm	41	2.2	0.610	0.360	43	

Connecting Barrier	HEI	Tbar	Dbar	IBV	Time Destroyed	Failure Type
4-126-0-E/1-112-0-Q	N/A	0.00	1.00	0.0000	7	dur
1-112-0-Q/4-92-0A-E	N/A	0.00	1.00	0.0000	4	dur
4-92-0A-E/1-74-2B-L	N/A	0.00	1.00	0.0000	30	dur
1-74-2B-L/1-92-2-Q	18.8	1.00	0.00	0.0000		therm
1-92-2-Q/1-79-0-Q	15.8	1.00	0.00	0.0000		therm

 Path no. 41 Path Length 5

Compt ID	Cum L	Ign Mode	EB Time	Compt Fuel	Therm IAM	Dur IAM	FRI Time	CBO
4-126-0-E	0.4400	orig	0	0.0	N/A	N/A	2	3
1-112-0-Q	0.6080	therm	2	0.0	0.440	0.300	4	5
4-92-0A-E	0.7256	dur	4	0.0	0.440	0.300	5	9
1-74-2B-L	0.9314	dur	8	12.1	0.840	0.750	19	
1-106-2-L	0.9796	therm	28	44.5	0.550	0.300	50	

Connecting Barrier	HEI	Tbar	Dbar	IBV	Time Destroyed	Failure Type
4-126-0-E/1-112-0-Q	N/A	0.00	1.00	0.0000	7	dur
1-112-0-Q/4-92-0A-E	N/A	0.00	1.00	0.0000	4	dur
4-92-0A-E/1-74-2B-L	N/A	0.00	1.00	0.0000	30	dur
1-74-2B-L/1-106-2-L	3.5	0.66	0.00	0.0234		therm

 Path no. 42 Path Length 5

Compt ID	Cum L	Ign Mode	EB Time	Compt Fuel	Therm IAM	Dur IAM	FRI Time	CBO
4-126-0-E	0.4400	orig	0	0.0	N/A	N/A	2	3
1-112-0-Q	0.6080	therm	2	0.0	0.440	0.300	4	5
4-92-0A-E	0.7256	dur	4	0.0	0.440	0.300	5	9
1-74-2B-L	0.9314	dur	8	12.1	0.840	0.750	19	
1-74-2A-L	0.9829	dur	19	12.3	0.840	0.750	23	

Connecting Barrier	HEI	Tbar	Dbar	IBV	Time Destroyed	Failure Type
4-126-0-E/1-112-0-Q	N/A	0.00	1.00	0.0000	7	dur
1-112-0-Q/4-92-0A-E	N/A	0.00	1.00	0.0000	4	dur
4-92-0A-E/1-74-2B-L	N/A	0.00	1.00	0.0000	30	dur
1-74-2B-L/1-74-2A-L	0.2	0.00	1.00	0.0000	19	dur

 Path no. 43 Path Length 5

Compt ID	Cum L	Ign Mode	EB Time	Compt Fuel	Therm IAM	Dur IAM	FRI Time	CBO
4-126-0-E	0.4400	orig	0	0.0	N/A	N/A	2	3
1-112-0-Q	0.6080	therm	2	0.0	0.440	0.300	4	5
4-92-0A-E	0.7256	dur	4	0.0	0.440	0.300	5	9
1-74-2B-L	0.9314	dur	8	12.1	0.840	0.750	19	
01-93-2-L	0.9849	dur	19	1.7	0.870	0.780	23	

Connecting Barrier	HEI	Tbar	Dbar	IBV	Time Destroyed	Failure Type
4-126-0-E/1-112-0-Q	N/A	0.00	1.00	0.0000	7	dur

1-112-0-Q/4-92-0A-E	N/A	0.00	1.00	0.0000	4	dur
4-92-0A-E/1-74-2B-L	N/A	0.00	1.00	0.0000	30	dur
1-74-2B-L/01-93-2-L	0.8	0.00	1.00	0.0000	19	dur

 Path no. 44 Path Length 5

Compt ID	Cum L	Ign Mode	EB Time	Compt Fuel	Therm IAM	Dur IAM	FRI Time	CBO
4-126-0-E	0.4400	orig	0	0.0	N/A	N/A	2	3
1-112-0-Q	0.6080	therm	2	0.0	0.440	0.300	4	5
4-92-0A-E	0.7256	dur	4	0.0	0.440	0.300	5	9
1-92-0-Q	0.8244	dur	8	10.4	0.610	0.360	55	
01-82-0-L	0.9856	dur	8	47.0	0.420	0.170	55	

Connecting Barrier	HEI	Tbar	Dbar	IBV	Time Destroyed	Failure Type
4-126-0-E/1-112-0-Q	N/A	0.00	1.00	0.0000	7	dur
1-112-0-Q/4-92-0A-E	N/A	0.00	1.00	0.0000	4	dur
4-92-0A-E/1-92-0-Q	N/A	0.00	1.00	0.0000	41	dur
1-92-0-Q/01-82-0-L	N/A	0.14	0.00	0.1508		therm

 Path no. 45 Path Length 4

Compt ID	Cum L	Ign Mode	EB Time	Compt Fuel	Therm IAM	Dur IAM	FRI Time	CBO
4-126-0-E	0.4400	orig	0	0.0	N/A	N/A	2	3
1-112-0-Q	0.6080	therm	2	0.0	0.440	0.300	4	5
4-92-0A-E	0.7256	dur	4	0.0	0.440	0.300	5	9
01-82-0-L	0.7722	dur	8	47.0	0.420	0.170	55	

Connecting Barrier	HEI	Tbar	Dbar	IBV	Time Destroyed	Failure Type
4-126-0-E/1-112-0-Q	N/A	0.00	1.00	0.0000	7	dur
1-112-0-Q/4-92-0A-E	N/A	0.00	1.00	0.0000	4	dur
4-92-0A-E/01-82-0-L	N/A	0.00	1.00	0.0000	41	dur

 Path no. 46 Path Length 4

Compt ID	Cum L	Ign Mode	EB Time	Compt Fuel	Therm IAM	Dur IAM	FRI Time	CBO
4-126-0-E	0.4400	orig	0	0.0	N/A	N/A	2	3
1-112-0-Q	0.6080	therm	2	0.0	0.440	0.300	4	5
4-92-0A-E	0.7256	dur	4	0.0	0.440	0.300	5	9
01-95-0-L	0.9177	dur	8	7.4	0.880	0.700	55	

Connecting Time Failure

Barrier	HEI	Tbar	Dbar	IBV	Destroyed	Type
4-126-0-E/1-112-0-Q	N/A	0.00	1.00	0.0000	7	dur
1-112-0-Q/4-92-0A-E	N/A	0.00	1.00	0.0000	4	dur
4-92-0A-E/01-95-0-L	N/A	0.00	1.00	0.0000	41	dur

 Path no. 47 Path Length 5

Compt ID	Cum L	Ign Mode	EB Time	Compt Fuel	Therm IAM	Dur IAM	FRI Time	CBO
4-126-0-E	0.4400	orig	0	0.0	N/A	N/A	2	3
1-112-0-Q	0.6080	therm	2	0.0	0.440	0.300	4	5
4-92-0A-E	0.7256	dur	4	0.0	0.440	0.300	5	9
01-102-0-E	0.7832	therm	7	0.0	0.390	0.210	8	30
02-102-0-E	0.8678	therm	13	26.2	0.390	0.210	15	

Connecting Barrier	HEI	Tbar	Dbar	IBV	Time Destroyed	Failure Type
4-126-0-E/1-112-0-Q	N/A	0.00	1.00	0.0000	7	dur
1-112-0-Q/4-92-0A-E	N/A	0.00	1.00	0.0000	4	dur
4-92-0A-E/01-102-0-E	N/A	0.00	1.00	0.0000	23	dur
01-102-0-E/02-102-0-E	N/A	1.00	0.00	0.0000		therm

 Path no. 48 Path Length 5

Compt ID	Cum L	Ign Mode	EB Time	Compt Fuel	Therm IAM	Dur IAM	FRI Time	CBO
4-126-0-E	0.4400	orig	0	0.0	N/A	N/A	2	3
1-112-0-Q	0.6080	therm	2	0.0	0.440	0.300	4	5
4-92-0A-E	0.7256	dur	4	0.0	0.440	0.300	5	9
01-102-0-E	0.7832	therm	7	0.0	0.390	0.210	8	30
01-95-0-L	0.9636	dur	8	7.4	0.880	0.700	55	

Connecting Barrier	HEI	Tbar	Dbar	IBV	Time Destroyed	Failure Type
4-126-0-E/1-112-0-Q	N/A	0.00	1.00	0.0000	7	dur
1-112-0-Q/4-92-0A-E	N/A	0.00	1.00	0.0000	4	dur
4-92-0A-E/01-102-0-E	N/A	0.00	1.00	0.0000	23	dur
01-102-0-E/01-95-0-L	N/A	0.73	0.27	0.0000	57	therm

 Path no. 49 Path Length 5

Compt ID	Cum L	Ign Mode	EB Time	Compt Fuel	Therm IAM	Dur IAM	FRI Time	CBO
4-126-0-E	0.4400	orig	0	0.0	N/A	N/A	2	3
1-112-0-Q	0.6080	therm	2	0.0	0.440	0.300	4	5
4-92-0A-E	0.7256	dur	4	0.0	0.440	0.300	5	9

1-99-1A-L	0.9314	dur	8	11.9	0.840	0.750	19
1-93-1-L	0.9878	therm	43	52.5	0.390	0.210	59

Connecting Barrier	HEI	Tbar	Dbar	IBV	Time Destroyed	Failure Type
4-126-0-E/1-112-0-Q	N/A	0.00	1.00	0.0000	7	dur
1-112-0-Q/4-92-0A-E	N/A	0.00	1.00	0.0000	4	dur
4-92-0A-E/1-99-1A-L	N/A	0.00	1.00	0.0000	30	dur
1-99-1A-L/1-93-1-L	3.0	0.29	0.00	0.0486		therm

 Path no. 50 Path Length 6

Compt ID	Cum L	Ign Mode	EB Time	Compt Fuel	Therm IAM	Dur IAM	FRI Time	CBO
4-126-0-E	0.4400	orig	0	0.0	N/A	N/A	2	3
1-112-0-Q	0.6080	therm	2	0.0	0.440	0.300	4	5
4-92-0A-E	0.7256	dur	4	0.0	0.440	0.300	5	9
1-99-1A-L	0.9314	dur	8	11.9	0.840	0.750	19	
1-106-1-Q	0.9554	therm	47	0.0	0.350	0.160	48	49
1-93-1-L	0.9848	therm	43	52.5	0.390	0.210	59	

Connecting Barrier	HEI	Tbar	Dbar	IBV	Time Destroyed	Failure Type
4-126-0-E/1-112-0-Q	N/A	0.00	1.00	0.0000	7	dur
1-112-0-Q/4-92-0A-E	N/A	0.00	1.00	0.0000	4	dur
4-92-0A-E/1-99-1A-L	N/A	0.00	1.00	0.0000	30	dur
1-99-1A-L/1-106-1-Q	35.4	1.00	0.00	0.0000		therm
1-106-1-Q/1-93-1-L	9.7	0.56	0.00	0.0197		therm

 Path no. 51 Path Length 6

Compt ID	Cum L	Ign Mode	EB Time	Compt Fuel	Therm IAM	Dur IAM	FRI Time	CBO
4-126-0-E	0.4400	orig	0	0.0	N/A	N/A	2	3
1-112-0-Q	0.6080	therm	2	0.0	0.440	0.300	4	5
4-92-0A-E	0.7256	dur	4	0.0	0.440	0.300	5	9
1-99-1A-L	0.9314	dur	8	11.9	0.840	0.750	19	
1-106-1-Q	0.9554	therm	47	0.0	0.350	0.160	48	49
1-107-1-Q	0.9715	therm	47	0.0	0.360	0.170	48	49

Connecting Barrier	HEI	Tbar	Dbar	IBV	Time Destroyed	Failure Type
4-126-0-E/1-112-0-Q	N/A	0.00	1.00	0.0000	7	dur
1-112-0-Q/4-92-0A-E	N/A	0.00	1.00	0.0000	4	dur
4-92-0A-E/1-99-1A-L	N/A	0.00	1.00	0.0000	30	dur
1-99-1A-L/1-106-1-Q	35.4	1.00	0.00	0.0000		therm
1-106-1-Q/1-107-1-Q	12.1	1.00	0.00	0.0000		therm

Path no. 52 Path Length 6

Compt ID	Cum L	Ign Mode	EB Time	Compt Fuel	Therm IAM	Dur IAM	FRI Time	CBO
4-126-0-E	0.4400	orig	0	0.0	N/A	N/A	2	3
1-112-0-Q	0.6080	therm	2	0.0	0.440	0.300	4	5
4-92-0A-E	0.7256	dur	4	0.0	0.440	0.300	5	9
1-99-1A-L	0.9314	dur	8	11.9	0.840	0.750	19	
1-107-1-Q	0.9561	therm	47	0.0	0.360	0.170	48	49
1-110-1-Q	0.9862	therm	39	70.4	0.430	0.210	44	

Connecting Barrier	HEI	Tbar	Dbar	IBV	Time Destroyed	Failure Type
4-126-0-E/1-112-0-Q	N/A	0.00	1.00	0.0000	7	dur
1-112-0-Q/4-92-0A-E	N/A	0.00	1.00	0.0000	4	dur
4-92-0A-E/1-99-1A-L	N/A	0.00	1.00	0.0000	30	dur
1-99-1A-L/1-107-1-Q	20.1	1.00	0.00	0.0000		therm
1-107-1-Q/1-110-1-Q	18.4	0.55	0.00	0.0197		therm

Path no. 53 Path Length 5

Compt ID	Cum L	Ign Mode	EB Time	Compt Fuel	Therm IAM	Dur IAM	FRI Time	CBO
4-126-0-E	0.4400	orig	0	0.0	N/A	N/A	2	3
1-112-0-Q	0.6080	therm	2	0.0	0.440	0.300	4	5
4-92-0A-E	0.7256	dur	4	0.0	0.440	0.300	5	9
1-99-1A-L	0.9314	dur	8	11.9	0.840	0.750	19	
1-110-1-Q	0.9763	therm	39	70.4	0.430	0.210	44	

Connecting Barrier	HEI	Tbar	Dbar	IBV	Time Destroyed	Failure Type
4-126-0-E/1-112-0-Q	N/A	0.00	1.00	0.0000	7	dur
1-112-0-Q/4-92-0A-E	N/A	0.00	1.00	0.0000	4	dur
4-92-0A-E/1-99-1A-L	N/A	0.00	1.00	0.0000	30	dur
1-99-1A-L/1-110-1-Q	4.9	0.61	0.00	0.0270		therm

Path no. 54 Path Length 5

Compt ID	Cum L	Ign Mode	EB Time	Compt Fuel	Therm IAM	Dur IAM	FRI Time	CBO
4-126-0-E	0.4400	orig	0	0.0	N/A	N/A	2	3
1-112-0-Q	0.6080	therm	2	0.0	0.440	0.300	4	5
4-92-0A-E	0.7256	dur	4	0.0	0.440	0.300	5	9
1-99-1A-L	0.9314	dur	8	11.9	0.840	0.750	19	
1-70-3A-L	0.9458	dur	19	21.5	0.390	0.210	23	

Connecting Barrier	HEI	Tbar	Dbar	IBV	Time Destroyed	Failure Type
4-126-0-E/1-112-0-Q	N/A	0.00	1.00	0.0000	7	dur
1-112-0-Q/4-92-0A-E	N/A	0.00	1.00	0.0000	4	dur
4-92-0A-E/1-99-1A-L	N/A	0.00	1.00	0.0000	30	dur
1-99-1A-L/1-70-3A-L	0.2	0.00	1.00	0.0000	19	dur

 Path no. 55 Path Length 6

Compt ID	Cum L	Ign Mode	EB Time	Compt Fuel	Therm IAM	Dur IAM	FRI Time	CBO
4-126-0-E	0.4400	orig	0	0.0	N/A	N/A	2	3
1-112-0-Q	0.6080	therm	2	0.0	0.440	0.300	4	5
4-92-0A-E	0.7256	dur	4	0.0	0.440	0.300	5	9
1-99-1A-L	0.9314	dur	8	11.9	0.840	0.750	19	
1-70-3A-L	0.9458	dur	19	21.5	0.390	0.210	23	
1-93-1-L	0.9874	therm	43	52.5	0.390	0.210	59	

Connecting Barrier	HEI	Tbar	Dbar	IBV	Time Destroyed	Failure Type
4-126-0-E/1-112-0-Q	N/A	0.00	1.00	0.0000	7	dur
1-112-0-Q/4-92-0A-E	N/A	0.00	1.00	0.0000	4	dur
4-92-0A-E/1-99-1A-L	N/A	0.00	1.00	0.0000	30	dur
1-99-1A-L/1-70-3A-L	0.2	0.00	1.00	0.0000	19	dur
1-70-3A-L/1-93-1-L	N/A	0.38	0.00	0.0335		therm

 Path no. 56 Path Length 6

Compt ID	Cum L	Ign Mode	EB Time	Compt Fuel	Therm IAM	Dur IAM	FRI Time	CBO
4-126-0-E	0.4400	orig	0	0.0	N/A	N/A	2	3
1-112-0-Q	0.6080	therm	2	0.0	0.440	0.300	4	5
4-92-0A-E	0.7256	dur	4	0.0	0.440	0.300	5	9
1-99-1A-L	0.9314	dur	8	11.9	0.840	0.750	19	
1-70-3A-L	0.9458	dur	19	21.5	0.390	0.210	23	
1-79-0-Q	0.9880	therm	41	2.2	0.610	0.360	43	

Connecting Barrier	HEI	Tbar	Dbar	IBV	Time Destroyed	Failure Type
4-126-0-E/1-112-0-Q	N/A	0.00	1.00	0.0000	7	dur
1-112-0-Q/4-92-0A-E	N/A	0.00	1.00	0.0000	4	dur
4-92-0A-E/1-99-1A-L	N/A	0.00	1.00	0.0000	30	dur
1-99-1A-L/1-70-3A-L	0.2	0.00	1.00	0.0000	19	dur
1-70-3A-L/1-79-0-Q	N/A	0.57	0.00	0.0233		therm

 Path no. 57 Path Length 5

Compt ID	Cum L	Ign Mode	EB Time	Compt Fuel	Therm IAM	Dur IAM	FRI Time	CBO
4-126-0-E	0.4400	orig	0	0.0	N/A	N/A	2	3
1-112-0-Q	0.6080	therm	2	0.0	0.440	0.300	4	5
4-92-0A-E	0.7256	dur	4	0.0	0.440	0.300	5	9
1-99-1A-L	0.9314	dur	8	11.9	0.840	0.750	19	
01-95-1-L	0.9849	dur	19	1.7	0.870	0.780	23	

Connecting Barrier	HEI	Tbar	Dbar	IBV	Time Destroyed	Failure Type
4-126-0-E/1-112-0-Q	N/A	0.00	1.00	0.0000	7	dur
1-112-0-Q/4-92-0A-E	N/A	0.00	1.00	0.0000	4	dur
4-92-0A-E/1-99-1A-L	N/A	0.00	1.00	0.0000	30	dur
1-99-1A-L/01-95-1-L	0.8	0.00	1.00	0.0000	19	dur

 Path no. 58 Path Length 6

Compt ID	Cum L	Ign Mode	EB Time	Compt Fuel	Therm IAM	Dur IAM	FRI Time	CBO
4-126-0-E	0.4400	orig	0	0.0	N/A	N/A	2	3
1-112-0-Q	0.6080	therm	2	0.0	0.440	0.300	4	5
4-92-0A-E	0.7256	dur	4	0.0	0.440	0.300	5	9
01-110-0-Q	0.8326	therm	5	0.0	0.520	0.390	6	9
01-102-0-E	0.8678	therm	7	0.0	0.390	0.210	8	30
02-102-0-E	0.9193	therm	13	26.2	0.390	0.210	15	

Connecting Barrier	HEI	Tbar	Dbar	IBV	Time Destroyed	Failure Type
4-126-0-E/1-112-0-Q	N/A	0.00	1.00	0.0000	7	dur
1-112-0-Q/4-92-0A-E	N/A	0.00	1.00	0.0000	4	dur
4-92-0A-E/01-110-0-Q	N/A	0.00	1.00	0.0000	26	dur
01-110-0-Q/01-102-0-E	N/A	0.00	1.00	0.0000	28	dur
01-102-0-E/02-102-0-E	N/A	1.00	0.00	0.0000		therm

 Path no. 59 Path Length 6

Compt ID	Cum L	Ign Mode	EB Time	Compt Fuel	Therm IAM	Dur IAM	FRI Time	CBO
4-126-0-E	0.4400	orig	0	0.0	N/A	N/A	2	3
1-112-0-Q	0.6080	therm	2	0.0	0.440	0.300	4	5
4-92-0A-E	0.7256	dur	4	0.0	0.440	0.300	5	9
01-110-0-Q	0.8326	therm	5	0.0	0.520	0.390	6	9
01-102-0-E	0.8678	therm	7	0.0	0.390	0.210	8	30
01-95-0-L	0.9778	dur	8	7.4	0.880	0.700	55	

Connecting Time Failure

Barrier	HEI	Tbar	Dbar	IBV	Destroyed	Type
4-126-0-E/1-112-0-Q	N/A	0.00	1.00	0.0000	7	dur
1-112-0-Q/4-92-0A-E	N/A	0.00	1.00	0.0000	4	dur
4-92-0A-E/01-110-0-Q	N/A	0.00	1.00	0.0000	26	dur
01-110-0-Q/01-102-0-E	N/A	0.00	1.00	0.0000	28	dur
01-102-0-E/01-95-0-L	N/A	0.73	0.27	0.0000	57	therm

 Path no. 60 Path Length 5

Compt ID	Cum L	Ign Mode	EB Time	Compt Fuel	Therm IAM	Dur IAM	FRI Time	CBO
4-126-0-E	0.4400	orig	0	0.0	N/A	N/A	2	3
1-112-0-Q	0.6080	therm	2	0.0	0.440	0.300	4	5
4-92-0A-E	0.7256	dur	4	0.0	0.440	0.300	5	9
01-110-0-Q	0.8326	therm	5	0.0	0.520	0.390	6	9
01-116-0-Q	0.8895	therm	5	15.9	0.630	0.340	8	

Connecting Barrier	HEI	Tbar	Dbar	IBV	Time Destroyed	Failure Type
4-126-0-E/1-112-0-Q	N/A	0.00	1.00	0.0000	7	dur
1-112-0-Q/4-92-0A-E	N/A	0.00	1.00	0.0000	4	dur
4-92-0A-E/01-110-0-Q	N/A	0.00	1.00	0.0000	26	dur
01-110-0-Q/01-116-0-Q	N/A	0.00	1.00	0.0000	37	dur

 Path no. 61 Path Length 5

Compt ID	Cum L	Ign Mode	EB Time	Compt Fuel	Therm IAM	Dur IAM	FRI Time	CBO
4-126-0-E	0.4400	orig	0	0.0	N/A	N/A	2	3
1-112-0-Q	0.6080	therm	2	0.0	0.440	0.300	4	5
4-92-0A-E	0.7256	dur	4	0.0	0.440	0.300	5	9
4-92-0-E	0.7969	therm	5	9.3	0.480	0.260	8	
1-92-2-Q	0.8738	therm	47	46.5	0.350	0.160	48	

Connecting Barrier	HEI	Tbar	Dbar	IBV	Time Destroyed	Failure Type
4-126-0-E/1-112-0-Q	N/A	0.00	1.00	0.0000	7	dur
1-112-0-Q/4-92-0A-E	N/A	0.00	1.00	0.0000	4	dur
4-92-0A-E/4-92-0-E	N/A	0.00	1.00	0.0000	8	dur
4-92-0-E/1-92-2-Q	18.4	0.96	0.00	0.0089		therm

 Path no. 62 Path Length 5

Compt ID	Cum L	Ign Mode	EB Time	Compt Fuel	Therm IAM	Dur IAM	FRI Time	CBO
4-126-0-E	0.4400	orig	0	0.0	N/A	N/A	2	3

1-112-0-Q	0.6080	therm	2	0.0	0.440	0.300	4	5
4-92-0A-E	0.7256	dur	4	0.0	0.440	0.300	5	9
4-92-0-E	0.7969	therm	5	9.3	0.480	0.260	8	
1-106-1-Q	0.8680	therm	47	0.0	0.350	0.160	48	49

Connecting Barrier	HEI	Tbar	Dbar	IBV	Time Destroyed	Failure Type
4-126-0-E/1-112-0-Q	N/A	0.00	1.00	0.0000	7	dur
1-112-0-Q/4-92-0A-E	N/A	0.00	1.00	0.0000	4	dur
4-92-0A-E/4-92-0-E	N/A	0.00	1.00	0.0000	8	dur
4-92-0-E/1-106-1-Q	35.6	1.00	0.00	0.0000		therm

 Path no. 63 Path Length 5

Compt ID	Cum L	Ign Mode	EB Time	Compt Fuel	Therm IAM	Dur IAM	FRI Time	CBO
4-126-0-E	0.4400	orig	0	0.0	N/A	N/A	2	3
1-112-0-Q	0.6080	therm	2	0.0	0.440	0.300	4	5
4-92-0A-E	0.7256	dur	4	0.0	0.440	0.300	5	9
4-92-0-E	0.7969	therm	5	9.3	0.480	0.260	8	
1-107-1-Q	0.8700	therm	47	0.0	0.360	0.170	48	49

Connecting Barrier	HEI	Tbar	Dbar	IBV	Time Destroyed	Failure Type
4-126-0-E/1-112-0-Q	N/A	0.00	1.00	0.0000	7	dur
1-112-0-Q/4-92-0A-E	N/A	0.00	1.00	0.0000	4	dur
4-92-0A-E/4-92-0-E	N/A	0.00	1.00	0.0000	8	dur
4-92-0-E/1-107-1-Q	20.2	1.00	0.00	0.0000		therm

 Path no. 64 Path Length 5

Compt ID	Cum L	Ign Mode	EB Time	Compt Fuel	Therm IAM	Dur IAM	FRI Time	CBO
4-126-0-E	0.4400	orig	0	0.0	N/A	N/A	2	3
1-112-0-Q	0.6080	therm	2	0.0	0.440	0.300	4	5
4-92-0A-E	0.7256	dur	4	0.0	0.440	0.300	5	9
4-92-0-E	0.7969	therm	5	9.3	0.480	0.260	8	
1-112-0-Q	0.8579	therm	2	0.0	0.440	0.300	4	5

Connecting Barrier	HEI	Tbar	Dbar	IBV	Time Destroyed	Failure Type
4-126-0-E/1-112-0-Q	N/A	0.00	1.00	0.0000	7	dur
1-112-0-Q/4-92-0A-E	N/A	0.00	1.00	0.0000	4	dur
4-92-0A-E/4-92-0-E	N/A	0.00	1.00	0.0000	8	dur
4-92-0-E/1-112-0-Q	122.8	0.00	1.00	0.0000	30	dur

Path no. 65 Path Length 3

Compt ID	Cum L	Ign Mode	EB Time	Compt Fuel	Therm IAM	Dur IAM	FRI Time	CBO
4-126-0-E	0.4400	orig	0	0.0	N/A	N/A	2	3
1-132-0A-L	0.8600	dur	2	10.0	0.840	0.750	15	
1-132-2-L	0.9648	dur	3	28.2	0.600	0.250	21	

Connecting Barrier	HEI	Tbar	Dbar	IBV	Time Destroyed	Failure Type
4-126-0-E/1-132-0A-L	N/A	0.00	1.00	0.0000	9	dur
1-132-0A-L/1-132-2-L	5.6	0.63	0.00	0.0521		therm

Path no. 66 Path Length 3

Compt ID	Cum L	Ign Mode	EB Time	Compt Fuel	Therm IAM	Dur IAM	FRI Time	CBO
4-126-0-E	0.4400	orig	0	0.0	N/A	N/A	2	3
1-132-0A-L	0.8600	dur	2	10.0	0.840	0.750	15	
1-74-2C-L	0.9836	dur	2	27.6	0.840	0.750	15	

Connecting Barrier	HEI	Tbar	Dbar	IBV	Time Destroyed	Failure Type
4-126-0-E/1-132-0A-L	N/A	0.00	1.00	0.0000	9	dur
1-132-0A-L/1-74-2C-L	6.9	0.73	0.00	0.0374		therm

Path no. 67 Path Length 3

Compt ID	Cum L	Ign Mode	EB Time	Compt Fuel	Therm IAM	Dur IAM	FRI Time	CBO
4-126-0-E	0.4400	orig	0	0.0	N/A	N/A	2	3
1-132-0A-L	0.8600	dur	2	10.0	0.840	0.750	15	
1-99-1B-L	0.9836	dur	2	26.1	0.840	0.750	15	

Connecting Barrier	HEI	Tbar	Dbar	IBV	Time Destroyed	Failure Type
4-126-0-E/1-132-0A-L	N/A	0.00	1.00	0.0000	9	dur
1-132-0A-L/1-99-1B-L	6.8	0.73	0.00	0.0378		therm

Path no. 68 Path Length 3

Compt ID	Cum L	Ign Mode	EB Time	Compt Fuel	Therm IAM	Dur IAM	FRI Time	CBO
4-126-0-E	0.4400	orig	0	0.0	N/A	N/A	2	3

1-132-0A-L	0.8600	dur	2	10.0	0.840	0.750	15
1-132-0B-L	0.9650	dur	15	3.0	0.840	0.750	19

Connecting Barrier	HEI	Tbar	Dbar	IBV	Time Destroyed	Failure Type
4-126-0-E/1-132-0A-L	N/A	0.00	1.00	0.0000	9	dur
1-132-0A-L/1-132-0B-L	0.0	0.00	1.00	0.0000	15	dur

□
□
□
□
□

HORNBEAM

06/24/97

MODEL RUN 9-67

PATH OPTION - SUMMARY LEVEL REPORT

LISTING OF ALL PATHS FROM 1-112-0-Q

READINESS CONDITION . YOKE
 CONFIGURATION Passive
 CASE. Worst
 ASSUMED LOCATION. . . at SEA
 RUN TIME. 60 minutes
 COMMENTS.
 Baseline, At Sea M Values

```

*****
PATHS FROM 1-112-0-Q
*****

```

					CUM L
1.	4-126-0-E	2-126-1-Q			0.7845
2.	4-126-0-E	2-126-2-Q	1-74-2C-L	1-74-2B-L	0.9882
3.	4-126-0-E	2-126-2-Q	1-124-2-L	1-132-0A-L	0.9892
4.	4-126-0-E	2-126-2-Q	1-124-2-L	1-74-2C-L	0.9846
5.	4-126-0-E	2-126-2-Q	1-132-0A-L		0.9527
6.	4-126-0-E	2-126-2-Q	1-132-0A-L	1-132-0B-L	0.9882
7.	4-126-0-E	2-126-2-Q	1-132-2-L	1-124-2-L	0.9576
8.	4-126-0-E	1-74-2C-L	1-106-2-L		0.9887
9.	4-126-0-E	1-74-2C-L	1-74-2B-L		0.9818
10.	4-126-0-E	1-99-1B-L	1-110-1-Q		0.9852
11.	4-126-0-E	1-99-1B-L	1-99-1A-L	1-106-1-Q	0.9882
12.	4-126-0-E	1-99-1B-L	1-99-1A-L	1-70-3A-L	0.9856
13.	4-126-0-E	1-132-0A-L	1-132-2-L		0.9848
14.	4-126-0-E	1-132-0A-L	1-132-0B-L		0.9818
15.	1-74-2C-L	1-106-2-L			0.9784
16.	1-74-2C-L	1-74-2B-L	1-92-2-Q		0.9878
17.	1-99-1B-L	1-110-1-Q			0.9716
18.	1-99-1B-L	1-124-1-L			0.9869
19.	1-99-1B-L	1-99-1A-L	1-106-1-Q	1-107-1-Q	0.9854
20.	1-99-1B-L	1-99-1A-L	1-107-1-Q		0.9833
21.	1-99-1B-L	1-99-1A-L	1-70-3A-L		0.9724
22.	01-110-0-Q	01-102-0-E	02-102-0-E		0.8354
23.	01-110-0-Q	01-102-0-E	01-95-0-L		0.9487
24.	01-110-0-Q	01-116-0-Q			0.7745
25.	01-116-0-Q				0.6728
26.	1-132-0A-L	1-132-2-L			0.9708
27.	1-132-0A-L	1-74-2C-L			0.9864
28.	1-132-0A-L	1-99-1B-L			0.9864
29.	1-132-0A-L	1-132-0B-L			0.9650
30.	4-92-0A-E	1-74-2B-L	1-92-2-Q		0.9659
31.	4-92-0A-E	1-74-2B-L	1-106-2-L		0.9867
32.	4-92-0A-E	1-74-2B-L	1-74-2A-L		0.9755
33.	4-92-0A-E	1-74-2B-L	01-93-2-L		0.9784

34.	4-92-0A-E	1-92-0-Q	01-82-0-L		0.9645
35.	4-92-0A-E	1-92-0-Q	1-70-3A-L		0.9520
36.	4-92-0A-E	01-82-0-L	01-93-2-L		0.9883
37.	4-92-0A-E	01-82-0-L	01-95-1-L		0.9883
38.	4-92-0A-E	01-95-0-L			0.8824
39.	4-92-0A-E	01-102-0-E	02-102-0-E		0.8111
40.	4-92-0A-E	01-102-0-E	01-95-0-L		0.9412
41.	4-92-0A-E	1-99-1A-L	1-106-1-Q	1-93-1-L	0.9783
42.	4-92-0A-E	1-99-1A-L	1-106-1-Q	1-107-1-Q	0.9592
43.	4-92-0A-E	1-99-1A-L	1-107-1-Q	1-110-1-Q	0.9853
44.	4-92-0A-E	1-99-1A-L	1-110-1-Q		0.9821
45.	4-92-0A-E	1-99-1A-L	1-70-3A-L		0.9226
46.	4-92-0A-E	1-99-1A-L	01-95-1-L		0.9784
47.	4-92-0A-E	01-110-0-Q	01-102-0-E	02-102-0-E	0.8848
48.	4-92-0A-E	01-110-0-Q	01-102-0-E	01-95-0-L	0.9641
49.	4-92-0A-E	01-110-0-Q	01-116-0-Q		0.8422
50.	4-92-0A-E	4-92-0-E	1-107-1-Q		0.9744
51.	4-92-0A-E	4-92-0-E	1-106-1-Q		0.9327

-
-
-

HORNBEAM

06/24/97

MODEL RUN 9-67

PATH OPTION - DETAIL LEVEL REPORT

INFORMATION ON ALL PATHS FROM 1-112-0-Q

READINESS CONDITION . YOKE
 CONFIGURATION Passive
 CASE. Worst
 ASSUMED LOCATION. . . at SEA
 RUN TIME. 60 minutes
 COMMENTS.
 Baseline, At Sea M Values

 Path no. 1 Path Length 3

Compt ID	Cum L	Ign Mode	EB Time	Compt Fuel	Therm IAM	Dur IAM	FRI Time	CBO
1-112-0-Q	0.4400	orig	0	1.5	N/A	N/A	2	3
4-126-0-E	0.7088	therm	9	0.0	0.480	0.260	11	12
2-126-1-Q	0.7845	dur	11	21.5	0.480	0.260	12	

Connecting Barrier	HEI	Tbar	Dbar	IBV	Time Destroyed	Failure Type
1-112-0-Q/4-126-0-E	N/A	1.00	0.00	0.0000	14	dur
4-126-0-E/2-126-1-Q	N/A	0.00	1.00	0.0000	11	dur

 Path no. 2 Path Length 5

Compt ID	Cum L	Ign Mode	EB Time	Compt Fuel	Therm IAM	Dur IAM	FRI Time	CBO
1-112-0-Q	0.4400	orig	0	1.5	N/A	N/A	2	3
4-126-0-E	0.7088	therm	9	0.0	0.480	0.260	11	12
2-126-2-Q	0.8107	dur	11	0.0	0.500	0.350	12	16
1-74-2C-L	0.9527	dur	3	29.2	0.840	0.750	25	
1-74-2B-L	0.9882	dur	6	12.6	0.840	0.750	29	

Connecting Barrier	HEI	Tbar	Dbar	IBV	Time Destroyed	Failure Type
1-112-0-Q/4-126-0-E	N/A	1.00	0.00	0.0000	14	dur
4-126-0-E/2-126-2-Q	N/A	0.00	1.00	0.0000	11	dur
2-126-2-Q/1-74-2C-L	N/A	0.00	1.00	0.0000	23	dur
1-74-2C-L/1-74-2B-L	0.2	0.00	1.00	0.0000	25	dur

 Path no. 3 Path Length 5

Compt ID	Cum L	Ign Mode	EB Time	Compt Fuel	Therm IAM	Dur IAM	FRI Time	CBO
1-112-0-Q	0.4400	orig	0	1.5	N/A	N/A	2	3
4-126-0-E	0.7088	therm	9	0.0	0.480	0.260	11	12
2-126-2-Q	0.8107	dur	11	0.0	0.500	0.350	12	16
1-124-2-L	0.8675	dur	12	30.3	0.550	0.300	30	
1-132-0A-L	0.9892	dur	3	10.6	0.840	0.750	25	

Connecting Barrier	HEI	Tbar	Dbar	IBV	Time Destroyed	Failure Type
1-112-0-Q/4-126-0-E	N/A	1.00	0.00	0.0000	14	dur
4-126-0-E/2-126-2-Q	N/A	0.00	1.00	0.0000	11	dur
2-126-2-Q/1-124-2-L	N/A	0.00	1.00	0.0000	23	dur
1-124-2-L/1-132-0A-L	4.1	0.51	0.00	0.0652		therm

 Path no. 4 Path Length 5

Compt ID	Cum L	Ign Mode	EB Time	Compt Fuel	Therm IAM	Dur IAM	FRI Time	CBO
1-112-0-Q	0.4400	orig	0	1.5	N/A	N/A	2	3
4-126-0-E	0.7088	therm	9	0.0	0.480	0.260	11	12
2-126-2-Q	0.8107	dur	11	0.0	0.500	0.350	12	16
1-124-2-L	0.8675	dur	12	30.3	0.550	0.300	30	
1-74-2C-L	0.9846	dur	3	29.2	0.840	0.750	25	

Connecting Barrier	HEI	Tbar	Dbar	IBV	Time Destroyed	Failure Type
1-112-0-Q/4-126-0-E	N/A	1.00	0.00	0.0000	14	dur
4-126-0-E/2-126-2-Q	N/A	0.00	1.00	0.0000	11	dur
2-126-2-Q/1-124-2-L	N/A	0.00	1.00	0.0000	23	dur
1-124-2-L/1-74-2C-L	6.7	0.73	0.00	0.0362		therm

 Path no. 5 Path Length 4

Compt ID	Cum L	Ign Mode	EB Time	Compt Fuel	Therm IAM	Dur IAM	FRI Time	CBO
1-112-0-Q	0.4400	orig	0	1.5	N/A	N/A	2	3
4-126-0-E	0.7088	therm	9	0.0	0.480	0.260	11	12
2-126-2-Q	0.8107	dur	11	0.0	0.500	0.350	12	16
1-132-0A-L	0.9527	dur	3	10.6	0.840	0.750	25	

Connecting Barrier	HEI	Tbar	Dbar	IBV	Time Destroyed	Failure Type
--------------------	-----	------	------	-----	----------------	--------------

1-112-0-Q/4-126-0-E	N/A	1.00	0.00	0.0000	14	dur
4-126-0-E/2-126-2-Q	N/A	0.00	1.00	0.0000	11	dur
2-126-2-Q/1-132-0A-L	N/A	0.00	1.00	0.0000	23	dur

Path no. 6 Path Length 5

Compt ID	Cum L	Ign Mode	EB Time	Compt Fuel	Therm IAM	Dur IAM	FRI Time	CBO
1-112-0-Q	0.4400	orig	0	1.5	N/A	N/A	2	3
4-126-0-E	0.7088	therm	9	0.0	0.480	0.260	11	12
2-126-2-Q	0.8107	dur	11	0.0	0.500	0.350	12	16
1-132-0A-L	0.9527	dur	3	10.6	0.840	0.750	25	
1-132-0B-L	0.9882	dur	25	3.1	0.840	0.750	29	

Connecting Barrier	HEI	Tbar	Dbar	IBV	Time Destroyed	Failure Type
1-112-0-Q/4-126-0-E	N/A	1.00	0.00	0.0000	14	dur
4-126-0-E/2-126-2-Q	N/A	0.00	1.00	0.0000	11	dur
2-126-2-Q/1-132-0A-L	N/A	0.00	1.00	0.0000	23	dur
1-132-0A-L/1-132-0B-L	0.0	0.00	1.00	0.0000	25	dur

Path no. 7 Path Length 5

Compt ID	Cum L	Ign Mode	EB Time	Compt Fuel	Therm IAM	Dur IAM	FRI Time	CBO
1-112-0-Q	0.4400	orig	0	1.5	N/A	N/A	2	3
4-126-0-E	0.7088	therm	9	0.0	0.480	0.260	11	12
2-126-2-Q	0.8107	dur	11	0.0	0.500	0.350	12	16
1-132-2-L	0.8580	dur	12	29.1	0.600	0.250	30	
1-124-2-L	0.9576	dur	12	30.3	0.550	0.300	30	

Connecting Barrier	HEI	Tbar	Dbar	IBV	Time Destroyed	Failure Type
1-112-0-Q/4-126-0-E	N/A	1.00	0.00	0.0000	14	dur
4-126-0-E/2-126-2-Q	N/A	0.00	1.00	0.0000	11	dur
2-126-2-Q/1-132-2-L	N/A	0.00	1.00	0.0000	23	dur
1-132-2-L/1-124-2-L	6.1	0.66	0.00	0.0477		therm

Path no. 8 Path Length 4

Compt ID	Cum L	Ign Mode	EB Time	Compt Fuel	Therm IAM	Dur IAM	FRI Time	CBO
1-112-0-Q	0.4400	orig	0	1.5	N/A	N/A	2	3
4-126-0-E	0.7088	therm	9	0.0	0.480	0.260	11	12
1-74-2C-L	0.9272	dur	3	29.2	0.840	0.750	25	
1-106-2-L	0.9887	therm	38	44.7	0.550	0.300	60	

Connecting Barrier	HEI	Tbar	Dbar	IBV	Time Destroyed	Failure Type
1-112-0-Q/4-126-0-E	N/A	1.00	0.00	0.0000	14	dur
4-126-0-E/1-74-2C-L	N/A	0.00	1.00	0.0000	18	dur
1-74-2C-L/1-106-2-L	2.1	0.34	0.00	0.0478		therm

 Path no. 9 Path Length 4

Compt ID	Cum L	Ign Mode	EB Time	Compt Fuel	Therm IAM	Dur IAM	FRI Time	CBO
1-112-0-Q	0.4400	orig	0	1.5	N/A	N/A	2	3
4-126-0-E	0.7088	therm	9	0.0	0.480	0.260	11	12
1-74-2C-L	0.9272	dur	3	29.2	0.840	0.750	25	
1-74-2B-L	0.9818	dur	6	12.6	0.840	0.750	29	

Connecting Barrier	HEI	Tbar	Dbar	IBV	Time Destroyed	Failure Type
1-112-0-Q/4-126-0-E	N/A	1.00	0.00	0.0000	14	dur
4-126-0-E/1-74-2C-L	N/A	0.00	1.00	0.0000	18	dur
1-74-2C-L/1-74-2B-L	0.2	0.00	1.00	0.0000	25	dur

 Path no. 10 Path Length 4

Compt ID	Cum L	Ign Mode	EB Time	Compt Fuel	Therm IAM	Dur IAM	FRI Time	CBO
1-112-0-Q	0.4400	orig	0	1.5	N/A	N/A	2	3
4-126-0-E	0.7088	therm	9	0.0	0.480	0.260	11	12
1-99-1B-L	0.9272	dur	3	28.2	0.840	0.750	25	
1-110-1-Q	0.9852	therm	49	70.8	0.430	0.210	54	

Connecting Barrier	HEI	Tbar	Dbar	IBV	Time Destroyed	Failure Type
1-112-0-Q/4-126-0-E	N/A	1.00	0.00	0.0000	14	dur
4-126-0-E/1-99-1B-L	N/A	0.00	1.00	0.0000	18	dur
1-99-1B-L/1-110-1-Q	3.0	0.36	0.00	0.0468		therm

 Path no. 11 Path Length 5

Compt ID	Cum L	Ign Mode	EB Time	Compt Fuel	Therm IAM	Dur IAM	FRI Time	CBO
1-112-0-Q	0.4400	orig	0	1.5	N/A	N/A	2	3
4-126-0-E	0.7088	therm	9	0.0	0.480	0.260	11	12
1-99-1B-L	0.9272	dur	3	28.2	0.840	0.750	25	
1-99-1A-L	0.9818	dur	6	12.5	0.840	0.750	29	

1-106-1-Q 0.9882 therm 57 0.0 0.350 0.160 58 59

Connecting Barrier	HEI	Tbar	Dbar	IBV	Time Destroyed	Failure Type
1-112-0-Q/4-126-0-E	N/A	1.00	0.00	0.0000	14	dur
4-126-0-E/1-99-1B-L	N/A	0.00	1.00	0.0000	18	dur
1-99-1B-L/1-99-1A-L	0.2	0.00	1.00	0.0000	25	dur
1-99-1A-L/1-106-1-Q	11.3	1.00	0.00	0.0000		therm

 Path no. 12 Path Length 5

Compt ID	Cum L	Ign Mode	EB Time	Compt Fuel	Therm IAM	Dur IAM	FRI Time	CBO
1-112-0-Q	0.4400	orig	0	1.5	N/A	N/A	2	3
4-126-0-E	0.7088	therm	9	0.0	0.480	0.260	11	12
1-99-1B-L	0.9272	dur	3	28.2	0.840	0.750	25	
1-99-1A-L	0.9818	dur	6	12.5	0.840	0.750	29	
1-70-3A-L	0.9856	dur	29	22.3	0.390	0.210	33	

Connecting Barrier	HEI	Tbar	Dbar	IBV	Time Destroyed	Failure Type
1-112-0-Q/4-126-0-E	N/A	1.00	0.00	0.0000	14	dur
4-126-0-E/1-99-1B-L	N/A	0.00	1.00	0.0000	18	dur
1-99-1B-L/1-99-1A-L	0.2	0.00	1.00	0.0000	25	dur
1-99-1A-L/1-70-3A-L	0.2	0.00	1.00	0.0000	29	dur

 Path no. 13 Path Length 4

Compt ID	Cum L	Ign Mode	EB Time	Compt Fuel	Therm IAM	Dur IAM	FRI Time	CBO
1-112-0-Q	0.4400	orig	0	1.5	N/A	N/A	2	3
4-126-0-E	0.7088	therm	9	0.0	0.480	0.260	11	12
1-132-0A-L	0.9272	dur	3	10.6	0.840	0.750	25	
1-132-2-L	0.9848	dur	12	29.1	0.600	0.250	30	

Connecting Barrier	HEI	Tbar	Dbar	IBV	Time Destroyed	Failure Type
1-112-0-Q/4-126-0-E	N/A	1.00	0.00	0.0000	14	dur
4-126-0-E/1-132-0A-L	N/A	0.00	1.00	0.0000	18	dur
1-132-0A-L/1-132-2-L	4.3	0.52	0.00	0.0348		therm

 Path no. 14 Path Length 4

Compt ID	Cum L	Ign Mode	EB Time	Compt Fuel	Therm IAM	Dur IAM	FRI Time	CBO
----------	-------	----------	---------	------------	-----------	---------	----------	-----

1-112-0-Q	0.4400	orig	0	1.5	N/A	N/A	2	3
4-126-0-E	0.7088	therm	9	0.0	0.480	0.260	11	12
1-132-0A-L	0.9272	dur	3	10.6	0.840	0.750	25	
1-132-0B-L	0.9818	dur	25	3.1	0.840	0.750	29	

Connecting Barrier	HEI	Tbar	Dbar	IBV	Time Destroyed	Failure Type
1-112-0-Q/4-126-0-E	N/A	1.00	0.00	0.0000	14	dur
4-126-0-E/1-132-0A-L	N/A	0.00	1.00	0.0000	18	dur
1-132-0A-L/1-132-0B-L	0.0	0.00	1.00	0.0000	25	dur

Path no. 15 Path Length 3

Compt ID	Cum L	Ign Mode	EB Time	Compt Fuel	Therm IAM	Dur IAM	FRI Time	CBO
1-112-0-Q	0.4400	orig	0	1.5	N/A	N/A	2	3
1-74-2C-L	0.8600	dur	3	29.2	0.840	0.750	25	
1-106-2-L	0.9784	therm	38	44.7	0.550	0.300	60	

Connecting Barrier	HEI	Tbar	Dbar	IBV	Time Destroyed	Failure Type
1-112-0-Q/1-74-2C-L	N/A	0.00	1.00	0.0000	37	dur
1-74-2C-L/1-106-2-L	2.1	0.34	0.00	0.0919		therm

Path no. 16 Path Length 4

Compt ID	Cum L	Ign Mode	EB Time	Compt Fuel	Therm IAM	Dur IAM	FRI Time	CBO
1-112-0-Q	0.4400	orig	0	1.5	N/A	N/A	2	3
1-74-2C-L	0.8600	dur	3	29.2	0.840	0.750	25	
1-74-2B-L	0.9650	dur	6	12.6	0.840	0.750	29	
1-92-2-Q	0.9878	therm	57	52.8	0.350	0.160	58	

Connecting Barrier	HEI	Tbar	Dbar	IBV	Time Destroyed	Failure Type
1-112-0-Q/1-74-2C-L	N/A	0.00	1.00	0.0000	37	dur
1-74-2C-L/1-74-2B-L	0.2	0.00	1.00	0.0000	25	dur
1-74-2B-L/1-92-2-Q	5.1	0.54	0.00	0.0163		therm

Path no. 17 Path Length 3

Compt ID	Cum L	Ign Mode	EB Time	Compt Fuel	Therm IAM	Dur IAM	FRI Time	CBO
1-112-0-Q	0.4400	orig	0	1.5	N/A	N/A	2	3
1-99-1B-L	0.8600	dur	3	28.2	0.840	0.750	25	

1-110-1-Q 0.9716 therm 49 70.8 0.430 0.210 54

Connecting Barrier	HEI	Tbar	Dbar	IBV	Time Destroyed	Failure Type
1-112-0-Q/1-99-1B-L	N/A	0.00	1.00	0.0000	37	dur
1-99-1B-L/1-110-1-Q	3.0	0.36	0.00	0.0901		therm

 Path no. 18 Path Length 3

Compt ID	Cum L	Ign Mode	EB Time	Compt Fuel	Therm IAM	Dur IAM	FRI Time	CBO
1-112-0-Q	0.4400	orig	0	1.5	N/A	N/A	2	3
1-99-1B-L	0.8600	dur	3	28.2	0.840	0.750	25	
1-124-1-L	0.9869	therm	49	33.2	0.550	0.300		

Connecting Barrier	HEI	Tbar	Dbar	IBV	Time Destroyed	Failure Type
1-112-0-Q/1-99-1B-L	N/A	0.00	1.00	0.0000	37	dur
1-99-1B-L/1-124-1-L	2.0	0.21	0.00	0.1109		therm

 Path no. 19 Path Length 5

Compt ID	Cum L	Ign Mode	EB Time	Compt Fuel	Therm IAM	Dur IAM	FRI Time	CBO
1-112-0-Q	0.4400	orig	0	1.5	N/A	N/A	2	3
1-99-1B-L	0.8600	dur	3	28.2	0.840	0.750	25	
1-99-1A-L	0.9650	dur	6	12.5	0.840	0.750	29	
1-106-1-Q	0.9773	therm	57	0.0	0.350	0.160	58	59
1-107-1-Q	0.9854	therm	57	0.0	0.360	0.170	58	59

Connecting Barrier	HEI	Tbar	Dbar	IBV	Time Destroyed	Failure Type
1-112-0-Q/1-99-1B-L	N/A	0.00	1.00	0.0000	37	dur
1-99-1B-L/1-99-1A-L	0.2	0.00	1.00	0.0000	25	dur
1-99-1A-L/1-106-1-Q	11.3	1.00	0.00	0.0000		therm
1-106-1-Q/1-107-1-Q	12.1	1.00	0.00	0.0000		therm

 Path no. 20 Path Length 4

Compt ID	Cum L	Ign Mode	EB Time	Compt Fuel	Therm IAM	Dur IAM	FRI Time	CBO
1-112-0-Q	0.4400	orig	0	1.5	N/A	N/A	2	3
1-99-1B-L	0.8600	dur	3	28.2	0.840	0.750	25	
1-99-1A-L	0.9650	dur	6	12.5	0.840	0.750	29	
1-107-1-Q	0.9833	therm	57	0.0	0.360	0.170	58	59

Connecting Barrier	HEI	Tbar	Dbar	IBV	Time Destroyed	Failure Type
1-112-0-Q/1-99-1B-L	N/A	0.00	1.00	0.0000	37	dur
1-99-1B-L/1-99-1A-L	0.2	0.00	1.00	0.0000	25	dur
1-99-1A-L/1-107-1-Q	7.0	0.75	0.00	0.0089		therm

 Path no. 21 Path Length 4

Compt ID	Cum L	Ign Mode	EB Time	Compt Fuel	Therm IAM	Dur IAM	FRI Time	CBO
1-112-0-Q	0.4400	orig	0	1.5	N/A	N/A	2	3
1-99-1B-L	0.8600	dur	3	28.2	0.840	0.750	25	
1-99-1A-L	0.9650	dur	6	12.5	0.840	0.750	29	
1-70-3A-L	0.9724	dur	29	22.3	0.390	0.210	33	

Connecting Barrier	HEI	Tbar	Dbar	IBV	Time Destroyed	Failure Type
1-112-0-Q/1-99-1B-L	N/A	0.00	1.00	0.0000	37	dur
1-99-1B-L/1-99-1A-L	0.2	0.00	1.00	0.0000	25	dur
1-99-1A-L/1-70-3A-L	0.2	0.00	1.00	0.0000	29	dur

 Path no. 22 Path Length 4

Compt ID	Cum L	Ign Mode	EB Time	Compt Fuel	Therm IAM	Dur IAM	FRI Time	CBO
1-112-0-Q	0.4400	orig	0	1.5	N/A	N/A	2	3
01-110-0-Q	0.6584	therm	3	0.0	0.520	0.390	4	7
01-102-0-E	0.7301	therm	5	0.0	0.390	0.210	6	28
02-102-0-E	0.8354	therm	11	26.2	0.390	0.210	13	

Connecting Barrier	HEI	Tbar	Dbar	IBV	Time Destroyed	Failure Type
1-112-0-Q/01-110-0-Q	N/A	0.00	1.00	0.0000	25	dur
01-110-0-Q/01-102-0-E	N/A	0.00	1.00	0.0000	26	dur
01-102-0-E/02-102-0-E	N/A	1.00	0.00	0.0000		therm

 Path no. 23 Path Length 4

Compt ID	Cum L	Ign Mode	EB Time	Compt Fuel	Therm IAM	Dur IAM	FRI Time	CBO
1-112-0-Q	0.4400	orig	0	1.5	N/A	N/A	2	3
01-110-0-Q	0.6584	therm	3	0.0	0.520	0.390	4	7
01-102-0-E	0.7301	therm	5	0.0	0.390	0.210	6	28
01-95-0-L	0.9487	dur	6	7.4	0.880	0.700	53	

Connecting Barrier	HEI	Tbar	Dbar	IBV	Time Destroyed	Failure Type
1-112-0-Q/01-110-0-Q	N/A	0.00	1.00	0.0000	25	dur
01-110-0-Q/01-102-0-E	N/A	0.00	1.00	0.0000	26	dur
01-102-0-E/01-95-0-L	N/A	0.61	0.39	0.0000	55	therm

 Path no. 24 Path Length 3

Compt ID	Cum L	Ign Mode	EB Time	Compt Fuel	Therm IAM	Dur IAM	FRI Time	CBO
1-112-0-Q	0.4400	orig	0	1.5	N/A	N/A	2	3
01-110-0-Q	0.6584	therm	3	0.0	0.520	0.390	4	7
01-116-0-Q	0.7745	therm	3	15.7	0.630	0.340	6	

Connecting Barrier	HEI	Tbar	Dbar	IBV	Time Destroyed	Failure Type
1-112-0-Q/01-110-0-Q	N/A	0.00	1.00	0.0000	25	dur
01-110-0-Q/01-116-0-Q	N/A	0.00	1.00	0.0000	35	dur

 Path no. 25 Path Length 2

Compt ID	Cum L	Ign Mode	EB Time	Compt Fuel	Therm IAM	Dur IAM	FRI Time	CBO
1-112-0-Q	0.4400	orig	0	1.5	N/A	N/A	2	3
01-116-0-Q	0.6728	therm	3	15.7	0.630	0.340	6	

Connecting Barrier	HEI	Tbar	Dbar	IBV	Time Destroyed	Failure Type
1-112-0-Q/01-116-0-Q	N/A	0.26	0.74	0.0000	44	dur

 Path no. 26 Path Length 3

Compt ID	Cum L	Ign Mode	EB Time	Compt Fuel	Therm IAM	Dur IAM	FRI Time	CBO
1-112-0-Q	0.4400	orig	0	1.5	N/A	N/A	2	3
1-132-0A-L	0.8600	dur	3	10.6	0.840	0.750	25	
1-132-2-L	0.9708	dur	12	29.1	0.600	0.250	30	

Connecting Barrier	HEI	Tbar	Dbar	IBV	Time Destroyed	Failure Type
1-112-0-Q/1-132-0A-L	N/A	0.00	1.00	0.0000	38	dur
1-132-0A-L/1-132-2-L	4.3	0.52	0.00	0.0669		therm

Path no. 27 Path Length 3

Compt ID	Cum L	Ign Mode	EB Time	Compt Fuel	Therm IAM	Dur IAM	FRI Time	CBO
1-112-0-Q	0.4400	orig	0	1.5	N/A	N/A	2	3
1-132-0A-L	0.8600	dur	3	10.6	0.840	0.750	25	
1-74-2C-L	0.9864	dur	3	29.2	0.840	0.750	25	

Connecting Barrier	HEI	Tbar	Dbar	IBV	Time Destroyed	Failure Type
1-112-0-Q/1-132-0A-L	N/A	0.00	1.00	0.0000	38	dur
1-132-0A-L/1-74-2C-L	5.4	0.61	0.00	0.0549		therm

Path no. 28 Path Length 3

Compt ID	Cum L	Ign Mode	EB Time	Compt Fuel	Therm IAM	Dur IAM	FRI Time	CBO
1-112-0-Q	0.4400	orig	0	1.5	N/A	N/A	2	3
1-132-0A-L	0.8600	dur	3	10.6	0.840	0.750	25	
1-99-1B-L	0.9864	dur	3	28.2	0.840	0.750	25	

Connecting Barrier	HEI	Tbar	Dbar	IBV	Time Destroyed	Failure Type
1-112-0-Q/1-132-0A-L	N/A	0.00	1.00	0.0000	38	dur
1-132-0A-L/1-99-1B-L	5.3	0.61	0.00	0.0553		therm

Path no. 29 Path Length 3

Compt ID	Cum L	Ign Mode	EB Time	Compt Fuel	Therm IAM	Dur IAM	FRI Time	CBO
1-112-0-Q	0.4400	orig	0	1.5	N/A	N/A	2	3
1-132-0A-L	0.8600	dur	3	10.6	0.840	0.750	25	
1-132-0B-L	0.9650	dur	25	3.1	0.840	0.750	29	

Connecting Barrier	HEI	Tbar	Dbar	IBV	Time Destroyed	Failure Type
1-112-0-Q/1-132-0A-L	N/A	0.00	1.00	0.0000	38	dur
1-132-0A-L/1-132-0B-L	0.0	0.00	1.00	0.0000	25	dur

Path no. 30 Path Length 4

Compt ID	Cum L	Ign Mode	EB Time	Compt Fuel	Therm IAM	Dur IAM	FRI Time	CBO
----------	-------	----------	---------	------------	-----------	---------	----------	-----

1-112-0-Q	0.4400	orig	0	1.5	N/A	N/A	2	3
4-92-0A-E	0.6080	dur	2	0.0	0.440	0.300	3	7
1-74-2B-L	0.9020	dur	6	12.6	0.840	0.750	29	
1-92-2-Q	0.9659	therm	57	52.8	0.350	0.160	58	

Connecting Barrier	HEI	Tbar	Dbar	IBV	Time Destroyed	Failure Type
1-112-0-Q/4-92-0A-E	N/A	0.00	1.00	0.0000	2	dur
4-92-0A-E/1-74-2B-L	N/A	0.00	1.00	0.0000	34	dur
1-74-2B-L/1-92-2-Q	5.1	0.54	0.00	0.0455		therm

 Path no. 31 Path Length 4

Compt ID	Cum L	Ign Mode	EB Time	Compt Fuel	Therm IAM	Dur IAM	FRI Time	CBO
1-112-0-Q	0.4400	orig	0	1.5	N/A	N/A	2	3
4-92-0A-E	0.6080	dur	2	0.0	0.440	0.300	3	7
1-74-2B-L	0.9020	dur	6	12.6	0.840	0.750	29	
1-106-2-L	0.9867	therm	38	44.7	0.550	0.300	60	

Connecting Barrier	HEI	Tbar	Dbar	IBV	Time Destroyed	Failure Type
1-112-0-Q/4-92-0A-E	N/A	0.00	1.00	0.0000	2	dur
4-92-0A-E/1-74-2B-L	N/A	0.00	1.00	0.0000	34	dur
1-74-2B-L/1-106-2-L	1.9	0.30	0.00	0.0685		therm

 Path no. 32 Path Length 4

Compt ID	Cum L	Ign Mode	EB Time	Compt Fuel	Therm IAM	Dur IAM	FRI Time	CBO
1-112-0-Q	0.4400	orig	0	1.5	N/A	N/A	2	3
4-92-0A-E	0.6080	dur	2	0.0	0.440	0.300	3	7
1-74-2B-L	0.9020	dur	6	12.6	0.840	0.750	29	
1-74-2A-L	0.9755	dur	29	12.8	0.840	0.750	33	

Connecting Barrier	HEI	Tbar	Dbar	IBV	Time Destroyed	Failure Type
1-112-0-Q/4-92-0A-E	N/A	0.00	1.00	0.0000	2	dur
4-92-0A-E/1-74-2B-L	N/A	0.00	1.00	0.0000	34	dur
1-74-2B-L/1-74-2A-L	0.2	0.00	1.00	0.0000	29	dur

 Path no. 33 Path Length 4

Compt ID	Cum L	Ign Mode	EB Time	Compt Fuel	Therm IAM	Dur IAM	FRI Time	CBO
----------	-------	----------	---------	------------	-----------	---------	----------	-----

1-112-0-Q	0.4400	orig	0	1.5	N/A	N/A	2	3
4-92-0A-E	0.6080	dur	2	0.0	0.440	0.300	3	7
1-74-2B-L	0.9020	dur	6	12.6	0.840	0.750	29	
01-93-2-L	0.9784	dur	29	1.8	0.870	0.780	33	

Connecting Barrier	HEI	Tbar	Dbar	IBV	Time Destroyed	Failure Type
1-112-0-Q/4-92-0A-E	N/A	0.00	1.00	0.0000	2	dur
4-92-0A-E/1-74-2B-L	N/A	0.00	1.00	0.0000	34	dur
1-74-2B-L/01-93-2-L	0.6	0.00	1.00	0.0000	29	dur

Path no. 34 Path Length 4

Compt ID	Cum L	Ign Mode	EB Time	Compt Fuel	Therm IAM	Dur IAM	FRI Time	CBO
1-112-0-Q	0.4400	orig	0	1.5	N/A	N/A	2	3
4-92-0A-E	0.6080	dur	2	0.0	0.440	0.300	3	7
1-92-0-Q	0.7491	dur	6	10.2	0.610	0.360	53	
01-82-0-L	0.9645	dur	6	46.7	0.420	0.170	53	

Connecting Barrier	HEI	Tbar	Dbar	IBV	Time Destroyed	Failure Type
1-112-0-Q/4-92-0A-E	N/A	0.00	1.00	0.0000	2	dur
4-92-0A-E/1-92-0-Q	N/A	0.00	1.00	0.0000	39	dur
1-92-0-Q/01-82-0-L	N/A	0.24	0.00	0.1897		therm

Path no. 35 Path Length 4

Compt ID	Cum L	Ign Mode	EB Time	Compt Fuel	Therm IAM	Dur IAM	FRI Time	CBO
1-112-0-Q	0.4400	orig	0	1.5	N/A	N/A	2	3
4-92-0A-E	0.6080	dur	2	0.0	0.440	0.300	3	7
1-92-0-Q	0.7491	dur	6	10.2	0.610	0.360	53	
1-70-3A-L	0.9520	dur	29	22.3	0.390	0.210	33	

Connecting Barrier	HEI	Tbar	Dbar	IBV	Time Destroyed	Failure Type
1-112-0-Q/4-92-0A-E	N/A	0.00	1.00	0.0000	2	dur
4-92-0A-E/1-92-0-Q	N/A	0.00	1.00	0.0000	39	dur
1-92-0-Q/1-70-3A-L	N/A	0.31	0.00	0.1722		therm

Path no. 36 Path Length 4

Compt ID	Cum L	Ign Mode	EB Time	Compt Fuel	Therm IAM	Dur IAM	FRI Time	CBO
----------	-------	----------	---------	------------	-----------	---------	----------	-----

1-112-0-Q	0.4400	orig	0	1.5	N/A	N/A	2	3
4-92-0A-E	0.6080	dur	2	0.0	0.440	0.300	3	7
01-82-0-L	0.6746	dur	6	46.7	0.420	0.170	53	
01-93-2-L	0.9883	dur	29	1.8	0.870	0.780	33	

Connecting Barrier	HEI	Tbar	Dbar	IBV	Time Destroyed	Failure Type
1-112-0-Q/4-92-0A-E	N/A	0.00	1.00	0.0000	2	dur
4-92-0A-E/01-82-0-L	N/A	0.00	1.00	0.0000	39	dur
01-82-0-L/01-93-2-L	2.8	0.28	0.00	0.2354		therm

 Path no. 37 Path Length 4

Compt ID	Cum L	Ign Mode	EB Time	Compt Fuel	Therm IAM	Dur IAM	FRI Time	CBO
1-112-0-Q	0.4400	orig	0	1.5	N/A	N/A	2	3
4-92-0A-E	0.6080	dur	2	0.0	0.440	0.300	3	7
01-82-0-L	0.6746	dur	6	46.7	0.420	0.170	53	
01-95-1-L	0.9883	dur	29	1.8	0.870	0.780	33	

Connecting Barrier	HEI	Tbar	Dbar	IBV	Time Destroyed	Failure Type
1-112-0-Q/4-92-0A-E	N/A	0.00	1.00	0.0000	2	dur
4-92-0A-E/01-82-0-L	N/A	0.00	1.00	0.0000	39	dur
01-82-0-L/01-95-1-L	2.8	0.28	0.00	0.2353		therm

 Path no. 38 Path Length 3

Compt ID	Cum L	Ign Mode	EB Time	Compt Fuel	Therm IAM	Dur IAM	FRI Time	CBO
1-112-0-Q	0.4400	orig	0	1.5	N/A	N/A	2	3
4-92-0A-E	0.6080	dur	2	0.0	0.440	0.300	3	7
01-95-0-L	0.8824	dur	6	7.4	0.880	0.700	53	

Connecting Barrier	HEI	Tbar	Dbar	IBV	Time Destroyed	Failure Type
1-112-0-Q/4-92-0A-E	N/A	0.00	1.00	0.0000	2	dur
4-92-0A-E/01-95-0-L	N/A	0.00	1.00	0.0000	39	dur

 Path no. 39 Path Length 4

Compt ID	Cum L	Ign Mode	EB Time	Compt Fuel	Therm IAM	Dur IAM	FRI Time	CBO
1-112-0-Q	0.4400	orig	0	1.5	N/A	N/A	2	3

4-92-0A-E	0.6080	dur	2	0.0	0.440	0.300	3	7
01-102-0-E	0.6903	therm	5	0.0	0.390	0.210	6	28
02-102-0-E	0.8111	therm	11	26.2	0.390	0.210	13	

Connecting Barrier	HEI	Tbar	Dbar	IBV	Time Destroyed	Failure Type
1-112-0-Q/4-92-0A-E	N/A	0.00	1.00	0.0000	2	dur
4-92-0A-E/01-102-0-E	N/A	0.00	1.00	0.0000	21	dur
01-102-0-E/02-102-0-E	N/A	1.00	0.00	0.0000		therm

 Path no. 40 Path Length 4

Compt ID	Cum L	Ign Mode	EB Time	Compt Fuel	Therm IAM	Dur IAM	FRI Time	CBO
1-112-0-Q	0.4400	orig	0	1.5	N/A	N/A	2	3
4-92-0A-E	0.6080	dur	2	0.0	0.440	0.300	3	7
01-102-0-E	0.6903	therm	5	0.0	0.390	0.210	6	28
01-95-0-L	0.9412	dur	6	7.4	0.880	0.700	53	

Connecting Barrier	HEI	Tbar	Dbar	IBV	Time Destroyed	Failure Type
1-112-0-Q/4-92-0A-E	N/A	0.00	1.00	0.0000	2	dur
4-92-0A-E/01-102-0-E	N/A	0.00	1.00	0.0000	21	dur
01-102-0-E/01-95-0-L	N/A	0.61	0.39	0.0000	55	therm

 Path no. 41 Path Length 5

Compt ID	Cum L	Ign Mode	EB Time	Compt Fuel	Therm IAM	Dur IAM	FRI Time	CBO
1-112-0-Q	0.4400	orig	0	1.5	N/A	N/A	2	3
4-92-0A-E	0.6080	dur	2	0.0	0.440	0.300	3	7
1-99-1A-L	0.9020	dur	6	12.5	0.840	0.750	29	
1-106-1-Q	0.9363	therm	57	0.0	0.350	0.160	58	59
1-93-1-L	0.9783	therm	53	52.8	0.390	0.210		

Connecting Barrier	HEI	Tbar	Dbar	IBV	Time Destroyed	Failure Type
1-112-0-Q/4-92-0A-E	N/A	0.00	1.00	0.0000	2	dur
4-92-0A-E/1-99-1A-L	N/A	0.00	1.00	0.0000	34	dur
1-99-1A-L/1-106-1-Q	11.3	1.00	0.00	0.0000		therm
1-106-1-Q/1-93-1-L	4.7	0.56	0.00	0.0281		therm

 Path no. 42 Path Length 5

Compt ID	Cum L	Ign Mode	EB Time	Compt Fuel	Therm IAM	Dur IAM	FRI Time	CBO
----------	-------	----------	---------	------------	-----------	---------	----------	-----

1-112-0-Q	0.4400	orig	0	1.5	N/A	N/A	2	3
4-92-0A-E	0.6080	dur	2	0.0	0.440	0.300	3	7
1-99-1A-L	0.9020	dur	6	12.5	0.840	0.750	29	
1-106-1-Q	0.9363	therm	57	0.0	0.350	0.160	58	59
1-107-1-Q	0.9592	therm	57	0.0	0.360	0.170	58	59

Connecting Barrier	HEI	Tbar	Dbar	IBV	Time Destroyed	Failure Type
1-112-0-Q/4-92-0A-E	N/A	0.00	1.00	0.0000	2	dur
4-92-0A-E/1-99-1A-L	N/A	0.00	1.00	0.0000	34	dur
1-99-1A-L/1-106-1-Q	11.3	1.00	0.00	0.0000		therm
1-106-1-Q/1-107-1-Q	12.1	1.00	0.00	0.0000		therm

 Path no. 43 Path Length 5

Compt ID	Cum L	Ign Mode	EB Time	Compt Fuel	Therm IAM	Dur IAM	FRI Time	CBO
1-112-0-Q	0.4400	orig	0	1.5	N/A	N/A	2	3
4-92-0A-E	0.6080	dur	2	0.0	0.440	0.300	3	7
1-99-1A-L	0.9020	dur	6	12.5	0.840	0.750	29	
1-107-1-Q	0.9532	therm	57	0.0	0.360	0.170	58	59
1-110-1-Q	0.9853	therm	49	70.8	0.430	0.210	54	

Connecting Barrier	HEI	Tbar	Dbar	IBV	Time Destroyed	Failure Type
1-112-0-Q/4-92-0A-E	N/A	0.00	1.00	0.0000	2	dur
4-92-0A-E/1-99-1A-L	N/A	0.00	1.00	0.0000	34	dur
1-99-1A-L/1-107-1-Q	7.0	0.75	0.00	0.0249		therm
1-107-1-Q/1-110-1-Q	5.4	0.55	0.00	0.0210		therm

 Path no. 44 Path Length 4

Compt ID	Cum L	Ign Mode	EB Time	Compt Fuel	Therm IAM	Dur IAM	FRI Time	CBO
1-112-0-Q	0.4400	orig	0	1.5	N/A	N/A	2	3
4-92-0A-E	0.6080	dur	2	0.0	0.440	0.300	3	7
1-99-1A-L	0.9020	dur	6	12.5	0.840	0.750	29	
1-110-1-Q	0.9821	therm	49	70.8	0.430	0.210	54	

Connecting Barrier	HEI	Tbar	Dbar	IBV	Time Destroyed	Failure Type
1-112-0-Q/4-92-0A-E	N/A	0.00	1.00	0.0000	2	dur
4-92-0A-E/1-99-1A-L	N/A	0.00	1.00	0.0000	34	dur
1-99-1A-L/1-110-1-Q	2.8	0.32	0.00	0.0667		therm

Path no. 45 Path Length 4

Compt ID	Cum L	Ign Mode	EB Time	Compt Fuel	Therm IAM	Dur IAM	FRI Time	CBO
1-112-0-Q	0.4400	orig	0	1.5	N/A	N/A	2	3
4-92-0A-E	0.6080	dur	2	0.0	0.440	0.300	3	7
1-99-1A-L	0.9020	dur	6	12.5	0.840	0.750	29	
1-70-3A-L	0.9226	dur	29	22.3	0.390	0.210	33	

Connecting Barrier	HEI	Tbar	Dbar	IBV	Time Destroyed	Failure Type
1-112-0-Q/4-92-0A-E	N/A	0.00	1.00	0.0000	2	dur
4-92-0A-E/1-99-1A-L	N/A	0.00	1.00	0.0000	34	dur
1-99-1A-L/1-70-3A-L	0.2	0.00	1.00	0.0000	29	dur

Path no. 46 Path Length 4

Compt ID	Cum L	Ign Mode	EB Time	Compt Fuel	Therm IAM	Dur IAM	FRI Time	CBO
1-112-0-Q	0.4400	orig	0	1.5	N/A	N/A	2	3
4-92-0A-E	0.6080	dur	2	0.0	0.440	0.300	3	7
1-99-1A-L	0.9020	dur	6	12.5	0.840	0.750	29	
01-95-1-L	0.9784	dur	29	1.8	0.870	0.780	33	

Connecting Barrier	HEI	Tbar	Dbar	IBV	Time Destroyed	Failure Type
1-112-0-Q/4-92-0A-E	N/A	0.00	1.00	0.0000	2	dur
4-92-0A-E/1-99-1A-L	N/A	0.00	1.00	0.0000	34	dur
1-99-1A-L/01-95-1-L	0.6	0.00	1.00	0.0000	29	dur

Path no. 47 Path Length 5

Compt ID	Cum L	Ign Mode	EB Time	Compt Fuel	Therm IAM	Dur IAM	FRI Time	CBO
1-112-0-Q	0.4400	orig	0	1.5	N/A	N/A	2	3
4-92-0A-E	0.6080	dur	2	0.0	0.440	0.300	3	7
01-110-0-Q	0.7609	therm	3	0.0	0.520	0.390	4	7
01-102-0-E	0.8111	therm	5	0.0	0.390	0.210	6	28
02-102-0-E	0.8848	therm	11	26.2	0.390	0.210	13	

Connecting Barrier	HEI	Tbar	Dbar	IBV	Time Destroyed	Failure Type
1-112-0-Q/4-92-0A-E	N/A	0.00	1.00	0.0000	2	dur
4-92-0A-E/01-110-0-Q	N/A	0.00	1.00	0.0000	24	dur
01-110-0-Q/01-102-0-E	N/A	0.00	1.00	0.0000	26	dur
01-102-0-E/02-102-0-E	N/A	1.00	0.00	0.0000		therm

 Path no. 48 Path Length 5

Compt ID	Cum L	Ign Mode	EB Time	Compt Fuel	Therm IAM	Dur IAM	FRI Time	CBO
1-112-0-Q	0.4400	orig	0	1.5	N/A	N/A	2	3
4-92-0A-E	0.6080	dur	2	0.0	0.440	0.300	3	7
01-110-0-Q	0.7609	therm	3	0.0	0.520	0.390	4	7
01-102-0-E	0.8111	therm	5	0.0	0.390	0.210	6	28
01-95-0-L	0.9641	dur	6	7.4	0.880	0.700	53	

Connecting Barrier	HEI	Tbar	Dbar	IBV	Time Destroyed	Failure Type
1-112-0-Q/4-92-0A-E	N/A	0.00	1.00	0.0000	2	dur
4-92-0A-E/01-110-0-Q	N/A	0.00	1.00	0.0000	24	dur
01-110-0-Q/01-102-0-E	N/A	0.00	1.00	0.0000	26	dur
01-102-0-E/01-95-0-L	N/A	0.61	0.39	0.0000	55	therm

 Path no. 49 Path Length 4

Compt ID	Cum L	Ign Mode	EB Time	Compt Fuel	Therm IAM	Dur IAM	FRI Time	CBO
1-112-0-Q	0.4400	orig	0	1.5	N/A	N/A	2	3
4-92-0A-E	0.6080	dur	2	0.0	0.440	0.300	3	7
01-110-0-Q	0.7609	therm	3	0.0	0.520	0.390	4	7
01-116-0-Q	0.8422	therm	3	15.7	0.630	0.340	6	

Connecting Barrier	HEI	Tbar	Dbar	IBV	Time Destroyed	Failure Type
1-112-0-Q/4-92-0A-E	N/A	0.00	1.00	0.0000	2	dur
4-92-0A-E/01-110-0-Q	N/A	0.00	1.00	0.0000	24	dur
01-110-0-Q/01-116-0-Q	N/A	0.00	1.00	0.0000	35	dur

 Path no. 50 Path Length 4

Compt ID	Cum L	Ign Mode	EB Time	Compt Fuel	Therm IAM	Dur IAM	FRI Time	CBO
1-112-0-Q	0.4400	orig	0	1.5	N/A	N/A	2	3
4-92-0A-E	0.6080	dur	2	0.0	0.440	0.300	3	7
4-92-0-E	0.7099	therm	3	9.2	0.480	0.260	6	
1-107-1-Q	0.9744	therm	57	0.0	0.360	0.170	58	59

Connecting Barrier	HEI	Tbar	Dbar	IBV	Time Destroyed	Failure Type
1-112-0-Q/4-92-0A-E	N/A	0.00	1.00	0.0000	2	dur

4-92-0A-E/4-92-0-E	N/A	0.00	1.00	0.0000	6	dur
4-92-0-E/1-107-1-Q	7.8	0.14	0.00	0.2502		therm

Path no. 51 Path Length 4

Compt ID	Cum L	Ign Mode	EB Time	Compt Fuel	Therm IAM	Dur IAM	FRI Time	CBO
1-112-0-Q	0.4400	orig	0	1.5	N/A	N/A	2	3
4-92-0A-E	0.6080	dur	2	0.0	0.440	0.300	3	7
4-92-0-E	0.7099	therm	3	9.2	0.480	0.260	6	
1-106-1-Q	0.9327	therm	57	0.0	0.350	0.160	58	59

Connecting Barrier	HEI	Tbar	Dbar	IBV	Time Destroyed	Failure Type
1-112-0-Q/4-92-0A-E	N/A	0.00	1.00	0.0000	2	dur
4-92-0A-E/4-92-0-E	N/A	0.00	1.00	0.0000	6	dur
4-92-0-E/1-106-1-Q	12.1	0.36	0.00	0.1865		therm

□
□
□

HORNBEAM
06/24/97
MODEL RUN 9-68

PATH OPTION - SUMMARY LEVEL REPORT
LISTING OF ALL PATHS FROM 1-157-2-Q

READINESS CONDITION . YOKE
CONFIGURATION Passive
CASE. Worst
ASSUMED LOCATION. . . at SEA
RUN TIME. 60 minutes
COMMENTS.
Baseline, At Sea M Values

PATHS FROM 1-157-2-Q					CUM L
1.	2-147-0-Q	1-157-0-E			0.8800
2.	1-150-2-L				0.7840
3.	1-157-0-E	1-132-0B-L			0.9436
4.	1-157-0-E	1-140-0-L			0.7848
5.	1-157-0-E	1-161-2-Q	2-161-0-Q	1-157-0-E	0.9749
6.	1-157-0-E	1-161-2-Q	1-157-0-E	1-132-0B-L	0.9768
7.	1-157-0-E	1-161-2-Q	1-157-0-E	1-140-0-L	0.9114
8.	1-161-2-Q	2-161-0-Q	1-157-0-E		0.9488
9.	1-161-2-Q	1-157-0-E	1-132-0B-L		0.9526
10.	1-161-2-Q	1-157-0-E	1-140-0-L		0.8192

HORNBEAM
06/24/97
MODEL RUN 9-68

PATH OPTION - DETAIL LEVEL REPORT

INFORMATION ON ALL PATHS FROM 1-157-2-Q

READINESS CONDITION . YOKE
CONFIGURATION Passive
CASE. Worst
ASSUMED LOCATION. . . at SEA
RUN TIME. 60 minutes
COMMENTS.
Baseline, At Sea M Values

Path no. 1 Path Length 3

Compt ID	Cum L	Ign Mode	EB Time	Compt Fuel	Therm IAM	Dur IAM	FRI Time	CBO
1-157-2-Q	0.2800	orig	0	0.0	N/A	N/A	1	7
2-147-0-Q	0.5824	therm	10	87.4	0.420	0.230	13	
1-157-0-E	0.8800	dur	1	0.0	0.730	0.510	2	13

Connecting Barrier	HEI	Tbar	Dbar	IBV	Time Destroyed	Failure Type
1-157-2-Q/2-147-0-Q	N/A	1.00	0.00	0.0000	25	dur
2-147-0-Q/1-157-0-E	63.2	0.92	0.08	-0.0000		therm

Path no. 2 Path Length 2

Compt ID	Cum L	Ign Mode	EB Time	Compt Fuel	Therm IAM	Dur IAM	FRI Time	CBO
1-157-2-Q	0.2800	orig	0	0.0	N/A	N/A	1	7
1-150-2-L	0.7840	dur	1	2.8	0.880	0.700	51	

Connecting Barrier	HEI	Tbar	Dbar	IBV	Time Destroyed	Failure Type
1-157-2-Q/1-150-2-L	N/A	0.00	1.00	0.0000	37	dur

Path no. 3 Path Length 3

Compt ID	Cum L	Ign Mode	EB Time	Compt Fuel	Therm IAM	Dur IAM	FRI Time	CBO
1-157-2-Q	0.2800	orig	0	0.0	N/A	N/A	1	7

1-157-0-E	0.6472	dur	1	0.0	0.730	0.510	2	13
1-132-0B-L	0.9436	therm	4	3.5	0.840	0.750		

Connecting Barrier	HEI	Tbar	Dbar	IBV	Time Destroyed	Failure Type
1-157-2-Q/1-157-0-E	N/A	0.00	1.00	0.0000	1	dur
1-157-0-E/1-132-0B-L	N/A	1.00	0.00	0.0000		therm

 Path no. 4 Path Length 3

Compt ID	Cum L	Ign Mode	EB Time	Compt Fuel	Therm IAM	Dur IAM	FRI Time	CBO
1-157-2-Q	0.2800	orig	0	0.0	N/A	N/A	1	7
1-157-0-E	0.6472	dur	1	0.0	0.730	0.510	2	13
1-140-0-L	0.7848	therm	4	33.9	0.390	0.210		

Connecting Barrier	HEI	Tbar	Dbar	IBV	Time Destroyed	Failure Type
1-157-2-Q/1-157-0-E	N/A	0.00	1.00	0.0000	1	dur
1-157-0-E/1-140-0-L	N/A	1.00	0.00	0.0000		therm

 Path no. 5 Path Length 5

Compt ID	Cum L	Ign Mode	EB Time	Compt Fuel	Therm IAM	Dur IAM	FRI Time	CBO
1-157-2-Q	0.2800	orig	0	0.0	N/A	N/A	1	7
1-157-0-E	0.6472	dur	1	0.0	0.730	0.510	2	13
1-161-2-Q	0.7036	therm	1	1.2	0.350	0.160	3	15
2-161-0-Q	0.9081	therm	16	798.5	0.690	0.480	18	
1-157-0-E	0.9749	dur	1	0.0	0.730	0.510	2	13

Connecting Barrier	HEI	Tbar	Dbar	IBV	Time Destroyed	Failure Type
1-157-2-Q/1-157-0-E	N/A	0.00	1.00	0.0000	1	dur
1-157-0-E/1-161-2-Q	N/A	0.00	1.00	0.0000	20	dur
1-161-2-Q/2-161-0-Q	N/A	1.00	0.00	0.0000	37	dur
2-161-0-Q/1-157-0-E	N/A	0.99	0.01	-0.0000		therm

 Path no. 6 Path Length 5

Compt ID	Cum L	Ign Mode	EB Time	Compt Fuel	Therm IAM	Dur IAM	FRI Time	CBO
1-157-2-Q	0.2800	orig	0	0.0	N/A	N/A	1	7
1-157-0-E	0.6472	dur	1	0.0	0.730	0.510	2	13
1-161-2-Q	0.7036	therm	1	1.2	0.350	0.160	3	15

1-157-0-E	0.8548	dur	1	0.0	0.730	0.510	2	13
1-132-0B-L	0.9768	therm	4	3.5	0.840	0.750		

Connecting Barrier	HEI	Tbar	Dbar	IBV	Time Destroyed	Failure Type
1-157-2-Q/1-157-0-E	N/A	0.00	1.00	0.0000	1	dur
1-157-0-E/1-161-2-Q	N/A	0.00	1.00	0.0000	20	dur
1-161-2-Q/1-157-0-E	N/A	0.00	1.00	0.0000	20	dur
1-157-0-E/1-132-0B-L	N/A	1.00	0.00	0.0000		therm

Path no. 7 Path Length 5

Compt ID	Cum L	Ign Mode	EB Time	Compt Fuel	Therm IAM	Dur IAM	FRI Time	CBO
1-157-2-Q	0.2800	orig	0	0.0	N/A	N/A	1	7
1-157-0-E	0.6472	dur	1	0.0	0.730	0.510	2	13
1-161-2-Q	0.7036	therm	1	1.2	0.350	0.160	3	15
1-157-0-E	0.8548	dur	1	0.0	0.730	0.510	2	13
1-140-0-L	0.9114	therm	4	33.9	0.390	0.210		

Connecting Barrier	HEI	Tbar	Dbar	IBV	Time Destroyed	Failure Type
1-157-2-Q/1-157-0-E	N/A	0.00	1.00	0.0000	1	dur
1-157-0-E/1-161-2-Q	N/A	0.00	1.00	0.0000	20	dur
1-161-2-Q/1-157-0-E	N/A	0.00	1.00	0.0000	20	dur
1-157-0-E/1-140-0-L	N/A	1.00	0.00	0.0000		therm

Path no. 8 Path Length 4

Compt ID	Cum L	Ign Mode	EB Time	Compt Fuel	Therm IAM	Dur IAM	FRI Time	CBO
1-157-2-Q	0.2800	orig	0	0.0	N/A	N/A	1	7
1-161-2-Q	0.3952	therm	1	1.2	0.350	0.160	3	15
2-161-0-Q	0.8125	therm	16	798.5	0.690	0.480	18	
1-157-0-E	0.9488	dur	1	0.0	0.730	0.510	2	13

Connecting Barrier	HEI	Tbar	Dbar	IBV	Time Destroyed	Failure Type
1-157-2-Q/1-161-2-Q	N/A	0.00	1.00	0.0000	13	dur
1-161-2-Q/2-161-0-Q	N/A	1.00	0.00	0.0000	37	dur
2-161-0-Q/1-157-0-E	N/A	0.99	0.01	-0.0000		therm

Path no. 9 Path Length 4

Compt ID	Cum L	Ign Mode	EB Time	Compt Fuel	Therm IAM	Dur IAM	FRI Time	CBO
----------	-------	----------	---------	------------	-----------	---------	----------	-----

1-157-2-Q	0.2800	orig	0	0.0	N/A	N/A	1	7
1-161-2-Q	0.3952	therm	1	1.2	0.350	0.160	3	15
1-157-0-E	0.7036	dur	1	0.0	0.730	0.510	2	13
1-132-0B-L	0.9526	therm	4	3.5	0.840	0.750		

Connecting Barrier	HEI	Tbar	Dbar	IBV	Time Destroyed	Failure Type
1-157-2-Q/1-161-2-Q	N/A	0.00	1.00	0.0000	13	dur
1-161-2-Q/1-157-0-E	N/A	0.00	1.00	0.0000	20	dur
1-157-0-E/1-132-0B-L	N/A	1.00	0.00	0.0000		therm

 Path no. 10 Path Length 4

Compt ID	Cum L	Ign Mode	EB Time	Compt Fuel	Therm IAM	Dur IAM	FRI Time	CBO
1-157-2-Q	0.2800	orig	0	0.0	N/A	N/A	1	7
1-161-2-Q	0.3952	therm	1	1.2	0.350	0.160	3	15
1-157-0-E	0.7036	dur	1	0.0	0.730	0.510	2	13
1-140-0-L	0.8192	therm	4	33.9	0.390	0.210		

Connecting Barrier	HEI	Tbar	Dbar	IBV	Time Destroyed	Failure Type
1-157-2-Q/1-161-2-Q	N/A	0.00	1.00	0.0000	13	dur
1-161-2-Q/1-157-0-E	N/A	0.00	1.00	0.0000	20	dur
1-157-0-E/1-140-0-L	N/A	1.00	0.00	0.0000		therm

HORNBEAM

06/24/97
MODEL RUN 9-69

PATH OPTION - SUMMARY LEVEL REPORT

LISTING OF ALL PATHS FROM 1-161-2-Q

READINESS CONDITION . YOKE
CONFIGURATION Passive
CASE. Worst
ASSUMED LOCATION. . . at SEA
RUN TIME. 60 minutes
COMMENTS.
Baseline, At Sea M Values

PATHS FROM 1-161-2-Q					CUM L
1.	2-161-0-Q	1-157-0-E			0.9391
2.	1-157-2-Q	2-147-0-Q	1-157-0-E		0.9038
3.	1-157-2-Q	1-150-2-L			0.8186
4.	1-157-0-E	1-132-0B-L			0.9436
5.	1-157-0-E	1-140-0-L			0.7848
6.	1-157-0-E	1-157-2-Q	2-147-0-Q	1-157-0-E	0.9528
7.	1-157-0-E	1-157-2-Q	1-150-2-L		0.9111

HORNBEAM

06/24/97

MODEL RUN 9-69

PATH OPTION - DETAIL LEVEL REPORT

INFORMATION ON ALL PATHS FROM 1-161-2-Q

READINESS CONDITION . YOKE
 CONFIGURATION Passive
 CASE Worst
 ASSUMED LOCATION . . . at SEA
 RUN TIME 60 minutes
 COMMENTS
 Baseline, At Sea M Values

 Path no. 1 Path Length 3

Compt ID	Cum L	Ign Mode	EB Time	Compt Fuel	Therm IAM	Dur IAM	FRI Time	CBO
1-161-2-Q	0.2800	orig	0	1.2	N/A	N/A	2	14
2-161-0-Q	0.7768	therm	15	798.5	0.690	0.480	17	
1-157-0-E	0.9391	dur	2	0.2	0.730	0.510	3	16

Connecting Barrier	HEI	Tbar	Dbar	IBV	Time Destroyed	Failure Type
1-161-2-Q/2-161-0-Q	N/A	1.00	0.00	0.0000	36	dur
2-161-0-Q/1-157-0-E	N/A	0.99	0.01	-0.0000		therm

 Path no. 2 Path Length 4

Compt ID	Cum L	Ign Mode	EB Time	Compt Fuel	Therm IAM	Dur IAM	FRI Time	CBO
1-161-2-Q	0.2800	orig	0	1.2	N/A	N/A	2	14
1-157-2-Q	0.3952	therm	3	0.0	0.350	0.160	4	13
2-147-0-Q	0.6492	therm	13	87.3	0.420	0.230	16	
1-157-0-E	0.9038	dur	2	0.2	0.730	0.510	3	16

Connecting Barrier	HEI	Tbar	Dbar	IBV	Time Destroyed	Failure Type
1-161-2-Q/1-157-2-Q	N/A	0.00	1.00	0.0000	14	dur
1-157-2-Q/2-147-0-Q	N/A	1.00	0.00	0.0000	28	dur
2-147-0-Q/1-157-0-E	60.8	0.98	0.02	0.0000		therm

 Path no. 3 Path Length 3

Compt ID	Cum L	Ign Mode	EB Time	Compt Fuel	Therm IAM	Dur IAM	FRI Time	CBO
1-161-2-Q	0.2800	orig	0	1.2	N/A	N/A	2	14
1-157-2-Q	0.3952	therm	3	0.0	0.350	0.160	4	13
1-150-2-L	0.8186	dur	4	2.8	0.880	0.700	54	

Connecting Barrier	HEI	Tbar	Dbar	IBV	Time Destroyed	Failure Type
1-161-2-Q/1-157-2-Q	N/A	0.00	1.00	0.0000	14	dur
1-157-2-Q/1-150-2-L	N/A	0.00	1.00	0.0000	40	dur

 Path no. 4 Path Length 3

Compt ID	Cum L	Ign Mode	EB Time	Compt Fuel	Therm IAM	Dur IAM	FRI Time	CBO
1-161-2-Q	0.2800	orig	0	1.2	N/A	N/A	2	14
1-157-0-E	0.6472	dur	2	0.2	0.730	0.510	3	16
1-132-0B-L	0.9436	therm	5	3.5	0.840	0.750		

Connecting Barrier	HEI	Tbar	Dbar	IBV	Time Destroyed	Failure Type
1-161-2-Q/1-157-0-E	N/A	0.00	1.00	0.0000	20	dur
1-157-0-E/1-132-0B-L	N/A	1.00	0.00	0.0000		therm

 Path no. 5 Path Length 3

Compt ID	Cum L	Ign Mode	EB Time	Compt Fuel	Therm IAM	Dur IAM	FRI Time	CBO
1-161-2-Q	0.2800	orig	0	1.2	N/A	N/A	2	14
1-157-0-E	0.6472	dur	2	0.2	0.730	0.510	3	16
1-140-0-L	0.7848	therm	5	33.9	0.390	0.210		

Connecting Barrier	HEI	Tbar	Dbar	IBV	Time Destroyed	Failure Type
1-161-2-Q/1-157-0-E	N/A	0.00	1.00	0.0000	20	dur
1-157-0-E/1-140-0-L	N/A	1.00	0.00	0.0000		therm

 Path no. 6 Path Length 5

Compt ID	Cum L	Ign Mode	EB Time	Compt Fuel	Therm IAM	Dur IAM	FRI Time	CBO
1-161-2-Q	0.2800	orig	0	1.2	N/A	N/A	2	14
1-157-0-E	0.6472	dur	2	0.2	0.730	0.510	3	16

1-157-2-Q	0.7036	therm	3	0.0	0.350	0.160	4	13
2-147-0-Q	0.8281	therm	13	87.3	0.420	0.230	16	
1-157-0-E	0.9528	dur	2	0.2	0.730	0.510	3	16

Connecting Barrier	HEI	Tbar	Dbar	IBV	Time Destroyed	Failure Type
1-161-2-Q/1-157-0-E	N/A	0.00	1.00	0.0000	20	dur
1-157-0-E/1-157-2-Q	N/A	0.00	1.00	0.0000	3	dur
1-157-2-Q/2-147-0-Q	N/A	1.00	0.00	0.0000	28	dur
2-147-0-Q/1-157-0-E	60.8	0.98	0.02	0.0000		therm

 Path no. 7 Path Length 4

Compt ID	Cum L	Ign Mode	EB Time	Compt Fuel	Therm IAM	Dur IAM	FRI Time	CBO
1-161-2-Q	0.2800	orig	0	1.2	N/A	N/A	2	14
1-157-0-E	0.6472	dur	2	0.2	0.730	0.510	3	16
1-157-2-Q	0.7036	therm	3	0.0	0.350	0.160	4	13
1-150-2-L	0.9111	dur	4	2.8	0.880	0.700	54	

Connecting Barrier	HEI	Tbar	Dbar	IBV	Time Destroyed	Failure Type
1-161-2-Q/1-157-0-E	N/A	0.00	1.00	0.0000	20	dur
1-157-0-E/1-157-2-Q	N/A	0.00	1.00	0.0000	3	dur
1-157-2-Q/1-150-2-L	N/A	0.00	1.00	0.0000	40	dur

Appendix D Analysis of Alternatives Results

The various reports produced in the analysis of alternatives on the 180' WLB using the target output option in SAFE, version 2.2, are documented in this appendix. In addition the appropriate Barrier Table associated with the two alternatives studied is included. The following tables correlate the results from SAFE computer run numbers for each alternative with page numbers in this appendix:

D.1 Only Fire Zone Bulkheads Insulated

Table D.1.1 Barrier Data: Only Fire Zone Bulkheads Insulated

D-2

SAFE Run Number	SAFE Output Option	Scenario	Page Number
11-78	Individual Target Option	XRAY, In Port, I, A, & M	D-29
11-79	Individual Target Option	XRAY, In Port, I, & A	D-30
11-80	Individual Target Option	XRAY, In Port, I, & M	D-31
11-81	Individual Target Option	XRAY, In Port, I	D-32
11-82	Individual Target Option	YOKE, In Port, I, A & M	D-33
11-83	Individual Target Option	YOKE, In Port, I, & A	D-34
11-84	Individual Target Option	YOKE, In Port, I, & M	D-35
11-85	Individual Target Option	YOKE, In Port, I	D-36
11-70	Individual Target Option	YOKE, At Sea, I, A & M	D-37
11-71	Individual Target Option	YOKE, At Sea, I, & A	D-38
11-72	Individual Target Option	YOKE, At Sea, I, & M	D-39
11-73	Individual Target Option	YOKE, At Sea, I	D-40

D.2 All Bulkheads Uninsulated

Table D.2.1 Barrier Data: All Bulkheads Uninsulated

D-41

SAFE Run Number	SAFE Output Option	Scenario	Page Number
12-86	Individual Target Option	XRAY, In Port, I, A, & M	D-68
12-87	Individual Target Option	XRAY, In Port, I, & A	D-69
12-88	Individual Target Option	XRAY, In Port, I, & M	D-70
12-89	Individual Target Option	XRAY, In Port, I	D-71
12-90	Individual Target Option	YOKE, In Port, I, A & M	D-72
12-91	Individual Target Option	YOKE, In Port, I, & A	D-73
12-92	Individual Target Option	YOKE, In Port, I, & M	D-74
12-93	Individual Target Option	YOKE, In Port, I	D-75
12-74	Individual Target Option	YOKE, At Sea, I, A & M	D-76
12-75	Individual Target Option	YOKE, At Sea, I, & A	D-77
12-76	Individual Target Option	YOKE, At Sea, I, & M	D-78
12-77	Individual Target Option	YOKE, At Sea, I	D-79

D.1.1 Barrier Data: Only Fire Zone Bulkheads Insulated

Barrier Material					Area	Therm	Durab	Door/	Readiness
<1>	<2>	<3>			ft2	adj	adj	Hatch	
			4-FP-0-W	FOREPEAK TANK	(CUI = W)				
B05	S3I	B05	3-9-0-E	BOW THRUSTER ROOM	96.6	0	0		
S2U	S3I	S2U	2-9-0-Q	CHAIN LKR	86.4	0	0		
S2U	S3I	S2U	2-9-0-E	DC SHOP	12.8	0	0		
S2U	S3I	S2U	2-9-0-E	DC SHOP	12.8	0	0		
B05	S3U		(none)	(weather bulkhead)	119.4	0	0		
B05	S3U		(none)	(weather bulkhead)	119.4	0	0		
S3U	S3U		(none)	(weather bulkhead)	57.7	0	0		
S3U	S3U		(none)	(weather bulkhead)	60.9	0	0		
S3U	S3U		(none)	(weather bulkhead)	60.9	0	0		
S3U	S3U		(none)	(weather bulkhead)	57.7	0	0		
S2U			1-FP-0-K	PAINT LKR	58.4	0	0		
S2U			1-6-0-Q	DECK WORKSHOP	42.7	0	0		
			3-9-0-E	BOW THRUSTER ROOM	(CUI = EM)				
B05	S3I	B05	4-FP-0-W	FOREPEAK TANK	96.6	0	0		
B05	S3I	B05	4-30-0-W	FRESH WATER TANK	113.4	0	0		
B05	S3I	B05	4-30-1-W	FRESH WATER TANK	63	0	0		
B05	S3I	B05	4-30-2-W	FRESH WATER TANK	63	0	0		
B05	S3U		(none)	(weather bulkhead)	231.8	0	0		
B05	S3U		(none)	(weather bulkhead)	231.8	0	0		
S2U			2-9-0-E	DC SHOP	284	0	0	HL	X
S2U			2-9-0-Q	CHAIN LKR	52	0	0		
			4-30-0-W	FRESH WATER TANK	(CUI = W)				
B05	S3I	B05	3-9-0-E	BOW THRUSTER ROOM	113.4	0	0		
B05		B05	4-30-1-W	FRESH WATER TANK	147	0	0		
B05		B05	4-30-2-W	FRESH WATER TANK	147	0	0		
B05	S3I	B05	3-44-0-A	MAIN HOLD	113.4	0	0		
S2U			2-30-0-Q	ENG LOG OFFICE	89	0	0		
D05			2-30-01-L	PASSAGE	57.9	0	0		
S2U			2-30-2-Q	E.M. SHOP & STORES	4.2	0	0		
			4-30-1-W	FRESH WATER TANK	(CUI = W)				
B05	S3I	B05	3-9-0-E	BOW THRUSTER ROOM	63	0	0		
B05		B05	4-30-0-W	FRESH WATER TANK	147	0	0		
B05	S3I	B05	3-44-0-A	MAIN HOLD	90.3	0	0		
B05	S3U		(none)	(weather bulkhead)	149.5	0	0		
D05			2-30-01-L	PASSAGE	14	0	0		
S2U			2-30-1-Q	ATON SHOP	33.3	0	0		
D05			2-36-1-Q	LAUNDRY	54.9	0	0		
			4-30-2-W	FRESH WATER TANK	(CUI = W)				
B05	S3I	B05	3-9-0-E	BOW THRUSTER ROOM	63	0	0		
B05		B05	4-30-0-W	FRESH WATER TANK	147	0	0		
B05	S3I	B05	3-44-0-A	MAIN HOLD	90.3	0	0		
B05	S3U		(none)	(weather bulkhead)	149.5	0	0		
S2U			2-30-01-L	PASSAGE	8.8	0	0		
S2U			2-30-2-Q	E.M. SHOP & STORES	74	0	0		

D.1.1 Barrier Data: Only Fire Zone Bulkheads Insulated

Barrier Material					Area	Therm	Durab	Door/	Readiness
<1>	<2>	<3>			ft2	adj	adj	Hatch	
S2U			2-41-2-Q	SHIPS SERVICE STORE	19.3	0	0		
			3-44-0-A	MAIN HOLD	(CUI = AA)				
B05	S3I	B05	4-30-0-W	FRESH WATER TANK	113.4	0	0		
B05	S3I	B05	4-30-1-W	FRESH WATER TANK	90.3	0	0		
B05	S3I	B05	4-30-2-W	FRESH WATER TANK	90.3	0	0		
B05	S3I	B05	3-56-0-Q	SEWAGE SPACE	315	0	0		
B05	S3U		(none)	(weather bulkhead)	126.4	0	0		
B05	S3U		(none)	(weather bulkhead)	126.4	0	0		
S2I			2-44-0-T	HATCH TRUNK	59.2	0	0	HO	O
S2I			2-44-01-L	PASSAGE	52.2	0	0		
S2I			2-44-1-L	CREW LOUNGE	107.2	0	0		
D05			2-44-2-L	CREWS BERTHING	129.4	0	0		
			3-56-0-Q	SEWAGE SPACE	(CUI = QA)				
B05	S3I	B05	3-44-0-A	MAIN HOLD	315	0	0		
B05	S3I	B05	3-68-1-A	GENERAL STORES	168	0	0	DWT	Y
B05	S3I	B05	3-68-2-A	DRY STORES	168	0	0		
B05	S3U		(none)	(weather bulkhead)	126.4	0	0		
B05	S3U		(none)	(weather bulkhead)	126.4	0	0		
S2I			2-44-01-L	PASSAGE	49.2	0	0		
S2I			2-44-1-L	CREW LOUNGE	44.4	0	0		
D05			2-44-2-L	CREWS BERTHING	100.8	0	0		
D05			2-57-0-L	CREW WR, WC & SH	77.1	0	0	HS	X
S2I			2-60-1-L	CREWS BERTHING	98.3	0	0		
			3-68-1-A	GENERAL STORES	(CUI = AS)				
B05	S3I	B05	3-56-0-Q	SEWAGE SPACE	168	0	0	DWT	Y
0		0	3-68-2-A	DRY STORES	63	0	0		
B05	S3I	B05	3-74-0-A	MEATS	31.5	0	0		
B05	S3I	B05	3-74-1-M	SMALL ARMS AMMUNITIO	63	0	0		
B05	S3I	B05	3-74-3-A	MAA STORAGE	77.7	0	0		
S2I	S3U		(none)	(weather bulkhead)	63.1	0	0		
S2I			2-44-01-L	PASSAGE	24.2	0	0	HS	X
S2I			2-60-1-L	CREWS BERTHING	68.2	0	0		
			3-68-2-A	DRY STORES	(CUI = AS)				
B05	S3I	B05	3-56-0-Q	SEWAGE SPACE	168	0	0		
0		0	3-68-1-A	GENERAL STORES	63	0	0		
B05	S3I	B05	3-74-0-A	MEATS	130.2	0	0		
B05	S3I	B05	3-74-2-Q	REEFER FLAT	42	0	0		
S2I	S3U		(none)	(weather bulkhead)	63.1	0	0		
S2I			2-44-01-L	PASSAGE	9.6	0	0		
D05			2-44-2-L	CREWS BERTHING	54	0	0		
D05			2-57-0-L	CREW WR, WC & SH	33.6	0	0		
			3-74-0-A	MEATS	(CUI = AR)				
B05	S3I	B05	3-68-1-A	GENERAL STORES	31.5	0	0		
B05	S3I	B05	3-68-2-A	DRY STORES	130.2	0	0		

D.1.1 Barrier Data: Only Fire Zone Bulkheads Insulated

Barrier Material				Area	Therm	Durab	Door/	Readiness
<1>	<2>	<3>		ft2	adj	adj	Hatch	
B05		S2I	3-74-2-Q	REEFER FLAT	73.5	0	0	
B05		S2I	3-74-2-Q	REEFER FLAT	35.7	0	0	
B05		B05	3-74-1-M	SMALL ARMS AMMUNITIO	73.5	0	0	
B05		B06	3-81-0-A	DAIRY	84	0	0	
B05		B05	3-81-2-L	PASSAGE	42	0	0	DJ NC
D05			2-74-0-L	CREWS BERTHING	107.8	0	0	
			3-74-2-Q	REEFER FLAT	(CUI = QA)			
B05	S3I	B05	3-68-2-A	DRY STORES	42	0	0	
S2I		B05	3-74-0-A	MEATS	73.5	0	0	
S2I		B05	3-74-0-A	MEATS	35.7	0	0	
S2I		B05	3-81-2-L	PASSAGE	42	0	0	DJ NC
S2I		S2I	3-85-0-A	FRUITS AND VEGETABLE	73.5	0	0	
B05	S3I	B05	4-92-0-E	GENERATOR ROOM	77.7	0	0	
S2I	S3U		(none)	(weather bulkhead)	115.5	0	0	
S2I	S3U		(none)	(weather bulkhead)	73.5	0	0	
D05			2-74-0-L	CREWS BERTHING	111.2	0	0	HL X
			3-74-3-A	MAA STORAGE	(CUI = AS)			
B05	S3I	B05	3-68-1-A	GENERAL STORES	77.7	0	0	
B05		B05	3-74-1-M	SMALL ARMS AMMUNITIO	73.5	0	0	
B05		B05	3-81-1-L	PASSAGE	42	0	0	DWT X
B05		B05	3-85-3-A	MAA LKR	79.8	0	0	
S2I	S3U		(none)	(weather bulkhead)	115.5	0	0	
D05			2-74-0-L	CREWS BERTHING	4.4	0	0	
D05			2-74-1-L	CREW WR, WC & SH	66	0	0	
			3-81-0-A	DAIRY	(CUI = AR)			
B06		B05	3-74-0-A	MEATS	84	0	0	
B06		B05	3-81-1-L	PASSAGE	42	0	0	
B06		B05	3-81-2-L	PASSAGE	42	0	0	DJ NC
B06		B06	3-85-0-A	FRUITS AND VEGETABLE	84	0	0	
D05			2-74-0-L	CREWS BERTHING	32	0	0	
			3-81-1-L	PASSAGE	(CUI = LP)			
B05		B05	3-74-1-M	SMALL ARMS AMMUNITIO	63	0	0	DWT X
B05		B05	3-74-3-A	MAA STORAGE	42	0	0	DWT X
B05		B06	3-81-0-A	DAIRY	42	0	0	
B05		B06	3-85-0-A	FRUITS AND VEGETABLE	73.5	0	0	
B05		B05	3-85-3-A	MAA LKR	73.5	0	0	DWT X
B05	S3I	B05	4-92-0-E	GENERATOR ROOM	63	0	0	
D05			2-74-0-L	CREWS BERTHING	64.3	0	0	HS X
			3-81-2-L	PASSAGE	(CUI = LP)			
B05		B05	3-74-0-A	MEATS	42	0	0	DJ NC
B05		S2I	3-74-2-Q	REEFER FLAT	42	0	0	DJ NC
B05		B06	3-81-0-A	DAIRY	42	0	0	DJ NC
B05		B06	3-85-0-A	FRUITS AND VEGETABLE	42	0	0	DJ NC
D05			2-74-0-L	CREWS BERTHING	16	0	0	

D.1.1 Barrier Data: Only Fire Zone Bulkheads Insulated

Barrier Material					Area	Therm	Durab	Door/	Readiness
<1>	<2>	<3>			ft2	adj	adj	Hatch	
			3-85-0-A	FRUITS AND VEGETABLES	(CUI	= AR)			
S2I		S2I	3-74-2-Q	REEFER FLAT	73.5	0	0		
B06		B06	3-81-0-A	DAIRY	84	0	0		
B06		B05	3-81-1-L	PASSAGE	73.5	0	0		
B06		B05	3-81-2-L	PASSAGE	42	0	0	DJ	NC
B05	S3I	B05	4-92-0-E	GENERATOR ROOM	126	0	0		
D05			2-74-0-L	CREWS BERTHING	84	0	0		
			3-85-3-A	MAA LKR	(CUI	= AG)			
B05		B05	3-74-3-A	MAA STORAGE	79.8	0	0		
B05		B05	3-81-1-L	PASSAGE	73.5	0	0	DWT	X
B05	S3I	B05	4-92-0-E	GENERATOR ROOM	77.7	0	0		
S2I	S3U		(none)	(weather bulkhead)	73.5	0	0		
D05			2-74-0-L	CREWS BERTHING	44.8	0	0		
			4-92-0-E	GENERATOR ROOM	(CUI	= EE)			
B05	S3I	B05	3-74-2-Q	REEFER FLAT	77.7	0	0		
B05	S3I	B05	3-81-1-L	PASSAGE	63	0	0		
B05	S3I	B05	3-85-0-A	FRUITS AND VEGETABLE	126	0	0		
B05	S3I	B05	3-85-3-A	MAA LKR	77.7	0	0		
S3U	S3I	S3U	4-116-0-F	DIESEL OIL TANK	111.3	0	0		
B05	S3I	B05	4-116-0-F	DIESEL OIL TANK	86.4	0	0		
B05	S3I	B05	4-116-1-F	DIESEL OIL TANK	94.5	0	0		
B05	S3I	B05	4-116-1-F	DIESEL OIL TANK	92.8	0	0		
S3U	S3I	S3U	4-116-2-F	DIESEL OIL TANK	92.4	0	0		
B05	S3I	B05	4-116-2-F	DIESEL OIL TANK	92.8	0	0		
S2I	S3I	S2U	2-74-0-L	CREWS BERTHING	257.6	0	0		
S3U	S3U		(none)	(weather bulkhead)	253.1	0	0		
S3U	S3U		(none)	(weather bulkhead)	253.1	0	0		
S2U	S3U		(none)	(weather bulkhead)	192	0	0		
S2U	S3U		(none)	(weather bulkhead)	192	0	0		
B05	S3U		(none)	(weather bulkhead)	11.2	0	0		
S2I			4-92-0A-E	FIDLEY	92.5	-90	-90	HL	X
D05			1-70-3A-L	CREW MESS	65.6	0	0		
S2I			1-74-2A-L	PASSAGE	22.5	0	0		
S2I			1-74-2B-L	PASSAGE	62.5	0	0		
S2I			1-74-2C-L	PASSAGE	12.8	0	0		
D05			1-91-2-L	PO-1 WC, WR & SH	51.8	0	0		
D05			1-92-0-Q	SCULLERY	43.5	0	0		
S2I			1-92-2-Q	DC LKR	15.6	0	0		
S2I			1-93-1-L	CPO MESS & REC	109.2	0	0		
S2I			1-99-1A-L	PASSAGE	61.8	0	0		
S2I			1-99-1B-L	PASSAGE	12	0	0		
D05			1-99-2-L	DISPENSARY	47.1	0	0		
D05			1-104-2-L	CPO WR, WC & SH	33	0	0		
S2I			1-106-1-Q	MOVIE LKR	4.2	0	0		
S2I			1-106-2-L	CPO BERTHING	75	0	0		
S2I			1-107-1-Q	MORALE LKR	7.8	0	0		

D.1.1 Barrier Data: Only Fire Zone Bulkheads Insulated

Barrier Material					Area	Therm	Durab	Door/	Readiness
<1>	<2>	<3>			ft2	adj	adj	Hatch	
S2I			1-110-1-Q	SHIPS OFFICE	63	0	0		
S2I			1-112-0-Q	AUXILIARY MACHINERY	27.2	-15	-15		
S3I			(none)	(weather overhead)	4.1	0	0		
			4-126-0-E	MAIN MOTOR ROOM	(CUI = EE)				
S3U	S3I	S3U	4-116-0-F	DIESEL OIL TANK	111.3	0	0		
B05	S3I	B05	4-116-0-F	DIESEL OIL TANK	80	0	0		
S3U	S3I	S3U	4-116-1-F	DIESEL OIL TANK	75.6	0	0		
S3U	S3I	S3U	4-116-2-F	DIESEL OIL TANK	73.5	0	0		
S3U	S3I	S3U	4-140-0-W	FRESH WATER TANK	176.4	0	0		
B05	S3I	B05	4-140-0-W	FRESH WATER TANK	80	0	0		
0		0	2-126-1-Q	MACHINE SHOP	112	0	0	DJ	NC
0		0	2-126-2-Q	A.C. EQUIPMENT	112	0	0		
S3I	S3U		(none)	(weather bulkhead)	152.9	0	0		
S3I	S3U		(none)	(weather bulkhead)	152.9	0	0		
S2U			2-126-1-Q	MACHINE SHOP	70	0	0		
S2U			2-126-2-Q	A.C. EQUIPMENT	81.2	0	0		
S2U			1-74-2C-L	PASSAGE	4.8	0	0		
S2U			1-99-1B-L	PASSAGE	8	0	0		
S2U			1-112-0-Q	AUXILIARY MACHINERY	40.8	-15	-15	HL	X
S2U			1-132-0A-L	PASSAGE	86.4	0	0	HS	X
			4-140-0-W	FRESH WATER TANK	(CUI = W)				
S3U	S3I	S3U	4-126-0-E	MAIN MOTOR ROOM	176.4	0	0		
B05	S3I	B05	4-126-0-E	MAIN MOTOR ROOM	80	0	0		
S3U	S3I	S3U	4-147-0-W	AFT PEAK TANK	126	0	0		
B05	S3I	B05	2-126-2-Q	A.C. EQUIPMENT	8	0	0		
B05		B05	3-140-1-W	FRESH WATER TANK	56	0	0		
B05		B05	3-140-2-W	FRESH WATER TANK	56	0	0		
B05		B05	2-147-0-Q	ENGINEERS STOREROOM	88	0	0		
S3U	S3U		(none)	(weather bulkhead)	77.7	0	0		
S3U	S3U		(none)	(weather bulkhead)	77.7	0	0		
S2U			3-140-1-W	FRESH WATER TANK	12.6	0	0		
S2U			3-140-2-W	FRESH WATER TANK	11.2	0	0		
D05			1-132-0B-L	PASSAGE	15.4	0	0		
S2U			1-140-0-L	WARDROOM	7	0	0		
D05			1-140-1-Q	PANTRY	54.6	0	0		
			4-147-0-W	AFT PEAK TANK	(CUI = W)				
S3U	S3I	S3U	4-140-0-W	FRESH WATER TANK	126	0	0		
S3U	S3U		(none)	(weather bulkhead)	21	0	0		
S3U	S3U		(none)	(weather bulkhead)	142.3	0	0		
S3U	S3U		(none)	(weather bulkhead)	142.3	0	0		
S2U			2-147-0-Q	ENGINEERS STOREROOM	88.2	0	0		
			2-9-0-Q	CHAIN LKR	(CUI = AG)				
S2U	S3I	S2U	4-FP-0-W	FOREPEAK TANK	86.4	0	0		
S2U		S2U	2-9-0-E	DC SHOP	40	0	0		
S2U		S2U	2-9-0-E	DC SHOP	86.4	0	0		

D.1.1 Barrier Data: Only Fire Zone Bulkheads Insulated

Barrier Material					Area	Therm	Durab	Door/	Readiness
<1>	<2>	<3>			ft2	adj	adj	Hatch	
S2U		S2U	2-9-0-E	DC SHOP	40	0	0		
S2U			3-9-0-E	BOW THRUSTER ROOM	52	0	0		
S2U			1-6-0-Q	DECK WORKSHOP	54	0	0	HS	X
			2-9-0-E	DC SHOP	(CUI	= QS)			
S2U	S3I	S2U	4-FP-0-W	FOREPEAK TANK	12.8	0	0		
S2U	S3I	S2U	4-FP-0-W	FOREPEAK TANK	12.8	0	0		
S2U		S2U	2-9-0-Q	CHAIN LKR	40	0	0		
S2U		S2U	2-9-0-Q	CHAIN LKR	86.4	0	0		
S2U		S2U	2-9-0-Q	CHAIN LKR	40	0	0		
S2U	S3I	S2I	2-30-0-Q	ENG LOG OFFICE	67.2	0	0		
S2U	S3I	S2I	2-30-01-L	PASSAGE	24	0	0	DWT	Y
S2U	S3I	S2I	2-30-1-Q	ATON SHOP	59.2	0	0		
S2U	S3I	S2I	2-30-2-Q	E.M. SHOP & STORES	70.4	0	0		
S3U	S3U		(none)	(weather bulkhead)	83.1	0	0		
S3U	S3U		(none)	(weather bulkhead)	93.6	0	0		
S3U	S3U		(none)	(weather bulkhead)	93.6	0	0		
S3U	S3U		(none)	(weather bulkhead)	83.1	0	0		
S2U			3-9-0-E	BOW THRUSTER ROOM	284	0	0	HL	X
S2U			1-6-0-Q	DECK WORKSHOP	44	0	0	HS	X
S2U			1-6-1-Q	A/N LKR	8.9	0	0		
S2U			1-6-2-Q	BOSN'S LKR	8.9	0	0		
S3I			(none)	(weather overhead)	330.2	0	0	HS	X
			2-30-0-Q	ENG LOG OFFICE	(CUI	= QO)			
S2I	S3I	S2U	2-9-0-E	DC SHOP	67.2	0	0		
B06		B05	2-30-01-L	PASSAGE	67.2	0	0	DJ	NC
B06		B05	2-30-01-L	PASSAGE	84.8	0	0		
B06		B05	2-30-2-Q	E.M. SHOP & STORES	84.8	0	0		
S2U			4-30-0-W	FRESH WATER TANK	89	0	0		
S3I			(none)	(weather overhead)	89	0	0		
			2-30-01-L	PASSAGE	(CUI	= LP)			
S2I	S3I	S2U	2-9-0-E	DC SHOP	24	0	0	DWT	Y
B05		B06	2-30-0-Q	ENG LOG OFFICE	67.2	0	0	DJ	NC
B05		B06	2-30-0-Q	ENG LOG OFFICE	84.8	0	0		
B05		S2I	2-30-1-Q	ATON SHOP	48	0	0	DJ	NC
B05		B05	2-30-2-Q	E.M. SHOP & STORES	24	0	0	DJ	NC
B05		B06	2-36-1-Q	LAUNDRY	64	0	0	DJ	NC
B05		B05	2-41-2-Q	SHIPS SERVICE STORE	27.2	0	0	DJ	NC
B05	S3I	B05	2-44-0-T	HATCH TRUNK	64	0	0		
B05	S3I	B05	2-44-01-L	PASSAGE	24	0	0	DWT	Y
B05	S3I	B05	2-44-1-L	CREW LOUNGE	6.4	0	0		
B05	S3I	B05	2-44-2-L	CREWS BERTHING	20.8	0	0		
D05			4-30-0-W	FRESH WATER TANK	57.9	0	0		
D05			4-30-1-W	FRESH WATER TANK	14	0	0		
S2U			4-30-2-W	FRESH WATER TANK	8.8	0	0		
S3I			(none)	(weather overhead)	80.8	0	0		

D.1.1 Barrier Data: Only Fire Zone Bulkheads Insulated

Barrier Material					Area	Therm	Durab	Door/	Readiness
<1>	<2>	<3>			ft2	adj	adj	Hatch	
			2-30-1-Q	ATON SHOP	(CUI = QS)				
S2I	S3I	S2U	2-9-0-E	DC SHOP	59.2	0	0		
S2I		B05	2-30-01-L	PASSAGE	48	0	0	DJ	NC
S2I		B05	2-36-1-Q	LAUNDRY	64	0	0		
S2I	S3U		(none)	(weather bulkhead)	48.2	0	0		
S2U			4-30-1-W	FRESH WATER TANK	33.3	0	0		
S3I			(none)	(weather overhead)	46.2	0	0		
			2-30-2-Q	E.M. SHOP & STORES	(CUI = AS)				
S2I	S3I	S2U	2-9-0-E	DC SHOP	70.4	0	0		
B05		B06	2-30-0-Q	ENG LOG OFFICE	84.8	0	0		
B05		B05	2-30-01-L	PASSAGE	24	0	0	DJ	NC
B05		B05	2-41-2-Q	SHIPS SERVICE STORE	59.2	0	0		
S2I	S3U		(none)	(weather bulkhead)	85.8	0	0		
S2U			4-30-0-W	FRESH WATER TANK	4.2	0	0		
S2U			4-30-2-W	FRESH WATER TANK	74	0	0		
S3I			(none)	(weather overhead)	101.8	0	0		
			2-36-1-Q	LAUNDRY	(CUI = QL)				
B06		B05	2-30-01-L	PASSAGE	64	0	0	DJ	NC
B05		S2I	2-30-1-Q	ATON SHOP	64	0	0		
S2I	S3I	S2U	2-44-1-L	CREW LOUNGE	76.8	0	0		
S2I	S3U		(none)	(weather bulkhead)	65.3	0	0		
D05			4-30-1-W	FRESH WATER TANK	54.9	0	0		
S3I			(none)	(weather overhead)	70.4	0	0		
			2-41-2-Q	SHIPS SERVICE STORE	(CUI = AS)				
B05		B05	2-30-01-L	PASSAGE	27.2	0	0	DJ	NC
B05		B05	2-30-2-Q	E.M. SHOP & STORES	59.2	0	0		
B05	S3I	B05	2-44-2-L	CREWS BERTHING	64	0	0		
S2I	S3U		(none)	(weather bulkhead)	27.6	0	0		
S2U			4-30-2-W	FRESH WATER TANK	19.3	0	0		
S3I			(none)	(weather overhead)	26.2	0	0		
			2-44-0-T	HATCH TRUNK	(CUI = TH)				
B05	S3I	B05	2-30-01-L	PASSAGE	64	0	0		
B05		B05	2-44-01-L	PASSAGE	28.8	0	0	DWT	Y
S2I		S2U	2-44-01-L	PASSAGE	59.2	0	0		
S2I		S2U	2-44-2-L	CREWS BERTHING	59.2	0	0		
S2U		S2I	2-44-2-L	CREWS BERTHING	35.2	0	0		
S2I			3-44-0-A	MAIN HOLD	59.2	0	0	HO	O
S3I			(none)	(weather overhead)	59.2	0	0	HS	X
			2-44-01-L	PASSAGE	(CUI = LP)				
B05	S3I	B05	2-30-01-L	PASSAGE	24	0	0	DWT	Y
B05		B05	2-44-0-T	HATCH TRUNK	28.8	0	0	DWT	Y
S2U		S2I	2-44-0-T	HATCH TRUNK	59.2	0	0		
B05		B05	2-44-1-L	CREW LOUNGE	36.8	0	0	DJ	NC
B05		B05	2-44-1-L	CREW LOUNGE	8	0	0		

D.1.1 Barrier Data: Only Fire Zone Bulkheads Insulated

Barrier Material					Area	Therm	Durab	Door/	Readiness
<1>	<2>	<3>			ft2	adj	adj	Hatch	
B05		B05	2-44-1-L	CREW LOUNGE	92.8	0	0		
0		0	2-44-2-L	CREWS BERTHING	38.4	0	0		
B06		B05	2-57-0-L	CREW WR, WC & SH	4.8	0	0		
B06		B05	2-57-0-L	CREW WR, WC & SH	73.6	0	0		
B06		B05	2-57-0-L	CREW WR, WC & SH	9.6	0	0		
B06		B05	2-57-0-L	CREW WR, WC & SH	68.8	0	0	DJ	NC
0		0	2-60-1-L	CREWS BERTHING	16	0	0		
0		0	2-60-1-L	CREWS BERTHING	36.6	0	0		
0		0	2-60-1-L	CREWS BERTHING	60.8	0	0		
0		0	2-60-1-L	CREWS BERTHING	14.4	0	0		
S2I	S3I	S2U	2-74-0-L	CREWS BERTHING	40	0	0		
B05	S3I	B05	2-74-1-L	CREW WR, WC & SH	9.6	0	0		
S2I			3-44-0-A	MAIN HOLD	52.2	0	0		
S2I			3-56-0-Q	SEWAGE SPACE	49.2	0	0		
S2I			3-68-1-A	GENERAL STORES	24.2	0	0	HS	X
S2I			3-68-2-A	DRY STORES	9.6	0	0		
S2I			1-68-0-L	COMPANIONWAY	19.1	0	0	HS	X
S2I			1-68-1-Q	HYD PUMP ROOM	12	0	0		
S3I			(none)	(weather overhead)	104	0	0		
			2-44-1-L	CREW LOUNGE	(CUI = LL)				
B05	S3I	B05	2-30-01-L	PASSAGE	6.4	0	0		
S2U	S3I	S2I	2-36-1-Q	LAUNDRY	76.8	0	0		
B05		B05	2-44-01-L	PASSAGE	36.8	0	0	DJ	NC
B05		B05	2-44-01-L	PASSAGE	8	0	0		
B05		B05	2-44-01-L	PASSAGE	92.8	0	0		
B05		B05	2-60-1-L	CREWS BERTHING	86.4	0	0		
S2I	S3U		(none)	(weather bulkhead)	129.9	0	0		
S2I	S3U		(none)	(weather bulkhead)	12.8	0	0		
S2I			3-44-0-A	MAIN HOLD	107.2	0	0		
S2I			3-56-0-Q	SEWAGE SPACE	44.4	0	0		
S3I			(none)	(weather overhead)	181.2	0	0		
			2-44-2-L	CREWS BERTHING	(CUI = L5)				
B05	S3I	B05	2-30-01-L	PASSAGE	20.8	0	0		
B05	S3I	B05	2-41-2-Q	SHIPS SERVICE STORE	64	0	0		
S2U		S2I	2-44-0-T	HATCH TRUNK	59.2	0	0		
S2I		S2U	2-44-0-T	HATCH TRUNK	35.2	0	0		
0		0	2-44-01-L	PASSAGE	38.4	0	0		
S2I		S2U	2-57-0-L	CREW WR, WC & SH	142.4	0	0	DJ	NC
S2I		S2U	2-57-0-L	CREW WR, WC & SH	49.6	0	0		
S2I	S3I	S2U	2-74-0-L	CREWS BERTHING	84.8	0	0		
S2I	S3U		(none)	(weather bulkhead)	240.4	0	0		
D05			3-44-0-A	MAIN HOLD	129.4	0	0		
D05			3-56-0-Q	SEWAGE SPACE	100.8	0	0		
D05			3-68-2-A	DRY STORES	54	0	0		
S2I			1-70-2-L	VESTIBULE	7.2	0	0		
S2I			1-70-4-L	PO-1 BERTHING	32	0	0		
S3I			(none)	(weather overhead)	294.9	0	0		

D.1.1 Barrier Data: Only Fire Zone Bulkheads Insulated

Barrier Material					Area	Therm	Durab	Door/	Readiness
<1>	<2>	<3>			ft2	adj	adj	Hatch	
			2-57-0-L	CREW WR, WC & SH	(CUI = LW)				
B05		B06	2-44-01-L	PASSAGE	4.8	0	0		
B05		B06	2-44-01-L	PASSAGE	73.6	0	0		
B05		B06	2-44-01-L	PASSAGE	9.6	0	0		
B05		B06	2-44-01-L	PASSAGE	68.8	0	0	DJ	NC
S2U		S2I	2-44-2-L	CREWS BERTHING	142.4	0	0	DJ	NC
S2U		S2I	2-44-2-L	CREWS BERTHING	49.6	0	0		
B05	S3I	B05	2-74-0-L	CREWS BERTHING	44.8	0	0		
D05			3-56-0-Q	SEWAGE SPACE	77.1	0	0	HS	X
D05			3-68-2-A	DRY STORES	33.6	0	0		
S2I			1-68-2-Q	HYD PUMP ROOM	19.3	0	0		
S2I			1-70-2-L	VESTIBULE	4.8	0	0		
S3I			(none)	(weather overhead)	85.6	0	0		
			2-60-1-L	CREWS BERTHING	(CUI = L5)				
0		0	2-44-01-L	PASSAGE	16	0	0		
0		0	2-44-01-L	PASSAGE	36.6	0	0		
0		0	2-44-01-L	PASSAGE	60.8	0	0		
0		0	2-44-01-L	PASSAGE	14.4	0	0		
B05		B05	2-44-1-L	CREW LOUNGE	86.4	0	0		
B05	S3I	B05	2-74-1-L	CREW WR, WC & SH	86.4	0	0		
S2I	S3U		(none)	(weather bulkhead)	110.4	0	0		
S2I			3-56-0-Q	SEWAGE SPACE	98.3	0	0		
S2I			3-68-1-A	GENERAL STORES	68.2	0	0		
S2I			1-68-1-Q	HYD PUMP ROOM	7.3	0	0		
S2I			1-70-1-L	VESTIBULE	12	0	0		
D05			1-70-3A-L	CREW MESS	25.6	0	0		
S3I			(none)	(weather overhead)	121.6	0	0		
			2-74-0-L	CREWS BERTHING	(CUI = L5)				
S2U	S3I	S2I	4-92-0-E	GENERATOR ROOM	257.6	0	0		
S2U	S3I	S2I	2-44-01-L	PASSAGE	40	0	0		
S2U	S3I	S2I	2-44-2-L	CREWS BERTHING	84.8	0	0		
B05	S3I	B05	2-57-0-L	CREW WR, WC & SH	44.8	0	0		
S2I		S2U	2-74-1-L	CREW WR, WC & SH	46.4	0	0		
S2I		S2U	2-74-1-L	CREW WR, WC & SH	24	0	0	DJ	NC
S2I		S2U	2-74-1-L	CREW WR, WC & SH	27.2	0	0		
S2I		S2U	2-74-1-L	CREW WR, WC & SH	40	0	0		
S2I		S2U	2-74-1-L	CREW WR, WC & SH	22.4	0	0		
S2I		S2U	2-74-1-L	CREW WR, WC & SH	20.8	0	0		
S2I	S3U		(none)	(weather bulkhead)	59.2	0	0		
S2I	S3U		(none)	(weather bulkhead)	144	0	0		
S2I	S3U		(none)	(weather bulkhead)	8	0	0		
D05			3-74-0-A	MEATS	107.8	0	0		
D05			3-74-2-Q	REEFER FLAT	111.2	0	0	HL	X
S2I			3-74-1-M	SMALL ARMS AMMUNITIO	15.1	0	0		
D05			3-74-3-A	MAA STORAGE	4.4	0	0		
D05			3-81-0-A	DAIRY	32	0	0		

D.1.1 Barrier Data: Only Fire Zone Bulkheads Insulated

Barrier Material					Area	Therm	Durab	Door/	Readiness
<1>	<2>	<3>			ft2	adj	adj	Hatch	
D05			3-81-1-L	PASSAGE	64.3	0	0	HS	X
D05			3-81-2-L	PASSAGE	16	0	0		
D05			3-85-0-A	FRUITS AND VEGETABLE	84	0	0		
D05			3-85-3-A	MAA LKR	44.8	0	0		
D05			1-70-3A-L	CREW MESS	70.8	0	0		
S2I			1-70-4-L	PO-1 BERTHING	114	0	0		
S2I			1-74-0-L	PASSAGE	34.6	0	0		
S2I			1-74-2A-L	PASSAGE	61.8	0	0		
S2I			1-77-0-Q	GYRO EQUIP	6	0	0		
S2I			1-77-1-L	COMPANIONWAY	13.3	0	0	HS	X
D05			1-79-0-Q	GALLEY	165.9	0	0		
S2I			1-85-2-L	COMPANIONWAY	13.2	0	0	HS	X
D05			1-91-2-L	PO-1 WC, WR & SH	9	0	0		
S3I			(none)	(weather overhead)	14.4	0	0		
			2-74-1-L	CREW WR, WC & SH	(CUI = LW)				
B05	S3I	B05	2-44-01-L	PASSAGE	9.6	0	0		
B05	S3I	B05	2-60-1-L	CREWS BERTHING	86.4	0	0		
S2U		S2I	2-74-0-L	CREWS BERTHING	46.4	0	0		
S2U		S2I	2-74-0-L	CREWS BERTHING	24	0	0	DJ	NC
S2U		S2I	2-74-0-L	CREWS BERTHING	27.2	0	0		
S2U		S2I	2-74-0-L	CREWS BERTHING	40	0	0		
S2U		S2I	2-74-0-L	CREWS BERTHING	22.4	0	0		
S2U		S2I	2-74-0-L	CREWS BERTHING	20.8	0	0		
B05	S3U		(none)	(weather bulkhead)	84.8	0	0		
D05			3-74-1-M	SMALL ARMS AMMUNITIO	26.9	0	0		
D05			3-74-3-A	MAA STORAGE	66	0	0		
D05			1-70-3A-L	CREW MESS	87.4	0	0		
S2I			1-74-0-L	PASSAGE	6.2	0	0		
			2-126-1-Q	MACHINE SHOP	(CUI = QS)				
B05	S3I	B05	4-116-1-F	DIESEL OIL TANK	99.2	0	0		
0		0	4-126-0-E	MAIN MOTOR ROOM	112	0	0	DJ	NC
B05	S3I	B05	3-140-1-W	FRESH WATER TANK	86.4	0	0		
S2I	S3U		(none)	(weather bulkhead)	112.7	0	0		
S2U			4-126-0-E	MAIN MOTOR ROOM	70	0	0		
S2I			1-99-1B-L	PASSAGE	4	0	0		
S2I			1-124-1-L	SR #1	49.2	0	0		
S2I			1-132-0A-L	PASSAGE	26.8	0	0		
S2I			1-132-1-L	SR #3	68.8	0	0		
S3I			(none)	(weather overhead)	13.6	0	0		
			2-126-2-Q	A.C. EQUIPMENT	(CUI = QA)				
B05	S3I	B05	4-116-0-F	DIESEL OIL TANK	6.4	0	0		
B05	S3I	B05	4-116-2-F	DIESEL OIL TANK	99.2	0	0		
0		0	4-126-0-E	MAIN MOTOR ROOM	112	0	0		
B05	S3I	B05	4-140-0-W	FRESH WATER TANK	8	0	0		
B05	S3I	B05	3-140-2-W	FRESH WATER TANK	84.8	0	0		
S2I	S3U		(none)	(weather bulkhead)	112.7	0	0		

D.1.1 Barrier Data: Only Fire Zone Bulkheads Insulated

Barrier Material					Area	Therm	Durab	Door/	Readiness
<1>	<2>	<3>			ft2	adj	adj	Hatch	
S2U			4-126-0-E	MAIN MOTOR ROOM	81.2	0	0		
S2I			1-74-2C-L	PASSAGE	8	0	0		
S2I			1-124-2-L	SR #2	46.8	0	0		
S2I			1-132-0A-L	PASSAGE	34.8	0	0		
S2I			1-132-2-L	SR #4	68.8	0	0		
S3I			(none)	(weather overhead)	15.2	0	0		
			3-140-1-W	FRESH WATER TANK	(CUI = W)				
B05		B05	4-140-0-W	FRESH WATER TANK	56	0	0		
B05	S3I	B05	2-126-1-Q	MACHINE SHOP	86.4	0	0		
B05		B05	2-147-0-Q	ENGINEERS STOREROOM	75.2	0	0		
B05	S3U		(none)	(weather bulkhead)	57.1	0	0		
S2U			4-140-0-W	FRESH WATER TANK	12.6	0	0		
S2U			1-140-0-L	WARDROOM	61.4	0	0		
S3I			(none)	(weather overhead)	9.3	0	0		
			3-140-2-W	FRESH WATER TANK	(CUI = W)				
B05		B05	4-140-0-W	FRESH WATER TANK	56	0	0		
B05	S3I	B05	2-126-2-Q	A.C. EQUIPMENT	84.8	0	0		
B05		B05	2-147-0-Q	ENGINEERS STOREROOM	73.6	0	0		
B05	S3U		(none)	(weather bulkhead)	57.1	0	0		
S2U			4-140-0-W	FRESH WATER TANK	11.2	0	0		
D05			1-132-0B-L	PASSAGE	5.6	0	0		
S2U			1-140-2-L	SR #6	57.6	0	0		
S3I			(none)	(weather overhead)	6.1	0	0		
			2-147-0-Q	ENGINEERS STOREROOM	(CUI = AS)				
B05		B05	4-140-0-W	FRESH WATER TANK	88	0	0		
B05		B05	3-140-1-W	FRESH WATER TANK	75.2	0	0		
B05		B05	3-140-2-W	FRESH WATER TANK	73.6	0	0		
B05	S3I	B05	2-161-0-Q	LAZARETTE	169.6	0	0		
B05	S3U		(none)	(weather bulkhead)	116.9	0	0		
B05	S3U		(none)	(weather bulkhead)	116.9	0	0		
S2U			4-147-0-W	AFT PEAK TANK	88.2	0	0		
D05			1-132-0B-L	PASSAGE	30	0	0		
S2U			1-140-0-L	WARDROOM	155.8	0	0		
S2U			1-140-2-L	SR #6	21.4	0	0		
D05			1-150-2-L	OFFICER WR, WC & SH	43.2	0	0		
S2U			1-157-0-E	STEERING GEAR SPACE	41.6	0	0	HS	X
S2U			1-157-1-Q	ARMORY	25.3	0	0		
S2U			1-157-2-Q	LINEN LKR	18.3	0	0		
S3I			(none)	(weather overhead)	20	0	0		
			2-161-0-Q	LAZARETTE	(CUI = QA)				
B05	S3I	B05	2-147-0-Q	ENGINEERS STOREROOM	169.6	0	0		
B05	S3U		(none)	(weather bulkhead)	18.2	0	0		
B05	S3U		(none)	(weather bulkhead)	10.2	0	0		
B05	S3U		(none)	(weather bulkhead)	51.2	0	0		
B05	S3U		(none)	(weather bulkhead)	33	0	0		

D.1.1 Barrier Data: Only Fire Zone Bulkheads Insulated

Barrier Material					Area	Therm	Durab	Door/	Readiness
<1>	<2>	<3>			ft2	adj	adj	Hatch	
B05	S3U		(none)	(weather bulkhead)	30.1	0	0		
B05	S3U		(none)	(weather bulkhead)	30.1	0	0		
B05	S3U		(none)	(weather bulkhead)	33	0	0		
B05	S3U		(none)	(weather bulkhead)	51.2	0	0		
B05	S3U		(none)	(weather bulkhead)	10.2	0	0		
B05	S3U		(none)	(weather bulkhead)	18.2	0	0		
S2U			1-157-0-E	STEERING GEAR SPACE	148	0	0	HS	X
S2U			1-157-1-Q	ARMORY	10.7	0	0		
S2U			1-161-2-Q	CG LKR	6.2	0	0		
S3I			(none)	(weather overhead)	15.9	0	0		
			1-FP-0-K	PAINT LKR	(CUI = K)				
B05		B05	1-6-0-Q	DECK WORKSHOP	112	0	0	DJ	NC
B05		B05	1-6-1-Q	A/N LKR	16	0	0		
B05		B05	1-6-2-Q	BOSN'S LKR	16	0	0		
B05	S2U		(none)	(weather bulkhead)	72.8	0	0		
B05	S2U		(none)	(weather bulkhead)	40	0	0		
B05	S2U		(none)	(weather bulkhead)	40	0	0		
B05	S2U		(none)	(weather bulkhead)	72.8	0	0		
S2U			4-FP-0-W	FOREPEAK TANK	58.4	0	0		
S2U			(none)	(weather overhead)	110.8	0	0		
			1-6-0-Q	DECK WORKSHOP	(CUI = QS)				
B05		B05	1-FP-0-K	PAINT LKR	112	0	0	DJ	NC
B05		B05	1-6-1-Q	A/N LKR	83.2	0	0	DJ	NC
B05		B05	1-6-2-Q	BOSN'S LKR	83.2	0	0	DJ	NC
B05	S2U		(none)	(weather bulkhead)	112	0	0	DJ	NC
S2U			4-FP-0-W	FOREPEAK TANK	42.7	0	0		
S2U			2-9-0-Q	CHAIN LKR	54	0	0	HS	X
S2U			2-9-0-E	DC SHOP	44	0	0	HS	X
S2I			(none)	(weather overhead)	145.6	0	0		
			1-6-1-Q	A/N LKR	(CUI = AG)				
B05		B05	1-FP-0-K	PAINT LKR	16	0	0		
B05		B05	1-6-0-Q	DECK WORKSHOP	83.2	0	0	DJ	NC
B05	S2U		(none)	(weather bulkhead)	48	0	0		
B05	S2U		(none)	(weather bulkhead)	59.7	0	0		
B05	S2U		(none)	(weather bulkhead)	29.4	0	0		
S2U			2-9-0-E	DC SHOP	8.9	0	0		
S2U			(none)	(weather overhead)	42.1	0	0		
			1-6-2-Q	BOSN'S LKR	(CUI = AG)				
B05		B05	1-FP-0-K	PAINT LKR	16	0	0		
B05		B05	1-6-0-Q	DECK WORKSHOP	83.2	0	0	DJ	NC
B05	S2U		(none)	(weather bulkhead)	48	0	0		
B05	S2U		(none)	(weather bulkhead)	89.1	0	0		
S2U			2-9-0-E	DC SHOP	8.9	0	0		
S2U			(none)	(weather overhead)	41.6	0	0		

D.1.1 Barrier Data: Only Fire Zone Bulkheads Insulated

Barrier Material					Area	Therm	Durab	Door/	Readiness
<1>	<2>	<3>			ft2	adj	adj	Hatch	
			1-68-0-L	COMPANIONWAY	(CUI	= LP)			
B05		B05	1-68-1-Q	HYD PUMP ROOM	41.6	0	0		
B05		B05	1-68-2-Q	HYD PUMP ROOM	41.6	0	0		
B05		B05	1-74-0-L	PASSAGE	28.8	0	0	DJ	NC
B05	S2U		(none)	(weather bulkhead)	15.8	0	0		
B05	S2U		(none)	(weather bulkhead)	15.8	0	0		
S2I			2-44-01-L	PASSAGE	19.1	0	0	HS	X
S2I			01-71-0-Q	CRANE CONTROL BOOTH	12.2	0	0		
S2I			(none)	(weather overhead)	7.9	0	0		
			1-68-1-Q	HYD PUMP ROOM	(CUI	= QA)			
B05		B05	1-68-0-L	COMPANIONWAY	41.6	0	0		
B05		B05	1-70-1-L	VESTIBULE	32	0	0		
B05		B05	1-74-0-L	PASSAGE	33.6	0	0	DJ	NC
B05	S2U		(none)	(weather bulkhead)	34.9	0	0		
S2I			2-44-01-L	PASSAGE	12	0	0		
S2I			2-60-1-L	CREWS BERTHING	7.3	0	0		
S2I			01-71-0-Q	CRANE CONTROL BOOTH	6.1	0	0		
S2I			(none)	(weather overhead)	13.2	0	0		
			1-68-2-Q	HYD PUMP ROOM	(CUI	= QA)			
B05		B05	1-68-0-L	COMPANIONWAY	41.6	0	0		
B05		B05	1-70-2-L	VESTIBULE	32	0	0		
B05		B05	1-74-0-L	PASSAGE	33.6	0	0	DJ	NC
B05	S2U		(none)	(weather bulkhead)	34.9	0	0		
S2I			2-57-0-L	CREW WR, WC & SH	19.3	0	0		
S2I			01-71-0-Q	CRANE CONTROL BOOTH	6.1	0	0		
S2I			(none)	(weather overhead)	13.2	0	0		
			1-70-1-L	VESTIBULE	(CUI	= LP)			
B05		B05	1-68-1-Q	HYD PUMP ROOM	32	0	0		
S2U		S2I	1-70-3A-L	CREW MESS	24	0	0	DJ	NO
S2U		S2I	1-70-3A-L	CREW MESS	32	0	0		
B05	S2U		(none)	(weather bulkhead)	24	0	0	DWT	X
S2I			2-60-1-L	CREWS BERTHING	12	0	0		
S2I			(none)	(weather overhead)	12	0	0		
			1-70-2-L	VESTIBULE	(CUI	= LP)			
B05		B05	1-68-2-Q	HYD PUMP ROOM	32	0	0		
S2U		S2I	1-70-4-L	PO-1 BERTHING	32	0	0		
B05		B05	1-74-2A-L	PASSAGE	24	0	0	DJ	NO
B05	S2U		(none)	(weather bulkhead)	24	0	0	DWT	X
S2I			2-44-2-L	CREWS BERTHING	7.2	0	0		
S2I			2-57-0-L	CREW WR, WC & SH	4.8	0	0		
S2I			(none)	(weather overhead)	12	0	0		
			1-70-3A-L	CREW MESS	(CUI	= LL)			
S2I		S2U	1-70-1-L	VESTIBULE	24	0	0	DJ	NO
S2I		S2U	1-70-1-L	VESTIBULE	32	0	0		

D.1.1 Barrier Data: Only Fire Zone Bulkheads Insulated

Barrier Material					Area	Therm	Durab	Door/	Readiness
<1>	<2>	<3>			ft2	adj	adj	Hatch	
B05		B05	1-74-0-L	PASSAGE	19.2	0	0	DJ	NO
B05		B05	1-77-1-L	COMPANIONWAY	36.8	0	0		
B05		B05	1-79-0-Q	GALLEY	8	-5	-5		
B05		B05	1-79-0-Q	GALLEY	88	-5	-5		
B05		B05	1-79-0-Q	GALLEY	28.8	-5	-5		
B05		B05	1-92-0-Q	SCULLERY	51.2	0	0	DJ	NO
B05		B05	1-93-1-L	CPO MESS & REC	24	0	0		
B05		B05	1-93-1-L	CPO MESS & REC	16	0	0		
B05		B05	1-93-1-L	CPO MESS & REC	40	0	0		
0		0	1-99-1A-L	PASSAGE	45.5	0	0		
B06	S2U		(none)	(weather bulkhead)	203.2	0	0		
B06	S2U		(none)	(weather bulkhead)	64	0	0		
D05			4-92-0-E	GENERATOR ROOM	65.6	0	0		
D05			2-60-1-L	CREWS BERTHING	25.6	0	0		
D05			2-74-0-L	CREWS BERTHING	70.8	0	0		
D05			2-74-1-L	CREW WR, WC & SH	87.4	0	0		
S2I			01-74-1-Q	CODE ROOM	11.6	0	0		
S2I			01-82-0-L	CO CABIN	13	0	0		
S2I			01-95-1-L	COMPANIONWAY	8.4	0	0		
S2I			(none)	(weather overhead)	251.8	0	0		
			1-70-4-L	PO-1 BERTHING	(CUI = L5)				
S2I		S2U	1-70-2-L	VESTIBULE	32	0	0		
S2I		S2U	1-74-2A-L	PASSAGE	6.4	-25	-25		
S2I		S2U	1-74-2A-L	PASSAGE	88	-25	-25	DJ	NC
S2I		S2U	1-85-2-L	COMPANIONWAY	35.2	0	0		
S2I		S2U	1-85-2-L	COMPANIONWAY	24	0	0		
S2I		NSU	1-91-2-L	PO-1 WC, WR & SH	40	0	0	DJ	NC
S2I	S2U		(none)	(weather bulkhead)	64	0	0		
S2I	S2U		(none)	(weather bulkhead)	161.6	0	0		
S2I			2-44-2-L	CREWS BERTHING	32	0	0		
S2I			2-74-0-L	CREWS BERTHING	114	0	0		
S2I			(none)	(weather overhead)	146	0	0		
			1-74-0-L	PASSAGE	(CUI = LP)				
B05		B05	1-68-0-L	COMPANIONWAY	28.8	0	0	DJ	NC
B05		B05	1-68-1-Q	HYD PUMP ROOM	33.6	0	0	DJ	NC
B05		B05	1-68-2-Q	HYD PUMP ROOM	33.6	0	0	DJ	NC
B05		B05	1-70-3A-L	CREW MESS	19.2	0	0	DJ	NO
B05		B05	1-74-2A-L	PASSAGE	35.2	0	0	DJ	NO
B05		B05	1-77-0-Q	GYRO EQUIP	16	0	0		
B05		B05	1-77-0-Q	GYRO EQUIP	24	0	0	DJ	NC
B05		B05	1-77-1-L	COMPANIONWAY	24	0	0	DJ	NC
B05		B05	1-79-0-Q	GALLEY	48	0	0		
S2I			2-74-0-L	CREWS BERTHING	34.6	0	0		
S2I			2-74-1-L	CREW WR, WC & SH	6.2	0	0		
S2I			01-74-0-L	CO SR	26.4	0	0		
S2I			01-74-1-Q	CODE ROOM	14.4	0	0		

D.1.1 Barrier Data: Only Fire Zone Bulkheads Insulated

Barrier Material					Area	Therm	Durab	Door/	Readiness
<1>	<2>	<3>			ft2	adj	adj	Hatch	
			1-74-2A-L	PASSAGE	(CUI	= LP)			
B05		B05	1-70-2-L	VESTIBULE	24	0	0	DJ	NO
S2U		S2I	1-70-4-L	PO-1 BERTHING	6.4	-25	-25		
S2U		S2I	1-70-4-L	PO-1 BERTHING	88	-25	-25	DJ	NC
B05		B05	1-74-0-L	PASSAGE	35.2	0	0	DJ	NO
0		0	1-74-2B-L	PASSAGE	25.3	0	0		
B05		B05	1-79-0-Q	GALLEY	108.8	0	0	DJ	NO
B05		B05	1-85-2-L	COMPANIONWAY	35.2	0	0		
B05		B05	1-85-2-L	COMPANIONWAY	24	0	0	DJ	NC
B05		NSU	1-91-2-L	PO-1 WC, WR & SH	22.4	0	0		
B05		NSU	1-91-2-L	PO-1 WC, WR & SH	24	0	0		
B05		NSU	1-91-2-L	PO-1 WC, WR & SH	48	0	0	DJ	NC
B05		B05	1-92-2-Q	DC LKR	48	0	0	DJ	NC
S2I			4-92-0-E	GENERATOR ROOM	22.5	0	0		
S2I			2-74-0-L	CREWS BERTHING	61.8	0	0		
S2I			01-74-0-L	CO SR	15.2	0	0		
S2I			01-82-0-L	CO CABIN	8.2	0	0		
S2I			01-89-2-Q	FAN ROOM	3.2	0	0		
S2I			01-93-2-L	COMPANIONWAY	5.2	0	0		
S2I			(none)	(weather overhead)	52.5	0	0		
			1-74-2B-L	PASSAGE	(CUI	= LP)			
0		0	1-74-2A-L	PASSAGE	25.3	0	0		
0		0	1-74-2C-L	PASSAGE	25.6	0	0		
B05		B05	1-92-2-Q	DC LKR	20.8	0	0		
S2U		S2I	4-92-0A-E	FIDLEY	108.8	0	0		
B05		NSU	1-99-2-L	DISPENSARY	56	-25	-25	DJ	NC
B05		B05	1-106-2-L	CPO BERTHING	19.2	-25	-25		
B05		B05	1-106-2-L	CPO BERTHING	48	-25	-25		
S2I			4-92-0-E	GENERATOR ROOM	62.5	0	0		
S2I			01-93-2-L	COMPANIONWAY	13.4	0	0	HO	O
S2I			(none)	(weather overhead)	46.3	0	0		
			1-74-2C-L	PASSAGE	(CUI	= LP)			
0		0	1-74-2B-L	PASSAGE	25.6	0	0		
B05		B05	1-106-2-L	CPO BERTHING	89.6	-25	-25	DJ	NC
B05		B05	1-112-0-Q	AUXILIARY MACHINERY	144	0	0	DJ	NC
B05		B05	1-124-2-L	SR #2	54.4	0	0		
B05		B05	1-132-0A-L	PASSAGE	25.6	0	0	DJ	NO
S2I			4-92-0-E	GENERATOR ROOM	12.8	0	0		
S2I			4-116-0-F	DIESEL OIL TANK	20	0	0		
S2I			4-116-2-F	DIESEL OIL TANK	12	0	0		
S2U			4-126-0-E	MAIN MOTOR ROOM	4.8	0	0		
S2I			2-126-2-Q	A.C. EQUIPMENT	8	0	0		
S2I			(none)	(weather overhead)	55.8	0	0		
			1-77-0-Q	GYRO EQUIP	(CUI	= QA)			
B05		B05	1-74-0-L	PASSAGE	16	0	0		
B05		B05	1-74-0-L	PASSAGE	24	0	0	DJ	NC

D.1.1 Barrier Data: Only Fire Zone Bulkheads Insulated

Barrier Material				Area	Therm	Durab	Door/	Readiness
<1>	<2>	<3>		ft2	adj	adj	Hatch	
B05		B05	1-77-1-L	COMPANIONWAY	16	0	0	
B05		B05	1-79-0-Q	GALLEY	24	0	0	
S2I			2-74-0-L	CREWS BERTHING	6	0	0	
S2I			01-74-1-Q	CODE ROOM	6	0	0	
			1-77-1-L	COMPANIONWAY	(CUI = LP)			
B05		B05	1-70-3A-L	CREW MESS	36.8	0	0	
B05		B05	1-74-0-L	PASSAGE	24	0	0	DJ NC
B05		B05	1-77-0-Q	GYRO EQUIP	16	0	0	
B05		B05	1-79-0-Q	GALLEY	20.8	0	0	
B05		B05	1-79-0-Q	GALLEY	24	0	0	
S2I			2-74-0-L	CREWS BERTHING	13.3	0	0	HS X
S2I			01-74-1-Q	CODE ROOM	13.8	0	0	
			1-79-0-Q	GALLEY	(CUI = QG)			
B05		B05	1-70-3A-L	CREW MESS	8	-5	-5	
B05		B05	1-70-3A-L	CREW MESS	88	-5	-5	
B05		B05	1-70-3A-L	CREW MESS	28.8	-5	-5	
B05		B05	1-74-0-L	PASSAGE	48	0	0	
B05		B05	1-74-2A-L	PASSAGE	108.8	0	0	DJ NO
B05		B05	1-77-0-Q	GYRO EQUIP	24	0	0	
B05		B05	1-77-1-L	COMPANIONWAY	20.8	0	0	
B05		B05	1-77-1-L	COMPANIONWAY	24	0	0	
B05		B05	1-92-0-Q	SCULLERY	54.4	0	0	
B05		B05	1-92-2-Q	DC LKR	20.8	0	0	
D05			2-74-0-L	CREWS BERTHING	165.9	0	0	
S2U			01-74-0-L	CO SR	19.2	0	0	
S2U			01-74-1-Q	CODE ROOM	12	0	0	
S2U			01-82-0-L	CO CABIN	129.9	0	0	
S2U			01-89-2-Q	FAN ROOM	5.3	0	0	
			1-85-2-L	COMPANIONWAY	(CUI = LP)			
S2U		S2I	1-70-4-L	PO-1 BERTHING	35.2	0	0	
S2U		S2I	1-70-4-L	PO-1 BERTHING	24	0	0	
B05		B05	1-74-2A-L	PASSAGE	35.2	0	0	
B05		B05	1-74-2A-L	PASSAGE	24	0	0	DJ NC
S2I			2-74-0-L	CREWS BERTHING	13.2	0	0	HS X
S2I			(none)	(weather overhead)	13.2	0	0	
			1-91-2-L	PO-1 WC, WR & SH	(CUI = LW)			
NSU		S2I	1-70-4-L	PO-1 BERTHING	40	0	0	DJ NC
NSU		B05	1-74-2A-L	PASSAGE	22.4	0	0	
NSU		B05	1-74-2A-L	PASSAGE	24	0	0	
NSU		B05	1-74-2A-L	PASSAGE	48	0	0	DJ NC
NSU		NSU	1-99-2-L	DISPENSARY	64	0	0	
NSU	S2U		(none)	(weather bulkhead)	70.4	0	0	
D05			4-92-0-E	GENERATOR ROOM	51.8	0	0	
D05			2-74-0-L	CREWS BERTHING	9	0	0	
S2I			(none)	(weather overhead)	62	0	0	

D.1.1 Barrier Data: Only Fire Zone Bulkheads Insulated

Barrier Material					Area	Therm	Durab	Door/	Readiness
<1>	<2>	<3>			ft2	adj	adj	Hatch	
			1-92-0-Q	SCULLERY	(CUI	= QG)			
B05		B05	1-70-3A-L	CREW MESS	51.2	0	0	DJ	NO
B05		B05	1-79-0-Q	GALLEY	54.4	0	0		
B05		B05	1-92-2-Q	DC LKR	48	0	0		
S2U		S2I	4-92-0A-E	FIDLEY	54.4	0	0		
D05			4-92-0-E	GENERATOR ROOM	43.5	0	0		
S2U			01-82-0-L	CO CABIN	34	0	0		
S2U			01-95-0-L	WR, WC & SH	9.5	0	0		
			1-92-2-Q	DC LKR	(CUI	= AG)			
B05		B05	1-74-2A-L	PASSAGE	48	0	0	DJ	NC
B05		B05	1-74-2B-L	PASSAGE	20.8	0	0		
B05		B05	1-79-0-Q	GALLEY	20.8	0	0		
B05		B05	1-92-0-Q	SCULLERY	48	0	0		
S2I			4-92-0-E	GENERATOR ROOM	15.6	0	0		
S2I			01-89-2-Q	FAN ROOM	2.4	0	0		
S2I			01-93-2-L	COMPANIONWAY	12	0	0		
			1-93-1-L	CPO MESS & REC	(CUI	= LL)			
B05		B05	1-70-3A-L	CREW MESS	24	0	0		
B05		B05	1-70-3A-L	CREW MESS	16	0	0		
B05		B05	1-70-3A-L	CREW MESS	40	0	0		
B05		B05	1-99-1A-L	PASSAGE	64	0	0	DJ	NC
B05		B05	1-106-1-Q	MOVIE LKR	12.8	0	0		
B05		B05	1-107-1-Q	MORALE LKR	24	0	0		
B05		B05	1-110-1-Q	SHIPS OFFICE	64	-5	-5		
B06	S2U		(none)	(weather bulkhead)	116.8	0	0		
S2I			4-92-0-E	GENERATOR ROOM	109.2	0	0		
S2I			(none)	(weather overhead)	110.8	0	0		
			4-92-0A-E	FIDLEY	(CUI	= QA)			
S2I		S2U	1-74-2B-L	PASSAGE	108.8	0	0		
S2I		S2U	1-92-0-Q	SCULLERY	54.4	0	0		
S2I		S2U	1-99-1A-L	PASSAGE	108.8	0	0		
S2I		S2U	1-112-0-Q	AUXILIARY MACHINERY	54.4	0	0	DO	O
S2I			4-92-0-E	GENERATOR ROOM	92.5	-90	-90	HL	X
S2I			01-82-0-L	CO CABIN	2	0	0		
S2I			01-95-0-L	WR, WC & SH	22.4	0	0		
S2I			01-102-0-E	VENT & UPTAKE SPACE	34	0	0		
S2I			01-110-0-Q	FAN & EQUIPMENT ROOM	34	0	0		
			1-99-1A-L	PASSAGE	(CUI	= LP)			
0		0	1-70-3A-L	CREW MESS	45.5	0	0		
B05		B05	1-93-1-L	CPO MESS & REC	64	0	0	DJ	NC
S2U		S2I	4-92-0A-E	FIDLEY	108.8	0	0		
0		0	1-99-1B-L	PASSAGE	24	0	0		
B05		B05	1-106-1-Q	MOVIE LKR	12.8	0	0		
B05		B05	1-106-1-Q	MOVIE LKR	20.8	0	0	DJ	NC

D.1.1 Barrier Data: Only Fire Zone Bulkheads Insulated

Barrier Material					Area	Therm	Durab	Door/	Readiness
<1>	<2>	<3>			ft2	adj	adj	Hatch	
B05		B05	1-107-1-Q	MORALE LKR	24	0	0	DJ	NC
B05		B05	1-110-1-Q	SHIPS OFFICE	16	-5	-5		
S2I			4-92-0-E	GENERATOR ROOM	61.8	0	0		
S2I			01-95-1-L	COMPANIONWAY	13.4	0	0	HO	O
S2I			(none)	(weather overhead)	45.7	0	0		
			1-99-1B-L	PASSAGE	(CUI	= LP)			
0		0	1-99-1A-L	PASSAGE	24	0	0		
B05		B05	1-110-1-Q	SHIPS OFFICE	88	-5	-5	DJ	NC
B05		B05	1-112-0-Q	AUXILIARY MACHINERY	144	0	0	DJ	NC
B05		B05	1-124-1-L	SR #1	56	-5	-5		
B05		B05	1-132-0A-L	PASSAGE	24	0	0	DJ	NO
S2I			4-92-0-E	GENERATOR ROOM	12	0	0		
S2I			4-116-0-F	DIESEL OIL TANK	20	0	0		
S2I			4-116-1-F	DIESEL OIL TANK	10	0	0		
S2U			4-126-0-E	MAIN MOTOR ROOM	8	0	0		
S2I			2-126-1-Q	MACHINE SHOP	4	0	0		
S2I			(none)	(weather overhead)	52.2	0	0		
			1-99-2-L	DISPENSARY	(CUI	= LM)			
NSU		B05	1-74-2B-L	PASSAGE	56	-25	-25	DJ	NC
NSU		NSU	1-91-2-L	PO-1 WC, WR & SH	64	0	0		
NSU		NSU	1-104-2-L	CPO WR, WC & SH	24	0	0		
NSU		NSU	1-104-2-L	CPO WR, WC & SH	20.8	0	0		
NSU		NSU	1-104-2-L	CPO WR, WC & SH	17.6	0	0		
NSU		B05	1-106-2-L	CPO BERTHING	20.8	0	0		
NSU	S2U		(none)	(weather bulkhead)	35.2	0	0		
D05			4-92-0-E	GENERATOR ROOM	47.1	0	0		
S2I			(none)	(weather overhead)	47.2	0	0		
			1-104-2-L	CPO WR, WC & SH	(CUI	= LW)			
NSU		NSU	1-99-2-L	DISPENSARY	24	0	0		
NSU		NSU	1-99-2-L	DISPENSARY	20.8	0	0		
NSU		NSU	1-99-2-L	DISPENSARY	17.6	0	0		
NSU		B05	1-106-2-L	CPO BERTHING	40	0	0	DJ	NC
NSU		B05	1-106-2-L	CPO BERTHING	40	0	0		
NSU	S2U		(none)	(weather bulkhead)	60.8	0	0		
D05			4-92-0-E	GENERATOR ROOM	33	0	0		
S2I			(none)	(weather overhead)	33	0	0		
			1-106-1-Q	MOVIE LKR	(CUI	= AG)			
B05		B05	1-93-1-L	CPO MESS & REC	12.8	0	0		
B05		B05	1-99-1A-L	PASSAGE	12.8	0	0		
B05		B05	1-99-1A-L	PASSAGE	20.8	0	0	DJ	NC
B05		B05	1-107-1-Q	MORALE LKR	20.8	0	0		
S2I			4-92-0-E	GENERATOR ROOM	4.2	0	0		
S2I			(none)	(weather overhead)	4.2	0	0		
			1-106-2-L	CPO BERTHING	(CUI	= L2)			

D.1.1 Barrier Data: Only Fire Zone Bulkheads Insulated

Barrier Material				Area	Therm	Durab	Door/	Readiness	
<1>	<2>	<3>		ft2	adj	adj	Hatch		
B05		B05	1-74-2B-L	PASSAGE	19.2	-25	-25		
B05		B05	1-74-2B-L	PASSAGE	48	-25	-25		
B05		B05	1-74-2C-L	PASSAGE	89.6	-25	-25	DJ	NC
B05		NSU	1-99-2-L	DISPENSARY	20.8	0	0		
B05		NSU	1-104-2-L	CPO WR, WC & SH	40	0	0	DJ	NC
B05		NSU	1-104-2-L	CPO WR, WC & SH	40	0	0		
B05		B05	1-124-2-L	SR #2	80	0	0		
S2I	S2U		(none)	(weather bulkhead)	97.6	0	0		
S2I			4-92-0-E	GENERATOR ROOM	75	0	0		
S2I			4-116-2-F	DIESEL OIL TANK	72	0	0		
S2I			(none)	(weather overhead)	147	0	0		
			1-107-1-Q	MORALE LKR	(CUI	= AG)			
B05		B05	1-93-1-L	CPO MESS & REC	24	0	0		
B05		B05	1-99-1A-L	PASSAGE	24	0	0	DJ	NC
B05		B05	1-106-1-Q	MOVIE LKR	20.8	0	0		
B05		B05	1-110-1-Q	SHIPS OFFICE	20.8	-5	-5		
S2I			4-92-0-E	GENERATOR ROOM	7.8	0	0		
S2I			(none)	(weather overhead)	7.8	0	0		
			1-110-1-Q	SHIPS OFFICE	(CUI	= QO)			
B05		B05	1-93-1-L	CPO MESS & REC	64	-5	-5		
B05		B05	1-99-1A-L	PASSAGE	16	-5	-5		
B05		B05	1-99-1B-L	PASSAGE	88	-5	-5	DJ	NC
B05		B05	1-107-1-Q	MORALE LKR	20.8	-5	-5		
B05		B05	1-124-1-L	SR #1	81.6	-5	-5		
B06	S2U		(none)	(weather bulkhead)	104.1	0	0		
S2I			4-92-0-E	GENERATOR ROOM	63	0	0		
S2I			4-116-1-F	DIESEL OIL TANK	72.2	0	0		
S2I			(none)	(weather overhead)	135.2	0	0		
			1-112-0-Q	AUXILIARY MACHINERY SPACE #3	(CUI	= QA)			
B05		B05	1-74-2C-L	PASSAGE	144	0	0	DJ	NC
S2U	S2I		4-92-0A-E	FIDLEY	54.4	0	0	DO	O
B05		B05	1-99-1B-L	PASSAGE	144	0	0	DJ	NC
B05		B05	1-132-0A-L	PASSAGE	16	0	0		
B05		B05	1-132-0A-L	PASSAGE	54.4	0	0		
B05		B05	1-132-0A-L	PASSAGE	16	0	0		
S2I			4-92-0-E	GENERATOR ROOM	27.2	-15	-15		
S2I			4-116-0-F	DIESEL OIL TANK	68	-15	-15		
S2U			4-126-0-E	MAIN MOTOR ROOM	40.8	-15	-15	HL	X
S2U			01-110-0-Q	FAN & EQUIPMENT ROOM	27.2	0	0		
S2U			01-116-0-Q	CLIP SHACK	34	0	0		
S2I			(none)	(weather overhead)	74.8	0	0		
			1-124-1-L	SR #1	(CUI	= L2)			
B05		B05	1-99-1B-L	PASSAGE	56	-5	-5		
B05		B05	1-110-1-Q	SHIPS OFFICE	81.6	-5	-5		
B05		B05	1-132-0A-L	PASSAGE	44.8	0	0	DJ	NC

D.1.1 Barrier Data: Only Fire Zone Bulkheads Insulated

Barrier Material					Area	Therm	Durab	Door/	Readiness
<1>	<2>	<3>			ft2	adj	adj	Hatch	
B05		B05	1-132-0A-L	PASSAGE	16	0	0		
B05		B05	1-132-1-L	SR #3	35.2	-10	-10		
B06	S2U		(none)	(weather bulkhead)	72	0	0		
S2I			4-116-1-F	DIESEL OIL TANK	30.5	0	0		
S2I			2-126-1-Q	MACHINE SHOP	49.2	0	0		
S2I			(none)	(weather overhead)	79.7	0	0		
			1-124-2-L	SR #2	(CUI = L2)				
B05		B05	1-74-2C-L	PASSAGE	54.4	0	0		
B05		B05	1-106-2-L	CPO BERTHING	80	0	0		
B05		B05	1-132-0A-L	PASSAGE	16	0	0		
B05		B05	1-132-0A-L	PASSAGE	43.2	0	0	DJ	NC
B05		B05	1-132-2-L	SR #4	32	0	0		
B06	S2U		(none)	(weather bulkhead)	70.6	0	0		
S2I			4-116-2-F	DIESEL OIL TANK	27.7	0	0		
S2I			2-126-2-Q	A.C. EQUIPMENT	46.8	0	0		
S2I			(none)	(weather overhead)	74.6	0	0		
			1-132-0A-L	PASSAGE	(CUI = LP)				
B05		B05	1-74-2C-L	PASSAGE	25.6	0	0	DJ	NO
B05		B05	1-99-1B-L	PASSAGE	24	0	0	DJ	NO
B05		B05	1-112-0-Q	AUXILIARY MACHINERY	16	0	0		
B05		B05	1-112-0-Q	AUXILIARY MACHINERY	54.4	0	0		
B05		B05	1-112-0-Q	AUXILIARY MACHINERY	16	0	0		
B05		B05	1-124-1-L	SR #1	44.8	0	0	DJ	NC
B05		B05	1-124-1-L	SR #1	16	0	0		
B05		B05	1-124-2-L	SR #2	16	0	0		
B05		B05	1-124-2-L	SR #2	43.2	0	0	DJ	NC
0		0	1-132-0B-L	PASSAGE	24	0	0		
B05		B05	1-132-1-L	SR #3	56	0	0		
B05		B05	1-132-1-L	SR #3	44.8	0	0	DJ	NC
B05		B05	1-132-1-L	SR #3	8	0	0		
B05		B05	1-132-2-L	SR #4	8	0	0		
B05		B05	1-132-2-L	SR #4	44.8	0	0	DJ	NC
B05		B05	1-132-2-L	SR #4	56	0	0		
B05		B05	1-140-0-L	WARDROOM	16	0	0	DJ	NC
B05		B05	1-140-1-Q	PANTRY	62.4	0	0		
S2U			4-126-0-E	MAIN MOTOR ROOM	86.4	0	0	HS	X
S2I			2-126-1-Q	MACHINE SHOP	26.8	0	0		
S2I			2-126-2-Q	A.C. EQUIPMENT	34.8	0	0		
S2I			(none)	(weather overhead)	148	0	0	HL	X
			1-132-0B-L	PASSAGE	(CUI = LP)				
0		0	1-132-0A-L	PASSAGE	24	0	0		
B05		B05	1-140-0-L	WARDROOM	80	0	0	DJ	NC
B05		B05	1-140-1-Q	PANTRY	56	0	0	DJ	NC
B05		B05	1-140-2-L	SR #6	80	0	0	DJ	NC
B05		B05	1-150-2-L	OFFICER WR, WC & SH	56	0	0	DJ	NC
B05		B05	1-157-0-E	STEERING GEAR SPACE	24	0	0	DJ	NC

D.1.1 Barrier Data: Only Fire Zone Bulkheads Insulated

Barrier Material					Area	Therm	Durab	Door/	Readiness
<1>	<2>	<3>			ft2	adj	adj	Hatch	
D05			4-140-0-W	FRESH WATER TANK	15.4	0	0		
D05			3-140-2-W	FRESH WATER TANK	5.6	0	0		
D05			2-147-0-Q	ENGINEERS STOREROOM	30	0	0		
S2I			(none)	(weather overhead)	51	0	0		
			1-132-1-L	SR #3	(CUI = L1)				
B05	B05		1-124-1-L	SR #1	35.2	-10	-10		
B05	B05		1-132-0A-L	PASSAGE	56	0	0		
B05	B05		1-132-0A-L	PASSAGE	44.8	0	0	DJ	NC
B05	B05		1-132-0A-L	PASSAGE	8	0	0		
B05	B05		1-140-0-L	WARDROOM	68.8	0	0		
B06	S2U		(none)	(weather bulkhead)	65	0	0		
S2I			2-126-1-Q	MACHINE SHOP	68.8	0	0		
S2I			(none)	(weather overhead)	68.8	0	0		
			1-132-2-L	SR #4	(CUI = L1)				
B05	B05		1-124-2-L	SR #2	32	0	0		
B05	B05		1-132-0A-L	PASSAGE	8	0	0		
B05	B05		1-132-0A-L	PASSAGE	44.8	0	0	DJ	NC
B05	B05		1-132-0A-L	PASSAGE	56	0	0		
B05	B05		1-140-2-L	SR #6	72	0	0		
B06	S2U		(none)	(weather bulkhead)	64.2	0	0		
S2I			2-126-2-Q	A.C. EQUIPMENT	68.8	0	0		
S2I			(none)	(weather overhead)	68.8	0	0		
			1-140-0-L	WARDROOM	(CUI = LL)				
B05	B05		1-132-0A-L	PASSAGE	16	0	0	DJ	NC
B05	B05		1-132-0B-L	PASSAGE	80	0	0	DJ	NC
B05	B05		1-132-1-L	SR #3	68.8	0	0		
B05	B05		1-140-1-Q	PANTRY	56	0	0		
B05	B05		1-140-1-Q	PANTRY	62.4	0	0	DJ	NO
B05	B05		1-157-0-E	STEERING GEAR SPACE	59.2	0	0		
B05	B05		1-157-1-Q	ARMORY	56	0	0		
B06	S2U		(none)	(weather bulkhead)	139.7	0	0		
S2U			4-140-0-W	FRESH WATER TANK	7	0	0		
S2U			3-140-1-W	FRESH WATER TANK	61.4	0	0		
S2U			2-147-0-Q	ENGINEERS STOREROOM	155.8	0	0		
S2I			(none)	(weather overhead)	224.2	0	0		
			1-140-1-Q	PANTRY	(CUI = QG)				
B05	B05		1-132-0A-L	PASSAGE	62.4	0	0		
B05	B05		1-132-0B-L	PASSAGE	56	0	0	DJ	NC
B05	B05		1-140-0-L	WARDROOM	56	0	0		
B05	B05		1-140-0-L	WARDROOM	62.4	0	0	DJ	NO
D05			4-140-0-W	FRESH WATER TANK	54.6	0	0		
S2I			(none)	(weather overhead)	54.6	0	0		
			1-140-2-L	SR #6	(CUI = L2)				
B05	B05		1-132-0B-L	PASSAGE	80	0	0	DJ	NC

D.1.1 Barrier Data: Only Fire Zone Bulkheads Insulated

Barrier Material				Area	Therm	Durab	Door/	Readiness
<1>	<2>	<3>		ft2	adj	adj	Hatch	
B05		B05	1-132-2-L	SR #4	72	0	0	
B05		B05	1-150-2-L	OFFICER WR, WC & SH	54.4	0	0	
B06	S2U		(none)	(weather bulkhead)	81.9	0	0	
S2U			3-140-2-W	FRESH WATER TANK	57.6	0	0	
S2U			2-147-0-Q	ENGINEERS STOREROOM	21.4	0	0	
S2I			(none)	(weather overhead)	79	0	0	
			1-150-2-L	OFFICER WR, WC & SH	(CUI = LW)			
B05		B05	1-132-0B-L	PASSAGE	56	0	0	DJ NC
B05		B05	1-140-2-L	SR #6	54.4	0	0	
B05		B05	1-157-2-Q	LINEN LKR	44.8	0	0	
B06	S2U		(none)	(weather bulkhead)	56.8	0	0	
D05			2-147-0-Q	ENGINEERS STOREROOM	43.2	0	0	
S2I			(none)	(weather overhead)	43.4	0	0	
			1-157-0-E	STEERING GEAR SPACE	(CUI = QA)			
B05		B05	1-132-0B-L	PASSAGE	24	0	0	DJ NC
B05		B05	1-140-0-L	WARDROOM	59.2	0	0	
B05		B05	1-157-1-Q	ARMORY	48	-15	-15	DJ NC
B05		B05	1-157-1-Q	ARMORY	40	0	0	
B05		B05	1-157-2-Q	LINEN LKR	32	0	0	DO O
B05		B05	1-161-2-Q	CG LKR	16	0	0	DO O
B05		B05	1-161-2-Q	CG LKR	20.8	0	0	
B06	S2U		(none)	(weather bulkhead)	25.3	0	0	
B06	S2U		(none)	(weather bulkhead)	28.8	0	0	
B06	S2U		(none)	(weather bulkhead)	38.2	0	0	
B06	S2U		(none)	(weather bulkhead)	26.5	0	0	
B06	S2U		(none)	(weather bulkhead)	26.5	0	0	
B06	S2U		(none)	(weather bulkhead)	38.2	0	0	
B06	S2U		(none)	(weather bulkhead)	28.8	0	0	
B06	S2U		(none)	(weather bulkhead)	25.3	0	0	
S2U			2-147-0-Q	ENGINEERS STOREROOM	41.6	0	0	HS X
S2U			2-161-0-Q	LAZARETTE	148	0	0	HS X
S2I			(none)	(weather overhead)	189.6	0	0	HS X
			1-157-2-Q	LINEN LKR	(CUI = AG)			
B05		B05	1-150-2-L	OFFICER WR, WC & SH	44.8	0	0	
B05		B05	1-157-0-E	STEERING GEAR SPACE	32	0	0	DO O
B05		B05	1-161-2-Q	CG LKR	28.8	0	0	
B06	S2U		(none)	(weather bulkhead)	35.8	0	0	
S2U			2-147-0-Q	ENGINEERS STOREROOM	18.3	0	0	
S2I			(none)	(weather overhead)	18.4	0	0	
			1-161-2-Q	CG LKR	(CUI = AG)			
B05		B05	1-157-0-E	STEERING GEAR SPACE	16	0	0	DO O
B05		B05	1-157-0-E	STEERING GEAR SPACE	20.8	0	0	
B05		B05	1-157-2-Q	LINEN LKR	28.8	0	0	
B06	S2U		(none)	(weather bulkhead)	17.9	0	0	
S2U			2-161-0-Q	LAZARETTE	6.2	0	0	

D.1.1 Barrier Data: Only Fire Zone Bulkheads Insulated

Barrier Material					Area	Therm	Durab	Door/	Readiness
<1>	<2>	<3>			ft2	adj	adj	Hatch	
S2I			(none)	(weather overhead)	6.2	0	0		
			01-71-0-Q	CRANE CONTROL BOOTH	(CUI	= C)			
B05		B05	01-74-0-L	CO SR	10.8	0	0		
B05		B05	01-74-1-Q	CODE ROOM	10.8	0	0		
B05		B05	02-74-0-Q	FAN ROOM	28.8	0	0		
S2I	S2U		(none)	(weather bulkhead)	23.8	0	0	DJ	NC
S2I	S2U		(none)	(weather bulkhead)	50.4	0	0		
S2I	S2U		(none)	(weather bulkhead)	23.8	0	0	DJ	NC
S2I			1-68-0-L	COMPANIONWAY	12.2	0	0		
S2I			1-68-1-Q	HYD PUMP ROOM	6.1	0	0		
S2I			1-68-2-Q	HYD PUMP ROOM	6.1	0	0		
S2I			(none)	(weather overhead)	24.5	0	0		
			01-74-0-L	CO SR	(CUI	= L1)			
B05		B05	01-71-0-Q	CRANE CONTROL BOOTH	10.8	0	0		
B05		B05	01-74-1-Q	CODE ROOM	53.2	0	0		
B05		B05	01-82-0-L	CO CABIN	49	0	0	DJ	NC
S2I	S2U		(none)	(weather bulkhead)	53.2	0	0		
S2I	S2U		(none)	(weather bulkhead)	7	0	0		
S2I	S2U		(none)	(weather bulkhead)	30.8	0	0		
S2I	S2U		(none)	(weather bulkhead)	14.4	0	0		
S2I			1-74-0-L	PASSAGE	26.4	0	0		
S2I			1-74-2A-L	PASSAGE	15.2	0	0		
S2U			1-79-0-Q	GALLEY	19.2	0	0		
S2I			02-74-0-Q	FAN ROOM	56	0	0		
D05			02-81-0-C	CHART ROOM	2.4	0	0		
			01-74-1-Q	CODE ROOM	(CUI	= C)			
B05		B05	01-71-0-Q	CRANE CONTROL BOOTH	10.8	0	0		
B05		B05	01-74-0-L	CO SR	53.2	0	0		
B05		B05	01-82-0-L	CO CABIN	49	0	0	DJ	NC
S2I	S2U		(none)	(weather bulkhead)	53.2	0	0		
S2I	S2U		(none)	(weather bulkhead)	4.2	0	0		
S2I	S2U		(none)	(weather bulkhead)	28	0	0		
S2I	S2U		(none)	(weather bulkhead)	14.4	0	0		
S2I			1-70-3A-L	CREW MESS	11.6	0	0		
S2I			1-74-0-L	PASSAGE	14.4	0	0		
S2I			1-77-0-Q	GYRO EQUIP	6	0	0		
S2I			1-77-1-L	COMPANIONWAY	13.8	0	0		
S2U			1-79-0-Q	GALLEY	12	0	0		
S2I			02-74-0-Q	FAN ROOM	53.2	0	0		
D05			02-81-0-C	CHART ROOM	4.2	0	0		
			01-82-0-L	CO CABIN	(CUI	= L1)			
B05		B05	01-74-0-L	CO SR	49	0	0	DJ	NC
B05		B05	01-74-1-Q	CODE ROOM	49	0	0	DJ	NC
B05		B05	01-89-2-Q	FAN ROOM	23.8	0	0		
B05		B05	01-89-2-Q	FAN ROOM	22.4	0	0		

D.1.1 Barrier Data: Only Fire Zone Bulkheads Insulated

Barrier Material					Area	Therm	Durab	Door/	Readiness
<1>	<2>	<3>			ft2	adj	adj	Hatch	
B05		B05	01-93-2-L	COMPANIONWAY	42	0	0	DJ	NC
B05		A2I	01-95-0-L	WR, WC & SH	25.2	0	0		
B05		A2I	01-95-0-L	WR, WC & SH	23.8	0	0	DJ	NC
B05		A2I	01-95-0-L	WR, WC & SH	25.2	0	0		
B05		B05	01-95-1-L	COMPANIONWAY	23.8	0	0	DJ	NC
S2I	S2U		(none)	(weather bulkhead)	98	0	0		
S2I	S2U		(none)	(weather bulkhead)	57.4	0	0		
S2I			1-70-3A-L	CREW MESS	13	0	0		
S2I			1-74-2A-L	PASSAGE	8.2	0	0		
S2U			1-79-0-Q	GALLEY	129.9	0	0		
S2U			1-92-0-Q	SCULLERY	34	0	0		
S2I			4-92-0A-E	FIDLEY	2	0	0		
D05			02-81-0-C	CHART ROOM	81.4	0	0		
S2I			02-81-2-L	PASSAGE	24.6	0	0		
D05			02-89-0-C	RADIO ROOM	80.4	0	0		
S2I			(none)	(weather overhead)	2.2	0	0		
			01-89-2-Q	FAN ROOM	(CUI = QF)				
B05		B05	01-82-0-L	CO CABIN	23.8	0	0		
B05		B05	01-82-0-L	CO CABIN	22.4	0	0		
B05		B05	01-93-2-L	COMPANIONWAY	23.8	0	0		
B05	S2U		(none)	(weather bulkhead)	22.4	0	0	DJ	NC
S2I			1-74-2A-L	PASSAGE	3.2	0	0		
S2U			1-79-0-Q	GALLEY	5.3	0	0		
S2I			1-92-2-Q	DC LKR	2.4	0	0		
S2U			02-81-2-L	PASSAGE	9.6	0	0		
			01-93-2-L	COMPANIONWAY	(CUI = LP)				
B05		B05	01-82-0-L	CO CABIN	42	0	0	DJ	NC
B05		B05	01-89-2-Q	FAN ROOM	23.8	0	0		
B05		A2I	01-95-0-L	WR, WC & SH	21	0	0		
S2I	S2U		(none)	(weather bulkhead)	23.8	0	0		
S2I	S2U		(none)	(weather bulkhead)	63	0	0	DJ	NC
S2I			1-74-2A-L	PASSAGE	5.2	0	0		
S2I			1-74-2B-L	PASSAGE	13.4	0	0	HO	O
S2I			1-92-2-Q	DC LKR	12	0	0		
S2I			02-81-2-L	PASSAGE	16.2	0	0		
D05			02-89-0-C	RADIO ROOM	2.2	0	0		
S2I			(none)	(weather overhead)	12.2	0	0		
			01-95-0-L	WR, WC & SH	(CUI = LW)				
A2I		B05	01-82-0-L	CO CABIN	25.2	0	0		
A2I		B05	01-82-0-L	CO CABIN	23.8	0	0	DJ	NC
A2I		B05	01-82-0-L	CO CABIN	25.2	0	0		
A2I		B05	01-93-2-L	COMPANIONWAY	21	0	0		
A2I		B05	01-95-1-L	COMPANIONWAY	44.8	0	0		
A2I		B05	01-102-0-E	VENT & UPTAKE SPACE	50.4	0	0		
S2U			1-92-0-Q	SCULLERY	9.5	0	0		
S2I			4-92-0A-E	FIDLEY	22.4	0	0		

D.1.1 Barrier Data: Only Fire Zone Bulkheads Insulated

Barrier Material					Area	Therm	Durab	Door/	Readiness
<1>	<2>	<3>			ft2	adj	adj	Hatch	
D05			02-89-0-C	RADIO ROOM	10.1	0	0		
S2I			(none)	(weather overhead)	23.8	0	0		
			01-95-1-L	COMPANIONWAY	(CUI = LP)				
B05		B05	01-82-0-L	CO CABIN	23.8	0	0	DJ	NC
B05		A2I	01-95-0-L	WR, WC & SH	44.8	0	0		
S2I	S2U		(none)	(weather bulkhead)	23.8	0	0		
S2I	S2U		(none)	(weather bulkhead)	44.8	0	0		
S2I			1-70-3A-L	CREW MESS	8.4	0	0		
S2I			1-99-1A-L	PASSAGE	13.4	0	0	HO	O
D05			02-89-0-C	RADIO ROOM	9.5	0	0		
S2I			(none)	(weather overhead)	12.2	0	0		
			01-102-0-E	VENT & UPTAKE SPACE	(CUI = TU)				
B05		A2I	01-95-0-L	WR, WC & SH	50.4	0	0		
B05		B05	01-110-0-Q	FAN & EQUIPMENT ROOM	50.4	0	0		
B05	S2U		(none)	(weather bulkhead)	35	0	0		
B05	S2U		(none)	(weather bulkhead)	35	0	0		
S2I			4-92-0A-E	FIDLEY	34	0	0		
S2I			02-102-0-E	UPTAKE	36	0	0		
			01-110-0-Q	FAN & EQUIPMENT ROOM	(CUI = QF)				
B05		B05	01-102-0-E	VENT & UPTAKE SPACE	50.4	0	0		
B05		B05	01-116-0-Q	CLIP SHACK	50.4	0	0		
B05	S2U		(none)	(weather bulkhead)	63	0	0		
B05	S2U		(none)	(weather bulkhead)	63	0	0		
S2I			4-92-0A-E	FIDLEY	34	0	0		
S2U			1-112-0-Q	AUXILIARY MACHINERY	27.2	0	0		
S2I			(none)	(weather overhead)	64.8	0	0		
			01-116-0-Q	CLIP SHACK	(CUI = C)				
B05		B05	01-110-0-Q	FAN & EQUIPMENT ROOM	50.4	0	0		
B05	S2U		(none)	(weather bulkhead)	50.4	0	0	DWT	X
B05	S2U		(none)	(weather bulkhead)	35	0	0		
B05	S2U		(none)	(weather bulkhead)	35	0	0		
S2U			1-112-0-Q	AUXILIARY MACHINERY	34	0	0		
S2I			(none)	(weather overhead)	36	0	0		
			02-74-0-Q	FAN ROOM	(CUI = QF)				
B05		B05	01-71-0-Q	CRANE CONTROL BOOTH	28.8	0	0		
S2U		S2I	02-81-0-C	CHART ROOM	44	0	0		
B05		B05	02-81-2-L	PASSAGE	12	0	0		
B05	S2U		(none)	(weather bulkhead)	28	0	0		
B05	S2U		(none)	(weather bulkhead)	0	0	0		
B05	S2U		(none)	(weather bulkhead)	28	0	0		
B05	S2U		(none)	(weather bulkhead)	4	0	0		
B05	S2U		(none)	(weather bulkhead)	4	0	0		
S2I			01-74-0-L	CO SR	56	0	0		
S2I			01-74-1-Q	CODE ROOM	53.2	0	0		

D.1.1 Barrier Data: Only Fire Zone Bulkheads Insulated

Barrier Material					Area	Therm	Durab	Door/	Readiness
<1>	<2>	<3>			ft2	adj	adj	Hatch	
D05			03-72-0-C	WHEELHOUSE	98	0	0		
S2I			(none)	(weather overhead)	14	0	0		
			02-81-0-C	CHART ROOM	(CUI = C)				
S2I	S2U		02-74-0-Q	FAN ROOM	44	0	0		
B05	B05		02-81-2-L	PASSAGE	64	0	0	DJ	NC
B05	B06		02-89-0-C	RADIO ROOM	88	0	0		
B05	B05		03-72-0-C	WHEELHOUSE	44	0	0		
B06	S2U		(none)	(weather bulkhead)	64	0	0		
D05			01-74-0-L	CO SR	2.4	0	0		
D05			01-74-1-Q	CODE ROOM	4.2	0	0		
D05			01-82-0-L	CO CABIN	81.4	0	0		
S2I			(none)	(weather overhead)	88	0	0		
			02-81-2-L	PASSAGE	(CUI = LP)				
B05	B05		02-74-0-Q	FAN ROOM	12	0	0		
B05	B05		02-81-0-C	CHART ROOM	64	0	0	DJ	NC
B05	B06		02-89-0-C	RADIO ROOM	75.2	0	0	DJ	NC
B05	B05		03-72-0-C	WHEELHOUSE	12	0	0		
B05	S2U		(none)	(weather bulkhead)	24	0	0		
B05	S2U		(none)	(weather bulkhead)	139.2	0	0		
S2I			01-82-0-L	CO CABIN	24.6	0	0		
S2U			01-89-2-Q	FAN ROOM	9.6	0	0		
S2I			01-93-2-L	COMPANIONWAY	16.2	0	0		
S2I			(none)	(weather overhead)	52.2	0	0		
			02-89-0-C	RADIO ROOM	(CUI = C)				
B06	B05		02-81-0-C	CHART ROOM	88	0	0		
B06	B05		02-81-2-L	PASSAGE	75.2	0	0	DJ	NC
B06	S2U		(none)	(weather bulkhead)	88	0	0		
B06	S2U		(none)	(weather bulkhead)	75.2	0	0		
D05			01-82-0-L	CO CABIN	80.4	0	0		
D05			01-93-2-L	COMPANIONWAY	2.2	0	0		
D05			01-95-0-L	WR, WC & SH	10.1	0	0		
D05			01-95-1-L	COMPANIONWAY	9.5	0	0		
S2I			(none)	(weather overhead)	103.4	0	0		
			02-102-0-E	UPTAKE	(CUI = TU)				
B05	S2U		(none)	(weather bulkhead)	115.2	0	0		
B05	S2U		(none)	(weather bulkhead)	80	0	0		
B05	S2U		(none)	(weather bulkhead)	115.2	0	0		
B05	S2U		(none)	(weather bulkhead)	80	0	0		
S2I			01-102-0-E	VENT & UPTAKE SPACE	36	0	0		
S2I			(none)	(weather overhead)	36	0	0		
			03-72-0-C	WHEELHOUSE	(CUI = C)				
B05	B05		02-81-0-C	CHART ROOM	44	0	0		
B05	B05		02-81-2-L	PASSAGE	12	0	0		
S2I	S2U		(none)	(weather bulkhead)	56	0	0		

D.1.1 Barrier Data: Only Fire Zone Bulkheads Insulated

Barrier Material					Area	Therm	Durab	Door/	Readiness
<1>	<2>	<3>			ft2	adj	adj	Hatch	
S2I	S2U		(none)	(weather bulkhead)	72	0	0	DJ	NC
S2I	S2U		(none)	(weather bulkhead)	112	0	0		
S2I	S2U		(none)	(weather bulkhead)	72	0	0	DJ	NC
D05			02-74-0-Q	FAN ROOM	98	0	0		
S2I			(none)	(weather overhead)	126	0	0		

INDIVIDUAL TARGET OPTION - SUMMARY LEVEL REPORT

RELATIVE LOSS FACTORS OF INDIVIDUAL TARGETS

READINESS CONDITION . XRAY
CONFIGURATION Passive, Automatic, and Manual
CASE. Worst
ASSUMED LOCATION. . . in Port
RUN TIME. 60 minutes
COMMENTS.
Alternative, In Port M Values, fire zone wt bulkheads insulated

Targets listed include all compartments in model run with Magnitude of Acceptable Loss 1-3 and Relative Loss Factor (RLF) > 0.0000.

TARGET COMPART.	Magnitude/Frequency -of Acceptable Loss-	Rel Freq of Loss FFS	Relative Loss Factor (RLF)
3-9-0-E	2 26 years	0.0081	0.2105
1-112-0-Q	2 26 years	0.0077	0.2003
01-110-0-Q	3 18 years	0.0102	0.1843
4-126-0-E	2 26 years	0.0056	0.1449
4-92-0-E	2 26 years	0.0051	0.1326
4-92-0A-E	2 24 years	0.0053	0.1282
01-102-0-E	2 23 years	0.0048	0.1103
2-126-2-Q	2 22 years	0.0042	0.0934
2-126-1-Q	2 22 years	0.0034	0.0759
1-110-1-Q	2 24 years	0.0028	0.0661
01-89-2-Q	3 18 years	0.0033	0.0601
1-157-0-E	2 26 years	0.0020	0.0508
1-92-0-Q	2 20 years	0.0025	0.0499
1-FP-0-K	1 30 years	0.0013	0.0402
01-74-1-Q	2 26 years	0.0014	0.0364
3-56-0-Q	2 24 years	0.0014	0.0331
1-68-2-Q	2 26 years	0.0011	0.0285
1-157-2-Q	3 12 years	0.0022	0.0259
02-81-0-C	2 26 years	0.0010	0.0257
2-147-0-Q	2 25 years	0.0010	0.0251
3-68-2-A	2 22 years	0.0011	0.0248
2-30-0-Q	2 25 years	0.0008	0.0204
2-161-0-Q	2 24 years	0.0008	0.0204
1-70-3A-L	2 24 years	0.0008	0.0197
03-72-0-C	2 26 years	0.0008	0.0195
3-68-1-A	2 21 years	0.0008	0.0176
02-74-0-Q	3 18 years	0.0009	0.0157
1-6-2-Q	2 22 years	0.0007	0.0147
1-6-1-Q	2 22 years	0.0007	0.0147
1-79-0-Q	2 26 years	0.0005	0.0127
3-44-0-A	2 24 years	0.0003	0.0061
02-89-0-C	2 26 years	0.0002	0.0061

INDIVIDUAL TARGET OPTION - SUMMARY LEVEL REPORT

RELATIVE LOSS FACTORS OF INDIVIDUAL TARGETS

READINESS CONDITION . XRAY
CONFIGURATION Passive and Automatic
CASE Worst
ASSUMED LOCATION . . . in Port
RUN TIME 60 minutes
COMMENTS
Alternative, In Port M Values, fire zone wt bulkheads insulated

Targets listed include all compartments in model run with Magnitude of Acceptable Loss 1-3 and Relative Loss Factor (RLF) > 0.0000.

TARGET COMPART.	Magnitude/Frequency -of Acceptable Loss-	Rel Freq of Loss FFS	Relative Loss Factor (RLF)
1-112-0-Q	2 26 years	0.0085	0.2203
3-9-0-E	2 26 years	0.0084	0.2192
01-110-0-Q	3 18 years	0.0112	0.2012
4-126-0-E	2 26 years	0.0062	0.1605
4-92-0-E	2 26 years	0.0056	0.1462
4-92-0A-E	2 24 years	0.0059	0.1408
01-102-0-E	2 23 years	0.0053	0.1208
1-110-1-Q	2 24 years	0.0044	0.1062
2-126-2-Q	2 22 years	0.0048	0.1048
2-126-1-Q	2 22 years	0.0046	0.1005
01-89-2-Q	3 18 years	0.0051	0.0916
1-92-0-Q	2 20 years	0.0042	0.0848
01-74-1-Q	2 26 years	0.0022	0.0578
1-157-0-E	2 26 years	0.0021	0.0551
1-70-3A-L	2 24 years	0.0019	0.0460
1-FP-0-K	1 30 years	0.0014	0.0432
3-68-2-A	2 22 years	0.0017	0.0374
3-56-0-Q	2 24 years	0.0015	0.0352
02-81-0-C	2 26 years	0.0013	0.0350
2-147-0-Q	2 25 years	0.0013	0.0330
1-68-2-Q	2 26 years	0.0013	0.0326
03-72-0-C	2 26 years	0.0011	0.0296
1-157-2-Q	3 12 years	0.0023	0.0273
2-30-0-Q	2 25 years	0.0010	0.0252
3-68-1-A	2 21 years	0.0011	0.0234
2-161-0-Q	2 24 years	0.0010	0.0229
02-74-0-Q	3 18 years	0.0012	0.0209
1-6-2-Q	2 22 years	0.0007	0.0158
1-6-1-Q	2 22 years	0.0007	0.0158
1-79-0-Q	2 26 years	0.0006	0.0146
02-89-0-C	2 26 years	0.0004	0.0093
3-44-0-A	2 24 years	0.0003	0.0078

INDIVIDUAL TARGET OPTION - SUMMARY LEVEL REPORT

RELATIVE LOSS FACTORS OF INDIVIDUAL TARGETS

READINESS CONDITION . XRAY
CONFIGURATION Passive and Manual
CASE Worst
ASSUMED LOCATION . . . in Port
RUN TIME 60 minutes
COMMENTS
Alternative, In Port M Values, fire zone wt bulkheads insulated

Targets listed include all compartments in model run with Magnitude of Acceptable Loss 1-3 and Relative Loss Factor (RLF) > 0.0000.

TARGET COMPART.	Magnitude/Frequency -of Acceptable Loss-	Rel Freq of Loss FFS	Relative Loss Factor (RLF)
3-9-0-E	2 26 years	0.0081	0.2105
1-112-0-Q	2 26 years	0.0078	0.2035
01-110-0-Q	3 18 years	0.0103	0.1854
4-126-0-E	2 26 years	0.0056	0.1465
4-92-0-E	2 26 years	0.0053	0.1376
4-92-0A-E	2 24 years	0.0053	0.1282
01-102-0-E	2 23 years	0.0048	0.1103
2-126-2-Q	2 22 years	0.0043	0.0943
01-89-2-Q	3 18 years	0.0048	0.0861
2-126-1-Q	2 22 years	0.0035	0.0767
1-79-0-Q	2 26 years	0.0026	0.0682
1-110-1-Q	2 24 years	0.0028	0.0661
01-74-1-Q	2 26 years	0.0020	0.0526
1-157-0-E	2 26 years	0.0020	0.0508
1-92-0-Q	2 20 years	0.0025	0.0499
1-FP-0-K	1 30 years	0.0013	0.0402
3-56-0-Q	2 24 years	0.0014	0.0331
1-68-2-Q	2 26 years	0.0012	0.0302
02-81-0-C	2 26 years	0.0011	0.0274
1-157-2-Q	3 12 years	0.0022	0.0259
2-147-0-Q	2 25 years	0.0010	0.0251
3-68-2-A	2 22 years	0.0011	0.0248
02-74-0-Q	3 18 years	0.0011	0.0207
1-70-3A-L	2 24 years	0.0009	0.0204
2-30-0-Q	2 25 years	0.0008	0.0204
2-161-0-Q	2 24 years	0.0008	0.0204
03-72-0-C	2 26 years	0.0008	0.0195
3-68-1-A	2 21 years	0.0008	0.0176
1-6-2-Q	2 22 years	0.0007	0.0147
1-6-1-Q	2 22 years	0.0007	0.0147
3-44-0-A	2 24 years	0.0003	0.0061
02-89-0-C	2 26 years	0.0002	0.0061

INDIVIDUAL TARGET OPTION - SUMMARY LEVEL REPORT

RELATIVE LOSS FACTORS OF INDIVIDUAL TARGETS

READINESS CONDITION . XRAY
CONFIGURATION Passive
CASE. Worst
ASSUMED LOCATION. . . in Port
RUN TIME. 60 minutes
COMMENTS.
Alternative, In Port M Values, fire zone wt bulkheads insulated

Targets listed include all compartments in model run with Magnitude of Acceptable Loss 1-3 and Relative Loss Factor (RLF) > 0.0000.

TARGET COMPART.	Magnitude/Frequency -of Acceptable Loss-	Rel Freq of Loss FFS	Relative Loss Factor (RLF)
1-112-0-Q	2 26 years	0.0087	0.2252
3-9-0-E	2 26 years	0.0084	0.2192
01-110-0-Q	3 18 years	0.0113	0.2026
4-126-0-E	2 26 years	0.0062	0.1625
4-92-0-E	2 26 years	0.0059	0.1530
4-92-0A-E	2 24 years	0.0059	0.1420
01-89-2-Q	3 18 years	0.0070	0.1253
01-102-0-E	2 23 years	0.0053	0.1219
1-110-1-Q	2 24 years	0.0044	0.1062
2-126-2-Q	2 22 years	0.0048	0.1059
2-126-1-Q	2 22 years	0.0046	0.1017
1-92-0-Q	2 20 years	0.0042	0.0848
1-79-0-Q	2 26 years	0.0031	0.0810
01-74-1-Q	2 26 years	0.0031	0.0799
1-157-0-E	2 26 years	0.0021	0.0551
1-70-3A-L	2 24 years	0.0020	0.0475
1-FP-0-K	1 30 years	0.0014	0.0432
02-81-0-C	2 26 years	0.0014	0.0377
3-68-2-A	2 22 years	0.0017	0.0374
1-68-2-Q	2 26 years	0.0014	0.0364
3-56-0-Q	2 24 years	0.0015	0.0352
2-147-0-Q	2 25 years	0.0013	0.0330
03-72-0-C	2 26 years	0.0011	0.0296
02-74-0-Q	3 18 years	0.0015	0.0275
1-157-2-Q	3 12 years	0.0023	0.0273
2-30-0-Q	2 25 years	0.0010	0.0252
3-68-1-A	2 21 years	0.0011	0.0234
2-161-0-Q	2 24 years	0.0010	0.0229
1-6-2-Q	2 22 years	0.0007	0.0158
1-6-1-Q	2 22 years	0.0007	0.0158
02-89-0-C	2 26 years	0.0004	0.0093
3-44-0-A	2 24 years	0.0003	0.0078

INDIVIDUAL TARGET OPTION - SUMMARY LEVEL REPORT

RELATIVE LOSS FACTORS OF INDIVIDUAL TARGETS

READINESS CONDITION . YOKE
CONFIGURATION Passive, Automatic, and Manual
CASE. Worst
ASSUMED LOCATION. . . in Port
RUN TIME. 60 minutes
COMMENTS.
Alternative, In Port M Values, fire zone wt bulkheads insulated

Targets listed include all compartments in model run with Magnitude of Acceptable Loss 1-3 and Relative Loss Factor (RLF) > 0.0000.

TARGET COMPART.	Magnitude/Frequency -of Acceptable Loss-	Rel Freq of Loss FFS	Relative Loss Factor (RLF)
3-9-0-E	2 26 years	0.0081	0.2105
1-112-0-Q	2 26 years	0.0077	0.2003
01-110-0-Q	3 18 years	0.0102	0.1843
4-126-0-E	2 26 years	0.0056	0.1449
4-92-0-E	2 26 years	0.0051	0.1326
4-92-0A-E	2 24 years	0.0053	0.1282
01-102-0-E	2 23 years	0.0048	0.1103
2-126-2-Q	2 22 years	0.0042	0.0934
2-126-1-Q	2 22 years	0.0034	0.0759
1-110-1-Q	2 24 years	0.0028	0.0661
01-89-2-Q	3 18 years	0.0033	0.0601
1-157-0-E	2 26 years	0.0020	0.0508
1-92-0-Q	2 20 years	0.0025	0.0499
1-FP-0-K	1 30 years	0.0013	0.0402
01-74-1-Q	2 26 years	0.0014	0.0364
1-68-2-Q	2 26 years	0.0011	0.0285
1-157-2-Q	3 12 years	0.0022	0.0259
02-81-0-C	2 26 years	0.0010	0.0257
2-147-0-Q	2 25 years	0.0010	0.0251
2-30-0-Q	2 25 years	0.0008	0.0204
2-161-0-Q	2 24 years	0.0008	0.0204
1-70-3A-L	2 24 years	0.0008	0.0197
03-72-0-C	2 26 years	0.0008	0.0195
02-74-0-Q	3 18 years	0.0009	0.0157
1-6-2-Q	2 22 years	0.0007	0.0147
1-6-1-Q	2 22 years	0.0007	0.0147
1-79-0-Q	2 26 years	0.0005	0.0127
02-89-0-C	2 26 years	0.0002	0.0061
3-44-0-A	2 24 years	0.0000	0.0008
3-56-0-Q	2 24 years	0.0000	0.0004

INDIVIDUAL TARGET OPTION - SUMMARY LEVEL REPORT

RELATIVE LOSS FACTORS OF INDIVIDUAL TARGETS

READINESS CONDITION . YOKE
CONFIGURATION Passive and Automatic
CASE. Worst
ASSUMED LOCATION. . . in Port
RUN TIME. 60 minutes
COMMENTS.
Alternative, In Port M Values, fire zone wt bulkheads insulated

Targets listed include all compartments in model run with Magnitude of Acceptable Loss 1-3 and Relative Loss Factor (RLF) > 0.0000.

TARGET COMPART.	Magnitude/Frequency -of Acceptable Loss-	Rel Freq of Loss FFS	Relative Loss Factor (RLF)
1-112-0-Q	2 26 years	0.0085	0.2203
3-9-0-E	2 26 years	0.0084	0.2192
01-110-0-Q	3 18 years	0.0112	0.2012
4-126-0-E	2 26 years	0.0062	0.1605
4-92-0-E	2 26 years	0.0056	0.1462
4-92-0A-E	2 24 years	0.0059	0.1408
01-102-0-E	2 23 years	0.0053	0.1208
1-110-1-Q	2 24 years	0.0044	0.1062
2-126-2-Q	2 22 years	0.0048	0.1048
2-126-1-Q	2 22 years	0.0046	0.1005
01-89-2-Q	3 18 years	0.0051	0.0916
1-92-0-Q	2 20 years	0.0042	0.0848
01-74-1-Q	2 26 years	0.0022	0.0578
1-157-0-E	2 26 years	0.0021	0.0551
1-70-3A-L	2 24 years	0.0019	0.0460
1-FP-0-K	1 30 years	0.0014	0.0432
02-81-0-C	2 26 years	0.0013	0.0350
2-147-0-Q	2 25 years	0.0013	0.0330
1-68-2-Q	2 26 years	0.0013	0.0326
03-72-0-C	2 26 years	0.0011	0.0296
1-157-2-Q	3 12 years	0.0023	0.0273
2-30-0-Q	2 25 years	0.0010	0.0252
2-161-0-Q	2 24 years	0.0010	0.0229
02-74-0-Q	3 18 years	0.0012	0.0209
1-6-2-Q	2 22 years	0.0007	0.0158
1-6-1-Q	2 22 years	0.0007	0.0158
1-79-0-Q	2 26 years	0.0006	0.0146
02-89-0-C	2 26 years	0.0004	0.0093
3-44-0-A	2 24 years	0.0000	0.0009
3-56-0-Q	2 24 years	0.0000	0.0004

INDIVIDUAL TARGET OPTION - SUMMARY LEVEL REPORT

RELATIVE LOSS FACTORS OF INDIVIDUAL TARGETS

READINESS CONDITION . YOKE
CONFIGURATION Passive and Manual
CASE. Worst
ASSUMED LOCATION. . . in Port
RUN TIME. 60 minutes
COMMENTS.
Alternative, In Port M Values, fire zone wt bulkheads insulated

Targets listed include all compartments in model run with Magnitude of Acceptable Loss 1-3 and Relative Loss Factor (RLF) > 0.0000.

TARGET COMPART.	Magnitude/Frequency -of Acceptable Loss-	Rel Freq of Loss FFS	Relative Loss Factor (RLF)
3-9-0-E	2 26 years	0.0081	0.2105
1-112-0-Q	2 26 years	0.0078	0.2035
01-110-0-Q	3 18 years	0.0103	0.1854
4-126-0-E	2 26 years	0.0056	0.1465
4-92-0-E	2 26 years	0.0053	0.1376
4-92-0A-E	2 24 years	0.0053	0.1282
01-102-0-E	2 23 years	0.0048	0.1103
2-126-2-Q	2 22 years	0.0043	0.0943
01-89-2-Q	3 18 years	0.0048	0.0861
2-126-1-Q	2 22 years	0.0035	0.0767
1-79-0-Q	2 26 years	0.0026	0.0682
1-110-1-Q	2 24 years	0.0028	0.0661
01-74-1-Q	2 26 years	0.0020	0.0526
1-157-0-E	2 26 years	0.0020	0.0508
1-92-0-Q	2 20 years	0.0025	0.0499
1-FP-0-K	1 30 years	0.0013	0.0402
1-68-2-Q	2 26 years	0.0012	0.0302
02-81-0-C	2 26 years	0.0011	0.0274
1-157-2-Q	3 12 years	0.0022	0.0259
2-147-0-Q	2 25 years	0.0010	0.0251
02-74-0-Q	3 18 years	0.0011	0.0207
1-70-3A-L	2 24 years	0.0009	0.0204
2-30-0-Q	2 25 years	0.0008	0.0204
2-161-0-Q	2 24 years	0.0008	0.0204
03-72-0-C	2 26 years	0.0008	0.0195
1-6-2-Q	2 22 years	0.0007	0.0147
1-6-1-Q	2 22 years	0.0007	0.0147
02-89-0-C	2 26 years	0.0002	0.0061
3-44-0-A	2 24 years	0.0000	0.0008
3-56-0-Q	2 24 years	0.0000	0.0004

INDIVIDUAL TARGET OPTION - SUMMARY LEVEL REPORT

RELATIVE LOSS FACTORS OF INDIVIDUAL TARGETS

READINESS CONDITION . YOKE
CONFIGURATION Passive
CASE. Worst
ASSUMED LOCATION. . . in Port
RUN TIME. 60 minutes
COMMENTS.
Alternative, In Port M Values, fire zone wt bulkheads insulated

Targets listed include all compartments in model run with Magnitude of Acceptable Loss 1-3 and Relative Loss Factor (RLF) > 0.0000.

TARGET COMPART.	Magnitude/Frequency -of Acceptable Loss-	Rel Freq of Loss FFS	Relative Loss Factor (RLF)
1-112-0-Q	2 26 years	0.0087	0.2252
3-9-0-E	2 26 years	0.0084	0.2192
01-110-0-Q	3 18 years	0.0113	0.2026
4-126-0-E	2 26 years	0.0062	0.1625
4-92-0-E	2 26 years	0.0059	0.1530
4-92-0A-E	2 24 years	0.0059	0.1420
01-89-2-Q	3 18 years	0.0070	0.1253
01-102-0-E	2 23 years	0.0053	0.1219
1-110-1-Q	2 24 years	0.0044	0.1062
2-126-2-Q	2 22 years	0.0048	0.1059
2-126-1-Q	2 22 years	0.0046	0.1017
1-92-0-Q	2 20 years	0.0042	0.0848
1-79-0-Q	2 26 years	0.0031	0.0810
01-74-1-Q	2 26 years	0.0031	0.0799
1-157-0-E	2 26 years	0.0021	0.0551
1-70-3A-L	2 24 years	0.0020	0.0475
1-FP-0-K	1 30 years	0.0014	0.0432
02-81-0-C	2 26 years	0.0014	0.0377
1-68-2-Q	2 26 years	0.0014	0.0364
2-147-0-Q	2 25 years	0.0013	0.0330
03-72-0-C	2 26 years	0.0011	0.0296
02-74-0-Q	3 18 years	0.0015	0.0275
1-157-2-Q	3 12 years	0.0023	0.0273
2-30-0-Q	2 25 years	0.0010	0.0252
2-161-0-Q	2 24 years	0.0010	0.0229
1-6-2-Q	2 22 years	0.0007	0.0158
1-6-1-Q	2 22 years	0.0007	0.0158
02-89-0-C	2 26 years	0.0004	0.0093
3-44-0-A	2 24 years	0.0000	0.0009
3-56-0-Q	2 24 years	0.0000	0.0004

INDIVIDUAL TARGET OPTION - SUMMARY LEVEL REPORT

RELATIVE LOSS FACTORS OF INDIVIDUAL TARGETS

READINESS CONDITION . YOKE
CONFIGURATION Passive, Automatic, and Manual
CASE. Worst
ASSUMED LOCATION. . . at SEA
RUN TIME. 60 minutes
COMMENTS.
Alternative, At Sea M Values, fire zone wt bulkheads insulated

Targets listed include all compartments in model run with Magnitude of Acceptable Loss 1-3 and Relative Loss Factor (RLF) > 0.0000.

TARGET COMPART.	Magnitude/Frequency -of Acceptable Loss-	Rel Freq of Loss FFS	Relative Loss Factor (RLF)
3-9-0-E	2 26 years	0.0079	0.2061
1-112-0-Q	2 26 years	0.0074	0.1921
01-110-0-Q	3 18 years	0.0098	0.1758
4-126-0-E	2 26 years	0.0054	0.1392
4-92-0-E	2 26 years	0.0049	0.1275
4-92-0A-E	2 24 years	0.0051	0.1227
01-102-0-E	2 23 years	0.0046	0.1066
2-126-2-Q	2 22 years	0.0040	0.0890
2-126-1-Q	2 22 years	0.0032	0.0704
1-110-1-Q	2 24 years	0.0023	0.0562
01-89-2-Q	3 18 years	0.0031	0.0559
1-157-0-E	2 26 years	0.0019	0.0495
1-92-0-Q	2 20 years	0.0022	0.0438
1-FP-0-K	1 30 years	0.0013	0.0393
01-74-1-Q	2 26 years	0.0013	0.0340
1-68-2-Q	2 26 years	0.0010	0.0266
1-157-2-Q	3 12 years	0.0021	0.0255
2-147-0-Q	2 25 years	0.0009	0.0234
02-81-0-C	2 26 years	0.0009	0.0227
2-161-0-Q	2 24 years	0.0008	0.0193
2-30-0-Q	2 25 years	0.0008	0.0192
03-72-0-C	2 26 years	0.0006	0.0168
1-70-3A-L	2 24 years	0.0007	0.0164
1-6-2-Q	2 22 years	0.0007	0.0144
1-6-1-Q	2 22 years	0.0007	0.0144
02-74-0-Q	3 18 years	0.0008	0.0144
1-79-0-Q	2 26 years	0.0005	0.0126
02-89-0-C	2 26 years	0.0002	0.0052
3-44-0-A	2 24 years	0.0000	0.0008
3-56-0-Q	2 24 years	0.0000	0.0003

INDIVIDUAL TARGET OPTION - SUMMARY LEVEL REPORT

RELATIVE LOSS FACTORS OF INDIVIDUAL TARGETS

READINESS CONDITION . YOKE
CONFIGURATION Passive and Automatic
CASE. Worst
ASSUMED LOCATION. . . at SEA
RUN TIME. 60 minutes
COMMENTS.
Alternative, At Sea M Values, fire zone wt bulkheads insulated

Targets listed include all compartments in model run with Magnitude of Acceptable Loss 1-3 and Relative Loss Factor (RLF) > 0.0000.

TARGET COMPART.	Magnitude/Frequency -of Acceptable Loss-	Rel Freq of Loss FFS	Relative Loss Factor (RLF)
1-112-0-Q	2 26 years	0.0085	0.2203
3-9-0-E	2 26 years	0.0084	0.2192
01-110-0-Q	3 18 years	0.0112	0.2012
4-126-0-E	2 26 years	0.0062	0.1605
4-92-0-E	2 26 years	0.0056	0.1462
4-92-0A-E	2 24 years	0.0059	0.1408
01-102-0-E	2 23 years	0.0053	0.1208
1-110-1-Q	2 24 years	0.0044	0.1062
2-126-2-Q	2 22 years	0.0048	0.1048
2-126-1-Q	2 22 years	0.0046	0.1005
01-89-2-Q	3 18 years	0.0051	0.0916
1-92-0-Q	2 20 years	0.0042	0.0848
01-74-1-Q	2 26 years	0.0022	0.0565
1-157-0-E	2 26 years	0.0021	0.0551
1-70-3A-L	2 24 years	0.0019	0.0460
1-FP-0-K	1 30 years	0.0014	0.0432
02-81-0-C	2 26 years	0.0013	0.0350
2-147-0-Q	2 25 years	0.0013	0.0330
1-68-2-Q	2 26 years	0.0012	0.0317
03-72-0-C	2 26 years	0.0011	0.0296
1-157-2-Q	3 12 years	0.0023	0.0273
2-30-0-Q	2 25 years	0.0010	0.0252
2-161-0-Q	2 24 years	0.0010	0.0229
02-74-0-Q	3 18 years	0.0011	0.0206
1-6-2-Q	2 22 years	0.0007	0.0158
1-6-1-Q	2 22 years	0.0007	0.0158
1-79-0-Q	2 26 years	0.0006	0.0146
02-89-0-C	2 26 years	0.0004	0.0093
3-44-0-A	2 24 years	0.0000	0.0009
3-56-0-Q	2 24 years	0.0000	0.0004

INDIVIDUAL TARGET OPTION - SUMMARY LEVEL REPORT

RELATIVE LOSS FACTORS OF INDIVIDUAL TARGETS

READINESS CONDITION . YOKE
CONFIGURATION Passive and Manual
CASE. Worst
ASSUMED LOCATION. . . at SEA
RUN TIME. 60 minutes
COMMENTS.
Alternative, At Sea M Values, fire zone wt bulkheads insulated

Targets listed include all compartments in model run with Magnitude of Acceptable Loss 1-3 and Relative Loss Factor (RLF) > 0.0000.

TARGET COMPART.	Magnitude/Frequency -of Acceptable Loss-	Rel Freq of Loss FFS	Relative Loss Factor (RLF)
3-9-0-E	2 26 years	0.0079	0.2061
1-112-0-Q	2 26 years	0.0075	0.1951
01-110-0-Q	3 18 years	0.0098	0.1768
4-126-0-E	2 26 years	0.0054	0.1407
4-92-0-E	2 26 years	0.0051	0.1323
4-92-0A-E	2 24 years	0.0051	0.1227
01-102-0-E	2 23 years	0.0046	0.1066
2-126-2-Q	2 22 years	0.0041	0.0898
01-89-2-Q	3 18 years	0.0045	0.0815
2-126-1-Q	2 22 years	0.0032	0.0711
1-79-0-Q	2 26 years	0.0025	0.0656
1-110-1-Q	2 24 years	0.0023	0.0562
1-157-0-E	2 26 years	0.0019	0.0495
01-74-1-Q	2 26 years	0.0018	0.0472
1-92-0-Q	2 20 years	0.0022	0.0438
1-FP-0-K	1 30 years	0.0013	0.0393
1-68-2-Q	2 26 years	0.0010	0.0266
1-157-2-Q	3 12 years	0.0021	0.0255
02-81-0-C	2 26 years	0.0009	0.0241
2-147-0-Q	2 25 years	0.0009	0.0234
2-161-0-Q	2 24 years	0.0008	0.0193
2-30-0-Q	2 25 years	0.0008	0.0192
02-74-0-Q	3 18 years	0.0010	0.0182
03-72-0-C	2 26 years	0.0006	0.0168
1-70-3A-L	2 24 years	0.0007	0.0164
1-6-2-Q	2 22 years	0.0007	0.0144
1-6-1-Q	2 22 years	0.0007	0.0144
02-89-0-C	2 26 years	0.0002	0.0052
3-44-0-A	2 24 years	0.0000	0.0008
3-56-0-Q	2 24 years	0.0000	0.0003

INDIVIDUAL TARGET OPTION - SUMMARY LEVEL REPORT

RELATIVE LOSS FACTORS OF INDIVIDUAL TARGETS

READINESS CONDITION . YOKE
CONFIGURATION Passive
CASE. Worst
ASSUMED LOCATION. . . at SEA
RUN TIME. 60 minutes
COMMENTS.

Alternative, At Sea M Values, fire zone wt bulkheads insulated

Targets listed include all compartments in model run with Magnitude of Acceptable Loss 1-3 and Relative Loss Factor (RLF) > 0.0000.

TARGET COMPART.	Magnitude/Frequency -of Acceptable Loss-	Rel Freq of Loss FFS	Relative Loss Factor (RLF)
1-112-0-Q	2 26 years	0.0087	0.2252
3-9-0-E	2 26 years	0.0084	0.2192
01-110-0-Q	3 18 years	0.0113	0.2026
4-126-0-E	2 26 years	0.0062	0.1625
4-92-0-E	2 26 years	0.0059	0.1530
4-92-0A-E	2 24 years	0.0059	0.1420
01-89-2-Q	3 18 years	0.0070	0.1253
01-102-0-E	2 23 years	0.0053	0.1219
1-110-1-Q	2 24 years	0.0044	0.1062
2-126-2-Q	2 22 years	0.0048	0.1059
2-126-1-Q	2 22 years	0.0046	0.1017
1-92-0-Q	2 20 years	0.0042	0.0848
1-79-0-Q	2 26 years	0.0031	0.0810
01-74-1-Q	2 26 years	0.0028	0.0734
1-157-0-E	2 26 years	0.0021	0.0551
1-70-3A-L	2 24 years	0.0020	0.0475
1-FP-0-K	1 30 years	0.0014	0.0432
02-81-0-C	2 26 years	0.0014	0.0377
2-147-0-Q	2 25 years	0.0013	0.0330
1-68-2-Q	2 26 years	0.0012	0.0317
03-72-0-C	2 26 years	0.0011	0.0296
1-157-2-Q	3 12 years	0.0023	0.0273
02-74-0-Q	3 18 years	0.0014	0.0259
2-30-0-Q	2 25 years	0.0010	0.0252
2-161-0-Q	2 24 years	0.0010	0.0229
1-6-2-Q	2 22 years	0.0007	0.0158
1-6-1-Q	2 22 years	0.0007	0.0158
02-89-0-C	2 26 years	0.0004	0.0093
3-44-0-A	2 24 years	0.0000	0.0009
3-56-0-Q	2 24 years	0.0000	0.0004

D.2.1 Barrier Data: All Bulkheads Uninsulated

Barrier Materials					Area	Therm	Durab	Hatch	Readiness
<1>	<2>	<3>			ft2	adj	adj		
			4-FP-0-W	FOREPEAK TANK	(CUI	= W)			
B05	S3I	B05	3-9-0-E	BOW THRUSTER ROOM	96.6	0	0		
S2U	S3I	S2U	2-9-0-Q	CHAIN LKR	86.4	0	0		
S2U	S3I	S2U	2-9-0-E	DC SHOP	12.8	0	0		
S2U	S3I	S2U	2-9-0-E	DC SHOP	12.8	0	0		
B05	S3U		(none)	(weather bulkhead)	119.4	0	0		
B05	S3U		(none)	(weather bulkhead)	119.4	0	0		
S3U	S3U		(none)	(weather bulkhead)	57.7	0	0		
S3U	S3U		(none)	(weather bulkhead)	60.9	0	0		
S3U	S3U		(none)	(weather bulkhead)	60.9	0	0		
S3U	S3U		(none)	(weather bulkhead)	57.7	0	0		
S2U			1-FP-0-K	PAINT LKR	58.4	0	0		
S2U			1-6-0-Q	DECK WORKSHOP	42.7	0	0		
			3-9-0-E	BOW THRUSTER ROOM	(CUI	= EM)			
B05	S3I	B05	4-FP-0-W	FOREPEAK TANK	96.6	0	0		
B05	S3I	B05	4-30-0-W	FRESH WATER TANK	113.4	0	0		
B05	S3I	B05	4-30-1-W	FRESH WATER TANK	63	0	0		
B05	S3I	B05	4-30-2-W	FRESH WATER TANK	63	0	0		
B05	S3U		(none)	(weather bulkhead)	231.8	0	0		
B05	S3U		(none)	(weather bulkhead)	231.8	0	0		
S2U			2-9-0-E	DC SHOP	284	0	0	HL	X
S2U			2-9-0-Q	CHAIN LKR	52	0	0		
			4-30-0-W	FRESH WATER TANK	(CUI	= W)			
B05	S3I	B05	3-9-0-E	BOW THRUSTER ROOM	113.4	0	0		
B05		B05	4-30-1-W	FRESH WATER TANK	147	0	0		
B05		B05	4-30-2-W	FRESH WATER TANK	147	0	0		
B05	S3I	B05	3-44-0-A	MAIN HOLD	113.4	0	0		
S2U			2-30-0-Q	ENG LOG OFFICE	89	0	0		
D05			2-30-01-L	PASSAGE	57.9	0	0		
S2U			2-30-2-Q	E.M. SHOP & STORES	4.2	0	0		
			4-30-1-W	FRESH WATER TANK	(CUI	= W)			
B05	S3I	B05	3-9-0-E	BOW THRUSTER ROOM	63	0	0		
B05		B05	4-30-0-W	FRESH WATER TANK	147	0	0		
B05	S3I	B05	3-44-0-A	MAIN HOLD	90.3	0	0		
B05	S3U		(none)	(weather bulkhead)	149.5	0	0		
D05			2-30-01-L	PASSAGE	14	0	0		
S2U			2-30-1-Q	ATON SHOP	33.3	0	0		
D05			2-36-1-Q	LAUNDRY	54.9	0	0		
			4-30-2-W	FRESH WATER TANK	(CUI	= W)			
B05	S3I	B05	3-9-0-E	BOW THRUSTER ROOM	63	0	0		
B05		B05	4-30-0-W	FRESH WATER TANK	147	0	0		
B05	S3I	B05	3-44-0-A	MAIN HOLD	90.3	0	0		
B05	S3U		(none)	(weather bulkhead)	149.5	0	0		
S2U			2-30-01-L	PASSAGE	8.8	0	0		
S2U			2-30-2-Q	E.M. SHOP & STORES	74	0	0		

D.2.1 Barrier Data: All Bulkheads Uninsulated

Barrier Materials					Area	Therm	Durab	Hatch	Readiness
<1>	<2>	<3>			ft2	adj	adj		
S2U			2-41-2-Q	SHIPS SERVICE STORE	19.3	0	0		
			3-44-0-A	MAIN HOLD	(CUI	= AA)			
B05	S3I	B05	4-30-0-W	FRESH WATER TANK	113.4	0	0		
B05	S3I	B05	4-30-1-W	FRESH WATER TANK	90.3	0	0		
B05	S3I	B05	4-30-2-W	FRESH WATER TANK	90.3	0	0		
B05	S3I	B05	3-56-0-Q	SEWAGE SPACE	315	0	0		
B05	S3U		(none)	(weather bulkhead)	126.4	0	0		
B05	S3U		(none)	(weather bulkhead)	126.4	0	0		
S2I			2-44-0-T	HATCH TRUNK	59.2	0	0	HO	O
S2I			2-44-01-L	PASSAGE	52.2	0	0		
S2I			2-44-1-L	CREW LOUNGE	107.2	0	0		
D05			2-44-2-L	CREWS BERTHING	129.4	0	0		
			3-56-0-Q	SEWAGE SPACE	(CUI	= QA)			
B05	S3I	B05	3-44-0-A	MAIN HOLD	315	0	0		
B05	S3I	B05	3-68-1-A	GENERAL STORES	168	0	0	DWT	Y
B05	S3I	B05	3-68-2-A	DRY STORES	168	0	0		
B05	S3U		(none)	(weather bulkhead)	126.4	0	0		
B05	S3U		(none)	(weather bulkhead)	126.4	0	0		
S2I			2-44-01-L	PASSAGE	49.2	0	0		
S2I			2-44-1-L	CREW LOUNGE	44.4	0	0		
D05			2-44-2-L	CREWS BERTHING	100.8	0	0		
D05			2-57-0-L	CREW WR, WC & SH	77.1	0	0	HS	X
S2I			2-60-1-L	CREWS BERTHING	98.3	0	0		
			3-68-1-A	GENERAL STORES	(CUI	= AS)			
B05	S3I	B05	3-56-0-Q	SEWAGE SPACE	168	0	0	DWT	Y
0		0	3-68-2-A	DRY STORES	63	0	0		
B05	S3I	B05	3-74-0-A	MEATS	31.5	0	0		
B05	S3I	B05	3-74-1-M	SMALL ARMS AMMUNITIO	63	0	0		
B05	S3I	B05	3-74-3-A	MAA STORAGE	77.7	0	0		
S2I	S3U		(none)	(weather bulkhead)	63.1	0	0		
S2I			2-44-01-L	PASSAGE	24.2	0	0	HS	X
S2I			2-60-1-L	CREWS BERTHING	68.2	0	0		
			3-68-2-A	DRY STORES	(CUI	= AS)			
B05	S3I	B05	3-56-0-Q	SEWAGE SPACE	168	0	0		
0		0	3-68-1-A	GENERAL STORES	63	0	0		
B05	S3I	B05	3-74-0-A	MEATS	130.2	0	0		
B05	S3I	B05	3-74-2-Q	REEFER FLAT	42	0	0		
S2I	S3U		(none)	(weather bulkhead)	63.1	0	0		
S2I			2-44-01-L	PASSAGE	9.6	0	0		
D05			2-44-2-L	CREWS BERTHING	54	0	0		
D05			2-57-0-L	CREW WR, WC & SH	33.6	0	0		
			3-74-0-A	MEATS	(CUI	= AR)			
B05	S3I	B05	3-68-1-A	GENERAL STORES	31.5	0	0		
B05	S3I	B05	3-68-2-A	DRY STORES	130.2	0	0		

D.2.1 Barrier Data: All Bulkheads Uninsulated

Barrier Materials					Area	Therm	Durab	Hatch	Readiness
<1>	<2>	<3>			ft2	adj	adj		
B05		S2I	3-74-2-Q	REEFER FLAT	73.5	0	0		
B05		S2I	3-74-2-Q	REEFER FLAT	35.7	0	0		
B05		B05	3-74-1-M	SMALL ARMS AMMUNITIO	73.5	0	0		
B05		B06	3-81-0-A	DAIRY	84	0	0		
B05		B05	3-81-2-L	PASSAGE	42	0	0	DJ	NC
D05			2-74-0-L	CREWS BERTHING	107.8	0	0		
			3-74-2-Q	REEFER FLAT	(CUI	= QA)			
B05	S3I	B05	3-68-2-A	DRY STORES	42	0	0		
S2I		B05	3-74-0-A	MEATS	73.5	0	0		
S2I		B05	3-74-0-A	MEATS	35.7	0	0		
S2I		B05	3-81-2-L	PASSAGE	42	0	0	DJ	NC
S2I		S2I	3-85-0-A	FRUITS AND VEGETABLE	73.5	0	0		
B05	S3I	B05	4-92-0-E	GENERATOR ROOM	77.7	0	0		
S2I	S3U		(none)	(weather bulkhead)	115.5	0	0		
S2I	S3U		(none)	(weather bulkhead)	73.5	0	0		
D05			2-74-0-L	CREWS BERTHING	111.2	0	0	HL	X
			3-74-3-A	MAA STORAGE	(CUI	= AS)			
B05	S3I	B05	3-68-1-A	GENERAL STORES	77.7	0	0		
B05		B05	3-74-1-M	SMALL ARMS AMMUNITIO	73.5	0	0		
B05		B05	3-81-1-L	PASSAGE	42	0	0	DWT	X
B05		B05	3-85-3-A	MAA LKR	79.8	0	0		
S2I	S3U		(none)	(weather bulkhead)	115.5	0	0		
D05			2-74-0-L	CREWS BERTHING	4.4	0	0		
D05			2-74-1-L	CREW WR, WC & SH	66	0	0		
			3-81-0-A	DAIRY	(CUI	= AR)			
B06		B05	3-74-0-A	MEATS	84	0	0		
B06		B05	3-81-1-L	PASSAGE	42	0	0		
B06		B05	3-81-2-L	PASSAGE	42	0	0	DJ	NC
B06		B06	3-85-0-A	FRUITS AND VEGETABLE	84	0	0		
D05			2-74-0-L	CREWS BERTHING	32	0	0		
			3-81-1-L	PASSAGE	(CUI	= LP)			
B05		B05	3-74-1-M	SMALL ARMS AMMUNITIO	63	0	0	DWT	X
B05		B05	3-74-3-A	MAA STORAGE	42	0	0	DWT	X
B05		B06	3-81-0-A	DAIRY	42	0	0		
B05		B06	3-85-0-A	FRUITS AND VEGETABLE	73.5	0	0		
B05		B05	3-85-3-A	MAA LKR	73.5	0	0	DWT	X
B05	S3I	B05	4-92-0-E	GENERATOR ROOM	63	0	0		
D05			2-74-0-L	CREWS BERTHING	64.3	0	0	HS	X
			3-81-2-L	PASSAGE	(CUI	= LP)			
B05		B05	3-74-0-A	MEATS	42	0	0	DJ	NC
B05		S2I	3-74-2-Q	REEFER FLAT	42	0	0	DJ	NC
B05		B06	3-81-0-A	DAIRY	42	0	0	DJ	NC
B05		B06	3-85-0-A	FRUITS AND VEGETABLE	42	0	0	DJ	NC
D05			2-74-0-L	CREWS BERTHING	16	0	0		

D.2.1 Barrier Data: All Bulkheads Uninsulated

Barrier Materials				Area	Therm	Durab	Hatch	Readiness
<1>	<2>	<3>		ft2	adj	adj		
			3-85-0-A	FRUITS AND VEGETABLES	(CUI = AR)			
S2I		S2I	3-74-2-Q	REEFER FLAT	73.5	0	0	
B06		B06	3-81-0-A	DAIRY	84	0	0	
B06		B05	3-81-1-L	PASSAGE	73.5	0	0	
B06		B05	3-81-2-L	PASSAGE	42	0	0	DJ NC
B05	S3I	B05	4-92-0-E	GENERATOR ROOM	126	0	0	
D05			2-74-0-L	CREWS BERTHING	84	0	0	
			3-85-3-A	MAA LKR	(CUI = AG)			
B05		B05	3-74-3-A	MAA STORAGE	79.8	0	0	
B05		B05	3-81-1-L	PASSAGE	73.5	0	0	DWT X
B05	S3I	B05	4-92-0-E	GENERATOR ROOM	77.7	0	0	
S2I	S3U		(none)	(weather bulkhead)	73.5	0	0	
D05			2-74-0-L	CREWS BERTHING	44.8	0	0	
			4-92-0-E	GENERATOR ROOM	(CUI = EE)			
B05	S3I	B05	3-74-2-Q	REEFER FLAT	77.7	0	0	
B05	S3I	B05	3-81-1-L	PASSAGE	63	0	0	
B05	S3I	B05	3-85-0-A	FRUITS AND VEGETABLE	126	0	0	
B05	S3I	B05	3-85-3-A	MAA LKR	77.7	0	0	
S3U	S3I	S3U	4-116-0-F	DIESEL OIL TANK	111.3	0	0	
B05	S3I	B05	4-116-0-F	DIESEL OIL TANK	86.4	0	0	
B05	S3I	B05	4-116-1-F	DIESEL OIL TANK	94.5	0	0	
B05	S3I	B05	4-116-1-F	DIESEL OIL TANK	92.8	0	0	
S3U	S3I	S3U	4-116-2-F	DIESEL OIL TANK	92.4	0	0	
B05	S3I	B05	4-116-2-F	DIESEL OIL TANK	92.8	0	0	
S2I	S3I	S2U	2-74-0-L	CREWS BERTHING	257.6	0	0	
S3U	S3U		(none)	(weather bulkhead)	253.1	0	0	
S3U	S3U		(none)	(weather bulkhead)	253.1	0	0	
S2U	S3U		(none)	(weather bulkhead)	192	0	0	
S2U	S3U		(none)	(weather bulkhead)	192	0	0	
B05	S3U		(none)	(weather bulkhead)	11.2	0	0	
S2I			4-92-0A-E	FIDLEY	92.5	-90	-90	HL X
D05			1-70-3A-L	CREW MESS	65.6	0	0	
S2I			1-74-2A-L	PASSAGE	22.5	0	0	
S2I			1-74-2B-L	PASSAGE	62.5	0	0	
S2I			1-74-2C-L	PASSAGE	12.8	0	0	
D05			1-91-2-L	PO-1 WC, WR & SH	51.8	0	0	
D05			1-92-0-Q	SCULLERY	43.5	0	0	
S2I			1-92-2-Q	DC LKR	15.6	0	0	
S2I			1-93-1-L	CPO MESS & REC	109.2	0	0	
S2I			1-99-1A-L	PASSAGE	61.8	0	0	
S2I			1-99-1B-L	PASSAGE	12	0	0	
D05			1-99-2-L	DISPENSARY	47.1	0	0	
D05			1-104-2-L	CPO WR, WC & SH	33	0	0	
S2I			1-106-1-Q	MOVIE LKR	4.2	0	0	
S2I			1-106-2-L	CPO BERTHING	75	0	0	
S2I			1-107-1-Q	MORALE LKR	7.8	0	0	

D.2.1 Barrier Data: All Bulkheads Uninsulated

Barrier Materials					Area	Therm	Durab	Hatch	Readiness
<1>	<2>	<3>			ft2	adj	adj		
S2I			1-110-1-Q	SHIPS OFFICE	63	0	0		
S2I			1-112-0-Q	AUXILIARY MACHINERY	27.2	-15	-15		
S3I			(none)	(weather overhead)	4.1	0	0		
			4-126-0-E	MAIN MOTOR ROOM	(CUI = EE)				
S3U	S3I	S3U	4-116-0-F	DIESEL OIL TANK	111.3	0	0		
B05	S3I	B05	4-116-0-F	DIESEL OIL TANK	80	0	0		
S3U	S3I	S3U	4-116-1-F	DIESEL OIL TANK	75.6	0	0		
S3U	S3I	S3U	4-116-2-F	DIESEL OIL TANK	73.5	0	0		
S3U	S3I	S3U	4-140-0-W	FRESH WATER TANK	176.4	0	0		
B05	S3I	B05	4-140-0-W	FRESH WATER TANK	80	0	0		
0		0	2-126-1-Q	MACHINE SHOP	112	0	0	DJ	NC
0		0	2-126-2-Q	A.C. EQUIPMENT	112	0	0		
S3I	S3U		(none)	(weather bulkhead)	152.9	0	0		
S3I	S3U		(none)	(weather bulkhead)	152.9	0	0		
S2U			2-126-1-Q	MACHINE SHOP	70	0	0		
S2U			2-126-2-Q	A.C. EQUIPMENT	81.2	0	0		
S2U			1-74-2C-L	PASSAGE	4.8	0	0		
S2U			1-99-1B-L	PASSAGE	8	0	0		
S2U			1-112-0-Q	AUXILIARY MACHINERY	40.8	-15	-15	HL	X
S2U			1-132-0A-L	PASSAGE	86.4	0	0	HS	X
			4-140-0-W	FRESH WATER TANK	(CUI = W)				
S3U	S3I	S3U	4-126-0-E	MAIN MOTOR ROOM	176.4	0	0		
B05	S3I	B05	4-126-0-E	MAIN MOTOR ROOM	80	0	0		
S3U	S3I	S3U	4-147-0-W	AFT PEAK TANK	126	0	0		
B05	S3I	B05	2-126-2-Q	A.C. EQUIPMENT	8	0	0		
B05		B05	3-140-1-W	FRESH WATER TANK	56	0	0		
B05		B05	3-140-2-W	FRESH WATER TANK	56	0	0		
B05		B05	2-147-0-Q	ENGINEERS STOREROOM	88	0	0		
S3U	S3U		(none)	(weather bulkhead)	77.7	0	0		
S3U	S3U		(none)	(weather bulkhead)	77.7	0	0		
S2U			3-140-1-W	FRESH WATER TANK	12.6	0	0		
S2U			3-140-2-W	FRESH WATER TANK	11.2	0	0		
D05			1-132-0B-L	PASSAGE	15.4	0	0		
S2U			1-140-0-L	WARDROOM	7	0	0		
D05			1-140-1-Q	PANTRY	54.6	0	0		
			4-147-0-W	AFT PEAK TANK	(CUI = W)				
S3U	S3I	S3U	4-140-0-W	FRESH WATER TANK	126	0	0		
S3U	S3U		(none)	(weather bulkhead)	21	0	0		
S3U	S3U		(none)	(weather bulkhead)	142.3	0	0		
S3U	S3U		(none)	(weather bulkhead)	142.3	0	0		
S2U			2-147-0-Q	ENGINEERS STOREROOM	88.2	0	0		
			2-9-0-Q	CHAIN LKR	(CUI = AG)				
S2U	S3I	S2U	4-FP-0-W	FOREPEAK TANK	86.4	0	0		
S2U		S2U	2-9-0-E	DC SHOP	40	0	0		
S2U		S2U	2-9-0-E	DC SHOP	86.4	0	0		

D.2.1 Barrier Data: All Bulkheads Uninsulated

Barrier Materials					Area	Therm	Durab	Hatch	Readiness
<1>	<2>	<3>			ft2	adj	adj		
S2U		S2U	2-9-0-E	DC SHOP	40	0	0		
S2U			3-9-0-E	BOW THRUSTER ROOM	52	0	0		
S2U			1-6-0-Q	DECK WORKSHOP	54	0	0	HS	X
			2-9-0-E	DC SHOP	(CUI = QS)				
S2U	S3I	S2U	4-FP-0-W	FOREPEAK TANK	12.8	0	0		
S2U	S3I	S2U	4-FP-0-W	FOREPEAK TANK	12.8	0	0		
S2U		S2U	2-9-0-Q	CHAIN LKR	40	0	0		
S2U		S2U	2-9-0-Q	CHAIN LKR	86.4	0	0		
S2U		S2U	2-9-0-Q	CHAIN LKR	40	0	0		
S2U	S3I	S2I	2-30-0-Q	ENG LOG OFFICE	67.2	0	0		
S2U	S3I	S2I	2-30-01-L	PASSAGE	24	0	0	DWT	Y
S2U	S3I	S2I	2-30-1-Q	ATON SHOP	59.2	0	0		
S2U	S3I	S2I	2-30-2-Q	E.M. SHOP & STORES	70.4	0	0		
S3U	S3U		(none)	(weather bulkhead)	83.1	0	0		
S3U	S3U		(none)	(weather bulkhead)	93.6	0	0		
S3U	S3U		(none)	(weather bulkhead)	93.6	0	0		
S3U	S3U		(none)	(weather bulkhead)	83.1	0	0		
S2U			3-9-0-E	BOW THRUSTER ROOM	284	0	0	HL	X
S2U			1-6-0-Q	DECK WORKSHOP	44	0	0	HS	X
S2U			1-6-1-Q	A/N LKR	8.9	0	0		
S2U			1-6-2-Q	BOSN'S LKR	8.9	0	0		
S3I			(none)	(weather overhead)	330.2	0	0	HS	X
			2-30-0-Q	ENG LOG OFFICE	(CUI = QO)				
S2I	S3I	S2U	2-9-0-E	DC SHOP	67.2	0	0		
B06		B05	2-30-01-L	PASSAGE	67.2	0	0	DJ	NC
B06		B05	2-30-01-L	PASSAGE	84.8	0	0		
B06		B05	2-30-2-Q	E.M. SHOP & STORES	84.8	0	0		
S2U			4-30-0-W	FRESH WATER TANK	89	0	0		
S3I			(none)	(weather overhead)	89	0	0		
			2-30-01-L	PASSAGE	(CUI = LP)				
S2I	S3I	S2U	2-9-0-E	DC SHOP	24	0	0	DWT	Y
B05		B06	2-30-0-Q	ENG LOG OFFICE	67.2	0	0	DJ	NC
B05		B06	2-30-0-Q	ENG LOG OFFICE	84.8	0	0		
B05		S2I	2-30-1-Q	ATON SHOP	48	0	0	DJ	NC
B05		B05	2-30-2-Q	E.M. SHOP & STORES	24	0	0	DJ	NC
B05		B06	2-36-1-Q	LAUNDRY	64	0	0	DJ	NC
B05		B05	2-41-2-Q	SHIPS SERVICE STORE	27.2	0	0	DJ	NC
B05	S3I	B05	2-44-0-T	HATCH TRUNK	64	0	0		
B05	S3I	B05	2-44-01-L	PASSAGE	24	0	0	DWT	Y
B05	S3I	B05	2-44-1-L	CREW LOUNGE	6.4	0	0		
B05	S3I	B05	2-44-2-L	CREWS BERTHING	20.8	0	0		
D05			4-30-0-W	FRESH WATER TANK	57.9	0	0		
D05			4-30-1-W	FRESH WATER TANK	14	0	0		
S2U			4-30-2-W	FRESH WATER TANK	8.8	0	0		
S3I			(none)	(weather overhead)	80.8	0	0		

D.2.1 Barrier Data: All Bulkheads Uninsulated

Barrier Materials					Area	Therm	Durab	Hatch	Readiness
<1>	<2>	<3>			ft2	adj	adj		
			2-30-1-Q	ATON SHOP	(CUI	= QS)			
S2I	S3I	S2U	2-9-0-E	DC SHOP	59.2	0	0		
S2I		B05	2-30-01-L	PASSAGE	48	0	0	DJ	NC
S2I		B05	2-36-1-Q	LAUNDRY	64	0	0		
S2I	S3U		(none)	(weather bulkhead)	48.2	0	0		
S2U			4-30-1-W	FRESH WATER TANK	33.3	0	0		
S3I			(none)	(weather overhead)	46.2	0	0		
			2-30-2-Q	E.M. SHOP & STORES	(CUI	= AS)			
S2I	S3I	S2U	2-9-0-E	DC SHOP	70.4	0	0		
B05		B06	2-30-0-Q	ENG LOG OFFICE	84.8	0	0		
B05		B05	2-30-01-L	PASSAGE	24	0	0	DJ	NC
B05		B05	2-41-2-Q	SHIPS SERVICE STORE	59.2	0	0		
S2I	S3U		(none)	(weather bulkhead)	85.8	0	0		
S2U			4-30-0-W	FRESH WATER TANK	4.2	0	0		
S2U			4-30-2-W	FRESH WATER TANK	74	0	0		
S3I			(none)	(weather overhead)	101.8	0	0		
			2-36-1-Q	LAUNDRY	(CUI	= QL)			
B06		B05	2-30-01-L	PASSAGE	64	0	0	DJ	NC
B05		S2I	2-30-1-Q	ATON SHOP	64	0	0		
S2I	S3I	S2U	2-44-1-L	CREW LOUNGE	76.8	0	0		
S2I	S3U		(none)	(weather bulkhead)	65.3	0	0		
D05			4-30-1-W	FRESH WATER TANK	54.9	0	0		
S3I			(none)	(weather overhead)	70.4	0	0		
			2-41-2-Q	SHIPS SERVICE STORE	(CUI	= AS)			
B05		B05	2-30-01-L	PASSAGE	27.2	0	0	DJ	NC
B05		B05	2-30-2-Q	E.M. SHOP & STORES	59.2	0	0		
B05	S3I	B05	2-44-2-L	CREWS BERTHING	64	0	0		
S2I	S3U		(none)	(weather bulkhead)	27.6	0	0		
S2U			4-30-2-W	FRESH WATER TANK	19.3	0	0		
S3I			(none)	(weather overhead)	26.2	0	0		
			2-44-0-T	HATCH TRUNK	(CUI	= TH)			
B05	S3I	B05	2-30-01-L	PASSAGE	64	0	0		
B05		B05	2-44-01-L	PASSAGE	28.8	0	0	DWT	Y
S2I		S2U	2-44-01-L	PASSAGE	59.2	0	0		
S2I		S2U	2-44-2-L	CREWS BERTHING	59.2	0	0		
S2U		S2I	2-44-2-L	CREWS BERTHING	35.2	0	0		
S2I			3-44-0-A	MAIN HOLD	59.2	0	0	HO	O
S3I			(none)	(weather overhead)	59.2	0	0	HS	X
			2-44-01-L	PASSAGE	(CUI	= LP)			
B05	S3I	B05	2-30-01-L	PASSAGE	24	0	0	DWT	Y
B05		B05	2-44-0-T	HATCH TRUNK	28.8	0	0	DWT	Y
S2U		S2I	2-44-0-T	HATCH TRUNK	59.2	0	0		
B05		B05	2-44-1-L	CREW LOUNGE	36.8	0	0	DJ	NC
B05		B05	2-44-1-L	CREW LOUNGE	8	0	0		

D.2.1 Barrier Data: All Bulkheads Uninsulated

Barrier Materials					Area	Therm	Durab	Hatch	Readiness
<1>	<2>	<3>			ft2	adj	adj		
B05		B05	2-44-1-L	CREW LOUNGE	92.8	0	0		
0		0	2-44-2-L	CREWS BERTHING	38.4	0	0		
B06		B05	2-57-0-L	CREW WR, WC & SH	4.8	0	0		
B06		B05	2-57-0-L	CREW WR, WC & SH	73.6	0	0		
B06		B05	2-57-0-L	CREW WR, WC & SH	9.6	0	0		
B06		B05	2-57-0-L	CREW WR, WC & SH	68.8	0	0	DJ	NC
0		0	2-60-1-L	CREWS BERTHING	16	0	0		
0		0	2-60-1-L	CREWS BERTHING	36.6	0	0		
0		0	2-60-1-L	CREWS BERTHING	60.8	0	0		
0		0	2-60-1-L	CREWS BERTHING	14.4	0	0		
S2I	S3I	S2U	2-74-0-L	CREWS BERTHING	40	0	0		
B05	S3I	B05	2-74-1-L	CREW WR, WC & SH	9.6	0	0		
S2I			3-44-0-A	MAIN HOLD	52.2	0	0		
S2I			3-56-0-Q	SEWAGE SPACE	49.2	0	0		
S2I			3-68-1-A	GENERAL STORES	24.2	0	0	HS	X
S2I			3-68-2-A	DRY STORES	9.6	0	0		
S2I			1-68-0-L	COMPANIONWAY	19.1	0	0	HS	X
S2I			1-68-1-Q	HYD PUMP ROOM	12	0	0		
S3I			(none)	(weather overhead)	104	0	0		
			2-44-1-L	CREW LOUNGE	(CUI = LL)				
B05	S3I	B05	2-30-01-L	PASSAGE	6.4	0	0		
S2U	S3I	S2I	2-36-1-Q	LAUNDRY	76.8	0	0		
B05		B05	2-44-01-L	PASSAGE	36.8	0	0	DJ	NC
B05		B05	2-44-01-L	PASSAGE	8	0	0		
B05		B05	2-44-01-L	PASSAGE	92.8	0	0		
B05		B05	2-60-1-L	CREWS BERTHING	86.4	0	0		
S2I	S3U		(none)	(weather bulkhead)	129.9	0	0		
S2I	S3U		(none)	(weather bulkhead)	12.8	0	0		
S2I			3-44-0-A	MAIN HOLD	107.2	0	0		
S2I			3-56-0-Q	SEWAGE SPACE	44.4	0	0		
S3I			(none)	(weather overhead)	181.2	0	0		
			2-44-2-L	CREWS BERTHING	(CUI = L5)				
B05	S3I	B05	2-30-01-L	PASSAGE	20.8	0	0		
B05	S3I	B05	2-41-2-Q	SHIPS SERVICE STORE	64	0	0		
S2U		S2I	2-44-0-T	HATCH TRUNK	59.2	0	0		
S2I		S2U	2-44-0-T	HATCH TRUNK	35.2	0	0		
0		0	2-44-01-L	PASSAGE	38.4	0	0		
S2I		S2U	2-57-0-L	CREW WR, WC & SH	142.4	0	0	DJ	NC
S2I		S2U	2-57-0-L	CREW WR, WC & SH	49.6	0	0		
S2I	S3I	S2U	2-74-0-L	CREWS BERTHING	84.8	0	0		
S2I	S3U		(none)	(weather bulkhead)	240.4	0	0		
D05			3-44-0-A	MAIN HOLD	129.4	0	0		
D05			3-56-0-Q	SEWAGE SPACE	100.8	0	0		
D05			3-68-2-A	DRY STORES	54	0	0		
S2I			1-70-2-L	VESTIBULE	7.2	0	0		
S2I			1-70-4-L	PO-1 BERTHING	32	0	0		
S3I			(none)	(weather overhead)	294.9	0	0		

D.2.1 Barrier Data: All Bulkheads Uninsulated

Barrier Materials					Area	Therm	Durab	Hatch	Readiness
<1>	<2>	<3>			ft2	adj	adj		
			2-57-0-L	CREW WR, WC & SH	(CUI	= LW)			
B05		B06	2-44-01-L	PASSAGE	4.8	0	0		
B05		B06	2-44-01-L	PASSAGE	73.6	0	0		
B05		B06	2-44-01-L	PASSAGE	9.6	0	0		
B05		B06	2-44-01-L	PASSAGE	68.8	0	0	DJ	NC
S2U		S2I	2-44-2-L	CREWS BERTHING	142.4	0	0	DJ	NC
S2U		S2I	2-44-2-L	CREWS BERTHING	49.6	0	0		
B05	S3I	B05	2-74-0-L	CREWS BERTHING	44.8	0	0		
D05			3-56-0-Q	SEWAGE SPACE	77.1	0	0	HS	X
D05			3-68-2-A	DRY STORES	33.6	0	0		
S2I			1-68-2-Q	HYD PUMP ROOM	19.3	0	0		
S2I			1-70-2-L	VESTIBULE	4.8	0	0		
S3I			(none)	(weather overhead)	85.6	0	0		
			2-60-1-L	CREWS BERTHING	(CUI	= L5)			
0		0	2-44-01-L	PASSAGE	16	0	0		
0		0	2-44-01-L	PASSAGE	36.6	0	0		
0		0	2-44-01-L	PASSAGE	60.8	0	0		
0		0	2-44-01-L	PASSAGE	14.4	0	0		
B05		B05	2-44-1-L	CREW LOUNGE	86.4	0	0		
B05	S3I	B05	2-74-1-L	CREW WR, WC & SH	86.4	0	0		
S2I	S3U		(none)	(weather bulkhead)	110.4	0	0		
S2I			3-56-0-Q	SEWAGE SPACE	98.3	0	0		
S2I			3-68-1-A	GENERAL STORES	68.2	0	0		
S2I			1-68-1-Q	HYD PUMP ROOM	7.3	0	0		
S2I			1-70-1-L	VESTIBULE	12	0	0		
D05			1-70-3A-L	CREW MESS	25.6	0	0		
S3I			(none)	(weather overhead)	121.6	0	0		
			2-74-0-L	CREWS BERTHING	(CUI	= L5)			
S2U	S3I	S2I	4-92-0-E	GENERATOR ROOM	257.6	0	0		
S2U	S3I	S2I	2-44-01-L	PASSAGE	40	0	0		
S2U	S3I	S2I	2-44-2-L	CREWS BERTHING	84.8	0	0		
B05	S3I	B05	2-57-0-L	CREW WR, WC & SH	44.8	0	0		
S2I		S2U	2-74-1-L	CREW WR, WC & SH	46.4	0	0		
S2I		S2U	2-74-1-L	CREW WR, WC & SH	24	0	0	DJ	NC
S2I		S2U	2-74-1-L	CREW WR, WC & SH	27.2	0	0		
S2I		S2U	2-74-1-L	CREW WR, WC & SH	40	0	0		
S2I		S2U	2-74-1-L	CREW WR, WC & SH	22.4	0	0		
S2I		S2U	2-74-1-L	CREW WR, WC & SH	20.8	0	0		
S2I	S3U		(none)	(weather bulkhead)	59.2	0	0		
S2I	S3U		(none)	(weather bulkhead)	144	0	0		
S2I	S3U		(none)	(weather bulkhead)	8	0	0		
D05			3-74-0-A	MEATS	107.8	0	0		
D05			3-74-2-Q	REEFER FLAT	111.2	0	0	HL	X
S2I			3-74-1-M	SMALL ARMS AMMUNITIO	15.1	0	0		
D05			3-74-3-A	MAA STORAGE	4.4	0	0		
D05			3-81-0-A	DAIRY	32	0	0		

D.2.1 Barrier Data: All Bulkheads Uninsulated

Barrier Materials					Area	Therm	Durab	Hatch	Readiness
<1>	<2>	<3>			ft2	adj	adj		
D05			3-81-1-L	PASSAGE	64.3	0	0	HS	X
D05			3-81-2-L	PASSAGE	16	0	0		
D05			3-85-0-A	FRUITS AND VEGETABLE	84	0	0		
D05			3-85-3-A	MAA LKR	44.8	0	0		
D05			1-70-3A-L	CREW MESS	70.8	0	0		
S2I			1-70-4-L	PO-1 BERTHING	114	0	0		
S2I			1-74-0-L	PASSAGE	34.6	0	0		
S2I			1-74-2A-L	PASSAGE	61.8	0	0		
S2I			1-77-0-Q	GYRO EQUIP	6	0	0		
S2I			1-77-1-L	COMPANIONWAY	13.3	0	0	HS	X
D05			1-79-0-Q	GALLEY	165.9	0	0		
S2I			1-85-2-L	COMPANIONWAY	13.2	0	0	HS	X
D05			1-91-2-L	PO-1 WC, WR & SH	9	0	0		
S3I			(none)	(weather overhead)	14.4	0	0		
			2-74-1-L	CREW WR, WC & SH	(CUI = LW)				
B05	S3I	B05	2-44-01-L	PASSAGE	9.6	0	0		
B05	S3I	B05	2-60-1-L	CREWS BERTHING	86.4	0	0		
S2U		S2I	2-74-0-L	CREWS BERTHING	46.4	0	0		
S2U		S2I	2-74-0-L	CREWS BERTHING	24	0	0	DJ	NC
S2U		S2I	2-74-0-L	CREWS BERTHING	27.2	0	0		
S2U		S2I	2-74-0-L	CREWS BERTHING	40	0	0		
S2U		S2I	2-74-0-L	CREWS BERTHING	22.4	0	0		
S2U		S2I	2-74-0-L	CREWS BERTHING	20.8	0	0		
B05	S3U		(none)	(weather bulkhead)	84.8	0	0		
D05			3-74-1-M	SMALL ARMS AMMUNITIO	26.9	0	0		
D05			3-74-3-A	MAA STORAGE	66	0	0		
D05			1-70-3A-L	CREW MESS	87.4	0	0		
S2I			1-74-0-L	PASSAGE	6.2	0	0		
			2-126-1-Q	MACHINE SHOP	(CUI = QS)				
B05	S3I	B05	4-116-1-F	DIESEL OIL TANK	99.2	0	0		
0		0	4-126-0-E	MAIN MOTOR ROOM	112	0	0	DJ	NC
B05	S3I	B05	3-140-1-W	FRESH WATER TANK	86.4	0	0		
S2I	S3U		(none)	(weather bulkhead)	112.7	0	0		
S2U			4-126-0-E	MAIN MOTOR ROOM	70	0	0		
S2I			1-99-1B-L	PASSAGE	4	0	0		
S2I			1-124-1-L	SR #1	49.2	0	0		
S2I			1-132-0A-L	PASSAGE	26.8	0	0		
S2I			1-132-1-L	SR #3	68.8	0	0		
S3I			(none)	(weather overhead)	13.6	0	0		
			2-126-2-Q	A.C. EQUIPMENT	(CUI = QA)				
B05	S3I	B05	4-116-0-F	DIESEL OIL TANK	6.4	0	0		
B05	S3I	B05	4-116-2-F	DIESEL OIL TANK	99.2	0	0		
0		0	4-126-0-E	MAIN MOTOR ROOM	112	0	0		
B05	S3I	B05	4-140-0-W	FRESH WATER TANK	8	0	0		
B05	S3I	B05	3-140-2-W	FRESH WATER TANK	84.8	0	0		
S2I	S3U		(none)	(weather bulkhead)	112.7	0	0		

D.2.1 Barrier Data: All Bulkheads Uninsulated

Barrier Materials					Area	Therm	Durab	Hatch	Readiness
<1>	<2>	<3>			ft2	adj	adj		
S2U			4-126-0-E	MAIN MOTOR ROOM	81.2	0	0		
S2I			1-74-2C-L	PASSAGE	8	0	0		
S2I			1-124-2-L	SR #2	46.8	0	0		
S2I			1-132-0A-L	PASSAGE	34.8	0	0		
S2I			1-132-2-L	SR #4	68.8	0	0		
S3I			(none)	(weather overhead)	15.2	0	0		
			3-140-1-W	FRESH WATER TANK	(CUI	= W)			
B05		B05	4-140-0-W	FRESH WATER TANK	56	0	0		
B05	S3I	B05	2-126-1-Q	MACHINE SHOP	86.4	0	0		
B05		B05	2-147-0-Q	ENGINEERS STOREROOM	75.2	0	0		
B05	S3U		(none)	(weather bulkhead)	57.1	0	0		
S2U			4-140-0-W	FRESH WATER TANK	12.6	0	0		
S2U			1-140-0-L	WARDROOM	61.4	0	0		
S3I			(none)	(weather overhead)	9.3	0	0		
			3-140-2-W	FRESH WATER TANK	(CUI	= W)			
B05		B05	4-140-0-W	FRESH WATER TANK	56	0	0		
B05	S3I	B05	2-126-2-Q	A.C. EQUIPMENT	84.8	0	0		
B05		B05	2-147-0-Q	ENGINEERS STOREROOM	73.6	0	0		
B05	S3U		(none)	(weather bulkhead)	57.1	0	0		
S2U			4-140-0-W	FRESH WATER TANK	11.2	0	0		
D05			1-132-0B-L	PASSAGE	5.6	0	0		
S2U			1-140-2-L	SR #6	57.6	0	0		
S3I			(none)	(weather overhead)	6.1	0	0		
			2-147-0-Q	ENGINEERS STOREROOM	(CUI	= AS)			
B05		B05	4-140-0-W	FRESH WATER TANK	88	0	0		
B05		B05	3-140-1-W	FRESH WATER TANK	75.2	0	0		
B05		B05	3-140-2-W	FRESH WATER TANK	73.6	0	0		
B05	S3I	B05	2-161-0-Q	LAZARETTE	169.6	0	0		
B05	S3U		(none)	(weather bulkhead)	116.9	0	0		
B05	S3U		(none)	(weather bulkhead)	116.9	0	0		
S2U			4-147-0-W	AFT PEAK TANK	88.2	0	0		
D05			1-132-0B-L	PASSAGE	30	0	0		
S2U			1-140-0-L	WARDROOM	155.8	0	0		
S2U			1-140-2-L	SR #6	21.4	0	0		
D05			1-150-2-L	OFFICER WR, WC & SH	43.2	0	0		
S2U			1-157-0-E	STEERING GEAR SPACE	41.6	0	0	HS	X
S2U			1-157-1-Q	ARMORY	25.3	0	0		
S2U			1-157-2-Q	LINEN LKR	18.3	0	0		
S3I			(none)	(weather overhead)	20	0	0		
			2-161-0-Q	LAZARETTE	(CUI	= QA)			
B05	S3I	B05	2-147-0-Q	ENGINEERS STOREROOM	169.6	0	0		
B05	S3U		(none)	(weather bulkhead)	18.2	0	0		
B05	S3U		(none)	(weather bulkhead)	10.2	0	0		
B05	S3U		(none)	(weather bulkhead)	51.2	0	0		
B05	S3U		(none)	(weather bulkhead)	33	0	0		

D.2.1 Barrier Data: All Bulkheads Uninsulated

Barrier Materials					Area	Therm	Durab	Hatch	Readiness
<1>	<2>	<3>			ft2	adj	adj		
B05	S3U		(none)	(weather bulkhead)	30.1	0	0		
B05	S3U		(none)	(weather bulkhead)	30.1	0	0		
B05	S3U		(none)	(weather bulkhead)	33	0	0		
B05	S3U		(none)	(weather bulkhead)	51.2	0	0		
B05	S3U		(none)	(weather bulkhead)	10.2	0	0		
B05	S3U		(none)	(weather bulkhead)	18.2	0	0		
S2U			1-157-0-E	STEERING GEAR SPACE	148	0	0	HS	X
S2U			1-157-1-Q	ARMORY	10.7	0	0		
S2U			1-161-2-Q	CG LKR	6.2	0	0		
S3I			(none)	(weather overhead)	15.9	0	0		
			1-FP-0-K	PAINT LKR	(CUI	= K)			
B05		B05	1-6-0-Q	DECK WORKSHOP	112	0	0	DJ	NC
B05		B05	1-6-1-Q	A/N LKR	16	0	0		
B05		B05	1-6-2-Q	BOSN'S LKR	16	0	0		
B05	S2U		(none)	(weather bulkhead)	72.8	0	0		
B05	S2U		(none)	(weather bulkhead)	40	0	0		
B05	S2U		(none)	(weather bulkhead)	40	0	0		
B05	S2U		(none)	(weather bulkhead)	72.8	0	0		
S2U			4-FP-0-W	FOREPEAK TANK	58.4	0	0		
S2U			(none)	(weather overhead)	110.8	0	0		
			1-6-0-Q	DECK WORKSHOP	(CUI	= QS)			
B05		B05	1-FP-0-K	PAINT LKR	112	0	0	DJ	NC
B05		B05	1-6-1-Q	A/N LKR	83.2	0	0	DJ	NC
B05		B05	1-6-2-Q	BOSN'S LKR	83.2	0	0	DJ	NC
B05	S2U		(none)	(weather bulkhead)	112	0	0	DJ	NC
S2U			4-FP-0-W	FOREPEAK TANK	42.7	0	0		
S2U			2-9-0-Q	CHAIN LKR	54	0	0	HS	X
S2U			2-9-0-E	DC SHOP	44	0	0	HS	X
S2I			(none)	(weather overhead)	145.6	0	0		
			1-6-1-Q	A/N LKR	(CUI	= AG)			
B05		B05	1-FP-0-K	PAINT LKR	16	0	0		
B05		B05	1-6-0-Q	DECK WORKSHOP	83.2	0	0	DJ	NC
B05	S2U		(none)	(weather bulkhead)	48	0	0		
B05	S2U		(none)	(weather bulkhead)	59.7	0	0		
B05	S2U		(none)	(weather bulkhead)	29.4	0	0		
S2U			2-9-0-E	DC SHOP	8.9	0	0		
S2U			(none)	(weather overhead)	42.1	0	0		
			1-6-2-Q	BOSN'S LKR	(CUI	= AG)			
B05		B05	1-FP-0-K	PAINT LKR	16	0	0		
B05		B05	1-6-0-Q	DECK WORKSHOP	83.2	0	0	DJ	NC
B05	S2U		(none)	(weather bulkhead)	48	0	0		
B05	S2U		(none)	(weather bulkhead)	89.1	0	0		
S2U			2-9-0-E	DC SHOP	8.9	0	0		
S2U			(none)	(weather overhead)	41.6	0	0		

D.2.1 Barrier Data: All Bulkheads Uninsulated

Barrier Materials					Area	Therm	Durab	Hatch	Readiness
<1>	<2>	<3>			ft2	adj	adj		
			1-68-0-L	COMPANIONWAY	(CUI	= LP)			
B05		B05	1-68-1-Q	HYD PUMP ROOM	41.6	0	0		
B05		B05	1-68-2-Q	HYD PUMP ROOM	41.6	0	0		
B05		B05	1-74-0-L	PASSAGE	28.8	0	0	DJ	NC
B05	S2U		(none)	(weather bulkhead)	15.8	0	0		
B05	S2U		(none)	(weather bulkhead)	15.8	0	0		
S2I			2-44-01-L	PASSAGE	19.1	0	0	HS	X
S2I			01-71-0-Q	CRANE CONTROL BOOTH	12.2	0	0		
S2I			(none)	(weather overhead)	7.9	0	0		
			1-68-1-Q	HYD PUMP ROOM	(CUI	= QA)			
B05		B05	1-68-0-L	COMPANIONWAY	41.6	0	0		
B05		B05	1-70-1-L	VESTIBULE	32	0	0		
B05		B05	1-74-0-L	PASSAGE	33.6	0	0	DJ	NC
B05	S2U		(none)	(weather bulkhead)	34.9	0	0		
S2I			2-44-01-L	PASSAGE	12	0	0		
S2I			2-60-1-L	CREWS BERTHING	7.3	0	0		
S2I			01-71-0-Q	CRANE CONTROL BOOTH	6.1	0	0		
S2I			(none)	(weather overhead)	13.2	0	0		
			1-68-2-Q	HYD PUMP ROOM	(CUI	= QA)			
B05		B05	1-68-0-L	COMPANIONWAY	41.6	0	0		
B05		B05	1-70-2-L	VESTIBULE	32	0	0		
B05		B05	1-74-0-L	PASSAGE	33.6	0	0	DJ	NC
B05	S2U		(none)	(weather bulkhead)	34.9	0	0		
S2I			2-57-0-L	CREW WR, WC & SH	19.3	0	0		
S2I			01-71-0-Q	CRANE CONTROL BOOTH	6.1	0	0		
S2I			(none)	(weather overhead)	13.2	0	0		
			1-70-1-L	VESTIBULE	(CUI	= LP)			
B05		B05	1-68-1-Q	HYD PUMP ROOM	32	0	0		
S2U		S2I	1-70-3A-L	CREW MESS	24	0	0	DJ	NO
S2U		S2I	1-70-3A-L	CREW MESS	32	0	0		
B05	S2U		(none)	(weather bulkhead)	24	0	0	DWT	X
S2I			2-60-1-L	CREWS BERTHING	12	0	0		
S2I			(none)	(weather overhead)	12	0	0		
			1-70-2-L	VESTIBULE	(CUI	= LP)			
B05		B05	1-68-2-Q	HYD PUMP ROOM	32	0	0		
S2U		S2I	1-70-4-L	PO-1 BERTHING	32	0	0		
B05		B05	1-74-2A-L	PASSAGE	24	0	0	DJ	NO
B05	S2U		(none)	(weather bulkhead)	24	0	0	DWT	X
S2I			2-44-2-L	CREWS BERTHING	7.2	0	0		
S2I			2-57-0-L	CREW WR, WC & SH	4.8	0	0		
S2I			(none)	(weather overhead)	12	0	0		
			1-70-3A-L	CREW MESS	(CUI	= LL)			
S2I		S2U	1-70-1-L	VESTIBULE	24	0	0	DJ	NO
S2I		S2U	1-70-1-L	VESTIBULE	32	0	0		

D.2.1 Barrier Data: All Bulkheads Uninsulated

Barrier Materials					Area	Therm	Durab	Hatch	Readiness
<1>	<2>	<3>			ft2	adj	adj		
B05		B05	1-74-0-L	PASSAGE	19.2	0	0	DJ	NO
B05		B05	1-77-1-L	COMPANIONWAY	36.8	0	0		
B05		B05	1-79-0-Q	GALLEY	8	-5	-5		
B05		B05	1-79-0-Q	GALLEY	88	-5	-5		
B05		B05	1-79-0-Q	GALLEY	28.8	-5	-5		
B05		B05	1-92-0-Q	SCULLERY	51.2	0	0	DJ	NO
B05		B05	1-93-1-L	CPO MESS & REC	24	0	0		
B05		B05	1-93-1-L	CPO MESS & REC	16	0	0		
B05		B05	1-93-1-L	CPO MESS & REC	40	0	0		
0		0	1-99-1A-L	PASSAGE	45.5	0	0		
B06	S2U		(none)	(weather bulkhead)	203.2	0	0		
B06	S2U		(none)	(weather bulkhead)	64	0	0		
D05			4-92-0-E	GENERATOR ROOM	65.6	0	0		
D05			2-60-1-L	CREWS BERTHING	25.6	0	0		
D05			2-74-0-L	CREWS BERTHING	70.8	0	0		
D05			2-74-1-L	CREW WR, WC & SH	87.4	0	0		
S2I			01-74-1-Q	CODE ROOM	11.6	0	0		
S2I			01-82-0-L	CO CABIN	13	0	0		
S2I			01-95-1-L	COMPANIONWAY	8.4	0	0		
S2I			(none)	(weather overhead)	251.8	0	0		
			1-70-4-L	PO-1 BERTHING	(CUI = L5)				
S2I		S2U	1-70-2-L	VESTIBULE	32	0	0		
S2I		S2U	1-74-2A-L	PASSAGE	6.4	-25	-25		
S2I		S2U	1-74-2A-L	PASSAGE	88	-25	-25	DJ	NC
S2I		S2U	1-85-2-L	COMPANIONWAY	35.2	0	0		
S2I		S2U	1-85-2-L	COMPANIONWAY	24	0	0		
S2I		NSU	1-91-2-L	PO-1 WC, WR & SH	40	0	0	DJ	NC
S2I	S2U		(none)	(weather bulkhead)	64	0	0		
S2I	S2U		(none)	(weather bulkhead)	161.6	0	0		
S2I			2-44-2-L	CREWS BERTHING	32	0	0		
S2I			2-74-0-L	CREWS BERTHING	114	0	0		
S2I			(none)	(weather overhead)	146	0	0		
			1-74-0-L	PASSAGE	(CUI = LP)				
B05		B05	1-68-0-L	COMPANIONWAY	28.8	0	0	DJ	NC
B05		B05	1-68-1-Q	HYD PUMP ROOM	33.6	0	0	DJ	NC
B05		B05	1-68-2-Q	HYD PUMP ROOM	33.6	0	0	DJ	NC
B05		B05	1-70-3A-L	CREW MESS	19.2	0	0	DJ	NO
B05		B05	1-74-2A-L	PASSAGE	35.2	0	0	DJ	NO
B05		B05	1-77-0-Q	GYRO EQUIP	16	0	0		
B05		B05	1-77-0-Q	GYRO EQUIP	24	0	0	DJ	NC
B05		B05	1-77-1-L	COMPANIONWAY	24	0	0	DJ	NC
B05		B05	1-79-0-Q	GALLEY	48	0	0		
S2I			2-74-0-L	CREWS BERTHING	34.6	0	0		
S2I			2-74-1-L	CREW WR, WC & SH	6.2	0	0		
S2I			01-74-0-L	CO SR	26.4	0	0		
S2I			01-74-1-Q	CODE ROOM	14.4	0	0		

D.2.1 Barrier Data: All Bulkheads Uninsulated

Barrier Materials				Area	Therm	Durab	Hatch	Readiness
<1>	<2>	<3>		ft2	adj	adj		
			1-74-2A-L	PASSAGE	(CUI = LP)			
B05		B05	1-70-2-L	VESTIBULE	24	0	0	DJ NO
S2U		S2I	1-70-4-L	PO-1 BERTHING	6.4	-25	-25	
S2U		S2I	1-70-4-L	PO-1 BERTHING	88	-25	-25	DJ NC
B05		B05	1-74-0-L	PASSAGE	35.2	0	0	DJ NO
0		0	1-74-2B-L	PASSAGE	25.3	0	0	
B05		B05	1-79-0-Q	GALLEY	108.8	0	0	DJ NO
B05		B05	1-85-2-L	COMPANIONWAY	35.2	0	0	
B05		B05	1-85-2-L	COMPANIONWAY	24	0	0	DJ NC
B05		NSU	1-91-2-L	PO-1 WC, WR & SH	22.4	0	0	
B05		NSU	1-91-2-L	PO-1 WC, WR & SH	24	0	0	
B05		NSU	1-91-2-L	PO-1 WC, WR & SH	48	0	0	DJ NC
B05		B05	1-92-2-Q	DC LKR	48	0	0	DJ NC
S2I			4-92-0-E	GENERATOR ROOM	22.5	0	0	
S2I			2-74-0-L	CREWS BERTHING	61.8	0	0	
S2I			01-74-0-L	CO SR	15.2	0	0	
S2I			01-82-0-L	CO CABIN	8.2	0	0	
S2I			01-89-2-Q	FAN ROOM	3.2	0	0	
S2I			01-93-2-L	COMPANIONWAY	5.2	0	0	
S2I			(none)	(weather overhead)	52.5	0	0	
			1-74-2B-L	PASSAGE	(CUI = LP)			
0		0	1-74-2A-L	PASSAGE	25.3	0	0	
0		0	1-74-2C-L	PASSAGE	25.6	0	0	
B05		B05	1-92-2-Q	DC LKR	20.8	0	0	
S2U		S2I	4-92-0A-E	FIDLEY	108.8	0	0	
B05		NSU	1-99-2-L	DISPENSARY	56	-25	-25	DJ NC
B05		B05	1-106-2-L	CPO BERTHING	19.2	-25	-25	
B05		B05	1-106-2-L	CPO BERTHING	48	-25	-25	
S2I			4-92-0-E	GENERATOR ROOM	62.5	0	0	
S2I			01-93-2-L	COMPANIONWAY	13.4	0	0	HO O
S2I			(none)	(weather overhead)	46.3	0	0	
			1-74-2C-L	PASSAGE	(CUI = LP)			
0		0	1-74-2B-L	PASSAGE	25.6	0	0	
B05		B05	1-106-2-L	CPO BERTHING	89.6	-25	-25	DJ NC
B05		B05	1-112-0-Q	AUXILIARY MACHINERY	144	0	0	DJ NC
B05		B05	1-124-2-L	SR #2	54.4	0	0	
B05		B05	1-132-0A-L	PASSAGE	25.6	0	0	DJ NO
S2I			4-92-0-E	GENERATOR ROOM	12.8	0	0	
S2I			4-116-0-F	DIESEL OIL TANK	20	0	0	
S2I			4-116-2-F	DIESEL OIL TANK	12	0	0	
S2U			4-126-0-E	MAIN MOTOR ROOM	4.8	0	0	
S2I			2-126-2-Q	A.C. EQUIPMENT	8	0	0	
S2I			(none)	(weather overhead)	55.8	0	0	
			1-77-0-Q	GYRO EQUIP	(CUI = QA)			
B05		B05	1-74-0-L	PASSAGE	16	0	0	
B05		B05	1-74-0-L	PASSAGE	24	0	0	DJ NC

D.2.1 Barrier Data: All Bulkheads Uninsulated

Barrier Materials				Area	Therm	Durab	Hatch	Readiness
<1>	<2>	<3>		ft2	adj	adj		
B05		B05	1-77-1-L	COMPANIONWAY	16	0	0	
B05		B05	1-79-0-Q	GALLEY	24	0	0	
S2I			2-74-0-L	CREWS BERTHING	6	0	0	
S2I			01-74-1-Q	CODE ROOM	6	0	0	
			1-77-1-L	COMPANIONWAY	(CUI = LP)			
B05		B05	1-70-3A-L	CREW MESS	36.8	0	0	
B05		B05	1-74-0-L	PASSAGE	24	0	0	DJ NC
B05		B05	1-77-0-Q	GYRO EQUIP	16	0	0	
B05		B05	1-79-0-Q	GALLEY	20.8	0	0	
B05		B05	1-79-0-Q	GALLEY	24	0	0	
S2I			2-74-0-L	CREWS BERTHING	13.3	0	0	HS X
S2I			01-74-1-Q	CODE ROOM	13.8	0	0	
			1-79-0-Q	GALLEY	(CUI = QG)			
B05		B05	1-70-3A-L	CREW MESS	8	-5	-5	
B05		B05	1-70-3A-L	CREW MESS	88	-5	-5	
B05		B05	1-70-3A-L	CREW MESS	28.8	-5	-5	
B05		B05	1-74-0-L	PASSAGE	48	0	0	
B05		B05	1-74-2A-L	PASSAGE	108.8	0	0	DJ NO
B05		B05	1-77-0-Q	GYRO EQUIP	24	0	0	
B05		B05	1-77-1-L	COMPANIONWAY	20.8	0	0	
B05		B05	1-77-1-L	COMPANIONWAY	24	0	0	
B05		B05	1-92-0-Q	SCULLERY	54.4	0	0	
B05		B05	1-92-2-Q	DC LKR	20.8	0	0	
D05			2-74-0-L	CREWS BERTHING	165.9	0	0	
S2U			01-74-0-L	CO SR	19.2	0	0	
S2U			01-74-1-Q	CODE ROOM	12	0	0	
S2U			01-82-0-L	CO CABIN	129.9	0	0	
S2U			01-89-2-Q	FAN ROOM	5.3	0	0	
			1-85-2-L	COMPANIONWAY	(CUI = LP)			
S2U		S2I	1-70-4-L	PO-1 BERTHING	35.2	0	0	
S2U		S2I	1-70-4-L	PO-1 BERTHING	24	0	0	
B05		B05	1-74-2A-L	PASSAGE	35.2	0	0	
B05		B05	1-74-2A-L	PASSAGE	24	0	0	DJ NC
S2I			2-74-0-L	CREWS BERTHING	13.2	0	0	HS X
S2I			(none)	(weather overhead)	13.2	0	0	
			1-91-2-L	PO-1 WC, WR & SH	(CUI = LW)			
NSU		S2I	1-70-4-L	PO-1 BERTHING	40	0	0	DJ NC
NSU		B05	1-74-2A-L	PASSAGE	22.4	0	0	
NSU		B05	1-74-2A-L	PASSAGE	24	0	0	
NSU		B05	1-74-2A-L	PASSAGE	48	0	0	DJ NC
NSU		NSU	1-99-2-L	DISPENSARY	64	0	0	
NSU	S2U		(none)	(weather bulkhead)	70.4	0	0	
D05			4-92-0-E	GENERATOR ROOM	51.8	0	0	
D05			2-74-0-L	CREWS BERTHING	9	0	0	
S2I			(none)	(weather overhead)	62	0	0	

D.2.1 Barrier Data: All Bulkheads Uninsulated

Barrier Materials					Area	Therm	Durab	Hatch	Readiness
<1>	<2>	<3>			ft2	adj	adj		
			1-92-0-Q	SCULLERY	(CUI	= QG)			
B05		B05	1-70-3A-L	CREW MESS	51.2	0	0	DJ	NO
B05		B05	1-79-0-Q	GALLEY	54.4	0	0		
B05		B05	1-92-2-Q	DC LKR	48	0	0		
S2U		S2I	4-92-0A-E	FIDLEY	54.4	0	0		
D05			4-92-0-E	GENERATOR ROOM	43.5	0	0		
S2U			01-82-0-L	CO CABIN	34	0	0		
S2U			01-95-0-L	WR, WC & SH	9.5	0	0		
			1-92-2-Q	DC LKR	(CUI	= AG)			
B05		B05	1-74-2A-L	PASSAGE	48	0	0	DJ	NC
B05		B05	1-74-2B-L	PASSAGE	20.8	0	0		
B05		B05	1-79-0-Q	GALLEY	20.8	0	0		
B05		B05	1-92-0-Q	SCULLERY	48	0	0		
S2I			4-92-0-E	GENERATOR ROOM	15.6	0	0		
S2I			01-89-2-Q	FAN ROOM	2.4	0	0		
S2I			01-93-2-L	COMPANIONWAY	12	0	0		
			1-93-1-L	CPO MESS & REC	(CUI	= LL)			
B05		B05	1-70-3A-L	CREW MESS	24	0	0		
B05		B05	1-70-3A-L	CREW MESS	16	0	0		
B05		B05	1-70-3A-L	CREW MESS	40	0	0		
B05		B05	1-99-1A-L	PASSAGE	64	0	0	DJ	NC
B05		B05	1-106-1-Q	MOVIE LKR	12.8	0	0		
B05		B05	1-107-1-Q	MORALE LKR	24	0	0		
B05		B05	1-110-1-Q	SHIPS OFFICE	64	-5	-5		
B06	S2U		(none)	(weather bulkhead)	116.8	0	0		
S2I			4-92-0-E	GENERATOR ROOM	109.2	0	0		
S2I			(none)	(weather overhead)	110.8	0	0		
			4-92-0A-E	FIDLEY	(CUI	= QA)			
S2I		S2U	1-74-2B-L	PASSAGE	108.8	0	0		
S2I		S2U	1-92-0-Q	SCULLERY	54.4	0	0		
S2I		S2U	1-99-1A-L	PASSAGE	108.8	0	0		
S2I		S2U	1-112-0-Q	AUXILIARY MACHINERY	54.4	0	0	DO	O
S2I			4-92-0-E	GENERATOR ROOM	92.5	-90	-90	HL	X
S2I			01-82-0-L	CO CABIN	2	0	0		
S2I			01-95-0-L	WR, WC & SH	22.4	0	0		
S2I			01-102-0-E	VENT & UPTAKE SPACE	34	0	0		
S2I			01-110-0-Q	FAN & EQUIPMENT ROOM	34	0	0		
			1-99-1A-L	PASSAGE	(CUI	= LP)			
0		0	1-70-3A-L	CREW MESS	45.5	0	0		
B05		B05	1-93-1-L	CPO MESS & REC	64	0	0	DJ	NC
S2U		S2I	4-92-0A-E	FIDLEY	108.8	0	0		
0		0	1-99-1B-L	PASSAGE	24	0	0		
B05		B05	1-106-1-Q	MOVIE LKR	12.8	0	0		
B05		B05	1-106-1-Q	MOVIE LKR	20.8	0	0	DJ	NC

D.2.1 Barrier Data: All Bulkheads Uninsulated

Barrier Materials				Area	Therm	Durab	Hatch	Readiness	
<1>	<2>	<3>		ft2	adj	adj			
B05		B05	1-107-1-Q	MORALE LKR	24	0	0	DJ	NC
B05		B05	1-110-1-Q	SHIPS OFFICE	16	-5	-5		
S2I			4-92-0-E	GENERATOR ROOM	61.8	0	0		
S2I			01-95-1-L	COMPANIONWAY	13.4	0	0	HO	O
S2I			(none)	(weather overhead)	45.7	0	0		
			1-99-1B-L	PASSAGE	(CUI	= LP)			
0		0	1-99-1A-L	PASSAGE	24	0	0		
B05		B05	1-110-1-Q	SHIPS OFFICE	88	-5	-5	DJ	NC
B05		B05	1-112-0-Q	AUXILIARY MACHINERY	144	0	0	DJ	NC
B05		B05	1-124-1-L	SR #1	56	-5	-5		
B05		B05	1-132-0A-L	PASSAGE	24	0	0	DJ	NO
S2I			4-92-0-E	GENERATOR ROOM	12	0	0		
S2I			4-116-0-F	DIESEL OIL TANK	20	0	0		
S2I			4-116-1-F	DIESEL OIL TANK	10	0	0		
S2U			4-126-0-E	MAIN MOTOR ROOM	8	0	0		
S2I			2-126-1-Q	MACHINE SHOP	4	0	0		
S2I			(none)	(weather overhead)	52.2	0	0		
			1-99-2-L	DISPENSARY	(CUI	= LM)			
NSU		B05	1-74-2B-L	PASSAGE	56	-25	-25	DJ	NC
NSU		NSU	1-91-2-L	PO-1 WC, WR & SH	64	0	0		
NSU		NSU	1-104-2-L	CPO WR, WC & SH	24	0	0		
NSU		NSU	1-104-2-L	CPO WR, WC & SH	20.8	0	0		
NSU		NSU	1-104-2-L	CPO WR, WC & SH	17.6	0	0		
NSU		B05	1-106-2-L	CPO BERTHING	20.8	0	0		
NSU	S2U		(none)	(weather bulkhead)	35.2	0	0		
D05			4-92-0-E	GENERATOR ROOM	47.1	0	0		
S2I			(none)	(weather overhead)	47.2	0	0		
			1-104-2-L	CPO WR, WC & SH	(CUI	= LW)			
NSU		NSU	1-99-2-L	DISPENSARY	24	0	0		
NSU		NSU	1-99-2-L	DISPENSARY	20.8	0	0		
NSU		NSU	1-99-2-L	DISPENSARY	17.6	0	0		
NSU		B05	1-106-2-L	CPO BERTHING	40	0	0	DJ	NC
NSU		B05	1-106-2-L	CPO BERTHING	40	0	0		
NSU	S2U		(none)	(weather bulkhead)	60.8	0	0		
D05			4-92-0-E	GENERATOR ROOM	33	0	0		
S2I			(none)	(weather overhead)	33	0	0		
			1-106-1-Q	MOVIE LKR	(CUI	= AG)			
B05		B05	1-93-1-L	CPO MESS & REC	12.8	0	0		
B05		B05	1-99-1A-L	PASSAGE	12.8	0	0		
B05		B05	1-99-1A-L	PASSAGE	20.8	0	0	DJ	NC
B05		B05	1-107-1-Q	MORALE LKR	20.8	0	0		
S2I			4-92-0-E	GENERATOR ROOM	4.2	0	0		
S2I			(none)	(weather overhead)	4.2	0	0		
			1-106-2-L	CPO BERTHING	(CUI	= L2)			

D.2.1 Barrier Data: All Bulkheads Uninsulated

Barrier Materials				Area	Therm	Durab	Hatch	Readiness
<1>	<2>	<3>		ft2	adj	adj		
B05		B05	1-74-2B-L	PASSAGE	19.2	-25	-25	
B05		B05	1-74-2B-L	PASSAGE	48	-25	-25	
B05		B05	1-74-2C-L	PASSAGE	89.6	-25	-25	DJ NC
B05		NSU	1-99-2-L	DISPENSARY	20.8	0	0	
B05		NSU	1-104-2-L	CPO WR, WC & SH	40	0	0	DJ NC
B05		NSU	1-104-2-L	CPO WR, WC & SH	40	0	0	
B05		B05	1-124-2-L	SR #2	80	0	0	
S2I	S2U		(none)	(weather bulkhead)	97.6	0	0	
S2I			4-92-0-E	GENERATOR ROOM	75	0	0	
S2I			4-116-2-F	DIESEL OIL TANK	72	0	0	
S2I			(none)	(weather overhead)	147	0	0	
			1-107-1-Q	MORALE LKR	(CUI = AG)			
B05		B05	1-93-1-L	CPO MESS & REC	24	0	0	
B05		B05	1-99-1A-L	PASSAGE	24	0	0	DJ NC
B05		B05	1-106-1-Q	MOVIE LKR	20.8	0	0	
B05		B05	1-110-1-Q	SHIPS OFFICE	20.8	-5	-5	
S2I			4-92-0-E	GENERATOR ROOM	7.8	0	0	
S2I			(none)	(weather overhead)	7.8	0	0	
			1-110-1-Q	SHIPS OFFICE	(CUI = QO)			
B05		B05	1-93-1-L	CPO MESS & REC	64	-5	-5	
B05		B05	1-99-1A-L	PASSAGE	16	-5	-5	
B05		B05	1-99-1B-L	PASSAGE	88	-5	-5	DJ NC
B05		B05	1-107-1-Q	MORALE LKR	20.8	-5	-5	
B05		B05	1-124-1-L	SR #1	81.6	-5	-5	
B06	S2U		(none)	(weather bulkhead)	104.1	0	0	
S2I			4-92-0-E	GENERATOR ROOM	63	0	0	
S2I			4-116-1-F	DIESEL OIL TANK	72.2	0	0	
S2I			(none)	(weather overhead)	135.2	0	0	
			1-112-0-Q	AUXILIARY MACHINERY SPACE #3	(CUI = QA)			
B05		B05	1-74-2C-L	PASSAGE	144	0	0	DJ NC
S2U	S2I		4-92-0A-E	FIDLEY	54.4	0	0	DO O
B05		B05	1-99-1B-L	PASSAGE	144	0	0	DJ NC
B05		B05	1-132-0A-L	PASSAGE	16	0	0	
B05		B05	1-132-0A-L	PASSAGE	54.4	0	0	
B05		B05	1-132-0A-L	PASSAGE	16	0	0	
S2I			4-92-0-E	GENERATOR ROOM	27.2	-15	-15	
S2I			4-116-0-F	DIESEL OIL TANK	68	-15	-15	
S2U			4-126-0-E	MAIN MOTOR ROOM	40.8	-15	-15	HL X
S2U			01-110-0-Q	FAN & EQUIPMENT ROOM	27.2	0	0	
S2U			01-116-0-Q	CLIP SHACK	34	0	0	
S2I			(none)	(weather overhead)	74.8	0	0	
			1-124-1-L	SR #1	(CUI = L2)			
B05		B05	1-99-1B-L	PASSAGE	56	-5	-5	
B05		B05	1-110-1-Q	SHIPS OFFICE	81.6	-5	-5	
B05		B05	1-132-0A-L	PASSAGE	44.8	0	0	DJ NC

D.2.1 Barrier Data: All Bulkheads Uninsulated

Barrier Materials				Area	Therm	Durab	Hatch	Readiness
<1>	<2>	<3>		ft2	adj	adj		
B05		B05	1-132-0A-L	PASSAGE	16	0	0	
B05		B05	1-132-1-L	SR #3	35.2	-10	-10	
B06	S2U		(none)	(weather bulkhead)	72	0	0	
S2I			4-116-1-F	DIESEL OIL TANK	30.5	0	0	
S2I			2-126-1-Q	MACHINE SHOP	49.2	0	0	
S2I			(none)	(weather overhead)	79.7	0	0	
			1-124-2-L	SR #2	(CUI = L2)			
B05		B05	1-74-2C-L	PASSAGE	54.4	0	0	
B05		B05	1-106-2-L	CPO BERTHING	80	0	0	
B05		B05	1-132-0A-L	PASSAGE	16	0	0	
B05		B05	1-132-0A-L	PASSAGE	43.2	0	0	DJ NC
B05		B05	1-132-2-L	SR #4	32	0	0	
B06	S2U		(none)	(weather bulkhead)	70.6	0	0	
S2I			4-116-2-F	DIESEL OIL TANK	27.7	0	0	
S2I			2-126-2-Q	A.C. EQUIPMENT	46.8	0	0	
S2I			(none)	(weather overhead)	74.6	0	0	
			1-132-0A-L	PASSAGE	(CUI = LP)			
B05		B05	1-74-2C-L	PASSAGE	25.6	0	0	DJ NO
B05		B05	1-99-1B-L	PASSAGE	24	0	0	DJ NO
B05		B05	1-112-0-Q	AUXILIARY MACHINERY	16	0	0	
B05		B05	1-112-0-Q	AUXILIARY MACHINERY	54.4	0	0	
B05		B05	1-112-0-Q	AUXILIARY MACHINERY	16	0	0	
B05		B05	1-124-1-L	SR #1	44.8	0	0	DJ NC
B05		B05	1-124-1-L	SR #1	16	0	0	
B05		B05	1-124-2-L	SR #2	16	0	0	
B05		B05	1-124-2-L	SR #2	43.2	0	0	DJ NC
0		0	1-132-0B-L	PASSAGE	24	0	0	
B05		B05	1-132-1-L	SR #3	56	0	0	
B05		B05	1-132-1-L	SR #3	44.8	0	0	DJ NC
B05		B05	1-132-1-L	SR #3	8	0	0	
B05		B05	1-132-2-L	SR #4	8	0	0	
B05		B05	1-132-2-L	SR #4	44.8	0	0	DJ NC
B05		B05	1-132-2-L	SR #4	56	0	0	
B05		B05	1-140-0-L	WARDROOM	16	0	0	DJ NC
B05		B05	1-140-1-Q	PANTRY	62.4	0	0	
S2U			4-126-0-E	MAIN MOTOR ROOM	86.4	0	0	HS X
S2I			2-126-1-Q	MACHINE SHOP	26.8	0	0	
S2I			2-126-2-Q	A.C. EQUIPMENT	34.8	0	0	
S2I			(none)	(weather overhead)	148	0	0	HL X
			1-132-0B-L	PASSAGE	(CUI = LP)			
0		0	1-132-0A-L	PASSAGE	24	0	0	
B05		B05	1-140-0-L	WARDROOM	80	0	0	DJ NC
B05		B05	1-140-1-Q	PANTRY	56	0	0	DJ NC
B05		B05	1-140-2-L	SR #6	80	0	0	DJ NC
B05		B05	1-150-2-L	OFFICER WR, WC & SH	56	0	0	DJ NC
B05		B05	1-157-0-E	STEERING GEAR SPACE	24	0	0	DJ NC

D.2.1 Barrier Data: All Bulkheads Uninsulated

Barrier Materials					Area	Therm	Durab	Hatch	Readiness
<1>	<2>	<3>			ft2	adj	adj		
D05			4-140-0-W	FRESH WATER TANK	15.4	0	0		
D05			3-140-2-W	FRESH WATER TANK	5.6	0	0		
D05			2-147-0-Q	ENGINEERS STOREROOM	30	0	0		
S2I			(none)	(weather overhead)	51	0	0		
			1-132-1-L	SR #3	(CUI	= L1)			
B05	B05		1-124-1-L	SR #1	35.2	-10	-10		
B05	B05		1-132-0A-L	PASSAGE	56	0	0		
B05	B05		1-132-0A-L	PASSAGE	44.8	0	0	DJ	NC
B05	B05		1-132-0A-L	PASSAGE	8	0	0		
B05	B05		1-140-0-L	WARDROOM	68.8	0	0		
B06	S2U		(none)	(weather bulkhead)	65	0	0		
S2I			2-126-1-Q	MACHINE SHOP	68.8	0	0		
S2I			(none)	(weather overhead)	68.8	0	0		
			1-132-2-L	SR #4	(CUI	= L1)			
B05	B05		1-124-2-L	SR #2	32	0	0		
B05	B05		1-132-0A-L	PASSAGE	8	0	0		
B05	B05		1-132-0A-L	PASSAGE	44.8	0	0	DJ	NC
B05	B05		1-132-0A-L	PASSAGE	56	0	0		
B05	B05		1-140-2-L	SR #6	72	0	0		
B06	S2U		(none)	(weather bulkhead)	64.2	0	0		
S2I			2-126-2-Q	A.C. EQUIPMENT	68.8	0	0		
S2I			(none)	(weather overhead)	68.8	0	0		
			1-140-0-L	WARDROOM	(CUI	= LL)			
B05	B05		1-132-0A-L	PASSAGE	16	0	0	DJ	NC
B05	B05		1-132-0B-L	PASSAGE	80	0	0	DJ	NC
B05	B05		1-132-1-L	SR #3	68.8	0	0		
B05	B05		1-140-1-Q	PANTRY	56	0	0		
B05	B05		1-140-1-Q	PANTRY	62.4	0	0	DJ	NO
B05	B05		1-157-0-E	STEERING GEAR SPACE	59.2	0	0		
B05	B05		1-157-1-Q	ARMORY	56	0	0		
B06	S2U		(none)	(weather bulkhead)	139.7	0	0		
S2U			4-140-0-W	FRESH WATER TANK	7	0	0		
S2U			3-140-1-W	FRESH WATER TANK	61.4	0	0		
S2U			2-147-0-Q	ENGINEERS STOREROOM	155.8	0	0		
S2I			(none)	(weather overhead)	224.2	0	0		
			1-140-1-Q	PANTRY	(CUI	= QG)			
B05	B05		1-132-0A-L	PASSAGE	62.4	0	0		
B05	B05		1-132-0B-L	PASSAGE	56	0	0	DJ	NC
B05	B05		1-140-0-L	WARDROOM	56	0	0		
B05	B05		1-140-0-L	WARDROOM	62.4	0	0	DJ	NO
D05			4-140-0-W	FRESH WATER TANK	54.6	0	0		
S2I			(none)	(weather overhead)	54.6	0	0		
			1-140-2-L	SR #6	(CUI	= L2)			
B05	B05		1-132-0B-L	PASSAGE	80	0	0	DJ	NC

D.2.1 Barrier Data: All Bulkheads Uninsulated

Barrier Materials					Area	Therm	Durab	Hatch	Readiness
<1>	<2>	<3>			ft2	adj	adj		
B05		B05	1-132-2-L	SR #4	72	0	0		
B05		B05	1-150-2-L	OFFICER WR, WC & SH	54.4	0	0		
B06	S2U		(none)	(weather bulkhead)	81.9	0	0		
S2U			3-140-2-W	FRESH WATER TANK	57.6	0	0		
S2U			2-147-0-Q	ENGINEERS STOREROOM	21.4	0	0		
S2I			(none)	(weather overhead)	79	0	0		
			1-150-2-L	OFFICER WR, WC & SH	(CUI = LW)				
B05		B05	1-132-0B-L	PASSAGE	56	0	0	DJ	NC
B05		B05	1-140-2-L	SR #6	54.4	0	0		
B05		B05	1-157-2-Q	LINEN LKR	44.8	0	0		
B06	S2U		(none)	(weather bulkhead)	56.8	0	0		
D05			2-147-0-Q	ENGINEERS STOREROOM	43.2	0	0		
S2I			(none)	(weather overhead)	43.4	0	0		
			1-157-0-E	STEERING GEAR SPACE	(CUI = QA)				
B05		B05	1-132-0B-L	PASSAGE	24	0	0	DJ	NC
B05		B05	1-140-0-L	WARDROOM	59.2	0	0		
B05		B05	1-157-1-Q	ARMORY	48	-15	-15	DJ	NC
B05		B05	1-157-1-Q	ARMORY	40	0	0		
B05		B05	1-157-2-Q	LINEN LKR	32	0	0	DO	O
B05		B05	1-161-2-Q	CG LKR	16	0	0	DO	O
B05		B05	1-161-2-Q	CG LKR	20.8	0	0		
B06	S2U		(none)	(weather bulkhead)	25.3	0	0		
B06	S2U		(none)	(weather bulkhead)	28.8	0	0		
B06	S2U		(none)	(weather bulkhead)	38.2	0	0		
B06	S2U		(none)	(weather bulkhead)	26.5	0	0		
B06	S2U		(none)	(weather bulkhead)	26.5	0	0		
B06	S2U		(none)	(weather bulkhead)	38.2	0	0		
B06	S2U		(none)	(weather bulkhead)	28.8	0	0		
B06	S2U		(none)	(weather bulkhead)	25.3	0	0		
S2U			2-147-0-Q	ENGINEERS STOREROOM	41.6	0	0	HS	X
S2U			2-161-0-Q	LAZARETTE	148	0	0	HS	X
S2I			(none)	(weather overhead)	189.6	0	0	HS	X
			1-157-2-Q	LINEN LKR	(CUI = AG)				
B05		B05	1-150-2-L	OFFICER WR, WC & SH	44.8	0	0		
B05		B05	1-157-0-E	STEERING GEAR SPACE	32	0	0	DO	O
B05		B05	1-161-2-Q	CG LKR	28.8	0	0		
B06	S2U		(none)	(weather bulkhead)	35.8	0	0		
S2U			2-147-0-Q	ENGINEERS STOREROOM	18.3	0	0		
S2I			(none)	(weather overhead)	18.4	0	0		
			1-161-2-Q	CG LKR	(CUI = AG)				
B05		B05	1-157-0-E	STEERING GEAR SPACE	16	0	0	DO	O
B05		B05	1-157-0-E	STEERING GEAR SPACE	20.8	0	0		
B05		B05	1-157-2-Q	LINEN LKR	28.8	0	0		
B06	S2U		(none)	(weather bulkhead)	17.9	0	0		
S2U			2-161-0-Q	LAZARETTE	6.2	0	0		

D.2.1 Barrier Data: All Bulkheads Uninsulated

Barrier Materials					Area	Therm	Durab	Hatch	Readiness
<1>	<2>	<3>			ft2	adj	adj		
S2I			(none)	(weather overhead)	6.2	0	0		
			01-71-0-Q	CRANE CONTROL BOOTH	(CUI	= C)			
B05		B05	01-74-0-L	CO SR	10.8	0	0		
B05		B05	01-74-1-Q	CODE ROOM	10.8	0	0		
B05		B05	02-74-0-Q	FAN ROOM	28.8	0	0		
S2I	S2U		(none)	(weather bulkhead)	23.8	0	0	DJ	NC
S2I	S2U		(none)	(weather bulkhead)	50.4	0	0		
S2I	S2U		(none)	(weather bulkhead)	23.8	0	0	DJ	NC
S2I			1-68-0-L	COMPANIONWAY	12.2	0	0		
S2I			1-68-1-Q	HYD PUMP ROOM	6.1	0	0		
S2I			1-68-2-Q	HYD PUMP ROOM	6.1	0	0		
S2I			(none)	(weather overhead)	24.5	0	0		
			01-74-0-L	CO SR	(CUI	= L1)			
B05		B05	01-71-0-Q	CRANE CONTROL BOOTH	10.8	0	0		
B05		B05	01-74-1-Q	CODE ROOM	53.2	0	0		
B05		B05	01-82-0-L	CO CABIN	49	0	0	DJ	NC
S2I	S2U		(none)	(weather bulkhead)	53.2	0	0		
S2I	S2U		(none)	(weather bulkhead)	7	0	0		
S2I	S2U		(none)	(weather bulkhead)	30.8	0	0		
S2I	S2U		(none)	(weather bulkhead)	14.4	0	0		
S2I			1-74-0-L	PASSAGE	26.4	0	0		
S2I			1-74-2A-L	PASSAGE	15.2	0	0		
S2U			1-79-0-Q	GALLEY	19.2	0	0		
S2I			02-74-0-Q	FAN ROOM	56	0	0		
D05			02-81-0-C	CHART ROOM	2.4	0	0		
			01-74-1-Q	CODE ROOM	(CUI	= C)			
B05		B05	01-71-0-Q	CRANE CONTROL BOOTH	10.8	0	0		
B05		B05	01-74-0-L	CO SR	53.2	0	0		
B05		B05	01-82-0-L	CO CABIN	49	0	0	DJ	NC
S2I	S2U		(none)	(weather bulkhead)	53.2	0	0		
S2I	S2U		(none)	(weather bulkhead)	4.2	0	0		
S2I	S2U		(none)	(weather bulkhead)	28	0	0		
S2I	S2U		(none)	(weather bulkhead)	14.4	0	0		
S2I			1-70-3A-L	CREW MESS	11.6	0	0		
S2I			1-74-0-L	PASSAGE	14.4	0	0		
S2I			1-77-0-Q	GYRO EQUIP	6	0	0		
S2I			1-77-1-L	COMPANIONWAY	13.8	0	0		
S2U			1-79-0-Q	GALLEY	12	0	0		
S2I			02-74-0-Q	FAN ROOM	53.2	0	0		
D05			02-81-0-C	CHART ROOM	4.2	0	0		
			01-82-0-L	CO CABIN	(CUI	= L1)			
B05		B05	01-74-0-L	CO SR	49	0	0	DJ	NC
B05		B05	01-74-1-Q	CODE ROOM	49	0	0	DJ	NC
B05		B05	01-89-2-Q	FAN ROOM	23.8	0	0		
B05		B05	01-89-2-Q	FAN ROOM	22.4	0	0		

D.2.1 Barrier Data: All Bulkheads Uninsulated

Barrier Materials					Area	Therm	Durab	Hatch	Readiness
<1>	<2>	<3>			ft2	adj	adj		
B05		B05	01-93-2-L	COMPANIONWAY	42	0	0	DJ	NC
B05		A2I	01-95-0-L	WR, WC & SH	25.2	0	0		
B05		A2I	01-95-0-L	WR, WC & SH	23.8	0	0	DJ	NC
B05		A2I	01-95-0-L	WR, WC & SH	25.2	0	0		
B05		B05	01-95-1-L	COMPANIONWAY	23.8	0	0	DJ	NC
S2I	S2U		(none)	(weather bulkhead)	98	0	0		
S2I	S2U		(none)	(weather bulkhead)	57.4	0	0		
S2I			1-70-3A-L	CREW MESS	13	0	0		
S2I			1-74-2A-L	PASSAGE	8.2	0	0		
S2U			1-79-0-Q	GALLEY	129.9	0	0		
S2U			1-92-0-Q	SCULLERY	34	0	0		
S2I			4-92-0A-E	FIDLEY	2	0	0		
D05			02-81-0-C	CHART ROOM	81.4	0	0		
S2I			02-81-2-L	PASSAGE	24.6	0	0		
D05			02-89-0-C	RADIO ROOM	80.4	0	0		
S2I			(none)	(weather overhead)	2.2	0	0		
			01-89-2-Q	FAN ROOM	(CUI = QF)				
B05		B05	01-82-0-L	CO CABIN	23.8	0	0		
B05		B05	01-82-0-L	CO CABIN	22.4	0	0		
B05		B05	01-93-2-L	COMPANIONWAY	23.8	0	0		
B05	S2U		(none)	(weather bulkhead)	22.4	0	0	DJ	NC
S2I			1-74-2A-L	PASSAGE	3.2	0	0		
S2U			1-79-0-Q	GALLEY	5.3	0	0		
S2I			1-92-2-Q	DC LKR	2.4	0	0		
S2U			02-81-2-L	PASSAGE	9.6	0	0		
			01-93-2-L	COMPANIONWAY	(CUI = LP)				
B05		B05	01-82-0-L	CO CABIN	42	0	0	DJ	NC
B05		B05	01-89-2-Q	FAN ROOM	23.8	0	0		
B05		A2I	01-95-0-L	WR, WC & SH	21	0	0		
S2I	S2U		(none)	(weather bulkhead)	23.8	0	0		
S2I	S2U		(none)	(weather bulkhead)	63	0	0	DJ	NC
S2I			1-74-2A-L	PASSAGE	5.2	0	0		
S2I			1-74-2B-L	PASSAGE	13.4	0	0	HO	O
S2I			1-92-2-Q	DC LKR	12	0	0		
S2I			02-81-2-L	PASSAGE	16.2	0	0		
D05			02-89-0-C	RADIO ROOM	2.2	0	0		
S2I			(none)	(weather overhead)	12.2	0	0		
			01-95-0-L	WR, WC & SH	(CUI = LW)				
A2I		B05	01-82-0-L	CO CABIN	25.2	0	0		
A2I		B05	01-82-0-L	CO CABIN	23.8	0	0	DJ	NC
A2I		B05	01-82-0-L	CO CABIN	25.2	0	0		
A2I		B05	01-93-2-L	COMPANIONWAY	21	0	0		
A2I		B05	01-95-1-L	COMPANIONWAY	44.8	0	0		
A2I		B05	01-102-0-E	VENT & UPTAKE SPACE	50.4	0	0		
S2U			1-92-0-Q	SCULLERY	9.5	0	0		
S2I			4-92-0A-E	FIDLEY	22.4	0	0		

D.2.1 Barrier Data: All Bulkheads Uninsulated

Barrier Materials					Area	Therm	Durab	Hatch	Readiness
<1>	<2>	<3>			ft2	adj	adj		
D05			02-89-0-C	RADIO ROOM	10.1	0	0		
S2I			(none)	(weather overhead)	23.8	0	0		
			01-95-1-L	COMPANIONWAY	(CUI = LP)				
B05		B05	01-82-0-L	CO CABIN	23.8	0	0	DJ	NC
B05		A2I	01-95-0-L	WR, WC & SH	44.8	0	0		
S2I	S2U		(none)	(weather bulkhead)	23.8	0	0		
S2I	S2U		(none)	(weather bulkhead)	44.8	0	0		
S2I			1-70-3A-L	CREW MESS	8.4	0	0		
S2I			1-99-1A-L	PASSAGE	13.4	0	0	HO	O
D05			02-89-0-C	RADIO ROOM	9.5	0	0		
S2I			(none)	(weather overhead)	12.2	0	0		
			01-102-0-E	VENT & UPTAKE SPACE	(CUI = TU)				
B05		A2I	01-95-0-L	WR, WC & SH	50.4	0	0		
B05		B05	01-110-0-Q	FAN & EQUIPMENT ROOM	50.4	0	0		
B05	S2U		(none)	(weather bulkhead)	35	0	0		
B05	S2U		(none)	(weather bulkhead)	35	0	0		
S2I			4-92-0A-E	FIDLEY	34	0	0		
S2I			02-102-0-E	UPTAKE	36	0	0		
			01-110-0-Q	FAN & EQUIPMENT ROOM	(CUI = QF)				
B05		B05	01-102-0-E	VENT & UPTAKE SPACE	50.4	0	0		
B05		B05	01-116-0-Q	CLIP SHACK	50.4	0	0		
B05	S2U		(none)	(weather bulkhead)	63	0	0		
B05	S2U		(none)	(weather bulkhead)	63	0	0		
S2I			4-92-0A-E	FIDLEY	34	0	0		
S2U			1-112-0-Q	AUXILIARY MACHINERY	27.2	0	0		
S2I			(none)	(weather overhead)	64.8	0	0		
			01-116-0-Q	CLIP SHACK	(CUI = C)				
B05		B05	01-110-0-Q	FAN & EQUIPMENT ROOM	50.4	0	0		
B05	S2U		(none)	(weather bulkhead)	50.4	0	0	DWT	X
B05	S2U		(none)	(weather bulkhead)	35	0	0		
B05	S2U		(none)	(weather bulkhead)	35	0	0		
S2U			1-112-0-Q	AUXILIARY MACHINERY	34	0	0		
S2I			(none)	(weather overhead)	36	0	0		
			02-74-0-Q	FAN ROOM	(CUI = QF)				
B05		B05	01-71-0-Q	CRANE CONTROL BOOTH	28.8	0	0		
S2U		S2I	02-81-0-C	CHART ROOM	44	0	0		
B05		B05	02-81-2-L	PASSAGE	12	0	0		
B05	S2U		(none)	(weather bulkhead)	28	0	0		
B05	S2U		(none)	(weather bulkhead)	0	0	0		
B05	S2U		(none)	(weather bulkhead)	28	0	0		
B05	S2U		(none)	(weather bulkhead)	4	0	0		
B05	S2U		(none)	(weather bulkhead)	4	0	0		
S2I			01-74-0-L	CO SR	56	0	0		
S2I			01-74-1-Q	CODE ROOM	53.2	0	0		

D.2.1 Barrier Data: All Bulkheads Uninsulated

Barrier Materials					Area	Therm	Durab	Hatch	Readiness
<1>	<2>	<3>			ft2	adj	adj		
D05			03-72-0-C	WHEELHOUSE	98	0	0		
S2I			(none)	(weather overhead)	14	0	0		
			02-81-0-C	CHART ROOM	(CUI	= C)			
S2I		S2U	02-74-0-Q	FAN ROOM	44	0	0		
B05		B05	02-81-2-L	PASSAGE	64	0	0	DJ	NC
B05		B06	02-89-0-C	RADIO ROOM	88	0	0		
B05		B05	03-72-0-C	WHEELHOUSE	44	0	0		
B06	S2U		(none)	(weather bulkhead)	64	0	0		
D05			01-74-0-L	CO SR	2.4	0	0		
D05			01-74-1-Q	CODE ROOM	4.2	0	0		
D05			01-82-0-L	CO CABIN	81.4	0	0		
S2I			(none)	(weather overhead)	88	0	0		
			02-81-2-L	PASSAGE	(CUI	= LP)			
B05		B05	02-74-0-Q	FAN ROOM	12	0	0		
B05		B05	02-81-0-C	CHART ROOM	64	0	0	DJ	NC
B05		B06	02-89-0-C	RADIO ROOM	75.2	0	0	DJ	NC
B05		B05	03-72-0-C	WHEELHOUSE	12	0	0		
B05	S2U		(none)	(weather bulkhead)	24	0	0		
B05	S2U		(none)	(weather bulkhead)	139.2	0	0		
S2I			01-82-0-L	CO CABIN	24.6	0	0		
S2U			01-89-2-Q	FAN ROOM	9.6	0	0		
S2I			01-93-2-L	COMPANIONWAY	16.2	0	0		
S2I			(none)	(weather overhead)	52.2	0	0		
			02-89-0-C	RADIO ROOM	(CUI	= C)			
B06		B05	02-81-0-C	CHART ROOM	88	0	0		
B06		B05	02-81-2-L	PASSAGE	75.2	0	0	DJ	NC
B06	S2U		(none)	(weather bulkhead)	88	0	0		
B06	S2U		(none)	(weather bulkhead)	75.2	0	0		
D05			01-82-0-L	CO CABIN	80.4	0	0		
D05			01-93-2-L	COMPANIONWAY	2.2	0	0		
D05			01-95-0-L	WR, WC & SH	10.1	0	0		
D05			01-95-1-L	COMPANIONWAY	9.5	0	0		
S2I			(none)	(weather overhead)	103.4	0	0		
			02-102-0-E	UPTAKE	(CUI	= TU)			
B05	S2U		(none)	(weather bulkhead)	115.2	0	0		
B05	S2U		(none)	(weather bulkhead)	80	0	0		
B05	S2U		(none)	(weather bulkhead)	115.2	0	0		
B05	S2U		(none)	(weather bulkhead)	80	0	0		
S2I			01-102-0-E	VENT & UPTAKE SPACE	36	0	0		
S2I			(none)	(weather overhead)	36	0	0		
			03-72-0-C	WHEELHOUSE	(CUI	= C)			
B05		B05	02-81-0-C	CHART ROOM	44	0	0		
B05		B05	02-81-2-L	PASSAGE	12	0	0		
S2I	S2U		(none)	(weather bulkhead)	56	0	0		

D.2.1 Barrier Data: All Bulkheads Uninsulated

Barrier Materials					Area	Therm	Durab	Hatch	Readiness
<1>	<2>	<3>			ft2	adj	adj		
S2I	S2U		(none)	(weather bulkhead)	72	0	0	DJ	NC
S2I	S2U		(none)	(weather bulkhead)	112	0	0		
S2I	S2U		(none)	(weather bulkhead)	72	0	0	DJ	NC
D05			02-74-0-Q	FAN ROOM	98	0	0		
S2I			(none)	(weather overhead)	126	0	0		

INDIVIDUAL TARGET OPTION - SUMMARY LEVEL REPORT

RELATIVE LOSS FACTORS OF INDIVIDUAL TARGETS

READINESS CONDITION . XRAY
 CONFIGURATION Passive, Automatic, and Manual
 CASE. Worst
 ASSUMED LOCATION. . . in Port
 RUN TIME. 60 minutes
 COMMENTS.
 Alternative, In Port M Values, all bulkheads are uninsulated

Targets listed include all compartments in model run with Magnitude of Acceptable Loss 1-3 and Relative Loss Factor (RLF) > 0.0000.

TARGET COMPART.	Magnitude/Frequency -of Acceptable Loss-	Rel Freq of Loss FFS	Relative Loss Factor (RLF)
3-9-0-E	2 26 years	0.0081	0.2105
1-112-0-Q	2 26 years	0.0077	0.2003
01-110-0-Q	3 18 years	0.0102	0.1843
4-126-0-E	2 26 years	0.0056	0.1449
4-92-0-E	2 26 years	0.0051	0.1326
4-92-0A-E	2 24 years	0.0053	0.1282
01-102-0-E	2 23 years	0.0048	0.1103
2-126-2-Q	2 22 years	0.0042	0.0934
2-126-1-Q	2 22 years	0.0034	0.0759
1-110-1-Q	2 24 years	0.0028	0.0661
01-89-2-Q	3 18 years	0.0033	0.0601
1-157-0-E	2 26 years	0.0020	0.0508
1-92-0-Q	2 20 years	0.0025	0.0499
1-FP-0-K	1 30 years	0.0013	0.0402
01-74-1-Q	2 26 years	0.0014	0.0364
3-56-0-Q	2 24 years	0.0014	0.0331
1-68-2-Q	2 26 years	0.0011	0.0285
1-157-2-Q	3 12 years	0.0022	0.0259
02-81-0-C	2 26 years	0.0010	0.0257
2-147-0-Q	2 25 years	0.0010	0.0251
3-68-2-A	2 22 years	0.0011	0.0248
2-30-0-Q	2 25 years	0.0008	0.0204
2-161-0-Q	2 24 years	0.0008	0.0204
1-70-3A-L	2 24 years	0.0008	0.0197
03-72-0-C	2 26 years	0.0008	0.0195
3-68-1-A	2 21 years	0.0008	0.0176
02-74-0-Q	3 18 years	0.0009	0.0157
1-6-2-Q	2 22 years	0.0007	0.0147
1-6-1-Q	2 22 years	0.0007	0.0147
1-79-0-Q	2 26 years	0.0005	0.0127
3-74-3-A	2 21 years	0.0004	0.0082
3-44-0-A	2 24 years	0.0003	0.0061
02-89-0-C	2 26 years	0.0002	0.0061

INDIVIDUAL TARGET OPTION - SUMMARY LEVEL REPORT

RELATIVE LOSS FACTORS OF INDIVIDUAL TARGETS

READINESS CONDITION . XRAY
CONFIGURATION Passive and Automatic
CASE. Worst
ASSUMED LOCATION. . . in Port
RUN TIME. 60 minutes
COMMENTS.

Alternative, In Port M Values, all bulkheads are uninsulated

Targets listed include all compartments in model run with Magnitude of Acceptable Loss 1-3 and Relative Loss Factor (RLF) > 0.0000.

TARGET COMPART.	Magnitude/Frequency -of Acceptable Loss-	Rel Freq of Loss FFS	Relative Loss Factor (RLF)
1-112-0-Q	2 26 years	0.0085	0.2203
3-9-0-E	2 26 years	0.0084	0.2192
01-110-0-Q	3 18 years	0.0112	0.2012
4-126-0-E	2 26 years	0.0062	0.1605
4-92-0-E	2 26 years	0.0056	0.1462
4-92-0A-E	2 24 years	0.0059	0.1408
01-102-0-E	2 23 years	0.0053	0.1208
1-110-1-Q	2 24 years	0.0044	0.1062
2-126-2-Q	2 22 years	0.0048	0.1048
2-126-1-Q	2 22 years	0.0046	0.1005
01-89-2-Q	3 18 years	0.0051	0.0916
1-92-0-Q	2 20 years	0.0042	0.0848
01-74-1-Q	2 26 years	0.0022	0.0578
1-157-0-E	2 26 years	0.0021	0.0551
1-70-3A-L	2 24 years	0.0019	0.0460
1-FP-0-K	1 30 years	0.0014	0.0432
3-68-2-A	2 22 years	0.0017	0.0374
3-56-0-Q	2 24 years	0.0015	0.0352
02-81-0-C	2 26 years	0.0013	0.0350
2-147-0-Q	2 25 years	0.0013	0.0330
1-68-2-Q	2 26 years	0.0013	0.0326
03-72-0-C	2 26 years	0.0011	0.0296
1-157-2-Q	3 12 years	0.0023	0.0273
2-30-0-Q	2 25 years	0.0010	0.0252
3-68-1-A	2 21 years	0.0011	0.0234
2-161-0-Q	2 24 years	0.0010	0.0229
02-74-0-Q	3 18 years	0.0012	0.0209
1-6-2-Q	2 22 years	0.0007	0.0158
1-6-1-Q	2 22 years	0.0007	0.0158
1-79-0-Q	2 26 years	0.0006	0.0146
3-74-3-A	2 21 years	0.0006	0.0136
02-89-0-C	2 26 years	0.0004	0.0093
3-44-0-A	2 24 years	0.0003	0.0078

INDIVIDUAL TARGET OPTION - SUMMARY LEVEL REPORT

RELATIVE LOSS FACTORS OF INDIVIDUAL TARGETS

READINESS CONDITION . XRAY
CONFIGURATION Passive and Manual
CASE. Worst
ASSUMED LOCATION. . . in Port
RUN TIME. 60 minutes
COMMENTS.
Alternative, In Port M Values, all bulkheads are uninsulated

Targets listed include all compartments in model run with Magnitude of Acceptable Loss 1-3 and Relative Loss Factor (RLF) > 0.0000.

TARGET COMPART.	Magnitude/Frequency -of Acceptable Loss-		Rel Freq of Loss FFS	Relative Loss Factor (RLF)
3-9-0-E	2	26 years	0.0081	0.2105
1-112-0-Q	2	26 years	0.0078	0.2035
01-110-0-Q	3	18 years	0.0103	0.1854
4-126-0-E	2	26 years	0.0056	0.1465
4-92-0-E	2	26 years	0.0053	0.1376
4-92-0A-E	2	24 years	0.0053	0.1282
01-102-0-E	2	23 years	0.0048	0.1103
2-126-2-Q	2	22 years	0.0043	0.0943
01-89-2-Q	3	18 years	0.0048	0.0861
2-126-1-Q	2	22 years	0.0035	0.0767
1-79-0-Q	2	26 years	0.0026	0.0682
1-110-1-Q	2	24 years	0.0028	0.0661
01-74-1-Q	2	26 years	0.0020	0.0526
1-157-0-E	2	26 years	0.0020	0.0508
1-92-0-Q	2	20 years	0.0025	0.0499
1-FP-0-K	1	30 years	0.0013	0.0402
3-56-0-Q	2	24 years	0.0014	0.0331
1-68-2-Q	2	26 years	0.0012	0.0302
02-81-0-C	2	26 years	0.0011	0.0274
1-157-2-Q	3	12 years	0.0022	0.0259
2-147-0-Q	2	25 years	0.0010	0.0251
3-68-2-A	2	22 years	0.0011	0.0248
02-74-0-Q	3	18 years	0.0011	0.0207
1-70-3A-L	2	24 years	0.0009	0.0204
2-30-0-Q	2	25 years	0.0008	0.0204
2-161-0-Q	2	24 years	0.0008	0.0204
03-72-0-C	2	26 years	0.0008	0.0195
3-68-1-A	2	21 years	0.0008	0.0176
1-6-2-Q	2	22 years	0.0007	0.0147
1-6-1-Q	2	22 years	0.0007	0.0147
3-74-3-A	2	21 years	0.0004	0.0082
3-44-0-A	2	24 years	0.0003	0.0061
02-89-0-C	2	26 years	0.0002	0.0061

INDIVIDUAL TARGET OPTION - SUMMARY LEVEL REPORT

RELATIVE LOSS FACTORS OF INDIVIDUAL TARGETS

READINESS CONDITION . XRAY
CONFIGURATION Passive
CASE. Worst
ASSUMED LOCATION. . . in Port
RUN TIME. 60 minutes
COMMENTS.

Alternative, In Port M Values, all bulkheads are uninsulated

Targets listed include all compartments in model run with Magnitude of Acceptable Loss 1-3 and Relative Loss Factor (RLF) > 0.0000.

TARGET COMPART.	Magnitude/Frequency -of Acceptable Loss-	Rel Freq of Loss FFS	Relative Loss Factor (RLF)
1-112-0-Q	2 26 years	0.0087	0.2252
3-9-0-E	2 26 years	0.0084	0.2192
01-110-0-Q	3 18 years	0.0113	0.2026
4-126-0-E	2 26 years	0.0062	0.1625
4-92-0-E	2 26 years	0.0059	0.1530
4-92-0A-E	2 24 years	0.0059	0.1420
01-89-2-Q	3 18 years	0.0070	0.1253
01-102-0-E	2 23 years	0.0053	0.1219
1-110-1-Q	2 24 years	0.0044	0.1062
2-126-2-Q	2 22 years	0.0048	0.1059
2-126-1-Q	2 22 years	0.0046	0.1017
1-92-0-Q	2 20 years	0.0042	0.0848
1-79-0-Q	2 26 years	0.0031	0.0810
01-74-1-Q	2 26 years	0.0031	0.0799
1-157-0-E	2 26 years	0.0021	0.0551
1-70-3A-L	2 24 years	0.0020	0.0475
1-FP-0-K	1 30 years	0.0014	0.0432
02-81-0-C	2 26 years	0.0014	0.0377
3-68-2-A	2 22 years	0.0017	0.0374
1-68-2-Q	2 26 years	0.0014	0.0364
3-56-0-Q	2 24 years	0.0015	0.0352
2-147-0-Q	2 25 years	0.0013	0.0330
03-72-0-C	2 26 years	0.0011	0.0296
02-74-0-Q	3 18 years	0.0015	0.0275
1-157-2-Q	3 12 years	0.0023	0.0273
2-30-0-Q	2 25 years	0.0010	0.0252
3-68-1-A	2 21 years	0.0011	0.0234
2-161-0-Q	2 24 years	0.0010	0.0229
1-6-2-Q	2 22 years	0.0007	0.0158
1-6-1-Q	2 22 years	0.0007	0.0158
3-74-3-A	2 21 years	0.0006	0.0136
02-89-0-C	2 26 years	0.0004	0.0093
3-44-0-A	2 24 years	0.0003	0.0078

INDIVIDUAL TARGET OPTION - SUMMARY LEVEL REPORT

RELATIVE LOSS FACTORS OF INDIVIDUAL TARGETS

READINESS CONDITION . YOKE
CONFIGURATION Passive, Automatic, and Manual
CASE. Worst
ASSUMED LOCATION. . . in Port
RUN TIME. 60 minutes
COMMENTS.
Alternative, In Port M Values, all bulkheads are uninsulated

Targets listed include all compartments in model run with Magnitude of Acceptable Loss 1-3 and Relative Loss Factor (RLF) > 0.0000.

TARGET COMPART.	Magnitude/Frequency -of Acceptable Loss-	Rel Freq of Loss FFS	Relative Loss Factor (RLF)
3-9-0-E	2 26 years	0.0081	0.2105
1-112-0-Q	2 26 years	0.0077	0.2003
01-110-0-Q	3 18 years	0.0102	0.1843
4-126-0-E	2 26 years	0.0056	0.1449
4-92-0-E	2 26 years	0.0051	0.1326
4-92-0A-E	2 24 years	0.0053	0.1282
01-102-0-E	2 23 years	0.0048	0.1103
2-126-2-Q	2 22 years	0.0042	0.0934
2-126-1-Q	2 22 years	0.0034	0.0759
1-110-1-Q	2 24 years	0.0028	0.0661
01-89-2-Q	3 18 years	0.0033	0.0601
1-157-0-E	2 26 years	0.0020	0.0508
1-92-0-Q	2 20 years	0.0025	0.0499
1-FP-0-K	1 30 years	0.0013	0.0402
01-74-1-Q	2 26 years	0.0014	0.0364
1-68-2-Q	2 26 years	0.0011	0.0285
1-157-2-Q	3 12 years	0.0022	0.0259
02-81-0-C	2 26 years	0.0010	0.0257
2-147-0-Q	2 25 years	0.0010	0.0251
2-30-0-Q	2 25 years	0.0008	0.0204
2-161-0-Q	2 24 years	0.0008	0.0204
1-70-3A-L	2 24 years	0.0008	0.0197
03-72-0-C	2 26 years	0.0008	0.0195
02-74-0-Q	3 18 years	0.0009	0.0157
1-6-2-Q	2 22 years	0.0007	0.0147
1-6-1-Q	2 22 years	0.0007	0.0147
1-79-0-Q	2 26 years	0.0005	0.0127
02-89-0-C	2 26 years	0.0002	0.0061
3-44-0-A	2 24 years	0.0000	0.0008
3-56-0-Q	2 24 years	0.0000	0.0004

INDIVIDUAL TARGET OPTION - SUMMARY LEVEL REPORT

RELATIVE LOSS FACTORS OF INDIVIDUAL TARGETS

READINESS CONDITION . YOKE
CONFIGURATION Passive and Automatic
CASE. Worst
ASSUMED LOCATION. . . in Port
RUN TIME. 60 minutes
COMMENTS.

Alternative, In Port M Values, all bulkheads are uninsulated

Targets listed include all compartments in model run with Magnitude of Acceptable Loss 1-3 and Relative Loss Factor (RLF) > 0.0000.

TARGET COMPART.	Magnitude/Frequency -of Acceptable Loss-	Rel Freq of Loss FFS	Relative Loss Factor (RLF)
1-112-0-Q	2 26 years	0.0085	0.2203
3-9-0-E	2 26 years	0.0084	0.2192
01-110-0-Q	3 18 years	0.0112	0.2012
4-126-0-E	2 26 years	0.0062	0.1605
4-92-0-E	2 26 years	0.0056	0.1462
4-92-0A-E	2 24 years	0.0059	0.1408
01-102-0-E	2 23 years	0.0053	0.1208
1-110-1-Q	2 24 years	0.0044	0.1062
2-126-2-Q	2 22 years	0.0048	0.1048
2-126-1-Q	2 22 years	0.0046	0.1005
01-89-2-Q	3 18 years	0.0051	0.0916
1-92-0-Q	2 20 years	0.0042	0.0848
01-74-1-Q	2 26 years	0.0022	0.0578
1-157-0-E	2 26 years	0.0021	0.0551
1-70-3A-L	2 24 years	0.0019	0.0460
1-FP-0-K	1 30 years	0.0014	0.0432
02-81-0-C	2 26 years	0.0013	0.0350
2-147-0-Q	2 25 years	0.0013	0.0330
1-68-2-Q	2 26 years	0.0013	0.0326
03-72-0-C	2 26 years	0.0011	0.0296
1-157-2-Q	3 12 years	0.0023	0.0273
2-30-0-Q	2 25 years	0.0010	0.0252
2-161-0-Q	2 24 years	0.0010	0.0229
02-74-0-Q	3 18 years	0.0012	0.0209
1-6-2-Q	2 22 years	0.0007	0.0158
1-6-1-Q	2 22 years	0.0007	0.0158
1-79-0-Q	2 26 years	0.0006	0.0146
02-89-0-C	2 26 years	0.0004	0.0093
3-44-0-A	2 24 years	0.0000	0.0009
3-56-0-Q	2 24 years	0.0000	0.0004

INDIVIDUAL TARGET OPTION - SUMMARY LEVEL REPORT

RELATIVE LOSS FACTORS OF INDIVIDUAL TARGETS

READINESS CONDITION . YOKE
CONFIGURATION Passive and Manual
CASE. Worst
ASSUMED LOCATION. . . in Port
RUN TIME. 60 minutes
COMMENTS.
Alternative, In Port M Values, all bulkheads are uninsulated

Targets listed include all compartments in model run with Magnitude of Acceptable Loss 1-3 and Relative Loss Factor (RLF) > 0.0000.

TARGET COMPART.	Magnitude/Frequency -of Acceptable Loss-	Rel Freq of Loss FFS	Relative Loss Factor (RLF)
3-9-0-E	2 26 years	0.0081	0.2105
1-112-0-Q	2 26 years	0.0078	0.2035
01-110-0-Q	3 18 years	0.0103	0.1854
4-126-0-E	2 26 years	0.0056	0.1465
4-92-0-E	2 26 years	0.0053	0.1376
4-92-0A-E	2 24 years	0.0053	0.1282
01-102-0-E	2 23 years	0.0048	0.1103
2-126-2-Q	2 22 years	0.0043	0.0943
01-89-2-Q	3 18 years	0.0048	0.0861
2-126-1-Q	2 22 years	0.0035	0.0767
1-79-0-Q	2 26 years	0.0026	0.0682
1-110-1-Q	2 24 years	0.0028	0.0661
01-74-1-Q	2 26 years	0.0020	0.0526
1-157-0-E	2 26 years	0.0020	0.0508
1-92-0-Q	2 20 years	0.0025	0.0499
1-FP-0-K	1 30 years	0.0013	0.0402
1-68-2-Q	2 26 years	0.0012	0.0302
02-81-0-C	2 26 years	0.0011	0.0274
1-157-2-Q	3 12 years	0.0022	0.0259
2-147-0-Q	2 25 years	0.0010	0.0251
02-74-0-Q	3 18 years	0.0011	0.0207
1-70-3A-L	2 24 years	0.0009	0.0204
2-30-0-Q	2 25 years	0.0008	0.0204
2-161-0-Q	2 24 years	0.0008	0.0204
03-72-0-C	2 26 years	0.0008	0.0195
1-6-2-Q	2 22 years	0.0007	0.0147
1-6-1-Q	2 22 years	0.0007	0.0147
02-89-0-C	2 26 years	0.0002	0.0061
3-44-0-A	2 24 years	0.0000	0.0008
3-56-0-Q	2 24 years	0.0000	0.0004

INDIVIDUAL TARGET OPTION - SUMMARY LEVEL REPORT

RELATIVE LOSS FACTORS OF INDIVIDUAL TARGETS

READINESS CONDITION . YOKE
CONFIGURATION Passive
CASE. Worst
ASSUMED LOCATION. . . in Port
RUN TIME. 60 minutes
COMMENTS.

Alternative, In Port M Values, all bulkheads are uninsulated

Targets listed include all compartments in model run with Magnitude of Acceptable Loss 1-3 and Relative Loss Factor (RLF) > 0.0000.

TARGET COMPART.	Magnitude/Frequency -of Acceptable Loss-	Rel Freq of Loss FFS	Relative Loss Factor (RLF)
1-112-0-Q	2 26 years	0.0087	0.2252
3-9-0-E	2 26 years	0.0084	0.2192
01-110-0-Q	3 18 years	0.0113	0.2026
4-126-0-E	2 26 years	0.0062	0.1625
4-92-0-E	2 26 years	0.0059	0.1530
4-92-0A-E	2 24 years	0.0059	0.1420
01-89-2-Q	3 18 years	0.0070	0.1253
01-102-0-E	2 23 years	0.0053	0.1219
1-110-1-Q	2 24 years	0.0044	0.1062
2-126-2-Q	2 22 years	0.0048	0.1059
2-126-1-Q	2 22 years	0.0046	0.1017
1-92-0-Q	2 20 years	0.0042	0.0848
1-79-0-Q	2 26 years	0.0031	0.0810
01-74-1-Q	2 26 years	0.0031	0.0799
1-157-0-E	2 26 years	0.0021	0.0551
1-70-3A-L	2 24 years	0.0020	0.0475
1-FP-0-K	1 30 years	0.0014	0.0432
02-81-0-C	2 26 years	0.0014	0.0377
1-68-2-Q	2 26 years	0.0014	0.0364
2-147-0-Q	2 25 years	0.0013	0.0330
03-72-0-C	2 26 years	0.0011	0.0296
02-74-0-Q	3 18 years	0.0015	0.0275
1-157-2-Q	3 12 years	0.0023	0.0273
2-30-0-Q	2 25 years	0.0010	0.0252
2-161-0-Q	2 24 years	0.0010	0.0229
1-6-2-Q	2 22 years	0.0007	0.0158
1-6-1-Q	2 22 years	0.0007	0.0158
02-89-0-C	2 26 years	0.0004	0.0093
3-44-0-A	2 24 years	0.0000	0.0009
3-56-0-Q	2 24 years	0.0000	0.0004

INDIVIDUAL TARGET OPTION - SUMMARY LEVEL REPORT

RELATIVE LOSS FACTORS OF INDIVIDUAL TARGETS

READINESS CONDITION . YOKE
 CONFIGURATION Passive, Automatic, and Manual
 CASE. Worst
 ASSUMED LOCATION. . . at SEA
 RUN TIME. 60 minutes
 COMMENTS.
 Alternative, At Sea M Values, all bulkheads are uninsulated

Targets listed include all compartments in model run with Magnitude of Acceptable Loss 1-3 and Relative Loss Factor (RLF) > 0.0000.

TARGET COMPART.	Magnitude/Frequency -of Acceptable Loss-	Rel Freq of Loss FFS	Relative Loss Factor (RLF)
3-9-0-E	2 26 years	0.0079	0.2061
1-112-0-Q	2 26 years	0.0074	0.1921
01-110-0-Q	3 18 years	0.0098	0.1758
4-126-0-E	2 26 years	0.0054	0.1392
4-92-0-E	2 26 years	0.0049	0.1275
4-92-0A-E	2 24 years	0.0051	0.1227
01-102-0-E	2 23 years	0.0046	0.1066
2-126-2-Q	2 22 years	0.0040	0.0890
2-126-1-Q	2 22 years	0.0032	0.0704
1-110-1-Q	2 24 years	0.0023	0.0562
01-89-2-Q	3 18 years	0.0031	0.0559
1-157-0-E	2 26 years	0.0019	0.0495
1-92-0-Q	2 20 years	0.0022	0.0438
1-FP-0-K	1 30 years	0.0013	0.0393
01-74-1-Q	2 26 years	0.0013	0.0340
1-68-2-Q	2 26 years	0.0010	0.0266
1-157-2-Q	3 12 years	0.0021	0.0255
2-147-0-Q	2 25 years	0.0009	0.0234
02-81-0-C	2 26 years	0.0009	0.0227
2-161-0-Q	2 24 years	0.0008	0.0193
2-30-0-Q	2 25 years	0.0008	0.0192
03-72-0-C	2 26 years	0.0006	0.0168
1-70-3A-L	2 24 years	0.0007	0.0164
1-6-2-Q	2 22 years	0.0007	0.0144
1-6-1-Q	2 22 years	0.0007	0.0144
02-74-0-Q	3 18 years	0.0008	0.0144
1-79-0-Q	2 26 years	0.0005	0.0126
02-89-0-C	2 26 years	0.0002	0.0052
3-44-0-A	2 24 years	0.0000	0.0008
3-56-0-Q	2 24 years	0.0000	0.0003

INDIVIDUAL TARGET OPTION - SUMMARY LEVEL REPORT

RELATIVE LOSS FACTORS OF INDIVIDUAL TARGETS

READINESS CONDITION . YOKE
CONFIGURATION Passive and Automatic
CASE. Worst
ASSUMED LOCATION. . . at SEA
RUN TIME. 60 minutes
COMMENTS.
Alternative, At Sea M Values, all bulkheads are uninsulated

Targets listed include all compartments in model run with Magnitude of Acceptable Loss 1-3 and Relative Loss Factor (RLF) > 0.0000.

TARGET COMPART.	Magnitude/Frequency -of Acceptable Loss-	Rel Freq of Loss FFS	Relative Loss Factor (RLF)
1-112-0-Q	2 26 years	0.0085	0.2203
3-9-0-E	2 26 years	0.0084	0.2192
01-110-0-Q	3 18 years	0.0112	0.2012
4-126-0-E	2 26 years	0.0062	0.1605
4-92-0-E	2 26 years	0.0056	0.1462
4-92-0A-E	2 24 years	0.0059	0.1408
01-102-0-E	2 23 years	0.0053	0.1208
1-110-1-Q	2 24 years	0.0044	0.1062
2-126-2-Q	2 22 years	0.0048	0.1048
2-126-1-Q	2 22 years	0.0046	0.1005
01-89-2-Q	3 18 years	0.0051	0.0916
1-92-0-Q	2 20 years	0.0042	0.0848
01-74-1-Q	2 26 years	0.0022	0.0565
1-157-0-E	2 26 years	0.0021	0.0551
1-70-3A-L	2 24 years	0.0019	0.0460
1-FP-0-K	1 30 years	0.0014	0.0432
02-81-0-C	2 26 years	0.0013	0.0350
2-147-0-Q	2 25 years	0.0013	0.0330
1-68-2-Q	2 26 years	0.0012	0.0317
03-72-0-C	2 26 years	0.0011	0.0296
1-157-2-Q	3 12 years	0.0023	0.0273
2-30-0-Q	2 25 years	0.0010	0.0252
2-161-0-Q	2 24 years	0.0010	0.0229
02-74-0-Q	3 18 years	0.0011	0.0206
1-6-2-Q	2 22 years	0.0007	0.0158
1-6-1-Q	2 22 years	0.0007	0.0158
1-79-0-Q	2 26 years	0.0006	0.0146
02-89-0-C	2 26 years	0.0004	0.0093
3-44-0-A	2 24 years	0.0000	0.0009
3-56-0-Q	2 24 years	0.0000	0.0004

INDIVIDUAL TARGET OPTION - SUMMARY LEVEL REPORT

RELATIVE LOSS FACTORS OF INDIVIDUAL TARGETS

READINESS CONDITION . YOKE
CONFIGURATION Passive and Manual
CASE. Worst
ASSUMED LOCATION. . . at SEA
RUN TIME. 60 minutes
COMMENTS.

Alternative, At Sea M Values, all bulkheads are uninsulated

Targets listed include all compartments in model run with Magnitude of Acceptable Loss 1-3 and Relative Loss Factor (RLF) > 0.0000.

TARGET COMPART.	Magnitude/Frequency -of Acceptable Loss-	Rel Freq of Loss FFS	Relative Loss Factor (RLF)
3-9-0-E	2 26 years	0.0079	0.2061
1-112-0-Q	2 26 years	0.0075	0.1951
01-110-0-Q	3 18 years	0.0098	0.1768
4-126-0-E	2 26 years	0.0054	0.1407
4-92-0-E	2 26 years	0.0051	0.1323
4-92-0A-E	2 24 years	0.0051	0.1227
01-102-0-E	2 23 years	0.0046	0.1066
2-126-2-Q	2 22 years	0.0041	0.0898
01-89-2-Q	3 18 years	0.0045	0.0815
2-126-1-Q	2 22 years	0.0032	0.0711
1-79-0-Q	2 26 years	0.0025	0.0656
1-110-1-Q	2 24 years	0.0023	0.0562
1-157-0-E	2 26 years	0.0019	0.0495
01-74-1-Q	2 26 years	0.0018	0.0472
1-92-0-Q	2 20 years	0.0022	0.0438
1-FP-0-K	1 30 years	0.0013	0.0393
1-68-2-Q	2 26 years	0.0010	0.0266
1-157-2-Q	3 12 years	0.0021	0.0255
02-81-0-C	2 26 years	0.0009	0.0241
2-147-0-Q	2 25 years	0.0009	0.0234
2-161-0-Q	2 24 years	0.0008	0.0193
2-30-0-Q	2 25 years	0.0008	0.0192
02-74-0-Q	3 18 years	0.0010	0.0182
03-72-0-C	2 26 years	0.0006	0.0168
1-70-3A-L	2 24 years	0.0007	0.0164
1-6-2-Q	2 22 years	0.0007	0.0144
1-6-1-Q	2 22 years	0.0007	0.0144
02-89-0-C	2 26 years	0.0002	0.0052
3-44-0-A	2 24 years	0.0000	0.0008
3-56-0-Q	2 24 years	0.0000	0.0003

INDIVIDUAL TARGET OPTION - SUMMARY LEVEL REPORT

RELATIVE LOSS FACTORS OF INDIVIDUAL TARGETS

READINESS CONDITION . YOKE
CONFIGURATION Passive
CASE. Worst
ASSUMED LOCATION. . . at SEA
RUN TIME. 60 minutes
COMMENTS.

Alternative, At Sea M Values, all bulkheads are uninsulated

Targets listed include all compartments in model run with Magnitude of Acceptable Loss 1-3 and Relative Loss Factor (RLF) > 0.0000.

TARGET COMPART.	Magnitude/Frequency -of Acceptable Loss-	Rel Freq of Loss FFS	Relative Loss Factor (RLF)
1-112-0-Q	2 26 years	0.0087	0.2252
3-9-0-E	2 26 years	0.0084	0.2192
01-110-0-Q	3 18 years	0.0113	0.2026
4-126-0-E	2 26 years	0.0062	0.1625
4-92-0-E	2 26 years	0.0059	0.1530
4-92-0A-E	2 24 years	0.0059	0.1420
01-89-2-Q	3 18 years	0.0070	0.1253
01-102-0-E	2 23 years	0.0053	0.1219
1-110-1-Q	2 24 years	0.0044	0.1062
2-126-2-Q	2 22 years	0.0048	0.1059
2-126-1-Q	2 22 years	0.0046	0.1017
1-92-0-Q	2 20 years	0.0042	0.0848
1-79-0-Q	2 26 years	0.0031	0.0810
01-74-1-Q	2 26 years	0.0028	0.0734
1-157-0-E	2 26 years	0.0021	0.0551
1-70-3A-L	2 24 years	0.0020	0.0475
1-FP-0-K	1 30 years	0.0014	0.0432
02-81-0-C	2 26 years	0.0014	0.0377
2-147-0-Q	2 25 years	0.0013	0.0330
1-68-2-Q	2 26 years	0.0012	0.0317
03-72-0-C	2 26 years	0.0011	0.0296
1-157-2-Q	3 12 years	0.0023	0.0273
02-74-0-Q	3 18 years	0.0014	0.0259
2-30-0-Q	2 25 years	0.0010	0.0252
2-161-0-Q	2 24 years	0.0010	0.0229
1-6-2-Q	2 22 years	0.0007	0.0158
1-6-1-Q	2 22 years	0.0007	0.0158
02-89-0-C	2 26 years	0.0004	0.0093
3-44-0-A	2 24 years	0.0000	0.0009
3-56-0-Q	2 24 years	0.0000	0.0004

Appendix E

Methodology for Assigning Probabilities of Flame Termination

The following guidelines may be used for assigning probabilities of flame termination in conjunction with the conduct of a fire safety analysis of a ship using the Ship Fire Safety Engineering Methodology (SFSEM). There are three ways a fire may terminate in a compartment:

1. The fire may self-terminate or extinguish I itself without any action on the part of the crew or without discharging a firefighting agent from any of the ship's fire extinguishing systems; this probability is referred to as the I-Value in the SFSEM.
2. The fire may be extinguished by the application of a firefighting agent from an installed or Automated fire extinguishing system with no human intervention other than activation of the system; this probability is referred to as the A-Value in the SFSEM.
3. The fire may be extinguished by the Manual application of a firefighting agent from a portable fire extinguisher, semi-portable fire extinguishing system or hoseline; this probability is referred to as the M-Value in the SFSEM.

As noted in the Theoretical Basis of the SFSEM [1], I, A, & M-values are determined by assigning probabilities to various subfactors that together affect the overall calculation of the probability of flame termination. Detailed information concerning the construction and use of network diagrams for the calculations of probabilities of flame termination are provided in Appendix F, Network Diagrams. Detailed information concerning the various conditions and parameters that influence each subfactor are provided in Appendix G, Fire Growth Factors.

The following guidelines are used to establish the spreadsheets and document various key parameters that are taken into account during the assignment of probabilities at the subfactor level. Specific guidance for assigning probabilities at the subfactor level is provided in the three attachments to these general guidelines. **Note, these are guidelines only, the engineer must alter recommended values based on experience and sound engineering judgment taking into account conditions expected or observed in each compartment.**

1. Assign a Compartment Use Indicator (CUI) to all compartments in accordance with the guidelines provided in the SAFE User Manual (Appendix H). [2]
2. Enter the Plan IDs, CUI assignments and Compartment Names, as the first three columns in an excel spreadsheet, sort on CUI and compartment name as the secondary sort.
3. Estimate FRI time in minutes for each CUI based on modeling/calculations and then alter up or down according to existing conditions in each compartment. Appendix G provides detailed information concerning the factors that affect FRI times. Insert FRI times in column 4 and note in the footer of the spreadsheet that FRI times are estimated.
4. Columns 5 and 6 are used to record the class of fire (A, B or C) that is most likely to occur in the compartment and the estimated size of the fire (small, medium, or large) that will likely be encountered by the fire party as they arrive on scene. Fire size is relative to the size of the compartment. The following table provides guidance of what constitutes a small, medium, and large fire in terms of the percentage of deck area occupied in compartments of varying size.

	Small Fire	Medium Fire	Large Fire
Small Compt	<50% of deck area	50%<deck area<75%	>75% deck area
Medium Compt	<33% of deck area	33%<deck area<66%	>66% deck area
Large Compt	<25% of deck area	25%<deck area<50%	>50% deck area

Some other factors that affect the judgment of fire size include FRI time, compartment geometry (ceiling height), fuel load, fuel type, fuel package distribution, ventilation, and fire scenario (spray fire, smoldering fire, flammable liquid pool fire etc.). The following table provides guidance of what constitutes a small, medium, and large fire in terms of these other factors.

	Small Fire	Medium Fire	Large Fire
FRI Time	FRI Time > 10 minutes	3 minutes < FRI Time < 10 minutes	FRI Time < 3 minutes
Ceiling Height	ceiling ht >9 ft	7 ft < ceiling ht < 9 ft	ceiling ht < 7 ft
Fuel Load	Fuel Load Density < 2 psf cellulose equivalents	2 psf cellulose equivalents < fuel load density < 4 psf cellulose equivalents	fuel load density > 4 psf cellulose equivalents
Fuel Type	primarily cellulose	cellulose and plastics	primarily plastics
Fuel Package Distribution	Most Fuel Packages separated greater than 1 meter apart	Most Fuel Packages separated by approximately 1 meter	Most Fuel Packages separated less than 1 meter apart
Ventilation	Little to No ventilation	Forced Ventilation or Open Doors To Interior Compartments	Large openings to Outside Air (weather)
Fire Scenario	Smoldering Fire	Pool Fire	Spray Fire

- Columns 7 and 8 are used to record the most probable ignition source and location in the compartment. For example "Galley Stove" (column 7) and "bulkhead" (column 8). Typical ignition sources include: lighting fixture, a specific electrical appliance, a specific motor or controller, a bunk, wastebasket, rag bag, etc. Locations are usually limited to one of the following: bulkhead, corner, center, overhead, bilges.
- Copy this spreadsheet such that three separate spreadsheets are established for I, A, and M-values. The ship's name, the parameter to be calculated (I, A, or M-Value) and the date are recommended for inclusion in the header of each spreadsheet; the footer may include additional information such as estimated or calculated FRI times, baseline analysis or analysis of a specific alternative, etc.

Attachment 1
Methodology for Assigning I-Values

1. Set up columns 9-13 to calculate I|EB (probability the fire will self-terminate or extinguish itself before full room involvement occurs given that established burning has occurred in the compartment) based on 3 subfactors as described in this attachment. The factors and subfactors should be shown as column headings and formulas should be embedded in the spreadsheet in accordance with the Theoretical Basis of the SFSEM. [1] Probabilities should be expressed as a number between 0 and 1 (two decimal places). Notes at the bottom of this spreadsheet should define the subfactors and factors as well as the formulas for calculating the I-values. Appendix B, Table B.6.1.1 in this report is the spreadsheet for calculating I values for the CGC HORNBEAM in accordance with the methodology explained in this appendix.
2. Column 9, Subfactor: "Iebar" - Fire Grows to the Enclosure Point. Assign a probability that the fire will grow from EB to the enclosure point. This probability is dependent on many elements including:
 - Fuel type, quantity, and distribution of fuel packages.
 - Bulk density of fuel and orientation of the fuel packages (i.e. vertical or horizontal).
 - Ignition temperature, location and deck area covered by ignition source.
 - Boundary insulation.
3. Column 10, Subfactor: "Icbar" - Fire Grows to the Ceiling Point. The probability that the fire will grow from the enclosure point to the ceiling point. This probability is dependent on many elements including:
 - Fuel type, quantity, and distribution of fuel packages.
 - Height of the fuel packages.
 - Boundary insulation and combustibility of bulkhead and ceiling linings.
 - Height of overhead
 - Ventilation Factor (i.e. $A \cdot H^{.5}$).Detailed information concerning these factors is provided in Appendix G: Fire Growth Factors in the Analysis of Ship Fire Safety.
4. Column 11, Subfactor: "Irbar" - Fire Grows to the Room Point. The probability that the fire will grow from the ceiling point to the room point. This probability is dependent on many elements including:
 - Fuel type, quantity, and distribution of fuel packages.
 - Boundary insulation and combustibility of bulkhead and ceiling linings.
 - Compartment width/depth ratio.
 - Ventilation Factor (i.e. $A \cdot H^{.5}$).
5. Column 12, Factor: "Ibar" - Probability that the fire will not self-terminate is calculated in accordance with the following formula: $Ibar = Iebar \cdot Icbar \cdot Irbar$.
6. Column 13, Factor: "I|EB" - Probability that the fire will self-terminate, before full room involvement given that established burning has occurred, is calculated in accordance with the following formula: $I|EB = 1 - Ibar$.
7. The spreadsheet will now show calculated values for I|EB. These values should be reviewed by comparing I-values between various CUIs and I-values for compartments having identical CUIs. The values typically range from ".25" for spaces with short FRI times, high fuel loads and significant probabilities of large fires to ".85" for Stairways, Passageways, and Sanitary Spaces with infinite FRI times, negligible fuel loads, and probabilities of small fires. If a set of I-values for a CUI or an individual compartment's I-value seems inconsistent with other I-

values the engineer should revisit the values assigned to the 3 individual subfactors and reassign more appropriate probabilities. This process should be repeated until the engineer is satisfied that the calculated I-values are reasonable and consistent.

Attachment 2 Methodology for Assigning A-Values

The compartments shown on this spreadsheet should be limited to those which have an automated fire extinguishing system. Typical automated systems include the following:

- CO2 Total Flooding System (typically installed in Flammable Liquids Storeroom, Paint Lockers, Engine Rooms, Auxiliary Machinery Spaces such as JP-5 Pump Rooms)
- AFFF Bilge Sprinkling Systems (typically installed in Engine Rooms, Auxiliary Machinery Spaces such as Steering Gear Rooms and Hydraulic Machinery Spaces)
- AFFF Sprinkling Systems (typically installed in Auxiliary Machinery Spaces such as Bow Thruster Machinery Rooms)
- Aqueous Potassium Carbonate (APC) Systems (typically installed in Galleys)
- Water Sprinkling Systems (typically installed in Cargo Holds)
- Halon/Halon Alternatives (e.g. FM 200) (typically installed in Engine Rooms)

1. Set up columns 9-25 to calculate A|EB (probability of an automated fire extinguishing system extinguishing the fire before full room involvement occurs given that established burning has occurred in the compartment) based on 12 subfactors as described in this attachment. The factors and subfactors should be shown as column headings and formulas should be embedded in the spreadsheet in accordance with the Theoretical Basis of the SFSEM. [1]. Probabilities should be expressed as a number between 0 and 1 (express probabilities to two decimal places). Notes should be included at the bottom of this spreadsheet that define the factors as well as the formulas for calculating the A-values. Appendix B, Table B.6.1.2 in this report is the spreadsheet for calculating A-values for the CGC HORNBEAM in accordance with the methodology explained in this appendix.
2. Column 9, Subfactor: "dan" - Detection of Fire. Estimate the percentage of time around the clock that the compartment is monitored by an automatic detection device or by a human. Note the percentage of time a compartment is monitored is usually higher than the percentage of time it is occupied. Reasons for this include the ability to observe conditions in one compartment from another compartment through open doors or hatches. Normally, the "dan" factor will not vary significantly between in port and at sea conditions since compartments with automated systems typically include automatic detection systems. However, two sets of A-Values should be prepared (i.e. In Port and At Sea) if "dan" values vary between in port and at sea conditions. Guidelines for assigning probabilities to the "dan" subfactor include the following:
 - If a compartment has multiple automatic detectors in a single zone, assign ".99"
 - If a compartment has a single detector in a single zone, assign ".95"
 - If a compartment has multiple automatic detectors but the compartment is one of many in a single zone, assign ".90"
 - If a compartment has a single detector but the compartment is one of many in a single zone, assign ".85"
 - If the following conditions are noted: missing or inoperative detectors, dead batteries or faulty wiring, reports of numerous false alarms, etc. the assigned probabilities should be reduced in accordance with the perceived reliability of the system.
 - The following guidelines apply to compartments without automatic detection devices
 - If a compartment is normally occupied part of the day, assign a value that is calculated by dividing the total number of hours a week the compartment is occupied

- by 168 and then increase this value to account for the possibility of observing fires from another compartment. This should result in values ranging from “.50” to “.80”.
- If a compartment is not normally occupied and is remotely located (i.e. out of the main stream of normal traffic) assign “.50” or less depending on its degree of remoteness.
3. Column 10, Subfactor: “nan” - Notification of the Bridge. Assign a value that is equal to “dan” if the compartment has an automatic detection device. For compartments without an automatic detection device assign “.90”.
 4. Column 11, Subfactor: “san” - Sound the Alarm. It is assumed that if the Bridge receives the notification, the alarm will be sounded due to the military discipline and training that can be expected on Coast Guard Cutters. However, there is a slight possibility of announcing the wrong location and there is a very remote probability that the PA system will be inoperative, thus a probability of “.95” is assigned.
 5. Column 12, Factor: “An” - Notification is calculated in accordance with the following formula: $An=dan*nan*san$.
 6. Column 13, Subfactor: “fap” - Secure the Fuel Supply. The primary concern here is the likelihood of securing the flammable liquid supply to potential spray fires. Main machinery Spaces (CUI=EM) on ships are normally equipped with remote fuel shut-off valves accessible from outside the compartment. Therefore assign “.80” to compartments with a CUI of “EM”. “QA” and “QE” spaces may be subject to flammable liquid spray fires but are not generally equipped with remote shut-off valves. Therefore assign values of “.70” to “.90” depending on the presence of internal combustion engines or flammable liquid fuel lines in these spaces. Assign a value of “1.00” to all other spaces unless they have internal combustion engines or flammable liquid fuel lines in the compartment.
 7. Column 14, Subfactor: “vap” - Secure the Ventilation. Forced ventilation is most likely installed in spaces with a CUI of “EM”, “TU” and “K”. Therefore ventilation in these spaces may not be secured with the certainty that it can in spaces without forced ventilation unless the automated suppression system automatically secures the ventilation system. Therefore in spaces with forced ventilation systems (e.g. CUI of “EM”, “TU” or “K”) assign a value of “.80” if the ventilation system is not automatically secured, assign a value of “.90” if the ventilation system is automatically secured. In all other spaces without forced ventilation assign a value of “.95”.
 8. Column 15, Subfactor: “pap” - Secure the Electrical Power. Due to the quantity of electrical motors and controllers installed in spaces with a CUI = “EM” or “EE” assign a value of “.80”. Most other spaces have, as a minimum, electrical lighting and may have electrical equipment installed in addition to lighting. Therefore in all other spaces assign values ranging from “.80” to “.90”.
 9. Column 16, Factor: “Ap” - Preparation is calculated in accordance with the following formula: $Ap=fap*vap*pap$.
 10. Column 17, Subfactor: “saa” - Alignment of Automated System. System alignment involves all the physical devices (e.g., electrical, mechanical, pneumatic, hydraulic) that must be properly configured for the system to work if activated. AFFF sprinkling systems primarily involves piping systems and valves, but the system also requires proper alignment of the AFFF proportioner and storage tank. CO2 systems are less complex in that they usually include fewer valves and other components compared to AFFF sprinkling systems. APC systems for deep fat fryers and Galley stoves include even fewer valves and components. Therefore the following guidelines are provided for assigning probabilities to the “saa” subfactor:

- AFFF Sprinkling: assign “.85”
 - CO2 Total Flooding: assign “.90”
 - Halon/Halon Alts: assign “.90”
 - APC System: assign “.95”
11. Column 18: Subfactor “aaa” - Agent Discharges from Nozzle. This subfactor describes the probability that an agent will flow from its storage location to the nozzle and discharge into the protected space. This probability is influenced by a potential blockage in the piping system, sufficient pressure to move the agent through the piping system and potential failure of the nozzles themselves. These systems are designed to be inherently reliable. Therefore the following guidelines are provided for assigning probabilities to the “aaa” subfactor:
- AFFF Sprinkling: assign “.90”
 - CO2 Total Flooding: assign “.95”
 - Halon/Halon Alts: assign “.95”
 - APC System: assign “.99”
12. Column 19: Subfactor “daa” - Agent Discharges on Fire. The design, location, and aim of the nozzles affect the ability of the agent to discharge directly on the fire. In addition the presence of high piled storage may block the agent from reaching the fire. Therefore the following guidelines are provided for assigning probabilities to the “daa” subfactor:
- AFFF bilge sprinkling: assign “.85”
 - AFFF overhead sprinkling: assign “.90”
 - CO2 Total Flooding: assign “1.00”
 - Halon/Halon Alts: assign “1.00”
 - APC System: assign “1.00”
 - Significant obstructions: assign “.80 or less” (does not apply to gaseous systems)
13. Column 20, Factor: “Aa” - Agent Application is calculated in accordance with the following formula: $Aa = saa * aaa * daa$.
14. Column 21: Subfactor “qae” - Quantity of Agent Adequate. There is an inexhaustible supply of sea water available on board ships. Therefore, assign a value of “1.00” for water sprinkling systems. Ships normally carry large quantities of AFFF concentrate, additional AFFF is also usually available from other ships who are called to assist in firefighting efforts. Therefore, assign a value of “.95” for AFFF sprinkling systems. CO2 and Halon systems are normally designed to flood the protected space one time. Spare bottles must be used for a second discharge and it is quite unlikely that there is sufficient quantity of agent on board to flood the space more than twice. Therefore, assign a value of “.90” for CO2 and Halon systems. APC systems are designed with adequate quantities of agent to extinguish up to large class B fires in deep fat fryers or Galley stoves. However, the agent may be exhausted before very large fires are fully extinguished. Therefore, assign a value of “.90” for APC systems
15. Column 22: Subfactor “cae” - Concentration of Agent Adequate. The spacing and design of the nozzles as well as the system discharge pressure influences the concentration of agent in APC systems as well as AFFF and water sprinkling systems. The size of the space, the quantity of agent discharged into the space and the leakage factors determine the concentration of agent in CO2 and Halon total flooding systems. Therefore the following guidelines are provided for assigning probabilities for the “cae” factor:
- AFFF Sprinkling: assign “1.00”
 - CO2 Total Flooding: assign “.90”
 - Halon/Halon Alts: assign “.90”
 - APC System: assign “1.00”

16. Column 23: Subfactor "bae" - Probability Blackout Occurs. The probability of blackout primarily depends on three factors: quantity of agent (accounted for in column 21), concentration of agent (accounted for in column 22), and the size of the fire (estimated in column 6). Therefore the following guidelines are provided to assign probabilities to the "bae" subfactor:
- In compartments where large-sized fires are expected assign a value of ".90"
 - In compartments where medium-sized fires are expected assign a value of ".95"
 - In compartments where small-sized fires are expected assign a value of ".99"
 - In multi-level engineering spaces assign a value of ".85" or less
17. Column 24: Factor "Ae" - Fire Extinguishment is calculated in accordance with the following formula: $Ae = qae * cae * bae$.
18. Column 25: Factor "A|EB" - The probability of Automated Fire Extinguishment before full room involvement given Established Burning has occurred is calculated in accordance with the following formula: $A|EB = An * Ap * Aa * Ae$.
19. The spreadsheet will now show calculated values for A|EB. These values should be reviewed by comparing A-values for various compartments with the same automated fire extinguishing system. The values typically range from ".50" for AFFF bilge sprinkling systems to .85 for APC systems to .90 for CO2 and Halon systems. Considerable variability has been noted in the probability of A|EB due to the range of probabilities assigned to the various subfactors for different compartments with the same automated system. In particular, the reliability of detection systems (subfactor "dan") varies greatly from ship to ship and compartment to compartment. If a set of A-values for a particular automated system or an individual compartment's A-value seems inconsistent with other A-values, the engineer should revisit the probabilities assigned to the 12 individual subfactors and reassign more appropriate values. This process should be repeated until the engineer is satisfied that the calculated A-values are reasonable and consistent.
20. After SAFE has been run on the baseline data set, actual FRI times will be part of the output results. It is extremely important that these calculated FRI times be compared to the estimated FRI times and updated in column 4. The engineer should revisit and change as necessary the assigned probabilities for affected subfactors and the size of the fire likely to be encountered by the fire party shown in column 6. The revised A|EB values should then be entered into SAFE as part of the baseline data set and the baseline results recalculated.

Attachment 3 Methodology for Assigning M-Values

1. Set up columns 9-25 to calculate M|EB (probability of manually extinguishing the fire before full room involvement occurs given that established burning has occurred in the compartment) based on 12 subfactors as described in this attachment. The factors and subfactors should be shown as column headings and formulas should be embedded in the spreadsheet in accordance with the Theoretical Basis of the SFSEM. [1]. Probabilities should be expressed as a number between 0.00 and 1.00 (express probabilities to two decimal places). Notes should be included at the bottom of this spreadsheet that define the subfactors and factors as well as the formulas for calculating the M-values. Appendix B, Table B.6.2.1 and Table B.6.3.1 in this report are the spreadsheets for calculating M-values In Port and At Sea for the CGC HORNBEAM in accordance with the methodology explained in this appendix.
2. Column 9, Subfactor: "dmn" - Detection of Fire. Estimate the percentage of time around the clock that the compartment is monitored by an automatic detection device or by a human. Note the percentage of time a compartment is monitored is usually higher than the percentage of time it is occupied. Reasons for this include the ability to observe conditions in one compartment from another compartment through open doors or hatches. Normally, the "dmn" factor will vary significantly between in port and at sea conditions, especially on ships with relatively few automatic detectors installed throughout the ship. Therefore, two sets of M-Values are normally prepared (i.e. In Port and At Sea). Guidelines for assigning probabilities to the "dmn" factor include the following:
 - If a compartment has multiple automatic detectors in a single zone, assign ".99"
 - If a compartment has a single detector in a single zone, assign ".95"
 - If a compartment has multiple automatic detectors but the compartment is one of many in a single zone, assign ".90"
 - If a compartment has a single detector but the compartment is one of many in a single zone, assign ".85"
 - Assign a value of "1.00" to the Bridge (aka Pilothouse) for At Sea conditions.
 - If the following conditions are noted: missing or inoperative detectors, dead batteries or faulty wiring, reports of numerous false alarms, etc. the assigned percentages should be reduced in accordance with the perceived reliability of the system.
 - The following guidelines apply to compartments without automatic detection devices
 - If a compartment is normally occupied part of the day, assign a value that is calculated by dividing the total number of hours a week the compartment is occupied by 168 and then increase this value to account for the possibility of observing fires from another compartment. This should result in values ranging from ".50" to ".80".
 - If a compartment is not normally occupied and is remotely located (i.e. out of the main stream of normal traffic) assign ".50" or less depending on its degree of remoteness.
3. Column 10, Subfactor: "nmn" - Notification of the Bridge. Assign a value that is equal to "dmn" if the compartment has an automatic detection device. For compartments without an automatic detection device assign ".90". Assign a value of "1.00" to the Bridge (aka Pilothouse) for At Sea conditions.
4. Column 11, Subfactor: "smn" - Sound the Alarm. It is assumed that if the Bridge receives the notification, the alarm will be sounded due to the military discipline and training that can be expected on Coast Guard Cutters. However, there is a slight possibility of announcing the

wrong location and there is a very remote probability that the PA system will be inoperative, thus a probability of “.95” is assigned. Assign a value of “1.00” to the Bridge (aka Pilothouse).

5. Column 12, Factor: “Mn” - Notification is calculated in accordance with the following formula: $Mn = dmn * nmn * smn$.
6. Column 13, Factor: “fmp” - Secure the Fuel Supply. The primary concern here is the likelihood of securing the flammable liquid supply to potential spray fires. Main machinery Spaces (CUI=EM) on ships are normally equipped with remote fuel shut-off valves accessible from outside the compartment. Therefore assign “.80” to compartments with a CUI of “EM”. “QA” and “QE” spaces may be subject to flammable liquid spray fires but are not generally equipped with remote shut-off valves. Therefore assign values of “.70” to “.90” depending on the presence of internal combustion engines or flammable liquid fuel lines in these spaces. Assign a value of “1.00” to all other spaces unless they have internal combustion engines or flammable liquid fuel lines in the compartment.
7. Column 14, Subfactor: “vmp” - Secure the Ventilation. Forced ventilation is most likely installed in spaces with a CUI of “EM”, “TU” and “K”. Therefore ventilation in these spaces may not be secured with the certainty that it can in spaces without forced ventilation. Therefore in spaces with a CUI of “EM”, “TU” or “K” assign a value of “.80” unless a compartment is equipped with an automated suppression system that automatically secures the ventilation. In this event assign a value of “.90”. In all other spaces without forced ventilation assign “.90”. In absolutely airtight spaces (no forced or natural ventilation) such as Voids and Water Tanks (CUI = “V” and “W”) assign a value of “1.00”.
8. Column 15, Subfactor: “pmp” - Secure the Electrical Power. Due to the quantity of electrical motors and controllers installed in spaces with a CUI = “EM” or “EE” assign a value of “.80”. Most other spaces have, as a minimum, electrical lighting and may have electrical equipment installed in addition to lighting. Therefore in all other spaces assign values ranging from “.80” to “.90”. In spaces without any electrical power including lighting such as Voids and Water Tanks (CUI = “V” or “W”) assign a value of “1.00”.
9. Column 16, Factor: “Mp” - Preparation is calculated in accordance with the following formula: $Mp = fmp * vmp * pmp$.
10. Column 17, Subfactor: “sma” - Firefighters Respond to the Scene. On a ship the firefighters do not have great distances to travel, however their ability to arrive on the scene prior to full room involvement conditions, is proportional to the assumed FRI time (estimated in column 4). Therefore the following guidelines are used to assign the probabilities to the “sma” subfactor:

FRI Time (minutes)	sma (probability)
1	.10
2	.30
3	.50
4	.70
5	.90
6-9	.95
>10	1

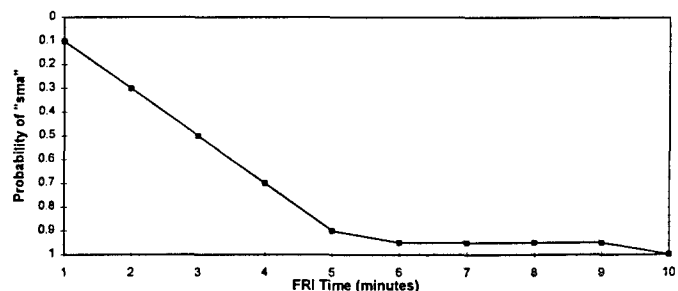

11. Column 18: Subfactor “ama” - Firefighters Access Compartment. The ability to access a compartment on a ship is directly affected by the likelihood that the compartment is locked (and therefore the time to obtain a key or break down the door). Spaces such as storerooms, staterooms, ship store, weapons spaces such as the Armory, medical spaces such as the

Dispensary and Sick Bay, and commissary spaces such as Dry Stores are quite likely to be locked, therefore these spaces are assigned a value of “.90”. Spaces such as Refrigerated Stores, Radio Room, and Combat Information Center are likely to be locked with high security heavy duty locks, therefore these spaces are assigned a value of “.80”. All other spaces are likely to be unlocked and are therefore assigned a value of “1.00”.

12. Column 19: Subfactor “dma” - Agent Discharges on Fire. The following factors directly affect the ability of the firefighters to discharge an agent directly on the fire: size of the compartment, number of levels in the compartment, amount of obstructions in the compartment. Therefore the following guidelines are provided for assigning probabilities to the “dma” subfactor:
 - Large sized space, single level, no obstructions: assign “.85”
 - Medium sized space, single level, no obstructions: assign “.90”
 - Small sized space, single level, no obstructions: assign “1.00”
 - Multi-level compartments: assign “.80”
 - Significant obstructions: assign “.80”
13. Column 20, Factor: “Ma” - Agent Application is calculated in accordance with the following formula: $Ma = sma * ama * dma$.
14. Column 21: Subfactor “qme” - Quantity of Agent Adequate. The preferred agent for extinguishing Class A fires is water. There is an inexhaustible supply of sea water available on board ships. Therefore, in compartments where class A fires (shown in column 5) are expected, assign a value of “1.00”. AFFF is the preferred agent for extinguishing Class B fires. Ships normally carry adequate quantities of AFFF concentrate, additional AFFF is also usually available from other ships who are called to assist in firefighting efforts. Therefore, in compartments where class B fires are expected, assign a value of “.95”. CO₂ is the preferred agent for extinguishing class C fires. CO₂ portable extinguishers are normally located in close proximity to spaces with a class C fire threat, additional CO₂ extinguishers are also stored in the Repair Locker. Therefore, in compartments where class C fires (see column 5) are expected, assign a value of “.90”.
15. Column 22: Subfactor “cme” - Concentration of Agent Adequate. The concentration of water for extinguishing class A fires is an important factor in building sprinkler systems. It is less of a factor in applying water from manually applied hose streams on ships. Therefore, in compartments where class A fires are expected, assign a value of “1.00”. Fire suppression systems on ships are carefully designed to produce AFFF in the appropriate concentration of 6%. Therefore, in compartments where Class B fires are expected, assign a value of “.95” to account for the possibility of a system malfunction in producing the correct concentration of agent. The concentration of CO₂ achieved with a portable extinguisher on a class C fire is a function of the size of the fire, the firefighting technique employed, and the quantity of extinguishers available. Therefore, in compartments where class C fires are expected, assign a value of “.90” to account for probable deficiencies in the applied concentration of CO₂.
16. Column 23: Subfactor “bme” - Probability Blackout Occurs. The probability of blackout primarily depends on three factors: quantity of agent (accounted for in column 19), concentration of agent (accounted for in column 20), and the size of the fire (estimated in column 6). The following guidelines are provided to assign probabilities to the “bme” subfactor:
 - In compartments where large-sized fires are expected assign a value of “.65”
 - In compartments where medium-sized fires are expected assign a value of “.80”
 - In compartments where small-sized fires are expected assign a value of “.95”

17. Column 24: Factor "Me" - Fire Extinguishment is calculated in accordance with the following formula: $Me = q_{me} * c_{me} * b_{me}$.
18. Column 25: Factor "M|EB" - The probability of Manual Fire Extinguishment before full room involvement given Established Burning has occurred is calculated in accordance with the following formula: $M|EB = M_n * M_p * M_a * M_e$.
19. The spreadsheet will now show calculated values for M|EB. These values should be reviewed by comparing M-values for various CUIs and M-values for compartments within CUIs. The values typically range from ".05" for engineering spaces with short FRI times, high fuel loads and significant probabilities of large class B spray fires to ".65" for Stairways, Passageways, and Sanitary Spaces with infinite FRI times, negligible fuel loads, and probabilities of small class A fires. If a set of M-values for a CUI or an individual compartment's M-value seems inconsistent with other M-values the engineer should revisit the probabilities assigned to the 12 individual factors and reassign more appropriate probabilities. This process should be repeated until the engineer is satisfied that the M-values are reasonable and consistent.
20. After SAFE has been run on the baseline data set, actual FRI times will be part of the output results. It is extremely important that these calculated FRI times be compared to the estimated FRI times and updated in column 4. The engineer should revisit and change as necessary the assigned probabilities for affected subfactors (primarily "sma" shown in column 17) and the size of the fire likely to be encountered by the fire party shown in column 6. The revised M|EB values should then be entered into SAFE as part of the baseline data set and the baseline results recalculated.

References

[1] Sprague, Chester M. and Dolph, Brian, "Theoretical Basis of the Ship Fire Safety Engineering Methodology", Report No. CG-D-30-96, Published in the National Technical Information Service (Accession No: AD- A319152), Final Report, September, 1996.

[2] Clouthier, Elizabeth; Rich, Doris; and Romberg, Betty, "Ship Applied Fire Engineering (SAFE) User Manual, Version 2.2, Report No. CG-D-10-96, Published in the National Technical Information Service (Accession No: AD- A310234), Final Report, March, 1996.

Appendix F

Network Diagrams for Flame Movement Analysis on Ships

INTRODUCTION

The Ship Fire Safety Engineering Methodology (SFSEM) is an adaptation of the Building Firesafety Method which has been under development since the early 1970's at Worcester Polytechnic Institute (WPI). The SFSEM, or Method, provides an integrated framework to facilitate a rigorous analysis of fire safety on surface ships. The Method can be applied to all types of ships such as passenger ships, merchant ships, U.S. Navy ships, and Coast Guard Cutters ranging from Icebreakers to Patrol Boats. The SFSEM is designed to analyze all aspects of fire safety including flame movement, smoke movement, people movement (egress analysis) and effects of fire on the structural frame.

The Method is a probabilistic based risk analysis methodology; as such it utilizes the engineering judgment of knowledgeable engineers for assigning the probabilistic values. A hierarchical series of network diagrams are used to calculate the probability of limiting the fire spread to a certain compartment or barrier in the vessel. Network diagrams have been developed for the analysis of the following modules in the SFSEM: ignition, established burning, and flame movement in the room of origin and adjacent rooms that are involved as a result of barrier failure. The purpose of this appendix is to provide detailed information concerning the construction and use of network diagrams for the flame movement module in the SFSEM.

NETWORK DIAGRAMS

TERMINOLOGY

Certain terms that apply to the network diagrams used in the SFSEM are defined here for consistency in usage and to eliminate confusion. Figure F-1 is the network diagram for flame limitation in the compartment of origin and is shown here for the purposes of defining terms and to illustrate the calculation of probabilities.

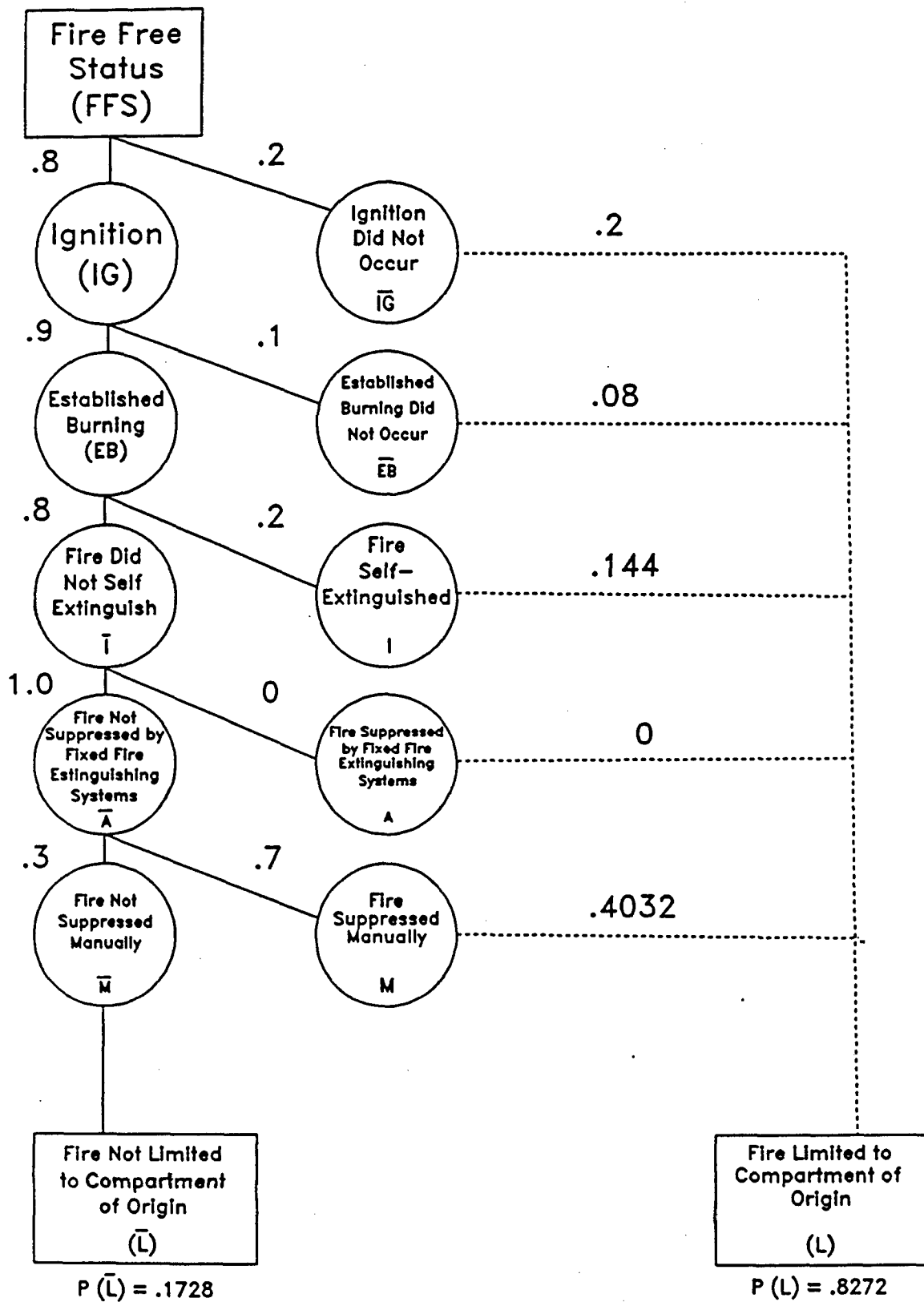

Figure F-1: Network Diagram for Fire Limitation to the Compartment of Origin

Network Diagram: Also known as balloon diagram, bubble diagram, and Markov Chain. A graphical representation of the logic, sequencing, and relationship of the different parts of the fire safety system on a ship. Figure F-1 is an example of a network diagram and shows the events considered in determining the probability of flame limitation in the compartment of origin.

Event: An unambiguous action or occurrence that can be easily stated in binary terms. For example ignition occurred or it did not. Another example is the fire is suppressed manually or it is not suppressed manually.

Outcome: The result of a series of events. The outcome: Fire Not Limited to the Compartment of Origin resulted from the five intermediate events between the beginning event: Fire Free Status and the terminal event or outcome.

Conditional Event. An event that can only occur if another event occurs first. For example Established Burning can only occur as a result of the Ignition event. In the SFSEM, conditional probabilities are stated: $P(EB|IG)$ which is read as the probability of Established Burning given Ignition. The abbreviated version: $P(EB)$ implies EB given Ignition to a knowledgeable engineer and is exactly equal to $P(EB|IG)$.

Independent Events. Events which contribute to, or can result in, a given outcome but are not conditional on each other. For example as shown in Figure F-1 there are five independent ways in which flames can be limited to the compartment of origin: IG, EB, I, A, or M.

BENEFITS AND DRAWBACKS

Network Diagrams are used extensively in the SFSEM therefore their advantages and disadvantages are listed here to provide insight into these analytical tools:

- Network diagrams are common in the literature.
- They provide flexibility in describing complex processes such as firefighting.
- A distinct disadvantage is that it is difficult and cumbersome to show the entire network. A hierarchy of networks and a way to keep them organized is usually required.
- Experience has shown that networks are easier to use when communicating with other design engineers.
- The event requirements for conditionality and independence are easily recognized.

RULES OF CONSTRUCTION AND CONVENTIONS

Network Diagrams are used in the SFSEM to evaluate the probability of certain events occurring. They are constructed in general accordance with the rules for calculation of conditional probabilities.

Rules of Construction

There are four basic rules for construction of network diagrams. These rules are listed here and illustrated in Figure F-1:

1. From any given event, the network must show all possible outcomes of future events.
2. The sum of all probabilities for the outcomes from any given event must equal 1.0.
3. The probability of an outcome along a continuous path is the product of the probabilities of the associated intermediate events in the network diagram ("AND" Gates).
4. The probability of an outcome is the sum of probabilities of all similar outcomes in the network diagram ("OR" Gates). For example, as shown in Figure F-1, $I|G$, $E|B$, $A|I$, and $M|A$ are all similar to "L" in that each outcome describes the limitation of flame movement.

Conventions

Certain conventions are used in the construction of network diagrams to aid in clarity and for consistency in presentation. These conventions are listed here and illustrated in Figure F-1:

- a. A sequential path of events are connected by solid lines. Dashed lines are used to indicate a transfer symbol to a terminal event.
- b. The networks show all possible outcomes, both success and failure, on the same diagram.
- c. The beginning event is assumed to have occurred (i.e., the probability is equal to 1.0) therefore there is no point in showing the complement of the beginning event. The outcome or terminal event is the event being analyzed.
- d. The sequence of intermediate events may or may not be important. If sequence is important the order of the events must be sequential. If sequence is not important the intermediate events are listed in a logical sequence if appropriate. A careful examination of the beginning and terminal events of sub-networks will reveal if the sequence of intermediate events of the higher level network was important.

Types of Network Diagrams

Network Diagrams are versatile tools for describing the logic used for analysis or for calculating results. In the SFSEM networks are constructed showing events in binary form. For example: the fire was extinguished or it was not, the fire was detected or it was not, etc. Networks are used in two ways: (1) to calculate a single value, and (2) to generate a cumulative value that varies with some parameter such as deck area or time.

The cumulative value network are typically used to illustrate the probability of limiting the fire spread to a certain deck area of a compartment. The single value networks are then used to calculate each data point in the cumulative value network. Figures F-6 and F-6A, F-7 and F-7A illustrate this concept. Since these figures contain multiple networks, notes on the figures explain which networks are single value and which are cumulative.

NETWORK DIAGRAMS FOR FLAME MOVEMENT

FLAME MOVEMENT IN BUILDINGS

A fire in a building typically starts in a room of origin and if the occupant cannot or does not extinguish the fire rapidly, the fire department is usually called to combat the fire. The goal of

the fire department is to limit the fire to the room of origin; if this is not feasible then they try to suppress the fire in adjacent rooms that become involved. The fire can progress from the room of origin to adjacent rooms by breaching floors, walls or ceilings. Figure F-2 is the network diagram for evaluating the probabilities of limiting the flames to either the room of origin or an adjacent room as explained in the following sections. The right hand side of the diagram shows the sequential events in the progress of the fire. The networks shown on the left and middle of the diagram are sub-networks which break down these events in more detail.

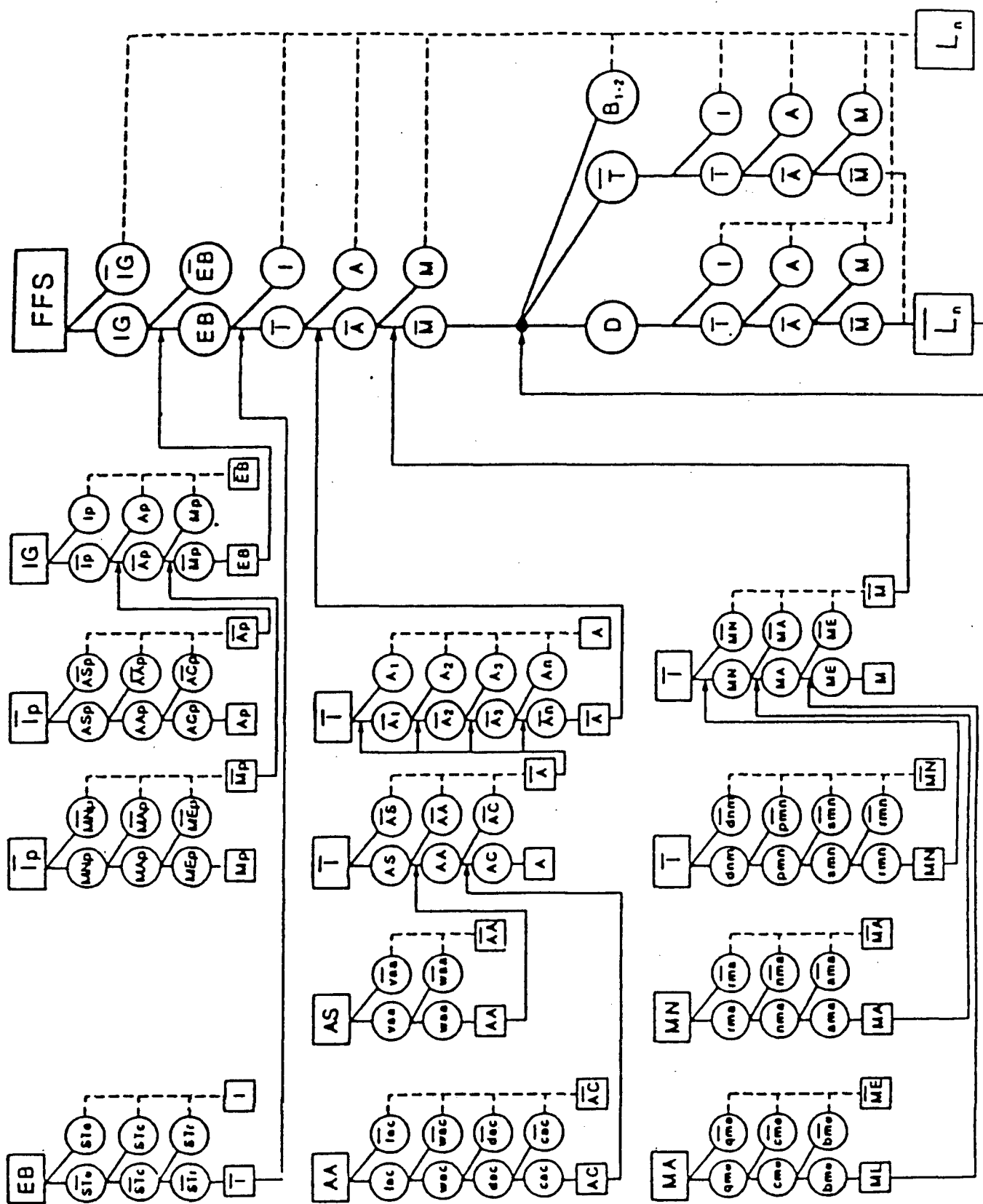

Figure F-2: Network Diagram For Limiting Flame Movement in Buildings

Flame Movement In the Room of Origin.

A building fire is combated either by the occupant or by the fire department assuming the building's sprinkler system was ineffective. The flame movement diagram shown in figure F-2 reflects this situation. The beginning event is fire free status and the terminal event is the desired outcome of Flame Limitation if a fire starts. Ignition is self explanatory and depends on the proper combination of the three elements of the classic fire triangle: heat, fuel, and oxygen. Established Burning (EB) for a building is usually defined as a flame approximately 10 inches high. This event also includes the probability that the occupant may be successful in extinguishing the fire, referred to as "first aid". I, A and M represent the three ways a fire can go out in a building once it has reached EB. I is the probability that the fire will go out by itself due to lack of fuel or oxygen. A is the automatic suppression event which is the probability that the building sprinkler system will suppress the flames without human intervention. M is the manual suppression event and denotes the effectiveness of the fire department in suppressing the fire with hose lines.

Flame Movement Beyond the Room of Origin.

If the fire is not limited to the room of origin it may spread to adjacent rooms by breaching a wall or a floor or a ceiling. Figure F-2 also shows the events that constitute this probability. It shows the two possible ways which a barrier (ceiling, floor or wall) can fail. These are a durability or massive failure (D) and a thermal or hot spot failure (T). "B" on the diagram signifies the complement of barrier failure or barrier success. If the barrier fails, fire can enter an adjacent room. If this occurs the three possible ways of extinguishing the fire for the room of origin apply to the adjacent room. As shown in Figure F-2 this process is repeated until the fire is limited.

FLAME MOVEMENT IN SHIPS

The network diagram developed for flame movement on ships is shown in Figure F-3. The definition of terms in Figure F-3 is shown in Table F-1. Figures F-4 through F-7 are sub-networks that break down the events shown in Figure F-3 in more detail. Acronyms are used extensively to eliminate clutter on the diagrams. Their definitions are provided in accompanying tables and also summarized in the List of Abbreviations and Symbols at the end of this appendix.

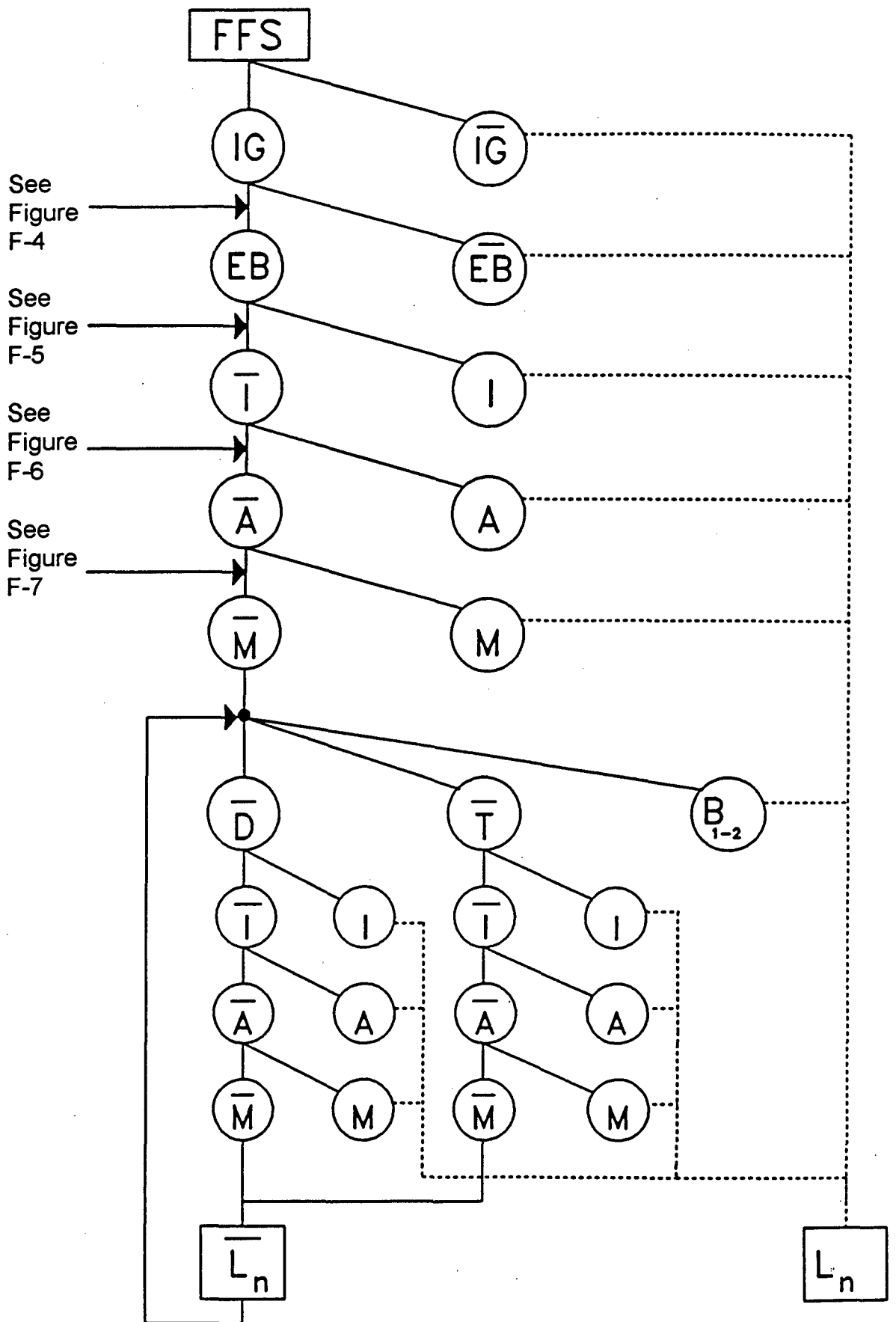

Figure F-3: Network Diagram for Limiting Flame Movement on Ships

Abbreviation	Definition
FFS	Fire free status
IG	Ignition
EB	Established burning
I	Self termination of fire
A	Fixed fire extinguishing system suppression of fire
M	Manual suppression of fire
Dbar*	Durability failure of barrier
Tbar*	Thermal failure of barrier
B	Barrier success in limiting fire
L	Limit of flame movement

* "bar" denotes the symbol over the acronym in a network diagram which signifies the contra-positive event.

Table F-1: Definition of Terms in Figure F-3

Flame Movement Diagram

Ships and buildings are alike in many respects. Ships are an assemblage of rooms called compartments linked by hallways called passageways and stairs called ladders. Walls that define rooms are referred to as bulkheads in compartments; floors are called decks and ceilings are called overheads. Terminology therefore is quite different but geometry and arrangement is not very different from multi-story buildings.

The fire threat in a ship includes class A fires in crew's quarters and officer staterooms, class B fires in machinery spaces, and class C fires in spaces such as the Radio Room, Engineering Control Center, and the Bridge. Buildings on the other hand are primarily concerned with class A fires. Accordingly they are usually equipped with water sprinkler systems. Ship stability is adversely affected by large quantities of firefighting water that may be generated by sprinklers. Stability concerns coupled with the diverse fire threat result in ships being equipped with a variety

of fixed fire extinguishing systems. These include aqueous film forming foam (AFFF) bilge sprinkler systems, Halon 1301 total flooding systems, CO₂ flooding systems, as well as sea water and fresh water sprinkling systems.

Ships, unlike buildings, cannot be totally abandoned to fight a fire. Certain spaces must remain occupied to operate the ships propulsion equipment and navigate the vessel. Therefore, fire protection equipment, in general, is not configured for automatic operation. Instead fixed firefighting systems are usually activated manually. This allows time for crewmembers to evacuate the space. In those cases where watchstanders must remain in the space, the total flooding system is carefully selected to ensure the firefighting agent is not lethal.

In summary, a more appropriate breakdown of the ways a fire can go out on a ship is self termination, suppression by fixed equipment and suppression by manual means such as hose lines, portable, and semi-portable equipment. These are shown in Figure F-3. Maximum similarity to buildings is maintained by using the letters I, A, and M, however the definition of these acronyms is different for the A value.

Prevent Established Burning

Ten inches is the defined height of flame for established burning both in ships and buildings. The network diagram for prevent established burning on ships differs from buildings in that automatic sprinkler systems are not present in ships, thus that event has been eliminated as shown in Figure F-4. Other events shown in Figure F-4 are similar to the counterpart diagram for buildings and the definition of terms in Figure F-4 shown in Table F-2 are similar to those for buildings as well.

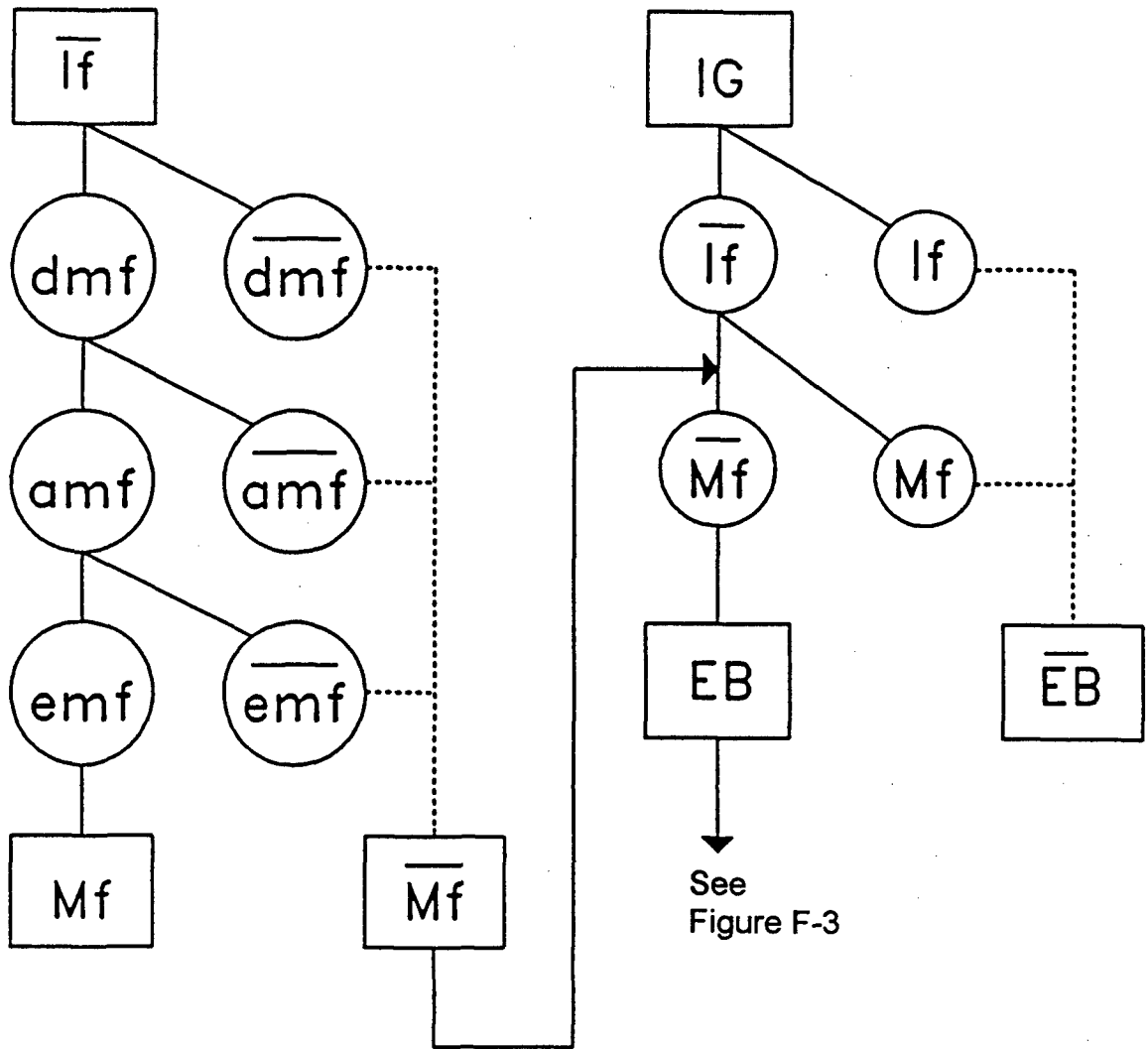

Figure F-4: Network Diagram for Prevent Established Burning on Ships

Abbreviation	Definition
If	Self termination prior to EB
Mf	Manual suppression prior to EB
dmf	Person discovering fire decides to attempt to extinguish fire before EB
amf	Agent application by person discovering fire before EB
emf	Extinguishment of fire by person discovering fire before EB

Table F-2: Definition of Terms in Figure F-4

Self Termination

Fires self-terminate for the same reasons in buildings as they do in ships. These factors include characteristics of the fuel, ventilation, thermal properties of the barriers, and room geometry. Appendix G provides a more detailed discussion concerning the factors which affect fire growth (the complement of flame limitation). The network diagram for self-termination of fires on ships is shown in Figure F-5. It is identical to the self-termination diagram for buildings. It should be noted that the so-called I curve which graphically depicts the probability of a fire to self-terminate is often referred to in terms of its complement: the fire growth hazard potential.

The acronyms in Figure F-5 are defined in Table F-3. In this table "enclosure point" is the point in fire growth when the flames first touch a vertical boundary in the compartment. The "ceiling point" denotes the time when the flames first reach the ceiling, and "room point" signifies when full room involvement has occurred.

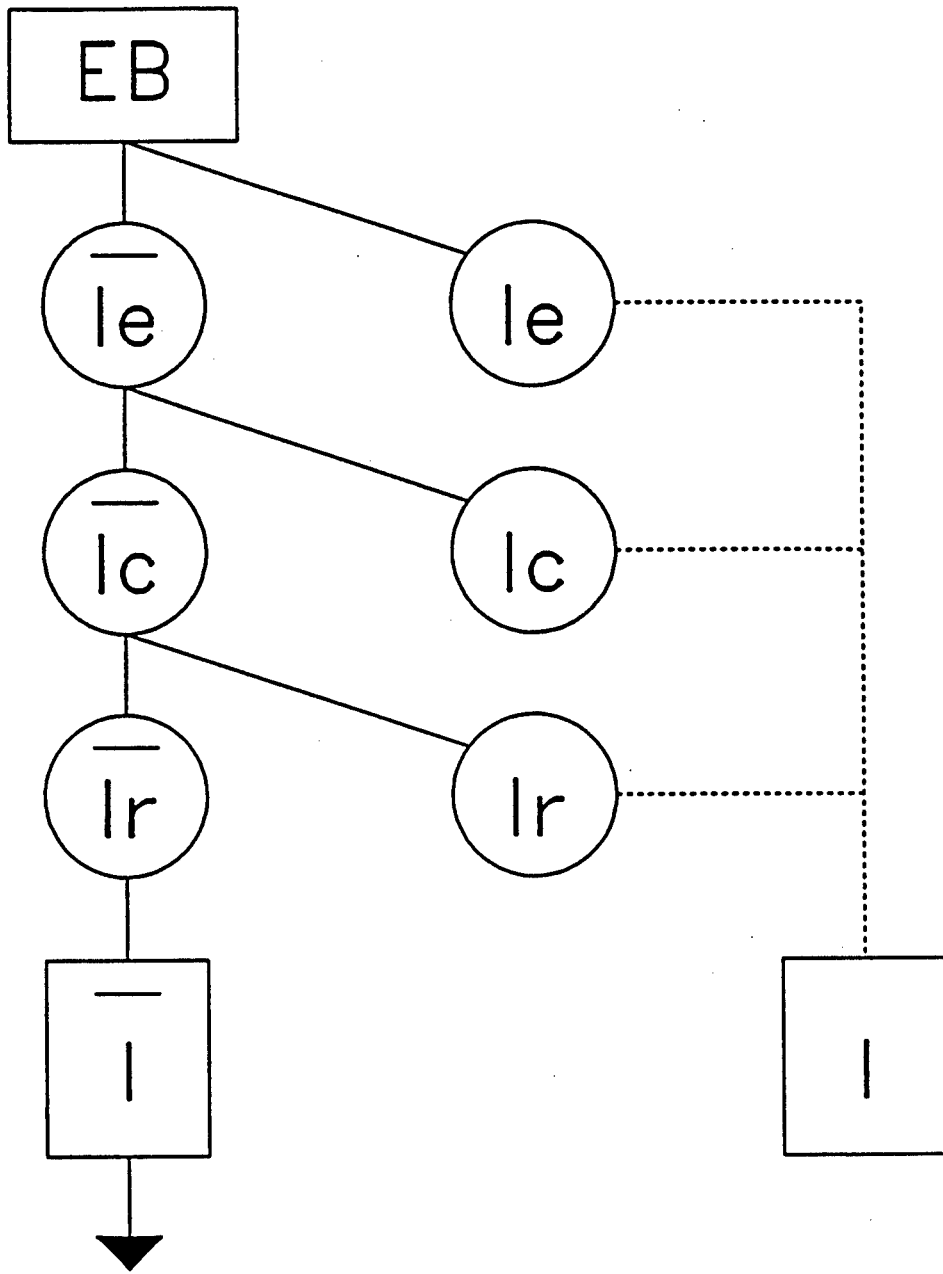

See Figure F-3

Figure F-5: Network Diagram for Self-Termination on Ships

Abbreviation	Definition
Ie	Self termination before enclosure point
Ic	Self termination before ceiling point
Ir	Self termination before room point

Table F-3: Definitions of terms in Figure F-5

Fixed Fire Extinguishing System Suppression

The network diagram for fixed fire extinguishing system suppression on ships is shown in Figures F-6 and F-6A. The acronyms used in these figures are defined in Table F-4. The major difference between this diagram and its counterpart for buildings is that ships are generally equipped with multiple, manually activated, fixed fire extinguishing systems discharging a variety of firefighting agents while buildings are equipped with a single, automatic, sprinkler system discharging water. It is still appropriate however, to consider the probabilities of extinguishment in sequentially expanding areas of the compartment being studied. The reason for this is that the probabilities of extinguishment vary with the area of the compartment and the related fire involvement. Therefore this network diagram, like its counterpart for buildings, is used to evaluate the probability of success of a particular fixed system to control or extinguish a fire within a specific deck area of the compartment.

The diagram is structured so that each fixed system that may be present in a compartment is evaluated separately and results accumulated as shown in Figure F-6. However, each system is evaluated for the same four components. These components are notification (An), compartment preparation (Ap), agent application (Aa), and fire extinguishment (Ae). Notification involves detection of the fire, notification of the Bridge and sounding the alarm with the location and class of fire. Preparation involves the necessary actions to prepare a compartment for the release of a firefighting agent. Agent application involves the reliability of the fixed firefighting system to release the agent onto the fire in the compartment when it is activated. Fire extinguishment involves the design of the fixed fire extinguishing system to successfully extinguish the fire. Each of these components is discussed in more detail in the following sections.

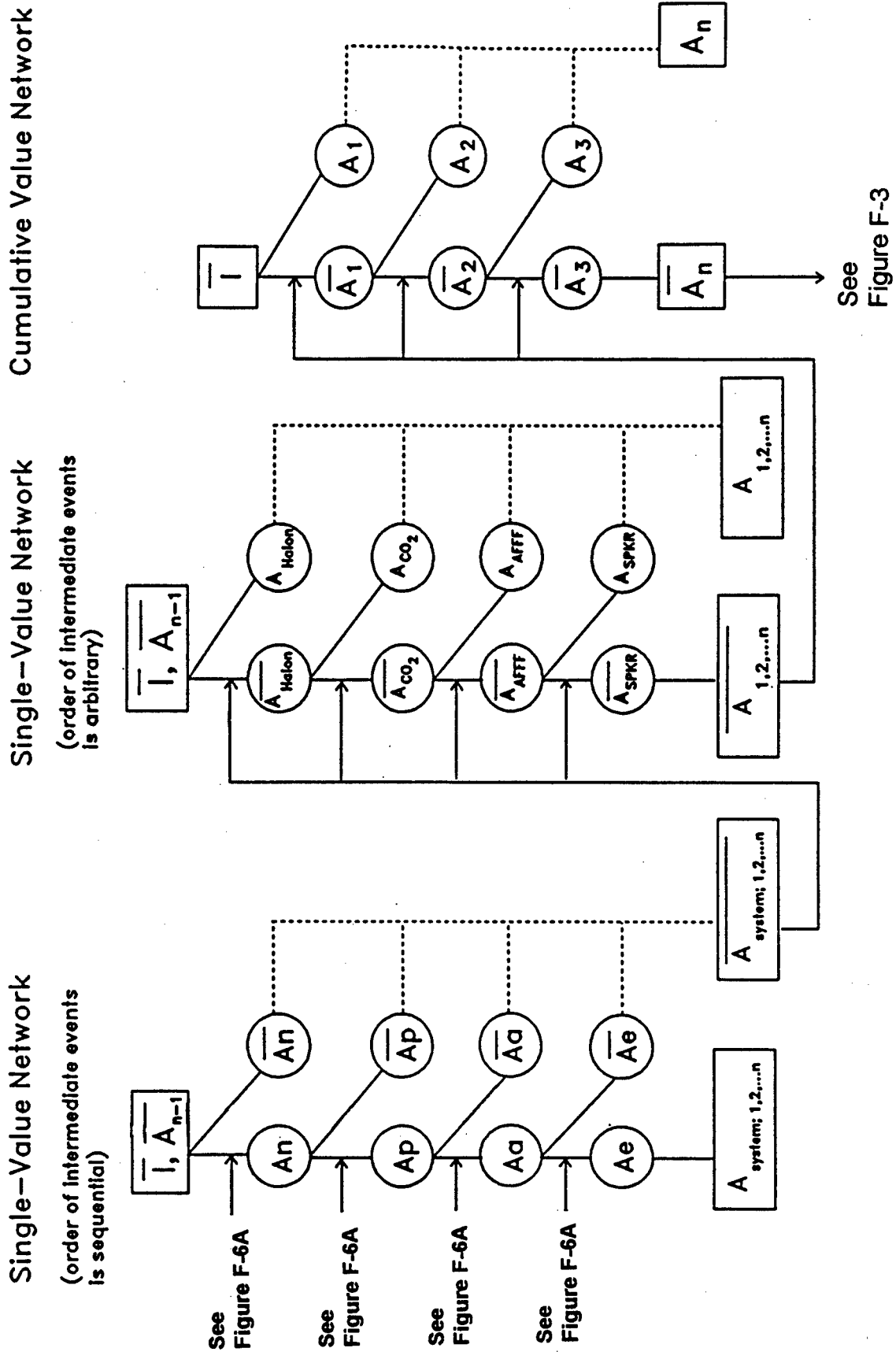
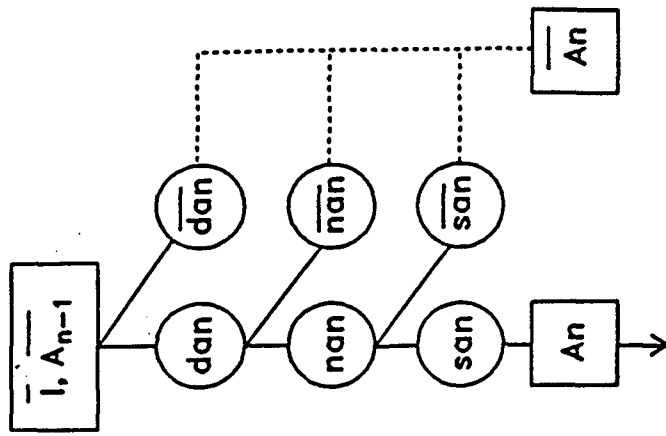
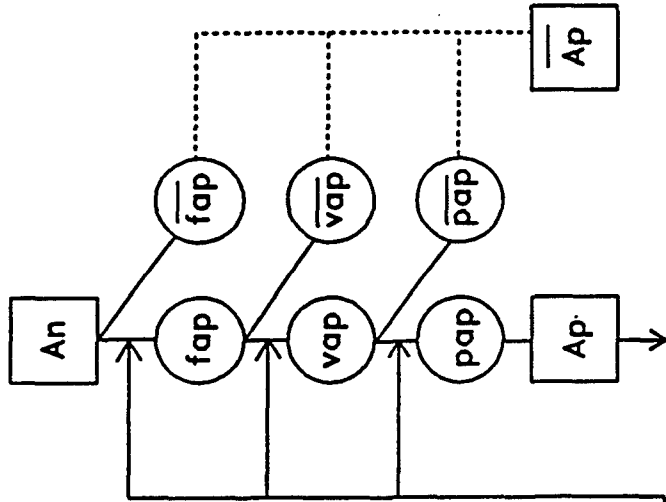

Figure F-6: Network Diagram for Fixed Fire Extinguishing System Suppression on Ships



See Figure F-6

All networks are single-value.
See text to determine if order
of intermediate events is
sequential or arbitrary.



See Figure F-6

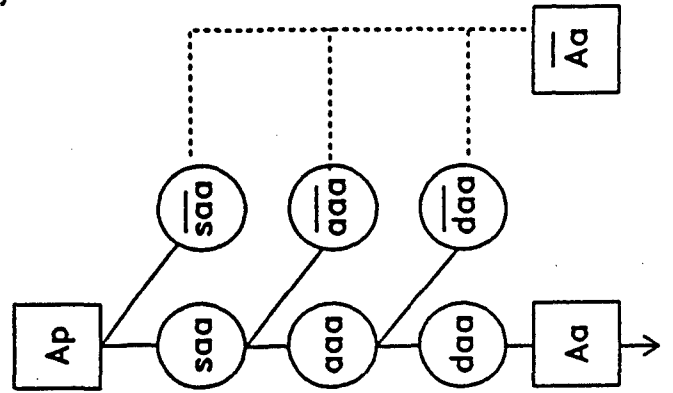

See Figure F-6

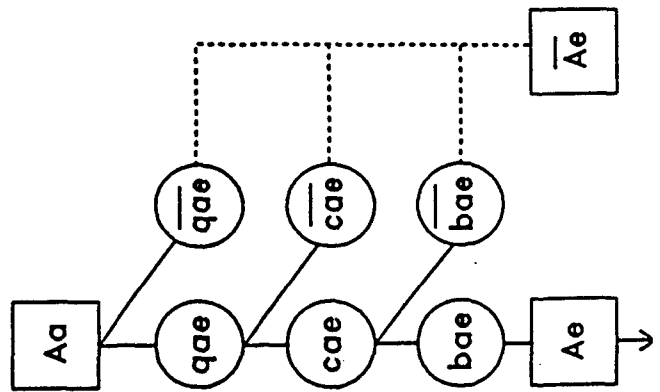
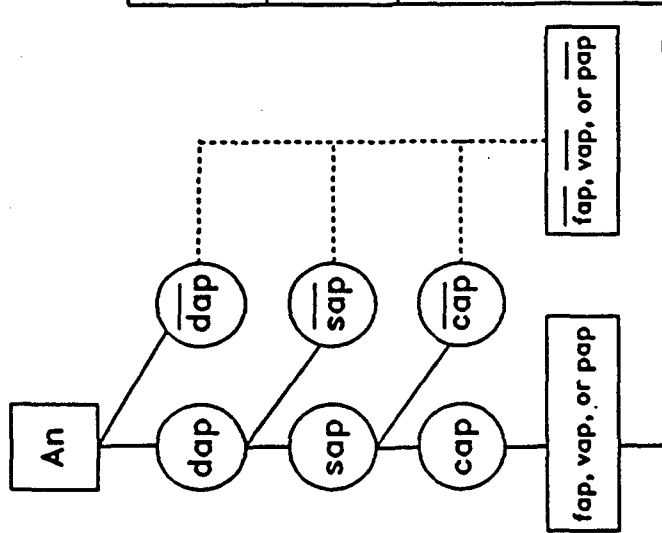

Figure F-6A: Continued from Figure F-6

Abbreviation	Definition
$A_1, A_2, A_3, \dots, A_n$	Fixed fire extinguishing system suppression before fire grows to size denoted by subscripts where n denotes full compartment
$A_{Halon}, A_{CO_2}, A_{AFFF}, A_{Sprkr}, \dots, A_n$	Suppression by type of fixed fire extinguishing system denoted by subscript
An	Notification of fire
Ap	Compartment preparation
Aa	Agent application
Ae	Fire extinguishment
dan	Detection of fire
nan	Notification of the Bridge of the fire
san	Sound the alarm with the location and class of fire
fap	Secure the fuel supply
vap	Secure (or provide) ventilation
pap	Secure the electrical power
dap	Decide to secure the fuel, ventilation or power
sap	Start to secure the fuel, ventilation or power
cap	Complete securing the fuel, ventilation or power
saa	Fixed firefighting system alignment for operation
aaa	Agent discharges from the nozzle into the compartment

Table F-4: Definition of Terms in Figures 6 and 6A (continued next page)

Abbreviation	Definition
daa	Agent discharges onto the fire in the compartment
qae	Quantity of agent sufficient to extinguish the fire
cae	Concentration of agent appropriate to extinguish the fire
bae	Blackout occurs due to fixed fire extinguishing system suppression

Table F-4: Definition of Terms in Figures 6 and 6A (continued)

The notification event is subdivided into three events as shown in Figure F-6A. These events are sequential in nature and include: detection of the fire (dan), notification of the bridge (nan), and sounding the alarm (san). Detection can be accomplished by an automatic installed fire/smoke detector or by a crewmember/passenger/watchstander discovering the fire. The notification event primarily depends on the routing of the information to the bridge. A person can be sent to the bridge or the telephone could be used or the automatic detector may alert the bridge electronically. The final event in this network is the sounding of the alarm with the location and class of fire. Obviously it is necessary for the firefighters to be notified of the class of fire and the proper location before they can respond with the appropriate equipment or to activate the appropriate fixed system.

The events that comprise the preparation event involve the fuel (fap), ventilation (vap) and electrical power (pap) in the compartment. The actions required in the preparation event must occur prior to the release of the firefighting agent in the compartment but their order is not important. Securing the fuel is critically important in machinery space fires and in the case of a class B spray fire. If the fuel supply is not secured, attempts to extinguish the fire are likely to be futile. Ventilation refers to the appropriate action required prior to release of the agent. This may include ventilating the space to exhaust the smoke and heat or, it may mean securing the ventilation blowers prior to releasing a total flooding gaseous agent such as Halon 1301 or CO₂. Electrical power is usually secured in a space prior to release of an agent and in the case of a class C fire it is critically important.

The preparation event, as shown in Figure F-6A, has been further subdivided with another network. This network involves three sequential actions that apply to each of the components in the preparation network. These events are the decision to secure the fuel, ventilation, or power (dap), the commencement of action to secure the fuel, ventilation, or power (sap), and the completion of the action to secure the fuel, ventilation, or power (cap). Since these actions are

required prior to releasing an agent and they consume valuable time at a crucial stage of fire growth, their evaluation could reveal problems in the firefighting doctrine of the vessel.

The sequential events that constitute the agent application component are system alignment (saa), agent discharges from the nozzle (aaa), and agent discharges on the fire in the compartment (daa). System alignment involves all the physical devices (e.g. electrical, mechanical, pneumatic, hydraulic) that have to be properly configured for the system to work when it is activated. The agent discharges from the nozzle event includes the probability that the firefighting agent will flow from its storage location to the nozzle and discharge into the compartment. The agent discharges on the fire event depends on the aim and location of the nozzle. Note, the agent application event for fixed firefighting systems is an indicator of the reliability of the particular system under evaluation. Since this event is a function of the system and not the deck area, the evaluation of this event only needs to be done once.

The events that comprise the fire extinguishment event are a function of compartment deck area. Therefore this event must be evaluated for a given deck area in the compartment. As shown in Figure F-6A the fire extinguishment event can be subdivided into the following three events that describe the design effectiveness of the fixed fire extinguishing system: Quantity of agent (qae), concentration of agent (cae), and blackout (bae). These events may be evaluated in any order. Agents in fixed systems include halon, carbon dioxide and AFFF and others which require a particular design concentration and quantity to be effective.

Manual Suppression

The occupant in a building is generally untrained in firefighting. Moreover, they are often encouraged to evacuate and notify the city fire department in the event of a fire. The fire department responds to the scene with a trained professional team of firefighters. In contrast, crewmembers on ships all receive some (minimum) amount of firefighting training and in general they cannot evacuate the ship, although they may be able to evacuate the compartment. Passengers in a ship are much like the occupants in a building. The fire department in a ship consists of a damage control team from a repair locker. If the fire department in a building fire desires assistance, they can call in a second alarm. Similarly, in a ship fire, the Master can request assistance from city firefighters if in port or the Coast Guard if at sea. Other ships can offer assistance if in close proximity as well. These conditions are reflected in the network diagram for manual suppression shown in Figure F-7 and F-7A. The various acronyms used in Figures F-7 and F-7A are defined in Table F-5.

Single-Value Network
(order of intermediate events
is sequential)

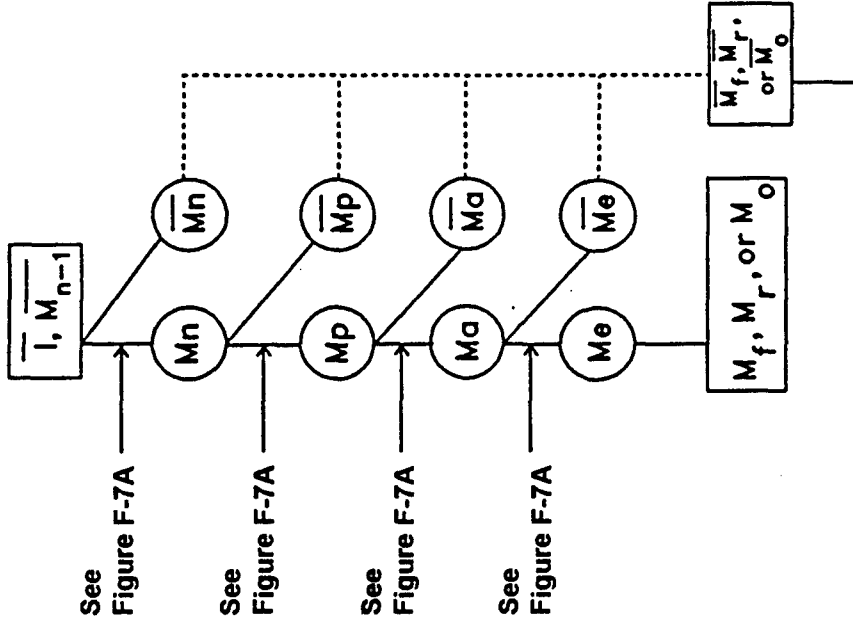

Single-Value Network
(order of intermediate events
is logical but arbitrary)

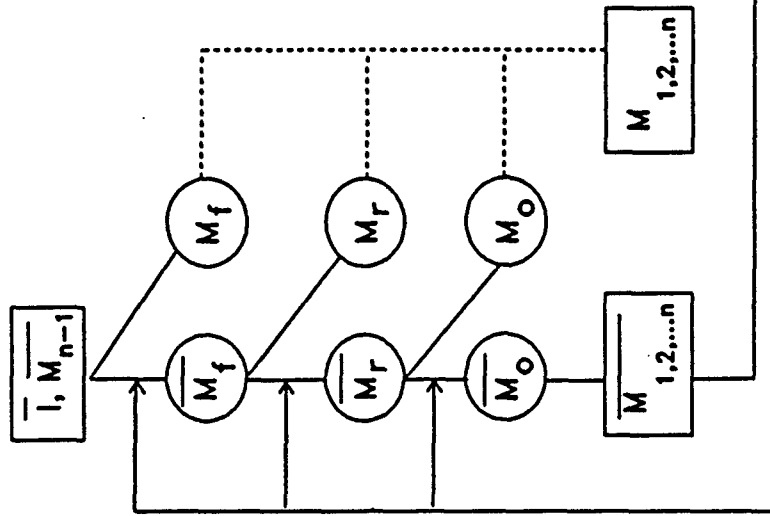

Cumulative Value Network

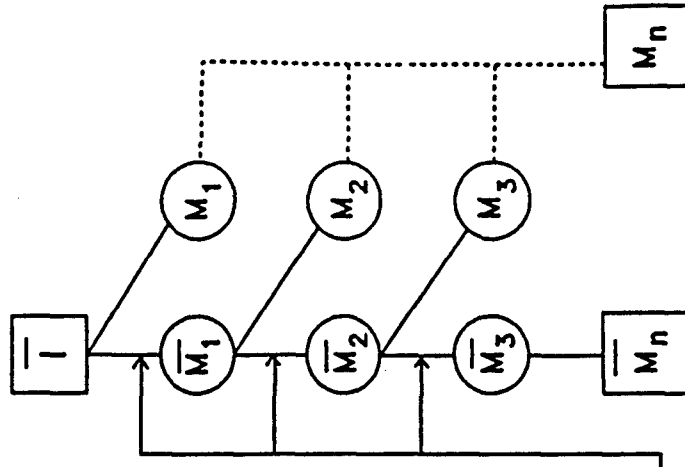

See
Figure F-3

Figure F-7: Network Diagram for Manual Suppression of Fire on Ships

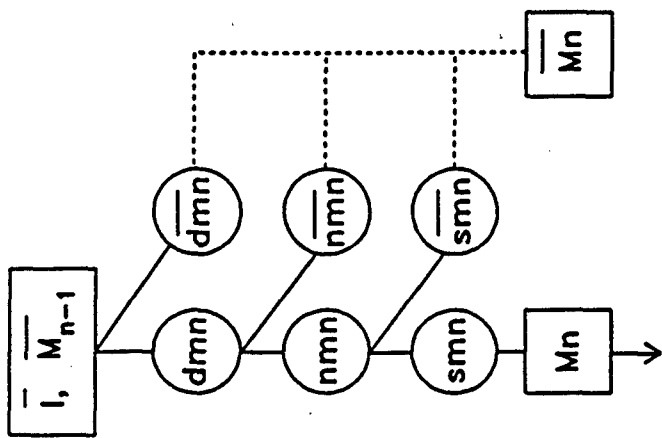

See Figure F-7

All networks are single-value. See text to determine if order of intermediate events is sequential or arbitrary.

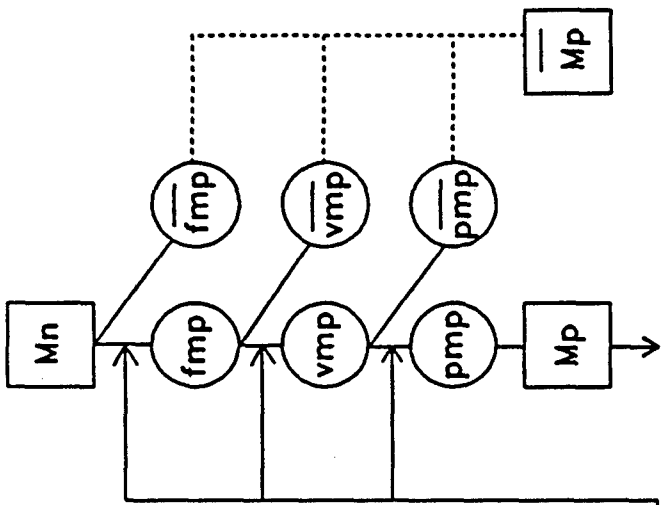

See Figure F-7

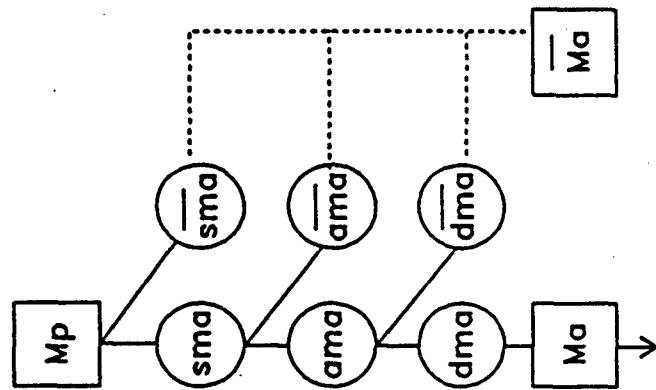

See Figure F-7

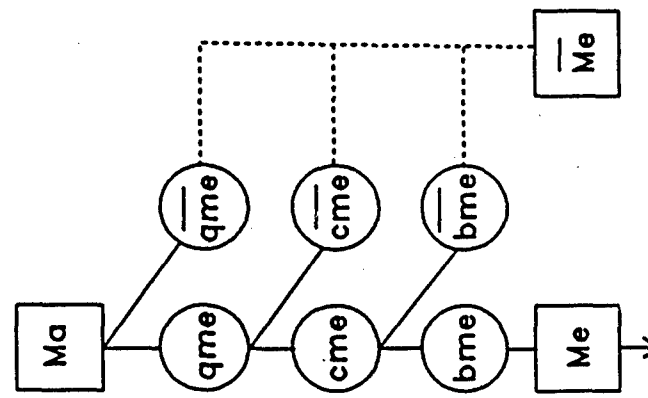
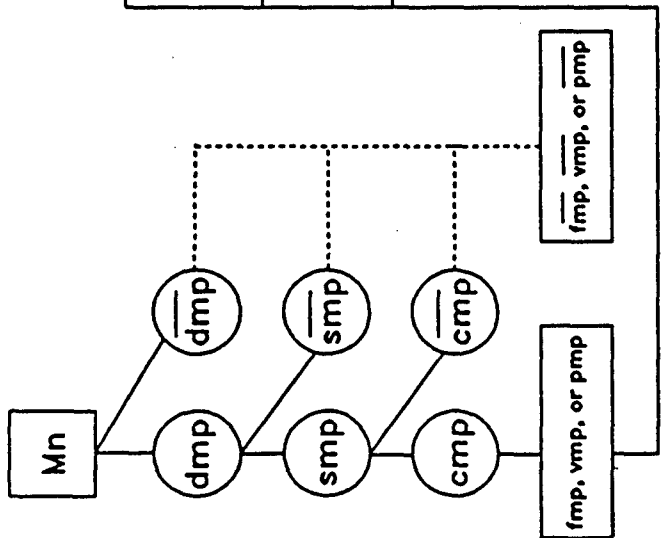

See Figure F-7

Figure F-7A: Continued from Figure F-7

Abbreviation	Definition
$M_1, M_2, M_3, \dots, M_n$	Manual extinguishment before fire grows to size denoted by subscript
M_f	Manual extinguishment by Flying Squad
M_r	Manual extinguishment by Repair Party
M_o	Manual extinguishment by outside assistance
Mn	Notification of fire
Mp	Compartment preparation
Ma	Agent application
Me	Fire extinguishment
dmn	Detection of fire
nmn	Notification of the Bridge of the fire
smn	Sound the alarm with the location and class of fire
fmp	Secure the fuel supply
vmp	Secure (or provide) ventilation
pmp	Secure electrical power
dmp	Decide to secure the fuel, ventilation or power
smp	Start to secure the fuel, ventilation or power
cmp	Complete securing the fuel, ventilation or power
sma	Firefighting response to scene of fire
ama	Firefighters access the compartment
dma	Agent discharges on the fire in the compartment

Table F-5: Definitions of Terms in Figures F-7 and F-7A (continued next page)

Abbreviation	Definition
qme	Quantity of agent sufficient to extinguish the fire
cme	Continuous discharge of agent on the fire
bme	Blackout occurs due to manual suppression

Table F-5: Definitions of Terms in Figures F-7 and F-7A (continued)

The major events in the evaluation of manual suppression are notification (Mn), compartment preparation (Mp), agent application (Ma), and fire extinguishment (Me). Each of these events is evaluated for one of three possible groups that could be attempting the manual suppression effort. The notification event involves the reliability of the fire detection system and the notification of the bridge so that the nature and location of the fire can be announced to all hands. Preparation involves appropriate action concerning the fuel, ventilation and electrical power in the affected compartment. Agent application involves the firefighters arriving on scene with the proper equipment, accessing the compartment and successfully applying the appropriate firefighting agent. The fire extinguishment event evaluates the probability that the techniques and equipment employed by the firefighters are successful in extinguishing the fire.

The firefighting efforts in a ship are increased with the severity of the fire. The flying squad is a team of three or four crewmembers who are specially trained and designated to respond immediately to the scene of a reported fire and hopefully extinguish it before it can grow in size. In the meanwhile, the repair party is assembling, dressing out in firefighting ensembles and manning hose lines. If the flying squad is unable to extinguish the fire the repair party will take over or complement the firefighting effort. In either event, the Master may decide to request assistance from other ships or other organizations such as the Coast Guard, Harbor Patrol, city Fire Department etc. The network diagram is structured to evaluate the probability of success of each of these groups as shown in Figure 7. One of the benefits of this type of evaluation is the ability to demonstrate and evaluate the relative effectiveness of each group.

The events in the manual suppression event closely parallel the events in the fixed firefighting suppression event. The notification and preparation events are identical - only the acronyms are different to distinguish them from the fixed firefighting suppression event although the definitions are precisely the same. The agent application and fire extinguishment events are parallel in construction but the events and definitions are different as explained in the following sections.

Agent application requires the firefighters to respond to the scene (sma), access the compartment (ama), and discharge agent on the fire (dma) in sequence as shown in Figure 7A. These actions are the same regardless of whether it is the flying squad, repair party or outside assistance, but the times required will most likely be quite different. Obviously it takes longer for a repair party to muster, dress out and respond than for the flying squad to respond directly upon hearing the announcement of a fire. Outside assistance has to travel to the ship first and then to

the scene in the ship second, so their time might very well be measured in hours compared to minutes for the repair party and seconds for the flying squad.

The fire extinguishment event in manual suppression involves the following three events as shown in figure 7A: quantity of agent (qme), continuous discharge of agent (cme), and blackout (bme). These events may be evaluated in any order. Training greatly influences the probability of these events. The proper quantity, type and location of firefighting equipment is another factor. The best firefighters would be unsuccessful without the proper equipment.

LIST OF ABBREVIATIONS AND SYMBOLS

A	Fixed fire extinguishing system suppression of fire
Aa	Agent application
aaa	Agent discharges from the nozzle into the compartment
Ae	Fire extinguishment
$A_{\text{Halon}}, A_{\text{CO}_2}, A_{\text{AFFF}}, A_{\text{Sprkr}}, \dots, A_n$	Suppression by type of fixed fire extinguishing system denoted by the subscript
ama	Firefighters access the compartment
amf	Agent application by person discovering fire before EB
An	Notification of fire
Ap	Compartment preparation
$A_1, A_2, A_3, \dots, A_n$	Fixed fire extinguishing system suppression before fire grows to the size denoted by the subscript
B	Barrier success in limiting fire
bae	Blackout occurs due to fixed extinguishing system suppression
bme	Blackout occurs due to manual suppression
cae	Concentration of agent appropriate to extinguish the fire
cap	Complete securing the fuel, ventilation or power
cme	Continuous discharge of agent on the fire
cmp	Complete securing the fuel, ventilation or power
Dbar	Durability failure of barrier
daa	Agent discharges onto the fire in the compartment
dap	Decide to secure the fuel, ventilation or power
dan	Detection of fire
dma	Agent discharges onto the fire in the compartment
dmf	Person discovering fire decides to attempt to extinguish fire before EB
dmp	Decide to secure the fuel, ventilation or power

dmn	Detection of fire
EB	Established burning
emf	Extinguishment of fire by person discovering fire before EB
fap	Secure the fuel supply
FFS	Fire free status
fmp	Secure the fuel supply
I	Self termination of fire
Ic	Self termination before ceiling point
Ie	Self termination before enclosure point
If	Self termination prior to EB
IG	Ignition
Ir	Self termination before room point
L	Limit of flame movement
M	Manual suppression of fire
Ma	Agent application
Me	Fire extinguishment
Mf	Manual suppression prior to EB
M _f	Manual extinguishment by Flying Squad
Mn	Notification of fire
M _o	Manual extinguishment By outside assistance
Mp	Compartment preparation
M _r	Manual extinguishment by Repair Party
M ₁ , M ₂ , M ₃ , ..., M _n	Manual extinguishment before fire grows to size denoted by subscript
nan	Notification of the Bridge of the fire
nmn	Notification of the Bridge of the fire
pap	Secure the electrical power
pmp	Secure the electrical power
qae	Quantity of agent sufficient to extinguish the fire
qme	Quantity of agent sufficient to extinguish the fire
saa	Fixed firefighting system alignment for operation
san	Sound the alarm with the location and class of fire
sap	Start to secure the fuel, ventilation or power

sma	Firefighters respond to scene of fire
smn	Sound the alarm with the location and class of fire
smp	Start to secure the fuel, ventilation or power
Tbar	Thermal failure of barrier
vap	Secure (or provide) ventilation
vmp	Secure (or provide) ventilation

Appendix G

Fire Growth Factors in the Analysis of Ship Fire Safety

INTRODUCTION

The Ship Fire Safety Engineering Methodology (SFSEM) is an adaptation of the Building Firesafety Method which has been under development since the early 1970s at Worcester Polytechnic Institute (WPI). The SFSEM provides an integrated framework to facilitate a rigorous analysis of fire safety on surface ships. The methodology can be applied to all types of ships including passenger ships, merchant ships such as tankers and cargo vessels, and military ships such as U.S. Navy ships and U.S. Coast Guard Cutters. The SFSEM is designed to analyze all aspects of fire safety including flame movement, smoke movement, people movement (egress analysis), and effects of fire on the structural frame of the vessel.

Flame movement is the central focus of the methodology and focuses on an analysis of the different ways a fire can be extinguished once established burning has been achieved in an enclosure fire. The three principle ways a fire can be extinguished are self-termination, suppression by manual firefighting efforts, and suppression by fixed, (automatic or automated) fire extinguishing systems. The approach used in the SFSEM is fundamentally probabilistic and utilizes the engineering judgment of the engineer/analyst in the selection of the subjective probabilities involved.

FIRE GROWTH HAZARD POTENTIAL

The probabilities associated with flame movement are calculated in network diagrams which were originally developed for use in buildings and later adapted for use in ships. Appendix F provides a detailed explanation of network diagrams and their application in the SFSEM. The network diagrams for flame movement include the events associated with the different ways a fire can be extinguished. This appendix focuses on the factors that influence the probability of self-termination during the period of fire growth from established burning (EB) to full room involvement (FRI). Self-termination and fire growth are complementary. Therefore if the factors that affect fire growth are understood and calculable, it is possible to quantify the fire growth hazard potential (FGHP) of a compartment. Subtracting this value from 1.0 would then yield the probability that the fire would self-terminate.

There are at least 14 factors which affect a compartment's FGHP, including ventilation, thermal properties of the compartment boundaries, geometry of the compartment, the fuel quantity, type, and arrangement, etc. The engineer/analyst mentally integrates these factors in the determination of the FGHP of each compartment. The focus of this appendix is a qualitative discussion of the various factors that influence fire growth. In addition, synergistic effects due to the interaction of different factors are examined.

Following ignition of an object in a room, the fire usually grows slowly to a point defined as Established Burning (EB). In the SFSEM, EB defines the point where the fire starts to grow according to the second power of time. This fire growth, if unchecked, will eventually result in full room involvement (FRI). At this point, the atmosphere is untenable and survival is impossible without protective clothing and a self-contained breathing apparatus. The time from EB to FRI is referred to as FRI time. Figure G-1 illustrates the shape of the fire growth curve and the three stages of fire growth after a fire achieves EB.

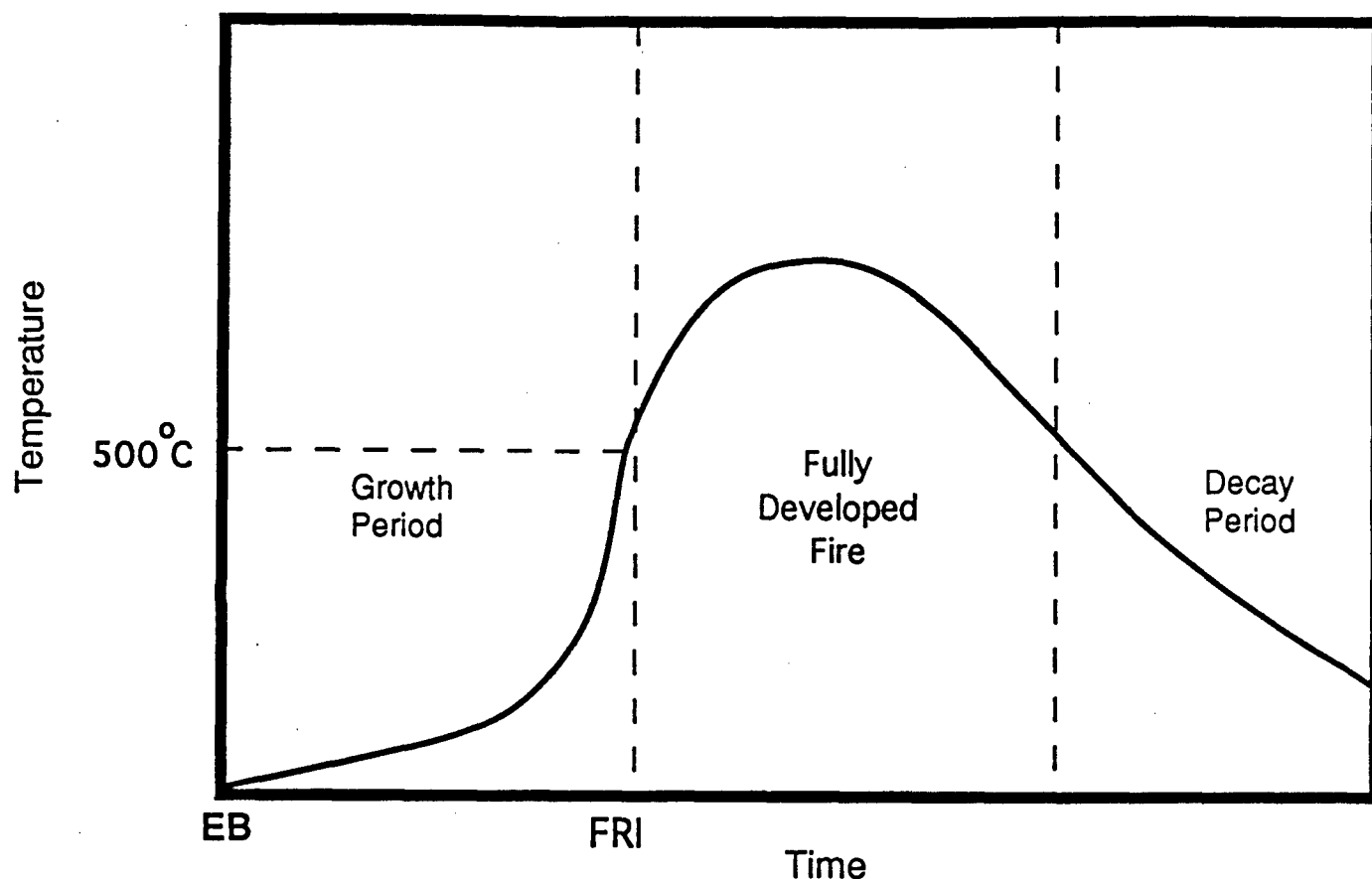

Figure G-1: Stages of Fire Growth in a Typical Compartment Fire

Flashover is a fire phenomena unique to enclosure fires. It is the sudden propagation of fire through the unburnt fire gases collecting under the ceiling. Flashover invariably leads to FRI, although FRI can be achieved without flashover. After FRI the fire is fully developed and maximum fire temperatures are generated. The fire resistance of a compartment's boundaries are designed to withstand the temperatures predicted in the fully developed fire realm. The fire growth period, however, is a major concern. There are two primary reasons for this concern:

1. Since survival is not possible subsequent to full room involvement, it is desirable to understand the factors that affect fire growth from EB to FRI so that time to FRI can be measured and probability of FRI can be reduced.

2. The design of a compartment's fire suppression systems is directly related to the fire growth hazard potential. If the variables that affect fire growth are such that an extremely fast growing fire is likely, a designer may incorporate automatic detection and a suitable automatic suppression such as a sprinkler system. On the other hand, if the likelihood of fast fire growth is small, the designer may decide that adequate protection of the space can be achieved with a portable fire extinguisher.

FACTORS THAT INFLUENCE FGHP

The FGHP describes the tendency of a fire to grow from established burning to full room involvement if the fire does not self-terminate for some reason. The fire growth period is shown in Figure G-1. Note the ordinate axis is compartment fire temperature. The shape of this curve is approximately the same if the ordinate is the heat release rate of the burning fuel, Q .

FRI Time in the fire growth period of an enclosure fire is deterministically calculated in the SFSEM according to the following algorithm developed by Deal and Beyler [1]:

$$\Delta T = Q / (\dot{M} c_p + h_k A_T)$$

where ΔT is the temperature rise in the compartment above ambient, Q is the heat release rate of the burning fuel, \dot{M} is the mass flow rate of air, c_p is the specific heat of air, h_k is the heat loss coefficient of the compartment boundaries, and A_T is the total bounding surface area. The Beyler/Deal algorithm is a temperature-based correlational algorithm developed from a simple energy balance in the compartment. It assumes the heat energy released by the burning fuel in a compartment fire is either exhausted out the ventilation openings or is lost through the boundaries of the compartment. The $(\dot{m} c_p)$ term accounts for the heat loss through the ventilation openings and the $(h_k A_T)$ term accounts for the heat loss through the boundaries. Since Q is in the numerator of the equation, an increase in the burning rate of the fuel will result in an increase in compartment fire temperature, thus an earlier onset of full room involvement. Therefore the heat release rate is a critical factor in fire growth. It has been shown that the rate of heat release for a majority of hydrocarbon fuels (cellulosics, plastics, and flammable liquids) can be characterized according to the following simple relationship:

$$Q = \alpha t^2$$

where α is the fire growth coefficient, and t is time. Fire growth coefficients have been determined experimentally for some types of fuel in warehouse/storage enclosures. [2] The $(\dot{m} c_p)$ term is in the denominator of the equation, therefore if the exhaust ventilation increases, the tendency of the fire to grow decreases (since c_p is a constant). Since the $(h_k A_T)$ term is also in the denominator it is clear that factors which enhance heat loss through the boundary will also impair fire growth. Therefore, large boundaries inhibit fire growth because they offer more surface area through which heat may be lost.

The algorithm for the determination of h_k in the SFSEM was developed originally by Deal and Beyler and later refined by Peatross and Beyler. [1, 3] The algorithm recognizes that in ships, boundaries can be thermally thin as in bare steel or bare aluminum for example, or thermally thick as in insulated boundaries. The appropriate choice therefore depends on the boundary's thermal

conductivity:

$$h_k = .4 \max ((k\rho c/t)^{0.5}, k/\delta) \text{ for } k < 40\text{W/mK (thermally thick)}$$

$$h_k = 30-18(1-\exp(-136t/\rho\delta c)) \text{ for } k > 40\text{W/mK (thermally thin)}$$

Thus the factors affecting fire growth are related to either the characteristics of the compartment (ventilation openings, bounding surface areas, thermal characteristics of the boundaries, etc.) or the characteristics of the fuel (quantity, type, heat release rate, etc.). In the following sections these characteristics are described in more detail with particular emphasis on the reasons they affect fire growth. The first-order effects of the individual factors in each category are discussed first followed by a general discussion of interactive effects.

Compartment Factors

The geometry of the compartment, its physical characteristics, and the thermal properties of the compartment boundaries have a major influence on the FGHP. As noted above, ventilation openings and heat loss also play an important role in fire growth. Ventilation openings in a ship compartment include open doors, hatches, and ladderways as well as vent duct openings in a forced ventilation system. Heat loss can occur through the ventilation (exhaust) system or through the boundaries.

a. Ventilation opening. When the ventilation opening is small, the amount of air that can reach the fire is small and the amount of heat that can be exhausted is small. Compartments in ships are often served by small natural vents in the form of 3 or 4 inch diameter pipes. In some compartments, forced ventilation systems are provided, in others heated or air conditioned air is recirculated from other compartments. The crew is trained to immediately close all accesses (doors and hatches) and secure all forced ventilation systems upon the discovery of a fire. Therefore, fires in ships are usually ventilation-controlled. This is a term that describes fire behavior where the amount of fuel that can be burned is dependent on the amount of oxygen available for combustion.

Experimental work has also shown that for ventilation-controlled fires the size and shape of the ventilation opening is important. The so-called ventilation factor, $A H^{0.5}$, where A is the area of the ventilation opening(s) and H is the mean height of the opening(s). The ventilation factor was developed for naturally ventilated compartment fires with a single window opening in the wall. It does not specifically apply to forced ventilation, overhead/deck vent openings, or to multiple vent openings. There is no clear consensus on how these conditions, which are frequently found in ships, should be considered in algorithms or equations which include the ventilation factor. The Theoretical Basis of the SFSEM report describes how the ventilation factor is calculated. [4]

b. Compartment geometry. In general, small rooms with tall ceilings are safer from a fire growth point of view than large rooms with low ceilings. Large rooms (in terms of volume) potentially could contain a greater quantity of combustibles. Low ceilings promote rapid radiant heat feedback which enhances fire growth. As the room gets larger, the fire gets hotter, because

cooling air flowing into the room is less able to cool the burning material. In a ship, compartments such as engine rooms, generator rooms, motor rooms, cargo holds, pilot houses, auxiliary machinery rooms, lazarettes, steering gear rooms, emergency diesel generator rooms, mess decks, etc. are considered large rooms. Some examples of medium sized rooms include berthing areas, staterooms, shops, labs, offices, etc. Examples of small rooms include gear lockers, passageways, companionways, closets, storerooms, galleys, sanitary spaces, and fan rooms.

c. Walls and ceiling lining. FRI time varies with the density of the wall lining as shown in Table 1. [5] A combustible lining will result in shorter FRI times compared to noncombustible lining, but this is not considered a significant variable. Combustible wall linings are rarely used in ships.

Material	Density (kg/m ³)	FRI Time (Min)
Brick	1600	23.5
Concrete	800	17.0
Sprayed Asbestos	320	8.0
Fiberboard	300	6.75

Table G-1: Variation of FRI Time with Density of Wall Lining

d. Thermal Diffusivity (k/ρc). The temperature of a structural element will rise faster if the material's thermal conductivity (k) is higher (more heat will flow into the material). But the quantity of heat required to heat up the material is also important which is determined by the material's thermal capacity or specific heat c. A material with a low specific heat will get hotter quicker than a material with high specific heat. Thermal diffusivity accounts for the heating up of a barrier material. It may be obtained by dividing the thermal conductivity by the volumetric thermal capacity, ρc.

If thermal insulation is on the exposed side of the barrier (toward the fire) its relatively low thermal conductivity will cause the heat to be re-radiated back toward the fire thus speeding up fire growth. Thomas and Bullen have shown FRI times for rooms with brick walls to be 20-30 minutes but if the bricks are insulated FRI times are reduced to 7-10 minutes. [6] The same paper points out that if the fire is a fast developing fire as in polymeric materials, the fire development may be so rapid that the effect of "ρc" is not apparent.

e. Thermal Inertia (kρc). Thomas and Bullen have shown that time to flashover is directly proportional to the square root of the thermal inertia or to a lesser power for faster growing fires as shown:

$$t_n = (k\rho c)^{1/1+2n}$$

where the fire growth rate is proportional to t^n . Therefore if the fire growth rate is linear (n=1) the time to flashover is proportional to the cube root of the thermal inertia. If the fire growth rate

is proportional to time squared, as it is assumed in the SFSEM, the time to flashover is proportional to the thermal inertia raised to the .2 power. This effect is only apparent if the insulating material (low kpc) is exposed to the fire as the internal surface of the enclosure. If a non-combustible wall lining of high thermal inertia is used to shield the insulation this effect is not observed in the relatively short times involved in fire growth.

This effect can be explained by the fact that in slow growing fires there is sufficient time to see the effect of the thermal inertia of the boundary acting to contain the heat thus reducing the time to flashover. In faster growing fires, there is less time for the insulation to have an effect and if the insulation is shielded there is no effect at all on the time to flashover.

Fuel Factors

The quantity, type, and arrangement of the fuel are all considered important factors in the probability of self-termination, or its complement: the FGHP.

a. Fuel Quantity. The amount of combustibles per unit floor area in an enclosure fire or fire load density is an important factor in fire growth. Higher fuel load densities are more likely to contribute to the spread of the fire.

b. Fuel Height. Tall combustible items are closer to the ceiling thus radiant heat feedback affects them sooner contributing to the spread of the fire. This effect is similar to the low ceilings effect discussed above.

c. Bulk Density. Combustible materials which have a large surface area to weight ratio given an adequate supply of air will burn much more rapidly than materials which have a low ratio. This is easily understood when one considers the difficulty of lighting a fire with large pieces of wood compared to starting the fire with small sticks of wood.

d. Fuel Arrangement. The first item ignited must be capable of producing and sustaining the necessary rate of heat release to ensure full room involvement or else another item must be ignited by the first in order for the rate of burning to increase. The tendency of a second item to ignite is dependent on the separation distance from the first item already burning. If the second item is close enough for direct flame impingement, then the second item will ignite. Otherwise the separation distance has to be close enough for radiant heat flux to ignite the second object. Associated closely with fuel arrangement is the location of the fuel relative to the boundaries. Fuel in close proximity to the walls or ceiling enhance radiative feedback thus contributing to fire growth.

e. Fuel Type. Fuel that has a low burning rate and a high ignition temperature contributes to low fire severity.

f. Ignition Source. Time to full room involvement is shorter with a central ignition source as opposed to an ignition source in the corner because the area of the initial fire increases more rapidly.

g. Ignition Source Area. The time to full room involvement also decreases with

increasing ignition source area.

INTERACTIVE EFFECTS

There are so many factors that affect fire growth it is difficult to determine the effect of one variable by simple tests. The traditional procedure is to vary one factor at a time and to represent the others in some typical arrangement. However certain factors affecting fire growth such as ignitability, location of the ignition source, fuel quantity and flame spread have interactive effects and can not be varied independently in a full scale test.

If the wall lining is combustible and becomes involved due to an ignition source in the corner, the time to full room involvement is greatly reduced. A similar but less dramatic interaction exists between height of the fuel and the bulk density of the fuel.

Separation distance of the fuel packs has to be close enough for radiant heat flux to ignite the second object; here ceiling height starts to affect this parameter since lower ceilings promote rapid radiant heat feedback.

FIRE GROWTH FACTORS IN DIFFERENT REALMS

Enclosure fires typically start with a fuel package overheating. As shown in Figure G-2, an enclosure fire will either self terminate or grow through stages called realms. In this appendix the discussion has focused on factors that influence fire growth potential in the three realms between EB and FRI shown as realms 3, 4 and 5 in Figure G-2. These particular realms comprise the fire growth period of an enclosure fire illustrated in Figure G-1.

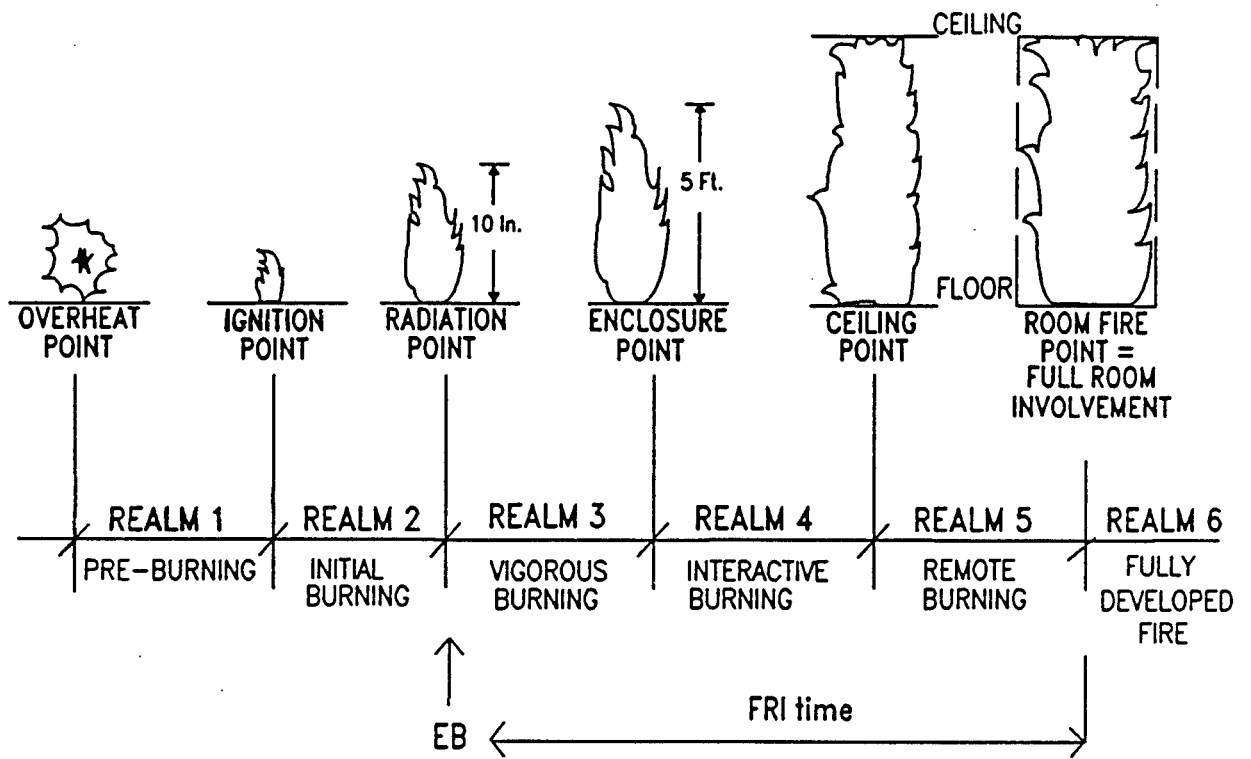

Figure G-2: Realms of Fire Growth and Transition Points

These three realms of fire growth also correspond to the following events in the network diagrams for I-values discussed in Appendix F: I_e , the probability that the fire will self-terminate before the fire involves a bulkhead, called the enclosure point; I_c , the probability that the fire will self-terminate before the fire involves the overhead, called the ceiling point; and I_r , the probability that the fire will self-terminate before the room point or full room involvement. The probability of self termination in each succeeding realm is less than in the preceding realm. This results in the characteristic shape of a typical I curve shown in Figure G-3 where the slope decreases with each succeeding realm.

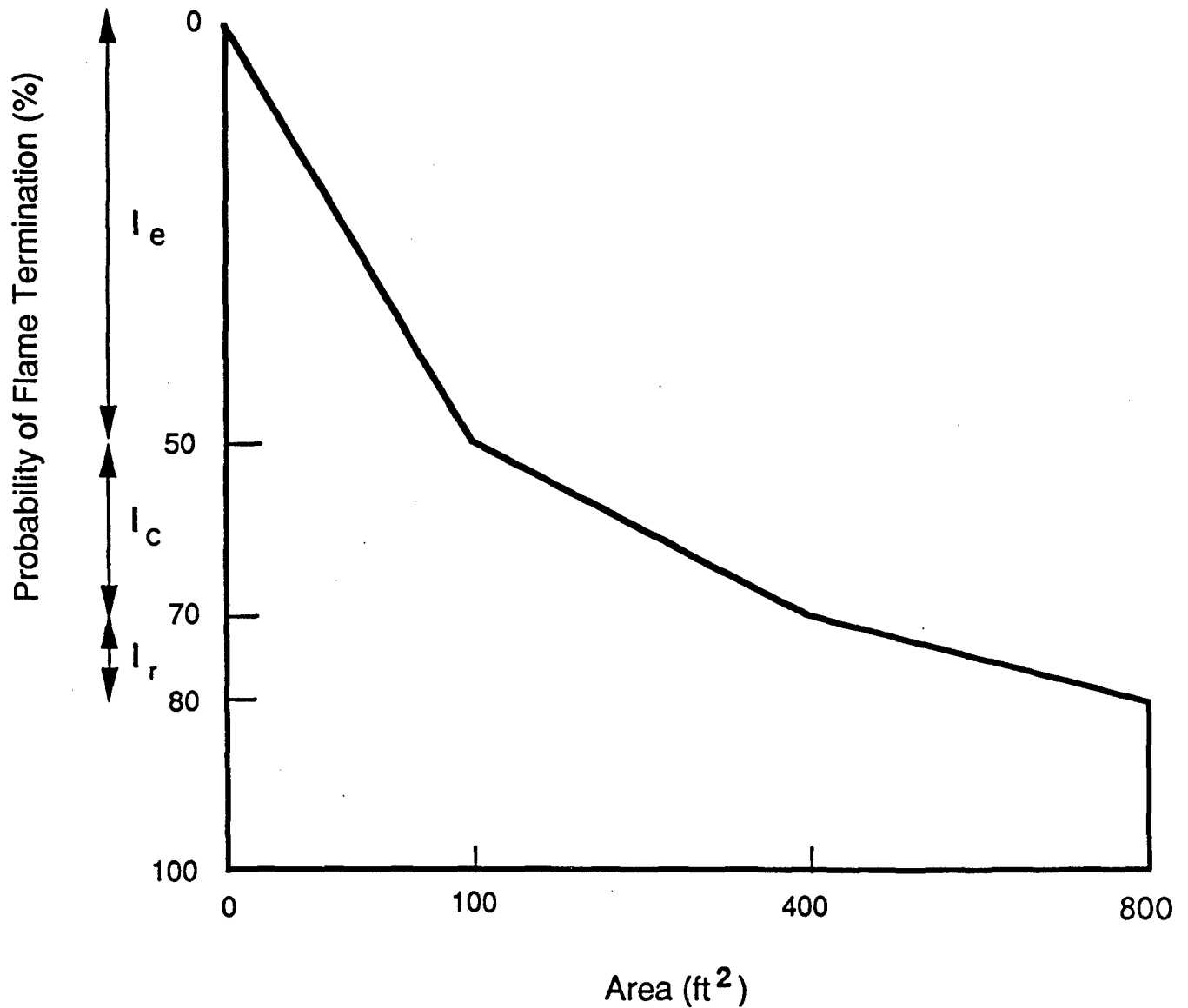

Figure G-3: Characteristic I Curve

The "vigorous burning realm" starts at the point of EB and extends until the enclosure point. The factors that affect fire growth in this realm are illustrated in Figure G-4.

The "interactive burning realm" starts at the enclosure point and ends at the ceiling point. The factors that affect fire growth in this realm are illustrated in Figure G-5.

The "remote burning realm" starts at the ceiling point and ends at the room point. The factors that affect fire growth in this realm are illustrated in Figure G-6.

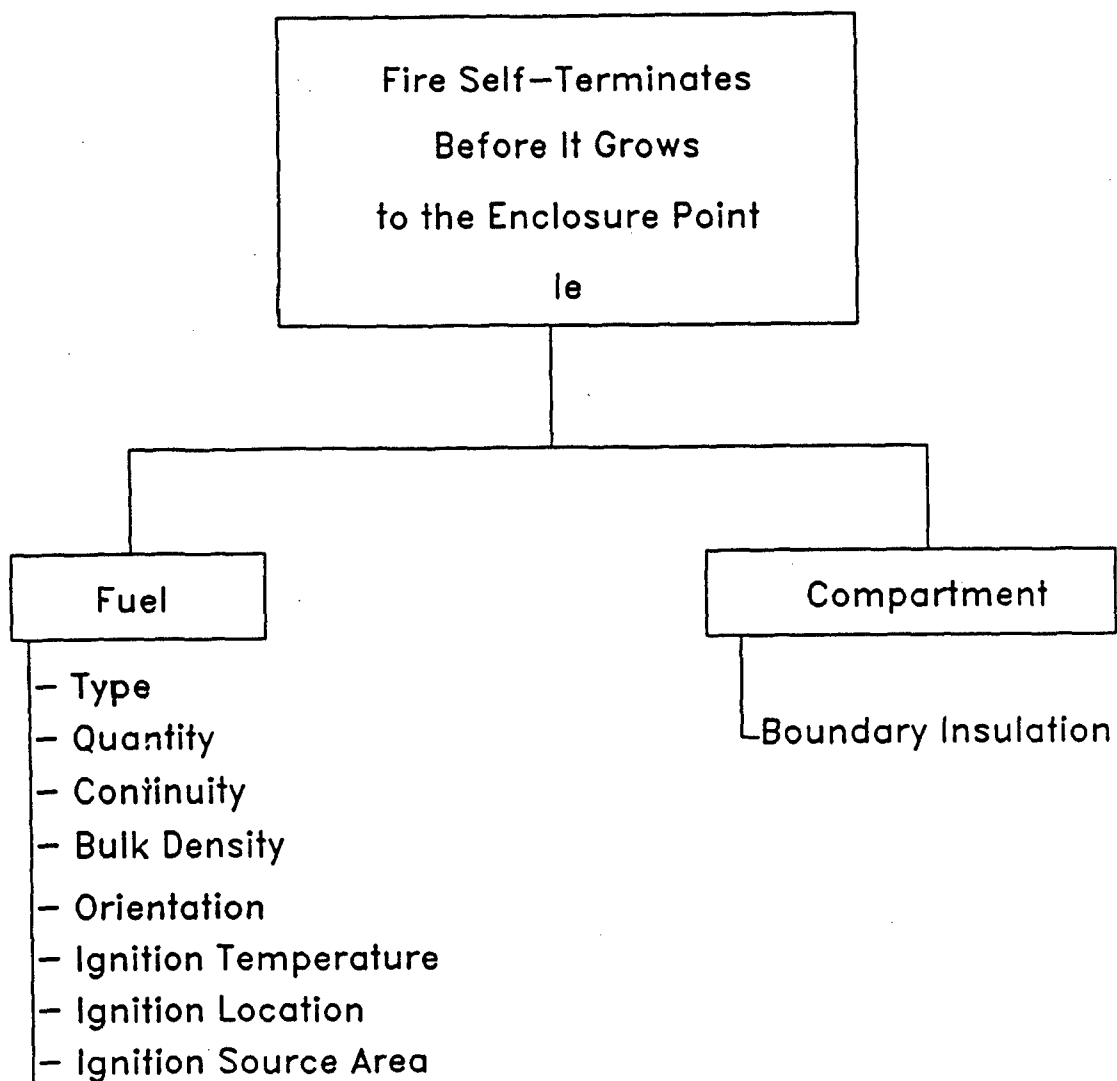

Figure G-4: Fire Growth Factors in the Vigorous Burning Realm

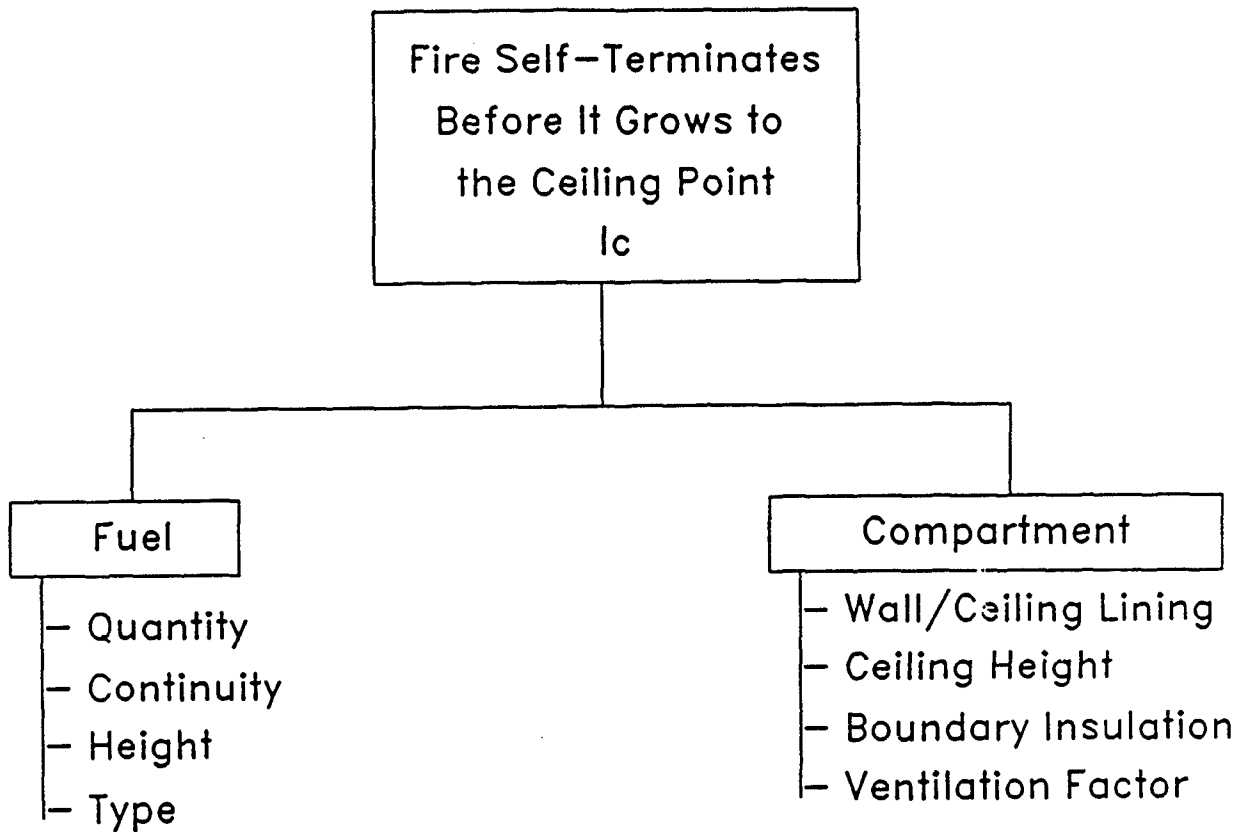

Figure G-5: Fire Growth Factors in the Interactive Burning Realm

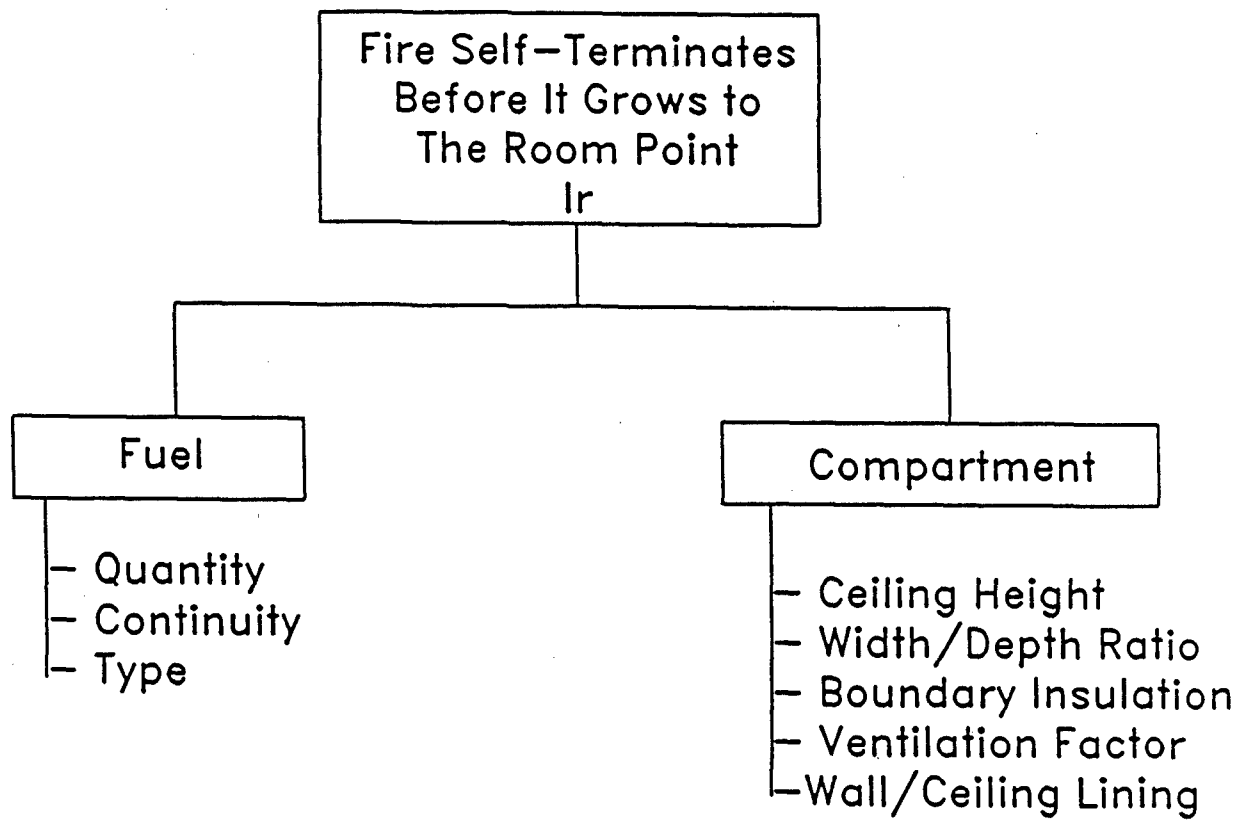

Figure G-6: Fire Growth Factors in the Remote Burning Realm

LIST OF ABBREVIATIONS AND SYMBOLS

FGHP	Fire Growth Hazard Potential
SFSEM	Ship Fire Safety Engineering Methodology
PIR	Polar Icebreaker Replacement
EB	Established Burning
FRI	Full Room Involvement
FRI Time	Elapsed time between EB and FRI
SAFE	Ship Applied Fire Engineering
k	Thermal Conductivity
ρ	Density
c	Thermal Capacity (specific heat)
kpc	Thermal Inertia
ρc	Volumetric Thermal Capacity
k/ ρc	Thermal Diffusivity
I _e	Probability that the fire will self-terminate before the enclosure point
I _c	Probability that the fire will self-terminate before the ceiling point
I _r	Probability that the fire will self-terminate before the room point or full room involvement
Q	Heat release rate of the burning fuel

REFERENCES

1. Deal, S. and Beyler, C., "Correlating Temperatures in Preflashover Room Fires", Journal of Fire Protection Engineering, [2], Number 2, 1990.
2. National Fire Protection Association 72E, "Standard on Automatic Fire Detectors", 1990.
3. Peatross, M., Beyler, C., and Back, G., "Validation of Full Room Involvement Time Correlation Applicable to Steel Ship Compartments", Final Report, November 1993.

4. Sprague, C., and Dolph, B., "Theoretical Basis of the Ship Fire Safety Engineering Methodology", Report No. CG-D-30-96, Final Report, September 1996.
5. Drysdale, D., "An Introduction to Fire Dynamics", John Wiley & Sons, 1985.
6. Thomas, P.H. and Bullen, M.L., "The Importance of Insulation in Fire Growth", Building Research Establishment Information Paper IP 19/79, August 1979.