



U.S. Department
of Transportation

**National Highway
Traffic Safety
Administration**



DOT HS 812 660

January 2019

Development of a Surrogate Shoulder Belt Retractor for Sled Testing Of Booster Seats

DISCLAIMER

This publication is distributed by the U.S. Department of Transportation, National Highway Traffic Safety Administration, in the interest of information exchange. The opinions, findings and conclusions expressed in this publication are those of the authors and not necessarily those of the Department of Transportation or the National Highway Traffic Safety Administration. The United States Government assumes no liability for its contents or use thereof. If trade or manufacturers' names are mentioned, it is only because they are considered essential to the object of the publication and should not be construed as an endorsement. The United States Government does not endorse products or manufacturers.

Suggested APA Format Citation:

Manary, M. A., Klinich, K. D., Boyle, K. J., Orton, N. R., Eby, B., & Weir, Q. (2019, January). *Development of a surrogate shoulder belt retractor for sled testing of booster seats*. (Report No. DOT HS 812 660). Washington, DC: National Highway Traffic Safety Administration.

Technical Report Documentation Page

1. Report No. DOT HS 812 660		2. Government Accession No.		3. Recipient's Catalog No.	
4. Title and Subtitle Development of a Surrogate Shoulder Belt Retractor for Sled Testing of Booster Seats				5. Report Date January 2019	
				6. Performing Organization Code	
7. Authors Manary, Miriam A., Klinich, Kathleen D., Boyle, Kyle, J., Orton, Nichole R., Eby, Brian, and Weir, Quentin				8. Performing Organization Report No.	
9. Performing Organization Name and Address University of Michigan Transportation Research Institute 2901 Baxter Rd. Ann Arbor MI 48109				10. Work Unit No. (TRAIS)	
				11. Contract or Grant No.	
12. Sponsoring Agency Name and Address National Highway Traffic Safety Administration 1200 New Jersey Avenue SE. Washington, DC 20590				13. Type of Report and Period Covered Final, July 2014-January 2016	
				14. Sponsoring Agency Code	
15. Supplementary Notes					
16. Abstract The goal of this research program was to develop a surrogate seat belt retractor that could be used repeatedly to evaluate booster seats using a seat belt system similar to that found in passenger vehicles. Dynamic sled tests of four different backless booster products, along with a no-booster condition, were performed using a preliminary revision of the FMVSS 213 buck, along with two vehicle seats. Seat belts that were evaluated include the fixed lap and shoulder belt currently used in FMVSS 213 testing, production seat belts with retractors from two vehicles, and a surrogate retractor developed for this project. The surrogate retractor was able to produce kinematics similar to those achieved with the production seat belt in a repeatable manner.					
17. Key Word Booster Seats, Surrogate Retractor, Static versus Dynamic Belts			18. Distribution Statement This document is available to the public through the National Technical Information Service, www.ntis.gov .		
19. Security Classif. (of this report)		20. Security Classif. (of this page)		21. No. of Pages 71	22. Price

Form DOT F 1700.7 (8-72)

Reproduction of completed page authorized

Table of Contents

Table of Contents	ii
List of Figures	iii
List of Tables	v
Introduction	1
<i>Background</i>	1
<i>Objectives</i>	2
Methods	3
<i>Commercial Hardware Survey</i>	3
<i>Development of the Surrogate Retractor</i>	4
<i>Sled Test Conditions</i>	1
Booster Seats	1
Test Bench	1
Test Protocol.....	5
Test Matrix.....	5
<i>MADYMO Modeling</i>	6
Results	8
<i>Seat Belt Survey</i>	8
<i>Development of Surrogate Retractor</i>	8
Observed Test Issues	14
Static Belt Versus Production Retractors.....	18
Production Belts by Seat Type	20
Surrogate Versus Production Retractor	24
<i>MADYMO Modeling</i>	30
Discussion and Conclusions	33
References	34
Appendix A: Instructions for Use of the UMTRI Surrogate Retractor	A-1
Appendix B: Engineering Drawings for the Surrogate Retractor Assembly	B-1

List of Figures

Figure 1.	Surrogate retractor developed by student design team.....	2
Figure 2.	Measurement of resting belt tension with force gauge.....	3
Figure 3.	Example of shoulder belt spool-out measurement using masking tape.....	3
Figure 4.	The surrogate shoulder belt retractor.....	4
Figure 5.	Constant force spring that connects to spindle and creates belt tension and retraction.....	5
Figure 6.	Booster seats used for testing: (a) TurboBooster, (b) Evenflo AMP, (c) Incognito, and (d) BubbleBum.....	1
Figure 7.	The preliminary 213 bench used for the test series.....	2
Figure 8.	Test with 2011 Ford Explorer (left) and 2011 Jeep Cherokee seat (right).	3
Figure 9.	Locations of belt anchorages for each bench.....	4
Figure 10.	Peak head excursion by belt, booster, and vehicle seat type.....	11
Figure 11.	Peak knee excursion by belt, booster, and vehicle seat type.....	11
Figure 12.	HIC by belt, booster, and vehicle seat type.....	12
Figure 13.	Chest acceleration (3ms) by belt, booster, and vehicle seat type.....	12
Figure 14.	Chest angle by belt, booster, and vehicle seat type.....	13
Figure 15.	Shoulder belt load by belt, booster, and vehicle seat type.....	13
Figure 16.	Retractor payout by belt, booster, and vehicle seat type.	14
Figure 17.	Example of test (NT1474) where the shoulder belt entered the gap beside the neck (right) resulting in a torn chest bib (left).....	15
Figure 18.	Example of ATD rolling out of the shoulder belt (NT1478).....	15
Figure 19.	Example of the pelvic belt entering the gap between ATD thigh and pelvis (NT1503).....	16
Figure 20.	Front-view comparison of the initial upper shoulder belt anchor point for the preliminary 213 buck with comparable data from U.S. vehicles and the current 213 test bench.....	17
Figure 21.	Lap and shoulder belt fit with no booster (top), a 50 mm thick booster (middle) and a 100 mm thick booster (bottom). Shoulder belt scores (SBS) are -23, -1, and 59.	18
Figure 22.	Comparison of ATD responses and belt loads from static (thin line – test NT1468) and production (thick line – test NT1467) seat belts when used with the Ford Explorer seat and the Evenflo AMP Booster.	19
Figure 23.	Comparison of ATD responses and belt loads from static (thin line – test NT1469) and production (thick line – test NT1470) seat belts when used with the Ford Explorer seat and the BubbleBum Booster.	19

Figure 24. Comparison of ATD responses and belt loads from static (thin line – test NT1474) and production (thick line – test NT1473) seat belts when used with the Jeep Cherokee seat and the Incognito Booster.	20
Figure 25. Comparison of ATD responses and belt loads from static (thin line – test NT1471) and production (thick line – test NT1472) seat belts when used with the Jeep Cherokee seat and the TurboBooster.	20
Figure 26. Evenflo AMP booster tested with production belt on Ford vehicle seat (blue – test NT1467) and new 213 buck (green-test NT1480).	21
Figure 27. TurboBooster tested with production belt on Jeep vehicle seat (red-test NT1472) and new 213 buck (green – test NT1479).	22
Figure 28. Evenflo AMP tested with fixed belt on Ford vehicle seat (blue – test NT1468) and new 213 buck (green – NT1477).	23
Figure 29. TurboBooster tested with fixed belt on Jeep vehicle seat (red – test NT1471) and new 213 buck (green – test NT1476).	23
Figure 30. Incognito tested with fixed belt on Jeep buck (red – test NT1474) and new 213 buck (green – test NT1478).	24
Figure 31. Comparison of ATD response and belt load data with three belt types: static (thin line – NT1477), surrogate retractor (med line – NT1482) and production retractor (thick line – test NT1480). All data collected on the preliminary 213 buck with Evenflo AMP booster.	25
Figure 32. Comparison of ATD response and belt load data with three belt types: static (thin line – NT1467), surrogate retractor (med line – NT1481) and production retractor (thick line – test NT1479). All data collected on the preliminary 213 buck with TurboBooster.	25
Figure 33. Comparison of ATD responses with surrogate (med line – NT1515) and production retractors (thick line – NT1505) on preliminary 213 buck with TurboBooster.	26
Figure 34. Two tests (NT1510 and 11) run with surrogate retractor and BubbleBum. (SBS= -8 and 4 mm)	29
Figure 35. Three tests (NT1508, 09, and 15) run with surrogate retractor and TurboBooster. (SBS= 12, 9 and 8)	29
Figure 36. Comparison of model (blue) and test (red) for Test NT1481 using the TurboBooster and surrogate retractor.	30
Figure 37. Kinematic comparison of model and test.	31
Figure 38. Change in torso angle versus peak knee-head excursion as D-ring shifted inboard.	32
Figure 39. Change in torso angle versus peak knee-head excursion as retractor spool-out increases.	32

List of Tables

Table 1.	First Series Test Matrix	6
Table 2.	Second Series Test Matrix.....	6
Table 3.	Complete Test Matrix with Test Numbers.....	7
Table 4.	Sled Series One Results	9
Table 5.	Sled Series Two Results	10
Table 6.	Comparison of kinematics with the TurboBooster using Ford production belt and surrogate retractor.	27
Table 7.	Comparison of kinematics with the BubbleBum using Ford production belt and surrogate retractor.	28

Introduction

Background

The Federal Motor Vehicle Safety Standard 213, “Child restraint systems” (FMVSS 213) test bench uses a static lap and shoulder belt to represent a nominal three-point vehicle belt for testing booster seats. Per the recent FMVSS 213 revisions, both the lap and shoulder belts are tensioned to 9 to 18 N (2 to 4 lbf) to approximate how snugly belts are typically worn in the field (Klinich, Reed, Ritchie, Manary, Schneider, & Rupp, 2008). However, nearly all vehicle shoulder belt systems include a retractor at the upper shoulder belt anchor point that stores excess webbing, provides a small initial tension to keep the belt in place on the occupant during travel, and locks shoulder belt spool-out when a crash is detected. These commercial retractors usually allow a small amount webbing spool-out during a crash event due to the slack generated as the stored webbing tightens around the spindle, combined with the amount of webbing that is released between the start of the impact and the time when the locking mechanism engages. This spool-out affects the upper body kinematics of the anthropomorphic test device (i.e., ATD or crash dummy) during the tests. One advantage of the shoulder retractor spool-out is that it allows some forward rotation of the torso under dynamic loading, which discourages the pelvis from submarining under the lap belt. Given that booster seats are currently dynamically evaluated in FMVSS 213 with static lap and shoulder belt systems, their designs likely do not consider the implications of how the vehicle belt retractor affects occupant kinematics.

Using an upper shoulder belt retractor during dynamic testing would produce a closer match to vehicle seat belt conditions. Testing with commercial “live” retractors is possible but adds expense and produces more variable results than a static belt, because a new retractor would be needed for each test. However, tests with production seat belts have helped identify some relevant issues with booster shoulder belt guide designs in the past. For example, in 2001 the magazine *Consumer Reports* observed that some boosters with clip-type shoulder belt guides had potential for inducing slack and resisting belt retraction that were not as prevalent with tunnel-type shoulder belt guides. A surrogate retractor with the performance characteristics of a commercial system, which is also repeatable and reusable, is a potential enhancement that could lead to booster designs that are more compatible with vehicle seat belts.

A previous University of Michigan senior engineering design student project called SPARK developed hardware for creating a surrogate retractor, shown in Figure 1, that had repeatable performance, adjustable initial belt tension from 4 to 20 N, and an adjustable amount of shoulder belt spool-out ranging between 25 and 100 mm (1-4 in.). The prototype retractor has been tested before and has been shown to be accurate and strong enough under testing conditions. However, the final design was bulky and not easy to use (Bohard, Foo, Fumo, Klochko, Mehta, & Raheja, 2008). Currently, the retractor would need to rest on the sled deck and cause an undesirable belt angle for the length of webbing going up to the D-ring, which would not be conducive to installation on the FMVSS 213 buck. The

current project built upon lessons learned during the student design project to create a new, more compact, reusable, repeatable, robust surrogate retractor.

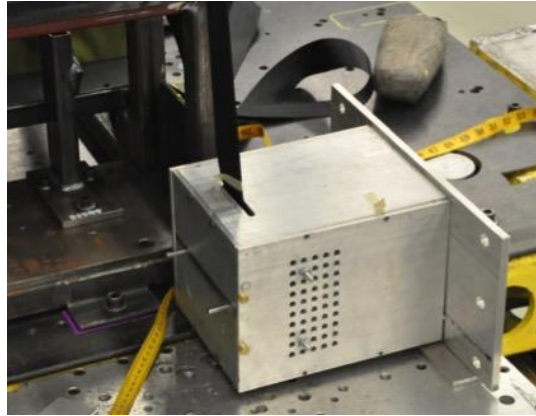

Figure 1. Surrogate retractor developed by student design team.

Objectives

This research program employed sled tests of booster seat systems to develop a reusable surrogate shoulder belt retractor that could be installed on the FMVSS 213 test buck.

Methods

Commercial Hardware Survey

To help establish initial performance targets for the surrogate retractor, a survey of commercial automotive shoulder belt retractor performance was conducted by measuring belt resting tension and webbing spool-out in response to belt jerk in a convenience sample of 20 vehicles in the UMTRI parking lot. In addition, an informal phone survey of restraint and vehicle manufacturers was conducted to determine if there are any industry target values for belt tension or spool-out. The resting belt tension was collected using a handheld belt force gauge as shown in Figure 2. The investigator also marked the shoulder belt with masking tape before performing a forceful belt tug to determine how much webbing was released by the retractor before lock-up. Figure 3 shows a typical measurement scenario of spool-out recreated in the lab.



Figure 2. Measurement of resting belt tension with force gauge.

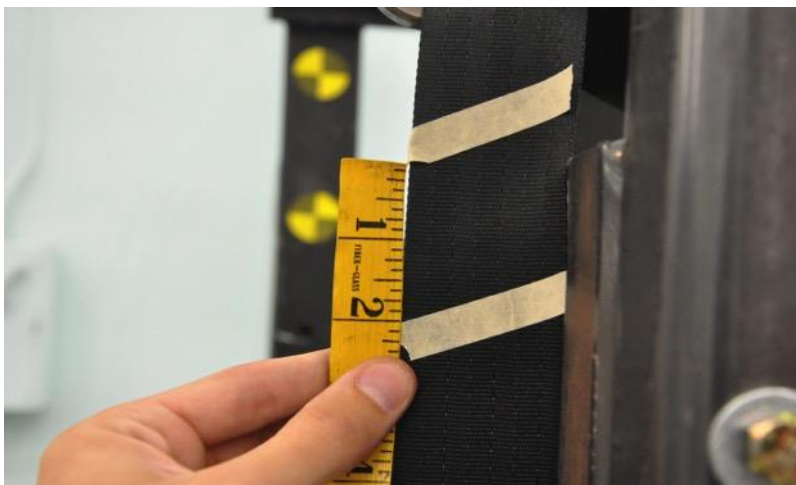

Figure 3. Example of shoulder belt spool-out measurement using masking tape.

Development of the Surrogate Retractor

The surrogate retractor developed for this project is shown in Figure 4. It consists of a split drum on a rotating spindle mounted between two end plates. A constant force spring attached to the long axis of the drum is used to control resistance to rotation about the spindle (Figure 5). The assembly is equipped with holes that allow a temporary pinning of the spindle rotation to set the webbing spool-out level and to make the process of loading the retractor with fresh webbing during test setup easier. Instructions for its use in this test series are included in **Appendix A**. Complete engineering drawings for the retractor are provided in **Appendix B**.

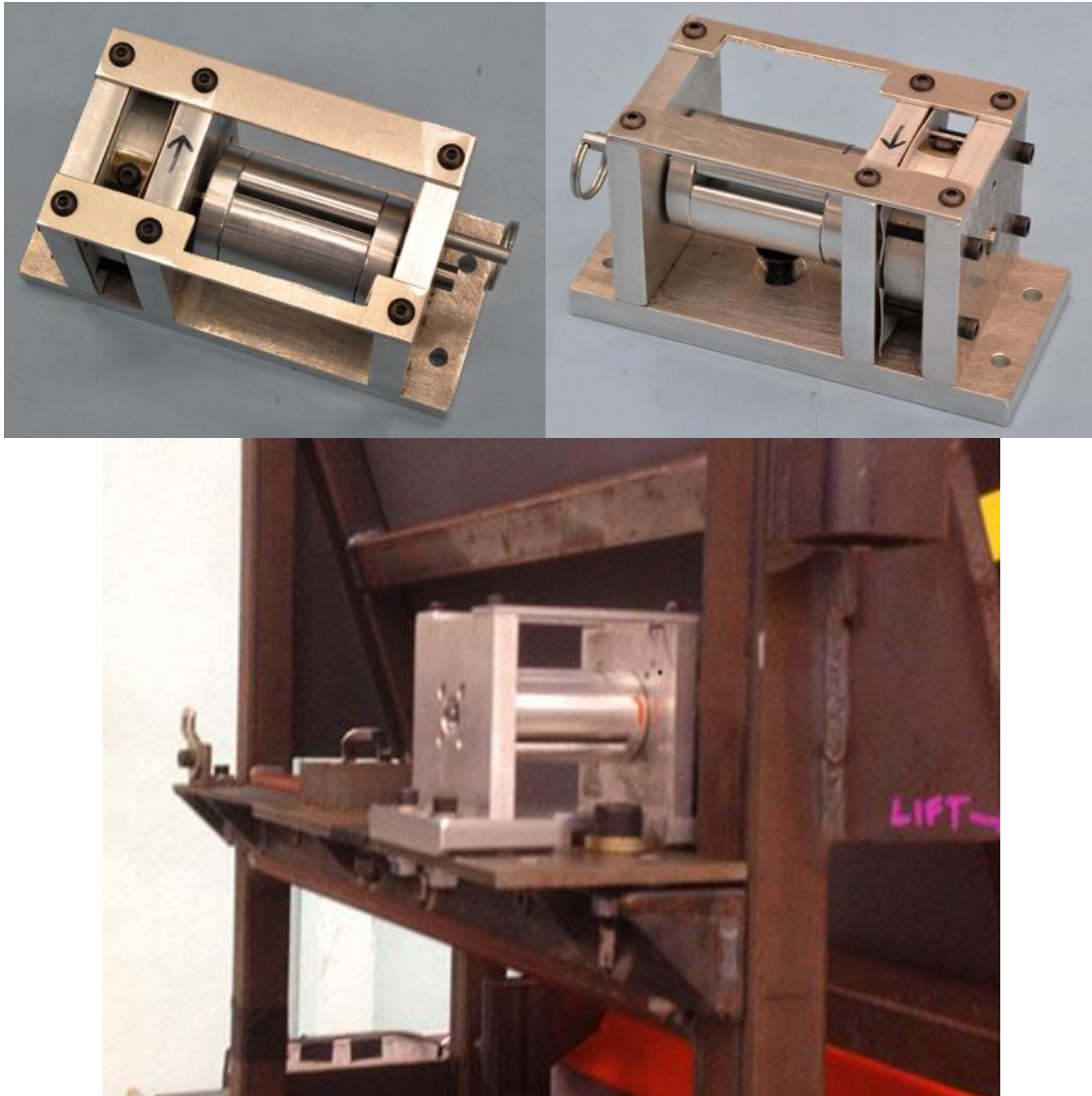

Figure 4. The surrogate shoulder belt retractor.



Figure 5. Constant force spring that connects to spindle and creates belt tension and retraction.

Sled Test Conditions

Booster Seats

The booster seats selected for the test series include the Graco TurboBooster (B1), the Evenflo AMP (B2), the Safety 1st “Incognito” (B3) and the BubbleBum inflatable (B4), all shown in Figure 6. The TurboBooster and the Evenflo AMP were selected because they provide both vertical boosting of the occupant and have rigid physical features to guide the lap belt onto the child’s pelvis. The Incognito and the BubbleBum were selected because they provide a lower level of boosting and have flexible pelvic belt guides. All boosters selected for testing were backless so that no booster feature would interfere with the evaluation of the surrogate retractor. All booster seats were used per the manufacturers’ instructions, but optional shoulder belt positioners were not used.



Figure 6. Booster seats used for testing:
(a) TurboBooster, (b) Evenflo AMP, (c) Incognito, and (d) BubbleBum.

Test Bench

Most of the tests were performed using a preliminary version of the test bench (shown in Figure 7) that has been proposed as a potential replacement for the FMVSS 213 frontal impact bench (hereafter referred to as the preliminary 213 bench). It consists of the vehicle seat portion of the buck assembly published in the Federal Docket (Federal Docket No. NHTSA-2013-0055-0002 [May 17, 2015]), except the lower anchors were placed 40 mm lower (per NHTSA’s directive). The bench also differs from the NPRM assembly in that the seat back has been extended upwards by 50 mm to create a longer/taller seat back support

surface. In addition, the shoulder belt anchor was moved for the second phase of testing according to the drawings posted in docket NHTSA-2013-0055-0008 (Aug. 25, 2015). This bench was mounted facing forward on the impact sled at the University of Michigan Transportation Research Institute (UMTRI). It was positioned so excursion measurements of ATDs with this bench would be consistent with those measured in tests performed on the current FMVSS 213 bench.



Figure 7. The preliminary 213 bench used for the test series.

In addition to testing with the preliminary 213 bench, testing was performed with two types of vehicle seats: a 2011 Jeep Cherokee second row outboard seat and a 2011 Ford Explorer second row outboard seat. The seats were mounted to the FMVSS 213 test buck so the fore-aft location of the H-point measured in an exemplar vehicle aligned with the fore-aft location of the H-point of the FMVSS 213 sled buck. This allowed excursion measurements calculated from video analysis during this test series to be comparable to the excursions measured in standard FMVSS 213 testing. The seat belts were mounted to the anchor points that approximate the locations of the anchor points found in the vehicles. Examples of pretest setup with these two seats are shown in Figure 8. In addition, plots showing the locations of the belt anchorages for each bench are shown in Figure 9. As described in the results, the D-ring location for the preliminary 213 bench was shifted between the first and second series of tests. Because the Jeep had the D-ring mounted inboard, the plots also contain a representation of the Jeep anchorages mirrored about the y-axis for easier comparison to other anchorages.



Figure 8. Test with 2011 Ford Explorer (left) and 2011 Jeep Cherokee seat (right).

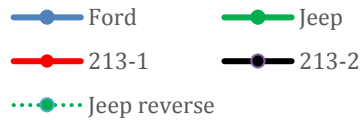
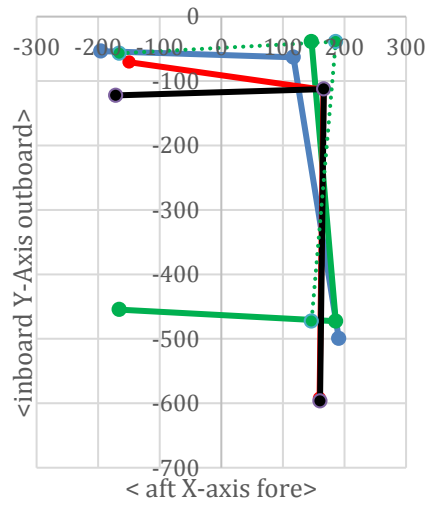
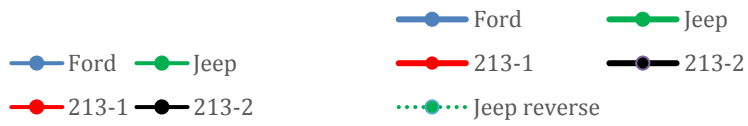
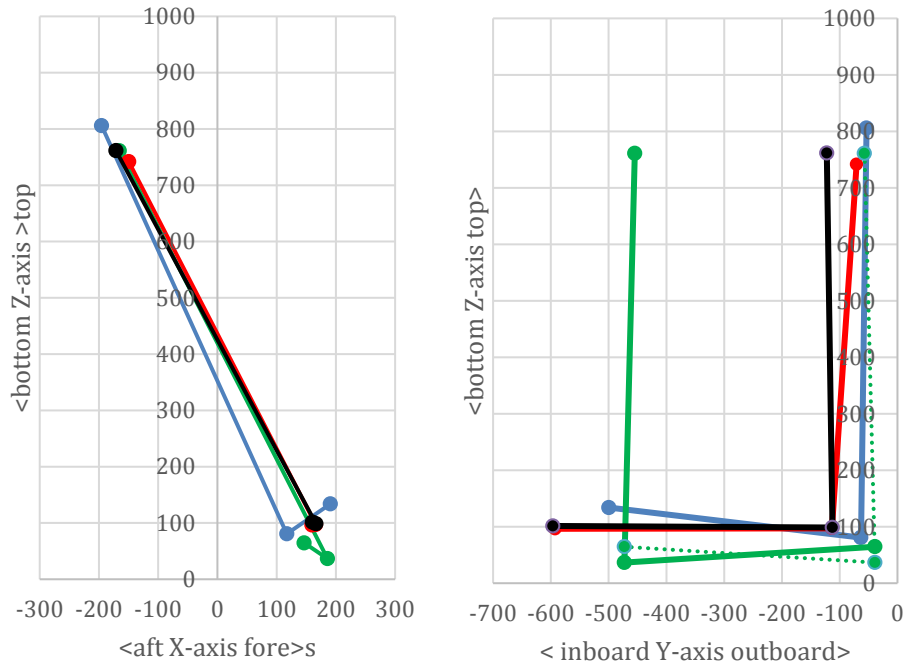

Figure 9. Locations of belt anchorages for each bench.

Test Protocol

The Hybrid III 6YO ATD (part 572 subpart S) was used for all tests to represent a child occupant using a booster seat. The ATD was instrumented with head, chest, and pelvis accelerometers. Load cells were installed in the upper and lower neck, lumbar spine, and upper and lower ASIS. Angular rate sensors were mounted to the spine box and pelvis and integrated to provide measures of torso and pelvis angle about the lateral axis.

The three-point belt anchorage specified for the preliminary 213 bench was used to mount three types of lap and shoulder belts: static belts as found in the current FMVSS 213, new commercial lap and shoulder belt with OEM retractors manufactured for a 2011 Jeep Cherokee and a 2011 Ford Explorer, and the proposed surrogate retractor. Additional tests were performed with static belts and production belts installed with the Cherokee and Explorer production seats. Belt load cells were used on the webbing of the three-point belt whenever possible, including some configurations with the production belt. However, when the load cells interfered with the retractor performance, they were left off. When production belts were used, they were “conditioned” by spooling them in and out three times before testing.

The current FMVSS 213 test protocol was used to place the booster on the bench and the Hybrid III 6YO ATD in the booster using the current 213 dummy positioning process (TP-213). A FARO arm 3D coordinate measurement system was used to document the position of the ATD, booster, and belt anchorage locations in each test. For tests with the static belts, the belt tensions were set at 9-18 N. In tests with the surrogate retractor and the commercial lap and shoulder belts, the belt tension was dictated by the retractor. The sled pulse used for testing was consistent across tests and close to that used for standard 213 testing.

Test Matrix

The testing was split into two series. Table 1 summarizes the matrix of test conditions for the first test series. The initial goal of the series was to evaluate boosters using commercial and static belts on each vehicle seat, then to repeat using the test bench with the same belt systems and the surrogate retractor. This approach would allow us to identify variations in responses from the belt characteristics as well as the seat characteristics, and to determine what kinematics would be reasonable to achieve with a surrogate retractor.

This series was abbreviated due to two ATD response problems. The first problem was that the shoulder belt was sliding into the gap next to the ATD neck and then tearing through the chest bib. The second problem was unexpected turnout of the ATD from the shoulder belt in the new buck configuration that led to a repositioning of the upper shoulder belt D-ring. Both issues are described fully in the results section.

Table 1. First Series Test Matrix

Seat	Belt	No Booster				
		B1	B2	B3	B4	
Jeep	Jeep		X		X*	
Jeep	Static		X		X*	
Explorer	Explorer			X		X
Explorer	Static			X		X
New Buck	Static	X	X	X**	X*	X***
New Buck	Commercial	X***	X	X**	X***	X***
New Buck	Surrogate	X***	X†	X†	X***	X***

X* - Shoulder belt enters the neck crevice and tear chest bib.

X** ATD uncharacteristically rolls out of shoulder belt.

X*** test condition planned but not run due to ATD difficulty.

X† test condition repeated to make sure ATD issue was not anomaly.

The second dynamic test series used only the preliminary 213 bench, all three seat belt conditions, and all five booster seat conditions (see Table 2). The bench setup was the same as in the first series except for the upper shoulder belt D-ring position. The D-ring anchor was moved inboard by 58 mm and rearward by 27 mm to more accurately reflect current vehicle locations, the geometry of the previous 213 upper shoulder belt anchorage, and to minimize potential for the shoulder belt to enter the gap between the dummy's shoulder and neck.

Table 2. Second Series Test Matrix

Seat	Belt	No Booster	Booster			
			B1	B2	B3	B4
New Buck	Static	X	X			X
New Buck	Commercial (Ford)	X	X			X
New Buck	Surrogate Retractor	X	XXX (3 runs)	X	X	XX (2 runs)

The full sled matrix from both series is shown in Table 3. Data from both test series were used to create and validate a MADYMO model of the test series.

MADYMO Modeling

The tests performed in this series were used to validate MADYMO models of the different boosters and seat belt conditions. The initial plan for modeling was to demonstrate how the range of commercial retractor conditions affect kinematics for the boosters tested, and to provide a recommended setting for the surrogate retractor that provides a realistic condition for booster testing. However, the variation in production retractor settings was much lower than originally anticipated. Instead, the MADYMO models were used to demonstrate how spool-out affects kinematics, as well as to demonstrate how kinematics vary with the lateral position of the shoulder belt anchor.

Table 3. Complete Test Matrix with Test Numbers

TestID	Seat Type	Belt Type	Booster Type
Series 1			
NT1467	Ford Explorer	Production	2 (AMP)
NT1468	Ford Explorer	Static	2 (AMP)
NT1469	Ford Explorer	Static	4 (Bubble)
NT1470	Ford Explorer	Production	4 (Bubble)
NT1471	Jeep Grand Cherokee	Static	1 (Turbo)
NT1472	Jeep Grand Cherokee	Production	1 (Turbo)
NT1473	Jeep Grand Cherokee	Production	3 (Incognito)
NT1474	Jeep Grand Cherokee	Static	3 (Incognito)
NT1475	New 213	Static	None
NT1476	New 213	Static	1 (Turbo)
NT1477	New 213	Static	2 (AMP)
NT1478	New 213	Static	3 (Incognito)
NT1479	New 213	Ford Production	1 (Turbo)
NT1480	New 213	Ford Production	2 (AMP)
NT1481	New 213	Surrogate Retractor	1 (Turbo)
NT1482	New 213	Surrogate Retractor	2 (AMP)
NT1483	New 213	Surrogate Retractor	2 (AMP)
NT1484	New 213	Surrogate Retractor	1 (Turbo)
Series 2			
NT1502	New 213	Static	1 (Turbo)
NT1503	New 213	Static	4 (Bubble)
NT1504	New 213	Static	None
NT1505	New 213	Ford Production	1 (Turbo)
NT1506	New 213	Ford Production	4 (Bubble)
NT1507	New 213	Ford Production	None
NT1508	New 213	Surrogate Retractor	1 (Turbo)
NT1509	New 213	Surrogate Retractor	1 (Turbo)
NT1510	New 213	Surrogate Retractor	4 (Bubble)
NT1511	New 213	Surrogate Retractor	4 (Bubble)
NT1512	New 213	Surrogate Retractor	2 (AMP)
NT1513	New 213	Surrogate Retractor	3 (Incognito)
NT1514	New 213	Surrogate Retractor	None
NT1515	New 213	Surrogate Retractor	1 (Turbo)

Results

Seat Belt Survey

Testing of the resting tension and spool-out in a convenience sample of vehicles found that all vehicles evaluated fell into a range of 25 to 50 mm (1 to 2 inches) and 9 to 18 N (2 to 4 lbf), respectively. (Complete data are not presented because initial results were collected by the student design team and only summary data are available.) In addition, conversations with several vehicle manufacturers indicated that with an occupant the size of the 6-year-old ATD, spool-out on the order of 25 to 50 mm would be expected. These findings guided the initial settings of the surrogate retractor to be 50 mm and 9 to 18 N (2 to 4 lb).

Development of Surrogate Retractor

The key response data from the 32 runs of the two sled test series are summarized in Table 4 and Table 5. All but two of the conditions tested met the FMVSS 213 criteria, including three that were run without boosters. The two exceptions were test NT1468 (Evenflo AMP, Ford Explorer Seat, static seat belt) with a high HIC and NT1507 (No booster, preliminary 213, Ford seat belt) where a 3 millisecond chest clip of 62 *g* was recorded.

Figure 10 to Figure 14 contain bar plots charting the head excursion, knee excursion, HIC, chest *G*'s, chest angle, shoulder belt load, and retractor payout. The plots do not include the three tests indicated by ** and *** in the tables. In these charts, the key element to examine is whether the surrogate retractor runs (gray bars) are closer to the Ford production runs (blue bars) than the static runs (black bars), for tests using the same booster seat and vehicle seat representation.

Table 4. Sled Series One Results

TestID	HIC (36 ms)	Chest 3ms Clip (g)	Chest Angle (deg)	Left Upper ASIS Force (N)	Left Lower ASIS Force (N)	Rt Upper ASIS Force (N)	Right Lower ASIS Force (N)	Result Neck Force (N)	Result Neck Moment (Nm)	Head Excur (mm)	Knee Excur (mm)	Shoulder Belt Force (N)	Retractor Payout (mm)
NT1467	845.5	46.6	-55.7	-151.4	-252.5	-318.0	-255.7	2144.8	28.6	577	658	4039	47
NT1468	1015.3	43.5	-36.3	129.7	-142.0	-206.2	-176.2	2455.3	47.2	556	650	4260	n/a
NT1469*	907.5	44.9	-25.7	-182.4	-129.7	-269.2	-238.8	4101.3	78.7	533	645	3789	n/a
NT1470*	904.6	45.2	-61.3	-444.8	-263.1	-453.0	-352.9	1960.3	25.1	601	652	3754	53
NT1471	628.3	42.8	-13.1	-113.8	108.1	193.9	214.7	2388.5	41.0	514	650	5013	n/a
NT1472	572.8	40.4	-21.1	124.7	-119.1	-130.5	-171.6	2002.6	38.1	557	676	3718	50
NT1473*	440.4	37.9	-33.6	-531.0	-308.5	-356.9	-308.2	1574.3	34.0	574	662	3335	72
NT1474**	311.4	35.3	-14.4	-353.9	-253.8	-337.8	-292.6	1587.4	29.9	488	625	5025	n/a
NT1475*	660.9	43.0	-10.9	-639.0	-576.9	-563.4	-541.8	2791.5	33.9	475	598	4357	n/a
NT1476 ^Φ	446.5	41.2	-52.0	-167.5	-219.7	-37.1	-53.5	1549.7	25.1	548	614	5301	n/a
NT1477	555.4	43.6	-28.5	-154.0	-161.4	-41.7	-73.6	1776.7	35.0	492	600	5435	n/a
NT1478*	536.5	42.6	-15.1	-387.4	-306.5	-338.0	-268.8	2399.5	36.4	477	601	4760	n/a
NT1479 ^Φ	505.6	46.6	-65.6	-198.8	-196.8	-72.2	-99.5	2048.3	26.1	618	636	n/a	86
NT1480	527.0	44.6	-60.7	-237.9	-199.2	-90.8	-126.5	2027.4	33.3	594	614	n/a	72
NT1481 ^Φ	553.9	48.9	-68.5	-228.8	-231.1	-62.9	-105.7	2197.0	38.3	637	629	5450	82
NT1482	781.2	48.4	-53.3	-184.9	-184.9	-90.1	-132.8	2420.1	43.5	579	606	5124	68
NT1483	742.1	50.0	-53.2	-231.4	-222.2	-97.5	-144.2	2335.8	42.9	577	610	n/a	78
NT1484 ^Φ	686.5	53.2	-73.1	-230.7	-255.1	-94.4	-140.8	2232.1	54.5	657	627	n/a	104

* The shoulder belt fell into a gap between the dummy's shoulder and neck assemblies.

** The shoulder belt fell into a gap between the dummy's shoulder and neck assemblies and the underlying bib assembly broke.

^Φ The dummy rolled out of the shoulder belt.

Table 5. Sled Series Two Results

TestID	HIC (36 ms)	Chest 3ms Clip (g)	Chest Angle (deg)	Left Upper ASIS Force (N)	Left Lower ASIS Force (N)	Right Upper ASIS Force (N)	Right Lower ASIS Force (N)	Result Neck Force (N)	Result Neck Moment (Nm)	Head Excur (mm)	Knee Excur (mm)	Shoulder Belt Force (N)	Retractor Payout (mm)
NT1502	612.3	47.3	-20.4	355.5	-595.5	167	-322.3	1801.4	46.2	508	622	3540	n/a
NT1503***	404.1	43.4	-8.1	-189.9	-560.9	-216.2	-453.6	2185.2	52.7	457	634	3276	n/a
NT1504***	441.7	49.9	-4.5	-906.1	-1047	-872.0	-1043.2	2331.6	29.2	454	590	3225	n/a
NT1505	747.4	47.2	-42.2	272.3	-821.6	193.9	-619.2	2217.4	35.3	572	635	4307	77
NT1506	804.5	50.4	-21.1	-432.1	-814.9	-473.6	-801.0	2483.8	55	544	653	4118	71
NT1507	766.7	62.9	-19.4	-1061	-100.4	-1059	-956.5	2049.1	38.5	553	649	3504	91
NT1508	859.9	55.6	-52.5	420.7	-809.0	178.2	-659.1	2584.5	40.6	608	627	4869	102
NT1509	795.4	56.4	-41.3	427.7	-983.9	185.5	-744.7	2272.4	36.9	565	621	4309	87
NT1510	574.0	46.2	-19.0	-311.6	-662.8	-368.5	-572.5	2137.5	38.3	483	625	3326	42
NT1511	788.6	50.2	-14.5	-328.3	-581.8	-358.6	-535.0	3007.3	46.4	508	630	3603	63
NT1512	883	53.6	-22.8	-277.3	-756.4	160.8	-615.6	2308.0	44.0	517	614	3909	65
NT1513	980.6	54.6	-19.3	-482.8	-939.1	-473	-958.1	2719.3	55.1	518	598	3951	61
NT1514	846.7	55.1	-24.9	-835.8	-1004	-791.9	-1011.3	2293.3	43.4	540	560	5135	63
NT1515	724.2	54.1	-39.9	437.5	-925.3	185.1	-805.0	2160.1	49.0	581	620	3972	70

*** The lap belt and lap shield went into a gap between the dummy's pelvis and thigh.

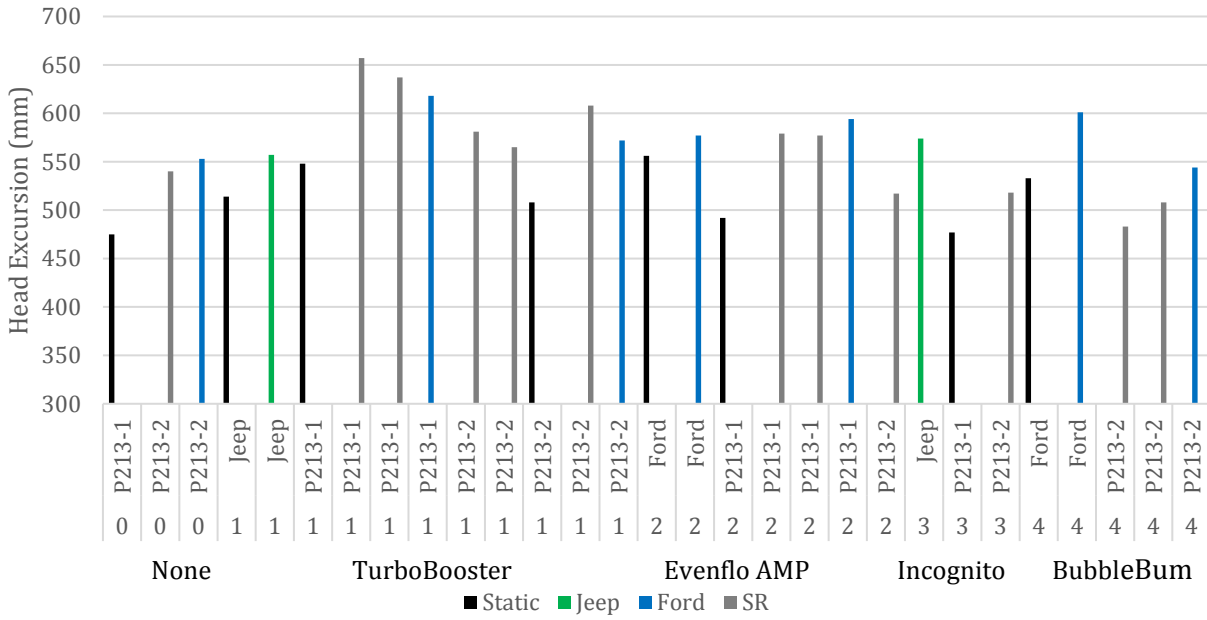

Figure 10. Peak head excursion by belt, booster, and vehicle seat type.

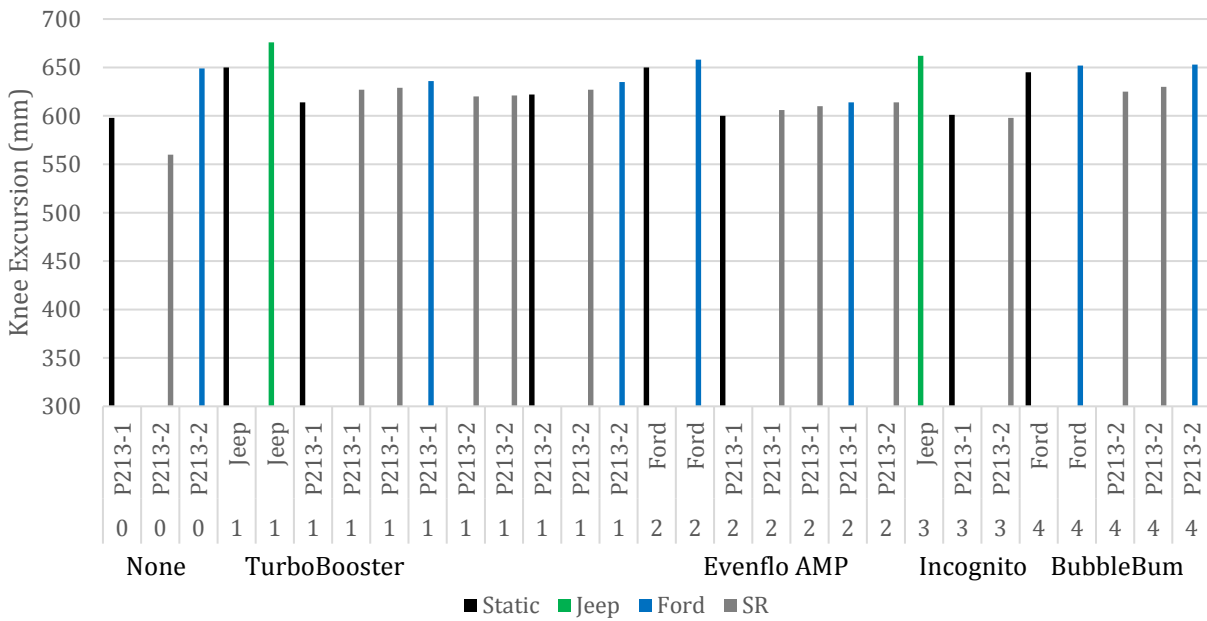

Figure 11. Peak knee excursion by belt, booster, and vehicle seat type.

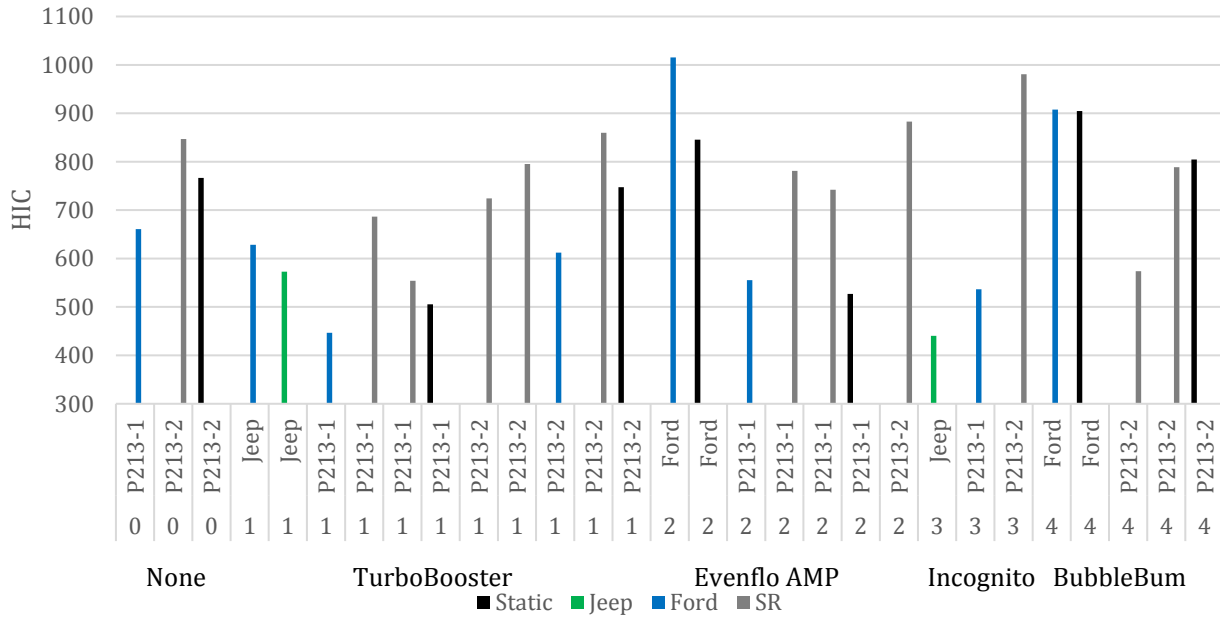

Figure 12. HIC by belt, booster, and vehicle seat type.

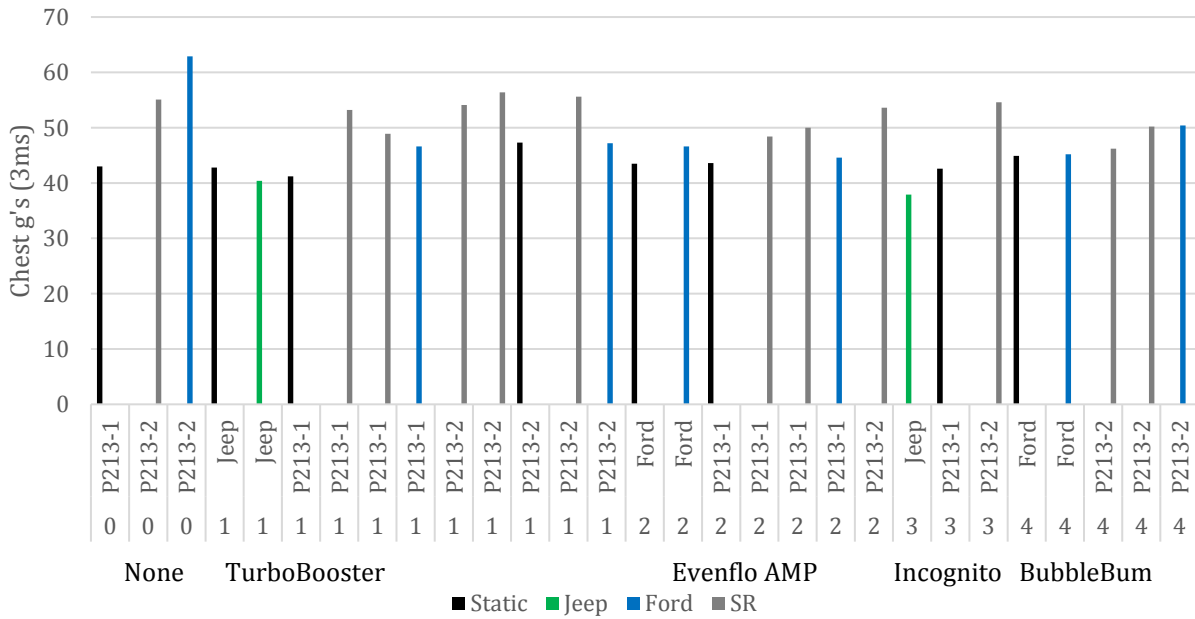

Figure 13. Chest acceleration (3ms) by belt, booster, and vehicle seat type.

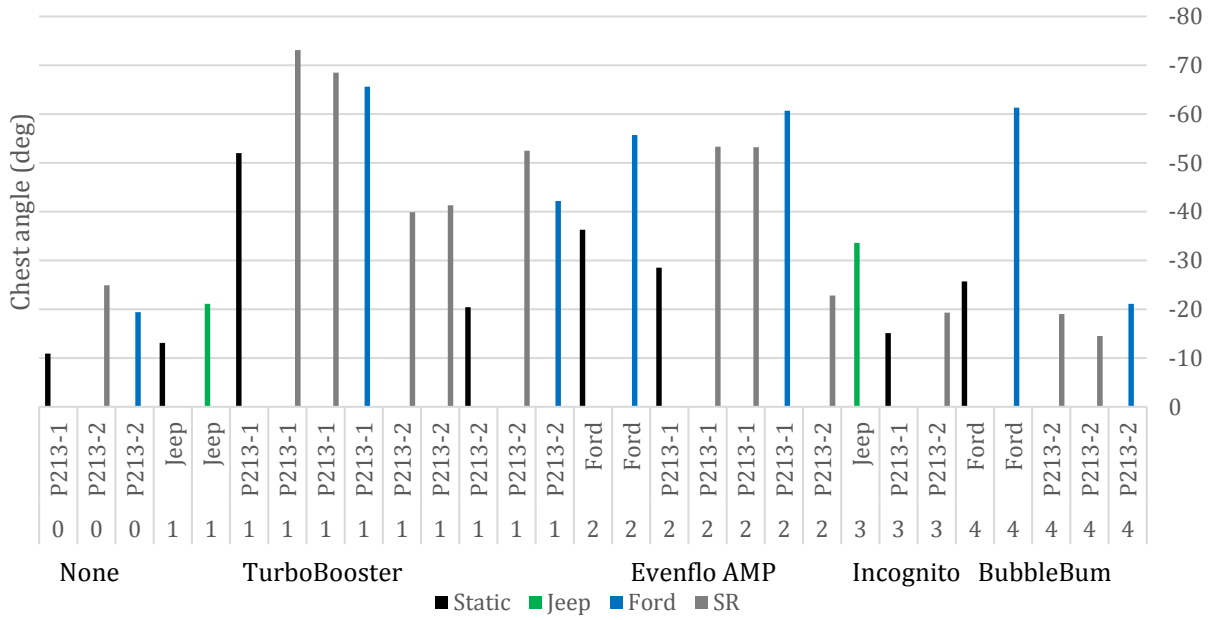

Figure 14. Chest angle by belt, booster, and vehicle seat type.

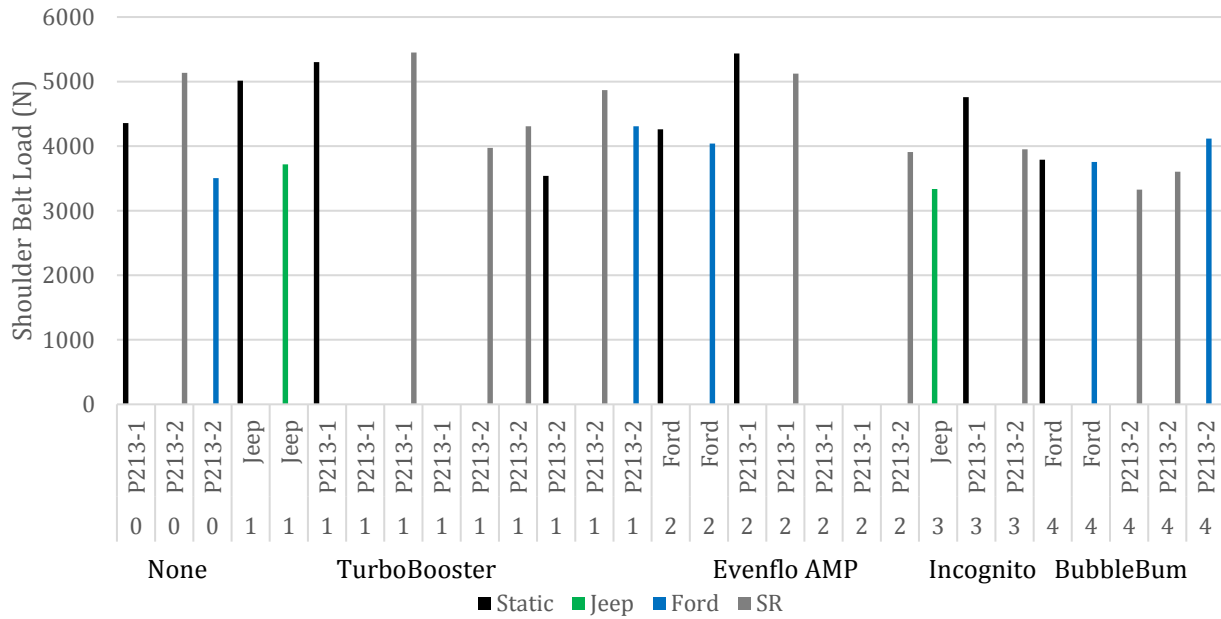

Figure 15. Shoulder belt load by belt, booster, and vehicle seat type.

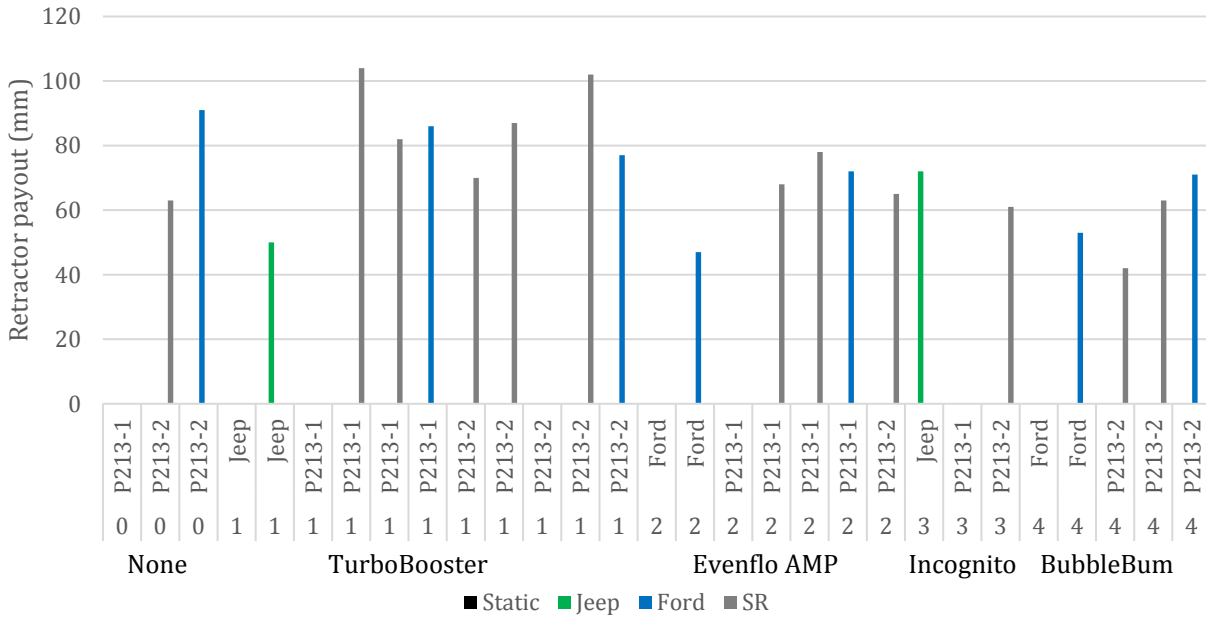

Figure 16. Retractor payout by belt, booster, and vehicle seat type.

Observed Test Issues

There were three dummy issues that sporadically occurred in the series and are not a function of backless booster seat design. Runs where these issues occurred are marked in Table 4 and Table 5 and these events need to be considered when analyzing the data. The three issues are:

- the shoulder belt entered the gap between the ATD neck and shoulder, sometimes tearing the bib assembly;
- the lap belt entered the gap between the ATD pelvis and thigh, (despite the use of the lap shield); and
- the ATD torso sometimes rolled out of the shoulder belt.

Figure 17 through Figure 19 show examples of these three issues. The first two, where the belt couples with the ATD in an unrealistic way, could influence the response data in a manner that is independent of booster or retractor performance. These anomalies did show some pattern with the test conditions. The two tests where the lap belt entered the ATD's pelvic-thigh gap were both static belt runs.

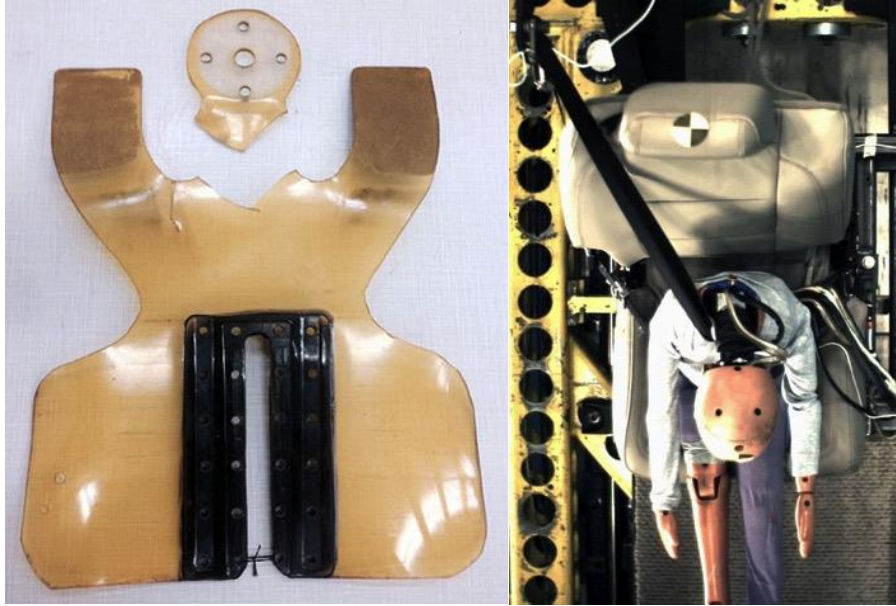

Figure 17. Example of test (NT1474) where the shoulder belt entered the gap beside the neck (right) resulting in a torn chest bib (left).



Figure 18. Example of ATD rolling out of the shoulder belt (NT1478).



Figure 19. Example of the pelvic belt entering the gap between ATD thigh and pelvis (NT1503).

The ATD roll out events were traced back to the location of the outboard upper shoulder anchor point. Figure 20 shows a front view schematic of belt anchorage locations where the origin of the graph is on the outboard lap belt anchor. Figure 20 plots the upper shoulder anchor point used for the first test series, along with the average location for the vehicle fleet (Ebert et al. 2014) and the location used on the current 213 buck. As evident, the preliminary 213 buck originally had an upper shoulder anchor point that was more outboard than the old 213 or the fleet average. A previous study on the effect of shoulder belt anchor location on belt fit and dynamic response showed substantial variation in kinematics when the belt was shifted over 50 mm outboard (Klinich, Reed, Ritchie, Manary, Schneider, & Rupp, 2008). After discussion with the NHTSA team, the anchor point on the preliminary buck was moved 58 mm inboard and 27 mm rearward for the second test series. Before shifting the location, the MADYMO model was used to confirm that the new location would be an effective solution. The new position resolved the rollout problem.

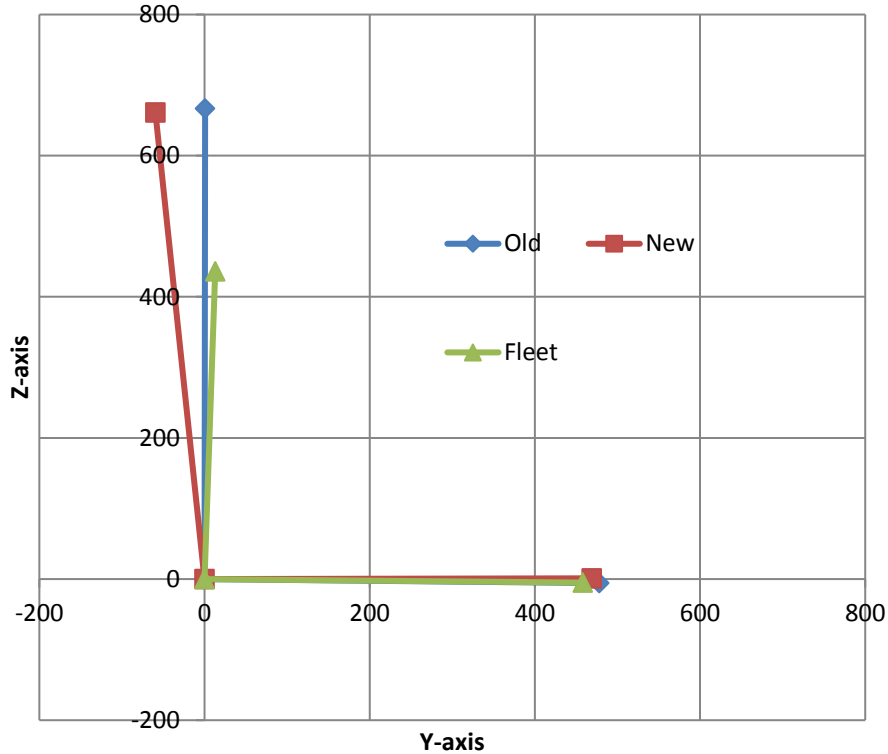

Figure 20. Front-view comparison of the initial upper shoulder belt anchor point for the preliminary 213 buck with comparable data from U.S. vehicles and the current 213 test bench.

The scenarios of the belt entering the gap on the side of the neck were all associated with conditions that provided a lower amount of vertical boost for the ATD (boosters 3, 4, or the no booster condition). These scenarios also had a starting belt fit with the shoulder belt closer to the neck than those boosters that raise the ATD position up more. Shoulder belt scores where the belt lodged in the shoulder gap ranged from -23 to 17 mm. Figure 21 compares the initial belt fit with no booster, booster 3 and booster 1. The higher position of the ATD shifts the shoulder belt to the middle of the ATD shoulder, while the more rigid lap belt guides place the lap belt flatter along the ATD's thighs.

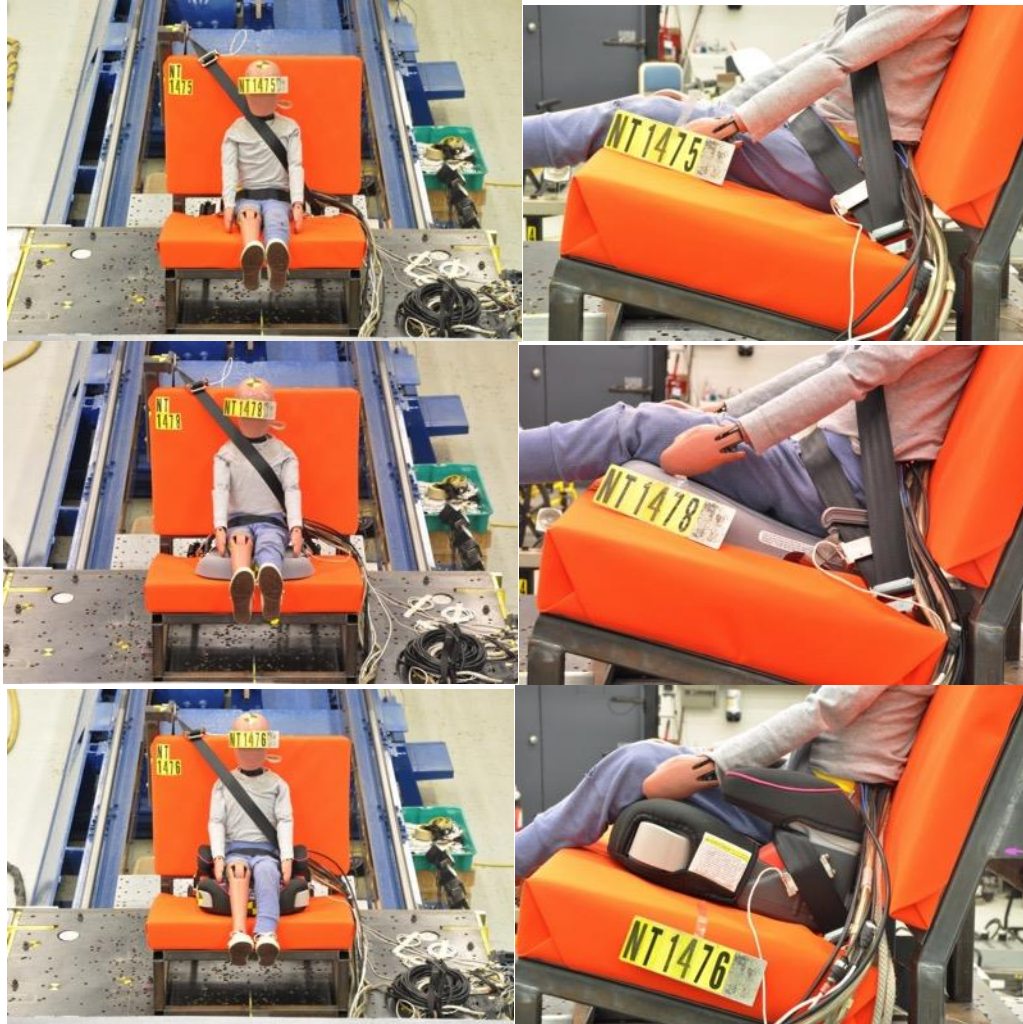

Figure 21. Lap and shoulder belt fit with no booster (top), a 50 mm thick booster (middle) and a 100 mm thick booster (bottom). Shoulder belt scores (SBS) are -23, -1, and 59.

Static Belt Versus Production Retractors

Figure 22 through Figure 25 compare static and production retractor belt performance when the seat type and booster type are held constant. In each graph, the thick line shows data from the production belt while the thin line shows data from the static belt.

These graphs show that the ATD head, chest, and pelvis accelerations (top row) are similar with both belt types. The shoulder belt load time history (middle left) shows that the static belt loads earlier and has a somewhat higher peak. The difference is larger with the Jeep belt compared to the Ford belt. The lap belt loads (center and middle right) are similar with the Evenflo AMP, higher with the production belt with the BubbleBum, similar in magnitude but start earlier with the static belt used with the Incognito, and different for the TurboBooster. For all three boosters, the production belt allows greater forward rotation of the ATD torso and higher head excursion (bottom left and right). Magnitudes of

the difference ranged from 5 to 40 degrees. Knee excursions were similar with the tests run on the Ford, but higher with the production belt on the jeep (bottom center).

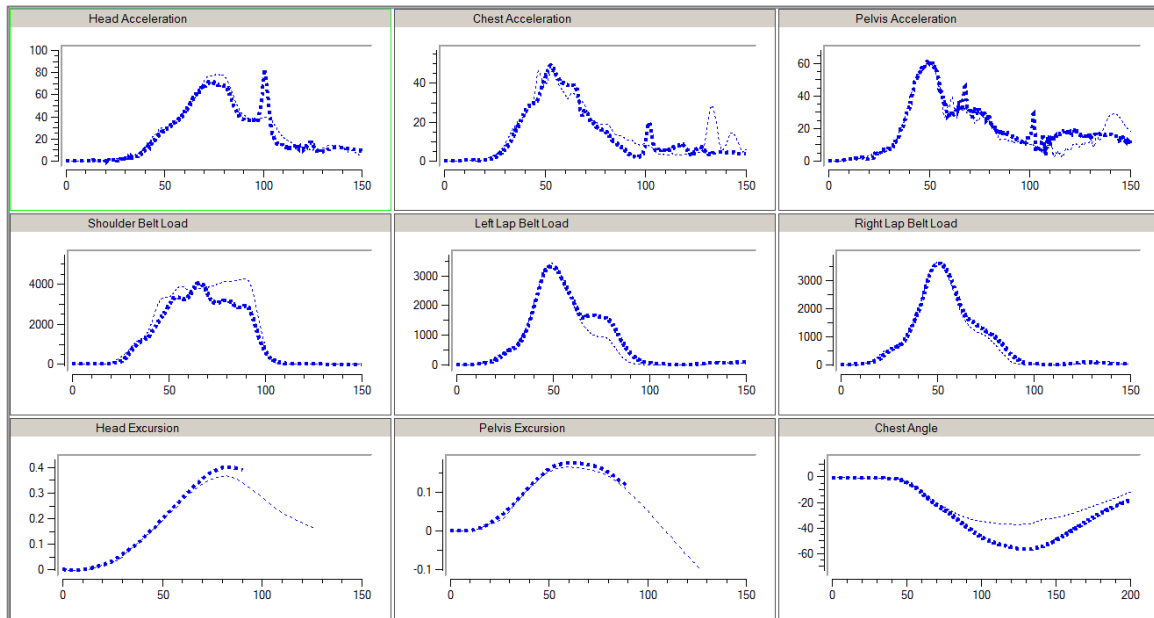

Figure 22. Comparison of ATD responses and belt loads from static (thin line – test NT1468) and production (thick line – test NT1467) seat belts when used with the Ford Explorer seat and the Evenflo AMP Booster.

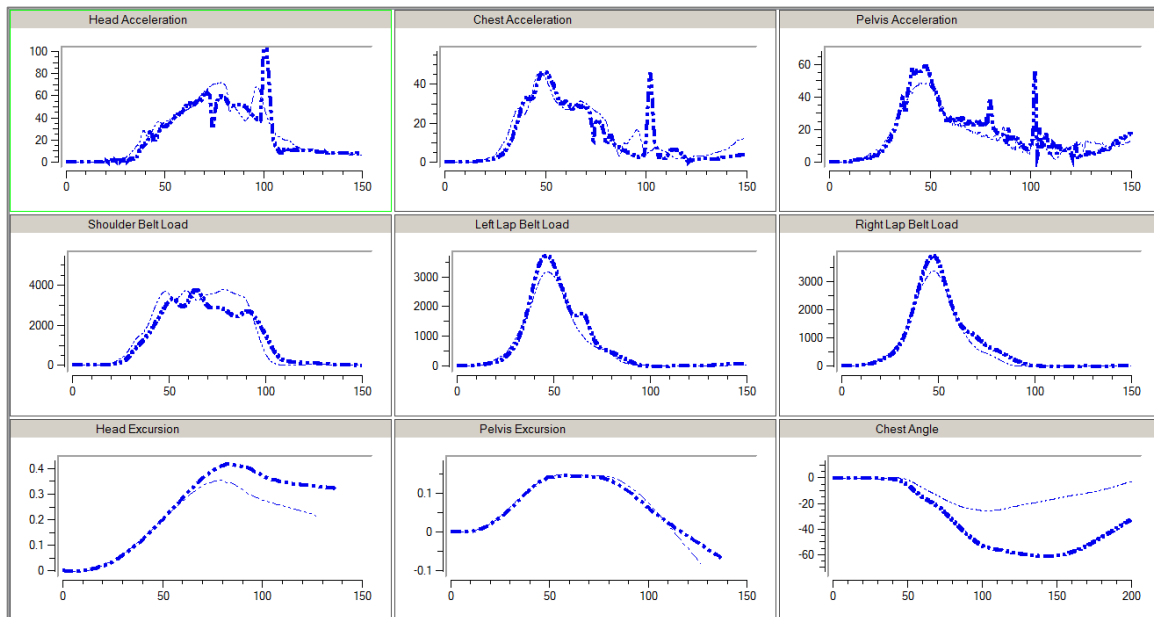

Figure 23. Comparison of ATD responses and belt loads from static (thin line – test NT1469) and production (thick line – test NT1470) seat belts when used with the Ford Explorer seat and the BubbleBum Booster.

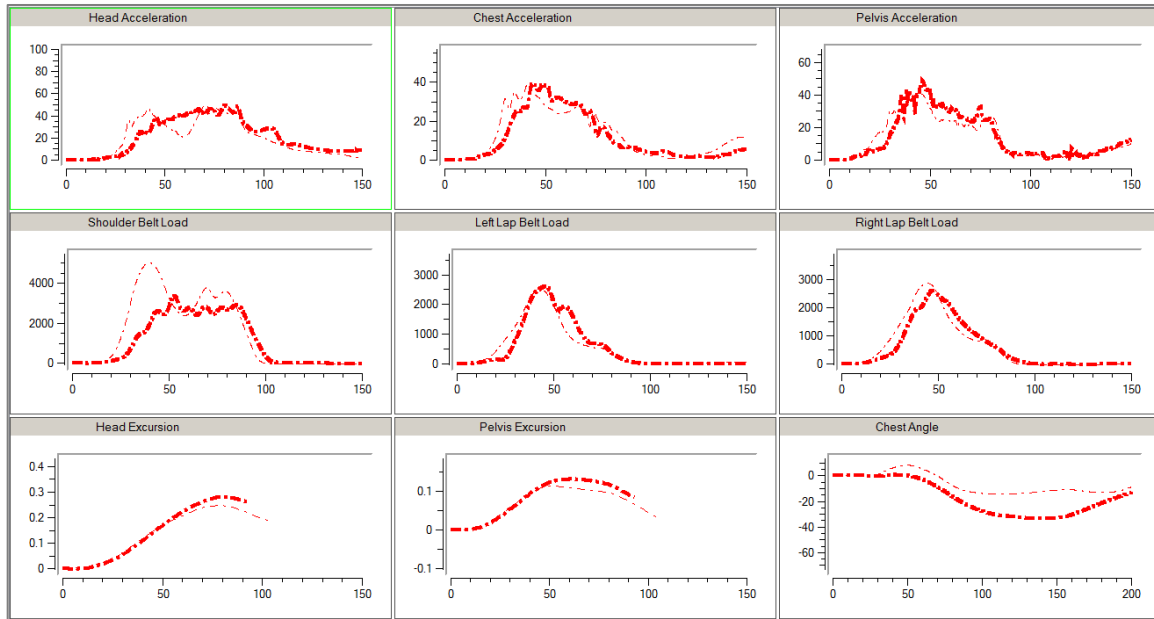

Figure 24. Comparison of ATD responses and belt loads from static (thin line – test NT1474) and production (thick line – test NT1473) seat belts when used with the Jeep Cherokee seat and the Incognito Booster.

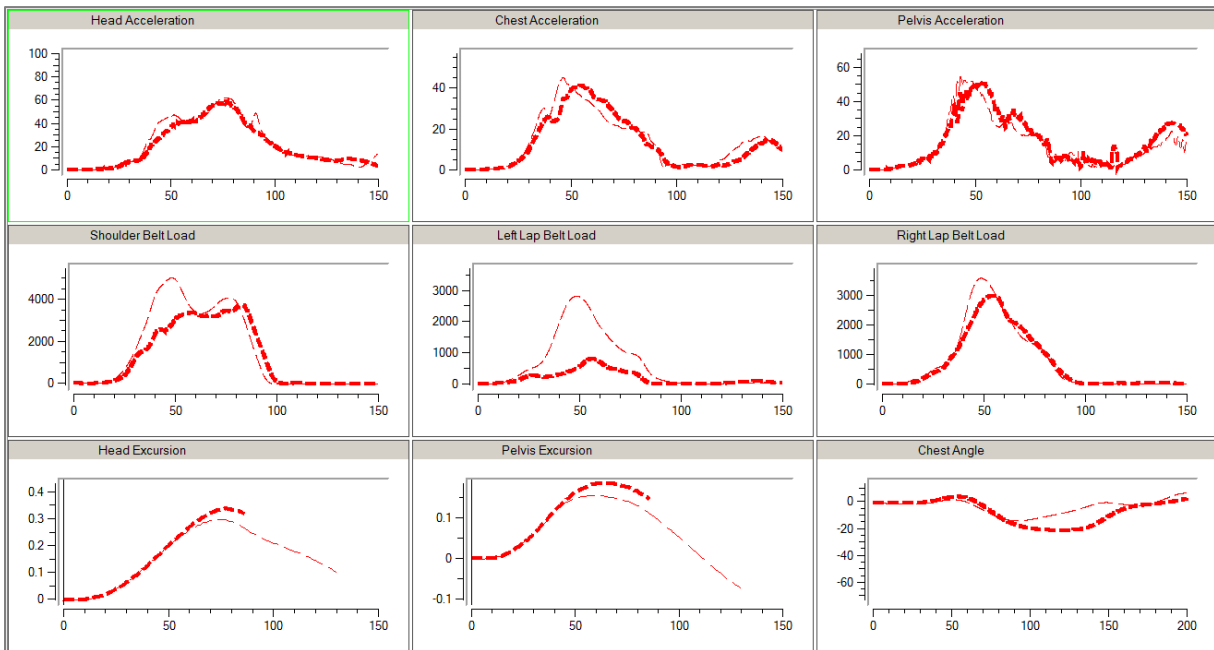

Figure 25. Comparison of ATD responses and belt loads from static (thin line – test NT1471) and production (thick line – test NT1472) seat belts when used with the Jeep Cherokee seat and the TurboBooster.

Production Belts by Seat Type

Differences in kinematics and response depend not only on the seat belt characteristics, but can be influenced by the vehicle seat and belt geometry. Figure 26 shows test results for the Evenflo AMP tested with the Ford production belt on the Ford seat and the preliminary 213

bench, while Figure 27 shows results for the TurboBooster tested with the Jeep production belt on the Jeep seat and the preliminary 213 bench. (Additional comparisons are not available for the Incognito and BubbleBum with production belts because of the test issues described previously.) The acceleration curves have a steeper slope on the preliminary 213 bench, and have a higher magnitude on the preliminary 213 bench when using the Jeep belt. Belt loads could not be measured with the production belt without interference on the preliminary 213 buck, so comparisons are not available. Head and knee excursions with the Ford production belt and the Evenflo AMP were slightly higher on the Ford seat compared to the preliminary 213 buck, while the rotation was slightly lower. With the Jeep production belt and TurboBooster, the Jeep seat had lower head excursion and higher knee excursion, and substantially less forward rotation.

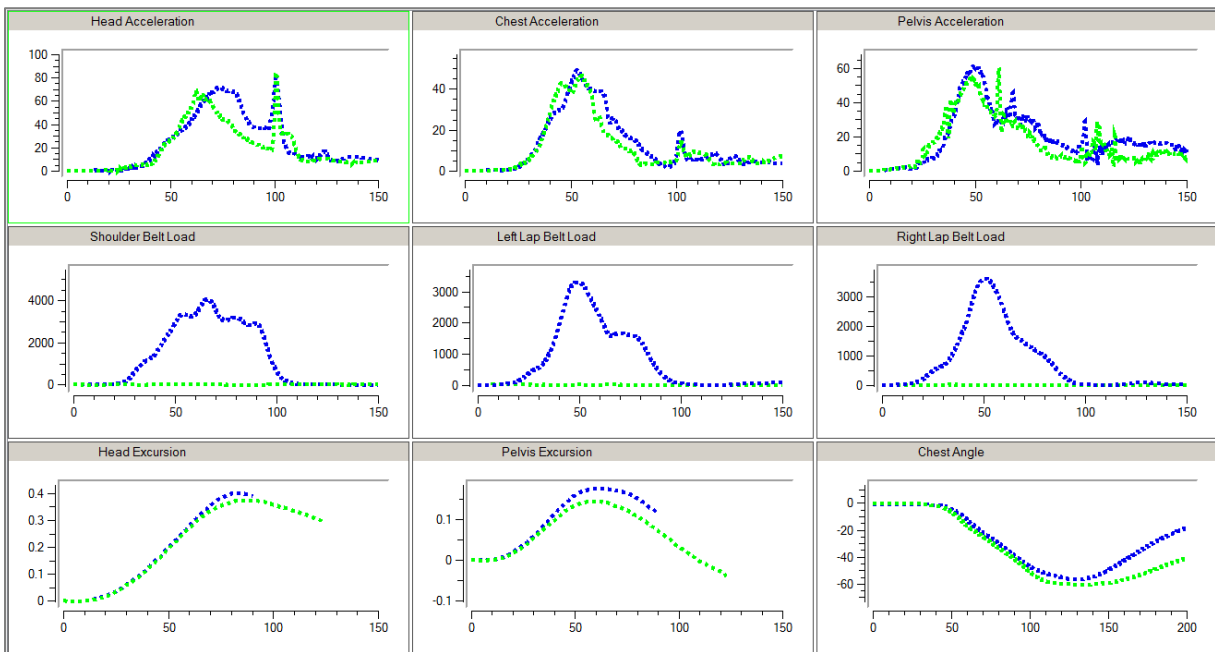

Figure 26. Evenflo AMP booster tested with production belt on Ford vehicle seat (blue – test NT1467) and new 213 buck (green-test NT1480).

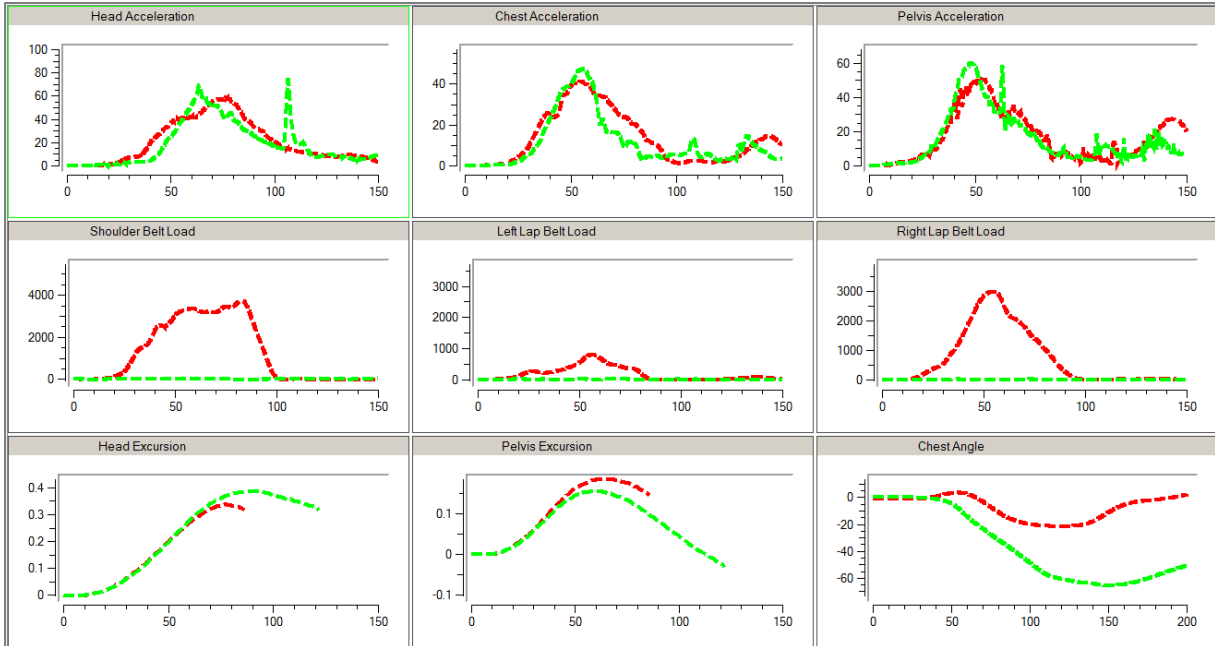

Figure 27. TurboBooster tested with production belt on Jeep vehicle seat (red-test NT1472) and new 213 buck (green – test NT1479).

Figure 28 through Figure 30 compare responses between the vehicle seats and preliminary 213 buck when fixed belts are used. For the Evenflo AMP, the differences are similar to those seen with the production belt. In addition, the preliminary 213 buck has lower lap belt loads but higher and earlier shoulder belt loads. For the TurboBooster, the trends seen with the production belt generally hold true, except the acceleration curves have different initial slopes. For the fixed belt comparison to the Jeep, the lap belt loads are higher and shoulder belt loads slightly lower with the production seat. When the Incognito is tested with fixed belts, differences are similar to those seen with the TurboBooster but lower in magnitude.

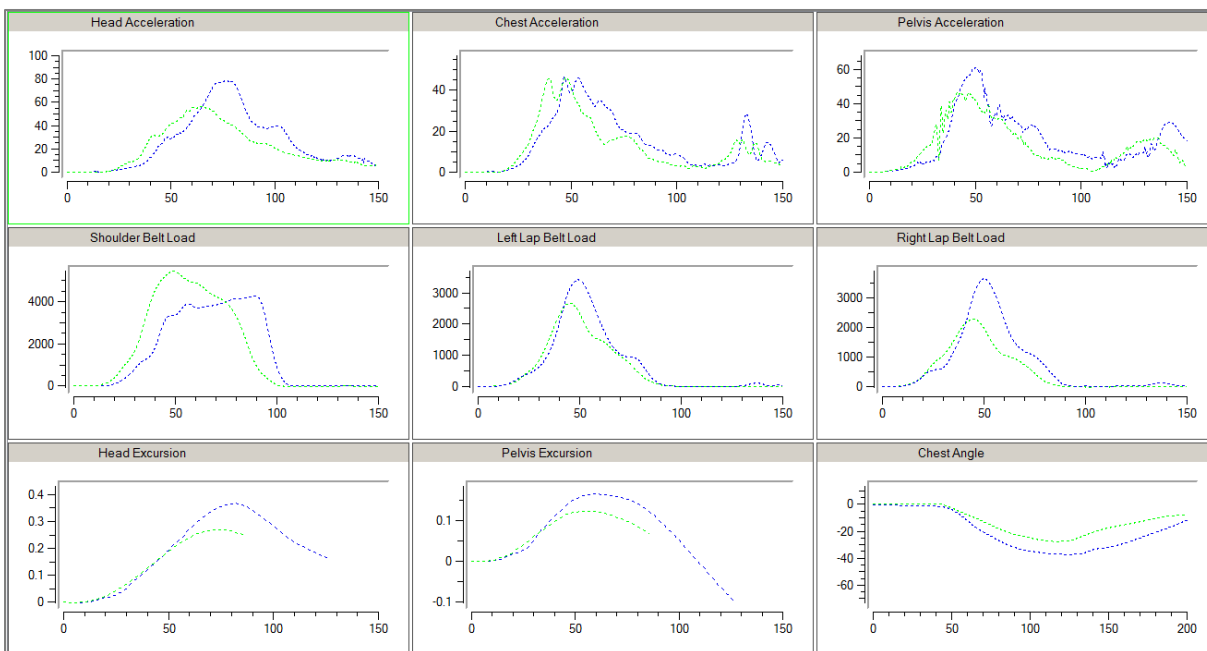

Figure 28. Evenflo AMP tested with fixed belt on Ford vehicle seat (blue – test NT1468) and new 213 buck (green – NT1477).

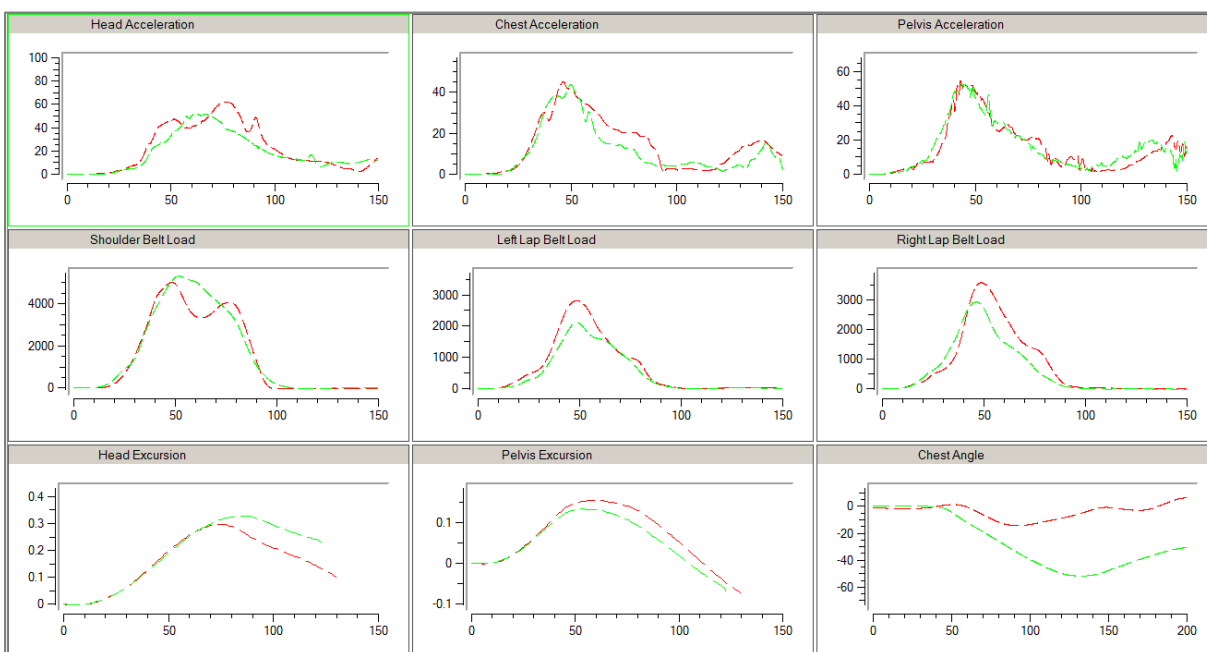

Figure 29. TurboBooster tested with fixed belt on Jeep vehicle seat (red – test NT1471) and new 213 buck (green – test NT1476).

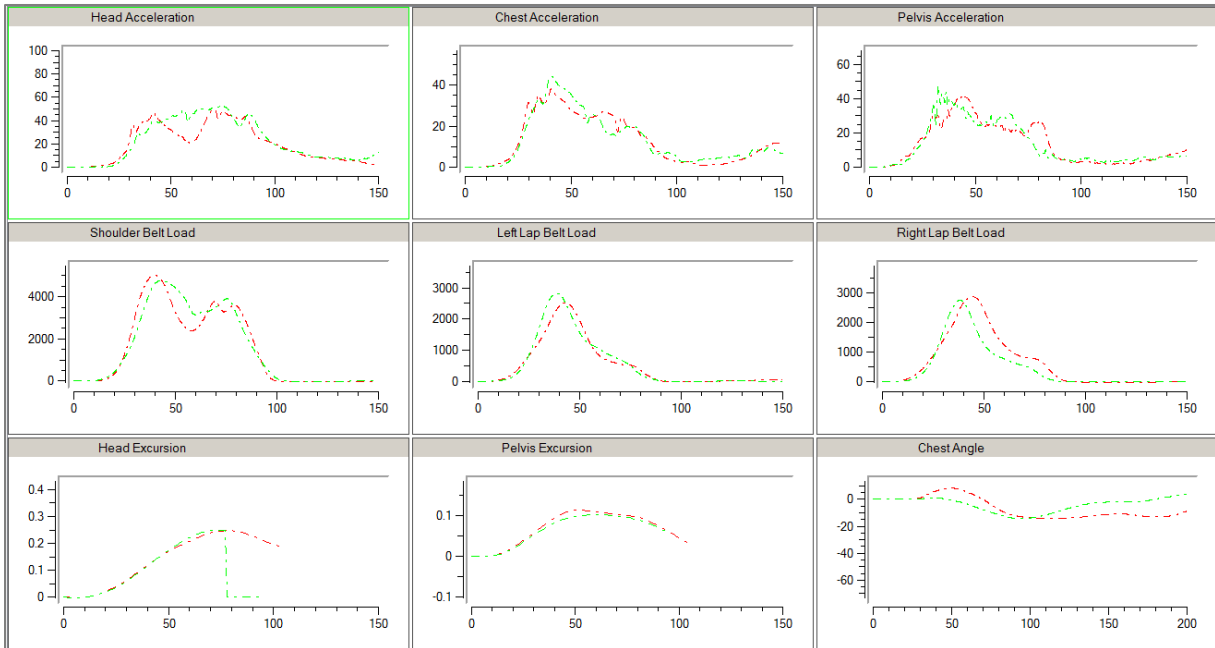

Figure 30. Incognito tested with fixed belt on Jeep buck (red – test NT1474) and new 213 buck (green – test NT1478).

Though limited by only a few sets of comparisons, the kinematics with production belt and the preliminary 213 buck are more similar to the Ford seat and belt than the Jeep seat and belt. The trends are similar when comparing the response of the fixed belt as well. For this reason, tuning of the surrogate retractor focused on matching the response of the Ford production belt.

Surrogate Versus Production Retractor

A comparison of the performance of the surrogate retractor, the static belt, and the Ford production retractor is shown in Figure 31 where all the data were collected on the preliminary 213 bench and with the Evenflo AMP booster. Figure 32 provides the same comparison of the three seat belt types used with the preliminary 213 bench and the TurboBooster. In this data, the spool-out of the surrogate retractor was set to 50 mm during set up and no belt loads were collected on the production belts because the load cell influenced retractor spool-out. These graphs show that ATD accelerations with all three belt types are similar, that setting an initial spool-out of approximately 50 mm (2 inches) on the surrogate produces a good match to the production belts. Because of the good correlation, no additional tests were performed with a lower spool-out setting. The response data from the static belt are different than both the retractor belts and produces higher shoulder belt loads, lower lap belt loads, lower head extrusion and lower torso rotation.

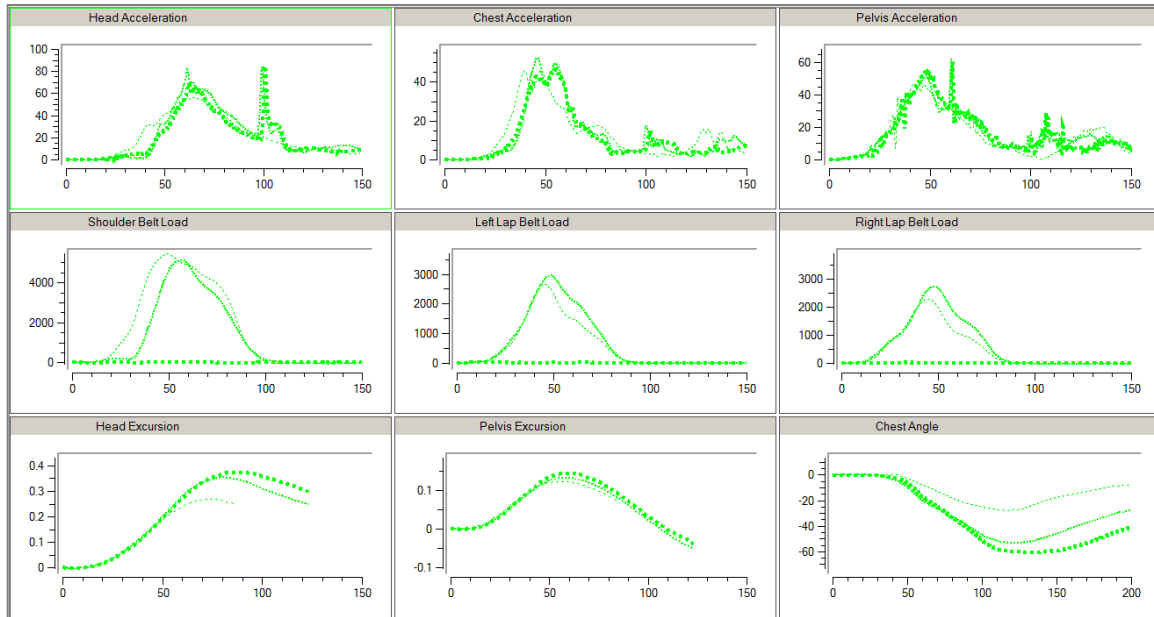

Figure 31. Comparison of ATD response and belt load data with three belt types: static (thin line – NT1477), surrogate retractor (med line – NT1482) and production retractor (thick line – test NT1480). All data collected on the preliminary 213 buck with Evenflo AMP booster.

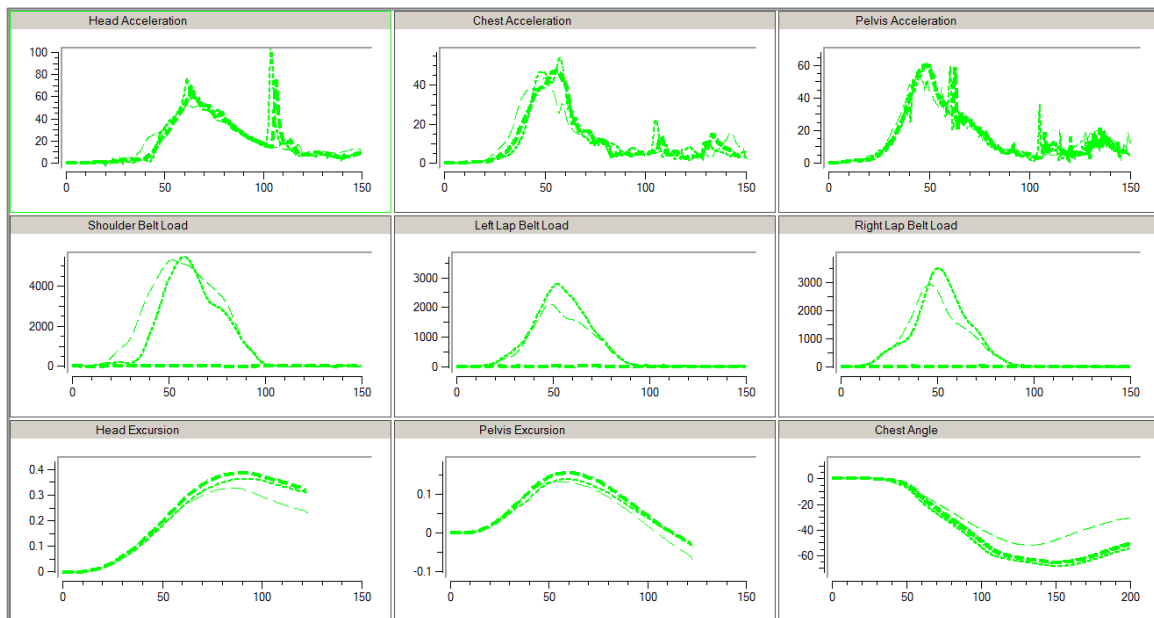

Figure 32. Comparison of ATD response and belt load data with three belt types: static (thin line – NT1467), surrogate retractor (med line – NT1481) and production retractor (thick line – test NT1479). All data collected on the preliminary 213 buck with TurboBooster.

Figure 33 shows data for the surrogate and production retractors where all responses are available and both are tested on the preliminary 213 buck with the TurboBooster. These graphs show that the surrogate retractor data matches closely with the production belts.

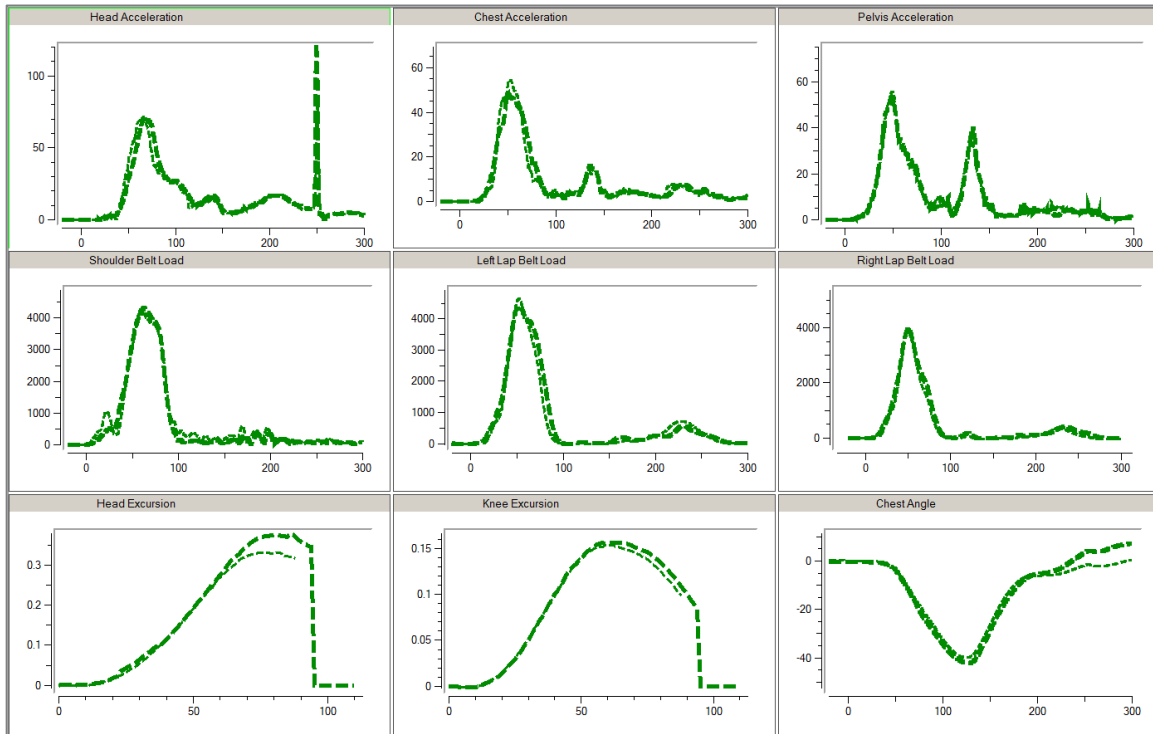

Figure 33. Comparison of ATD responses with surrogate (med line – NT1515) and production retractors (thick line – NT1505) on preliminary 213 buck with TurboBooster.

The ATD kinematics on the preliminary 213 buck using the Ford production belt (left) and the surrogate retractor (right) are shown in Table 6 for the TurboBooster and 0 for the BubbleBum.

Table 6. Comparison of kinematics with the TurboBooster using Ford production belt and surrogate retractor.

















TB	Ford Production Belt (NT1505)	Surrogate Retractor (NT1515)
T0		
T30		
T60		
T90		

Table 7. Comparison of kinematics with the BubbleBum using Ford production belt and surrogate retractor.

BB	Ford Production Belt (NT1506)	Surrogate Retractor (NT1511)
T0		
T30		
T60		
T90		

Additional tests were performed to check repeatability with the surrogate retractor as shown in Figure 34 and Figure 35. Differences in kinematics are likely due to slightly different initial positions of the shoulder belt.

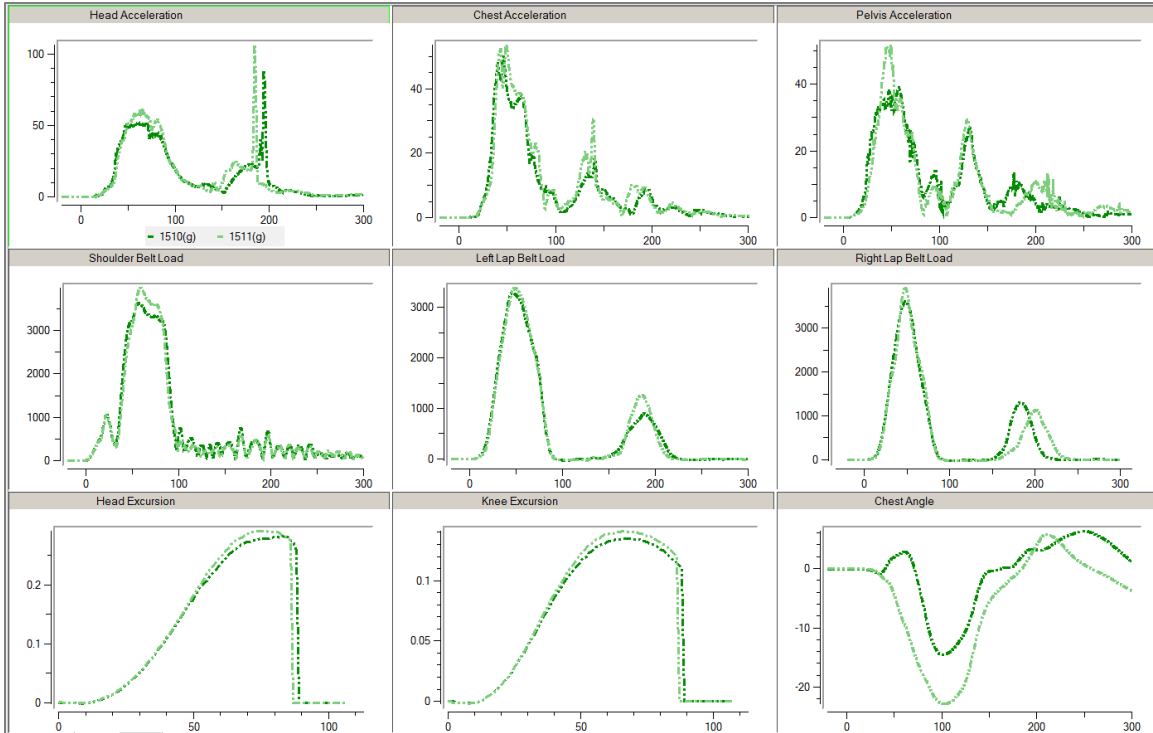

Figure 34. Two tests (NT1510 and 11) run with surrogate retractor and BubbleBum. (SBS= -8 and 4 mm)

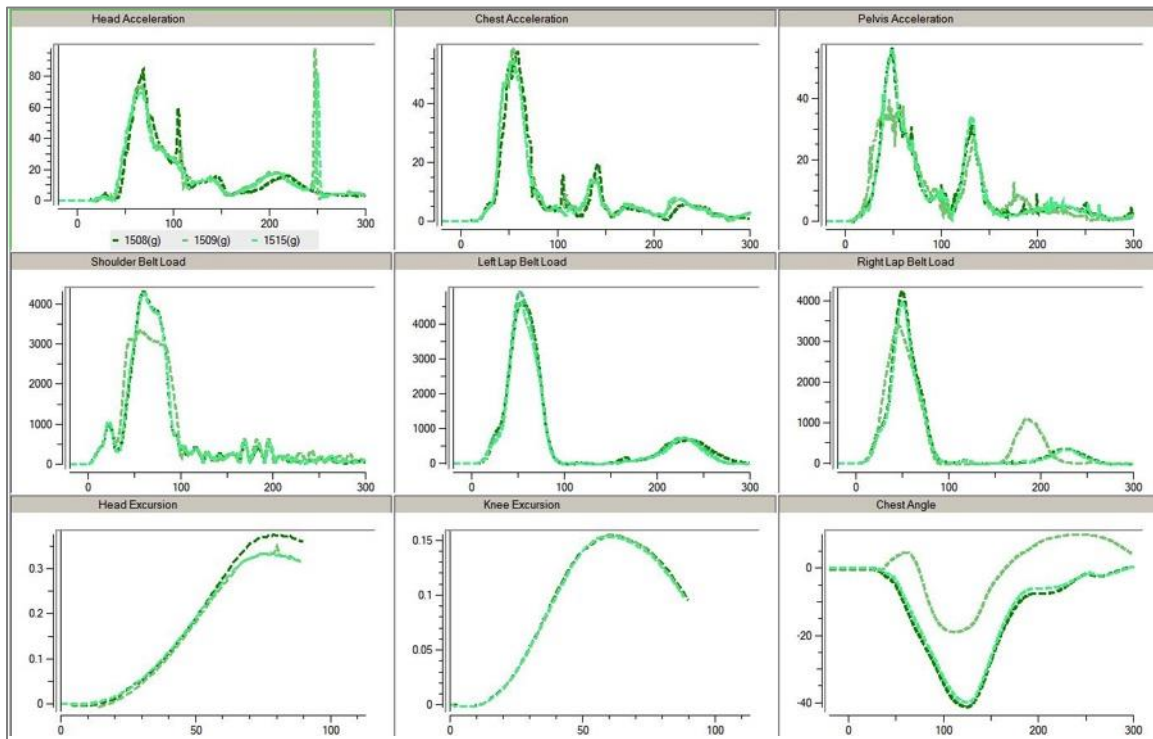

Figure 35. Three tests (NT1508, 09, and 15) run with surrogate retractor and TurboBooster. (SBS= 12, 9 and 8)

MADYMO Modeling

An example of one of the MADYMO validations is shown in Figure 36 showing the test response in red and model response in blue. An animation comparing the model and test is shown in Figure 37.

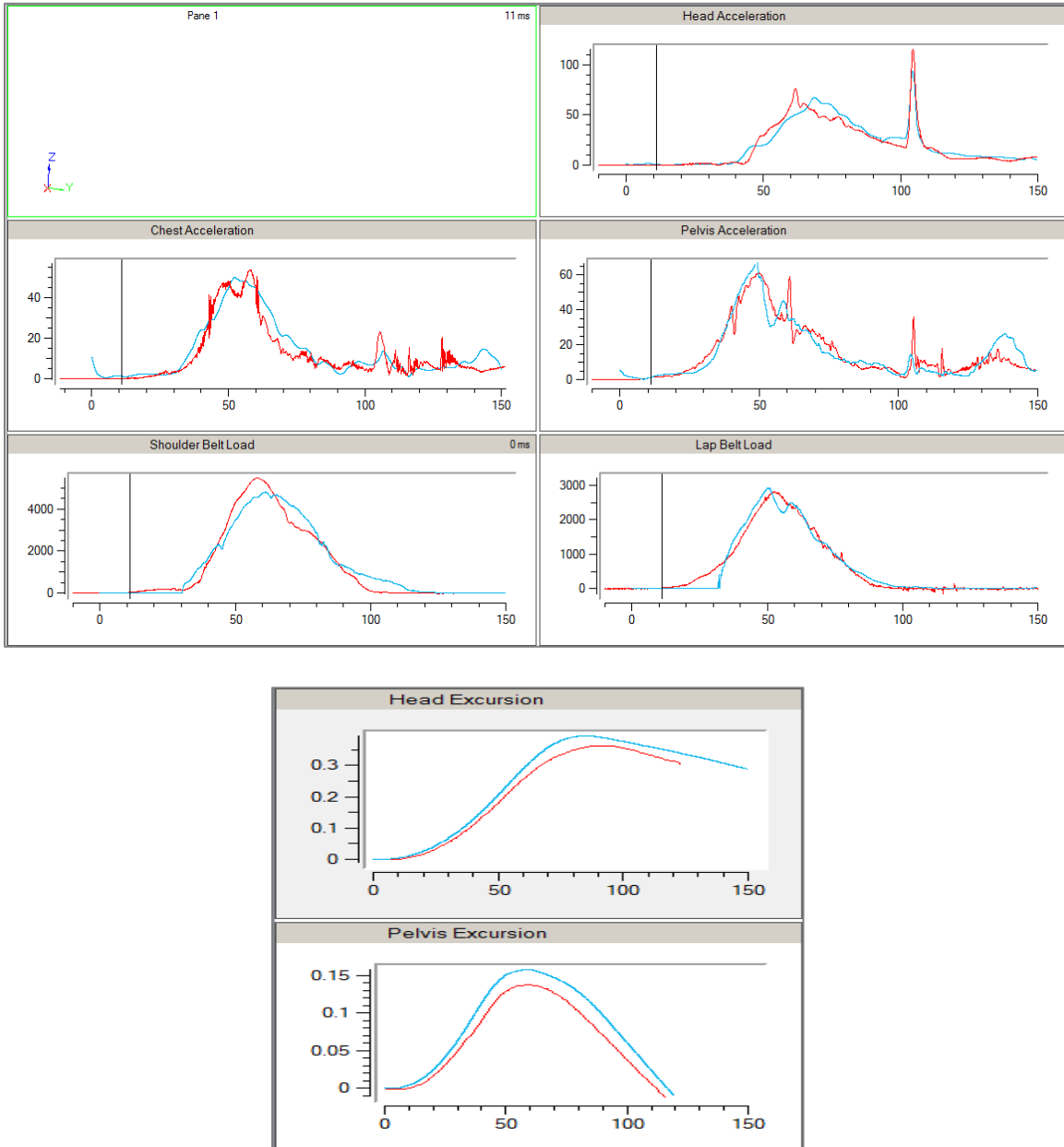

Figure 36. Comparison of model (blue) and test (red) for Test NT1481 using the TurboBooster and surrogate retractor.



Figure 37. Kinematic comparison of model and test.

The MADYMO models were used to check whether shifting the D-ring would resolve the issues regarding rollout. Results are shown in Figure 38. The model was also used to examine the effect of varying spool-out within the range measured among production vehicles. The effect of varying spool-out is small compared to the effect of D-ring location as indicated in Figure 39.

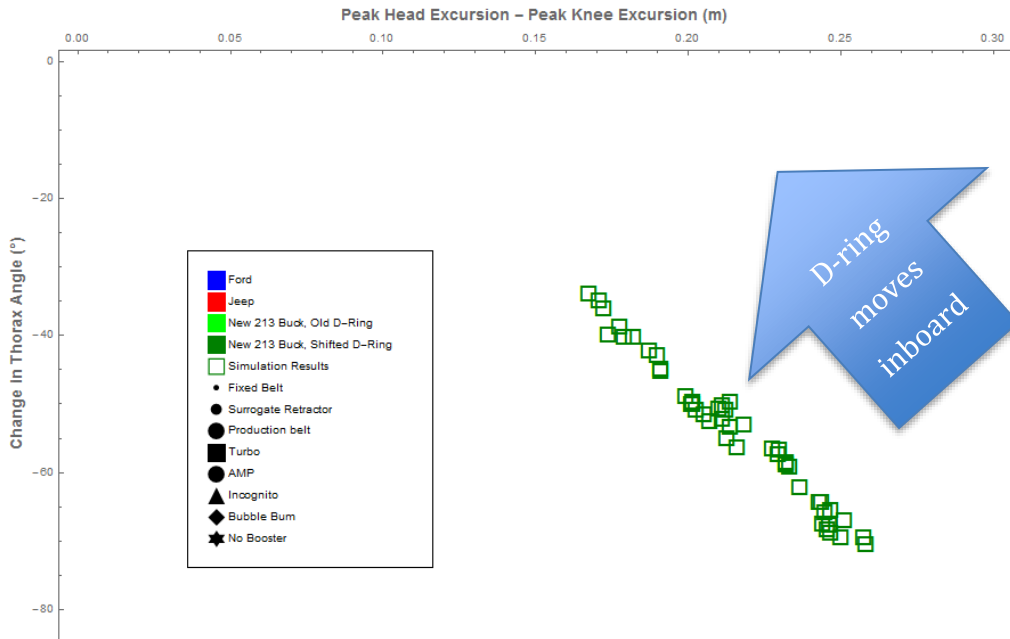

Figure 38. Change in torso angle versus peak knee-head excursion as D-ring shifted inboard.

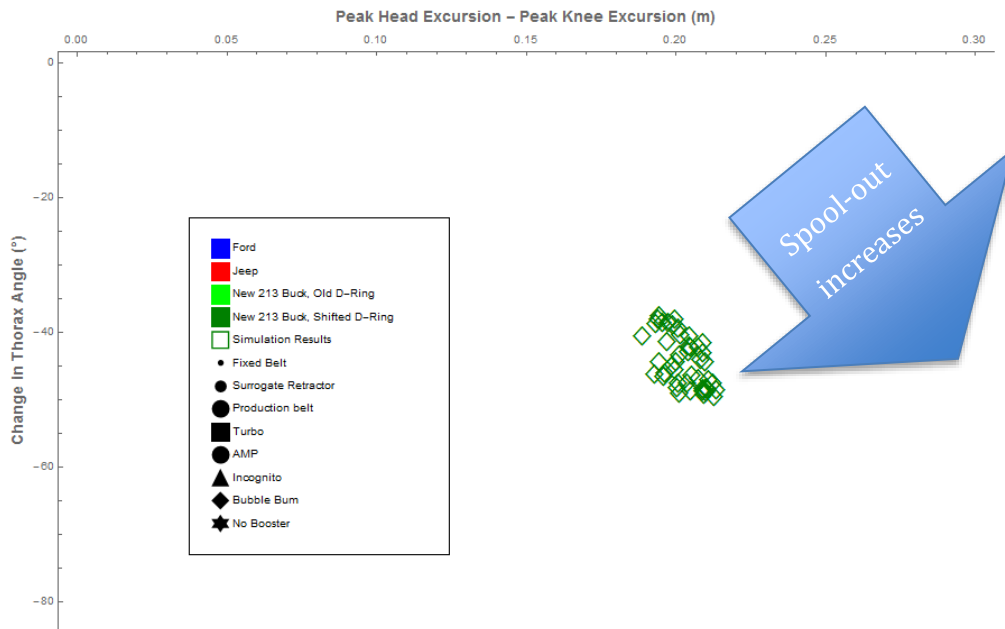

Figure 39. Change in torso angle versus peak knee-head excursion as retractor spool-out increases.

Discussion and Conclusions

This research program developed a surrogate seat belt retractor that could be used repeatedly to evaluate booster seats using a seat belt system similar to that found in passenger vehicles. The data show that the performance of the surrogate retractor closely matches the performance of production seat belt systems tested. Both the surrogate and production retractors consistently produced more forward torso motion than the static seat belt currently used in FMVSS 213. Use of the surrogate retractor when evaluating boosters may allow improvements in booster design that consider the effect of spool-out provided by vehicle retractors. Additional testing of the surrogate retractor should be performed to further check repeatability and reproducibility. In particular, tests should be performed using boosters with backs and shoulder belt routing features and evaluate more than four products. For the surrogate retractor (as well as some of the production runs), adding a belt-attached shoulder belt load cell affected the performance of the retractor. Future evaluation of the retractor should further investigate whether measuring load at the upper D-ring anchor bolt through the use of a multi-axis, instrumented, and threaded mount can provide equivalent belt loading data.

This study originally intended to use MADYMO models of each test to provide insight on tuning the surrogate retractor parameters. Given that the range of parameters in production belts was smaller than anticipated, use of the MADYMO models was limited. However, validated models of all test conditions are available for future studies.

References

CFR Title 49, Transportation, Part 571.213; Child restraint systems.

Klinich, K. D., Reed, M. P., Ritchie, N. L., Manary, M. A., Schneider, L.W., & Rupp, J. D. (2008, September). *Assessing child belt fit, Volume II: Effect of restraint configuration, booster seat designs, seating procedure, and belt fit on the dynamic response of the Hybrid III 10YO ATD in sled tests* (Report No. UM-2008-49-2). Washington, DC: National Highway Traffic Safety Administration. Available at <https://deepblue.lib.umich.edu/bitstream/handle/2027.42/-64460/102443.pdf?sequence=1&isAllowed=y>

Notice of Proposed Rulemaking: Federal Motor Vehicle Safety Standards [213]; Child Restraint Systems, Child Restraint Systems-Side Impact Protection, Federal Register Docket number NHTSA-2014-0012. Available at <https://federalregister.gov/a/2014-01568>

Bohard, K., Foo, J., Fumo, D., Klochko, C., Mehta, M., & Raheja, S. (2008) SPARK: SeatBelt [sic] Stopper: A Surrogate Seatbelt [sic] Retractor. (Unpublished Final Design Project Presentation, University of Michigan School of Engineering).

Appendix A
Instructions for Use of the UMTRI Surrogate Retractor

Instructions for using the UMTRI Surrogate Retractor

1. During retractor build, the orientation of the spring should be such that it is coiled in the clockwise direction when looking at the spring side of the retractor. The inner end of the spring should be punched and bolted to the spring-side shaft of the retractor. The outer end of the spring is bolted to the housing tube. In this configuration, to tension the retractor, the spindle should only be rotated in the counter clockwise direction (opposite of spring coil direction). See drawings in appendix B for more details.
2. Mount the retractor assembly at mid height on the back of the test bench, at approximately the same vertical height as the tether anchor. The surrogate retractor should be oriented with the long axis of the spindle aligned with the direction of impact and the spring side of the retractor facing forward. The surrogate retractor should be mounted under the D-ring to be used, and located so that the webbing path will be vertical between the retractor and the D-ring.
3. Turn the spindle 10 half turns to create the 213-specified belt tension and allow for the 50 mm (2 inches) of spool-out during the test. Note that the spindle should only be turned in the direction indicated by the arrow on top, (clockwise when viewed from behind) so that the spring will work correctly and not break.
4. Pin the spindle in place to prevent rotation.
5. Thread the webbing through the split drum of the surrogate retractor, creating a webbing tail of 150-200 mm (6-8 inches). Attach the webbing tail to the webbing exiting the other side of the retractor using a crashworthy 3-bar clip.
6. Unpin the surrogate retractor and allow 50 mm (2 inches) of the webbing to wrap around the spindle. Re-pin the retractor.
7. Route the long end of the webbing through the D-ring, across the ATD chest, through the inboard webbing anchor and to the outboard lap belt webbing anchor.
8. Secure the webbing at the outboard lap belt anchor, removing all excess belt from the system.
9. Unpin the surrogate retractor before the test.

Appendix B

Engineering Drawings for the Surrogate Retractor Assembly

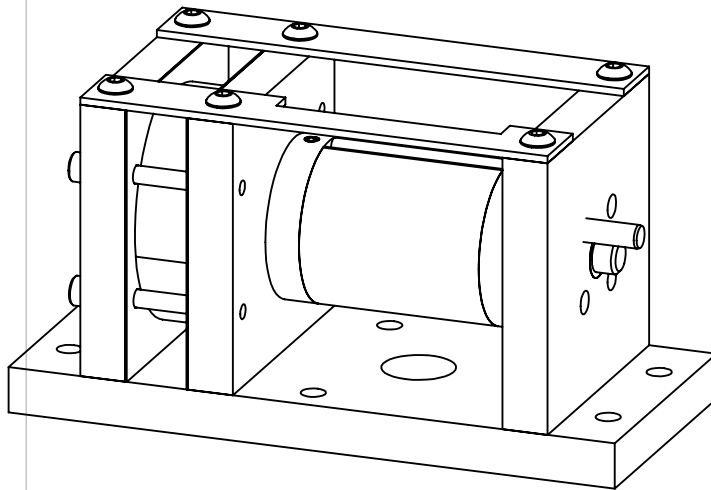

ITEM NO.	PART NAME	DESCRIPTION	QTY.
1	Belt_Attach_Assem	Assembly on seperate sheet	1
2	Bottom_Plate		1
3	Front_Plate		1
4	Spring_Plate_In		1
5	Teflon_Sheet_In		1
6	teflon_sheet_out		1
7	Spring_Plate_Out		1
8	Top_Rein_Straight	Reinforcement piece on top	1
9	Top_Rein_Cut	Reinforcement piece on top	1
10	1346k11_End_Rotary_Shafft	Rotating shaft on opposite side of spring	1
11	1346k11_Spring_Side_Rotary_Shafft	Rotating shaft, spring connected	1
12	6381K451	3/8" Diameter, 1/2" OD, 1/2" length sleeve	3
13	Spring_housing_cut	Aluminium tube with edge cut	1
14	spring_stop_spacer		1
15	HX-SHCS 0.19-32x0.75x0.75-N		1
16	9293K54	Constant Force Spring, .01" thick, .99" wound OD, .625" width, .73" wound ID	1
17	SBHCSCREW 0.164-32x0.375-HX-N		1
18	SBHCSCREW 0.19-32x0.375-HX-N		1
19	MSHXNUT 0.190-32-D-N		1
20	HX-SHCS 0.19-32x1.5x1.125-N	Spring Plate connecting bolts	4
21	SBHCSCREW 0.19-32x0.5-HX-N		6
22	SCHCSCREW 0.25-20x1x1-HX-N		4
23	DPM 0.25x1.5		1

UNLESS OTHERWISE SPECIFIED:	CREATED	7/21/2015	ASSEMBLY	
	LAST SAVED	4/7/2017	Surrogate Retractor	
	DRAWN BY	KB	DESCRIPTION	
	PHONE	+1 (734) 936-0960	Surrogate Retractor	
INTERPRET GEOMETRIC TOLERANCING PER:	ASME Y14.5-1994	FILENAME		
MATERIAL	Various	Seat Belt Retractor		
FINISH		SIZE	DWG. NO.	REV
		A		2
		SCALE: 1:2	WEIGHT: 5.3 lb	SHEET 1 OF 4



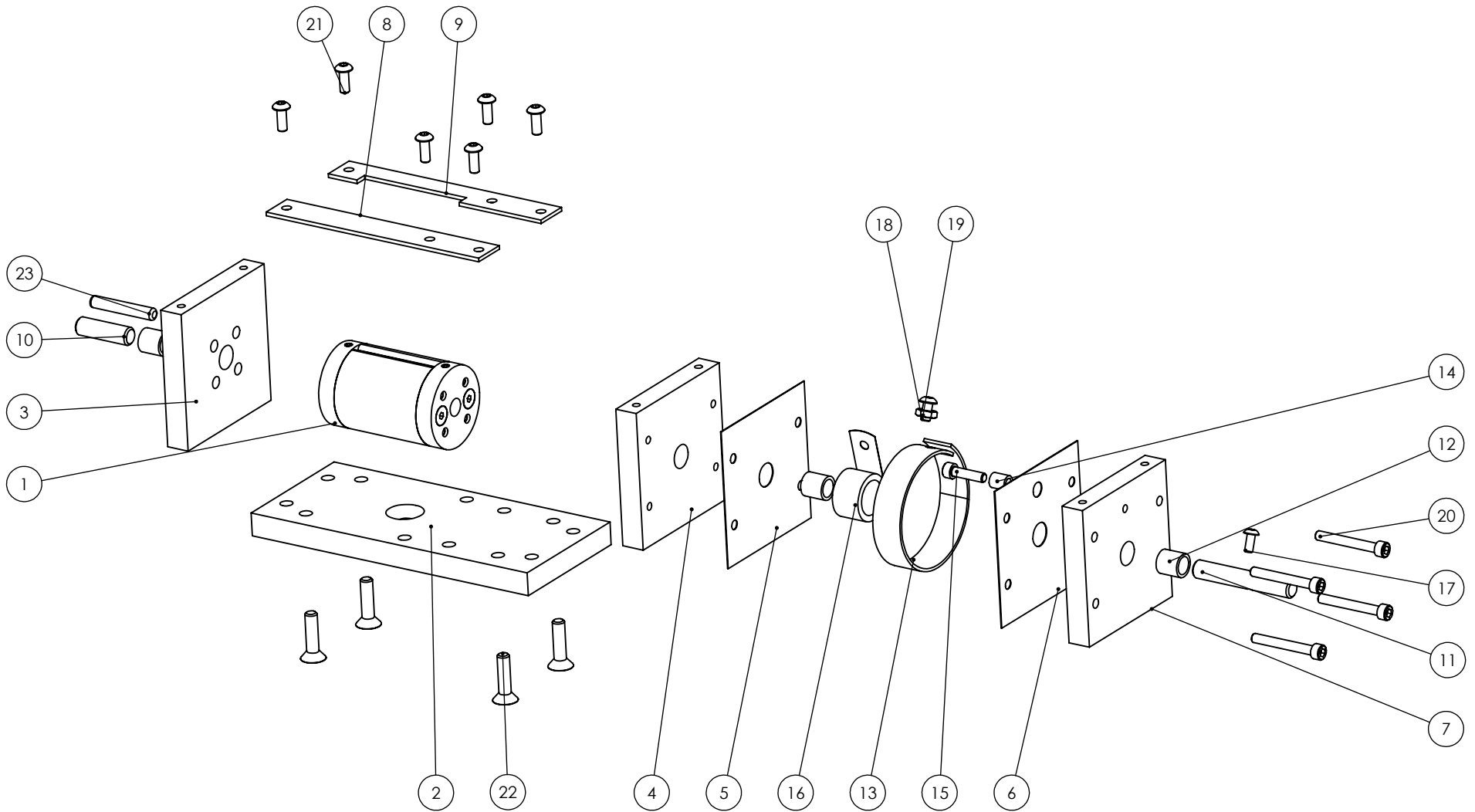

UNLESS OTHERWISE SPECIFIED:	CREATED	7/21/2015	ASSEMBLY		
	LAST SAVED	4/7/2017	Surrogate Retractor		
	DRAWN BY	KB	DESCRIPTION		
	PHONE	+1 (734) 936-0960	Exploded View		
INTERPRET GEOMETRIC TOLERANCING PER:	ASME Y14.5-1994		FILENAME		
MATERIAL	Various		Seat Belt Retractor		
FINISH	 2901 Baxter Rd Ann Arbor, MI 48109		SIZE	DWG. NO.	REV
			A		2
			SCALE: 1:2	WEIGHT: 5.3 lb	SHEET 2 OF 4

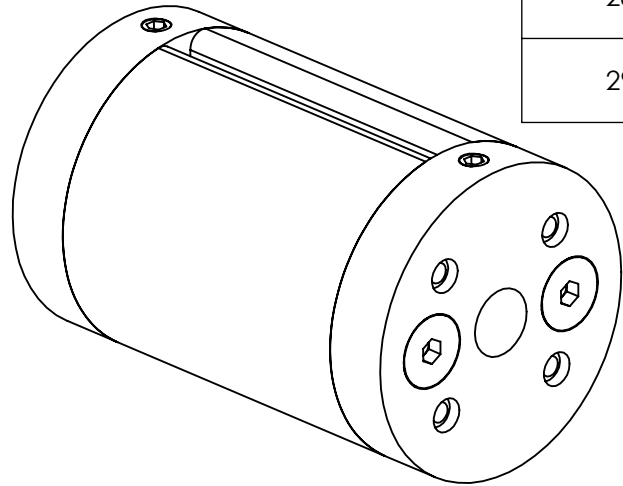

ITEM NO.	PART NAME	DESCRIPTION	QTY.
24	Belt_Attach_End1		1
25	Belt_Attach_End2		1
26	Belt_Attach_Body		2
27	DPM 0.1875x0.75		6
28	SSFLATSKT 0.19-32x0.5-HX-N	Set Screws	2
29	SCHCSCREW 0.19-32x0.75x0.75-HX-N		4

UNLESS OTHERWISE SPECIFIED:	CREATED	7/21/2015	ASSEMBLY	
	LAST SAVED	4/7/2017	Belt Attach Assem	
	DRAWN BY	KB	DESCRIPTION	
	PHONE	+1 (734) 936-0960	Belt Attach Assem	
INTERPRET GEOMETRIC TOLERANCING PER:	ASME Y14.5-1994	FILENAME		
MATERIAL	Various	Belt_Attach_Assem		
FINISH		SIZE	DWG. NO.	REV
		A	1	2
		SCALE: 1:1	WEIGHT: 0.56 lb	SHEET 3 OF 4



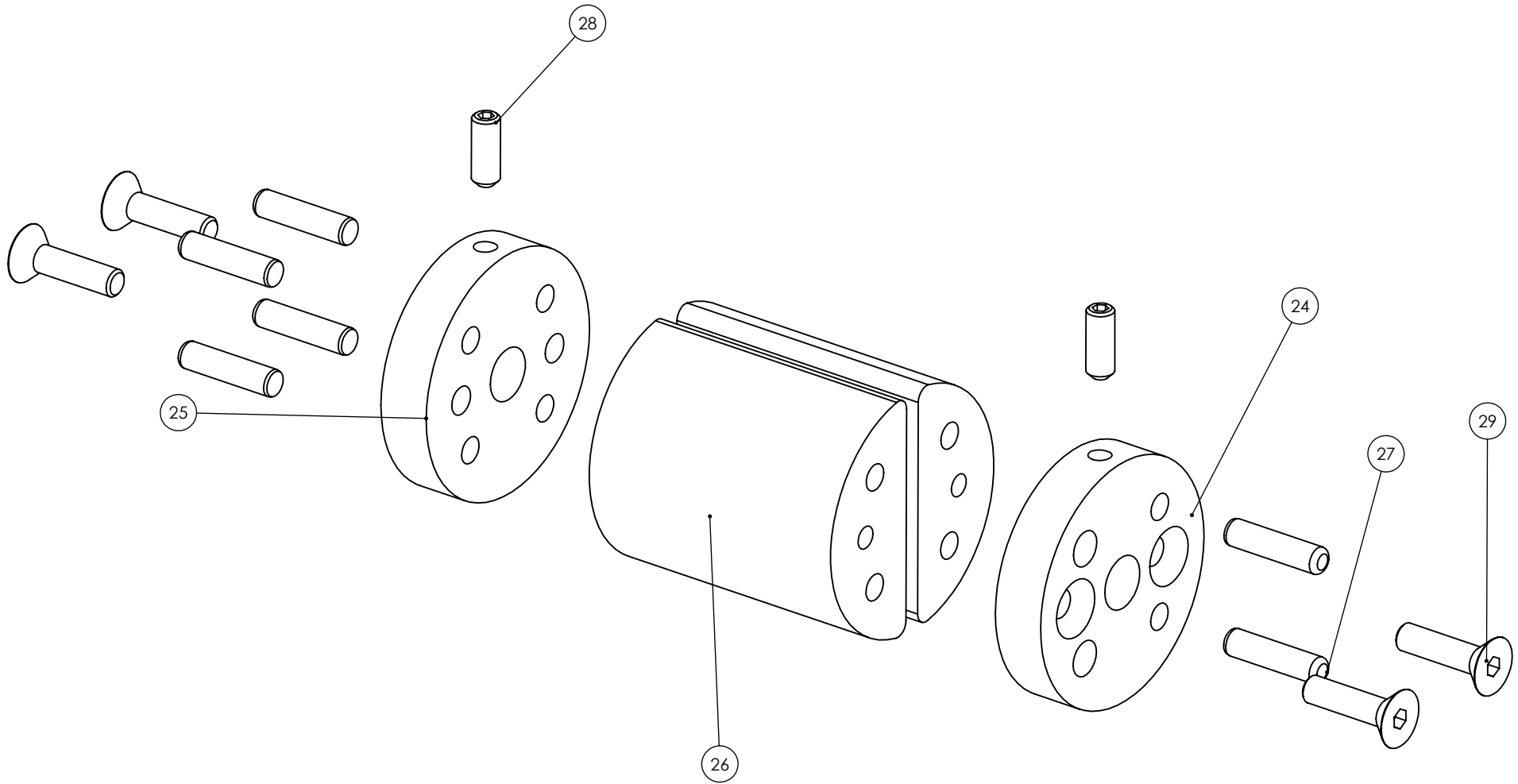

UNLESS OTHERWISE SPECIFIED:	CREATED	7/21/2015	ASSEMBLY		
	LAST SAVED	4/7/2017	Belt Attach Assem		
	DRAWN BY	KB	DESCRIPTION		
	PHONE	+1 (734) 936-0960	Exploded View		
INTERPRET GEOMETRIC TOLERANCING PER:	ASME Y14.5-1994		FILENAME		
MATERIAL	Various		Belt_Attach_Assem		
FINISH			SIZE	DWG. NO.	REV
			A	1	2
			SCALE: 1:1	WEIGHT: 0.56 lb	SHEET 4 OF 4



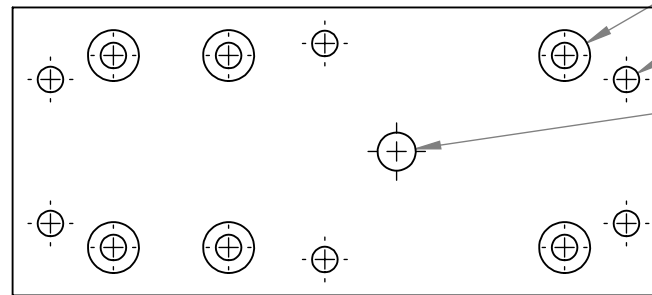
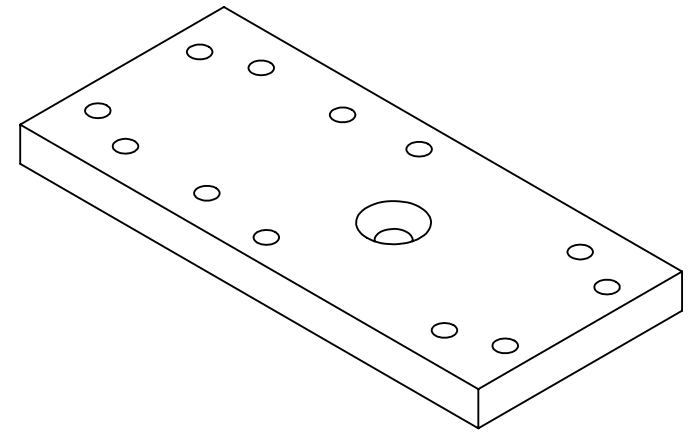
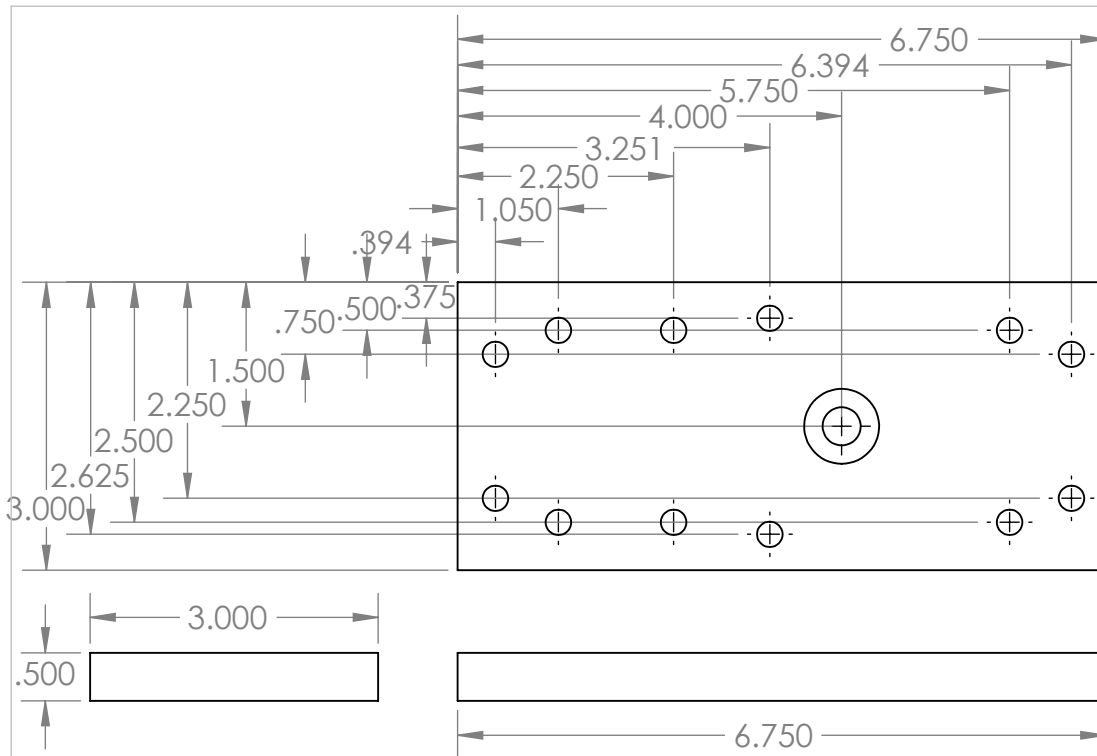

6X ϕ .266 THRU ALL
 \surd ϕ .531 X 82°

6X ϕ .266 THRU ALL

ϕ .397 THRU ALL
 \surd ϕ .781 X 82°

UNLESS OTHERWISE SPECIFIED:

DIMENSIONS ARE IN INCHES
 TOLERANCES:
 FRACTIONAL $\pm 1/64$
 ANGULAR: MACH $\pm 1^\circ$ BEND $\pm 2^\circ$
 TWO PLACE DECIMAL ± 0.01
 THREE PLACE DECIMAL ± 0.005

INTERPRET GEOMETRIC
 TOLERANCING PER: ASME Y14.5-1994

MATERIAL
 6061-T6

FINISH

CREATED 1/9/2015
 LAST SAVED 5/1/2017
 DRAWN BY KB
 PHONE +1 (734) 936-1109



ASSEMBLY

DESCRIPTION

FILENAME
 Bottom_Plate

SIZE A	DWG. NO. 2	REV 2
SCALE: 1:2	WEIGHT: 0.94 lb	SHEET 1 OF 1

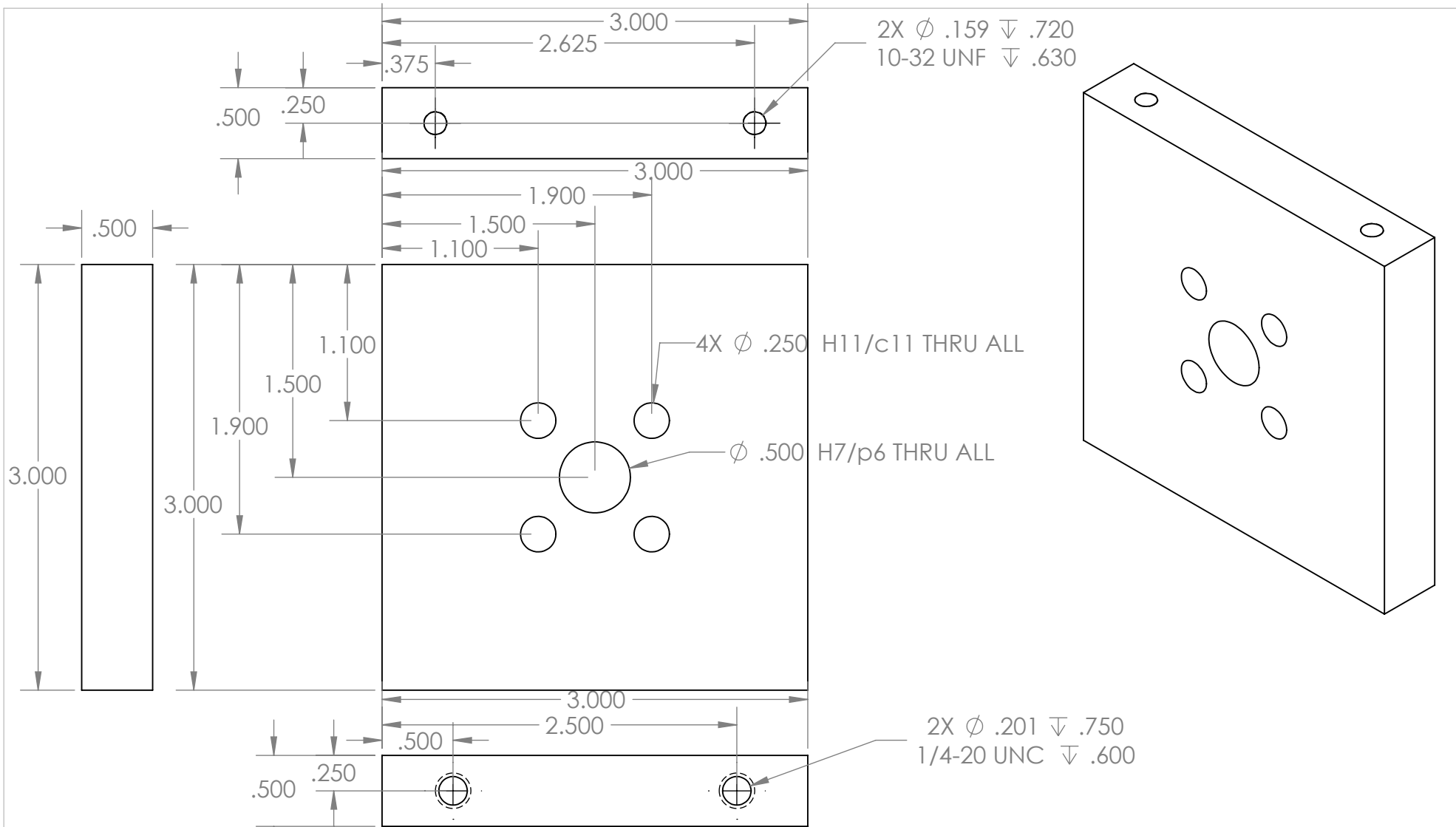

UNLESS OTHERWISE SPECIFIED:
 DIMENSIONS ARE IN INCHES
 TOLERANCES:
 FRACTIONAL ±1/64
 ANGULAR: MACH ±1° BEND ±2°
 TWO PLACE DECIMAL ±0.01
 THREE PLACE DECIMAL ±0.005

INTERPRET GEOMETRIC TOLERANCING PER: ASME Y14.5-1994

MATERIAL
 6061-T6

FINISH

CREATED 1/9/2015
 LAST SAVED 5/1/2017
 DRAWN BY KB
 PHONE +1 (734) 936-1109



ASSEMBLY		
DESCRIPTION		
FILENAME Front_Plate		
SIZE A	DWG. NO. 3	REV 2
SCALE: 1:1	WEIGHT: 0.41 lb	SHEET 1 OF 1

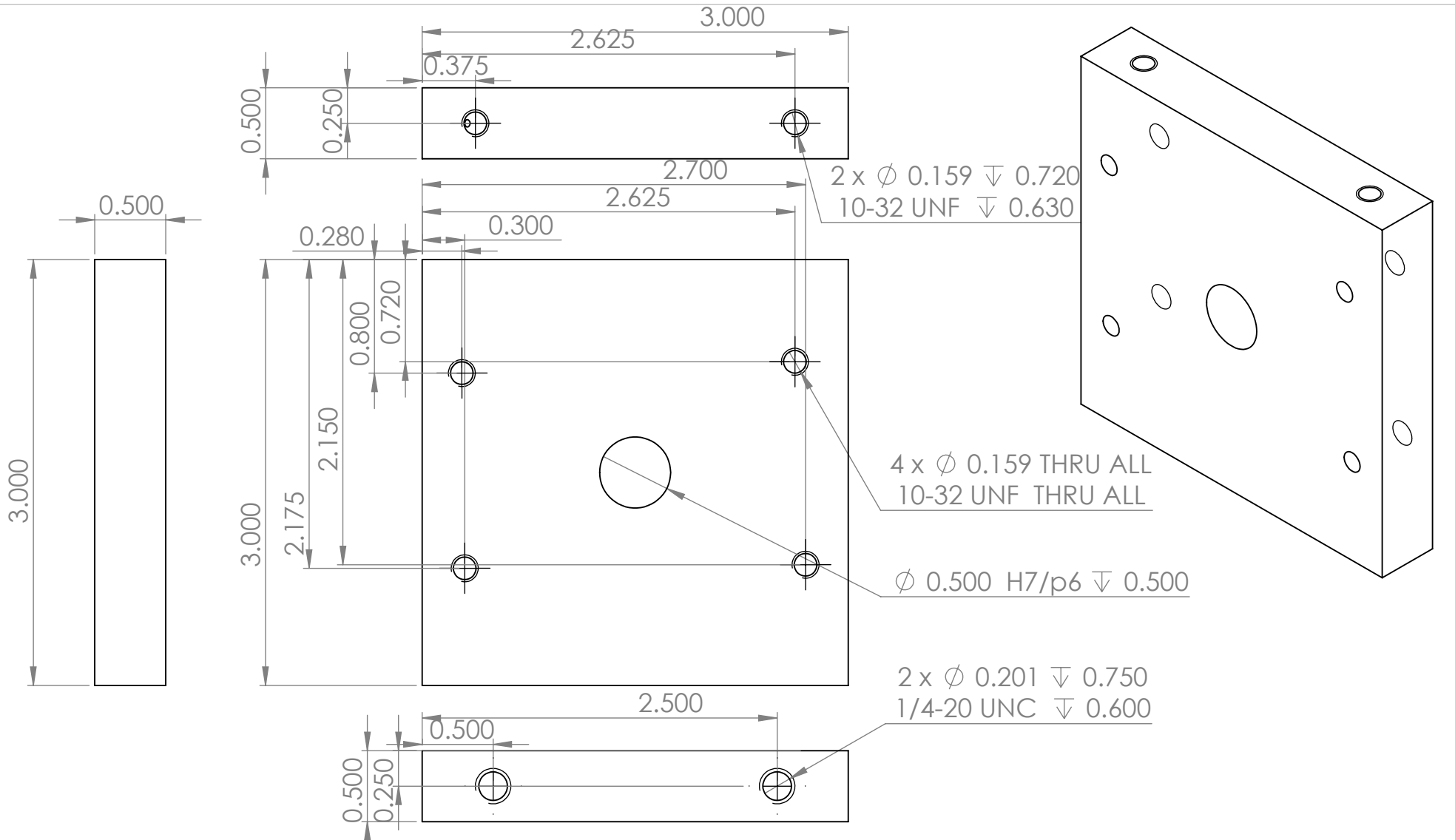

UNLESS OTHERWISE SPECIFIED: DIMENSIONS ARE IN INCHES TOLERANCES: FRACTIONAL $\pm 1/64$ ANGULAR: MACH $\pm 1^\circ$ BEND $\pm 2^\circ$ TWO PLACE DECIMAL ± 0.01 THREE PLACE DECIMAL ± 0.005 INTERPRET GEOMETRIC TOLERANCING PER: ASME Y14.5-1994 MATERIAL 6061-T6 FINISH	CREATED 4/6/2017 LAST SAVED 5/1/2017 DRAWN BY KB PHONE +1 (734) 936-1109	ASSEMBLY		
	FILENAME Spring_Plate_In		DESCRIPTION	
	 2901 Baxter Rd Ann Arbor, MI 48109		SIZE A	DWG. NO. 4
			SCALE: 1:1	WEIGHT: 0.42 lb
		REV 2		
		SHEET 1 OF 1		

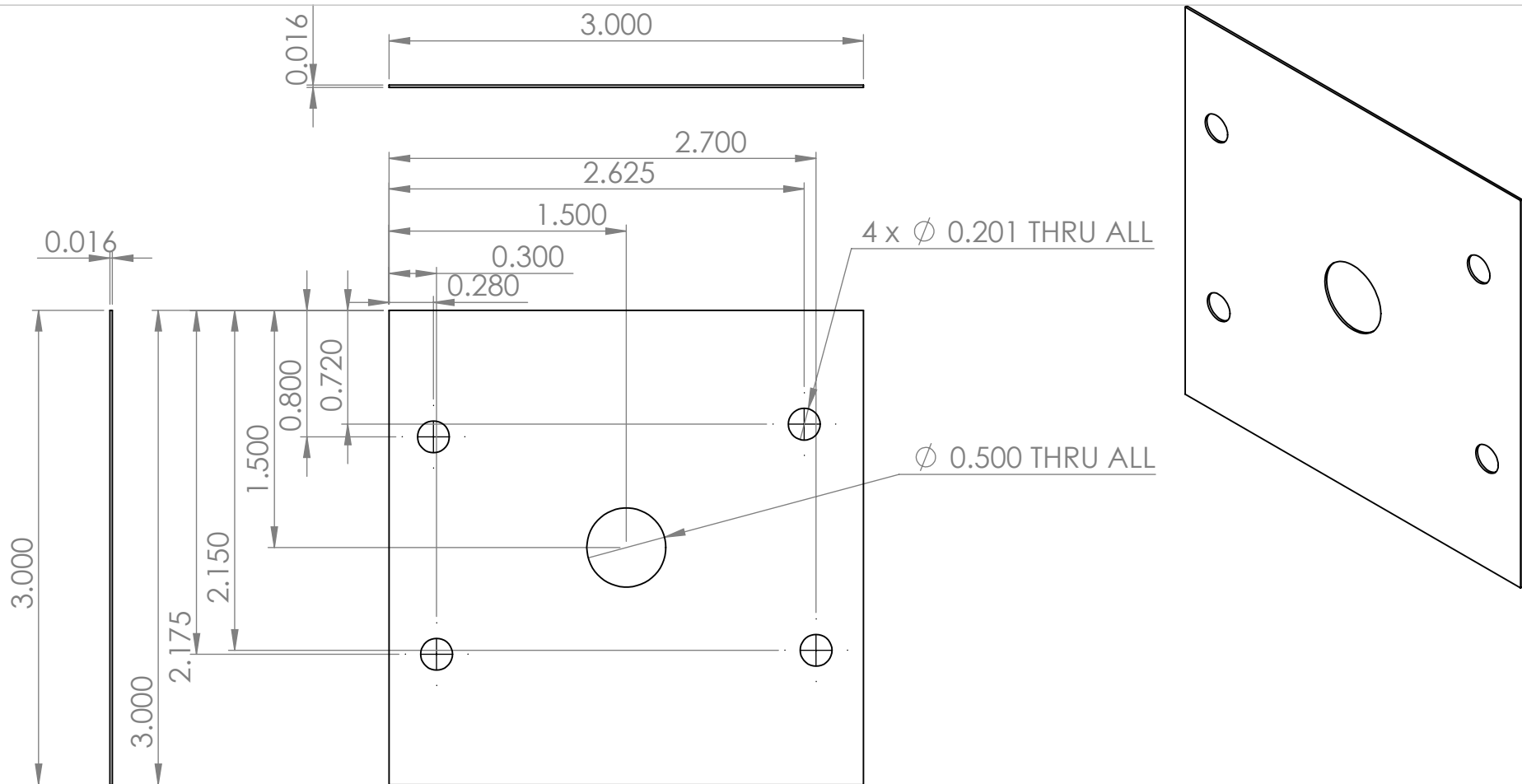

UNLESS OTHERWISE SPECIFIED: DIMENSIONS ARE IN INCHES TOLERANCES: FRACTIONAL $\pm 1/64$ ANGULAR: MACH $\pm 1^\circ$ BEND $\pm 2^\circ$ TWO PLACE DECIMAL ± 0.01 THREE PLACE DECIMAL ± 0.005	CREATED	7/21/2015	ASSEMBLY	
	LAST SAVED	4/6/2017	DESCRIPTION	
	DRAWN BY	KB		
	PHONE	+1 (734) 936-1109		
INTERPRET GEOMETRIC TOLERANCING PER: ASME Y14.5-1994	 2901 Baxter Rd Ann Arbor, MI 48109		FILENAME	
MATERIAL			Teflon_Sheet_In	
PTFE (general)			SIZE	DWG. NO.
FINISH	A	5	2	
	SCALE: 1:1	WEIGHT: 0.01 lb	SHEET 1 OF 1	

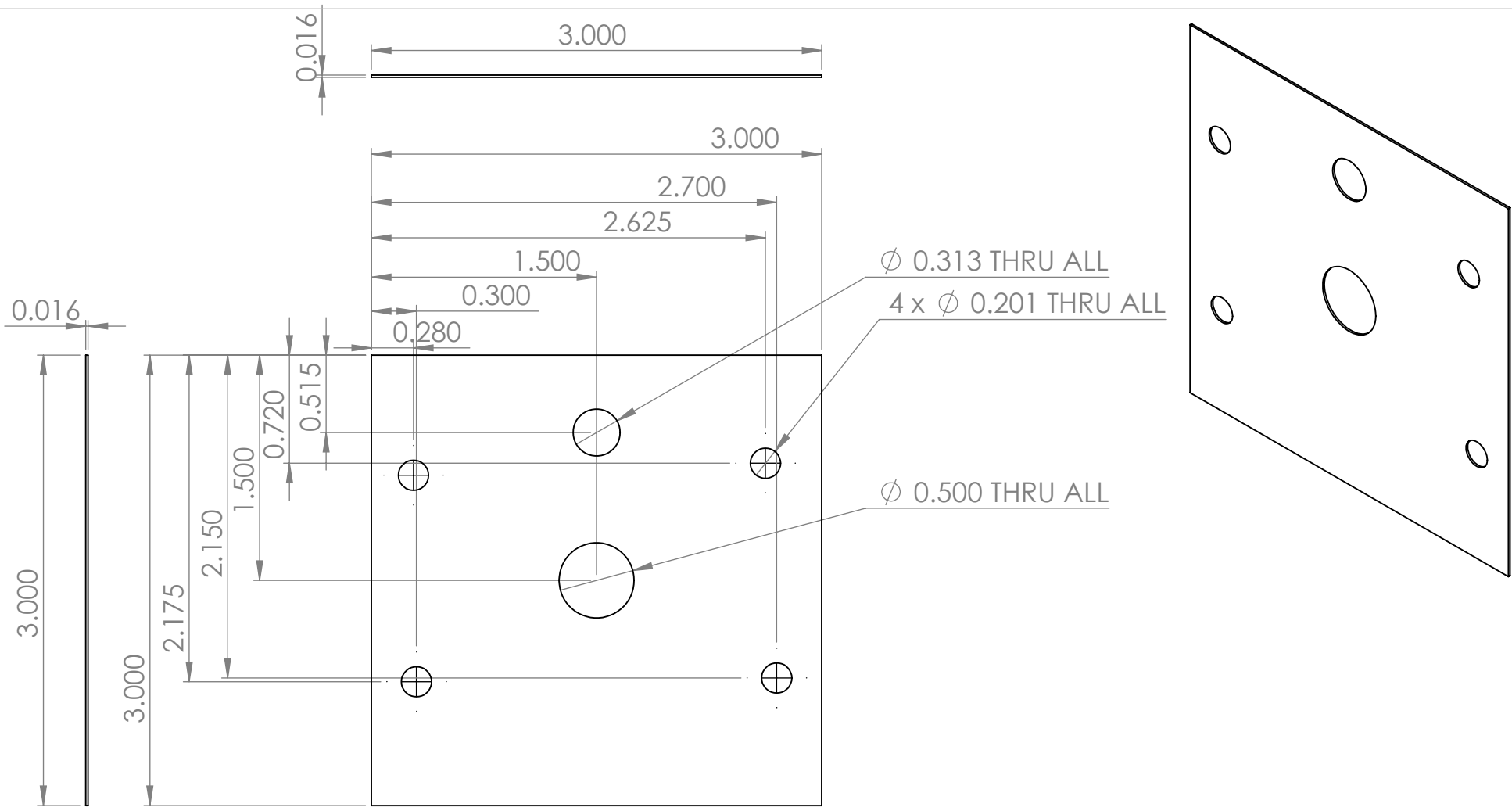

UNLESS OTHERWISE SPECIFIED: DIMENSIONS ARE IN INCHES TOLERANCES: FRACTIONAL $\pm 1/64$ ANGULAR: MACH $\pm 1^\circ$ BEND $\pm 2^\circ$ TWO PLACE DECIMAL ± 0.01 THREE PLACE DECIMAL ± 0.005	CREATED 4/6/2017	ASSEMBLY	
	LAST SAVED 4/6/2017	DESCRIPTION	
	DRAWN BY KB	FILENAME Teflon_Sheet_Out	
	PHONE +1 (734) 936-1109	SIZE A	DWG. NO. 6
INTERPRET GEOMETRIC TOLERANCING PER: ASME Y14.5-1994	 2901 Baxter Rd Ann Arbor, MI 48109		SCALE: 1:1
MATERIAL PTFE (general)			WEIGHT: 0.01 lb
FINISH			

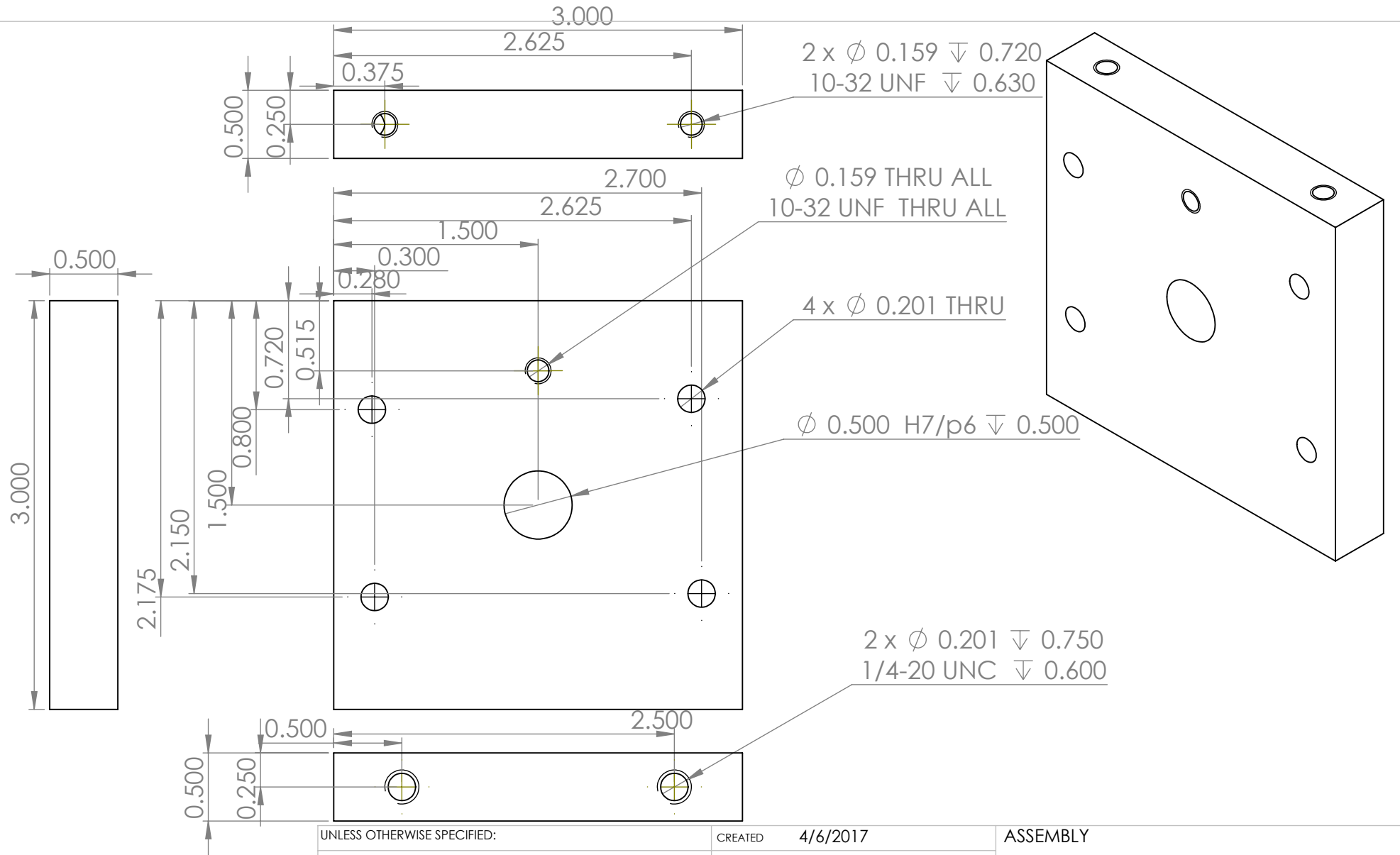

UNLESS OTHERWISE SPECIFIED:

DIMENSIONS ARE IN INCHES
TOLERANCES:
FRACTIONAL $\pm 1/64$
ANGULAR: MACH $\pm 1^\circ$ BEND $\pm 2^\circ$
TWO PLACE DECIMAL ± 0.01
THREE PLACE DECIMAL ± 0.005

INTERPRET GEOMETRIC
TOLERANCING PER: ASME Y14.5-1994

MATERIAL
6061-T6

FINISH

CREATED 4/6/2017
LAST SAVED 5/1/2017
DRAWN BY KB
PHONE +1 (734) 936-1109

M
UMTRI
2901 Baxter Rd
Ann Arbor, MI 48109

ASSEMBLY

DESCRIPTION

FILENAME
Spring_Plate_Out

SIZE **A** DWG. NO. 7

REV **2**

SCALE: 1:1

WEIGHT: 0.41 lb

SHEET 1 OF 1

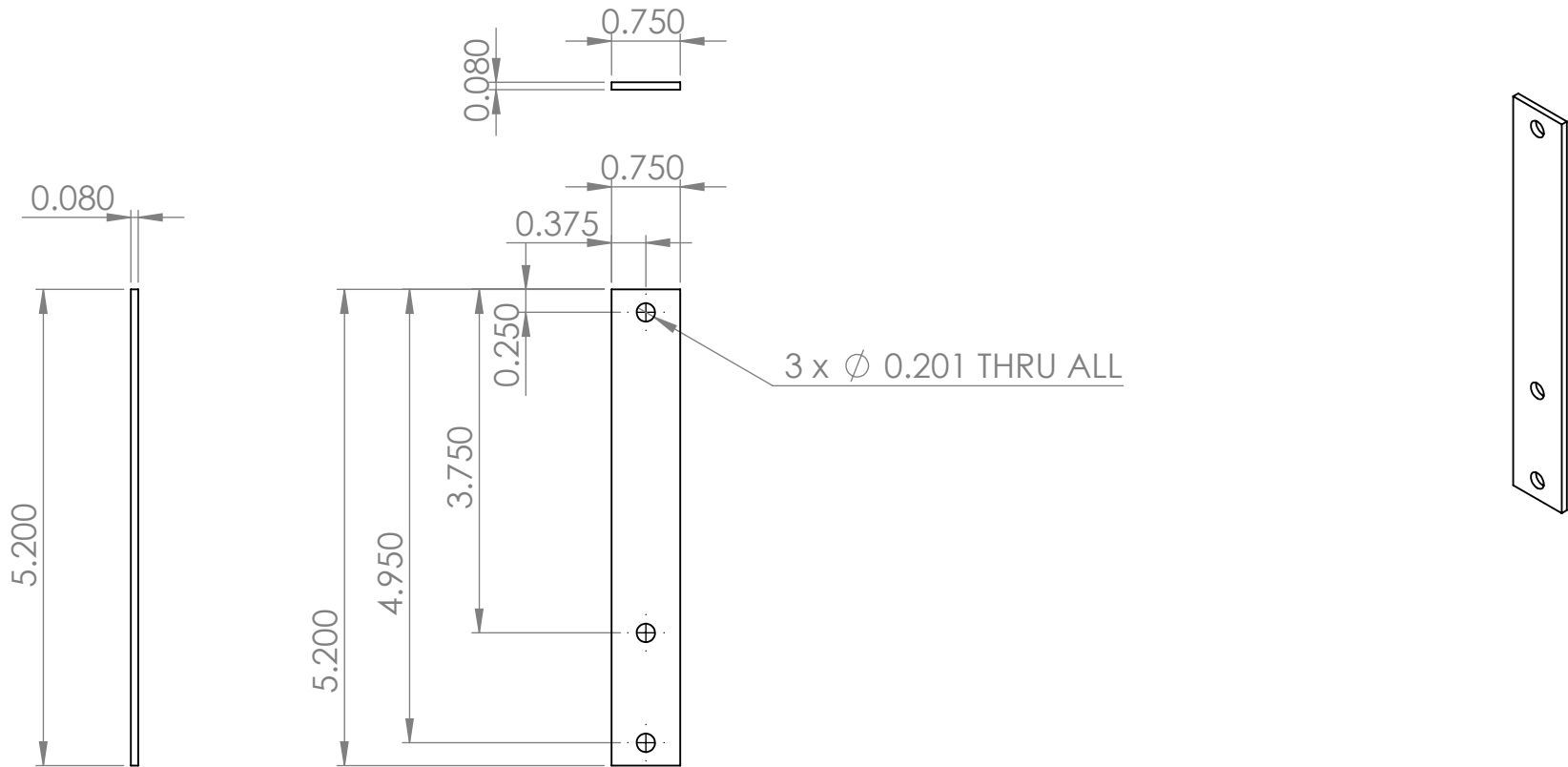

UNLESS OTHERWISE SPECIFIED: DIMENSIONS ARE IN INCHES TOLERANCES: FRACTIONAL $\pm 1/64$ ANGULAR: MACH $\pm 1^\circ$ BEND $\pm 2^\circ$ TWO PLACE DECIMAL ± 0.01 THREE PLACE DECIMAL ± 0.005	CREATED 4/6/2017	ASSEMBLY	
	LAST SAVED 5/1/2017	DESCRIPTION	
	DRAWN BY KB	FILENAME Top_Rein_Straight	
	PHONE +1 (734) 936-1109	SIZE A	DWG. NO. 8
INTERPRET GEOMETRIC TOLERANCING PER: ASME Y14.5-1994	 2901 Baxter Rd Ann Arbor, MI 48109		SCALE: 1:1
MATERIAL 6061-T6			WEIGHT: 0.03 lb
FINISH			

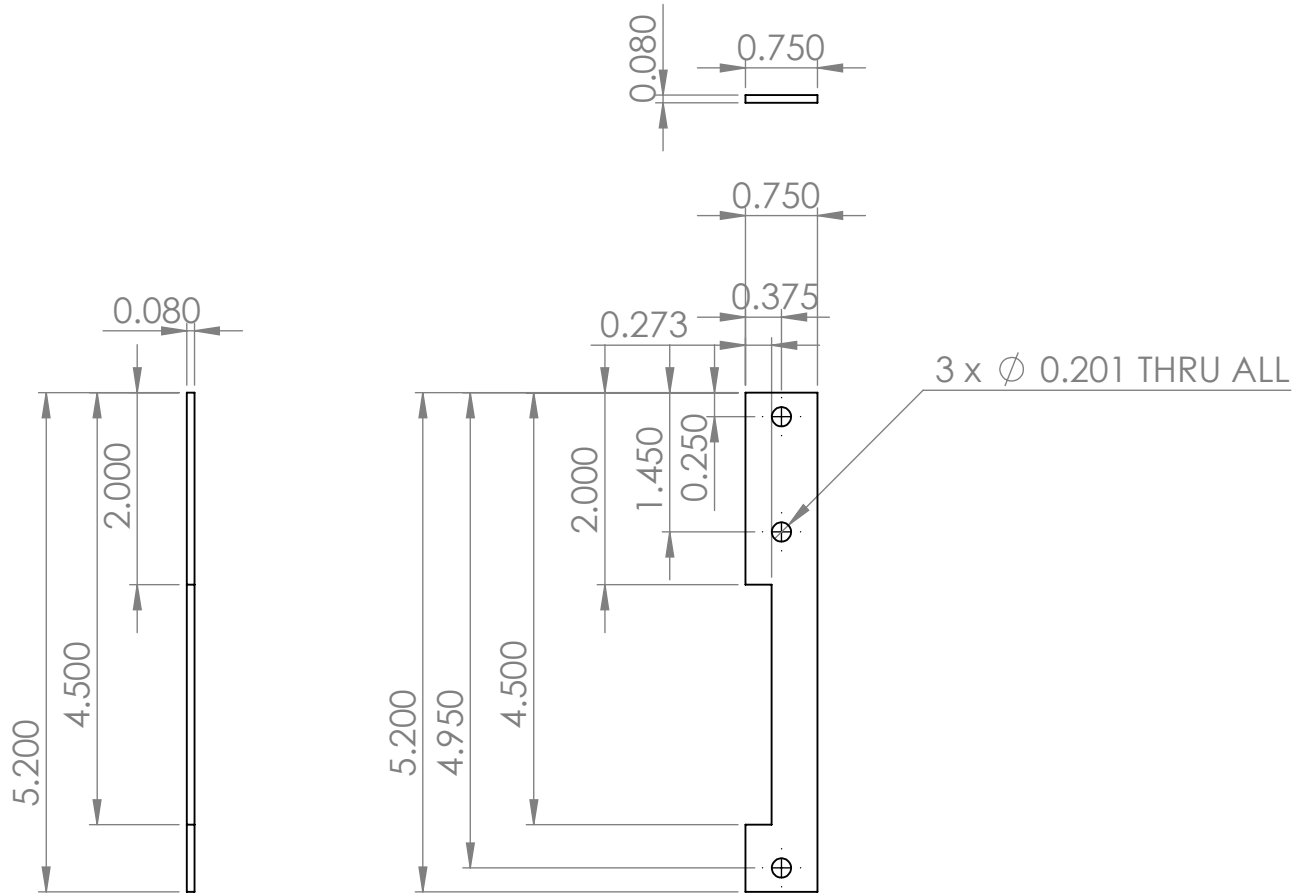

UNLESS OTHERWISE SPECIFIED: DIMENSIONS ARE IN INCHES TOLERANCES: FRACTIONAL $\pm 1/64$ ANGULAR: MACH $\pm 1^\circ$ BEND $\pm 2^\circ$ TWO PLACE DECIMAL ± 0.01 THREE PLACE DECIMAL ± 0.005	CREATED	4/6/2017	ASSEMBLY		
	LAST SAVED	5/1/2017	DESCRIPTION		
	DRAWN BY	KB			
	PHONE	+1 (734) 936-1109			
INTERPRET GEOMETRIC TOLERANCING PER: ASME Y14.5-1994	 2901 Baxter Rd Ann Arbor, MI 48109		FILENAME Top_Rein_Cut		
MATERIAL 6061-T6			SIZE A	DWG. NO. 9	REV 2
FINISH			SCALE: 1:2	WEIGHT: 0.02 lb	SHEET 1 OF 1

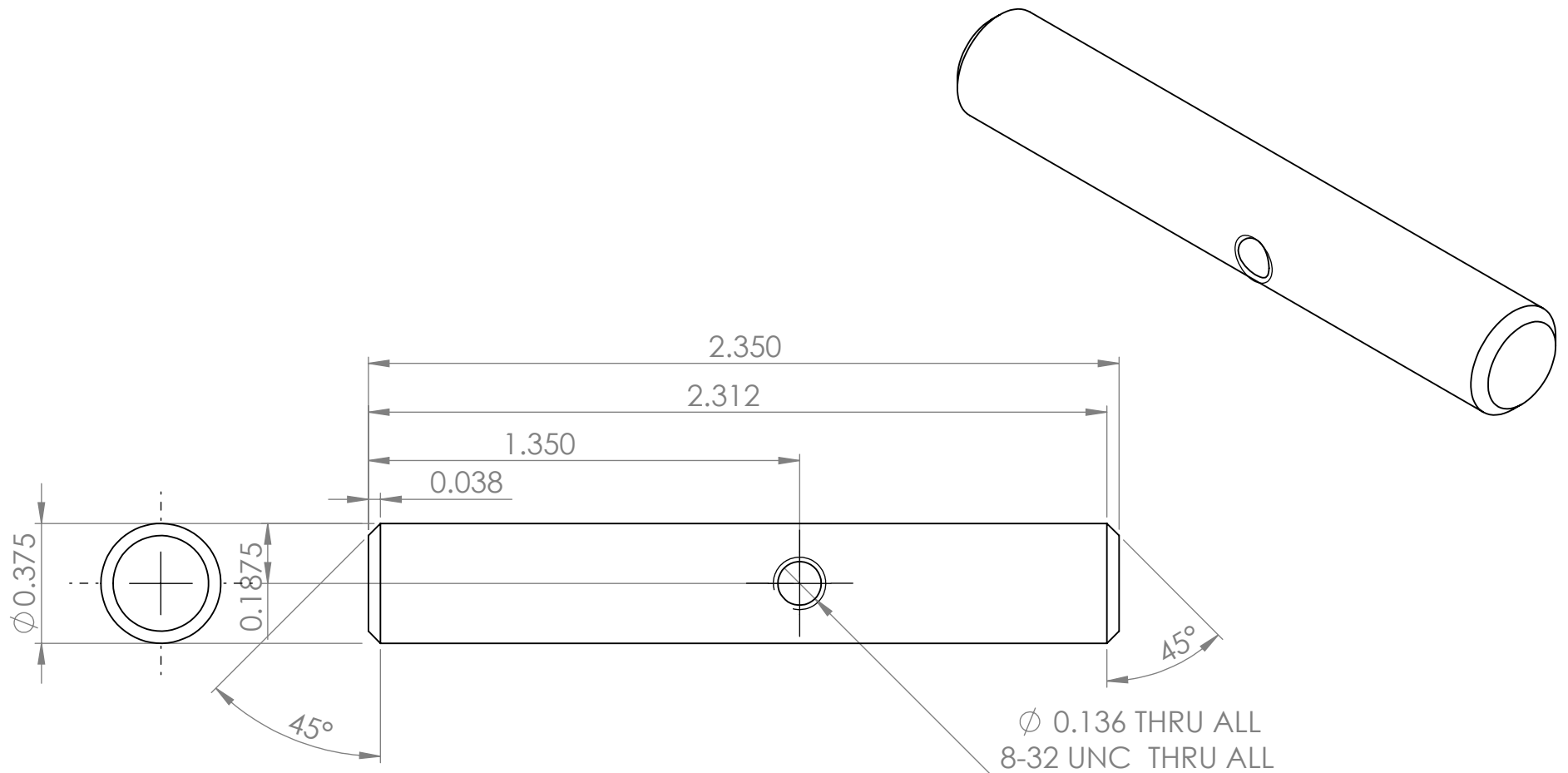

UNLESS OTHERWISE SPECIFIED:		CREATED	4/6/2017	ASSEMBLY		
DIMENSIONS ARE IN INCHES		LAST SAVED	5/1/2017	DESCRIPTION		
TOLERANCES:		DRAWN BY	KB			
FRACTIONAL $\pm 1/64$		PHONE	+1 (734) 936-1109	FILENAME		
ANGULAR: MACH $\pm 1^\circ$ BEND $\pm 2^\circ$		 2901 Baxter Rd Ann Arbor, MI 48109		1346k11_Spring_Side_Rotary_Shaft		
TWO PLACE DECIMAL ± 0.01				SIZE	DWG. NO.	REV
THREE PLACE DECIMAL ± 0.005				A	11	2
INTERPRET GEOMETRIC TOLERANCING PER: ASME Y14.5-1994		SCALE: 2:1		WEIGHT: 0.07 lb	SHEET 1 OF 1	
MATERIAL		1566 Steel Hardness RC25				
FINISH						

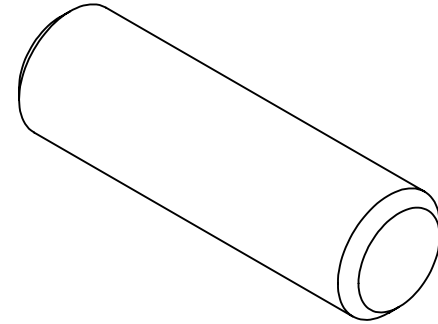
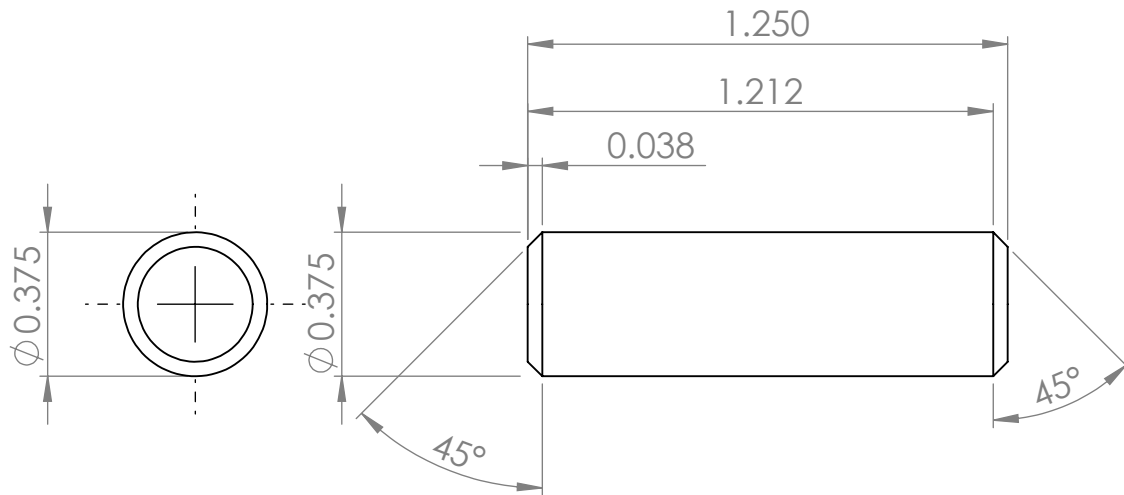

UNLESS OTHERWISE SPECIFIED: DIMENSIONS ARE IN INCHES TOLERANCES: FRACTIONAL $\pm 1/64$ ANGULAR: MACH $\pm 1^\circ$ BEND $\pm 2^\circ$ TWO PLACE DECIMAL ± 0.01 THREE PLACE DECIMAL ± 0.005	CREATED 4/6/2017	ASSEMBLY	
	LAST SAVED 5/1/2017	DESCRIPTION	
	DRAWN BY KB	FILENAME 1346k11_End_Rotary_Shaft	
	PHONE +1 (734) 936-1109	SIZE A	DWG. NO. 10
INTERPRET GEOMETRIC TOLERANCING PER: ASME Y14.5-1994			SCALE: 2:1
MATERIAL 1566 Steel Hardness RC25			WEIGHT: 0.04 lb
FINISH			

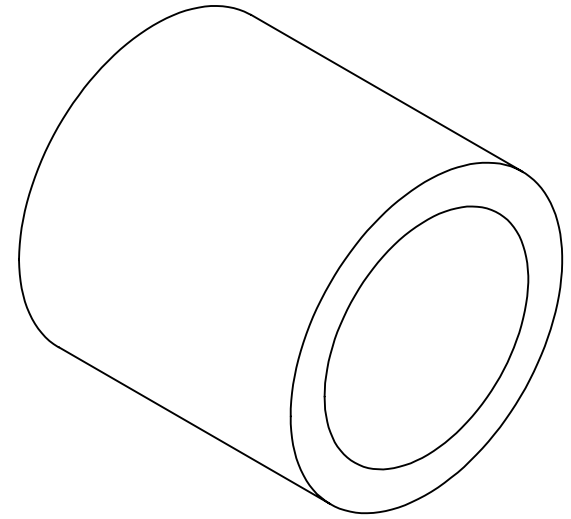
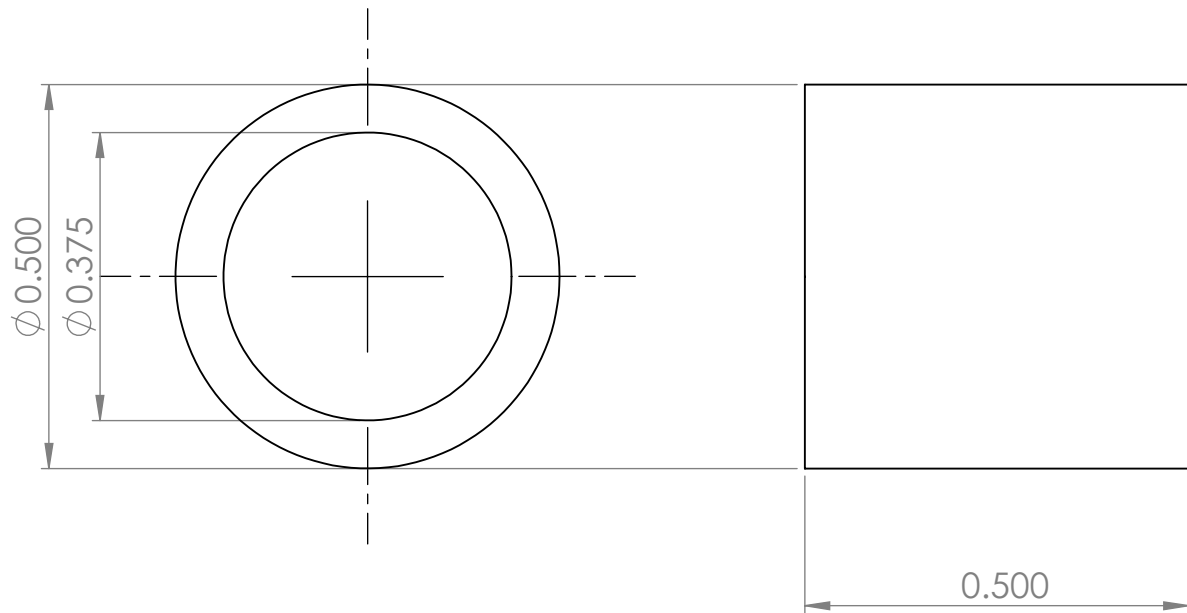

UNLESS OTHERWISE SPECIFIED:		CREATED	4/7/2017	ASSEMBLY		
DIMENSIONS ARE IN INCHES		LAST SAVED	4/7/2017	DESCRIPTION		
TOLERANCES:		DRAWN BY				
FRACTIONAL $\pm 1/64$		PHONE	+1 (734) 936-1109	FILENAME		
ANGULAR: MACH $\pm 1^\circ$ BEND $\pm 2^\circ$		 2901 Baxter Rd Ann Arbor, MI 48109		6381K451_MULTIPURPOSE SLEEVE BRNG		
TWO PLACE DECIMAL ± 0.01				SIZE	DWG. NO.	REV
THREE PLACE DECIMAL ± 0.005				A	12	
INTERPRET GEOMETRIC TOLERANCING PER: ASME Y14.5-1994				SCALE: 4:1	WEIGHT: 0.01 lb	SHEET 1 OF 1
MATERIAL						
Brass						
FINISH						

5

4

3

2

1

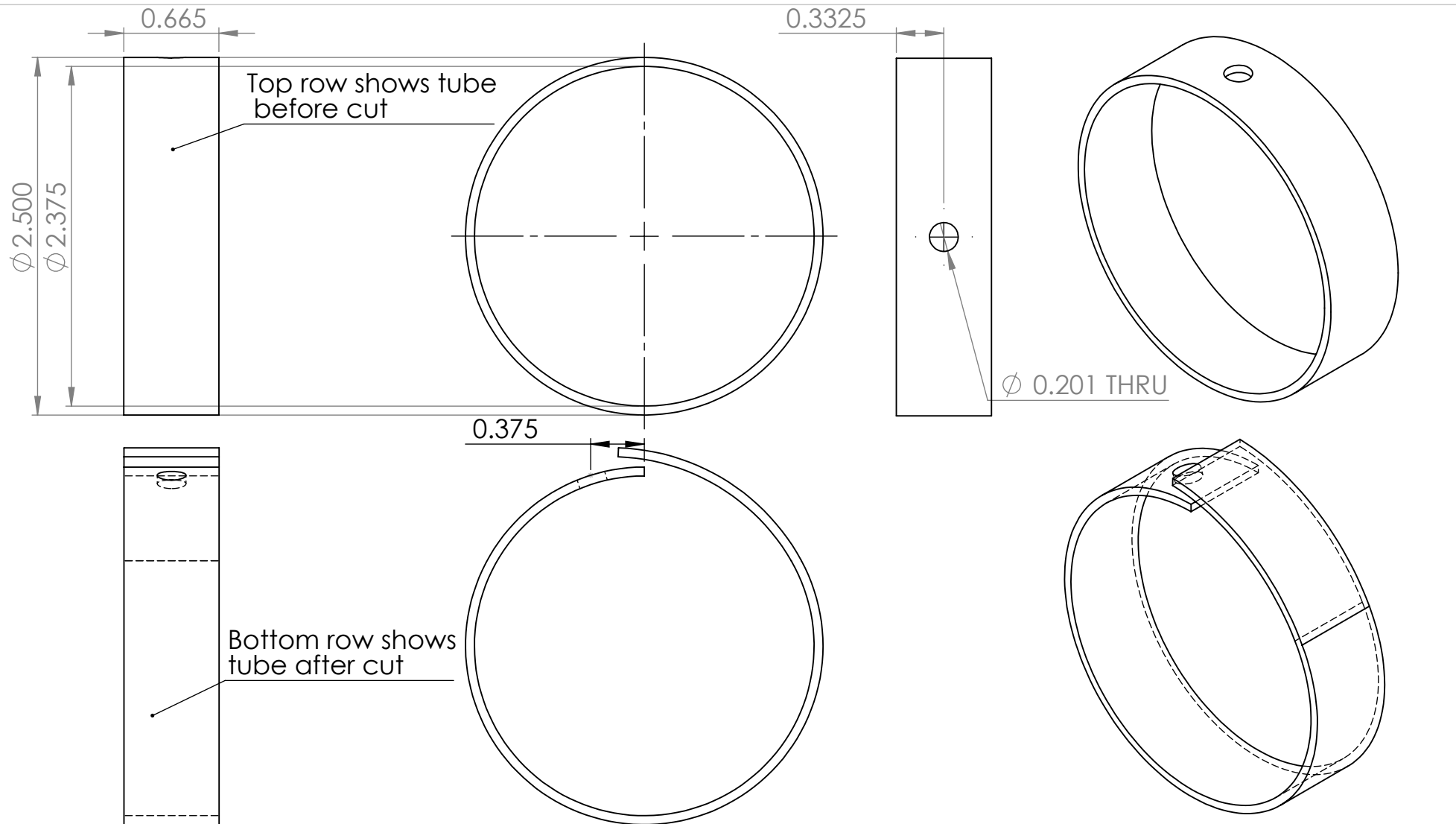

UNLESS OTHERWISE SPECIFIED: DIMENSIONS ARE IN INCHES TOLERANCES: FRACTIONAL $\pm 1/64$ ANGULAR: MACH $\pm 1^\circ$ BEND $\pm 2^\circ$ TWO PLACE DECIMAL ± 0.01 THREE PLACE DECIMAL ± 0.005 INTERPRET GEOMETRIC TOLERANCING PER: ASME Y14.5-1994 MATERIAL Aluminium 6061 T6 FINISH	CREATED 7/21/2015 LAST SAVED 4/7/2017 DRAWN BY KB PHONE +1 (734) 936-1109	ASSEMBLY DESCRIPTION Aluminium tube cut and fit into spring plate bolts		
	 2901 Baxter Rd Ann Arbor, MI 48109	FILENAME Spring_Housing_Cut		
		SIZE A	DWG. NO. 13	REV 2
		SCALE: 1:1	WEIGHT: 0.03 lb	SHEET 1 OF 1

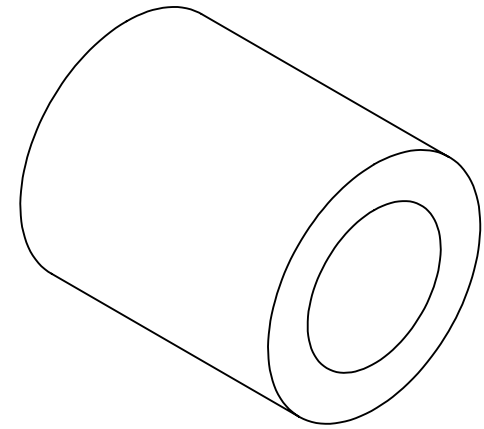
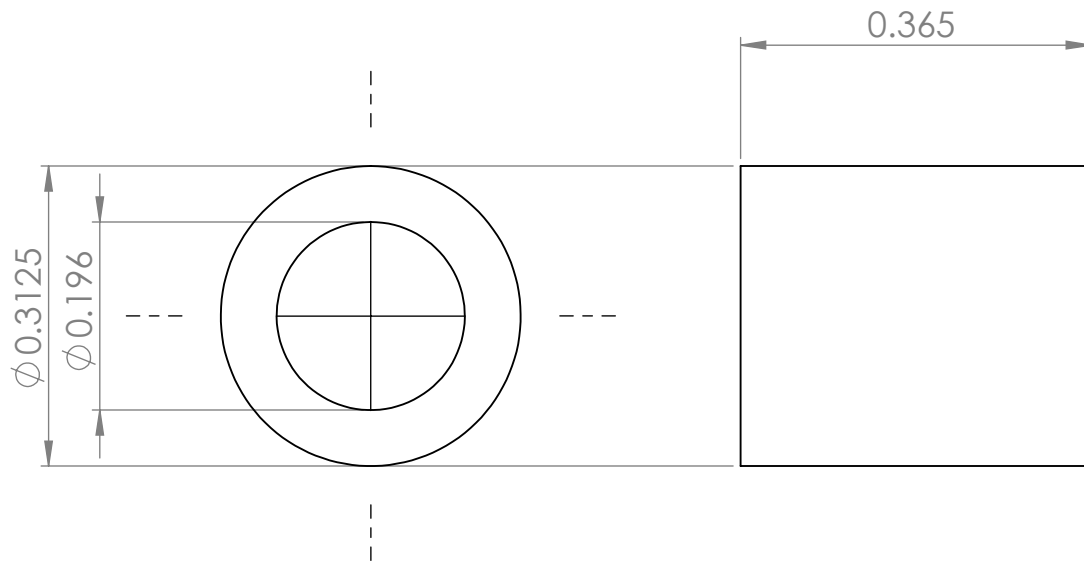

UNLESS OTHERWISE SPECIFIED: DIMENSIONS ARE IN INCHES TOLERANCES: FRACTIONAL $\pm 1/64$ ANGULAR: MACH $\pm 1^\circ$ BEND $\pm 2^\circ$ TWO PLACE DECIMAL ± 0.01 THREE PLACE DECIMAL ± 0.005	CREATED 4/7/2017	ASSEMBLY		
	LAST SAVED 4/7/2017	DESCRIPTION		
	DRAWN BY KB	FILENAME Spring_Stop_Spacer		
	PHONE +1 (734) 936-1109	SIZE A	DWG. NO. 14	REV 2
INTERPRET GEOMETRIC TOLERANCING PER: ASME Y14.5-1994			SCALE: 5:1	
MATERIAL Plain Carbon Steel			WEIGHT: 0.00 lb	SHEET 1 OF 1
FINISH				

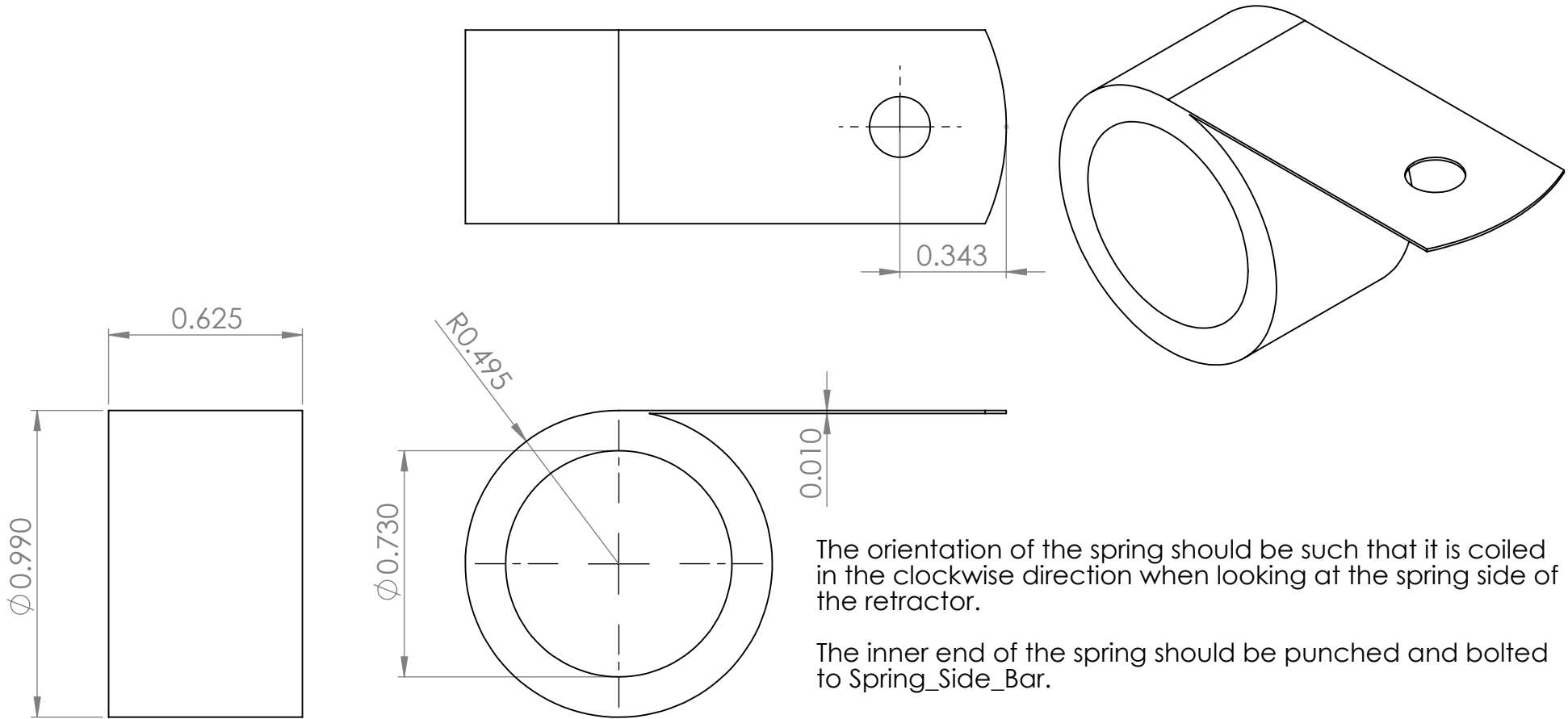

The orientation of the spring should be such that it is coiled in the clockwise direction when looking at the spring side of the retractor.

The inner end of the spring should be punched and bolted to Spring_Side_Bar.

The outer end of the spring is bolted to Spring_housing_cut.

In this configuration, to tension the retractor, the spindle should only be rotated in the counter clockwise direction (opposite of spring coil direction).

UNLESS OTHERWISE SPECIFIED: DIMENSIONS ARE IN INCHES TOLERANCES: FRACTIONAL $\pm 1/64$ ANGULAR: MACH $\pm 1^\circ$ BEND $\pm 2^\circ$ TWO PLACE DECIMAL ± 0.01 THREE PLACE DECIMAL ± 0.005	CREATED	4/7/2017	ASSEMBLY		
	LAST SAVED	4/27/2017	DESCRIPTION		
	DRAWN BY		FILENAME		
	PHONE	+1 (734) 936-1109	9293K540_STAINLESS STEEL CONSTANT-FORCE SPRING		
INTERPRET GEOMETRIC TOLERANCING PER: ASME Y14.5-1994			SIZE	DWG. NO.	REV
MATERIAL			A	16	
301 Stainless Steel					
FINISH			SCALE: 2:1	WEIGHT: lb	SHEET 1 OF 1

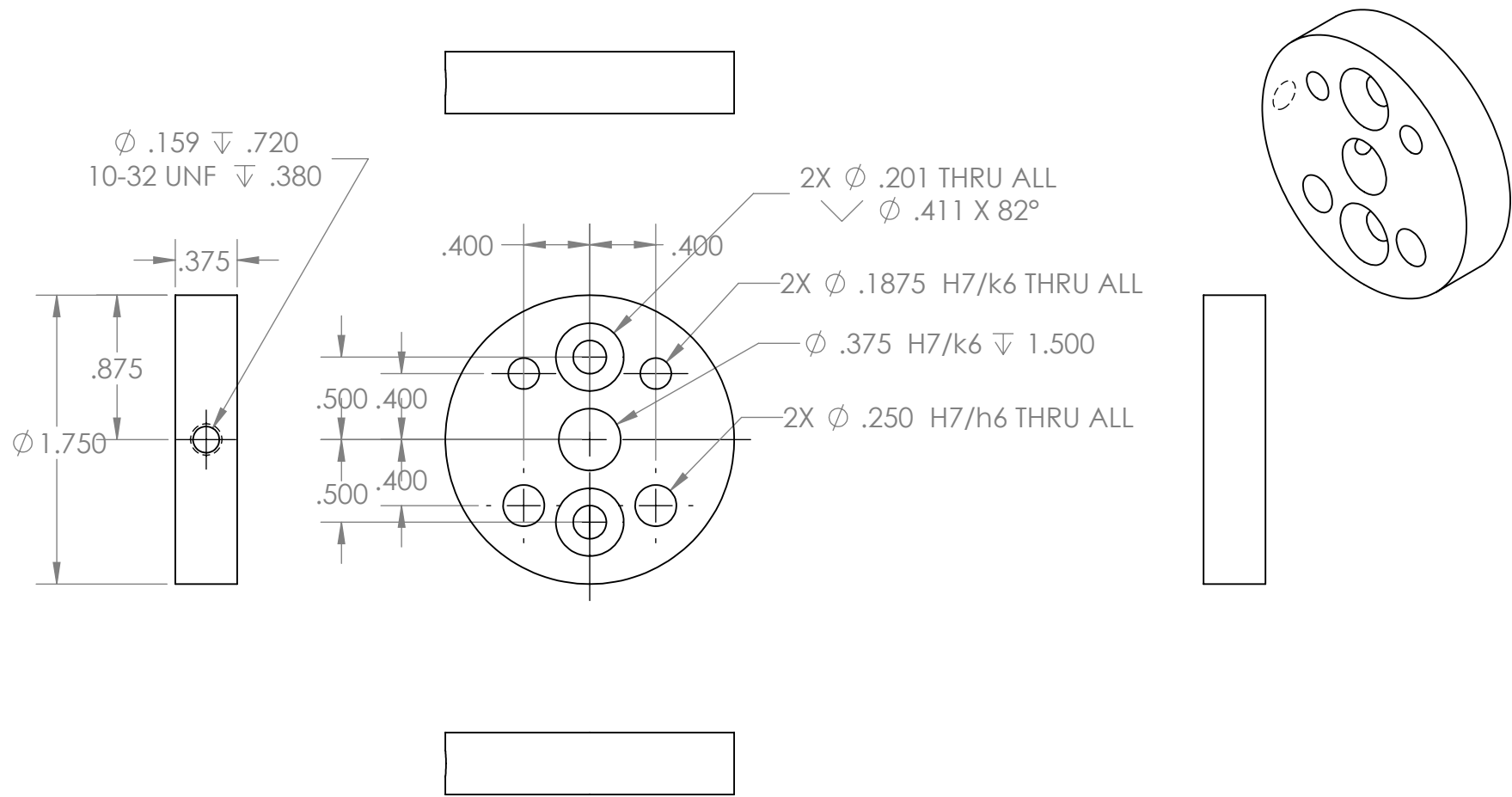

UNLESS OTHERWISE SPECIFIED: DIMENSIONS ARE IN INCHES TOLERANCES: FRACTIONAL $\pm 1/64$ ANGULAR: MACH $\pm 1^\circ$ BEND $\pm 2^\circ$ TWO PLACE DECIMAL ± 0.01 THREE PLACE DECIMAL ± 0.005	CREATED 1/9/2015	ASSEMBLY	
	LAST SAVED 5/1/2017	DESCRIPTION	
	DRAWN BY KB	FILENAME Belt_Attach_End1	
	PHONE +1 (734) 936-1109	SIZE A	DWG. NO. 24
INTERPRET GEOMETRIC TOLERANCING PER: ASME Y14.5-1994	 2901 Baxter Rd Ann Arbor, MI 48109		SCALE: 1:1
MATERIAL 6061-T6			WEIGHT: 0.07 lb
FINISH			

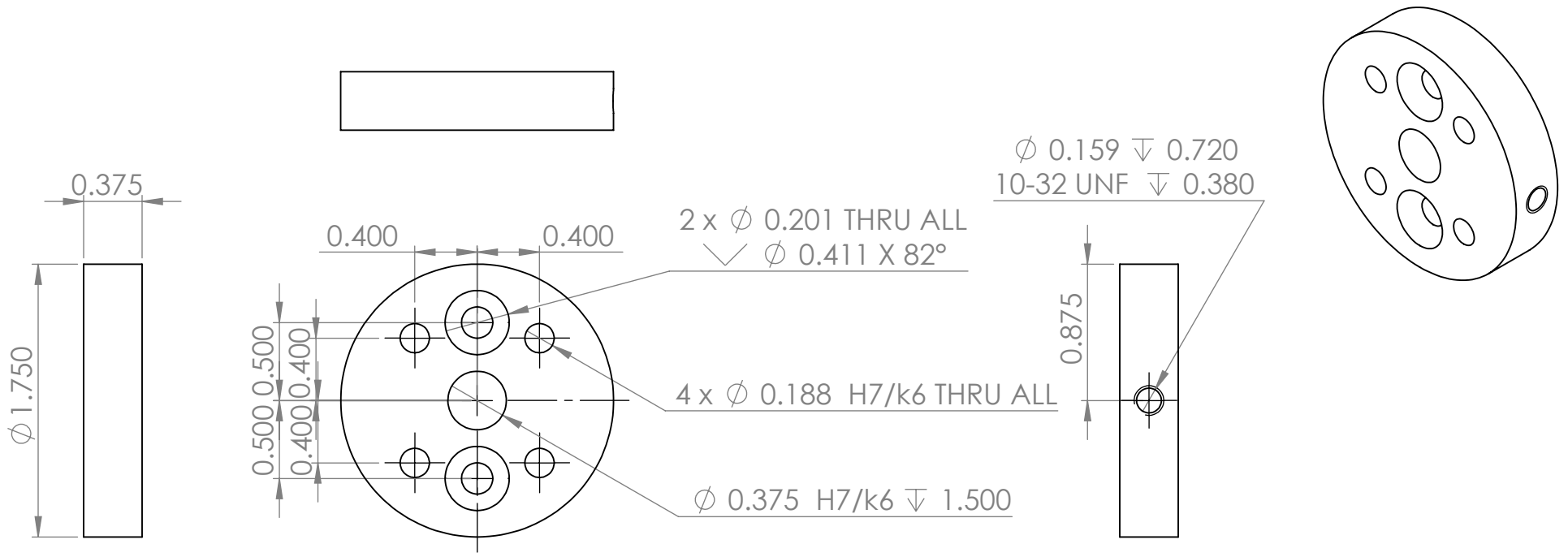

UNLESS OTHERWISE SPECIFIED: DIMENSIONS ARE IN INCHES TOLERANCES: FRACTIONAL ±1/64 ANGULAR: MACH ±1° BEND ±2° TWO PLACE DECIMAL ±0.01 THREE PLACE DECIMAL ±0.005 INTERPRET GEOMETRIC TOLERANCING PER: ASME Y14.5-1994 MATERIAL 6061-T6 FINISH	CREATED 4/4/2017	ASSEMBLY		
	LAST SAVED 5/1/2017	DESCRIPTION		
	DRAWN BY KB	FILENAME Belt_Attach_End2		
	PHONE +1 (734) 936-1109	SIZE A	DWG. NO. 25	REV 2
		SCALE: 1:1	WEIGHT: 0.08 lb	SHEET 1 OF 1
2901 Baxter Rd Ann Arbor, MI 48109				

5

4

3

B-21

2

1

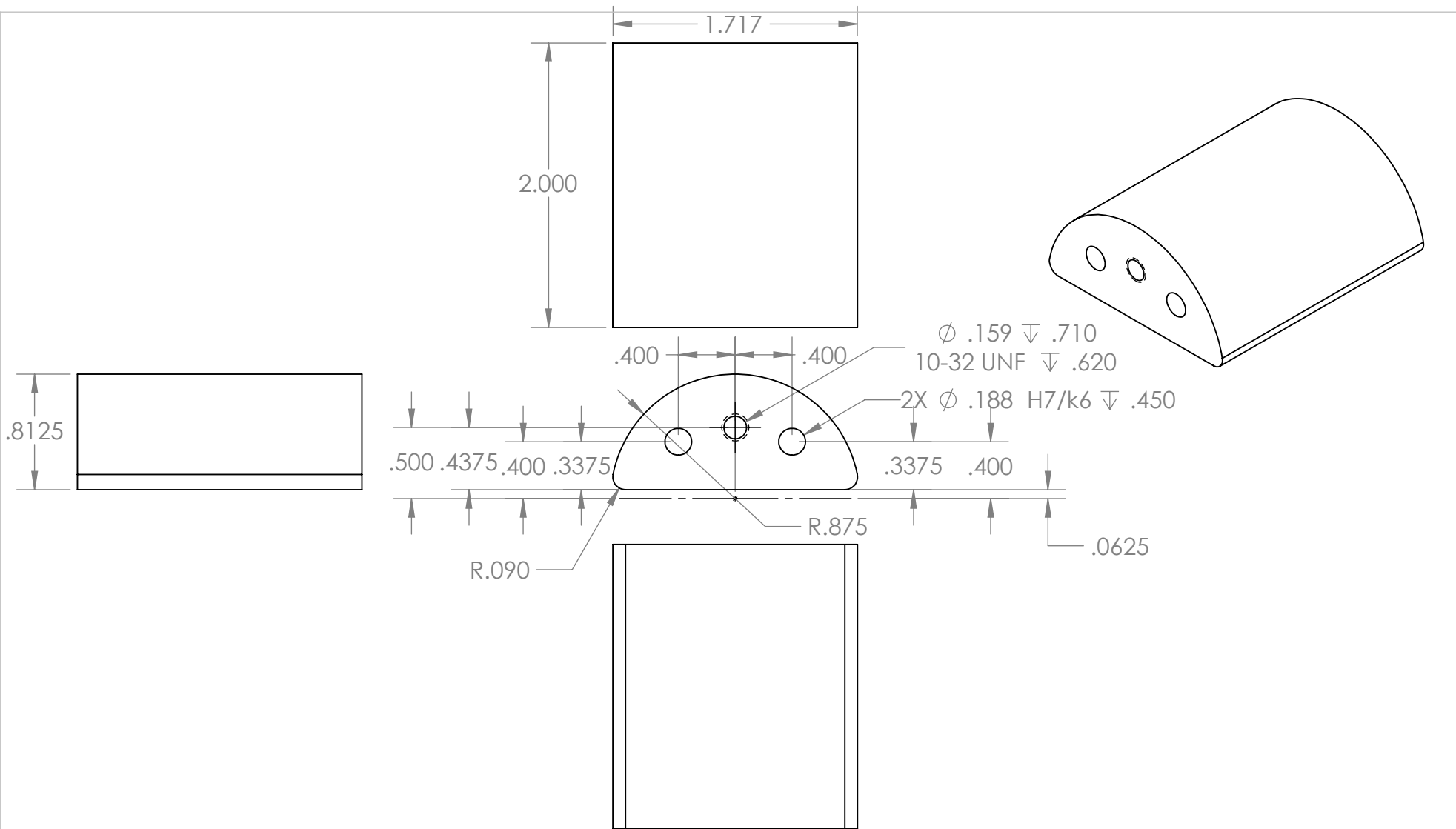

UNLESS OTHERWISE SPECIFIED: DIMENSIONS ARE IN INCHES TOLERANCES: FRACTIONAL $\pm 1/64$ ANGULAR: MACH $\pm 1^\circ$ BEND $\pm 2^\circ$ TWO PLACE DECIMAL ± 0.01 THREE PLACE DECIMAL ± 0.005	CREATED 1/9/2015	ASSEMBLY			
	LAST SAVED 5/1/2017	DESCRIPTION			
	DRAWN BY KB	FILENAME Belt_Attach_Body			
	PHONE +1 (734) 936-1109	SIZE A	DWG. NO. 26	REV 2	
INTERPRET GEOMETRIC TOLERANCING PER: ASME Y14.5-1994	 2901 Baxter Rd Ann Arbor, MI 48109		SCALE: 1:1	WEIGHT: 0.20 lb	SHEET 1 OF 1
MATERIAL 6061-T6			FINISH		

DOT HS 812 660
January 2019



U.S. Department
of Transportation
**National Highway
Traffic Safety
Administration**

