

Inspection and QA/QC for ABC Projects

Final Report
December 2018



Sponsored by

Accelerated Bridge Construction
University Transportation Center

U.S. Department of Transportation
Office of the Assistant Secretary for
Research and Technology



About the ABC-UTC

The Accelerated Bridge Construction University Transportation Center (ABC-UTC) is a Tier 1 UTC sponsored by the U.S. Department of Transportation Office of the Assistant Secretary for Research and Technology (USDOT/OST-R). The mission of ABC-UTC is to reduce the societal costs of bridge construction by reducing the duration of work zones, focusing special attention on preservation, service life, construction costs, education of the profession, and development of a next-generation workforce fully equipped with ABC knowledge.

About the BEC

The mission of the Bridge Engineering Center (BEC), which is part of the Institute for Transportation (InTrans) at Iowa State University, is to conduct research on bridge technologies to help bridge designers/owners design, build, and maintain long-lasting bridges. The mission of InTrans is to develop and implement innovative methods, materials, and technologies for improving transportation efficiency, safety, reliability, and sustainability while improving the learning environment of students, faculty, and staff in transportation-related fields.

ISU Non-Discrimination Statement

Iowa State University does not discriminate on the basis of race, color, age, ethnicity, religion, national origin, pregnancy, sexual orientation, gender identity, genetic information, sex, marital status, disability, or status as a U.S. veteran. Inquiries regarding non-discrimination policies may be directed to Office of Equal Opportunity, 3410 Beardshear Hall, 515 Morrill Road, Ames, Iowa 50011, Tel. 515-294-7612, Hotline: 515-294-1222, email eooffice@iastate.edu.

Notice

The contents of this report reflect the views of the authors, who are responsible for the facts and the accuracy of the information presented herein. The opinions, findings and conclusions expressed in this publication are those of the authors and not necessarily those of the sponsors.

This document is disseminated under the sponsorship of the U.S. DOT UTC program in the interest of information exchange. The U.S. Government assumes no liability for the use of the information contained in this document. This report does not constitute a standard, specification, or regulation.

The U.S. Government does not endorse products or manufacturers. If trademarks or manufacturers' names appear in this report, it is only because they are considered essential to the objective of the document.

Quality Assurance Statement

The Federal Highway Administration (FHWA) provides high-quality information to serve Government, industry, and the public in a manner that promotes public understanding. Standards and policies are used to ensure and maximize the quality, objectivity, utility, and integrity of its information. The FHWA periodically reviews quality issues and adjusts its programs and processes to ensure continuous quality improvement.

Technical Report Documentation Page

1. Report No. ABC-UTC-2013-C3-ISU03-Final	2. Government Accession No.	3. Recipient's Catalog No.			
4. Title and Subtitle Inspection and QA/QC for ABC Projects		5. Report Date December 2018			
		6. Performing Organization Code			
7. Author(s) Nazik Citir, Simon Laflamme (orcid.org/0000-0001-5666-3215), Katelyn Freeseaman (orcid.org/0000-0003-0546-3760), Michael Scott (orcid.org/0000-0002-2424-702X), David Eisenmann (orcid.org/0000-0002-8083-5328), and Brent Phares (orcid.org/0000-0001-5894-4774)		8. Performing Organization Report No.			
9. Performing Organization Name and Address Bridge Engineering Center Iowa State University 2711 South Loop Drive, Suite 4700 Ames, IA 50010-8664		10. Work Unit No. (TRAIS)			
		11. Contract or Grant No. DTRT13-G-UTC41			
12. Sponsoring Organization Name and Address <table style="width: 100%; border: none;"> <tr> <td style="width: 50%; border: none;"> Accelerated Bridge Construction University Transportation Center Florida International University 10555 W. Flagler Street, EC 3680 Miami, FL 33174 </td> <td style="width: 50%; border: none;"> US Department of Transportation Office of the Assistant Secretary for Research and Technology And Federal Highway Administration 1200 New Jersey Avenue, SE Washington, DC 201590 </td> </tr> </table>		Accelerated Bridge Construction University Transportation Center Florida International University 10555 W. Flagler Street, EC 3680 Miami, FL 33174	US Department of Transportation Office of the Assistant Secretary for Research and Technology And Federal Highway Administration 1200 New Jersey Avenue, SE Washington, DC 201590	13. Type of Report and Period Covered Final Report (October 2017- December 2018)	
		Accelerated Bridge Construction University Transportation Center Florida International University 10555 W. Flagler Street, EC 3680 Miami, FL 33174	US Department of Transportation Office of the Assistant Secretary for Research and Technology And Federal Highway Administration 1200 New Jersey Avenue, SE Washington, DC 201590		
14. Sponsoring Agency Code					
15. Supplementary Notes Visit www.abc-utc.fiu.edu for other ABC reports.					
16. Abstract The effectiveness of cast-in-place joints and other connections are of critical importance for ABC projects. While high strength materials are being used for these in-field connections, there is a general lack of existing research regarding inspection of joint quality and performance prior to opening to traffic. While these joints are intended to be constructed quickly, poor quality performance/construction will be detrimental to the equally important longevity of construction. This report evaluates the capabilities of existing nondestructive testing technologies that could be used to determine bond and joint strength between pre-formed deck panels and the cast-in-place joint strips, and other ABC components of interest. The results of the information collection will be used to assess the feasibility of various techniques for further implementation in QA/QC efforts relating to ABC projects.					
17. Key Words accelerated bridge construction—ABC quality assurance—ABC quality control—nondestructive testing		18. Distribution Statement No restrictions.			
19. Security Classification (of this report) Unclassified.	20. Security Classification (of this page) Unclassified.	21. No. of Pages 36	22. Price		

(this page is intentionally left blank)

Inspection and QA/QC for ABC Projects

Final Report
December 2018

Principal Investigator: Katelyn Freeseaman
Bridge Engineering Center, Institute for Transportation
Iowa State University

Co-Principal Investigator: Brent Phares
Bridge Engineering Center, Institute for Transportation
Iowa State University

Authors

Nazik Citir, Simon Laflamme, Katelyn Freeseaman, Michael Scott,
David Eisenmann, and Brent Phares

Sponsored by

Accelerated Bridge Construction University Transportation Center



ACCELERATED BRIDGE CONSTRUCTION
UNIVERSITY TRANSPORTATION CENTER

A report from

Bridge Engineering Center
Institute for Transportation
Iowa State University
2711 South Loop Drive, Suite 4700
Ames, IA 50010-8664
Phone: 515-294-8103 / Fax: 515-294-0467
www.intrans.iastate.edu

DISCLAIMER

The contents of this report reflect the views of the authors, who are responsible for the facts and the accuracy of the information presented herein. This document is disseminated in the interest of information exchange. The report is funded, partially or entirely, by a grant from the U.S. Department of Transportation's University Transportation Program. However, the U.S. Government assumes no liability for the contents or use thereof.

TABLE OF CONTENTS

ACKNOWLEDGMENTS	vii
1. INTRODUCTION	1
2. OVERVIEW OF NON-DESTRUCTIVE TESTING METHODS.....	2
Audio-Visual Methods.....	2
Acoustic-Seismic Methods	4
Electro-Magnetic Methods.....	8
Thermal Methods	8
Radiographic Methods	9
Summary of NDE Methods	9
3. NDE CASE STUDIES.....	11
4. FIELD FEASIBILITY STUDY.....	14
Technical Approach	14
Field Data Collection	15
Data Analysis	15
Results.....	16
5. CONCLUSIONS.....	23
REFERENCES	25

LIST OF FIGURES

Figure 1. Chain drag equipment (left) and hammer sounding tools (right)	3
Figure 2. Acoustic emission measuring system: Formation and detection of AE signals	4
Figure 3. Working principle of impact echo method	5
Figure 4. Conceptual diagram of direct ultrasonic testing for detection of a void and a crack	6
Figure 5. Latest model of MIRA	7
Figure 6. DAA GPR platform in action, including AVA antenna and synchronized IMU/GPS	15
Figure 7. Full view at deck level of Keg Creek Bridge including bridge deck and ground features	16
Figure 8. Keg Creek Bridge GPR data (span 1) including key response features	16
Figure 9. Keg Creek Bridge fused GPR and LIDAR results (span 2)	17
Figure 10. Keg Creek Bridge fused GPR and LIDAR results, zoom view (span 2)	17
Figure 11. Keg Creek Bridge results showing fused GPR and LIDAR results in a zoom view of span 2 plus reinforcing steel (light blue hyperbolas), concrete deck bottom surface reflection (green), and steel beam (purple) responses	18
Figure 12. Keg Creek Bridge results showing fused GPR and LIDAR bridge deck responses to surface and subsurface features: (a) in three spans and (b) in zoomed span 1	18
Figure 13. Keg Creek Bridge results showing fused GPR and LIDAR bridge deck responses showing 3D reinforcing steel locations	19
Figure 14. Keg Creek Bridge beams and diaphragms (LIDAR results): (a) zoom view and (b) showing all three spans	20
Figure 15. Keg Creek Bridge beam, diaphragms, and column caps (LIDAR results): (a) zoom view from below and (b) all three spans	20
Figure 16. Keg Creek Bridge beam, diaphragms, column caps, and columns (LIDAR results): (a) zoom view from below and (b) all three spans	21
Figure 17. Full view of Keg Creek Bridge including bridge deck showing (a) side zoom view and (b) all three spans from above	21

LIST OF TABLES

Table 1. Reviewed NDE methods for inspection of ABC structures	10
Table 2. Comparison of NDE techniques for various types of damage	13
Table 3. Summary of findings regarding applicability	23

ACKNOWLEDGMENTS

This project was supported by the Accelerated Bridge Construction University Transportation Center (ABC-UTC at <https://abc-utc.fiu.edu/>) at Florida International University (FIU), as the lead institution, with Iowa State University, the University of Nevada-Reno, the University of Oklahoma, and the University of Washington as partner institutions. The authors would like to acknowledge the ABC-UTC support.

The research team would like to extend special appreciation to the ABC-UTC and the U.S. Department of Transportation Office of the Assistant Secretary for Research and Technology for funding this project.

The authors would like to thank the Research Advisory Panel members: Ahmad Abu-Hawash (Iowa DOT), Hoda Azari (FHWA), and Shane Boone (BDI). Thanks should also be given to ADOJAM, LLC for their contributions regarding field testing efforts using airborne ground penetrating radar (GPR).

1. INTRODUCTION

Recent advances in materials and construction methods have caused increased adoption of accelerated bridge construction (ABC) techniques. While ABC leads to notable benefits such as lower costs and shorter closure times, the construction team must ensure that prefabricated elements, cast-in-place elements, and field-constructed joints and connections will perform as designed in order to guarantee structural integrity. A solution is to perform nondestructive evaluation (NDE) for inspection and quality assurance/quality control (QA/QC) purposes.

Various NDE techniques, such as ground penetrating radar, eddy current, ultrasonic methods, and acoustic emission can be used for the monitoring of bridge components (IAEA 1999). These techniques can be leveraged on-site to ascertain the quality of components, joints, and overall construction activities throughout the project.

Currently, there is a lack of QA/QC incorporated into ABC projects with respect to joints and other cast-in-place components. While great research and expertise has gone into the design of ABC projects to ensure needed safety and capacity requirements, the bond strength and quality of the materials used in the field are not currently assessed after final placement.

For instance, a variety of cast-in-place joint design details are used on ABC projects. These designs aim to ensure adequate bond between the joining members, while also providing high strength material within the joint itself. Testing after the joints are placed is not currently performed to assess the actual bond and performance attained. Nondestructive evaluation offers a unique opportunity to address this need.

The objective of this report was to present a thorough literature review of NDE techniques and their associated capabilities, and subsequently gauge the technology's ability to specifically perform QA/QC for ABC structures. Chapter 2 presents the primary NDE techniques in the context of ABC applications. The methods are categorized into five main groups:

- Audio-visual
- Acoustic-seismic
- Electro-magnetic
- Thermal
- Radiographic

Chapter 3 presents case studies from the literature and feasibility studies comparing NDE methods. Results from case studies are summarized, and the potential opportunities and limitations of the NDE techniques are discussed.

Chapter 4 covers the results of a field feasibility study that was performed using airborne ground penetrating radar (GPR), combining drone technology with this electro-magnetic technique. Chapter 5 presents the conclusions from this research project.

2. OVERVIEW OF NON-DESTRUCTIVE TESTING METHODS

In this chapter, NDE methods are reviewed from a generalized standpoint, keeping in mind the context of their potential applications to ABC structures. Techniques are categorized into five main groups: audio-visual, acoustic seismic, electro-magnetic, radiographic, and thermal methods.

Audio-Visual Methods

Audio-visual methods are techniques that heavily rely on an inspector's experience and judgement. The most common type is a general visual inspection, which can be assisted by various technologies such as computer-aided vision from drones. Other popular techniques are leverage hammer sounding and chain dragging. These methods are described in the following sections.

Visual Inspection

Visual inspection is used to detect flaws and anomalies on the surface of components. The method can be particularly useful as an initial step to identify potential anomalies or damage from salient features to guide the next steps in the inspection process, which can be more costly and time consuming (IAEA 1999). During the visual inspection stage, the overall geometric characteristic of a component is investigated, along with the existence of leaks, alignment of connections, etc. Visual inspection can be categorized as direct, remote, or translucent visual testing (IAEA 2012). The visual inspection process can be improved by leveraging existing technologies, such as optical instruments (e.g., hand magnifying glass, illuminated magnifier, and inspection glass), computer-assisted viewing systems (e.g., high resolution still photos and videos), charge coupled devices, and boroscopes. More specialized inspections can also use liquid penetrant tests and magnetic particle tests to provide visual feedback on defects that could otherwise be difficult to observe.

Recent advancements in imaging technology have also allowed for visual inspections of greater resolution via opportunities such as light detection and ranging (LIDAR). LIDAR can be used for high-resolution geospatial imaging and is based on laser return times to formulate three-dimensional (3D) representations of the medium. The resulting imagery can then be inspected visually for material geometries and locating needs. This technology is explored further in the Field Feasibility Study chapter of this report.

Opportunities and Limitations

Visual inspection methods are simple, fast, and economical. Compared with other NDT techniques that require cutting-edge equipment, visual inspection is relatively inexpensive and does not rely on extensive training (IAEA 2012). It can be applied to any type of materials and geometries. However, visual inspection can only identify surface discontinuities. Some of the identified defects that are visible on the surface can also be difficult to quantify, such as the

depth or extent of defects (IAEA 2012). Due to the nature of visual inspections, other NDT methods may be needed to confirm the accuracy of measurements and detection (IAEA 1999).

Hammer Sounding/Chain Drag

Hammer sounding and chain dragging are commonly used to detect the severity of delaminations in concrete structures. A common chain drag test includes at least four segments of 1 in. link chain of 0.25 in. diameter steel of 18 in. length (Scheff and Chen 2012), as shown in Figure 1 (left).



FHWA 2018, © Rutgers University

Figure 1. Chain drag equipment (left) and hammer sounding tools (right)

Following the drag of the chain or stroke of the hammer (Figure 1 [right]), the inspector listens to the resulting sound. The presence of delamination will provoke an audible change in sound, whereas the flexural oscillations of the delaminated areas are perceived as a hollow sound in the range of 1 to 3 kHz. An undamaged concrete deck will result in a clear ringing sound. (Gucunski et al. 2013). The sounding procedures for measuring delamination in concrete bridge decks are covered in ASTM D4580/D4580M-12 (2012). The procedure calls for a grid system to be utilized on the concrete bridge deck to map the delaminated areas from test results.

Opportunities and Limitations

For a trained inspector, the chain drag method is faster than the hammer sounding method and damaged areas can be mapped easily (FHWA 2018). However, the technique is limited to the presence of delamination areas on exposed horizontal surfaces. The hammer sounding method is more effective for detecting of delaminations on smaller, or vertical, areas (Gucunski et al. 2013). Both techniques are limited to concrete bridge decks and are not effective on asphalt overlays. Also, results might be variable depending on the skill or experience of the inspector. It is a labor-intensive method that requires traffic management to reduce noise, which may be costly and undesirable for critical, high-volume roadways (FHWA 2018).

Acoustic-Seismic Methods

Acoustic Emission

Acoustic emission (AE) methods rely on the transmission of elastic waves. The method is generally utilized to measure tensile, fatigue, weld, and metallurgical properties and to evaluate the initiation and propagation of cracks, friction, strain rate, wear, spalling, erosion effects, and corrosion (IAEA 1999). The acoustic emission examination of concrete structures is covered in ASTM E3100-17 (2017). The standard includes the selection, setup, and performance verification of AE mechanisms to detect damage on concrete structures including buildings, bridges, tunnels, decks, hydraulic structures, piers, and pre- and post-tensioned structures. Transducers are utilized to obtain or listen to strain energy released by plastic deformations or fractures, as illustrated in Figure 2.

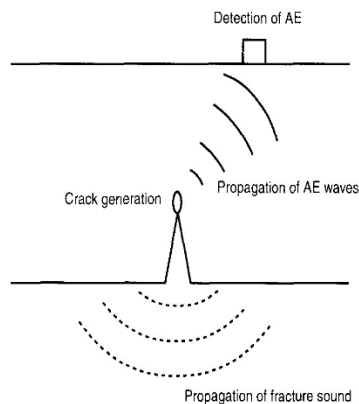

Ohtsu 1996, Copyright © ICE Publishing, republished with permission obtained through the Copyright Clearance Center, Inc.

Figure 2. Acoustic emission measuring system: Formation and detection of AE signals

The rate and density of these signals generated from plastic deformation or fracture can be used to diagnose damage (IAEA 1999).

Opportunities and Limitations

AE methods can be utilized during construction and in-service for the monitoring of components, leak detection and location, in-process weld monitoring, mechanical property testing and characterization, fatigue cracks, fiber fractures, fiber matrix debonding, matrix micro-cracks, and delamination (Gholizadeh 2016). The method can also be used online by installing permanent sensors, enabling process control (Lu 2010). However, AE requires acoustic coupling with the component of interest. Noise, temperature, and poor acoustic connections may affect the results adversely. Steel produces poor signals, while concrete attenuates signals (IAEA 1999). AE are very complex, and use of the method requires a highly skilled inspector/engineer to relate acoustic emission data to damage mechanisms (Gholizadeh 2016). Finally, AE is difficult to apply on large surfaces, because of the small distance required between the sensors and actuators.

Impact Echo

Impact echo (IE) is a stress-wave technique used to detect flaws in concrete, measure its thickness, and evaluate its quality (Sack and Olson 1995). In addition, IE can be used to assess delaminations, vertical cracks, and conditions around steel reinforcing bars (Gucunski et al. 2011). The technique is applicable for plate-like structures, such as bridge decks, slabs, and walls (Rehman et al. 2016) and consists of applying an impact load on the surface of the monitored component to generate a transient pulse in the structure. When the material is suddenly impacted, stress waves are rapidly spread through the material. A signal transducer is placed onto the surface to measure longitudinal waves reflected by a flaw, as illustrated in Figure 3 (Scott et al. 2003).

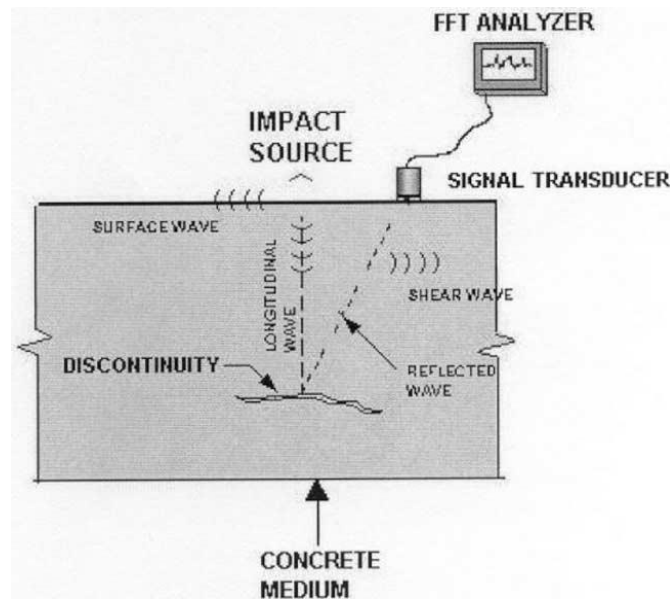

Scott et al. 2003, © 2002 Elsevier Ltd., all rights reserved, used with permission

Figure 3. Working principle of impact echo method

The signal is often analyzed in the Fourier domain (FFT transducer). Inspection using IE is covered by standard ASTM C1383-15 (2015).

Opportunities and Limitations

The IE method is applicable to concrete structures for the detection of defects such as delaminations, surface opening cracks, ducts, voids, and overlay bonding, and to evaluate the modulus of elasticity, compressive strength, and grouting characteristics (Rehman et al. 2016). The equipment is typically light and portable (Davis et al. 1996), and data interpretation is relatively simple and can be automated. However, use of the IE method requires an impact device, and collection of impacts at more than one location for high accuracy. It cannot be used to determine concrete-steel bond strength (Lee et al. 2014). In addition, it is adversely affected by air voids, aggregate, reinforcing steel, etc., and analogous to the AE method, the accuracy

depends on the contact between the receiver and the surface, which can be difficult for rough concrete surfaces (Abramo 2011).

Ultrasonic Testing

Ultrasonic testing (UT) measures the speed of sound propagating through an inspected material and estimates material strength and elastic modulus; it can be used to detect internal defects such as cracking, honeycombing, voids, decay, etc. (Sutan and Meganathan 2003). It is a useful method to indirectly monitor the development of material strength, such as concrete, based upon modulus values (Freeseman et al. 2016a). It can also be used to determine layer thickness and concrete uniformity (Blitz and Simpson 1995). Many variations of the UT method exist, employing transducers that vary in number and type.

In general, the method uses an electro-acoustical transducer in contact with the concrete surface to produce ultrasonic pulses. There are three types of waves generated by a transducer: surface, shear, and longitudinal waves, each utilized to measure different characteristics (Blitz and Simpson 1995). When a wave arrives, the defects and/or boundaries of different materials in the concrete generate compression and longitudinal waves propagating through the material. The longitudinal waves are the first ones to reach the receiving transducer. The received pulses are measured and analyzed to assess the material under inspection.

The transducers generating the ultrasonic pulse can be arranged in three different positions. These directions are between opposite faces (direct), adjacent faces (semi-direct), and the same faces (indirect). The arrangement depends on the component's geometry and accessibility. In the direct method, the transmitting and receiving transducers are placed on opposite faces of the concrete specimen. This technique is preferred, when possible, because the maximum energy is propagated at right angles. Figure 4 illustrates an example for detection of a void and a crack.

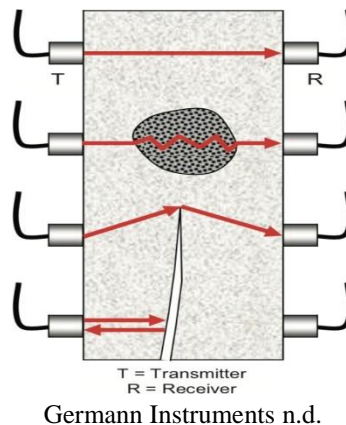

Figure 4. Conceptual diagram of direct ultrasonic testing for detection of a void and a crack

When the first pulse propagates through concrete and encounters the void, the pulse spreads through the void which alters its transit time (Sutan and Meganathan 2003). The transit time is

also affected by the presence of a crack. If the crack is sufficiently large, the pulse will reflect back. Standard ASTM C597-16 (2016) covers the propagation velocity of longitudinal stress waves.

Other devices utilize multiple transducers, such as an ultrasonic array device called MIRA. This device employs 40 dry point contact transducers, which negate the need for time-consuming surface coupling. In addition, the large number of transducers allows for a larger surface to be assessed. These characteristics both lead to increased measurement acquisition efficiency. Shear waves, which also eliminate sensitivity to moisture conditions, are utilized. The device is pictured in Figure 5.



Figure 5. Latest model of MIRA

The 40 transducers are arranged in sets of four, with each set of transducers interacting with the remaining nine sets, resulting in 45 unique transducer pairs. This device has been used for concrete thickness determination, locating reinforcement bars, and detecting delaminations and other damage manifestations (Freeseaman 2016c).

Opportunities and Limitations

UT has been shown to be reliable, relatively inexpensive, and easy to use for the internal inspection of concrete (Blitz and Simpson 1995). It is known to be accurate in the determination of the quality and uniformity of concrete. Nevertheless, some UT methods are also dependent on the quality of contact between the transducers and the surface, which limits its applicability for rough concrete surfaces (Sutan and Meganathan 2003). It is also known to be less reliable in predicting the strength of concrete (Blitz and Simpson 1995). Finally, while the method is easy to use, the analysis of data is complex and requires skilled inspectors/engineers to assess a material's condition, in particular for concrete under moisture and/or with embedded metallic components (IAEA 2002). Ultrasonic linear array methods help to overcome these limitations via the employment of dry point contact transducers which emit shear waves. They have also shown promise regarding the evaluation of heavily reinforced elements, an asset when ABC components are of interest (Freeseaman et al. 2016b). However, these methods still require a skilled operator for data analysis.

Electro-Magnetic Methods

Ground Penetrating Radar

GPR is generally used for geotechnical investigation and condition assessment of bridge decks. It may be used to detect the location, position, and spacing of embedded steel components in concrete, to evaluate the thickness of a concrete slab, to detect damage in concrete such as water leakage, voids, etc., and to assess the interface between concrete and the sub-base (Lim and Cao 2013).

A GPR system is comprised of three main components: an antenna, a control unit, and a power supply. Antennas are ground coupled (bowtie) or air coupled (horn) antennas of different frequencies, typically ranging from 500 MHz to 1.6 GHz (ground coupled) and 1 GHz to 2.5 GHz (air coupled) (Maierhofer 2003). The frequency of the antenna determines the maximum theoretical distance which the GPR unit can penetrate, with lower frequencies penetrating the subsurface deeper than higher frequencies (Penhall Technologies 2018). The control unit includes electronics stimulating a pulse of electromagnetic (EM) waves that are sent into the ground by the antenna. A portion of this energy is reflected back to the antenna when an interface between materials of dissimilar dielectric constants is encountered (Spraggs et al. 2012). The reflected signals are detected by a receiver antenna, where the arrival time and amplitude are recorded. The inspection of asphalt-covered concrete bridge decks using GPR is detailed in ASTM D6087-08 (2015).

Opportunities and Limitations

GPR can be used to detect the locations of reinforcement, prestressing strands, cables, voids, cracks, and delaminations in concrete, and to estimate the concrete cover depth, density, and moisture content variations on site (Main Roads Western Australia 2012). However, GPR is more expensive and requires expert training to analyze the data. Also, it is generally limited to the detection of a defect without its identification. Calibration of GPR equipment is complex, because the penetration of EM waves depends on the material conditions (e.g., wet/dry) which is not typically known a priori (IAEA 2002).

Thermal Methods

Thermal NDT methods include the measurement or mapping of surface temperatures as heat is transferred. The simplest thermal measurement is conducted by making point measurements with a thermocouple. More sophisticated methods exist, such as infrared (IR) cameras, which can collect thermal information quickly over a large surface without requiring contact. IR thermography methods can be divided into two groups: passive and active methods. Passive IR thermography requires the use of IR cameras only. The inspection is conducted during or immediately after a thermal cycle. Active IR requires various types of heaters or coolers in addition to IR cameras for thermal stimulation of tested components. The IR thermography

inspection for concrete bridge decks is covered by standard ASTM (2007) to detect delamination in concrete structures.

Opportunities and Limitations

IR thermography is a practical option to inspect large surface areas in a short period of time. The technique can be used to detect delaminations, internal voids, and cracks over bridge decks. Data can be easily analyzed to compute a percentage of deteriorated area over a monitored surface (Davis et al. 1998). However, IR thermography leverages expensive equipment and requires proper environmental conditions for inspection. It is a surface method and cannot be used to detect volumetric features such as depth or thickness (Davis et al. 1998).

Radiographic Methods

Radiography can be used to detect porosity, voids, and structural features through differences in thickness or density. In addition, radiography is commonly used for inspection of welds, castings, and various structural components (Mishin 1997). Using radiography, 2D images of concrete can be obtained showing the attenuation of different materials (e.g., concrete versus embedded steel) and air voids (Ciolko and Tabatabai 1999). The principle is based on the utilization of X-rays and gamma rays.

X-rays have a relatively short wavelength, approximately 1/10,000 the wavelength of visible length (Brownjohn et al. 2008). They can be used to visualize a 3D object in two-dimensional (2D) planes. Gamma rays have a shorter wavelength, approximately 1/1,000,000 the wavelength of visible light (Brownjohn et al. 2008). They are used to investigate the internal characteristics of a material, such as the location and condition of steel reinforcement, voids, and variability in concrete properties. Radiographic inspection is covered by standard ASTM e1742/e1742M-18 (2018).

Opportunities and Limitations

The radiographic method is ideal to visualize the internal characteristics of a component (Halmshaw 1991). However, the method is expensive to apply, time-consuming, and poses radiation hazards (NDT Resource Center 2018b). The technique is also difficult to apply in-situ due to the equipment constraints (Bungey et al. 2006). Its accuracy is also affected by environmental conditions and temperature variations, and the application of the method requires highly trained personnel.

Summary of NDE Methods

Table 1 summarizes the NDE methods reviewed previously, listing their associated general applications for ABC.

Table 1. Reviewed NDE methods for inspection of ABC structures

NDE Method	General applications for ABC structure
Visual Inspection	Rapid detection of flaws and anomalies on the surface, and inspection of leaks and alignment of connections
Hammer-Sound and Chain Drag	Detect the area of delaminations and spalls in concrete
Acoustic Emission (AE)	Leak detection and location, in-process weld monitoring, mechanical property testing and characterization, monitoring of fatigue cracks, fiber fractures, fiber matrix debonding, matrix micro-cracks, and delamination
Impact Echo (IE)	Detection of delamination, surface opening cracks, ducts, voids, and overlay bonding, and evaluation of the modulus of elasticity, compressive strength, and grouting characteristics
Ultrasonic Testing (UT)	Inspection of the internal structure of concrete, such as quality and uniformity of concrete, location of reinforcement, as well as defect and anomaly detection. Capabilities depend upon the quantity and type of transducer employed by the device
Ground Penetrating Radar (GPR)	Location of reinforcement, prestressing strands, cables, voids, cracks, and delaminations in concrete, and estimation of concrete cover depth, density, and moisture content variations
Infrared (IR) Thermography	Rapidly inspect large surfaces to detect delamination, internal voids, and cracks over bridge decks
X-ray and Gamma-ray	Visualization of internal characteristics of a component

It is also necessary to note that technological advancements in the field of robotics and automation have recently allowed for greater efficiencies in the listed technologies. An example of this type of advancement is provided in the in-depth field feasibility study in Chapter 4, combining drone and GPR technology.

While the automation and/or robotic technology is not specifically elaborated upon in this review, it is important to mention that these advancements can be combined with the nondestructive technologies described previously to achieve greater capabilities. The advanced system in most cases has a greater initial cost due to the increased technology, but often makes up for this long term via its improved efficiency with respect to data acquisition.

It is also important to acknowledge that the combination of multiple nondestructive testing technologies often provides the greatest benefit as individual capabilities can be capitalized upon and combined for optimum analysis. This merging of technology is discussed in greater detail in the case studies chapter of this report.

3. NDE CASE STUDIES

This chapter explores specific case studies that have employed the various technologies detailed previously. Note that these case studies were often not for ABC projects, but their general findings can have broader implications for possible ABC applications. These case studies are briefly described, followed by an in-depth field case study (Chapter 4) that was performed as part of this research.

Scott et al. (2003) evaluated the deterioration of bridge decks by assessing three NDE methods that included GPR, chain drag sounding, and IE. The study showed results from the three techniques were consistent with the results taken from coring. However, a few disadvantages were pointed out by the research. First, the chain drag method had inconsistencies and faults, because it was dependent upon the inspector's judgement. Second, while the IE method reduced errors based on subjectivity, it was time consuming, and yielded some inaccuracies. Comparing results from the chain drag and IE methods, IE showed higher sensitivity to the proximity of flaws and a higher percentage of bridge deck delaminations were found. Third, the GPR system proved to be faster at conducting the bridge deck evaluation and was easier to deploy.

Researchers in Grosse et al. (2005) developed an impactor for IE capable of generating high impact energy for the detection of discontinuities and boundary layers at greater depths. The device was capable of distinguishing large voids via faster and more accurate data acquisition. The apparatus was tested on a steel reinforced concrete bridge over a 96 m length to detect voids due to aging.

In research conducted by Oh et al. (2012), the authors studied three different NDE techniques consisting of air-coupled IE, IR thermography, and chain-drag sounding, for field applicability of deck inspections. It was found that IE had high sensitivity to internal delaminations; it could accurately assess delamination locations, area, and shapes over the entire inspected deck surface; and chain drag sounding was not reliable in detecting shallow delaminations. In addition, both the air-coupled IE and IR methods showed good performance under traffic load and ambient conditions, respectively.

Andrzej and Marta (2014) also studied IE and IR to diagnose the structural integrity of concrete bridge structures. IR was found to be fast at the scanning of large concrete areas. IE was used to obtain more detailed measurements on limited sections of the deck.

The study described in Sack and Olson (1995) applied IE, spectral analysis of surface waves (SASW), and UT. IE was used to measure the concrete thickness, crack depths, and overall concrete quality. The SASW method was used to measure depth of freeze-thaw damage. UT was used to evaluate the condition of materials together with defect locations and concrete strength based on compression wave velocity.

A case study conducted on the Aubonne Bridge was detailed in Hassan et al. (1995). Sets of nine cores were extracted at 28 days, three months, and eight months to assess the performance of UT

at assessing the quality of concrete. For each sample, the modulus of elasticity, compressive strength, density, and pulse velocity were measured using UT. The NDE method was accurate between 28 days and three months.

Research was conducted by Sutan and Meganathan (2003) to compare direct and indirect UT for void detection and depth measurement in early-aged concrete. These methods were applied on five reinforced concrete specimens constructed with voids at known locations. Both methods were accurate at locating the voids. However, the performance of indirect UT diminished with concrete age.

Alani et al. (2014) combined visual inspection, GPR, and IBIS-S (deflection and vibration detection sensor system with interferometry capability) to assess the condition of the Pentagon Road Bridge in England. The combination of techniques showed how to overcome some disadvantages associated with single-use techniques, such as the deterioration of GPR performance in the presence of water, and deterioration of ultrasounds in the presence of moisture.

Villain et al. (2012) discussed the combination of various NDE methods. The authors combined GPR and IE to evaluate the condition of concrete in marine environments.

Iyer et al. (2005) proposed the use of ultrasound C-scan imaging for the monitoring of corrosion of embedded steel in post-tensioned concrete bridges. The method was capable of detecting corrosion and voids.

The use of NDE for the detection of internal swelling reactions (ISR) was investigated by Metalssi et al. (2015). Results showed that GPR was not capable of detecting ISR, but could identify zones having potential ISR risks depicted by lower amplitude and lower velocity waves from higher water content. Electrical resistivity methods were also sensitive to the presence of moisture and chemicals. The ultrasonic wave attenuation technique was able to locate zones for which the mechanical properties were altered due to the concrete expansion.

Along the same line, Sargolzahi et al. (2010) studied NDE methods for the identification of alkali-silica reaction (ASR) in a laboratory environment using UT and nonlinear acoustic methods. Both methods were shown to be reliable at detecting ASR, although the nonlinear acoustic method showed higher sensitivity to ASR.

Findings from Rens et al. (2005) compared the performance of various NDE techniques in assessing common damage types in bridges. Table 2 from their work is reproduced below, exhibiting opportunities and limitations of various methods.

Table 2. Comparison of NDE techniques for various types of damage

NDE technique	Efflorescence	Cracking	Delamination and Spall	Relative Cost
Acoustic emission	P	P	P	High
Electrical methods	P	P	F	Low
Impact-echo	P	G	G	Low
Magnetic methods	G	F	F	Low
Radar	P	P	G	High
Radiography	P	F	F	High
Sonic methods	P	P	G	Low
Surface hardness methods	P	P	P	Low
Thermography	P	P	G	High
Acoustic tomography	F	G	G	Low
Ultrasonic	F	G	G	Low

F = fair, G = good, and P = poor

Source: Adapted from Rens et al. 2005

4. FIELD FEASIBILITY STUDY

In addition to reviewing the literature for previous implementation of NDE methods, a field feasibility study was performed by ADOJAM, LLC using airborne GPR. This technology was explored to assess capabilities for the evaluation of existing infrastructure and ABC scenarios, and is called the ADOJAM Difficult Access Advanced Ground Penetrating Radar (DAA GPR) platform.

Although other nondestructive testing methods previously detailed were not studied in the field, a unique opportunity to assess airborne GPR was presented and explored on an ABC bridge in Iowa. This field feasibility study provides an example of the future work that is needed on the other highlighted technologies in order to determine actual feasibility for ABC inspections. The results of this preliminary field study are detailed in this chapter.

DAA GPR is an airborne-capable small unmanned aircraft system (sUAS) platform with unique, integrated sensing and measurement capabilities and the potential to provide actionable civil infrastructure asset information. DAA GPR sensing and measurement capabilities include spatially synchronized surface LIDAR data together with subsurface GPR data. Concrete infrastructure deterioration and QC/QA features, such as surface cracking, are readily detectable with LIDAR, while subsurface voids, moisture, and larger cracks are often detectable with radar. In addition, QC/QA features can be measured and evaluated via DAA GPR prior to ABC fit up, reducing costs. This approach may permit accelerated bridge construction to proceed uninterrupted and on schedule while QC/QA benefits of DAA GPR can be rapidly obtained when bridge components are delivered to the construction site (as they are most readily accessible for DAA GPR measurements).

Initial DAA GPR testing performed for this study included an Iowa Department of Transportation (DOT) ABC site known as the Keg Creek Bridge in Pottawattamie County, which was constructed in 2011.

Technical Approach

The methodology utilized to evaluate sampled bridge and pavement sites for the present study included surface LIDAR measurements and subsurface GPR measurements, synchronized via accurate inertial measurement unit/global positioning system (IMU/GPS) for subsequent data fusion post-processing. The ADOJAM DAA GPR system, shown in Figure 6, included a compact GPR with a low frequency antipodal Vivaldi antenna (AVA), having a center frequency of approximately 1.3 GHz and an effective ultra-wide band (UWB) frequency range from 500 MHz to >3 GHz.



Figure 6. DAA GPR platform in action, including AVA antenna and synchronized IMU/GPS

The synchronized IMU/GPS on this system includes two GNSS GPS antennas. These antennas were mounted starboard and port, while IMU/GPS electronics were mounted ventrally on the sUAS for the subject study.

The DAA GPR system is currently flown by a remote pilot in command (PIC) with terrain following and sensing aids. Flight control also has potential to be automated via a programmable on board controller. Current Federal Aviation Administration (FAA) rules require a remote PIC for relevant applications to civil infrastructure, but automation is anticipated to be increasingly allowable in the future. This automation potential is an important consideration to continue to increase inspection efficiency.

Field Data Collection

In the subject field study, DAA GPR is deployed with a GPR sensor payload and synchronized with its on-board global positioning system/inertial navigation unit (GPS/INU) payload, traversing the area of interest at low altitude (within a few feet of the ground or less). To achieve efficient site coverage, the GPR is flown in straight line patterns at regularly spaced intervals. Subsequently, payloads are swapped and the LIDAR sensor is deployed, flying at higher altitudes to capture broader on-site features (in addition to many surface details, such as cracks).

Data Analysis

DAA GPR data from pavement sites and the Keg Creek Bridge site were analyzed using ADOJAM's proprietary airborne GPR techniques (removing flight altitude variation and providing for subsequent LIDAR/GPR data fusion). Fused LIDAR/GPR data was visualized via fully integrated *.PLY binary data files. Fused data can be visualized and manipulated in a flexible point cloud environment.

Results

Outputs produced by DAA GPR technologies include example GPR results from Keg Creek Bridge (shown in Figure 7, with key span 1 response features in Figure 8), and DAA GPR data fusion results comprised of fully integrated GPR and LIDAR output (Figures 9 through 13).

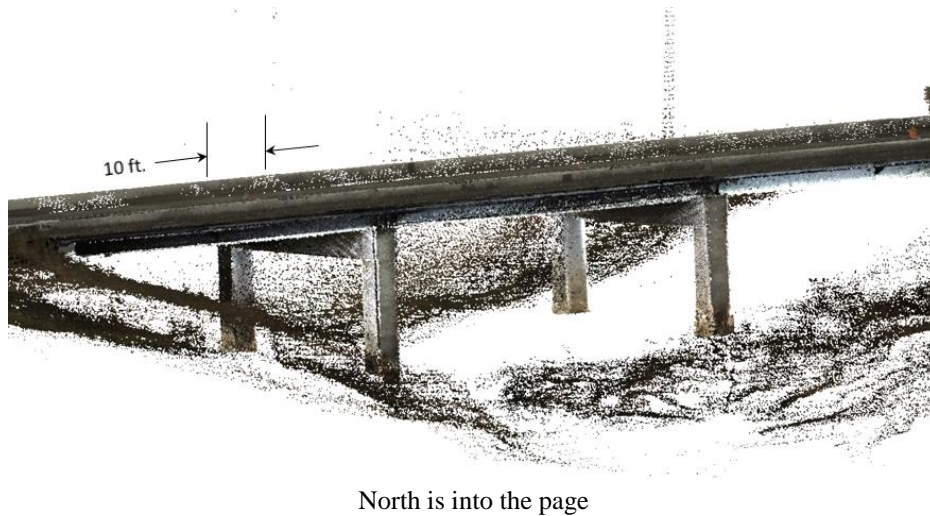

Figure 7. Full view at deck level of Keg Creek Bridge including bridge deck and ground features

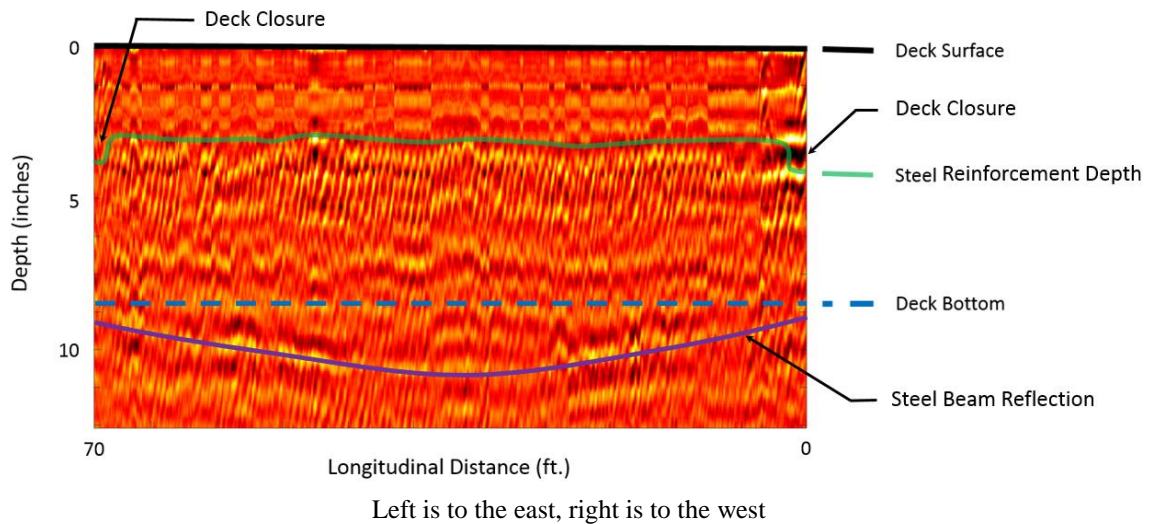
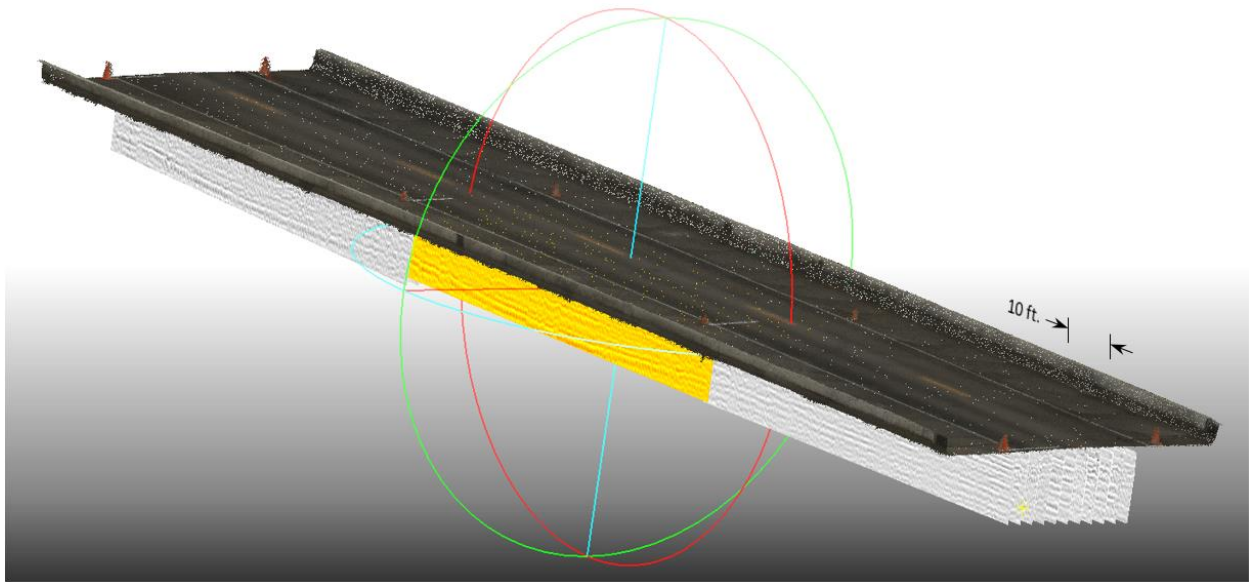
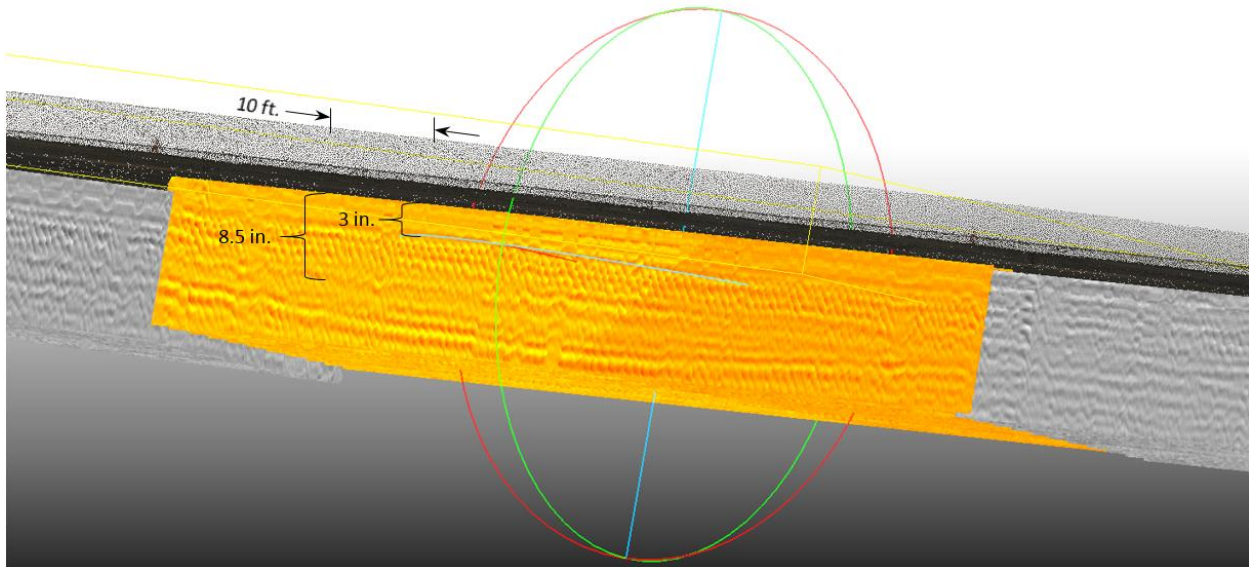

Figure 8. Keg Creek Bridge GPR data (span 1) including key response features



North is to the right (orthogonal to the bridge direction of travel)

Figure 9. Keg Creek Bridge fused GPR and LIDAR results (span 2)



North is to the right (orthogonal to the bridge direction of travel)

Figure 10. Keg Creek Bridge fused GPR and LIDAR results, zoom view (span 2)

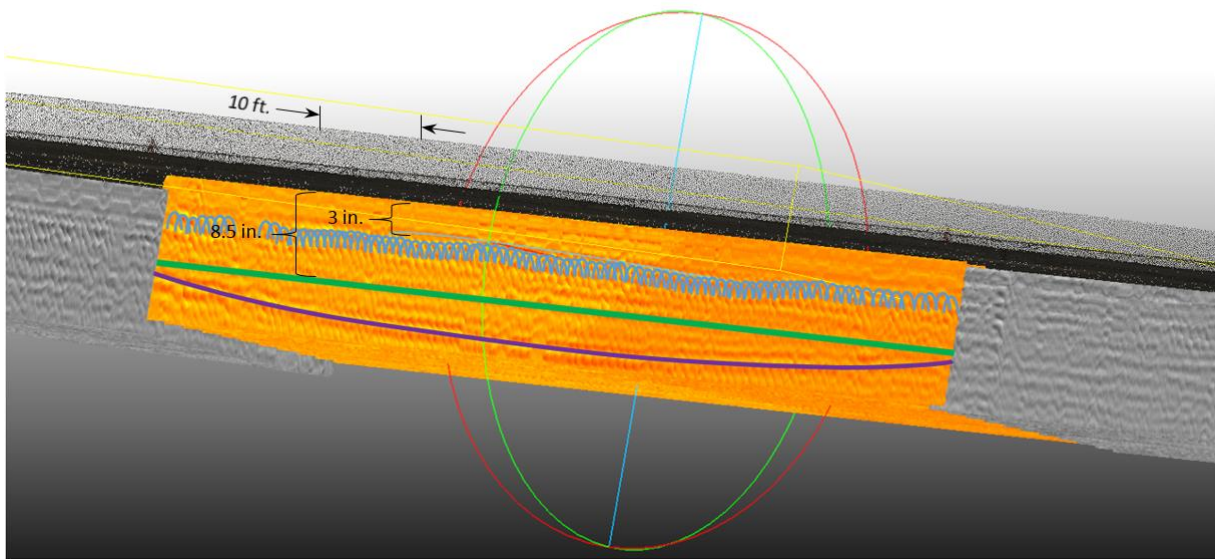

North is to the right (orthogonal to the bridge direction of travel)

Figure 11. Keg Creek Bridge results showing fused GPR and LIDAR results in a zoom view of span 2 plus reinforcing steel (light blue hyperbolas), concrete deck bottom surface reflection (green), and steel beam (purple) responses

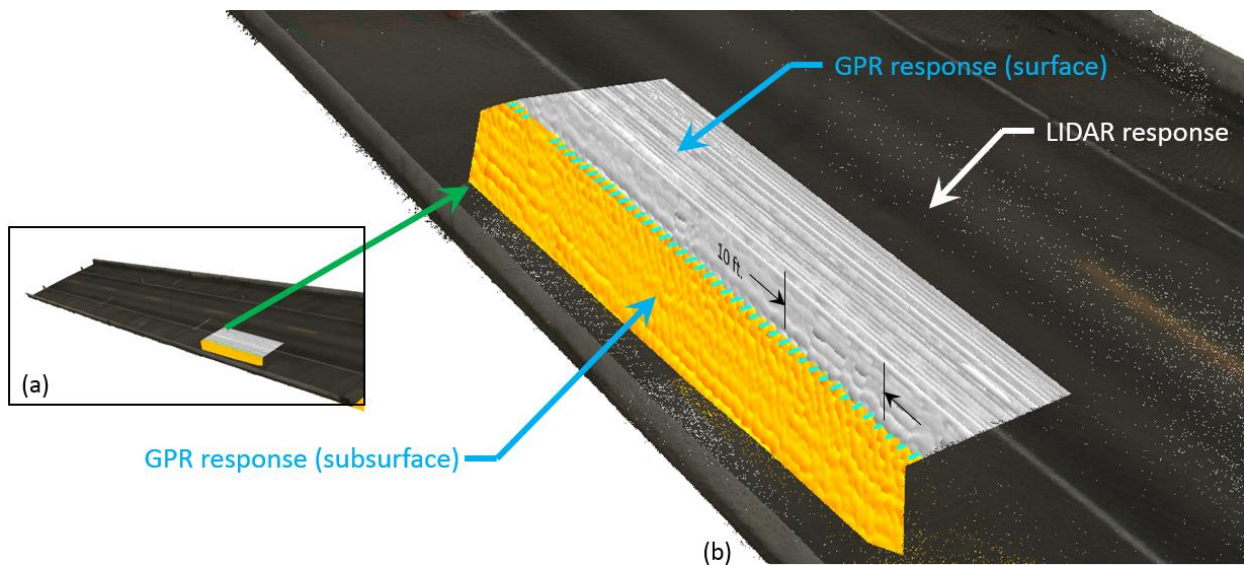

North is to the right (orthogonal to the bridge direction of travel)

Figure 12. Keg Creek Bridge results showing fused GPR and LIDAR bridge deck responses to surface and subsurface features: (a) in three spans and (b) in zoomed span 1

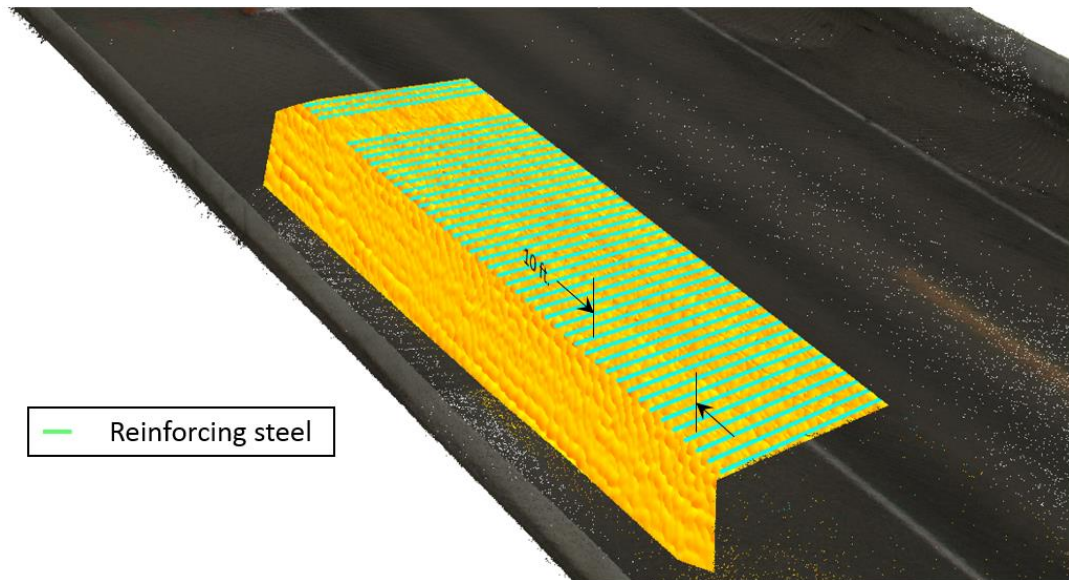

North is to the right (orthogonal to the bridge direction of travel)

Figure 13. Keg Creek Bridge results showing fused GPR and LIDAR bridge deck responses showing 3D reinforcing steel locations

Integrated data fusion outputs offer significant advantages for analysis, as surface and subsurface data can be viewed from any angle and can be geometrically partitioned/sliced to view or analyze any captured internal or external bridge deck detail of interest. Figure 9 shows GPR data from all three Keg Creek Bridge spans in succession (where span 2 GPR data is highlighted in a yellow to orange color plot to indicate the central span).

Figures 10 through 13 show GPR data fusion features, including detected steel reinforcement, concrete cover depth, and material characteristics.

In addition, LIDAR data can be subdivided into components to evaluate bridge beams, diaphragms, pier caps, piers, deck features, parapets and much more (as shown in Figures 14 through 17). Relevant to ABC fit up, component geometric and condition information is obtainable via DAA GPR prior to assembly.

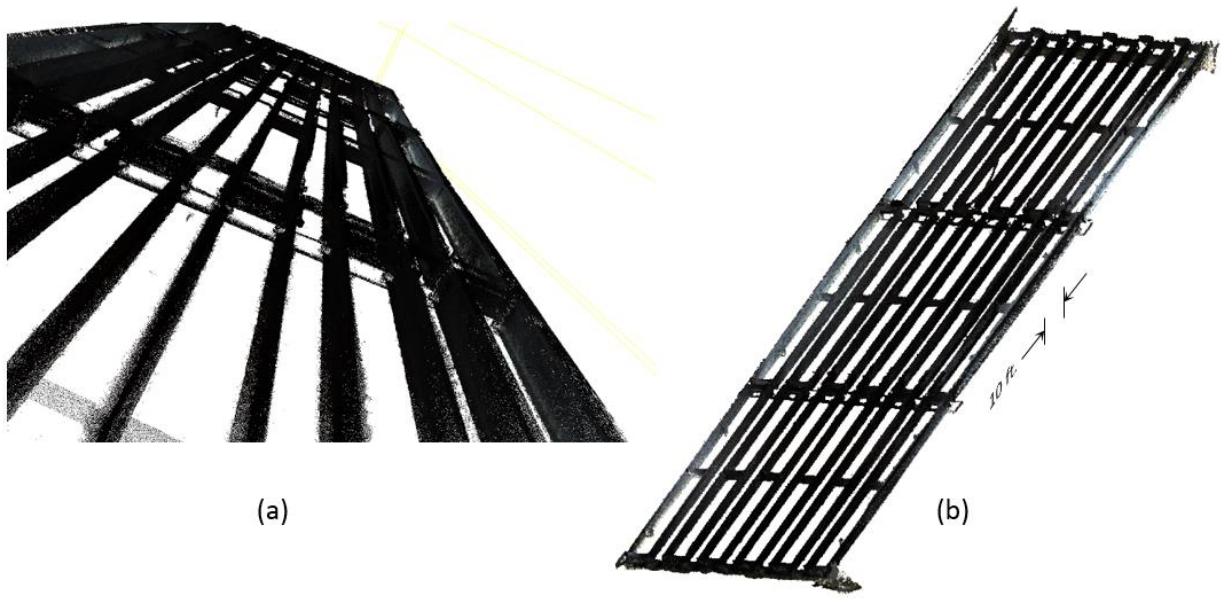

(a)

(b)

North is to the left

Figure 14. Keg Creek Bridge beams and diaphragms (LIDAR results): (a) zoom view and (b) showing all three spans

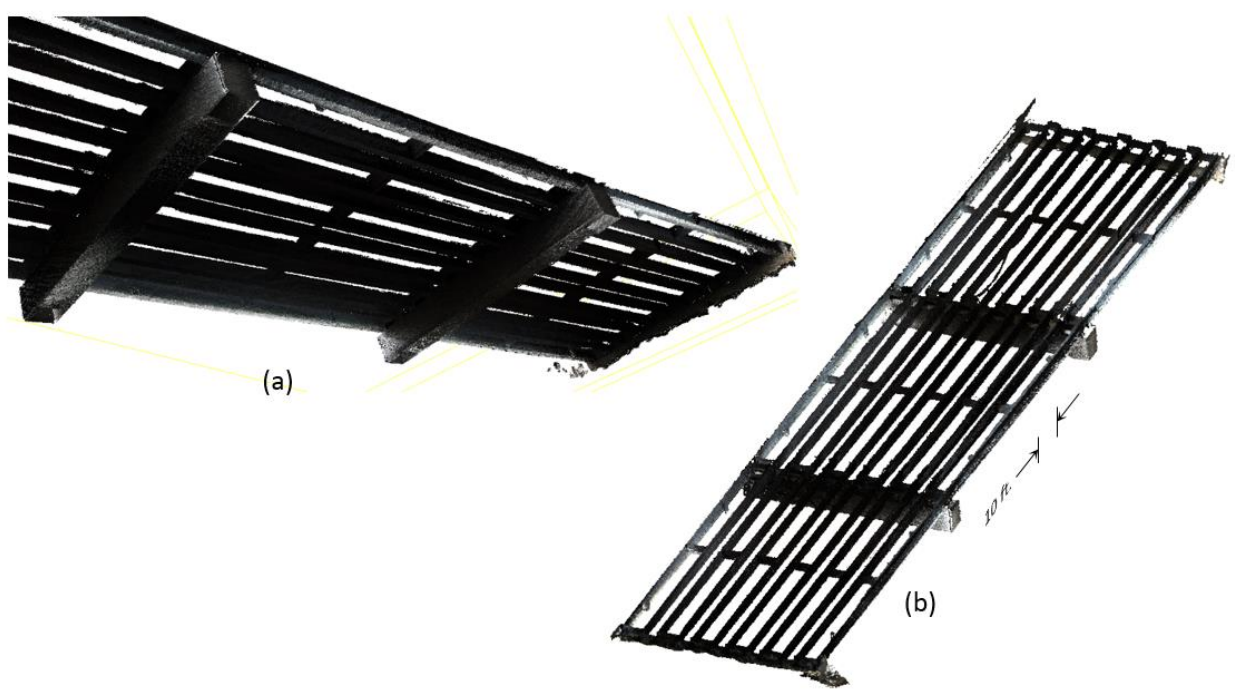

(a)

(b)

North is to the left

Figure 15. Keg Creek Bridge beam, diaphragms, and column caps (LIDAR results): (a) zoom view from below and (b) all three spans

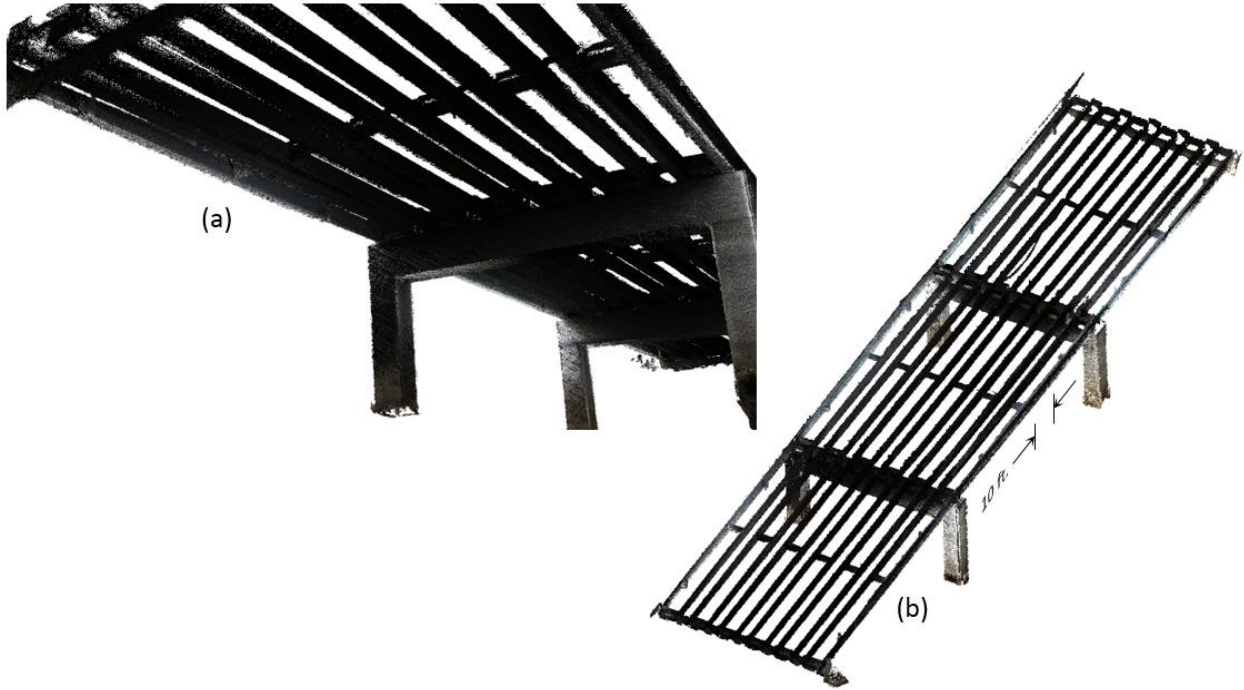

North is to the left

Figure 16. Keg Creek Bridge beam, diaphragms, column caps, and columns (LIDAR results): (a) zoom view from below and (b) all three spans



North is to the left

Figure 17. Full view of Keg Creek Bridge including bridge deck showing (a) side zoom view and (b) all three spans from above

Fully integrated visualizations of Keg Creek Bridge results show how the bridge deck surface and subsurface geometry can be accurately represented and interpreted for each bridge span.

Correspondence between surface and subsurface features of interest indicates airborne DAA GPR results can be used to perform relevant evaluations efficiently and accurately using the present system. System enhancements are anticipated to make DAA GPR even more useful.

5. CONCLUSIONS

In this report, various NDE methods with potential applications to ABC structures were reviewed. Their working principles were summarized, and their opportunities and limitations were discussed. A chapter was devoted to comparative studies of NDE methods for concrete bridge inspection, with an accompanying field feasibility study for airborne GPR. Table 3 is a summary of general findings on NDE methods for ABC applications, which should only be used for general guidance.

Table 3. Summary of findings regarding applicability

NDE Method	Cost	Delaminations	Expertise Level
Visual Inspection	Low	F	Low
Hammer-Sounding and Chain Drag	Low	F	Low
Impact Echo (IE)	Low	G	Medium
Ultrasonic Testing (UT)	Medium	G	Medium
Ground Penetrating Radar (GPR)	Medium	G	Medium
Infrared (IR) Thermography	Medium	G	Medium
Radiographic	High	F	High

This table is similar to one presented by Rens et al. (2005), but it was updated based on technological advancements over the last decade. The following categories are expressed:

- Cost: Low, Medium, and High cost
- Delaminations: Good, Fair, and Poor capability
- Expertise Level: Low, Medium, and High

The listed NDE methods are being extensively researched, and some of their proposed variations in the literature can yield good performance at detecting non-listed anomalies. Also, as discussed and presented in the case studies, various NDE techniques can be combined to empower the inspection process and capitalize on multiple individual technology strengths to achieve greater detection capabilities.

Based on the results from this study, it is recommended that GPR, ultrasound, and thermographic methods be further explored via laboratory or field studies. These methods show the greatest promise when considering efficiency, cost, and overall detection capabilities.

With respect to GPR, both traditional and airborne methods may prove beneficial for QA/QC of ABC projects. Airborne GPR may be a powerful tool during the project to provide overall constructability verification in conjunction with traditional GPR data.

Ultrasound and thermographic methods would allow for quality assessments of joints and other components, via material property assessments, anomalies, bond quality, and other means.

It is anticipated that a combination of methods would provide the most powerful assessment due to each one's unique capabilities.

REFERENCES

- Abramo, D. 2011. *Impact-echo modeling and imaging techniques*. MS thesis. Northeastern University, Boston, MA.
- Alani, A. M., M. Aboutalebi, and G. Kilic. 2014. Integrated health assessment strategy using NDT for reinforced concrete bridges. *NDT & E International*, Vol. 61, pp. 80–94.
- Andrzej, M. and M. Marta. 2014. Modern NDT systems for structural integrity examination of concrete bridge structures. *Procedia Engineering*, Vol. 91, pp. 418–423.
- ASTM C597-16. 2016. *Standard test method for pulse velocity through concrete*. ASTM International, West Conshohocken, PA.
- ASTM C1383-15. 2015. *Standard test method for measuring the p-wave speed and the thickness of concrete plates using the impact-echo method*. ASTM International, West Conshohocken, PA.
- ASTM D4580/D4580M-12. 2012. *Standard practice for measuring delaminations in concrete bridge decks by sounding*. ASTM International, West Conshohocken, PA.
- ASTM D4788. 2007. *Standard test method for detecting delaminations in bridge decks using infrared thermography*. ASTM International, West Conshohocken, PA.
- ASTM D6087-08. 2015. *Standard test method for evaluating asphalt-covered concrete bridge decks using ground penetrating radar*. ASTM International, West Conshohocken, PA.
- ASTM E1742/E1742M-18. 2018. *Standard practice for radiographic examination*. ASTM International, West Conshohocken, PA.
- ASTM E3100-17. 2017. *Standard guide for acoustic emission examination of concrete structures*. ASTM International, West Conshohocken, PA.
- Blitz, J. and G. Simpson. 1995. *Ultrasonic methods of non-destructive testing*. Non-Destructive Evaluation Series, Volume 2. Springer Science + Business Media, Berlin, Germany.
- Brownjohn, J. M., Y. Fujino, D. Inaudi, and Z. Wu. 2008. Structural identification of constructed systems: experimental considerations. Paper presented at Structures Congress 2008: Crossing Borders, April 24–26, Vancouver, BC, Canada.
<https://ascelibrary.org/doi/pdf/10.1061/41016%28314%29139>.
- Bungey, J. H. and M. Grantham. 2006. *Testing of concrete in structures*. Fourth Edition. CRC Press, London, UK.
- Davis, A., K. Lozen, T. Rowe, B. P. Simons, L. D. Olson, G. G. Clemena, N. A. Cumming, R. S. Jenkins, R. W. Poston, P. H. Read, W. M. K. Roddis, and M. J. Sansalone. 1998. ACI 228.2R-98. *Nondestructive test methods for evaluation of concrete in structures*. American Concrete Institute, Farmington Hills, MI.
- Davis, A. G., B. H. Hertlein, M. K. Lim, and K. Michols. 1996. Impact-echo and impulse response stress-wave methods: advantages and limitations for the evaluation of highway pavement concrete overlays. In *Proceedings Volume 2946, Nondestructive Evaluation of Bridges and Highways*, International Society for Optical Engineering. pp. 88–97.
- FHWA. 2018. *NDE Web Manual-Hammer Sound & Chain Drag (HSCD)*. Washington, DC.
https://fhwaapps.fhwa.dot.gov/ndep/DisplayTechnology.aspx?tech_id=16.
- Freeseaman, K., K. Hoegh, and L. Khazanovich. 2016a. *Concrete Strength Required to Open to Traffic*. Center for Transportation Studies, University of Minnesota, Minneapolis, MN.
<http://hdl.handle.net/11299/177641>.

- Freeseaman, K., L. Khazanovich, K. Hoegh, A. Nojavan, A. E. Schultz, and S. Chao. 2016b. Nondestructive monitoring of subsurface damage progression in concrete columns damaged by earthquake loading. *Engineering Structures*, Volume 114, pp. 148-157. <http://dx.doi.org/10.1016/j.engstruct.2016.02.017>.
- Freeseaman, K. 2016c. Nondestructive Evaluation Advancements for Damage Detection in Concrete. PhD thesis. University of Minnesota, Minneapolis, MN. <http://hdl.handle.net/11299/182269>.
- Germann Instruments. n.d. PUNDIT (portable ultrasonic nondestructive digital indicating tester). Germann Instruments, Evanston, IL. <http://www.germann.org/TestSystems/PUNDIT/PUNDIT.pdf>.
- Gholizadeh, S. 2016. A review of non-destructive testing methods of composite materials. *Procedia Structural Integrity*, Vol. 1, pp. 50–57.
- Grosse, C., H. Reinhardt, M. Krüger, and R. Beutel. 2005. Application of impact-echo techniques for crack detection and crack parameter estimation in concrete. Paper presented at the 11th International Conference on Fracture: ICF 11, March 20–25, Turin, Italy.
- Gucunski, N., A. Imani, F. Romero, S. Nazarian, D. Yuan, H. Wiggenhauser, P. Shokouhi, A. Taffe, and D. Kutrubes. 2013. *Nondestructive testing to identify concrete bridge deck deterioration*. SHRP 2 Report, Transportation Research Board, Washington, DC.
- Gucunski, N., F. Romero, S. Kruschwitz, R. Feldmann, and H. Parvardeh. 2011. *Comprehensive bridge deck deterioration mapping of nine bridges by nondestructive evaluation technologies*. Center for Advanced Infrastructure and Transportation, Rutgers University, Piscataway, NJ, and Federal Highway Administration, Washington, DC.
- Halmshaw, R. 1991. *Non-destructive testing*. Second Edition. Butterworth-Heinemann, Oxford, UK.
- Hassan, M., O. Burdet, and R. Favre. 1995. Ultrasonic measurements and static load tests in bridge evaluation. *NDT & E International*, Vol. 28, No. 6, pp. 331–337.
- IAEA. 1999. *Non-destructive testing: A guidebook for industrial management and quality control personnel*. International Atomic Energy Agency, Vienna, Austria. p. 296.
- IAEA. 2002. *Guidebook on non-destructive testing of concrete structures*. Training Course Series No. 17. International Atomic Energy Agency, Vienna, Austria. p. 242.
- IAEA. 2012. *Training guidelines in non-destructive testing techniques: Leak testing at level 2*. International Atomic Energy Agency, Vienna, Austria. p. 185.
- Iyer, S. R., S. K. Sinha, and A. J. Schokker. 2005. Ultrasonic c-scan imaging of post-tensioned concrete bridge structures for detection of corrosion and voids. *Computer-Aided Civil and Infrastructure Engineering*, Vol. 20, No. 2, pp. 79–94.
- Lee, S., N. Kalos, and D. H. Shin. 2014. Non-destructive testing methods in the U.S. for bridge inspection and maintenance. *KSCE Journal of Civil Engineering*, Vol. 18, No. 5, pp. 1322–1331.
- Lim, M. K. and H. Cao. 2013. Combining multiple NDT methods to improve testing effectiveness. *Construction and Building Materials*, Vol. 38, pp. 1310–1315.
- Lu, Y. 2010. *Non-destructive evaluation on concrete materials and structures using cement-based piezoelectric sensor*. PhD thesis. Hong Kong University of Science and Technology, Hong Kong.
- Maierhofer, C. 2003. Nondestructive evaluation of concrete infrastructure with ground penetrating radar. *Journal of Materials in Civil Engineering*, Vol. 15, No. 3, pp. 287–297.

- Main Roads Western Australia. 2012. *Detailed non-destructive bridge inspection guidelines. Concrete and Steel Bridges (Level 3 Inspections)*. No. 6706-02-2241.
- Metalssi, O. O., B. Godart, and F. Toutlemonde. 2015. Effectiveness of nondestructive methods for the evaluation of structures affected by internal swelling reactions: A review of electric, seismic and acoustic methods based on laboratory and site experiences. *Experimental Techniques*, Vol. 39, No. 2, pp. 65–76.
- Mishin, A. 1997. Portable linear electron accelerator for electron beam curing of composites, non-destructive testing and other applications. In *Proceedings of the Seventh International Conference on Structural Faults and Repair*, July 8, Edinburgh, Scotland, UK.
- NDT Resource Center. 2018a. *Introduction to Acoustic Emission Testing*. https://www.nde-ed.org/EducationResources/CommunityCollege/Other%20Methods/AE/AE_Index.htm.
- NDT Resource Center. 2018b. *Nature of Penetrating Radiation*. <https://www.nde-ed.org/EducationResources/CommunityCollege/Radiography/Physics/nature.htm>.
- Oh, T., S. H. Kee, R. W. Arndt, J. S. Popovics, and J. Zhu. 2012. Comparison of NDT methods for assessment of a concrete bridge deck. *Journal of Engineering Mechanics*, Vol. 139, No. 3, pp. 305–314.
- Ohtsu, M. 1996. The History and Development of Acoustic Emission in Concrete Engineering. *Magazine of Concrete Research*, Vol. 48, No. 177, pp. 321–330. <https://www.icevirtuallibrary.com/doi/10.1680/mac.1996.48.177.321>.
- Penhall Technologies. 2018. *Concrete Scanning using GPR*. Penhall Technologies, Irving, TX. <https://www.penhall.com/concrete-scanning-gpr/>.
- Rehman, S. K. U., Z. Ibrahim, S. A. Memon, and M. Jameel. 2016. Nondestructive test methods for concrete bridges: A review. *Construction and Building Materials*, Vol. 107, pp. 58–86.
- Rens, K. L., C. L. Nogueira, and D. J. Transue. 2005. Bridge management and nondestructive evaluation. *Journal of Performance of Constructed Facilities*, Vol. 19, No. 1, pp. 3–16.
- Sack, D. A. and L. D. Olson. 1995. Advanced NDT methods for evaluating concrete bridges and other structures. *NDT & E International*, Vol. 28, No. 6, pp. 349–357.
- Sargolzhahi, M., S. A. Kodjo, P. Rivard, and J. Rhazi. 2010. Effectiveness of nondestructive testing for the evaluation of alkali–silica reaction in concrete. *Construction and Building Materials*, Vol. 24, No. 8, pp. 1398–1403.
- Scheff, J. J. and R. H. Chen. 2012. Bridge decks inspection using chain drag and ground penetrating radar. Paper presented at the Engineering Mechanics Conference 2000, May 21–24, Austin, TX.
- Scott, M., A. Rezaizadeh, A. Delahaza, C. G. Santos, M. Moore, B. Graybeal, and G. Washer. 2003. A comparison of nondestructive evaluation methods for bridge deck assessment. *NDT & E International*, Vol. 36, No. 4, pp. 245–255.
- Spraggs, K. R., L. H. Sneed, A. Belarbi, and N. L. Anderson. 2012. Field investigation of spalling in partial-depth precast concrete bridge decks using nondestructive testing. *PCI Journal*, Vol. 57, No. 2, pp. 80–93.
- Sutan, N. M. and M. Meganathan. 2003. A comparison between direct and indirect method of ultrasonic pulse velocity in detecting concrete defects. *Russian Journal of Nondestructive Testing*, Vol. 8, pp. 1–9.

Villain, G., Z. M. Sbartai, X. Dérobert, V. Garnier, and J. P. Balayssac. 2012. Durability diagnosis of a concrete structure in a tidal zone by combining NDT methods: laboratory tests and case study. *Construction and Building Materials*, Vol. 37, pp. 893–903.