

1. Report No. FHWA-RD-93-063		2. Government Accession No.		3. Recipient's Catalog No.	
4. Title and Subtitle TESTING OF NEW BRIDGE RAIL AND TRANSITION DESIGNS Volume VI: Appendix E 32-in (813-mm) New Jersey Safety Shape				5. Report Date June 1997	
				6. Performing Organization Code	
7. Author(s) C. Eugene Buth, T. J. Hirsch, and Wanda L. Menges				8. Performing Organization Report No. Research Foundation 7069-Vol. VI	
9. Performing Organization Name and Address Texas Transportation Institute The Texas A&M University System College Station, Texas 77843-3135				10. Work Unit No. NCP No. 3A5C0042	
				11. Contract or Grant No. DTFH61-86-C-00071	
12. Sponsoring Agency Name and Address Office of Safety & Traffic Operations R&D Federal Highway Administration 6300 Georgetown Pike McLean, Virginia 22101-2296				13. Type of Report and Period Covered Final Report August 1986 - September 1993	
				14. Sponsoring Agency Code	
15. Supplementary Notes Research performed in cooperation with DOT, FHWA Research Study Title: Pooled Funds Bridge Rail Study Contracting Officer's Technical Representative (COTR) - Charles F. McDevitt					
16. Abstract Full-scale crash tests with a 5,400-lb (2 450-kg) pickup and an 1,800-lb (8 165-kg) truck were performed on a New Jersey safety shape concrete parapet to confirm that it would meet requirements for performance level two of the 1989 <i>Guide Specifications for Bridge Railings</i> . Performance was acceptable. A structural analysis of the parapet with the specified reinforcing steel indicates it will resist a force of 74 kips (329 kN) from a colliding vehicle. This volume is the sixth in a series. The other volumes in the series are: Volume I: Technical Report; Volume II: Appendix A, "Oregon Side Mounted Bridge Railing;" Volume III: Appendix B, "BR27D Bridge Railing;" Volume IV: Appendix C, "Illinois 2399-1 Bridge Railing;" Volume V: Appendix D, "32-in (813-mm) Concrete Parapet Bridge Railing;" Volume VII: Appendix F, "32-in (813-mm) F-Shape Bridge Railing;" Volume VIII: Appendix G, "BR27C Bridge Railing;" Volume IX: Appendix H, "Illinois Side Mount Bridge Rail;" Volume X: Appendix I, "42-in (1.07-m) Concrete Parapet Bridge Railing;" Volume XI: Appendix J, "42-in (1.07-m) F-Shape Bridge Railing;" Volume XII: Appendix K, "Oregon Transition;" Volume XIII: Appendix L, "32-in (813-mm) Thrie-Beam Transition;" and Volume XIV: Appendix M, "Axial Tensile Strength of Thrie and W-Beam Terminal Connectors."					
17. Key Words Bridge Rail, Longitudinal Barriers, Barrier Collision Forces, Ultimate Strength, Yieldline Analysis, Full-Scale Crash Tests, Highway Safety			18. Distribution Statement No restrictions. This document is available to the public through the National Technical Information Service 5285 Port Royal Road Springfield, Virginia 22161		
19. Security Classif. (of this report) Unclassified		20. Security Classif. (of this page) Unclassified		21. No. of Pages 65	22. Price

SI* (MODERN METRIC) CONVERSION FACTORS

APPROXIMATE CONVERSIONS TO SI UNITS

APPROXIMATE CONVERSIONS FROM SI UNITS

Symbol	When You Know	Multiply By	To Find	Symbol	Symbol	When You Know	Multiply By	To Find	Symbol
LENGTH					LENGTH				
in	inches	25.4	millimeters	mm	mm	millimeters	0.039	inches	in
ft	feet	0.305	meters	m	m	meters	3.28	feet	ft
yd	yards	0.914	meters	m	m	meters	1.09	yards	yd
mi	miles	1.61	kilometers	km	km	kilometers	0.621	miles	mi
AREA					AREA				
in ²	square inches	645.2	square millimeters	mm ²	mm ²	square millimeters	0.0016	square inches	in ²
ft ²	square feet	0.093	square meters	m ²	m ²	square meters	10.764	square feet	ft ²
yd ²	square yards	0.836	square meters	m ²	m ²	square meters	1.195	square yards	yd ²
ac	acres	0.405	hectares	ha	ha	hectares	2.47	acres	ac
mi ²	square miles	2.59	square kilometers	km ²	km ²	square kilometers	0.386	square miles	mi ²
VOLUME					VOLUME				
fl oz	fluid ounces	29.57	milliliters	mL	mL	milliliters	0.034	fluid ounces	fl oz
gal	gallons	3.785	liters	L	L	liters	0.264	gallons	gal
ft ³	cubic feet	0.028	cubic meters	m ³	m ³	cubic meters	35.71	cubic feet	ft ³
yd ³	cubic yards	0.765	cubic meters	m ³	m ³	cubic meters	1.307	cubic yards	yd ³
MASS					MASS				
oz	ounces	28.35	grams	g	g	grams	0.035	ounces	oz
lb	pounds	0.454	kilograms	kg	kg	kilograms	2.202	pounds	lb
T	short tons (2000 lb)	0.907	megagrams (or "metric ton")	Mg (or "t")	Mg (or "t")	megagrams (or "metric ton")	1.103	short tons (2000 lb)	T
TEMPERATURE (exact)					TEMPERATURE (exact)				
°F	Fahrenheit temperature	$5(F-32)/9$ or $(F-32)/1.8$	Celcius temperature	°C	°C	Celcius temperature	$1.8C + 32$	Fahrenheit temperature	°F
ILLUMINATION					ILLUMINATION				
fc	foot-candles	10.76	lux	lx	lx	lux	0.0929	foot-candles	fc
fl	foot-Lamberts	3.426	candela/m ²	cd/m ²	cd/m ²	candela/m ²	0.2919	foot-Lamberts	fl
FORCE and PRESSURE or STRESS					FORCE and PRESSURE or STRESS				
lbf	poundforce	4.45	newtons	N	N	newtons	0.225	poundforce	lbf
lbf/in ²	poundforce per square inch	6.89	kilopascals	kPa	kPa	kilopascals	0.145	poundforce per square inch	lbf/in ²

NOTE: Volumes greater than 1000 l shall be shown in m³.

* SI is the symbol for the International System of Units. Appropriate rounding should be made to comply with Section 4 of ASTM E380.

(Revised September 1993)

TABLE OF CONTENTS

<u>Chapter</u>	<u>Page</u>
1. DESIGN OF RAILING	1
2. CRASH TEST PROCEDURES	3
3. FULL-SCALE CRASH TESTS	7
TEST 7069-12	7
Test Description	7
Test Results	7
Conclusions	8
TEST 7069-14	31
Test Description	31
Test Results	31
Conclusions	32
4. STRENGTH CALCULATIONS	57
REFERENCES	59

LIST OF FIGURES

<u>Figure No.</u>	<u>Page</u>
1. 32-in (813-mm) New Jersey safety shape	2
2. Vehicle before test 7069-12	9
3. Vehicle/safety shape geometrics for test 7069-12	10
4. 32-in (813-mm) New Jersey safety shape before test 7069-12	11
5. Vehicle properties for test 7069-12	12
6. 32-in (813-mm) New Jersey safety shape after test 7069-12	14
7. Vehicle after test 7069-12	15
8. Damage to undercarriage of test vehicle	16
9. Summary of results for test 7069-12	17
10. Sequential photographs for test 7069-12	21
11. Perpendicular sequential photographs for test 7069-12	23
12. Vehicle angular displacements for test 7069-12	24
13. Vehicle longitudinal accelerometer trace for test 7069-12 (accelerometer located near center-of-gravity)	25
14. Vehicle lateral accelerometer trace for test 7069-12 (accelerometer located near center-of-gravity)	26
15. Vehicle vertical accelerometer trace for test 7069-12 (accelerometer located near center-of-gravity)	27
16. Vehicle longitudinal accelerometer trace for test 7069-12 (accelerometer located at front of vehicle)	28
17. Vehicle lateral accelerometer trace for test 7069-12 (accelerometer located at front of vehicle)	29
18. Vehicle longitudinal accelerometer trace for test 7069-12 (accelerometer located at rear of vehicle)	30
19. Vehicle before test 7069-14	33
20. Vehicle/safety shape geometrics for test 7069-14	34
21. 32-in (813-mm) New Jersey safety shape before test 7069-14	35
22. Vehicle properties for test 7069-14	36
23. 32-in (813-mm) New Jersey safety shape after test 7069-14	37
24. Right side of vehicle after test 7069-14	38
25. Damage to right front and right rear wheels	39
26. Left side of vehicle after test 7069-14	40
27. Dummies before and after test 7069-14	41
28. Summary of results for test 7069-14	42
29. Sequential photographs for test 7069-14	44
30. Perpendicular sequential photographs for test 7069-14	46
31. Interior sequential photographs for test 7069-14	47
32. Vehicle angular displacements for test 7069-14	48
33. Vehicle longitudinal accelerometer trace for test 7069-14 (accelerometer located near center-of-gravity)	49

LIST OF FIGURES (Continued)

<u>Figure No.</u>		<u>Page</u>
34.	Vehicle lateral accelerometer trace for test 7069-14 (accelerometer located near center-of-gravity)	50
35.	Vehicle vertical accelerometer trace for test 7069-14 (accelerometer located near center-of-gravity)	51
36.	Vehicle longitudinal accelerometer trace for test 7069-14 (accelerometer located at front of vehicle)	52
37.	Vehicle lateral accelerometer trace for test 7069-14 (accelerometer located at front of vehicle)	53
38.	Vehicle longitudinal accelerometer trace for test 7069-14 (accelerometer located at rear of vehicle)	54
39.	Vehicle lateral accelerometer trace for test 7069-14 (accelerometer located at rear of vehicle)	55

LIST OF TABLES

<u>Table No.</u>		<u>Page</u>
1.	Evaluation of crash test no. 7069-12	18
2.	Bridge railing performance levels and crash test criteria	19
3.	Evaluation of crash test no. 7069-14	43

CHAPTER 1. DESIGN OF RAILING

The 32-in (813-mm) New Jersey safety shape was designed to meet performance level two of the 1989 *Guide Specifications for Bridge Railings*.⁽¹⁾ The design force of 56 kips (249 kN) was a uniformly distributed line force 42 in (1.07 m) long located at least 29 in (737 mm) above the roadway surface.

A cross section of the railing design is shown in figure 1. Total height of the safety shape is 32 in (813 mm). The thickness of the unit is 15 in (381 mm) at its base and varies along the height, tapering to a minimum of 6 in (152 mm) at the top. The slope at the bottom of the rail serves to minimize the damage done to vehicles impacting at low angles by causing the front tire to ride up on the parapet and to be redirected with limited contact between the body of the vehicle and the parapet.

Eight #4 longitudinal bars were used in the safety shape. The vertical steel was #5 stirrups at 8-in (203-mm) spacing. Specified concrete strength was 3,600 psi (24 804 kPa) at 28 days, and specified steel yield was 60,000 psi (413 400 kPa). The cantilevered deck was supported on a foundation so that the deck overhang was 39 in (991 mm).

The strength of the railing was computed using yieldline analysis procedures.⁽²⁾ The strength computations are presented in Chapter 4. The analysis predicts the length of the failure mechanism to be 8.1 ft (2.50 m) and the total ultimate load capacity to be 74 kips (329 kN). The analysis also shows that the yield lines are confined to the parapet rather than extending into the bridge deck.

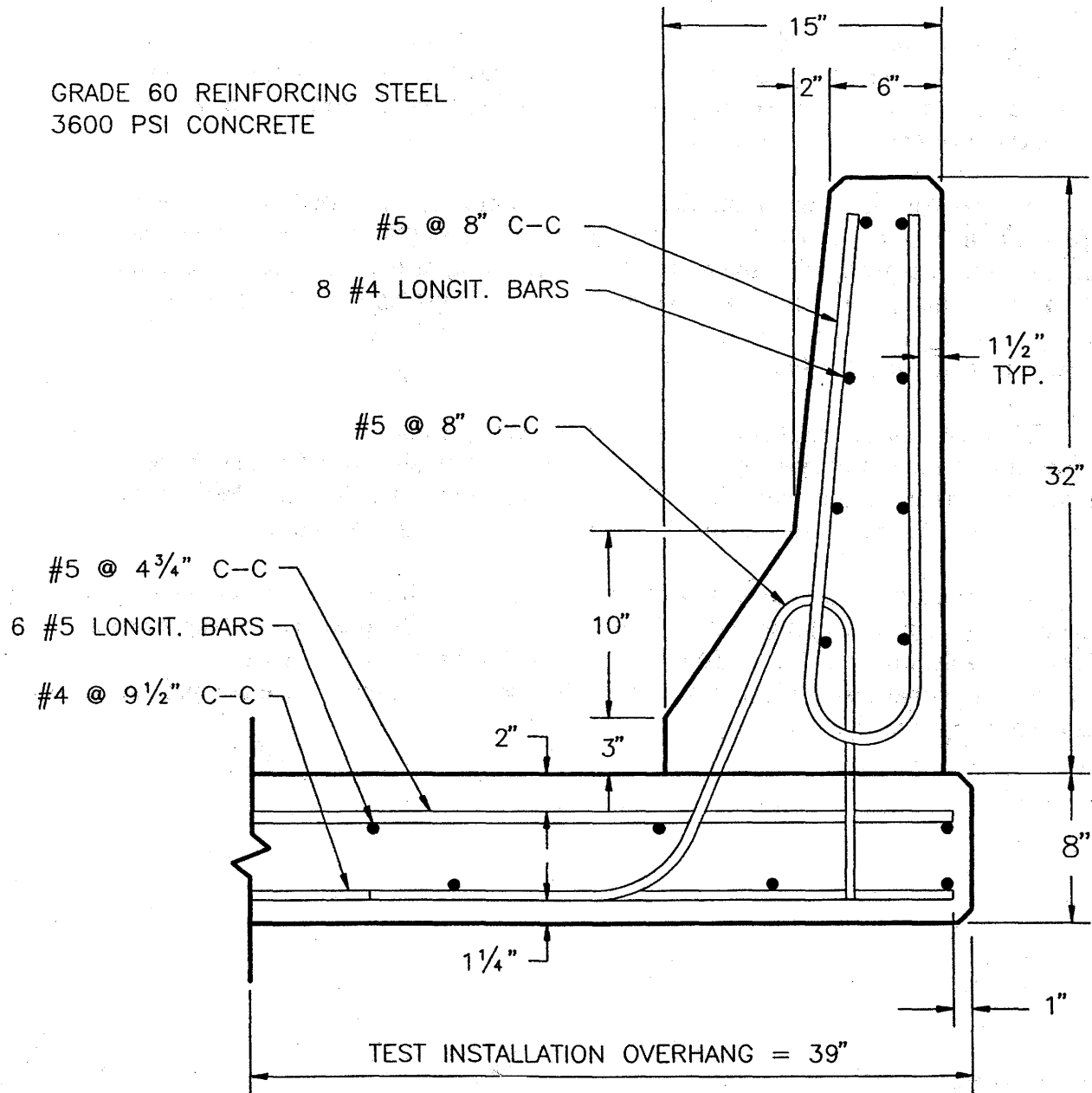

1 in = 25.4 mm
1 psi = 6.89 kPa

Figure 1. 32-in (813-mm) New Jersey safety shape.

CHAPTER 2. CRASH TEST PROCEDURES

This railing was tested to performance level two requirements.⁽¹⁾ The following nominal test conditions were used:

18,000-lb (8 172-kg) truck | 50 mi/h (80.5 km/h) | 15 degrees (test 7069-12)
5,400-lb (2 452-kg) pickup | 60 mi/h (96.6 km/h) | 20 degrees (test 7069-14)

Each vehicle was equipped with triaxial accelerometers mounted near the center-of-gravity, biaxial accelerometers forward of the center-of-gravity and biaxial accelerometers in the rear of each vehicle. The accelerometers were strain gauge type with a linear millivolt output proportional to acceleration. In addition, each vehicle was instrumented with three solid-state angular rate transducers also mounted near the center-of-gravity to measure yaw, pitch, and roll rates. The electronic signals from the accelerometers and transducers were transmitted to a base station by means of constant bandwidth FM/FM telemetry link for recording on magnetic tape and displaying on a real-time strip chart. Provision was made for transmission of calibration signals before and after the test, and an accurate time reference signal was simultaneously recorded with the data.

Pressure sensitive contact switches on the bumper of each vehicle were actuated just prior to impact by wooden dowels to indicate the elapsed time over a known distance to provide a measurement of impact velocity. Each initial contact also produced an "event" mark on the data record to establish the instant of impact.

The multiplex of data channels transmitted on one radio frequency was received at a data acquisition station and demultiplexed into separate tracks of Intermediate Range Instrumentation Group (I.R.I.G.) tape recorders. After the test, the data were played back from the tape machines, filtered with an SAE J211 filter, and digitized using a microcomputer for analysis and evaluation of performance.

The digitized data obtained from the electronic transducers were then processed using two computer programs: DIGITIZE AND PLOTANGLE. Brief descriptions on the functions of these two computer programs are as follows.

The DIGITIZE program uses digitized data from vehicle-mounted linear accelerometers to compute occupant/compartments impact velocities, time of occupant/compartments impacts after vehicle impacts, highest 0.010-s averages of vehicle accelerations after occupant/compartments impacts, and times of highest 0.010-s averages.

The DIGITIZE program also calculates a vehicle impact velocity and the change in vehicle velocity at the end of each impulse period. In addition, maximum average accelerations over 0.050-s intervals in each of three directions are computed. Acceleration versus time curves for the longitudinal, lateral, and vertical directions are then plotted from the digitized data of the vehicle-mounted linear accelerometers using a commercially available software package (QUATTRO PRO). For each of these graphs, a 0.050-s average window was calculated at

the center of the 0.050-s interval and then plotted with the first 0.050-s average plotted at 0.026 s.

The PLOTANGLE program uses the digitized data from the yaw, pitch, and roll rate charts to compute angular displacement in degrees at 0.001-s intervals and instructs a plotter to draw a reproducible plot: yaw, pitch, and roll versus time. It should be noted that these angular displacements are sequence dependent with the sequence being yaw-pitch-roll for the data presented herein. These displacements are in reference to the vehicle-fixed coordinate system with the initial position and orientation of the vehicle-fixed coordinate system being that which existed at initial impact.

The pickup in test 7069-14 was equipped with two Alderson Research Laboratories Hybrid II, 50th percentile anthropomorphic dummies. One dummy was placed in the driver's seat, and the other one was placed in the passenger's seat. Both were uninstrumented and were restrained with standard restraint equipment. The single-unit truck in test 7069-12 carried no dummies.

Photographic coverage of the test included three high-speed cameras: one placed to have a field of view parallel to and aligned with the safety shape, one placed perpendicular to the front of the installation, and a third placed overhead with a field of view perpendicular to the ground and directly over the impact point. There was also a high-speed camera placed onboard the pickup to record the motions of the dummies during the test. A flash bulb activated by pressure sensitive tape switches was positioned on the impacting vehicle to indicate the instant of contact with the safety shape and was visible from each camera. The films from these high-speed cameras were analyzed on a computer-linked motion analyzer to observe phenomena occurring during the collision and to obtain time-event, displacement, and angular data. A 16-mm movie cine, a professional video camera, and a 3/4-in (19-mm) video recorder along with 35-mm still cameras were used for documentary purposes and to record conditions of the safety shape before and after the test.

The 18,000-lb (8 172-kg) truck was guided into the safety shape using a remote control guidance system. Immediately prior to impact with the safety shape, the fuel supply to the engine was shut off and the truck was released to be free-wheeling and unrestrained. The truck remained free-wheeling and unrestrained, i.e., no steering or braking inputs, until the truck cleared the immediate area of the test site. Brakes on the truck were then activated to bring the truck to a safe and controlled stop.

The pickup was towed into the test installation using a steel cable guidance and reverse tow system. A steel cable for guiding the pickup was stretched along the path, anchored at each end, and threaded through an attachment to the front wheel of the pickup. Another steel cable was connected to the pickup, passed around a pulley near the impact point, through a pulley on the tow vehicle, and then anchored to the ground such that the tow vehicle moved away from the test site. A 2-to-1 speed ratio between the pickup and tow vehicle existed with this system. Immediately prior to impact with the test installation, the pickup was released to be free-wheeling and unrestrained. The pickup remained free-wheeling, i.e., no steering or braking inputs, until the pickup cleared the immediate area of

the test site. At this time brakes on the pickup were activated to bring the pickup to a safe and controlled stop.

CHAPTER 3. FULL-SCALE CRASH TESTS

TEST 7069-12

Test Description

The 1982 GMC single-unit truck (figures 2 and 3) was directed into the 32-in (813-mm) New Jersey safety shape (figure 4) using a remote control guidance system. Empty weight of the vehicle was 10,900 lb (4 949 kg) and its test inertia weight was 18,000 lb (8 172 kg). The height to the lower edge of the vehicle bumper was 19.5 in (495 mm) and it was 32.0 in (813 mm) to the top of the bumper. Other dimensions and information on the test vehicle are given in figure 5. The vehicle was free-wheeling and unrestrained just prior to impact.

The speed of the vehicle at impact was 51.6 mi/h (83.1 km/h) and the angle of impact was 15.5 degrees. The vehicle impacted the safety shape approximately 23 ft (7.01 m) from the end. Shortly after impact, the right front wheel began to ride up the face of the safety shape. At 0.093 s, the axle broke on the right side and the left front tire became airborne. The vehicle began to slowly redirect as the rear end began to slide toward the safety shape. The lower edge of the front bumper reached the top of the safety shape at 0.101 s. At 0.312 s, the left rear wheels became airborne, and the front of the vehicle reached a maximum height of approximately 1 ft (305 mm) above the safety shape. As the vehicle rode along the top of the safety shape, it continued to roll to the right and reached maximum redirection at 0.324 s at an angle of 8.6 degrees into the safety shape. At about 0.627 s, the front of the vehicle extended over the safety shape by one-half of the width of the vehicle. By 1.040 s, the vehicle attained a maximum roll angle of 44 degrees to the right and began to right itself. As the vehicle slid off the end of the safety shape, it continued to roll to the left (away from the railing). The vehicle subsequently came to rest on its left side 75 ft (22.86 m) from the end of the safety shape.

As can be seen in figure 6, the safety shape received cosmetic damage and some scraping and gouging. There were tire marks on the face and top of the safety shape. The top of the safety shape was scraped along the remaining length by the undercarriage of the truck. The vehicle was in contact with the safety shape for 77 ft (23.47 m).

The vehicle sustained extensive damage to the right side as shown in figures 7 and 8. Maximum crush at the right front corner at bumper height was 8.0 in (203 mm). The front axle was torn off the vehicle, and the undercarriage damaged. There was damage to the U-bolts, Pittman arm rod, steering arm, brake lines, and leaf spring bolts. The outer right rear wheel rim and tire were damaged. The fuel tank also sustained damage.

Test Results

Impact speed was 51.6 mi/h (83.1 km/h), and the angle of impact was 15.5 degrees. The exit speed and the effective coefficient of friction were not attainable. The vehicle did not become parallel while in contact with the safety shape (8.6 degrees into the safety shape

at 0.324 s). Occupant impact velocity was 13.4 ft/s (4.1 m/s) in the longitudinal direction and 10.2 ft/s (3.1 m/s) in the lateral direction. The highest 0.010-s occupant ridedown accelerations were -3.0 g (longitudinal) and 4.9 g (lateral). These data and other pertinent information from the test are summarized in figure 9 and tables 1 and 2. Sequential photographs are shown in figure 10 and 11, and vehicle angular displacements are displayed in figure 12. Vehicular accelerations versus time traces filtered with SAE J211 filters are presented in figures 13 through 18. These data were further analyzed to obtain 0.050-s average accelerations versus time. The maximum 0.050-s averages measured at the center-of-gravity were -3.2 g (longitudinal) and 2.5 g (lateral).

Conclusions

The 32-in (813-mm) New Jersey safety shape contained and redirected the test vehicle with no lateral movement of the safety shape. There was no intrusion into the occupant compartment and very little deformation of the compartment. The vehicle trajectory at loss of contact indicates minimum intrusion into adjacent traffic lanes; however, the vehicle did not remain upright after collision. See figure 9 and table 1 for more details.

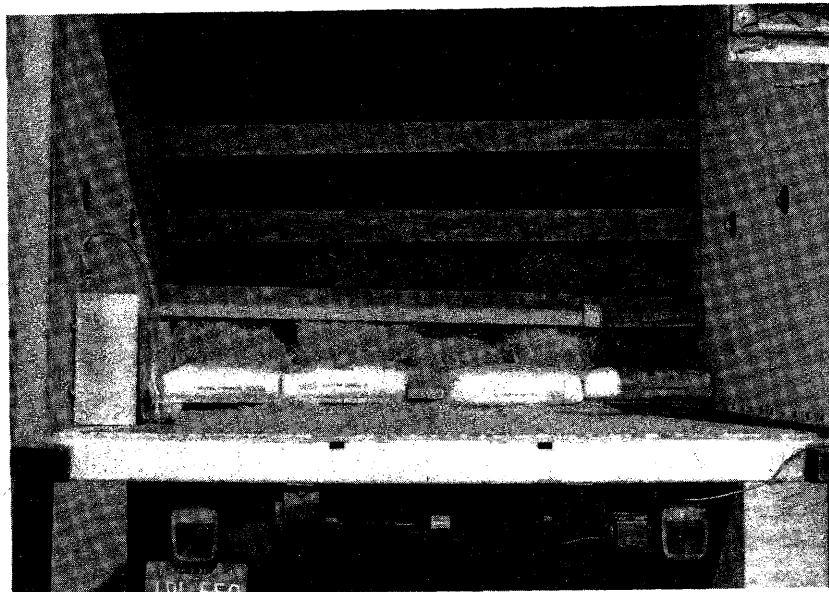

Figure 2. Vehicle before test 7069-12.

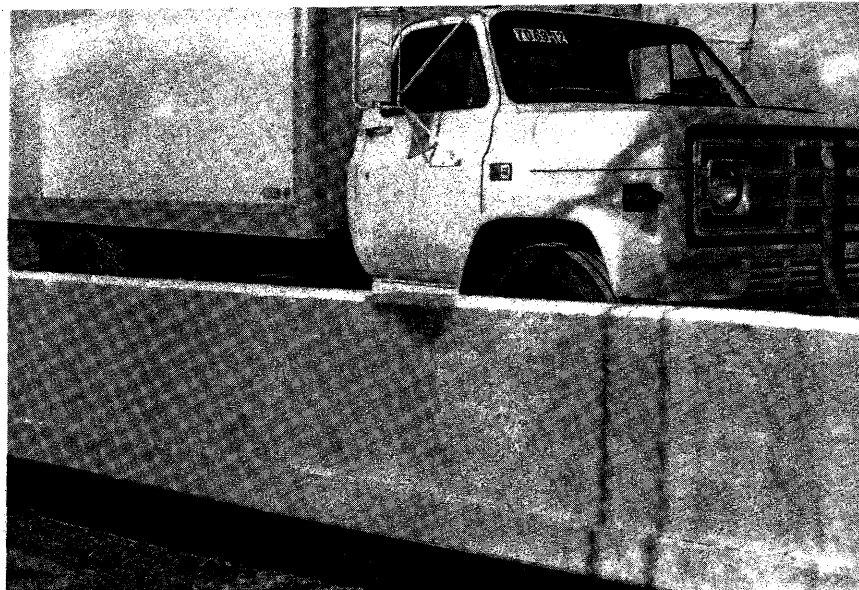

Figure 3. Vehicle/safety shape geometrics for test 7069-12.

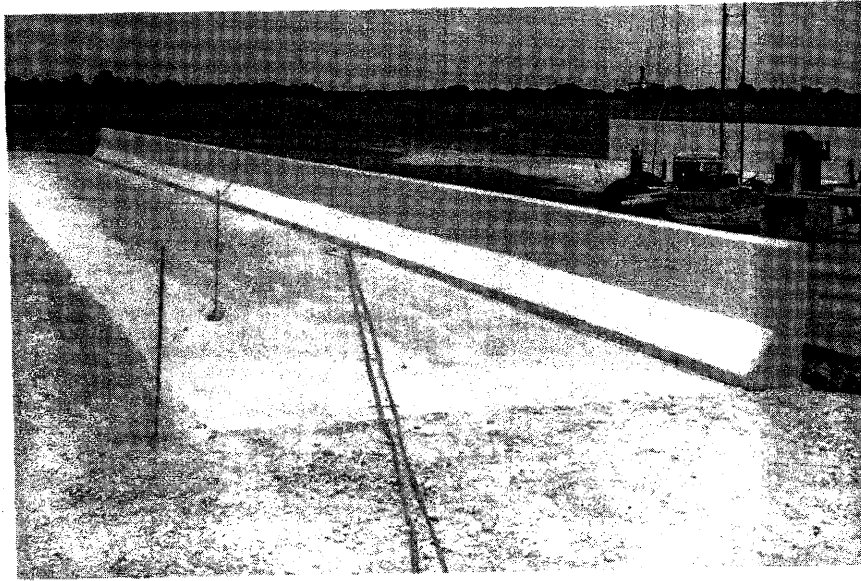
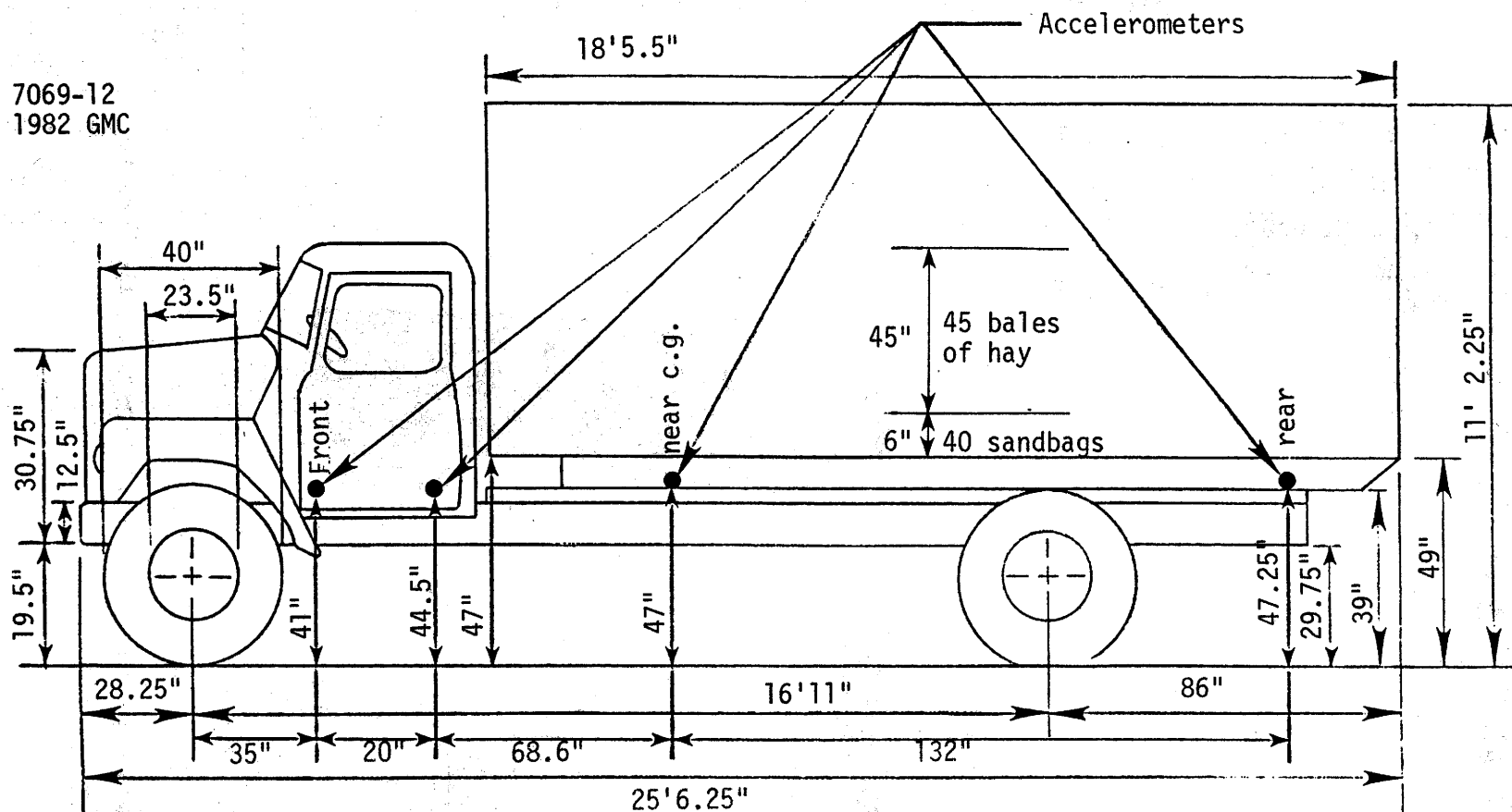

Figure 4. 32-in (813-mm) New Jersey safety shape before test 7069-12.

EMPTY WEIGHTSWeight on Front Axle : LF 2,390 RF 2,390Weight on Rear Axle : LR 2,900 RR 3,220TOTAL EMPTY WEIGHT : 10,900LOADED WEIGHTSWeight on Front Axle : LF 3,490 RF 3,550Weight on Rear Axle : RF 5,360 RR 5,600TOTAL LOADED WEIGHT : 18,000

1 in = 25.4 mm

1 lb = 0.454 kg

Figure 5. Vehicle properties for test 7069-12.

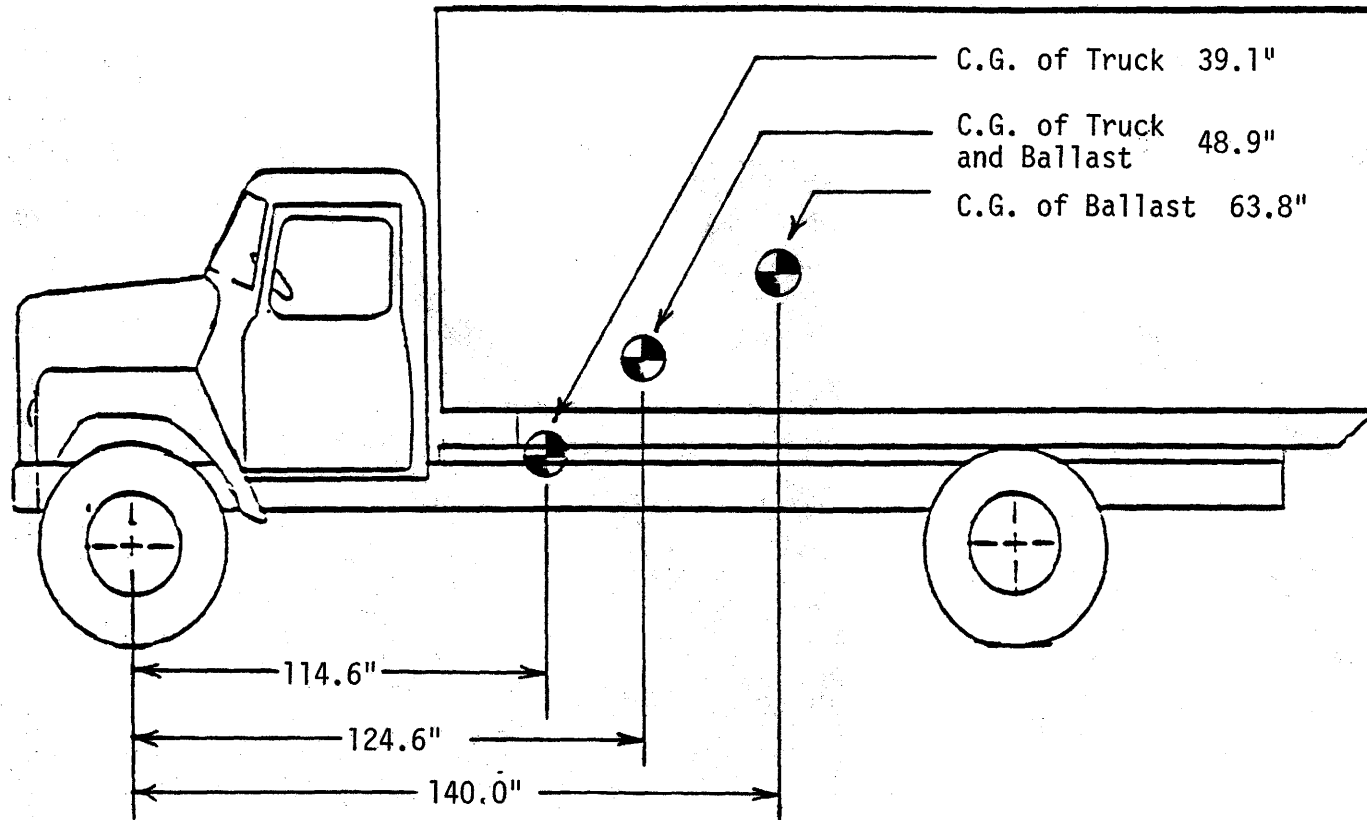

EMPTY WEIGHTS

Weight on Front Axle	<u>4780 lb.</u>
Weight on Rear Axle	<u>6120 lb.</u>
TOTAL EMPTY WEIGHT	<u>10,900 lb.</u>

1 in = 25.4 mm
1 psi = 6.89 kPa

LOADED WEIGHTS

Weight on Front Axle	<u>7040 lb.</u>
Weight on Rear Axle	<u>10,960 lb.</u>
TOTAL LOAD WEIGHT	<u>18,000 lb.</u>

Figure 5. Test vehicle properties for test 7069-12 (continued).

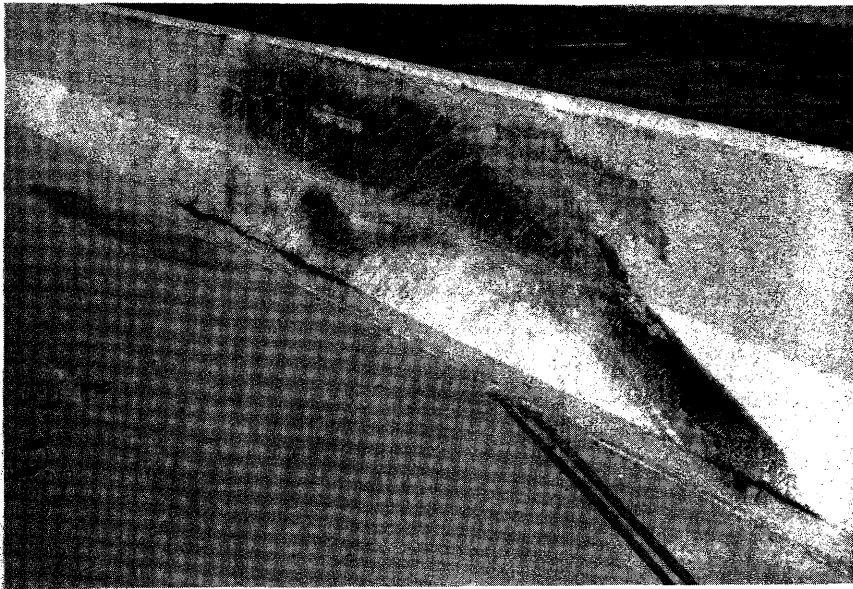
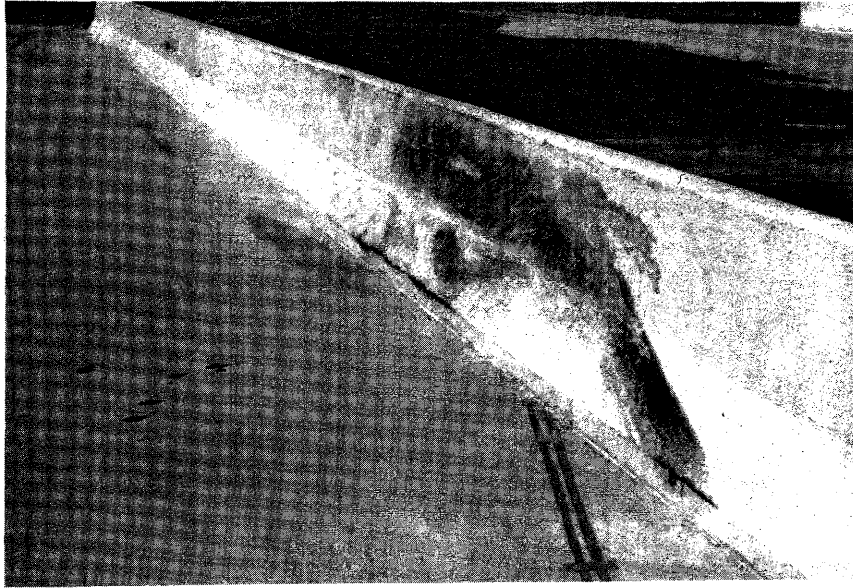

Figure 6. 32-in (813-mm) New Jersey safety shape after test 7069-12.

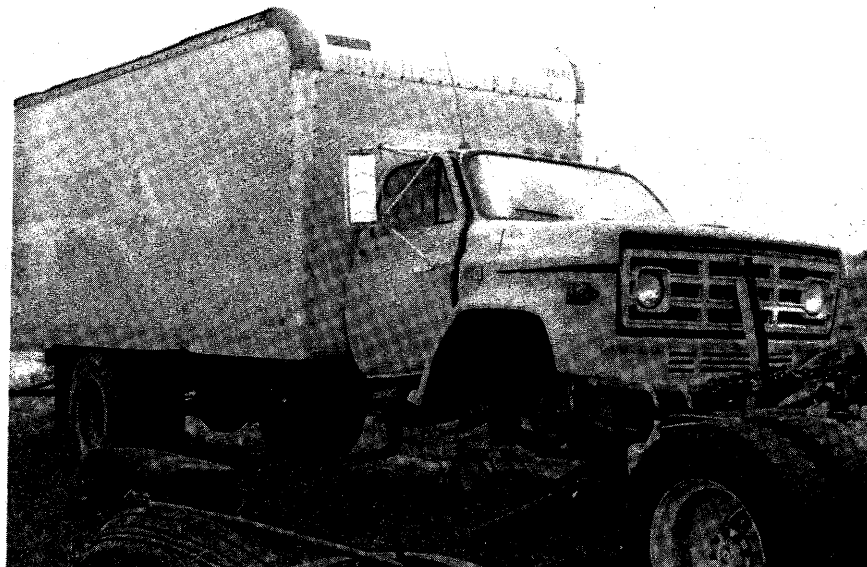
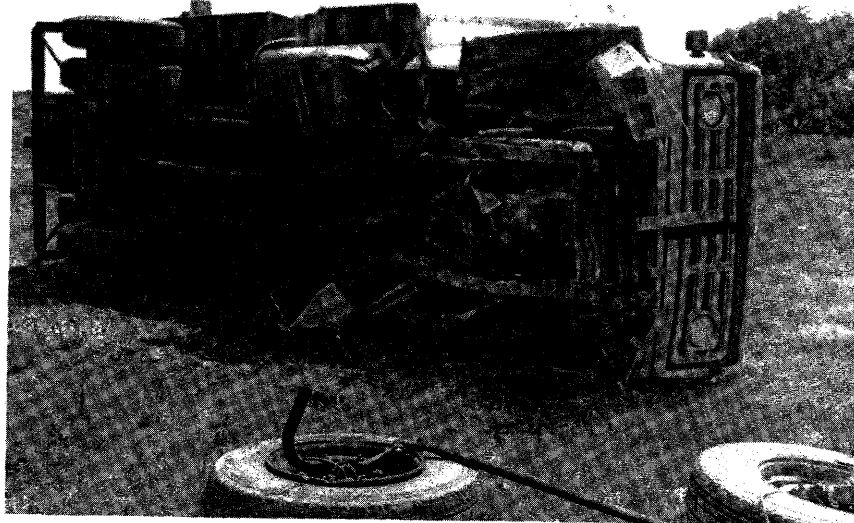

Figure 7. Vehicle after test 7069-12.

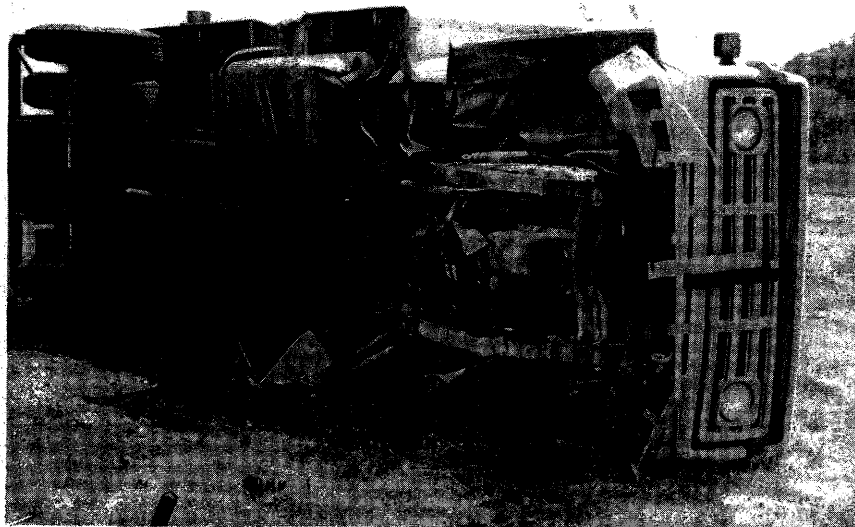
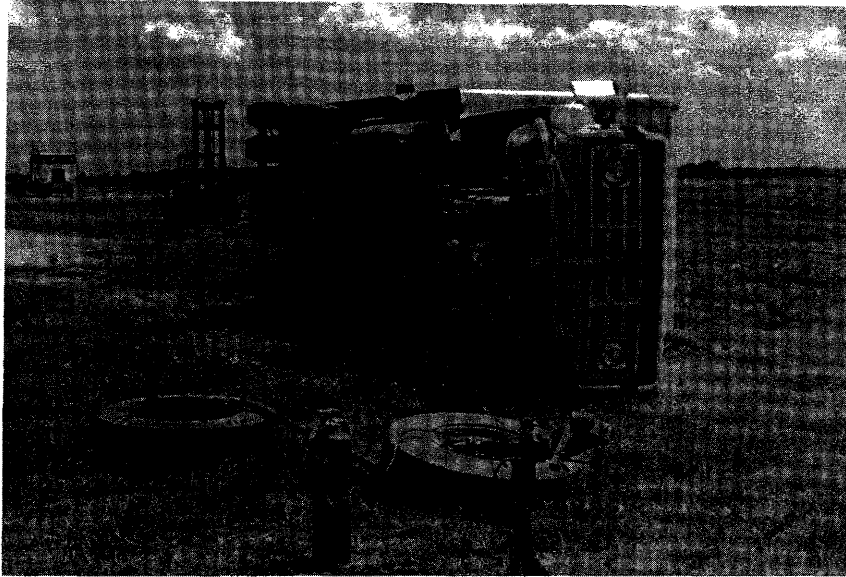

Figure 8. Damage to undercarriage of test vehicle.

Table 1. Evaluation of crash test no. 7069-12.
 {32-in (813-mm) New Jersey Safety Shape [18,000 lb (2 172 kg)|51.6 mi/h (83.1 km/h)|15.5 degrees]}

CRITERIA		TEST RESULTS		PASS/FAIL
A.	Must contain vehicle	Vehicle was contained		Pass
B.	Debris shall not penetrate passenger compartment	No debris penetrated passenger compartment		Pass
C.	Passenger compartment must have essentially no deformation	Acceptable deformation		Pass
D.	Vehicle must remain upright	Vehicle did not remain upright		Fail
E.	Must smoothly redirect the vehicle	Vehicle was smoothly redirected		Pass
F.	Effective coefficient of friction			
	<u>μ</u>	<u>Assessment</u>	<u>μ</u>	<u>Assessment</u>
	0 - .25	Good	N/A	N/A
	.26 - .35	Fair		
	> .35	Marginal		
G.	Shall be less than			
	<u>Occupant Impact Velocity - ft/s (m/s)</u>	<u>Occupant Impact Velocity - ft/s (m/s)</u>		N/A
	Longitudinal Lateral	Longitudinal	Lateral	
	30 (9.2) 25 (7.6)	13.4 (4.1)	10.2 (3.1)	
	<u>Occupant Ridedown Accelerations - g's</u>	<u>Occupant Ridedown Accelerations - g's</u>		N/A
	Longitudinal Lateral	Longitudinal	Lateral	
	15 15	-3.0	4.9	
H.	Exit angle shall be less than 12 degrees	about 2 degrees		Pass

* A, B, C are required. D, E, F, and H are desired. G is not applicable for this test. (see table 2)

Table 2. Bridge railing performance levels and crash test criteria.
(Excerpt from 1989 AASHTO *Guide Specifications for Bridge Railings*)⁽¹⁾

		TEST SPEEDS—mph ^{1,2}			
		TEST VEHICLE DESCRIPTIONS AND IMPACT ANGLES			
PERFORMANCE LEVELS		Small Automobile	Pickup Truck	Medium Single-Unit Truck	Van-Type Tractor-Trailer ⁴
			W = 1.8 Kips A = 5.4' ± 0.1' B = 5.5' H _{cg} = 20" ± 1" θ = 20 deg.	W = 5.4 Kips A = 8.5' ± 0.1' B = 6.5' H _{cg} = 27" ± 1" θ = 20 deg.	W = 18.0 Kips A = 12.8' ± 0.2' B = 7.5' H _{cg} = 49" ± 1" θ = 15 deg.
	PL-1	50	45		
	PL-2	60	60	50	
	PL-3	60	60		50
CRASH TEST EVALUATION CRITERIA ³	Required	a, b, c, d, g	a, b, c, d	a, b, c	a, b, c
	Desirable ⁵	e, f, h	e, f, g, h	d, e, f, h	d, e, f, h

Notes:

1. Except as noted, all full-scale tests shall be conducted and reported in accordance with the requirements in NCHRP Report No. 230. In addition, the maximum loads that can be transmitted from the bridge railing to the bridge deck are to be determined from static force measurements or ultimate strength analysis and reported.

2. Permissible tolerances on the test speeds and angles are as follows:

Speed	-1.0 mph	+2.5 mph
Angle	-1.0 deg.	+2.5 deg.

Tests that indicate acceptable railing performance but that exceed the allowable upper tolerances will be accepted.

3. Criteria for evaluating bridge railing crash test results are as follows:

- The test article shall contain the vehicle; neither the vehicle nor its cargo shall penetrate or go over the installation. Controlled lateral deflection of the test article is acceptable.
- Detached elements, fragments, or other debris from the test article shall not penetrate or show potential for penetrating the passenger compartment or present undue hazard to other traffic.
- Integrity of the passenger compartment must be maintained with no intrusion and essentially no deformation.
- The vehicle shall remain upright during and after collision.
- The test article shall smoothly redirect the vehicle. A redirection is deemed smooth if the rear of the vehicle or, in the case of a combination vehicle, the rear of the tractor or trailer does not yaw more than 5 degrees away from the railing from time of impact until the vehicle separates from the railing.
- The smoothness of the vehicle-railing interaction is further assessed by the effective coefficient of friction, μ :

μ	Assessment
0-0.25	Good
0.26-0.35	Fair
>0.35	Marginal

where $\mu = (\cos\theta - V_p/V)/\sin\theta$

Table 2. Bridge railing performance levels and crash test criteria.
 (Excerpt from 1989 AASHTO *Guide Specifications for Bridge Railings*)⁽¹⁾
 (continued)

g. The impact velocity of a hypothetical front-seat passenger against the vehicle interior, calculated from vehicle accelerations and 2.0-ft. longitudinal and 1.0-ft. lateral displacements, shall be less than:

Occupant Impact Velocity—fps	
Longitudinal	Lateral
30	25

and the vehicle highest 10-ms average accelerations subsequent to the instant of hypothetical passenger impact should be less than:

Occupant Ridedown Acceleration—g's	
Longitudinal	Lateral
15	15

h. Vehicle exit angle from the barrier shall not be more than 12 degrees. Within 100 ft. plus the length of the test vehicle from the point of initial impact with the railing, the railing side of the vehicle shall move no more than 20-ft. from the line of the traffic face of the railing. The brakes shall not be applied until the vehicle has traveled at least 100-ft. plus the length of the test vehicle from the point of initial impact.

4. Values A and R are estimated values describing the test vehicle and its loading. Values of A and R are described in the figure below and calculated as follows:

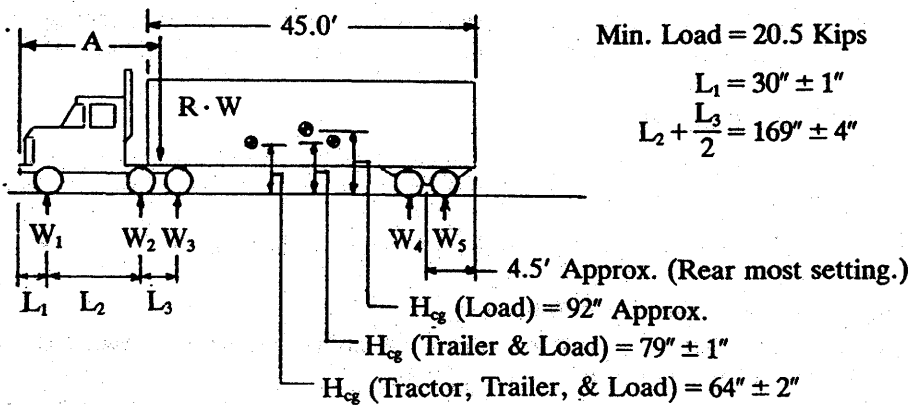

Min. Load = 20.5 Kips

$$L_1 = 30'' \pm 1''$$

$$L_2 + \frac{L_3}{2} = 169'' \pm 4''$$

$$A = L_1 + \frac{W_2 L_2 + W_3 (L_2 + L_3)}{W_1 + W_2 + W_3}$$

$$R = \frac{W_1 + W_2 + W_3}{W}$$

$$W = W_1 + W_2 + W_3 + W_4 + W_5$$

= total vehicle weight.

5. Test articles that do not meet the desirable evaluation criteria shall have their performance evaluated by a designated authority that will decide whether the test article is likely to meet its intended use requirements.

1 mi = 1.61 km
1 kip = 4.45 kN
1 in = 25.4 mm

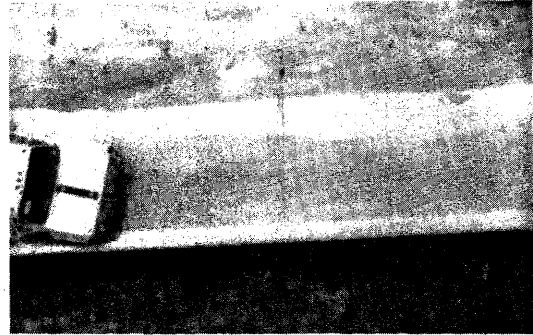

0.000 s

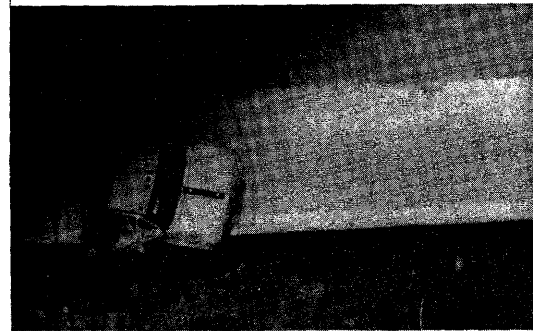

0.152 s

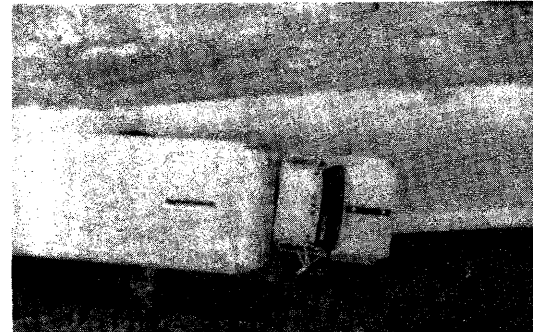
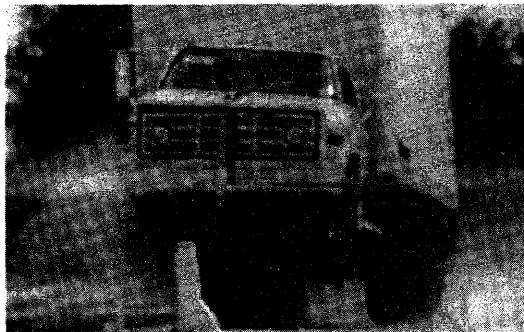

0.304 s

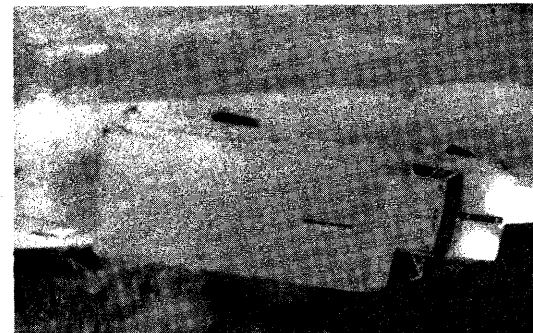

0.456 s

Figure 10. Sequential photographs for test 7069-12.



0.608 s

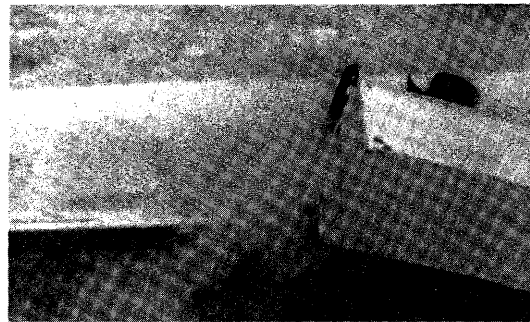
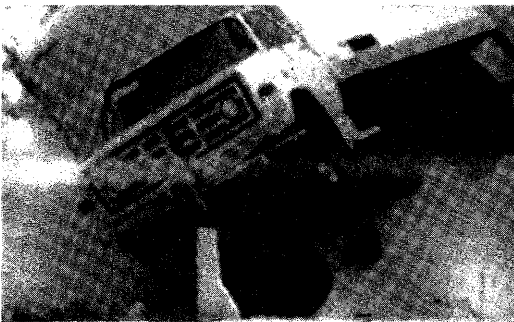

0.760 s

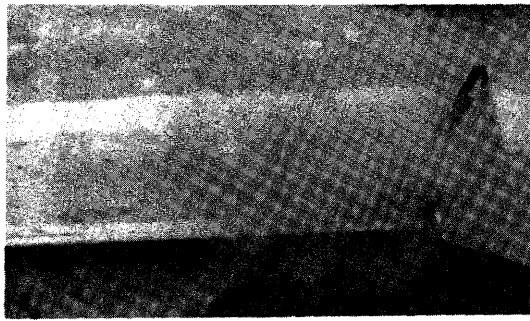
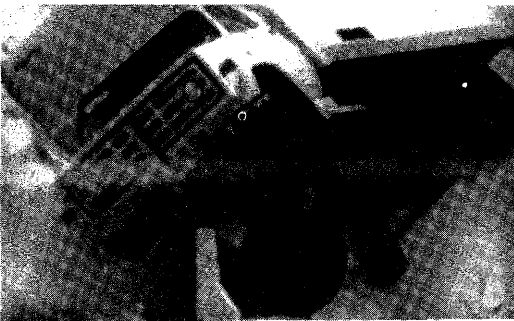

0.912 s

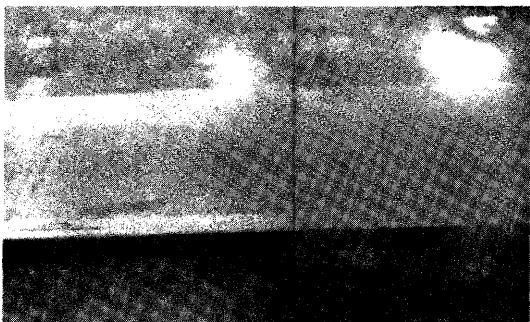
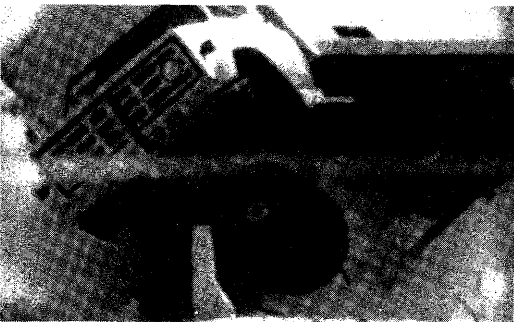

1.067 s

Figure 10. Sequential photographs for test 7069-12 (continued).

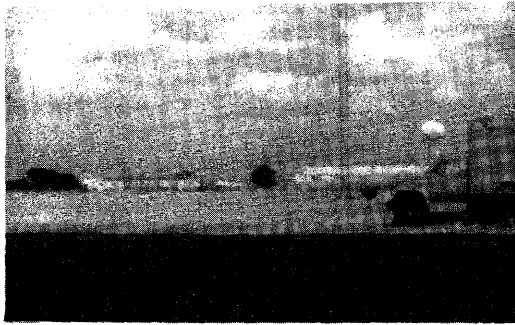

0.000 s

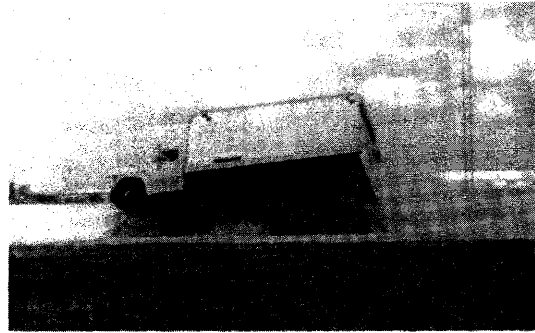

0.608 s

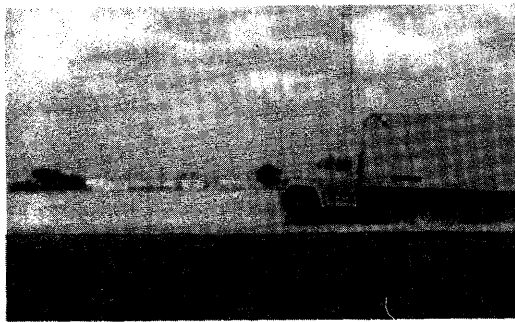

0.152 s

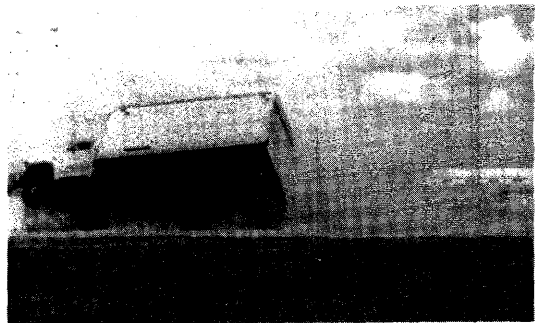

0.760 s

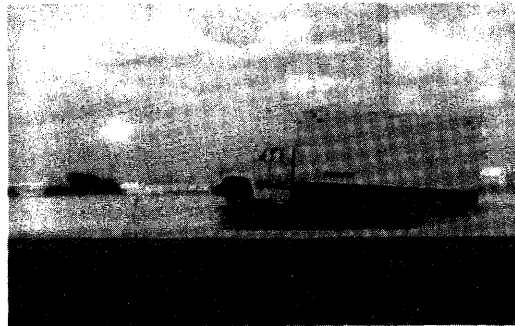

0.304 s

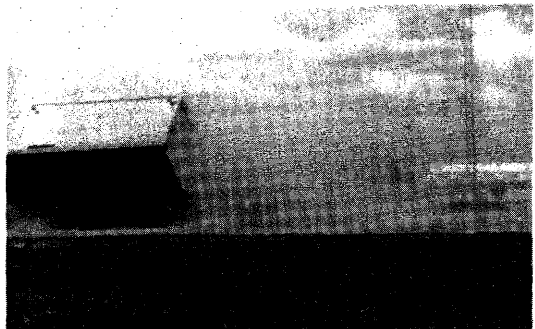

0.912 s

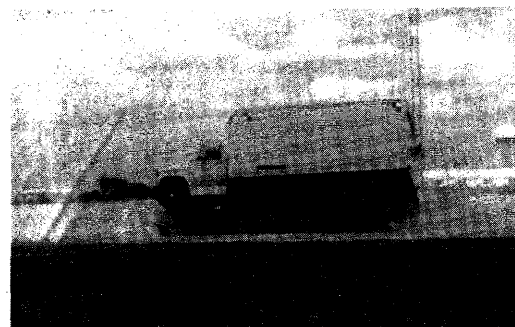

0.456 s

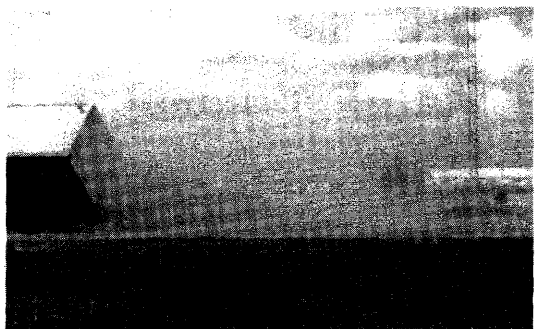

1.607 s

Figure 11. Perpendicular sequential photographs for test 7069-12.

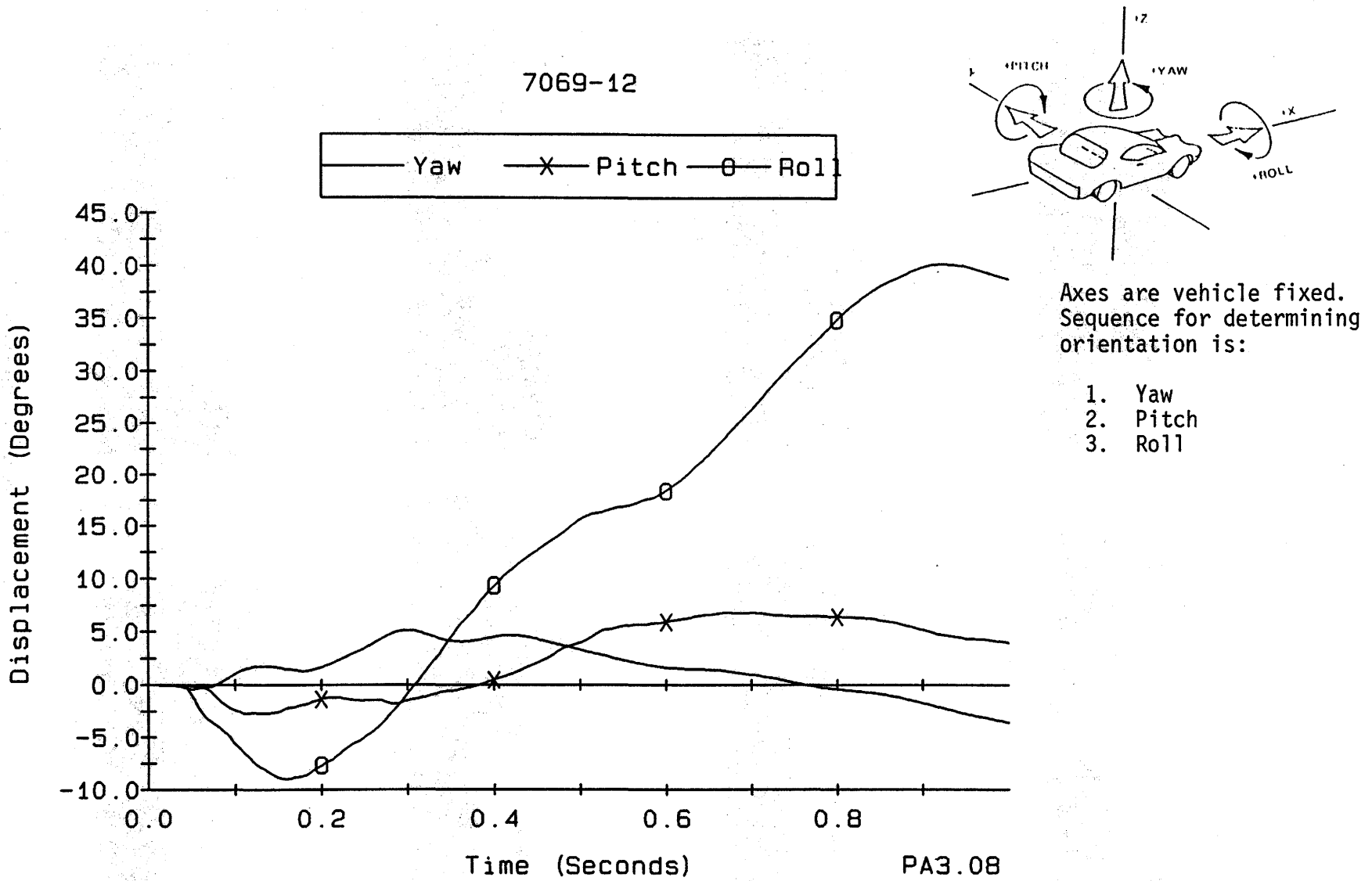

Figure 12. Vehicle angular displacements for test 7069-12.

CRASH TEST 7069-12
Accelerometer near center-of-gravity

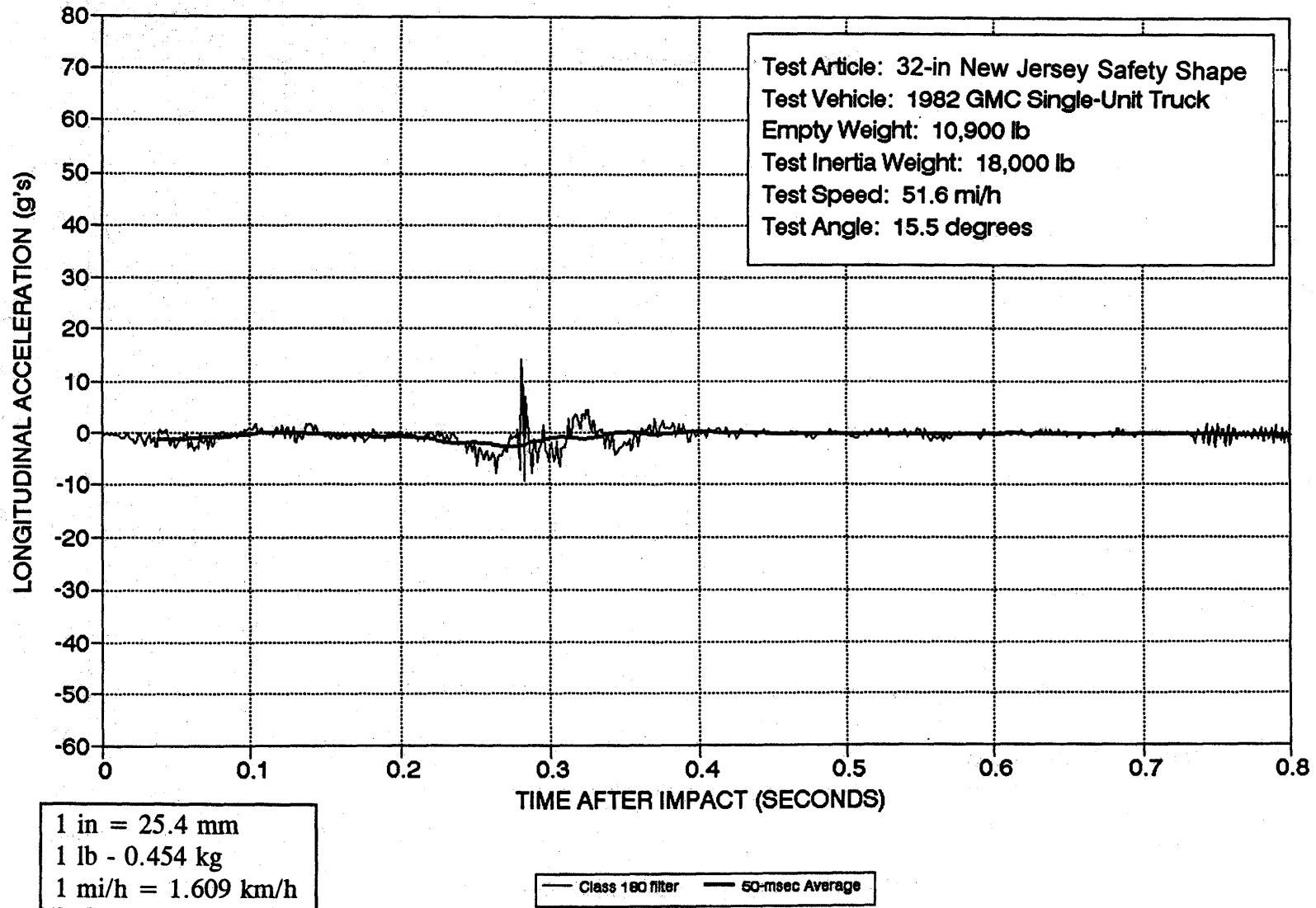

Figure 13. Vehicle longitudinal accelerometer trace for test 7069-12 (accelerometer located near center-of-gravity).

CRASH TEST 7069-12
Accelerometer near center-of-gravity

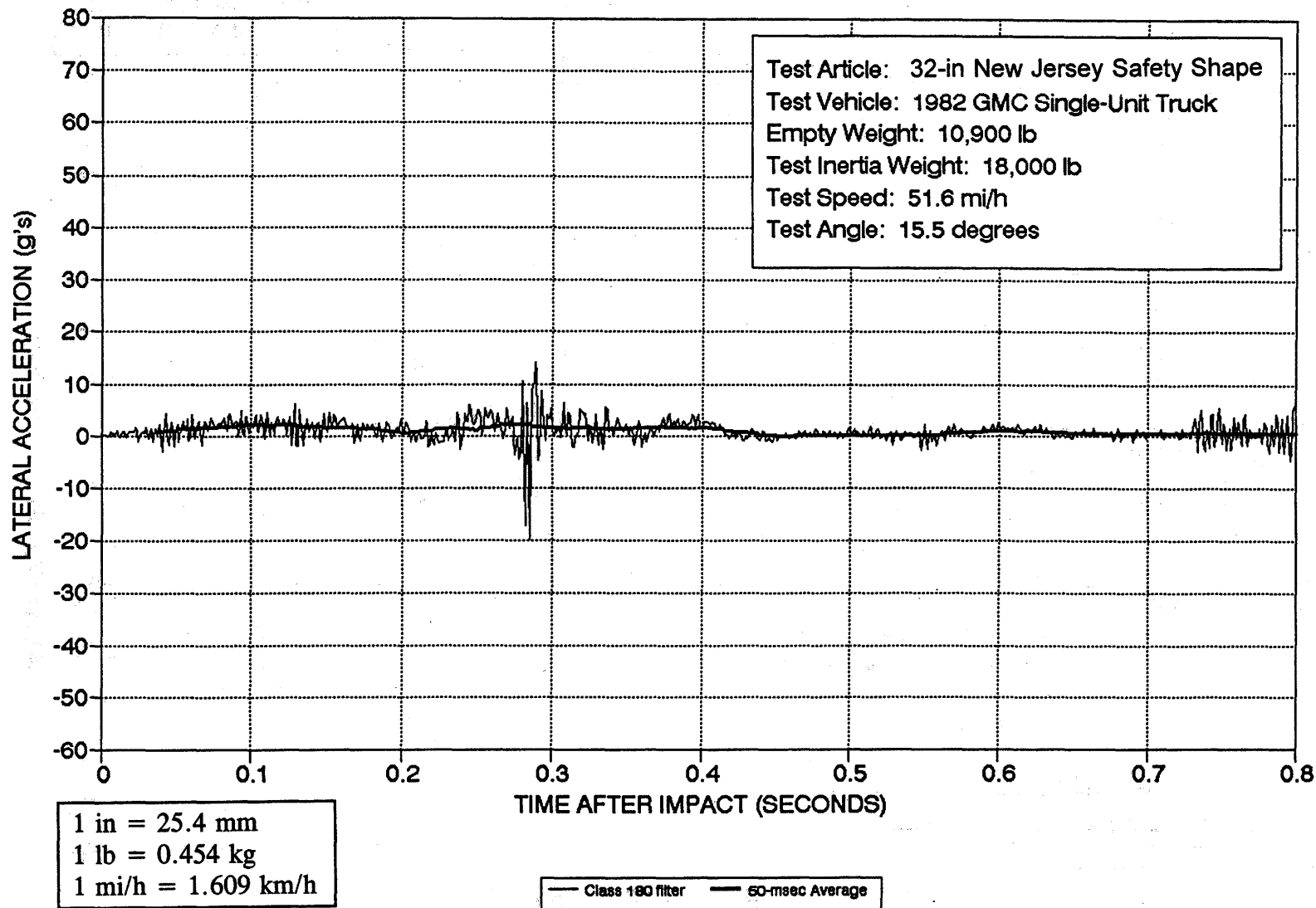

Figure 14. Vehicle lateral accelerometer trace for test 7069-12 (accelerometer located near center-of-gravity).

CRASH TEST 7069-12

Accelerometer near center-of-gravity

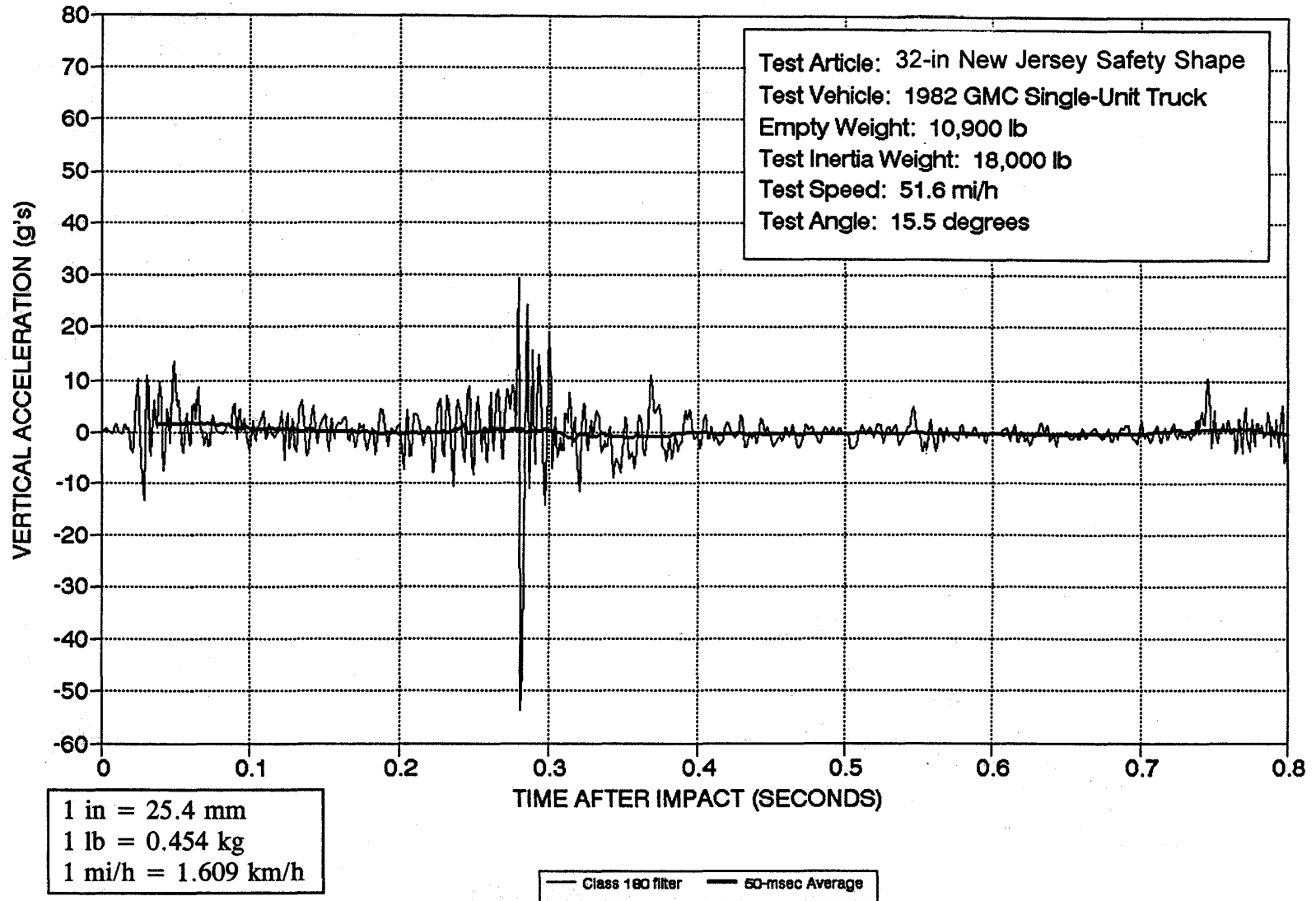

Figure 15. Vehicle vertical accelerometer trace for test 7069-12 (accelerometer located near center-of-gravity).

CRASH TEST 7069-12

Accelerometer at front of vehicle

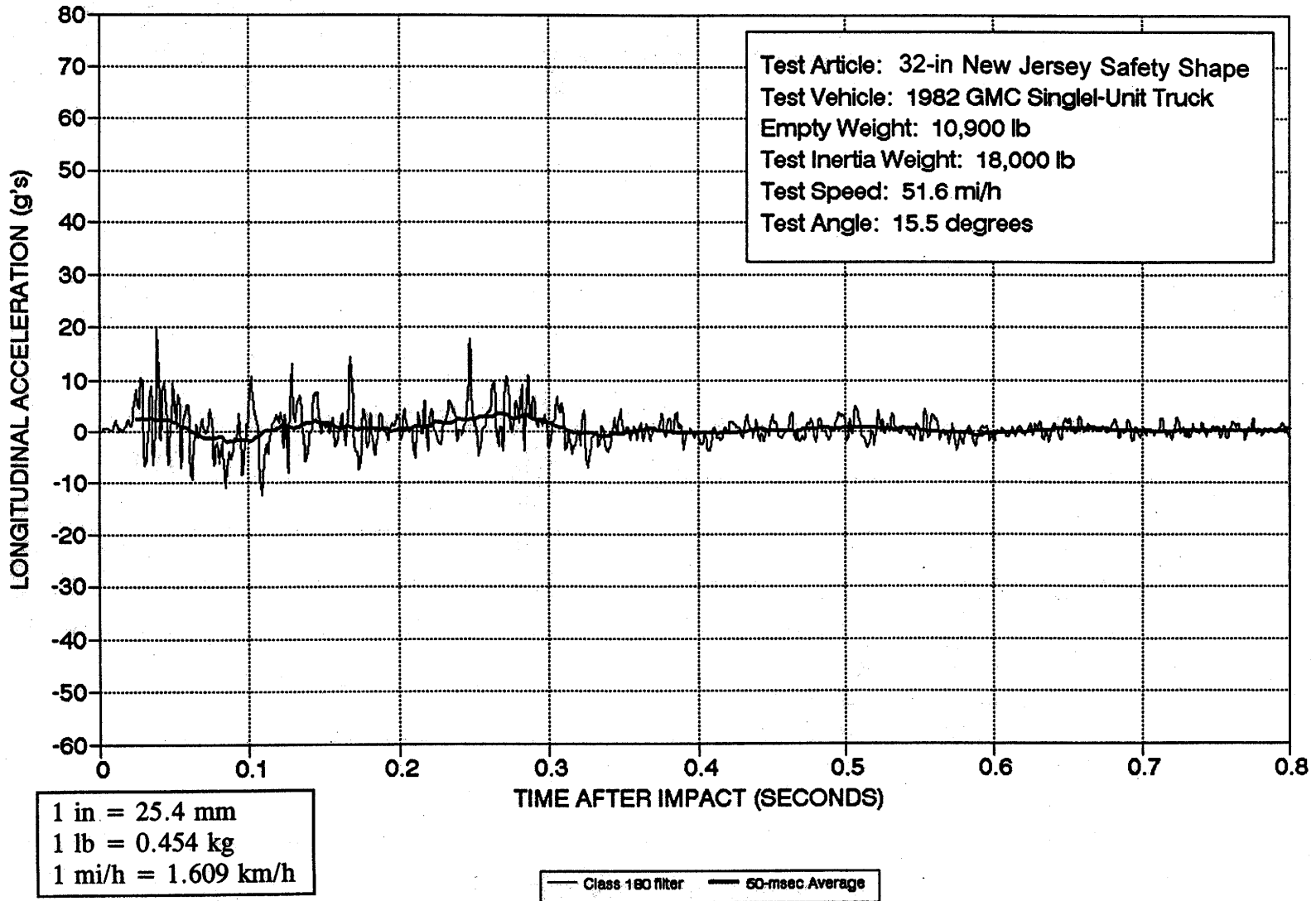

Figure 16. Vehicle longitudinal accelerometer trace for test 7069-12 (accelerometer located at front of vehicle).

CRASH TEST 7069-12
Accelerometer at front of vehicle

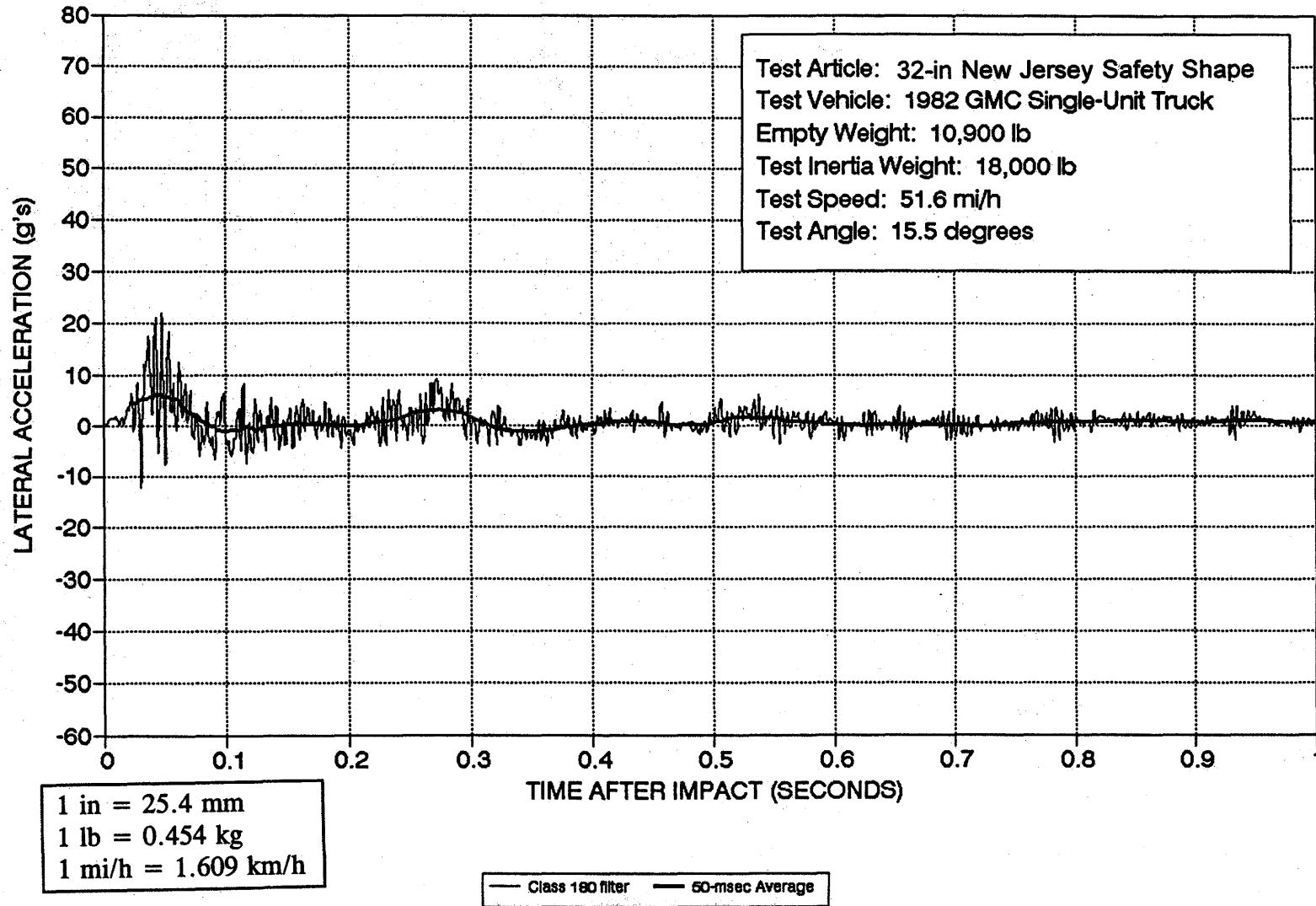

Figure 17. Vehicle lateral accelerometer trace for test 7069-12
(accelerometer located at front of vehicle).

CRASH TEST 7069-12
Accelerometer at rear of vehicle

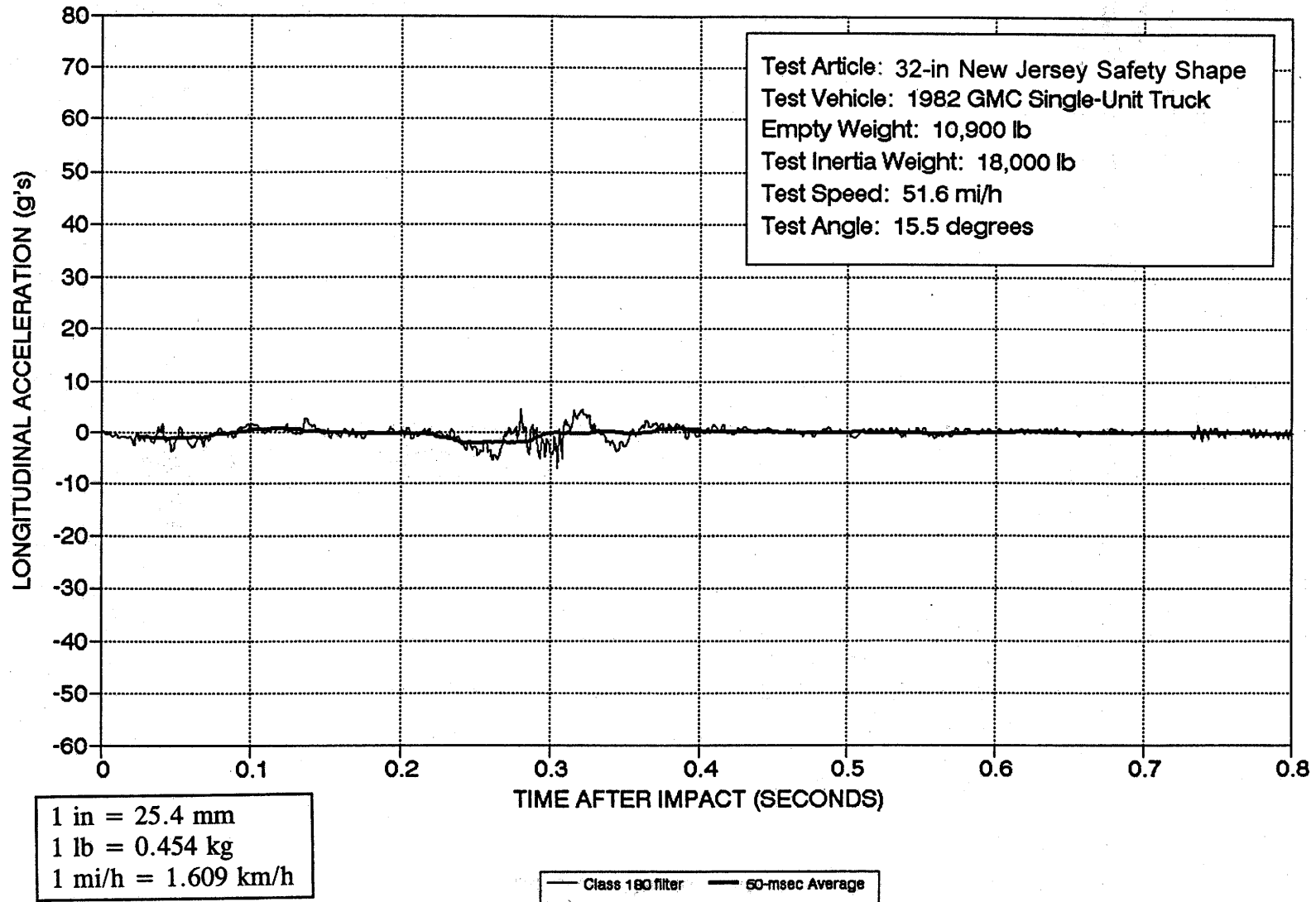

Figure 18. Vehicle longitudinal accelerometer trace for test 7069-12 (accelerometer located at rear of vehicle).

TEST 7069-14

Test Description

The 1981 Chevrolet Custom Deluxe C-20 pickup (figures 19 and 20) was directed into the 32-in (813-mm) New Jersey safety shape (figure 21) using a reverse tow and guidance system. Test inertia mass of the vehicle was 5,390 lb (2 447 kg) and its gross static mass was 5,724 lb (2 599 kg). The height to the lower edge of the vehicle bumper was 16.25 in (412.8 mm) and it was 25.5 in (648 mm) to the top of the bumper. Other dimensions and information on the test vehicle are given in figure 22. The vehicle was free-wheeling and unrestrained just prior to impact.

The speed of the vehicle at impact was 57.7 mi/h (92.9 km/h) and the angle of impact was 20.6 degrees. The vehicle impacted the safety shape approximately 11 ft (3.35 m) from the end. Shortly after impact, the right front wheel began to ride up the face of the safety shape. At 0.060 s, the dummies began to move to the right. The vehicle began to redirect at 0.103 s, and the left front tire became airborne at 0.195 s. By 0.241 s, the vehicle was traveling parallel to the safety shape at a speed of 37.1 mi/h (59.7 km/h). At 0.356 s, the vehicle became completely airborne, and the front of the vehicle reached a maximum height of approximately 23 in (584 mm) above the bridge deck. While still airborne, the vehicle lost contact with the safety shape at 0.365 s traveling at 35.8 mi/h (57.6 km/h) and 0.9 degrees. The left front wheel of the vehicle touched ground at 0.532 s after impact. The brakes were then applied, and the vehicle yawed clockwise and came to rest 280 ft (85.34 m) from the point of impact.

As can be seen in figure 23, the safety shape received cosmetic damage and some scraping and gouging. There were tire marks on the face and top of the safety shape. The vehicle was in contact with the safety shape for 15 ft (4.57 m).

The vehicle sustained extensive damage to the right side as shown in figures 24 and 25. Maximum crush at the right front corner at bumper height was 12.0 in (305 mm). The right front suspension system broke away from the vehicle, and the right rear tire and wheel rim broke at the welded connection points. There was damage to the right ball joints and tie rods, as well as the upper and lower control arms. The left rear tire aired out and is shown in figure 26. Figure 27 shows before and after photographs of the test dummies.

Test Results

Impact speed was 57.7 mi/h (92.9 km/h) and the angle of impact was 20.6 degrees. The vehicle lost contact with the safety shape traveling at 35.8 mi/h (57.6 km/h) and 0.9 degrees. The effective coefficient of friction was calculated to be 0.83. Occupant impact velocity was 17.8 ft/s (5.4 m/s) in the longitudinal direction and 18.7 ft/s (5.7 m/s) in the lateral direction. The highest 0.010-s occupant ridedown accelerations were -5.1 g (longitudinal) and 9.2 g (lateral). These data and other pertinent information from the test are summarized in figure 28 and table 3. Sequential photographs are shown in figure 29 through 31, and vehicle angular displacements are displayed in figure 32. Vehicular

accelerations versus time traces filtered with SAE J211 filters are presented in figures 33 through 39. These data were further analyzed to obtain 0.050-s average accelerations versus time. The maximum 0.050-s averages measured at the center-of-gravity were -6.6 g (longitudinal) and 7.3 g (lateral).

Conclusions

The 32-in (813-mm) New Jersey safety shape contained and smoothly redirected the test vehicle with no lateral movement of the safety shape. There was no intrusion into the occupant compartment and minimal deformation of the compartment. The vehicle trajectory at loss of contact indicates minimum intrusion into adjacent traffic lanes. The vehicle remained upright and relatively stable during the collision. See figure 28 and table 3 for more details.



Figure 19. Vehicle before test 7069-14.

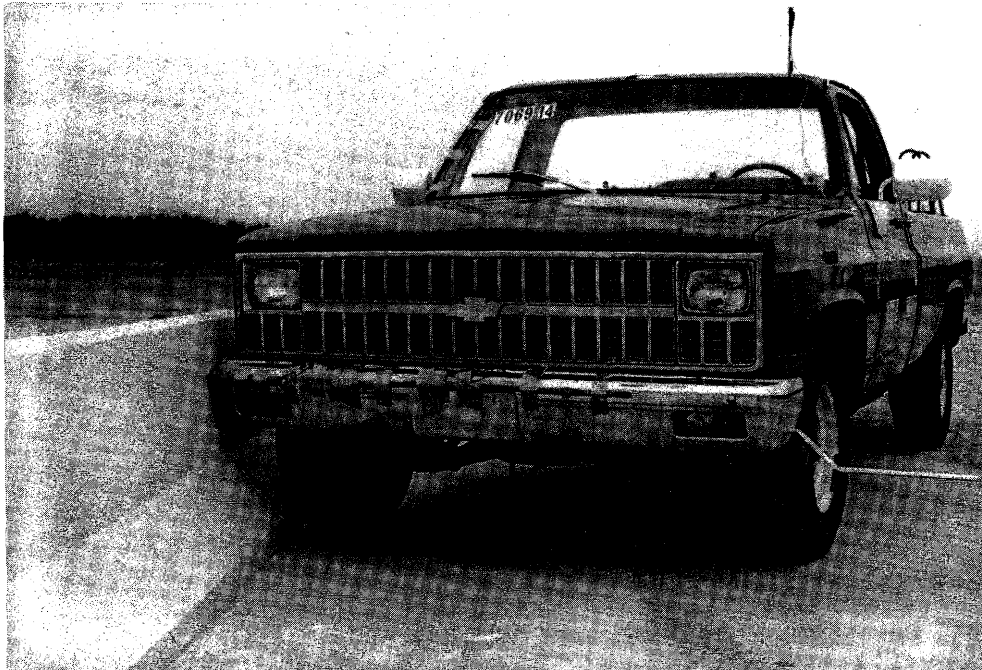

Figure 20. Vehicle/safety shape geometrics for test 7069-14.

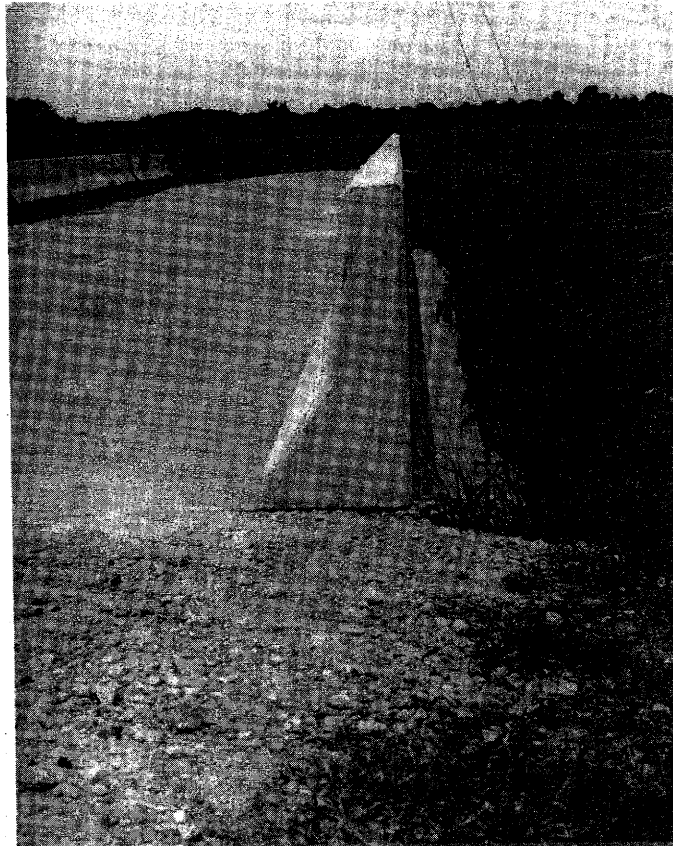
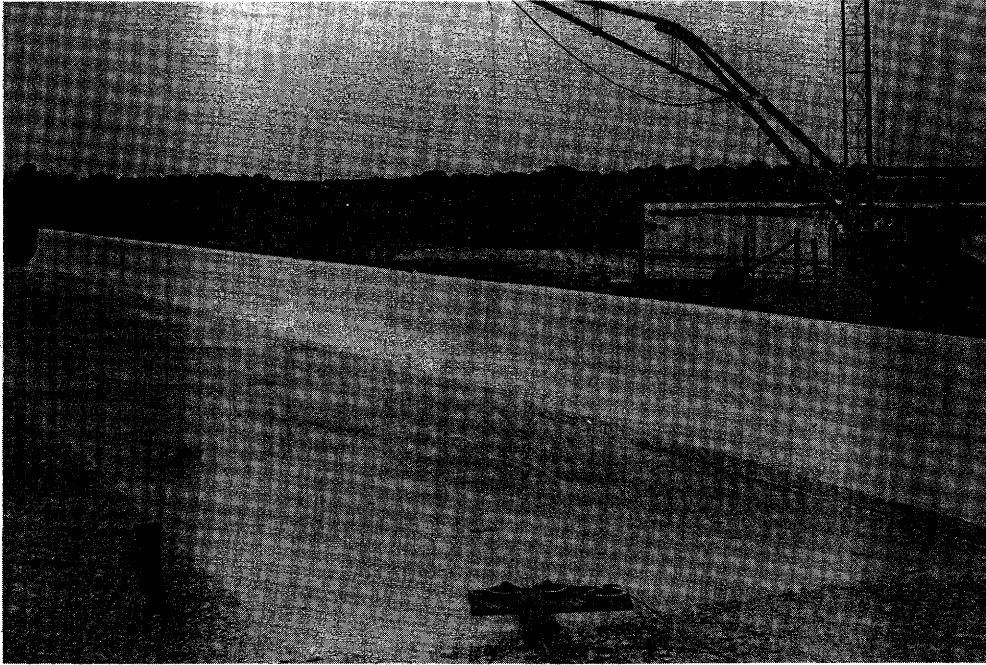

Figure 21. 32-in (813-mm) New Jersey safety shape before test 7069-14.

Date: _____ Test No.: 7069-14 VIN: 1GCGC24M4BF388851

Make: Chevrolet Model: Custom Deluxe Year: 1981 Odometer: 131484

Tire Size: 9.50x16.5 Ply Rating: 8 Bias Ply: x Belted: _____ Radial: _____

Tire Condition: good _____
 fair x
 badly worn _____

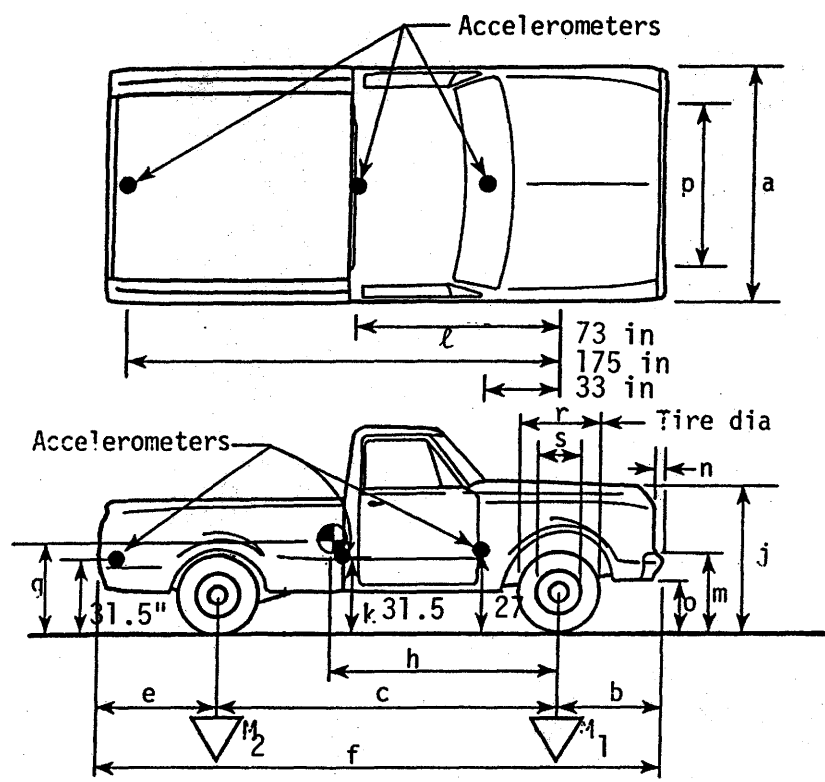

Vehicle Geometry - inches

a	<u>79.25</u>	b	<u>32.75</u>
c	<u>131.25</u>	d*	<u>70.75</u>
e	<u>47.75</u>	f	<u>211.75</u>
g	<u>26.5</u>	h	<u>68.6</u>
i	<u>----</u>	j	<u>43.75</u>
k	<u>31.5</u>	l	<u>73.0</u>
m	<u>25.5</u>	n	<u>4.0</u>
o	<u>16.25</u>	p	<u>65.75</u>
r	<u>29.75</u>	s	<u>17.25</u>

Engine Type: V-8
 Engine CID: 350

Transmission Type:
 Automatic or Manual
 FWD or RWD or 4WD

Body Type: Pick-up

Steering Column Collapse Mechanism:

- Behind wheel units
- Convoluted tube
- Cylindrical mesh units
- Embedded ball
- NOT collapsible
- Other energy absorption
- Unknown

4-wheel weight for c.g. det. lf 1304 rf 1269 lr 1424 rr 1393

Mass - pounds	Curb	Test Inertial	Gross Static
M_1	<u>2722</u>	<u>2573</u>	<u>2772</u>
M_2	<u>2169</u>	<u>2817</u>	<u>2952</u>
M_T	<u>4891</u>	<u>5390</u>	<u>5724</u>

Note any damage to vehicle prior to test:
Windshield cracked - outlined with marker

Brakes:
 Front: disc x drum _____
 Rear: disc _____ drum x

*d = overall height of vehicle

1 in = 25.4 mm
 1 lb = 0.454 kg

Figure 22. Vehicle properties for test 7069-14.

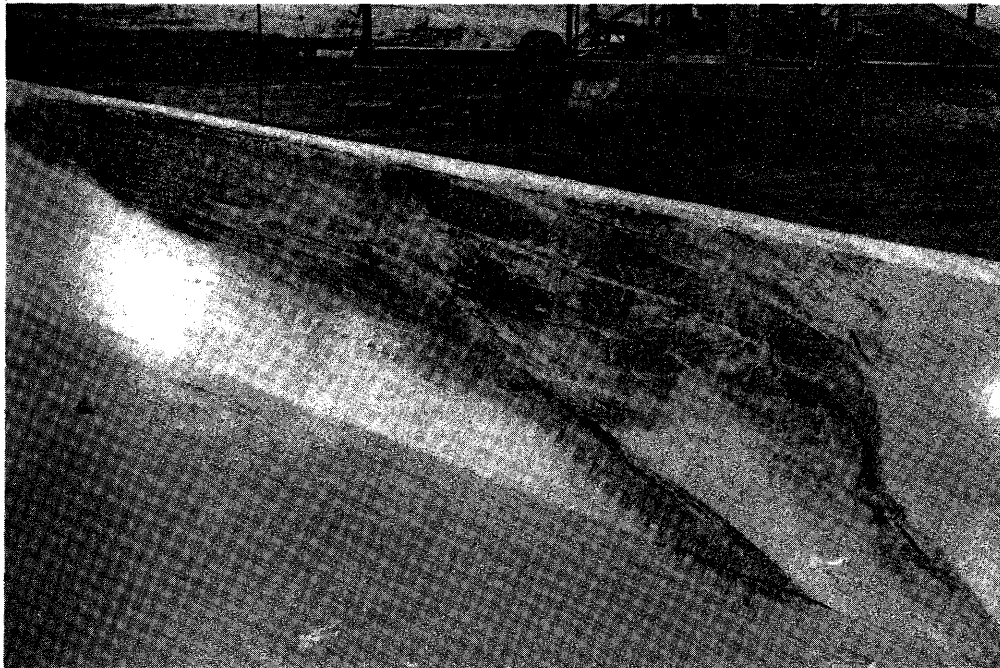
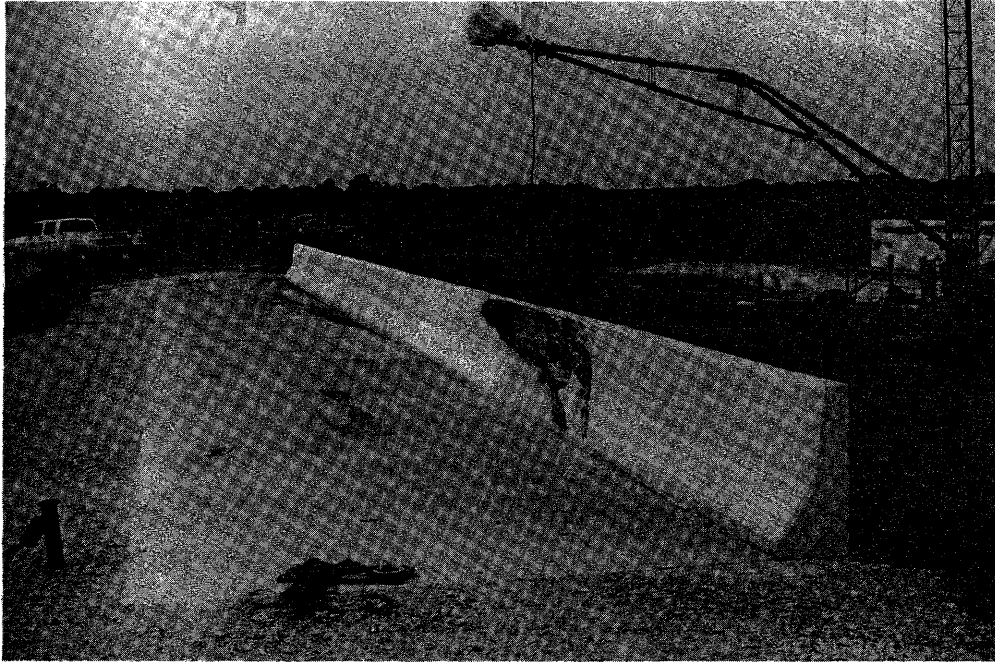

Figure 23. 32-in (813-mm) New Jersey safety shape after test 7069-14.

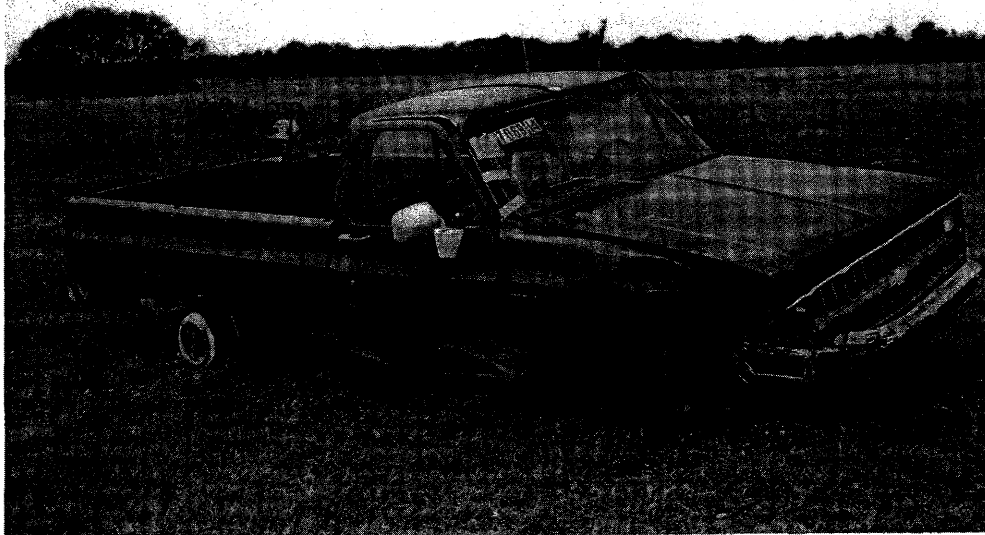

Figure 24. Right side of vehicle after test 7069-14.

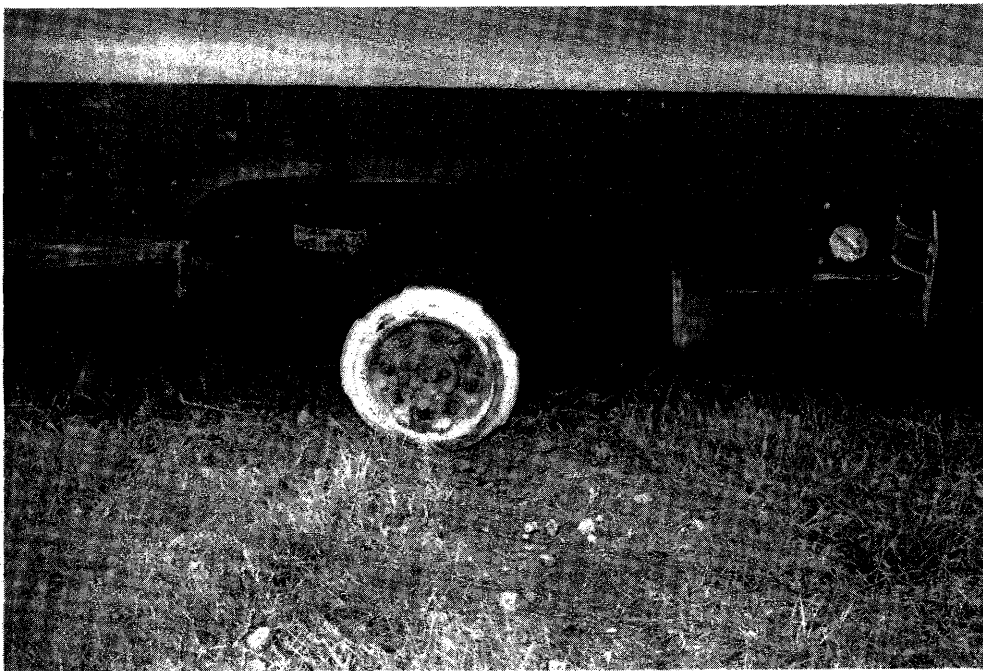
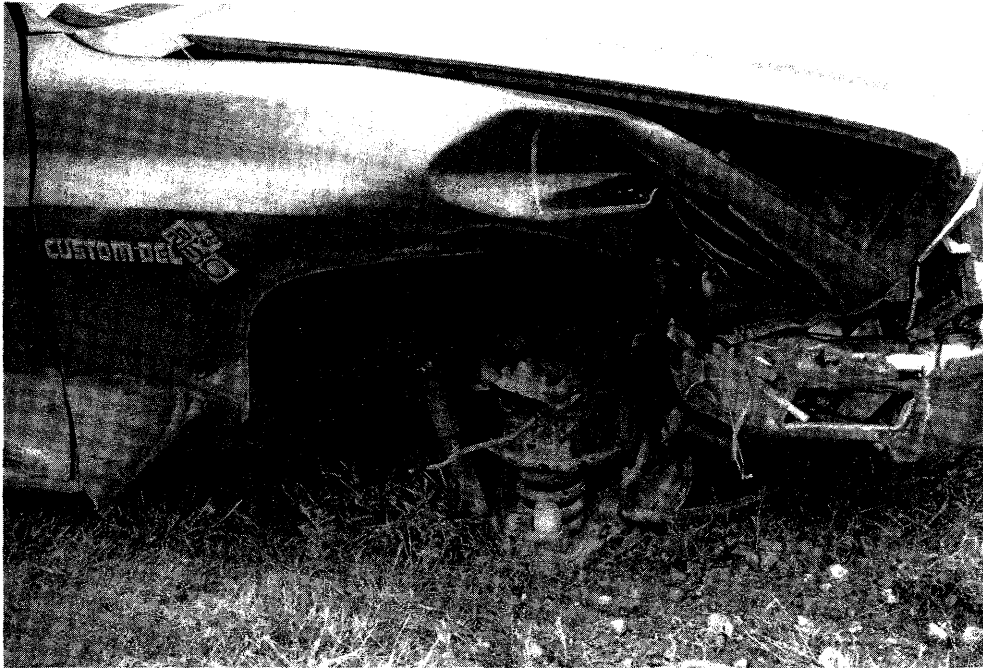

Figure 25. Damage to right front and right rear wheels.



Figure 26. Left side of vehicle after test 7069-14.

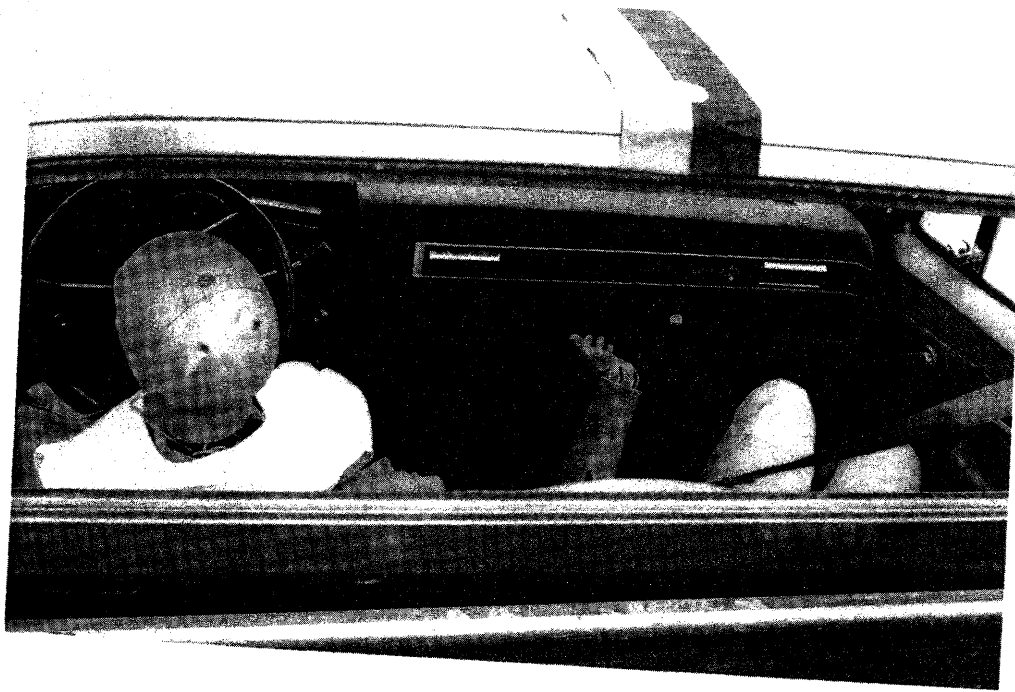
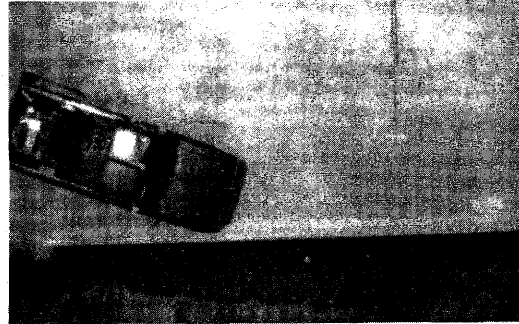
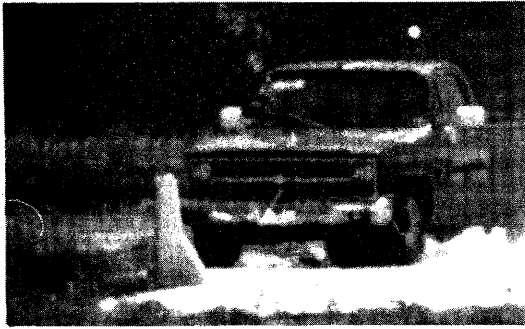

Figure 27. Dummies before and after test 7069-14.

Table 3. Evaluation of crash test no. 7069-14.
 {32-in (813-mm) New Jersey Safety Shape [5,390 lb (2 447 kg)|57.7 mi/h (92.9 km/h)|20.6 degrees]}

<u>CRITERIA</u>		<u>TEST RESULTS</u>		<u>PASS/FAIL*</u>
A.	Must contain vehicle	Vehicle was contained		Pass
B.	Debris shall not penetrate passenger compartment	No debris penetrated passenger compartment		Pass
C.	Passenger compartment must have essentially no deformation	Acceptable deformation		Pass
D.	Vehicle must remain upright	Vehicle did remain upright		Pass
E.	Must smoothly redirect the vehicle	Vehicle was smoothly redirected		Pass
F.	Effective coefficient of friction			
	<u>μ</u>	<u>μ</u>	<u>Assessment</u>	
	0 - .25	0.83	Marginal	Pass
	.26 - .35			
	> .35			
G.	Shall be less than			
	<u>Occupant Impact Velocity - ft/s (m/s)</u>	<u>Occupant Impact Velocity - ft/s (m/s)</u>		N/A
	Longitudinal	Longitudinal	Lateral	
	N/A	17.8 (5.4)	18.7 (5.7)	
	Lateral			
	N/A			
	<u>Occupant Ridedown Accelerations - g's</u>	<u>Occupant Ridedown Accelerations - g's</u>		N/A
	Longitudinal	Longitudinal	Lateral	
	N/A	-5.1	9.2	
	Lateral			
	N/A			
H.	Exit angle shall be less than 12 degrees	about 0.9 degrees		Pass

* A, B, C, and D are required. E, F, G, and H are desired. (See table 2)



0.000 s

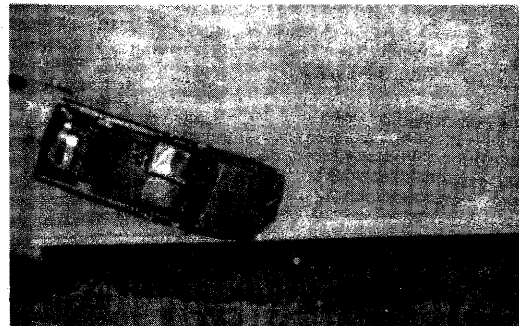

0.050 s

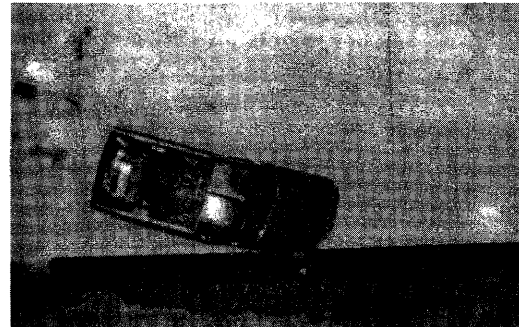

0.101 s

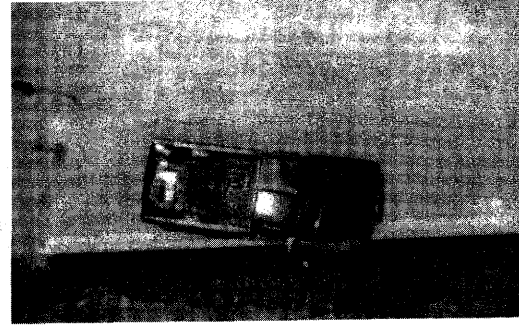
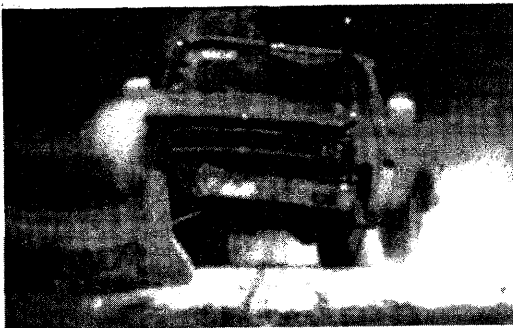

0.151 s

Figure 29. Sequential photographs for test 7069-14.

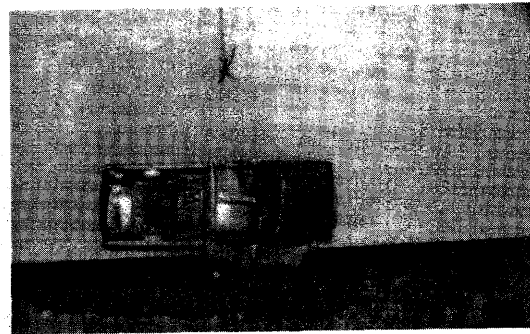
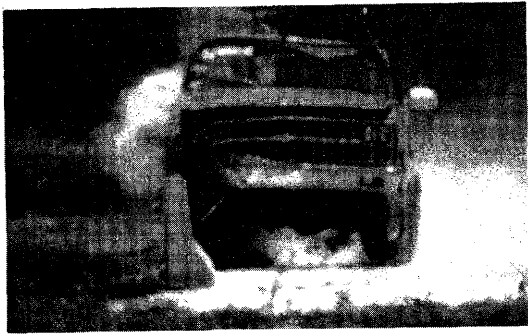

0.201 s

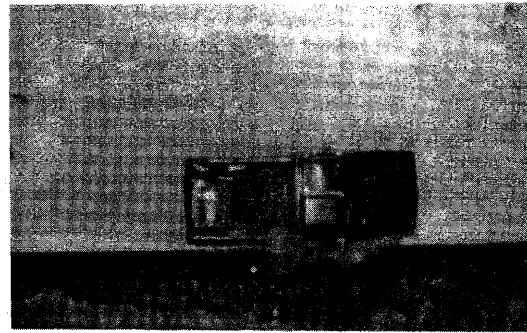
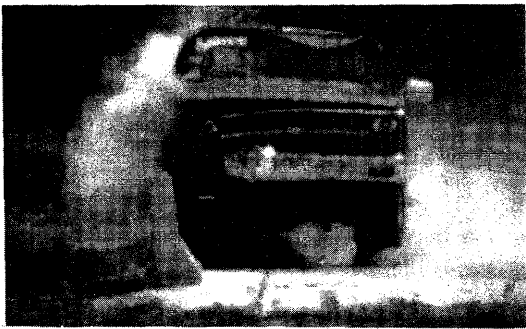

0.252 s

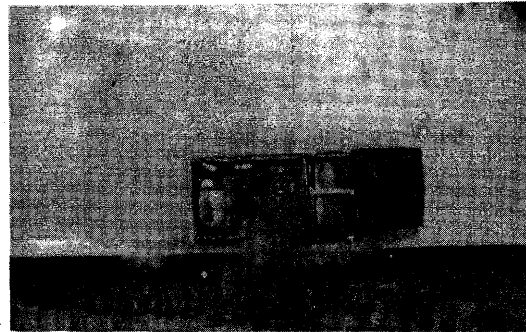
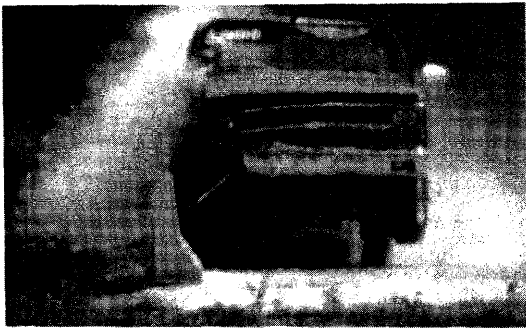

0.314 s

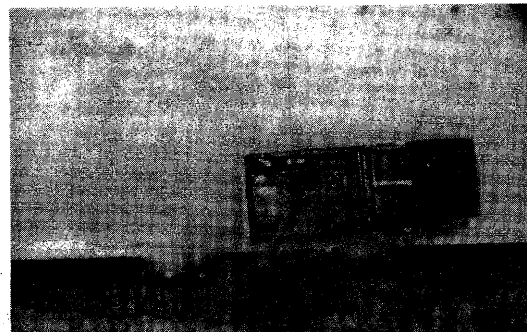
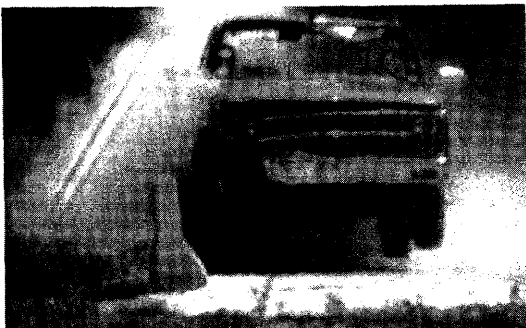

0.377 s

Figure 29. Sequential photographs for test 7069-14 (continued).

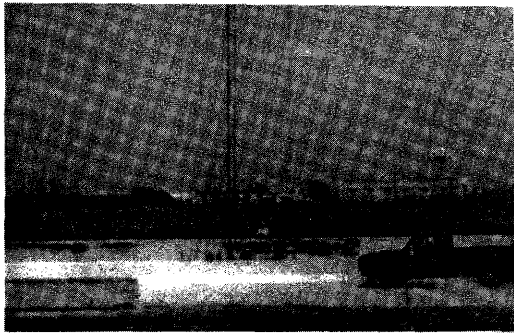

0.000 s

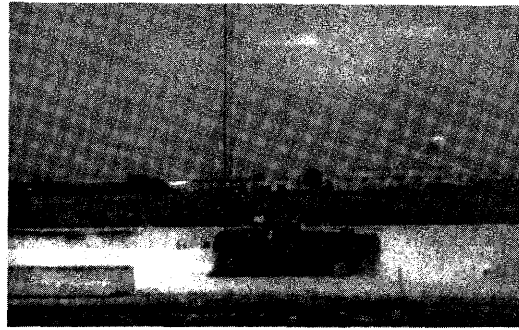

0.201 s

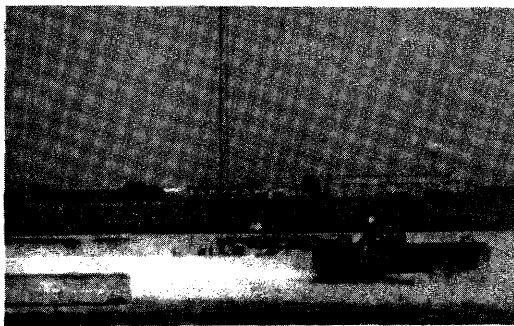

0.050 s

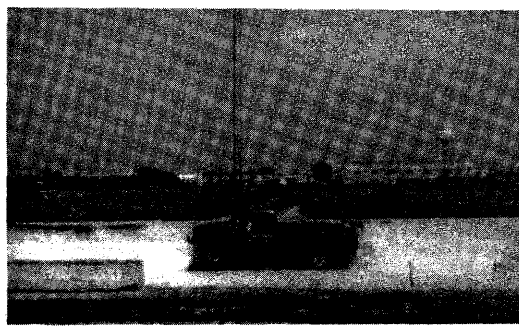

0.252 s

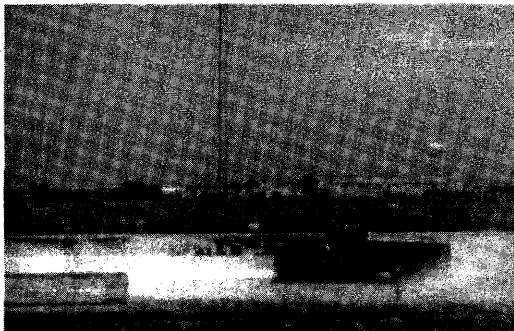

0.101 s

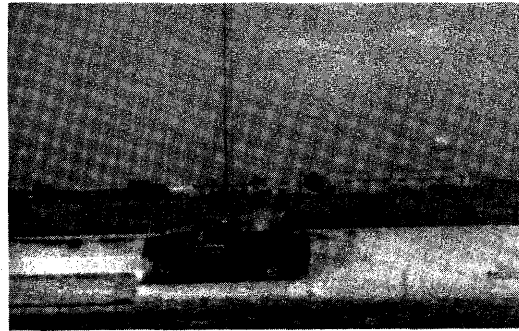

0.314 s

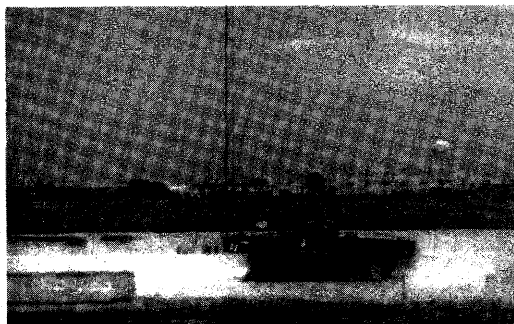

0.151 s

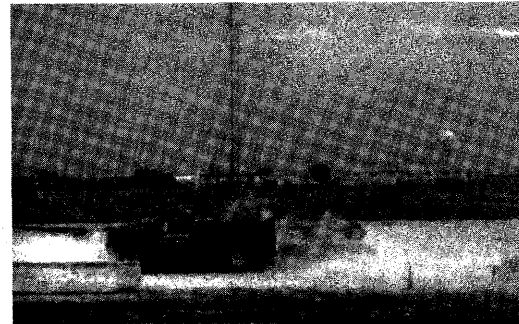

0.377 s

Figure 30. Perpendicular sequential photographs for test 7069-14.



0.000 s

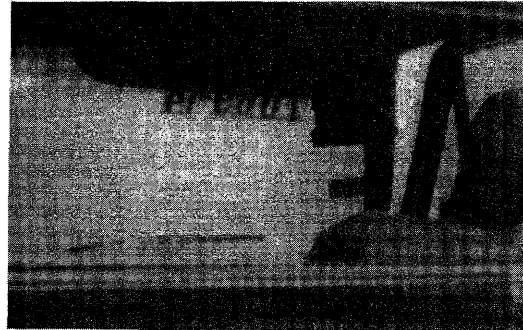

0.203 s

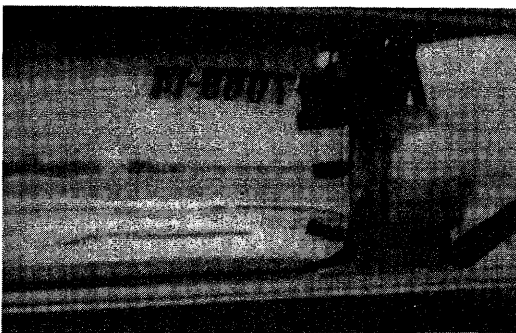

0.048 s



0.251 s



0.096 s



0.311 s

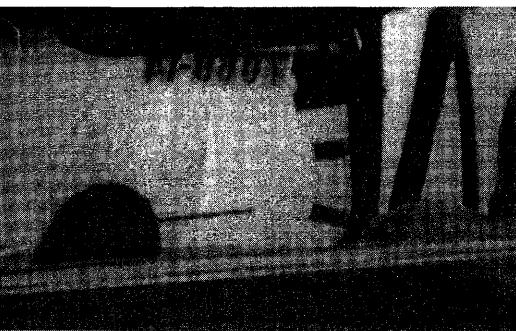

0.155 s



0.328 s

Figure 31. Interior sequential photographs for test 7069-14.

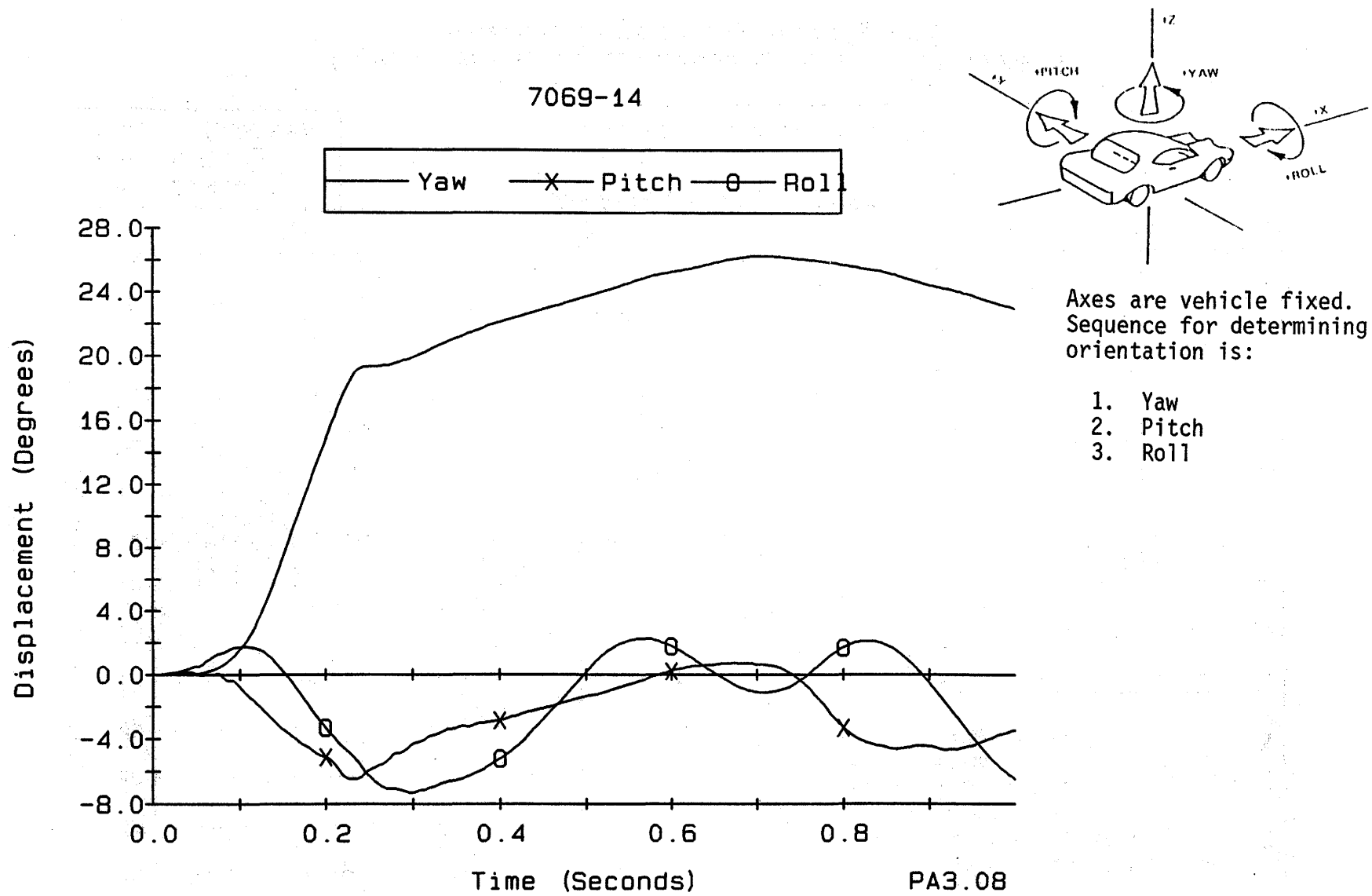

Figure 32. Vehicle angular displacements for test 7069-14.

CRASH TEST 7069-14
Accelerometer near center-of-gravity

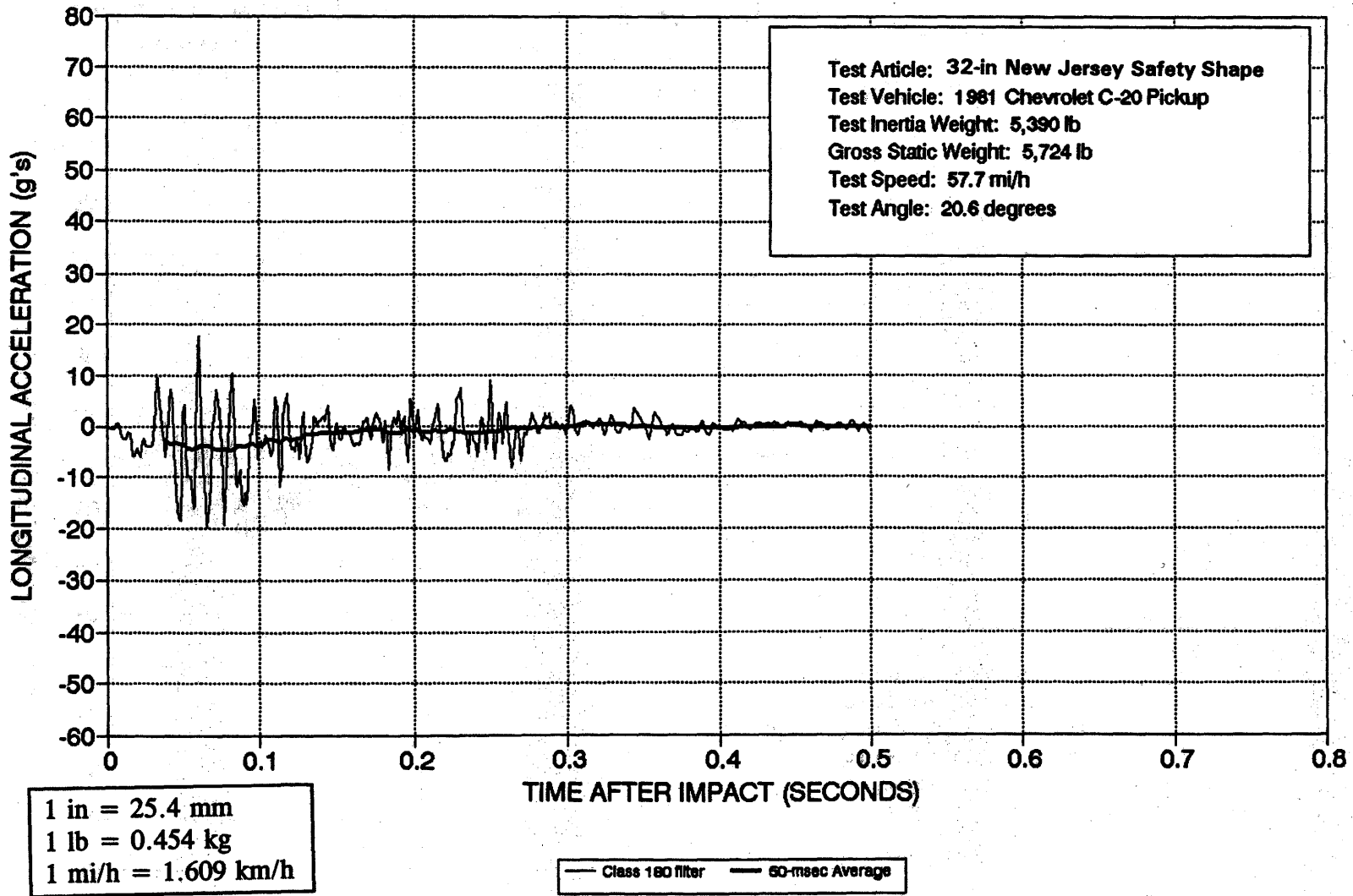

Figure 33. Vehicle longitudinal accelerometer trace for test 7069-14 (accelerometer located near center-of-gravity).

CRASH TEST 7069-14
Accelerometer near center-of-gravity

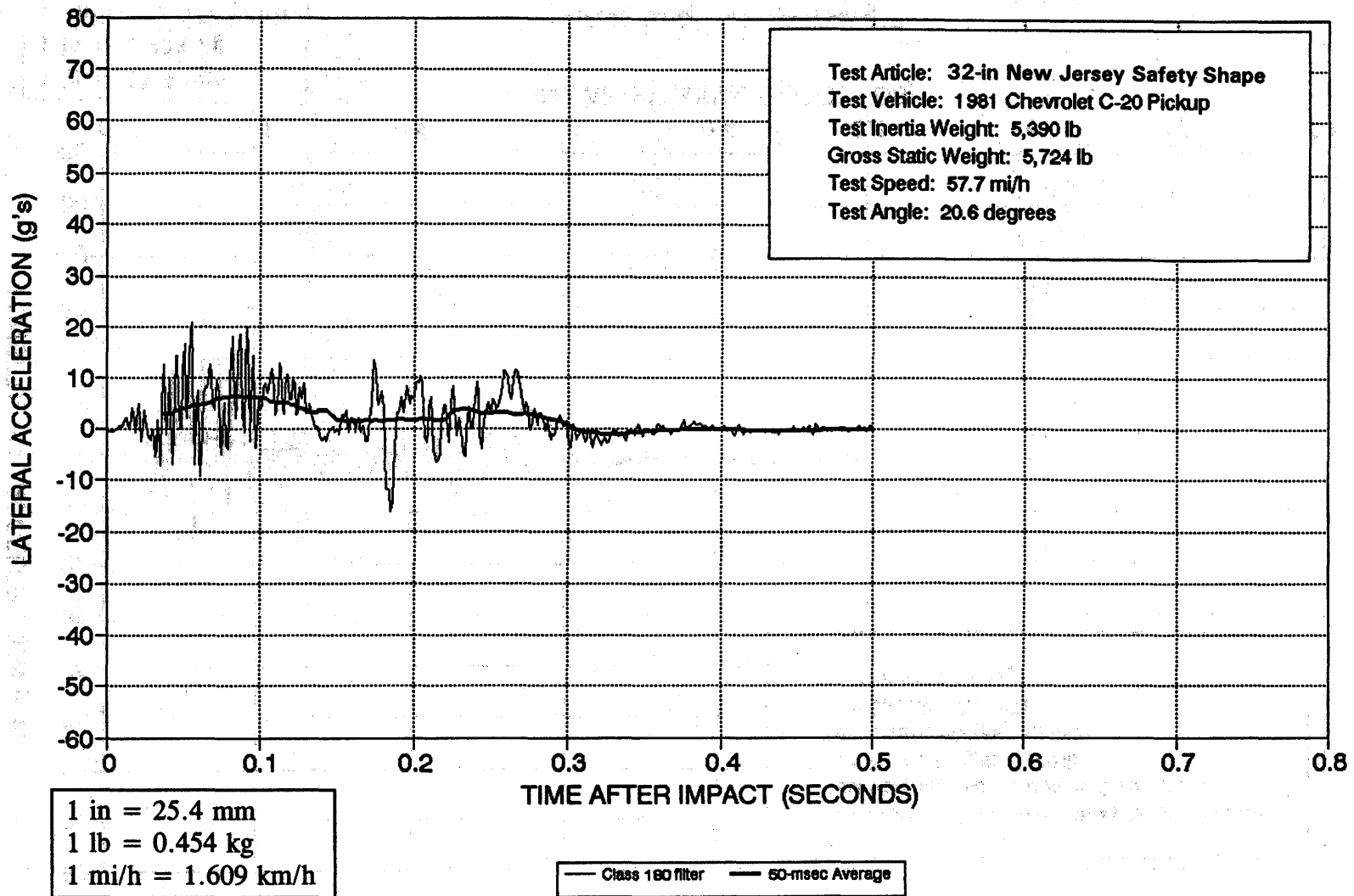

Figure 34. Vehicle lateral accelerometer trace for test 7069-14 (accelerometer located near center-of-gravity).

CRASH TEST 7069-14
Accelerometer near center-of-gravity

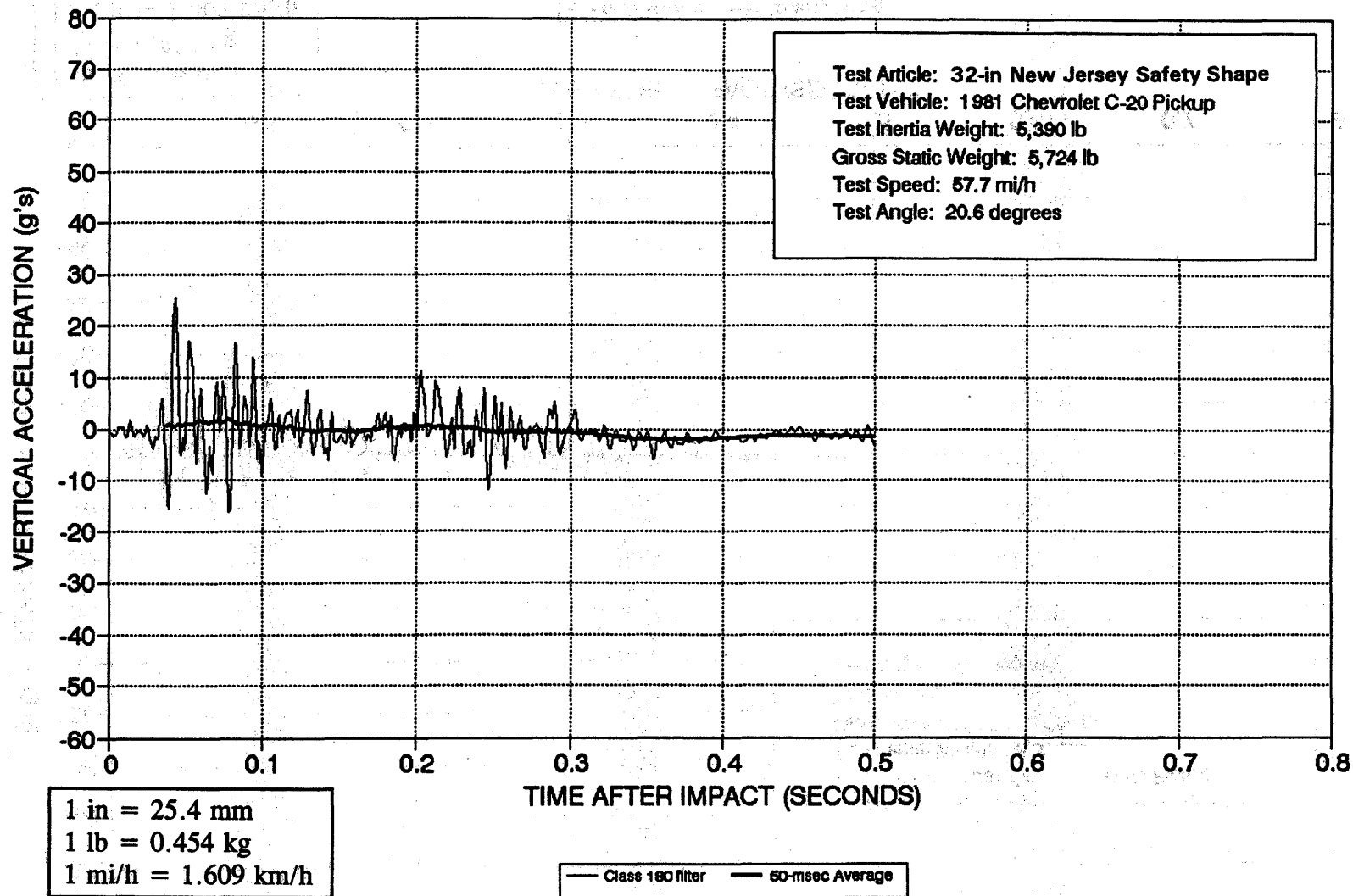

Figure 35. Vehicle vertical accelerometer trace for test 7069-14 (accelerometer located near center-of-gravity).

CRASH TEST 7069-14
Accelerometer at front of vehicle

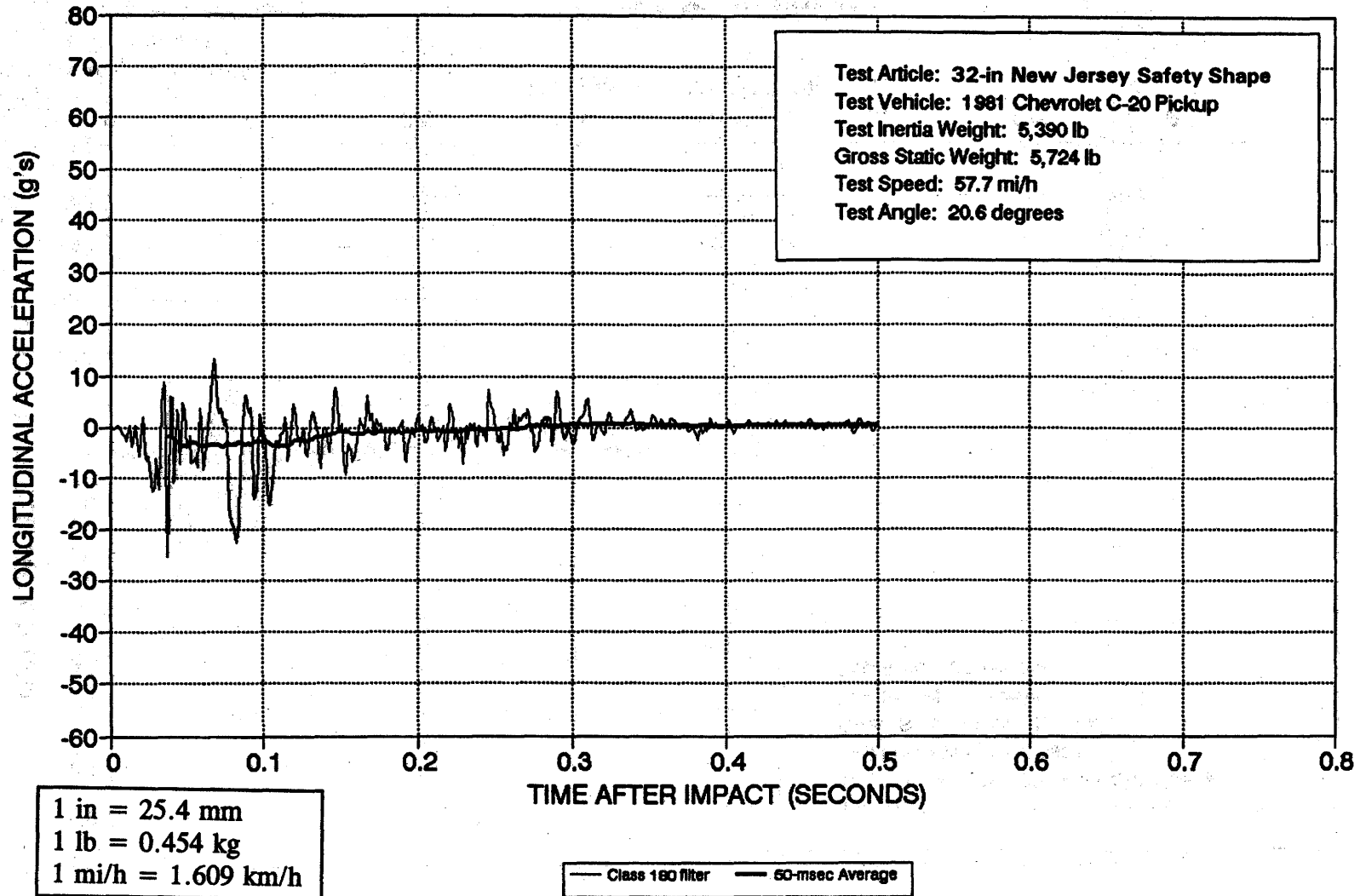
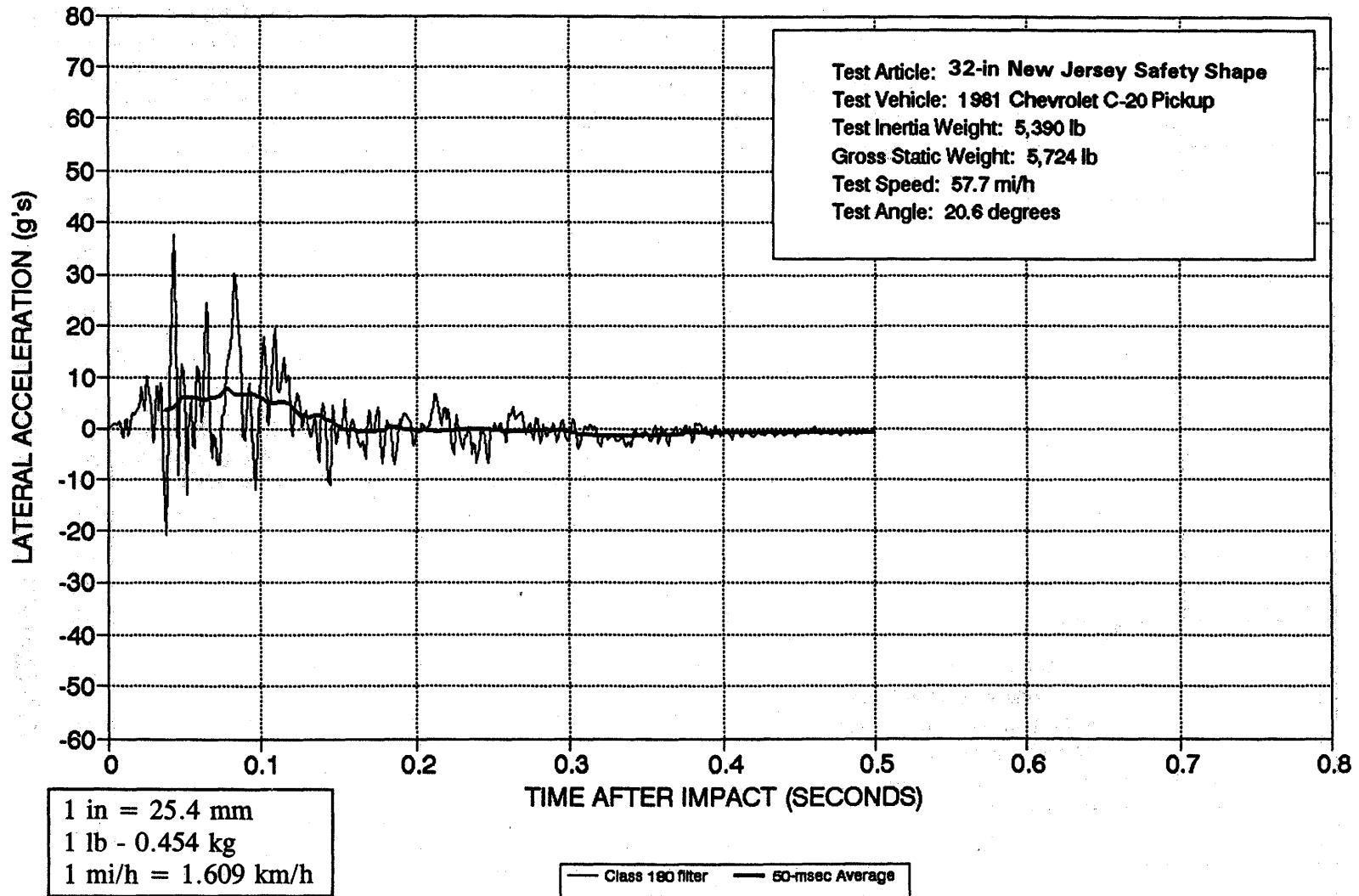

Figure 36. Vehicle longitudinal accelerometer trace for test 7069-14 (accelerometer located at front of vehicle).

CRASH TEST 7069-14
Accelerometer at front of vehicle



53

Figure 37. Vehicle lateral accelerometer trace for test 7069-14 (accelerometer located at front of vehicle).

CRASH TEST 7069-14
Accelerometer at rear of vehicle

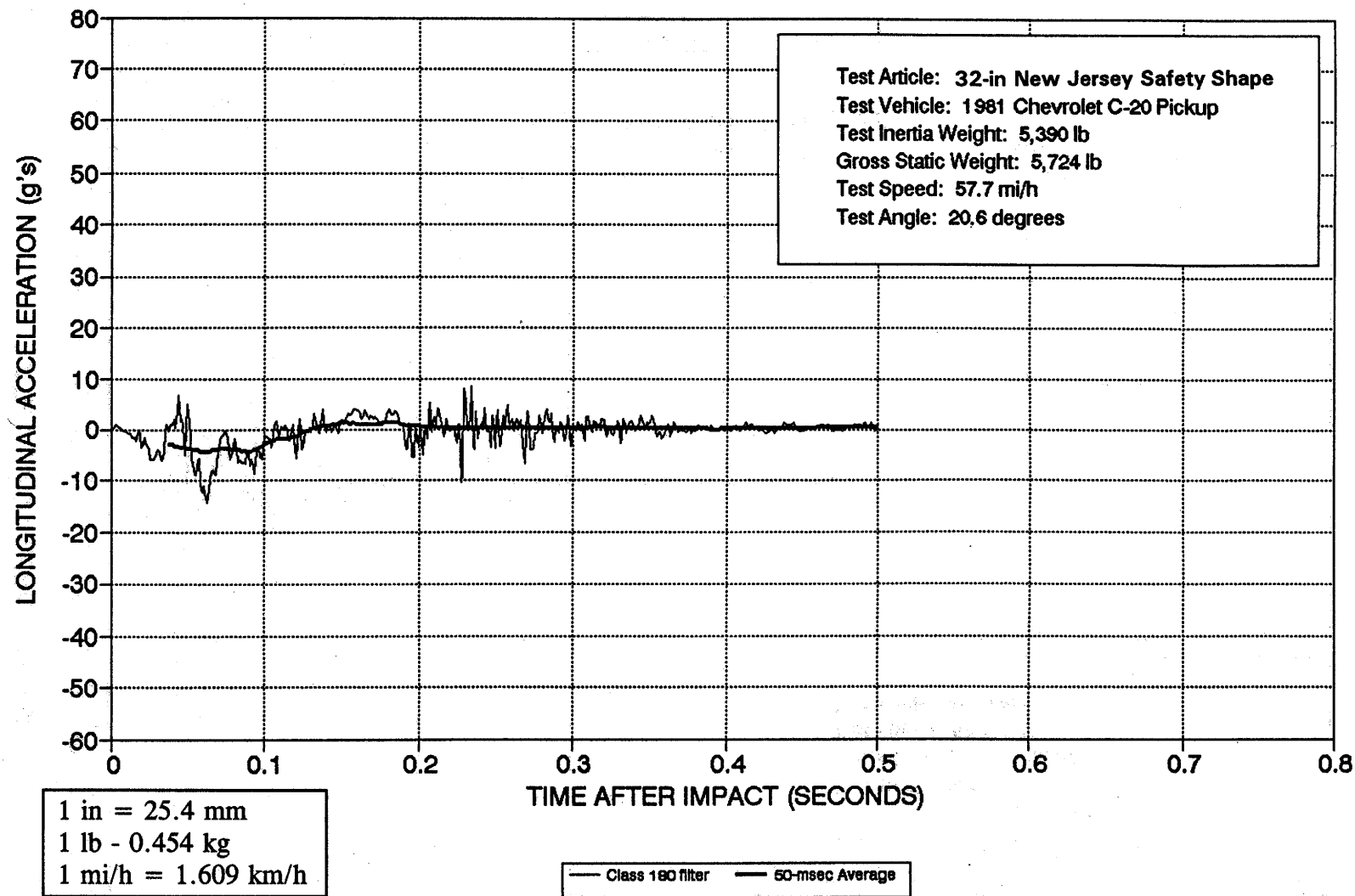

Figure 38. Vehicle longitudinal accelerometer trace for test 7069-14 (accelerometer located at rear of vehicle).

CRASH TEST 7069-14
Accelerometer at rear of vehicle

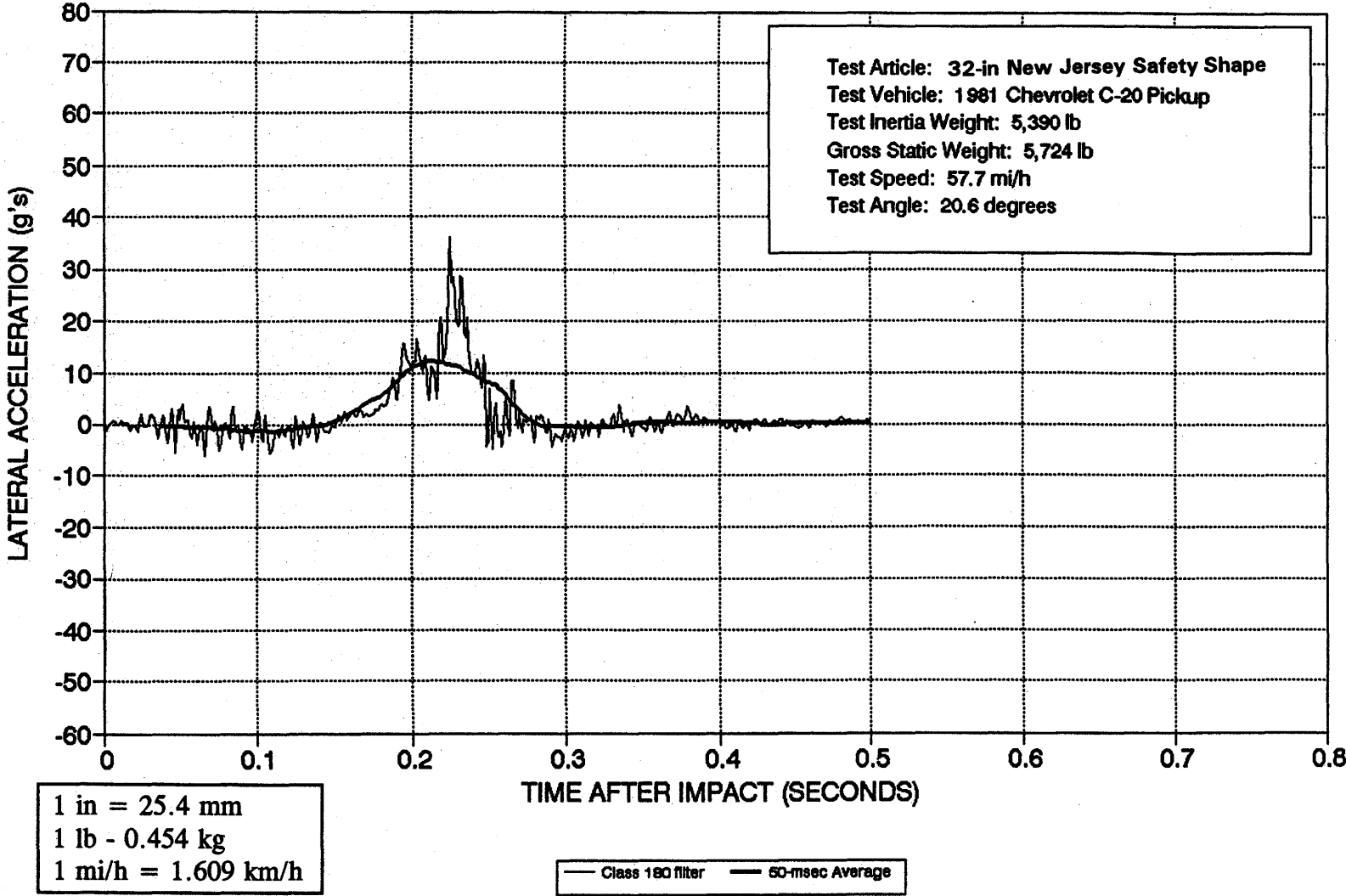

Figure 39. Vehicle lateral accelerometer trace for test 7069-14 (accelerometer located at rear of vehicle).

CHAPTER 4. STRENGTH CALCULATIONS

Analysis of the strength of the railing is based on an ultimate strength yieldline mechanism.⁽²⁾ Force from a colliding vehicle is idealized as being a uniformly distributed line load extending over 3.5 ft (1.07 m) in the longitudinal direction. The load may be applied at any location along the railing. The yieldline failure pattern is illustrated in figure 40. At ultimate strength, yield moments are developed along the yield lines indicated. The length, L , of the yieldline pattern is dependent upon relative bending moment capacities of the section in the horizontal and vertical direction. The length may be computed using the equation for L in figure 40.

For this railing, the computed idealized cantilever moment capacity, M_c , is 12.17 ft-k/ft (5525 m-k/m). The moment capacity in the longitudinal direction of the idealized section, M_w , is 7.98 ft-k/ft (3623 m-k/m).

In order to maintain the yieldline pattern in the parapet, the strength of the deck must be greater than the strength of the parapet. Analysis shows that the moment capacity of the deck is 16.07 k-ft/ft (7996 m-k/m) which is greater than M_c .

The total strength of the mechanism is found using the equation for $(wl)_{ult}$ given in figure 40. The resulting length of mechanism, L , is 8.11 ft (2.47 m), and the total ultimate capacity, $(wl)_{ult}$, at a height of 42 in (1.07 m) is 73.9 kips (329 kN).

32

$$M_b = 0$$

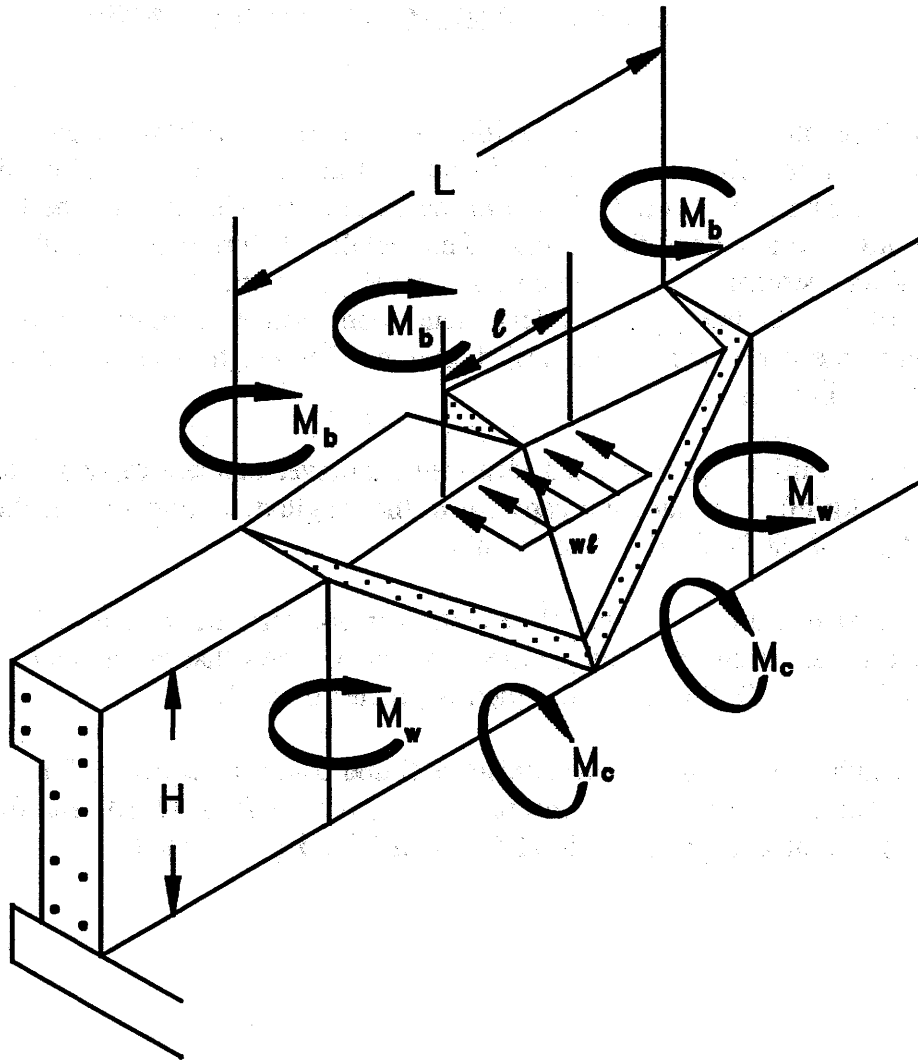

$$L = \frac{l}{2} + \sqrt{\left(\frac{l}{2}\right)^2 + \frac{8H(M_b + M_w H)}{M_c}}$$

$$(wl)_{ult} = \frac{8M_b}{L - \frac{l}{2}} + \frac{8M_w H}{L - \frac{l}{2}} + \frac{M_c L^2}{H\left(L - \frac{l}{2}\right)}$$

Figure 40. Yieldline failure pattern for concrete parapet.

REFERENCES

1. *Guide Specifications For Bridge Railings*, American Association of State Highway and Transportation Officials (AASHTO), Washington, DC, 1989.
2. Hirsch, T. J., "Analytical Evaluation of Texas Bridge Rails to Contain Buses and Trucks," Research Report 230-2, Texas Transportation Institute, Texas A&M University, College Station, TX, August 1978.



SUBJECT Yield line Failure Analysis
for 32" Parapet

BY: W. Williams
 CKD: _____

CLIENT Texas Transportation Institute

- Given: 1.) Report entitled "Testing of New Bridge Rail and Transition Designs
 Volume VI: Appendix E
 32-in (813-mm) New Jersey Safety Shape"
 2.) Calculation Results as presented on pages 57 & 58.

- Find: 1.) Results for "L" & "wl_{ult}" for 32" Parapet and compare these results as
 presented for 42" Parapet.

Given the following input parameters:

$$l := 3.5\text{ft} \quad M_c := 12.17 \frac{\text{kip}\cdot\text{ft}}{\text{ft}} \quad M_w := \frac{7.98\text{kip}\cdot\text{ft}}{\text{ft}}$$

$$M_{\text{deck}} := 16.07\text{kip}\cdot\text{ft} \quad M_b := 0\text{kip}\cdot\text{ft} \quad H := 32\text{in}$$

H=32"

- 1.) Calculate "L" & Compare to value on page 57:

$$L := \frac{l}{2} + \sqrt{\left(\frac{l}{2}\right)^2 + \frac{8 \cdot H \cdot (M_b + M_w \cdot H)}{M_c}}$$

L = 8.103 ft

"L" for 32 inches is same for value in text !!!

- 2.) Calculate (wl)_{ult} and compare to value on page 57:

$$wl_{\text{ult}} := \frac{8 \cdot M_b}{L - \frac{l}{2}} + \frac{8 \cdot M_w \cdot H}{L - \frac{l}{2}} + \frac{M_c \cdot L^2}{H \cdot \left(L - \frac{l}{2}\right)}$$

wl_{ult} = 73.96 kips

wl_{ult} is same for 32" wall versus value in text (page 57)



SUBJECT Yield line Failure Analysis
for 42" Parapet

BY: W. Williams
 CKD: _____

CLIENT Texas Transportation Institute

- Given: 1.) Report entitled "Testing of New Bridge Rail and Transition Designs
 Volume VI: Appendix E
 32-in (813-mm) New Jersey Safety Shape"
 2.) Calculation Results as presented on pages 57 & 58.

- Find: 1.) Results for "L" & "wl_{ult}" for 42" Parapet and compare these results as
 presented for in the text.

Given the following input parameters:

$$l := 3.5\text{ft} \quad M_c := 12.17 \frac{\text{kip}\cdot\text{ft}}{\text{ft}} \quad M_w := \frac{7.98\text{kip}\cdot\text{ft}}{\text{ft}}$$

$$M_{\text{deck}} := 16.07\text{kip}\cdot\text{ft} \quad M_b := 0\text{kip}\cdot\text{ft} \quad H := 42\text{in}$$

H=42"

- 1.) Calculate "L" & Compare to value on page 57:

$$L := \frac{l}{2} + \sqrt{\left(\frac{l}{2}\right)^2 + \frac{8 \cdot H \cdot (M_b + M_w \cdot H)}{M_c}}$$

L = 9.955 ft

"L" for 42 inches is different from value in text !!!

- 2.) Calculate (wl)_{ult} and compare to value on page 57:

$$wl_{\text{ult}} := \frac{8 \cdot M_b}{L - \frac{l}{2}} + \frac{8 \cdot M_w \cdot H}{L - \frac{l}{2}} + \frac{M_c \cdot L^2}{H \cdot \left(L - \frac{l}{2}\right)}$$

wl_{ult} = 69.23 kips

wl_{ult} is different from value in text (page 57)

