

| | | | |
|---|--|---|--|
| 1. Report No. FHWA-RD-93-059 | 2. Government Accession No. | 3. Recipient's Catalog No. | |
| 4. Title and Subtitle TESTING OF NEW BRIDGE RAIL AND TRANSITION DESIGNS Volume II: Appendix A Oregon Side Mounted Bridge Railing | | 5. Report Date | 6. Performing Organization Code |
| 7. Author(s) C. Eugene Buth, T. J. Hirsch, and Wanda L. Menges | | 8. Performing Organization Report No. Research Foundation 7069-Vol. II | |
| 9. Performing Organization Name and Address Texas Transportation Institute The Texas A&M University System College Station, Texas 77843-3135 | | 10. Work Unit No. NCP No. 3A5C0042 | 11. Contract or Grant No. DTFH61-86-C-00071 |
| 12. Sponsoring Agency Name and Address Office of Safety & Traffic Operations R&D Federal Highway Administration 6300 Georgetown Pike McLean, Virginia 22101-2296 | | 13. Type of Report and Period Covered Final Report August 1986 - September 1993 | |
| 15. Supplementary Notes Research performed in cooperation with DOT, FHWA Research Study Title: Pooled Funds Bridge Rail Study Contracting Officer's Technical Representative (COTR) - Charles F. McDevitt | | 14. Sponsoring Agency Code | |
| 16. Abstract The Oregon side-mounted bridge railing consists of a 10-gauge thrie-beam mounted on W6x15 posts. A structural analysis of the railing indicates it will resist approximately 25 kips (111 kN) from a colliding vehicle. Full-scale crash tests demonstrated acceptable performance for performance level one of the 1989 <i>Guide Specifications for Bridge Railings</i> . This volume is the second in a series. The other volumes in the series are: Volume I: Technical Report; Volume III: Appendix B, "BR27D Bridge Railing;" Volume IV: Appendix C, "Illinois 2399-1 Bridge Railing;" Volume V: Appendix D, "32-in (810-mm) Concrete Parapet Bridge Railing;" Volume VI: Appendix E, "32-in (810-mm) New Jersey Safety Shape;" Volume VII: Appendix F, "32-in (810-mm) F-Shape Bridge Railing;" Volume VIII: Appendix G, "BR27C Bridge Railing;" Volume IX: Appendix H, "Illinois Side Mount Bridge Rail;" Volume X: Appendix I, "42-in (1.07-m) Concrete Parapet Bridge Railing;" Volume XI: Appendix J, "42-in (1.07-m) F-Shape Bridge Railing;" Volume XII: Appendix K, "Oregon Transition;" Volume XIII: Appendix L, "32-in (810-mm) Thrie-Beam Transition;" and Volume XIV: Appendix M, "Axial Tensile Strength of Thrie and W-Beam Terminal Connectors." | | | |
| 17. Key Words Bridge Rail, Longitudinal Barriers, Barrier Collision Forces, Ultimate Strength, Full-Scale Crash Tests, Highway Safety | | 18. Distribution Statement No restrictions. This document is available to the public through the National Technical Information Service 5285 Port Royal Road Springfield, Virginia 22161 | |
| 19. Security Classif. (of this report) Unclassified | 20. Security Classif. (of this page) Unclassified | 21. No. of Pages 60 | 22. Price |

SI* (MODERN METRIC) CONVERSION FACTORS

APPROXIMATE CONVERSIONS TO SI UNITS

APPROXIMATE CONVERSIONS FROM SI UNITS

| Symbol | When You Know | Multiply By | To Find | Symbol | Symbol | When You Know | Multiply By | To Find | Symbol |
|--|----------------------------|----------------------------|------------------------|-------------------|-------------------------------------|------------------------|-------------|----------------------------|-----------------|
| LENGTH | | | | | LENGTH | | | | |
| in | inches | 25.4 | millimeters | mm | mm | millimeters | 0.039 | inches | in |
| ft | feet | 0.305 | meters | m | m | meters | 3.28 | feet | ft |
| yd | yards | 0.914 | meters | m | m | meters | 1.09 | yards | yd |
| mi | miles | 1.61 | kilometers | km | km | kilometers | 0.621 | miles | mi |
| AREA | | | | | AREA | | | | |
| in ² | square inches | 645.2 | square millimeters | mm ² | mm ² | square millimeters | 0.0016 | square inches | in ² |
| ft ² | square feet | 0.093 | square meters | m ² | m ² | square meters | 10.764 | square feet | ft ² |
| yd ² | square yards | 0.836 | square meters | m ² | m ² | square meters | 1.195 | square yards | ac |
| ac | acres | 0.405 | hectares | ha | ha | hectares | 2.47 | acres | mi ² |
| mi ² | square miles | 2.59 | square kilometers | km ² | km ² | square kilometers | 0.386 | square miles | |
| VOLUME | | | | | VOLUME | | | | |
| fl oz | fluid ounces | 29.57 | milliliters | ml | ml | milliliters | 0.034 | fluid ounces | fl oz |
| gal | gallons | 3.785 | liters | l | l | liters | 0.264 | gallons | gal |
| ft ³ | cubic feet | 0.028 | cubic meters | m ³ | m ³ | cubic meters | 35.71 | cubic feet | ft ³ |
| yd ³ | cubic yards | 0.765 | cubic meters | m ³ | m ³ | cubic meters | 1.307 | cubic yards | yd ³ |
| NOTE: Volumes greater than 1000 l shall be shown in m ³ . | | | | | | | | | |
| MASS | | | | | MASS | | | | |
| oz | ounces | 28.35 | grams | g | g | grams | 0.035 | ounces | oz |
| lb | pounds | 0.454 | kilograms | kg | kg | kilograms | 2.202 | pounds | lb |
| T | short tons (2000 lb) | 0.907 | megagrams | Mg | Mg | megagrams | 1.103 | short tons (2000 lb) | T |
| TEMPERATURE (exact) | | | | | TEMPERATURE (exact) | | | | |
| °F | Fahrenheit temperature | 5(F-32)/9 or (F-32)/1.8 | Celcius temperature | °C | °C | Celcius temperature | 1.8C + 32 | Fahrenheit temperature | °F |
| ILLUMINATION | | | | | ILLUMINATION | | | | |
| fc | foot-candles | 10.76 | lux | l | lx | lux | 0.0929 | foot-candles | fc |
| fl | foot-Lamberts | 3.426 | candela/m ² | cd/m ² | cd/m ² | candela/m ² | 0.2919 | foot-Lamberts | fl |
| FORCE and PRESSURE or STRESS | | | | | FORCE and PRESSURE or STRESS | | | | |
| lbf | poundforce | 4.45 | newtons | N | N | newtons | 0.225 | poundforce | lbf |
| psi | poundforce per square inch | 6.89 | kilopascals | kPa | kPa | kilopascals | 0.145 | poundforce per square inch | psi |

* SI is the symbol for the International System of Units. Appropriate rounding should be made to comply with Section 4 of ASTM E380.

(Revised August 1992)

TABLE OF CONTENTS

| <u>Chapter</u> | <u>Page</u> |
|---------------------------------|-------------|
| 1. DESIGN OF RAILING | 1 |
| 2. CRASH TEST PROCEDURES | 3 |
| 3. FULL-SCALE CRASH TESTS | 5 |
| TEST 7069-17 | 5 |
| Test Description | 5 |
| Test Results | 6 |
| Conclusions | 6 |
| TEST 7069-18 | 25 |
| Test Description | 25 |
| Test Results | 25 |
| Conclusions | 26 |
| 4. STRENGTH CALCULATIONS | 49 |
| REFERENCES | 54 |

LIST OF FIGURES

| <u>Figure No.</u> | <u>Page</u> |
|---|-------------|
| 1. Oregon side-mounted bridge railing | 2 |
| 2. Vehicle/bridge railing geometrics for test 7069-17 | 7 |
| 3. Oregon side-mounted bridge railing (front view) before test 7069-17 | 8 |
| 4. Oregon side-mounted bridge railing (rear view) before test 7069-17 | 9 |
| 5. Vehicle properties for test 7069-17 | 11 |
| 6. Oregon side-mounted bridge railing after test 7069-17 | 11 |
| 7. Damage to posts 4 and 5, test 7069-17 | 12 |
| 8. Vehicle after test 7069-17 | 13 |
| 9. Summary of results for test 7069-17 | 14 |
| 10. Sequential photographs for test 7069-17 | 18 |
| 11. Dummy before and after test 7069-17 | 20 |
| 12. Vehicle angular displacements for test 7069-17 | 21 |
| 13. Vehicle longitudinal accelerometer trace for test 7069-17 (accelerometer located near center-of-gravity) | 22 |
| 14. Vehicle lateral accelerometer trace for test 7069-17 (accelerometer located near center-of-gravity) | 23 |
| 15. Vehicle vertical accelerometer trace for test 7069-17 (accelerometer located near center-of-gravity) | 24 |
| 16. Vehicle before test 7069-18 | 27 |
| 17. Oregon side-mounted bridge railing (front view) before test 7069-18 | 28 |
| 18. Oregon side-mounted bridge railing (rear view) before test 7069-18 | 29 |
| 19. Vehicle properties for test 7069-18 | 30 |
| 20. Oregon side-mounted bridge railing after test 7069-18 | 31 |
| 21. Damage to post 8, test 7069-18 | 32 |
| 22. Damage to post 9, test 7069-18 | 33 |
| 23. Vehicle after test 7069-18 | 34 |
| 24. Summary of results for test 7069-18 | 35 |
| 25. Sequential photographs for test 7069-18 | 37 |
| 26. Dummies before and after test 7069-18 | 39 |
| 27. Vehicle angular displacements for test 7069-18 | 40 |
| 28. Longitudinal accelerometer trace for test 7069-18 (accelerometer located near center-of-gravity) | 41 |
| 29. Lateral accelerometer trace for test 7069-18 (accelerometer located near center-of-gravity) | 42 |
| 30. Vertical accelerometer trace for test 7069-18 (accelerometer located near center-of-gravity) | 43 |
| 31. Longitudinal accelerometer trace for test 7069-18 (accelerometer located at front of vehicle) | 44 |
| 32. Lateral accelerometer trace for test 7069-18 (accelerometer located at front of vehicle) | 45 |
| 33. Longitudinal accelerometer trace for test 7069-18 (accelerometer located at rear of vehicle) | 46 |

LIST OF FIGURES (continued)

| <u>Figure No.</u> | | <u>Page</u> |
|-------------------|--|-------------|
| 34. | Lateral accelerometer trace for test 7069-18 (accelerometer located at rear of vehicle) | 47 |
| 35. | Plan view illustrating some possible failure mechanisms | 50 |
| 36. | Force diagrams for analysis of post strength | 51 |
| 37. | Analysis of flexural strength of thrie-beam rail element | 52 |

LIST OF TABLES

| <u>Table No.</u> | | <u>Page</u> |
|------------------|---|-------------|
| 1. | Evaluation of crash test no. 7069-17 | 15 |
| 2. | Bridge railing performance levels and crash test criteria | 16 |
| 3. | Evaluation of crash test no. 7069-18 | 36 |

CHAPTER 1. DESIGN OF RAILING

The Oregon side mounted railing was designed to meet performance level one of the 1989 Guide Specifications.⁽¹⁾ The design force of 24 kips (107 kN) was a uniformly distributed line force 42 in (1.07 m) long located at 18 in (457 mm) above the roadway surface.

A cross section of the railing design is shown in figure 1. Total height of the railing is 28 in (711 mm). It consists of W6x15 (A36) vertical steel posts spaced 6 ft-3 in (1.9 m) apart. The posts are mounted with four 3/4-in (19-mm) high strength (A325) bolts to the side face of a prestressed concrete slab panel. The upper two post mounting bolts are designed to carry tensile forces while the lower two post mounting bolts are designed to carry the compressive forces.

The rail element consists of one 10-gauge steel (grade 50) thrie beam. Splice joints are spaced every 12 ft-6 in (1.9 m). The calculated strength of this railing is 24.9 kips (110.8 kN).

It should be noted that the thrie-beam rail element does not develop a full plastic moment when loaded by a colliding vehicle. Forces from the vehicle tend to flatten the cross section. Furthermore, the section is made from thin sheets, and local buckling tends to occur. It is also noted that when significant lateral deflection occurs, the thrie-beam begins to carry significant load in axial tension. These aspects of behavior are not included in the strength analysis. Consequently, the accuracy or confidence in the predicted values of strength are reduced.

During fabrication of the prestressed concrete deck planks, the sockets for the upper anchor bolts were partially filled with concrete. This prevented the upper anchor bolts from being threaded sufficiently to tighten against the post. The remedial measure chosen by the construction worker and not observed by the inspector was to shorten the anchor bolt. This resulted in inadequate engagement of the bolts, and premature failure of the bolt threads occurred in the first crash test. The situation was corrected by cleaning the concrete from the sockets and reinstalling bolts of the correct length.

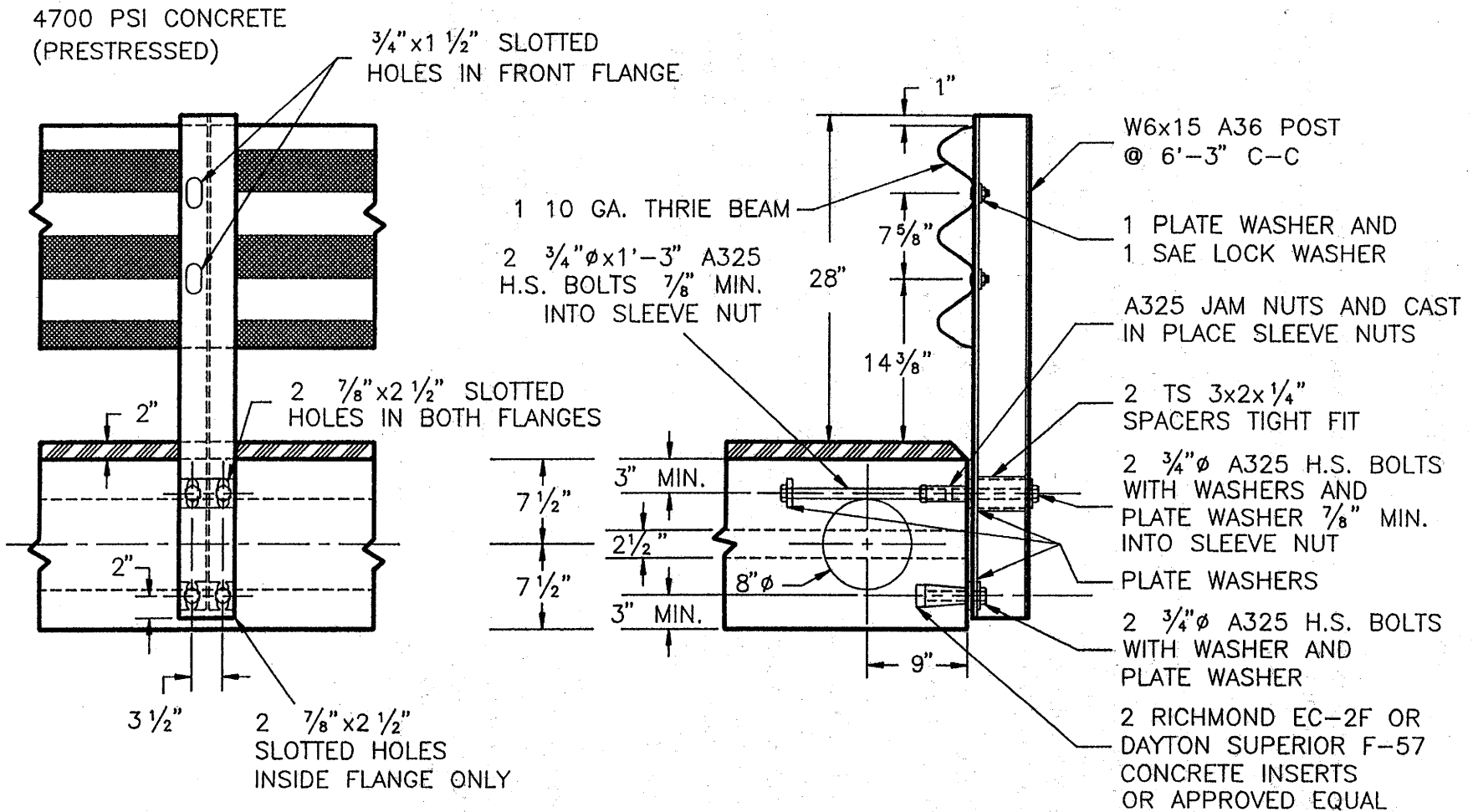

1 in = 25.4 mm
1 psi = 6.89 kPa

Figure 1. Oregon side-mounted bridge railing.

CHAPTER 2. CRASH TEST PROCEDURES

The Oregon side-mounted bridge railing was tested to performance level one requirements.⁽¹⁾ The following nominal test conditions were used:

1,800-lb (817-kg) passenger car | 60 mi/h (96.5 km/h) | 20 degrees (test 7069-17)
5,400-lb (2 452-kg) pickup | 65 mi/h (104.6 km/h) | 20 degrees (test 7069-18)

Not correct

Each vehicle was instrumented with three solid-state angular rate transducers to measure yaw, pitch, and roll rates and a triaxial accelerometer mounted near the center-of-gravity to measure accelerations in the longitudinal, lateral, and vertical directions. In addition, on the pickup a biaxial accelerometer was mounted in the rear of the vehicle to measure longitudinal and lateral accelerations. The accelerometers were strain gauge type with a linear millivolt output proportional to acceleration. The electronic signals from the accelerometers and transducers were transmitted to a base station by means of constant bandwidth FM/FM telemetry link for recording on magnetic tape and displaying on a real-time strip chart. Provision was made for transmission of calibration signals before and after the test, and an accurate time reference signal was simultaneously recorded with the data.

Pressure sensitive contact switches on the bumper of each vehicle were actuated just prior to impact by wooden dowels to indicate the elapsed time over a known distance to provide a measurement of impact velocity. Each initial contact also produced an "event" mark on the data record to establish the instant of impact.

The multiplex of data channels transmitted on one radio frequency was received at a data acquisition station and demultiplexed into separate tracks of Intermediate Range Instrumentation Group (I.R.I.G.) tape recorders. After the test, the data were played back from the tape machines, filtered with a SAE J211 filter, and digitized using a microcomputer for analysis and evaluation of performance. The digitized data obtained from the electronic transducers were then processed using two computer programs: DIGITIZE and PLOTANGLE. Brief descriptions on the functions of these two computer programs are as follows.

The DIGITIZE program uses digitized data from vehicle-mounted linear accelerometers to compute occupant/compartiment impact velocities, time of occupant/compartiment impact after vehicle impact, highest 0.010-s average of vehicle acceleration after occupant/compartiment impact, and time of highest 0.010-s average. The DIGITIZE program also calculates a vehicle impact velocity and the change in vehicle velocity at the end of a given impulse period.

The DIGITIZE program also calculates a vehicle impact velocity and the change in vehicle velocity at the end of a given impulse period. In addition, maximum average accelerations over 0.050-s intervals in each of three directions are computed. Acceleration versus time curves for the longitudinal, lateral, and vertical directions are then plotted from

the digitized data of the vehicle-mounted linear accelerometers using a commercially available software package (QUATTRO PRO). For each of these graphs, a 0.050-s average window was calculated at the center of the 0.050-s interval and then plotted with the first 0.050-s average plotted at 0.026 s.

The PLOTANGLE program uses the digitized data from the yaw, pitch, and roll rate charts to compute angular displacement in degrees at 0.001-s intervals and instructs a plotter to draw a reproducible plot: yaw, pitch, and roll versus time. It should be noted that these angular displacements are sequence dependent with the sequence being yaw, pitch, and roll for the data presented herein. These displacements are in reference to the vehicle-fixed coordinate system with the initial position and orientation of the vehicle-fixed coordinate system being that which existed at initial impact.

Alderson Research Laboratories Hybrid II, 50th percentile anthropomorphic dummies were used in the passenger car and the pickup. One uninstrumented dummy was placed in the driver's position of the passenger car and two uninstrumented dummies in the pickup-- one in the driver's position and one in the passenger's position. The dummies were restrained with standard restraint equipment.

Photographic coverage of the test included four high-speed cameras: one over head with a field of view perpendicular to the ground and directly over the impact point, one placed to have a field of view parallel to and aligned with the railing system at the downstream end, a third placed perpendicular to the front of the railing system, and the fourth was placed onboard the vehicle to record the actions of the dummy(ies) during the test. A flash bulb activated by pressure sensitive tape switches was positioned on the impacting vehicle to indicate the instant of contact with the railing system and was visible from each camera. The films from these high-speed cameras were analyzed on a computer linked Motion Analyzer to observe phenomena occurring during the collision and to obtain time-event, displacement, and angular data. A 16-mm movie cine, a professional video camera and 3/4-in (19 mm) video recorder along with 35-mm still cameras were used for documentary purposes and to record conditions of the test vehicle and railing system before and after the test.

Each test vehicle was towed into the test installation using a steel cable guidance and reverse tow system. A steel cable for guiding the test vehicle was stretched along the path, anchored at each end and threaded through an attachment to the front wheel of the test vehicle. Another steel cable was connected to the test vehicle and then anchored to the ground such that the tow vehicle moved away from the test site. A 2-to-1 speed ratio between the test vehicle and tow vehicle existed with this system. Immediately prior to impact with the railing system, the test vehicle was released to be free-wheeling and unrestrained. The test vehicle remained free-wheeling, i.e., no steering or braking inputs until the vehicle cleared the immediate area of the test site at which time brakes on the test vehicle were activated to bring the vehicle to a safe and controlled stop.

CHAPTER 3. FULL-SCALE CRASH TESTS

TEST 7069-17

Test Description

The 1980 Honda Civic (figure 2) was directed into the Oregon side-mounted bridge railing (figures 3 and 4) using a cable reverse tow and guidance system. Test inertia mass of the vehicle was 1,800 lb (817 kg) and its gross static mass was 1,970 lb (894 kg). The height to the lower edge of the vehicle bumper was 14.0 in (356 mm) and it was 19.75 in (502 mm) to the top of the bumper. Other dimensions and information on the test vehicle are given in figure 5. The vehicle was free-wheeling and unrestrained just prior to impact.

The speed of the vehicle at impact was 52.2 mi/h (84.0 km/h) and the angle of impact was 19.7 degrees. The vehicle impacted the bridge railing approximately 20.6 ft (6.3 m) from the end. The vehicle began to redirect at 0.042 s after impact. By 0.175 s the vehicle was traveling parallel to the bridge railing at a speed of 44.0 mi/h (70.8 m), and shortly thereafter the rear of the vehicle impacted the bridge railing. The vehicle lost contact with the bridge railing at 0.261 s traveling at 42.7 mi/h (68.7 km/h) and 7.1 degrees. The brakes were applied 82 ft (25 m) from impact and the vehicle yawed clockwise. The vehicle subsequently came to rest 172 ft (52 m) down and 30 ft (9 m) behind the point of impact.

As can be seen in figures 6 and 7, the railing received moderated damage. Maximum lateral deflection was 0.5 in (13 mm) at the top of post 5. The vehicle was in contact with the bridge railing for 9.3 ft (2.8 m).

At post 4, the top anchor bolts connecting the post to the bridge deck showed structural distress. One bolt was pulled from the anchor insert in the concrete. Post 5 was bent outward about 0.5 in (13 mm) at the top and the top anchor bolts showed structural distress. One of the bolts in this post was also pulled from the anchor insert.

After-test examination of anchor bolts in all the posts showed that the bolts had been cut off during construction and, in some, only three or four threads were engaged in the anchor insert. The plans called for a minimum of 7/8 in (22 mm) thread engagement. Evidently, concrete had flowed into the anchors during fabrication of the prestressed deck slabs and the anchor bolts had been cut off to prevent them from bottoming out. This was not detected in our construction inspection process. Prior to the next test, concrete was removed from all anchor inserts and new full-length anchor bolts were installed.

The vehicle sustained damage to the right side as shown in figure 8. Maximum crush at the right front corner at bumper height was 9.0 in (229 mm). The strut and constant velocity joint on the right side were damaged. The right front wheel was canted inward at the bottom and pushed back into the fender well. The right side window was broken out by the head of the dummy. Also, damage was done to the front bumper, hood, grill, radiator and fan, the right front quarter panel, and the right door.

Test Results

Impact speed was 52.2 mi/h (84.0 km/h) and the angle of impact was 19.7 degrees. The speed of the vehicle at time of parallel was 44.0 mi/h (70.8 km/h). The vehicle lost contact with the railing traveling at 42.7 mi/h (68.7 km/h). The exit angle between the vehicle path and the railing was 7.1 degrees. Occupant impact velocity was 18.8 ft/s (5.7 m/s) in the longitudinal direction and 18.9 ft/s (5.8 m/s) in the lateral direction. The highest 0.010-s occupant ridedown accelerations were -1.8 g (longitudinal) and 4.5 g (lateral). These data and other pertinent information from the test are summarized in figure 9 and tables 1 and 2. Sequential photographs are shown in figure 10 and the initial and final resting positions of the dummy are shown in figure 11. Vehicle angular displacements are displayed in figure 12. Vehicular accelerations versus time traces filtered with SAE J211 filters are presented in figures 13 through 15. These data were further analyzed to obtain 0.050-s average accelerations versus time. The maximum 0.050-s averages measured at the center-of-gravity were -5.2 g in the longitudinal direction and 8.4 g in the lateral direction.

Conclusions

The Oregon side-mounted bridge railing contained the test vehicle with minimal lateral movement of the bridge railing. There was no intrusion into the occupant compartment and no deformation of the compartment. The vehicle remained upright and relatively stable during the collision. The bridge railing smoothly redirected the vehicle and the effective coefficient of friction was considered fair. The occupant risk factors were within the limits recommended in the 1989 American Association of State Highway and Transportation Department Officials (AASHTO) *Guide Specifications For Bridge Railings*. The vehicle trajectory at loss of contact indicates minimum intrusion into adjacent traffic lanes. See figure 9 and table 1 for more detail.



Figure 2. Vehicle/bridge railing geometrics for test 7069-17.

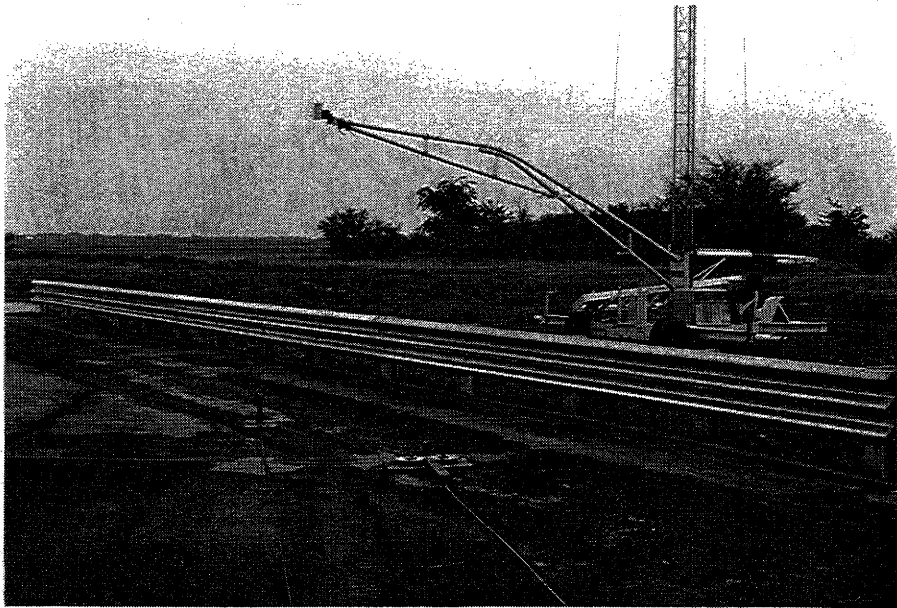

Figure 3. Oregon side-mounted bridge railing (front view) before test 7069-17.

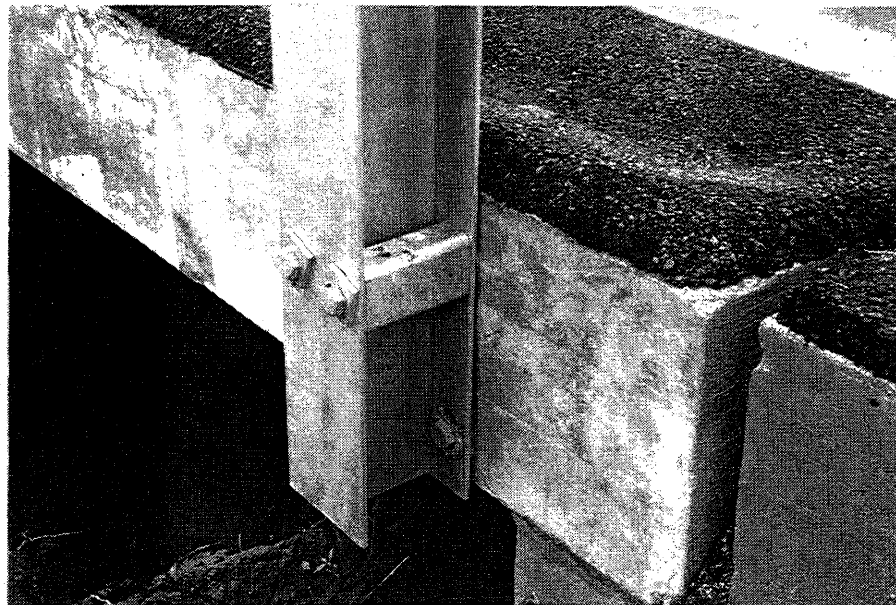
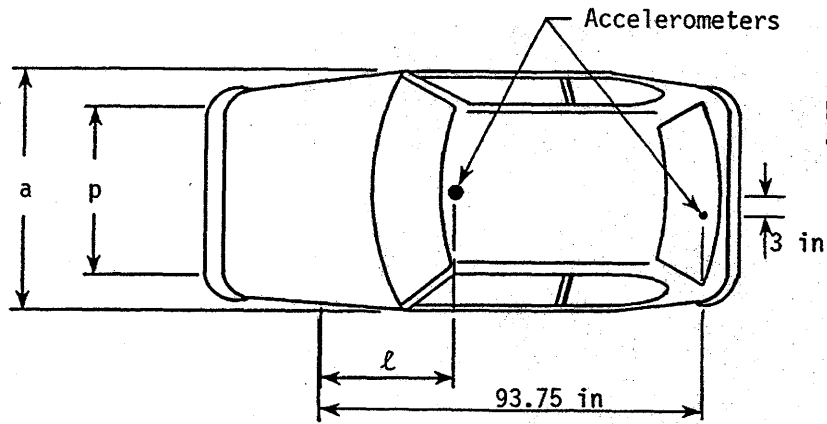

Figure 4. Oregon side-mounted bridge railing (rear view) before test 7069-17.

Date: _____ Test No.: 7069-17 VIN: SL53208S000645

Make: Honda Model: Civic Year: 1980 Odometer: 63169

Tire Size: 155 SR 12 Ply Rating: 3 Bias Ply: Belted: Radial: x



Tire Condition: good
fair x

Height of rear badly worn accelerometer = 23 in

Vehicle Geometry - inches

| | | | |
|---|--------------|----|---------------|
| a | <u>62.50</u> | b | <u>29</u> |
| c | <u>88.25</u> | d* | <u>53</u> |
| e | <u>29</u> | f | <u>146.25</u> |
| g | <u>---</u> | h | <u>32.6</u> |
| i | <u>----</u> | j | <u>29.75</u> |
| k | <u>16</u> | l | <u>26.75</u> |
| m | <u>19.75</u> | n | <u>4</u> |
| o | <u>14</u> | p | <u>54</u> |
| r | <u>21.5</u> | s | <u>13.25</u> |

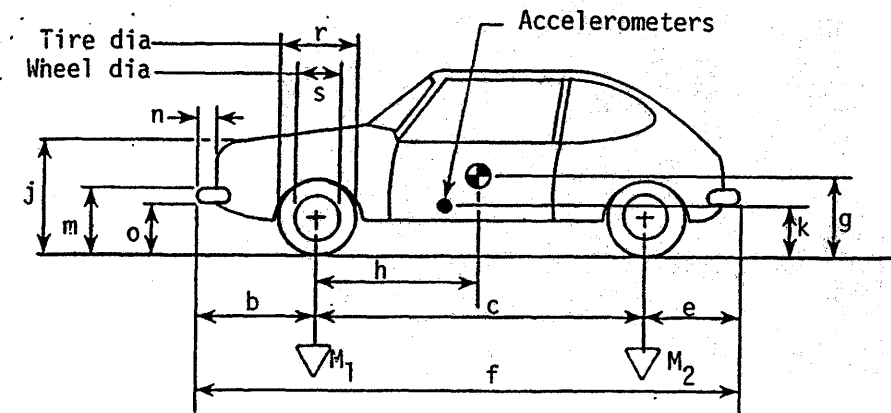

4-wheel weight for c.g. det. lf 614 rf 522 lr 324 rr 340

| Mass - pounds | Curb | Test Inertial | Gross Static |
|---------------|-------------|---------------|--------------|
| M_1 | <u>1120</u> | <u>1136</u> | <u>1221</u> |
| M_2 | <u>610</u> | <u>664</u> | <u>749</u> |
| M_T | <u>1730</u> | <u>1800</u> | <u>1970</u> |

Note any damage to vehicle prior to test:

Engine Type: 4 cylinder

Engine CID: _____

Transmission Type:

Automatic or Manual
FWD or RWD or 4WD

Body Type: Hatch back

Steering Column Collapse Mechanism:

- Behind wheel units
- Convoluted tube
- Cylindrical mesh units
- Embedded ball
- NOT collapsible
- Other energy absorption
- Unknown

Brakes:

Front: disc x drum
Rear: disc drum x

*d = overall height of vehicle

1 in = 25.4 mm
1 lb = 0.454 kg

Figure 5. Vehicle properties for test 7069-17.

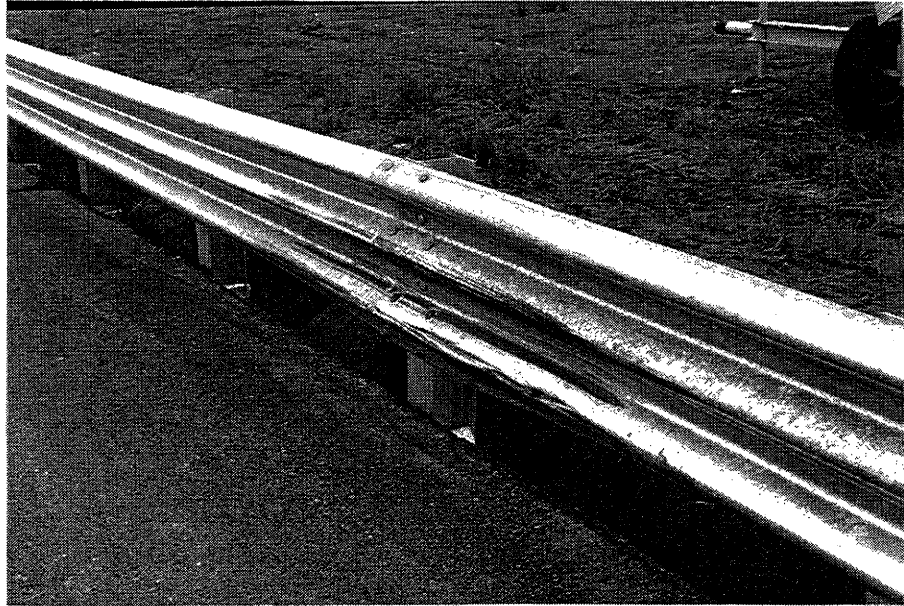

Figure 6. Oregon side-mounted bridge railing after test 7069-17.

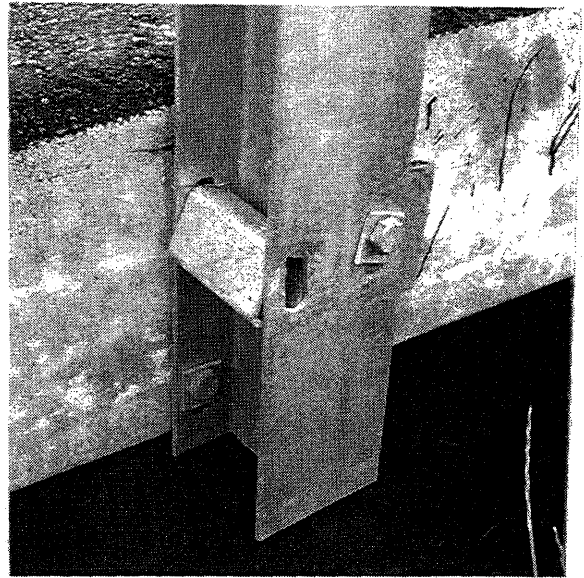
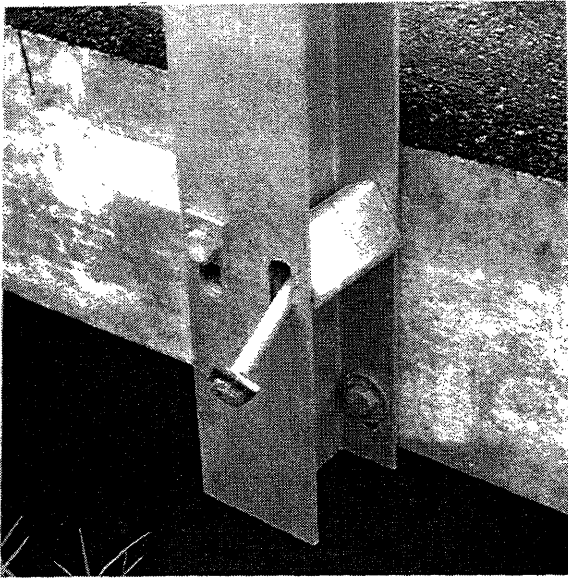

Figure 7. Damage to posts 4 and 5, test 7069-17.

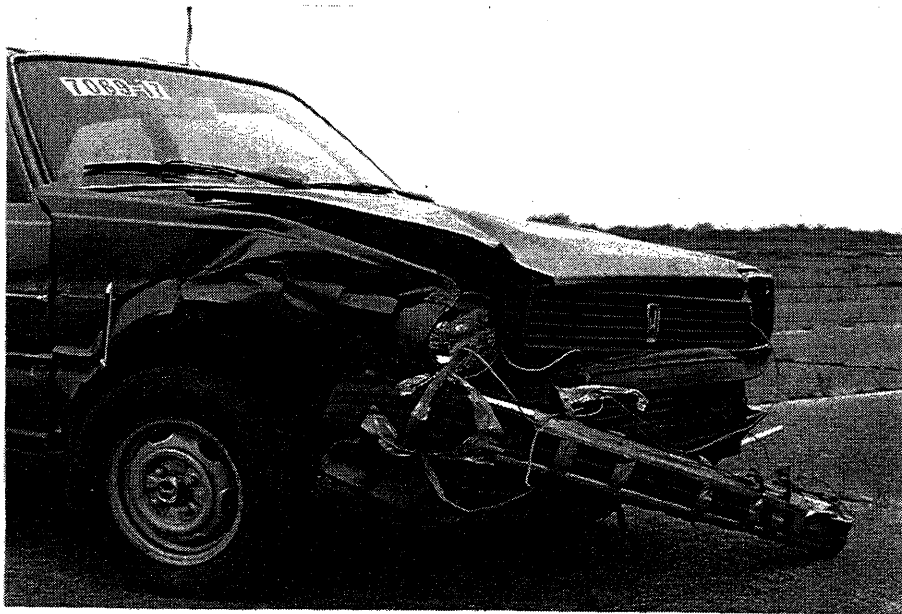
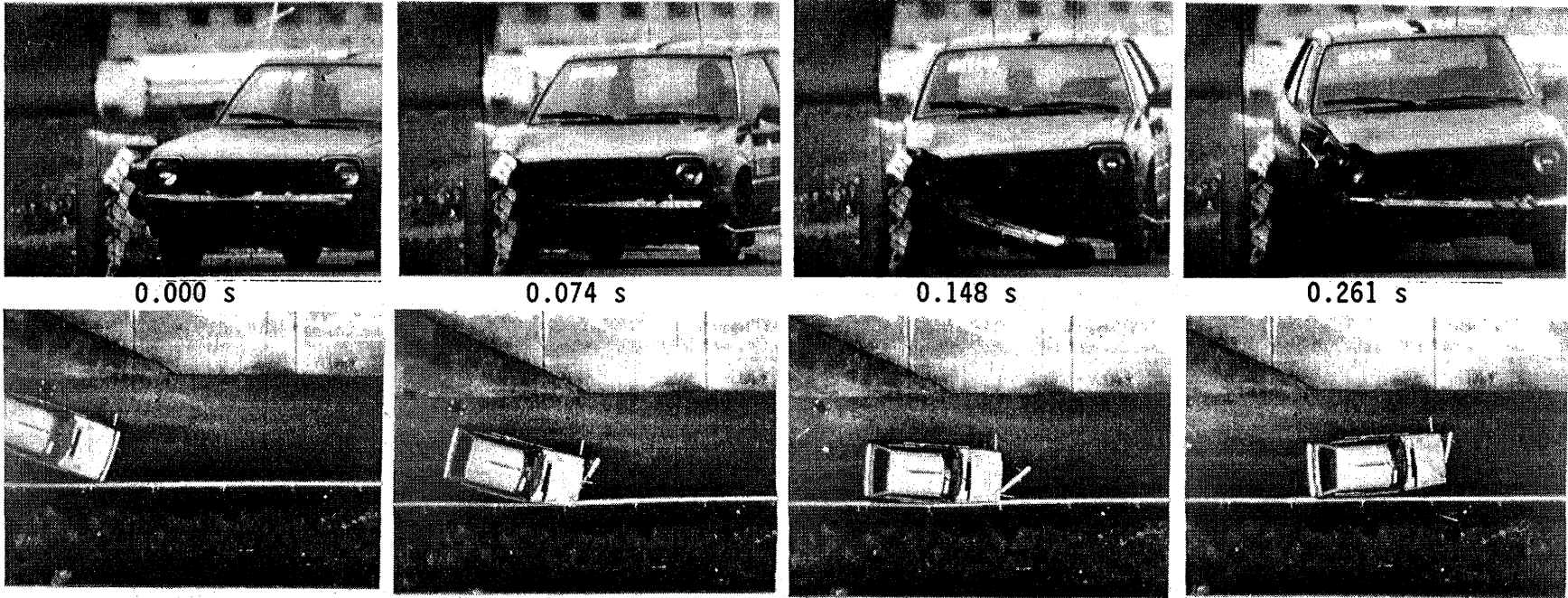
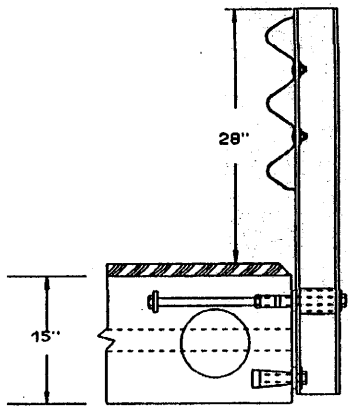

Figure 8. Vehicle after test 7069-17.



14



(1 in = 25.4 mm)

| | | | |
|-------------------------------|---------------------------------------|---|-----------------------|
| Test No. | 7069-17 | Impact Speed. . . . | 52.2 mi/h (84.0 km/h) |
| Date | 05/10/89 | Impact Angle. . . . | 19.7 deg |
| Test Installation . . . | Oregon Side-Mounted Bridge Railing | Speed at Parallel . . | 44.0 mi/h (70.8 km/h) |
| Installation Length . . | 85 ft (26 m) | Exit Speed | 42.7 mi/h (68.7 km/h) |
| Test Vehicle | 1980 Honda Civic | Exit Trajectory . . . | 7.1 deg |
| Vehicle Weight | | Vehicle Accelerations (Max. 0.050-sec Avg) | |
| Test Inertia | 1,800 lb (817 kg) | Longitudinal. . . . | -5.2 g |
| Gross Static | 1,970 lb (894 kg) | Lateral | 8.4 g |
| Vehicle Damage Classification | | Occupant Impact Velocity | |
| TAD | 01FR4 & 01RFQ3 | Longitudinal. . . . | 18.8 ft/s (5.7 m/s) |
| CDC | 01FREK2 & 01RFEW3 | Lateral | 18.9 ft/s (5.8 m/s) |
| Maximum Vehicle Crush . | 9.0 in (229 mm) | Occupant Ridedown Accelerations | |
| | | Longitudinal. . . . | -1.8 g |
| | | Lateral | 4.5 g |

Figure 9. Summary of results for test 7069-17.

Table 1. Evaluation of crash test no. 7069-17.
 {Oregon Side-Mounted Bridge Railing [1,800 lb (817 kg)|52.2 mi/h (84 km/h)|19.7 degrees]}

| CRITERIA | | TEST RESULTS | | PASS/FAIL* |
|----------|--|--|-------------------|------------|
| A. | Must contain vehicle | Vehicle was contained | | Pass |
| B. | Debris shall not penetrate passenger compartment | No debris penetrated passenger compartment | | Pass |
| C. | Passenger compartment must have essentially no deformation | Acceptable deformation | | Pass |
| D. | Vehicle must remain upright | Vehicle did remain upright | | Pass |
| E. | Must smoothly redirect the vehicle | Vehicle was smoothly redirected | | Pass |
| F. | Effective coefficient of friction | | | |
| | <u>μ</u> | <u>μ</u> | <u>Assessment</u> | |
| | 0 - .25 | .29 | Fair | Pass |
| | .26 - .35 | | | |
| | > .35 | | | |
| G. | Shall be less than | | | |
| | <u>Occupant Impact Velocity - ft/s (m/s)</u> | <u>Occupant Impact Velocity - ft/s (m/s)</u> | | Pass |
| | Longitudinal | Longitudinal | Lateral | |
| | 30 (9.2) | 18.8 (5.7) | 18.9 (5.8) | |
| | <u>Occupant Ridedown Accelerations - g's</u> | <u>Occupant Ridedown Accelerations - g's</u> | | Pass |
| | Longitudinal | Longitudinal | Lateral | |
| | 15 | -1.8 | 4.5 | |
| H. | Exit angle shall be less than 12 degrees | Exit angle was 7.1 degrees | | Pass |

* A, B, C, D and G are required. E, F, and H are desired. (See table 2)

Table 2. Bridge railing performance levels and crash test criteria.
(Excerpt from 1989 AASHTO *Guide Specifications for Bridge Railings*)⁽¹⁾

| | | TEST SPEEDS—mph ^{1,2} | | | |
|---|------------------------|---|--|--|--|
| | | TEST VEHICLE DESCRIPTIONS AND IMPACT ANGLES | | | |
| PERFORMANCE LEVELS | | Small Automobile | Pickup Truck | Medium Single-Unit Truck | Van-Type Tractor-Trailer ⁴ |
| | | | W = 1.8 Kips A = 5.4' ± 0.1' B = 5.5' H _{cg} = 20" ± 1" θ = 20 deg. | W = 5.4 Kips A = 8.5' ± 0.1' B = 6.5' H _{cg} = 27" ± 1" θ = 20 deg. | W = 18.0 Kips A = 12.8' ± 0.2' B = 7.5' H _{cg} = 49" ± 1" θ = 15 deg. |
| | PL-1 | 50 | 45 | | |
| | PL-2 | 60 | 60 | 50 | |
| | PL-3 | 60 | 60 | | 50 |
| CRASH TEST EVALUATION CRITERIA ³ | Required | a, b, c, d, g | a, b, c, d | a, b, c | a, b, c |
| | Desirable ⁵ | e, f, h | e, f, g, h | d, e, f, h | d, e, f, h |

Notes:

- Except as noted, all full-scale tests shall be conducted and reported in accordance with the requirements in NCHRP Report No. 230. In addition, the maximum loads that can be transmitted from the bridge railing to the bridge deck are to be determined from static force measurements or ultimate strength analysis and reported.
- Permissible tolerances on the test speeds and angles are as follows:

| | | |
|-------|-----------|-----------|
| Speed | -1.0 mph | +2.5 mph |
| Angle | -1.0 deg. | +2.5 deg. |

Tests that indicate acceptable railing performance but that exceed the allowable upper tolerances will be accepted.

- Criteria for evaluating bridge railing crash test results are as follows:
 - The test article shall contain the vehicle; neither the vehicle nor its cargo shall penetrate or go over the installation. Controlled lateral deflection of the test article is acceptable.
 - Detached elements, fragments, or other debris from the test article shall not penetrate or show potential for penetrating the passenger compartment or present undue hazard to other traffic.
 - Integrity of the passenger compartment must be maintained with no intrusion and essentially no deformation.
 - The vehicle shall remain upright during and after collision.
 - The test article shall smoothly redirect the vehicle. A redirection is deemed smooth if the rear of the vehicle or, in the case of a combination vehicle, the rear of the tractor or trailer does not yaw more than 5 degrees away from the railing from time of impact until the vehicle separates from the railing.
 - The smoothness of the vehicle-railing interaction is further assessed by the effective coefficient of friction, μ :

| μ | Assessment |
|-----------|------------|
| 0-0.25 | Good |
| 0.26-0.35 | Fair |
| >0.35 | Marginal |

where $\mu = (\cos\theta - V_p/V)/\sin\theta$

Table 2. Bridge railing performance levels and crash test criteria.
 (Exerpt from 1989 AASHTO *Guide Specifications for Bridge Railings*)⁽¹⁾
 (continued)

- g. The impact velocity of a hypothetical front-seat passenger against the vehicle interior, calculated from vehicle accelerations and 2.0-ft. longitudinal and 1.0-ft. lateral displacements, shall be less than:

| Occupant Impact Velocity—fps | |
|------------------------------|---------|
| Longitudinal | Lateral |
| 30 | 25 |

and the vehicle highest 10-ms average accelerations subsequent to the instant of hypothetical passenger impact should be less than:

| Occupant Ridedown Acceleration—g's | |
|------------------------------------|---------|
| Longitudinal | Lateral |
| 15 | 15 |

- h. Vehicle exit angle from the barrier shall not be more than 12 degrees. Within 100 ft. plus the length of the test vehicle from the point of initial impact with the railing, the railing side of the vehicle shall move no more than 20-ft. from the line of the traffic face of the railing. The brakes shall not be applied until the vehicle has traveled at least 100-ft. plus the length of the test vehicle from the point of initial impact.

4. Values A and R are estimated values describing the test vehicle and its loading. Values of A and R are described in the figure below and calculated as follows:

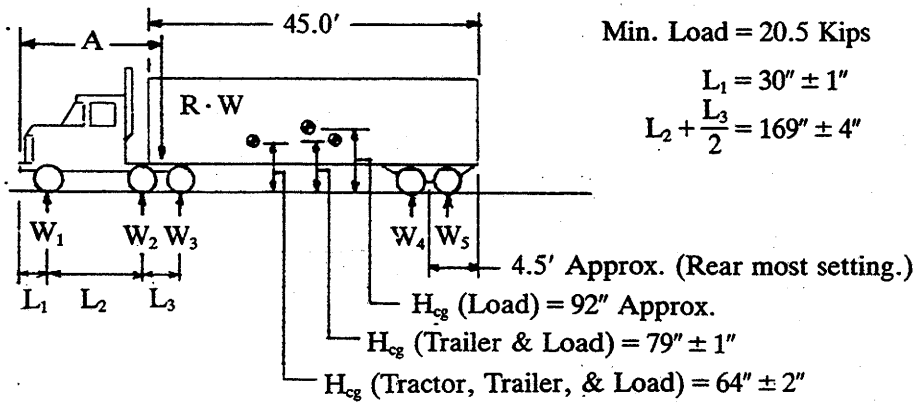

Min. Load = 20.5 Kips

$$L_1 = 30'' \pm 1''$$

$$L_2 + \frac{L_3}{2} = 169'' \pm 4''$$

$$A = L_1 + \frac{W_2 L_2 + W_3 (L_2 + L_3)}{W_1 + W_2 + W_3}$$

$$R = \frac{W_1 + W_2 + W_3}{W}$$

$$W = W_1 + W_2 + W_3 + W_4 + W_5$$

= total vehicle weight.

5. Test articles that do not meet the desirable evaluation criteria shall have their performance evaluated by a designated authority that will decide whether the test article is likely to meet its intended use requirements.

| |
|-----------------|
| 1 mi = 1.61 km |
| 1 kip = 4.45 kN |
| 1 in = 25.4 mm |

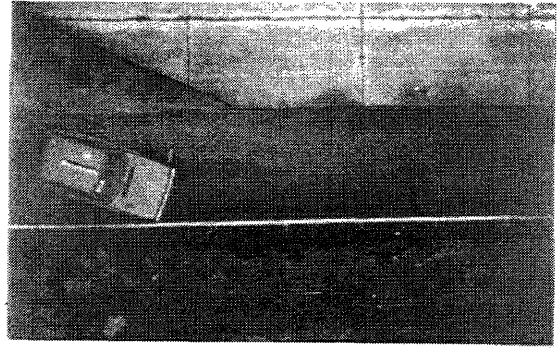

0.000 s

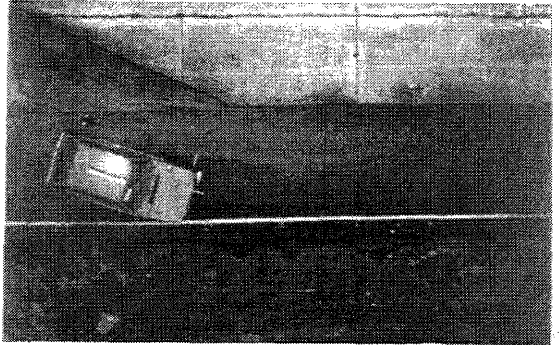

0.037 s

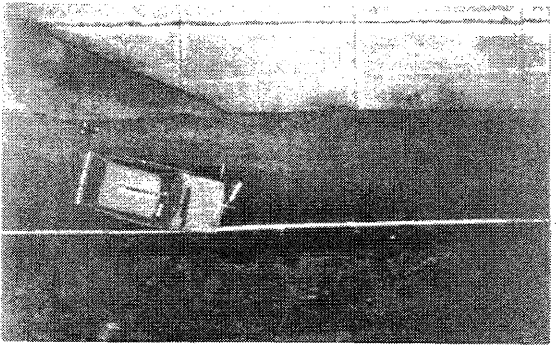
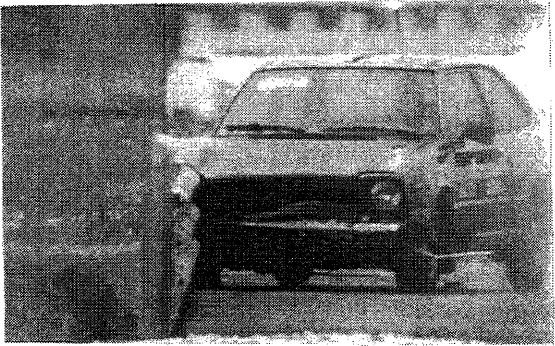

0.074 s

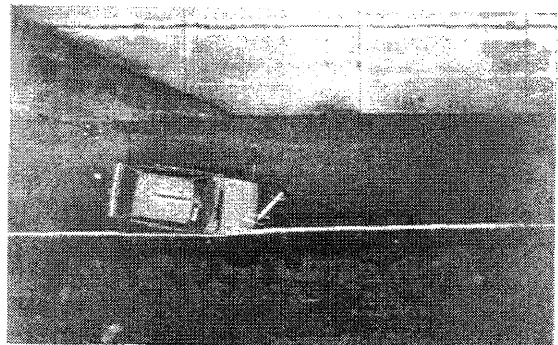

0.111 s

Figure 10. Sequential photographs for test 7069-17.



0.148 s

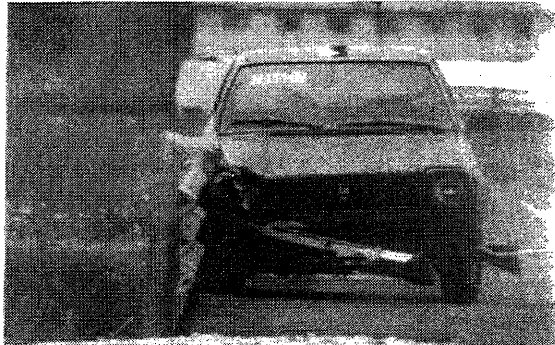
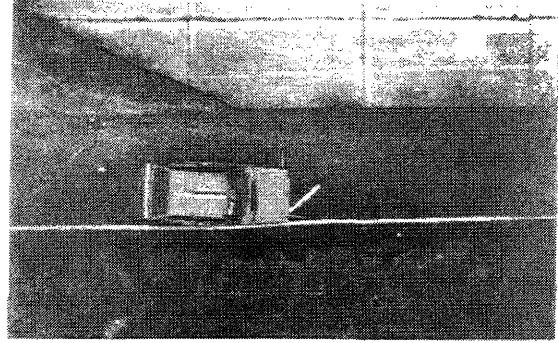

0.185 s

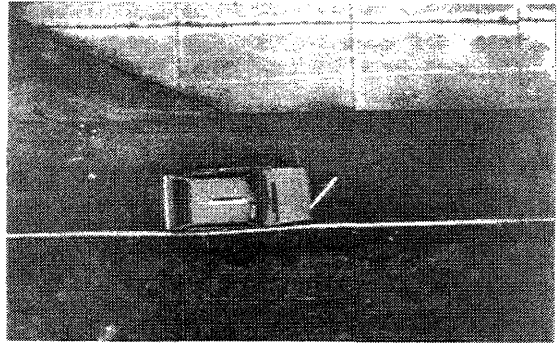

0.222 s

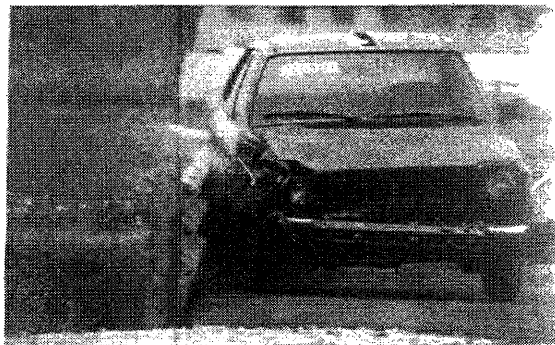
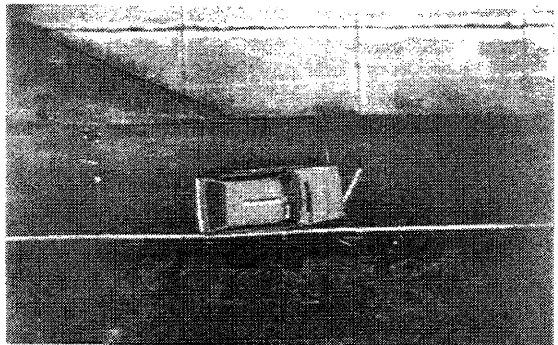

0.261 s

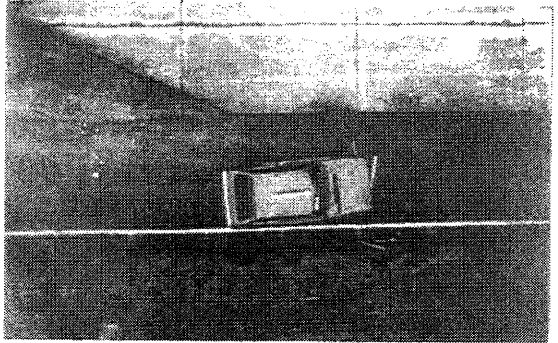

Figure 10. Sequential photographs for test 7069-17 (continued),

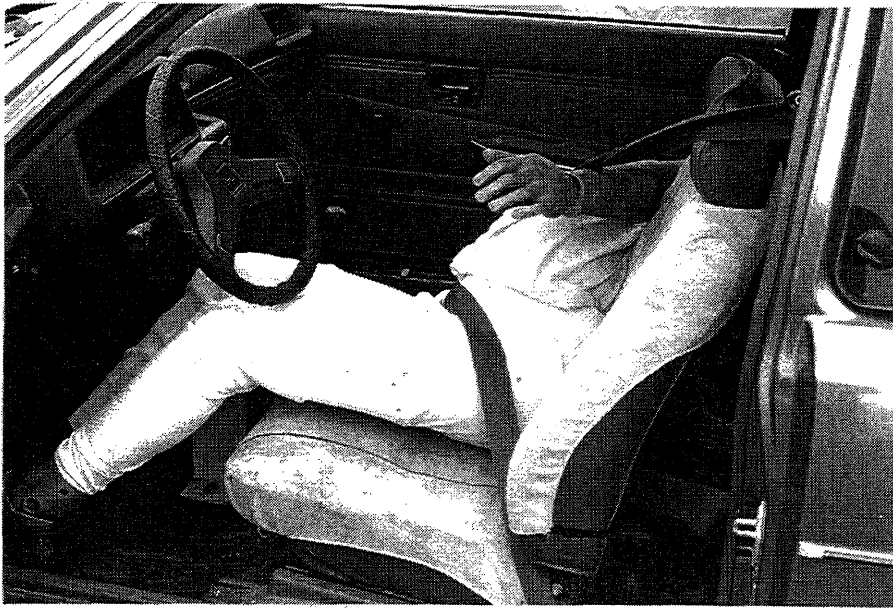

Figure 11. Dummy before and after test 7069-17.

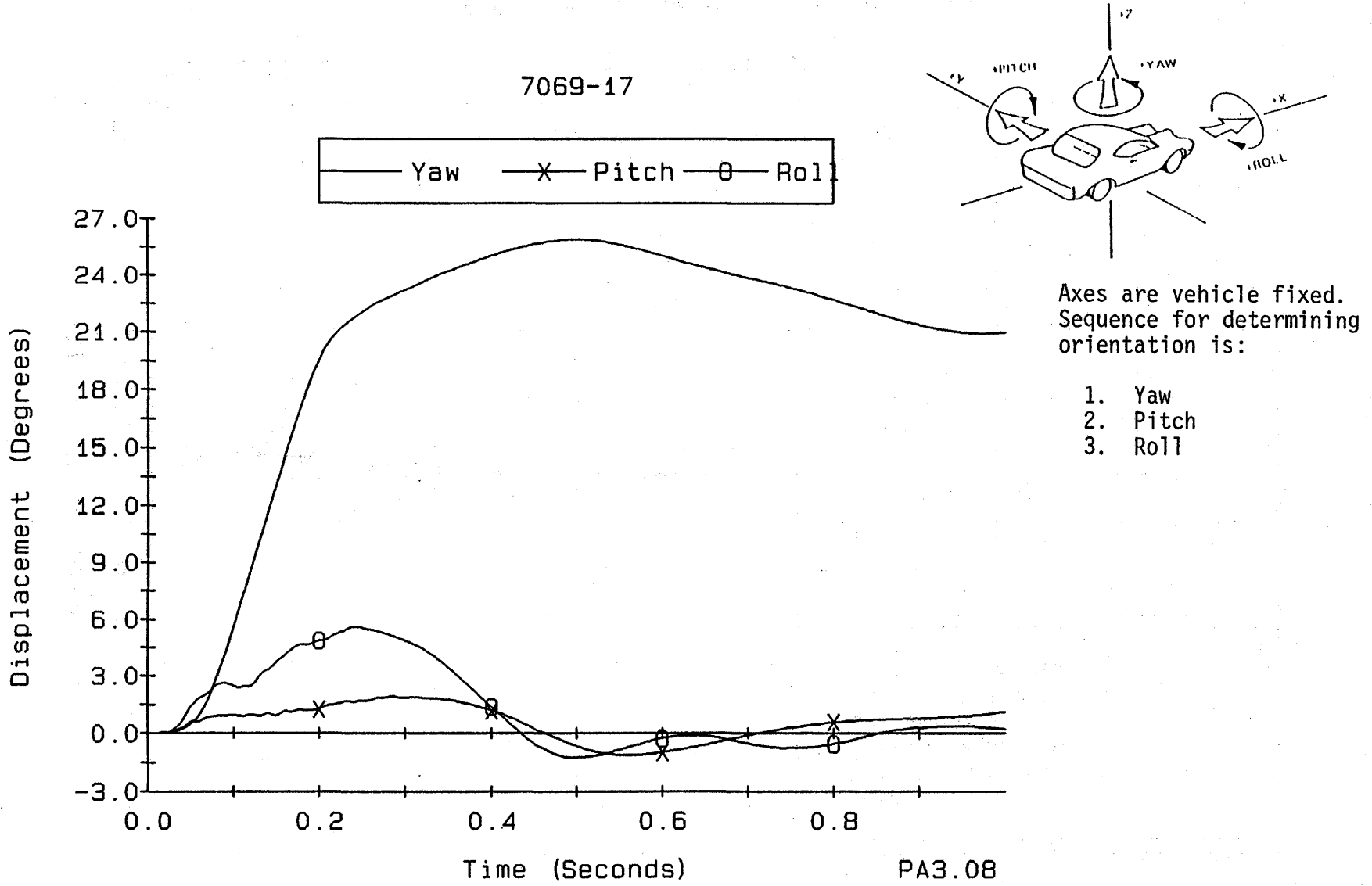

Figure 12. Vehicle angular displacements for test 7069-17

CRASH TEST 7069-17

Accelerometer near center-of-gravity

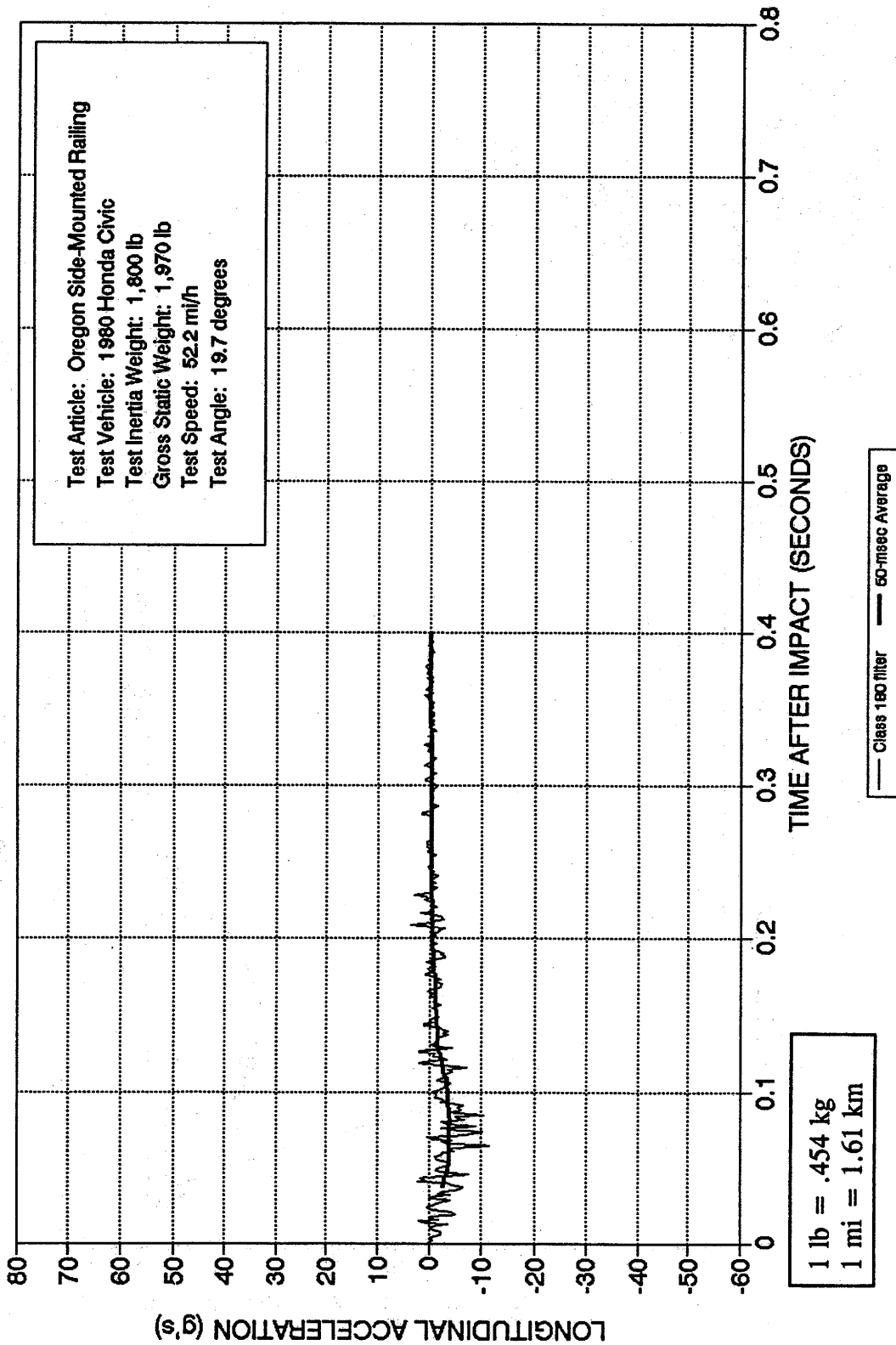

Figure 13. Vehicle longitudinal accelerometer trace for test 7069-17 (accelerometer located near center-of-gravity).

CRASH TEST 7069-17

Accelerometer near center-of-gravity

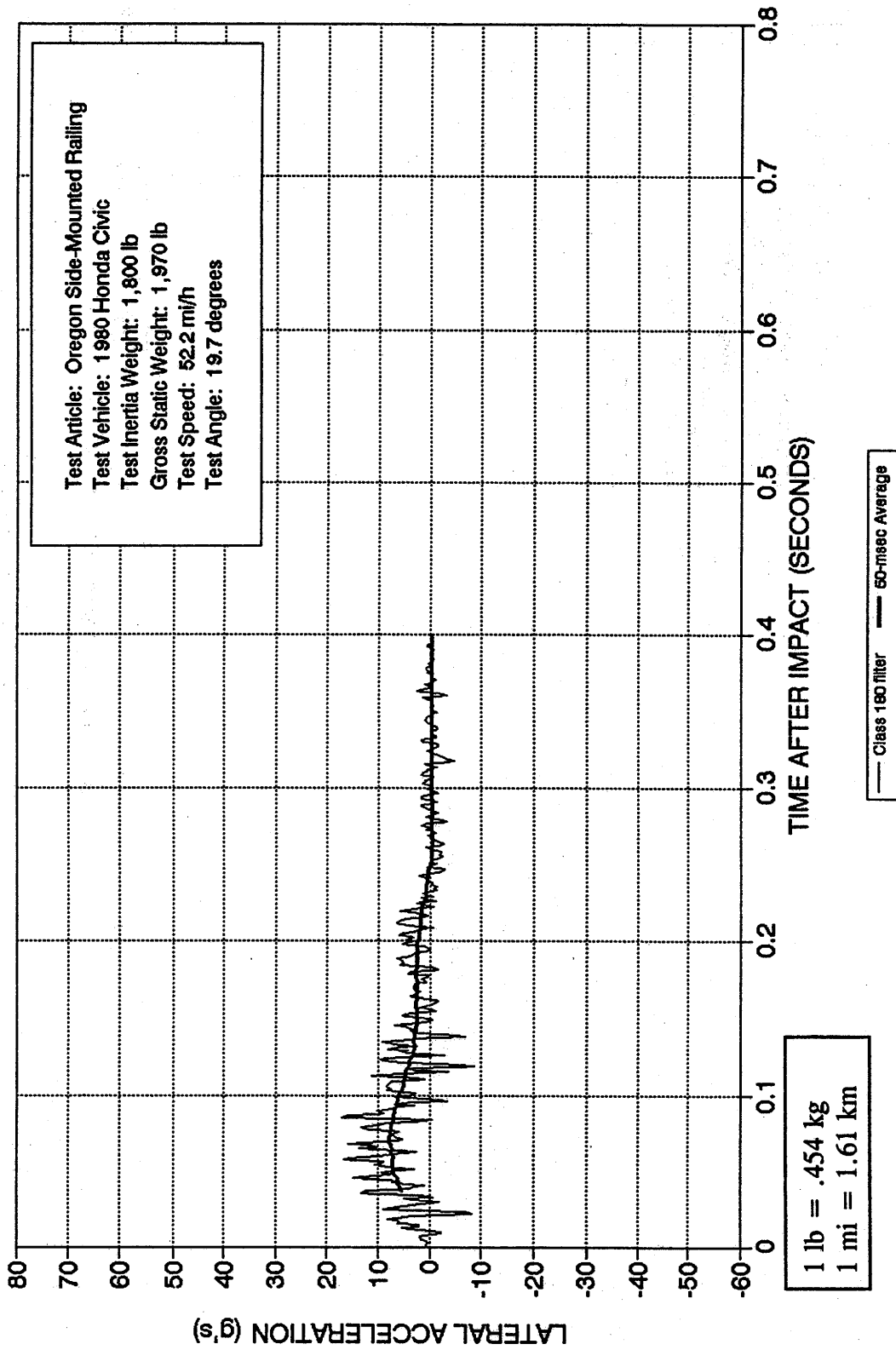

Figure 14. Vehicle lateral accelerometer trace for test 7069-17 (accelerometer located near center-of-gravity).

CRASH TEST 7069-17
Accelerometer near center-of-gravity

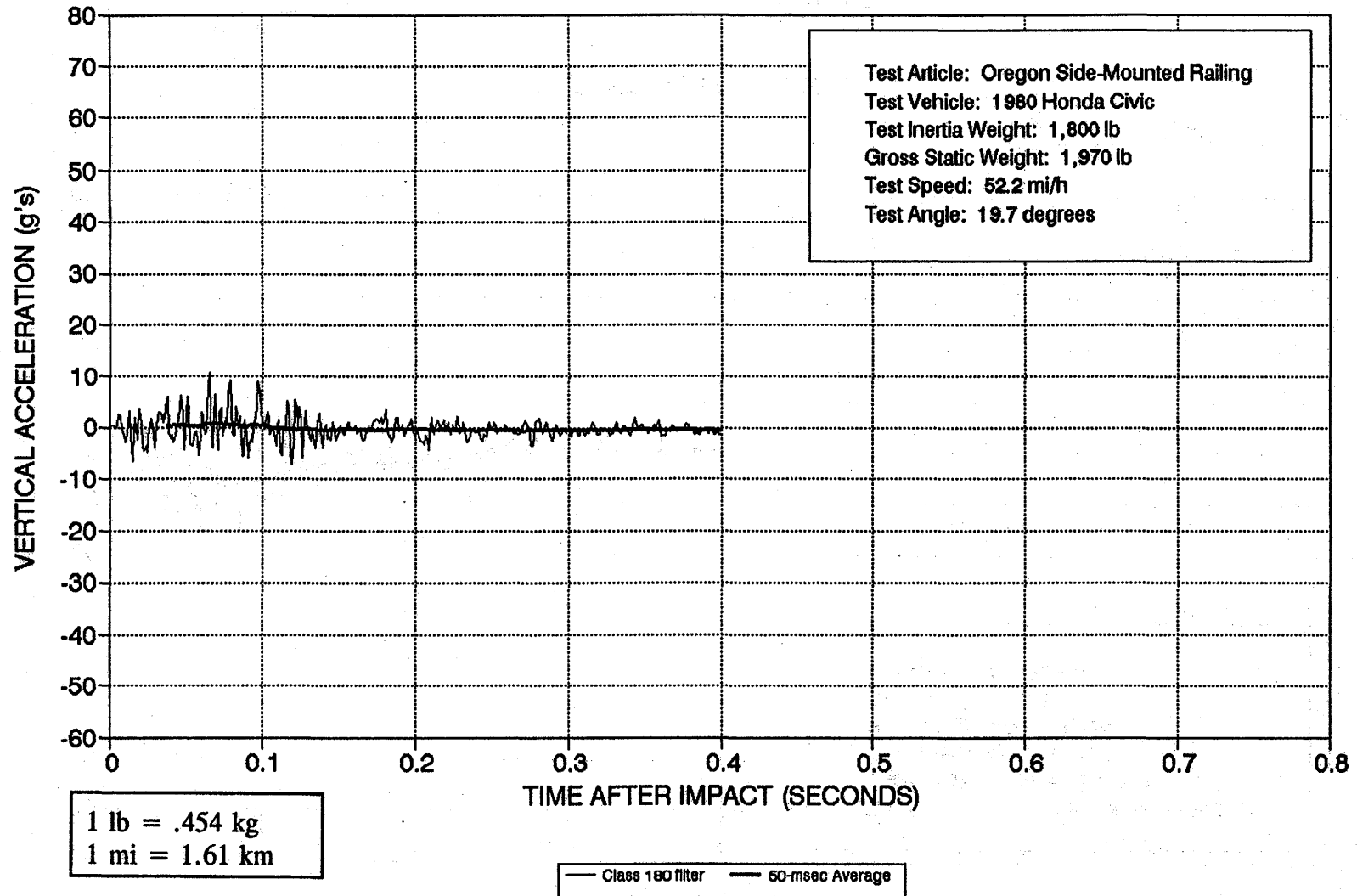

Figure 15. Vehicle vertical accelerometer trace for test 7069-17
(accelerometer located near center-of-gravity).

TEST 7069-18

Test Description

The 1982 Chevrolet Custom Deluxe truck (figure 16) was directed into the Oregon side-mounted bridge railing (figure 17 and 18) using a cable reverse tow and guidance system. Test inertia mass of the vehicle was 5,400 lb (2 452 kg) and its gross static mass was 5,737 lb (2 605 kg). The height to the lower edge of the vehicle bumper was 17.75 in (451 mm) and it was 27.0 in (686 mm) to the top of the bumper. Other dimensions and information on the test vehicle are given in figure 19. The vehicle was free-wheeling and unrestrained just prior to impact.

The speed of the vehicle at impact was 46.1 mi/h (74.2 km/h) and the angle of impact was 20.9 degrees. The vehicle impacted the bridge railing approximately 41.3 ft (12.6 m) from the end. The vehicle began to redirect at 0.054 s. By 0.234 s the vehicle was traveling parallel to the bridge railing at a speed of 38.2 mi/h (61.5 km/h), and at approximately the same time the rear of the vehicle impacted the railing. The vehicle lost contact with the bridge railing at 0.458 s traveling at 35.9 mi/h (57.8 km/h) and 10.9 degrees. The brakes were applied 38 ft (11.6 m) from impact and the vehicle yawed clockwise. The vehicle subsequently came to rest 150 ft (45.7 m) down and 10 ft (3 m) behind the point of impact.

As can be seen in figures 20 through 22, the railing received moderate damage. At post 8 the upper deck bolts connecting the post to the bridge deck were bent and the post was bent back 1.5 in (38 mm) at the bridge deck surface. Post 9 was bent 2.5 in (64 mm), the upper deck bolt on the right side was bent, and the upper deck bolt on the left side pulled through the outer flange. Post 10 was slightly twisted. Maximum lateral deflection was 13.0 in (330 mm) at the top of the thrie-beam between posts 8 and 9. The vehicle was in contact with the bridge railing for 16.3 ft (5.0 m).

The vehicle sustained damage to the right side as shown in figure 23. Maximum crush at the right front corner at bumper height was 6.5 in (165 mm). The right front tire aired out and the rim was bent. The right side window was broken out by the head of the dummy. Also, damage was done to the front bumper, hood, grill, the right front and rear quarter panels, and the right door.

Test Results

Impact speed was 46.1 mi/h (74.2 km/h) and the angle of impact was 20.8 degrees. The speed of the vehicle at time of parallel was 38.2 mi/h (61.5 km/h). The vehicle lost contact with the railing traveling at 35.9 mi/h (57.8 km/h) and 10.9 degrees. Occupant impact velocity was 17.1 ft/s (5.2 m/s) in the longitudinal direction and 11.7 ft/s (3.6 m/s) in the lateral direction. The highest 0.010-s occupant ridedown accelerations were -3.6 g (longitudinal) and 8.8 g (lateral). These data and other pertinent information from the test are summarized in figure 24 and table 3. Sequential photographs are shown in figure 25 and initial and final resting positions of the dummies is shown in figure 26. Vehicular angular

displacements are displayed in figure 27. Vehicular accelerations versus time traces filtered with SAE J211 filters are presented in figures 28 through 34. These data were further analyzed to obtain 0.050-s average accelerations versus time. The maximum 0.050-s averages measured at the center-of-gravity were -3.8 g (longitudinal) and 6.7 g (lateral).

Conclusions

The Oregon side-mounted bridge railing contained the test vehicle with minimal lateral movement of the bridge railing. There was no intrusion into the occupant compartment and no deformation of the compartment. The vehicle remained upright and relatively stable during the collision. The bridge railing smoothly redirected the vehicle and the effective coefficient of friction was considered fair. The occupant risk factors were within the limits recommended in the 1989 AASHTO guide specifications.⁽¹⁾ The vehicle trajectory at loss of contact indicates minimum intrusion into adjacent traffic lanes. See figure 24 and table 3 for more detail.



Figure 16. Vehicle before test 7069-18

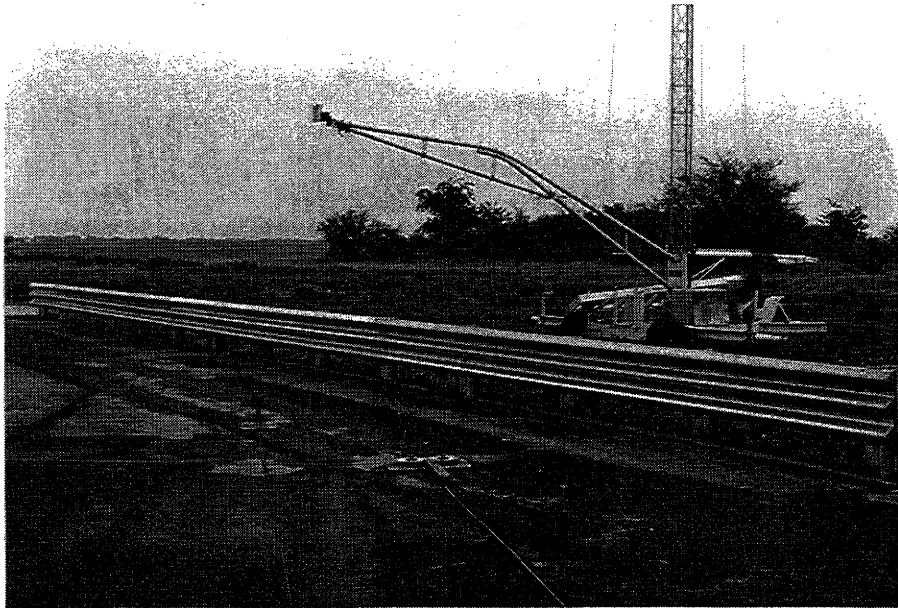

Figure 17. Oregon side-mounted bridge railing (front view) before test 7069-18.

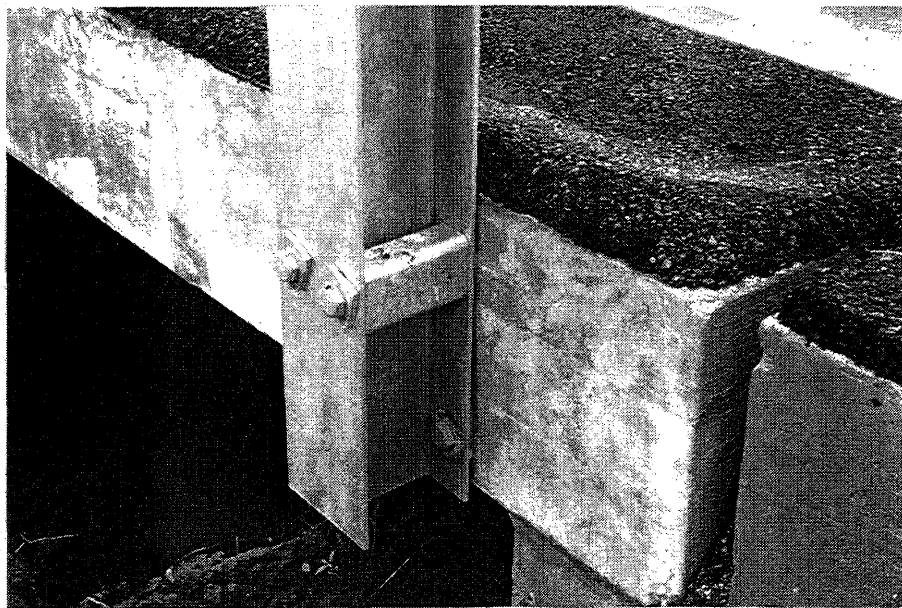
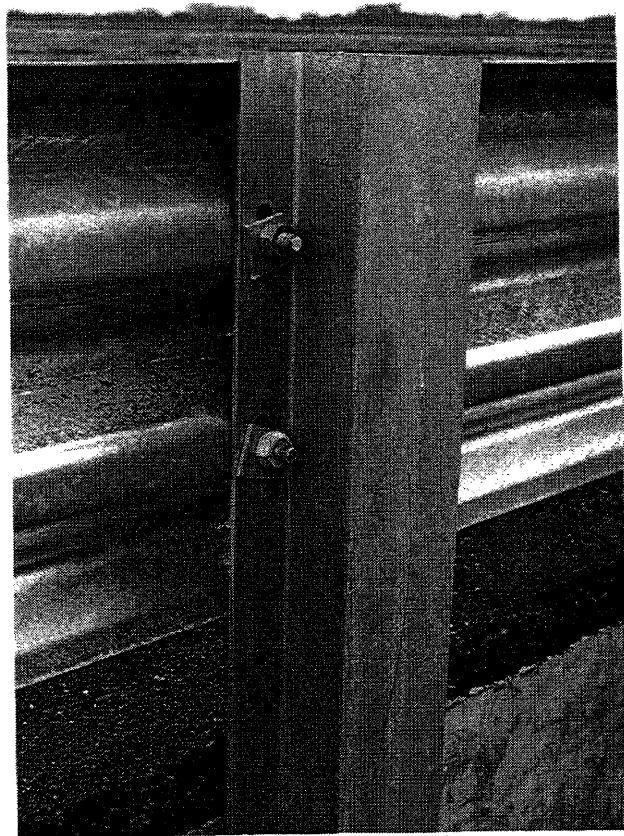

Figure 18. Oregon side-mounted bridge railing (rear view) before test 7069-18.

Date: _____ Test No.: 7069-18 VIN: 1GCF24H0CS118605

Make: Chevrolet Model: Custom Deluxe Year: 1982 Odometer: 104682

Tire Size: 9.50 16.5 LT Ply Rating: 8 Bias Ply: x Belted: Radial:

Tire Condition: good
 fair x
 badly worn

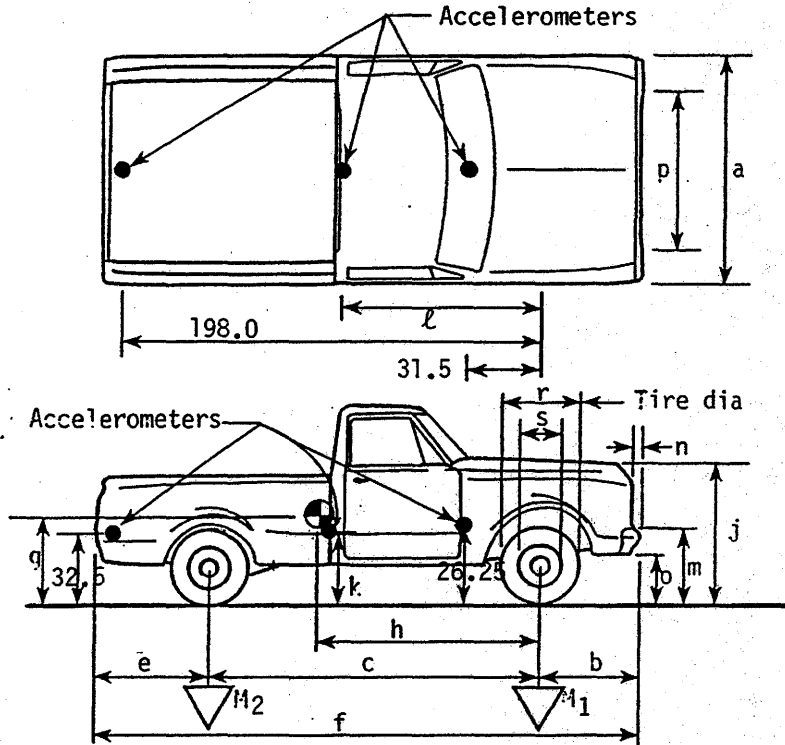

Vehicle Geometry - inches

| | | | |
|---|--------------|----|---------------|
| a | <u>78.75</u> | b | <u>31.5</u> |
| c | <u>131.5</u> | d* | <u>71</u> |
| e | <u>50.25</u> | f | <u>213.25</u> |
| g | <u>--</u> | h | <u>70.9</u> |
| i | <u>----</u> | j | <u>45.75</u> |
| k | <u>31</u> | l | <u>73.5</u> |
| m | <u>27</u> | n | <u>3.5</u> |
| o | <u>17.75</u> | p | <u>66.25</u> |
| r | <u>30</u> | s | <u>17.25</u> |

Engine Type: V-8
 Engine CID: 350

Transmission Type:
Automatic or Manual
FWD or RWD or 4WD

Body Type: Pick-up
 Steering Column Collapse Mechanism:
Behind wheel units
Convolute tube
Cylindrical mesh units
Embedded ball
NOT collapsible
Other energy absorption
Unknown

4-wheel weight for c.g. det. lf 1272 rf 1217 lr 1467 rr 1444

| Mass - pounds | Curb | Test Inertial | Gross Static |
|----------------|-------------|---------------|--------------|
| M ₁ | <u>2449</u> | <u>2489</u> | <u>2687</u> |
| M ₂ | <u>1813</u> | <u>2911</u> | <u>3050</u> |
| M _T | <u>4262</u> | <u>5400</u> | <u>5737</u> |

Note any damage to vehicle prior to test:

Brakes:
 Front: disc x drum
 Rear: disc drum x

*d = overall height of vehicle

1 in = 25.4 mm
 1 lb = .454 kg

Figure 19. Vehicle properties for test 7069-18.

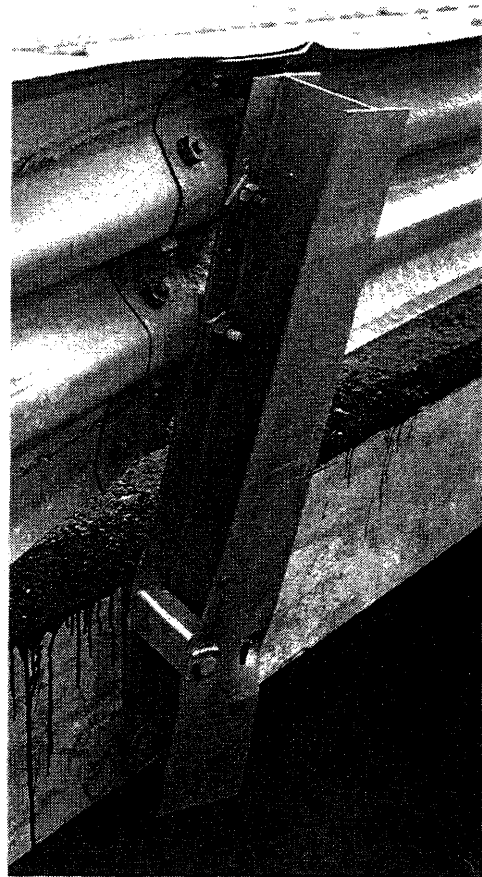
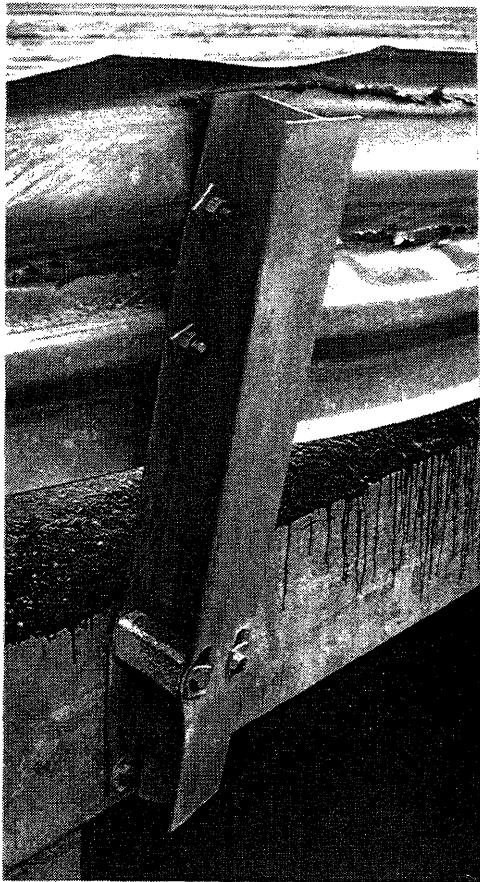
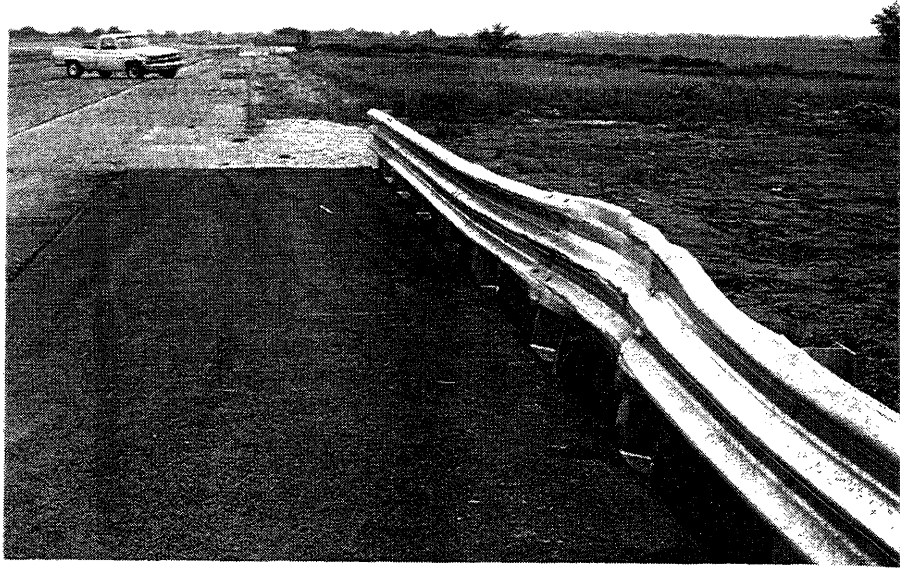

Figure 20. Oregon side-mounted bridge railing after test 7069-18.

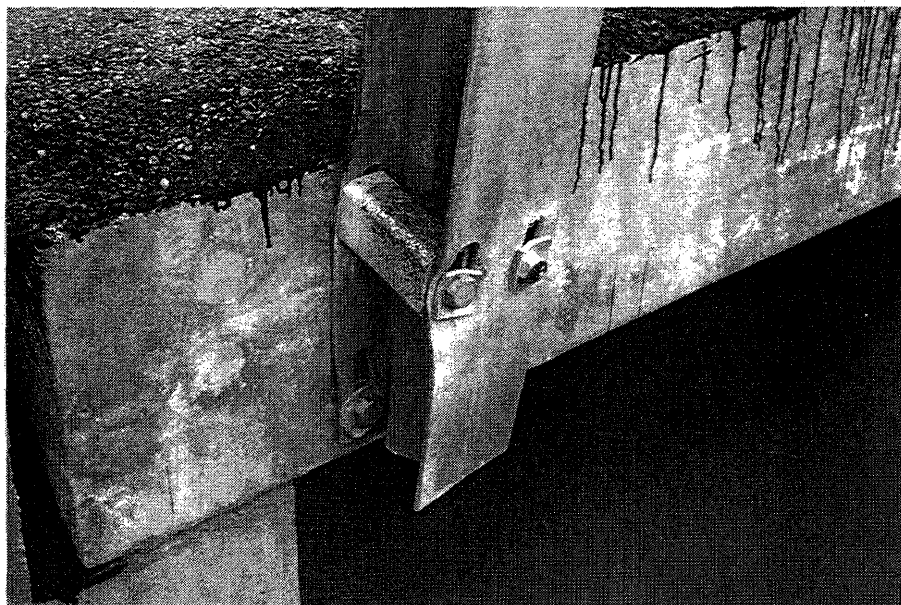

Figure 21. Damage to post 8, test 7069-18.

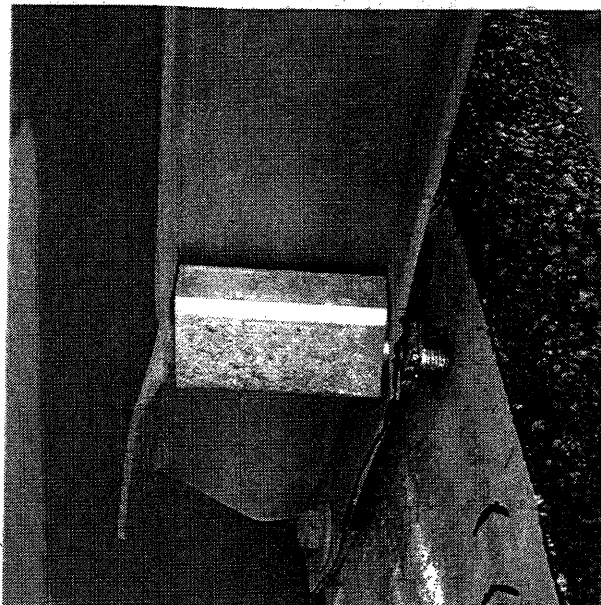
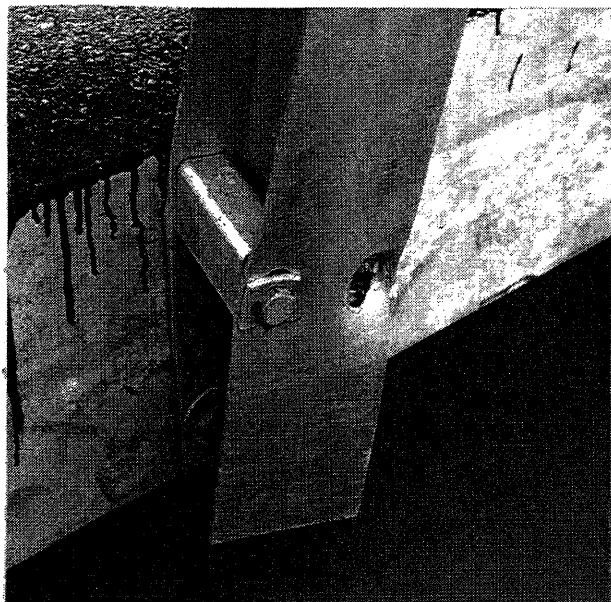

Figure 22. Damage to post 9, test 7069-18.

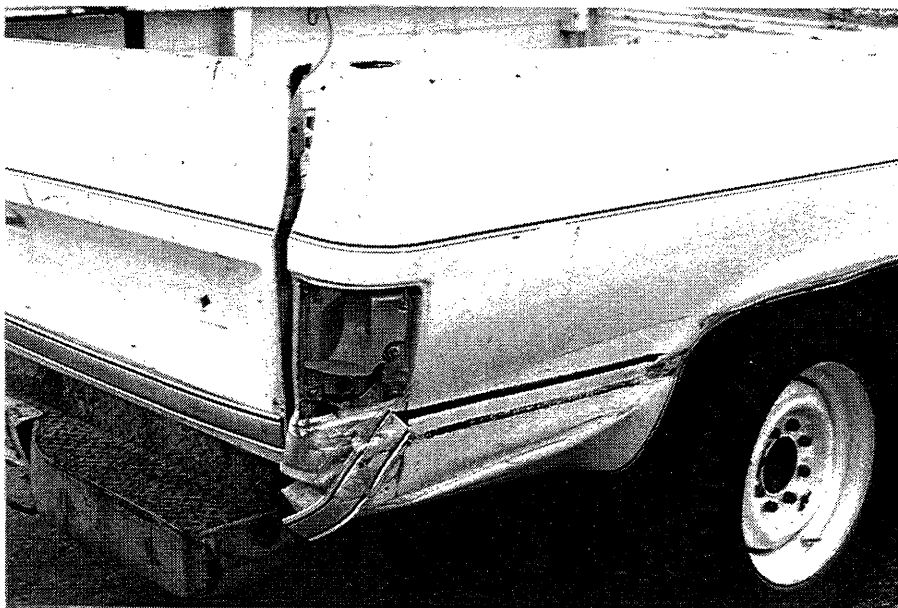
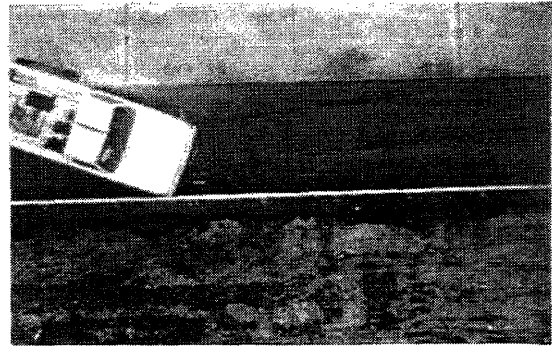

Figure 23. Vehicle after test 7069-18.

Table 3. Evaluation of crash test no. 7069-18.
 {Oregon Side-Mounted Bridge Railing [5,400 lb (2 452 kg)|46.1 mi/h (74.2 km/h)|20.9 degrees]}

| CRITERIA | | TEST RESULTS | | PASS/FAIL* |
|----------|--|--|-------------------|------------|
| A. | Must contain vehicle | Vehicle was contained | | Pass |
| B. | Debris shall not penetrate passenger compartment | No debris penetrated passenger compartment | | Pass |
| C. | Passenger compartment must have essentially no deformation | Acceptable deformation | | Pass |
| D. | Vehicle must remain upright | Vehicle did remain upright | | Pass |
| E. | Must smoothly redirect the vehicle | Vehicle was smoothly redirected | | Pass |
| F. | Effective coefficient of friction | <u>μ</u> | <u>Assessment</u> | |
| | | 0 - .25 | Good | |
| | | .26 - .35 | Fair | |
| | | > .35 | Marginal | |
| | | <u>μ</u> | <u>Assessment</u> | |
| | | .29 | Fair | Pass |
| G. | Shall be less than | | | |
| | <u>Occupant Impact Velocity - ft/s (m/s)</u> | <u>Occupant Impact Velocity - ft/s (m/s)</u> | | |
| | Longitudinal Lateral | Longitudinal | Lateral | Pass |
| | 30 (9.2) 25 (7.6) | 17.1 (5.2) | 11.7 (3.6) | |
| | <u>Occupant Ridedown Accelerations - g's</u> | <u>Occupant Ridedown Accelerations - g's</u> | | |
| | Longitudinal Lateral | Longitudinal | Lateral | Pass |
| | 15 15 | -3.6 | 8.8 | |
| H. | Exit angle shall be less than 12 degrees | Exit angle was 10.9 degrees | | Pass |

* A, B, C, and D are required. E, F, G and H are desired. (See table 2)



0.000 s

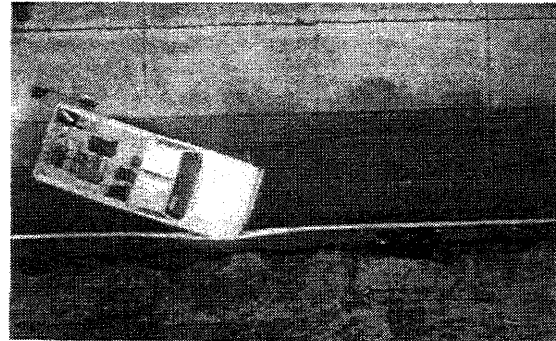

0.062 s

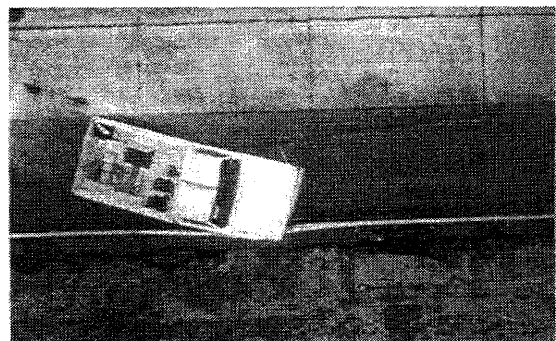

0.123 s

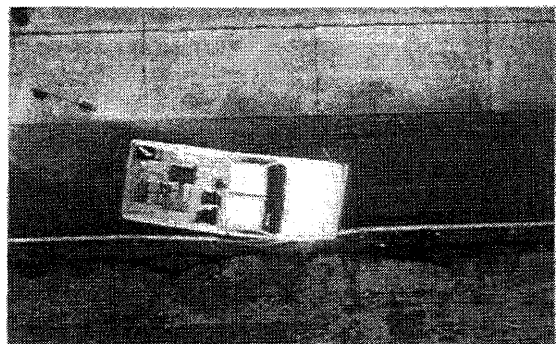
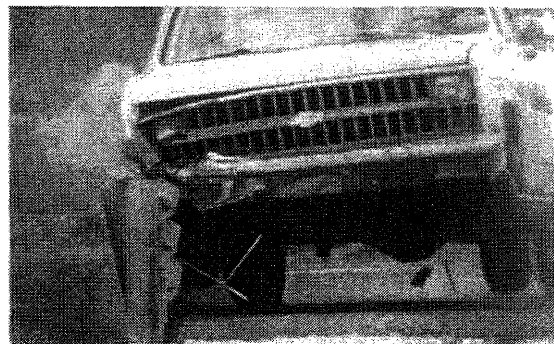

0.185 s

Figure 25. Sequential photographs for test 7069-18.

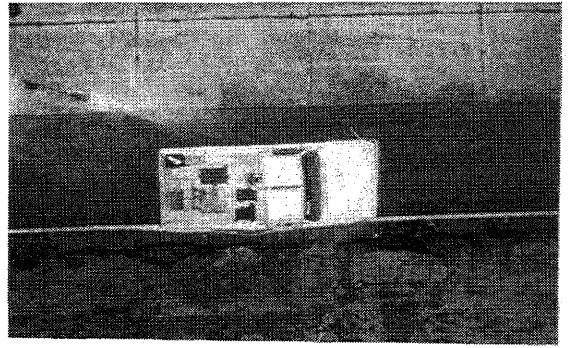
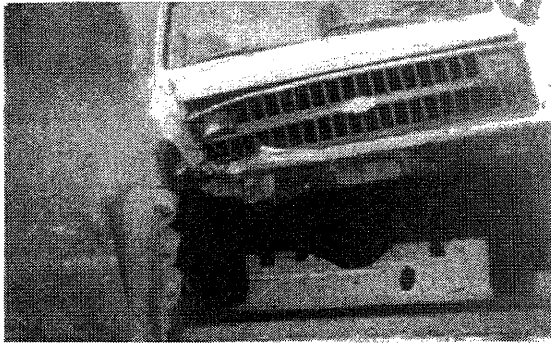

0.246 s

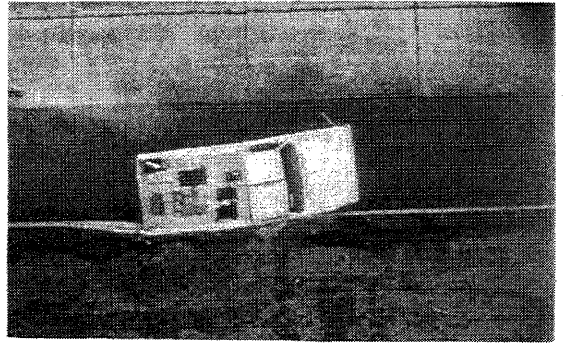
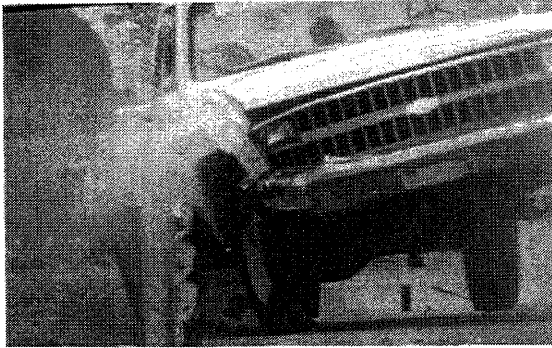

0.308 s

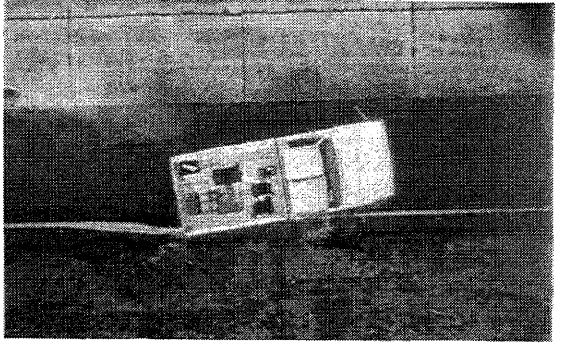
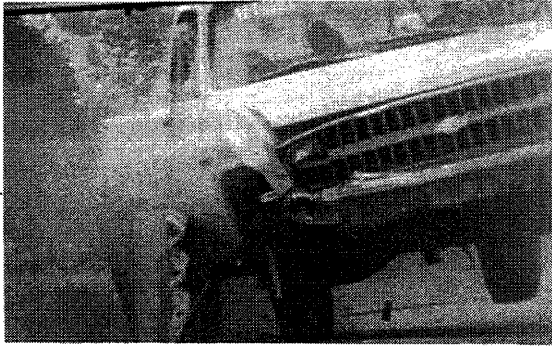

0.369 s

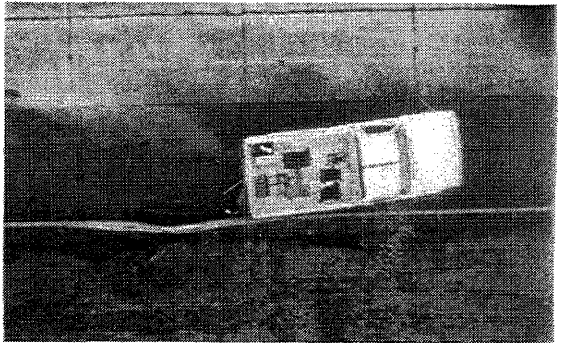
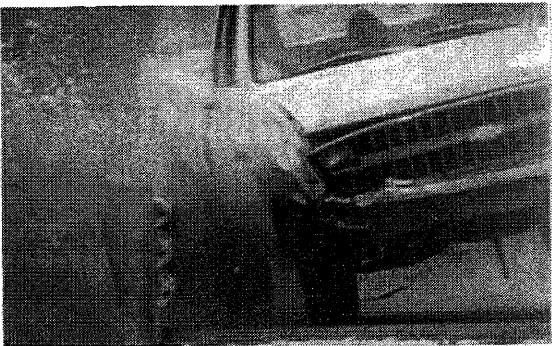

0.480 s

Figure 25. Sequential photographs for test 7069-18 (continued).



Figure 26. Dummies before and after test 7069-18.

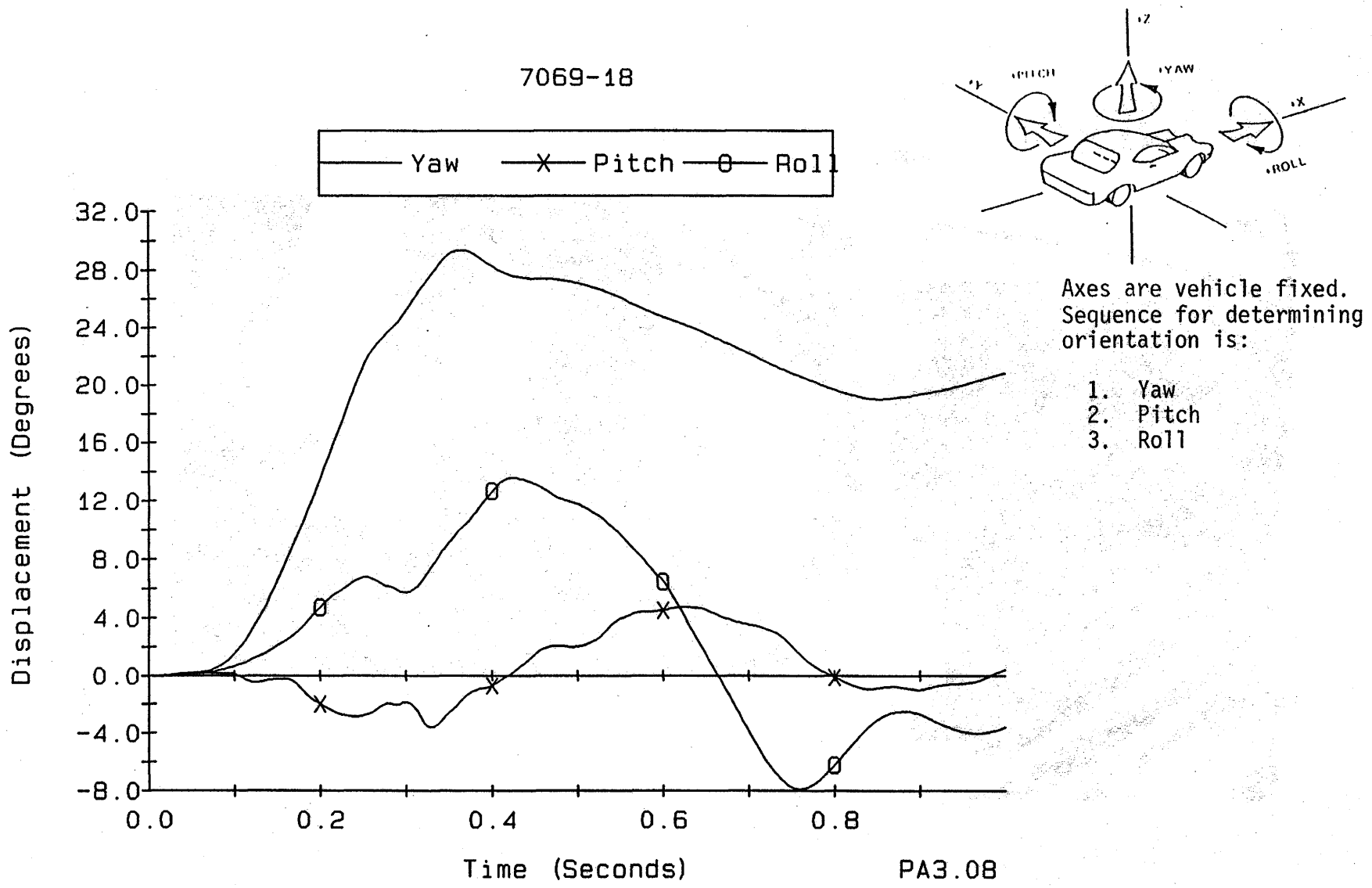

Figure 27. Vehicle angular displacements for test 7069-18.

CRASH TEST 7069-18

Accelerometer near center-of-gravity

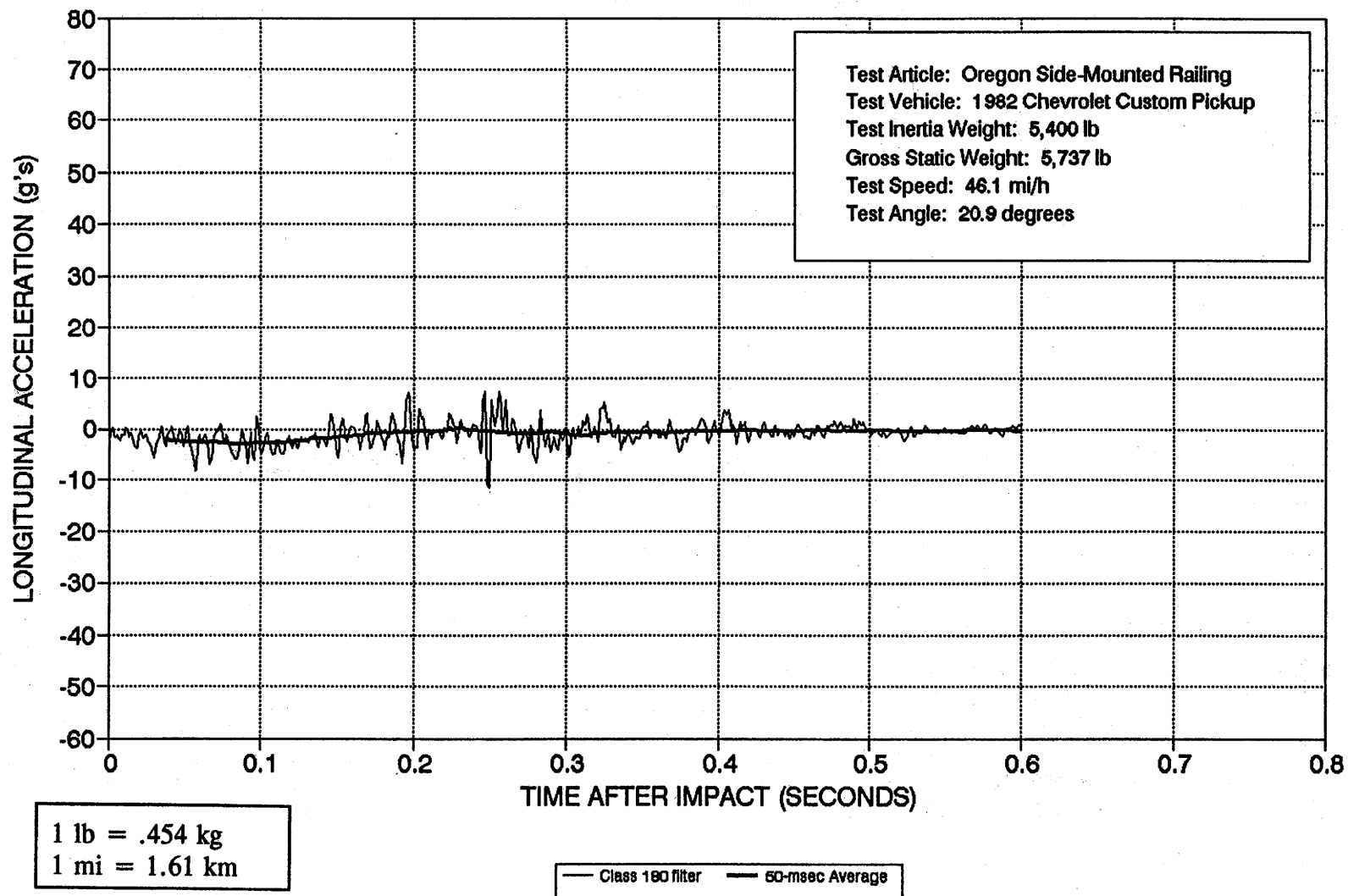

Figure 28. Longitudinal accelerometer trace for test 7069-18 (accelerometer located near center-of-gravity).

CRASH TEST 7069-18

Accelerometer near center-of-gravity

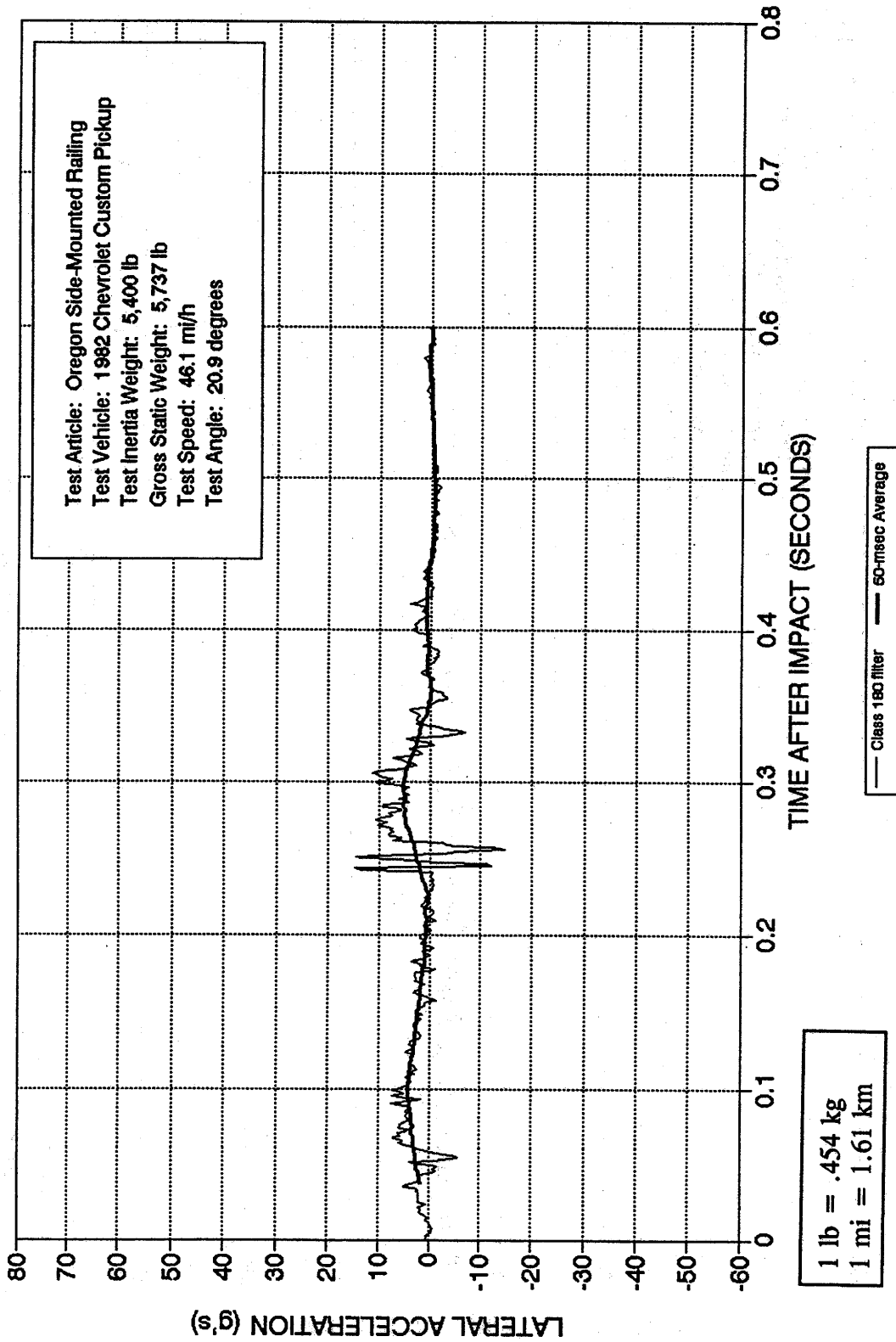

Figure 29. Lateral accelerometer trace for test 7069-18 (accelerometer located near center-of-gravity).

CRASH TEST 7069-18

Accelerometer near center-of-gravity

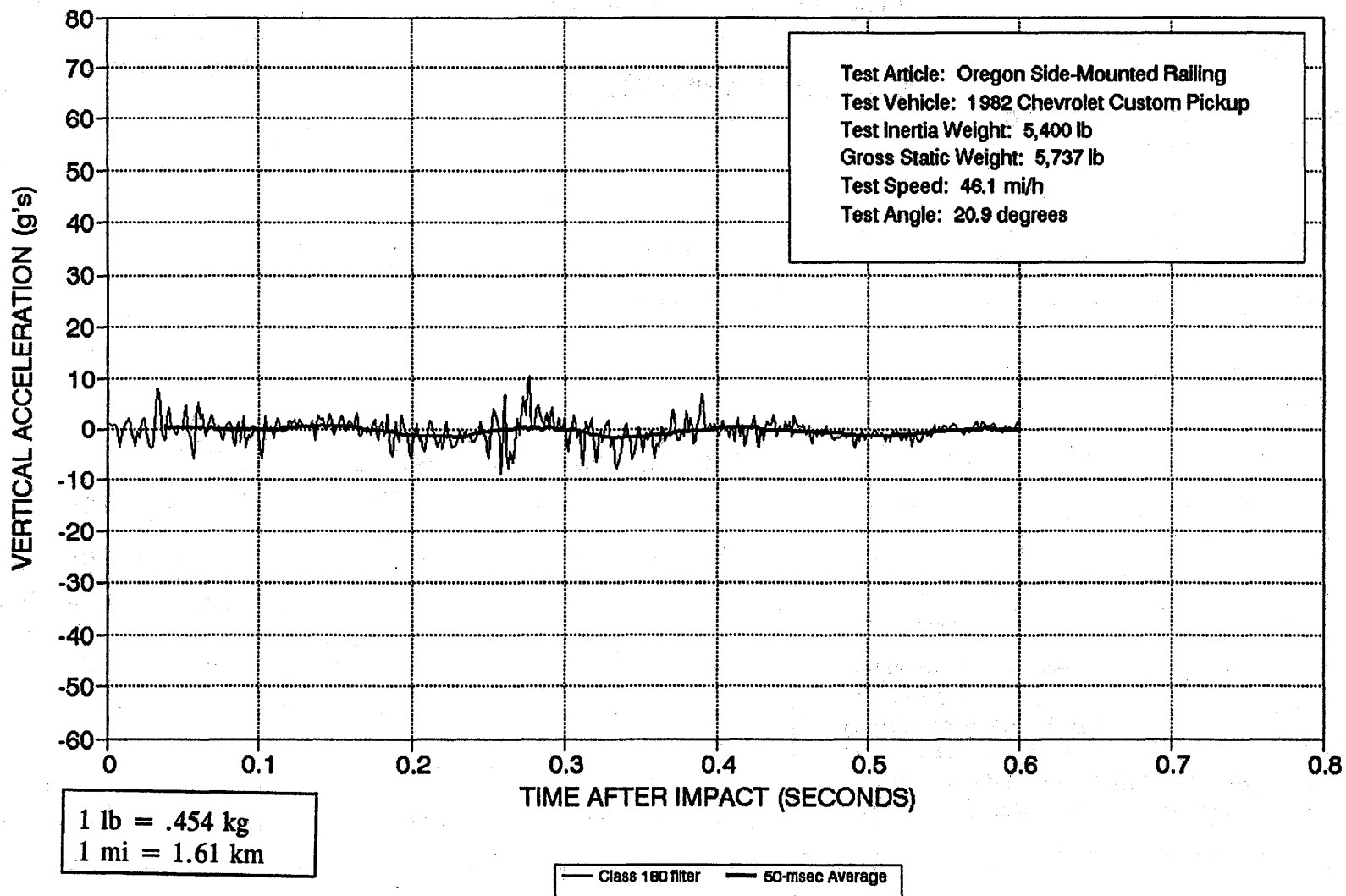

Figure 30. Vertical accelerometer trace for test 7069-18 (accelerometer located near center-or-gravity).

CRASH TEST

Accelerometer at front of vehicle

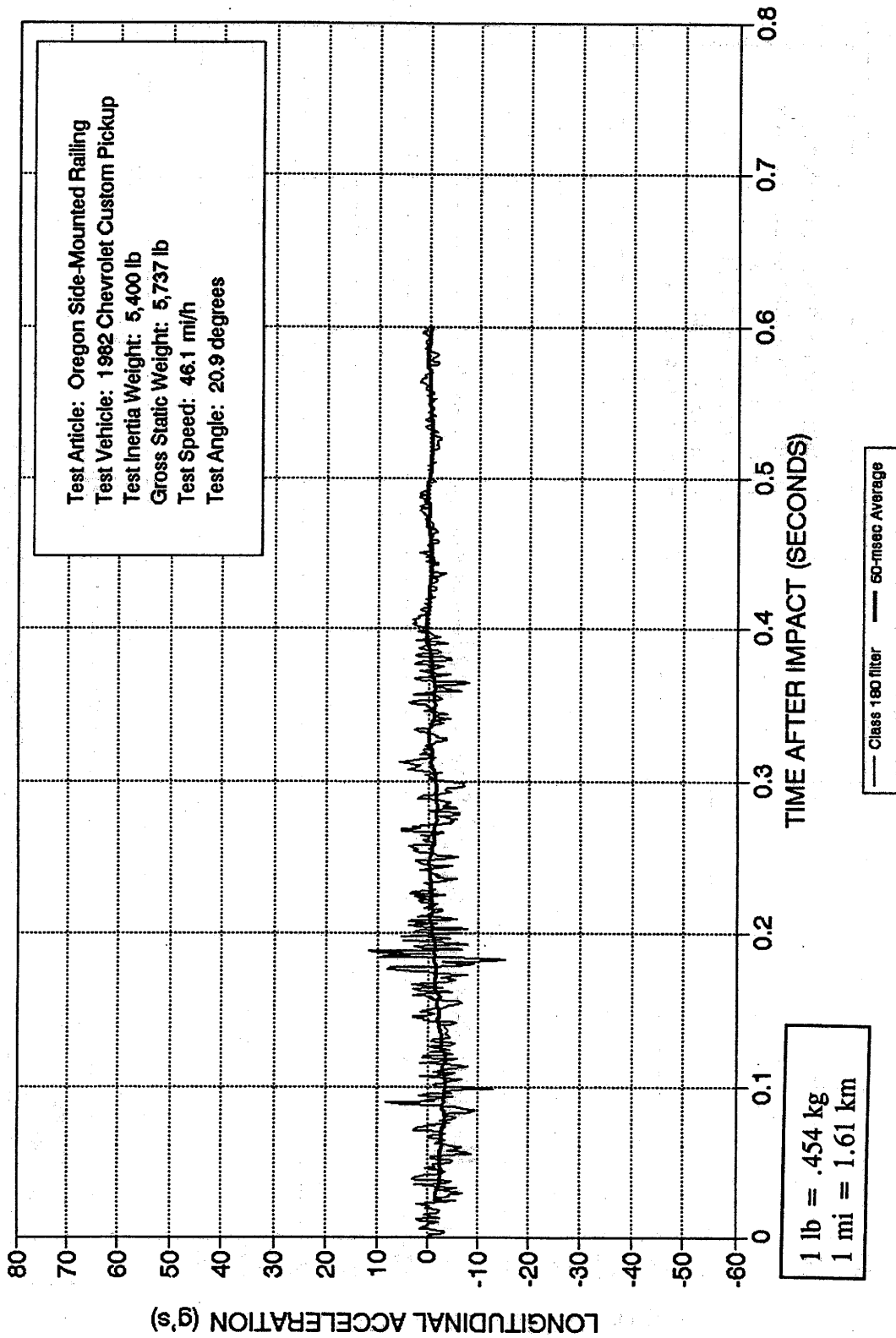

Figure 31. Longitudinal accelerometer trace for test 7069-18
(accelerometer located at front of vehicle).

CRASH TEST

Accelerometer at front of vehicle

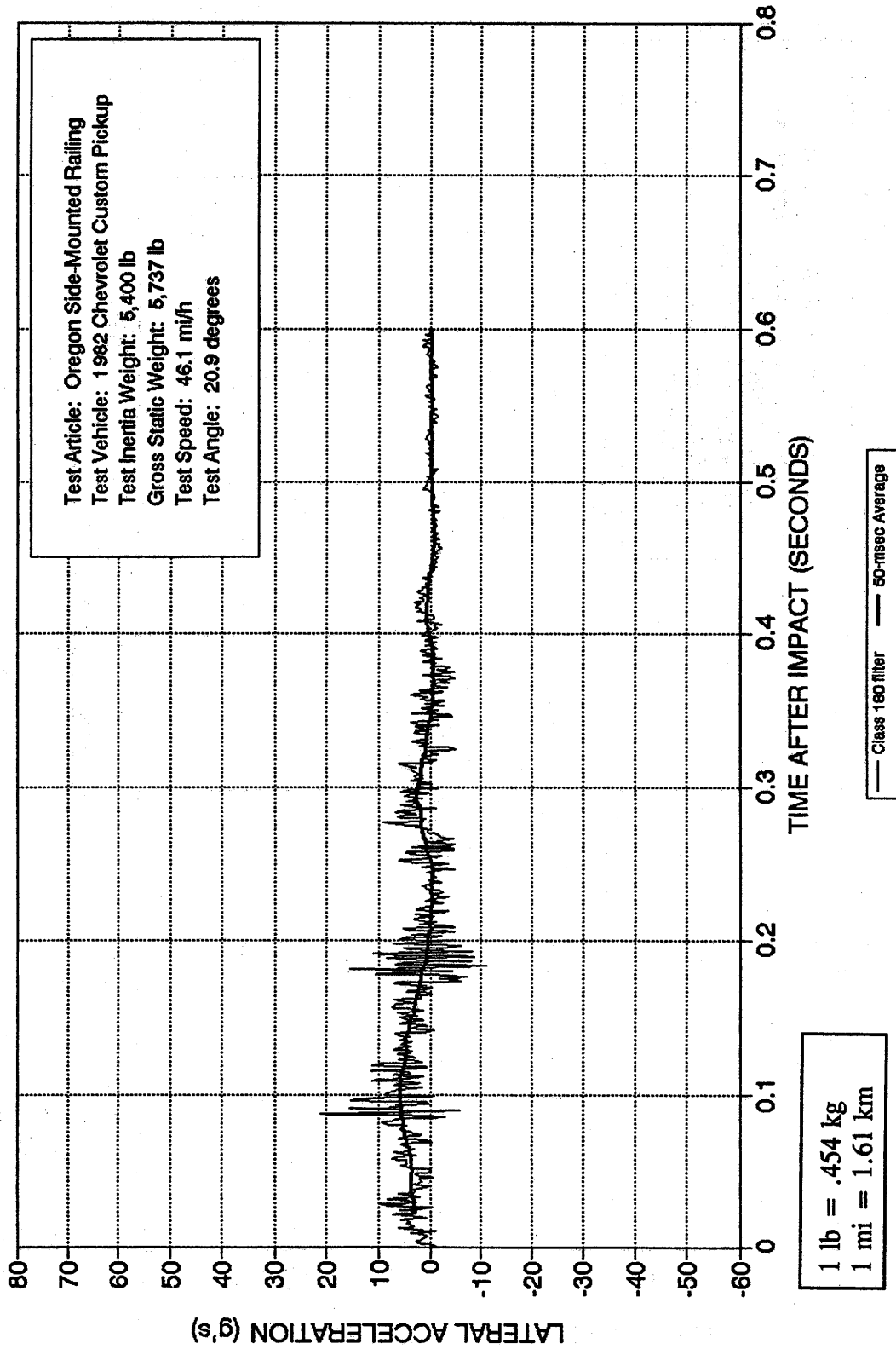

Figure 32. Lateral accelerometer trace for test 7069-18 (accelerometer located at front of vehicle).

CRASH TEST

Accelerometer at rear of vehicle

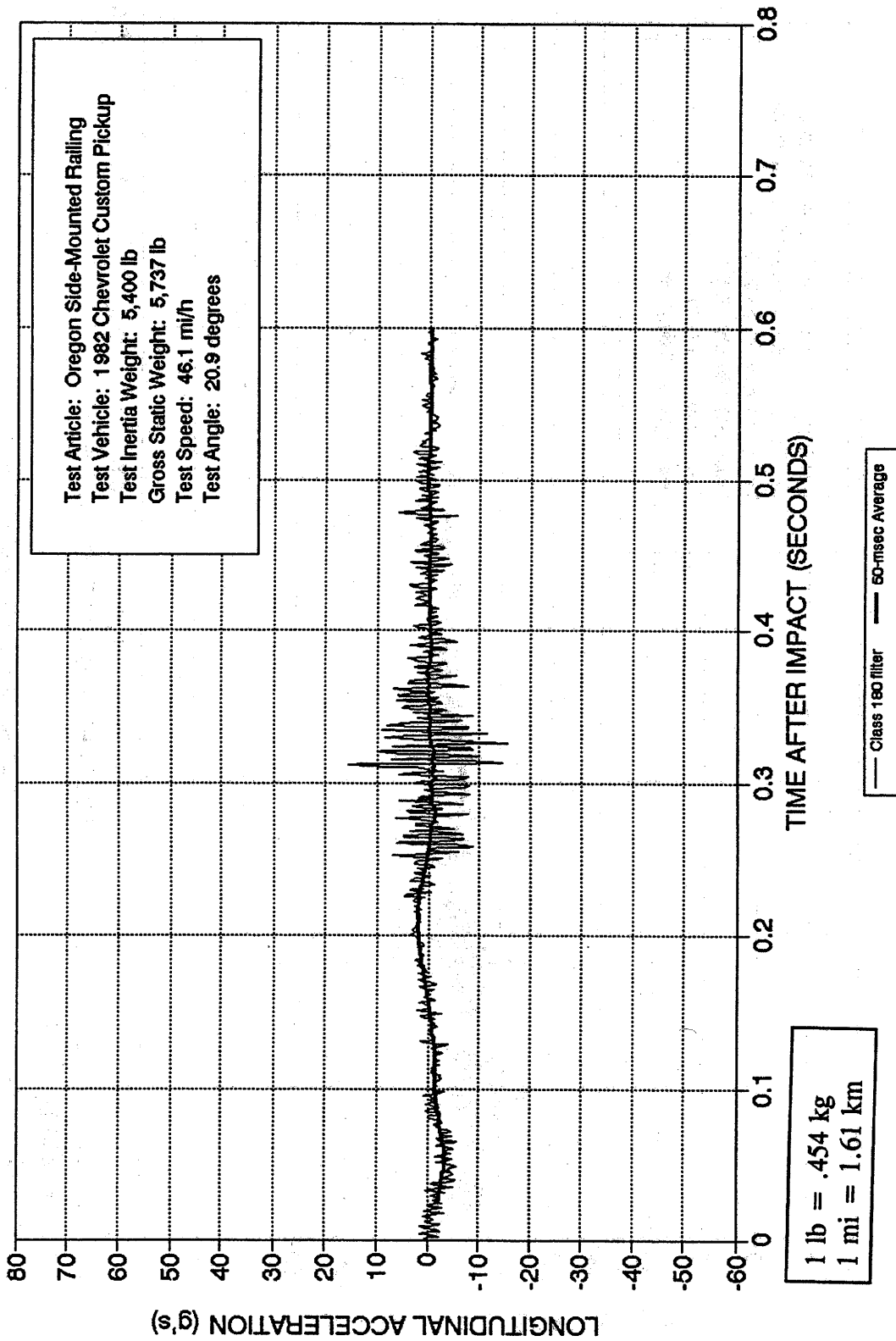

Figure 33. Longitudinal accelerometer trace for test 7069-18 (accelerometer located at rear of vehicle).

CRASH TEST

Accelerometer at rear of vehicle

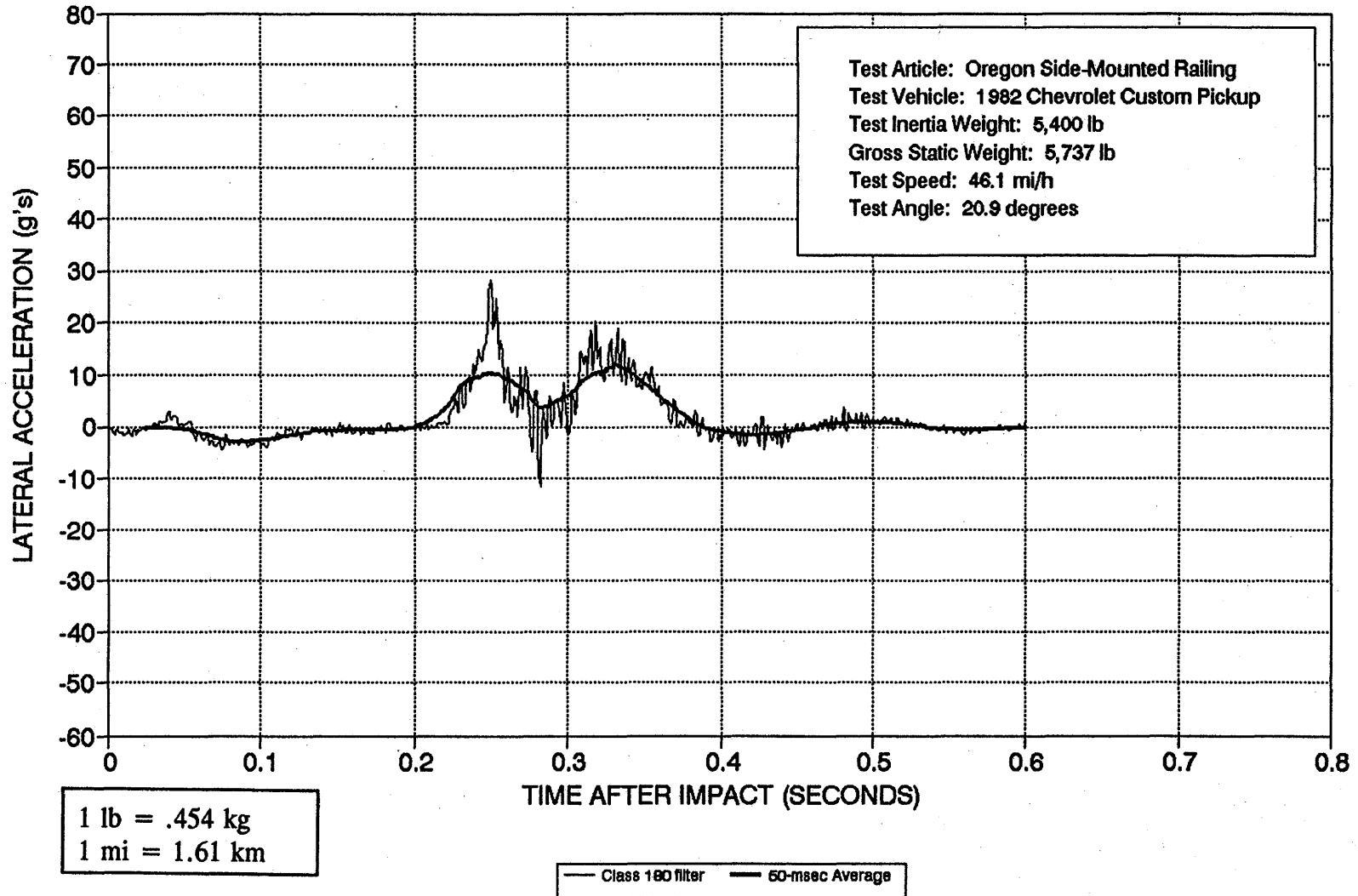

Figure 34. Lateral accelerometer trace for test 7069-18
(accelerometer located at rear of vehicle)

CHAPTER 4. STRENGTH CALCULATIONS

Analysis of the strength of the railing is based on a plastic hinge, ultimate strength failure mechanism.⁽³⁾ Force from a colliding vehicle is idealized as being a uniformly distributed line load extending over 3.5 ft (1.07 m). The load may be applied at any location along the railing. Possible failure mechanisms are illustrated in figure 35. Relative strengths of the rail element and the posts will determine the controlling mechanism. Plastic hinges will form in the rail element and posts to form the controlling mechanism. Values of plastic moments for these elements are needed to compute the strength of the railing. Details of these elements are given in figure 36.

For analysis of the strength of the post, a plastic hinge is assumed at the top anchor bolts and applied force is assumed at midheight of the thrie-beam rail element (figure 36). The gross plastic section modulus for the W6x15 post is 10.8 in^3 ($177 \times 10^3 \text{ mm}^3$). The net plastic section modulus considering the four holes in the flanges is 8.2 in^3 ($134 \times 10^3 \text{ mm}^3$). The plastic moment capacity, M_p , of the post is 295 in-kips (33.3 kN-m). The resulting lateral load resistance of the post would be 12.7 kips (56.5 kN).

Analysis of the strength of the connection of the post to the bridge deck based on the tensile strength of the top anchor bolts shows that the connection has adequate strength to develop a plastic hinge in the post.

The strength of the thrie-beam rail element cannot be analyzed accurately with simple procedures. The cross section has thin elements that will buckle before a plastic hinge forms. Also, flattening of the section in the impact area and at posts usually occurs. Computations of moment capacity of the rail element (figure 37) indicate a moment capacity of about 168 in-kips (19.0 kN-m).

Strengths for the plastic mechanisms for the various possible failure modes are computed using the equations given in figure 35. For a single-span failure mechanism, the strength is 24.9 kips (111 kN); for two spans, it is 25.2 kips (112 kN); for three spans, it is 25.3 kips (113 kN); and for four spans, it is 27.3 kips (121 kN). The mechanism having the lowest value is the controlling mechanism. For this railing, it is the two-span mechanism with a strength of 24.9 kips (111 kN).

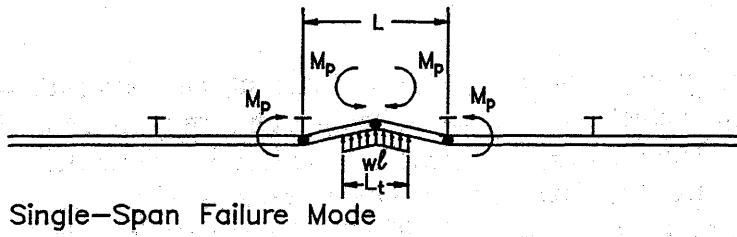

$$wL = \frac{16M_p}{2L - L_t}$$

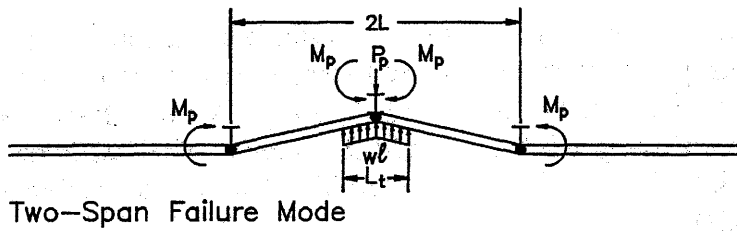

$$wL = \frac{16M_p + 4P_p L}{4L - L_t}$$

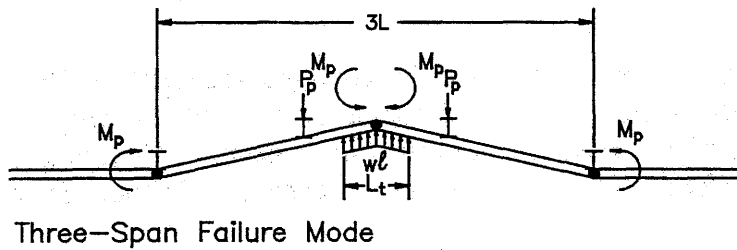

$$wL = \frac{16M_p + 8P_p L}{6L - L_t}$$

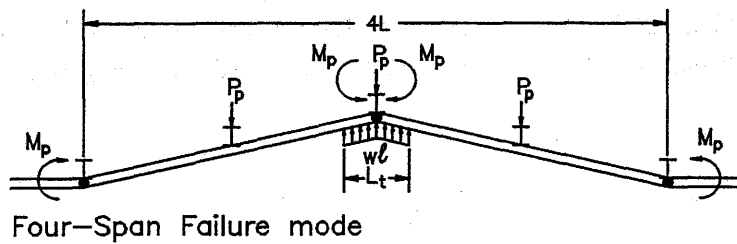

$$wL = \frac{16M_p + 16P_p L}{8L - L_t}$$

Longer mechanisms may also be possible.

Figure 35. Plan view illustrating some possible failure mechanisms.

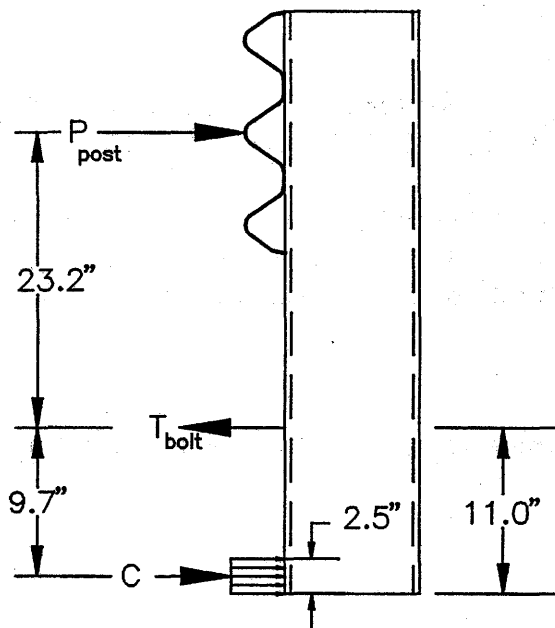
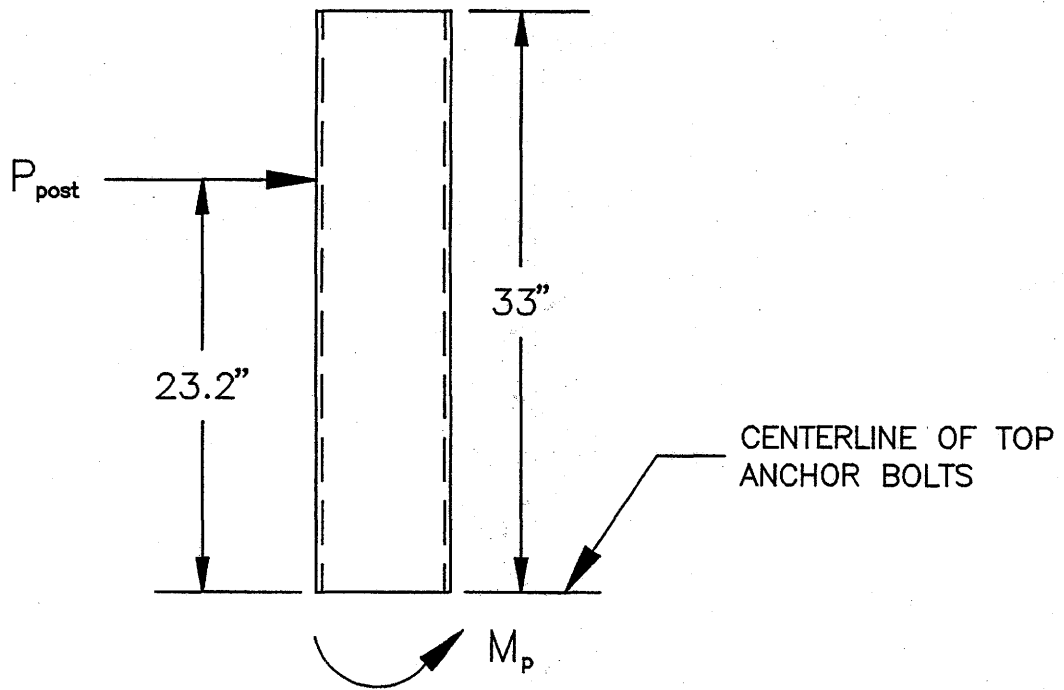
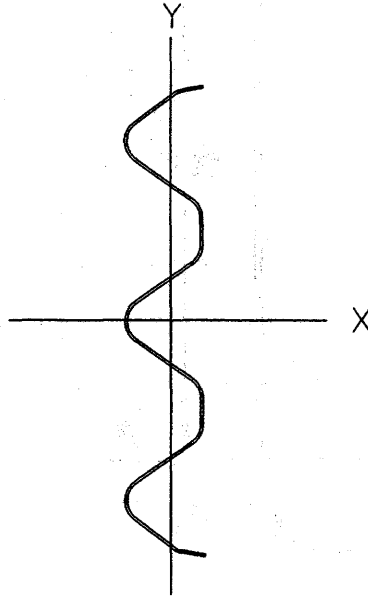

Figure 36. Force diagrams for analysis of post strength.



$$F_y = 50 \text{ ksi (345 kPa)}; F_u = 70 \text{ ksi (482 kPa)}; \text{Thickness} = 10 \text{ gauge}$$

$$S_y = 2.80 \text{ in}^3 (46 \times 10^3 \text{ mm}^3); Z_y = 3.92 \text{ in}^3 (64 \times 10^3 \text{ mm}^3)$$

The moment capacity M_p lies somewhere between $F_y S_y$ and $F_y Z_y$; however, exact capacity is unknown because the cross section changes shape as it begins to form a plastic hinge. Additionally, vehicle impact causes it to lose its original shape. For this analysis, M_p will be taken as the average of $F_y S_y$ and $F_y Z_y$.

$$M_p = \frac{F_y(Z_y + S_y)}{2} = \frac{50(3.92+2.80)}{2} = 168 \text{ k-in (19,000 kN-mm)} = 14.0 \text{ k-ft (19 kN-m)}$$

Figure 37. Analysis of flexural strength of three-beam rail element.

REFERENCES

1. *Guide Specifications For Bridge Railings*, American Association of State Highway and Transportation Officials (AASHTO), Washington, D.C. 1989.
2. "Load & Resistance Factor Design," *Manual of Steel Construction*, American Institute of Steel Construction, Inc., First Edition, 1986.
3. Hirsch, T. J., "Analytical Evaluation of Texas Bridge Rails to Contain Buses and Trucks," Research Report 230-2, Texas Transportation Institute, Texas A&M University, College Station, TX, August 1978.

