

**Intelligent Transportation Systems (ITS)  
Commercial Vehicle Operations (CVO)**

**Project Plan  
for Commercial Vehicle Information Systems  
and Networks (CVISN)  
Electronic Data Interchange (EDI)  
Standards Development and Deployment**

**Version 2.0**

**December 2, 1996**

*Prepared for*

*US Department of Transportation  
Federal Highway Administration  
400 Seventh Street, SW  
Washington, DC 20590*

*Prepared by*



*The Johns Hopkins University  
Applied Physics Laboratory  
Johns Hopkins Road  
Laurel, MD 20723*

## Note

The purpose of this document is to provide information on the planning for the development and deployment of EDI standards for Commercial Vehicle Information Systems and Networks (CVISN). The status, priorities, and schedules for this effort are continually being updated. This version of the plan contains the current set of that information.

If you would like to be added to distribution, please contact:

The Johns Hopkins University  
Applied Physics Laboratory  
Johns Hopkins Road  
Laurel, MD 20723  
Ms. Theresa G. Nester

Phone: (301) 953-6000 extension 8760  
Fax: (301) 953-6 149  
E-Mail: [theresa.nester@jhuapl.edu](mailto:theresa.nester@jhuapl.edu)

For more information, or to request a copy of this document, visit our site on the World Wide Web:

<http://www.jhuapl.edu/cvo/>

## Project Plan for CVISN EDI Standards Development and Deployment

### Table of Contents

<u>Topic</u>	<u>Page</u>
<b>1. Project Description</b> .....	1
1.1 Overview .....	1
1.2 Scope and Approach .....	2
1.3 Assumptions/Constraints .....	<b>6</b>
<b>2. Deliverables</b> .....	7
2.1 Implementation Guide Contents .....	7
2.2 Preliminary TS Use and Feedback .....	8
2.3 Long-Term Implementation Guide Maintenance and User Support .....	9
<b>3. Work Breakdown Structure</b> .....	10
<b>4. Organizations Involved</b> .....	11
<b>5. Schedule</b> .....	16
 <b><u>Appendices:</u></b>	
Appendix A EDI-Related Interface Definitions .....	A-1
Appendix B Development Schedule for CVISN EDI Implementation Guides .....	B-1
Appendix C Flat File Documentation .....	C-1
Appendix D Distribution List .....	D-1

# 1. Project Description

## 1.1 Overview

Under DOT Contract DTFH61-95-C-00098, The Johns Hopkins University Applied Physics Laboratory (JHU/APL) is developing an architecture for commercial vehicle information systems and networks (CVISN) and the Safety and Fitness Electronic Records (SAFER) System. As part of this work, APL will prepare or coordinate the preparation of documentation for the electronic data interchange (EDI) of all safety-related information and credentials associated with commercial vehicle (CV) operations. This document is the project plan for that effort. It is being updated approximately three times a year, following each regularly scheduled meeting of the ANSI Accredited Standards Committee (ASC) x1.2.

APL is collaborating with other organizations to produce these EDI standards. Figure 1-1 summarizes the three categories of transaction sets (TS) and associated documentation to be prepared. The requirements for CV-related EDI data exchanges to be standardized are defined in **JHU/APL** POR-96-6986, CVISN EDI Interface Requirements. EDI data flows are defined in that document to the data element level.

**Figure 1-1  
Strategy for Completion of CVISN EDI Standards**

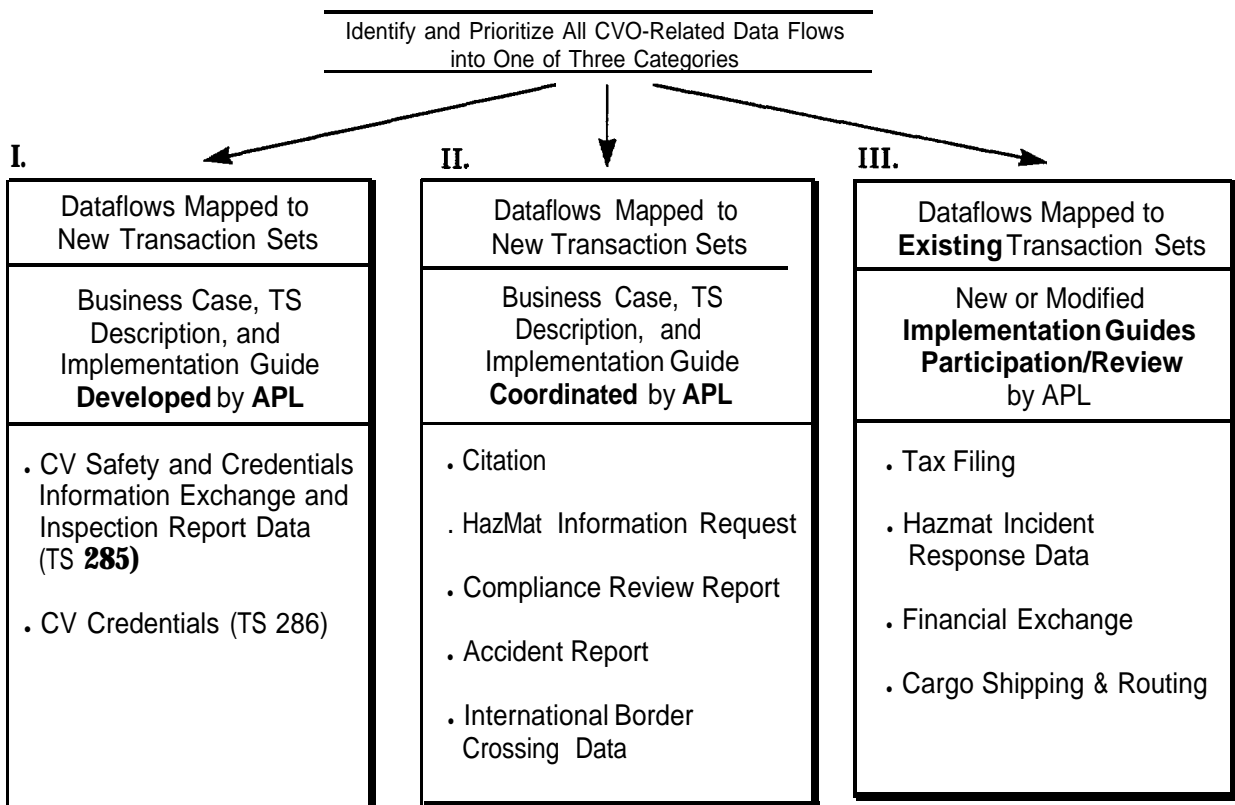

CV-related EDI data flows are identified and defined in Appendix A. Each data flow in the appendix corresponds to an example message in the EDI implementation guides being developed by JHU/APL.

Documentation will be consistent in scope and format to other transaction set documentation adopted by the EDI community. The data segments in the transaction sets will accommodate data defined in existing paper forms. It is acknowledged that all states currently do not use the same or similar forms or even the same data elements for CVO credentials. The transaction sets will include a representative superset of data elements and data segments defined in existing paper forms used by carriers and state agencies; documentation will provide mapping information and example transactions.

## 1.2 Scope and Approach

The EDI requirements defined in the JHU/APL CVISN EDI Interface Requirements Document will be used to identify existing EDI transaction sets that can be used to satisfy CVISN needs. Where no such standards exist, the requirements will be used to develop and gain ANSI approval for new transaction sets. The process for development of CVISN EDI X12 standards is outlined in Figure 1-2. This plan covers the steps highlighted.

**Figure 1-2  
CVISN EDI Standards Development Process**

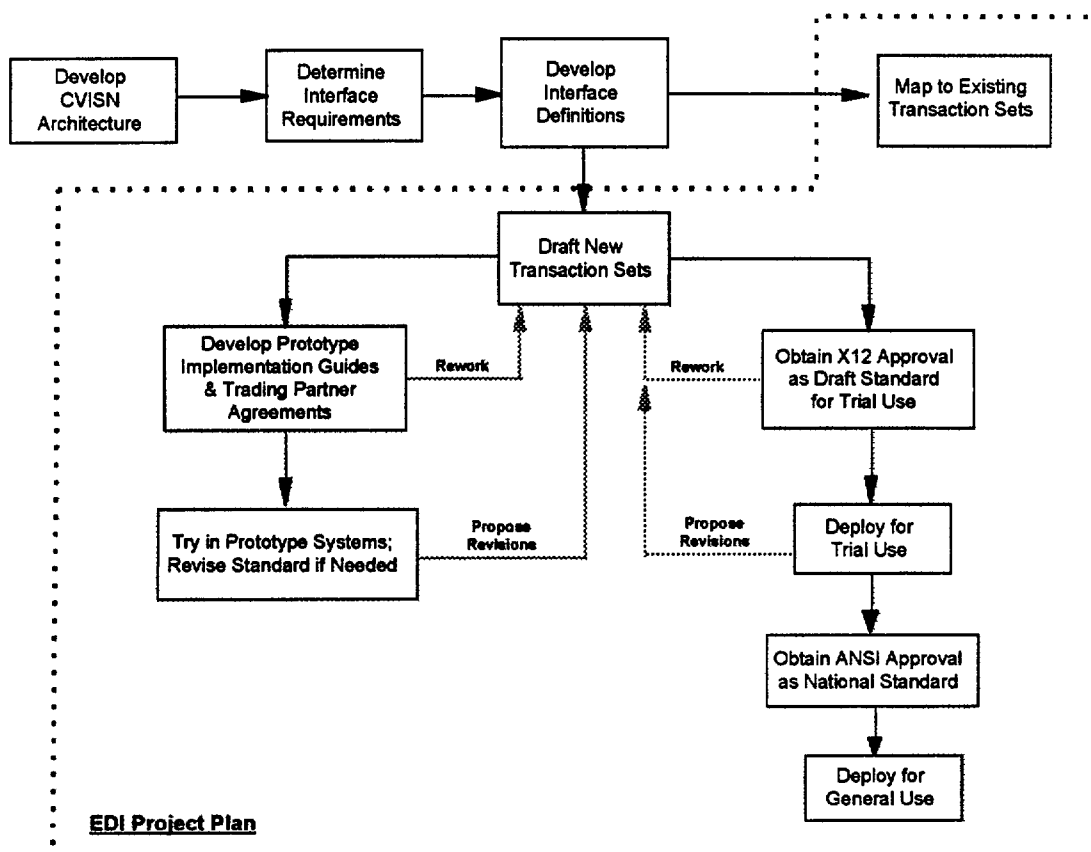

## 1.2 Scope and Approach (Continued)

Interface and migration to EDI for Administration, Commerce, and Transport (EDIFACT) standards is a long-term goal, beyond the scope of this version of the document. There are several separate layers of approval required for EDIFACT standards. EDIFACT plans will be added in future issues of this document.

The EDI X12 transaction sets and documentation described in this plan are summarized in the following table.

Table 1-1  
CVO-Related Transaction Sets

Transaction Set Subject	Responsible Organization	Other Potential Information Sources Users
Description	Implementation Guide Due	Status/Remarks
<b>TS 285 – Safety and Credentials Information Exchange</b>	JHU/APL	SAFER System
- Request and send snapshots and reports	12/1/96	TS 285 approved by X12 ballot; Draft standard for Trial Use
<b>TS 286 – Commercial Vehicle Credentials</b>		TS 286 in X12 review process; ballot in February 1997
- Submit electronic application for credentials; - Return credential data to applicants; - Exchange application data among jurisdictions		
IRP Credential -	10/1/96	States, carriers, 1-Stops, AAMVA, IRP Inc, RSIS
IRP Interstate -	12/1/96	States, carriers, IRS Inc. RSIS
IFTA Credential -	2/1/97	States, carriers, 1-Stops, IFTA Inc, NY Regional Proc Ctr RSIS
Oversize/Overweight Credential -	4/1/97	States, carriers, MW 1-Stop/AAMVA, RSIS
SSRS/UCR Credential -	6/1/97	States, carriers, 1-Stops
HazMat Credential -	TBD	States, carriers, RSIS
HazMat Interstate -	TBD	States, carriers, RSIS
FHVUT Credential -	TBD	States, carriers, SW 1-Stop, IRS
Title Credential -	TBD	States, carriers, AAMVAnet
SSRS/UCR Interstate -	TBD	States, carriers
<b>TS xxx – Safety Data Reports</b>	JHU/APL	Planned transaction set for safety-related issues
Compliance Review Report	TBD	Send review results, OOS notifications, and carrier warnings/notifications
Inspection Report Data	TBD	Inspection results, OOS notifications, and carrier warnings/notifications
Citation	TBD	Used to transmit notice of legal violations; US Courts
Accident Report	TBD	Used to transmit data on accidents
HazMat Information Request	TBD	Request information on HazMat shipments
<b>TS 813 – Quarterly Fuel Tax Filing</b>	FTA, BSWG	
File fuel tax returns with taxing authorities	TBD	X12-approved standard
<b>TS 826 – Interstate Fuel Tax</b>		
Send data on fuel tax filings among jurisdictions	TBD	X12-approved standard
<b>EDIFACT – Int'l Border Clearance Data</b>	NATAP	
Import/Export and related data	TBD	Includes trade, customs, and safety data
<b>Financial Exchange Transaction Sets</b>		
<b>TS 210, 810, 858 – Invoice</b>	Complete	X12-approved standards
<b>TS 812, 820, 823 – Payment</b>	Complete	X12-approved standards
<b>TS 821, 827 – Report</b>	Complete	X12-approved standards
<b>TS 129, 213, 838 – Rates</b>	Complete	X12-approved standards
<b>Cargo Shipping &amp; Routing Transaction Sets</b>		
<b>TS 120, 204, 213, 214, 217, 250, 362, 440, 856, 858, 882</b>	Complete	X12-approved standards

## 1.2 Scope and Approach (Continued)

The American National Standards Institute (ANSI) Accredited Standards Committee (ASC) is responsible for the approval and maintenance of all X12 format EDI transaction sets and their associated standards. The standardization status for the new CV-related EDI transaction sets is presented in Table 1-2.

Table 1-2  
Approval Status of CV-Related EDI X12 Standards

Activity/Event	TS 285	TS 286	TS xxx
	Safety and Credentials Information Exchange	Commercial Vehicle Credentials	Safety Data Reports
Requirements/Design Complete	Jan 95	Apr 96	(Apr 97)
Proposal Formally Submitted to X12 ASC	Feb 95	May 96	(May 97)
Draft Formally Presented to X12 ASC	Oct 95	Oct 96	(Oct 97)
TS to Ballot	Jun 96	(Feb 97)	(Feb 98)
Approved as Draft Standard for Trial Use	Oct 96	(Jun 97)	(Jun 98)
Accepted as X12 Standard/Production	(Oct 97)	(Jun 98)	(Jun 99)

(MMM YY) = Date Anticipated or Scheduled

### 1.2.1 New Transaction Sets – Documentation Led by APL

The near-term effort will focus on documentation for the Category I transaction sets:

- CV Safety & Credentials Information Exchange (TS 285)
- CV Credentials Transaction Set (TS 286)

The priority for the transaction sets and credential types to be addressed will be consistent with general interest in the ITS/CVO user community, as follows:

1. International Registration Plan (IRP)/Registration Credentials (TS 286)
2. CV Safety & Credentials Information Exchange (TS 285) – which includes Commercial Vehicle Information System (CVIS) interfaces
3. IRP Interstate Transactions (TS 286)
4. International Fuel Tax Agreement (IFTA)/Fuel Tax Credentials (TS 286)
5. Oversize/Overweight (OS/OW) Permits (TS 286)
6. Single State Registration System (SSRS)/Unified Carrier Register (UCR) Operating Authority Credentials (TS 286)
7. Title Credential Transactions (TS 286)
8. Hazardous Materials (HazMat) Permits/Registration (TS 286)
9. SSRS/UCR Interstate (TS 286)

## 1.2 Scope and Approach (Continued)

The Category I transaction sets (TS 285 and TS 286) will support:

- Mainline screening and checks/inspections at roadside sites
- Data assembly and database maintenance for CVO credentials and safety data
- Application, delivery, status, and state exchange of all credential information (carrier to state, state to carrier, and state to state)
- Screening of applicants for credentials
- Industry self-checks
- Interface with the Safety and Fitness Electronic Records (SAFER) System

TS 285 has been approved by the ANSI ASC X12 Committee as a draft standard for trial use. TS 286 has been submitted to the committee, and approval for ballot is anticipated in February 1997. The schedule for all implementation guide deliverables associated with the above transaction sets and credential types is given in Section 5.0. APL will work with RS Information Systems (RSIS), the prototype states, the One-Stop projects, the X-12 Standards Committee, the American Association of Motor Vehicle Administrators (AAMVA), and other organizations to complete the required documentation for the above transaction sets.

In addition, APL will supply AAMVA with initial draft versions of the implementation guides as they become available. Early iterations with AAMVA and other state/user group representatives on this initial material will help ensure all user requirements are incorporated in the transaction set guidelines. This process is more fully described in Section 2.2.

### 1.2.2 New Transaction Sets - Documentation Coordinated by APL

APL will coordinate the preparation of implementation guides for the following Category II EDI transaction sets:

- Citation
- HazMat Information Request
- Compliance Review Report
- Accident Report
- International Border Crossing Data

APL will work with RS Information Systems, the Border Crossing projects, the X12 Standards Committee, and other FHWA contractors to complete a comprehensive set of required documentation for each of the above transaction sets. Other organizations may also directly supply complete deliverables, or input subsets/reviews, as coordinated. In some cases, the documentation "coordination" process performed by APL may mean simply including a copy of a contractor's documentation in the set of comprehensive CVISN material. The organizations to be contacted are identified in Section 4.



## 1.2 Scope and Approach (Continued)

### 1.2.3 Existing Transaction Sets - Implementation Guided Involving APL Participation

As necessary, APL will also participate in the preparation of implementation guide documentation for the following Category III EDI transaction sets:

- Tax Filing
- HazMat Incident Response Data
- Financial Exchange
- Cargo Shipping and Routing

The organizations to be contacted are identified in Section 4.

## 1.3 Assumptions/Constraints

Key assumptions and known limitations include:

- Carriers and states will continue to transition from paper to electronic transactions. They will continue to express interest and requirements for EDI systems related to CV safety, registration, operating authority, taxes, and clearance information. These stakeholders will participate in the definition and review of the EDI standards.
- The organizations listed in Section 4 will work with APL to cooperatively support the development of the transaction set documentation.
- Review and technical feedback on all draft documentation will be completed in a timely manner.

## 2. Deliverables

### 2.1 Implementation Guide Contents

This section of the plan specifies the contents of Implementation Guides for EDI-related interfaces. The purpose of the EDI Implementation Guides is to provide guidance and reference information to public and private agencies to implement and maintain one or more EDI-related connections. The contents of each implementation guide are based on the topics suggested in the ASC X12 EDI Implementation Reference Manual Guidelines. The primary audience for each implementation guide is an experienced EDI programmer, tasked with implementing a transaction set message system.

The implementation guides will use the following outline:

<b>1.0 Introduction</b>	
.	Purpose
.	Scope
•	Associated Transaction Sets
•	Responsible Organizations
<b>2.0 Business Case and Other Considerations</b>	
•	Business Case - TS purpose, applications, operational environment, interfaces
•	Timing of Transactions
0	Security
•	Recovery Procedures
•	Legal Considerations
<b>3.0 Maintenance Support</b>	
•	Maintaining Guidelines
•	Maintaining X12 Standards
•	Version/Release Timing
<b>4.0 References</b>	
•	General EDI
•	Hardware and Communications
•	ITS/CVO and Credential Transaction
<b>5.0 Transaction Set Table</b>	
•	Transaction Set Table
•	Change History
<b>6.0 Transaction Set Segment Usage Guide</b>	
•	Segment characteristics, identification of data elements used, and usage notes
<b>7.0 Example Transactions</b>	
•	Annotated, representative transactions per credential type
<b>Appendix A - Transaction Flow</b>	- Transaction sequence data flows
<b>Appendix B - Validation Checks</b>	- A set of rules for checking transaction set examples
<b>Appendix C - Example Data Values</b>	- Actual data values of carrier/driver/vehicle information
<b>Appendix D - State Variations</b>	- State-specific implementation details
<b>Appendix E - Code Table References</b>	- EDI TS code table references

## 2.2 Preliminary TS Use and Feedback

Preliminary, unofficial transaction sets will be drafted and used for:

- Testing
- State Prototypes
- General User Interest

Draft sections of EDI implementation guides will be released to interested users for early feedback and reference. Presentations to the ANSI ASC, request for ballot, and official approval as an X12 standard will proceed in parallel to prototype testing.

In addition, APL and AAMVA will follow a four-step process for progressively involving stakeholders with proposed transaction set usage as a means of receiving early user feedback on the usefulness of transaction sets and examples.

1. AAMVA will review and informally comment on draft sections of the EDI implementation guides.
  2. AAMVA will convene a meeting or conference telephone call to include AAMVA, APL, and two to four critical state representatives to review the revised message sets resulting from step one. The resulting message sets will be the basis for the package that is briefed at the next ASC trimester meeting.
  3. At some later date, perhaps in conjunction with an existing meeting, the message sets will be presented to a larger group of state representatives.
  4. At some later date, and in an appropriate forum, a “Motor Carriers Information Systems” Conference will be convened. The conference will cover general implementation issues, and will be open to all interested stakeholders.
-

### 2.3 Long-Term Implementation Guide Maintenance and User Support

Long-term maintenance of the implementation guides for user “production support” is needed for:

- . Uniformity
  - Point of contact for user feedback, complaints, suggestions, etc.
  - Maintaining and promulgating changes to the standard
  - Documentation and tracking of state-unique uses of the TS; information management

Many existing organizations are well-suited to maintain the implementation guides identified in this plan, FHWA and APL will contact these organizations to solicit their interest in this task. Tentative assignments are proposed in the following table.

Table 2-1  
Proposed Organizations to Maintain EDI Implementation Guides

Implementation Guide	Organization
TS 285 - Safety and Credentials Information Exchange	To be supplied
TS 286 - IRP Credentials	IRP, Inc.
TS 286 - IRP Interstate	IRP, Inc.
TS 286 - IFTA Credentials	IFTA, Inc.
TS 286 - Oversize/Overweight Credentials	To be supplied
TS 286 - SSRS/URC Credentials	To be supplied
TS 286 - SSRS/URC Interstate	To be supplied
TS 286 - Title Credentials	To be supplied
TS 286 - Hazardous Materials Permits	To be supplied
TS xxx - Compliance Review Report	To be supplied
TS xxx - Inspection Report Data	To be supplied
TS xxx - Citation	To be supplied
TS xxx - Accident Report	To be supplied
TS xxx - HazMat Information Request	To be supplied

### 3. Work Breakdown Structure

The work breakdown structure (WBS) for this project is configured around documentation. The WBS is shown in the following diagram.

**Figure 3-1  
Work Breakdown Structure  
for CVISN EDI Standards Development**

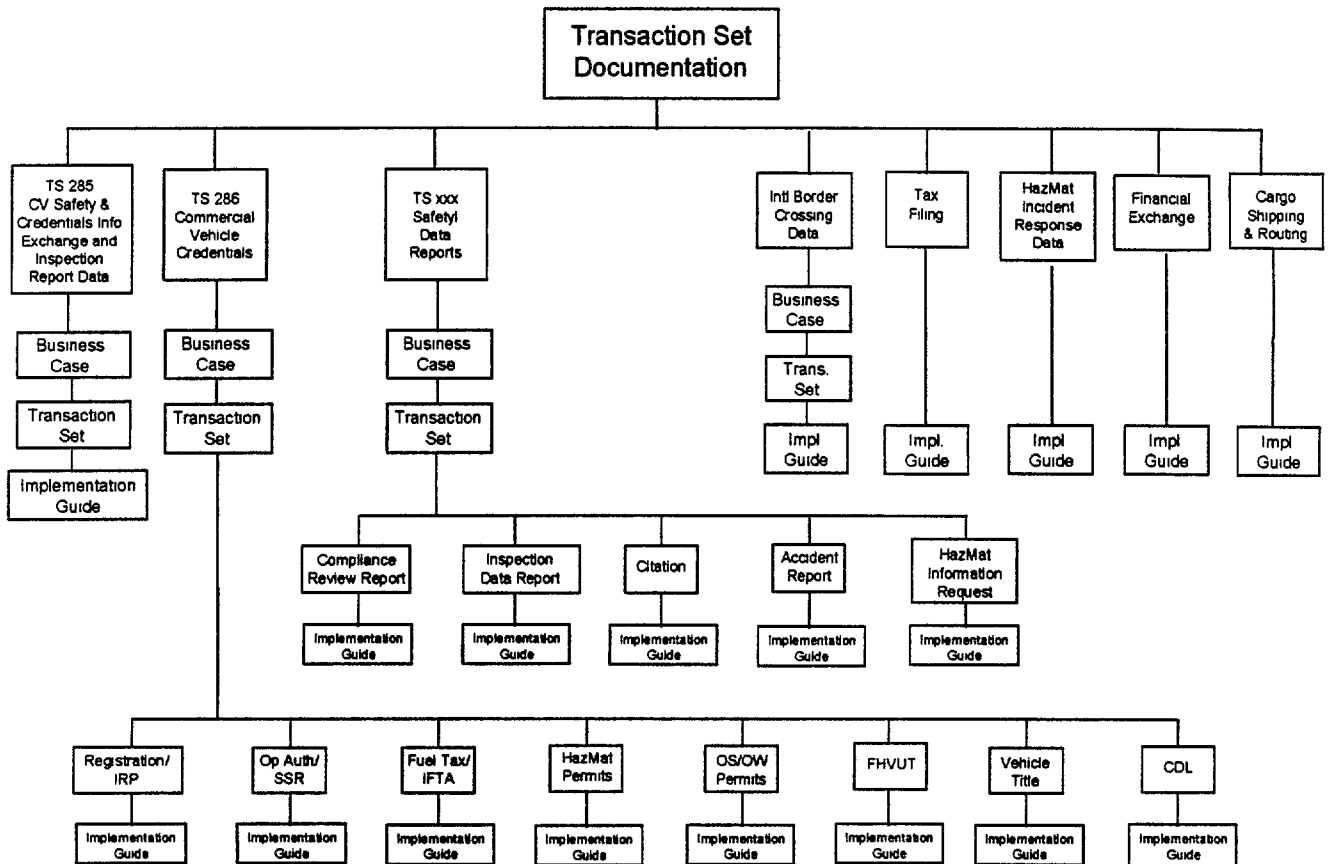

#### 4. Organizations Involved

The following organizations will directly participate or be consulted during the preparation of the EDI standards documentation identified in this plan:

##### FHWA -

The US Department of Transportation Federal Highway Administration is sponsoring the coordination of the EDI transaction sets identified in Section 1.1 and encouraging their use in commercial vehicle operations nationwide. Point of contact: Mr. Mike Curtis, (703) 285-2991.

##### JHU/APL -

The Johns Hopkins University Applied Physics Laboratory has been tasked by FHWA to prepare or coordinate the preparation of documentation associated with the above transaction sets. Point of contact: Dr. Edward Moses, (301) 953-6000, X3461.

Resource Names (Initials) found in the development schedules in Section 5.1:

Karen Goldee (KTG)  
John Hardy (JDH)  
Sherley Lee (SAL)  
Edward Moses (EJM)

##### RSIS -

RS Information Systems is developing transaction sets and graphical user interfaces (GUI) for an IRP clearinghouse and a HazMat clearinghouse, primarily for state-to-state applications. RSIS is assisting APL in the development and documentation of similar areas in the Credentials Transaction Set 286. Point of contact: Mr. Glen Marier, (703)734-7800.

Resource Names (Initials) found in the development schedules in Section 5.1:

Matt Linehan (ML)  
Glen Marier (GM)  
Jude Nagurney (JN)

##### Intelligent Decision Technologies, Ltd. (Southwest One-Stop)

Intelligent Decision Technologies (IDT), a participant in the Southwest Electronic One-Stop Shopping (EOSS) project, is developing software to enable commercial vehicle operators to obtain all required tax and regulatory credentials from a single source. The initial focus is on electronic credentialing for IFTA, IRP, and SSRS. Point of contact: Ms. Terri Ungerman, (303) 652-0332.

#### 4. Organizations Involved (Continued)

##### Midwest One-Stop -

The Midwest Electronic One-Stop Shopping (MEOSS) Operational Test will provide an automated means for motor carriers to obtain registration, fuel tax, operating authority, and oversize/overweight permits. The Iowa Transportation Center (ITC) is responsible for overall project management. Point of contact: Mr. Bill McCall, (515) 2948103.

##### HELP One-Stop -

HELP One Stop is a proprietary system that accepts and processes applications from carriers for IRP, IFTA, Weight/Distance, and SSRS/UCR credentials. It provides credentials and credential information to HELP Pre-Pass for those carriers registered for that program. Point of contact: Mr. Jim Gentner, (602) 252-1598.

##### NATAP -

The North American Trade Automation Prototype is a demonstration project for how North American international trade/transactions and custom operations could function. FHWA point of contact: Mr. Lee Jackson, (202) 366-4415. US Department of the Treasury point of contact: Mr. William Nolle, (202) 927- 1826.

##### FTA-

The Federation of Tax Administrators is an organization representing and addressing issues of concern to state tax administrators. Point of contact: Mr. Harley Duncan, (202) 624-5890

##### BSWG -

The Base State Working Group on Uniform Motor Carrier Programs is a working group composed of state officials to facilitate state responses in meeting the mandate established in Section 4008 of the Motor Carrier Act of 1991. The Base State System is a cooperative agreement under which an interstate carrier traveling in more than one jurisdiction will choose one state as a base jurisdiction. Thereafter, the base jurisdiction is responsible for all interactions with the carrier. BSWG point of contact: Mr. Thorn Rubel/NGA, (202) 624-7740

#### 4. Organizations Involved (Continued)

##### CVIS -

The Commercial Vehicle Information System is a multi-state project to determine the feasibility of linking safety fitness to vehicle registration. CVIS is a cooperative effort between the federal government, states, motor carrier, and related industries/service providers. CVIS point of contact: Ms. Bonnie Bass/FHWA, (202) 366-7298.

##### SAFER Steering Committee

Safety and Fitness Electronic Records (SAFER) is an on-line system that will return standard carrier safety and fitness information to the requestor in a snapshot and report format. The SAFER Steering Committee was formed by FHWA to provide technical guidance during the development life cycle of the SAFER System. SAFER point of contact: Mr. Paul North, JHU/APL, (301) 953-6627.

##### US Courts -

A private organization working with AAMVA to develop a list of XI2 EDI codes for traffic violations. US Courts has expressed an interest in coordinating with APL in the area of EDI codes for commercial vehicle operations. Points of contact: Mr. Rich Goldschmidt/US Courts; Dr. Edward Moses/APL (301) 953-6000 X346 1.

##### AAMVAnet, Inc. -

The American Association of Motor Vehicle Administrators network (AAMVAnet) is a nationwide computer-based network that carries driver/carrier information between databases. AAMVAnet, Inc. is a non-profit organization that manages the system, providing both networking support and information system development for US DMVs. Point of contact: Mr. Charlie Katz, (703) 908-5766.

##### IRP, Inc. -

The International Registration Plan (IRP) is a basestate agreement for collecting registration and apportioning taxes from interstate motor carriers. Point of contact: Mr. Stan Kelly/IRP, Inc., (703) 908-5765.

##### IFTA, Inc. -

The International Fuel Tax Agreement (IFTA) is a basestate agreement among states for collecting and disbursing fuel use tax. Managed by IFTA, Inc., the system allows a motor carrier to report all travel and pay any taxes due to any IFTA jurisdiction to the carrier's basestate. Point of contact: Mr. Bob McKee/IFTA, Inc., (602) 839-4382.



#### 4. Organizations Involved (Continued)

##### NY Regional Processing Center -

The New York Fuel Tax System is a set of software for a multi-jurisdiction tax processing system developed by the New York State Department of Taxation and Finance, and operated by the New York State Regional IFTA Processing Center. The center supports fuel tax financial transactions and recaps, allowing a motor carrier to report all travel and pay any taxes due any IFTA jurisdiction to the carrier's base state. Point of contact: Mr. John Goggin, (518) 457-6860.

##### Maryland -

As a participant in the CVISN prototype project, the state of Maryland is expected to participate in the identification of CVO-related data flows that are applicable to electronic data interchange systems. Points of contact: Ms. Debbie Roger&HA (IRP, CDL), (410) 787-7848; Mr. Steve Taylor/Comptroller's Office (IFTA), (4 10) 974-3145, Ms. Dolores Strausser/SHA (OS/OW), (410) 582-5734.

##### Virginia -

As a participant in the CVISN prototype project, the state of Virginia is expected to participate in the identification of CVO-related data flows that are applicable to electronic data interchange systems within the state. Points of contact: Mr. Jerry Fern/DMV (IRP, IFTA), (804) 367-8487, Ms. Judy Vesely/DMV (CDL), (804) X7-0130, Mr. Ken Jennings/VDOT (OS/OW), (804) 786-5081.

##### California -

As a CVISN Pilot State, California is expected to participate in the identification of CVO-related data flows that are applicable to electronic data interchange systems within the state. Pilot State Manager: Lt. Tim Clark, (916) 445-1865

##### Colorado -

As a CVISN Pilot State, Colorado is expected to participate in the identification of CVO-related data flows that are applicable to electronic data interchange systems within the state. Pilot State Manager: Mr. Phillip Vasquez, (303) 205-5688

##### Connecticut -

As a CVISN Pilot State, Connecticut is expected to participate in the identification of CVO-related data flows that are applicable to electronic data interchange systems within the state. Pilot State Manager: Mr. Dennis Walsh, (860) 5662634

#### 4. **Organizations Involved (Continued)**

##### **Kentucky -**

As a CVISN Pilot State, Kentucky is expected to participate in the identification of CVO-related data flows that are applicable to electronic data interchange systems within the state. Pilot State Manager: Mr. Ed Logsdon, (502) 564-7000

##### **Michigan -**

As a CVISN Pilot State, Michigan is expected to participate in the identification of CVO-related data flows that are applicable to electronic data interchange systems within the state. Pilot State Manager: Mr. Eric Dhanak, (517) 335699 1

##### **Minnesota -**

As a CVISN Pilot State, Minnesota is expected to participate in the identification of CVO-related data flows that are applicable to electronic data Interchange systems within the state. Pilot State Manager: Ms. Cathy Erickson, (612) ZIG-8533

##### **Oregon/Washington -**

As dual CVISN Pilot States, Oregon and Washington are expected to participate in the identification of CVO-related data flows that are applicable to electronic data interchange systems within the state. Pilot State Manager: Capt. Tim Erickson, (360) 753-0302; Asst. Program Manager: Mr. Morgan Balough, (206) 543-0078



## **APPENDIX A - EDI-RELATED INTERFACE DEFINITIONS**

Each set of facing pages in this appendix defines an EDI-related data flow interface. Each data flow corresponds to an example message in the EDI implementation guides being developed by JHU/APL.

In this appendix, information for each interface includes:

- Identification Information
  - + Data Flow Name
  - + ID Number
  - + Transaction Set or Flat File Name
  - + Implementation Guide Name
  - + Implementation Guide Due Date
  - + Data Flow Description
- APL Point of Contact
- Organizations Reviewing and/or Contributing to the Implementation Guide
  - + Name(s)
  - + Point of Contact
  - + Communication Information
- States Implementing the Interface
  - + State Name
  - + Date Implemented/Scheduled
- Other Remarks

**Appendix A**  
**EDI-Related Data Flow**  
**Interface Definition and Scheduling Information**

ID Number:	Implementation Guide Name:
Data Flow Name:	Implementation Guide Due Date:
Transaction Set or Flat File Name:	
Source:	
Destination:	
Data Flow Description:	

Associated Transaction Sets/Data Flows:

APL Point of Contact: Name: Phone: E-mail:  Contributing/Reviewing Organization: Name: Phone: E-mail:  Contributing/Reviewing Organization: Name: Phone: E-mail:  Contributing/Reviewing Organization: Name: Phone: E-mail:  Contributing/Reviewing Organization: Name: Phone: E-mail:  Contributing/Reviewing Organization: Name: Phone: E-mail:  Contributing/Reviewing Organization: Name: Phone: E-mail:	States Implementing this interface			
	<table border="1" style="width: 100%; border-collapse: collapse;"> <thead> <tr> <th style="width: 80%;">State</th> <th style="width: 20%;">Date</th> </tr> </thead> <tbody> <tr> <td style="height: 150px;"> </td> <td> </td> </tr> </tbody> </table>	State	Date	
State	Date			
Other Remarks:				

# EDI-Related Data Flows

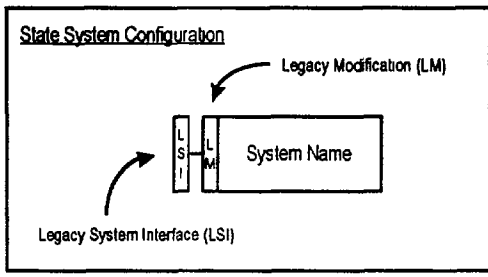
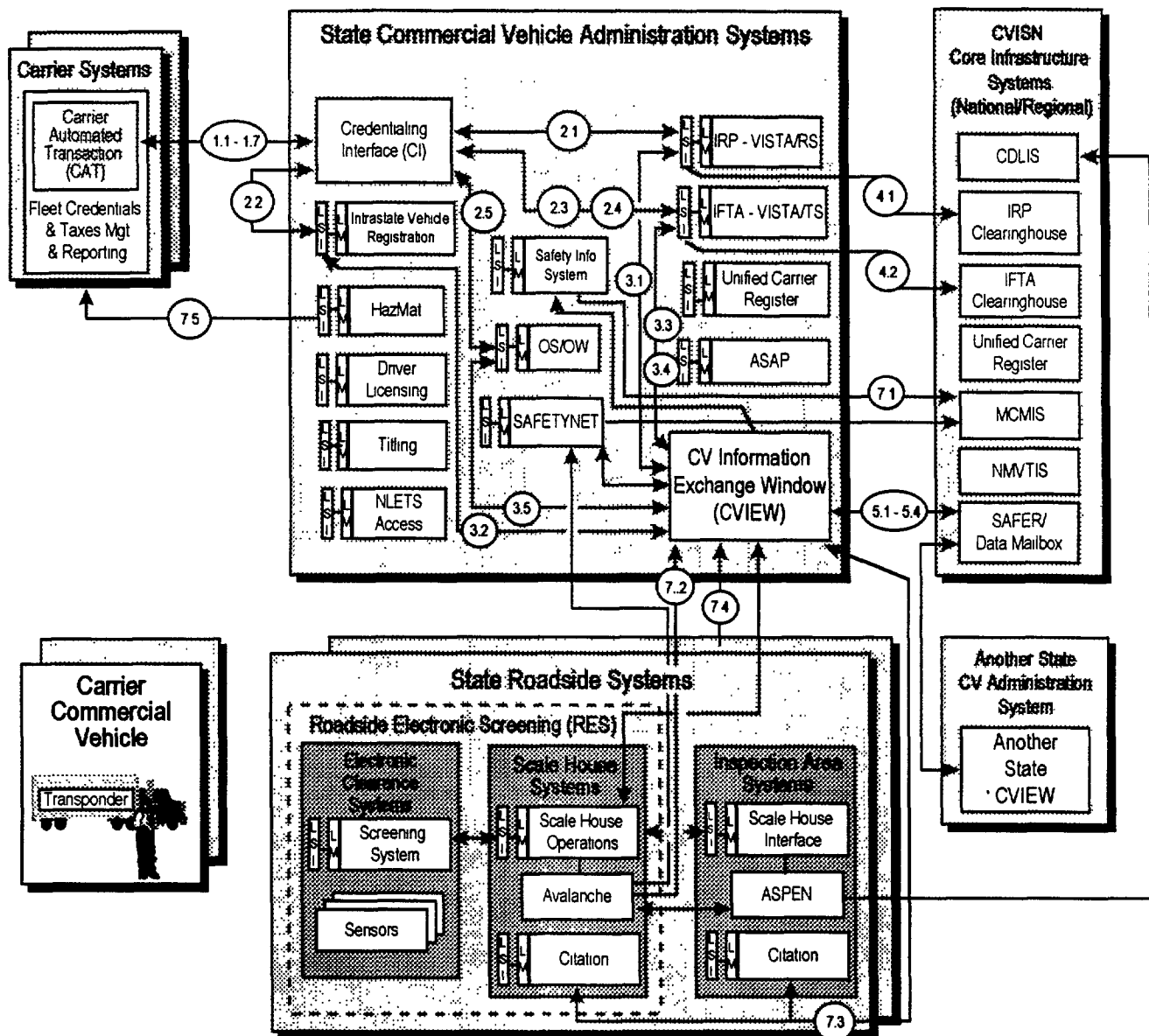

## EDI-Related Data Flow - Vehicle Registration

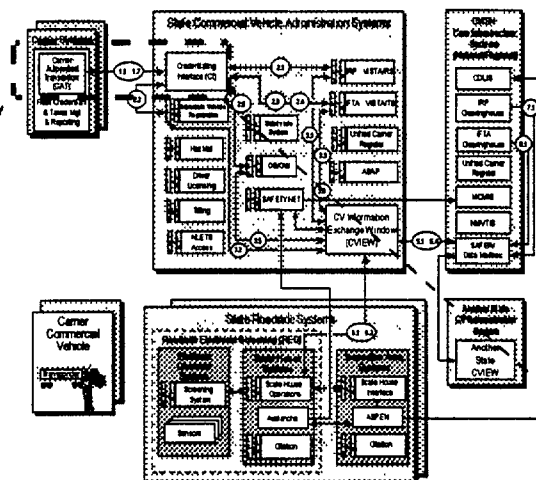

### 1.1 Vehicle Registration - TS 286

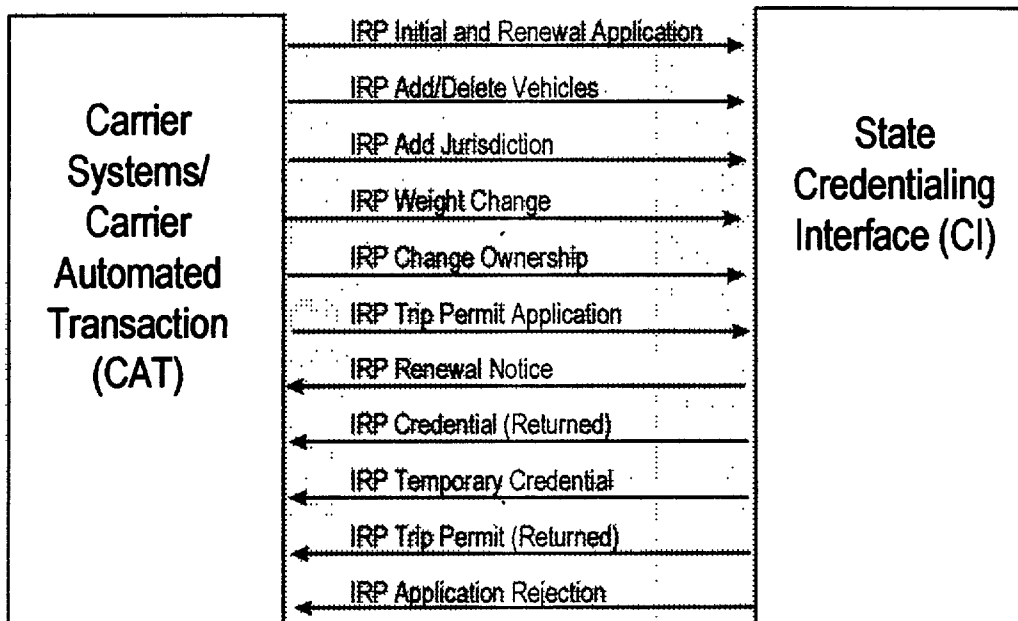

**Appendix A**  
**EDI-Related Data Flow**  
**Interface Definition and Scheduling Information**

ID Number: 1.1		Implementation Guide Name: IRP Credential Transaction	
Data Flow Name: IRP Vehicle Registration		Implementation Guide Due Date: 10/15/96	
Transaction Set or Flat File Name: TS 286, Commercial Vehicle Credentials			
Source: CAT (Carrier origin) or State CI (State origin)			
Destination: State CI (Carrier origin) or CAT (State origin)			
Data Flow Description: Credential transactions associated with the International Registration Plan (IRP) for commercial vehicles that take place between an applicant and an issuing jurisdiction.			
Associated Transaction Sets/Data Flows: TS 997 (Functional acknowledgment), TS 810 (Invoice), TS 820 (Payment Order/ Remittance Advice), TS 864 (Text message)			
APL Point of Contact: Name: Edward J. Moses Phone: (301) 953-6000 x3461 E-mail: ed.moses@jhuapl.edu  Contributing/Reviewing Organization: RS Information Systems Name: Glen Marier Phone: (301) 953-6000 x3612 E-mail: MarieGA@central.ssd.jhuapl.edu  Contributing/Reviewing Organization: AAMVA/MW I-Stop Name: Charlie Katz Phone: (703) 908-5766 E-mail: usamvck1@ibmmail.com  Contributing/Reviewing Organization: IDT/SW I-Stop Name: Terri Ungerman Phone: (303) 652-0332 E-mail: 76042.1763@compuserve.com  Contributing/Reviewing Organization: IRP, Inc. Name: Stan Kelly Phone: (703) 9085765 E-mail:  Contributing/Reviewing Organization: HELP I-Stop Name: Jim Gentner Phone: (602) 252-1598 E-mail:  Contributing/Reviewing Organization: CVIS Name: Bonnie Bass/FHWA Phone: (202) 366-7298 E-mail: bbass@intergate.dot.gov		<b>States Implementing this Interface</b>	
		State	Date
		California	
		Colorado	
		Connecticut	
		Kentucky	
		Maryland	
		Michigan	
		Minnesota	
		Oregon/Washington	
		Virginia	
		Other Remarks:	



## EDI-Related Data Flow - IFTA Registration

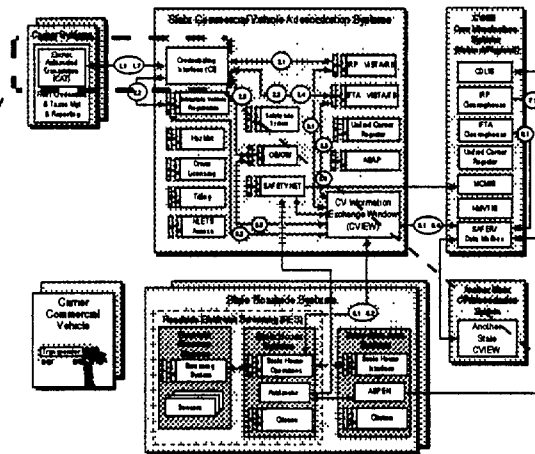

### 1.2 IFTA Registration - TS 286

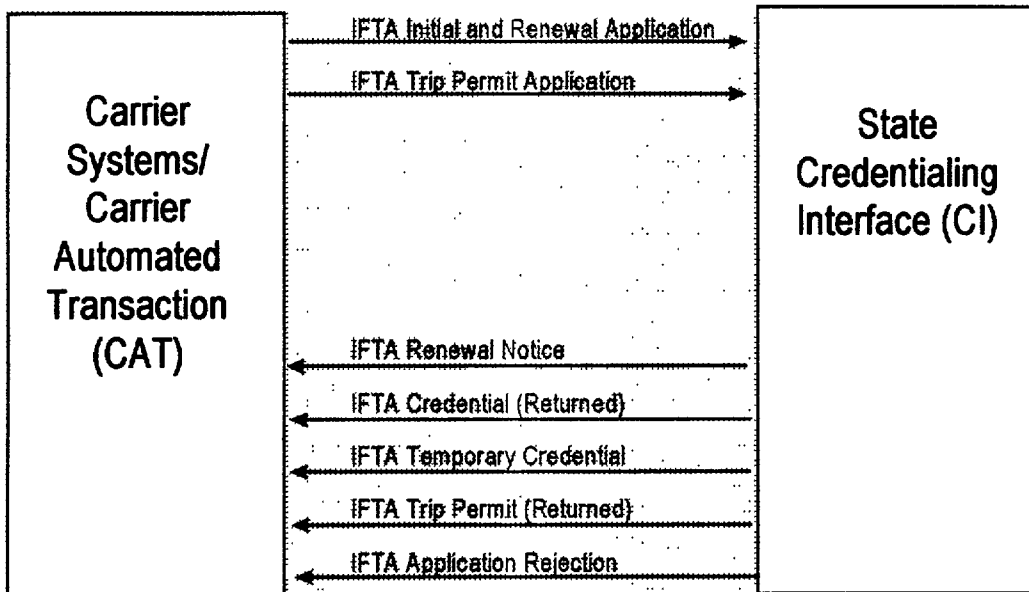

**Appendix A**  
**EDI-Related Data Flow**  
**Interface Definition and Scheduling Information**

ID Number: 1.2	Implementation Guide Name: IFTA Registration																			
Data Flow Name: IFTA Registration	Implementation Guide Due Date: 2/1/97																			
Transaction Set or Flat File Name: TS 286, Commercial Vehicle Credentials Source: CAT (Carrier origin) or State CI (State origin) Destination: State CI (Carrier origin) or CAT (State origin)																				
Data Flow Description: Credential transactions associated with the International Fuel Tax Agreement (IFTA) for commercial vehicles that take place between an applicant and an issuing jurisdiction.																				
Associated Transaction Sets/Data Flows: TS 997 (Functional acknowledgment), TS 810 (Invoice), TS 820 (Payment Order/Remittance Advice), TS 864 (Text message), TS 813 (Quarterly Fuel Tax Filing)																				
APL Point of Contact: Name: Edward J. Moses Phone: (301) 953-6000 x3461 E-mail: ed.moses@jhuapl.edu  Contributing/Reviewing Organization: RS Information Systems Name: Glen Marier Phone: (301) 9536000 x3612 E-mail: MarieGA@central.ssd.jhuapl.edu  Contributing/Reviewing Organization: AAMVA/MW 1-Stop Name: Charlie Katz Phone: (703) 9085766 E-mail: usamvck1@ibmmail.com  Contributing/Reviewing Organization: IDT/SW 1-Stop Name: Terri Ungerman Phone: (303) 652-0332 E-mail: 76042.1763@compuserve.com  Contributing/Reviewing Organization: IFTA, Inc. Name: Bob McKee Phone: (602) 839-4382 E-mail:  Contributing/Reviewing Organization: HELP I-Stop Name: Jim Gentner Phone: (602) 252-1598 E-mail:  Contributing/Reviewing Organization: FTA Name: Harley Duncan Phone: (202) 6245890 E-mail:	States Implementing this Interface																			
	<table border="1"> <thead> <tr> <th style="width: 80%;">State</th> <th style="width: 20%;">Date</th> </tr> </thead> <tbody> <tr><td>California</td><td></td></tr> <tr><td>Colorado</td><td></td></tr> <tr><td>Connecticut</td><td></td></tr> <tr><td>Kentucky</td><td></td></tr> <tr><td>Maryland</td><td></td></tr> <tr><td>Michigan</td><td></td></tr> <tr><td>Minnesota</td><td></td></tr> <tr><td>Oregon/Washington</td><td></td></tr> <tr><td>Virginia</td><td></td></tr> </tbody> </table>	State	Date	California		Colorado		Connecticut		Kentucky		Maryland		Michigan		Minnesota		Oregon/Washington		Virginia
State	Date																			
California																				
Colorado																				
Connecticut																				
Kentucky																				
Maryland																				
Michigan																				
Minnesota																				
Oregon/Washington																				
Virginia																				
	Other Remarks:  TS 826 deals with the application and return of an IFTA credential, not actual tax filings (TS 813).																			

## EDI-Related Data Flow - IFTA Tax Filing

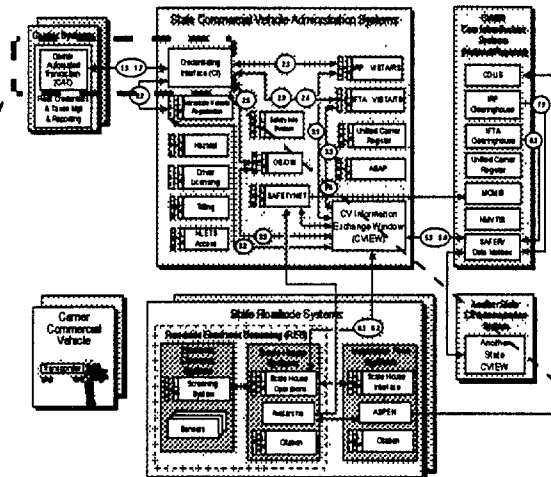

### 1.3 IFTA Tax Filing - TS 813

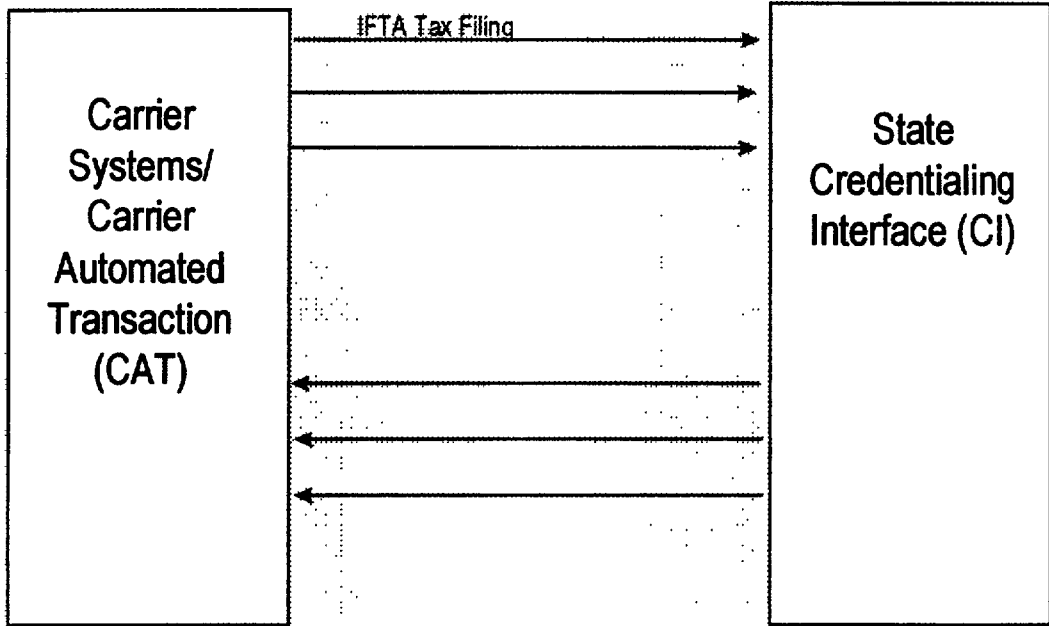

**Appendix A**  
**EDI-Related Data Flow**  
**Interface Definition and Scheduling Information**

ID Number: 1.3	Implementation Guide Name: TS 813, IFTA Tax Filing																			
Data Flow Name: IFTA Tax Filing	Implementation Guide Due Date: (Complete)																			
Transaction Set or Flat File Name: TS 813, Quarterly Fuel Tax Filing Source: CAT (Carrier origin) or State CI (State origin) Destination: State CI (Carrier origin) or CAT (State origin)																				
Data Flow Description: File fuel tax returns with taxing authorities.																				
Associated Transaction Sets/Data Flows: TS 997 (Functional acknowledgment), TS 810 (Invoice), TS 820 (Payment Order/ Remittance Advice), TS 884 (Text message), TS 288 (Commercial Vehicle Credentials)																				
<b>APL Point of Contact:</b> Name: Edward J. Moses Phone: (301) 953-8000 x3481 E-mail: ed.moses@jhuapl.edu  <b>Contributing/Reviewing Organization: RS Information Systems</b> Name: Glen Marier Phone: (301) 953-8000 x3812 E-mail: MarieGA@central.ssd.jhuapl.edu  <b>Contributing/Reviewing Organization: IFTA, Inc.</b> Name: Bob McKee Phone: (602) 839-4382 E-mail:  <b>Contributing/Reviewing Organization: NY Regional Process Ctr.</b> Name: John Goggin Phone: (518) 457-6860 E-mail:  <b>Contributing/Reviewing Organization: FTA</b> Name: Harley Duncan Phone: (202) 624-5890 E-mail:  <b>Contributing/Reviewing Organization:</b> Name: Phone: E-mail:  <b>Contributing/Reviewing Organization:</b> Name: Phone: E-mail:	<b>States Implementing this Interface</b>																			
	<table border="1" style="width: 100%; border-collapse: collapse;"> <thead> <tr> <th style="width: 80%;">State</th> <th style="width: 20%;">Date</th> </tr> </thead> <tbody> <tr><td>California</td><td></td></tr> <tr><td>Colorado</td><td></td></tr> <tr><td>Connecticut</td><td></td></tr> <tr><td>Kentucky</td><td></td></tr> <tr><td>Maryland</td><td></td></tr> <tr><td>Michigan</td><td></td></tr> <tr><td>Minnesota</td><td></td></tr> <tr><td>Oregon/Washington</td><td></td></tr> <tr><td>Virginia</td><td></td></tr> </tbody> </table>	State	Date	California		Colorado		Connecticut		Kentucky		Maryland		Michigan		Minnesota		Oregon/Washington		Virginia
State	Date																			
California																				
Colorado																				
Connecticut																				
Kentucky																				
Maryland																				
Michigan																				
Minnesota																				
Oregon/Washington																				
Virginia																				
	Other Remarks:																			

## EDI-Related Data Flow - Operating Authority Credential

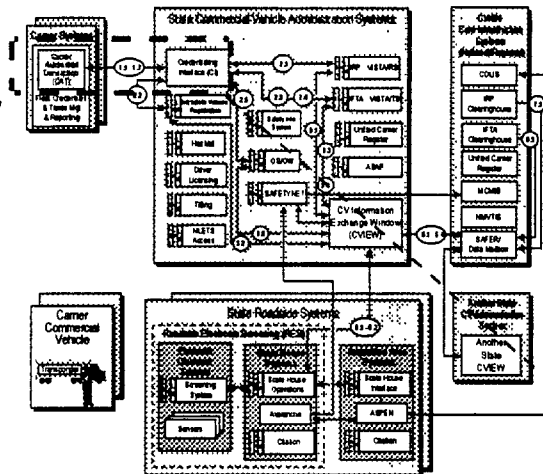

### 1.4 Operating Authority - TS 286

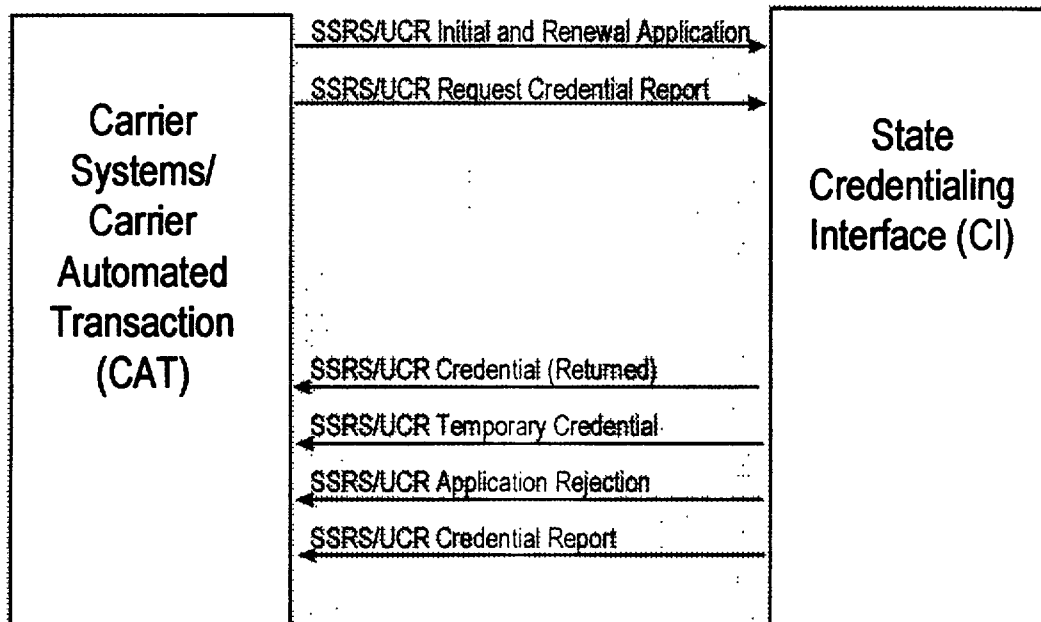

**Appendix A**  
**EDI-Related Data Flow**  
**Interface Definition and Scheduling Information**

ID Number: 1.4		Implementation Guide Name: TS 286 SSRS/UCR Credentials																							
Data Flow Name: Operating Authority		Implementation Guide Due Date: 6/1/97																							
Transaction Set or Flat File Name: TS 286, Commercial Vehicle Credentials																									
Source: CAT (Carrier origin) or State CI (State origin)																									
Destination: State CI (Carrier origin) or CAT (State origin)																									
Data Flow Description: Credential transactions associated with the Single State Registration System (SSRS)/ Unified Carrier Register (UCR) for commercial vehicles that take place between an applicant and an issuing jurisdiction for operating authority.																									
Associated Transaction Sets/Data Flows: TS 997 (Functional acknowledgment), TS 810 (Invoice), TS 820 (Payment Order/ Remittance Advice), TS 864 (Text message)																									
<b>APL Point of Contact:</b> Name: Edward J. Moses Phone: (301) 953-6000 x3461 E-mail: ed.moses@jhuapl.edu  <b>Contributing/Reviewing Organization: RS Information Systems</b> Name: Glen Marier Phone: (301) 953-6000 x3612 E-mail: MarieGA@central.ssd.jhuapl.edu  <b>Contributing/Reviewing Organization: AAMVA/MW 1-Stop</b> Name: Charlie Katz Phone: (703) 908-5766 E-mail: usamvck1@ibmmail.com  <b>Contributing/Reviewing Organization: IDT/SW 1-Stop</b> Name: Terri Ungerman Phone: (303) 652-0332 E-mail: 76042.1763@compuserve.com  <b>Contributing/Reviewing Organization: HELP I-Stop</b> Name: Jim Gentner Phone: (602) 252-1598 E-mail:  <b>Contributing/Reviewing Organization: CVIS</b> Name: Bonnie Bass/FHWA Phone: (202) 366-7298 E-mail: bbass@intergate.dot.gov  <b>Contributing/Reviewing Organization:</b> Name: Phone: E-mail:		<table border="1" style="width: 100%; border-collapse: collapse;"> <thead> <tr> <th colspan="2" style="text-align: center;">States Implementing this interface</th> </tr> <tr> <th style="width: 70%; text-align: center;">State</th> <th style="width: 30%; text-align: center;">Date</th> </tr> </thead> <tbody> <tr><td>California</td><td></td></tr> <tr><td>Colorado</td><td></td></tr> <tr><td>Connecticut</td><td></td></tr> <tr><td>Kentucky</td><td></td></tr> <tr><td>Maryland</td><td></td></tr> <tr><td>Michigan</td><td></td></tr> <tr><td>Minnesota</td><td></td></tr> <tr><td>Oregon/Washington</td><td></td></tr> <tr><td>Virginia</td><td></td></tr> </tbody> </table> Other Remarks:		States Implementing this interface		State	Date	California		Colorado		Connecticut		Kentucky		Maryland		Michigan		Minnesota		Oregon/Washington		Virginia	
States Implementing this interface																									
State	Date																								
California																									
Colorado																									
Connecticut																									
Kentucky																									
Maryland																									
Michigan																									
Minnesota																									
Oregon/Washington																									
Virginia																									

## EDI-Related Data Flow - Oversize/Overweight Application

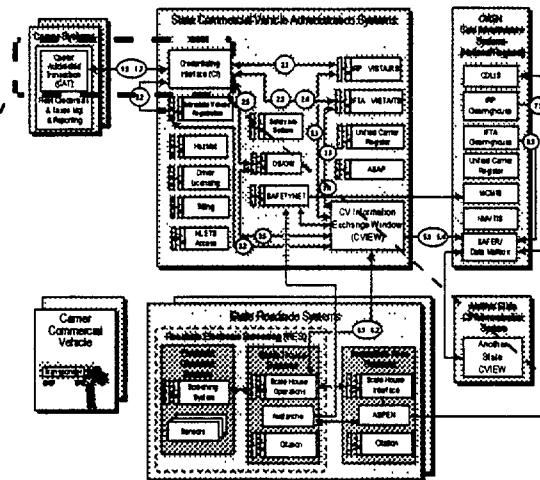

### 1.5 Oversize/Overweight Application - TS 286

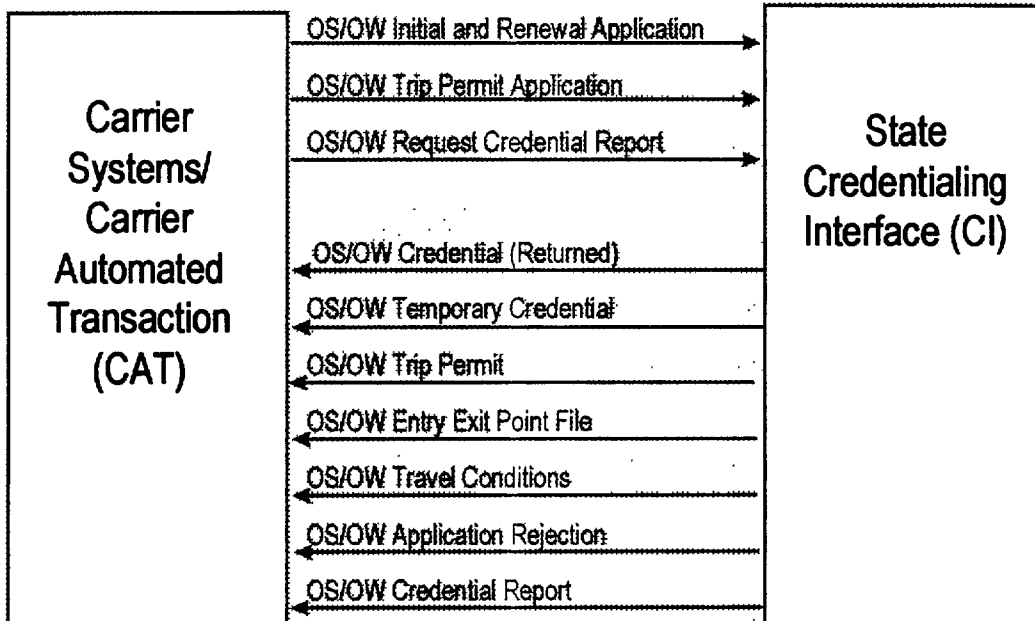

**Appendix A**  
**EDI-Related Data Flow**  
**Interface Definition and Scheduling Information**

ID Number 1.5		Implementation Guide Name: TS 266, OS/OW Credential	
Data Flow Name: Oversize/Overweight Application		Implementation Guide Due Date: 4/1/97	
Transaction Set or Flat File Name: TS 266, Commercial Vehicle Credentials			
Source: CAT (Carrier origin) or State CI (State origin)			
Destination: State CI (Carrier origin) or CAT (State origin)			
Data Flow Description: Credential transactions associated with Oversize/Overweight Permits for commercial vehicles that take place between an applicant and an issuing jurisdiction.			
Associated Transaction Sets/Data Flows: TS 997 (Functional acknowledgment), TS 810 (Invoice), TS 820 (Payment Order/ Remittance Advice), TS 864 (Text message)			
APL Point of Contact: Name: Edward J. Moses Phone: (301) 953-6000 x3461 E-mail: ed.moses@jhuapl.edu  Contributing/Reviewing Organization: RS Information Systems Name: Glen Marier Phone: (301) 9536000 x3612 E-mail: MarieGA@central.ssd.jhuapl.edu  Contributing/Reviewing Organization: AAMVA/MW 1-Stop Name: Charlie Katz Phone: (703) 9085766 E-mail: usamvck1@ibmmail.com  Contributing/Reviewing Organization: Name: Phone: E-mail:  Contributing/Reviewing Organization: Name: Phone: E-mail:  Contributing/Reviewing Organization: Name: Phone: E-mail:  Contributing/Reviewing Organization: Name: Phone: E-mail:		States Implementing this Interface	
		State	Date
		California	
		Colorado	
		Connecticut	
		Kentucky	
		Maryland	
		Michigan	
		Minnesota	
		Oregon/Washington	
		Virginia	
		Other Remarks:	



## EDI-Related Data Flow - HazMat Application

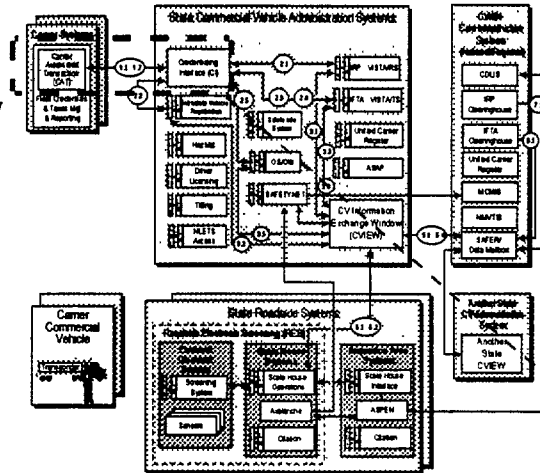

### 1.6 HazMat Application - TS 286

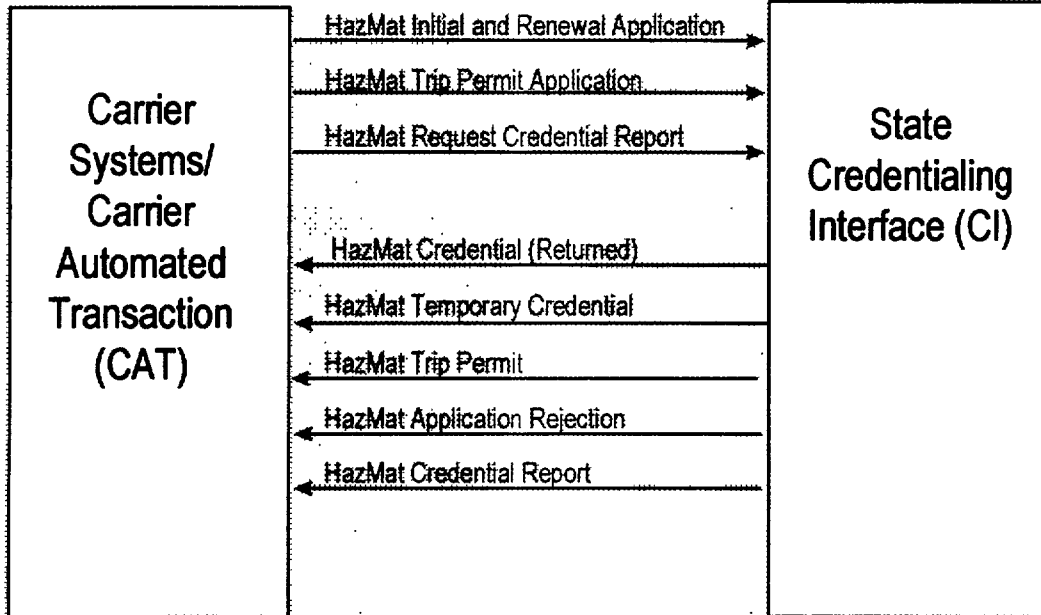

Appendix A  
 EDI-Related Data Flow  
 Interface Definition and Scheduling Information

ID Number: 1.6	Implementation Guide Name: TS 286 HazMat Credential																	
Data Flow Name: HazMat Application	Implementation Guide Due Date: TBD																	
Transaction Set or Flat File Name: TS 286, Commercial Vehicle Credentials																		
Source: CAT (Carrier origin) or State CI (State origin)																		
Destination: State CI (Carrier origin) or CAT (State origin)																		
Data Flow Description: Credential transactions associated with the HazMat permitting/registration for commercial vehicles that take place between an applicant and an issuing jurisdiction.																		
Associated Transaction Sets/Data Flows: TS 997 (Functional acknowledgment), TS 810 (Invoice), TS 820 (Payment Order/ Remittance Advice), TS 864 (Text message)																		
APL Point of Contact: Name: Edward J. Moses Phone: (301) 953-6000 x3461 E-mail: ed.moses@jhuapl.edu  Contributing/Reviewing Organization: RS Information Systems Name: Glen Marier Phone: (301) 953-6000 x3612 E-mail: MarieGA@central.ssd.jhuapl.edu  Contributing/Reviewing Organization: Name: Phone: E-mail:  Contributing/Reviewing Organization: Name: Phone: E-mail:  Contributing/Reviewing Organization: Name: Phone: E-mail:  Contributing/Reviewing Organization: Name: Phone: E-mail:	States Implementing this Interface																	
	<table border="1" style="width: 100%; border-collapse: collapse;"> <thead> <tr> <th style="width: 80%;">State</th> <th style="width: 20%;">Date</th> </tr> </thead> <tbody> <tr><td>California</td><td></td></tr> <tr><td>Colorado</td><td></td></tr> <tr><td>Connecticut</td><td></td></tr> <tr><td>Kentucky</td><td></td></tr> <tr><td>Maryland</td><td></td></tr> <tr><td>Michigan</td><td></td></tr> <tr><td>Minnesota</td><td></td></tr> <tr><td>Oregon/Washington</td><td></td></tr> </tbody> </table>	State	Date	California		Colorado		Connecticut		Kentucky		Maryland		Michigan		Minnesota		Oregon/Washington
State	Date																	
California																		
Colorado																		
Connecticut																		
Kentucky																		
Maryland																		
Michigan																		
Minnesota																		
Oregon/Washington																		
	Other Remarks:																	

## EDI-Related Data Flow - Vehicle Title

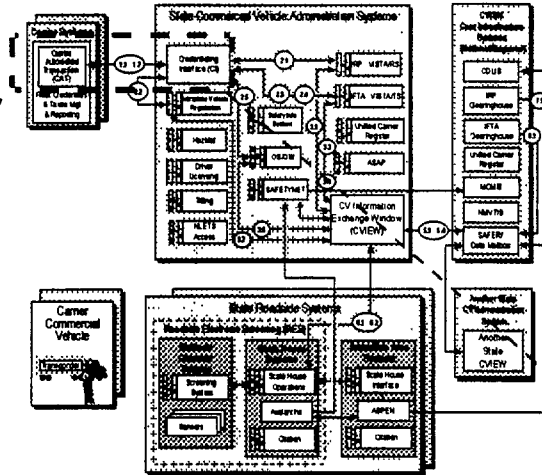

### 1.7 Vehicle Title Application - TS 286

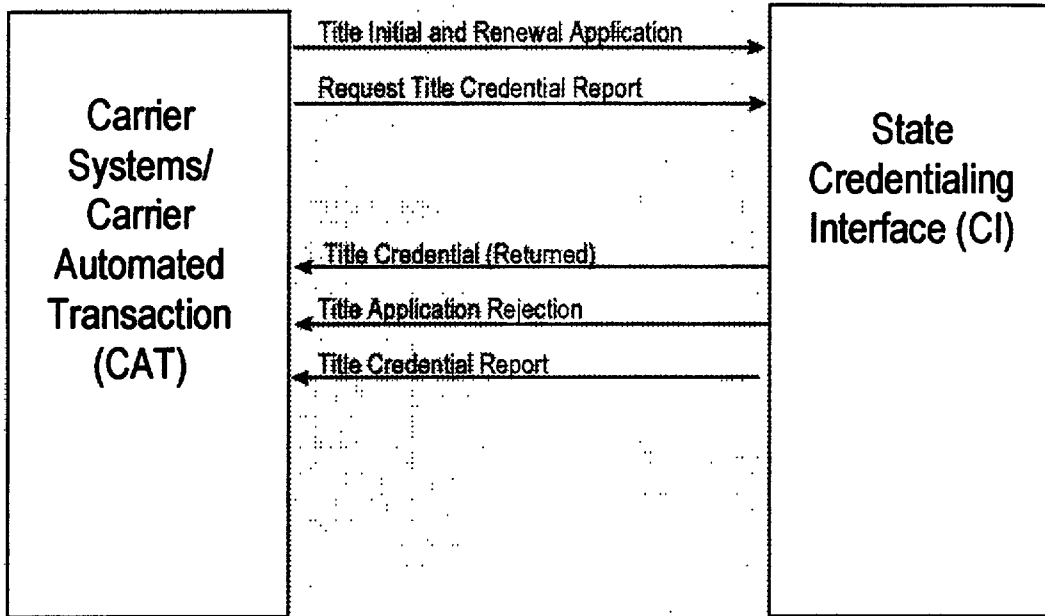

Appendix A  
EDI-Related Data Flow  
Interface Definition and Scheduling Information

ID Number: 1.7	Implementation Guide Name: TS 288 Vehicle Title
Data Flow Name: Vehicle Title Application	Implementation Guide Due Date: TBD
Transaction Set or Flat File Name: TS 288, Commercial Vehicle Credentials	
Source: CAT (Carrier origin) or State CI (State origin)	
Destination: State CI (Carrier origin) or CAT (State origin)	
Data Flow Description: Credential vehicle title transactions that take place between an applicant and an issuing jurisdiction.	
Associated Transaction Sets/Data Flows: TS 997 (Functional acknowledgment), TS 810 (invoice), TS 820 (Payment Order/ Remittance Advice), TS 884 (Text message)	
APL Point of Contact: Name: Edward J. Moses Phone: (301) 953-6000 x3461 E-mail: ed.moses@jhuapl.edu  Contributing/Reviewing Organization: RS Information Systems Name: Glen Marier Phone: (301) 953-6000 x3612 E-mail: MarieGA@central.ssd.jhuapl.edu  Contributing/Reviewing Organization: AAMVAnet Name: Jay Maxwell Phone: (703) 9084268 E-mail: usamvmhy@ibmmail.com  Contributing/Reviewing Organization: CVIS Name: Bonnie Bass/FHWA Phone: (202) 366-7298 E-mail: bbass@intergate.dot.gov  Contributing/Reviewing Organization: Name: Phone: E-mail:  Contributing/Reviewing Organization: Name: Phone: E-mail:  Contributing/Reviewing Organization: Name: Phone: E-mail:	States Implementing this Interface
	State
	California Colorado Connecticut Kentucky Maryland Michigan Minnesota Oregon/Washington Virginia
	Other Remarks:

## EDI-Related Data Flow - IRP Vehicle Registration - Flat File to VISTA/RS -

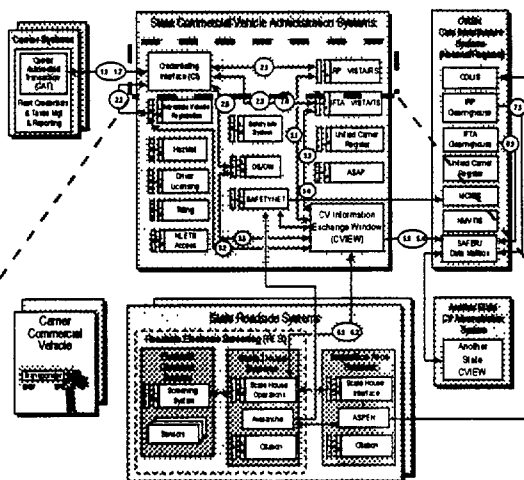

### 2.1 IRP Vehicle Registration -Flat File to VISTA/RS

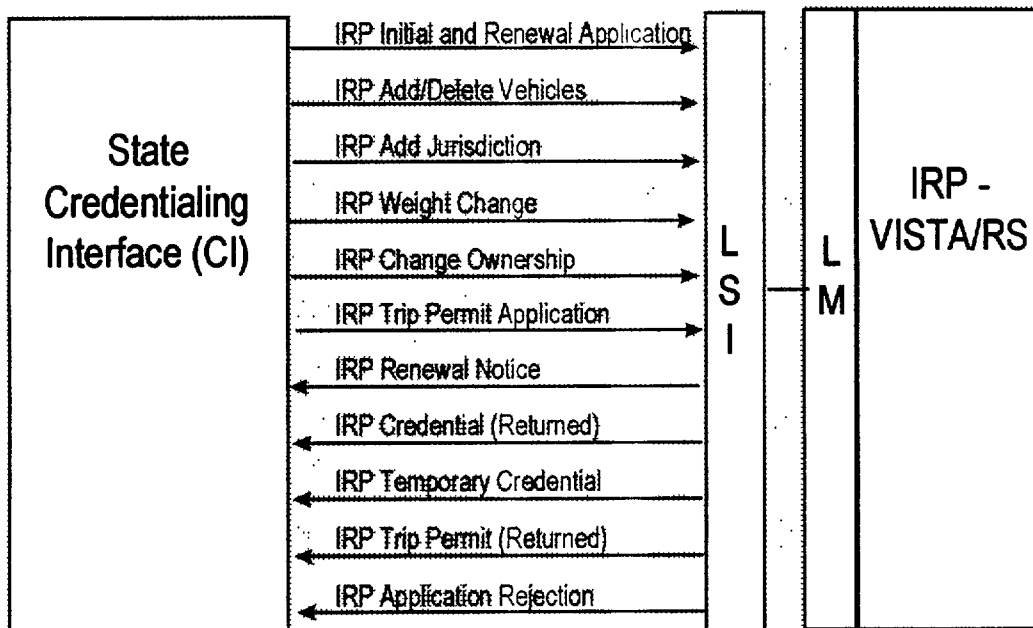

Appendix A  
 EDI-Related Data Flow  
 Interface Definition and Scheduling Information

ID Number: 2.1	Implementation Guide Name: TBD																								
Data Flow Name: IRP Vehicle Registration	Implementation Guide Due Date: TBD																								
Transaction Set or Flat File Name: Flat File to VISTA/RS																									
Source: CI (State origin) or IRP-VISTA/RS (VISTA origin)																									
Destination: IRP-VISTA/RS (State origin) or CI (VISTA origin)																									
Data Flow Description: IRP vehicle registration information exchanged between the state CI and IRP-VISTA/RS system.																									
Associated Transaction Sets/Data Flows: N/A																									
APL Point of Contact: Name: Edward J. Moses Phone: (301) 953-6000 x3461 E-mail: ed.moses@jhuapl.edu  Contributing/Reviewing Organization: Name: Phone: E-mail:  Contributing/Reviewing Organization: Name: Phone: E-mail:  Contributing/Reviewing Organization: Name: Phone: E-mail:  Contributing/Reviewing Organization: Name: Phone: E-mail:  Contributing/Reviewing Organization: Name: Phone: E-mail:	<table border="1" style="width: 100%; border-collapse: collapse;"> <thead> <tr> <th colspan="2" style="text-align: center;">States Implementing this Interface</th> </tr> <tr> <th style="width: 80%;">State</th> <th style="width: 20%;">Date</th> </tr> </thead> <tbody> <tr> <td>California</td> <td></td> </tr> <tr> <td>Colorado</td> <td></td> </tr> <tr> <td>Connecticut</td> <td></td> </tr> <tr> <td>Kentucky</td> <td></td> </tr> <tr> <td>Maryland</td> <td></td> </tr> <tr> <td>Michigan</td> <td></td> </tr> <tr> <td>Minnesota</td> <td></td> </tr> <tr> <td>Oregon/Washington</td> <td></td> </tr> <tr> <td>Virginia</td> <td></td> </tr> <tr> <td colspan="2" style="height: 150px; vertical-align: top;">Other Remarks:</td> </tr> </tbody> </table>	States Implementing this Interface		State	Date	California		Colorado		Connecticut		Kentucky		Maryland		Michigan		Minnesota		Oregon/Washington		Virginia		Other Remarks:	
States Implementing this Interface																									
State	Date																								
California																									
Colorado																									
Connecticut																									
Kentucky																									
Maryland																									
Michigan																									
Minnesota																									
Oregon/Washington																									
Virginia																									
Other Remarks:																									



Appendix A  
 EDI-Related Data Flow  
 Interface Definition and Scheduling Information

ID Number: 2.2	Implementation Guide Name: TBD																			
Data Flow Name: Intrastate Vehicle Registration	Implementation Guide Due Date: TBD																			
Transaction Set or Flat File Name: Flat file to Intrastate Vehicle Registration																				
Source: CI (state origin) or Intrastate Vehicle Registration (Intrastate system origin)																				
Destination: Intrastate Vehicle Registration (state origin) or CI (intrastate system origin)																				
Data Flow Description: IRP intrastate vehicle registration information exchanged between the state CI and the Intrastate Vehicle Registration System.																				
Associated Transaction Sets/Data Flows: N/A																				
APL Point of Contact: Name: Edward J. Moses Phone: (301) 953-6000 x3461 E-mail: ed.moses@jhuapl.edu  Contributing/Reviewing Organization: Name: Phone: E-mail:  Contributing/Reviewing Organization: Name: Phone: E-mail:  Contributing/Reviewing Organization: Name: Phone: E-mail:  Contributing/Reviewing Organization: Name: Phone: E-mail:  Contributing/Reviewing Organization: Name: Phone: E-mail:  Contributing/Reviewing Organization: Name: Phone: E-mail:	States Implementing this Interface																			
	<table border="1" style="width: 100%; border-collapse: collapse;"> <thead> <tr> <th style="width: 80%;">State</th> <th style="width: 20%;">Date</th> </tr> </thead> <tbody> <tr><td>California</td><td></td></tr> <tr><td>Colorado</td><td></td></tr> <tr><td>Connecticut</td><td></td></tr> <tr><td>Kentucky</td><td></td></tr> <tr><td>Maryland</td><td></td></tr> <tr><td>Michigan</td><td></td></tr> <tr><td>Minnesota</td><td></td></tr> <tr><td>Oregon/Washington</td><td></td></tr> <tr><td>Virginia</td><td></td></tr> </tbody> </table>	State	Date	California		Colorado		Connecticut		Kentucky		Maryland		Michigan		Minnesota		Oregon/Washington		Virginia
State	Date																			
California																				
Colorado																				
Connecticut																				
Kentucky																				
Maryland																				
Michigan																				
Minnesota																				
Oregon/Washington																				
Virginia																				
	Other Remarks:																			



## EDI-Related Data Flow - IFTA Registration - Flat File to VISTA/TS -

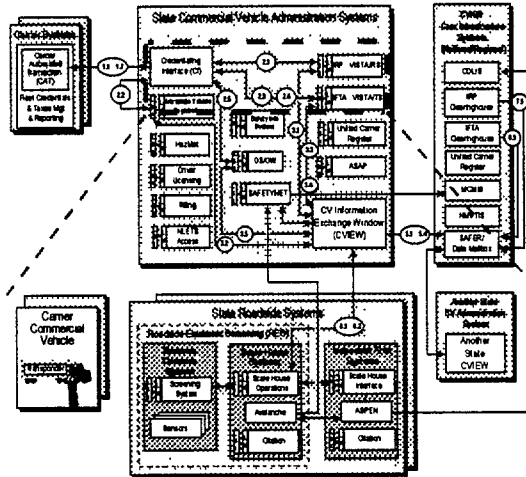

### 2.3 IFTA Registration - Flat File to VISTA/TS

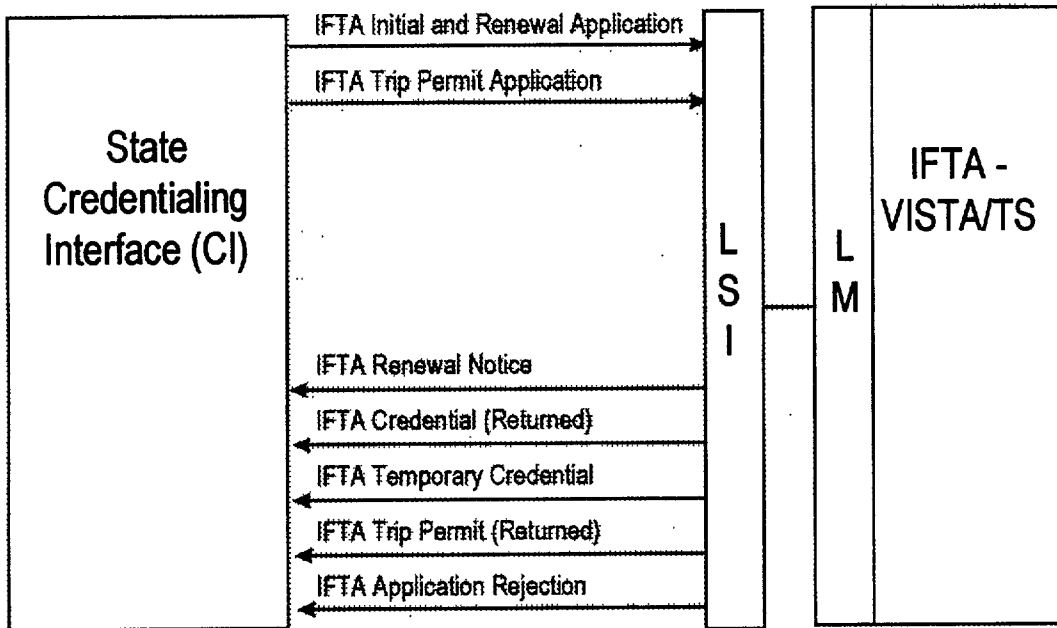

Appendix A  
EDI-Related Data Flow  
Interface Definition and Scheduling Information

ID Number: 2.3	Implementation Guide Name: TBD																								
Data Flow Name: IFTA Registration to VISTATS	Implementation Guide Due Date: TBD																								
Transaction Set or Flat File Name: Flat File to VISTA/TS																									
Source: State CI (state origin) or IFTA-VISTA/TS (VISTA origin)																									
Destination: IFTA-VISTA/TS (state origin) or State CI (VISTA origin)																									
Data Flow Description: IFTA credentialing information exchanged between the state CI and the IFTA-VISTA/TS System.																									
Associated Transaction Sets/Data Flows: TS 813 (Quarterly Fuel Tax Filing)																									
APL Point of Contact: Name: Edward J. Moses Phone: (301) 953-6000 x3461 E-mail: ed.moses@jhuapl.edu  Contributing/Reviewing Organization: Name: Phone: E-mail:  Contributing/Reviewing Organization: Name: Phone: E-mail:  Contributing/Reviewing Organization: Name: Phone: E-mail:  Contributing/Reviewing Organization: Name: Phone: E-mail:  Contributing/Reviewing Organization: Name: Phone: E-mail:  Contributing/Reviewing Organization: Name: Phone: E-mail:	<table border="1" style="width: 100%; border-collapse: collapse;"> <thead> <tr> <th colspan="2" style="text-align: center;">States Implementing this Interface</th> </tr> <tr> <th style="text-align: center;">State</th> <th style="text-align: center;">Date</th> </tr> </thead> <tbody> <tr> <td>California</td> <td></td> </tr> <tr> <td>Colorado</td> <td></td> </tr> <tr> <td>Connecticut</td> <td></td> </tr> <tr> <td>Kentucky</td> <td></td> </tr> <tr> <td>Maryland</td> <td></td> </tr> <tr> <td>Michigan</td> <td></td> </tr> <tr> <td>Minnesota</td> <td></td> </tr> <tr> <td>Oregon/Washington</td> <td></td> </tr> <tr> <td>Virginia</td> <td></td> </tr> <tr> <td colspan="2" style="height: 150px; vertical-align: top;">Other Remarks:</td> </tr> </tbody> </table>	States Implementing this Interface		State	Date	California		Colorado		Connecticut		Kentucky		Maryland		Michigan		Minnesota		Oregon/Washington		Virginia		Other Remarks:	
States Implementing this Interface																									
State	Date																								
California																									
Colorado																									
Connecticut																									
Kentucky																									
Maryland																									
Michigan																									
Minnesota																									
Oregon/Washington																									
Virginia																									
Other Remarks:																									

## EDI-Related Data Flow - IFTA Tax Filing

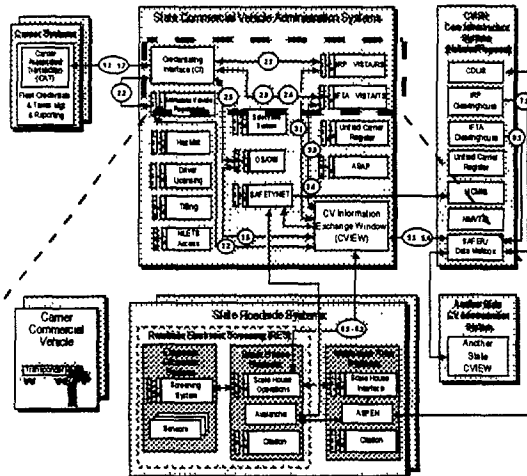

### 2.4 IFTA Tax Filing - TS 813 or Flat File to VISTA/TS

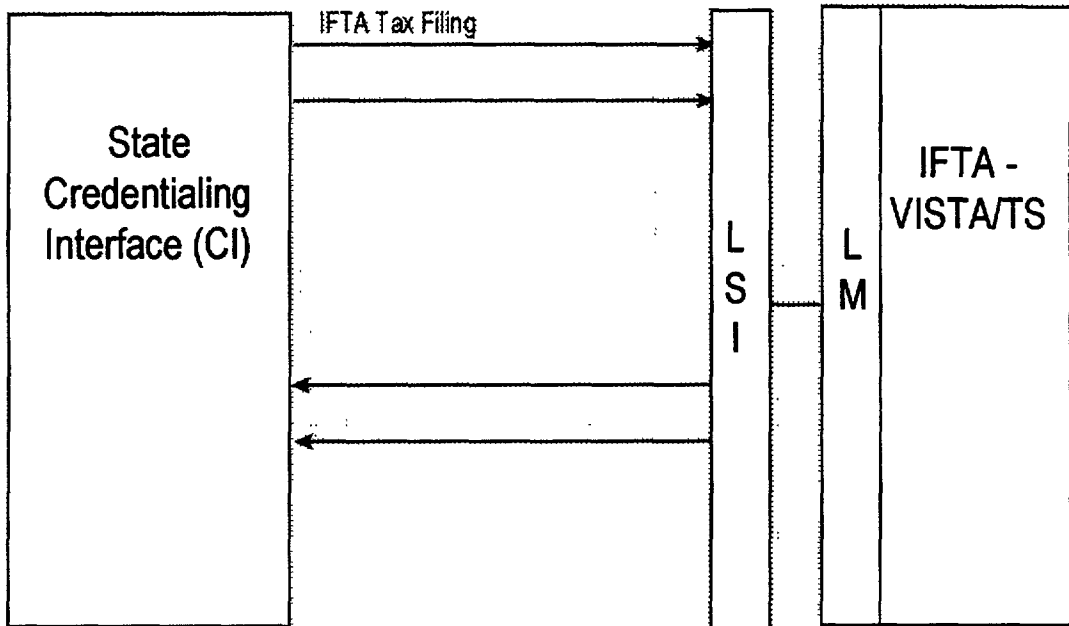

Appendix A  
 EDI-Related Data Flow  
 Interface Definition and Scheduling Information

ID Number: 2.4	Implementation Guide Name: TS 813 Tax Filing																						
Data Flow Name: IFTA Tax Filing to VISTA/TS	Implementation Guide Due Date: (Complete)																						
Transaction Set or Flat File Name: TS 813, Quarterly Fuel Tax Filing																							
Source: State CI (state origin) or IFTA-VISTA/TS (VISTA origin)																							
Destination: IFTA-VISTA/TS (state origin) or State CI (VISTA origin)																							
Data Flow Description: IFTA tax filing information exchanged between the state CI and IFTA-VISTA/TS system.																							
Associated Transaction Sets/Data Flows:																							
APL Point of Contact: Name: Edward J. Moses Phone: (30 1) 953-6000 x346 1 E-mail: ed.moses@jhuapl.edu  Contributing/Reviewing Organization: Name: Phone: E-mail:  Contributing/Reviewing Organization: Name: Phone: E-mail:  Contributing/Reviewing Organization: Name: Phone: E-mail:  Contributing/Reviewing Organization: Name: Phone: E-mail:  Contributing/Reviewing Organization: Name: Phone: E-mail:	<table border="1" style="width: 100%; border-collapse: collapse;"> <thead> <tr> <th colspan="2" style="text-align: center;">States Implementing this Interface</th> </tr> <tr> <th style="text-align: center;">State</th> <th style="text-align: center;">Date</th> </tr> </thead> <tbody> <tr> <td>California</td> <td></td> </tr> <tr> <td>Colorado</td> <td></td> </tr> <tr> <td>Connecticut</td> <td></td> </tr> <tr> <td>Kentucky</td> <td></td> </tr> <tr> <td>Maryland</td> <td></td> </tr> <tr> <td>Michigan</td> <td></td> </tr> <tr> <td>Minnesota</td> <td></td> </tr> <tr> <td>Oregon/Washington</td> <td></td> </tr> <tr> <td>Virginia</td> <td></td> </tr> </tbody> </table> Other Remarks:	States Implementing this Interface		State	Date	California		Colorado		Connecticut		Kentucky		Maryland		Michigan		Minnesota		Oregon/Washington		Virginia	
States Implementing this Interface																							
State	Date																						
California																							
Colorado																							
Connecticut																							
Kentucky																							
Maryland																							
Michigan																							
Minnesota																							
Oregon/Washington																							
Virginia																							

## EDI-Related Data Flow - IRP Summary Data

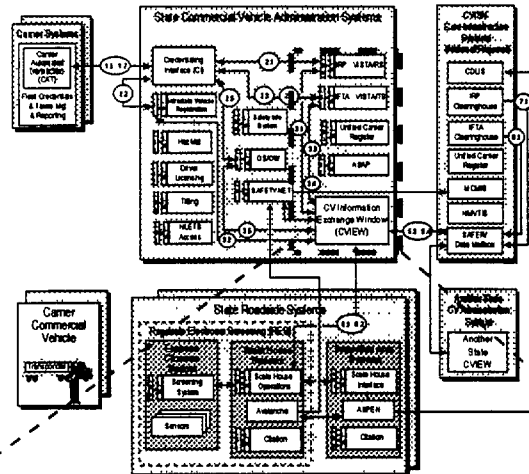

### 3.1 IRP Summary Data - Flat File

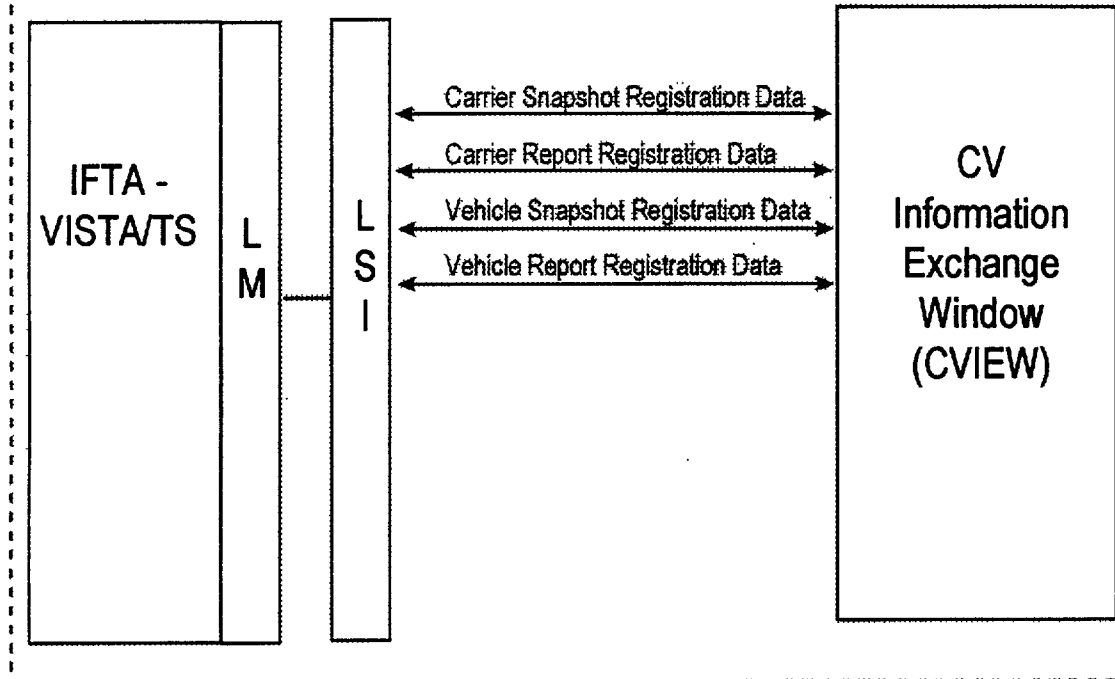

**Appendix A**  
**EDI-Related Data Flow**  
**Interface Definition and Scheduling Information**

ID Number: 3.1	Implementation Guide Name: TBD																								
Data Flow Name: IRP Summary Data	Implementation Guide Due Date: TBD																								
Transaction Set or Flat File Name: EDI File or Flat File of IRP summary data																									
Source: IFTA-VISTA/TS (VISTA origin) or CVIEW (SAFER origin)																									
Destination: SAFER (via CVIEW) or IFTA-VISTA/TS (SAFER origin)																									
Data Flow Description: IRP Summary Data exchange between IFTA-VISTA/TS and SAFER (via CVIEW). Carrier/Vehicle snapshot and reports.																									
Associated Transaction Sets/Data Flows: TS 285, Safety and Credentials Information Exchange																									
<p>APL Point of Contact:  Name: Edward J. Moses  Phone: (301) 953-6000 x3461  E-mail: ed.moses@jhuapl.edu</p> <p>Contributing/Reviewing Organization:  Name:  Phone:  E-mail:</p> <p>Contributing/Reviewing Organization:  Name:  Phone:  E-mail:</p> <p>Contributing/Reviewing Organization:  Name:  Phone:  E-mail:</p> <p>Contributing/Reviewing Organization:  Name:  Phone:  E-mail:</p> <p>Contributing/Reviewing Organization:  Name:  Phone:  E-mail:</p>	<table border="1" style="width: 100%; border-collapse: collapse;"> <thead> <tr> <th colspan="2" style="text-align: center;">States Implementing this Interface</th> </tr> <tr> <th style="width: 80%;">State</th> <th style="width: 20%;">Date</th> </tr> </thead> <tbody> <tr><td>California</td><td></td></tr> <tr><td>Colorado</td><td></td></tr> <tr><td>Connecticut</td><td></td></tr> <tr><td>Kentucky</td><td></td></tr> <tr><td>Maryland</td><td></td></tr> <tr><td>Michigan</td><td></td></tr> <tr><td>Minnesota</td><td></td></tr> <tr><td>Oregon/Washington</td><td></td></tr> <tr><td>Virginia</td><td></td></tr> <tr> <td colspan="2" style="height: 150px; vertical-align: top;">Other Remarks:</td> </tr> </tbody> </table>	States Implementing this Interface		State	Date	California		Colorado		Connecticut		Kentucky		Maryland		Michigan		Minnesota		Oregon/Washington		Virginia		Other Remarks:	
States Implementing this Interface																									
State	Date																								
California																									
Colorado																									
Connecticut																									
Kentucky																									
Maryland																									
Michigan																									
Minnesota																									
Oregon/Washington																									
Virginia																									
Other Remarks:																									

## EDI-Related Data Flow - Intrastate Registration Summary Data

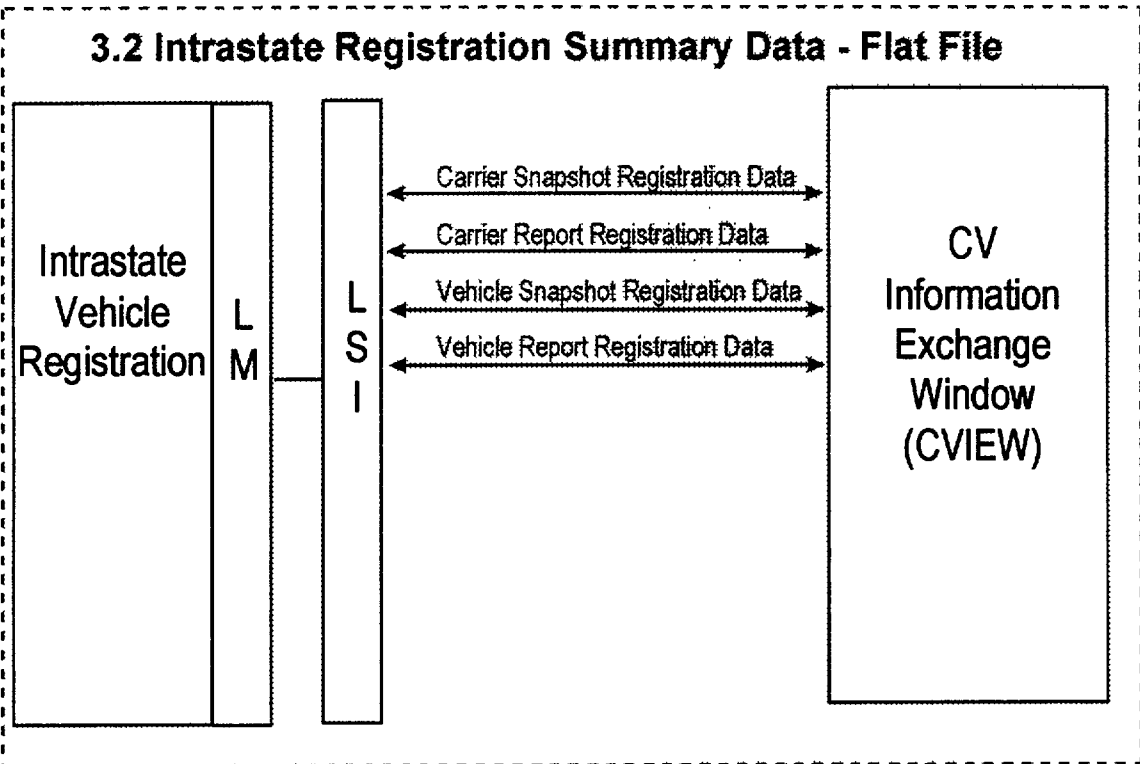
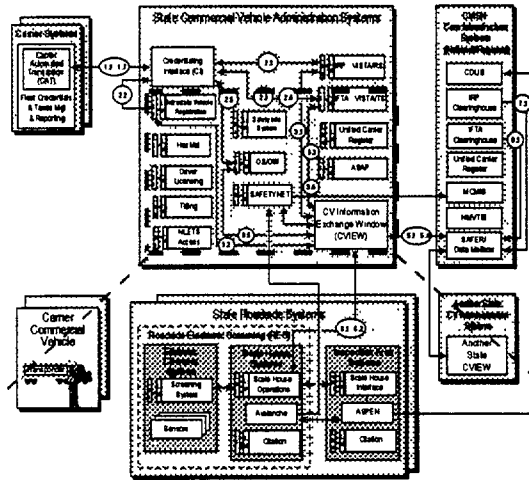

**Appendix A**  
**EDI-Related Data Flow**  
**Interface Definition and Scheduling Information**

ID Number: 3.2	Implementation Guide Name: TBD
Data Flow Name: Intrastate Registration Summary Data	Implementation Guide Due Date: TBD
Transaction Set or Flat File Name: EDI File or Flat File of Intrastate Registration Summary Data	
Source: Intrastate Vehicle Registration System (state origin) or SAFER (via CVIEW)	
Destination: SAFER (state origin) or Intrastate Vehicle Registration System (SAFER origin)	
Data Flow Description: Intrastate registration summary data exchanged between Intrastate Vehicle Registration System and SAFER (via CVIEW). Carrier/vehicle snapshot and reports.	

Associated Transaction Sets/Data Flows: TS 265, Safety and Credentials Information Exchange

APL Point of Contact: Name: Edward J. Moses Phone: (301) 953-6000 x3461 E-mail: ed.moses@jhuapl.edu  Contributing/Reviewing Organization: Name: Phone: E-mail:  Contributing/Reviewing Organization: Name: Phone: E-mail:  Contributing/Reviewing Organization: Name: Phone: E-mail:  Contributing/Reviewing Organization: Name: Phone: E-mail:  Contributing/Reviewing Organization: Name: Phone: E-mail:	States Implementing this Interface																			
	<table border="1" style="width: 100%; border-collapse: collapse;"> <thead> <tr> <th style="width: 80%;">State</th> <th style="width: 20%;">Date</th> </tr> </thead> <tbody> <tr><td>California</td><td></td></tr> <tr><td>Colorado</td><td></td></tr> <tr><td>Connecticut</td><td></td></tr> <tr><td>Kentucky</td><td></td></tr> <tr><td>Maryland</td><td></td></tr> <tr><td>Michigan</td><td></td></tr> <tr><td>Minnesota</td><td></td></tr> <tr><td>Oregon/Washington</td><td></td></tr> <tr><td>Virginia</td><td></td></tr> </tbody> </table>	State	Date	California		Colorado		Connecticut		Kentucky		Maryland		Michigan		Minnesota		Oregon/Washington		Virginia
State	Date																			
California																				
Colorado																				
Connecticut																				
Kentucky																				
Maryland																				
Michigan																				
Minnesota																				
Oregon/Washington																				
Virginia																				
	Other Remarks:																			



## EDI-Related Data Flow - IFTA Status Data

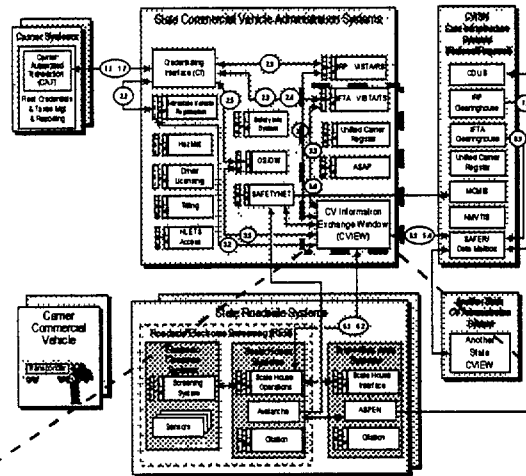

### 3.3 IFTA Status Data - Flat File

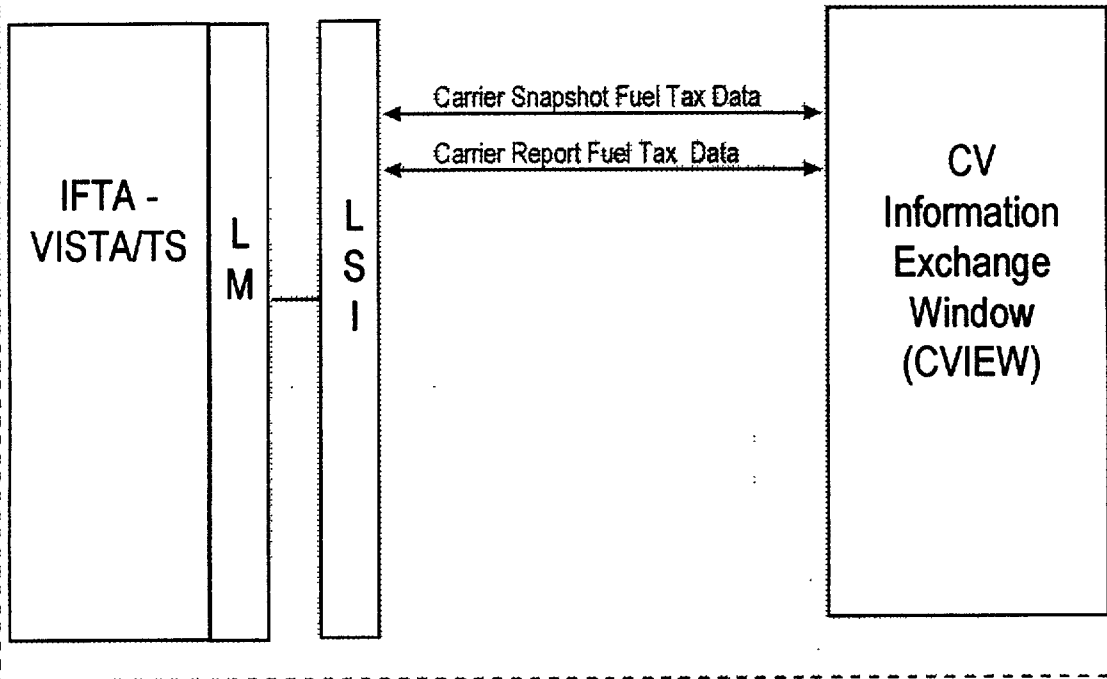

**Appendix A**  
**EDI-Related Data Flow**  
**Interface Definition and Scheduling Information**

ID Number: 3.3	Implementation Guide Name: TBD	
Data Flow Name: IFTA Status Data	Implementation Guide Due Date: TBD	
Transaction Set or Flat File Name: EDI File or Flat File of IFTA status data		
Source: IFTA VISTA/TS System (state origin) or CVIEW (SAFER origin)		
Destination: SAFER via CVIEW (state origin) or IFTA-VISTA/TS (SAFER origin)		
Data Flow Description: IFTA status data exchanged between IFTA VISTA/TS System and SAFER (via CVIEW). Carrier/vehicle snapshot and reports of fuel tax data.		
Associated Transaction Sets/Data Flows: TS 285 (Safety and Credentials Information Exchange); TS 813 (Quarterly Fuel Tax Filing)		
APL Point of Contact: Name: Edward J. Moses Phone: (301) 953-6000 x3461 E-mail: ed.moses@jhuapl.edu  Contributing/Reviewing Organization: Name: Phone: E-mail:  Contributing/Reviewing Organization: Name: Phone: E-mail:  Contributing/Reviewing Organization: Name: Phone: E-mail:  Contributing/Reviewing Organization: Name: Phone: E-mail:  Contributing/Reviewing Organization: Name: Phone: E-mail:  Contributing/Reviewing Organization: Name: Phone: E-mail:	<b>States Implementing this Interface</b>	
	State	Date
	California Colorado Connecticut Kentucky Maryland Michigan Minnesota Oregon/Washington Virginia	
	Other Remarks:	

## EDI-Related Data Flow - IFTA Status Data

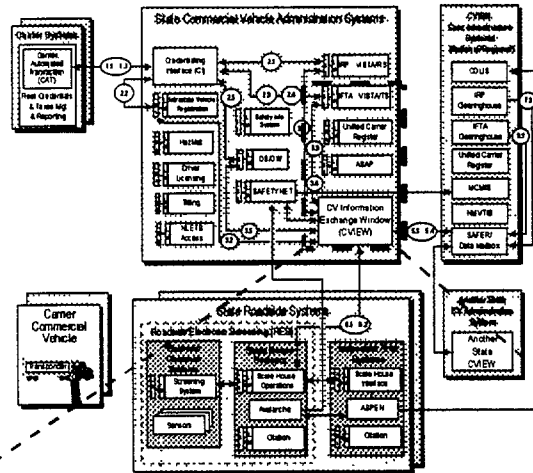

### 3.4 IFTA Tax Filing - TS 813 or Flat File

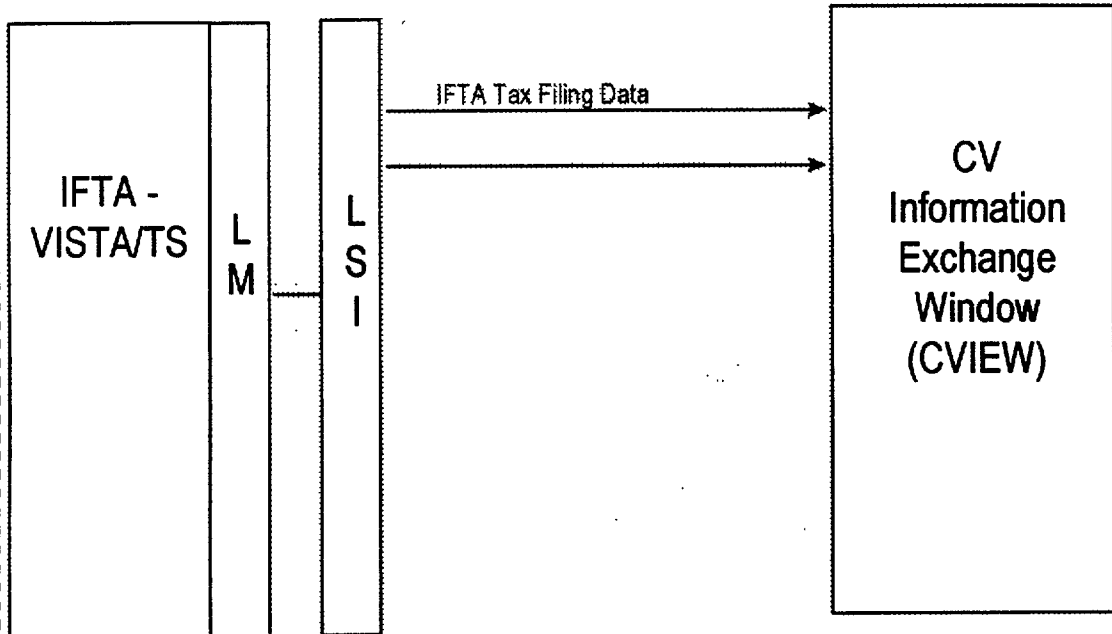

**Appendix A**  
**EDI-Related Data Flow**  
**Interface Definition and Scheduling Information**

ID Number	3.4	Implementation Guide Name:	TS 813, IFTA Tax Filing
Data Flow Name:	State IFTA Tax Filing Data	Implementation Guide Due Date:	(Complete)
Transaction Set or Flat File Name: TS 813 EDI File or Flat File			
Source: IFTA-VISTA/TS (state origin)			
Destination: CVIEW (state origin)			
Data Flow Description: IFTA Tax Filing Data sent to state CVIEW system in EDI or flat file format.			

Associated Transaction Sets/Data Flows:

	States Implementing this Interface
	State                      Date
APL Point of Contact: Name: Edward J. Moses Phone: (30 1) 953-6000 x346 1 E-mail: ed.moses@jhuapl.edu	California Colorado Connecticut Kentucky Maryland Michigan Minnesota Oregon/Washington Virginia
Contributing/Reviewing Organization: Name: Phone: E-mail:	
Contributing/Reviewing Organization: Name: Phone: E-mail:	
Contributing/Reviewing Organization: Name: Phone: E-mail:	
Contributing/Reviewing Organization: Name: Phone: E-mail:	
Contributing/Reviewing Organization: Name: Phone: E-mail:	
Other Remarks:	

# EDI-Related Data Flow - OS/OW Summary Data

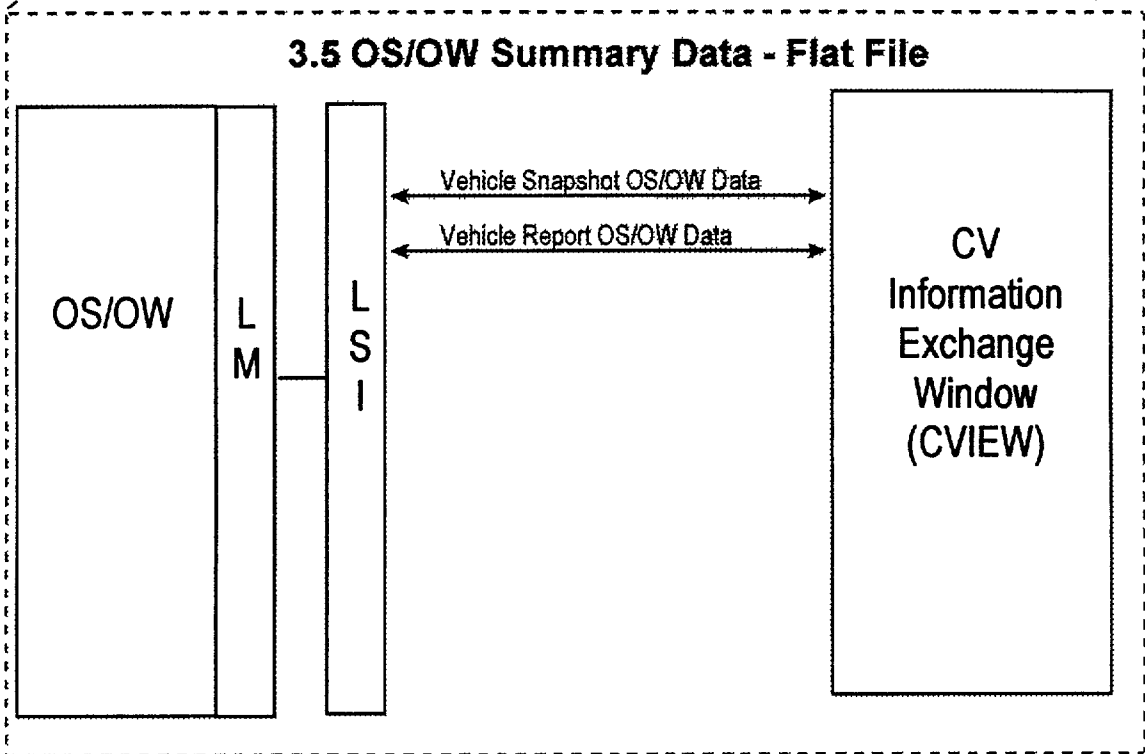
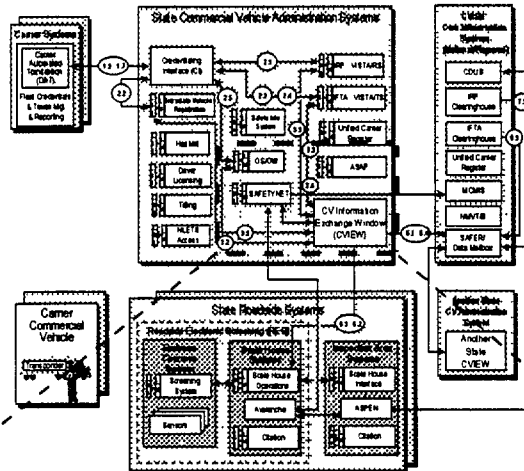

**Appendix A**  
**EDI-Related Data Flow**  
**Interface Definition and Scheduling Information**

ID Number: 3.5	Implementation Guide Name: TED																				
Data Flow Name: OS/OW summary data	Implementation Guide Due Date: TBD																				
Transaction Set or Flat File Name: EDI File or Flat file of OS/OW data																					
Source: State OS/OW System (state origin) or CVIEW (SAFER origin)																					
Destination: SAFER via CVIEW (state origin) or OS/OW System (SAFER origin)																					
Data Flow Description: Oversize/overweight summary data exchanged between the state oversize/overweight system and SAFER (via CVIEW). Vehicle snapshots and reports of OS/OW data.																					
Associated Transaction Sets/Data Flows: TS 285, Safety and Credentials information Exchange																					
<b>States Implementing this Interface</b>																					
	<table border="1" style="width: 100%; border-collapse: collapse;"> <thead> <tr> <th style="width: 80%;">State</th> <th style="width: 20%;">Date</th> </tr> </thead> <tbody> <tr> <td>California</td> <td></td> </tr> <tr> <td>Colorado</td> <td></td> </tr> <tr> <td>Connecticut</td> <td></td> </tr> <tr> <td>Kentucky</td> <td></td> </tr> <tr> <td>Maryland</td> <td></td> </tr> <tr> <td>Michigan</td> <td></td> </tr> <tr> <td>Minnesota</td> <td></td> </tr> <tr> <td>Oregon/Washington</td> <td></td> </tr> <tr> <td>Virginia</td> <td></td> </tr> </tbody> </table>	State	Date	California		Colorado		Connecticut		Kentucky		Maryland		Michigan		Minnesota		Oregon/Washington		Virginia	
State	Date																				
California																					
Colorado																					
Connecticut																					
Kentucky																					
Maryland																					
Michigan																					
Minnesota																					
Oregon/Washington																					
Virginia																					
APL Point of Contact: Name: Edward J. Moses Phone: (301) 953-6000 x3461 E-mail: ed.moses@jhuapl.edu  Contributing/Reviewing Organization: GDS Name: Jonathon Tarr Phone: E-mail:  Contributing/Reviewing Organization: Name: Phone: E-mail:  Contributing/Reviewing Organization: Name: Phone: E-mail:  Contributing/Reviewing Organization: Name: Phone: E-mail:  Contributing/Reviewing Organization: Name: Phone: E-mail:  Contributing/Reviewing Organization: Name: Phone: E-mail:	Other Remarks:																				

## EDI-Related Data Flow - Interstate Registration Data

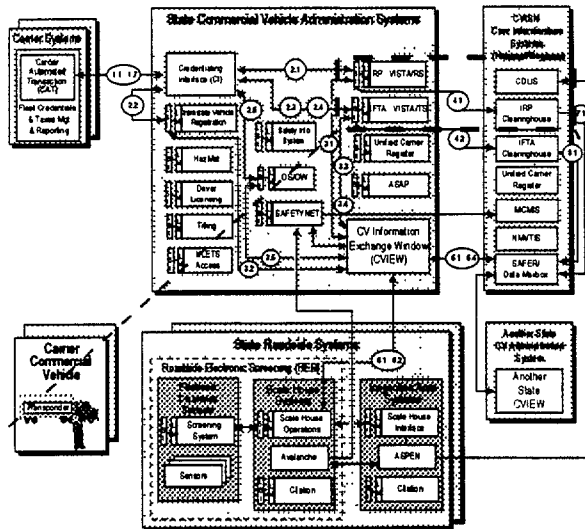

### 4.1 Interstate Registration Data - TS 286 or Flat File

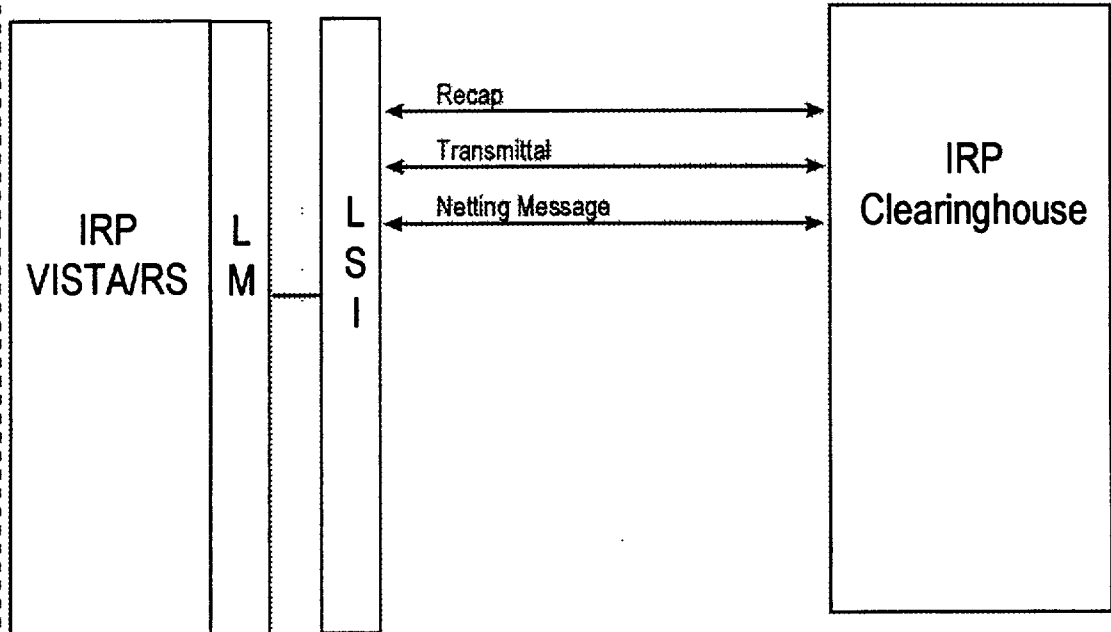

**Appendix A**  
**EDI-Related Data Flow**  
**Interface Definition and Scheduling Information**

ID Number: 4.1	Implementation Guide Name: TS 286, IRP Interstate																			
Data Flow Name: Interstate Registration Data	Implementation Guide Due Date: 12/1/96																			
Transaction Set or Flat File Name: TS 286, Commercial Vehicle Credentials - IRP Interstate (or Flat File)																				
Source: IRP VISTA/RS (state origin) or IRP Clearinghouse																				
Destination: IRP Clearinghouse (state origin) or IRP VISTA/RS System (IRP Clearinghouse origin)																				
Data Flow Description: Interstate registration data exchanged between the IRP VISTA/RS and the IRP Clearinghouse. Recap, transmittal, and netting messages.																				
Associated Transaction Sets/Data Flows: TS 997 (Functional acknowledgment), TS 810 (Invoice), TS 820 (Payment Order/Remittance Advice), TS 864 (Text message)																				
APL Point of Contact: Name: Edward J. Moses Phone: (301) 953-6000 x3461 E-mail: ed.moses@jhuapl.edu  Contributing/Reviewing Organization: RS Information Systems Name: Glen Marier Phone: (301) 9536000 x3612 E-mail: MarieGA@central.ssd.jhuapl.edu  Contributing/Reviewing Organization: AAMVA/MW 1-Stop Name: Charlie Katz Phone: (703) 9086766 E-mail: usamvck1@ibmmail.com  Contributing/Reviewing Organization: IDT/SW 1-Stop Name: Terri Ungerman Phone: (303) 652-0332 E-mail: 76042.1763@compuserve.com  Contributing/Reviewing Organization: IRP, Inc. Name: Stan Kelly Phone: (703) 908-5765 E-mail:  Contributing/Reviewing Organization: HELP I-Stop Name: Jim Gentner Phone: (602) 252-1598 E-mail:  Contributing/Reviewing Organization: CVIS Name: Bonnie Bass/FHWA Phone: (202) 366-7298 E-mail: bbass@intergate.dot.gov	States Implementing this Interface																			
	<table border="1"> <thead> <tr> <th style="text-align: center;">State</th> <th style="text-align: center;">Date</th> </tr> </thead> <tbody> <tr><td>California</td><td></td></tr> <tr><td>Colorado</td><td></td></tr> <tr><td>Connecticut</td><td></td></tr> <tr><td>Kentucky</td><td></td></tr> <tr><td>Maryland</td><td></td></tr> <tr><td>Michigan</td><td></td></tr> <tr><td>Minnesota</td><td></td></tr> <tr><td>Oregon/Washington</td><td></td></tr> <tr><td><b>Virginia</b></td><td></td></tr> </tbody> </table>	State	Date	California		Colorado		Connecticut		Kentucky		Maryland		Michigan		Minnesota		Oregon/Washington		<b>Virginia</b>
State	Date																			
California																				
Colorado																				
Connecticut																				
Kentucky																				
Maryland																				
Michigan																				
Minnesota																				
Oregon/Washington																				
<b>Virginia</b>																				
	Other Remarks:																			



## EDI-Related Data Flow - State Credentials Data to SAFER

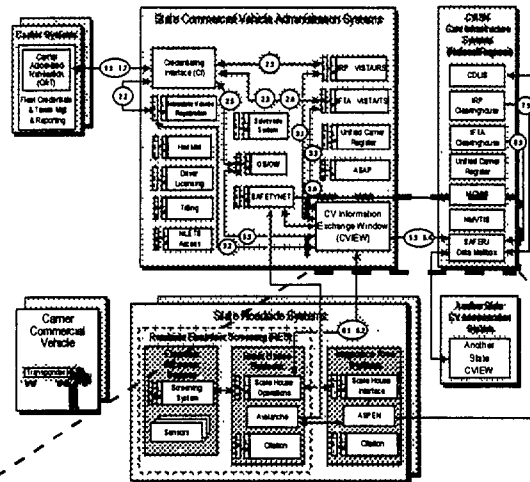

### 5.1 State Credentials Data to SAFER - TS 285

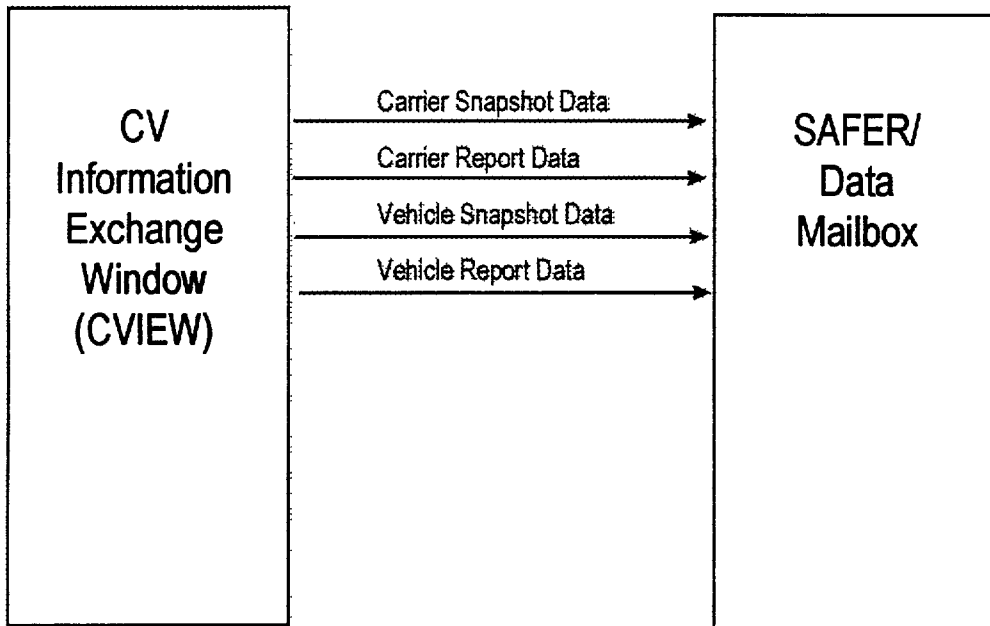

**Appendix A**  
**ED&Related Data Flow**  
**Interface Definition and Scheduling Information**

ID Number: 5.1	Implementation Guide Name: TS 285, CV Safety and Credentials Information Exchange
Data Flow Name: State Credentials Data to SAFER	Implementation Guide Due Date: 12/1/96
Transaction Set or Flat File Name: TS 285, CV Safety and Credentials Information Exchange	
Source: CVIEW (state origin) or SAFER	
Destination: SAFER (state origin) or CVIEW (SAFER origin)	
Data Flow Description: State credentials data sent from CVIEW to SAFER. Carrier/vehicle snapshot and report data.	

Associated Transaction Sets/Data Flows:

APL Point of Contact: Name: Paul D. North Phone: (301) 953-6627 E-mail: paul.north@jhuapl.edu  Contributing/Reviewing Organization: SAIC Name: Phone: E-mail:  Contributing/Reviewing Organization: SAFER TSC Name: Phone: E-mail:  Contributing/Reviewing Organization: Name: Phone: E-mail:  Contributing/Reviewing Organization: Name: Phone: E-mail:  Contributing/Reviewing Organization: Name: Phone: E-mail:	States Implementing this Interface																			
	<table border="1" style="width: 100%; border-collapse: collapse;"> <thead> <tr> <th style="width: 80%;">State</th> <th style="width: 20%;">Date</th> </tr> </thead> <tbody> <tr><td>California</td><td></td></tr> <tr><td>Colorado</td><td></td></tr> <tr><td>Connecticut</td><td></td></tr> <tr><td>Kentucky</td><td></td></tr> <tr><td>Maryland</td><td></td></tr> <tr><td>Michigan</td><td></td></tr> <tr><td>Minnesota</td><td></td></tr> <tr><td>Oregon/Washington</td><td></td></tr> <tr><td>Virginia</td><td></td></tr> </tbody> </table>	State	Date	California		Colorado		Connecticut		Kentucky		Maryland		Michigan		Minnesota		Oregon/Washington		Virginia
State	Date																			
California																				
Colorado																				
Connecticut																				
Kentucky																				
Maryland																				
Michigan																				
Minnesota																				
Oregon/Washington																				
Virginia																				
	Other Remarks:  TS 285 <b>was approved</b> by XI2 ballot and designated a Draft Standard for Trial Use (DSTU).																			

# EDI-Related Data Flow - SAFETYNET Data to SAFER

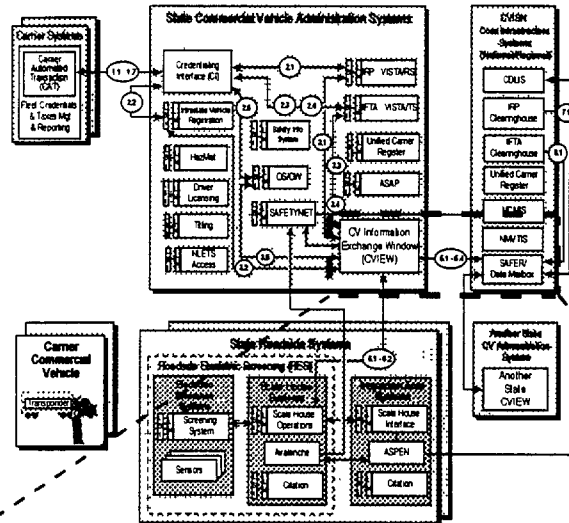

## 5.2 SAFETYNET Data to SAFER - TS 285

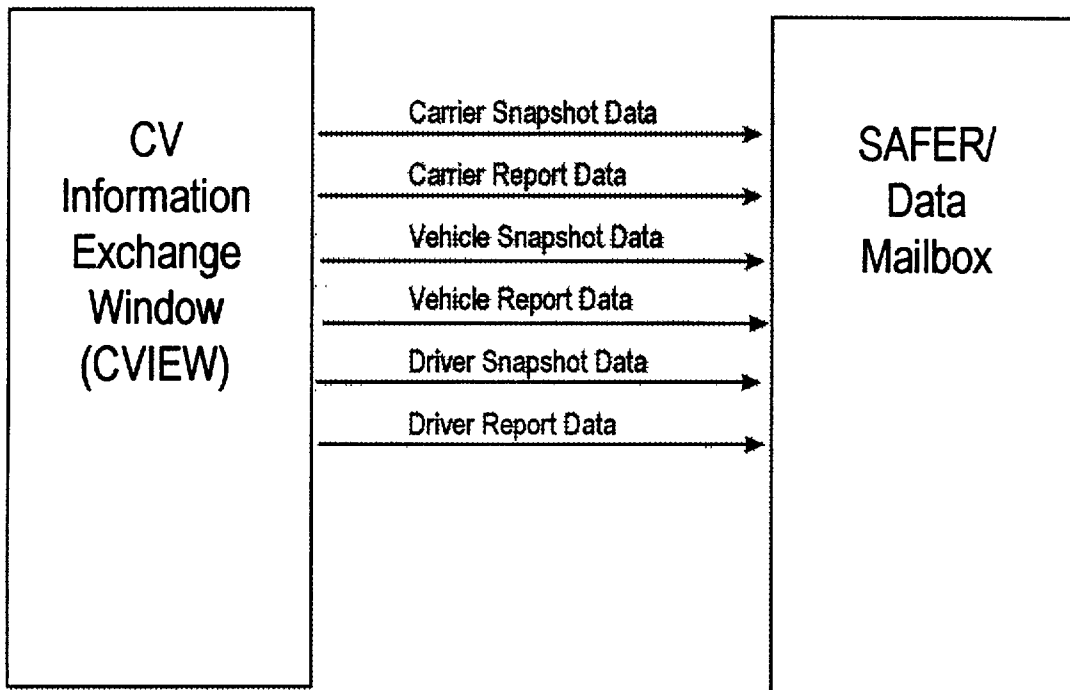

**Appendix A**  
**EDI-Related Data Flow**  
**Interface Definition and Scheduling Information**

ID Number: 5.2	Implementation Guide Name: TS 285. CV Safety and Credentials Information Exchange																			
Data Flow Name: SAFETYNET Data to SAFER	Implementation Guide Due Date: 12/1/96																			
Transaction Set or Flat File Name: TS 285, CV Safety and Credentials information Exchange																				
Source: CVIEW (state origin)																				
Destination: SAFER																				
Data Flow Description: State SAFETYNET data sent from SAFETYNET (via CVIEW) to SAFER. Carrier/vehicle snapshot and report data.																				
Associated Transaction Sets/Data Flows:																				
APL Point of Contact: Name: Paul D. North Phone: (301) 953-6627 E-mail: paul.north@jhuapl.edu  Contributing/Reviewing Organization: SAIC Name: Phone: E-mail:  Contributing/Reviewing Organization: SAFER TSC Name: Phone: E-mail:  Contributing/Reviewing Organization: Name: Phone: E-mail:  Contributing/Reviewing Organization: Name: Phone: E-mail:  Contributing/Reviewing Organization: Name: Phone: E-mail:	States Implementing this Interface																			
	<table border="1" style="width: 100%; border-collapse: collapse;"> <thead> <tr> <th style="width: 80%;">State</th> <th>Date</th> </tr> </thead> <tbody> <tr><td>California</td><td></td></tr> <tr><td>Colorado</td><td></td></tr> <tr><td>Connecticut</td><td></td></tr> <tr><td>Kentucky</td><td></td></tr> <tr><td>Maryland</td><td></td></tr> <tr><td>Michigan</td><td></td></tr> <tr><td>Minnesota</td><td></td></tr> <tr><td>Oregon/Washington</td><td></td></tr> <tr><td>Virginia</td><td></td></tr> </tbody> </table>	State	Date	California		Colorado		Connecticut		Kentucky		Maryland		Michigan		Minnesota		Oregon/Washington		Virginia
State	Date																			
California																				
Colorado																				
Connecticut																				
Kentucky																				
Maryland																				
Michigan																				
Minnesota																				
Oregon/Washington																				
Virginia																				
	Other Remarks:  TS 285 <b>was</b> approved by XI2 ballot and designated a Draft Standard for Trial Use (DSTU).																			

## EDI-Related Data Flow - Data Query to SAFER

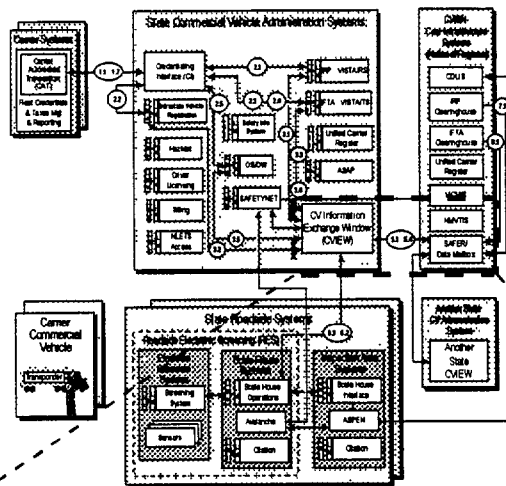

### 5.3 Data Query to SAFER - TS 285

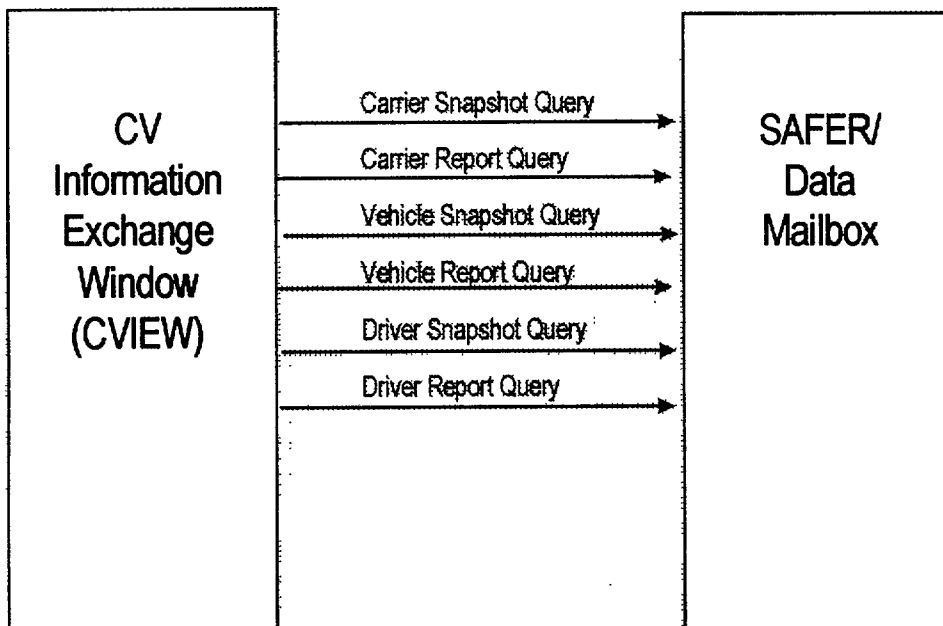

**Appendix A**  
**EDI-Related Data Flow**  
**Interface Definition and Scheduling Information**

ID Number: 5.3	Implementation Guide Name: TS 285, CV Safety and Credentials Information Exchange																						
Data Flow Name: Data Query to SAFER	Implementation Guide Due Date: 12/1/96																						
Transaction Set or Flat File Name: TS 285, CV Safety and Credentials Information Exchange																							
Source: CVIEW																							
Destination: SAFER/Data Mailbox																							
Data Flow Description: State data query sent from CVIEW to SAFER. Carrier/vehicle/driver snapshot and report data request.																							
Associated Transaction Sets/Data Flows:																							
<p>APL Point of Contact:  Name: Paul D. North  Phone: (301) 953-6627  E-mail: paul.north@jhuapl.edu</p> <p>Contributing/Reviewing Organization: SAIC  Name:  Phone:  E-mail:</p> <p>Contributing/Reviewing Organization: SAFER TSC  Name:  Phone:  E-mail:</p> <p>Contributing/Reviewing Organization:  Name:  Phone:  E-mail:</p> <p>Contributing/Reviewing Organization:  Name:  Phone:  E-mail:</p> <p>Contributing/Reviewing Organization:  Name:  Phone:  E-mail:</p>	<table border="1" style="width: 100%; border-collapse: collapse;"> <thead> <tr> <th colspan="2" style="text-align: center;">States Implementing this Interface</th> </tr> <tr> <th style="width: 80%;">State</th> <th style="width: 20%;">Date</th> </tr> </thead> <tbody> <tr> <td>California</td> <td></td> </tr> <tr> <td>Colorado</td> <td></td> </tr> <tr> <td>Connecticut</td> <td></td> </tr> <tr> <td>Kentucky</td> <td></td> </tr> <tr> <td>Maryland</td> <td></td> </tr> <tr> <td>Michigan</td> <td></td> </tr> <tr> <td>Minnesota</td> <td></td> </tr> <tr> <td>Oregon/Washington</td> <td></td> </tr> <tr> <td>Virginia</td> <td></td> </tr> </tbody> </table> <p>Other Remarks:   TS 285 was approved by XI2 ballot and designated a Draft Standard for Trial Use (DSTU).</p>	States Implementing this Interface		State	Date	California		Colorado		Connecticut		Kentucky		Maryland		Michigan		Minnesota		Oregon/Washington		Virginia	
States Implementing this Interface																							
State	Date																						
California																							
Colorado																							
Connecticut																							
Kentucky																							
Maryland																							
Michigan																							
Minnesota																							
Oregon/Washington																							
Virginia																							

## EDI-Related Data Flow - Data Response from SAFER

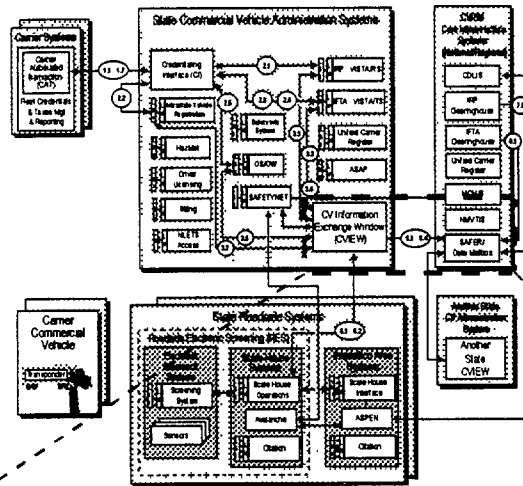

### 5.4 Data Response from SAFER - TS 285

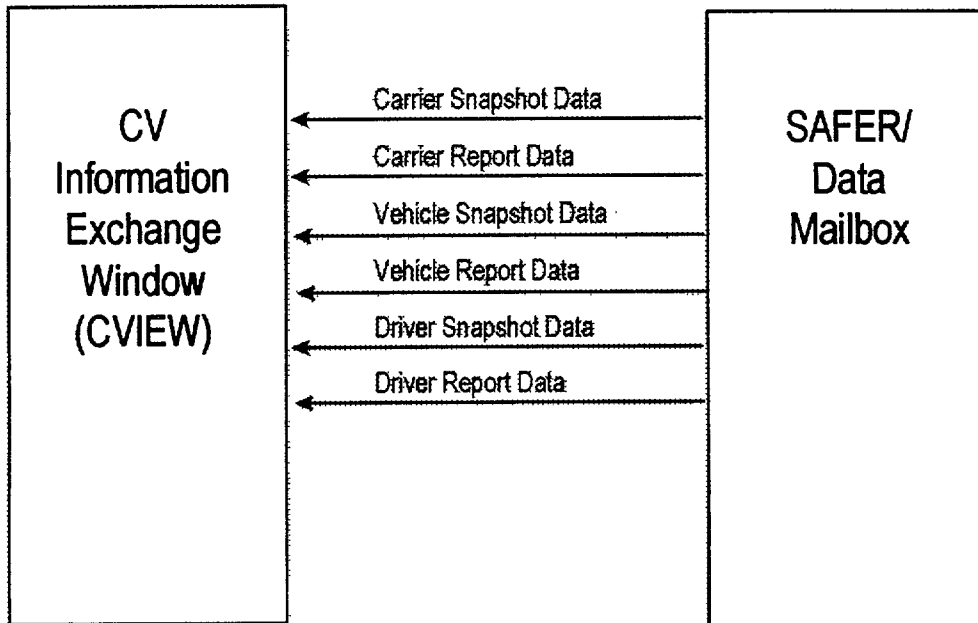

**Appendix A**  
**EDI-Related Data Flow**  
**Interface Definition and Scheduling Information**

ID Number: 5.4	Implementation Guide Name: TS 265, CV Safety and Credentials information Exchange																						
Data Flow Name: Data Response from SAFER	Implementation Guide Due Date: 12/1/96																						
Transaction Set or Flat File Name: TS 265, CV Safety and Credentials Information Exchange																							
Source: SAFER/Data Mailbox																							
Destination: CVIEW																							
Data Flow Description: Response from SAFER to state data query. Carrier/vehicle/driver data in snapshot and report format.																							
Associated Transaction Sets/Data Flows:																							
<p>APL Point of Contact:  Name: Paul D. North  Phone: (301) 953-6627  E-mail: paul.north@jhuapl.edu</p> <p>Contributing/Reviewing Organization: SAIC  Name:  Phone:  E-mail:</p> <p>Contributing/Reviewing Organization: SAFER TSC  Name:  Phone:  E-mail:</p> <p>Contributing/Reviewing Organization:  Name:  Phone:  E-mail:</p> <p>Contributing/Reviewing Organization:  Name:  Phone:  E-mail:</p> <p>Contributing/Reviewing Organization:  Name:  Phone:  E-mail:</p> <p>Contributing/Reviewing Organization:  Name:  Phone:  E-mail:</p>	<table border="1" style="width: 100%; border-collapse: collapse;"> <thead> <tr> <th colspan="2" style="text-align: center;">States Implementing this Interface</th> </tr> <tr> <th style="width: 80%;">State</th> <th style="width: 20%;">Date</th> </tr> </thead> <tbody> <tr> <td>California</td> <td></td> </tr> <tr> <td>Colorado</td> <td></td> </tr> <tr> <td>Connecticut</td> <td></td> </tr> <tr> <td>Kentucky</td> <td></td> </tr> <tr> <td>Maryland</td> <td></td> </tr> <tr> <td>Michigan</td> <td></td> </tr> <tr> <td>Minnesota</td> <td></td> </tr> <tr> <td>Oregon/Washington</td> <td></td> </tr> <tr> <td>Virginia</td> <td></td> </tr> </tbody> </table> <p>Other Remarks:   TS 285 was approved by XI2 ballot and designated a Draft Standard for Trial Use (DSTU).</p>	States Implementing this Interface		State	Date	California		Colorado		Connecticut		Kentucky		Maryland		Michigan		Minnesota		Oregon/Washington		Virginia	
States Implementing this Interface																							
State	Date																						
California																							
Colorado																							
Connecticut																							
Kentucky																							
Maryland																							
Michigan																							
Minnesota																							
Oregon/Washington																							
Virginia																							



## EDI-Related Data Flow - Roadside Data Query to SAFER

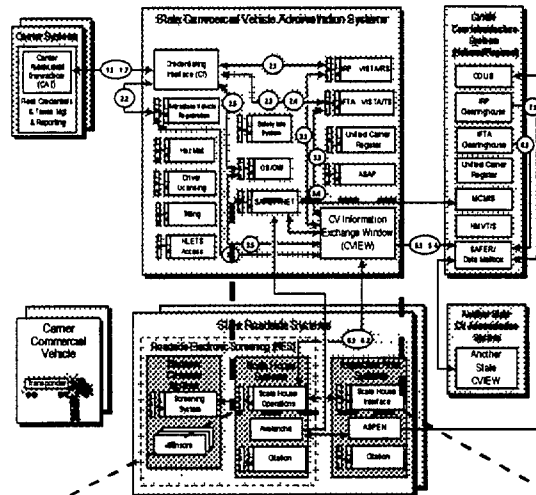

### 6.1 Roadside Data Query to SAFER - TS 285

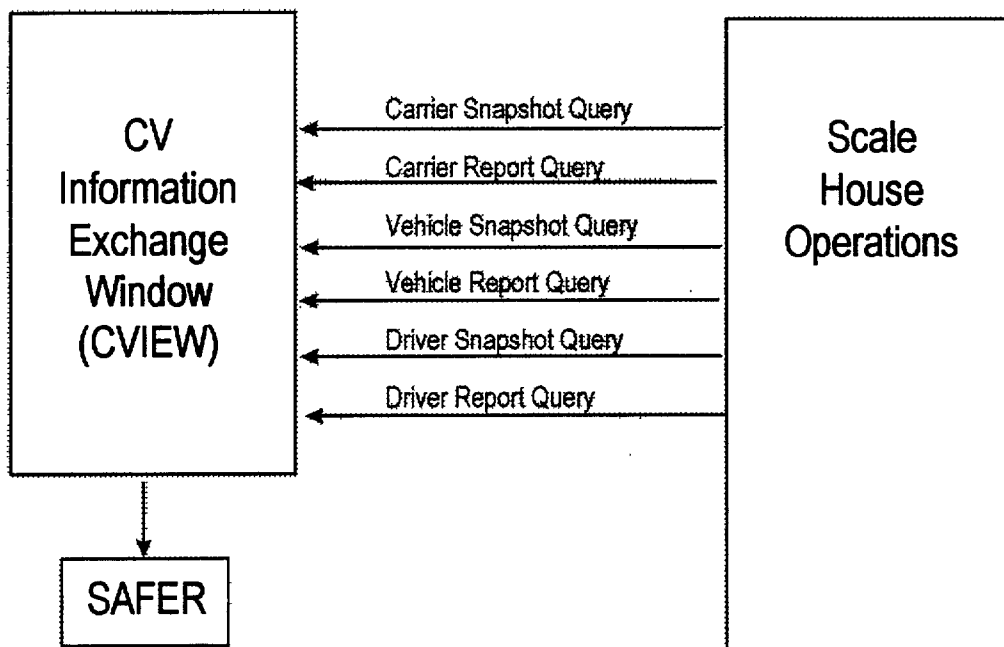

**Appendix A**  
**EDI-Related Data Flow**  
**Interface Definition and Scheduling Information**

ID Number: 6.1	Implementation Guide Name: TS 265, CV Safety and Credentials Information Exchange																						
Data Flow Name: Roadside Data Query to SAFER	Implementation Guide Due Date: 12/1/96																						
Transaction Set or Flat File Name: TS 285, CV Safety and Credentials Information Exchange																							
Source: State Roadside Scalehouse System																							
Destination: SAFER (via CVIEW)																							
Data Flow Description: Carrier/vehicle/driver snapshot and report data sent from state roadside operations to SAFER (via CVIEW). <u>intrastate</u> queries should be satisfied by CVIEW; without SAFER involvement.																							
Associated Transaction Sets/Data Flows:																							
<p>APL Point of Contact:  Name: Paul D. North  Phone: (301) 953-6627  E-mail: paul.north@jhuapl.edu</p> <p>Contributing/Reviewing Organization: SAIC  Name:  Phone:  E-mail:</p> <p>Contributing/Reviewing Organization: SAFER TSC  Name:  Phone:  E-mail:</p> <p>Contributing/Reviewing Organization:  Name:  Phone:  E-mail:</p> <p>Contributing/Reviewing Organization:  Name:  Phone:  E-mail:</p> <p>Contributing/Reviewing Organization:  Name:  Phone:  E-mail:</p>	<table border="1" style="width: 100%; border-collapse: collapse;"> <thead> <tr> <th colspan="2" style="text-align: center;">States Implementing this Interface</th> </tr> <tr> <th style="text-align: center;">State</th> <th style="text-align: center;">Date</th> </tr> </thead> <tbody> <tr> <td>California</td> <td></td> </tr> <tr> <td>Colorado</td> <td></td> </tr> <tr> <td>Connecticut</td> <td></td> </tr> <tr> <td>Kentucky</td> <td></td> </tr> <tr> <td>Maryland</td> <td></td> </tr> <tr> <td>Michigan</td> <td></td> </tr> <tr> <td>Minnesota</td> <td></td> </tr> <tr> <td>Oregon/Washington</td> <td></td> </tr> <tr> <td>Virginia</td> <td></td> </tr> </tbody> </table> <p>Other Remarks:   TS 285 was approved by XI2 ballot and designated a Draft Standard for Trial Use (DSTU).</p>	States Implementing this Interface		State	Date	California		Colorado		Connecticut		Kentucky		Maryland		Michigan		Minnesota		Oregon/Washington		Virginia	
States Implementing this Interface																							
State	Date																						
California																							
Colorado																							
Connecticut																							
Kentucky																							
Maryland																							
Michigan																							
Minnesota																							
Oregon/Washington																							
Virginia																							

# EDI-Related Data Flow - Roadside Data Response from SAFER

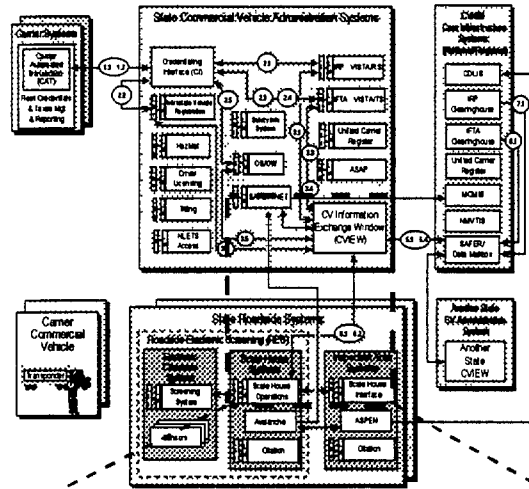

## 6.2 Roadside Data Response from SAFER - TS 285

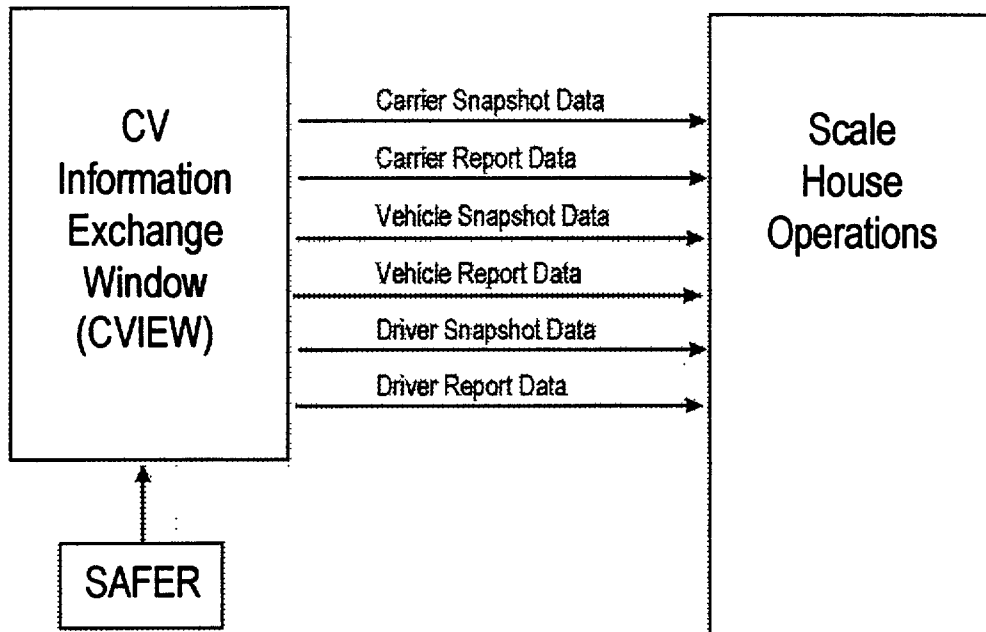

**Appendix A**  
**EDI-Related Data Flow**  
**Interface Definition and Scheduling Information**

ID Number: 6.2	Implementation Guide Name: TS 285, CV Safety and Credentials Information Exchange																			
Data Flow Name: IFTA Status Data	Implementation Guide Due Date: 12/1/96																			
Transaction Set or Flat File Name: TS 285, CV Safety and Credentials Information Exchange Source: IFTA Clearinghouse Destination: SAFER/Data Mailbox																				
Data Flow Description: Carrier fuel tax data in snapshot and report format sent from the IFTA Clearinghouse to SAFER.																				
Associated Transaction Sets/Data Flows: TS 813 (Quarterly Fuel Tax Filing)																				
APL Point of Contact: Name: Paul D. North Phone: (301) 953-6627 E-mail: paul.north@jhuapl.edu  Contributing/Reviewing Organization: SAIC Name: Phone: E-mail:  Contributing/Reviewing Organization: SAFER TSC Name: Phone: E-mail:  Contributing/Reviewing Organization: Name: Phone: E-mail:  Contributing/Reviewing Organization: Name: Phone: E-mail:  Contributing/Reviewing Organization: Name: Phone: E-mail:	States Implementing this Interface																			
	<table border="1"> <thead> <tr> <th style="width: 80%;">State</th> <th style="width: 20%;">Date</th> </tr> </thead> <tbody> <tr><td>California</td><td></td></tr> <tr><td>Colorado</td><td></td></tr> <tr><td>Connecticut</td><td></td></tr> <tr><td>Kentucky</td><td></td></tr> <tr><td>Maryland</td><td></td></tr> <tr><td>Michigan</td><td></td></tr> <tr><td>Minnesota</td><td></td></tr> <tr><td>Oregon/Washington</td><td></td></tr> <tr><td>Virginia</td><td></td></tr> </tbody> </table>	State	Date	California		Colorado		Connecticut		Kentucky		Maryland		Michigan		Minnesota		Oregon/Washington		Virginia
State	Date																			
California																				
Colorado																				
Connecticut																				
Kentucky																				
Maryland																				
Michigan																				
Minnesota																				
Oregon/Washington																				
Virginia																				
	Other Remarks:  TS 285 was approved by XI2 ballot and designated a Draft Standard for Trial Use (DSTU).																			

# EDI-Related Data Flow - Safety Data Reports

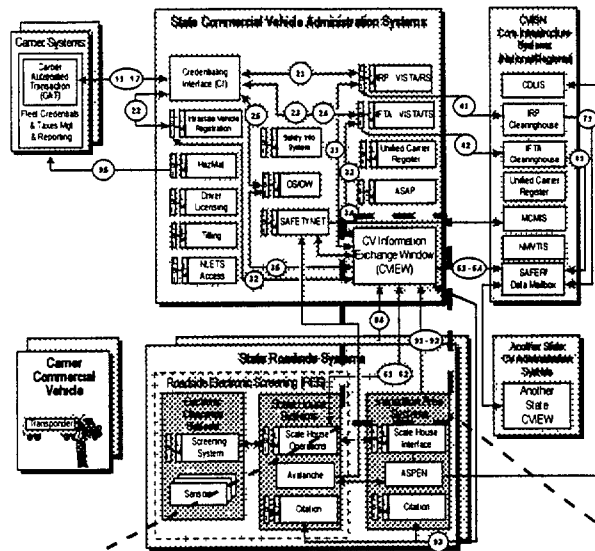

## *Preliminary Interface Definition*

### 7.1 Compliance Review Report - TS xxx

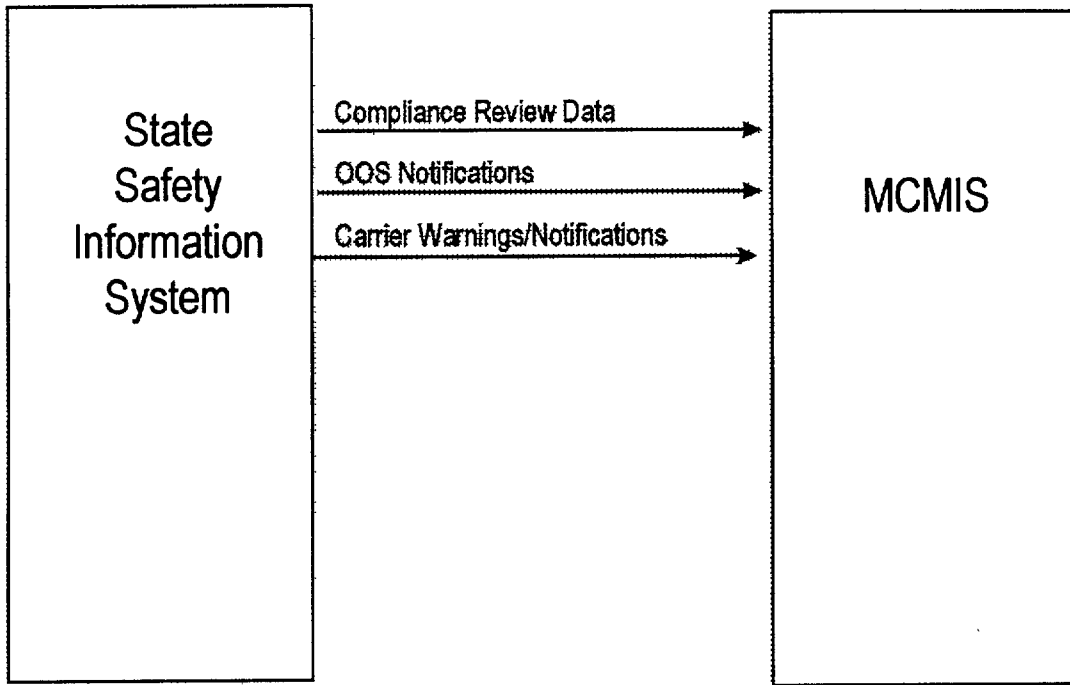

## Appendix A EDI-Related Data Flow Interface Definition and Scheduling Information

### PRELIMINARY INTERFACE DEFINITION

ID Number: 7.1	Implementation Guide Name: TS xxx, CV Safety Data Reports																								
Data Flow Name: Compliance Review Report	Implementation Guide Due Date: TBD																								
Transaction Set or Flat File Name: TS xxx, CV Safety Data Reports																									
Source: State Safety Information System																									
Destination: MCMIS																									
Data Flow Description: Compliance review results, out-of-service notifications, and carrier warnings/notifications from State Safety Information System to MCMIS.																									
Associated Transaction Sets/Data Flows:																									
<p>APL Point of Contact:  Name: Edward J. Moses  Phone: (301) 953-6000 x3461  E-mail: ed.moses@jhupl.edu</p> <p>Contributing/Reviewing Organization:  Name:  Phone:  E-mail:</p> <p>Contributing/Reviewing Organization:  Name:  Phone:  E-mail:</p> <p>Contributing/Reviewing Organization:  Name:  Phone:  E-mail:</p> <p>Contributing/Reviewing Organization:  Name:  Phone:  E-mail:</p> <p>Contributing/Reviewing Organization:  Name:  Phone:  E-mail:</p>	<table border="1" style="width: 100%; border-collapse: collapse;"> <thead> <tr> <th colspan="2" style="text-align: center;">States Implementing this Interface</th> </tr> <tr> <th style="width: 80%;">State</th> <th style="width: 20%;">Date</th> </tr> </thead> <tbody> <tr> <td>California</td> <td></td> </tr> <tr> <td>Colorado</td> <td></td> </tr> <tr> <td>Connecticut</td> <td></td> </tr> <tr> <td>Kentucky</td> <td></td> </tr> <tr> <td>Maryland</td> <td></td> </tr> <tr> <td>Michigan</td> <td></td> </tr> <tr> <td>Minnesota</td> <td></td> </tr> <tr> <td>Oregon/Washington</td> <td></td> </tr> <tr> <td>Virginia</td> <td></td> </tr> <tr> <td colspan="2" style="height: 100px; vertical-align: top;">Other Remarks:</td> </tr> </tbody> </table>	States Implementing this Interface		State	Date	California		Colorado		Connecticut		Kentucky		Maryland		Michigan		Minnesota		Oregon/Washington		Virginia		Other Remarks:	
States Implementing this Interface																									
State	Date																								
California																									
Colorado																									
Connecticut																									
Kentucky																									
Maryland																									
Michigan																									
Minnesota																									
Oregon/Washington																									
Virginia																									
Other Remarks:																									

# EDI-Related Data Flow - Safety Data Reports

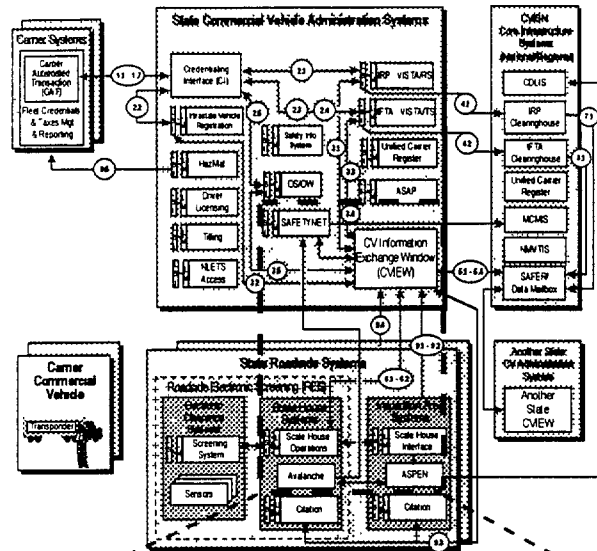

## *Preliminary Interface Definition*

### 7.2 Inspection Report Data - TS xxx

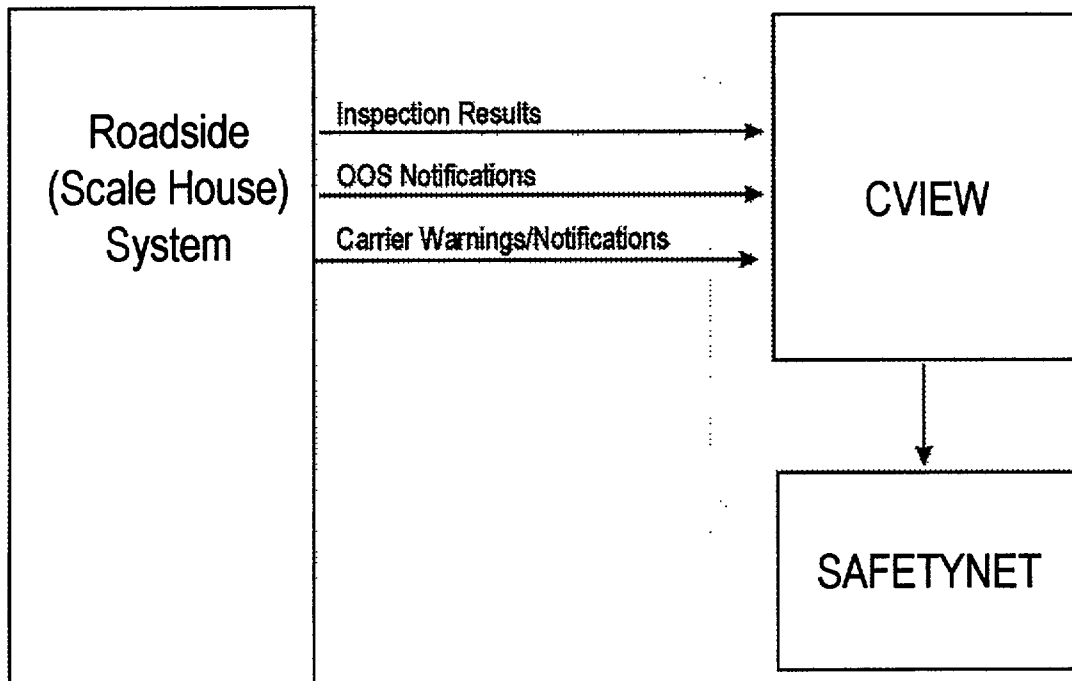

**Appendix A**  
**EDI-Related Data Flow**  
**Interface Definition and Scheduling Information**

PRELIMINARY INTERFACE DEFINITION

ID Number: <b>7.2</b>	Implementation Guide Name: TS xxx, <b>CV Safety Data Reports</b>																								
Data Flow Name: <b>Inspection Report Data</b>	Implementation Guide Due Date: TBD																								
Transaction Set or Flat File Name: <b>TS xxx, CV Safety Data Reports</b>																									
Source: State <b>Roadside System Inspection Area (Scale House Interface/Operations)</b>																									
Destination: <b>SAFETYNET via CVIEW</b>																									
Data Flow Description: <b>inspection results, out-of-service notifications, and carrier warnings/notifications from 'Roadside' (ASPEN/Avalanche?) to SAFETYNET via CVIEW. Potential EDI interface is Avalanche to CVIEW.</b>																									
Associated Transaction Sets/Data Flows:																									
APL Point of Contact: Name: <b>Edward J. Moses</b> Phone: (301) 9536000 x3461 E-mail: ed.moses@jhuapl.edu  Contributing/Reviewing Organization: Name: Phone: E-mail:  Contributing/Reviewing Organization: Name: Phone: E-mail:  Contributing/Reviewing Organization: Name: Phone: E-mail:  Contributing/Reviewing Organization: Name: Phone: E-mail:  Contributing/Reviewing Organization: Name: Phone: E-mail:	<table border="1" style="width: 100%; border-collapse: collapse;"> <thead> <tr> <th colspan="2" style="text-align: center;">States Implementing this Interface</th> </tr> <tr> <th style="text-align: center;">State</th> <th style="text-align: center;">Date</th> </tr> </thead> <tbody> <tr> <td>California</td> <td></td> </tr> <tr> <td>Colorado</td> <td></td> </tr> <tr> <td>Connecticut</td> <td></td> </tr> <tr> <td>Kentucky</td> <td></td> </tr> <tr> <td>Maryland</td> <td></td> </tr> <tr> <td>Michigan</td> <td></td> </tr> <tr> <td>Minnesota</td> <td></td> </tr> <tr> <td>Oregon/Washington</td> <td></td> </tr> <tr> <td>Virginia</td> <td></td> </tr> <tr> <td colspan="2">Other Remarks:</td> </tr> </tbody> </table>	States Implementing this Interface		State	Date	California		Colorado		Connecticut		Kentucky		Maryland		Michigan		Minnesota		Oregon/Washington		Virginia		Other Remarks:	
States Implementing this Interface																									
State	Date																								
California																									
Colorado																									
Connecticut																									
Kentucky																									
Maryland																									
Michigan																									
Minnesota																									
Oregon/Washington																									
Virginia																									
Other Remarks:																									



# EDI-Related Data Flow - Safety Data Reports

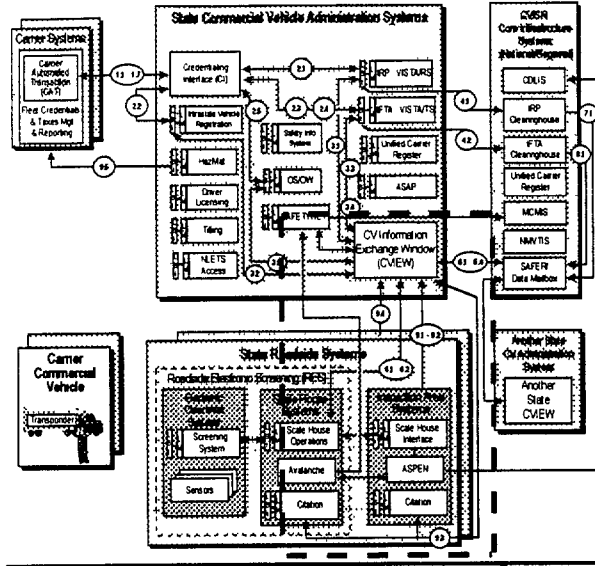

## *Preliminary Interface Definition*

### 7.3 Citation - TS xxx

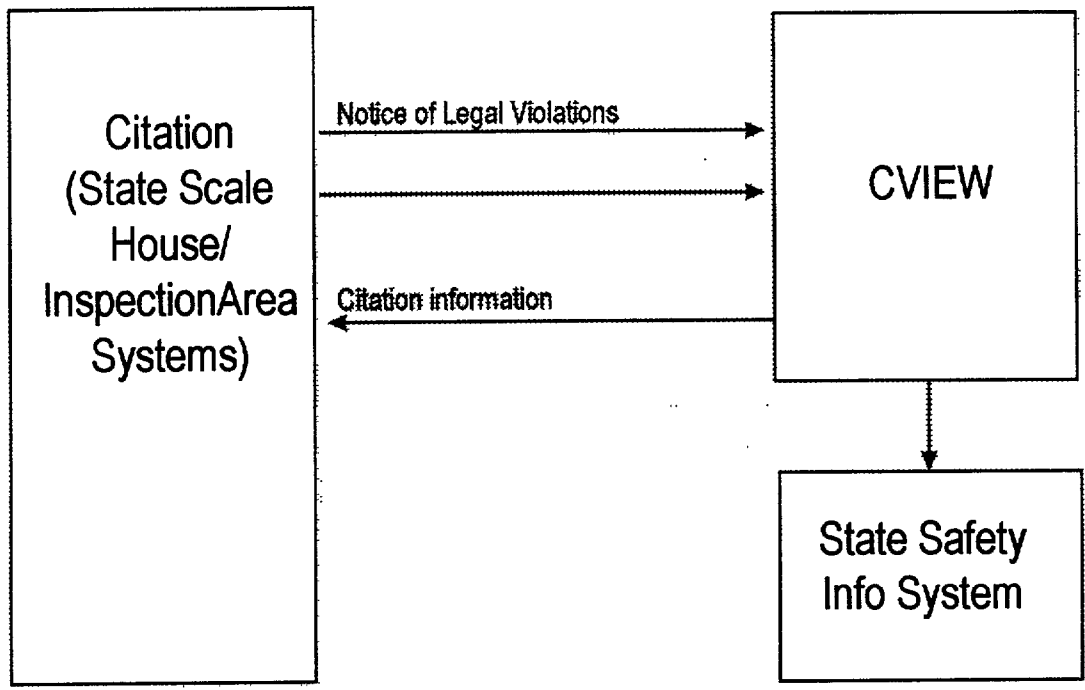

**Appendix A**  
**EDI-Related Data Flow**  
**Interface Definition and Scheduling Information**

**PRELIMINARY INTERFACE DEFINITION**

ID Number: 7.3	Implementation Guide Name: TS xxx, CV Safety Data Reports
Data Flow Name: Citation Information	Implementation Guide Due Date: TBD
Transaction Set or Flat File Name: TS xxx, CV Safety Data Reports	
Source: State Citation - RES/Inspection Area Systems	
Destination: State CVIEW/Safety Information System	

Data Flow Description: Transmission of legal violations from Citation (in Scale House or Inspection Area Systems) to CVIEW, then from CVIEW to State's Safety Information System.

Associated Transaction Sets/Data Flows:

APL Point of Contact: Name: Edward J. Moses Phone: (301) 953-6000 x3461 E-mail: ed.moses@jhuapl.edu	States Implementing this Interface	
	State	Date
Contributing/Reviewing Organization: Name: Phone: E-mail:	California Colorado Connecticut Kentucky Maryland Michigan Minnesota Oregon/Washington Virginia	
Contributing/Reviewing Organization: Name: Phone: E-mail:		
Contributing/Reviewing Organization: Name: Phone: E-mail:		
Contributing/Reviewing Organization: Name: Phone: E-mail:	Other Remarks:	
Contributing/Reviewing Organization: Name: Phone: E-mail:		
Contributing/Reviewing Organization: Name: Phone: E-mail:		

# EDI-Related Data Flow - Safety Data Reports

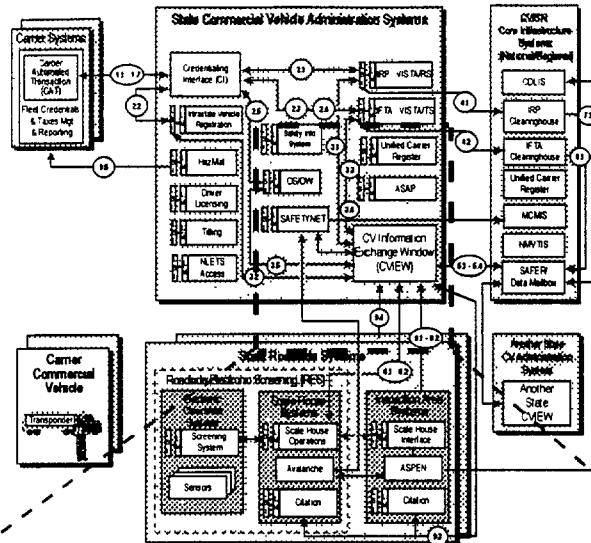

## *Preliminary Interface Definition*

### 7.4 Accident Report - TS xxx

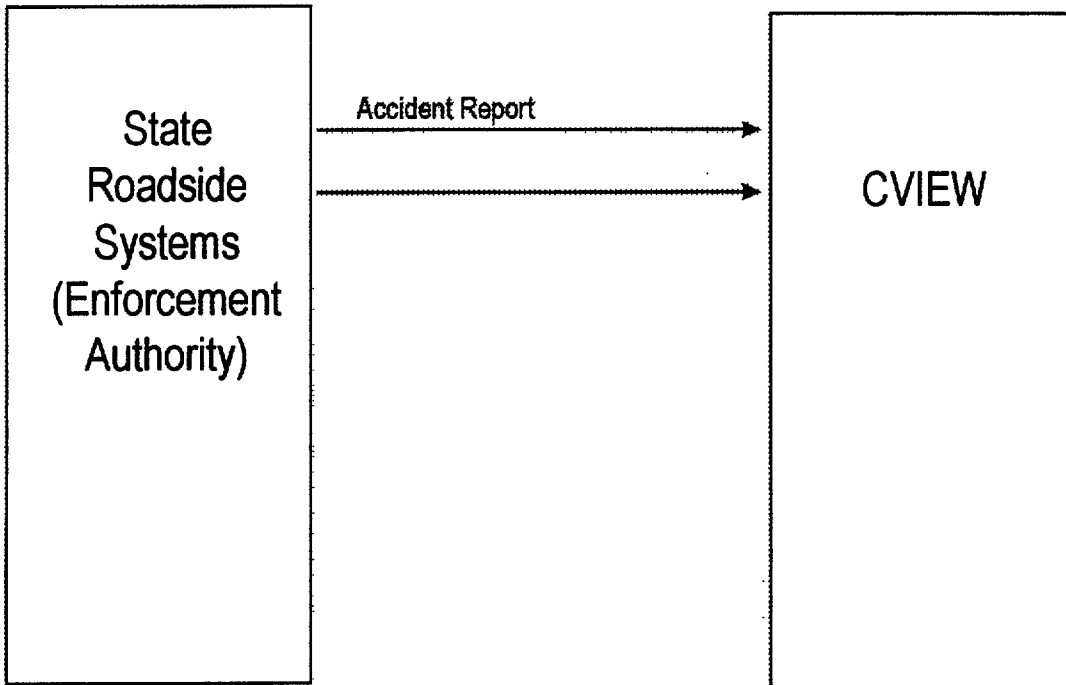

**Appendix A**  
**EDI-Related Data Flow**  
**Interface Definition and Scheduling Information**

*PRELIMINARY INTERFACE DEFINITION*

ID Number: 7.4	Implementation Guide Name: TS xxx, CV Safety Data Reports
Data Flow Name: Accident Report	Implementation Guide Due Date: TBD
Transaction Set or Flat File Name: TS xxx, CV Safety Data Reports	
Source: State Roadside Systems/Enforcement Authorities	
Destination: State Safety Information System via CVIEW	

Data Flow Description: Information on accidents

Associated Transaction Sets/Data Flows:

APL Point of Contact: Name: Edward J. Moses Phone: (301) 953-6000 x3461 E-mail: ed.moses@jhuapl.edu  Contributing/Reviewing Organization: Name: Phone: E-mail:  Contributing/Reviewing Organization: Name: Phone: E-mail:  Contributing/Reviewing Organization: Name: Phone: E-mail:  Contributing/Reviewing Organization: Name: Phone: E-mail:  Contributing/Reviewing Organization: Name: Phone: E-mail:  Contributing/Reviewing Organization: Name: Phone: E-mail:	States Implementing this Interface	
	State	Date
	California Colorado Connecticut Kentucky Maryland Michigan Minnesota Oregon/Washington Virginia	
	Other Remarks:	

# EDI-Related Data Flow - Safety Data Reports

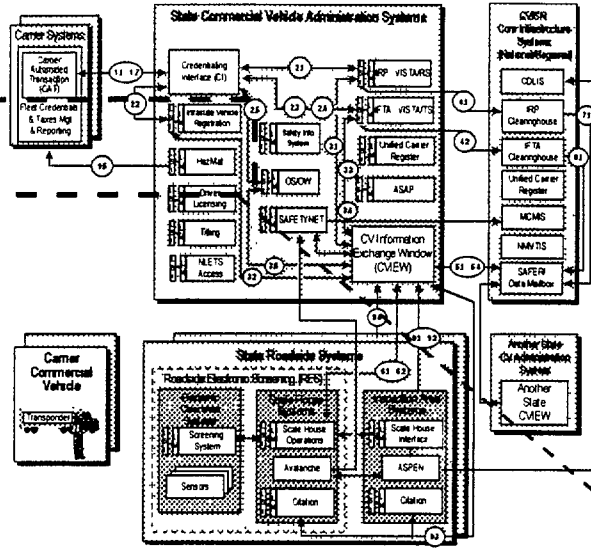

## *Preliminary Interface Definition*

### 7.5 HazMat Information Request - TS xxx

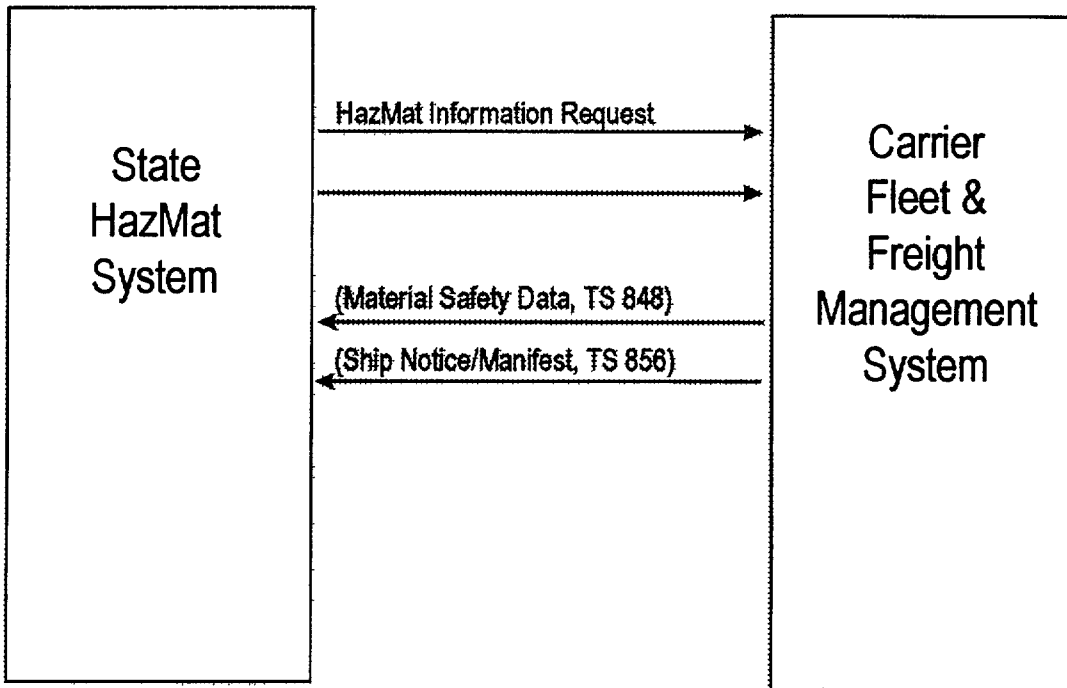

**Appendix A**  
**EDI-Related Data Flow**  
**Interface Definition and Scheduling Information**

**PRELIMINARY INTERFACE DEFINITION**

ID Number: 7.5	Implementation Guide Name: TS xxx, CV Safety Data Reports
Data Flow Name: HazMat Information Request	Implementation Guide Due Date: TBD
Transaction Set or Flat File Name: TS xxx, CV Safety Data Reports	
Source: State HazMat System	
Destination: Carrier Fleet and Freight Management System	

Data Flow Description: Request for information on HazMat shipments

Associated Transaction Sets/Data Flows: TS 848, Material Safety Data Sheets; TS 856, Ship Notice/Manifest

APL Point of Contact: Name: Edward J. Moses Phone: (301) 953-6000 x3461 E-mail: ed.moses@jhuapl.edu  Contributing/Reviewing Organization: Name: Phone: E-mail:  Contributing/Reviewing Organization: Name: Phone: E-mail:  Contributing/Reviewing Organization: Name: Phone: E-mail:  Contributing/Reviewing Organization: Name: Phone: E-mail:  Contributing/Reviewing Organization: Name: Phone: E-mail:  Contributing/Reviewing Organization: Name: Phone: E-mail:  Contributing/Reviewing Organization: Name: Phone: E-mail:	States Implementing this Interface	
	State	Date
	California Colorado Connecticut Kentucky Maryland Michigan Minnesota Oregon/Washington Virginia	
	Other Remarks:	

## **APPENDIX B - Development Schedule for CVISN EDI Implementation Guides**

The following tables identify the work assignments for each section of the implementation guide and the due dates for each document.

# EDI Implementation Guides Section Assignments

Last Updated 11/27/96

Overall Responsibility for IG	CV Credentials (TS 286) Implementation Guides												TS 285 Safety IG				TS xxx - Safety Data Reports				HazMat Incident Response	EDIFACT International Border Clearance				
	IRP		IFTA		OSOW		SSRS/UCR		H a z M a t		FHVUT		Title		Compliance Review Rpt		Inspection Report Data		Citiation/Accident Report				HazMat Info Request		TS 813 Fuel Tax Filing	TS 826 Interstate Fuel Tax
	Credential	Interstate	EJM	EJM	GM	GM	GM	GM	GM	GM	GM	GM	GM	GM	GM	GM	GM	GM	GM	GM			GM	GM		
Due Date - Implementation Guide	10/1/96	12/1/96	2/1/97	4/1/97	6/1/97	8/1/97	TU	GM	EJM	EJM	EJM	EJM	TBD	TBD	TBD	TBD	TBD	TBD	TBD	TBD	TBD	TBD	TBD	TBD	TBD	
5.0 Transaction Set	JDH	EJM	ML	EJM	EJM	EJM	TBD	TBD	TBD	TBD	TBD	TBD	TBD	TBD	TBD	TBD	TBD	TBD	TBD	TBD	TBD	TBD	TBD	TBD	TBD	
6.0 Segment Usage Guide for IRP	GM			GM	GM	GM																				
Carrier to State/State to Carrier/Genetic Interstate																										
"Recap"																										
"Transmit"																										
Netting Message																										
7.0 Example Transactions																										
Initial and Renewal Application Supplements																										
Add/Delete Vehicles																										
Change Weight																										
Change Vehicle Owner																										
Trip Permit Application																										
State to Carrier																										
Renewal Notice																										
Credential (Returned)																										
Temporary Credential (Returned)																										
Trip Permit (Credential)																										
Entry Exit Point File																										
Travel Conditions																										
Application Rejection																										
Generic																										
Request Credential Report																										
Credential Report																										
Interstate																										
"Recap"																										
"Transmit"																										
Netting Message																										
Appendix A - Transaction Flow																										
Appendix B - Validation Checks																										
Appendix C - Example Data Values																										
Appendix D - State-Specific Impl Details																										
Appendix E - Flat File Equivalence Format																										
Appendix F - Code Table References																										

= Initial material exists for this section  
 = Section completed



EDI Implementation Guides - IRP  
 Section Assignments and Status

Last Updated 11/27/96

	CV Credentials (TS 286) IRP Implementation Guides											Status/Remarks
	IRP Credential					IRP Interstate						
	1st Draft for Review	Due Date	Expected Date	Primary Responsible	Staff Supporting	1st Draft for Review	Due Date	Expected Date	Primary Responsible	Staff Supporting		
Complete Implementation Guide	9/18/96	10/1/96	10/1/96	EJM	KTG, GM, JDH	11/20/96	12/1/96	12/13/96	EJM	KTG, GM, JDH	Implementation Guide for IRP Credentials distributed on October 15, 1996	
1.0 - 4.0 Introduction/BUS, Case/Structure	9/6/96	10/1/96	10/1/96	JDH		11/20/96	12/1/96	12/13/96	EJM			
5.0 Transaction Set	9/6/96	10/1/96	10/1/96	KTG		11/20/96	12/1/96	12/13/96	KTG			
6.0 Segment Usage Guide for IRP	9/6/96	10/1/96	10/1/96		KTG, GM, JDH	11/20/96	12/1/96	12/13/96				
Carrier to State/State to Carrier/Generc Interstate	8/28/96	10/1/96	10/1/96	GM								
"Recap"												
"Transmittal"												
Netting Message												
7.0 Example Transactions	9/6/96	9/20/96	10/1/96			11/20/96	12/1/96	12/13/96	GM			
Carrier to State												
Initial and Renewal Application Supplements	8/28/96	8/30/96	10/1/96	KTG								
Add/Delete Vehicles	9/6/96	9/20/96	10/1/96	EJM								
Add Jurisdictions	9/6/96	9/20/96	10/1/96	EJM								
Change Weight	9/6/96	9/20/96	10/1/96	EJM								
Change Vehicle Owner	9/6/96	9/20/96	10/1/96	GM								
Trip Permit Application	9/6/96	9/20/96	10/1/96	GM								
State to Carrier												
Renewal Notice	9/6/96	9/20/96	10/1/96	GM								
Credential (Returned)	9/6/96	9/20/96	10/1/96	EJM								
Temporary Credential (Returned)	9/6/96	9/20/96	10/1/96	GM								
Trip Permit (Credential)	9/6/96	9/20/96	10/1/96	GM								
Entry Exit Point File												
Travel Conditions												
Application Rejection	9/6/96	9/20/96	10/1/96	EJM								
Generic												
Request Credential Report												
Credential Report												
Interstate												
"Recap"												
"Transmittal"												
Netting Message												
Appendix A - Transaction Flow	8/30/96	9/4/96	10/1/96	RLW		11/20/96	12/1/96	12/13/96	EJM			
Appendix B - Validation Checks				HRH		11/20/96	12/1/96	12/13/96	EJM			
Appendix C - Example Data Values	8/15/96	9/30/96	10/1/96	TU		11/20/96	12/1/96	12/13/96	EJM			
Appendix D - State-Specific Impl Details				(TBD)								
Appendix E - Flat File Equivalence Format												
Appendix F - Code Table References	9/6/96	9/30/96	10/1/96	JDH					KTG			

☐ = Initial material exists for this section  
 ☒ = Section completed

**EDI Implementation Guide - TS 285  
Section Assignments**

Last Updated 11/27/96

	CV Safety & Credentials Information Exchange (TS 285)					Status/Remarks
	1st Draft for Review	Due Date	Expected Date	Primary Responsible	Staff Supporting	
<b>Complete Implementation Guide</b>	11/20/96	12/1/96	12/13/96	KTG	EJM, GM	TS 285 Implementation Guide includes sections on related TS 997 (Acknowledgement) and TS 864 (Text)
1.0 - 4.0 Introduction/Bus Case/Structure	11/20/96	12/1/96	12/13/96	KTG		
5.0 Transaction Set	11/20/96	12/1/96	12/13/96	KTG		
6.0 Segment Usage Guide for IRP	11/20/96	12/1/96	12/13/96	KTG		
Carrier to State/State to Carrier/Generic Interstate						
"Recap"						
"Transmittal"						
Netting Message						
7.0 Example Transactions	11/20/96	12/1/96	12/13/96	KTG		
Carrier to State						
Initial and Renewal Application						
Supplements						
Add/Delete Vehicles						
Add Jurisdictions						
Change Weight						
Change Vehicle Owner						
Add/Delete Carrier Weight Group						
Trip Permit Application						
State to Carrier						
Renewal Notice						
Credential (Returned)						
Temporary Credential (Returned)						
Trip Permit (Credential)						
Entry Exit Point File						
Travel Conditions						
Application Rejection						
Generic						
Request Credential Report						
Credential Report						
Interstate						
"Recap"						
"Transmittal"						
Netting Message						
Appendix A - Transaction Flow	11/20/96	12/1/96	12/13/96	KTG		
Appendix B - Validation Checks	11/20/96	12/1/96	12/13/96	HRH		
Appendix C - Example Data Values	11/20/96	12/1/96	12/13/96	KTG		
Appendix D - State-Specific Impl Details				(TBD)		
Appendix E - Flat File Equivalence Format						
Appendix F - Code Table References	11/20/96	12/1/96	12/13/96	KTG		

☐ = Initial material exists for this section  
☒ = Section completed

**EDI Implementation Guides - IFTA**  
**Section Assignments and Status**

Last Updated 11/27/86

	CV Credentials (TS 288) IFTA Implementation Guides						Status/Remarks
	1st Draft for Review	Due Date	Expected Date	IFTA Credential		Staff Supporting	
				Primary Responsible	Supporting		
Complete Implementation Guide	1/20/87	2/1/87	2/1/87	GM	ML, EJ, M, KTG		
1.0 - 4.0 Introduction/Bus, Case/Structure	1/20/87	2/1/87	2/1/87	<input type="checkbox"/> ML			
5.0 Transaction Set	1/20/87	2/1/87	2/1/87	<input checked="" type="checkbox"/> KTG			
6.0 Segment Usage Guide for IRP	1/20/87	2/1/87	2/1/87				
Carrier to State/State to Carrier/Generic Interstate	1/20/87	2/1/87	2/1/87	<input type="checkbox"/> GM	EM, KG, JH		
"Recap"							
"Transmittal"							
Netting Message							
7.0 Example Transactions	1/20/87	2/1/87	2/1/87	--	--		
Carrier to State	1/20/87	2/1/87	2/1/87	<input type="checkbox"/> GM	EM, KG, JH		
Supplements							
Initial and Renewal Application							
Add/Delete Vehicles							
Add Jurisdictions							
Change Weight							
Change Vehicle Owner							
Trip Permit Application	1/20/87	2/1/87	2/1/87	<input type="checkbox"/> GM			
State to Carrier							
Renewal Notice	1/20/87	2/1/87	2/1/87	<input type="checkbox"/> GM			
Credential (Returned)	1/20/87	2/1/87	2/1/87	<input type="checkbox"/> GM			
Temporary Credential (Returned)	1/20/87	2/1/87	2/1/87	<input type="checkbox"/> GM			
Trip Permit (Credential)	1/20/87	2/1/87	2/1/87	<input type="checkbox"/> GM			
Entry Exit Point File							
Travel Conditions							
Application Rejection	1/20/87	2/1/87	2/1/87	<input type="checkbox"/> GM			
Generic							
Request Credential Report							
Credential Report							
Interstate							
"Recap"							
"Transmittal"							
Netting Message							
Appendix A - Transaction Flow	1/20/87	2/1/87	2/1/87	RLW			
Appendix B - Validation Checks	1/20/87	2/1/87	2/1/87	HRH			
Appendix C - Example Data Values	1/20/87	2/1/87	2/1/87	TU			
Appendix D - State-Specific Impl Details				(IBD)			
Appendix E - Fiat File Equivalence Format							
Appendix F - Code Table References	1/20/87	2/1/87	2/1/87	JDH			

= Initial material exists for this section  
 = Section completed

**EDI Implementation Guide - OS/OW  
Section Assignments and Status**

Last Updated 11/27/96

	CV Credentials (TS 286) Oversize/Overweight IG						Status/Remarks
	OS/OW Credential						
	1st Draft for Review	Due Date	Expected Date	Primary Responsible	Staff Supporting		
<b>Complete Implementation Guide</b>	3/15/97	4/1/97	4/1/97	EJM	EJM,KTG,JDH		
1.0 - 4.0 Introduction/Bus. Case/Structure	3/15/97	4/1/97	4/1/97	<input type="checkbox"/> EJM			
5.0 Transaction Set	3/15/97	4/1/97	4/1/97	<input checked="" type="checkbox"/> KTG			
6.0 Segment Usage Guide for IRP	3/15/97	4/1/97	4/1/97	..			
Carrier to State/State to Carrier/Generic Interstate	3/15/97	4/1/97	4/1/97	GM	EJM,KTG,JDH		
"Recap"							
"Transmittal"							
Netting Message							
7.0 Example Transactions Carrier to State	3/15/97	4/1/97	4/1/97	..			
Initial and Renewal Application	3/15/97	4/1/97	4/1/97	<input type="checkbox"/> GM	EJM,KTG,JDH		
Supplements							
Add/Delete Vehicles							
Add Jurisdictions							
Change Weight							
Change Vehicle Owner							
Trip Permit Application State to Carrier	3/15/97	4/1/97	4/1/97	<input type="checkbox"/> GM			
Renewal Notice							
Credential (Returned)	3/15/97	4/1/97	4/1/97	<input type="checkbox"/> GM			
Temporary Credential (Returned)	3/15/97	4/1/97	4/1/97	<input type="checkbox"/> GM			
Trip Permit (Credential)	3/15/97	4/1/97	4/1/97	<input type="checkbox"/> GM			
Entry Exit Point File	3/15/97	4/1/97	4/1/97	<input type="checkbox"/> GM			
Travel Conditions	3/15/97	4/1/97	4/1/97	<input type="checkbox"/> GM			
Application Rejection	3/15/97	4/1/97	4/1/97	<input type="checkbox"/> GM			
Generic							
Request Credential Report	3/15/97	4/1/97	4/1/97	<input type="checkbox"/> GM			
Credential Report	3/15/97	4/1/97	4/1/97	<input type="checkbox"/> GM			
Interstate							
"Recap"							
"Transmittal"							
Netting Message							
Appendix A - Transaction Flow	3/15/97	4/1/97	4/1/97	RLW			
Appendix B - Validation Checks	3/15/97	4/1/97	4/1/97	HRH			
Appendix C - Example Data Values	3/15/97	4/1/97	4/1/97	<input type="checkbox"/> TU			
Appendix D - State-Specific Impl Details				(TBD)			
Appendix E - Flat File Equivalence Format							
Appendix F - Code Table References	3/15/97	4/1/97	4/1/97	<input type="checkbox"/> JDH			

= Initial material exists for this section  
 = Section completed

# EDI Implementation Guide - Title Section Assignments and Status

Last Updated 11/27/86

CV Credentials (TS 286) Title Implementation Guide							Status/Remarks
Title Credential							
1st Draft for Review	Due Date	Expected Date	Primary Responsible	Staff Supporting			
<b>Complete Implementation Guide</b>							
	TBD	TBD	TBD	TBD			
1.0 - 4.0 Introduction/Bus. Case/Structure	TBD	TBD	TBD				
5.0 Transaction Set	TBD	TBD	TBD	<input checked="" type="checkbox"/> KTG			
6.0 Segment Usage Guide for IRP	TBD	TBD	TBD				
Carrier to State/State to Carrier/Generic Interstate	TBD	TBD	TBD				
"Recap"							
"Transmittal"							
Netting Message							
7.0 Example Transactions	TBD	TBD	TBD				
Carrier to State	TBD	TBD	TBD				
Initial and Renewal Application	TBD	TBD	TBD				
Supplements							
Add/Delete Vehicles							
Add Jurisdictions							
Change Weight							
Change Vehicle Owner							
Trp Permit Application							
State to Carrier							
Renewal Notice							
Credential (Returned)	TBD	TBD	TBD				
Temporary Credential (Returned)							
Trp Permit (Credential)							
Entry Exit Point File							
Travel Conditions							
Application Rejection	TBD	TBD	TBD				
Generic							
Request Credential Report	TBD	TBD	TBD				
Credential Report	TBD	TBD	TBD				
Interstate							
"Recap"							
"Transmittal"							
Netting Message							
Appendix A - Transaction Flow	TBD	TBD	TBD		RLW		
Appendix B - Validation Checks	TBD	TBD	TBD		HRH		
Appendix C - Example Data Values	TBD	TBD	TBD		<input type="checkbox"/> TU		
Appendix D - State-Specific Impl Details	TBD	TBD	TBD				
Appendix E - Flat File Equivalence Format							
Appendix F - Code Table References	TBD	TBD	TBD		<input type="checkbox"/> JDH		

= Initial material exists for this section  
 = Section completed

**EDI Implementation Guides - HazMat  
Section Assignments and Status**

Last Updated 11/27/96

Complete Implementation Guide	CV Credentials (TS 286) HazMat Implementation Guides										Status/Remarks
	HazMat Credential					HazMat Interstate					
	1st Draft for Review	Due Date	Expected Date	Primary Responsible	Staff Supporting	1st Draft for Review	Due Date	Expected Date	Primary Responsible	Staff Supporting	
<b>Complete Implementation Guide</b>	TBD	TBD	TBD	EJM		TBD	TBD	TBD	EJM		
<b>1.0 - 4.0 Introduction/Bus. Case/Structure</b>	TBD	TBD	TBD			TBD	TBD	TBD			
<b>5.0 Transaction Set</b>	TBD	TBD	TBD	KTG		TBD	TBD	TBD			
<b>6.0 Segment Usage Guide for IRP</b>	TBD	TBD	TBD			TBD	TBD	TBD			
<b>Carrier to State/State to Carrier/Carrier to State/State to State/State to Interstate</b>	TBD	TBD	TBD								
<b>"Recap"</b>						TBD	TBD	TBD			
<b>"Transmittal"</b>											
<b>Netting Message</b>											
<b>7.0 Example Transactions</b>	TBD	TBD	TBD			TBD	TBD	TBD			
<b>Carrier to State</b>											
<b>Initial and Renewal Application</b>	TBD	TBD	TBD								
<b>Supplements</b>											
<b>Add/Delete Vehicles</b>											
<b>Add Jurisdictions</b>											
<b>Change Weight</b>											
<b>Change Vehicle Owner</b>											
<b>Trip Permit Application</b>	TBD	TBD	TBD								
<b>State to Carrier</b>											
<b>Renewal Notice</b>											
<b>Credential (Returned)</b>	TBD	TBD	TBD								
<b>Temporary Credential (Returned)</b>	TBD	TBD	TBD								
<b>Trip Permit (Credential)</b>	TBD	TBD	TBD								
<b>Entry Exit Point File</b>											
<b>Travel Conditions</b>											
<b>Application Rejection</b>	TBD	TBD	TBD								
<b>Generic</b>											
<b>Request Credential Report</b>	TBD	TBD	TBD								
<b>Credential Report</b>	TBD	TBD	TBD								
<b>Interstate</b>											
<b>"Recap"</b>						TBD	TBD	TBD			
<b>"Transmittal"</b>											
<b>Netting Message</b>											
<b>Appendix A - Transaction Flow</b>	TBD	TBD	TBD	RLW		TBD	TBD	TBD	RLW		
<b>Appendix B - Validation Checks</b>	TBD	TBD	TBD	HRH		TBD	TBD	TBD	HRH		
<b>Appendix C - Example Data Values</b>	TBD	TBD	TBD	TU		TBD	TBD	TBD	TU		
<b>Appendix D - State-Specific Impl Details</b>	TBD	TBD	TBD			TBD	TBD	TBD			
<b>Appendix E - Fiat File Equivalence Format</b>											
<b>Appendix F - Code Table References</b>	TBD	TBD	TBD	JDH		TBD	TBD	TBD	JDH		

= Initial material exists for this section  
 = Section completed

**EDI Implementation Guide - FHVUT  
Section Assignments and Status**

Last Updated 11/27/96

CV Credentials (TS 286) FHVUT Implementation Guide							Status/Remarks
CV Credentials			FHVUT Credential		Primary Responsible	Staff Supporting	
1st Draft for Review	Due Date	Expected Date	CV Credentials	FHVUT Credential			
<b>Complete Implementation Guide</b>							
1.0 - 4.0 Introduction/Bus, Case/Structure	TBD	TBD	TBD	TBD	TBD		
5.0 Transaction Set	TBD	TBD	TBD	TBD	<input checked="" type="checkbox"/> KTG		
6.0 Segment Usage Guide for IRP	TBD	TBD	TBD	TBD			
Carrier to State/State to Carrier/Generic Interstate	TBD	TBD	TBD	TBD			
"Recap"							
"Transmittal"							
Netting Message							
7.0 Example Transactions	TBD	TBD	TBD	TBD			
Carrier to State	TBD	TBD	TBD	TBD			
Initial and Renewal Application	TBD	TBD	TBD	TBD			
Supplements							
Add/Delete Vehicles							
Add Jurisdictions							
Change Weight							
Change Vehicle Owner							
Trip Permit Application							
State to Carrier							
Renewal Notice							
Credential (Returned)	TBD	TBD	TBD	TBD			
Temporary Credential (Returned)							
Trip Permit (Credential)							
Entry Exit Point File							
Travel Conditions							
Application Rejection	TBD	TBD	TBD	TBD			
Generic							
Request Credential Report	TBD	TBD	TBD	TBD			
Credential Report	TBD	TBD	TBD	TBD			
Interstate							
"Recap"							
"Transmittal"							
Netting Message							
Appendix A - Transaction Flow	TBD	TBD	TBD	TBD		RLW	
Appendix B - Validation Checks	TBD	TBD	TBD	TBD		HRH	
Appendix C - Example Data Values	TBD	TBD	TBD	TBD		<input type="checkbox"/> TU	
Appendix D - State-Specific Impl Details	TBD	TBD	TBD	TBD			
Appendix E - Flat File Equivalence Format							
Appendix F - Code Table References	TBD	TBD	TBD	TBD		<input type="checkbox"/> JDH	

= Initial material exists for this section  
 = Section completed

## **APPENDIX C - Flat File Documentation**

This appendix identifies the documentation to be prepared that define the format and content of the flat files interfaces identified in Appendix A.

This information is to be supplied in the next version of this plan.



## **Appendix D - Distribution List**

The following tables specify the distribution of the EDI Project Plan and the EDI-related implementation guides.

:

## Distribution List for EDI Project Plan and Implementation Guides

Document Type/Due Date	286 I R P		TS 285		286		286 SSRS/UCR		286		286 H a z M a t			286 Report Transaction Set - TS xxx (New)			
	Project Plan	Credential	Interstate	IFTA	OS/OV	Credential	Interstate	Title	Credential	Interstate	FHVUT	Compliance Rvw	Inspection	Calibration	Accident		
Organization/Name	11/30/96	10/1/96	12/1/96	12/1/96	2/1/97	4/1/97	6/1/97	TBD	TBD	TBD	TBD	TBD	TBD	TBD	TBD		
<b>FHWA</b>																	
Mike Curtis	1	1	1	1	1	1	1	1	1	1	1	1	1	1	1		
Tom Hillegass	1	1	1	1	1	1	1	1	1	1	1	1	1	1	1		
Doug McKevey	1	1	1	1	1	1	1	1	1	1	1	1	1	1	1		
Mike Onder	1	1	1	1	1	1	1	1	1	1	1	1	1	1	1		
Mike Schagrin	1	1	1	1	1	1	1	1	1	1	1	1	1	1	1		
Bonnie Bass (CVIS)	1																
<b>Alabama</b>																	
Robert McKay	1	1	1	1													
<b>Arkansas</b>																	
Tom Barlow	1	1	1	1													
<b>California</b>																	
Tim Clark	2	2	2	2	2	2	2	2	2	2	2	2	2	2	2		
Gary Nishite	1	1	1	1													
<b>Colorado</b>																	
Philip Vasquez	2	2	2	2	2	2	2	2	2	2	2	2	2	2	2		
Jak Berry	1	1	1	1													
<b>Connecticut</b>																	
Diana Moxon	2	2	2	2	2	2	2	2	2	2	2	2	2	2	2		
<b>Iowa</b>																	
Bill McCall	1	1	1	1	1	1	1	1	1	1	1	1	1	1	1		
Stuart McDaniel	1	1	1	1	1	1	1	1	1	1	1	1	1	1	1		
Ruth Skuzacak (CVIS)	1	1	1	1													
<b>Kentucky</b>																	
Ed Logsdon	2	2	2	2	2	2	2	2	2	2	2	2	2	2	2		
<b>Maryland</b>																	
Nicholas Owens	2	2	2	2	2	2	2	2	2	2	2	2	2	2	2		
Debbie Rogers	1	1	1	1													
Dolores Strausser	1																
Stephen Taylor	1			1	1												
<b>Michigan</b>																	
Enc Dhanak	2	2	2	2	2	2	2	2	2	2	2	2	2	2	2		
Rajina Smith	1	1	1	1													
<b>Minnesota</b>																	
Cathy Enckson	2	2	2	2	2	2	2	2	2	2	2	2	2	2	2		
Gary Baran	1	1	1	1	1	1	1	1	1	1	1	1	1	1	1		
Christopher Conway	1	1	1	1	1	1	1	1	1	1	1	1	1	1	1		
Carol Ann Sather	1			1													
<b>Missouri</b>																	
Barbara Hague	1	1	1	1													
Robert McFadden	1	1	1	1													
William Wilson	1			1													
<b>New York</b>																	
Brian Digman	1			1													
John Goggin	1	1	1	1	1												
<b>Oklahoma</b>																	
W. Paul Connelly	1			1													
<b>Oregon/Washington</b>																	
Tim Enckson	2	2	2	2	2	2	2	2	2	2	2	2	2	2	2		
Bob Bennett	1			1													
<b>South Carolina</b>																	
Terry Garber	1	1	1	1	1												
<b>Virginia</b>																	
Richard Holcomb	2	2	2	2	2	2	2	2	2	2	2	2	2	2	2		
Jerry Fern	1	1	1	1	1												
Ken Jennings																	
Judy Vesely	1	1	1	1													

## Distribution List for EDI Project Plan and Implementation Guides (Continued)

Document Type/Due Date Organization/Name	EDI	286 I R P		TS 285	286	286	286 SSRS/UCR		286	286 H a z M a t		286	Report Transaction Set - TS xxx (New)			
	Project Plan 11/30/96	Credentia 10/1/96	Interstate 12/1/96	12/1/96	IFTA 2/1/97	OS/OW 4/1/97	Credentia 8/1/97	Interstate TBD	Title TBD	Credentia TBD	Interstate TBD	FHVUT TBD	Compliance Rvw TBD	Inspection TBD	Citation TBD	Accident TBD
Charlie Katz/AAMVA	1	1	1	1	1	1	1	1	1	1	1	1	1	1	1	1
Carlos Deguma/AAMV/Anet	1	1	1	1	1	1	1	1	1	1	1	1	1	1	1	1
Mary Mack/AAMV/Anet	1	1	1	1	1	1	1	1	1	1	1	1	1	1	1	1
Karen Massey/AAMV/Anet	1	1	1	1	1	1	1	1	1	1	1	1	1	1	1	1
Joanne Mathias/AAMV/Anet	1	1	1	1	1	1	1	1	1	1	1	1	1	1	1	1
Jay Maxwell/AAMV/Anet	1	1	1	1	1	1	1	1	1	1	1	1	1	1	1	1
Nancy Means/AAMV/Anet	1	1	1	1	1	1	1	1	1	1	1	1	1	1	1	1
Mark Solomon/AAMV/Anet	1	1	1	1	1	1	1	1	1	1	1	1	1	1	1	1
Patti Coman/AAMV/Anet/CVI	1	1	1	1	1	1	1	1	1	1	1	1	1	1	1	1
Norm Litter/Am Bus Assn	1	1	1	1	1	1	1	1	1	1	1	1	1	1	1	1
John Papale/AMS	1	1	1	1	1	1	1	1	1	1	1	1	1	1	1	1
Doug Anderson/ATA	1	1	1	1	1	1	1	1	1	1	1	1	1	1	1	1
Jonathon Lyon/IFTA	1	1	1	1	1	1	1	1	1	1	1	1	1	1	1	1
Jonathon Tam/GDS	1	1	1	1	1	1	1	1	1	1	1	1	1	1	1	1
Peter Burns, HELP, Inc.	1	1	1	1	1	1	1	1	1	1	1	1	1	1	1	1
Jim Gentner/HELP	1	1	1	1	1	1	1	1	1	1	1	1	1	1	1	1
Henry Horsey/IDT	1	1	1	1	1	1	1	1	1	1	1	1	1	1	1	1
Tam Ungeman/IDT	1	1	1	1	1	1	1	1	1	1	1	1	1	1	1	1
Robert McKee/IFTA	1	1	1	1	1	1	1	1	1	1	1	1	1	1	1	1
Brian Halls/IRP, Inc	1	1	1	1	1	1	1	1	1	1	1	1	1	1	1	1
Stan Kelly/IRP, Inc	1	1	1	1	1	1	1	1	1	1	1	1	1	1	1	1
Richard Easley/ITS America (JHU/APL CVO Library)	10	5	5	5	5	5	5	5	5	5	5	5	5	5	5	5
Diane Kober/Lockheed	1	1	1	1	1	1	1	1	1	1	1	1	1	1	1	1
Dale Pickford/Lockheed	1	1	1	1	1	1	1	1	1	1	1	1	1	1	1	1
Brad Sofokles/Lockheed	1	1	1	1	1	1	1	1	1	1	1	1	1	1	1	1
Jason Sten/Lockheed	1	1	1	1	1	1	1	1	1	1	1	1	1	1	1	1
Andy Schick/Wittek	1	1	1	1	1	1	1	1	1	1	1	1	1	1	1	1
Thom Rubel/NGA	1	1	1	1	1	1	1	1	1	1	1	1	1	1	1	1
Carmen Daecher, Pennoni A	1	1	1	1	1	1	1	1	1	1	1	1	1	1	1	1
William Vach/POLK, Inc	1	1	1	1	1	1	1	1	1	1	1	1	1	1	1	1
Scott Amey/RSIS	1	1	1	1	1	1	1	1	1	1	1	1	1	1	1	1
Bruce Cargill/RSIS	1	1	1	1	1	1	1	1	1	1	1	1	1	1	1	1
Ali Hooshman/RSIS	1	1	1	1	1	1	1	1	1	1	1	1	1	1	1	1
Glen Marler/RSIS	1	1	1	1	1	1	1	1	1	1	1	1	1	1	1	1
Charles Minahan/RSIS	1	1	1	1	1	1	1	1	1	1	1	1	1	1	1	1
Jude Nagurney/RSIS	1	1	1	1	1	1	1	1	1	1	1	1	1	1	1	1
Tom Kingman/UPS	1	1	1	1	1	1	1	1	1	1	1	1	1	1	1	1
Richard Horn/Volpe	1	1	1	1	1	1	1	1	1	1	1	1	1	1	1	1
Donald Wright/Volpe	1	1	1	1	1	1	1	1	1	1	1	1	1	1	1	1
Warren Dunham/WBSA	1	1	1	1	1	1	1	1	1	1	1	1	1	1	1	1
TOTALS	99	77	77	84	80	57	54	54	45	43	42	43	42	42	42	42

If you would like to be added to distribution, please contact:

The Johns Hopkins University  
Applied Physics Laboratory  
Johns Hopkins Road  
Laurel, MD 20723  
Ms. Theresa G. Nester

Phone: (301) 953-6000 extension 8760  
Fax: (301) 953-6149  
E-Mail: [theresa.nester@jhuapl.edu](mailto:theresa.nester@jhuapl.edu)

For more information, or to request a copy of this document, visit our site on the World Wide Web:

<http://www.jhuapl.edu/cvo/>