

Current Planning  
Guidelines and Design  
Standards Being Used  
by State and Local  
Agencies for Bicycle  
and Pedestrian  
Facilities

**National Bicycling  
And Walking Study**

U.S. Department  
of Transportation

**Federal Highway  
Administration**

### *Foreword*

This case study was prepared under contract for the Federal Highway Administration by Greenways Incorporated.

### *Notice*

This document is disseminated under the sponsorship of the Department of Transportation in the interest of information exchange. The United States Government assumes no liability for its contents or use thereof.

The United States Government does not endorse products or manufacturers. Trademarks or manufacturers' names may appear herein only because they are considered essential to the object of this document.

The contents of this report reflect the views of the authors, who are responsible for the facts and accuracy of the data presented herein. The contents do not necessarily reflect the official policy of the Department of Transportation.

This report does not constitute a standard, specification, or regulation.

---

# **National Bicycle and Walking Study**

Current Planning Guidelines and Design  
Standards Being Used by State and Local Agencies  
for Bicycle and Pedestrian Facilities

**The Federal Highway Administration**

August 1992

---



# Table of Contents

Executive Summary	vii
Section 1: Case Study Methodology .....	1
Section 2: Summary of Selected Planning Guidelines and Design Standards .....	3
<b>A. National Studies, Guidelines, and Standards</b>	
AASHTO Guide for the Development of Bicycle Facilities .....	4
"Reviewing the '81 AASHTO Guide," Bicycle Forum Issues 26-29 .....	4
Manual on Uniform Traffic Control Devices .....	4
Planning, Design, and Maintenance of Pedestrian Facilities .....	5
Planning and Implementing Pedestrian Facilities in Suburban and Developing Rural Areas .....	5
Guidelines for Creating Greenways .....	5
Design and Maintenance Manual for Multiuse Trails .....	6
<b>B. State Agency Plans</b>	
Arizona Department of Transportation .....	6
Caltrans	7
Colorado Department of Transportation .....	7
Delaware Department of Transportation .....	8
Florida Department of Transportation .....	8
Minnesota Department of Transportation .....	10
New Jersey Department of Transportation .....	11
North Carolina Department of Transportation .....	12
Ohio Department of Transportation .....	12
Oregon Department of Transportation .....	13
Pennsylvania Trails Program, Bureau of State Parks .....	14
State of Washington Department of Transportation .....	14
Wisconsin Department of Transportation .....	15
<b>C. Local Agency Plans</b>	
Denver, Colorado, Department of Public Works .....	15
Eugene, Oregon, Public Works Department .....	16

---

Madison, Wisconsin, Department of Transportation .....	17
Tucson, Arizona, Department of Transportation.....	17
Seattle, Washington, Engineering Department .....	18
<b>Section 3: Similarities and Differences Among Guidelines and Standards</b> .....	<b>19</b>
<b>A. The Use of AASHTO</b> .....	<b>19</b>
<b>B. Beyond AASHTO</b> .....	<b>20</b>
<b>Chapter 1---Planning</b>	
Planning Processes .....	20
Selecting the Type of Facility .....	24
Liability and Safety Factors .....	27
<b>Chapter 2----Design</b>	
<i>Bicycle Roadway Improvements</i> .....	28
Drainage Grates .....	28
Railroad Crossings .....	29
Pavements .....	31
Traffic Control Devices .....	31
Shoulders.....	32
Wide Curb Lanes .....	33
Bicycle Routes .....	34
Bicycle Lanes .....	34
Bicycle Lane Widths.....	38
Intersections with Bicycle Lanes .....	39
Supplemental Roadway Topics .....	41
Bridges and Structures .....	41
Placement of Appurtenances .....	43
Physically Separated Roadway Facilities .....	43
Canyon Improvements .....	43
Cattle Guards.....	43
<i>Bicycle Paths</i> .....	44
Separation between Bicycle Paths and Roadways .....	44
Width and Clearance.....	44
Design Speed .....	45
Horizontal Alignment and Superelevation .....	45
Grade 46	
Sight Distance .....	46
Intersections .....	46
Signing and Marking .....	48
Pavement Structure .....	48
Structures.....	49

Drainage .....	51
Lighting .....	51
Restriction of Motor Vehicle Traffic .....	51
Multiuse .....	53
<b><i>Supplemental Bicycle Facilities</i></b> .....	55
Parking Facilities .....	56
Bicycle Interface with Public Transit .....	57
Route Maps .....	57
<b><i>General Comments</i></b> .....	57
Manual Organization .....	57
Review Processes .....	59
Class I, II, III & IV Facility Designations .....	59
Spatial Standards .....	59
<b>Chapter 3----Operation and Maintenance</b> .....	61
<b>C. The Use of MUTCD</b> .....	62
<b>D. Beyond MUTCD</b> .....	62
Signs .....	62
Markings .....	65
<b>E. Pedestrian Facility Standards</b> .....	67
Planning and Implementing Pedestrian Facilities in Suburban and Developing Rural Areas (NCHRP 294A) .....	68
Planning, Design, and Maintenance of Pedestrian Facilities .....	68
The Florida Pedestrian Safety Plan .....	69
Linking Land Use and Transportation: Design Strategies to Serve HOV's and Pedestrians .....	70
Eugene Sidewalk Program .....	71
<b>Section 4: Planning and Design Enforcement</b> .....	79
State of California .....	79
State of New Jersey .....	80
State of North Carolina .....	81
State of Ohio .....	82
State of Oregon .....	83
State of Wisconsin .....	84
City of Eugene, Oregon .....	84
City of Seattle, Washington .....	85
<b>section 5: Best Practices</b> .....	87

**Section 6: Appendices**

Appendix A: Reference Bibliography .....91  
Appendix B: Reference List of Project Contacts .....97



# Executive Summary





## Executive Summary

In November 1991, the 102nd United States Congress enacted sweeping legislation that will significantly change the way in which all Americans think about transportation issues and view the future of growth and prosperity of our Nation. The Intermodal Surface Transportation Efficiency Act of 1991 (ISTEA) represents the first comprehensive review of our Nation's transportation system since the 1950's, and provides new direction for examining and resolving our modern transportation needs.

Contained within ISTEA are several provisions for increasing the emphasis on bicycle and pedestrian facility development, programming and education. Specifically:

- *Sections 1024 and 1025* require that States and Metropolitan Planning Organizations include bicycle and pedestrian transportation facilities in all annual and long range Transportation Improvement Plans (TIP);
- *Section 1033* defines that States may use funds from the Surface Transportation Program, Congestion Mitigation Program, National Highway System projects, and Federal Lands Highway program to develop pedestrian walkways and bicycle transportation facilities. Additionally, each State is now required to have a full-time Bicycle and Pedestrian Coordinator before it can access allocated ISTEA funds beginning in FY 1993;
- *Section 1007* defines bicycling and walking facilities as one of ten Transportation Enhancements eligible for funding under Surface Transportation Program funding; and
- *Section 1302* defines the National Recreational Trails Fund Act as a trust fund, financed from taxes paid on the purchase of fuels for recreational vehicles and other outdoor equipment, that can be used to develop primarily off-road facilities.

ISTEA provides the opportunity, legislative support, and funding to increase bicycle and pedestrian facility development, programming, and education in States and local communities. However, this can only be realized if State and local transportation programs develop sound planning guidelines and safe, efficient design standards for facility development.

To help in this effort, the Federal Highway Administration (FHWA) is conducting the National Bicycle and Walking Study. This report, commissioned by the FHWA in February 1992, is one of 24 case studies comprising the overall study.

It is the goal of this case study report to define current planning guidelines and design standards that are being used by States and localities for the development of bicycle and pedestrian facilities, and identify state-of-the-art practices that can be used as models by other communities for the successful development of these facilities.

Since 1981, most State and local agencies have relied on the American Association of State Highway and Transportation Officials (AASHTO) *Guide for the Development of Bicycle Facilities* as the legally defensible and primary source of planning guidelines and design standards. This publication was revised and updated in 1991. In addition, new standards and guidelines are originating at the State and local levels that reflect the changing needs of bicyclists and pedestrians.

These plans are taking into consideration new technologies that are producing more sophisticated bicycles; new grass-roots movements to encourage access to public lands; new land use planning concepts to encourage alternative transportation modes; new Federal standards relating to persons with disabilities; and new philosophies based on 20 years of experience in bicycle facility planning and design.

The emphasis of bicycle and pedestrian programs, and the planning guidelines and design standards which mold them, are changing. In the past, safety issues have been prominent. To protect the health, safety, and welfare of our Nation's citizens this must continue to be emphasized, but access issues also move to the forefront.

We think of the United States as a mobile society, but in fact, we are becoming less and less mobile. Certain segments of our population - the very young, the very old, the urban poor---- are finding it increasingly difficult to travel within and between our rapidly growing communities. As our Nation's transportation system continues to grow, bicycling and walking must be thought of as valuable transportation modes and become fully integrated in the overall system.

To assist States and localities in obtaining current, state-of-the-art information on bicycle and pedestrian facility design, this case study report presents a compilation of the best practices in use across the country.

The report focuses on current national standards and how State and local agencies are exceeding these standards. It examines how successful programs have become successful, and what mechanisms local and State agencies have put in place to enforce adopted transportation guidelines and standards.

There is no empirical evidence that suggests that State modifications to national guidelines creates facilities that are any safer or more easily accessible. More research is needed on this subject. However, some of the early modifications to national guidelines have since appeared in many other guidelines and standards produced recently.

State and local plans typically go in greater depth and detail on individual topics of concern. They also clarify national standards and are able to factor regional considerations into the development of guidelines. And finally, State and local agencies have had a lot of intimate, hands-on experience in designing, developing, maintaining and operating pedestrian and bicycle facilities throughout the past twenty years. To this end, this case study report contains model recommendations for change as we enter the 1990's and beyond.

# Section 1

## Case Study Methodology



# Case Study Methodology

The objective of this case study, as defined by the Federal Highway Administration, is to "investigate planning guidelines and design standards for bicycle/pedestrian facilities currently used by States and localities, and determine which of these could serve as models for use by other communities."

To accomplish this objective, the consultant was asked to contact not more than nine State and local bicycle and pedestrian program officials/agencies to determine the state-of-the-practice. The consultant was asked to define what reference documents are being used, how these are used, and what mechanisms exist at the State and local levels to ensure conformance with these documents. With the state-of-the-practice defined, the FHWA also requested that the consultant identify which of the available documents best meets the bicycle and pedestrian facility design, development and management needs of State and local agencies.

From this mandate, the consultant collected, reviewed and assimilated planning guidelines and design standards for bicycle and pedestrian facilities from across the country. Several of these plans were already housed in the consultant's extensive in-house library. Additionally, nine States and five municipalities were contacted and asked to provide current information for the case study.

One of the major obstacles that was faced in preparing this report is the fact that with the passage of ISTEA, several States and local bicycle/pedestrian programs have already begun to revise their guidelines and standards, thus some information was still in draft form as it was being reviewed for this report. These preliminary plans were included to ensure that this case study reflects the most recent effort under way with regard to bicycle and pedestrian transportation.

After a thorough review of the literature was complete, the consultant identified and compared the similarities and differences of each separate document/program, noted where State and local standards followed or exceeded Federal or national objectives contained in documents such as the American Association of State Highway and Transportation Officials (AASHTO), Uniform Vehicle Code (UVC) and Manual on Uniform Traffic Control Devices (MUTCD), and defined best practices as individual components and as entire programs-to serve as models for other communities to examine and emulate.

This report, therefore, describes the process and products of the consultant's investigations, provides the reader with a summary of best guidelines and standards that are currently being used

to develop successful bicycle and pedestrian facilities and programs, and defines reference documents that should be obtained in order to maintain the leading edge of facility design.

This case study report is further divided into the following sections:

•**Section 2: Summary of Selected Planning Guidelines and Design Standards** provides a description of those documents and programs that exemplify the state of the practice.

•**Section 3: Similarities and Differences Among Guidelines and Standards** provides discussions on how individual State and local manuals differ from each other and how they deviate from AASHTO, UVC and MUTCD on specific planning and design issues.

•**Section 4: Planning and Design Enforcement** is a description of those mechanisms that are used by the Federal Government, States, and localities to ensure that guidelines and standards are appropriately followed and implemented in facility development and management.

•**Section 5: Best Practices** is a listing of the best of the best current bicycle and pedestrian guidelines, standards, and programs.

•The **Appendices** contain a listing of agency contact persons and a bibliography of documents that were reviewed for this case study.

**Note:**

Certain documents referenced within this report were in draft form at the time of the case study research. States and municipalities provided these preliminary documents to the consultant in an effort to compile the most up-to-date bicycle and pedestrian information available. Some of this information may be modified and/or expanded in the final versions of these newest guidelines and standards.

Verbal and/or written permission was obtained to duplicate and include all line drawings, graphic illustrations, specifications, standards, guidelines and other relevant material contained within the case study report.

The consultant has made every effort to attribute references to information to their original source. However, as bicycle and pedestrian facility planning has gained popularity throughout the years, a network of information sharing has occurred. This sharing has allowed a certain number of best practices to become widespread throughout the country. The process has, however, also made it difficult to determine genealogies and origins of specific information and graphic illustrations.



Section 2  
Summary of Selected  
Planning Guidelines and  
Design Standards





# Summary of Selected Planning Guidelines and Design Standards

This section of the case study report identifies selected State and local agencies which have developed exemplary bicycle and pedestrian planning guidelines and design standards. The reference documents included in this case study represent the state of the art, as well as current practice, in facility planning and development. Also covered are the national standards that have been used by many State and local agencies to create their documents.

Overall, there is a wealth of information available on bicycle facility development, and an absence of information, plans and programs related to pedestrian facilities. Bicycling issues were addressed fairly heavily in the 1970's, while pedestrian facilities are just now beginning to receive consideration in transportation planning.

A disproportionate amount of State plans are included within this summary, as opposed to local plans. This is attributed to the fact that in the past, exemplary guidelines and standards have largely originated at the Federal or national level and have then flowed through State agencies and organizations to local communities. There have been exceptions, such as Eugene, Oregon, and Madison, Wisconsin, which have created local standards based on their own successful experiences with specific facilities. However, communities have largely turned to State or Federal practices to guide local design development.

It also follows that funding sources have, for the most part, been initiated at the Federal or State level. Local communities have more typically matched a Federal or State initiative than generated local capital initiatives for bicycle and pedestrian facility development.

Within the following text, bicycle and pedestrian guidelines, standards, and programs are described under the headings of national, State, and local. The programs are ordered from A to Z, with no preference given toward best practices. The descriptive text does, however, provide qualitative evaluations of each individual plan or program, and summarizes those aspects of each document that differ from other manuals currently in use across the Nation.

## **A. National Studies, Guidelines, and Standards**

### **AASHTO Guide for the Development of Bicycle Facilities**

This design manual, published by the American Association of State Highway and Transportation Officials, is the basic reference for bicycle facility designers all across the country. It has been adopted, in part or in its entirety, by most State and local agencies. In conjunction with the *Manual on Uniform Traffic Control Devices* (MUTCD), it is often the only reference publication used to plan and design bicycle facilities.

*The Guide for the Development of Bicycle Facilities* was first published in 1981, based on a 1974 AASHTO publication entitled *Guide to Bicycle Routes* and early bicycle facility design work underway in the State of California. In 1991, AASHTO's Task Force on Geometric Design updated the document.

The AASHTO *Guide* focuses primarily on facility design, and also touches on the subjects of planning and operations and maintenance. The design chapter presents an extensive fourteen-page discussion of separated, off-road bicycle paths, but only seven pages are devoted to roadway improvements—the current emphasis of bicycle transportation nationwide. General design considerations and provisions for bicycle parking are also briefly covered.

The 1991 *Guide* includes photographs of properly designed bicycle facilities and, in the bike path section, technical charts and graphs that provide engineering minimums for design factors such as curve radii, stopping distances, length of vertical curves and lateral clearances on horizontal curves. The appendix also contains helpful reference information to familiarize designers with relevant sections of the *Uniform Vehicle Code* (UVC) and the *Model Traffic Ordinance* (MTO).

#### **"Reviewing the '81 AASHTO Guide," *Bicycle Forum* Issues 26 - 29**

This recently published article is a four-part series offering the National Bicycle Policy Project's (NBPP) comments on the 1981 AASHTO *Guide*. The 1991 AASHTO revision was a relatively limited update, and the discussions contained in these *Bicycle Forum* articles provide an understanding into where bicycle facility design is heading as we enter the last decade of this century.

Comments from a panel of some of the most experienced people in the field of bicycle facility design give suggestions on how the AASHTO *Guide* could be improved, while providing valuable insight into current planning and design practices employed by various State and local agencies.

### **Manual on Uniform Traffic Control Devices**

The purpose of traffic control devices and warrants for their use is to help ensure highway safety by providing for the orderly and predictable movement of all traffic, motorized and nonmotorized, throughout the national highway transportation system. For this reason the *Manual on Uniform Traffic Control Devices* (MUTCD) was developed.

This national manual for streets and highways sets forth the basic principles that govern the design and usage of traffic control devices, such as signs, pavement markings, signals and islands.

Included within the MUTCD are specifications for pedestrian signals and traffic controls for bicycle facilities,

The standards presented in this manual are required by statute, in virtually all States, to conform to a State manual that shall be in conformance with the national MUTCD. In this way, the publication is used for planning and designing all bicycle and pedestrian facilities across the country.

### **Planning, Design, and Maintenance of Pedestrian Facilities**

This design manual was completed for the FHWA in March 1989 by Research, Development, and Technology. It provides the current practices pertaining to the development of pedestrian facilities and serves as an excellent resource for organizations and agencies interested in developing urban pedestrian projects. It offers one of the most complete guides for State and local pedestrian facility development, and draws on the experiences of many different local programs, which is why it is included within this study.

*Planning, Design, and Maintenance of Pedestrian Facilities* is a primary source document for urban pedestrian facility problems that are most frequently encountered by traffic engineering professionals.

### **Planning and Implementing Pedestrian Facilities In Suburban and Developing Rural Areas**

This national report, *NCHRP Report 294A*, provides state-of-the-art information on pedestrian facility planning, design, and implementation. It was prepared for the National Cooperative Highway Research Program, Transportation Research Board in June 1987 by a team of consultants in association with AASHTO and the FHWA. As with the FHWA March 1989 report, this document provides States and localities with an excellent summary of information related to pedestrian facility design development. However, this document provides more explanation of pedestrian facilities related to commercial, office, residential and shopping center development in suburban and rural areas. Thus it is 'a good complement to the FHWA report.

*NCHRP Report 294A* also provides a clear and concise description of a model process for including pedestrian facilities within the context of urban and suburban development. It defines pedestrian travel behavior and accident characteristics, common problems with suburban pedestrian facilities, considerations for highway right-of-ways, and implementation strategies.

The report contains a number of excellent and illustrative photos, line drawings, graphs, charts, and scenarios that reinforce recommendations within the text and offer the reader good examples of successful facility design development.

### **Guidelines for Creating Greenways**

This document is currently being published by Island Press; a copy of the final manuscript was reviewed for inclusion within this report. Authored by Charles A. Flink and Robert M. Seams, two national experts on greenway and multiuse trail design, this book offers detailed design recommen-

dations for planning, designing, developing, and maintaining multiuse bicycle and pedestrian off road trail facilities. Topics that *Guidelines for Creating Greenways* focuses on, which are not contained in other material reviewed, include: siting of multiuse bicycle/pedestrian facilities within riparian or floodplain lands, solutions to user conflicts, a variety of trail types-from single tread, single purpose to multitread, multipurpose, maintenance programs, liability, safety and security recommendations, trail tread development recommendations, and construction cost estimates.

The manuscript is a "how-to" guide and contains numerous line drawings and illustrations of design details and development specifications.

### **Design and Maintenance Manual for Multiuse Trails**

A second national "how-to" guide for developing off-road facilities is currently being produced by the Rails-to-Trails Conservancy, Washington, D.C. *Design and Maintenance Manual for Multiuse Trails* looks at how a variety of man-made linear corridors, such as abandoned railways, canals and utility lands, can be successfully transformed into multipurpose trails. Co-authored by nine greenway, bikeway and trail development experts, the soon-to-be-published book includes chapters on getting started, planning, designing and managing multiuse trails, and maximizing a trail's potential.

Helpful information not found in other sources includes a detailed listing of factors to consider in conducting physical site inventories and cultural/community assessments. Guidelines are also given on how to involve the public and adjacent landowners in planning for trails, how different soils affect the trail design and different surfacing materials that are recommended to be used in various settings, how to design signage systems based on the shapes, colors, sizes, placement and desired use of signs, and how to lay out parking lots and other support facilities that are often needed along a multiuse trail.

## **B. State Agency Plans**

### **Arizona Department of Transportation**

This agency has developed a comprehensive bicycle design manual, entitled *Arizona Bicycle Facilities Planning and Design Guidelines*, that pulls together key elements of other exemplary national and State planning and design documents. Text in the guide is supplemented with crisp illustrations and excellent cross-references to the location of vital information. The clean design and layout of the publication creates one of the most well-organized and easy-to-read technical references available.

Produced in 1988, the manual is based on the current philosophies commonly employed in bicycle facility planning and design. These underlying philosophies include:

- 1) The bicycle is a vehicle and is entitled to share the roadway with other vehicles except where prohibited.

- 2) Bicycle facilities are alternatives and should be appropriately selected to fit specific transportation circumstances. Sidewalk bikeways are discouraged.
- 3) Shared roadway facilities, if properly designed, can afford greater safety to the cyclist than totally separate facilities.
- 4) Bicycling is an effective and efficient means of alternative transportation, and should be encouraged throughout the State.

The most unique aspect of the Arizona manual, apart from other documents reviewed, is the appendix that provides scale drawings and engineering specifications for typical signage to be used in constructing on-road and off-road bicycle facilities.

## **Caltrans**

The California Department of Transportation, known as Caltrans, was a pioneer in developing bicycle planning guidelines and design standards. Their 1978 publication, entitled *Planning and Design Criteria for Bikeways in California*, formed the basis for the 1981 AASHTO guide, and text and graphics from this publication have since appeared in several other State and local bicycle design manuals.

Caltrans has since published *Bikeway Planning and Design*. This manual was reproduced from the overall California DOT *Highway Design Manual*. Its contents were selected and assembled together so that bicycle facility planners and designers had a complete bicycle document that functioned independently of their *Highway Design Manual* (HDM).

The manual is comprised directly of sections from the California *HDM*. It differentiates mandatory standards from advisory standards by listing each in separate tables at the beginning of the publication, and setting mandatory standards in bold type within the text. Discussions are based upon shared roadway and Class I, II and III bikeways.

Along with the inclusion of bicycle facility planning and design in the *HDM*, Caltrans has integrated sections on bicycling into their *Statutes Relating to the California Department of Transportation* and the *State of California Vehicle Code*. In addition, Caltrans prepares an annual report to the legislature on the *Development of Nonmotorized Facilities*, pursuant to the California Streets and Highways Code Section 156.7. These three documents present policies that aid in enforcing uniform specifications and symbols, ensuring compliance with design criteria, and managing the Caltrans Bicycle Program.

## **Colorado Department of Transportation**

At the time of this case study report, the State Department of Transportation was in the process of preparing *Colorado Bikeways Standards and Design Guidelines*. This up and coming publication is a compilation of the most recent and state-of-the-art information available from national and State sources.

In addition to pulling together exemplary standards and guidelines, the Colorado DOT reorganized the presentation of material. Rather than following the same outline as AASHTO and other State publications, *Colorado Bikeways Standards and Design Guidelines* provides an introduction to bicycle facilities by discussing bikeway functions, users and reasons why people bicycle. Each type of on-street and off-street bikeway is discussed first in general terms of why they are needed, where they should be considered, and what are the problems and advantages associated with each. Then, in a separate chapter, technical details and specific design standards are presented. In addition, CDOT has added current information on ISTEA, common misconceptions in bicycle facility design, and innovative details specific to their State, such as designing for rugged mountain terrain.

At the time of review for this case study, the manual was in draft text form only-no graphics, chapter headings or bold type had been added to improve readability. Yet, this was one of the most easy-to-follow publications reviewed because material is presented in a logical order that follows the typical thought process one must go through to plan, select and design bicycle facilities.

Other relevant information furnished by the State of Colorado for this case study includes *CDOT Pedestrian and Bicycle Policy Draft*, the 1991 Colorado Bicycling Advisory Board *Annual Report* to the Governor, and House Bill No. 1246 which concerns traffic laws relating to bicycles and to the operators thereof.

### **Delaware Department of Transportation**

One of the most recently completed plans on alternative transportation modes is *Strategies for a Statewide Bicycle/Pedestrian Plan*. This plan is included in the case study because it is one of the earliest to implement recommendations contained in the 1991 ISTEA. The report suggests a strategy for DelDOT to pursue in taking a lead role in a coordinated approach to developing and using walking and bicycling facilities.

This plan provides a vision for the 1990s, with a Task Force approach recommended for developing user-friendly infrastructure and providing incentives, services and support facilities. The report outlines in detail the duties, topics of concern, and proposed member composition of three specific task forces:

- \* Outreach and Support Task Force
- \* Facilities and Services Task Force
- \* Laws and Safety Task Force

The document offers guidelines for planning only; no facility design standards are included. But the approach documented, and the extensive listing of reference materials warrants inclusion of this plan in the case study report.

### **Florida Department of Transportation**

The State of Florida currently provides the Nation's most comprehensive approach to bicycle and pedestrian facility design development. The Florida DOT Division of Planning has developed several excellent manuals to assist in their efforts to superimpose alternative modes over the existing statewide transportation system.



The first of these manuals, entitled *Bicycle Facilities Planning and Design Manual: Official Standards*, was developed in 1982 to provide individuals and agencies in the State of Florida with the information necessary to plan, locate, select and design bicycle facilities and transportation systems. The use of this manual is intended to establish uniform facilities in conformance to AASHTO, and as such, text on design criteria comes almost verbatim out of the AASHTO guide. However, important information contained within the text is easy to find, as all mandatory minimum standards are underlined. In addition, helpful graphics and illustrations accompany the text.

Of particular value to metropolitan planning areas is supplemental information on bicycle system transportation planning. The manual outlines a 14-step planning process developed and successfully implemented for the Gainesville Urban Area study.

*The Development Manual for Comprehensive Regional Bicycle Plans*, January 1985, is a second publication intended to guide each of Florida's 21 Metropolitan Planning Organizations through the process of preparing an Urban Area Bicycle Plan for their region. It is an invaluable tool for local government agencies, as well as regional transportation planning organizations, which describes exactly what process communities need to go through, step by step, to develop and approve a bicycle plan.

Florida's *Development Manual* is the only resource publication encountered during research for this FHWA Case Study that focused exclusively on guidelines on how to implement the planning process. The document is so complete that it even contains blank data collection forms for direct use by local jurisdictions and a model Comprehensive Regional Bicycle Plan report outline.

A companion publication printed in 1985, *Bicycle Facilities Design Training Course*, was developed and distributed by the Department of Transportation as an aid to State, regional and local engineers, planners and others seeking an improved means of increasing the mobility and safety of those using Florida's roadways. In conjunction with the production of this report, the DOT offered 4-hour training courses on bicycle transportation design.

*Bicycle Facilities Design Training Course* relies heavily on illustrations and graphics to explain the underlying principles of bicycle facility planning and design. It is very easy to understand and serves as an excellent reference document for readers unfamiliar with technical engineering subject matter. Helpful policy statements and liability information are found in the appendix.

The most recent publication to come from the Florida DOT expands this agency's leadership in developing bicycle facilities to developing ones for pedestrian use. The *Florida Pedestrian Safety Plan*, February 1992, takes the four E's of bicycling—engineering, education, enforcement and encouragement—and applies them to walking. These four topics are discussed in depth, with full chapters devoted to each. Itemized discussions on issues and recommendations, supplemental reference materials, quotes, illustrations and photographs are used to present the State's existing problem of pedestrian safety and the proposed solutions that will make Florida pedestrian-friendly within three years.

*The Florida Pedestrian Safety Plan* is intended to serve as a 1990's guide to all Florida communities, regional and State Governments, nonprofit groups, and others wishing to implement countermeasures to the problems of pedestrian safety. It represents the most comprehensive, innovative and committed statewide approach to sidewalk development and pedestrian safety program implementation.

### **Minnesota Department of Transportation**

Minnesota's *Bikeway Design Manual* contains adopted State bikeway design standards which are intended to maximize fully the value of existing roadways for bicyclists. Because more flexibility is provided, the MN/DOT standards permit improvements to be made that will result in greater uniformity of highway geometries over major lengths of roadway.

Three types of bikeways are focused on:

- Rural Design Bikeway---any section of public road that has shoulders and ditches.
- Municipal Design Bikeway --- all other public road sections within corporate limits, generally with curb and/or gutter.
- Off-Road Bikeways---a travel corridor separated from the road structure and specifically designed for nonmotorized transportation.

One of the most innovative aspects of the *Bikeway Design Manual* is a technique for determining appropriate bikeways standards by using Bikeway Design Tables. Under this system, shoulder surface widths, through lane widths, parking use, and ADTs are evaluated to determine what type of improvement is needed.

Other original, in-depth material covered in this manual includes bridges and grade separations, intersection treatments, traffic controls for bicycles, erosion control during bikeway construction, and vegetation control. In addition, the process by which bikeway plans are prepared by local governmental agencies for funding through MN/DOT programs is outlined. Details are given on how to prepare and submit complete bikeway plans-which include title sheets, estimated quantities and typical sections, plan and profile sheets, and cross-section sheets.

A second publication produced for the State of Minnesota is *Plan B, The Comprehensive State Bicycle Plan: Realizing the Bicycle Dividend*. This plan provides a framework to support and guide the development of bicycling in Minnesota. The publication covers a lot of general goals and objectives for bicycling and outlines the state of bicycling in Minnesota today. Most important to the development of facilities are the goals and objectives outlined for accessing facilities and implementing planning and administrative recommendations.

---

## New Jersey Department of Transportation

It is the policy of NJDOT to promote the increased use of the bicycle as a means of personal transportation and to provide for bicycle traffic by taking into account the needs of this mode in all State-funded transportation projects and programs. In 1981, NJDOT developed 11 bicycle planning and design guidelines for policy implementation. To help those persons responsible for State-funded transportation improvements follow the guidelines and comply with the State's bicycle policy, NJDOT developed *Bicycle Compatible Roadways-Planning and Design Guidelines*.

The report is an expanded version of the 11 guidelines for accommodating bicycles within the State's transportation network. Contents include:

- \* Space for Lane Sharing
- \* Drainage Grates
- \* Utility Covers and Other Surface Irregularities
- \* Signalized Intersections
- \* Railroad Crossings
- \* Maintenance
- \* Placement of Guidebeams, Light Standards, Sign Posts, etc.
- \* Unimproved Intersecting Streets and Driveways
- \* Transportation Systems Management (TSM) Type Improvements
- \* Unavoidable Obstructions
- \* Bicycle Mobility or Accessibility Studies

*Bicycle Compatible Roadways* consists of comprehensive original text that goes into greater detail than AASHTO's guidelines for roadway improvements and introduces subject matter not covered in other State and local standards. Focusing exclusively on roadway improvements, this report establishes three general sets of roadway conditions based upon traffic volumes, mix and speeds. Defining specific roadway conditions allows the NJDOT to provide guidelines, such as pavement widths and special situation design requirements, for the development of the best type of facility for each condition. The report also covers common details typically not addressed in most standards and guidelines, such as unavoidable roadway obstacles and placement of appurtenances.

Graphics of roadway cross-sections do an excellent job of depicting the spatial requirements of bicycles and other vehicles for each condition. Unlike most cross-section illustrations, the graphics in this report demonstrate the need for the amount of space recommended in each type of roadway by dimensioning vehicle sizes and safe separation distances. Other unique graphics in the report depict specific elements of facility design, such as bicycle compatible maintenance and preferred drainage grate placement.

## **North Carolina Department of Transportation**

*The North Carolina Bicycle Facilities Planning and Design Guidelines* was in draft form at the time of this case study research and has not yet been adopted by NCDOT; however, it looks to be one of the most comprehensive facility design development manuals in the Nation. The manual is filled with technical text, details and illustrations, engineering specifications, descriptive photographs and references to supplemental documentation on a wide variety of topics.

Of particular value is a nine-page, planning section, which discusses a planning process detailing how to develop goals, objectives and a planning framework, analyze local conditions, develop problem statements, generate solution ideas, produce an overall plan, implement projects and evaluate results. Bicycle parking facilities and operation and maintenance issues are also covered in greater depth than in other State and national guidelines.

The appendices contain information specific to North Carolina, but applicable to other States and localities. This includes the NCDOT Bicycle Policy, the State's Bicycle Transportation Improvement Process (TIP), sections from the national and State MUTCD, bicycle facility signs specific to North Carolina, and a listing of manufacturers of flangeway fillers or rubberized railroad crossings.

Probably the most comprehensive and technically detailed of all documents reviewed, the *North Carolina Bicycle Facilities Planning and Design Guidelines* is representative of the direction in which bicycle facility planning and design is headed in the 1990's.

## **Ohio Department of Transportation**

The Ohio Department, of Transportation operates one of the most successful bicycle programs in the United States, in terms of Federal dollars that have been spent on bicycle facility development. ODOT relies on Federal guidelines for planning, designing and developing a wide variety of successful bicycle facilities throughout the State.

*Policy and Procedure for Bicycle Projects* is the only design manual currently available from the Ohio DOT. It is based on AASHTO and MUTCD, with some changes that make the Ohio standards more stringent than Federal guidelines. It is a very dry, but clear and concise technical manual that defines policies, procedures, development specifications, and funding for the statewide bicycle facility development program. All of the graphics within the manual are re-published from other sources including the complete MUTCD bicycle signage section.

One section of this manual that sets it apart from AASHTO and other State guidelines is a chapter on the Project Development Process. ODOT has outlined what a local government agency needs to do to qualify for Federal funding under their bicycle program. The process includes submitting letters of application, conducting a field review of the project, completing a Program Form, examining environmental considerations, and developing detailed construction plans. Also included is a project development time chart that lists the length, elapsed time, and maximum time that is expected to complete each task.

ODOT has developed additional standards and policies pertaining to bicycle facility development. These include requiring submission of an overall bicycle plan along with applications for individual projects, a policy for highway shoulder treatment for bicycles, and guidelines for retaining walls on bicycle projects.

### **Oregon Department of Transportation**

In March 1988, the Oregon DOT Bicycle Program Office and the Oregon Bicycle Advisory Committee developed the *State of Oregon Bicycle Master Plan*. The primary purpose of this document is to give direction and guidance to the Highway Division's Bicycle Program. It also serves to provide uniform guidance for local government bicycle programs.

Content includes background information, details of the Oregon Bicycle Program, and guidelines for bikeway design and operation. Topics covered include:

- |                                    |                                      |
|------------------------------------|--------------------------------------|
| * The Cycling Environment          | * Designated Bicycle Routes          |
| * Oregon Pioneer Bicycle Laws      | * Basic Bikeway Design Standards     |
| * Administrative Organization      | * Signing and Striping               |
| * Bicycle Facility Funding Sources | * Operation and Maintenance          |
| * Program Goals and Objectives     | * Safety, Education, and Enforcement |
| * Expenditure Priorities           |                                      |

The language of the report, overall publication design and the use of graphics and descriptive photographs are very user-friendly, as the *Bicycle Master Plan* is intended to help citizens who are interested in bicycling to clearly understand Oregon's Bicycle Program. As such, this is one of the most easy-to-read documents reviewed as part of this case study.

As many states have done, Oregon has adopted the *AASHTO Guide for Development of bicycle Facilities* with minor changes and supplements. However, rather than repeating the AASHTO text verbatim in their plan, Oregon DOT summarizes technical details in easy-to-understand language and provides supplements and exceptions to the AASHTO guidelines in the appendices, a technique that has worked very well.

Other useful information includes a section describing beneficial practices and practices to be avoided based on the Oregon Highway Division's years of experience using various bicycle design practices. The appendices of the report contain policy statements and copies of Oregon statutes on bicycling.

The Department of Transportation is currently revising the 1988 *Master Plan* to reflect current trends in bicycle facility planning and design. The most notable addition to be contained within the 1992 version will be a new section on planning, which covers statewide planning and coordination, and planning principles for Urban Bicycle Route Systems. 'Ibis and other information is being added to the *Bicycle Master Plan* to reflect the latest experiences of the Oregon Highway Division with regard to bicycle facilities. It is hoped that local communities, and other States, can use the new information, updated philosophies and past experiences of the Oregon DOT to establish bicycling as an integrated transportation mode for the 1990's and beyond.

## **Pennsylvania Trails Program, Bureau of State Parks**

In 1980, an exemplary design manual for nonmotorized, off-road facility development was produced by the State of Pennsylvania Bureau of State Parks Trails Program. *Nonmotorized Trails: An Introduction to Planning and development* defines, in substantial detail, the planning and design of off-road trails for bicycling, walking and hiking, as well as for snow skiing, horseback skiing, and nonmotorized boating. Trail development for persons with disabilities is also defined.

The manual discusses the aesthetic and environmental considerations of off-road trail layout, the anatomy of a trail, and defines the physical requirements of different trail types. Although focusing on recreational trails, information contained within the publication is relevant for multiple-use transportation facilities. This is a particularly useful guide for bicycle and pedestrian paths that deviate from roadway or highway rights of way.

## **State of Washington Department of Transportation**

In another nonmotorized facilities plan, the State of Washington addresses bicycle and pedestrian development through a concise document that is a component of an overall 1989 *Design Manual*. Section 1020.04, "Facilities for Nonmotorized Transportation," offers recommendations for pedestrian facility design and development, oriented mostly toward urban facilities. This is a typical definition and description of pedestrian facility design/development issues that can be found within many other States' design and engineering guidelines and standards. Bicycle facility planning is organized according to the Class 1, II, III, and IV bikeway designations, but otherwise follows the AASHTO guidelines.

*The Bicycle Policy* adopted by the State of Washington is unique when compared to other State bicycle facilities policies in that it focuses on bridges and intermodal transportation:

*The roadway and bridge system should continue to form the basis for the bicycle facility network. The roadway and bridge system should be maintained and improved to help ensure safe access by bicyclists. Bicyclists should have access to other modes of transportation to ensure smooth intermodal connections.*

A third publication is the *Washington State Transportation Policy Plan*, produced by the Subcommittee on Bicycle Transportation. This 1991 report was developed to provide direction and coordination for bicycle planning, facility development, and programs in State and local agencies.

An entire chapter of the *Policy Plan* is devoted to transportation facilities in the State that need to better accommodate bicycling. Current problems are encountered with both urban and rural roadways that are not designed for safe bicycle use; a lack of integration between bicycling and other travel modes; and bicycle paths that are inadequately maintained or poorly connected to the transportation system. Text covers roadways and separate paths, intermodal facilities, and facilities at the work place or final destination point.

The final document reviewed is a very unique and comprehensive study of the link between transit systems and pedestrians. *Linking Land Use and Transportation: Design Strategies to Serve HOV's and Pedestrians* was prepared for the State of Washington Department of Transportation by Richard Untermann, Professor of Landscape Architecture at the University of Washington. The primary purpose of the study is to define the concept of "Suburban Centers" by which commuters can walk or bike to transit stops and travel in special outboard High Occupant Vehicle (HOV) lanes to and from work, instead of driving their cars to a Park-and-Ride lot.

The report lacks specific design details, however, it does provide a number of planning guidelines and recommendations that are based on a review of actual field conditions typical to many American communities.

### **Wisconsin Department of Transportation**

*The State of Wisconsin DOT uses their Facilities Development Manual to guide the planning and development of all bicycle facilities. Bicycling has been integrated within this overall manual and can be found within the following sections:*

- \* Chapter 3: Facilities Development Process
  - design study reports
- \* Chapter 11: Design
  - cross-section elements for rural highways and freeways
  - dimensions and design classes
  - other elements affecting geometric design
  - recreation trails/routes
- \* Chapter 21: Environmental Documents, Reports and Permits
  - other required environmental documentation
  - Section 4(f) evaluation

Standards established in the *Facilities Development Manual* are applicable to all types of highway improvements on the State Trunk Highway System, other street/highway systems for which Federal-aid highway funds may be used, State facilities funded with Wisconsin DOT-administered funds, and other highways and roads for which the DOT may act as administrative agent.

## **C. Local Agency Plans**

### **Denver, Colorado, Department of Public Works**

In May 1991, the City and County of Denver hired a full-time Bicycle and Pedestrian Planner and began a Bicycle Program within the Public Works Transportation Planning Section.

One of the most significant developments to come from the new program is *Construction Detour Standards for Bikeways and Multiuse Trails*. These criteria were developed as a result of the need to provide quality construction zone operations and detours on bikeway trail facilities, for both Public

Works and Park and Recreation facilities. The standards address user safety, motor vehicle and construction equipment use of a bikeway, and operations that disturb the trail for less than one day and for more than one day. A special signage plan has also been developed for construction detours and ramp closures.

### **Eugene, Oregon, Public Works Department**

The 1986 Eugene-Springfield Metropolitan Transportation Plan addresses the principal modes of transportation used for travel within the metropolitan area, including autos, buses, bicycles and walking. *Transplan* contains several progressive public policies on land use, planning and coordination, implementation, parking and alternate modes that address increasing opportunities for people to walk and bike in the urban area.

In 1990, the City of Eugene prepared the supplemental *Transplan Policies Related to Alternative Transportation Modes* for a work session on alternative transportation. The Eugene Public Works Department extracted all *Transplan* policies which have a direct bearing on alternate modes, and supplemented this information with assessments of current practices relating to the policies and recommendations for action within the City's evolving transportation work plan. The policies represent the leading edge of alternate modes planning and address bicycle/pedestrian issues from a comprehensive viewpoint.

The Eugene Bikeway Program has been active for 21 years, and has been able to institutionalize bicycling within the various divisions of city government. Over the years, the *Eugene Code* has had several sections added to promote development of bicycle and walking facilities, including:

- \* Requiring sidewalks and driveway approaches to be constructed by those applying for building pen-nits.
- \* Providing for public access ways when platting city blocks.
- \* Providing for public access along the Willamette River.
- \* Requiring bicycle storage for all multiple dwelling units based on the number of units, and in industrial and commercial districts based on a percentage of the required automobile parking standards. In addition, the code calls out required size and placement of parking facilities.

In addition, several exemplary construction details for elements of bicycle facility design have been developed as *City of Eugene Standard Drawings*. These include standards for intersection treatments, driveway and alley aprons, removable bollards, 5-foot-wide curb and gutters, access ramps, sidewalks, and bike-proof drainage grates.

The most recent state-of-the-art material to be developed by the Eugene Department of Public Works Transportation Division is the *Eugene Sidewalk Program*. A draft of this August 1992 report was reviewed for inclusion within Case Study #24.



The *Eugene Sidewalk Program: An Update of Sidewalk Needs* is a formal program to set sidewalk priorities and adequately address the most critical deficiencies in pedestrian transportation. The program, which reviewed and updated the 1980 Eugene Sidewalk Program, provides direction for developing annual sidewalk construction projects based on existing and future pedestrian demand and safety needs. Eugene developed an innovative Priority Point System, based on street classifications and pedestrian attractor points, to establish a phased construction program for missing sidewalk segments throughout the city.

### **Madison, Wisconsin, Department of Transportation**

The City of Madison generally follows AASHTO's *Guide for the Development of Bicycle Facilities and the Manual of Uniform Traffic Control Devices for the design and marking of facilities*.

As a supplement, A *Bicycle Transportation Plan for the City of Madison and Dane County, Wisconsin* provides guidelines for where bicycle facilities are needed and guidelines for on-road versus off-road facilities. The appendix of this document also specifies typical street cross sections in greater detail than AASHTO. Included are arterials, local streets, arterials with bike/bus lanes and collector streets.

The City of Madison addresses both bicycling and walking in the *Madison General Ordinance*. The zoning code requires bicycle parking facilities at new developments, and the general planning section of the code requires public walkways and sidewalks to be installed within all public right-of-ways. In addition, standard street sections include specifications for sidewalks and the City's Engineering Division has recently developed a standard for five types of sidewalk ramps.

### **Tucson, Arizona, Department of Transportation**

Tucson's Alternative Modes Program officially became a component of the city's Department of Transportation in 1988. The primary emphasis of the program is to increase community awareness of bicycle and pedestrian transportation alternatives, and to direct public transit activities in the Tucson metropolitan region. The program is currently funding the development of several bicycle and pedestrian demonstration projects and is implementing other programs that serve to increase bicycle and pedestrian facilities citywide, including: participating in the Arizona DOT bicycle locker grant program, conducting a bicycle inventory study, completing a bikeway capital improvement program, instituting a bicycle parking ordinance along with development standards, and implementing a bike on buses campaign.

Tucson is also very interested in congestion mitigation and making improvements to local air quality, and is implementing a Travel Reduction Program that incorporates bicycle usage, transit and pedestrians as solutions. Tucson is currently conducting a Regional Bicycle Facility Inventory Study which makes use of Geographical Information Systems (GIS) to inventory all existing bicycle facilities.

At present, Tucson does not have a municipal design manual for bicycle and pedestrian facility development. Through the Inventory Study, the city has established definitions and a classification

*Facilities Planning and Design Guidelines* for a majority of facility development issues. However, several specific municipal initiatives have also been undertaken to address local concerns.

One of the principal guides for facility development has been the *Major Streets and Routes Plan* developed by the city in 1982 and amended six times, most recently in 1987. This plan addresses long range transportation needs, policies, solutions and programs for the city through the year 2005. It recognizes that much of the transportation network is already in place, and focuses on providing additional capacity to the existing system with minimal disruption to existing land uses, and providing safe and efficient transportation solutions. Under general design and development guidelines of the plan, where feasible, identified major streets are to be designed with a 17-foot outside lane to provide cyclists with a dedicated 5-foot-wide bicycle lane. Additionally, on-street parking is discouraged to promote safe, free flowing traffic and maintain capacity. Finally, all major streets shall include "pedestrian ways"--sidewalks built on streets and across bridges. The *Major Streets and routes Plan* also identifies roadway cross sections for 64,76,90, 100, 120, and 150 foot rights of way, all of which include pedestrian and bicycle transportation on both sides of each street.

Tucson has developed development standards for Pedestrian Access and Bicycle Parking. The *Bicycle Parking Ordinance* is very progressive and includes a listing of manufacturers who build lockers and racks that satisfy the city's parking requirements. The listing also rates the level of security provided by each type of facility. Bicycle parking is determined as a percentage of off-street auto spaces, which varies with each land use.

### **Seattle, Washington, Engineering Department**

Seattle has become very well known as a bicycle-friendly city. It was named the number one cycling city in America in the April '90 issue of *Bicycling Magazine*, and was ranked number five in a May '92 article on the world's best cities for cycling. But Seattle has not developed their own planning guidelines/design standards manual for bicycle facilities.

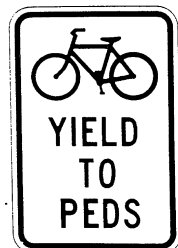
Seattle's AASHTO-based *Street Design Manual*, adopted by the Board of Public Works, is used as a tool for reviewing, all street design projects within the city. City staff rely on sound engineering judgement and priorities, in conjunction with AASHTO, to make Seattle a bicycle-friendly community.

Through an informal process, either the Bicycle Coordinator or Bicycle Program Planner sits on a Review Team of Engineering Staff that meets weekly or monthly to review all progress on the planning and design of a specific project. In this manner, bicycle staff have input into all phases of planning, designing, and constructing all streets within Seattle.

The system has worked so well that bicycling has become institutionalized within the various divisions of local government. The words "bicycle" and "bicycling" appear in almost every document, and thus no special bicycle facilities design manual is needed.

## Section 3

# **Similarities and Differences Among Guidelines and Standards**





# Similarities and Differences Among Guidelines and Standards

Many State and local agencies across the United States use differing planning guidelines and design standards for bicycle and pedestrian facilities. The Federal Highway Administration authorized this case study to determine what guidelines and standards are being used and developed, and which documents best meet the needs of State and local agencies.

Case study research has found that many of the guidelines being used are very similar---the bulk of the text reads the same, graphics depict identical situations, and reports are organized in similar formats. However, differences do exist. Sometimes subtle, sometimes appearing as entire chapters, innovative and helpful information is appearing in the newest bicycle/pedestrian guidelines and standards being developed in the United States.

This section of the case study report therefore focuses on these similarities and differences, and references where bits and pieces of specific information on bicycle and pedestrian issues can be found.

## A. The Use of AASHTO

Since 1981, the *Guide for the Development of Bicycle Facilities*, published by the American Association of State Highway and Transportation Officials, has been the basic reference document for bicycle facility planners and designers across the country. It has been adopted in its entirety, or with minor changes, and forms the basis of many States' facility standards.

The AASHTO guide contains short chapters on planning and operations/ maintenance, with the majority of the document being devoted to facility design. It is comprehensive, yet intentionally vague, so as not to set forth strict standards, but rather, to present sound guidelines that will be valuable in attaining good design that is sensitive to the needs of both bicyclists and other users. Minimums are given only where further deviation from desirable values would result in unacceptable safety compromises.

## **B. Beyond AASHTO**

As a blanket publication intended to serve as reference material for the entire country, the *AASHTO Guide for the Development of Bicycle Facilities* fulfills its purpose. However, when revised in August 1991, many experienced bicycle people had hoped to see additional revisions made to the *Guide* so that it could better serve the needs of the bicycling public. (See "Reviewing the '81 AASHTO Guide" a four-part article published in Issues 26 - 29 of *Bicycle Forum*.) These proposed revisions were based on the experiences of States and municipalities who were actively planning, designing, and constructing bicycle facilities.

Since 1981, several of these agencies had developed their own, modified versions of the AASHTO guide. Some documents stressed planning; others recommended specific details for solving typical bicycle facility design problems. In some cases, AASHTO standards were made more flexible to adapt to local conditions; many times they were expanded and made more stringent to ensure that local facilities would be designed to meet individual State and community needs.

For the most part, the content and organization of the *Guide* has been followed in local and State manuals. For this reason, the following text is organized according to the three chapters outlined in AASHTO. The case study text summarizes new material introduced in other manuals and highlights elements of bicycle planning and design that are discussed in greater detail in other publications. State and local guidelines that deviate from or exceed AASHTO standards are also included.

## **Chapter -Planning**

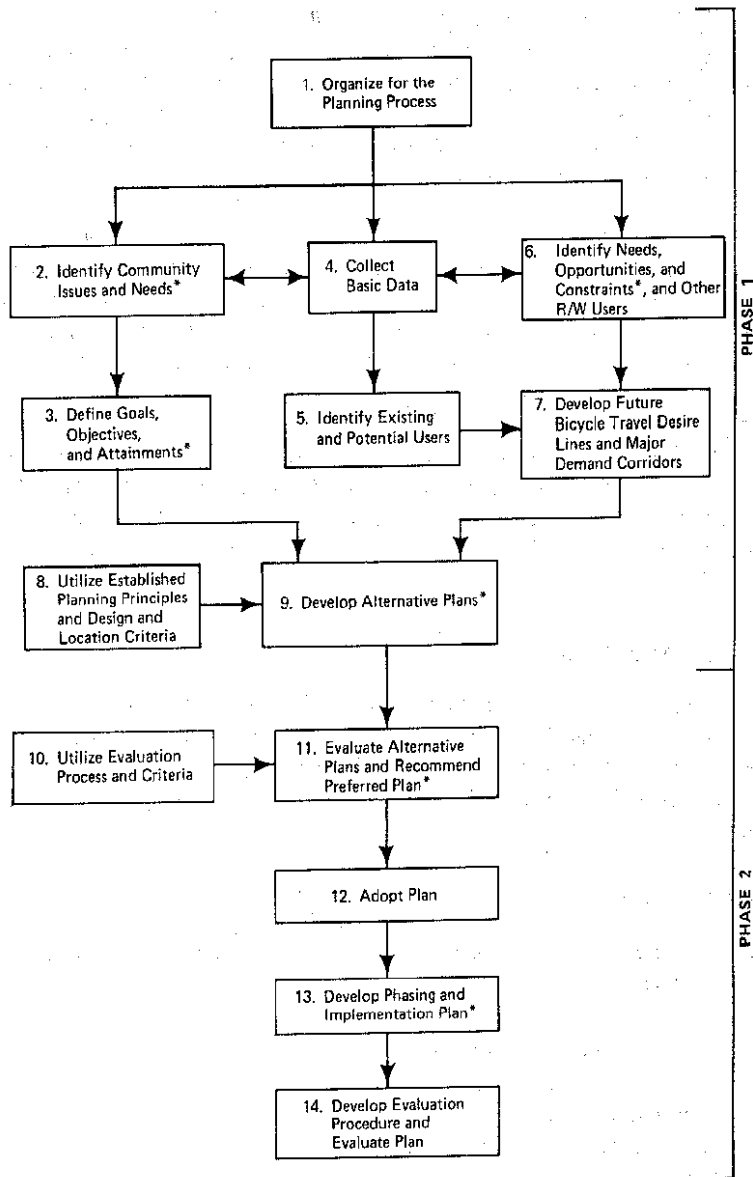
The AASHTO guide provides a brief overview of planning considerations for bicycles, a discussion of types of facility improvements, and a description of factors to consider when locating a facility. Additional planning information was researched as part of this case study to determine which documents could serve as models for use by other communities. The best supplemental information includes:

### **Planning Processes**

North Carolina's soon-to-be-published guidelines include a nine-page planning section that discusses a detailed process consisting of the following steps:

- 1) develop goals and objectives
- 2) develop planning framework
- 3) analyze local conditions
- 4) develop problem statements
- 5) generate solution ideas
- 6) develop overall plan and select solutions
- 7) implement projects
- 8) evaluate results and revise

**Figure 1. Comprehensive Bicycle Transportation Planning Process**



\*Major Public Participation Recommended

Source: STATE OF FLORIDA  
Bicycle Facilities Planning and Design Manual

- Florida DOT has developed a comprehensive bicycle transportation planning process, based on the approach used for the Gainesville Urban Area Bicycle System Study. Figure 1 summarizes the two-phase, 14-step process. Twenty-five pages of detailed, itemized text further explain this process in Florida's *Bicycle Facilities Planning and Design Manual*.
- In addition, the Florida DOT has produced a *Development Manual for Comprehensive Regional Bicycle Plans* which is an excellent planning tool for local Government agencies, as well as regional transportation planning organizations. The manual:
  - ) discusses the urban transportation planning process
  - ) provides background on bicycle use, problems and programs
  - ) describes the comprehensive urban area bicycle planning effort
  - ) covers the critical topics of coordination and citizen participation
  - ) addresses data collection and analysis
  - ) discusses the development objectives for a regional or local plan and provides a set of sample objectives which may be used with only minor revisions
  - ) identifies recommended actions to achieve the stated objectives
  - ) treats the all-important topic of program implementation, along with such requisite tasks as setting priorities, scheduling and funding-also discusses the preparation of the documentation designed to be included in the Metropolitan Planning Organization's (MPO) regular transportation planning documents
  - ) offers suggestions for presenting the plan and its various supporting documents to the appropriate committees, organizations and governments for approval.
- *DelDOT's Strategies for a Statewide Bicycle/Pedestrian Plan* focuses on the organization of a proposed approach to coordinating the planning of bicycle and pedestrian facilities and services in Delaware. By establishing three individual planning task forces, local and State agencies and organizations are provided a long-term planning structure in which to address concerns for bicycle and pedestrian transportation.

The recommended task forces, and their specific areas of concern, are as follows:

- 1) Outreach and Support Task Force-encouragement and enforcement, recreation and activities, training of staff
- 2) Facilities and Services Task Force-funding, property acquisition and operating rights, planning and design, maintenance



- 
- 3) Laws and Safety Task Force-safety and education, law enforcement, legal and legislative affairs.

\* The State of Oregon is currently revising their 1988 *Bicycle Master Plan* to reflect the newest thinking in bicycle facility planning. A major addition appearing in the new plan is a section outlining the following planning principles that should be used when preparing corridor plans, developing project plans, approving local grant applications, or reviewing local and regional bicycle system plans:

- 1) provide direct and continuous bikeways along all arterial and major collector routes to accommodate commuting and other bicyclists
- 2) provide bike lanes on most urban arterial and major collector routes
- 3) provide the continuation of all statewide highway routes and county bicycle routes into and through urban areas
- 4) provide a network of bicycle routes that provide convenient access to schools, residential, commercial, and recreation areas
- 5) where necessary, provide separate bike path routes which cross over physical barriers to bicycle travel.

\* Several States, including Florida and Arizona, promote using the following criteria in selecting the proper location for bicycle facilities:

- 1) location criteria for increasing accessibility-potential use, access, directness, existing barriers, delays
- 2) location criteria for promoting bicycle safety-use conflicts, accidents, traffic volumes and speeds, truck and bus traffic, pavement surface quality, maintenance, on-street parking
- 3) location criteria for improving security
- 4) location criteria for improving the riding environment-air quality, attractiveness, grades.

\* The original 1978 *Planning and Design Criteria for Bikeways in California*, from which AASHTO is based, includes a section entitled "The Decision to Develop Bikeways." This text is critical to the process of bicycle facility planning, as it outlines the reasons for developing bikeways and reminds readers of the commitments involved in designing and maintaining these facilities.

\* Similarly, the *Colorado Bikeways Standards and Design Guidelines* provides valuable discussions on the functions of bikeways---for transportation rather than recreation---and key charac-

teristics of bikeway users. The reasons why people bicycle, typical bicycling destinations, and real safety versus perceived safety are discussed as part of facility planning.

### Selecting the Type of Facility

Many of the guidelines and standards publications reviewed as part of this case study contain a heading similar to this. Most use this portion of their document to introduce and define bikeway classifications-shared roadway, bicycle routes, wide curb lanes, bike lanes, and bike paths. Some, however, go on to give specific guidelines, formulas, and average daily traffic counts for when each of these facility types are warranted.

- \* The New Jersey DOT does not recommend employing route signing or lane striping unless there is a special need for it. Instead, the DOT determines the amount of paved surface width necessary to accommodate shared vehicular and bicycle modes by examining traffic volumes, mix, and *speeds*. *Bicycle Compatible Roadways* outlines three general conditions that call for three different widths of useable paved surface in the curb lane or right hand lane plus shoulder. The text provides detailed discussions on the requirements and special situations for each, summarized as follows:

#### Condition I

- \* traffic volumes: light, less than 1200 ADT
- \* traffic mix: can vary
- \* traffic speeds: can vary
- Facility Type: shared travel lanes, 12' minimum width

#### Condition IIA

- \* traffic volumes: moderate to heavy, more than 1200 ADT
- \* traffic mix: minimal volumes of heavy trucks
- \* traffic speeds: 55 mph or less

-or-

#### Condition IIB

- \* traffic volumes: can vary
- \* traffic mix: can include heavy trucks
- \* traffic speeds: 45 mph or less
- Facility Type: 15' of shared paved surface in the outside lane or outside lane plus useable shoulder

#### Condition III

- \* traffic volumes: moderate to heavy
- \* traffic mix: includes more than minimal volumes of heavy trucks
- \* traffic speeds: greater than 45 mph
- Facility Type: 18' of shared paved surface in the outside lane or paved shoulder adjacent to the outside lane

- \* In Minnesota, bikeway design standards have been developed based on the relationship between the characteristics of the road design (bicycle driving area) to the average daily motorized traffic.

MN/DOT has created Bikeway Design Tables to help designers understand existing road situations and determine bikeway design options.

These design tables are matrices that relate roadway characteristics such as road type, shoulder surface and width, and parking use to the width of through travel lanes. Based on the average daily traffic (ADT) of a given road, the matrix then determines the suitability of the road for bicycle transportation.

When using the MN/DOT tables, road sections that currently rate "good" or "fair" are generally not eligible for shoulder or off-road construction. If a suitable parallel road or off-road bikeway exists, funding from the MN/DOT will be denied. Off-road design will be considered if shoulder construction cannot enhance the road to "good" or "fair" status.

The Minnesota DOT has also established three evaluation factors to help determine the appropriate standard or type of facility to use. These are:

- 1) identifying the major bikeway section or principal travel route
  - 2) evaluating a roadway for bicycle travel needs
  - 3) evaluating minor routes or tributary bikeways.
- The State of Oregon uses three general guidelines, based on bicycle use, to determine how designated bicycle routes should be signed. Bicycle use refers to the average daily use during the 3 months of highest use.

No Signing---when bicycle use is less than 20 bikes a day.

Bike Route Signing (shared roadways and shoulder bikeways)---when bicycle use is significant, 20 to 50 bikes a day.

Bike Lane Designation-in all urban areas, and rural areas where bicycle use exceeds 50 bikes a day, designate lanes if a 4- to 6-foot width is available for bicycle use. If not, sign as a Bike Route only.

In addition to these guidelines, the State of Oregon uses one or more of the following criteria to designate Statewide Bicycle Routes:

- 1) demand
  - 2) continuity and linking
  - 3) advantages of the riding environment.
- The draft version of the *Colorado Bikeways Standards and Design Guidelines* includes the following general rules pertaining to traffic volumes and speeds when developing on-street bicycle facilities:

A facility where motorized vehicle speed exceeds 55 mph or where daily volume exceeds 40,000 vehicles should not be designated as a bicycle facility. Highways which exceed these speed and volume limits are acceptable if there is a minimum 8-foot shoulder.

Wide curb lanes are appropriate bicycle facilities where traffic speeds and volumes are tolerable for shared roadway facilities. In general, roadways where speeds are not more than 45 mph and volumes are not higher than 20,000 vehicles per day are acceptable candidates for wide curb lane facilities.

Roadways where motorized vehicle speed exceeds 35 mph or where volume exceeds 10,000 vehicles per day should not be recommended for use by youthful or inexperienced adult bicyclists. When these limits are exceeded, alternate routes with speeds and volumes below 35 mph and 10,000 vehicles per day should be provided.

In addition, the plan specifies that wide curb lanes should typically not be designated as bike routes if they carry truck/bus volumes of more than 5 percent of ADT. Bike lanes may be accommodated on roadways with a truck/bus volume of more than 5 percent.

- A draft of an FHWA Research Study prepared by the Bicycle Federation of America and the Center for Applied Research, entitled *The Effects of bicycle Accommodations on Bicycle/Motor Vehicle Safety and Traffic Operations*, defines a different method for determining the most appropriate facility type. This manual advocates a two-tiered approach to facility selection: 1) that there are two distinct type of bicyclists---group A the advanced bicyclist, and Group B/C basic riders and children; and 2) that a supply driven approach rather than a demand driven approach should be used in providing appropriate facilities--that is to say "If you build them they will come."

Based on the type of bicyclist and supply side facilities required, your bicycle facility network should be planned and designed to satisfy the following performance criteria:

- accessibility
- directness
- ease of implementation
- continuity, attractiveness
- cost

This information is evaluated and plotted to define the safest and most suitable routes for travel. Once the desired lines of travel are established, these are then compared to a host of traffic operation and design factors to ultimately determine the appropriate facility type, such as:

- traffic volume
  - under 2,000 ADT
  - 2,000 to 10,000 ADT
  - over 10,000 ADT
- average motor vehicle speeds (not posted but actual)
  - 20 to 30 mph
  - 30 to 40 mph
  - 40 to 50 mph
  - over 50 mph

- traffic mix-especially with regard to bus and truck traffic
- on-street parking
- sight distance
- number of intersections

Recommendations are made for wide curb lanes, bicycle lanes, shoulders, separated bicycle paths, and shared lanes. Additionally, shared roadways without special bicycle treatments are also noted in the report.

### **Liability and Safety Factors**

Inclusion of this type of information in bicycle facility planning guidelines is critical. Many local agencies believe that a designated facility or route map creates an absolute liability. Planning manuals should provide insight into what liabilities are, how properly implemented bicycle plans can reduce risk, and specify that bicycle facilities should address liability issues through proper design and maintenance or risk management plans.

Likewise, safety factors and accident studies should influence bicycle facility planning. Accident relationships exist for intersections, driveways and other elements of bicycle facility design. Studies have shown that the old bicycle planning philosophy of completely separating bicycles from motor vehicles has not solved safety problems. Bicycles and motorized traffic are compatible and often afford greater safety for the bicyclist.

The new Colorado design manual sums it up well: "The development of well conceived bikeways can have a positive effect on bicyclist and motorist behavior. Conversely, poorly conceived bikeways can be counterproductive to education and enforcement programs, as well as being a safety hazard and liability. No facility at all is better than a facility that will encourage unsafe riding habits or promote violations of the law."

## Chapter 2-Design

This chapter, which forms the majority of AASHTO's text, discusses a wide range of facility improvements which can enhance bicycle transportation. The text is subdivided into three sections--roadway improvements, bicycle paths, and supplemental facilities.

### Bicycle Roadway Improvements

This section of the AASHTO *Guide for the Development of Bicycle Facilities* focuses on a variety of improvements that can be made to existing roadways.

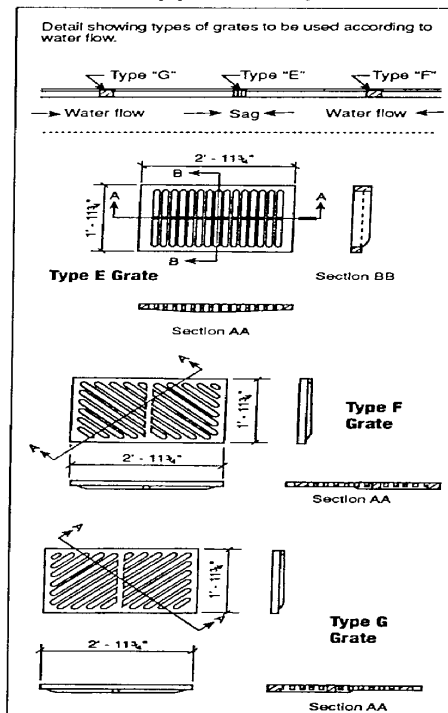
Improvements range from the simple replacement of unsafe drainage grates to the development of supplemental on-road bicycle facilities.

The following text references state-of-the-art planning guidelines and design standards covering supplemental information on each topic covered in AASHTO. This information is contained within the case study report to provide insight into what additional material is being used to guide the development of on-road facilities across the country:

#### Drainage Grates

- Figure 2 is taken from the North Carolina *Planning and Design Guidelines*, which details three DOT-approved bicycle-safe drainage grates for use according to varying types of water flow.
- New Jersey's *Bicycle Compatible Roadways* specifies that stream flow drainage grates should not be used except in unique or unusual situations which require their use. As an alternate, NJDOT's Drainage Section has developed a bicycle-safe drainage grate with acceptable hydraulic characteristics, illustrated in Figure 3, for use in all normal applications. In addition, drainage grates shall only be placed outside of the lane sharing area, as depicted in Figure 4.

**Figure 2. Bicycle-Safe Drainage Grates Approved by NCDOT**



Source: NORTH CAROLINA PLANNING AND DESIGN GUIDELINES

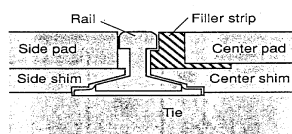
**Figure 3**  
See page 29-A

**Figure 4**  
See page 29-B

## Railroad Crossings

- Railroad-highway grade crossings should ideally be at a right angle to the rails. However, since this is not always possible, several local and State plans offer useful graphics that depict how to cross tracks at skewed intersections. Some of the most complete illustrations, found on the following page, come from Minnesota. These graphics depict three alternatives for bikeway/ railroad crossings. Figure 6 depicts a widened roadway shoulder and supplemental pavement striping. Figures 7 and 8 illustrate having a bikeway cross tracks independently of the roadway--- Figure 7 at a 90° crossing with standard curve widenings, and Figure 8 at a 45° angle with widened bike path pavement to allow bicyclists to cross as close to 90' as possible.
- Information on commercial available flangeway fillers is one of many supplemental details included in North Carolina's new *Planning and Design Guidelines*. On low-speed, lightly travelled railroad tracks, flangeway filler can eliminate dangerous nonright angle crossings by filling the gap between the inside railbed and the rail, as illustrated in Figure 5.

**Figure 5. Cross-Section of Rubberized Railroad Crossing with Flangeway Filler Strip; for Low-Speed Angle Crossings**

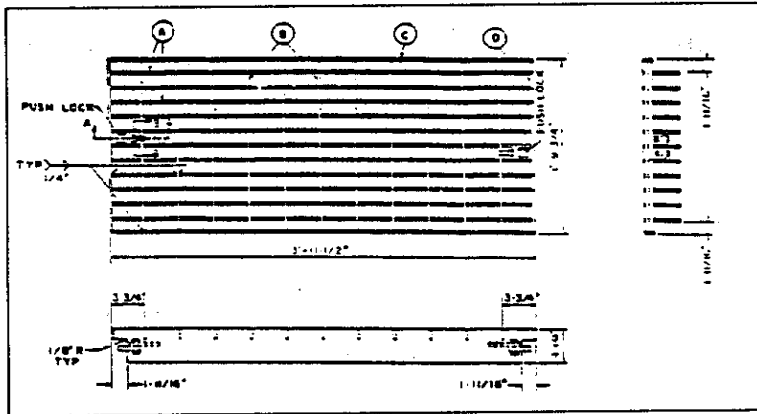


Source: NORTH CAROLINA PLANNING AND DESIGN GUIDELINES

It is important to note that flangeway fillers should not be used on high-speed main railway lines, as they do not compress fast enough and trains may derail. Use is recommended only for low-speed angle crossings.

- The State of Oregon places special warning signs (see page 67 of this case study, "Beyond MUTCD") when a railroad crossing clearly poses a hazard to bicyclists and cannot be improved.

**Figure 3. Detail of Bicycle Safe Inlet Grate**

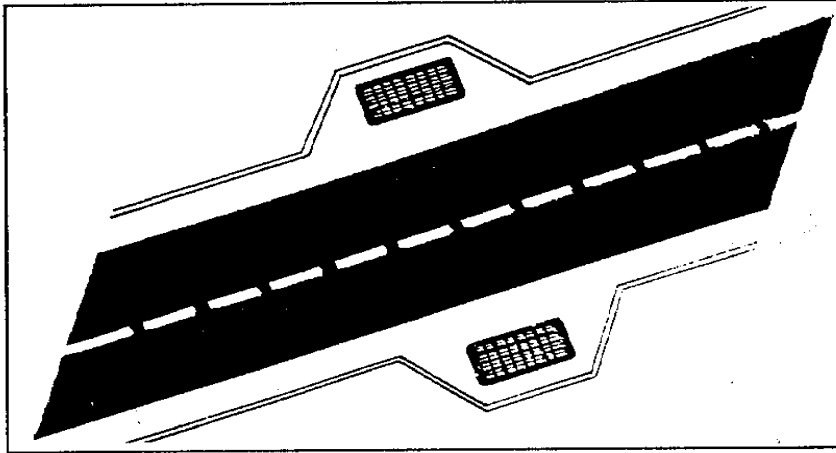




29-A

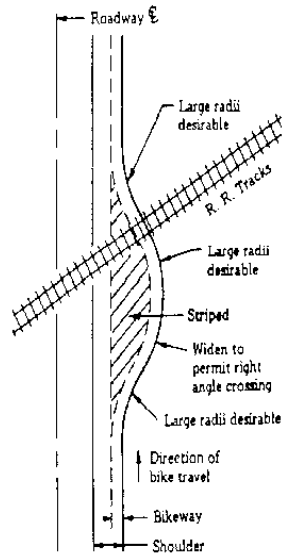
29-B

**Figure 4. Bike Compatible Drainage  
Grate Placement**

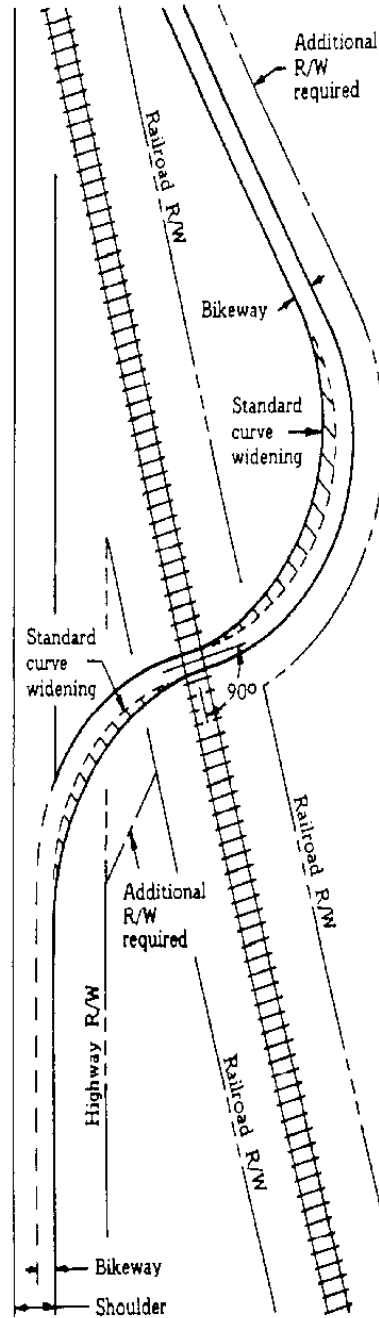




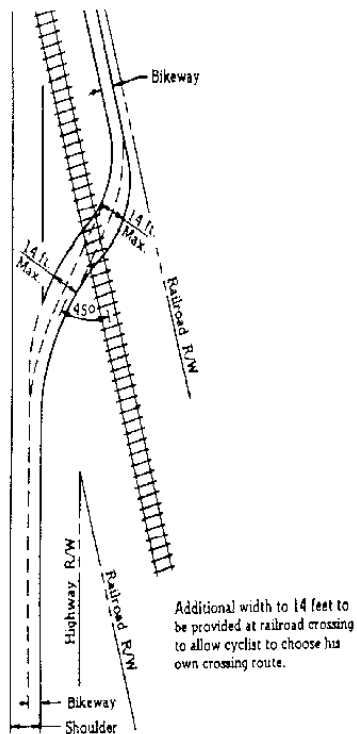
**Figure 6: Widened Shoulder**



**Figure 7: 90° Crossing  
(most desirable)**



**Figure 8. 45° Crossing  
(less desirable)**



Source: MINNESOTA BIKEWAY DESIGN MANUAL

North Carolina DOT recommends a similar treatment, using a W 11-1 warning sign with an appropriate message, such as "BIKES CROSS AT RIGHT ANGLE."

## Pavements

This section of AASHTO offers a brief discussion of pavement surface irregularities including gaps, holes, bumps, and uneven pavement edge widths.

- The draft version of Colorado's new guidelines goes on to state that "narrow slots in the surface that could catch a bicycle wheel, such as a gap in the longitudinal joint between two concrete slabs, should not be more than 1/2-inch wide. Ridges in the pavement that could cause bicyclists to lose control, such as the joint between the pavement and a concrete gutter or utility cover, should not be more than 3/8 inch high when parallel-to travel or 3/4-inch high when perpendicular to travel."
- Caltrans specifies the same surface tolerances as Colorado, with a note saying that stricter tolerances should be achieved on new bikeway construction.

In addition, the Caltrans *Highway Design Manual* addresses uniform surface quality as follows: "For rideability on new construction, the finished surface of bikeways should not vary more than .02 foot from the lower edge of an 8-foot-long straight edge when laid on the surface in any direction."

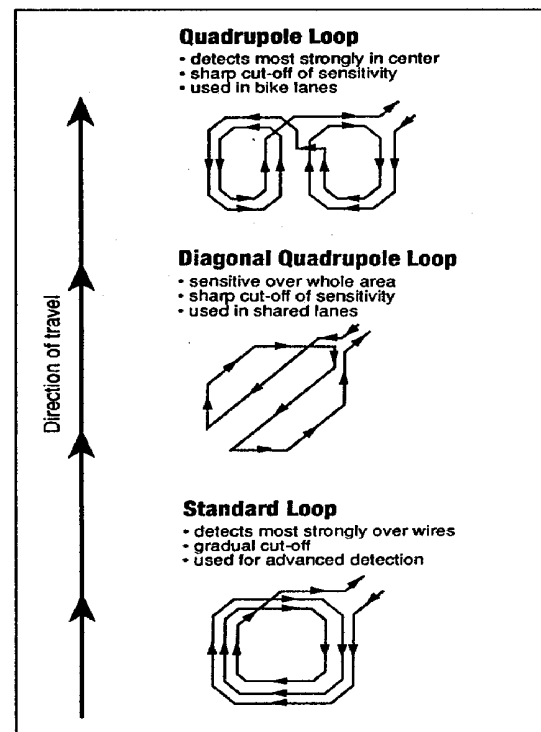
## Traffic Control Devices

- Based on recent research into bicycle-sensitive loop detectors, several of the newest planning and design manuals are specifying the type of traffic control devices to be used at traffic actuated signals. This information is included as part of the standards text, or added as an appendix, and is often based on a *Traffic Signal Bicycle Detection Study* completed in 1985 by the City of San Diego. See Figure 9.

Bikecentennial, the author of North Carolina's new guidelines, summarizes preferred options for loop detectors as follows:

- 1) Quadruple Loops for bicycle lane or bicycle path situations, where the location of the bicycle can be easily predicted

**Figure 9. Recommended Loop Types for Bicycle Detection**

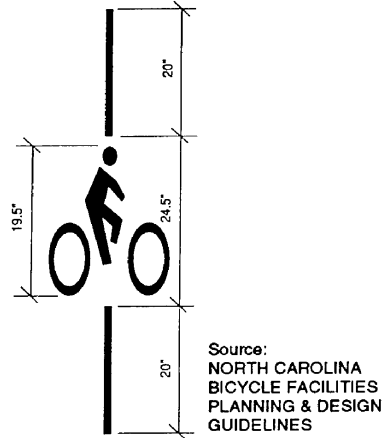


Source: NORTH CAROLINA PLANNING AND DESIGN GUIDELINES

2) Diagonal Quadruple Loops for shared roadway conditions where the exact location of the bicycle cannot be easily predicted. In most shared-road situations, the diagonal quadruple is preferred.

3) Standard Loops are the least desirable detectors for sensing bicycles. Some jurisdictions apply pavement markings, as depicted in Figure 10, over the most sensitive part of the standard loop, generally the right edge of the loop. However, this treatment requires a significant expenditure of effort and money to test and mark the location, and inform the public of the marking's meaning.

**Figure 10. Pavement Markings for Standard Loops**



•Minnesota's *Bikeway Design Manual* contains excellent discussions on the use and placement of traffic signals for bicyclists. Seven blocks of text pull information from MUTCD and cover clearance intervals, programmed vehicle signals and semi-actuated controllers for shared-use roadway facilities, plus the use of signals for separated bikeway facilities.

**Shoulders**

- The State of Oregon advocates the use of paved shoulders on many rural highways and roads. Oregon DOT specifies a desirable shoulder width of 6 feet, 2 feet more than AASHTO standards. Where 6 feet is not practical to achieve because of physical or economical constraints, a minimum width of 4 feet may be designated. In addition, when it is necessary to add paved shoulders to roadways for bicycle use, "paving an asphalt panel 10 feet in width is preferred. This eliminates a joint at the edge of the existing pavement and allows the new asphalt to feather into the existing pavement between the motor vehicle wheel tracks."
- California's Highway Design Manual contains a standard for paved shoulder widths that outlines treatments for both freeways/expressways and conventional highways with various lane conditions. Where applicable, the left and right shoulder widths are treated separately. Widths range from 2 or 4 feet for the left shoulder of freeway ramps, to 8-foot widths for the right shoulder of freeway ramps and conventional multilane highways. A 10-foot width is recommended for the right hand shoulder of freeways and expressways that allow for bicycle use.
- It is also relevant to note here that various State and local agencies have preferences for one type of bicycle facility over another. New Jersey, for example, discourages the development of shoulder bikeways. Instead, NJDOT promotes the use of wide outside lanes, because these lanes

permit motor vehicles to migrate into the area where bicycles normally operate, "sweeping" the pavement free of debris such as sand, gravel, and grit.

### Wide Curb Lanes

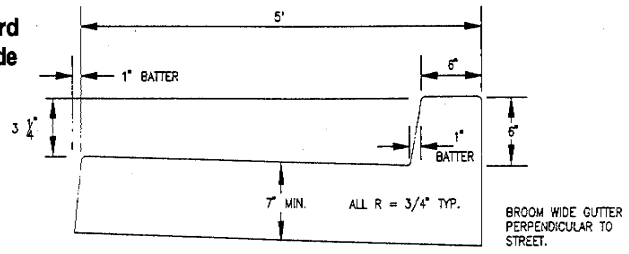
- The widths of outside curb lanes in New Jersey vary according to traffic volumes, mix, and speeds found on different roadways. Widths range from a 15-foot outside lane or lane plus shoulder, to an 18-foot wide right hand lane. *Bicycle Compatible Roadways* describes and graphically illustrates why recommended amounts of space are needed for each roadway condition. (See pages 24-25 of this case study report.)
- The Tucson, Arizona, *Major Streets and Routes Plan* contains provisions for the safe use of major streets by bicyclists. Capital improvements projects on major streets---arterials and collectors--- shall be designed with 17-foot outside lanes to allow space for bicycle traffic next to the curb. This width allows room to provide 5-foot striped bike lanes, where feasible.
- The American Association of State Highway and Transportation Officials, the National Advisory Committee on Uniform Traffic Control Devices, and several State and local agencies have commented in favor of reducing existing inside vehicle lanes from 12 feet to 11 feet for the purpose of widening the right-hand lane for bicycle use. Of course, this should only be performed after careful review of present and projected traffic characteristics along a corridor.
- For a different form of wide curb lanes, the City of Eugene, Oregon, builds 4-1/2-foot-wide concrete gutters, instead of the usual 1-foot width. (See Figure 11). The wide gutter provides

**Figure 11**  
See page 33-A

a smoother, more useable space for bicyclists since the longitudinal joint between the roadway and gutter is moved out of the area in which bicycles travel. In addition, the contrast between the light concrete gutter and dark asphalt street provides a natural bike/car separation at no additional cost.

- *Colorado Bikeways Standards and Design Guidelines* recommends wide curb lanes between 13.5 and 15 feet, not including gutter pan. The manual goes on to state that "wide curb lanes are often the only improvement that is needed to accommodate bicyclists, but striped bike lanes and designated facilities tend to encourage more bicycle use in those areas."

**Figure 11. Standard  
Integral 5-foot-wide  
Curb & Gutter**



Source: CITY OF EUGENE  
STANDARD DRAWINGS





## Bicycle Routes

- The State of Colorado recommends designated, signed routes for providing continuity to other bicycle facilities (usually bicycle lanes), or to designate preferred routes through high-demand corridors. The "Bikeway Functions" section of this publication includes helpful explanations of the purposes of bicycle routes and other designated facilities.
- Eugene, Oregon, employs an innovative use of corner flares along some of the city's curb and gutter streets that are designated bicycle routes. As depicted in Figure 12, Eugene has several signed routes that have separate path characteristics created by the installation of semi-diverters on narrow streets. The flared diverters channel car traffic to parallel arterial streets, turning shared-use neighborhood streets into streets that have more bicycle traffic than intersecting streets have car traffic.

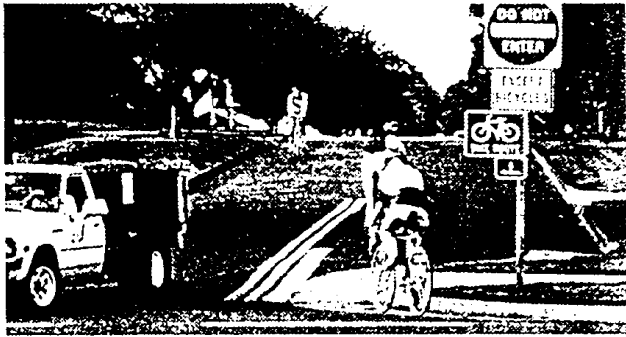
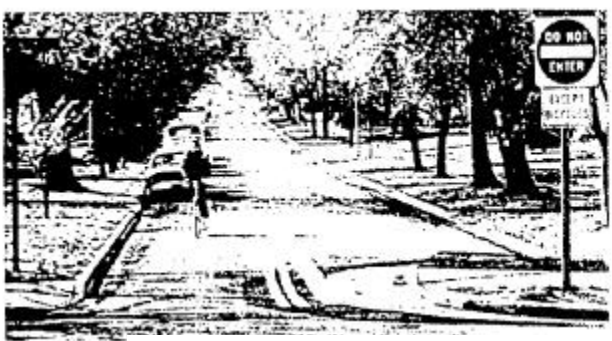
**Figure 12**  
**See page 34-A**

## Bicycle Lanes

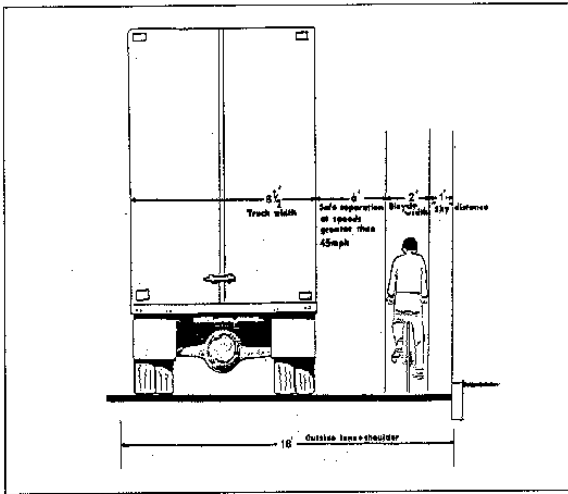
- In this section of the AASHTO *Guide*, three typical bicycle lane cross-sectional graphics are included. Treatments of curbed streets with parking, curbed streets without parking, and streets or highways without curb or gutter are represented.

The Federal Highway Administration and several individual States have created similar cross-sectional graphics for different bicycle lane applications, as well as for streets with lanes for shared motor vehicle and bicycle use.

A representative selection of graphic styles is presented in Figures 13-21 on the following three pages to provide insight into how various graphic techniques can help readers to better understand written subject matter.

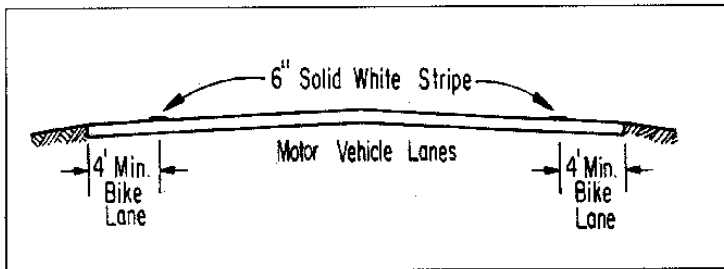


34-A



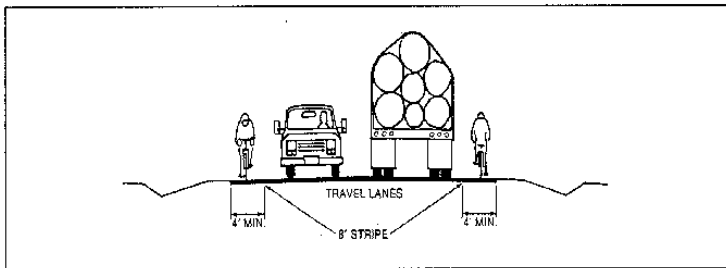
**Figure 13. Pavement Width Requirements**

Source: NEW JERSEY DEPARTMENT OF TRANSPORTATION



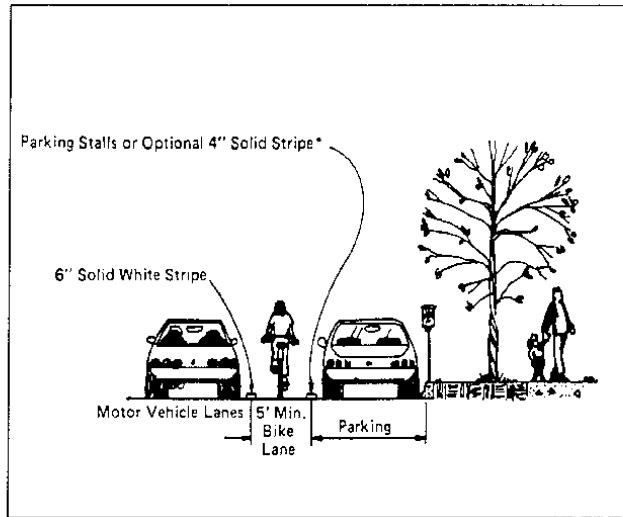
**Figure 14. Typical Roadway in Outlying Areas Parking Restricted**

Source: CALTRANS



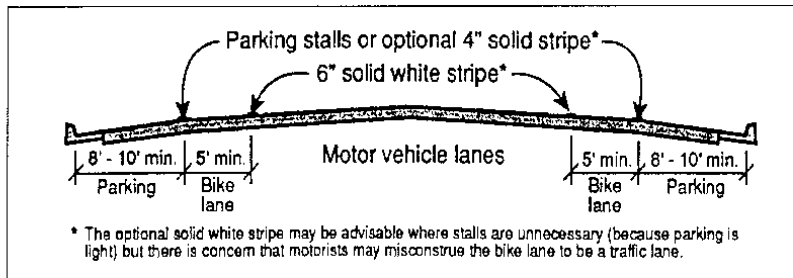
**Figure 15. Minimum Width for Bike Lanes**

Source: OREGON DEPARTMENT OF TRANSPORTATION



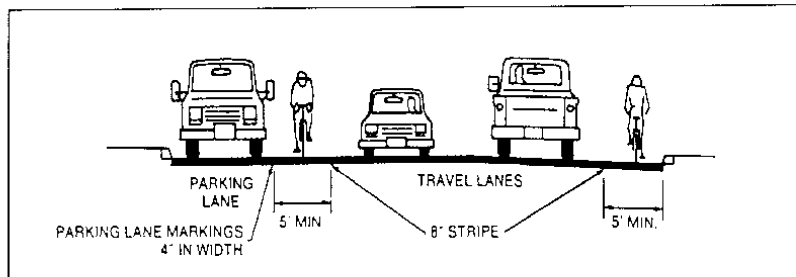
**Figure 16. Curbed Street with Striped Parking**

Source: FEDERAL HIGHWAY ADMINISTRATION



**Figure 17. Striped Parking**

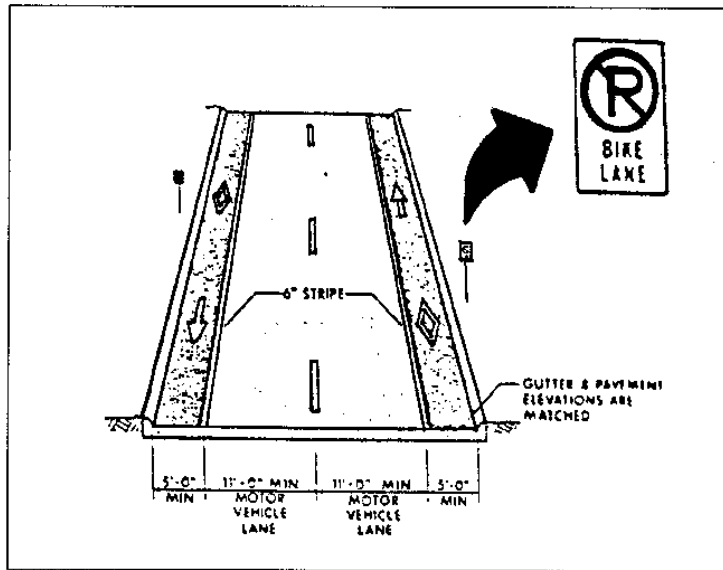
Source: NORTH CAROLINA DEPARTMENT OF TRANSPORTATION



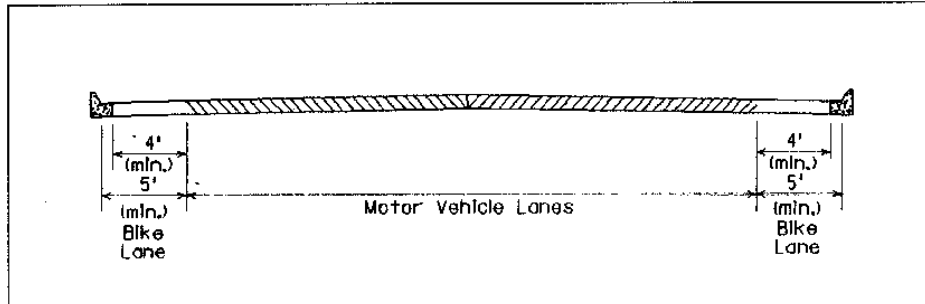
**Figure 18. Minimum Width for Bike Lanes**

Source: OREGON DEPARTMENT OF TRANSPORTATION

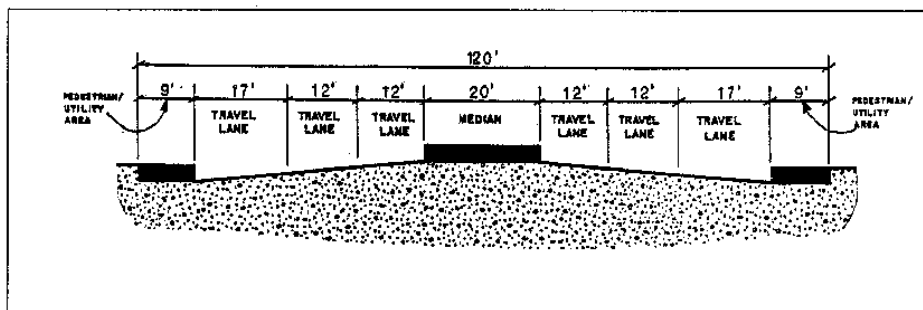




**Figure 19. Bike Lane Next to Curb and Gutter**  
 Source: STATE OF FLORIDA DEPARTMENT OF TRANSPORTATION



**Figure 20. Curbed Street without Parking**  
 Source: AMERICAN ASSOCIATION OF STATE HIGHWAY AND TRANSPORTATION OFFICIALS



**Figure 21. 120' Right-of-Way**  
 Source: CITY OF TUCSON DEPARTMENT OF TRANSPORTATION



Adding another dimension to the cross-sections, by placing vehicles and bicyclists on the roadways, immediately brings scale to the drawings. Dimensioning individual vehicle lanes also helps to clarify cross-sectional illustrations.

Two graphic styles offer particular value to readers of standards and guidelines who are not adept at reading technical information. These include the State of Florida's use of perspective illustrations as found in their *Bicycle Facilities Design Training Course* manual, and the New Jersey Department of Transportation's technique of labeling the spatial requirements of vehicles as well as the separation distances required between transportation modes.

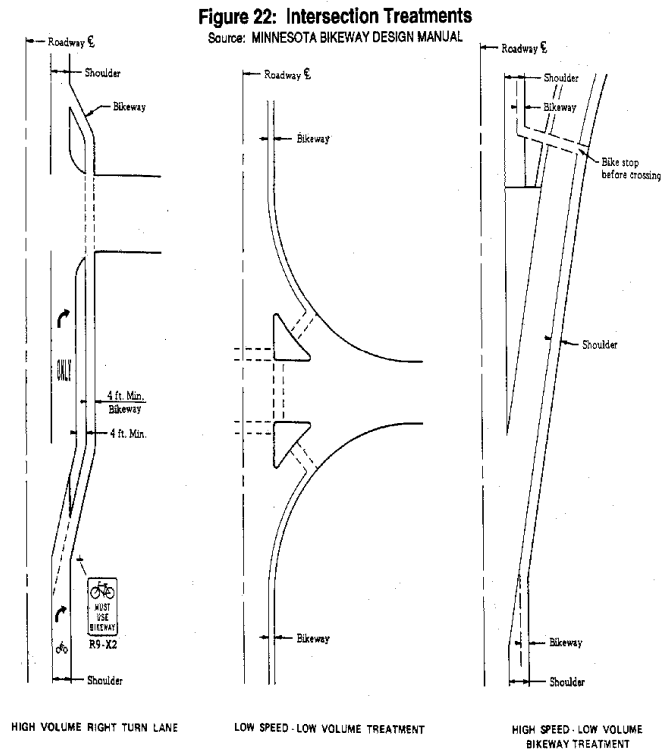
- The Caltrans Highway Design Manual contains a special provision for shared-use parking/bike lanes based on time of use. This type of bike lane should be considered only if the vast majority of bicycle travel would occur during the hours of the parking prohibition, and only if there is a firm commitment to enforce the prohibition.
- The standard reads: "Striping bike lanes next to curbs where parking is prohibited only during certain hours shall be done only in conjunction with special signing to designate the hours bike lanes are to be effective."
- The City of Madison, Wisconsin, has developed an innovative design to reduce bus-bike conflicts along University Avenue, part of a major cross-town arterial that cuts through the University of Wisconsin campus. The most unique design feature of this project is an 8-foot wide westbound bike lane that puts bicyclists between buses and cars. This lane reduces the "leapfrog" effect of buses and bicycles continually passing each other at each bus stop.
- One of Florida DOT's mandatory safety design criteria states that raised barriers (e.g. raised traffic bars and asphalt concrete dikes) or raised pavement markers shall not be used to designate bike lanes.
- Several States, such as Florida, California and Washington, include an advisory note in their official standards discouraging the use of bicycle lanes on long, steep downgrades. Where bicycle speeds of greater than 30 or 35 mph are expected, bicycles move into the traffic lanes to increase bicyclists' sight distance and maneuverability. Or, when bike lanes are used on steep grades, additional width or a dashed line shall be provided to accommodate higher bicycle speeds.

### **Bicycle Lane Widths**

- The only exception to this section of the AASHTO *Guide* was found in the State of Oregon. Their *Bicycle Master Plan* states that the desirable width for a one-way bike lane is 6 feet. Where 6 feet is not practical to achieve because of physical or economic constraints, a minimum width of 4 feet—the AASHTO standard—may be designated as a bike lane.
- *The Bicycle Master Plan* also states that "bike lanes in excess of 6 feet in width are undesirable as they encourage riding two abreast and also may be mistaken for a motor vehicle lane."

## Intersections with Bicycle Lanes

- Probably the best and most complete discussion of intersections is found in the *State of Minnesota Bikeway Design Manual*. Figure 22 depicts a selection of representative figures on intersection treatments taken from this manual.



An eight-page "Intersection Treatment" section in the *Minnesota Bikeway Design Manual* covers the following:

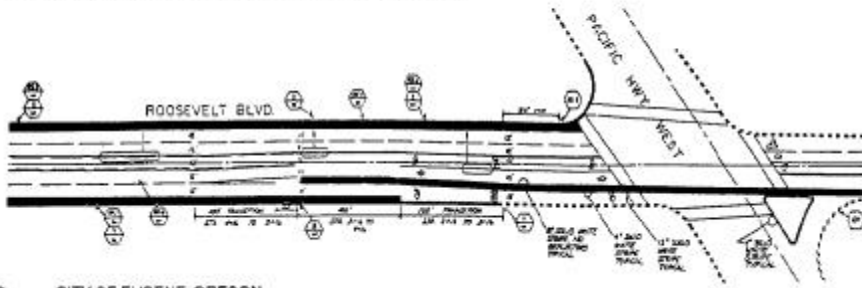
- 1) design applications
- 2) conflicts that intersections present-including the left turning bicyclist and the right turning motorist vs. the bicyclist

- 3) possible solutions to intersection problems
  - 4) field evaluations of intersections
  - 5) on-road bikeway treatments at intersections-including lane continuation, lane to intersection and lane termination treatments
  - 6) special features of on-road bikeway treatments through intersections---including low and high volume right turn lanes, channelized free turning lanes, right turn on red, two- way continuous left turn lane, and a bypass lane at "T" and four-way intersections.
- Other good discussions of intersection treatments can be found in Washington's *Design Manual*, Florida's *Official Standards* and Arizona's *Guidelines*. Although not as comprehensive as Minnesota's text, these manuals go into greater detail than the AASHTO *Guide*, discussing the use of various pavement marking treatments for different intersection conditions.
  - Treatment of bicycle lanes at street intersections demands special attention, especially when the right auto lane becomes a right turn only lane. In this situation, the City of Eugene has developed an innovative solution, as illustrated in Figure 23. Bicycle lane pavement markings overlap for 100 feet at the beginning of the turn lane and a "Bikes Merge" sign is posted. This overlapping of bike lanes gives bicyclists more distance in which to merge to the left.

**Figure 23**  
**See Page 40-A**

- Where there are heavy volumes of left-turning bicycles, *Planning and Design Criteria for Bikeways in California* states that a separate turning lane for bicyclists may be provided. Such a lane can provide for a more orderly flow of bicycles and motor vehicles in the turning movement, as depicted in Figure 24.

**Figure 23. Overlapping Bicycle Lanes at Intersections with Right Turn Only Lanes**



Source: CITY OF EUGENE, OREGON

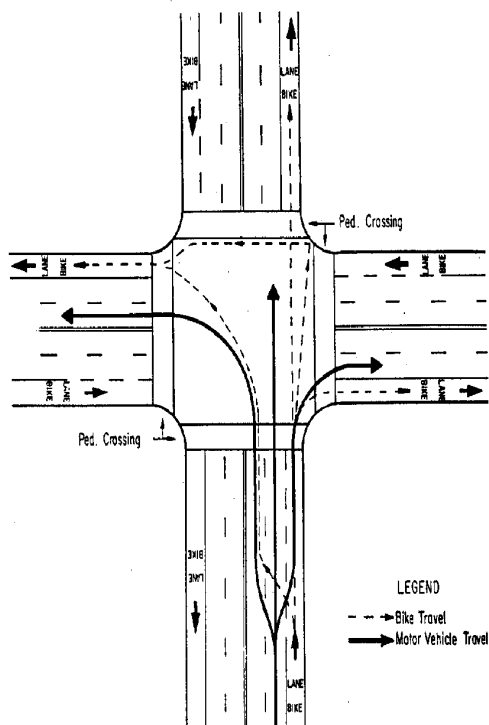
40-A



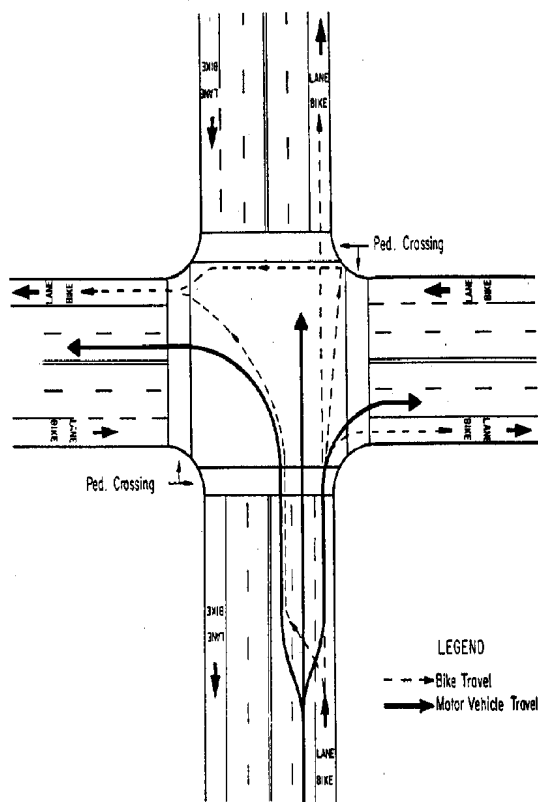


- Figure 25 of a multilane street intersection has found its way into almost all of the documents reviewed as part of this case study. Originating in the 1978 Caltrans publication *Planning and Design Criteria for Bikeways*, this illustration has been found useful to help planners and designers consider the variety of typical bicycle and auto movements that occur at the intersections of multilane streets containing designated bicycle lanes.

**Figure 25. Typical Bicycle/Auto Movement at Intersections of Multilane Streets**



**Figure 25. Typical Bicycle/Auto Movement at Intersections of Multilane Streets**



### Supplemental Roadway Topics

The following topics are not itemized for discussion in AASHTO, but are covered in several State and local planning guidelines and standards:

#### *Bridges and Structures*

The most frequently encountered addition to the AASHTO *Guide* is a section on roadway bridges and structures. While AASHTO discusses bridges under off-road paths, several other plans include detailed discussions on retrofitting existing roadway bridges, designing new bridges, and properly approaching bridges with bicycle facilities. A summary of the best available information is given below:

- North Carolina Bicycle Facilities Planning and Design Guidelines has added a four-page section to their AASHTO-based text that discusses design treatment of structures, bridges, tunnels, underpasses and interchanges. Discussions center around traffic conditions such as bicycle traffic volume, bicycle crash experience, motor vehicle traffic volume and percent of truck/RV traffic; land use and transportation system factors such as proximity to bicycle traffic generators, alternate routes, connecting roadways and bicycle accommodations; and the structure's geometries including length, elevation and width.

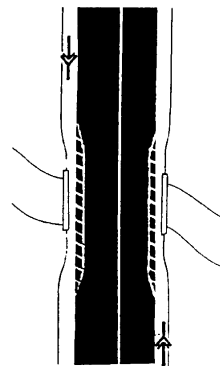
According to Bikecentennial, author of the guidelines, improving a bridge for bicycle use involves analyzing static obstructions, surface problems, width constraints and approaches. Bridge decks should optimally accommodate bicyclists with either 6-foot-wide minimum paved shoulders or 14-foot-wide minimum outside lanes, depending on traffic speed. Bicycle provisions should continue for at least 1,000 feet on either side of a bridge in order to ensure a safe transition.

The preferred bicycle solution in high speed tunnels is a minimum 4-foot-wide outside shoulder. Adequate lighting is also required for safety.

- The draft 1992 version of *Colorado Bikeways Standards and Design Guidelines* contains a discussion on coordinating bikeways on highway bridges with approach bikeways. The guideline states that the useable width of a bicycle facility should not neck down at bridges or underpasses. Other key elements include using a separate two-way facility to approach a two way bike path on one side of a highway bridge, and providing a physical separation to offset the adverse effects of having bicycles traveling against motor vehicle traffic.

Bridge railings or fences placed between traffic lanes and bikeways should be at least 4.5 feet high to minimize the likelihood of bicyclists falling over the railings. Standard bridge railings that are lower than 4.5 feet should be retrofitted with lightweight upper railings or chain link fence suitable for restraining bicyclists.

- Existing narrow bridges create constrictions to mixed bicycle and motor vehicle travel. If a narrow bridge is an unavoidable obstacle, (i.e., it is not feasible to widen the structure to accommodate bicycles) the New Jersey DOT recommends using zebra warning striping on the shoulders, as depicted at right. The pavement striping functions to shift motor vehicle traffic away from the bridge parapet and provide space for bicycles.
- The Oregon Highway Division has found that including sidewalk ramps on major bridge crossings is a beneficial practice in bicycle facility design. When bridge sidewalks are of



**Figure 26.**  
**Bicycle**  
**Compatible**  
**Striping for**  
**Unavoidable**  
**Obstacles**

Source: NEW  
JERSEY BICYCLE  
COMPATIBLE  
ROADWAYS

---

an adequate width for safe bicycle use, ramps deserve consideration, especially when narrow traffic lanes or narrow bridge shoulders exist.

### ***Placement of Appurtenances***

- New Jersey's *Bicycle Compatible Roadways---Planning and Design Guidelines* specifies a 1 foot minimum "shy distance" between curbing or pavement edge and all sign posts, light standards, utility poles, beam guide rails and similar appurtenances in order to make certain that as much of the paved surface as possible is useable by bicycle traffic. When insufficient width to accommodate bicycle traffic exists, these appurtenances should, where feasible, be set back far enough to allow room for future widenings to bring pavement widths into conformance with design guidelines.

### ***Physically Separated Roadway Facilities***

- The Oregon Highway Division recommends the use of concrete shoulder barriers under circumstances where it is desirable to separate the bike lane from a motor vehicle travel lane. The use of 31-inch-high concrete barriers are deemed superior to other separators because they offer significant safety, as well as help prevent litter from building up on the bikeway.

### ***Canyon Improvements***

- Unique to Colorado's standards, this guideline has application for all facilities developed in areas of hilly terrain and on narrow, winding roadways. The guideline reads as follows:

"Uphill bicycle traffic should be provided a climbing lane---a maintained shoulder or bike lane that has a minimum width of 4 feet. Narrow shoulders are not appropriate for bicyclists traveling downhill at a high rate of speed. A wide outside lane is preferred. If a climbing lane is provided on the uphill, and no shoulder or bike lane is provided on the downhill, it is important to apply an uphill arrow to the pavement on the climbing side, along with other bike lane symbols, so that bicyclists understand that the climbing lane is a one-way facility.

Unless shoulders of 6 feet or wider are located on the downhill, all turnouts on the downhill should be paved so that bicyclists can safely pull over and let motorists pass if necessary."

### ***Cattle Guards***

- Another unique standard, this time from California, would be good to employ in any rural area. The Caltrans *Highway Design Manual* simply states that "the presence of cattle guards along any roadway where bicyclists are expected should be clearly marked with adequate advance warning." Used at intersections of fencing and roadways, cattle guards are slotted or grated areas in a road's surface that prohibit a cow from walking across a roadway.

## Bicycle Paths

Separated bike paths are given detailed discussion in the AASHTO *Guide for the Development of bicycle Facilities*. Text includes engineering formulas, charts, tables and technical details. Since this topic has been covered so thoroughly in AASHTO, most State and local plans have adopted this section directly into their planning and design manuals. Little supplemental information is being used by other agencies, but where applicable, the material is summarized as follows:

### Separation between Bicycle Paths and Roadways

AASHTO provides a very detailed discussion of the hazards of placing separate bicycle paths within roadway rights-of-way. Nearly every States' standards manual reviewed for this case study adheres to this philosophy.

### Width and Clearance

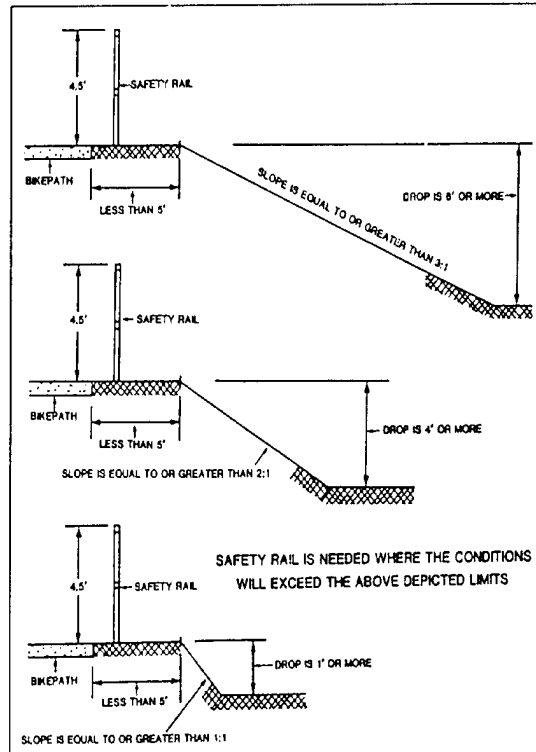
- Many agencies specify recommendations for the use of safety rails along side slopes when there is less than a 5-foot separation from the edge of the bike path pavement to the top of the slope.

Several State plans define the steep slope condition and treatment as depicted in Figure 27.

This same separation is called for between a bike path and the edge of a roadway to confirm to both bicyclists and motorists that the bicycle path functions as an independent facility for bicycles. Most State standards also confer with AASHTO's recommendations that when the distance between a roadway and a parallel bike path is less than 5 feet, a 4.5-foot tall barrier should be constructed to prevent conflicts between facilities.

Section 1020 of the Washington State DOT *Design Manual* provides a good supplement to AASHTO's separation standards. The manual specifies that "vertical concrete surfaces adjacent to bicyclists or pedestrian facilities should be smooth to avoid snagging of clothing or abrasive injuries from contact with the surface. Where bicycles use facilities located behind guard-rail, the protruding bolts on the guardrail should be cut off."

**Figure 27. Bike Path Safety Rails Along Side Slopes**



Source: ARIZONA BICYCLE FACILITIES PLANNING & DESIGN GUIDELINES

## Design Speed

- AASHTO provides a general standard for design speed that is cited in most statewide design standards. As a supplement, design manuals for Florida, Colorado, North Carolina, and Minnesota state that the use of speed bumps or similar surface obstructions, intended to slow down bicyclists in advance of intersections, shall not be used on bicycle path design due to the hazards they present.
- North Carolina's proposed guidelines briefly touch upon the issue of mountain bikes and their relative design speeds on unpaved trails, stating that "with the growing popularity of mountain bicycles, provision of unpaved trails is likely to increase ... Quite possibly speeds on some types of unpaved trails will equal or exceed those on paved trails . . . The engineer should exercise proper care when dealing with this new area of design."

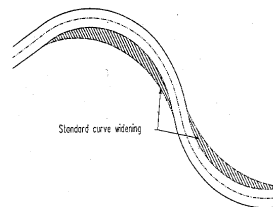
## Horizontal Alignment and Superelevation

AASHTO's standard charts for bike path alignment and superelevation are found in most local and statewide design manuals.

- For sharp curves of less than 100-foot radius, Washington State DOT Facilities for Nonmotorized *Transportation* includes a chart that specifies additional pavement width necessary. This following diagram is also provided to indicate appropriate areas for widening:

Figure 28. Bikeway  
Curve Widening for  
Various Radii

Radius (feet)	Additional Pavement Width (feet)
0 - 25	4
25 - 50	3
50 - 75	2
75 - 100	1
100 +	0



## Grade

- Severe grades can present one of the greatest hazards on off-road bicycle paths, often due to the fact that these paths weave across steep floodplain banks. Most design guidelines adhere to AASHTO's standards for maximum grades on bike paths: "Grades over 5 percent and less than 500-feet long are acceptable when a higher design speed is used and additional width is provided."
- North Carolina's *Bicycle Facilities Planning and Design Guidelines* contains an excellent supplemental discussion of the negative effects of severe grades on off-road bike paths, especially pertaining to novice riders.
- Colorado's new plan specifies an absolute maximum grade for a bike path at 8.33 percent, and states that "sustained grades should be limited to percent should a wide range of riders be accommodated."
- Minnesota's *Bikeway Design Manual* specifies that, under optimal conditions, a grade of 5 percent should continue for no more than 100 feet, and distances of more than 500 feet should be avoided. Likewise, a grade of 2 percent should not be longer than 500 feet, and 2 percent for over 1,500 feet should be avoided.

## Sight Distance

AASHTO provides the most comprehensive standards for minimum stopping sight distances available, as well as a short description of safety measures to be taken in areas where minimum stopping sight distances can not be met.

- The State of Minnesota DOT further clarifies stopping sight distances for downhill grades in tabular form, as depicted in Figure 29.

**Figure 29. Stopping Distance for Downhill Grades**

Design Speed mph	Grade %			
	0% feet	5% feet	10% feet	15% feet
10	50	50	60	70
15	85	90	100	130
20	130	140	160	200
25	175	200	230	300
30	230	260	310	400

Source: MINNESOTA BIKEWAY DESIGN MANUAL

## Intersections

- Minnesota's *Bikeway Design Manual* provides the most detailed description of off-road bicycle path intersections than any other publication reviewed. The manual describes Minnesota's design philosophy for off-road paths that cross roadways at intersections. In these circumstances, the bikeway should function as a crosswalk, forcing the bicyclist to stop or yield before entering the roadway. See Figure 30.

The Minnesota manual states that the reason for this design is to take advantage of the intersection traffic control and to avoid having the bicyclist passing between stopped vehicles waiting for the signals to change.

In addition, the manual describes safety design considerations necessary at independent crossings to reduce the hazards associated with these intersections.

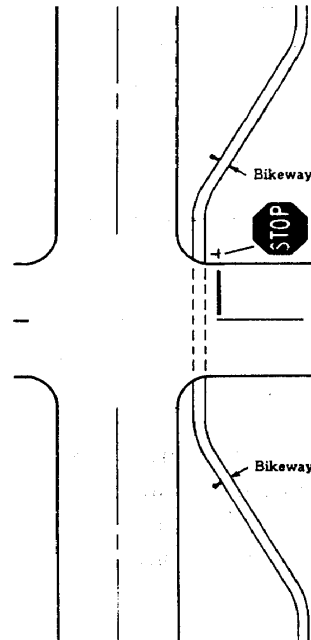
It should be noted that a detailed description of off-road bike path/railroad crossings is also covered in this manual. Reference page 30 of this case study.

Arizona's *Bicycle Facilities Planning and Design Guidelines* contain two unique diagrams depicting bike path intersections, as shown below. However, no accompanying text is provided to describe these intersection treatments.

Since 1976, Eugene, Oregon, has required driveway lips of less than 1/2-inch between streets and driveway surfaces. This specification reduces bicycle spills and bent bike wheels caused by one or two-inch lips or joints between pavement surfaces.

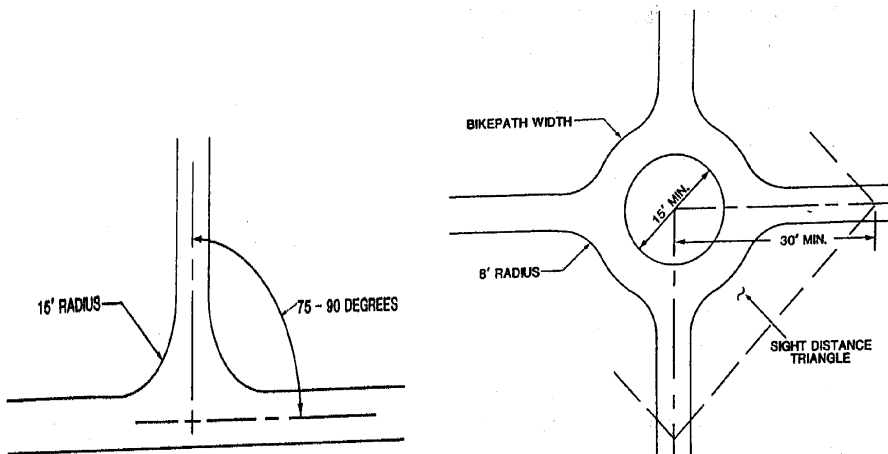
Colorado's *Bikeways Standards and Design Guidelines* indicates a maximum grade of the approaches to intersections to be 5 percent, and states that "consideration should be given

**Figure 30. Offset Bikeways Intersection Treatment**



Source: MINNESOTA BIKEWAY DESIGN MANUAL

**Figure 31 Bikepath Intersection**



Source: ARIZONA BICYCLE FACILITIES PLANNING AND DESIGN GUIDELINES





to a flat approach plateau preceded by a short, steep section in areas where slopes are unavoidable."

Colorado also presents a section on bike path/bike path intersections, describing a Y-configuration with paths that intersect as perpendicular as possible. No graphic is provided, however, to illustrate this concept.

### Signing and Marking

- North Carolina's *Bicycle Facilities Planning and Design Guidelines* gives an excellent elaboration of bike path striping considerations, mentioning that some thermoplastic tapes can be slippery when wet and therefore should be avoided.

The guide also notes the importance of signage, markings, and barricades during bikeway construction activities, and cites the MUTCD for these standards.

- Denver, Colorado, recently developed an innovative construction detour signage program for use during construction on the Platte River Bike Trail. It includes a signage plan for ramp closure, signage plan for construction detours, proposed warning sign array and the development of special signs as described in the MUTCD section of this case study-see page 62. The signage program is also accompanied by a written specification, *Construction Detour Standards for Bikeways and Multiuse Trails*, for contractors and construction equipment.
- Eugene, Oregon uses 4-inch-wide edge stripes and centerlines to help guide bicyclists at night, as well as to route bicyclists around curves and other hazards. The stripes are sometimes used as a substitute to path lighting.

### Pavement Structure

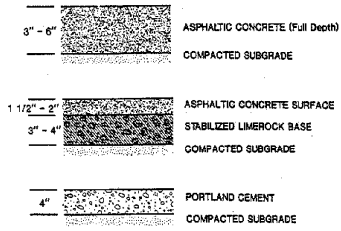
Choice of pavement type for bike paths varies in depth and material--either asphaltic or portland cement concrete. AASHTO contains a general discussion about the selection and design of pavement which has been accepted and incorporated into "modern" design manuals; however, the AASHTO *Guide* does not specify standard pavement depths.

As a supplement to AASHTO, typical pavement cross sections are provided in the several State manuals, represented in Figures 32 - 35.

- A unique standard for determining pavement surfacing depth is found in the Washington State *DOT Facilities for Nonmotorized Transportation*. Asphalt concrete depth is determined by the R value of the subgrade. Most States, however, use standard AASHTO language stating that a qualified engineer should evaluate the subgrade in order to determine most appropriate surfacing.
- The Colorado DOT specifies cross slope requirements for bike paths as follows: "For rideability on new construction, the finished surface of bikeways should not vary more than 0.02 foot from the lower edge of an 8-foot-long straight edge when laid on the surface in any direction."

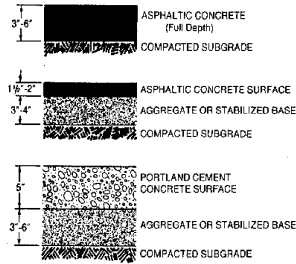
**Figure 32**

Source: ARIZONA BICYCLE FACILITIES PLANNING AND DESIGN GUIDELINES



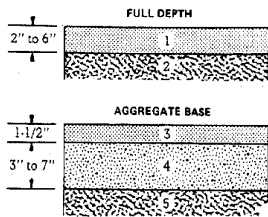
**Figure 33**

Source: STATE OF OREGON BICYCLE MASTER PLAN



**Figure 34**

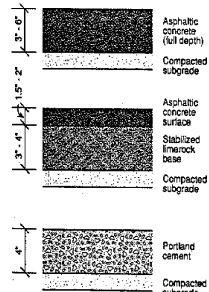
Source: MINNESOTA BIKEWAY DESIGN MANUAL



1. Spec. 2331 Wearing Course (Full Depth)
2. Compacted Subgrade
3. Spec. 2331 Wearing Course
4. Class S Aggregate Base
5. Compacted Subgrade

**Figure 35**

Source: NORTH CAROLINA BICYCLE FACILITIES PLANNING AND DESIGN GUIDELINES

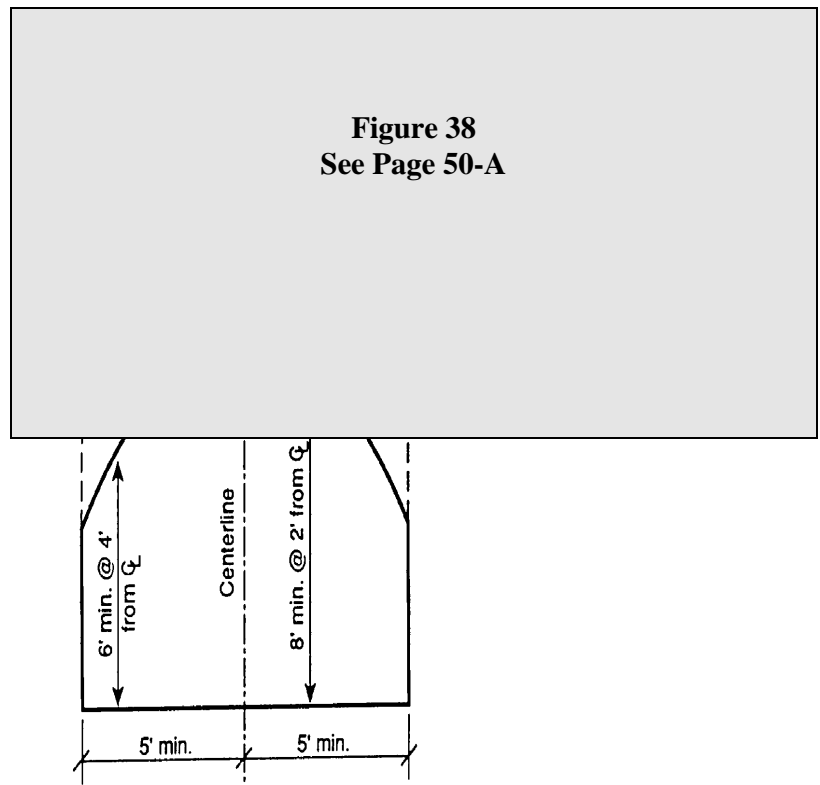
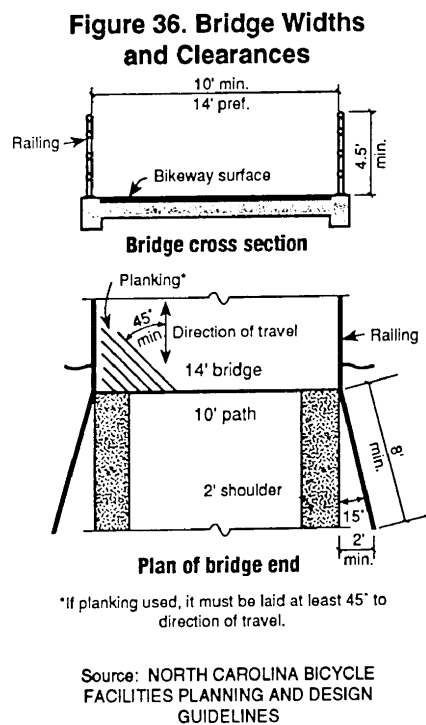


## **Structures**

- Independent bicycle bridges are often decked with wood planking. It is the standard practice of several agencies to specify smooth joints between decking boards, which must be placed bark side up so that they curl downward rather than upward. Some agencies also prefer that the decking boards be laid at 45° angles to prevent diversion of bicycle wheels. The State of Colorado also notes that wood decking gets icy and slippery in wet winter weather.
- A detailed section on underpass treatments, bridges and overpasses is provided in Colorado's new guidelines. For underpasses, the manual gives standard height requirements, graphics that show how to cross through existing box culverts of less than 8 feet, convenient location of

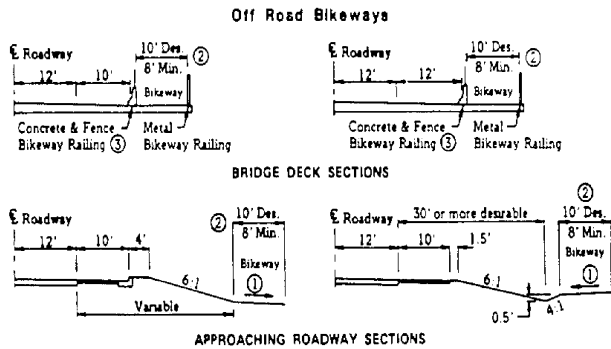
underpasses, and drainage considerations. For bicycle bridges, the following topics are addressed: minimum widths, surface treatments to reduce slippage, curves near or on bridges, and flared railings extending from abutments. For overpasses, the manual cites the CDOT standard pedestrian overcrossing design, as well as other considerations.

- As with roadway bridges, the *North Carolina Bicycle Facilities Planning and Design Guidelines* contains excellent supplemental information on the design of bike path structures, including independent bridges, suspended bridges, underpasses and tunnels. Representative bridge and tunnel graphics are also provided, as depicted below.



- It is sometimes necessary to route a bike path across an existing highway bridge, providing that the bridge has adequate width and can withstand the structural modifications necessary to make a safe connection. Minnesota's *Bikeway Design Manual* provides a complete description of two-directional bikeways that adjoin one side of a highway bridge, including section drawings that show bridge deck

**Figure 38. Designs for Bridge Decks with Bikeways**

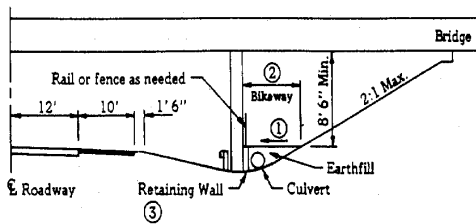


**NOTES:**

- ① 0.2 ft./ft. slope
- ② Minimum width. Includes provision for pedestrians.
- ③ If shoulder width is  $\geq 6'$  no fence is required on top of barrier.

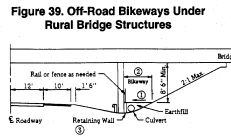
See section F. WIDTHS AND CLEARANCES for explanation of bikeway width.

**Figure 39. Off-Road Bikeways Under Rural Bridge Structures**





Other detailed drawings contained in the manual illustrate treatments for off-road bikeways under bridge structures in both urban and rural situations, for modifications to existing facilities, and for the design of new facilities. An example illustration is shown in Figure 39.



## Drainage

- Colorado's *Bikeways Standards and Design Guidelines* states that the bike path should be designed with a minimum 2-year, but ideally a 5-year or more design flood frequency. No other reference was found to design flood frequencies.
- Minnesota DOT adheres to AASHTO's standards for bike path cross drainage, however their *Bikeway Design Manual* includes some additional information regarding minimum culvert sizes of 18 inches and the use of drainage grates along bike path edges.
- The City of Madison Engineering Division has developed one of the best standards for a typical bike path section. This detail, shown in Figure 40, covers not only cross drainage, but also construction procedures for off-road bike paths.

## Lighting

- In Colorado, it is suggested that lighting should be provided continuously in tunnels or underpasses that are particularly dark during the daytime. North Carolina DOT also recommends vandal resistant light fixtures.

## Restriction of Motor Vehicle Traffic

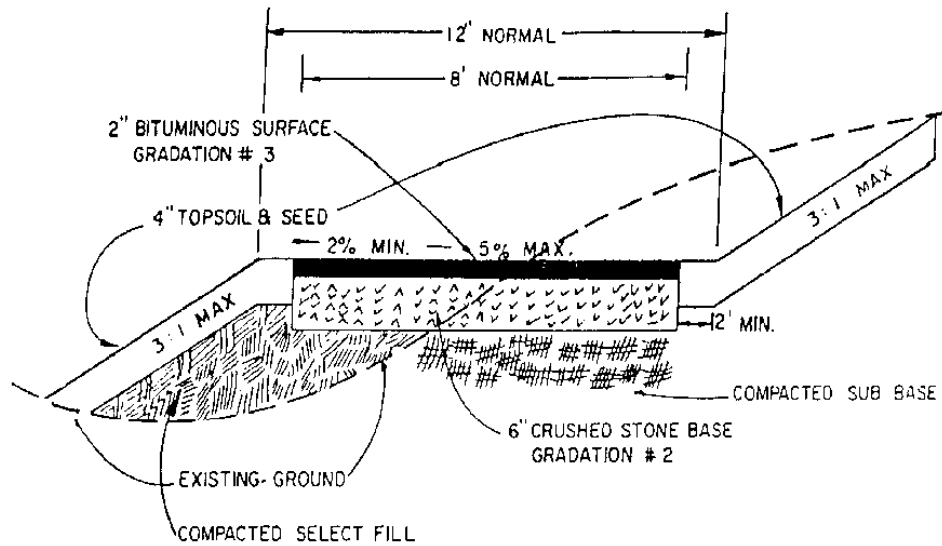
AASHTO discusses placement of bollards at path entrances to discourage motor vehicle use. The topic is often covered in greater detail in State and local plans, many of which discuss the number of bollards to be used, use of pavement markings and the placement of a bollard in the center of a bike path to separate directions of travel. See Figure 41.

- Several bicycle facility designers feel that the use of bollards is hazardous to bicyclists. As described in AASHTO, an alternative method of restricting entry by motor vehicles is to split the bicycle path at entrances into two narrower paths that are separated by low landscaping.

**Figure 40. Typical Section Bike Path**

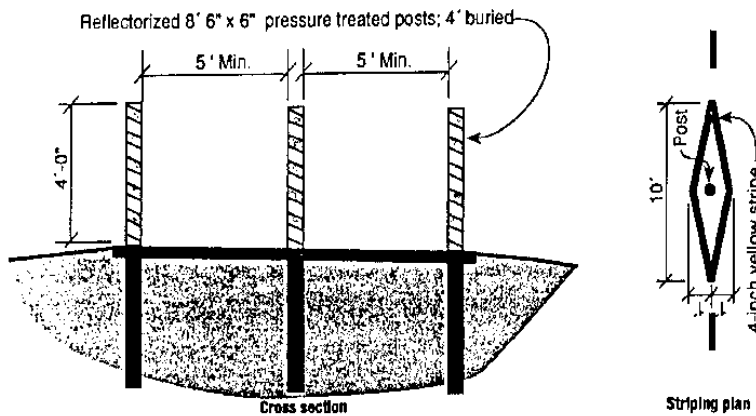
**NOTES:**

- 1) Grading shall include removing vegetation and topsoil to a depth of 8 inches and leveling and compacting the subbase. Grading shall be measured in stations of actual grading completed and paid for at the unit price bid for grading.
- 2) Select fill as required to obtain a suitable cross-section shall be placed and compacted in 6-inch maximum lifts.
- 3) The Contractor shall place, water, and compact 6 inches of crushed stone base course. The Contractor shall prime the stone and pave the width indicated with 2 inches of bituminous surface course. Any exposed stone shall be topsoiled and seeded.
- 4) All disturbed areas shall be topsoiled and seeded.



Source: CITY OF MADISON, WISCONSIN, ENGINEERING DIVISION

**Figure 41. ReflectORIZED Post Barrier and Striping Used to Keep Motor Vehicles off Bicycle Paths**



Source: NORTH CAROLINA BICYCLE FACILITIES PLANNING & DESIGN GUIDELINES  
CALIFORNIA HIGHWAY DESIGN MANUAL



Many local and State agencies advocate use of this split entrance/ exit ramp system, and often illustrate the concept as in Figure 42.

- Another alternative is presented in Colorado's *Bikeways Standards and Design Guidelines*. This manual states that the best way to restrict motor vehicles on bike paths is to mount a black on white sign: "No Unauthorized Motor Vehicles." Where there is a history of motor vehicle violations, bollards are recommended only as a last resort, as they present a hazard to bicyclists. The State of Oregon also takes this position.

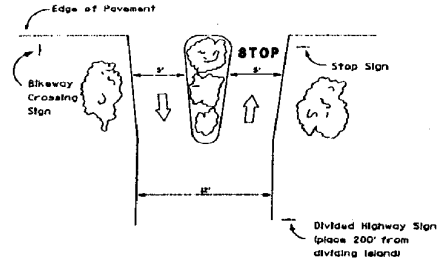
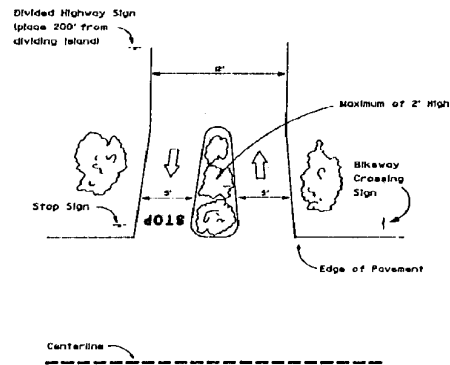
### Multiuse

- The State bicycle standards reviewed for this case study confer with AASHTO's general discouragement of bicycle paths as multiuse facilities. However, both Florida and Colorado provide more detail about situations in which sidewalk improvements are acceptable as interim measures. Such conditions would include neighborhood streets with low bicycle and automobile speeds that are near elementary schools and parks, which are often used by young, inexperienced bicyclists.
- *Planning and design Criteria for Bikeways in California* includes a section addressing multipurpose recreational trails, recommending that these facilities be signed and designated as recreational paths, not bikeways. However, if a trail is to serve primarily bicycle travel, it should be developed in accordance with standards for Class II bikeways.

With the growing popularity of greenways and tightened project development budgets, the joint use of bike paths by others and the development of multiple use facilities are current facility design topics. If projects look to be used by pedestrians, equestrians, roller bladers, skate boarders and others, it is beneficial to design them to multiuse standards, which often exceed bicycle facility standards in path width.

While national "standards" for multiuse trail widths do not exist, there are three publications that do an excellent job of addressing the issue of multiuse and providing applicable guidelines. These publications include Pennsylvania's *Nonmotorized Trails/An Introduction to Planning and Development*; *Guidelines for Creating Greenways* co-authored by Flink and Seams and published by Island Press; and the Rails-to-Trails Conservancy's *Design and Management Manual for Multiuse Trails*. Examples of the type of information contained in these documents follows.

**Figure 42. Split Bicycle Path to Restrict Entry by Motor Vehicles**



Source: OHIO DOT

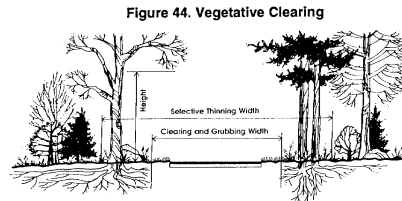
- To accommodate a wide variety of user groups in various settings the *Design and Management Manual for Multiuse Trails* recommends the following widths:

**Figure 43. Recommended Tread Widths for Multi-Use Trails**

<u>Single Tread (for all users)</u>	<u>Urban</u>	<u>Suburban</u>	<u>Rural</u>
All non-motorized users	16 feet	12 feet	10 feet
All non-motorized users, except equestrians	12 feet	10 feet	8 feet
Non-motorized and snowmobilers	16 feet	12 feet	10 feet

Source: DESIGN AND MANAGEMENT MANUAL FOR MULTI-USE TRAILS  
RAILS-TO-TRAILS CONSERVANCY

- Guidelines for Creating Greenways* contains a similar set of standards for Multiuse and greenway trail treads. In addition, this book contains horizontal and vertical clearances as applicable to major trail users. See Figure 44.



<u>Trail Type</u>	<u>Clearing &amp; Grubbing Width</u>	<u>Selective Thinning width</u>	<u>Clearing Height</u>
6 foot hiking only	10 feet	20 feet	8 feet
8-foot pedestrian only	14 feet	24 feet	8 feet
10 foot pedestrian only	26 feet	8 feet	
8-foot bicycle only	16 feet	26 feet	10 feet
10 foot bicycle/pedestrian	18 feet	28 feet	10 feet
6-foot horse only	12 feet	22 foot	12 feet
10 foot horse/pedestrian	16 feet	26 feet	12 feet
8-foot cross-country ski only	12 feet	22 feet	8 feet
12 foot snowmobile only	20 feet	30 feet	10 feet
18 foot ski/snowmobile	36 feet	10 feet	

- As a publication that looks beyond the construction of trails, *Guidelines for Creating Greenways* examines the greenway concept from a comprehensive viewpoint. As such, it establishes standards for placement of an off-road trail into a greenway corridor and recommendations for

corridor widths that allow the overall greenway, as well as the trail, to be multipurpose in nature. See

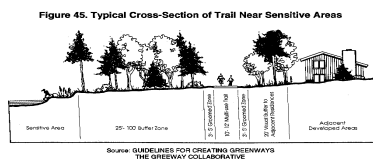


Figure 45.

- *Nonmotorized Trails/An Introduction to Planning and Development* by the Pennsylvania Trails Program contains excellent discussions on types of surface materials for use in constructing bicycle and Multiuse trails, stating that, "There is no *one* best material for *all* trails. Items such as user density, location, terrain, soils, budget, and use by other vehicles all have an effect on surface materials choice."

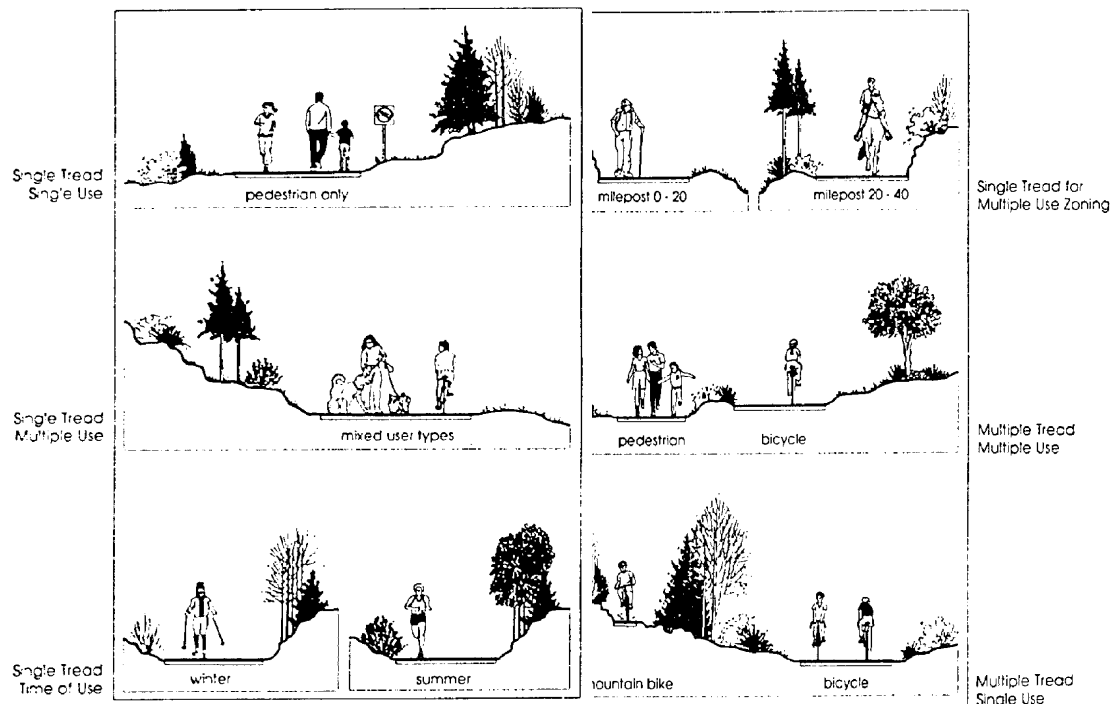
The manual goes on to discuss the advantages and disadvantages of concrete, asphalt, soil cement, stabilized earth gravel, limestone fines and other alternative surfacing materials.

- *Guidelines for Creating Greenways* discusses tread types, in addition to surfacing types, for Multiuse trail design. The publication identifies six different types of treads for multiuse trails which represent different ways that the physical trail surface is designed and shaped to accommodate the trail user. These standards for providing for user separation are illustrated in Figure 46.

## Supplemental Bicycle Facilities

In this section, AASHTO discusses general bicycle parking requirements and the need to provide these facilities, and briefly mentions bicycle interface with public transit and bicycle route maps.

**Figure 46. Type of Trail Treads**



Source: GUIDELINES FOR CREATING  
 GREENWAYS  
 THE GREENWAY COLLABORATIVE

**Parking Facilities**

- Eugene, Oregon, has an exemplary parking ordinance that has been in effect long enough that racks can be found throughout the city in abundance. The *Eugene Code* specifies that each space shall be a minimum six feet long, two feet wide, and shall be provided with a minimum overhead clearance of 6 feet.
- Although somewhat dated, *Bicycle Forum*, Fall 1978, contains an article entitled, "The Bicycle Parking Link." This article offers valuable information on bicycle parking ordinances and codes; bicycle storage facility types and design-including location, weather protection, security and safety; and includes several tables comparing different types and manufacturers of storage racks. The discussions are so complete that the State of Florida included it directly into the appendices of their official standards.
- Bikecentennial has thoroughly covered the topic of bicycle parking in North Carolina's new manual. Discussions on choosing bicycle parking devices center around deciding on the level of security needed, looking at how the device works, deciding on the number of spaces needed,

determining whether vandalism is a factor, considering the budget and contacting other users of parking devices.

The manual also contains excellent discussions on locational factors such as long-term versus short-term parking needs, popular destinations, protection for bike parking located next to car parking or travel lanes, location away from pedestrian paths, yet within view of windows and people, protection from weather, and potential expansion/project phasing.

### **Bicycle Interface with Public Transit**

With bicycle facility design philosophies of the 1990's focusing more on coordinated systems, the topic of intermodal transportation is beginning to appear in the newest guidelines and standards. As yet, it is only covered in general terms.

However, the City of Phoenix Bike-on-Bus Demonstration Program is an exemplary intermodal transportation program. As programs such as this are further studied and documented, this section of guidelines and standards manuals will become filled in more completely.

### **Route Maps**

- The best mapping information comes from the NCDOT. *North Carolina Bicycle Facilities Planning and Design Guidelines* discusses the following types of bicycle user maps: maps of bicycle facility locations, bicycle suitability maps, hybrid maps and individual route maps. Each type of map follows a slightly different approach and fulfills a different purpose.

In addition, the NCDOT Office of Bicycle and Pedestrian Transportation has developed several mapping handouts including "Some Thoughts on Producing Bicycle Maps," "Design Recommendations for Urban Bicycle Maps," and "Recreational Mapping." These papers cover a wide range of mapping issues such as printing techniques, costs, features to be included and common mapping pitfalls.

### **General Comments**

In completing this comparison of similarities and differences between AASHTO and State and local guidelines and standards, there were some general features that distinguished some of the best documents from the others. Most noticeable was document organization.

Other distinguishing items that do not fall under the general subject categories found in AASHTO include descriptions of bikeway planning and development processes, the designation of different types of bicycle facilities, and inclusion of information on spatial standards.

### **Manual Organization**

Since the AASHTO *Guide* was published in 1981, several States have adopted the AASHTO guidelines into their own bicycle facility standards, and other States and localities have further modified and improved upon these early State plans. In the process, a distillation of content and

organization has occurred. Several of the newest planning guidelines and design standards have picked up on this, and are rethinking the way in which subject matter is presented.

- The new manual about to be published by the State of Colorado probably has the best organization of all guidelines and standards reviewed. For reference, a condensed outline of this manual's organization is provided below:

- Introduction*
- Definitions*
- Bikeway Functions*
  - Introduction*
  - The Users*
  - Safety vs. Perceived Safety*
  - Facility Type and Selection*
    - On-Street Facilities*
    - Off-Street Facilities*
- Design*
  - Roadway Improvements*
  - Off-Street Paths*

Bike lanes, wide curb lanes, designated bicycle routes, and bike paths are addressed in two separate sections of the guide-facility type and selection and design. In this manner, all discussions on the functions, advantages, and disadvantages of each facility type are introduced before the technical text and detailed specifications begin. This organization is easy to follow because it is patterned after the methodical thought process that one must go through to first determine what type of facility is needed and then determine how it must be designed.

- Another new publication is the *North Carolina Bicycle Facilities Planning and Design Guidelines*. The format of this document follows the same order as AASHTO, but it is prominently subdivided into eight chapters instead of three:

- Introduction*
- Planning for Bicycle Use*
- Roadway Improvements*
- Bicycle Lanes*
- Bicycle Routes*
- Bicycle Paths*
- Supplemental Facilities*
- Operation and Maintenance*

This report organization de-emphasizes separated bike paths and places importance on the various types of roadway facilities, which combine to form a coordinated bicycle transportation system.

## Review Processes

The North Carolina and Ohio Departments of Transportation have included detailed discussions of their transportation Improvements Program (TEP) and Project Development Process respectively. (See pages 79-85 of the Enforcement section of this report for details.)

Since a bicycle planning/design guidelines manual is often the only reference publication that nonengineers have available to them, inclusion of this type of information is good to provide insight into the complete process involved in planning and implementing bicycle transportation facilities.

### Class I, II, III, & IV Facility Designations

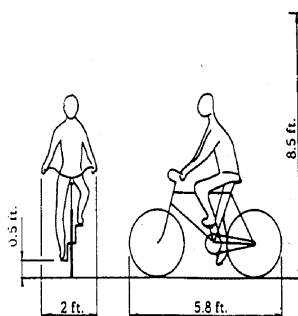
Most State and local plans designate bicycle facilities by the names referenced in the AASHTO *Guide for the Development of Bicycle Facilities*. However, there is a group of States, including California and Washington, that use a different set of bikeway facility designations:

- Class I Bikeway---bike path
- Class II Bikeway---bike lanes
- Class III Bikeway---bike routes
- Class IV Bikeway---shared roadway with no designation

Case study research has revealed no explanation to the origin of these designations, or to the advantages thereof. The only benefit of not using them appears to be that the numbers tend to represent a hierarchy of facilities, when in actuality each type of facility has its own specific function and purpose.

### Spatial Standards

Several State manuals begin their design sections with the spatial requirements of bicycles. Inclusion of this type of information, as illustrated below, is very helpful to establish why bicycle facilities must be designed to meet or exceed minimum standards.



TYPICAL BICYCLE & RIDER DIMENSIONS

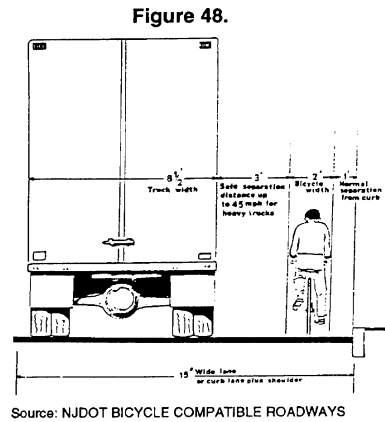
#### CHARACTERISTICS

Width  
Length  
Height  
Vertical  
Pedal clearance

DIM

Source: MINNESOTA BIKEWAY DESIGN MANUAL

- New Jersey's Bicycle Compatible Roadways further illustrates spatial requirements in cross-section diagrams of different roadway conditions. These illustrations, one of which is depicted at left, delineates the lane widths required for different vehicles, the safe separation distances between vehicles traveling at different speeds and bicycles, the space needed for actual bicycle travel, and the normal separation distance between the area used by bicycles and the curb.
- In addition to the physical space taken up by the bicycle and rider, Minnesota's *Bikeway Design Manual* also states that minimum dimensions for design considerations should also include allowance for lateral clearance to obstructions and allowance for clearance to other hazards.



As illustrated in Figure 49, the following maneuvering allowa

**Figure 49. Clearances**

<u>Type of Clearance</u>	<u>Desirable Distance</u> <u>feet</u>
<b>Maneuvering Allowance</b>	
- handlebars to edge (for wobble)	1.0
- between bicycles (regardless of direction)	2.5
- between bicycles and pedestrians	2.5
- between bicycles and motor vehicles	4.0 (minimum)
<b>Lateral Clearance (static obstructions)</b>	
- parked cars	2.0
- curb drop-off	2.0
- utility poles, trees, hydrants, fences, railings, etc.	2.0
- soft shoulders	1.5
- sloped drop-off	1.0
- raised curb	1.0
<b>Vertical Clearances</b>	8.5 (10' desirable)

Source: MINNESOTA BIKEWAY DESIGN MANUAL





- Planning and budgeting are key factors that contribute to successful maintenance programs. The *North Carolina Bicycle Facilities Planning and Design Guidelines* cautions that the growth of bicycle facility mileage should be carefully watched to assure that funding is commensurate with operational responsibilities. In addition, the plan notes that standards of bicycle facility care may ultimately be determined by the courts.

The North Carolina plan also goes into substantial detail on specific maintenance aspects of off-road paths--including inspection, signs and traffic markings, visibility, illumination, sight distance and vegetation clearing, surface repair, drainage, sweeping and cleaning, trash pick-up, litter control, fencing, structural deterioration, special facilities such as steps and ramps, and enforcement issues.

## C. The Use of MUTCD

*The Manual on Uniform Traffic Control Devices* (MUTCD) is the national standard guiding the use and design of all signs, markings, signals, islands, and special traffic control procedures used on streets and highways throughout the country. Many States have in turn developed their own statewide MUTCDs based on the standards set forth by the U.S. Department of Transportation Federal Highway Administration.

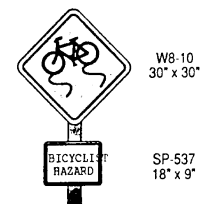
Therefore, all bicycle and pedestrian standards and guidelines reviewed as part of this case study contain sections of the MUTCD, or make reference to its authority.

## D. Beyond MUTCD

Some State and local leaders in the field of bicycle facility design have gone even further and developed supplemental signs and markings not contained within this document. These specifications are listed below to allow other State and local agencies to model after their innovations:

### Signs

- *The State of Oregon Bicycle Master Plan* dedicates an entire chapter to guidelines for providing uniform signing and marking of all bikeways on the State highway system. Their guidelines include usage and facility characteristics warranting no signing, bike route signing, and bike lane signing. The plan also includes general guidelines for placement and spacing of roadway facility signs, signs for bike paths, and specific heavy-use bike path control guidelines.
- The warning and information signs at right and top of page 63 were created by the NC DOT and are specific to North Carolina



The "Bicyclist Hazard" subplate, when combined with the W8-10 warning sign, is intended to warn bicyclists of the presence of a surface condition that could cause them to lose control.

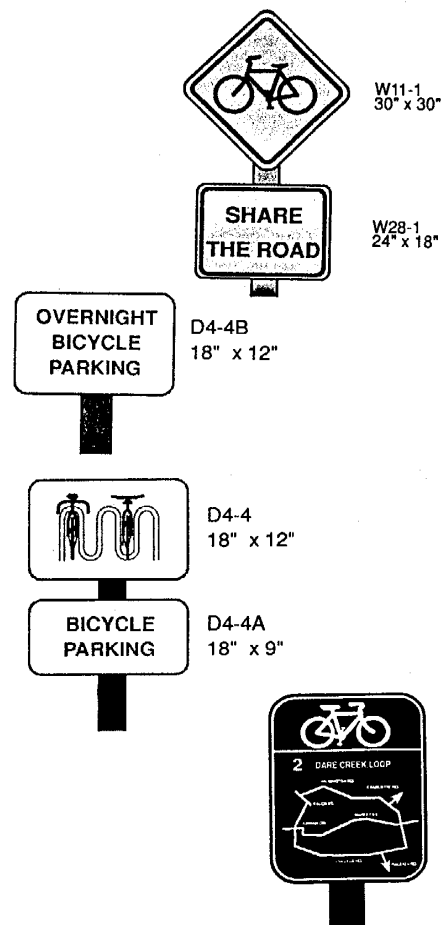
The "Share the Road" subplate, when combined with the W 11-1 warning sign, is "intended to increase bicyclists' visibility without designating the signed roadway as a preferred bicycle route. It is intended a discourage inexperienced bicyclists from using the roadway as a preferred

The D4-4B is a special purpose sign that identifies bicycle parking which may be used overnight.

The D4-4 and D4-4A are special purpose signs intended to show bicyclists how to use a Ribbon Rack-type parking device.

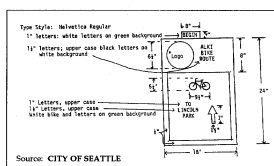
A bicycle map schematic sign is an alternative to using the standard MUTCD D11-1 "Bike Route" sign in urban areas. The sign at left, which may be combined with directional arrow subplates, is intended to give bicyclists more guidance than the DI I -1 does, particularly in a community with multiple intersecting loop-type bike routes.

Figure 52. North Carolina Signs



Source: NCDOT

Figure 53



Source: CITY OF SEATTLE

\* The City of Seattle has developed a standard treatment for directional signs that are to be placed at key decision points throughout the city's system of bikeways. Figure 53 depicts Seattle's signage de-sign detail.

- Design guidelines produced by Caltrans contain a section based on Section 2376 of the California *Streets and Highways Code*. Uniform standard regulatory signs, standard warning signs, and standard guide signs are identified, graphically depicted, defined in terms of color and size, and the standard application and location for each is given. An example is given below:

SR 33A



Black on White  
30" x 30"

**FIGURE 54**

Application: The SR33A sign shall be used on freeways where bicyclists are required to exit.

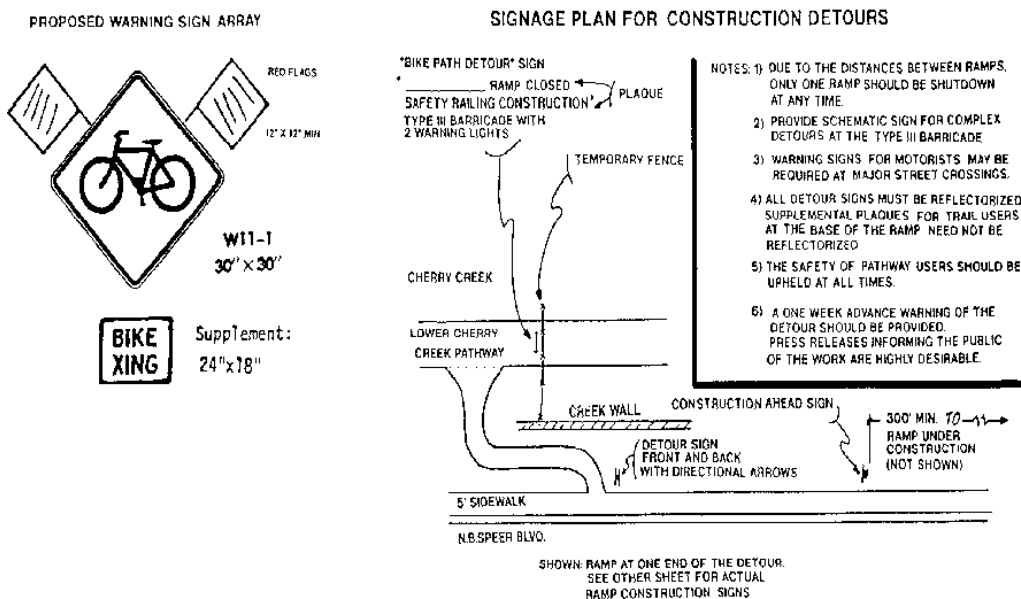
Location: Erect in the standard position in advance of the exit.

Source: PLANNING AND DESIGN CRITERIA FOR BIKEWAYS IN CALIFORNIA

- Denver, Colorado, has developed construction detour standards for bikeways and multiuse trails. The standards include written specifications on criteria to be considered to provide quality construction zone operations and detours on bikeway trail facilities.

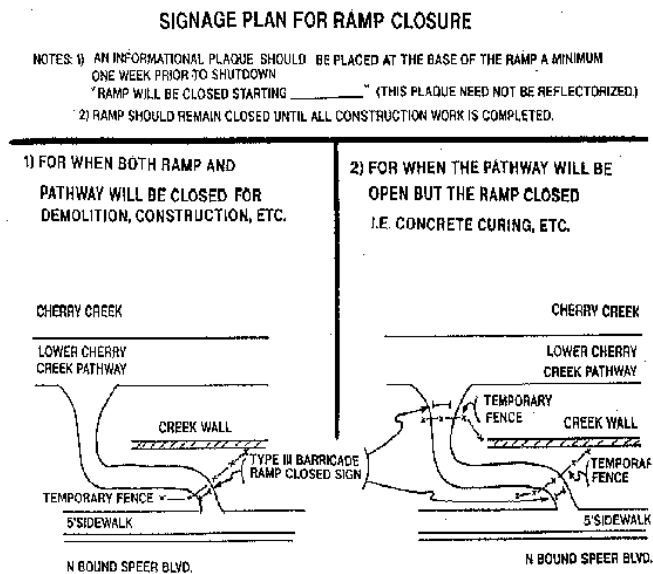
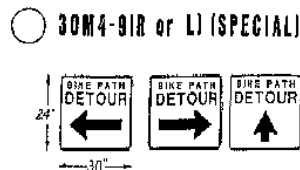
As part of the standards, the Department of Public Works has developed a signage plan for construction detours, a signage plan for ramp closure, special path closure and detour signs, and a Bike Xing warning sign array. See Figure 55.

**Figure 55. Construction Detour Signage Program**



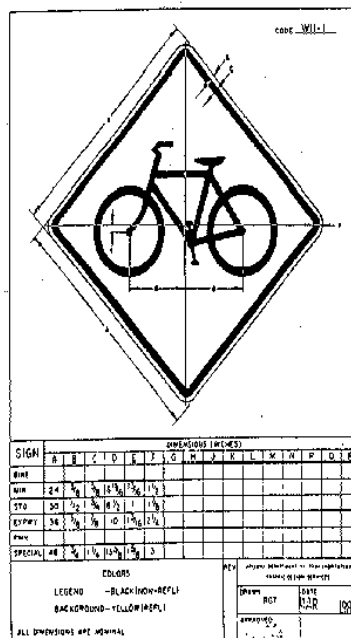


**Figure 55. Construction Detour Signage Program (cont.)**



Source: CITY AND COUNTY OF DENVER, COLORADO

**Figure 56. Sign Specifications**



Source: ARIZONA DOT

- Appendix D of *Arizona Bicycle Facilities Planning & Design Guidelines* contains engineering specifications for typical signs that are used for bicycle lanes and trails in Arizona. One example is depicted in Figure 56.
- Based on MUTCD, the Oregon State Highway Division Traffic Engineering Section has developed a standard for bicycle path signing details. Regulatory signs and warning signs are included, some of which are original to the State. See Figure 58 on the following page.

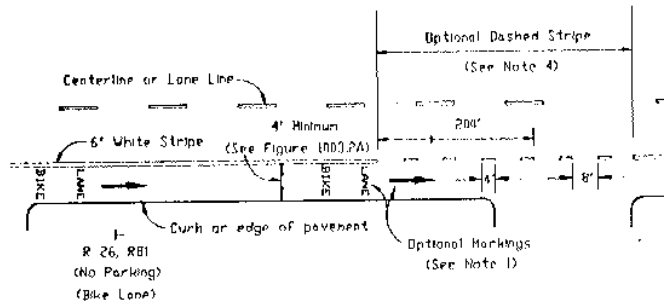
**Markings**

- The State of Oregon has also developed MUTCD-based standards for bicycle pavement markings for bicycle lanes, bike crossings, and bike path crossings of railroads. Their standards call for smaller size lettering on bicycle facilities than is typically used to mark roadway facilities. See Figure 59.

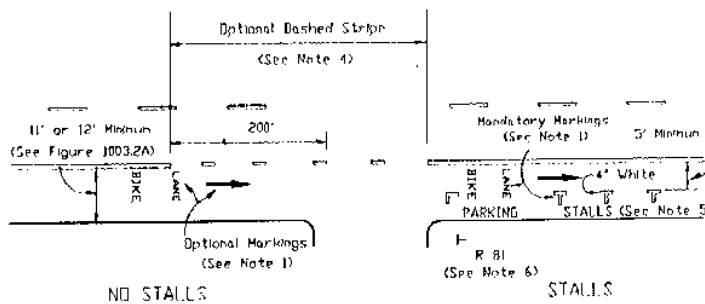


### Figure 57. Bike Lane Signing and Marking

WHERE VEHICLE PARKING IS PROHIBITED



WHERE VEHICLE PARKING IS PERMITTED



Source: CALTRANS

### Figure 58. Bicycle Signing Details—Regulatory Signs and Warning Signs

LOW  
 NARROW  
 SLOW  
 KEEP RIGHT  
 BICYCLES YIELD TO PEDESTRIANS  
 BIKES CROSS ON WALK SIGNAL ONLY  
 BICYCLE  
 BICYCLISTS THIS IS A MULTU-USE PATH REDUCE SPEED WATCH FOR PEDESTRIANS

TYPICAL SIGN INSTALLATION FOR SEPARATED BICYCLE FACILITIES

Sign Number	Sign Name	Sign Type	Sign Size
09A-1-1	LOW	Regulatory	36" x 36"
09A-2-1	NARROW	Regulatory	36" x 36"
09A-3-1	SLOW	Regulatory	36" x 36"
09A-4-1	KEEP RIGHT	Regulatory	36" x 36"
09A-5-1	BICYCLE	Warning	36" x 36"
09A-6-1	BICYCLISTS THIS IS A MULTU-USE PATH REDUCE SPEED WATCH FOR PEDESTRIANS	Warning	36" x 36"
09A-7-1	BICYCLES YIELD TO PEDESTRIANS	Regulatory	36" x 36"
09A-8-1	BIKES CROSS ON WALK SIGNAL ONLY	Regulatory	36" x 36"

OPREC STATE HIGHWAY DIVISION  
 TRAFFIC ENGINEERING SECTION  
 STANDARD  
 BICYCLE SIGNING DETAILS  
 REGULATORY SIGNS & WARNING SIGNS  
 DATE: 10/15/03  
 SCALE: 1/8" = 1'-0"





**Figure 59**  
**See Page 67-A**

- Planning and Design Criteria for Bikeways in California and the State's *Highway Design Manual* contain the figures at right which further explain procedures for bike lane signs and markings.
- Detailed information on pavement markings is available through the Federal Highway Administration, Office of Highway Safety. Publication #HTO-20 details how to delineate and mark the standard alphabet, as well as special use pavement markings such as the bicycle symbol.

## **E. Pedestrian Facility Standards**

Compared with the extensive collection of reference materials reviewed for bicycle facility planning and design, there is not a lot of pedestrian information included in this case study report. This is not to say that pedestrian information does not exist, but rather that the needs of pedestrians have not been addressed as completely in the past as have the needs of bicyclists. Pedestrian transportation has, and continues to be, under emphasized at the State and local levels.

For this reason, the consultant did not find a significant amount of state-of-the-art pedestrian standards. Even the quantity and quality of standards for providing and designing sidewalks is low. And most do not even focus on the real needs of pedestrians-origins, destinations, direct travel routes, and access issues.



At the State and local levels, pedestrian issues are dealt with inadequately. In the past, programs have centered around safety and sidewalks. In the future, they must address developing a coordinated system of pedestrian transportation, which is effectively integrated with other transportation modes, and improved access to those systems.

Pedestrian policies also need to shift focus from safety to access. Policies are overall blanket statements adopted by States and municipalities. They serve as guiding principles and therefore influence adopted statutes and laws, and all facilities developed as a result of this legislative action.

There are two national reports, one statewide plan and two local plans that offer excellent guidance on the direction in which pedestrian facility planning, design and policy making needs to head in the future. In addition to information contained within Section 2 of this report, the strengths of each of these documents are summarized below, with representative graphics from each publication contained in Figures 60-73 on pages 72-77.

### **Planning and Implementing Pedestrian Facilities in Suburban and Developing Rural Areas (NCHRP 294A)**

This national report provides States and localities with an excellent summary of information relating to pedestrian facilities. It provides a clear vision on how pedestrian facilities can be integrated into the context of urban and suburban development. Chapters focus on:

- the nature of the suburban and rural pedestrian problem
- planning for pedestrian facilities within the context of the overall planning process
- pedestrian-sensitive site planning
- planning for pedestrian facilities in the highway right-of-way
- implementation

### **Planning, Design, and Maintenance of Pedestrian Facilities**

This manual, prepared for the Federal Highway Administration, offers excellent graphic illustrations of good and poor pedestrian facility design, handy reference charts, graphs and tables, and sample worksheets that can be copied for use on individual projects.

*Planning, Design, and Maintenance of Pedestrian Facilities* is a primary source document for urban pedestrian facilities that are most frequently encountered by traffic engineering professionals. It examines, in extensive detail, a variety of issues related to pedestrian facility design, development, and maintenance, including:

- pedestrian trip generation
- traffic flow relationships
- level of service
- sidewalk design/installation
- crosswalk design/installation
- overpasses and underpasses

- traffic control devices
- pedestrian facility maintenance

Detailed engineering and urban planning worksheets are provided in Appendix A of the manual that can easily be duplicated for use on local projects. These include Walkway Analysis, Crosswalk Analysis, and Traffic Volume Analysis. A five-page summary of Pedestrian Facility Problems and Solutions is provided in Appendix B of the report which serves as a quick reference guide for the community activist, politician, urban planner and design professional. Special attention is given to School Zone Treatments, and several case studies are provided in Appendix D of the report that illustrate successful School and Child Safety Programs. The manual contains an extensive bibliography that defines 111 sources of information on pedestrian facility research, planning, design, development, and maintenance.

### **The Florida Pedestrian Safety Plan**

Faced with a growing conflict between automobile traffic and pedestrian traffic, and record pedestrian fatalities in the 1980's, the State of Florida Department of Transportation produced this comprehensive Plan in February 1992. The forward to the Plan was authored by Transportation Secretary Ben Watts, who defines the State's commitment to pedestrian safety---"Within three years, the FDOT will provide high levels of pedestrian related spending of State and Federal dollars on all appropriate urban roadways." With this commitment, the Florida Safety Plan represents the most progressive pedestrian -strategy in the United States, and a model program for all other State transportation agencies.

Although the plan is called a *Safety Plan*, it focuses beyond safety needs and recommendations for safety improvements. The plan addresses the need for access for the pedestrian "design customer"-the child, the elder citizen, the physically challenged and the poor, who represent those citizens most in need of improved pedestrian transportation facilities. In addition, the plan offers equal consideration of pedestrian and motor vehicle needs, promoting a compact and affordable solution to urban design.

The plan is divided into five subsections, with full chapters devoted to engineering, education, enforcement and implementation:

- Engineering goals include establishing a minimum width for sidewalks as 5 feet; designing and developing all intersections to be pedestrian-friendly; providing pedestrian facilities within typical parking lots; providing mid-block crossings on major urban streets; and training transportation professionals through an established curriculum to provide safe walking environments in all Florida communities by the year 2010.
- Education goals define the need to create a uniform and statewide education program that includes implementing a school-based traffic safety education program; developing a general public awareness campaign about pedestrian safety; educating transportation officials; examining injuries and deaths by age group; accommodating the needs

of the elderly; providing law enforcement officials with the authority to arrest drunken pedestrians; and conducting traffic safety programs for adults through health care providers and driver education programs.

- Enforcement goals include encouraging the safety of pedestrians through improved legislation; establishing a Statewide campaign to establish criminal statutes for intoxicated pedestrians (alcohol consumption was present within 38.5 percent of the pedestrian fatalities); teaching pedestrian safety in all driver violator programs; and updating Florida traffic laws to conform with the Uniform Vehicle Code.
- Implementation goals provide for the enactment of legislative, education and enforcement recommendations by the year 1995, and include recommendations for leadership, funding, networking and community-based programs.

The plan contains a number of design and engineering recommendations which are borrowed from other publications, including the *National Cooperative Highway Research Program Report 294A* (described above) and the Institute of Traffic Engineers (ITE) *Residential Streets Design Manual*.

The Planning and Engineering section of the *Florida Pedestrian Safety Plan* does an excellent job of pulling, small bits of pedestrian information from other transportation planning and highway design documents, and assembling it into one convenient, user-friendly publication. For readers who desire more technical information, references are given to resource publications and page numbers where supporting details can be found.

The following planning and engineering issues are addressed in terms of policy recommendations and design or technical recommendations:

- Sidewalks
- Intersections
- Parking/Safe Access
- Mid-Block Crossings
- Work Zone Pedestrian Traffic
- Planning for Pedestrians
- Training the Pros

*The Florida Pedestrian Safety Plan* serves as a model comprehensive, innovative, and committed approach to addressing pedestrian issues.

### **Linking Land Use and Transportation: Design Strategies to Serve HOV's and Pedestrians**

This very unique and comprehensive study of the link between transit systems and pedestrians was prepared for the State of Washington Department of Transportation by Richard Untermann, Professor of Landscape Architecture at the University of Washington. This document contains valuable information on certain aspects of pedestrian facility planning and design. Although not as comprehensive as the Florida plan, the study presents progressive philosophies and state-of-the-art implementation strategies for pedestrian transportation.

The primary purpose of the study is to define the concept of "Suburban Centers" by which commuters can walk or bicycle to transit stops and travel in a "special outboard High Occupant Vehicle (HOV) lane to and from work, instead of driving their cars to a Park-and-Ride lot." Untermann describes Park-and-Ride lots as "expensive to construct and maintain, commuters must own their own vehicle that can be left unused during the day, and congestion, air pollution, and fuel wastage still remains."

*Linking Land Use and Transportation* makes a number of recommendations, mostly with regard to planning and design changes that must occur in suburban development patterns in order to develop more efficient mass transit systems and provide commuters with viable alternative modes of transportation between heavily used origins and destinations. The report concludes that walking and bicycling are inexpensive, nonpolluting, energy efficient modes of transportation that have largely been ignored in the context of modern urban and suburban development. In striving to accommodate pedestrians and bicyclists, many benefits can be realized including healthier citizens (via regular exercise), cleaner communities (water and air pollution), reduced urban congestion, and an overall improvement in the quality of life.

The report lacks specific design details, however, it does provide a number of planning guidelines and recommendations that are based on a review of actual field conditions that are typical of many American communities. Some example recommendations from this report include:

- install "Pedestrian Friendly Sidewalks" as 6 feet wide in low density residential areas and 8 feet wide in business and apartment districts.
- eliminate the "free right turn lanes" found in many U.S. cities, as these lanes "speed up traffic, and increase the discomfort and apparent danger to pedestrians."
- prohibit drive-ins (again extremely common in the U.S.) because they "pollute and waste energy while waiting in line..."

### **Eugene Sidewalk Program**

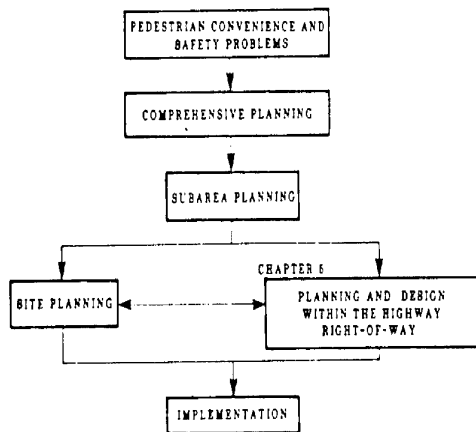
A draft of this document was provided by the Eugene Public Works Transportation Division for inclusion in this case study report. The document outlines the City of Eugene's philosophy for providing for pedestrian safety and mobility through a well established sidewalk system. The program stems from the adopted goals and policies for alternative modes of transportation as defined in both the *Metro Plan and TransPlan*.

*The Eugene Sidewalk Program* identifies existing mechanisms for installing sidewalks through the building permit process, street construction projects, City Council or City Engineer initiated projects, and property owner initiated projects. It summarizes the recommendations of the 1980 *Eugene Sidewalk Program*, and provides a status update on the success of the earlier program. The 1992 program is designed to provide direction for developing annual sidewalk construction projects based on existing and future pedestrian demand and safety needs.

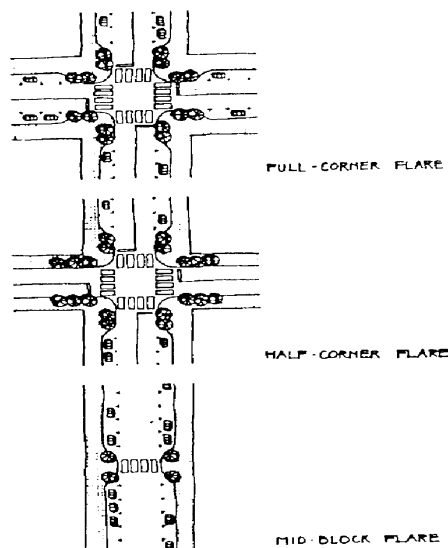
Probably the most critical component of this plan is the *Sidewalk Priority Program*. Existing sidewalks throughout the community were mapped on the city's Geographical Information System (GIS) and a priority point system was then developed to guide construction of the missing sidewalk segments. The prioritization is based on street classifications and pedestrian attractors. Major arterials, minor arterials, collector streets and busy local streets were examined, as well as six "pedestrian attractor" features---school locations, typical school walking routes, parks and recreation, commercial facilities, bus routes, and the availability of alternative walkways.

By examining and weighting all of these criteria, the City of Eugene has developed a model program that addresses the most critical pedestrian deficiencies in their multimodal transportation system.

**Figure 60. Flow of the Pedestrian Planning, Design, and Implementation Process**

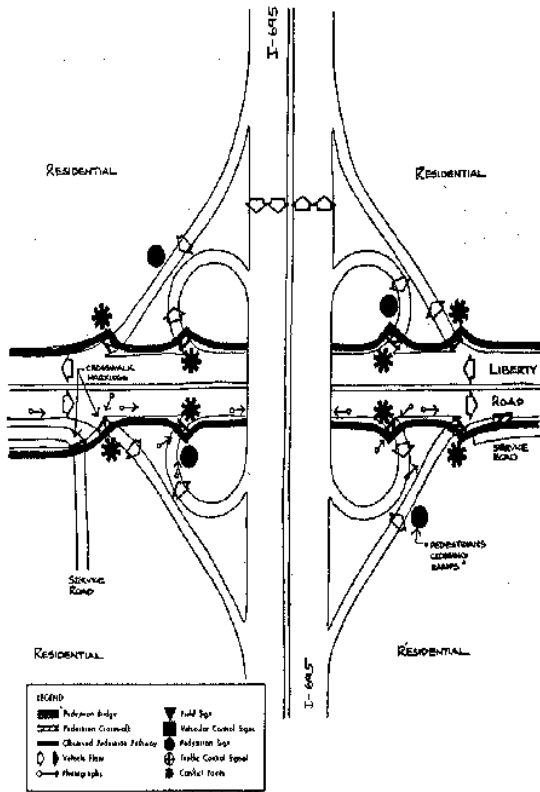


**Figure 61. Alternative Sidewalk Flare Designs**

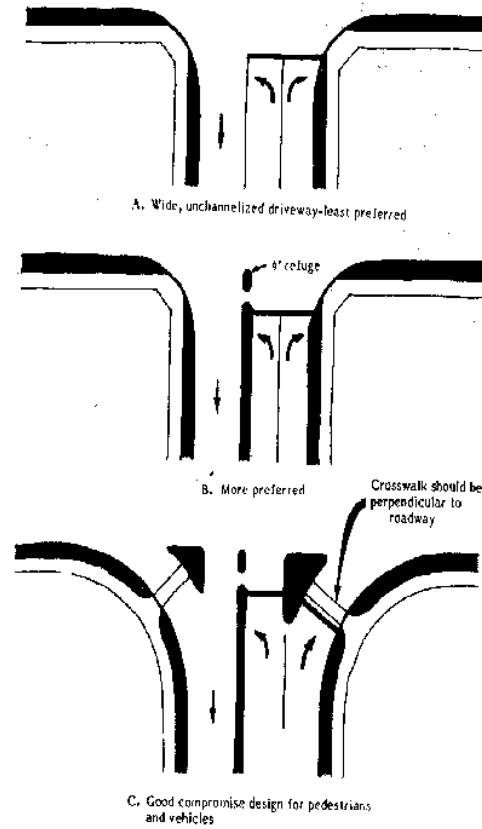




**Figure 62. Pedestrian Accommodations at an Arterial-Freeway Interchanges**

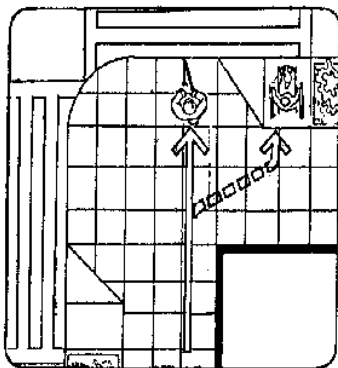


**Figure 63. Alternative Sidewalk Flare Designs**

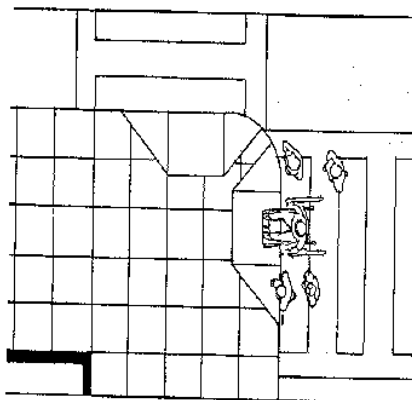


Source: PLANNING AND IMPLEMENTING PEDESTRIAN FACILITIES IN SUBURBAN AND DEVELOPING RURAL AREAS

**Figure 64. Recommended Installation of Curb Ramp out of the Direct Line of Pedestrian Travel**

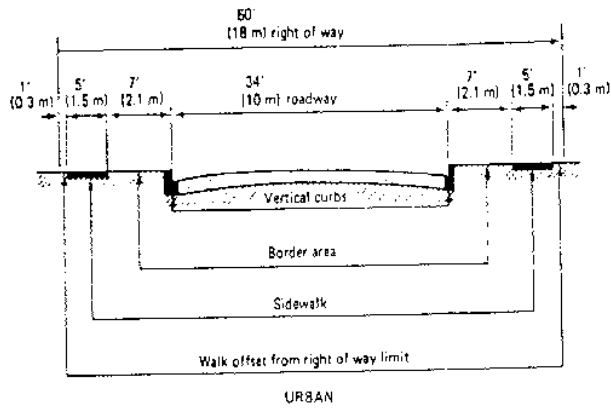


**Figure 65. Undesirable Placement of Adjacent Curb Ramps Too Close Together**

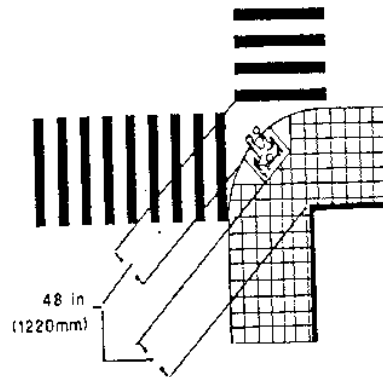




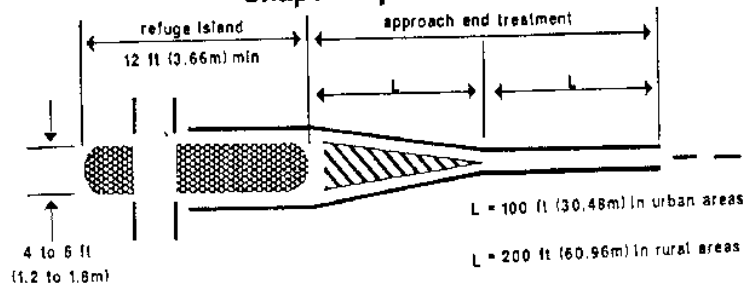
**Figure 66. Typical Cross-Section Residential Roadway**



**Figure 67. Overrun Distances at Top & Bottom Curb Ramps for Safe Wheelchair Use**



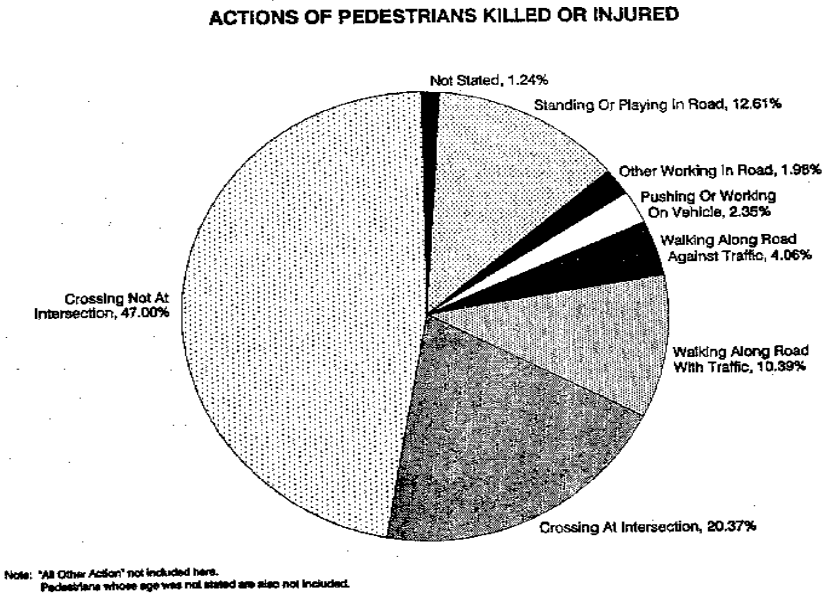
**Figure 68. Refuge Islands Size and Shape Requirements**



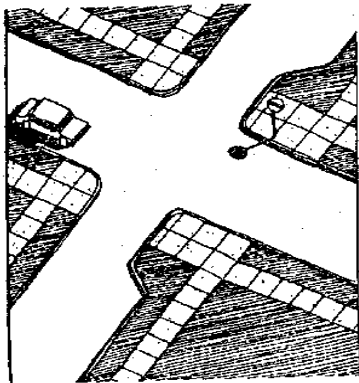
Source: PLANNING, DESIGN, AND MAINTENANCE OF PEDESTRIAN FACILITIES



**Figure 69. 1990 Florida Pedestrian Crashes**



**Figure 70. Use of Semi-Diverter, Bulbouts, or Flares to Reduce Crossing Distances for Pedestrians**

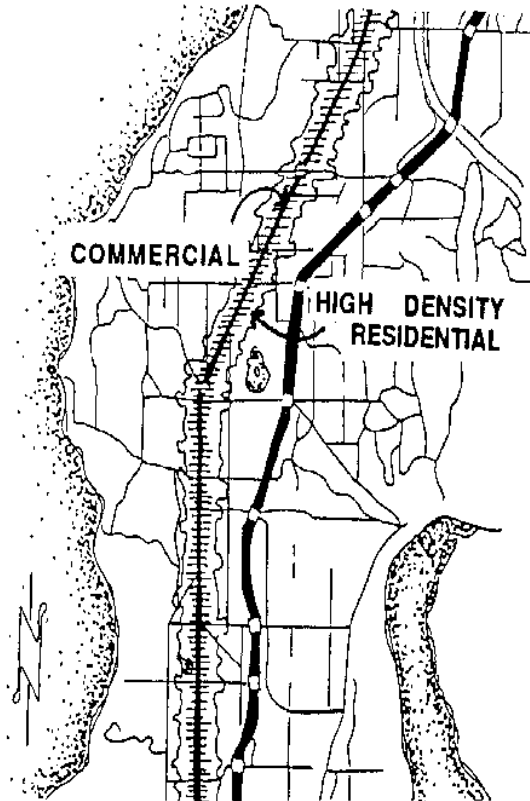


*Semi-Diverter, bulbouts, flares* - Used in neighborhoods to reduce crossing distances for pedestrians, and to calm the speed of turning traffic to acceptable neighborhood levels. Through such treatments motorists realize they have entered a people place. The motorist should feel that they are intruding. (Illustration from the *I.T.E. Residential Street Design and Traffic Control* manual, courtesy of Prentice Hall.)

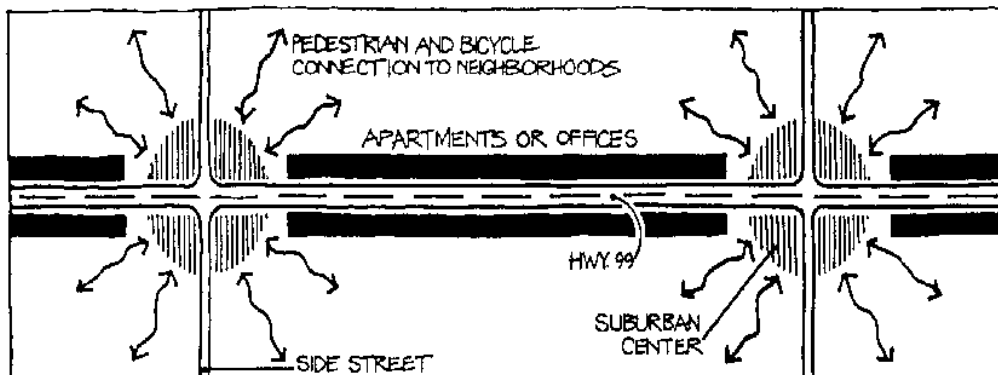
Source: FLORIDA PEDESTRIAN SAFETY PLAN



**Figure 71. Diagrammatic Existing Land Uses**



**Figure 72. Conceptual Diagram of HOV and Pedestrian-Friendly Land Uses**



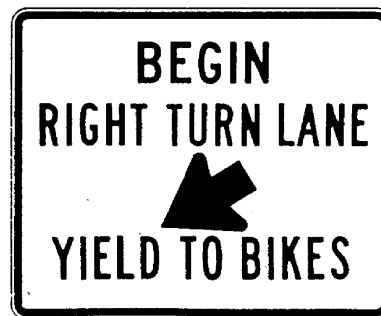




**Figure 73.**  
**City of Eugene Missing Sidewalk Segment Inventory**  
(See Page 99 at the end of this document)

# Section 4

## Planning and Design Enforcement



## Planning and Design Enforcement

States and localities use a variety of mechanisms to ensure that planning guidelines and design standards are adhered to. Methods of achieving compliance include regulatory policies such as laws and statutes; operating procedures that guide the development process through set standards; and incentive programs to encourage compliance to nonmandatory rules.

It is often the case that cities and States with older bicycle programs have developed more complete and comprehensive enforcement programs tailored to the particular needs of the region. Several older bicycle programs have successfully institutionalized enforcement procedures, so that the development of bicycle facilities is a standard and mandatory part of community transportation planning.

The following is a brief description of the most exemplary bicycle planning and design enforcement programs from across the United States.

### State of California

California has one of the most extensive policies for the encouragement of bicycling. In 1975, the State legislature passed the California Bikeways Act, declaring that "traffic congestion, air pollution, noise pollution, public health, energy shortages, consumer costs, and land use considerations resulting from a primary reliance on the automobile for transportation are sufficient reasons to provide for multimodal transportation systems." The Act further stipulates the need for a bicycle transit system "to achieve the functional commuting needs of the employee, student, businessman, and shopper as the foremost consideration in route selection, to have the physical safety of the bicyclists and bicyclists' property as a major planning component, and to have the capacity to accommodate bicyclists of all ages and skills."

In February 1991, Caltrans developed the Office of Bicycle Facilities (OBF) which oversees bicycle transportation development for the department. A two-person staff is headquartered in Sacramento, and the 12 district offices of Caltrans have "at least one person responsible for managing bicycle program activities."

The Bikeways Act further defines minimum design criteria and uniform specifications and symbols for facility development, and mandates that all "city, county and regional departments of public works, parks and recreation, planning agencies and other local agencies having authority over,

or responsibility for the development of bikeways shall utilize all minimum safety design criteria..." Variations from the set standards must be approved by the Office of Project Planning and Design Approval.

California's *Bikeway Planning and Design* manual sets forth both mandatory and advisory standards, and is explicit on the application of each. Mandatory standards always use the word "shall," and are considered essential to the achievement of overall design objectives. (Note: General planning criteria are included as mandatory standards.) Advisory standards allow greater flexibility in application, and use the word "should."

Additionally, *Bikeway Planning and Design* sets forth mandatory procedural requirements, which include permits, licenses, required tests, clearances, and so forth, which Caltrans is required to comply with by law. These mandatory requirements are clearly indicated within the manual.

California addresses the differences between State standards and AASHTO standards. The policy states: "AASHTO policies and standards . . . do not always satisfy California conditions. When standards differ, the instructions in this manual govern, except when necessary for FHWA project approval."

The State of California's funding policies serve as the greatest incentive for local bicycle facility design compliance with set standards. Several funding sources are available through the State, including a Bicycle Lane Account, State Highway Account, Federal-Aid funds, and local Transportation Development funds available through each county. The requirements for receiving funding through these sources clearly state that the project must meet set standards. The presence of a local bicycle program manager in each of the 12 district offices of Caltrans helps to assure that the standards are met.

## **State of New Jersey**

NJDOT began a program in 1989 that ensures that bicycling is considered in every transportation project. The NJDOT requires bureau managers, regional design directors, project lead unit supervisors, and so forth, to complete a "Bicycle Planning and Design Guidelines Certification Questionnaire" for all State-funded transportation projects within their area of responsibility. This includes new construction, reconstruction, resurfacing projects, utility, sign or guide beam installations, and drainage and intersection improvements. A copy of the Questionnaire (See Figure 74) is forwarded to the Pedestrian/Bicycle Advocate prior to the stage of project development where levels of action are determined.

The NJDOT also has a policy outlining the division of responsibilities in regard to addressing, the needs of bicycle traffic in the planning, design, construction and operation of DOT projects. Responsibilities are outlined for the Deputy Commissioner and the managers/directors of the divisions of Project Planning and Development, Roadway Design, Construction and Maintenance Engineering Support, Mobility Management, Project Location, and Environmental Analysis.

**Figure74:  
Certification  
Questionnaire**

**NJDOT BICYCLE PLANNING AND DESIGN GUIDELINES**  
**CERTIFICATION QUESTIONNAIRE**

Project Title:

Project Location and Limits:

Project Description: (Type of project; include typical cross section, and Level of Action report)

1. Will the project provide sufficient width of paved space (as defined in Bicycle Compatible Roadways) to accommodate shared use by bicycle and motor vehicle traffic? Yes ----- No ----- If "no, explain.
2. Will the project provide for the installation of "bicycle" drainage grates as per All Design Units Memorandum dated 1/26/83? Yes --- -- No ---- If "no," explain.
3. will all traffic signals installed as part of the project accommodate bicycle traffic as outlined in Bicycle compatible Roadways? Yes --- -- No ---- If "no," explain.
4. Will all guide beam, sign posts, lighting standards, utility poles, etc., within project limits be placed in accordance with guidelines provided in Bicycle Compatible Roadway Yes ----- No ----- If "no," explain.
5. Will all intersecting streets, driveways, curb cuts, and railroad grade crossings be paved in accordance with guidance provided in Bicycle Compatible Roadways? Yes ---- No ---- If "no," explain.
6. Will the project provide lighting, signing, or other measures to mitigate any remaining obstruction, construction, or barriers to bicycle traffic? Yes No If "no," explain.

Signed \_\_\_\_\_

Source  
NJDOT  
PROCEDURE NO.  
1.409-A

**State of North Carolina**

North Carolina officially recognized the bicycle as a form of transportation through the Bicycle and Bikeways Act of 1974. The NCDOT Bicycle Policy sets forth planning and design guidelines for bikeways throughout the State, and the NCDOT Office of Bicycle and Pedestrian Transportation has worked for more than a decade to promote these guidelines. In 1991, technical assistance was provided to bikeway designers through a bicycle facility design workshop held by the NCDOT.

The NCDOT has developed one of the most comprehensive review processes for local bicycle project requests. Requests are handled through an annual Transportation Improvement Process (TIP). Eligible projects include independent bikeways, which are separate from any other roadway

improvements, and incidental improvements, which are "piggybacked" onto regular roadway improvements, such as widening or repaving.

Transportation officials, and in some cases private citizen groups, may request bicycle improvement projects at annual TIP meetings held across the State. A formal survey is filled out for each request. The NCDOT Bicycle Committee reviews all requests and recommends the adoption and scheduling, for some of the projects.

Elected bicycle projects must meet certain criteria in order to be considered for funding, including cost limitations (must be less than \$300,000), right-of-way availability, national design standards, set transportation purpose, preliminary project approval from the public jurisdiction, local area involvement, inclusion in the transportation or bicycle planning process, and project need.

Planning and design standards are enforced in North Carolina in several ways. First, the NCDOT Office of Bicycle and Pedestrian Transportation conducts a comprehensive feasibility study for each project that is scheduled on the TIP. Should a project be found cost prohibitive or impossible to construct to the set standards, the project is removed from the funding list. Also, bikeway construction documents are regularly reviewed by the NCDOT for compliance to standards. The bicycle facility must receive approval in order to receive funding from the State.

## **State of Ohio**

Ohio provides an excellent example of the project development process and enforcement procedures in Chapter 3 of *Policy and Procedure for Bicycle Projects*. This section outlines the process for receiving Federal construction funds for bikeway projects, which includes a complete field review and feasibility study. The locality must demonstrate the transportation value of the proposed facility, and must execute legislation that stipulates a commitment to maintain and police the facility. Environmental considerations are included in the preliminary review of the project.

Ohio's bicycle funding procedures regulate those projects that may be considered for Federal funding. Under these stipulations, all projects must be part of an overall area bikeway plan, and may not be considered "recreational" in nature.

An explicit design review and approval process is also provided in the *Policy and Procedure for Bicycle Projects*. Reviews are required for line, grade and typical section drawings, site plans, drainage plans, traffic control and lighting, and right-of-way plans. A preliminary review and final review is specified. ODOT also lists the sheets normally submitted within a set of construction plans for a bikeway.

ODOT's *Policy and Procedure for Bicycle Projects* includes project development time charts that show the bicycle facility planning, procedure in a step-by-step format. This chart includes a time slot for ODOT and FHWA review of projects. The manual also makes reference to project elements that may deviate from the design criteria. A written request must be submitted to the Bicycle Transportation Administration that fully explains the reasons for failing to meet the criteria.

**Figure 75: Project Development Time Chart (in weeks)**

DESCRIPTION	LENGTH	ELAPSED	TIME
		MIN	Max
Project placed on regional plan, local plan & Transportation Improvement, Program		0	
Field review	1-3	1	3
Preparation of program and environmental form	2-8	3	11
Local consent legislation	2-4	5	15
ODOT and FHWA review of project	1-3	6	18
Environmental review	2-26	8	44
Plan preparation	5-15	13	59
Line, Grade, & Typical Section review	4-8	17	67
Typical, Size & Location review,(bridge only)	4-8	21	75
Final plan	2-8	23	83
Field & Office Check of plans	3-8	26	91
Completion of drawings	1-5	27	96
Purchase of right-of-way	0-52	27	148
Preparation for contract sale	22-26	49	174

Source: OHIO POLICY AND PROCEDURE FOR BICYCLE PROJECTS

## State of Oregon

In the 1971 regular session, the Oregon Legislative Assembly passed "House Bill 1700" which requires that whenever highways, roads or streets are being constructed, reconstructed or relocated, footpaths and bicycle trails will be built, including curb cuts or ramps, as part of these projects. The law further requires that the amount expended by the Oregon Transportation Commission shall never in any one fiscal year be less than 1 percent of the funds received from the Highway Fund.

The results of this law, as documented for FY 1987, show a State Highway Division annual bicycle/footpath expenditure amount of \$1,811,426. Oregon cities required expenditures for the same fiscal year totalled \$341,909 and county expenditures equalled \$579,579.

The Oregon DOT has also developed a policy statement on Eligible Bikeway Charges to identify those activities and construction items which shall be charged to the Bicycle Trail Allotment and applied toward the 1 percent minimum. Specific policy guidelines have been established for funding administration, development, construction, and maintenance.

The Oregon DOT has established guidelines for approving independent bikeway projects as parallel bicycle routes. Project funding is granted when set planning criteria are met. The DOT has also developed an "Application for Funding Assistance for Bikeway Construction," to be completed by counties or communities seeking assistance, and a "Bikeway Project Rating Sheef 'for evaluating the application.

## State of Wisconsin

The Wisconsin DOT (WisDOT) Facilities Development Manual is an excellent example of bicycle facility "mainstreaming" into development policies. Bicycle projects are incorporated into the general roadway construction program and therefore must go through the same evaluation procedure as roadway projects.

## City of Eugene, Oregon

The City of Eugene, Oregon, provides an excellent local example of bicycle planning review and enforcement procedures. The City established a Bicycle Advisory Committee in 1970 that reviews all bicycle facility planning projects and oversees the City's bicycle planning efforts.

Eugene has developed some progressive planning policies to ensure that bicycles and pedestrians are an integral part of the overall transportation system. Land-use and development patterns are set to encourage the development of bicycle facilities, including provisions for bicycle path connections between and within adjacent developments, right-of-way acquisition to accommodate future bicyclin-needs, and development of traffic management techniques and an arterial street system that attracts through automobiles and trucks off local streets. Eugene also requires that developers develop plans for bicycle and pedestrian transportation, as well as roadways for automobiles, when making requests for re-zoning.

Eugene has an exemplary parking ordinance that has been in effect long enough that racks can be found throughout the city in abundance. The *Eugene Code* specifies that each space shall be a minimum 6 feet long, 2 feet wide, and shall be provided with a minimum overhead clearance of 6 feet.

Multiple residential units are required to provide x bicycle storage spaces per type of dwelling unit. In industrial and commercial districts, the minimum number of spaces equals 10 percent of the number of spaces required for automobiles, with at least two spaces required in all commercial district developments. Locking is required for all spaces in commercial areas. Locking and cover is required in all industrial districts and commercial sites with more than IO required bicycle parking spaces.

*The Eugene Code* has locational requirements as well, specifying that required spaces shall be located a maximum of two times the distance between building entrances used by automobile occupants and the nearest parking spaces to those entrances. The Public Works Department is currently involved in a transportation study that will include additional recommendations for improving these bicycle parking requirements.



Eugene has developed several incentive programs to encourage compliance with bicycle transportation policies. For example, the City has established parking programs for congested areas that discourage long-term employee parking, developed incentives for employers to subsidize transit fares for their employees and customers, and expanded parking enforcement programs and increased parking fines for motor vehicles.

## **City of Seattle, Washington**

The City of Seattle, Washington, conducts the majority of their bicycle facility planning and design work in-house. However, when the Engineering Department does hire an outside consultant, there are three items always included in the Request for Proposals (RFP) process:

- 1) The RFP specifically calls for firms with bicycle expertise.
- 2) Part of the grading on the RFP review sheet includes an evaluation of a firm's bicycle and pedestrian experience - typically 20 to 30 percent of the overall score.
- 3) The interview panel/selection committee has a member representing bicycle and pedestrian issues.

Seattle has not developed an official city-wide planning and design standards manual for bicycle and pedestrian facilities - the city relies on AASHTO and MUTCD, as incorporated into their *Street Design Manual*, and most importantly, the engineering judgement of the Bicycle Coordinator and Bicycle Program Planner.

These two staff positions review all street design projects within the city. The Seattle Engineering Department implements a "flat" project management style in which each project is assigned a manager who oversees a project from conception through construction. The project manager is assisted by a team of people who meet weekly or monthly to review all progress on facility development. In this manner, bicycle staff work on specific project teams, and have input into all phases of planning and design.

# Section 5 Best Practices



## Best Practices

What constitutes "best practices?" This case study defines best practices as those that offer exemplary or model planning guidelines, design standards, development strategies, and management programs that lead to successful bicycle and pedestrian systems and programs.

It is very difficult to judge best practices for bicycle and pedestrian facilities because empirical data related to usage, conflict, and user satisfaction is often times lacking. At times, best practice can be defined as simply "being in existence"---for example the Florida Pedestrian Safety Plan is the only statewide pedestrian facility design manual found through this research. Fortunately, this manual is an excellent comprehensive guide for developing pedestrian facilities, and is therefore highly recommended as a "best practice."

Best practice can also be defined as those guidelines and standards that most effectively promote safety, are inexpensive to implement and manage, and provide the most effective service to the user. AASHTO guidelines serve these purposes in a general sense, and are nationally recognized as the legal and fundamental basis for State and local facility development.

Those States and localities that suggest modifications to AASHTO standards were carefully reviewed, and included if they represent possible models for use by other agencies and communities. Modifications are often regional in nature, addressing specific topographic and climate constraints of an area. In addition, several State and local design manuals modify AASHTO's language to present a more "user friendly" document. At times, these manuals present excellent discussions of why certain design standards are necessary, which is useful in convincing sceptics of the importance of the standards.

The following listing of plans and programs exemplify the best practices and most effective presentations of planning guidelines and design standards found in the United States. These plans are viewed as models for States and localities in the development of state-of-the-art design manuals.

Best new compilation of material  
from existing plans and guidelines

*State of Colorado Bikeways  
Standards and Design Guidelines*

Best document for including detailed  
technical information on a variety  
of specific bike design issues

*State of North Carolina Bicycle  
Facilities Planning and Design  
Guidelines*

Best documents focusing on planning for bicycle facilities

*State of Florida Bicycle Facilities Planning and Design Manual*

*State of Florida Development Manual For Comprehensive Regional Bicycle Plans*

Best publications for people unfamiliar with bicycle facility design and technical subject matter

*State of Oregon Bicycle Master Plan*

*State of Florida Bicycle Facilities Design Training Course*

Best standards for bicycle construction detours

*City and County of Denver Construction Detour Standards for Bikeways and Multi- Use Traits*

Best standards for developing bicycle signage

*State of Arizona Bicycle Facilities Planning and Design Guidelines*

Best use of graphics in publications to illustrate various bicycle needs *and Design Guidelines*

*State of New Jersey Bicycle Compatible Roadways - Planning*

*State of Florida Bicycle Facilities Design Training Course*

*State of Minnesota Bikeway Design Manual*

Best manual for on-road facilities

*State of New Jersey Bicycle Compatible Roadways - Planning and Design Guidelines*

Best references for multi-use trails and off-road paths

*Guidelinesfor Creating Greenways*

*Design and Management Manual or Multi-Use Traits*

Best design and engineering enforcement mechanisms

*State of California Highway Design Manual*

Best integration of bicycle facilities into transportation planning

*City of Seattle, Washington*

	<b><i>State of Wisconsin Facilities Development Manual</i></b>
	<b><i>State of California Highway Design Manual</i></b>
Best operational procedures for bicycle facility planning and development	<b><i>State of North Carolina Bicycle Facilities Planning and Design Guidelines</i></b>
	<b><i>State of Ohio Policy and Procedure or Bicycle Projects</i></b>
Best incentives for bicycle facility development	<b><i>City of Eugene, Oregon: Transplan Policies Related to Alternative Transportation Modes</i></b>
Best all-around pedestrian plan	<b><i>State of Florida Pedestrian Safety Plan</i></b>

Section 6

**Appendices**



## Appendix A: Reference Bibliography

Information on specific projects contained within this case study report was obtained from one of two sources: the review of draft and published plans, reports and newsletters on various pedestrian and bicycle-related issues, as listed below, and through direct contact with the persons listed in *Appendix B*.

### Arizona

Arizona Bicycle Facilities Planning, and Design Guidelines. November 1988. Facilities Planning Committee of the Arizona Bicycle Task Force.

City of Tucson Development Standards, Bicycle Parking Facility Design Requirements. May 1990. City of Tucson Planning Department, Tucson, AZ.

City of Tucson Development Standards, Pedestrian Access. October 1990. City of Tucson Planning Department, Tucson, AZ.

Major Streets and Routes Plan. 1985. City of Tucson Planning Department, Tucson, AZ.

Mountain Avenue - Bicycle, Pedestrian and Landscape Demonstration Project. April 1990. The City of Tucson Department of Transportation, Tucson, AZ.

Bike Rights. "Tucson Alternate Modes Coordinator," 1991. City of Tucson, Tucson, AZ.

Tucson Bicycle Inventory Study. February 1992. Arizona Department of Environmental Quality, City of Tucson, Tucson, AZ.

Tucson Bicycle Parking Ordinance. 1990. City of Tucson Alternate Modes Coordinator, City of Tucson, Tucson, AZ.

### California

Highway Design Manual, Fourth Edition, July 1990.

Highway Design Manual, Bikeway Planning and design, Fourth Edition, July 1990. California Department of Transportation, Sacramento, CA.

Development of Nonmotorized Transportation Facilities. December 1991. Annual Report to the Legislature, California Department of Transportation, Sacramento, CA.

Planning, and Design Criteria for Bikeways in California. June 1978. California Department of Transportation, Sacramento, CA.

State of California Vehicle Code. 1987. State of California Department of Transportation, Sacramento, CA.

## **Colorado**

CDOT Transportation Design Guidelines Manual, Bikeway Standards Chapter, 1992 Preliminary Draft. Colorado Department of Transportation.

CDOT Pedestrian and Policy Draft Bicycle Policy. 1992. Colorado Department of Transportation.

Colorado Bicycling, Advisory Board 1991 Annual Report to the Governor. October 1991. Colorado Bicycling Advisory Board.

Colorado Bikeways Standards and Design Guidelines. Preliminary Draft. Colorado Department of Transportation.

*Construction Detour Standards for Bikeways and Multi- Use Trails (for both Public Works and Parks and Recreation facilities).* City and County of Denver, Denver, CO.

*Denver Bicycle Master Plan - Bicycle Commuter Questionnaire.* 1992. City of Denver Department of Public Works. Denver, CO.

*House Bill No. 1246, Concerning traffic laws relating to bicycles and to the operators thereof.* 1988. General Assembly of the State of Colorado.

State Recreational Trails Master Plan: Non-Motorized , . March 1985. Colorado Division of Parks and Outdoor Recreation, Denver, CO.

## **Delaware**

Strategies for a Statewide Bicycle/Pedestrian Plan. December 1991. Delaware Department of Transportation, Dover, DE.

## **Florida**

Bicycle Facilities Planning and Design Manual: Official Standards. October 1982. Florida Department of Transportation, Division of Planning, Tallahassee, FL.

Bicycle Sketch Plan. Florida Department of Transportation, Tallahassee, FL.



Bicycle Transportation Facilities Design Training, Course. 1985. Florida Department of Transportation, Tallahassee, FL.

Bicycle Federation of America and Kimley-Horn and Associates, Inc. Development Manual for Comprehensive Regional Bicycle Plans. January 1985. Florida Department of Transportation, Tallahassee, FL.

Facilities Planning and Design Manual. 1982. Florida Department of Transportation, Tallahassee, FL.

## Minnesota

Bikeway Design Manual, February 1983. Minnesota Department of Transportation.

Plan B: The Comprehensive State Bicycle Plan. February 1992. Minnesota Department of Transportation.

## New Jersey

Feldman, William. Bicycle Compatible Roadways - Planning and Design Guidelines. December 1982. The New Jersey Department of Transportation.

*Department of Transportation Policy on Bicycle Transportation.* August 7, 1989. The New Jersey Department of Transportation.

*Department of transportation Procedure on Bicycle Transportation.* August 7, 1989. The New Jersey Department of Transportation.

## North Carolina

Bicycle Facility Planning and Engineering 1990. Workbook presented at the North Carolina Bicycle Facility Workshop, Raleigh, NC.

North Carolina Department of Transportation Bicycle Policy. April 1991. North Carolina Department of Transportation.

Williams, John. North Carolina Bicycle Facilities Planning and Design Guidelines. Preliminary Draft. By BikeCentennial for the North Carolina Department of Transportation, Bicycle Program, Raleigh, NC.

Supplement to the Manual on Uniform Traffic Control Devices for Streets and Highways. 1990. North Carolina Department of Transportation Traffic Engineering Branch.

## Ohio

*Bicycle Transportation: § 217 Bicycle Transportation and Pedestrian Walkway.* SEC 126. Section 217 of Title 23, United States Code.

*Funding of ODOT-Federal Bicycle Transportation Program.* October 5, 1983. Ohio Department of Transportation, Columbus, OH.

*General Information Regarding the ODOT Bicycle Program.* August 1990. State of Ohio Department of Transportation.

*Guidelines for Retaining Walls on Bicycle Projects.* May 3, 1989. Inter-office communication of the Ohio Department of Transportation, Columbus, OH.

*ODOT Long Range Bicycle Plan: Outline.* Ohio Department of Transportation, Columbus, OH.

*Ohio Revised Code: Bicycle Laws.* January 1991. State of Ohio Department of Transportation, Columbus, OH.

*Overall Bicycle Plan.* Ohio Department of Transportation.

*Pedestrian and Bicycle Accommodations and Projects.* SEC 652. 23 CFR Ch. 1. April 1, 1987 Edition. Federal Highway Administration, DOT.

Policy and Procedure for Bicycle Projects. Fourth Edition. January 1988. Ohio Department of Transportation, Columbus, OH.

*Policy for Highway Shoulder Treatment for Bicycles.* September 26, 1985. Ohio Department of Transportation, Columbus, OH.

## Oregon

1992 Oregon Bicycle Plan. 1992 Preliminary Draft. Oregon Department of Transportation, Technical Services Branch, Salem, OR.

Alternative Transportation Program Guide. Oregon Department of Transportation.

Anderson, Chris and Dave Reinhard. *Transplan Policies Related to Alternative Transportation Modes.* October 1990. Public Works Department, Transportation Division. City of Eugene, Eugene, OR.

Bicycles in Cities: The Eugene Experience. Vols. I - XII. 1981. Bikeways Oregon. Eugene, OR.

*City of Eugene Design Standards.* February 1992. City of Eugene Engineering Department, Eugene, OR.

City of Eugene Code, various sections pertaining to bicycle provisions and requirements. Eugene, OR.

Eugene Sidewalk Program: An Update of Sidewalk Needs. August 1992 Draft. City of Eugene Public Works Transportation Division.

Eugene-Springfield Metropolitan Area Transportation Plan, May 1986. Lane Council of Governments, Eugene, OR.

.State of Oregon Bicycle Master Plan. March 1988. Oregon Department of Transportation, Highway Division, Salem, OR.

## Wisconsin

Bicycle Transportation Plan for Madison and Dane County. April 1991. City of Madison, Department of Transportation in cooperation with the Dane County Regional Planning Commission, Madison, WI.

Facilities Development Manual. Wisconsin Department of Transportation, Madison, WI.

## Washington

Publication 1020: Facilities for Non-motorized Transportation, June 1989. Washington State Department of Transportation Design Manual, Olympia, WA.

Washington State Transportation Policy Plan - Subcommittee on Bicycle Transportation-Final Report. August 1991. Washington State Department of Transportation, Olympia, WA.

## General/National

*Bicycle and Pedestrian Facilities in the Federal-Aid Highway Program.* September 1990. U.S. Department of Transportation Federal Highway Administration.

Bicycle Forum Technical Note Series, #F1-F2, P1-P3. Published by Bike Centennial, Missoula, MT.

Bicycle Planning and Design. R.W. Mayer. 1978. Landscape Architecture Technical Information Series. Vol. 1, No. 1. American Society of Landscape Architects. Washington, D.C.

Design and Management Manual for Multi-Use Trails, Draft copy. Edited by Karen-Lee Ryan. Rails-to-Trails Conservancy. Washington, D.C.

Flink, Charles A. and Robert M. Seams. Guidelines for Creating Greenways. Draft copy. The Greenway Collaborative. Denver, CO and Raleigh, NC.

Guide for Development of Bicycle Facilities. August 1991. American Association of State Highway and Transportation Officials. Washington, D.C.

Guide for Development of New Bicycle Facilities, 1981. American Association of State Highway and Transportation Officials. Washington, D.C.

Inglis, Dawn. State Bicycle Planning Programs: -A Survey of Ten States. December 1991. Student paper, Georgia Institute of Technology, College of Architecture.

Intermodal Surface Transportation Efficiency Act of 1991. November 1991. House of Representatives Report 102-404, Washington, D.C.

Manual on Uniform Traffic Control Devices for Streets and Highways. 1988 Edition. U.S. Department of Transportation Federal Highway Administration.

National Cooperative Highway Research Program Report 294A: Planning, and Implementing Pedestrian Facilities in Suburban and Developing Rural Areas. June 1987. Transportation Research Board, Washington, D.C.

Planning, Design and Maintenance of Pedestrian Facilities. March 1989. Publication No. FHWA-IP-88-019, U.S. Department of Transportation.

Bicycle Forum. *Reviewing the '81 AASHTO Guide: Parts I and 2*.

Standard Alphabets for Highway Signs and Pavement Markings. 1977; reprinted 1982. U.S. Department of Transportation Federal Highway Administration. Washington, D.C.

Untermann, Richard K. Linking, Land Use and Transportation: Design Strategies to Serve HOV's and Pedestrian. June 1991. University of Washington.

Wilkinson, Bill; Andy Clarke; Bruce Epperson; and Dick Knoblauch. The Effects of Bicycle Accommodations On Bicycle/Vehicle Safety and Traffic Operations. May 1992. FHWA Contract DTFH61-89-C-00088. U.S. Department of Transportation Federal Highway Administration. Washington, D.C.

Wilkinson and Moran. Highway Route Designation Criteria for Bicycle Routes, Final Report and Handbook. 1986. Bicycle Federation of America, Washington, D.C.

## Appendix B: Reference List of Project Contacts

The following reference is a listing of persons who assisted in preparing FHWA Case Study #24 by providing literature, returning telephone calls, and furnishing supplemental information on the planning guidelines, design standards, and public policies included within this case study. We thank them for their time, effort, and assistance in completing this work, and for their longstanding commitment to improving our bicycling and pedestrian transportation system.

### CALIFORNIA

Richard L. Blunden  
Chief, Office of Bicycle Facilities  
Department of Transportation  
Division of Highways  
1120 N Street Room 4500  
P.O. Box 942874, Mail Station #38  
Sacramento, CA 94274-0001  
(916) 653-0036

Rick Knapp, Deputy District Director  
Planning and Programming  
Department of Transportation  
District 1, P.O. Box 3700  
Eureka, CA 95502-3700  
(707) 445-6413

### COLORADO

Nancy Dutko  
Colorado Department of Transportation  
4201 E. Arkansas Avenue, Room 225  
Denver, Colorado 80222  
(303) 757-9982

### DELAWARE

Edward H. Daino  
Project Manager, Planning  
Delaware Department of Transportation  
P.O. Box 778  
Dover, DE 19903  
(302) 7394348

### DENVER, COLORADO

James Mackay, P.E., Bicycle and Pedestrian  
Planner  
Transportation Planning Section  
200 W. 14th Avenue, Room 302  
Denver, CO 80204  
(303) 640-3958

### EUGENE, OREGON

Diane Bishop  
Bicycle and Alternative Modes Coordinator  
Public Works Department  
Transportation Division  
858 Pearl Street Suite 300  
Eugene, OR 97401  
(503) 687-5218

### FLORIDA

Dan Burden  
Florida Department of Transportation  
605 Suwannee Street, MS 82  
Tallahassee, FL 32399  
(904) 487-1200

### MADISON, WISCONSIN

Arthur Ross  
Pedestrian-Bicycle Safety Coordinator  
Department of Transportation  
Madison Municipal Building  
215 Martin Luther King, Jr. Boulevard  
P.O. Box 2986  
Madison, WI 53701-2986  
(608) 2664761

MINNESOTA

Greg Pates, Transportation Planner  
Bicycle Planning Unit  
Program Management Division  
807 Transportation Building  
St. Paul, MN 55155  
(612) 296-1650

NEW JERSEY

William Feldman  
New Jersey Department of Transportation  
1035 Parkway Avenue  
Trenton, NJ 08625  
(609) 530-8062

NORTH CAROLINA

Tom Norman, Facilities Specialist  
Office of Bicycle and Pedestrian Transportation  
P.O. Box 25201  
Raleigh, North Carolina 2761 1  
(919) 733-2804

OHIO

Sharon Todd, Bicycle Coordinator  
Ohio Department of Transportation  
25 S. Front Street Room 418  
Columbus, Ohio 43212  
(614) 644-8660

OREGON

Michael Ronkin  
Oregon State Highway Division  
200 Transportation Building  
Salem, OR 973 10  
(503) 378-3432

SEATTLE, WASHINGTON

Peter Lagerway  
Bicycle Coordinator  
Seattle Engineering Department  
Department of Transportation  
700 Municipal Building, 600 Fourth Avenue  
Seattle, WA 98104  
(206) 684-7583

TUCSON, ARIZONA

Keith P. Walzak  
Alternate Modes Coordinator  
Planning and Programming Division  
Department of Transportation  
P.O. Box 27210  
Tucson, AZ 85726-7210  
(602) 791-4371

WASHINGTON

Clifford E. Mansfield, P.E.  
Design Management Engineer  
Washington State Department of Transportation  
Transportation Building, Room 2C 11  
Olympia, WA 98504-5201  
(206) 753-4461

WISCONSIN

Catherine Ratte  
Pedestrian/Bicycle Safety Program Manager  
Office of Transportation Safety  
Wisconsin Department of Transportation  
4802 Sheboygan Avenue  
Madison, WI 53707  
(608) 267-3155



Planning Guidelines and Design Standards Used by State and Local Agencies for bicycle and Pedestrian Facility

Eugene Sidewalk Program Appendix A: Missing Sidewalk Seements, All Streets  
 January 29, 1992

Street Segment Description					Missing Sidewalk Info.				Pedestrian Attraction Points								
Rank	Street Name	From	To	Street Side	Frontage	Approx Frontage	Number Parcels	% Frontage	Basic Points* (1-10)	School Within 1/4 Mile (10)	Typical School walk Rte (10)	Park/Rec Within 1/4 Mile (8)	Comm't within 1000' (6)	Bus Route (6)	No Alt Walk Available (5)	Total Priority Points	Notes
238	1st Avenue	Seneca	Bartelson	S	5,710	5,010	17	87.74%	6	0	0	0	0	6	5	17	7
239	1st Avenue	Seneca	Bartelson	N	5,850	5,850	12	100.00%	6	0	0	0	0	6	5	17	7
201	2nd Avenue	Blair	Van Buren	N	440	390	1	88.64%	4	10	0	0	6	0	0	20	7
47	2nd Avenue	Blair	Taylor	S	650	650	5	100.00%	6	10	10	0	0	6	5	37	7
241	2nd Avenue	Taylor	Garfield	S	2,120	1,590	15	75.00%	6	0	0	0	0	6	5	17	7
240	2nd Avenue	Taylor	Garfield	N	2,240	790	3	35.27%	6	0	0	0	0	6	5	17	7
195	3rd Avenue	Willamette	Lincoln	N	1,150	1,150	3	100.00%	4	0	0	6	6	0	5	21	
202	4th Avenue	Pearl	Ferry	N	1,000	330	2	33.00%	6	0	0	a	6	0	0	20	
275	5th Avenue	Almaden	Chambers	S	680	650	5	95.59%	4	0	0	0	6	0	5	15	
276	5th Avenue	Almaden	Chambers	N	680	110	2	16.18%	4	0	0	0	6	0	5	15	
308	5th Avenue	Highway 99 N	Seneca	S	2,810	2,660	13	94.66%	6	0	0	0	6	0	0	12	7 13
307	5th Avenue	Highway 99 N	Seneca	N	2,940	2,940	13	100.00%	6	0	0	0	6	0	0	12	7 13
171	7th Place	Bailey Hill	7th Avenue	N	5,800	5,130	19	88.45%	6	0	0	0	6	6	5	23	7
170	7th Place	Bailey Hill	7th Avenue	S	5,850	4,130	15	70.60%	6	0	0	0	6	6	5	23	7
164	8th Avauue	Grant	Garfield	N	650	210	2	32.31%	4	0	0	8	6	6	0	24	7
150	11th Avenue	Bailey Hill	Bertelson	N	3,660	2,460	19	67.21%	8	0	0	0	6	6	5	25	7
147	11th Avenue	Bailey Hill	Bertelson	S	3,580	2,140	13	59.78%	8	0	0	0	6	6	5	25	7
206	11th Avenue	Beltline	Terry	S	3,860	3,860	5	100.00%	9	0	0	0	6	0	5	19	1 7
205	11th Avenue	Beltline	Terry	N	3,730	3,730	8	100.00%	8	0	0	0	6	0	5	19	1 7
152	11th Avenue	Bertelson	Beltline	N	2,540	2,540	10	100.00%	8	0	0	0	6	6	5	25	7
149	11th Avenue	Bertelsen	Beltline	S	2,750	2,440	12	88.73%	8	0	0	0	6	6	5	25	7
67	11th Avenue	Chambers	Hayes	N	810	420	7	51.85%	9	0	0	8	6	6	5	33	
68	11th Avenue	Chmbers	Hayes	S	810	550	6	67.90%	8	0	0	8	6	6	5	33	
151	11th Avenue	Conger	Bailey Hill	S	3,550	1,920	13	51.27%	8	0	0	0	6	6	5	25	7
148	11th Avenue	Conger	Bailey Hill	N	5,550	440	4	12.39%	8	0	0	0	6	6	5	25	7
207	11th Avenue	Terry	GreenHill	S	5,500	5,500	11	100.00%	8	0	0	0	6	0	5	19	1 8 9
208	11th Avenue	Terry	Green Hill	N	5,500	5,500	7	100.00%	8	0	0	0	6	0	5	19	1
100	12th Avenue	Polk	Chmben	N	1,270	220	4	17.32%	4	10	10	0	6	0	0	30	
312	16th Avenue	Riverview	Agusta	S	340	220	0	64.71%	6	0	0	0	0	0	5	11	
311	16th Avenue	Riverview	Augusta	N	160	60	4	37.50%	6	0	0	0	0	0	5	11	
243	17th Avenue	Acron Park	Buck	S	300	300	4	100.00%	4	0	0	8	0	0	5	17	1
242	17th Avenue	Acron Park	Buck	N	240	240	2	100.00%	4	0	0	8	0	0	5	17	1





