

ornl

**OAK RIDGE
NATIONAL
LABORATORY**

LOCKHEED MARTIN 

MANAGED AND OPERATED BY
LOCKHEED MARTIN ENERGY RESEARCH CORPORATION
FOR THE UNITED STATES
DEPARTMENT OF ENERGY

ORNL-27 (3-96)

RECEIVED

APR 0 8 1998

OSTI

ORNL/TM-13503

**Cesium Removal Demonstration
Utilizing Crystalline Silicotitanate
Sorbent for Processing Melton
Valley Storage Tank Supernate:
Final Report**

J. F. Walker, Jr.
P. A. Taylor
R. L. Cummins
B. S. Evans
S. D. Heath
J. D. Hewitt
R. D. Hunt
H. L. Jennings
J. A. Kilby
D. D. Lee
S. Lewis-Lambert
S. A. Richardson
R. F. Utrera

MASTER *gdr*

DISTRIBUTION OF THIS DOCUMENT IS UNLIMITED

This report has been reproduced directly from the best available copy.

Available to DOE and DOE contractors from the Office of Scientific and Technical Information, P.O. Box 62, Oak Ridge, TN 37831; prices available from (423) 576-8401, FTS 626-8401.

Available to the public from the National Technical Information Service, U.S. Department of Commerce, 5285 Port Royal Rd., Springfield, VA 22161.

This report was prepared as an account of work sponsored by an agency of the United States Government. Neither the United States Government nor any agency thereof, nor any of their employees, makes any warranty, express or implied, or assumes any legal liability or responsibility for the accuracy, completeness, or usefulness of any information, apparatus, product, or process disclosed, or represents that its use would not infringe privately owned rights. Reference herein to any specific commercial product, process, or service by trade name, trademark, manufacturer, or otherwise, does not necessarily constitute or imply its endorsement, recommendation, or favoring by the United States Government or any agency thereof. The views and opinions of authors expressed herein do not necessarily state or reflect those of the United States Government or any agency thereof.

DISCLAIMER

Portions of this document may be illegible in electronic image products. Images are produced from the best available original document.

Chemical Technology Division

**Cesium Removal Demonstration Utilizing Crystalline Silicotitanate Sorbent
for Processing Melton Valley Storage Tank Supernate: Final Report**

J. F. Walker, Jr.
P. A. Taylor
R. L. Cummins
B. S. Evans
S. D. Heath*
J. D. Hewitt
R. D. Hunt

H. L. Jennings
J. A. Kilby†
D. D. Lee
S. Lewis-Lambert‡
S. A. Richardson
R. F. Utrera*

*Office of Radiation Protection, ORNL.

† Kelly Scientific Resources, Oak Ridge, Tennessee.

‡Office of Quality Services, ORNL.

Date Published: March 1998

Prepared by
OAK RIDGE NATIONAL LABORATORY
Oak Ridge, Tennessee 37831-6285
managed by
LOCKHEED MARTIN ENERGY RESEARCH CORP.
for the
U.S. DEPARTMENT OF ENERGY
under contract DE-AC05-96OR22464

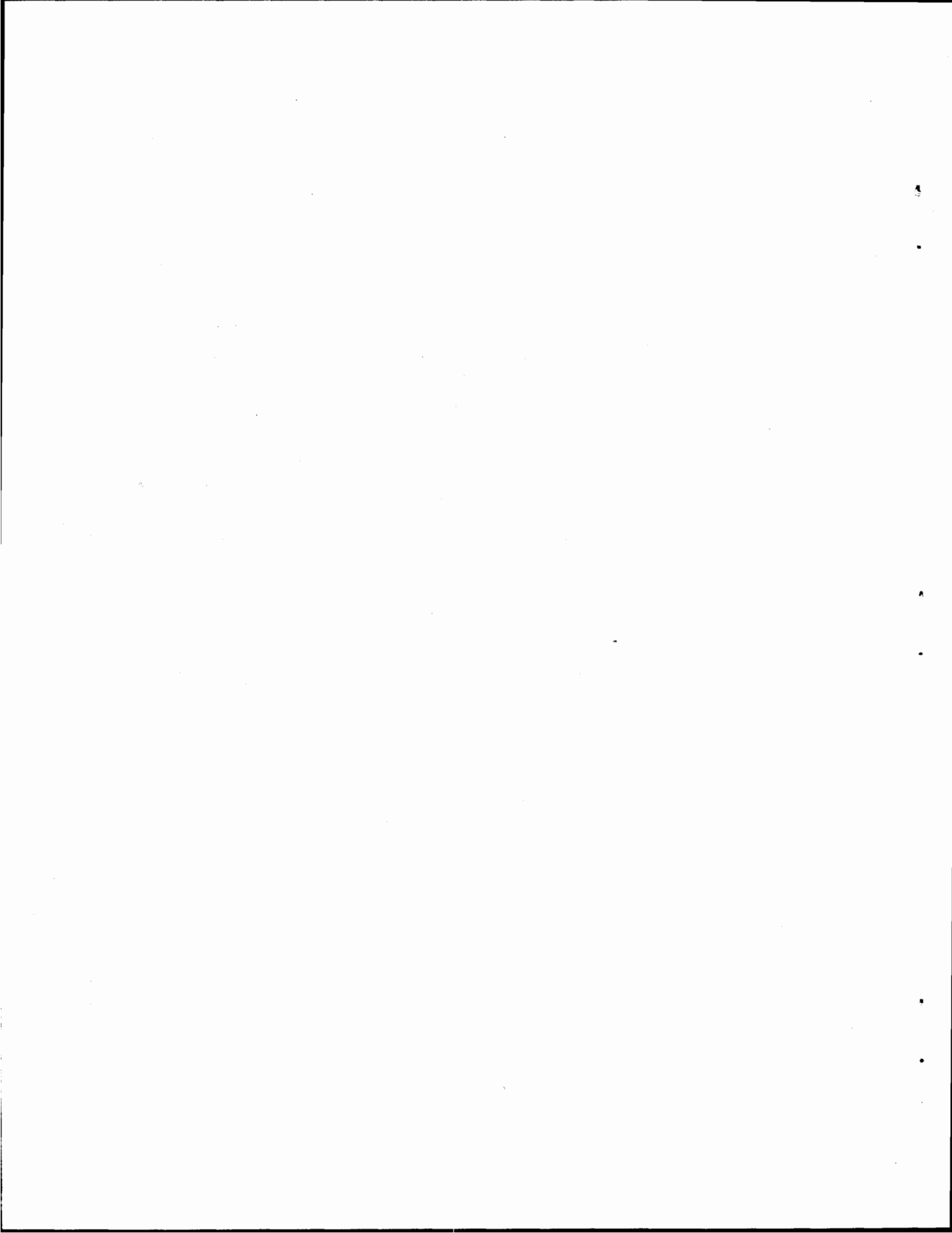

CONTENTS

	Page
LIST OF TABLES	v
LIST OF FIGURES	vii
ACRONYMS	xi
ABSTRACT	xiii
1. INTRODUCTION	1
2. SCHEDULE	4
3. SORBENT SELECTION FOR THE CsRD	8
3.1 CRYSTALLINE SILICOTITANATE	21
4. COLD-TEST LOOP EVALUATION OF CST	23
4.1 RESIN SLUICING INTO COLUMN	28
4.2 SORBENT BACKWASHING AND CONDITIONING	29
4.3 PRESSURE DROP THROUGH THE ION-EXCHANGE COLUMN	31
4.4 SORBENT DRYING	33
4.5 SORBENT SLUICING FROM THE COLUMN	33
4.6 SORBENT STABILITY	35
5. DESIGN AND INSTALLATION OF THE CsRD SYSTEM	37
6. DOCUMENTATION REQUIREMENTS AND MANAGEMENT ASSESSMENT PRIOR TO STARTUP	51
7. CESIUM REMOVAL DEMONSTRATION RUNS	53
7.1 CESIUM REMOVAL DEMONSTRATION RUN 1	56
7.1.1 Radiation Dose Evaluation for Run 1	60
7.1.2 Shipment of Loaded Sorbent to SRS	62
7.2 CESIUM REMOVAL DEMONSTRATION RUN 2	65
7.2.1 Radiation Dose Evaluation for Run 2	66
7.3 CESIUM REMOVAL DEMONSTRATION RUN 3	70
7.4 CESIUM REMOVAL DEMONSTRATION RUN 4	76
7.4.1 Radiation Protection During run 4	81
7.5 MASS TRANSFER PARAMETERS	86
8. BENCH-SCALE SUPPORT	93
9. DECONTAMINATION AND DISMANTLING OF THE CsRD SYSTEM	100
10. SUMMARY	107
11. CONCLUSIONS	110
12. ACKNOWLEDGMENTS	112
13. REFERENCES	114
Appendix A. MATERIAL SAFETY DATA SHEET (MSDS) FOR THE UOP IONSIV® ION EXCHANGER TYPE IE-911	A-1
Appendix B. COST SUMMARY FOR THE CsRD (DOES NOT INCLUDE OVERHEAD CHARGES)	B-1

CONTENTS (contd.)

Appendix C.	SUMMARY OF THE CRITERIA AND DOCUMENTATION REQUIREMENTS NEEDED FOR STARTUP RECOMMENDATIONS BY THE MANAGEMENT ASSESSMENT TEAM	C-1
Appendix D.	CONDITIONING PROCEDURES UTILIZED FOR THE CST SORBENT USED IN THE CsRD AT ORNL	D-1
Appendix E.	OPERATIONAL INSTRUCTIONS FOR THE CsRD ION- EXCHANGE SYSTEM	E-1
Appendix F.	PREOPERATIONAL CHECKLIST FOR THE CsRD	F-1
Appendix G.	REMOTE TRANSFER PROCEDURE FOR THE 30-gal DRUMS OF CESIUM-LOADED SORBENT	G-1

LIST OF TABLES

Table	Page
1 Analysis of the W-27 supernate used for the bench-scale sorbent selection tests after pH adjustment to 12.85, settling, and filtration	12
2 Summary of breakthrough data for the bench-scale, hot-cell runs	14
3 Summary of results for qualification of the candidate sorbents	17
4 Summary of results for discrimination of the qualifying sorbents	18
5 Approximate composition of UOP IONSIVE® Ion Exchanger Type IE-911	24
6 Analytical results for the simulant solution used in the cold test loop (CTL) system and for shake-down tests with the actual CsRD system	28
7 Average feed concentrations for CsRD runs 2-4	55
8 Radiation readings taken during movement of drum of dried sorbent containing ~112 Ci of ¹³⁷ Cs from the sluicing/drying skid to the shielded storage area in Building 7877	87
9 Radiation readings taken during movement of drum of dried sorbent containing ~266 Ci of ¹³⁷ Cs from the sluicing/drying skid to the shielded storage area in Building 7877	88
10 Details for each of the waste packages, consisting of the drum of dried sorbent, the drum shield, and the concrete vault, used for storage at the SWSA at ORNL	89
11 Run conditions and ion-exchange transport parameters for CsRD run	91
12 Run conditions and ion-exchange transport parameters for laboratory-scale tests	92
13 Summary of the bench-scale runs conducted in support of the full-scale CsRD	95

LIST OF TABLES (contd.)

Table	Page
14 Loading data from analysis of the solids from the bench-scale small-column tests	98
15 Analytical results of the TCLP analysis for RCRA metals of the loaded CST sorbent from the bench-scale simulations	99
16 Dose rate readings from skid 2 following backwashing of the filter and ion-exchange columns	104

LIST OF FIGURES

Figure		Page
1	Summary schedule for the CsRD through fiscal year 1997	7
2	Simplified schematic diagram of the experimental bench-scale system used to evaluate the candidate sorbents for the CsRD	9
3	Schematic diagram of the cold-test loop used to evaluate the crystalline silicotitanate sorbent	25
4	Photograph of the cold-test loop used to evaluate the crystalline silicotitanate sorbent	26
5	Sorbent bed expansion for various flow rates in the tests with the cold-test loop	30
6	Pressure drop across the ion-exchange column with water and simulant solutions from cold-test-loop data	32
7	Relative humidity of air from the 50-L ion-exchange column during drying operations in the cold-test loop	34
8	Comparison of the particle size distributions of CST sorbent samples	36
9	Piping and instrument diagram for the CsRD feed tank skid and the ion-exchange skid	38
10	Piping and instrument diagram for the CsRD sorbent sluicing/drying skid	39
11	Layout of the three CsRD skids in Building 7877	40
12	Photograph of the CsRD feed tank skid with no shielding	41
13	Photograph of the CsRD ion-exchange skid with no shielding	42
14	Photograph of the CsRD sorbent sluicing/drying skid	43
15	Photograph of the CsRD processing facility after installation of shielding	44

LIST OF FIGURES (contd.)

Figure		Page
16	Photograph of fill head for the CsRD system being remotely removed from the sorbent dewatering/storage container	48
17	Photograph showing shielded containers, shielded remote transfer bell, lead brick-shielded area, and remote vermiculite hopper for the CsRD	49
18	Photograph of a loaded type B carrier being prepared for shipment to SRS	50
19	Scaled drawing showing locations of Buildings 7863 and 7877 and the underground storage tanks	52
20	Scaled drawing of CsRD area, showing locations where routine measurements of dose rates were taken	61
21	Breakthrough curves for ^{137}Cs and ^{134}Cs during run 2 of the CsRD	67
22	Breakthrough curves for ^{60}Co , ^{90}Sr , and U during run 2 of the CsRD	68
23	Dose rates inside and outside the process building during CsRD run 2 ...	69
24	Breakthrough curves for ^{137}Cs , ^{134}Cs , and total cesium for CsRD run 3 for both columns in series	71
25	Breakthrough curves for ^{137}Cs , ^{134}Cs , and total cesium for CsRD run 3 lead column	72
26	Breakthrough curves for Ba, Pb, Rb, and Zn for CsRD run 3	74
27	Breakthrough curves for ^{60}Co , ^{90}Sr , Sr, and U during CsRD run 3	75
28	Breakthrough curve for ^{137}Cs for the CsRD run 4 lead column	78
29	Breakthrough curve for ^{137}Cs for CsRD run 4 for the first two columns in series	79
30	Cumulative volume of supernate processed during CsRD run 4 vs ^{137}Cs fractional breakthrough	80

LIST OF FIGURES (contd.)

Figure		Page
31	Pressure drop across the filter and the two ion-exchange columns during CsRD run 4	82
32	Comparison of actual dose rates from CsRD run 4 with the dose rate predicted by the model	83
33	Comparison of ^{137}Cs breakthrough curves for the full-scale and bench-scale runs at 3 BV/h	96
34	Comparison of ^{137}Cs breakthrough curves for the full-scale and bench-scale runs at 6 BV/h	97
35	Locations of dose-rate readings from skid 2 following backwashing of the filter and the ion-exchange columns.	103

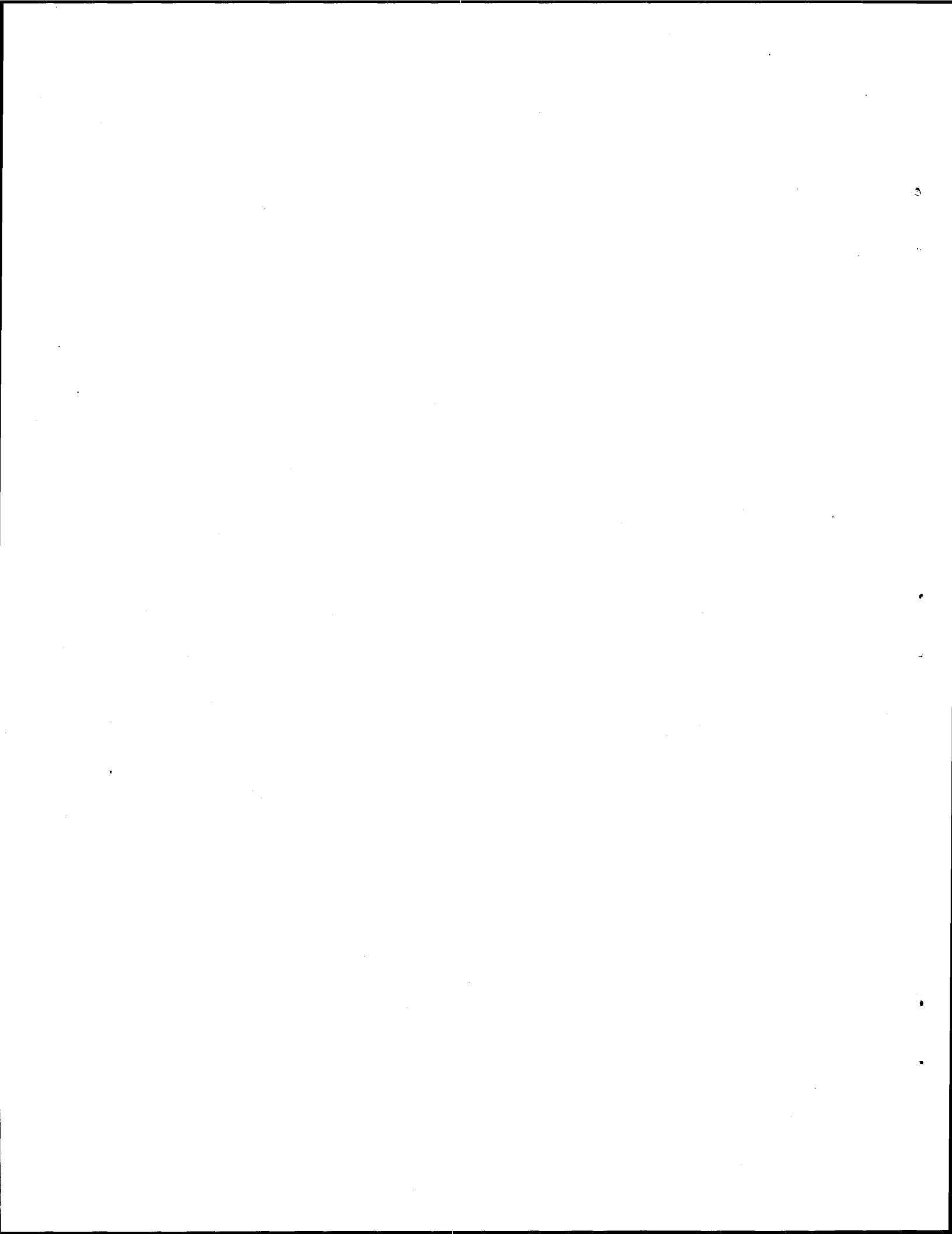

ACRONYMS

BV	bed volumes
CRADA	Cooperative Research and Development Agreement
CST	crystalline silicotitanate
DOE	Department of Energy
EM	Department of Energy's Office of Environmental Management
ESP	Efficient Separations and Processing Program
HLW	high-level waste
HTO	hydrous titanium oxide
INEL	Idaho National Engineering Laboratory
LLLW	liquid-low-level waste
LLW	low-level waste
MAT	Management Assessment Team
MVST	Melton Valley Storage Tanks
NRC	Nuclear Regulatory Commission
NTS	Nevada Test Site
ORNL	Oak Ridge National Laboratory
OST	Office of Science and Technology
OWM	Office of Waste Management
RCO	Radiation Control Officer
RF	resorcinol formaldehyde
SRS	Savannah River Site
SSA	System Safety Analysis
SWSA	Solid Waste Storage Area
TCLP	Toxicity Characteristic Leaching Procedure
TFA	Tank Focus Area
TSR	Technical Safety Requirements
WAC	Waste Acceptance Criteria
WMRAD	Waste Management and Remedial Action Division

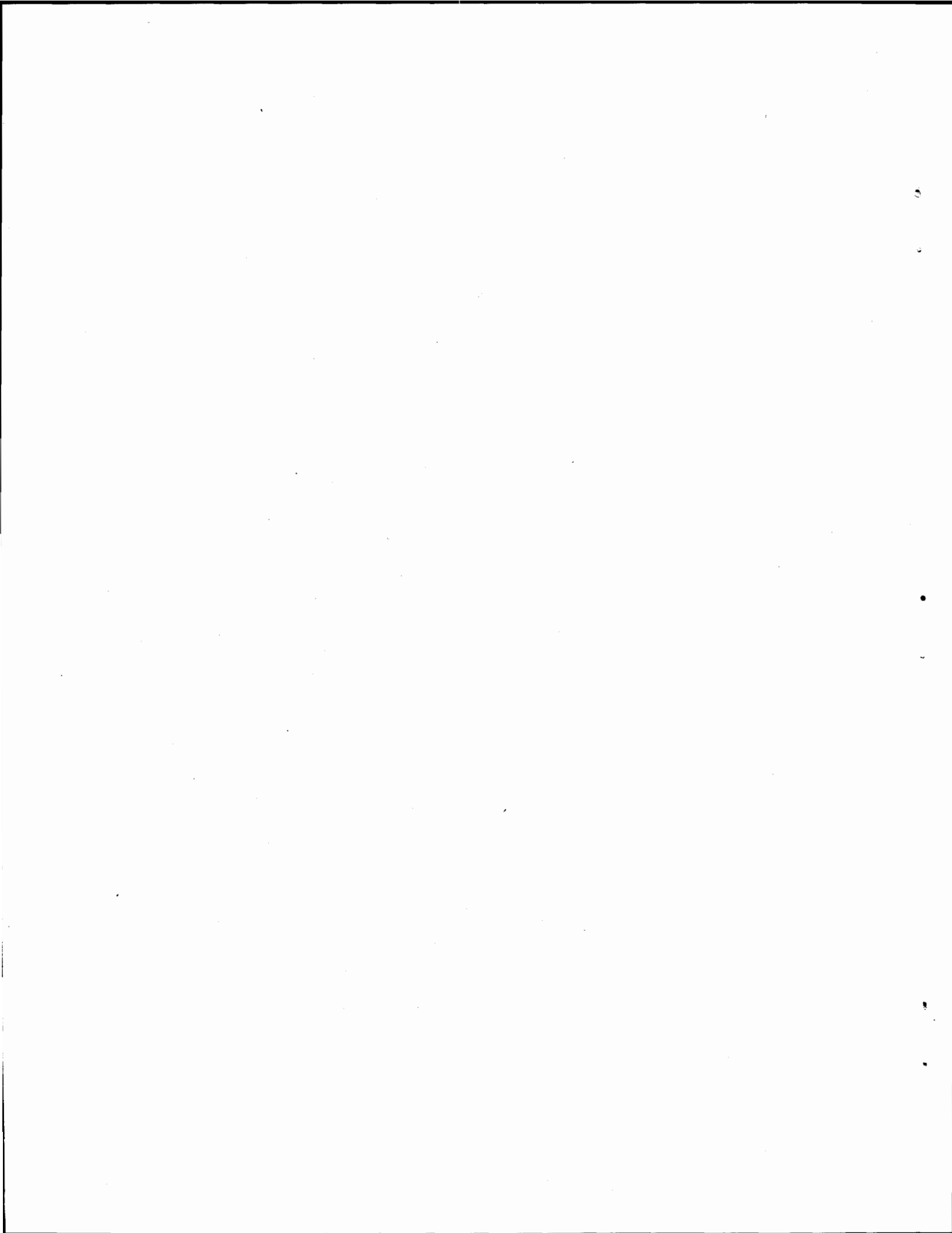

ABSTRACT

This report provides details of the Cesium Removal Demonstration (CsRD), which was conducted at Oak Ridge National Laboratory (ORNL) on radioactive waste from the Melton Valley Storage Tanks. The CsRD was the first large-scale use of state-of-the-art sorbents being developed by private industry for the selective removal of cesium and other radionuclides from liquid wastes stored across the DOE complex. The crystalline silicotitanate sorbent used in the demonstration was chosen because of its effectiveness in laboratory tests using bench-scale columns. The demonstration showed that the cesium could be removed from the supernate and concentrated on a small-volume, solid waste form that would meet the waste acceptance criteria for the Nevada Test Site.

During this project, the CsRD system processed >115,000 L (30,000 gal) of radioactive supernate with minimal operational problems. Sluicing, drying, and remote transportation of the sorbent, which could not be done on a bench scale, were successfully demonstrated. The system was then decontaminated to the extent that it could be contact maintained with the use of localized shielding only. By utilizing a modular, transportable design and placement within existing facilities, the system can be transferred to different sites for reuse. The initial unit has now been removed from the process building and is presently being reinstalled for use in baseline operations at ORNL.

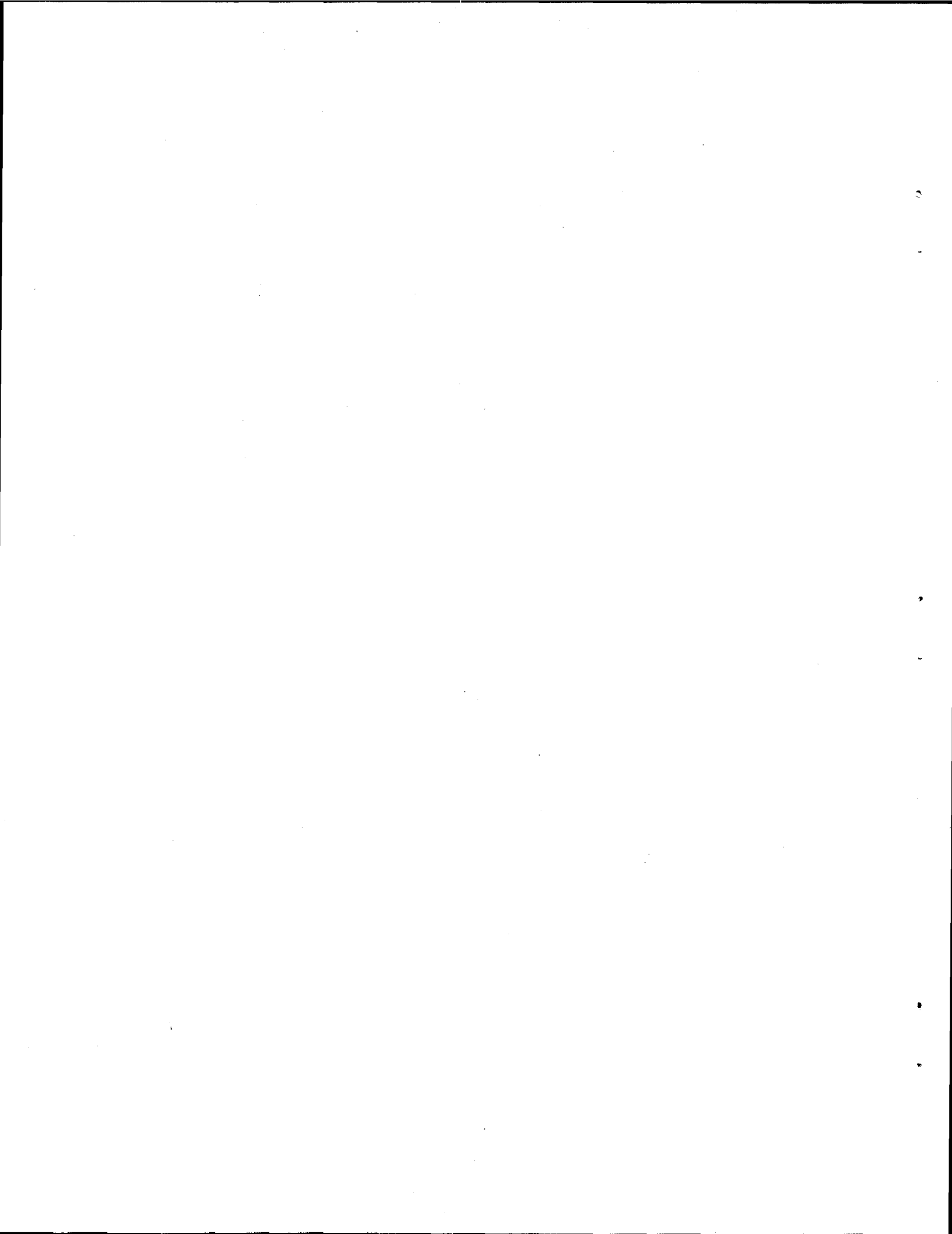

1. INTRODUCTION

The Office of Environmental Management (EM) is responsible for remediating the legacy of radioactive and chemically hazardous wastes at contaminated sites and facilities throughout the U.S. Department of Energy's (DOE's) nuclear weapons complex. EM has established an aggressive, innovative program of applied research and development to develop the advanced technologies necessary to accomplish this task. EM is divided into seven Deputy Assistant Secretarial Offices, each of which has different responsibilities and functions. Two of these are the Office of Science and Technology (OST) and the Office of Waste Management (OWM).

The OST has established the Tank Focus Area (TFA) to manage and carry out an integrated national program of technology development for tank waste remediation. The TFA is responsible for the development, testing, evaluation, and deployment of remediation technologies within a system architecture to characterize, retrieve, treat, concentrate, and dispose of radioactive waste stored in underground storage tanks at the DOE facilities. DOE underground storage tanks located at Hanford, the Savannah River Site (SRS), Idaho National Engineering and Environmental Laboratory (INEEL), and the Oak Ridge National Laboratory (ORNL) contain over 90 million gallons of high-level and low-level radioactive waste that must be remediated. A large fraction of the DOE tank waste is considered high-level waste (HLW); however, it is neither cost-effective nor practical to dispose of all of this waste to meet the requirements of the HLW repository

program and the Nuclear Waste Policy Act.¹ A large portion of the tank waste exists as a liquid solution (supernate) that contains soluble radionuclides, along with high concentrations of sodium and potassium salts. In general, the radionuclides constitute less than 5% of the waste and cesium is the primary source of radiation. As a result, the majority of the liquid could be disposed of as low-level waste (LLW) at a much lower cost if the radioactivity could be reduced below the Nuclear Regulatory Commission (NRC) limits. The TFA Pretreatment Functional Area has been tasked with developing and demonstrating the chemical processes necessary for removing the radionuclides from the bulk liquid supernate and concentrating it into a small HLW fraction.

The OWM provides for minimizing, treating, storing, and disposing of DOE wastes as soon as possible in order to protect people and the environment from the hazards of those wastes. This office carries out program planning and budgeting, evaluation and intervention, and representation functions associated with the management of radioactive HLW, LLW, and transuranic wastes. The ORNL OWM has determined that waste management operations at ORNL would benefit from removing cesium from liquid-low level waste (LLLW). The LLLW supernate in the Melton Valley Storage Tanks (MVST) has become increasingly difficult to manage because of the increasing cesium concentrations in those tanks. These increasing cesium concentrations result from radiochemical processing operations at ORNL, such as the processing of irradiated Mark 42 target fuel elements at the Radiochemical Engineering Development Center. The cesium concentration in the MVST liquid supernate processed during the first

solidification campaign in 1988 averaged 840 Bq/mL and, as a result of the above-mentioned process changes at ORNL, has increased for each subsequent solidification campaign.² The cesium concentrations for all MVSTs currently average 7.6×10^5 Bq/mL, with three of the eight tanks exceeding 1×10^6 Bq/mL.³ As a result, ORNL OWM has included the need for cesium removal in baseline waste processing plans.

Since cesium removal is a priority for both OST and OWM, these two offices have jointly funded a Cesium Removal Demonstration (CsRD). A full-scale demonstration has been conducted at ORNL using actual radioactive supernate from the MVST. Approximately 114,000 L (30,000 gal) of supernate has been processed. The sorbent chosen for the CsRD, a crystalline silicotitanate (CST) ion-exchange material, was selected based on its effectiveness in batch and small-scale column tests using both simulants and actual waste supernates from the MVST. This is the first large-scale demonstration of the new state-of-the-art ion sorbents being developed jointly by DOE and private industry. The primary objectives for the CsRD were to (1) process up to 100,000 L (25,000 gal) of radioactive supernate; (2) demonstrate the use of modular, transportable equipment in existing facilities; (3) evaluate decontamination for hands-on maintenance and possible transfer to other sites; (4) compare bench-scale and full-scale data; (5) provide loaded sorbent for vitrification studies; (6) concentrate the cesium on small-volume solid waste forms and package the latter to meet the Waste Acceptance Criteria (WAC) for the NTS; and (7) provide a full-scale operational system for use in baseline activities at ORNL after the demonstration has been completed.

Although the CsRD was conducted at ORNL, the information produced will also be useful to Hanford and SRS because the MVST supernate is similar in chemical and radiological composition to that of the underground storage tank wastes stored at those sites. Hanford has included ion exchange for the concentration of radionuclides in their baseline plans, and SRS has expressed interest in ion exchange as an alternative to their In-Tank Precipitation (ITP) process, which uses sodium tetraphenylborate to precipitate the cesium.

2. SCHEDULE

The CsRD was initially conceived in FY 1994 and funded in the last quarter of FY 1994 by the OWM. In FY 1995 the project was funded by OST (then the Office of Technology Development). In FY 1996 and FY 1997, the demonstration was jointly funded by OST and OWM. The CsRD was completed in FY 1998 with funding from OST.

Initial scoping was done during the last quarter of FY 1994 and the first quarter of FY 1995. In early FY 1995, two operational milestones were set and the project schedule was developed based on those milestones. The milestones were (1) to start processing radioactive waste before the end of FY 1996 and (2) to complete processing radioactive waste prior to the end of FY 1997. In order to meet those milestones, a very aggressive schedule was developed. A "Design Alternatives Report for the Cesium Removal Demonstration" was completed in January 1995.⁴ This report evaluated the alternatives

for conducting a CsRD at ORNL. Factors considered included sorbent alternatives, facility alternatives, process alternatives, process waste disposal alternatives, and relative cost comparisons. The recommendation was made that the design of the CsRD system move forward, based on information obtained to date from tests with resorcinol formaldehyde (RF) resin because more information was available on this resin than on other considered sorbents and because other considered sorbents were not available at that time in engineered forms. Other recommendations included that the system be designed so that (1) other potential sorbents could be used if engineered forms became available in time for the demonstration, (2) the demonstration be conducted in the LLLW solidification facility (Building 7877), (3) vitrification of the loaded resin be demonstrated at the SRS, and (4) permanent disposal of the loaded and/or vitrified sorbent at the NTS be pursued. From FY 1995 through FY 1997, several changes were made to the scope of the CsRD as the result of three decisions: (1) in October 1995, to utilize the loaded sorbent from the CsRD in a vitrification demonstration at SRS; (2) in January 1996, to change the sorbent to be used from RF resin to CST; and (3) in October 1996, to vitrify only a portion of the loaded sorbent at SRS and have the remainder processed to meet the WAC for direct disposal at NTS without further immobilization.

ORNL and SRS personnel worked closely together to develop plans, procedures, and schedules for CST vitrification tests. The original plan called for ORNL to ship all of the loaded sorbent to SRS and for SRS to vitrify and ship the sorbent to the NTS for final disposal. However, when analysis of the loaded sorbent indicated that the sorbent was

not hazardous as defined by the Toxicity Characteristic Leaching Procedure (TCLP) and, therefore, needed no additional stabilization prior to permanent disposal, the OST decided only ~15% of the total volume of spent sorbent would be vitrified and the remainder would be certified for direct disposal at NTS. This meant that ORNL had to put into place a program to analyze and certify all of the waste that was being sent to NTS.

Because the CST was much more efficient than RF in terms of cesium loading, the scope change from RF to CST meant that the levels of radiation would be much higher than had previously been expected; therefore, modifications had to be made so that the entire operation could be controlled remotely. Additional remote equipment had to be designed and constructed, and the crane in the processing facility had to be replaced with a higher-capacity, remotely operated crane.

A summary schedule for the CsRD through FY 1997 is presented in Fig. 1. It should be noted that even though several changes in scope were made during the course of the project, the two initial milestones to begin processing of radioactive waste in FY 1996 and to complete processing of radioactive waste in FY 1997 were not changed and were completed on schedule.

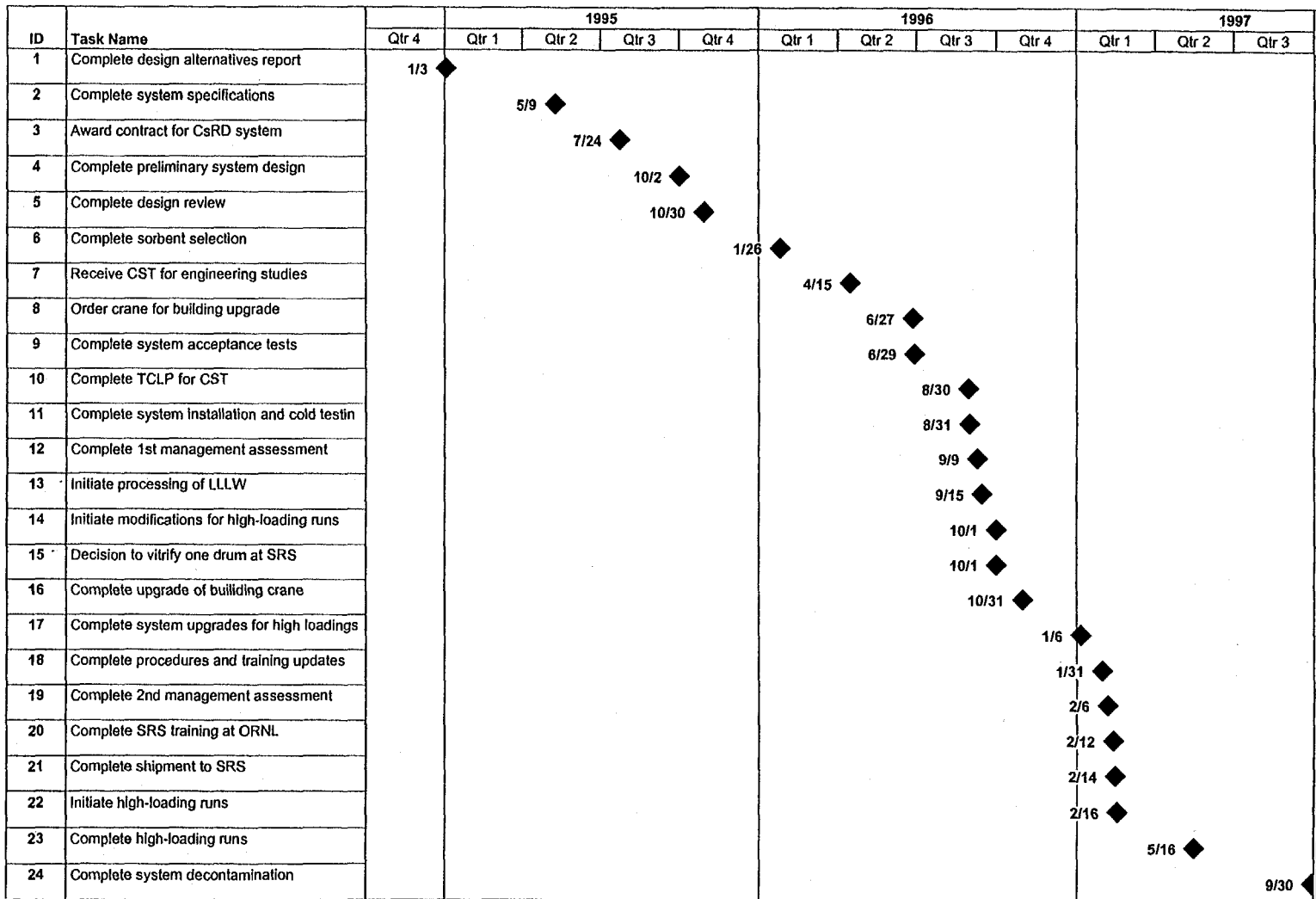

Fig. 1. Summary schedule for the CsRD through fiscal year 1997.

3. SORBENT SELECTION FOR THE CsRD

The sorbent used for the CsRD was selected from state-of-the-art ion-exchange materials that are primarily being developed through the DOE-EM's Efficient Separations and Processing (ESP) Cross-Cutting Program. Six candidate ion-exchange materials were evaluated for potential use in the demonstration. These included (1) CS-100, an organic resin from Rohm & Haas; (2) crystalline silicotitanate (CST) IONSIV® IE-911, an inorganic sorbent from UOP Molecular Sieves; (3) potassium cobalt hexacyanoferrate (KCoFeC), an inorganic granular material from Eichrom Industries; (4) resorcinol formaldehyde (RF), an organic resin from Boulder Scientific; (5) SuperLig 644C, an organic resin from IBC Advanced Technologies; and (6) WWL Web with SuperLig 644C, an organic resin bound in a proprietary organic web structure from 3M Corporation.

A bench-scale experimental system was set up in hot cell C of Building 4501 at ORNL to generate the data necessary to evaluate the candidate sorbents. Details of the installation of the equipment in the hot cell and of the procedures used have been previously reported.⁵ A simplified schematic diagram of the bench-scale system is presented in Fig. 2. The feed was added to a storage tank and then pumped through Gelman GWV high-capacity, in-line 0.45- μ m filters into a 2-L feed tank. Transfers into the feed tank could be made at flow rates up to 70 mL/min, and additions to the feed tank could be

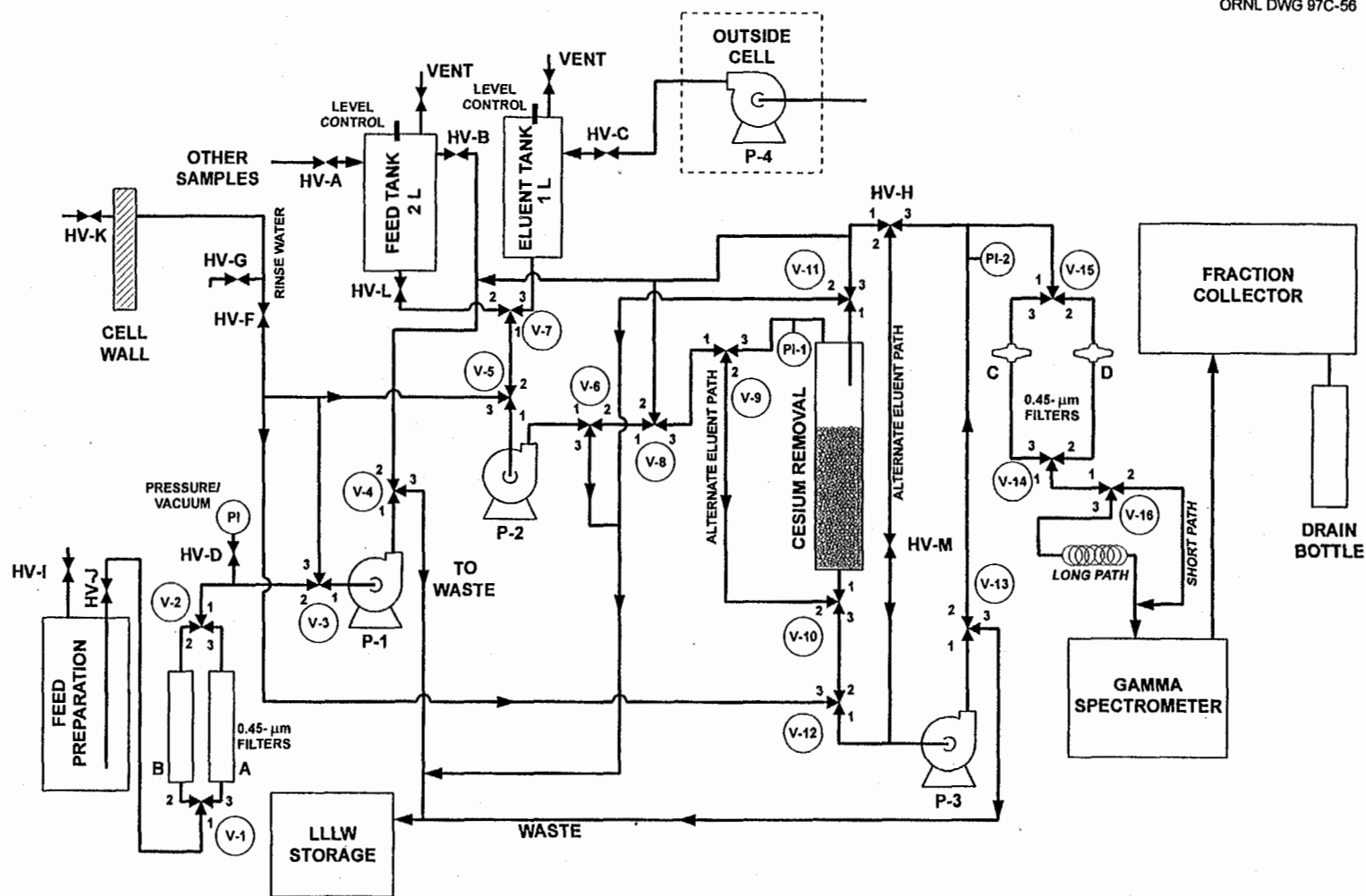

Fig. 2. Simplified schematic diagram of the experimental bench-scale system used to evaluate the candidate sorbents for the CsRD.

made during runs without disrupting operation of the system. The supernate was pumped from the feed tank through the column containing the ion-exchange material. The columns, which were made of glass, were 1.5 cm ID by 15 cm tall and had polypropylene end fixtures. Details of the columns and their preparation have been previously reported.⁵ The supernate was pumped in the downflow direction, and elution cycles were conducted in both upflow and downflow directions. A separate 1-L tank was used to feed the eluent to the ion-exchange columns. Flow rates for both loading and elution could be varied from 0.2 to 20 mL/min. The effluent from the ion-exchange columns passed through a 0.45- μ m Gelman AquaPrep-V filter to trap particulates from the columns. The system contained two filters in parallel that could be switched if plugging occurred. The filtered effluent passed through an on-line sodium iodide gamma detector, and samples were collected using a fraction collector before the effluent was collected in a plastic bottle. Samples from the fraction collector were analyzed to validate the calibration of the gamma detector and to provide more detailed analyses when necessary. Details of the detector and fraction collector can be found in ORNL/TM-13169.⁵ After being loaded, the column was removed from the experimental system and from the cell to measure the quantity of ¹³⁷Cs on the sorbent.

The supernate used to generate the data necessary for the sorbent selection was obtained in April 1995 from MVST W-27. The W-27 supernate sample had a pH of 7.2, while the pH levels in the other MVSTs ranged from 10 to 13. Sodium hydroxide was added to the bottles of supernate to increase the pH of the supernate to ~13 prior to conducting the

bench-scale column tests. After pH adjustment, the solids were allowed to settle and the supernate was filtered. Analysis of the supernate indicated that it contained approximately 3.2×10^5 Bq/mL ^{137}Cs , 7.07×10^{-6} M total cesium, 0.26 M potassium, and ~ 4.7 M sodium. A detailed analysis of the filtered W-27 supernate is presented in Table 1.

Column tests were conducted with all of the candidate sorbents. Details of the tests, including run descriptions, breakthrough curves, elution curves, and operational problems, can be found in ORNL/TM-13169.⁶ A summary of the breakthrough data for these runs is presented in Table 2.

The ion-exchange selection criteria were divided into two separate categories: (1) qualifiers and (2) discriminators. Qualifiers were criteria that had to be met for the sorbent to be considered for use in the CsRD, and discriminators were criteria used to differentiate between those sorbents that qualified. Qualifying criteria included: (1) commercial availability, (2) applicability of the sorbent to MVST W-27 supernate and other DOE waste streams, and (3) the impact on the final waste form. To be considered commercially available, the sorbent had to be available in quantities sufficient for preliminary engineering-scale tests needed to design and set operating conditions for the CsRD and for processing up to 100,000 L (25,000 gal) of MVST supernate. The applicability of a given sorbent to MVST W-27 supernate and other DOE waste streams meant that the sorbent material had to be effective for cesium removal from the MVST

Table 1. Analysis of the W-27 supernate used for the bench-scale sorbent selection tests after pH adjustment to 12.85, settling, and filtration

Analysis	Concentration (Bq/mL)	Concentration (mg/L)	Concentration (mol/L)
⁶⁰ Co	680		
¹³⁷ Cs	320,000		
¹³⁴ Cs	1,400		
⁹⁰ Sr	65,000		
As		0.00890	
Se		<0.005	
Br		288	0.0036
Cl		3180	0.090
F		<7.5	
NO ₃		322000	5.194
PO ₄		<30	
SO ₄		1540	0.016
OH			0.071
Hg		0.090	4.49 × 10 ⁻⁷
Ag		0.055	5.10 × 10 ⁻⁷
Al		0.847	3.14 × 10 ⁻⁵
Ba		8.040	5.85 × 10 ⁻⁵
Be		<0.0022	
Ca		89.100	0.00222
Cd		0.220	1.96 × 10 ⁻⁶
Co		<0.12	
Cr		2.960	5.69 × 10 ⁻⁵
Cs		0.935	7.04 × 10 ⁻⁶

Table 1 (continued)

Analysis	Concentration (Bq/mL)	Concentration (Bq/mL)	Concentration (mol/L)
Cu		<0.0319	
Fe		<0.0352	
K		10300	0.263
Mg		<0.298	
Mn		<0.0055	
Na		113,000	4.935
Ni		1.22	2.08×10^{-5}
Pb		0.009	4.44×10^{-5}
Rb		1.1	1.29×10^{-5}
Sb		<0.218	
Th		<0.440	
Ti		<0.005	
U		<1.0	
V		<0.0561	
Zn		0.473	7.23×10^{-6}

Table 2. Summary of breakthrough data for the bench-scale, hot-cell runs

Sorbent	Flow rate (CV/h ^a)	CV to 1% breakthrough	CV to 10% breakthrough	CV to 50% breakthrough
RF-Run 1	7	8	14	45
RF-Run 2	3	10	22	36
RF-Run 3	6	8	17	46
Cs-100	3	3	8	17
SuperLig-Run 2	6	-	9	95
CST-Run 1	3	110	190	350
CST-Run 2	6	80	170	350
3M WWL	49	-	40	60
KCoFeC	9	-	90	225

^a CV = column volumes (volume of sorbent in column).

W-27 supernate, which was to be processed in the CsRD. In addition, it had to be effective in removing cesium from the supernate of at least one other storage tank within the DOE complex. The impact on the final waste form qualifier meant that the sorbent had to be capable of being vitrified.

The three discriminating criteria were: (1) applicability of the sorbent to the W-27 supernate, (2) applicability of the sorbent to DOE waste streams other than the W-27 supernate, and (3) cost considerations. The applicability of the sorbent to the W-27 supernate meant that selection would favor those sorbents that performed better on the W-27 supernate, which was to be used in the full-scale CsRD. Performance measures included sorbent capacity, sorbent kinetics, decontamination factor (DF), and operability. The sorbent also had to generate less secondary waste than the quantity of W-27 supernate processed.

Determination of the applicability of the sorbent to DOE waste streams other than the MVST W-27 discriminating criteria was intended to account for the potential to use the sorbent over the range of supernate compositions at Hanford, Savannah River, and ORNL. Representatives from each site were asked to evaluate the applicability of the sorbents being considered for use in their particular waste streams using the performance measures listed above.

The final discriminating criterion involved cost considerations. This included the costs of the sorbent, preprocessing requirements, costs of elution, loading capacity versus resin costs, and transportation costs.

A summary of the results for qualification of the candidate sorbents is presented in Table 3. Two of the sorbents, Cs-100 and potassium cobalt hexacyanoferrate, were disqualified because their manufacturers could not provide a written guarantee that the sorbents would be available in the quantities necessary to complete the CsRD on schedule.

The performance data obtained during the column tests with W-27 supernate were further analyzed for the four qualifying sorbents. The results were then used to estimate the costs for using the various sorbents. A summary of the results for the discrimination of the qualifying sorbents is presented in Table 4.

In terms of the applicability to DOE remediation, there are large volumes of wastes at Hanford, Savannah River, West Valley, and Oak Ridge having many characteristics similar to the MVST supernate; however, the sorbents have not been tested on most of the actual supernates. Given the range in the gross characteristics of the wastes, it was concluded that each of the four materials was potentially applicable to other important DOE wastes. Also, the kinetics of each of the qualified sorbents had to exceed the flow

Table 3. Summary of results for qualification of the candidate sorbents

Sorbent	Commercial availability	Applicability to MVST W-27 and other DOE waste streams	Impact on final waste form	Qualified
Cs-100	No	Yes	Acceptable	No
CST	Yes	Yes	Acceptable	Yes
KCoFeC	No	No	Acceptable	No
RF	Yes	Yes	Acceptable	Yes
SuperLig 644C	Yes	Yes	Acceptable	Yes
3M WWL	Yes	Yes	Acceptable	Yes

Table 4. Summary of results for discrimination of the qualifying sorbents

Qualified sorbent	Kinetics (CV/h)	Sorbent capacity at 50% breakthrough	Average decontamination factor from 0 to 50%	Operational Problems	Sorbent only	Transportation included	Applicability to other DOE sites
CST	3-6	350	8.3	None	83	150	ND ^b
RF	3-7	36-46	6.7	Loading-bleeding and bed contraction	102	487	ND
				Sample preparation-125% swelling			
SuperLig	3-6	95	3.1	Loading-bleeding and clumping	116	291	ND
				Sample preparation-100% swelling			
3M WWL	50	60	8.3	Loading-Bleeding, high-pressure drop; solids in effluent and eluent	337	442	ND
				Sample Preparation-swelling			

^aCV = Column volumes.

^bND = No discrimination.

rate of 3.2 column volumes/hour (CV/h) set for the CSRD and the Hanford baseline plan.

All sorbents exceeded the minimum flow rate.

The hot cell column tests on the W-27 supernate were used to determine the sorbent capacity and the DF factor for each of the qualified sorbents. Supernate was pumped through each of the sorbents until the ^{137}Cs concentration in the effluent was 50% of that in the feed. The amount of waste processed divided by the volume of the column (of filter cartridge in the case of the 3M WWL Web) yielded a normalized measure of the capacity of the sorbent, with a higher capacity preferred. The capacity and the order of preference were as follows: (1) the CST at 350 CV, (2) the SuperLig at 95 CV, (3) the 3M WWL Web at 60 CV, and the RF resin at 36 CV. The area under each cesium breakthrough curves was integrated from 0 to 50% to determine the overall DF. The order of preference, in terms of the average DF, was (1) the CST at 8.3, (1) the 3M WWL Web at 8.3, (3) the RF resin at 6.7, and (4) the SuperLig 644C at 3.1.

With the exception of the CST, potential processing problems were encountered with each of the qualified sorbents even though the preprocessing requirements provided by the vendors were followed in each case. For these materials, it must be determined if observed bleeding and solids in the effluent pose the likelihood of actual processing failure or of the addition of deleterious compounds to the decontaminated waste (which could impact future remediation efforts).

From results of the bench-scale tests, it was estimated that 270 L of CST IONSIVE IE-911, 1050 L of RF resin, 500 L of SuperLig 644C, or 750 cartridges of 3M WWL web would be required to treat 100,000 L of W-27 supernate if each column was loaded to 50% breakthrough and not regenerated. The costs provided by vendors for these quantities of sorbents are presented in Table 4. Sorbent regeneration processing is a potential operation for both the RF resin and the SuperLig 644C, which are both regenerable with 0.5 M nitric acid. Even though the 3 WWL web with SuperLig 644C was eluted with 0.5 M nitric acid, 3M stated that its WWL web cartridges are for single use. It should be noted that (1) regeneration processing is an added expense and (2) the savings in the cost of sorbent required would be reduced to an unknown extent by increases in processing and equipment costs. Since elution costs and the practical number of loading cycles for each regenerable sorbent had not been determined at the time of this evaluation, any additional costs or cost savings resulting from regeneration were not considered.

The baseline plan was to ship the cesium-loaded sorbents from ORNL to the SRS for vitrification. Space limitations at the SRS vitrification facility required that each shipment be limited to 225-L or less. A transportation cost estimate of ~\$35,000 per 225-L shipment was based on estimates provided by Chem-Nuclear Systems, Inc., and VECTRA Corporation. The sum of the total cost for the sorbent and the transportation cost for each qualified sorbent is listed in Table 4. The transportation costs take into account swelling of the sorbents during pretreatment. The order of preference, in terms

of sorbent plus transportation costs, is (1) CST at \$153,000; (2) SuperLig 644C at \$291,000; (3) 3M WWL Web with SuperLig 644C at \$442,000; and (4) RF resin at \$487,000.

Based on the results of evaluation of discriminating criteria, CST IONSIV IE-911 was selected for use in the CsRD. It was the only sorbent with no limiting operational problems and was rated first on all discrimination criteria except one. Even though the IONSIV IE-911 did not rate first in terms of kinetic performance, its kinetic performance was quite acceptable.

3.1 CRYSTALLINE SILICOTITANATE

Amorphous hydrous titanium oxide (HTO) materials were developed at Sandia National Laboratories in the 1960s and 1970s to prepare electroactive ceramic materials for defense applications. They were investigated for use in radioactive waste stabilization because of their ion-exchange properties and their potential for conversion to a stable ceramic form. Work with HTO materials for high-level nuclear waste processing was initiated in 1975 at ORNL in collaboration with Sandia. The HTO absorbed most of the cationic radionuclides but had essentially no affinity for the highly soluble and radioactive cesium. About 1980, the program to develop amorphous HTO ion exchangers for application to nuclear wastes was concluded on the basis of DOE's decision to select glass instead of ceramics as the baseline waste form. Further

development of HTO materials at Sandia for use as catalysts for coal liquification and other applications was continued through the DOE Fossil Energy Program. As part of this effort, a new type of exchanger called CST was prepared by personnel from Sandia and Texas A&M University. Testing of this material demonstrated that the CST had a large affinity for cesium in the presence of high sodium concentrations.⁶

Before CST technology could be considered for large-scale radioactive waste processing, it was necessary to develop a commercial source of granular material suitable for column use. A Cooperative Research and Development Agreement (CRADA) between Sandia and UOP was signed in March 1994, and UOP was awarded a license to produce and market the CST technology. In September 1994, UOP prepared the first large-scale batch of TAM-5, the powdered form of CST shown in laboratory tests to be effective for the removal of cesium in the presence of high sodium concentrations. This material, which was given the name UOP IONSIV® Ion Exchanger Type IE-910, became commercially available in October 1994. In January 1995 UOP delivered the first engineered form of CST for evaluation, and by December 1995 a final formulation had been selected and the material declared commercially available. This material was given the name UOP IONSIV® Ion Exchanger Type IE-911. In January 1996 the UOP IONSIV® Ion Exchanger Type IE-911 was chosen for use in the CsRD at ORNL, based on the results of bench-scale testing.^{5,6}

The approximate composition of the UOP IONSIV[®] Ion Exchanger Type IE-911 is presented in Table 5. This granular material has a particle size from 30 to 60 mesh and a bulk density of 1 g/cm³. Other properties of the UOP IONSIVE[®] Ion Exchanger Type IE-911 have been published by Miller and Brown;⁶ the material safety data sheet (MSDS) can be found in Appendix A.

4. COLD-TEST LOOP EVALUATION OF CST

A cold-test loop (CTL) system was designed, constructed, and installed in the high bay of Building 2528 and operated in order to provide input for design and operation of the full-scale CsRD system. This system was used to evaluate the transport properties (sluicing, pumping, and integrity), the hydraulic performance of the ion-exchange column, and the drying requirements of the CST sorbent prior to conducting the hot demonstration. The CTL was designed to be similar to the full-scale CsRD system with regard to size and operation.

A schematic diagram of the CsRD system is presented in Fig. 3; a photograph is shown in Fig. 4. The ion-exchange column (C1) of the CTL was fabricated from 12-in.-diam, 28-in.-tall Lexan pipe, which was enclosed on the bottom by a 12-in.-diameter sched 40 stainless steel pipe cap and on the top by a 12-in.-diam, 0.5-in.-thick stainless steel plate. The volume of the column was ~50 L. The center pipe of the column was connected to three Johnson screens, each with a pore size of 177 μm , which allowed solutions or air to

**Table 5. Approximate composition of UOP IONSIVE®
Ion Exchanger Type IE-911^a**

Material	Approximate weight percent
Silicon dioxide	15-45
Titanium dioxide	20-40
Sodium oxide	5-20
Trade secret material	15-25
Trade secret metal oxide	0-25
Aluminum oxide (nonfibrous)	0-10
Copper oxide	0-2
Calcium oxide	0-2
Chromium oxide	0-2
Magnesium oxide	0-2

^aD. D. Lee, J. R. Travis, and M. R. Gibson, *Hot Demonstration of Proposed Commercial Cesium Removal Technology*, Oak Ridge National Laboratory, Oak Ridge, TN, ORNL/TM-13169, December 1997.

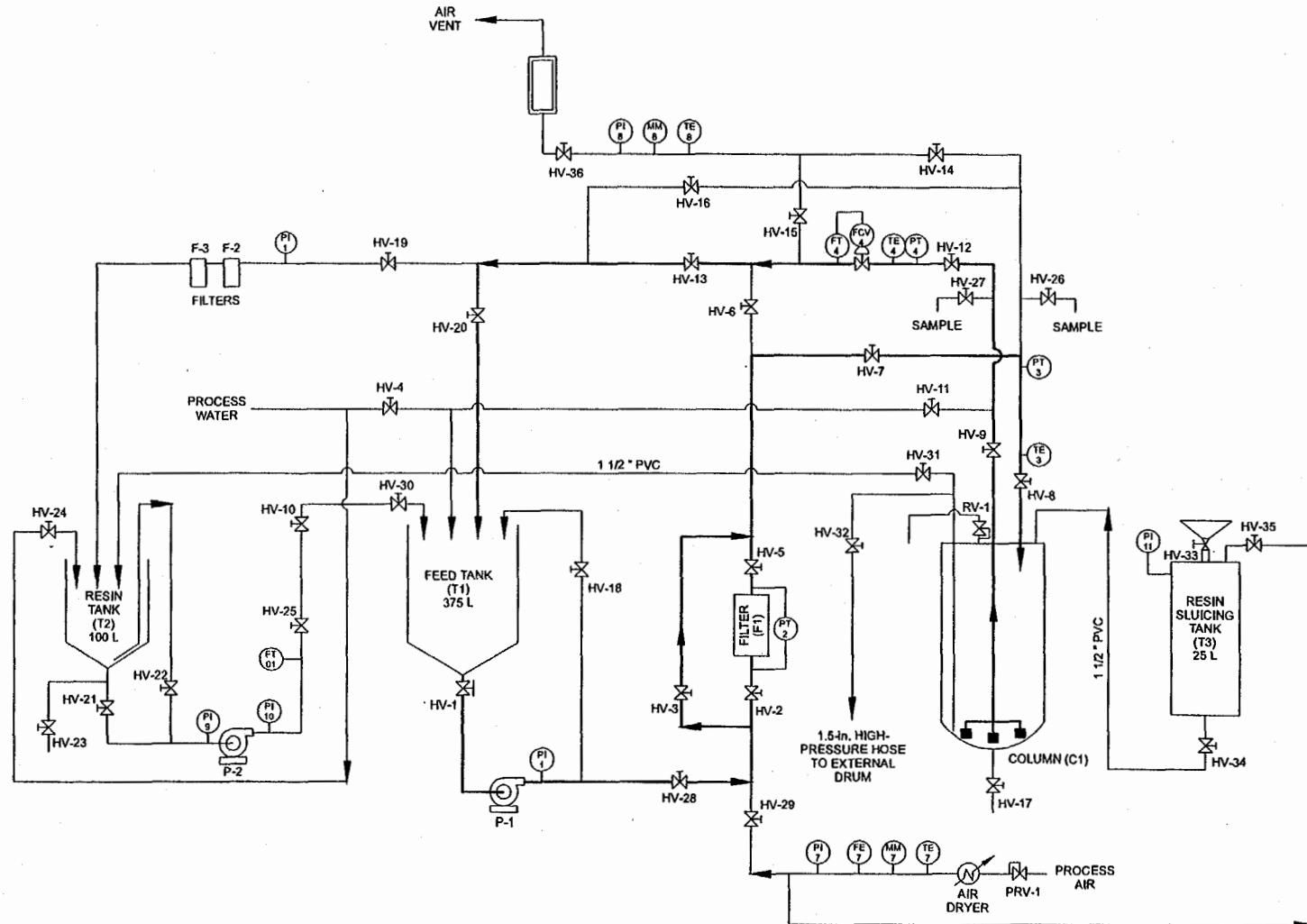

Fig. 3. Schematic diagram of the cold-test loop used to evaluate the crystalline silicotitanate sorbent.

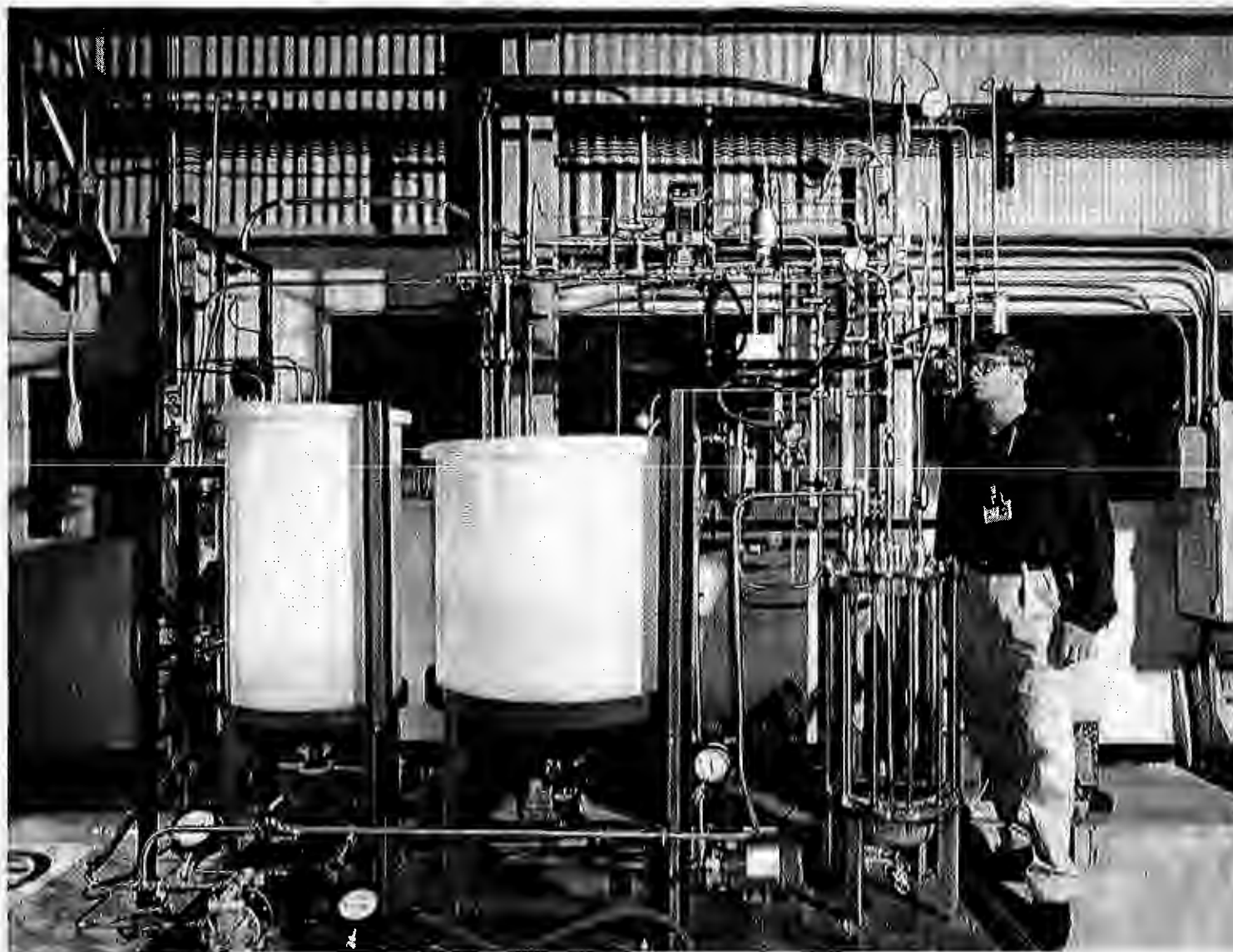

Fig. 4. Photograph of the cold-test loop used to evaluate the crystalline silicotitanate sorbent.

exit the column while retaining the sorbent. The column was rated for a working pressure of 50 psi and was equipped with a 30-psi relief valve. A 375-L polyethylene tank (T1) was used to hold the simulant feed, and a 100-L polyethylene tank (T2) was used to collect filtered effluent from the ion-exchange column. Tank T2 was also used for collecting sorbent sluiced from the column. Alternatively, sorbent could be sluiced from the column into a separate drum. The pressure vessel (T3) used to sluice sorbent into the column was fabricated from stainless steel and had a capacity of 25 L. A 1.5-in. PVC pipe was used to connect the bottom of the pressure vessel with the top of the ion-exchange column. The tank and piping were rated for a working pressure of 100 psi. An Azonix μ MAC-1050 controller running FIX-32 software by Intellusion controlled the flow rates of pumps P1 and P2 and recorded flow rates, temperatures, pressures, and the moisture levels of all air streams.

An MVST simulant solution originally used on another research and development project at ORNL was utilized as the simulant for testing in the CTL and for shakedown testing of the actual CsRD system. Sodium nitrate was added in order to increase the nitrate concentration of this simulant to the desired $\sim 300,000$ mg/L. The analytical results for the modified simulant are presented in Table 6. All metals not listed in Table 6 were below the detection limit on the inductively coupled plasma (ICP) spectroscopic scan.

Table 6. Analytical results for the simulant solution used in the cold test loop (CTL)^a system and for shakedown tests with the actual CsRD system

Component	Concentration (mg/L)	Component	Concentration (mg/L)
NO ₃	302,000	Ba	0.6
Na	91,000	Ca	1.6
B	26	Li	1.3
Mg	25		

^aCTL = cold test loop.

4.1 Resin Sluicing Into Column

The sorbent used in the CTL experiments was a CST material provided by UOP Molecular Sieves, Corporation (MT. Laurel, NJ) under the tradename IONSIV[®] IE-911 (lot No. 999096810001). A total of 30 L of IONSIV[®] IE-911 was sluiced into the ion-exchange column in three batches. For each sluicing operation, 8 L of water followed by 10 L of IONSIV[®] IE-911 was added to the sorbent sluicing tank (T3) through the top funnel. Another 2 L of water was then added to rinse any sorbent from the funnel and inlet piping into the sluice vessel. The top valve (HV-33) was subsequently closed, and the tank was pressurized with air to 20 psi. The bottom valve (HV-34) was opened, and the sorbent was sluiced into the ion-exchange column. In order to remove residual sorbent from the sluice vessel, two additional 4-L batches of water were added to the tank and sluiced into the ion-exchange column. Visual inspection of the sluice vessel through the top 2-in. ball valve did not reveal any sorbent left inside the tank after the second batch of water. The sorbent sluicing operation was repeated with two additional 10-L

batches of CST sorbent so that the column contained a total of 30 L of sorbent. The sorbent sluiced easily, and no problems were encountered with the sluicing operations, except that valve HV-34 was difficult to operate by the end of these operations.

Examination of this 1.5-in PVC ball valve showed that (1) sorbent fines were stuck in the valve and (2) the ball was scratched. Thus, a stainless steel ball valve with polyethylene packing (the type that had been specified for the CsRD system) was ordered and subsequently installed for additional testing. No problems with the new valve were encountered during the additional tests.

4.2 SORBENT BACKWASHING AND CONDITIONING

The sorbent in the ion-exchange column was backwashed with tap water to remove fines. The maximum flow rate that could be supplied was 15.8 L/min, which expanded the sorbent bed to 37.5 L. The expanded sorbent-bed volumes for various flow rates are presented in Fig. 5. The column was backwashed for 6.5 h and ~6,000 L of water was used to remove the fines from the sorbent. A sample of the effluent water was filtered through various pore-size filters to determine the size of the sorbent fines. Most of the fines were removed on a 5- μm filter; the rest of them were removed on a 3- μm filter.

The IONSIV® IE-911 manufacturer has recommended that the sorbent be conditioned with dilute sodium hydroxide solution to stabilize the sorbent material at the same pH as the solution that will be processed. Therefore, the feed tank was filled with 150 L of tap

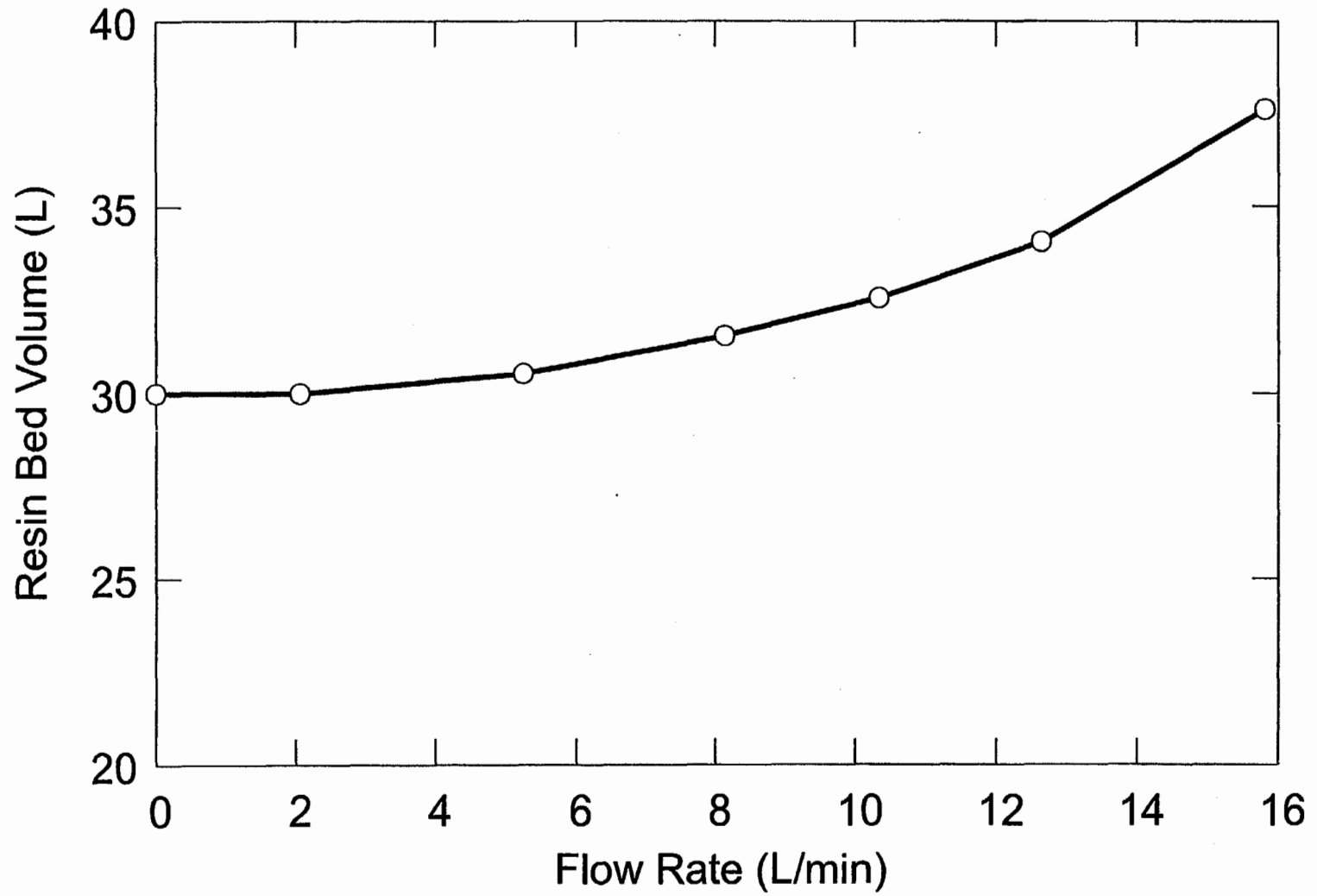

30

Fig. 5. Sorbent bed expansion for various flow rates in the tests with the cold-test loop.

water, which was recirculated down through the 30 L of sorbent in the ion-exchange column at a flow rate of 4 L/min. Sodium hydroxide was periodically added to adjust the pH to a level above 10. A total of 2535 g of sodium hydroxide was added over a period of 21 h to stabilize the recirculating solution at a pH of 10.

It should be noted that the CTL was used to backwash and condition all the sorbent used in the CsRD. This allowed the technicians who would operate the CsRD system to gain experience in handling the CST sorbent. It also allowed extensive testing of the stainless steel valve and the high-pressure hose that were specified for use in the CsRD system prior to introducing radioactive supernate to the CsRD system.

4.3 PRESSURE DROP THROUGH THE ION-EXCHANGE COLUMN

The pressure drop across the ion-exchange column was measured at various flow rates using water and simulant solutions, both with and without sorbent in the column. In the tests with sorbents, the columns contained 30 L of sorbent material. The results, which are summarized in Fig. 6, indicated that the pressure drop caused by the ion-exchange columns in the full-scale CsRD would be minimal.

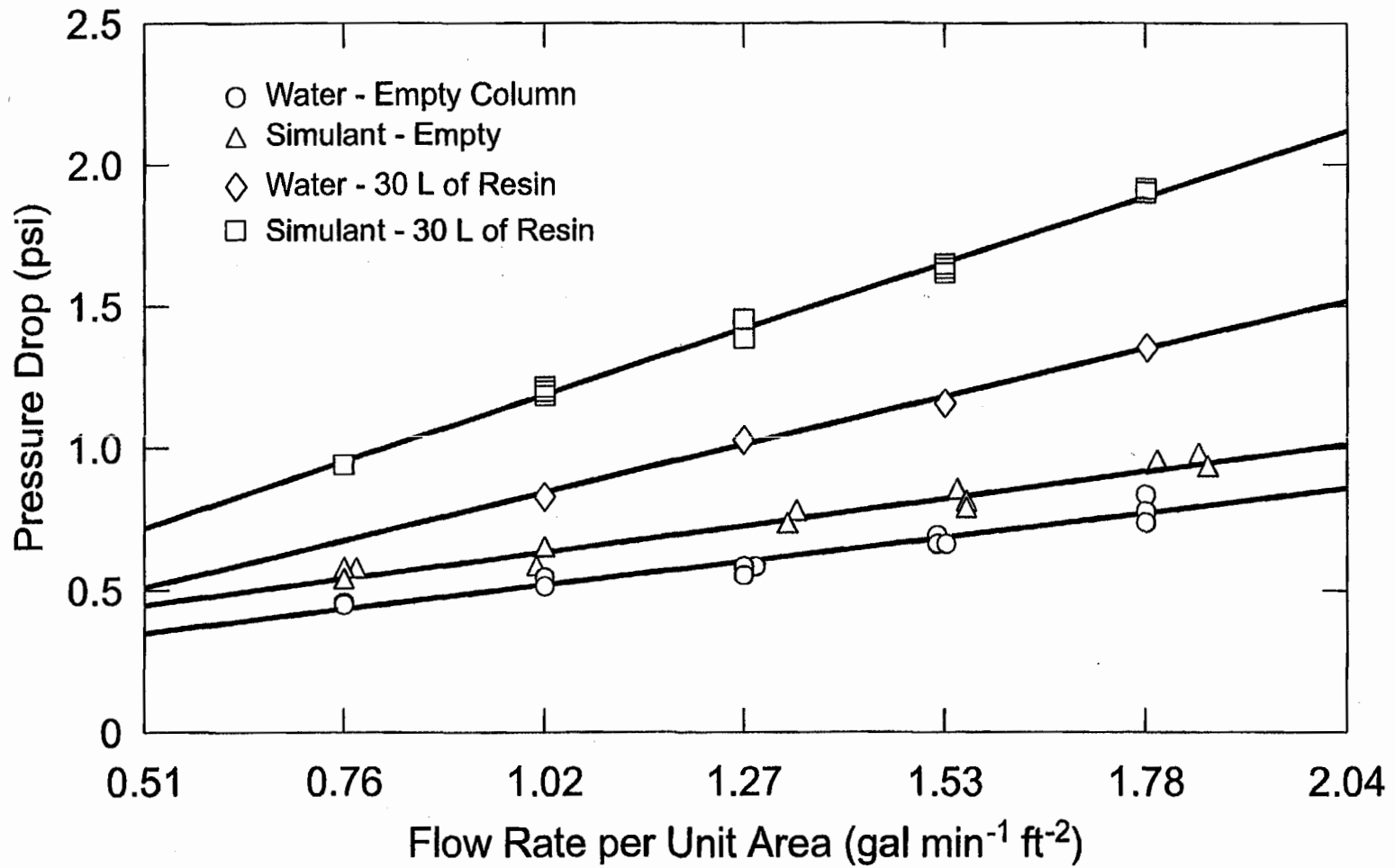

Fig. 6. Pressure drop across the ion-exchange column with water and simulant solutions from cold-test-loop data.

4.4 SORBENT DRYING

The 30 L of sorbent in each ion-exchange column was rinsed with two 45-L batches of water to remove most of the simulant solution. The water was then drained from the bottom of the column, and a small amount of compressed air was used to remove any remaining free water. The sorbent was dried by using plant air, which flowed down through the sorbent and out of the screened center pipe. The average flow rate was 7.3 std ft³/min; the relative humidity of the plant air averaged 0.3%. The relative humidity of the air leaving the column is shown in Fig. 7. A sample of the sorbent from the bottom of the column was obtained after 100 h of drying (45,400 std ft³ of air), and the amount of water in the sorbent was determined by weight loss at 100°C after 24 h. The sorbent contained 10 wt % water, as compared with 23 wt % water for the as-received sorbent. The sorbent sample from the column flowed easily and did not contain any visible water. The CsRD has a 150-std ft³/min blower, which was used to dry the sorbent. Tests with this blower demonstrated that the sorbent could be adequately dried within a few hours.

4.5 SORBENT SLUICING FROM THE COLUMN

After the drying tests had been completed, the column was filled with water to rewet the 30 L of sorbent. Twenty pounds per square inch of air was then introduced to the top of the column to sluice the sorbent through a 1.5-in.-diam high-pressure hose into a drum.

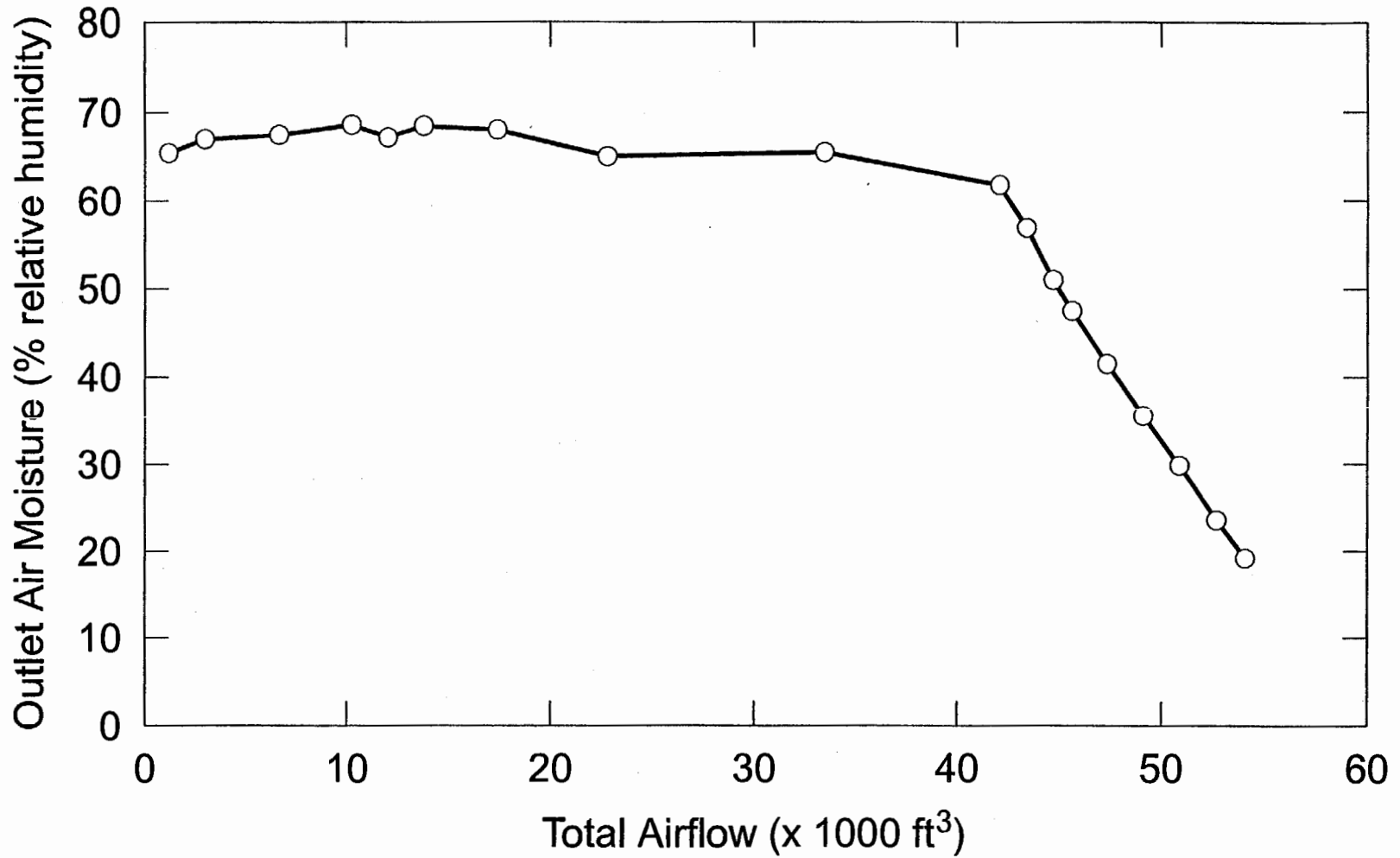
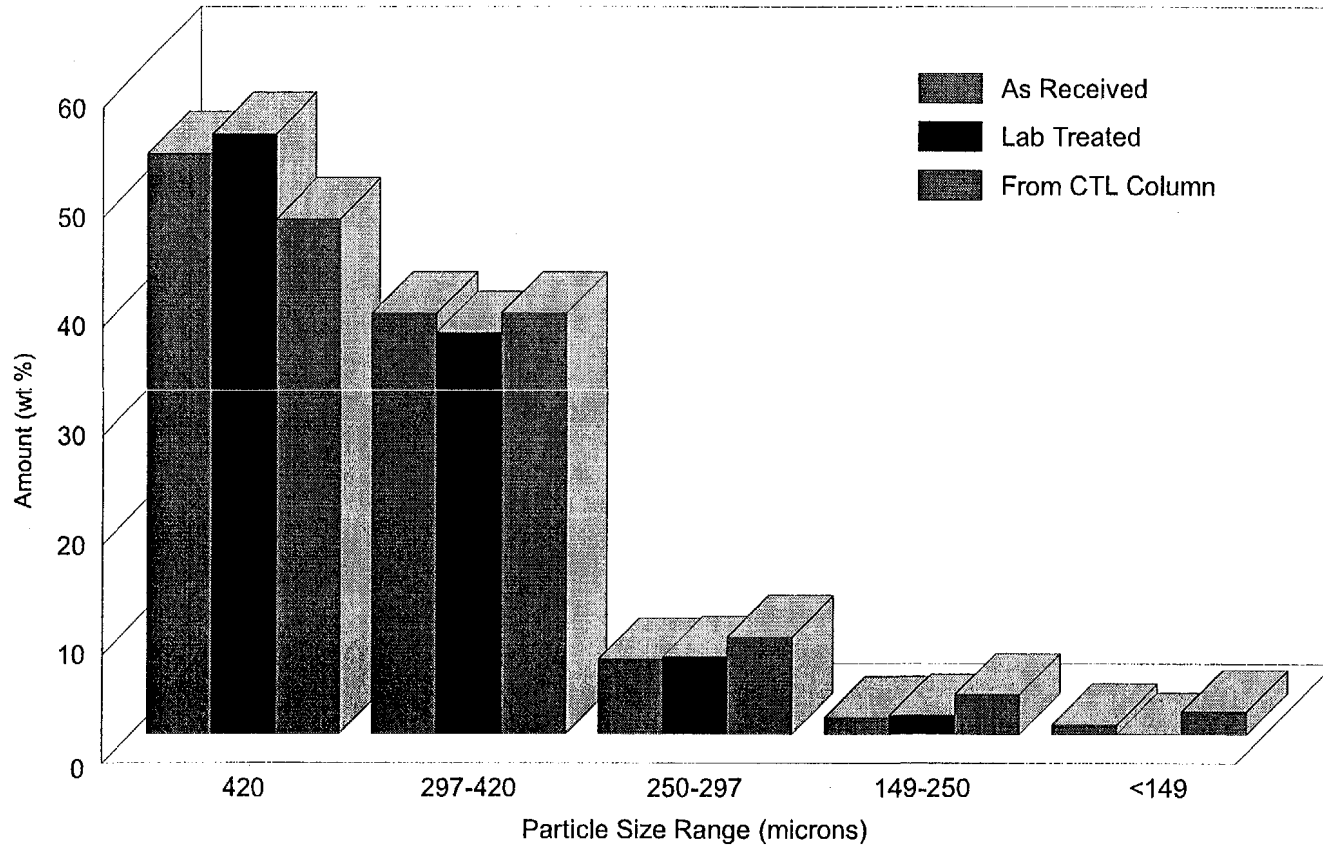

Fig. 7. Relative humidity of air from the 50-L ion-exchange column during drying operations in the cold-test loop.

After the first sluicing operation, ~10 L of sorbent remained in the column. An additional ~15 L of water was added to the column, and 20 psi of air was again used to sluice the remaining sorbent. After the second sluicing, the sorbent had been removed down to the bottom of the sluice line in the column, which was about 6 cm from the bottom of the column. Water was added to the column for a third time, and air was introduced down through the center pipe and out the Johnson screens. This operation helped suspend the sorbent in the water, and most of the sorbent was sluiced from the column. The small amount of sorbent remaining was below the level of the Johnson screens. These results illustrate the importance of locating the sluice line very near the bottom of the ion-exchange column.

4.6 SORBENT STABILITY

The particle size distribution of a sample of sorbent used in the CTL system was determined. These results are presented in Fig. 8, along with the measured particle size distributions of both as-received sorbent and a sorbent sample that had been backwashed and conditioned in the laboratory. The data show that the sorbent used in the CTL had a larger portion of fine particles, which indicated that the sluicing operations broke up some of the sorbent particles; however, the quantity of fines was still relatively low.



36

Fig. 8. Comparison of the particle size distributions of CST sorbent samples.

5. DESIGN AND INSTALLATION OF THE CsRD SYSTEM

Design specifications for the CsRD system were finalized, and the contract for design and fabrication of the system was put out for competitive bid on May 9, 1995.⁷ On July 24, 1995, the contract was awarded to TTI Engineering (Walpole, MA). Details of the equipment costs are presented in Appendix B. The system was delivered on July 12, 1996, and installation and testing with water and simulants at ORNL were completed by August 31, 1996.

The CsRD system was designed to be a modular, mobile system and was supplied on three separate skids: (1) a feed tank skid, (2) an ion-exchange skid, and (3) a sorbent sluicing/drying skid. The as-built piping and instrument drawings (P&ID) for these three skids are presented in Figs. 9 and 10, and the layout of the three skids in Building 7877 is shown in Fig. 11. Photographs of the feed tank skid, the ion-exchange skid, and the sorbent sluicing/drying skid without shielding are presented in Figs. 12-14, respectively. An overhead view of the processing facility after the shielding had been put in place is presented in Fig. 15.

The feed tank skid consists of a nominal 1890-L (500-gal) feed tank and two progressive cavity pumps. One of the progressive cavity pumps was used to control the flow to the ion-exchange columns at flows up to 19 L/min (5 gal/min). The feed tank (TK-1) was shielded on four sides by 2-1/2 in. of lead shot encased between 1/4-in. steel plates.

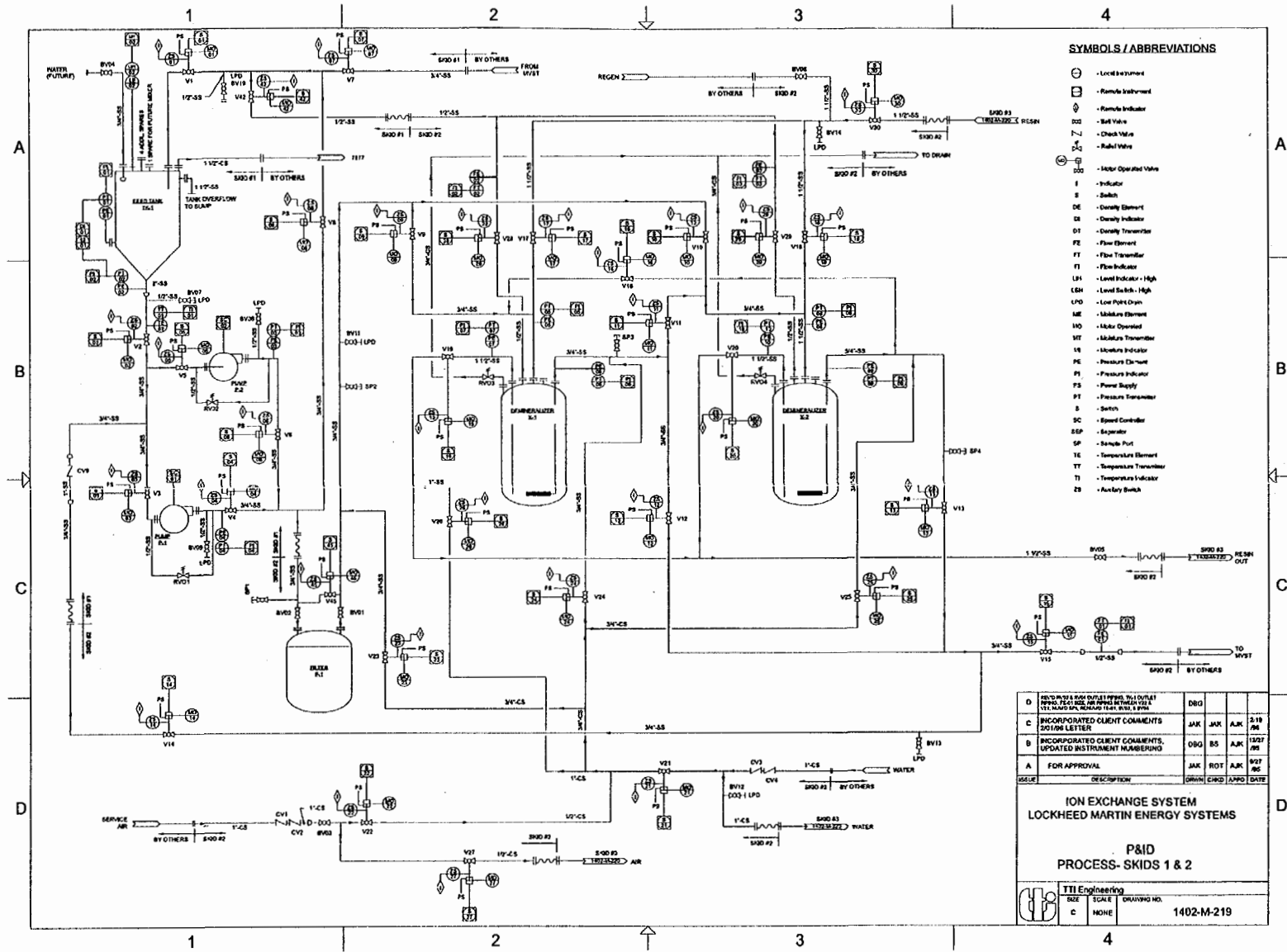

Fig. 9. Piping and instrument diagram for the CsRD feed tank skid and the ion-exchange skid.

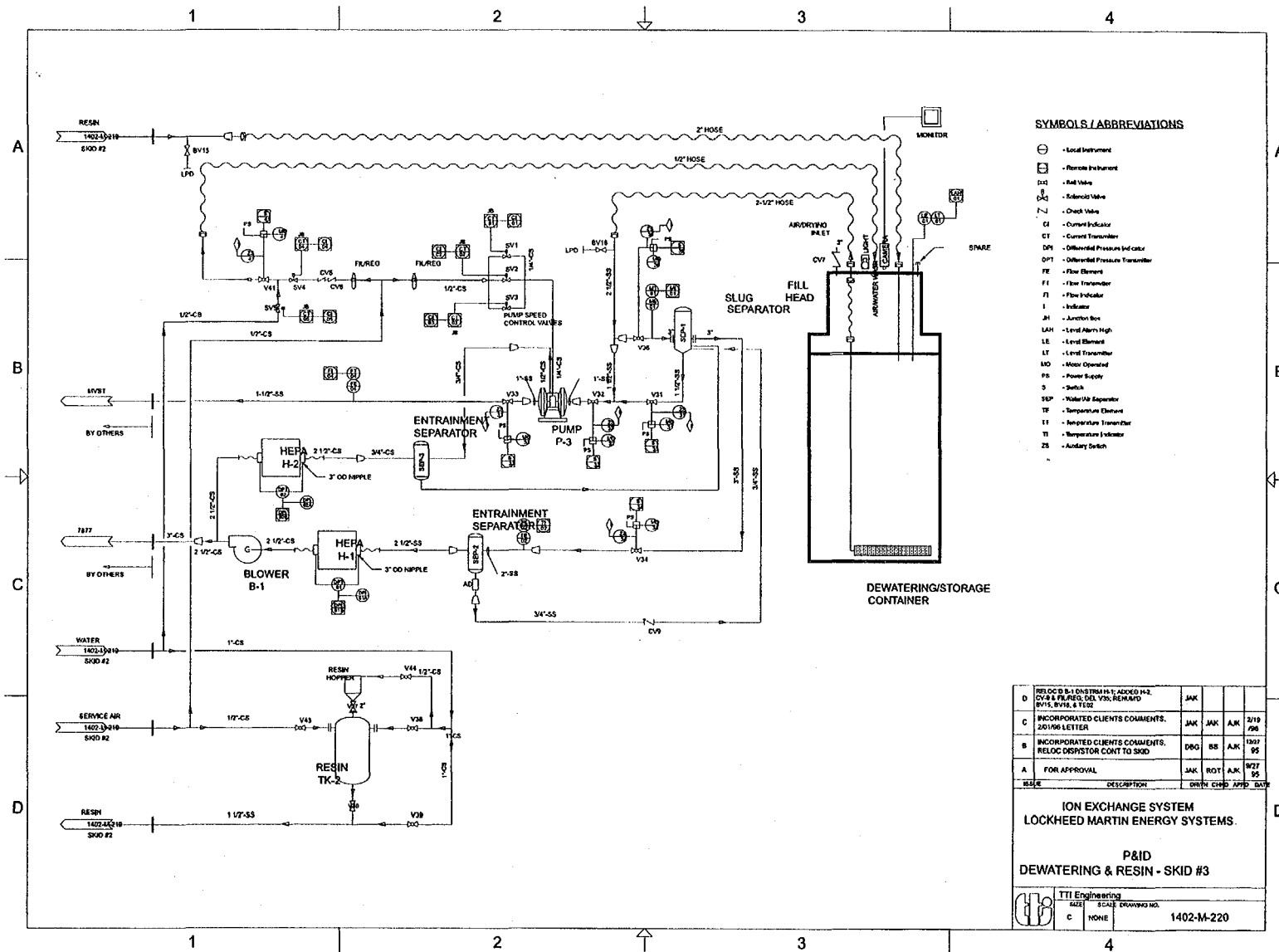

Fig. 10. Piping and instrument diagram for the CsRD sorbent sluicing/drying skid.

40

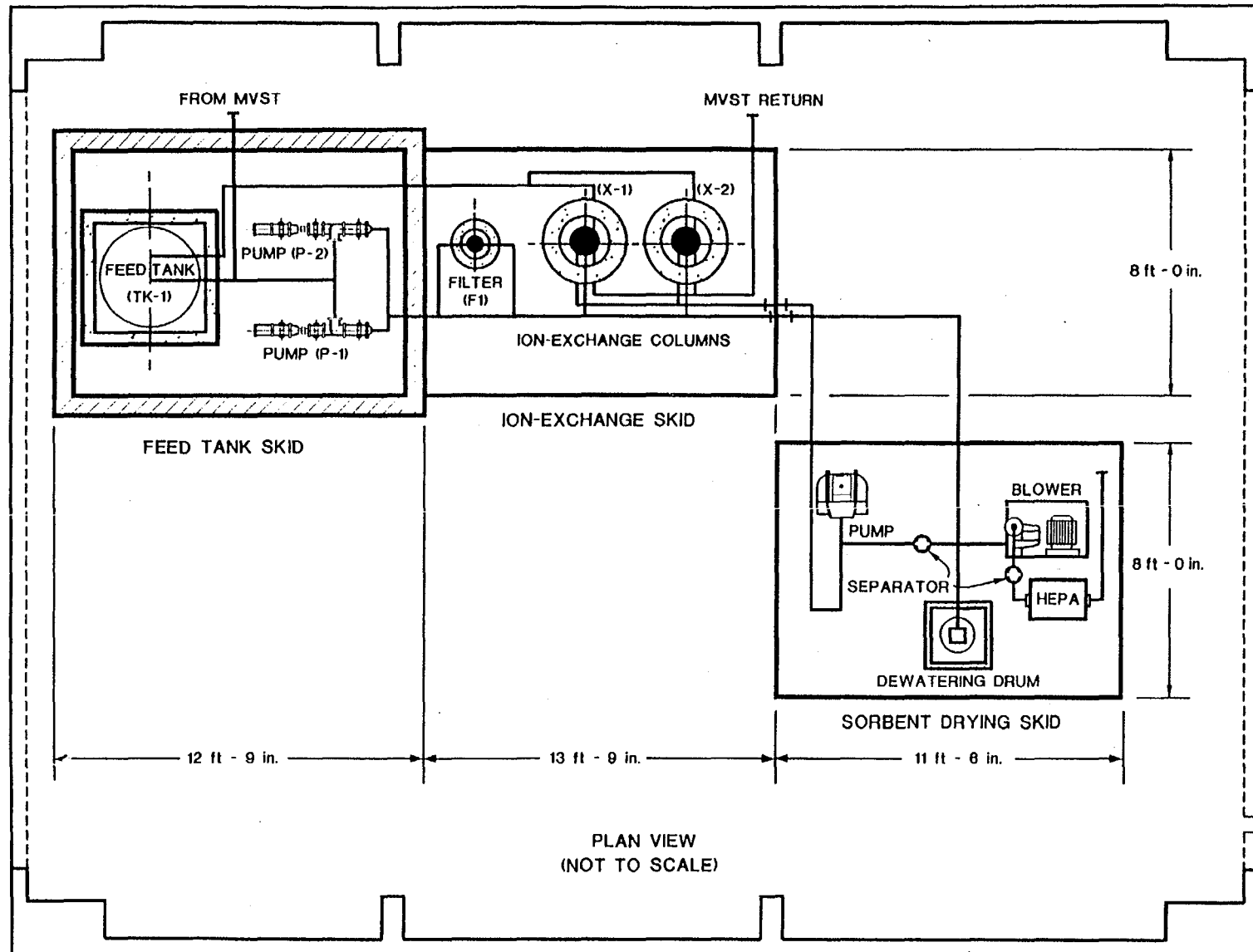

Fig. 11. Layout of the three CsRD skids in Building 7877.



Fig. 12. Photograph of the CsRD feed tank skid with no shielding.

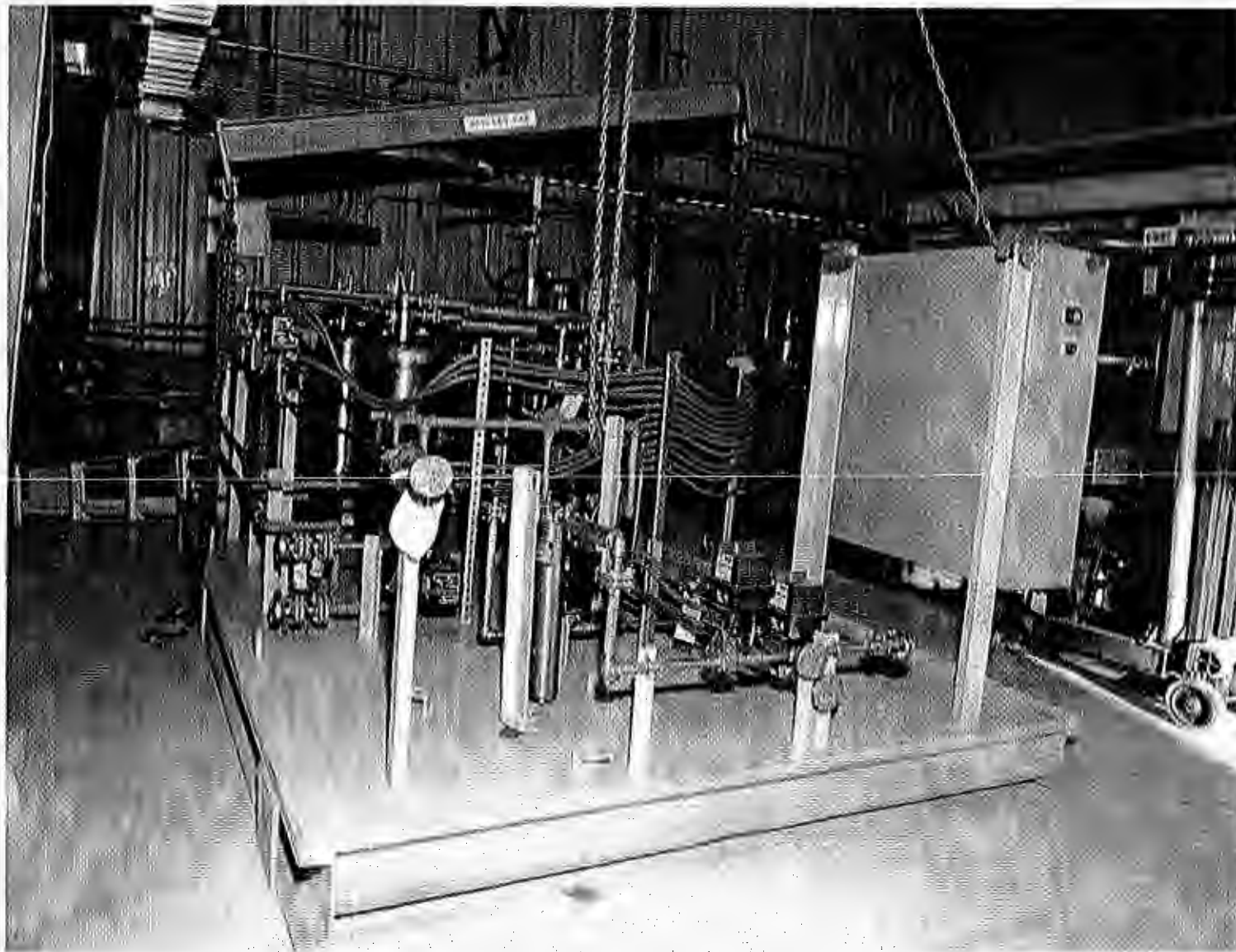

Fig. 13. Photograph of the CsRD ion-exchange skid with no shielding.

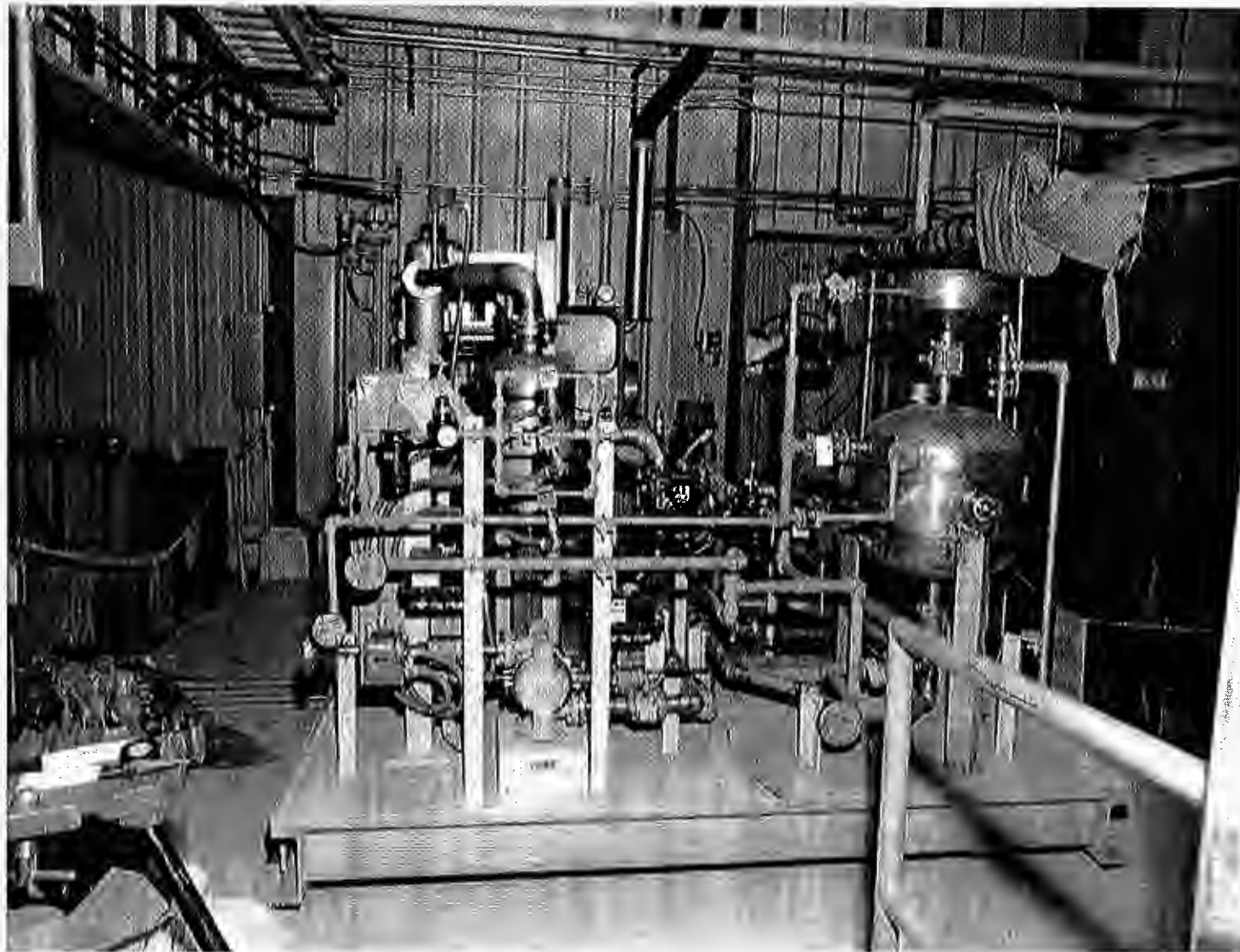

Fig. 14 Photograph of the CsRD sorbent sluicing/drying skid.

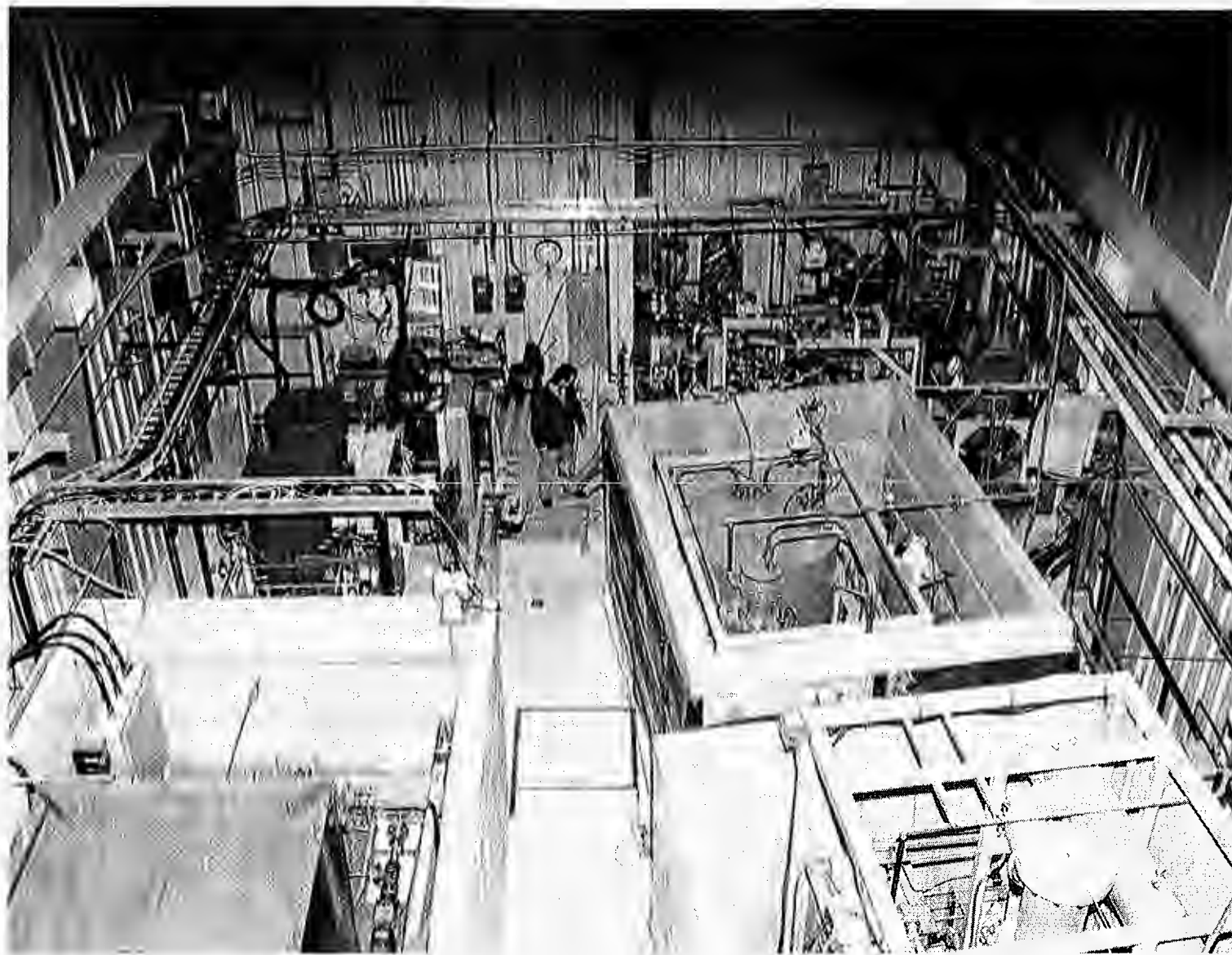

Fig. 15. Photograph of the CsRD processing facility after installation of shielding.

Penetrations ranging from 1-1/2 to 8 in. in diameter were provided in the side panels for process piping. The sides were designed to be removed individually to provide access to the tank, if necessary. The four sides supported a 4-in. steel plate that shielded the top of the tank. To provide additional protection from radiation exposure, a ~20-cm (8-in.)-thick concrete shield was placed around the feed tank skid. This shield consisted of four stackable sections with a total height of ~213 cm (7 ft). The concrete shield, which was not part of the original design, was designed and manufactured by CPI Concrete Products (Memphis, TN).

The ion-exchange skid consists of a 25- μ m stainless steel, backwashable filter (F-1), two ion-exchange vessels (X-1 and X-2), and associated piping and controls. Piping and controls were provided so that the CsRD columns could be operated independently, in series with either column leading, or in parallel. The flow could also be diverted around the filter if desired. All connections to both the filter housing and the columns are from the top.

The ion-exchange vessels, which are ~30-cm-ID by 97-cm-high (12-in.-ID by 38-in.-high) were fabricated from 316L stainless steel and rated for 150 psig. The columns were supplied with 100-mesh Johnson screens. The sides of the filter and ion-exchange columns were shielded by 5-3/8 in. and 5-1/2 in., respectively, of lead shot contained between 1/4-in. rolled plate, and the tops were shielded by 4-in.-thick steel plate. The CsRD system was designed so that the filter or columns could be remotely removed with

or without the shielding still in place. (Prior to the remote operation, process personnel would have to go into the process building to release the quick disconnects located external to the vessel shielding.) During processing, a sampler modified at ORNL was used to take samples remotely from the filter inlet as well as the inlet and effluent from both columns.

The sorbent sluicing/drying skid contains a stainless sorbent loading tank (TK-2) that is ~50 cm OD by ~60 cm high. The sorbent loading tank is rated for pressures up to 150 psig. Sorbent to be sluiced into the ion-exchange columns is manually loaded into TK-2, water is added to the tank, and the tank is pressurized. This skid also contains equipment for dewatering the sorbent after it has been removed from the ion-exchange columns. Before sorbent is sluiced from the ion-exchange column, the fill head is placed on a 30-gal stainless steel dewatering/storage container, which is used to catch and store the spent sorbent. The fill head contains a camera and a light for monitoring the sluicing and drying operations, a level probe to determine the height of the slurry in the drum, and high-pressure hoses for sluicing and drying operations. The dewatering/storage container has spiral-wound filters that allow water to be pumped from the sorbent and air to be pulled through the sorbent for drying purposes. This container is shielded radially by ~9 cm (3.5 in.) of lead shot encased between 1/4-in. rolled steel plates. After the sorbent has been sluiced into the drum, a diaphragm pump (P-3) is actuated to remove the water from the dewatering/storage container. A blower (B-1) is then energized to pull ambient air through the sorbent and through two separators. When the in-line relative humidity

probe (MI-01) indicates that the sorbent is dry, P-3 and B-1 are de-energized. The fill head is remotely removed, and a remote hopper is used to add vermiculite to the drum of sorbent to ensure that no free water exists in the drum prior to shipment. A photograph of the fill head being remotely removed from the dewatering/storage container is presented in Fig.16. A special lidding device is then used to remotely place a lid on the drum and seal it.

A shielded transfer bell with a grappling device is subsequently used to remotely transfer the drum of spent sorbent to a shielded storage area inside the processing facility. The storage area consists of shielded containers (i.e., drum shields) designed to hold individual drums of spent sorbent. These drum shields have ~ 9 cm of poured lead contained between 0.635-cm (1/4-in.) rolled steel plates, an ~10-cm (4-in.) steel plate top, and a 7.6-cm (3-in.) steel plate bottom. Three of the individual containers are contained within an ~10 cm (4-in.) thick lead brick wall. The shielded containers, the shielded remote transfer bell, the lead brick-shielded area, and the remote vermiculite hopper can be seen in Fig. 17. If over-the-road transportation is necessary to ship the containers of sorbent, the shielded transfer bell is used to remotely transfer the drums of sorbent to a type B carrier. A photograph of a loaded type B carrier being prepared for shipment to SRS is presented in Fig. 18.

The control system for the CsRD system was designed and installed by the ORNL Instrumentation and Controls Division. The controller was the μ DCS-Plus manufactured

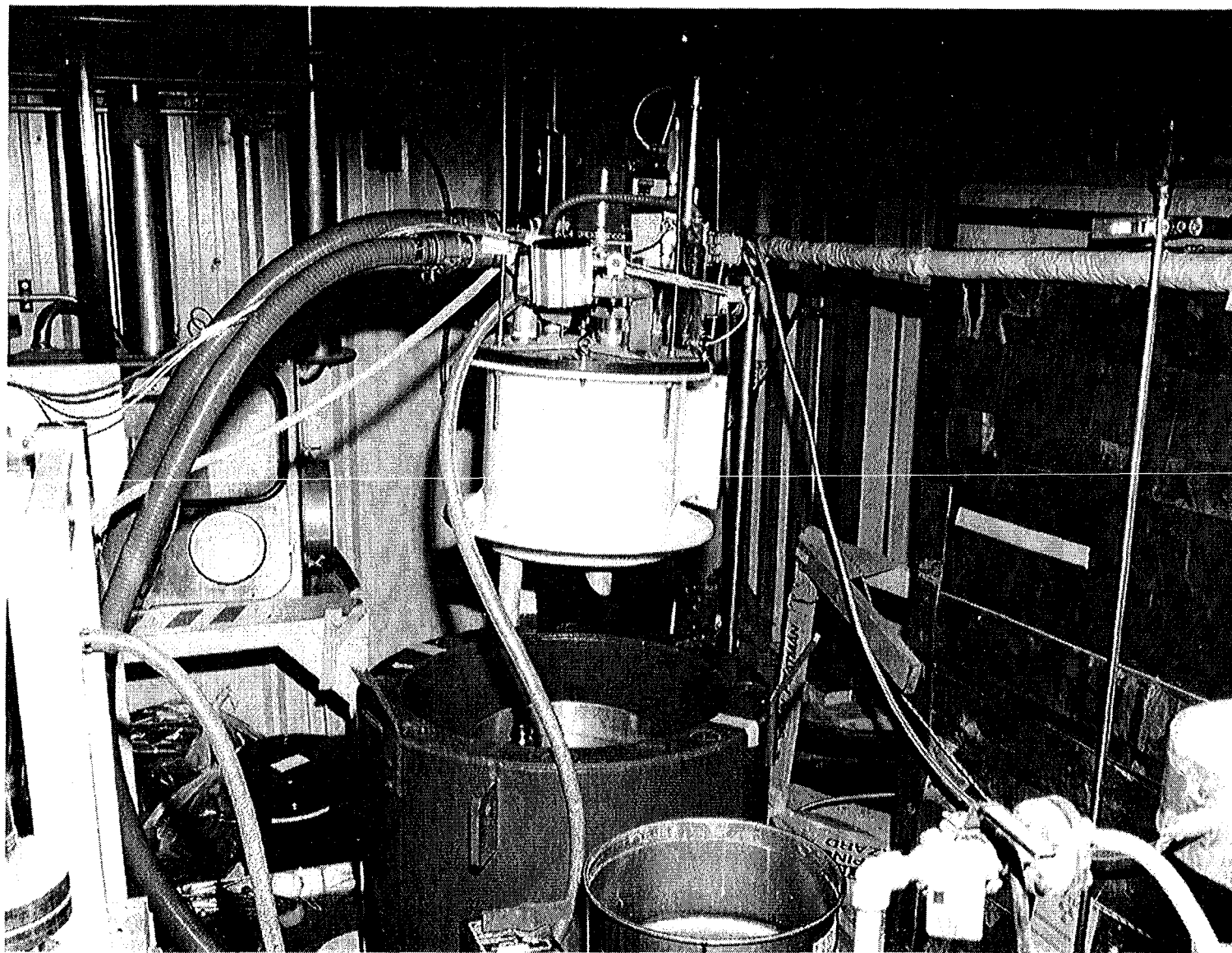

Fig. 16. Photograph of fill head for the CsRD system being remotely removed from the sorbent dewatering/storage container.



Fig. 17. Photograph showing shielded containers, shielded remote transfer bell, lead brick-shielded area, and remote vermiculite hopper for the CsRD.



Fig. 18. Photograph of a loaded type B carrier being prepared for shipment to SRS.

by Azonix, and the software was FIX-32 provided by Intellusion. It should also be noted that it was necessary to install a remote crane system in Building 7877 prior to moving the drums of spent sorbent. The crane (6-ton capacity), runways, and hoist were manufactured by ACCO. The bottom rotating block assembly was manufactured by GANTREX, and the radio control system was manufactured by Cattron, Inc. All remote operations were controlled from Building 7863, which was ~130 ft from the CsRD system located in Building 7877. A scaled drawing showing the locations of Buildings 7863, and 7877 and the underground storage tanks is presented in Fig. 19.

6. DOCUMENTATION REQUIREMENTS AND MANAGEMENT ASSESSMENT PRIOR TO STARTUP

Prior to operation with radioactive waste, a Management Assessment Team (MAT) was appointed to assess the readiness of the CsRD for processing MVST supernate. This independent review was in accordance with guidelines in the Energy Systems Waste Management Organization guidance document, ES/WM-62, and addressed readiness criteria in three areas: (1) facility and equipment; (2) management control plans, procedures, and permits; and (3) personnel. Members of the MAT included personnel from the Chemical Technology Division, the Office of Quality Programs and Inspection Division, the Office of Operational Readiness and Facility Safety Division, the Waste Management and Remedial Action Division, and the Office of Safety and Health Protection Division. Two assessments were conducted. The first of these, which was completed on September 9, 1996, recommended that the CsRD be allowed to initiate

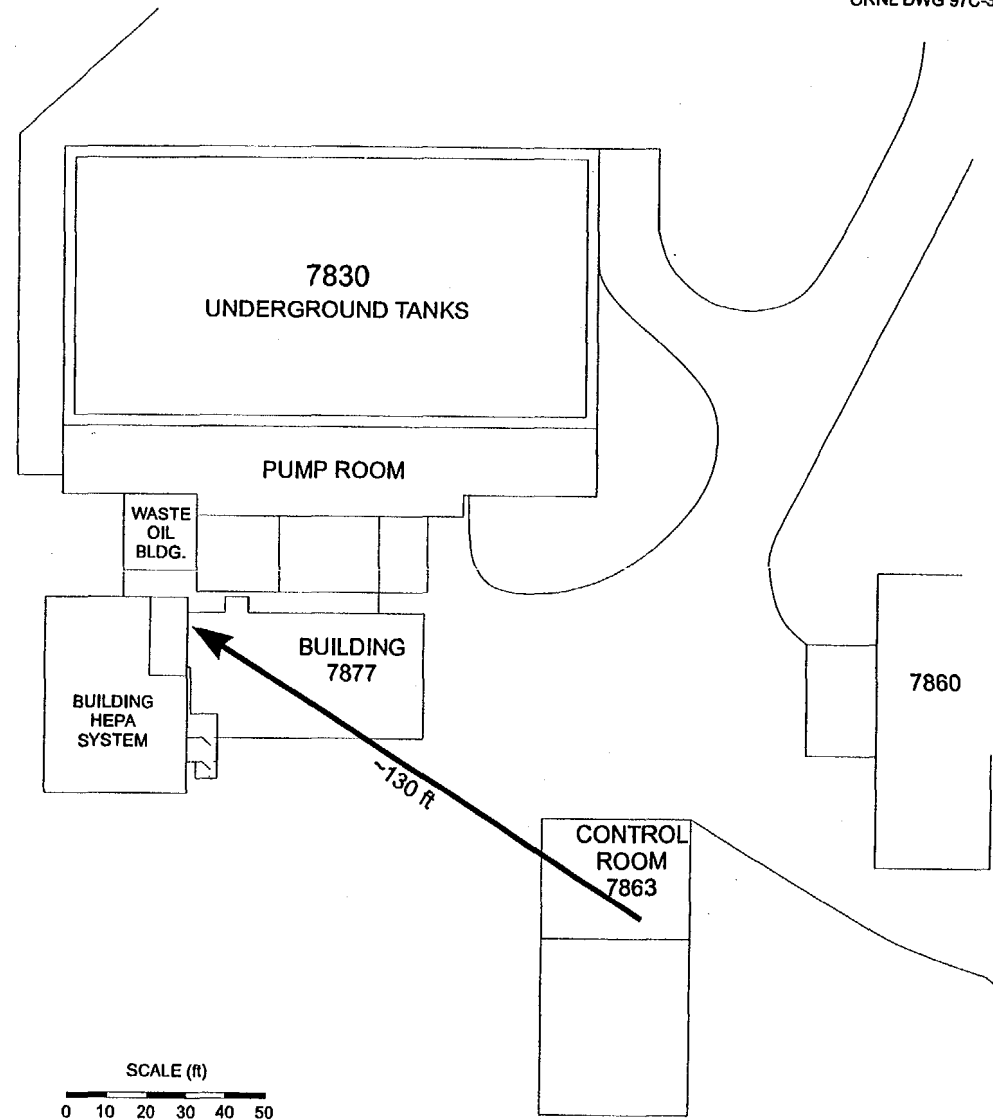

Fig. 19. Scaled drawing showing locations of Buildings 7863 and 7877 and the underground storage tanks.

processing of MVST supernate, with the loading limited to ~25 Ci of ^{137}Cs . The MAT then reconvened on January 14, 1997, in order to assess such issues as (1) items that were tracked from the initial run, (2) review of operating logs from the initial run, and (3) operation of the newly installed remote crane in Building 7877. On February 7, 1997, the MAT recommended that the CsRD be allowed to restart and complete operations. A summary of the startup criteria and documentation requirements reviewed by the MAT can be found in Appendix C.

7. CESIUM REMOVAL DEMONSTRATION RUNS

Four CsRD runs were conducted in this campaign. The first one was a single-column, low-loading run designed to test the system and procedures prior to the full-loading runs. It was completed in September 1996, meeting the milestone of Secretary of Energy, Hazel O'Leary, to President Clinton for initiation of operation in FY 1996. A total of ~23 Ci of ^{137}Cs was loaded onto 38 L (10 gal) of sorbent. The sorbent from this run was shipped to the SRS for use in a vitrification demonstration.

The second run consisted of a single 38-L column of sorbent operated at 3 bed volumes (BV) per hour. Approximately 18,028 L (4,763 gal) of Melton Valley Storage Tank (MVST) supernate was processed prior to 50% breakthrough of ^{137}Cs ; ~154 Ci of ^{137}Cs was loaded on the sorbent.

The third run consisted of the operation of two 38-L columns of sorbent in series at a flow rate of 6 BV/h. Approximately 39,061 L (10,320 gal) of supernate was processed with the lead and lag columns reaching ~80% and ~47% breakthrough of ^{137}Cs , respectively. The lead column loaded a total of ~222 Ci of ^{137}Cs and the lag column loaded ~112 Ci of ^{137}Cs .

The fourth run involved the use of three columns, each containing 38 L of sorbent. The system was initially started with two columns in series. The lead column (column 1) reached 55% breakthrough of ^{137}Cs after processing ~28,346 L (7,489 gal) and loading ~253 Ci of ^{137}Cs . Column 1 was then removed from service, the lag column (column 2) was moved into the lead column position, and a column with new sorbent (column 3) was placed in the lag column position. Analyses indicate that column 2 loaded ~266 Ci and column 3 loaded ~112 Ci, for a total of ~631 Ci of ^{137}Cs removed during run 4.

During the entire operational period, ~ 115,757 L (30,583 gal) of supernate was processed and ~1,142 Ci of ^{137}Cs was removed from that supernate and loaded onto 70 gal of sorbent. The average feed concentration for each of runs 2-4 is presented in Table 7. It should be noted that analyses for run 1 are not included because cross-contamination occurred between the samples for this run. The EM-50 milestone to complete the processing of up to 94,625 L (25,000 gal) of MVST supernate by July 31, 1997, was met, as was the EM-30 milestone to remove at least 520 Ci of radioactive cesium by June 30, 1997. The sorbent from the last three runs will be stored at the

Table 7. Average feed concentrations for CsRD runs 2-4

Component	Run 2	Run 3	Run 4
¹³⁷ Cs (Bq/mL)	417,500	398,000	490,000
¹³⁴ Cs (Bq/mL)	5,650	5,170	13,000
⁶⁰ Co (Bq/mL)	395	372	320
⁹⁰ Sr (Bq/mL)	1,675	1,280	823
Ba (mg/L)	0.618	0.776	0.31
Ca (mg/L)	2.41	4.25	71.7
Cr (mg/L)	3.27	3.82	4.03
Cs (mg/L)	0.966	1.79	0.678
Hg (mg/L)	0.0811		
K (mg/L)	16,150	16,700	20,100
Mg (mg/L)	<0.075	0.341	0.25
NO ₃ (mg/L)	270,000		
Pb (mg/L)	2.4	0.623	0.35
Rb (mg/L)	2.64	4.08	2.19
Sr (mg/L)	1.143	1.24	0.43
U (mg/L)	8.86	11.7	20.7
Zn (mg/L)	0.852	0.842	0.98

ORNL solid waste storage area (SWSA) until it can be shipped off-site for permanent disposal. Laboratory analysis has shown that the loaded sorbent is nonhazardous and no further stabilization is necessary prior to disposal. Details of the individual CsRD runs are presented in the subsections that follow.

7.1 CESIUM REMOVAL DEMONSTRATION RUN 1

The first CsRD run was initiated with the goal of loading ~25 Ci of ^{137}Cs prior to shutdown. The primary reason the first run was limited to ~25 Ci of ^{137}Cs was to provide information for later runs, when loadings would be much higher (i.e., >200 Ci of ^{137}Cs per column and as much as 1000 Ci of ^{137}Cs present in the processing building) and the risk of radiation exposure to individuals would be much greater. The information to be provided included (1) verification of operational procedures during an actual run with radioactive supernate, (2) verification of the ion-exchange system functionality during an actual run with radioactive supernate, (3) verification of the performance of the sorbent sluicing/drying system with cesium-loaded sorbent, (4) verification that the loaded sorbent could be sluiced if operational problems occurred as the result of the sorbent having to remain in the column for a long period, (5) verification of remote transfer equipment and procedures utilizing cesium-loaded sorbent, (6) verification of transportation procedures and equipment using cesium-loaded sorbent, (7) verification of the operation of the remote sampler, and (8) measurement of radiation levels during sluicing and transfer of the loaded sorbent to assist in determining the expected radiation

levels at higher loadings. In addition, the first run served to provide material for use by SRS for a vitrification demonstration and for training SRS personnel at ORNL in the procedures to be required for the remote transfer of the radioactive sorbent.

On completion of its assessment on September 12, 1996, the Management Assessment Team recommended that the CsRD project be allowed to proceed with startup of operations. On September 13, the WMRAD Director granted approval of startup. Thus, 38 L of conditioned CST sorbent was loaded into ion-exchange column X-1 on September 13. (A copy of the procedure used for conditioning the sorbent can be found in Appendix D, and copies of the operational procedures for the ion-exchange operations can be found in Appendix E.) At ~5:15 a.m. on September 15, a preoperational inspection of the system was conducted and supernate from MVST W-29 was introduced into the CsRD feed tank (TK-1). At ~7:30 a.m., the supernate flow to the X-1 ion-exchange column was initiated at a set flow rate of ~ 3 BV/h. The system operated with no problems until ~1:30 p.m., when a leak detection alarm sounded and the system automatically shut down. The Radiation Control Officer (RCO) for the project entered the process building and determined that liquid was present in two of the skid catch pans. Radiation readings indicated that the liquid was probably processed supernate. It was determined that a valve had been inadvertently opened, thereby allowing process effluent to enter a sump drain connected to the containment pan. Some of the liquid had backed up in the sump drain and then entered the containment pan, where it set off the leak detection device located in the containment pan. Fortunately, the containment pans

contained the leak, the moisture sensor detected the leak, and the control system automatically shut down the CsRD system.

To correct the problem, the liquid was drained to the sump and pumped back to the MVSTs. The skids were rinsed with water, and the liquid was wiped up. The system was then shut down and allowed to dry so that the RCO could take smears from the catch pans to determine the extent of contamination. Since these smears indicated little contamination, the system was restarted at ~11:30 a.m. on September 17 at 3 BV/h. After approximately 1 h of operation, the flow rate was first increased to ~4.5 BV/h; it was increased further to 6 BV/h after an additional hour of operation. The system operated at 6 BV/h for ~5 h with no problems before being shut down at ~9:00 p.m. on September 17, when it was estimated that the goal of loading ~25 Ci ^{137}Cs had been reached. A total of 1893 L (500 gal) of MVST W-29 supernate had been processed.

Evaluation of the operations and data after run 1 revealed a few problems that needed to be corrected prior to the next run. Therefore, several items were added to the pre-operational check list, and the check list was reissued. A copy of the final revision of the preoperational check list is presented in Appendix F. A few minor changes were also made to the operating screen control panel to facilitate monitoring the process. Finally, the analytical data showed cross-contamination of samples taken during run 1, thereby making it impossible to determine the quantity of cesium loaded from the operational data. From the bench-scale simulations, it was estimated that 22 Ci of ^{137}Cs had loaded

onto the sorbent. Prior to the next scheduled run, modifications were made to the sampler and to the sampling procedures. Dye tracer tests were conducted with the system and the sampler to ensure that the cross-contamination problems had been eliminated.

During the next 4 months, the crane in the process building was upgraded to increase the capacity and to allow remote operation of the crane from the CsRD control room. This was necessary prior to movement of the spent sorbent from the first CsRD run. On February 9, 1997, preparations were made to sluice the sorbent loaded with the 22 Ci of ^{137}Cs from ion-exchange column X-1 to the sorbent drying skid. (The operational procedure for the sluicing operations can be found in Appendix E.) The loaded sorbent had been rinsed with water immediately following the first loading campaign but had been allowed to sit in the column for 146 days. Initial attempts to backwash the column failed because the inlet backwash line had become plugged with sorbent. This had not occurred in any of the cold tests with process water or surrogate. After the air to the ion-exchange skid had been increased to 60 psi, it was successfully used to clear the blocked backwash line. Then the sluicing operation was completed according to procedures, with no additional problems being noted. Drying of the sorbent was subsequently initiated, using the procedures found in Appendix E. After the sorbent was dried, the drum of loaded sorbent was remotely transferred to the sorbent storage area in the process building (see procedure in Appendix G).

7.1.1 Radiation Dose Evaluation for Run 1

The scaled drawing of the CsRD area presented in Fig. 20 identifies the locations where dose rates were routinely measured during operations. A maximum dose rate of 100 mR/h outside Building 7877 during sluicing operations occurred at point W1. A maximum of 15 mR/h occurred on the south side at point N. After the sluicing operation was completed, the dose rates at W1 and W2 decreased to 1.0 mR/h and 1.5 mR/h, respectively.

Radiation readings were also taken outside and inside of Building 7877 during movement of the drum of dried, loaded sorbent. The transfer bell was designed to mate with the sluicing drum shield, which contained the drum of loaded sorbent. The transfer bell was lowered onto the sluicing drum shield, the grappling mechanism in the transfer bell remotely picked up the drum of loaded sorbent, and the crane remotely picked up the transfer bell containing the sorbent to a height of ~183 cm (6 ft) above the floor directly over the sluicing drum shield. With the sorbent at this location, the radiation readings at points N and W1 read 1 mR/h and 7 mR/h, respectively. The bell was then lowered within ~5 cm of the floor and moved to a position between the ion-exchange skid and the sluicing/drying skid. With the bell in this position and the radiation instrument located off to the side of the transfer bell, there was no detectable increase in the radiation level over that of the background level. The bell was lifted to a height of ~45 cm off the floor, and the radiation instrument slid on the floor to the approximate center of the bell. At

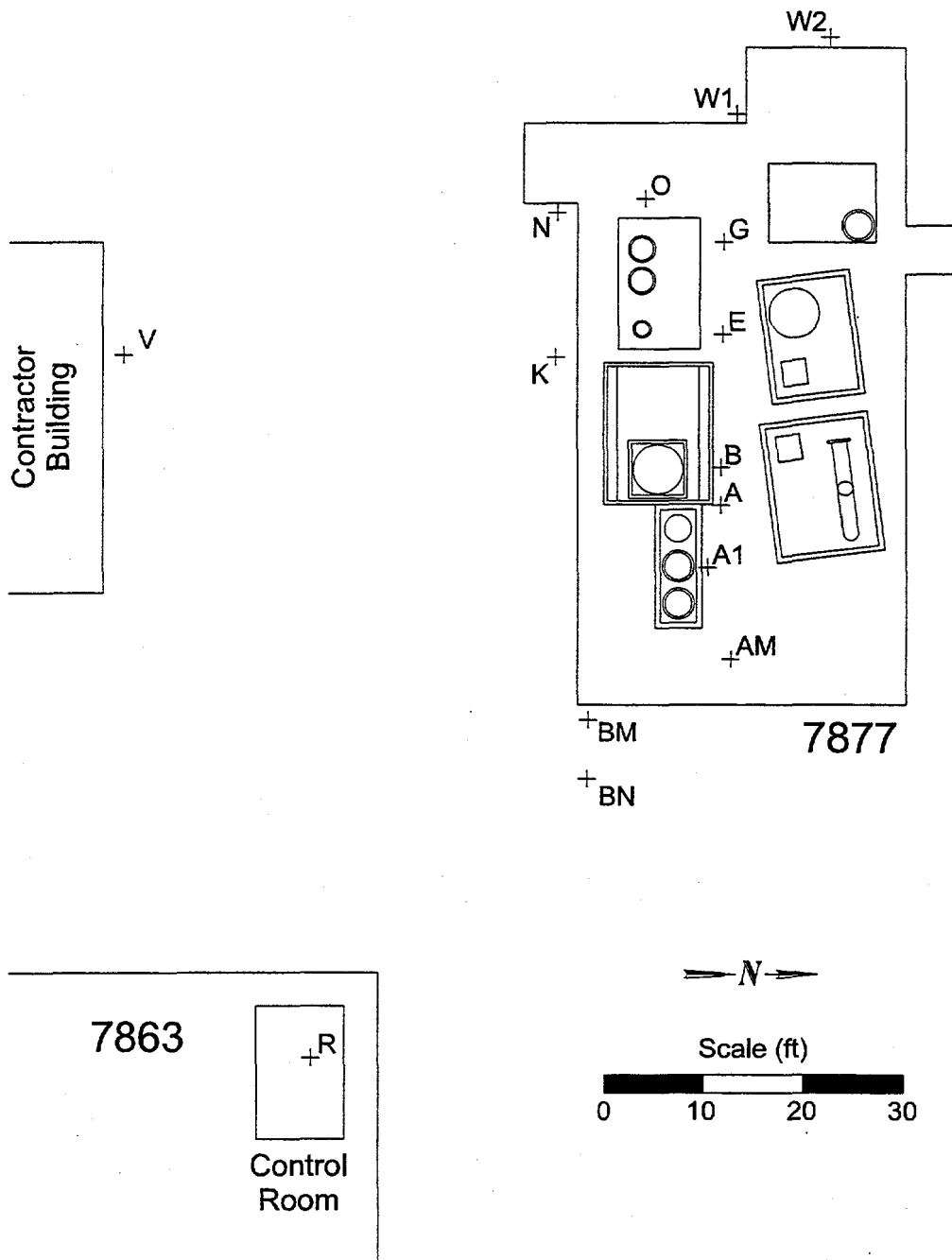

Fig. 20. Scaled drawing of CsRD area with locations where routine measurements of dose rates were taken during operations identified.

this point, the radiation level was 20 R/h. The drum of sorbent was then placed in the first drum shield located in the shielded sorbent storage area and the transfer bell removed. The drum of sorbent read ~12 R/h on contact at the top of the drum and ~35R/h at contact on the sides of the drum. When the lid was placed on the drum shield, the contact reading on the top of the drum shield read ~60 mR/h, while the contact reading on the sides of the drum shield at the bottom read ~1 mR/h.

7.1.2 Shipment of Loaded Sorbent to SRS

On February 10, 1997, the type B shipping cask to be used for transport of the sorbent to SRS was delivered to ORNL. The cask was provided by Molten Metals Technology of Tennessee, who was awarded the shipping contract for the spent sorbent through a competitive bid. On February 11, a dry run was conducted to verify the transfer procedures found in Appendix G and to test an alignment plate designed to promote proper alignment between the shielded transfer bells at ORNL and SRS with the transportation cask. On February 12, the drum of loaded sorbent was transferred to the type B cask. An empty drum was also placed inside the cask to be used at SRS for verification of alignment and for procedure verification prior to removal of the drum of radioactive sorbent at SRS. The shipping cask left ORNL on February 14 and arrived at SRS on February 15.

ORNL and SRS personnel had worked closely to design, fabricate, and test lifting/shielding fixtures (i.e., shielded transfer bell) and other remotely operated equipment that will be compatible with facilities at both sites and with the transportation cask that was used for the shipment. ORNL acquired the lifting/shielding fixture for SRS, which was very similar to the ORNL lifting/shielding fixture, through a memorandum purchase order provided by SRS. ORNL also contracted with a vendor for transportation of the sorbent from ORNL to SRS.

From February 10 to 12, personnel from SRS visited ORNL to observe the dry run and the remote transfer of the loaded sorbent, as well as to receive training on (1) removal of the transportation cask from the vendor trailer, (2) placement of the cask in the remote facility, and (3) remote loading and unloading of the 30-gal containers that will be used to ship the radioactive sorbent. This training was arranged to assist SRS personnel with their operations following arrival of the transportation cask at SRS. Discussions with SRS personnel indicated that the training exercises and observation of the dry run and the transfer of the loaded sorbent were very beneficial to them. Items noted as particularly helpful included the following:

1. A tape was made of the training operations and a copy provided to the SRS personnel. This tape was used to train additional personnel at SRS.

2. The ability to examine the cask, trailer, alignment plate, and shoring that were used, as well as to compare them with the design drawings, prior to arrival at SRS was extremely valuable.
3. SRS personnel were able to obtain a copy of the *Radiation Services Manual*, which helped them with the preparation of procedures and documentation.
4. The experience gained during the training exercises enabled SRS personnel to save considerable time in the development and testing of their remote crane procedures. The SRS operators were able to learn about the differences in depth perception that would occur with different camera angles, the difficulties that result with remote operations due to decreased depth perception, and the use of alignment tools to assist in the remote operations.
5. SRS personnel were able to determine that they needed additional tools, equipment, and rigging for the unloading operation at SRS. They were then able to communicate those needs to personnel at SRS, who located the additional items prior to arrival of the cask at SRS.
6. The SRS Radiation Control Officer was able to obtain information regarding the radiation levels on the outside of the 30-gal containers, the transportation cask, and the lifting/shielding fixtures. She was able to observe the ORNL Health

Physics technician taking the readings, as well as "smearing" the inside and outside of the carrier for transferable contamination. This information assisted SRS greatly in mitigating their ALARA concerns and in determining how to provide Health Physics support for the off-loading operation.

7. In a "practice" run, SRS personnel loaded an empty drum in the cask and then proceeded to remove it (prior to the removal of the radioactive drum). This exercise allowed them to verify proper alignment and remote operational procedures prior to lifting the radioactive material.
8. ORNL personnel placed alignment markings on the transfer cask to assist SRS personnel in the remote removal of the drum from the shipping cask.

7.2 CESIUM REMOVAL DEMONSTRATION RUN 2

Column X-1 was loaded with ~38 L of conditioned CST sorbent on February 13, 1997. Flow of W-29 supernate at 3 BV/h to this column was started on February 16 at ~10:00 a.m., initiating CsRD run 2. Flow to the column was terminated on February 23 at ~12:30 p.m. after ~18,028 L (4,763 gal) of supernate had been processed. No major operational problems were encountered during this run.

Breakthrough curves for ^{137}Cs and ^{134}Cs during run 2 are presented in Fig. 21. As can be seen, the breakthrough curves for ^{137}Cs and ^{134}Cs are essentially identical. Breakthroughs of 1 % and 50 % for both ^{137}Cs and ^{134}Cs occurred at ~ 75 and 475 BV, respectively. The sorbent loaded ~ 154 Ci of ^{137}Cs and 2.1 Ci of ^{134}Cs . Breakthrough curves for ^{60}Co , ^{90}Sr , Sr, and U are presented in Fig. 22. Essentially all of the ^{90}Sr was removed from the supernate, and the CST did not load ^{60}Co . The uranium was loaded by the sorbent, with 50% breakthrough occurring after ~ 120 bed volumes of supernate had been processed.

7.2.1 Radiation Dose Evaluation for Run 2

Dose rates were recorded at various locations inside and outside the process building (see Fig. 20) while the supernate was being processed. Dose rates for three of these points can be seen in Fig. 23. The highest dose rate during processing occurred at point E, where the dose rate increased from ~ 1.5 mR/h to ~ 7.8 mR/h. The sluicing/drying procedures found in Appendix E and the remote transfer procedures in Appendix G were used during this run. After the sorbent had been dried (~ 2.5 h required) and prior to sealing the drum, 38 L (10 gal) of vermiculite was added to the top of the drum, by remote means, to ensure that no free liquid was present in the drum, thus meeting the waste acceptance criteria for the NTS.

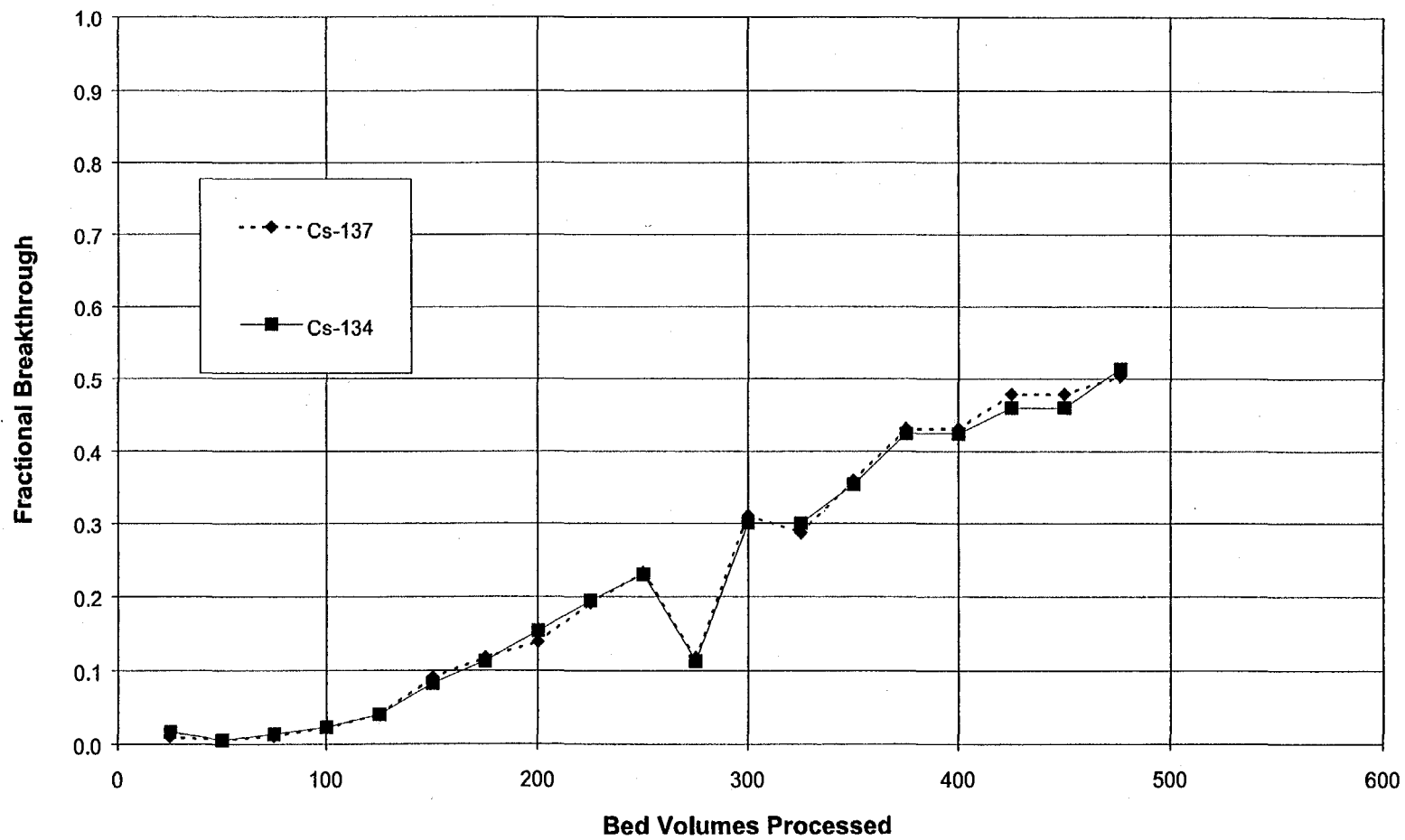

Fig. 21. Breakthrough curves for ^{137}Cs and ^{134}Cs during run 2 of the CsRD.

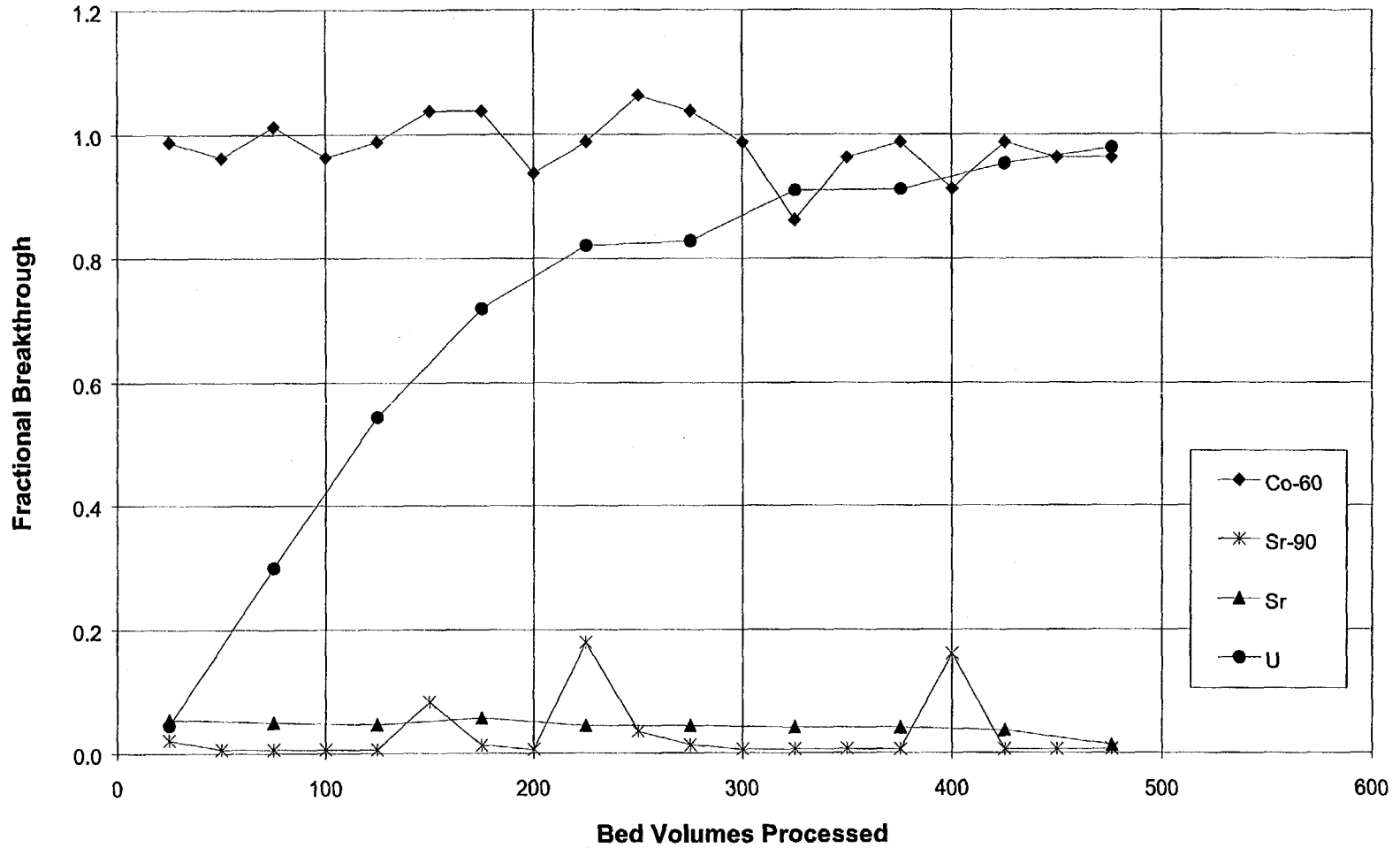

Fig. 22. Breakthrough curves for ^{60}Co , ^{90}Sr , and U during run 2 of the CsRD.

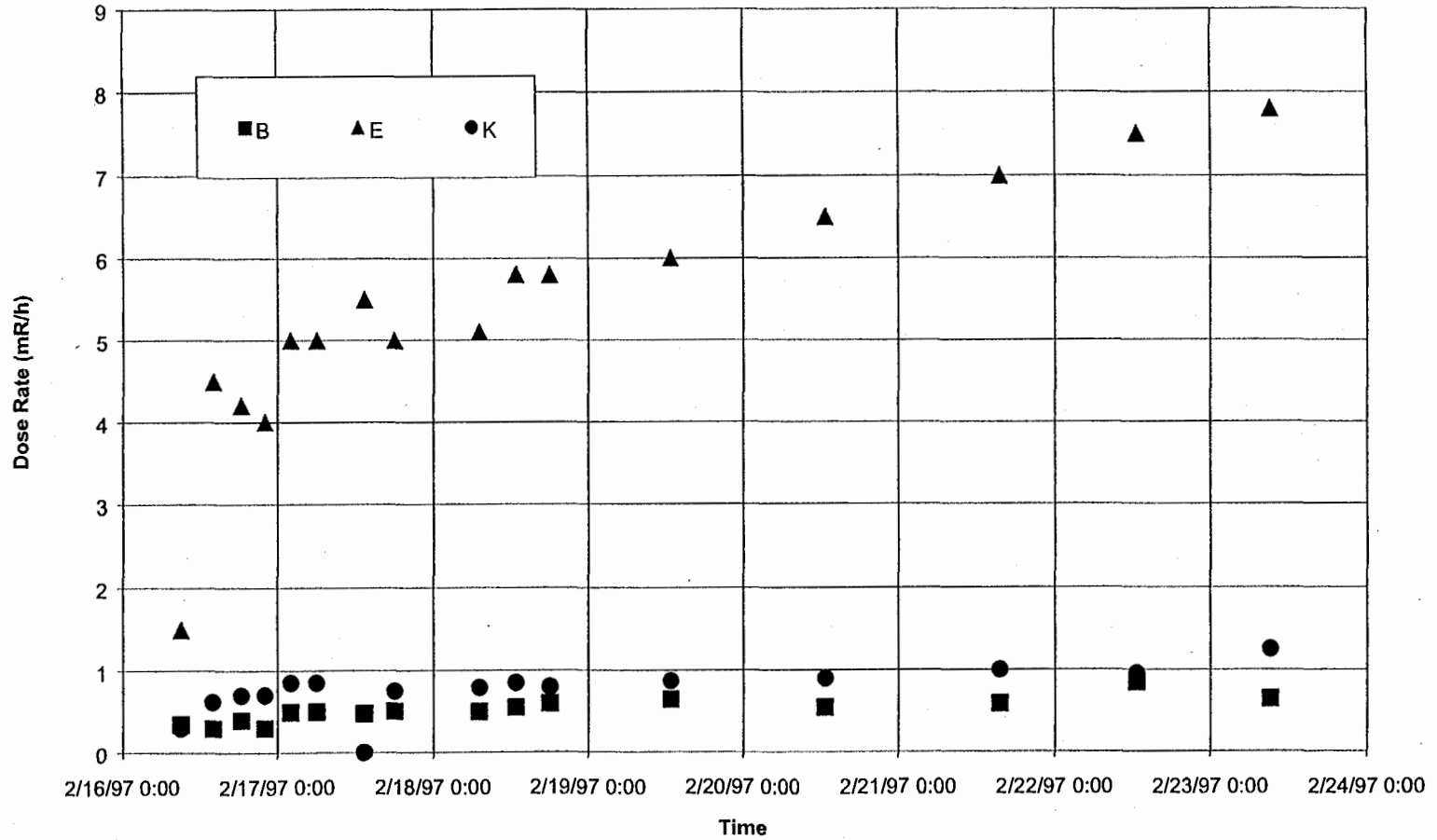

Fig. 23. Dose rates inside and outside the process building during CsRD run 2.

7.3 CESIUM REMOVAL DEMONSTRATION RUN 3

Approximately 38 L of conditioned CST sorbent was added to each ion-exchange column on February 26, 1997. Supernate processing for the third run was initiated on March 3 at ~8:45 a.m. by operating the CsRD system with two columns in series at a flow rate of ~3.8 L/min (6 BV/h for each individual column and 3 BV/h for the two columns in series). The system was then shut down on March 6 at ~4:00 p.m. after ~11,635 L (3,074 gal) of supernate had been processed. This shutdown was scheduled to allow determination of the effect a prolonged shutdown would have on the breakthrough curve. During this shutdown, the sorbent was allowed to remain in the supernate solution. Maintenance was also conducted on the CsRD system during the shutdown. During operation, a check valve had failed to completely seat and, as a result, some of the feed solution was leaking from the feed tank into the effluent line and being transferred back to the W-30 MVST. Since the flow meter and the flow totalizer used to record the flow through the ion-exchange columns were on the effluent line from the second column, this leak did not compromise the data collected during the run. The system was restarted at 2:00 a.m. on March 16 at a flow rate of ~3.8 L/min and was completed at ~4:45 a.m. on March 23 after ~39,061 L (10,320 gal) of supernate had been processed.

Breakthrough curves for ^{137}Cs , ^{134}Cs , and total Cs are presented for the columns in series and for the lead column for the third CsRD run, respectively, in Figs. 24 and 25. As can be seen, the ^{137}Cs , ^{134}Cs , and total Cs track each other well. This is to be expected

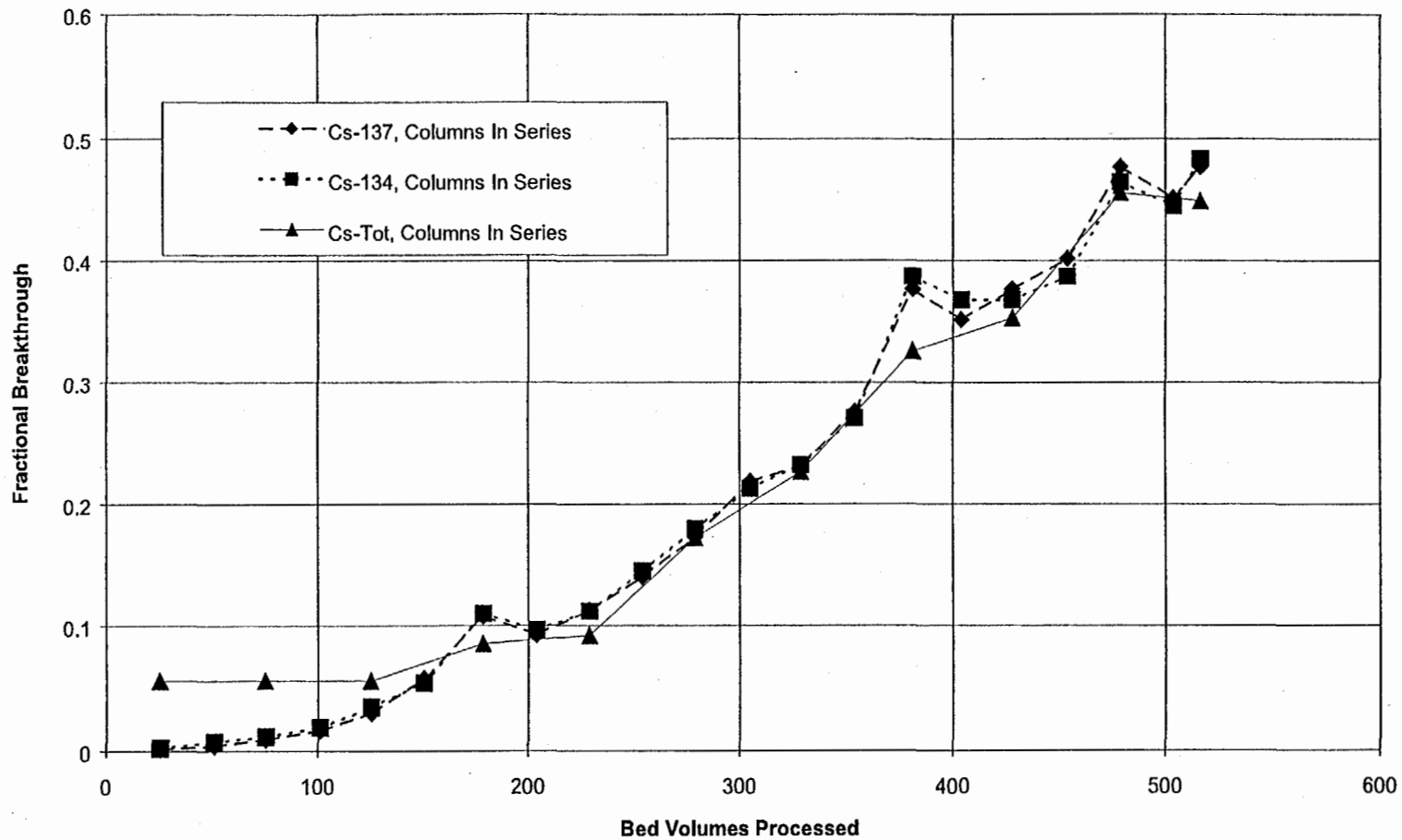

Fig. 24. Breakthrough curves for ^{137}Cs , ^{134}Cs , and total cesium for CsRD run 3 for both columns in series.

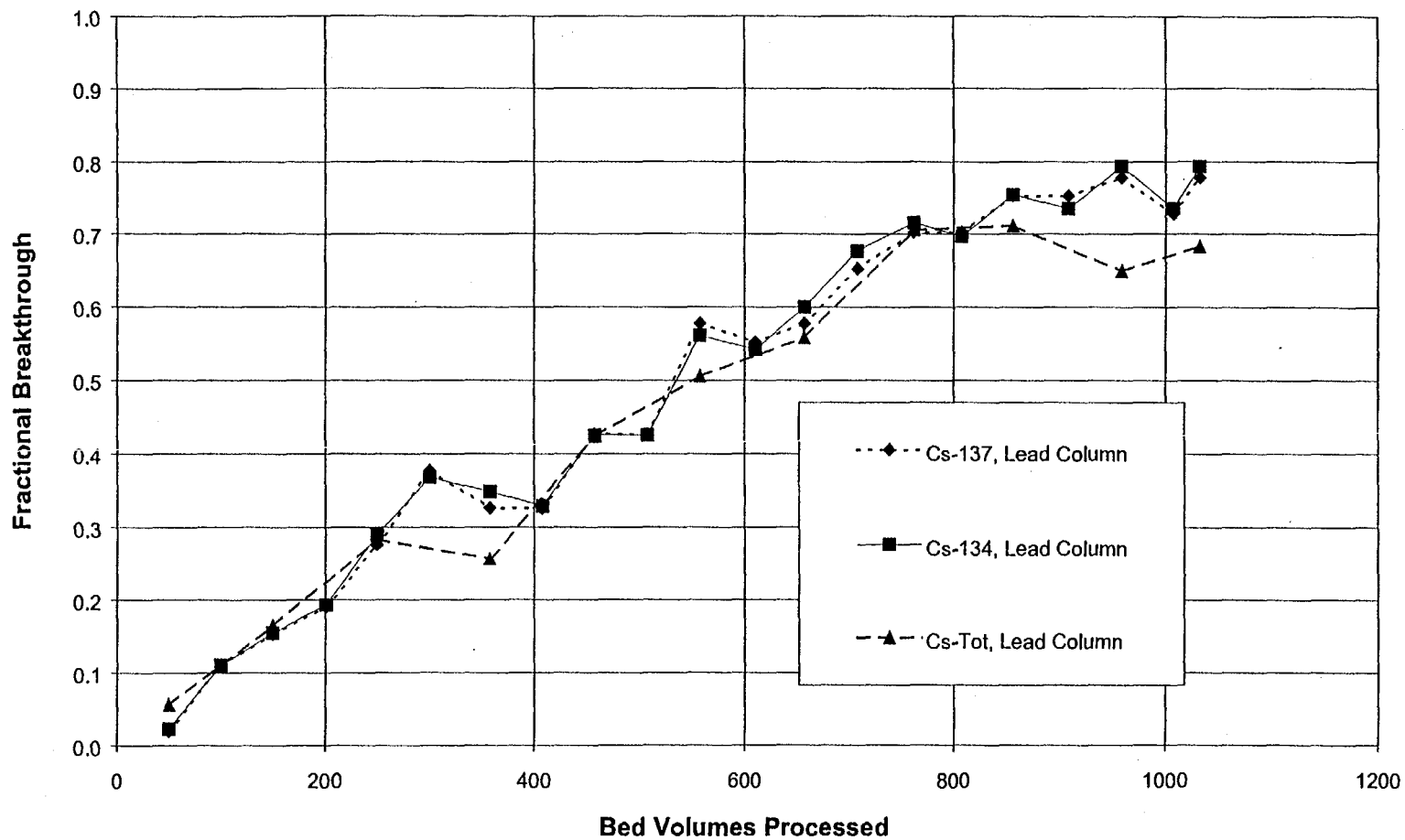

Fig. 25. Breakthrough curves for ^{137}Cs , ^{134}Cs , and total cesium for CsRD run 3 lead column.

because ion-exchange processes do not significantly differentiate between isotopes. Figure 24 shows that 1% breakthrough of ^{137}Cs and ^{134}Cs occurred after ~75–80 bed volumes had been processed and ~47% breakthrough occurred after ~470 bed volumes had been processed. Both of these values compare well with data for the second CsRD run, which was also conducted at 3 BV/h. The ^{137}Cs loading for both columns during the third run totaled ~334 Ci, which averages 4.4 Ci/L. This value also compares favorably with that for the second run, 4.1 Ci/L. A slightly higher capacity per unit volume of sorbent could be expected in the third run because the fractional breakthrough in the third run was slightly less than that in the second run.

As can be seen from Fig. 25, the fractional breakthrough for the first column in series during the third CsRD run was taken to about 80%. This column loaded ~222 Ci of ^{137}Cs . Also, the effect of the ~10-day shutdown, with the sorbent allowed to sit in the supernate solution, can be seen from this figure. The scheduled shutdown, which occurred at ~300 BV, did not have a negative impact on the loading of ^{137}Cs after the system was restarted. This indicates that in full-scale operations the ion-exchange process could be shut down for several days without causing a decrease in the expected loading, thus adding considerable flexibility to the operation.

Breakthrough curves for Ba, Pb, Rb, and Zn for the third run are presented in Fig. 26, and breakthrough curves for ^{90}Sr , ^{60}Co , Sr, and U are presented in Fig. 27. These are also typical of data collected from the second CsRD run. Loading curves for Ba, Pb, and Rb

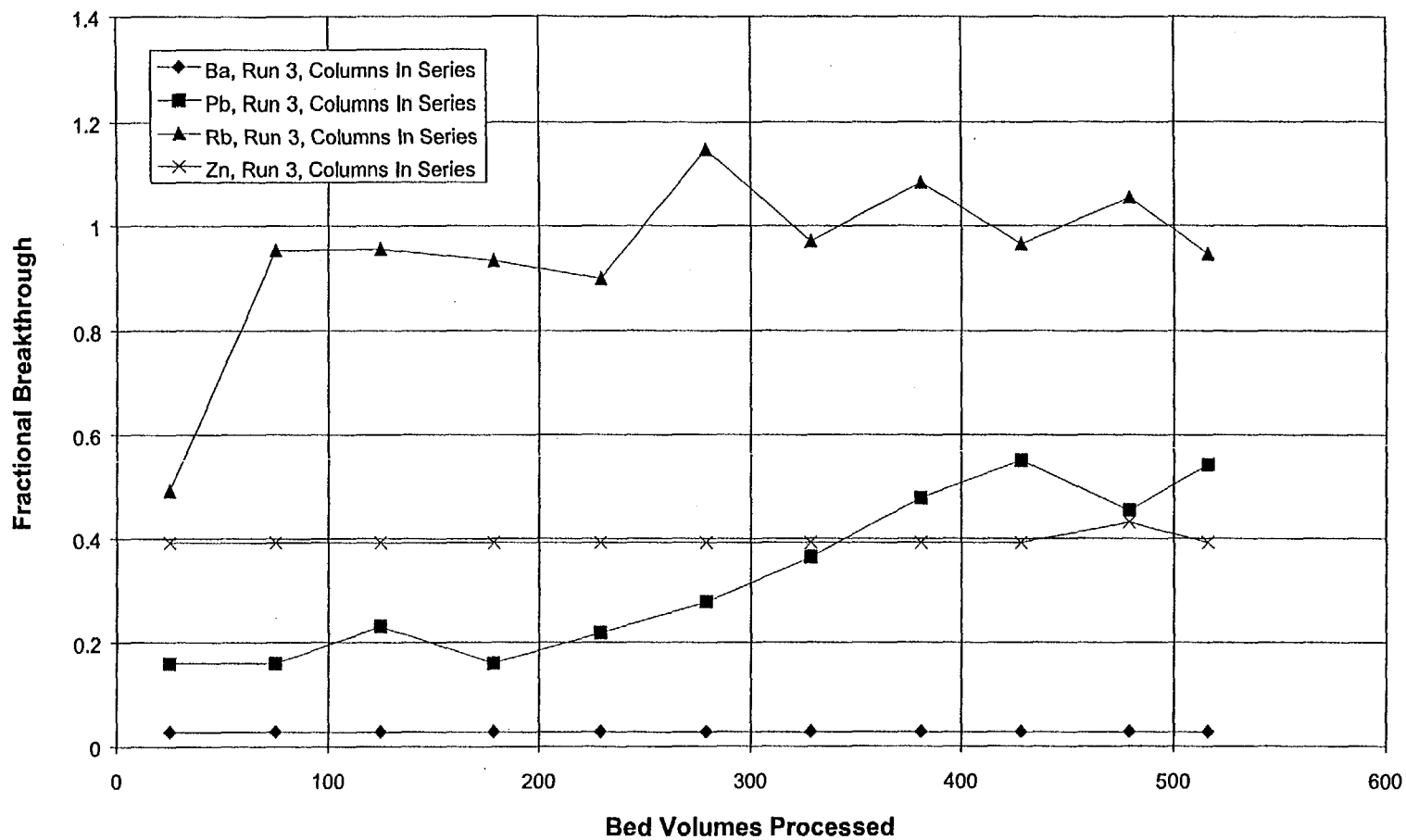

Fig. 26. Breakthrough curves for Ba, Pb, Rb, and Zn for CsRD run 3.

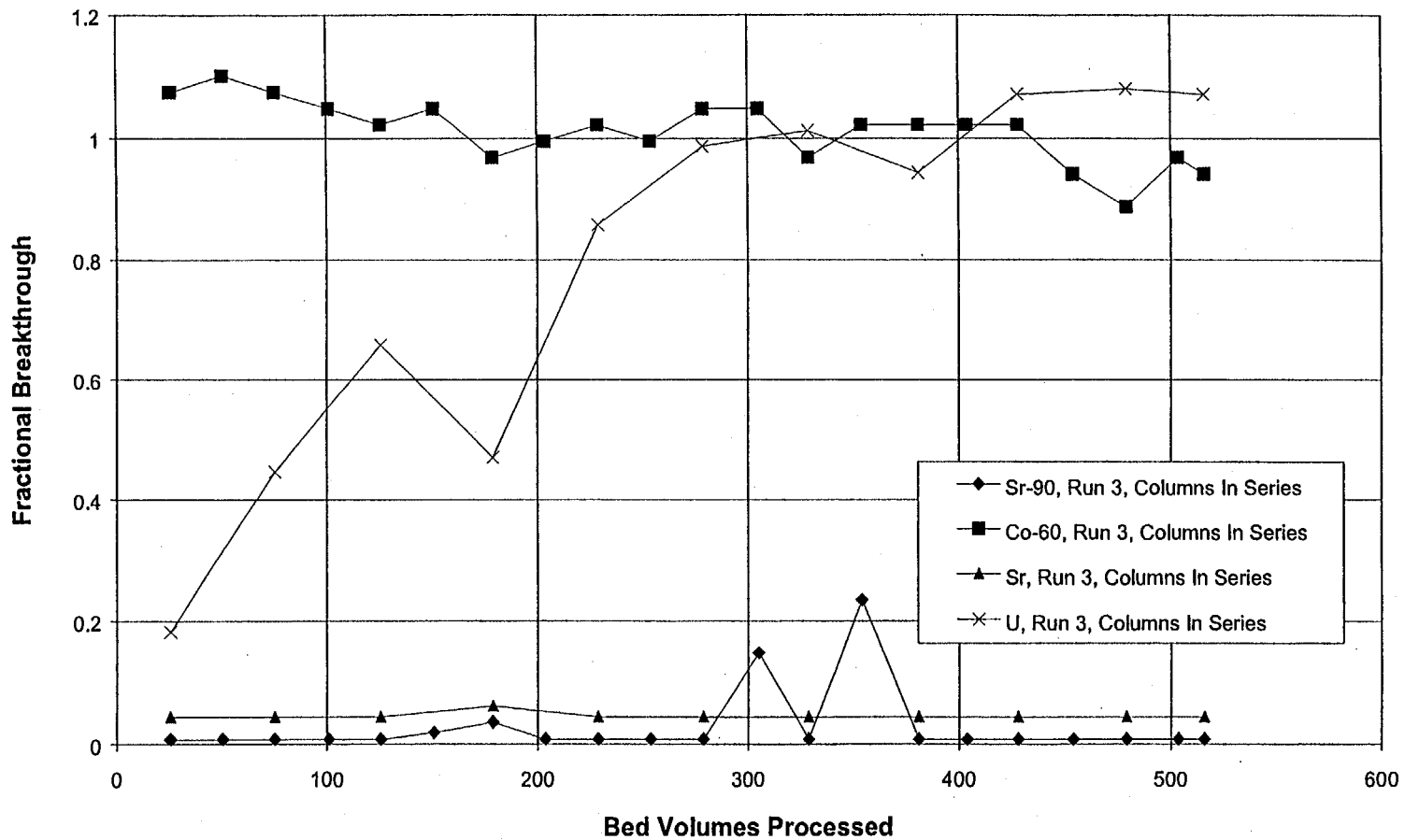

Fig. 27. Breakthrough curves for ^{60}Co , ^{90}Sr , Sr, and U during CsRD run 3.

were generated to determine whether these RCRA metals loaded on the sorbent and analyses of the radionuclides were required by the Technical Safety Requirements of the project. It was noted from the ICP analysis, which provided concentrations of some of the RCRA metals, that zinc also loaded on the sorbent. The loading curve for zinc was included for general information.

7.4 CESIUM REMOVAL DEMONSTRATION RUN 4

The fourth and final CsRD run was initiated at ~7:45 a.m. on May 5, 1997, and completed at ~8:00 p.m. on May 16, 1997. This was a three-column run, with each column containing 38 L of sorbent. The lead column (column 1) reached 55% breakthrough of ^{137}Cs after ~28,346 L (7,489 gal) had been processed and ~253 Ci of ^{137}Cs had been loaded. Column 1 was then removed from service, the lag column (column 2) was moved into the lead-column position, and a column with new sorbent (column 3) was placed in the lag-column position. Analyses indicate that column 2 loaded ~266 Ci of ^{137}Cs and column 3 loaded ~112 Ci of ^{137}Cs , for a total of ~631 Ci of ^{137}Cs removed during run 4. The flow rate during the initial portion of the run, 3.8 L/min (3 BV/h for the system), was increased to 7.6 L/min (6 BV/h for the system) for the final portion of the run.

Breakthrough curves for ^{137}Cs for the lead column and for the first two columns in series for run 4, prior to the changeout of the sorbent in the lead column, are presented in

Figs. 28 and 29, respectively. As can be seen, ~590 BV was required to reach 50% breakthrough in the lead column. This compares with ~470 BV required for 50% breakthrough of ^{137}Cs in the lead column during run 3. The discrepancy in the capacity for ^{137}Cs between runs 3 and 4 can be attributed to the differences in feed concentrations. After the third CsRD run had been completed, there was not enough supernate in the W-29 MVST feeding the CsRD system to complete run 4; therefore, two MVSTs were combined to resolve this problem. A summary of the supernate concentrations for the three runs can be found in Table 7. The concentration of radioactive cesium was higher in run 4 than in run 3; however, the total cesium concentration was less. Therefore, one would expect to load more radioactive cesium during run 4. The loading curves for ^{134}Cs , total Cs, ^{90}Sr , total Sr, ^{60}Co , U, Ba, Pb, Rb, and Zn were typical of those previously presented for earlier CsRD runs.

A graph of the cumulative volume of supernate processed during the fourth run vs the ^{137}Cs fractional breakthrough is presented in Fig. 30. The high fractional breakthrough for column 2 in the lag position at the initiation of this run can probably be attributed to residual loaded sorbent remaining in the lag column from the previous run. Since the inlet concentration to the lag column was very low at the beginning of the run prior to breakthrough from the lead column, any residual loaded sorbent from the previous run would tend to skew the fractional breakthrough for the lag column to the high side initially.

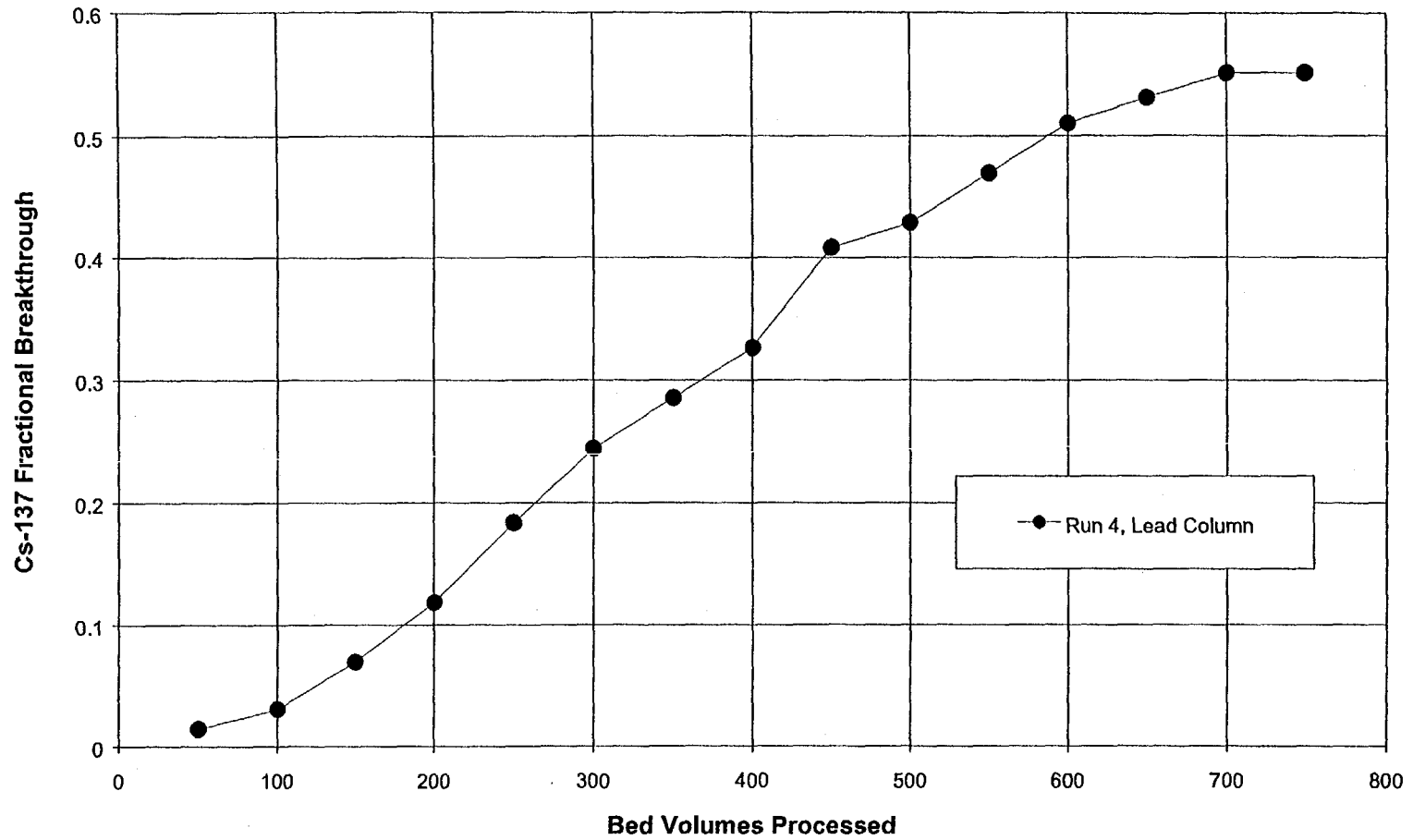

Fig. 28. Breakthrough curve for ^{137}Cs for the CsRD run 4 lead column.

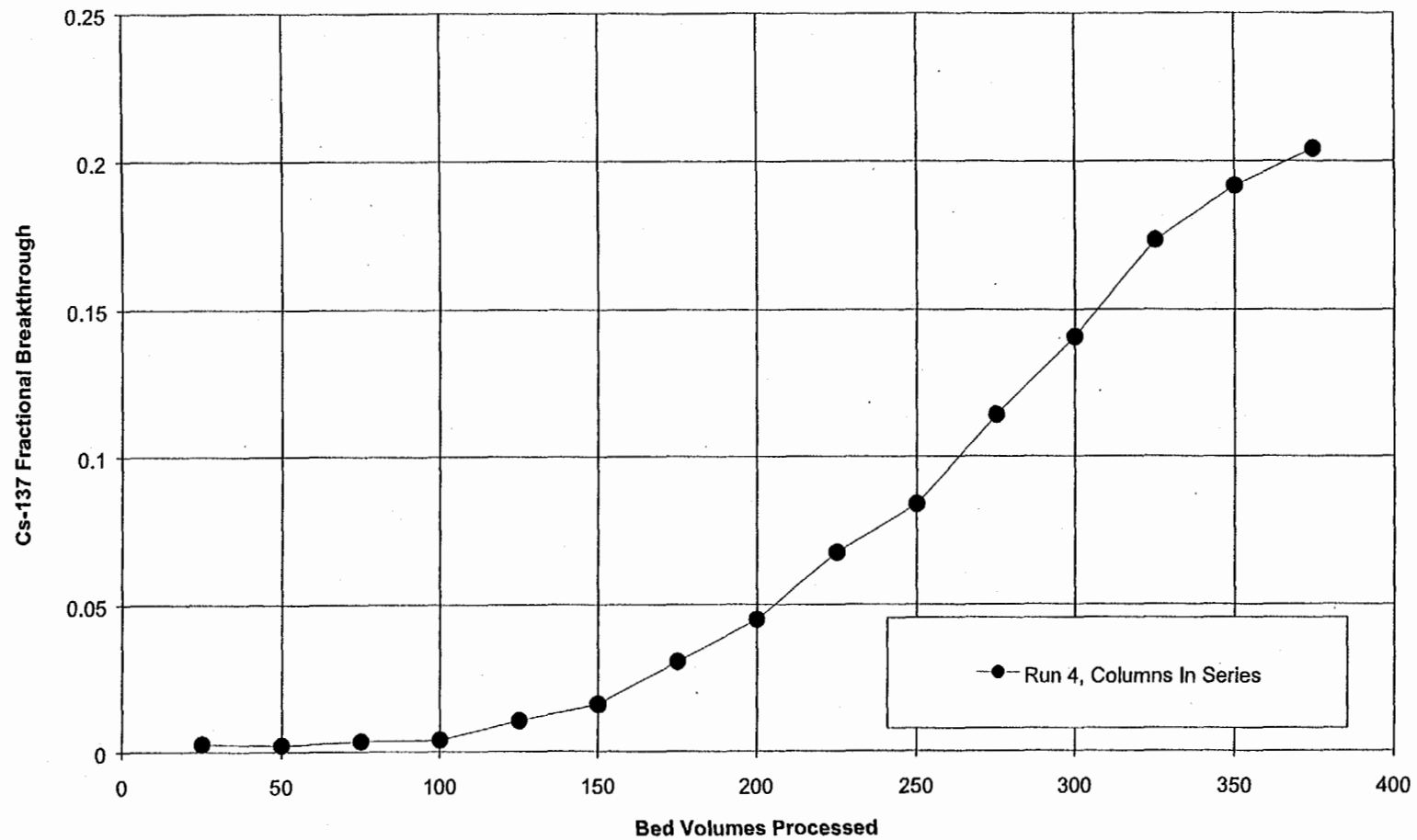

Fig. 29. Breakthrough curve for ^{137}Cs for CsRD run 4 for the first two columns in series.

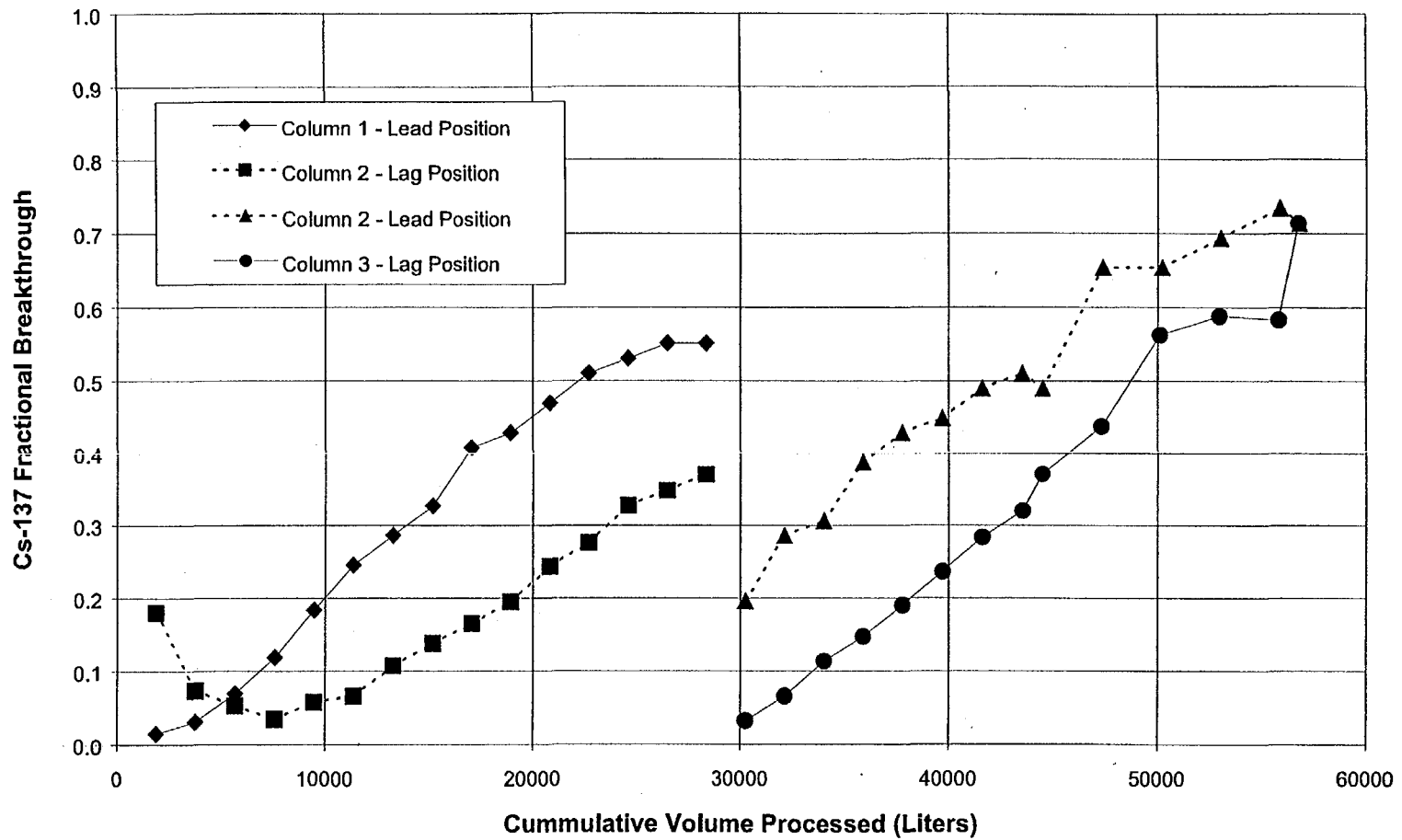

Fig. 30. Cumulative volume of supernate processed during CsRD run 4 vs the ^{137}Cs fractional breakthrough.

The pressure drop across the filter and the individual ion-exchange columns during run 4 is presented in Fig. 31. At a flow rate of 3.8 L/min, the pressure drop across both columns varied from ~1 to 1.3 psi. This agreed well with results of tests with simulants in the cold-test loop prior to the start of the operations with the radioactive supernate. In those tests, the pressure drop at a flow rate of 3.8 L/m (1 gal/min) was ~1.3 psi. Pressure drop versus flow rate per unit area for the simulant tests is presented in Fig. 6. When the flow rate was increased to 7.6 L/min (2 gal/min), the pressure drop rose rapidly to the 2.1–2.6 range. No data were taken with the simulants in the cold-test loop at the higher flow rate. The pressure drop did not increase appreciably during this run for the filter or the ion-exchange columns, indicating that solids were not collecting on the filter or on the ion-exchange beds.

7.4.1 Radiation Protection During Run 4

During CsRD run 4, detailed information was kept on the quantity of ^{137}Cs in the feed tank, the ion-exchange columns, and the storage area along with the radiation levels at various points in the process building for comparison with dose-rate models provided by the Office of Radiation Protection. A graphical comparison of the actual dose-rates and the model predictions is presented in Fig. 32 (see Fig. 20 for the location of dose points).

The shielding code used to determine the dose rate(s) for the various main sources was QADM0D-GP. This program calculates gamma-ray fluxes, dose rates, or heating rates at

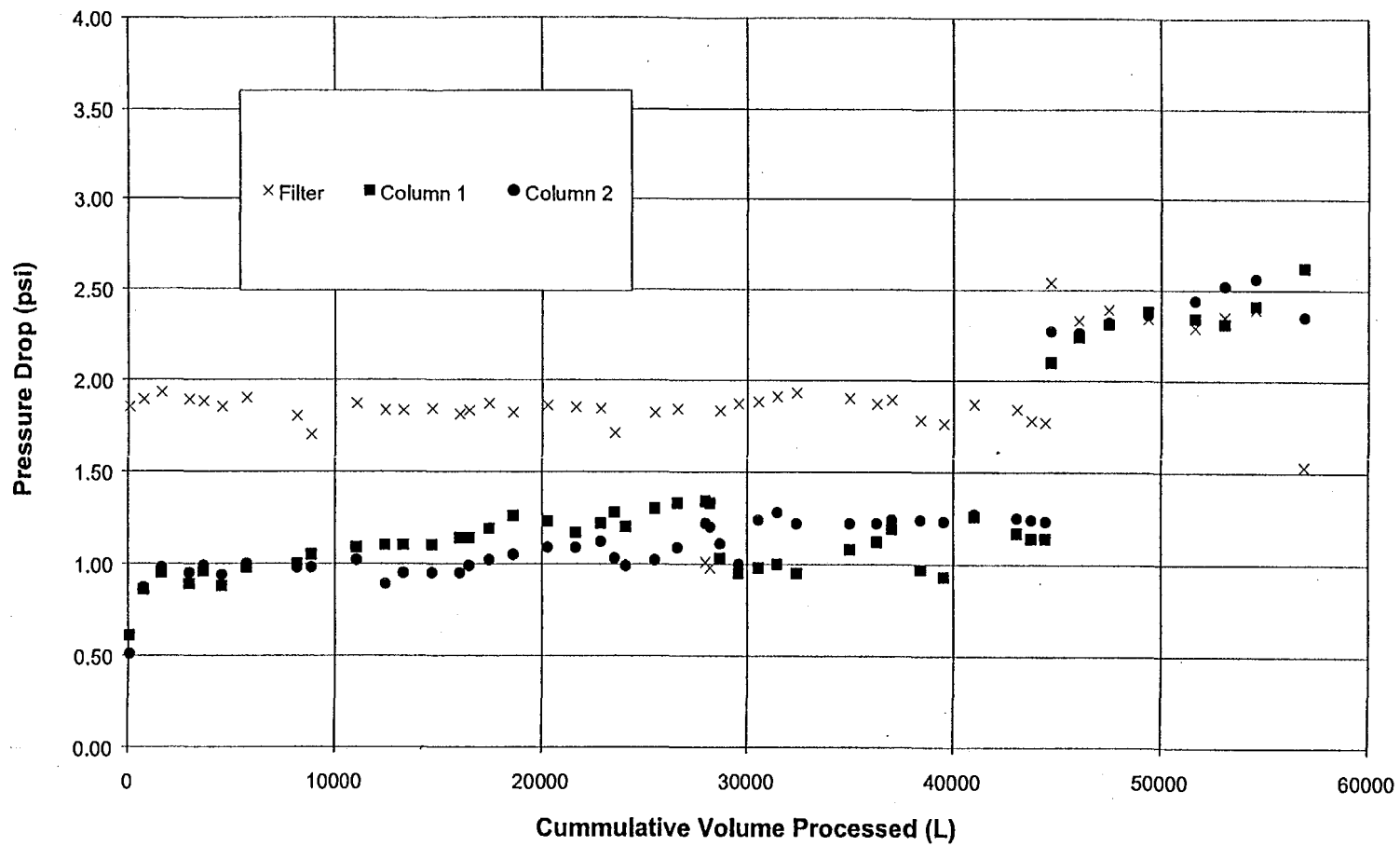

Fig. 31. Pressure drop across the filter and the two ion-exchange columns during CsRD run 4.

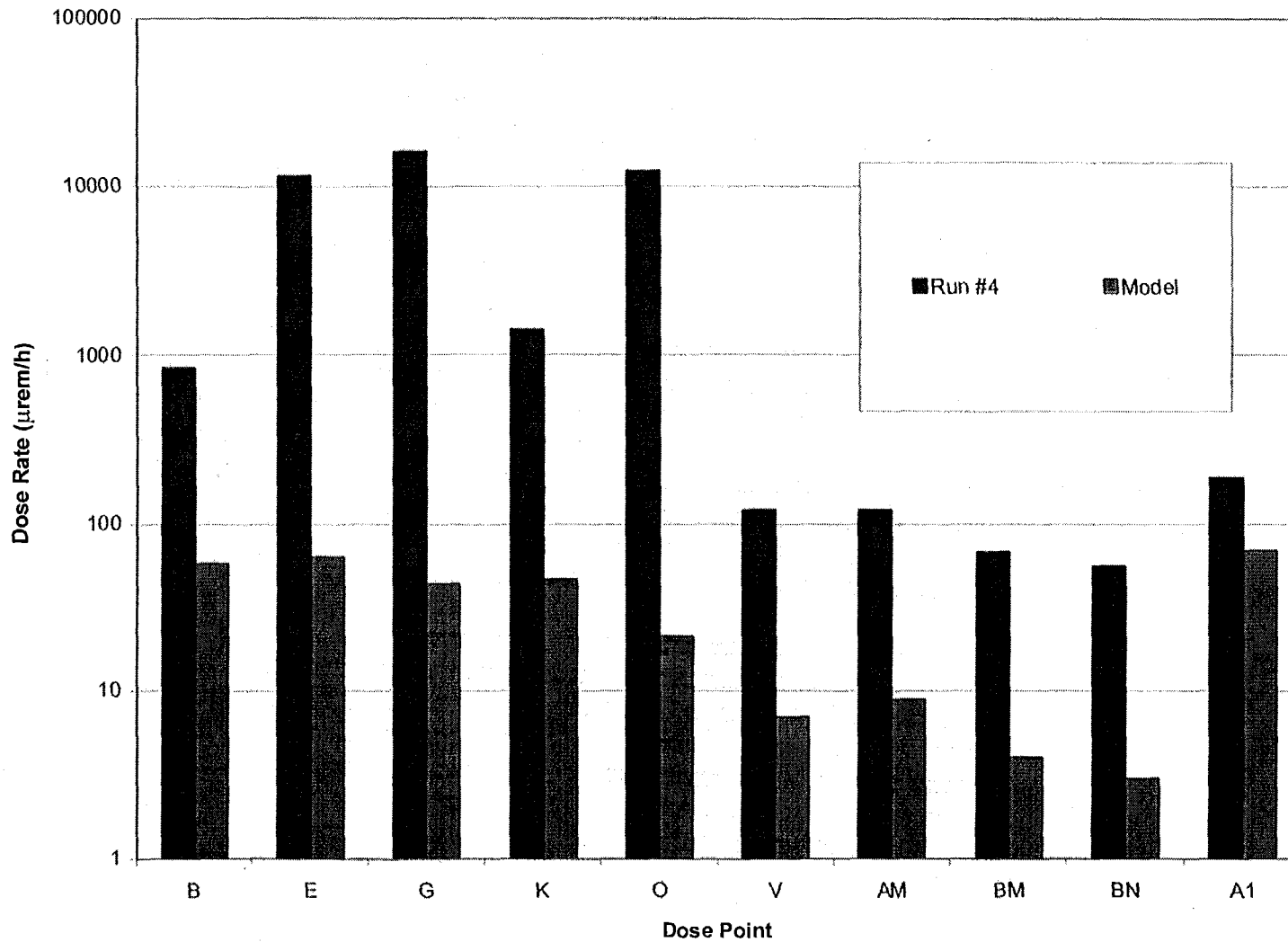

Fig. 32. Comparison of actual dose rates from CsRD run 4 with the dose rate predicted by the model.

discrete locations within a complex source-geometry configuration by representing a volume-distributed source by a number of point isotropic sources and computing the distance through all regions traversed by the line-of-sight from the source point to a desired receiver point. From these distances and the characteristics of the materials within them, energy-dependent exponential attenuation factors and energy-dependent buildup factors from gamma rays are applied to calculate both the direct gamma-ray dose and the gamma-ray dose with buildup. QUADM0D-GP employs the faster geometry routines to define region boundaries with the general quadric surface equation.

Additional features of the PC version are as follows: (1) use of the geometric progression buildup factors; (2) addition of a subroutine to allow use of updated mass attenuation coefficients (without coherent scattering); (3) addition of a subroutine to compute flux-to-dose rate conversion factors for arbitrary photon energies; (4) increase of the number of allowable computed source-point locations (from 500 to 3000); (5) increase of the exponential function minimum (from -180.218 to -87.0) in KERNEL to avoid underflows; and (6) installation of a "card image" routine to print formatted input data at the beginning.

Assumptions made for the initial data input were: (1) laboratory analysis was used as the feed tank concentration and the filter concentration; (2) a 200-Ci loading was used in each ion-exchange column; (3) 200 Ci was present in each of the drums in the drum storage area; (4) the stacked lead was the only shielding for the drum storage area; and (5) no transfer lines would be modeled. Changes to original geometric configurations were

demonstrated using Microshield 4.21 and more simplistic geometries. The correction factor was generated and then later applied to the semifinal dose rate to account for the extra shielding. Changes made for the dose rates presented in Fig. 32 include: (1) the concentration of ^{137}Cs in the feed tank was determined to be 12.5 Ci; (2) column X-1 contained 100 Ci of ^{137}Cs , and column X-2 contained 255 Ci of ^{137}Cs ; and (3) the temporary leaded storage area inside Building 7877 contained 253 Ci of ^{137}Cs .

Measured dose rates versus calculated dose rates are roughly within one order of magnitude for all points except those closest to the unshielded transfer lines and to the sampling station. At the time the input files for the shielding code were being generated, the piping and sampler location were not known. Therefore, the unshielded transfer lines and the sampling station were not included in the original calculations. As can be seen from Fig. 32, the actual radiation level was higher in all locations than that predicted by the model. This indicates that the radiation from the unshielded transfer and process lines, which were not included in the model, was substantial.

After completion of processing during the fourth CsRD run, the sorbent located in column X-1 (i.e., column 3 in Fig. 30), which had loaded ~ 112 Ci of ^{137}Cs , was sluiced into the dewatering/storage drum located on the sorbent sluicing/drying skid. During the sluicing operations, the maximum dose rates at points W1 and N were 1000 and 135 mR/h, respectively. Standard operating procedures were used to dry the sorbent. After drying, ~ 56 L of vermiculite was remotely added on top of the sorbent, a lid was

remotely placed on top of the drum, and the shielded transfer bell was used to transport the drum to the shielded storage area located in Building 7877. Radiation readings during the transportation of the drum of sorbent are presented in Table 8.

After the drum containing the dried sorbent from column X-1 had been stored in the shielded storage area, sluicing and drying of the sorbent located in column X-2, which had loaded ~266 Ci of ^{137}Cs , were initiated. Standard operating procedures were utilized to sluice, dry, and transfer the sorbent. The maximum dose rates during sluicing of the sorbent at points W1 and N were 1600 and 120 mR/h, respectively. Radiation readings during the transportation of the drum of sorbent are presented in Table 9.

All of the drums of loaded sorbent from the CsRD were removed from Building 7877 and placed in the SWSA at ORNL to await final off-site disposal. Each drum remained in an individual shield, which is detailed in Sect. 5 of this report, and each drum shield was placed in an individual concrete vault. Details for each of these waste packages are provided in Table 10.

7.5 MASS TRANSFER PARAMETERS

Doulah and Jafar ⁸ have developed a method to calculate the ion-exchange transport parameters, such as distribution coefficient and mass transfer zone height, from the shape of the breakthrough curve. The breakthrough curves for run 2 and for the first column in

Table 8. Radiation readings taken during movement of drum of dried sorbent containing ~112 Ci of ¹³⁷Cs from the sluicing/drying skid to the shielded storage area in Building 7877

Location of drum of sorbent	Dose point	Dose rate (mR/h)
In dewatering/drying drum shield with transfer bell mated to dewatering/drying drum shield	W1	50
In shielded transfer bell with transfer bell ~3 m above floor over dewatering/drying drum shield	W1	80
In shielded transfer bell with transfer bell ~3 m above floor over tank TK-2	W1	300
In shielded transfer bell with transfer bell ~3 m above floor over dose point G (see Fig. 20)	W1	180
In shielded transfer bell with transfer bell ~0.46 m (18 in.) above floor over dose point G (see Fig. 20)	W1	30
In shielded transfer bell with transfer bell ~0.31 m (12 in.) above floor over dose point G (see Fig. 20)	Below transfer bell	210
In drum shield located inside shielded sorbent storage area with lid off drum shield	Top of drum	55,000
In drum shield located inside shielded sorbent storage area with lid off drum shield	Side of drum	460,000
In drum shield located inside shielded sorbent storage area with lid on drum shield	Top of drum shield	380

Table 9. Radiation readings taken during movement of drum of dried sorbent containing ~266 Ci ¹³⁷Cs from the sluicing/drying skid to the shielded storage area in Building 7877

Location of drum of sorbent	Dose point	Dose rate (mR/h)
In dewatering/drying drum shield with transfer bell mated to dewatering/drying drum shield	W1	9
In shielded transfer bell with transfer bell ~3 m above floor over dewatering/drying drum shield	W1	100
In shielded transfer bell with transfer bell ~3 m above floor over tank TK-2	W1	700
In shielded transfer bell with transfer bell ~3 m above floor over dose point G (see Fig. 20)	W1	400
In shielded transfer bell with transfer bell ~0.61 m (24 in.) above floor over dose point G (see Fig. 20)	W1	60
In shielded transfer bell with transfer bell ~0.31 m (12 in.) above floor over dose point G (see Fig. 20)	Below transfer bell	280,000
In drum shield located inside shielded sorbent storage area with lid off drum shield	Top of drum	100,000
In drum shield located inside shielded sorbent storage area with lid off drum shield.	Side of drum	620,000
In drum shield located inside shielded sorbent storage area with lid on drum shield	Top of drum shield	780

Table 10. Details for each of the waste packages, consisting of the drum of dried sorbent, the drum shield, and the concrete vault, used for storage at the SWSA at ORNL

Drum	Drum ID	Drum shield ID	Dose rate at contact top (mR/h)	Dose rate at contact sides (mR/h)	Dose rate at contact bottom (mR/h)	Vault ID	Dose rate at contact sides (mR/h)	Dose rate at 1 m sides (mR/h)
1	X10I9512507	X10C9700976	390	10	3900	X10C9700295	-	-
2	X10I9512508	X10C9700977	440	20	5200	X10C9700317	-	-
3	X10I9512509	X10C9700978	330	6	3500	X10C9700318	-	-
4	X10I9512519	X10C9700979	740	70	6500	X10C9700386	500	80
5	X10I9512520	X10C9700980	400	60	3800	X10C9700387	600	80
6	X10I9512521	X10C9700981	710	55	7400	X10C9700388	350	18

runs 3 and 4 were used to calculate the parameters. The results are shown in Table 11; comparable results for the laboratory-scale tests are shown in Table 12. A method for predicting distribution coefficients specifically for the CST sorbent, based on the composition of the feed solution, has been developed by Zheng et al.⁹ The results from this method are also listed in Tables 11 and 12.

Runs 2 and 3 used the same feed solution at two different flow rates. Since the mass transfer coefficient increases almost linearly as the flow rate (and the fluid velocity) increases, film diffusion is significant in controlling the mass transfer process. The feed solution for run 4 contained a much lower total cesium concentration, which decreased the saturation capacity of the sorbent. The columns used in the CsRD were relatively short and squat, having an aspect diameter-to-bed-height ratio of 1:1.5, which gives a low number of theoretical plates. This results in a relatively early breakthrough of cesium, since the height of a theoretical plate (mass transfer zone) is only slightly shorter than the bed height of the CST sorbent in the columns. The two different methods for calculating the distribution coefficient give similar results. The Zheng method predicts a lower distribution coefficient for run 4, based on the lower cesium and higher potassium concentration in the feed solution, than for runs 2 and 3. The breakthrough curve analysis shows that run 4 actually had a higher distribution coefficient.

All of the laboratory-scale tests used the same feed solution as that for runs 2 and 3 of the CsRD. Both CST-6 and -7 had only one column each, while CST-8 used two columns in

Table 11. Run conditions and ion-exchange transport parameters for CsRD runs

Run conditions	Run No.		
	2	3	4
CST bed height, cm	45	45	45
Flow rate, BV/h	3.0	6.0	6.0
Superficial velocity, cm/min	2.58	5.17	5.17
Initial cesium concentration, meq/L	0.0135	0.0135	0.0051
Calculated parameters			
Distribution coefficient, L/kg	831	856	1035
Height of a theoretical plate, cm (mass transfer zone, 5% to 95%)	37.0	41.0	38.8
Number of theoretical plates	1.22	1.10	1.16
Liquid-phase mass transfer coefficient, 1/h	0.0040	0.0074	0.0064
Cs saturation capacity, meq/g	0.011	0.012	0.0053
Zheng et al. ^a distribution coefficient, L/kg	885	885	861

^aZ. Zheng, D. Gu, and R. G. Anthony, "Estimation of Cesium Ion Exchange Distribution Coefficients for Concentrated Electrolytic Solutions When Using Crystalline Silicotitanates," *Ind. Eng. Chem. Res.* **34**, 2142-47 (1995).

Table 12. Run conditions and ion-exchange transport parameters for laboratory-scale tests

Run Conditions	Run no.		
	CST-6	CST-7	CST-8
CST bed height, cm	6.1	7.6	14
Flow rate, BV/h	6.0	3.0	3.0
Superficial velocity, cm/min	0.57	0.36	0.66
Initial cesium concentration, meq/L	0.0135	0.0135	0.0135
Calculated Parameters			
Distribution coefficient, L/kg	587	670	593
Height of theoretical plate, cm (mass transfer zone, 5% to 95%)	4.37	5.48	9.13
Number of theoretical plates	1.40	1.39	1.53
Liquid-phase mass transfer coefficient, 1/h	0.0148	0.00456	0.00786
Cs saturation capacity, meq/g	0.0079	0.0095	0.0080
Zheng et al. ^a distribution coefficient, L/kg	885	885	885

^aZ. Zheng, D. Gu, and R. G. Anthony, "Estimation of Cesium Ion Exchange Distribution Coefficients for Concentrated Electrolytic Solutions When Using Crystalline Silicotitanates," *Ind. Eng. Chem. Res.* **34**, 2142-47 (1995).

series. The laboratory-scale columns had a higher aspect ratio than the CsRD columns, ranging from 1:4 for one column to 1:9 for two columns in series. The laboratory-scale tests also generally showed a higher mass transfer coefficient as the fluid velocity increased, supporting the theory that film diffusion is significant in controlling the mass transfer process. Operational factors in the CsRD process that increase the effect of film diffusion on the process include the small size and high porosity of the CST sorbent, as well as the relatively low liquid velocity through the sorbent. The performance of the CST sorbent could probably be improved by using taller columns and correspondingly higher liquid velocities. However, since the current system is adequate for treatment of the waste at ORNL, there are no plans for a major redesign of the system at this time.

8. BENCH-SCALE SUPPORT

Bench-scale simulations using the actual supernate being processed in the full-scale CsRD were conducted in the Building 4505 hot cell. The bench-scale equipment used in these simulations was the same as that used to provide data in the sorbent selection process for the CsRD; it was described in Sect. 3 of this report. In addition, a 25- μm filter was placed upstream of the ion-exchange column(s) in the bench-scale simulation to better simulate the full-scale demonstration. The primary objectives of the bench-scale simulations were (1) to allow direct comparisons of the breakthrough curves for the bench-scale and full-scale systems using the same feed and similar operating conditions, and (2) to provide samples of loaded sorbent for analysis to document that the loaded

CST sorbent from the CsRD was not hazardous as defined by the Toxicity Characteristic Leaching Procedure (TCLP) for RCRA metals.

Four bench-scale simulations with small columns were conducted. A summary of these runs is provided in Table 13. Figures 33 and 34 provide comparisons of the ^{137}Cs breakthrough curves for the full-scale and bench-scale runs at 3 BV/h and 6 BV/h, respectively. The bench-scale and full-scale data show very good agreement, indicating that laboratory-scale column data can be successfully used to design full-scale ion-exchange systems. It should be noted that there was less scatter in the bench-scale data than in the data from the full-scale CsRD system. This can be attributed to the fact that longer counting times were used in the analyses of the samples from the bench-scale operations.

Loading data from analyses of the solids from the bench-scale small column tests are presented in Table 14. These data were obtained by dissolving the spent CST sorbent from the bench-scale tests in concentrated acid and then analyzing the liquid. Analyses of the solids from the bench-scale test corroborate the loading curves from the full-scale CsRD, which showed that Cs, Sr, and U were removed from the supernate while Co was not. Data from the bench scale test also show that Pu was removed from the supernate.

Results of the TCLP analyses, for RCRA metals, of the loaded CST sorbent from the bench-scale simulation tests are presented in Table 15. As can be seen, the

Table 13. Summary of bench-scale runs conducted in support of the full-scale CsRD

Run No.	Description of run
CST-5	Single-column run at 6 BV/h to ~60% breakthrough of ^{137}Cs ; first documentation that the loaded CST sorbent was not hazardous as defined by the TCLP for RCRA metals
CST-6	Single-column run at 6 BV/h to ~90% breakthrough of ^{137}Cs
CST-7	Single-column run at 3 BV/h to ~50% breakthrough of ^{137}Cs
CST-8	Two columns in series run with ^{137}Cs breakthrough from the second column at ~50%

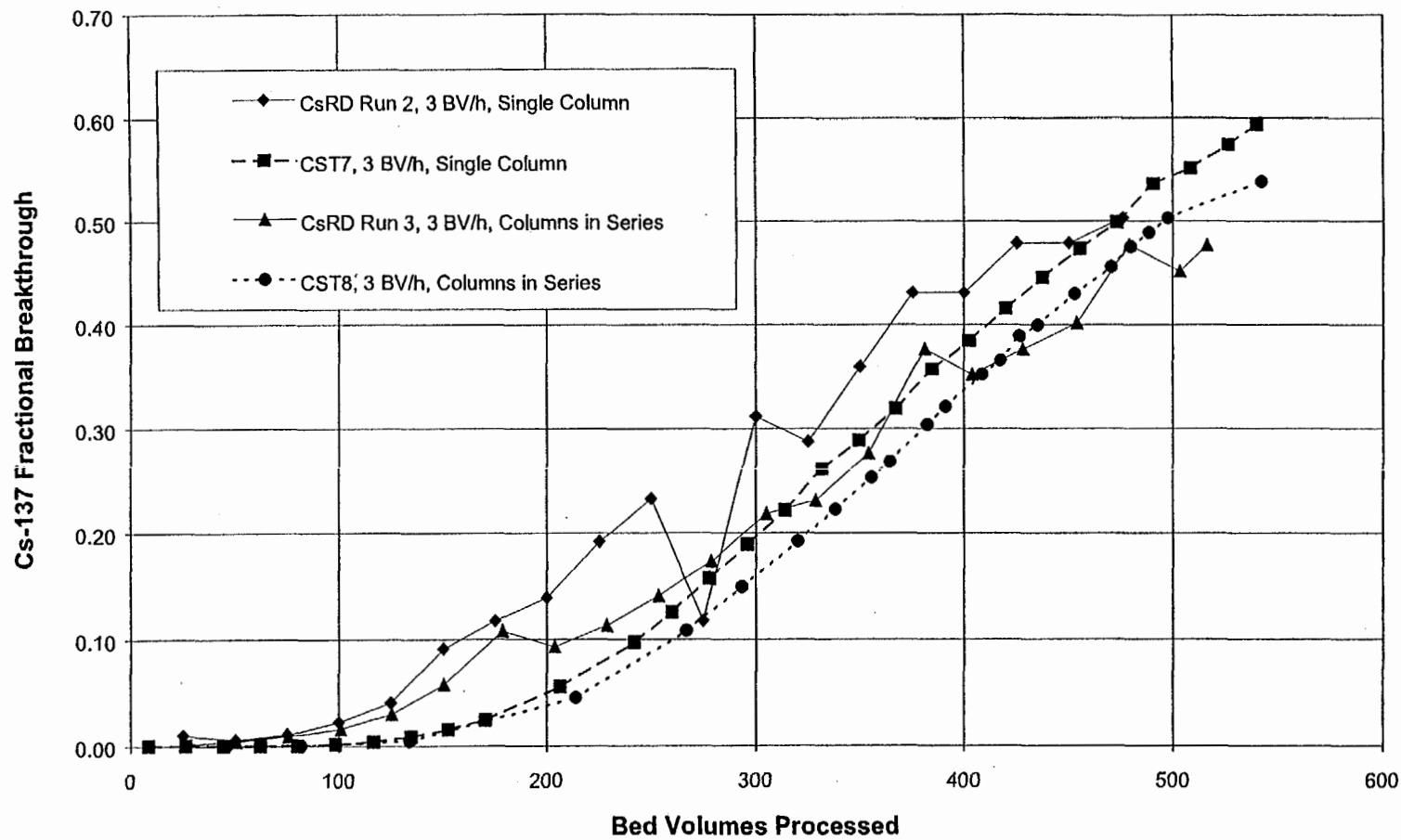

Fig. 33. Comparison of ^{137}Cs breakthrough curves for the full-scale and bench-scale runs at 3 BV/h.

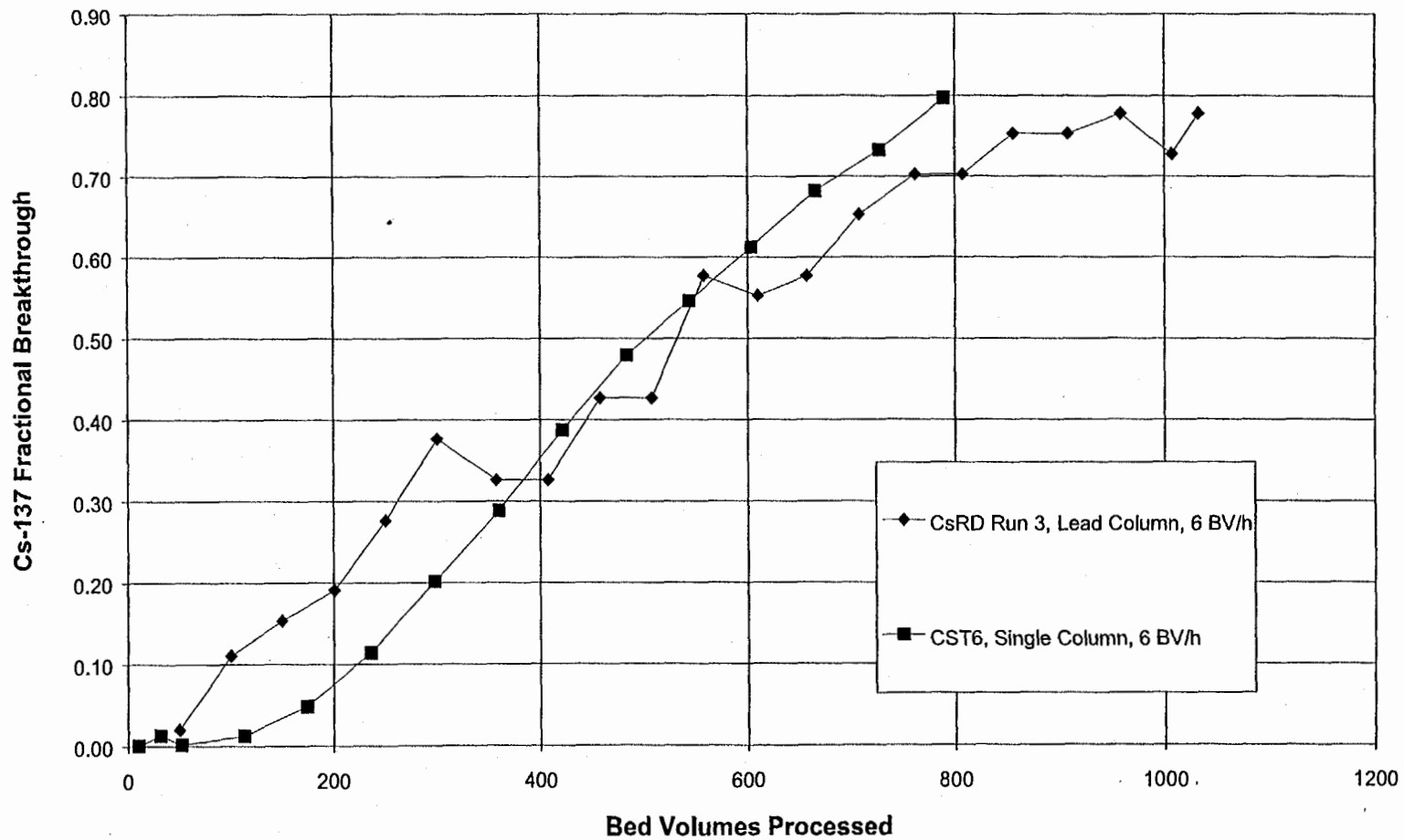

Fig. 34. Comparison of ¹³⁷Cs breakthrough curves for the full-scale and bench-scale runs at 6 BV/h.

Table 14. Loading data from analysis of the solids from the bench-scale, small-column tests

Component	Run no.		
	CST-6	CST-7	CST-8
⁶⁰ Co, Bq/g	-	<87,000	-
¹³⁴ Cs, Bq/g	-	1.6 × 10 ⁶	1.8 × 10 ⁶
¹³⁷ Cs, Bq/g	1.7 × 10 ⁸	1.2 × 10 ⁸	1.5 × 10 ⁸
Gross Alpha, Bq/g	6,600	3,700	5,000
Gross Beta, Bq/g	2.0 × 10 ⁸	1.5 × 10 ⁸	1.8 × 10 ⁸
Total Pu, Bq/g	480	150	440
²³⁸ Pu, Bq/g	320	100	292
²³⁹ Pu and ²⁴⁰ Pu, Bq/g	170	50	150
⁹⁹ Tc, Bq/g	<180	<231	<271
Total rad. Sr, Bq/g	1.7 × 10 ⁷	1.6 × 10 ⁵	2.5 × 10 ⁶
U, mg/kg	3,640	2,440	1,440
²³³ U, atom %	0.1276	0.1280	0.1272
²³⁴ U, atom %	0.0035	<0.0001	0.0015
²³⁵ U, atom %	0.3296	0.3369	0.3476
²³⁶ U, atom %	0.0049	0.0035	0.0061
²³⁸ U, atom %	99.534	99.53160	99.5176

Table 15. Analytical results of the TCLP analyses for RCRA metals, of the loaded CST sorbent from the bench-scale simulations

Run No.	As (mg/L)	Ba (mg/L)	Cd (mg/L)	Cr (mg/L)	Pb (mg/L)	Hg (mg/L)	Se (mg/L)	Ag (mg/L)
Regulatory limit	5.0	100	1.0	5.0	5.0	0.2	1.0	5.0
CST-5	<0.16	1.8	<0.02	<0.05	<0.29	<0.002	0.31	<0.07
CST-6	<0.0125	0.415	<0.05	<0.0125	0.140	<0.0525	<0.01525	<0.05
CST-7	<0.00625	0.274	<0.0250	0.0125	0.0221	<0.00375	<0.00625	<0.0250
CST-7, duplicate	<0.00625	0.280	<0.0250	0.0113	0.0415	<0.00375	<0.00625	<0.0250
CST-8	<0.0063	0.066	<0.0250	<0.0063	0.037	<0.0038	<0.0063	<0.0250
CST-8, duplicate	<0.0063	0.019	<0.0250	<0.0063	0.019	<0.0038	<0.0063	<0.0250

concentrations of the RCRA metals in the leachate are much less than the regulatory limit set for hazardous waste. This meets part of the waste acceptance criteria required for permanent disposal at the Nevada Test Site (NTS). The NTS Program Manager for Waste Management at ORNL is preparing waste profiles for the individual waste packages (i.e., the individual drums of loaded CST sorbent with vermiculite added as an absorbent to ensure that there is no free liquid in the waste package). These waste packages meet the NTS Waste Acceptance Criteria, and it is expected that the waste profiles will be accepted and the waste packages will be shipped to NTS for permanent disposal. Details of the waste profiles for the CsRD have been documented by the NTS Program Manager for Waste Management at ORNL.¹⁰

9. DECONTAMINATION AND DISMANTLING OF THE CsRD SYSTEM

After the operational phase of the CsRD was completed, decontamination of the system was initiated. The first step in the decontamination process was to flush the lines used for sluicing the sorbent from the ion-exchange skid (skid 2), with water, which flowed to the sorbent sluicing drying skid (skid 3) and then into the dewatering/storage drum located on skid 3. Details of the piping and skid placement can be found in Figs. 9-11. This dewatering/storage drum on skid 3 contained the spent sorbent from the fourth CsRD run and any spent sorbent flushed from the sluice lines collected on top of the spent sorbent. After the flushing operations had been completed, the sorbent was dried and remotely moved to the temporary storage area within Building 7877. Dose readings on the sluice

lines, which were constructed from high-pressure hose, indicated that the radiation levels for the hose was <200 mR/h. These hoses were removed from the system and placed in a B-25 burial box for disposal because it was probable that grains of spent sorbent remained on their interiors.

The next step was to backwash the filter and the columns. The filter was backwashed with ~190 L (50 gal) of water, and each column was backwashed with ~75 L (20 gal) of water. The standard operating procedures found in Appendix E were used, and the backwash water was pumped back to the MVST W-29 tank. After the filter and columns had been backwashed, flushing of the feed tank skid (skid 1) was initiated. For the first flushing operation, ~75 L of water was placed in the feed tank and then cycled from the feed tank, through pump P-1 at a flow rate of ~10 L/min, and back to the feed tank for ~15 min. The water was subsequently pumped to MVST W-29. Two additional 15-min flush cycles, with ~75 L of water used for each cycle, were then conducted; the water was recycled back to the tank through pump P-2 at a flow rate of ~10 L/min. Following the second and third flushes, the dose rate at the opening to the feed tank shield opening was 5 R/h and the dose rate at RV01 and RV02 was 1 R/h. Spent sorbent appeared to be present in the line between the feed tank and pumps P-1 and P-2. These lines were subsequently flushed by recirculating water through the feed tank, both pumps, column X-1, and back to the feed tank at a flow rate of 38 L/min for ~15 min. The objective was to increase the flow rate to a sufficiently high level to mobilize the spent sorbent in the line between the feed tank and the feed pumps and collect it in column X-1.

Following this flushing operation, the dose rate at the feed tank shield opening decreased from 5 R/h to 2.4 R/h and the dose rate at RV01 and RV02 decreased from 1 R/h to 650 mR/h. This flushing operation was then repeated two more times, with air being introduced to the line to create additional turbulence. After this flushing operation had been completed, the dose rate through the shield opening decreased from 2.4 R/h to 220 mR/h and the dose rate at RV01 and RV02 decreased from 650 mR/h to 450 mR/h. Water from the flushing operations was then routed to MVST W-29.

On completion of the above-mentioned flushing operations, dose readings were taken from skid 2. Skid 2 was then flushed again with process water and air. The locations where the dose readings were taken are presented in Fig. 35, and the dose rates after the initial and second rinses are presented in Table 16. These dose rates indicated that residual spent sorbent was being moved from place to place in the piping between the filter and the first ion-exchange column. Additional flushing with clean water reduced the dose rates in this piping to <200 mR/h.

Dismantling of the CsRD system was subsequently initiated. After the top three sections of the concrete shield had been removed from around skid 1 (the feed tank skid), a dose rate of 12 R/h was measured inside the remaining bottom section of the concrete shield. The radiation was due to residual sorbent present in the discharge line between the bottom of the feed tank and the feed pump. This sorbent had been introduced into the feed tank by the operations involved in backwashing the ion-exchange columns. Water

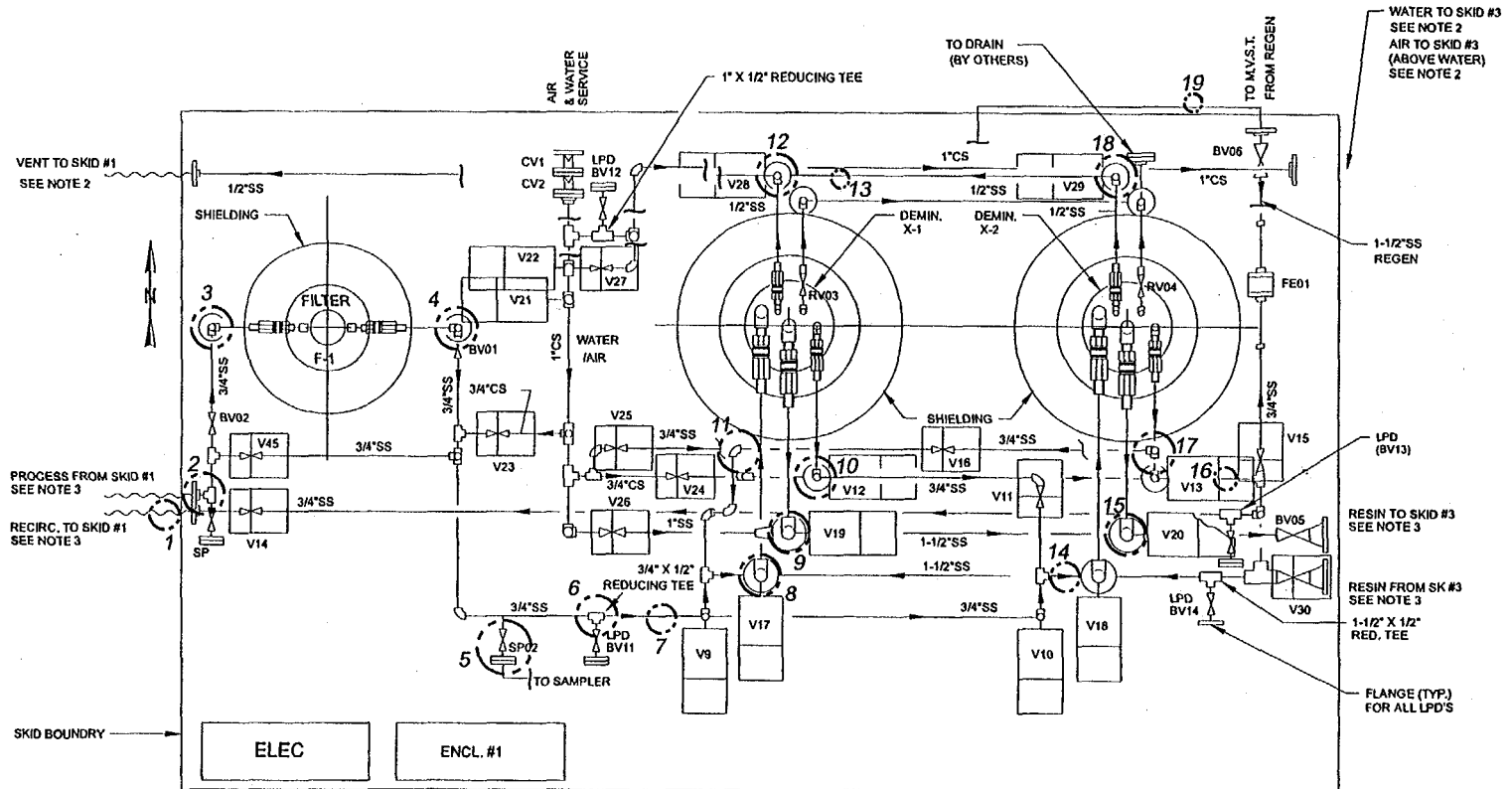

Fig. 35. Locations of dose-rate readings from skid 2 following backwashing of the filter and the ion-exchange columns.

Table 16. Dose-rate readings from skid 2 following backwashing of the filter and ion-exchange columns

Position	Dose rate after initial rinse (mR/h)	Dose rate after second rinse (mR/h)
1	300	300
2	200	200
3	150	150
4	200	200
5	500	700
6	100	200
7	250	250
8	580	1000
9	425	425
10	200	300
11	2000	400
12	40	40
13	48	48
14	400	350
15	250	250
16	300	300
17	350	350
18	30	30
19	12	12
20	60	60

was added to the top of the feed tank, and this line was flushed; the effluent was pumped back to the MVST W-29. The dose rate in the discharge line increased from 12 R/h to 17 R/h, indicating that additional sorbent was being washed from the sides of the feed tank and collecting in the line. This line was then flushed with two batches of a nitric acid-water mixture (3.9 L of concentrated nitric acid poured into ~57 L of water), and the effluent was pumped back into MVST W-29. Following these two rinses, the dose rate in the discharge line decreased from 17 R/h to 520 mR/h. Dose readings on the top, sides, and cone of the feed tank were 10 mR/h, 80 mR/h, and 2 R/h, respectively. A third acid-water rinse reduced the dose in the feed tank to 1.6 R/h. Additional acid-water rinses were not conducted because the pump used to return the rinse water to MVST W-29 failed. The discharge line was disconnected and sealed with a blind flange, and connecting piping between the three skids was removed. Building 7877 and the exterior surfaces of all three skids were then decontaminated. Because the smears indicated that the transferable contamination was < 2500 dpm beta/gamma per 100 cm², personnel from the Office of Radiation Protection considered the system to be safe for removal and storage. Thus, it was removed and placed in a storage tent at the MVST site. The system was decontaminated to the extent that it can be contact-maintained with local shielding. Company clothes, Tyvek suits, shoe covers, and gloves had to be worn during work on the exterior of the system. A respirator was also required when accessing the interior of the piping or vessels.

It should be noted that flushing the discharge line from the CsRD feed tank with dilute nitric acid was very effective in reducing the dose rate even though the CST sorbent is nonregenerable and the acid does not strip the radioactive cesium from the sorbent. Prior to the acid rinse, the CST sorbent particles seemed to stick to the inside surfaces of the tank and pipes. The acid rinse stripped the CST particles from the inner surfaces of the tank and pipes, and these particles were flushed from the system.

10. SUMMARY

A full-scale Cesium Removal Demonstration (CsRD) has been jointly funded by the Department of Energy's (DOE) Office of Science and Technology (OST) and Office of Waste Management (OWM). The CsRD was conducted at ORNL using actual radioactive supernate from the MVST. The sorbent chosen for the demonstration, a crystalline silicotitanate (CST) ion-exchange material, was selected on the basis of its effectiveness in batch and small-scale column tests, using both simulants and actual waste supernates from the MVST. This is the first large-scale demonstration of the new state-of-the-art ion-exchange sorbents being developed jointly by DOE and private industry. The primary objectives for the CsRD were to (1) demonstrate the use of modular, transportable equipment in existing facilities (2) process up to 100,000 L (25,000 gal) of radioactive supernate; (3) evaluate decontamination for hands-on maintenance and possible transfer to other sites; (4) compare bench-scale and full-scale data; (5) provide loaded sorbent for vitrification studies; (6) concentrate the cesium on small-volume, solid

waste forms and package these waste forms to meet the Waste Acceptance Criteria (WAC) for the NTS; and (7) provide a full-scale operational system for use in baseline activities at ORNL after the demonstration was completed.

The CsRD system, which was designed by TTI Engineering (Walpole, MA) and fabricated by Walter N. Yoder and Sons (Cumberland, MD), was a modular, mobile system consisting of three skids: (1) a feed tank skid, (2) an ion-exchange skid, and (3) a sorbent sluicing/drying skid. The system was placed in ORNL Building 7877, which provided secondary containment and a HEPA ventilation system. The system was operated remotely from Building 7863, which was located ~100 ft from Building 7877.

Four runs were conducted during the CsRD campaign. The first of these was a single-column, minimal-loading run designed to test the system and procedures prior to the full-loading runs. It was completed in September 1996, meeting Secretary of Energy Hazel O'Leary's milestone to President Clinton for initiation of operation in FY 1996. A total of ~23 Ci of ^{137}Cs was loaded onto 38 L (10 gal) of sorbent. The sorbent from this run was shipped to the SRS for use in a vitrification demonstration using a joule-heated melter within the Savannah River Technology Center Shielded Cells. The remotely operated vitrification process included preparation of the melter feed, vitrification in an 1150°C melter, and analysis of the glass product for both composition and durability. The campaign processed approximately 20 kg of cesium-loaded CST in 80 h of operation.

The glass product contained between 50 and 55 wt % loaded CST. Details of the CST vitrification demonstration have been published by Andrews et al.¹¹

The second run consisted of a single 38-L column of sorbent operated at 3 BV/h.

Approximately 18,028 L (4,763 gal) of Melton Valley Storage Tank (MVST) supernate was processed prior to 50% breakthrough of ¹³⁷Cs, and ~154 Ci ¹³⁷Cs was loaded on the sorbent.

The third run consisted of the operation of two 38-L columns of sorbent operated in series at a flow rate of 6 BV/h. Approximately 39,061 L (10,320 gal) of supernate was processed, with the lead and lag columns reaching ~80 and ~47% breakthroughs of ¹³⁷Cs, respectively. The lead column loaded a total of ~222 Ci of ¹³⁷Cs, and the lag column loaded ~112 Ci.

The fourth run was a three-column run, with each column containing 38 L of sorbent.

The system was initially started with two columns in series. The lead column (column 1) reached 55% breakthrough of ¹³⁷Cs after ~28,346 L (7,489 gal) had been processed and ~253 Ci of ¹³⁷Cs had been loaded. Column 1 was then removed from service, the lag column (column 2) was moved into the lead-column position, and a column with new sorbent (column 3) was placed in the lag-column position. Analyses indicate that column 2 loaded ~266 Ci and column 3 loaded ~112 Ci of ¹³⁷Cs for a total of ~631 Ci of ¹³⁷Cs removed during run 4.

During the entire operational period, ~115,757 L (30,583 gal) of supernate was processed and ~1,142 Ci of ^{137}Cs was removed from that supernate and loaded onto 70 gal of CST sorbent. Following operation, the system was decontaminated to the extent that it could be contact maintained and, if necessary, shipped for use at another site. The system was then turned over to the Waste Management and Remedial Action Division for use in their baseline operations. The EM-50 milestone to complete the processing of up to 94,625 L (25,000 gal) of MVST supernate by July 31, 1997, was met, and the EM-30 milestone to remove at least 520 Ci of radioactive cesium by June 30, 1997, was also met. Laboratory analysis of the spent sorbent has shown that it is nonhazardous; thus, no further stabilization is necessary prior to disposal. The sorbent from last three runs will be stored at the ORNL solid waste storage area (SWSA) until it can be shipped off-site for permanent disposal. The Nevada Test Site Program Manager for Waste Management at ORNL is preparing waste profiles for the individual waste packages (i.e., the individual drums of loaded CST sorbent with vermiculite added as an absorbent to ensure there is no free liquid in the waste package). These waste packages meet the NTS WAC, and it is expected that the waste profiles will be accepted and the waste packages will be shipped to NTS for permanent disposal. Data analysis also confirmed that the cesium breakthrough curves for both the bench-scale columns and the full-scale columns agreed very well, indicating that the bench-scale data can be used to design a full-scale ion-exchange system.

11. CONCLUSIONS

The CsRD conducted at ORNL was the first large-scale use of state-of-the-art sorbents being developed by private industry for selective removal of cesium and other radionuclides from liquid wastes stored across the DOE complex. The CST sorbent was chosen for the demonstration because of its effectiveness in laboratory tests using bench-scale columns. The demonstration showed that the cesium could be removed from the supernate and concentrated on a small-volume, solid waste form that would meet the waste acceptance criteria for the NTS. The loaded sorbent, even without additional immobilization, is nonhazardous as determined by the RCRA TCLP. The sorbent can also be vitrified with a 50 to 55% waste loading of CST. Comparison of data from the bench-scale columns and the columns from the full-scale demonstration system confirm that data from the bench-scale tests can be used to design full-scale ion-exchange systems based on the CST sorbent.

In terms of operations, the CsRD system was able to process >115,000 L (30,000 gal) of radioactive supernate with minimal operational problems. Sluicing, drying, and remote transportation of the sorbent, which could not be done on a bench scale, were successfully demonstrated. The system was able to be decontaminated sufficiently that it could be contact maintained with the use of localized shielding. The system, which was removed from the process building in order to perform the demonstration runs, is now being reinstalled in the process building. Therefore, by utilizing a modular, transportable

design and placing it within existing facilities, we have shown that the system can be transported to different sites after use. The CsRD system is currently being modified for use in baseline operations at ORNL.

12. ACKNOWLEDGMENTS

The authors express their appreciation to the many people who contributed to the successful development and commercialization of crystalline silicotitanates, and much of this work is summarized and/or referenced within this document. In particular, the co-inventors of the CSTs were the late R. G. (Bob) Dosch (Sandia) and Rayford G. Anthony and C. V. Philip (Texas A&M).

There were also a number of other investigators at laboratories deserving of recognition for experimental contributions and support. These include Lane Bray and Garrett Brown at Battelle Pacific Northwest National Laboratory, Zane Egan and Doug Lee at Oak Ridge National Laboratory, Dan McCabe at Savannah River, and Ted Boreck and William Connors at West Valley Nuclear Services Co. In addition to the experimentalists named, the support and contributions of numerous lab personnel at all the facilities are also acknowledged.

The authors also wish to thank the U.S. Department of Energy (DOE) Office of Environmental Management's (EM's) Tank Focus Area and Office of Waste Management for jointly funding this work. Also greatly appreciated were programmatic contributions from Jacquie Noble-Dial, DOE-ORO Program Manager; Phil McGinnis, TFA Pretreatment Technical Integration Manager; and his technical assistant, Tim Welch. The authors appreciate the contributions of Sherry Gibson as the initial DOE-HQ

Program Manager and as the DOE Field Manager during actual operations. The authors also wish to thank J. R. Travis and T. A. Dillow, of the Chemical Technology Division's Chemical and Energy Research Section, for their contributions to the bench-scale sorbent testing and sorbent selection, as well as S. T. Rudell, R. T. Carvin, and C. B. Scott, of the Waste Management and Remedial Action Division, for use of their facilities and for operational support. In addition, they would like to express appreciation to Darro Ferrara, John Harbour, and Mary Andrews, of the Westinghouse Savannah River Company, for their cooperation and effort in the shipment of the spent sorbent to the Savannah River Site.

13. REFERENCES

1. *Radioactive Tank Waste Remediation Focus Area Technology Summary*, DOE/EM-0295, August 1996.
2. S. M. Robinson, Martin Marietta Energy Systems, Inc., Internal Correspondence to J. S. Baldwin, C. A. Manrod, C. B. Scott, and J. R. Trabalka, Dec. 7, 1994.
3. V. L. Fowler, Martin Marietta Energy Systems, Inc., Internal Correspondence to Distribution, Apr. 5, 1995.
4. J. F. Walker, Jr., and E. L. Youngblood, *Design Alternatives Report for the Cesium Removal Demonstration*, Oak Ridge National Laboratory, Oak Ridge, Tenn., ORNL/TM-12939, September 1995.
5. D. D. Lee, J. R. Travis, and M. R. Gibson, *Hot Demonstration of Proposed Commercial Cesium Removal Technology*, Oak Ridge National Laboratory, Oak Ridge, Tenn., ORNL/TM-13169, December 1997.
6. J. E. Miller and N. E. Brown, *Development and Properties of Crystalline Silicotitanate (CST) Ion Exchangers for Radioactive Waste Applications*, Sandia National Laboratories, Albuquerque, N.M., SAND97-0771, April 1997.
7. W. Besancenez, Lockheed Martin Energy Research Corp. Procurement, LMER Contract No. 74X-KAR12V.
8. M. S. Doulah and S. A. Jafar, "A Method for the Prediction of Mass-Transfer Parameters in an Ion-Exchange Process," pp. 293-305 in *Ion Exchange for Industry*, M. Streat, ed., Ellis Horwood, Ltd., Chichester, England, 1988.
9. Z. Zheng, D. Gu, and R. G. Anthony, "Estimation of Cesium Ion Exchange Distribution Coefficients for Concentrated Electrolytic Solutions When Using Crystalline Silicotitanates," *Ind. Eng. Chem. Res.* **34**, 2142-47 (1995).
10. M. K. Ford, *Waste Characterization Executive Summary: Cesium Removal Demonstration Waste*, MMES-ORNL00003, 1998.
11. M. K. Andrews, T. L. Fellingner, D. M. Ferrara, J. R. Harbour, and D. T. Herman, *Vitrification of Cesium-Loaded Crystalline Silicotitanate (CST) in the Shielded Cells Melter*, WSRC-TR-97-00314, Sept. 30, 1997.

Appendix A

**MATERIAL SAFETY DATA SHEET (MSDS) FOR THE
UOP IONSIV[®] ION EXCHANGER TYPE IE-911**

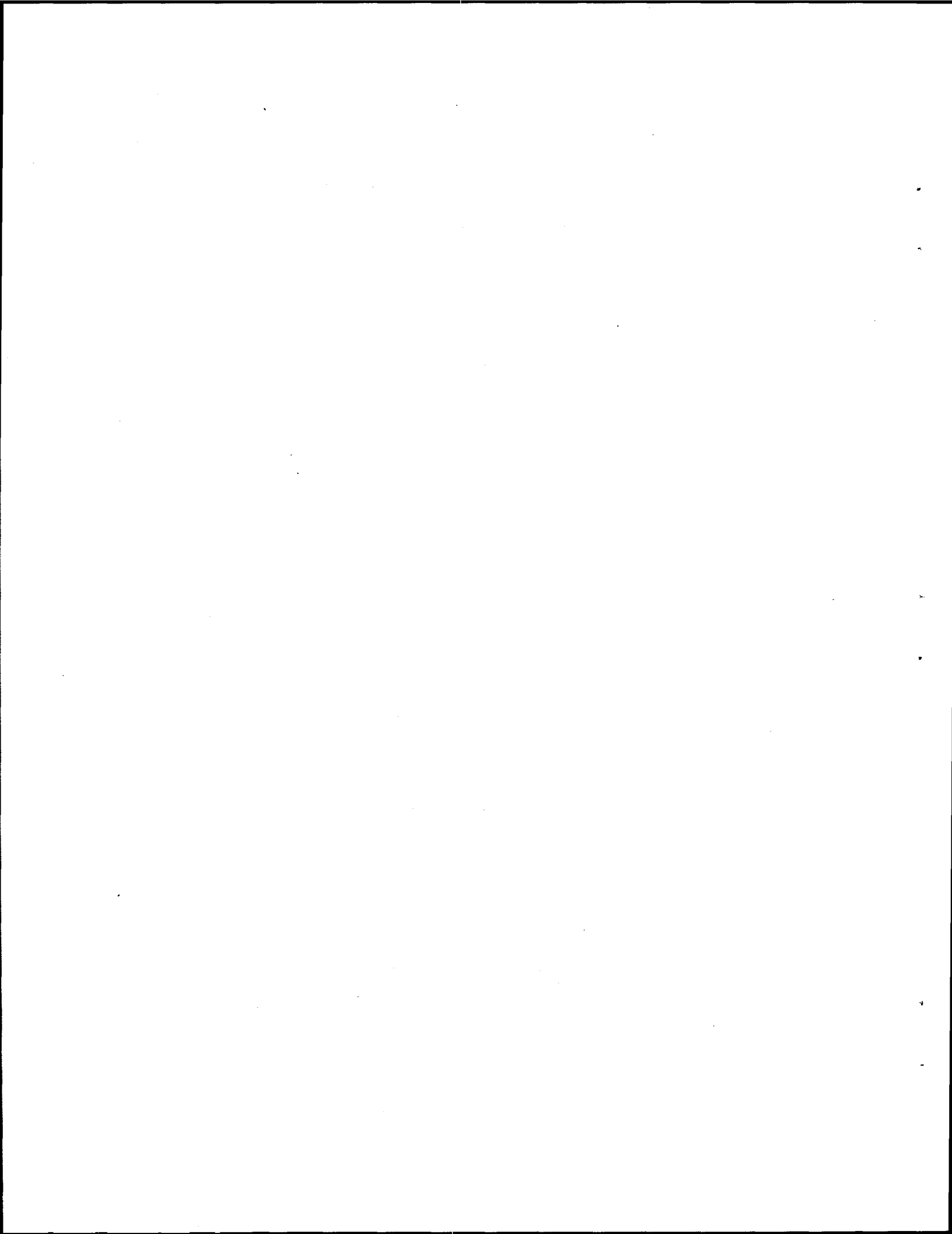



Material Safety Data Sheet

1. EXPERIMENTAL PRODUCT AND COMPANY IDENTIFICATION

Page 1 of 5
January 1996

PRODUCT: UOPTM IONSIVTM Ion Exchanger Type IE-911

UOP
25 E. Algonquin Road
Des Plaines, IL 60017-5017
Telephone: 847-391-3189
FAX: 847-391-2953
Telex: 211442

Emergency Assistance
24 Hour Emergency Telephone Numbers:
USA: UOP 847/391-2123
Chemtrac 800/424-9300
Canada: Canutac 613/986-6686
Outside USA: Chemtrac 202/483-7618

2. COMPOSITION

<u>MATERIAL</u>	<u>CAS No.</u>	<u>~WT%</u>	<u>1995-96 ACGIH TLV-TWA (1995 OSHA PEL-TWA)</u>
Silicon dioxide	7631-86-9	15 - 45	10 mg/m ³ as Si total dust (15 mg/m ³ as Si total dust) (5 mg/m ³ as Si respirable dust)
Titanium dioxide	13463-67-7	20 - 40	10 mg/m ³ (15 mg/m ³ as respirable dust)
Sodium oxide	1313-59-3	5 - 20	None established
Trade Secret material	Trade Secret	15 - 25	None established
Trade Secret metal oxide	Trade Secret	0 - 25	5 mg/m ³ , STEL 10 mg/m ³ (5 mg/m ³ , STEL 10 mg/m ³)
Aluminum oxide (non-fibrous)	1344-28-1	0 - 10	10 mg/m ³ total dust 5 mg/m ³ respirable dust (15 mg/m ³ total dust) (5 mg/m ³ respirable dust)
Copper oxide	1317-38-0	0 - 2	None established
Calcium oxide	1305-78-8	0 - 2	2.0 mg/m ³ (5.0 mg/m ³)
Chromium oxide	1308-38-9	0 - 2	None established
Magnesium oxide	1309-48-4	0 - 2	10 mg/m ³ (15 mg/m ³)

ACGIH - American Conference of Governmental Industrial Hygienists
OSHA - Occupational Safety and Health Administration
TLV - Threshold Limit Value
TWA - Time Weighted Average
PEL - Permissible Exposure Limit

3. HAZARDS IDENTIFICATION

EMERGENCY OVERVIEW:

This white crystalline powder may cause skin and eye irritation. Inhalation of dust may cause respiratory irritation. Product is considered to have a low oral toxicity.

© Copyright 1996 UOP All rights reserved

POTENTIAL HEALTH EFFECTS:

- Primary Routes of Exposure:** Contact with skin and eyes. Exposure may also occur via inhalation or ingestion if product dust is generated during handling. Product ingestion is unlikely but may occur if proper safety/hygiene procedures are not followed.
- Skin Contact:** The solid or dust may cause irritation with repeated or prolonged exposure.
- Eye Contact:** Solid or dust may cause irritation or reddening due to mechanical action. Mild to moderate irritation of eye membrane may also occur possibly resulting in swelling.
- Inhalation:** May cause irritation of the nose and throat, accompanied by cough and chest discomfort. Prolonged inhalation may cause lung damage.
- Ingestion:** This product is considered to have a low order of toxicity.

Carcinogenicity Classification:

- IARC:** Titanium dioxide and Silicon dioxide - Not classifiable as human carcinogens (Group 3). None of the other components are classified.
- NTP:** None of the product components are classified.
- OSHA:** None of the product components are classified.

4. FIRST AID MEASURES

- Skin:** Wash affected area with soap and water. If irritation occurs, obtain medical attention.
- Eyes:** Flush with water for at least 15 minutes. If irritation persists, obtain medical attention.
- Inhalation:** Remove affected person to fresh air. If breathing is difficult, oxygen may be needed; obtain medical attention.
- Ingestion:** Do not induce vomiting. Victim should drink large quantities of milk, gelatin solution or water. Obtain medical attention.

5. FIRE FIGHTING MEASURES

- Flash Point:** Not applicable
- Method:** Not applicable
- Extinguishing Media:** Material does not burn. Use media appropriate for surrounding fire (carbon dioxide, dry chemical or foam).
- Fire and Explosion Hazard:** Used material may contain products of a hazardous nature. The user of this product must identify the hazards of the retained material and inform the fire fighters of these hazards.

6. ACCIDENTAL RELEASE MEASURES:

Isolate the affected area; restrict entry to the affected area to personnel wearing proper personal protective equipment. Special attention should be given to respiratory and eye protection, because recovery of material can be expected to generate dust. Vacuum or shovel up spilled material, placing it into appropriate recovery drums or containers.

7. HANDLING AND STORAGE

Store in tightly closed, properly labeled containers. Do not take internally. Avoid repeated or prolonged contact with skin. Avoid contact with eyes and inhalation of dust.

8. EXPOSURE CONTROLS AND PERSONAL PROTECTION

- Respiratory:** Where natural ventilation is inadequate, use mechanical ventilation, other engineering controls or a toxic dust respirator (in USA NIOSH/MSHA-approved) to prevent inhalation of dust.
- Skin:** Chemical-resistant gloves and work uniform as necessary to prevent repeated or prolonged skin contact.
- Eye:** Safety glasses or goggles as necessary to prevent eye contact.

9. PHYSICAL AND CHEMICAL PROPERTIES

These data do not represent technical or sales specifications.

Boiling Point:	Not applicable	Solubility in Water:	Insoluble
Bulk Density:	Not available	% Volatile:	Not applicable
Vapor Pressure:	Not applicable	Appearance:	White Crystalline Powder
Vapor Density:	Not applicable	Odor:	Odorless
Pour Point:	Not applicable	pH in 10% aqueous slurry:	approximately 11
Freezing Point:	Not applicable	Physical State:	Solid
Specific Gravity:	Not applicable		

10. STABILITY AND REACTIVITY

Stability:	Stable.
Conditions to Avoid:	None known.
Hazardous Decomposition Products:	None.
Hazardous Polymerization:	Will not occur.
Incompatible Materials:	Avoid contact with acid and easily oxidized materials.

11. TOXICOLOGICAL INFORMATION

No data available for this product, the following data is for a similar product:

Oral LD50	>5 g/kg (rat)
Eye Irritation	The product is no more than moderately irritating to the eyes of rabbits. No corneal damage was seen. Iritis was seen in 2/6 animals after 1 hour, but none was seen after 48 hours. All 6 rabbits showed irritation of the conjunctiva after 1 hour, but after 72 hours only 1 still showed the irritation.
Skin Irritation	The product is no more than slightly irritating to the skin of rabbits; only barely perceptible erythema was noted at the 1-hr score time in 2/6 rabbits, score of 1 for 2/6 rabbits (maximum possible score is 8).
Skin Sensitization	The product was found not to produce skin sensitization in guinea pigs.
Cytotoxicity	The product is classified in the nondetectable category according to the IERL cytotoxicity scheme (Sandhu, 1979). The product was considered to be noncytotoxic to rabbit alveolar macrophage cells at concentrations less than or equal to 1000 µg/ml.

12. ECOLOGIC INFORMATION

No data currently available.

13. DISPOSAL CONSIDERATIONS

Dispose of product in accordance with all applicable government regulations. The unused product and its components are not listed by generic name or trademark name in the U.S. EPA's Resource Conservation and Recovery Act (RCRA) Hazardous Waste Management Regulations and do not possess any of the four identifying characteristics of hazardous waste.

14. TRANSPORTATION INFORMATION

DOT Hazard Classification: Not Regulated
ID Number: Not Applicable
IMO Hazard Classification: Not Regulated
ID Number: Not Applicable

15. REGULATORY INFORMATION

U.S. TOXIC SUBSTANCES CONTROL ACT (TSCA): All the ingredients of this product are registered in accordance with TSCA.

U.S. SUPERFUND AMENDMENTS AND REAUTHORIZATION ACT (SARA) TITLE III, SECTION 313: The following component(s) in this product is subject to the reporting requirements of section 313 of the Emergency Planning and Community Right-To-Know Act, 40 CFR 372: --none--

EUROPEAN INVENTORY OF EXISTING COMMERCIAL CHEMICAL SUBSTANCES (EINECS): The components of this preparation are included on the EINECS.

Silicon dioxide	2315454
Titanium dioxide	2366755
Sodium oxide	2152089
Trade Secret Material	listed
Trade Secret Material	listed
Aluminum oxide	2156916
Copper oxide	2152691
Calcium oxide	2151389
Chromium oxide	2151609
Magnesium oxide	2151719

16. OTHER INFORMATION

For additional information concerning this product contact the following:

**For health, safety & environmental
information, please contact:**

Product Stewardship Manager
Health, Safety and Environmental Department
UOP
25 E. Algonquin Rd.
Des Plaines, IL 60017-5017
Telephone: (847) 391-3189
Fax: (847) 391-2953

**For technical or product purchasing
information, please contact:**

Account Manager
UOP
307 Fellowship Road
Suite 207
Mt Laurel, New Jersey 08054
Telephone: (609) 727-9400
Fax: (609) 727-9545

PRODUCT EMERGENCIES

If you have a product-related emergency, resulting in an incident such as a spill or release of product, human exposure, etc., and need assistance from UOP, please call us at the following number:

24 Hour EMERGENCY Telephone Number: (847) 391-2123

The data and recommendations presented in this data sheet concerning the use of our product and the materials contained therein are believed to be accurate and are based on information which is considered reliable as of the date hereof. However, the customer should determine the suitability of such materials for his purpose before adopting them on a commercial scale. Since the use of our products by others is beyond our control, no guarantee, express or implied, is made and no responsibility assumed for the use of this material or the results to be obtained therefrom. Information on this form is furnished for the purpose of compliance with Government Health and Safety Regulations and shall not be used for any other purposes. Moreover, the recommendations contained in this data sheet are not to be construed as a license to operate under, or a recommendation to infringe, any existing patents, nor should they be confused with state, municipal or insurance requirements, or with national safety codes.

UOP

Date: January 1996

Revision: 1

Supersedes: February 1995

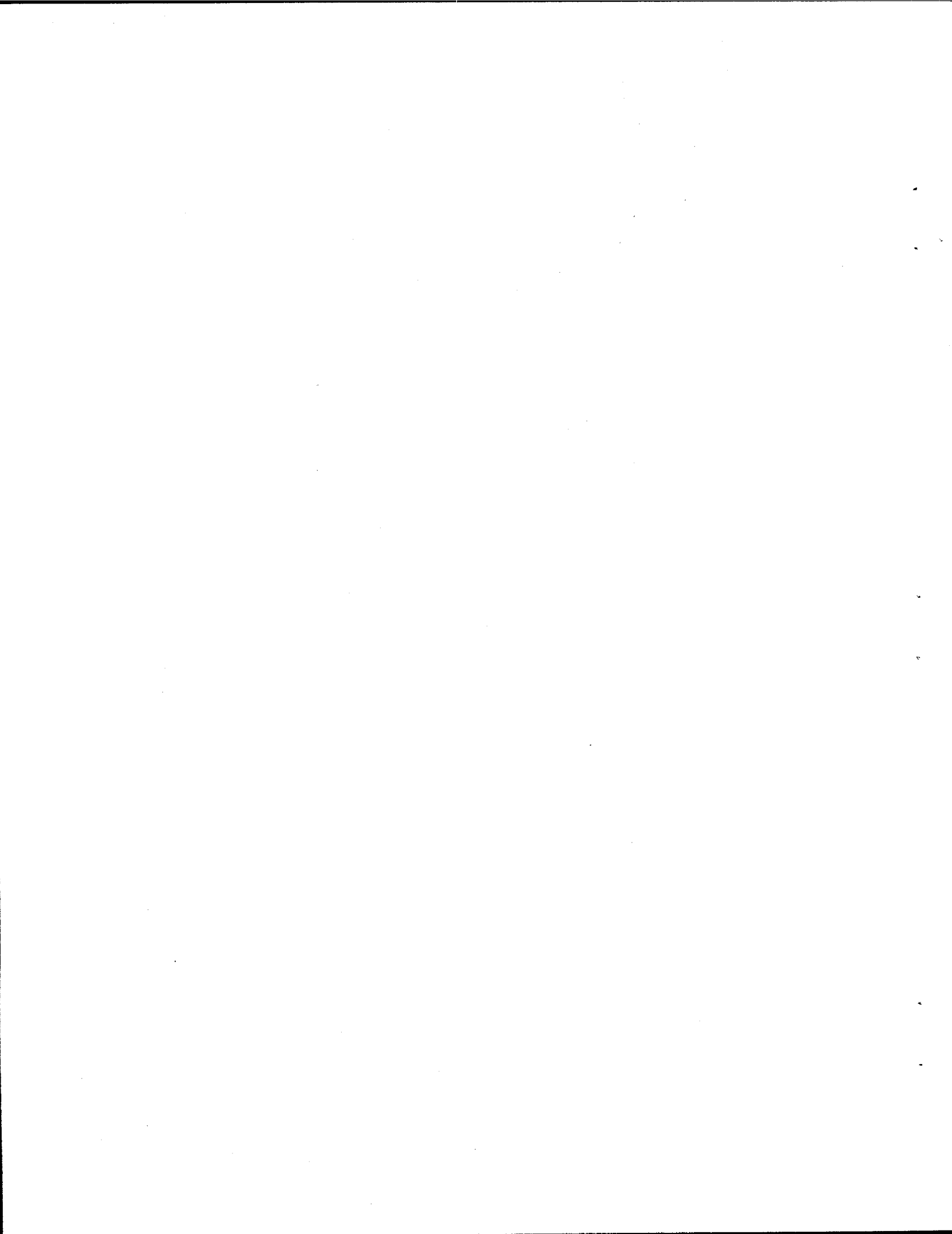

Appendix B

**COST SUMMARY FOR THE CsRD
(DOES NOT INCLUDE OVERHEAD CHARGES)**

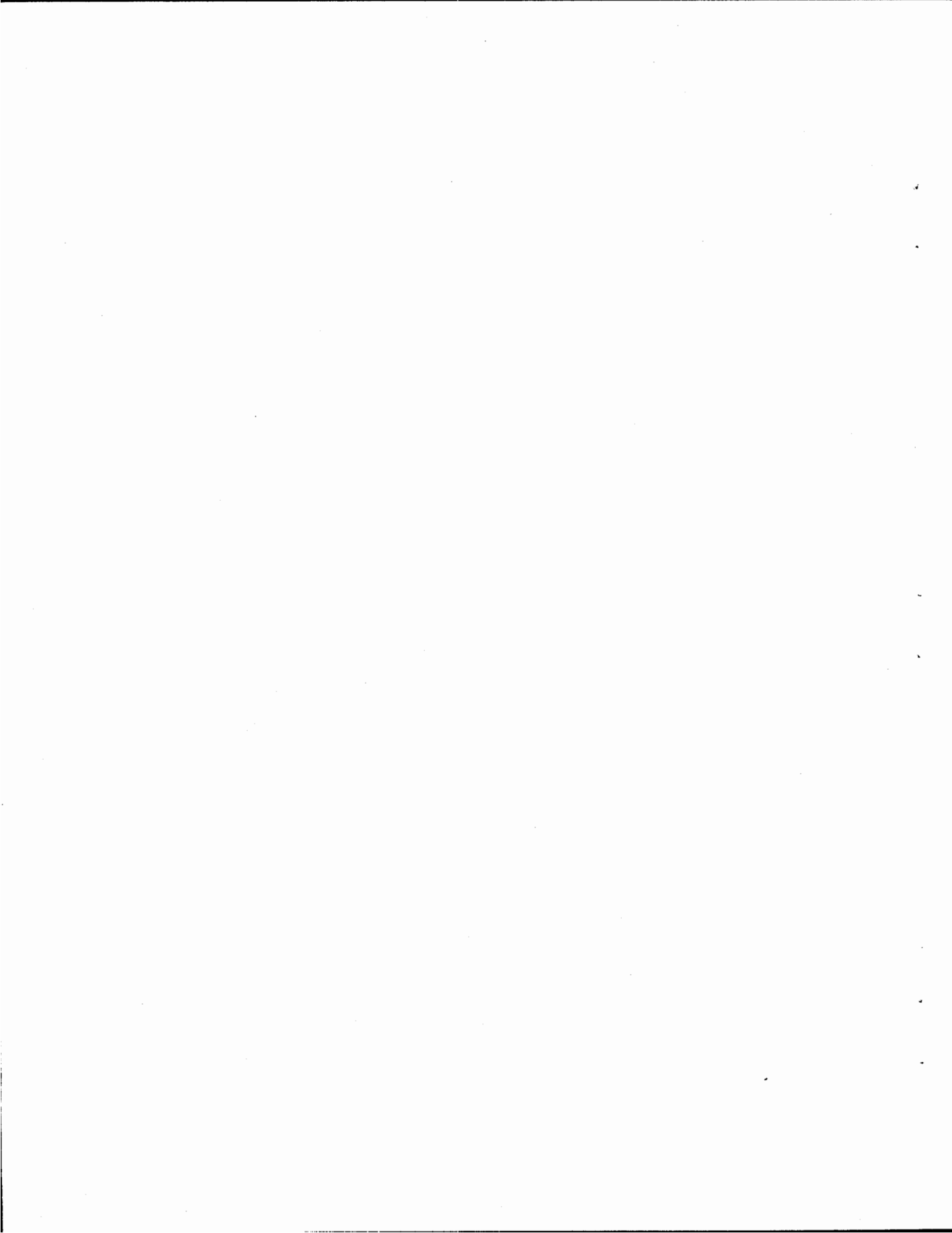

Design and data for CsRD (feed skid, ion-exchange skid, drying/sluicing skid)	\$132,356
CsRD equipment and fabrication	\$392,024
Dewatering containers at \$850 each	\$ 6,800
Additional ion-exchange columns at \$5,800 each	\$ 0
Transfer shields (includes design)	\$100,940
Dewatering shields	\$ 25,300
Drum shields (three without lead)	\$ 42,000
Stainless canisters for shipment to SRS	\$ 44,136
Spare parts for CsRD system	\$ 9,159
High-density concrete shield for feed tank skid	\$ 24,787
Design and drawings for high-density concrete feed tank skid shield	\$ 5,963
Remote camera equipment	\$ 9,646
Crane upgrade (equipment and support analysis)	\$ 35,998
Central Procurement costs	\$ 16,000
Miscellaneous Central Procurement costs	\$ 8,000
Information Management Central costs	\$ 10,000
Central Engineering costs for design support	\$ 50,000
Central Engineering costs for System Safety Engineering	\$ 40,000
Central Continuing Education costs	\$ 6,000
Subcontract for System Safety Analysis and Technical Safety Requirements documentation	\$ 30,500

Miscellaneous P&E materials (pipe, fittings, paint, etc.)	\$ 15,000
Sorbent costs (24 ft ³)	\$184,600
Installation of CsRD system and control room (P&E)	\$173,897
P&E support (Crane installation and testing, decontamination support, dismantling and removal of CsRD system)	\$118,000
I&C support (Control system design, system installation and shakedown, instrument calibration, documentation, operational troubleshooting)	\$ 52,000
Control system for CsRD (controller, computer, software, equipment)	\$ 46,500
Labor for wiring of control system	\$ 24,750
Labor for programming of control system	\$ 10,000
Cold-Test Facility equipment costs	\$ 48,073
Installation of Cold-Test Facility	\$ 30,000
Operation of Cold-Test Facility	\$ 70,000
Health Physics labor for installation and startup	\$ 40,000
Health Physics labor during operations and decontamination	\$145,000
Labor costs for CsRD operation	\$450,000
Analytical costs from CsRD operations	\$ 90,000
Analytical costs for analysis of loaded sorbent from bench-scale runs	\$ 27,000
QA support prior to startup approval (documentation, readiness assessment)	\$ 24,000
Labor for system decontamination, waste disposal, and documentation	\$350,000
QA support after startup (documentation, followup readiness assessment, (procedure changes)	\$ 15,000

Costs for shipment of loaded sorbent from ORNL to SRS	\$ 15,200
Costs for support plate used for shipment of loaded sorbent to SRS	\$ 17,080
LMES Transportation Technology costs	\$ 6,000
Waste Management Costs (documentation and transportation of loaded sorbent)	\$ 21,000
Division Management costs	\$ 5,400
Health and Safety costs	\$ 22,000
Subcontract costs (Test plan, ALARA plan, Lessons Learned review, TSR training, sampling plan)	\$ 45,000
Project management and reporting	\$100,000
CTD installation support	\$ 50,000
Preparation and approval of procedures	\$ 60,000
Document preparation and approvals (work plans, TSR, SSA, critical lift plan, waste management plan)	\$ 70,000
Shakedown of CsRD system prior to startup	\$ 40,000
Interaction with vendors and design reviews	\$ 40,000
Training to comply with procedures	\$ 30,000
Sorbent preparation	\$ 20,000
Bench-scale support	\$240,000
Waste certification	\$150,000

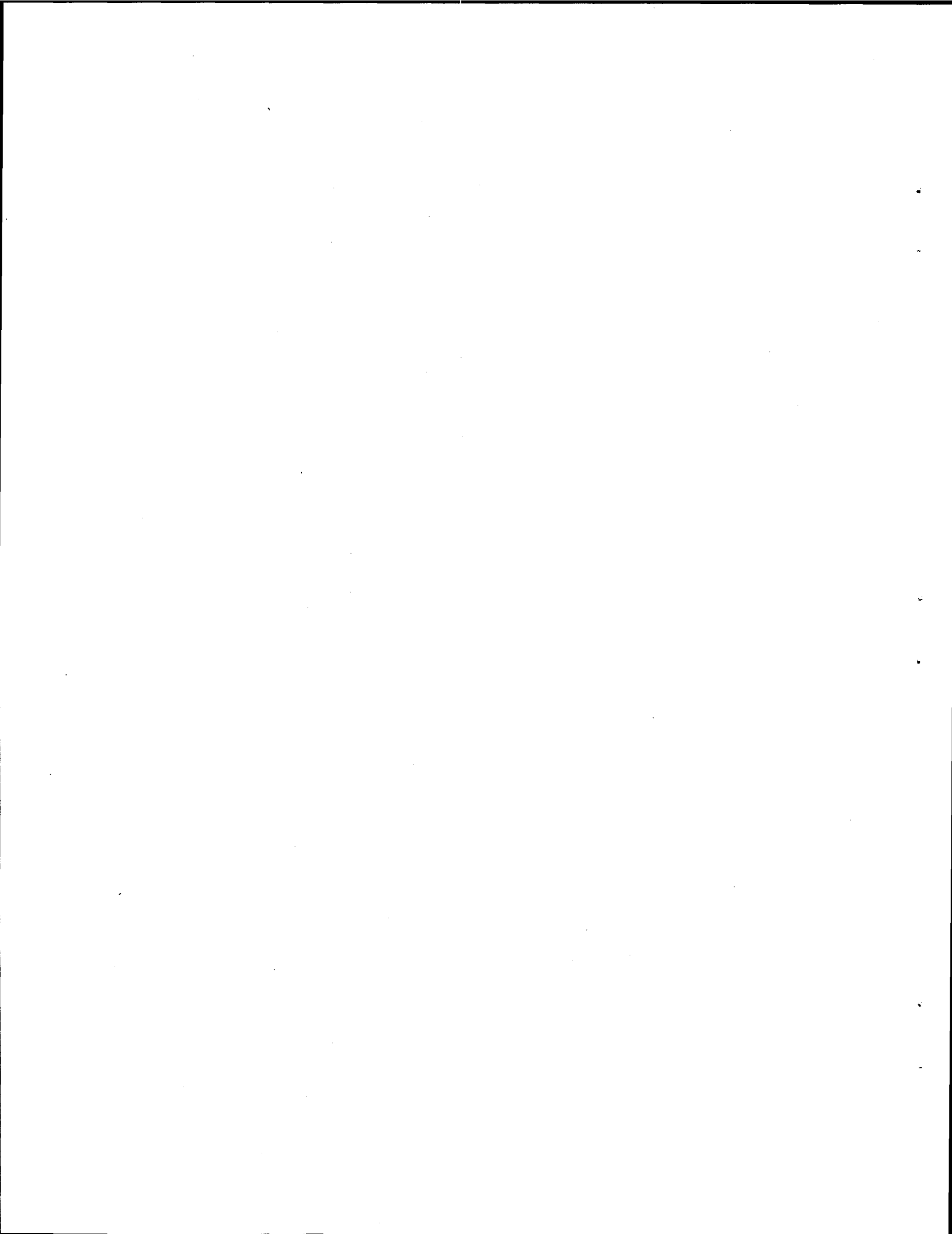

Appendix C

**SUMMARY OF THE CRITERIA AND DOCUMENTATION REQUIREMENTS
NEEDED FOR STARTUP RECOMMENDATIONS BY THE
MANAGEMENT ASSESSMENT TEAM**



Item No.	Criteria	Requirement To Satisfy Criteria
1.0	FACILITY AND EQUIPMENT	The facility is the responsibility of the Liquid and Gaseous Waste Operations Division under the Waste Management and Remedial Action Department.
1.1	Ion-Exchange Equipment and facilities.	The Chemical Technology Division (CTD) will operate the equipment during the demonstration.
1.1.1A	Five-ton hoist was tested and is functional.	P&E tested and provided letter documentation, including QA test.
1.1.1B	Five-ton hoist was modified to six-ton and for remote operations. Modifications were tested, and the hoist is functional.	P&E modified hoist for increased capacity and for remote operations and also tested the modifications. P&E provided letter of documentation, which included a QA test.
1.1.2A	Ion-exchange system was installed and met OSHA regulations.	The ORNL Safety Department inspected the system and issued a report stating the system met OSHA regulations.
1.1.2B	Piping for the ion-exchange system has been installed and welding requirements met.	ORNL Maintenance conducted an inspection and issued a report that welding requirements had been met.
1.1.2C	All electrical components were installed and electrical requirements were met.	ORNL Electrical inspectors conducted an inspection, all deficiencies noted were corrected, and the inspectors issued a report stating that all requirements had been met.
1.1.3A	Equipment was marked/labeled and in agreement with the operational procedures and drawings.	CTD inspected the system and provided documentation in the project registered notebook that these criteria were met.
1.1.4A	Shielding around the feed tank was in place and labeled as a confined space.	CTD inspected the system and provided documentation in the project registered notebook that these criteria were met.

1.1.5	Ion-exchange system instrumentation was calibrated	The vendor provided calibration records. I&C verified the calibration, entered the instruments into the maintenance recall system, and provided documentation on the calibration verification.
1.1.6	Instrumentation and equipment were put on a preventive maintenance program (PMP).	I&C and P&E developed the PMP.
1.1.7	Preoperational testing of the ion-exchange system was completed.	Tests with process water and surrogates were performed and documented by CTD personnel.
1.1.8	Safety shower and eye-wash stations in Building 7877 were tested and were functional.	These were inspected by P&E and documented by CTD personnel.
1.1.9	Radiation equipment was checked and was functional.	Health Physics personnel inspected the equipment and provided the documentation.
1.1.10	Communication equipment was operational.	Communication was inspected by CTD personnel and documented in the project log book.
1.1.11	Transfer bell was installed, tested, and was functional.	CTD personnel completed the inspection and documentation.
1.1.12	Access to Building 7877 (High Radiation Area) was controlled.	Controlled keys were provided to necessary personnel.
1.2	Melton Valley Storage Tank (MVST) decant system.	Decant system was operated by CTD personnel during demonstration.
1.2.1	Integrated tests of the pump module/decant system were completed, and the system was functional.	LGWOD personnel tested the system and documented that it was functional.

1.2.2	Decantation assembly is only pulling supernate (i.e., no solids are in the supernate).	Samples pulled and analyzed showed no sludges in the supernate. The Analytical Services Organization provided documentation that no solids were present in the supernate.
1.2.3	Supernate lines from the MVST were checked for leaks.	I&C conducted test based on the pressure change in the annulus of the double-walled transfer piping and provided documentation that there was no leak.
1.2.4	Supernate transfer system instrumentation and controls were calibrated, tested and found to be functional.	I&C calibrated the instrument, tested the instruments, and provided the necessary documentation.
1.3	Utilities and Support Services	
1.3.1	Fire protection system service in Building 7877 was functional	Fire protection personnel conducted a test of the fire protection systems in Building 7877 and provided documentation that they were functional.
1.3.2	Analytical laboratory was appraised of the requirements to support sample analysis	The analytical laboratory was supplied a list of the required analyses and the required schedule.
1.3.3	All waste supernate to be treated in the demonstration was transferred from MVST W-27 to W-29	LGWOD transferred the supernate and provided documentation that the transfer was complete.
1.3.4A	Sample for Technical Safety Requirements was pulled from W-29 and sent to the analytical laboratory.	LGWOD pulled the sample, and chain-of-custody forms were used to provide documentation.
1.3.4B	Sample for the Hot Cell Verification was pulled from W-29 and sent to the analytical laboratory.	LGWOD pulled the sample, and chain-of-custody forms were used to provide documentation.
1.3.5A	Analytical results for the Hot Cell Verification sample were received.	The laboratory analyzed the sample and provided output for documentation.

1.3.6	CsRD emergency services were tested and were functional.	CTD and LGWOD personnel tested the service and provided the necessary documentation.
1.3.7	Process water in Building 7877 was available.	CTD personnel confirmed that process water was available and provided the necessary documentation.
1.3.8	Personnel protective equipment was available and ready in Building 7863.	Equipment requirements were documented in radiation work permit, and CTD personnel provided documentation that all necessary equipment was available and ready.
1.3.9	Air delivery system was functional.	CTD personnel confirmed that the air delivery system was functional and documented this in the log book.
1.3.10	HVAC serving Building 7877 provided containment, was tested, and was functional at specified conditions.	CTD and LGWOD tested and provided the necessary documentation.
2.0	MANAGEMENT CONTROL PLANS, PROCEDURES, AND PERMITS	
2.1	As-built drawings for the CsRD system were available.	ORNL prepared and issued the as-built drawings.
2.2	ALARA plan for CsRD activities was written and approved.	The ALARA plan was prepared by CTD personnel and approved by the Office of Radiation Protection.
2.3	Startup date was chosen and approved.	The startup date of 9/15/96 was set by CTD and approved by LGWOD.
2.4	Radiation Protection and Office of Safety and Health Protection manuals were available in the CsRD control room (Building 7863).	A hard copy of the manuals was placed in the control room by CTD personnel.
2.5	Quality assurance plan and addendum for the CsRD were in place for the CsRD.	The EDS QA plan was utilized, and an addendum was prepared for the CsRD.

2.6	Criticality control documentation was in place for the CsRD.	An evaluation was conducted by the Office of Operational Readiness and Facility Safety to determine the need for a criticality control document. The Office of Operational Readiness and Facility Safety documented that a criticality control document was not necessary.
2.7	Local Emergency Manual was available for use in the CsRD control room in Building 7863.	Emergency Preparedness reviewed and updated the existing manual. CTD provided documentation that the manual had been updated.
2.8	Configuration control procedure was approved.	The existing Document No. WMLGWO-606.5 control copy at Building 3130 was utilized.
2.9A	DOE Order 5480.31 was reviewed for applicability of need for formal readiness review.	CTD provided a notification letter to WMRD providing justifications for not requiring a formal readiness review prior to startup of the CsRD system. This was transmitted from WMRAD to DOE.
2.9B	DOE Order 5480.31 was reviewed for applicability of need for formal readiness review.	DOE provided a letter to WMRAD that a formal readiness review for the CsRD was not necessary.
2.10	Lessons Learned was reviewed prior to startup of the CsRD.	CTD personnel reviewed the Lessons Learned database, which provided documentation that the criteria had been completed.
2.11	Operating air permit was received from the state of Tennessee and posted at the Ion-Exchange Facility.	A letter from was received from ORNL Compliance stating that the existing air permit was acceptable.
2.12	Permit by rule covering the CsRD was written and approved.	A letter was received from ORNL Compliance stating that the existing permit was acceptable.

2.13A	ES&H permit requirements (federal, state, local, site) were met.	CTD personnel reviewed the requirements with ORNL Compliance personnel and documented that no additional permits were needed.
2.13B	Analysis of sorbent was completed to determine if the loaded sorbent was hazardous as defined by RCRA.	A TCLP was performed on a loaded sorbent sample by a certified laboratory. The laboratory determined that the sorbent passed the TCLP and was not hazardous.
2.14	NEPA determination was prepared, and the approved documentation was in place.	CTD personnel provided a copy of the approved NEEPA Categorical Exclusion for the CsRD.
2.15	A System Safety Analysis (SSA) and a Technical Safety Review (TSR) for the CsRD were prepared and approved.	These documents were prepared by ORNL Engineering personnel and approved by DOE (document nos. EDS CsRD-12 and SAA/7877-WMRAD/SEE-2/R0.)
2.16	Operational Readiness Self-Assessment check list was prepared and approved.	This document was prepared by CTD personnel and served as a self-assessment preparation for the management assessment.
2.17	Training plan was prepared and approved.	The training plan was prepared by ORNL WMRAD (document no. EDS CsRD-11).
2.18	A lifting plan was prepared and approval for a critical lift was received.	P&E provided the lift plan and it was approved by the Hoisting and Rigging Committee (ESAMS # S3634).
2.19	Conduct of Facility Operations, along with Conduct of Facility Matrix, was prepared and approved.	The existing plan for LGWOD was utilized (document nos. CsRD-14 and 15).
2.20	Project work plan was prepared and approved.	The plan was prepared by CTD personnel and approved by LGWOD (document no. EDS CsRD-1).
2.21	Vendor operation and maintenance manuals for the CsRD system were controlled and located in the CsRD control room in Building 7863	Documentation was provided by CTD personnel (document no. EDS CsRD-17)

2.22	Operating procedures for the CsRD system, auxiliary system, and support system were prepared, approved, controlled, and located in Building 7863.	This was issued by CTD as formal procedures (ORNL/CF-96/25).
2.23	Waste Management Plan was prepared and approved.	Chemical Technology Division personnel prepared the plan, and WMRAD approved the plan (EDS CsRD-18).
2.24	Material Safety Data Sheets (MSDS) were available at the CsRD control room.	CTD personnel identified all chemicals and provided documentation that MSDS were available in the control room.
2.25	Radiation work prejob planning had been completed, and a Radiation Work Permit was issued.	Health Physics issued the Radiation Work Permit (RWP 3 3017-96-0027).
2.26	QA surveillance was completed and prestart items were closed out.	Documentation was provided by CTD personnel and signed off by QA personnel.
2.27	Memorandum of Understanding (MOU) between CTD and WMRAD was written and approved.	CTD personnel wrote the MOU, and it was approved by CTD and WMRAD.
2.28	MOU between CTD and SRS was written and approved.	CTD wrote the MOU, and it was approved by DOE personnel at Oak Ridge, Hanford, and Savannah River.
3.0	PERSONNEL	
3.1	Adequate staff were identified and were available for the CsRD activities.	CTD identified personnel and provided documentation that they were available.
3.2 3.3	Available staff were trained in accordance with the training plan requirements.	CTD personnel provided training records of identified personnel to the WMRAD training department.
3.4	Identified staff were health physics prepared (TLDs, whole body counts, etc.), as appropriate.	Health Physics personnel provided the necessary documentation.

3.5	Laboratory Shift Supervisor (LSS) was notified of the CsRD schedule.	CTD personnel provided documentation that the LSS had been notified.
3.6	Maintenance services were notified and were available to support the CsRD.	CTD personnel notified P&E and I&C and obtained documentation that these organizations were aware of the CsRD schedule and were available for support.
R2-1	Shipping waiver for Shipping Readiness Assessment and Transportation issued.	The WMRAD Director provided documentation that a Shipping Readiness Assessment was not necessary.
R2-2	Configuration determination.	WMRAD provided documentation that this was not needed prior to startup.
R2-3	Disposition of loaded sorbent.	A letter documented that WMRAD would accept the loaded sorbent for storage at ORNL.
R2-4	Assessment of additional items resulting from Run No. 1.	The Management Assessment Team reviewed the operating log from the first run and provided documentation that assessment of additional items was not warranted.
R2-5	Radiation prejob planning was completed and RWP issued.	Health Physics issued RWP No. 3017-97-0004A.
R2-6	Volumetric status of W-29 and W-30.	WMRAD provided documentation that the volumes in W-29 and W-30 were adequate for the additional planned processing.
R2-7	The dose data were compared with the shielding model predictions.	The Office of Operational Readiness and Facility Safety provided comparisons from the first run.
R2-8	Radiation flow detector issues.	Documentation was provided that this was not applicable for the CsRD operation.
R2-9	ALARA concerns regarding lid closure on drum shields.	Health Physics personnel provided an evaluation of the lid closure procedure from an ALARA perspective.
R2-10	Functional testing of vermiculite hopper completed.	CTD functionally tested the vermiculite hopper and provided documentation that it performed in accordance with design.

Appendix D

**CONDITIONING PROCEDURE UTILIZED FOR THE
CST SORBENT USED IN THE CsRD AT ORNL**

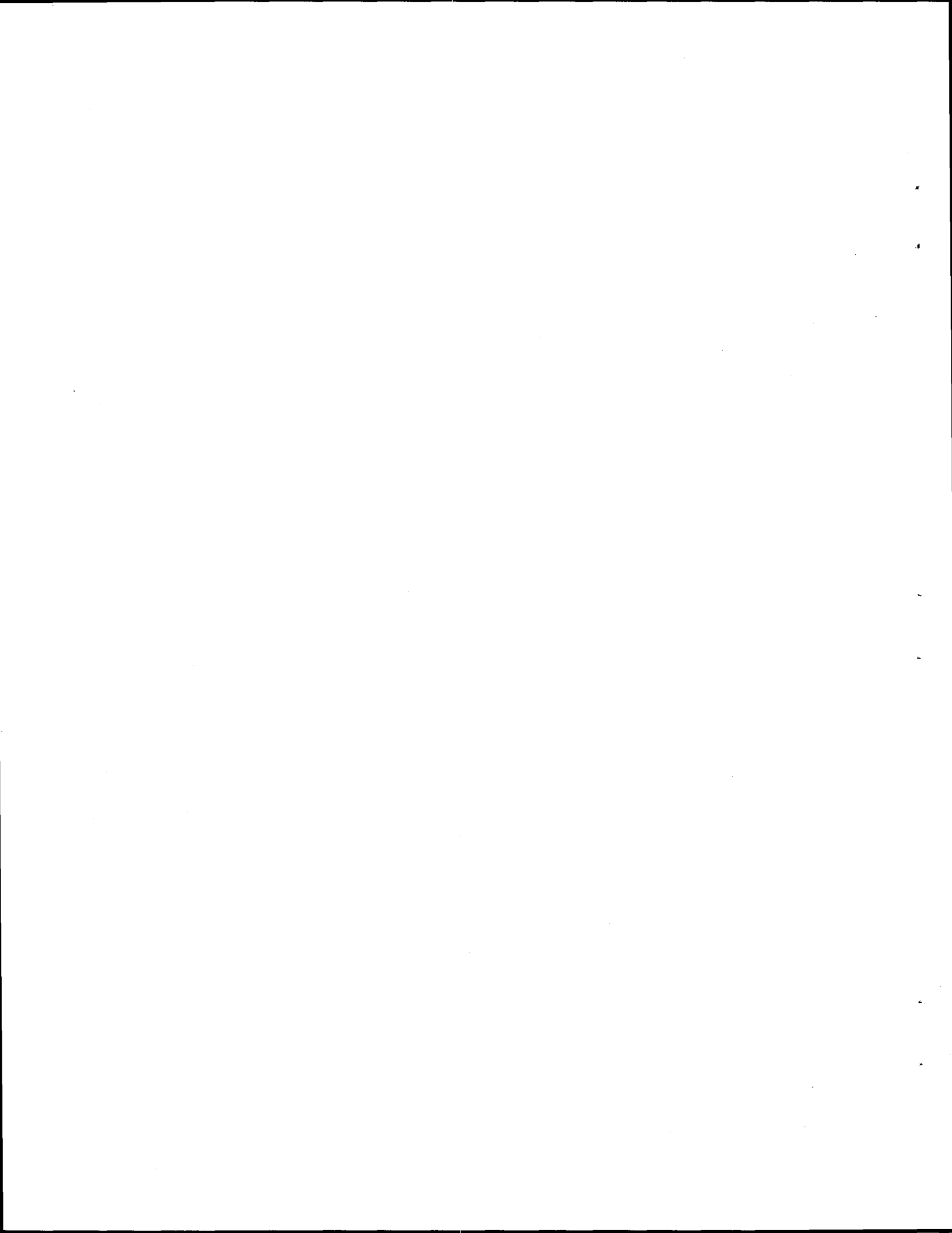

Workaid Number: **EDS-CsRD-20**

Date: 08/22/96

Revision: 1

Cesium Removal Demonstration (CsRD) Sorbent Preparation Workaid

Title: Cesium Removal Demonstration (CsRD) Sorbent Preparation Workaid

Purpose: To provide instructions for CsRD personnel in sorbent preparation activities using the Cold-Test Loop in Building 2528.

Scope: Qualified and trained CsRD personnel only.

Acronyms:

CsRD	Cesium Removal Demonstration
CST	Crystalline Silico-titanate sorbent (IONSIV IE-911, UOP Molecular Sieves, Inc.)
CTL	Cold-Test Loop (an engineering-scale model of the CsRD equipment)
MVST	Melton Valley Storage Tanks

General Information:

The CST sorbent that will be used in the CsRD will be backwashed to remove fines, and pretreated with dilute sodium hydroxide (NaOH) using the CTL equipment in Building 2528, to prepare the sorbent for use in the CsRD. The sorbent must be stabilized at a pH of about 12.5 to prevent formation of aluminum hydroxide precipitates when the MVST supernate first contacts the sorbent. This workaid follows recommendations contained in a letter ("IONSIV IE-911 Bed Preparation & Pretreatment Guidelines", May 13, 1996) from Dennis Fennelly, UOP Molecular Sieves, Inc., to Joseph Walker, ORNL. The type of high-pressure hose and ball valves used in the CsRD will also be tested while sluicing the sorbent.

Action Steps:

A. Documentation:

The results for each batch of sorbent that is prepared, including backwash flowrate and time, amount of NaOH, and final pH, will be entered on the attached checklist and in a registered logbook. The source drum and the target drum for each batch of sorbent should also be recorded. The lot number, or other identifying numbers, for the drums of sorbent received should be recorded. If the sorbent drums are not individually numbered, then a unique number should be marked on each drum.

Workaid Number: **EDS-CsRD-20**

Date: 08/22/96

Revision: 1

Cesium Removal Demonstration (CsRD) Sorbent Preparation Workaid

B. Sorbent Sluicing Into Column:

About 30 L of CST sorbent will be sluiced into the ion-exchange column (C1) of the CTL for backwashing and pH adjustment. Add about 8 L of water to the Sorbent-Sluicing Tank (T3) through the top funnel and valve (HV-33). Add about 10 L of CST sorbent, and rinse down the funnel with an additional 2 L of water. Record the weight of the sorbent added. Close HV-33 and pressurize T3 to about 15 psi with air by opening HV-35. Establish a venting path from C1 by opening HV-9, HV-12, FCV-4, HV-13 and HV-20. Open HV-34 to sluice the sorbent from T3 to C1 and then close HV-35. Close HV-34 and add about 4 L of water to T3 through HV-33. Close HV-33, open HV-35 and open HV-34 to sluice any remaining sorbent from T3, and then close HV-35 and HV-34. Repeat the above steps twice more to sluice a total of about 30 L of CST sorbent into the ion-exchange column.

C. Sorbent Backwashing

Remove the fines from the sorbent by flowing water up through the sorbent and to the drain. Connect a hose just above HV-8, run the end of the hose to the building drain, and open HV-8. Close HV-12 and then open HV-11 and HV-9 to flow water up through sorbent and out through the hose to the building drain. Regulate the flowrate using HV-11 to expand the sorbent bed in C1 to about 45 L. Measure the flowrate from the hose using a graduated cylinder. Keep the water flowing until fines are not visible in the exiting water. Record the flowrate and the total backwashing time in the logbook.

D. Adjustment of Sorbent pH:

The as-received CST sorbent is slightly acidic, so the sorbent must be stabilized at a pH compatible with the MVST supernate before it is used in the CsRD. Add about 50 gal. of water to T1. Add 4 Kg of 50 wt% NaOH solution to water in T1. Use pump P-1 to recirculate this solution through the sorbent in C1 at a flowrate of about 1 gpm, using valve HV-28 to control the flowrate. Measure the pH of the solution periodically, and add NaOH as needed to maintain the pH at about 12.5. Continue this process until the pH of the recirculating solution has been stable at about 12.5 for several hours. Turn off the recirculation pump. Record the total amount of NaOH used and the time required to treat each batch of sorbent.

Workaid Number: **EDS-CsRD-20**

Date: 08/22/96

Revision: 1

Cesium Removal Demonstration (CsRD) Sorbent Preparation Workaid

E. Sorbent Sluicing From Column:

Use water and air pressure to sluice the sorbent from C1 into a drum. Close HV-2, HV-5, HV-7, HV-8, HV-13, HV-15 and HV-28. Open HV-29, HV-3, HV-6, FCV-4 and HV-9 to pressurize C1 to about 15 psi with air. Place the end of the high pressure hose (connected to HV-32) into the target drum for the treated sorbent, and then open HV-32 to sluice the sorbent into the drum. Close HV-29 and then HV-32, and add about 10 L of water to C1 by opening HV-11. Repeat the sluicing operation until most of the sorbent has been removed from C1. Dewater the sorbent in the drum using a piece of stainless steel tubing with a Johnson Screen attached and an air-operated diaphragm pump.

Repeat the above steps until all of the CST sorbent that will be used in the CsRD has been prepared. Once all the sorbent has been prepared, arrange for transfer to Building 7877. Upon receipt at Building 7877, conduct a visual inspection and record the results in the official operations logbook.

Approved By: _____

CsRD Principal Investigator

Date

Workaid Number: EDS-CsRD-20

Date: 08/22/96

Revision: 1

Cesium Removal Demonstration (CsRD) Sorbent Preparation Workaid

Checklist For Sorbent Preparation

Date	Run #	Source Drum of Sorbent	Backwash Flowrate (L/min)	Backwash Time (hr)	Amount NaOH (Kg)	pH Adjustment Time (hr)	Final pH of solution	Target Drum for Sorbent	Initials	Comments
	1									
	2									
	3									
	4									
	5									
	6									
	7									
	8									
	9									
	10									
	11									

Workaid Number: EDS-CsRD-20

Date: 08/22/96

Revision: 1

Cesium Removal Demonstration (CsRD) Sorbent Preparation Workaid

Checklist For Sorbent Preparation

Date	Run #	Source Drum of Sorbent	Backwash Flowrate (L/min)	Backwash Time (hr)	Amount NaOH (Kg)	pH Adjustment Time (hr)	Final pH of solution	Target Drum for Sorbent	Initials	Comments
	12									
	13									
	14									
	15									
	16									
	17									
	18									
	19									
	20									
	21									
	22									

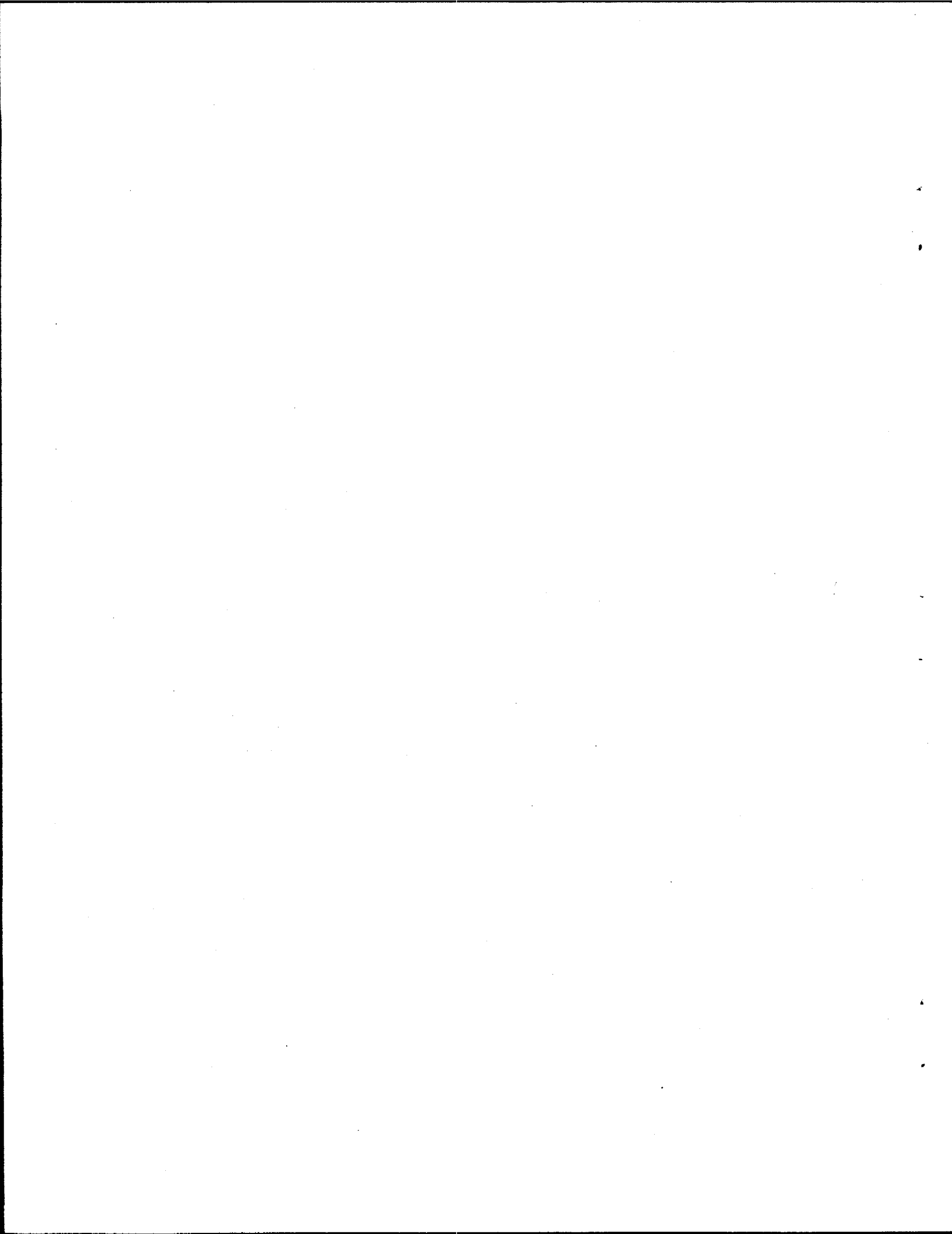

Appendix E

**OPERATIONAL INSTRUCTIONS FOR THE CsRD
ION-EXCHANGE SYSTEM**

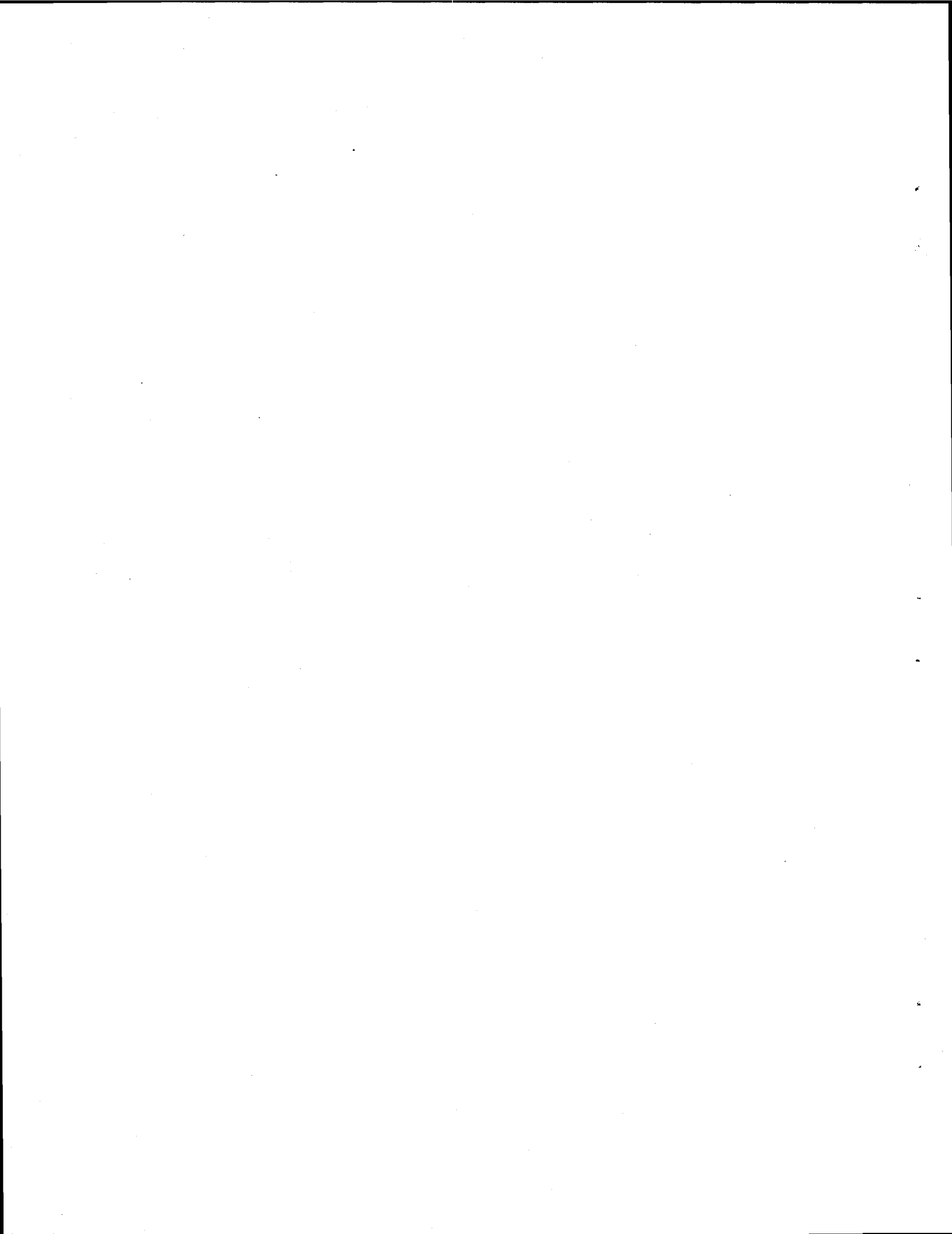

Workaid Number: EDS-CsRD-07

Date: 02/07/97

Revision: 5

Transfer Bell Operation Workaid

Title: Transfer Bell Operation Workaid

Purpose: To provide instructions in the operation of the Cesium Removal Demonstration Transfer Bell.

Scope: Qualified and trained CsRD personnel only

Acronyms:

CRO	Control Room Operator
CsRD	Cesium Removal Demonstration
MVST	Melton Valley Storage Tanks
IES	Ion Exchange System
CDAS	Control & Data Acquisition System
W-29, 30	Feed and effluent tanks, respectively, in the MVST system
ES panel	The permanently installed alarm panel on the west side of Building 7863
TSR	Technical Safety Requirements for CsRD project, DOE document # TSR/7877-WMRAD/SSE-2/R0

General Information:

Coverage of this document is limited to operations involving the CsRD storage drum, transfer bell, and remotely operated crane. Frequency of the transfer bell operation will be dictated by the *operating schedule* contained in **EDS-CsRD-01, CsRD Work Plan**, and will be carried out by means of this document. Prior to any lifting operation, the operators will have a prelift meeting and document this on Attachment 3.

Action Steps:

A. Documentation:

Upon completion of any transfer bell operation, notation will be made in the official operations logbook.

Upon shipment of the radioactive resin to Savannah River; a chain of custody form (Attachment 2) will be completed and sent with the Bill of Lading or Manifest.

Transfer Bell Operation Workaid

B. Transfer of Resin Drum from Dewatering Skid to Temporary Storage:

Prior to sending contaminated resin from columns to the resin drum, several preliminary steps are required in order to minimize the personnel exposure to radioactive materials. These steps are listed in the prestart checklist as follows:

Prestart Checklist

1. Resin Drum and Fillhead.
 - ___ a. Position clean, empty resin drum in drum shield on dewatering/drying skid. Aligning marks on the internal plate of the drum and the drum shield. This will assure proper alignment of all processing equipment and the resin drum.
 - ___ b. Place fillhead on resin drum, carefully aligning the transfer, vent and suction lines.
 - ___ c. Secure camlock fitting suction line using the tee handles extending from the top of the fillhead.
 - ___ d. Verify proper connection and/or operation of the following lines to the fillhead.
 - Resin transfer hose
 - Dewatering /drying hose
 - Rinse water supply hose
 - Offgas vent hose
 - Fillhead power cable
 - Camera power cable
 - Light power cable
 - Camera signal cable
 - ___ e. Position all connecting lines so free motion of fillhead to storage location is possible.
2. Absorbent Hopper.
 - ___ a. Position hopper in Building 7877 to enable remote connection of the crane hook.
 - ___ b. Load hopper with approximately 2 cubic feet (15 gal) of absorbent.
 - ___ c. Verify that hopper valve is closed with no leakage.
3. Lidding Device.
 - ___ a. Place device in support bracket provided in Building 7877, aligning marks on the lifting ring and the lid support plate.
 - ___ b. Install lid, ring and bolt on device, carefully aligning all pieces with the release tabs and the air wrench.
 - ___ c. Verify air supply isolation valve is open and air pressure is 80 psig minimum of dry, filtered air.
 - ___ d. Position air supply hose so free movement of lidding device from stand to resin drum is possible.

Operation Instruction (Date, Initial, and Check as completed): _____

Transfer Bell Operation Workaid

C. Remote Operations for Resin Drum Transfer:

1. Remove fillhead from resin drum.
 - a. Align the crane hook with the lifting ring on the top of the fillhead.
 - b. Lift the fillhead from the drum. Using remote camera, verify that the camlock fitting has properly released from the resin drum internal connections. Continue hoisting until fillhead is completely clear of the top of the drum and drum shield.
 - c. Move fillhead approximately 6 feet south of the resin drum and place on fillhead stand, carefully watching to prevent connecting lines from snagging any objects. During this operation, the hook may be rotated to allow for better alignment of the fillhead on the stand.
 - d. Disengage hook from lifting ring.
2. Add absorbent to resin drum.
 - a. Align the crane hook with the lifting ring on the top of the absorbent hopper.
 - b. Position the absorbent hopper over the resin drum by aligning the hopper lower plate with the top of the drum shield. The alignment tab on the hopper will assure the proper alignment of the hopper discharge with the large hole in the internal plate of the resin drum. The discharge valve of the absorbent hopper will open as it is lowered onto the drum shield and close as it is removed. Using remote cameras, verify that the absorbent has transferred to the resin drum.
 - c. Lift the absorbent hopper until it is clear of the drum shield.
 - d. Move absorbent hopper to storage location and disengage hook from lifting ring.
3. Place lid on resin drum using lidding fixture.
 - a. Align the crane hook with the lifting ring on the top of the drum lidding fixture.
 - b. Position the drum lidding fixture on the top of resin drum. Alignment of this fixture with the drum shielding will assure the proper positioning with respect to the resin drum.
 - c. Secure the lid on the resin drum by operating the air ratchet controlled by the "AIR WRENCH" icon on the system control screen. Using remote cameras, check the lid, ring and bolt on the resin drum to verify that they are properly installed and that the bolt has sheared from the ratchet.
 - d. Lift the drum lidding fixture until it is completely clear of the top of the drum and the drum shield.
 - e. Move the drum lidding fixture to its storage position and place on stand.
 - f. Disengage hook from lifting ring.
4. Transfer of resin drum to temporary storage area.
 - a. Align hook with lifting ring on top of drum transfer shielding.
 - b. Lift drum transfer shielding and move to location over the dewatering drum shield. Carefully align the drum transfer shielding with the drum shielding using the alignment marks on each, and lower into place. This should assure the proper positioning of the lifting fixture in relation to the resin drum.
 - c. Lower the hook and the transfer shield lifting post until the lifting fixture has contacted the resin drum. This should engage the lifting fixture and secure the resin

Transfer Bell Operation Workaid

drum. An indicator on the lifting post, just below the lifting ring, will be at the top of the slot to verify the proper position of the fixture.

C. Remote Operations for Resin Drum Transfer (cont.):

- d. Slowly hoist the hook and lifting post to lift the resin drum into the transfer shielding. The indicator provided on the lifting post should be slightly above the bottom of the slot to verify the position of the resin drum in the lifting fixture. If the indicator falls to the bottom of the slot, the drum has not been secured. Stop and repeat Step 4c. When resin drum has been lifted to a position inside the transfer shield, safety latches will automatically close to secure the drum in the event of an accidental release of the drum from the lifting fixture.
- e. Lift transfer shield to height that will clear resin transfer tank (approximately 6 feet) and move south, as shown on Figure 1, until clear of tank. At this location, the transfer shield should be lowered to a height of approximately 12 inches from the floor. Due to the levels of radiation associated with the resin drum and the lack of shielding on the bottom of the transfer shield, as much of the transfer as possible should be performed at this height.
- f. Slowly move transfer shield east, maneuvering between the concrete shielding surrounding the processing skids. At one point, the clearance between the Cesium Removal feed skid and the Out of Tank Evaporator skid shielding will be approximately 3 inches on each side of the transfer shield. Extreme care should be taken at this point not to allow any contact between the transfer shield and the concrete shielding.
- g. When the transfer shield is aligned with the temporary storage area in the northeast corner of Building 7877, move the transfer shield south, hoisting to allow for clearance of the lead bricks and the drum shield. Align the transfer shield with one of the drum shielding units located inside of the lead brick shielding.
- h. Lower the transfer shielding onto the drum shield selected, carefully aligning them, using the indicator marks on each to assure proper positioning of the resin drum. Continue to lower the hook and the transfer shield lifting post. Shortly after the load of the transfer shielding has been removed from the lifting post, the safety latches will open, allowing the drum to lower into the drum storage shielding. When the drum position indicator on the lifting post is at the top of the slot, the resin drum is resting on the bottom of the drum shield, and the drum lifting fixture should automatically release the drum. Carefully hoist the hook and lifting post. The drum position indicator on the lifting post should be at the bottom of the slot to verify that the drum has been released. If not, stop, and repeat this step until the drum is successfully released.
- i. Hoist the transfer shield until it will clear the drum shield and lead bricks and move to storage position in Building 7877.

Transfer Bell Operation Workaid

- ___ j. Disengage hook from lifting ring.
- ___ k. HP will enter Building 7877 and take readings to determine radiation levels at contact and at one meter. The technician will also smear outside of resin drum to determine if transferable contamination is present.

C. Remote Operations for Resin Drum Transfer (cont.):

- 5. Place cover on drum shielding.
 - ___ a. Move hook to storage location of drum shielding cover and align hook with lifting ring on top of lid.
 - ___ b. Hoist shielding cover to height sufficient to clear storage area wall and drum shielding and align shielding cover with drum shielding.
 - ___ c. Lower shielding cover into place carefully positioning it to assure its proper alignment with the drum shield.
 - ___ d. Disengage hook from lifting ring.

Operation Instruction (Date, Initial, and Check as completed): _____

Note:

Before shipping cask will be accepted for use, an HP will survey the inner and outer surfaces of the cask. Radiation levels must be below DOT units allowable for transportation. If rejected, cask will be reclosed and returned to vendor for decontamination.

D. Transfer of Resin Drum from Temporary Storage Area to Shipping Casks:

Prior to the transfer of the resin drums from the temporary storage area to the shipping cask, LMER Plant and Equipment personnel will be required to move the shipping cask into the hibay of Building 7877 and remove the bolts securing the lid to the shipping cask. This operation will result in the location of the shipping cask in the northeast end of the hibay as shown in Figure 1.

- 1. Removal of shipping cask lid.
 - ___ a. Move hook to location of shipping cask and align with lifting ring on shipping cask lid.
 - ___ b. Hoist shipping cask lid to a height sufficient to clear the shipping cask, move lid to a clear location and lower to floor.
 - ___ c. Disengage hook from lifting ring.
- 2. Remove cover from drum shielding in temporary storage area.
 - ___ a. Move hook to location of drum shielding cover in temporary storage area and align with lifting ring of selected shielding cover.

Transfer Bell Operation Workaid

- b. Hoist drum shielding cover from selected shielding until it is clear of the lead brick shielding surrounding the storage area, move cover to a clear location and lower to floor.
- c. Disengage hook from lifting ring.
- 3. Transfer of resin drum to shipping cask.
 - a. Align hook with lifting ring on top of drum transfer shielding.
 - b. Lift drum transfer shielding and move to location over the selected drum shielding in the temporary storage area. Carefully align the drum transfer shielding with the drum shielding using the alignment marks on each, and lower into place. This should assure the proper positioning of the lifting fixture in relation to the resin drum.

D. Transfer of Resin Drum from Temporary Storage Area to Shipping Casks (cont.):

- c. Lower the hook and the transfer shield lifting post until the lifting fixture has contacted the resin drum. This should engage the lifting fixture and secure the resin drum. An indicator on the lifting post, just below the lifting ring, will be at the top of the slot to verify the proper position of the fixture.
- d. Slowly hoist the hook and lifting post to lift the resin drum into the transfer shielding. The indicator provided on the lifting post should be slightly above the bottom of the slot to verify the position of the resin drum in the lifting fixture. If the indicator shows that the resin drum has not been secured, stop and repeat Step 3c. When resin drum has been lifted to a position inside the transfer shield, safety latches will automatically close to secure the drum in the event of an accidental release of the drum lifting fixture.
- e. Lift transfer shield to height that will clear lead bricks shielding surrounding the temporary storage area and move south, as shown on Figure 1, until clear of bricks. At this location, the transfer shield should be lowered to a height of approximately 6 inches. Due to the levels of radiation associated with the resin drum and the lack of shielding on the bottom of the transfer shield, as much of the transfer as possible should be performed at this height.
- f. Slowly move the transfer shielding until it is close to the shipping cask, and then hoist the shielding and align it with one of the three openings in the shipping cask internal frame. Tabs have been provided on the frame to aid in alignment.
- g. Lower the transfer shielding onto the shipping cask frame, carefully aligning them using the indicator marks on each, to assure proper positioning of the resin drum. Continue to lower the hook and transfer shield lifting post. Shortly after the load has been removed from the lifting post, the safety latches will open, allowing the drum to lower into the shipping cask. When the drum position indicator on the lifting post is at the top of the slot, the resin drum is resting on the bottom of the shipping cask frame, and the drum lifting fixture will automatically release the drum. Carefully

Transfer Bell Operation Workaid

hoist the hook and lifting post. The drum position indicator on the lifting post should be at the bottom of the slot to verify that the drum has been released. If not, stop, and repeat this step until the drum is successfully released.

- ___ h. Hoist the transfer shield until it is clear of the shipping cask and move to storage position in Building 7877.
- ___ i. Disengage hook from lifting ring.
- 4. Place cover on shipping cask.
 - ___ a. Move hook to storage location of shipping cask cover and align hook with lifting ring on top of lid.
 - ___ b. Hoist cask cover to height sufficient to clear shipping cask and align cover with shipping cask.
 - ___ c. Lower cask cover into place carefully positioning it to assure its proper alignment with the shipping cask. Alignment pins have been provided to aid in the proper alignment of the lid and the shipping cask.

D. Transfer of Resin Drum from Temporary Storage Area to Shipping Casks (cont.):

- ___ d. Disengage hook from lifting ring.

Operation Instruction (Date, Initial, and Check as completed): _____

At this point, remote operations are complete for this transfer. LMER Plant and Equipment personnel will be required to enter building, secure lid to shipping cask, and then remove cask from building for placement onto trailer and subsequent shipment offsite.

Attachments:

- 1. Figure: Building 7877
- 2. Attachment 2: Chain of Custody for Sorbent Transfer
- 3. Attachment 3: Prelift Meeting Attendance Sheet

Approved By: _____

CsRD Principal Investigator

Date

Appendix F

PREOPERATIONAL CHECKLIST FOR THE CsRD

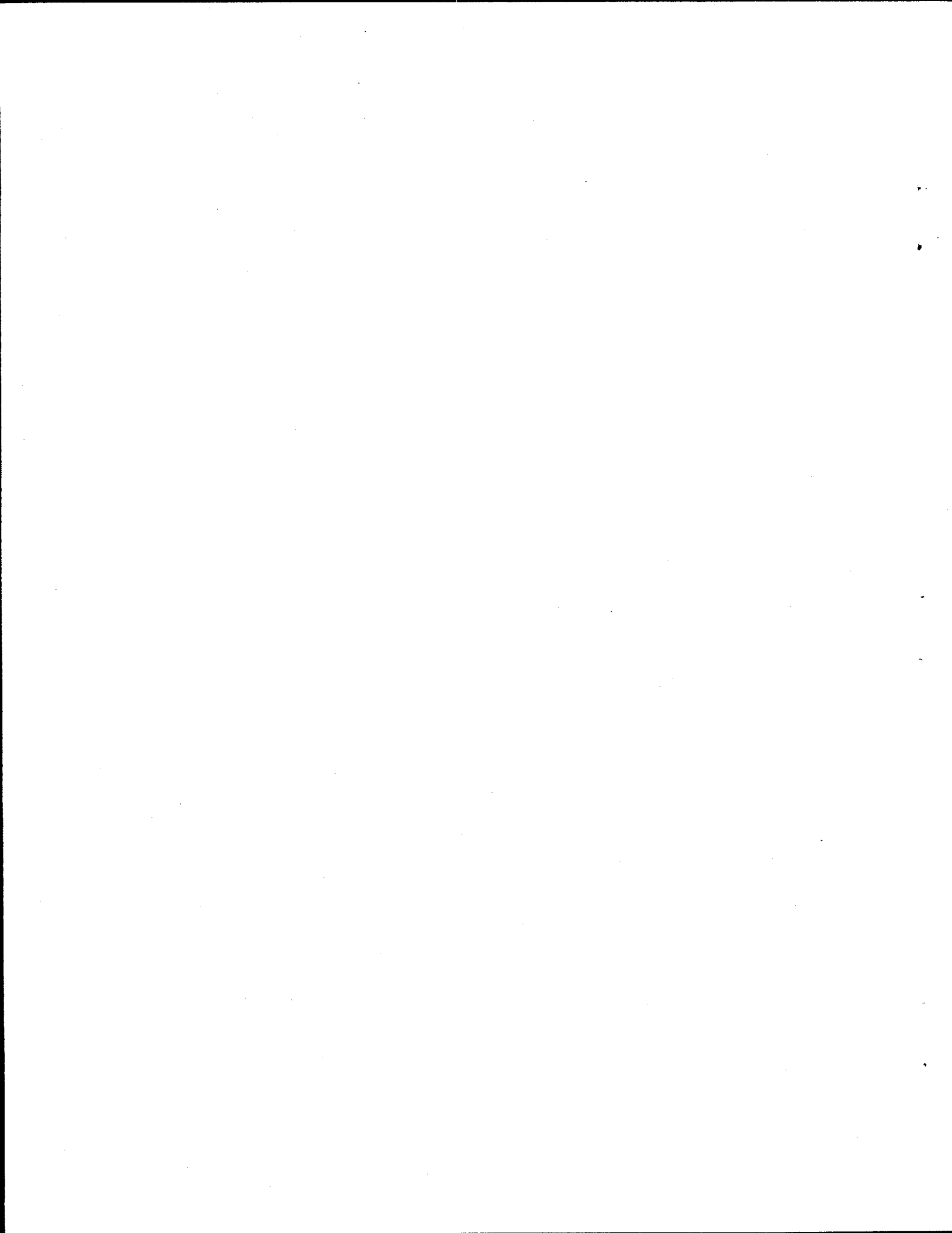

Workaid Number: **EDS-CsRD-21**

Date: 02/06/97

Revision: 1

Preoperational Startup Inspection Checklist/Workaid

Title: Preoperational Startup Inspection Checklist

Purpose: To provide a checklist for insuring that all pre-run conditions are correct and appropriate for startup or restart of the CsRD system after prolonged shutdown.

Scope: Qualified and trained CsRD personnel only.

Acronyms:

BV	Ball Valve
HP	Health Physicist
PPE	Personal Protective Equipment
EDS	Engineering Development Section
UPS	Uninterruptable Power Supply
CsRD	Cesium Removal Demonstration

General Information:

Coverage of this document is limited to operations outlined in **EDS-CsRD-05, CsRD Ion Exchange Systems Workaid**. This checklist shall be used any time the CsRD system has been shut down for an extended period of time. It can also serve as a guide for system alignment and setup prior to startup after any non-routine operation.

Inspection Action Items:

Technician Signature

Date

- _____ All valves on skids are aligned as appropriate for mode of pending operation. (*Please refer to CsRD Project Workaids for appropriate valve alignment.*)
- _____ All skid-located drain valves are aligned as appropriate for mode of pending operation.
- _____ BV-16 and SV11 are in the CLOSED position.
- _____ Drain valve BV-17 in line to sump drum is in the OPEN position.
- _____ Air-supply line on north wall of Building 7877 is in the OPEN position and supply pressure is set to appropriate value for pending operation.
- _____ Air-supply valve in 7830 is OPEN for supply of air to 7877.
- _____ Water-supply valve in 7830 is OPEN for supply of water to 7877.
- _____ Water-supply valve on north wall of Building 7877 is in the OPEN position, and delivery

Workaid Number: EDS-CsRD-21

Date: 02/06/97

Revision: 1

Preoperational Startup Inspection Checklist/Workaid

pressure is adequate.

- _____ Fill-head is in appropriate position and connected as outlined in CsRD procedures.
- _____ Shielding modules are in place around tank TK-1, filter F-1, column X-1, column X-2, dewatering drum, spent-resin storage containers, and Skid 1.
- _____ Lead blankets are placed appropriately on feed line.
- _____ Walkway into 7877 is not obstructed.
- _____ Intercom is operational for two-way communication.
- _____ Sampler is set up correctly for mode of pending operation.
- _____ Correct bottles are in place. Sample bottles are labeled correctly for pending mode of operation.
- _____ Electrical supply to all disconnects and circuit breakers is turned on.
- _____ Power-supply disconnect switch or circuit breaker is in the ON position.
- _____ There is no standing water in the sump.
- _____ There is no standing water on any skid.
- _____ There is no evidence of leakage at any point in the system.
- _____ Moisture sensors are correctly positioned in skid pans.
- _____ Skid pans are coated with anti-C coating.
- _____ All administrative controls (signs, etc.) are in place.
- _____ HP has determined that rad areas are defined and marked correctly.
- _____ Crane is energized, operational, and placed appropriately for pending mode of operation.
- _____ Transfer Bell is operational and correctly located.
- _____ Crane Operations Workaid has been reviewed, and equipment located accordingly.

Workaid Number: EDS-CsRD-21

Date: 02/06/97

Revision: 1

Preoperational Startup Inspection Checklist/Workaid

- _____ All idle equipment and items that are not to be used have been checked by HP and removed from building.
- _____ Heaters are in place and thermostats set correctly for wintertime operation, if appropriate.
- _____ HP Frisking station is operational and has been checked.
- _____ Air monitor and monitrons are in place and operational as appropriate for pending operation.
- _____ Adequate supplies of rad bags, shoe covers, tape, scissors, and other utility items are present.
- _____ Cans for disposal of PPE and trash are present and placed appropriately.
- _____ Lead pigs for samples are present and in proper location.
- _____ Appropriate people and organizations including Chris Scott, Steve Rudell, and the Waste Operations Control Center have been notified that operation is about to commence.
- _____ Appropriate analytical laboratory has been notified when samples will be pending.
- _____ All building keys are controlled by EDS personnel.
- _____ Appropriate volume of absorbent material is loaded in the absorbent hopper.
- _____ Lidder device is operational and correctly located.
- _____ Air lines have been purged of any moisture that may be present.

Workaid Number: **EDS-CsRD-21**

Date: 02/06/97

Revision: 1

Preoperational Startup Inspection Checklist/Workaid

COMPUTER/CONTROLS/SUPPLIES:

- _____ All computer controls are functioning normally.
- _____ All alarms cleared on the EDS system.
- _____ All alarms are cleared on the Waste Ops alarm panel.
- _____ Sampler control system operates correctly.
- _____ Sample-select screen has been cleared to allow for samples to be taken in appropriate bottles.
- _____ Camera systems are functioning normally. This includes cameras, monitors, pan-and-tilts, and switches.
- _____ Switch for fill-head light and camera is operational.
- _____ Communication systems including telephone, radio, intercom systems are available and functioning properly.
- _____ Computer systems are plugged into UPS.
- _____ All PPE supplies needed for appropriate dress-out are at site, and in controlled cabinets.
- _____ HP monitoring instruments are available and operational.
- _____ Operations Logbook is located at site, and enough space is left to record operational log.
- _____ Sample Logbook is located at site, and enough space is left to record sample data.
- _____ Appropriate procedures, permits, and checklist are in control room and ready for use.

Approved By: _____ **CsRD Principal Investigator** **Date**

Appendix G

**REMOTE TRANSFER PROCEDURE FOR THE 30-gal DRUMS
OF CESIUM-LOADED SORBENT**

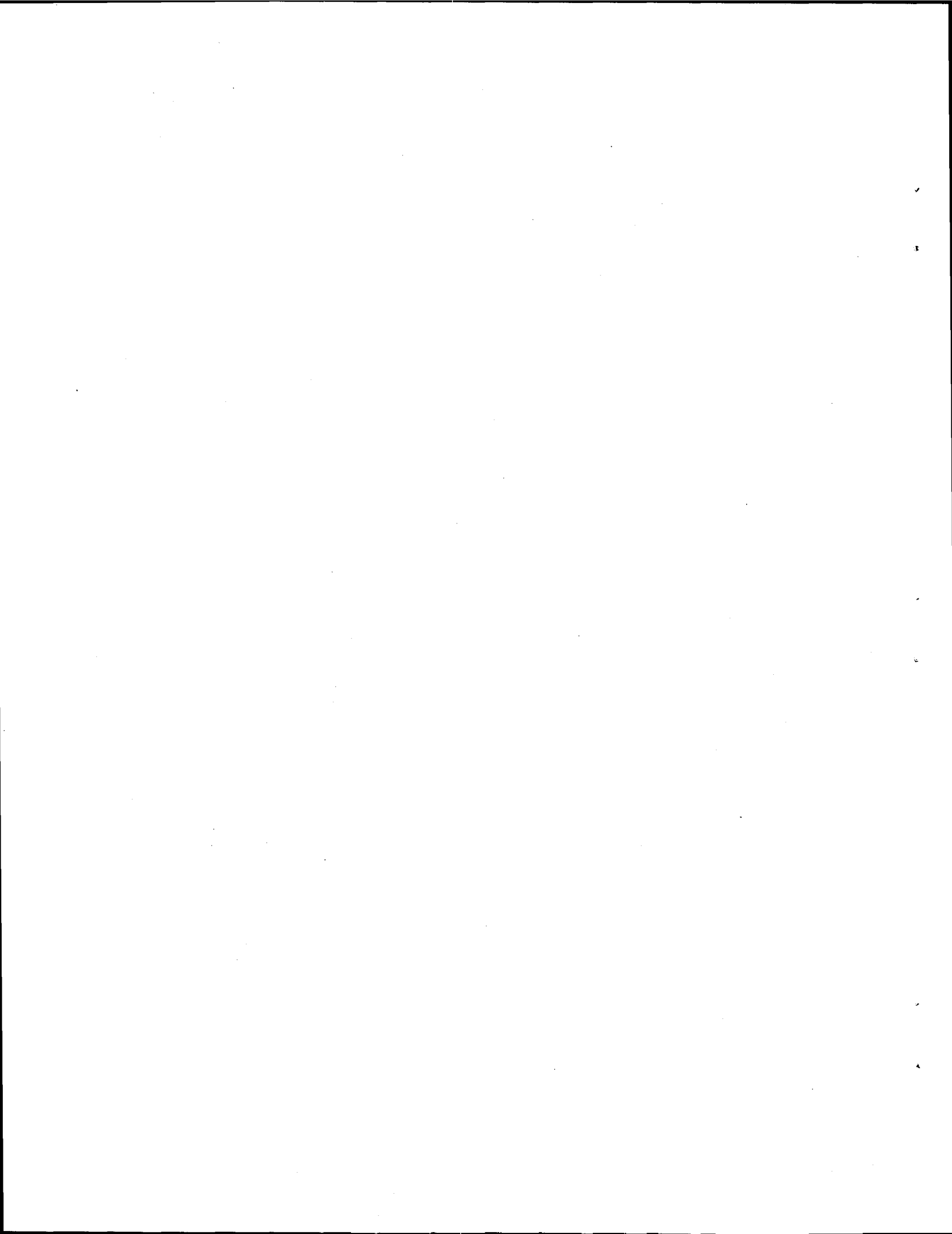

Workaid Number: **EDS-CsRD-07**

Date: 02/07/97

Revision: 5

Transfer Bell Operation Workaid

Title: **Transfer Bell Operation Workaid**

Purpose: To provide instructions in the operation of the Cesium Removal Demonstration Transfer Bell.

Scope: Qualified and trained CsRD personnel only

Acronyms:

CRO	Control Room Operator
CsRD	Cesium Removal Demonstration
MVST	Melton Valley Storage Tanks
IES	Ion Exchange System
CDAS	Control & Data Acquisition System
W-29, 30	Feed and effluent tanks, respectively, in the MVST system
ES panel	The permanently installed alarm panel on the west side of Building 7863
TSR	Technical Safety Requirements for CsRD project, DOE document # TSR/7877-WMRAD/SSE-2/R0

General Information:

Coverage of this document is limited to operations involving the CsRD storage drum, transfer bell, and remotely operated crane. Frequency of the transfer bell operation will be dictated by the *operating schedule* contained in **EDS-CsRD-01**, **CsRD Work Plan**, and will be carried out by means of this document. Prior to any lifting operation, the operators will have a prelift meeting and document this on Attachment 3.

Action Steps:

A. Documentation:

Upon completion of any transfer bell operation, notation will be made in the official operations logbook.

Upon shipment of the radioactive resin to Savannah River; a chain of custody form (Attachment 2) will be completed and sent with the Bill of Lading or Manifest.

Transfer Bell Operation Workaid

B. Transfer of Resin Drum from Dewatering Skid to Temporary Storage:

Prior to sending contaminated resin from columns to the resin drum, several preliminary steps are required in order to minimize the personnel exposure to radioactive materials. These steps are listed in the prestart checklist as follows:

Prestart Checklist

1. Resin Drum and Fillhead.
 - ___ a. Position clean, empty resin drum in drum shield on dewatering/drying skid. Aligning marks on the internal plate of the drum and the drum shield. This will assure proper alignment of all processing equipment and the resin drum.
 - ___ b. Place fillhead on resin drum, carefully aligning the transfer, vent and suction lines.
 - ___ c. Secure camlock fitting suction line using the tee handles extending from the top of the fillhead.
 - ___ d. Verify proper connection and/or operation of the following lines to the fillhead.
 - Resin transfer hose
 - Dewatering /drying hose
 - Rinse water supply hose
 - Offgas vent hose
 - Fillhead power cable
 - Camera power cable
 - Light power cable
 - Camera signal cable
 - ___ e. Position all connecting lines so free motion of fillhead to storage location is possible.
2. Absorbent Hopper.
 - ___ a. Position hopper in Building 7877 to enable remote connection of the crane hook.
 - ___ b. Load hopper with approximately 2 cubic feet (15 gal) of absorbent.
 - ___ c. Verify that hopper valve is closed with no leakage.
3. Lidding Device.
 - ___ a. Place device in support bracket provided in Building 7877, aligning marks on the lifting ring and the lid support plate.
 - ___ b. Install lid, ring and bolt on device, carefully aligning all pieces with the release tabs and the air wrench.
 - ___ c. Verify air supply isolation valve is open and air pressure is 80 psig minimum of dry, filtered air.
 - ___ d. Position air supply hose so free movement of lidding device from stand to resin drum is possible.

Operation Instruction (Date, Initial, and Check as completed): _____

Transfer Bell Operation Workaid

C. Remote Operations for Resin Drum Transfer:

1. Remove fillhead from resin drum.
 - ___ a. Align the crane hook with the lifting ring on the top of the fillhead.
 - ___ b. Lift the fillhead from the drum. Using remote camera, verify that the camlock fitting has properly released from the resin drum internal connections. Continue hoisting until fillhead is completely clear of the top of the drum and drum shield.
 - ___ c. Move fillhead approximately 6 feet south of the resin drum and place on fillhead stand, carefully watching to prevent connecting lines from snagging any objects. During this operation, the hook may be rotated to allow for better alignment of the fillhead on the stand.
 - ___ d. Disengage hook from lifting ring.
2. Add absorbent to resin drum.
 - ___ a. Align the crane hook with the lifting ring on the top of the absorbent hopper.
 - ___ b. Position the absorbent hopper over the resin drum by aligning the hopper lower plate with the top of the drum shield. The alignment tab on the hopper will assure the proper alignment of the hopper discharge with the large hole in the internal plate of the resin drum. The discharge valve of the absorbent hopper will open as it is lowered onto the drum shield and close as it is removed. Using remote cameras, verify that the absorbent has transferred to the resin drum.
 - ___ c. Lift the absorbent hopper until it is clear of the drum shield.
 - ___ d. Move absorbent hopper to storage location and disengage hook from lifting ring.
3. Place lid on resin drum using lidding fixture.
 - ___ a. Align the crane hook with the lifting ring on the top of the drum lidding fixture.
 - ___ b. Position the drum lidding fixture on the top of resin drum. Alignment of this fixture with the drum shielding will assure the proper positioning with respect to the resin drum.
 - ___ c. Secure the lid on the resin drum by operating the air ratchet controlled by the "AIR WRENCH" icon on the system control screen. Using remote cameras, check the lid, ring and bolt on the resin drum to verify that they are properly installed and that the bolt has sheared from the ratchet.
 - ___ d. Lift the drum lidding fixture until it is completely clear of the top of the drum and the drum shield.
 - ___ e. Move the drum lidding fixture to its storage position and place on stand.
 - ___ f. Disengage hook from lifting ring.
4. Transfer of resin drum to temporary storage area.
 - ___ a. Align hook with lifting ring on top of drum transfer shielding.
 - ___ b. Lift drum transfer shielding and move to location over the dewatering drum shield. Carefully align the drum transfer shielding with the drum shielding using the alignment marks on each, and lower into place. This should assure the proper positioning of the lifting fixture in relation to the resin drum.
 - ___ c. Lower the hook and the transfer shield lifting post until the lifting fixture has contacted the resin drum. This should engage the lifting fixture and secure the resin

Transfer Bell Operation Workaid

drum. An indicator on the lifting post, just below the lifting ring, will be at the top of the slot to verify the proper position of the fixture.

C. Remote Operations for Resin Drum Transfer (cont.):

- ___ d. Slowly hoist the hook and lifting post to lift the resin drum into the transfer shielding. The indicator provided on the lifting post should be slightly above the bottom of the slot to verify the position of the resin drum in the lifting fixture. If the indicator falls to the bottom of the slot, the drum has not been secured. Stop and repeat Step 4c. When resin drum has been lifted to a position inside the transfer shield, safety latches will automatically close to secure the drum in the event of an accidental release of the drum from the lifting fixture.
- ___ e. Lift transfer shield to height that will clear resin transfer tank (approximately 6 feet) and move south, as shown on Figure 1, until clear of tank. At this location, the transfer shield should be lowered to a height of approximately 12 inches from the floor. Due to the levels of radiation associated with the resin drum and the lack of shielding on the bottom of the transfer shield, as much of the transfer as possible should be performed at this height.
- ___ f. Slowly move transfer shield east, maneuvering between the concrete shielding surrounding the processing skids. At one point, the clearance between the Cesium Removal feed skid and the Out of Tank Evaporator skid shielding will be approximately 3 inches on each side of the transfer shield. Extreme care should be taken at this point not to allow any contact between the transfer shield and the concrete shielding.
- ___ g. When the transfer shield is aligned with the temporary storage area in the northeast corner of Building 7877, move the transfer shield south, hoisting to allow for clearance of the lead bricks and the drum shield. Align the transfer shield with one of the drum shielding units located inside of the lead brick shielding.
- ___ h. Lower the transfer shielding onto the drum shield selected, carefully aligning them, using the indicator marks on each to assure proper positioning of the resin drum. Continue to lower the hook and the transfer shield lifting post. Shortly after the load of the transfer shielding has been removed from the lifting post, the safety latches will open, allowing the drum to lower into the drum storage shielding. When the drum position indicator on the lifting post is at the top of the slot, the resin drum is resting on the bottom of the drum shield, and the drum lifting fixture should automatically release the drum. Carefully hoist the hook and lifting post. The drum position indicator on the lifting post should be at the bottom of the slot to verify that the drum has been released. If not, stop, and repeat this step until the drum is successfully released.
- ___ i. Hoist the transfer shield until it will clear the drum shield and lead bricks and move to storage position in Building 7877.

Transfer Bell Operation Workaid

- ___ j. Disengage hook from lifting ring.
- ___ k. HP will enter Building 7877 and take readings to determine radiation levels at contact and at one meter. The technician will also smear outside of resin drum to determine if transferable contamination is present.

C. Remote Operations for Resin Drum Transfer (cont.):

- 5. Place cover on drum shielding.
 - ___ a. Move hook to storage location of drum shielding cover and align hook with lifting ring on top of lid.
 - ___ b. Hoist shielding cover to height sufficient to clear storage area wall and drum shielding and align shielding cover with drum shielding.
 - ___ c. Lower shielding cover into place carefully positioning it to assure its proper alignment with the drum shield.
 - ___ d. Disengage hook from lifting ring.

Operation Instruction (Date, Initial, and Check as completed): _____

Note:

Before shipping cask will be accepted for use, an HP will survey the inner and outer surfaces of the cask. Radiation levels must be below DOT units allowable for transportation. If rejected, cask will be reclosed and returned to vendor for decontamination.

D. Transfer of Resin Drum from Temporary Storage Area to Shipping Casks:

Prior to the transfer of the resin drums from the temporary storage area to the shipping cask, LMER Plant and Equipment personnel will be required to move the shipping cask into the hibay of Building 7877 and remove the bolts securing the lid to the shipping cask. This operation will result in the location of the shipping cask in the northeast end of the hibay as shown in Figure 1.

- 1. Removal of shipping cask lid.
 - ___ a. Move hook to location of shipping cask and align with lifting ring on shipping cask lid.
 - ___ b. Hoist shipping cask lid to a height sufficient to clear the shipping cask, move lid to a clear location and lower to floor.
 - ___ c. Disengage hook from lifting ring.
- 2. Remove cover from drum shielding in temporary storage area.
 - ___ a. Move hook to location of drum shielding cover in temporary storage area and align with lifting ring of selected shielding cover.

Transfer Bell Operation Workaid

- ___ b. Hoist drum shielding cover from selected shielding until it is clear of the lead brick shielding surrounding the storage area, move cover to a clear location and lower to floor.
- ___ c. Disengage hook from lifting ring.
- ___ 3. Transfer of resin drum to shipping cask.
 - ___ a. Align hook with lifting ring on top of drum transfer shielding.
 - ___ b. Lift drum transfer shielding and move to location over the selected drum shielding in the temporary storage area. Carefully align the drum transfer shielding with the drum shielding using the alignment marks on each, and lower into place. This should assure the proper positioning of the lifting fixture in relation to the resin drum.

D. Transfer of Resin Drum from Temporary Storage Area to Shipping Casks (cont.):

- ___ c. Lower the hook and the transfer shield lifting post until the lifting fixture has contacted the resin drum. This should engage the lifting fixture and secure the resin drum. An indicator on the lifting post, just below the lifting ring, will be at the top of the slot to verify the proper position of the fixture.
- ___ d. Slowly hoist the hook and lifting post to lift the resin drum into the transfer shielding. The indicator provided on the lifting post should be slightly above the bottom of the slot to verify the position of the resin drum in the lifting fixture. If the indicator shows that the resin drum has not been secured, stop and repeat Step 3c. When resin drum has been lifted to a position inside the transfer shield, safety latches will automatically close to secure the drum in the event of an accidental release of the drum lifting fixture.
- ___ e. Lift transfer shield to height that will clear lead bricks shielding surrounding the temporary storage area and move south, as shown on Figure 1, until clear of bricks. At this location, the transfer shield should be lowered to a height of approximately 6 inches. Due to the levels of radiation associated with the resin drum and the lack of shielding on the bottom of the transfer shield, as much of the transfer as possible should be performed at this height.
- ___ f. Slowly move the transfer shielding until it is close to the shipping cask, and then hoist the shielding and align it with one of the three openings in the shipping cask internal frame. Tabs have been provided on the frame to aid in alignment.
- ___ g. Lower the transfer shielding onto the shipping cask frame, carefully aligning them using the indicator marks on each, to assure proper positioning of the resin drum. Continue to lower the hook and transfer shield lifting post. Shortly after the load has been removed from the lifting post, the safety latches will open, allowing the drum to lower into the shipping cask. When the drum position indicator on the lifting post is at the top of the slot, the resin drum is resting on the bottom of the shipping cask frame, and the drum lifting fixture will automatically release the drum. Carefully

Transfer Bell Operation Workaid

hoist the hook and lifting post. The drum position indicator on the lifting post should be at the bottom of the slot to verify that the drum has been released. If not, stop, and repeat this step until the drum is successfully released.

- ___ h. Hoist the transfer shield until it is clear of the shipping cask and move to storage position in Building 7877.
- ___ i. Disengage hook from lifting ring.
- 4. Place cover on shipping cask.
 - ___ a. Move hook to storage location of shipping cask cover and align hook with lifting ring on top of lid.
 - ___ b. Hoist cask cover to height sufficient to clear shipping cask and align cover with shipping cask.
 - ___ c. Lower cask cover into place carefully positioning it to assure its proper alignment with the shipping cask. Alignment pins have been provided to aid in the proper alignment of the lid and the shipping cask.

D. Transfer of Resin Drum from Temporary Storage Area to Shipping Casks (cont.):

- ___ d. Disengage hook from lifting ring.

Operation Instruction (Date, Initial, and Check as completed): _____

At this point, remote operations are complete for this transfer. LMER Plant and Equipment personnel will be required to enter building, secure lid to shipping cask, and then remove cask from building for placement onto trailer and subsequent shipment offsite.

Attachments:

- 1. Figure: Building 7877
- 2. Attachment 2: Chain of Custody for Sorbent Transfer
- 3. Attachment 3: Prelift Meeting Attendance Sheet

Approved By: _____

CsRD Principal Investigator

Date

INTERNAL DISTRIBUTION

- | | | |
|--------------------|-------------------------|------------------------------------|
| 1. D. A. Bostick | 23. S. Kirkham | 45. C. B. Scott |
| 2. R. T. Carvin | 24. D. Lee | 46. J. L. Stellern |
| 3. J. L. Collins | 25. S. A. Lewis-Lambert | 47-51. P. A. Taylor |
| 4. D. G. Cope | 26. B. E. Lewis | 52. J. R. Trabalka |
| 5. A. G. Croff | 27. J. M. Lynch | 53. R. F. Utrera |
| 6. R. L. Cummins | 28. J. J. Maddox | 54. D. C. VanEssen |
| 7. S. M. DePaoli | 29-33. C. P. McGinnis | 55. S. D. VanHoesen |
| 8. B. S. Evans | 34. L. E. McNeese | 56-75. J. F. Walker |
| 9. J. R. Farmer | 35. D. R. McTaggart | 76. J. S. Watson |
| 10. L. L. Farr | 36. T. H. Monk | 77. T. D. Welch |
| 11. M. K. Ford | 37. T. E. Myrick | 78. R. J. Wood |
| 12. J. D. Hewitt | 38. R. C. Orrin | 79. Central Research
Library |
| 13. R. D. Hunt | 39. D. J. Peterson | 80. Laboratory Records,
RC |
| 14. H. L. Jennings | 40. J. H. Platfoot | 81-82. Laboratory Records,
OSTI |
| 15. R. T. Jubin | 41. S. A. Richardson | |
| 16. C. M. Kendrick | 42. S. M. Robinson | |
| 17-21. T. E. Kent | 43. S. T. Rudell | |
| 22. J. A. Kilby | 44. T. F. Scanlan | |

EXTERNAL DISTRIBUTION

83. M. K. Andrews, Savannah River Technology Center, P.O. Box 616, Aiken, SC 29808
84. R. G. Anthony, Department of Chemical Engineering, Texas A&M University, College Station, TX 77843
85. N. E. Brown, 6608 Loftus, NE, Albuquerque, NM 87109
86. L. D. Bustard, Sandia National Laboratories, P.O. Box 5800, MS: 0728, Albuquerque, NM 87185-5800.
87. S. M. Gibson, U.S. Department of Energy, Oak Ridge Operations, P.O. Box E, Oak Ridge, TN 37831
88. J. Noble-Dial, U.S. Department of Energy, Oak Ridge Operations, P.O. Box E, Oak Ridge, TN 37831
89. Darro Ferrara, Savannah River Technology Center, P.O. Box 616, Aiken, SC 29808
90. P. W. Gibbons, Numatec Hanford Corporation, P.O. Box 1970, MS: H5-61, Richland, WA 99352
91. T. S. Gutmann, U.S. Department of Energy, Savannah River Operations Office, P.O. Box A, Aiken, SC 29802

92. John Harbour, Savannah River Technology Center, P.O. Box 616, Aiken, SC 29808
93. E. W. Holtzscheiter, Westinghouse Savannah River Company, Savannah River Technology Center, Building 773-A, Rm. A-229 MS: 28, Aiken, SC 29802
94. J. O. Honeyman, Lockheed Martin Hanford Corporation, P.O. Box 1500, MS: G3-21, Richland, WA 99352
95. A. M. Jensen, Lockheed Martin Idaho Technologies Company, P.O. Box 1625, MS:3204, Idaho Falls, ID 83415-3204
96. C. S. Louie, U.S. Department of Energy, Richland Operations Office, P.O. Box 550, MSIN: B4-55, Richland, WA 99352
97. Dan McCabe, Savannah River Technology Center, P.O. Box 616, Aiken, SC 29808
98. Jim Miller, Sandia National Laboratories, P.O. Box 5800, Albuquerque, NM 87185-0710
99. Cavanaugh Mims, U.S. Department of Energy, Oak Ridge Operations, P.O. Box E, Oak Ridge, TN 37831
100. Johnny Moore, U.S. Department of Energy, Oak Ridge Operations, P.O. Box E, Oak Ridge, TN 37831
101. J. P. Morin, Westinghouse Savannah River Company, Savannah River Technology Center, 703-H Bldg., Aiken, SC 29808
102. J. R. Noble-Dial, U.S. Department of Energy, Oak Ridge Operations Office, P.O. Box 2001, Oak Ridge, TN 37830-8620
103. Gary L. Riner, U.S. Department of Energy, Oak Ridge Operations, P.O. Box E, Oak Ridge, TN 37831
103. L. H. Sullivan, Los Alamos National Laboratory, P.O. Box 1663, Los Alamos, NM 87545
104. T. R. Thomas, Lockheed Martin Idaho Technologies Company, P.O. Box 1625, MSIN 3458, Idaho Falls, ID 83415-3423
106. Benjamin Sklar, TTI Engineering, 1600 Providence Highway, Walpole, MA 02081
107. Gary Stegen, c/o Jim Valentine, Lockheed Martin Idaho Technologies, P.O. Box 1625, Idaho Falls, Idaho 83415-3211
108. Walt L. Tamosaitis, Savannah River Technology Center, P.O. Box 616, Aiken, SC 29808
109. P. E. Woodall, U.S. Department of Energy, Idaho Operations Office, 750 DOE Place (MS 1145), Idaho Falls, ID 83402
110. E. Lloyd Youngblood, 198 N. Purdue, Apt. 103, Oak Ridge, TN 37830
- 111-115. Tanks Focus Area Technical Team, c/o G. C. Notch, Pacific Northwest National Laboratory, P.O. Box 999, MSIN K9-69, Richland, WA 99352
116. Tanks Focus Area Management Team, c/o J. A. Frey, U.S. Department of Energy, Richland Operations Office, P.O. Box 550, MS: K8-50, Richland, WA 99352