

NAVAL POSTGRADUATE SCHOOL Monterey, California



THESIS

**COMMAND AND CONTROL OF SPECIALIZED
AVIATION ASSETS:
A NEW OPERATIONAL CONCEPT**

by

Reginald F. Davis

December 2001

Thesis Advisor:
Second Reader:

William Kemple
David Tucker

Approved for public release; distribution is unlimited

Report Documentation Page

Report Date 19 Dec 2001	Report Type N/A	Dates Covered (from... to) -
Title and Subtitle Command and Control of Specialized Aviation Assets: A New Operational Concept	Contract Number	
	Grant Number	
	Program Element Number	
Author(s) Davis, Reginald F.	Project Number	
	Task Number	
	Work Unit Number	
Performing Organization Name(s) and Address(es) Naval Postgraduate School Monterey, California	Performing Organization Report Number	
Sponsoring/Monitoring Agency Name(s) and Address(es)	Sponsor/Monitor's Acronym(s)	
	Sponsor/Monitor's Report Number(s)	
Distribution/Availability Statement Approved for public release, distribution unlimited		
Supplementary Notes		
Abstract		
Subject Terms		
Report Classification unclassified	Classification of this page unclassified	
Classification of Abstract unclassified	Limitation of Abstract UU	
Number of Pages 95		

THIS PAGE INTENTIONALLY LEFT BLANK

REPORT DOCUMENTATION PAGE			<i>Form Approved OMB No. 0704-0188</i>
Public reporting burden for this collection of information is estimated to average 1 hour per response, including the time for reviewing instruction, searching existing data sources, gathering and maintaining the data needed, and completing and reviewing the collection of information. Send comments regarding this burden estimate or any other aspect of this collection of information, including suggestions for reducing this burden, to Washington headquarters Services, Directorate for Information Operations and Reports, 1215 Jefferson Davis Highway, Suite 1204, Arlington, VA 22202-4302, and to the Office of Management and Budget, Paperwork Reduction Project (0704-0188) Washington DC 20503.			
1. AGENCY USE ONLY	2. REPORT DATE December 2001	3. REPORT TYPE AND DATES COVERED Master's Thesis	
4. TITLE AND SUBTITLE: Command and Control of Specialized Aviation Assets: A New Operational Concept			5. FUNDING NUMBERS
6. AUTHOR(S) Reginald F. Davis			
7. PERFORMING ORGANIZATION NAME(S) AND ADDRESS(ES) Naval Postgraduate School Monterey, CA 93943-5000			8. PERFORMING ORGANIZATION REPORT NUMBER
9. SPONSORING / MONITORING AGENCY NAME(S) AND ADDRESS(ES) N/A			10. SPONSORING / MONITORING AGENCY REPORT NUMBER
11. SUPPLEMENTARY NOTES The views expressed in this thesis are those of the author and do not reflect the official policy or position of the Department of Defense or the U.S. Government.			
12a. DISTRIBUTION / AVAILABILITY STATEMENT Approved for Public Release; distribution is unlimited			12b. DISTRIBUTION CODE
13. ABSTRACT (maximum 200 words) Currently, US military forces deploy and employ under the auspices of separate systems. Deployment occurs via the Joint Chiefs of Staff managed process called Joint Operational Planning and Employment System (JOPES). Employment of forces occurs under the direction of a combatant theater commander. In the case of special operations forces, the employment process is managed by a Joint Special Operations Task Force (JSOTF) commander and is known as Time Sensitive Planning. Special operations forces are able to execute jointly planned and rehearsed special operations missions within 96 hours of receiving a warning order. The JOPES deployment system may take days to complete the coordination required to deploy military forces overseas. However, control of those military forces, and therefore mission preparation, does not currently pass to the theater commanders until the forces arrive in theater. Depending on the method of transportation, this deployment window may take as long as a week. Although in some cases, deployments can be accomplished in a matter of days. This is the exception rather than the rule, though. The net effect is that the timeliness of military responses to crises is limited not only by the distance to the frontline, but also by the speed of the current JOPES and mission planning processes. This is true for special operations forces as well as conventional military forces. This thesis will offer a new operational concept for the deployment, employment, and command and control of specialized air power.			
14. SUBJECT TERMS Special Operations, SOF, Command and Control, Concept of Operations, Aviation			15. NUMBER OF PAGES 95
			16. PRICE CODE
17. SECURITY CLASSIFICATION OF REPORT Unclassified	18. SECURITY CLASSIFICATION OF THIS PAGE Unclassified	19. SECURITY CLASSIFICATION OF ABSTRACT Unclassified	20. LIMITATION OF ABSTRACT UL

THIS PAGE INTENTIONALLY LEFT BLANK

Approved for public release; distribution is unlimited

**COMMAND AND CONTROL OF SPECIALIZED AVIATION ASSETS:
A NEW OPERATIONAL CONCEPT**

Reginald F. Davis
Major, United States Air Force
M.S., Embry-Riddle Aeronautical University, 1997

Submitted in partial fulfillment of the
requirements for the degree of

**MASTER OF SCIENCE IN DEFENSE ANALYSIS
(COMMAND, CONTROL, AND COMMUNICATIONS)**

from the
THIS PAGE INTENTIONALLY LEFT BLANK
NAVAL POSTGRADUATE SCHOOL

December 2001

Author: 
Reginald F. Davis

Approved by: 
William G. Kemple, Thesis Advisor

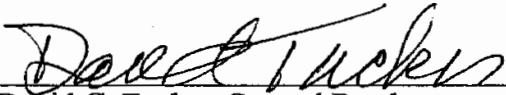
David C. Tucker, Second Reader

Gordon H. McCormick, Chair
Department of Defense Analysis

THIS PAGE INTENTIONALLY LEFT BLANK

ABSTRACT

Currently, US military forces deploy and employ under the auspices of separate systems. Deployment occurs via the Joint Chiefs of Staff managed process called Joint Operational Planning and Employment System (JOPES). Employment of forces occurs under the direction of a combatant theater commander. In the case of special operations forces, the employment process is managed by a Joint Special Operations Task Force (JSOTF) commander and is known as Time Sensitive Planning. Special operations forces are able to execute jointly planned and rehearsed special operations missions within 96 hours of receiving a warning order.

The JOPES deployment system may take days to complete the coordination required to deploy military forces overseas. However, control of those military forces, and therefore mission preparation, does not currently pass to the theater commanders until the forces arrive in theater. Depending on the method of transportation, this deployment window may take as long as a week, although in some cases, deployments can be accomplished in a matter of days. This is the exception rather than the rule, though. The net effect is that the timeliness of military responses to crises is limited not only by the distance to the frontline, but also by the speed of the current JOPES and mission planning processes. This is true for special operations forces as well as conventional military forces.

This thesis will offer a new operational concept for the deployment, employment, and command and control of specialized air power.

THIS PAGE INTENTIONALLY LEFT BLANK

TABLE OF CONTENTS

I.	SPECIAL OPERATIONS DOCTRINE	1
A.	THE ORIGIN OF SPECIAL OPERATIONS DOCTRINE.....	1
B.	SPECIAL OPERATIONS DOCTRINE TODAY.....	2
C.	THESIS OBJECTIVE.....	3
II.	SPECIALIZED AIRPOWER DEFINED.....	5
A.	UNITED STATES ARMY SPECIAL OPERATIONS COMMAND.....	5
B.	AIR FORCE SPECIAL OPERATIONS COMMAND.....	6
1.	<i>Transportation Aircraft.....</i>	6
2.	<i>Information Warfare and Attack Aircraft.....</i>	7
3.	<i>Locations of Air Force Special Operations Command Aircraft.....</i>	7
4.	<i>Additional Specialized Airpower Units.....</i>	9
C.	SUMMARY.....	10
III.	INNOVATIONS IN COMMAND AND CONTROL OF AIRPOWER.....	11
A.	PACIFIC AIR FORCES.....	11
B.	SPECIAL OPERATIONS COMMAND, PACIFIC.....	12
C.	COMMAND AND CONTROL OF AIRPOWER IN PACIFIC COMMAND.....	14
IV.	JOPEs AND TIME SENSITIVE PLANNING	17
A.	THE JOINT OPERATIONAL PLANNING AND EXECUTION SYSTEM.....	17
B.	USSOCOM AND JOINT SPECIAL OPERATIONS TASK FORCES.....	19
C.	TIME SENSITIVE PLANNING	21
D.	THE JOINT SPECIAL OPERATIONS AIR COMPONENT COMMANDER.....	23
E.	JOPEs AND TIME SENSITIVE PLANNING REVIEWED.....	24
V.	THEATER JSOAC OPERATIONAL CONCEPT.....	27
A.	INTRODUCTION.....	27
B.	JOPEs DEPICTION.....	28
C.	THEATER JSOAC DEPICTION.....	29
D.	THEATER JSOAC OPERATIONAL CONCEPT.....	30
VI.	THEATER JSOAC SOFTWARE SYSTEMS.....	39
A.	MARINE AIR-GROUND TASK FORCE WARFARE SIMULATION.....	40
1.	<i>MTWS Structure.....</i>	40
2.	<i>MTWS Features.....</i>	41
3.	<i>SOF-MTWS Interfaces.....</i>	43
4.	<i>MTWS Summary.....</i>	44
B.	JOINT CONFLICT AND TACTICAL SIMULATION SYSTEM.....	44
1.	<i>JCATS Features.....</i>	45
2.	<i>JSOAC Application of JCATS.....</i>	46
3.	<i>JCATS Summary.....</i>	48
C.	SPECIAL OPERATIONS FORCES PLANNING AND REHEARSAL SYSTEM.....	49
1.	<i>SOFPARS Structure.....</i>	49
2.	<i>JSOAC Use of SOFPARS.....</i>	51
3.	<i>SOFPARS Summary.....</i>	53
D.	SUMMARY OF SOFTWARE SYSTEMS.....	53
VII.	A FRAMEWORK OF COMPARISON FOR COMMAND AND CONTROL ORGANIZATIONS.....	57
A.	SOURCES OF CRITERIA.....	57
B.	THE SELECTED CRITERIA.....	58
1.	<i>Speed.....</i>	58
2.	<i>Conservation of Forces.....</i>	60
3.	<i>Operational Security.....</i>	60
C.	SUMMARY.....	61

VIII.	COMPARISON OF TIME SENSITIVE PLANNING AND THE THEATER JSOAC CONCEPT.....	63
	A. SPEED.....	63
	B. CONSERVATION OF FORCES.....	65
	C. OPERATIONAL SECURITY.....	67
	D. SUMMARY.....	69
IX.	ADDITIONAL RESEARCH OPPORTUNITIES.....	71
	A. POTENTIAL ISSUES.....	71
	B. ADDITIONAL AREAS OF RESEARCH.....	73
	APPENDIX A: THEATER JSOAC INFORMATION FLOWS.....	77
	LIST OF REFERENCES.....	81
	INITIAL DISTRIBUTION LIST.....	83

I. SPECIAL OPERATIONS DOCTRINE

Special operations forces conduct military missions in unforgiving operational environments. Special operations forces routinely work in conditions of near and total darkness and inclement weather for extended periods of time in order to be where and when they are least expected. Specialized aviation forces support their ground counterparts by transporting and resupplying special operations teams anywhere on the globe. When additional firepower is needed, special operations aircraft can provide close air support from rotary and fixed wing platforms. Special operations forces train together extensively to be able to succeed in any environment. This has been true from the inception of special operations forces in the United States military. Training as a joint fighting force is a cornerstone that the United States Special Operations Command has instilled in its land, air, and maritime special operations forces.

A. THE ORIGIN OF SPECIAL OPERATIONS DOCTRINE

However, the nature of potential future conflicts is in flux. While the climates special operations forces face may not change significantly in years to come, the nature and location of future conflicts may be far different from the operational environments our military currently prepares to face. The way special operations forces must prepare for and execute missions in these changing times must also change. While Joint Vision 2020 and SOF Vision 2020 focus on the nature of future conflicts, current special operations doctrine is based on our historical experiences. The foundational doctrine special operations forces adhere to is linked to a seminal event in our institutional history. Understanding what happened in the aftermath of the crash in Iran at Desert One in 1979 sheds some light on how the current special operations mission planning, rehearsal, and execution cycle developed.

The Holloway Commission examined the planning and execution of the military mission to rescue the American hostages held by the Iranian government in 1980. The

report published by the commission detailed the contributing factors that led to the aborted rescue attempt and subsequent death of eight American military members on Operation Eagle Claw. In addition to citing differences in training and operational limitations on similar aircraft flown by the different services, the commission identified the overarching desire to preserve security as a causal factor in the mission failure. Mission commanders practiced sections of the overall mission in phases at separate locations throughout the United States. During the more than yearlong process of defining and refining the mission execution sequence, the entire force was never assembled to conduct a full-scale dress rehearsal prior to the actual mission execution. The commission surmised that the communication and mechanical problems the rescue force encountered could have been disclosed and remedied had a rehearsal been conducted (Kreisher, 1999).

B. SPECIAL OPERATIONS DOCTRINE TODAY

Current doctrine addressing planning for special operations directly reflects this finding. Special operations forces generally deploy to forward staging or operating bases (FSB or FOB) where they form an ad hoc organization of ground, aviation, and maritime forces plus maintenance and support personnel. These organizations are called Joint Special Operations Task Forces. Once assembled, the task force begins a planning cycle that is programmed to last 96 hours and includes integrated coordination between all forces involved with the mission. The process also includes a series of mass briefings and a full-scale rehearsal on a practice target that replicates the actual target. The primary mission plan and contingency plans are continually updated to account for emerging changes in the climate, political, and threat situations throughout the four day cycle (Joint Publication 3-05.5, 1993). This process is exercised routinely and is used to prepare special operations forces to respond to real-world contingencies.

However, as Joint Vision 2020 and SOF Vision 2020 point out, demographics and information access is changing the likely nature of conflict in the world. The reduction of American military forces and infrastructure overseas poses logistical support issues to all military planners in the Department of Defense. While the 96-hour process is a rapid

paced cycle to assemble and train a highly capable military force, the pace of international communications and information transfer through the internet and traditional broadcast media makes even a 96-hour process seem unresponsive. All too often, commercial media provides the initial indication of a crisis to military leaders and the general public. Then media attention tends to shift to coverage of potential US military responses; ironically, adversaries and US planners gain intelligence from the same public sources (Joint Vision 2020, 2000).

The technological developments that have enabled the information age in the speed and fidelity of international communications capabilities are also available to military planners. During the era of the hostage rescue attempt in Iran, there was no truly reliable method for military forces to practice their flight profiles without assembling and actually flying their aircraft. Thus, there is an emphasis in the 96-hour cycle on gathering the Joint Special Operations Task Force in a central location where a dress rehearsal can be conducted. Now, however, high-fidelity aircraft flight simulators, standardized electronic maps and chart data, and widespread access to a secure government internet allows military forces to share information without being physically collocated. Unfortunately, there is no doctrine or set of standardized procedures to incorporate these technological advances in the deployment, planning, and employment of special operations forces.

C. THESIS OBJECTIVE

This thesis offers a new operational concept for the deployment and employment of special operations forces in the United States military. Since much of special operations missions rely on aviation support for transportation, resupply, and protection, this thesis focuses on the command and control processes associated with special operations aviation forces. This thesis defines the elements of special operations aviation capabilities, describes the current force deployment and employment process, and describes an existing and innovative arrangement for the command and control of aviation forces. Next, a description of a new operational concept for deploying and employing special operations aviation forces is offered and is followed by a short

preview of key technological innovations the new operational concept would warrant. A set of criteria is offered by which the two command and control processes can be analyzed and a comparison of the current and the proposed concepts is conducted. Finally, a recommendation for additional research is proposed to further refine this concept with the goal of augmenting existing special operations doctrine.

II. SPECIALIZED AIRPOWER DEFINED

Specialized airpower is not defined specifically in Department of Defense publications. However, a description of specialized aircraft and their capabilities is necessary to understand the operational concepts described in this thesis. Three of the four services contribute special operations forces to the United States Special Operations Command; the United States Marine Corps does not field special operations forces under the auspices of the United States Special Operations Command. Naval Special Warfare Command, the United States Navy's component to the United States Special Operations Command, has no organic aviation capabilities and therefore there are no naval organizations included in the definition of specialized airpower. Thus, only Army and Air Force special operations forces are included in the definition of specialized aviation. Specialized aviation is defined as aerospace-related combat and combat support capabilities that are assigned to the United States Special Operations Command.

A. UNITED STATES ARMY SPECIAL OPERATIONS COMMAND

The United States Army Special Operations Command has command of ground forces that include Army Special Forces and Rangers as well as Civil Affairs and Psychological Operations forces. The command also includes specially modified helicopters and highly trained aircrew members assigned to the 160th Special Operations Aviation Regiment. The helicopters encompass a mix of close air support, attack, and mid-range and long-range transport helicopters. The 160th Special Operations Aviation Regiment conducts insertion and extraction of special operations forces, aerial security, armed attack, electronic warfare, and command and control support. The weapon systems the 160th Special Operations Aviation Regiment flies includes MH-47D\A Chinook, MH-60K\L Blackhawk, and A\M\TH-6 Little Bird helicopters. Most of these helicopters are equipped with armor plating, defensive and offensive firepower systems, electronic warfare gear, additional fuel tanks, and refueling probes. The 160th Special

Operations Aviation Regiment aircraft are stationed at Fort Campbell, Kentucky. Additionally, two small detachments from the regiment are stationed at Pacific Command and Southern Command. If additional helicopters are needed, strategic airlift aircraft must be used for airlift support when deploying to overseas theaters of operation. Collectively, the 160th Special Operations Aviation Regiment is known as Task Force 160 (SOF Posture Statement, 2000).

B. AIR FORCE SPECIAL OPERATIONS COMMAND

Air Force Special Operations Command contributes the largest number of specialized aviation forces to the United States Special Operations Command. Aircraft that Air Force Special Operations Command units operate fall into three categories: transportation, information warfare, and attack.

1. Transportation Aircraft

There are three variants of fixed wing transport aircraft in the Air Force Special Operations Command (AFSOC). They are the MC-130P Combat Shadow, MC-130E Combat Talon, and MC-130H Combat Talon II. The first two versions are equipped to conduct inflight refueling of specially modified helicopters from all services. All three specialized transport aircraft are able to penetrate enemy defenses using a combination of low altitude flight, terrain following\terrain avoidance radar systems, adverse-weather penetration, and electronic warfare techniques. The primary mission of these specially modified transport aircraft is to infiltrate ground teams and their equipment via airdrop procedures, to land on unimproved airstrips, and to resupply special operations ground forces once they are in the field. AFSOC's MH-53J\M Pave Low III\IV long-range helicopters perform the same roles as the fixed wing transports, plus they provide close in fire support and exfiltration for ground teams.

2. Information Warfare and Attack Aircraft

Information warfare is supported in Air Force Special Operations Command by the EC-130E Commando Solo aircraft that broadcasts radio and television signals while airborne. All of the fixed wing transport aircraft can also conduct information warfare support via airdrop of leaflets. AC-130H Spectre and AC-130U Spooky Gunships are the primary attack weapon systems Air Force Special Operations Command employs. These aircraft are equipped with infrared sensors, high-resolution television cameras, and air to ground beacon-tracking systems that are used to aim the 40mm and 105mm cannons onboard the aircraft. The AC-130U aircraft also uses synthetic aperture radar to locate targets in adverse weather and has a 25mm cannon added to its armament. The Gunships employ their sensors and weapons in a variety of roles including armed reconnaissance, close air support, and interdiction support for special operations and conventional missions (SOF Posture Statement, 2000).

3. Locations of Air Force Special Operations Command Aircraft

Air Force Special Operations Command aircraft are stationed in Europe, Asia, and the United States, Figure 1. MC-130H and MC-130P airlifters with MH-53J helicopters are assigned at both RAF Mildenhall in the United Kingdom and Kadena, Airbase in Japan. There are also MC-130H and MH-53J aircraft assigned at Hurlburt Field, Florida. MC-130P aircraft are assigned to the 16th Special Operations Wing at Hurlburt Field, however the aircraft are based across town at Eglin Air Force Base in Fort Walton Beach, Florida. AC-130H and AC-130U gunships are also assigned at Hurlburt Field. EC-130E Commando Solo aircraft are assigned to a National Guard unit at Harrisburg, Pennsylvania and MC-130E aircraft are assigned to the Air Force Reserve Command and stationed at Duke Field, Florida. All the fixed wing aircraft are capable of transoceanic flight, although the AC-130's require inflight-refueling support, while the helicopters require strategic airlift aircraft to deploy overseas.

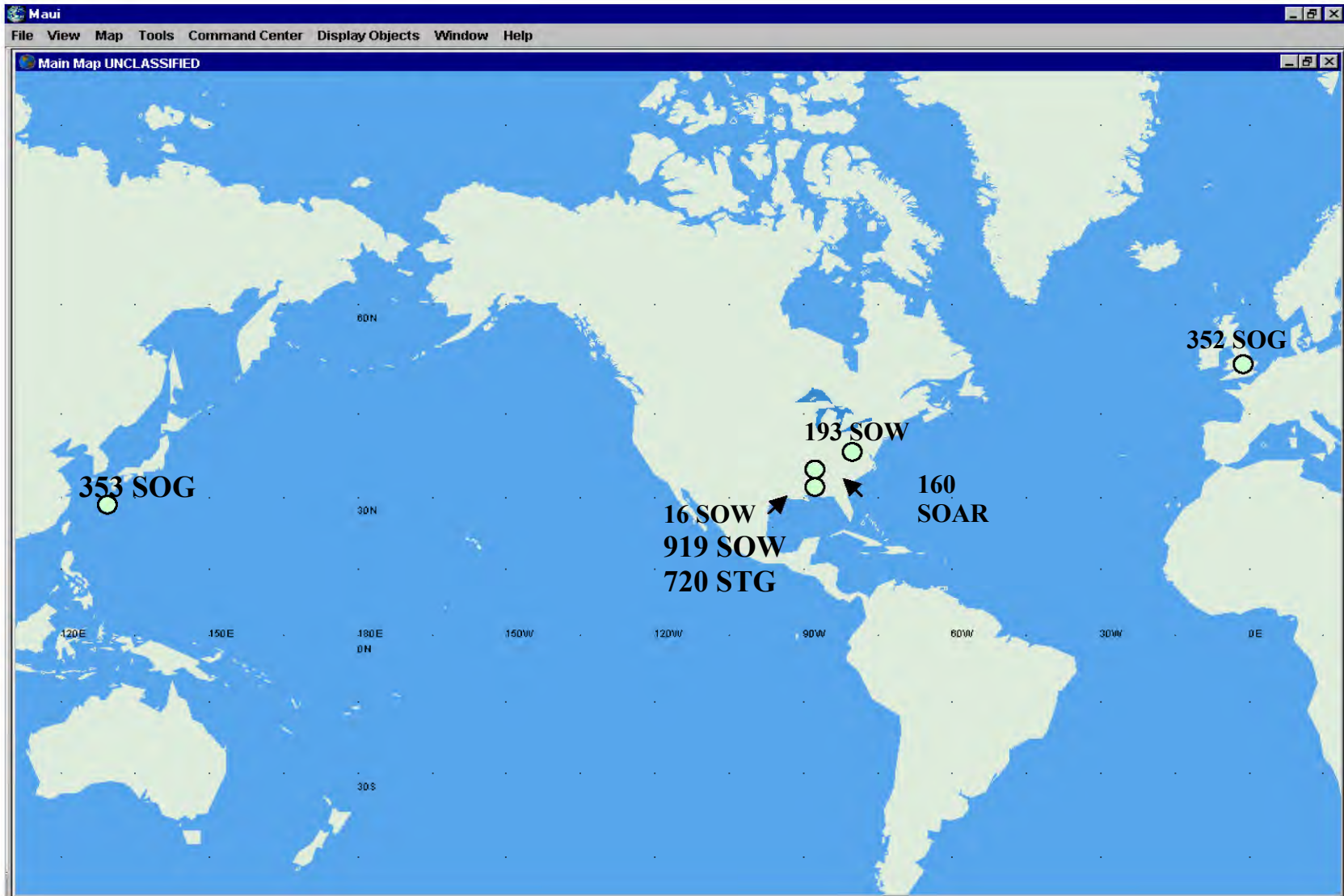

8

Figure 1. Locations of Specialized Aviation Assets

4. Additional Specialized Airpower Units

Air Force Special Operations Command's specialized airpower includes more than aircraft and aircrews. Special Tactics Squadrons, the Air Force's special operations ground element, provide three primary functions in support of special operations missions. First, they execute control of austere airfields by conducting air traffic and ground control of specialized aviation forces at night, under blacked-out lighting conditions, and in close coordination with special operations ground force commanders. The personnel who are qualified to control airfields are called Combat Control Teams. Second, Special Tactics personnel provide combat medical care for wounded personnel under austere conditions. Finally, Special Tactics Squadron members train side by side with the Army and Navy special operations forces. They hold the same qualifications in scuba, mountaineering, extended patrolling, weapons, airborne procedures, and other skills as Army and Navy special operations ground forces. While attached to Special Forces units or Navy Sea-Air Land teams, the Special Tactics personnel perform critical ground-to-air communications roles for resupply, close air support, and exfiltration support from conventional and specialized aviation assets. Air Force Special Operations Command's Special Tactics personnel are also capable of performing independent special operations missions. There are active duty Special Tactics Squadrons located at Ft Lewis, Washington; Fayetteville, North Carolina; Hurlburt Field, Florida; RAF Mildenhall, United Kingdom; and Kadena Airbase, Japan (SOF Posture Statement, 2000).

This thesis does not address all the specialized aviation capabilities assigned to United States Special Operations Command. For example, Air Force Special Operations Command has Combat Weather Squadrons and a unique unit that conducts foreign internal defense missions as aviation trainers that are not described here. However, for the purposes of this thesis, a general understanding of the mission areas of the primary specialized aviation units that usually deploy as part of Joint Special Operations Task Forces is adequate.

C. SUMMARY

United States Army Special Operations Command provides specially modified attack and extended-range rotary wing forces to the United States Special Operations Command. The Air Force Special Operations Command provides aviation forces to United States Special Operations Command that conduct specialized transportation, information warfare, and attack capabilities. Air Force Special Operations Command also includes Special Tactics Squadrons that support peer special operations forces on the ground. The process by which aviation forces are organized in response to crises and contingencies in one theater of operations is presented in the next chapter.

III. INNOVATIONS IN COMMAND AND CONTROL OF AIRPOWER

Pacific Command, like every other regional theater of operations, integrates command and control organizations from all the services and functional commands in the Department of Defense. Pacific Command, however, is unique among the theater commands in two significant ways. First, the sheer volume of territory in which Pacific Command forces are responsible for protecting America's national interests is daunting. Pacific Command military units cover more than 105 million square miles of territory that reaches from Alaska to Hawaii to Australia to India and Madagascar. The second distinction relates directly to the first; Pacific Command's area of responsibility spans three of the world's largest bodies of water. While Pacific Command is a joint organization, the constraints and opportunities represented by sea power effect every aspect of the command's activities including special operations activities.

A. PACIFIC AIR FORCES

Pacific Command executes command and control from specially designed ships as part of maritime task forces. Because of the great expanses of oceans combined with a lack of extensive forward based United States forces throughout the theater, Pacific Command joint task force commanders can plan, prepare, and accomplish control of air, maritime, and land missions from sea. Maneuverability and security are innate advantages of stationing a commander and his battlestaff on a ship. While advances in military communications capabilities have made command and control from ship based cells possible, the limit of work and berthing space is one significant drawback to executing command and control from ships. For example, planning and controlling air missions from a land based Air Operations Center can require upwards of 1,000 personnel to plan future operations, coordinate with land, special operations, and maritime forces, control air space, and execute daily flight control. Ships simply do not

have the space for the personnel and equipment needed to conduct sustained command and control of joint air forces.

Two subordinate aviation command echelons in Pacific Command have addressed this disadvantage in separate but similar initiatives. Pacific Air Forces, the United States Air Force's aerospace component to the Pacific Command, and Special Operations Command, Pacific, the commander of all theater special operations forces in the Pacific Command, both are developing a split command and control function to support theater aviation missions. Pacific Air Forces (PACAF) is building an organization of command and control experts based at Hickam Air Force Base, Hawaii. The Air Operations Center onboard the command and control ship will be a much smaller detachment of aviation planners who will focus on executing one daily flying plan at a time. The Air Operations Center in Hawaii will plan and coordinate future aviation missions in the 48-hour and later time frames. Both Air Operations Centers will fall under the command of the Joint Task Force commander and the designated Joint Force Air Component Commander. This forward and rear split of command and control depends on extensive coordination and highly reliable communication links between the command ships, the rear Air Operations Center, carrier based aviation units, and land based aircraft units in the theater.

B. SPECIAL OPERATIONS COMMAND, PACIFIC

PACAF's Air Operations Control units are still in the initial phases of operational capability. The Air Operations Center's facilities are being constructed and personnel selection and training is underway. However, the Special Operations Command, Pacific (SOCPAC) has established a Joint Special Operations Air Component Command. Prior to the establishment of this new command and control element at SOCPAC, the 353d Special Operations Group of Air Force Special Operations Command was the de facto special operations air component commander in the Pacific theater. However, the addition of a special operations aviation detachment of the Army's Task Force 160 helicopters in the Pacific theater led to a need to integrate a joint command and control

structure in SOCPAC. The Joint Special Operations Air Component Command conducts planning, controlling, and coordinating functions for specialized aviation missions on behalf of the designated JSOTF Commander. SOCPAC's Joint Special Operations Air Component Command is a permanent organization that integrates special operations air missions with the Joint Force Air Component Commander's Air Operations Center during joint task force operations. This is done primarily through a Special Operations Liaison Element that resides in the Air Operations Center, but is under the command of the JSOTF Commander. SOCPAC's Joint Special Operations Air Component is also headquartered in Hawaii, but is not collocated with PACAF's Air Operations Center.

SOCPAC's Joint Special Operations Air Component is sparsely staffed with detachments of personnel stationed in the theater alongside the specialized aviation units. The Joint Special Operations Air Component is headquartered in Hawaii with the SOCPAC staff. The proposed manning at the headquarters element includes Air Force and Army rotary wing air operations planners, airspace planners, a Special Tactics planner, a communications and computer expert, a small administrative support section, and the Joint Special Operations Air Component Commander. The Deputy Joint Special Operations Air Component Commander leads the detachment at Kadena Air Base, Japan that is resident with the 353d Special Operations Group. This detachment has a proposed manning that includes Army personnel specialist, a two-person intelligence section, a four-person operations section, and a two-person logistics section. The operations section at the Kadena detachment would include an Army rotary wing planner, an Army special operations ground force planner, a Naval Special Warfare planner, and the director of operations. The last detachment in the SOCPAC Joint Special Operations Air Component organization is stationed at Osan Air Base, Korea. Seven personnel under a single operations section with specialties encompassing intelligence, administration, air operations and plans, and logistics plans are slated to man the detachment in the Republic of Korea.

SOCPAC's standing in-theater Joint Special Operations Air Component with its resident detachments has a unique concept of operations. The Joint Special Operations Air Component personnel will fall under the operational control of a JSOTF when

formed in response to an exercise or contingency. If the contingency is a theater wide effort, the Joint Special Operations Air Component's chain of command could lead directly to the theater Joint Force Special Operations Component Commander, the same command echelon to which JSOTFs would report. As such, the Joint Special Operations Air Component would coordinate the daily interfaces with the task force Air Operations Centers to ensure specialized aviation support activities gain the support needed from its conventional airpower counterparts in the overall Joint Task Force. Additionally, the standing Joint Special Operations Air Component will represent a core of regionally oriented experts that can act as a "docking station" (Mobley, 2001) for augmenting forces and their planning staffs as the JSOTF forms. For example, according to USSOCOM Directive 525-8 a fully staffed Joint Special Operations Air Component would consist of 97 personnel to enable continuous command and control of specialized aviation missions. The core of 31 people in SOCPAC's Joint Special Operations Air Component and detachments would form the initial command and control backbone for air planning in a JSOTF as it transitions from daily operations to contingency response operations.

Standing Joint Special Operations Air Component Commands, and other similar joint operational command and control organizations, can accomplish another important role. The working relationships that can be developed by working with conventional theater counterparts on a routine basis can be capitalized on during contingency missions. This is true also of the relationships within a standing Joint Special Operations Air Component Command. Since Army, Navy, and Air Force special operations experts would work together in SOCPAC's detachments in Hawaii, Japan, and the Republic of Korea, there is likely to be an efficiency benefit when bringing the three different services together to plan and coordinate special operations aviation missions.

C. COMMAND AND CONTROL OF AIRPOWER IN PACIFIC COMMAND

Pacific Air Forces Command and Special Operations Command, Pacific both have initiated reorganizations of their command and control of theater air assets. Pacific

Air Forces, the conventional arm of the United States Air Force in the Pacific theater, has opted for a split command and control function with a standing Air Operations Center structure in Hawaii that supports forward deployed Joint Force Air Component Commanders air plans. This splits the responsibilities for executing the current daily air tasking order in the forward area of operations from the planning and coordinating tasks for future daily air tasking orders in the rear area. Along with the benefits of continuity and regional expertise associated with a full-time command and control organization, this forward-rear split reduces the number of people and amount of equipment needed to flow to forward operating locations. This aspect is particularly important in Pacific Command since their forward operating locations are often within the limited confines of a ship.

Special Operations Command, Pacific, the theater special operations organization that is a subordinate unified command for the Commander in Chief of Pacific Command, also established a unique command and control organization to plan and coordinate specialized aviation missions in the Pacific theater. SOCPAC established detachments of special operations aviation mission planning and support experts in three locations throughout the Pacific theater. These detachments are collocated at the home bases of the special operations aviation units in Japan and the Republic of Korea, as well as stationing the command detachment of the Joint Special Operations Air Component with the SOCPAC headquarters in Hawaii. All three detachments perform planning and coordination tasks to ensure specialized aviation missions receive the appropriate airspace, logistics, intelligence, information, and conventional aerospace support from theater and national assets on behalf of a Joint Force Special Operations Component Commander and JSOTF Commanders during exercises and contingencies. In peacetime, SOCPAC's Joint Special Operations Air Component Commander and the detachments work with the special operations forces assigned in theater to coordinate their aviation support requirements but report to the SOCPAC commander.

THIS PAGE INTENTIONALLY LEFT BLANK

IV. JOPES AND TIME SENSITIVE PLANNING

The procedures used by the Joint Chiefs of Staff and theater commanders to form and employ Joint Special Operations Task Forces are embodied in the Joint Operational Planning and Execution System and the Time Sensitive Planning Process. A notional formation of a Joint Special Operations Task Force is described in this chapter by focusing on the actors primarily associated with the deployment of special operations forces assigned to a Joint Special Operations Task Force. The VITE organizational analysis software package is used to relate the relevant Department of Defense levels of command with their actions at each stage of the Joint Operational Planning and Execution System. The same VITE-based organizational analysis program is used to replicate the Time Sensitive Planning cycle used by Joint Special Operations Task Forces to plan special operations missions. The VITE diagrams are intended to provide an organizational view of the special operations deployment and employment processes.

A. THE JOINT OPERATIONAL PLANNING AND EXECUTION SYSTEM

The President of the United States, with the advice of the National Security Advisor, Secretary of State, and other executive cabinet members, develops the National Security Strategy based on a geo-political vision of the world and America's role in realizing that vision. The President then employs economic, diplomatic, political, and military means, traditionally known as the instruments of national power, in shaping the world to achieve the National Security Strategy.

The Joint Chiefs of Staff are responsible for identifying the roles and appropriate force structures needed by the military to support the National Security Strategy. The first step in this process is defining a National Military Strategy that supports the National Security Strategy. Theater, functional, specified, and unified military commanders base their assessments, operational plans, supporting plans, and force deployment schedules on the National Military Strategy. The Joint Operational Planning and Execution System

is the process by which the Joint Chiefs and military commanders translate the National Military Strategy into theater campaign plans that support the National Security Strategy.

Military commanders conduct two types of planning activities as part of the Joint Operational Planning and Execution System. Deliberate Planning occurs before a crisis develops and results in several products used by the Joint Chiefs of Staff, theater commanders, and service staffs. These products include an integrated force list, a time-phased force deployment sequence, supporting plans, and a campaign plan. Crisis Action Planning begins when a situation occurs that is not addressed by a previously developed campaign plan. Since this form of planning is conducted in response to a real-world event, an Operations Plan and an Execute Order are the products of Crisis Action Planning. Deliberate Planning is a proactive process and Crisis Action Planning is reactive. Both planning processes are part of the overall Joint Operational Planning and Execution System. The Joint Operational Planning and Execution System concludes with the arrival of forces and the formation of task forces to conduct military missions in theater (JP 5.0 Doctrine for Planning Joint Operations, 1995).

The sequence of events and the organizations associated with deploying special operations forces are depicted in Figure 2. Figure 2 also shows the association of these organizations with the steps in the Joint Operational Planning and Execution System. The Joint Chiefs of Staff initiate the deployment process in response to a National Command Authority tasking. These taskings result from a theater commander request for forces to defuse a crisis or implement a deliberate plan. The theater command monitors the deployment process and prepares to receive military forces as they arrive in theater. United States Special Operations Command serves primarily as a liaison between the Joint Chiefs of Staff and the United States Army Special Operations Command, the Air Force Special Operations Command, and the Naval Special Warfare Command. These in turn provide planning expertise as well as special operations qualified personnel and weapons systems to the theater commanders. Individual line units are the weapon systems—highly trained personnel combined with in-depth knowledge of their missions, equipment, and tactics--that conduct special operations missions. This complex process of coordinating the theater commander with special operations capabilities and deploying

these forces can take as little as 12 hours or as long as two weeks to complete. The length of time allotted to deployment is constrained by the nature of the developing situation in the operational theater. All special operations forces, therefore, maintain a rapid-response capability.

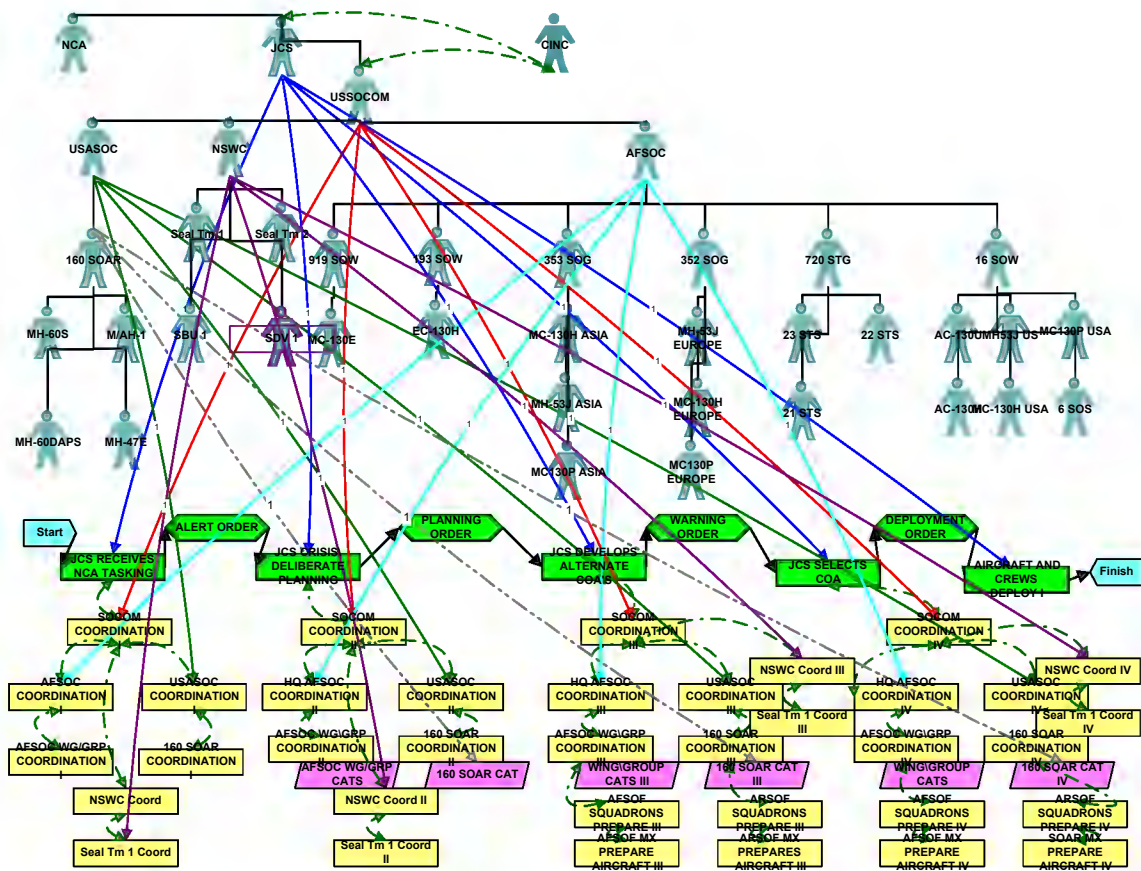

Figure 2. Joint Operational Planning and Execution System – Deployment Processes

B. USSOCOM AND JOINT SPECIAL OPERATIONS TASK FORCES

The United States Special Operations Command (USSOCOM) and sub-unified theater Special Operations Commands participate in the Joint Operational Planning and

Execution System as both supported and supporting commands. Every regionally defined theater command has an integrally assigned Special Operations Command organization. Special Operations Commands reflect the spectrum of special operations capabilities. Officers and enlisted personnel from Air Force Special Operations, Army Special Operations ground and air units, and Navy Special Operations units coordinate theater wide training, conduct deliberate and contingency planning, and facilitate special operations task forces formed in their theaters.

There are other command elements involved with executing Deliberate and Crisis Action Plans with special operations forces. These include USSOCOM's Army, Air Force and Navy component headquarters and their subordinate special operations units. When formed in an operational theater to conduct special operations, these forces are organized into a Joint Special Operations Task Force. If part of a larger Joint Task Force comprised of conventional military forces, the Joint Special Operations Task Force is co-equal in authority to the Joint Task Force commander's land, maritime, and air component commanders as depicted in Figure 3. In order to coordinate special operations missions, the Joint Special Operations Task Force establishes several liaison teams that attach to the Joint Task Force's conventional land and air components. Special operations missions rarely require extensive coordination with conventional maritime units, so formal liaison elements are not routinely established between a Joint Special Operations Task Force and the maritime component in a Joint Task Force. Alternately, if established as a separate task force in a theater, the Joint Special Operations Task Force reports directly to the theater commander and accepts authority for any attached conventional forces in addition to commanding assigned special operations forces.

Joint Special Operations Task Forces organize to perform a variety of missions. These missions include humanitarian assistance, combat search and recovery/personnel recovery, special reconnaissance, close air support, armed reconnaissance, psychological operations, and direct action (raids, demolition, capture, etc.) Special operations capabilities can be integrated with other Joint Task Force components to support their missions or directly by the Joint Task Force commander as a stand-alone employment

option. This flexibility, combined with their small operational and logistical footprints, make Joint Special Operations Task Forces attractive options for theater and Joint Task Force commanders (JP 3-05 Doctrine for Special Operations, 1998).

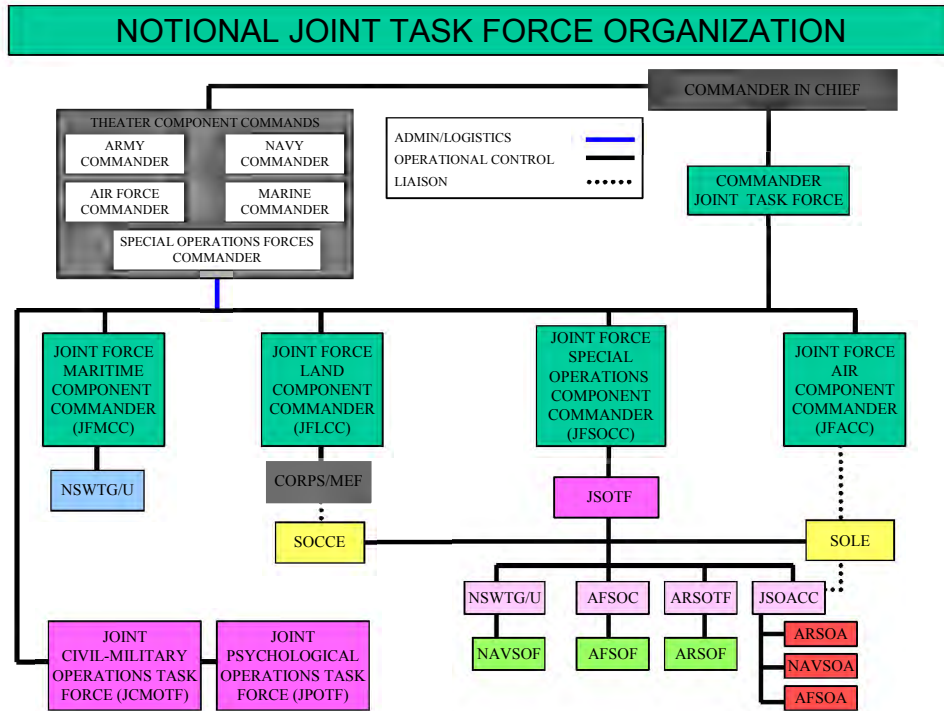

Figure 3. Joint Task Force and Joint Special Operations Task Force Command Relationships

C. TIME SENSITIVE PLANNING

The special operations mission planning process is known as Time Sensitive Planning. Four days after receiving a Warning Order from a joint task force commander, special operations forces can be prepared to execute a joint service, rehearsed special operations mission that incorporates air, ground, and maritime forces plus the requisite command and control of all assigned special operations and conventional forces. This is possible because USSOCOM and its component organizations adhere to a time sequenced procedure that begins with the Joint Special Operations Task Force (JSOTF)

commander receiving a Warning Order. The special operations commander designates a Mission Planning Agency from one of the special operations elements assigned to the JSOTF. The rest of the task force becomes Mission Support Agencies for that particular mission. The Mission Planning Agency then conducts Mission Analysis, drafts a Concept of Operations, develops Courses of Action, and begins detailed Mission Planning including a Mission Rehearsal. The agencies and the steps involved in the Time Sensitive Planning, informally known as the 96 Hour Planning Cycle, are highlighted in Figure 4.

The JSOTF staff supports the Mission Planning Agency by providing planning guidance and coordinating an integrated Operations Order between the Army, Navy, and Air Force elements within the task force. Additionally, the service commanders assigned to the JSOTF participate in the Course of Action selection with the JSOTF commander.

Air support for special operations missions is arguably the most complex aspect of planning and executing special operations missions. Specialized air support missions range from insertion, resupply, and exfiltration of ground and maritime teams to armed reconnaissance, interdiction, escort, and close air support from radio, television, and pamphlet based psychological operations to in-flight helicopter refueling, field medical trauma care, long-range, secure ground to air communication, and control of austere landing, extraction, and drop zones. The Joint Special Operations Air Component Commander is the agent within the JSOTF who is responsible for coordinating all specialized air support for special operations missions.

The ground teams and aircrew members who will actually participate in the mission conduct Detailed Mission Planning together. This is where the bulk of Air Support Requests originate. Extensive coordination occurs between the participants as planning progresses. Rehearsals include "static" or ground practices followed by a flying rehearsal of as many parts of the mission as practical. These rehearsals allow participants and mission commanders the opportunity to hone the execution sequence, identify critical events, and determine the overall chance of mission success. Additionally, rehearsals allow commanders to exercise contingency plans like Combat Search and Rescue procedures, simulated battle damage to aircraft, and casualty care/evacuation plans. The

next step in the Time Sensitive Planning process is to critique the mission plan based on lessons learned from the rehearsal, revise the plan as necessary, and reconstitute the force while awaiting an Execute Order (JP 3-05.5 Joint Special Operations Targeting and Mission Planning Procedures).

D. THE JOINT SPECIAL OPERATIONS AIR COMPONENT COMMANDER

The Joint Special Operations Air Component Commander initiates coordination activities when the Mission Planning and other Mission Support Agencies generate Air Support Requests. These coordination activities include identifying aircraft configuration and aircrew requirements, airspace reservations, in-flight refueling needs, weather and communication support, Combat Search and Rescue/Personnel Recovery options, and other aviation support such as Suppression of Enemy Air Defenses, escort aircraft, diversionary attacks, etc. The Joint Special Operations Air Component Commander

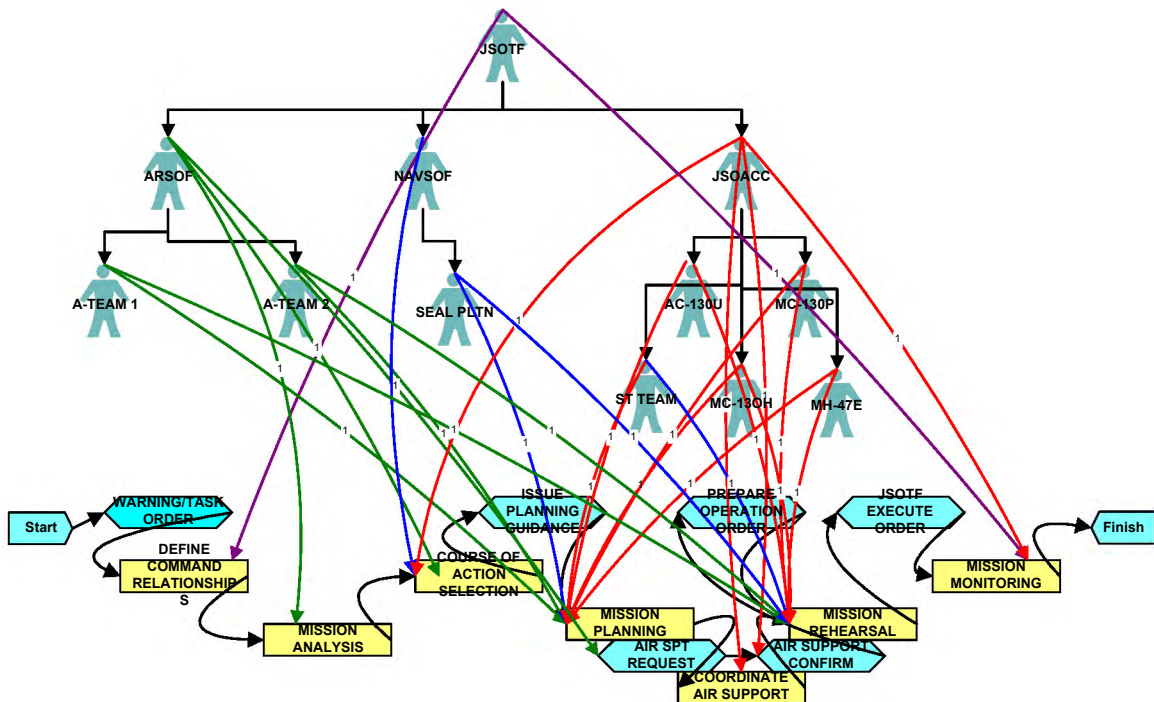

Figure 4. Special Operations Forces--Time Sensitive Planning

issues an Air Support Confirmation for each approved Air Support Request. The details of unsupportable Air Support Requests are negotiated between the Joint Special Operations Air Component Commander's staff and the Mission Planning and Support Agency to resolve conflicts. The Joint Special Operations Air Component Commander's objective is to maximize specialized air support to the JSOTF's missions.

E. JOPES AND TIME SENSITIVE PLANNING REVIEWED

The JOPES force deployment process is designed to provide an orderly transfer of military capability from a peacetime posture to a crisis or contingency response footing. The process originates with the President identifying the National Security Strategy from which the Joint Chiefs of Staff of the United States Military develop a National Military Strategy. Unified theater and functional commanders devise Operational and Supporting Plans to address likely contingencies as part of the Deliberate Planning cycle. Crisis Action Planning is the part of the JOPES process that responds to unforeseen international events.

JSOTFs form in theaters of operation under the authority of theater commanders or Joint Task Forces commanders. Army, Navy, and Air Force special operations forces assigned to support a theater commander report to the JSOTF commander. These special operations forces follow the Time Sensitive Planning process that integrates air and ground components in the task force to produce a thoroughly conceived and rehearsed plan of operations. Although designed to take four days, omitting or compressing stages in the current planning cycle can accelerate the 96-hour sequence. Execute Orders rarely arrive at the 96-hour point, so the JSOTF continues to refine the plan until it is executed or the crisis diffuses.

This methodology is followed by the Department of Defense to assemble and prepare special operations forces to conduct operational missions. While DoD's JOPES and special operations' Time Sensitive Planning processes can be completed quickly in comparison to the time it would take to assemble and prepare a similar conventional force for combat, the changing nature of the future global environment may make the current

process seem to be too slow. The timeliness of military responses to crises is dictated not only by the distance to the conflict, but also by the speed of the current JOPES and special operations mission planning processes. Responsive is further hindered by the ad hoc nature of JSOTFs themselves. Attempting to establish internal and external working relationships while simultaneously trying to take into account the limitations and opportunities inherent in each theater of operations can cause delays in mission planning. The following chapter introduces a new special operations organization and concept of operations that may be more responsive than the current deployment and employment process.

THIS PAGE INTENTIONALLY LEFT BLANK

V. THEATER JSOAC OPERATIONAL CONCEPT

A. INTRODUCTION

The Theater Joint Special Operations Air Component (JSOAC) operational concept differs in several ways from the current Time Sensitive Planning process currently in use by special operations forces. Rather than forming the aviation planning and command cell after a JSOTF forms as is currently done, the Theater JSOAC concept proposes that a full time core of command and control experts, the Theater JSOAC staff, reside in each regional theater of operations. The Theater JSOAC would report to the commander of the theater Special Operations Command on a day-to-day basis. The Theater JSOAC would coordinate the initial phases of the current Time Sensitive Planning cycle during crisis or contingency responses as home-based aircraft begin flowing towards staging bases in the theater. Rather than tasking the primary aircrews to ferry their own special operations aircraft to an intermediate staging base (ISB), the primary aircrews would stay home and begin planning under the direction of the Theater JSOAC. Non-mission aircrews would deploy the aircraft to the theater. The non-mission aircrews would remain at the ISB(s) as a reserve in case one of the mission aircrew members fell ill. If not needed to fill in on the primary mission, the ferry crews would be available to return the aircraft to their home bases after the mission. Mission aircrews would arrive in theater on follow-on military or commercial airlift after the aircraft arrive at the ISB(s).

This process is conceptualized and contrasted with the current JOPES and Time Sensitive Planning process in the following series of diagrams. The figures depict the sequence of a notional deployment of special operations aviation and ground forces to the European theater of operations. In the scenario, a crisis occurs on the European continent that necessitates an evacuation of American citizens. The JOPES and Time Sensitive Planning process is shown in the first set of figures.

C. JOPES DEPICTION

Figure 5 shows liaison personnel from several special operations units in the United States and Europe meeting at Special Operations Command-Europe, or SOCEUR, after the National Command Authority decides to implement a course of action featuring special operations forces. The liaisons work with the SOCEUR planners to develop specific courses of action and force lists of special operations and conventional support units required to evacuate the American citizens. One of the first decisions the SOCEUR staff must make is the location of a suitable pre-mission staging base. Once selected, advanced echelons, or ADVON, forces of logisticians, contractors, weapon systems planners, and security force personnel fly to the forward operating base (FOB) to begin preparations to receive the main air and ground special operations forces.

SOCEUR requests that the National Command Authority issue deployment orders, Figure 6, for the necessary aircraft and ground forces to assemble at the selected forward operating base. Also, the JSOTF commander is selected and a battlestaff composed of representatives from SOCEUR and the deploying units forms at the forward operating base. The battlestaff refines the preliminary courses of action while aircraft, aircrew, and support personnel arrive at the forward operating base. Continuing developments from the crisis area are incorporated into the Time Sensitive Planning process.

Figure 7 focuses on the Time Sensitive Planning sequence followed at the forward operating base. The JSOTF commander selects the specific course of action the battlestaff believes will offer the best opportunity for success with the minimum degree of acceptable risk. Next, special operations air and ground forces work together to integrate their separate parts of the overall mission. Subordinate task forces of special operations units are organized to accomplish supporting tasks. For instance, Task Force Red might be charged with the responsibility of seizing and controlling an airfield at Target "B" while Task Force Grey might have the job of transferring American citizens from a rally point at Target "A" to Target "B". Optimally, a full-scale flying rehearsal of the whole plan is conducted away from the crisis area following extensive briefings and

contingency planning. Once confident that the special operations task force is sufficiently prepared to accomplish the actual mission, the JSOTF commander requests authorization to execute the rescue operation. The Time Sensitive Planning process ends with the recovery of JSOTF aircraft, aircrew, and ground personnel back at the forward operating base.

C. THEATER JSOAC DEPICTION

The Theater JSOAC concept of operations begins in the same way as the combined JOPES and Time Sensitive Planning process. Figure 8 shows liaisons from the same units meeting at SOCEUR in response to the National Command Authority's selection of a special operations response to the fictional crisis in Europe. However, rather than establishing a forward operating base close to the crisis area, SOCEUR planners send ADVON elements to separate intermediate staging bases. Ideally, these bases would be located at existing military airfields that the added special operations forces could use as a cover for their presence in Europe.

Figure 9 illustrates the simultaneous deployment and synthetic planning steps at the heart of the Theater JSOAC concept. Non-mission aircrews fly the fixed wing special operations aircraft to the separate staging bases. Helicopters are shipped by strategic airlift to one of the intermediate staging bases. In this example, specialized transport aircraft and helicopters assemble at an existing United States airfield in England while psychological operations, fire support, and other support aircraft assemble elsewhere in theater. Mission aircrews at their home stations begin mission area familiarization and initial planning under the direction of the Theater JSOAC at SOCEUR. Specialized aviation units use full motion aircraft simulators, mission rehearsal devices, or computerized mission planning, modeling, and simulation systems and standardized mission data from the Theater JSOAC to prepare for the evacuation mission. Once it appears the mission will likely continue to the execution phase, ground forces deploy to ISB "A" to rendezvous with the specialized transport aircraft. Mission aircrews are also flown by commercial transportation or military transport to join their aircraft at ISB "A"

and ISB “B”, respectively. The JSOTF and JSOAC battlestaffs more than likely would flow to the ISB with the preponderance of forces. However, since the Theater JSOAC concept is based on distributed command and control, the JSOTF and JSOAC battlestaffs do not need to be collocated to accomplish special operations missions.

Finally, Figure 10 shows the mini-rehearsals conducted at the ISBs under the direction of the JSOTF. Once the execute order is given, aircraft depart from the ISBs in sequence to arrive at Target “A” and Target “B” with their subordinate task forces. A recovery base is established near the crisis area manned by maintenance personnel, security forces, and a command element as the assault forces launch from the ISBs. The recovery base can serve as an emergency landing base for special operations aircraft, a launching base for search and recovery forces, or as a transload and refueling location following the evacuation mission. Once the evacuation mission is complete, special operations ground and air forces would return to the ISBs or the recovery base.

D. THEATER JSOAC OPERATIONAL CONCEPT

The Theater JSOAC process of deploying and employing specialized aviation forces is more than a new command and control proposal. It offers commanders of theater special operations commands a faster process for applying specialized airpower to respond to crises and contingencies. Rather than forming an ad hoc command and control organization at the same time special operations air and ground forces are forming, the Theater JSOAC concept establishes the command and control nucleus around which specialized airpower can coalesce. This nucleus will bring a regional awareness and stronger working relationships that can expedite the planning and execution phase of a crisis or contingency response. The concept relies on and leverages the expanded global communications capabilities throughout the Department of Defense. Information will be distributed to special operations forces in and out of theater through secure electronic mail, telephone, message traffic, and DoD’s internet. In addition, the ability to link flying simulators together so that aircrews in separate locations can rehearse their missions together synthetically will significantly increase the fidelity of

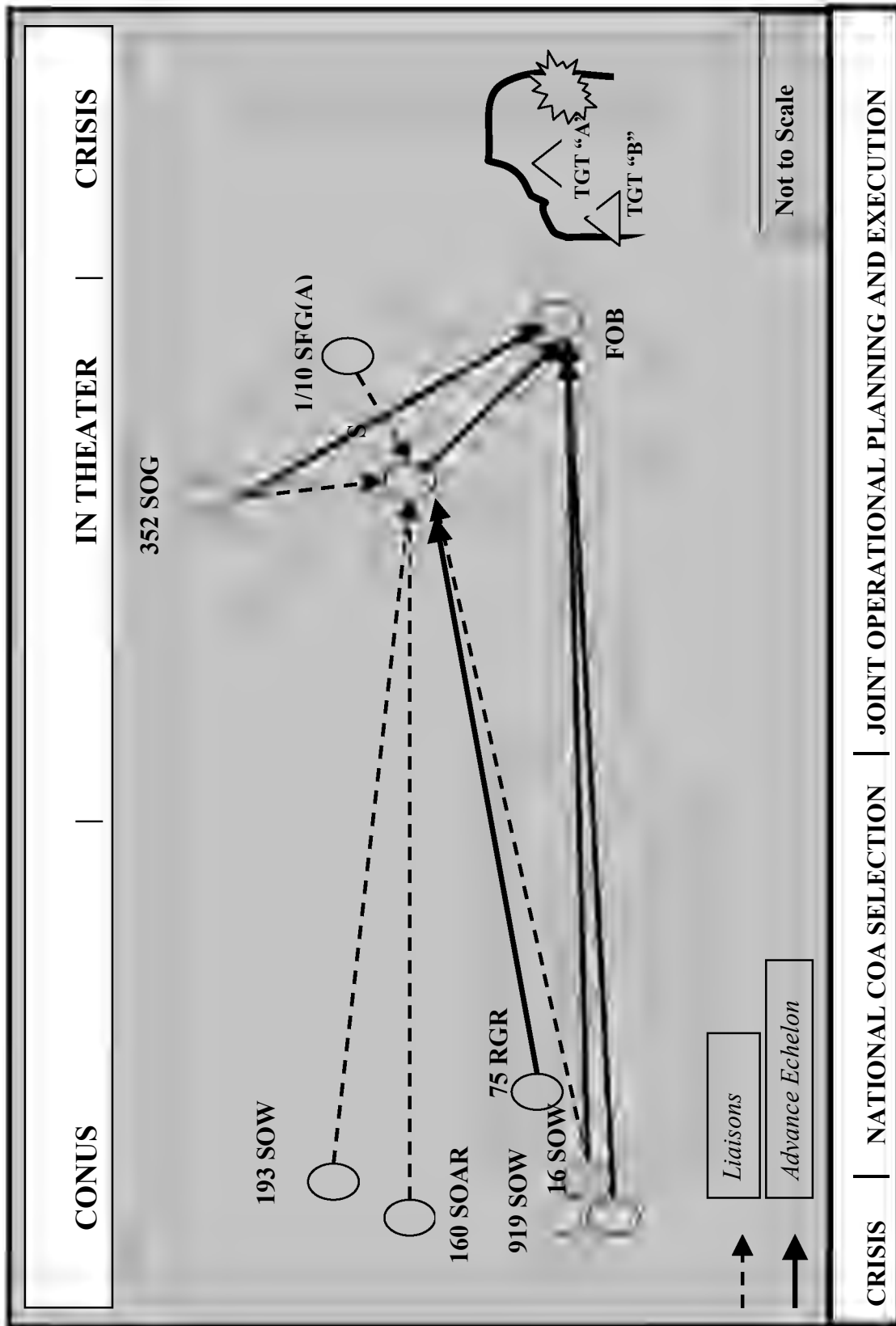
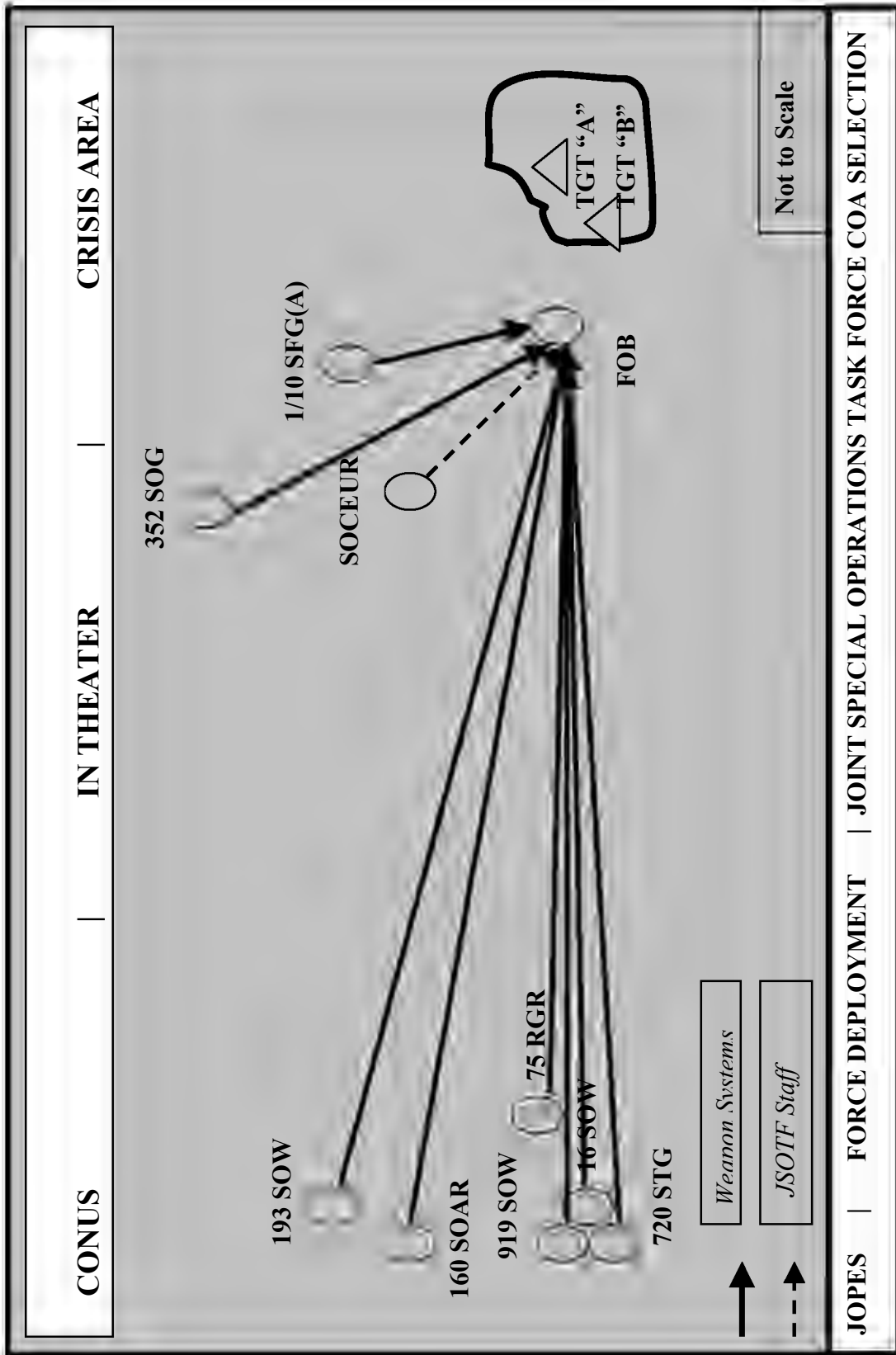

Figure 5. Initial Liaison (LNO) and Advance Echelon (ADVON) Deployment



JOPEB | FORCE DEPLOYMENT | JOINT SPECIAL OPERATIONS TASK FORCE COA SELECTION

Figure 6. Specialized Aviation Deployment

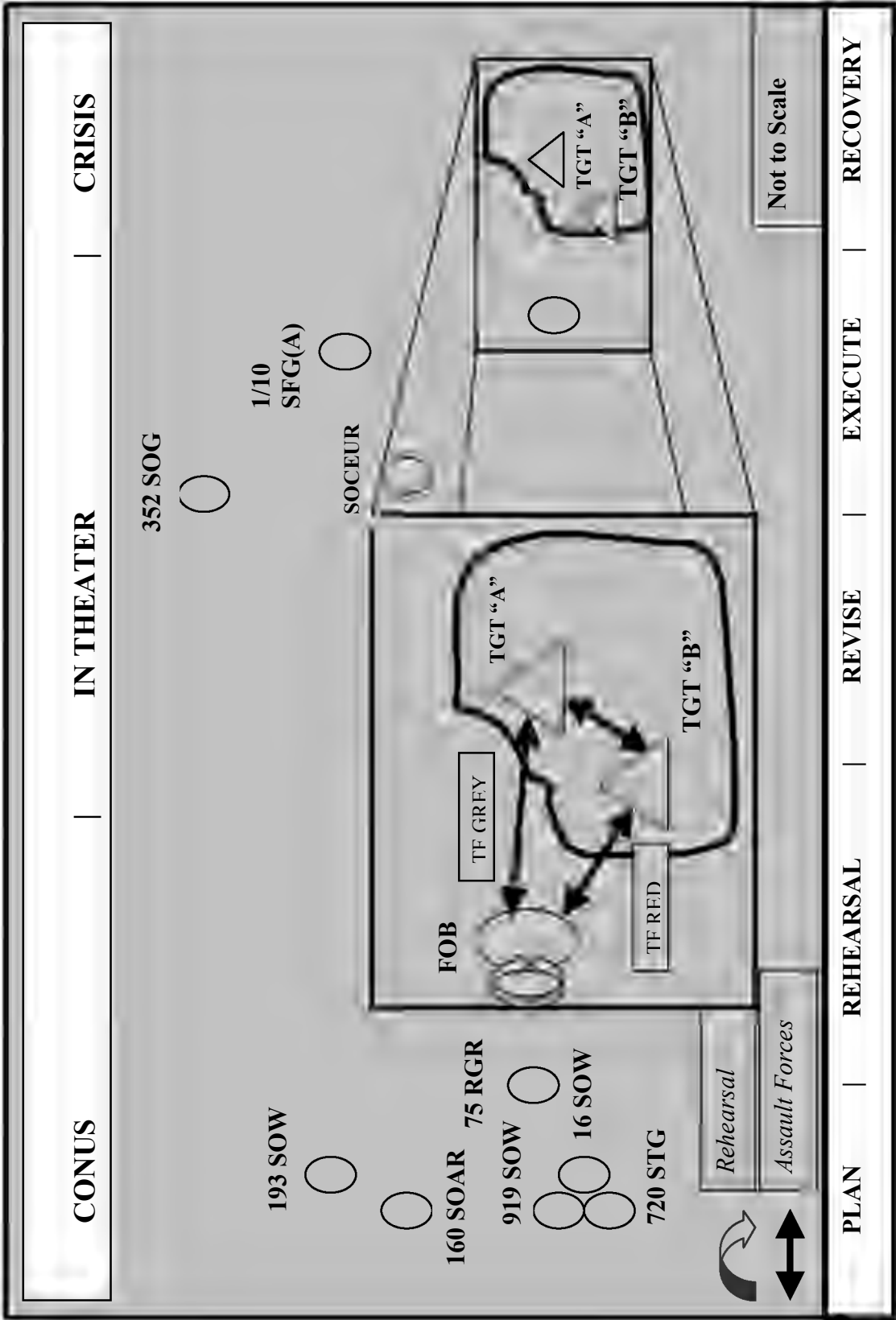
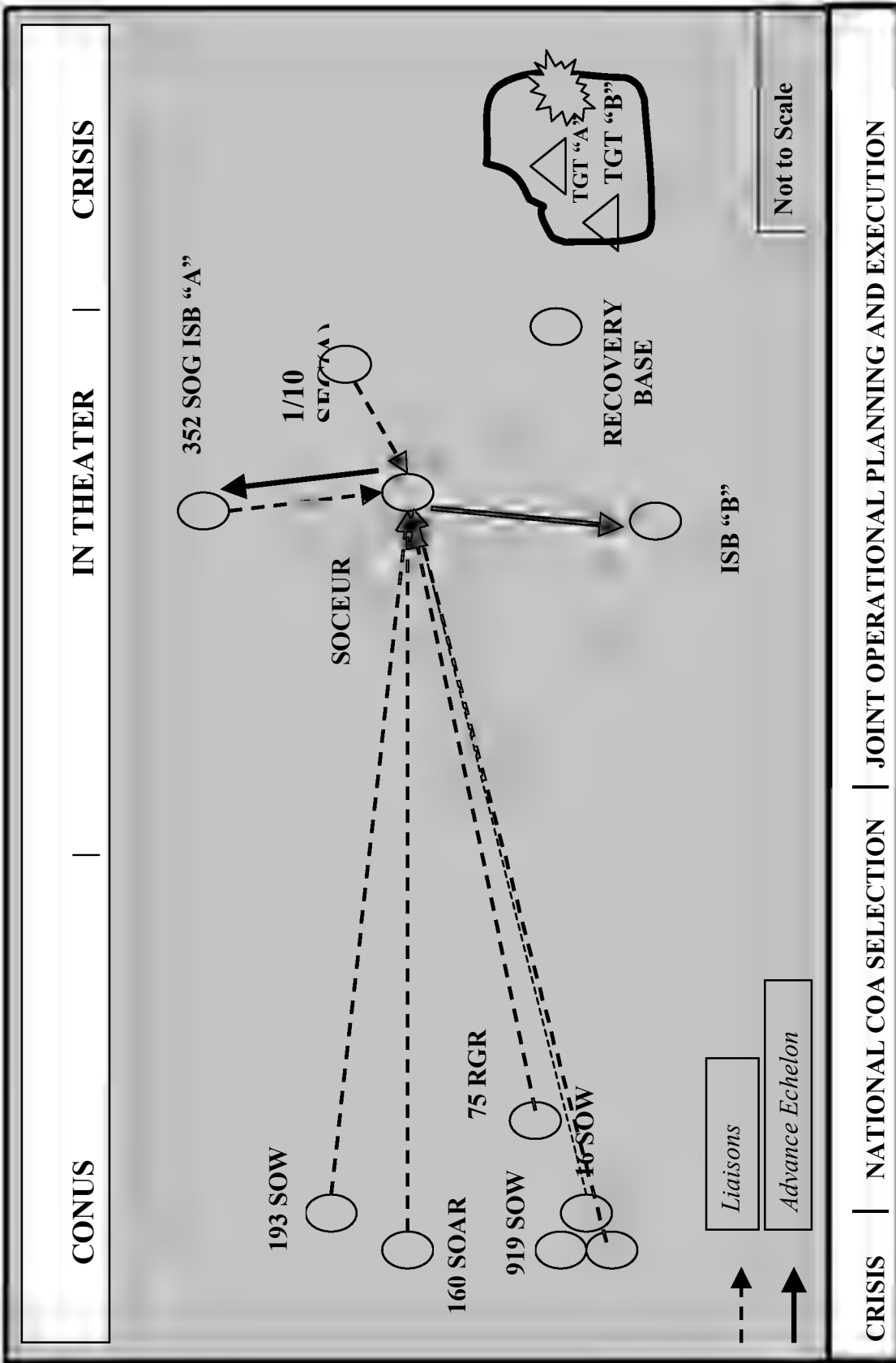

Figure 7. JSOTF Time Sensitive Planning



CRISIS | NATIONAL COA SELECTION | JOINT OPERATIONAL PLANNING AND EXECUTION

Figure 8. Initial Liaison (LNO) and Advanced Echelon (ADVON) Deployment

mission preparation efforts. Using simulators to practice operational missions rather than actually flying the aircraft also allows maintenance personnel additional time to preserve the aircraft for the real mission. Furthermore, command and control software systems with a simulation capability will allow JSOAC commanders to rehearse contingency options and prepare the battlestaff to execute the command and control functions during the real mission. In summary, the Theater JSOAC operational concept provides highly capable and well-prepared specialized aviation forces to execute special operations missions around the world, now and in future operational environments.

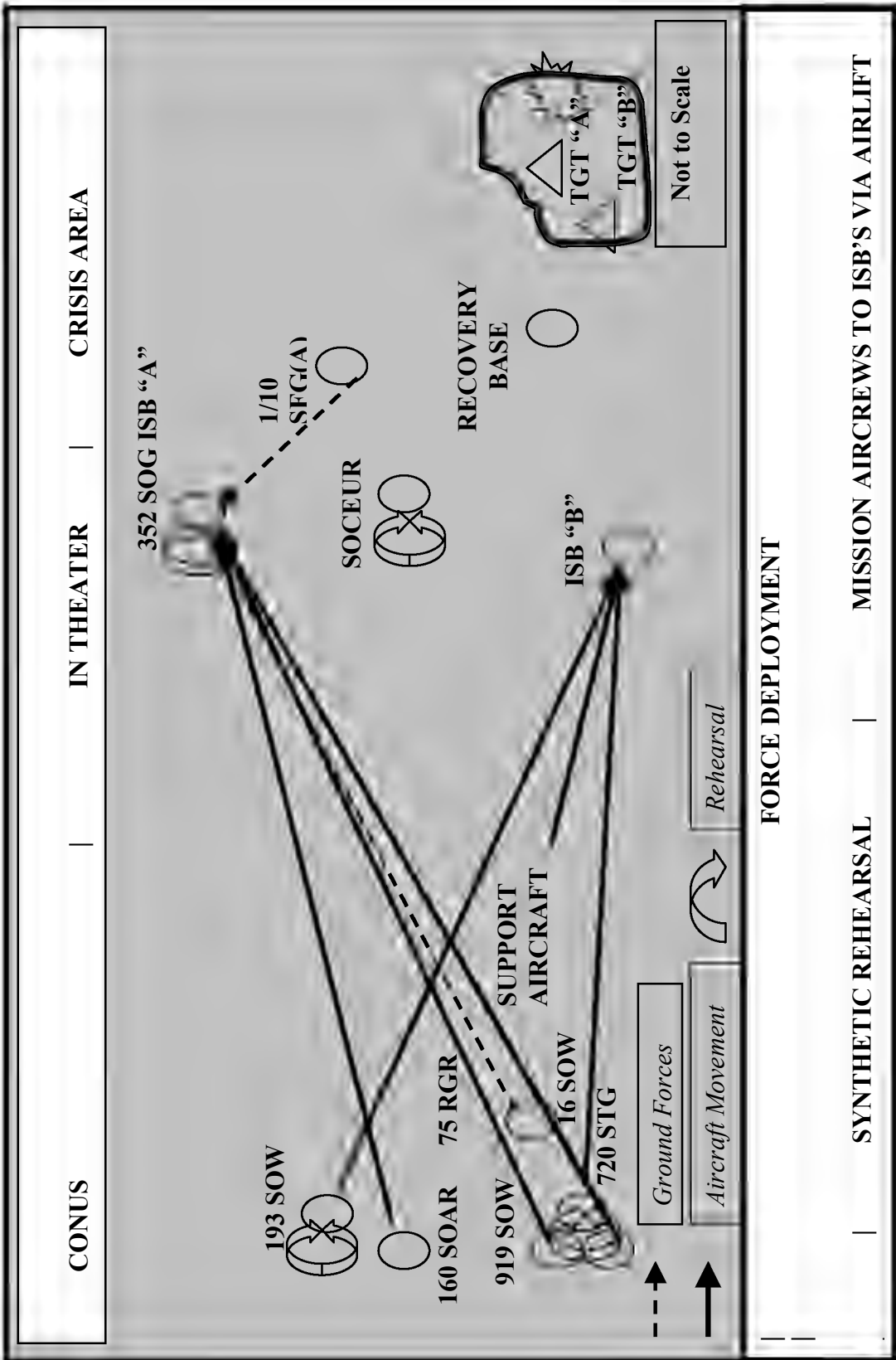

Figure 9. Specialized Aviation Forces Deployment

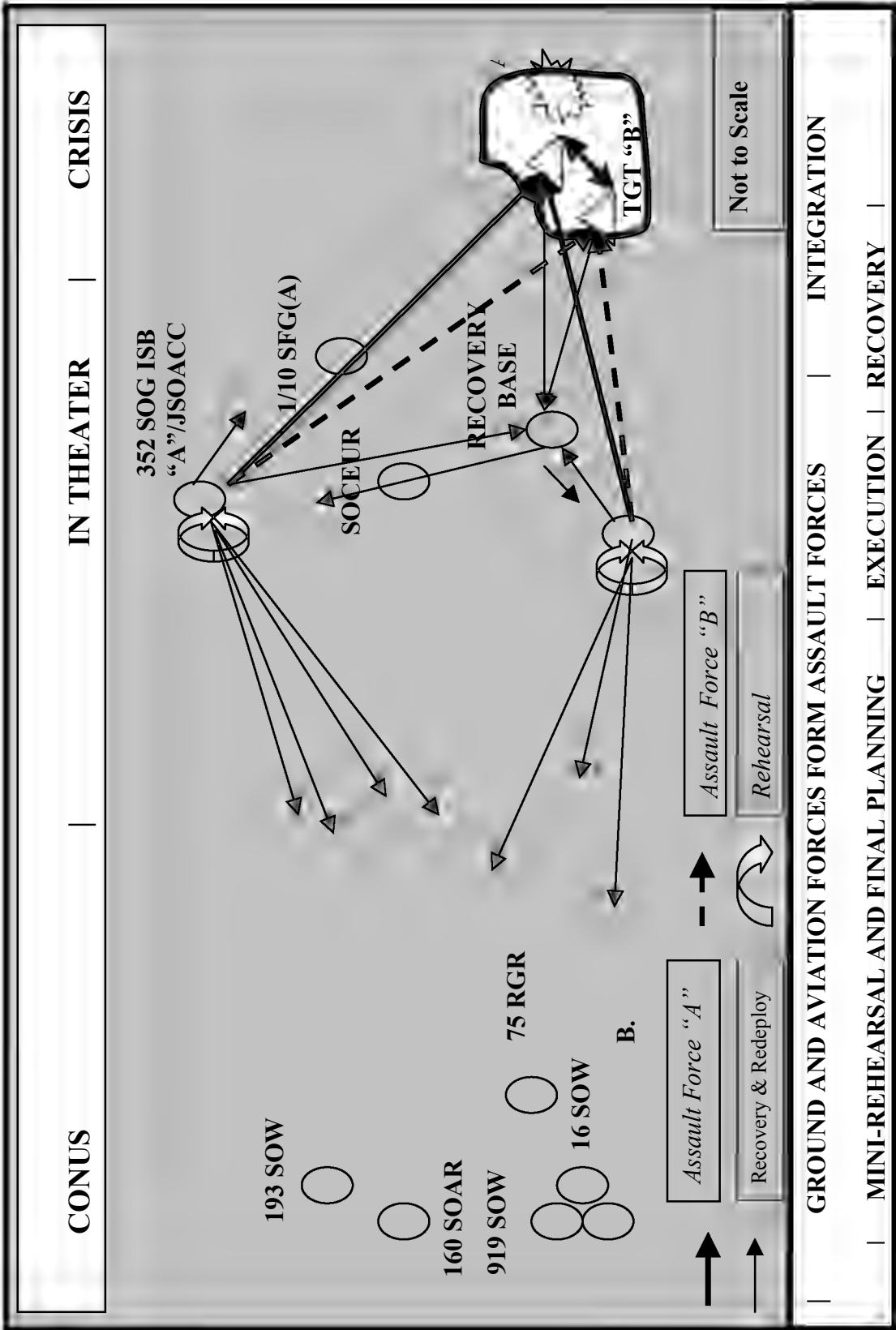

Figure 10. Specialized Forces Employment

THIS PAGE INTENTIONALLY LEFT BLANK

VI. THEATER JSOAC SOFTWARE SYSTEMS

Modeling and simulation of combat represents an area of technological innovation that could enable the Theater JSOAC concept of operations. While all four services utilize models and simulations to test doctrinal concepts and analyze proposed force structures, the use of computer systems to evaluate alternate courses of action, conduct mission rehearsals, and execute command and control of operational forces is an emerging concept in the Department of Defense. Special operations forces do not yet routinely use computerized models and simulations for operational command and control purposes. However, some existing models, simulations, and flight planning systems are potential command and control tools for Theater JSOACs.

Since the Marine Corps and United States Special Operations Command share some similarities in organization and mission areas, an examination of the way the Marine Corps incorporates computer-based modeling and simulation may yield useful insights for special operations commanders. The Marine Air-Ground Task Force Tactical Warfare Simulation may be adapted for use by Theater JSOAC planners. Other military models and simulation software are also available in the Department of Defense that replicate adversary and friendly weapon systems. One such software system is called the Joint Conflict and Tactical Simulation System. An aircraft flight planning software package is a third type of software program that could potentially be used as a command and control tool by a Theater JSOAC. The Special Operations Forces Planning and Rehearsal System incorporates features that make it attractive to specialized aviation mission planners. A review of the structure and features of these software systems can be useful in determining the requisite qualities of a command and control software system designed to meet the specific needs of a Theater JSOAC.

A. MARINE AIR-GROUND TASK FORCE WARFARE SIMULATION

The Marine Corps uses a computer based warfare simulation software package to train Marine Air-Ground Task Force (MAGTF) commanders and battle staffs on their wartime duties. The software, called the MAGTF Tactical Warfare Simulation or MTWS, is a map-based wargame that simulates the characteristics of friendly, neutral, and enemy maritime, amphibious, ground, and air combat elements. An operator using the MTWS program can define missions for virtually every aspect of combat a MAGTF could encounter. MTWS operators input the locations, dispositions, and actions of the actual and simulated combat units then report simulated battle results back to the MAGTF commanders and exercise referees. MAGTF battle staff's have to assess changing combat situations based on the same information presented in the same formats the MAGTF would receive if the Marines were involved in actual combat. MTWS accomplishes this level of realism by generating US Message Text Formatted reports based on simulation results. MTWS can also electronically distribute the message traffic to command echelons participating in the exercise either directly or via the Global Command and Control System. In this way, Marine Corps command elements gain high fidelity training in their combat missions.

1. MTWS Structure

As Scrivener (2000) points out, MTWS, although not difficult to learn, is a complex system that is not always intuitive. MTWS is based on the UNIX operating system and consists of a local area network of dedicated computer servers and operator workstations. The workstations, however, can function under the Windows operating system. There are three classes or functions of computers in the MTWS network. The main terminal is called the MTWS System Control or MSC. The MSC is the heart of MTWS and links the workstations to the databases and administrative functions. The MTWS Application Network or MAN, can number between one and seven workstations

that process the simulation computations. Adding additional MAN workstations allows simultaneous processing to occur and is useful on larger scale exercises and simulations to preclude processor overload. The third class of computers is the user interface into the simulation, which is called an MTWS Display Station, or MDS. MTWS can support up to 75 MDS workstations each having separate user privileges to access different forces. For example, MTWS allows the operator to select which messages are received by each specific MDS. All three of these MTWS computers are UNIX- based. The MTWS Advanced User Interface, MAUI, is the only portion of MTWS that is accessible via the Windows operating system. The MAUI is actually a software application that resides in the memory of a Windows-based personal computer attached to the MSC by an ethernet network. Computers with MAUI loaded on them serve the same function as the MDS computers.

The MAUI and MDS are the main interfaces Marine Corps exercise planners use to input data into the MTWS simulation. Marine ground units can be defined in details that include ammunition, weaponry, method of transportation, effects of fatigue, etc. Air units are organized by aircraft type and mission, standard configuration loads of armament, and even fuse settings on bombs and missiles. Amphibious units can be similarly defined using the MAUI or MDS interface. Additionally, airfields can be “built” by MTWS users and aviation units can be assigned to use the airfields as home bases. MTWS provides the ability to construct man-made objects such as minefields, roads, and bridges using operator-defined civil engineering units, as well.

2. MTWS Features

All the MAUI interfaces can be accessed using a combination of list windows, text-entry fields, and mouse-on-map clicking. List windows open automatically and offer the MAUI user a list of allowable variables for a given text entry field. Text entry fields allow the MTWS operator to input unique names for elements such as units and airfields. Mouse-on-map clicking is the most useful technique for defining geographical locations by latitude-longitude or military grid reference system. For example, using MAUI a unit

can be defined by listing the “legal” unit types, typing in a name for the unit, and then placing it in the MTWS virtual world by mouse-clicking on the map (Scrivener, 2000). Once defined, units can be assigned missions to accomplish based on their unit types and capabilities. Units are selected and “commanded” in MTWS using similar lists, text entry, and mouse pointing interfaces as the ones used to create the simulated units.

The ability to coordinate mission events relative to an H-hour is another useful feature of MTWS. An artillery barrage, for example, can be scheduled to begin 1 hour prior to an H-hour and end after ten minutes. Aircraft attacks could last from H-hour minus 50 minutes to H-hour minus 30 minutes. Advance echelons of combat engineers could clear obstacles from H-hour minus 25 minutes to H-hour minus 5 minutes. Next, a wave of amphibious assault vehicles can be scheduled to reach a beachhead at H-hour. Finally, follow-on reinforcements could be slated to arrive an hour after H-hour. Using an H-hour in MTWS is one way that MAGTF’s coordinate actual missions. Marine Corps planners can better determine the optimal time for execution during the planning phase, while also deconflicting individual unit portions of the overall mission, by using H-hours with MTWS simulations (Scrivener, 2000).

MTWS allows operators to suspend a simulation and store it for later replay. This allows mission planners to develop several variations using the same basic set of forces and geography. Rather than having to start from the beginning each time, a planner need only recall a previously saved mission, make whatever changes are warranted, and save the edited version as a new simulation. Mission success factors like casualties inflicted and incurred, sorties flown, resources used, etc. for each simulation are reported to the operator by MTWS. These capabilities in MTWS permit planners to evaluate different courses of action for friendly, neutral, and enemy forces and determine the course of action that offers the best chance of mission success (Garrabrants, 2001).

Marine Corps commanders can also use MTWS to rehearse a battle staff’s responses to contingency situations. Ideally, the course of action selected by the MAGTF staff would account for the enemy’s most likely counter-actions balanced against the enemy’s most dangerous option. However, MAGTF commanders still face uncertainties and their battle staffs benefit from training to react to less likely, yet still irksome events.

Operators can make real-time inputs into a mission profile while a simulation is running in MTWS. Operators portraying opposition forces, or OPFOR, can also make real-time inputs to the scenario. For example, a Marine commander who wants to exercise a search and rescue contingency during an MTWS simulation, can direct the OPFOR operator to “shoot down” a friendly aircraft. MTWS will remove the aircraft from the simulation, generate the appropriate report, and the MAGTF battle staff would have to respond to the aircraft loss. If the MAGTF commander wishes to, he can also direct the MTWS operators to halt the execution in order to reinforce a lesson or correct a mistake made by the battle staff. The ability to interact with the simulation on a real-time basis is a key strength of the MTWS system (Blais).

3. SOF-MTWS Interfaces

Many of MTWS’ attributes are applicable to the JSOTF mission planning and execution process. For instance, one special operations mission is to conduct airfield seizures for use as staging areas for non-combatant evacuation or other follow-on operations. The ability to construct and name airfields on the electronic map in MTWS supports this type of special operations mission. MTWS also allows the operator to modify the generic capabilities of aircraft already defined in the simulation thereby creating new aircraft with specific performance characteristics. JSOAC planners can group these unique aircraft into formations named by call signs or squadron names. Using an H-hour also controls timing on special operations missions. Since MTWS can be used as a means of determining alternate courses of action, JSOAC commanders can weigh the costs and benefits of employing special operations forces in different combinations to accomplish the same mission. Simulating neutral and enemy forces is also an important consideration in planning special operations mission since many such operations take place in urban and developed areas. A non-combatant evacuation for instance, is a mission that involves potential interaction with hostile and civil forces. Finally, since special operations forces usually operate with minimal assets, JSOTF battle staffs must be able to generate efficient and accurate responses to contingencies to

preserve chances for mission success. The ability to rehearse a JSOAC battle staff with the MTWS system improves the likelihood of making better command decisions during real missions.

4. MTWS Summary

Special operations forces rely on unconventional factors to achieve mission success in asymmetric combat situations. Whereas conventional forces employ mass and maneuver to generate combat power, special operations combat power is derived from the unique weapon systems combined with highly trained special operators. Special operations personnel purposely execute missions in weather and terrain conditions that conventional forces do not fare well in. However, MTWS does not reflect special operations combat strengths in the simulation. Although using weather as a camouflaging technique to mask aircraft movement and delay detection is modeled by MTWS (Blais), there is no adjustment made for special operations forces ability to successfully operate in difficult terrain and inclement weather. Conventional forces with superior firepower, albeit inferior morale, mission focus, and tenacity would routinely defeat special operations forces in a MTWS simulation. This is the key issue underpinning a JSOACs potential reluctance to accept MTWS as a useful mission planning and course of action evaluation tool.

B. JOINT CONFLICT AND TACTICAL SIMULATION SYSTEM

The Joint Conflict and Tactical Simulation System (JCATS) is a wargaming software package that models a wide range of military capabilities. Air combat, land warfare, and both surface and subsurface naval warfare are represented in this simulation. Operators can control individual vehicles and soldiers on a digitally based map and terrain presentation. Vehicles include ships, aircraft, tanks, artillery pieces, rocket launchers, helicopters, fighting vehicles, submarines, etc. Soldiers can be defined to reflect different types of infantry abilities based on the equipment they carry. These

weapons include claymore mines, rifles, grenades, and sensing devices in addition to body armor and headgear. Ancillary equipment is also included in the simulation such as surface and air radars, airfield control towers, and enhanced buildings that soldiers and vehicles can enter and interact with in the simulation. For example, depending on the structural qualities of a building, a vehicle can breach the walls by firing a round at it or a soldier can create an opening with an explosive charge.

1. JCATS Features

JCATS allows the user to group soldiers and vehicles into more complex weapon systems. These complex weapon systems can then be assigned to one of ten task forces per side in the simulation. There are three sides that are represented in JCATS: friendly, enemy, and neutral. For instance, dismounted infantry can be paired with a fighting vehicle and several fighting vehicles can be combined with scout and attack helicopters and organic artillery assets to form the core of a mechanized infantry unit. These units can be named as a task force and issued commands by the operator as an aggregate or elements can be controlled individually. This ability to define military units from the bottom up, allows users to reflect the variety of organizations found in the real military.

JCATS includes some useful mission planning and preparation tools in addition to the force organization tools. Commands issued to units can be keyed to the system clock, so actions of separate units or entities can be coordinated to occur simultaneously or in sequence. Routes can also be defined with delay points, activities, defensive postures, rules of engagement changes, and set speed of movement plus other options. Once defined, routes can be saved, named, and copied for use by other vehicles or formations. Another aspect of planning that JCATS models is detection rings and line of sight fans. These field of view wedges can be displayed on the JCATS map presentation and centered on an entity or group. The detection distances are based on the digitally derived terrain elevation and the sensor characteristics of the selected weapon system. So, a tank with an infrared sensor will have a smaller fan than an aircraft with an onboard radar system.

Two additional sets of tools or attributes, which are integral to the conflict aspect of JCATS, are the acquisition and attrition routines. Acquisition is based on detection rings and line of sight orientation and is classified in one of four levels. The levels range from basic detection of another entity, classification of the detected object into a generic description like tracked vehicle, recognition as to a specific type of object, and finally identification as to allegiance of the object. Attrition is defined within JCATS by a combination of factors that include armor, range, armament or warhead, and detection. The lowest level is suppression, which equates to placing an entity into a fully defensive mode. The next level is a firepower or mobility kill. Firepower kills prevent an entity from offensively firing its associated weapons yet still allows the unit to maneuver. Mobility kills on the other hand allow firing weapons but not movement. Catastrophic kills combine firepower and mobility kills.

2. JSOAC Application of JCATS

Joint Special Operations Aviation Component Command planners can use these aspects of JCATS to prepare to support JSOTF missions. Individual specialized aviation aircraft can be defined in JCATS based on their real world capabilities. For instance, unrefueled flight duration, fuel storage capacities, and fuel burn rates can all be set so that an aircraft's performance is accurately portrayed in the simulation. Planners can also define characteristics of Special Tactics Teams, such as radios, night vision gear, weapons, and ammunition loads. Once defined, groups of aircraft such as long-range helicopters and low-level transport planes can be associated into flights of aircraft. Special Tactics Teams and other special operations ground forces can also be grouped into units. Next the planner can use JCATS to mount the ground force troops onto the helicopters and transports. Planners can also use the simulation to pre-plan movement routes for the helicopters to reach landing zones and aircraft to reach airfields or airdrop zones. Planners can then dismount the ground forces by parachute or by walking off the helicopters and aircraft. JCATS can next be used to define ground routes with delays at specific nodes to conduct defensive or offensive combat operations. Helicopters and

aircraft can finally be used as exfiltration platforms by having the troops mount the helicopters and aircraft for the return flights.

These are the basic functions associated with specialized aviation assets. JCATS can also be used to simulate other specialized aviation assets like close air support and interdiction fires from AC-130 aircraft and MH-53M, MH-60DAPS, and AH-6 helicopters. Special operations aviation planners can do this by defining the respective armament on each weapon system. These aircraft can then be assigned separate routes that parallel the transport helicopters and aircraft or they can be assigned routes directly to ground targets. Other functions such as flights of psychological warfare aircraft are easy to model in JCATS, also. However, the effects of psychological warfare such as radio and television broadcasts and leaflet airdrops are not modeled in JCATS. Once the planners initiated the simulation, the JCATS entity acquisition and attrition models would detect enemy and neutral entities and compute the effects the specialized aviation assets' weapons have on the entities.

JCATS also supports course of analysis selection. Planners can construct any number of alternate sets of aircraft formations, flight routes, and activities to accomplish the same objective. Planners can then run the simulation repeatedly and observe the results in terms of detection and attrition of the specialized aviation forces. The cumulative results from these alternate sets of mission formations can also be compared against each other to determine, based on the JCATS simulation, which approach that is likely to yield the least friendly casualties, the highest chance of success, or requires the minimal number of assets. In order to appropriately assess the alternate courses of action for specialized aviation forces, which is highly dependent on the special operations ground force elements scheme of maneuver, it is important that all alternate options be judged against the same enemy order of battle and environmental conditions.

However, once the specialized aviation commander selects a course of action, JCATS can further be used to refine the plan by altering the environmental conditions and enemy disposition in the simulation. Since JCATS is inherently designed to be used in a computer network environment, synthetic inter-theater and intra-theater mission preview can be conducted by the in-theater specialized aviation component with mission

aircrews at their home stations. The special operations aviation planners, who will serve as the battle staff during the execution phase of a special operations mission, can use JCATS to rehearse their responses to unpredictable events. For example, an aircraft can be “shot down” in the JCATS simulation and the battle staff would then have to rehearse their search and recovery options while determining whether the mission is still viable. This aspect of JCATS is perhaps its greatest strength as a command and control software tool.

3. JCATS Summary

These factors support a Joint Special Operations Aviation Component use of the JCATS simulation as a command and control aid in planning and rehearsing the aviation support to special operations missions. Yet JCATS has limiting factors as well. Although, JCATS will run on desktop and laptop systems, it is based on the Red Hat Linux operating system. Although some computer systems are dual-bootable with Red Hat and Windows operating systems, Red Hat is not in widespread use throughout the Department of Defense in general or among special operations forces, specifically. Furthermore, JCATS is based on a client-server computer architecture and is sufficiently complex that a system administrator would be required at each location, deployed and home station, where JCATS would be installed. In other words, mission planners could not likely fulfill the dual roles of weapons systems experts and JCATS system administrators. Also, the route files, flight performance data, and enroute time calculations that JCATS produces are incompatible with flight and mission planning software tools currently used by specialized aviation units. This means that the aircrews would have to manually translate the JCATS routes into suitable formats of position, speed, and direction of flight that will work in both the approved mission planning software and the aircraft’s mission computers. There are other less troublesome aspects to JCATS utility as a specialized aviation command and control tool, yet the inability of the system to directly translate routes of flight into existing software mission tools would result in more time spent on “administrative” data conversion and entry instead of

mission planning and rehearsal by the mission aircrews. Although, this may be a seemingly insignificant detail, the opportunity for transcription and translation errors coupled with the need to maintain separate mission-planning systems combine to mitigate the usefulness of JCATS as an optimum command and control tool for specialized aviation missions.

C. SPECIAL OPERATIONS FORCES PLANNING AND REHEARSAL SYSTEM

The Special Operations Forces Planning and Rehearsal System is another software package that could potentially serve as a command and control tool for Joint Special Operations Air Components. Although the name implies an application to ground, maritime, and aviation aspects of special operations forces, the Special Operations Forces Planning and Rehearsal System (SOFPARS) is primarily an aviation-planning program. SOFPARS is certified by United States Special Operations Command for use as a flight and mission planning software system for use by Air Force and Army Special Operations Aviation units. The SOFPARS program, like the other software tools previously introduced, uses a map-based presentation along with terrain elevation data to plan individual and formation flights.

1. SOFPARS Structure

Since it was designed to function as an automated flight planning system, SOFPARS includes several databases that relate directly to flying. These databases include airfield and radio navigation aid information files available from the Federal Aviation Administration (FAA). Aircraft performance data are stored in separate databases in SOFPARS. Individual aircraft are modeled in SOFPARS according to their characteristics such as fuel capacity, fuel burn rates, climb rates, airspeeds, and cargo carrying capacity. Flight planning involves determining a route of flight, selecting an altitude to fly, choosing an airspeed and computing aircraft performance based on these

factors plus the wind speed and direction along the selected route of flight. SOFPARS will compute the direction, distance, effective airspeeds, enroute times, fuel burned, and fuel remaining at each turn point along the route of flight. Turn points can be entered into the flight plan by pointing and clicking on the map presentations or by typing in the latitude and longitude or the Military Grid Reference System coordinates of the turn point. Names of previously defined points like navigation aids, airfields, FAA checkpoints, and user defined points can be entered manually. A turn point can also be defined as a specified range and bearing from a navigation aid; SOFPARS will use the coordinate position of the navigation aid, apply the distance and direction of the range and bearing, and compute the coordinate position of the new turn point trigonometrically. SOFPARS also incorporates inflight refueling missions by allowing the flight planner to add or delete available fuel at any turn point in the flight. Flight planners can also enter a delay time at a turn point, subsequent fuel computations will reflect the delay time according to the airspeed, altitude, and burn rate. The route of flight will display on the map presentation as the planner designs each leg. SOFPARS flight planning functions enable flight planners to calculate routes of flight, save them, print them, and transfer them to floppy disks in formats that are compatible with aircraft mission computers. This allows crew members to reduce the amount of time spent manually entering data at the aircraft prior to flight.

SOFPARS is also a mission planning tool for special operations aviation missions. Mission planning differs from flight planning in one significant aspect; mission planning involves flight planning to avoid detection and engagement by adversary surface to air radars, missile systems, and anti-aircraft artillery pieces. SOFPARS depicts detection and engagement probabilities for specific surface to air threats as applied to specific aircraft by displaying color-coded rings on top of the map screen. The radius of the rings is determined by the terrain elevation at the threat system's location compared to the altitude of the aircraft, the characteristics of the threat system's radar, and the size of the aircraft being analyzed. By displaying these rings on the same presentation as the route of flight, an air planner can adjust the aircraft route to avoid or delay detection by adversary anti-aircraft threats. SOFPARS also allows

planners to enter additional mission related information such as communication frequencies, parachute data for airdrop missions, and firing orbit parameters for AC-130H/U profiles. These features enable specialized aviation mission planners to consolidate most of the relevant mission related data in one system and electronically transfer mission data to aircrews.

2. JSOAC Use of SOFPARS

Joint Special Operations Air Component planners could employ other aspects of SOFPARS to conduct command and control. Special use airspace such as no fly zones, buffer zones, refueling tracks, orbit points, checkpoints, and other examples of airspace control measures can be defined and depicted on the SOFPARS map displays. For example, multiple routes flown by different aircraft can be displayed on the same SOFPARS map. SOFPARS will “fly” the routes based on take off or arrival times specified by the planner and then determine any potential conflicts vertical and lateral separation of aircraft. This also allows commanders to visualize planned airflows, sequences of events, and alter routes to avoid potential midair collisions.

The rehearsal aspect of the SOFPARS system is less of an interactive process than it is a mission preview of segments of a flight route. SOFPARS can display terrain, imagery, and map data from a variety of perspectives and the program can also incorporate motion into previews. The SOFPARS operator defines field of view, angle of depression, lighting conditions, and elevation parameters and the selected view is shown in a window inset on the SOFPARS screen. For example, imagery of a target building or helicopter landing zone can be loaded into the SOFPARS database and a prediction of the way the target or objective area would look on the aircraft’s sensors (synthetic aperture radar, infrared detection set, and/or low light television camera) from the planned direction and altitude. These map insets can be printed as part of SOFPARS mission documents which the crews can carry with them in flight. Aircrews can also virtually watch the view on a SOFPARS computer that they would see outside their cockpit as they flew along their route. This feature allows crews to conduct in-depth

mission planning of landing zones, target areas, and difficult terrain features prior to actually flying their missions.

SOFPARS can also be useful to special operations mission planners during the execution phase of special operations aviation missions. SOFPARS is configured to accept near real-time position reports of actual aircraft as they are flying. Specific symbols representing these actual aircraft and their positions will display on the SOFPARS map. SOFPARS will also display actual adversary systems as they are identified by threat detection systems such as J-STARS, AWACS, or other electronic surveillance platforms. SOFPARS can simultaneously display the formations synthetically “flying” their planned routes of flight along with the near real-time actual aircraft positions. The special operations air planners can visually track actual mission progress against the planned sequence of events more effectively than the current process of using a text-based execution checklist alone.

Visualizing aircraft positions in the command center can also reduce the time needed to respond to a combat search and recovery mission. Joint doctrine and Special Operations doctrines both emphasize the requirement for forces to provide their own search and recovery procedures, processes, and techniques. Every special operations mission includes a dedicated Personnel Recovery team that can include refueling tankers, helicopters, Special Tactics para-rescuemen, and Special Forces, Rangers, or SEALs to provide tactical security. Special operations Personnel Recovery Teams also have an organic command and control structure that is subordinate to the overall joint mission commander. As such, the Personnel Recovery command and control element must develop, rehearse, and execute alternate recovery plans as part of the battlestaff. During execution of a search and recovery mission, acquiring an accurate and reliable position is the critical event when an aircraft is shot down or has an inflight emergency that forces it to crash or land in hostile territory. “Seeing” where a stricken aircraft was last reported on the SOFPARS map presentation as compared to where the aircraft was supposed to be, can greatly reduce the initial confusion associated with trying to determine which aircraft is missing and where to begin searching.

3. SOFPARS Summary

SOFPARS enjoys an advantage over other potential command and control software systems a JSOAC might employ. As a fielded system already in use by Air Force special operations aircrews, SOFPARS has evolved into a more robust and transportable computer system. The capability to transfer flight and mission data from SOFPARS to the mission computers in each special operations aircraft is a key attribute of no other software system. SOFPARS operates in the standard Windows operating system environment on laptop and desktop computers in networked or stand alone configurations. While not a true simulation, SOFPARS offers the ability for aircrews and planners to conduct in-depth study of imagery and terrain features from various perspectives and representations. Having a mental image of what an objective, whether it is a specific building or a landing zone, is expected to look like on night vision goggles, infrared detection set, or a low light level television could be critical during mission execution.

However, because SOFPARS was designed to be a flight and mission-planning program, it does not include combat loss models. There is no interaction between the aircraft and adversary threat systems loaded into the SOFPARS databases. SOFPARS also lacks an analytical tool that compares the likely results of alternate courses of action. Yet, the ability to visualize alternate flight routes and formations can still aid special operations air planners in refining courses of action, particularly in deconflicting routes of flight.

D. SUMMARY OF SOFTWARE SYSTEMS

Software systems for the command and control of specialized aviation missions are integral enablers of the Theater JSOAC concept. JSOAC planners could use such a computer system to model adversary and friendly courses of action. Once a course of action is selected, the software system could be used to prepare the JSOAC as transfer generic flight paths, threat locations, and other mission data to home-based aircrews by

electronically transmitting the applicable files to each unit. As changes in the mission data occur, the JSOAC staff could post the new information to a secure website and notify the aircrews that new data is available. The aircrews would download the changes from the website, refine their individual routes of flight, and transmit the new routes back to the JSOAC. The JSOAC would then deconflict the new routes and update the master plan. This distributed form of mission planning with the Theater JSOAC staff controlling the master data file is the cornerstone of the Theater JSOAC operational concept.

The three software systems introduced in this chapter represent a variety of modeling, simulation, and planning capabilities available to mission planners. Each offers strengths and weaknesses as potential tools for the command and control of specialized aviation missions. The Marine Air Ground Task Force Tactical Warfare Simulation focuses on Marine Corps air, land, and amphibious combat missions at an entity or combat unit level of detail. Although some weapon systems from other services are included in the simulation, Marine Corps equipment predominates. The Joint Conflict and Tactical System, on the other hand, includes weapon systems from all the services. Furthermore, the JCATS combat simulation details combat units down to individual personnel and vehicles. JCATS does allow planners to aggregate groups of weapons and personnel into dissimilar fighting units and task forces. Both MTWS and JCATS are combat simulations that reduce the numbers and effectiveness of friendly, enemy, and neutral forces based on interactions between the forces in the wargames. The Special Operations Forces Planning and Rehearsal System is a set of computer based flight and mission planning programs. Since it is not a wargame like MTWS and JCATS, SOFPARS has a limited modeling capability. Nor does SOFPARS, with the exception of surface-to-air radar and missile systems, include models of ground or naval weapon systems. However, special operations aircrews already use SOFPARS as an authorized computerized flight and mission planning system. As such, SOFPARS can readily be used to disseminate a common ground threat picture, airspace control measures, and detailed routes of flight among special operations air planners and aircrews.

While MTWS and JCATS have more robust capabilities than SOFPARS in terms of casualty analysis for course of action comparison, SOFPARS flight deconfliction

program is a useful command and control tool. A benefit all three programs share is an ability to synthetically “fly” planned air sorties and represent a mission progress with animation or motion. MTWS and SOFPARS can also import near-real time aircraft position updates and superimpose them on the same map presentation with planned missions. This capability for commanders to see where aircraft are versus where they were planned to be is a significant advantage over the current text-based checklist process currently used by special operations battlestaffs.

These are not the only modeling, simulation, wargames, and flight planning programs available to special operations mission planners. Nor are any of them specifically designed to serve as command and control tools as they apply to operational mission planning, rehearsal, and execution. However, these three software systems adequately represent the range of functionality that future command and control software systems for specialized aviation could include.

THIS PAGE INTENTIONALLY LEFT BLANK

VII. A FRAMEWORK OF COMPARISON FOR COMMAND AND CONTROL ORGANIZATIONS

A. SOURCES OF CRITERIA

Selecting a reasonable set of criteria becomes troublesome when trying to compare doctrinal concepts that are based on different sets of military capabilities. Although there are no perfect criteria for comparing doctrinal concepts, using universal qualities shared by the concepts under review and applying them objectively can lead to a practical solution. This chapter outlines the steps taken to determine reasonable criteria to compare the JOPES and Time Sensitive Planning processes with the Theater JSOAC concept of operations.

The Department of Defense does not have criteria to evaluate specialized aviation operational concepts. Several likely candidates are available, however from both Joint and United States Air Force doctrine. The principles of war as applied to United States military forces are one such example. These principles include objective, unity of command, offense, mass, economy of force, maneuver, surprise, security, and simplicity. (Joint Publication 1, 2000) Since the operational concepts under review are based on employing United States military aviation forces, the principles published by the United States Air Force on aerospace power are also eligible criteria. The principles of aerospace power include centralized control and decentralized execution, synergy, flexibility and versatility, priority, balance, concentration, and persistence (Air Force Doctrine Document-1, 1997). Neither the United States Special Operations Command nor its subordinate commands with specialized aviation forces; the United States Army Special Operations Command and the Air Force Special Operations Command publish any specific principles or tenets applicable to the command and control of specialized aviation.

A third source of possible criteria comes from the description of command and control processes known as Observation-Oriented-Decision-Action, or O-O-D-A loops. The cycle of Observation-Oriented-Decision-Action describes the sequence

commanders and their staffs follow in apprising a military situation, determining possible responses to shape the strategic and tactical situations to their advantage, selecting a course of action to pursue, and finally arraying their forces and implementing the command decision. The essence of the O-O-D-A loop concept is that the battle staff that can cycle through these loops more efficiently, in terms of accuracy and speed, will achieve an advantage over their opponents. Applying combat power at a faster and more persistent battle tempo than an adversary can actually create a sense of paralysis in an enemy's O-O-D-A process. For example, if an adversary plans an action based on intelligence that indicates a particular force is going to be in a specific location for a given time, but that force advances its position then the adversary must re-enter the Observe phase of the O-O-D-A loop. Whichever command staff can flow through the loop faster relative to their adversary's speed will likely prevail (Boyd).

B. THE SELECTED CRITERIA

These principles of war and aerospace power published by the Joint Chiefs of Staff and United States Air Force Air Staff, respectively, offer potential criteria that, if applied appropriately, can be used as a framework for comparison of command and control concepts. Recognizing these operational concepts are largely centered on command and control functions supports the relevance of the O-O-D-A loop concept as a source of criteria also.

1. Speed

Although other criteria may exist, there are three elements that stand out from the sources listed above as the most applicable in judging the viability of the way specialized aviation forces deploy and employ. The three criteria are speed, conservation of forces, and operational security. Speed can be thought of as responsiveness or timeliness of the entire military organization that forms in response to a contingency tasking. Speed as it applies to evaluating operational concepts is the consistent ability to generate, and then

apply combat force to a mission in the least practical amount of time. Speed is derived from the principles of war addressing offense and surprise, the Air Force principle of persistence, and the application of O-O-D-A loops. Conservation of forces relates to the limited number of specialized aviation assets available in the Department of Defense inventory. Once committed to a specific mission in a specific theater of operations, the aircraft, aircrews, maintenance, and support personnel are not available for use by other theater commands. An operational concept that needlessly ties up these limited numbers of military aircrew and aircraft for extended periods of time is less attractive than an operational concept that delays the commitment to deploy and employ as long as practical. Worldwide commitments of these “low-density, high-demand” capabilities make conservation of special forces imperative in general, and of specialized aviation forces in particular. Conservation of forces combines the principles of economy of force and mass, as well as the aerospace tenets of flexibility and versatility. Finally, operational security is the third criteria. Protecting one’s military capability from access by an adversary is fundamental to the success of any military operation. Operational security is a subset of the security principle of war.

Since operational concepts are concerned with the length of time it takes to translate military potential into combat capability, speed becomes a measure of comparison to differentiate between operational concepts. However, the question arises as to when to begin measuring the speed of a military response. Special operations commanders cannot change the JOPES cycle, so the point at which the Joint Chiefs of Staff publishes a warning order is the same for either operational concept. The end point for measuring responsiveness must also be determined. The time an execute order is published is not directly controlled by special operations commanders either. However, the point at which special operations commanders report their forces are ready to be employed is a factor in determining when superior commanders issue an execute order. This point of readiness depends on the process used to assemble, plan, and rehearse the joint special operations task force. Therefore, speed should be measured from the time a warning order is published to the time special operations commanders report their forces are prepared to execute their assigned mission.

2. Conservation of Forces

Conservation of forces is the second criteria. From a macro perspective, the conservation of forces refers to the ability to provide forces for multiple contingencies within a relatively short time frame. The term conservation of forces combines several concepts that include the ability to continue or maximize mission qualification training and also allow adequate maintenance preparation time to bring specialized aircraft from training capabilities to at least mission capable, and preferably mission ready status. Finally, the conservation of forces umbrella refers to a commander's ability to remain flexible in controlling forces from pre-deployment throughout mission execution. A variation of this aspect of conservation of forces is known as unity of command among airpower advocates in the United States Air Force. In this instance, command flexibility is accomplished by maintaining visibility of the location and mission capability, of both aircraft, aircrew, maintenance support packages, and specialized aviation ground combat forces from the time the weapon systems are assigned to an emerging mission in a geographic theater. An adequate degree of oversight enables commanders to respond to changes in the operational situation by reshaping the forces under his command, coordinating logistics and maintenance requirements enroute so aircraft arrive prepared to fly, or even by canceling their deployment prior to arriving in theater. Conservation of forces then is seen both from the vantage point of the specialized aviation commanders at general in terms of preserving combat capability for other missions and from the point of view of a gaining operational commander in terms of in-transit visibility that supports operational flexibility.

3. Operational Security

Operational security is the third criteria used to compare alternate concepts of operation as applied to specialized airpower. Operational security entails hiding, disguising, or dispersing forces and other measures taken to deny information regarding military intent from any party that is not part of a friendly chain of command.

Operational security relies on proactive defensive measures that are designed to frustrate intelligence-gathering efforts by adversaries, agencies sympathetic to anti-US initiatives, and can also defend against media inquiries. Ideally, operational security measures are integrated throughout the deployment, employment, and redeployment phases of any military mission. Typical operational security measures include, but are not limited to, using secure telephone and electronic mail communication means, shredding or safeguarding all written materials, enforcing prohibitions on classified discussions in non-secure areas, and even go so far as to include the removal of insignia and unit patches that identify specific mission capabilities.

Another aspect of operational security involves what is known as a logistics “footprint”. Whenever a military organization deploys to a forward operating area, some degree of interaction with the local population, particularly in instances of contracting activities with local vendors, occurs. In many locations around the world, potable bottled water, electricity, aviation and vehicle fuel, hangar and office space, lodging, rental vehicles, food and sanitation services, et cetera must be purchased or rented to support the military mission. The logistics personnel who arrange for these necessary items often arrive in advance of the operational, support, and maintenance forces in order to establish the work and living arrangements. The number and type of contractual arrangements made to support the military force can be an indication of the size of the forces being deployed and the length of time they expect to be deployed. Thus, the logistics “footprint” can be an indicator of operational capabilities or at least, an indication that a military force is on the way.

D. SUMMARY

Speed, conservation of force, and operational security are the three criteria used to evaluate alternate operational concepts involving the deployment and employment of specialized aviation forces in this analysis. The three elements are derived from published Department of Defense doctrine endorsed by the Joint Chiefs of Staff and the United States Air Force Air Staff. A widely accepted model of command and control

activities known as the Observe-Orient-Decide-Act loop is also a source for the selected criteria. Although not all of the principles of war and tenets of aerospace power are used as bases of evaluation, these three offer a set of relevant and adequate criteria with which to proceed.

VIII. COMPARISON OF TIME SENSITIVE PLANNING AND THE THEATER JSOAC CONCEPT

The proposed Theater JSOAC concept of operations represents a potential improvement over the JOPES and Time Sensitive Planning processes as a way in which specialized aviation forces are deployed and employed by the Department of Defense. Applying the three criteria identified in the previous chapter to evaluate these alternate methods of deploying and employing specialized aviation forces may yield some insight into the viability of adopting the Theater JSOAC concept. Speed, conservation of forces, and operational security are characteristics of military missions that commanders and their staffs must consider whenever faced with employing combat capabilities. Commanders, however, have little empirical information with which to make such decisions. The same is true when comparing operational and doctrinal concepts. Rather, a qualitative judgment must be made based on the experience, instinct, and insight of those who compare the two concepts. The following comparison of operational concepts is approached from just such a qualitative perspective.

A. SPEED

Speed refers to the total time from when a crisis or contingency occurs to the time special operations aviation forces are prepared to execute their assigned missions. In the case of the current sequential deployment and employment process, this total time includes phased segments. These segments include high level JOPES planning and course of action analysis, pre-deployment activities at the unit level, deployment of aircraft, aircrews, and support forces, and finally planning, rehearsal, and mission execution phases. Since both deployment processes depend on the same overarching JOPES process to run its course prior to initiating deployment actions, and since the proposed Theater JSOAC process does not alter the JOPES cycle, it is reasonable to assume the JOPES cycle would take the same amount of time to complete regardless of

which specialized aviation deployment process is in effect. Therefore, the JOPES processing time is held constant. Pre-deployment activities occur at the unit level and include actions such as recalling aircrew members and support personnel, ensuring individual mobility criteria are met for the personnel who are selected to deploy, and preparing aircraft for combat versus training missions. Once aircraft maintenance repairs are completed, the aircraft generally do not fly again until the deployment order is issued. Again, both deployment methods would follow the same sequence so the time required to complete pre-deployment actions at home-stations would be the same for both the JOPES and Time Sensitive Planning and the Theater JSOAC concepts.

The actual deployment of the aircraft would also be equal under both processes. The time it takes for an aircraft to fly from their home-station or for a helicopter to be packaged for shipment to a theater is the same in both cases. However, an advantage in the speed of response is evident when comparing the planning, rehearsal, and execution elements. In the sequential JOPES and Time Sensitive Planning process, these three elements do not occur until the aircraft and aircrews arrive in the theater of operation. Then, after a nominal 96 hours, special operations aircrews and ground forces would be ready to execute their assigned mission. The advantage of the Theater JSOAC concept is that key members of the primary aircrews would conduct planning and some aspects of mission rehearsal from home-station while non-primary aircrews ferry the combat aircraft to the theater of operations. The primary aircrews would then be flown to meet their special operations aircraft at the staging base. Depending on the aircraft and distance to the theater, this parallel method of simultaneous deployment while planning and rehearsing could result in an increase in responsiveness. The critical element in measuring speed in this context is not based on which method of deployment and employment takes less time in any singular case. Specific deployment examples can be found demonstrating that a compressed version of the Time Sensitive Planning process could result in as fast a response as the Theater JSOAC process and vice versa. Speed, in this context, is more appropriately considered as a relative comparison of the Time Sensitive Planning process and the Theater JSOAC processes, as they would likely be used in most crisis and contingency responses.

B. CONSERVATION OF FORCES

Special operations forces in general, and specialized aviation forces in particular, are scarce resources. Yet, in their contingency war plans, every regional theater lays claim to more specialized aviation forces than are assigned in their regions. Central Command and Southern Command have the fewest assigned special operations aviation forces while Pacific Command has the most. However, all the regional commanders expect special operations forces to be readily available when contingencies occur in their areas of responsibility. This scarcity in the supply of special operations aircraft in the face of operational demands places a premium on conserving the overall supply of available specialized aviation forces.

Conservation does not mean that commanders of special operations aircraft have the authority to deny those aircraft to theater commanders. Rather, conservation implies preserving the availability of the weapon systems and aircrews as much as practical prior to committing them to a specific theater of operations. Once committed to one theater, the aircraft, aircrews, and support personnel fall under the sole operational command of the gaining theater commander. When conflicts arise over the disposition of these forces, such as when two crises occur in different theaters at the same time, the respective theater commanders must confer with the Joint Staff and United States Special Operations Command to determine which special operations forces will be assigned to which theater commander. While this situation does not occur often, the possibility of high demand, low density weapons systems like the EC-130 and AC-130 aircraft being requested by more than one theater command is a concern. Assigned and attached special operations forces remain in theater until released by the theater commander. As such, those aircraft and aircrews are not available for taskings to meet the mission requirements of other theater commanders when crises arise. Conservation of forces should be viewed from the macro perspectives of the regional theater commanders as well as from the special operations force providers.

Both deployment and employment processes offer advantages in terms of conservation of forces. The Time Sensitive Planning process ensures the gaining theater

commander, through the designated joint task force commander and JSOTF commander, can execute direct command and control of their assigned forces. As a crisis evolves, having forces on hand supports a commander's need to maintain operational flexibility. Under the JOPES and Time Sensitive Planning deployment process, special operations aircrew and aircraft would already be at the forward operating base, so theater commanders would not have to re-initiate the JOPES process to gain operational control of specialized aviation assets. Conversely, theater commanders are not always quick to release special operations forces when a crisis stabilizes. In the past, special operations force providers have made accommodations with theater commanders to conserve specialized aviation forces. For example, aircraft could be authorized to return to their home station while the theater commander retained tasking authority over those aircraft. Basically, special operations commanders agree to remain on an alert status while at home station in exchange for the opportunity to conduct maintenance upgrades on their aircraft, reconstitute and train their aircrews, and rotate support personnel. This arrangement is a compromise for the theater commander because the aircraft would have to fly back to the theater before a new planning and execution cycle could begin. On the other hand, the theater commander retains operational command of a specified number of aircraft and aircrews throughout the redeployment at home station, so there would be no requirement to initiate the JOPES process to return the aircraft to the theater. Theaters which keep scarce specialized aviation forces deployed in theater on a contingency basis must balance their operational requirements with the need to reconstitute special operations aviation capabilities for use by other theater commanders.

The proposed Theater JSOAC deployment and employment process supports conservation of specialized aviation forces from the points of view of theater commanders and special operations force providers. Theater commanders would gain operational control of the mission aircrews for planning and rehearsal purposes during the initial stages of a contingency or crisis. In addition to receiving a more situationally aware and better prepared set of aircrews if a contingency response ultimately results in a deployment order, the proposed process also allows theater commanders to exercise flexibility prior to bringing forces into the theater. As a group, the regional theater

commanders potentially gain the benefit of access to mission aircrews sooner in the crisis and contingency response cycle. It would be possible for different aircrews to plan different missions for different theater commanders from the same home station under the Theater JSOAC process. Depending on the number of aircraft required for such multiple missions, either one or all of the deployments could be supported. If however, one crisis resolved itself and no longer required an aircraft deployment, the other missions would not have suffered for a lack of aircrew and aircraft prior to beginning mission planning. By integrating detailed planning activities as soon as practical following the National Command Authority decision to employ special operations forces, Theater JSOAC planners retain the option to initiate aircraft deployment when it is appropriate based on the developing crisis. In situations where a crisis unfolds rapidly, the Theater JSOAC process allows for aircraft movement and mission planning to begin right away.

On the other hand, if a crisis appears to stabilize prior to issuing deployment orders, special operations aircrews would have remained at home station and therefore be available to respond to other theater commanders' requirements. The Time Sensitive Planning process would result in aircraft movement and, therefore, commitment to a single theater commander even prior to extensive mission planning occurring. Once in theater, the aircraft and aircrews would remain in place, and unavailable to other theater commanders, until the crisis is resolved or the special operations force is re-deployed. So, from the perspective of special operations force providers at United States Special Operations Command, United States Army Special Operations Command, and Air Force Special Operations Command, the Theater JSOAC deployment and employment process allows the same number of aircrews and aircraft to support operational theater commanders more so than the Time Sensitive Planning process does.

C. OPERATIONAL SECURITY

Operational security is a cornerstone of success in special operations missions. Since both methods of employment and deployment rely on secure communications between theater-based command and control staffs and home based aircrews, the risk to

overall security from a communications breach is the same for Time Sensitive Planning and the new Theater JSOAC proposal. However, communications are not the only source of military capability related information that commanders must secure.

Another aspect of operational security extends to indicators of the size and capability of a military force that an adversary or their sympathizers may notice. Such information includes the amount of water purchases, the number and duration of lodging reservations, and additional security measures at airfields in areas or countries that are near to crisis regions. These and several other arrangements are critical to supporting special operations personnel as they prepare to execute combat missions. Unfortunately, they are also indicators of military presence and, indirectly, of the likely size and composition of those forces.

The current Time Sensitive Planning process requires a physical location at or near an airfield for special operations forces to assemble while planning, rehearsal, and preparation occurs. Ideally, this forward operating base, also known as an intermediate staging base, would be located within the operational flight range of the special operations aircraft in relation to the objective area. The longer the special operations aircraft and personnel remain at the staging base, the greater the risk that an adversary will become aware of their presence. Even though such an adversary may not know the exact special operations mission plan, an adversary might take additional security measures based on the knowledge that a military force is within range. These additional precautions could complicate the nature of the crisis and reduce the chances for a successful special operations mission. Granted, under the Time Sensitive Planning process, the nominal duration of a special operations contingent would only be approximately eight days; 96 hours for planning and preparation with two days to prepare the force reception and another one or two days to close down the staging base following the departure of the main force.

The Theater JSOAC concept for employing and deploying special operations aviation assets could help alleviate many of the operational security issues related to staging bases. Where practical, assembling aviation forces at airfields with an existing military force prior to launching the execution phase could help mask the presence of a

special operations aviation force. Establishing a recovery base closer to the objective area immediately prior to executing the mission, would also limit exposure in the forward area. However, if a suitable airfield with a military presence is not available, the overall time spent at the staging base could be reduced under the Theater JSOAC proposal. By arriving at the staging base with much of the preliminary planning and some portion of the rehearsal already accomplished, less total time would be needed for the aircrews to reach the execution phase. Establishing split staging bases is another approach to mitigating the risk to operational security. Since the Theater JSOAC concept integrates distributed mission planning from the theater to home based forces (in effect, establishing command and control of geographically separated units), coordinating a special operations mission that originates from multiple staging bases would be easier than attempting to do so under the Time Sensitive Planning process. A corresponding reduction in support requirements at each staging base would further lower the risk of compromise or detection of a special operations force located within range of an objective area. Furthermore, if special operations aircraft and the personnel who fly and support them are deployed to staging or recovery bases for a shorter duration, then the risk of exposure to the overall mission is reduced.

D. SUMMARY

The current special operations deployment process rates well against all three criteria and enjoys the credibility of having been successfully employed on real world operations since its adoption in the late 1980's. Yet, from a qualitative point of view, the Theater JSOAC proposal for deploying and employing specialized aviation rates better when compared to the same criteria. Although untested, this new concept offers the potential for special operations commanders to react to crises faster while conserving the overall availability of finite specialized aviation assets and reducing some operational security concerns. The Time Sensitive Planning process provides a rapid reaction capability for theater commanders as compared to the time it would take to assemble, train, plan, rehearse, and execute a mission using a conventional task force of a similar

size and composition. But, given the anticipated global environment with the near complete diffusion of worldwide information resources and media access, the requirement for military forces to respond faster, with fewer forces, while maintaining a sufficient degree of security is becoming critical to success in future special operations missions. Therefore, based on a qualitative view of these criteria, the new Theater JSOAC proposal for deploying and employing special operations aviation capabilities, should it prove technologically, organizationally, and doctrinally feasible, warrants further analysis.

IX. ADDITIONAL RESEARCH OPPORTUNITIES

Enabling the Theater JSOAC proposal as presented in this thesis requires more than modeling and simulation capabilities. Other technological developments would be incorporated into standing theater-based Joint Special Operations Air Component Commands. These new technologies address some of the same capabilities raised by the analysis of existing wargames in the previous chapter. For example, an ability to share the same data virtually across extended networks and geographic distances could potentially result in a more complete understanding of events that impact mission success. Also, an ability to communicate simultaneously between theater-based mission planners and aircrews at their home stations could reduce the overall mission planning time. Planners and aircrews would not have to wait for a series of messages, whether they are distributed electronically or otherwise, and then attempt to correlate proposals from other agents in sequential mission planning process. There are other aspects related to implementing this new deployment and employment concept.

A. POTENTIAL ISSUES

Organizational changes would have to accompany the doctrinal changes associated with this new way of bringing specialized aviation to bear in operational missions. These organizational changes would have to occur across special operations agencies from special operations headquarters, force providers, and force employers. United States Special Operations Command has already identified the manning requirements for theater-based Joint Special Operations Air Component Commands. However, finding personnel with the appropriate operational, planning, and educational experiences in specialized aviation missions may well be a challenge. Also, defining professional career paths for the personnel assigned to future Joint Special Operations Air Component Commands would help secure an ongoing source of capable planners and commanders for these theater staffs. These are some personnel related issues this concept would raise.

There are also logistical issues to address. A subtext of this concept is the ferrying of mission aircraft by non-mission aircrews, in the case of fixed wing aircraft, and deploying rotary wing aircrews separate from their helicopters. Logistical concerns arise when repairs need to be made while enroute to or at the staging bases. Should maintenance personnel fall under the command of the Joint Special Operations Air Component, the JSOTF Logistics and Maintenance staff, or should they remain the responsibility of the deploying unit? This question is key when one accepts the rationale that the benefit of ferrying aircraft is negated if the aircraft is not able to fly the operational mission when it arrives in theater. Another logistics issue relates to the movement of the non-mission aircrews, support staffs, and maintenance support from home bases directly to recovery fields as a mission execution unfolds. It is entirely possible that this demand on airlift resources could make the overall operational concept untenable.

Under this new concept, aircrews at their home stations would fall under the operational command of a theater Joint Special Operations Air Component Command prior to deploying. Currently, home station planners coordinate with, but do not work for forward based command and control structures. There is a potential for friction between the requirements of the commander “over there” and the commander “right here” that could work to undermine the benefit of mission planning and preparation while awaiting deployment. For example, a common sense of mission focus and urgency is easier to develop among the personnel who live and work together as they prepare for combat missions. Preparing in isolation from their counterparts while also facing the influences of professional and personal responsibilities at home might diminish the benefits this concept offers.

The sub-unified theater Special Operations Commands would also experience changes. Shifting from the current focus on regional engagement and exercise management to conducting the command and control of specialized aviation assets would require a change in mindsets and resourcing. Currently, only the commander of the Special Operations Command, Pacific also serves as the standing commander of an operational theater task force. As such, this officer maintains a combat oriented command

and control capability that includes a joint operations center and the expertise in assigned personnel to conduct command and control of special operations and assigned conventional forces in Pacific theater. Other commanders of theater Special Operations Commands have the authority to act as JSOTF commanders when they form in response to a crisis or contingency. However, they do not maintain a continuing capability to conduct operational command and control of special operations forces in their theaters.

Resourcing the implementation of any new military capability or in this case, doctrinal change, eventually comes down to one question: where will the funding come from? Although relatively few hardware purchases (possibly computers and communication upgrades) would be needed to resource this concept, several indirect costs could be associated with its implementation. Manning and personnel related costs, for example, could increase at theater Special Operations Commands as additional personnel are assigned at these locations on permanent change of station orders. Flying hour programs, which are the indexes for Operations and Maintenance funding in the United States Air Force, might be affected by the frequency of aircraft deployments for exercises and contingencies under this new scheme.

D. ADDITIONAL AREAS OF RESEARCH

Fortunately, the Department of Defense has a process in place to field new technologies, operational concepts, and develop doctrines prior to employing them in crises and contingencies. United States Joint Force Command's J-9 Division is responsible for what is known as Joint Experimentation. The J-9 Division is currently addressing three command and control concepts that could enable the new operational concept proposed in this thesis. The three concepts under review are Joint Interactive Planning, Common Relevant Operational Picture, and Adaptive Joint Command and Control (US Joint Forces Command-J9, 2000).

Joint Interactive Planning as envisioned by the Experimentation Directorate will enable decision-making and implementation at an operational level faster than an adversary. This is accomplished by sequencing from a serial decision making process to

a more parallel one. Automated decision support software, collaborative communication tools, intelligent software agents, and operationalizing the use of models and simulations. Joint Interactive Planning relies on assured and reliable availability to a Global Information Grid to provide both the communication links and common situational awareness of battlespace elements (US Joint Forces Command-J9, 2000).

This common situational awareness is the foundation of the second concept the Experimentation Directorate is analyzing. The Common Relevant Operational Picture is more of a tailorable menu of information choices than it is a single presentation of combat related data. Users are able to choose the information relevant for the roles they fulfill in planning and executing a combat mission. For example, the planner who is responsible for logistics issues would less likely be concerned with viewing an enemy order of battle presentation overlaid with a weather depiction. On the other hand, that same logistician might be keenly interested in the weather conditions and forecasts at maintenance depots in the theater. The Common Relevant Operational Picture seeks to capitalize on advances in data fusion and information management techniques to evolve existing Department of Defense Service sponsored databases and the Global Command and Control System into an integrated, all source “virtual information warehouse” (US Joint Forces Command-J9, 2000).

Adaptive Joint Command and Control reflects a re-organization of joint task force command and control structures. Small, flexible, and mobile command echelons would deploy to forward areas and rely on secure, long range communications via the Global Information Grid to exchange operational information with their parent command and control organization in garrison. These small command and control units would take advantage of Joint Interactive Planning capabilities and the Common Relevant Operational Picture to execute their missions (US Joint Forces Command-J9, 2000).

The command and control of specialized aviation forces should adapt to incorporate the changes in the operational, technological, and organizational environments of the current age. Operationally, responsiveness may well be the critical aspect that determines whether a special operations mission succeeds. But misunderstandings of what the mission is and what the assembled force can accomplish,

caused by focusing on speed of maneuver, may also risk mission success. Technological advances in communications and computing power offer the possibility for improved mission planning and rehearsal without having to physically assemble the task force and fly aircraft. Also, smaller, forward-based command elements are capable of controlling widely dispersed special operations forces as a result of the same technological advances. The parallel planning, synthetic rehearsal, and split command and control elements of the proposed operational concept are not unique to specialized aviation missions. In fact, Pacific Command, Special Operations Command, Pacific, and Joint Forces Command are three organizations within the Department of Defense who are already exploring ways to leverage similar operational, technological, and organizational opportunities with their respective military missions and capabilities.

The operational concept proposed in this thesis is a theory, and like most theories it has strengths and weaknesses. This thesis has explored these potential benefits and risks from a descriptive and qualitative perspective. It is not an exhaustive and quantitative analysis because this we do not have the experiential data that can only be derived from actually implementing the concept. There may well be other factors that testing this theory may reveal, both positive and negative, that were not addressed in this thesis. As such, this concept is not mature enough to be considered a doctrine for the command and control of specialized aviation forces.

However, this operational concept may have peaked the interest of those responsible for developing special operations doctrine and those charged with commanding specialized aviation missions. To that end, I would suggest that this theory merits further exploration and sponsorship by the special operations community. In order to determine its usefulness, this proposed concept should be included in the Joint Forces Command exercise and experimentation cycle. There, any improvements in joint warfighting capabilities resulting in this new operational concept, as they apply to the command and control of specialized aviation, can be incorporated into special operations doctrine.

THIS PAGE INTENTIONALLY LEFT BLANK

APPENDIX A: THEATER JSOAC INFORMATION FLOWS

The vice commander of the Air Force Special Operations Command commissioned an analysis of existing command and control architecture entitled “AFSOC’s Command and Control Information Requirements” (1998). The goal was first to establish the baseline of all the processes and technologies employed across the breadth of command activities in a joint special operations air component. These activities range from weather forecasting, keeping track of aircraft maintenance status, reporting on aircrew readiness, and collecting intelligence information, among other actions. The second aspect of the analysis was to establish the requirements for an overarching command and control network or “system of systems” to link the identified command functions. The resulting report identified many of the internal and external sets of information flows associated with a special operations aviation component.

These information flows were presented in the report in relation to the DoD functional staffs organization separated by personnel, administration, intelligence, operations, communications, logistics, etc. within the command cell. The diagram at Figure 11 depicts this structure and the components of a typical joint special operations air component command and control cell. Pertinent external agencies such as the Joint Force Special Operations Component Commander, the Joint Task Force Air Operations Center, weather, intelligence, and home station units are included, as well. Since special operations aviation missions are primarily flown to support special operations ground units, these ground elements, Mission Planning Authorities, are included in the diagram, also. Functions within the operations section are further delineated to more clearly illustrate the information flows related to planning and conducting operational missions. The operations division is generally the central staff in an aviation command and control cell and therefore, it generates the bulk of the information flows.

The report’s analysis of the existing command and control architecture revealed there was little commonality among the separate computer and communications systems being used by AFSOC special operations command and control staffs. This lack of interoperability was due to systems designs that did not include requirements to share

data between computer programs used by different staff functions. For example, intelligence related database and analysis software tools were not initially designed to integrate adversary threat system status and location information with flight and mission planning programs. The report recommended an integrating approach that links the existing computer systems while accommodating new technologies. This proposed architecture, as depicted in Figure 12, is a modification of the client-server computer topology model in which individual software programs, the clients, are connected to a secure local area network within the special operations air component. A set of communication and processing computers called servers, route voice, video, and text data and provides access to external communication links. In essence, the analysis on AFSOC's report focuses on improving the communications infrastructure associated with conducting command and control, rather than identifying requirements to improve the individual computer based processes that are used to accomplish command and control.

The report effectively illustrates the range of information flows that occur within a command and control organization that conduct special operations aviation activities. Its recommendations reflect a Joint Special Operations Air Component commander's complete staff responsibilities ranging from administration, personnel, communications, maintenance, and logistics. The report does not delve into the individual computer systems and software programs used within the staff sections. Rather, the emphasis is placed on integrating the information flows within and between the various agencies associated with the command and control of specialized aviation missions.

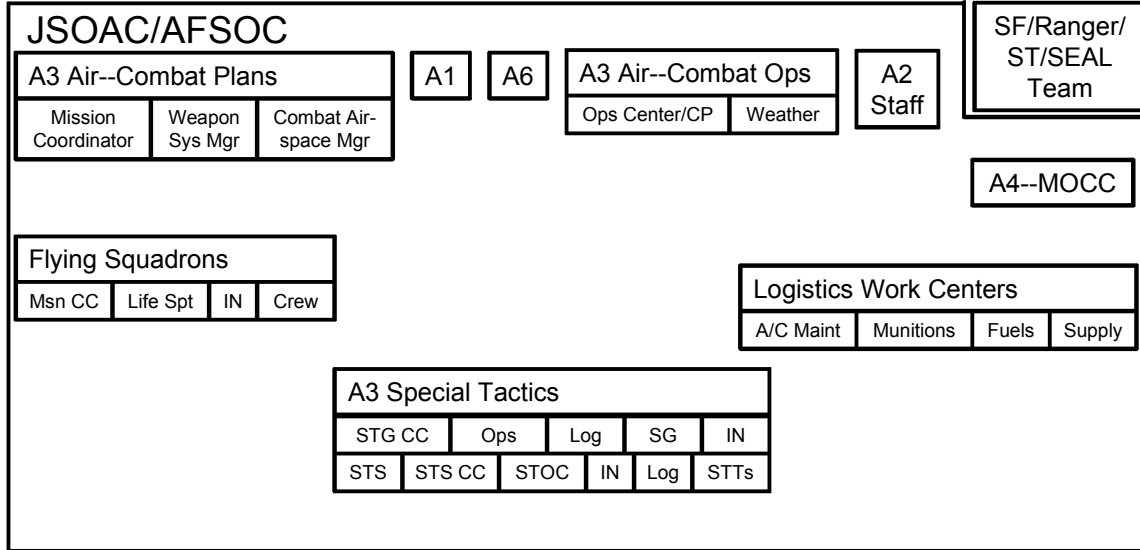

Figure 11. Typical Joint Special Operations Air Component Structure From AFSOC's Command and Control Information Requirements, 1998

LIST OF REFERENCES

- AFSOC's Command and Control Information Requirements (1998). Published by Headquarters Air Force Special Operations Command, Hurlburt Field, FL.
- Air Force Doctrine Document-1 (September, 1997). Retrieved November 12, 2001 from the World Wide Web: <http://afpubs.hq.af.mil/pubfiles/af/dd/afdd1/afdd1.pdf>
- Blais, C. (No Date). Marine Air-Ground Task Force (MAGTF) Tactical Warfare Simulation (MTWS). Retrieved 5 June 2001 from the World Wide Web: <http://www.scs.org/confernc/elecsim/elecsim94/mtws>
- Boyd, J. (No Date). OODA Loop Briefing Slides: Material excerpted from "The Essence of Winning and Losing" Retrieved November 12, 2000 from the World Wide Web: http://www.d-n-i.net/FCS_Folder/boyd.htm
- Garrabrants, M. (January, 2001). Marine Air-Ground Task Force (MAGTF) Tactical Warfare Simulation (MTWS) System Overview. Retrieved from the World Wide Web on 5 June 2001: http://www.ijwa.org/projects/USMC/MTWS_Overview01_files/frame.htm
- Joint Publication 1 (November, 2000). Joint Warfare of the Armed Forces of the United States. Retrieved March 20, 2001 from the World Wide Web: http://www.dtic.mil/doctrine/jel/new_pubs/jp1.pdf
- Joint Publication 3-05 Doctrine for Joint Special Operations (1998, 17 April). Retrieved November 12, 2000 from the World Wide Web: http://www.dtic.mil/doctrine/jel/new_pubs/jp3_05.pdf
- Joint Publication 3-05.5 Joint Special Operations Forces Targeting and Mission Planning Procedures. (1993, 10 August). Retrieved November 12, 2000 from the World Wide Web: http://www.dtic.mil/doctrine/jel/new_pubs/jp3_05.5.pdf
- Joint Publication 5-0 Doctrine for Planning Joint Operations (1995). Retrieved November 12, 2000 from the World Wide Web: http://www.dtic.mil/doctrine/jel/new_pubs/jp5_0.pdf
- Joint Vision 2020 (June 2000). Retrieved October 5, 2000 from the World Wide Web: <http://www.dtic.mil/jv2020/jv2020a.pdf>

- Kreisher, O. (January, 1999). Desert One. Vol. 82, No. 1. Air Force Magazine. Retrieved October 05, 2000 from the World Wide Web:
<http://www.afa.org/magazine/0199desertone.html>
- Levitt, R. (1999). The ViteProject handbook: A User's Guide to Modeling and Analyzing Project Work Processes and Organizations. Copyright 1999 Vite
- Mobley, D., (2001). PACOM JSOAC: Organization and Command Relationships. Material excerpted from official briefings presented to the Commander of the Special Operations Command, Pacific.
- Reiner, K., (28 September 2000). ePM Announces ViteProject 3.0. Retrieved November 9, 2000 from the World Wide Web: http://www.epm.cc/ecc_release.html
- Scrivener, F. (2000). Beginner's User Guide for the MAGTF Tactical Warfare Simulation, Naval Postgraduate School, Monterey, CA
- SOF Posture Statement 2000 (April, 2000). Retrieved November 12, 2001 from the World Wide Web: <http://www.defenselink.mil/pubs/sof/>
- SOF Vision 2020 (No Date). Retrieved November 12, 2001 from the World Wide Web: <http://www-cgsc.army.mil/djco/sof/vision.htm>
- US Joint Forces Command-J9, (20 December 2000) Information Superiority-Command and Control Concepts White Paper. United States Joint Forces Command, Norfolk VA
- USSOCOM Directive 525-8, (26 Jan 1999) Military Operations: Joint Special Operations Air Component

INITIAL DISTRIBUTION LIST

1. Defense Technical Information Center
Fort Belvoir, VA
2. Dudley Knox Library
Naval Postgraduate School
Monterey, CA
3. Associate Professor William Kemple
Naval Postgraduate School
Monterey, CA
4. GEN Charles Holland
US Special Operations Command
MacDill AFB, FL
5. United States Special Operations Command
SOOP-JE
MacDill AFB, FL
6. COL Donn Kegel
National War College
Fort McNair
Washington, DC
7. Jennifer Duncan
Department of Defense Analysis
Naval Postgraduate School
Monterey, CA

8. Library
Army War College
Carlisle Barracks, PA
9. Library
Naval War College
Newport, RI
10. Strategic Studies Group
Naval War College
Newport, RI
11. Department of Military Strategy
National War College
Ft. McNair
Washington, DC
12. US Army Command and General Staff College
ATTN: Library
Ft. Leavenworth, KS
13. Library
Air War College
Maxwell AFB, AL
14. US Military Academy
ATTN: Library
West Point, NY

15. US Naval Academy
ATTN: Library
Annapolis, MD

16. Maraquat Memorial Library
US Army John F. Kennedy Special Warfare Center
Ft. Bragg, NC

17. US Air Force Special Operations School
Hurlburt Field, FL