



THE STATE OF NEW HAMPSHIRE
DEPARTMENT OF TRANSPORTATION



CAROL A. MURRAY
Commissioner

June 25, 2002

GILBERT S. ROGERS
Assistant Commissioner

Re: *Best Management Practices for Routine Roadway
Maintenance Activities in New Hampshire*

There are approximately 16,853 miles of roadway in this State requiring yearly maintenance. An important component of the maintenance program is drainage control. This is principally conducted through the replacement of culverts, cleanout of the channels leading to the culverts and repair of stream banks abutting our roadways.

Many of these routine maintenance activities require a dredge and fill permit for conducting work in areas commonly associated with roadway drainage. To provide better management of routine roadway maintenance activities in the future, the NH Department of Transportation (NHDOT), in conjunction with the NH Department of Environmental Services (NHDES), has developed this manual of *Best Management Practices (BMPs)*.

The intent of this manual is to provide a menu of best management practices from which all roadway maintenance personnel may select practices appropriate to specific sites and conditions and employ the most responsive control measures for protecting the environment. This manual is not a panacea for all conditions, and NHDOT recognizes other methods of protecting our natural resources can be appropriate and warranted in certain circumstances. This manual can be improved and amended by NHDOT and NHDES as feedback is provided relative to its effectiveness. Additionally, as other BMPs are developed and improved, they too can be incorporated into future iterations.

In conjunction with this manual, NHDES is in the process of adopting a new Administrative Rule (Wt 303.05(q)) that would allow for a notification process for certain activities conducted in accordance with the best management practices detailed in this manual. A dredge and fill permit would not be required for these activities. Throughout this manual are descriptions of, and references to this notification process. There is also a copy of a completed notification form to reference when the new rule is adopted and has become effective. Until such time as the rule becomes effective, the notification process described herein **DOES NOT APPLY**.

NHDOT hopes that the methodologies and activities herein are of assistance to you in protecting our valuable water resources during your small-scale roadway maintenance projects.

If you have questions, comments, concerns or suggestions please direct them to me at the Department of Transportation.

Very truly yours,

Kevin T. Nyhan
Senior Environmental Manager
Bureau of Environment
Rm. 160 Tel. (603) 271-1553
E-mail – knyhan@dot.state.nh.us

KTN:ktn
S:\STAFF\Ktn\BMPS\Manual\Coverlet.doc

BEST
MANAGEMENT
PRACTICES for

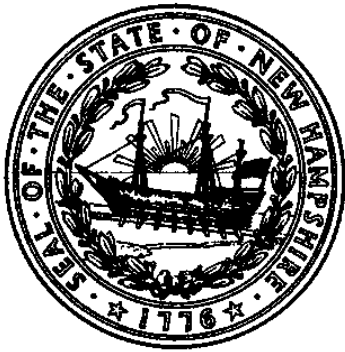

ROUTINE
ROADWAY
MAINTENANCE
ACTIVITIES
IN
NEW HAMPSHIRE

August 2001

Acknowledgements

A number of engineering and environmental professionals contributed in the development of this manual. Without the assistance of the following individuals, the compilation of information and preparation of this manual would not have been possible:

Frederic C. Murphy, Special Programs Manager, NH Department of Transportation, Bureau of Environment

William R. Hauser, Administrator, NH Department of Transportation, Bureau of Environment

Dennis A. Croteau, Engineering Technician, NH Department of Transportation, District One

John “Jack” Cilley, Assistant District Engineer, NH Department of Transportation, District Two

Michael P. Pillsbury, Assistant District Engineer, NH Department of Transportation, District Four

Kenneth N. Kettenring, Administrator, NH Department of Environmental Services, Wetlands Bureau

Lori L. Sommer, Transportation and Mitigation Officer, NH Department of Environmental Services, Wetlands Bureau

Prepared by: **Kevin T. Nyhan**
Senior Environmental Manager
NH Department of Transportation
Bureau of Environment

This manual represents many working hours in a joint effort between the NH Department of Environmental Services and the NH Department of Transportation.



For more copies, contact:
DOT Bureau of Environment
PO Box 00483, 1 Hazen Drive
Concord, NH 03302-00483
(603)271-3226

This manual is also available online at:

WWW.NHDOT.COM

TABLE OF CONTENTS

	Page
CHAPTER 1: INTRODUCTION	
Background	1-1
Purpose	1-1
Definitions	1-2
General Conditions	1-6
Project Notification	1-7
CHAPTER 2: ROUTINE ROADWAY MAINTENANCE ACTIVITIES	
Chapter Introduction	2-1
Culvert Extension	2-2
Culvert Replacement and Relocation	2-4
Embankment Stabilization	2-7
Headwall Repair, Replacement and Construction	2-10
Roadside Ditch Maintenance	2-12
CHAPTER 3: BEST MANAGEMENT PRACTICES	
Chapter Introduction	3-1
Dredging Roadside Ditches	3-2
Filter Bags	3-3
In-stream Sediment Trapping Device	3-4
Outlet Protection/Stone Riprap	3-5
Sandbags	3-6
Sediment Retention Basins	3-7
Seeding	3-8
Silt Fence	3-9
Stone Check Dams	3-10
Straw or Hay Bales	3-11
Temporary Diversions	3-12
Topsoiling and Mulching	3-13
Turbidity Curtains	3-14
CHAPTER 4: APPENDICES	
Chapter Introduction	4-1
Complete <i>Notification of Routine Roadway and Railway Maintenance Activities</i>	4-2
Designated Rivers	4-6
Towns with Designated Prime Wetlands	4-8
Shoreland Protection Act Fact Sheet	4-9

INTRODUCTION

Background

The New Hampshire Department of Transportation (NHDOT) and other state municipalities maintain approximately 16,853 miles of roadway in this state. Many of these roads are on location originally laid out by New Hampshire's settlers and many miles are new location roadways constructed in recent years. In both instances, routine maintenance activities are performed on a yearly basis to preserve their integrity. An important component of the maintenance program is drainage control. This is principally conducted through the replacement of culverts, cleanout of the channels leading to the culverts and repair of stream banks abutting our roadways.

Many of these routine maintenance activities require a wetland permit for filling or excavation/dredging in areas commonly associated with roadway drainage. To provide better management of routine maintenance activities in the future, the NHDOT, in conjunction with the New Hampshire Department of Environmental Services Wetlands Bureau (DES Wetlands Bureau), has developed this manual of Best Management Practices (BMPs).

Purpose

On a daily basis, maintenance personnel identify roadway drainage structures requiring various levels of improvement. Because these maintenance professionals have an intimate understanding of existing site conditions and their job requirements, they are best able to manage these activities. This manual will act as a management tool and as a technical guideline for routine maintenance activities that impact wetlands. These routine maintenance activities include culvert replacements, extension of culverts, changing the orientation of existing culverts, stream bank stabilization, roadside ditch maintenance, and headwall repair, replacement and construction.

The intent of this manual is to provide a menu of best management practices from which all roadway maintenance personnel may select practices appropriate to specific sites and conditions and employ the most responsive control measures for protecting the environment.

It is important to note that this is **NOT** a technical engineering manual. Design recommendations and/or specifications for individual activities originate from qualified representatives, designated by an activity sponsor.

Definitions

Activity Sponsor- An entity proposing a routine roadway maintenance activity, including, but not limited to, a NHDOT maintenance district, municipality, other state agency, or the maintenance department of railway or private roadway.

Appropriate Design- Design recommendations and specifications determined by a policy and/or authorized representative of an individual activity sponsor.

Authorized Representative- A qualified contact, designated by an activity sponsor, who may be contacted by the Department of Environmental Services, when appropriate, relative to activity-specific concerns.

Bank- The transitional slope adjacent to the edge of a surface water body delineated at its lower limit by the normal high water of surface water bodies, and for a wetland, the line that separates upland from wetland, and at its upper limit by either a break in slope or, for a wetland, the line that separates upland from wetland.

Best Management Practices- Proper methods to be used during roadside maintenance for the control and dispersal of water associated with maintained roadways in order to minimize erosion, reduce sediment and temperature changes in streams.

Bog- A wetland distinguished by stunted evergreen trees and shrubs, peat deposits, poor drainage, and/or highly acidic soil and/or water conditions.

Cofferdam- A watertight temporary structure enclosing part of a body of water to enable it to be pumped dry for construction purposes.

Culvert- A structure installed beneath the surface of the ground (with or without inlet devices for collecting surface and sub surface water) to convey the water to a suitable outlet.

Designated Prime Wetland – Areas meeting the definition of a wetland determined to merit special protection due to their size, unspoiled character, fragile condition or other relevant factors making them of substantial significance (See Appendix 3).

Designated River – That portion of a river which has been specifically designated by the general court. Each designated river is protected and managed to maintain and enhance instream river values such as water quality and instream flows (See Appendix 2).

Drainage Swale (Treatment Swale)- A natural or constructed channel shaped or graded and established with suitable vegetation as needed for the safe disposal of runoff water.

Diversions- Structures, including sandbags, culverts and other means, constructed to allow water to flow around a proposed construction area.

Dredge- To dig, excavate, or otherwise disturb the contour or integrity of sediments in the bank or bed of a wetland, a surface water body, or other area within the jurisdiction of the DES Wetlands Bureau.

Embankment- A protective bank or wall constructed of mounded earth or other fill material.

Erosion- Wearing away of the surface of the land, by action of water or wind.

Erosion Control- Methods used to contain soil particles and to prevent them from being displaced or washed down slopes by rainfall or run-off. These methods include, but are not limited to: (a) seeding, (b) mulching or (c) using hay bales, siltation fences, or impermeable materials.

Fill- as a noun – Any rock, soil, gravel, sand or other such material that has been deposited or caused to be deposited by human activity.

Fill- as a verb – To place or deposit materials in or on a wetland, surface water body, bank or otherwise in or on an area within the jurisdiction of the DES Wetlands Bureau.

Forested Wetland- A wetland class where the area is dominated by trees.

Geotextile/Jute Matting- Products used as soil reinforcement agents and as filter mediums. They are made of synthetic fibers manufactured in a woven or loose non-woven manner to form a blanket like product.

Highest Observable Tideline- A line defining the farthest landward limit of tidal flow, not including storm events, than can be recognized by indicators such as the presence of a strand line of flotsam and debris, the landward margin of salt tolerant vegetation, or a physical barrier that blocks farther flow of the tide.

Low Water Periods- Those times during the year when the water depth and flow is equal to, or less than the water depth and flow typically achieved in the later summer months (July and August) at a particular site. This does not include times immediately after or prior to moderate to large precipitation events when flow rates may rise.

Marsh- A low-lying area with standing water or saturated soil for a sufficient portion of the year that is dominated by such species as reeds, cattails, sedge, grass-like or other emergent vegetation.

Mulch- A natural or artificial layer of plant residue or other materials covering the land surface that conserves moisture, holds soil in place, aids in establishing plant cover, and minimizes temperature fluctuations.

Nontidal Wetland- A wetland not subject to periodic inundation by tidal waters.

Outlet Protection- A rock lined apron or other acceptable energy dissipater placed between the outlet of a pipe and a stable downstream area.

Perennial Stream- A watercourse that flows for either 9 months in the previous year or all year in 6 of the previous 10 years. It contains a streambed scoured channel and flows within banks as defined above.

Riprap- Angular rock or other large aggregate placed to protect stream banks, bridge abutments, outflow of drainage structures, or other erodible sites from running water.

RSA 482-A Jurisdiction- *See Wetlands Bureau Jurisdiction.*

Sand Dune – A hill or ridge of sand piled up by the wind and commonly found on the seacoast.

Seasonal Stream- A watercourse that flows for sufficient time to remove vegetation, develops and maintains a defined scoured channel with evidence of sediment transport and is either connected downstream to another jurisdictional area or is greater than 75 continuous feet in length.

Sediment/Silt- Soil material or particulate matter that has been detached, transported, suspended, or settled in water.

Sediment Retention Basin - A structure that temporarily stores sediment laden water typically pumped from a cofferdam and slowly releases it to the surface water system. It is formed by excavation and/or by building a small embankment or by the installation of silt fence and hay bales. Coarse sediment particles settle out, trapped in the basin while clean water reenters surface water.

Shoreland Protection Act – The state law that establishes standards for the subdivision, use and development of the shorelands of the state’s public waters. The development standards that it provides are the minimum standards necessary to protect the public waters of the State of New Hampshire (See Appendix 4).

Silt fence- A temporary barrier of geotextile fabric (filter cloth) attached to supporting posts and entrenched into the soil; used to intercept sediment laden runoff from small areas of disturbed soil.

Stone Fill Class A- Stone shall be irregular in shape with approximately 50 percent of the mass having a minimum volume of 12 ft³, approximately 30 percent of the mass ranging between 3 and 12 ft³, approximately 10 percent of the mass ranging between 1 and 3 ft³, and the remainder of the mass composed of spalls.

Stone Fill Class B- Stone shall be irregular in shape with approximately 50 percent of the mass having a minimum volume of 3 ft³, approximately 40 percent of the mass ranging between 1 and 3 ft³, and the remainder of the mass composed of spalls.

Straw or Hay Bale Barrier- A temporary barrier of straw or hay bales laid end-to-end, installed across or at the toe of a slope, or other appropriate area.

Swamp- A wetland dominated by trees and/or shrubs, with standing water or saturated soils for a sufficient portion of the year that often has a “hummocky” appearance and buttressed roots. Dominant, full sized trees may include red maple, black ash, black willow, black spruce, tamarack, or white cedar.

Tidal Wetland- A wetland whose vegetation, hydrology or soils are influenced by periodic inundation of tidal waters.

Turbidity Curtain- A floating boom with suspended silt fence used to contain a work area where water conditions will not allow the staking of silt fence.

Undisturbed Tidal Buffer Zone- The area extending landward 100 feet from the highest observable tideline. This area can contain wetlands, transitional areas, and natural upland areas.

Wetland- An area that is inundated or saturated by surface or groundwater at a frequency and duration sufficient to support, and that under normal circumstances do support, a prevalence of vegetation typically adapted for life in saturated soil conditions. Wetlands generally include swamps, marshes, bogs, and similar areas.

Wetlands Bureau Jurisdiction- The regulatory authority under RSA 482-A. These areas include wetlands (freshwater and saltwater); streams; rivers, their banks and channels; lakes and their shores; sand dunes; mud flats, uplands adjacent to prime wetlands and the tidal buffer zone.

General Conditions that Apply for All Routine Roadway Maintenance Activities

Before any routine roadway maintenance activity is undertaken, appropriate siltation, erosion, flow and turbidity controls shall be established to limit surface water impacts to temporarily disturbed areas in the immediate vicinity of the activity. These controls shall be maintained until the area has fully stabilized. These BMPs apply through a notification process for activities that, by virtue of their size and nature, are unlikely to cause harm to protected resources or to have an adverse impact on the public good or on adjacent property owners. Other activities, not meeting the criteria set forth herein, shall not be covered under this notification procedure and will require an activity sponsor to apply for a New Hampshire Wetlands Bureau Wetlands and Non-site Specific Permit.

Work shall not involve movement of tracked or wheeled equipment into or through surface waters or wetlands, but only on dry or frozen ground.

Dredged material shall be placed out of RSA 482-A jurisdiction.

Work within surface waters shall be done "in the dry," either during periods of low water or behind appropriately designed temporary diversions or sandbag cofferdams.

No work shall occur on land not owned by the activity sponsor without a written release from all owners of property that will be impacted, or written notification, at least five calendar days prior to the start of work, to all owners of property that will be impacted. A copy of the property owner notice or release shall be provided to the Department along with the Notification Form.

All work shall be in accordance with the Comprehensive Shoreland Protection Act (CSPA), and shall not involve removal of trees from areas within CSPA jurisdiction.

A copy of the notification shall be posted in a prominent location at the worksite.

No work shall be done in or adjacent to municipally designated prime wetlands, within ¼ mile of a NH Designated River or in bogs, marshes, tidal wetlands, undisturbed tidal buffer zone or sand dunes.

Siltation, erosion and turbidity controls shall be installed in accordance with this manual, maintained to ensure that there is no water quality degradation and left in place until the area is stabilized.

In addition to the above conditions, an activity sponsor should be aware of the following caveats for a proposed routine roadway maintenance activity:

Operating in accordance with this manual, and under the notification process shall not convey a property right.

Operating in accordance with this manual, and under the notification process shall not authorize any injury to property of others, nor invasion of rights of others.

Operating under this notification process does not relieve the responsible party from the requirement to obtain all other applicable federal, state, and local permits or approvals.

Project Notification

To operate under this notification process, the activity sponsor shall complete a “*Notification of Routine Roadway and Railway Maintenance Activities*” form (available from the DES Wetlands Bureau at 603-271-2147, or by downloading a copy from their website at <http://www.des.state.nh.us/wetlands>) and it shall contain the following:

Name, address and telephone number of an authorized representative of the activity sponsor;

The location of the proposed activity(ies) with the nearest street address(es), town and name of water body(ies), if applicable;

A brief description of the activity, identifying the particular sections of the manual under which the activity qualifies;

An appropriate United States Geological Survey topographical map (USGS Quadrangle) with the proposed location clearly identified;

Sketches showing construction design and materials to be used;

Photograph(s) of the proposed worksite showing existing structures, surrounding land and subject waterbody.

An authorized representative of the activity sponsor shall sign and date the notification form.

The activity sponsor will need three (3) photocopies of this form and all required attachments, map(s) and sketch(es). Mail the original set to DES Wetlands Bureau, PO Box 0095, 6 Hazen Drive, Concord, NH 03302-0095. Provide one (1) to the municipal conservation commission and one (1) to the board of selectmen, if there is one, at least five calendar days prior to the commencement of work. The remaining photocopy shall be posted in a prominent location at the worksite visible to inspecting personnel.

For an example of a complete *Notification of Routine Roadway and Railway Maintenance Activities* see Appendix 1

ROUTINE

ROADWAY

MAINTENANCE

ACTIVITIES

The following section entitled “Routine Roadway Maintenance Activities” is intended to provide a brief description of the activities covered under this “permit by notification” process. Each activity described herein contains the following:

- Description. This section describes the maintenance activity and provides detailed specifications of the finished product.
- Conditions where activity applies. This section details the existing, site-specific conditions and construction requirements, for a site requiring improvements.
- Guidelines. This list of requirements is the minimum expected of the activity sponsor relative to a proposed action. It includes recommended BMPs, construction requirements and DES Wetlands Bureau restrictions.
- Sketch. The “sketch blanks” for each maintenance activity are included to demonstrate the minimum expected requirements for a sketch. These sketches may be copied and used for a proposed activity with proper dimensioning, when deemed appropriate, and submitted as part of the notification form to meet requirement #10 of the *Notification of Routine Roadway and Railway Maintenance Activities*.

The activities herein CAN BE COMBINED to fit site-specific situations that might not be addressed by one activity. For example, an activity sponsor may propose to relocate (skew) and extend a culvert, as well as construct a headwall, PROVIDED the criteria for each individual activity is not exceeded.

Additionally, multiple activities CAN BE COVERED under this notification process. For example, an activity sponsor may propose to replace two culverts at separate locations, PROVIDED each site is in the same town and the work at each site does not exceed the individual activity requirements.

IF ANY ASPECT OF A PROPOSED ACTIVITY EXCEEDS ANY OF THE CRITERIA SET FORTH WITHIN THIS SECTION, A STANDARD DREDGE AND FILL PERMIT MUST BE OBTAINED FROM THE DES WETLANDS BUREAU BEFORE ANY WORK IN JURISDICTIONAL AREAS CAN BEGIN.

List of Maintenance Activities

Culvert Extension at the Same Location
Culvert Replacement and Relocation
Embankment Stabilization
Headwall Repair, Replacement and Construction
Roadside Ditch Maintenance

Culvert Extension at the Same Location.

Description: Culverts needing extension for various reasons including roadway widening, slope stabilization, guardrail elimination, etc. Extension of the culvert may occur up to 10 feet on each side of the culvert (i.e. 10' at the inlet and 10' at the outlet).

Conditions where practice applies:

1. The culvert is a single culvert up to and including 36" in diameter and conveys a stream and/or storm water runoff.
2. The inlet and/or outlet requires extension of 10 feet or less beyond the existing inlet and/or outlet.
3. The culvert diameter remains the same or is increased no more than 50% (up to a maximum 36" diameter). Example: a 15" culvert could be replaced by an 18" culvert.

Guidelines:

- The work shall be done during low water periods or "in the dry."
- There shall be no excavation in free flowing water.
- Appropriate erosion and sediment controls shall be installed prior to any excavation.
See BMPs 1-13.
- Prior to any excavation, the existing streambed elevation at the location of the proposed inlet shall be determined. Controls to assure the inlet elevation of the extension or replacement culvert is the same as the original streambed elevation shall be established (See Page 2-5).
- Proper trenching practices for culvert installation shall be followed. The width of the trench bottom should be twice the width of the culvert. Trench sidewalls shall be appropriately designed.
- Dredged material must be placed outside of DES Wetlands Bureau jurisdiction.
- The soil around and over the culvert shall be compacted in small layers to prevent seepage along the pipe and reduce settlement of the road over the culvert. The excavated material should be used for the backfill.
- The inlet and outlet shall be stabilized with appropriate measures to protect from erosion.
See BMP 4.

- Within three days of final grading, all disturbed soil areas shall be seeded and mulched.
See BMPs 7 & 12.
- Erosion and sediment controls shall remain in place until the area is stabilized.
- Monitor daily for subsequent erosion until area is stable. Repair as necessary.

IF ANY ASPECT OF THE PROPOSED ACTIVITY EXCEEDS ANY OF THE ABOVE CRITERIA, A PERMIT MUST BE OBTAINED FROM THE DES WETLANDS BUREAU.

SKETCH BLANK:

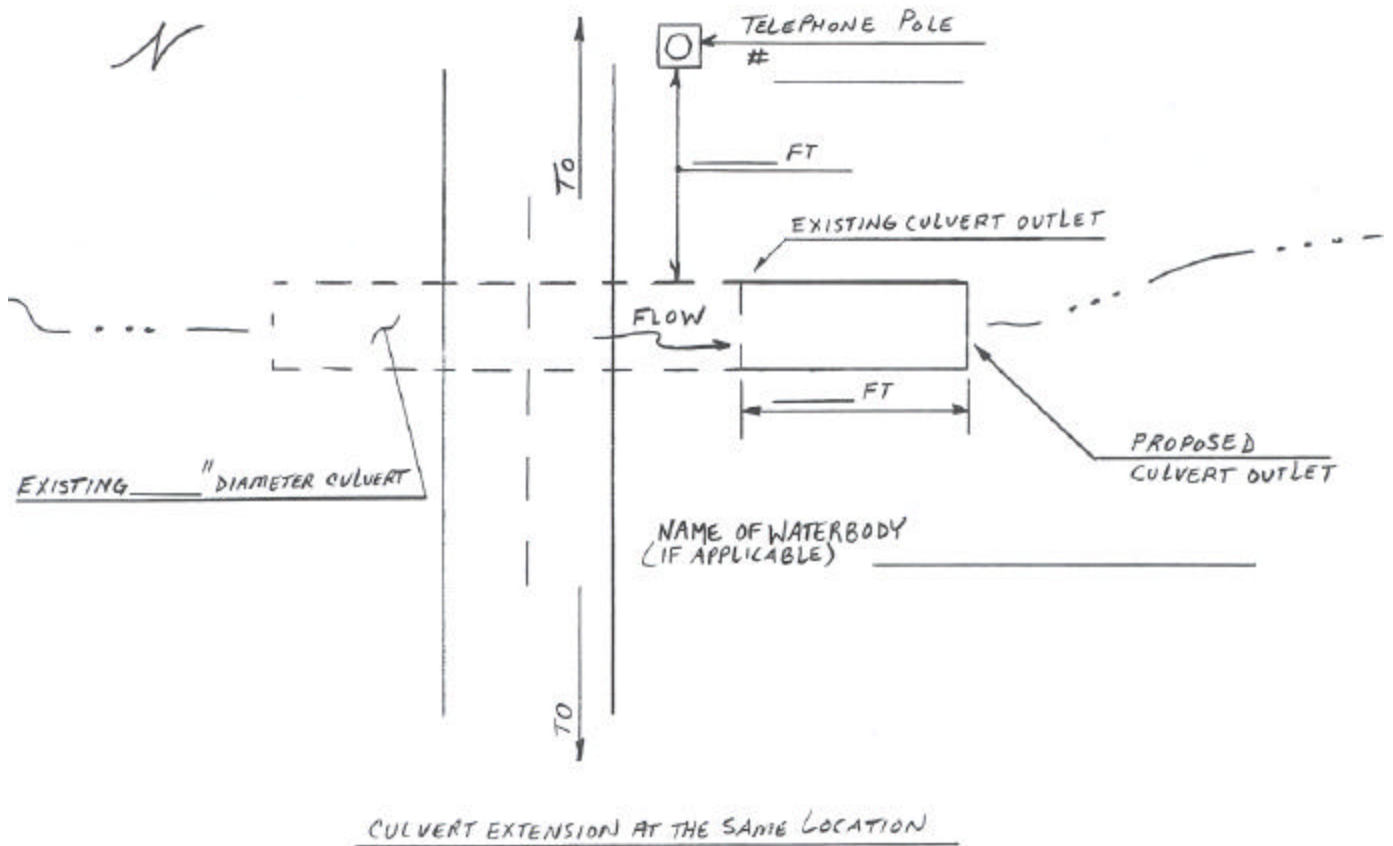

Culvert Replacement and Relocation

Description: Replacement of a culvert that may have been damaged or corroded or is no longer able to perform its intended function. Replace the culvert at the same invert elevation.

Conditions where practice applies:

1. The culvert is a single culvert up to and including 36" in diameter and conveys water to a suitable outlet.
2. The inlet or outlet may or may not require extension.
3. The culvert diameter remains the same or is increased no more than 50% (up to a maximum 36" diameter).

Guidelines:

- The work shall be done during low water periods or "in the dry."
- There shall be no excavation in free flowing water.
- Appropriate erosion and sediment controls shall be installed prior to any excavation.
See BMPs 2-3, 5-6, 8-10 & 13.
- The maximum size for a replacement culvert shall be 36" in diameter. The replacement culvert shall not exceed 50% of the original size culvert, however in no instances shall the culvert exceed 36" in diameter. Culverts may be circular or elliptical depending on the site conditions.
- The replacement culvert may be relocated (skewed) to provide for better flow characteristics, better drainage control and to subsequently prevent erosion, provided the following criteria are met:
 - Neither the relocated (skewed) inlet nor outlet (nor the sum of their differences) is greater than 50 feet from their original locations, and
 - The total length of streambed channel that is to be filled must be less than 50 linear feet, including riprap to be used at the proposed culvert outlet.
 - If both the inlet and outlet are relocated (skewed), their elevations shall be such that the culvert will maintain the pre-construction flow.
- A culvert shall not be relocated (skewed) within a perennial stream.
- Proper trenching practices for culvert installation shall be followed. The width of the trench bottom should be twice the width of the culvert. Trench sidewalls shall be appropriately designed.

- Prior to any excavation, the inlet elevation shall be determined. Controls to assure the replacement culvert is set at the same elevation shall be established.**
- Dredged material shall be placed outside DES Wetlands Bureau jurisdiction.
- The soil around and over the culvert shall be compacted in small layers to prevent seepage along the pipe and reduce settlement of the road over the culvert. The excavated material should be used for the backfill.
- The inlet and outlet shall be stabilized with appropriate measures to protect from erosion.
See BMP 4.
- Within three days of final grading all disturbed soil areas shall be seeded and mulched.
See BMPs 7 & 12.
- Erosion and sediment controls shall remain in place until the area is stabilized.
- Monitor daily for subsequent erosion until area is stable. Repair as necessary.

IF ANY ASPECT OF THE PROPOSED ACTIVITY EXCEEDS ANY OF THE ABOVE CRITERIA, A PERMIT MUST BE OBTAINED FROM THE DES WETLANDS BUREAU.

**There are a number of ways to accomplish this. One method would be to establish a reference stake (hardwood riser) in a position that will assure it remains undisturbed during the culvert replacement. This stake should be marked with the exact distance to the center of the culvert at the inlet and the cut measurement to the flow line at the inlet.

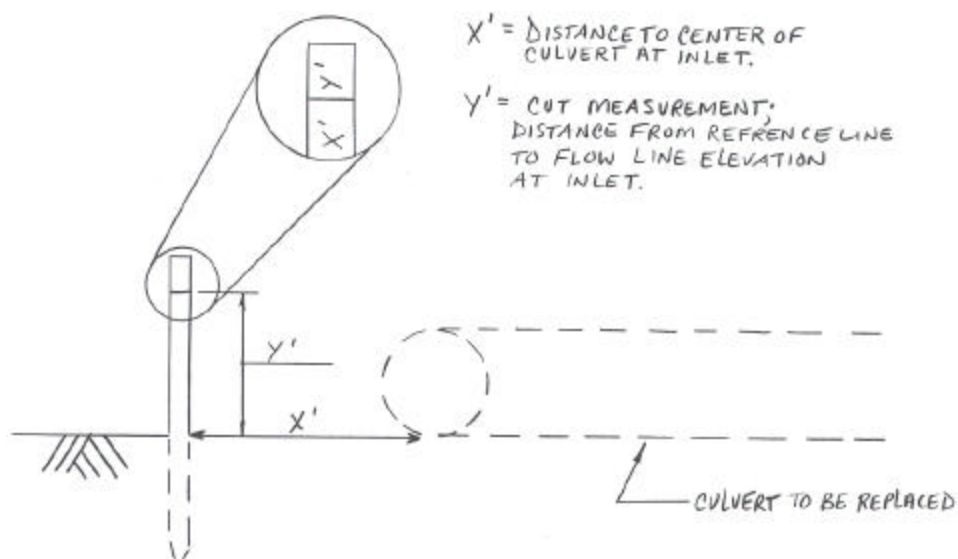

SKETCH BLANKS:

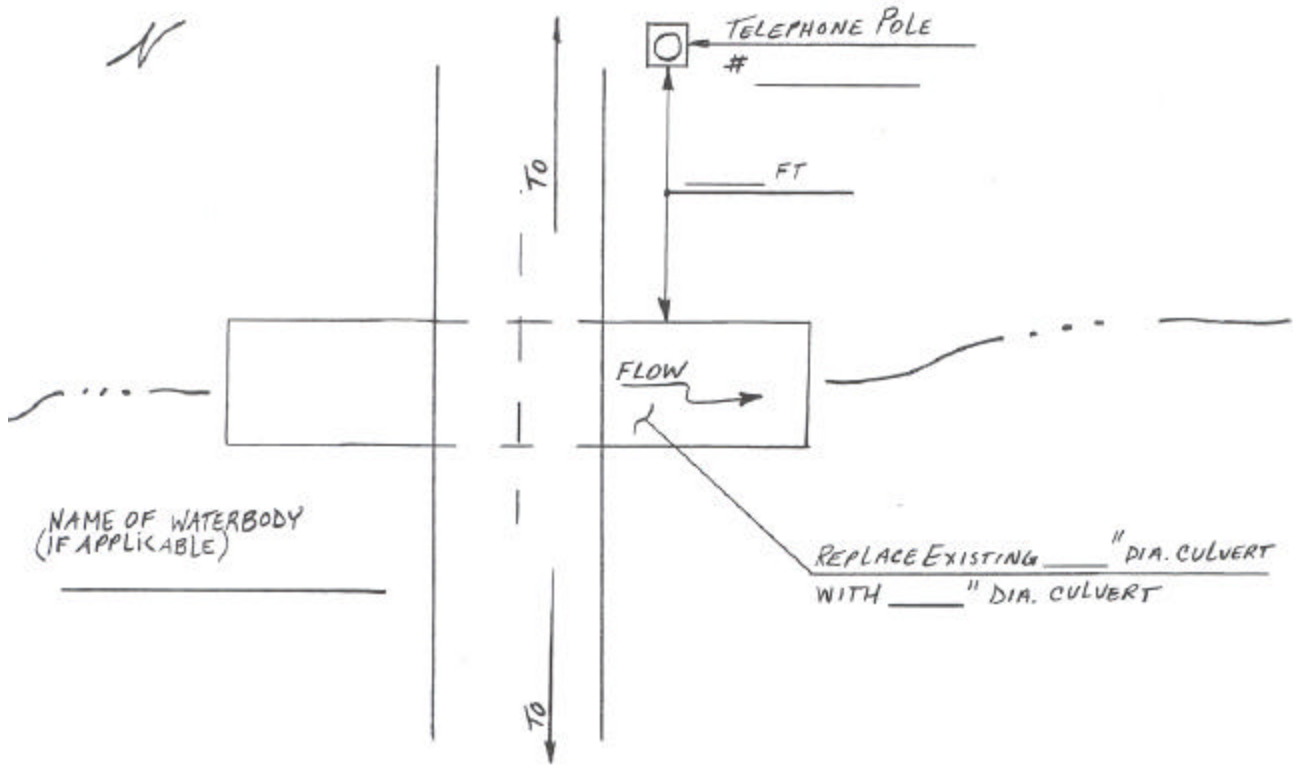

REPLACE CULVERT AT SAME LOCATION

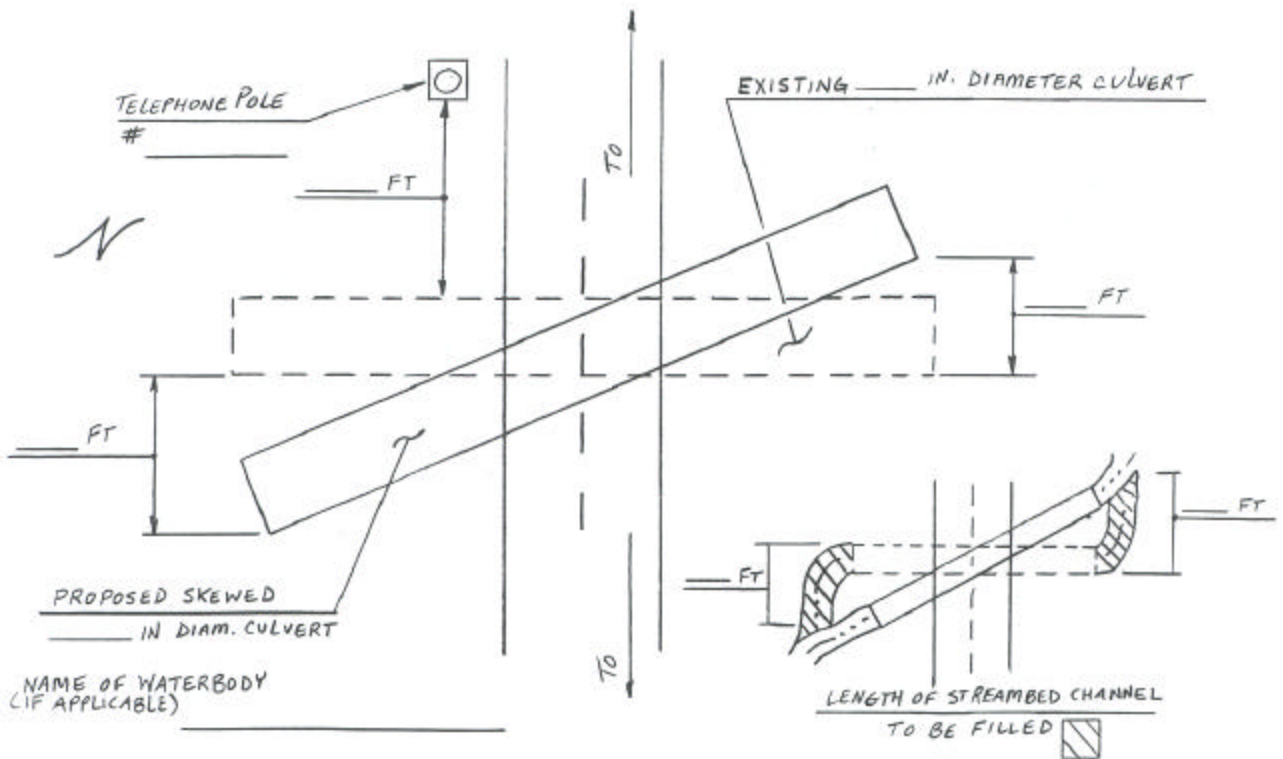

SKEWING AN EXISTING CULVERT

Embankment Stabilization

Description: Restore an eroded embankment between a roadway and a seasonal stream, or other wetland, caused by surface runoff or stream turbulence. Re-establish and stabilize an existing roadway embankment in order to preserve the integrity and safety of the roadway, and to prevent further erosion and sedimentation adjacent to a wetland.

Conditions Where Practice Applies:

1. Wherever surface runoff or stream turbulence has eroded a roadway embankment adjacent to an intermittent stream or other wetland.
2. The embankment is not adjacent to a perennial stream, river, lake or pond.
3. The eroded bank represents a safety hazard to the traveling public, jeopardizes the integrity of the roadway or is causing siltation of, or otherwise affecting, the flow or quality of a wetland.

Guidelines:

- Each work area shall be no more than 50 feet wide (length along the edge of a DES Wetlands Bureau jurisdictional area) and the height of the work area shall be limited to what can be reached from the roadway surface without placing equipment on the slope or in the wetland.
- All disturbed surfaces in the work area should be stabilized as soon as possible using stone fill, vegetation or other approved methods to reduce the potential for further erosion.
- All seeded areas shall be covered with mulch, jute matting or other appropriate device for erosion control until the vegetation is reestablished.
See BMPs 7 & 12.
- The work area shall be contained using hay bales or silt fence at the toe of slope to prevent sediment and other debris from getting into the wetland and the accumulated silt shall be removed as required during construction to maintain their effectiveness.
See BMPs 5, 8-11.
- Surface runoff shall be diverted away from the work area by means of berms, hay bales, sandbags or diversion ditches to prevent further erosion of the disturbed areas during construction.
- Erosion and sediment controls shall remain in place until the area is stabilized.
- Whenever possible, the work should be scheduled so it is done during low water periods and in the dry. In some instances sandbag cofferdams can be used to divert stream flow.

- The work should progress in segments along the toe of slope to limit the amount of exposed surfaces and the work should be done from the bottom up so the areas immediately adjacent to the wetland are stabilized first. In cases where stone fill is used, the larger size stone should be placed at the bottom to stabilize the toe of slope next to the wetland first and to provide a firm foundation for the rest of the slope.
- Areas subject to concentrated runoff, turbulent stream flow or whose slope is 2:1 or steeper should be stabilized with stone fill. In areas of high flow and turbulence, stone fill should be used. Wherever possible, stone fill should be used only from the high water level down so the rest of the slope can be re-vegetated. A 1-foot layer of clean, free-draining granular backfill should be placed under the stone fill if the native material is unsuitable. The toe of the stone fill should be keyed into the channel bottom to counteract slippage unless suitable material already exists in the channel.
- Monitor daily for subsequent erosion until area is stable. Repair as necessary.

IF ANY ASPECT OF THE PROPOSED ACTIVITY EXCEEDS ANY OF THE ABOVE CRITERIA, A PERMIT MUST BE OBTAINED FROM THE DES WETLANDS BUREAU.

SKETCH BLANK:

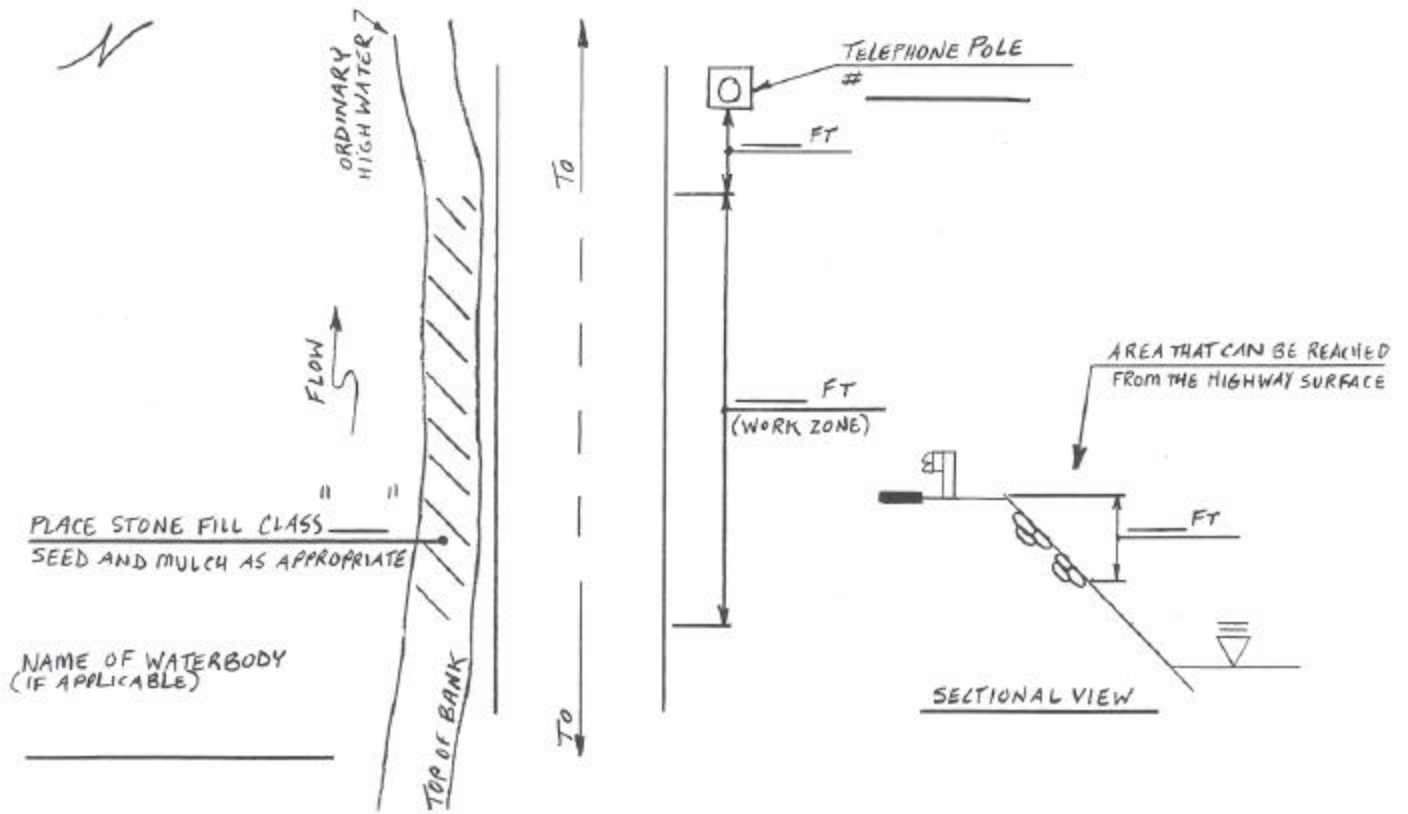

EMBANKMENT STABILIZATION

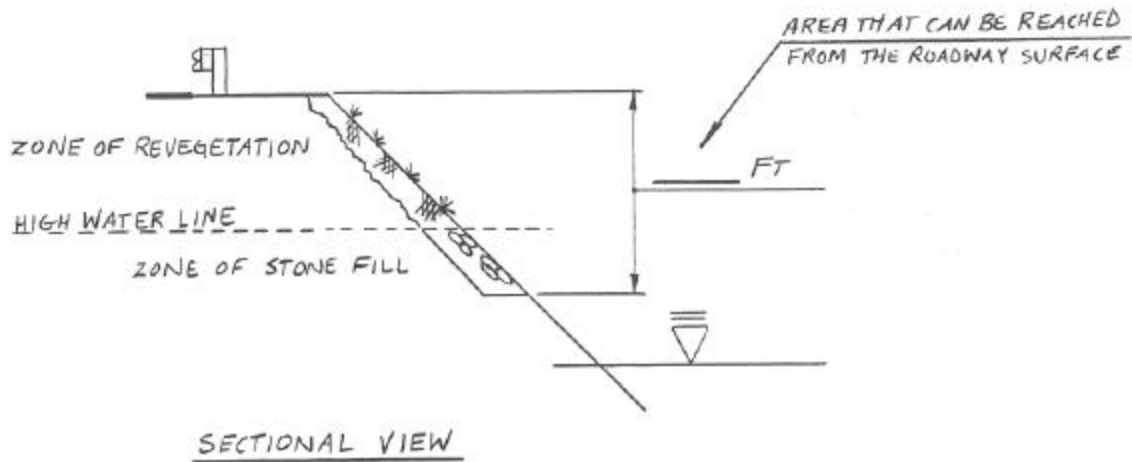

Headwall Repair, Replacement and Construction

Description: Repair or replace an existing culvert headwall in the same location where deterioration has caused partial or complete failure. Construct headwall if erosion is occurring or sedimentation warrants. If a change in the culvert diameter is required, an appropriately designed, proportional change in the headwall size is allowed. Culvert extension may be required.

Conditions where practice applies:

1. The culvert is a single culvert up to and including 36" in diameter and conveys water to a suitable outlet.
2. The inlet and/or outlet may or may not require extending.

Guidelines:

- The work is to be done during low water periods or "in the dry."
- Erosion and sediment controls shall be installed prior to any excavation.
See BMPs 2-10, 12-13.
- Water diversion measures shall be provided, as appropriate, to allow proper construction of the new headwall.
See BMP 11.
- The proposed work area shall be dewatered when appropriate to facilitate construction.
- Monitor daily for subsequent erosion until area is stable. Repair as necessary.

IF ANY ASPECT OF THE PROPOSED ACTIVITY EXCEEDS ANY OF THE ABOVE CRITERIA, A PERMIT MUST BE OBTAINED FROM THE DES WETLANDS BUREAU.

SKETCH BLANK:

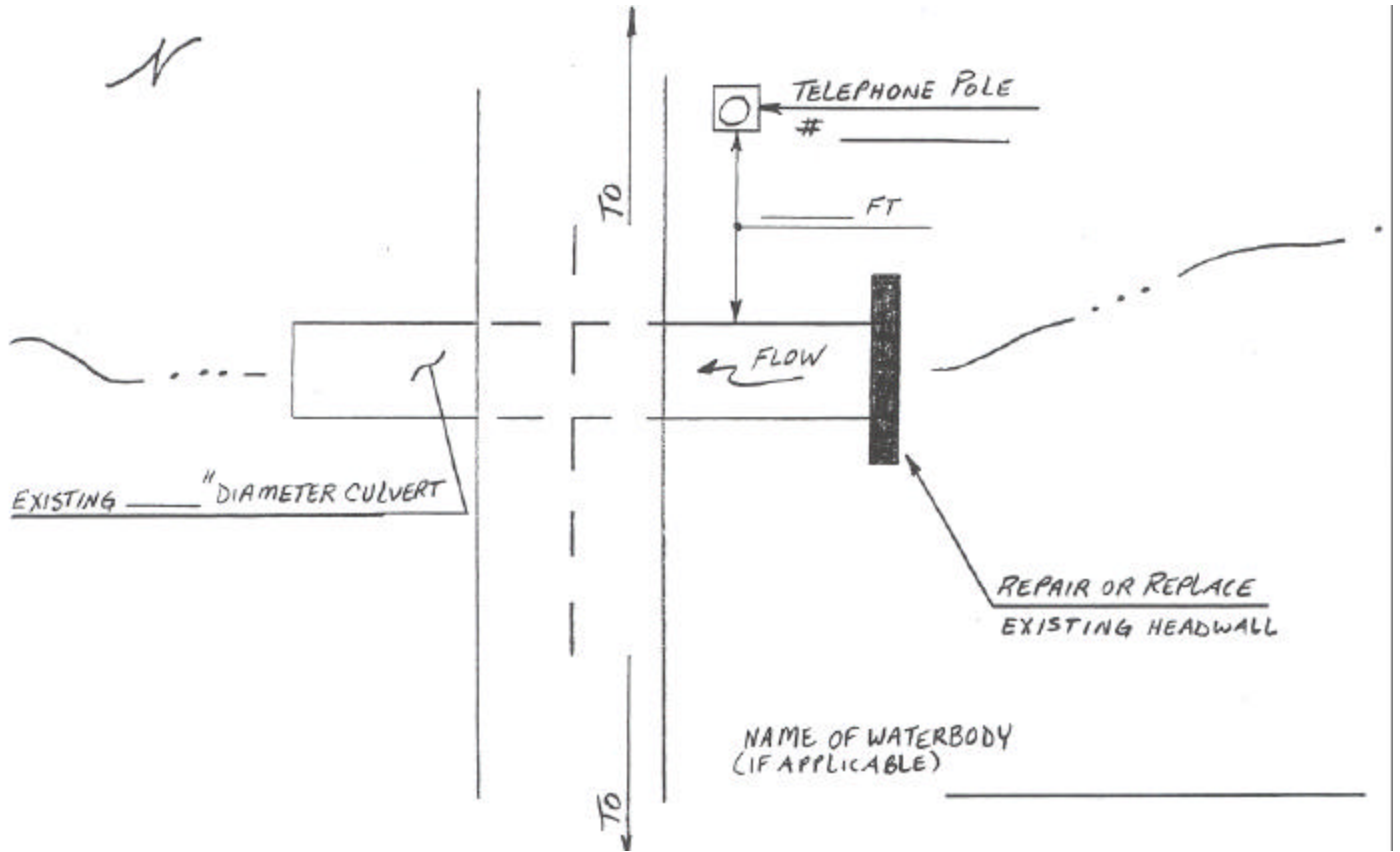

HEADWALL REPAIR / REPLACEMENT & CONSTRUCTION

Roadside Ditch Maintenance

Description: Maintaining manmade drainage channels, normally running parallel to the roadway, constructed to convey roadway runoff, sheet runoff and seasonal flows. Sediment, winter sand, leaves, excessive vegetation and other debris periodically accumulate and eventually impede proper drainage flow. Periodic cleaning by hand or machine is required to restore proper channel flow to keep culverts, basins and other drainage structures operational. Cleanout of culvert inlets and outlets is allowed, provided all the following conditions and guidelines are met.

Conditions where practice applies:

1. The ditch is a manmade channel running parallel to the roadway.
2. The ditch does not carry a perennial stream.
3. The ditch has a defined channel and banks.

Guidelines:

- Dredging shall be conducted during low water periods and “in the dry.”
- Adequate siltation control measures shall be in place before dredging operations begin.
See BMPs 5, 8-10.
- The ditch length, width and height shall be dredged back to its original dimensions.
See BMP 1.
- All efforts shall be made to retain existing vegetation, especially along the ditch slopes to maintain slope stability.
- When feasible, begin dredge at fixed flow elevation points (i.e. culvert inlets/outlets, catch basin inlets, etc.).
- Dredged material shall be placed out of DES Wetlands Bureau jurisdiction.
- Ditch side slopes shall be seeded and mulched as soon as possible after dredging.
- Silt controls shall remain in place until the area has stabilized.
- Seed and mulch side slopes as appropriate to prevent subsequent erosion.
See BMPs 7 & 12.
- Monitor daily for subsequent erosion until area is stable. Repair as necessary.

IF ANY ASPECT OF THE PROPOSED ACTIVITY EXCEEDS ANY OF THE ABOVE CRITERIA, A PERMIT MUST BE OBTAINED FROM THE DES WETLANDS BUREAU.

SKETCH BLANK:

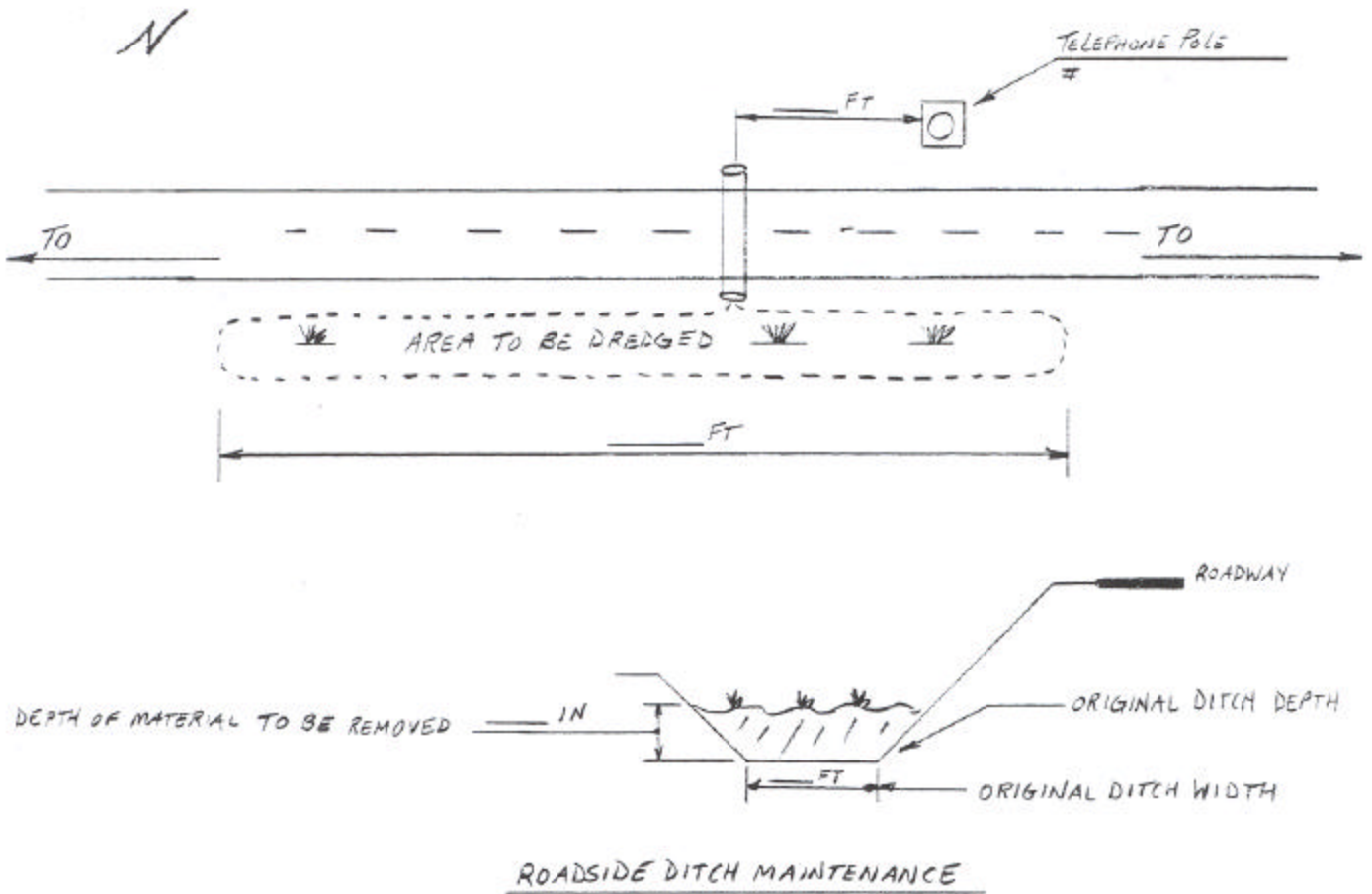

BMPs

Most routine maintenance projects take only a few days to complete. However, significant damage to the work area and environment may occur long after project completion unless appropriate measures are taken to avoid it. Until vegetation has been reestablished, these sites are highly vulnerable to erosion from heavy rains and high runoff. Even periods of drought can be harmful by retarding growth of seeded areas. Failure to properly protect worksites can prove costly by increasing turbidity, sedimentation and erosion in surface waters and wetlands. In most instances it also requires manpower and equipment to return to the site to repair damage. The party responsible for completing the work shall consider, and implement as necessary, the following Best Management Practices to protect worksites temporarily during the construction phase of an activity, as well as following activity completion.

The Best Management Practices described in the following section, in most circumstances, should not be employed individually. When combined with other best management practices and techniques, they become much more effective at limiting disturbance and ensuring a proposed work area will return to its pre-construction, environmentally stable condition.

List of Best Management Practices

- BMP #1 Dredging Roadside Ditches
- BMP #2 Filter Bags
- BMP #3 In-stream Sediment-Trapping Devices
- BMP #4 Outlet Protection/Stone Riprap
- BMP #5 Sandbags
- BMP #6 Sediment Retention Basins
- BMP #7 Seeding
- BMP #8 Silt fence
- BMP #9 Stone Check Dams
- BMP #10 Straw or Hay Bales
- BMP #11 Temporary Diversions
- BMP #12 Topsoiling and Mulching
- BMP #13 Turbidity Curtains

BMP #1

Dredging Roadside Ditches

Dredging of roadside ditches is most commonly achieved with a backhoe or excavator. Dredging should begin at a fixed point when practicable, such as culvert inlets, outlets, catch basins, etc. All dredged materials shall be placed outside of DES Wetlands Bureau jurisdictional areas. Dredge the ditch length; width and height back to its original dimensions.

Careful precaution shall be taken as not to disturb vegetated ditch areas not requiring dredging, such as side slopes, etc.

Straw or hay bales, silt fence and/or sandbags shall be placed at the limits of dredging to ensure that washout of sediment does not occur when it rains both during and after construction. These measures will slow water movement through the work zone and retain any suspended sediment while allowing water to continue through.

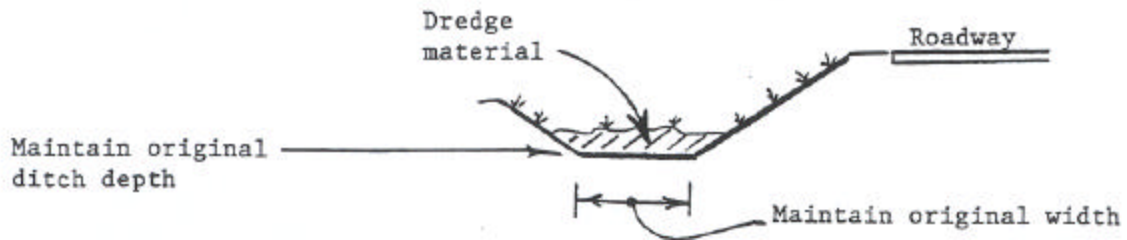

DREDGE LIMITS

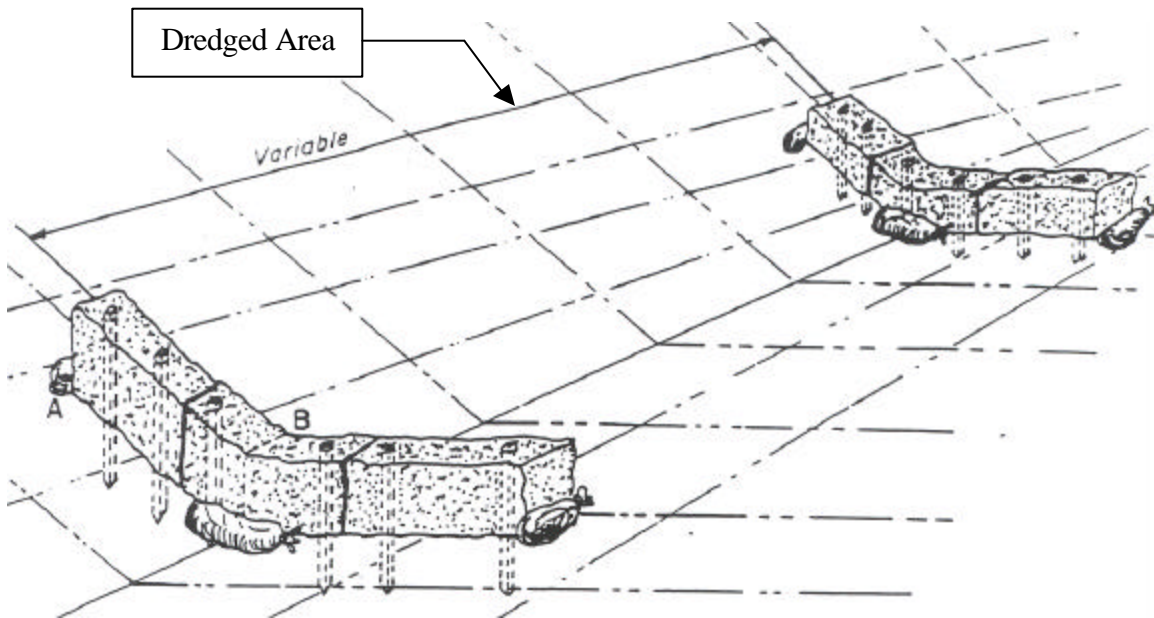

DREDGED AREA PROTECTION

BMP #2

Filter Bags

Filter bags can be used as an effective filter medium to contain sand, silt and sediment when dewatering a proposed work area. In situations where there is not sufficient available space to construct a sediment retention basin, filter bags can be used effectively. They may also be used in conjunction with a sediment retention basin when discharge is particularly turbid.

Filter bags shall meet the following specifications and adhere to the following guidelines:

- They are constructed of a non-woven geotextile fabric.
- Only one six-inch discharge hose will be allowed per filter bag.
- Bag capacity will be exceeded beyond 2,000 gallons per minute.
- Typical, recommended bag dimensions are 15 feet by 13.25 feet.
- To help prevent punctures, geotextile fabric shall be placed beneath the filter bag when used in wooded locations.
- Hose clamps shall be used to secure the discharge hose to the filter bag.

When maintaining filter bags to ensure proper function, the following conditions shall apply:

- Prior to removing the bag from the hose, the bag will be tied off below the end of the hose, allowing the bag to drain.
- To avoid rupture, the bags will be attended and pumping rates monitored.
- Once the bag is inflated to a height of four (4) feet, pumping shall stop to avoid rupture.
- Filter bags used during construction shall be bundled and removed for proper disposal.

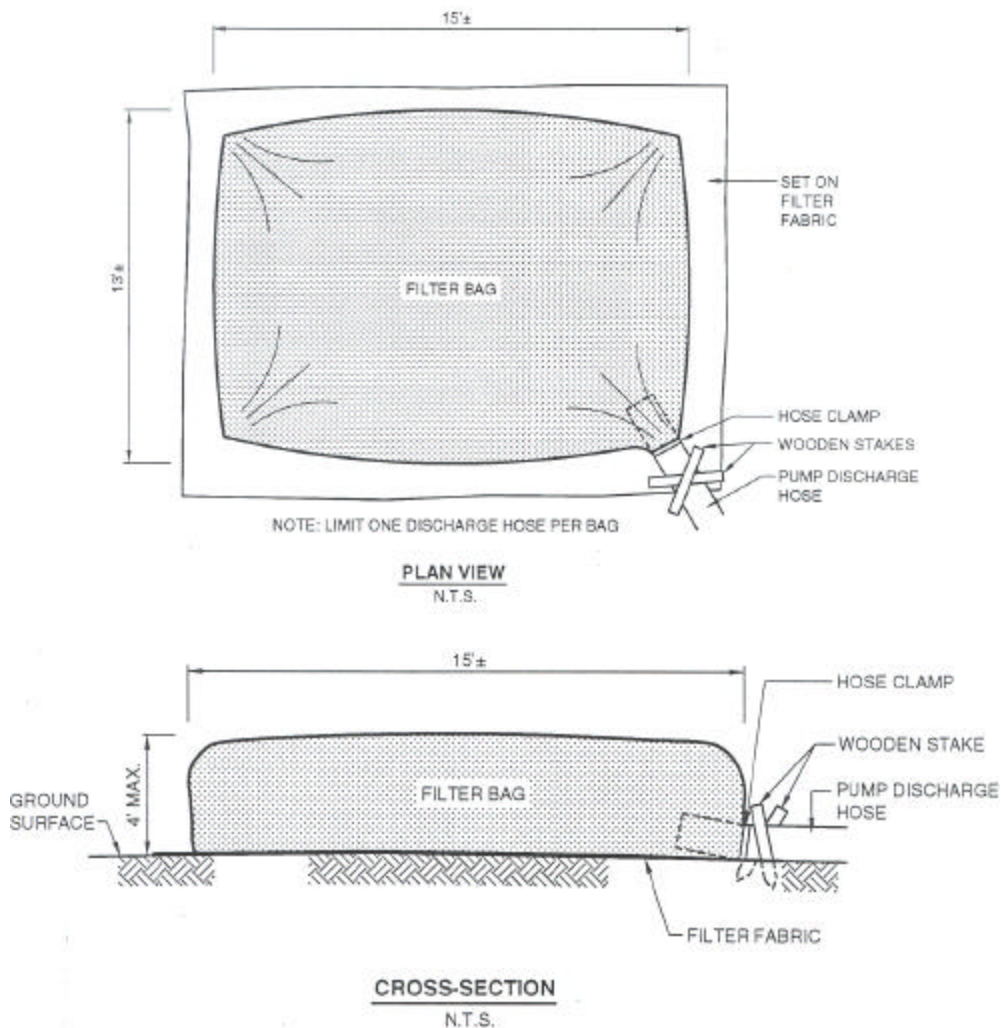

BMP #3

In-stream Sediment-Trapping Devices

Silt fence may be installed downstream from a proposed work area as an in-stream sediment-trapping device. The silt fence spans the stream channel and bank and allows water to pass through or over it, while retaining suspended sediments stirred up as a result of construction. This method of containing the work is not applicable in areas of high flow (approximately greater than three feet per second (3 FPS)) and other BMPs should be considered.

Even though work is being conducted during months that typically promote low water conditions, seasonal increases in water flow can result from precipitation events. This BMP is used as a precautionary measure should a rise in water and/or flows occur. If water in the work areas were to increase, an in-stream sediment-trapping device would prevent increases in turbidity and sedimentation downstream. This BMP can, and at times should be, used in conjunction with other BMPs depending upon proposed work. Sandbags and/or check dams can be used as a first line of defense with an in-stream sediment-trapping device downstream as a second defense.

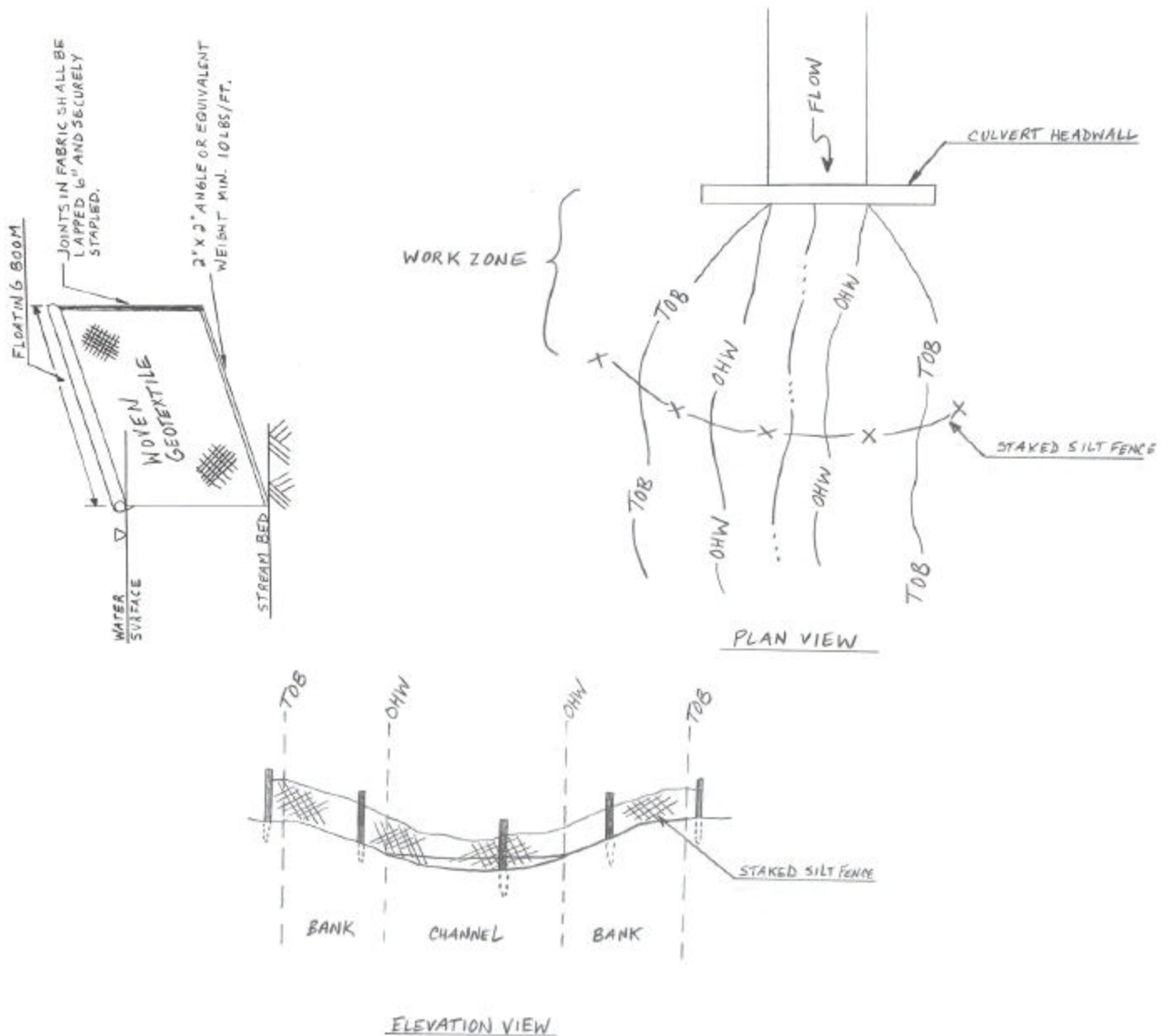

BMP #4

Outlet Protection/Stone Riprap

The outlets of pipes and structurally lined channels are points of critical erosion potential. Storm water, which is transported through man-made conveyance systems at design capacity, generally reaches a velocity that exceeds the capacity of the receiving channel or area to resist erosion. To prevent scour at culvert outlets, a flow transition structure is needed which will absorb the initial impact of the flow and reduce the flow velocity to a level which will not erode the receiving channel or area. For culvert outlets, riprap provides adequate armor for the immediate area around the outlet subject to erosion.

The amount of riprap to be used shall be the minimum possible to achieve adequate dissipation of erosive potential as appropriately designed by the activity sponsor.

The gradation of stone to be used shall be determined by the activity sponsor based on field conditions so that no loss of stone occurs as a result of water flow through the culvert.

All other necessary and appropriate BMPs shall be employed to ensure that no increases in sedimentation, erosion and/or turbidity result.

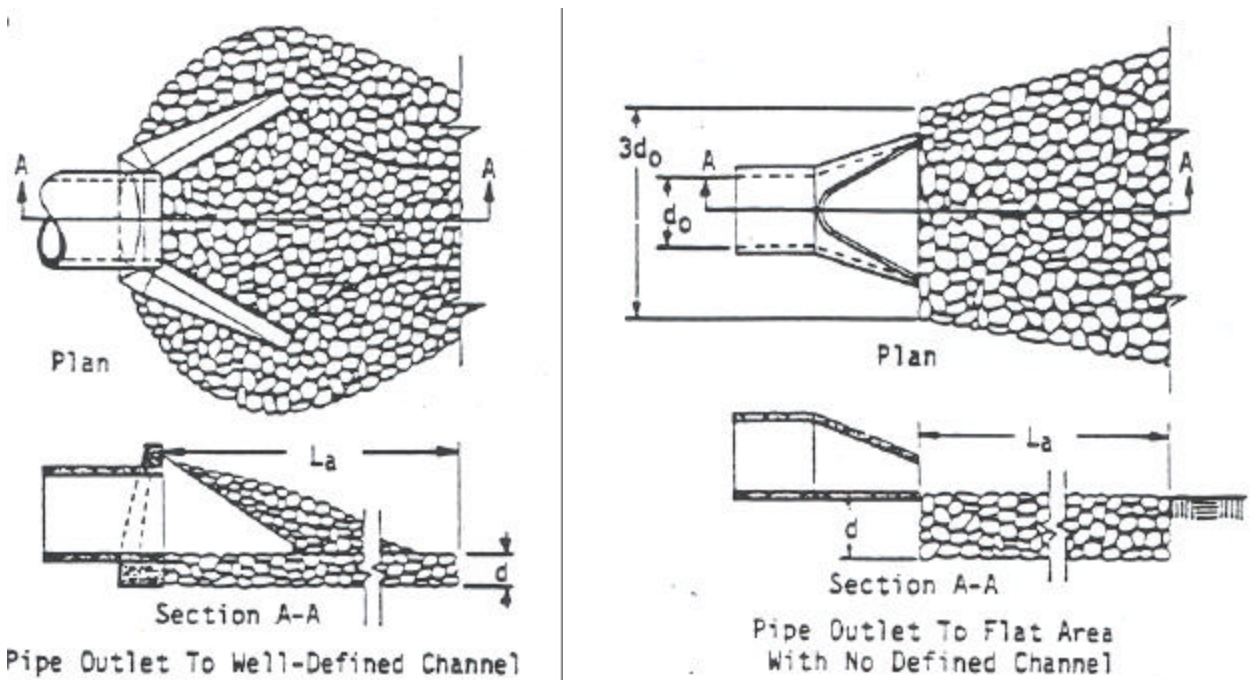

PIPE OUTLET PROTECTION

BMP #5

Sandbags

Sandbags work well as diversion structures, temporary cofferdams, sediment control devices and temporary flow dissipaters during any number of routine roadway maintenance activities.

When appropriately designed and used as a cofferdam, these sandbags are stable enough for water to pond behind them. The ponded water behind the dam structure can then be pumped to a sediment retention basin or filter bag to allow work to be performed in-the-dry.

When used in conjunction with other BMPs, sandbags can be useful at:

- ensuring that sediment does not enter surface waters or wetlands while stabilizing exposed soil surfaces;
- helping to retain sediment in a sediment retention basin; and
- diverting and/or dissipating runoff water during roadside ditch maintenance.

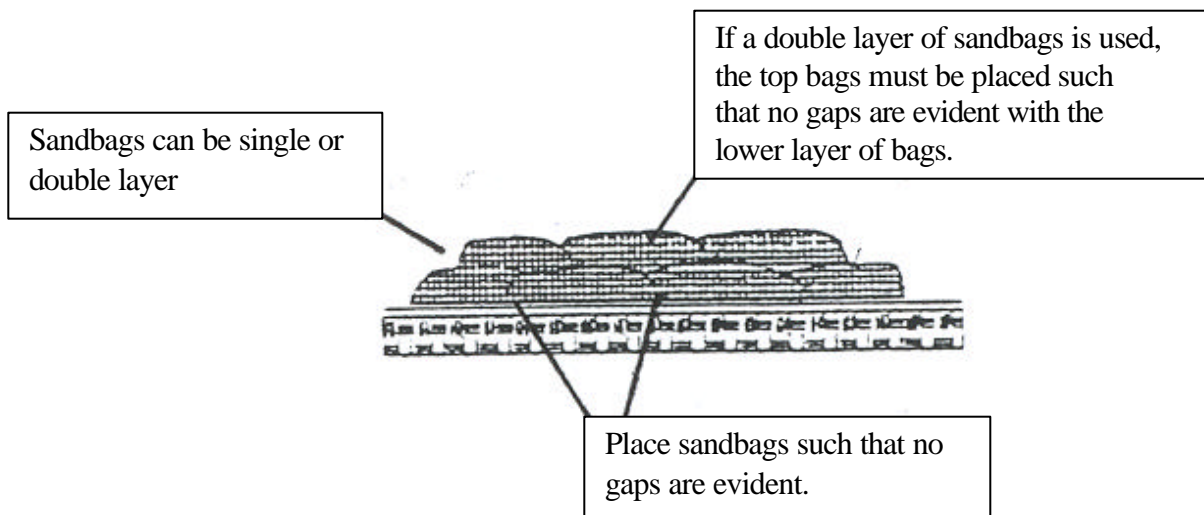

Sandbags used as a cofferdam below:

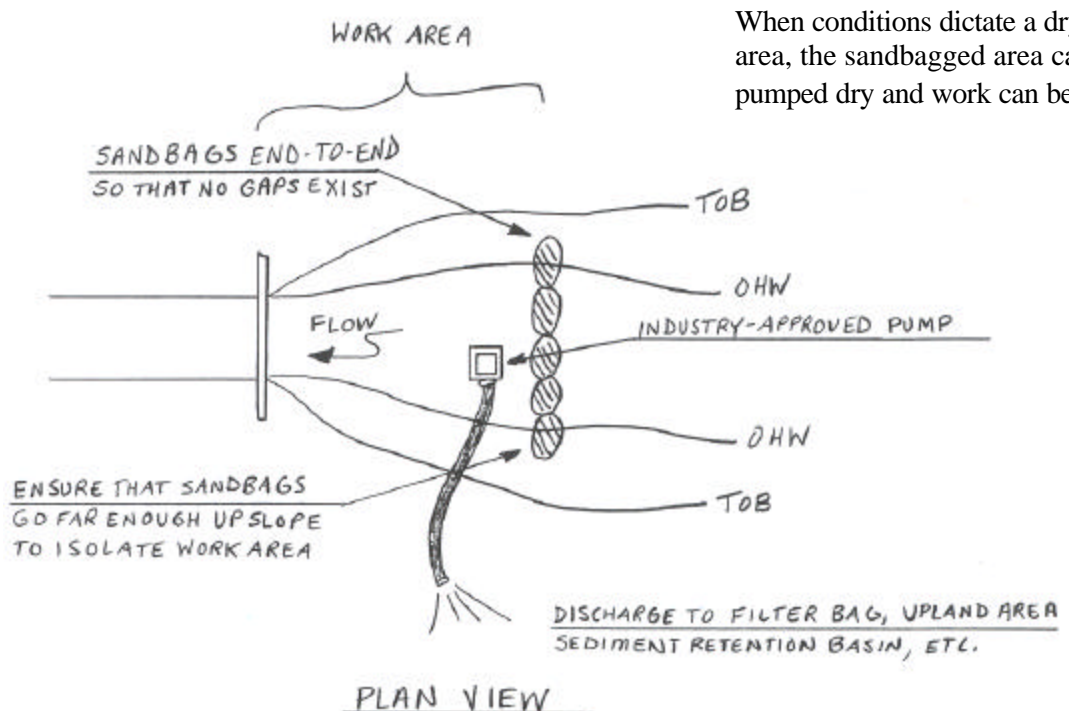

BMP #6

Sediment Retention Basins

A sediment retention basin is a temporary confined area, typically constructed of a combination of silt fence and hay bales, used to trap sediment. When a work area is dewatered, water is pumped to a basin located in an undisturbed upland. The basin traps suspended sediments, allowing clean water to flow through the filter medium, over the ground and back into the subject water body.

At a minimum, the basin shall have twenty (20) feet of an undisturbed vegetative buffer between it and a surface water, wetland or bank. A 100 foot vegetated setback or the use of a filter bag (BMP #2), in conjunction, is preferred for turbid discharge.

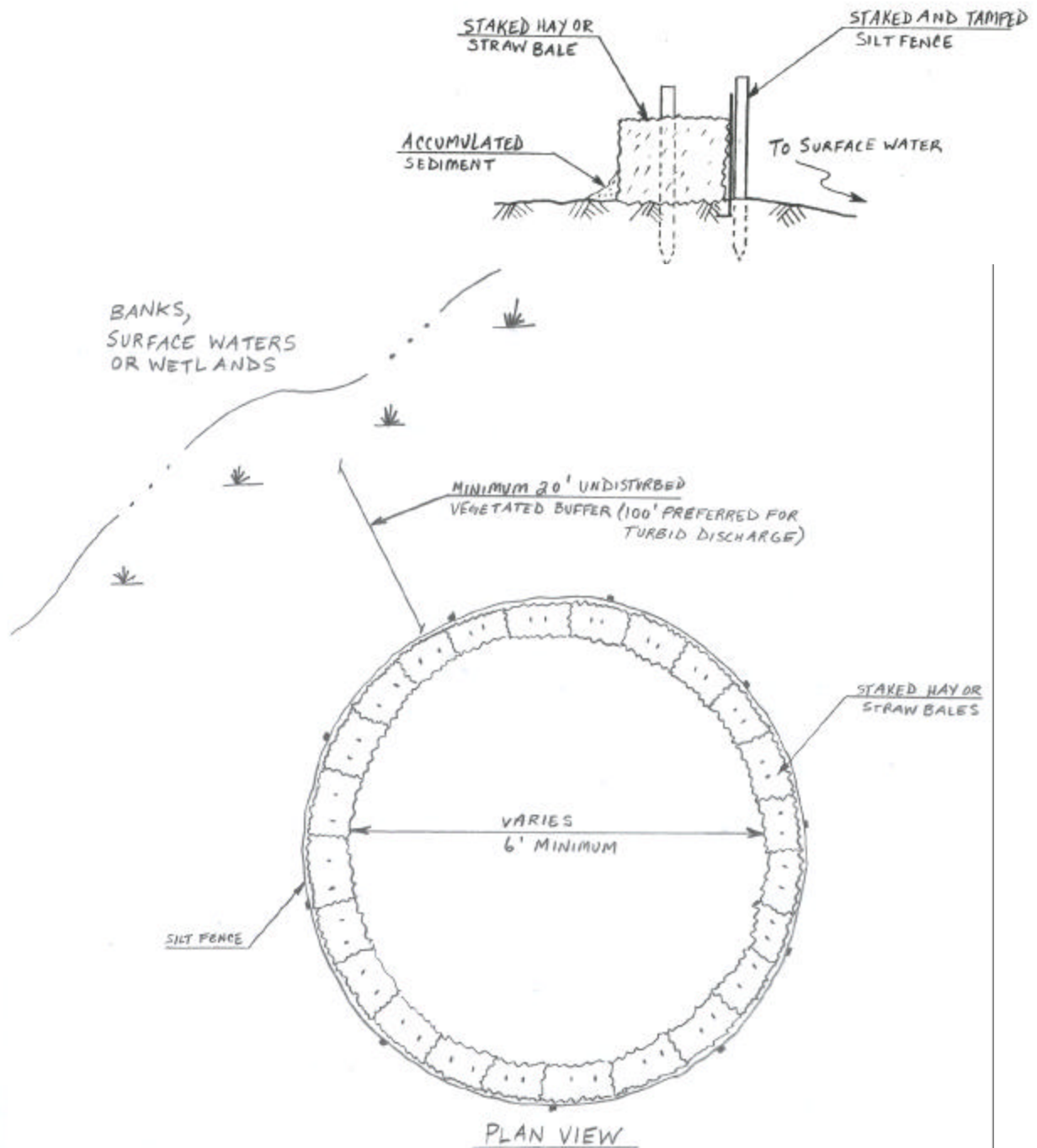

BMP #7

Seeding

Establish grasses and legumes on highly erodible soils or critically eroding areas. Seeding an area will stabilize soil, reduce damage from sediment, maintain or improve water quality and reduce stormwater runoff.

Depending upon site conditions, seeding mixtures shall conform to Section 644.2.2 or 644.2.3 of the 1997 version of the publication by the State of New Hampshire Department of Transportation entitled Standard Specifications for Road and Bridge Construction.

2.2 Park seed Type 15 shall normally be used on loam areas. This seed mixture shall conform to Table 1.

Table 1 – Park Seed Type 15

Kind of Seed	Minimum Purity (%)	Minimum Germination (%)	Pounds/Acre
Creeping Fescue	96	85	40
Perennial Ryegrass	98	90	50
Kentucky Bluegrass	97	85	25
Redtop	95	80	5
TOTAL			120

2.3 Slope seed Type 44 shall normally be used for all slope work, and shall conform to Table 2 unless amended by the Engineer to suit special local conditions encountered

Table 2 – Slope Seed Type 44

Kind of Seed	Minimum Purity (%)	Minimum Germination (%)	Pounds/Acre
Creeping Red Fescue	96	85	35
Perennial Ryegrass	98	90	30
Redtop	95	80	5
Alsike Clover	97	90	5
Birdsfoot Trefoil	98	80	5
TOTAL			80

BMP #8

Silt Fence

Synthetic silt fence normally provides better temporary channel protection than hay bales. Silt fence permits sediments to settle out while allowing water to seep through. However, careful installation of the fence can be critical. If not installed properly, ponding behind the fence during high runoff can occur, potentially causing collapse.

Silt fence can be used at the toe of a roadway slope or embankment adjacent to a wetland or surface water. They may be used in conjunction with hay or straw bales when greater sediment trapping capabilities are desired.

Fence should be installed in a trench and tamped into the existing soil.

Additional stakes may be used for support.

Rope or wire tie downs can be installed where higher runoffs can occur.

Inspect and maintain fence regularly.

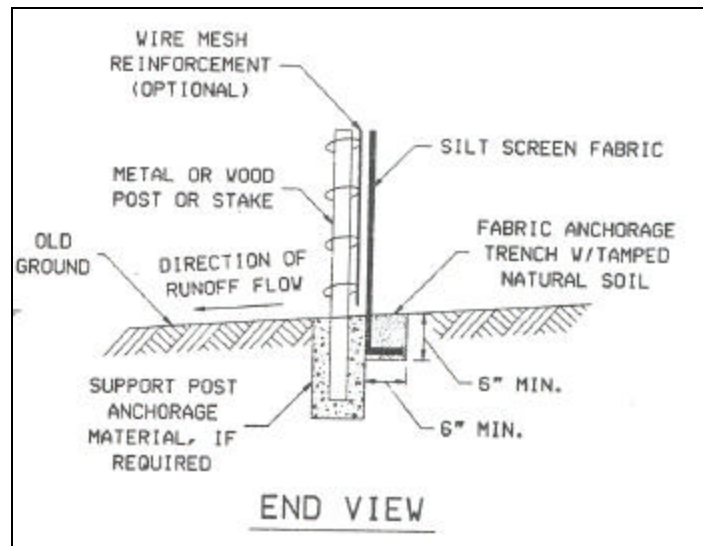
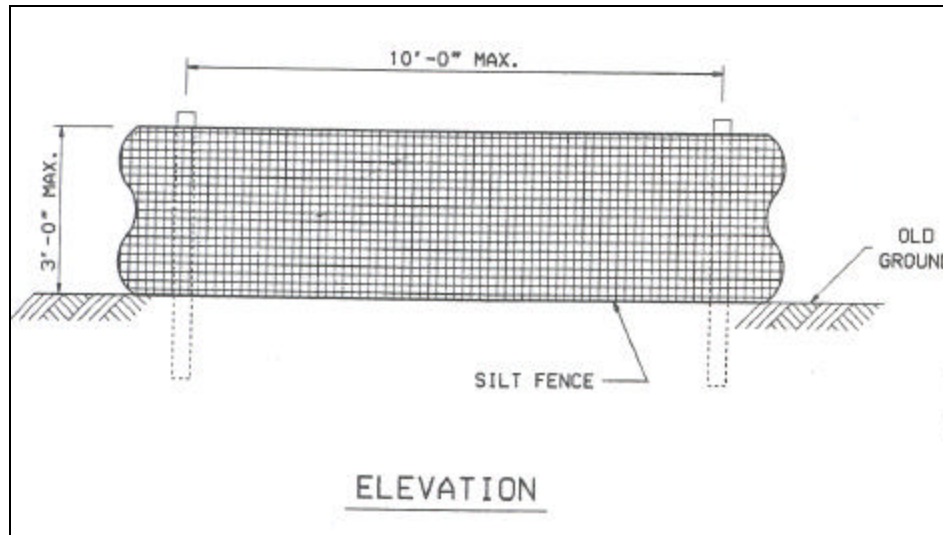

BMP #9

Stone Check Dams

Stone check dams work well in areas of steep flow line slopes and high runoff potential. These structures are often constructed in a ditch as a permanent erosion protection measure. Stone check dams can be constructed quickly and easily, are low maintenance, exhibit excellent filtration properties and provide long-term channel protection. These structures are recommended in ditches with high erosion potential.

In cases of high flow, where silt fence and/or hay bales or an in-stream sediment-trapping device will not be effective in retaining sediment while allowing water to pass clean, stone check dams may prove more appropriate and effective.

If stone check dams are being used in a series, the top of a downstream one shall be no lower in elevation than the bottom of an upstream one.

Upon activity completion, a check dam shall be entirely removed and the work area returned to its pre-construction, stable condition.

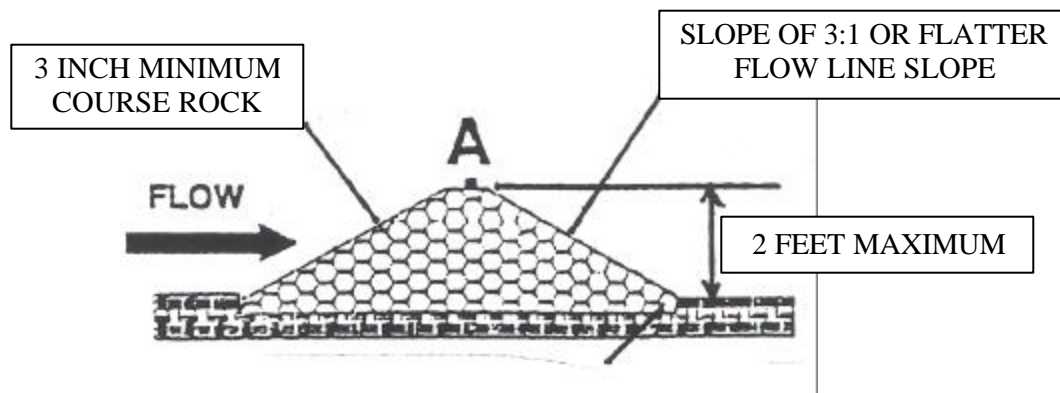

SIDE VIEW

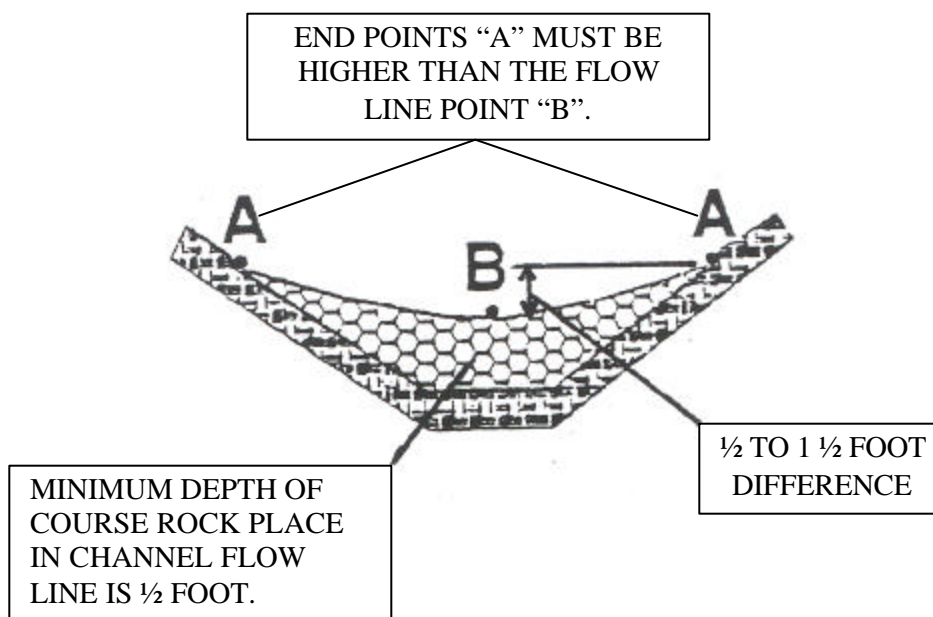

FRONT VIEW

BMP #10

Straw or Hay Bales

Straw or hay bale barriers intercept and detain small amounts of sediment from unprotected areas of limited extent and reduce runoff velocity down a slope. They work well in conjunction with silt fence.

Although hay bales have been the traditional choice for erosion protection, careful consideration should be taken during the selection process. Runoff waters may not readily seep through the bales. Water can pond behind the bale structures and flow around, between, and under the structures causing channel degradation and sediment transportation. However, hay bales may be beneficial as temporary check structures under the following conditions:

- Channel receives low volume flows.
- Flow line slopes are less than 2%.
- Installed in a trench, staked, and backfilled.

Enough bales should be used on the channel side slopes to force runoff over the bales, rather than around the structure.

Bales should be inspected and maintained frequently.

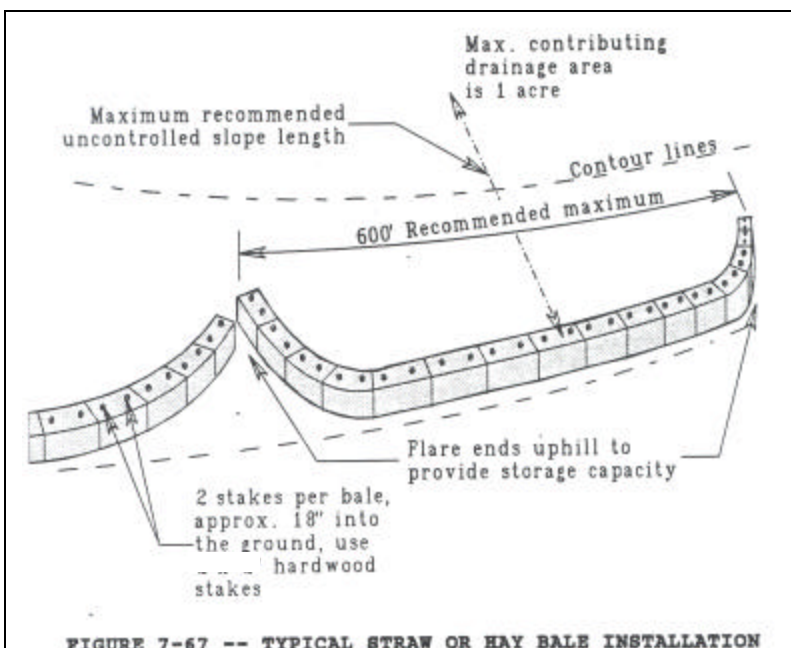
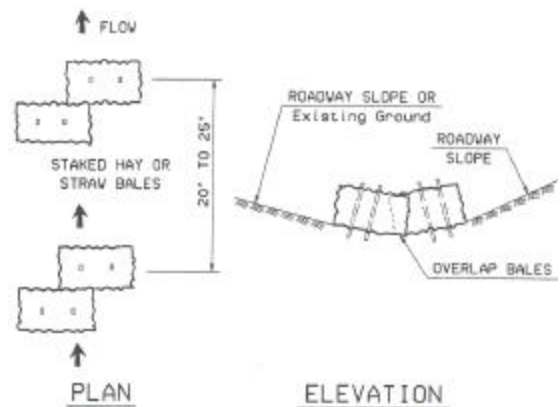

FIGURE 7-67 -- TYPICAL STRAW OR HAY BALE INSTALLATION

BMP #11

Temporary Diversions

In areas subject to rapid water movement, a temporary dam can be constructed with sandbags upstream of a headwall in such a way as to minimize erosion and resulting water turbidity. The dam prevents water from entering the proposed work zone and directs flow into the temporary diversion pipe. The opposite end of the diversion pipe is inserted into the existing culvert, thus allowing clean flow to pass through the work zone. The pipe to be used shall be of sufficient size to carry the water flow. The structure shall be completely removed upon the completion of work.

The sandbags shall be stacked no higher than sufficient to direct water into the diversion pipe. They shall be appropriately designed to ensure work zone safety is not compromised, while maintaining water quality controls.

When conditions dictate a dry work area, the sandbagged area (BMP #5) can be pumped dry to a sediment retention basin and work can begin.

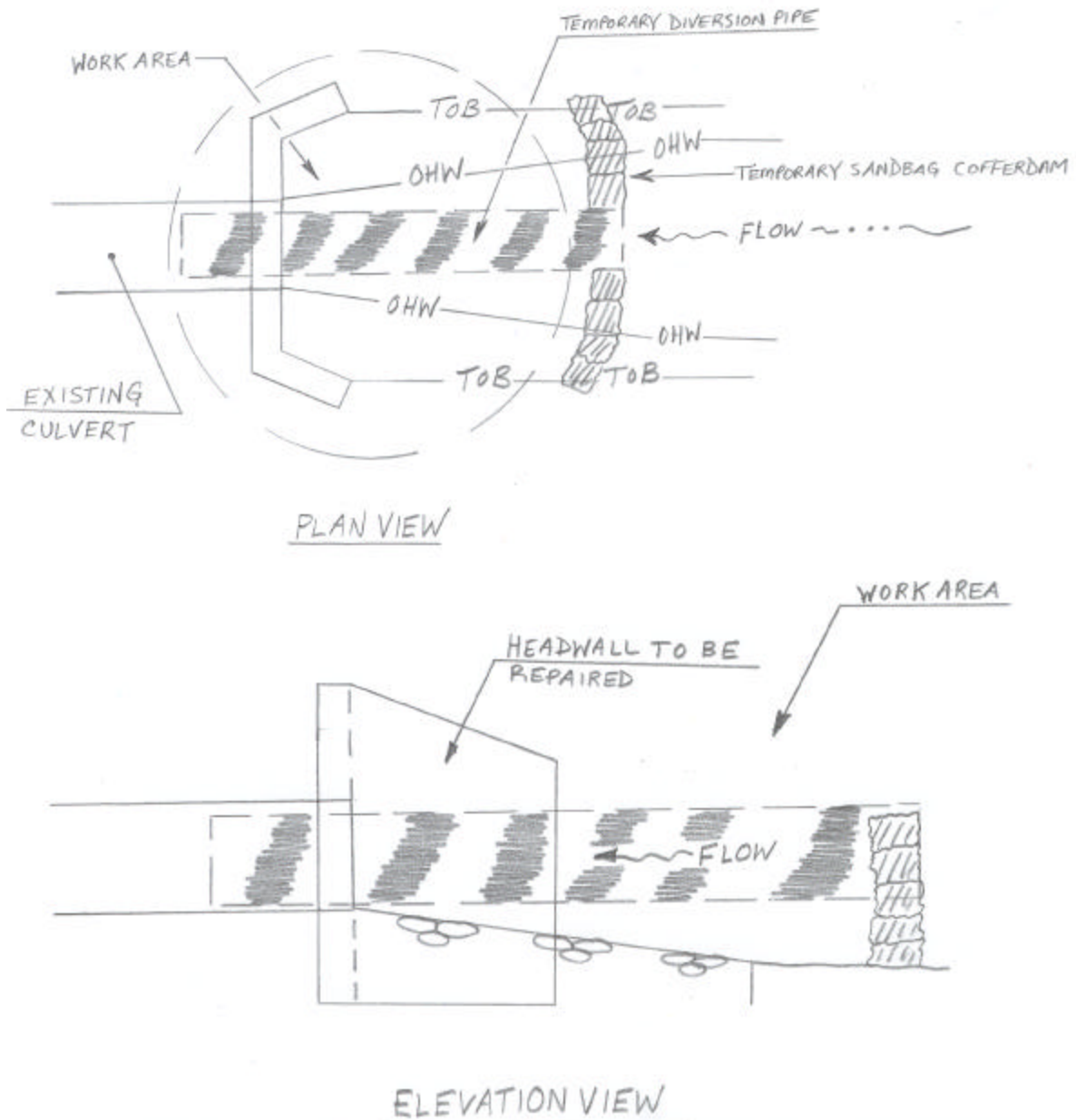

BMP #12

Topsoiling

Apply topsoil on any planting site where the soil is droughty, or low in inherent fertility, and where the addition of topsoil is necessary to correct these conditions. Topsoil should be applied to any site where its addition is otherwise desirable to facilitate the establishment or maintenance of vegetative cover.

Take all necessary precautions to ensure that topsoil remains on exposed soil surfaces and does not enter adjacent surface waters or wetlands.

Topsoil shall be free of weeds and invasive species.

CUBIC YARD OF TOPSOIL REQUIRED TO COVER

<u>Unsettled Depth (Inches)</u>	<u>1000 Square Feet</u>	<u>One Acre</u>
5	15	672
6	18	806
7	21	1014

Mulching

Apply mulch on highly erodible soils, on critically eroding areas, and on areas where conservation of moisture will facilitate plant establishment. Mulching conserves moisture, reduces runoff and erosion, controls weeds, helps establish plant cover, and improves water quality. Mulch shall be placed on the seeded area within 48 hours after seeding.

Mulch shall be composed of wood fiber, hay or straw

Hay and straw mulch shall be fluffed while spreading.

Mulch shall be applied at approximately 3 tons per acre.

Take all necessary precautions to ensure that mulch remains on exposed soil surfaces and does not enter adjacent surface waters or wetlands.

BMP #13

Turbidity Curtains

In some instances, the depth of water downstream from a proposed work area may be too deep for an in-stream, silt fence-sediment trap to be effective, such as the outlet of a ponded area. At these times, turbidity curtains prove to work effectively in retaining suspended sediment. The barrier consists of a wire-mesh supported silt fence attached to a floating boom. The boom remains afloat, on top of the water, while the filtration mechanism, anchored to the streambed, retains suspended sediments in the work area.

Even though work is being conducted during months that typically promote low water conditions, seasonal increases in water flow can result from precipitation events. This BMP is used as a precautionary measure should a rise in water and/or flows occur. If water in the work areas were to increase, an in-stream sediment-trapping device would prevent increases in turbidity and sedimentation. This BMP can, and at times should be, used in conjunction with other BMPs depending upon proposed work. Sandbags and/or check dams can be used as a first line of defense with turbidity curtain downstream as a second defense.

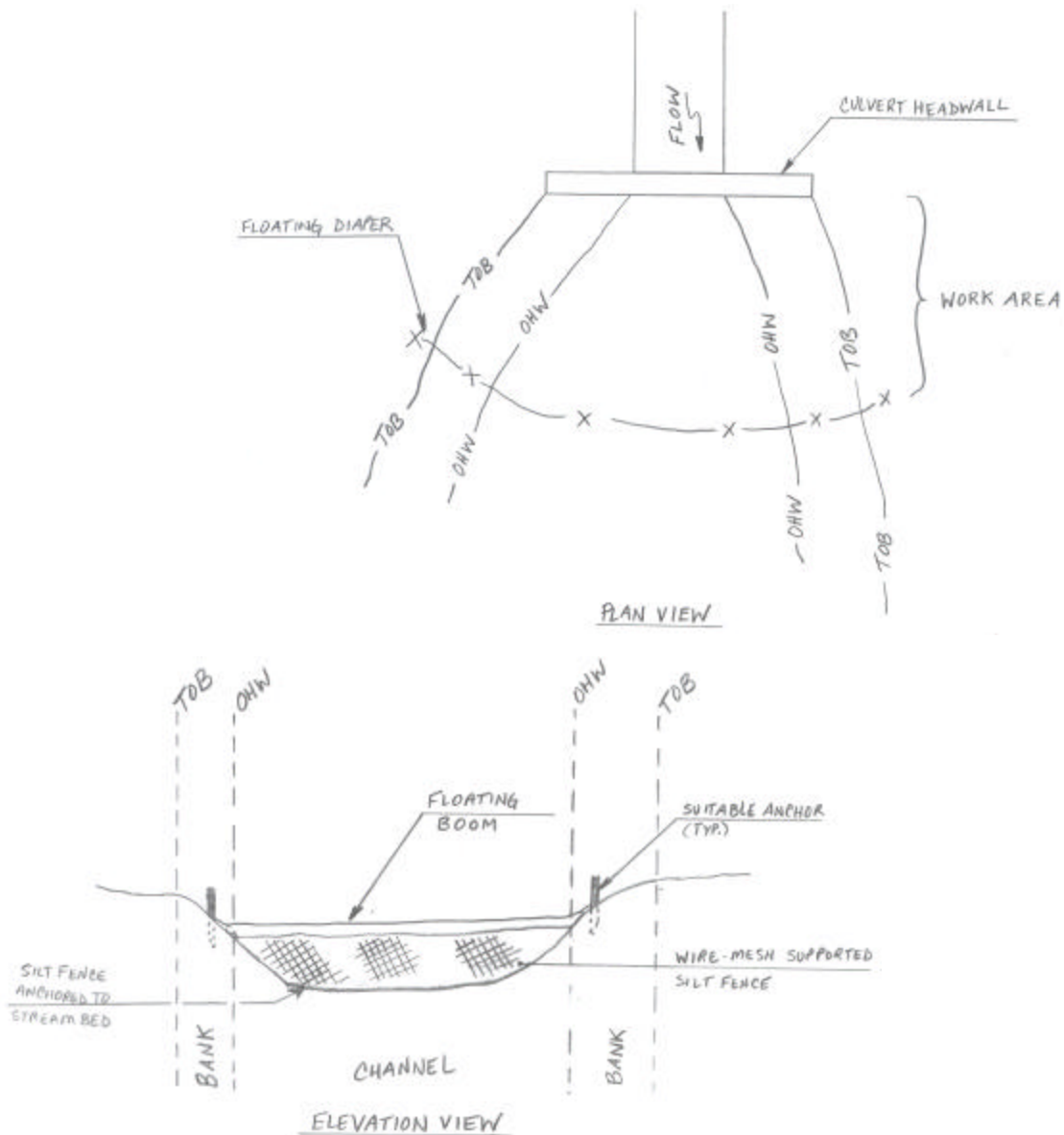

APPENDICES

The information provided in this chapter is intended to serve as a reference tool. Under some circumstances more information may be required by an activity sponsor that is not covered in this manual. In these instances, an activity sponsor should contact the Department of Environmental Services Wetlands Bureau at 271-2147 or visit them online at www.des.state.nh.us.

List of Appendices

- Appendix #1 Complete *Notification of Routine Roadway and Railway Maintenance Activities*
- Appendix #2 NH Designated Rivers
- Appendix #3 Towns with Designated Prime Wetlands
- Appendix #4 Shoreland Protection Act Fact Sheet

Appendix #1



NOTIFICATION OF ROUTINE ROADWAY AND RAILWAY MAINTENANCE ACTIVITIES



Please complete the following by checking the appropriate box to the right (*terms in bold are defined in the manual*):

1. Will the proposed roadway maintenance activity require disturbance in or adjacent to surface waters or in wetlands? YES NO

If you answered NO, you do not need to file this form, nor any other wetland application. If you answered YES, continue to question 2.

2. Does the proposed activity involves work within the limits of surface waters to be conducted in the dry, either at **low water periods**, or behind **appropriately designed temporary diversions**;
OR
Does the proposed activity involve **only** embankment stabilization, outside surface waters or wetlands? YES NO

If you answered NO, you must file a standard dredge and fill application and no work in a jurisdictional area can begin until a permit is received. If you answered YES, continue to question 3.

3. Does the proposed activity impact **bogs, marshes, sand dunes, tidal wetlands, undisturbed tidal buffer zones, designated prime wetlands**, or fall within 1/4 mile of a **NH Designated River**? YES NO

If you answered YES, you must file a standard dredge and fill application and no work in a jurisdictional area can begin until a permit is received. If you answered NO, continue to question 4.

4. Does the proposed activity involve...
- a. extending an existing culvert more than 10 feet at the inlet and/or outlet? YES NO
 - b. replacing an existing 36" diameter or larger culvert with a new culvert greater than 36" in diameter, or an increase in culvert size of more than 50%? YES NO
 - c. relocating (skewing) an existing culvert so that the inlet and/or outlet (or the sum of their difference) is greater than 50 feet from their original location, or the total length of streambed channel to be filled is greater than 50 linear feet? YES NO
 - d. dredging roadside ditches that: 1) are **NOT** manmade, 2) carry a **perennial stream**, 3) do **NOT** have a defined channel and banks, 4) do **NOT** run parallel with the roadway? YES NO
 - e. stabilizing a roadway embankment adjacent to a perennial stream or river? YES NO

If you answered YES to any of questions 4a-4e, you must file a standard dredge and fill application and no work within a jurisdictional area can begin until a permit is received. If you answered NO to questions 4a-4e, continue through question 13.

5. Identify the sponsor (i.e. DOT Maintenance District, Municipality, State Agency, etc.) of the proposed Routine Maintenance Activity, and provide the name of an authorized representative, his/her address and daytime phone number.

NH DOT BUREAU OF ENVIRONMENT
Activity Sponsor

KEVIN T. NYHAN
Authorized Representative

PO BOX 483 / HAZENDR. CONCORD NH 03302-0083
PO Box/Street Town State Zip

603-871-3226
Telephone

FOR DES OFFICE USE ONLY:

Notification received _____ File # _____
date received initial(s)

6. Identify the location of the proposed activity(ies) with the nearest street address(es), town and name of water body(ies).

Street address(es) and town: 4 HAZEN DRIVE
CONCORD, NH 03301

Name of water body(ies): N/A
(If applicable)

7. Activity Description: REPLACE A 12" RCP WITH A 15" RCP IN THE SAME LOCATION.
EXTEND BOTH THE INLET AND OUTLET 6' TO ACCOMMODATE
SHOULDER WIDENING. CONSTRUCT A HEADWALL AT THE OUTLET.
PROJECT WILL ENHANCE ROADWAY SAFETY.

8. Sections of BMP manual under which activity qualifies (Check All That Apply):

- Culvert Extension in Same Location Relocating an Existing Culvert Replacing Culvert in Same Location
 Roadside Ditch Maintenance Embankment Stabilization Headwall Repair, Replacement and Construction

9. Attach a copy of a USGS Quadrangle (topographical map) with the proposed location clearly identified.

10. Attach sketches showing construction design (see manual of Best Management Practices for Routine Roadway Maintenance Activities in New Hampshire for examples and templates.)

11. Attach color photograph(s) of proposed work site showing existing structures, surrounding land, and subject waterbody.

12. By signing below the applicant is certifying that: 1) all information provided in this notification is accurate and correct; 2) all work will conform to Best Management Practices for Routine Roadway Maintenance Activities in New Hampshire; 3) copies of this application have been provided to the town conservation commission and/or board of selectmen.

Kevin Nylon
Signature of authorized representative

DATE: 8/29/01

13. You will need three (3) photocopies of this form and all required attachments, map(s) and sketch(es). Mail the original set to the DES Wetlands Bureau, 4 Hazen Drive PO Box 0095, Concord, NH 03302-0095. Provide one (1) to the municipal conservation commission and one (1) to the board of selectmen, if there is one, at least five calendar days prior to the commencement of work. The remaining photocopy shall be posted in a prominent location at the worksite.

You may proceed with the proposed activity upon proper filing of a complete notification

****CONDITIONS****

All Routine Roadway Maintenance Activities are subject to the following general conditions.

1. Work shall not involve movement of tracked or wheeled equipment into or through surface waters or wetlands, but only on dry or frozen ground.
2. Dredged material shall be placed out of RSA 482-A (DES Wetlands Bureau) jurisdiction.
3. Work within surface waters shall be done "in the dry," either during periods of low water or behind appropriately designed temporary diversions or sandbag cofferdams.
4. No work shall occur on land not owned by the activity sponsor without a release from all owners of property that will be impacted, or written notification, at least five calendar days prior to the start of work, to all owners of property that will be impacted. A copy of the property owner notice or release shall be provided to the Department along with the Notification Form.
5. All work shall be in accordance with the Comprehensive Shoreland Protection Act (CSPA), and shall not involve removal of trees from areas within CSPA jurisdiction.
6. A copy of the notification shall be posted in a prominent location at the worksite.
7. No work shall be done in or adjacent to municipally designated prime wetlands, within ¼ mile of a NH Designated River or in bogs, marshes, tidal wetlands, undisturbed tidal buffer zone or sand dunes.
8. Siltation, erosion and turbidity controls shall be installed in accordance with "Best Management Practices for Routine Roadway Maintenance Activities," maintained to ensure that there is no water quality degradation and left in place until the area is stabilized.

PROVIDE PHOTOGRAPH(S) BELOW



View at Inlet



View at Outlet

PROVIDE SKETCH BELOW

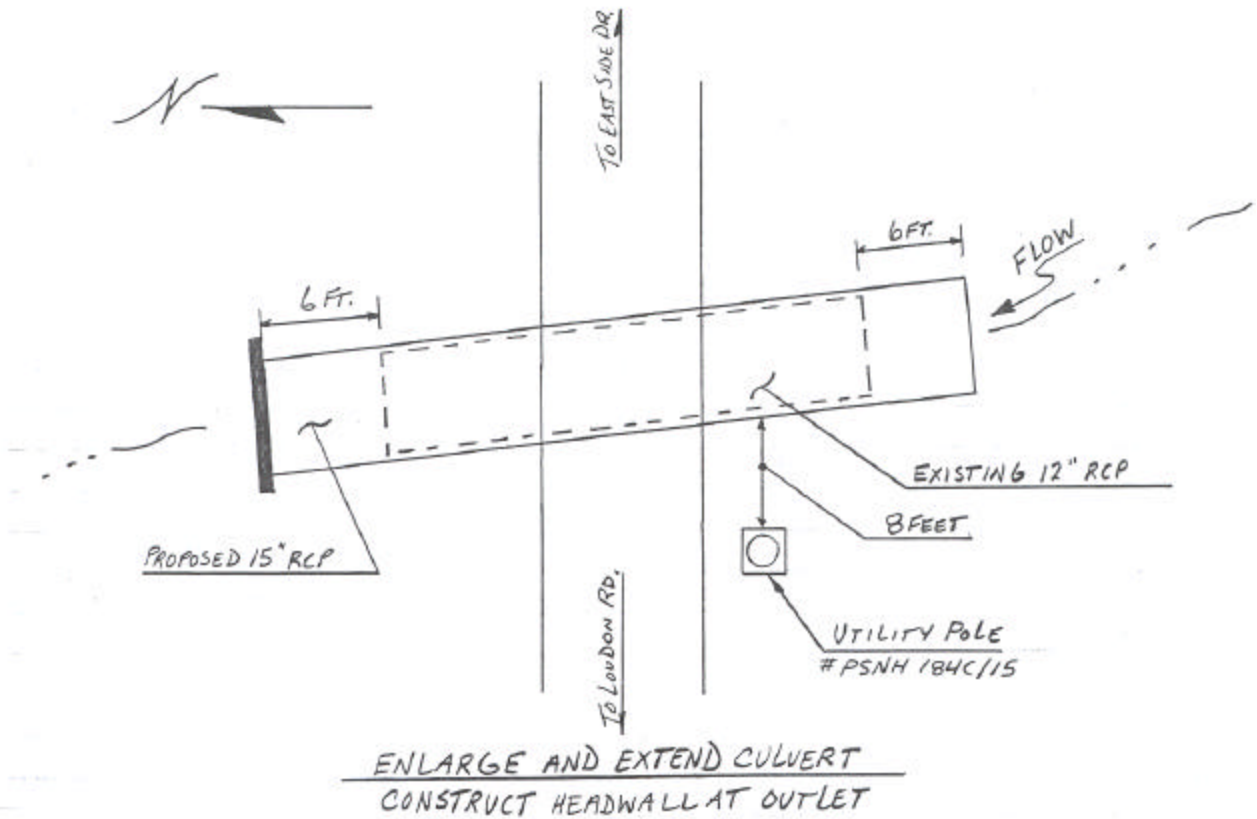



Concord, NH Quadrangle





Appendix 2

DESIGNATED RIVERS

NH Rivers Management & Protection Program
June 2000

Designated Rivers

- | | | |
|-----|-------------------------|---------|
| 1. | Ashuelot River | 6/07/93 |
| 2. | Cold River | 7/20/99 |
| 3. | Connecticut River | 7/14/92 |
| 4. | Contoocook River | 6/28/91 |
| 5. | Exeter River | 8/11/95 |
| 6. | Lamprey River | 6/26/90 |
| 7. | Merrimack River (Lower) | 6/26/90 |
| 8. | Merrimack River (Upper) | 6/26/90 |
| 9. | Pemigewasset River | 6/28/91 |
| 10. | Piscataquog River | 7/16/93 |
| 11. | Saco River | 6/26/90 |
| 12. | Souhegan River | 5/28/00 |
| 13. | Swift River | 6/26/90 |

RIVER CLASSIFICATION	
	COMMUNITY
	RURAL-COMMUNITY
	RURAL
	NATURAL

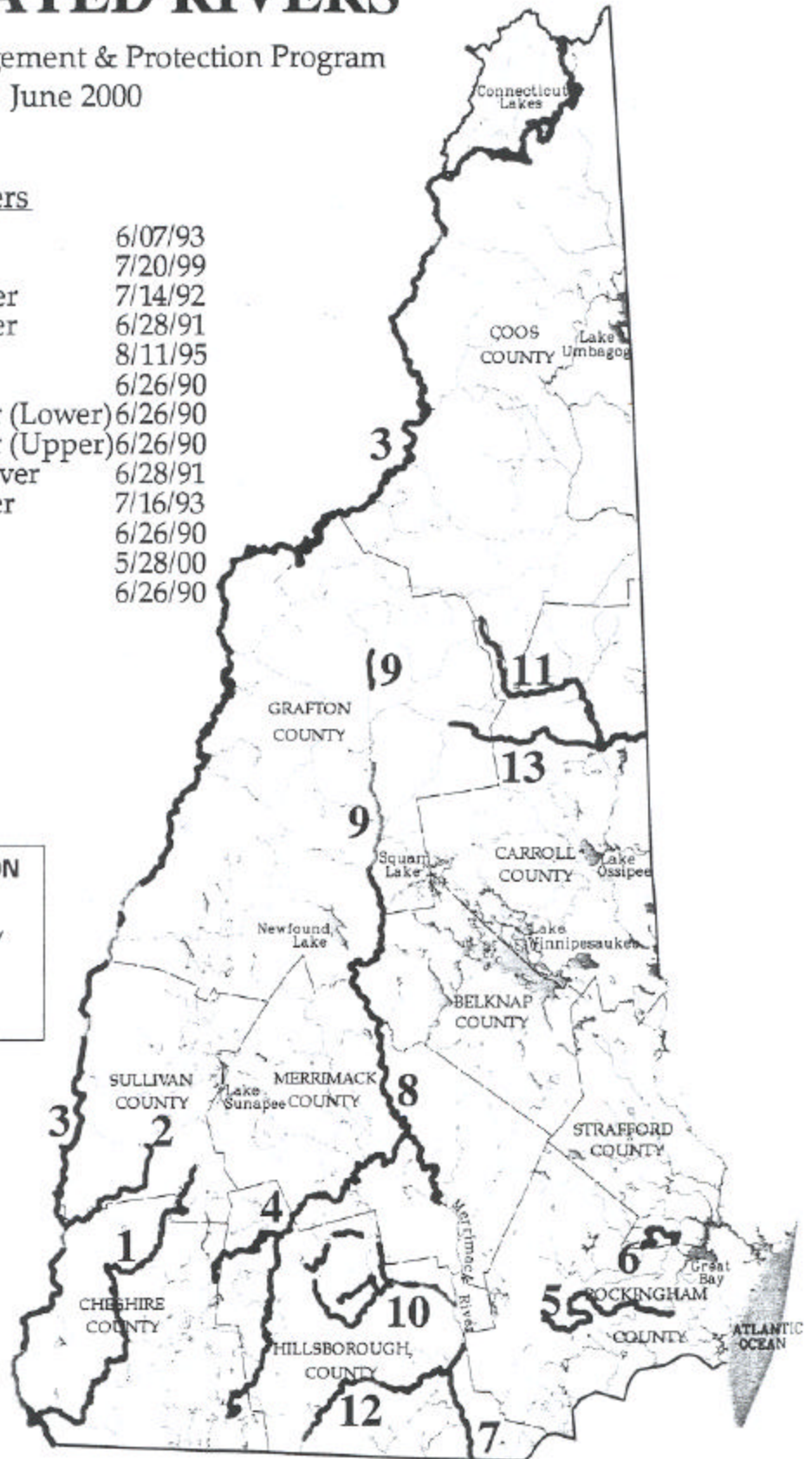

*Current information relative to Designated Rivers is available by calling 271-8856 or by visiting the Rivers Management and Protection Program online at www.des.state.nh.us/rivers.

The intent of the Rivers Management Program of the Department of Environmental Services is as follows as determined by **RSA 483:2 Program Established; Intent.**

There is established within the department of environmental services the New Hampshire rivers management and protection program. It is the intent of the legislature that the New Hampshire rivers management and protection program shall complement and reinforce existing state and federal water quality laws, and that instream flows are maintained along protected rivers, or segments thereof, in a manner that will enhance or not diminish the enjoyment of outstanding river characteristics pursuant to RSA 483:1. It is also the intent of the legislature that, through said program, the scenic beauty and recreational potential of such rivers shall be restored and maintained, that riparian interests shall be respected, and that nothing in this chapter shall be interpreted to preempt any land and zoning authority granted to municipal bodies under RSA title LXIV.

The following list of designated rivers and the Towns that encompass them is provided as a reference tool only. For a more detailed description of these river segments, please call the DES Rivers Management Coordinator (271-8865) or visit their website at http://www.des.state.nh.us/rivers*

Ashuelot- Washington, Lempster, Marlow, Gilsum, Sullivan, Surry, Keene, Swanzey, Winchester, Hinsdale

Cold- Acworth, Lempster, Langdon, Alstead, Walpole

Connecticut- Pittsburgh, Clarksville, Stewartstown, Colebrook, Columbia, Stratford, Northumberland, Lancaster, Dalton, Littleton, Monroe, Bath, Haverhill, Piermont, Orford, Lyme, Hanover, Lebanon, Plainfield, Cornish, Claremont, Charlestown, Walpole, Westmoreland, Chesterfield, Hinsdale

Contoocook (including the North Branch, Middle Branch and South Branch)- Rindge, Jaffrey, Peterborough, Hancock, Greenfield, Bennington, Stoddard, Antrim, Deering, Hillsborough, Henniker, Hopkinton, Concord, Boscawen

Exeter- Chester, Sandown, Danville, Fremont, Raymond, Brentwood, Exeter

Lamprey Lee, Durham

Merrimack- Franklin, Northfield, Boscawen, Canterbury, Concord, Bow, Merrimack, Litchfield, Nashua, Hudson

Pemigewasset- Franconia Notch State Park, Franconia, Thornton, Campton, Plymouth, Holderness, Ashland, Bridgewater, New Hampton, Bristol, Hill, Sanbornton, Franklin

Piscataquog- Deering, Weare, New Boston, Francestown, Lyndenborough, Goffstown, Manchester

Saco- Crawford Notch State Park, Harts Location, Bartlett, Conway

Souhegan- New Ipswich, Greenville, Wilton, Milford, Amherst, Merrimack,

Swift- White Mountain National Forest, Livermore, Waterville Valley, Albany, Conway

* This information is current as of the date of publication of this manual.

Appendix #3

New Hampshire Communities with Designated Prime Wetlands

Andover	Meredith
Barrington	Nashua
Bow	New London
Brookline	Pelham
Derry	Salem
Enfield	Sanbornton
Exeter	Sandwich
Gilford	Tamworth
Holderness	Weare
Hooksett	Wolfeboro

Note:

Prime wetlands are designated by a municipality according to the requirements of [RSA 482-A: 15](#) and [Chapter Wt 700](#) of the DES administrative rules. The municipality chooses to evaluate the wetlands within its boundaries. Typically, the evaluation method used is *Method for Comparative Evaluation of Nontidal Wetlands in New Hampshire* (1991) or *Method for the Evaluation and Inventory of Vegetated Tidal Marshes in New Hampshire (Coastal Method)* (1993). Field and "desk-top" data are used for the evaluation process. The municipality evaluates the functions and values of the identified wetlands. Once the community has selected wetlands to designate as prime, the municipality holds a public hearing before the residents of the community vote on the designation. Once the municipality approves the wetlands for designation as prime, the municipality provides to the DES Wetlands Bureau a copy of the study and tax maps with the designated prime wetlands identified. DES will review the submission from the municipality to ensure that it is complete and in accordance with Wt 702.03. Once the submission is considered complete, DES will apply to any future projects that are in or adjacent to a prime wetland the rules and law that are applicable. All projects that are in or adjacent to a prime wetland are classified as major projects. All major projects require a field inspection by DES and all prime wetland projects require a public hearing to be conducted by DES.

For more information relative to designated prime wetlands, please contact the Department of Environmental Services Wetlands Bureau at (603)271-2147, or visit them on-line at <http://www.des.state.nh.us/>

ENVIRONMENTAL Fact Sheet



6 Hazen Drive, Concord, New Hampshire 03301 · (603) 271-3503 · www.state.nh.us/ides

WD-BB-36

1997

Minimum Shoreland Protection Standards, RSA 483-B

LIMITS WITHIN THE PROTECTED SHORELAND

Prohibited Uses (RSA 483-B:9, II)

- Establishment/expansion of salt storage yards, auto junk yards, solid waste & hazardous waste facilities.
- Use low phosphate, slow release nitrogen fertilizer from 250 feet to 25 feet.

250 ft

Uses Requiring State Permits

- Public water supply facilities (RSA 483-B:9, III)
- Public water & sewage treatment facilities (RSA 483-B:9, IV)
- Public utility lines (RSA 483-B:9, IV-b)
- Existing solid waste facilities (RSA 483-B:9, IV-c)
- All activities regulated by the DES Wetlands Bureau per RSA 482-A (RSA 483-B:9, II(c))

Other Restricted Uses

- All new lots, including those in excess of 5 acres, are subject to subdivision approval by DES. (RSA 483-B:9, V(b)(1))
- Setback requirements for all new septic systems are determined by soil characteristics. (RSA 483-B:9, V(b)(2))
- Minimum lot size in areas dependent on septic systems determined by soil type. (RSA 483-B:9, V(e)(1))
- Alteration of Terrain Permit standards reduced from 100,000 square feet to 50,000 square feet. (RSA 483-B:6, I(d))
- Lots for residential units in areas dependent on on-site sewage & septic systems shall be sized so as not to exceed 1 unit per 150 feet of shoreland frontage. (RSA 483-B:9, V(e)(2))

NATURAL WOODLAND BUFFER RESTRICTIONS (RSA 483-B:9, V(a))

- Where existing, a natural woodland buffer must be maintained.
- Tree cutting limited to 50% of the basal area of trees, and 50% of the total number of saplings in a 20 year period. A healthy, well-distributed stand of trees, saplings, shrubs, and ground covers must be maintained.
- Stumps and their root systems must remain intact in the ground within 50 feet of the reference line.
- The opening for building construction is limited to 25 feet outward from the building, septic system, and driveway.
- The opening for accessory structures is limited to 10 feet outward from the footprint.

150 ft

NEW SEPTIC SYSTEM LEACHFIELD SETBACKS (RSA 483-B:9, V(b)(2))

- 125 feet where soil down gradient of leachfield is porous sand & gravel.
- 100 feet for soils with a restrictive layer within 18 inches of natural soil surface.
- 75 feet minimum setback from rivers.
- 75 feet where soil map indicates presence of all other soil types.

125 ft

100 ft

75 ft

PRIMARY BUILDING LINE*

- Primary structure setback 50 feet from the reference line. (RSA 483-B:9, II(B))
- Pesticide use is prohibited within 25 feet of reference line. (Pes 1001.02)
- Fertilizer use is prohibited within 25 feet of reference line. (RSA 483-B:9, II(d))
- Accessory structure setback 20 feet from the reference line. (EnvWs 1405.04)

50 ft

25 ft.

20 ft.

REFERENCE LINE (RSA 483-B:4, XVII)

- For coastal waters = highest observable tide line
- For rivers = ordinary high water mark
- For natural fresh waterbodies = natural mean high water level
- For artificially impounded fresh waterbodies = water line at full pond

* If a municipality establishes a shoreland setback for primary buildings, whether greater or lesser than 50 feet, that defines the Primary Building Line for that municipality.



NOTIFICATION OF ROUTINE ROADWAY AND RAILWAY MAINTENANCE ACTIVITIES



Please complete the following by checking the appropriate box to the right (*terms in bold are defined in the manual*):

1. Will the proposed roadway maintenance activity require disturbance in or adjacent to surface waters or in wetlands? YES NO

If you answered **NO**, you do not need to file this form, nor any other wetland application. If you answered **YES**, continue to question 2.

2. Does the proposed activity involve work within the limits of surface waters to be conducted in the dry, either at **low water periods**, or behind **appropriately designed temporary diversions**;
OR
Does the proposed activity involve only embankment stabilization, outside surface waters or wetlands? YES NO

If you answered **NO**, you must file a standard dredge and fill application and no work in jurisdictional area can begin until a permit is received. If you answered **YES**, continue to question 3.

3. Does the proposed activity impact **bogs, marshes, sand dunes, tidal wetlands, riparian buffer zones, designated prime wetlands**, or fall within 1/4 mile of **any** of the above? YES NO

If you answered **YES**, you must file a standard dredge and fill application and no work in jurisdictional area can begin until a permit is received. If you answered **NO**, continue to question 4.

4. Does the proposed activity involve:
 a. extending an existing culvert more than 10 feet? YES NO
 b. replacing an existing culvert with a new culvert of a larger diameter or more than 36 inches, or installing a new culvert of more than 50 inches? YES NO
 c. creating a new culvert, or extending an existing culvert, at the inlet and/or outlet (or the sum of the difference between the inlet and outlet) of more than 10 feet from their original location, or the length of a new channel or fill is greater than 50 linear feet? YES NO
 d. changing a road or driveway that is **NOT** manmade, 2) carry a **perennial stream**, 3) **NOT** have defined channel and banks, 4) do **NOT** run parallel with the roadway? YES NO
 e. stabilizing a roadway embankment adjacent to a perennial stream or river? YES NO

If you answered a **YES** to any of questions 4a-4e, you must file a standard dredge and fill application and no work within a jurisdictional area can begin until a permit is received. If you answered **NO** to questions 4a-4e, continue through question 13.

5. Identify the sponsor (i.e. DOT Maintenance District, City/Town, State Agency, Private Road Owner, etc.) of the proposed Routine Maintenance Activity, and provide the name of an authorized representative, his/her address and work phone number.

Activity Sponsor _____

Authorized Representative _____

PO Box/Street _____ Town _____ State _____ Zip _____

Telephone _____

FOR DES OFFICE USE ONLY:

Notification received _____ File # _____
date received _____ initial(s) _____

6. Identify the location of the proposed activity(ies) with the nearest street address(es), town and name of water body(ies).

Street address(es) and town: _____

Name of water body(ies): _____
(If applicable)

7. Activity Description: _____

8. Sections of BMP manual under which activity qualifies (*Check All That Apply*):

- Culvert Extension in Same Location Relocating an Existing Culvert Replacing Culvert in Same Location
- Roadside Ditch Maintenance Embankment Stabilization Headwall Repair, Replacement and Construction

9. Attach a copy of a USGS Quadrangle (topographical map) with the proposed location clearly identified.

10. Attach sketches showing construction design (see manual of Best Management Practices for Routine Roadway Maintenance Activities in New Hampshire for examples and templates.)

11. Attach color photograph(s) of proposed work site showing existing structures, surrounding land, and adjacent water body.

12. **By signing below the applicant is certifying that:** 1) all information provided in this notification is true and correct; 2) all work will conform to Best Management Practices for Routine Roadway Maintenance Activities in New Hampshire; 3) copies of this application have been provided to the town committee at the location of the project.

Signature of authorized representative _____

13. You will need three (3) photocopies of all required documents and sketches to be submitted to the DES Wetlands Bureau, 6 Hellen Drive, Concord, NH 03301. Provide a copy of the notification to the town committee at least five (5) calendar days prior to the commencement of work. The notification shall be posted in a prominent location at the worksite.

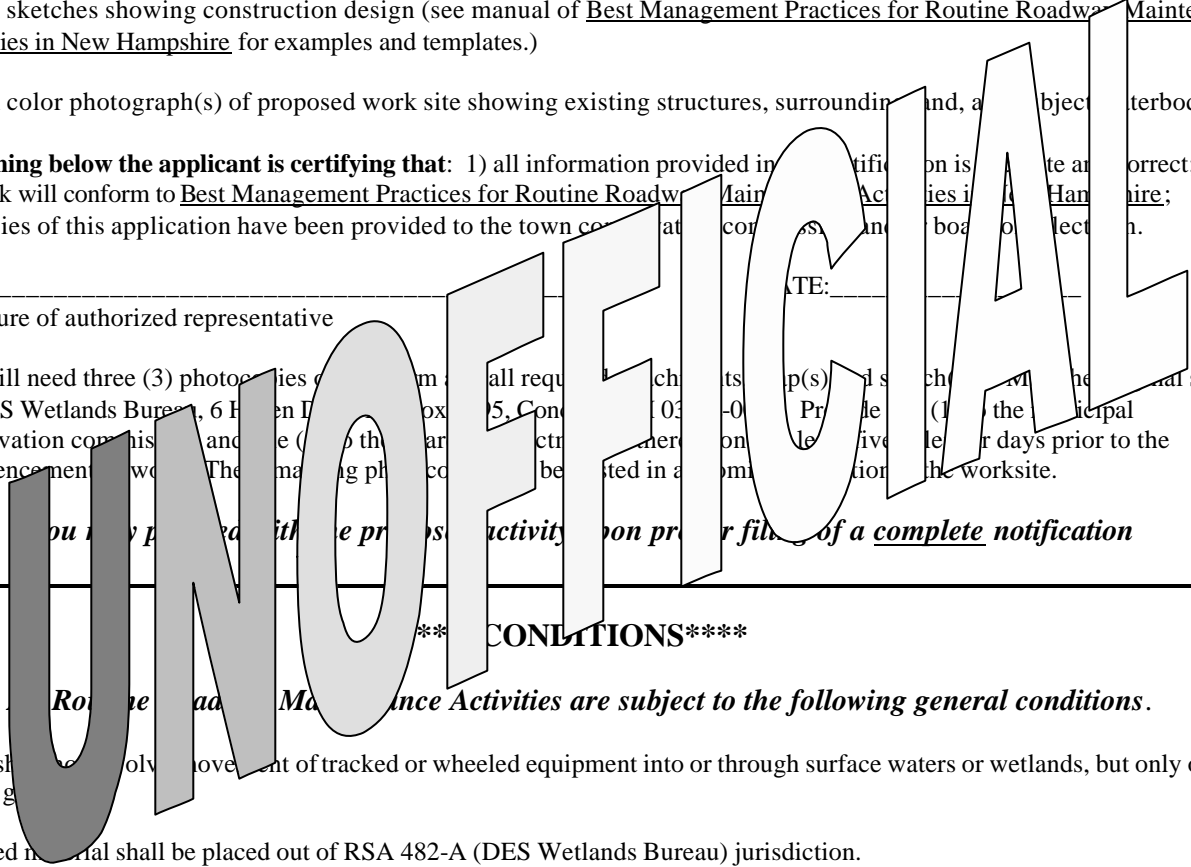

you may proceed with the proposed activity upon proper filing of a complete notification

**** CONDITIONS ****

Routine Roadway Maintenance Activities are subject to the following general conditions.

1. Work shall not involve movement of tracked or wheeled equipment into or through surface waters or wetlands, but only on dry or frozen ground.
2. Dredged material shall be placed out of RSA 482-A (DES Wetlands Bureau) jurisdiction.
3. Work within surface waters shall be done "in the dry," either during periods of low water or behind appropriately designed temporary diversions or sandbag cofferdams.
4. No work shall occur on land not owned by the activity sponsor without a release from all owners of property that will be impacted, or written notification, at least five calendar days prior to the start of work, to all owners of property that will be impacted. A copy of the property owner notice or release shall be provided to the Department along with the Notification Form.
5. All work shall be in accordance with the Comprehensive Shoreland Protection Act (CSPA), and shall not involve removal of trees from areas within CSPA jurisdiction.
6. A copy of the notification shall be posted in a prominent location at the worksite.
7. No work shall be done in or adjacent to municipally designated prime wetlands, within 1/4 mile of a NH Designated River or in bogs, marshes, tidal wetlands, undisturbed tidal buffer zone or sand dunes.
8. Siltation, erosion and turbidity controls shall be installed in accordance with "Best Management Practices for Routine Roadway Maintenance Activities," maintained to ensure that there is no water quality degradation and left in place until the area is stabilized.

PROVIDE PHOTOGRAPH(S) BELOW

UNOFFICIAL