

*Midwest States' Regional Pooled Fund Research Program  
Fiscal Year 2002-2003 (Year 13)  
Research Project Number SPR-03(017)  
NDOR Sponsoring Agency Code RFP-03-04*

# **EVALUATION OF A MODIFIED THREE CABLE GUARDRAIL ADJACENT TO STEEP SLOPE**

Submitted by

Ryan J. Terpsma  
Undergraduate Research Assistant

Dean L. Sicking, Ph.D., P.E.  
Professor and MwRSF Director

John D. Reid, Ph.D.  
Professor

Karla A. Polivka, M.S.M.E., E.I.T.  
Research Associate Engineer

John R. Rohde, Ph.D., P.E.  
Associate Professor

Ronald K. Faller, Ph.D., P.E.  
Research Assistant Professor

## **MIDWEST ROADSIDE SAFETY FACILITY**

University of Nebraska-Lincoln  
527 Nebraska Hall  
Lincoln, Nebraska 68588-0529  
(402) 472-0965

Submitted to

## **MIDWEST STATES' REGIONAL POOLED FUND PROGRAM**

Nebraska Department of Roads  
1500 Nebraska Highway 2  
Lincoln, Nebraska 68502

MwRSF Research Report No. TRP-03-192-08

March 4, 2008

## Technical Report Documentation Page

1. Report No. <b>TRP-03-192-08</b>	2.	3. Recipient's Accession No.	
4. Title and Subtitle <b>Evaluation of a Modified Three Cable Guardrail Adjacent to Steep Slope</b>		5. Report Date <b>March 4, 2008</b>	
		6.	
7. Author(s) <b>Terpsma, R.J., Polivka, K.A., Sicking, D.L., Rohde, J.R., Reid, J.D., Faller, R.K.</b>		8. Performing Organization Report No. <b>TRP-03-192-08</b>	
9. Performing Organization Name and Address <b>Midwest Roadside Safety Facility (MwRSF) University of Nebraska-Lincoln 527 Nebraska Hall Lincoln, NE 68588-0529</b>		10. Project/Task/Work Unit No.	
		11. Contract © or Grant (G) No. <b>SPR-3(017)</b>	
12. Sponsoring Organization Name and Address <b>Midwest States' Regional Pooled Fund Program Nebraska Department of Roads 1500 Nebraska Highway 2 Lincoln, Nebraska 68502</b>		13. Type of Report and Period Covered <b>Final Report 2002-2008</b>	
		14. Sponsoring Agency Code <b>RFPF-03-04</b>	
15. Supplementary Notes <b>Prepared in cooperation with U.S. Department of Transportation, Federal Highway Administration</b>			
16. Abstract (Limit: 200 words)  <p>The three cable guardrail system is most commonly used to protect motorists from roadside slopes. Due to the fact that the system is limited to sites where relatively large barrier displacement is acceptable, concern arises when the system must be placed close to steep roadside slopes.</p> <p>The objective of this study was to evaluate a three cable barrier system placed adjacent to 1.5H:1V slopes. The three cable system in this test utilized quarter-post spacing. In addition, the offset from the slope break point was 1,219 mm (4 ft).</p> <p>One full-scale crash test, a 2,032-kg (4,481-lb) pickup truck impacting at a speed of 99.1 km/h (61.6 mph) and at an angle of 23.6 degrees, was conducted and reported in accordance with the requirements specified in the National Cooperative Highway Research Program (NCHRP) Report No. 350, <i>Recommended Procedures for the Safety Performance Evaluation of Highway Features</i>.</p> <p>Based on the results and analysis of the full scale test, it was determined that the three cable guardrail system with quarter-post spacing and 1,219 mm (4 ft) offset from the slope break point performed adequately according to NCHRP Report No. 350 TL-3 requirements.</p>			
17. Document Analysis/Descriptors <b>Highway Safety, Roadside Appurtenances, Cable Guardrail, Slope, Cable Anchor, Crash Testing, Compliance Testing</b>		18. Availability Statement <b>No restrictions. Document available from: National Technical Information Services, Springfield, Virginia 22161</b>	
19. Security Class (this report) <b>Unclassified</b>	20. Security Class (this page) <b>Unclassified</b>	21. No. of Pages <b>91</b>	22. Price

## **DISCLAIMER STATEMENT**

The contents of this report reflect the views of the authors who are responsible for the facts and the accuracy of the data presented herein. The contents do not necessarily reflect the official views nor policies of the State Highway Departments participating in the Midwest States' Regional Pooled Fund Research Program nor the Federal Highway Administration. This report does not constitute a standard, specification, or regulation.

## **ACKNOWLEDGMENTS**

The authors wish to acknowledge several sources that made a contribution to this project: (1) the Midwest States' Regional Pooled Fund Program funded by the Connecticut Department of Transportation, Illinois Department of Transportation, Iowa Department of Transportation, Kansas Department of Transportation, Minnesota Department of Transportation, Missouri Department of Transportation, Nebraska Department of Roads, Ohio Department of Transportation, South Dakota Department of Transportation, Wisconsin Department of Transportation, and Wyoming Department of Transportation for sponsoring this project; (2) J. Mark Burroughs and Steve Jackson with Bekaert Corporation for donating the cable materials; and (3) MwRSF personnel for constructing the barrier and conducting the crash test.

Acknowledgment is also given to the following individuals who made a contribution to the completion of this research project.

### **Midwest Roadside Safety Facility**

R.W. Bielenberg, M.S.M.E., E.I.T., Research Associate Engineer  
J.C. Holloway, M.S.C.E., E.I.T., Research Manager  
C.L. Meyer, B.S.M.E., E.I.T., Research Engineer II  
S.K. Rosenbaugh, M.S.C.E., E.I.T., Research Associate Engineer  
A.T. Russell, B.S.B.A., Laboratory Mechanic II  
K.L. Krenk, B.S.M.A, Field Operations Manager  
A.T. McMaster, Laboratory Mechanic I  
Undergraduate and Graduate Assistants

### **Connecticut Department of Transportation**

Dionysia Oliveira, Transportation Engineer 3

### **Illinois Department of Transportation**

David Piper, P.E., Highway Policy Engineer

### **Iowa Department of Transportation**

David Little, P.E., Assistant District Engineer  
Deanna Maifield, Methods Engineer  
Chris Poole, Transportation Engineer Specialist

### **Kansas Department of Transportation**

Ron Seitz, P.E., Bureau Chief  
Rod Lacy, P.E., Road Design Leader  
Scott King, P.E., Road Design Leader

### **Minnesota Department of Transportation**

Mohammad Dehdashti, P.E., Design Standard Engineer  
Michael Elle, P.E. Design Standard Engineer

### **Missouri Department of Transportation**

Joseph G. Jones, Technical Support Engineer

### **Nebraska Department of Roads**

Amy Starr, Research Engineer  
Phil TenHulzen, P.E., Design Standards Engineer  
Jodi Gibson, Research Coordinator

### **Ohio Department of Transportation**

Dean Focke, P.E., Standards Engineer

### **South Dakota Department of Transportation**

David Huft, Research Engineer  
Bernie Clocksin, Lead Project Engineer  
Paul Oien, Project Engineer

### **Wisconsin Department of Transportation**

John Bridwell, Standards Development Engineering  
Erik Emerson, Standards Development Engineering

**Wyoming Department of Transportation**

William Wilson, P.E., Standards Engineer

**Federal Highway Administration**

John Perry, P.E. Nebraska Division Office

Danny Briggs, Nebraska Division Office

**Dunlap Photography**

James Dunlap, President and Owner

# TABLE OF CONTENTS

	Page
TECHNICAL REPORT DOCUMENTATION PAGE .....	i
DISCLAIMER STATEMENT .....	ii
ACKNOWLEDGMENTS .....	iii
TABLE OF CONTENTS .....	vi
List of Figures .....	viii
List of Tables .....	x
1 INTRODUCTION .....	1
1.1 Problem Statement .....	1
1.2 Objective .....	2
1.3 Scope .....	2
2 TEST REQUIREMENTS AND EVALUATION CRITERIA .....	4
2.1 Test Requirements .....	4
2.2 Evaluation Criteria .....	4
3 TEST CONDITIONS .....	7
3.1 Test Facility .....	7
3.2 Vehicle Tow and Guidance System .....	7
3.3 Test Vehicle .....	7
3.4 Data Acquisition Systems .....	10
3.4.1 Accelerometers .....	10
3.4.2 Rate Transducers .....	12
3.4.3 High-Speed Photography .....	12
3.4.4 Pressure Tape Switches .....	14
3.4.5 Three Cable End Terminal Instrumentation .....	14
3.4.5.1 Load Cells .....	14
3.4.5.2 String Potentiometers .....	15
4 THREE CABLE GUARDRAIL .....	19
5 CRASH TEST .....	36
5.1 Test CS-2 .....	36
5.2 Test Description .....	36
5.3 Barrier Damage .....	38
5.4 Vehicle Damage .....	39
5.5 Occupant Risk Values .....	40
5.6 Load Cell and String Potentiometer Results .....	41

5.7 Discussion .....	42
6 SUMMARY, CONCLUSIONS, AND RECOMMENDATIONS .....	61
7 REFERENCES .....	63
8 APPENDICES .....	64
APPENDIX A - Three Cable Guardrail System Drawings in English Units .....	65
APPENDIX B - Test Summary Sheet in English Units, Test CS-2 .....	78
APPENDIX C - Occupant Compartment Deformation Data, Test CS-2 .....	80
APPENDIX D - Accelerometer and Rate Transducer Data Analysis, Test CS-2 .....	84



## List of Figures

	Page
Figure 1. Test Vehicle, Test CS-2	8
Figure 2. Vehicle Dimensions, Test CS-2	9
Figure 3. Vehicle Target Locations, Test CS-2	11
Figure 4. Locations of High-Speed Cameras, Test CS-2	13
Figure 5. Upstream End Load Cell Positioning	16
Figure 6. Downstream End Load Cell Positioning	17
Figure 7. String Potentiometer Positioning	18
Figure 8. Three Cable Guardrail System Layout	21
Figure 9. Three Cable Guardrail End Terminal Details	22
Figure 10. Cable Anchor Bracket Details	23
Figure 11. Cable Anchor Bracket Details	24
Figure 12. Anchor Bracket Base Details	25
Figure 13. Cable Release Lever Details	26
Figure 14. Three Cable Guardrail Support Post Details	27
Figure 15. Bearing Strut Details	28
Figure 16. Cable Support Post Upper Details	29
Figure 17. Cable Support Post Base Details	30
Figure 18. Cable Support Post Base Assembly Details	31
Figure 19. Cable Line Post Details	32
Figure 20. Three Cable Guardrail System Adjacent to Slope	33
Figure 21. Three Cable Guardrail System Adjacent to Slope	34
Figure 22. Three Cable Guardrail System Adjacent to Slope	35
Figure 23. Summary of Test Results and Sequential Photographs, Test CS-2	43
Figure 24. Additional Sequential Photographs, Test CS-2	44
Figure 25. Additional Sequential Photographs, Test CS-2	45
Figure 26. Additional Sequential Photographs, Test CS-2	46
Figure 27. Documentary Photographs, Test CS-2	47
Figure 28. Impact Location, Test CS-2	48
Figure 29. Final Position, Test CS-2	49
Figure 30. System Damage, Test CS-2	50
Figure 31. System Damage, Test CS-2	51
Figure 32. System Damage, Test CS-2	52
Figure 33. System Damage, Test CS-2	53
Figure 34. End Anchor Damage, Test CS-2	54
Figure 35. Vehicle Damage, Test CS-2	55
Figure 36. Vehicle Damage, Test CS-2	56
Figure 37. Undercarriage Damage, Test CS-2	57
Figure 38. Occupant Compartment Deformation, Test CS-2	58
Figure 39. Force-Time History for the Cables at the Upstream Anchor, Test CS-2	59
Figure 40. Displacement-Time History Plot for Upstream Anchor, Test CS-2	60
Figure A-1. Three Cable Guardrail System Layout (English)	66

Figure A-2. Three Cable Guardrail End Terminal Details (English) .....	67
Figure A-3. Cable Anchor Bracket Details (English) .....	68
Figure A-4. Cable Support Upper Post Details (English) .....	69
Figure A-5. Anchor Bracket Base Details (English) .....	70
Figure A-6. Cable Release Lever Details (English) .....	71
Figure A-7. Three Cable Guardrail Support Post Details (English) .....	72
Figure A-8. Bearing Strut Details (English) .....	73
Figure A-9. Cable Support Post Upper Details (English) .....	74
Figure A-10. Cable Support Post Base Details (English) .....	75
Figure A-11. Cable Support Post Base Assembly Details (English) .....	76
Figure A-12. Cable Line Post Details (English) .....	77
Figure B-1. Summary of Test Results and Sequential Photographs, Test CS-2 .....	79
Figure C-1. Occupant Compartment Deformation Data - Set 1, Test CS-2 .....	81
Figure C-2. Occupant Compartment Deformation Data - Set 2, Test CS-2 .....	82
Figure C-3. Occupant Compartment Deformation Index (OCDI), Test CS-2 .....	83
Figure D-1. Graph of Longitudinal Deceleration, Test CS-2 .....	85
Figure D-2. Graph of Longitudinal Occupant Impact Velocity, Test CS-2 .....	86
Figure D-3. Graph of Longitudinal Occupant Displacement, Test CS-2 .....	87
Figure D-4. Graph of Lateral Deceleration, Test CS-2 .....	88
Figure D-5. Graph of Lateral Occupant Impact Velocity, Test CS-2 .....	89
Figure D-6. Graph of Lateral Occupant Displacement, Test CS-2 .....	90
Figure D-7. Graph of Roll, Pitch, and Yaw Angular Displacements, Test CS-2 .....	91

## List of Tables

	Page
Table 1. NCHRP Report No. 350 Test Level 3 Crash Test Conditions .....	5
Table 2. NCHRP Report No. 350 Evaluation Criteria for Crash Tests .....	6
Table 3. Load Cell Results, Test CS-2 .....	41
Table 4. Summary of Safety Performance Evaluation Results .....	62

# 1 INTRODUCTION

## 1.1 Problem Statement

Three cable guardrail was one of the first roadside barrier systems developed. The design incorporates steel cables mounted on widely spaced posts. As a vehicle penetrates into the barrier, the cables are stretched producing tension forces that act as re-directive forces and push the vehicle back toward the travel way. The barrier posts are designed to bend under moderate lateral loading, which limits the accelerations applied to impacting vehicles. Further, cable tension diminishes as an impacting vehicle begins to move out of the system, thereby minimizing the risk of vehicles being projected back into the traffic stream in an uncontrolled manner, potentially causing secondary impacts. Cable guardrail's excellent performance record is normally attributed to the low lateral stiffness of the system and its ability to limit secondary collisions (1-2).

Cable barrier is economical to install. Materials used in a cable barrier system are less costly than most other barriers. In addition, the low cross-sectional area of the cable barrier eliminates problems with snow drifting that plague W-beam guardrail and shaped concrete barriers.

The limitations and disadvantages of the three cable guardrail are highlighted by the same concepts that identify its advantages. The flexibility of the system permits large lateral displacements, which limits the use of the barrier to shield motorists from fixed objects placed near the travel way. In addition, the barrier's flexibility leads to long damaged sections during even moderate collisions. Finally, many highway agencies have reported that slack often develops in the barrier cables, which generates a need for periodic maintenance.

The three cable guardrail is most commonly used to protect motorists from roadside slopes. However, concern arises when the barrier must be placed close to a steep slope. In the late 1960's,

tests conducted by the Ontario Department of Highways led to the conclusions that the cable spacing influenced a vehicle's tendency to snag on guardrail components, and that the deflection of a guardrail was directly related to the stiffness of the posts used in the system (3). Full-scale crash tests conducted by the New York State Department of Transportation (NYDOT) have shown that the cable guardrail can provide adequate safety performance for large sedans when placed near 2H:1V roadside slopes (4-5).

Researchers at the Midwest Roadside Safety Facility (MwRSF) conducted a test with a ¾-ton pickup truck on a standard, three cable guardrail set back 305 mm (12 in.) from the slope break point of a 1.5:1 slope (6). The system consisted of 1,600-mm (63-in.) long, S76x8.5 (S3x5.7) line posts spaced 4,877 mm (16 ft) on center. During the Test Level 3 (TL-3) 2000P crash test, the posts rotated without much soil resistance, resulting in the vehicle becoming completely airborne and encroaching onto the steep slope. As a result, the front-impact side of the vehicle dropped below the vehicle c.g., thus causing the re-directive forces applied by the cable system to be significantly below the c.g. of the vehicle. This induced a “tripping” effect and applied a roll moment on the vehicle, causing the vehicle to roll over the cables and come to rest at the bottom of the embankments. Thus, an analysis of the test results revealed that the standard, three cable guardrail system set back 305 mm (12 in.) from the slope break point of a 1.5:1 slope performed unsatisfactorily according to the TL-3 safety performance criteria presented in the National Cooperative Highway Research Program (NCHRP) Report No. 350 (7). However, it should be noted that there exists a potential for improved barrier performance adjacent to steep slopes at lower impact severities, such as at reduced impact speeds or angles.

## **1.2 Objective**

The objectives of this research project were to implement the design modifications to the three cable system adjacent to a steep slope as described in the recommendations of Reference 6, and to evaluate its safety performance when installed adjacent to a 1.5H:1V roadside slope. The three cable guardrail system was to be evaluated according to the TL-3 safety performance criteria set forth in the NCHRP Report No. 350, *Recommended Procedures for the Safety of Performance Evaluation of Highway Features (7)*.

## **1.3 Scope**

The research objectives were achieved by performing several tasks. First, the original three cable guardrail design was modified with the recommendations from the previous testing of the three cable guardrail (6). After the design recommendations had been implemented, the cable guardrail system was fabricated and constructed at the MwRSF's outdoor test facility. Following fabrication of the cable system, a full-scale vehicle crash test was performed using a ¾-ton pickup truck, weighing approximately 2,000 kg (4,409 lbs), with a target impact speed and angle of 100.0 km/h (62.1 mph) and 25 degrees, respectively. Next, the test results were analyzed, evaluated, and documented. Finally, conclusions and recommendations were made that pertain to the safety performance of the cable guardrail adjacent to a steep slope system.

## **2 TEST REQUIREMENTS AND EVALUATION CRITERIA**

### **2.1 Test Requirements**

Longitudinal barriers, such as three-cable guardrail, must satisfy the requirements provided in NCHRP Report No. 350 to be accepted for use on National Highway System (NHS) new construction projects or as a replacement for existing designs not meeting current safety standards. According to TL-3 of NCHRP Report No. 350, the longitudinal barriers must be subjected to two full-scale vehicle crash tests. The two crash tests are as follows:

1. Test Designation 3-10. An 820-kg (1,808-lb) small car impacting the barrier at a nominal speed and angle of 100.0 km/h (62.1 mph) and 20 degrees, respectively.
2. Test Designation 3-11. A 2,000-kg (4,409-lb) pickup truck impacting the barrier at a nominal speed and angle of 100.0 km/h (62.1 mph) and 25 degrees, respectively.

However, the higher impact energy associated with the pickup truck test produces larger barrier deflections and greatly increases the likelihood of vehicle rollover as compared to the small car test. Therefore, the 2,000-kg (4,409-lb) pickup truck test was selected as sufficient to evaluate the performance of the cable guardrail adjacent to steep slopes, and the 820-kg (1,808-lb) small car test was considered unnecessary for this project. The test conditions for TL-3 longitudinal barriers are summarized in Table 1.

### **2.2 Evaluation Criteria**

Evaluation criteria for full-scale vehicle crash testing are based in three appraisal areas: (1) structural adequacy; (2) occupant risk; and (3) vehicle trajectory after collision. Criteria for structural adequacy are intended to evaluate the ability of the barrier to contain, redirect, or allow controlled vehicle penetration in a predictable manner. Occupant risk evaluates the degree of hazard to occupants in the impacting vehicle. Vehicle trajectory after collision is a measure of the potential

for the post-impact trajectory of the vehicle to cause subsequent multi-vehicle accidents. This criterion also indicates the potential safety hazard for the occupants of the other vehicle or the occupants of the impacting vehicle when subjected to secondary collisions with other fixed objects. These three evaluation criteria are defined in Table 2. The full-scale vehicle crash test was conducted and reported in accordance with the procedures provided in NCHRP Report No. 350 (7).

Table 1. NCHRP Report No. 350 Test Level 3 Crash Test Conditions

Test Article	Test Designation	Test Vehicle	Impact Conditions			Evaluation Criteria <sup>1</sup>
			Speed		Angle (degrees)	
			(km/h)	(mph)		
Longitudinal Barrier	3-10	820C	100	62.1	20	A,D,F,H,I,K,M
	3-11	2000P	100	62.1	25	A,D,F,K,L,M

<sup>1</sup> Evaluation criteria explained in Table 2



Table 2. NCHRP Report No. 350 Evaluation Criteria for Crash Tests

Structural Adequacy	A. Test article should contain and redirect the vehicle; the vehicle should not penetrate, underride, or override the installation although controlled lateral deflection of the test article is acceptable.
Occupant Risk	D. Detached elements, fragments or other debris from the test article should not penetrate or show potential for penetrating the occupant compartment, or present an undue hazard to other traffic, pedestrians, or personnel in a work zone. Deformations of, or intrusions into, the occupant compartment that could cause serious injuries should not be permitted.
	F. The vehicle should remain upright during and after collision although moderate roll, pitching, and yawing are acceptable.
	H. Longitudinal and lateral occupant impact velocities should fall below the preferred value of 9 m/s (29.5 ft/s), or at least below the maximum allowable value of 12 m/s (39.4 ft/s).
	I. Longitudinal and lateral occupant ridedown accelerations should fall below the preferred value of 15 g's, or at least below the maximum allowable value of 20 g's.
Vehicle Trajectory	K. After collision it is preferable that the vehicle's trajectory not intrude into adjacent traffic lanes.
	L. The occupant impact velocity in the longitudinal direction should not exceed 12 m/s (39.4 ft/s), and the occupant ridedown acceleration in the longitudinal direction should not exceed 20 g's.
	M. The exit angle from the test article preferably should be less than 60 percent of test impact angle measured at time of vehicle loss of contact with test device.

## **3 TEST CONDITIONS**

### **3.1 Test Facility**

The testing facility is located at the Lincoln Air-Park on the northwest (NW) side of the Lincoln Municipal Airport and is approximately 8.0 km (5 mi.) NW of the University of Nebraska-Lincoln.

### **3.2 Vehicle Tow and Guidance System**

A reverse cable tow system with a 1:2 mechanical advantage was used to propel the test vehicle. The distance traveled and the speed of the tow vehicle were one-half that of the test vehicle. The test vehicle was released from the tow cable before impact with the barrier system. A digital speedometer on the tow vehicle increases the accuracy of the test vehicle impact speed.

A vehicle guidance system developed by Hinch (8) was used to steer the test vehicle. A guide-flag, attached to the front-right wheel and the guide cable, was sheared off before impact with the barrier system. The 9.5-mm (0.375-in.) diameter guide cable was tensioned to approximately 15.6 kN (3,500 lbs), and supported laterally and vertically every 30.48 m (100 ft) by hinged stanchions. The hinged stanchions stood upright while holding up the guide cable, but as the vehicle was towed down the line, the guide-flag struck and knocked each stanchion to the ground. The vehicle guidance system was approximately 299 m (981 ft) long.

### **3.3 Test Vehicle**

For test CS-2, a 1999 Chevy C2500 ¾-ton pickup truck was used as the test vehicle. The test inertial and gross static weights were 2,033 kg (4,481 lbs). The test vehicle is shown in Figure 1, and vehicle dimensions are shown in Figure 2.



Figure 1. Test Vehicle, Test CS-2

Date: 11/1/2006 Test Number: CS-2 Model: 2000p/C2500  
 Make: Chevrolet Vehicle I.D.#: 1GCGC24R0XR707650  
 Tire Size: LT245/75 R16 Year: 1999 Odometer: 212447

\*(All Measurements Refer to Impacting Side)

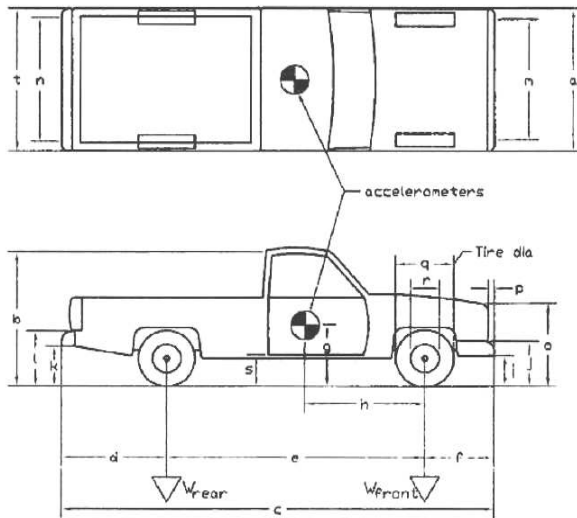

GWR	F	4100
	R	8000
	Tot.	8600

Weights kg (lbs)	Curb	Test Inertial	Gross Static
W-front	1242 (2738)	1177 (2594)	1177 (2594)
W-rear	939.4 (2071)	855.9 (1887)	855.9 (1887)
W-total	2181 (4809)	2033 (4481)	2033 (4481)

Vehicle Geometry -- mm (in.)

a	1892 (74.5)	b	1867 (73.5)
c	5537 (218.0)	d	1283 (50.5)
e	342.9 (13.5)	f	914.4 (36.0)
g	669.9 (26.375)	h	1429 (56.25)
i	450.9 (17.75)	j	660.4 (26.0)
k	590.6 (23.25)	l	768.4 (30.25)
m	1600 (63.0)	n	1622 (63.875)
o	1026 (40.375)	p	82.55 (3.25)
q	755.7 (29.75)	r	444.5 (17.5)
s	476.3 (18.75)	t	1842 (72.5)
Wheel Center Height Front	358.8 (14.125)		
Wheel Center Height Rear	368.3 (14.5)		
Wheel Well Clearance (FR)	908.1 (35.75)		
Wheel Well Clearance (RR)	952.5 (37.5)		
Frame Height (FR)	406.4 (16.0)		
Frame Height (RR)	673.1 (26.5)		
Engine Type	8 CYL. GAS		
Engine Size	5.7L		

Transmission Type:

Automatic  
RWD

Note any damage prior to test: None

Figure 2. Vehicle Dimensions, Test CS-2

The longitudinal component of the center of gravity was determined using the measured axle weights. The location of the final center of gravity is shown in Figures 1 and 2.

Square black and white-checked targets were placed on the vehicle to aid in the analysis of the high-speed videos, as shown in Figure 3. Round, checkered targets were placed on the center of gravity, the driver's side door, the passenger's side door, and the roof of the vehicle. The remaining targets were located for reference so that they could be viewed from the high-speed cameras for film analysis.

The front wheels of the test vehicle were aligned for camber, caster, and toe-in values of zero so that the vehicle would track properly along the guide cable. One 5B flash bulbs was mounted on the hood and another mounted on the roof of the vehicle to pinpoint the time of impact with the barrier on the high-speed film and E/cam video. The flash bulbs were fired by a pressure tape switch mounted on the front face of the bumper. A remote-controlled brake system was installed in the test vehicle so the vehicle could be brought safely to a stop after the test.

### **3.4 Data Acquisition Systems**

#### **3.4.1 Accelerometers**

One triaxial piezoresistive accelerometer system with a range of  $\pm 200$  g's was used to measure the acceleration in the longitudinal, lateral, and vertical directions at a sample rate of 10,000 Hz. The environmental shock and vibration sensor/recorder system, Model EDR-4M6, was developed by Instrumented Sensor Technology (IST) of Okemos, Michigan and includes three differential channels as well as three single-ended channels. The EDR-4 was configured with 6 MB of RAM memory and a 1,500 Hz lowpass filter. Computer software, "DynaMax 1 (DM-1)" and "DADiSP", was used to analyze and plot the accelerometer data.

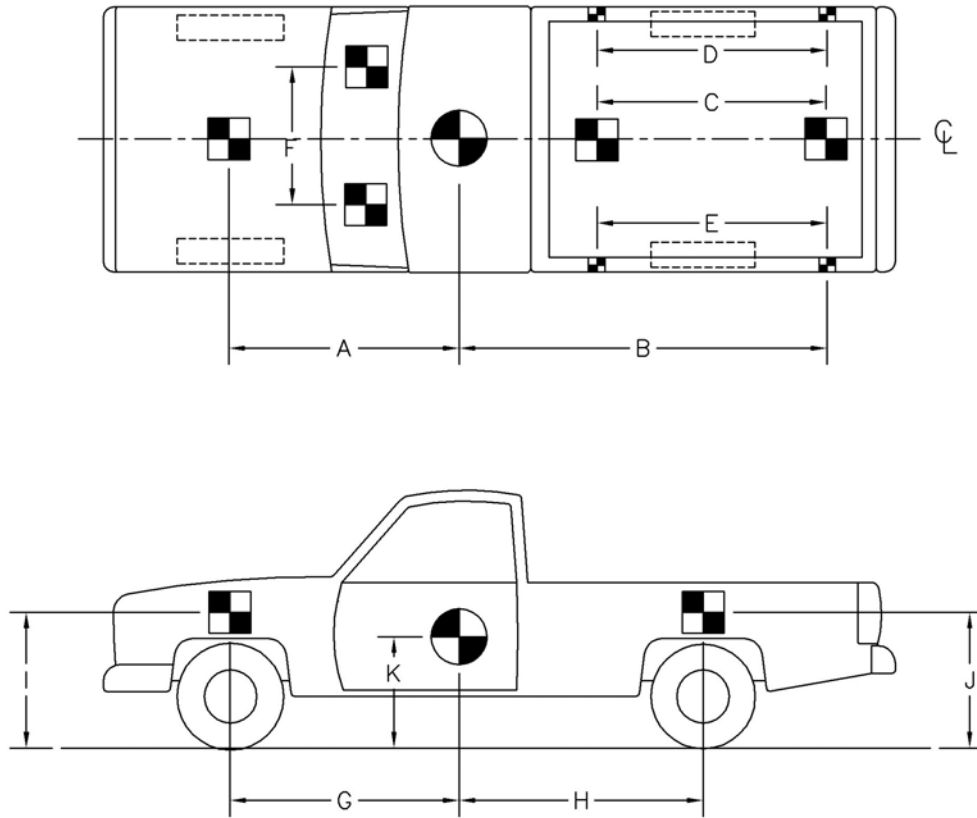

TEST #: <u>CS-2</u>			
TARGET GEOMETRY -- mm (in.)			
A	<u>1657 (65.25)</u>	D	<u>2153 (84.75)</u>
B	<u>2467 (97.125)</u>	E	<u>2153 (84.75)</u>
C	<u>1537 (60.5)</u>	F	<u>940 (37.0)</u>
		G	<u>1429 (56.25)</u>
		H	<u>2057 (81.0)</u>
		J	<u>1057 (41.625)</u>
		K	<u>670 (26.375)</u>
		I	<u>1010 (39.75)</u>

Figure 3. Vehicle Target Locations, Test CS-2

Another triaxial piezoresistive accelerometer system with a range of  $\pm 200$  g's was also used to measure the acceleration in the longitudinal, lateral, and vertical directions at a sample rate of 3,200 Hz. The environmental shock and vibration sensor/recorder system, Model EDR-3, was also developed by Instrumental Sensor Technology (IST) of Okemos, Michigan. The EDR-3 was configured with 256 kB of RAM memory and a 1,120 Hz lowpass filter. Computer software, "DynaMax 1 (DM-1)" and "DADiSP", was used to analyze and plot the accelerometer data.

### **3.4.2 Rate Transducers**

An Analog Systems 3-axis rate transducer with a range of 1,200 degrees/sec in each of the three directions (pitch, roll, and yaw) was used to measure the rates of motion of the test vehicle. The rate transducer was mounted inside the body of the EDR-4M6 and recorded data at 10,000 HZ to a second data acquisition board inside the body of the EDR-4M6 housing. The raw data measurements were then downloaded, converted to the appropriate Euler angles for analysis, and plotted. Computer software, "DynaMax 1 (DM-1)" and "DaDiSP", was used to analyze and plot rate transducer data.

### **3.4.3 High-Speed Photography**

For test CS-2, four high-speed AOS VITcam video cameras, with operating speeds of 500 frames/sec, were used to film the crash test. Four Canon digital video and one JVC digital video camera, all with standard operating speed of 29.97 frames/sec, were also used to film the crash test. Camera details and a schematic of all nine camera locations for test no. CS-2 are shown in Figure 4. The AOS videos were analyzed using the ImageExpress MotionPlus software. Actual camera speed and camera divergence factors were considered in the analysis of the high-speed videos.

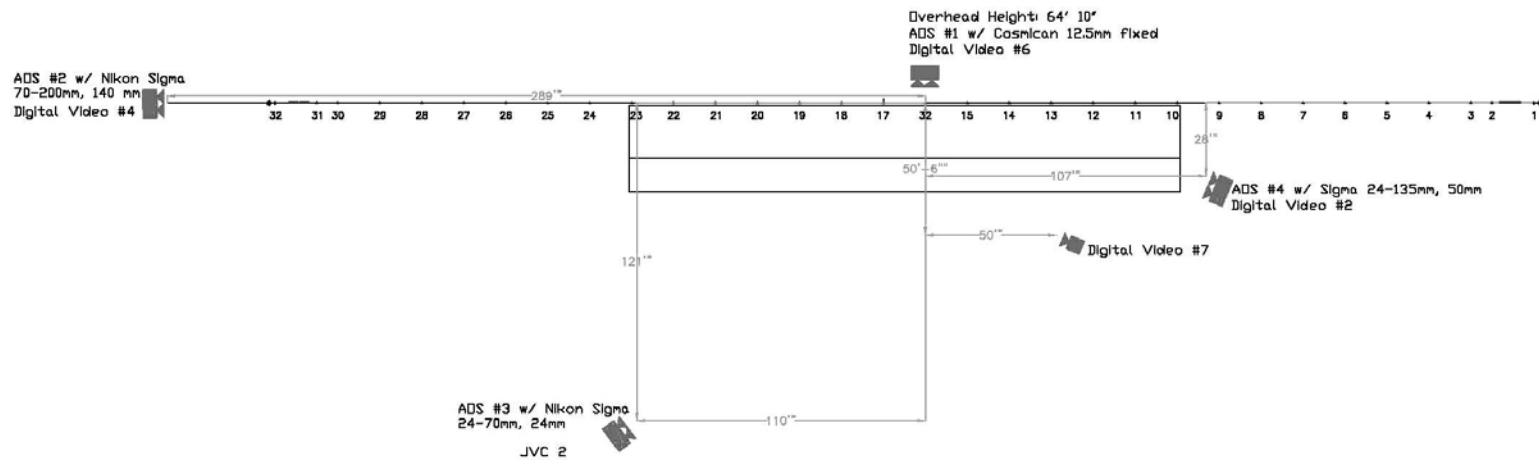

Figure 4. Locations of High-Speed Cameras, Test CS-2



### **3.4.4 Pressure Tape Switches**

For test CS-2, five pressure-activated tape switches, spaced at 2-m (6.56-ft) intervals, were used to determine the speed of the vehicle before impact. Each tape switch fired a strobe light which sent an electronic timing signal to the data acquisition system as the right-front tire of the test vehicle passed over it. Test vehicle speed was determined from electronic timing mark data recorded using TestPoint software. Strobe lights and high-speed video analysis are used only as a backup in the event that vehicle speed cannot be determined from the electronic data.

### **3.4.5 Three Cable End Terminal Instrumentation**

Electronic sensors were placed near the terminal anchor of the three cable guardrail system. The types of sensors used for the crash test were load cells and string potentiometers and are described following.

#### **3.4.5.1 Load Cells**

Six load cells were installed along the three cable guardrail system. The load cells were positioned in line and at both ends of the three individual cables to measure the forces transferred to the end terminal anchors. The three load cells on the upstream end were placed between post nos. 3 and 4, as shown in Figure 5. The three load cells on the downstream end were placed between post nos. 90 and 91, as shown in Figure 6.

The load cells were Transducer Techniques TLL-50K load cells with a load range up to 222.4 kN (50,000 lbs). During the test, output voltage signals from the load cells were sent to a Keithly Metrabyte DAS-1802HC data acquisition board, acquired with TestPoint software, and stored permanently on the computer. The sample rate of the load cells was 10,000 samples per second (10,000 Hz).

### **3.4.5.2 String Potentiometers**

A string potentiometer (linear variable displacement transducer) was installed on the end terminal anchor to monitor longitudinal displacement of the anchor. The positioning of the string potentiometer on the upstream end of the terminal is shown in Figure 7.

The string potentiometer used was a UniMeasure PA-50 string potentiometer with a range of 1.27 m (50 in.). A Measurements Group Vishay Model 2310 signal conditioning amplifier was used to condition and amplify the low-level signals to high-level outputs for multichannel, simultaneous dynamic recording on TestPoint software. After each signal was amplified, it was sent to a Keithly Metrabyte DAS-1802HC data acquisition board, and then stored permanently on the computer. The sample rate of the string potentiometers was 10,000 samples per second (10,000 Hz).

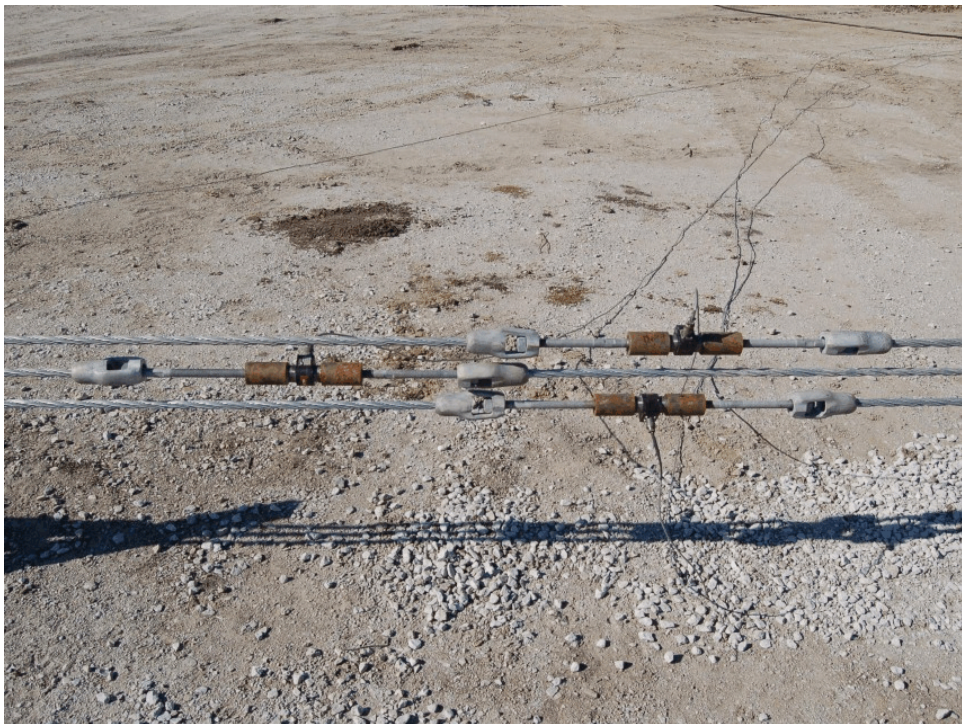

Figure 5. Upstream End Load Cell Positioning



Figure 6. Downstream End Load Cell Positioning



Figure 7. String Potentiometer Positioning

#### 4 THREE CABLE GUARDRAIL

The systems overall length was 150.57 m (494 ft) and consisted of four major structural components: (1) wire rope; (2) posts; (3) cable compensator end assemblies, and (4) tangent anchor assemblies. Design details are shown in Figures 8 through 19. The corresponding English-unit drawings are shown in Appendix A. Photographs of the test installation are shown in Figures 20 through 22.

Three 19-mm ( $\frac{3}{4}$ -in.) diameter cables comprised of 3x7 wire rope were used for the rail elements. The cable rails were supported by ninety-two guardrail posts with an uppermost mounting height of 762 mm (30 in.) and with 76-mm (3-in.) incremental spacing for the two lower cables, as shown in Figure 9. The cables were tightened with the use of cable compensators, also shown in Figure 9. The ends of the cables were threaded rods that terminated in the cable anchor. The threaded rods were attached to the cable anchor with three 51-mm (2-in.) diameter washers and two 19-mm ( $\frac{3}{4}$ -in.) diameter Grade 5 nuts.

The line posts consisted of 1,600-mm (63-in.) long S76x8.5 (S3x5.7) rolled steel sections with a 203-mm x 610-mm x 6-mm (8-in. x 24-in. x  $\frac{1}{4}$ -in.) soil plate welded along the back flange of the post, as shown in Figure 19. The line posts were spaced 1,219 mm (48 in.) on center with a soil embedment depth of 762 mm (30 in.). The line posts were set 1,219 mm (48 in.) back from the slope breakpoint.

Post nos. 1 through 7 and 86 through 92 were part of the tangent cable end anchor system as developed as part of a previous study, *Design and Evaluation of a Low-Tension Cable Guardrail End Terminal System* (9). The anchor bracket post, post nos. 1 and 92, were W152x37.2 (W6x25) steel sections with a 610-mm x 610-mm x 13-mm (24-in. x 24 in. x  $\frac{1}{2}$ -in.) soil plate. The anchor post

was embedded to a depth of 2,438 mm (96 in.), as shown in Figures 2 and 5. A 368-mm x 229-mm x 13-mm (14 ½-in. x 9-in. x ½-in.) plate welded to the top of the anchor post to which the cable anchor bracket was bolted with four 19-mm diameter x 64-mm long (¾-in. x 2.5-in.) Grade 5 hex head bolts.

Post nos. 2 and 91 were configured with S76x8.5 (S3x5.7) sections measuring 838 mm (33 in.) long for the slip posts with W152x13.4 (W6x9) sections measuring 1,829 mm (72 in.) long foundation posts. The foundation post was embedded to a depth 1,778 mm (70 in.). A slip base plate was welded to the bottom of the slip post and the top of the foundation post, as shown in Figures 14 and 15. Four 13-mm diameter x 51-mm (½-in. x 2 in.) long ASTM A307 bolts with nuts and washers to form the slip base configuration.

Post nos. 3 through 7 and 86 through 90 were also slip posts that were configured with S76x8.5 (S3x5.7) sections and W152x13.4 (W6x9) sections. These posts were identical to post nos. 2 and 91, except the cable bracket was replaced with three cable hooks as shown in Figures 16 and 17. The top cable hook was located 90 mm (3 ½ in.) down from the top of the post with the middle and lower cable 166 mm and 242 mm (6 ½ in. and 9 ½ in.) from the top of the post, respectively.

A 48.7-m long x 6.1-m wide (160-ft x 20-ft) pit was excavated behind the cable system. In order to develop a 1.5H:1V slope, the pit's profile was identified by horizontal and vertical components of 6.1 m (240 in.) and 4.1 m (160 in.), respectively, as shown in Figures 8 and 20.

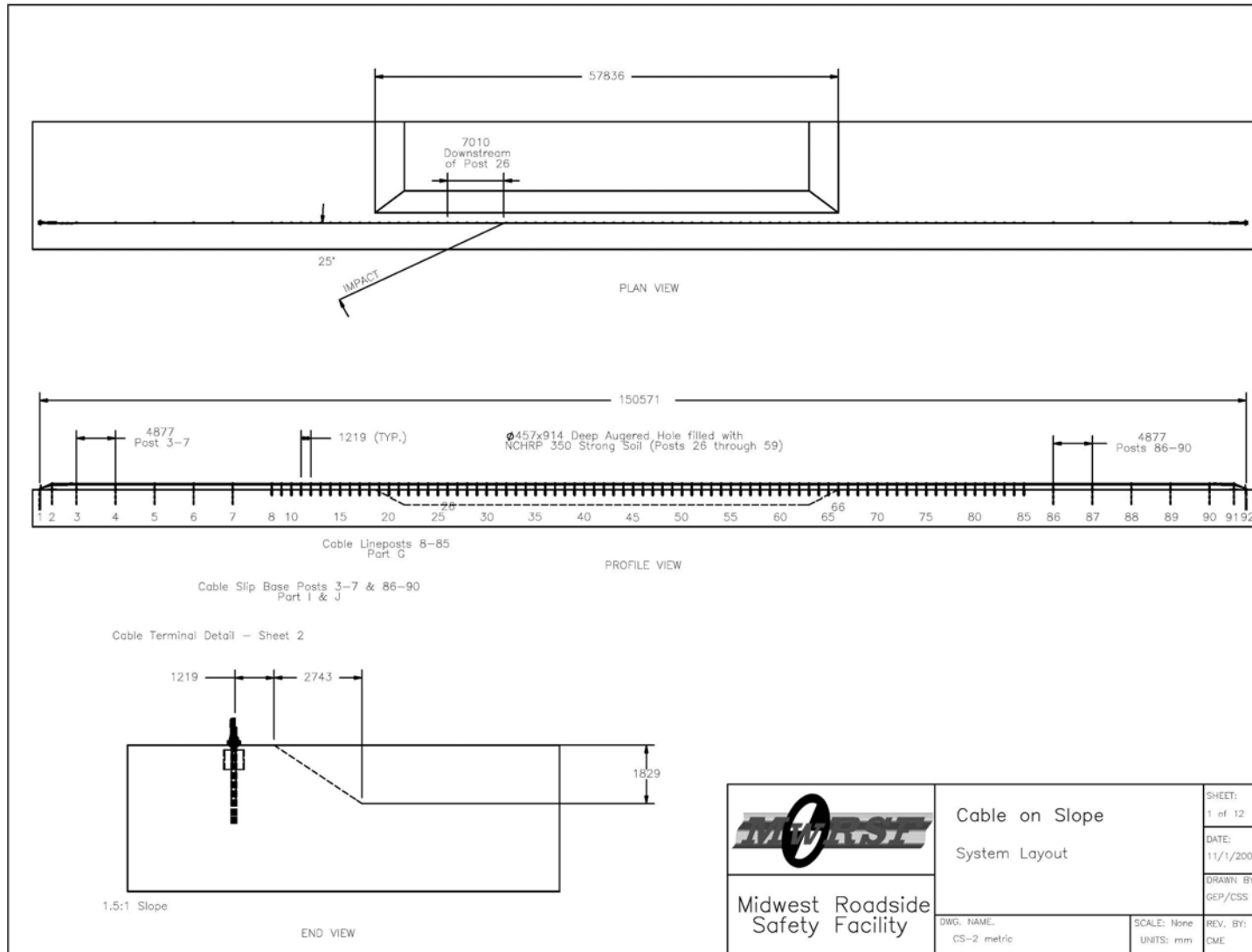

Figure 8. Three Cable Guardrail System Layout



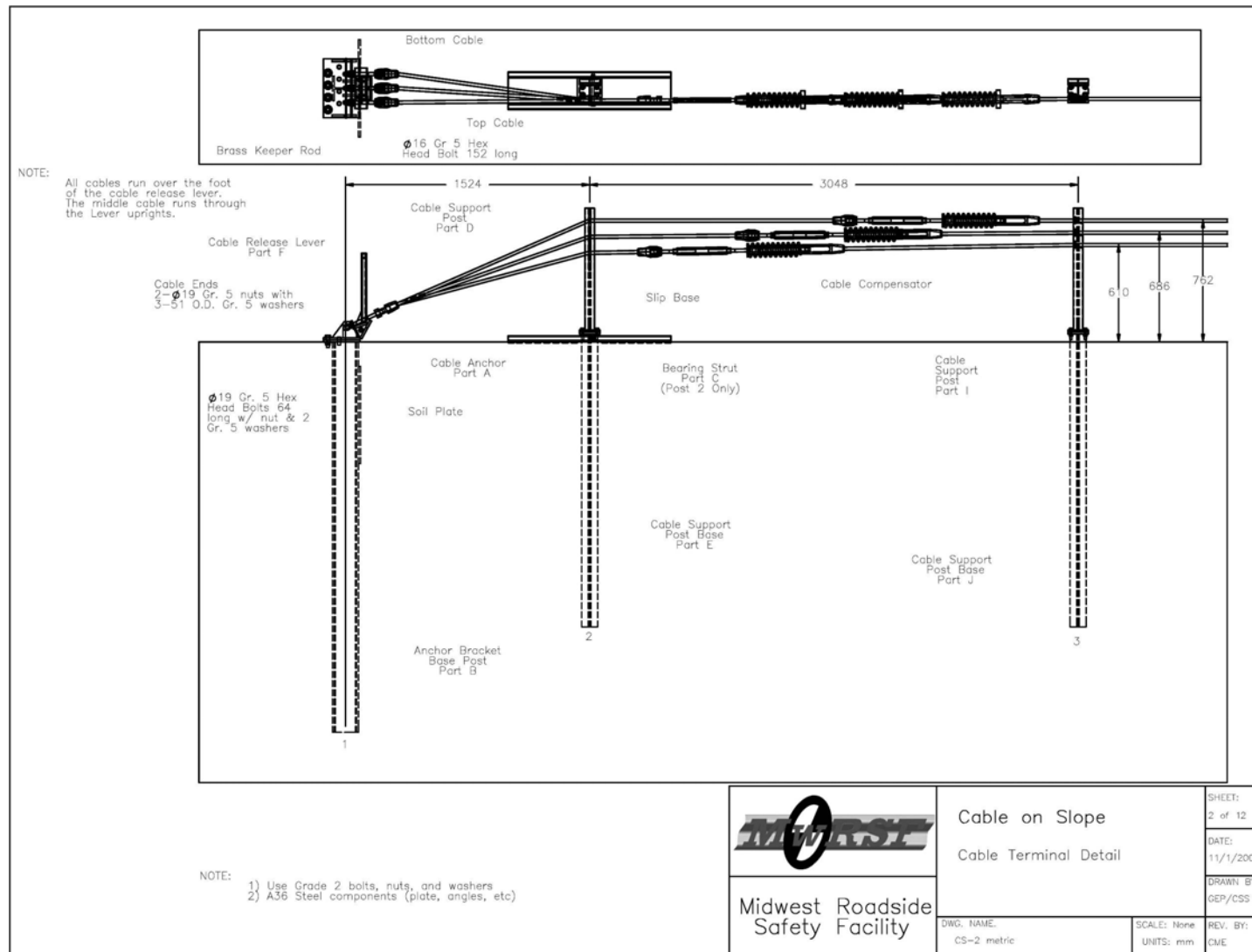
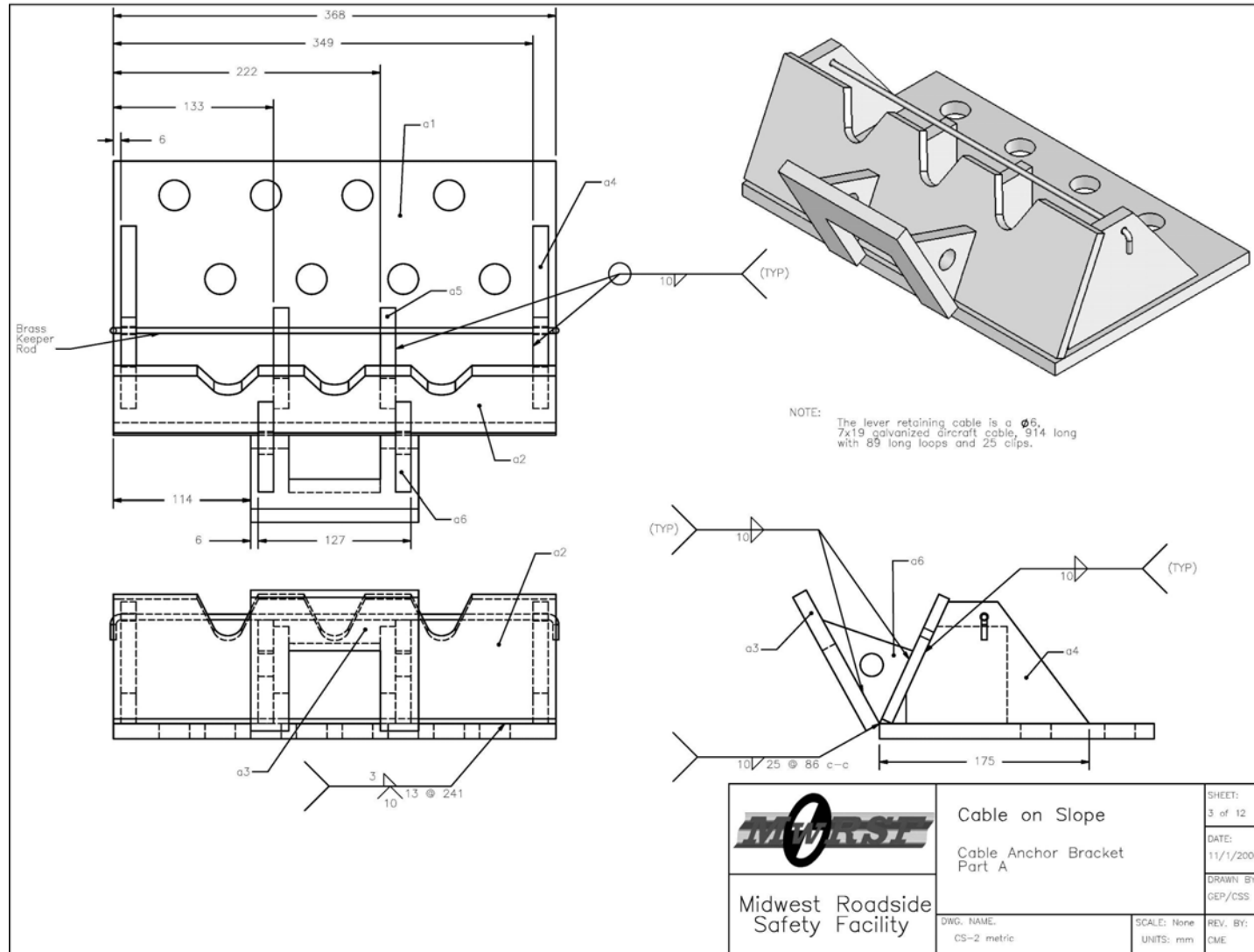

Figure 9. Three Cable Guardrail End Terminal Details



	Cable on Slope	SHEET: 3 of 12
	Cable Anchor Bracket Part A	DATE: 11/1/2006
Midwest Roadside Safety Facility	DWG. NAME: CS-2 metric	SCALE: None UNITS: mm
		REV. BY: CME
		DRAWN BY: GEP/CSS

Figure 10. Cable Anchor Bracket Details



	<b>Cable on Slope</b>	SHEET: 4 of 12
	Cable Anchor Bracket Part A Details	DATE: 11/1/2006
Midwest Roadside Safety Facility	DWG. NAME: CS-2 metric	SCALE: None UNITS: mm
		REV. BY: CME

Figure 11. Cable Anchor Bracket Details

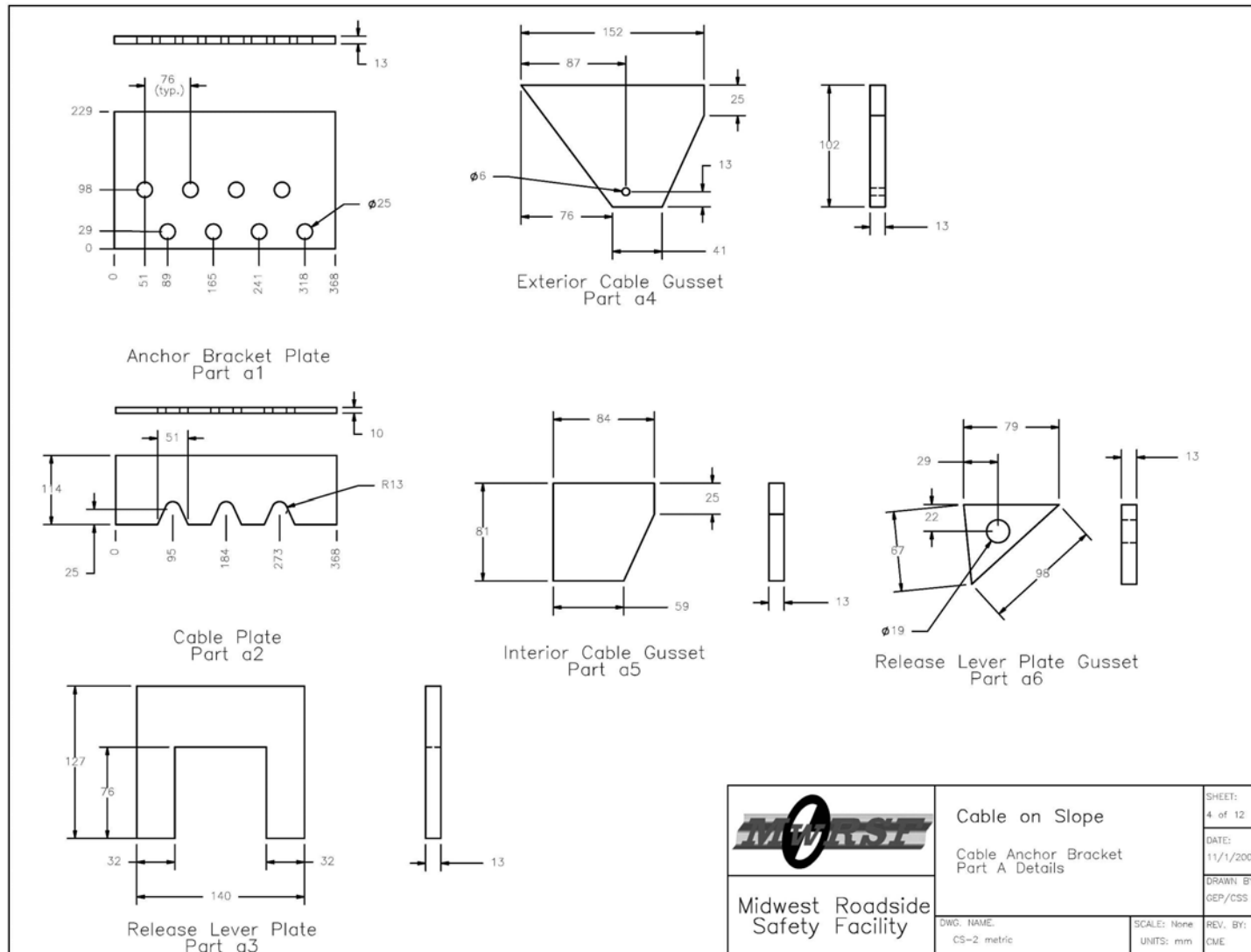
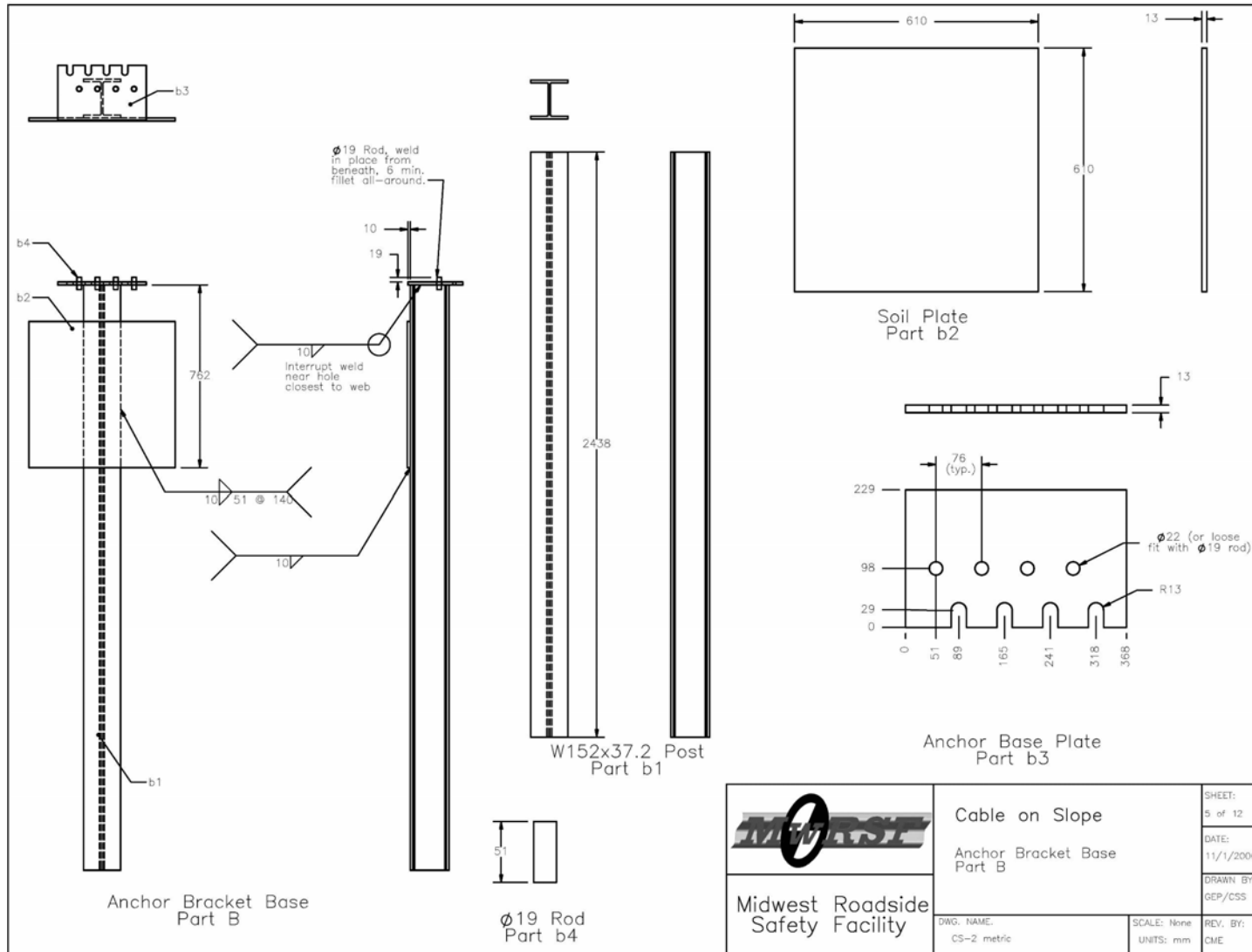

Figure 12. Anchor Bracket Base Details

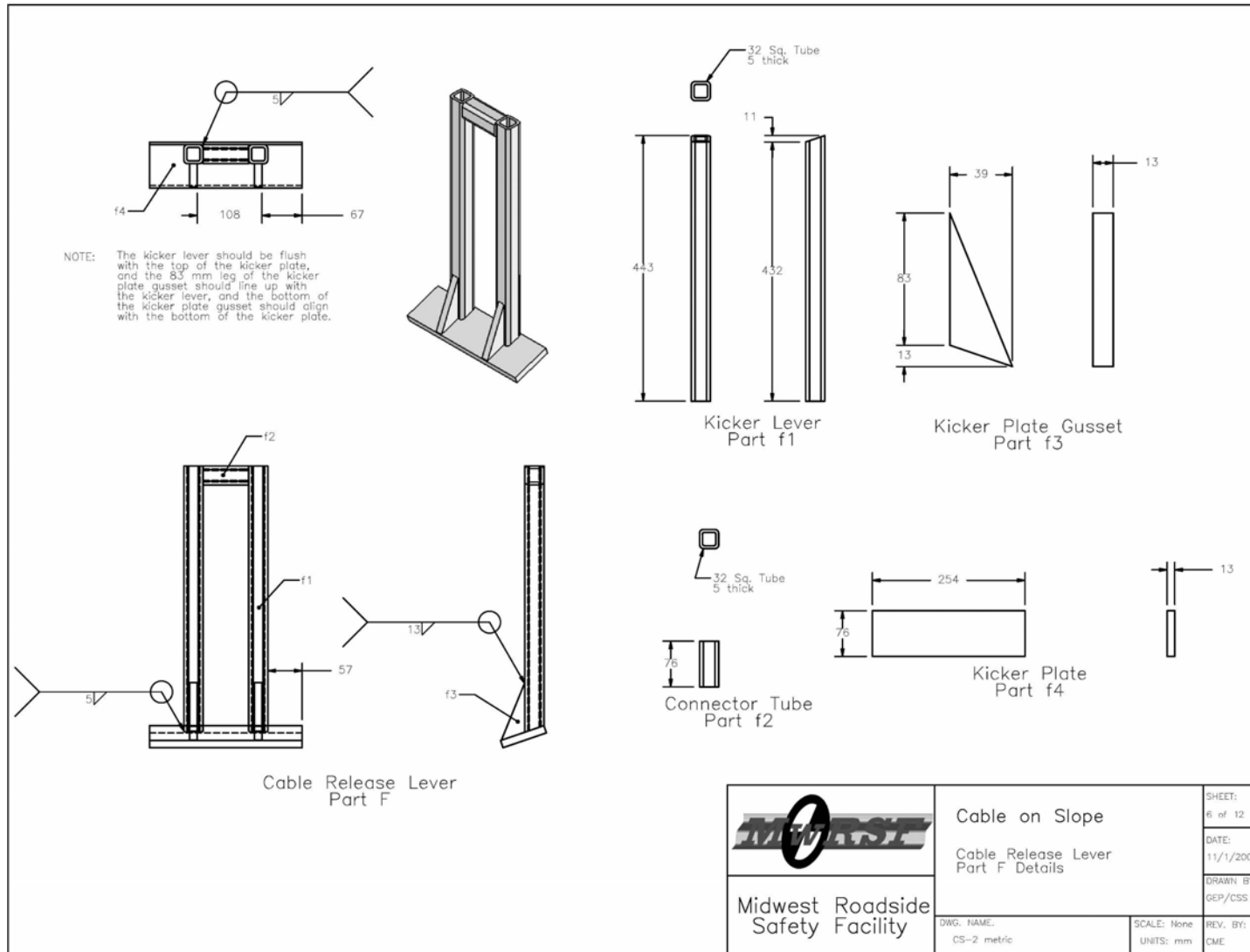

Figure 13. Cable Release Lever Details

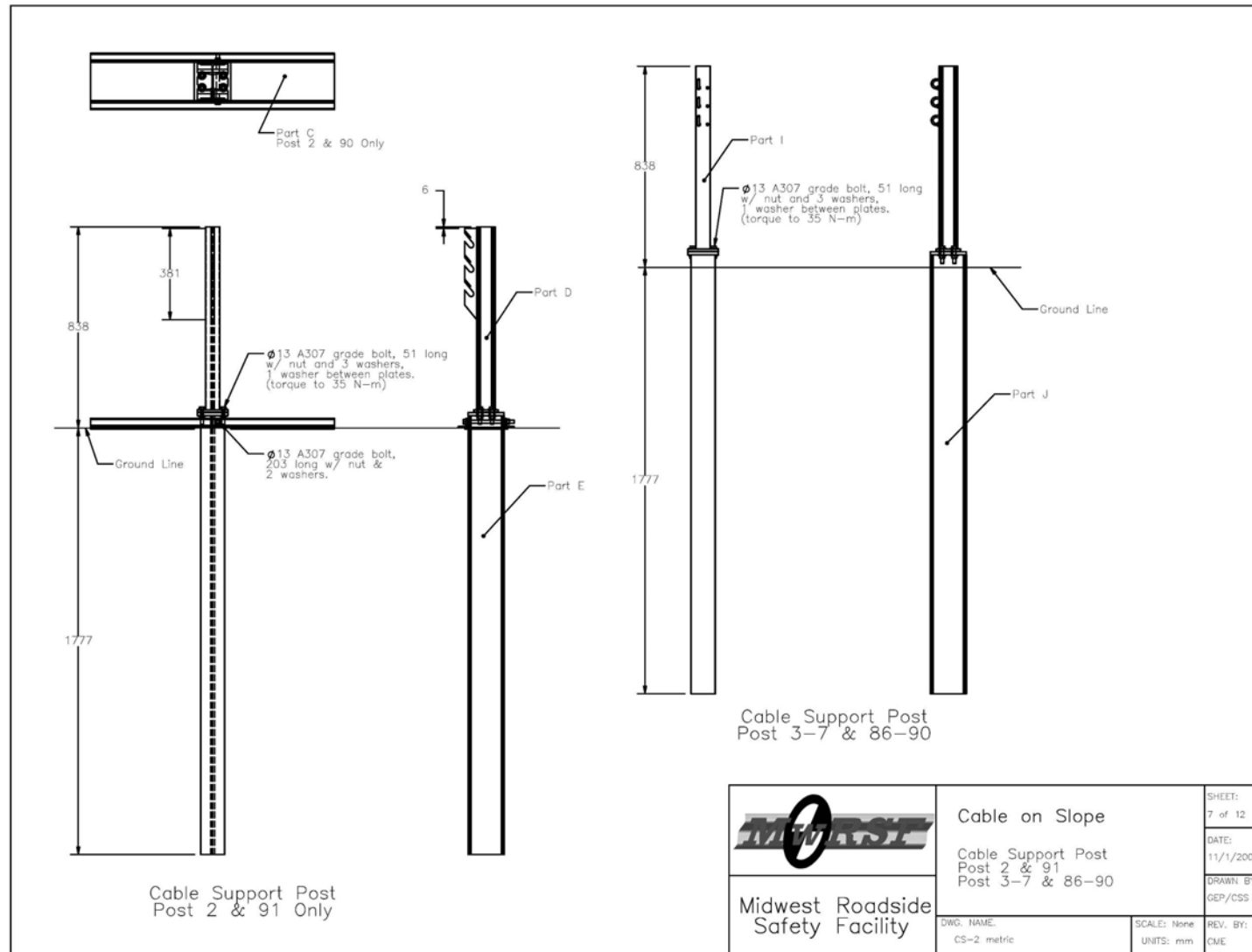

Figure 14. Three Cable Guardrail Support Post Details

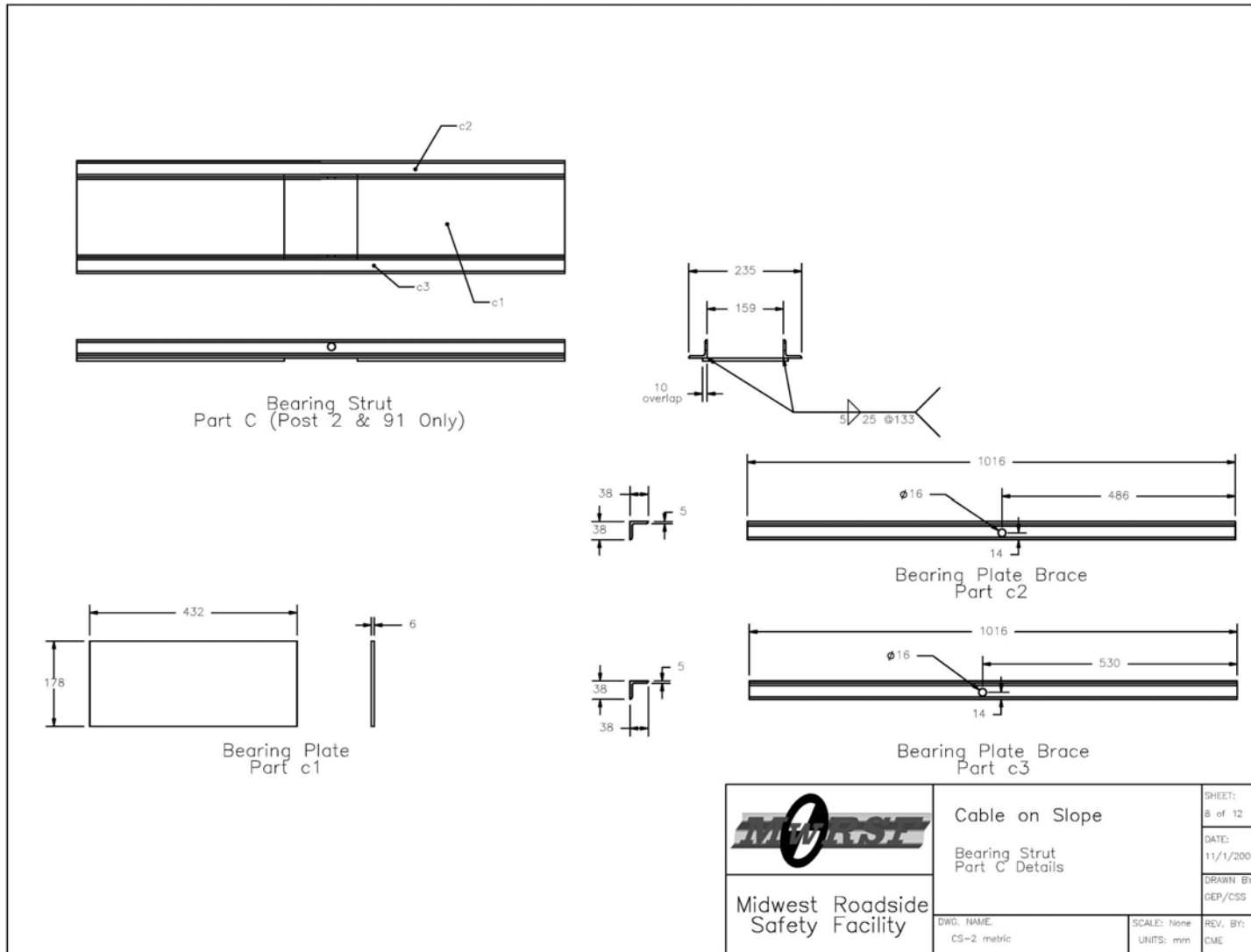

Figure 15. Bearing Strut Details

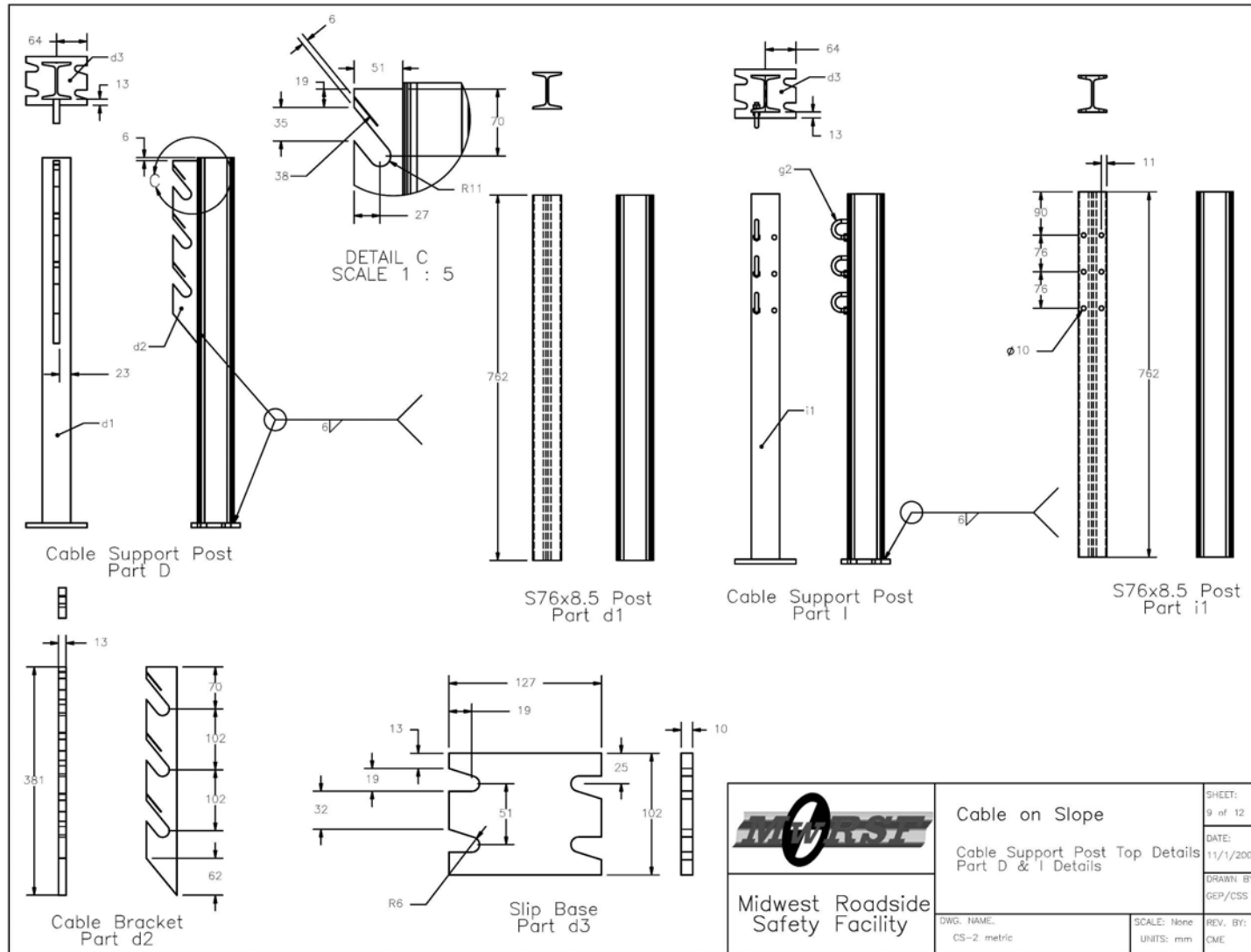

Figure 16. Cable Support Post Upper Details



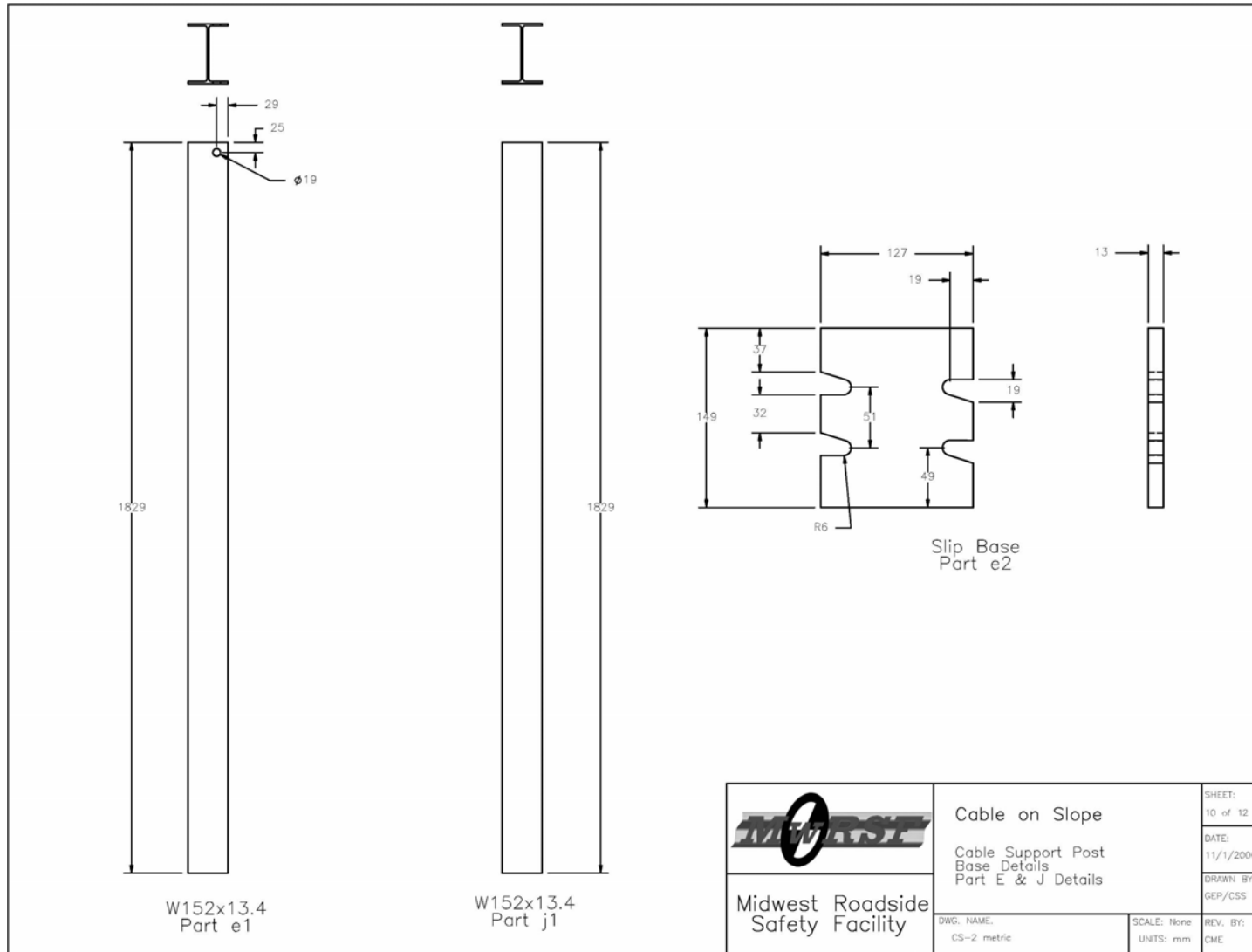
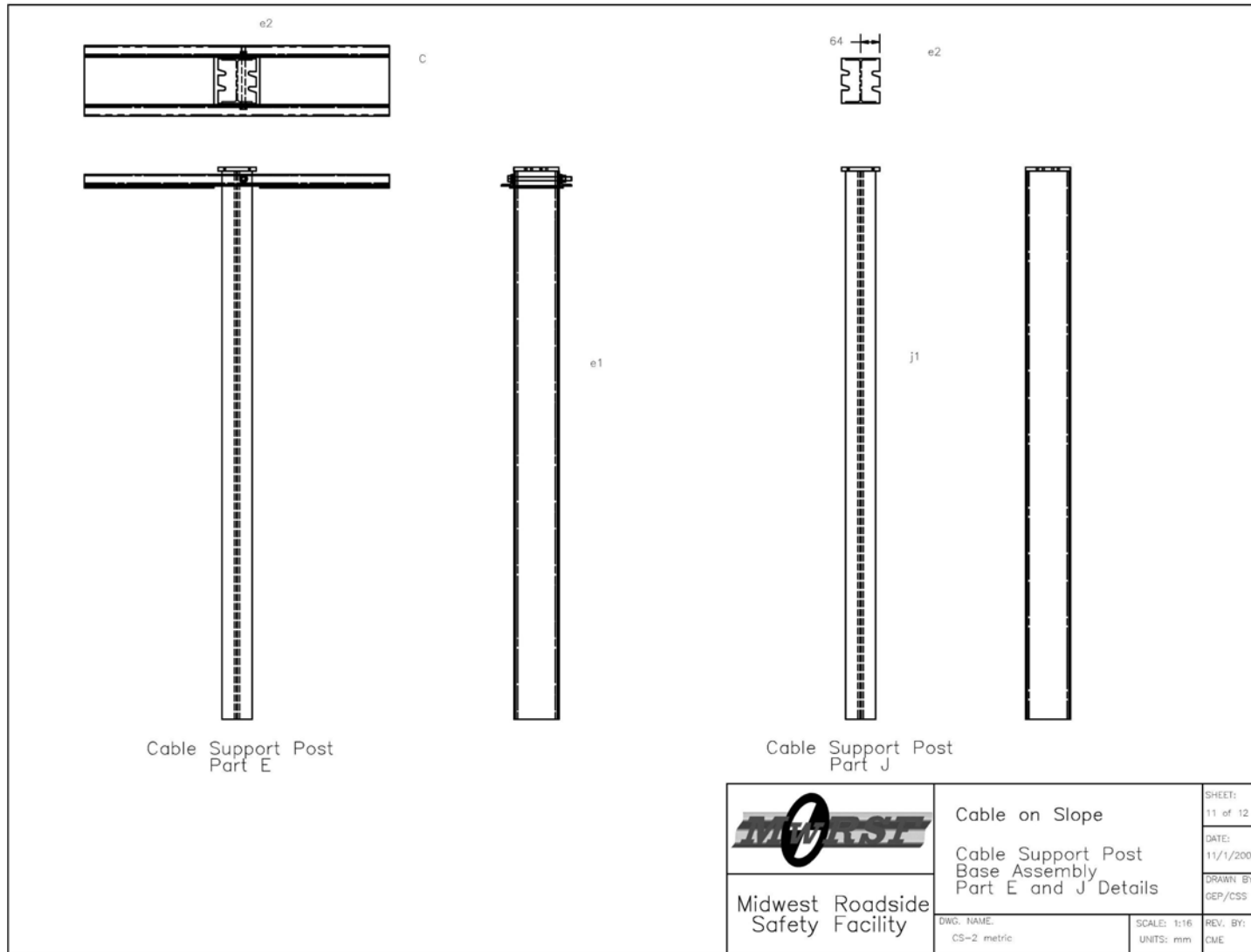

Figure 17. Cable Support Post Base Details



	Cable on Slope	SHEET: 11 of 12
	Cable Support Post Base Assembly Part E and J Details	DATE: 11/1/2006
Midwest Roadside Safety Facility	DWG. NAME: CS-2 metric	SCALE: 1:16 UNITS: mm
		REV. BY: CME

Figure 18. Cable Support Post Base Assembly Details

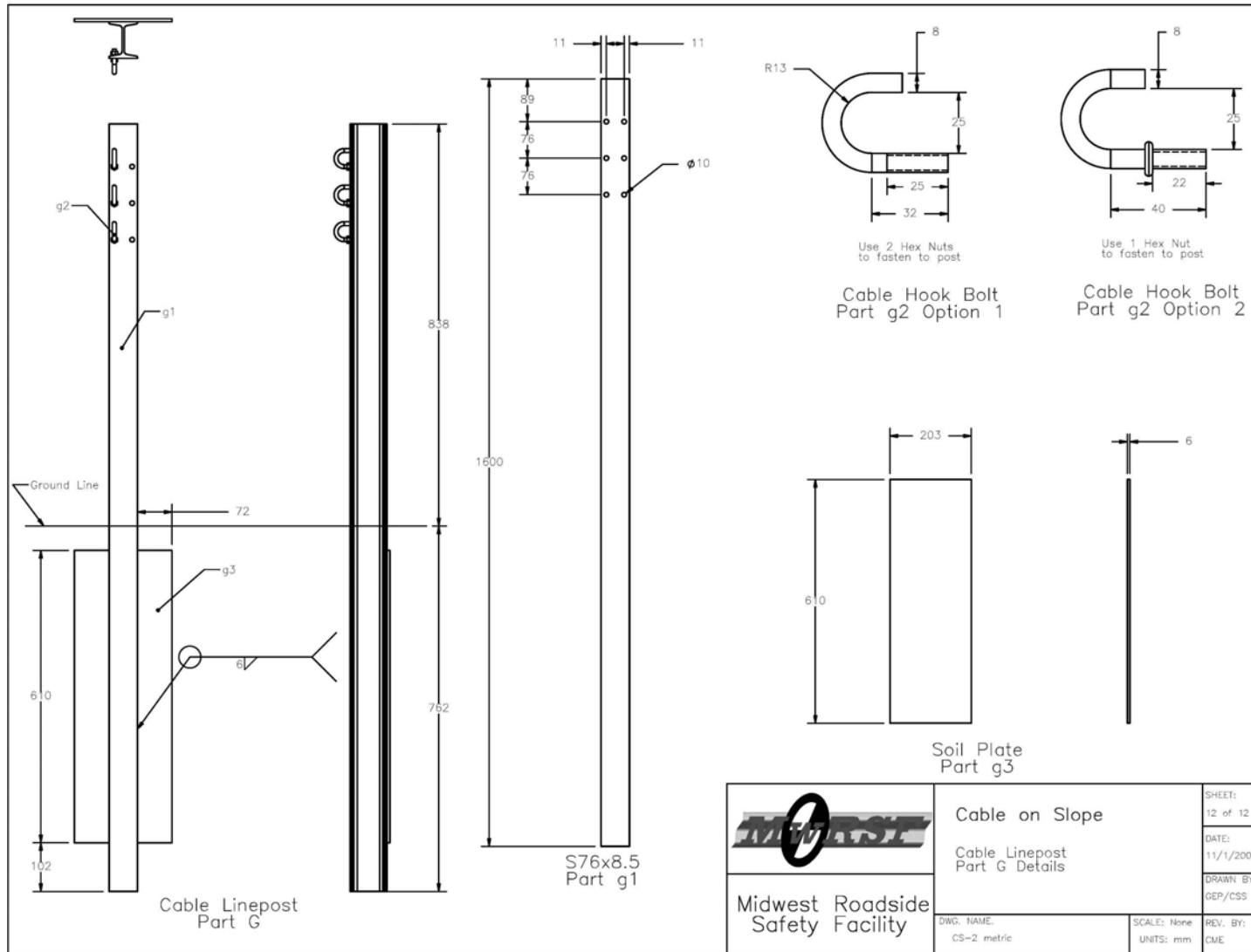

Figure 19. Cable Line Post Details



Figure 20. Three Cable Guardrail System Adjacent to Slope



34

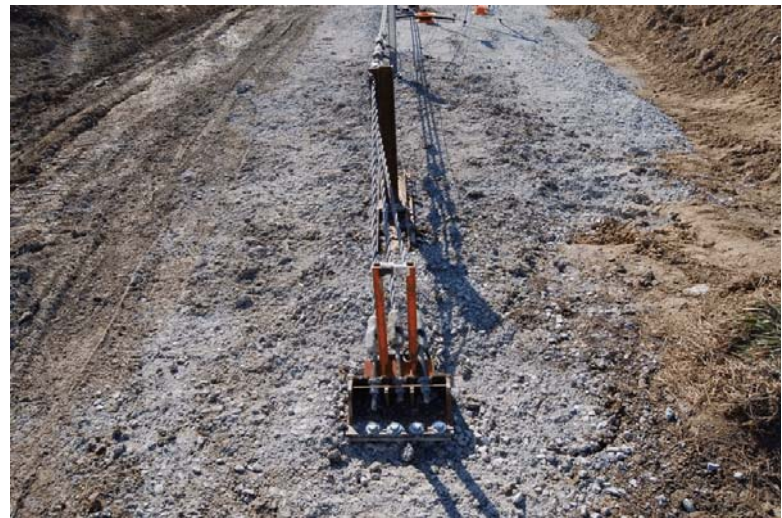

Figure 21. Three Cable Guardrail System Adjacent to Slope



Figure 22. Three Cable Guardrail System Adjacent to Slope

## **5 CRASH TEST**

### **5.1 Test CS-2**

The 2,032-kg (4,481-lb) pickup truck impacted the three cable guardrail system at a speed of 99.1 km/h (61.6 mph) and at an angle of 23.6 degrees. A summary of the test results and the sequential photographs are shown in Figure 23. The summary of the test results and sequential photographs in English units are shown in Appendix B. Additional sequential photographs are shown in Figures 24 through 26. Documentary photographs of the crash test are shown in Figure 27.

### **5.2 Test Description**

Initial vehicle impact was to occur between post nos. 31 and 32, or 305 mm (1 ft) upstream from the centerline of post no. 32, as shown in Figure 28. Actual vehicle impact occurred at post no. 32. At 0.002 sec after impact post no. 32 deflected both laterally and longitudinally. At 0.020 sec, the vehicle contacted post no. 33. At 0.028 sec, the three cables wrap around the left-front corner of the truck. At 0.034 sec, the cables caused slight deformation to the left-front quarter panel of the truck. At 0.054 sec, post no. 34 deflected laterally and longitudinally. At 0.064 sec, the left-front tire of the vehicle completely traversed the original post line as the truck continued downstream. At 0.076 sec, the truck ran over post no. 33 with the front of the truck in contact with post no. 34. At 0.094 sec, post no. 35 deflected as the truck continued out over the slope breakpoint. At 0.124 sec, the right-front bumper of the truck contacted post no. 35. At 0.130 sec, post no. 36 deflected. At 0.150 sec, the truck yawed as it began to redirect out of the system. At this same time, post no. 37 deflected. At 0.154 sec, the top cable detached from post no. 36. At 0.156 sec, the front of the truck contacted post no. 36. At 0.160 sec, all three cables released from post no. 36. At 0.178 sec, post no. 38 deflected. At 0.180 sec, the left-front tire of the truck became airborne, and the front

bumper of the truck contacted post no. 37. At 0.186 sec, the top cable was detached from post no. 37. At 0.208 sec, post no. 39 deflected. At 0.216 sec, the top cable released from post no. 38. At 0.226 sec, the right-front tire of the truck ramped up post no. 36 and became airborne. At 0.234 sec, post no. 40 deflected. At this same time, all three cables released from post no. 38. At 0.246 sec, the front bumper separated from the truck due to the force from the released cables. At 0.254 sec, the top cable detached from post no. 39. At 0.266 sec, the truck encountered negative roll toward the left-side as it redirected. At 0.272 sec, the truck contacted post no. 39. At 0.276 sec, the other two cables released from post no. 39. At 0.288 sec, the top cable released from post no. 40. At 0.290 sec, post no. 41 deflected. At .314 sec, the other two cables released from post no. 40. At 0.316 sec, the front of the truck contacted post no. 40. At 0.322 sec, post no. 42 deflected and the left-rear tire became airborne as it traversed completely over the slope breakpoint. At 0.348 sec, the truck encountered significant roll toward the left-side. At 0.382 sec, the truck contacted post no. 41, and the left-front tire contacted the ground. At 0.384 sec, all three cables released from post no. 42. At 0.396 sec, the front of the vehicle pitched negatively downward with both rear tires airborne. At 0.410 sec, right-front tire contacted post no. 40, and post no. 43 deflected laterally. At 0.498 sec, post no. 44 deflected. At 0.532 sec, the truck reaches its maximum negative roll of -24.5 degrees. At 0.560 sec, the truck rolled back toward the right side with the front end of the truck pointed upward on the slope. At 0.564 sec, the front of the vehicle contacted post no. 43. At 0.622 sec, post no. 45 deflected, and at 0.690 sec, the front of the truck impacted post no. 45. At 0.696 sec, the left-front tire of the truck became airborne as the truck traveled back across the slope breakpoint. At 0.750 sec, the truck became parallel to the system with a resultant velocity of 62.7 km/h (39.0 mph). At 0.758 sec, both front tires are airborne due to the truck traversing back across the slope



breakpoint. At 0.764 sec, the truck continued to roll positively towards the right side. At 0.822 sec, the truck's right-front tire contacted the ground as the truck continued traveling downstream. At 0.924 sec, the truck reached its maximum positive roll of 14.7 degrees. At 0.966 sec, the truck began to exit the system. At 1.118 sec, the truck exited the system at a trajectory angle of 13.2 degrees and at a resultant velocity of 54.2 km/h (33.7 mph). At 1.184 sec, the rear of the truck yawed away from the system causing the truck to turn back toward the system. At 1.288 sec, all four tires were back in contact with the ground. At 1.890 sec, the truck redirected back into the system. At 2.652 sec, the truck came to rest 42.9 m (140.9 ft) downstream from impact with the front bumper in contact with post no. 68 and the left-front wheel on top of post no. 67. The trajectory and final position of the pickup truck are shown in Figures 23 and 29.

### **5.3 Barrier Damage**

Damage to the barrier was moderate, as shown in Figures 30 through 34. Barrier damage consisted mainly of deformed line posts, stretched cable, and soil failure. The length of vehicle contact was approximately 19.7 m (64 ft - 8 in.), which spanned from the upstream edge of post no. 32 through the upstream edge of post no. 48.

The system's upstream anchor deflected longitudinally 51 mm (2 in.) downstream. Soil cracking with a radius of 356 mm (14 in.) was found on the downstream side of the upstream anchor. The downstream anchor deflected upstream 38 mm (1.5 in.). All three cables were detached from post nos. 33 through 48. The bottom cable released from post nos. 32 and 49. Soil cracking was also found around post no. 7. Post no. 31 deflected backward 25 mm (1 in.). Post no. 32 deflected backward about 51 mm (2 in.). Post no. 33 was rotated and bent backward to where the top of the post was 279 mm (11 in.) above the ground. The top cable hook fractured off of post no. 33. Post

nos. 34 and 35 were also rotated and bent backward with the tops of the posts 356 mm (14 in.) above the ground. Minor gouging was found on post no. 34. Post nos. 36 through 48 experienced weak axis bending. The tops of post nos. 36 through 48 were bent to 152 mm (6 in.), 305 mm (12 in.), 533 mm (21 in.), 533 mm (21 in.), 406 mm (16 in.), 419 mm (16.5 in.), 457 mm (18 in.), 533 mm (21 in.), 533 mm (21 in.), 610 mm (24 in.), 508 mm (20 in.), 470 mm (18.5 in.), and 406 (16 in.) above the ground respectively. Minor gouging was found on the upstream side of post nos. 37 and 41 through 44. Local buckling 279 mm (11 in.) from the top was found on the upstream side of post no. 38. Local buckling was found 305 mm (12 in.) from the top on the upstream-back flange of post no. 39. Minor gouging was found on the front face of post nos. 46 through 48. The remainder of the downstream posts were not damaged.

The permanent set of the barrier system is shown in Figure 28. The upstream and downstream cable anchor ends encountered slight permanent set deformations. The maximum lateral permanent set post deflection was 578 mm (22.75 in.) at the centerline of post no. 36 as measured in the field. The maximum lateral dynamic cable deflection was 3,163 mm (124.5 in.), as determined from high-speed digital video analysis. The working width of the system was found to be 3,318 mm (130.6 in.).

#### **5.4 Vehicle Damage**

Exterior vehicle damage was moderate as shown in Figures 35 through 38. Occupant compartment deformations to the left side of the floorboard were judged insufficient to cause serious injury to the vehicle occupants as shown in Figure 38. Maximum longitudinal deflections of 6.35 mm (0.25 in.) were located along the front of the driver's side floor panel. A maximum lateral deflection of 13 mm (0.5 in.) was located on the right-front corner of the driver's side floor panel.

Maximum vertical deflections of 6.35 mm (0.25 in.) were located along the right side of the driver's side floor panel near the front of the vehicle and in the center of the driver's side floor panel as well. Complete occupant compartment deformations and the corresponding locations are provided in Appendix C.

Damage was concentrated on the left-front corner and left side of the vehicle. The left-front quarter panel buckled inward. The left-front corner of the bumper was bent back toward the engine compartment. The inside wall of the left-front tire was punctured and the right-front wheel well was severely damaged. The steering knuckle was pushed into the strut frame. The front of the hood was deformed upward slightly. Significant cable friction damage was found on the entire left side of the vehicle. The left-rear quarter panel was deformed outward. Major denting and gouging was found on the exhaust pipe. The right side, rear, and top of the vehicle as well as all window glass remained undamaged.

### **5.5 Occupant Risk Values**

The longitudinal and lateral occupant impact velocities were determined to be -4.16 m/s (-13.64 ft/s) and 3.42 m/s (11.22 ft/s), respectively. The maximum 0.010-sec average occupant ridedown deceleration in the longitudinal and lateral directions were -5.73 g's and 6.96 g's, respectively. Both the occupant impact velocities (OIVs) and occupant ridedown decelerations (ORDs) were within the suggested limits provided in NCHRP Report No. 350. The THIV and PHD values were determined to be 5.14 m/s (16.86 ft/s) and 8.27 g's, respectively. The results of the occupant risk, as determined from the accelerometer data, are summarized in Figure 23. Results are shown graphically in Appendix D. The results from the rate transducer are also shown graphically in Appendix D.

## 5.6 Load Cell and String Potentiometer Results

As previously discussed, load cells were installed in each cable at both ends of the system to monitor the loads transferred to the anchor through the cables. A string potentiometer was also installed at the upstream end to record dynamic displacement of the steel post anchor. The results of the load cell data is summarized in Table 3. Note that only the results from the upstream load cells are presented because the downstream load cells did not produce usable data.

The total cable load was summed and plotted, as shown in Figure 39. The maximum force acting on the upstream anchor was 109.60 kN (24.64 kips). The dissection of the total cable loading to the contribution of each individual cable is also shown in Figure 39. The top cable at the upstream anchor sustained a maximum load of 34.56 kN (7.77 kips). The middle cable experienced a maximum load of 36.79 kN (8.27 kips). The resultant force applied to the bottom cable at the upstream anchor was determined to be 39.41 kN (8.86 kips).

Table 3. Load Cell Results, Test CS-2

Load Type	Maximum Cable Load		Time
	kN	kips	sec
Maximum Combined Cable Load	109.60	24.64	0.37
Maximum Load in Top Cable	34.56	7.77	0.37
Maximum Load in Middle Cable	36.79	8.27	0.37
Maximum Load in Bottom Cable	39.41	8.86	0.37

Anchor displacement was also of primary concern in the evaluation of the three cable system. The displacement time history of the upstream anchor is shown in Figure 40. The driven steel post

anchor on the upstream end of the barrier had a maximum displacement of 76.75 mm (3.01 in.) at 0.46 sec.

## **5.7 Discussion**

The analysis of the test results for test no. CS-2 showed that the three cable barrier system with quarter-post spacing and located 1,219 mm (4 ft) in front of a 1.5:1 slope impacted with the 2000P vehicle adequately contained and redirected the vehicle with controlled lateral displacements of the barrier system. There were no detached elements nor fragments which showed potential for penetrating the occupant compartment nor presented undue hazard to other traffic. Deformations of, or intrusion into, the occupant compartment that could have been caused serious injury did not occur. The vehicle did not penetrate nor ride over the barrier and remained upright during and after the impact. The vehicle's post impact trajectory revealed no intrusion into adjacent traffic lanes. The vehicle's exit angle was 16.3 degrees, as determined by high-speed film analysis, which was slightly higher than the preferable exit angle of 14.2 degrees. The longitudinal occupant impact velocity and ridedown deceleration were within the required limitations. Therefore, test no. CS-2 was determined to be acceptable according to the TL-3 safety performance criteria found in NCHRP Report No. 350.



0.000 sec

0.180 sec

0.396 sec

0.498 sec

0.690 sec

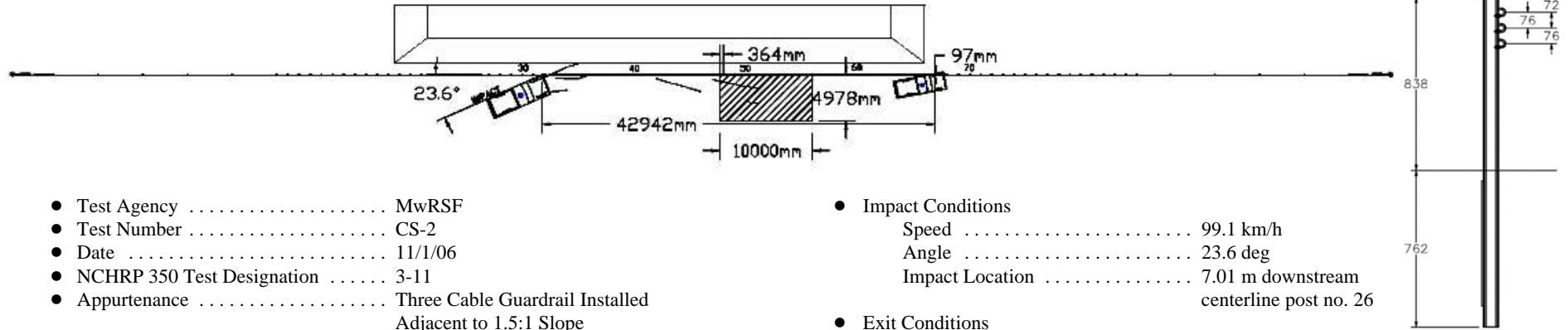

43

- Test Agency ..... MwRSF
- Test Number ..... CS-2
- Date ..... 11/1/06
- NCHRP 350 Test Designation ..... 3-11
- Appurtenance ..... Three Cable Guardrail Installed Adjacent to 1.5:1 Slope
- Total Length ..... 150.85 m
- Key Elements - Wire Rope
  - Diameter ..... 19 mm
  - Size ..... 7x19
  - Top Mounting Height ..... 762 mm
  - Incremental Spacing ..... 76 mm
- Key Elements - End Anchor Posts
  - Post Nos. 1 and 92 ..... W152x37.2 by 2,438 mm long
  - Post Nos. 2 and 91 ..... S76x8.5 by 838 mm long with W152x13.4 by 1,829 mm long
- Key Elements - Slip-Base Post
  - Post Nos. 3-7 and 86-90 ..... S76x8.5 by 838 mm long with W152x13.4 by 1,829 mm long
  - Spacing ..... 4,877 mm
- Key Elements - Line Posts
  - Post Nos. 8-85 ..... S76x8.5 by 1,600-mm long
  - Spacing ..... 1,219 mm
- Type of Soil ..... Grading B - AASHTO M 147-65 (1990)
- Test Vehicle
  - Type/Designation ..... 2000P
  - Make and Model ..... 1999 Chevrolet C2500 pickup truck
  - Curb ..... 2,182 kg
  - Test Inertial ..... 2,033 kg
  - Gross Static ..... 2,033kg

- Impact Conditions
  - Speed ..... 99.1 km/h
  - Angle ..... 23.6 deg
  - Impact Location ..... 7.01 m downstream centerline post no. 26
- Exit Conditions
  - Speed ..... 52.8 km/h
  - Angle ..... 16.3 deg
  - Exit Box Criterion ..... Passed
- Post-Impact Trajectory
  - Vehicle Stability ..... Satisfactory
  - Stopping Distance ..... 42.94 m downstream in contact with barrier
- Occupant Impact Velocity
  - Longitudinal ..... -4.16 m/s < 12 m/s
  - Lateral (not required) ..... 3.42 m/s
- Occupant Ridedown Deceleration (10 msec avg.)
  - Longitudinal ..... -5.73 g's < 20 g's
  - Lateral (not required) ..... 6.96 g's
- THIV (not required) ..... 5.14 m/s
- PHD (not required) ..... 8.27 g's
- Test Article Damage ..... Moderate
- Test Article Deflections
  - Permanent Set ..... 578 mm
  - Dynamic ..... 3,163 mm
  - Working Width ..... 3,317 mm
- Vehicle Damage ..... Moderate
  - VDS<sup>10</sup> ..... 11-FL-2
  - CDC<sup>11</sup> ..... 12FYES3
  - Maximum Deformation ..... 12.7 mm at front of left-side floorpan

Figure 23. Summary of Test Results and Sequential Photographs, Test CS-2



0.000 sec



0.696 sec



0.076 sec



0.966 sec



0.246 sec



0.758 sec



0.476 sec



1.288 sec

Figure 24. Additional Sequential Photographs, Test CS-2



0.000 sec



0.314 sec



0.124 sec



0.464 sec



0.214 sec



0.568 sec



0.254 sec



0.726 sec

Figure 25. Additional Sequential Photographs, Test CS-2





0.000 sec



0.362 sec



0.058 sec



0.514 sec



0.116 sec



0.714 sec



0.214 sec



1.082 sec

Figure 26. Additional Sequential Photographs, Test CS-2



Figure 27. Documentary Photographs, Test CS-2



Figure 28. Impact Location, Test CS-2



Figure 29. Final Position, Test CS-2



Figure 30. System Damage, Test CS-2



51

Figure 31. System Damage, Test CS-2



52

Figure 32. System Damage, Test CS-2



Figure 33. System Damage, Test CS-2





Figure 34. End Anchor Damage, Test CS-2



Figure 35. Vehicle Damage, Test CS-2



Figure 36. Vehicle Damage, Test CS-2



Figure 37. Undercarriage Damage, Test CS-2



Figure 38. Occupant Compartment Deformation, Test CS-2

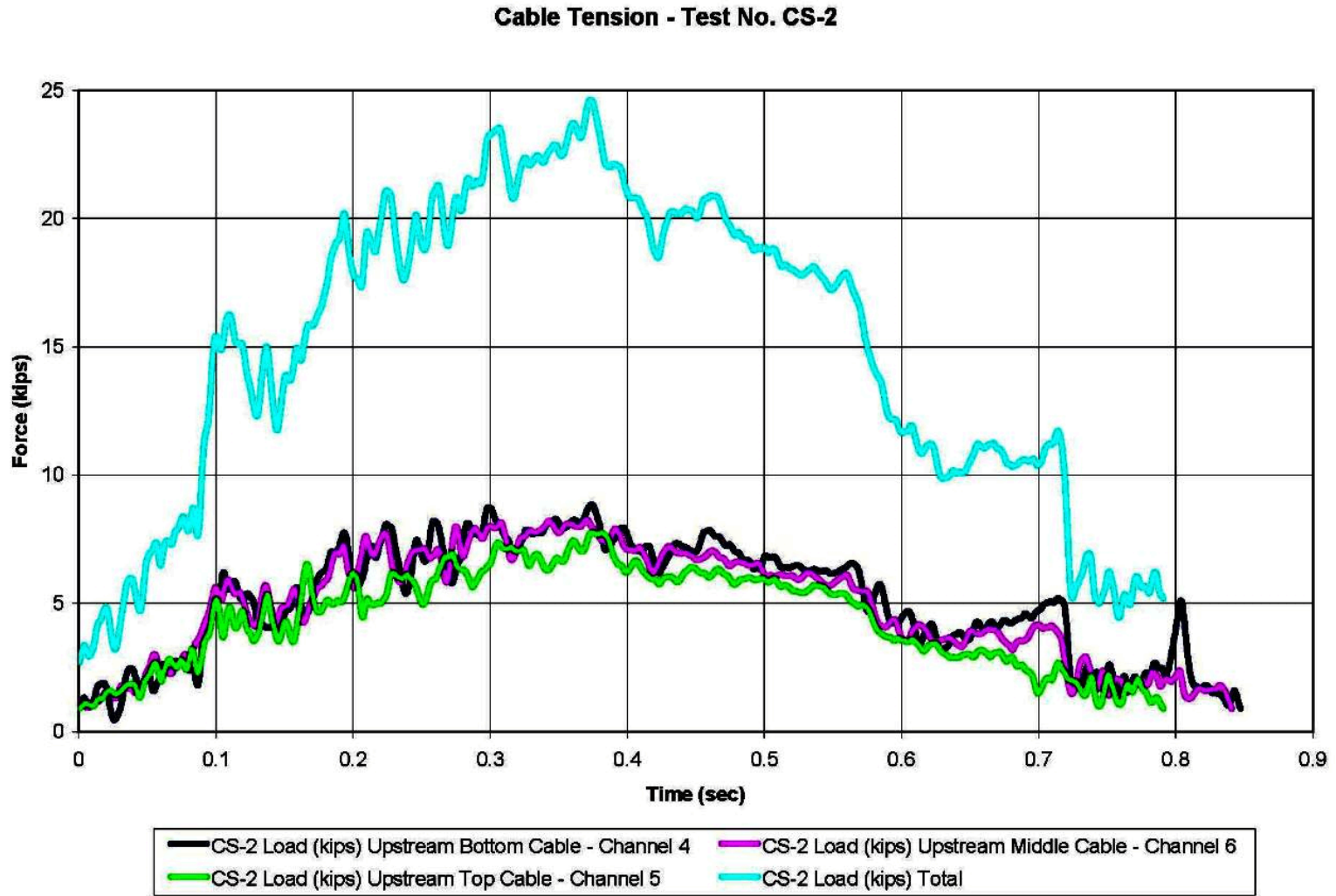

Figure 39. Force-Time History for the Cables at the Upstream Anchor, Test CS-2

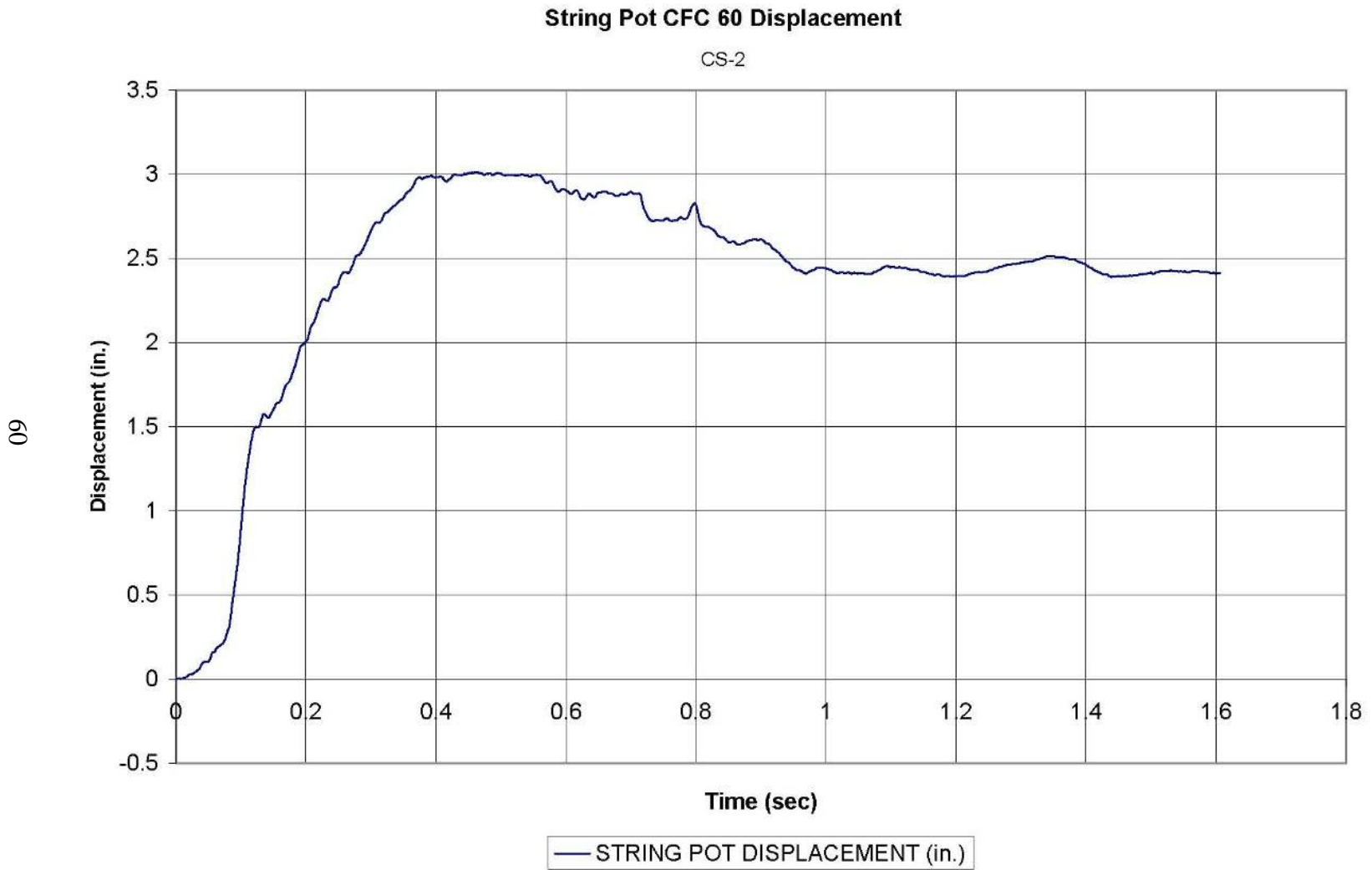

Figure 40. Displacement-Time History Plot for Upstream Anchor, Test CS-2

## **6 SUMMARY, CONCLUSIONS, AND RECOMMENDATIONS**

A three cable barrier system with a tangent end terminal for use adjacent to a steep slope was constructed and full-scale vehicle crash tested. The standard three cable system was modified by reducing the post spacing to quarter-post spacing. In addition, the offset from the slope breakpoint was increased to 1,219 mm (4 ft) and a tangent end terminal was utilized on both the upstream and downstream ends. One full-scale vehicle crash test, using a ¾-ton pickup truck vehicle, was performed on the modified system and was determined to be acceptable according to the TL-3 safety performance criteria presented in NCHRP Report No. 350. A summary of the safety performance evaluation is provided in Table 4. The results of this test indicate that this design is suitable for use on Federal-aid highways. Any significant modifications to the cable barrier system for use adjacent to a steep slope would require additional analysis and can only be verified through the use of full-scale crash testing.



Table 4. Summary of Safety Performance Evaluation Results

Evaluation Factors	Evaluation Criteria	Test CS-2
Structural Adequacy	A. Test article should contain and redirect the vehicle; the vehicle should not penetrate, underride, or override the installation although controlled lateral deflection of the test article is acceptable.	S
Occupant Risk	D. Detached elements, fragments or other debris from the test article should not penetrate or show potential for penetrating the occupant compartment, or present an undue hazard to other traffic, pedestrians, or personnel in a work zone. Deformations of, or intrusions into, the occupant compartment that could cause serious injuries should not be permitted.	S
	F. The vehicle should remain upright during and after collision although moderate roll, pitching, and yawing are acceptable.	S
Vehicle Trajectory	K. After collision it is preferable that the vehicle's trajectory not intrude into adjacent traffic lanes.	S
	L. The occupant impact velocity in the longitudinal direction should not exceed 12 m/s (39.4 ft/s), and the occupant ridedown acceleration in the longitudinal direction should not exceed 20 g's.	S
	M. The exit angle from the test article preferably should be less than 60 percent of test impact angle measured at time of vehicle loss of contact with test device.	S

S - Satisfactory  
 U - Unsatisfactory  
 NA - Not Available

## 7 REFERENCES

1. Griffen, J., "Highway Safety Barrier System Will Cut Accident Rates", *Better Roads*, February 2002.
2. Sposito, B. and Johnson, S., *Three-Cable Median Barrier Final Report*, Oregon Department of Transportation, Research Report No. OR-RD-99-03, July 1998.
3. Smith, P., *Development of a Three-Cable Guide Rail System and Other Guide Rail Tests, 1967-1968*, Ontario Department of Highways, Report No. RR157, March 1970.
4. Graham, M. D., Burnett, W. C., Gibson, J. L., and Freer, R.H., *New Highway Barriers: The Practical Application of Theoretical Design*, Highway Research Record No. 174, 1967.
5. Whitmore, J. L., Picciocca, R. G., and Snyder, W.A., *Testing of Highway Barriers and Other Safety Accessories*, Research Report No. 38, Engineering Research and Development Bureau, New York State Department of Transportation, December 1976.
6. Nelson, R. M., Sicking, D. L., Faller, R. K., Reid, J. D., Rohde, J. R., Polivka, K. A., and Hascall, J. A., *Evaluation of Alternate Cable Anchor Designs and Three-Cable Guardrail Adjacent to Steep Slope*, Final Report to the Midwest States' Regional Pooled Fund Program, Transportation Research Report No. TRP-03-155-05, Midwest Roadside Safety Facility, University of Nebraska-Lincoln, Lincoln, Nebraska, February 3, 2005.
7. Ross, H. E., Sicking, D. L., Zimmer, R. A., and Michie, J. D., *Recommended Procedures for the Safety Performance Evaluation of Highway Features*, National Cooperative Research Program (NCHRP) Report No. 350, Transportation Research Board, Washington, D.C., 1993.
8. Hinch, J., Yang, T-L, and Owings, R., *Guidance Systems for Vehicle Testing*, ENSCO, Inc., Springfield, VA 1986.
9. Hitz, R.A., Molacek, K.J., Stolle, C.S., Polivka, K.A., Faller, R.K., Rohde, J.R., Sicking, D.L., and Reid, J.D., *Design and Evaluation of a Low-Tension Cable Guardrail End Terminal System*, Draft Report to the Midwest States' Regional Pooled Fund Program, Transportation Research Report No. TRP-03-131-08, Project No. SPR-3(017)-Years 11,14,15, Project Codes: RFPF-01-03, RFPF-04-07, RFPF-05-03, Midwest Roadside Safety Facility, University of Nebraska-Lincoln, In Progress 2008.
10. *Vehicle Damage Scale for Traffic Investigators*, Second Edition, Technical Bulletin No. 1, Traffic Accident Data (TAD) Project, National Safety Council, Chicago, Illinois, 1971.
11. *Collision Deformation Classification - Recommended Practice J224 March 1980*, Handbook Volume 4, Society of Automotive Engineers (SAE), Warrendale, Pennsylvania, 1985.

## 8 APPENDICES

## **APPENDIX A**

### **Three Cable Guardrail System Drawings in English Units**

Figure A-1. Three Cable Guardrail System Layout (English)

Figure A-2. Three Cable Guardrail End Terminal Details (English)

Figure A-3. Cable Anchor Bracket Details (English)

Figure A-4. Cable Support Upper Post Details (English)

Figure A-5. Anchor Bracket Base Details (English)

Figure A-6. Cable Release Lever Details (English)

Figure A-7. Three Cable Guardrail Support Post Details (English)

Figure A-8. Bearing Strut Details (English)

Figure A-9. Cable Support Post Upper Details (English)

Figure A-10. Cable Support Post Base Details (English)

Figure A-11. Cable Support Post Base Assembly Details (English)

Figure A-12. Cable Line Post Details (English)

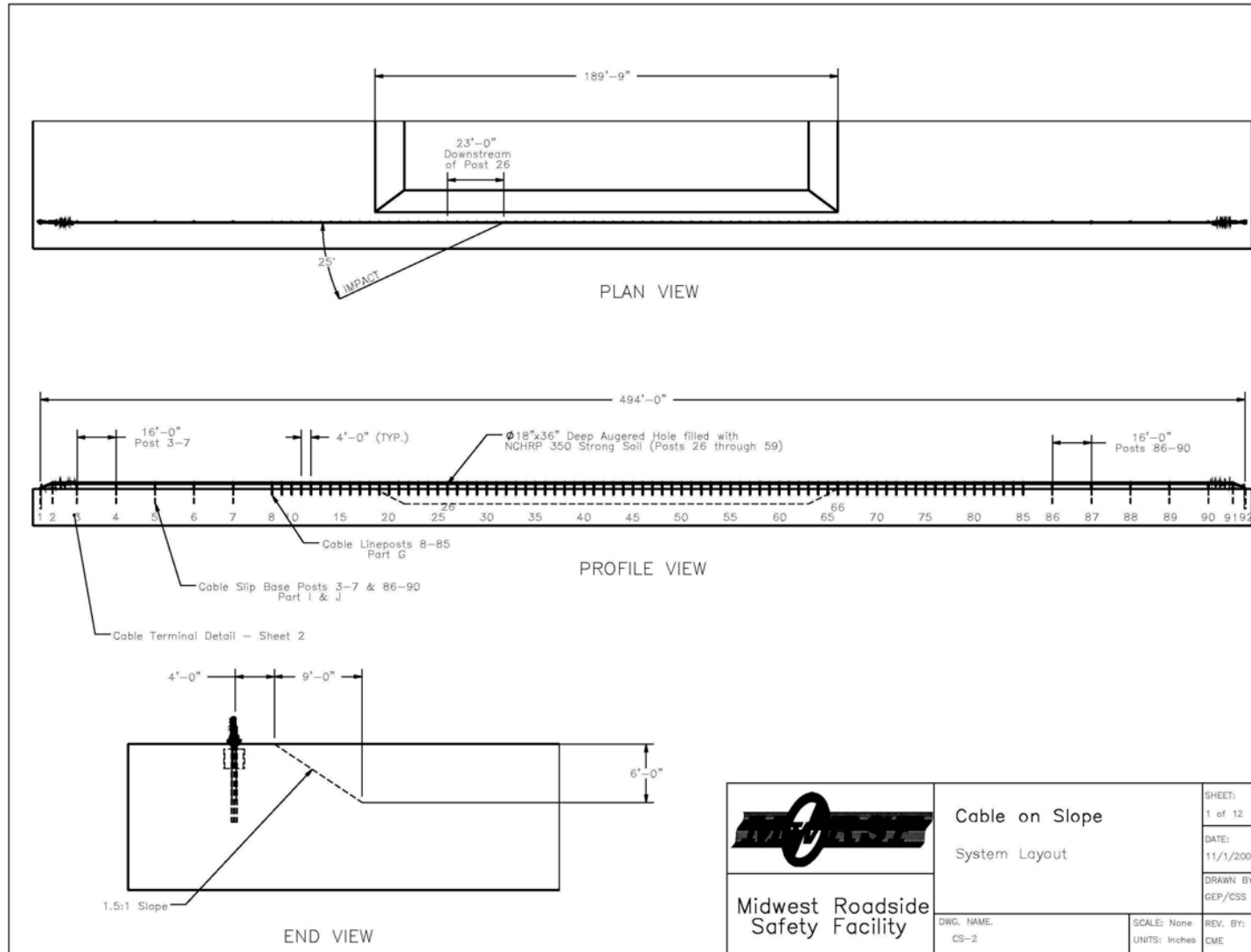

	Cable on Slope System Layout		SHEET: 1 of 12
	Midwest Roadside Safety Facility		DATE: 11/1/2006
DWG. NAME: CS-2	SCALE: None UNITS: Inches	REV. BY: CME	DRAWN BY: GEP/CSS

Figure A-1. Three Cable Guardrail System Layout (English)

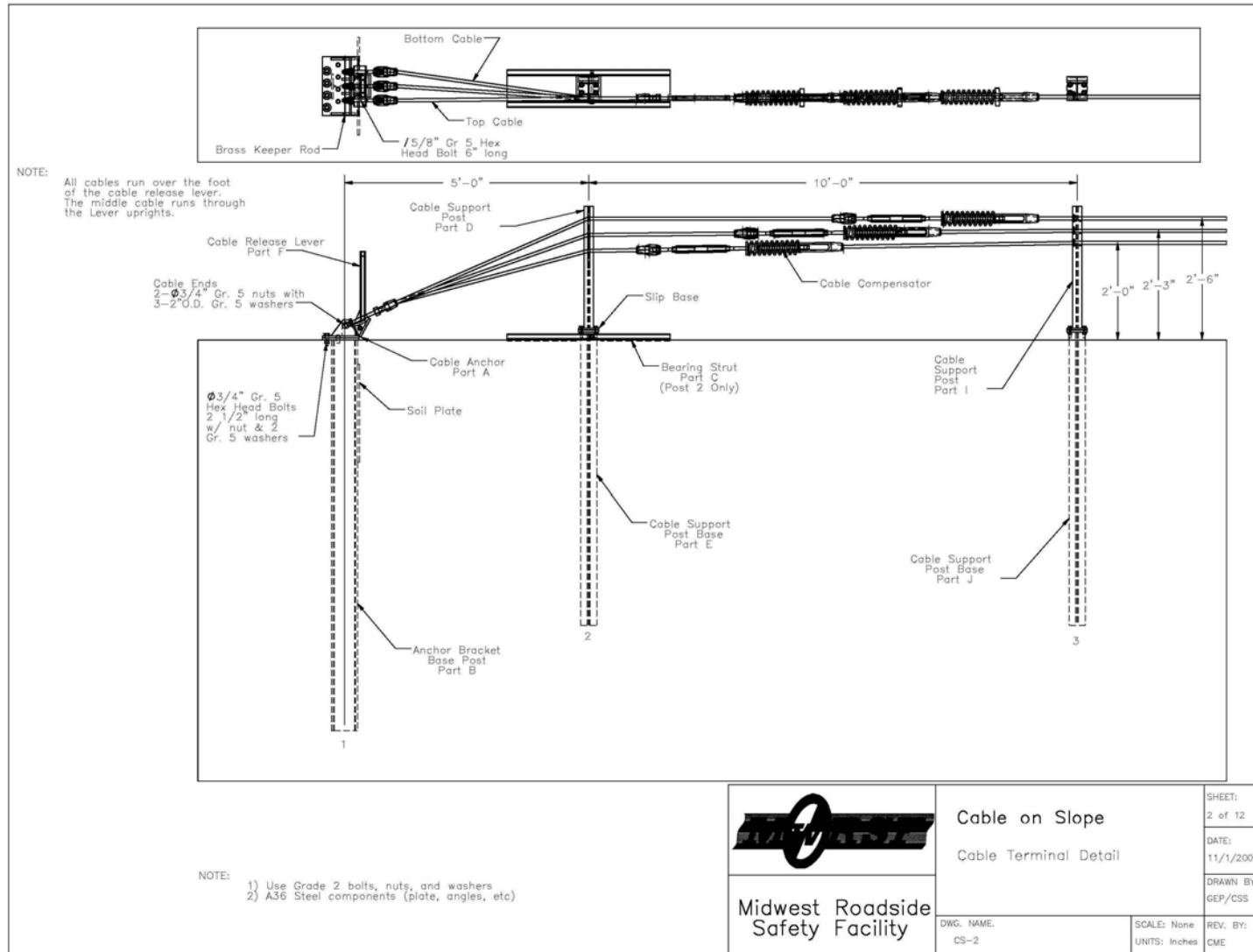

Figure A-2. Three Cable Guardrail End Terminal Details (English)

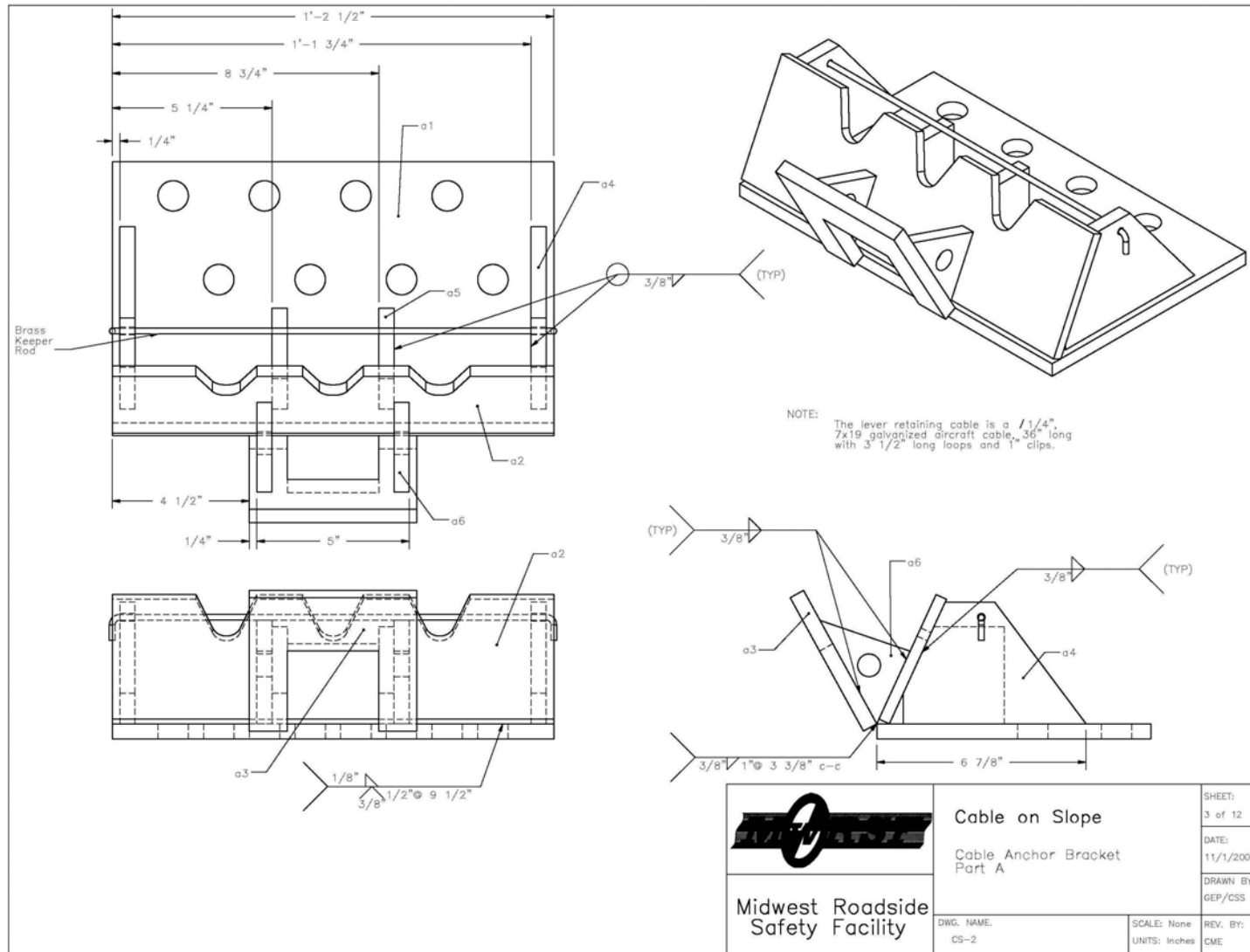
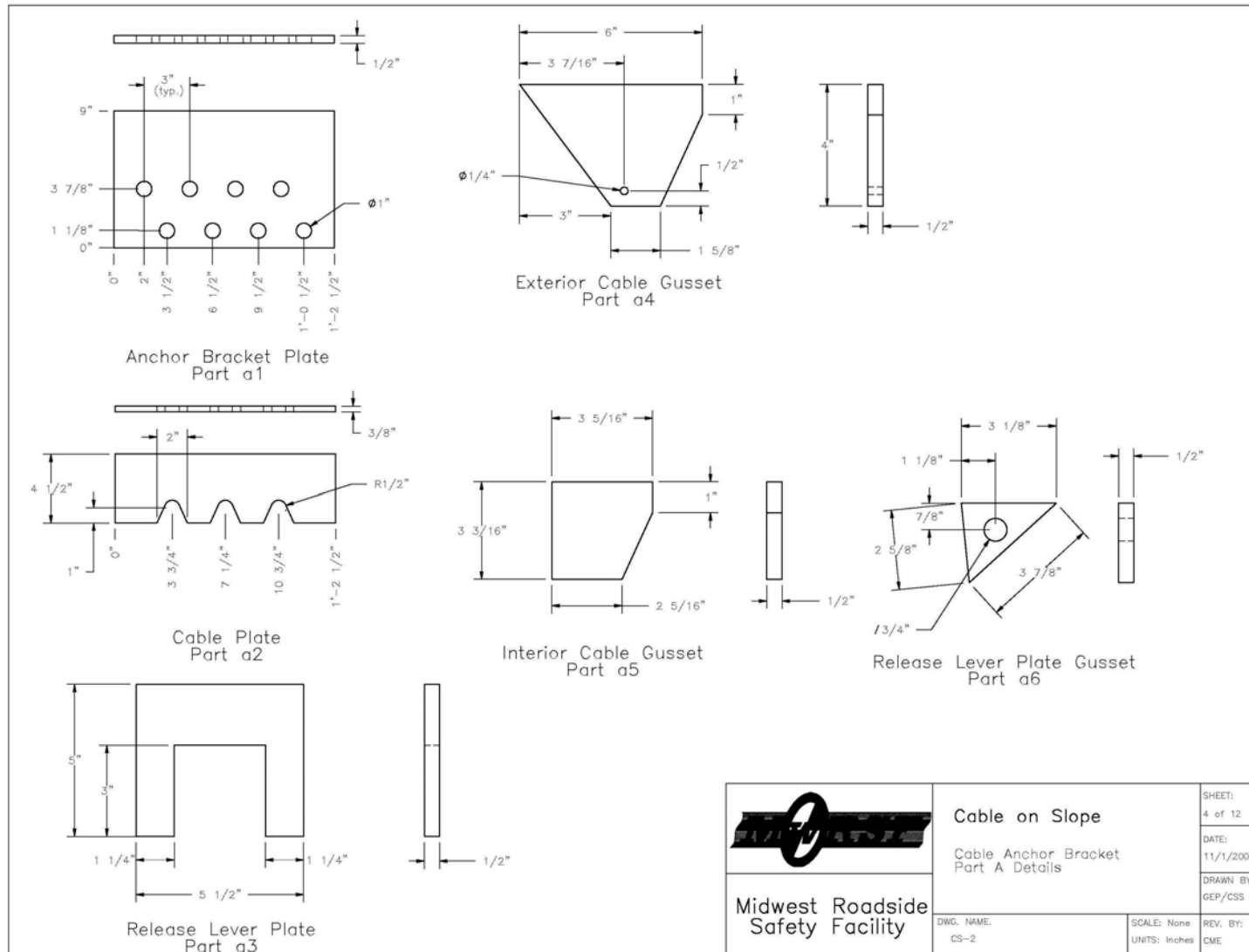

Figure A-3. Cable Anchor Bracket Details (English)



	<b>Cable on Slope</b> Cable Anchor Bracket Part A Details		SHEET: 4 of 12
	DWG. NAME: CS-2		DATE: 11/1/2006 DRAWN BY: GEP/CSS
Midwest Roadside Safety Facility		SCALE: None UNITS: Inches	REV. BY: CME

Figure A-4. Cable Support Upper Post Details (English)



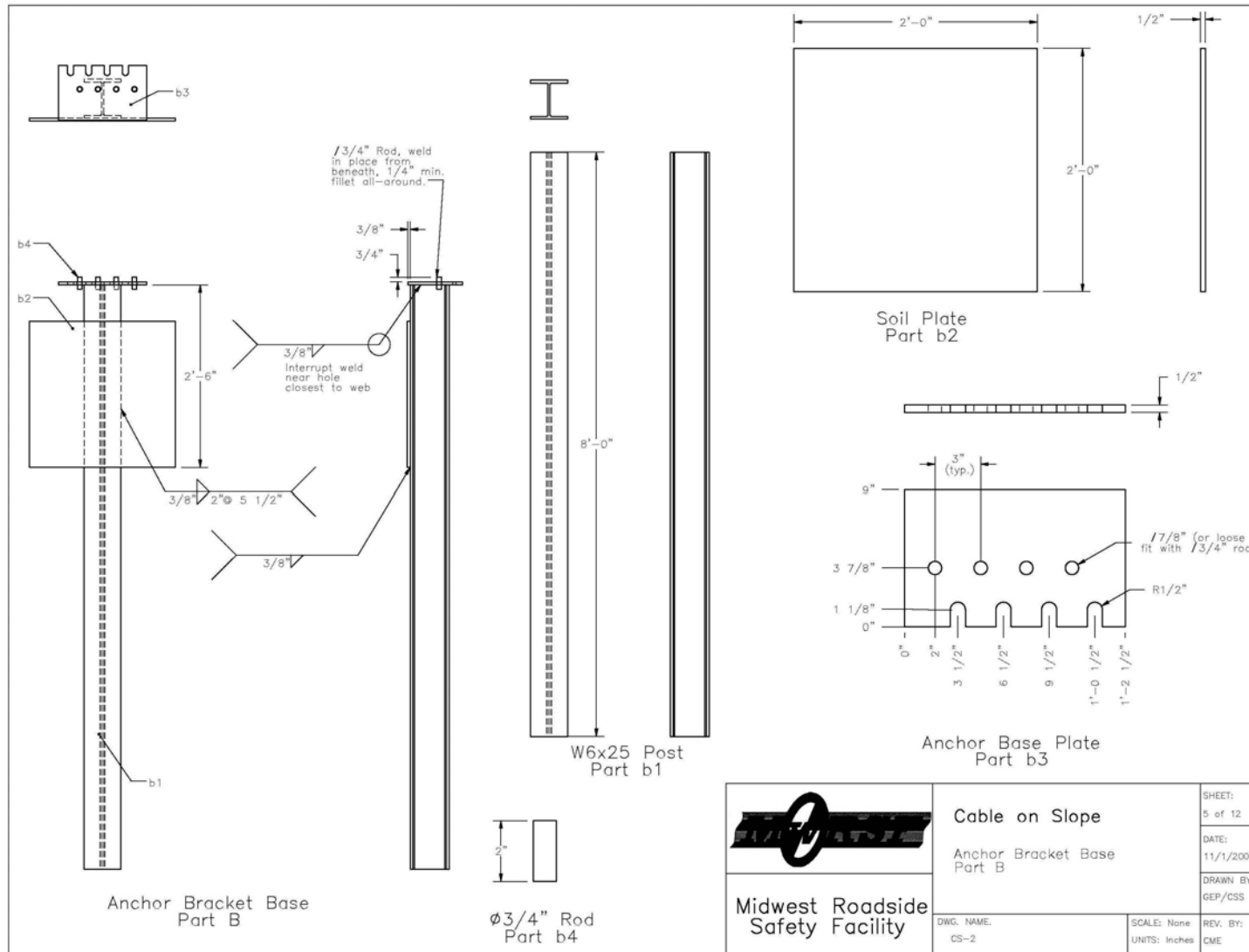

	<b>Cable on Slope</b> Anchor Bracket Base Part B	SHEET: 5 of 12 DATE: 11/1/2006 DRAWN BY: GEP/CSS
	DWG. NAME: CS-2	SCALE: None UNITS: Inches

Figure A-5. Anchor Bracket Base Details (English)

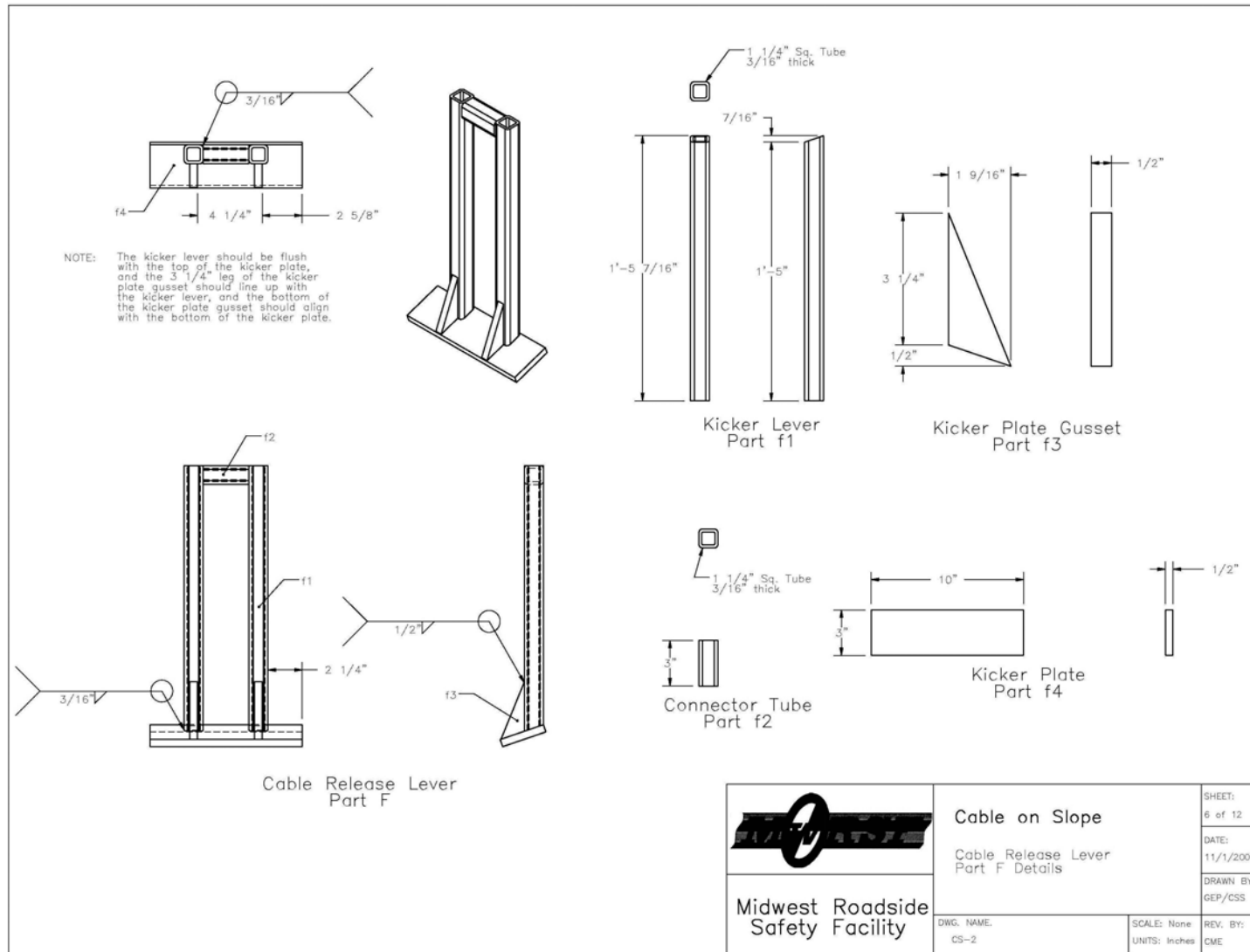

Figure A-6. Cable Release Lever Details (English)

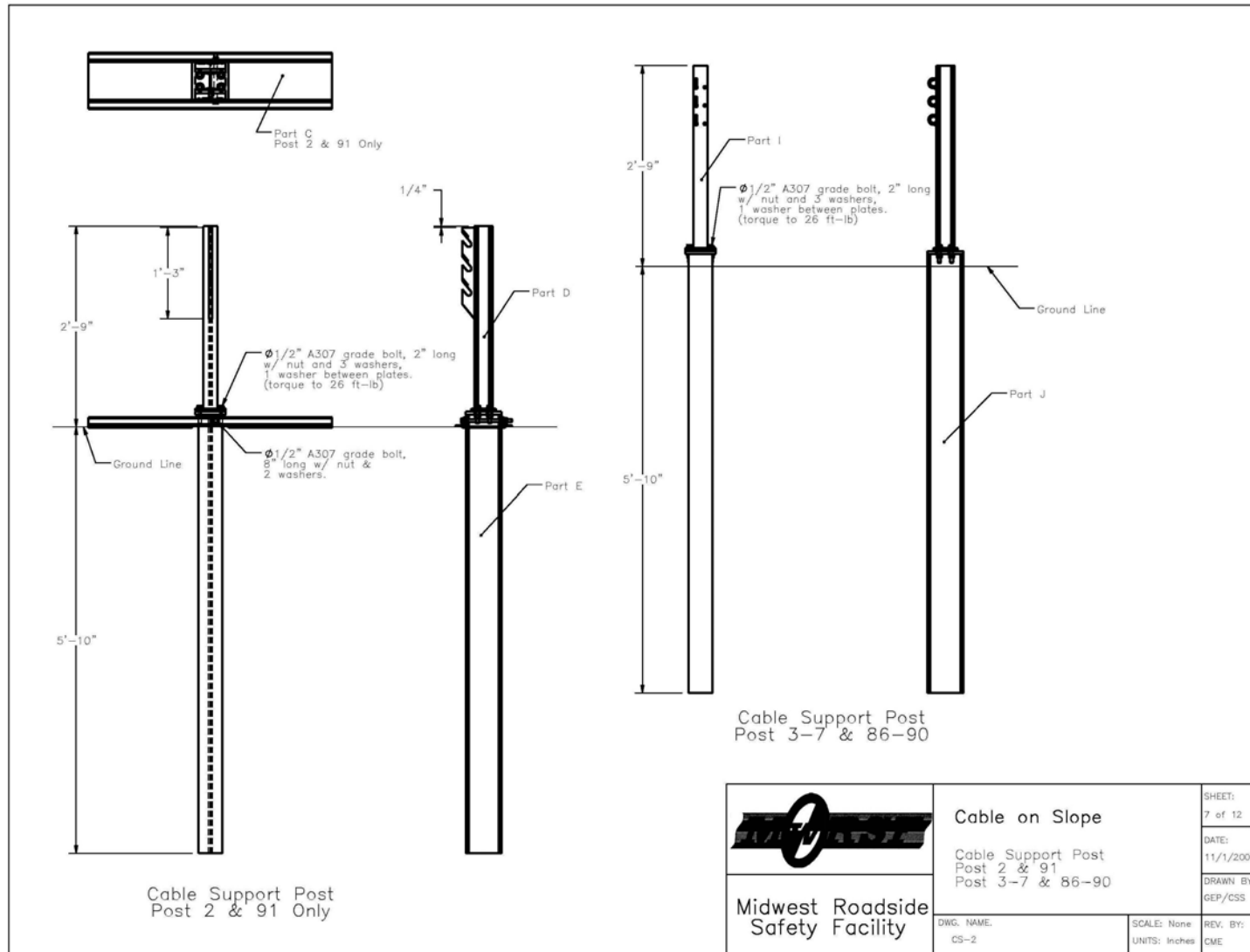

Figure A-7. Three Cable Guardrail Support Post Details (English)

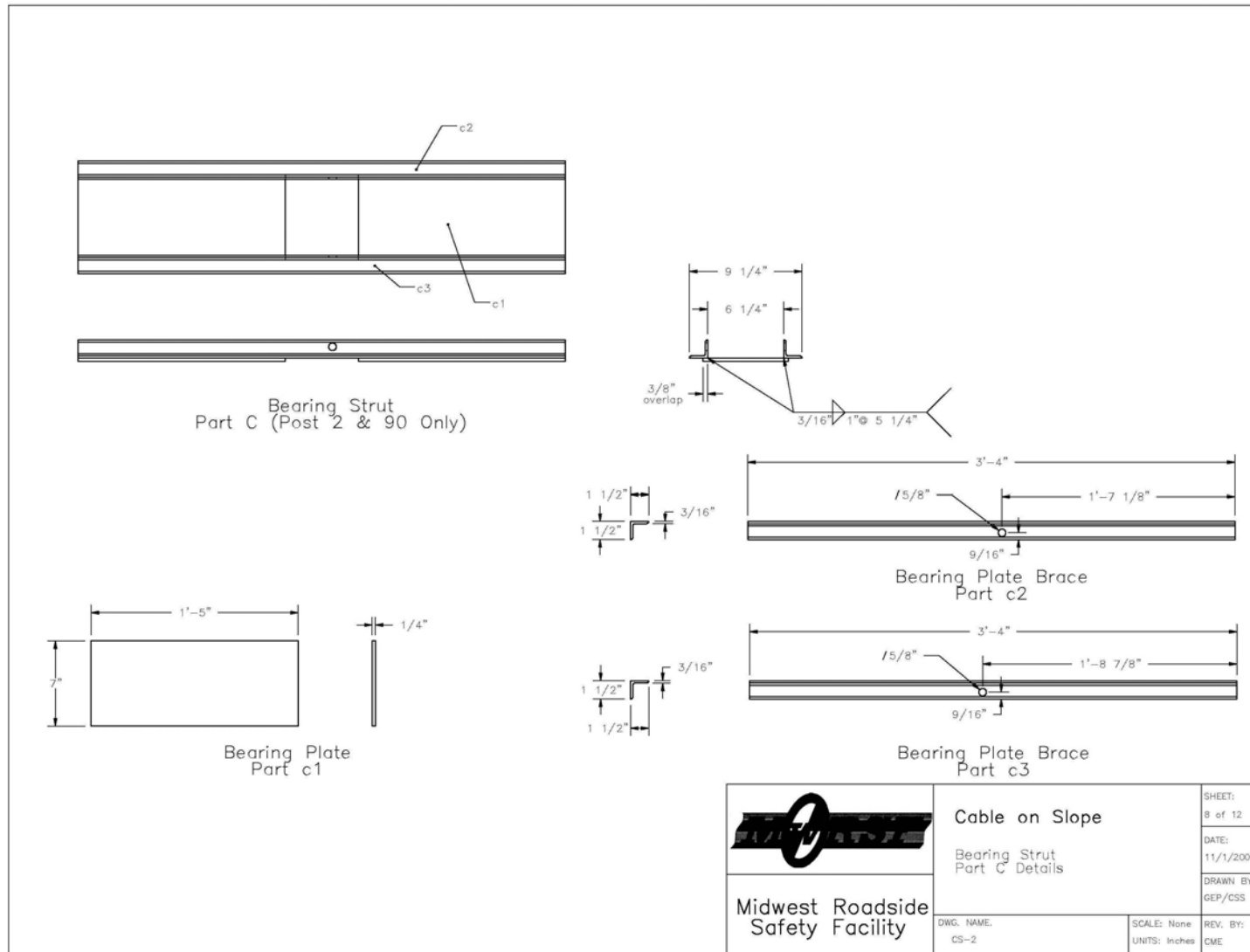

Figure A-8. Bearing Strut Details (English)

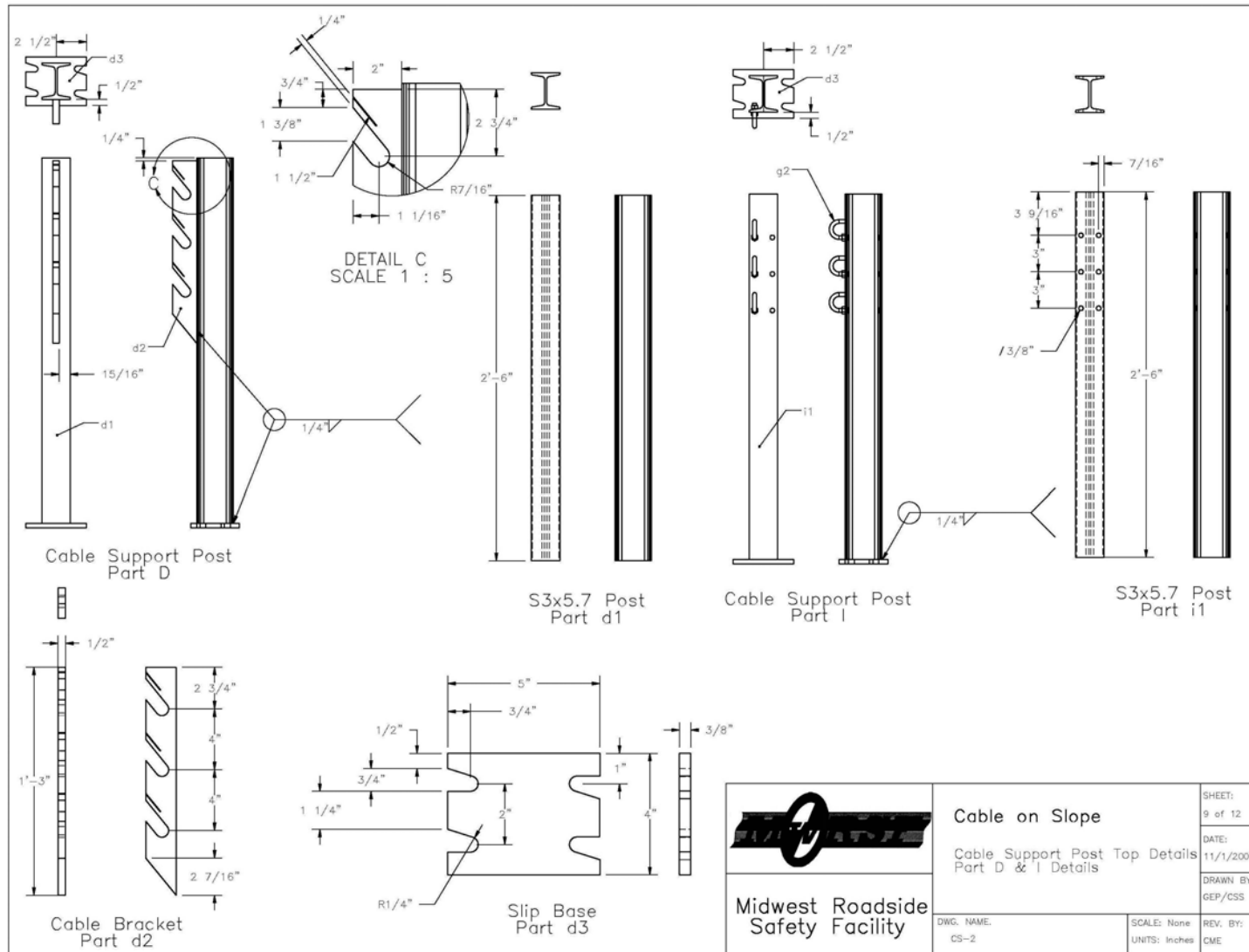

Figure A-9. Cable Support Post Upper Details (English)

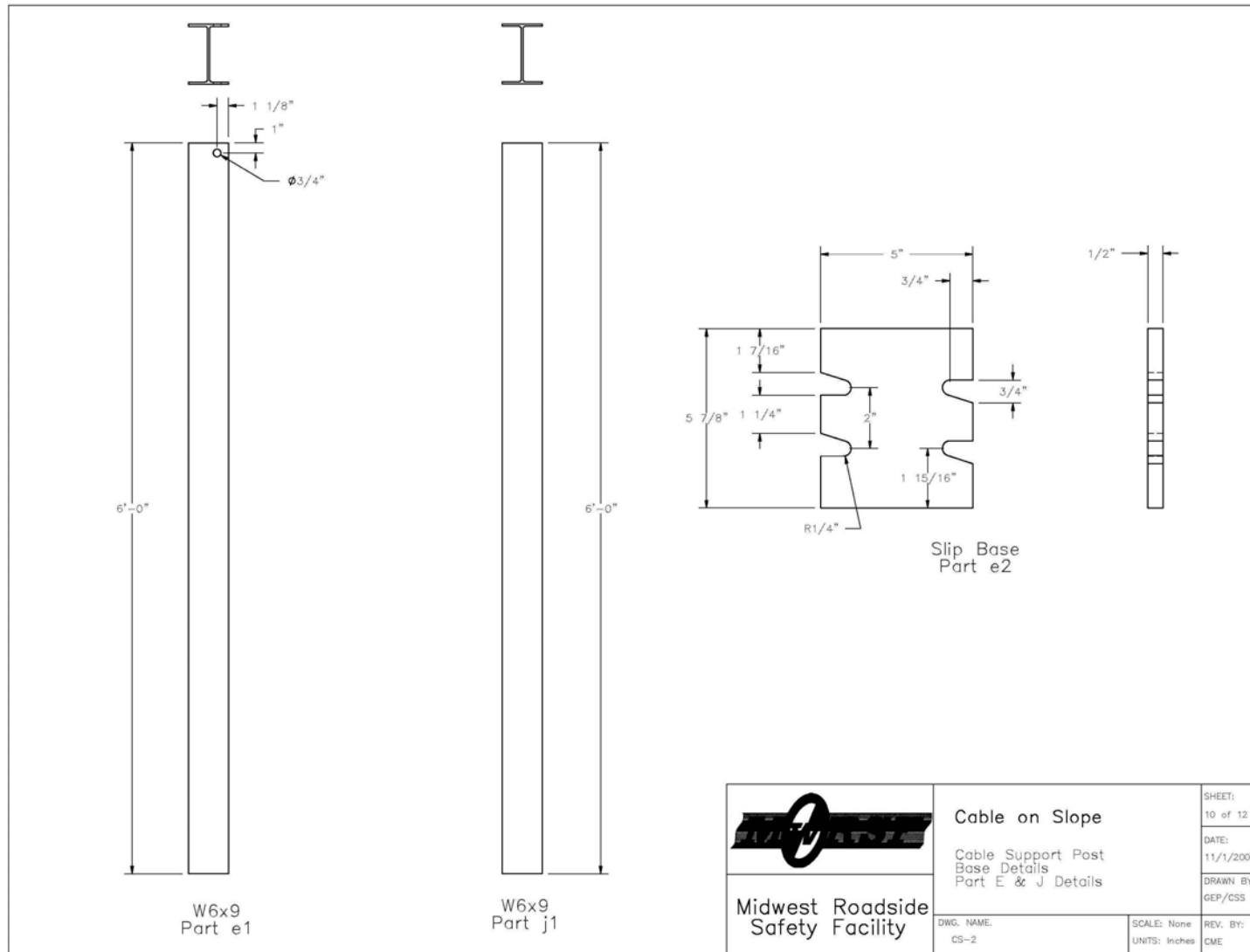

Figure A-10. Cable Support Post Base Details (English)

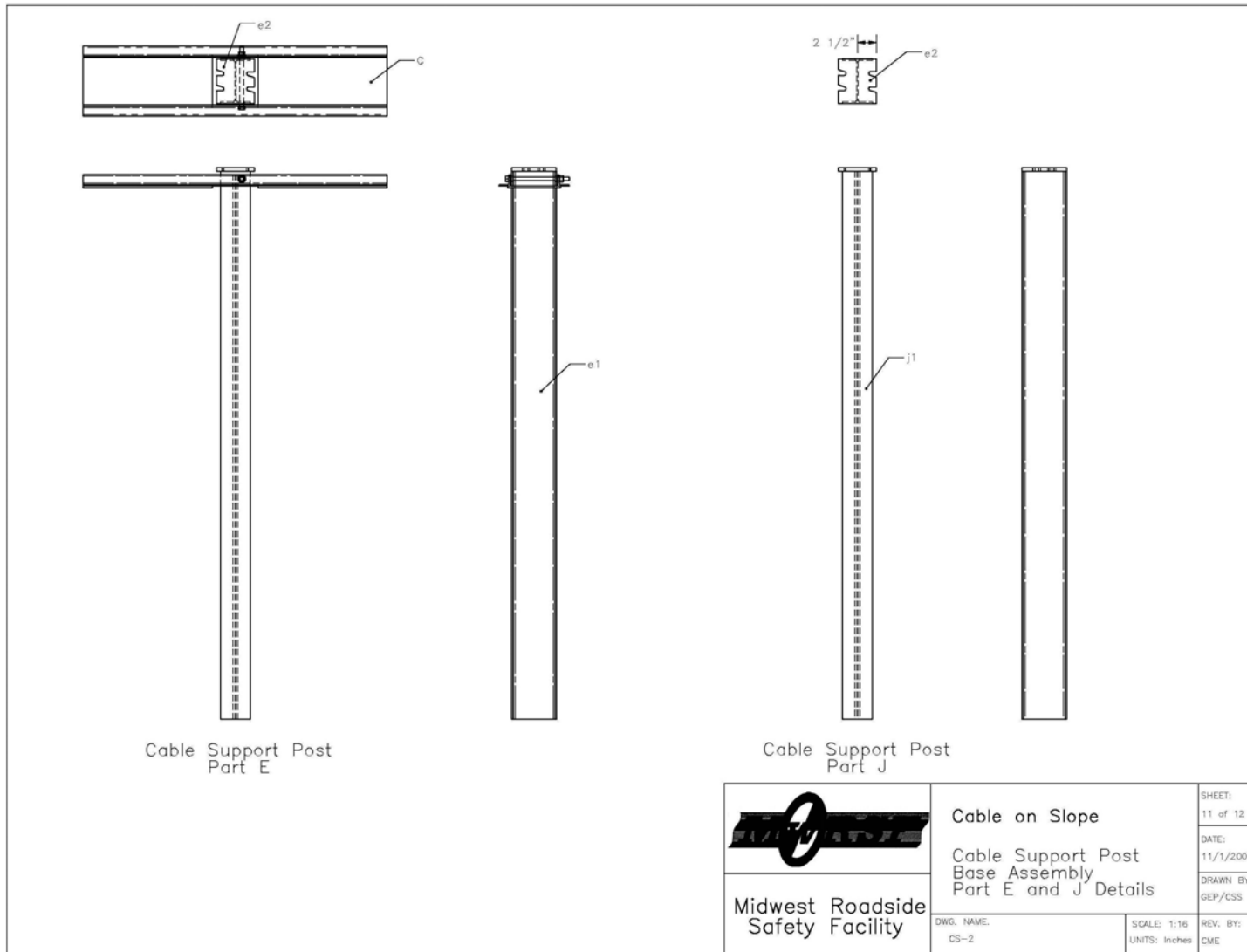

Figure A-11. Cable Support Post Base Assembly Details (English)

77

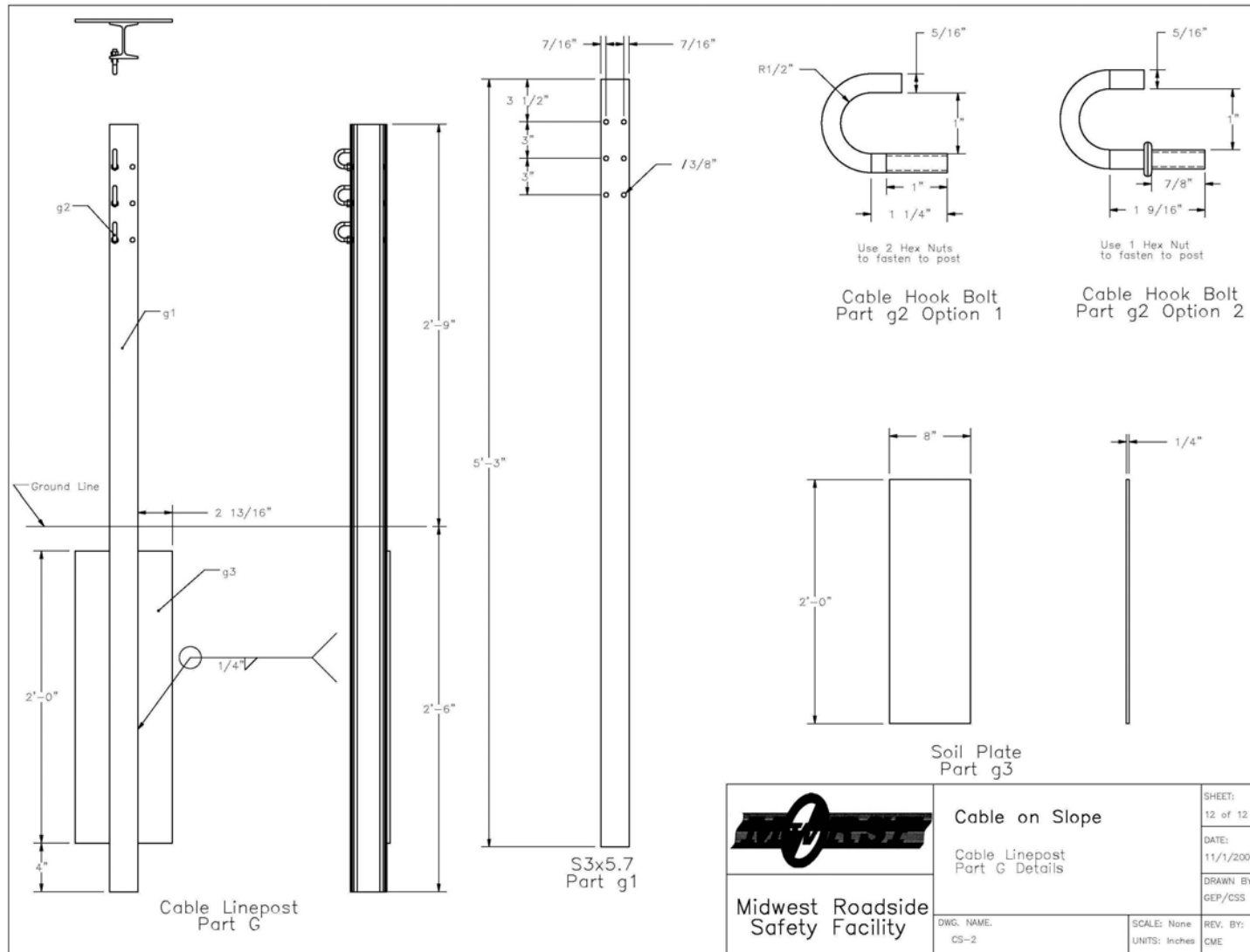

Figure A-12. Cable Line Post Details (English)



**APPENDIX B**

**Test Summary Sheet in English Units, Test CS-2**

Figure B-1. Summary of Test Results and Sequential Photographs (English), Test CS-2



0.000 sec

0.180 sec

0.396 sec

0.498 sec

0.690 sec

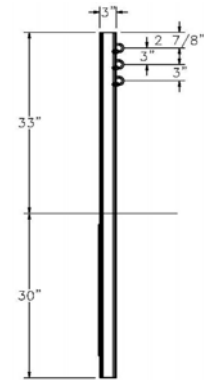
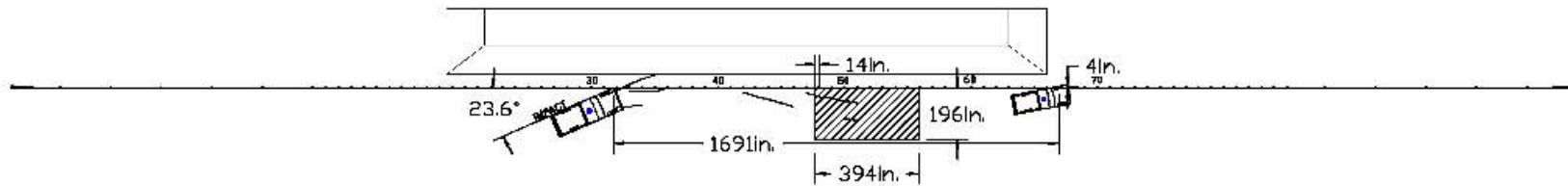

79

- Test Agency ..... MwRSF
- Test Number ..... CS-2
- Date ..... 11/1/06
- NCHRP 350 Test Designation ..... 3-11
- Appurtenance ..... Three Cable Guardrail Installed Adjacent to 1.5:1 Slope
- Total Length ..... 151 ft
- Key Elements - Wire Rope
  - Diameter ..... 3/4 in.
  - Size ..... 7x19
  - Top Mounting Height ..... 30 in.
  - Incremental Spacing ..... 3 in.
- Key Elements - End Anchor Posts
  - Post Nos. 1 and 92 ..... W6x25 by 96 in. long
  - Post Nos. 2 and 91 ..... S3x5.7 by 30 in. long with W6x9 by 72 in. long
- Key Elements - Slip-Base Post
  - Post Nos. 3-7 and 86-90 ..... S3x5.7 by 33 in. long with W6x9 by 72 in. long
  - Spacing ..... 192 in.
- Key Elements - Line Posts
  - Post Nos. 8-85 ..... S3x5.7 by 63 in. long
  - Spacing ..... 48 in.
- Type of Soil ..... Grading B - AASHTO M 147-65 (1990)
- Test Vehicle
  - Type/Designation ..... 2000P
  - Make and Model ..... 1999 Chevrolet C2500 pickup truck
  - Curb ..... 4,810 lbs
  - Test Inertial ..... 4,482 lbs
  - Gross Static ..... 4,482 lbs
- Impact Conditions
  - Speed ..... 61.6 mph
  - Angle ..... 23.6 deg
  - Impact Location ..... 23 ft downstream centerline of post no. 26
- Exit Conditions
  - Speed ..... 32.8 mph
  - Angle ..... 16.3 deg
  - Exit Box Criterion ..... Passed
- Post-Impact Trajectory
  - Vehicle Stability ..... Satisfactory
  - Stopping Distance ..... 140.9 ft downstream in contact with barrier
- Occupant Impact Velocity
  - Longitudinal ..... -13.6 ft/s < 39.4 ft/s
  - Lateral (not required) ..... 11.2 ft/s
- Occupant Ridedown Deceleration (10 msec avg.)
  - Longitudinal ..... -5.73 g's < 20 g's
  - Lateral (not required) ..... 6.96 g's
- THIV (not required) ..... 16.9 ft/s
- PHD (not required) ..... 8.27 g's
- Test Article Damage ..... Moderate
- Test Article Deflections
  - Permanent Set ..... 22.75 in.
  - Dynamic ..... 124.5 in.
  - Working Width ..... 130.6 in.
- Vehicle Damage ..... Moderate
  - VDS<sup>10</sup> ..... 11-FL-2
  - CDC<sup>11</sup> ..... 12FYES3
  - Maximum Deformation ..... 0.5 in. at front of left-side floorpan

Figure B-1. Summary of Test Results and Sequential Photographs, Test CS-2

## **APPENDIX C**

### **Occupant Compartment Deformation Data, Test CS-2**

Figure C-1. Occupant Compartment Deformation Data - Set 1, Test CS-2

Figure C-2. Occupant Compartment Deformation Data - Set 2, Test CS-2

Figure C-3. Occupant Compartment Deformation Index, Test CS-2

VEHICLE PRE/POST CRUSH INFO  
Set-1

TEST: CS-2  
VEHICLE: 1999 Chevy C2500

Note: If impact is on driver side need to  
enter negative number for Y

POINT	X	Y	Z	X'	Y'	Z'	DEL X	DEL Y	DEL Z
1	57.25	-27.75	-1.75	57.5	-27.5	-1.75	0.25	0.25	0
2	57.25	-20.25	-3.5	57.25	-20	-3.5	0	0.25	0
3	57	-13	-4.5	57.25	-13	-4.5	0.25	0	0
4	53.75	-5	-1.5	54	-5	-1.25	0.25	0	0.25
5	52.75	-0.75	-1.25	52.75	-0.75	-1.25	0	0	0
6	52	-27.75	-5.75	52	-27.75	-5.75	0	0	0
7	52.25	-20	-7.5	52.25	-20	-7.5	0	0	0
8	51.25	-12	-7.5	51.25	-12.5	-7.25	0	-0.5	0.25
9	48.5	-4.75	-3.25	48.5	-4.75	-3	0	0	0.25
10	47	-1	-3.5	47	-1	-3.25	0	0	0.25
11	45.5	-18.25	-7.25	45.75	-18.25	-7.5	0.25	0	-0.25
12	44.25	-19.75	-8.25	44.25	-19.75	-8.5	0	0	-0.25
13	45	-12	-9	45	-12	-9	0	0	0
14	43	-4.5	-4	43	-4.5	-4	0	0	0
15	42.75	-0.25	-4.25	42.5	-0.25	-4	-0.25	0	0.25
16	39.5	-28	-7.75	39.5	-28.25	-7.75	0	-0.25	0
17	39.25	-19.5	-8.75	39.25	-19.75	-9	0	-0.25	-0.25
18	38.75	-11.75	-9.5	38.75	-11.5	-9.5	0	0.25	0
19	38	-4.5	-4.75	38	-4.5	-4.75	0	0	0
20	37.5	-0.75	-5	37.5	-0.75	-4.75	0	0	0.25
21	34	-28	-7.75	33.75	-28	-7.75	-0.25	0	0
22	34	-19.5	-9	34	-19.5	-9	0	0	0
23	34.75	-11.25	-9.75	34.75	-11	-9.75	0	0.25	0
24	34	-5	-5.5	34	-5	-5.25	0	0	0.25
25	33.75	-0.75	-5.5	34	-0.5	-5.25	0.25	0.25	0.25
26	26.75	-20.5	-8	26.75	-20.5	-8	0	0	0
27	27.5	-13.75	-8.75	27.25	-14	-8.75	-0.25	-0.25	0
28	28	-3.5	-6	28	-3.5	-5.75	0	0	0.25
29									
30									

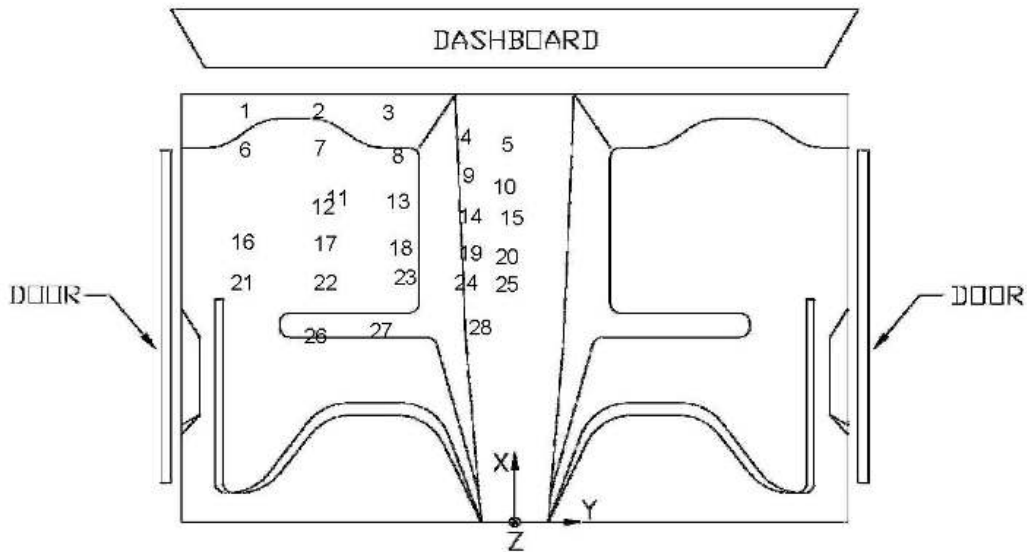

Figure C-1. Occupant Compartment Deformation Data - Set 1, Test CS-2

VEHICLE PRE/POST CRUSH INFO  
Set-2

TEST: CS-2  
VEHICLE: 1999 Chevy C2500

Note: If impact is on driver side need to enter negative number for Y

POINT	X	Y	Z	X'	Y'	Z'	DEL X	DEL Y	DEL Z
1	51	-19.25	-2.5	51.25	-19	-2.25	0.25	0.25	0.25
2	51	-11.75	-3.75	51	-11.5	-3.75	0	0.25	0
3	50.75	-4.5	-4.5	51	-4.5	-4.25	0.25	0	0.25
4	47.5	3.5	-1.25	47.75	3.5	-1.25	0.25	0	0
5	46.5	7.75	-1	46.5	7.75	-1	0	0	0
6	45.75	-19.25	-6.25	45.75	-19.25	-6	0	0	0.25
7	46	-11.5	-7.5	46	-11.5	-7.25	0	0	0.25
8	45	-3.5	-7.5	45	-4	-7.25	0	-0.5	0.25
9	42.25	3.75	-3	42.25	3.75	-3	0	0	0
10	40.75	7.5	-3	40.75	7.5	-3	0	0	0
11	39.25	-9.75	-7.5	39.5	-9.75	-7.5	0.25	0	0
12	38	-11.25	-8.25	38	-11.25	-8.25	0	0	0
13	38.75	-3.5	-9	38.75	-3.5	-8.75	0	0	0.25
14	36.75	4	-3.75	36.75	4	-3.75	0	0	0
15	36.5	8.25	-3.75	36.25	8.25	-3.5	-0.25	0	0.25
16	33.25	-19.5	-7.75	33.25	-19.75	-7.75	0	-0.25	0
17	33	-11	-8.5	33	-11.25	-8.5	0	-0.25	0
18	32.5	-3.25	-9.25	32.5	-3	-9.25	0	0.25	0
19	31.75	4	-4.25	31.75	4	-4.25	0	0	0
20	31.25	7.75	-4.5	31.25	7.75	-4.5	0	0	0
21	27.75	-19.5	-7.75	27.5	-19.5	-7.75	-0.25	0	0
22	27.75	-11	-8.5	27.75	-11	-8.5	0	0	0
23	28.5	-2.75	-9.25	28.5	-2.5	-9.25	0	0.25	0
24	27.75	3.5	-5	27.75	3.5	-4.75	0	0	0.25
25	27.5	7.75	-5	27.75	8	-4.75	0.25	0.25	0.25
26	20.5	-12	-7.5	20.5	-12	-7.5	0	0	0
27	21.25	-5.25	-8.25	21	-5.5	-8	-0.25	-0.25	0.25
28	21.75	5	-5.25	21.75	5	-5.25	0	0	0
29									
30									

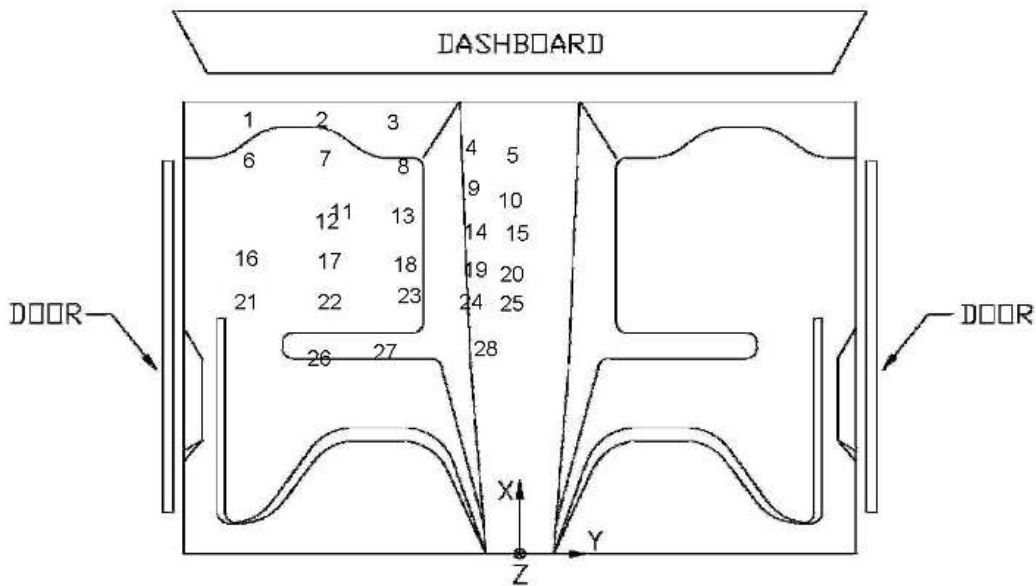

Figure C-2. Occupant Compartment Deformation Data - Set 2, Test CS-2

**Occupant Compartment Deformation Index (OCDI)**

Test No. CS-2  
 Vehicle Type: 1999 Chevy C2500

OCDI = XXABCDEFGHI

XX = location of occupant compartment deformation

A = distance between the dashboard and a reference point at the rear of the occupant compartment, such as the top of the rear seat or the rear of the cab on a pickup

B = distance between the roof and the floor panel

C = distance between a reference point at the rear of the occupant compartment and the motor panel

D = distance between the lower dashboard and the floor panel

E = interior width

F = distance between the lower edge of right window and the upper edge of left window

G = distance between the lower edge of left window and the upper edge of right window

H = distance between bottom front corner and top rear corner of the passenger side window

I = distance between bottom front corner and top rear corner of the driver side window

**Severity Indices**

- 0 - if the reduction is less than 3%
- 1 - if the reduction is greater than 3% and less than or equal to 10 %
- 2 - if the reduction is greater than 10% and less than or equal to 20 %
- 3 - if the reduction is greater than 20% and less than or equal to 30 %
- 4 - if the reduction is greater than 30% and less than or equal to 40 %

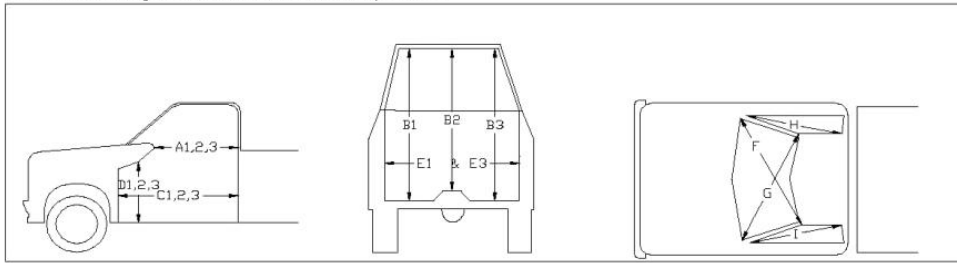

where,  
 1 = Passenger Side  
 2 = Middle  
 3 = Driver Side

**Location:**

Measurement	Pre-Test (in.)	Post-Test (in.)	Change (in.)	% Difference	Severity Index
A1	39.50	39.75	0.25	0.63	0
A2	40.00	40.00	0.00	0.00	0
A3	39.75	39.75	0.00	0.00	0
B1	48.00	48.25	0.25	0.52	0
B2	41.75	41.75	0.00	0.00	0
B3	46.25	46.25	0.00	0.00	0
C1	59.50	59.25	-0.25	-0.42	0
C2	54.00	54.00	0.00	0.00	0
C3	57.75	57.75	0.00	0.00	0
D1	21.50	21.50	0.00	0.00	0
D2	16.50	16.50	0.00	0.00	0
D3	22.50	22.50	0.00	0.00	0
E1	62.25	62.25	0.00	0.00	0
E3	64.00	64.00	0.00	0.00	0
F	53.75	53.75	0.00	0.00	0
G	53.75	53.50	-0.25	-0.47	0
H	40.25	40.25	0.00	0.00	0
I	39.50	39.50	0.00	0.00	0

[Note: Maximum severity index for each variable (A-I) is used for determination of final OCDI value]

Final OCDI: XXABCDEFGHI  
 LF 0 0 0 0 0 0 0 0 0

Figure C-3. Occupant Compartment Deformation Index (OCDI), Test CS-2

## **APPENDIX D**

### **Accelerometer and Rate Transducer Data Analysis, Test CS-2**

Figure D-1. Graph of Longitudinal Deceleration, Test CS-2

Figure D-2. Graph of Longitudinal Occupant Impact Velocity, Test CS-2

Figure D-3. Graph of Longitudinal Occupant Displacement, Test CS-2

Figure D-4. Graph of Lateral Deceleration, Test CS-2

Figure D-5. Graph of Lateral Occupant Impact Velocity, Test CS-2

Figure D-6. Graph of Lateral Occupant Displacement, Test CS-2

Figure D-7. Graph of Roll, Pitch, And Yaw Angular Displacement, Test CS-2

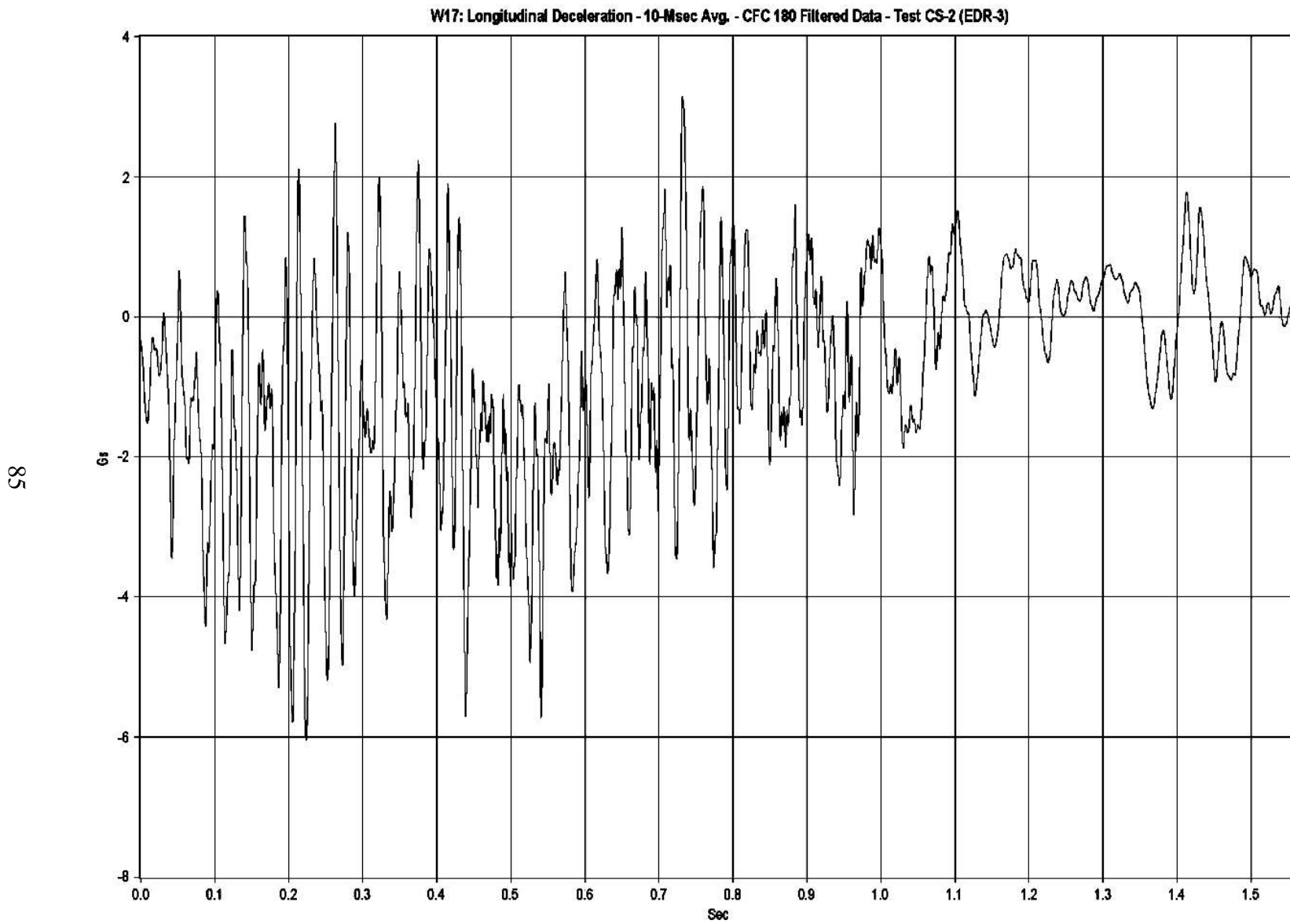

Figure D-1. Graph of Longitudinal Deceleration, Test CS-2



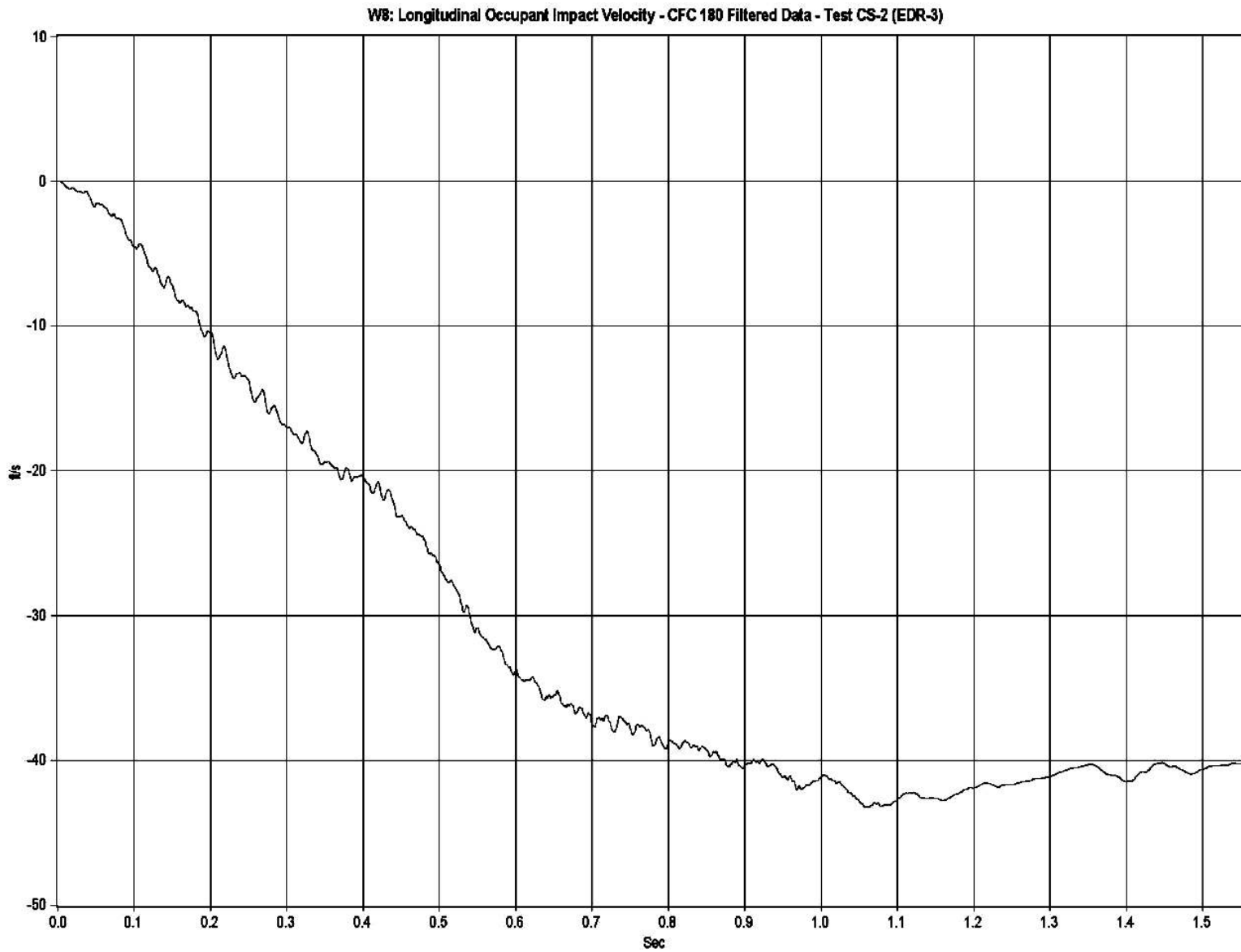

Figure D-2. Graph of Longitudinal Occupant Impact Velocity, Test CS-2

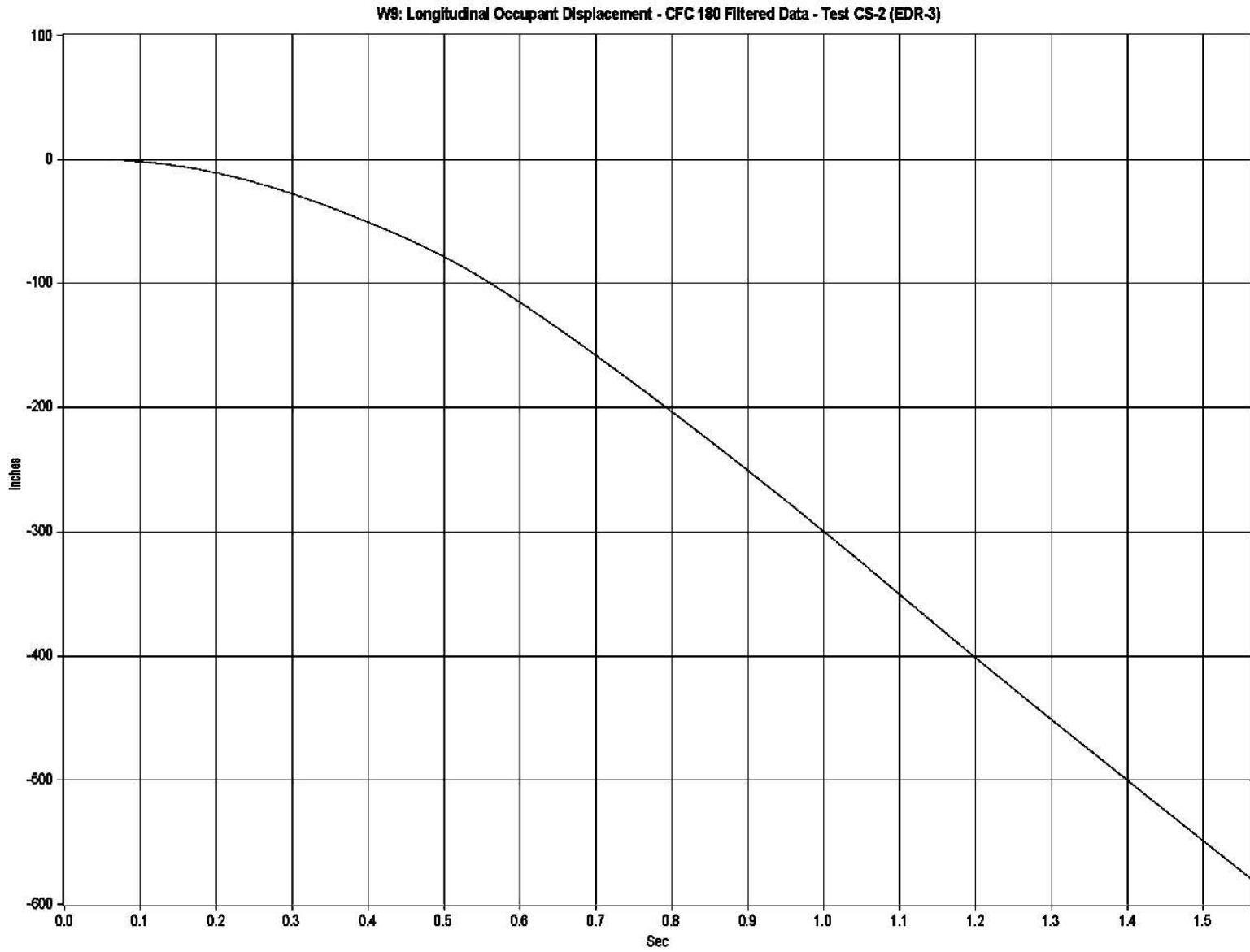

Figure D-3. Graph of Longitudinal Occupant Displacement, Test CS-2

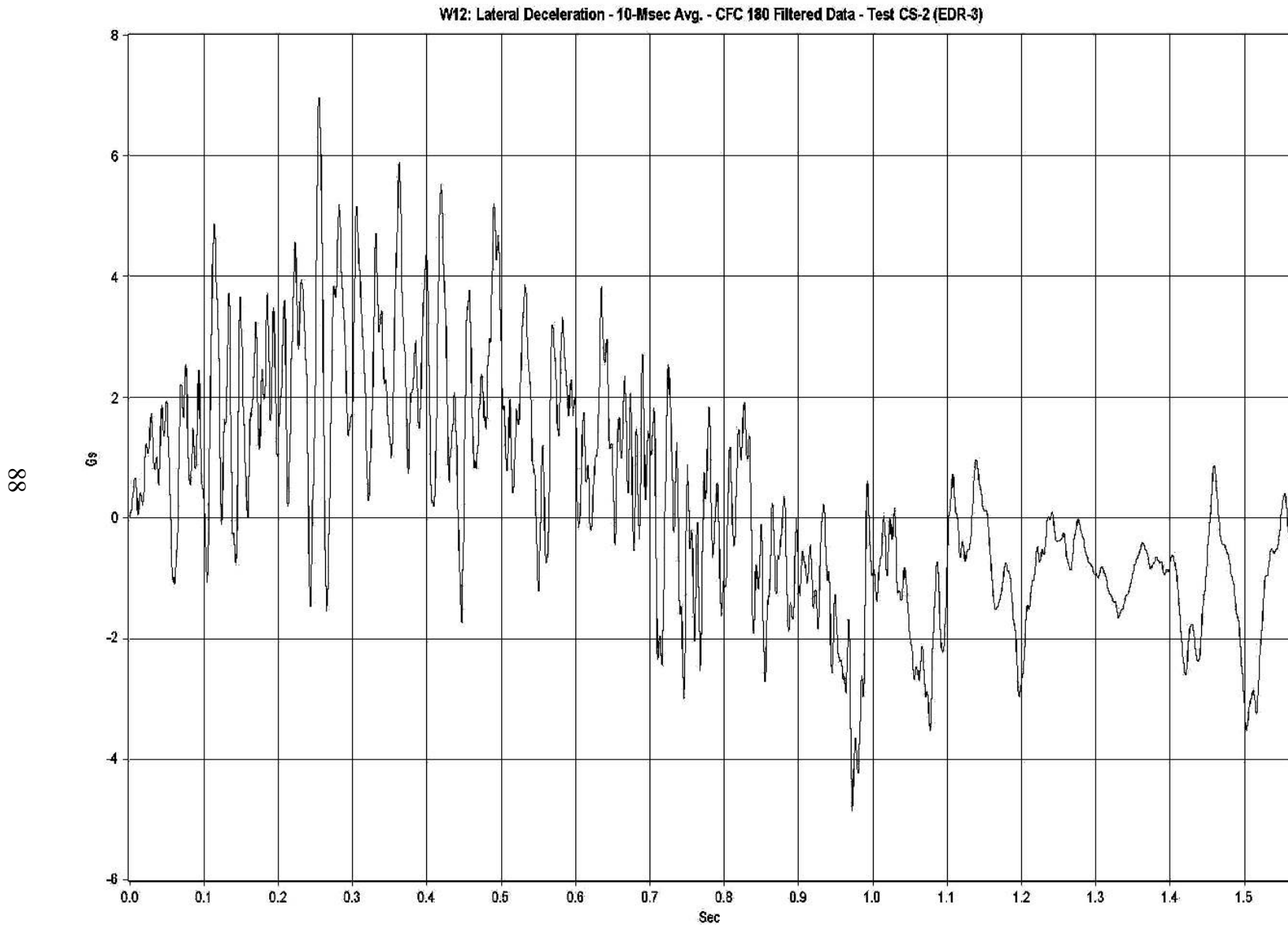

Figure D-4. Graph of Lateral Deceleration, Test CS-2

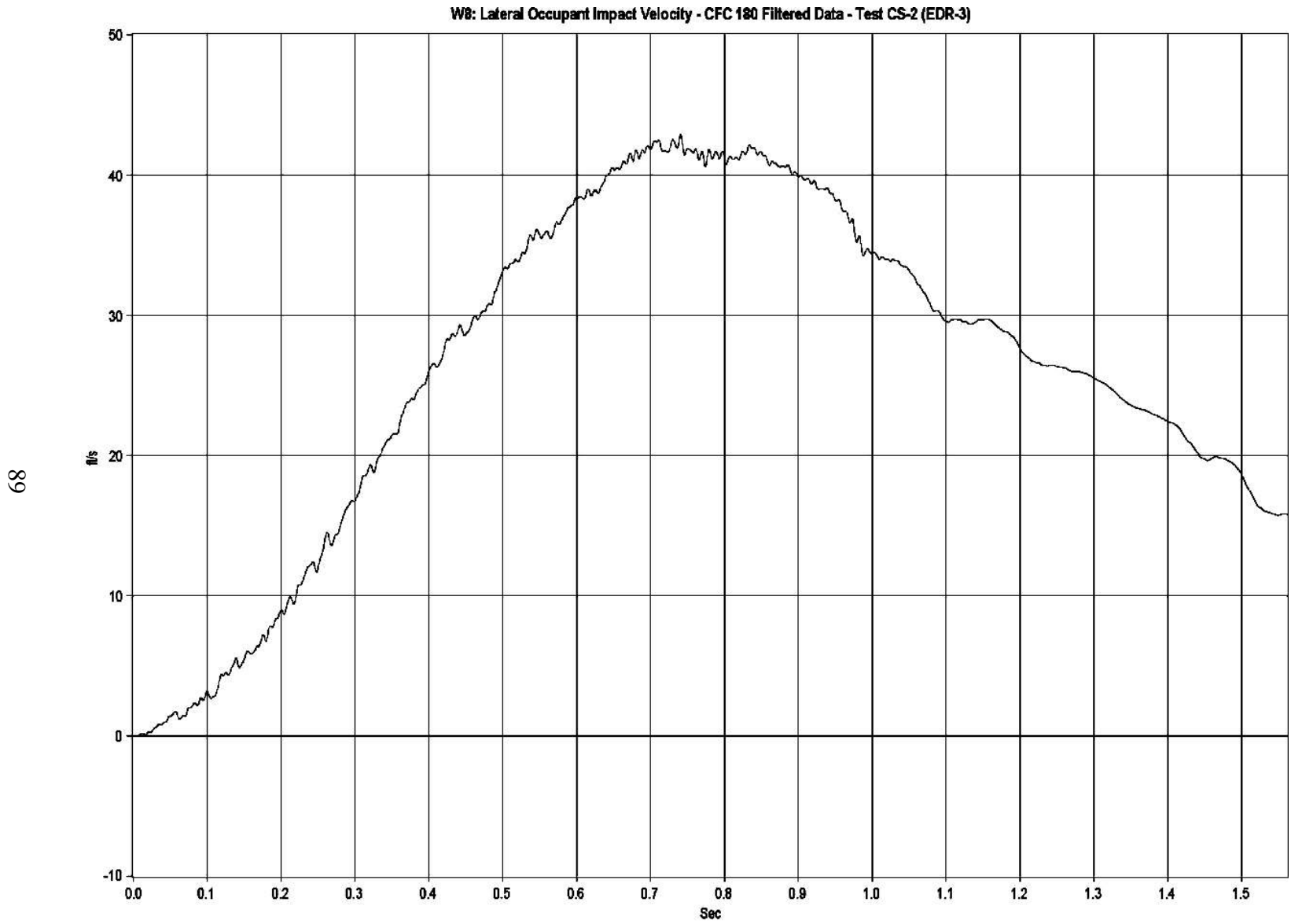

Figure D-5. Graph of Lateral Occupant Impact Velocity, Test CS-2

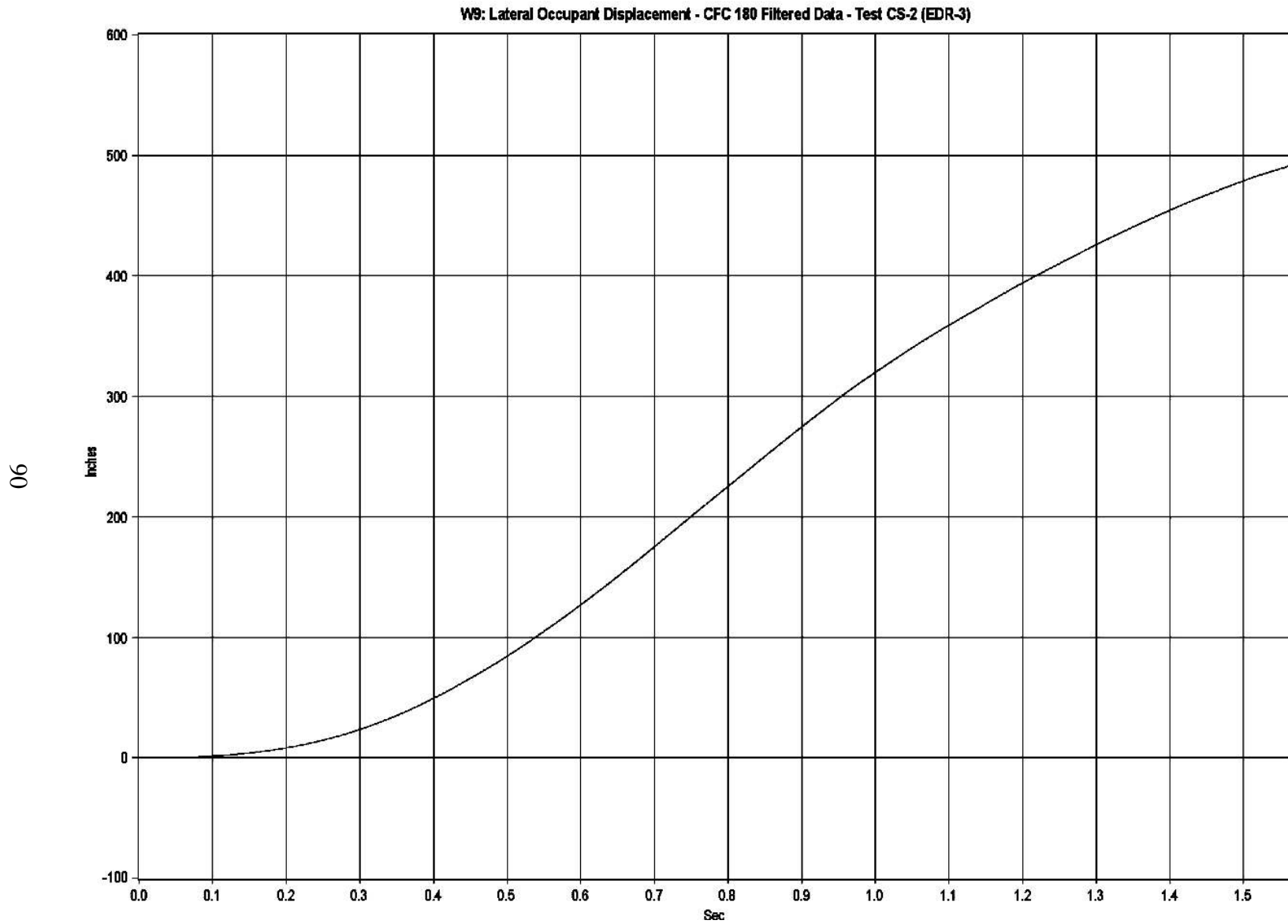

Figure D-6. Graph of Lateral Occupant Displacement, Test CS-2

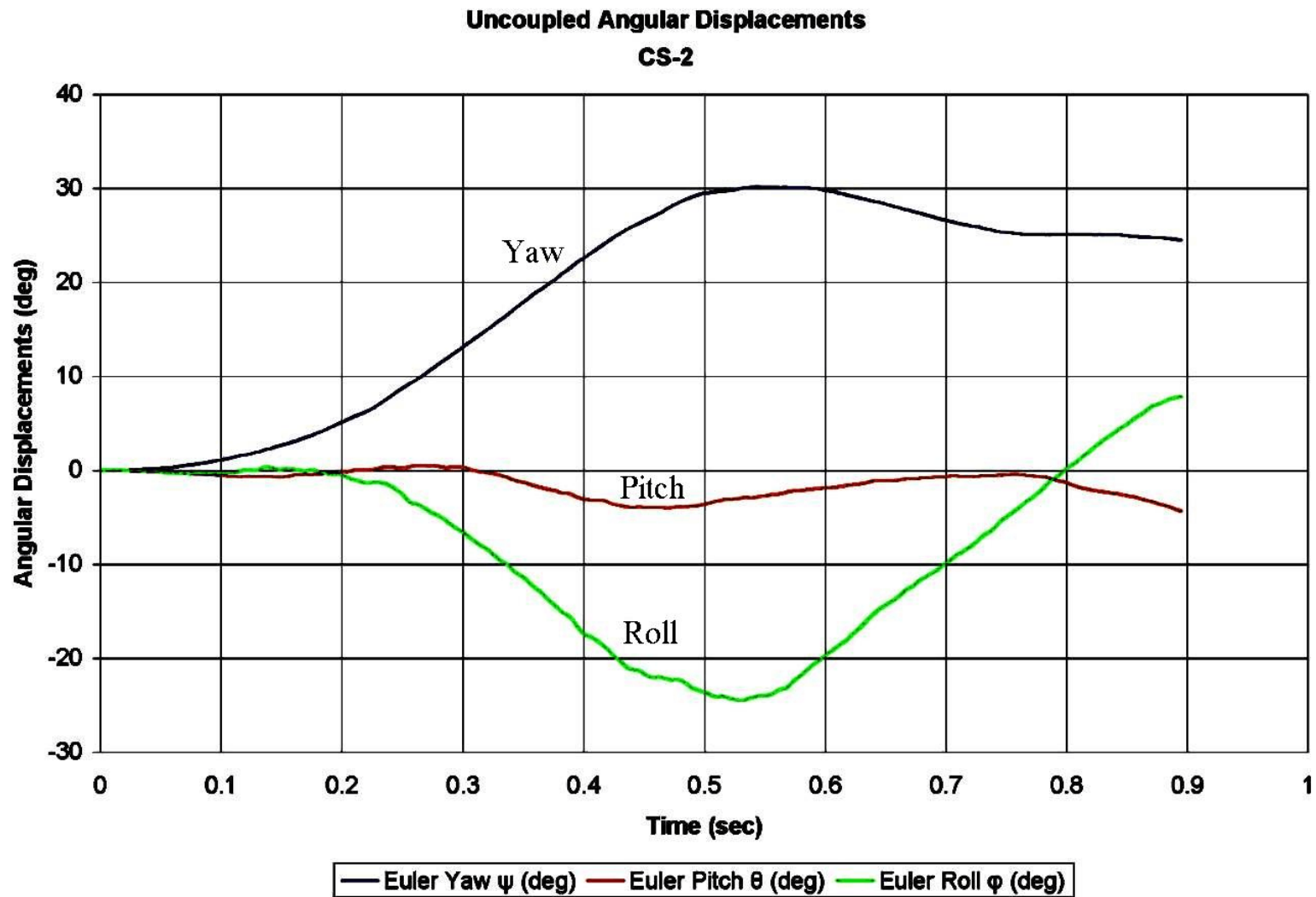

Figure D-7. Graph of Roll, Pitch, and Yaw Angular Displacements, Test CS-2