

*Midwest States Regional Pooled Fund Research Program
Fiscal Year 2005-2006 (Year 16)
Research Project Number SRP-03(017)
NDOR Sponsoring Agency Codes RFPF-06-07 and RFPF-06-09*

DEVELOPMENT OF A TEMPORARY CONCRETE BARRIER TO PERMANENT CONCRETE MEDIAN BARRIER APPROACH TRANSITION

Submitted by

Mitch J. Wiebelhaus Undergraduate Research Assistant	Ryan J. Terpsma, B.S.M.E., E.I.T. Graduate Research Assistant
Karla A. Lechtenberg, M.S.M.E., E.I.T. Research Associate Engineer	John D. Reid, Ph.D. Professor
Ronald K. Faller, Ph.D., P.E. Research Assistant Professor	Robert W. Bielenberg, M.S.M.E., E.I.T. Research Associate Engineer
John R. Rohde, Ph.D., P.E. Associate Professor	Dean L. Sicking, Ph.D., P.E. Professor and MwRSF Director

MIDWEST ROADSIDE SAFETY FACILITY

University of Nebraska-Lincoln
130 Whittier Building
2200 Vine Street
Lincoln, Nebraska 68583-0853
(402) 472-0965

Submitted to

MIDWEST STATES REGIONAL POOLED FUND PROGRAM

Nebraska Department of Roads
1500 Nebraska Highway 2
Lincoln, Nebraska 68502

MwRSF Research Report No. TRP-03-208-10

July 15, 2010

Technical Report Documentation Page

1. Report No. TRP-03-208-10	2.	3. Recipient's Accession No.	
4. Title and Subtitle DEVELOPMENT OF A TEMPORARY CONCRETE BARRIER TO PERMANENT CONCRETE MEDIAN BARRIER APPROACH TRANSITION		5. Report Date July 15, 2010	
		6.	
7. Author(s) Wiebelhaus, M.J., Terpsma, R.J., Lechtenberg, K.A., Faller, R.K., Sicking, D.L., Bielenberg, R.W., Reid, J.D., and Rohde, J.R.		8. Performing Organization Report No. TRP-03-208-10	
9. Performing Organization Name and Address Midwest Roadside Safety Facility (MwRSF) University of Nebraska-Lincoln 130 Whittier Building 2200 Vine Street Lincoln, NE 68583-0853		10. Project/Task/Work Unit No.	
		11. Contract © or Grant (G) No. SPR-03(017)	
12. Sponsoring Organization Name and Address Midwest States Regional Pooled Fund Program Nebraska Department of Roads 1500 Nebraska Highway 2 Lincoln, Nebraska 68502		13. Type of Report and Period Covered Final Report 2005-2010	
		14. Sponsoring Agency Code RFPF-06-07 and RFPF-06-09	
15. Supplementary Notes Prepared in cooperation with U.S. Department of Transportation, Federal Highway Administration			
16. Abstract (Limit: 200 words) <p>The objective of this research was to design a transition from temporary concrete barriers to a permanent concrete barrier for median application. The researchers at Midwest Roadside Safety Facility utilized a combination of free standing and tied down Kansas Temporary Barriers and a dual nested thrie beam for the transition to the single slope permanent barrier as well as a transition cap.</p> <p>Two full-scale vehicle crash tests were performed on the system. The first was with a ½-ton pickup truck which impacted the temporary barriers 56 ¾ in. (1,432 mm) upstream from the permanent barrier, at a speed and angle of 62.4 mph (100.7 km/h) and 24.7 degrees, respectively. The second crash test was performed also using a ½-ton truck which impacted the temporary barriers 54 ft - 6 ¾ in. (16.6 m) upstream from the permanent barrier, at a speed and angle of 62.2 mph (100.1 km/h) and 26.2 degrees, respectively. Both tests were conducted and reported in accordance with requirements specified in the <i>Manual for Assessing Safety Hardware</i> (MASH) and were determined to be acceptable according to the Test Level 3 (TL-3) evaluation criteria.</p>			
17. Document Analysis/Descriptors Highway Safety, Transition, Temporary Barrier, Single Slope Barrier, Work Zones, Longitudinal Barriers, Concrete Barriers, Median Barrier		18. Availability Statement No restrictions. Document available from: National Technical Information Services, Springfield, Virginia 22161	
19. Security Class (this report) Unclassified	20. Security Class (this page) Unclassified	21. No. of Pages 172	22. Price

DISCLAIMER STATEMENT

The contents of this report reflect the views of the authors who are responsible for the facts and the accuracy of the data presented herein. The contents do not necessarily reflect the official views nor policies of the State Highway Departments participating in the Midwest States Regional Pooled Fund Research Program nor the Federal Highway Administration. This report does not constitute a standard, specification, or regulation.

UNCERTAINTY OF MEASUREMENT STATEMENT

The Midwest Roadside Safety Facility (MwRSF) has determined the uncertainty of measurements for several parameters involved in non-standard testing of roadside safety hardware as well as in standard full-scale crash testing of roadside safety features. Information regarding the uncertainty of measurements for critical parameters is available upon request by the sponsor and the Federal Highway Administration.

The Independent Approving Authority (IAA) for the data contained herein was Mr. Scott K. Rosenbaugh.

ACKNOWLEDGMENTS

The authors wish to acknowledge several sources that made a contribution to this project:

(1) the Midwest States Regional Pooled Fund Program funded by the California Department of Transportation, Connecticut Department of Transportation, Illinois Department of Transportation, Iowa Department of Transportation, Kansas Department of Transportation, Minnesota Department of Transportation, Missouri Department of Transportation, Nebraska Department of Roads, New Jersey Department of Transportation, Ohio Department of Transportation, South Dakota Department of Transportation, Wisconsin Department of Transportation, and Wyoming Department of Transportation for sponsoring this project and MwRSF personnel for constructing the barriers and conducting the crash tests.

Acknowledgment is also given to the following individuals who made a contribution to the completion of this research project.

Midwest Roadside Safety Facility

J.C. Holloway, M.S.C.E., E.I.T., Research Manager
C.L. Meyer, B.S.M.E., E.I.T., Research Engineer II
S.K. Rosenbaugh, M.S.C.E., E.I.T., Research Associate Engineer
A.T. Russell, B.S.B.A., Shop Manager
K.L. Krenk, B.S.M.A, Maintenance Mechanic
A.T. McMaster, Laboratory Mechanic
Undergraduate and Graduate Research Assistants

California Department of Transportation

Gary Gauthier, Roadside Safety Research Specialist
Wes Lum, E.E., Office Chief National Liaison

Connecticut Department of Transportation

Dionysia Oliveira, Transportation Engineer 3

Illinois Department of Transportation

David Piper, P.E., Acting Safety Implementation Engineer

Iowa Department of Transportation

David Little, P.E., Assistant District Engineer
Deanna Maifield, P.E., Methods Engineer
Chris Poole, P.E., Litigation/Roadside Safety Engineer

Kansas Department of Transportation

Ron Seitz, P.E., Bureau Chief
Rod Lacy, P.E., Metro Engineer
Scott King, P.E., Road Design Leader

Minnesota Department of Transportation

Michael Elle, P.E., Design Standard Engineer

Missouri Department of Transportation

Joseph G. Jones, P.E., Engineering Policy Administrator

Nebraska Department of Roads

Amy Starr, P.E., Research Engineer
Phil TenHulzen, P.E., Design Standards Engineer
Jodi Gibson, Research Coordinator

New Jersey Department of Transportation

Richard Jaffee, Executive Manager, Civil Engineering Department

Ohio Department of Transportation

Dean Focke, P.E., Roadway Standards Engineer (retired)
Michael Blin, P.E., Standards and Geometrics Engineer

South Dakota Department of Transportation

David Huft, Research Engineer
Bernie Clocksin, Lead Project Engineer

Wisconsin Department of Transportation

John Bridwell, P.E., Standards Development Engineer
Erik Emerson, P.E., Standards Development Engineer

Wyoming Department of Transportation

William Wilson, P.E., Standards Engineer

Federal Highway Administration

John Perry, P.E., Nebraska Division Office
Danny Briggs, Nebraska Division Office

Dunlap Photography

James Dunlap, President and Owner

TABLE OF CONTENTS

	Page
Technical Report Documentation Page	I
DISCLAIMER STATEMENT	ii
UNCERTAINTY OF MEASUREMENT STATEMENT	ii
ACKNOWLEDGMENTS	iii
TABLE OF CONTENTS	vi
List of Figures	viii
List of Tables	xii
1 INTRODUCTION	1
1.1 Problem Statement	1
1.2 Research Objective	1
1.3 Scope	3
2 LITERATURE REVIEW	4
2.1 Approach Transition Between Temporary Concrete Barrier And Rigid Barrier	4
3 COMMON TRANSITION SITUATIONS	5
4 DEVELOPMENT OF A TEMPORARY CONCRETE BARRIER TRANSITION	9
4.1 Design Considerations	9
4.2 System Details	11
5 CIP DETERMINATION UTILIZING COMPUTER SIMULATION	35
6 TEST REQUIREMENTS AND EVALUATION CRITERIA	42
6.1 Test Requirements	42
6.2 Evaluation Criteria	43
7 TEST CONDITIONS	45
7.1 Test Facility	45
7.2 Vehicle Tow and Guidance System	45
7.3 Test Vehicles	45
7.4 Simulated Occupant	53
7.5 Data Acquisition Systems	53
7.5.1 Accelerometers	53
7.5.2 Rate Transducers	54
7.5.3 High-Speed Photography	55

7.5.4 Pressure Tape Switches 55

8 CRASH TEST NO. 1 59

 8.1 Test TCBT-1 59

 8.2 Weather Conditions 59

 8.3 Test Description 59

 8.4 Barrier Damage 60

 8.5 Vehicle Damage 62

 8.6 Occupant Risk Values 63

 8.7 Discussion 63

9 CRASH TEST NO. 2 83

 9.1 Test TCBT-2 83

 9.2 Weather Conditions 83

 9.3 Test Description 83

 9.4 Barrier Damage 85

 9.5 Vehicle Damage 87

 9.6 Occupant Risk Values 88

 9.7 Discussion 88

10 SUMMARY AND CONCLUSIONS 104

11 RECOMMENDATIONS 107

12 REFERENCES 111

13 APPENDICES 113

 Appendix A. Usage Summary for Temporary Barrier Transitions Survey 114

 Appendix B. Details of Temporary Barrier Transitions Obtained from the States 118

 Appendix C. 32 in. Temporary F-Shape Barrier to Permanent Barrier Transitions ... 136

 Appendix D. Vehicle Center of Gravity Determination 145

 Appendix E. Vehicle Deformation Records 148

 Appendix F. Accelerometer and Rate Transducer Data Analysis, Test No. TCBT-1 .. 156

 Appendix G. Accelerometer and Rate Transducer Data Analysis, Test No. TCBT-2 . 164

List of Figures

	Page
Figure 1. Temporary Concrete Barrier Transition Types	2
Figure 2. Temporary Concrete Barriers to Permanent Barrier Transition Options	8
Figure 3. Temporary F-Shape Barrier to Permanent Concrete Median Barrier	10
Figure 4. System Layout Details, Test Nos. TCBT-1	15
Figure 5. Thrie Beam Details, Test Nos. TCBT-1 and TCBT-2	16
Figure 6. Cap Anchoring Details, Test Nos. TCBT-1 and TCBT-2	17
Figure 7. Permanent to Temporary End View, Test Nos. TCBT-1 and TCBT-2	18
Figure 8. Thrie-Beam and End Shoe Details, Test Nos. TCBT-1 and TCBT-2	19
Figure 9. Kansas Barrier Details, Test Nos. TCBT-1 and TCBT-2	20
Figure 10. Temporary Barrier Details, Test Nos. TCBT-1 and TCBT-2	21
Figure 11. Temporary Barrier Details, Test Nos. TCBT-1 and TCBT-2	22
Figure 12. California Permanent Barrier Details, Test Nos. TCBT-1 and TCBT-2	23
Figure 13. Bill of Bars (Temporary Barrier) Details, Test Nos. TCBT-1 and TCBT-2	24
Figure 14. Bill of Bars (California Permanent Barrier) Details, Test Nos. TCBT-1 and TCBT-2	25
Figure 15. Barrier Connection Details, Test Nos. TCBT-1 and TCBT-2	26
Figure 16. Connection Pin, Asphalt Pin, and Blockout Details, Test Nos. TCBT-1 and TCBT-2	27
Figure 17. Cap Rail Transition Details, Test Nos. TCBT-1 and TCBT-2	28
Figure 18. Cap and End Plate Details, Test Nos. TCBT-1 and TCBT-2	29
Figure 19. Gusset Details, Test Nos. TCBT-1 and TCBT-2	30
Figure 20. System Layout Details, Test Nos. TCBT-2	31
Figure 21. Temporary Concrete Barrier to Permanent Concrete Barrier Transition, Test No. TCBT-1 and TCBT-2	32
Figure 22. Temporary Concrete Barrier to Permanent Concrete Barrier Transition, Test No. TCBT-1 and TCBT-2	33
Figure 23. Temporary Concrete Barrier to Permanent Concrete Barrier Transition, Test No. TCBT-1 and TCBT-2	34
Figure 24. TCB Transition CIP-2000P 100 km/h at 25 degree-Impact Location-Test TCBT-2	37
Figure 25. TCB Transition CIP - 2000P 100 km/h at 25 degree - 150 ms - Test No. TCBT-2 ..	38
Figure 26. TCB Transition CIP - 2000P 100 km/h at 25 degree - 300 ms - Test No. TCBT-2 ..	39
Figure 27. TCB Transition CIP - 200p 100 km/h at 25 degree - Test No. TCBT-2	40
Figure 28. CIP Determination Plots - Test No. TCBT-2	41
Figure 29. Test Vehicle, Test No. TCBT-1	46
Figure 30. Test Vehicle Dimensions, Test No. TCBT-1	47
Figure 31. Test Vehicle, Test No. TCBT-2	49
Figure 32. Test Vehicle Dimensions, Test No. TCBT-2	50
Figure 33. Vehicle Target Locations, Test No. TCBT-1	51
Figure 34. Vehicle Target Locations, Test No. TCBT-2	52
Figure 35. Locations of Cameras, Test TCBT-1	57
Figure 36. Locations of Cameras, Test TCBT-2	58

Figure 37. Summary of Test Results and Sequential Photographs, Test No. TCBT-2 65
Figure 38. Additional Sequential Photographs, Test No. TCBT-1 66
Figure 39. Additional Sequential Photographs, Test No. TCBT-1 67
Figure 40. Additional Sequential Photographs, Test No. TCBT-1 68
Figure 41. Additional Sequential Photographs, Test No. TCBT-1 69
Figure 42. Documentary Photographs, Test No. TCBT-1 70
Figure 43. Impact Location, Test No. TCBT-1 71
Figure 44. Vehicle Final Position and Trajectory, Test No. TCBT-1 72
Figure 45. System Damage, Test No. TCBT-1 73
Figure 46. System Damage, Test No. TCBT-1 74
Figure 47. System Damage, Test No. TCBT-1 75
Figure 48. Asphalt Pin Damage, Test No. TCBT-1 76
Figure 49. Asphalt Pin Damage, Test No. TCBT-1 77
Figure 50. Asphalt Pin Damage, Test No. TCBT-1 78
Figure 51. Vehicle Damage, Test No. TCBT-1 79
Figure 52. Vehicle Damage, Test No. TCBT-1 80
Figure 53. Undercarriage Damage, Test No. TCBT-1 81
Figure 54. Occupant Compartment Deformation, Test No. TCBT-1 82
Figure 56. Additional Sequential Photographs, Test No. TCBT-2 91
Figure 57. Additional Sequential Photographs, Test No. TCBT-2 92
Figure 58. Additional Sequential Photographs, Test No. TCBT-2 93
Figure 59. Documentary Photographs, Test No. TCBT-2 94
Figure 60. Impact Location, Test No. TCBT-2 95
Figure 61. Final Position and Trajectory Marks, Test No. TCBT-2 96
Figure 62. System Damage, Test No. TCBT-2 97
Figure 63. System Damage, Test No. TCBT-2 98
Figure 64. System Damage, Test No. TCBT-2 99
Figure 65. Vehicle Damage, Test No. TCBT-2 100
Figure 66. Vehicle Damage, Test No. TCBT-2 101
Figure 67. Undercarriage Damage, Test No. TCBT-2 102
Figure 68. Occupant Compartment Damage, Test No. TCBT-2 103
Figure 69. Temporary F-Shape Barrier to Permanent Concrete Median Barrier 110
Figure A-1. Example of Survey Letter to NDOR - Page 1 of 2 115
Figure A-2. Example of Survey Letter to NDOR - Page 2 of 2 116
Figure A-3. Usage Summary for Temporary Barrier Transitions Survey 117
Figure B-1. South Dakota Details of Temporary Barrier to Bridge End Transition -
Page 1 of 2 119
Figure B-2. South Dakota Details of Temporary Barrier to Bridge End Transition -
Page 2 of 2 120
Figure B-3. South Dakota Details of Temporary Barrier Transition 121
Figure B-4. South Dakota Details of Temporary Barrier End Block 122
Figure B-5. South Dakota Details of Temporary Barrier End Block 123
Figure B-6. South Dakota Details of Temporary Barrier End Block 124
Figure B-7. Nebraska Details of Temporary Barrier Transitions 125

Figure B-8. Nebraska Temporary Barrier Transitions 126
Figure B-9. Minnesota Details of Temporary Barrier Transitions 127
Figure B-10. Minnesota Details of Temporary Barrier Transitions 128
Figure B-11. Minnesota Details of Temporary Barrier Transitions 129
Figure B-12. Minnesota Details of Temporary Barrier Transitions 130
Figure B-13. Minnesota Details of Temporary Barrier Transitions 131
Figure B-14. Minnesota Details of Temporary Barrier Transitions 132
Figure B-15. Minnesota Details of Temporary Barrier Transitions 133
Figure B-16. Minnesota Details of Temporary Barrier Transitions 134
Figure B-17. Minnesota Details of Temporary Barrier Transitions 135
Figure C-1. 32 in. Temporary F-Shape Barrier to 42 in. Median NJ Barrier 137
Figure C-2. 32 in. Temporary F-Shape Barrier to 42 in. Median TX Single-Slope Barrier ... 138
Figure C-3. 32 in. Temporary F-Shape Barrier to 42 in. Median CA Single-Slope Barrier ... 139
Figure C-4. 32 in. Temporary F-Shape Barrier to 42 in. Vertical Median Barrier 140
Figure C-5. 32 in. Temporary Wide F-Shape Barrier to 42 in. Median NJ Barrier 141
Figure C-6. 32 in. Temporary Wide F-Shape Barrier to 42 in. Median TX Single-Slope
Barrier 142
Figure C-7. 32 in. Temporary Wide F-Shape Barrier to 42 in. Median CA Single-Slope
Barrier 143
Figure C-8. 32 in. Temporary Wide F-Shape Barrier to 42 in. Vertical Median Barrier 144
Figure D-1. Vehicle Mass Distribution, Test No. TCBT-1 146
Figure D-2. Vehicle Mass Distribution, Test No. TCBT-2 147
Figure E-1. Occupant Compartment Deformation Data, Test TCBT-1 149
Figure E-2. Occupant Compartment Deformation Index (OCDI), Test TCBT-1 150
Figure E-3. Occupant Compartment Deformation Data - Set 1, Test TCBT-2 151
Figure E-4. Occupant Compartment Deformation Data - Set 2, Test TCBT-2 152
Figure E-5. Occupant Compartment Deformation Index (OCDI), Test TCBT-2 153
Figure E-6. Exterior Vehicle Crush (NASS) - Front, Test TCBT-1 154
Figure E-7. Exterior Vehicle Crush (NASS) - Front, Test TCBT-2 155
Figure F-1. 10-ms Average Longitudinal Deceleration (EDR-3), Test No. TCBT-1 157
Figure F-2. Longitudinal Occupant Impact Velocity (EDR-3), Test No. TCBT-1 158
Figure F-3. Longitudinal Occupant Displacement (EDR-3), Test No. TCBT-1 159
Figure F-4. 10-ms Average Lateral Deceleration (EDR-3), Test No. TCBT-1 160
Figure F-5. Lateral Occupant Impact Velocity (EDR-3), Test No. TCBT-1 161
Figure F-6. Lateral Occupant Displacement (EDR-3), Test No. TCBT-1 162
Figure F-7. Yaw Angular Displacements, Test No. TCBT-1 163
Figure G-1. 10-ms Average Longitudinal Deceleration (EDR-3), Test No. TCBT-2 165
Figure G-2. Longitudinal Occupant Impact Velocity (EDR-3), Test No. TCBT-2 166
Figure G-3. Longitudinal Occupant Displacement (EDR-3), Test No. TCBT-2 167
Figure G-4. 10-ms Average Lateral Deceleration (EDR-3), Test No. TCBT-2 168
Figure G-5. Lateral Occupant Impact Velocity (EDR-3), Test No. TCBT-2 169
Figure G-6. Lateral Occupant Displacement (EDR-3), Test No. TCBT-2 170
Figure G-7. Graph of Roll, Pitch and Yaw Angular Displacements, Test No. TCBT-2 171

List of Tables

	Page
Table 1. Summary of Temporary Barrier Transition State Survey	7
Table 2. MASH Test Level 3 Crash Test Conditions	44
Table 3. MASH Evaluation Criteria for Crash Tests	44
Table 4. Weather Conditions, Test No. TCBT-1	59
Table 5. Sequential Description of Impact Events, TCBT-1	60
Table 6. Weather Conditions, Test No. TCBT-2	83
Table 7. Sequential Description of Impact Events, TCBT-2	84
Table 8. Summary of Safety Performance Evaluation Results - MASH	106

1 INTRODUCTION

1.1 Problem Statement

In practice, temporary concrete barriers must be connected and transitioned to many types of barriers, as shown in Figure 1. Sometimes the temporary concrete barriers are connected to similarly shaped permanent concrete barriers while at other times, they must be connected to vertical concrete barriers, tubular steel bridge railings, W-beam guardrail, thrie-beam guardrail, and open concrete bridge railings. Unfortunately, there has been little effort devoted to this issue and only the transition between safety shaped concrete barriers and temporary concrete barriers has been designed (1). Thus, there is a need to identify the temporary barrier transition situations that the Pooled Fund states need.

Identifying the temporary barrier transition designs that are needed and their usage characteristics is necessary to develop transition designs for resolving these problems. However, addressing all of the possible transition situations would be costly. Thus, since only a small number of transitions will actually be developed, identifying the most prominent need is required. This will ultimately lead to the development of a transition between temporary concrete barrier systems and other types of longitudinal barrier system. The new design should provide a significant improvement in safety of the motoring public.

1.2 Research Objective

The objectives of this research were to (1) identify the most prominent transition need between temporary concrete barriers and other types of barriers and (2) develop a temporary concrete barrier transition for the highest priority situation. The transition design was to be evaluated



Figure 1. Temporary Concrete Barrier Transition Types

according to the Test Level 3 (TL-3) safety performance criteria set forth in the Manual for Assessing Safety Hardware (MASH) (2).

1.3 Scope

The research objective was achieved through the completion of several tasks. First, a survey of the Midwest States Regional Pooled Fund members was conducted to identify the most prominent transition need with respect to temporary concrete barriers. Next, a brainstorming session was undertaken to design a temporary concrete barrier transition for the most prominent need. After the transition design was developed, a computer simulation modeling was undertaken to analyze and determine the Critical Impact Points (CIPs) for the transition. Two full-scale vehicle crash tests were performed on the transition system. The crash tests utilized ½-ton pickup trucks, each weighing approximately 5,004 lb (2,270 kg). The targeted impact conditions for the tests were an impact speed of 62.1 mph (100.0 km/h) and an impact angle of 25 degrees. Next, the test results were analyzed, evaluated, and documented. Finally, conclusions and recommendations were made that pertain to the safety performance of the design for a temporary concrete barrier transition.

2 LITERATURE REVIEW

2.1 Approach Transition Between Temporary Concrete Barrier And Rigid Barrier

In 2005, MwRF designed and evaluated a transition from free-standing temporary concrete barrier to rigid concrete barrier (1). This design was developed for roadside applications and was not intended for use in median installations. The test installation consisted of five rigidly constrained barriers on the downstream end, four transition barriers, and thirteen free-standing barriers on the upstream end. The rigid barrier end was simulated by bolting down the final five F-shape barriers with 1 1/8-in. (29-mm) diameter B7 threaded rod epoxied into the concrete at an embedment depth of 12 in. (304 mm). The transition to free-standing barrier utilized a transition in stiffness over the four barriers with a varied spacing of an asphalt pin tie-down system in the traffic-side. The first barrier in the transition (also the one adjacent to the free-standing barriers) had a single pin at the downstream end on the traffic side face of the barrier. The second barrier had pins installed at the two outermost hole locations on the traffic side face of the barrier. The final two barriers had all three pins installed on the traffic-side. The free standing barrier and the bolted down barrier were joined by loop and pin connection at the joint. To reduce the potential for vehicle snag at the joints, nested thrie beam was also bolted across both sides of the barrier at the joint between the pinned barrier and the rigid barrier system. In test no. FTB-2, a 4,475-lb (2,030-kg) pickup truck impacted the system 48 in. (1,219 mm) upstream of the joint between barrier nos. 14 and 15, which are the first two pinned barriers in the transition at a speed of 63.8 mph (102.7 km/h) and at an angle of 26.1 degrees. During the impact, the vehicle was safely redirected, and the test was determined to be acceptable according to the TL-3 safety performance criteria of test designation 3-21 found in NCHRP Report No. 350 (3).

3 COMMON TRANSITION SITUATIONS

At the onset of this project, the Midwest States Regional Pooled Fund states were surveyed to determine which types of temporary concrete barrier approach transitions are needed, which types are currently used, and which types are the most important. The initial survey sent to each of the Pooled Fund states is shown in Appendix A. The states were given eight types of commonly used temporary concrete barrier transitions and invited to add their own as desired. For each transition, the states were asked to (1) identify the usefulness of the transition; (2) identify the approximate percentage of all temporary barrier transitions that each type composes; and (3) rank the transition types in order of importance.

Nine out of the thirteen surveyed states responded to the initial survey. Photographs and details of various temporary barrier transitions were also obtained from the states and are shown in Appendix B. After compiling the responses from the states, the various transition needs were organized into a limited number of design categories that resulted in the smallest number of full-scale crash tests as possible. Priorities for the project were assigned based on: (1) the importance of the transition to the States participating in the Pooled Fund Program; (2) the number of different systems that can be addressed simultaneously; and (3) the potential for the development of a successful design. According to the responses and as summarized in Table 1, the most useful transitions were those connecting temporary concrete barriers to permanent concrete safety shape barriers and permanent concrete vertical barriers. The highest percentage of all the transitions currently in use were those connecting temporary concrete barriers to permanent concrete safety shape barriers and tubular steel bridge railings. In rank of importance, transitions to permanent concrete safety shape barriers were again at the top, followed by transitions to W-beam guardrail.

As the most popular in all three categories, the transition between temporary concrete barriers and permanent concrete safety shape barriers was chosen for development of a transition solution. Realizing that such a transition may be applicable to more than one type of permanent concrete barrier, the researchers expanded the scope of the design to include both vertical concrete parapets, safety shape barriers, and single-slope barriers, but intending to only test the most critical. Since an NCHRP Report No. 350 compliant design for the transition between temporary concrete barriers and permanent safety shaped barriers for roadside applications was recently developed (1), a median application was selected for this study.

After making the initial selection, the researchers determined that two possible configurations for a median barrier transition situation exist, an end-to-end barrier transition or an offset-overlap barrier transition, as shown in Figure 2. Thus, a second survey was sent to the Pooled Fund states asking them to select their most common configuration. Eight states replied to the additional survey with five selecting the end-to-end barrier transition and three selecting the offset-overlap transition. Therefore, the project was to proceed with the design of an end-to-end transition between a permanent concrete barrier and a series of temporary concrete safety shape barriers for median applications, as shown as Option 2 in Figure 2.

Table 1. Summary of Temporary Barrier Transition State Survey

Transition Type - Temporary Concrete Safety Shape Barrier Transitioning to:	Usefulness Summary: (1)					Percent (2)	Rank (3)
	Not Useful	Somewhat Useful			Very Useful		
W-Beam Guardrail	1	2	3	4	<u>5</u>	30%	2
Thrie-Beam Guardrail	1	<u>2</u>	3	4	5	0%	6
Permanent Concrete Vertical Barrier	1	2	3	<u>4</u>	5	15%	3
Permanent Concrete Safety Shape Barrier	1	2	3	4	<u>5</u>	40%	1
Temporary Concrete Safety Barrier	1	2	3	4	<u>5</u>	10%	4
Tubular Steel Bridge Railing	<u>1</u>	2	3	4	5	0%	7
Open Concrete Bridge Railing	1	2	3	<u>4</u>	5	5%	5
Box-Beam Guardrail	<u>1</u>	2	3	4	5	0%	8
Other:							
	1	2	3	4	5		

Note: States completing the survey were asked to:

- (1) Identify how useful the development of the listed transition would be to your state by circling a number from 1 to 5.
- (2) Include the approximate percentage of temporary barrier transitions which are comprised of the listed transitions.
- (3) Rank the transition types in order of their benefit to your state with 1 being the most beneficial.
- (4) Include pictures, details, and drawings concerning temporary concrete barrier transitions, including all those listed below.

OPTION 1 - OFFSET OVERLAP TRANSITION

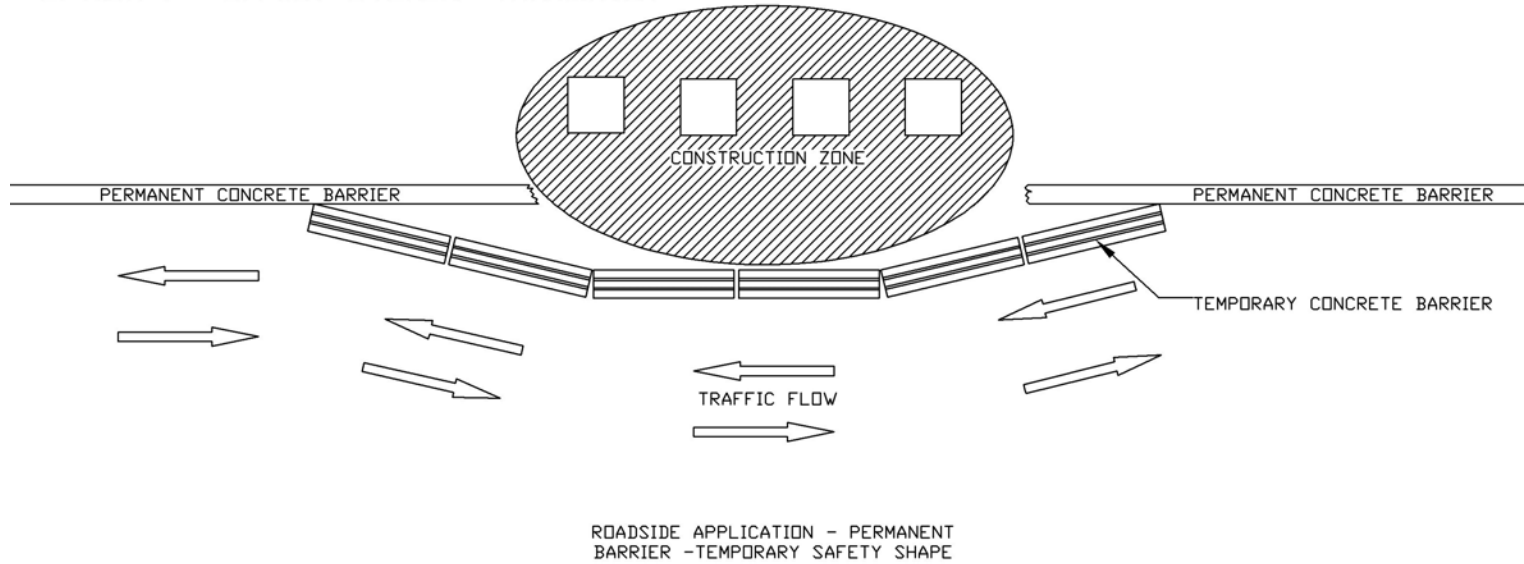

OPTION 2 - END-TO-END TRANSITION

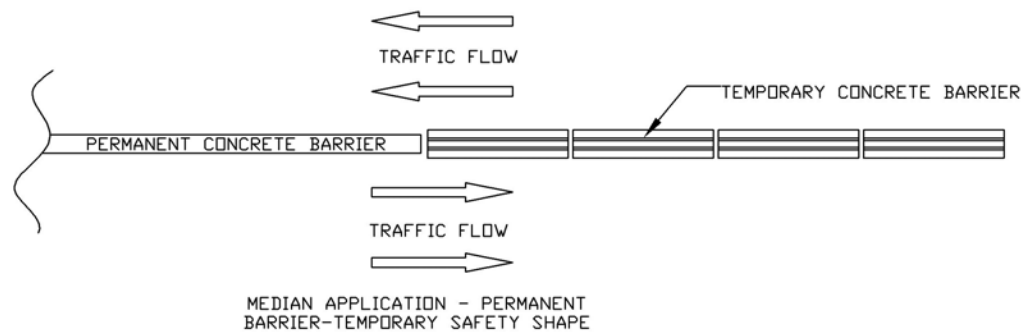

Figure 2. Temporary Concrete Barriers to Permanent Barrier Transition Options

4 DEVELOPMENT OF A TEMPORARY CONCRETE BARRIER TRANSITION

4.1 Design Considerations

The next phase of the research was to determine the type of permanent concrete barrier that would be the most critical when used in an approach transition. To make this determination, the shapes of various permanent median barrier designs were compared to the shape of both the narrow and wide versions of the 32-in. (813-mm) tall F-shape temporary barrier. The following comparisons were completed:

1. 32-in. (813-mm) F-shape temporary barrier to 32-in. and 42-in. (813-mm and 1,067-mm) F-shape and New Jersey (NJ) -shape median barriers,
2. 32-in. (813-mm) F-shape temporary barrier to 32-in. and 42-in. (813-mm and 1,067-mm) Texas (TX) and California (CA) single-slope median barriers,
3. 2-in. (813-mm) F-shape temporary barrier to 32-in. and 42-in. (813-mm and 1,067-mm) vertical median barriers,
4. 32-in. (813-mm) wider F-shape temporary barrier to 32-in. and 42-in. (813-mm and 1,067-mm) F-shape and NJ-shape median barriers,
5. 32-in. (813-mm) wider F-shape temporary barrier to 32-in. and 42-in. (813-mm and 1,067-mm) TX and CA single-slope median barriers,
6. 32-in. (813-mm) wider F-shape temporary barrier to 32-in. and 42-in. (813-mm and 1,067-mm) vertical median barriers.

Detailed drawings of each of these scenarios are shown in Appendix C.

From the comparison of the various shapes, it was determined that the 42-in. (1,067 mm) tall CA single-slope median barrier provided the worst case situation. Comparison of the F-shape temporary barrier geometry with the single-slope barrier showed that there was a high potential for vehicle snag on the sides of the permanent barrier as well as on the 10 in. (254 mm) height difference of the barriers, as shown in Figure 3. It was determined that shifting the temporary barrier

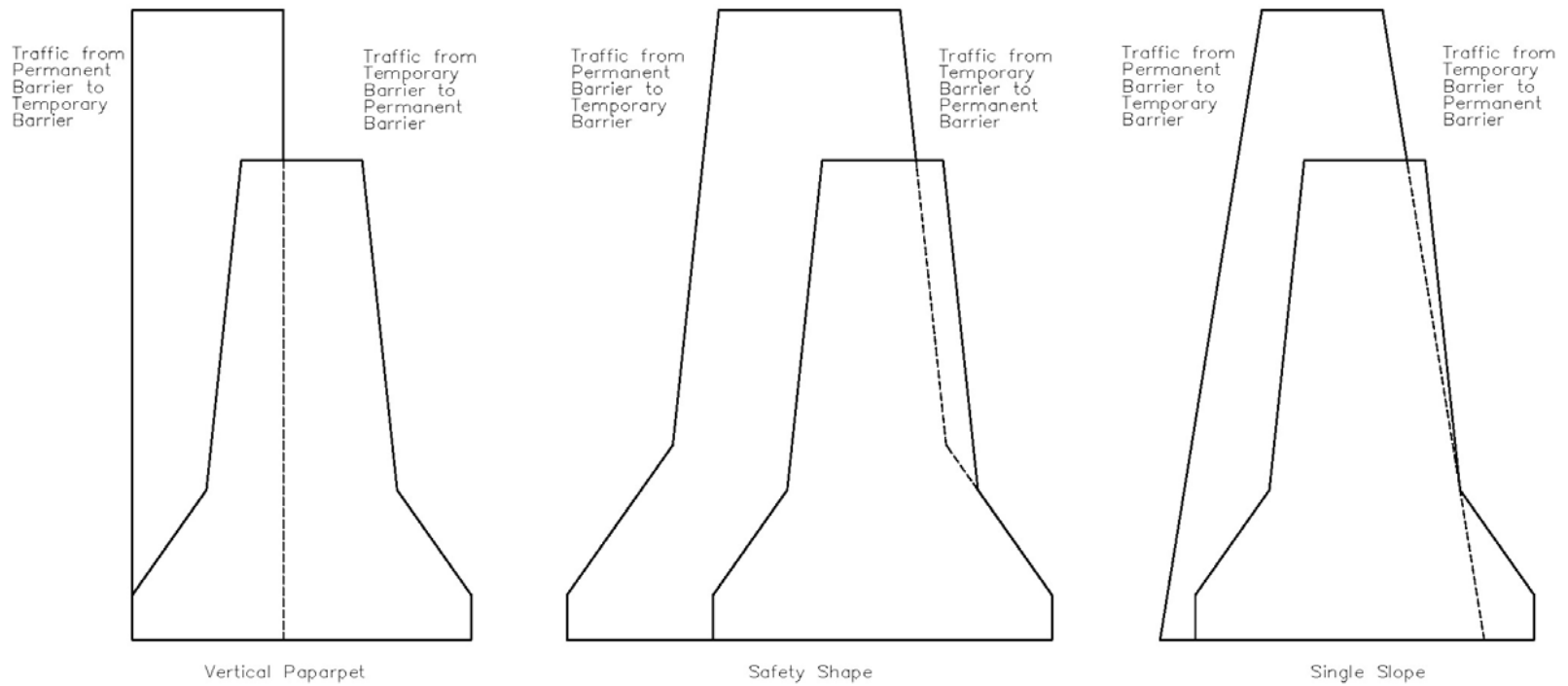

Note: (1) The 32" temporary F-shape barrier is shown as the front barrier.

Figure 3. Temporary F-Shape Barrier to Permanent Concrete Median Barrier

toward the traffic-flow side of the single-slope so that the slope breakpoint at the top of the toe of the temporary barrier lines up with the traffic-side face of the permanent single slope would help alleviate some of the snag potential on the single-slope barrier. This asymmetrical placement would only present a safety concern if the temporary barrier were used to separate traffic flowing in the same direction, such as in a gore area. However, it was believed that this situation would be better treated with a barrier end treatment.

4.2 System Details

The 166-ft 10-in. (50.9-m) long test installation details for a transition from temporary concrete barriers to a permanent concrete barrier are shown in Figures 4 through 20. The test installation consisted of a rigid parapet, four transition barriers, eight free-standing barriers on the upstream end, and a transition cap. The transition and free-standing barriers were installed on a 3-in. (76-mm) thick asphalt pad. Photographs of the test installation are shown in Figures 21 through 23.

The transition utilized a varied spacing of the asphalt pin tie-down system to create a transition in stiffness over a series of four barrier segments. The asphalt pins used in the design were 1 ½ -in. (38-mm) diameter x 38 ½-in (978-mm) long ASTM A36 steel pins with 3-in. x 3-in. x ½-in. (76-mm x 76-mm x 13-mm) ASTM A36 steel cap plates with a 1 ½ -in. (38.1-mm) diameter hole in the center. The steel cap was welded on to the pin on both the top and bottom surfaces of the plate at a position of 36 in. (914 mm) from the bottom of the pin to the top of the plate. These pins were installed in the holes on both the front and back faces of the four barriers in the transition section of the installation. The first barrier in the transition (the one adjacent to the free-standing barrier) had a single pin at the downstream end on both the front and back sides. The second barrier had pins installed at the two outermost hole locations on both the front and back faces. The final two barriers

had all three pins installed on both the front and back faces.

In order to reduce the potential vehicle snag at the joint between the pinned barriers and the rigid parapet, a transition cap and nested thrie beam sections were added. The nested 12-gauge thrie beam sections were bolted across both sides of the barrier at the joint between the pinned barrier and the rigid parapet. It should be noted that 10-gauge thrie beam can be substituted for the nested 12-gauge in actual installations if desired. The thrie beam was bolted to the barriers using five $\frac{3}{4}$ -in. (19-mm) diameter x 6-in. (152-mm) long, Power Fasteners Wedge-Bolt Anchors at each end of the beam, as shown in Figure 16. In addition, the middle of the thrie section was attached to the pinned barrier with two $\frac{3}{4}$ -in (19-mm) diameter Grade 5 bolts and $\frac{3}{4}$ -in (19-mm) diameter RedHead Multi-Set II Drop-in Anchors. A wooden spacer block was used to offset the thrie beam from the concrete barrier on the back side of the installation. The two bolts on the front face were 1 $\frac{3}{4}$ in. (44 mm) long, while the two on the back face were 5 $\frac{1}{2}$ in. (140 mm) long. The 12-gauge ASTM A36 steel cap was 6 $\frac{1}{16}$ in. (154 mm) and 8 $\frac{1}{8}$ in. (206 mm) wide at the top and bottom, respectively, with a height of 10 in. (254 mm). Four 12-gauge ASTM A36 gussets were stitch welded on three sides inside the cap. The cap details are shown in Figures 17 through 19.

The concrete barrier utilized of Iowa's Concrete Barrier Mix, which was configured with a minimum 28-day concrete compressive strength of 5,000 psi (34.5 MPa). A minimum concrete cover varied at different rebar positions within the barrier. A minimum concrete cover of 2 in. (51 mm) was used along the top of the vertical stirrup rebar and at the bottom of the longitudinal rebar. Minimum concrete cover of 1 $\frac{3}{4}$ in. (44 mm) and 1 in. (25 mm) were used along the sides of the vertical stirrup rebar and at the rebar around the anchor bolt block, respectively. All steel

reinforcement in the barrier conformed to ASTM A615 Grade 60 rebar, except for the loop bars which were ASTM A706 Grade 60 rebar. The barrier reinforcement details are shown in Figure 11.

Barrier reinforcement consisted of three No. 5 and two No. 4 longitudinal bars, twelve No. 4 bars for the vertical stirrups, and six No. 6 bars for the anchor bolt block reinforcement loops. Each of the five longitudinal rebar was 12 ft 2 in. (3.71 m) long. The vertical spacing of the lower, middle, and upper longitudinal bars were 6 ½ in. (165 mm), 14 ½ in. (368 mm), and 29 ⅛ in. (780 mm) from the ground to their centers, respectively. The vertical stirrups were 72-in. (1,829-mm) long and were bent into the shape of the barrier. Their spacing varied longitudinally, as shown in Figure 11. The reinforcing steel loops used around the tie-down anchor holes in the barrier were 35 in. (889 mm) long, were bent into a U-shape, and were used to reinforce the anchor bolt area.

The barriers used a pin and loop type connection comprised of two sets of three rebar loops on each barrier interconnection. Each loop assembly was configured with three ASTM A706 Grade 60 No. 6 bars that were bent into a loop shape. The vertical pin used in the connection consisted of a 1 ¼ in. (32-mm) diameter x 28-in. (711-mm) long round bar comprised of ASTM A36 steel. The pin was held in place using one 2 ½-in. wide x 4-in. long x ½-in. thick (64-mm x 102-mm x 13-mm) ASTM A36 steel plate with a 1 ⅜-in. (35-mm) diameter hole centered on it. The plate was welded 2 ½ in. (64 mm) below the top of the pin. A gap of 3 ⅝ in. (92 mm) between the ends of two consecutive barriers was formed from the result of pulling the connection taut.

The single-slope permanent concrete barrier was 21 ½ in. (545 mm) and 8 in. (203 mm) wide at the base and top, respectively, with an overall height of 42 in. (1,067 mm) from the ground to the top of the barrier. The single-slope concrete barrier had a overall length of 13 ft - 4 in. (4,064 mm). The concrete used for the barrier consisted of Nebraska 47-BD Mix Type 3, with a minimum 28-day

concrete compressive strength of 5,000 psi (34.5 MPa). A minimum concrete cover of 2 in. (51 mm) was used along the entire barrier. All the steel reinforcement in the barrier was ASTM A615 Grade 60 rebar. The barrier reinforcement details, which consisted of ten No. 5 longitudinal bars and fourteen No. 4 and thirteen No. 6 bars for the vertical stirrups are shown in Figures 12 and 14. The single-slope barrier employed a 30-in. deep by 36-in. wide (762-mm x 914-mm) reinforced concrete footing at its base. The footing was tied to the single slope barrier with fourteen No. 6 vertical stirrups that were tied to the No. 4 vertical stirrups in the barrier with No. 5 bars.

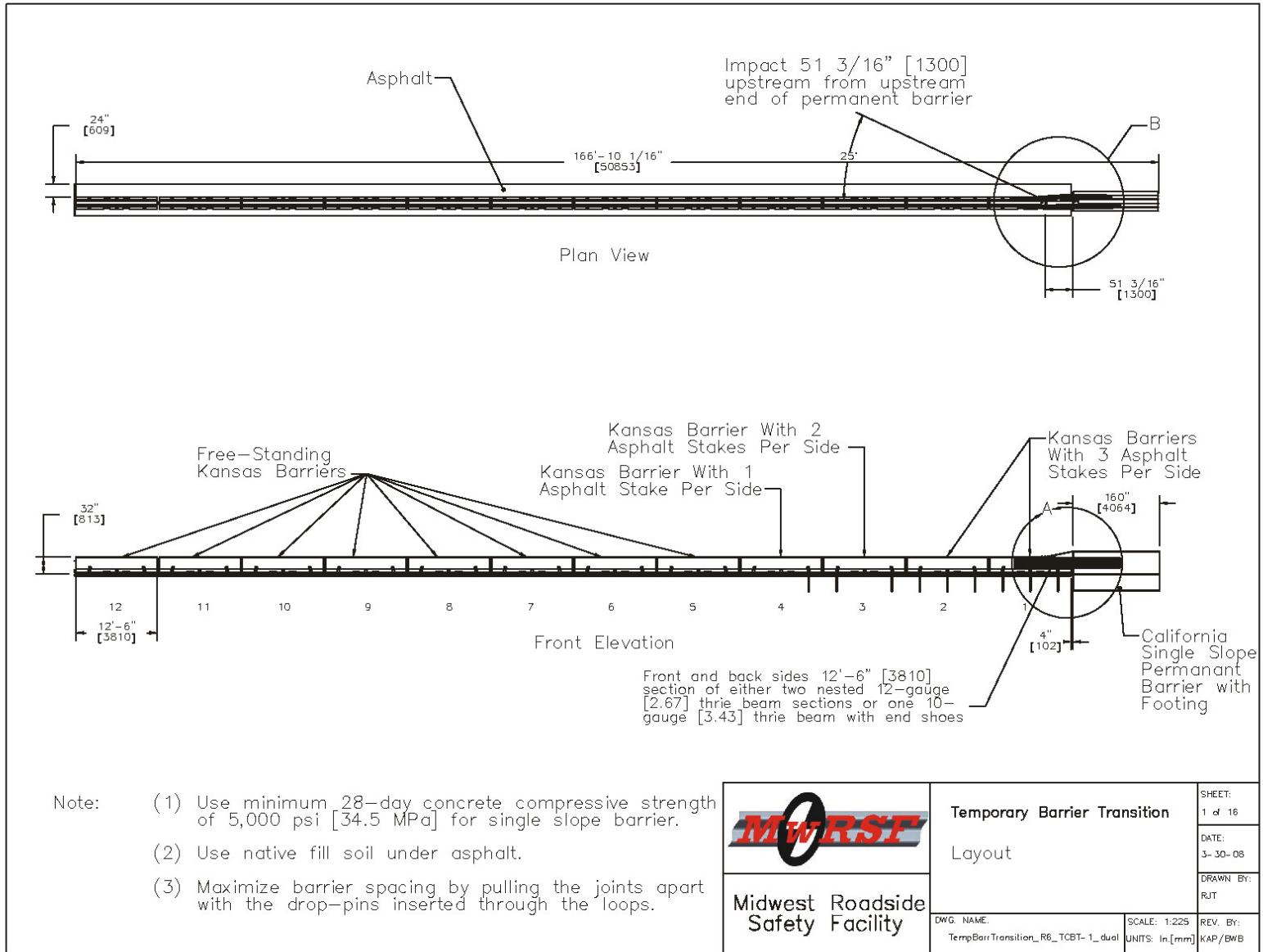

Figure 4. System Layout Details, Test Nos. TCBT-1

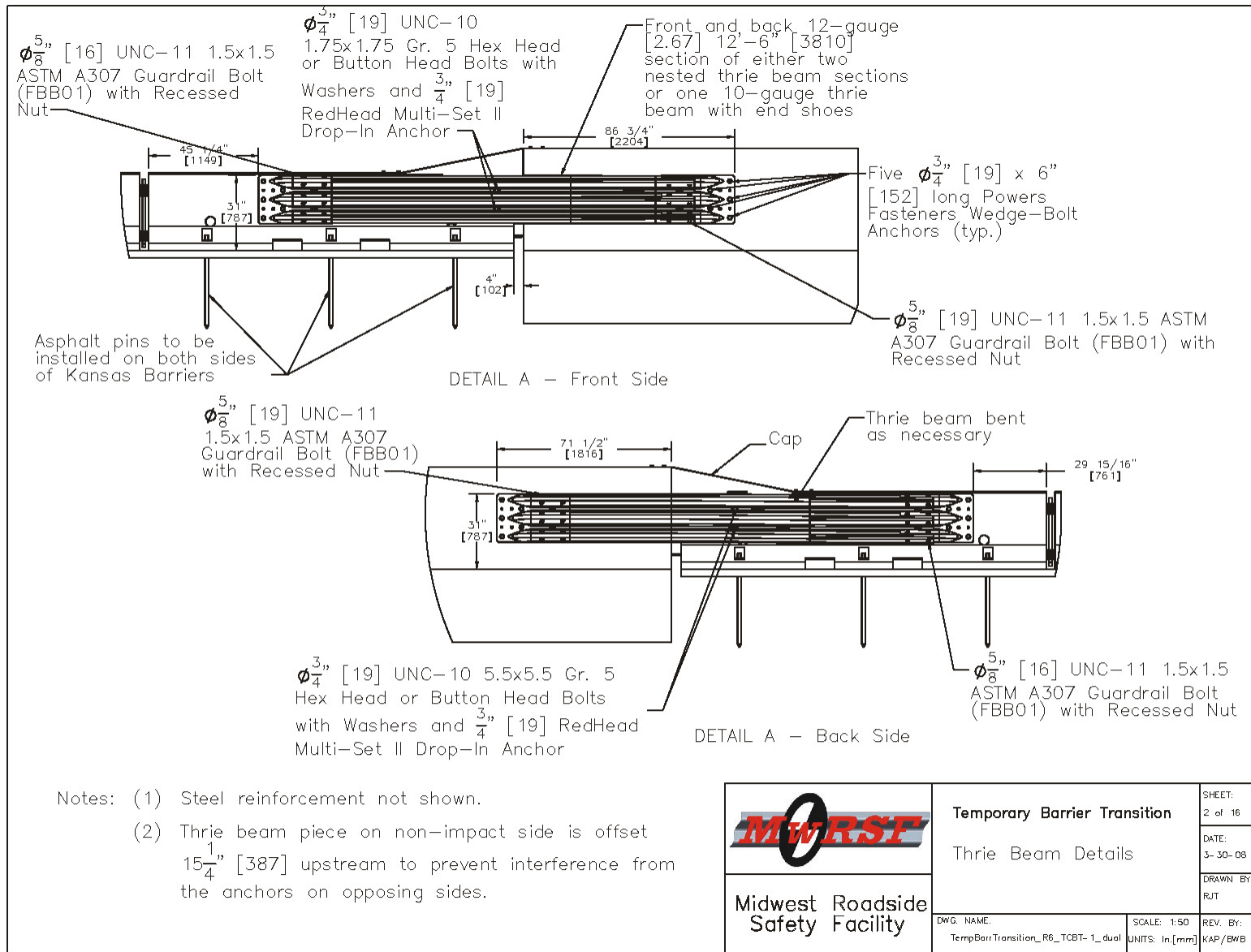

Figure 5. Thrie Beam Details, Test Nos. TCBT-1 and TCBT-2

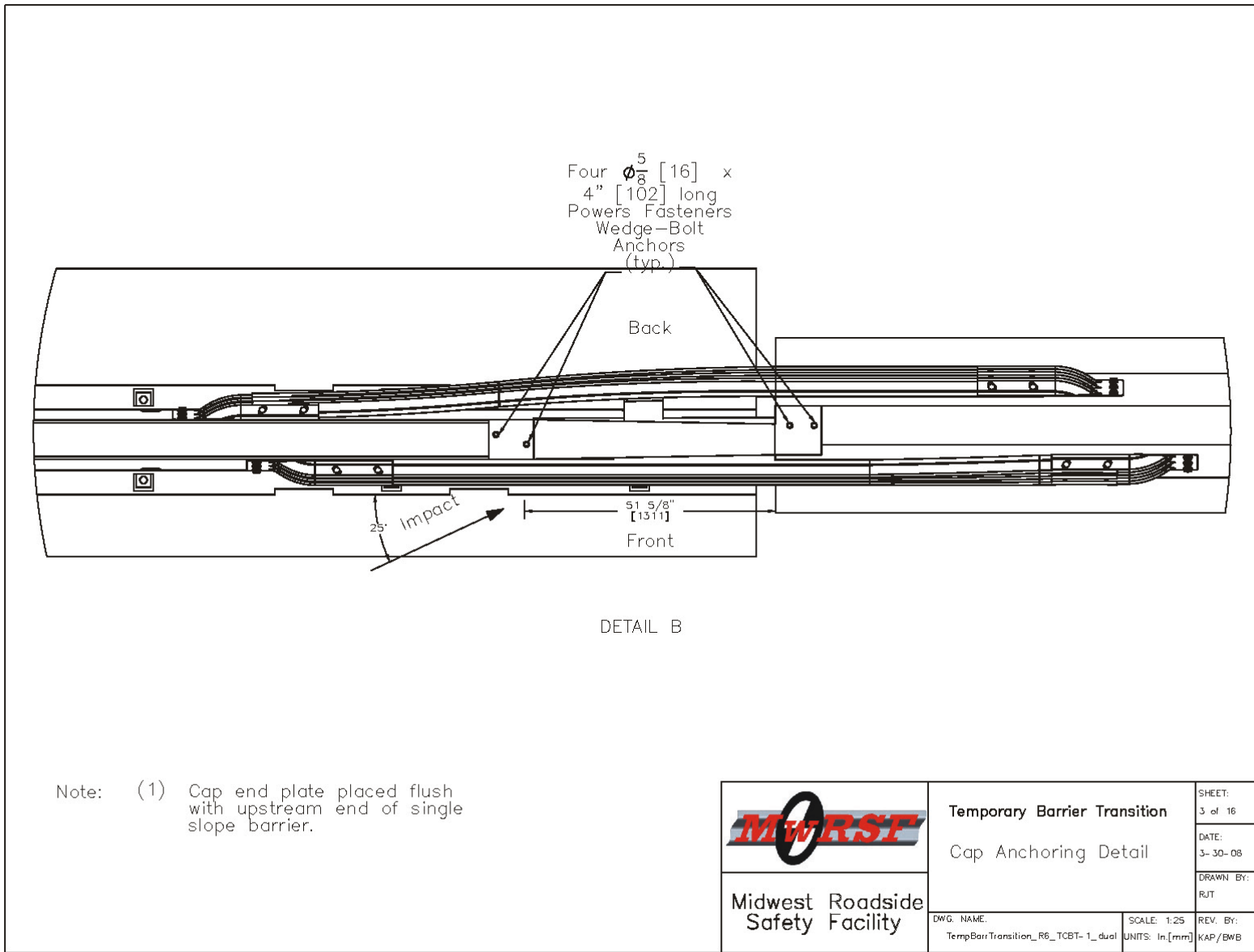

Figure 6. Cap Anchoring Details, Test Nos. TCBT-1 and TCBT-2

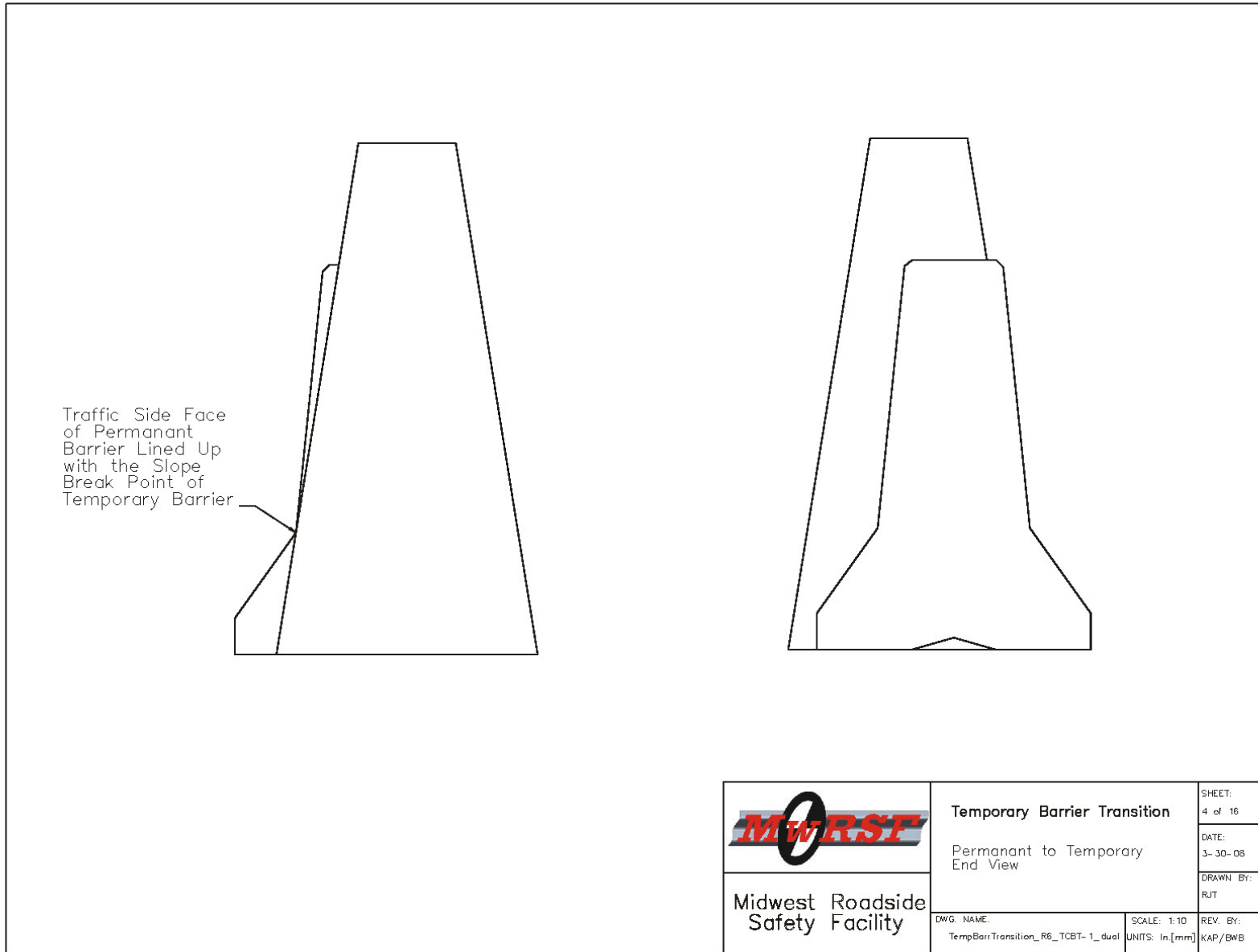

Figure 7. Permanent to Temporary End View, Test Nos. TCBT-1 and TCBT-2

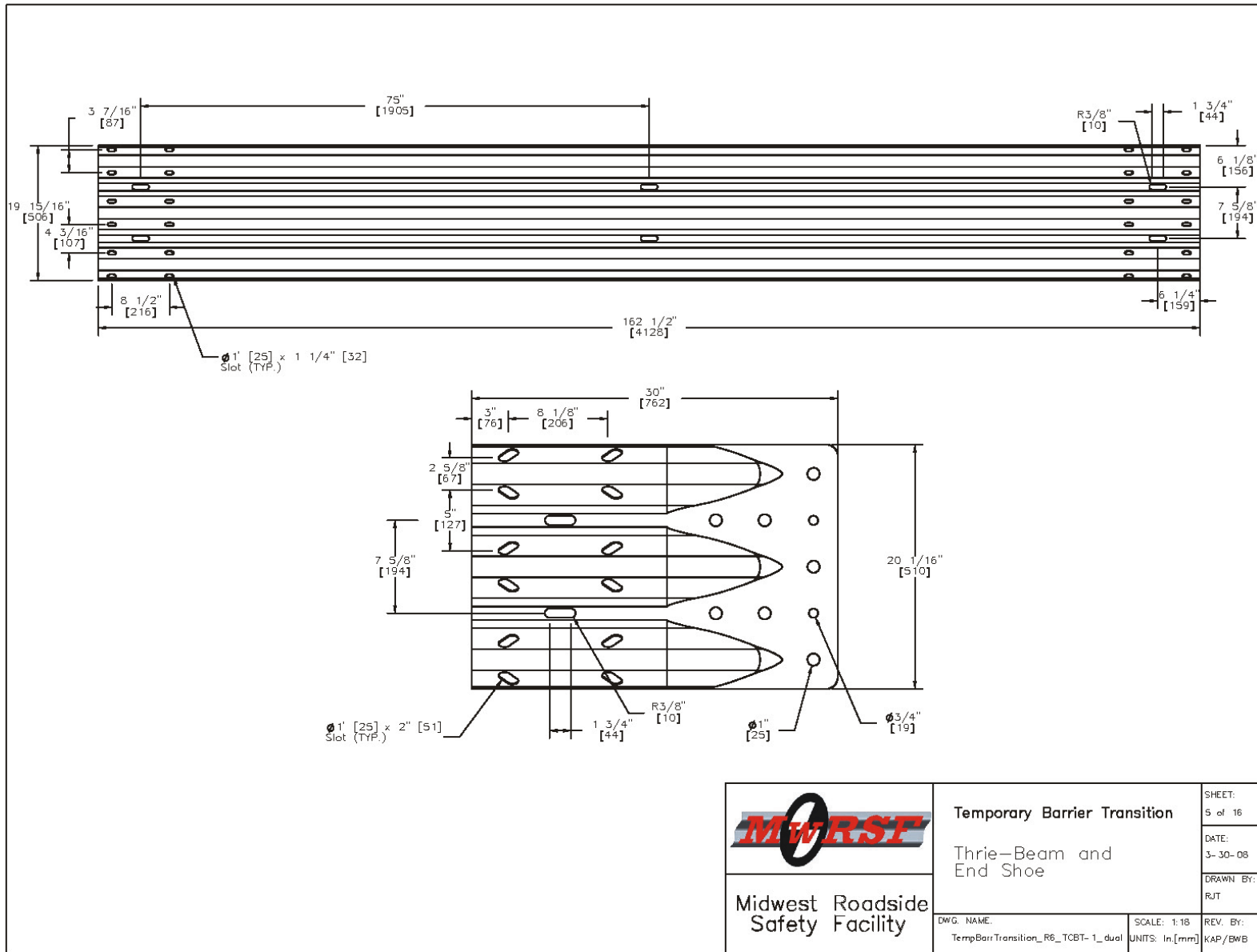

Figure 8. Thrie-Beam and End Shoe Details, Test Nos. TCBT-1 and TCBT-2

20

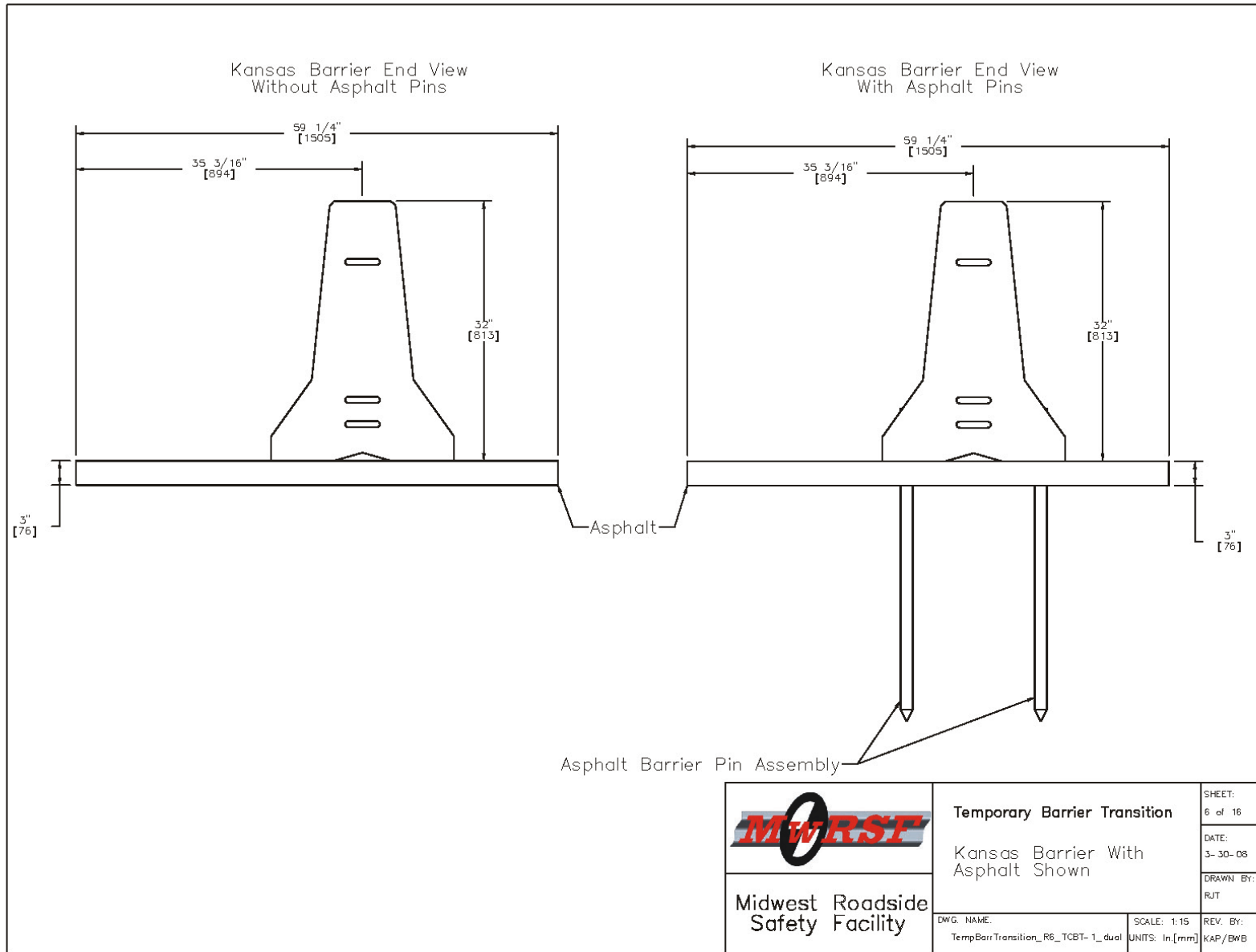
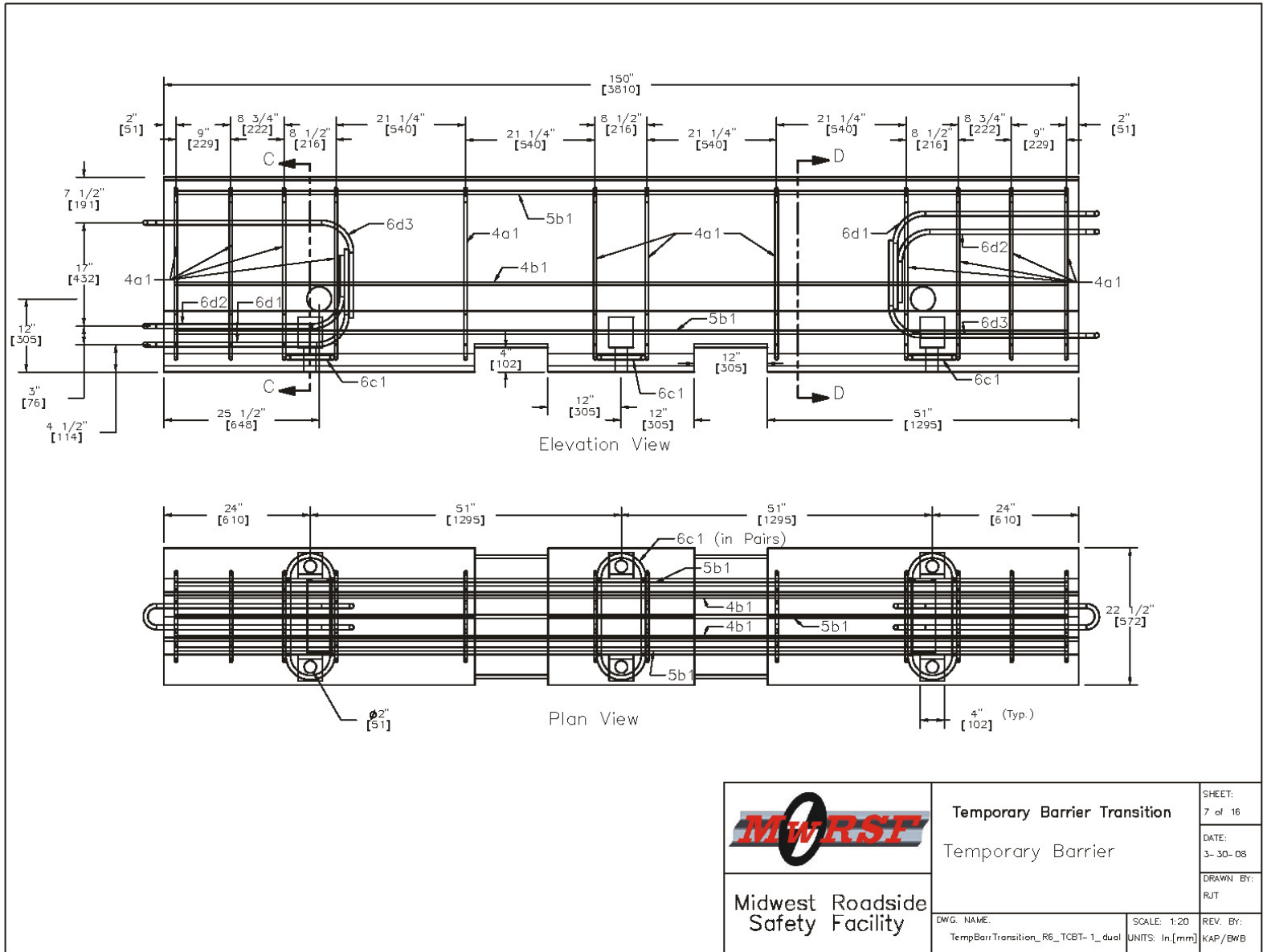

Figure 9. Kansas Barrier Details, Test Nos. TCBT-1 and TCBT-2



 Midwest Roadside Safety Facility	Temporary Barrier Transition Temporary Barrier		SHEET: 7 of 16
			DATE: 3-30-08
			DRAWN BY: RJT
DWG. NAME: TempBarr Transition_R6_TCBT-1_dual		SCALE: 1:20 UNITS: In.[mm]	REV. BY: KAP/BWB

Figure 10. Temporary Barrier Details, Test Nos. TCBT-1 and TCBT-2

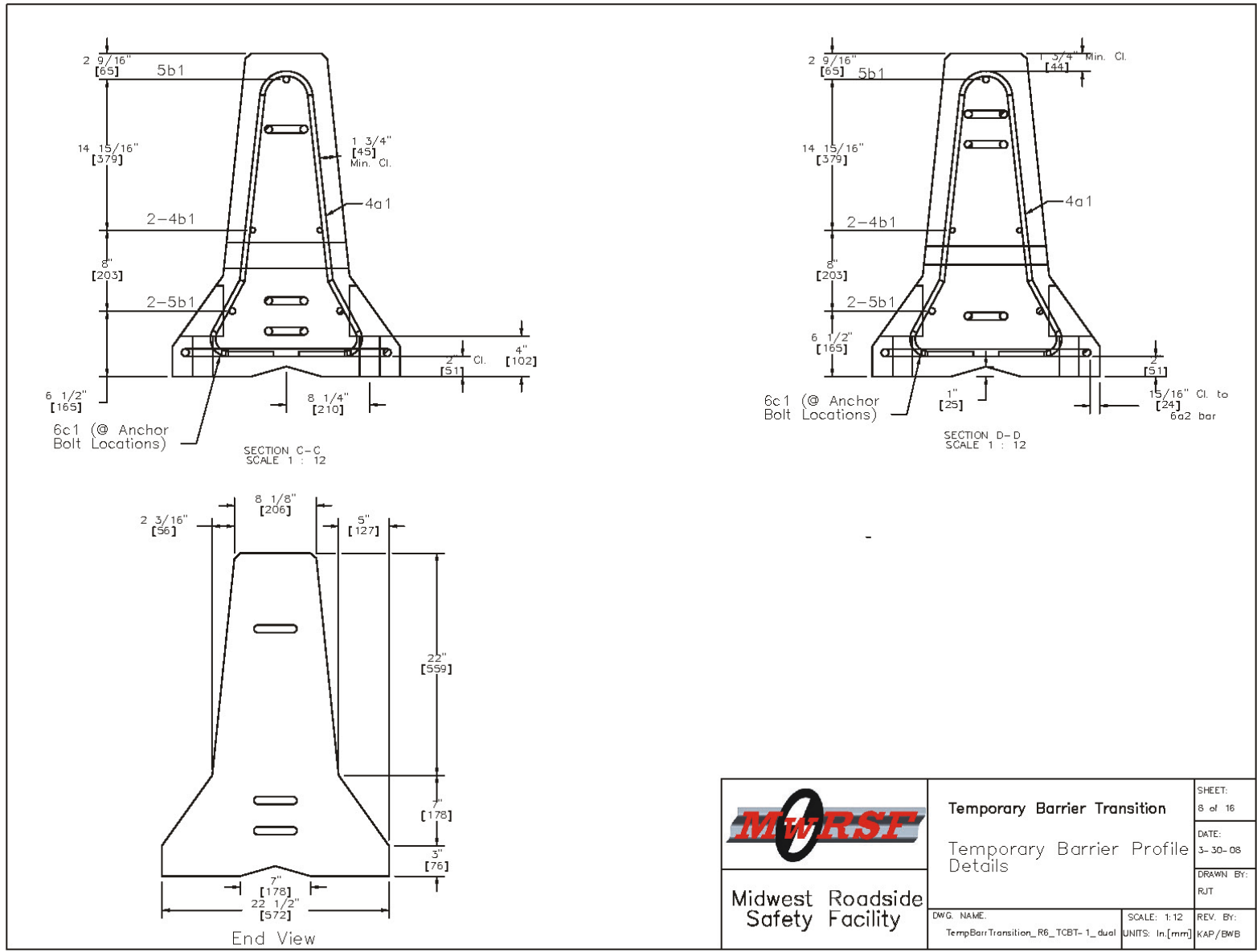



Figure 11. Temporary Barrier Details, Test Nos. TCBT-1 and TCBT-2

 Midwest Roadside Safety Facility	Temporary Barrier Transition	SHEET: 8 of 16
	Temporary Barrier Profile Details	DATE: 3-30-08
	DWG. NAME: TempBarrTransition_R6_TCBT-1_dual	DRAWN BY: RJT
	SCALE: 1:12 UNITS: In, [mm]	REV. BY: KAP/BWB

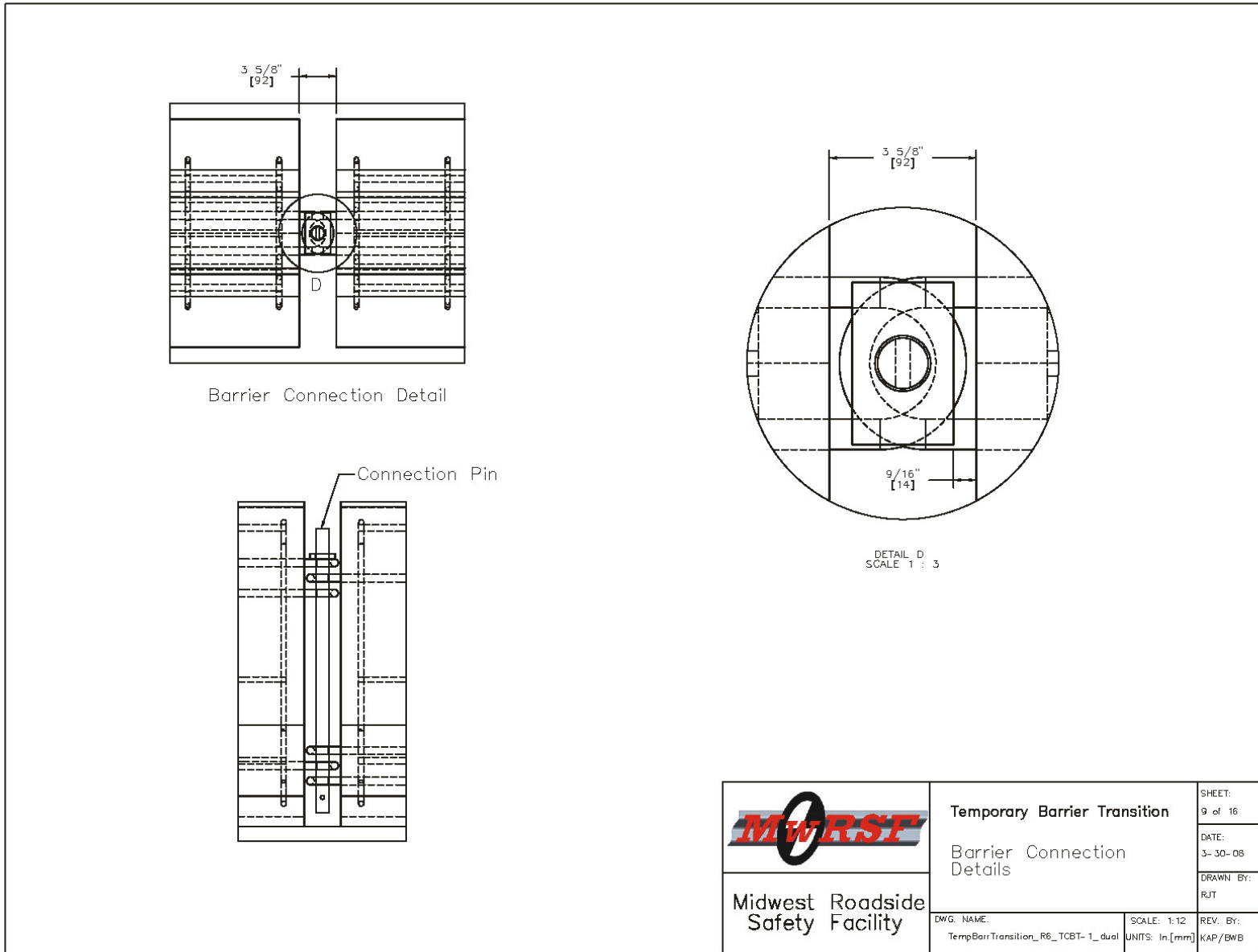

Figure 12. California Permanent Barrier Details, Test Nos. TCBT-1 and TCBT-2

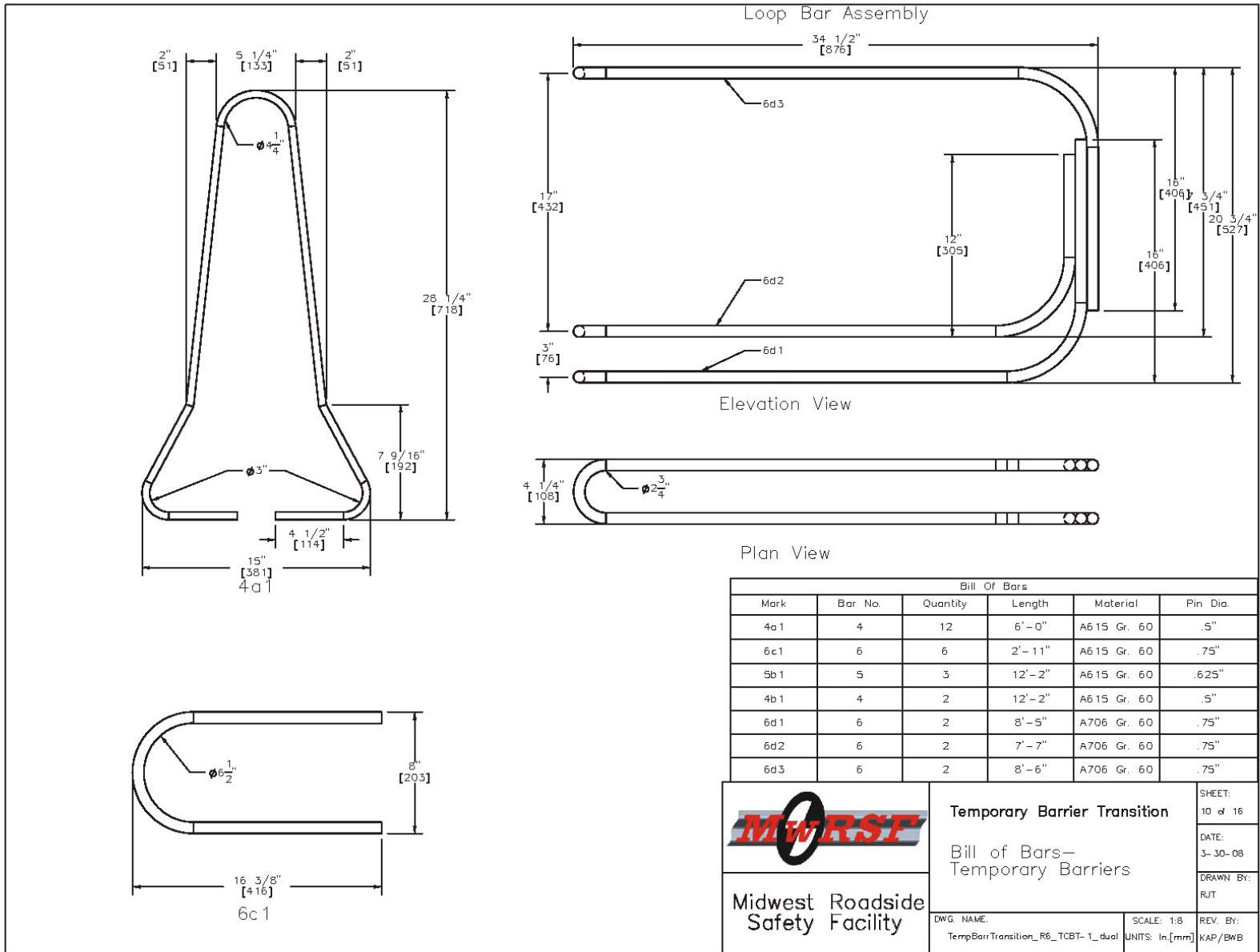

Figure 13. Bill of Bars (Temporary Barrier) Details, Test Nos. TCBT-1 and TCBT-2

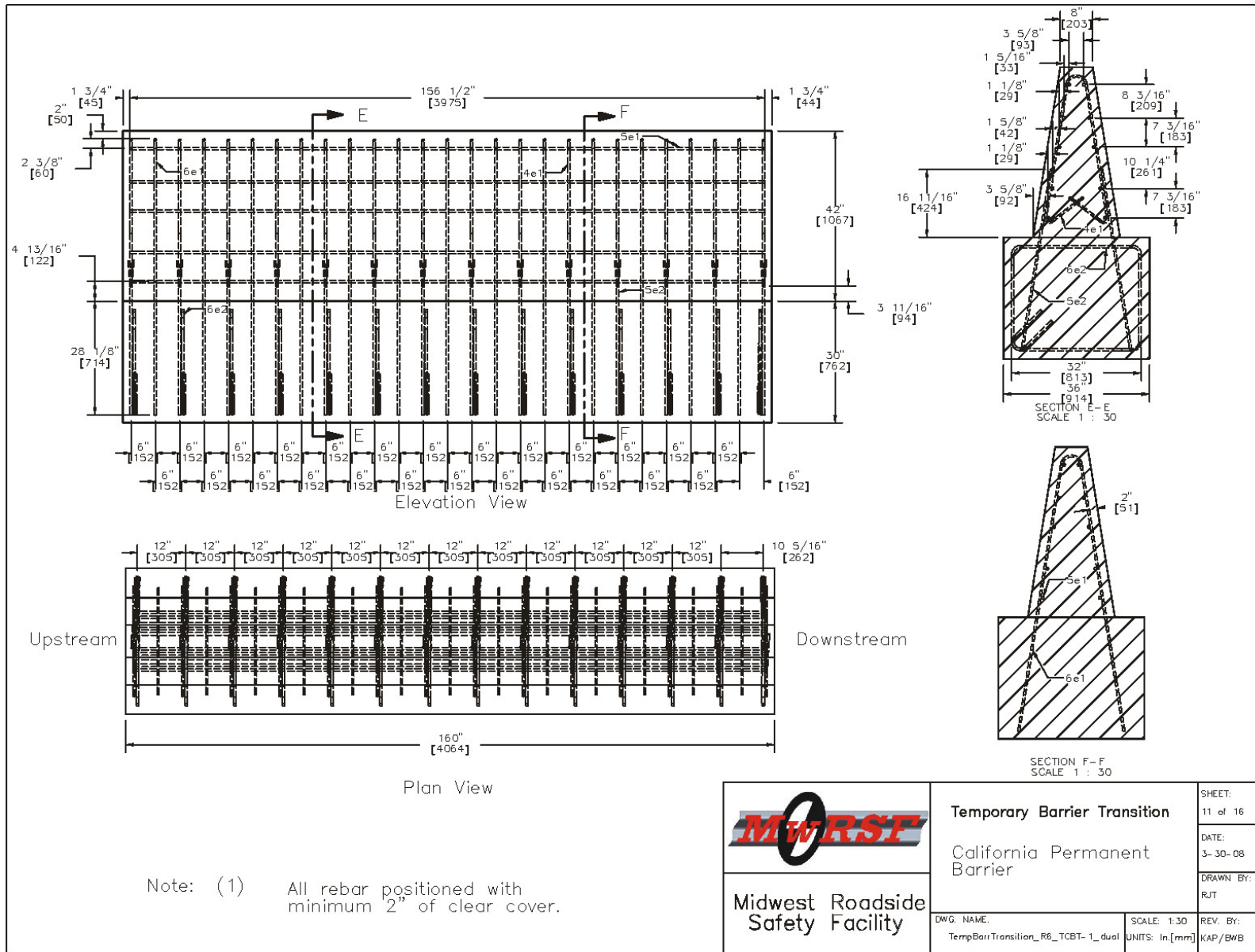

Figure 14. Bill of Bars (California Permanent Barrier) Details, Test Nos. TCBT-1 and TCBT-2

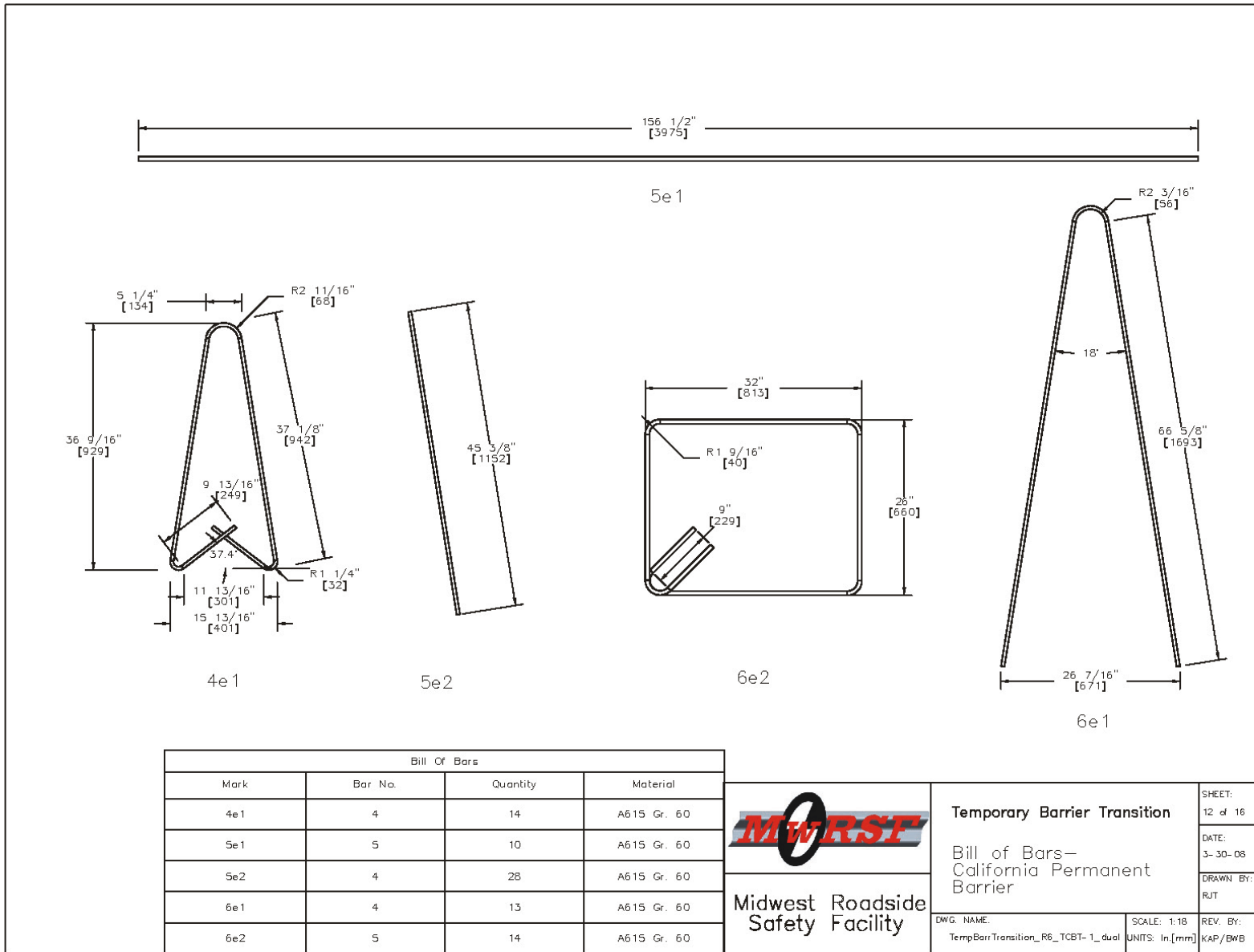

Figure 15. Barrier Connection Details, Test Nos. TCBT-1 and TCBT-2

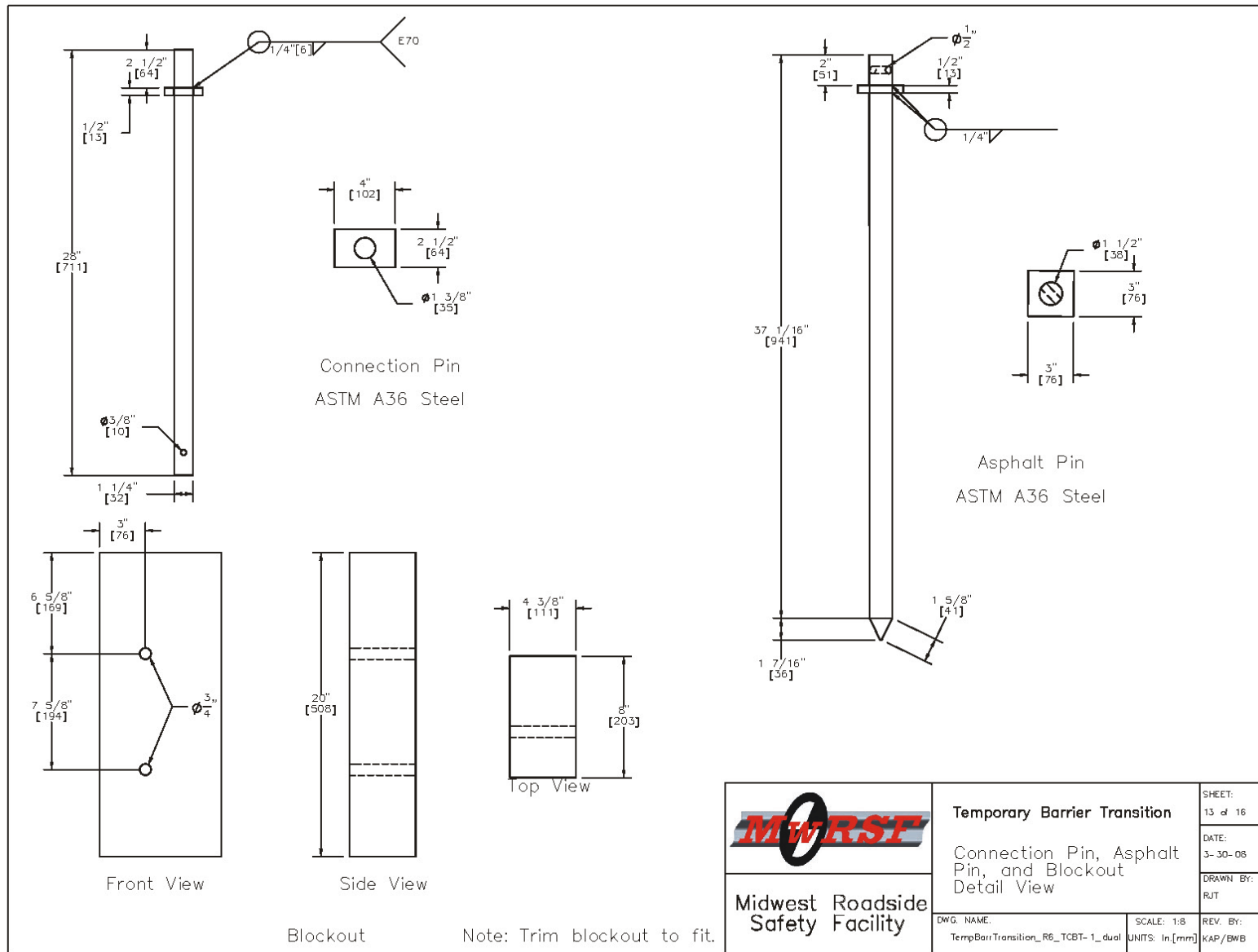

Figure 16. Connection Pin, Asphalt Pin, and Blockout Details, Test Nos. TCBT-1 and TCBT-2

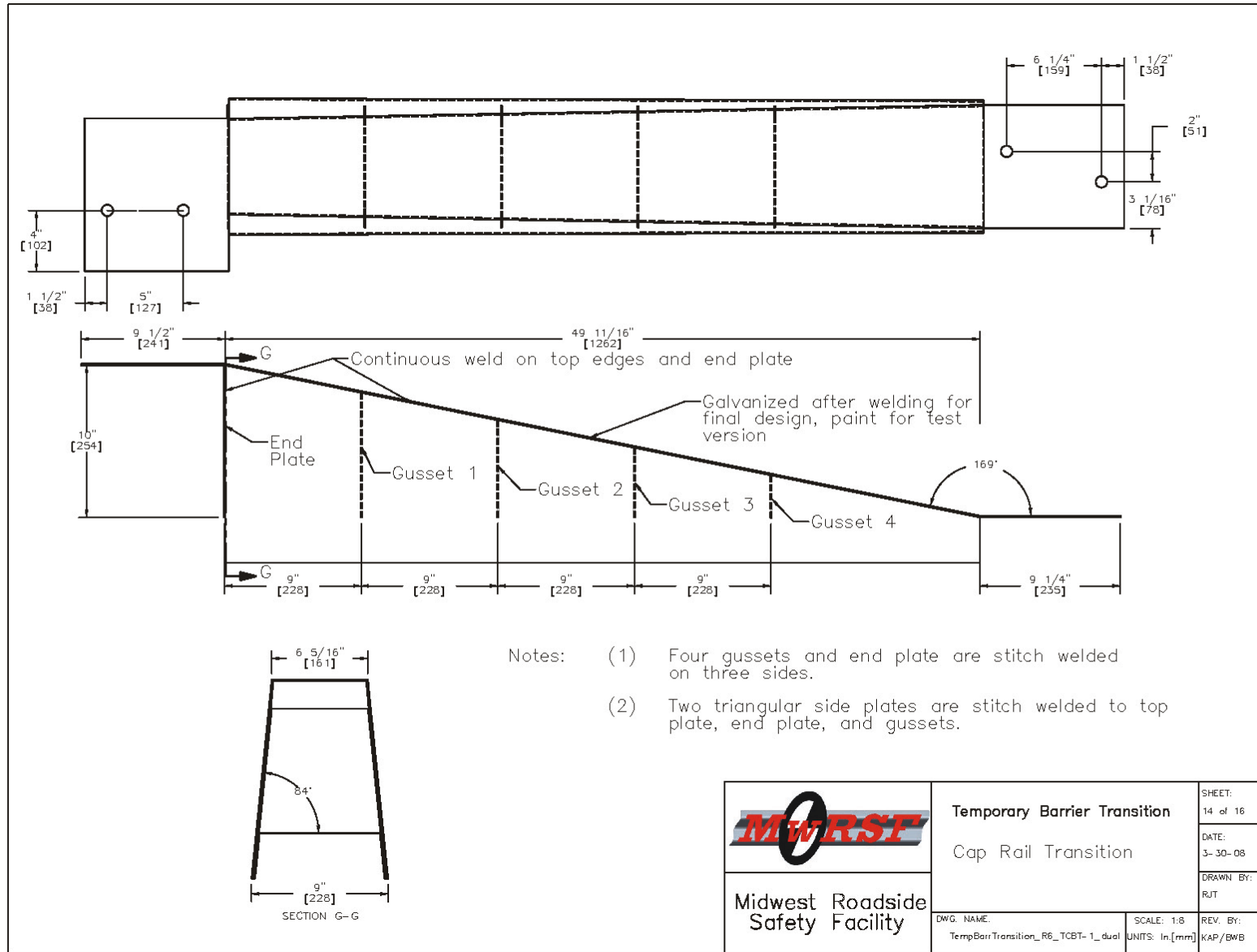

Figure 17. Cap Rail Transition Details, Test Nos. TCBT-1 and TCBT-2

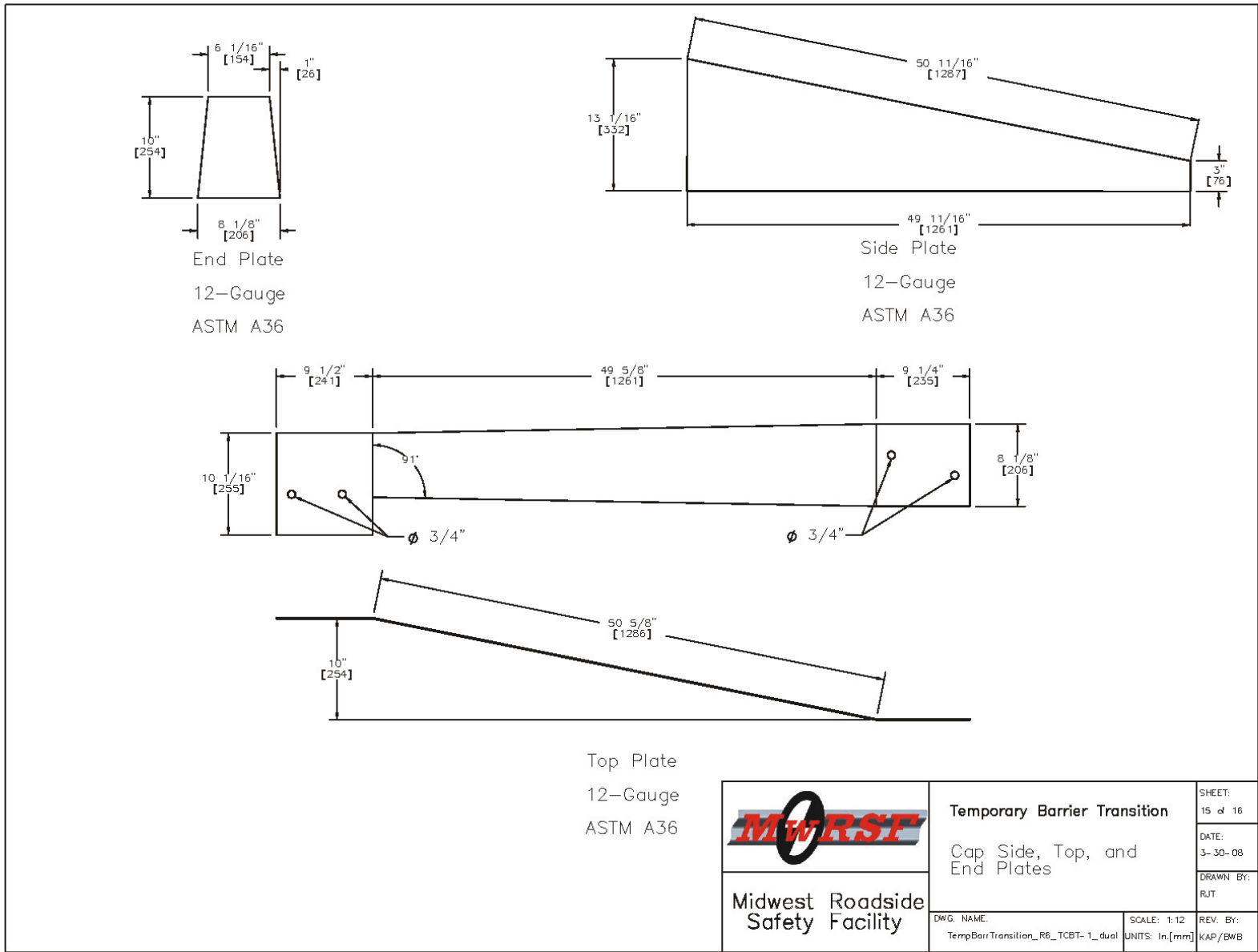
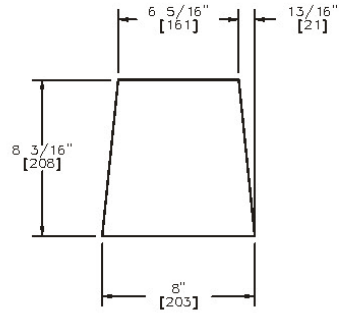
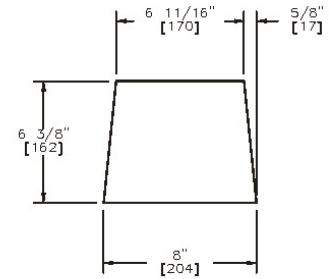

Figure 18. Cap and End Plate Details, Test Nos. TCBT-1 and TCBT-2



Gusset 1
12-Gauge
ASTM A36



Gusset 2
12-Gauge
ASTM A36

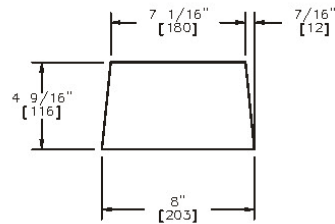

Gusset 3
12-Gauge
ASTM A36

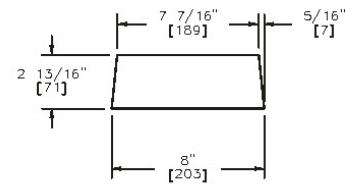

Gusset 4
12-Gauge
ASTM A36

	Temporary Barrier Transition Gussets		SHEET: 16 of 16
	Midwest Roadside Safety Facility		DATE: 3-30-08
DWG. NAME: TempBarriTransition_R6_TCBT-1_dual		SCALE: 1:8 UNITS: In./mm	DRAWN BY: RJT
			REV. BY: KAP/BWB

Figure 19. Gusset Details, Test Nos. TCBT-1 and TCBT-2

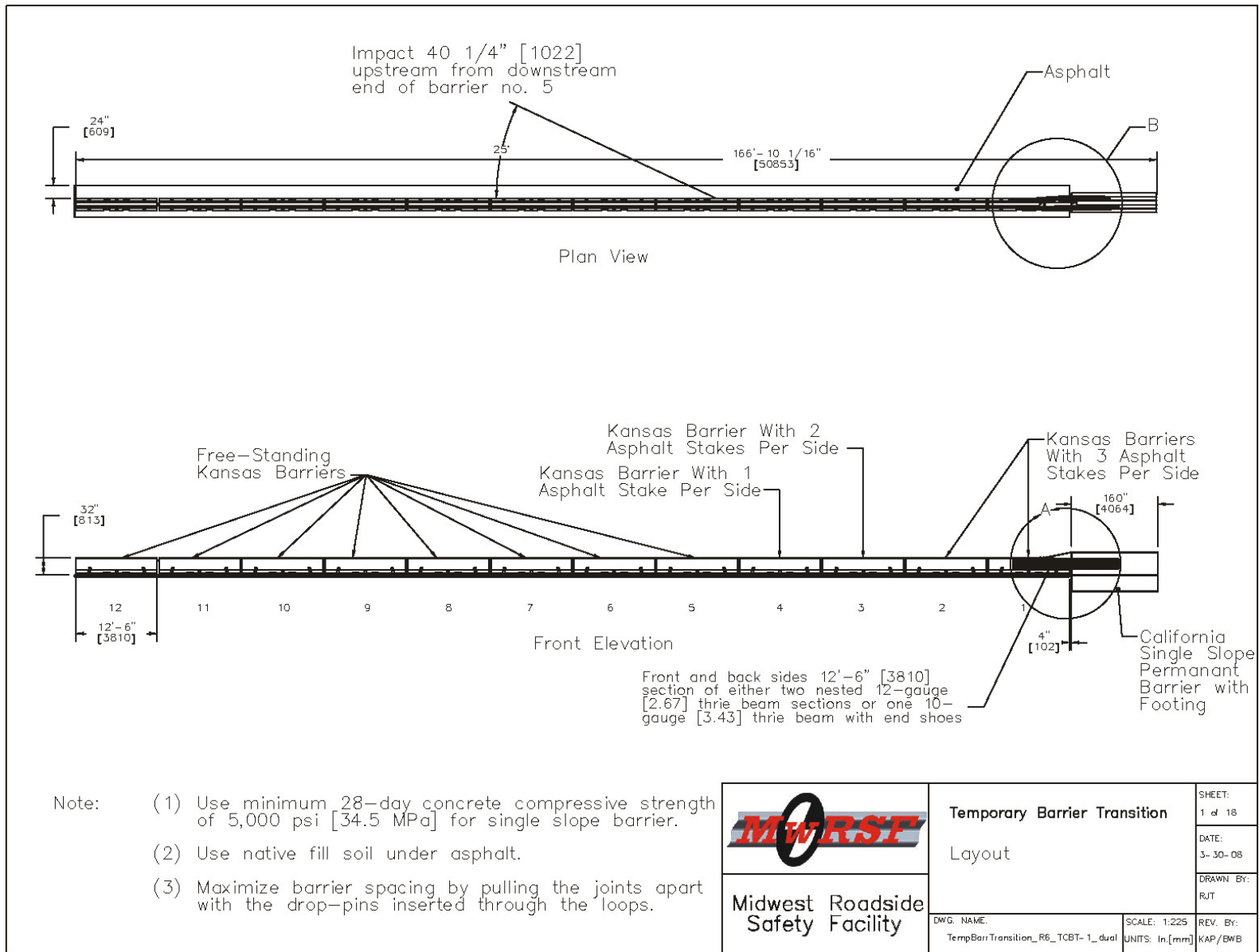

Figure 20. System Layout Details, Test Nos. TCBT-2



Figure 21. Temporary Concrete Barrier to Permanent Concrete Barrier Transition, Test No. TCBT-1 and TCBT-2



Figure 22. Temporary Concrete Barrier to Permanent Concrete Barrier Transition, Test No. TCBT-1 and TCBT-2



Figure 23. Temporary Concrete Barrier to Permanent Concrete Barrier Transition, Test No. TCBT-1 and TCBT-2

5 CIP DETERMINATION UTILIZING COMPUTER SIMULATION

LS-DYNA was used to determine the critical impact point (CIP) for the second full-scale crash test on the TCB transition, test TCBT-2. For this CIP, barrier deflections are expected potentially causing pocketing in the system resulting in potentially unstable vehicle behavior or vehicle override of the system. A detailed model of the TCB was built and impacted at various locations along the barrier to determine the likely CIP. Selected results of the simulations are shown in Figures 24 thru 27. Four different cases are presented:

Case A – impact just upstream of barrier 3

Case B – impact ½ barrier length upstream from Case A

Case C – impact 1 barrier length upstream from Case A (just upstream of barrier 4)

Case D – impact 1½ barrier lengths upstream from Case A

Determination of the CIP considered evaluation of the stability of the impacting vehicle as well as examination of vehicle behavior including barrier motions such as displacement, roll and yaw. Top view sequential for the four cases are shown in Figure 24 (initial impact), Figure 25 (at 150 ms), and Figure 26 (at 300 ms). Downstream views are shown in Figure 27 (at 300 ms and 500 ms). Barrier displacement, barrier roll, and barrier yaw are shown in Figure 28.

Case A exhibited relatively limited barrier motion and although the vehicle exhibited the most pitch, that motion did not cause any significant indication of the vehicle becoming unstable and thus Case A was ruled out for the CIP. Impacts downstream of Case A were expected to produce even lower barrier motions due to the increased constrain on the barriers in the transition. Case D appeared to have the smoothest redirection of the vehicle and was thus ruled out for the CIP. Cases B and C demonstrated somewhat similar behavior, but researchers concluded that Case C had higher

barrier motions overall and slightly more vehicle roll than Case B. Thus, Case C was chosen as the CIP for test TCBT-2.

It should be noted that the CIP for the downstream CIP adjacent to permanent barrier was chosen as 4.3 ft (1.3 m) upstream of the permanent barrier. This value is based on guidance for CIP values for rigid barriers and temporary concrete barriers provided in Table 2.6 in MASH. It represents the distance upstream of a post or joint in a rigid barrier that has increased potential for vehicle snag. Due to the high stiffness of the anchored temporary concrete barrier sections adjacent to the permanent barrier, it was believed that this CIP location would be sufficient to determine the potential for snag on the rigid median barrier.

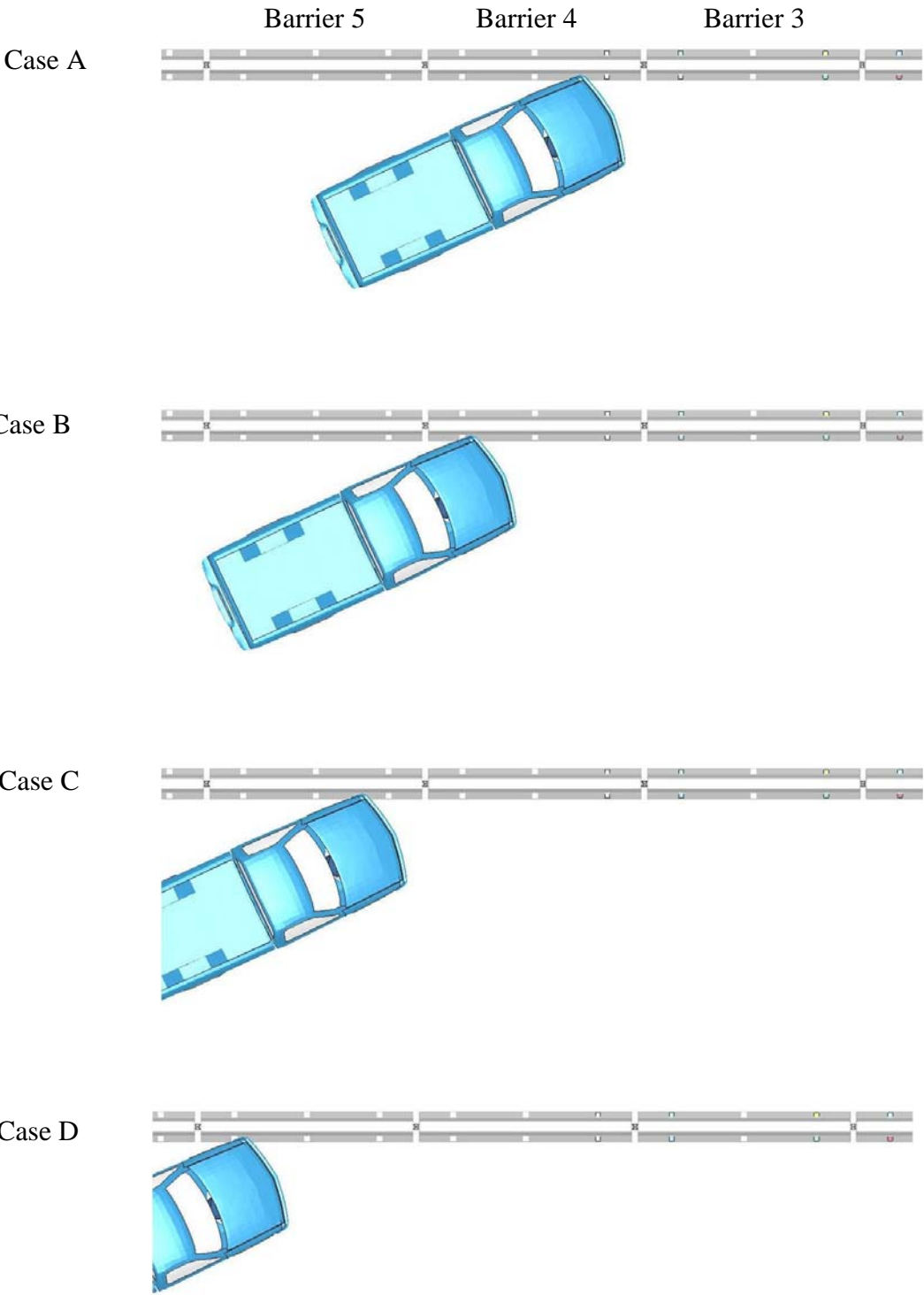

Figure 24. TCB Transition CIP-2000P 100 km/h at 25 degree-Impact Location-Test TCBT-2

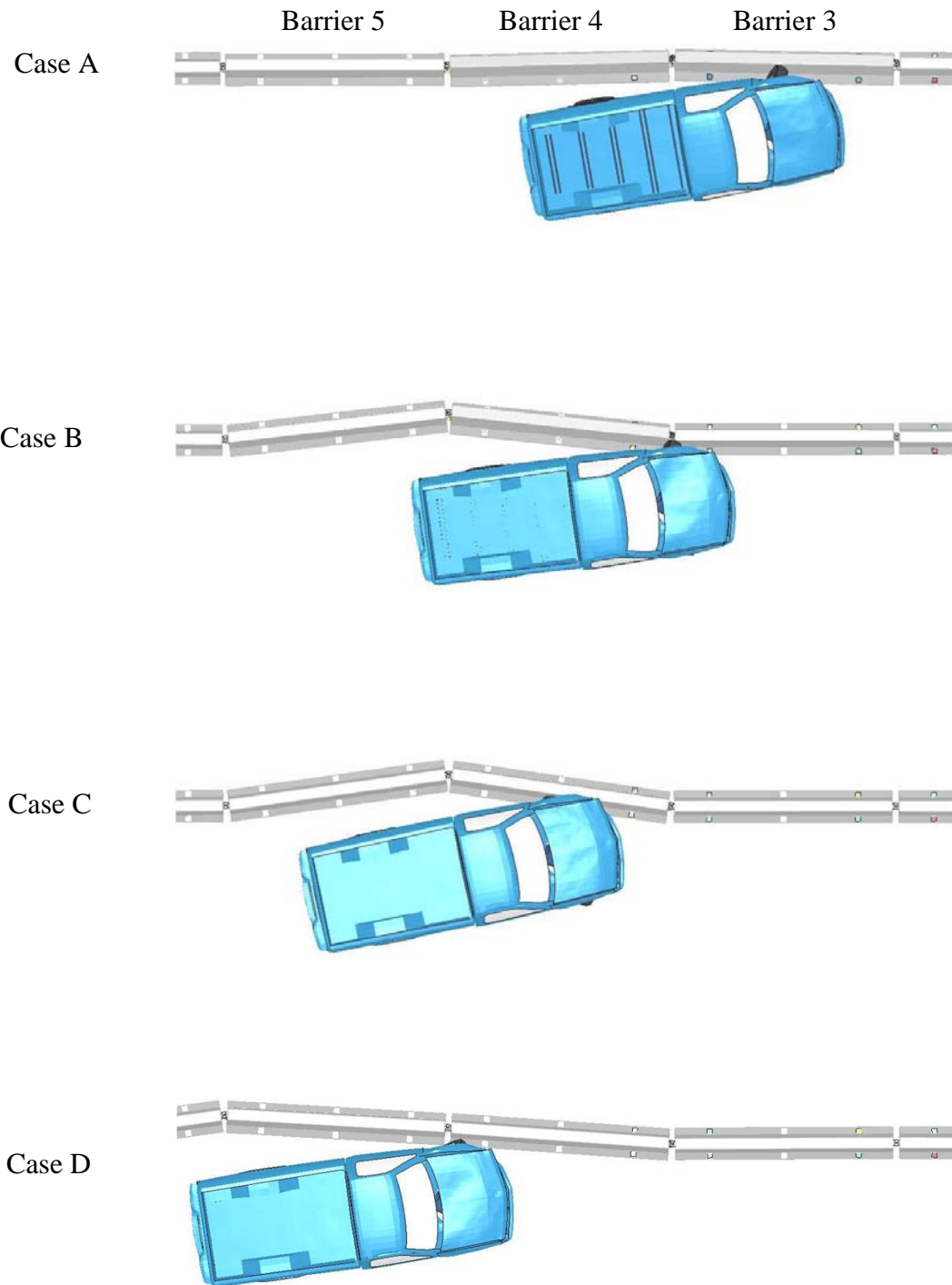

Figure 25. TCB Transition CIP - 2000P 100 km/h at 25 degree - 150 ms - Test No. TCBT-2

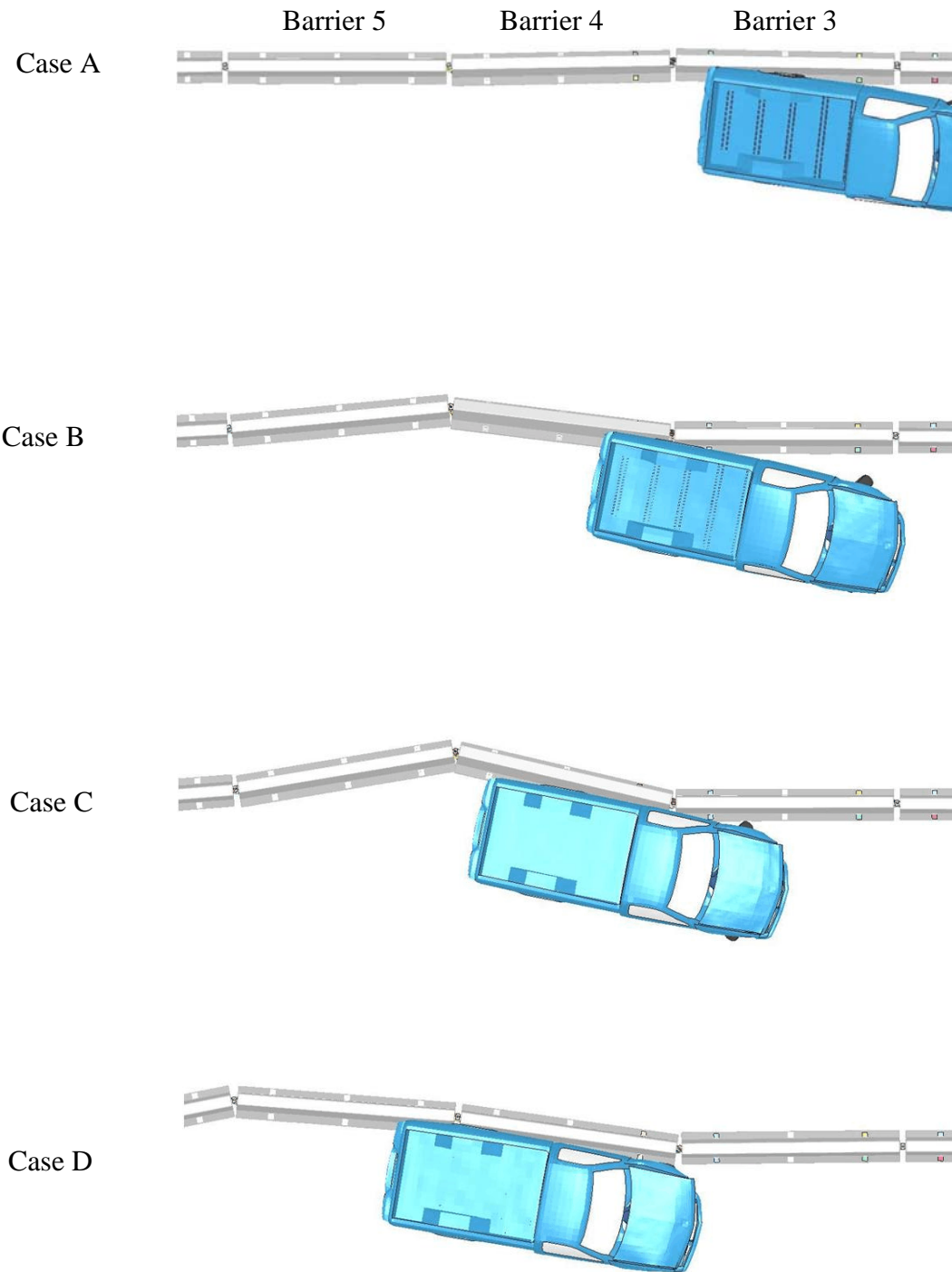

Figure 26. TCB Transition CIP - 2000P 100 km/h at 25 degree - 300 ms - Test No. TCBT-2

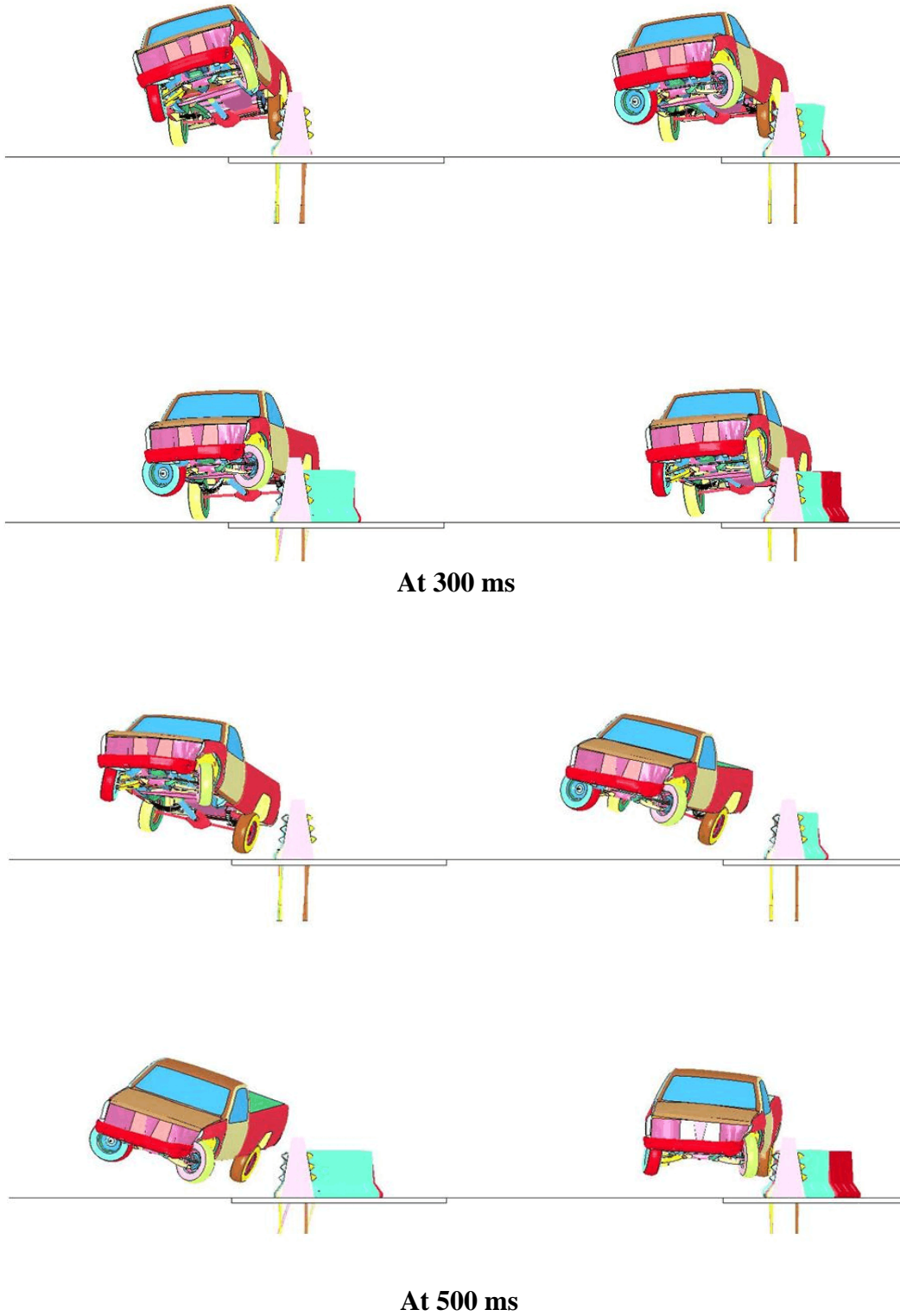
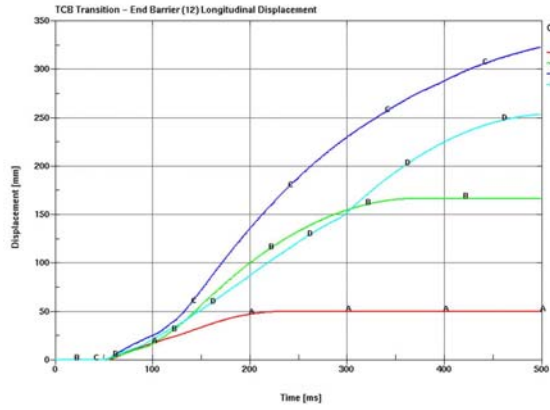
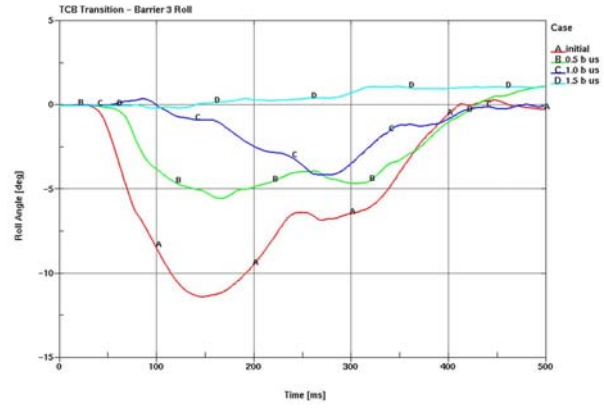

Figure 27. TCB Transition CIP - 200p 100 km/h at 25 degree - Test No. TCBT-2



Long. Displacement of Barrier 12 (end)



Barrier 3 Roll

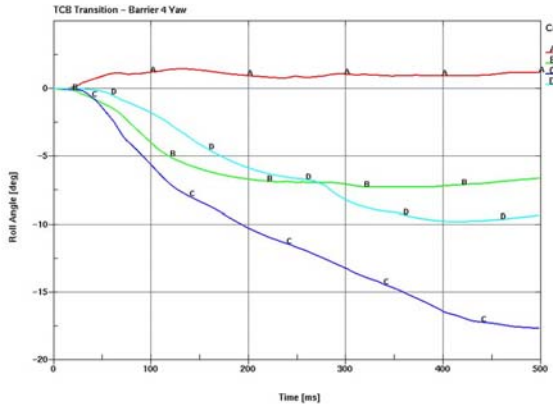

Barrier 4 Yaw

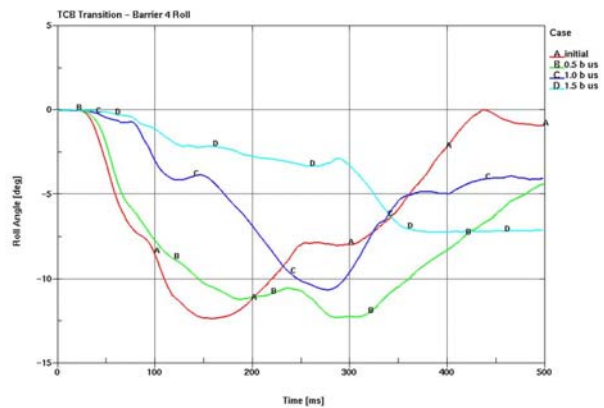

Barrier 4 Roll

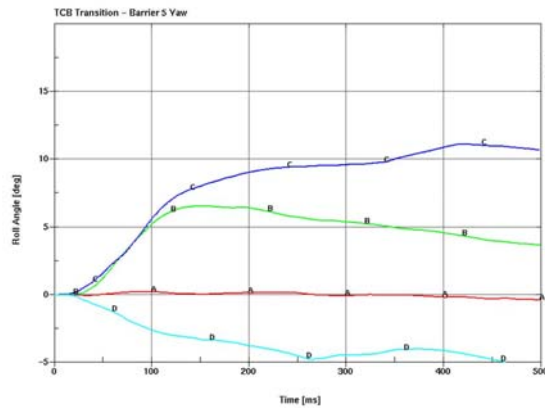

Barrier 5 Yaw

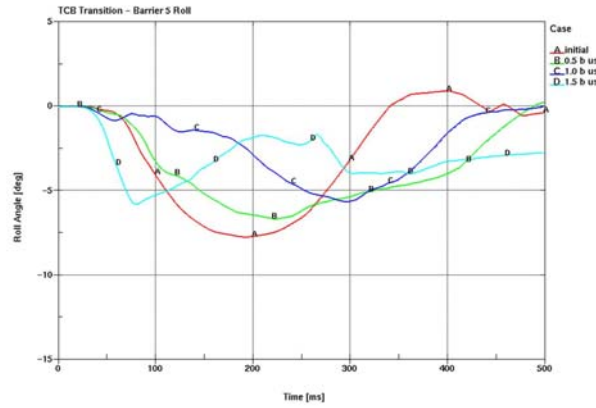

Barrier 5 Roll

Figure 28. CIP Determination Plots - Test No. TCBT-2

6 TEST REQUIREMENTS AND EVALUATION CRITERIA

6.1 Test Requirements

Approach transitions, such as temporary concrete barrier transitions, must satisfy impact safety standards in order to be accepted by the Federal Highway Administration (FHWA) for use on National Highway Systems (NHS) construction projects or as a replacement for existing designs not meeting current safety standards. According to TL-3 of MASH, longitudinal barriers must be subjected to two full-scale vehicle crash tests. The two full-scale crash tests are as follows:

1. Test Designation 3-20, consisting of a 2,425-lb (1,100-kg) small car impacting the barrier system at a nominal speed and angle of 62.1 mph (100.0 km/h) and 25 degrees, respectively.
2. Test Designation 3-21, consisting of a 5,004-lb (2,270-kg) pickup truck impacting the barrier system at a nominal speed and angle of 62.1 mph (100 km/h) and 25 degrees, respectively.

A rigid, F-shaped bridge rail was successfully impacted by a small car weighing 1,800 lb (893 kg) at 60.1 mph (96.7 km/h) and 21.4 degrees according to the American Association of State Highway and Transportation Officials (AASHTO) Guide Specifications for Bridge Railings (4-5). In the same manner, rigid New Jersey safety shape barriers struck by small cars have also been shown to meet safety performance standards (6-7). In addition, a New Jersey safety shape barrier was impacted by a passenger car weighing 2,579 lb (1,170 kg) at 60.8 mph (97.9 km/h) and 26.1 degrees according to the TL-3 standards set forth in MASH (8). Furthermore, temporary New Jersey safety shape concrete median barriers have experienced only slight barrier deflection when impacted by small cars and behave similar to rigid barriers (9). The transition was designed to prevent any vehicle snag for the small car or truck with no exposed face of barrier when traffic is flowing in opposing directions, as shown in Figure 7. This asymmetrical placement would only present a safety

concern if the temporary barrier were used to separate traffic flowing in the same direction, such as in a gore area. As such, 2,425-lb (1,100-kg) passenger car test was deemed unnecessary for this project. Two Critical Impact Points (CIP's) needed to be evaluated for the approach transition. The first CIP was located adjacent to the point where the transition attaches to the permanent barrier and is used to evaluate snag and pocketing near the hazard. The second CIP was located near the upstream end of the transition and is used to evaluate the stiffness transition, which can cause pocketing and vehicle instability. The test conditions for TL-3 longitudinal barriers are summarized in Table 2.

6.2 Evaluation Criteria

Evaluation criteria for full-scale vehicle crash testing are based on three appraisal areas: (1) structural adequacy; (2) occupant risk; and (3) vehicle trajectory after collision. Criteria for structural adequacy are intended to evaluate the ability of the barrier to contain, redirect, or allow controlled vehicle penetration in a predictable manner. Occupant risk evaluates the degree of hazard to occupants in the impacting vehicle. Vehicle trajectory after collision is a measure of the potential for the post-impact trajectory of the vehicle to cause subsequent multi-vehicle accidents. This criterion also indicates the potential safety hazard for the occupants of other vehicles or the occupants of the impacting vehicle when subjected to secondary collisions with other fixed objects. These three evaluation criteria are summarized in Table 3 and defined in greater detail in MASH (2). The full-scale vehicle crash tests were conducted and reported in accordance with the procedures provided in MASH.

Table 2. MASH Test Level 3 Crash Test Conditions

Test Article	Test Designation	Test Vehicle	Impact Conditions			Evaluation Criteria ¹
			Speed		Angle (degrees)	
			(mph)	(km/h)		
Longitudinal Barrier	3-20	1100C	62.1	100	25	A,D,F,H,I
	3-21	2270P	62.1	100	25	A,D,F,H,I

¹ Evaluation Criteria explained in Table 3.

Table 3. MASH Evaluation Criteria for Crash Tests

Structural Adequacy	A. a	Test article should contain and redirect the vehicle or bring the vehicle to controlled stop; the vehicle should not penetrate, underide, or override the installation although controlled lateral deflection of the test article is acceptable.
Occupant Risk	D.	Detached elements, fragments or other debris from the test article should not penetrate or show potential for penetrating the occupant compartment, or present an undue hazard to other traffic, pedestrians, or personnel in a work zone. Deformations of, or intrusions into, the occupant compartment should not exceed limits set forth in Section 5.3 and Appendix E of MASH.
	F.	The vehicle should remain upright during and after collision. The maximum roll and pitch angles are not to exceed 75 degrees.
	H.	Longitudinal and lateral occupant impact velocities should fall below the preferred value of 30.0 ft/s (9.1 m/s), or at least below the maximum allowable value of 40.0 ft/s (12.2 m/s).
	I.	Longitudinal and lateral occupant ridedown accelerations should fall below the preferred value of 15.0 g's, or at least below the maximum allowable value of 20.49 g's.

7 TEST CONDITIONS

7.1 Test Facility

The testing facility is located at the Lincoln Air Park on the northwest side of the Lincoln Municipal Airport and is approximately 5 mi. (8.0 km) northwest of the University of Nebraska-Lincoln.

7.2 Vehicle Tow and Guidance System

A reverse cable tow system with a 1:2 mechanical advantage was used to propel the test vehicle. The distance traveled and the speed of the tow vehicle were one-half that of the test vehicle. The test vehicle was released from the tow cable before impact with the barrier system. A digital speedometer on the tow vehicle increases the accuracy of the test vehicle impact speed.

A vehicle guidance system developed by Hinch (10) was used to steer the test vehicle. A guide-flag, attached to the front-left wheel and the guide cable, was sheared off before impact with the barrier system. The $\frac{3}{8}$ -in. (9.5-mm) diameter guide cable was tensioned to approximately 3,500 lb (15.6 kN), and supported laterally and vertically every 100 ft (30.48 m) by hinged stanchions. The hinged stanchions stood upright while holding up the guide cable, but as the vehicle was towed down the line, the guide-flag struck and knocked each stanchion to the ground. For tests TCBT-1 and TCBT-2, the guidance systems were 900 ft (274 m) long.

7.3 Test Vehicles

For test no. TCBT-1, a 2002 Dodge Ram 1500 Quad Cab pickup truck was used as the test vehicle. The test inertial and gross static weights were 5,006 lb (2,271 kg) and 5,175 lb (2,347 kg), respectively. The test vehicle is shown in Figure 29, and vehicle dimension are shown in Figure 30.

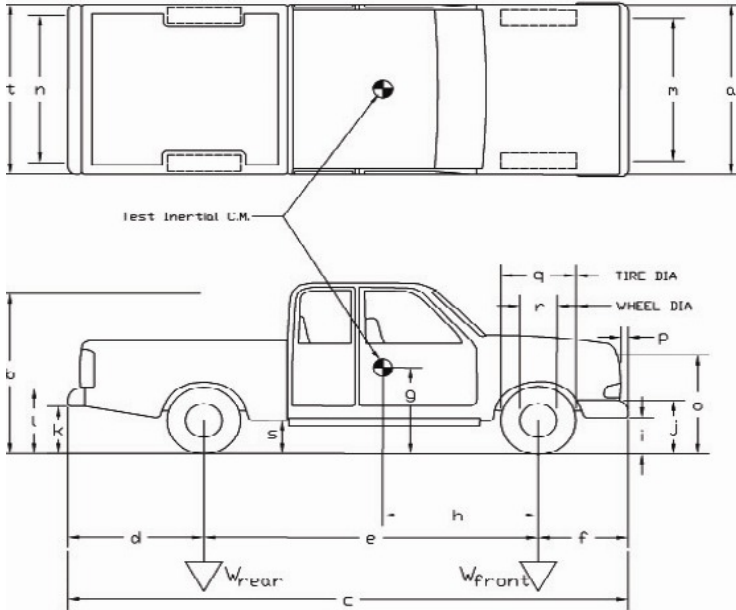

Figure 29. Test Vehicle, Test No. TCBT-1

Date:	<u>4/4/2008</u>	Test Number:	<u>TCBT-1</u>	Model:	<u>Ram 1500 Q.C.</u>
Make:	<u>Dodge</u>	Vehicle I.D.#:	<u>ID7HA1DM225681989</u>		
Tire Size:	<u>265/70 R17</u>	Year:	<u>2002</u>	Odometer:	<u>110519</u>

*(All Measurements Refer to Impacting Side)

Vehicle Geometry -- in. (mm)



a	<u>78.0 (1981)</u>	b	<u>75.0 (1905)</u>
c	<u>227.25 (5772)</u>	d	<u>47.5 (1207)</u>
e	<u>140.25 (3562)</u>	f	<u>39.5 (1003)</u>
g	<u>28.125 (714)</u>	h	<u>65.0 (1651)</u>
i	<u>14.5 (368)</u>	j	<u>25.0 (635)</u>
k	<u>21.0 (533)</u>	l	<u>29.25 (743)</u>
m	<u>68.0 (1727)</u>	n	<u>67.75 (1721)</u>
o	<u>42.5 (1080)</u>	p	<u>4.0 (102)</u>
q	<u>30.75 (781)</u>	r	<u>10.5 (267)</u>
s	<u>15.5 (394)</u>	t	<u>75.0 (1905)</u>

Wheel Center Height Front	<u>14.75 (375)</u>
Wheel Center Height Rear	<u>14.75 (375)</u>
Wheel Well Clearance (F)	<u>34.75 (883)</u>
Wheel Well Clearance (R)	<u>37.75 (959)</u>

Frame Height (F)	<u>17.0 (432)</u>
Frame Height (R)	<u>25.5 (648)</u>
Engine Type	<u>8 CYL. GAS</u>
Engine Size	<u>4.7</u>

Transmission Type:
 Automatic Manual
 FWD RWD 4WD

Weights lbs (kg)	Curb	Test Inertial	Gross Static
W-front	<u>2826 (1282)</u>	<u>2769 (1256)</u>	<u>2873 (1303)</u>
W-rear	<u>2145 (973)</u>	<u>2236 (1014)</u>	<u>2302 (1044)</u>
W-total	<u>4971 (2255)</u>	<u>5006 (2271)</u>	<u>5175 (2347)</u>

GVWR Ratings

Front	<u>3650</u>
Rear	<u>3900</u>
Total	<u>6650</u>

Dummy Data

Type:	<u>Hybrid II</u>
Mass:	<u>170 lbs</u>
Seat Position:	<u>Passenger, Full Rearward</u>

Note any damage prior to test: none

Figure 30. Test Vehicle Dimensions, Test No. TCBT-1

For test no. TCBT-2, a 2003 Dodge Ram 1500 Quad Cab pickup was used as the test vehicle. The test inertial and gross static weights were 4,990 lb (2,263 kg) and 5,160 lb (2,341 kg), respectively. The test vehicle is shown in Figure 31, and vehicle dimensions are shown in Figure 32.

The Suspension Method (11) was used to determine the vertical component of the center of gravity (c.g.) for the pickup trucks. This method is based on the principle that the c.g. of any freely suspended body is in the vertical plane through the point of suspension. The vehicle was suspended successively in three positions, and the respective planes containing the c.g. were established. The intersection of these planes pinpointed the location of the center of gravity. The longitudinal component of the c.g. was determined using the measured axle weights. The location of the final centers of gravity are shown in Figures 30 and 32 through 34. The c.g. calculations and ballast information are shown in Appendix D.

Square black and white-checkered targets were placed on the vehicles to aid in the analysis of the high-speed AOS videos, as shown in Figures 33 and 34. Checkered targets were placed at the c.g. on the left-side door, the right-side door, and the roof of the vehicle. The remaining targets were located for reference so that they could be viewed from the high-speed cameras for video analysis.

The front wheels of the test vehicles were aligned for camber, caster, and toe-in values of zero so that the vehicles would track properly along the guide cable. A 5B flash bulb was mounted near the middle of the vehicle's dash to pinpoint the time of impact with the test article on the high-speed video footage. The flash bulb was fired by a pressure tape switch mounted at the impact corner of the bumper. A remote-controlled brake system was installed in the test vehicle so the vehicle could be brought safely to a stop after the test.



Figure 31. Test Vehicle, Test No. TCBT-2

Date: 4/23/2008 Test Number: TCBT-2 Model: Ram 1500 Q.C.
 Make: Dodge Vehicle I.D.#: 1D7HA18K73J619050
 Tire Size: 265/70 R17 Year: 2003 Odometer: 58889

*(All Measurements Refer to Impacting Side)

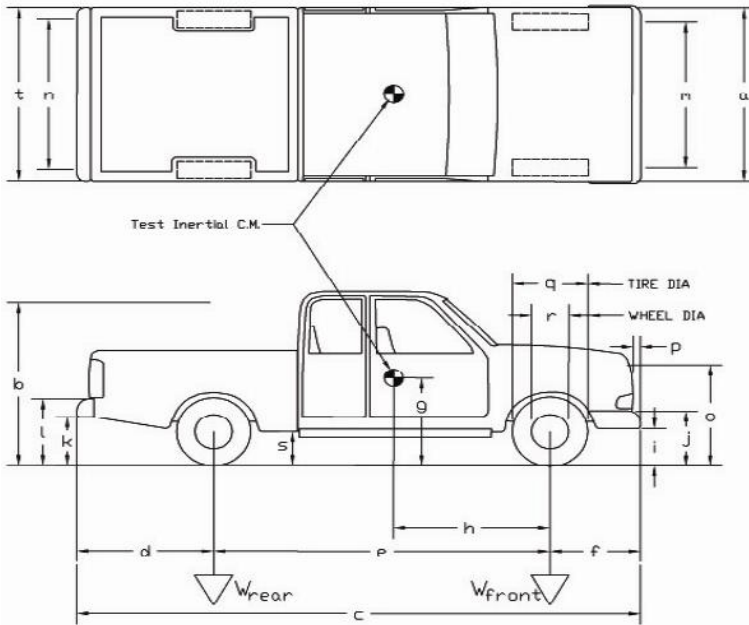

Vehicle Geometry -- in. (mm)

a	78.0 (1981)	b	74.75 (1899)
c	227.75 (5785)	d	48.0 (1219)
e	140.25 (3562)	f	39.5 (1003)
g	28.25 (718)	h	64.25 (1632)
i	15.75 (400)	j	26.0 (660)
k	21.0 (533)	l	29.25 (743)
m	67.5 (1715)	n	67.5 (1715)
o	43.75 (1111)	p	3.0 (76)
q	31.5 (800)	r	18.5 (470)
s	16.25 (413)	t	75.0 (1905)
Wheel Center Height Front		15.0 (381)	
Wheel Center Height Rear		15.0 (381)	
Wheel Well Clearance (F)		35.5 (902)	
Wheel Well Clearance (R)		38.25 (972)	
Frame Height (F)		17.75 (451)	
Frame Height (R)		25.125 (638)	
Engine Type		8 CYL. GAS	
Engine Size		4.7	
Transmission Type:			
Automatic		Manual	
FWD		RWD	
		4WD	

Weights lbs (kg)	Curb	Test Inertial	Gross Static
W-front	2699 (1224)	2689 (1220)	2783 (1262)
W-rear	2206 (1001)	2301 (1044)	2374 (1077)
W-total	4905 (2225)	4990 (2263)	5160 (2341)

GVWR Ratings

Front	3650
Rear	3900
Total	6650

Dummy Data

Type:	Hybrid II
Mass:	170 lbs
Seat Position:	Passenger, Full Rearward

Note any damage prior to test: none

Figure 32. Test Vehicle Dimensions, Test No. TCBT-2

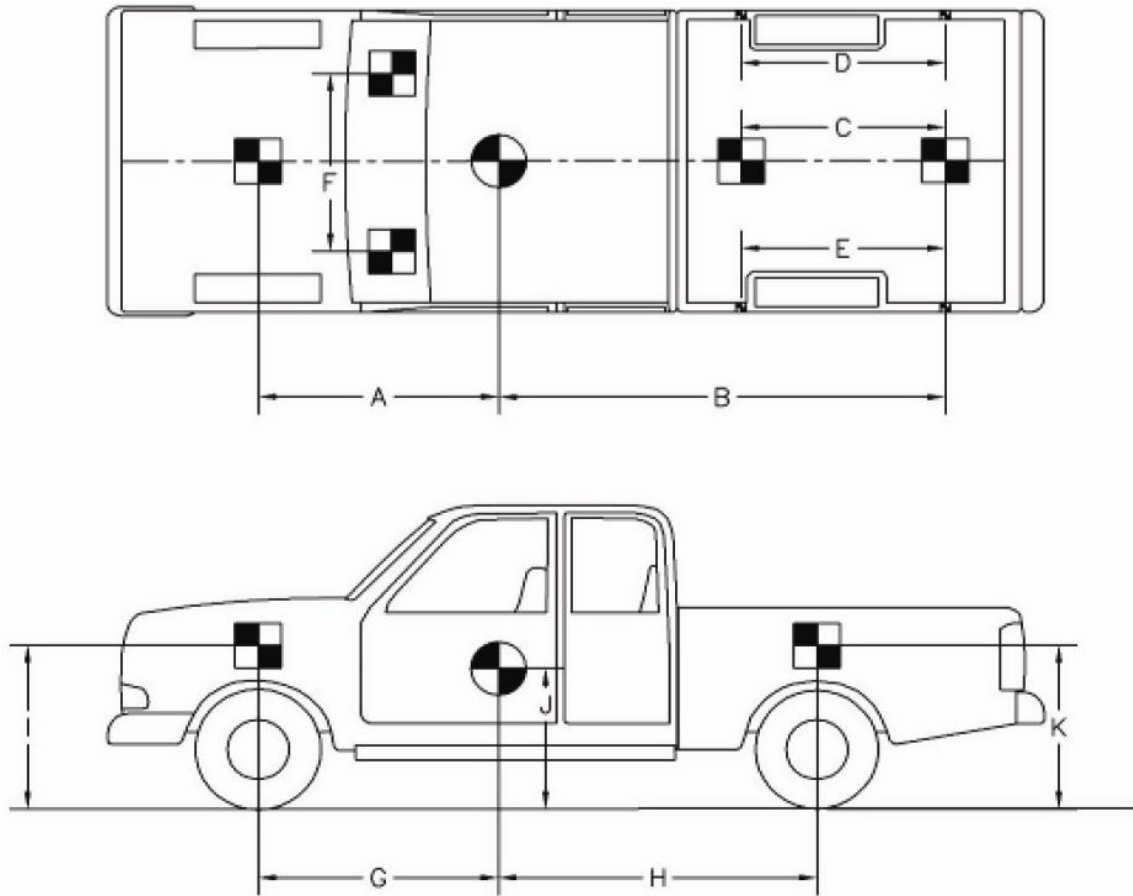

TEST #: TCBT-1					
TARGET GEOMETRY-- in. (mm)					
A	<u>75.625</u>	<u>(1921)</u>	E	<u>64.0</u>	<u>(1626)</u>
B	<u>100.5</u>	<u>(2553)</u>	F	<u>48.375</u>	<u>(1229)</u>
C	<u>48.0</u>	<u>(1219)</u>	G	<u>65.0</u>	<u>(1651)</u>
D	<u>64.0</u>	<u>(1626)</u>	H	<u>75.25</u>	<u>(1911)</u>
			I	<u>39.0</u>	<u>(991)</u>
			J	<u>21.125</u>	<u>(537)</u>
			K	<u>41.75</u>	<u>(1060)</u>

Figure 33. Vehicle Target Locations, Test No. TCBT-1

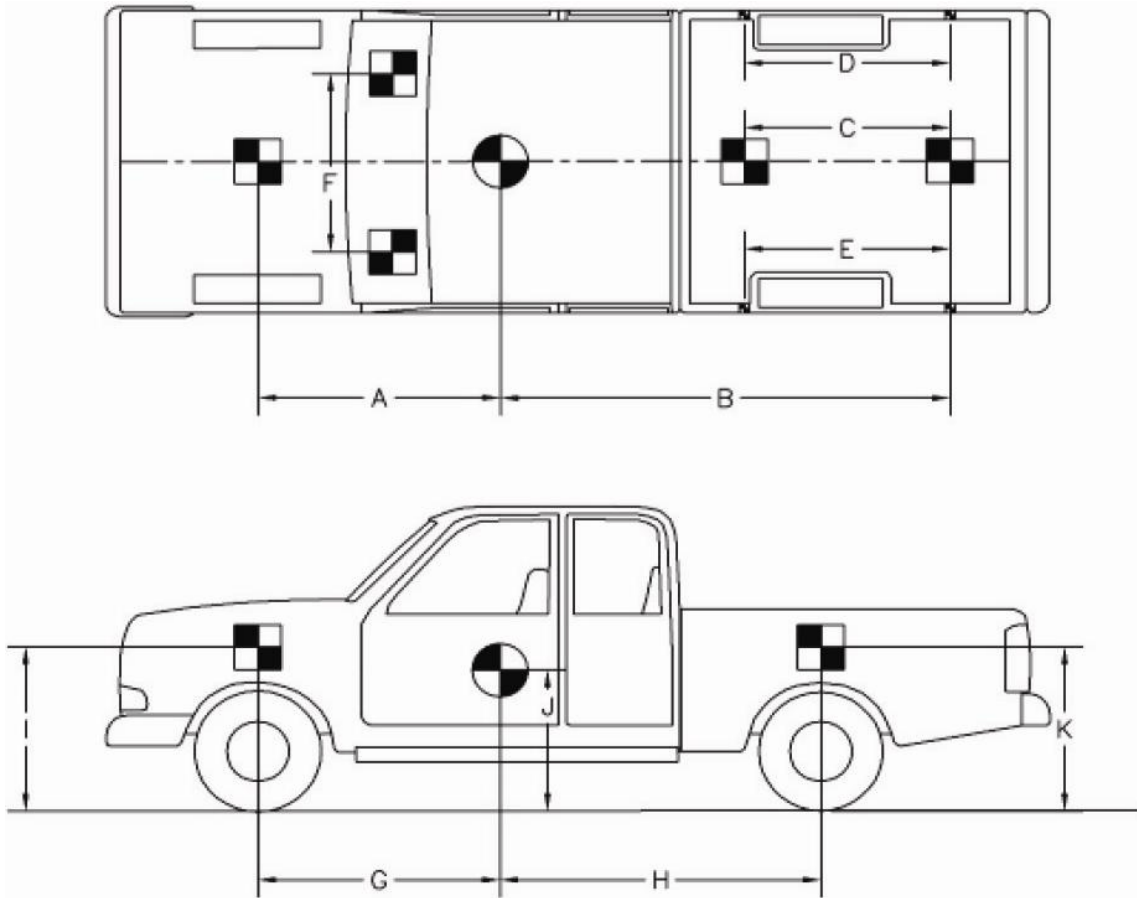

TEST #: TCBT-2					
TARGET GEOMETRY-- in. (mm)					
A	<u>75.25</u>	<u>(1911)</u>	E	<u>64.0</u>	<u>(1626)</u>
B	<u>99.25</u>	<u>(2521)</u>	F	<u>54.25</u>	<u>(1378)</u>
C	<u>42.75</u>	<u>(1086)</u>	G	<u>64.25</u>	<u>(1632)</u>
D	<u>64.0</u>	<u>(1626)</u>	H	<u>76.0</u>	<u>(1930)</u>
			I	<u>39.875</u>	<u>(1013)</u>
			J	<u>28.25</u>	<u>(718)</u>
			K	<u>42.875</u>	<u>(1089)</u>

Figure 34. Vehicle Target Locations, Test No. TCBT-2

7.4 Simulated Occupant

For test nos. TCBT-1 and TCBT-2, a Hybrid II 50th Percentile Adult Male Dummy was placed in the right-front seat of the test vehicle with the seat belt fastened. The dummy was equipped with clothing and footwear and had a final weight of 170 lb (77 kg). The dummy was manufactured by Android Systems of Carson California under model no. 572 and serial no. 451. As recommended by MASH, the dummy was not included in calculating the c.g location.

7.5 Data Acquisition Systems

7.5.1 Accelerometers

One triaxial piezoresistive accelerometer system with a range of ± 200 g's was used to measure the acceleration in the longitudinal, lateral, and vertical directions at a sample rate of 10,000 Hz. The environmental shock and vibration sensor/recorder system, Model EDR-4M6, was developed by Instrumented Sensor Technology (IST) of Okemos, Michigan and includes three differential channels as well as three single-ended channels. The EDR-4 was configured with 6 MB of RAM memory and a 1,500 Hz lowpass filter. "DynaMax 1 (DM-1)" and a customized Microsoft Excel worksheet were used to analyze and plot the accelerometer data.

Another triaxial piezoresistive accelerometer system with a range of ± 200 g's was also used to measure the acceleration in the longitudinal, lateral, and vertical directions at a sample rate of 3,200 Hz. The environmental shock and vibration sensor/recorder system, Model EDR-3, was developed by Instrumented Sensor Technology (IST) of Okemos, Michigan. The EDR-3 was configured with 256 kB of RAM memory and a 1,120 Hz lowpass filter. "DynaMax 1 (DM-1)" and a customized Microsoft Excel worksheet were used to analyze and plot the accelerometer data.

An additional accelerometer system was used to measure the acceleration in the longitudinal, lateral, and vertical directions at a sample rate of 10,000 Hz. The environmental shock and vibration sensor/recorder system, a two-Arm piezoresistive accelerometer, was developed by Endevco of San Juan Capistrano, California. Three accelerometers were used to measure each of the longitudinal, lateral, and vertical accelerations independently. Data was collected using a Sensor Input Module (SIM), Model TDAS3-SIM-16M, which was developed by Diversified Technical Systems, Inc. (DTS) of Seal Beach, California. The SIM was configured with 16 MB SRAM memory and 8 sensor input channels with 250 kB SRAM/channel. The SIM was 19 mounted on a TDAS3-R4 module rack. The module rack is configured with isolated power/event/communications, 10BaseT Ethernet and RS232 communication, and an internal backup battery. Both the SIM and module rack are crashworthy. “DTS TDAS Control” and a customized Microsoft Excel worksheet were used to analyze and plot the accelerometer data.

7.5.2 Rate Transducers

An Analog Systems 3-axis rate transducer with a range of 1,200 degree/sec in each of the three directions (pitch, roll, and yaw) was used to measure the rates of motion of the test vehicles. The rate transducer was mounted inside the body of the EDR-4M6 and recorded data at 10,000 Hz to a second data acquisition board inside the EDR-4M6 housing. The raw data measurements were then downloaded, converted to the appropriate Euler angles for analysis, and plotted. “DynaMax 1 (DM-1)” and a customized Microsoft Excel worksheet were used to analyze and plot the rate transducer data.

An additional angular rate sensor was used. The ARS-1500 has a range of 1,500 degrees/sec in each of the three directions (pitch, roll, and yaw) and was used to measure the rates of rotation

of the test vehicle. The angular rate sensor was mounted on an aluminum block inside the test vehicle at the center of gravity and recorded data at 10,000 Hz to the SIM. The raw data measurements were then downloaded, converted to the proper Euler angles for analysis, and plotted. “DTS TDAS Control” and a customized Microsoft Excel worksheet were used to analyze and plot the angular rate sensor data.

7.5.3 High-Speed Photography

For test TCBT-1, five high-speed AOS VITcam digital video cameras, with operating speeds of 500 frames/sec, were used to film the crash test. Two Canon digital video cameras and four JVC digital video cameras, all with a standard operating speed of 29.97 frames/sec, were also used to film the crash test. Camera details and a schematic of all eleven camera locations for test no. TCBT-1 are shown in Figure 35.

For test TCBT-2, four high-speed AOS VITcam digital video cameras, with operating speeds of 500 frames/sec, were used to film the crash test. One Canon digital video camera and two JVC digital video cameras, all with a standard operating speed of 29.97 frames/sec, were also used to film the crash test. Camera details and a schematic of all seven camera locations for test no. TCBT-2 are shown in Figure 36.

The AOS videos were analyzed using the Image Express MotionPlus Software. Actual camera speed and camera divergence factors were considered in the analysis of the high-speed videos.

7.5.4 Pressure Tape Switches

For both tests, five pressure-activated tape switches, spaced at 6.56-ft (2-m) intervals, were used to determine the speed of the vehicle before impact. Each tape switch fired a strobe light which

sent an electronic timing signal to the data acquisition system as the right-front tire of the test vehicle passed over it. Test vehicle speeds were determined from electronic timing mark data recorded using TestPoint software. Strobe lights and high-speed video analysis are used only as a backup method in the event that vehicle speed cannot be determined from the electronic data.

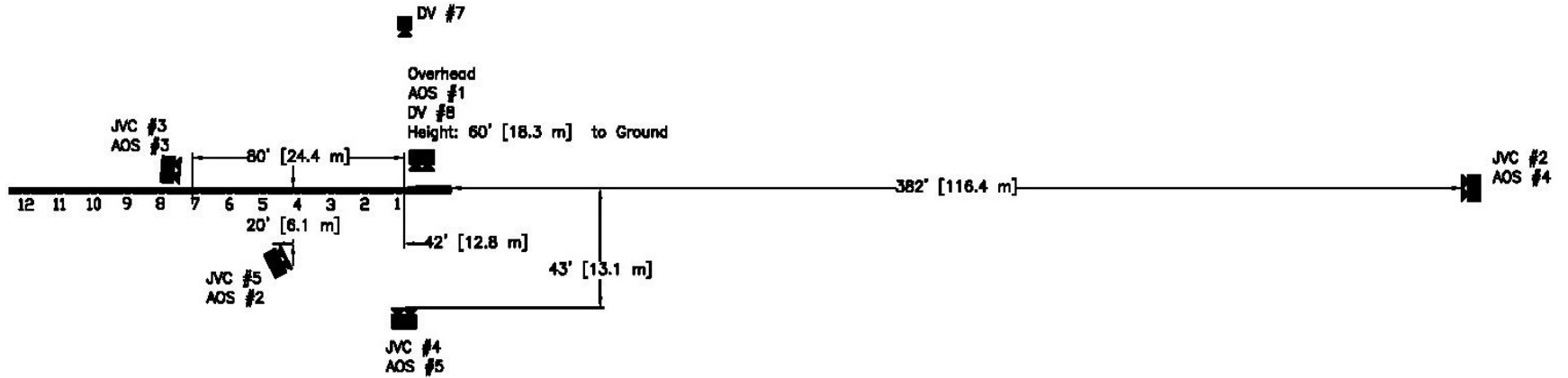

Camera Summary

	No.	Type	Operating Speed (frames/sec)	Lens	Lens Setting
High-Speed Video	1	Vitcam CTM	500	12.5 mm Fixed	-
	2	Vitcam CTM	500	Sigma 24-135	24
	3	Vitcam CTM	500	Fujinon 50 mm Fixed	-
	4	Vitcam CTM	500	Sigma 70-200	135
	5	Vitcam Gigabit	500	Sigma 24-70	24
Digital Video	2	JVC - GZ-MC40u (Everio)	29.97		
	3	JVC - GZ-MC40u (Everio)	29.97		
	4	JVC - GZ-MC40u (Everio)	29.97		
	5	JVC - GZ-MC27u (Everio)	29.97		
	7	Canon-ZR90	29.97		
	8	Canon-ZR90	29.97		

Figure 35. Locations of Cameras, Test TCBT-1

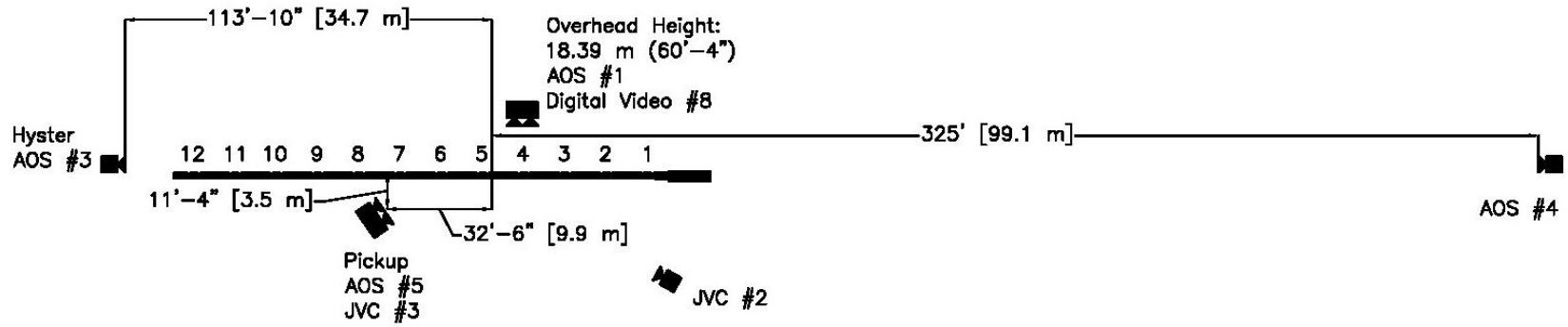

Camera Summary

	No.	Type	Operating Speed (frames/sec)	Lens	Lens Setting
High-Speed Video	1	Vitcam CTM	500	12.5 mm Fixed	-
	3	Vitcam CTM	500	Sigma 24-70	28
	4	Vitcam CTM	500	Sigma 70-200	135
	5	Vitcam Gigabit	500	Sigma 24-135	35
Digital Video	2	JVC - GZ-MC40u (Everio)	29.97		
	3	JVC - GZ-MC40u (Everio)	29.97		
	8	Canon-ZR90	29.97		

Figure 36. Locations of Cameras, Test TCBT-2

8 CRASH TEST NO. 1

8.1 Test TCBT-1

The 5,175-lb (2,347-kg) pickup truck, with the dummy placed in the right-front seat, impacted the temporary concrete barrier to permanent barrier transition, at a speed of 62.5 mph (100.6 km/h) and at an angle of 24.7 degrees. Test no. TCBT-1 was performed to evaluate the transition directly adjacent to the permanent median barrier. A summary of the test results and sequential photographs are shown in Figure ?. Additional sequential photographs are shown in Figures 38 through 41. Documentary photographs of the crash test are shown in Figure 42.

8.2 Weather Conditions

Test No. TCBT-1 was conducted on April 4, 2008 at approximately 2:45 pm. The weather condition were reported, as shown in Table 4.

Table 4. Weather Conditions, Test No. TCBT-1

Temperature	60 ° F
Humidity	31 %
Wind Speed	14 mph
Wind Direction	Southwest
Sky Conditions	Scattered Thunderstorm
Visibility	10.0 Statute Miles
Pavement Surface	Dry
Previous 3-Day Precipitation	0.32 in.
Previous 7-Day Precipitation	1.14 in.

8.3 Test Description

Initial vehicle impact was to occur 51 ⁵/₈ in. (1,311 mm) upstream from the upstream end of the permanent barrier, as shown in Figure 43. Actual vehicle impact occurred 56 ³/₈ in. (1,432 mm) upstream from the upstream end of the permanent barrier. Table 5 contains a sequential description

of the impact events. The final position of the vehicle was determined to be 208 ft - 10 ½ in. (63.7 m) downstream of impact and 32 ft - 6 ½ in. (9.9 m) laterally behind the traffic-side face of the system. The trajectory and final position of the vehicle are shown in Figures ? and 44.

Table 5. Sequential Description of Impact Events, TCBT-1

Time (sec)	EVENT
0.002	the right-side headlight deformed
0.010	the right-front corner of the fender protruded over the system
0.024	barrier no. 1 deflected
0.034	the front of the vehicle contacted the permanent concrete barrier
0.046	the truck began to yaw away from the system
0.062	the right-front tire contacted the upstream end of the permanent barrier
0.080	the truck began to roll toward the system
0.188	the vehicle became parallel to the system with a resultant velocity of 49.8 mph (80.2 km/h)
0.196	the right-rear tire impacted the transition
0.216	the rear of the truck began to pitch upward
0.318	the vehicle exited the system at a trajectory angle of 4.2 degrees and a resultant velocity of 48.6 mph (78.2 km/h)

8.4 Barrier Damage

Damage to the system was moderate, as shown in Figures 45 through 50. Barrier damage consisted of scrapes and contact marks on temporary concrete barriers, permanent barrier, and the thrie beam section, cracking of temporary barrier sections, and deformed thrie beam. The length of the vehicle contact along the transition was approximately 14 ft - 1 5/8 in. (4.3 m), which spanned

from 56 $\frac{3}{8}$ in. (1,432 mm) upstream from the upstream end of the permanent barrier to 44 in. (1,117 mm) upstream from the downstream end of the permanent barrier.

The thrie beam transition encountered deformation, flattening, and minor tears. Flattening and deformation of the thrie beam rail occurred from 4 in. (102 mm) downstream from impact to 60 in. (1,524 mm) downstream from impact. A 2 $\frac{1}{4}$ in. (57 mm) tear in the nested thrie beam rail on the traffic-side was found 34 in. (864 mm) downstream from impact which was caused by the truck dragging across the midspan. The thrie beam rail on the non-impact side underwent slight bending at the center of the beam. The transition cap was deformed and a slight twist on top of the cap down on the traffic-side. The concrete permanent barrier had minor contact marks above and downstream of the transition.

The downstream end of barrier no. 1 rotated $\frac{1}{4}$ (6 mm) toward the non-impact-side. Several of the asphalt pins were pulled up due to barrier rotation. The traffic-side downstream end pin of barrier no. 1 was pulled up $\frac{1}{8}$ in. (3 mm). The traffic-side middle pin of barrier no. 1 was pulled up $\frac{1}{8}$ in. (3 mm). The traffic-side upstream end pin of barrier no. 1 was pulled up $\frac{1}{8}$ in. (3 mm). The non-traffic-side downstream end pin of barrier no. 1 was pulled up $\frac{1}{16}$ in. (2 mm). The non-traffic-side middle pin of barrier no. 1 was pulled up $\frac{1}{16}$ in. (2 mm). Concrete spalling was observed around the holes in the toe of the barrier near the first two pins upstream of the single-slope barrier on the impact side of the barrier no.1 and near the middle pin on the backside of barrier no. 1.

The permanent set of the barrier system is shown in Figure 46. The maximum lateral permanent set barrier deflection was $\frac{1}{4}$ in. (6 mm) at the downstream end of barrier no. 1. The maximum lateral dynamic barrier deflection was 2.6 in. (67 mm) on middle of the non-impact-side of the thrie beam, as determined from highspeed digital video analysis. The working width of the system was found to be 24 $\frac{7}{8}$ in. (632 mm).

8.5 Vehicle Damage

Vehicle damage was moderate, as shown in the Figures 51 through 54. Occupant compartment deformations to the right side of the floorboard were judged insufficient to cause serious injury to the vehicle occupants, as shown in Figure 54. Maximum longitudinal deflections of 6 in. (152 mm) were located near the front-center of the right-side floor pan. Maximum lateral deflections of 2 ¾ in. (70 mm) were located at the front-right of the right-side floor pan. Maximum vertical deflections of 5 ¼ in. (133 mm) were located near the front-center of the right-side floor pan. Complete occupant compartment deformations and the corresponding locations are provided in Appendix E.

Damage was concentrated on the right-front corner of the vehicle. The front bumper bent approximately 90 degrees 13 in. (330 mm) from the right side with the end in the wheel well area. The right-front corner was deformed inward toward the engine compartment. The right-front corner of the hood was deformed. The right-front wheel well is covered in black tire marks. The right-front upper and lower control arms were severely damaged. Scrapes and contact marks were found along the entire right side of the vehicle. Major sheet metal deformations were found above the right-side wheel well and along the lower portion of the right-side doors, not allowing the right side doors to open. The right side door buckled outward from the inside causing a 5-7 in. (127-178 mm) gap along the top frame of the door and a 1-6 in. (25-152 mm) gap along the side of the door. The right-rear bumper was deformed inward and flattened flush with rear quarter panel. Contact marks were found on the right-rear hubcap. The right-side taillight housing was dislodged. The right-front tire was cut severely about 6-8 in. (152-203 mm) and detached from the vehicle, except for the being attached only by the brake line. All other tires remained attached. Spider-web cracking was found on the

bottom, left, and right sides of the windshield. No other window damage occurred. The roof and the left side of the vehicle remained undamaged.

8.6 Occupant Risk Values

The longitudinal and lateral occupant impact velocities were determined to be -22.68 ft/s (-6.91 m/s) and 26.99 ft/s (8.23 m/s), respectively. The maximum 0.010-sec average occupant ridedown acceleration in the longitudinal and lateral directions were -4.66 g's and 6.76 g's, respectively. It is noted that the occupant impact velocities (OIVs) and occupant ridedown accelerations (ORAs) were within the suggested limits provided in MASH. The THIV and PHD values were determined to be 31.69 ft/s (9.66 m/s) and 7.66 g's, respectively. The results of the occupant risk, as determined from the accelerometer data, are summarized in Figure ?. The results are shown graphically in Appendix F. The results from the rate transducer are shown graphically in Appendix F. Due to technical difficulties EDR-4 and DTS did not collect data, but the EDR-4 did collect angular data from the rate transducers.

8.7 Discussion

The analysis of the test results for test no. TCBT-1 showed that the temporary concrete barrier to permanent concrete barrier transition adequately contained and redirected the 2270P vehicle without significant permanent displacement of the barrier. There were no detached elements nor fragments which showed potential for penetrating the occupant compartment nor presented undue hazard to other traffic. Deformations of, or intrusion into, the occupant compartment that could have caused serious injury did not occur. The test vehicle did not penetrate nor ride over the guardrail system and remained upright during and after the collision. Vehicle roll, pitch, and yaw angular displacements were noted, but they were deemed acceptable because they did not adversely influence occupant risk safety criteria nor cause rollover. After impact, the vehicle exited the barrier

at an angle of 4.2 degrees and its trajectory did not violate the bounds of the exit box. Therefore, test no. TCBT-1 conducted on the temporary concrete barrier to permanent barrier concrete transition was determined to be acceptable according to the TL-3 safety performance criteria of test designation no. 3-21 found in MASH.



0.000 sec

0.024 sec

0.068 sec

0.180 sec

0.304 sec

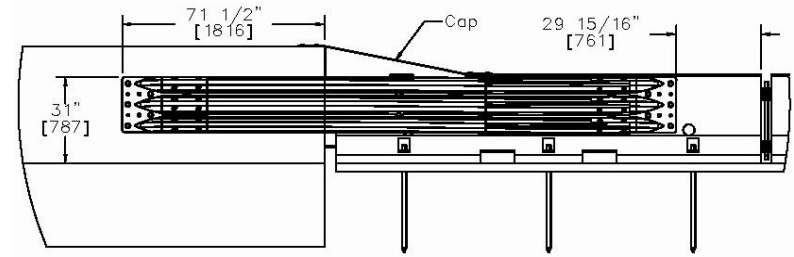
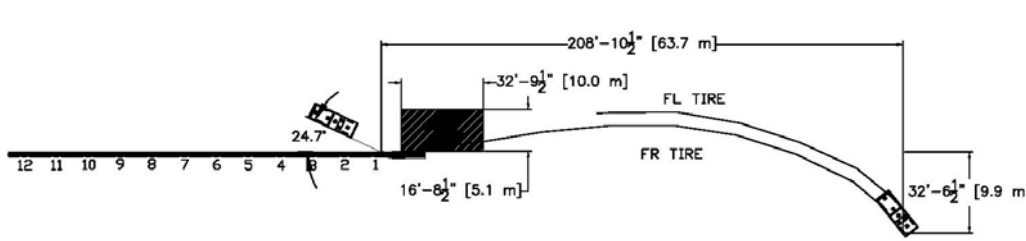

- Test Agency MwRSF
- Test Number TCBT-1
- Date 4/4/2008
- MASH Test Designation 3-21
- Appurtenance Temporary Concrete Barrier to Permanent Concrete Barrier Transition
- Total Length 166 ft - 10 in. (50.9 m)
- Key Elements - Temporary Barriers
 - Description Kansas F-shape
 - Length 12 ft - 6 in. (3,810 mm)
 - Base Width 22 1/2 in. (572 mm)
 - Height 32 in. (813 mm)
- Key Elements - Permanent Barrier
 - Description California Single Sloped Concrete Barrier
 - Top Width 8 in. (203 mm)
 - Base Width 21 1/2 in. (545 mm)
 - Height 42 in. (1,067 mm)
- Key Elements - Cap
 - Length 68 7/16 in. (1,738 mm)
 - Height 10 in. (256 mm)
- Type of Soil None
- Test Vehicle
 - Type/Designation 2270P
 - Make and Model 2002 Dodge Ram 1500 Quad Cab
 - Curb 4,971 lbs (2,255 kg)
 - Test Inertial 5,006 lbs (2,271 kg)
 - Gross Static 5,175 lbs (2,347 kg)
- Impact Conditions
 - Speed 62.5 mph (100.6 km/h)
 - Angle 24.7 degrees
 - Impact Location 56 3/8 in. (1,432 mm) upstream of permanent barrier

- Exit Conditions
 - Speed 48.6 mph (78.2 km/h)
 - Angle 4.2 degrees
 - Exit Box Criterion Pass
- Post-Impact Trajectory
 - Vehicle Stability Satisfactory
 - Stopping distance 208 ft - 10 1/2 in. (63.7 m) downstream
32 ft - 6 1/2 in. (9.9 m) laterally behind
- Occupant Impact Velocity
 - Longitudinal -22.68 ft/s (-6.91 m/s) < 40 ft/s (12.2 m/s)
 - Lateral 26.99 ft/s (8.23 m/s) < 40 ft/s (12.2 m/s)
- Occupant Ride Down Deceleration
 - Longitudinal -4.66 g's < 20.49 g's
 - Lateral 6.76 g's < 20.49 g's
- THIV (not required) N/A
- PHD (not required) N/A
- Test Article Damage Moderate
- Test Article Deflections
 - Permanent Set N/A
 - Dynamic 2.6 in. (66 mm)
 - Working Width 24 7/8 in. (632 mm)
- Vehicle Damage Moderate
 - VDS¹² 1-RFQ-5
 - CDC¹³ 01-RFEE5
 - Maximum Deformation 6 in. (152 mm) at front-center floorboard
- Angular Displacement
 - Roll N/A
 - Pitch N/A
 - Yaw N/A

Figure 37. Summary of Test Results and Sequential Photographs, Test No. TCBT-2



0.000 sec



0.242 sec



0.034 sec



0.346 sec



0.096 sec



0.476 sec



0.182 sec



0.522 sec

Figure 38. Additional Sequential Photographs, Test No. TCBT-1



0.000 sec



0.200 sec



0.024 sec



0.282 sec



0.060 sec



0.392 sec



0.170 sec



0.514 sec

Figure 39. Additional Sequential Photographs, Test No. TCBT-1



0.000 sec



0.182 sec



0.024 sec



0.216 sec

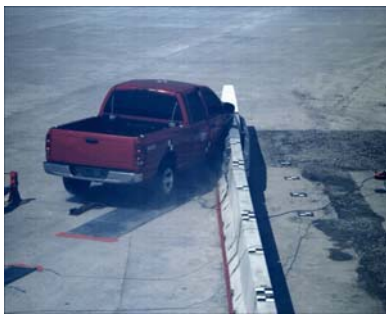

0.058 sec

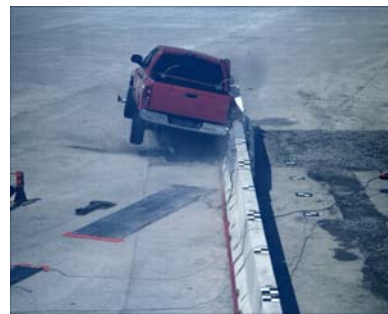

0.244 sec

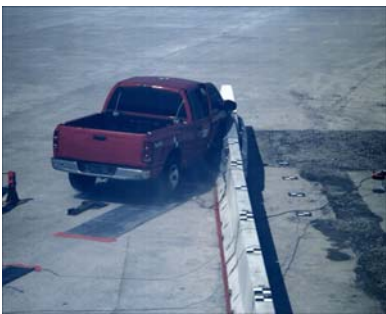

0.072 sec



0.258 sec

Figure 40. Additional Sequential Photographs, Test No. TCBT-1



0.000 sec



0.128 sec



0.012 sec



0.196 sec



0.024 sec



0.224 sec



0.068 sec



0.280 sec

Figure 41. Additional Sequential Photographs, Test No. TCBT-1



Figure 42. Documentary Photographs, Test No. TCBT-1



Figure 43. Impact Location, Test No. TCBT-1



Figure 44. Vehicle Final Position and Trajectory, Test No. TCBT-1



Figure 45. System Damage, Test No. TCBT-1



Figure 46. System Damage, Test No. TCBT-1

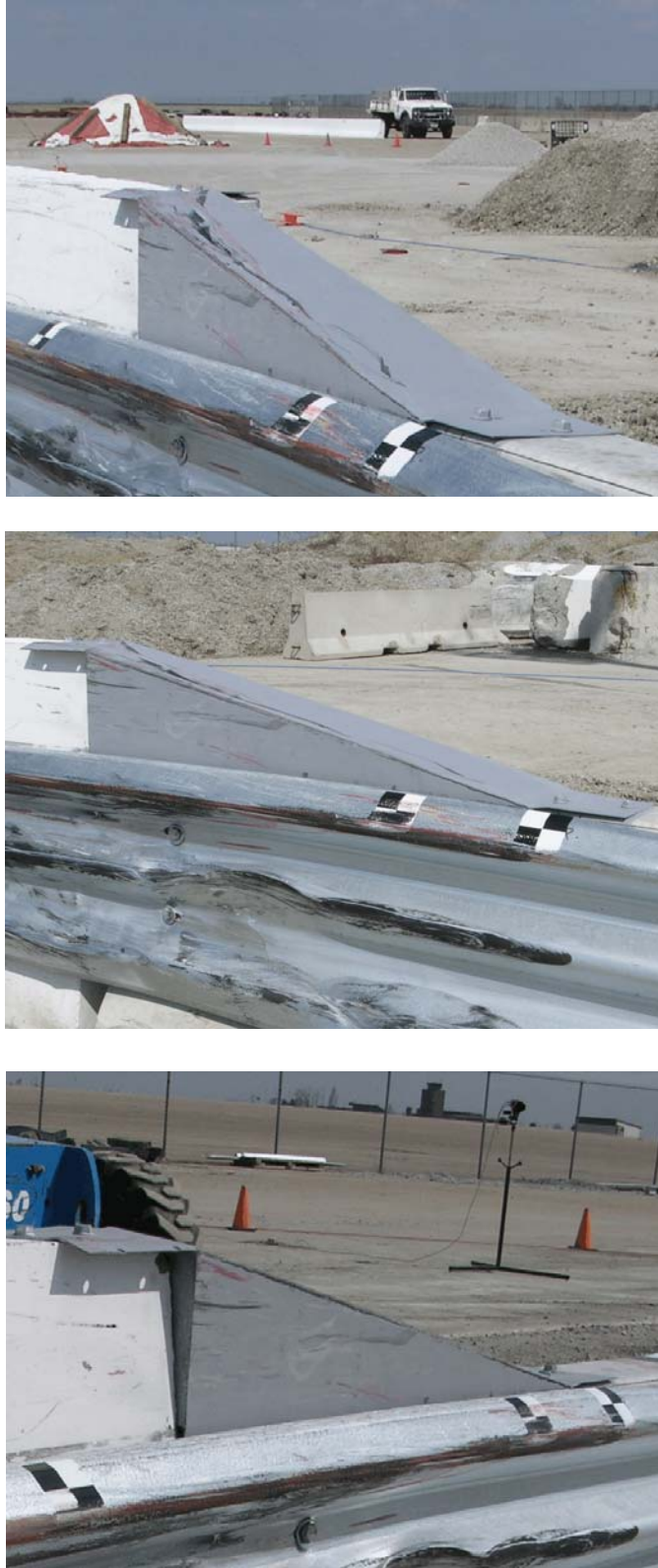

Figure 47. System Damage, Test No. TCBT-1



Barrier No. 1 Traffic Side Downstream



Barrier No. 1 Non-Traffic Side Downstream



Barrier No. 1 Traffic Side Midspan



Barrier No. 1 Non-Traffic Side Midspan



Barrier No. 1 Traffic Side Upstream



Barrier No. 1 Non-Traffic Side Upstream

Figure 48. Asphalt Pin Damage, Test No. TCBT-1



Barrier No. 2 Traffic Side Downstream



Barrier No. 2 Non-Traffic Side Downstream



Barrier No. 2 Traffic Side Midspan



Barrier No. 2 Non-Traffic Side Midspan



Barrier No. 2 Traffic Side Upstream



Barrier No. 2 Non-Traffic Side Upstream

Figure 49. Asphalt Pin Damage, Test No. TCBT-1



Barrier No. 3 Traffic Side Downstream



Barrier No. 3 Non-Traffic Side Upstream



Barrier No. 3 Traffic Side Upstream



Barrier No. 4 Traffic Side Downstream



Barrier No. 3 Non-Traffic Side Downstream



Barrier No. 4 Non-Traffic Side Downstream

Figure 50. Asphalt Pin Damage, Test No. TCBT-1



79

Figure 51. Vehicle Damage, Test No. TCBT-1



Figure 52. Vehicle Damage, Test No. TCBT-1



Figure 53. Undercarriage Damage, Test No. TCBT-1



Figure 54. Occupant Compartment Deformation, Test No. TCBT-1

9 CRASH TEST NO. 2

9.1 Test TCBT-2

The 5,160-lb (2,341-kg) pickup truck impacted, with the dummy placed in the right-front seat, the temporary concrete barrier to permanent concrete barrier transition at a speed of 62.2 mph (100.1 km/h) and at an angle of 26.2 degrees. Test no. TCBT-2 was performed to evaluate the upstream end of the approach transition. A summary of the test results and sequential photographs are shown in Figure 37, 55. Additional sequential photographs are shown in Figures 56 through 58. Documentary photographs of the crash test are shown in Figure 59.

9.2 Weather Conditions

Test No. TCBT-2 was conducted on April 23, 2008 at approximately 12:00 pm. The weather condition were reported, as shown in Table 6.

Table 6. Weather Conditions, Test No. TCBT-2

Temperature	74 ° F
Humidity	48 %
Wind Speed	21 mph
Wind Direction	South
Sky Conditions	Clear
Visibility	10.0 Statute Miles
Pavement Surface	Dry
Previous 3-Day Precipitation	0 in.
Previous 7-Day Precipitation	1.44 in.

9.3 Test Description

Initial vehicle impact was to occur 3 ft - 4 ¼ in. (1,022 mm) upstream from the downstream end of barrier no. 5, as shown in Figure 60. Actual vehicle impact occurred 3 ft - 5 ¼ in. (1,048 mm)

upstream from the downstream end of barrier no. 5. Table 7 contains a sequential description of the impact events. The vehicle came to rest 184 ft (56.1 m) downstream from impact and 67 ft - 7 ¼ in. (20.6 m) laterally away from the traffic-side face of the barrier. The trajectory and final position of the vehicle are shown in Figures 37, 55 and 61.

Table 7. Sequential Description of Impact Events, TCBT-2

Time (sec)	EVENT
0.002	the right corner of the front bumper was deformed inward
0.018	barrier nos. 4 and 5 began to deflect
0.024	the vehicle began to redirect away from system
0.052	cracks formed at the base on the traffic-side of barrier no. 4
0.062	barrier no. 3 began to deflect
0.068	the right-front tire exploded
0.088	barrier no. 4 cracked near its middle on top and traffic-side
0.102	barrier no. 6 began to deflect
0.124	barrier no. 3 began to deflect
0.168	the front of the vehicle was located at the downstream end of barrier no. 4
0.180	the front of the vehicle pitched upward
0.206	the vehicle became parallel to the system with a resultant velocity of 50.1 mph (80.7 km/h)
0.238	the right-side of the vehicle impacted upstream end of barrier no. 4
0.252	the front of the vehicle lost contact with the barrier and the right-front tire disengaged from the vehicle
0.268	the right taillight contacted barrier no. 4 and fractured
0.308	the right-rear tire exploded
0.332	the vehicle was completely airborne with all tires off the ground, but still in contact with the barrier
0.346	the vehicle exited the system at a trajectory angle of 14.0 degrees and a resultant velocity of 43.0 mph (69.1 km/h)

9.4 Barrier Damage

Damage to the system was moderate, as shown in Figures 62 through 64. Barrier damage consisted of scrapes, contact marks, and concrete spalling on temporary concrete barriers and asphalt pin deflections, cracking of temporary barrier sections, and fractured temporary barriers. The length of the vehicle contact along the transition was approximately 17 ft - 1 ½ in. (5.2 m), which spanned from 41 ¼ in. upstream of the downstream end of barrier no. 5 to 8 in. (203 mm) downstream from the upstream end of barrier no. 3.

Tire marks, scrapes, and cracking of the concrete were visible on barrier segment nos. 3 through 5. The traffic-side of barrier no. 5 had concrete spalling on the upstream end of the barrier. Concrete spalling occurred around the rear upstream asphalt pin of barrier no. 3 which was 19 in. (483 mm) long by 7 in. (178 mm) high. Concrete spalling also occurred around the rear downstream asphalt pin of barrier no. 3 which began at the downstream end and continued for 44 in. (1,118 mm). The top of barrier no. 3 on the upstream end had significant contact marks. Barrier no. 4 rolled toward the back of the system exposing the upstream end of barrier no. 3 to the truck. Barrier no. 4 was cracked in half and rebar was fractured at the midsection. Concrete spalling was found on the backside of barrier no. 4 beginning at the lower downstream end and continued 32 in. (813 mm) along the bottom of the barrier. The traffic-side of barrier no. 5 had tire and minor contact marks on the downstream end.

Deformation to several concrete temporary barrier loop joints and connection pins were noted in the impact region. The bottom loop on the downstream end of barrier no. 5 deformed ½ in. (13 mm) toward the traffic-side of the system. The top loop on the upstream end of barrier no. 4 deformed ¼ in. (6 mm) toward the traffic-side of the system. The bottom loop on the downstream

end of barrier no. 4 deformed 2 ½ in. (64 mm) toward the back of the system. The connection pin between barrier nos. 3 and 4 has a ¾ in. (10 mm) deflection starting 4 in. down from the top end and a deflection of ½ in. (13 mm) deflection starting 4 ½ in. (114 mm) up from the bottom end. The pins between barrier nos. 4 and 5 has a ⅝ in. (16 mm) deflection starting 6 ½ in. (165 mm) up from the bottom end.

Deformation to several asphalt pins were also noted in the impact region. The non-traffic-side downstream end pin of barrier No. 2 has deflection of ¾ in. (9 mm) centered at 12 in. from the top end. The traffic-side upstream and downstream end pins of barrier no. 3 were pulled up 1 in. (25 mm). The non-traffic-side upstream end pin of barrier No. 3 has a deflection of ½ in. (13 mm) centered at 7 ¼ in. (184 mm) from the top end. The non-traffic-side downstream end pin of barrier No. 3 has a deflection of ⅛ in. (3 mm) centered at 7 in. (178 mm) from the top end. The traffic-side downstream end pin of barrier No. 4 has a deflection of 1 ½ in. (38 mm) centered at 14 in. (356 mm) from the top end and was pulled up 7 ½ in. (191 mm). The non-traffic-side downstream end pin of barrier No. 4 has a deflection of 1 ½ in. (38 mm) centered at 11 in. (279 mm) from the top end.

The permanent set of the barrier system is shown in Figure 62. The maximum lateral permanent set barrier deflection was 34 in. (864 mm) at the downstream end of barrier no. 5, as measured in the field. It should be noted that the barrier segments upstream of impact had permanent set longitudinal deflections between 5 in. and 6 in. (127 mm and 152 mm) downstream. The maximum lateral dynamic barrier deflection was 34 in. (864 mm) at the upstream end of barrier no. 5, as determined from highspeed digital video analysis. The working width of the system was found to be 55.8 in. (1,117 mm).

9.5 Vehicle Damage

Vehicle damage was moderate, as shown in the Figures 65 through 68. Occupant compartment deformations to the right side of the floorboard were judged insufficient to cause serious injury to the vehicle occupants, as shown in Figure 68. Maximum longitudinal deflections of 2 in. (51 mm) was located front center of the right-side floor pan. Maximum lateral deflections of 1 ¾ in. (44 mm) was located at the front center of the right-side floor pan. Maximum vertical deflections of 2 ½ in. (64 mm) was located front right of the right-side floor pan. Complete occupant compartment deformations and the corresponding locations are provided in Appendix E.

Damage was concentrated on the right-front corner of the vehicle. The right-front corner was deformed inward toward the engine compartment. The right side of the front bumper wrapped around truck frame at 90 degrees. The right-front headlight housing disengaged from the vehicle. The right-front fender damaged along entire length and folded down and inward. The right-front wheel assembly disengaged from upper and lower control arms. Heavy contact mark were found along the frame and gussets from right-front wheel coming off. Contact marks spanned the entire right side of the vehicle which was centered just above the wheel wells. Heavy damage was found on the right-front door. The lower hinges of the right-front door were pulled away from the door. A triangular section measuring 6 in. (152 mm) by 10 in. (254 mm) was ripped open on the lower front corner of the right-rear door. The lower half B pillar was deformed on the right-rear door. Glass was wedged out of the right-rear door but was not broken. The drive shaft was disengaged. Heavy damage was observed on the bottom of the right-rear door. Glass popped out of the left-rear door but was not broken. The right-rear wheel was disengaged from the vehicle. The spare tire and tail gate were disengaged from the vehicle. The rear bumper deformed and was not in contact with

the vehicle towards the left and right sides. The roof, hood, and left side of the vehicle remained undamaged.

9.6 Occupant Risk Values

The longitudinal and lateral occupant impact velocities were determined to be -12.78 ft/s (-3.90 m/s) and 18.56 ft/s (5.66 m/s), respectively. The maximum 0.010-sec average occupant ridedown acceleration in the longitudinal and lateral directions were -18.69 g's and 13.29 g's, respectively. It is noted that the occupant impact velocities (OIVs) and occupant ridedown accelerations (ORAs) were within the suggested limits provided in MASH. The THIV and PHD values were determined to be 20.58 ft/s (6.27 m/s) and 19.00 g's, respectively. The results of the occupant risk, as determined from the accelerometer data, are summarized in Figure 37, 55. The results are shown graphically in Appendix G. The results from the rate transducer are shown graphically in Appendix G. Due to technical difficulties EDR-4 and DTS did not collect acceleration data, but the EDR-4 did collect angular data from the rate transducer.

9.7 Discussion

The analysis of the test results for test no. TCBT-2 showed that the temporary concrete barrier to permanent concrete barrier transition adequately contained and redirected the 2270P vehicle. There were no detached elements nor fragments which showed potential for penetrating the occupant compartment nor presented undue hazard to other traffic. Deformations of, or intrusion into, the occupant compartment that could have caused serious injury did not occur. The test vehicle did not penetrate nor ride over the guardrail system and remained upright during and after the collision. Vehicle roll, pitch, and yaw angular displacements were noted, but they were deemed acceptable because they did not adversely influence occupant risk safety criteria nor cause rollover.

After collision, the vehicle's trajectory revealed minimum intrusion into adjacent traffic lanes. The vehicle did not exit the barrier within the exit box yet still exited the barrier smoothly. Therefore, test no. TCBT-2 conducted on the temporary concrete barrier to permanent concrete barrier transition was determined to be acceptable according to the TL-3 safety performance criteria of test designation no. 3-21 found in MASH.

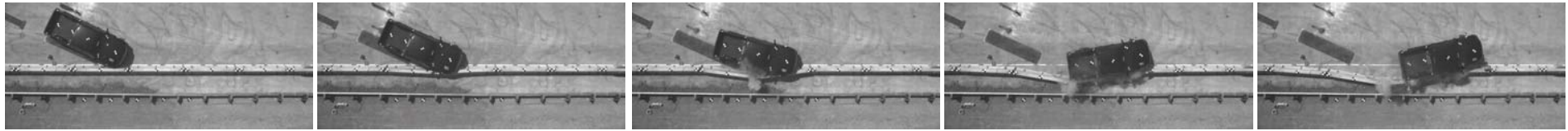

0.000 sec

0.060 sec

0.120 sec

0.246 sec

0.322 sec

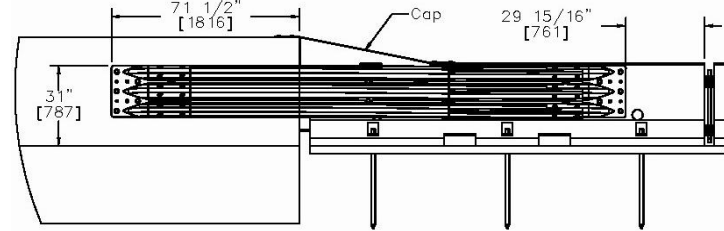
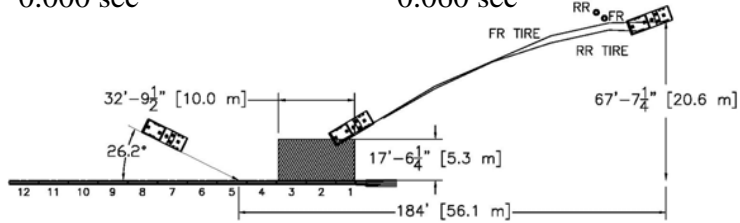

- Test Agency MwRSF
- Test Number TCBT-2
- Date 4/23/2008
- MASH Test Designation 3-21
- Appurtenance Temporary Concrete Barrier to Permanent Concrete Barrier Transition
- Total Length 166 ft - 10 in. (50.9 m)
- Key Elements - Temporary Barriers
 - Description Kansas F-shape
 - Length 12 ft - 6 in. (3,810 mm)
 - Base Width 22 1/2 in. (572 mm)
 - Height 32 in. (813 mm)
- Key Elements - Permanent Barrier
 - Description California Single Sloped Concrete Barrier
 - Top Width 8 in. (203 mm)
 - Base Width 21 1/2 in. (545 mm)
 - Height 42 in. (1,067 mm)
- Key Elements - Cap
 - Length 68 7/16 in. (1,738 mm)
 - Height 10 in. (256 mm)
- Type of Soil None
- Test Vehicle
 - Type/Designation 2270P
 - Make and Model 2003 Dodge Ram 1500 Quad Cab
 - Curb 4,905 lbs (2,225 kg)
 - Test Inertial 4,990 lbs (2,263 kg)
 - Gross Static 5,160 lbs (2,241 kg)
- Impact Conditions
 - Speed 62.2 mph (100.1 km/h)
 - Angle 26.2 degrees
 - Impact Location 41 1/4 in. (1,048 mm) upstream from the downstream end of barrier no. 5

- Exit Conditions
 - Speed 43.0 mph (69.1 km/h)
 - Angle 14.0 degrees
 - Exit Box Criterion Failed
- Post-Impact Trajectory
 - Vehicle Stability Satisfactory
 - Stopping distance 184 ft (56.1 m) downstream 67 ft - 7 1/4 in. (20.6 m) laterally in front
- Occupant Impact Velocity (EDR-3)
 - Longitudinal -12.78 ft/s (-3.90 m/s) < 40 ft/s (12.2 m/s)
 - Lateral 18.56 ft/s (5.66 m/s) < 40 ft/s (12.2 m/s)
- Occupant Ride Down Deceleration (EDR-3)
 - Longitudinal -18.69 g's < 20.49 g's
 - Lateral 13.29 g's < 20.49 g's
- THIV (not required) 20.58 ft/s (6.27 m/s)
- PHD (not required) 19.00 g's
- Test Article Damage Moderate
- Test Article Deflections
 - Permanent Set 34 in. (864 mm)
 - Dynamic 44.3 in. (1,125 mm)
 - Working Width 55.8 in. (1,417 mm)
- Vehicle Damage Moderate
 - VDS¹² 1-RD-6
 - CDC¹³ 01-RDEE9
 - Maximum Deformation 2 1/2 in. (64 mm) at the front-right floorboard
- Angular Displacement
 - Roll 7.8 degrees
 - Pitch -27.5 degrees
 - Yaw -38.2 degrees

Figure 55. Summary of Test Results and Sequential Photographs, Test No. TCBT-2



0.000 sec



0.346 sec



0.068 sec



0.430 sec



0.138 sec



0.746 sec



0.256 sec



1.436 sec

Figure 56. Additional Sequential Photographs, Test No. TCBT-2



0.000 sec



0.202 sec



0.028 sec



0.238 sec



0.068 sec



0.332 sec



0.124 sec



0.424 sec

Figure 57. Additional Sequential Photographs, Test No. TCBT-2



0.000 sec



0.126 sec



0.028 sec



0.152 sec



0.052 sec



0.234 sec



0.096 sec



0.288 sec

Figure 58. Additional Sequential Photographs, Test No. TCBT-2



Figure 59. Documentary Photographs, Test No. TCBT-2



Figure 60. Impact Location, Test No. TCBT-2



Figure 61. Final Position and Trajectory Marks, Test No. TCBT-2



Figure 62. System Damage, Test No. TCBT-2



Figure 63. System Damage, Test No. TCBT-2



Figure 64. System Damage, Test No. TCBT-2



100

Figure 65. Vehicle Damage, Test No. TCBT-2



101

Figure 66. Vehicle Damage, Test No. TCBT-2

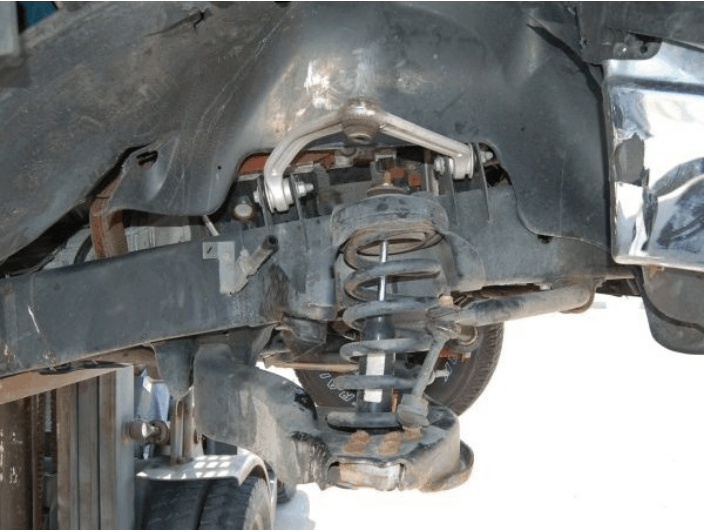

Figure 67. Undercarriage Damage, Test No. TCBT-2



Figure 68. Occupant Compartment Damage, Test No. TCBT-2

10 SUMMARY AND CONCLUSIONS

The barrier system developed during the research described herein was an approach transition between free-standing, F-shape temporary concrete barrier and permanent concrete median barrier. An analysis of common median barrier geometries identified the critical median barrier design for the approach transition as the 42-in. tall CA single-slope median barrier due to its height as compared to the F-shape temporary concrete barrier. Evaluation of the approach transition required testing at two CIP locations. The first was a CIP to evaluate vehicle interaction with the permanent barrier and the second was a CIP to evaluate the stiffness transition near the upstream end of the system. Full-scale crash testing at both CIP locations demonstrated that the impacting vehicle was safely and smoothly redirected, and the testing of the approach transition was judged acceptable according to the TL-3 safety criteria set forth in MASH. A summary of the safety performance evaluation is provided in Table 8.

The first full-scale crash test, test no. TCBT-1, was performed on the temporary concrete barrier to permanent concrete barrier transition according to test designation 3-21 of MASH. The test consisted of a 5,175-lb (2,347-kg) pickup truck impacting the transition system at a speed of 62.5 mph (100.6 km/h) and at an angle of 24.7 degrees. The impact point of this test was 56 $\frac{3}{8}$ in. (1,432 mm) upstream from the upstream end of the permanent barrier. The test results were determined to be acceptable according to MASH safety requirements as the pickup truck was smoothly redirected and remained upright throughout the impact event.

The second full-scale crash test, test no. TCBT-2, was performed on the temporary concrete barrier to permanent concrete barrier transition according to test designation 3-21 of MASH. The test consisted of a 5,161-lb (2,341-kg) pickup truck impacting the transition at a speed of 62.2 mph

(100.1 km/h) and at an angle of 26.2 degrees. The impact point of this test was 41 ¼ in. (1,048 mm) upstream from the downstream end of barrier no. 5. The test results were determined to be acceptable according to MASH safety requirements as the pickup truck was smoothly redirected and remained upright throughout the impact event.

Table 8. Summary of Safety Performance Evaluation Results - MASH

Evaluation Factors	Evaluation Criteria	Test No. TCBT-1	Test No. TCBT-2	
Structural Adequacy	A. Test article should contain and redirect the vehicle or bring the vehicle to a controlled stop; the vehicle should not penetrate, underride, or override the installation although controlled lateral deflection of the test article is acceptable.	S	S	
Occupant Risk	D. Detached elements, fragments or other debris from the test article should not penetrate or show potential for penetrating the occupant compartment, or present an undue hazard to other traffic, pedestrians, or personnel in a work zone. Deformations of, or intrusions into, the occupant compartment should not exceed limits set forth in Section 5.3 and Appendix E of MASH.	S	S	
	F. The vehicle should remain upright during and after collision. The maximum roll and pitch angles are not to exceed 75 degrees.	S	S	
	H. Occupant Impact Velocities (OIV) (see Appendix A, Section A5.3 of MASH for calculation procedure) should satisfy the following limits:	S	S	
	Occupant Impact Velocity Limits, ft/s (m/s)			
	Component			Preferred
Lateral and Longitudinal	30 ft/s (9.1 m/s)	40 ft/s (12.2 m/s)		
I. The Occupant Ridedown Acceleration (ORA) (see Appendix A, Section A5.3 of MASH for calculation procedure) should satisfy the following limits:	S	S		
Occupant Ridedown Acceleration Limits (g's)				
Component			Preferred	Maximum
Longitudinal and Lateral	15.0 g's	20.49 g's		

S - Satisfactory U - Unsatisfactory
M - Marginal NA - Not Available

11 RECOMMENDATIONS

The approach transition described herein was designed for use with the Kansas F-shape temporary concrete barrier system. Therefore, it should not be used with other temporary concrete barrier systems or joint designs without further study. Although it is likely that this approach transition can be adapted to other approved temporary concrete barrier systems, it is first necessary to consider several factors, such as barrier connections, segment lengths, reinforcement, and geometry.

The approach transition design between free-standing and permanent concrete median barrier detailed in this report should be applied when designers are attaching free-standing temporary concrete barrier in the median to permanent concrete barriers or tie-down temporary barrier systems that provide a high degree of constraint on lateral deflection. This requires that the approach transition be applied when free-standing F-shape temporary barriers are connected to permanent concrete barrier, the bolt-through tie-down system for concrete roadways, or the asphalt pin tie-down system. When the approach transition is used in conjunction with the bolt-through tie-down system or the asphalt pin tie-down system, the thrie beam guardrail on the downstream end of the transition is not necessary due to the similar stiffness and deflection levels of the tie-down barriers and the transition. Use of the thrie beam sections is required when the system is attached to rigid barriers to reduce the potential for vehicle snag.

It should also be noted that the approach transition design used constraint pins on both sides of the barrier due to the system's application in the median. However, the researchers cannot recommend using anchorage on both sides of the temporary barrier segment in order to create a median installation of temporary concrete barrier with limited deflection without further testing.

There are concerns that placing anchorage on back side of the barrier can induce increased vertical rotation of the barrier segments which could increase the potential for vehicles to climb the sloped barrier face and become unstable.

The approach transition design was tested with the 42-in. (1,067 mm) tall, CA single-slope median barrier because this barrier was identified as the most critical barrier design for the transition. However, there are other permanent concrete median barriers that can be attached to the approach transition as long as the following guidelines are applied.

1. If the permanent median barrier is 32-in. (813 mm) high, the sloped, steel transition cap is not required for the transition. For barriers with heights greater than 32-in. (813 mm) high, the steel transition cap is required. The cap design can be adjusted for different height and shape barriers as long as adjusted cap provides equivalent slope, permanent barrier coverage, barrier overlap, structural capacity, and anchorage as the original design.
2. Alignment of the temporary barrier system with the permanent barrier may also change when the transition is applied to different permanent barrier geometries, as shown in Figure 69. When attaching to a single-slope barrier profile, the slope break point between the toe of the barrier and the main face of the barrier should be aligned flush with the oncoming traffic side of the single-slope barrier. For safety shape barriers, the toe of the temporary barrier should be aligned flush with the toe of the oncoming traffic side of the median barrier. Vertical median barriers require that the toe of the temporary barrier segments on the reverse direction traffic side be aligned with the base of the permanent barrier on the reverse direction traffic side. These alignments will prevent vehicle snag for oncoming traffic on the

permanent median barrier while preventing snag on the toe of the barrier for reverse direction impacts.

3. The three beam sections that span the gap between the end of the temporary barrier and the permanent median barrier should be used in all instances except when the transition leads into the bolt-through tie-down system or the asphalt pin tie-down system, as described previously.

Finally, the researchers believe that the bolt-through tie-down system developed previously could be safely applied to transitions on concrete surfaces using the configuration developed herein. The asphalt pin and bolt-through tie-down systems are believed to possess similar lateral restraint and thus can be interchanged in the transition design as needed.

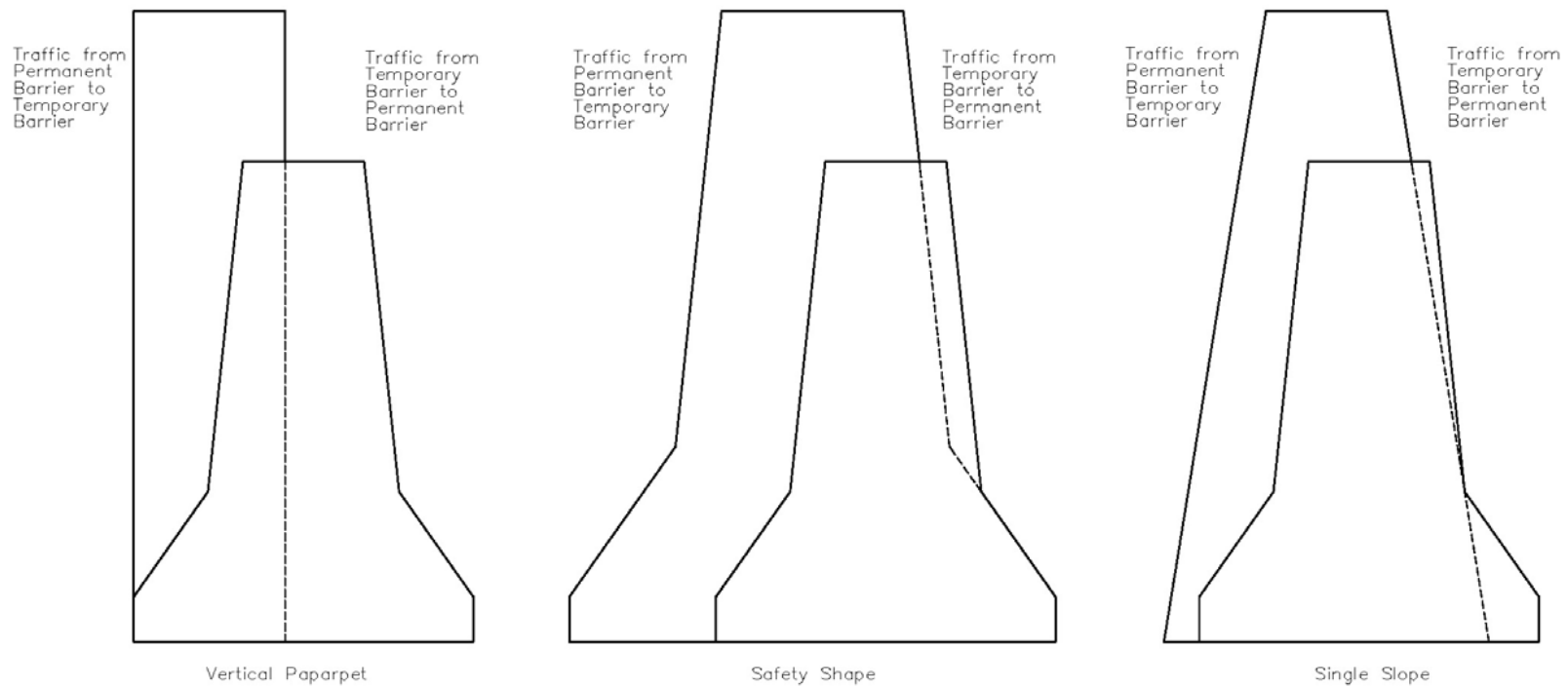

Note: (1) The 32" temporary F-shape barrier is shown as the front barrier.

Figure 69. Temporary F-Shape Barrier to Permanent Concrete Median Barrier

12 REFERENCES

1. Bielenberg, R.B., Faller, R.K., Rohde, J.R., Reid, J.D., Sicking, D.L., and Holloway, J.C., *Development of Tie-Down and Transition Systems for Temporary Concrete Barrier on Asphalt Road Surfaces*, Final Report to Midwest States Regional Pooled Fund Program, Transportation Report No. TRP-03-180-06, Midwest Roadside Safety Facility, University of Nebraska-Lincoln, February 23, 2007.
2. Sicking, D.L., Mak, K.K., Rohde, J.R., and Reid, J.D., *Manual for Assessing Safety Hardware - Draft Report*, National Cooperative Research Program (NCHRP), Project 22-14(2) Panel, 2008.
3. Ross, H.E., Sicking, D.L., Zimmer, R.A., and Michie, J.D., *Recommended Procedures for the Safety Performance Evaluation of Highway Features*, National Cooperative Research Program (NCHRP) Report No. 350, Transportation Research Board, Washington, D.C., 1993.
4. Buth, C.E., Hirsch, T.J., and McDevitt, C.F., *Performance Level 2 Bridge Railings*, Transportation Research Record No. 1258, Transportation Research Board, National Research Council, Washington, D.C., 1990.
5. *Guide Specifications for Bridge Railings*, American Association of State Highway and Transportation Officials (AASHTO), Washington, D.C., 1989.
6. Bronstad, M.E., Calcote, L.R., and Kimball, C.E., Jr., *Concrete Median Barrier Research-Vol.2 Research Report*, Report No. FHWA-RD-77-4, Submitted by the Office of Research and Development, Federal Highway Administration, Performed by Southwest Research Institute, San Antonio, TX, March 1976.
7. Buth, C.E., Campise, W.L., Griffin III, L.I., Love, M.L., and Sicking, D.L., *Performance Limits of Longitudinal Barrier Systems-Volume I: Summary Report*, FHWA/RD-86/153, Final Report to the Federal Highway Administration, Office of Safety and Traffic Operations R&D, Performed by Texas Transportation Institute, Texas A&M University, College Station, TX, May 1986.
8. Polivka, K.A., Faller, R.K., Sicking, D.L., Rohde, J.R., Bielenberg, B.W., Reid, J.D., and Coon, B.A., *Performance Evaluation of the Permanent New Jersey Safety Shape Barrier - Update to NCHRP 350 Test No. 3-10 (2214NJ-1)*, Final Report to the Transportation Research Board, National Research Council, National Cooperative Highway Research Program (NCHRP), NCHRP Project No. 22-14(2), Transportation Research Report No. TRP-03-177-06, Midwest Roadside Safety Facility, University of Nebraska-Lincoln, October 13, 2006.

9. Fortuniewicz, J.S., Bryden, J.E., and Phillips, R.G., Crash Tests of Portable Concrete Median Barrier for Maintenance Zones, Report No. FHWA/NY/RR-82/102, Final Report to the Office of Research, Development, and Technology, Federal Highway Administration, Performed by Engineering Research and Development Bureau, New York State Department of Transportation, December 1982.
10. Hinch, J., Yang, T-L, and Owings, R., *Guidance Systems for Vehicle Testing*, ENSCO, Inc., Springfield, VA 1986.
11. *Center of Gravity Test Code - SAE J874 March 1981*, SAE Handbook Vol. 4, Society of Automotive Engineers, Inc., Warrendale, Pennsylvania, 1986.
12. *Vehicle Damage Scale for Traffic Investigators*, Second Edition, Technical Bulletin No. 1, Traffic Accident Data (TAD) Project, National Safety Council, Chicago, Illinois, 1971.
13. *Collision Deformation Classification - Recommended Practice J224 March 1980*, Handbook Volume 4, Society of Automotive Engineers (SAE), Warrendale, Pennsylvania, 1985.

13 APPENDICES

APPENDIX A

Usage Summary for Temporary Barrier Transitions Survey

February 2, 2006

Mr. Phil Tenhulzen
Nebraska Department of Roads
1500 Highway 2
P.O. Box 94759
Lincoln, NE 68509-4759

Dear Mr. Tenhulzen:

The Midwest Roadside Safety Facility (MwRSF) is in the initial phase of a temporary barrier project that will ultimately lead to the development of a transition between temporary barrier systems and other types of longitudinal barrier system. The project is sponsored by the Midwest States Pooled Fund Program in year 16.

In practice, temporary concrete barriers must be connected and transitioned to many types of barrier, such as permanent concrete safety-shape barriers, vertical concrete barriers, tubular steel bridge railings, W- beam guardrail, thrie-beam guardrail, and open concrete bridge railings. Sample photographs of existing field installations have been included below. Since only a small number of transitions will actually be developed, identifying the most prominent need is required.



Figure A-1. Example of Survey Letter to NDOR - Page 1 of 2

After compiling the various transition needs, they will be organized into a limited number of design categories that will result in the smallest number of full-scale crash tests as possible. Priorities for the project will be assigned based on: (1) the importance of the transition to the States participating in the Pooled Fund Program; (2) the number of different systems that can be addressed simultaneously; and (3) the potential for the development of a successful NCHRP Report 350 design.

To complete the initial phase of the project, the researchers at MwRSF need to establish which transitions provide the greatest value to the Pooled Fund states. Thus, MwRSF researchers need to know which transitions are the most common, what types of transitions are being used for each case, and what standard plan or drawing details have been established for such transitions.

Please take a moment to reply with the following information:

- Any details, state standards, plans, or special plans concerning any type of temporary barrier transitions, including but not limited to all types mentioned previously.
- Any photographs of current or past temporary barrier transition installations.
- A completed copy of the enclosed temporary barrier transition usage summary.

Questions should be directed to Jason Hascall, MwRSF research engineer, at (402) 472-9043 or jhascall@unlserve.unl.edu. The completed form and all additional documents should be mailed, faxed, or E-mailed to:

Jason Hascall
527 Nebraska Hall
P.O. Box 880529
Lincoln, NE 68588-0529
(402) 472-9043
FAX: (402) 472-2022
jhascall@unlserve.unl.edu

Please reply no later than **February 24, 2006**. Thank you for your efforts and time.

Sincerely,

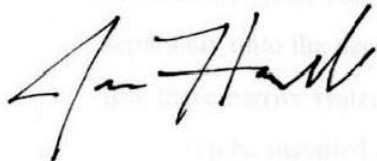

Jason Hascall, M.S.C.E., E.I.T.
Research Engineer

Usage Summary for Temporary Barrier Transitions

- (1) Identify how useful the development of the listed transition would be to your state by circling a number from 1 to 5.
- (2) Include the approximate percentage of temporary barrier transitions which are comprised of the listed transition.
- (3) Rank the transition types in order of their benefit to your state with 1 being the most beneficial.
- (4) Include pictures, details, and drawings concerning temporary concrete barrier transitions, including all those listed below.

Transition Type - Temporary Concrete Safety Shape Barrier Transitioning to:	Usefulness Summary: (1)					Percent (2)	Rank (3)
	Not Useful	Somewhat Useful			Very Useful		
W-beam Guardrail	1	2	3	4	5		
Thrie-Beam Guardrail	1	2	3	4	5		
Permanent Concrete Vertical Barrier	1	2	3	4	5		
Permanent Concrete Safety Shape Barrier	1	2	3	4	5		
Temporary Concrete Safety Shape Barrier	1	2	3	4	5		
Tubular Steel Bridge Railing	1	2	3	4	5		
Open Concrete Bridge Railing	1	2	3	4	5		
Box-Beam Guardrail	1	2	3	4	5		
Other:							
	1	2	3	4	5		
	1	2	3	4	5		

Please direct questions or return completed form to:

Jason Hascall
 Midwest Roadside Safety Facility
 527 Nebraska Hall
 P.O. Box 880529
 Lincoln, NE 68588
 (402) 472-9043
 FAX: (402) 472-2022

Figure A-3. Usage Summary for Temporary Barrier Transitions Survey

APPENDIX B

Details of Temporary Barrier Transitions Obtained from the States

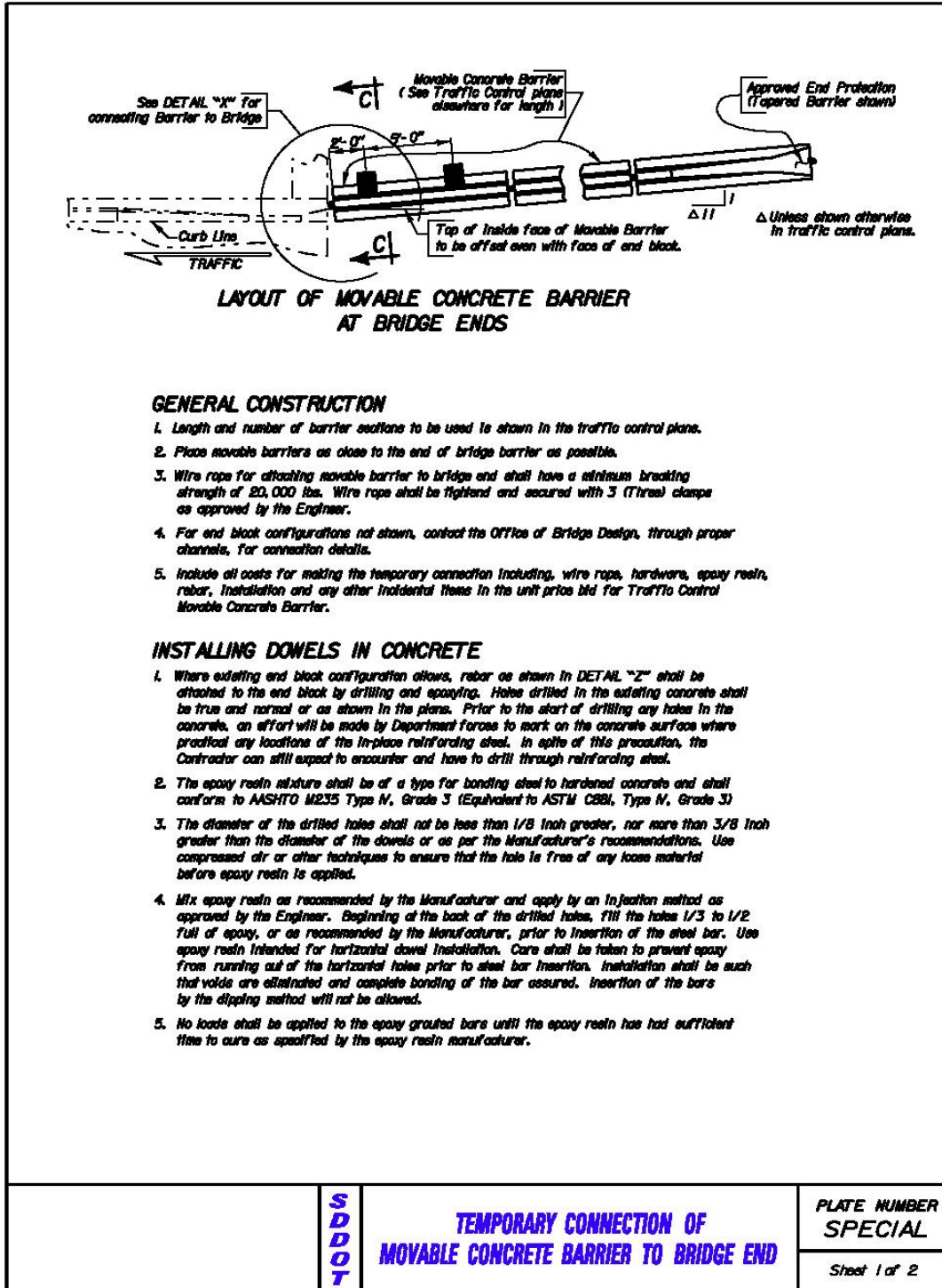

Figure B-1. South Dakota Details of Temporary Barrier to Bridge End Transition - Page 1 of 2

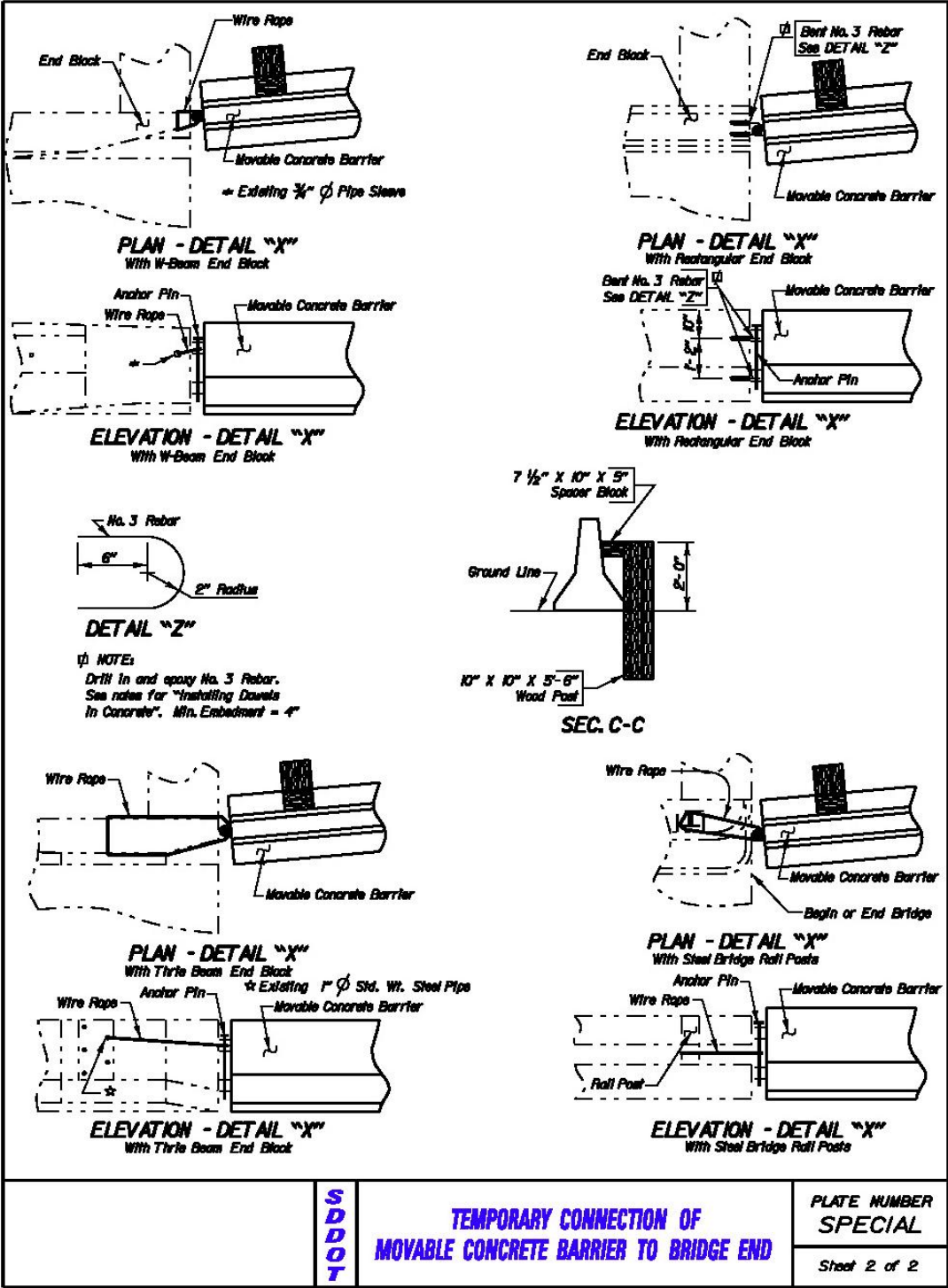

Figure B-2. South Dakota Details of Temporary Barrier to Bridge End Transition - Page 2 of 2

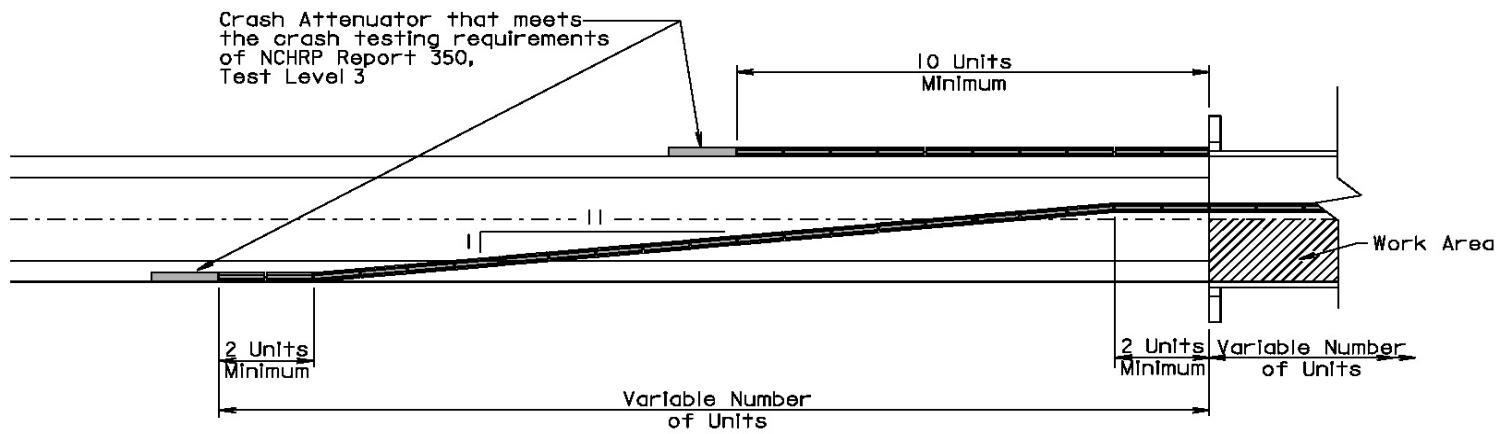

Figure B-3. South Dakota Details of Temporary Barrier Transition

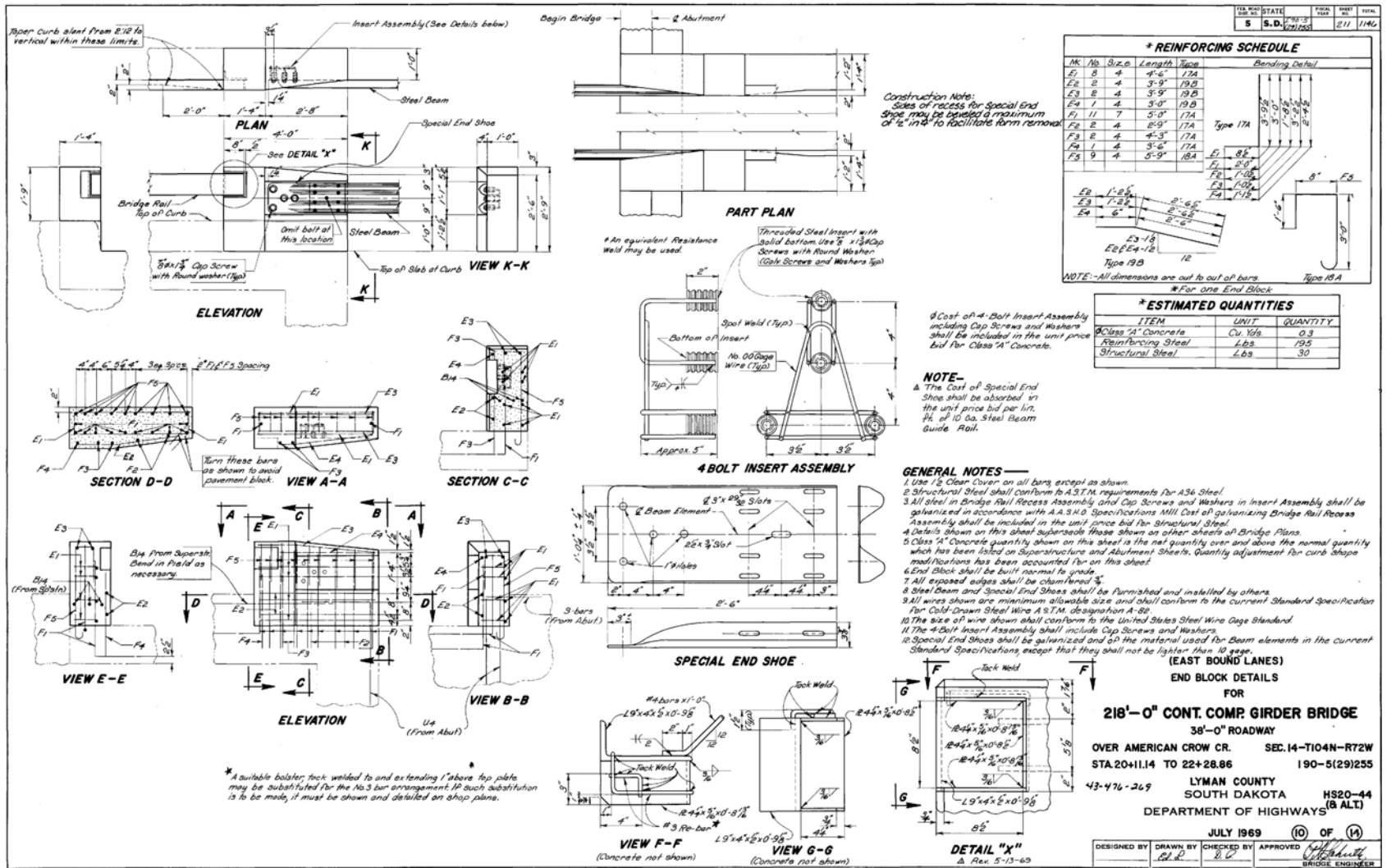
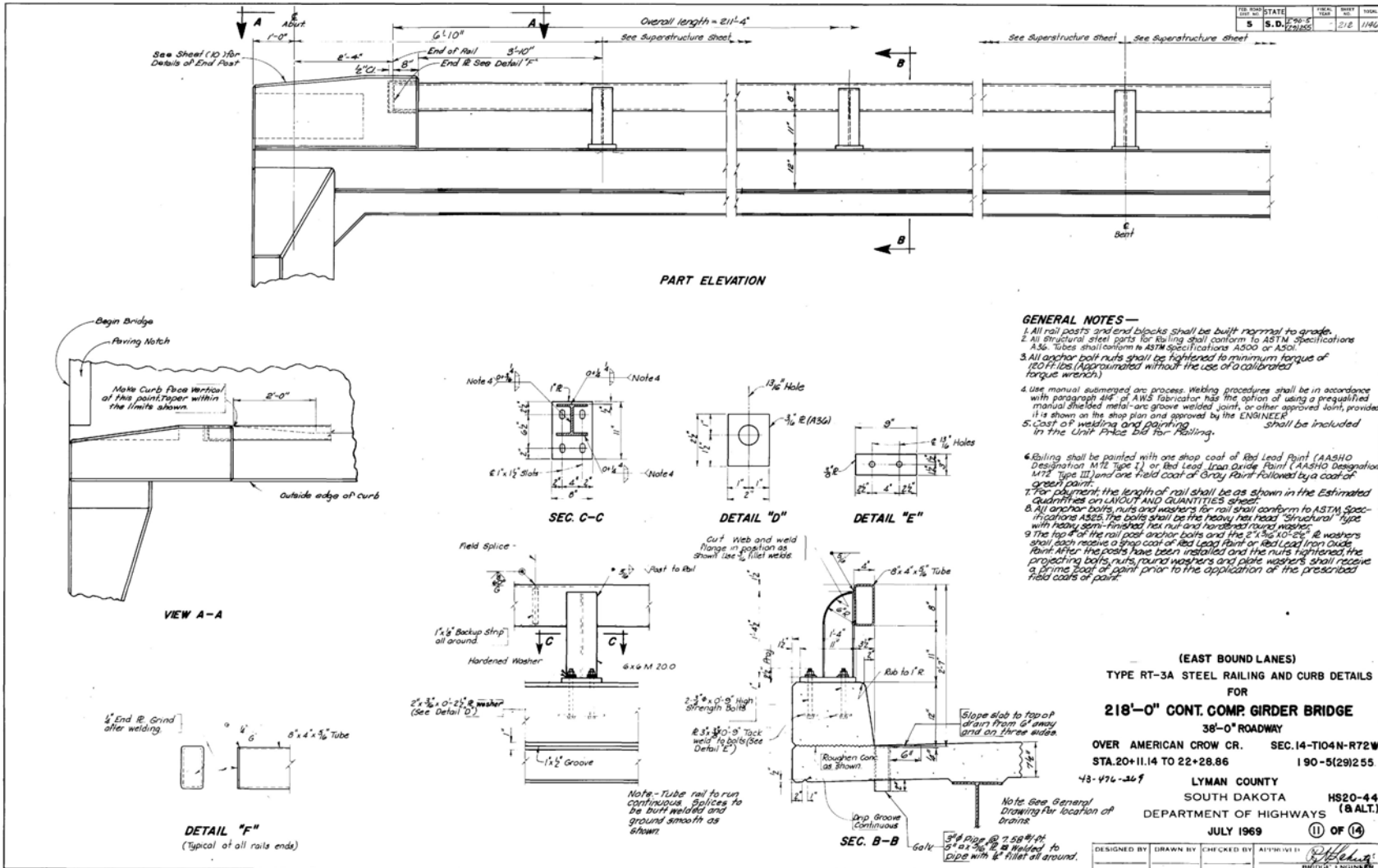

Figure B-4. South Dakota Details of Temporary Barrier End Block



123

Figure B-5. South Dakota Details of Temporary Barrier End Block

MWRSF Report No. TRP-03-208-10 July 15, 2010

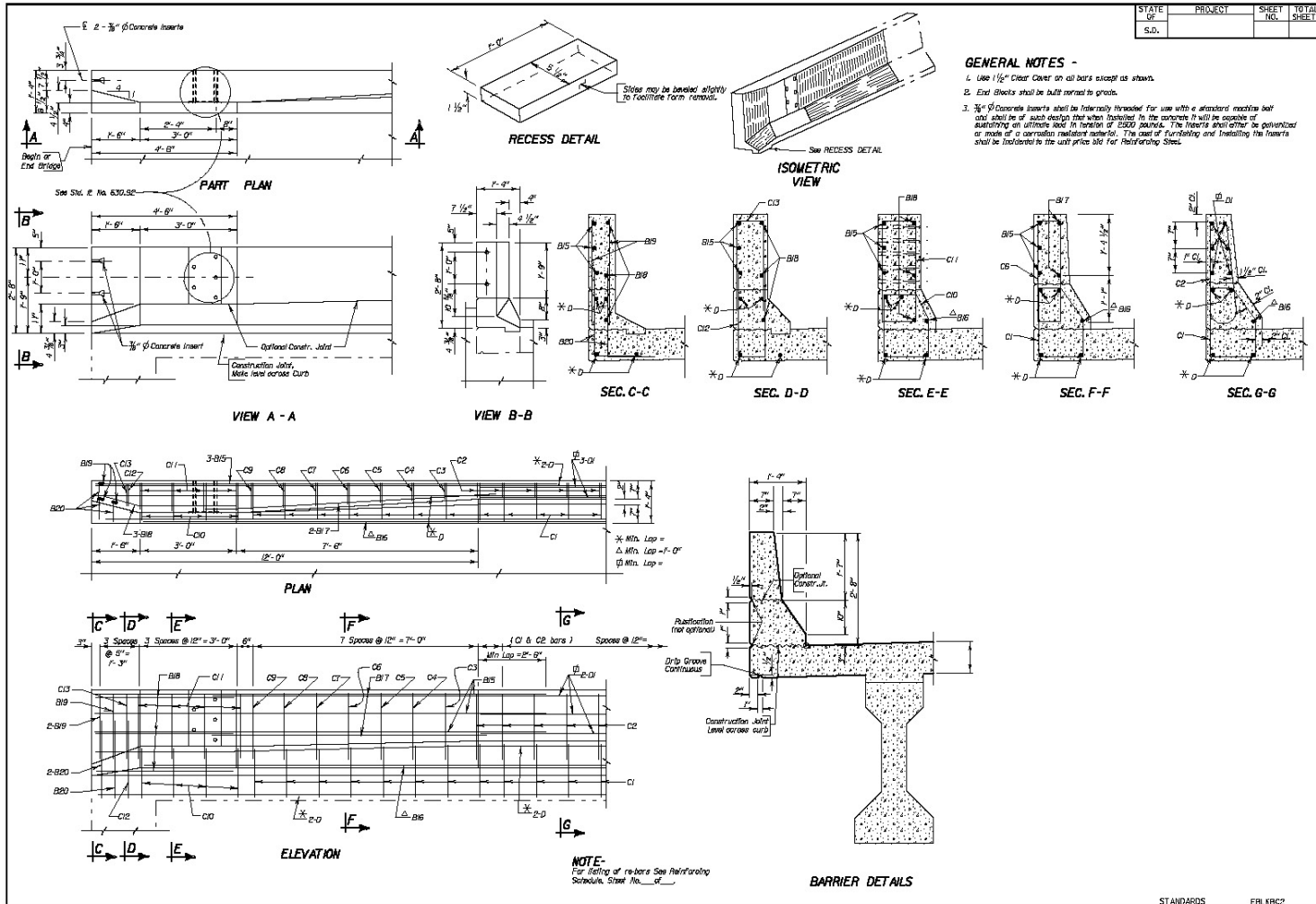

Figure B-6. South Dakota Details of Temporary Barrier End Block



Figure B-8. Nebraska Temporary Barrier Transitions

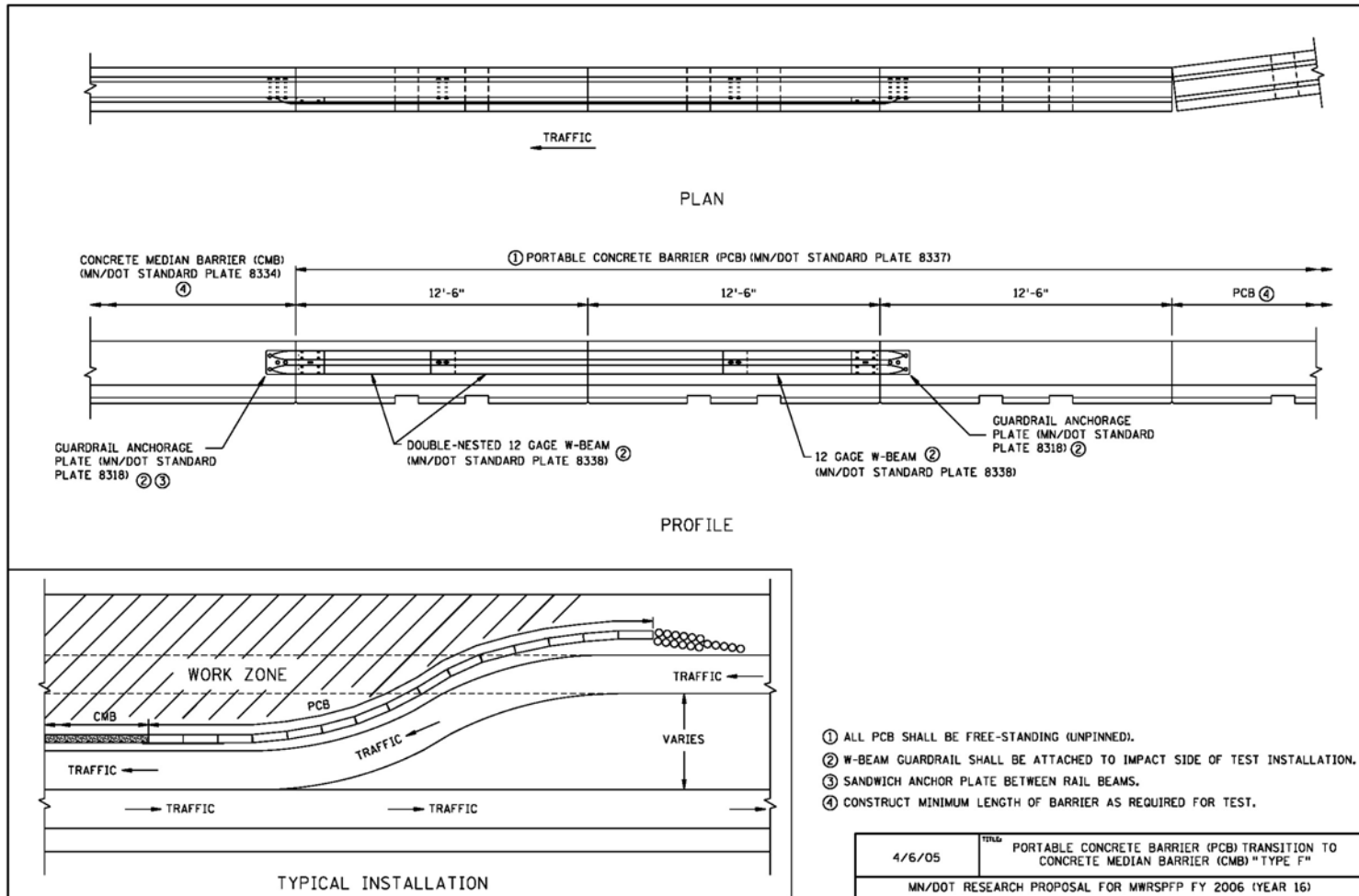

Figure B-9. Minnesota Details of Temporary Barrier Transitions

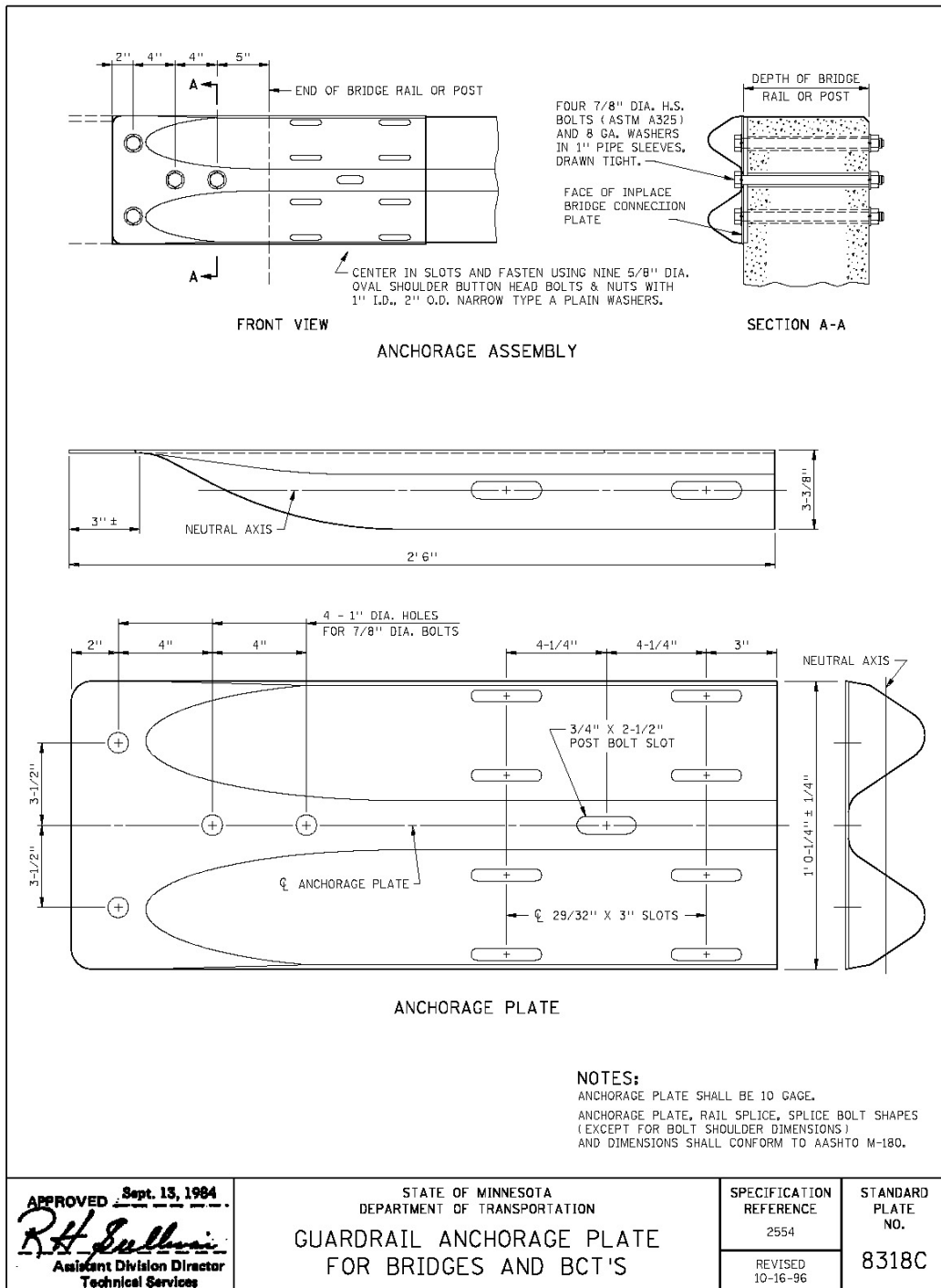

Figure B-10. Minnesota Details of Temporary Barrier Transitions

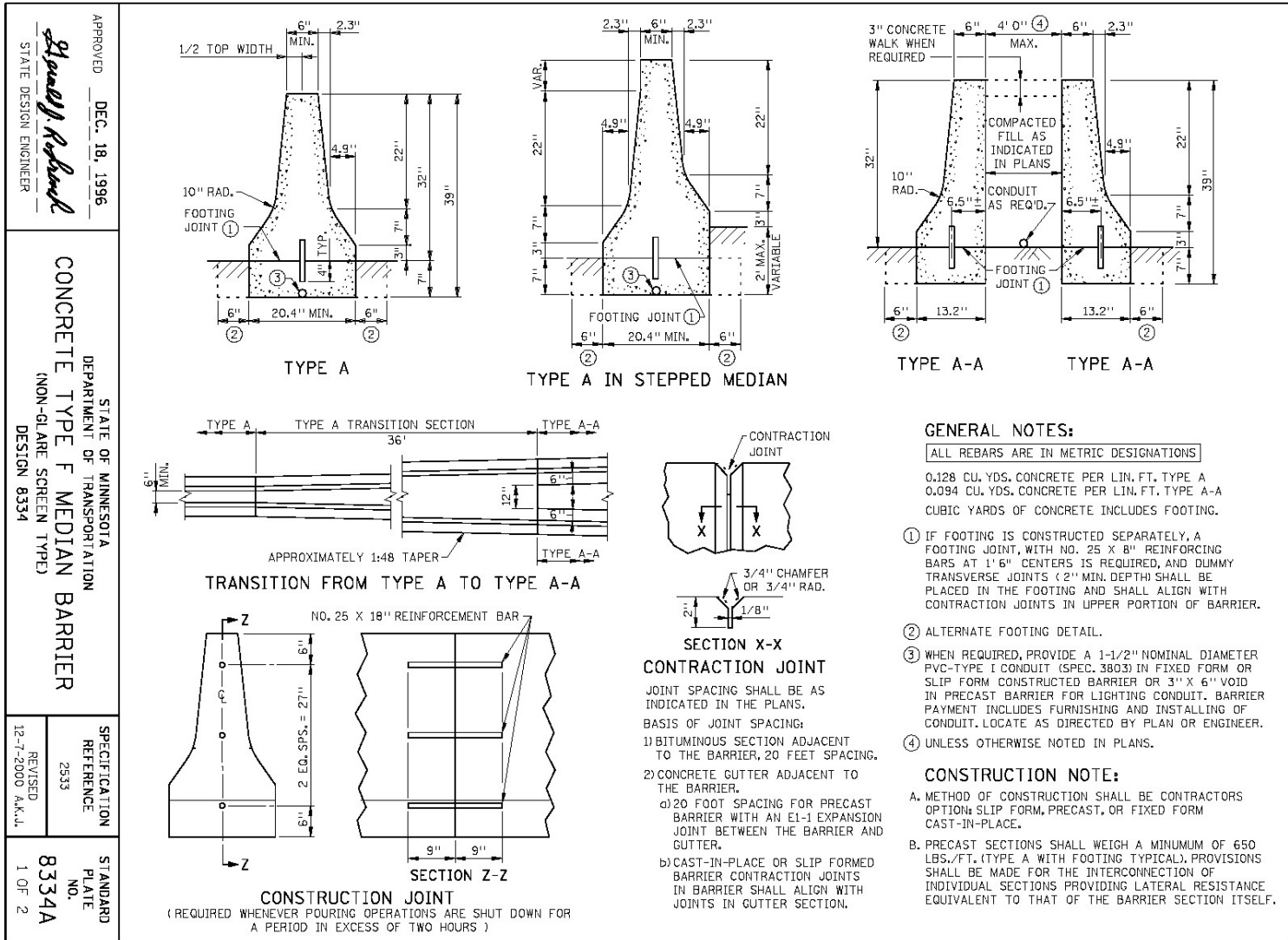

Figure B-11. Minnesota Details of Temporary Barrier Transitions

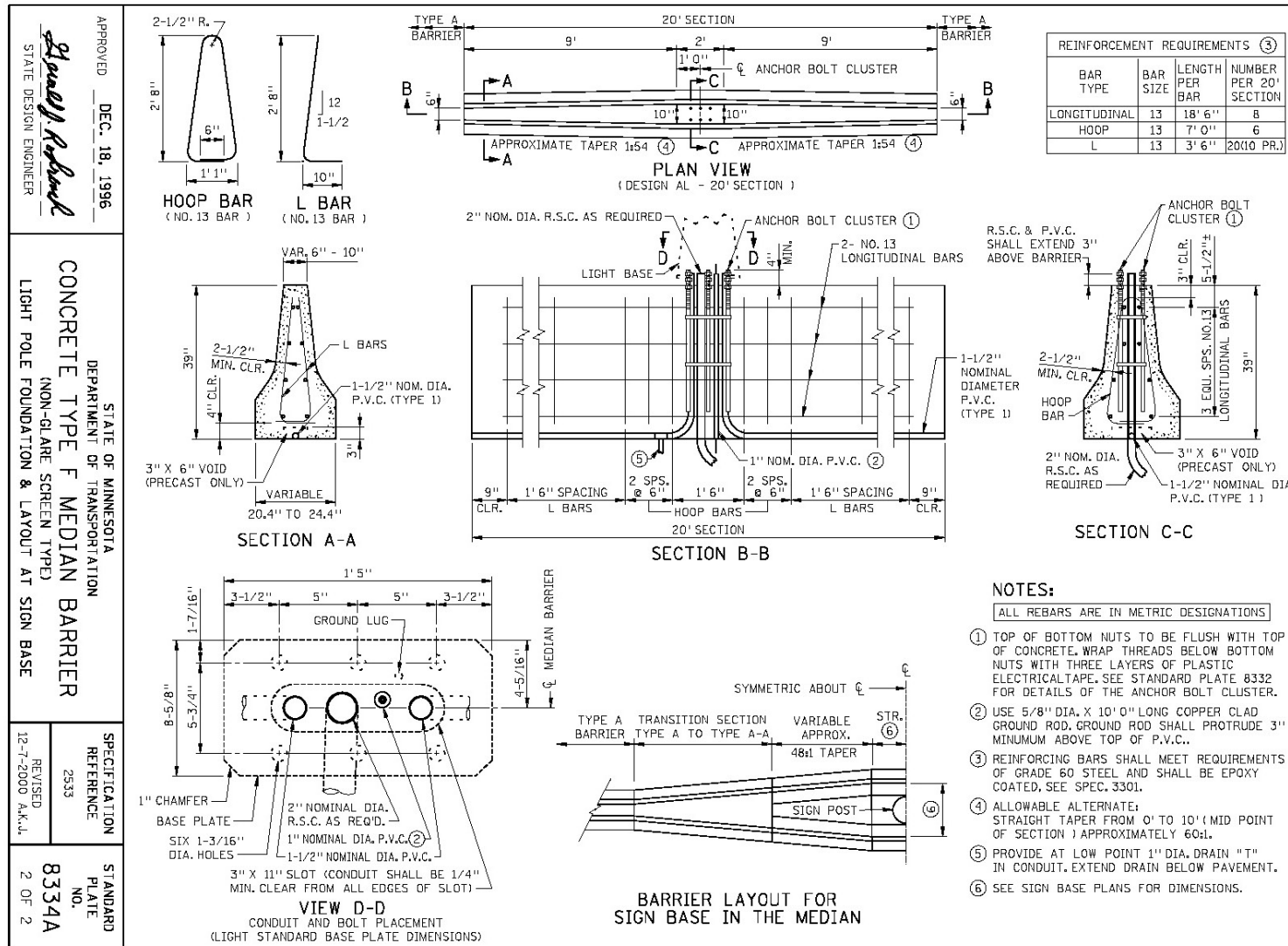

Figure B-12. Minnesota Details of Temporary Barrier Transitions

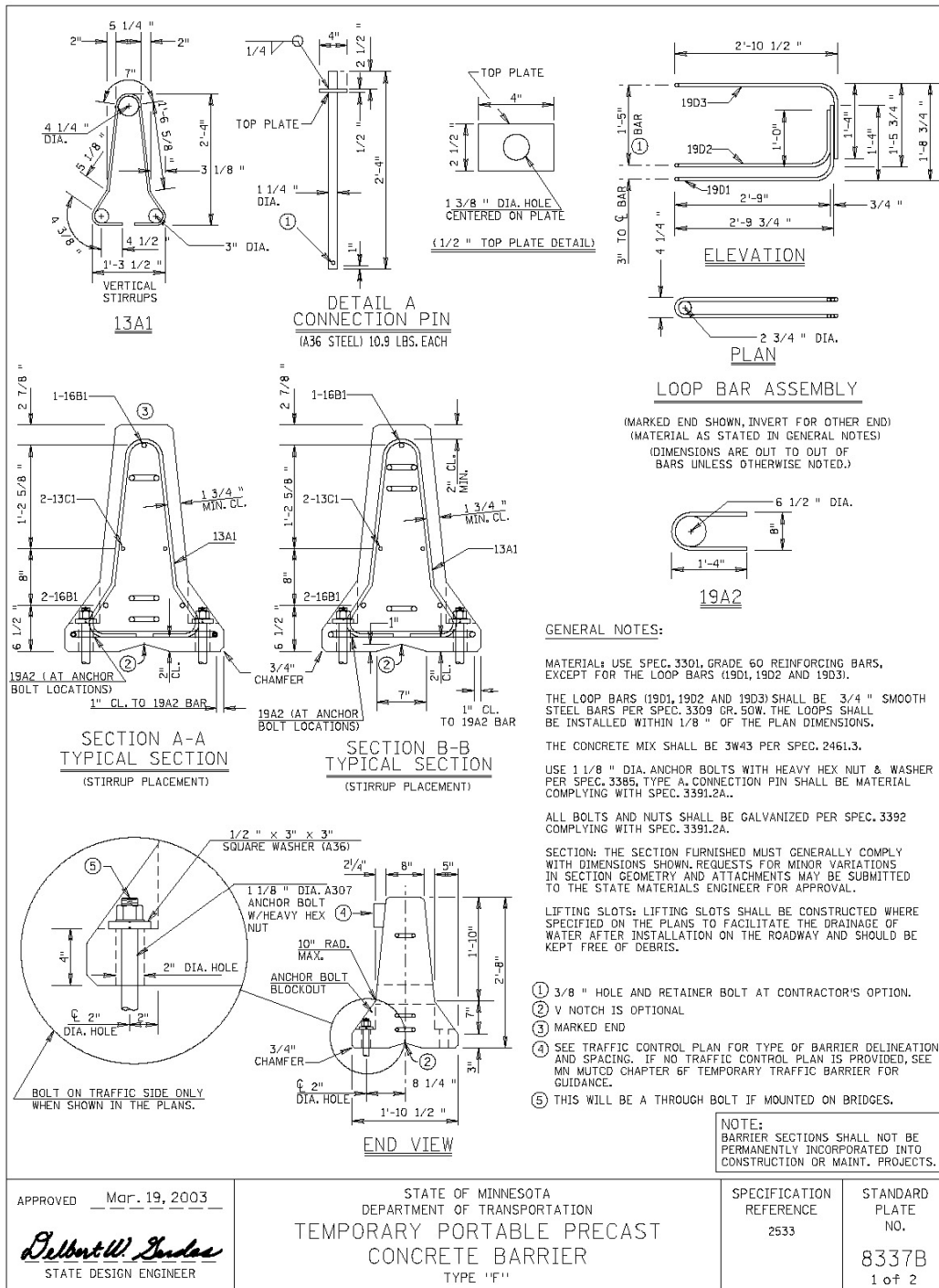

Figure B-13. Minnesota Details of Temporary Barrier Transitions

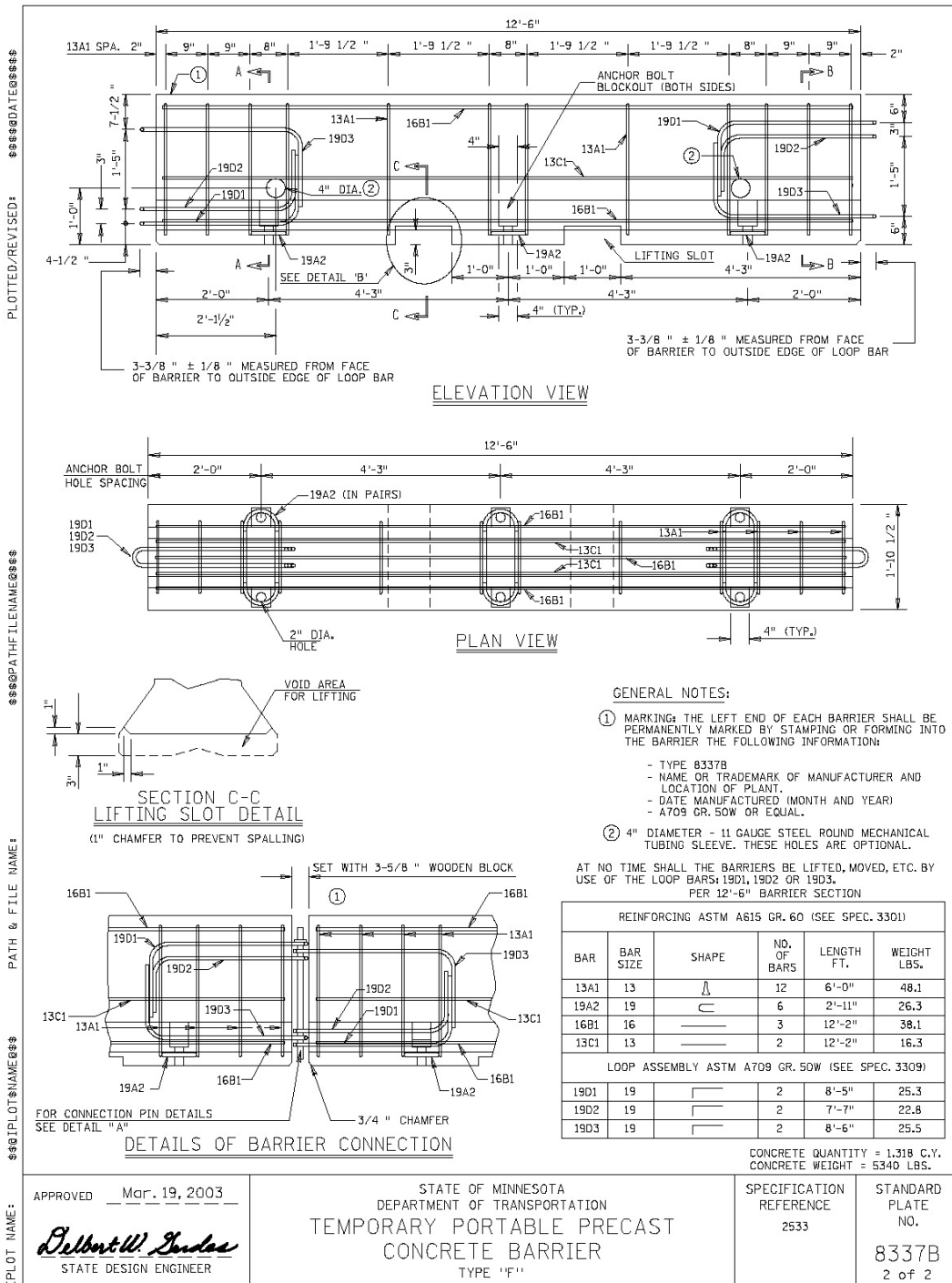

Figure B-14. Minnesota Details of Temporary Barrier Transitions

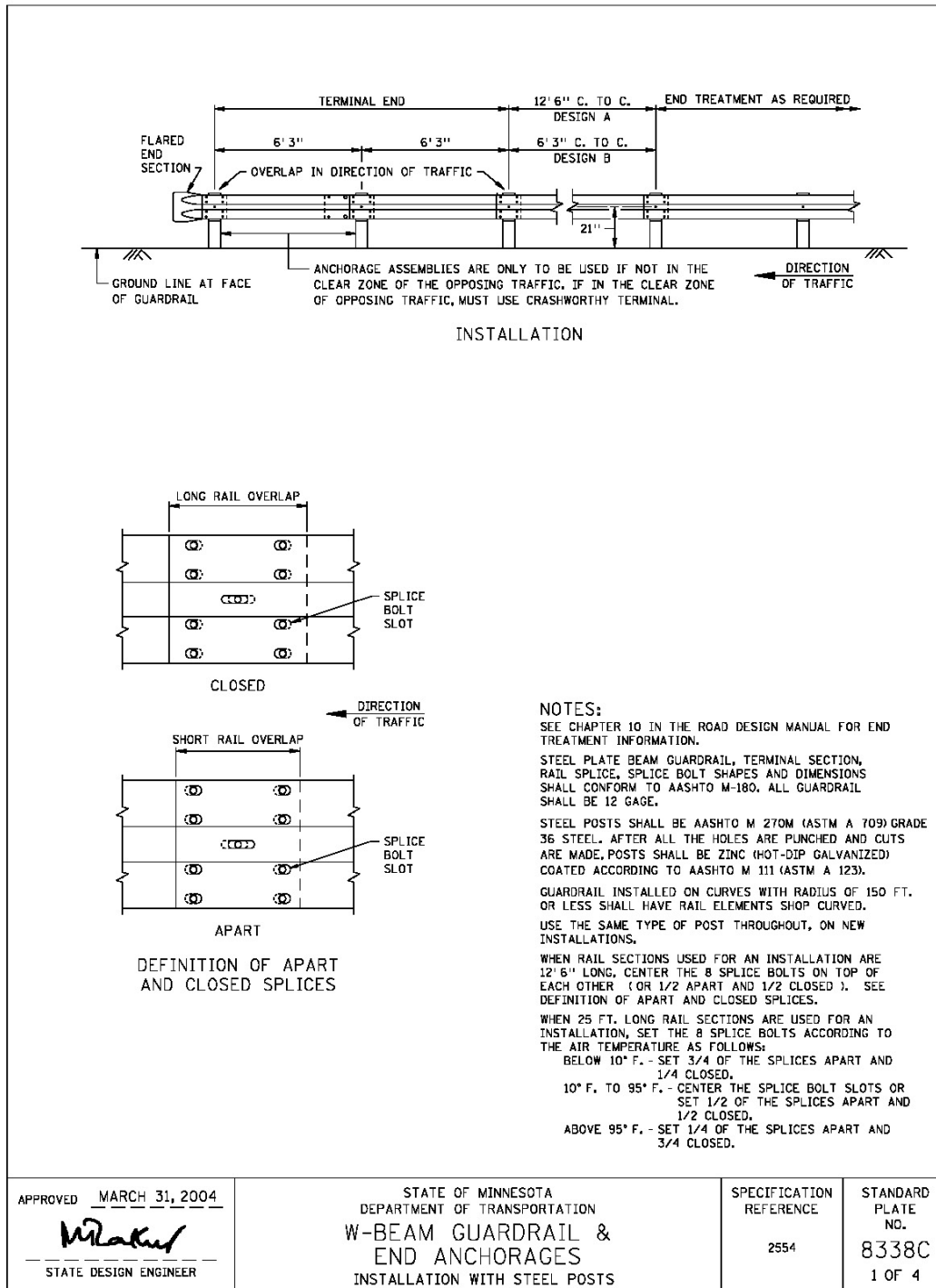

Figure B-15. Minnesota Details of Temporary Barrier Transitions

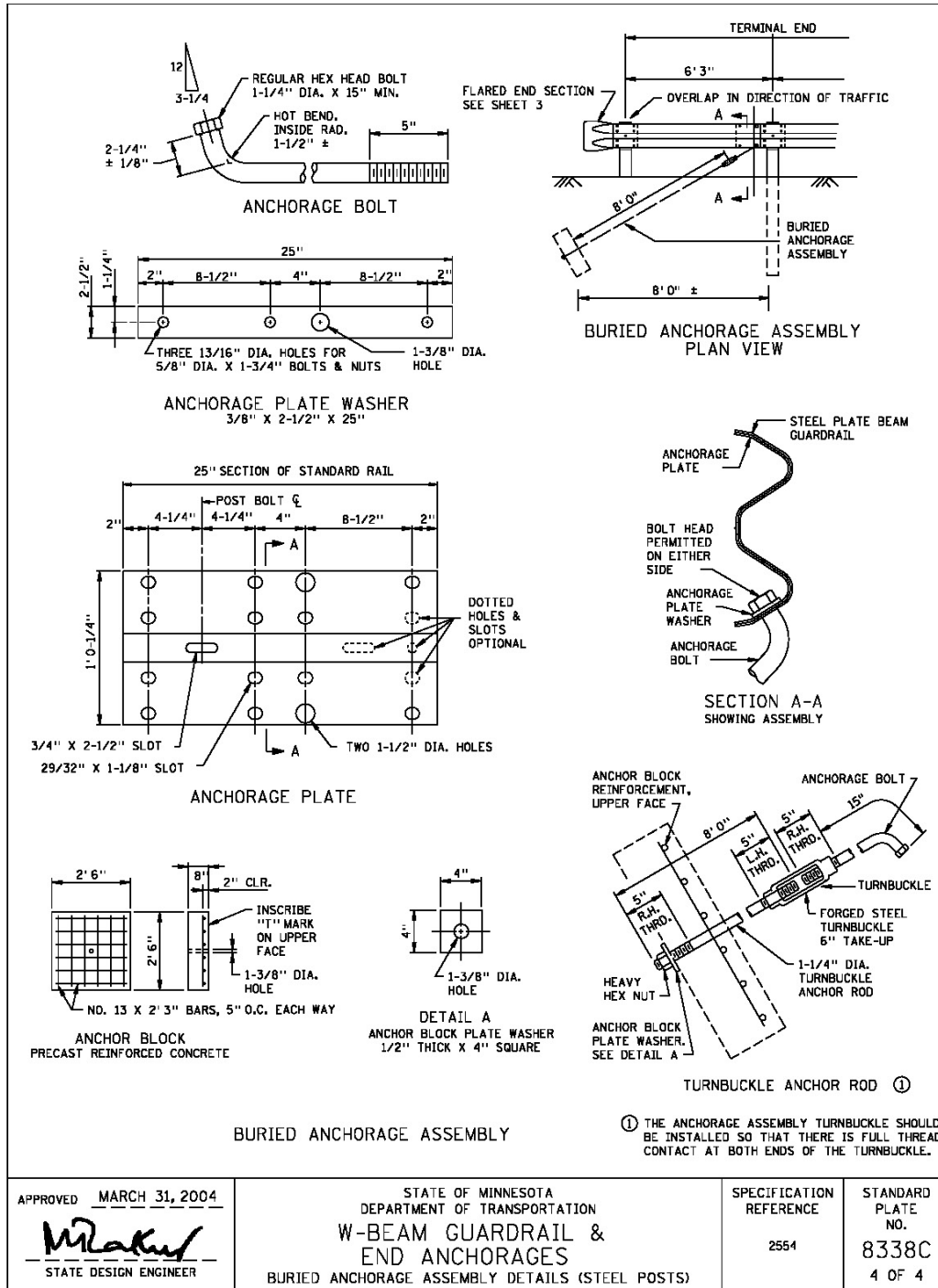

Figure B-16. Minnesota Details of Temporary Barrier Transitions

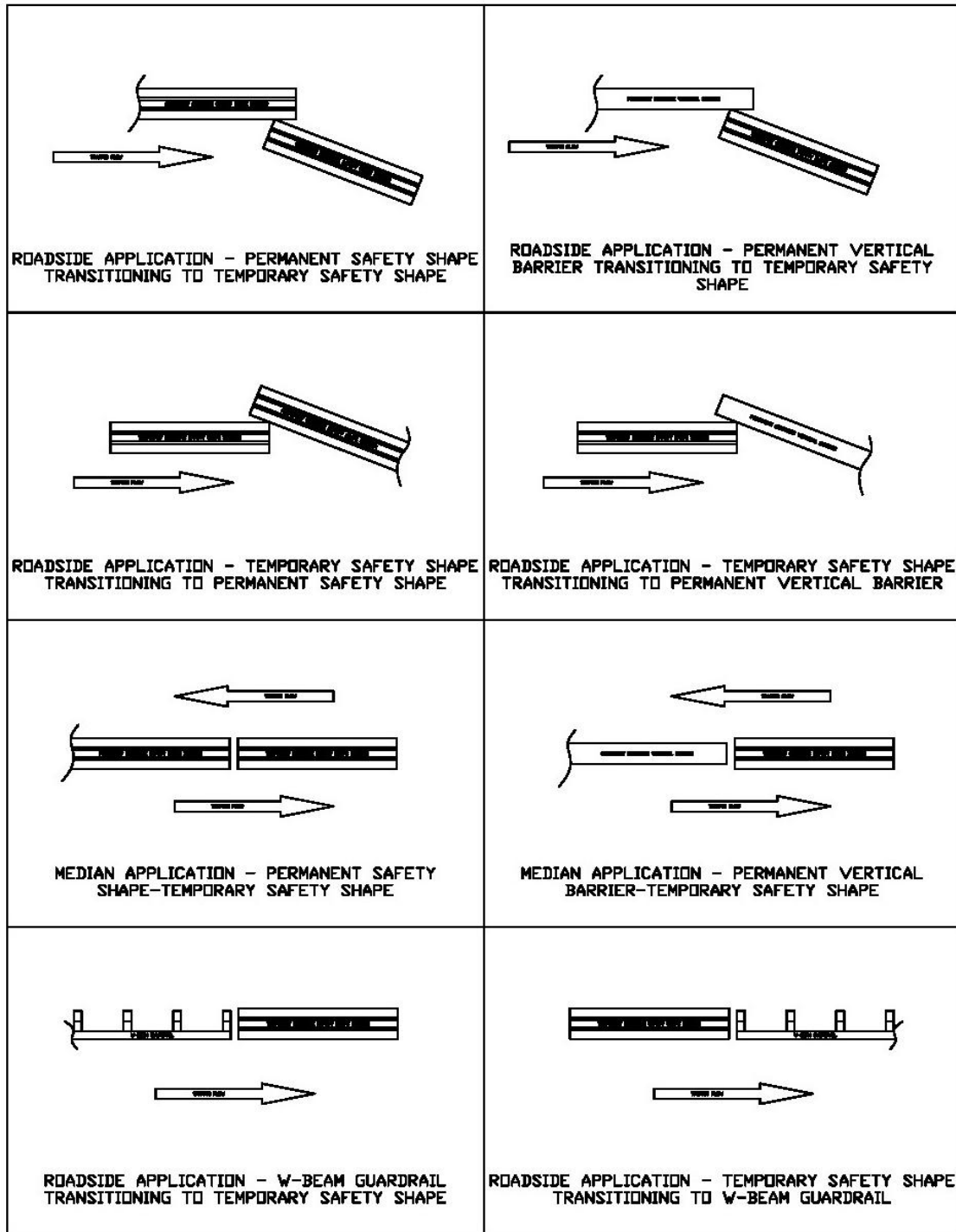

Figure B-17. Minnesota Details of Temporary Barrier Transitions

APPENDIX C

32 in. Temporary F-Shape Barrier to Permanent Barrier Transitions

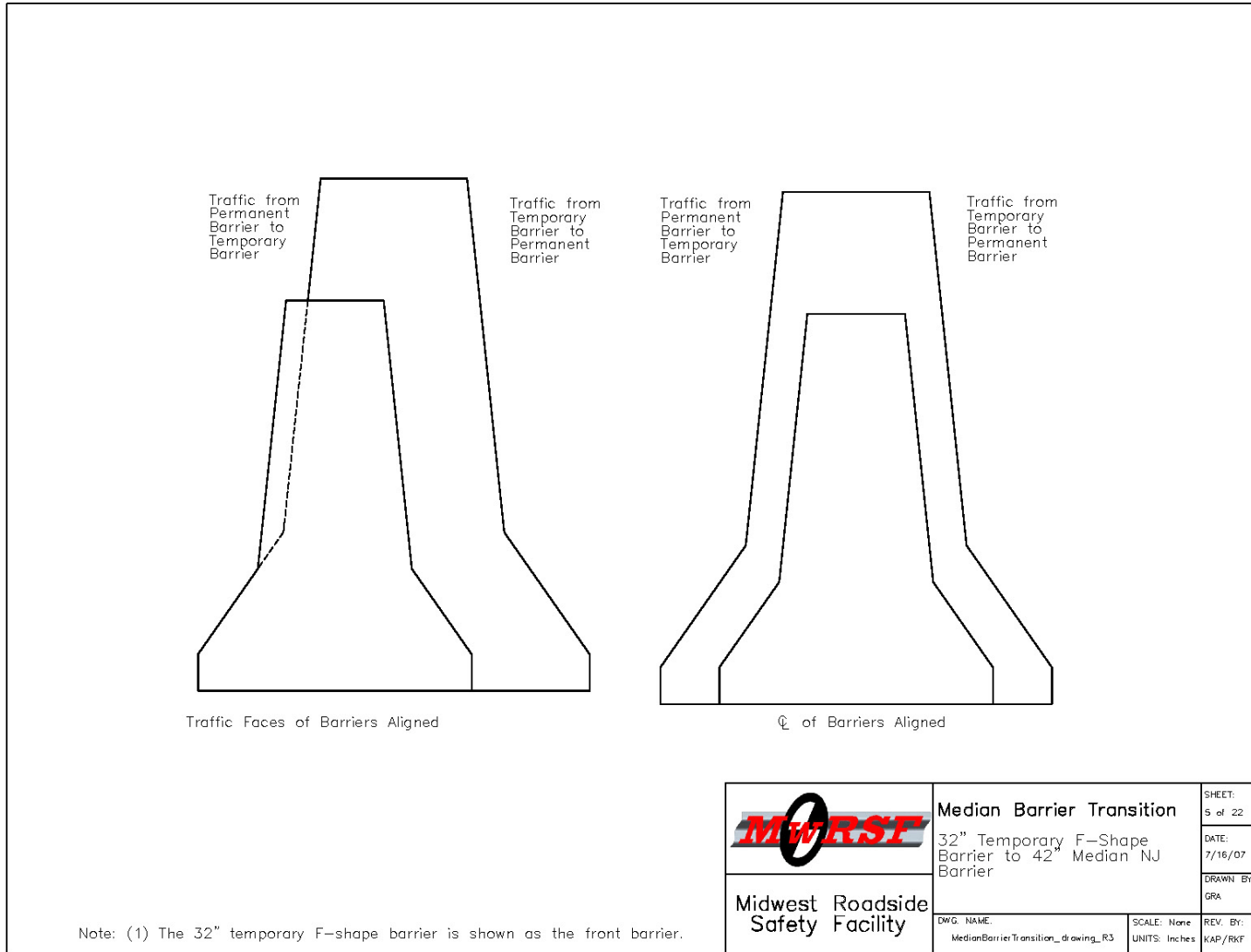

Figure C-1. 32 in. Temporary F-Shape Barrier to 42 in. Median NJ Barrier

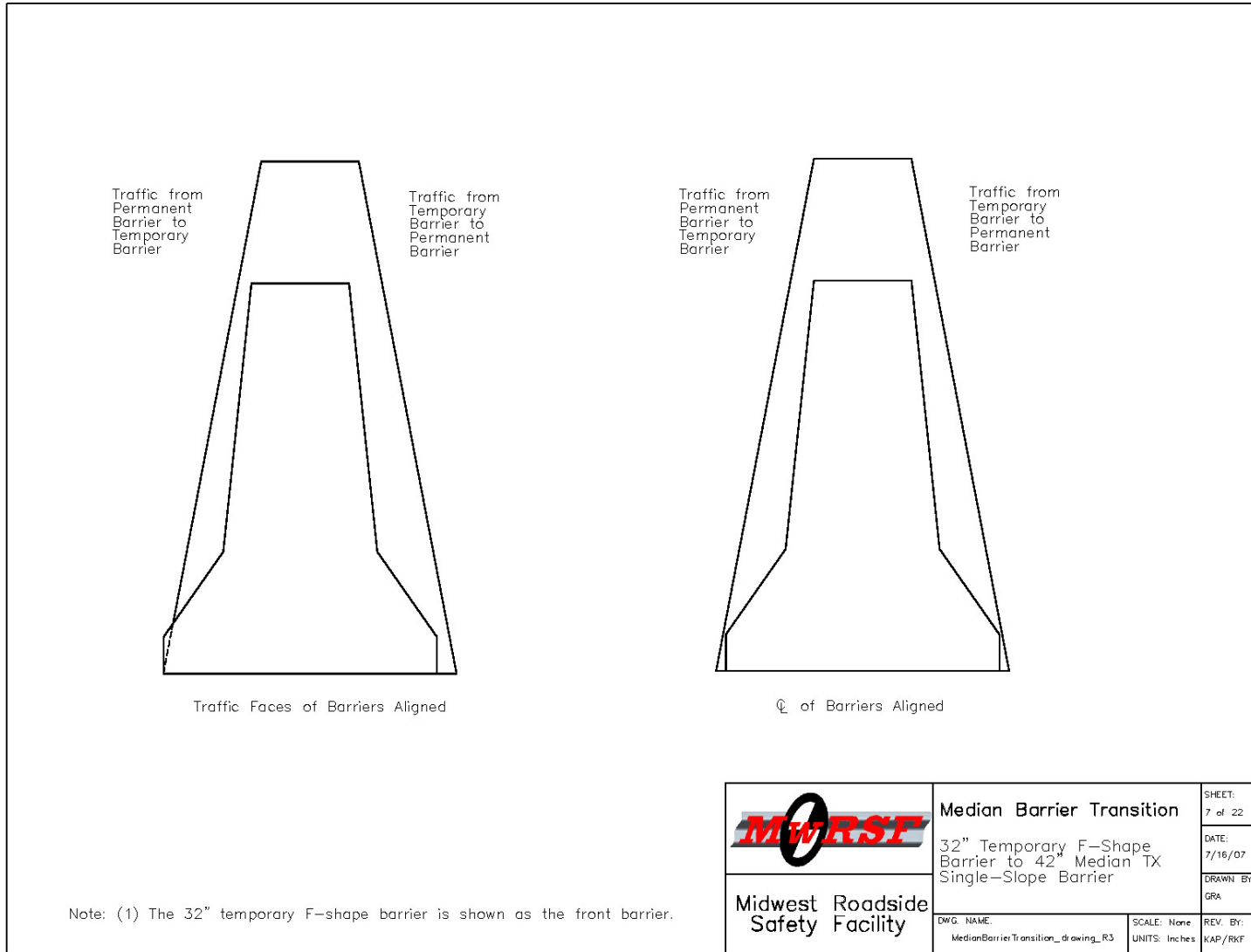

Figure C-2. 32 in. Temporary F-Shape Barrier to 42 in. Median TX Single-Slope Barrier

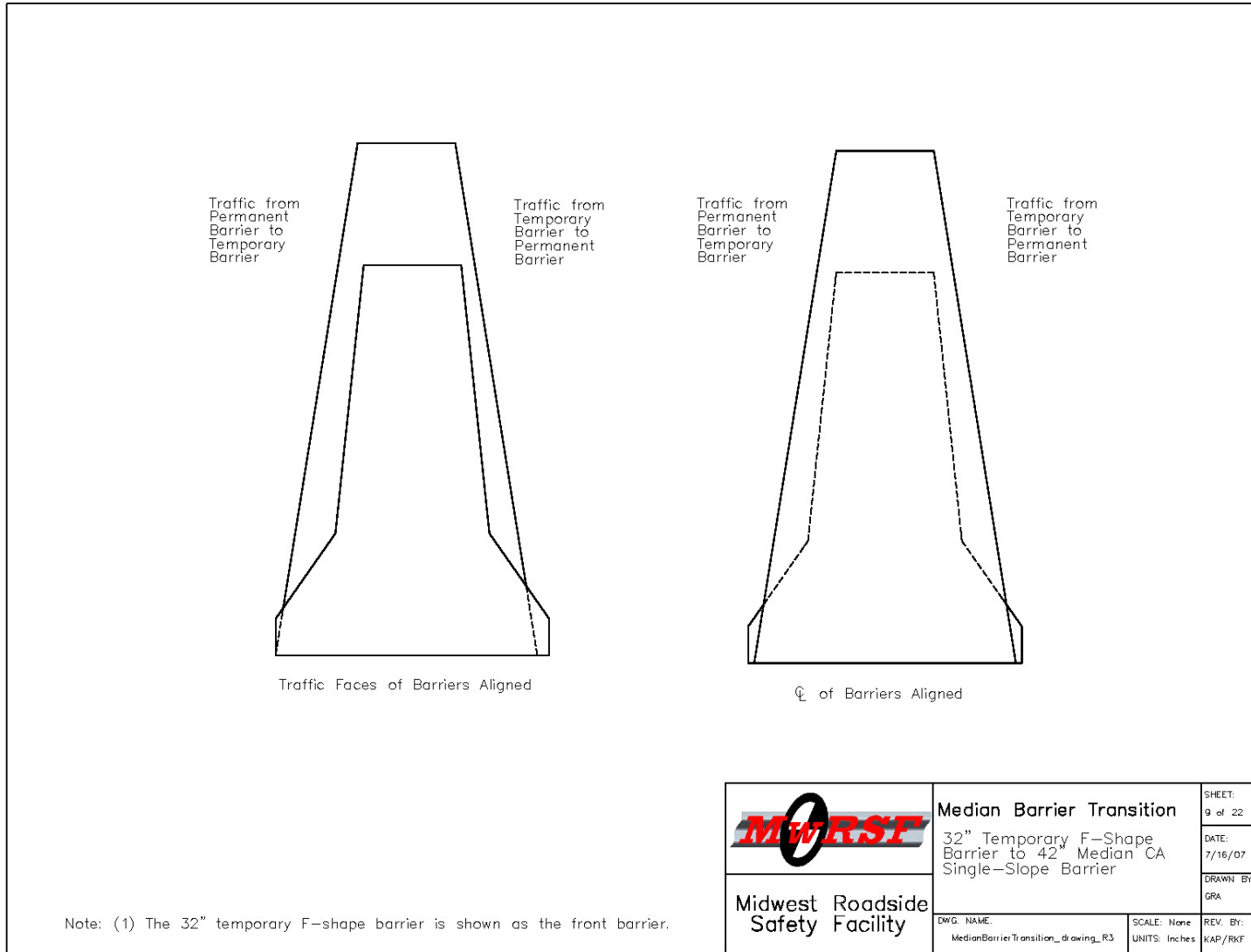

Figure C-3. 32 in. Temporary F-Shape Barrier to 42 in. Median CA Single-Slope Barrier

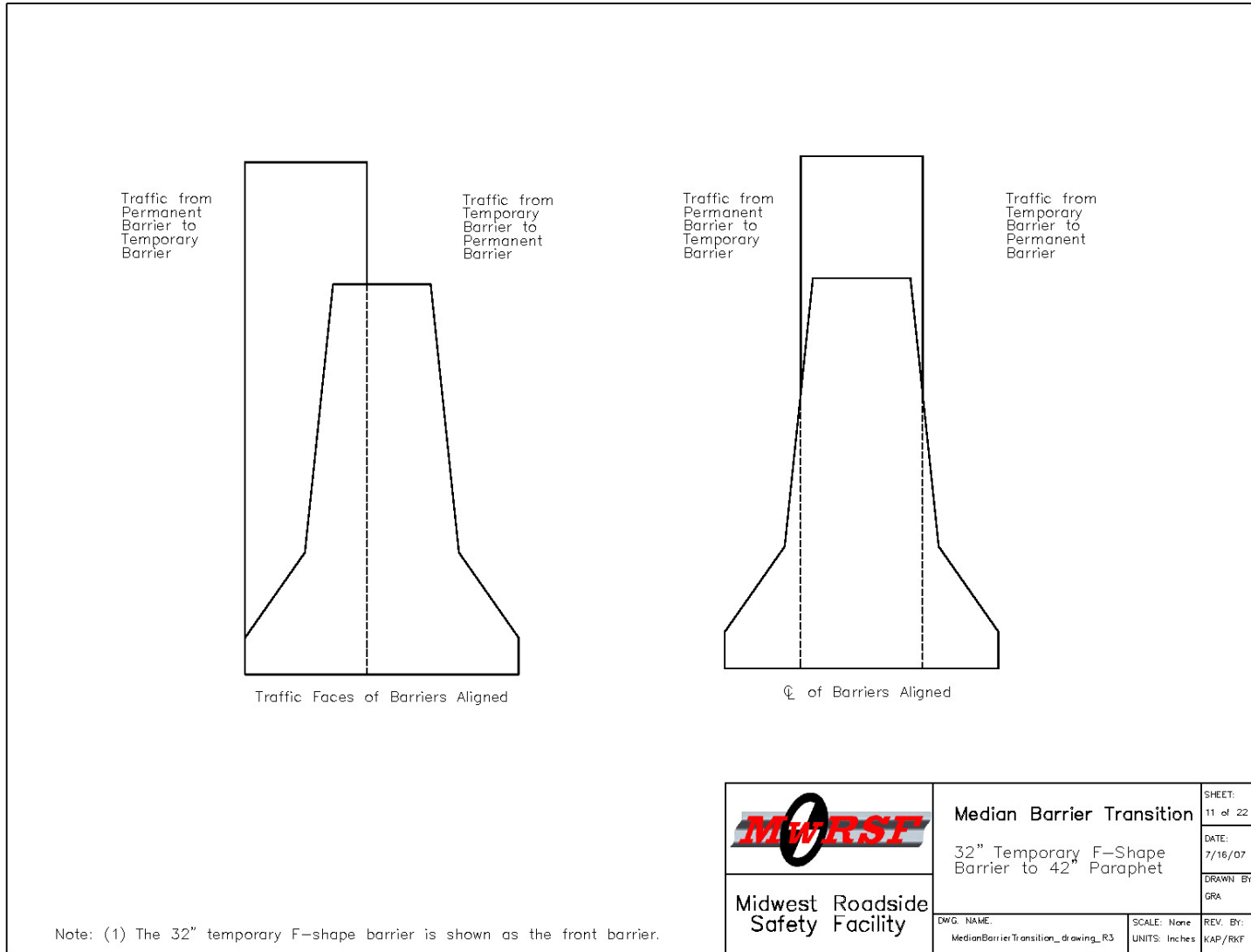

Figure C-4. 32 in. Temporary F-Shape Barrier to 42 in. Vertical Median Barrier

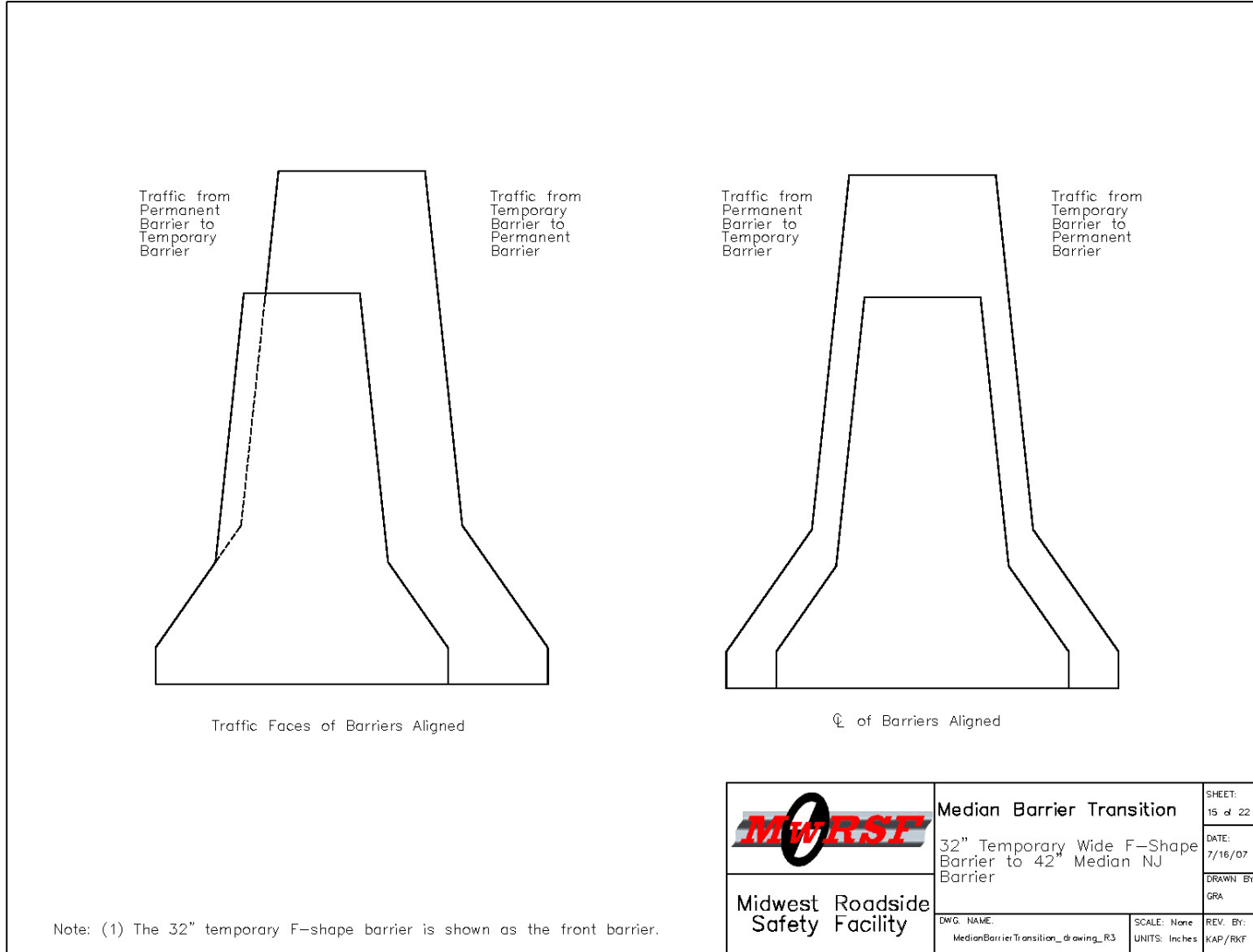

Figure C-5. 32 in. Temporary Wide F-Shape Barrier to 42 in. Median NJ Barrier

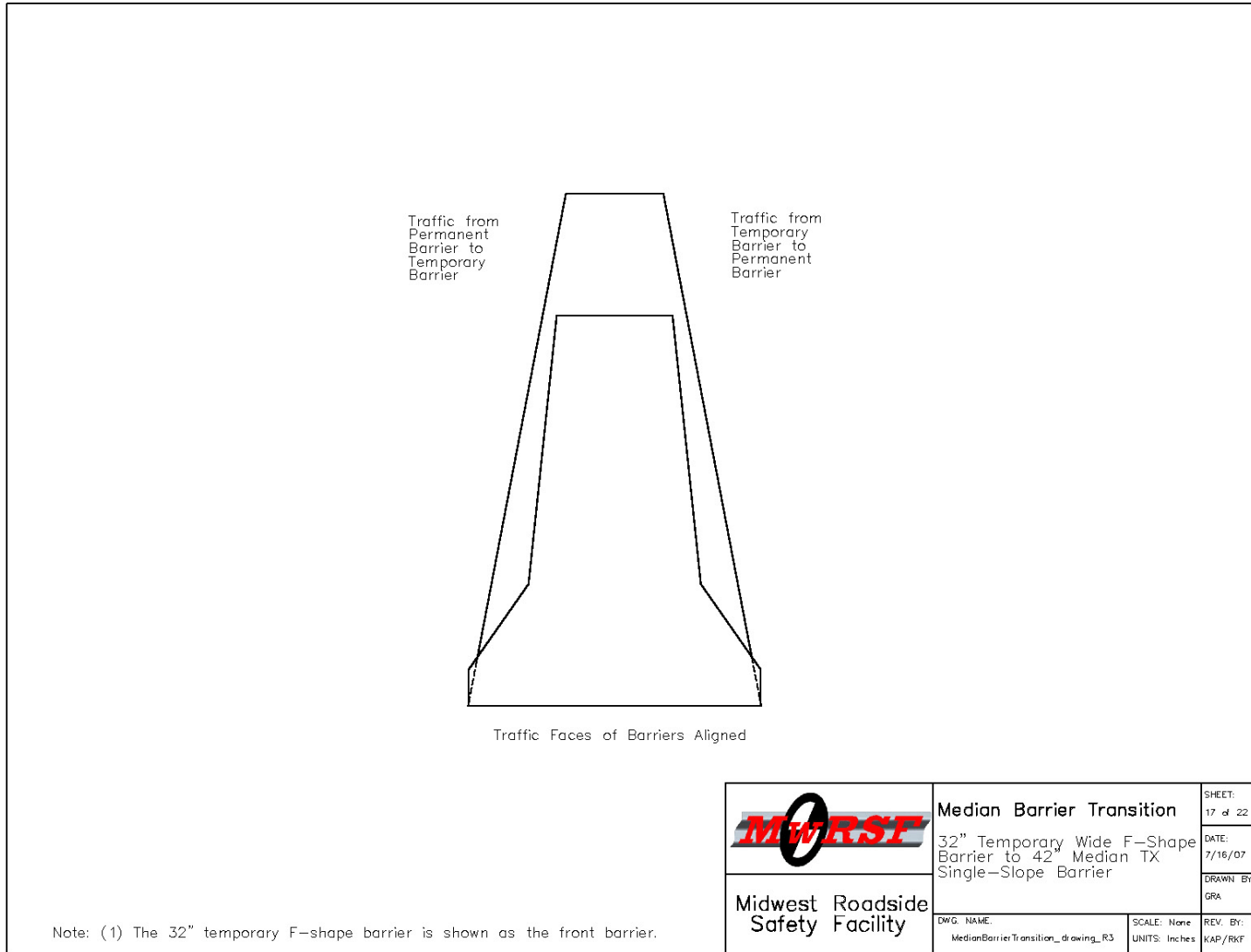

Figure C-6. 32 in. Temporary Wide F-Shape Barrier to 42 in. Median TX Single-Slope Barrier

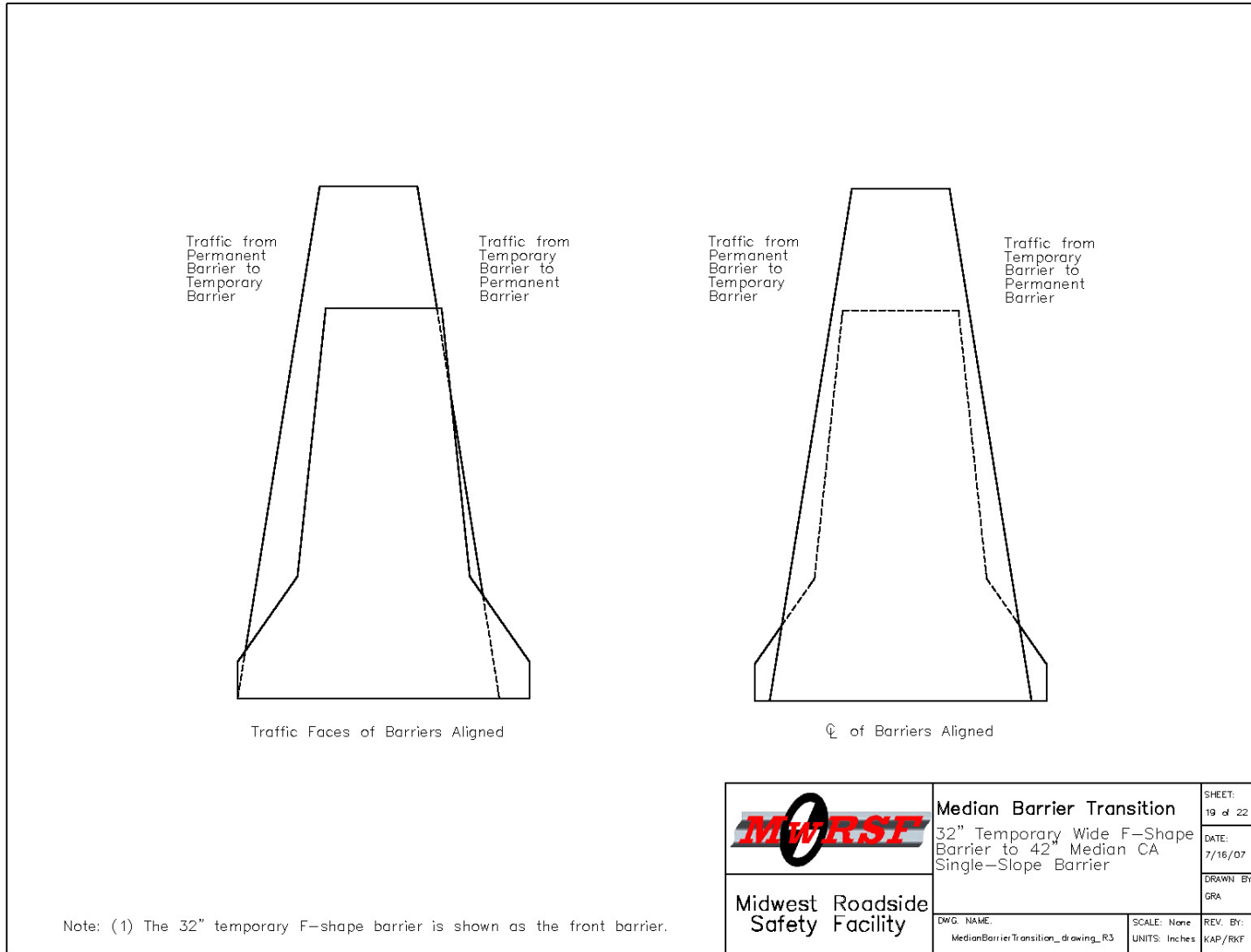

Figure C-7. 32 in. Temporary Wide F-Shape Barrier to 42 in. Median CA Single-Slope Barrier

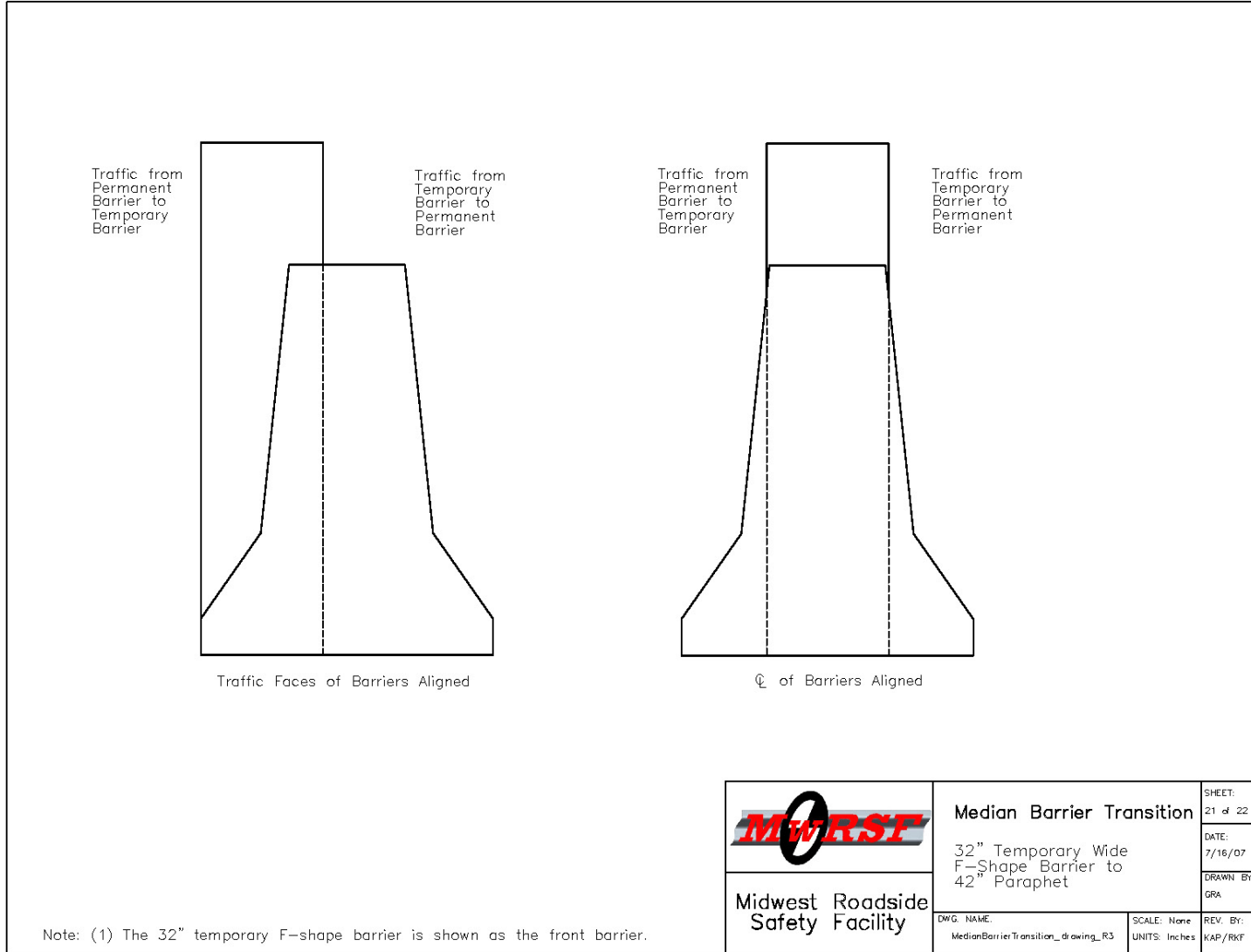

Figure C-8. 32 in. Temporary Wide F-Shape Barrier to 42 in. Vertical Median Barrier

APPENDIX D

Vehicle Center of Gravity Determination

TCBT-1		Vehicle: 2002 Dodge Ram 1500QC				
Vehicle CG Determination						
VEHICLE	Equipment	Weight	Long CG	Vert CG	HOR M	Vert M
+	Unbalasted Truck	4971	62.5	28.3	310687.5	140679.3
+	Brake receivers/wires	5	116	51	580	255
+	Brake Frame	5	34	31	170	155
+	Brake Cylinder	22	74	29	1628	638
+	Strobe Battery	6	74	30	444	180
+	Hub	27	0	15	0	405
+	CG Plate (EDRs)	8	54	32	432	256
-	Battery	-44	-7	45	308	-1980
-	Oil	-10	8	19	-80	-190
-	Interior	-72	44	24	-3168	-1728
-	Fuel	-176	111	20	-19536	-3520
-	Coolant	-16	-18	35	288	-560
-	Washer fluid	0	-15	35	0	0
BALLAST	Water	175	111	20	19425	3500
	Misc. (DTS equip)	20	74	27	1480	540
	Misc. (Spare tire)	70	161	24	11270	1680
TOTAL WEIGHT		4991			323928.5	140310.3
					64.90252	28.11266

wheel base 140.25

NCHRP 350 Targets		CURRENT	Difference
Test Inertial Weight	5000	4991	-9.0
Long CG	62	64.90	2.90252
Vert CG	28	28.11	0.11266

Note, Long. CG is measured from front axle of test vehicle

Curb Weight		
	Left	Right
Front	1442	1384
Rear	1101	1044
FRONT	2826	
REAR	2145	
TOTAL	4971	

Actual test inertial weight		
	Left	Right
Front	1382	1388
Rear	1135	1101
FRONT	2770	
REAR	2236	
TOTAL	5006	

Figure D-1. Vehicle Mass Distribution, Test No. TCBT-1

TCBT-2		Vehicle: 2003 Dodge Ram 1500QC				
		Vehicle CG Determination				
VEHICLE	Equipment	Weight	Long CG	Vert CG	HOR M	Vert M
+	Unbalasted Truck	4905	62.5	28.3	306562.5	138811.5
+	Brake receivers/wires	5	116	51	580	255
+	Brake Frame	5	34	31	170	155
+	Brake Cylinder	22	74	29	1628	638
+	Strobe Battery	6	74	30	444	180
+	Hub	27	0	15	0	405
+	CG Plate (EDRs)	8	54	32	432	256
-	Battery	-44	-7	45	308	-1980
-	Oil	-9	8	19	-72	-171
-	Interior	-60	44	24	-2640	-1440
-	Fuel	0			0	0
-	Coolant	0	-18	35	0	0
-	Washer fluid	0	-15	35	0	0
BALLAST	Water				0	0
	Misc. (DTS equip)	20	74	27	1480	540
	Misc. (ballast plates)	99	112	32	11088	3168
					0	0
					319980.5	140817.5
	TOTAL WEIGHT	4984			64.20154	28.25391

wheel base 140.25

NCHRP 350 Targets		CURRENT	Difference
Test Inertial Weight	5000	4984	-16.0
Long CG	62	64.20	2.20154
Vert CG	28	28.25	0.25391

Note, Long. CG is measured from front axle of test vehicle

Curb Weight		
	Left	Right
Front	1442	1384
Rear	1101	1044
FRONT	2826	
REAR	2145	
TOTAL	4971	

Actual test inertial weight		
	Left	Right
Front	1336	1345
Rear	1177	1132
FRONT	2681	
REAR	2309	
TOTAL	4990	

Figure D-2. Vehicle Mass Distribution, Test No. TCBT-2

APPENDIX E

Vehicle Deformation Records

VEHICLE PRE/POST CRUSH INFO

TEST: TCBT-1
VEHICLE: 2002 Ram 1500 Q.C. 4x2

Note: If impact is on driver side need to enter negative number for Y

POINT	X	Y	Z	X'	Y'	Z'	DEL X	DEL Y	DEL Z
1	27.75	13.5	-1.5	25.75	14	0.25	-2	0.5	1.75
2	31.5	19.75	-3.75	27.5	19.25	0	-4	-0.5	3.75
3	32	25	-2.25	26	25.75	3	-6	0.75	5.25
4	29.5	29.5	-1.5	27	28.25	1.5	-2.5	-1.25	3
5	23.75	11	-2	23	10.5	0	-0.75	-0.5	2
6	25.25	17	-5.75	22.75	17.25	-3.25	-2.5	0.25	2.5
7	25.75	23.5	-8	20.5	21.25	-3.75	-5.25	-2.25	4.25
8	26.5	30.25	-6	23	27.5	-3.75	-3.5	-2.75	2.25
9	19.25	8.25	-3.25	18	8.75	-1.75	-1.25	0.5	1.5
10	21.25	15.5	-6.75	18.25	15.75	-4	-3	0.25	2.75
11	23	22.5	-9	18.75	20.75	-6.75	-4.25	-1.75	2.25
12	23	29.75	-8.5	20.25	27.5	-6.5	-2.75	-2.25	2
13	14	0.5	-3.5	13.75	0.5	-3.5	-0.25	0	0
14	14.5	7.25	-3.5	14.5	7	-3.25	0	-0.25	0.25
15	16.75	15.25	-10.25	15.5	14.75	-9	-1.25	-0.5	1.25
16	17	23	-10	15.25	22.5	-10	-1.75	-0.5	0
17	17	29.75	-10	16.5	28.5	-10.75	-0.5	-1.25	-0.75
18	9	0.75	-4	9	0.75	-4	0	0	0
19	10	7.25	-3.75	10	7.5	-3.75	0	0.25	0
20	12.75	15.25	-10.25	12.5	14.5	-10.5	-0.25	-0.75	-0.25
21	13.5	24	-10	13.5	23.25	-11.5	0	-0.75	-1.5
22	12.75	30.75	-9.75	12.5	29.75	-10.75	-0.25	-1	-1
23	1.5	0.5	-3.25	1.5	0.5	-3	0	0	0.25
24	1.5	4.75	-3.25	1.5	4.5	-3	0	-0.25	0.25
25	1.5	9.25	-3.75	1.5	9	-3.5	0	-0.25	0.25
26	1	14.75	-5.5	1	14	-5.75	0	-0.75	-0.25
27	1	21.75	-5.25	1	20.75	-5.75	0	-1	-0.5
28	1	28	-5	1	27	-5.75	0	-1	-0.75
29									
30									

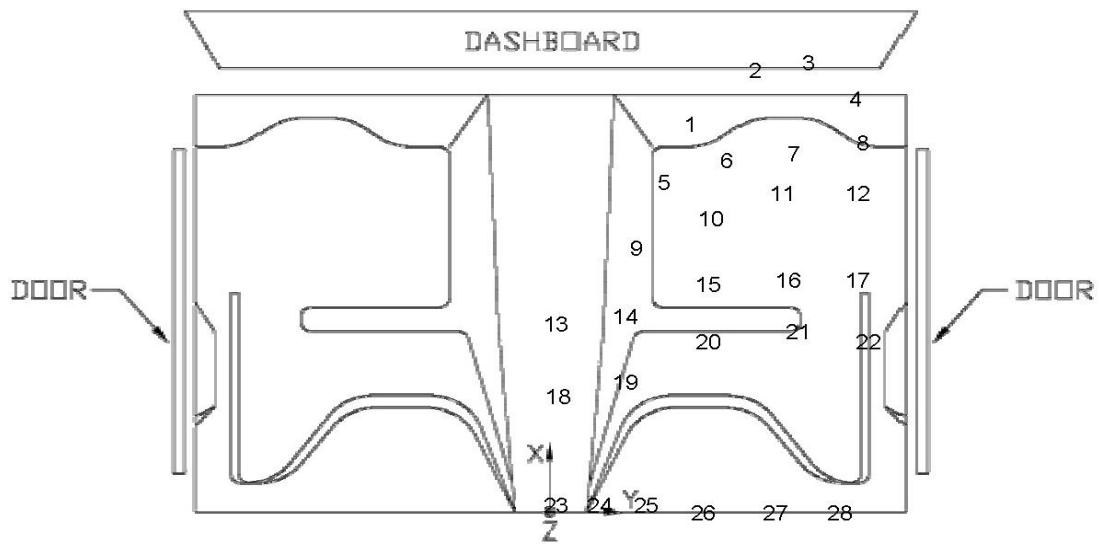

Figure E-1. Occupant Compartment Deformation Data, Test TCBT-1

Occupant Compartment Deformation Index (OCDI)

Test No. TCBT-1
Vehicle Type: 2002 Dodge Ram 1500

OCDI = XXABCDEFGHI

XX = location of occupant compartment deformation

A = distance between the dashboard and a reference point at the rear of the occupant compartment, such as the top of the rear seat or the rear of the cab on a pickup

B = distance between the roof and the floor panel

C = distance between a reference point at the rear of the occupant compartment and the motor panel

D = distance between the lower dashboard and the floor panel

E = interior width

F = distance between the lower edge of right window and the upper edge of left window

G = distance between the lower edge of left window and the upper edge of right window

H = distance between bottom front corner and top rear corner of the passenger side window

I = distance between bottom front corner and top rear corner of the driver side window

Severity Indices

- 0 - if the reduction is less than 3%
- 1 - if the reduction is greater than 3% and less than or equal to 10 %
- 2 - if the reduction is greater than 10% and less than or equal to 20 %
- 3 - if the reduction is greater than 20% and less than or equal to 30 %
- 4 - if the reduction is greater than 30% and less than or equal to 40 %

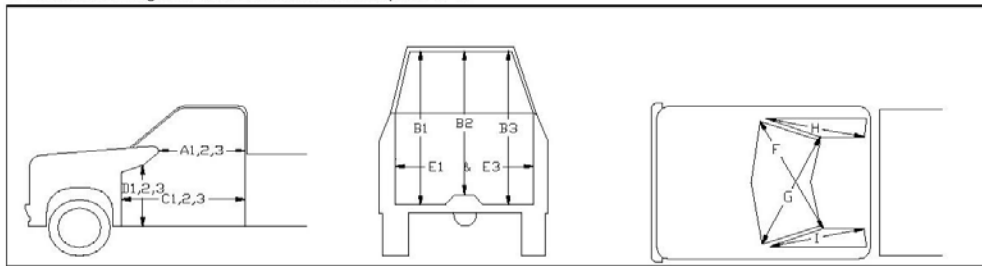

where,
1 = Passenger Side
2 = Middle
3 = Driver Side

Location:

Measurement	Pre-Test (in.)	Post-Test (in.)	Change (in.)	% Difference	Severity Index
A1	56.00	56.00	0.00	0.00	0
A2	52.50	52.75	0.25	0.48	0
A3	57.00	57.75	0.75	1.32	0
B1	48.00	47.75	-0.25	-0.52	0
B2	42.25	42.75	0.50	1.18	0
B3	47.50	48.75	1.25	2.63	0
C1	68.00	68.00	0.00	0.00	0
C2	51.00	50.75	-0.25	-0.49	0
C3	69.50	65.00	-4.50	-6.47	1
D1	23.00	23.00	0.00	0.00	0
D2	13.50	13.75	0.25	1.85	0
D3	22.75	24.75	2.00	8.79	1
E1	65.25	62.50	-2.75	-4.21	1
E3	65.00	64.50	-0.50	-0.77	0
F	57.75	57.50	-0.25	-0.43	0
G	54.50	54.25	-0.25	-0.46	0
H	39.00	39.00	0.00	0.00	0
I	39.50	39.50	0.00	0.00	0

Note: Maximum severity index for each variable (A-I) is used for determination of final OC DI value

XX A B C D E F G H I
Final OC DI: RF 0 0 1 1 1 0 0 0 0

Figure E-2. Occupant Compartment Deformation Index (OCDI), Test TCBT-1

VEHICLE PRE/POST CRUSH INFO
Set-1

TEST: TCBT-2
VEHICLE: 2003 Ram 1500 Q.C. 4x2

Note: If impact is on driver side need to enter negative number for Y

POINT	X	Y	Z	X'	Y'	Z'	DEL X	DEL Y	DEL Z
1	26.25	12.5	-0.25	26.25	12.5	-0.25	0	0	0
2	29	16.75	-2.75	28.75	16.5	-1.5	-0.25	-0.25	1.25
3	31.5	23.25	-1.75	29.5	21.5	0.5	-2	-1.75	2.25
4	29	29.5	-0.5	29.5	27.75	2	0.5	-1.75	2.5
5	19.75	8	-1.5	19.5	8	-1.25	-0.25	0	0.25
6	20.75	11.5	-2.75	20.5	11.25	-2.75	-0.25	-0.25	0
7	22	16.5	-4.75	21.75	15.5	-5	-0.25	-1	-0.25
8	23.25	24.25	-6.75	21.5	22.75	-5.25	-1.75	-1.5	1.5
9	23.5	30.25	-6.25	21.75	28.75	-5.25	-1.75	-1.5	1
10	12	5	-3	12	5	-2.75	0	0	0.25
11	12.5	9.75	-6.75	12.5	8.75	-7	0	-1	-0.25
12	12.5	16.5	-8.75	12.5	15.5	-8.5	0	-1	0.25
13	13.5	25	-8	12.5	24.25	-7.25	-1	-0.75	0.75
14	14	29.75	-7.75	13.5	29.25	-7.5	-0.5	-0.5	0.25
15	5.75	2.75	-3.25	6	2.75	-3.25	0.25	0	0
16	5.5	8.25	-3.75	5.5	8.5	-3.5	0	0.25	0.25
17	8.5	13.25	-8.75	8.25	12.5	-9.25	-0.25	-0.75	-0.5
18	8	23	-8	7.5	22.75	-8.5	-0.5	-0.25	-0.5
19	8	29.5	-7.25	8	29.25	-8.5	0	-0.25	-1.25
20	0.75	2	-2.75	0.75	2	-2.75	0	0	0
21	0.75	6.5	-2.5	0.75	6.5	-2.25	0	0	0.25
22	0.5	11.5	-4.5	0.5	11.25	-4.75	0	-0.25	-0.25
23	0.5	17	-4	0.5	16.75	-4.5	0	-0.25	-0.5
24	0.75	22	-3.75	0.75	21.5	-4.5	0	-0.5	-0.75
25	0.75	28.5	-3.25	0.75	28.25	-4.25	0	-0.25	-1
26	18.5	16.5	-8.75	18	15.75	-9	-0.5	-0.75	-0.25
27	18.5	25.5	-8.5	17.5	25	-7.5	-1	-0.5	1
28									
29									
30									

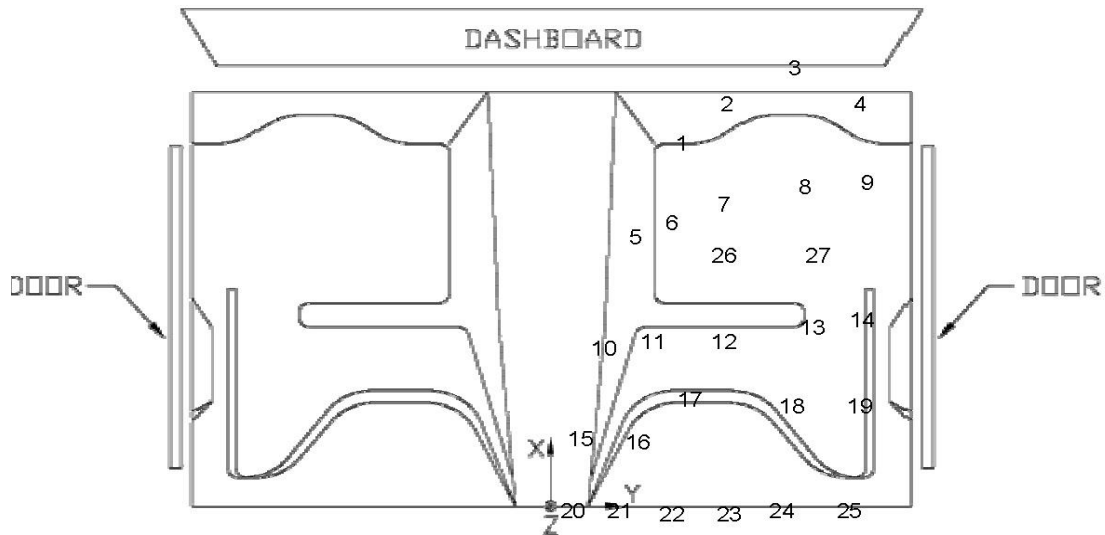

Figure E-3. Occupant Compartment Deformation Data - Set 1, Test TCBT-2

VEHICLE PRE/POST CRUSH INFO
Set-2

TEST: TCBT-2
VEHICLE: 2003 Ram 1500 Q.C, 4x2

Note: If impact is on driver side need to enter negative number for Y

POINT	X	Y	Z	X'	Y'	Z'	DEL X	DEL Y	DEL Z
1	49.25	14.75	-0.75	49.25	14.75	-0.25	0	0	0.5
2	52	19	-2	51.75	18.75	-1.75	-0.25	-0.25	0.25
3	54.5	25.5	-2.5	52.5	23.75	0	-2	-1.75	2.5
4	52	31.75	-1.25	52.5	30	1	0.5	-1.75	2.25
5	42.75	10.25	-1.75	42.5	10.25	-1.5	-0.25	0	0.25
6	43.75	13.75	-3.25	43.5	13.5	-3	-0.25	-0.25	0.25
7	45	18.75	-5.5	44.75	17.75	-5.5	-0.25	-1	0
8	46.25	26.5	-7.5	44.5	25	-6	-1.75	-1.5	1.5
9	46.5	32.5	-7.25	44.75	31	-6	-1.75	-1.5	1.25
10	35	7.25	-3	35	7.25	-3	0	0	0
11	35.5	12	-7.25	35.5	11	-7.5	0	-1	-0.25
12	35.5	18.75	-9.5	35.5	17.75	-9.25	0	-1	0.25
13	36.5	27.25	-9.25	35.5	26.5	-8.25	-1	-0.75	1
14	37	32	-9	36.5	31.5	-8.5	-0.5	-0.5	0.5
15	28.75	5	-3.25	29	5	-3.25	0.25	0	0
16	28.5	10.5	-4.25	28.5	10.75	-4	0	0.25	0.25
17	31.5	15.5	-9.5	31.25	14.75	-9.75	-0.25	-0.75	-0.25
18	31	25.25	-9	30.5	25	-9.5	-0.5	-0.25	-0.5
19	31	31.75	-8.5	31	31.5	-9.5	0	-0.25	-1
20	23.75	4.25	-3	23.75	4.25	-2.75	0	0	0.25
21	23.75	8.75	-3	23.75	8.75	-2.75	0	0	0.25
22	23.5	13.75	-5.25	23.5	13.5	-5.5	0	-0.25	-0.25
23	23.5	19.25	-5	23.5	19	-5.5	0	-0.25	-0.5
24	23.75	24.25	-5	23.75	23.75	-5.5	0	-0.5	-0.5
25	23.75	30.75	-4.75	23.75	30.5	-5.75	0	-0.25	-1
26	41.5	18.75	-9.5	41	18	-9.25	-0.5	-0.75	0.25
27	41.5	27.75	-9.5	40.5	27.25	-8	-1	-0.5	1.5
28							0	0	0
29									
30									

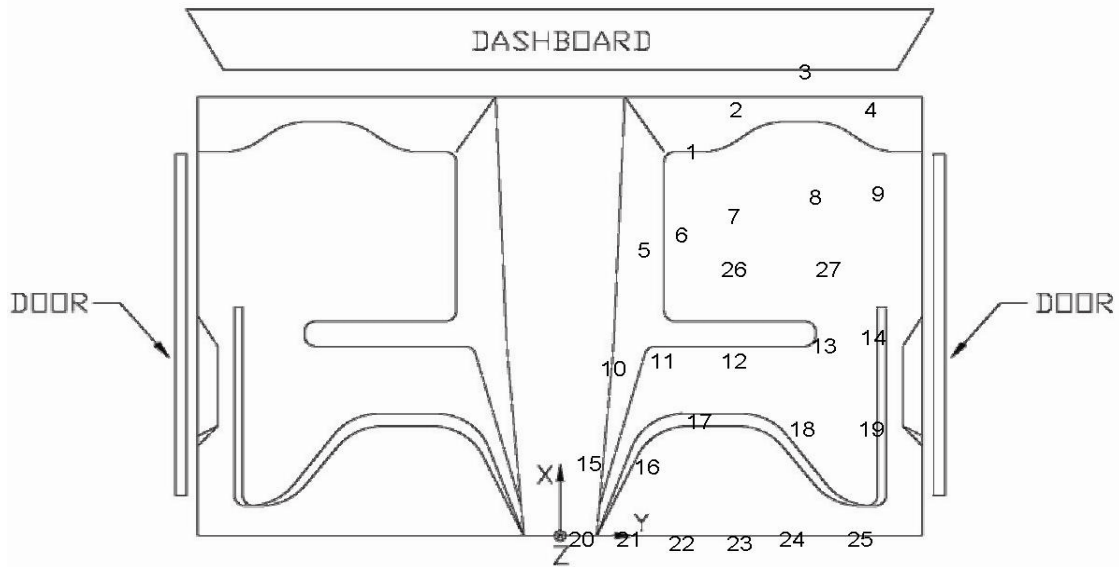

Figure E-4. Occupant Compartment Deformation Data - Set 2, Test TCBT-2

Occupant Compartment Deformation Index (OCDI)

Test No. TCBT-2
Vehicle Type: 2003 Dodge Ram 1500

OCDI = XXABCDEFGHI

XX = location of occupant compartment deformation

A = distance between the dashboard and a reference point at the rear of the occupant compartment, such as the top of the rear seat or the rear of the cab on a pickup

B = distance between the roof and the floor panel

C = distance between a reference point at the rear of the occupant compartment and the motor panel

D = distance between the lower dashboard and the floor panel

E = interior width

F = distance between the lower edge of right window and the upper edge of left window

G = distance between the lower edge of left window and the upper edge of right window

H = distance between bottom front corner and top rear corner of the passenger side window

I = distance between bottom front corner and top rear corner of the driver side window

Severity Indices

- 0 - if the reduction is less than 3%
- 1 - if the reduction is greater than 3% and less than or equal to 10 %
- 2 - if the reduction is greater than 10% and less than or equal to 20 %
- 3 - if the reduction is greater than 20% and less than or equal to 30 %
- 4 - if the reduction is greater than 30% and less than or equal to 40 %

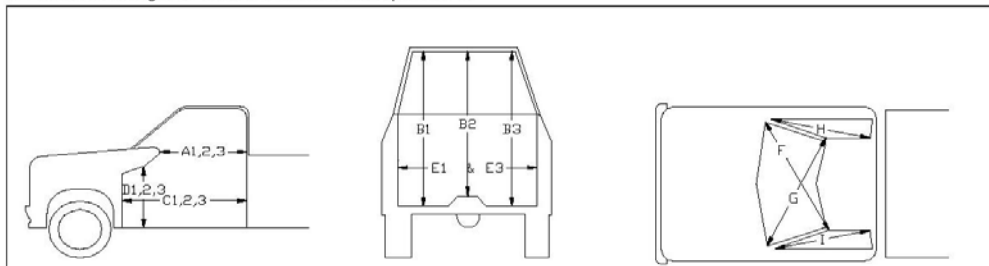

where,
1 = Passenger Side
2 = Middle
3 = Driver Side

Location:

Measurement	Pre-Test (in.)	Post-Test (in.)	Change (in.)	% Difference	Severity Index
A1	50.75	55.25	4.50	8.87	1
A2	50.00	50.00	0.00	0.00	0
A3	55.50	55.00	-0.50	-0.90	0
B1	44.00	44.00	0.00	0.00	0
B2	42.25	42.00	-0.25	-0.59	0
B3	46.00	47.00	1.00	2.17	0
C1	67.25	67.25	0.00	0.00	0
C2	47.50	47.50	0.00	0.00	0
C3	64.25	61.75	-2.50	-3.89	1
D1	23.50	23.50	0.00	0.00	0
D2	13.25	13.25	0.00	0.00	0
D3	22.25	22.50	0.25	1.12	0
E1	65.50	64.00	-1.50	-2.29	0
E3	64.75	63.25	-1.50	-2.32	0
F	57.00	56.75	-0.25	-0.44	0
G	57.50	57.25	-0.25	-0.43	0
H	36.75	36.75	0.00	0.00	0
I	37.00	37.00	0.00	0.00	0

Note: Maximum severity index for each variable (A-I) is used for determination of final OCDI value

Final OCDI: XX A B C D E F G H I
RF 1 0 1 0 0 0 0 0 0

Figure E-5. Occupant Compartment Deformation Index (OCDI), Test TCBT-2

Date: 4/4/2008 Test Number: TCBT-1
Make: Dodge Model: Ram 1500 Q.C. Year: 2002

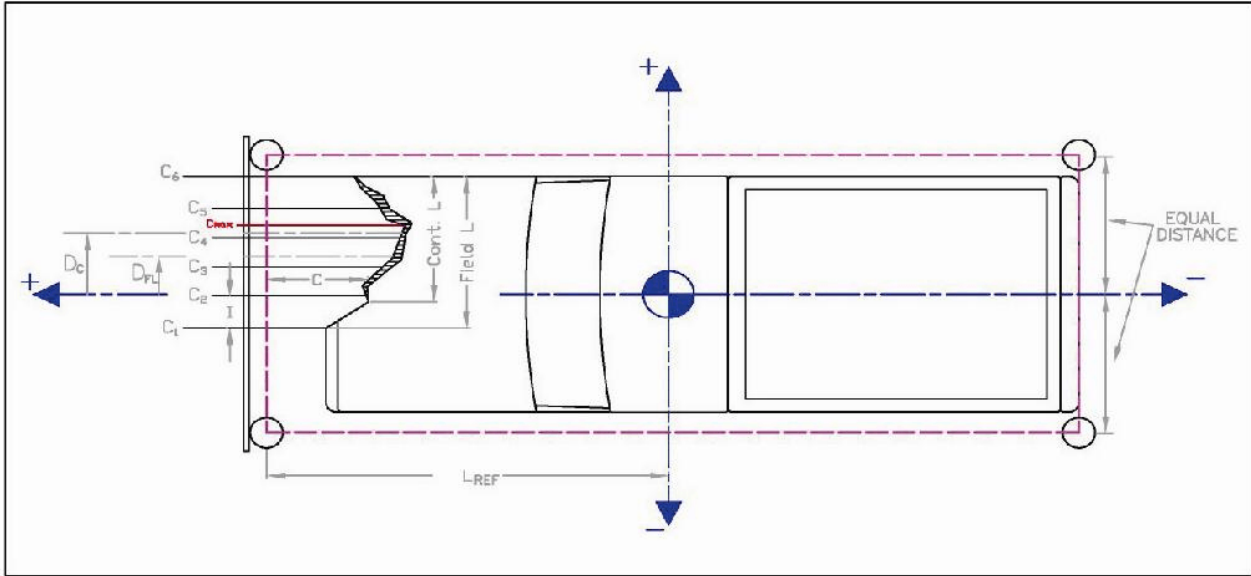

	in.	(mm)
Distance from C.G. to reference line - L_{REF} :	110.25	(2800)
Width of contact and induced crush - Field L:	39	(991)
Crush measurement spacing interval ($L/5$) - I:	7.8	(198)
Distance from center of vehicle to center of Field L - D_{FL} :	19.5	(495)
Width of Contact Damage:	16	(406)
Distance from center of vehicle to center of contact damage - D_c :	31	(787)

	Crush Measurement		Lateral Location		Original Profile Measurement		Dist. Between Ref. Lines		Actual Crush	
	in.	(mm)	in.	(mm)	in.	(mm)	in.	(mm)	in.	(mm)
C ₁	3.75	(95)	0	(0)	10.25	(260)	-4.5	-(114)	-2	-(51)
C ₂	4	(102)	7.8	(198)	10.4844	(266)			-1.9844	-(50)
C ₃	7	(178)	15.6	(396)	11.6563	(296)			-0.1563	-(4)
C ₄	20.5	(521)	23.4	(594)	13.3906	(340)			11.6094	(295)
C ₅	NA	#####	31.2	(792)	16.8125	(427)			#####	#####
C ₆	NA	#####	39	(991)	29	(737)			#####	#####
C _{MAX}	20.5	(521)	23.4	(594)	13.3906	(340)			11.6094	(295)

Figure E-6. Exterior Vehicle Crush (NASS) - Front, Test TCBT-1

Date: 4/23/2008 Test Number: TCBT-2
Make: Dodge Model: Ram 1500 Q.C. Year: 2003

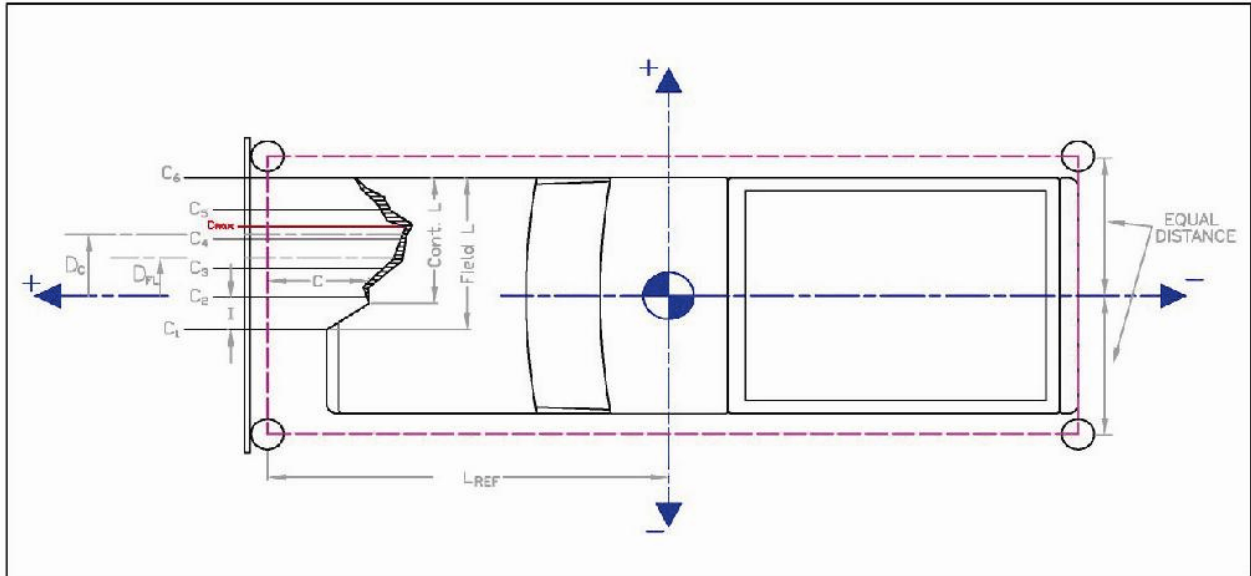

	in.	(mm)
Distance from C.G. to reference line - L_{REF} :	109	(2769)
Width of contact and induced crush - Field L:	23.5	(597)
Crush measurement spacing interval ($L/5$) - I:	4.7	(119)
Distance from center of vehicle to center of Field L - D_{FL} :	27.25	(692)
Width of Contact Damage:	23.5	(597)
Distance from center of vehicle to center of contact damage - D_c :	27.25	(692)

	Crush Measurement		Lateral Location		Original Profile Measurement		Dist. Between Ref. Lines		Actual Crush	
	in.	(mm)	in.	(mm)	in.	(mm)	in.	(mm)	in.	(mm)
C ₁	8.5	(216)	15.5	(394)	11.6563	(296)	-5	(-127)	1.84375	(47)
C ₂	11.5	(292)	20.2	(513)	12.5	(318)			4	(102)
C ₃	23	(584)	24.9	(632)	13.9531	(354)			14.0469	(357)
C ₄	29.75	(756)	29.6	(752)	15.9063	(404)			18.8438	(479)
C ₅	NA	#####	34.3	(871)	19.5938	(498)			#####	#####
C ₆	NA	#####	39	(991)	29	(737)			#####	#####
C _{MAX}	29.75	(756)	29.6	(752)	15.9063	(404)			18.8438	(479)

Figure E-7. Exterior Vehicle Crush (NASS) - Front, Test TCBT-2

APPENDIX F

Accelerometer and Rate Transducer Data Analysis, Test No. TCBT-1

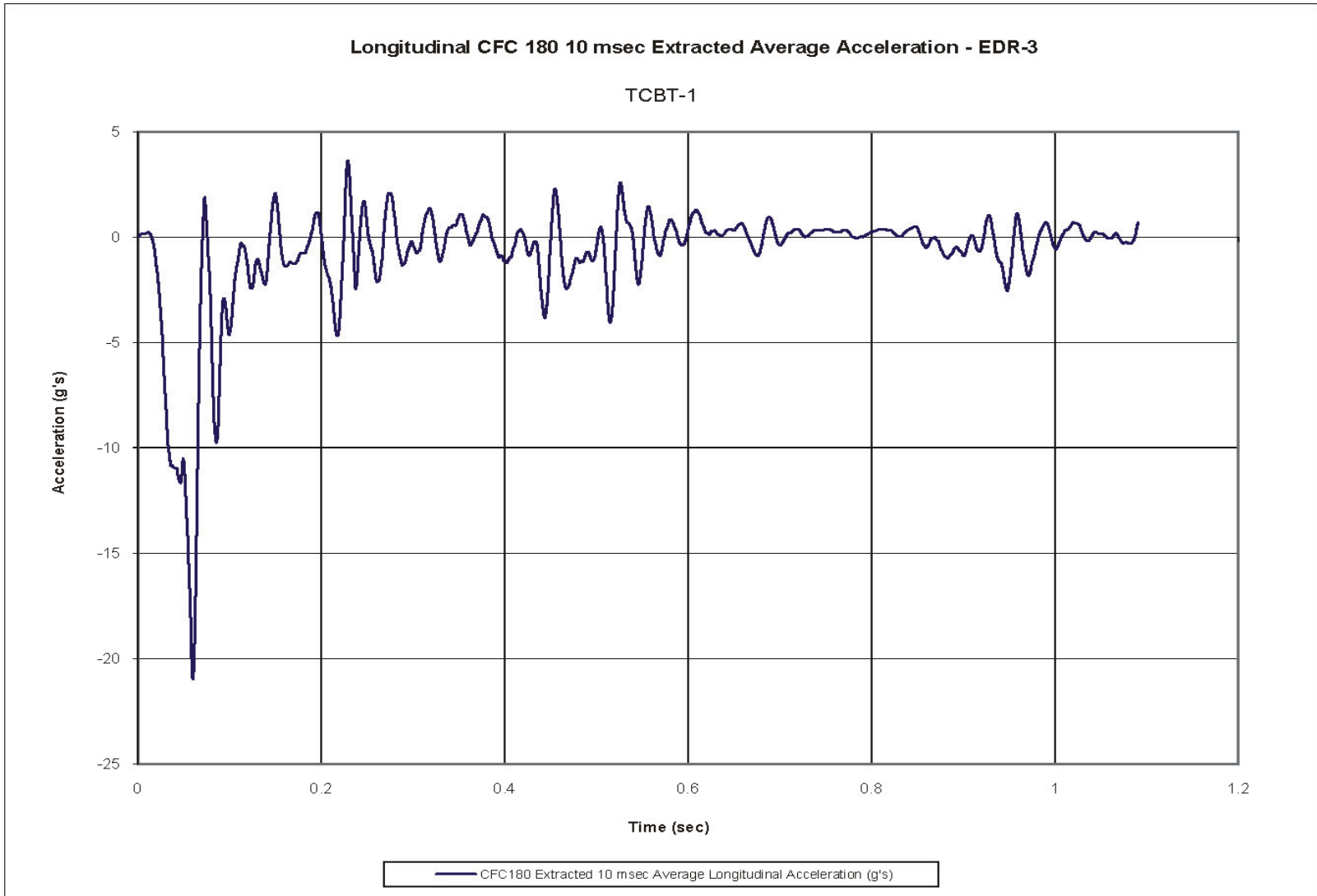

Figure F-1. 10-ms Average Longitudinal Deceleration (EDR-3), Test No. TCBT-1

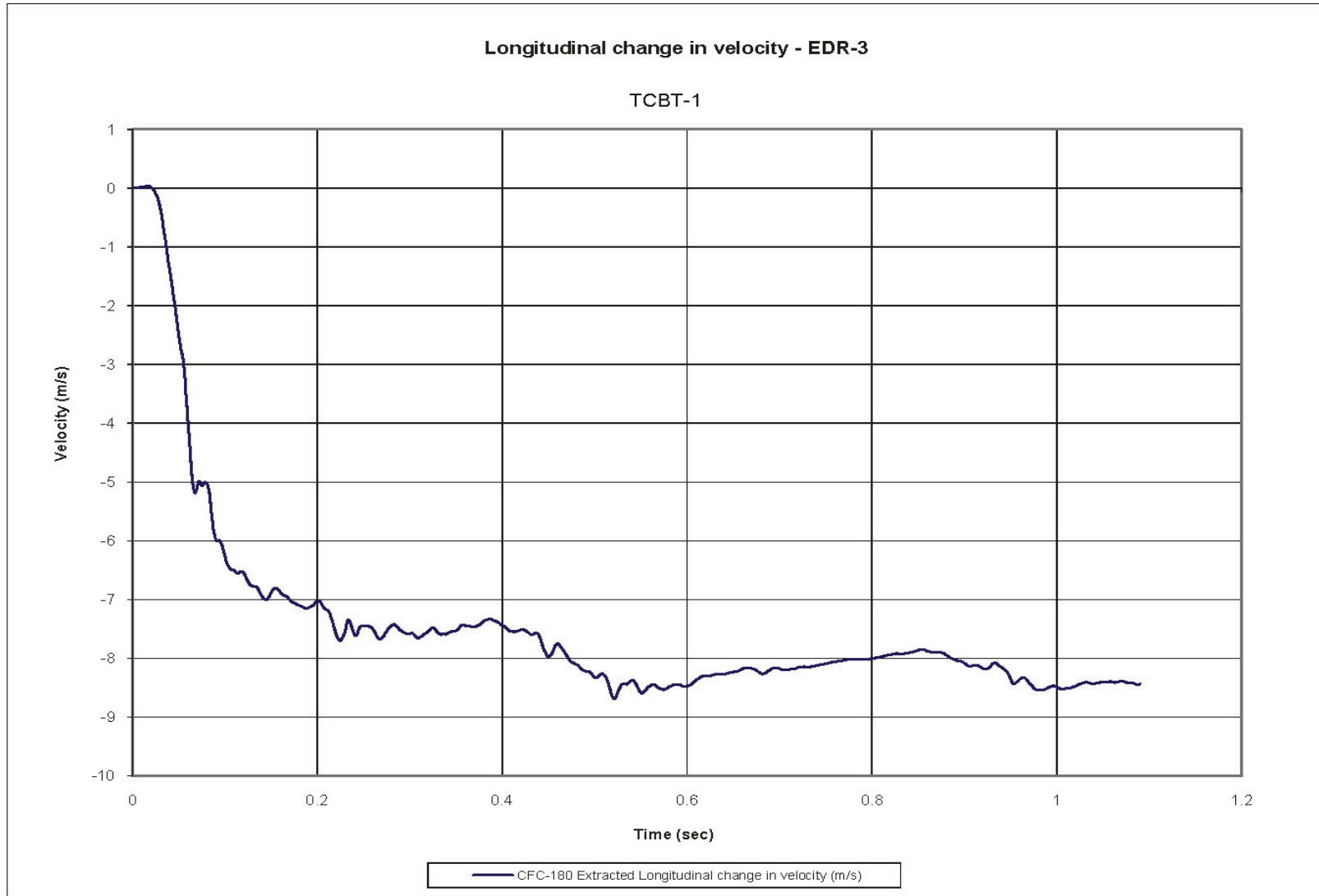

Figure F-2. Longitudinal Occupant Impact Velocity (EDR-3), Test No. TCBT-1

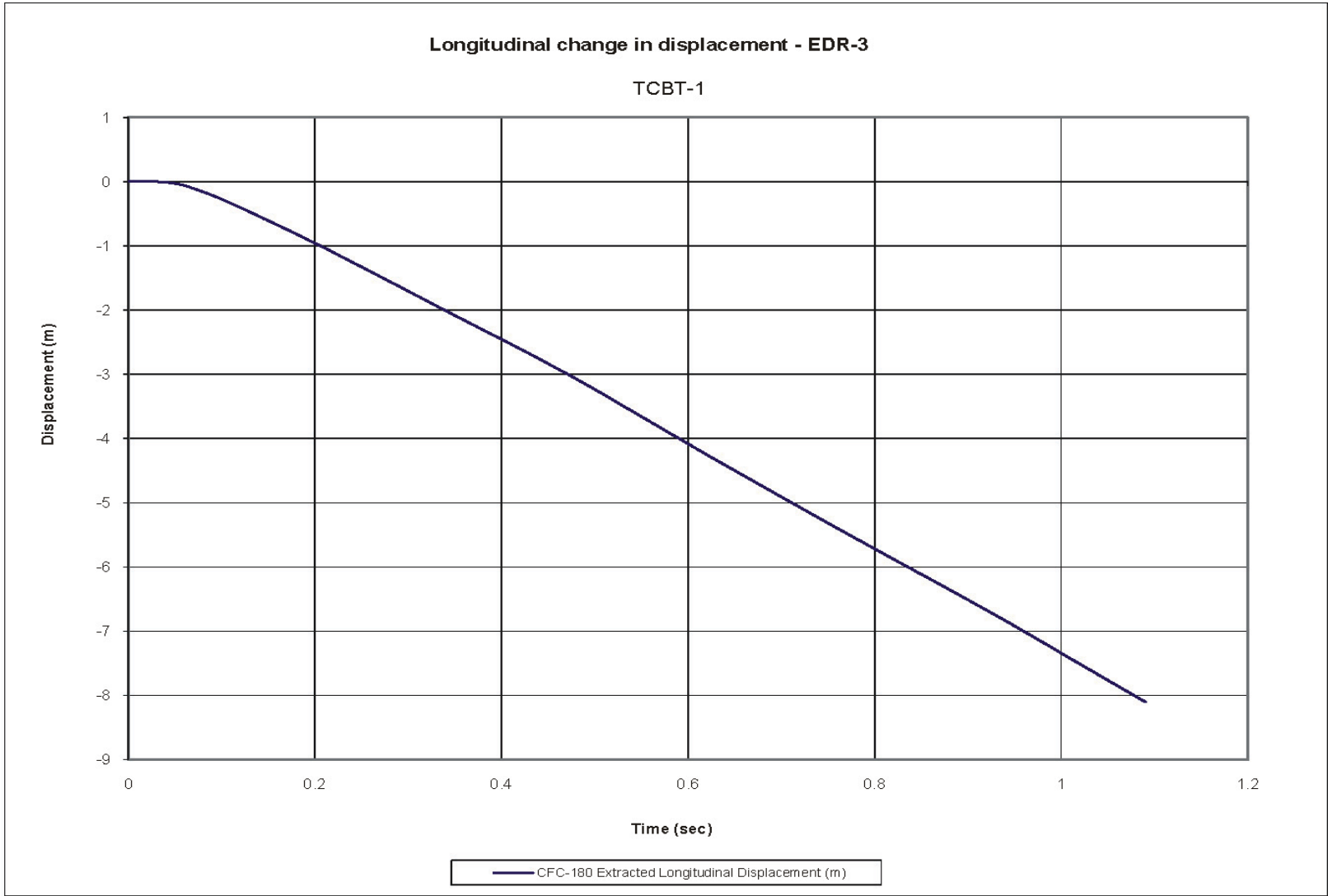

Figure F-3. Longitudinal Occupant Displacement (EDR-3), Test No. TCBT-1

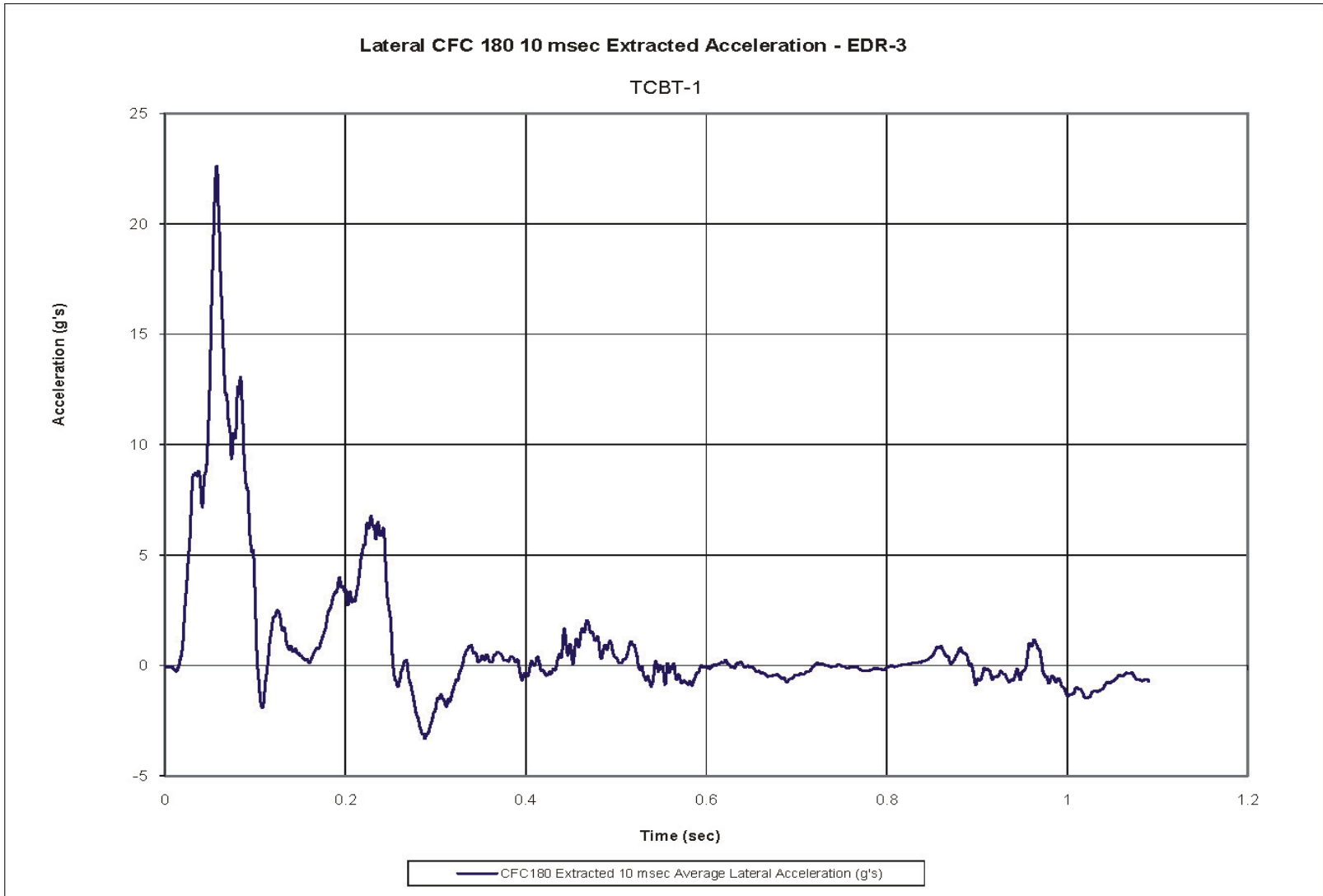

Figure F-4. 10-ms Average Lateral Deceleration (EDR-3), Test No. TCBT-1

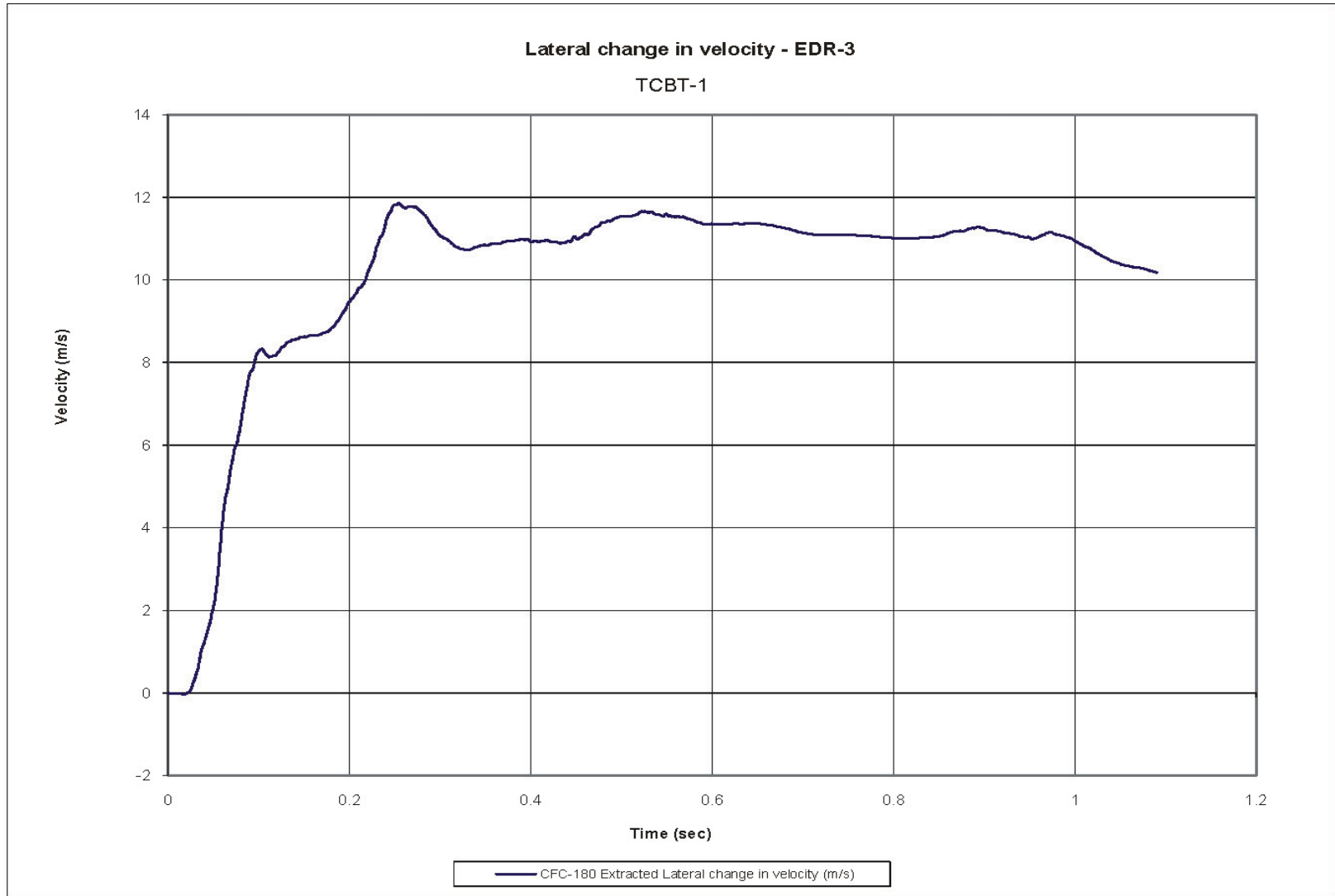

Figure F-5. Lateral Occupant Impact Velocity (EDR-3), Test No. TCBT-1

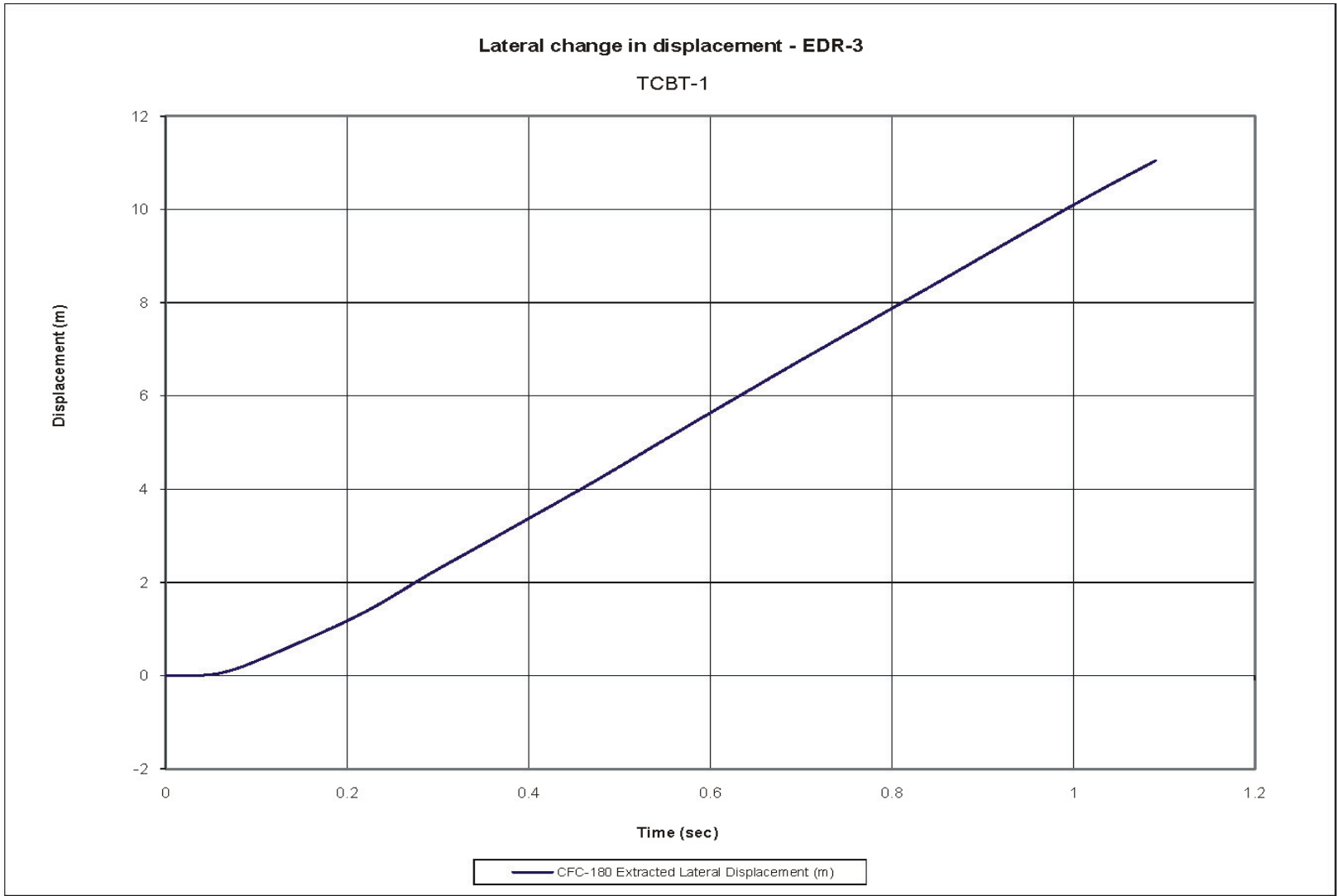

Figure F-6. Lateral Occupant Displacement (EDR-3), Test No. TCBT-1

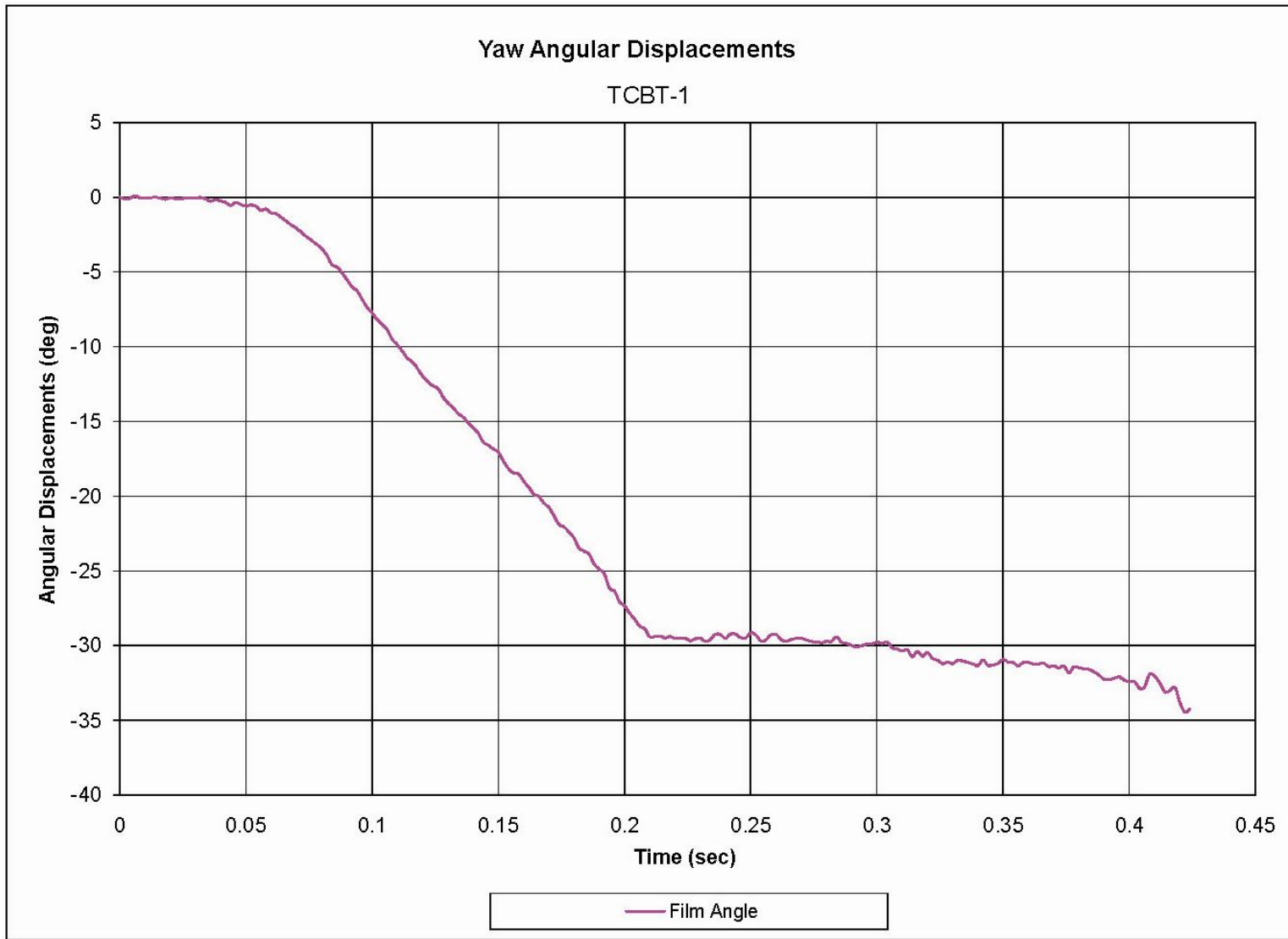

Figure F-7. Yaw Angular Displacements, Test No. TCBT-1

APPENDIX G

Accelerometer and Rate Transducer Data Analysis, Test No. TCBT-2

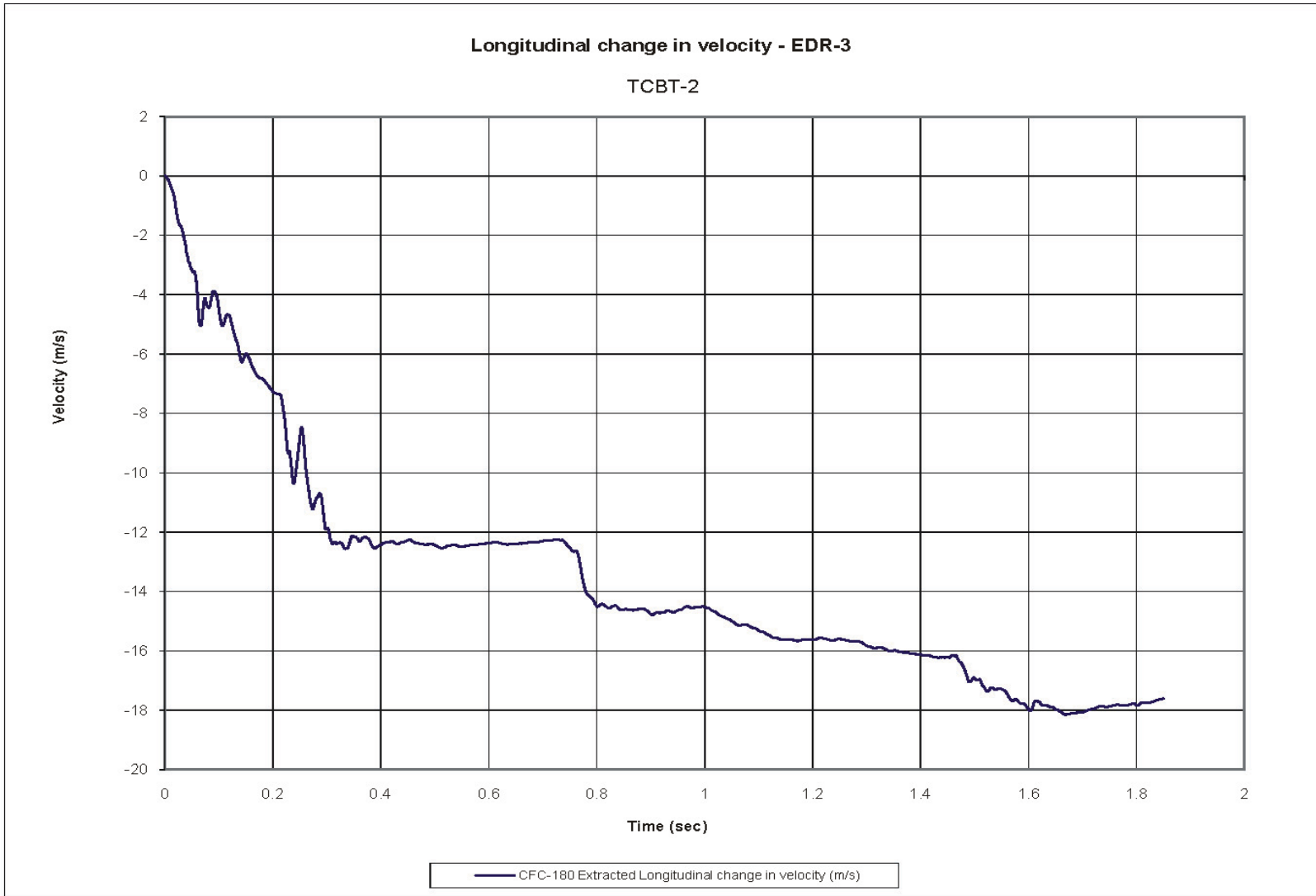

Figure G-1. 10-ms Average Longitudinal Deceleration (EDR-3), Test No. TCBT-2

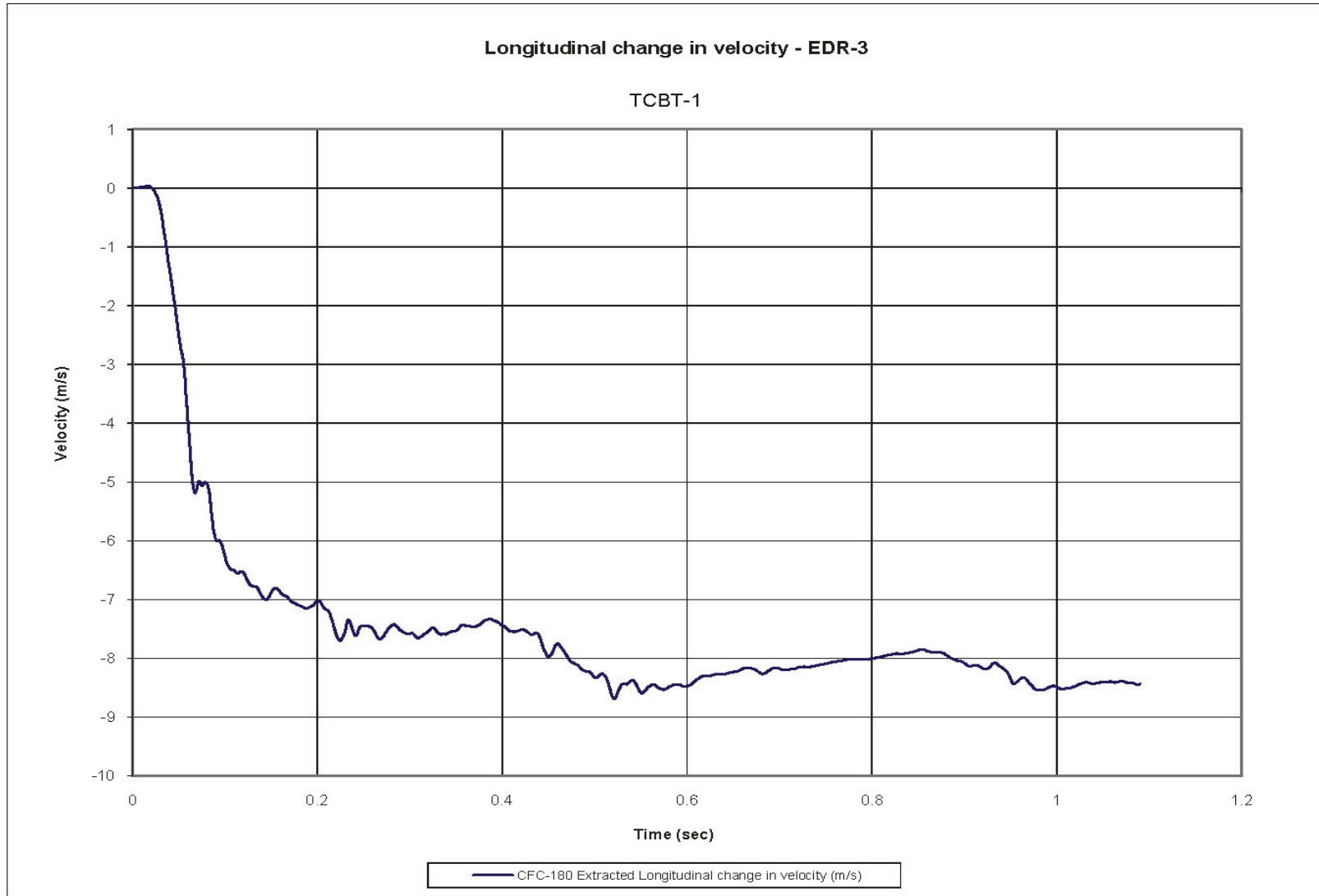

Figure G-2. Longitudinal Occupant Impact Velocity (EDR-3), Test No. TCBT-2

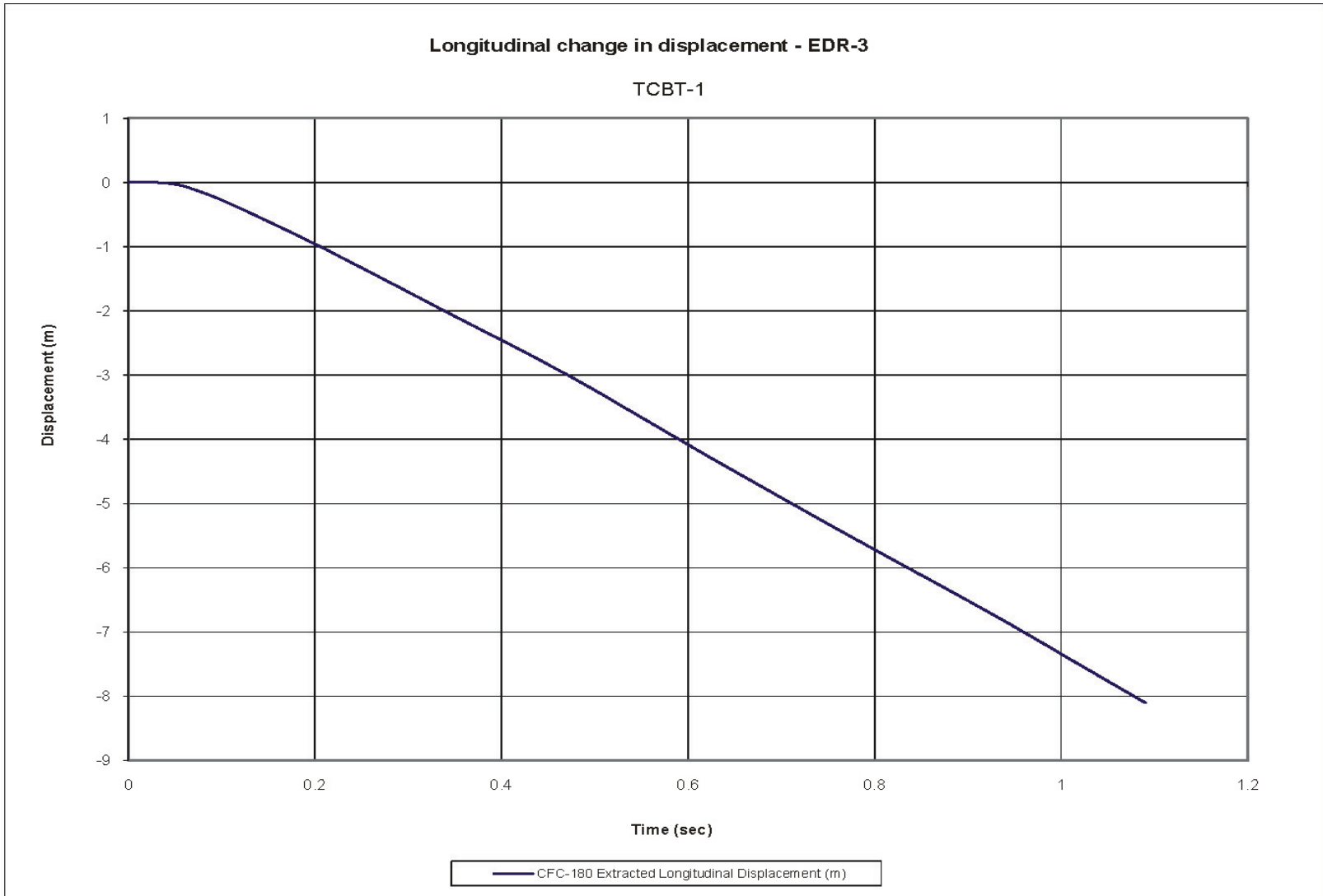

Figure G-3. Longitudinal Occupant Displacement (EDR-3), Test No. TCBT-2

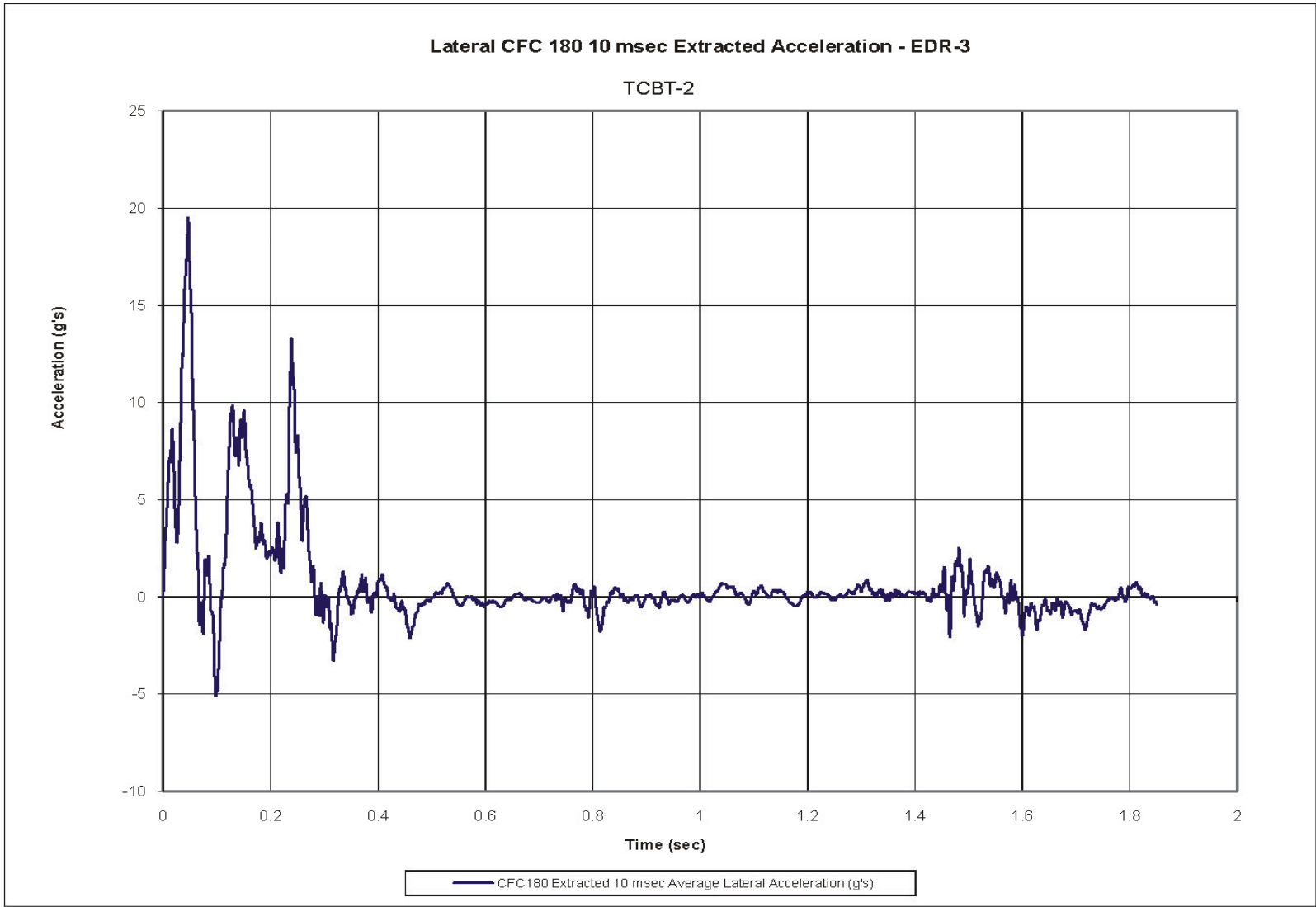

Figure G-4. 10-ms Average Lateral Deceleration (EDR-3), Test No. TCBT-2

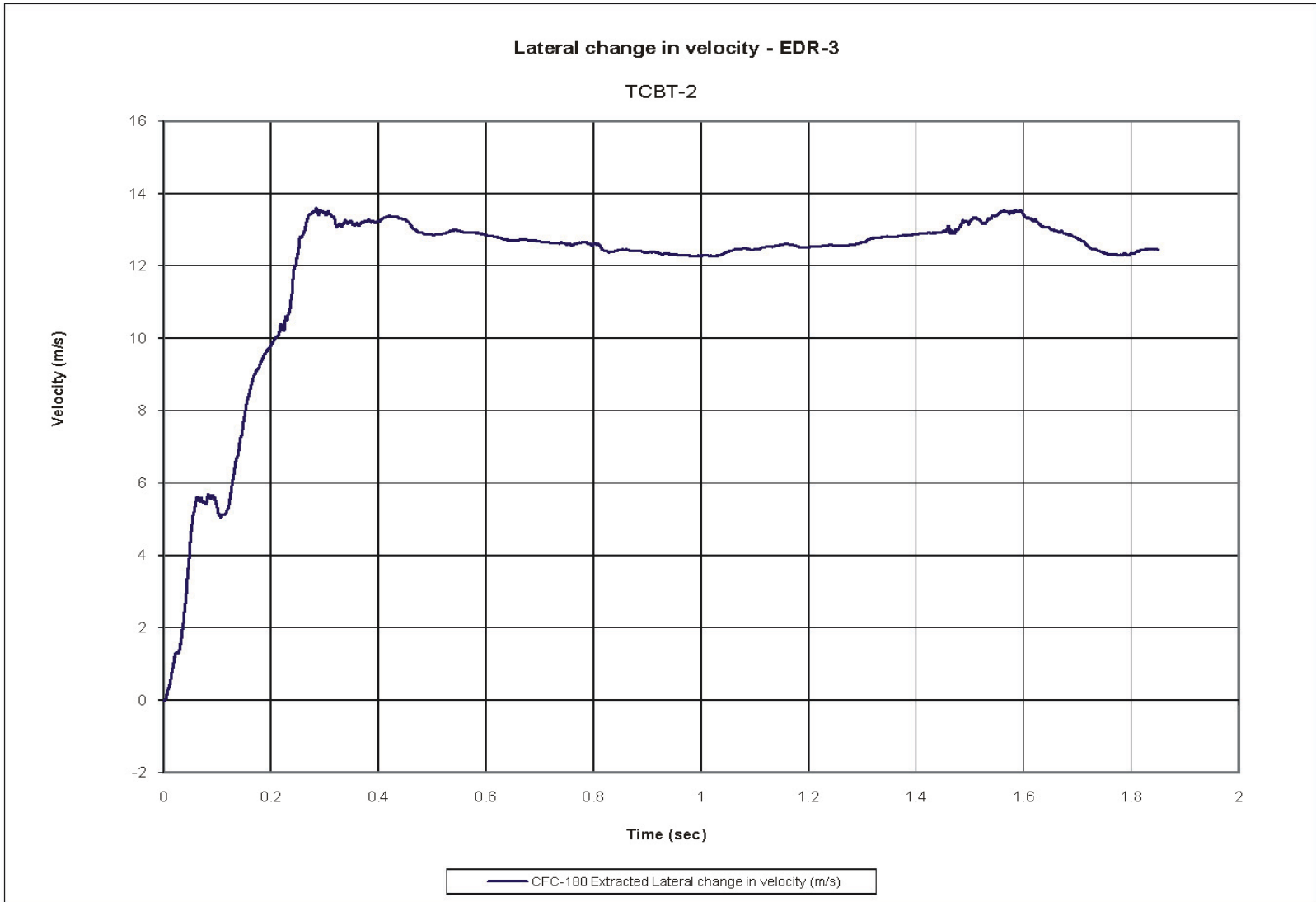

Figure G-5. Lateral Occupant Impact Velocity (EDR-3), Test No. TCBT-2

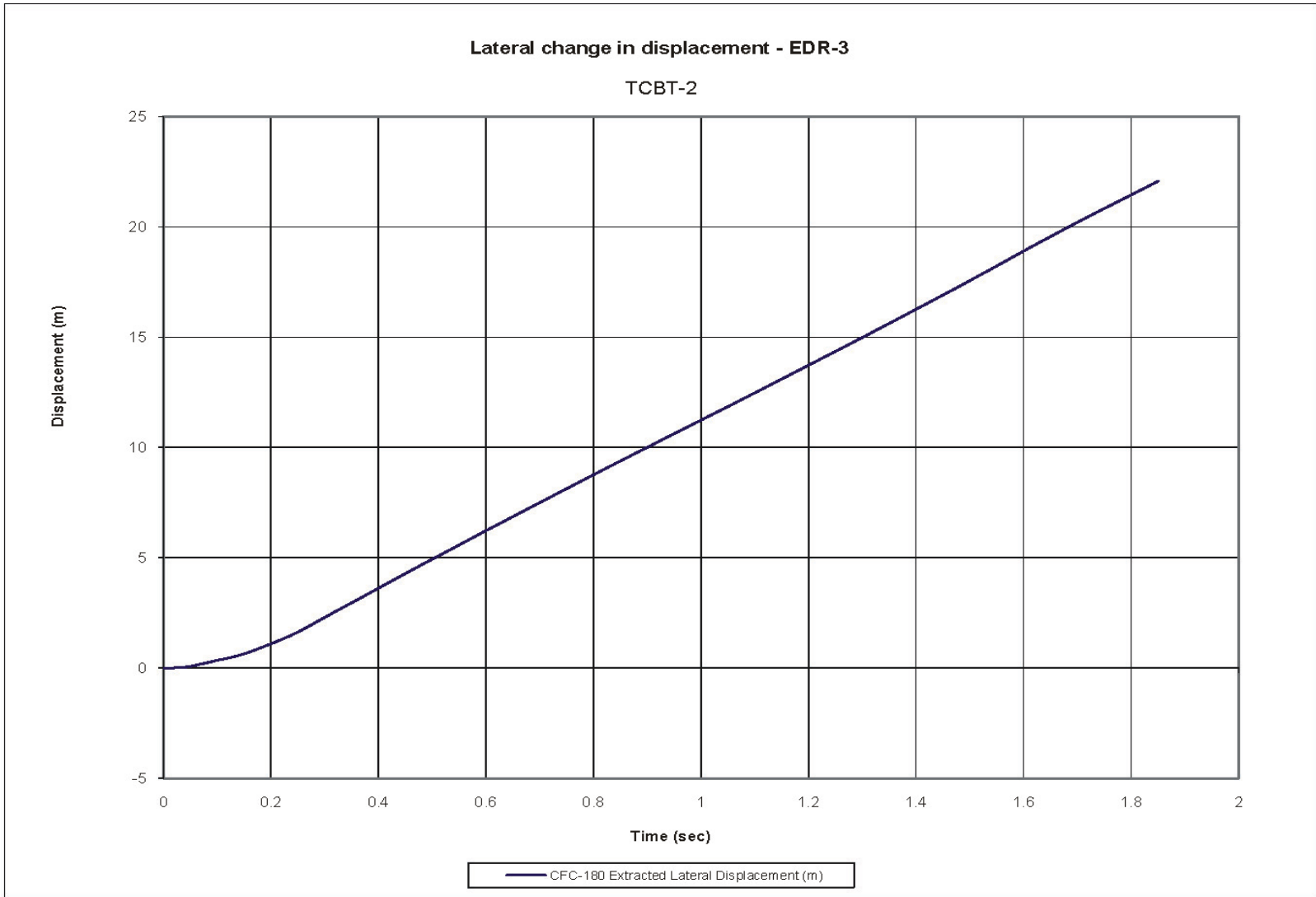

Figure G-6. Lateral Occupant Displacement (EDR-3), Test No. TCBT-2

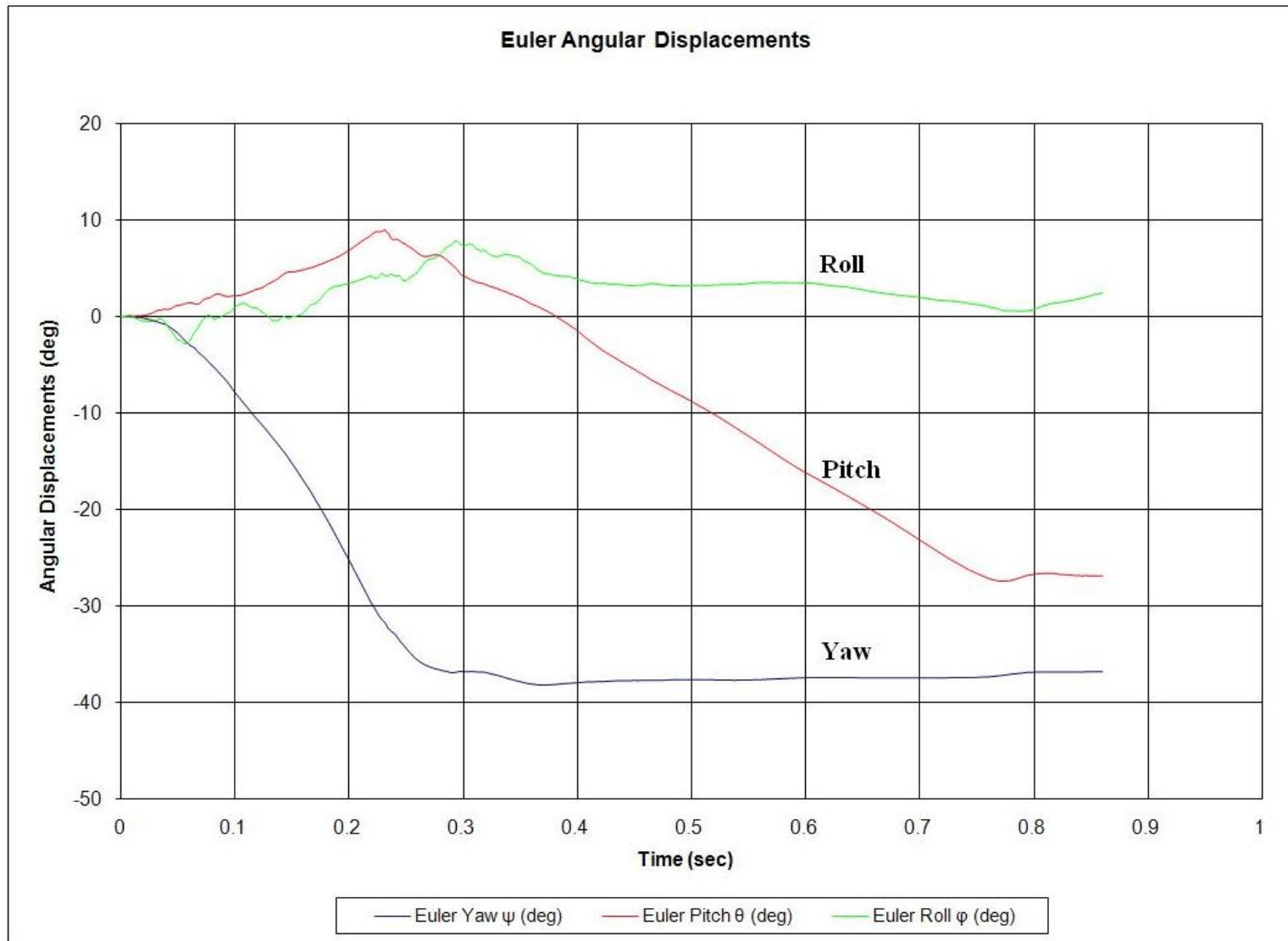

Figure G-7. Graph of Roll, Pitch and Yaw Angular Displacements, Test No. TCBT-2

END OF DOCUMENT